

AUSTRALIA'S NUMBER ONE ELECTRONICS MAGAZINE

ELECTRONICS

AUSTRALIA

Registered by Australia Post — publication No. NBP0240.

APRIL 1983

AUST \$2.10 NZ \$2..60

INSIDE THIS ISSUE:

- **Stereo simulator**
- **Touch controlled light dimmer**
- **EMP: the new nuclear danger**
- **Eight-channel mixer**
- **Add speech to your TRS-80**

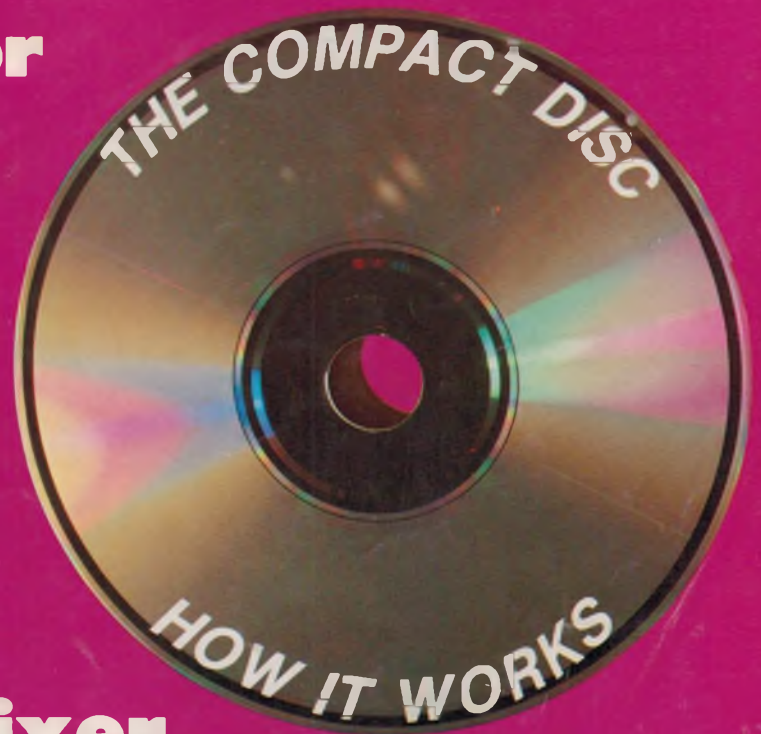

PLUS ALL OUR USUAL FEATURES

**BONUS 156-PAGE
DICK SMITH CATALOGUE**





Space Considerations

Boost the capacity and performance of your system with Saturn disk drives from Ampec. These proven micro-Winchester drives provide a high performance upgrade for existing minifloppy-based systems — and a compact, low-cost alternative to 8 and 14 in. Winchester-based systems.

The Ampec Saturn ST 506 offers you a storage capacity of 6.38 megabytes unformatted or 5 megabytes formatted, with the same physical size and mounting as the minifloppy disk drives . . . the same DC power requirements as minifloppies . . . and a similar, simple interface.

For even more capacity, choose the Ampec Saturn ST 412 with storage of 12.76 megabytes unformatted or 10 megabytes formatted. This drive uses the same interface as the ST 506, is the same physical size and mounting, and DC

voltage requirements; it features low heat dissipation (25 watts typical) and a projected service life of 11,000 hours MTBF.

For OEMs seeking the maximum in capacity and performance, Ampec, with its Saturn hard disk drives, does offer the absolute in peripherals.



AMPEC

The absolute in peripheral thinking.

(02) 818 1166 (03) 878 8788 (07) 57 9366 (08) 212 6068 (09) 272 7511

ELECTRONICS

AUSTRALIA

Volume 45, No. 4
April, 1983

AUSTRALIA'S LARGEST SELLING ELECTRONICS MAGAZINE

Elaborate, versatile 8-Channel Mixer



Designed for musical groups, this unit will mix-down from eight inputs to two outputs, with equalisers, pan-pot, and foldback facilities. Full constructional details on p74.

Low cost stereo simulator



Our new Stereo Simulator is cheap enough for most pockets, small enough to fit inside most amplifier or tuner cabinets, and provides a worthwhile spread for mono sound. See p48.

Next Month in EA

See page 140

FEATURES

ELECTROMAGNETIC PULSE <i>One bomb could black out a nation</i>	14
ANZCAN — CABLE TO CANADA <i>Australian achievement</i>	20
WIND GENERATOR <i>Further design thoughts</i>	24
50 & 25 YEARS AGO <i>AWA on 7 metres, robot trains</i>	120

HIFI, VIDEO AND REVIEWS

COMPACT DISC <i>Controls and programming</i>	36
AUDIO, VIDEO ELECTRONICS <i>Recent releases</i>	40
HIFI REVIEW <i>Technics SL-Q20 automatic turntable</i>	44

PROJECTS AND CIRCUITS

STEREO SIMULATOR <i>For tuners and VCRs</i>	48
TOUCH-LAMP DIMMER <i>Light control at a touch</i>	58
BALANCED 8-CHANNEL MIXER <i>With comprehensive facilities</i>	74
PRE-AMP FOR MOVING COIL CARTRIDGES <i>Optimised for low noise</i>	84
THE KINGSWOOD CARPENTER'S LEVEL <i>For Kingswood carpenters</i>	86
HOW TO MAKE A BUZZER <i>Simple beginner's project</i>	90
CIRCUIT AND DESIGN IDEAS <i>Model railway signal override etc</i>	72

PERSONAL COMPUTERS

COMPUVOICE FOR TRS-80 <i>Add-on versatility</i>	92
SHARP PC-1500 POCKET COMPUTER <i>Powerful, portable, expandable</i>	122
MICROCOMPUTER NEWS <i>Motorola evaluation board for MC68000</i>	128

COLUMNS

FORUM <i>More about AM; how diode detectors work</i>	32
THE SERVICEMAN <i>How to acquire a CRO — and still need one</i>	68
SHORTWAVE SCENE <i>Huge increase in world radio audience</i>	113
RECORD REVIEWS <i>Classical, popular & special interest</i>	114

DEPARTMENTS

EDITORIAL	3	NEW PRODUCTS	104
NEWS HIGHLIGHTS	8	INFORMATION CENTRE	138
LETTERS TO THE EDITOR	99	MARKETPLACE	142
BOOKS AND LITERATURE	100	NOTES AND ERRATA	141

When you're ready to 'face' the music we have a tip for reduced distortion.

The hyperelliptical stylus tip, acclaimed for its low distortion and high trackability, is now available in a whole series of Shure pickups. Whether you're seeking to reproduce the full dynamic range of today's new superdiscs, or simply to obtain maximum listening pleasure from treasured records in your collection, you'll find an HE pickup with the combination of features and performance that best meets your needs from the models below.



M95HE
Features high trackability, flat frequency response, low loss/high output magnetic pole piece, at a modest price.

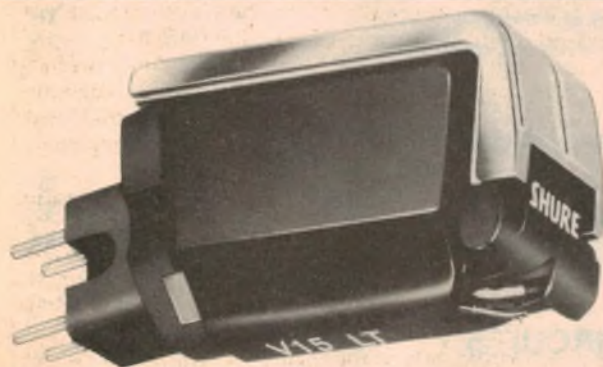

V15LT & M97LT
(Linear Tracking Models.) Get the most from advanced technology linear tracking turntables! Performance comparable to V15IV and M97HE respectively.

M97HE-AH "the Headliner".
All the design and performance of the M97HE plus the simplicity of plug-in connection. Allows instant attachment to the tone arm of most turntables.

M97HE
Top of the line features and excellent performance at an intermediate price. Features Dynamic Stabilizer and SIDE-GUARD stylus protector.

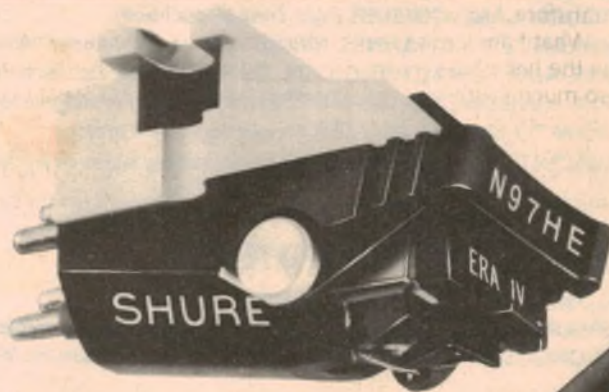

MV30HE
Sleek, integral pickup/arm carrier combination for use with SME Series III and SME Series IIIS tone arms. Performance similar to V15IV.



V15 Type IV
Perfectionists choice! With unprecedented trackability, ultra-flat response. Dynamic Stabilizer, low effective stylus mass.

hi fi

SHURE

AUDIO ENGINEERS P/L 342 Kent Street Sydney NSW 2000 (02) 29 6731	NOMIS ELECTRONICS 689 South Road Black Forest SA 5035 (08) 293 4896	AUDIO ENGINEERS Qld 47 Castlemaine Street Milton Qld 4064 (07) 369 9670	AUDIO ENGINEERS Vic 2A Hill Street Thornbury Vic 3071 (03) 44 3295	MARKETEC 18 King William Street Sth Fremantle WA 6162 (09) 335 8275
--	---	---	--	---



Editorial Viewpoint

EDITOR-IN-CHIEF

Neville Williams
F.I.R.E.E. (Aust.) (VK2XV)

EDITOR

Leo Simpson
B. Bus. (NSWIT)

ASSISTANT EDITOR

Greg Swain, B.Sc. (Hons. Sydney)

TECHNICAL PROJECTS

John Clarke, B.E. (Elect. NSWIT)
Peter Vernon, B.A. L.L.B. (NSW)
Jeff Skeen
Colin Dawson

PRODUCTION

Danny Hooper

GRAPHICS

Robert Flynn

SECRETARIAL

Pam Hilliar

ADVERTISING MANAGER

Selwyn Sayers

CIRCULATION MANAGER

Alan Parker

Mutually assured destruction: an engineer's dream

Any sane person who reads the article on the "Electromagnetic pulse threat from nuclear blast" beginning on page 14 of this issue may be excused for thinking that it is in some way connected with April Fools' day. Sadly, it is not. We present it as a serious report on the current thinking of strategic planners in the United States.

It seems as though the likelihood of people being killed in a nuclear conflict is not their main worry. Apparently, they are worried that the US would be unable to carry out a limited nuclear war because their military communications could be disabled by a pre-emptive nuclear strike in the upper atmosphere. This then is likely to cause a reversion to the older US policy of Mutually Assured Destruction (MAD).

Engineers are now addressing the problem of how to "harden" military communications and computers against damage due to these extreme electromagnetic pulses generated by nuclear explosions. The story of this new threat first appeared in the American Institute of Electronic and Electrical Engineers publication "Spectrum" in May 1981.

What really concerns me is that the people who conceive these diabolical ideas in the first place, are first and foremost, engineers. So, in recent years, we have seen the development and awesome use of really potent guided missiles together with the devising of desperate countermeasures such as the radar-guided Phalanx gatling gun; the concept of mass-drivers and the so-called "rail gun" and the spectre of orbiting atomic-powered laser weapons.

While all of these ideas originally existed only in the realms of fantasy, the single-minded efforts of engineers (and physicists, if you like) have, or will eventually, transform most of them into devilish reality.

What I am saying here is that engineers have conceived and proposed these ideas in the first place. Then they have gone to the military forces and said, "If you give us so much money we will develop this marvellous weapons system." And the military, recognising a lethal system when they see it, say, "Yes, yes, let's have it."

Engineers on both sides of the political fence must therefore shoulder a great deal of the responsibility for the continuing arms' race. I wonder how many engineers think of this when they are researching new weapons systems.

Leo Simpson

Editorial and Advertising Office

57 Regent St, Chippendale 2008.
Phone (02) 699 3622 Telex 25027.
Postal Address: PO Box 163, Chippendale, 2008.
Advertising Sales Manager: Sel Sayers.

Melbourne — 392 Little Collins St, Melbourne
3000. Phone (03) 602 3033
Representative: Mark Christian.

Adelaide — Charles F. Brown & Associates
Ltd, 178 Fullarton Rd, Dulwich 5065
Representative: Sandy Shaw (08) 332 7711.

Perth — 454 Murray Street, Perth 6000.
Representative: Ashley Croft (09) 321 8217.

Circulation Office

Unit 3B, Sydneygate, Waterloo, 2018.
Phone (02) 699 2388.

Subscriptions

Subscription Dept, John Fairfax & Sons Ltd,
GPO Box 506, Sydney 2001.
Enquiries: Phone (02) 20944, ext 2589.

Distribution

Distributed in NSW by Magazine Promotions,
57 Regent St, Chippendale; in Victoria by
Magazine Promotions, 392 Little Collins
Street, Melbourne; in South Australia by
Magazine Promotions, 101-105 Waymouth St,
Adelaide; in Western Australia by Magazine
Promotions, 454 Murray Street, Perth; in
Queensland by Gordon and Gotch (A'asia) Ltd;
in Tasmania by Ingle Distributors, 93 Mac-
quarie St, Hobart; in New Zealand by Gordon
and Gotch (NZ) Ltd, Adelaide Rd, Wellington.

Registered by Australia Post — publication No.
NBPO240.

Copyright. All rights reserved.

Devices or arrangements shown in this magazine may embody patents. Information is furnished without responsibility for its ultimate use, or for failure of equipment to operate as expected, or for any damage, loss or injury which may be sustained. Material intended for publication is submitted at the sender's risk and, while care will be taken, responsibility for any possible loss will not be accepted by "Electronics Australia".

Printed by Magazine Printers Pty Ltd, of Regent Street, Chippendale and Masterprint Pty Ltd of Dubbo NSW for Magazine Promotions, of Regent St, Chippendale.

ISSN 0313-0150

* Recommended and maximum price only.

YOUR COPY'S MISSING?

DICK SMITH CATALOGUE

83/84 OUT NOW

The new Dick Smith 1983 Catalogue is out. Did you find your copy in the issue? No? Alas, alack. How can you possibly last out 1983 without you Dick Smith catalogue - the data section alone is worth its weight in microprocessors. Duck into Dick's nearest store now for your copy. At 95¢ it's the years biggest bargain!

Some of the advertised lines have only limited stocks. **HURRY** while stocks last!



DICK SMITH

SUPERB LITTLE MATRIX PRINTER

We've broken the \$400 barrier for a computer printer! A sprocket feed dot-matrix printer uses ordinary fan-fold paper (up to 204mm wide). Great for high resolution graphics. At this incredible price can you afford to miss out? Cat. X-3252

~~WAS \$495~~ **ONLY \$349**

LIMITED STOCK!



SAVE OVER \$140

SAVE OVER \$18

AMAZING HANDHELD Printer Calculator

A Printer/Calculator that you can hold in the palm of your hand! This attractive calculator has a ten digit liquid crystal display as well as percentage, square root, tab (floating decimal point) key, print function etc. Outstanding value! Cat. Q-3020

~~WAS \$67~~ **ONLY \$49.95**



SAVE OVER \$13

3 Way Hi Fi Speakers for Cars



SAVE \$10

Get the same performance in your car as you'd expect at home! 3 way, wedge type (ideal for rear parcel shelf). Complete with brackets for vertical or roof mounting if you wish. Cat. A-7082

~~WAS \$89.50~~ **ONLY \$79.50 pr.**

DUAL CONE SPEAKERS

A pair of high quality dual cone speakers with extended frequency response. The most popular speaker on the market & these Dick Smith units are equal to the big names! They have 280 gram magnet and are rated at 4 ohms. Complete with superb metal mesh grille and all the hardware required to mount them, including mounting template. Cat. A-7080

ONLY \$19.95 pr. ~~WAS \$32.50~~



Give your Computer a voice!



VOTRAX Synthesizer

Yes! Your computer can actually talk. Not only talk, but in clear intelligible English. It connects to any computer's RS-232 port. The unique Votrax Type'n Talk opens up a whole new world of computing - it comes complete with a detailed User manual & power supply. All you add is a speaker. Cat. X-3290

~~WAS \$549~~ **ONLY \$449**

SAVE \$100

FRED SOUND SYNTHESIZER

Give your System 80 the ability to produce music with this sound synthesizer. It plugs directly into the expansion connector with the audio output connecting directly into the AUX, TAPE or TUNER facilities of most Hi Fi amplifiers.

SAVE OVER \$30



ONLY \$129 ~~WAS \$172~~

SPACE SHUTTLE GAME

It even looks like the space shuttle! This is one that will keep the kids (and you) amused for hours. When they're not busy playing the exciting shuttle game they can pretend they're the Shuttle pilot! Cat. Y-1145

ONLY \$29.95 ~~WAS \$24.95~~



SONIC INVADERS

Sonic Invaders is here! Looks like something out of Star Wars and it even plays the famous Star Wars tune every time you turn it on! Features multi-coloured display with realistic sound effects - look out Darth Vader! Cat. Y-1153

ONLY \$39 ~~WAS \$49~~



SAVE \$10

NORMALLY \$20 to \$25 EA!

ONLY \$15.95

RECORD YOUR FAVOURITE MOVIES VIDEO TAPE VHS 180

The greatest value you'll find! Top quality, famous RCA brand video cassettes at a give-away price. 3 hours length. Hurry - stocks strictly limited. Limit 10 tapes per customer. Cat. C-3410



MIDLAND 100M 8 CHANNEL

Marine Transceiver

NOW ONLY \$99

A superb, compact transceiver that will complement any boat! 8 channels with digital readout, receive & transmit meter & MORE! Why risk your life on the high seas? Cat. D-1407

BOAT RADIO SPECIAL PRICE

~~WAS \$142~~

SAVE \$43

WAREHOUSE CLEARANCE

Gold Detector

Actually sorts Trash from Treasure!
This superb Metal Detector is so easy to use and yet it features advanced microprocessor technology. No digging up beer can, this detector discriminates between Trash & treasure. Ideal for throwing in the car when you go away

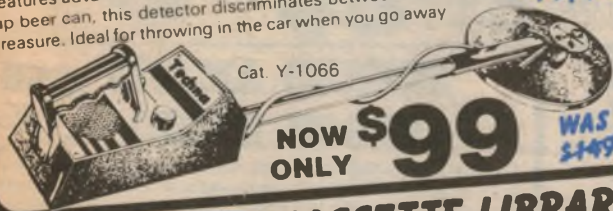

Cat. Y-1066

NOW ONLY \$99 ~~WAS \$149~~



~~WAS \$119~~
ONLY

\$99

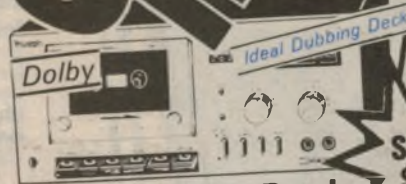

Triumph Metal Cassette Deck

This baby Metal Cassette Deck has all the features of the 'Big ones', but at such a low price! It looks good and sounds great. Has all the features of those bigger more expensive units: Dolby Noise Reduction, Metal Chrome and normal tape selection, Auto stop, LED VU meters, soft eject and MUCH MUCH MORE!
Cat. A-3503

SAVE \$16

Delux Tool/Work Box

Don't leave those tools scattered everywhere! Throw them all into this rugged tool box. Ideal also for:
● fishing ● tradesmen ● technicians ● artists etc etc.
Lid has a carry handle fitted, and the box can be padlocked for security. Overall size (closed) 430 x 230 x 200mm
Cat. H-2600



ONLY \$29.50
~~WAS \$32.50~~

HITACHI TAPE TUMBLES!

Famous name Hitachi C90 low noise at a low low price!



ONLY \$2.50
~~WAS \$6.50~~
LIMITED STOCK!

Cat. C-3065

CASSETTE LIBRARY

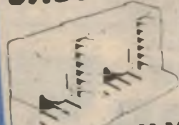

ONLY \$4.95
~~WAS \$6.50~~

Cassette storage problems? Her's a way to neatly stack you cassettes. Each unit can interlock with another. Also comes with self tapping screws. There's 6 holders in each box & each one holds 5 cassettes - that's 30 cassettes! Cat. C-3800

TECHNOLOGICAL BREAK THROUGH

AMAZING DIGILOG



Yes! Two watches in one: a superbly styled case contains a very accurate digital watch PLUS an analog type - with no moving parts! The face & hands are actually made up of LCD displays! Includes countdown timer, alarm & stopwatch Cat. Y-1045

ONLY \$32.50
~~WAS \$49.50~~

DIGITAL DIALLING & MUSIC PHONE

It's a bargain!

Looks great and has heaps of features:
● Ringer ON/OFF switch ● Stylish push button keyboard ● 20 digit redial capacity per number ● unlimited digital dialling capacity ● access pause for PABX systems



ONLY \$39.95

Telecom Permit No. CS2/31/88

OVER 1500 SOLD

Cat. Y-1186

UTILITY BOX

Small heavy duty box with compartments for small items such as screws, resistors, capacitors etc.
Dimensions: 218(L) x 110(w) x 33(h)mm. Cat. H-2590

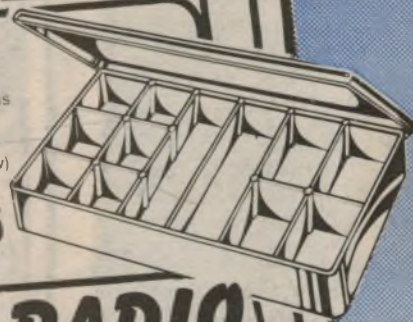

ONLY \$2.95
~~WAS \$3.95~~

CLOCK RADIO

Electronic Display

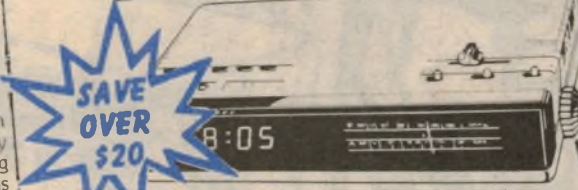

SAVE OVER \$20

Wake up to the sound of your favourite radio station - with the thought that you've saved \$\$\$\$ too!
Features AM & superb FM radio plus an alarm buzz (if you need it) as well as a sleep timer! So don't miss this incredible bargain. Cat. A-4444

ONLY \$25.50
~~WAS \$27.50~~
LIMITED STOCK!

3 WAY LANTERN

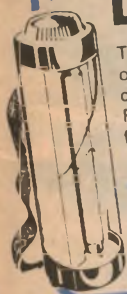

The ideal lamp for campers, on the boat, even when the car breaks down! Features: Fluorescent lamp, plus flasher and flash light.

ONLY \$9.50
~~SAVE OVER \$5.00~~

Cat. Y-1084

Take anywhere Stereo SOUND TRIPPER

Take your favourite radio programmes wherever you go with this amazing AM/FM radio with light weight headphones. Just think whatever you're doing, at work or play, you need never be without great stereo sound again! Powered by 4 pen light batteries (supplied).

cat. A-4330

ONLY \$39
~~WAS \$49.50~~



SAVE OVER \$10

See page 98 for full address details

DICK SMITH Electronics

PSE 4466 JW INC IN NSW



BARGAIN PCB PACK

10 ASSORTED

MAIL ORDER ONLY

~~\$25~~ WORTH OF PCB'S for
\$3.00 From past EA & ETI projects

Instructions included
LIMITED STOCK
BE QUICK!

Cat. H-8210

LESS THAN COST

STORE SPECIAL
PCB's For \$1.00
WITH INSTRUCTIONS
FROM THESE **LIMITED STOCK**
PROJECTS

- | | |
|-------------------|--------------------|
| Speed Sentry | LCD Timer |
| Light Chaser | Low Fuel Indicator |
| Dual Trace Switch | Hot Canary |
| Stereo Booster | Car Alarm Mk1 |
| Metal Detector | |

MAIL ORDER SPECIAL!



Cat. M-9551

PLUG PACK
50mA
20V DC

\$4.95

BELOW COST



Great savings on the CRAIG LANGUAGE TRANSLATOR

WERE SELLING FOR \$250!

We've made a huge scoop purchase of these units at way below the manufacturers cost! Translates any language into English or the reverse! Great for overseas travellers, students, politicians etc.

Cat. Y-1340

Great range of modules available

Japanese	(Y-1342)	\$19.50
German	(Y-1343)	\$19.50
Italian	(Y-1344)	\$19.50
Spanish	(Y-1348)	\$19.50
Phonetics	(Y-1347)	\$9.50
Bar & Wine Guide	(Y-1345)	\$10.00
Calorie Counter	(Y-1346)	\$9.50

Buy a Craig & get the Bar & Wine Guide (Y-1345) & Calorie Counter (Y-1346) FREE! WORTH \$18.50

NOW ONLY

\$89.50



WAS ~~\$36.50~~ ETI METAL DETECTOR

Build one & you could find a fortune!

WOW! An induction balance metal detector at an amazing price! From Electronics Today International, this detector is the equivalent of many induction balance detectors in the hundreds-of-dollars bracket! All components are supplied including the meter, the box, coil wire etc. but the coil former and dowel for the shaft are left up to you (you've probably got something in the garage you could use!) Are you ready to go out & find a fortune? You could with this beauty! Cat. K-3100



SAVE \$7.00

ONLY \$29.50

Quality AM Car Radio

Live in a non-FM area? Why waste your money on an FM car radio? But don't be caught with an 'el cheapo' car radio either - you could be sorry. This one is great quality, easy to fit & suits all negative earth cars.

WAS \$52 NOW ONLY \$39

Cat. A-5980

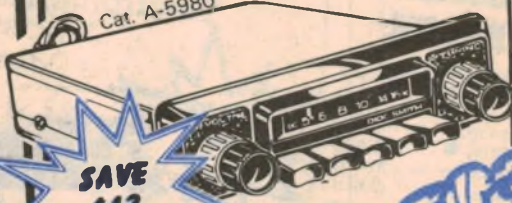

SAVE \$13

High Impedance multimeter 10 MEG FET INPUT

For the professional who wants the lowest circuit loading... you want the highest input impedance. The FET input multimeter gives you a huge 10M input impedance on DC voltage, and a highly respectable 1M on AC voltage. Batteries, test leads and instructions supplied. Cat. Q-1200



WAS \$78.00 NOW ONLY \$59

SAVE \$13.00

STEREO AM/FM CLOCK RADIO

SAVE \$10

WAS \$59.95

The very latest in clock radios - it's stereo! No longer will you have to put up with the 'tinny' sound that most mono AM/FM radios give you: now you can wake up to brilliant tone stereo music! It features a superb modern styling with a huge LED display. It also has another unique feature: a 'time set' lock underneath the radio, so the kids can't change your time setting. Cat. A-4445

ONLY

\$49.95



Battery back-up for power failure

HOT CANARY

This great gimmick kit will keep any child, or adult amused for hours! An electrical bird noise maker that sounds just like a real bird singing! Cat. K-3395

WAS \$15.50 NOW ONLY \$7.95



SAVE OVER \$7.00

TV Antenna Clip

Strong plated springs with screw terminals and coloured plastic handles. A quicker way to connect or disconnect the antenna lead-in cable to the TV set, FM or radios, etc. Ideal when using portable sets. Cat. L-4236



ONLY

60c

POT PACKS

75 POTS

75 POTS for \$9.95

Cat. R-7102

Selection includes mixed values: Dual Gang, Single Gang & Switch Pots

UNBELIEVABLE VALUE AT TODAY'S PRICES!

Portable stereo Cassette

This fantastic go anywhere miniature cassette player is ideal for skiers, walkers, office workers etc. Takes a full size cassette. Supplied with carry strap plus 1 set of light weight headphones with provision for one other.

INCLUDES HEADPHONES

WAS \$99 ONLY **\$49⁵⁰**

SAVE \$30

LIMITED STOCK



Stereo Booster Amp

WAS 29.50 ONLY **\$24⁵⁰**



This easy to build kit can economically upgrade the power of your car's stereo system to 12.5W RMS per channel. Based on a rugged IC amp module and works with all negative earth systems. Cat. K-3493

Handy BNC Adaptor

Adapt your input terminals on the Dick Smith Laboratory Oscilloscope from 'banana' socket to BNC type. Cat. Q-1281

ONLY **\$6⁹⁵**



WORLD MAP/TIME WATCH WITH ALARM



Now you can tell the time anywhere in the world! Shows time in 20 different time zones and actually has an LCD diagram of the world! Even has a dual melody alarm! Cat. Y-1051

SAVE OVER \$20

WAS \$84.95 ONLY **\$44⁵⁰**

ITOH 8300P DOT MATRIX PRINTER

The Itoh 8300P features high speed, bi-directional printing (125 characters per second) with full upper & lower case character set. It accepts standard fan-fold sprocketed paper up to 240mm wide. This means you can do 80, 40 or 132 column printing. Fitted with standard centronics type parallel port. A great seller with great features. Cat. X-3255

WAS \$920 NOW ONLY **\$699**

SAVE OVER \$200



LCD Build-in Module

The experimenter's special! Accurate quartz LCD Module ideal for building into projects. Not just a clock - also a time & controller.

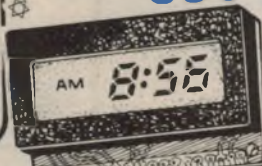

Full Data Sheet Supplied Cat. Y-1050

WAS \$19.50 NOW ONLY **\$9⁹⁵** SAVE OVER \$9.00

Digital LED Alarm Clock/Thermometer Module

Famous NATIONAL SEMICONDUCTOR Brand Module features huge bright red digital display, 6 display modes, time & temperature display (both °C & °F), alarm & control for clock, radio, etc. 12 or 24 hour operation. A full featured movement for use in thermometer, alarm clock, clock radio, instrument panel clock and appliance timer applications. Complete National data sheet included. Cat. Y-1653

WAS \$34.95

NOW **\$12⁹⁵**

UNDER 1/2 PRICE

AMAZING VALUE

Basic Transistor Course

Kenian 218 pages

Do you understand how the transistor works? If not, this book will explain it all - how it works and how it works with other components - resistors, capacitors, coils etc. Cat. B-1567

WAS \$9.95

ONLY **\$6⁹⁵**



Display Electronics

Designed to introduce the hobbyist to the world of opto-electronics. Learn how injection laser diodes, liquid crystal displays, electro-luminescent displays & charge coupled devices used for image sensing in solid state TV cameras work. Special projects include a modern version of the one-armed bandit, electronic dice, games to test reaction time, and a micro-computer with binary & octal readouts. Cat. B-1844

WAS \$7.50 NOW ONLY **\$4⁹⁵**

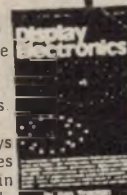

The Complete Book of Electric Vehicles

Sheldon R. Shackel 16 pages

The most complete & fact filled book available today, describing in detail commercially built electric cars, trucks, cycles, trains and buses. The information supplied is supported with photographs & a history of each vehicle. Speed data, home built vehicles, state-of-the-art & what the future holds are all covered. Cat. B-2400

ONLY **\$9⁹⁵**



MORE BOOK BARGAINS

HOW TO BUY & USE MINICOMPUTERS & MICROCOMPUTERS	\$9.50
Cat. B-1276	
INTERFACING TO S-100 BUS	\$10.95
Cat. B-2341	
IC TIMER HANDBOOK	\$5.95
Cat. B-1610	
INTERFACE HANDBOOK	\$7.95
Cat. B-2309	
DISCOVER FORTH	\$14.95
Cat. B-2334	
LEARNING TRS 80 LEVEL 2	\$14.95
Cat. B-2336	
INTRO INTO MICROCOMPUTERS	\$9.50
Cat. B-2340	

WAREHOUSE CLEARANCE BE QUICK!

See page 98 for full address details

INC IN NSW

DICK SMITH Electronics





News Highlights

Big guns enter the personal computer scene

The personal computer market has changed radically in recent months with the entry of two very large contenders, IBM and Matsushita. In early February, IBM introduced its Personal Computer on to the Australian market and it is almost certain to become the leader in a very short time. At this stage though, it is not clear just where its major market lies.

In the US, IBM has sold more than 200,000 machines since its Personal Computer was launched there in August 1981. IBM plans to spend \$1 million in promoting the machine and has arranged for the initial setting up of 41 retail outlets throughout Australia.

IBM claim to be aiming their marketing strategy mainly at the small business and professional user and indeed the machine is priced to appeal to this market, starting at \$3224 for the basic machine with one disk drive but without video display. However, the choice of the large department stores Myer and Grace Bros, as well as Computerland, as the major outlets indicates that they also have a major interest in the domestic market.

It remains to be seen whether small business owners and professional men will happily approach these outlets or whether they will expect the computer sales people to chase them.

Hot on the heels of the IBM personal computer is Matsushita's Panasonic JB-3000. This machine is completely software-compatible with the IBM machine, to the extent that one can take a disk out of the IBM machine operating with say, Visicalc, and slot it into the JB-3000 and it will take up without any pause or interruption. Or vice versa. As far as hardware is concerned, there are extensive differences between the two machines.

At this early stage in the game, the JB-3000 appears to have the more extensive range of hardware available. This includes equipment such as expansion units, extra disk drives and memory boards, colour monitors and printers of



This is IBM's PC business system which includes two disc drives, B&W monitor, dot matrix printer and DOS software at a price of \$6510.

various types. However, the range of US-sourced peripherals and products for the IBM machine is enormous and growing every day. A recent count indicated that some 1200 different products, hardware and software, had been produced by other manufacturers since its original US release.

IBM envisage that a standard business system will comprise a keyboard, central processor with 64K of RAM, two 320 kilobyte disk drives, a high resolution

green phosphor video display, a bidirectional 80 character-per second dot matrix printer (with printer adapter and cable), plus IBM disc operating system. This will set the buyer back \$6510.

The price for an equivalent system using the Panasonic JB-3000 is \$5998. In Australia, the JB-3000 will be distributed by the Computer Company, a division of Singer. It also will be retailed by Myer and Grace Bros, alongside IBM, as well as by specialist sales organisations.



This is some of the range of equipment currently available for the JB-3000 computer, all of it made by Matsushita.

Parrot's pecking penchant poses peculiar problems

Research to microwave dish rescue

Some of Telecom's problems, as they say are "strictly for the birds".

It seems that parrots and magpies have taken a liking to the very thin (0.15mm) Teflon plastic windows used to seal the feeder tubes to Telecom's microwave dishes. The constant pecking damages the windows, interrupting services and leading to costly repairs to the antennas.

Microwaves carry telephone, telex and data communications across long distances throughout Australia. The microwave beams are transmitted and received from metal dish antennas fed via hollow metal tubes in the centre of the dish. The beam enters and leaves these tubes through a plastic window because they cannot pass through metal. A sealed window is used because the tube is kept pressurised with dry air to avoid corrosion.

Parrots and magpies have been attacking the plastic windows, eating through them and causing the air pressure in the waveguides to drop, allowing moisture to enter and making the waveguide unusable.

Telecom is not taking the problem lying down. The Commission's Research Department has begun tests in a parrot aviary in the Sir Healesville Sanctuary near Melbourne. Researchers are trying



PHOTO COURTESY TELECOM NEWS

out thicker (1.5mm) windows in six different types of plastic, selected because they transmit microwaves with negligible attenuation and have promising weather resisting properties.

The various windows are being exposed to attack by several different species of parrots to obtain information on the performance of the plastic and the preferences of the parrots. None of the materials are toxic and no microwaves

are being transmitted through the windows during the tests.

In Sydney, the problem is magpies. Five covers on microwave dishes on top of the Redfern terminal have been replaced in recent months and the magpies keep coming back for more!

Presumably the plastic that is shown to be most distasteful to the birds will be the material of choice in the construction of future waveguide windows.

IBM spy case: Hitachi pleads guilty

Rarely has the gulf of incomprehensibility between the US and Japan been so wide as in the seven months since the FBI disclosed that it had arrested employees and associates of Hitachi and Mitsubishi Electric, for trying to "steal" industrial secrets from US computer giant IBM.

While the Japanese have not officially admitted that they did anything wrong — at least by Japanese standards — Hitachi agreed to plead guilty in a before-trial plea bargaining settlement. As a result the company was fined \$US10,000 and two of its employees fined \$US10,000 and \$US4000 respectively. (They could have been given a five year prison sentence.)

In a carefully phrased statement, Hitachi sought to justify the plea bargaining settlement on a number of grounds. These included the desire to allow the two employees to rejoin their families, the current economic situation, and the

need to arrive at an early settlement.

Hitachi officials also hinted that the company had "assurances" that the pound of flesh IBM would seek in a civil suit would not be cut from Hitachi's heart.

Two legal gulfs, between Japan and the western world, made obvious by the case, were the differing attitudes to industrial espionage, and the concept of plea-bargaining, something which is quite new to the Japanese.

Meanwhile, Mitsubishi's case is still to come to court and, so far, Mitsubishi appears less inclined to arrive at a before-trial settlement. It is possible that they may fight the case on a plea of "entrapment".

In fact, the question has been raised as to what extent IBM encouraged the FBI to set up the trap in the first place, with the idea of discrediting two serious business rivals.

New radar trap foils detectors

Radar speed traps that cannot be sensed by radar detectors are the latest device in the battle between motorists and police in New Jersey, USA.

The new radar equipment relies on a "beam interrupter" switch which permits the police to cut off the radar beam without turning off the instrument. When a suspect comes within range the police can turn on the beam instantly and the offender receives no warning from a radar detector until it is too late to slow down.

Manufacturers of radar detectors are not impressed however. "Once the officer activates the unit to obtain a speed reading on a vehicle, every detector-equipped motorist within its range will receive a warning" says one manufacturer.

New Jersey state police believe that the beam interrupters have shown their effectiveness, however.

HMS Sheffield destroyed by a "friend"!

One of the puzzles of the Falklands war was how HMS Sheffield came to be hit by an Exocet missile, in spite of the most modern missile detection equipment which it carried. As commonly happens, it wasn't the equipment which failed, but the software it was given.

Most of the Royal Navy ships carried equipment known as ESM (Electronic Support Measures) which is designed to detect all radar transmissions within range, and identify them. Since it is only a receiving system it does not betray the presence of its own ship.

It identifies the missile or vessel from which the radar pulses originate by observing the transmission frequency, type of modulation if any, and the pulse repetition rate. These data are then fed to a memory containing details of all

known or likely radar sources and, if it is identified as of enemy origin, the alarm will be raised automatically.

Once detected, there are several forms of defence against the Exocet, one of the most popular being the dispersal of "chaff"; large quantities of fine metal strips which confuses the Exocet radar.

So what went wrong? The simple fact is that the Exocet missile was not listed in the ESM memory, and the reason was that the Royal Navy ships, including the Sheffield, carried the Exocet missile

themselves. The naval chiefs of staff feared that if their own ships raised the alarm every time one of them fired an Exocet, the result would be chaos.

But after the Sheffield was lost the brass changed their mind and all ESM equipment was reprogrammed. Significantly, no more navy ships were lost to the Exocet and only one, the Glamorgan, was hit. Even so, the warning came soon enough to allow the ship to be manoeuvred so that only the stern was hit.

The Royal Navy is now seeking an improved form of ESM; one which will be more intimately coupled to the appropriate defence mechanisms, and thus reduce the time needed to bring these into action.

Delco chooses Motorola AM stereo



The current AM stereo scene in the United States is still very much in a state of flux, with upwards of five different systems suggested and the FCC having bowed out, advising the industry to make up its own mind.

But one system, Motorola's, received a boost recently when General Motors' Delco Electronics division decided to use it in their car radio receivers. Delco invited the industry to submit systems for evaluation, and three, Magnavox, Harris, and Motorola, responded. Motorola's was selected after extensive tests.

Meanwhile, the Japanese firm of Sansui Electric Ltd is determined to score whichever system is finally chosen, or if several systems are operated together. It has developed a set which will handle any one of four systems, automatically identifying the system and selecting the appropriate processing circuitry.

Automatic lighting system detects body heat

An automatic lighting system which turns lights on when a person enters a room and turns them off when the room is empty is being marketed in Australia by the Otis Elevator Company Pty Ltd.

Called "Infracon", the system has had considerable success in the United States following its introduction there early last year. Otis' parent company developed the Infracon after surveys had shown that lighting costs were the largest single operating expense in office buildings.

The system works by detecting the heat given off by the occupant of a room. When a person enters a room the sensor installed in the ceiling turns the lights on automatically, turning them off again 12 minutes after the person leaves the room – or 12 minutes after the sensor can no longer detect infrared from a moving source.

According to the company, users in the United States have found another "benefit" in the area of increased office



The "Infracon" sensor unit is simply mounted in the ceiling.

production. Since the device turns on the lights when it detects a moving source of heat, it will also turn them off when movement ceases. As the company says, "Workers who sit at their desks for long periods without any noticeable movement will find themselves, quite literally, in the dark".

LONG LIVE THE VALVE!

Valves may be a thing of the past as far as the average appliance user is concerned, and most valve plants have either closed or are about to do so. But not totally. West Germany's Siemens AG valve plant is actually expanding.

Siemens' West Berlin plant produces around 15,000 transmitting valves a year, but is expanding the plant at a cost of several million dollars to cope with an anticipated annual increase of 8%.

A major cause of the increased demand is the increasing use of transmitters in the emerging countries, expansion in established markets, plus normal replacement requirements.

New system doubles cable TV capacity

Two pictures for the price of one? Well, two pictures in the channel space of one is what the General Electric company of the US is promising with a recently developed system called Comband. It is aimed at doubling the capacity of any cable TV system.

How? Since we seldom get something for nothing, something has to give and, in this case, it's picture quality. The system brings the two pictures into exact line sync, then takes each pair of lines in each picture and averages the information to produce one line.

Each picture is then transmitted with half the normal number of lines, interleaved with half the lines from the other picture. At the receiving end each line is repeated to produce the normal number of lines.

The company claims that because information on adjacent lines is usually similar the loss is hardly noticeable.

Micros for British schools

Nearly all of Britain's state schools are expected to be equipped with a computer by 1984. Already, all 6000 secondary schools in the UK have at least one computer, provided under a scheme organised by Britain's Department of Industry and the program has now been extended to primary schools.

Kenneth Baker, Minister for Information Technology at the Department, describes today's children as the "keyboard generation" because on leaving school many of them will need to be able to use a computer in their employment.



"One of the most exciting and challenging engineering projects in the world" – a pumped water storage scheme built entirely inside a slate mountain in North Wales. It is a hydro-electric system which uses off-peak generating capacity to pump water to a lake above the mountain, which is then released to generate power during peak periods. The scheme has a total capacity of 1880MW, of which 1320MW can be fed into the national grid within 10 seconds of demand; the fastest response of any comparable scheme in the world.

The released water travels through a 3.2km tunnel and drives six turbines. It is stored in a lake below the mountain and the turbines function as pumps to lift it back to the upper lake in the off-peak period. The picture shows engineers assembling the stator on one of the pump turbines. It is so large that it had to be erected on site.

It was for this reason that the "Micros in Schools" plan was introduced. Under the plan, the Department of Industry funds half the cost of a computer to help with teaching and special projects, with the balance of the cost raised by the school. Schools are given a choice of two machines, both made in Britain; the RM 380Z by Research Machines, of Oxford

and the BBC Microcomputer made by Acorn Computers. The Sinclair Spectrum was recently added to the approved list.

Since the offer was extended to primary schools late last year more than 4000 applications have been received and the Department of Industry now believes that all 27,000 primary schools will eventually buy a computer.

LETTER QUALITY PRINTER AND K.S.R. TERMINAL AND ELECTRONIC TYPEWRITER

Our range of printer/terminals using industry leader electronic typewriters is now expanded to offer you:

print speeds of 12 to 25 cps
10, 12 and 15 pitch standard
proportional spacing on most models
up to 30 typestyles, carbon or nylon ribbons

Optional printer buffers of up to 32K eliminate unnecessary waiting time on your computer. RS232c interfacing is standard. Parallel (Centronics) and IEEE also available. For those with heavy printing loads, we are also able to supply a dedicated daisy wheel printer giving 50 cps (35 cps using Shannon text), 1/120" horizontal spacing and 1/96" vertical — from only \$1695.

INCA developed the STOL interface for Olivetti's ET221 — we have the experience to understand interfacing problems. Call or write:



33 Ryde Road, Pymble, NSW, 2073

data systems pty. ltd.

PO BOX 200, Pymble, NSW, 2073

Phone (02) 498 6933



FROM
\$935
ex tax

JAYCAR ZERO

ALL SPECIALS SHOWN ON THIS PAGE ARE EITHER



Fully
Guaranteed
\$12.50
\$36.50
INTRIGUING

For years and years 240V mains powered strobes have been selling for between \$30 and \$40. Even kits are around \$36. So why is it that Jaycar can sell a 240V strobe — guaranteed — for \$12.50? We can tell you for a start that we're not selling them below cost. Even at \$12.50 we're doing OK.

Why so cheap?

Well they were made for a well known electronics chain. Their Q.C. (Quality Control) Department rejected them on the grounds that around 5% of them were faulty. That was an unacceptable figure considering the very good name that the chain has in this country. All goods were rejected (even the 95% good ones) and sent back to the importer.

The importer came to us with his problem. We said that we would sell them PROVIDED we could offer a 90 day guarantee on the item.

Whilst all stock has been checked and the duds weeded out we STILL feel that even at \$12.50 you deserve a comeback if we sell you faulty goods.

So that's it. You get a 240V strobe that is perfectly OK for \$12.50.

Compare THAT with the \$36.50 that you will pay elsewhere.

It's almost too good to be true except for one thing. It's true.

FULL 90 DAY WARRANTY — Cat. XM7005

JUMBO SPEAKER CABLE

Now you can have super-quality cable without breaking the bank! Each conductor contains a MASSIVE 259 strands of 0.12mm wire!! It could carry 30 amps! Great for Hi Fi or high power amps.



Only \$2.50/m
100m \$2.00/m
Cat. WB1732

4116 RAMs 150ns — GOING CHEAP

We have secured a quantity of 4116 (150ns) RAMs at a price which means great savings to you. Why are they cheap? Well they don't actually have 4116 branded on them. They have 9016 FPC on their little backs. They are used in a well known TV game computer and this is the 'House Number' for their 4116. If you have ever had to buy a non-standard replacement part you will know that the 'House Number' part can be VERY expensive. We don't want to sell them as 9016 FPC's we want to sell them as 4116's — and at a great price. The normal (i.e. lower than most) price for our 250NS 4116 is \$2.50. You can grab a 9016 FPC (150NS) 1 off for only \$1.95!!! For larger quantities see below.

Cat. Z28419



1-9 pcs \$1.95
10-24 pcs \$1.85
25-99 pcs \$1.75
100+ \$1.65

This price includes sales tax!!

GE Consumer Products

Smoke Detector
CONSUMER FLOP — CONSUMER FLOP
CLUB, HOTEL, HOSTEL & MOTEL MANAGERS
PLEASE NOTE



Cat. LA5006

FROM \$12.50

— Contains Americium 241 Ionization Chamber

— Contains very loud solid state buzzer

— 12 month factory warranty.

One of the greatest consumer flops of the last decade was the Ionization Chamber Smoke Detector. Even though it is a brilliant product (reliable compact, easy installation, fail-safe etc) it just did not sell. Human nature being what it is finds safety-oriented products just not worth the investment. We all know that accidents and fires never happen to US!! As smoke is the greatest killer in a fire, the market research gurus thought that such a product would have a wide appeal. When they were \$49.50 no-one wanted them. The price fell to a very reasonable \$29.50 and still they stayed on the shelf. We have now been instructed to clear them for less than 1/3 of \$29.50.

QUANTITY PRICES

1-\$14.50: 2-5 \$13.50ea: 6-10 \$13.00ea: 10 up \$12.50ea

Burglar Alarm

GENERAL ELECTRIC

FROM \$23.95

Cat. LA5004

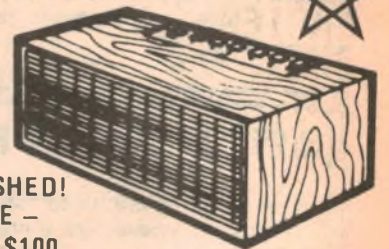

BURGLAR ALARM SLASHED!
HUGE SCOOP PURCHASE —
ONCE SOLD FOR OVER \$100

Amazingly low price for a full feature ultrasonic proximity/burglar alarm. + Completely self contained + 12 month manufacturer guarantee + Instant or delayed alarm + Handsome imitation woodgrain + Cabinet measures 180(w)x85(h)x100(d)mm + Programmable multi-code disable switch + Single 9V Alkaline battery* lasts one year + unit beeps when battery gets low + Contains receiver element designed for greater sensitivity without false triggering + Uses state-of-the-art LSI circuitry + Worth the money in parts alone + Comprehensive 24 page manual included + Comes complete with 4 window deterrent stickers + Absolutely no installation needed * Battery extra.

1-\$29.50: 2-5 \$25ea: 6-10 \$24.50ea: 10up \$23.95ea

MORE HAVE BEEN FOUND!!

We keep surprising ourselves by finding more of the Smoke Detector and the Burglar Alarm — but it's true!

We still think that this is great news as these products have been very popular indeed. We have literally sold thousands and we will still sell the remaining stocks at fantastic low prices. The Smoke Detector is still selling for \$14.50 and the Burglar Alarm is still 1/2 the price of its nearest competitor!

INFLATION SALE

THE SAME PRICE AS LAST YEAR – OR BELOW!

low cost hi fi system



Woofer not to same scale as other components



FROM \$24.98

That's right a 3-WAY Hi Fi speaker kit from only \$24.98!! Each kit contains a massive 10" (250mm) woofer, cone midrange and DOME tweeter!! You also get, at no extra charge, the special crossover capacitors! The system is rated at approximately 20 watts RMS so it is ideal as an economical but reasonably powerful main Hi Fi unit or as a second system for another room or outdoors. Each 3 way kit comes with a recommended enclosure design which you can build yourself easily! You would normally pay well over \$60.00 for the equivalent from major kit speaker suppliers so this represents an outstanding bargain!

BUT HURRY ONLY 250 PAIRS

Sensitivity of system: 93dB/1m/1 watt
Cat. AK 3700

P.S. Bonus. These speakers are made in JAPAN, not a South Asian country

3 - WAY SPEAKER SYSTEM

\$29.95 a set

2 SETS (6 SPKR) FOR STEREO
ONLY \$49.96



UNBELIEVABLE SAMPLE BAG OFFER!
A huge 20" x 10" bag FILLED with goodies

\$5⁵⁰ 1983

Once again we have a GIANT Easter Showbag. This is the third year of our showbag and the 1983 bag is by far our best!

But we do not have nearly as many bags this year so it is VERY IMPORTANT to get your order in early! (We also don't have room to describe the bag in detail)

Once again the huge 20" x 10" bag is filled with goodies including:

Hardware pack, Resistor pack, Knob pack, P.V.C. (spaghetti sleeving), 3 x Hobby Electronics Mags, 1 x Phantom comic, a 2 watt Audio IC with circuit and dozens of other parts. (Note: not all bags are exactly the same and we reserve the right to delete some advertised items from the bag but promise to make it up with other components of equal or greater value)

ZERO INFLATION! THE SAME PRICE AS LAST YEAR \$5.50

Post and packing on this item is \$2.00 – because of staggering rate increases this year.

MORE EDGE CONNECTOR BARGAINS

Over the past 6 months we have sold thousands of quality PCB edge connectors. And STILL we have more bargains!!

Edge Connector No. 1

This component has a 0.1" pitch 72 way (2 x 36) configuration. Each contact is heavily gold plated and bifurcated for lower contact resistance. The 0.025 square terminations will PC mount or take one level of wire wrap. The body is moulded in high quality Diallyl Phthalate with integrally moulded mounting feet on the ends. Outstanding quality for the price.

1 - 9 \$2.95
10 - \$2.45

Cat. HE 8655

Edge Connector No. 2

This component has a 0.156" pitch 86 way (2 x 43) configuration. Once again each contact is heavily gold plated and bifurcated. The termination is of the solder-lug type. The body is identical in fashion to the HE 8655

1 - 9 \$3.45
10 - \$2.95

Cat. HE 8656

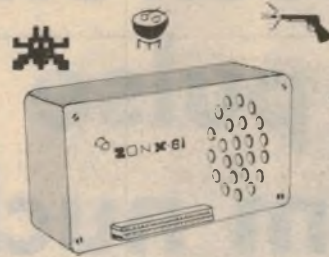

PRICE SLASHED!!

SAVE \$10

\$59⁵⁰

~~\$69.50~~

SINCLAIR ZX-81 COMPUTER SOUND GENERATOR

Make amazing sound effects with your Sinclair Computer.

- The ZON X 81 SOUND UNIT is completely self contained and especially designed for use with the ZX 81. It just plugs in – no dismantling or soldering.
- No power pack, batteries, leads or other extras
- Manual Volume Control on panel – ample volume from built in loudspeaker
- Standard ZX 81 – 16K RAM pack or printer can be plugged into ZON X 81 Sound Unit without affecting normal ZX 81 operation.
- Huge range of possible sounds for games or: Music, Helicopters, Sci Fi, Space Invaders, Explosions, Gun Shots, Drums, Planes, Lasers, Organs, Bells, Tunes, Chords etc. or whatever you devise!
- Uses 3 channel sound chip giving programme control of pitch, volume of tones and noise, all with envelope control
- Easily added to existing games or programmes using a few simple "BASIC" lines
- FULL instructions with many examples of how to obtain effects and the programmes, supplied
- Extension card at base of unit allows further use of Sinclair Expansion Card Cat. KJ6620

BELOW COST EA & ETI

But only at our Carlingford store. That's right, to encourage you to visit our Carlingford store you can buy the LATEST ISSUE of EA or ETI for ONE DOLLAR! That is definitely BELOW our cost price. But ONLY at the carlingford store. (The post and packing charges make mail ordering EA & ETI uneconomical) PLEASE DO NOT ASK FOR THIS OFFER AT OUR YORK STREET STORE



only \$1

BELOW COST

APRIL - ZERO INFLATION MONTH

\$49
SAVE \$10

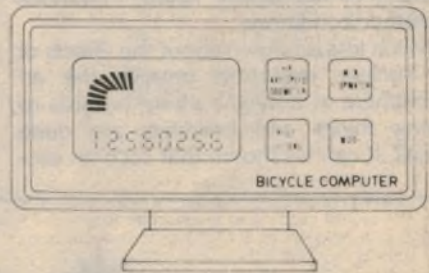

BICYCLE COMPUTER

- Digital computer for your bike!
- Works on wheels 20" thru 27"
- Bar type speed indicator to 60Km/hr or 60 miles/hour
- Digital odometer and tripmeter
- Stopwatch function
- Average speed calculation
- 12 hour clock display
- Detachable
- Speed transducer included
- Liquid crystal display with micro lights for night use

We were selling these units for \$59.00 before Christmas. A compact 115(W) x 52(H) x 45(D)mm. Readout unit only dimensions. Cat. XC 2005

Jaycar NUMBER 1 FOR KITS

125 YORK STREET SYDNEY 2000
PHONE 264 6688 TELEX 72293

NEVILLES CORNER
Cnr. CARLINGFORD & PENNANT HILLS ROAD
CARLINGFORD

PHONE 872 4434

MAIL ORDERS TO: BOX K 21 HAYMARKET SYDNEY 2000

POST AND PACKING CHARGES:
\$5 - \$9.95 \$1.50 \$10 - \$2.00 \$12.00
\$25 - \$49.95 \$4.50 \$50 - \$60 - \$5.00 \$60.00 - \$75.00
\$100.00 - \$5.00

Mail Order By **BANKCARD**
Via Your Phone



One bomb could black out a nation

Electromagnetic pulse threat from nuclear blast

Nuclear devices exploded above the atmosphere may not hurt people or damage property on the ground in the conventional sense. But such explosions can produce an effect similar to a giant lightning strike and wipe out communications and power supply systems over huge areas, effectively crippling a nation's military forces.

by BRIAN DANCE

The two nuclear bombs used as weapons of war, and most of the nuclear test explosions, have been carried out in the atmosphere, at about ground level or underground. The biological effects on humans and animals, as well as the effect on military and civilian property, have been well studied as regards the damage caused by radiation, the heat flash, and subsequent fires. The air pressure waves have been investigated, and much is also known about the hazard of radioactive fallout in various weather conditions.

Much less is known about the effects of a nuclear explosion outside the atmosphere at a height where hazards to living things and buildings are quite small. It can be shown that such an exo-

atmospheric explosion can produce short duration, but very intense, electric and magnetic fields which can destroy almost all semiconductor devices, which are not completely screened, over an area as large as a whole continent. This electromagnetic pulse (EMP) could render all radio transmitters and receivers useless and would also cause the telephone system to fail, since modern systems are largely dependent on electronic switching. Modern vehicle electronic ignition systems would be put out of action, as would many vital military computers.

At the same time, the power line systems would be tripped into the off state (possibly with permanent damage to the insulation) in much the same way

as the lightning of electrical storms causes power lines to be tripped. However, EMP tripping would act over a far greater area.

(The effect would appear to be akin to that commonly experienced in the immediate vicinity of a lightning strike, where the electromagnetic field can induce destructive voltages in devices connected to antennas, telephone wires, and power lines, except that this is on a vast scale. Ed.)

EMP does not present a direct hazard to human life but it does pose a serious hazard to electrical and electronic equipment.

Thus, it can destroy the effectiveness of unprotected military equipment over a huge area, and hence the capacity of a

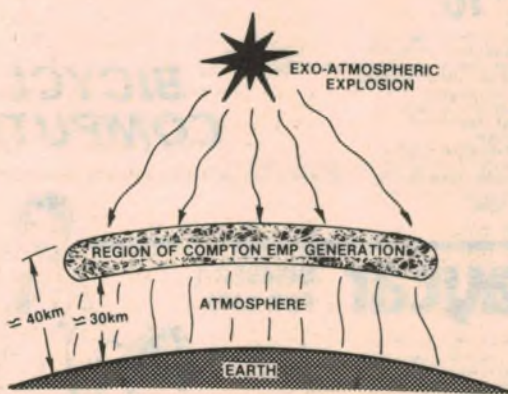

Fig. 1

A nuclear explosion above the atmosphere would create intense EMP effects on the Earth's surface.

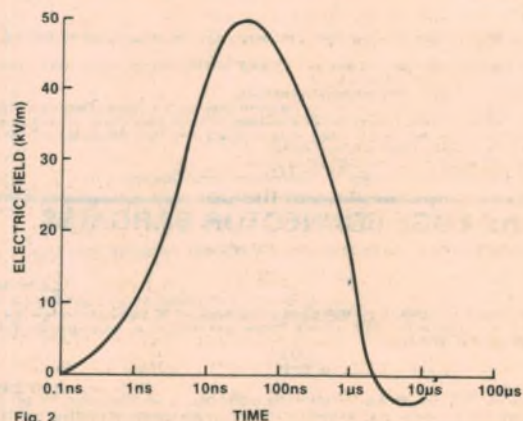

Fig. 2

A one megatonne explosion would generate fields of up to 50kV/metre, with a rise time of 10ns.



nation to respond to a nuclear attack.

The formation of the electromagnetic pulse is due to several mechanisms, but by far the greatest contribution is an extremely intense burst of gamma radiation at the instant of the explosion. Fission bombs, in which heavy elements such as uranium or plutonium split into lighter atoms, and fusion bombs (thermonuclear or hydrogen bombs) in which light atoms fuse together to produce heavier atoms, both produce EMP effects.

If the explosion occurs high in the atmosphere (Fig. 1), most of the high energy gamma rays will travel some distance through the rarefied air and will knock electrons out of molecules of the air in their flight (the Compton effect). The heavy positive ions move relatively slowly, but the light energetic electrons formed in this way form an electric charge which rapidly moves a distance of some hundreds of kilometres. This separation of electric charges in the upper atmosphere creates enormous voltages which give rise to the intense EMP effect at the surface of the earth.

All nuclear explosions generate at least a localised EMP effect. If the explosion occurs in the middle of the atmosphere, the resulting fields are relatively symmetrical and they therefore almost cancel at considerable distance from the explosion. However, where the explosion is above the atmosphere, the variation of atmospheric density with altitude

provides the asymmetry required for maximum EMP effect.

Maximum EMP effect is believed to occur when the explosion is at an altitude of between 40 and 500km, but the size of the effect depends on the energy yield of the weapon. Most of the EMP currents occur at an altitude of about 30km.

(50kV/m peak intensity)

A large hydrogen bomb with a yield of one megatonne may produce a peak intensity field of some 50kV/m at the Earth's surface. As shown in Fig. 2, the peak pulse intensity is reached in about 10ns and its total duration is of the order of 1 μ s. This is quite long enough to irreparably damage semiconductor devices.

Power lines and telephone lines are very effective at picking up the extreme voltage gradients produced by EMP. It has been calculated that a large explosion could produce a short pulse of some ten million volts on power and telephone lines across the whole of a continent such as Australia, the USA, or Europe, while currents of the order of 10,000A may momentarily flow in power lines; possibly more than a hundred times the design capacity.

Pulses from power and telephone lines are readily picked up by other equipment in their vicinity which can thus be destroyed. In addition, the higher frequency components of the pulses can be picked up by quite short wires and can

damage electronic equipment to which these wires are connected, no matter whether the equipment is operating or not. Radio aerials are obvious sources of EMP pickup, but far smaller wires will be able to pick-up enough voltage to produce semiconductor damage.

Component sensitivity

Semiconductor devices are inherently far more sensitive to EMP than the thermionic valves used in the past. Indeed, the fact that thermionic valves can be a million times more resistant is one of the reasons why the implications of EMP were not fully appreciated at an earlier date.

It is most interesting to note that when a Soviet defector flew a Russian MIG-25 fighter aircraft to Japan in 1976, this very advanced aircraft had a body shell arranged as a Faraday shield, with its on-board communications equipment employing sub-miniature thermionic valves rather than semiconductor devices.

The sensitivity of semiconductor devices varies widely, power transistors needing around ten times the energy to damage them than small signal transistors. Integrated circuits may be a thousand times more sensitive than small signal transistors.

The most resistant components are large iron-cored transformers, electric motors and other large components. However, the effects on specified items are difficult to predict owing to the many

Electromagnetic pulse threat to communications

ways in which the equipment can be arranged and the large number of methods by which damage can occur. The position is complicated by the lack of information on the precise EMP characteristics formed by weapons of a given type. (Nuclear powers are naturally unwilling to publish details of their weapons.)

EMP hardening

It is vital to national security that military equipment is made as resistant to EMP as possible. The process of building in or adding such resistance is known as "hardening". EMP hardening can be extremely expensive (and virtually impossible in the case of large structures such as power lines) and therefore it is only military rather than civilian equipment which is hardened.

Almost all items of military equipment currently produced are hardened against EMP effects, although there are obvious degrees of hardening and complete

screens to meet various requirements. This company considers wire mesh screening inadequate. As indicated in Fig. 4, a 6mm network of 0.5mm diameter wire in the form of a double screen is not adequate in upper radio frequency regions.

For their most sensitive computers, the Swiss have decided that it is more economical to place them some 600m under the Alps than to thoroughly screen them on the surface. In the case of power and telephone lines, it is probably not economically feasible to bury them over long distances at an adequate depth, so surge arrestors are more practical for this type of problem.

The use of fibre optics for long distance communications, and even for short distances between units which are EMP hardened, is basically very attractive because fibre optics do not pick up EMP and can carry high data rates. However, fibre optics are somewhat susceptible to moderate doses of nuclear radiation which reduces their transparency, at

The last observed effect of EMP produced by an exo-atmospheric explosion occurred in 1962 when a 1.4 megatonne thermonuclear weapon was detonated about 400km above Johnson Island in the Pacific Ocean. It extinguished street lights in Hawaii some 1300km away and caused other unexpected results, yet the effects on local radio and radar were not very prominent, for reasons not fully understood. Doubtless the sparse population of the area and the wide use of thermionic valve equipment played an important part in reducing the effects.

Following this, a theory of EMP generation was evolved in detail, but before the US could test this theory, it had signed an agreement not to perform atmospheric tests, although some initial tests were carried out using underground nuclear explosions which can generate a limited amount of EMP.

Most current EMP testing is carried out using EMP simulators which generate an electro-magnetic field which resembles a nuclear EMP as closely as possible. Initially, simulators were able to test individual components only, but in 1980 the US Air Force Weapons Laboratory in New Mexico brought into operation an EMP simulator which can hold a B-52 bomber. It operates by discharging two 5MV pulses into transmission lines surrounding the aircraft. The United Kingdom has three EMP simulators at its Atomic Weapons Research Establishment, Aldermaston.

All simulators are inevitably compromises between economy, the size of the equipment they can accept, and the problems caused by the intense electromagnetic fields which are generated in the vicinity. Pulses are often generated by discharging capacitors through a gas gap, but must have a very rapid rise time.

Although huge sums are spent on simulators, it is clearly impossible to construct one large enough to test a telephone or power line network. Work on screened cables has indicated that great improvements may be obtained against EMP — possibly up to 120dB/m or more. However, much of the work on large systems remains theoretical.

The cost of satellite communications is falling so rapidly that military and civilian long-distance links are using this technique far more frequently. To some extent satellites can be hardened against EMP before launching and, unlike other long-distance communications networks, can be laboratory tested for the effectiveness of this hardening.

Strategic implications

In the event of a nuclear war, the availability of first class communications

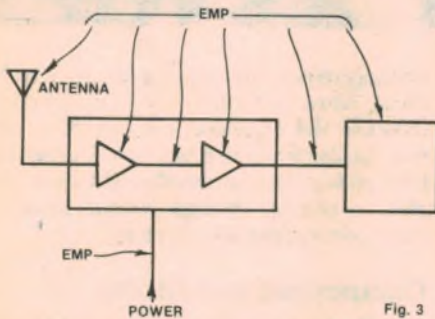

Fig. 3

Pulses would affect all stages of electronic equipment. Fig. 4 shows the effectiveness of various shielding materials.

protection may be impossible. The computers in missiles and military aircraft are usually especially well hardened against EMP, but the problems presented are very different from the hardening of, say, 100,000 army radio receivers.

EMP may affect a simple piece of equipment at many points as indicated in Fig. 3. Some manufacturers such as the M.O. Valve Co of London and Siemens of Munich manufacture gas filled surge protectors which can operate at extremely high speeds (under 1ns). If connected between sensitive points (usually all signal and power inputs and outputs) and ground, they will short circuit the EMP so that it is unlikely to damage the equipment.

Really thorough screening and double screening helps to provide at least some protection against EMP. Siemens produce rooms shielded like a Faraday cage, but use welded iron shields and copper

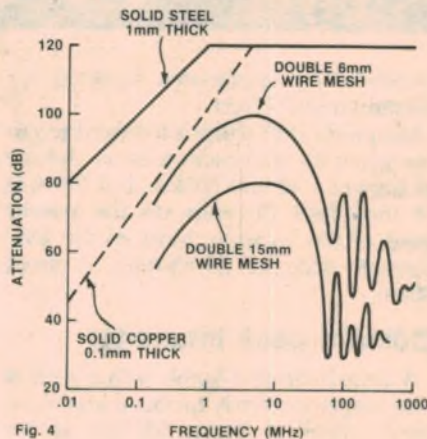

Fig. 4

least for a time. Much work is being carried out to try to develop fibre optics which minimise this problem.

Although the electronic systems handling the signal before it is converted into light pulses need careful EMP hardening, this may be carried out by using a shielded enclosure for the whole system with the power input protected and only the optical fibre emerging from the unit. Current military trends are very strongly towards using screened rooms for central transmission through optical fibre cables.

Testing

When one has finished a job in almost any field of electronics, the final stage is to test the equipment. Unfortunately it is most difficult to test the performance of the hardening systems used against EMP and, the larger the equipment, the more difficult testing becomes.

Buy from a good sound company

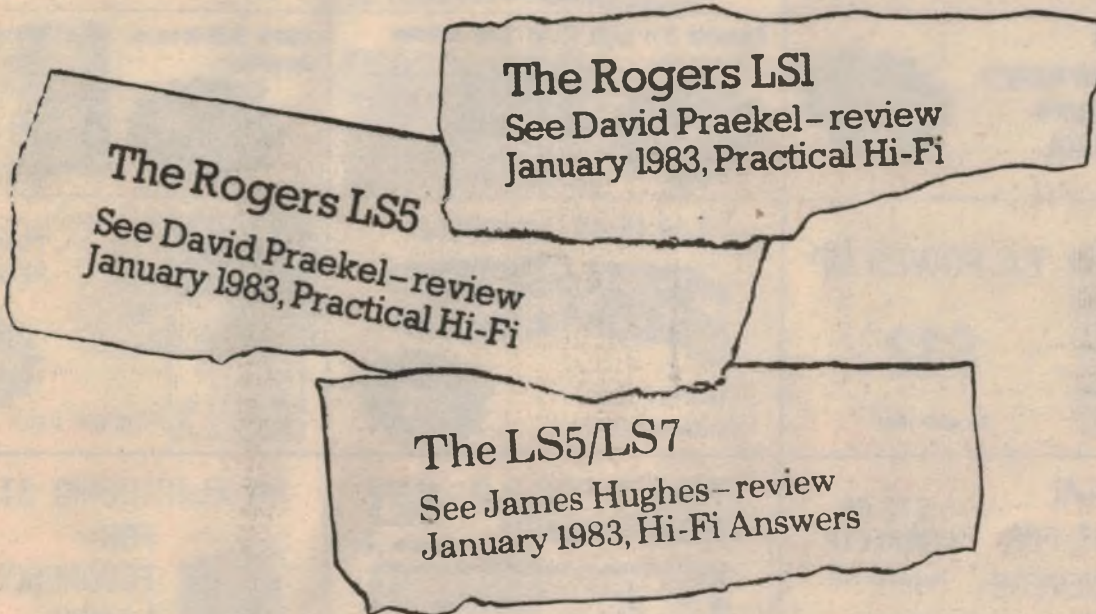

When Rogers set out to design a new series of loudspeakers especially for use in the home they were determined to keep to their own self-imposed high standards. The result was that the superb crystal crisp clarity of the LS3/5A BBC monitor, the Studio 1 and the rest of the professional range is now captured in the LS1, LS5 and LS7.

Rogers
BRITISH  HIGH FIDELITY

DISTRIBUTED BY:
AUDIO 2000
P.O. Box 107, Brookvale NSW 2100. Tel: (02) 939-2159.

Please send me further information on Rogers speakers.

NAME _____
ADDRESS _____
POSTCODE _____
Ref SW2 _____

Electromagnetic pulse threat

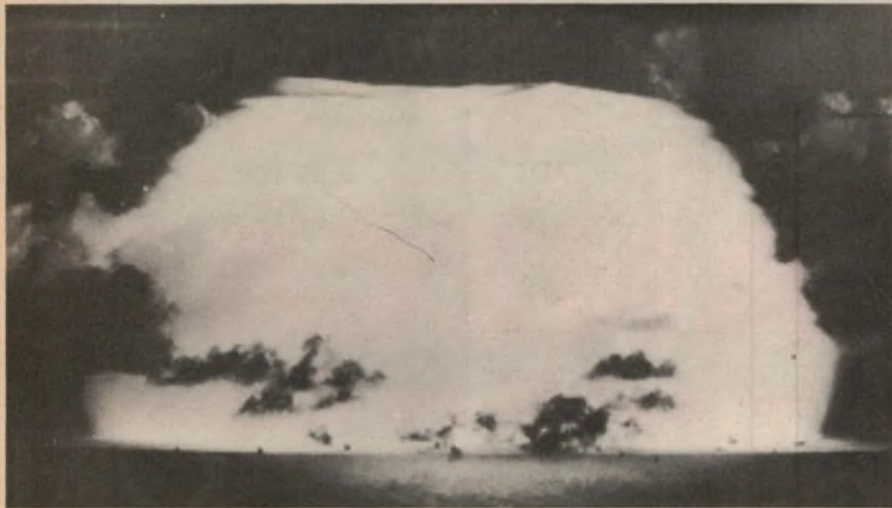

and reliable electricity supplies would be absolutely vital to the population surviving the first onslaught. These factors, together with ample computing power and vehicle reliability, would be essential to any nation requiring to make a nuclear response to the initial attack.

Nuclear EMP effects threaten to disturb the very sensitive balance of power which seems to have kept the world free from any major war since the end of World War II in 1945. Some people believe that no matter how much hardening is put into equipment, only a "use it or lose it" war philosophy can work. This can only lead to a "trigger happy" situation where ideas of "controlled" nuclear war give way to the older idea of Mutually Assured Destruction (MAD).

To make the situation even more delicate, there is the risk that a country may not even get the warning of a rocket carrying an EMP weapon entering its atmospheric space. Many satellites orbit the earth, and a suitable satellite with a nuclear charge could be exploded at will, reducing any warning time to milliseconds. Such a danger is thought by some people to make the idea of a "flexible nuclear weapon-for-weapon" response untenable, an all-out nuclear war being the only possibility. Who can forecast the position unless and until the effects of hardening systems have been thoroughly tested using exo-atmospheric nuclear explosions?

Although there remains much to be learned about the effects of EMP, the nuclear powers certainly have weapons which have been specifically designed for the purpose of paralysing the communications and mains power supplies of a country.

Except for the EMP effect, such weapons would not affect people or buildings and would not necessarily be regarded as a nuclear attack, so a con-

ventional war could follow with one or both sides having lost much of their communications and power systems. The limited number of hardened military systems which survived would be overburdened by the demand for communications and even emergency fire and ambulance requirements would have to give way to military communications needs.

As the rise time of an EMP is in the nanosecond region, the whole communications system of a nation could be lost almost instantaneously. If the nation detected the rocket carrying the EMP weapon, it could have a warning period of perhaps a few minutes — if that long — before the EMP wiped out control over its armed forces. Many experts therefore fear that this could result in a philosophy of ordering a full scale nuclear response in the very early stages of a suspected attack.

It is horrific to think about the implications of such a situation which could result in a full nuclear war, perhaps in error, because one nation sends a rocket carrying an unknown, and possibly innocent, payload above the air space of another nation. Much depends on the amount of confidence the "attacked" nation has in its hardened communications systems, but no one really knows the exact performance of such systems because of the atmospheric nuclear test ban agreement.

It is significant that Edward Teller (known as the "father" of the US hydrogen bomb) is reported to have said that he would like to roll back the test ban so that more can be learned about EMP and its implications for the balance of power. The US is ready to carry out exo-atmospheric nuclear tests for EMP investigations and to check effectiveness of EMP hardening if ever the partial test ban treaty should be lifted.

Software for the Super-80 Computer

The programs are:

POKER MACHINE SIMULATION:

This simulated poker machine keeps a record of your winnings and unlike the real ones, you can set a limit on your losses

CALENDAR CALCULATOR:

This program displays or prints out a calendar for any year of the 20th century — and keeps track of paydays!

OTHELLO GAME:

The game of Othello, or Reversi, is played on an 8 x 8 grid with counters of two colours. This one has a "help" option

INVESTMENT ANALYSIS:

How much money can you make investing for a fixed term of years at current interest rates? Find out with this program

GUESSING GAME:

Is it animal, vegetable or mineral, a place, name or a car? Play against your friends, trying to guess the object

LIST AND SORT:

This program lets you compile lists of up to 500 items, arrange them in alphabetical order and save them on cassette tape

FRED THE SHRINK:

Got a problem? Perhaps Fred can help. Talk things over with your computer — it may give you a new perspective on life!

SIMPLE MATHS DRILL:

A great one for the kids — or to test your own arithmetic skills. It tells you the right answer, with comments if you goof

LOTTO NUMBER SELECTOR:

We don't guarantee you'll win your fortune, but this program makes picking Lotto numbers easy. It's fun to use, too.

TRIANGLE SOLUTIONS:

Computerised trigonometry at your service. If you think you know all the angles, try this program for size.

MORTAR ATTACK GAME:

Match wits with the computer! See how long you can hold out in this challenging game of mortar bombardment

CAVES & MONSTERS:

Go adventuring in the maze. You must fight monsters and find the treasure, but be careful — the monsters get tougher as you go

AMATEUR Q CODE TUTORIAL:

If you're thinking of going for your amateur radio licence, or just want to find out what all those "Q" codes mean, try this.

DIRECTORY FOR CARAVAN PARKS:

Owners of caravan parks can keep track of who's where with this program. It can be adapted to other applications too.

SUPER-POKEY GAME:

Another poker machine game, but this one has graphics. For the budget conscious, you can set an upper limit on your stake

TATTSLOTTO NUMBERS:

For those south of the border we present a program to select numbers for Tattsлото entries. Good luck.

Note: this book is exclusive to, and available only from, Electronics Australia, 57 Regent St, Chippendale 2008, PRICE: \$4 or by mail order from Electronics Australia, PO Box 163, Chippendale, NSW 2008. PRICE: \$5.



ANZCAN

— cable to Canada

Bondi Beach. Volunteers prepare to lay the ANZCAN cable in the trench prepared for it, seen in the background.

January 11, 1983, will become a landmark for Australian communications, marking the beginning, from the Australian end, of the ANZCAN cable laying project. The ANZCAN cable, to run from Sydney to Vancouver, is to replace the COMPAC cable which set out from Sydney nearly 20 years ago.

by PHILIP WATSON

The exact venue, on both occasions, was Sydney's famous Bondi Beach, not far from the Overseas Telecommunications Commission (OTC) terminal building at Paddington, and a logical place to terminate a cable. When the COMPAC cable was commissioned nearly 20 years ago it provided 80 telephone channels to Canada, and thence to Britain and Europe. Compared with the two or three tenuous radio-telephone channels which was our sole voice link in those days, 80 top quality circuits was luxury indeed.

But Australia's international telephone and other traffic is growing at 30% each year, and COMPAC is no longer adequate. The ANZCAN cable will provide 1840 3kHz telephone circuits, some of which will be subdivided to provide telex, facsimile, and data circuits. The total cost will be \$400 million, of which

OTC, as the major partner, will contribute \$200 million.

The cable will go first to Norfolk Island, a distance of 978 nautical miles, and from which a branch will run to Auckland, NZ (732nm), while the main run goes on from Norfolk Island to Suva (995nm). From Suva the longest leg commences, to Hawaii, 2990nm away, and from there another long leg, 2466nm, runs to Vancouver. Once there, there are plenty of circuits to take the signals across the Canadian continent to the east coast, and thence via trans-Atlantic cables to Britain and Europe.

On that Tuesday morning, January 11, the cable ship "Mercury" lay off Bondi Beach with some 500nm of cable in her hold. Before she could head for Norfolk Island the Sydney end of the cable had to be brought ashore and terminated, and a large group of professionals and

volunteers had been organised to do the job. There were also plenty of spectators, many of whom would also be called upon to help before the morning was over.

On the grassy slope behind the southern end of the beach was a large marquee, in and around which numerous officials from OTC and STC (Standard Telephones & Cables) welcomed visitors and explained what it was all about. Down on the beach bulldozers were completing a deep trench they had gouged in the sand from the water's edge to the retaining wall, where the cable was to join its underground counterpart to Paddington.

There was also a team of Telecom Construction Branch workers with a couple of powerful winches on heavy vehicles, just behind the retaining wall. Then, when all was ready, a motorised rubber surf boat brought ashore a light line, carried the last few yards through the surf by a Bondi lifesaver, then hauled across the beach to the winch.

Once on the winch the line was hauled in quickly bringing ashore a much heavier line and, on the end of that, the cable itself. As the cable was paid out

from the stern of the ship red plastic floats were attached every few metres, to keep the cable clear of the bottom. It was a long job, but the end eventually reached the beach and was winched across the sand.

When enough cable was ashore it then had to be moved bodily sideways and lowered into the prepared trench, and this was where volunteers from the spectators were called in to help. The cable is bulky and heavy, and their effort was much more than a token gesture. But the job was eventually done and the cable lay zig-zag pattern in the wide trench.

One by one the floats were removed and the cable settled to the ocean floor, the last step before "Mercury" headed for Norfolk Island. In fact, the cable on board was only sufficient for about half the journey, at which point she would have to head off to reload.

Back in the official marquee it was champagne and smoked Canadian salmon — or something a little more Australian for those who preferred it — as everyone celebrated. Helium-filled balloons floated skywards and the atmosphere was jubilant.

The ANZCAN cable was on its way.

In fact, those concerned had reason to celebrate because, behind all the razzmatazz, there is a story of a major Australian achievement; a story which is all the more welcome at a time when there are plenty who believe that Australian technology, particularly high technology, can no longer compete with overseas countries.

Standard Telephones & Cables Ltd of the UK won the \$300 million contract to supply and install the cable between Sydney and Vancouver. (The Nippon Electric Company won the contract for the Norfolk Island-New Zealand segment.) The cable itself was made in England but needed to be fitted with over 1000 repeaters; one approximately every 12 km.

And this is where Australia came into the picture. Under the terms of the contract and the Government's offset policy a proportion of the work was sub-contracted to Australian industry. More precisely, 450 of the repeaters were to be built by STC in Australia. The result was a \$10 million factory at Liverpool, NSW with the necessary skilled workers and clean room facilities; one of only five in the world. The sub-contract was worth \$78 million to Australian industry.

And the confidence in Australia's capability appears to have been fully justified. As one of the STC executives commented: "In the realms of high technology, such as is needed for this job, Australia can more than hold its own, both technically and economically, with the rest of the world."

Which is a compliment indeed for



Mr Peter Meulman, ANZCAN system manager for OTC, examines a shipment of Australian-made repeaters, with Mr Eric Foster, STC director.

Australian industry because undersea repeater manufacture is one of the most exacting tasks in the world, ranking with satellite and space technology.

A primary requirement for any undersea repeater is, obviously, reliability; it is expected to operate on the ocean floor, possibly 6km down, in a very hostile environment, for at least 25 years without any attention. For this reason it must be built from the most reliable components available, by the most highly skilled operators, in a virtually perfect environment.

The repeaters are assembled in a clean room which excludes all dust larger than six microns. Staff wear special clothing

and no make-up, smoking, or eating is allowed in the area. All electronic components are tested and individually numbered, and these data permanently filed. All steel parts are given ultrasonic and X-ray examination, with all joints X-rayed in three dimensions. All soldered joints are examined through magnifying glasses.

Complete repeaters are exhaustively tested before being sealed in their undersea housing. One test involves storage at 2°C for 28 days under constant electronic monitoring. When passed, each repeater is enclosed in a polyethylene sleeve, then hermetically

Continued on p136.

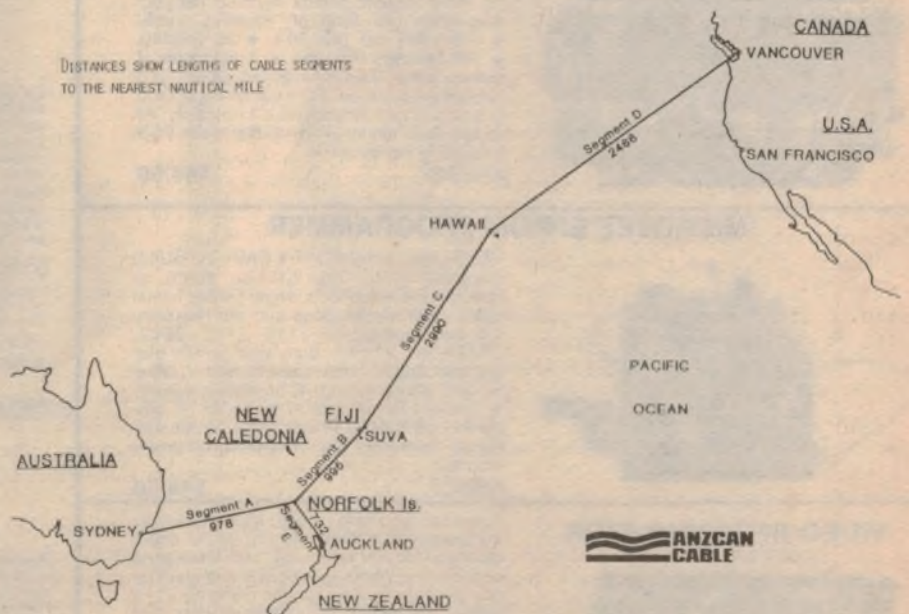

This map of the ANZCAN Cable route gives some idea of the immensity of the cable laying task. Note the Suva/Hawaii segment, nearly 3000 nautical miles.

POWER CONTROL KITS

See EA November, 1982



POWER UP

A MUST FOR YOUR COMPUTER SYSTEM

This great new Project from EA is the answer to a Maidens Prayer What Does it Do?

A single 240v mains plug and lead feeds one unswitched master 240v outlet plus 4 switched 240v outlets. With say a hi-fi system, plug your main equipment item (e.g. Amp) into the master outlet and whenever you "switch on" your amp - presto - mains power is applied to the other 4 outlets i.e. simply "turning on" your amp turns on your tape cassette, tuner, turntable, graphic equaliser without mains spikes, plops etc.

Just the shot for your Computer System. The Altronics Kit includes case and all outlets.

Cat K6000 \$39.50

GO ANYWHERE 240V PWR. KITS

See EA May and June 82. These great new inverter kits enable you to power 240V appliances for your car, caravan or boat. (From Standard 12V car battery.)

40 WATT

Suits small appliances, i.e. turntable, tape deck, shaver etc. Variable frequency adjustment enables accurate speed control of turntable motors.



IC Sockets Provided

K6700 \$55.00

300 WATT

Fully regulated and overload protected XTAL locked frequency.

NOW USING HIGH EFFICIENCY TRANSFORMER

Use to power hi-fi, TV sets and for emergency lighting.



- Gold plating on both PCB edge and edge connector.
- Low age rate parallel resonant XTAL used.
- Sockets for all IC's.

K6750 \$199.50

\$10 DELIVERY ANYWHERE IN AUSTRALIA!

NEW UNIVERSAL DC-DC INVERTER

SEE ETI MAG. SEPT. 1982

Rated at 200 watts this versatile inverter can be simply configured for virtually any desired input/output voltage required by the winding format of T2.

Typical input voltages: 12/24/32 V. Typical output voltages available: + 50, + 15, + 40, 1400 V.

Now you can use high power hi-fi and PA amps for your boat, caravan etc.

K 6509 includes metal case \$39.50



40W FLUORESCENT LIGHT INVERTER FOR 12V BATTERY OPERATION

Self-oscillating, push-pull inverter operates above the audible frequency range and is capable of driving two 20 watt or one 40 watt fluorescent tube to 150% of normal (240 volt operation) efficiency.

Great for camping, working on the car, and of course, during power blackouts!

Complete boxed kit, including all winding wire.

K 6505 Includes Metal Case \$37.50

ELECTRONIC FLOURO STARTER

(SEE EA OCT. 1982)



Save a fortune on Fluoro Tubes

- ★ Extends the life of your fluoro tubes by 1,000's of hours
- ★ Instant "ON" — no more flickering at switch on

K6300 \$4.95

COMPUTER KITS

16 CHANNEL COMPUTER OUTPUT DRIVER

(SEE ETI NOV 1982)



Drive Relays Motors. Solenoids etc under software control. Do something useful with your computer. Like cook toast control the hot water system. control anything that your imagination can think of. Altronics supply

- ★ TIP 31B's not BD 139's
- ★ IC Sockets
- ★ DIP Headers Provided
- ★ 1 full meter of rainbow cable
- Two independent groups of 8 outputs are provided. Each can be configured to sink 3 2 or 1 Amps from a 12v supply. All components mount on 1 double sided PCB for ease of construction

K9653 \$44.50

'MICROBEE' EPROM PROGRAMMER

VERSATILE. LOW COST & EASY TO BUILD

Great new project from ETI (Jan 1983). All components mount on a single printed circuit board. Unit simply plugs into the Microbee 10 port. Suitable for 2716 2732, 2532, 2732A and 2764's. Burn your games programmes and eliminate cassette loading times

- ★ Zero insertion force IC socket for eproms
- ★ Sockets for all other IC
- ★ 1 x 2716 supplied — get started straight away
- ★ Kit supplied in deluxe jiffy box. all mounting hardware included

K9668 \$48.50

VIDEO RF MODULATOR

(SEE ETI OCT 1981)



If you cannot afford a Video Monitor for your computer this is the kit for you. Super stable oscillator design and very low modulation distortion

- ★ Works with both B & W and Colour TV sets
- ★ Suitable for computers, TV games, TV pattern generators or what have you
- ★ Deluxe kit featuring heavy duty diecast box for RF shielding
- ★ Input and output sockets

K9760 \$17.50

ETI'S BRILLIANT NEW DIRECT-CONNECT COMPUTER MODEM



Employs unique 'Commutated Filter' design overcoming virtually all the problems involved with conventional modems.

Super flexible unit facilitates communications between computers over cables, the telephone network and radio links.

Unit connects to a standard RS 232 interface and is capable of both 1200/75 Baud and 300/300 Baud transmission and reception

- ★ Line switching; answer and dialing facilities on board.
- ★ EXCLUSIVES: ★ Plated through, double sided PCB
- ★ Complete set of IC sockets
- ★ Kit requires 85 IN914 Diodes for programming these are included
- ★ Ceralock resonator and matching balanced load capacitor used for long life and high accuracy
- ★ Telecom approved isolating transformer and Reed relays included.

K 9644 (See ETI Oct 82) \$169.50

MODEM MONITOR AND CASE OPTION I

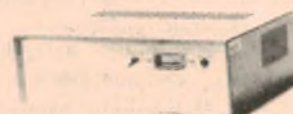

Having built the modems for our own computer use ALTRONICS strongly recommend (as do ETI) the inclusion of Audio and Visual Monitoring (signal strength). Our K 9645 includes all the components listed on Page 23 October ETI, custom ALTRONICS PCB, speaker, panel meter, front panel and case to house these options plus the full modem.

K 9645 Modem Option I ONLY \$30.00

ALTRONICS ... ALTRONICS ... ALTRONICS ... ALTRONICS ...

ALTRONICS ... ALTRONICS ... ALTRONICS ... ALTRONICS ...

Further thoughts on wind powered generators

Quite a few readers have "had a go" at building wind-powered generators since *Electronics Australia* published a brief article on the subject in July 1978. This article looks at shortcomings in the original design, details an improved propeller, and discusses alternator requirements.

by T. C. THRUM*

In an article entitled "Building a Wind Generator" (EA July, 1978), John Andrews described how to carve a 1.8m propeller for a wind generator. Windmills have always fascinated me so I decided to have a go. I have a good background in electronic, electrical, and mechanical engineering, but precision woodcarving was something I hadn't tackled before.

I manufactured the propeller as described in the article except for the copper foil on the leading edge. Instead I coated the whole prop with epoxy resin. I was amazed at how well the finished article turned out, especially the balance, which can be precisely adjusted. Since then I have carved a 2.4m and a 3m propeller both of which have been tested, and a 4.5m model which is awaiting the final balancing.

To obtain the correct dimensions for the larger props, I did some research into the basic design only to find some discrepancies in the dimensions used in the article published in EA. The basic method of construction is sound and, providing care is taken with the accuracy, the results can be quite rewarding. However, I suggest one does not attempt the feat of construction unless they have access to a hand-held power planer and belt sander.

The critical dimension of a propeller is the pitch, ie the angle of the driving face of the prop to the wind. The pitch continually changes from the tip to the centre of the blade, and determines the speed of the prop, provided that it is not overloaded. In designing a complete wind generator one does not design the speed of the prop to suit the generator; rather one designs the generator to suit the speed of the propeller.

The critical factor that determines the designed speed of the prop is the tip speed wind ratio. This is the ratio of the velocity of the tip of the prop to the velocity of the wind. The accepted ratio to produce the best efficiency is approximately 6:1, ie the tip of the prop should travel at six times the velocity of the wind.

If the tip speed ratio is reduced greatly below this value, efficiency will be lost unless a greater number of blades is used. Similarly, increasing the tip speed ratio also results in loss of efficiency due to air friction, as well as increasing the disintegrating forces as the rotational speed increases.



In a 40km/h wind the author's installation delivers 13.8V at 18A (250W).

The power supplied by the wind depends on the area swept by the prop and, since $area = \pi R^2$, if you double the diameter you obtain four times the output power. The other characteristic of wind generators to keep in mind is that the energy contained in the wind is a cube function, ie if the wind velocity doubles the energy available increases by a factor of eight. This is why it is imperative that the site for the generator be carefully selected as a difference of a few kilometres per hour in wind speed can make a big difference in output power.

Pitch calculation

If we were to draw a circle scribed by the tip of the blade and another circle half way down the blade and then work out the area of the outer annulus and the area of the inner circle, we would discover that the area swept by the outer half of the blade is three times that swept by the inner half. It is therefore the outer section which is of most importance, and it is here that our calculations should begin.

The velocity of the tip of the prop will be the theoretical no load velocity (which is calculated by the pitch angle and the wind speed) minus the slip (which is caused by air friction on the blade; bearing and gearing friction; and the load produced by the alternator). The amount of slip produced is the determining factor in matching the generator to the propeller. Using a vector diagram we can calculate the exact pitch at the tip of the blade, as shown in Fig. 1.

If we divide the length of the blade into

* Para Hills West, South Australia, 5096.

small equal sections we can now determine the pitch change; ie the shape of the blade. The wind velocity vector will stay the same but the blade speed vector will vary proportionally as the distance from the centre of the blade; ie at one half the distance from the centre the pitch will be twice that at the tip. With the prop dimensions described in the July, 1978 issue it will be found that in a 40km/h wind the no load speed should be 2724rpm.

This figure is calculated as follows: In a 40km/h wind the distance travelled by the wind in one minute = 666.6 metres.

If the pitch angle is 2.48° (as in the July 1978 design; see Fig. 1), then the no load distance travelled by the prop tip in one minute = $666.6 / (\tan 2.48^\circ) = 15,391$ metres. This produces a tip speed ratio of 23. Since the diameter of the prop is 1.8m, the circumference described by the prop tip is 5.65 metres. Therefore, prop speed in a 40km/h wind is $15,391 / 5.65 = 2724$ rpm.

According to the EA July, 1978 article the prop speed should be 900rpm in a 40km/h wind. Therefore the prop is working with a 66% slip and is close to a stall condition. If the pitch angle were to be made three times larger (7.5°) then the torque produced by the prop would be three times greater and hence we would get three times the power for the same wind speed. If another figure for pitch is calculated half way along the prop then a similar discrepancy is obtained.

In my opinion, the tip speed ratio is far too high. Drag at the higher speed is far too great and it will make an almighty roar if it reaches full speed. The 3.05m prop that I manufactured had a tip speed ratio of 10, to match the alternator, which was direct drive, and in a 40km/h wind the propeller was rotating at 700 to 800rpm. I stepped outside to see what type of aircraft was flying around, only to realise it was my wind generator. It was roaring like a light aircraft waiting for takeoff. Because the pitch of the EA prop is so fine, this also makes for harder starting in light winds.

A 1.8-metre propeller

To construct a 1.8m prop, I suggest that you begin with a dressed wooden blank measuring 180cm \times 15cm \times 5cm. This must be shaped according to Fig. 2 and the dimensions given in Table 1. Mark out each half of the blank as indicated by Fig. 2 and saw off the shaded portions. Clean the saw marks with a plane then, along each trailing edge, mark off the distances shown in the table and join each point with a smooth pencil line. The driving slopes are now planed down so that a smooth surface connects the leading edge to the pencil line all the way along the blade.

Make sure that the prop is correctly

Fig. 1: From the vector diagram at right the pitch of the tip of the EA prop design can be calculated.

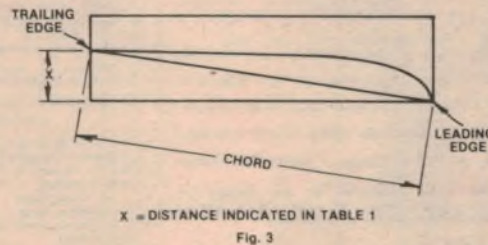
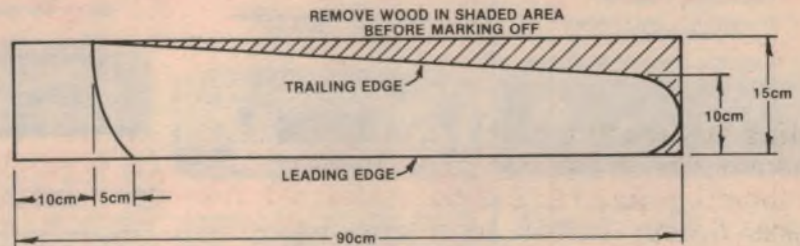
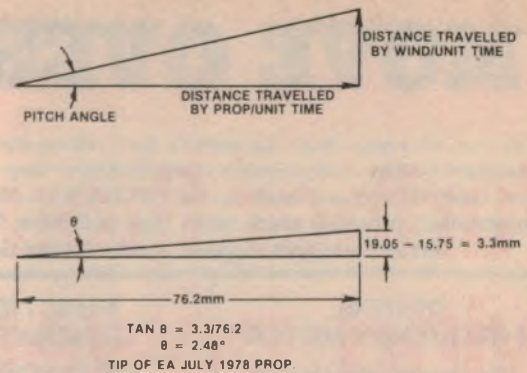

Fig. 2, above, shows the initial shaping of the block from which the propeller is carved. Shaded area must be removed before marking off. Fig. 3 at left shows the dimensions which are referred to in Table 1.

balanced after each operation as described in July 1978. It is not sufficient to balance the finished prop by removing some timber at random from the heavier side.

Note also that I have referenced the trailing edge dimensions from the front of the blank rather than from the rear as in the original article.

Once the driving slopes have been completed, the back surfaces must be shaped to reduce air friction and weight. Fig. 3 is a cross-section diagram of the final shape of the back surface. Finally, the finished product can be coated with K36 epoxy resin to protect it from the elements. This coating can also be combined with a Dynel cloth (which is the recommended combination with K36 resin) or with normal fibreglass cloth to increase the overall strength of the prop.

The K36 epoxy/Dynel combination is recommended since its expansion rate closely matches that of wood, whereas normal fibreglass epoxy has a quite different expansion rate.

The above propeller should deliver close to 70 watts in a 20km/h wind, and 500 watts in a 35km/h wind. However bearing, gearing and alternator losses must be taken into account in a practical system. The pitch of the prop is approx-

imately 9.5° , while theoretical no-load prop speed is 347rpm in a 20km/h wind, 520rpm in a 30km/h wind, and 694rpm in a 40km/h wind.

To manufacture a larger propeller, the chord width can be proportioned to the length of the prop designed; ie if the

TABLE 1

Distance from centre of blank (cm)	Distance from front of blank (cm)
5	0
10	0
15	5.1
20	5.1
25	5.1
30	5.1
35	5.1
40	5.0
45	4.4
50	3.9
55	3.4
60	3.05
65	2.8
70	2.5
75	2.25
80	2.05
85	1.9
90	1.75

Electricity from the wind

prop is twice the length, the chord should be twice as wide. The actual size of the chord determines the efficiency of the prop at different wind speeds. A narrow chord will work better at high wind speeds due to lower wind friction; a wider chord will work better in the lower wind speeds, producing less slip.

The alternator

Obtaining an alternator to suit the above propeller will be extremely difficult unless it is tailor made. However, a car alternator or generator can serve as a starting point. Each has its own advantages and disadvantages. An alternator is self current limiting due to an inherent property known as synchronous reactance, which simplifies regulator construction. However, this tends to make the alternator a little less efficient than the generator.

A generator, on the other hand, has a larger set of brushes and usually has a sleeve bearing on the rear end which adds up to more friction and more frequent maintenance. This friction is an important consideration, especially when the prop is stationary and light winds have to set the unit in motion.

Once the prop gathers speed, friction is less of a problem.

The speed of the alternator (or generator) is critical if we are to obtain the maximum possible power output. Power is equal to voltage multiplied by current, and the voltage is proportional to both the magnetic flux and the speed of the rotor. The flux is proportional to the field current up to the magnetic saturation of the iron; ie if the field current is doubled, the output voltage is doubled, but remember that the excitation power will be four times greater ($P = I^2R$).

Since there is a limit to the flux we can provide (due to magnetic saturation of the iron), careful speed selection is the only option left (except for the number of turns on the stator coils which I will go into next month). Because the speed of the prop in a 20km/h wind is 340rpm without slip and the minimum rotor speed for 14.4 volts output is approximately 1000rpm, a 3:1 speed increase is required. I suggest a 4:1 increase in ratio to allow for prop slip.

In a 40km/h wind, the prop is capable of delivering 500W and the alternator will be doing 2000rpm. Since the alternator is only about 50% efficient, the output current will be around 18A (250W) which is quite reasonable.

Alternator bench tests

I have run a series of bench tests on a 55A 12V Bosch alternator fitted with an in-built regulator. The alternator was

driven using a normal fan belt from a 750W DC motor with an HT Holden crankshaft pulley mounted on its shaft. The DC motor was speed-controlled using SCRs to vary the armature current, and both the armature voltage and armature current were monitored to establish the power supplied to the crankshaft pulley so that overall system efficiency could be monitored.

The copper, iron, bearing and windage losses of the DC motor were subtracted from the measured input power to obtain the correct results. Both the DC motor and the alternator under test had slotted discs attached to their shafts. These discs interrupted photocell circuits, the outputs of which were fed into a frequency counter to provide a direct reading of revs per minutes.

Tests on the alternator involved plotting field voltage against rpm with no load. One problem that came to light was that at the minimum rpm necessary to provide a 14.4V output (around 960rpm), the voltage across the field was 11.5V. Under these conditions the input power required was 110W and the excitation power was 40W. At a slightly higher speed, the field dropped to 7V and the input power required dropped to 63W.

Designing for efficiency

This phenomenon is explained by the fact that, at low rpm, the flux developed by the field is sufficient to saturate the iron, thus producing excessive iron losses. The alternator pulley also proves to be a problem. Because power = torque \times speed, the torque required to turn the alternator increases at the lower revs. A point is reached where the belt starts to lose grip on the pulley.

This becomes regenerative. As the alternator loses speed, the regulator supplies more field current and the torque required by the alternator increases, thus further increasing the slip between the belt and the pulley. Increasing the DC motor speed appeared to have little effect, but removing the load did prove effective in regaining traction between the belt and the pulley. An alternative solution is to increase the diameter of the pulley, but this also increases the size of the drive pulley.

Another solution is to add some resistance in series with the field to prevent saturation. A 2 ohm 12W resistor was used, and this proved to be very effective in the above system which, unlike a car engine, provided very little drive power at low speeds.

I suspect that if some resistance were added to the alternator field of the system in July, 1978 EA, the output power would be increased considerably,



This Dunlite commercial installation provides a maximum continuous output of 2kW in a 40km/h wind and is available with a selection of output voltages. Features include a three phase alternator with solid-state regulator and an automatic feathering mechanism to protect the prop and alternator in high winds. A disc brake on the prop simplifies maintenance and installation. For further information contact Dunlite at PO Box 100, Hindmarsh, SA 5007 or offices in other states.

because it would allow the prop to rotate closer to its designed operating speed.

The efficiency of the Bosch alternator plus V belt drive was in the 45% to 60% region for output currents of 3 to 30A, provided that the field voltage was considerably below 12V and the belt was not slipping. In fact, the field voltage to provide this range of efficiency varied between 2V and 6.7V and the alternator speed range varied from 1500rpm to 3000rpm. An output current of 30A at 14.2V at 2000rpm was measured with 50% efficiency and a 6.7V field voltage.

It is interesting to note that the power loss in the output diodes is considerable. If the alternator is run at its 55A maximum, then the current per diode leg is 0.577 Idc = 31.7A RMS. Assuming a 1V drop across each diode (which is probably being conservative), then the loss per diode is 31.7W. Since there are six diodes in the rectifier stack, the total loss in the output diodes is 190W.

Looked at another way, the power output of the alternator is $14.4 \times 55 = 729W$, so there is 982W entering the rectifier. This means that the power loss in the rectifier is 19.4%.

Next month we will look at some ways of overcoming the various problems, including the use of gearing systems and alternative alternators. We will also discuss the overall design of a wind generator system, the most essential element of which is planning. ☺

ELLISTRONICS

PROPRIETARY LIMITED

289 Latrobe Street, Melbourne 3000. Phone: (03) 602 3499 Telex AA37758 Listron



LINEAR

The UA1458 is a monolithic pair of internally Compensated High Performance Amplifiers constructed using the Fairchild Planar Epitaxial process. They are intended for a wide range of analog applications where board space or weight are important.

25¢

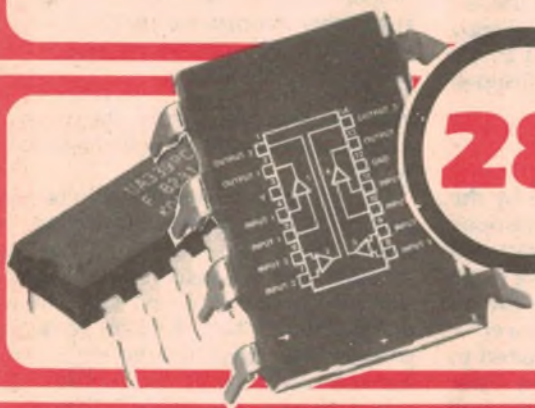
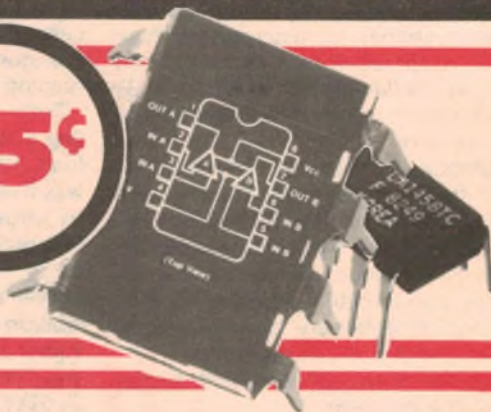

28¢

The UA339 consists of four independent precision voltage comparators designed specifically to operate from a single power supply. Operation from split power supply is also possible and the low power supply current drain is independent of the supply voltage range.

The UA 4136 Monolithic Quad Operational Amplifier consists of four independent high-gain, internal frequency-compensated op amps. They are specifically designed for low noise signal processing applications such as audio preamplifiers and signal conditioners. They are constructed using the Fairchild Planar Epitaxial process.

68¢

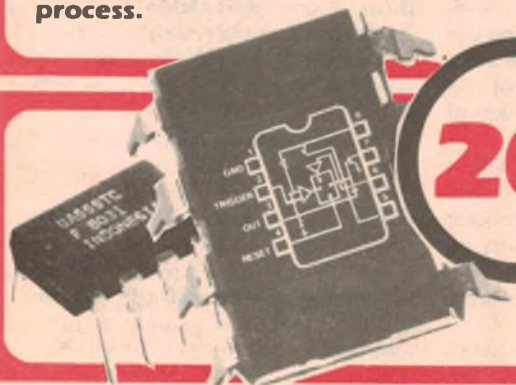
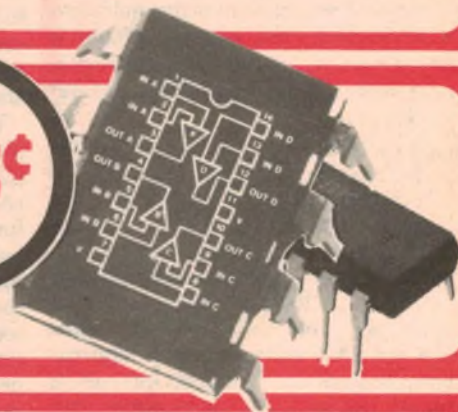

20¢

The UA555 Timing Circuit is a very stable controller for producing accurate time delays or oscillations. In the time delay mode, the delay time is precisely controlled by an external resistor and one capacitor. In the oscillator mode, the frequency and duty cycle are both accurately controlled with two external resistors and one capacitor.



Bankcard
Mail Orders
Welcome

Please debit my Bankcard.
Bankcard No.
Expiry Date
Name

Signature

Prices subject to change without notice. Phone or write for quantity discounts.
MAIL ORDERS: To ELLISTRONICS, 289 Latrobe Street, Melbourne, Vic 3000.
Minimum pack and post \$2.00. Phone (03) 602 3499

ELUSTRONICS

PROPRIETARY LIMITED

289 Latrobe Street, Melbourne 3000. Phone: (03) 602 3499 Telex AA37758 Listron

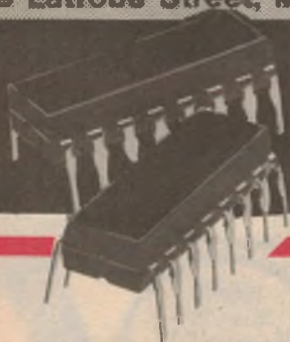

LINEAR

OPERATIONAL AMPLIFIERS

UA101HM	.86
UA108HM	1.46
UA1458HC	.66
UA1458TC	.25
UA1558HM	.93
UA201HC	.63
UA201TC	.28
UA224DV	.92
UA248DC	1.44
UA2902PV	.53
UA301AHC	.66
UA301ATC	.21
UA308HC	.39
UA308TC	.29
UA324DC	.98
UA324PC	.37
UA3303PC	.35
UA3403DC	.67
UA3403PC	.67
UA348DC	1.03
UA348PC	.71
UA4136DC	1.03
UA4136PC	.68
UA709HC	.53
UA709TC	.29
UA714HC	1.50
UA715DC	1.70
UA715HC	1.70
UA725HC	1.36
UA725TC	.41
UA739DC	1.53
UA739PC	.68
UA741HC	.55
UA741TC	.20

OPERATIONAL AMPLIFIERS

UA747DC	.77
UA747HC	.85
UA747PC	.53
UA748HC	.55
UA748TC	.29
UA749DC	1.54
UA749PC	.92
UA759HC	1.62
UA759U1C	.94
UA776HC	.94
UA776TC	.52
UA798TC	.43
UAF771PC	.34
UAF772PC	.61
UAF774PC	1.18

COMPARATORS

UA111HM	1.08
UA139DM	1.39
UA239DC	1.00
UA239PC	.58
UA2901DC	.68
UA2901PC	.33
UA311HC	.59
UA311TC	.27
UA3302DC	.60
UA3302PC	.32
UA339DC	.72
UA339PC	.28
UA710DC	.55
UA710HC	.55
UA710PC	.35
UA711HC	.55
UA734DC	2.38

COMPARATORS

UA734HC	2.56
UA760DC	1.02
UA760HC	1.10

SPECIAL FUNCTIONS

UA2240DC	1.10
UA2240PC	.93
UA3086DC	.48
UA3086PC	.28
UA555TC	.20
UA556PC	.46
UA726HC	9.10
UA727HC	15.25
UA733DC	.60
UA733HC	.77
UA733PC	.49
UA7392DC	1.70
UA7392PC	1.10

ALL PRICES PLUS TAX

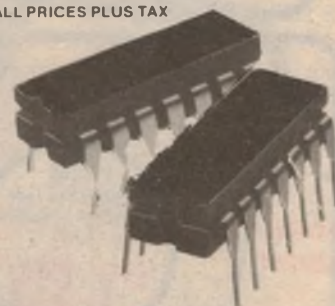

PRODUCTS MANUFACTURED BY

FAIRCHILD

A Schlumberger Company

ONE OF THE WORLD'S LEADING SEMICONDUCTOR MANUFACTURERS

ELLISTRONICS

PROPRIETARY LIMITED

289 Latrobe Street, Melbourne 3000. Phone: (03) 602 3499 Telex AA37758 Listron

VERSA®

Distributed by Ellistronics P/L.
A new range of high quality Electronic Components for professional and enthusiast.

The advertisement displays a collection of electronic tools, each with a circular callout containing its model name, specifications, and price. The tools are arranged in a grid-like fashion against a dark background.

Model	Specifications	Price
IT-820	8 to 20 Pin IC Insertion Tool	\$2.99
IT-22	22 Pin IC Insertion Tool	\$3.25
IT-2428	24 to 28 Pin IC Insertion Tool	\$3.35
IT-3640	36 to 40 Pin IC Insertion Tool	\$3.80
CIT-22	22 Pin IC Insertion Tool	\$3.80
CIT-820	8 to 20 Pin IC Insertion Tool	\$3.55
CIT-2428	24 to 28 Pin IC Insertion Tool	\$4.05
CIT-3640	36 to 40 Pin IC Insertion Tool	\$4.35
DT-200	Desoldering Tool Aluminium Body	\$7.05
DT-250	CMOS Safe Desoldering Tool Aluminium Body	\$8.65
DT-900	Desoldering Tool Large Plastic Body	\$9.99
ET-840	IC Extraction Tool Removes all sizes IC's	\$1.25

Desoldering tool spares. Upper or lower O Rings 15¢ ea. Teflon Tips 95¢ ea. Special CMOS safe tip for Dt 250 \$1.75 ea. All Desolderers have tremendous suction and tip bore is automatically cleaned. All VERSA products are fully guaranteed. Prices Plus 7.5% Sales tax.



Bankcard
Mail Orders
Welcome

Please debit my Bankcard

Bankcard No
Expiry Date
Name
Signature

Prices subject to change without notice. Phone or write for quantity discounts.
MAIL ORDERS: To ELLISTRONICS, 289 Latrobe Street, Melbourne, Vic 3000.
Minimum pack and post \$2.00. Phone (03) 602 3499

ELECTRONICS

PROPRIETARY LIMITED

289 Latrobe Street, Melbourne 3000. Phone: (03) 602 3499 Telex AA37758 Listron

C. Itoh PRINTERS



PRO-WRITER 8510A
120 CPS Dot Matrix Parallel

\$725
(\$795 Incl. Tax)



STARWRITER F-10
40 CPS Daisy Wheel

\$1400
(\$1600 Incl. Tax)

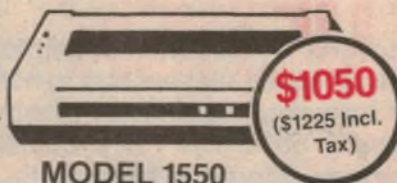

MODEL 1550

\$1050
(\$1225 Incl. Tax)

MITSUBISHI DISK DRIVES

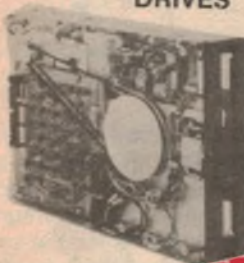

M2896-63

Slimline 8" Disk Drive, Double Sided, Double Density, No AC Power Required, 3ms track to track, 1.6 mbytes unformatted, 77 track/side, 10⁶ bit soft error rate.
\$495 + tax Box & Power supply to suit \$95 + tax

M2894

Standard size 8" drive, Double sides, double density, 3ms track to track access, 1.6 mbytes unformatted, 77 track/side, 10⁶ bit soft error rate.
\$495 + tax Box & Power Supply \$95 + tax

M4854

Slimline 5 1/4" disk drive, Double sides, double density, 96 track/inch, 9621 bits/inch, 1.6 mbytes unformatted, 3ms track to track access, 77 track/side.
\$395 + tax Box & Power Supply \$65 + tax

M4853

Slimline 5 1/4" disk drive, Double sides, double density, 1 mbyte unformatted, 3ms track to track, 80 track/side, 5922 bits/inch, Steel band drive system.
\$375 + tax Box & Power Supply \$65 + tax

MPI DISC DRIVES

(to suit Tandy & system 80 etc computers) with Box & Power supplies

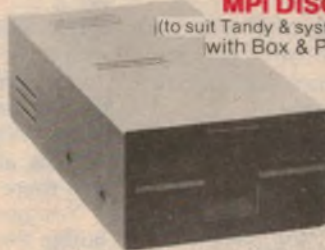

1 DRIVE

B51 **\$295 + tax**
B52 **\$375 + tax**
B91 **\$460 + tax**
B92 **\$550 + tax**

2 DRIVES

B51 **\$525 + tax**
B52 **\$650 + tax**
B91 P.O.A.
B92 P.O.A.

VERSA

SOLDERLESS PROTOTYPE BREADBOARD

A completely new design and we believe far superior to any other. Designed around two interlocking modular units, the WBU-DN is a distribution strip for power, etc. and contains 100 contacts grouped in clusters of five. The WBU-TN is the terminal strip containing 630 contacts in two separate rows of five interconnected contacts each separated by a 300 μ median. Contacts are made from non-corrosive nickel alloy and are reliable for more than 50,000 insertions. The boards accept all DIP size including RTL, TTL, DTL, CMOS and most passive devices and interconnect with 20 to 29 AWG solid wire. All boards are interlocking and elements are mounted on ground plane. Ideal for H.F., High Speed, Low Noise application. WBU2NA thru WBU-BN mounted on an aluminum base plate complete with non scratch rubber feet and appropriate binding posts. Price plus 20% sales tax. All units are packed in attractive display carton.

WBU-DN
\$1.68

WBU-TN
\$8.98

WBU-4-3N
\$16.88

WBU-TN
\$6.05

WBU-2-IN
\$7.72

WBU-6N
\$31.15

WBU-4-IN
\$20.53

WBU-4N
\$22.17

WBU-8N
\$42.70

VERBATIM DISCS

5 1/4" SOFT SECTORED

-S-Side Double Density **\$30.00/10**
-D-Side double Density **\$47.50/10**

8" SOFT SECTORED

-S-Sided Double Density **\$32.00/10**
-D-Sided Double Density **\$49.00/10**





FORUM

Conducted by Neville Williams

MORE ABOUT AM: How diode detectors work

Last month's discussion of amplitude modulated waveforms took up so much space that we had to hold over the matter of AM detection. The following explanation of how a diode detector operates will hopefully be a little more complete and convincing than what is commonly offered in basic texts.

Just to demonstrate that we don't always pick on other people's publications, Fig. 1 is taken from our own handbook "Basic Electronics".

It is a fairly traditional diagram showing:

- (a) A tuned input circuit, as for a beginner's "crystal set" and, below it an amplitude modulated radio frequency waveform.
- (b) the addition of a diode detector and the way in which it passes on only one half of the modulated waveform.
- (c) The further addition of a bypass capacitor C1, which substantially eliminates the half-cycles of RF carrier energy, passing on only the contour shape which is virtually the audio information required.

While this kind of explanation may be sufficient in the context of a beginner's crystal set, it certainly does not provide an adequate rectifier-based concept of

diode detection — as mentioned last month.

I am reminded of my first introduction to the game of snooker, at a holiday hotel. When I protested that I knew nothing about the game, I was assured that there was nothing to it.

"You use the cue and the white ball to nudge the other balls into the pockets.

"Come on . . . have a go!"

But, as I got involved in the game, I discovered that there were a few rules and conventions that needed to be understood before one could participate intelligently.

It's a bit like that with diode detection and the sketchy nature of Fig. 1. So let's start again.

Fig. 2 shows a diode detector configuration which is fairly typical of what has been used in both valve and solid-state AM receivers — usually superhet receivers. (A particular polarity has been assumed for the diode but this does not affect the basic reasoning.)

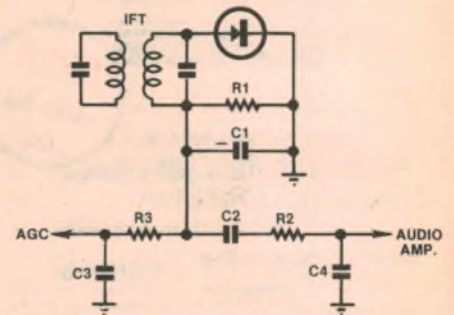

Fig. 2: Basic circuit configuration for a diode detector in a superhet receiver.

Signal is fed to the detector from the secondary of the final IF transformer, with one end connecting to the diode anode and the other to the diode cathode (and chassis earth) via the two parallel-connected components, resistor R1 and capacitor C1.

Resistor R1 must be large enough in value to present a practical load for the diode detector (or rectifier) but small enough to be a practical source resistance for the outgoing audio signal. Typical values lie within the range 47k Ω to 470k Ω .

Capacitor C1, in association with R1, must provide a long time constant in respect to the carrier frequency (or IF) but a short time constant in respect to the audio modulation. To put it another way, it must constitute an effective bypass for RF but not for AF (audio frequency). Typical values lie within the range 1000pF to 100pF.

Other components in Fig. 2 will be referred to later.

Fig. 3, included mainly for completeness, is a conventional diode conduction curve. While ever the anode is negative with respect to cathode, no current can flow through the diode. However, as the anode is made positive with respect to cathode, current begins to flow and increases, more or less linearly, with the magnitude of the applied voltage. The action is essentially the same as that of a rectifier.

Fig. 4 is a composite graph which seeks to illustrate the voltage and current

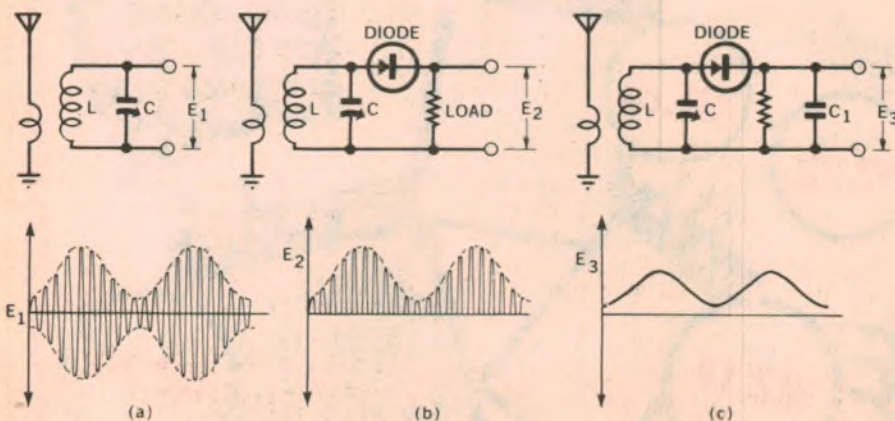

Fig. 1: This diagram, reproduced from "Basic Electronics" typifies simple diode detector explanations. It shows (a) a modulated input waveform; (b) the rectifying effect of a diode and (c) the recovered audio signal.

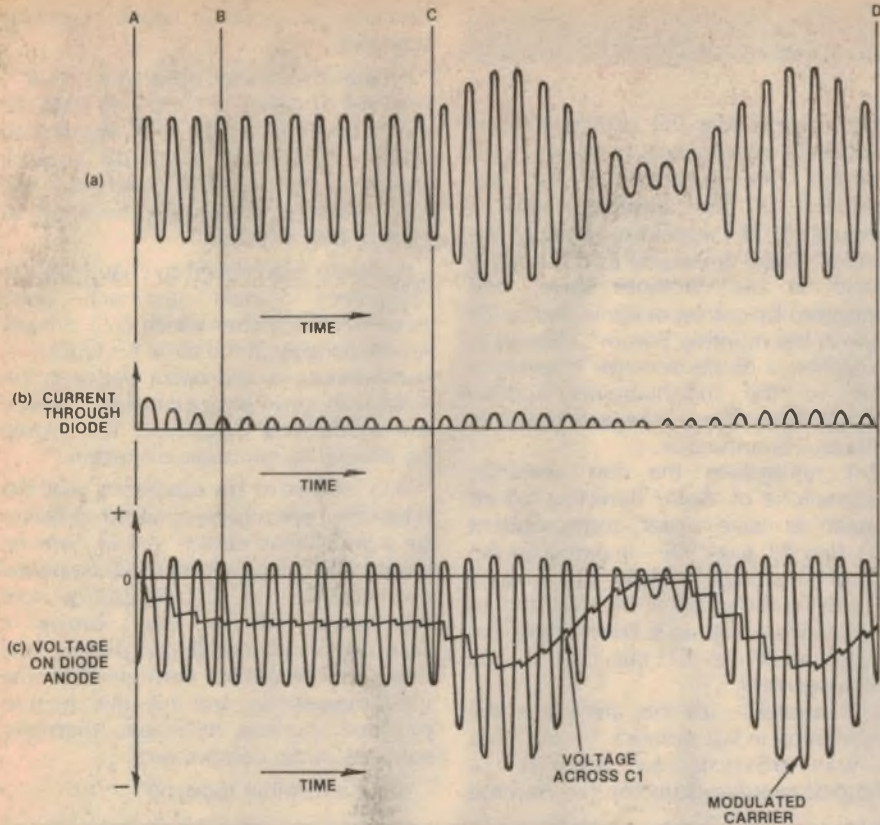

Fig. 4: Diagram (a) illustrates an input signal, unmodulated (A to C) and amplitude modulated (C to D). Diagram (b) shows the current pulses through the diode, which charge the storage capacitor (C1 in Fig. 2) thereby DC shifting the RF input waveform as in diagram (c). The voltage across C1 can be filtered to isolate the audio signal, and also the DC component for automatic gain control.

relationships in a typical diode detector circuit (eg Fig. 2) plotted against time.

Fig. 4a depicts an RF (or IF) input signal, which is unmodulated between A and C, but amplitude modulated between C and D.

If this signal was to be applied to a detector circuit (eg Fig. 2) the first few positive-going half-cycles would cause heavy uni-directional current pulses through the diode, through the secondary of the IF transformer, and through capacitor C1, building up across it a charge negative with respect to chassis-earth.

The initial charging pulses and the build-up in the voltage across C1 is illustrated respectively in Figs. 4b and 4c, in the time interval A to B.

In short, in the presence of an unmodulated signal, a diode detector circuit tends rapidly to reach a state of equilibrium such that the energy drawn from the tips of the positive-going half-cycles is just sufficient to maintain the charge across the bypass/storage capacitor (C1 in Fig. 2).

As a corollary to this, the charge or voltage across C1 assumes an average value slightly less than the peak value of the RF input to the diode.

Figs. 4a and 4b illustrate the attainment of equilibrium (time period A to B) and

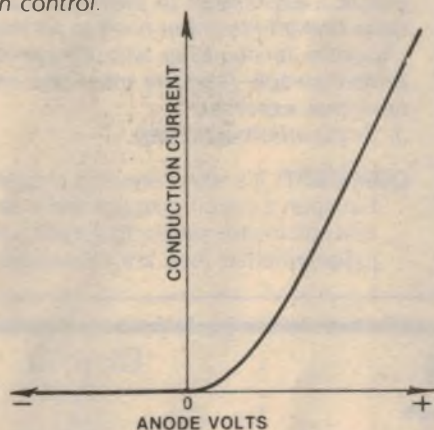

Fig. 3: The conduction curve for a diode detector is essentially similar to that of a rectifier.

the equilibrium state with non-modulated input (time period B to C).

When the waveform is amplitude modulated, as from point C onwards, the detector still tends to maintain the voltage across C1 at just below the peak value of the RF input waveform, even though it is now varying at an audio rate. (Obviously, for this to happen, the time constant of C1/R1 must be short enough for the charge across C1 to fluctuate in accordance with the highest modulation frequency).

So we end up with Fig. 4c, which shows:

UV LIGHT BOX

- 4 × 20" UV Tubes
- Electronic Timer
- Sliding Tray
- Safety Micro-switch
- \$295.00 (+S.T.)

DEVELOP/ETCH TANK

- Rigid PVC
- Heater
- Standard Hose Fittings
- 24" Wide 12" High
- \$195.00 (+S.T.) 2
- Compartment \$285.00
- (+S.T.) 3 Compartment

KALEX

101 Burgundy St.
Heidelberg 3084
(03) 458 2976
Telex AA 37678
MELTON
(03) 743 1011

ELECTRONIC COMPONENTS &
ACCESSORIES

● SPECIALIST SCHOOL
SUPPLIERS ●

Mail — Purchase From Hong Kong

Personnel Computers
TV Monitors
Printers
Disc Drivers
Computer Accessories
Radio Cassette Recorders
Digital Clock Radios
Car Radio Cassettes
Electronic Components

If you are looking for excellent quality electronic products manufactured in Far East countries with almost factory price, write to us now for free catalogue.

COBO INTERNATIONAL ENTERPRISES

P.O. Box 335 Shatin N.T.
Hong Kong

1. The positive-going peaks of the RF input signal substantially aligned just on the conductive side of the diode characteristic.
2. An RF envelope DC shifted by reason of the diode rectifier action and alignment of the positive-going peaks.
3. A voltage across C1 which contains a DC component, the recovered audio modulation, and a residual ripple at the carrier frequency.

(Readers familiar with television technology will doubtless recognise points 1 and 2 above as being the exact parallels of what goes on in a DC Restorer stage).

Referring back to Fig. 2, the DC component can be blocked by coupling capacitor C2, while the RF component can be attenuated by series resistor R2 and RF bypass C4. If desired, the DC component can be isolated and preserved for purposes of AGC (automatic gain control) by means of a long time-constant filter, R3/C3.

How does all this stack up in respect to the discussion that has gone before?

Very well, I would say.

(1) It assumes that the passband of the tuned circuits preceding the detector will be sufficiently wide to admit the carrier and a substantial proportion of the sidebands. To the extent that the outer sidebands are attenuated — as happens in most AM receivers — the higher frequency audio components are diminished or lost, irrespective of whether we analyse the effect in terms of their absence from a "mixer" calculation, (frequency domain), or from a summed voltage waveform (time domain).

(2) It accepts that the carrier/sideband frequency components that do pass through the selective circuits are summed at the detector into a modulated RF waveform having the general shape envisaged in the original article in our October issue, and supported by correspondents and by Dr Imrie in last month's "Forum". Viewed as a rectifier, a diode detector is sensitive only to the instantaneous applied voltage, not to the subtleties of how that voltage was arrived at.

(3) It rationalises the too simplistic explanations of diode detectors which appear to have upset correspondent D.D. (Jan '83, page 99) — in particular the role of the storage capacitor (C1 in Fig. 2) in bridging the peaks of the cycles in an RF waveform. Fig. 4c acknowledges the storage effect of C1 but puts it into proper context.

(4) It satisfies — for me, anyway — the observation in last month's "Forum" that it was possible to present "a straightforward explanation (in the time

domain) of how a diode detector operates."

I made the further observation that "I regard it as easier to cope with than the mixer concept, which D.D. appears to prefer". In fairness, I did do a quick survey of textbooks to hand, old and new, without discovering anything to change that opinion.

If you do feel moved to champion the "frequency domain" approach, don't overlook the matter which D.D. himself leaves hanging in the air in his letter: . . . some mixing would occur between the sidebands, producing a product of twice the modulating frequency. This would be likened to harmonic distortion."

D.D. seems to be suggesting that the mixer concept requires that the detector be a non-linear device — and here he would be talking about a fundamental characteristic, not just departures from the ideal diode, etc. Being a (fundamentally) non-linear device, any mixer will generate harmonics of the input frequencies, and then mix them to produce spurious resultants, therefore spurious audio components.

What a horrible thought!

Readers can think up bright ideas . . .

I would like to suggest that "Electronics Australia" set aside a small space each month for readers to request electronic circuits which would give practical expression to their ideas. I'm sure that many readers can think up quite brilliant ideas but have to let them drop because they do not have the expertise to come up with an appropriate circuit. It is obvious that many brilliant people read the magazine and they are able to help because they have that expertise.

J. S. (Scarborough, Qld).

COMMENT: It's an interesting thought, although there is often a huge gap between a circuit concept and a developed working unit. Let's put it to the test and invite readers to submit some of these bright ideas so that we can judge whether they are reasonably capable of development.

IAN J. TRUSCOTT'S

CORNER BAYSWATER AND EASTFIELD ROADS,
CROYDON, VICTORIA. 3136.

(03) 723 3860

ELECTRONIC WORLD

SPECIALISING IN SALES AND SERVICE TO —

CAR RADIOS



C.B.



AND MARINE

CONTACT US FOR ALL YOUR 27MHZ AND 477MHZ REQUIREMENTS

OUR VAST RANGE OF COMPONENTS TO SUIT THE ELECTRONIC ENTHUSIAST INCLUDES: RESISTORS — CAPACITORS — IC's — POTENTIOMETERS — HEAT SINKS — CABINETS — PLUGS AND SOCKETS OF MOST KINDS.

WE ALSO STOCK A RANGE OF TEST AND ASSEMBLY GEAR
TO HELP THE HOBBY TYPE ELECTRONIC BUFF

WE ARE SPECIALISTS IN TV, STEREO AND MOST ELECTRICAL REPAIRS.

JAYCAR NUMBER 1 FOR NEW PRODUCTS

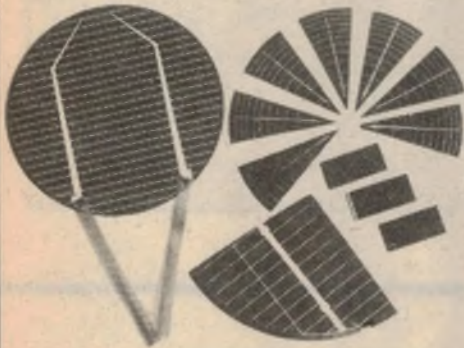

LOW COST SILICON PHOTO CELLS

We now stock a COMPLETE range of high efficiency Silicon Solar Cells. All cells will give 0.45V under rated load and they can be stacked in series or in parallel for higher current.

Cat. No	Description	Price	
		1-9	10+
ZM9002	Rect. 10x20mm 45mA	\$2.95	\$2.45
ZM9003	3" diameter 1 amp	\$29.50	\$26.50
ZM9004	3" diameter x 30° segment 78mA	\$3.50	\$3.25
ZM9005	4" diameter x ¼ segment 450mA	\$12.95	\$12.45

NEW! INSULATION DISPLACEMENT CONNECTORS & RIBBON CABLE!!

I.D. Insulation displacement. The quick and reliable way of making multiple connections to computer peripheral connectors. Great for Disc Drives, Printers etc. Crimp them yourself and save a fortune!!

Connectors:

- 16 pin DIP HEADER Cat. PI6550 \$1.99
- 24 pin DIP HEADER Cat. PI6555 \$2.50
- P.C. Edge Connector 34 way (suits 5¼" Disk drive) Cat. PI6560 \$8.50
- 25 pin Cannon 'D' male Cat. PI6575 \$8.95
- 25 pin Cannon 'D' female Cat. PI6576 \$8.95

Cable:

- 16 way Cat. WM4502 \$1.50/metre
- 25 way (suit DB25's & 24 way DIP) Cat. WM4504 \$2.50/metre
- 34 way for Disk Drives Cat. WM4506 \$3.45/metre

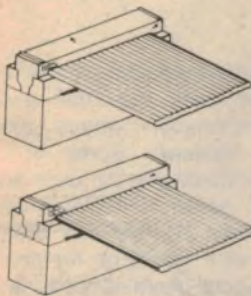

COMPLETELY BUILT AND TESTED - NOT A KIT!!



THE BEST CAR COMPUTER BELOW \$200

Send SAE for more information.

CONTAINS EQUIVALENT OF THOUSANDS OF TRANSISTORS - USES MASSIVE CUSTOM LSI CHIP TO ACHIEVE LOW PRICE

only \$199 complete

FEATURES

- INSTANT FUEL CONSUMPTION IN LITRES/100KM AND MPG!! (MOST OTHERS HAVE ONLY ONE OF THE ABOVE! JUST SWITCH FROM ONE TO THE OTHER AS YOU DRIVE ALONG.
- INSTANT SPEED, TIME AND OTHER FUEL DATA.
- VISUAL AND AUDIBLE EXCESS SPEED ALARM.



Video Enhancer

NOT A KIT - BUILT AND TESTED...

Cat. AV6500

\$89



Unbelievable but true. This unit enables you to actually IMPROVE a copy of a recorded video tape. How? By amplifying the top end of the video signal by a small amount. This sharpens up the detail of the picture. Dubs can actually look better than the original. Works as a video distribution amplifier as well. Will drive up to 4 VCR's from one VCR input.

VIDEO STABILISER Cat. AV6502

As many of you know, many video tapes, - especially from the USA have the sync pulses suppressed to prevent unauthorised copying of the original dub. This process is fine because it hinders unauthorised re-recording (dubbing) of material. It is annoying though when you hire the original and find that the "Copyguard" is causing problems with your TV. The AV6502 re-inserts the sync pulses automatically and restores stability.

WARNING! The AV6502 is intended solely for the use above. Whilst the AV6502 will virtually remove copyguard on a tape copy (and hence restore the picture) it is against the law to unlawfully copy copyright material.

The AV6502 looks almost identical to the AV6500 **ONLY \$79.95**

"PANBRAKE" SHEET METAL FOLDER \$69.50



- Handles up to 16 gauge aluminium!
 - Slotted upper clamping bar allows complex corner bends etc.
 - Handles material up to 445mm wide!
- Save a fortune building metalwork yourself!!!

ONLY \$69.50

Now you can afford one in your own workshop. Make your own chassis, boxes, brackets etc. (Please allow \$8 for freight as it is very heavy!!)

Motorola Piezo

We have a great range of these piezo electric horns and dome tweeters.

- Cat. AS3110 KSN1005A 50 watt PA horn square \$16.00 each
- Cat. AS3112 KSN1025A 100 watt PA horn rect. \$26.00 each
- Cat. AS3114 KSN1038 50 watt Hi Fi horn round \$16.00 each
- Cat. AS3116 KSN1039 50 watt Hi Fi dome \$14.00 each
- Cat. AS3118 KSN1071 50 watt dual element 1 source \$24.00 each



Jaycar NUMBER 1 FOR KITS

125 YORK STREET SYDNEY 2000
PHONE 264 8888 TELEX 72793
"NEVILLES CORNER"
Cnr CARLINGFORD & PENNANT HILLS ROAD
CARLINGFORD
PHONE 872 4444

MAIL ORDERS TO: BOX K 30 HAYTJARRET, SYDNEY 2000
POST AND PACKING CHARGE C
\$5 \$8.99 \$15.50 \$22 \$28.99 \$35.50
\$25 \$49.99 \$64.50 \$70 \$99.99 \$114.50
\$100 \$149.50

Mail Order By **BANKCARD**
Via Your Phone



COMPACT disc DIGITAL AUDIO

A close-up of the front panel of the Sanyo DAD-8 compact disc player, pictured last month. The top section of the panel (right) has mainly to do with manual operation, the readouts indicating that the elapsed playing time is 18'27" and that track number 5 is being played. The lower section of the panel (far right) is for programmed play.

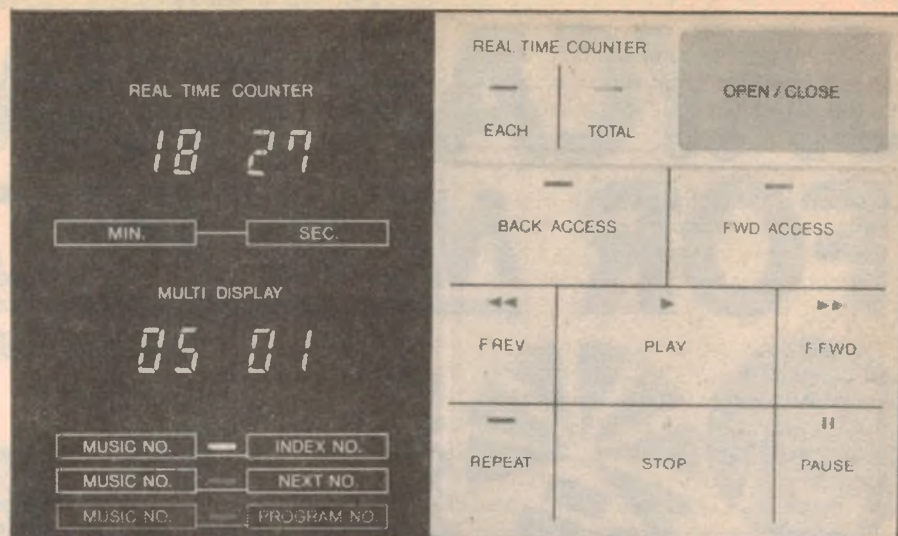

▲ MANUAL PLAY

Controls & Programming

The new CD (Compact Disc) players, due to be released any time now on the Australian hifi market, will usher in a new era, not only in technology and performance, but in the method of access to the music stored in their 4 to 5km-long spiral of digital signals. Manual manipulation is out; push-buttons are in.

by NEVILLE WILLIAMS

The disc format has always had the advantage of providing ready access to the music. Even in the old 78rpm days, one could lift the pickup out of the groove at any time and repeat a verse or skip a section, as desired — all within a second or so.

You can't do that with tape. To repeat a phrase or skip from one program segment to another, tape has to be spooled through the intervening distance — a tedious and time-consuming business, even when aided by a counter or sub-sonic cueing.

The new compact disc retains the traditional advantage of immediate access to any segment of the recording — but with a vital difference: there is no provision for human fingers to manipulate the laser pickup head, or even get near the mechanism while the disc is spinning. Playback is initiated, repeated, paused, terminated — or whatever — by electro-mechanical actuators controlled from the front panel by push-buttons.

What's more, the automated response is very fast (virtually instantaneous), very clean (no clicks or plops)

and very precise (to an exact musical note or phrase). It completely outperforms any system of cueing ever devised for conventional discs.

Partial push-button operation is, of course, already well established in the context of traditional phono decks. Partly as a sales feature, but also with the intention of discouraging clumsy fingers, phono deck manufacturers have long since provided push-buttons or levers to initiate Start, Stop, Pause and Repeat, as well as for speed change and record size.

However, there is a practical limit to the degree to which conventional disc playback can be automated. For example, there are three possible sizes but, even if the diameter is sensed by external means, it cannot be related with certainty to the playing speed. Nor are there any clues, other than the printing on the label, as to the total playing time of the tracks, or of the whole side, or the recording mode: mono/stereo/quadraphonic.

When the compact disc came up for discussion as a potential hifi industry standard, there was common agree-

ment that every effort would be made to encode into the track essential and standardised information about the format and the contents. Some of it could be used for display to the user on a readout panel; some of it would be used for basic Play, Repeat and Stop functions; some of it would be for pre-programming, special playback options, etc.

The digital system lends itself to this sort of intervention, partly because the signal information can be so readily manipulated, and partly because the digital control "clock" in every player provides a precise timer/counter reference during the entire replay cycle.

It does not follow that all compact disc players will take full advantage of the encoded information or, for that matter, that listeners will use all the facilities on the players they own. The important thing is that provision has been made from the outset and been adopted as a world-wide recording standard.

The following is a summary — based on a Sony brochure — of the

supplementary information which can be encoded into a compact disc and used to control playback in conjunction with the digital clock system of the player:

LEAD-IN SIGNAL: Inserted at the position in the signal pit spiral where the flow of information begins. Alerts the pickup head to start reading systematically from that point.

TABLE OF CONTENTS: Encoded into the pre-program area. It provides information about the start time of each selection to follow, along with the total number and playing time of selections. This can be read, before the program starts, to facilitate program search. It can also be displayed on a read-out panel.

possible to gain precise and rapid access to any part of the program signal, as well as precise random replay in any order.

LEAD-OUT SIGNAL: Indicated the end of the flow of information. Unless pre-programmed to repeat play, it would cause the deck to switch off, ready for disc recovery.

From the information to hand, it is evident that the compact disc players to be released on the Australian market in the forthcoming weeks and months will use the same kind of push-button controls and markings as already made familiar by VCRs (video cassette recorders).

All are certain to have "feather touch" buttons, pads or levers on the front

3. Another slim-line model but with horizontal top loading;

4. A "super-compact" model, Scandinavian style, with top loading, small inclined front panel, and touch levers rather than pads.

Some variations can be expected also in the precise names and functions of the controls and in the extent of the programmed play provisions.

The Sanyo DAD-8 player, for example, offers a "16 selection program play", whereas the "new Product Information" brochure from Technics describes the programming capacity for their SL-P10 as: "up to 63 steps in all". Elsewhere, they say: "up to 99 bands (the maximum established as standard for the compact disc) can be programmed for automatic play in any order".

As with VCRs, the extent of the facilities provided is a commercial judgment involving what potential customers are likely to fancy or require, can cope with or fail to understand, will opt for or reject as too expensive!

BY WAY OF EXAMPLE:

While the user manual that comes with a CD player will normally provide all the appropriate information for that model, purely by way of illustration we show a close-up of the display and control panel of the Sanyo DAD-8, pictured in last month's article.

Prominent in the top right-hand corner of the control panel is a pad marked "Open-Close", which gives access to the record holder, to load and recover the disc.

Right in the centre of the control panel are pads marked "Play" and "Stop" — obvious functions.

Apart from switching the equipment on, these three pads — Open/Close, Play and Stop — are the only ones that need concern someone who merely wants an hour of background music. In fact, the Stop pad might be considered redundant because, at the end of the final track, the player reverts automatically to "Pause" and then, after about 5 minutes, to "Stop".

Certain other controls are sufficiently self-evident to hold no terrors for the timid.

Pressing the Pause pad interrupts play temporarily, but it can be resumed at exactly the same point by subsequently pressing the Play PAD. Unlike a VCR, the Pause mode does not carry the risk of wearing the tape (or disc) and the pickup head. Even so, a CD player will normally revert to Stop mode after about 5 minutes but playback can still be resumed at the same spot on the disc by pressing the Play pad again.

PROGRAMMED PLAY

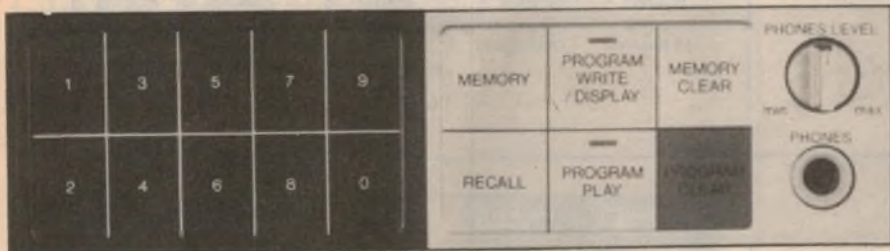

CONTROL CODES: Basically technical in character, these codes distinguish between 2-channel and possible 4-channel recordings. They can indicate the use or otherwise of pre-emphasis and, if necessary, initiate an automatic circuit change in the replay system, to suit.

MUSIC START FLAG: Borrowed from computer terminology, the music start "flag" is a signal inserted at the start of the program and between selections, whether or not the intervening period is silent, as normal, or occupied by bridging chords. By counting "Flags", the CD player can recognise the number and the precise starting point of each new selection on a disc.

TRACK NUMBER AND INDEX: Selections recorded on a disc can be numbered from 1 through to 99. Each bar in a piece of music can also be addressed up to 99.

TIME CODE: Keeps track of the time lapse from the start of each selection in minutes and seconds, with a potential accuracy of 1/75th second. At the end of each track, it counts down 3-2-1-0 to the exact start of the next track. This makes it

panel, operating in conjunction with "logic" control circuitry.

In this system, touching any given pad indicates to an internal microprocessor that a certain operating mode is being called for: Play, Pause, Repeat, Fast Forward, etc. So instructed, the microprocessor interrupts the existing mode and sequences the electro-mechanical actuators to initiate the one called for. It will also change any display readouts to suit.

Logic controls make it unnecessary for the user to remember precautions like "always press the Stop lever before . . ." The microprocessor is programmed to do things in the right order and therefore protects the internal mechanism, as well as simplifying operation for the user.

As with video cassette recorders, the layout of the control pads on the front panel varies from one model player to another, depending on the general styling.

A Philips brochure, for example, shows four distinctly different players from their overseas range:

1. A fairly tall unit with vertical front loading for the discs;
2. A less tall, "slim-line" player with horizontal front disc loading;

CD: controls & programming — continued

Say you particularly like the track being played — or something distracted your attention — and you want to hear it again? Very simple: press the "Back Access" pad and the DAD-8 will interrupt play, and, within a few seconds, locate the beginning of the track and commence replay, spot on the first note.

Alternatively, you might dislike a track. Again, no worry: Press the FWD (Forward) Access pad and the player skips forward automatically to the starting point of the next track.

Nor is that all. Reference to the user manual points out that, by clicking the Back or Forward Access pads a number of times the player will go back

or forward by that number of start points, or "Flags", to use the terminology referred to earlier. Three Back Access clicks and the player jumps back two tracks prior to the one currently being played. Four Forward Access clicks, and it jumps forward four tracks, in each case commencing play mode at the Flag signal and counting down 3-2-1-0 to the first note of the nominated track.

The "F REV" (Fast Reverse) and "F FWD" (Fast Forward) pads provide another way of hunting through an hour-long program. Pressing either one, when the deck is in play mode, mutes the sound while the replay head glides above the record in the appropriate

direction. When the pad is released, play commences immediately at that point. It's just like lowering the pickup at random points across the surface of an LP disc, except that it's done without scrapes or clicks or plops by the CD player's own internal mechanism.

The remaining pad in the central group is marked "Repeat" and, when this is triggered, it causes the disc to repeat indefinitely until the instruction is cancelled. The beauty of this facility is the knowledge that, with no contact between the disc and pickup system, prolonged play does not occasion wear, as it would do with any other disc or tape system to date.

There is nothing difficult or obscure about any of these manual play options and they would have a familiar ring to *(Continued overleaf)*

<p>Assuming that the disc contains the bands shown to the right . . .</p> <p>1) You want to play the entire disc from start to finish: press the PLAY key.</p>	
<p>2) You want to play bands 2, 4, and 1, in that order.</p> <p>2 ent 4 ent 1 PLAY</p>	
<p>3) You want to play band 1 from the 2-minute point to the end, then band 3 from the 3 minute 18 second point to the end.</p> <p>1 * 2 ent 3 * 3 * 1 8 PLAY</p>	
<p>4) You want to play bands 2 through 4.</p> <p>2 ent ent 4 PLAY or 2 ent 3 ent 4 PLAY</p>	
<p>5) You want to play band 3 from the 1 minute 23 second point to the 3 minute 47 second point. (This sort of programming would be used if you wanted to hear only a certain violin solo in a classical piece, for example.)</p> <p>3 * 1 * 2 3 ent ent 3 * 3 * 4 7 PLAY</p>	

Here is a segment from the User Manual of the Technics SL-P10 compact disc player showing how the programming

facility can be used not just to play whole tracks in random sequence but timed segments of tracks, as well.

The change to excellence in sound...

TU - 750

TU - 710

PMA - 750
80W + 80W

PMA - 710
40W + 40W

DR - F7

DR - 170

needn't cost you a fortune.

Denon, the name associated worldwide with professional audio equipment has available in Australia their range of high quality integrated stereo amplifiers, tuners and cassette tape decks, incorporating the most advanced features at competitive prices.

High performance amplifiers, analog and digital tuners, and cassette tape decks featuring both Dolby "B" & "C", are the result of 30 years of research and technology, offering you the

ultimate combinations of performance, reliability and cosmetic styling.

See the exciting range of amplifiers, tuners and cassette decks at your Denon dealer now, you'll find their prices rather exciting as well.

DENON

Professional Audio Brand.



AMALGAMATED WIRELESS (AUSTRALASIA) LIMITED
554 Parramatta Road, Ashfield, NSW 2131 Phone 797 5757

Canberra	Melbourne	Launceston	Adelaide	Brisbane	Townsville	Perth
80 5200	560 4533	44 5155	272 2366	44 1631	79 6155	271 0888



Audio-video Electronics

HIFI • HOME VIDEO • PROFESSIONAL AUDIO

Audio, video cassettes

PDMagnetics is a new name on the Australian audio hifi scene but it stands for a cooperative venture between Philips and Du Pont for the manufacture in Belgium of a new line of audio and video magnetic recording tape.

If anyone knows anything about magnetic tape, it should be Philips, who developed both the compact audio cassette and the style-setting Philips video cassette recorders, through to the present-day, highly regarded Video 2000 system.

Du Pont, in turn, were primarily responsible for the development of chromium-dioxide magnetic coatings, for which they still hold world patents. The new line of PDMagnetics VHS and Beta videocassettes, using Du Pont's "second generation" CR02 coating, has already launched on the Australian market and been shown to produce outstanding results.

Pictured on the right are the new



compact audio cassettes from PDMagnetics, featuring three different coatings:

- Tri-Oxide Ferro — a high output wide range, low noise ferric tape for normal bias and normal $120\mu\text{S}$ equalisation.
- 500 Crolyn — high output, extended range, low noise CR02 tape requiring "Chromium" bias and equalisation.
- 1100 Metal — described as an

ultra-coercivity Type IV tape, requiring "metal" bias and $70\mu\text{S}$ equalisation.

PDMagnetics audio and video cassettes are being distributed in Australia through Marantz, a subsidiary of European Philips. The tapes are available through major audio and video outlets but, in the event of difficulty, information can be obtained from Marantz interstate branches or direct from Marantz Australia Pty Ltd, 19 Chard Rd, Brookvale, NSW 2100. Phone (02) 939 1900.

Digital for Studios 301

EMI have equipped their recording complex at 301 Castlereagh St, Sydney with Sony 2-channel digital equipment — a PCM1610 digital processor, two BVU200B recorders and an DAE1100 editing unit.

The equipment has already been used to record two albums with the Sydney Symphony Orchestra at the ABC's Chatswood studios, and the Pavarotti/Sutherland/Bonyng concert at the Sydney Opera House.

Apart from direct recording, EMI point out that the equipment will allow them to handle mix-downs from multi-track sources without further loss of quality, as well as to provide local mastering of digital material from overseas. The format is also compatible with mastering requirements for the new compact discs.

For further information, contact Steve Shurtz or Dave Hudson at Studios 301 on the Sydney number 20 912.



Ortofon MC cartridges

Ortofon produced their first moving coil cartridge in 1948, their activities culminating last year in the release of their highly regarded MC 200 (pictured at top right) using a silver coloured integrated headshell.

This has now been supplemented by a "junior" version in a similar but blue coloured headshell. Designated as MC 100, it uses much the same internal structure as the MC 200, with an aluminium cantilever and nude, elliptical diamond stylus, user replaceable. It also features an adjustable overhang facility.

Versions with universal cartridge shell mountings have also been added to the range — the MC 200 U and the MC

CD: controls & programming — continued

anyone accustomed to operating a VCR. Nor should there be any difficulty in understanding the associated readouts.

The "Real Time Counter" at the top can present two sets of information. When the "Each" pad alongside it is activated, the Real Time display indicates minus 3-2-1-0 seconds to the cue point, then begins to count upwards again from 00 00 minutes and seconds for the duration of the track. It repeats this sequence as each new track follows the last.

If the "Total" pad is triggered, instead, the Real Time Counter reverts purely to indicating the cumulative playing time to the relevant point in the record. And here the sophistication of the time coding becomes apparent. It is immaterial how the reading head reaches any given track — by normal play, back or forward access, or fast forward or reverse, it automatically derives and displays the exact playing time to that point.

In addition, the two readout digits to the lower left display the number of the track being played, or being traversed by the pickup head when in fast forward or reverse mode. By watching either the track number or the Total Time display, one can judge quite closely

what part of the record is being played or scanned.

The remaining display digits and the pads along the bottom of the panel all have to do with the memory programming, which allows up to 16 selections to be played in any order. If desired, individual tracks can be repeated within a program, and the entire program repeated by pre-setting the Repeat pad.

However, the programming instructions for the DAD-8 player are about as tedious and peculiar to the model as they are for other CD players and there would be no point in detailing them here. When you buy a CD player, or a VCR for that matter, the only logical course is to sit down with the user manual and work through the programming instructions until you get the hang of them!

Just by way of interest, however, we have included a segment from the brochure on the Technics SL-P10 CD player, which illustrates the program entry procedure for that model, involving not only bands but time segments as well. Having listed these and other procedures, Technics observe that they are examples of possible programming ideas.

100 U. Specifications and performance are identical to that of the integrated shell models and special attention has been paid to compatibility requirements with typical headshells.

Ortofon is represented in Australia by Harmon Australia Pty Ltd, now based at 297 City Rd, Sth Melbourne. Phone (03) 690 6200.

New Pioneer turntable

Presumably motivated by the design of video disc players and, more recently, of compact disc players, Pioneer have come up with two new phono players, the top-of-the-line PL88F and the back-up model PL44F.

Both use a rigid, rectangular housing which is sufficiently rugged to be installed beneath other components and sustain loads of up to 40kg.

Both use front loading and touch buttons on the front panel which, in association with an in-built microprocessor, control the motor and the movement of the tonearm. A high output moving coil cartridge is fitted but, in addition, an optical system examines the surface of each disc, noting the number of tracks and the unrecorded segments between them. This makes it possible for the decks to be programmed to play (and repeat) tracks in any order.

JACK LEWIS, 1910-1983

Jack Lewis, the founder and one-time proprietor of Classic Radio, National Radio Supplies and Paragon Radio, died recently at the age of 73. In many ways, he was the personification of an era.

Jack Lewis was born in Braidwood, NSW, the son of a stock and station agent and, like other young people in the era, saw at first hand the birth of wireless and its adoption into Australian homes.

Bitten quite early by the "bug", Jack began to build and sell wireless sets in about 1930, using the back verandah of his home as his "factory". It was in this same period that Australia's indigenous radio industry began to boom, with local components and receivers taking over from imported products. Many young men, who had become involved with wireless at an amateur or hobby level, were caught up by the tide and either formed companies of their own or built careers in larger organisations.

In 1938, as one of the former group, Jack bought a property in Parramatta Rd, Ashfield, NSW, not far from the rapidly expanding AWA factory. Jack



lived in the house and set up "Classic Radio" in the backyard.

After the war, Jack became involved in military and factory surplus disposals and established two main outlets — Paragon Radio and National Radio Supplies. His three companies became regular advertisers in this magazine.

Jack was a busy man, in those days. He developed and marketed his own line of Classic tape recorders, selling both to private customers and government departments. He produced amplifiers and receivers, and marketed kits for magazine projects.

In later years, Jack's most frequent lament was the wind-down of Australian consumer electronics in favour of the imported product. In this lifetime, an industry had grown, and boomed and faded. (W.N.W.)

The new JBL L15. Its sound will take your breath away. Its price won't.



If you think high performance audio has to be expensive or large, we've got a great surprise for you — the new JBL L15 compact loudspeaker. While only 375 mm (14¾") high, this astonishing 2-way system combines clean, clear, accurate sound with incredible power capacity, high efficiency and ultra-low distortion — all requirements for the digital age. Designed with the aid of computer models and laser interferometry, the JBL L15 does not need a huge amplifier to provide good volume levels; however you can use an amplifier up to 100 watts/channel. At any volume, the JBL L15 creates a lifelike, three dimensional sound quality.

Finished in oiled American black walnut veneer, the L15 is hand-rubbed to bring out the natural grain structure of the wood. For a detailed brochure or the location of your nearest JBL High Fidelity Dealer, contact:

Harman Australia, LMB 12, PO Nth Ryde
NSW. 2113. (02) 887 3233.

\$538 pair.

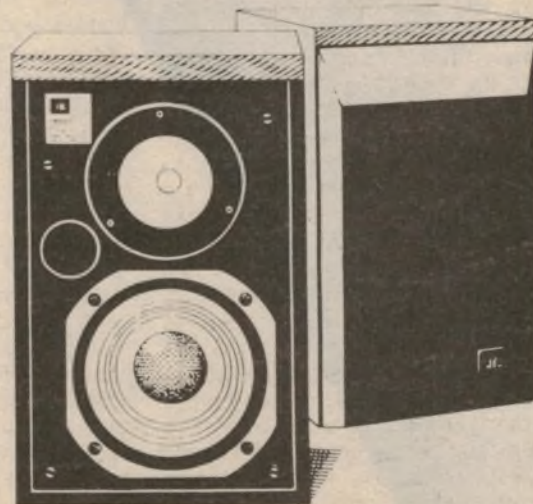

Why Direct

Don't tangle with Technics.

The majority of audio systems – even the most beautifully designed – have something ugly to hide.

It's that mass of jumbled-up connecting leads that you find, all too easily, at the rear of the equipment. Not only are they ugly, they're inconvenient, too.

And as audio components become smaller, the problem becomes bigger and more unsightly.

To solve this problem, Technics developed their Direct Connector systems, which eliminate all audio connecting leads between the tuner, amplifier, graphic equalizer and cassette deck.

Each of these components features a special flip-up connector to allow them to be literally plugged in to each other!

It's an elegant piece of Technics technology that results in a stylish, neat installation that can be put together or taken down for re-location in a matter of seconds.

The 315 Series.

But Direct Connector capability is not the only innovative feature in this new and compact series from Technics.

The SL-5 direct-drive, linear-tracking turntable employs its own plug-in connector system for the pickup cartridge.

This unique Technics development has been adopted as a World Standard.

It means you can compare and evaluate cartridges from leading manufacturers like Audio Technica, Ortofon, Shure, Stanton, Empire, Pickering, ADC and, of course, Technics without conventional setting up procedures.

Technics developed Connector systems.

No adjustment of tracking weight or bias correction is needed.

The innovations continue in the rest of the components: the SU-5 amplifier includes a Super Bass switch to enhance the bass response of a speaker system without inducing bass boom; the ST-5 quartz synthesizer digital tuner provides random access memory for 16 pre-set stations; the SH-E5 graphic equalizer – offers adjustment of 12 audio bands from 16Hz to 32Hz on each channel; whilst the RS-5 cassette deck – has soft touch controls, auto selection of metal, CrO₂ and normal tape settings plus convenient Cue and Review functions.

Finally, a pair of SB-F5 speakers with horn-type tweeters and bass reflex porting turn the high quality electrical signals of the rest of the system into the high quality sound you expect.

Compact components, full-size warranty.

All components in this series are perfectly matched in styling and performance.

And all are covered by a full 2-year warranty backed by Technics' reputation. Visit your Technics stockist soon and experience the superb styling and brilliant sound of Technics' compact Series 315 for yourself.



Technics

National Panasonic (Australia) Pty Ltd

Expanding the music experience.

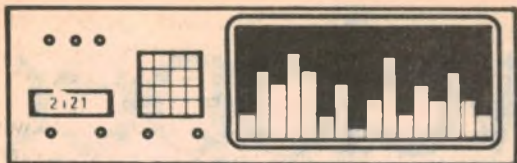

Audio Review

Technics SL-Q20 automatic turntable

Despite the imminent release of the compact disc players, conventional phonograph record players will be around for quite a while yet. This month we examine a new release from Technics, the SL-Q20 turntable.

The Technics SL-Q20 is a conventionally styled turntable with a satin silver finish. It has a straight tonearm terminating in a Technics P-mount cartridge. These cartridges have a different output pin arrangement to normal cartridges, the pins being narrower and spaced closer together. They are simply plugged into a small socket on the end of the tonearm and locked into place with a small screw.

The P-mount style of cartridge and matching arm connector was originated by Technics for their SL-10 linear turntable. The P-mount system has now been licensed to a number of prominent cartridge manufacturers such as Shure, Stanton, ADC, Empire and Ortofon. The system does away with all the fiddly adjustments for setting up cartridges and standardises cartridge mass, compliance, tracking forces and stylus position (for uniform overhang).

Front panel controls on the SL-Q20 include pushbuttons for the on-off switch, 33 and 45rpm speed selection controls and the stop (or record cancel) switch. A slide switch labelled cueing, provides mechanical control of the tonearm height during cueing operations. The front panel controls are accessible even with the perspex dust cover closed. This is a worthwhile feature for it eliminates the delicate job of opening and closing the dustcover, usually with the stylus on the record, to gain access to the turntable controls. If required, the dustcover can be detached from the turntable to allow free access to the record and tonearm.

The motor used in the Technics SL-Q20 is a DC type employing fixed armature coils and a magnet assembly driving the platter directly. With the platter in position on the turntable, the magnet assembly is suspended so that it just clears the printed circuit board (PCB) attached to the base of the turntable.

The toothed portion of the magnet



assembly passes over two Hall effect sensors which detect the position of the magnet assembly and switch current to the two armature coils located under the PCB. Attraction (or repulsion) between the magnetic fields of the coils and the magnet assembly causes the magnet assembly, and hence the platter, to rotate.

The circular portion on the PCB contains an etched track which generates a signal as the magnet assembly rotates above it. This signal is proportional to the speed of the turntable and is compared by a phase locked loop to a reference signal derived from a 4.193MHz quartz crystal. Any variations in the turntable speed are therefore sensed immediately and corrected.

Although the motor does not appear to provide a great deal of torque, initial start-up is very quick. In fact, the platter is locked to speed within half a revolution. Undoubtedly this is aided by the light weight of the turntable platter — a little over 1.2kg including mat.

A light emitting diode (LED) connected to a frequency divided version of the crystal reference signal forms a strobe light which illuminates a pattern on the side of the turntable platter.

The instruction manual claims the SL-Q20 is a fully automatic turntable. However, we believe the classification should be changed to semi-automatic. There is no provision for the turntable to begin playing a record automatically. Instead, the user must place the stylus over the lead-in groove on the record then operate the cueing control to lower the stylus onto the record.

At the end of play there is the familiar automatic sequence which lifts the stylus from the record, returns the tonearm to its rest and switches the turntable off. During this sequence the tonearm is mechanically operated via a lever mechanism powered from a small cog attached to the turntable spindle.

Initial unpacking and setting up of the SL-Q20 turntable is very easy since every adjustment including tracking force and antiskating is factory preset. This will undoubtedly appeal to many people who simply do not want to be bothered with the fiddly adjustments required to set up a normal turntable and cartridge.

The tracking force and the antiskating are user adjustable over a $\frac{1}{2}g$ range centred on the optimum setting for the cartridge, 1.25g. In use, the tracking force is set to the value recommended by the cartridge manufacturer then the antiskating control is adjusted so that its reading is the same as the tracking force. A slightly more refined way of setting the antiskating is to play a test record and monitor the distortion in both channels while adjusting the antiskating control. When the distortion in both channels is equal, and at its lowest point, the antiskating is set to the optimum position.

Before conducting our tests we measured the stylus tracking force both to see if the scale fitted to turntable was accurate, and to check that the stylus would be tested at its recommended tracking force, 1.25g. With the stylus force set to 1.25g on the turntable control we measured the actual force on the

stylus as 1.05g using our stylus gauge. This is a fairly large error and could point to a fault in the review sample.

We were able to set the stylus force to the correct value, 1.25g, by adjusting the tracking force control until it indicated slightly less than 1.5g. The antiskating control also suffered from the same problem since when the stylus was adjusted for a correct force of 1.25g, the required antiskating setting for minimum distortion was substantially in line with the stylus force setting, ie, about 1.5g.

The SL-Q20 comes equipped with a moving magnet cartridge. The model number, P24, stamped on the cartridge is part of a larger Technics model number, EPC-P24. This number is not given in the instruction manual however data on the cartridge specifications and the replacement stylus is listed. The stylus fitted to the cartridge uses a conical diamond, somewhat surprising considering the turntable is in the medium price range.

Quoting from the instruction booklet, the claimed frequency response of the cartridge fitted to the SL-Q20 is from 10Hz to 30kHz (no levels given). More importantly, frequency response is also specified to be within ± 1 dB from 20Hz to 10kHz. Channel separation is quoted as being 22dB at 1kHz and output voltage as 7mV at 1kHz 10cm/s with a channel balance of 2dB.

Our test results, taken from 50Hz to 20kHz, revealed that the left channel almost met the ± 1 dB frequency response specification, being within ± 0.5 dB over the range 50Hz to 10kHz. Above 10kHz, cartridge resonance inductance causes a slight response peak of +4dB at 16kHz. Separation from the right to the left channel at 1kHz was measured as 30dB. This was significantly better than the specification of 22dB.

As usual there was a drop in the separation between channels at the resonant frequency of the cartridge. In this case separation dropped to 9dB at 16kHz.

Test results on the right hand channel showed it to be worse than the left hand channel, failing to meet the +1dB from 20Hz to 10kHz frequency response specification. The response of the right channel was measured at +0.5dB to -1.5dB over the range 50Hz to 10kHz. Above 10kHz there was a broad resonance peak of +2dB from 16 to 20kHz. Separation from the left channel to the right channel at 1kHz was 17dB, well below the specified 22dB. This figure deteriorated to only 4dB at the cartridge resonance frequency, 16kHz.

At a tracking force of 1.25g the cartridge would not track the +12dB drum track of the W&C 25/2434 test record and similarly mistracked level 5 of the sibilance and bass drum tracks on the Shure Era III test record. These results in-

dicade an average tracking performance.

Examination of the cartridge output when replaying a 1kHz square wave showed an initial 30% overshoot on the leading edge of the square wave followed by two cycles of ringing with a frequency around 10kHz. This ringing, although well damped, ideally should have a frequency somewhere outside the audio band to avoid possible degrading of transients.

The output voltage of the cartridge when replaying a 5cm/s, 1kHz sinewave was measured as 3.15mV for the left channel and 3.55mV for the right channel. This gives a channel balance of 1dB at 1kHz, comfortably inside the specification of "within 2dB".

Using the Shure TTR 117 test record, we found the tonearm-cartridge

the effects of the record, cartridge or tonearm. Technics obtain the measurement by monitoring the built-in frequency generator of the motor assembly.

The usual method of measuring wow and flutter involves playing a test record containing a constant tone and monitoring the tone for wow and flutter. This method has a problem in that record warps or eccentricities cause additional wow and flutter in the test tone, making the record player appear worse than it actually is. The Technics method, since it eliminates these errors, does have some advantages over the recorded tone method.

On the other hand though, the Technics method does not take into account the effects of drag produced by the stylus as the record rotates. While

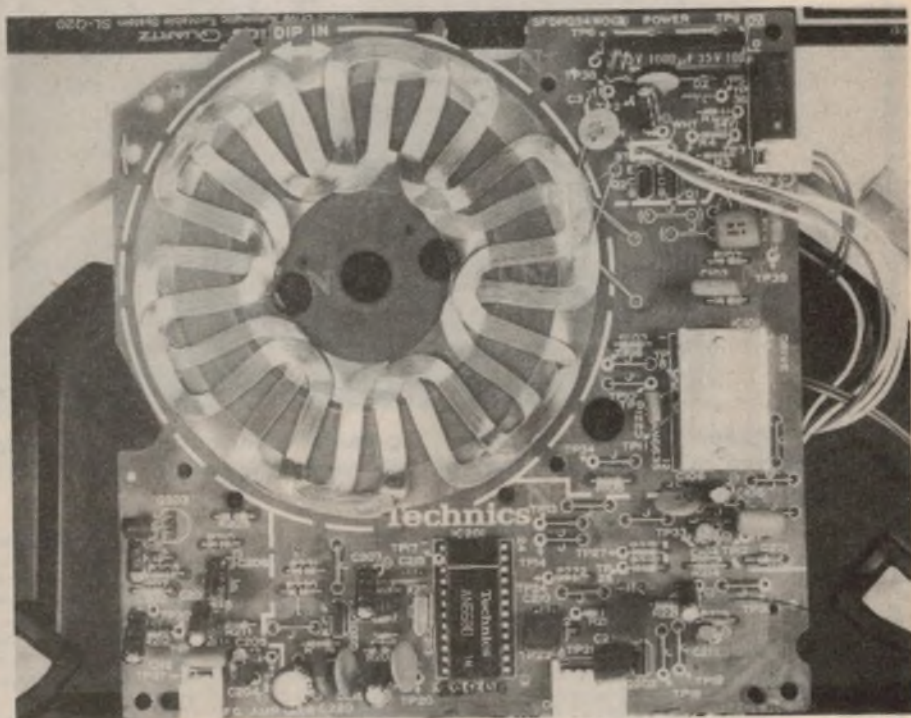

The PCB of the Technics SL-Q20 carries the armature windings for the motor.

mechanical resonant frequency to lie between 10 and 11Hz. This is within the preferred range of 8 to 14Hz.

On typical records the cartridge gave a good account of itself. As might be expected from the slight rise in the response at the high end, it sounded very good on strings, particularly violin. At the same time, it performed well on complex orchestra passages. There was some tendency to emphasise surface noise although not unduly so.

The instruction manual for the Technics SL-Q20 lists three different figures for the wow and flutter, .012%wrms, .025%wrms (JIS C5521) and $\pm 0.35\%$ peak (IEC 98A weighted). The first rating, according to the instruction manual, applies to the turntable assembly including platter but excludes

the amount of drag may appear negligible, it can be enough to degrade the wow and flutter performance of a turntable. For this reason we prefer to measure wow and flutter by the DIN 45507 method which uses a test record containing a 3.15kHz tone.

We obtained a wow and flutter reading of .08% using this technique, a reasonably good figure but by no means the best we have ever obtained.

While measuring the wow and flutter, we noticed a periodic variation in the sound of the 3.15kHz tone. Using the pattern of bars in the strobe light as a reference, we were able to determine that this variation in tone was due to a once per revolution correction pulse applied to the motor.

Continued on page 142.

RITRONICS WHOLESALE PTY LTD

425 HIGH STREET NORTHCOTE 3070 MELBOURNE (03) 489-8131

48-50 A'BECKETT STREET MELBOURNE (03) 347-9251

"BIG BOARD II"

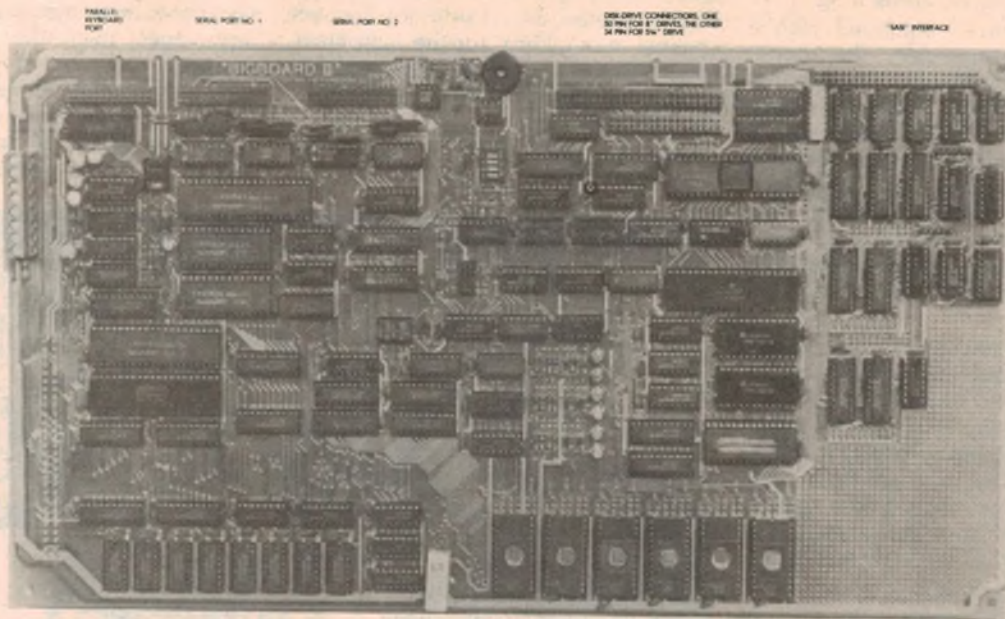

EPROMs shown only for clarity.

STD Bus Connector

Prototyping Area

Jim Ferguson, the designer of the "Big Board" distributed by Digital Research: Computers, has produced a stunning new computer that we will begin shipping in November called "Big Board II", it has the following features:

4 MHz Z80 — CPU AND PERIPHERAL CHIPS

The Ferguson computer runs at 4 MHz. Its monitor code is lean, uses Mode 2 interrupts, and makes good use of the Z80-A DMA chip.

64K DYNAMIC RAM + 4K STATIC CRT RAM + 24K E(E)PROM OR STATIC RAM

"Big Board II" has the three memory banks. The first memory bank has eight 4164 RAMs that provide 60K of user space and 4K of monitor space. The second memory bank has two 2Kx8 SRAMs for the memory mapped CRT display and space for six 2732 As, 2Kx8 static RAMs, or pin-compatible E(E)PROMs. The third memory bank is for RAM or ROM added to the board via the STD bus. Whether bought as a bare board, a full kit, or assembled and tested, it comes with a 200 nS2732A EPROM containing the monitor.

MULTIPLE-DENSITY CONTROLLER FOR SS/DS FLOPPY DISKS

The new Ferguson single-board computer has a multiple density disk controller. It can use 1793, 1797, or 8877 controller chips since it generated the signal with TTL parts. The board has two connectors for disk signal with 34 pins for 5.25" drives, the other with 50 pins 8" drives.

VASTLY IMPROVED CRT DISPLAY

The new Ferguson SBC uses a 6845s CRT controller and 8002 Video Attributed controller to produce a display that will rival the display of quality terminals. Characters are formed by a 5x7 dot matrix on 15.75 KHz monitors and 7x9 dot matrix on 18.60 KHz monitors. The display is user programmable with the default display 24 lines of 80 characters.

STD BUS CONNECTOR

The Ferguson computer brings its bus signals to a convenient place on the PC board where users can solder an DSTD, bus cards can be plugged directly into it, and it can as well be connected by bus cable to industry-standard card cages.

DMA

The new Ferguson computer has a Z80-A DMA chip that will allow byte-wise data transfers at 500K bytes per second and bit serial transfers via the Z80-A S10 at 880K bytes per second with serial processor overhead, though the monitor for the new computer uses the DMA chip mainly for transferring data to and from disk, the chip can readily be used for other things since its "wait/ready" pin can be connected under software control to some half a dozen signal lines. When a hard-disk subsystem is connected to the "Big Board II" via its "SASI" interface, the DMA chip makes breathtaking disk performance possible.

"SASI" INTERFACE FOR WINCHESTER DISKS

The "Big Board II" implements the Host portion of the "Shugart Associates Systems Interface". Adding a Winchester disk drive is no harder than attaching a floppy-disk drive. A user simply 1: Runs a 50-conductor ribbon cable from a header on the board to any of several inexpensive controller cards for Winchester drives that implement the controller portion of the SASI interface. 2: Cables the controller to an appropriate drive, and 3: Provides power for the controller-card and drive. Since our CBIOS contains code for communication with hard-disk, that's all a user has to do to add a Winchester to a system!

A Z80-A S10/0 = TWO ASYNCHRONOUS/SYNCHRONOUS SERIAL PORTS A PARALLEL KEYBOARD PORT = FOUR OTHER PARALLEL PORTS USER I/O

The new Ferguson single-board computer has one parallel port for an ASCII keyboard and four others for user defined I/O. When the computer is powered-up or reset, the monitor looks for a carriage return at the keyboard and serial ports. If the first carriage-return the monitor gets comes from the parallel keyboard, the monitor uses the board's video display circuitry to communicate with the user via a CRT. If the first carriage-return is typed at an ASCII terminal attached to a serial port, the monitor autabauds and makes the terminal the system console.

TWO Z80-A CTCs = EIGHT PROGRAMMABLE COUNTERS/TIMERS

The new Ferguson computer has two Z80-A CTCs. One is used to clock data into and out of the Z80-A S10/0, while the other is for systems and application use.

PROM PROGRAMMING CIRCUITRY AND SOFTWARE

The new Ferguson SBC has circuitry and drivers for programming 2716s, 2732(A)s, or pin-compatible (E)EPROMs. Software \$25 extra.

CP/M

CP/M with Russell Smith's CBIOS for the new Ferguson computer is available for \$220. The CBIOS is available separately for \$65.

Actual board size: 39.6cm x 22.2cm. 5 inch BIOS being developed. Approx price \$95.

Pricing and Availability:

Availability: 2 weeks delivery.

In single quantities full kits costs \$750.00 + tax, and A&T'd computers cost \$895. There are attractive discounts that range to 35% for OEM's and dealers. For details about them please call Rod Irving on (03) 489 7099. ie-3 Ferguson II "Big Board" are less 20% off the one-off price, hard disks disk controllers, boxes and power supply to suit both 8" & 5 1/4" systems will be available.

Errors and omissions excepted.

RITRONICS WHOLESALE PTY LTD

DISCOUNT CITY STORE

YOU WILL NEVER HAVE TO PAY FULL PRICE FOR COMPONENTS AGAIN

48-50 A'BECKETT STREET, MELBOURNE, 3000. PH: (03) 347 9251
MAIL ORDER TO P.O. BOX 235, NORTHCOTE 3070.

M2896-63 THE MITSUBISHI RANGE OF DISK DRIVES
Slimline 8" Disk Drive, Double Sided, Double Density, No AC Power required, 3ms track to track, 1.6 mbytes unformatted, 77 track/side, 10° bit soft error rate
\$495 + tax Box & Power supply to suit \$95 + tax

M2894
Standard size 8" drive, Double sides, double density, 3ms track to track access, 1.6 mbytes unformatted, 77 track/side, 10° bit soft error rate
\$495 + tax Box & Power Supply \$95 + tax

M4854
Slimline 5 1/4" disk drive, Double sides, double density, 96 track/inch, 9621 bits/inch, 1.6 mbytes unformatted, 3ms track to track access, 77 track/side
\$395 + tax Box & Power Supply \$85 + tax

M4853
Slimline 5 1/4" disk drive, Double sides, double density, 1 mbyte unformatted, 3ms track to track, 80 track/side, 5922 bits/inch, Steel band drive system
\$375 + tax Box & Power Supply \$85 + tax

VERBATIM DISCS
5 YEAR DATALIFE GURANTEE

		Per Box of 10
MD525-01	Single Sided, Double Density	29.50
MD525-10	SSDD 10 Sectors 40 Tracks	31.00
MD525-16	SSDD 16 Sectors 40 Tracks	31.00
MD550-01	Double Sided, Double Density	47.50
MD550-10	DSDD 10 Sectors 40 Tracks	49.50
MD550-16	DSDD 16 Sectors 40 Tracks	49.50
MD577-01	SSDD Soft Sect 80 Tracks	49.50
MD577-10	SSDD 10 Sectors 80 Tracks	57.00
MD577-16	SSDD 16 Sectors 80 Tracks	57.00
MD557-01	DSDD Soft Sect 80 Tracks	59.00
MD557-16	DSDD 16 Sectors 80 Tracks	59.00



HI TECHNOLOGY
PRODUCTS AND
EXPERIENCE

LINEAR REGULATORS

UA309KC	1.00
UA317KC	1.65
UA317UC	0.95
UA494PC	2.60
UA723PC	0.38
UA780KC	0.99
UA780UC	0.45
UA7808UC	0.45
UA7812KC	1.00
UA7812UC	0.45
UA7815KC	1.00
UA7815UC	0.45
UA7818KC	1.00
UA7818UC	0.50
UA7824KC	1.00
UA7824UC	0.50
UA78L05AWC	0.27
UA78L12AWC	0.27
UA78L82AWC	0.27
UA78S40DC	1.70
UA7905KC	1.05
UA7905UC	0.45
UA7908KC	1.05
UA7908UC	0.50
UA7912KC	1.05
UA7912UC	0.50
UA7915KC	1.00
UA7915UC	0.50
UA78L15AWC	0.27

HYBRID REGULATORS

SH1805	9.50
SH323C	4.50
UA78H05SC	4.50
UA78H12SC	6.00
UA78HGSC	6.20
UA79HGSC	10.00
UA78P05SC	8.50

TRANSISTORS

BD139	0.23
BD140	0.23
MJ802	2.40
2N3055	0.55
BU326	1.20
BU326	1.20
BUX80	2.10
2N3771	2.50
2N3772	2.50
2N3773	2.50
FND500	0.78
FND507	0.78
MAN74A	0.65
MAN72A	0.65
4N28	0.60
4N33	0.70
BDU64B	2.90
BDU65B	2.90
AD149	1.50
2SK134	3.80
2SJ49	3.80
W02	0.20
W04	0.25
IN5401	0.10
IN5404	0.12
BC547	0.05
BC548	0.05
BC549	0.05
C1220	0.65
SC141D	0.65

MEMORY SPECIALS

27C16	CMOS PROM	\$9.50
27C32	CMOS PROM	\$12.50
58725	2Kx8 RAM	\$4.50
2716	500NS	\$2.75
2732	450NS	\$4.50
2764	250NS	\$9.00
4164	150NS	\$5.00
	per 100 +@	\$4.00
Z80 CPU		\$3.40
Z80A CPU		\$3.60
Z80 CTC		\$3.20
Z80A CTC		\$3.75
Z80 P10		\$2.90
Z80A P10		\$3.40
Z80 S10		\$8.00
Z80A S10		\$10.00
6800		\$2.70
6802		\$3.70
6809		\$8.60
6821		\$1.00
6840		\$3.20
6845		\$8.40
6850		\$1.40
8212		\$1.10
8216		\$1.04
8224		\$1.30
8255		\$2.15
8155		\$3.70
4011		\$0.14
4016		\$0.24
4017		\$0.44
4023		\$0.16
4028		\$0.45
4040		\$0.52
4051		\$0.49
4066		\$0.28
4081		\$0.16
4511		\$0.49
4520		\$0.55
74LS00		\$0.13
74LS04		\$0.14
74LS14		\$0.19
74LS30		\$0.16
74LS32		\$0.13
74LS47		\$0.34
74LS90		\$0.26
74LS161		\$0.33
74LS240		\$0.45
74LS244		\$0.42
74LS245		\$0.55
74LS366		\$0.25
74LS367		\$0.25

8" VERBATIM

FD32-1000	Single Sided, Single Density	32.00
FD32-8000	Single Sided, Double Density	54.00
FD32-9000	SSDD Critically Certified	51.00
FD34-1000	Single Sided, Single Density	32.00
FD34-8000	Single Sided, Double Density	51.00
FD10-4008	Double Sided, Single Density	59.00
FD10-4015	Double Sided, Single Density	59.00
FD10-4026	Double Sided, Single Density	59.00
FF32-2000	SD FLIPPY FLOPPY	62.00
FF34-2000	SD FLIPPY FLOPPY	62.00
DD32-4000	Double Sided, Double Density	54.00
DD34-4001	Double Sided, Double Density	49.00
DD34-4008	Double Sided, Double Density	51.00
DD34-4015	Double Sided, Double Density	53.00
DD34-4026	Double Sided, Double Density	55.00

100MHz Probe Stes, great value @ \$23.00 + Tax

Greenpar

PROBE ACCESSORIES

Can be ordered as individual items, standard kit or comprehensive kit
Items 1-6 are standard accessories supplied where appropriate with probe kits

Items 1-12 from the comprehensive kit

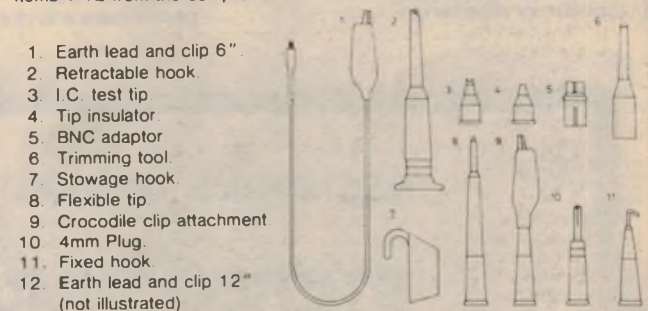

TRIOS CS1560 A II CROS..... \$425.00 + Tax

ALL PRICES PLUS 20% TAX. TRANSISTORS PLUS 32.5% TAX.
POST \$2 HEAVY ITEMS EXTRA

RITRONICS WHOLESALE PTY LTD

MAIL ORDER to PO Box 235, Northcote 3070 Victoria.

Minimum MAIL ORDER \$20.00

Simple circuit uses three low-cost ICs

Stereo simulator for tuners & VCRs

Built around three low-cost op amp ICs, this simple circuit can produce simulated stereo sound from virtually any monophonic source. It can be built as a self-contained unit or installed inside an existing piece of equipment.

by COLIN DAWSON

Anyone who has built the Playmaster wide-band AM tuner (Dec, 1982 – March, 1983) will be aware that the quality of transmitted AM programs is much higher than generally accepted. In fact, it quite often approaches that of FM transmissions. But, after the initial euphoria of this discovery has subsided, the listener's satisfaction may be dampened by the inherent limitations of mono sound which, by comparison with stereo, can sound a little dull.

Our new Stereo Simulator was designed expressly to overcome this limitation, although it can also be used with other monophonic signal sources such as VCRs and TV sets. In fact, we made up two versions of the unit, and installed one permanently in the chassis of the AM tuner. The other version was fitted inside a small plastic case to serve as a self-contained unit, and features optional mono/stereo switching.

Actually it was only last September that we presented a stereo synthesizer using a bucket brigade device. Is this previous design superseded already? No. The new design has the attraction of much lower cost but it does not offer quite the same even stereo spread of the September 1982 BBD design. Even so, the effect is very worthwhile and certainly should contribute to your listening pleasure.

Another advantage of this particular unit is its small size which generally allows it to fit inside existing equipment (including the Playmaster AM Tuner).

The accompanying specifications panel shows the performance of our prototype unit. Note that these figures were obtained with the unit powered from an unregulated 9V plugpack supply. Both the signal-to-noise ratio and distortion figures are improved slightly when a regulated supply is used. Even so, the performance is quite satisfactory and the

distortion figure of 0.1% can generally be regarded as conservative – at most frequencies it is only about .05%

Some readers may think it strange that the signal-to-noise ratio is different in the left and right channels, but this is simply a result of our having taken the measurements with respect to a 1kHz signal. At this frequency (and in fact at most frequencies), the left and right channels have different gain and hence different noise levels.

We can't claim to have derived genuine stereo from a mono recording – it is simply not possible to recover spatial information that was not recorded in the first place. In this respect, the term "stereo" is something of a misnomer since the simulator does not provide a signal with any directional information. What it does do is diffuse the "point source" effect of normal mono, creating a certain amount of artificial separation



This self-contained version of the Stereo Simulator includes the LED power indicator and optional mono/stereo switching. It can be powered from a 9V plugpack or any convenient 9-15V DC supply.

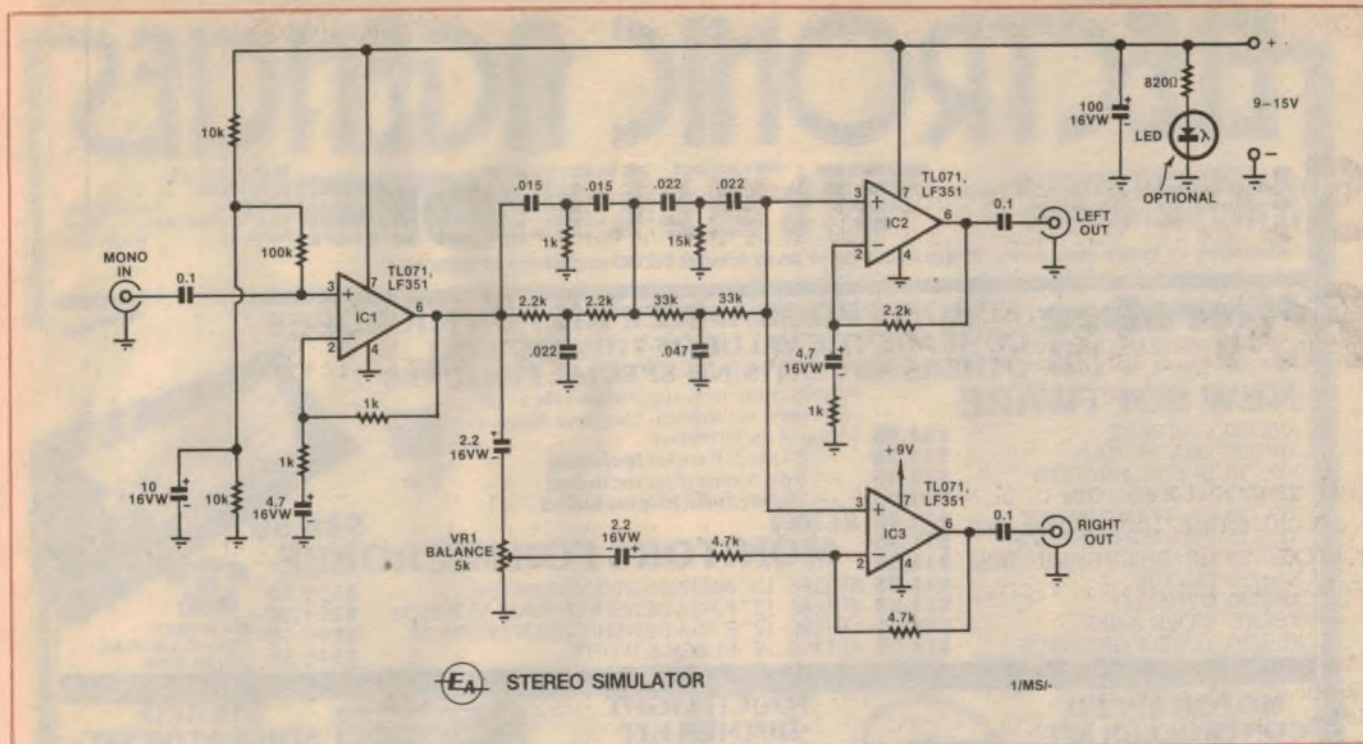

The circuit consists of an op amp buffer (IC1), a twin-T filter network, and output amplifiers IC2 and IC3.

or spread. The result is a signal which sounds as though it could be stereo -- hence the term "stereo simulator."

How it works

The simulator creates "left" and "right" channels from the original mono signal by means of filters. This method has been used in many circuits over the years and in its crudest form is comparable to siting the tweeter of a speaker system on one side of the room and the woofer on the other.

Our circuit employs two twin T filters which cause notches in the frequency response at 200Hz and 5kHz in one channel. This is quite effective, but strictly conventional. The interesting aspect of this circuit is how the signal for the other channel is derived. Usually, this would simply be the unfiltered input signal, but in this circuit is the difference between the input signal and filtered signal. This is a far more realistic approach since the sum of the two outputs gives the original signal, yet the left and right channel signals are quite different.

Fig. 1 shows the response of the two channels, with the notches at 200Hz and 5kHz appearing in the left channel. The right channel response features a single 25dB notch centred on 1kHz.

Twin T filters are so named because they consist of two T sections -- one section uses an R, 2C network and the other an R/2, C network. When the values are chosen precisely, the filter gives a narrow notch with almost total cancellation at its centre frequency. Actually, the

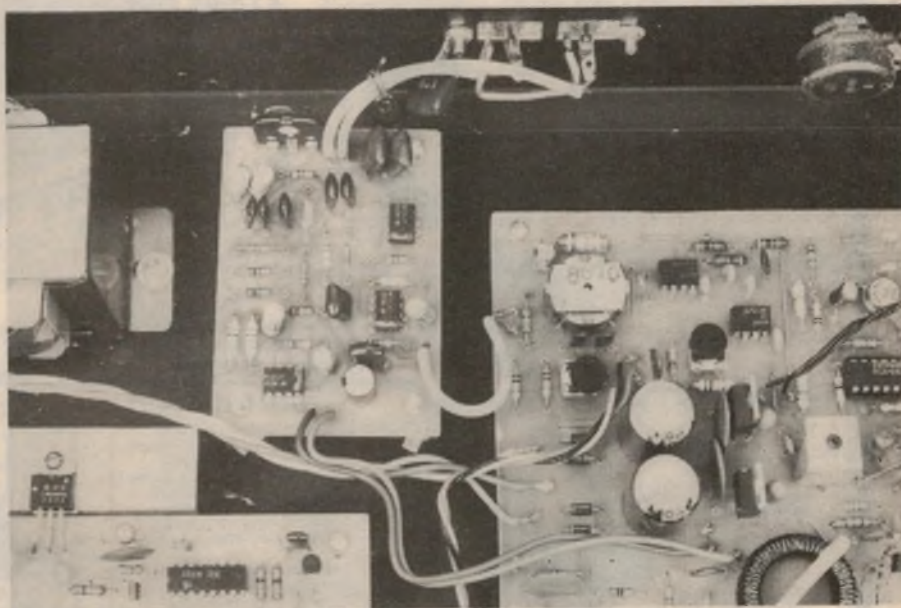

This photograph shows the assembled PCB mounted inside the chassis of the Playmaster AM Tuner. Power for the simulator is derived from the main tuner PCB at right.

SPECIFICATIONS

SIGNAL-TO-NOISE RATIO	60dB (left channel); 56dB (right channel)
DISTORTION (both channels)	0.1%
GAIN	(see graph)
CURRENT DRAIN	6.5mA without LED, 17mA with LED

Measurements were taken with respect to 100mV output at 1kHz using an unregulated 9V plugpack supply. Signal-to-noise ratio and distortion figures can be expected to improve slightly with a regulated supply.

BILL EDGE'S

ELECTRONIC AGENCIES

115-117 Parramatta Rd. Concord 2137
(Corner Parramatta Rd & Lloyd George Ave)
Telephone (02) 745 3077 (two lines)
117 York St. Sydney Phone 29 2098

Mail Orders:
PO Box 185
Concord
2137

	NSW & ACT ONLY	VIC SA QLD TAS WA NT
\$1	— \$ 9.99	\$1 — \$ 9.99
\$10	— \$24.99	\$10 — \$24.99
\$25	— \$49.99	\$25 — \$49.99
\$50	— \$99.99	\$50 — \$99.99
\$100	— of more \$150	\$100 — of more \$150



TRADING HOURS
BOTH STORES
Mon-Fri 9 am-5:30 pm
York St Thursday 8 pm
Saturday 9 am-12 pm

All heavy or bulky items (over 20kg) sent Comet Road Freight \$12.00 anywhere in Australia

MicroBee EPROM PROGRAMMER KIT FOR MICROBEE

XE5000 16k PLUS \$449
XE5100 32k PLUS \$549

COMPARE THE VALUE OF THIS KIT WITH OTHERS ADVERTISING SPECIAL FEATURES

NEW SOFTWARE

XE6700 CAR RACE	\$11.95
XE6705 DEATH TRAP	\$11.95
XE6710 BREAKTHROUGH	\$11.95
XE6715 WORMSQUIRM	\$11.95
XE6720 EXTENDED BASIC	\$11.95
XE6725 PRINTER GRAPHICS	\$11.95
XE6730 GRAPHICS GAME TOOL	\$14.95
XE6735 EUCHRE	\$11.95
XE6740 OTHELLO	\$11.95
XE6205 WORK-A-BEE	\$14.75
XE6210 TURTLE GRAPHICS	\$14.75

All the components supplied plus the usual extra parts which keeps Electronic Agencies on top of the kit market.

- 24 pin 21F socket **included**
- 5 dip header plugs **included**
- 15 pin parallel plug **included**

KE7003

MONITORS FOR MICROBEE

XE1186 12" MICRON GREEN MONITOR	\$199.50
XE1188 12" KAGA DENSHI ORANGE MONITOR	\$299.00
XE1190 12" KAGA DENSHI GREEN MONITOR	\$299.00
XE1192 12" BLACK & WHITE	\$149.50

\$46.50



MICROBEE
PHONE ORDERS
(02) 29 2098

MOTOR SPEED CONTROLLER KIT

See ETI Apr 83.
KE7006
\$19.95



TOUCH LIGHT DIMMER KIT

See EA Apr 83
Complete kit including all hardware. KE7007
\$19.95



STEREO SIMULATOR KIT

See EA Apr 83
All parts supplied including box, front panel, etc. but excluding plug pack
Plug Pack \$9.95. Cat ME7721
KE7008
\$19.95

SPEAKER SPECIALS

PHILIPS AD01610/T8 TWEETER
As used in ET14000. 100w RMS system handling
This month only \$12.95
CE2013. Normally \$16.95

MOTOROLA KSN1025 PIEZO HORN

No Crossover needed. Over 100w RMS
This month only \$19.50
CE2028. Normally \$27.00

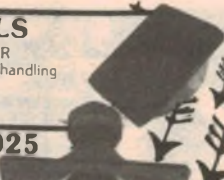

PHILIPS ADO2160/Sq 8 MIDRANGE

As used in ET14000
This month only \$35.00
Usually \$45.00
CE2085



PIONEER 8" WOOFER

30w RMS White Cone
This month only \$12.50
Normally \$16.50
CE2111

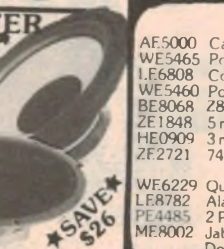

PHILIPS WOOFER 12"

AD12250AW
100w RMS
as used in ET14000
Normally \$95
This month \$69 CE2135



HEATSHRINK TUBING

You asked for it so here it is. Heatshrink tubing in 2 metre packs. Shrinks to 1/2 its size

WE8270	\$1.80
WE8272	\$1.80
WE8274 1/4"	\$2.20
WE8276	\$2.95
WE8278 1/2"	\$4.25
WE8262 Assorted	\$2.75



SIX HOUR TURNAROUND ON MAIL ORDER

NEW PRODUCTS

AE5000	Cassette Player suit Microbee	\$49.50
WE5465	Power Lead Suit Sony equipment	\$ 6.95
LE6808	Coax Wall Skt - Large plate	\$ 3.50
WE5460	Power lead, cia plug to 4 way plug 12v	\$ 3.50
BE8068	280 Microcomputer Handbook	\$18.50
ZE1848	5 mm Bright Led 200 mcd	65c
HE0909	3 mm LED Mounting Bezel Pk 15	95c
ZF2721	74C221 used in MBee burner	\$ 2.95
WE6229	Quality Braided Single Shielded Cable	or 8c each 70c mt
LE8782	Alarm Pressure Mat for Stairs	\$ 9.75
PE4485	2 Pin 240v Plug straight pins	\$ 1.20
ME8002	Jabel Mains. Filter	\$89.00
	Don't pay \$109.00	

LATEST PCB'S

ET1668	Microbee Programmer	\$ 4.50
ET11511	Temp Immers Cntr lr	\$ 3.80
ET11510	Trains Points (A & B)	\$ 6.40
ET11334	Car Auto Tester	\$ 4.80
ET1488	60w Amp Module	\$14.30
EA83A02	Audio Osc/AM Tuner	\$ 3.80
EA83WB1	Wheatstone & Res Box	\$ 3.40
EA83EG1	Led Hedhand	\$ 3.00
EA83TV1	TV Sound Killer	\$11.40



QUALITY DPST ROTARY SWITCH

3 AMP 240V. Made by MSP
Not 99c
ONLY 50c each
SE1500

COMPARE OUR STANDARD PRICE ON BC547, 548, 549 10c each.
BC557, 558, 559

PIEZO SCREAMER

White in colour, this device gives off about 120 db of virtually unbearable noise
LE8923 \$36.50

PIONEER 12" GUITAR SPEAKER

Many sold for band work
CE2380 \$49.50

BISHOP GRAPHICS NOW AVAILABLE

— Make your own Printed Circuit Boards in minutes. As used in schools and colleges. See our add next month or phone for details

EXCLUSIVE
ALL ELECTRONIC AGENCIES KITS OVER \$20 INCLUDE OUR REFERENCE MANUAL. WHY SETTLE FOR ANYTHING LESS.

KITS

KE1825	Upgraded Transistor Assisted Ignition	\$ 35.00	KE6600	ET1660 Colour Computer	\$ 99.00	KE5000	ET15000 Pre Amp	\$279.00
KE1850	Breakerless Ignition	\$ 19.50	KE6602	Colour Option for ET1660	\$ 13.50	KE1088	Driveway Sentry	\$ 32.00
KE1635	Electric Fence	\$ 15.00	KE6603	Video RF Modulator	\$ 14.50	KE1100	Microwave Oven Leak Detector	\$ 14.95
KE7000	Train Controller (short form)	\$ 39.50	KE6601	Keys for ET1660	\$ 32.00	KE1110	Cylon Voice	\$ 18.95
KE7001	Balanced Input Preamp	\$ 19.50	KE4076	Digital Readout	\$ 41.00	KE1150	FM Wireless Mic	\$ 7.50
KE7002	Nicod Float Charger	\$ 14.95	KE4085	300w Inverter kit	\$195.00	KE1155	Voice Canceller	\$ 20.00
KE7003	Eprom Burner for Microbee	\$ 46.50	KE1940	Power Up	\$ 39.50	KE1600	Negative Ion Generator	\$ 39.00
KE7004	Red Light Flasher (Alarm type)	\$ 19.50	KE1055	Super Siren	\$ 22.00	KE1630	Windspeed Meter	\$ 46.50
KE7005	Auto Tester	\$ 17.00	KE5060	Graphic Equaliser	\$199.00	KE1631	Wind Director Meter	\$ 29.50
KE1460	Metal Detector ET11500	\$199.00	KE5050	ET15000 Power Amp	\$315.00	KE1725	Delux Car Alarm	\$ 29.50

values used in our filter networks are not selected critically and this has resulted in notches of about 20dB. Although this could be improved by choosing "ideal" components, the degree of cancellation is already sufficient and any further improvement would be purely academic.

In fact, if the notches were made very deep and very narrow, the left channel would sound almost identical to the original mono input. On the other hand, we would get very little sound from the right channel since it would consist of just two very narrow bands of signal centred on 200Hz and 5kHz. This is clearly not what we want.

The response of the filters has also been modified to a certain extent by the interaction between stages, since the two filters are directly coupled. We have minimised this interaction, however, by placing the 5kHz filter first — it has a relatively low impedance and is thus not unduly loaded by the higher impedance of the following 200Hz filter. While interaction between the filters could have been completely eliminated by an op-amp buffer stage, the improvement would again be of only academic interest. And, as we've already seen, we don't want the filters to have a really sharp response.

Circuit details

The filter network is driven by a Fet-input op amp buffer (IC1) which isolates it from the line output of the tuner or VCR, etc. A voltage divider consisting of two 10kΩ resistors sets the bias to the non-inverting input to half supply so that the op amp can function from a single supply rail. This bias is applied to IC1 via a 100kΩ resistor, with decoupling provided by a 10μF capacitor.

IC1 is configured as a non-inverting amplifier with unity gain and frequency roll-off below 40Hz set by the 4.7μF feedback capacitor. The mono input signal is AC-coupled to the non-inverting input (pin 3), while the output (pin 6) feeds directly into the twin T filter network and also, via a 2.2μF capacitor, to one side of a 5kΩ trimpot (VR1). The other side of the trimpot is grounded and the signal available on its wiper used to drive the following right channel output stage.

The left and right channel output stages consist of two more non-inverting amplifiers, again using Fet-input op amps (IC2 and IC3). The filtered signal from the twin T network is applied to the non-inverting input in each case. IC2 applies a gain of around two to this signal which subsequently becomes available as the left channel output. Note that since there is a DC path through the filter net-

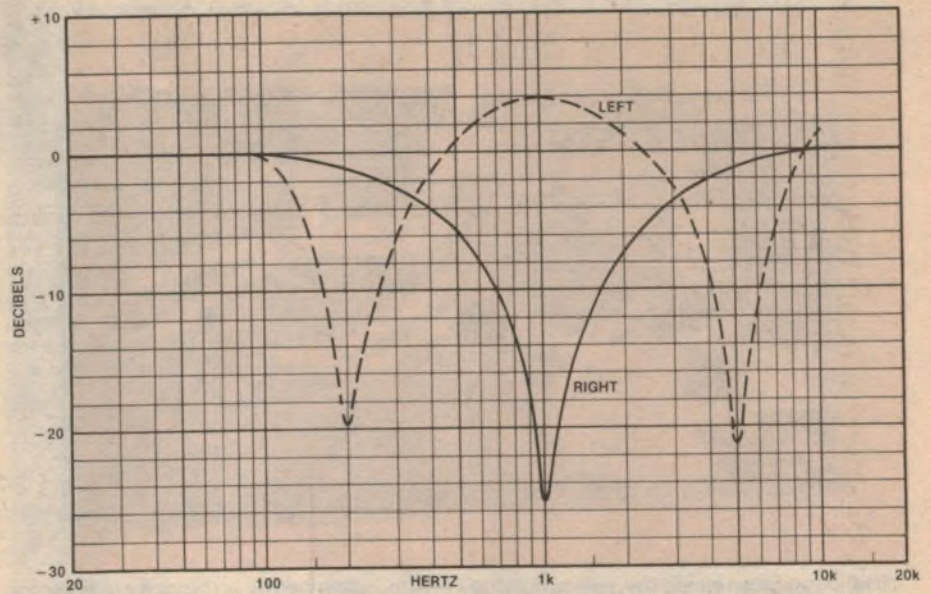
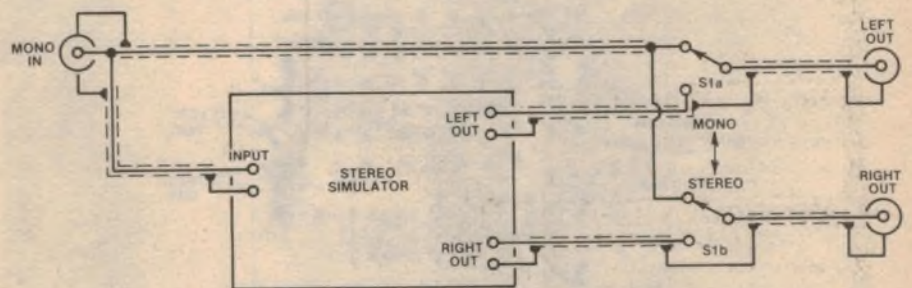

Fig. 1
This graph plots the response of the left and right channels.



OPTIONAL MONO-STEREO SWITCHING

Fig. 2

Wiring details for optional mono/stereo switching. Note use of shielded cable for all input and output connections to the PCB and switch.

work, it is not necessary to provide biasing for IC2 and IC3.

IC3 is wired as a differential amplifier and functions rather differently to IC1 and IC2. In this case, different signals are applied to the non-inverting and inverting inputs — the signal from the twin T filter network appears on the non-inverting input, while the signal on the inverting input is derived from VR1 and is a buffered version of the original mono input. The output of IC3 represents the difference between these two signals.

Thus, when the signals on pins 2 and 3 of IC3 are common (ie, they have the same phase and amplitude), they are cancelled and IC3 has no output. When the signals are no longer common, only partial (or nil) cancellation occurs depending upon the relative phase and amplitude differences between them.

Note that the gain of IC2 (as set by the ratio of the 2.2kΩ and 1kΩ feedback resistors) compensates for the inherently "lossy" nature of the twin T filter network, at least as far as the left channel is concerned. Trimpot VR1 adjusts the gain of IC3 in the right channel, and functions as both a "depth of stereo" control and a balance control. In fact, the actual setting of VR1 tends to be a compromise between these two functions.

The response curves accompanying this article (Fig. 1) indicate that the output of IC3 has a very deep null at 1kHz. The depth of this null depends on the setting of VR1 and the results indicated are for what is considered an optimum adjustment.

Power for the circuit can be derived

We estimate that the current cost of parts for this project is approximately

\$12

for the PCB version. The self-contained version will cost about \$20 (does not include the plugpack supply). These prices include sales tax.

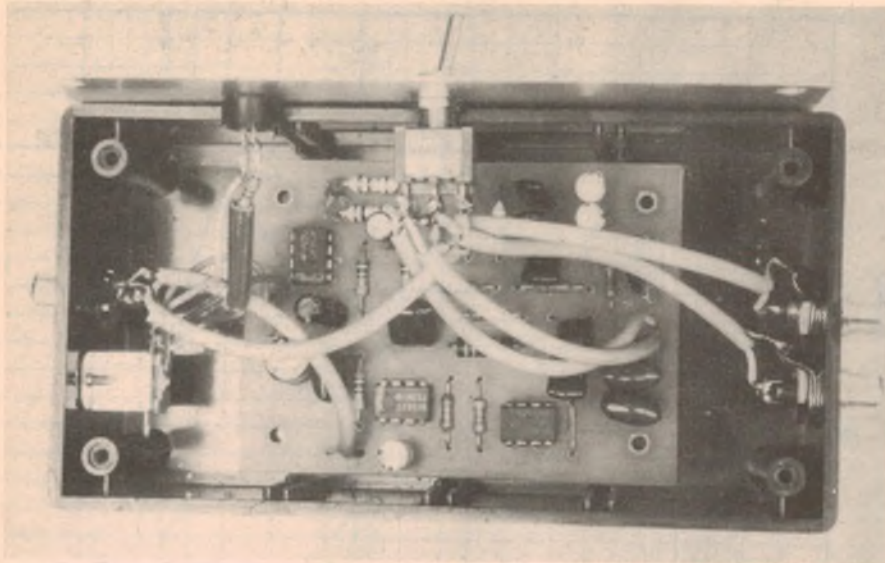

Above is a view inside the self-contained version, while below is the parts overlay for the PCB. Be sure to mount all polarised components the right way round.

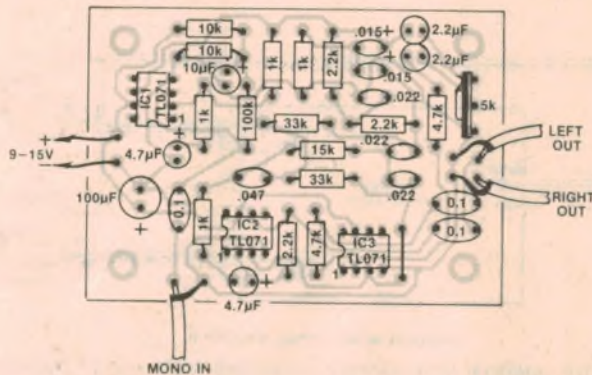

from any convenient 9-15V DC supply, eg a 9V plugpack, a 9V battery, or a 9-15V supply rail inside existing equipment. A 100µF electrolytic capacitor decouples the supply, while power indication is provided by a LED wired in series with an 820Ω current limiting resistor across the supply rails. This indicator LED is optional and can be included if the circuit is to be built as a self-contained unit.

Finally, it is possible to include optional mono-stereo switching using a single DPDT toggle switch. Fig 2. shows the circuit details. In the stereo position, switch S1 selects the left and right outputs of the Stereo Simulator. In the mono position, the simulator is bypassed and S1 selects the mono input signal line.

Construction

The simulator is built on a small printed circuit board (PCB) measuring 80 x 57mm and coded 83ms4. Mount the parts on the PCB according to the parts overlay diagram, beginning with the resistors and then moving on to the capacitors and ICs. Don't forget the wire

link adjacent to IC3, and make sure that you install the ICs and electrolytic capacitors the right way round.

We recommend that you use PC stakes for all external connections to the PCB — they make the job of wiring that much easier.

From here, the construction procedure depends on where you are mounting the board. Before mounting the unit inside an existing piece of equipment, check that it can be installed so that doesn't foul controls or cover ventilation slots, and that a 9-15V DC supply rail is available. You should also check that there is space on the rear panel to mount the extra output socket. In most cases, this will be an RCA socket but should, of course, match the existing socket.

In the case of the Playmaster AM tuner, the PCB is mounted towards the rear of the chassis between the power transformer and the main tuner board. The rear panel already has stereo output sockets, and it is a simple matter to rewire these for stereo. First, drill four

mounting holes in the bottom of the cabinet, and install the PCB on 19mm stand-offs. The tuner output now becomes the input to the simulator, while the simulator's outputs are connected to the RCA sockets on the back panel of the tuner.

Power is derived from the main tuner board. This board has a +15V output which is used to power the alignment module during the alignment procedure. Once alignment is complete, this output is normally unused and thus provides a convenient point from which to derive the positive supply. The negative (earth) side of the simulator supply should be

PARTS LIST

- 1 printed circuit board, code 83ms4, 80 x 57mm
- 4 19mm standoffs
- 3 TL071, LF351 Fet-input op amps

CAPACITORS

- 1 100µF/16VW electrolytic
- 1 10µF/16VW electrolytic
- 2 4.7µF/16VW electrolytic
- 2 2.2µF/16VW electrolytic
- 3 0.1µF greencap (metallised polyester)
- 1 .047µF greencap
- 3 .022µF greencap
- 2 .015µF greencap

RESISTORS (¼W, 5%)

- 1 x 100kΩ, 2 x 33kΩ, 1 x 15kΩ, 2 x 10kΩ, 2 x 4.7kΩ, 3 x 2.2kΩ, 4 x 1kΩ, 1 x 5kΩ 10mm vertical trimpot

ADDITIONAL PARTS FOR SELF-CONTAINED VERSION

- 1 plastic utility box, 130 x 67 x 40mm
- 1 Scotchcal front panel, 125 x 63mm
- 3 RCA sockets (screw-mount)
- 1 DPDT toggle switch
- 1 socket to suit plugpack supply
- 1 red LED and bezel
- 1 820Ω resistor (¼W, 5%)

MISCELLANEOUS

Machine screws and nuts, shielded cable, hook-up wire solder etc.

connected to the nearby "G" (ground) terminal on the tuner PCB.

If you wish to include the optional mono-stereo switching, we suggest that you mount the switch on the rear panel. Note that all signal connections to and from the simulator should be run in shielded cable to avoid hum pick-up. The indicator LED and its series 820Ω resistor are not needed in this application.

For the self-contained version, we mounted the PCB in a plastic utility box

Not 50 . . . Not 60 . . . But 70MHz For Only \$1595*!

And that's with 4 Channels & 8 Traces

1mV Sensitivity!



Trio CS-2070

Features include:

- 4 Channel, 8 Trace display making use of alternating delayed sweep.
- Dual sweep with completely independent A and B sweeps.
- 1mV/Div. sensitivity all the way to 70 MHz.
- Sweep time to 5nS/Div. for easy-viewing of fast signals.
- Delayed sweep intensity control.
- Bright, Clear CRT.
- 100MHz Version available (CS-2100A)
- Price does not include probes

Best Value Scope on the Market Today! \$525*

Proven reliability — Over 2500 in service in Australia.
Used by industry, schools and hobbyists.



Trio CS-1560All 15MHz DualTrace Triggered Sweep

- Sensitivity 10mV/Div. (Triggers at 0.5 Div. Typ.)
- CH1, CH2, DUAL, ADD, and SUB
- Risetime 23nS
- XY Mode
- Triggered Sweep and Auto.
- Sweep Time 0.5µS/Div. - 0.5S/Div. and XY
- Price does not include probes.

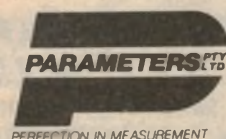

5MHz Lab Sweep/Function Generator with lin/log Sweep \$945*



B & K Model 3030

- Generates sine, square, triangle, positive square, negative square, positive ramp, negative ramp and waveforms
- Covers .001Hz to 5MHz
- 4 decade, 10,000:1 log sweep range.
- 3 decade, 1,000:1 linear sweep range
- High-accuracy Kelvin-Varley frequency sweep start stop controls
- Wide range variable symmetry control for virtually any wave shape
- Calibrated output attenuation from 10dB to 60dB

250MHz Probes

High Performance at half the price you're used to! — Call For Prices

New from Greenpar — The Reliable Manufacturer!



- 1:1, 10:1 or switched versions
- Slender bodies for tight spots
- Sprung hook connection for accessing high density boards
- Tip insulator and I.C. tip supplied as standard

True R.M.S. 4 3/4 Digit Multimeter with Frequency Counter Now Only \$395*



Thurlby 1504

- 4 3/4 digits (±32,768 counts)
- 10µV, 10mΩ/1nA resolution
- 0.03% basic dcV accuracy (1503-HA)
- True RMS ac functions (1504)
- LCD, fully field portable
- Current measurement to 25 amps
- 7 functions including frequency
- Outstanding price/performance ratio
- Model 1503 Now \$349

Measure Temperature with Almost Any Multimeter B & K Model TP28/30 Temperature Probe \$120*/\$135*

Plugs into almost any digital or analogue multimeter for a temperature readout



- Ranges -50°C to +150°C and -200°C to +482°C
- Selectable °F or °C
- Resolution 0.01° with 1.7°C accuracy
- Measures surfaces, liquids or gases
- Will drive a chart recorder

20Hz to 200KHz Audio Oscillator Outstanding Value \$149*

- Frequency Range 20Hz to 200kHz
- Sine/Square Wave
- Output Voltage to 10V RMS
- Deviation within ± 1dB
- Distortion Less Than 0.5%
- Compact and lightweight

Trio AG-202A



Parameters Pty. Ltd. Sydney (02) 439 3288 Melbourne (03) 580 7444

Adelaide: PROTRONICS (08) 212 3111
TRIO ELECTRIX (08) 51 6718
K. D. FISHER & CO (08) 277 3288
Brisbane: ST LUCIA ELECTRONICS (07) 52 3547
L.E. BOUGHEN (07) 369 1277
Canberra: GEORGE BROWN & CO. (062) 80 4355
ORTEX (062) 82 4995
Hobart: IMBROSS (002) 34 9899
GEORGE HARVEY (002) 34 2233

Launceston: GEORGE HARVEY ELECTRIC (003) 31 6533
Melbourne: RADIO PARTS GROUP (03) 329 7888
GEORGE BROWN & CO (03) 419 3355
ELLISTRONICS (03) 602 3282
D. G. E. SYSTEMS (049) 89 1625
GEORGE BROWN (049) 89 6399

Perth: W. J. MONCREIFF CO. (09) 325 5277
PROTRONICS (09) 362 1044
Rockhampton: PURELY ELECTRONICS (079) 2 1058
Sydney: GEORGE BROWN & CO (02) 519 5855
DAVID REID ELECTRONICS (02) 29 6601
RADIO DESPATCH SERVICE (02) 211 0191
NORTEK (077) 79 8600
Wollongong: MACELEC (042) 29 1455

* All prices Plus Sales Tax if applicable

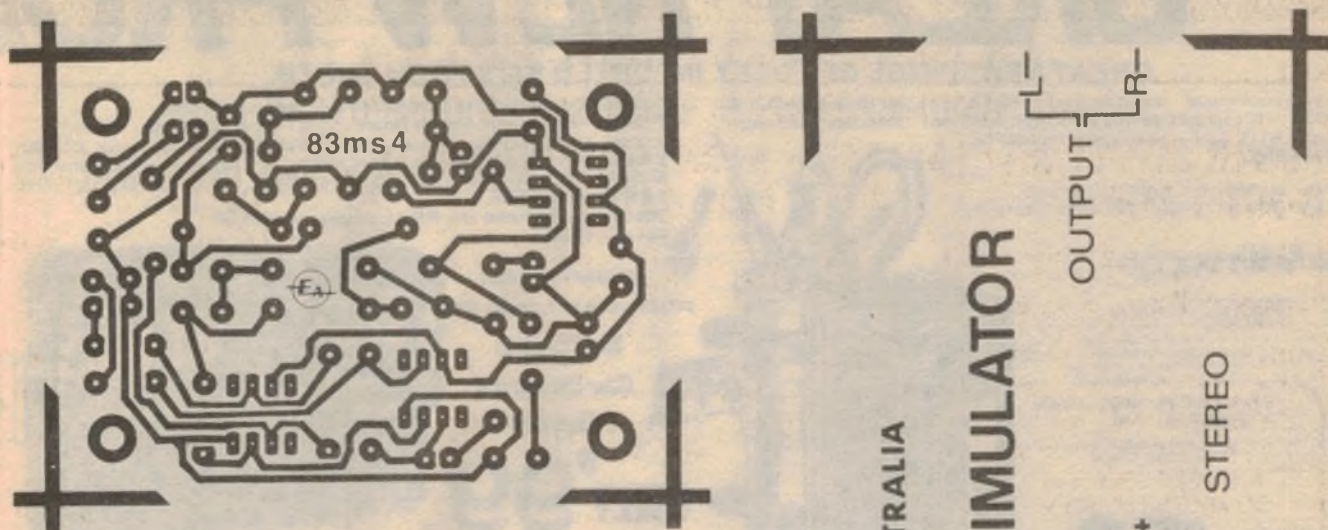

Here are actual size artworks for the PCB and front panel.

measuring 130 x 65 x 40mm. This is fitted with RCA input/output sockets and a power socket, together with the LED indicator and optional mono-stereo switching. A front panel made from self-adhesive Scotchcal material provides an attractive finish to the unit.

The first job is to affix the Scotchcal label to the lid of the box, and drill mounting holes for the switch and indicator LED. This done, mounting holes may be drilled in the box for the RCA sockets, power socket and PCB. As shown in the photograph, the RCA input socket and the power socket are mounted on the left hand side of the box, while the two RCA output sockets are mounted on the right hand side.

The various items of hardware may now be mounted in position and the wiring completed. As before, all input and output connections (including those to the switch) should be run in shielded cable. Connections to the power socket and LED can be run using multistrand hook-up wire. Don't forget to solder the 820Ω resistor in series with the LED.

It is a good idea to check the polarity of the power socket terminals with a multimeter before making the connections to the PCB. You will almost certainly damage the ICs if power is applied with reversed polarity.

To test the unit, first apply power and check that the LED illuminates. If all is well, disconnect the plugpack and connect the simulator into circuit. The mono input accepts the signal from the program source, while the left and right outputs go to the amplifier line inputs. If you have an integrated tuner/amplifier, the tuner signal will be available at the "Tape

Out" outputs. The simulator outputs should then be connected to the "Tape Monitor" inputs on the amplifier.

Apply power and check that everything functions normally with switch S1 in the "mono" position. Finally, switch to "stereo" and adjust VR1 for the most satisfying sound. Your "Stereo Simulator" is now ready for use.

As explained earlier, this device will not endow the music with any directional information. For example, you will not be able to positively identify the lead guitarist as being right of centre. Nevertheless, the simulator has a satisfying "spread" effect and you will certainly know when it is working.

2FC, 2BL, 2GB, 2UE, 2KY, 2UW, 2CH 2WS, 2SM and 2EA have a major problem:

Whilst AM stations go to great lengths to ensure that the signal that they transmit is of the highest possible quality the problem is, that most manufacturers produce tuners that do the reverse!

AM broadcasts sound great!

The AM section in a typical FM/AM tuner has a frequency response of about 40-2,000Hz. This makes it OK for news and information but music sounds BLECCH.

Audiosound AM tuners cover 20Hz-13kHz-3dB. They have a distortion free sound quality that subjectively sounds like FM with the occasional crackle. And they have a stereo simulator circuit. Why put up with muddy AM quality when the rest of your system sounds great?

Remember the first time?

Remember when you replaced your tin boxes with true Hi-Fi speakers? An Audiosound tuner will make the same

quantum jump — you can actually enjoy AM broadcasting for it's sound quality alone. If your dealer doesn't have these superb tuners, phone Audiosound on 938 2068. Audiosound have been transforming the quality of AM broadcasts since 1970. An Audiosound tuner really does *make a difference*. **AM101 \$299***

audiosound 

Contractors to the Australian Broadcasting Commission

GREAT NEW PROD

GREAT NEW RANGE OF FULLY IMPORTED KITS FROM THE UK

Each kit is complete down to the last nut & bolt. All fittings included!
SX-2000. UK's largest selling electronic ignition! "Reactive Discharge" system - NOT CDI - with great reliability.
 Cat. KJ-6650

● FIT ALL 12V NEGATIVE EARTH VEHICLES
 (UTILISING COIL & CONTACT BREAKER IGNITION)

Sparkrite SX2000

- A Reactive Discharge System combines all features of the SX500 plus
- Reactive Discharge electronics combining all the advantages of both Inductive and Capacitive Discharge for maximum spark performance
- Gives the most thorough combustion of air/fuel ratios especially current lean mixture emission controlled engines
- Voted 'Accessory of the Year' and the best as tested by Popular Motoring Magazine
- Patented clip to coil fitting
- Systems Function Light as well as Static Timing Light
- The ultimate brand leading contact breaker triggered system

Value **\$59**



Brilliant Computer Programmable Car Security System
 This kit, the famous British Sparkrite AT-80 is absolutely unique. It uses a self-adhesive sensor-pad that attaches to the inside of your glass windscreen. You have a special key fob (2 are supplied) and you program YOUR SPECIAL CODE in from the OUTSIDE OF THE CAR to get back in. The windscreen pad is a REAL deterrent sticker!
 Cat. KJ-6660

'COMPUTER PROGRAMMABLE'
 Electronic Car Security System
\$ ONLY 99



- Guards doors, boot, bonnet PLUS radio tape and auxiliary fog spot lamps. Also inhibits ignition
- Flashes headlights and intermittently sounds horn for both visual and audible alarm
- Unique programmable personal code entry system to arm and disarm

TX-2002. Breakerless ignition! Full fitting kit to convert 90% of all cars! All contactless hardware supplied. No drilling or tapping. You can easily convert - and even use your points to work the TX-2002!
 Cat. KJ-6652

Sparkrite TX2002

- A Reactive Discharge System - with unique auxiliary circuit. Combines all features of the TX1002 plus
- Reactive Discharge electronics combining all the advantages of Inductive and Capacitive Discharge for maximum spark performance
- Gives the most thorough combustion of air/fuel ratios especially current lean mixture emission controlled engines
- Unique 3 way change over switch incorporating an auxiliary back up circuit. ELECTRONIC OFF AUXILIARY
- Robust die cast case. Fully resistant to moisture and heat
- The ultimate system. REACTIVE DISCHARGE CONTACTLESS OR CONTACT TRIGGERED. AUXILIARY BACK UP CIRCUIT. CLIP TO COIL FITTING. FOUR CONNECTIONS ONLY. ALL PARTS IN ONE BOX TO FIT OVER 500 APPLICATIONS



TX APPLICATIONS

\$115

CONTACTLESS - Using Magnetic 'Hall Effect' triggerhead to replace the points

- Replaces contact breaker set completely
- Maintenance free - no wearing parts
- As easy to fit as changing your contact breaker set
- All parts in one box - no separate fitting kit required

TX-1002. Slightly lower powered version of the TX-2002. Ideal for most 4 cylinder cars. All fitting pieces included!
 Cat. KJ-6651

Sparkrite TX1002

- An Inductive Discharge System
- Can be operated utilizing 'Hall Effect' triggerhead or existing contact breaker
- Extended dwell inductive Discharge for maximum spark efficiency
- Three position switch
- Static Timing Light
- Systems Function Light
- Patented clip to coil fitting
- Robust die cast case
- Fully waterproof
- Protected from the hostile environment of the engine compartment



THE BRAND LEADER

\$79

How it works.

An advanced feature of the Sparkrite AT 80 is the unique arming facility. You do not have to drill the exterior body panels to fit the usual 'limited key number' switch. The AT 80 is armed with a special magnetic key fob which enables you to programme your personal security code through the windscreen to a special sensor pad attached to the inside of the screen. Your security code can be changed at any time by simply flicking a switch on the control module and re-programming your new code. A code acceptance light flashes in the windscreen sensor pad as the code is entered.

Sparkrite AT-80

MAGIDICE



The best electronic dice ever made! Firstly, this is not a kit. It is completely built and tested. Basically the MAGIDICE is a glistening black cube measuring 75mm on all sides. It has 6 LED's set into the top of the cube under a red filter (the filter LOOKS black as well). When the switch in the base is turned on, a wave of the hand over the top of the cube causes the circuit to operate. The cube beeps and gives you a guaranteed random dice "throw" in the form of illuminated LED's. There are no buttons to press and you don't even have to touch the cube! The last number will remain until you note or wave your hand over the unit to "throw" another number. This (patented) product makes an absolutely unique gift and comes attractively presented.
 Cat. XC-2006

Please note that a 9V battery snap (supplied) must be fitted to use on local 9V standard cell.

BRILLIANT FUN

GREAT GIFT \$19.95

AT LONG LAST!

Blank rack standard 19" wide front panels. Yes, after many requests we now stock quality front panels for the three popular rack sizes.

Each panel is punched out of 2.5mm thick material, finished, black anodized and punched with oval mounting holes on standard I.E.C. centres.

- Cat. HB-5430 - 1 1/2" (45mm) **\$8.95**
- Cat. HB-5432 - 3 1/2" (88mm) **\$11.95**
- Cat. HB-5434 - 5 1/4" (132mm) **\$14.95**

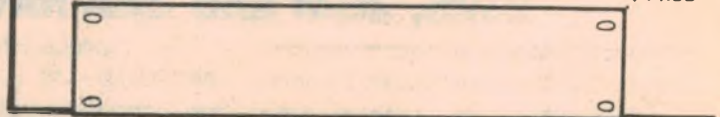

Sparkrite

The Brandleaders in Auto Electronics

the ultimate in
 electronic
 ignition

UCTS - LOW PRICES COMPUTER SENSATION!!

You may have wondered why Jaycar did not (until now) sell home computers. We had many reasons but our main one was that we were not entirely "happy" with any of the units currently on the market. The closest we came to what we thought was a pretty good computer was the Apple. We thought that it was, quite frankly expensive. However it was sold and serviced throughout Australia by a reputable sales network - so there was no need for Jaycar!

That's why we got so excited when we saw the "Micro Professor MkII". It is the closest thing that we have seen to be software compatible with the Apple. Yes, we know what you're thinking. It's NOT one of those cheap Taiwanese "Apple" copies which infringe Apples' copyright. The Micro Professor MkII is a completely new and unique design in its own right. It just so happens that most of the widely distributed Apple software will run on this machine. O.K. But why so excited? LOOK AT THE PRICE! Check out the STANDARD FEATURES of this unit. Sit down. Think about it and COMPARE what you get with the Micro Professor MkII as STANDARD that are options on other machines!!



Cat. YC1300

Only \$598

- 64K OF RAM SUPPLIED STANDARD all that you are ever likely to need.
- Text, Lo and Hi resolution graphics STANDARD
- Video AND TV (RF) output STANDARD
- Easy-to-use manual included in the price (over 248 pages)
- Power supply included as STANDARD
- Centronics printer interface STANDARD
- Multitech BASIC is compatible with APPLE II BASIC. Most APPLE software will run on the Micro Professor MkII

SPECIFICATIONS

CPU	R6502
ROM	16K Bytes
RAM	64K Bytes
BASIC	More than 90 instructions stronger than those for Apple II
Interpreter	Memory mapped into system RAM
Video Display	Type Mode
	Text, low-resolution graphics, high resolution graphics (3 modes are mixed)
	Screen Format
	Character Set
	Character Type
	Graphics Capacity
	1920 blocks (low resolution) in 40 x 48 array, 53760 dots (high resolution) in 280 x 192 array
Keyboard	Number of Colors
Cassette	49 alphanumeric and function keys
Software	Interface
Printer	Cartridge Interface
Display	Interface
Remote	Interface
Speaker	Control Paddle
Power	Used for education & entertainment
	8 ohm, 55mm, 0.25W
	A switching power supply is provided to convert AC power to required power supply
Dimensions	241 x 175 x 30mm

COOLING FANS 240VAC

Quality Ball Race construction, now you pay no more for quieter, much longer lasting and more efficient ball-bearing fans from Jaycar!

TWO POPULAR SIZES:

12 WATTS - 80x80x42(d)

\$24.95 Cat. YX2510

13.5 WATTS - 119x119x25(d)

\$27.50 Cat. YX2514



MAGAZINE BINDER

Keep your precious (and expensive) magazines in order for easy reference. Smart blue colour with gold lettering. Heavy gauge and richly chromed metal fittings. LOW IMPORT PRICE ONLY \$4.95

4 up \$4.50 each



Cat. BB7000



Jaycar NUMBER 1 FOR KITS

125 YORK STREET SYDNEY 2000
PHONE 264 6688 TELEX 72293
"NEVILLES CORNER"
Cnr. CARLINGFORD & PENNANT HILLS ROAD,
CARLINGFORD
PHONE 872 4444
MAIL ORDERS TO: BOX K 39 HAYMARKET, SYDNEY 2000

POST AND PACKING CHARGES
\$5 - \$8.99 (31.50) \$10 - \$14.99 (43.20)
\$25 - \$49.99 (54.50) \$50 - \$99.99 (65.50)
\$100 and over (76.50)

ALL IN SALES PRICES
\$4 - \$9.99 (5.20)
\$10 - \$14.99 (12.00)
\$15 - \$19.99 (18.00)
\$20 - \$24.99 (24.00)
\$25 - \$29.99 (30.00)
\$30 - \$34.99 (36.00)
\$35 - \$39.99 (42.00)
\$40 - \$44.99 (48.00)
\$45 - \$49.99 (54.00)
\$50 - \$54.99 (60.00)
\$55 - \$59.99 (66.00)
\$60 - \$64.99 (72.00)
\$65 - \$69.99 (78.00)
\$70 - \$74.99 (84.00)
\$75 - \$79.99 (90.00)
\$80 - \$84.99 (96.00)
\$85 - \$89.99 (102.00)
\$90 - \$94.99 (108.00)
\$95 - \$99.99 (114.00)

Mail Order By **BANKCARD**
Via Your Phone



Control your lights with the

Touch-lamp Dimmer

This completely new dimmer circuit uses a Siemens integrated circuit and a Triac to turn lamps on and off with just a light touch on a wall panel. Alternatively, you can dim or brighten the lamps to any desired level by merely touching the panel for two or three seconds — very classy! The circuit also has very effective EMI suppression and has optional remote sensing for two-way or multi-way lamp switching.

Our last wall-mounted light dimmer was published in April 1973 (File 2/PC/18) but for the last six or seven years it has been cheaper to buy rather than build a light dimmer. To date, all commercially available domestic dimmers have been very similar in design to the above EA dimmer and have incorporated a separate switch and a knob for the dimming function. As such, they dim lamps effectively but most produce significant interference to AM radio.

Recently, at least one manufacturer has produced a touch-operated dimmer which is an attractive innovation. Just a light touch on the metal wall-plate switches the lamp(s) on or off and leaving your hand on the wall-plate for a couple of seconds lets you dim (or brighten) the lamp(s) to any desired level from full brightness to completely off. This occurs very smoothly.

The EA Touch-lamp Dimmer is functionally equivalent to this commercial touch dimmer but can be built for about half the cost and uses an improved design which we will detail later. From now on then, knobs are out and touching is in!

This new Touch-lamp Dimmer incorporates a facility which is not available or possible with any knob-operated dimmer. While all dimmers can be used in conjunction with two-way or multi-way switches, dimming of the lamps could only be done at the dimmer itself. This stands to reason. However, this new dimmer has optional remote sensing whereby additional wall plates can be used for multi-way switching or dimming.

In a large room or hallway it is possible

to have two, three or more touchplates, any of which can switch the lamps on or off or dim them. In addition, this can be done with less wiring than is needed for a conventional multiway switch installation and the additional touch plates will probably cost less than the relatively expensive "intermediate" switches usually required.

The Touch-lamp Dimmer circuit is mounted on a small printed circuit board behind a blank face plate from the HPM Decorator range. This has the standard mounting holes of normal switch plates. On the front face is clipped a blank metallic plate which may be satin silver or gold finished aluminium or stainless steel, or brass. This gives a very good finish to the Dimmer.

Phase-controlled Triac

As with all other dimmer circuits, the Touch-lamp Dimmer employs a Triac.

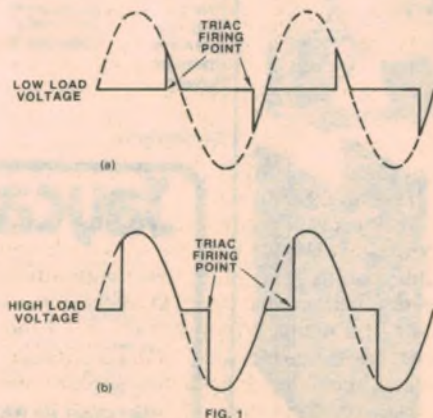

These diagrams show how a Triac is used for phase control.



by JOHN CLARKE

This is controlled by a new Siemens light dimmer IC, the S576A.

The Triac is an AC power control device originally developed by General Electric about 18 years ago. It is a bidirectional thyristor (SCR) device which can be triggered into conduction for both voltage polarities by a signal applied to its gate.

After being triggered into conduction, the Triac remains in conduction until the supply voltage decreases to zero or reverses in polarity, when it turns off. Used with AC, a Triac can be triggered into conduction at any point on either half of the mains cycle by a low voltage signal of either polarity applied between the gate and terminal one of the Triac.

Since the Triac is only a switching device which is either fully conducting or open circuit, the only means of power control is to apply variable periods of mains voltage in each half wave mains cycle. This is called phase control. The later in the half-cycle the Triac fires, the less the average voltage applied to the lamp and the dimmer the lamp. This can be seen in Fig. 1a. If the mains is switched early in the mains cycle, then the proportion of voltage applied to the lamp is high and the lamp will appear fully on. This can be seen in Fig. 1b.

To trigger the Triac at the requisite period in the mains cycle some form of phase detection of the mains voltage is necessary as well as a trigger signal to fire the Triac. This is where the light dimmer IC, the Siemens S576, comes into the picture.

Upon receiving a sensor or extension input signal via the touchplate on the

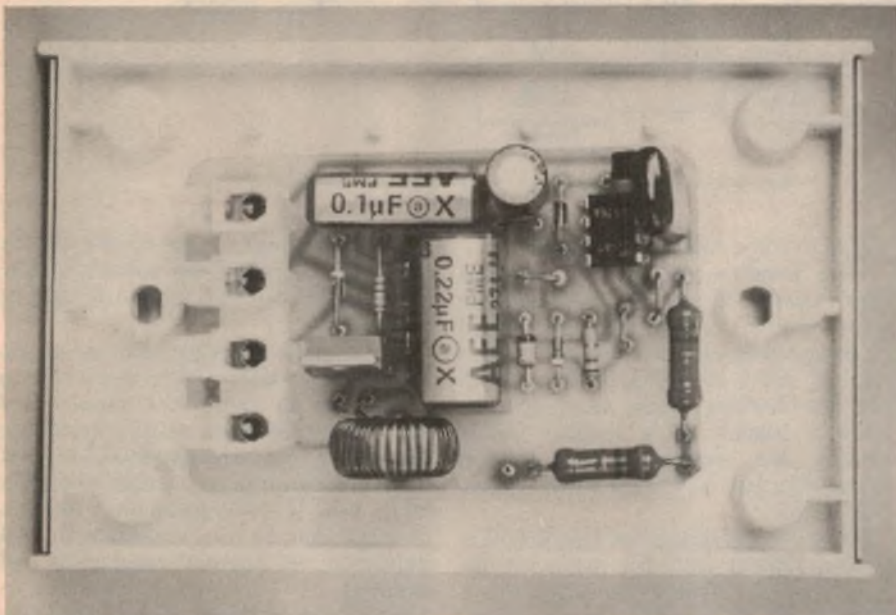
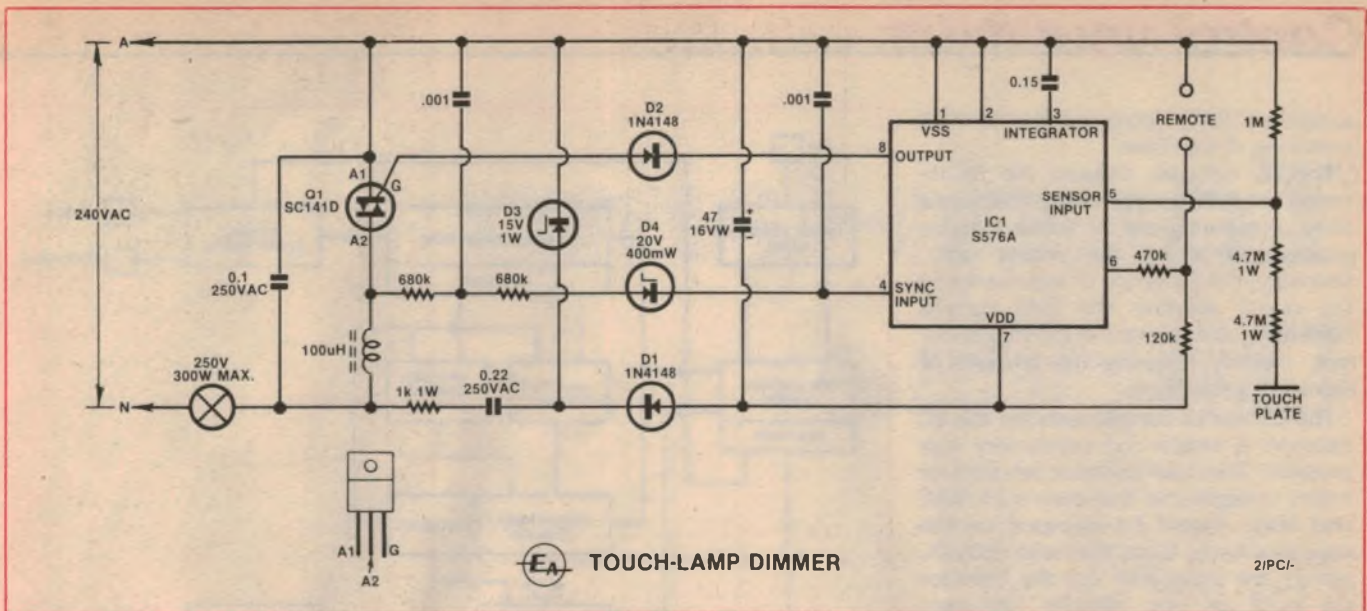

This photograph shows the dimmer circuit mounted on the back of the face plate.

Touch-lamp Dimmer or slave remote switch, analysis of the signal is made. Signals shorter than 50ms are regarded as a disturbance and are ignored by the circuit; signals of between 50 and 400ms duration are considered as on/off control; and signals which last longer than 400ms are considered as up/down dimming control.

S576 dimmer IC

Fig. 2 shows a simplified block diagram of the S576A light dimmer/switch IC. This comprises the functional logic to decode whether an on/off or dimming function is required and to provide a constant brightness previously set by dimming. Three external connections to the IC are shown. These are the frequency reference, F_{ref} ; sensor and extension inputs; and the Triac output driver.

The brightness counter is an up/down digital counter which provides information about the required phase angle for the Triac gate pulse. The on/off control sets the phase angle for maximum brightness when "on" is selected and the minimum phase angle for "off". The up/down dimming control starts the brightness counter cycling through its dimming cycle of dark-to-bright-to-dark phase angle counting.

The cycle counter covers the same counting range as the brightness counter and counts over the full range once every half mains cycle in synchronism with the mains. When the count of the brightness counter and cycle counter are equal, the Triac driver sends a 40µs gate pulse to the Triac. If the brightness counter value equals the cycle counter late in the mains cycle then the Triac also

fires late in the mains cycle and a dim lamp results. Conversely, if the brightness counter equals the cycle counter early in the mains cycle a bright lamp results.

The firing angle limiter blocks the comparator if the cycle counter is outside the phase angle control range; nominally set at 35 degrees (minimum brightness) and 152 degrees (maximum brightness).

Synchronisation with the mains frequency is derived from the F_{ref} input. A phase locked loop (PLL) is used to multiply the mains frequency to 102.4kHz and operates as follows: A voltage controlled oscillator (VCO) generates a 102.4kHz signal that is divided by 2048 to the mains frequency of 50Hz with the frequency divider. The divider frequency is compared with the incoming mains frequency and an error voltage is generated by the PLL. This is filtered and controls the frequency of the VCO such that the divided output of the VCO is kept in phase with the mains frequency.

The frequency divider is tapped at several division ratios and these clock signals are used for timing the remainder of the circuit.

Touch-lamp Dimmer circuit

The circuit for the Touch-lamp Dimmer is relatively simple and consists of the 576 IC, a Triac, several diodes, capacitors and resistors and a choke. The remote switch circuit consists of two low cost transistors, a capacitor, several resistors and three diodes. We shall discuss the Touch-lamp Dimmer circuit first.

The Triac, serving the purpose of the mains switch, is connected between the mains active and the lamp via the 100µH choke. This choke, in conjunction with the 0.1µF capacitor, is used to suppress the considerable electromagnetic in-

Touch-lamp dimmer

terference (EMI) produced by the fast switching of the Triac.

The LC network reduces the RF interference in two ways. Firstly, it acts as a filter, attenuating any RF which may be propagated along the mains lead. Secondly, the presence of inductance in the circuit prevents the load current from rising at a fast rate at the trigger instant, thereby reducing the amount of harmonic generation.

The choice of components for the LC network is critical for satisfactory suppression. The capacitor must be rated for mains voltages and that means 250VAC and 50Hz should be stamped on the capacitor body. Capacitors with 600VDC ratings are unsuitable. For the inductor we used an iron powder ring core manufactured by Neosid, type 17-132-10, which is specifically intended for EMI suppression.

We are particularly pleased with the effectiveness of the resulting EMI suppression in this new dimmer circuit. While many commercial dimmers do contain components for EMI suppression they are largely ineffective. The effectiveness of the EMI suppression is largely due to the Neosid iron powder toroid. This has a number of advantages compared with coils wound on ferrite rods that we have specified for previous Triac circuits.

First, because the coil is wound on a toroid instead of a rod, there is negligible radiation of flux and hence there is no strong field of interference in the immediate vicinity of the dimmer. Second, because there are relatively few turns and they can be tightly wound, the coil winding does not buzz audibly which can be obtrusive if you are close to the dimmer.

Third, because the iron powder is a lossy material which does not have the high Q of the ferrite rod material, there is less likelihood of ringing occurring in the circuit which can make the interference

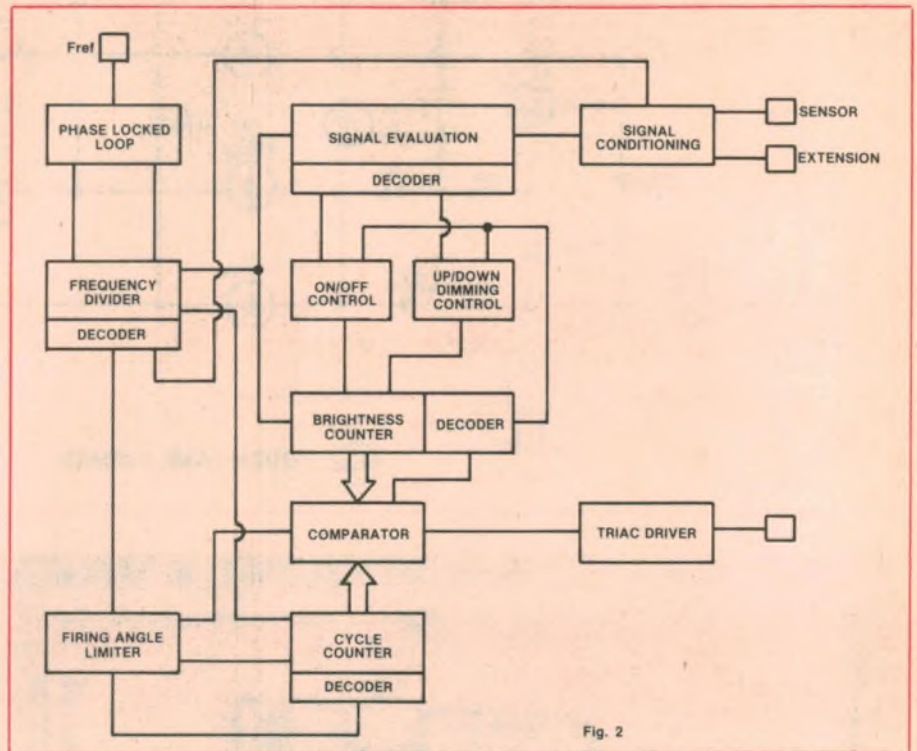

Fig. 2

worse in some frequency bands.

Note: Readers wishing to adapt this filter network to suppress interference from commercial light dimmers should be aware that our circuit is rated for a total of 300W incandescent lamp load. Circuits handling bigger loads will require a suitably large toroid. Neosid toroids are available from Watkin Wynne Pty Ltd, 32 Falcon Street, Crows Nest, 2065.

A low voltage supply for the S576 IC is derived directly from the mains via the 0.22 μ F current limiting capacitor and a 1k Ω resistor. By using the capacitor reactance to limit the current rather than a large value resistor, heat dissipation is minimal. Diodes D1 and D3 operate in conjunction with the 0.22 μ F capacitor as

a "charge pump" for the 47 μ F capacitor while D3 performs the additional function of limiting the supply voltage to about 15V.

The 0.22 μ F capacitor acts as an impedance of 15k Ω at 50Hz and limits the current to an average of about 16mA when the full mains voltage is impressed across the Triac; ie, when the Triac is off. The minimum phase angle when the Triac fires is 35 degrees and the low average current thus developed is still sufficient for zener regulation and filtering.

Incidentally, while current is drawn by the circuit at all times, even when lamps are off, the actual power consumption (with lamps off) is of the order of 0.25W which is too small to be registered by the

Below are actual-size artworks for the two printed circuit boards.

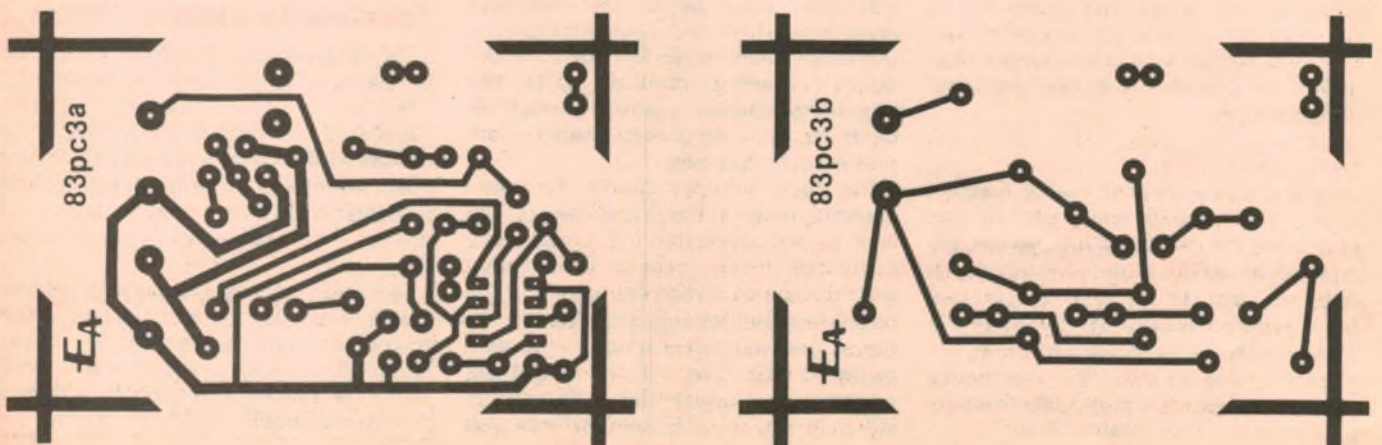

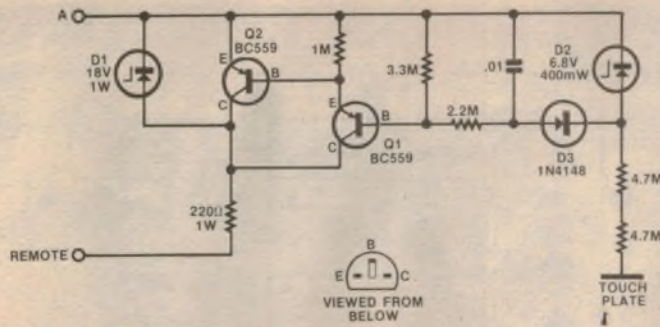

TOUCH-LAMP DIMMER REMOTE CONTROL
2/PCI-

This optional circuit can be used for multi-way switching.

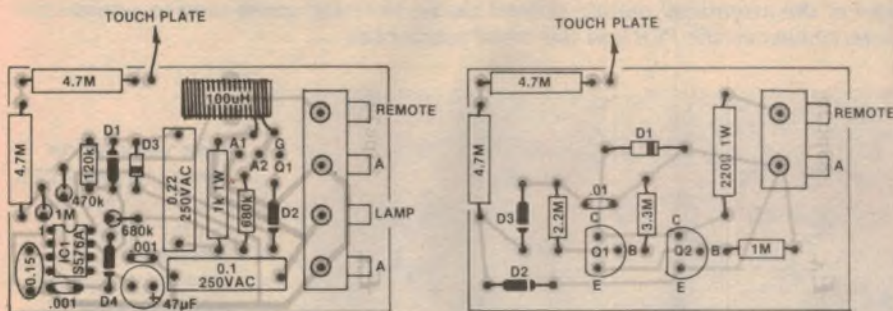

Parts layout for the main circuit (left) and the remote switching circuit (right).

domestic watt-hour meter.

Negative gate triggering for the Triac is provided from pin 8 of IC1. Diode D2 reduces positive voltages which can be produced at the gate of the Triac during the triggered state by about 0.6V to prevent damage to the IC.

The phase locked loop input to IC1 (pin 4, the sync input) is derived from the Triac A2 terminal via two 680kΩ resistors and a series 20V zener diode, in conjunction with two .001μF capacitors. This relatively complex two stage filter was found necessary to make the circuit proof against the effects of mains control tones. Without the filter circuit, mains tones would cause the lamps to flicker badly.

Two 4.7MΩ resistors are used in series from the sensor input of the IC to the touch plate. These must be each rated at 500V to provide sufficient electrical isolation between the user at the touch plate and the mains active. We used Philips CR52 resistors which are 18mm long and 5.2mm in diameter, and which have a 0.67W rating. Better still, use two Philips VR37 resistors, which are smaller and have considerably better voltage ratings. The VR37 resistors have a light-blue body 10mm long and the 5% tolerance band is depicted in yellow paint rather than gold, because metal particles degrade the high voltage properties.

Touch plate operation relies on the resistance of the body to ground. Normally the sensor input, pin 5, is held at active potential (240VAC) until the touch plate is touched. This brings the sensor input to a sufficient level below active to trigger the IC.

Remote switch circuit

The remote switch circuit is designed to connect to the Remote terminal of the dimmer circuit. If this terminal is brought to active potential, the extension input, pin 6 of IC1, will provide control to the circuit in a similar manner to control with the pin 5 input. It is necessary to implement remote operation using extra circuitry since if pin 5 were just extended, the extra line capacitance would false-trigger the IC.

When the sensor input is touched, the resulting earth-going voltage at this input is sufficient to charge the .01μF capacitor until the voltage reaches the 6.8V zener voltage minus the drop across the 1N4148 diode. The first transistor (Q1) is switched on due to the base current through the 2.2MΩ resistor connected to the capacitor. This transistor in turn switches on transistor (Q2), which ties the remote input high.

When contact to the sensor input is released, the .01μF capacitor discharges via the 2.2MΩ and 3.3MΩ resistors. This removes the base current to transistor

Parts List

- 1 PCB, 83pc3a, 47 x 72mm
- 1 HPM Decorator blank grid, DR770/GF blank
- 1 HPM Decorator blank metallic finish cover plate (DR blank)
- 1 4-way insulated mains terminal block
- 1 Neosid iron powder ring core, 17-132-10
- 1.2m of 0.5mm diameter enamelled copper wire
- 1 compression spring, 3mm dia x 5mm long, solderable wire
- 1 SC141D 6A Triac
- 1 5576A light dimmer/switch IC
- 1 20V/400mW zener diode
- 1 15V/1W zener diode
- 2 1N4148, 1N914 silicon diodes

CAPACITORS

- 1 47μF/16VW PC
- 1 0.22μF/250VAC
- 1 0.15μF metallised polyester
- 1 0.1μF/250VAC metallised dielectric
- 2 .001μF metallised polyester

RESISTORS (1/2W, 5% unless noted)

- 2 x 4.7MΩ Philips CR52 or VR37, 1 x 1MΩ, 2 x 680kΩ, 1 x 470kΩ, 1 x 120kΩ, 1 x 1kΩ.

Remote extension

- 1 PCB, code 82pc3b, 47 x 72mm
- 1 HPM Decorator blank grid, DR770/GF blank
- 1 HPM Decorator blank metallic finish cover plate (DR blank)
- 1 2-way insulated mains terminal block
- 1 compression spring, 3mm dia, 5mm long, solderable wire
- 2 BC559 PNP transistors
- 1 18V/1W zener diode
- 1 6.8V/400mW zener diode
- 1 1N4148 small signal diode
- 1 .01μF metallised polyester capacitor

RESISTORS (1/2W, 5% unless noted)

- 2 x 4.7MΩ Philips CR52 or VR37, 1 x 3.3MΩ, 1 x 2.2MΩ, 1 x 1MΩ, 1 x 220Ω 1W.

MISCELLANEOUS

- Solder, insulating tubing, epoxy resin adhesive.

We estimate that the current cost of parts for this project is approximately

\$20

for the Touch-lamp Dimmer and

\$9

for the remote extension. These figures include sales tax.

Q1 which in turn removes the base drive to Q2. The $1M\Omega$ resistor at the base of transistor Q2 ensures that the transistor will be off. The response time of the circuit is dependent upon the $.01\mu F$ capacitor and associated resistors. It takes approximately 2ms to switch on the transistors after touching the sensor input, and about 30ms to switch off after contact ceases.

The 18V zener diode and 220Ω resistor provide protection for transistor Q2 in the event that connections to the circuit are transposed, in which case the zener is forward-biased and acts as a normal diode. When connected correctly, the zener protects the transistors against excessive collector-emitter voltages.

The maximum lamp load which may be connected to the Dimmer is 300 watts although we imagine that most users will be content with far less than this. The maximum load rating is set partly by the size of toroid, as mentioned before, and by the maximum power due to conduction (IR) losses which the Triac can withstand without having an efficient heatsink fitted.

Construction

We constructed our Touch-lamp Dimmer circuit on a PCB coded 83pc3a and measuring 47×72 mm, while the remote switch is constructed on a PCB coded 83pc3b and measuring 47×72 mm. The PCB layout for the dimmer is unusual in some respects. Some of the components are very cramped and three resistors are mounted vertically. The two $4.7M\Omega$ resistors are mounted away from the copper tracks of the active mains circuitry to ensure high isolation between the touch plate and the mains.

We shall discuss construction assuming that the remote switch will be constructed as well. If only the dimmer is to be built, the comments relating to the remote switch PCB can be ignored.

Since safety of this circuit can be jeopardised by wrong components inserted in the touch plate resistive string, we expect that at least one kit supplier will provide the PCBs with the $4.7M\Omega$ resistors already soldered into the boards. This will ensure that the correct values have been used. Apart from this, assembly of the remainder of the components will require insertion into the PCBs.

Follow the PCB overlay diagrams during construction. Note that the diodes, Triac, electrolytic capacitor and the IC must be oriented correctly.

The four-way insulated terminal block is secured to the PCB using short lengths of 1mm diameter wire inserted into the copper pads allocated for the terminals. Alternatively, PC stakes can be used in

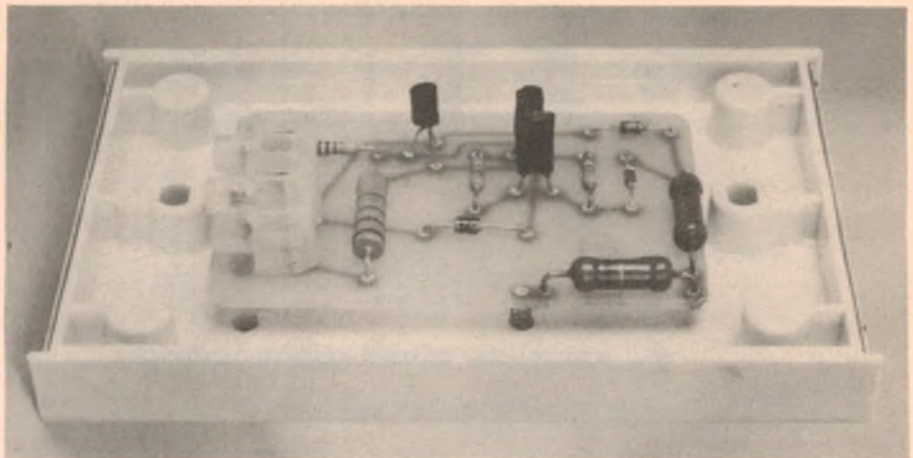

View of the assembled remote control circuit. Note the spring used to provide the contact between the PCB and the metal touch plate.

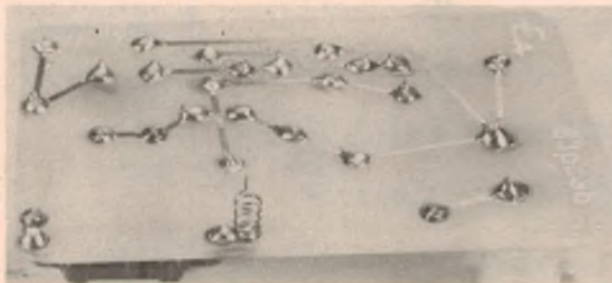

Rear view of the remote control PCB, showing how the contact spring is mounted. A similar scheme is used for the main PCB.

place of the wire.

The toroid is wound with 37 turns of 0.5mm enamelled copper wire. Wind each turn tightly so that it touches the next winding at the centre of the core. When winding is complete, twist the two ends together and, leaving about 10mm of free length, clean each end of the wire with a knife or file.

The wound toroid is secured to the



The metal touch plate simply clips into position over the grid plate.

PCB with a short piece of tinned copper wire strapping through the centre of the toroid and looped into the holes allocated in the PCB. The ends of this wire are soldered to the copper pads. Ensure that the wire is tight before soldering.

The dimmer PCB is centrally located on the rear of the grid plate and a hole drilled in the grid plate directly opposite the touch plate pick-up point on the PCB. We used a small spring made from solderable wire to provide the contact between the PCB and the touch plate. This spring is soldered at right angles to the copper side of the PCB, and protrudes through the hole drilled in the grid plate to provide a reliable contact.

Note that the HPM grid plate has eight plastic cylindrical protrusions on one side of the moulding. Four of these will have to be trimmed with side cutters to provide clearance for the PCB.

An alternative to using the spring for contact to the metallic decorator plate is to flare out the strands of multistrand hook-up wire and sandwich these between the front panel and plastic grid.

Isolation of the touch plate should now be checked. Use a multimeter set to measure the highest range. The resistance between the active terminal of the circuit and the touch plate should be about $10M\Omega$ or you should get a very small deflection on the meter if the meter does not resolve resistances this

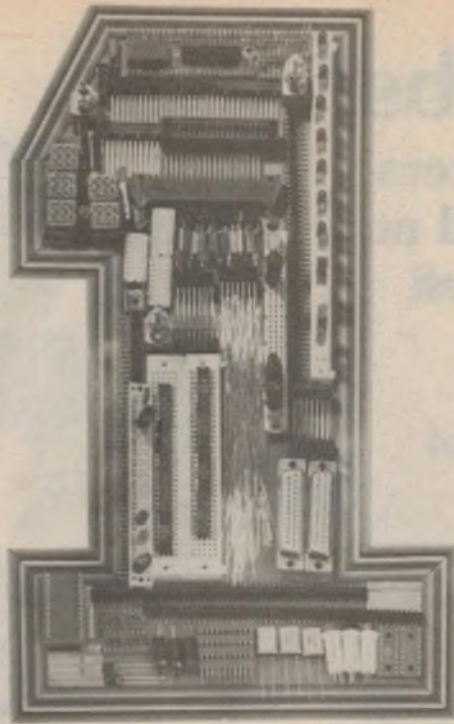

No.1 for any bits.

In the electronic component field today, being No. 1 is tough. At the new Ampec Trade Shop, we already have a No. 1 address . . . and No. 1 service and prices . . . and always the

No. 1 products. Quite simply, we want to be No. 1 with you. Here are some of our current specials available while stocks last — prices do not include sales tax.



Digital Multimeter

3½ digit LCD multimeter with 10 amp range. ME 531 — \$45.00

These prices while stocks last — sales tax not included.

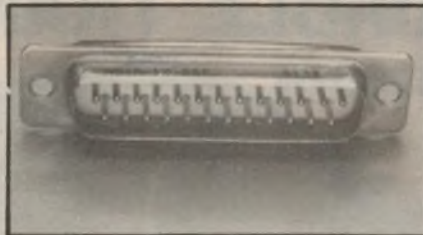

D Connectors

ADIN — 1S — 25P	\$1.91
ADIN — 1S — 25	\$2.82
ADIN — 1S — 9S	\$2.49
ADIN — 1 — 9P	\$1.89
ADIN — 15S	\$3.51
ADIN — 15P	\$2.52

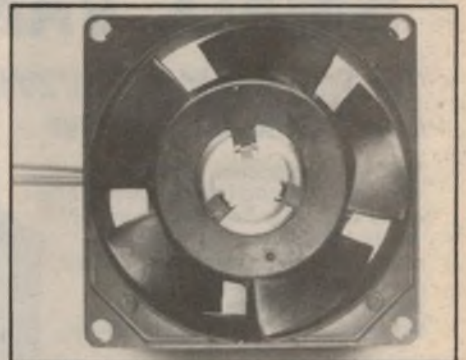

Fans

4" fan — 240V EP114-38	\$11.00
3" fan — 240V EP 75-38	\$11.00

The Ampec Trade Shop

No. 1 Wellington Street, Rozelle, NSW 2039

Phone: 818 1166

AMPEL
The absolute in peripheral thinking.



... and now we have

Collet Knobs*

and caps and pointers
and figure dials and nut
covers ... and they all
fit together to
form competitively
priced, vibration-proof
and very satisfying
knob
assemblies

Call us NOW!
to talk about your requirements ...
from single to O.E.M. custom made quantities.



C&K Electronics (Aust.) Pty Limited

15 Cowper Street Parramatta NSW 2150
PO Box 229 Parramatta NSW 2150 Telephone (02) 635 0799 Telex 23404
Agents Melb. 598 2333/Adel. 277 3288/Bris. 369 1277/Perth 275 5522/Hobart 34 2233/
Laun. 31 6533

Bringing you the excellence of International Professional components

* Manufactured by
SIFAM LTD England

AS NEAR AS YOU'LL GET TO A SMALL VARIABLE TRANSFORMER

The Ferguson PL1.5-18/20VA Multi-tap Low Profile Transformer

Ideal for development situations or
where the secondary voltage needs to be
easily adjustable. Takes you from 1.5V to
18V in 1.5V steps. Simply plug and
unplug the pinlok connectors till you
get the voltage you want. Twin
secondaries provide up to 2.2A.
Numerous centre-tap configurations.

- **SERIES CONNECTION (1.11A)**
1.5V, 3V, 4.5V, 6V, 7.5V, 9V, 10.5V, 12V,
13.5V, 15V, 16.5V, 18V
**Additional Series
Configurations (1.11A)**
9V-6V-1.5V-0-1.5V-6V-9V or
9V-7.5V-3V-0-3V-7.5V-9V
Centre Tap Configurations (1.11A)
1.5V-0-1.5V, 3V-0-3V, 4.5V-0-4.5V,
6V-0-6V, 7.5V-0-7.5V, 9V-0-9V
- **PARALLEL CONNECTION (2.22A)**
1.5V, 3V, 4.5V, 6V, 7.5V, 9V

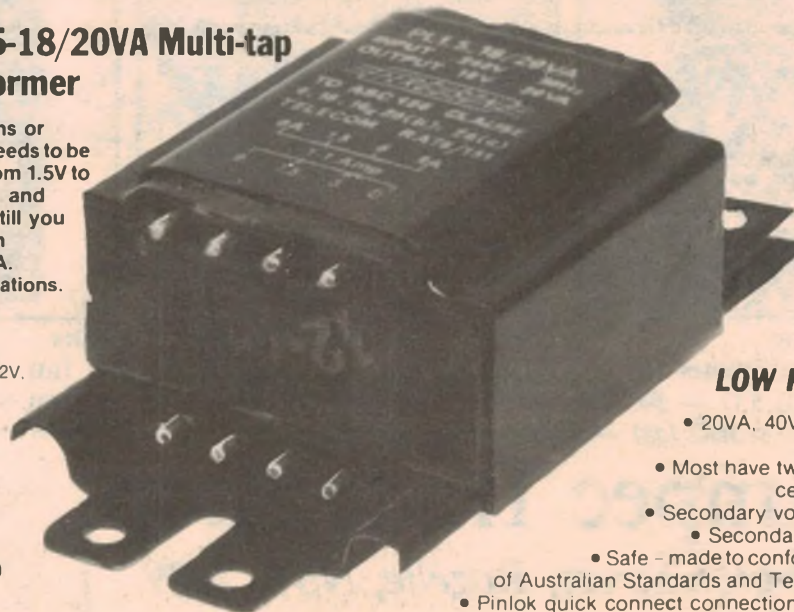

CHECK THE WHOLE FERGUSON LOW PROFILE RANGE

- 20VA, 40VA and 60VA ratings -
use two to get 120VA
- Most have twin secondaries to give
centre-taps if necessary
- Secondary voltages from 6V to 40V
• Secondary currents up to 6.6A
- Safe - made to conform to relevant clauses
of Australian Standards and Telecom Australia specs.
- Pinlok quick connect connections • Made in Australia



FERGUSON TRANSFORMERS PTY LTD

331 High Street Chatswood N.S.W. 2067. Tel: (02) 407 0261. Telex: AA25728
Branch Office: 181-183 Hawke Street, West Melbourne Vic. 3003
Tel: (03) 328 2843 Telex: AA33510

high. This test will ensure that there is no fault at the touch plate likely to cause electrocution.

If the circuit fails this test, check firstly that the correct value resistors are used and secondly that there are no solder bridges from the resistors to any other tracks on the PCB.

Finally, the PCB be affixed with epoxy resin to the rear of the grid plate.

Installation

Installation involves removing the old switch plate and replacing it with the new Touch-lamp Dimmer. The size of the dimmer PCB and associated components are designed to fit within the cutout of a standard wall box. Wiring involves only inserting the two switch wires into the terminal block of the dimmer PCB. If the slave remote control unit is to be used, two extra wires are needed to connect between the main dimmer unit and the remote slave unit. These wires will already be in place if the dimmer is replacing a normal two-way switch.

Before installing the dimmer, it is important to disconnect the mains power. This should be done by switching off the power at the switchboard and removing the relevant fuse. Keep the fuse with you to prevent someone else reinserting it unexpectedly. If circuit breakers are installed in the switchboard, then these should be switched off.

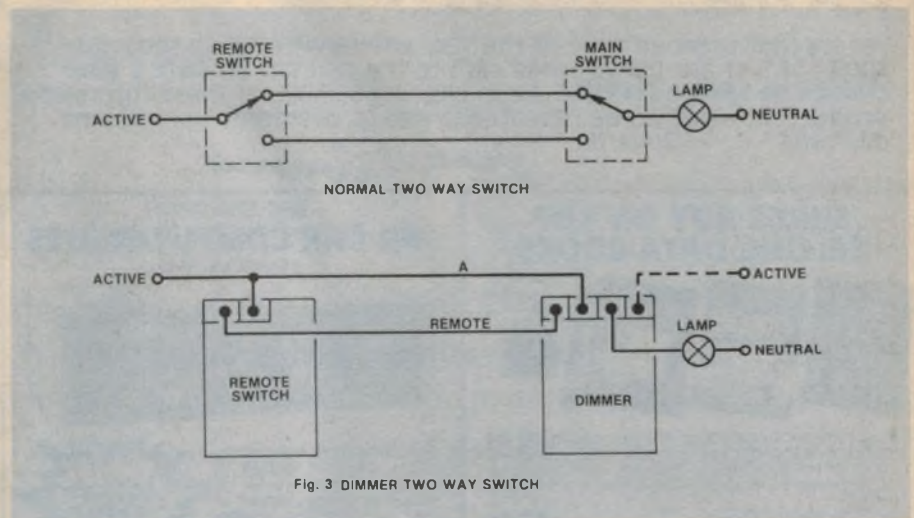

Note that when connecting the dimmer to the wiring, the active lead should be inserted into the outside terminal of the terminal block. In some cases it may be unclear which lead is the active and which lead is from the light socket. Try one combination first and screw the dimmer to the wall. Turn on the power and test the dimmer. If it does not function, disconnect the power and reverse the leads.

Fig. 3 shows the wiring normally used for two-way switches and the equivalent wiring for the Touch-lamp Dimmer and remote switch. Note that the outside active terminal on the Touch-lamp Dimmer is now spare and may be used for bridg-

ing or connections to additional remote switches. Note also that you can have as many remote switches as you like – all you have to do is wire them in parallel, but be careful not to transpose the active and remove connections.

After some period of usage, the light dimmer may collect dust and an oily film on the polycarbonate plate. This can decrease the resistance between the touch plate and earth and cause false triggering of the dimmer. Generally a wipe over of the front surfaces with a clean cloth will remedy this. In stubborn cases it may be necessary to clean the entire plastic grid and between the metal touch plate and grid plate.

Software for the Super-80

Note: this book is exclusive to, and available only from, Electronics Australia, 57 Regent Street, Chippendale, NSW, 2008. PRICE \$4.00 or by mail order from Electronics Australia, PO Box 163 Chippendale, NSW, 2008. PRICE \$5.00.

**Software
for the
Super-80
Computer**

\$5.00*

An "Electronics Australia" publication

To Electronics Australia, PO Box 163, Chippendale 2008

Please send me copies of "Software for the Super-80 Computer" at \$5.00 each (includes post and packing)

NAME

ADDRESS

POSTCODE

I enclose cheque/postal order to the value of \$

Please charge by Bankcard \$

Bankcard Number 496

Expiry Date Cardholder Signature

If you are using Bankcard, be sure to include your full address (not a PO Box)

TAX TIME SELLOUT

Yes it's that dreaded time of the year where we have to shell out 1000's of \$ of our hard earned cash to the taxman! **So here's your chance to save a fortune** we're clearing \$50,000 of these top selling products at never to be repeated prices to overcome our present dilemma — Regards,

Jack O'Donnell



SUPER BUY ON TOP SELLING DATA BOOKS



Motorola microprocessors are fast becoming the industry standard. Every enthusiast should be aware of the basic design features and capabilities of the powerful Motorola range. Now at affordable prices

MEMORY DATA B 1113.....	\$6.00
LINEAR DATA B 1114.....	\$6.50
INTERFACE DATA B 1115.....	\$9.00
OPTO DATA B 1118.....	\$6.00
MICROPROCESSOR DATA B 1120.....	\$12.00
MECL DATA B 1100.....	\$6.50
POWER DATA B 1101.....	\$10.00
MASTER SELECTION GUIDE B 1104.....	\$3.50
CMOS DATA B 1105.....	\$7.50
SCHOTTKY TTL DATA B 1109.....	\$6.50

BARGAIN OF '83 EA CAR COMPUTER KITS

EA AUGUST 1982

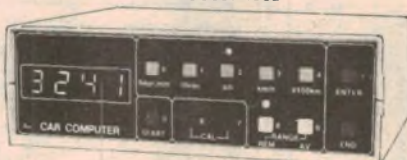

Car computers are becoming a standard feature in many modern cars. EA KIT Features digital readout of fuel consumption, speed, fuel level, range before fuel runs out, ETA of destination and many more.

\$129.00
SAVE \$50.00

COMPLETE KIT INCLUDES: Plated through PCB, programmed EPROM, genuine Moray fuel flow sensor, tallshaft speed sensor, quality Pactec case, genuine Motorola CPU.

ORDER AS K 9999.....**\$129**

LIMITED QUANTITY — SO BE QUICK
Bankcard holders phone now to reserve yours.

VINYL BINDER

Holds 12 magazines, each on a spring out wire rod. Just the shot for each year's set of Electronics Australia, ETI or any of your favourite magazine.

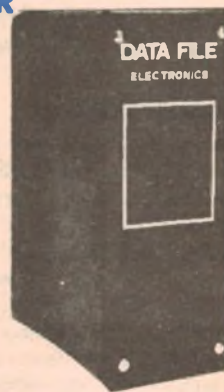

Suits all A4 size publications (275 x 210). Very smart Royal Blue colour with beautiful gold embossing.

B 9999...**\$5.00**

TECHNICIAN'S UTILITY PARTS CASE



H 0449
Now
\$5 ea

Lightweight and durable this Parts Case is a **MUST!**

Featuring:— Clear lid (tell contents at a glance); Positive action snap lock; 30 partition combinations.

EVERY HOBBYIST SHOULD HAVE A COUPLE!

CREDIT CARD CALCULATOR

Extra thin, quality altronics import. Ideal for student, business man and overseas traveller for those currency conversions etc — and at our price who needs "Duty Free?" Slips neatly into the wallet.

Exclusive:

- Metric / Imperial Conversion Table.
- Nifty wallet included

Now only.....
\$12.50

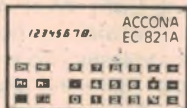

NICAD RECHARGEABLE

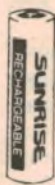

AA PENLIGHT 1.2V 500MAH

Manufactured by the makers of famous "National" brand Electronic products. Charge at 45-50 MA (14-16 hours). Will outlast well over 1000 recharge cycles with average use.

S 5020.....Now **\$1.70 ea**

MIC INSERT ELECTRET

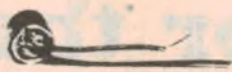

Great little replacement for tape recorders, etc. Handy for hobby projects. Includes data sheet and application circuit.

50 Hz - 15 KHz

C 0170.....Now **\$1.50 ea**

MINI SPEAKER 57mm



Large Ferrite Magnet. Ideal replacement speaker. Great for hobby projects.

C 0610... ~~\$1.95~~
Now **\$1.00 ea**

CEILING SPEAKER GRILL



Suits 200 mm (8 in.) speaker. Ideal for PA/Background music systems, extension speakers etc. Colour: White.

C 0800..... ~~\$2.75~~
Now Incredible **\$1.50 ea**

VELOSTAT

Non-static sheeting for storing CMOS IC's, LSI's etc. 1000 times better than aluminium foil. Will store up to 150 IC's on one 225 x 150mm sheet.

H 0500.....**\$2.50 per sheet**

DIL SWITCHES GOLD PLATE SELF WIPING CONTACTS



EA
S 3050 4 Way **\$1.25**
S 3060 8 Way **\$1.75**

STICK ON RUBBER FEET



H 0940 12mm Stickon 4.....	.75
H 0942 12mm Stickon 100.....	\$8.50
H 0950 20mm Stickon 4.....	.80
H 0952 20mm Stickon 100....	\$10.00

HEATSINK COMPOUND

Heat conducting paste facilitates heat transfer from semi to Heatsink. One tube good for up to 30 TO3 package semiconductors.

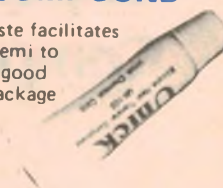

H 1600...7.5g Pack.....	\$1.20
New trade pack	
H 1610...150g Pack.....	\$7.50
SAVE UP TO 33%	

PRICE SLAUGHTER ON GENUINE HITACHI MOSFETS (PRIME SPEC.)

Z 1510 2SK 134

Z 1512 2SJ 49

\$5.90 each — \$5.50 10 up



ALTRONICS ... ALTRONICS ... ALTRONICS ... ALTRONICS ...

ALTRONICS ... ALTRONICS ... ALTRONICS ... ALTRONICS ...

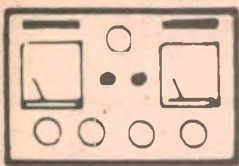

The Serviceman

How to acquire a CRO — and still need one!

"What happens to the breakdown man, when the breakdown van breaks down?" This somewhat cynical question, from an old music hall song, is a good reminder that the highly complex service devices, which we use to repair our highly complex appliances, are themselves not immune to breakdown.

The story concerns a CRO; a device which has always been regarded as more or less the top of the line, in both complexity and usefulness, as far as the average serviceman is concerned. I remember the first time I saw the circuit of a CRO, in the days when we managed with a multimeter and, if we were lucky, a valve tester.

I was most impressed by its seeming complexity even though, I now realise, it was a most elementary approach to this type of equipment. Today's CROs, like most other devices, are incredibly complex by comparison, but they are also equally impressive in performance. The simple circuit I mentioned would have been doing well to cover the audio spectrum, whereas these days we expect any CRO worthy of the name to cover at least the video spectrum, with a lot of other facilities thrown in.

SECOND CRO

Which brings me to the CRO in question. The story actually concerns an out-of-town colleague who was in the market for a particular type of CRO. He already possessed a CRO which he used on his workbench, but wanted something smaller, simpler, and cheaper which he could carry in the service van. Experience had convinced him that there were many occasions when access to even a simple CRO could mean the difference between finishing the job in the home or bringing it back to the shop.

The trouble was, he couldn't find what he wanted. His idea was a 75mm screen, single trace, compact unit which, above all, wouldn't break the bank. For its intended role he calculated that an investment of up to around \$300 was about all that could be justified.

By comparison, all the catalogues seemed to start with 100mm screens, with dual trace facilities and a whole host of other luxury features, were portable only in the two-hands sense, and cost at least twice what he had in mind. So, he just kept on looking.

Then he happened to mention his quest to a colleague who lives and works a lot closer to our seething metropolis, hoping that he might be better acquainted with the market. His friend couldn't help him directly, but suggested he contact an acquaintance who ran a certain warehouse, which dealt in test equipment generally, among other things.

And so my colleague rang the dealer and nominated the kind of CRO he wanted — and the price structure he had in mind. The dealer shook his head — or made equivalent noises over the phone; he couldn't think of any such simple design and certainly nothing in the price range nominated.

In fact, after some general discussion



"I was going to give it a thump, but then I thought — better leave it to an expert with the technical know-how!"

and polite exchanges my colleague was about to terminate the conversation, when the dealer suddenly recalled something which might interest him. It was a new unit which had proved to be defective on delivery from the importers, but which had been bought at a price which did not include any guarantee period. If he sent it back to the importers for repair he would have to stand the cost of such repairs.

TOO HARD

He had hesitated to become involved in the extra expense at the time and the instrument had been put on the "too hard" shelf, where it had resided for a long time; so long, in fact, that the dealer had only been reminded of it during a recent stocktaking. While he had forgotten its exact specifications, he did concede that it was a little more elaborate than my colleague had in mind. On the other hand it was reasonably compact and, more importantly, he would be prepared to make an "all-faults" deal, around my colleague's nominated figure, just to get it off his books.

And so a tentative agreement was reached and, because my colleague could not conveniently come to the city for several weeks, it was arranged that his colleague would visit the warehouse, inspect the instrument, and report his findings.

This he duly did and he and the dealer unpacked the instrument and studied its features and specifications. It turned out to be a 100mm screen, with dual trace, 15MHz bandwidth, 10mV sensitivity, and a good range of timebase settings. Assuming that it could be made to work it would be a very attractive instrument.

Next they plugged it in to see what, if anything, it would do, the dealer having long since forgotten why it had been put aside. In fact, it did nothing; no sign of a trace or any screen illumination of any kind. Until it was switched off, that is — then there was a brief glimpse of a horizontal trace as it flashed from top to

bottom of the screen. And switching on again quickly, while the tube was still hot, produced the same effect in reverse, from the bottom to the top of the screen.

And that was the report that went back to my colleague. Both he and his friend agreed that it looked like a tempting deal. Not only were the specifications attractive, but the brief glimpse of the horizontal trace was most significant. It meant that the tube was OK, and that the EHT circuit, the horizontal timebase, and the horizontal amplifiers were all functioning. In short, it looked like a vertical amplifier fault.

And so my colleague asked his friend to clinch the deal. He would post the dealer a cheque and his friend would take delivery and hold the instrument until he visited the city in a few weeks' time to pick it up. All went as planned, and my colleague eventually unpacked the CRO on his own bench.

Convinced that it was a vertical amplifier fault, this was the first part of the circuit he went for in the service manual; a very good service manual, incidentally, which was also a factor which helped him make the original decision. As is common practice, the deflection plates are driven by a pair of heavy duty transistors in push-pull, these being driven, in turn, by another push-pull pair.

The output transistors were a pair of 2SC1012As, fed from a 210V rail via collector load resistors of 6.8k Ω , 7W rating. My colleague fully expected to find that these two stages were not properly balanced, due to either a fault directly in their own circuitry, or in the preceding driver stages.

His first step was to make a voltage check around these two stages. The collector volts were not shown in the circuit but, working on the rail voltage, and a bit of guesstimation, he expected to find about 150 to 160V at these points. In fact, the first collector he measured was at 170V, which seemed reasonable, but the other one was at only 12V. Little wonder that the trace was off the screen.

The next question was, was it due to a fault in the transistor, or in the previous stage to which it was directly coupled? Thinking about it, and particularly the drastic nature of the fault, my colleague considered it most likely to be in the stage concerned; probably a collector/emitter short in the transistor.

His first inclination was to pull out the suspect transistor and replace it, the only snag being that he didn't have a spare of that type number on hand. And, in view of the balanced nature of the circuit, anything other than a very near equivalent, would probably still throw things out of balance. On the other hand, almost anything would have to be better than what was in there.

After some thought, and some hunting through his stocks, he came up with a BS458; a type commonly used in RGB output stages. Replacement was relatively simple and this time the CRO behaved somewhat differently. The horizontal trace swept across the screen again, but this time much slower.

Even more importantly, it was now possible to bring the trace to the edge of the screen by means of the vertical centering control. A voltage check confirmed the improvement, but also that there was still a gross imbalance. The collector voltage had now risen to about 70; a lot better than 12, but far short of what was needed.

But at least the point had been proved; a good transistor in that position was clearly all that was needed. But how easy was it going to be to get the right transistor? Or would it be necessary to find a better replacement and, logically, replace both stages?

It was while he was musing thus that it occurred to him that he hadn't even bothered to test the faulty transistor and confirm what he had assumed was a breakdown. So he put it on the tester and found, to his surprise, that it tested normally in every respect. So what was going on? Was it breaking down at high voltage, or was it intermittent?

It took only a few minutes to put it back into circuit, whereupon the CRO behaved exactly as the makers had intended it should; a perfectly stable trace which could be easily centered with the control in its mid-position. An intermittent fault? Well, it took time to clarify that, but it is now many months since these events took place, and it hasn't missed a beat.

THE REAL FAULT?

So what did cause the malfunction? We shall probably never know, but my colleague's theory is that it was a sliver of solder, probably too fine to be seen at a casual glance, which either shorted the collector and emitter directly, or so upset the circuit that the transistor drew excessive current. (It was overheating the 6.8k Ω , 7W load resistor.)

If it was, then the simple act of removing the suspect transistor, plus the two following operations, could easily have melted the solder and put everything back to normal. It's only a theory, of course, and a rather tenuous one, but stranger things have happened.

In the meantime he has acquired a beautiful instrument, at a bargain price plus a service job that took less than an hour and did not call for a single component replacement. It also contradicts the popular adage, when CROs first moved into servicing, which insisted that, "You need a CRO to fix a CRO".

MICROPROCESSORS AND PERSONAL COMPUTERS



Microprocessors and personal computers, little more than a dream a few years ago, are now changing the face of electronics. This book introduces the basic concepts, describes a selection of microprocessor and personal computer systems, and details a build-it-yourself computer designed especially for beginners.

HERE ARE THE CONTENTS:

PERSONAL COMPUTERS: TANDY ELECTRONICS TRS-80 PERSONAL COMPUTER, EXIDY SORCERER PERSONAL COMPUTER SYSTEM, HEATH H8 HOME COMPUTER SYSTEM, HEATH H11 16 BIT MINICOMPUTER KIT, COMPUCOLOR II PERSONAL COMPUTER SYSTEM

MISCELLANEOUS EQUIPMENT: E & M ELECTRONICS CASSETTE INTERFACE KIT, PARATRONICS MODEL 100A LOGIC ANALYSER, PARATRONICS MODEL 10 TRIGGER EXPANDER, LEAR SIEGLER ADM 3 VIDEO TERMINAL KIT, TAPE READER KIT FOR HOBBY COMPUTERS, SINGNETICS INSTRUCTOR 50 TRAINING SYSTEM

DREAM 6800 COMPUTER: INTRODUCTION TO THE DREAM 6800, BUILDING THE DREAM 6800 COMPUTER, INTERESTING PROGRAMS FOR THE DREAM 6800, CHIP 8 PROGRAMMING FOR THE DREAM 6800, DREAM 6800 POWER SUPPLY

GENERAL: THE PERSONAL COMPUTER REVOLUTION, MICROPROCESSORS: THE BASIC CONCEPTS, PLOT BIORHYTHMS WITH YOUR TRS 80, UNDERSTANDING BASIC PT 1, UNDERSTANDING BASIC PT 2, GIVE YOUR COMPUTER AN RS-232C INTERFACE

MICROPROCESSORS: INTEL 8080A & SDK-80 EVALUATION KIT, INTEL 8085 & SDK-85 SYSTEM DESIGN KIT, MOTOROLA 6800 & MEK6800D2 EVALUATION KIT, MOTOROLA 6802D3 EVALUATION KIT, NATIONAL SEMICONDUCTOR SCMP CHIP & EVALUATION KIT, SINGNETICS 2650 CHIP & EVALUATION SYSTEMS, FAIRCHILD F8 & F8 DESIGN EVALUATION KIT, MOSTEK F8 & MOSTEK EVALUATION KIT, SINGNETICS 8X300 & EVALUATION KIT, NATIONAL SEMICONDUCTOR PACE & DEVELOPMENT SYSTEM, TEXAS INSTRUMENTS TM990/189 TRAINING SYSTEM

Available from "Electronics Australia", 57 Regent St, Chippendale, NSW. **PRICE \$5.00** OR by mail order from "Electronics Australia", PO Box 163, Chippendale, 2008. **PRICE \$5.90.**

L. E. CHAPMAN

122 PITT ROAD, NTH CURL CURL.
MAIL ORDERS: BOX 156, DEE WHY, NSW. 2099.
TELEPHONE 93-1848.

SUPER SPECIAL

GRAMOPHONE motor and pickup 3 speed stereo balanced arm.

240 volt \$9.75
PP NSW \$1.50
Interstate \$2.75
WA \$4



SUPER SPECIAL FM STEREO KITS

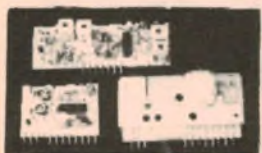

Sets of 3 modules includes FM tuner decoder and if detector. Circuit diagram supplied.

ONLY \$22 PP \$1.40

Send stamped envelope for copy of Electronics Australia magazine review of the units.

ELECTROS

47µF 25V	470µF 16V	1000µF 63V
5 for \$1	5 for \$1	
220µF 16V	47µF 16V	47µF 200V
10 for \$1	5 for \$1	3 for \$1
1000µF 16V	22µF 16V	1000µF 25V
5 for \$1	5 for \$1	5 for \$1
2.5µF 350V	2500µF 16V	680µF 35V
5 for \$1	5 for \$1	2 for \$1
470µF 40V	16µF 350V	
5 for \$1	4 for \$1	
220µF 50V	47µF 160V	
4 for \$1	5 for \$1	
470µF 35V	330µF 63V	
4 for \$1	5 for \$1	
220µF 50V	22µF 160V	
4 for \$1	5 for \$1	
1000µF 10V	25µF 63V	
5 for \$1	5 for \$1	
220µF 10V	470µF 63V	
10 for \$1	3 for \$1	
47µF 25V	47µF 25V	
5 for \$1	5 for \$1	
47µF 50V	330MFD 16V	
5 for \$1	2 for \$1	
470µF 25V	2000MFD 25V	
5 for \$1	2 for \$1	
220µF 63V	1000µF 50V	
4 for \$1	\$1 each	

CAPACITORS

0.47MFD 100V	10 for \$1
220µF 63V	5 for \$1
5 for \$1	
0.0068µF 1500V	3 for \$1
5 for \$1	
0.0039µF 1500V	3 for \$1
5 for \$1	
0.06µF 400V	5 for \$1
5 for \$1	
0.015µF 250V	10 for \$1
5 for \$1	
680K 250V	5 for \$1
5 for \$1	
47K 630V	5 for \$1
5 for \$1	
2.2 200V	5 for \$1

BSR DELUX RECORD PLAYER

11 INCH TURNTABLE CUING DEVICE SHIELDED MOTOR MAGNETIC CARTRIDGE

P&P NSW — \$4.50; INT — \$5.50
WA — \$6.50
NT — \$6.50



SPEAKERS 2 1/2 INCH 2 FOR \$1

MSP SPEAKERS

8 INCH DUAL CONE 15 OHM 8 WATT

\$5 PP NSW \$1.80
INTERSTATE \$2.75
WA, TAS, NT \$4



DUAL VU METER \$3



CLOCK MODULE



including transformer and touch micro switches to suit \$5.50

SLIDE POTS

1/2 meg dual	50 cents
1 meg dual	50 cents
2 meg dual	50 cents
25K dual	50 cents
250K dual	50 cents
1K dual	50 cents
50K single	30 cents
250K single	30 cents
10K single	30 cents

VU & BALANCE METERS

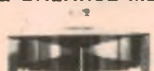

12K 100µA \$2.00 STEREO VU \$3.00

SPEAKER SYSTEMS \$35 PAIR

Two 6" Dual Cone Magnavox Speakers in each cabinet 10 watts RMS
P&P NSW \$4.50 INT \$5.50 WA \$6.50 — NT \$6.50

POTS ROTARY

1/2 Meg	30c
1 Meg	30c
100K	30c
100K Switch	50c
50K Double Pole Switch	50c
7 500	30c
10K Switch	50c
250K	30c
50K	30c
20K	30c
10K Min Pots	25c
50 ohm	50c
1/2 or 1 Meg Switch	50c
1/2 1 meg dual Concentric tapped at 100K	\$1
2 meg ganged double pole switch	\$1
1 5 meg dual ganged	50c
2 meg ganged log	\$1
1 meg dual ganged	\$1
1/2 meg dual ganged LIN	75c
25K 50K dual ganged Concentric double switch	\$1
200K single line	30c
20K wire wound	75c
dual log 10K	75c
100K dual ganged linear pots	75c
10K sub min log pots	50c
250K ganged pots	75c
25K lin ganged pots	75c

SPECIAL MAGNAVOX SPEAKERS \$20 PAIR

10 INCH WOOFER 10 INCH MID RANGE 8 OHM SYSTEM, 20 WATTS RMS



P&P NSW \$3.50 — INT \$4.50 — WA \$5.50
NT \$6.50

TUNING CAPACITORS

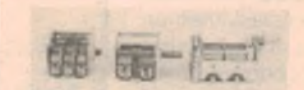

AM, FM \$3
3 Gang \$2 2 Gang \$1.50

SOANAR LEADS WITH FIBRE OPTICS



OPTICAL FIBRE CABLES

Are now available in continuous lengths in multiples of one metre to a maximum of 1 kilometre. The 125 Micron Fibre in 2.7mm diameter cable is designed for high flexibility and tensile strength and can be supplied plain or fitted with connectors at the factory.

CONNECTORS

Enable fibre optic cables to be joined together or coupled to transmitters, receivers and other active components.



CUTTING & STRIPPING TOOLS

S311S — Cuts optical fibre squarely for a mirror-like surface.

S211 — Removes covering from optical fibre.



ACTIVE COMPONENTS

Emitters, Detector/Preamplifiers, Transmitting and Receiving Modules suitable for medical electronics, industrial controls, security, computer and peripheral systems.



Technical Information Available on Request

SOANAR

SOANAR ELECTRONICS PTY. LTD.
INCORPORATED IN VICTORIA

30-32 Lexton Road, Box Hill, Vic., 3128, Australia.

VICTORIA: 840 1222

QUEENSLAND: 52 1131

N.S.W.: 789 6733

WEST AUST: 381 9522

STH. AUST: 42 8918

TASMANIA: 31 6533

THE SERVICEMAN — Continued

And rather ironically, the exercise didn't really solve my colleague's original problem. The new CRO is far too good to bash around in the van and has taken pride of place on his workbench, replacing the older one he previously used. And that's too big to lug around from house to house, so he's still looking for a small, lightweight, single trace, 75mm CRO which won't cost him a fortune.

Any suggestions?

FUNNY CUSTOMERS

In the January, 1983, notes I presented some short stories from J.L. of Tasmania, dealing mainly with the oddballs one encounters in the servicing game. I couldn't accommodate all that J.L. had contributed on that occasion, so here are the remainder.

"Mrs Know-it-all" wanted one of those coloured antennas — "The one with lots of arms on it." She was convinced that only one of these would clear up her picture, whereas she lived in millivolt area and almost any antenna, or even a piece of wet string, should have given her all the signal she needed.

Nothing I could say would convince her that the antenna she already had was more than adequate and that it had to be a cable problem. She insisted that I install a coloured antenna and I settled for one with a few more "arms" than the existing one, though she would have preferred many more.

In fact, and as I expected, it made not a scrap of difference and only then would she agree to let me inspect the feeder. The cable was OK where it came down the side of the house to floor level and went through the foundations. The snag was that it had been cut off about 30cm inside the foundations. Coming through the floor under the TV set was another 30cm of cable — with a gap of about six metres between them! (Don't ask me why.)

She paid the bill, but I wonder if she ever told her husband why six metres of cable cost so much!

Some customers are a nuisance — in a pathetic sort of way. Like "Mr Vertical hold". I won't see him again because he was a (very) elderly resident of an old people's home and has now changed channels for the last time.

A few years ago his TV set failed and he put off having it repaired because he couldn't afford the service fee. Then he learned that I called at the home two or three times a month and only charged residents labour and parts, and asked me to fix his set.

Six months later his set lost vertical hold and he asked me to call and fix it. I

showed him how to adjust the vertical hold and made only a nominal charge. Over the next year I had to tend his set every time I visited the home, and always to re-set the vertical hold. I suspected that he was altering the control himself, but couldn't convince him that it did not need to be touched.

The matron solved the mystery when she told me that he had no family or friends and that I was the only outside visitor he ever saw. He enjoyed having me in to "fix" his set and to have a short chat. He always insisted on paying me, but appeared not to notice that my "couple of dollars" fee was a lot less than the other residents paid for repairs.

As I said; a rather pathetic story.

Most servicemen are plagued with customers who create their own faults, though not necessarily deliberately. I was reminded of this while reading a 1967 edition of the Serviceman (June, 1967) where an elderly gent called for help when his sound failed; he had turned down the volume control and had forgotten that he had done so.

LOST COLOUR

I have one like that — a little old lady I call "Mrs Colour". She called me late one night to complain that her set had lost colour while she was watching the ABC. She had had the same trouble a few months before when she had mis-adjusted the fine tuning. Thinking it could be the same trouble, I asked her if the commercial channel had also lost colour. When she said yes, I asked if the colour control had been turned down, but she insisted that this was in its usual position. At which point it became obvious that I would have to visit her home to sort things out.

Next morning I faced the offending set and it was indeed showing a colourless ABC test pattern. I pressed the commercial button and up came a perfect colour picture. Back to the ABC and a quick fiddle with the fine tuning gave a perfect colour picture.

The explanation? The little old lady never watched the commercial channel and simply assumed that no colour on one channel automatically meant no colour on the other.

The trouble is that these little old ladies and dear old gentlemen are usually pensioners. Those who pay their bills are often battlers who deserve any discount I give them. Others, often two-car, three-telephone types, demand a "pensioner discount" and then offer to pay next pension day. The little old lady is one of the former type, but just how long can I go on subsidising her pension? 

Desolder in seconds!

WITH

Soderwick

DESOLDERING BRAID

Select from standard or

NEW
FINEBRAID

1. Hold Soderwick on termination with hot soldering tip. Wicking action soaks up solder.

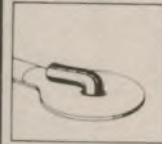

2. Remove tip and braid. Termination is left clean and solder-free.

- Fast, safe and easy.
- Soaks up molten solder like a sponge.
- Acts as a heat sink to protect circuits and components.
- Six braid widths available.

Buy from your
electronic parts supplier

DISTRIBUTED BY
ROYSTON ELECTRONICS

NSW (02) 709 5293 QLD (07) 277 4311
VIC (03) 543 5122 S.A. (08) 42 6655
TAS (002) 34 2233 W.A. (09) 381 5500

F582



AUSTRALIAN
BROADCASTING COMMISSION

BROADCAST ENGINEERING OFFICER GD.1

The ABC has a vacancy in its Design and Development Laboratory for a Broadcast Engineering Officer to undertake investigations and projects involving minor design of equipment for Radio and TV broadcasting systems and facilities.

Applicants must have the Electronics and Communications Certificate (NSW) or equivalent and the Television Operators' Certificate of Proficiency or equivalent, with at least six years' relevant experience in the maintenance of electronic equipment and a knowledge of radio/television operational systems.

SALARY: \$19,110-\$21,260 p.a.

Applications to Employment Officer (BH), ABC, GPO Box 487, Sydney, 2001. Mark envelope "Application - Confidential" and include details of qualifications and experience, telephone number and copies of two recent testimonials or the names of two referees. Applications close Monday, 18 April 1983.

52-102

Circuit & Design Ideas

Interesting circuit ideas from readers and technical literature. While this material has been checked as far as possible for feasibility, the circuits have not been built and tested by us. As a consequence, we cannot accept responsibility, enter into correspondence or provide constructional details.

Model railway signal override system

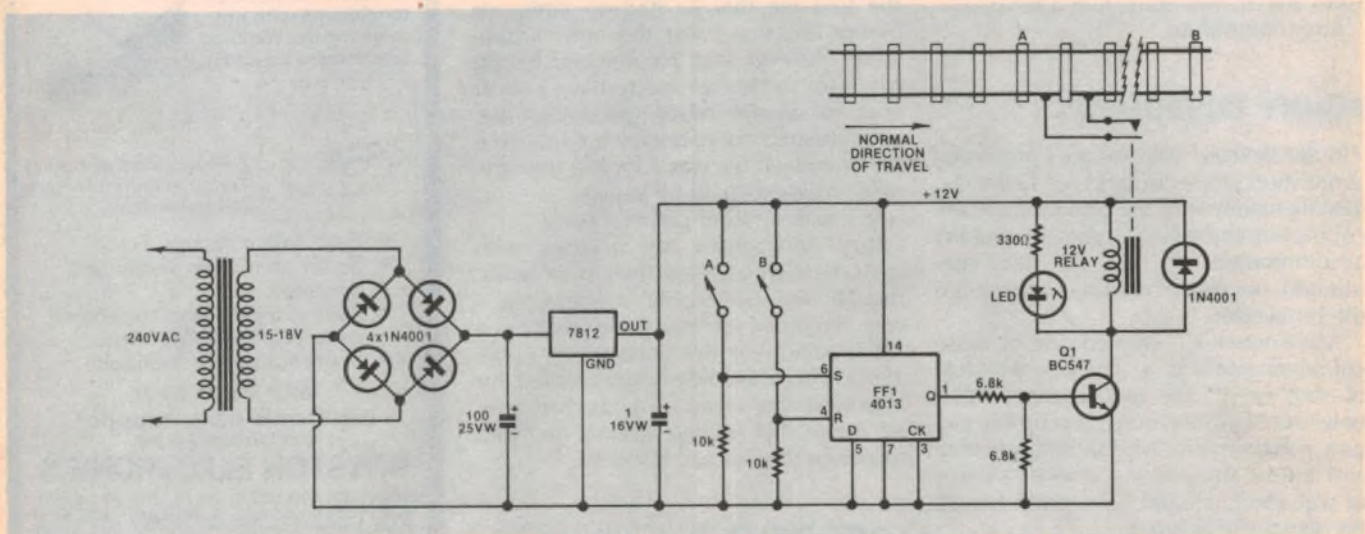

Most model railway layouts use signalling systems which create a dead section of track beyond any signal set at "stop", thus halting an approaching train automatically. But this presents a problem when it is desired to use the dead section for shunting, with a train moving briefly into it from the opposite direction.

The accompanying circuit solves this problem. A train approaching from left to right, against a signal, will meet a dead

track, while a train moving from right to left will energise the track, but for its own use only.

Train-sensing contacts, such as reed switches, are located at each end of the section (A and B) and connect to the "set" and "reset" terminals respectively of flip-flop FF1. A train travelling from right to left will activate contact A, set the flip-flop, and drive its output high.

This will turn on transistor Q1, close the relay, and energise the track. When

the train leaves the track, to the right, it will be left energised, but a train approaching from the left will activate contact B, reset the flip-flop and de-energise the track.

The series LED and 330Ω resistor provide visual indication that the section of track has been energised. The power supply is conventional and consists of a bridge rectifier driving a 3-terminal +12V regulator IC (7812).

From "Elektor", December, 1982.

Power failure indicator

The purpose of this simple circuit is to indicate, after power has been restored, that there has been a power failure, no matter how momentary. Such an indication can be important in the case of mains-operated clocks, or any other device which requires adjustment after a mains failure.

The circuit is built around a single 4011 quad NAND gate IC. IC1a and IC1b are wired as an RS flip-flop, while IC1c form a standard two-gate CMOS oscillator. The oscillator runs at about 5Hz and is enabled (ie, it runs) whenever pin 13 of IC1c is high.

Pin 13 is controlled by the flip-flop. When power is first applied, pin 1 of IC1a is held low by the 10nF capacitor. Since pin 2 is also initially low, pins 3 and 13 will go high, thus enabling the oscillator which flashes the LED at a 5Hz rate.

If switch S1 is now pressed, the reset pin (pin 6) is pulled low and pins 4 and 2 are forced high. At the same time, pin 1 will have gone high due to rapid charging of the 10μF capacitor via the 1kΩ resistor, with the result that pin 13 goes low. This disables the oscillator and turns off the LED, a condition that prevails while ever power is maintained.

If the power fails, the same sequence of events will occur when it is subsequently restored. The LED will continue to

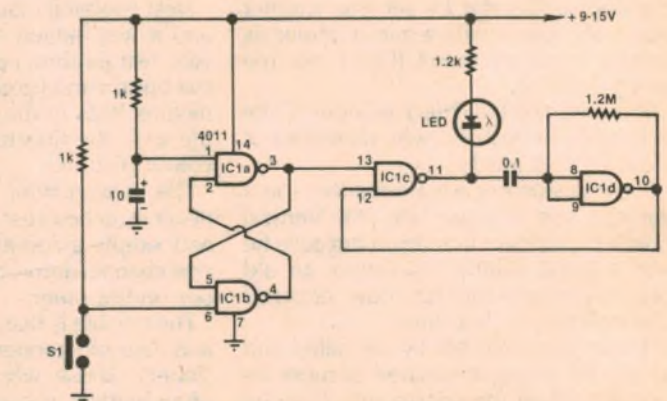

flash to indicate the power failure until the circuit is reset by switch S1.

The circuit requires a power supply of 9-15V dc, and this must be derived from the supply to the device being monitored.

M. Azzopardi, Sunshine North, Vic.

The Sony CDP101

The magic of digital audio becomes a magnificent reality.

Digital Audio is a revolution. The greatest advance in home music reproduction since the gramophone record. As you'd expect, Sony is the leader of this revolution with its magnificent CDP-101 player that offers you original studio master quality at home.



response over the entire audible range • dynamic range and signal to noise ratio over 90dB • perfect channel separation • immeasurable wow and flutter • negligible distortion.

Sony's CDP-101 uses an optical laser pick-up (incorporating three micro processors), it is easier to use than a conventional turntable and connects easily to your existing system.

Other features include • fully automatic linear skate front disc loading

For the technically minded, the specifications read more convincingly than any superlatives • flat frequency

- automatic music sensor • dual function digital readout of playtime • audible fast forward and reverse • 10 function wireless remote control.

Compact Discs Last Forever

Just 12 cms in diameter, the Compact Disc plays up to 60 minutes of music. It's protected from scratches, dust and finger prints by a plastic coating; and because the pick-up is a laser beam, deterioration is non-existent. Reproduction remains perfect virtually forever.

Hundreds of titles will be available with many more to follow from major companies such as CBS.

CDP-101 Specifications

Frequency Range	5Hz-20Hz \pm 0.5dB
Dynamic Range	more than 90dB
S/N	more than 90dB
Channel Separation	more than 90dB (at 1kHz)
Harmonic Distortion	less than 0.004% (at 1kHz)
Wow and Flutter	immeasurable



The CDP-101 will be generally available May 1 throughout Australia but for a demonstration now, contact Sony for the name of your nearest dealer.

Sydney (02) 266 0655, Adelaide and N.T. (08) 212 2877, Brisbane (07) 44 6554, Perth (09) 323 8686,
Melbourne (03) 419 3133, Launceston (003) 44 3078, Wollongong (042) 71 5777.

We pay our engineers while they



The day you join the Air Force you start receiving a salary. Even though you're a full time student either at the RMIT (Royal Melbourne Institute of Technology) or the WAIT (Western Australian Institute of Technology).

At the WAIT you can study communications or electronics. At the RMIT you can study mechanical, aeronautical, electrical or communications/electronics engineering.

All of them lead to a degree.

When you graduate as an officer you will be posted to one of several RAAF bases.

There you will undertake design projects, supervise maintenance and have the management of maintenance resources for some of the most sophisticated equipment in the country.

BECOME MUCH MORE THAN AN ENGINEER.

As a graduate officer you have more than merely an engineering degree. Because in the RAAF you are also given training in management and administration.

So by the time you're about 22, you will be much further advanced than your civilian counterparts. Not only because of your technical expertise, but also your capacity to accept responsibility. After all, by then you could be in charge of a hangar full of aeroplanes and anything up to 30 men.

To enter the Engineer Cadet Scheme you must be an Australian citizen under 20 on January 1st of your year of entry and meet our selection requirements.

're still studying to be engineers.



You must also be matriculated or be doing your matriculation this year.

If you're not doing your matriculation until next year you may be eligible for a RAAF scholarship to help you through.

Either way, ring any RAAF Careers Adviser or fill out the coupon and we'll send you more information.

MELBOURNE	(03) 61 3731
SYDNEY	(02) 212 1011
CANBERRA	(062) 82 2333
PERTH	(09) 325 6222
ADELAIDE	(08) 212 1455
HOBART	(002) 34 7077
BRISBANE	(07) 226 2626

Once you know you want to be an engineer, join the Air Force. It's more than a degree.



Application forms are available now.
Mail to: RAAF Careers Office, GPO Box
XYZ, in your State Capital

I would like more information on:
 The RAAF Engineer Cadet Scheme
 RAAF ECS Scholarship

Name

Address

..... Postcode

Birthdate

Air Force Officer.
Engineer Cadet Scheme

Authorised by the Director General of Recruiting, Department of Defence

**ACT
NOW**

AFE50.DPS.13

COLOUR GENIE

The Versatile Computer

Enter the exciting world of computing with the EG2000 Colour Genie

- * Low Priced — Compare the Features.
- * Clear & Defined Colourfull Graphics.
- * Fully Expandable — Compare the Prices.
- * Extended Microsoft Basic

- Children & Adults love Video Games.
- Home Accounting.
- Small Business Computing.
- Educational Purposes.

**CALL OR WRITE FOR
LOCATION OF YOUR
NEAREST COLOUR GENIE
DEALER.**

\$449⁰⁰

INCLUDES CASSETTE RECORDER



WE DARE TO COMPARE

FEATURES	COLOUR GENIE	VIC 20	TRS 80 COLOUR	ATARI 400
ROM	16K	8K	8K	10K
RAM on Board	16K	5K	4K	8K
Max. RAM on Board	32K	5K	32K	16K
Professional Typewriter Keyboard	YES	YES	NO	NO
R.F. with sound modulators built-in	YES	NO	YES	YES
Built in Power Supply	YES	NO	YES	YES
RS-232C Built-in	YES	NO	YES	NO
Sound	YES	YES	YES	YES
Screen Display	24 x 40	22 x 23	16 x 32	24 x 40
Programmable Characters	YES	NO	NO	NO
Upper/Lower Case Characters	YES	YES	YES	NO
Dedicated Graphics	YES	YES	NO	YES
User-Programmable Function keys	8	NO	NO	NO
CPU	Z80	6502	6809E	6502
Clock Speed	2.2MHz	1 MHz	0.89MHz	1.8MHz
Baud rate	1200	300	1200	1200
Price including	\$449	\$399	\$784	\$758

**FOR FURTHER INFORMATION CONTACT BERTAS INTERNATIONAL PTY LTD
P.O. BOX 294, BOX HILL, VIC. (03) 288 7708**

Unbeatable features at unbelievable price!

Now you can enter the exciting world of computing with the EG2000 Colour Genie Computer. It's incredibly low-priced and so easy to use even a child can be computing in minutes.

With high-resolution graphics, brilliant colours and sound, kids will love playing games on the Colour Genie. But the Colour Genie is more than just a video games machine. The Colour Genie has many practical applications — you can set up a budget and keep track of expenses, use it in the office as a word processor, even teach the kids maths or typing.

Want to learn to program? The Colour Genie uses the BASIC language — the simplest and easiest-to-use program language, and with the comprehensive, entertaining "from the ground up" double manuals, you will be writing your own programs with vivid colour graphics displays and exciting sound in no time at all!

The Colour Genie is never out of date. Unlike video games machines, it is completely expandable. All the interface capabilities are there: you simply add to it a range of low-priced accessories such as joysticks, light-pens, printers.

At last, a computer with all the features you would expect of a more expensive brand-name computer. Except the price. The Colour Genie.

Maximum power . . . minimum price

Our new 16K BASIC ROM gives you 8 vivid colours, a sound generator high-resolution graphics Simple commands let you quickly produce drawings, diagrams, charts, and more. With our powerful 16K BASIC ROM, you have 128 dedicated graphics symbols and an optional 128 software selectable graphics characters — a total of 256 graphics. Now you can create spectacular colour graphics at an amazingly low price! For true professional-level computing.

BASIC commands and mathematical functions

Active commands

AUTO	DELETE	RUN
CLEAR	EDIT	SYSTEM
CLOAD	LIST	TROFF
VERIFY	LLIST	TRON
CONT	NEW	RENUM
CSAVE		

Programming commands

CLEAR	LET
DATA	LPRINT
DEFDBL	ON n GOSUB
DEFINT	ON n GOTO
DEFSNG	ON ERROR
	GOTO
DEFSTR	PRINT
DIM	PRINT@
ERROR	PRINT TAB
END	PRINT USING
FOR NEXT	PRINT#
GOSUB	READ
GOTO	RESTORE
IF THEN ELSE	RETURN
INKEY\$*	RESUME
INPUT	REM
INPUT#	STOP

Sound commands

SOUND
PLAY

String functions

ASC	LEN	STR\$
CHR\$	MID\$	STRING\$
LEFT\$	RIGHT\$	VAL

Arithmetic functions

ABS	CSNG	RANDOM
ATN	EXP	RND
CDBL	FIX	SGN
CINT	INT	SIN
COS	LOG	SQR
		TAN

Graphic functions

CLS	SHAPE	FCLS
COLOUR	PAINT	CIRCLE
LGR	BGRD	SCALE
PLOT	NBGRD	FCOLOUR
FILL	FGR	FILL
NPLOT	NSHAPE	SHAPE

Special functions

INP	POKE	VARPTR *
OUT	POS*	CALL
PEEK	MEM	

Joystick commands

JOY1X	JOY1Y
JOY2X	JOY2Y
KEY PAD1	KEY PAD2

Editing commands

NEWLINE	— record all changes
SPACEBAR	— move cursor one space to the right
BACKSPACE	— move cursor back to the left
SHIFT	— escape from Insert command
H	— hack and insert
I	— insert
X	— insert at end of line
L	— list line
A	— cancel all editing changes
E	— save all editing changes
Q	— back to Active Command level with no change
D	— delete
C	— change
S	— search
K	— delete specified characters

Dedicated functions

LIST	— RENUM
RUN	— DELETE
AUTO	— CLOAD
EDIT	— CSAVE

A completely new design for stage or studio with

Balanced 8-chan

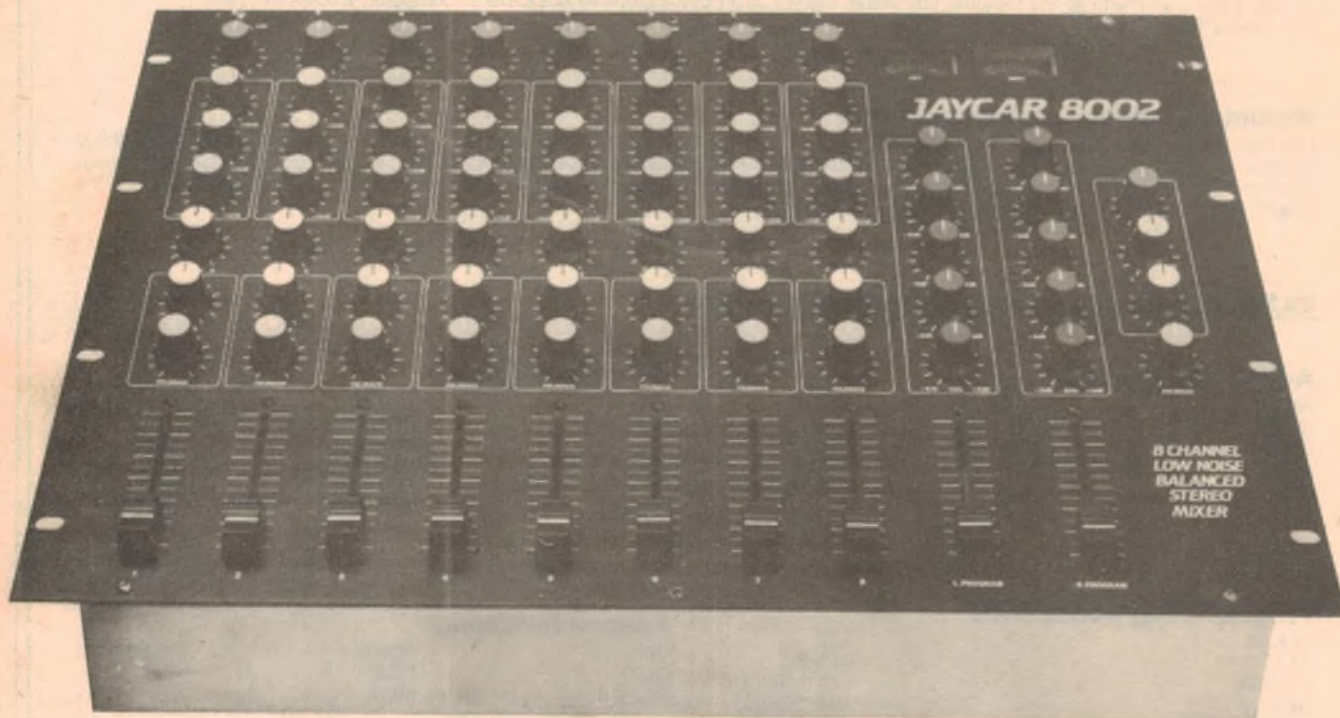

For a long time now there has been a need for an up-to-date mixer design with low noise output and comprehensive facilities at a reasonable price. Therefore we are pleased to present this new high performance design in conjunction with Jaycar Pty Ltd.

by LEO SIMPSON

The design of this mixer was specially commissioned by Jaycar to meet the requirements of typical band groups performing on stage or in a studio. The unit uses low noise op amps throughout and balanced inputs and outputs to minimise hum pickup and grounding loops. The large number of control features plus the simple construction method make this a very attractive mixer at a particularly keen price.

Physical layout

At first sight, a comprehensive mixer such as this Jaycar 8002 looks dreadfully complex but in just a little time the overall scheme becomes apparent and logical. The "8002" designation, by the way, comes from the fact the mixer has

eight input channels mixing down to two output channels.

Two physical modes of operation are possible. First, since the mixer panel is designed to fit a 19-inch rack, it may be used vertically, with the panel height being 355mm. Second, the chassis has been arranged to allow the unit to be used in a free-standing situation, with a sloped control panel. We think most users will prefer the latter arrangement but that is just our opinion.

All told, there are 70 knobs, ten 60mm sliders and eight toggle switches, making for a total of 88 controls on the panel. And that is not counting the power switch toggle on the back panel. Each knob is colour-coded so that its function, in each particular channel, is clarified.

With the aid of this colour-coding and the logical panel layout, we feel that most users will become quickly familiar with the unit and will not have to peer at control labels each time an adjustment has to be made.

Mixing Features

Essentially, the large number of controls is the result of the duplication of controls for each input channel. The eight input channel controls are arranged in eight columns, starting from the lefthand side of the panel.

At the very top of each column is a toggle switch to select either microphone or line input. Just below this is an attenuator knob for initial signal level adjustment. Below this is a group of three knobs which provide a three-band equaliser giving a range of ± 12 dB boost and cut at treble, midrange and bass frequencies.

There is an assumption here that each instrumentalist will have a preamplifier which may possibly incorporate fuzz or other effects and so will have a line level signal of several hundred millivolts

inbuilt equalisers on each channel

nel Master Mixer

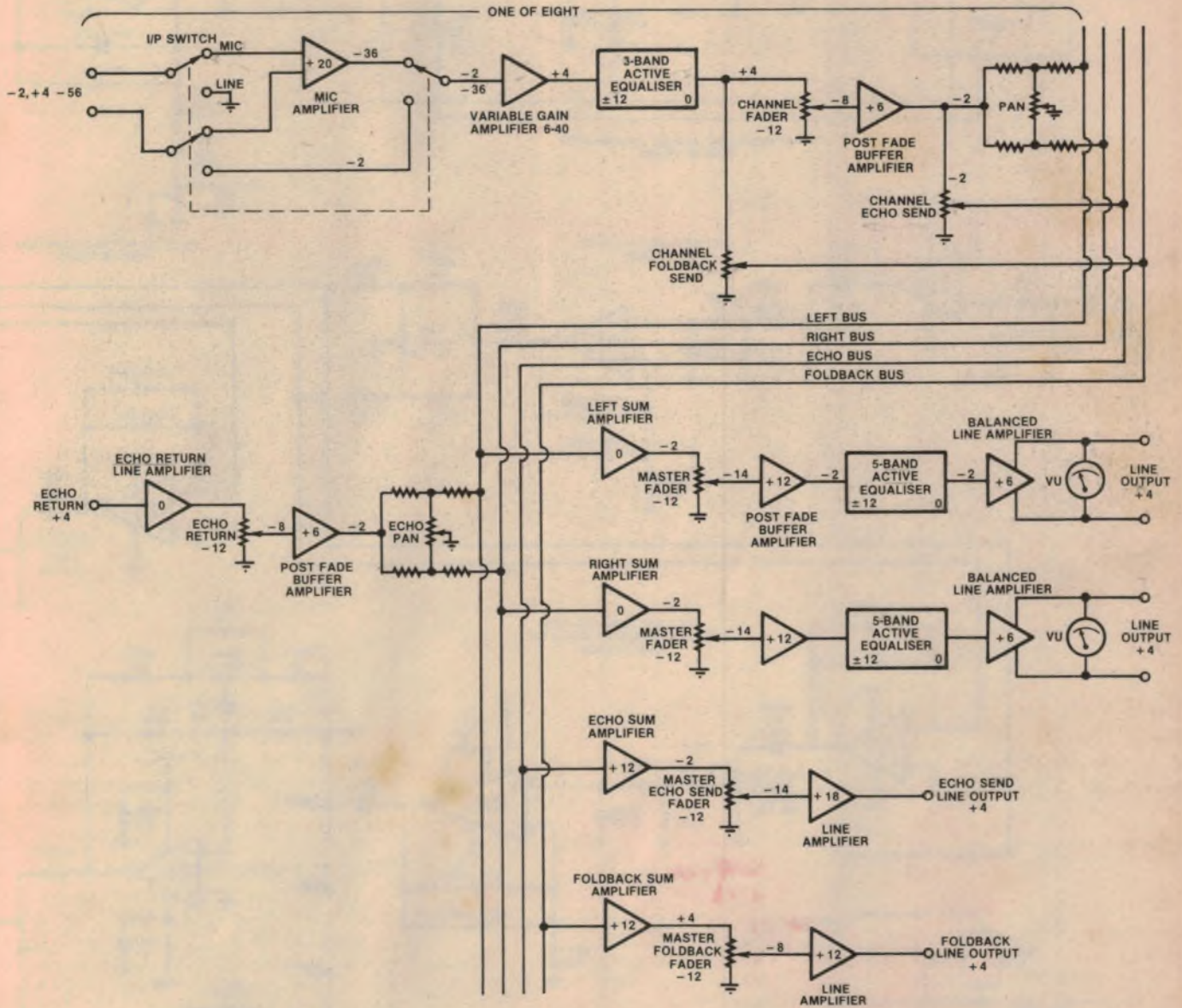

rather than the low level high impedance output direct from a guitar.

Next, below the three-band equaliser is the pan pot. This allows the input signal to be directed to either left or right channel outputs or any combination between the two. The word "pan" by the way, derives from "panoramic" camera motion in film and television work. By suitably manipulating the pan pot, an instrument or vocalist can be made to float from left to right or vice versa.

Below the pan pot is a grouping of two

control knobs which provide for Effects (sends) and Foldback. The Effects knob determines how much of the input signal is fed to an effects output which may provide reverberation, echo, phaser, flanger or other effect.

The Foldback control determines how much of the input signal is fed to a "foldback" amplifier and speakers on stage so that the players can actually hear their own playing or a lead player. Only one foldback channel is provided which is possibly the only important area

Over the page is the circuit diagram for the Mixer. To save space, only one input channel (of eight) and one output channel (of two) are shown. For the same reason, only two of the five equaliser bands are shown. Component values for the other bands will be given next month.

of compromise in this design.

Finally, at the base of each column is a 60mm slider which is the Fader for the particular input channel. Since each of the channel controls is multiplied by

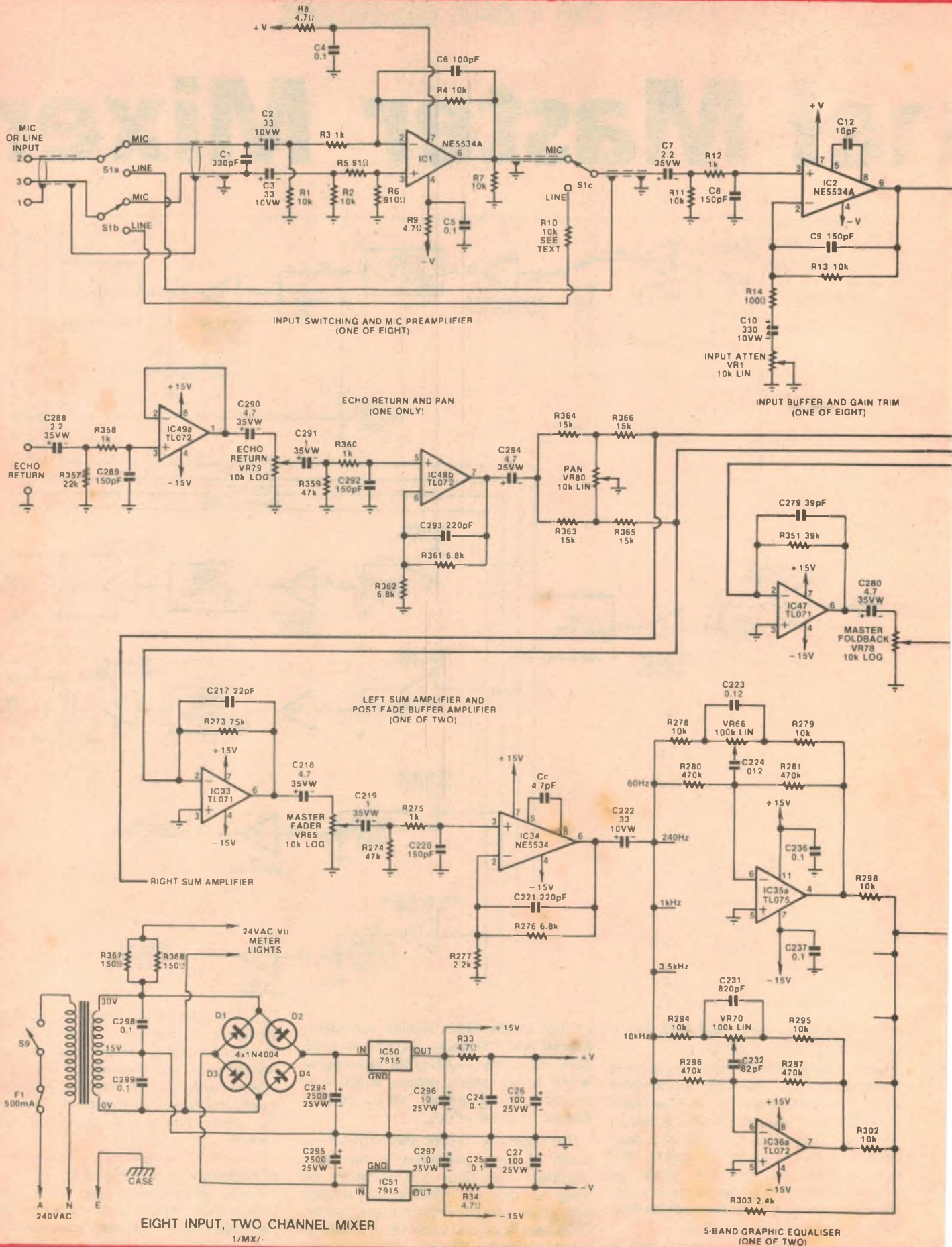

EIGHT INPUT, TWO CHANNEL MIXER
1/MX/

5-BAND GRAPHIC EQUALISER
(ONE OF TWO)

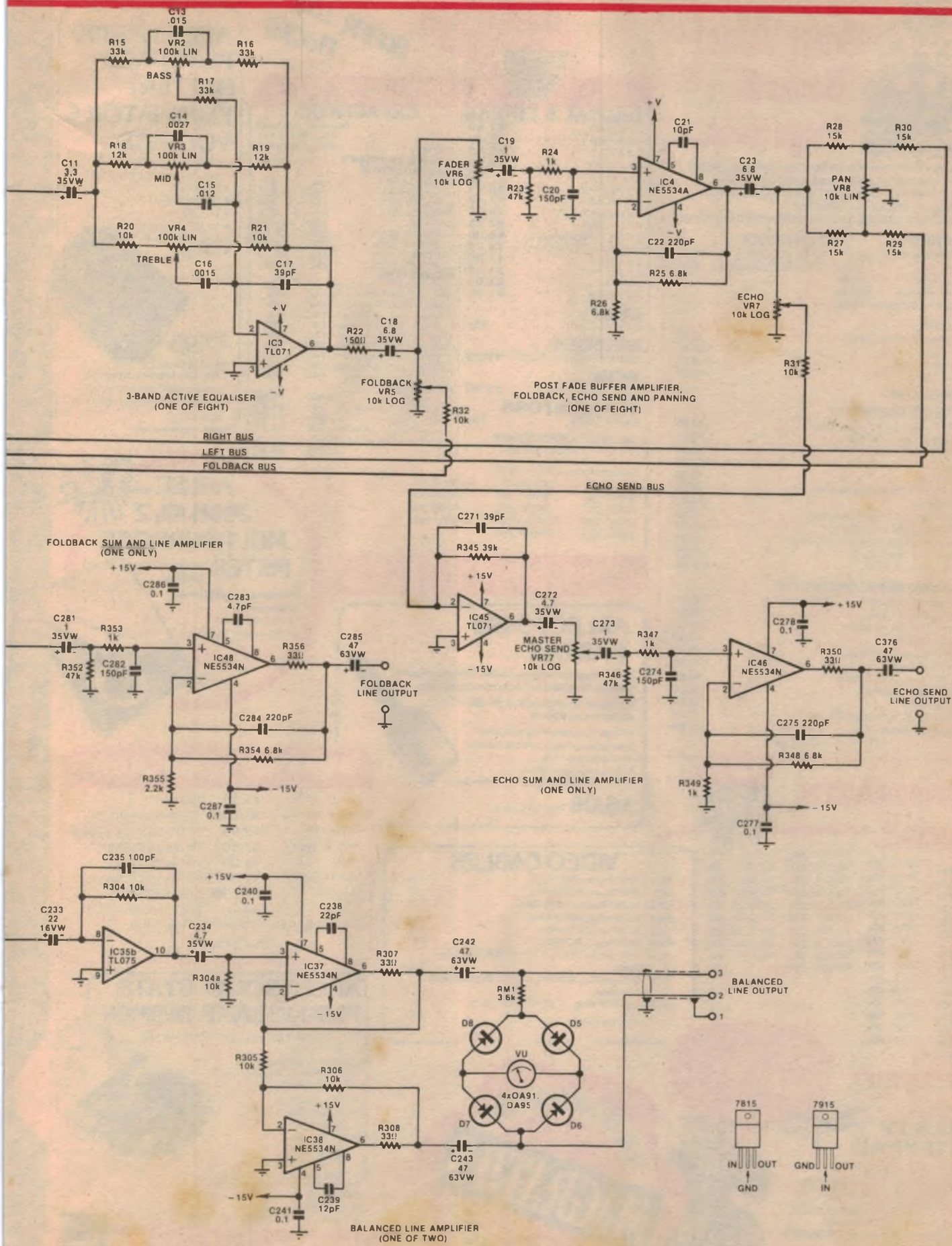



Great Value! Books & Magazines.

- COLOUR COMPUTER NEWS • COLOUR COMPUTER NEWS
 - SYSTEM 68 - APPLICATIONS • 68 MICRO JOURNAL
 - MICRO 80 • APPLE ORCHARD • CREATIVE COMPUTING
 - AUSTRALIAN PERSONAL COMPUTER
- WE ALSO HAVE A RANGE OF OTHER MAGAZINES IN STOCK!

FAIRCHILD

Bipolar Memory Databook \$8.00
CMOS Databook \$9.00
A Linear Databook \$12.50
MOS Memory Databook \$8.00

MOTOROLA

CMOS Databook \$9.00
Schottky TTL Databook \$8.00

PHILLIPS

Building Hi-Fi Speaker Systems \$6.50
Semiconductors Pt 2 \$10.00
Semiconductors Pt 3 \$10.00
General Catalogue 81 82 \$10.00

DATA BOOKS

TEXAS INSTRUMENTS

Software Design for Micro Processors \$14.95
1981 Supplement - TTL Data \$6.25
Linear Control Circuits \$3.90
Interface Circuits \$16.00
MOS Memory \$8.35
Bipolar Microcomputer Components \$9.99
TTL Data Book \$12.50
Understanding Solid State Electronics \$7.95
Understanding Computer Science \$7.95
Understanding Communications Systems \$7.95
Understanding Optonics \$7.95
Beginners Basic TI-99 4A \$14.95

NATIONAL SEMICONDUCTOR

Audio Radio Handbook \$6.50
Advanced Bipolar Logic \$6.50
Linear Applications Handbook \$18.00
Transistor Data Book \$7.50
Voltage Regulator Handbook \$8.00
Memory Data Book \$7.00
Series 80 Board Level Computer \$6.00
Hybrid Products Databook \$9.00
Logic Data Book \$9.00
MM 54HC 74HC High-Speed CMOS \$2.50
The Reliability Handbook \$16.00

All Publications Tax Code A

Semiconductor Specials.

4001 23c	7411 30c	74LS11 23c	74LS83 75c
4002 30c	7413 45c	74LS12 23c	74LS85 30c
4007 23c	7414 45c	74LS14 55c	74LS90 30c
4013 30c	7420 23c	74LS15 23c	74LS93 30c
4015 55c	7430 23c	74LS20 23c	74LS123 30c
4042 45c	7432 23c	74LS27 23c	74LS157 30c
7400 23c	7442 45c	74LS30 23c	74LS174 30c
7402 23c	7444 23c	74LS32 23c	74LS240 75c
7403 23c	7474 30c	74LS42 30c	74LS245 90c
7404 30c	7475 45c	74LS74 30c	
7405 30c	7476 45c		
7406 30c	7490 45c		
7407 30c	7493 45c		
7408 30c	74121 45c		
7410 23c			

SUPER
BARGAINS AT
MAGRATH'S

HILLS TV ANTENNAE

Designed to provide the best possible reception in your area. Built to highest electrical standards. Simple, lightweight, strong and easy to install.

EFC2 Metro Antenna \$39.77
EFC3 Fringe area Antenna \$66.81
FM3 Outdoor FM Antenna \$23.35



6 For The Price
Of 5!

SUPER LOW
PRICES

6 PACK SPECIALS

DIGITAL & LINEAR

6x4016B	\$1.50
6x4066B	\$2.40
6x4511B	\$3.45
6x74LS00	\$1.00
6x74LS04	\$1.00
6x74LS14	\$2.00
6x74LS90	\$2.10
6xLM340KC 12	\$6.00
6xLM340T 5	\$2.55
6xUA317UC Regulator	\$6.00
6xUA348PC Op Amp	\$4.25
6x74C00	\$1.00
6x74C107	\$1.50
6x74C04	\$1.00
6x74C02	\$1.00

LEDs
6xMV5053S \$35c

BRIDGES
6xKBPC602 6A 200V \$5.00

SCRs
6x6006L 6A 600V \$4.00

TRANSISTORS
6xPN2222A \$25c

BOURNS TRIMPOTS 3006P
\$5.16 - Tax Code C

Standard Range 100Ω-1MEGΩ	
3006P-101	3006P-201
3006P-102	3006P-202
3006P-103	3006P-203
3006P-104	3006P-204
3006P-105	3006P-205

CAPACITORS

	Normal Price	Special Price Per Each Pack of 6
3TO12 CERAMIC TRIMMERS	50c	\$2.50
ELECTROLYTICS		
2.2Mid 25V RB s	16c	80c
10Mid 16V RB s	16c	80c
10Mid 25V RB s	16c	80c
25Mid 25V RB s	17c	85c
47Mid 16V	20c	\$1.00
47Mid 25V RB s	22c	\$1.10
100Mid 10V RB s	20c	\$1.00
100Mid 25V RB s	26c	\$1.30
220Mid 25V RB s	36c	\$1.80
POLYESTERS		
001Mid 100V Greencaps	8c	40c
0047Mid 100V Greencaps	8c	40c
01Mid 100V Greencaps	14c	70c
012Mid 100V Greencaps	14c	70c
022Mid 100V Greencaps	14c	70c
033Mid 100V Greencaps	14c	70c
039Mid 100V Greencaps	14c	70c
056Mid 100V Greencaps	14c	70c
068Mid 100V Greencaps	14c	70c
1Mid 100V Greencaps	14c	70c
HARDWARE		
RC A Plugs	20c	\$1.00
RCA Chassis sockets	35c	\$1.75
3.5mm Plugs mono	20c	\$1.00
3.5mm Chassis sockets	35c	\$1.75
MS102 Push to make switch	35c	\$1.75

ARLEC PS499 PLUG PACK BATTERY ELIMINATOR 6 VOLTAGE

Suitable for 3V-4.5V-6V-7.5V
9V-12V equipment to 300mA

- Flash Guns
- Electric Models
- Toys, etc.
- 12 months guarantee
- Cassette Recorders
- Calculators



\$7.95

Plus Tax Code C
Eliminates batteries by running equipment direct from the mains electricity supply. SEC approved.

Ask about our other 6 Pack
Specials There's lots more

ARLEC PS493 KARPAK

Multi-Voltage Car Adaptor Powers: Transistor Radios, Cassette Recorders, etc. from your Car Battery.

Suitable for 3V-4.5V-6V-7.5V-9V-12V equipment to 800mA

- Plugs into cigarette lighter socket
- 5-way plug connects to the majority of radios, recorders etc.
- Includes polarity selector
- 12 months guarantee SEC Approved

\$6.06 Plus Tax Code C



ARLEC 200H Mk 2 MULTIPURPOSE METER

for electrical testing.

Measures Voltage, Current and Resistance.
• SEC Approved
• 12 months Guarantee

\$15.40
Plus Tax
Code C

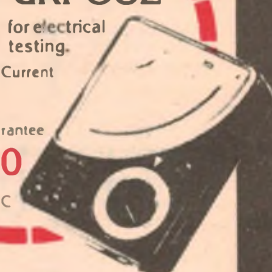

MEMORY BARGAINS

HM6116P-3	\$5.99	250 ns
MB2764-30	\$10.96	300 ns 64K EPROM
MB8118	\$3.95	120 ns 16384 X 1 RAM
MM2708Q	\$2.80	450 ns 8K EPROM
MB8114 NLC	\$4.00	300 ns CERAMIC
HN-62532G	\$7.00	450 ns 32K EPROM
S6834	\$13.30	512 x 8 EPROM
S6810	\$4.70	128 x 10 RAM 450 NS
MC68000-LB	\$99.95	8 MHz CPU

PLUS TAX CODE C

ARLEC SOLID STATE PLUG-IN LAMP DIMMER

Provides complete control over lamp brightness - saves money!
12 months guarantee
For table lamps, standard lamps, bedside lamps, etc. ...

- 500 watts output
- Includes Radio Interference Suppression
- SEC Approved

\$9.57 Plus Tax
Made in Australia Code B

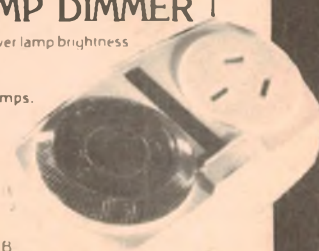

TAX CODE
A - EXEMPT C - 20%
B - 7.5% D - 32.5%

55 A'BECKETT STREET
MELBOURNE, 3000.
Tel (03) 347 1122 Telex AA31001



BALANCED 8-CHANNEL MASTER MIXER

eight, so far we have accounted for eight switches and eight faders plus 56 knobs.

VU meters

On the righthand side of the panel, at the top, are two VU meters for monitoring the left and right outputs. Below these meters are two columns of five knobs which provide five-band equalisers for each output channel. And below the equalisers are the two master faders, one for each output channel.

Finally, on the far righthand side of the mixer panel is a column of four knobs which controls the effects and foldback channels. The effects channel (echo, etc), can be panned into left or right output channels.

On the rear panel is the power switch already mentioned plus a fuseholder. There are three 6.5mm jack sockets, one each for the foldback line output, the effects send line, and the effects return line. For the eight inputs there are female Cannon XL sockets while for the two outputs there are male Cannon XL sockets.

Block diagram

Some idea of the control functions can be gained by examining the block diagram on the first page of this article. This shows one input channel (of which there are eight), the two output channels with their five-band equalisers and VU-metering plus the foldback and effects (echo) amplifier circuitry.

One point which should become immediately obvious is that, while the control layout of the mixer panel is logical and easy to use, it does not really relate to the signal flow through the circuitry — for example, the pan pot for each channel comes after the channel fader. These differences do not make the mixer control layout any less valid and so can be regarded as unimportant.

Refer now to the block diagram and the chain of circuitry across the top starting with the "mic amplifier". Input to the microphone amplifier is made via balanced low impedance lines and the signal is amplified by 20dB (10 times). If the signal level is at line level, ie, around several hundred millivolts, the mic amplifier is switched and the input line is unbalanced. From there, the signal is coupled to a variable gain amplifier which can provide a range of gain from +6dB (two times) to +40dB (100 times). The output from this amplifier is then fed to a three-band equaliser and thence coupled to the "foldback send" control and the channel fader.

The signal from the fader wiper is fed to a further amplifier stage with a gain of +6dB. This is called, appropriately

This photo shows the construction method employed in the new Mixer. Four different PC board designs are employed. Note the balanced input and output sockets.

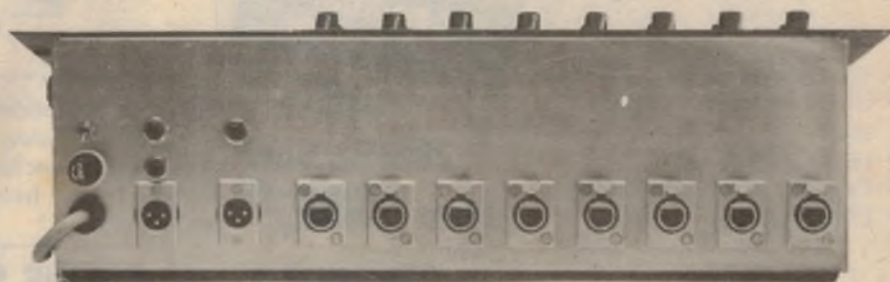
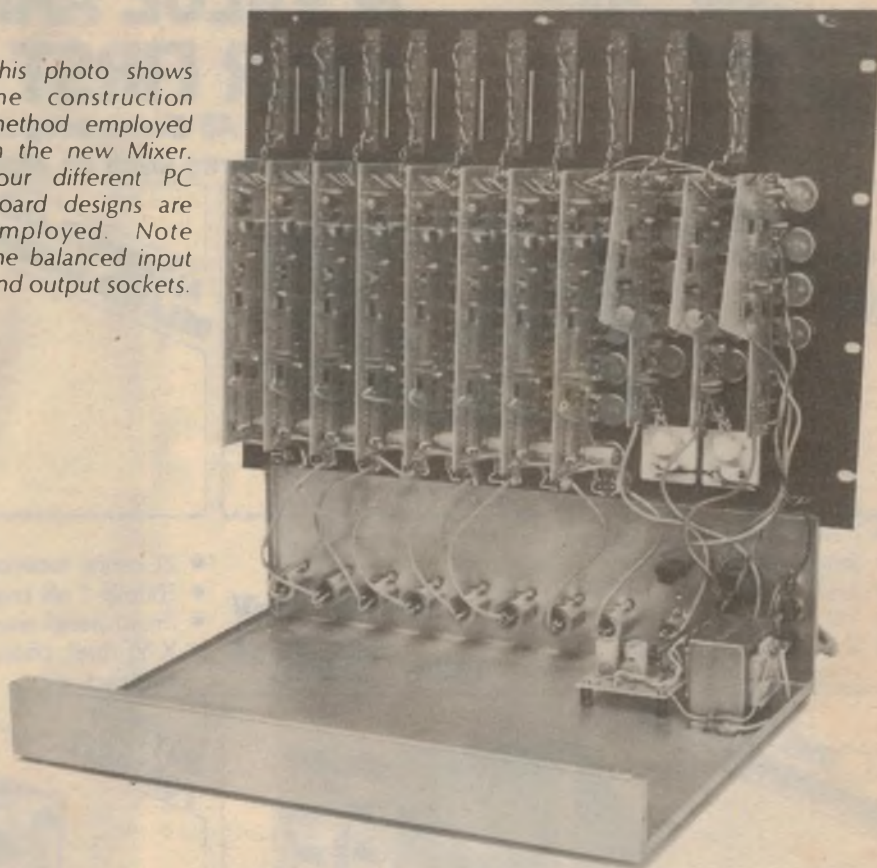

This is the business end of the Mixer, showing the power switch, mains fuse and the input and output sockets.

enough, a "post fade buffer amplifier" because it comes after the fader and it does buffer the fader signal against any undue loading by following circuitry which happens to be the effects send (echo) and the pan pot networks.

All of the circuitry so far described on the block diagram is multiplied by eight times, to account for the eight input channels. And signals from the foldback send, effects send and pan pot go to four signal bus lines which are labelled on the diagram.

The rest of the block diagram is fairly self-evident except to note that the two main outputs, left and right, use balanc-

ed output lines while the echo send and foldback line outputs are unbalanced.

Signal levels are shown on the block diagram in "dBm", ie, referred to a one milliwatt signal in a 600Ω line. This 0dBm reference level is 0.775 volts across 600Ω. By way of explanation, the input signal levels are shown as -2, +4, -56. The first two figures refer to the intended range of line input levels of -2 to +4dBm or approximately 600mV to 1.2 volts RMS.

Similarly, -56dBm corresponds to a signal level of about 1mV RMS, which is in the ball-park for a low impedance microphone signal.

THINKING ABOUT
BUYING A SCOPE?

FOR PERFORMANCE & VALUE AARON HAS TO BE YOUR FIRST SCOPE CHOICE

All these scopes are dual trace and incorporate
the latest features such as high brightness rectangular CRTs.

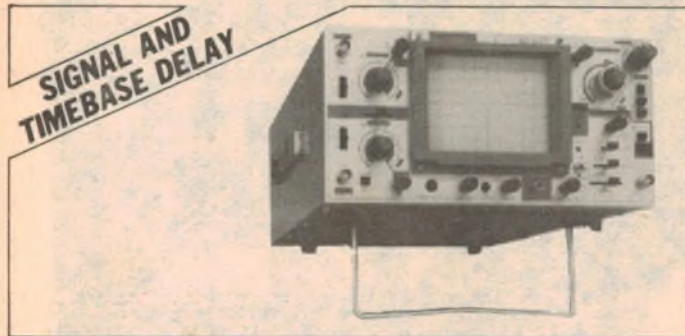

SIGNAL AND
TIMEBASE DELAY

- 7.7nS risetime
- Single sweep
- Trigger delay
- TV sync
- X-Y, dual, chop, add, subtract etc.

45MHz/1mV
BS625 **\$990.00**



ALTERNATE AND
DELAYED TIMEBASE

- 21 range timebase
- 100mS-1 μ S trigger delay
- Front panel trace rotate
- X-Y, dual, chop, add, subtract etc.

35MHz/1mV
BS635 **\$790.00**



BUILT-IN
COMPONENT TESTER

- Check components on screen
- 19 range timebase
- Triggerable to over 30MHz
- 17nS risetime

New low price
for popular
AARON scope
\$485.00
20MHz/5mV
BS601 ~~\$550.00~~



BATTERY
PORTABLE

- 2 hour operation from built-in NiCad battery
- Automatic recharging
- Auto trigger free run
- TV sync

15MHz/2mV
BS310 **\$720.00**

QUICK SPEC CHECK

MODEL	B'WIDTH	SENS	SIG DEL	TRIG DEL	SCREEN	T'BASE
625	45MHz	1mV	Y	Y	150mm	0.2 μ S - 0.5S div
635	35MHz	1mV	N	Y	150mm	0.1 μ S - 0.5S div
601	20MHz	5mV	N	N	150mm	0.5 μ S - 0.5S div
310	15MHz	2mV	N	N	95mm	0.5 μ S - 0.5S div

All prices are plus sales tax if applicable and subject to change without notice.

ELMEASCO

Instruments Pty. Ltd.

P.O. Box 30, Concord
N.S.W. 2137
13-15 McDonald Street,
Mortlake, N.S.W.
Telephone (02) 736 2888
Telex 25887

P.O. Box 107, Mt. Waverley
Victoria 3149
21-23 Anthony Drive,
Mt. Waverley, Victoria
Telephone (03) 233 4044
Telex 36206

Adelaide: (08) 271 1839
Brisbane: (07) 369 8688
Perth: (09) 398 3362

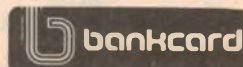

COLINE SP100 PROBE

Professional 100MHz
probe offering x1, ref, x10
positions. 1.5m lead with
BNC connector and
selection of tips.

Complete in heavy
duty plastic pouch. **\$25.00**



MAIL COUPON FOR FREE GUIDE

Please send me a copy of your shortform
oscilloscope guide.

NAME _____

ADDRESS _____

_____ P CODE _____

TELEPHONE _____

N.S.W. Ames Agency 699 4524 • George Brown 519 5855 • Davred 29 6601 • DGE Systems (049) 69 1625 • Radio
Despatch 211 0191 • Vimcom (042) 28 4400 VICTORIA Radio Parts 329 7888 • Browntronic 419 3986 • G B Telespares
328 4301 • Eianco 428 4345 • Ellistronics 602 3282 QUEENSLAND L E Boughen 36 1277 • Colourview Wholesale
275 3188 • Audiotronics 44 7566 • Electronic Shop (075) 32 3632 • Nortek (077) 79 8600 • W G Watson (079) 27 1099
S.A. Protronics 212 3111 • Trio Electrix 51 6718 W.A. Atkins Carlyle 321 0101 • Hinc Eng 381 4477 • Brookes
276 8888 • Protronics 362 1044 A.C.T. Achee (062) 80 6576 N.T. Thew & McCann (089) 84 4999 T.A.S. G.H.E. Electronics
31 6533 & 34 2233



Circuit diagram

The general concept depicted in the block diagram is fleshed out in the two page circuit diagram although even here, there is insufficient space to show all the circuitry. Therefore, only one (of eight) of the input channels is shown and one (of two) of the output channels.

Starting at the same point as we did in the block diagram, look at IC1 the microphone preamplifier which has balanced inputs. The input impedance of this stage is essentially set by the sum of R3, R5 and R6, which gives a figure of $2k\Omega$. This is higher than the nominal impedance for typical balanced microphones normally used with transformer coupling but has been selected as an optimum for a balanced active circuit.

IC2, the variable gain amplifier following the mic/line switch S1c, is a conventional non-inverting op amp circuit. IC3, the following three-band equaliser stage, uses Baxandall feedback circuitry to provide what is really a three-range tone control with fairly broad bands.

IC4 is the post-fade buffer amplifier. As with IC1 and IC2, this uses the Signetics NE5534A low noise op amp. But whereas the reason for selecting this op amp for IC1 and IC2 is its low noise, it has been selected for IC4 because of its ability to drive low impedance loads. The same can be said of IC37 and IC38 which are of the balanced line output drivers.

The other op amps used in the mixer are Texas type TL071 and its multiple op amp relatives, the TL072 and TL075. These op amps are also notable for their good low noise performance and high slew rate limit which is far better than the old standard workhorse, the 741.

5-band equaliser

The five band equaliser involving ICs 34, 35 and 36 is of particular interest. It is not a gyrator design as was the Playmaster graphic equaliser published in May 1979. Instead it is based on an octave analyser published in the National Semiconductor Audio Handbook. Effec-

tively what happens in the circuit is that the audio signal from IC34 is split into five bands which are separately amplified by five adjustable gain band-pass stages.

The five bands are then added together again by IC35b which is a summer amplifier with the odd aspect of R303 which acts to subtract the original signal from the sum. It is subtracted rather than added because each equaliser section is an inverter stage

There is little else in the circuit which requires particular comment. In summary, we think that this is a most practical design using high performance ICs to obtain low parts count.

Mechanical design

The mechanical design of the mixer is as practical as the electronic design. Four different PC board designs are employed, one for the input channels (eight of these), one for the five band

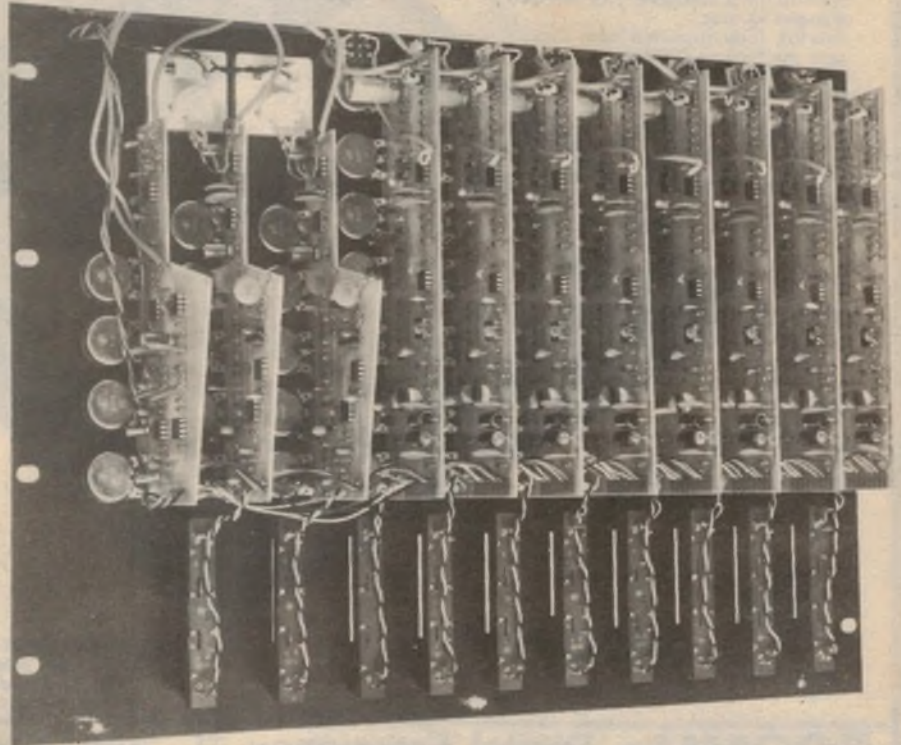

Very little wiring is required for the Mixer and what little there is mostly repetitive. All potentiometers are soldered directly to the PC boards.

(note that only two of the five equaliser sections are shown on the circuit) and R303 delivers an uninverted signal.

Subtraction is necessary in order to maintain unit gain through the whole equaliser circuit. If R303 was not present, the output signals would be five times the input signal.

IC49a and IC49b provide the effects (echo) return and pan control functions while IC47 and IC48 provide the master foldback control function. Similarly, IC45 and IC46 provide the effects (echo) send function.

The power supply is straightforward and uses a 30V centre-tapped transformer and bridge rectifier to provide balanced supply rails. These are regulated to +15VDC with three-terminal regulators.

equalisers and line output drivers (two of these), one for the effects and foldback output drivers (one only), and one for the power supply board.

All potentiometers, with the exception of the main sliders, are mounted directly on the respective PC board. This minimises control wiring and provides the method of mounting the boards themselves to the control panel.

Next month

Next month we shall conclude with the presentation of the full construction details of the mixer, including component layout diagrams for each of the four PC boards. Kits for the project are available now from Jaycar stores at 125 York Street, Sydney or Cnr Carlingford and Pennant Hills Road, Carlingford. ☛

THE BEST KIT LINE

YOUR WAGES ARE FROZEN, OURS ARE TOO. SO ARE OUR KIT PRICES — QUALITY FOR NO MORE!

LOW COST DIGITAL MULTIMETER KIT

BY POPULAR DEMAND

Ref: EA March 1983 (This month)
Almost everyday we are asked for a multimeter kit. Up until now we thought that it was just not worth it considering the fine low-cost built-up units available. The DP2010 changed all that.

This kit, fully imported from the UK uses the famous DPM-05 custom LCD/Voltmeter to achieve phenomenal accuracy at very modest cost!

All parts are included to complete the meter including an attractive and colourful front panel.
(a 9V battery is required)

Set of test probes to suit \$2.95

Probe to suit Cat. WT5312

ONLY \$2.50

Eveready 216 (red)

9V Battery Cat. SB2370
ONLY \$1.40

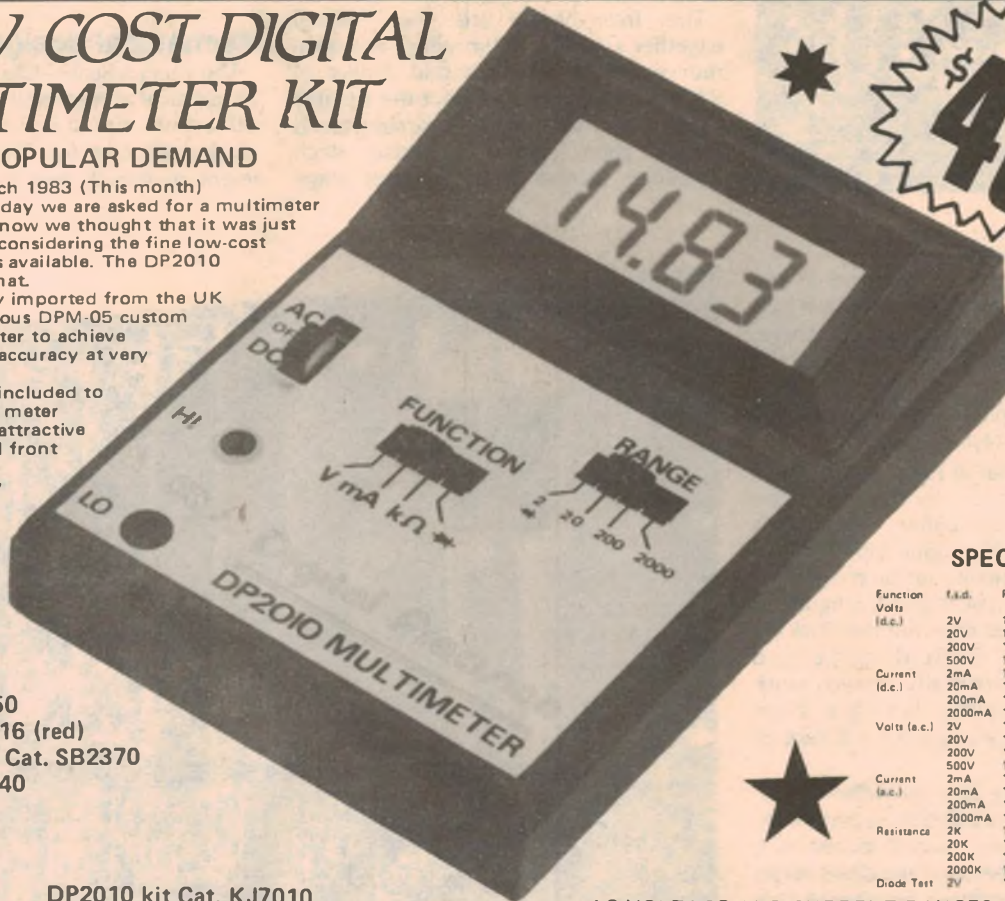

ONLY \$45

DP2010 kit Cat. KJ7010
ONLY \$45

SPECIFICATIONS

Function	f.s.d.	Resolution	Accuracy	Protection
Volts (d.c.)	2V	1mV	1%: 1 digit	500V for
	20V	10mV	1%: 1 digit	one minute
	200V	100mV	1%: 1 digit	
	500V	1V	1%: 1 digit	
Current (d.c.)	2mA	100µA	1%: 1 digit	1A/250V
	20mA	10µA	1%: 1 digit	
	200mA	100µA	3%: 1 digit	
	2000mA	1mA	5%: 1 digit	
Volts (a.c.)	2V	1mV	2%: 5 digit	500V for
	20V	10mV	2%: 5 digit	one minute
	200V	100mV	2%: 5 digit	
	500V	1V	2%: 5 digit	
Current (a.c.)	2mA	100µA	2%: 5 digit	1A/250V
	20mA	10µA	2%: 5 digit	
	200mA	100µA	4%: 5 digit	
	2000mA	1mA	7%: 5 digit	
Resistance	2K	1	1%: 1 digit	260V
	20K	10	1%: 1 digit	r.m.s.
	200K	100	1%: 1 digit	
	2000K	1K	1%: 1 digit	
Diode Test	2V	1mV	1%: 1 digit	260V r.m.s.

AC VOLTAGE AND CURRENT RANGES

When S3a selects a.c. functions the output from either the voltage attenuator or current shunts is fed through C1 to remove any d.c. component.

500MHz Digital Frequency Period Meter

REF: EA Dec '81 — Feb '82



ONLY \$119

Other people may appear to be selling this kit for less. But you GET less!!! Exclusive Jaycar features:

- * Heavy gauge front panel. Pre-punched and silkscreened. (NOT Scotchcal).
- * Low aging rate 10.000MHz crystal
- * Quality IC sockets provided (A MUST)
- * All metal film resistors used (1% 50ppm)
- * Thermalloy heatsink for +5V reg.

Beware of advertised units that do not conform to the original design. They may have inferior performance.

EXCLUSIVE

Gold plated BNC Input Connectors
500MHz option only \$26 extra KA1392
50MHz version \$119 Cat. KA1390
Tilting bail to suit ONLY \$4.95

EA dual tracking P/S



Ref: EA March '82
Cat. KA1410

\$89.50

Extremely versatile power supply: Will give plus & minus 1.3V to 22V at up to 2 amps PLUS A FIXED +5V@0.9A. The supply is completely protected against short circuits, overloads and thermal runaway. A large meter with voltage calibration is supplied as well as IC sockets. A quality kit.

STEREO STEREO STEREO STEREO

Synthesiser

Creates a very realistic stereo sound from mono sources i.e. AM tuners, TV or video units
Very easy to build and comes complete.

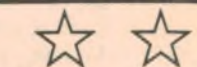

Short Form Version Only
\$39.50

Cat. KA1476

Ref: EA September 1982

COMPLETE ONLY

\$49.50

Cat. KA1478

HEART RATE MONITOR

Ref: EA 7/82



Cat. KA1466

This unit enables you to measure your own pulse instantly and accurately. It is light enough even for joggers to carry. A must for people who may have heart problems. Complete kit including LCD Display.

WAS \$79

SAVE \$10

NOW \$69

UP IN '83-JAYCAR*

CAN AM SOUND LIKE FM? WE THINK SO! ☆☆☆☆☆

magnificent! NEW EA Wide-band AM Tuner ☆

AM Tuner alignment kit ref: EA March 83
This simple project enables you to accurately align your EA wideband tuner.
Cat. KA1515 \$7.99

Ref: EA Dec-Jan 82-83

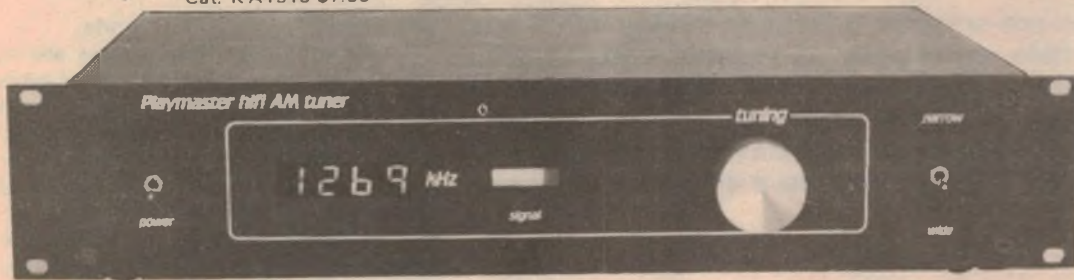

Australia is one of the few countries in the world where wideband AM is transmitted. In fact a good quality AM signal can be much better than its FM counterpart!! Anyone who has suffered from FM multipath distortion will know what we mean. The Playmaster AM tuner is a true broad-bandwidth superhet design. See the frequency response graph in November EA 1982. Once again, the Jaycar kit is a high quality approach. Jaycar supplies an exclusive front panel design that differs from the original EA design. The Jaycar kit provides all components to complete the project INCLUDING a completely pre-punched cabinet.

FANTASTIC VALUE AT ONLY

\$249

Cat. KA1498

NEW FUEL CONSUMPTION METER

Ref: EA March 1983

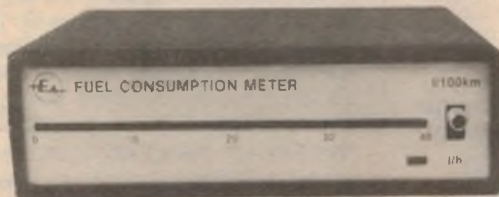

Now you have NO EXCUSE to monitor the excesses of your driving habits! At this price your fuel cost savings will pay for the unit very quickly! Kit including all electronics and pre-punched case —

Cat. KA1518 \$49.50 GENUINE MORAY FUEL SENSOR Cat. XC2020 \$69.50 TAILSHAFT SENSOR TO SUIT Cat. XC2026 \$14.50

TRANSISTOR ASSISTED IGNITION

Ref: EA January 1983. Latest version of this fantastically popular kit!! The Jaycar kit comes with a genuine DIE CAST box — as used in the EA prototype. Beware of others that use flimsy sheet metal boxes!! Ask us about the OPTO option.

Cat. KA1506



ONLY \$35

NEW EPROM programmer for the MicroBee

Fantastic little accessory for the popular "MicroBee" computer. The Jaycar kit contains all components including the following SPECIAL features:

- 28 pin IC socket included!
- 3 x 16 pin "PERSONALITY PLUG" HEADERS
- 15 pin PARALLEL CONNECTOR
- IC sockets for all logic devices including personality socket.

ALL THIS FOR ONLY \$39.95!

Cat. KE4650

24 pin ZIF socket to suit only \$12.95 Cat. P16522



Jaycar NUMBER 1 FOR KITS

225 YORK STREET SYDNEY 2000
PHONE 264 1616 TELE 72273
78 VILLES CORNER
C/O CARLINGFORD & PENNANT HILLS ROAD
CARLINGFORD
PHONE 872 4833
MAIL ORDERS TO: BOX K 22 MARLBOROUGH SYDNEY 2000
POST AND PACKING CHARGES:
NSW \$5.95 (incl GST) SA \$6.95 (incl GST)
VIC \$6.95 (incl GST) WA \$6.95 (incl GST)
QLD \$6.95 (incl GST) NT \$6.95 (incl GST)
TAS \$6.95 (incl GST)

Mail Order By **BANKCARD** Via Your Phone



Universal preamplifier for MC cartridges

The Universal Phono pre-amplifier described in May 1982 was one of our best to date, particularly as regards signal-to-noise ratio. Nevertheless, the S/N ratio was a compromise between the needs of both the moving magnet and moving coil cartridges it was designed to serve. This article explains how to optimise it for moving coil cartridges, for those who have an exclusive need.

Before delving into the actual modification, it may be helpful to look at the whole subject of signal-to-noise (S/N) ratio in pre-amplifiers, some of the factors effecting it, how it is measured, and some of the limitations of current measuring standards.

The IHF-A-202 "Standard Methods of Measurement for Audio Amplifiers, 1978" specifies a standard input (source)

termination of 100Ω and a standard input reference level of 500μV at 1000Hz for moving coil (MC) amplifier inputs. These specifications can produce results which are quite misleading. For example, many pre-amplifiers quote basically similar S/N figures (around 75dB) for both MC and MM (moving magnet) modes, yet even the untrained ear can detect that the noise is noticeably increased when the

pre-amplifier is in the MC mode.

To illustrate why these figures are so unrealistic, let us consider the figures specified for the MM type pickup. These call for a source of termination of 1000Ω and an input of 5mV at 1000Hz. These figures are quite realistic and are based on the assumption that most MM cartridges generate 1mV/cm/s, and that the reference level for disc recordings lies between 3.5 and 5cm/s.

By comparison, typical MC cartridges produce only 20 to 30μV/cm/s, or about 100 to 150μV from the same 3.5 to 5cm/s disc reference level. On this basis the IHF figure of 500μV is between four to five times (12 to 14dB) higher than practical output figures. On this basis we suggest that a more practical reference level would be between 100 and 150μV; the lower figure for preference.

A second important factor in assessing signal-to-noise ratio is the source, or cartridge, resistance. Ideally, the S/N ratio of an amplifier should improve by 10dB for every decade that this resistance is reduced, ie, a 10Ω source resistance should produce a 10dB improvement over a 100Ω value. And, while the IHF standard specifies 100Ω as the test value for MC cartridges, typical cartridges have values considerably less than this, many lying in the region two to 10Ω.

Thus an amplifier designer who tests an MC amplifier on the basis of the IHF standard, with a 100Ω source resistance, may be inadvertently underrating his amplifier's capability, when used with a typical (say) 10Ω cartridge. Alternatively, two different amplifiers, with identical MC S/N ratios, according to the IHF standard, can produce quite different results when tested with a practical cartridge of only 10Ω.

More realistically, S/N ratios for an MC input should be quoted for source resistances of not only 100Ω, but also for 10Ω and short circuit. This would give a far clearer picture of the performance of the preamplifier and also give some indication of the noise versus resistance trend.

All of which is simply by way of leading up to some practical changes to our Universal Phono Preamplifier, and the

Moving Coil Mode

Noise below 500μV input level at 1kHz

Input Termination	May 1982 version (LM394s)	New version (2SC2545)
Open circuit	75dB	77dB
100Ω	77dB	78dB
10Ω	78dB	82.5dB
Short circuit	79dB	84dB

Moving Magnet Mode

Noise below 5mV input level at 1kHz

Input Termination	May 1982 version	New version
Open circuit	66dB	64dB
22kΩ	74dB	72.5dB
18kΩ	75dB	73.5dB
* 10kΩ	77.5dB	76.5dB
1kΩ	86dB	85.5dB
100Ω	91dB	91dB
10Ω & short circuit	91dB	91.5dB

The above tests were made with a 20Hz to 20kHz bandwidth, unweighted.

*Approximately equivalent to a Stanton 500 cartridge.

Four 2SC2545 transistors are used in each channel for optimum MC signal/noise ratio.

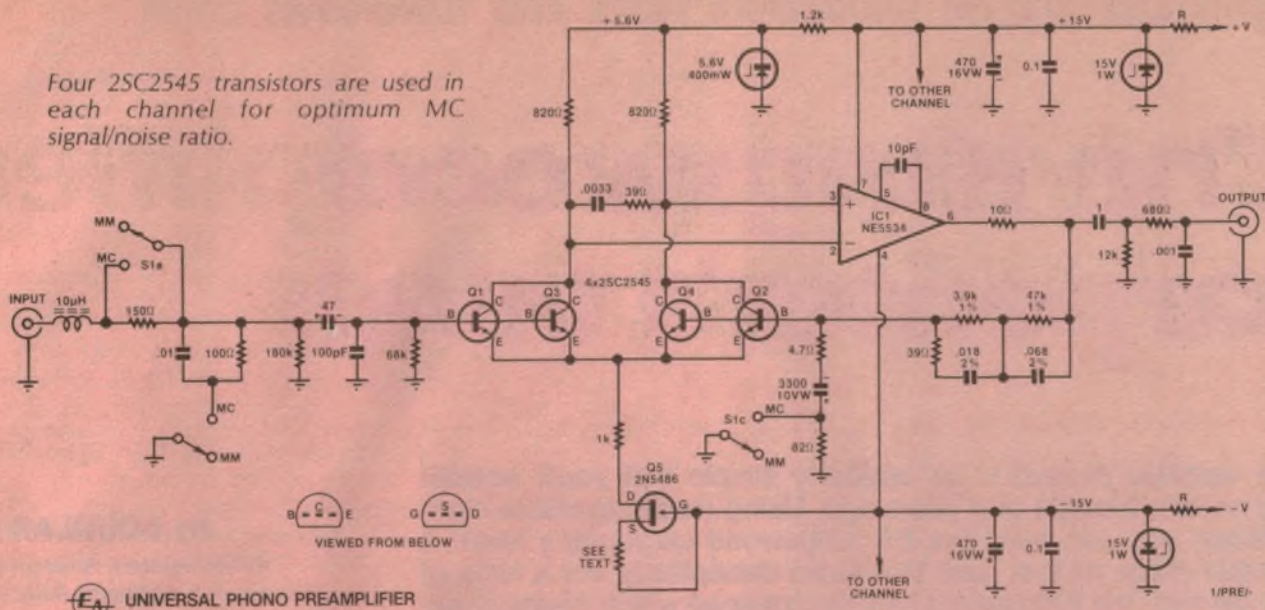

UNIVERSAL PHONO PREAMPLIFIER

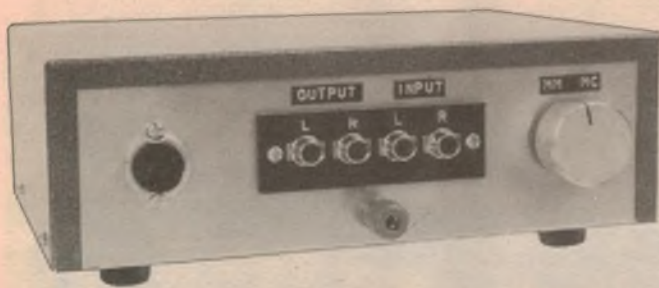

results we achieved with them. As originally presented this amplifier showed a change of only 1dB for an input termination change from 100Ω to 10Ω. This wasn't as bad as it sounds, considering that it was a dual purpose. MM/MC amplifier which was not really optimised for either mode.

4dB improvement

Subsequently, we investigated the possibility of improving on these figures by optimising the characteristics for MC cartridges – albeit with a probable trade-off in S/N ratio for MM cartridges. And we are pleased to report that we have been able to achieve a 4dB improvement in S/N ratio when operating from a 10Ω source.

As expected, the S/N ratio for the MM mode deteriorated (by approximately 1.5dB), but which is still a more than satisfactory performance. And it does seem to prove that, in its original form, this offered what was probably the best compromise between the MM and MC codes.

So, if you are interested in the MC mode, here's how to get that extra 4dB of snush. The design of a low noise preamplifier hinges on using low-noise input transistors with a very low intrinsic

base resistance. Intrinsic base resistance varies inversely as the collector current density, but tends to level off as the current density is increased above a level where the transistor characteristics become non-linear.

To further complicate matters, transistor noise increases directly as the collector current is increased, so that there is an optimum current density beyond which the increase in noise offsets the decrease in intrinsic base resistance (and the decrease in noise which it provides).

At the time of writing the two transistors best suited to this circuit are the National Semiconductor LM394 (as used in the original), and the Hitachi 2SC2545. The latter was tried in the original circuit, and its high order of performance confirmed, but it was not available in quantity. This situation has now changed. (There may be other types which would suit, but we are not aware of them.)

Investigating the 2SC2545 we found that it is capable of approximately 2dB better noise than the LM394 when operating from source resistance of 10Ω or less. In fairness, however, the situation appears to reverse when the source resistance is increased above 1000Ω, the LM394 giving slightly better results in these circumstances.

By paralleling the first stage transistors

If the best signal-to-noise ratio figures are to be achieved the case needs to be of all-steel construction.

we halve the intrinsic base resistance (provided the h_{ie} figures are reasonably matched) and this is the major contribution to the 4dB improvement. However, it was also necessary to increase the current density to optimise the 2SC2545 operating conditions.

The exact changes are shown on the accompanying modified circuit, but are as follows.

- (1) The 2.2kΩ decoupling resistor between the +15V rail and the 5.6V zener diode is reduced to 1.2kΩ.
- (2) The two LM394s are replaced with four 2SC2545 connected as parallel pairs.
- (3) The 2N5485 FET is changed to a 2N5486, with a 2N5489 as a second but less desirable choice.
- (4) The 2.7kΩ resistor between the 2SC2545 emitters and the 2N5486 drain is reduced to 1kΩ.
- (5) The 390Ω resistor between the 2N5486 source and gate is changed to a value, determined experimentally, which increases the total input stage current density from an original 1.7mA to 4.9mA.

(Component numbers quoted are for one channel only.)

Some of the voltages shown on the original circuit will also be changed as follows.

Input stage collectors: +3.6V (was +4.9V)

Input stage bases: -0.3V (was 0.1V)

Input stage emitters: -0.9V (was -0.7V)

FET drain: -5.8V (was -5.5V)

Details of the improved performance figures are given in the accompanying panel.

Hitachi low-noise 2SC2545 transistors are available as a stock item from Jaycar Pty Ltd.

Special April project has no special use

The Kingswood carpenter's level

This versatile project is so devilishly simple that you'll wonder why no one thought of it years ago. Using readily available components, you can build the EA Kingswood carpenter's level. A valuable piece of test gear that looks deceptively like a lump of four-be-two, the Kingswood has performance which meets or exceeds the rigorous TABSA* standards.

by DOUGLAS FIR

*Timbergetters' Amateur Brain Surgeons Association

Amongst other functions, the Kingswood can be used as a spirit level although it doesn't use anything as unscientific as spirit. Instead, it has two mercury switches driving LED indicators. In this way, the level can provide precision measurements of better than $\pm 45^\circ$. In addition to a multitude of measurement applications, the Kingswood — with its genuine woodgrain finish — will complement any decor. In fact, it will look so good, your friends will never believe you built it yourself!

Whereas a normal spirit level is difficult to use when the light fails, the LED indicators of the Kingswood electronic level enable it to be used in total darkness. What a boon this will prove to handymen and tradesmen who will now be able to finish their jobs without even being able to see the work!

A LED is mounted at each end of the device and, in the event of an imbalance, one of these will be illuminated. It is placed on the item to be tested in the same way as a conventional level. When a LED is lit, that end is high.

The mercury switches are fixed to adjustable mounting plates and this facilitates calibration. Once the device is in a known level attitude, the mounting plate for each switch is adjusted to the point where the LEDs are just extinguished. This can be checked with a spirit level.

A problem which quickly became apparent with the prototype level was that the mercury switches have a large amount of hysteresis. Irrespective of our efforts to critically adjust the device, the LEDs would remain extinguished over a large range of angles. In practice, this can be partially overcome by taking measurements at the point where the



The Kingswood — not quite on the level! Don't forget the greasy handprint.

LED just extinguishes rather than the point where it just illuminates. This may require that one end of the level be lifted manually to trigger one of the LEDs. If the LED extinguishes when the level is lowered, the item under test is very nearly level.

Even if you have no interest in building, the Kingswood may still prove a worthwhile project. For example, if you are concerned with the safety of crawling insect repellents, it is definitely for you. Totally effective against dirty, disease carrying insects, it is entirely safe for humans and is also available in a

range of low irritant fragrances.

An integral handle provides the Kingswood with easy portability so that you need never be without it. Hence you can enjoy the prestige and security of your own lump of four-be-two wherever you go. Imagine the advantages — a guaranteed seat on the train every day, no approaches from religious cults seeking donations, immediate attention in busy banks and stores and many others. Of course, to derive the maximum advantage from the Kingswood, it must be used with the correct facial expression; the mouth must be set into a vicious sneer and the whites of the eyes must be prominently displayed.

Profuse salivation tends to improve the results.

You may well ask how such a project came about. It all started when one of our staff members spotted a damaged cargo pallet in the Magazine Promotions basement. To most people, this would have looked like nothing more than a

We estimate that the current cost of this project is more than it is worth.

\$?

This includes sales tacks.

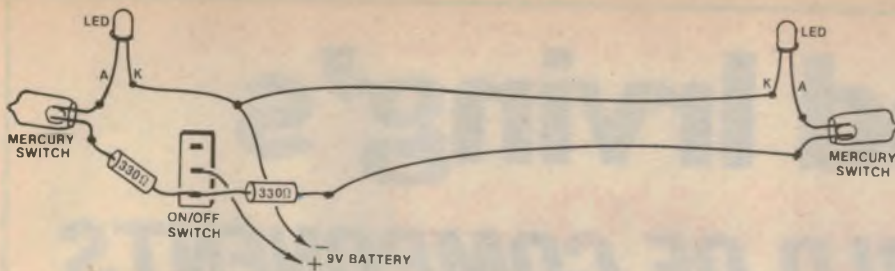

Wiring diagram for the Kingswood carpenter's level. At least one component can be eliminated – no prizes for guessing which one.

pile of broken timber. With an uncharacteristic burst of perception (he's still recovering) the said staff member recognized the basis of a project. Working with the kind of inspired dedication that usually only punctuates his pay day, the timber was miraculously transformed. Hence, in a fit of demented enthusiasm, the EA Kingswood was born and, of course, you reap the benefit!

The most difficult aspect of construction is transforming a normal lump of four-be-two into a genuine Kingswood. Note that only four-be-two is suitable for this application – we understand that some kit sellers intend to supply 100 x 50mm, but don't be conned. Proper four-be-two it must be. The length of the finished item must be 1023.75mm on the bottom and a bit shorter on the top.

It is essential that all the splits, dents and other forms of damage be installed properly. For an expert job, send the Kingswood for a long trip on a NSW freight train. Interstate or NZ readers should air freight their Kingswood to NSW to take advantage of our excellent service in this respect. The greasy hand prints can be obtained free of charge at most garages.

The switch mounting plates can be cut from a sheet of timber approximately 5mm thick using a hole saw of about 35mm. As you can see from the accompanying photograph, most of the components are recessed into the timber. The mounting plate recesses can also be cut with the 35mm saw and a slightly larger one can be used to cut cover plates if they are required. As far as the battery compartment is concerned, the best method is probably to use a sharp chisel. This is likely to be a time-

consuming process, so any intelligent constructor will probably give up at this stage.

What, still persevering? Well then, glue the mercury switches to their mounting plates. They should form a complementary pair, ie, a mirror image of each other. A point to watch is the orientation of the switch contacts. With the plate lying on a horizontal surface, the contacts should be side by side – not one above the other. This seemingly minor detail makes a significant difference to the amount of hysteresis.

Most of the foregoing components can be regarded as optional, but we have now come to the one accessory which can be regarded as essential to the Kingswood – namely, the handle. Our handle was borrowed from an EA high power inverter. Inverter kits are available for about \$200, and as an added advantage, they have two handles. Why not build two Kingswoods!

Wiring for this project is really quite simple. You'll need two bits of wire whose length is determined by the ratio of the Kingswood to the speed of light in a glass of milk divided by the supplementary number of three or four other bits which are shorter by the square of the number you first thought of. Solder them to any parts which look as though they ought to have something soldered to them and which might otherwise be inclined to fall out when the device is processed by a garbage compactor.

If all this leaves you feeling a little confused, refer to the wiring diagram but whatever you do, don't refer to me. I'll be on leave or completing my psychiatric treatment.

More ideas to use

the Boschert

3-terminal regulators.

Here are some more ideas for these flexible, efficient 25KHz 3-terminal switching regulators. Each unit provides a single, adjustable, regulated output from raw positive DC sources. You can also get a negative output from a positive input. They are complete functional blocks and no complex circuitry is necessary to make them operate.

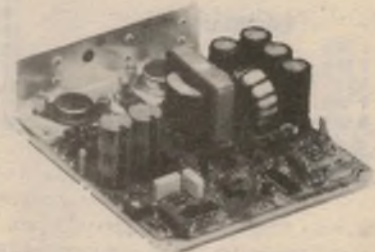

Model	Input	Output
3T12AP4030	+ 10 to 40V	+4.5 to 30V, 12A
3T12AP6030	+ 20 to 60V	+4.5 to 30V, 12A
3T5AN4030	+ 10 to 40V	-4.5 to -30V, 5A
3T20AP6015	+ 20 to 60V	+4.5 to 15V, 20A

More ideas:

Typical Connection

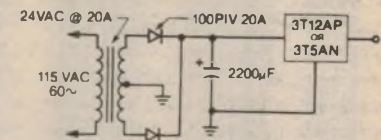

Higher input voltages to the 3T module will reduce stress on the rectifier diodes, input capacitor and 3T module.

High Voltage Power Distribution

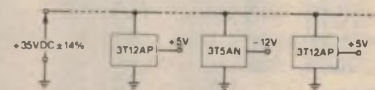

Minimises IR drops, provides excellent local regulation, accepts wide input voltage range, including brownout.

Prices: 5 and 12A versions, \$130, 20A version \$165. Sales Tax and freight is additional. Quantity discount is available.

AMTEX

ELECTRONICS

11 Spring Street,
Chatswood 2067

Phone: (02) 411 1323

Fundamentals of SOLID STATE



FUNDAMENTALS OF SOLID STATE

Fundamentals of Solid State is in its second reprinting, showing how popular it has been. It provides a wealth of information on semiconductor theory and operation, delving much deeper than very elementary works, but without the maths and abstract theory which make many of the more specialised texts very heavy going. 'Solid State' has also been widely acclaimed in colleges as recommended reading – but it's not just for the student. It's for anyone who wants to know just a little bit more about the operation of semiconductor devices.

Available from "Electronics Australia", 57 Regent St, Chippendale.
PRICE: \$3.50 OR by mail order from "Electronics Australia", PO Box 163, Chippendale 2008. PRICE: \$4.40.



Rod Irving's

WIDE WORLD OF COMPONENTS

THIS MONTH'S SPECIALS

EXPIRES 30TH APRIL 1983

VERBATIM DISCS

5 1/4 S.S.D.D.	\$36.00	Box/10
5 1/4 D.S.D.D.	\$49.00	Box/10
8" S.S.S.D.	\$38.00	Box/10
8" D.S.D.D.	\$54.00	Box/10

CRYSTALS

1 MHz	6.00
2 MHz	4.00
3.579 MHz	1.00
4 MHz	2.00
8 MHz	2.00
12 MHz	2.00
16 MHz	2.00
32 MHz	2.00

IC SOCKETS ECONOMY LOW COST

	1.9	10.25	25+
8 PIN	30	.25	20
14 PIN	40	.30	25
16 PIN	40	.35	30
18 PIN	50	.45	40
20 PIN	55	.50	45
22 PIN	60	.55	50
24 PIN	60	.55	50
28 PIN	60	.55	50
40 PIN	70	.60	55

PRECISION MACHINED GOLD INSERT

	1.9	10.25
8 PIN	1.20	1.00
14 PIN	1.60	1.40
16 PIN	1.90	1.70
18 PIN	2.00	1.80
20 PIN	2.20	2.00
22 PIN	2.40	2.20
24 PIN	2.60	2.40
28 PIN	2.90	2.70
40 PIN	4.40	4.00

WIRE WRAP SOCKETS

	1.9	10.25	25+
8 PIN	1.20	1.00	80
14 PIN	1.40	1.20	1.00
16 PIN	1.60	1.40	1.20
18 PIN	1.90	1.70	1.50
20 PIN	2.20	2.00	1.80
22 PIN	2.40	2.30	2.10
24 PIN	2.50	2.30	2.10
28 PIN	2.80	2.60	2.50
40 PIN	3.30	2.90	2.60

NORMAL STOCK LINES

ERRORS AND OMISSIONS EXCEPTED

6821	1.20	74S132	3.50	74S482	11.90	74C85	2.30	74LS04	30	74LS148	1.20	74LS326	2.20	6507	11.00	LM10CH	7.50	LM709-14	1.00
2650	15.00	74S133	1.20	74S289	7.90	74C86	1.20	74LS05	35	74LS151	90	74LS327	2.20	6520	5.50	LM301	50	UA710CN	1.00
2651	12.00	74S134	1.40			74C89	6.90	74LS08	30	74LS152	1.95	74LS352	2.20	5521	5.90	LM301H	1.50	LM711	1.20
BD139	35	74S135	2.30	74H		74C90	1.60	74LS09	30	74LS153	70	74LS353	2.20	5522	10.00	LM302H	6.50	LM723	.75
BD140	35	74S138	3.30	74H00	80	74C93	1.50	74LS10	30	74LS154	1.75	74LS354	3.95	5522A	11.00	LM305H	1.50	LM723CH	1.50
LM3915	3.20	74S139	3.30	74H01	80	74C95	1.80	74LS11	30	74LS155	1.20	74LS365	60	5532	60	LM307CN	1.00	LM725	4.75
LM380	1.00	74S140	1.90	74H02	80	74C107	2.20	74LS12	30	74LS156	1.20	74LS366	60	5545	60	LM308	1.00	UA739	2.75
TEA1002	14.50	74S151	3.10	74H03	80	74C150	6.50	74LS13	50	74LS157	60	74LS367	60	6551	12.90	LM308H	1.80	741	.50
4164	5.50	74S152	2.90	74H04	90	74C151	4.20	74LS14	60	74LS158	80	74LS368	60	2650	23.00	LM309K	1.90	UA747	1.30
74C926	5.50	74S153	3.10	74H05	90	74C154	6.00	74LS15	30	74LS160	80	74LS373	1.50	2651	8.00	LM310N	3.20	UA748	.80
ICL7106	12.50	74S154	2.90	74H06	110	74C157	3.75	74LS16	45	74LS161	45	74LS374	1.75	6802	10.00	LM310H	3.20	MC1310	9.50
ICL7107	15.50	74S155	3.10	74H07	80	74C160	1.90	74LS19	45	74LS162	45	74LS375	85	6808	12.50	LM311	.80	MC1312	6.90
ICL7109	27.50	74S156	5.90	74H10	80	74C161	1.90	74LS20	30	74LS163	30	74LS377	2.15	6809	17.00	LM311H	1.80	MC1314	6.90
ICL7116	21.50	74S157	5.90	74H11	80	74C162	2.00	74LS21	30	74C164	2.00	74LS378	1.90	6810	3.50	LM311H	2.50	MC1315	7.50
ICL7117	21.50	74S158	7.90	74H12	80	74C163	2.00	74LS22	30	74C165	1.90	74LS379	1.90	6820	5.50	LM317K	4.50	MC1327	6.50
ICL7660	4.90	74S159	11.50	74H15	80	74C166	1.90	74LS24	55	74C173	1.50	74LS386	5.50	6821	1.80	LM319	3.50	MC1350	1.30
ICL7663	4.90	74S160	4.50	74H20	90	74C167	1.90	74LS26	30	74C174	1.50	74LS390	1.80	6822	1.80	LM319	3.50	MC1408L	7.50
ICL7664	4.90	74S161	4.50	74H21	90	74C173	1.50	74LS27	35	74C175	1.50	74LS393	1.80	6844	6.50	LM319	1.20	MC1437	3.50
ICM7211	12.50	74S162	4.50	74H22	90	74C174	1.50	74LS28	35	74C192	1.90	74LS395	2.00	6844	15.00	LM324	1.50	MC1445	3.75
ICM7261A	47.50	74S163	8.50	74H40	90	74C175	1.50	74LS30	30	74C193	1.90	74LS396	2.50	6347	32.00	LM325	4.50	MC1456	1.50
ICM7216B	42.50	74S164	8.50	74H50	90	74C192	1.90	74LS32	30	74C195	1.90	74LS398	3.00	6850	7.50	LM326	4.50	MC1458	1.20
ICM7217A	18.50	74S165	8.50	74H52	90	74C193	1.90	74LS33	35	74C199	1.90	74LS400	5.50	6865	10.00	LM344Z	1.70	MC1466L	14.50
ICM7218A	18.50	74S166	3.30	74H53	90	74C195	1.90	74LS37	35	74C200	14.00	74LS419	80	6875	13.50	LM335Z	2.20	MC1469R	6.90
ICM7224A	48.50	74S167	2.90	74H54	90	74C200	14.00	74LS38	40	74C221	2.40	74LS192	80	74LS441	5.50	280CPU	7.00	MC1488	1.20
ICM7226A	48.50	74S168	2.90	74H55	90	74C240	2.60	74LS40	40	74C242	2.60	74LS193	80	74LS442	5.50	280CPU	8.00	MC1489	1.20
ICM7227A	18.50	74S169	2.90	74H60	90	74C244	2.60	74LS42	80	74C246	2.60	74LS194	80	74LS443	5.50	280CPU	16.00	MC1494	7.50
ICM7231A	15.50	74S170	2.90	74H61	90	74C373	3.00	74LS47	180	74C374	3.00	74LS195	1.25	74LS445	2.20	280CPU	4.50	MC1495	6.90
ICM7240	7.50	74S214AN	P.O.A.	74H62	90	74C374	3.00	74LS48	180	74C901	1.50	74LS196	1.25	74LS446	5.50	280AP10	6.50	LF351-N	80
ICM7242	3.90	74S225	10.90	74H64	90	74C902	1.00	74LS54	40	74C902	1.00	74LS197	1.20	74LS447	5.50	280ACT	6.50	LF356N	1.40
ICM7250	7.90	74S226	7.90	74H65	90	74C903	1.00	74LS55	40	74C903	1.00	74LS221	1.20	74LS448	5.50	280ACT	8.50	LF357	1.40
ICM7260	7.90	74S240	6.90	74H71	1.40	74C903	1.00	74LS55	40	74C904	1.00	74LS222	1.20	74LS449	5.50	280DMA	16.00	LM1596	2.30
ICM7555	1.90	74S241	6.90	74H72	1.20	74C904	1.00	74LS63	2.80	74C904	1.00	74LS224	1.20	74LS490	3.20	280ADMA	19.00	LM1812	10.50
ICM7556	2.50	74S244	9.90	74H73	1.80	74C905	15.00	74LS73	50	74C905	15.00	74LS242	1.50	74LS490	3.20	280AS10	19.00	LM1830	3.90
		74S251	3.90	74H74	1.80	74C906	1.00	74LS74	50	74C906	1.00	74LS243	1.50	74LS541	11.95	280S10	16.00	LM2907	3.50
		74S253	4.90	74H76	1.90	74C907	1.00	74LS75	50	74C907	1.00	74LS244	1.50	74LS562	2.75	AY-3-8910	14.50	LM2917 14 pin	3.40
		74S257	3.30	74H78	1.90	74C908	1.70	74LS76	55	74C908	1.70	74LS247	1.50	74LS562	2.75	AY-3-2513	14.50	LM379-S	7.95
		74S258	3.30	74H87	7.90	74C910	1.70	74LS77	55	74C910	1.70	74LS248	1.40	74LS562	2.75	AY-3-2513	14.50	LM380 8 pin	1.40
		74S260	2.90	74H101	1.80	74C911	1.25	74LS78	55	74C911	1.25	74LS248	1.40	74LS562	2.75	MM5303	7.50	LM380 14 pin	1.50
		74S274	P.O.A.	74H102	1.80	74C912	12.50	74LS78	55	74C912	12.50	74LS248	1.40	74LS562	2.75	S1883	8.50	CA3028	2.00
		74S275	P.O.A.	74H103	2.50	74C914	2.50	74LS83	100	74C914	2.50	74LS249	1.30	74LS562	2.75	S1883	8.50	CA3046	1.90
		74S280	P.O.A.	74H106	2.50	74C915	2.00	74LS86	70	74C915	2.00	74LS251	90	74LS562	2.75	MM5303	7.50	CA3056	6.50
		74S281	P.O.A.	74H108	2.50	74C917	12.50	74LS90	40	74C917	12.50	74LS252	90	74LS562	2.75	LMH002CH	7.50	CA3059	5.95
		74S282	9.90	74H113	1.10	74C918	1.90	74LS91	70	74C918	1.90	74LS253	90	74LS562	2.75	LMH007H	7.50	CA3080	1.50
		74S283	3.30	74H114	1.10	74C920	12.50	74LS92	70	74C920	12.50	74LS254	90	74LS562	2.75	LMH071	7.50	CA3086	1.80
		74S287	3.30	74H114	1.10	74C921	12.50	74LS93	65	74C921	12.50	74LS255	90	74LS562	2.75	LMH071	7.50	CA3089	3.90
		74S288	3.60	74H183	7.90	74C922	6.50	74LS93	65	74C922	6.50	74LS256	90	74LS562	2.75	LMH071	7.50	CA3130E	1.60
		74S299	13.90			74C923	6.50	74LS96	100	74C923	6.50	74LS257	90	74LS562	2.75	LMH071	7.50	CA3130T	1.90
		74S301	12.90	74C		74C925	7.90	74LS107	60	74C925	7.90	74LS258	90	74LS562	2.75	LMH071	7.50	CA3140E	1.60
		74S314	P.O.A.	74C00	60	74C926	7.90	74LS109	60	74C926	7.90	74LS259	90	74LS562	2.75	LMH071	7.50	CA3140T	1.90
		74S330	P.O.A.	74C02	60	74C927	7.90	74LS112	60	74C927	7.90	74LS260	90	74LS562	2.75	LMH071	7.50	LM3401	1.20
		74S337	P.O.A.	74C04	60	74C928	8.00	74LS113	60	74C928	8.00	74LS261	90	74LS562	2.75	LMH071	7.50	LM3401	1.20
		74S373	9.90	74C08	60	74C929	8.00	74LS114	60	74C929	8.00	74LS262	90	74LS562	2.75	LMH071	7.50	LM3401	1.20
		74S374	9.90	74C10	60	74C930	9.50	74LS114	60	74C930	9.50	74LS263	90	74LS562	2.75	LMH071	7.50	LM3401	1.20
		74S381	9.90	74C14	1.00	74C930	2.75	74LS122	90	74C930	2.75	74LS264	90						



3C141E	1.95	BF458	1.00	TIP122	3.45	2N5656	2.50	74109	60	9305	2.40	8379	1.50	OPTO	OM350	9.50	4096	2.40	
3C142D	2.95	BF459	1.00	TIP125	2.90	2N5770	3.00	74110	80	9307	3.80	8282	6.90	4N25	1.20	IM65X08CPE	5.00	4097	6.50
3C146D	2.85	BF469	90	TIP127	3.40	2N5777	1.50	74111	80	9308	2.60	8283	6.50	4N26	1.20	XR2206	6.50	4098	2.90
3C146M	2.95	BF470	90	TIP145	3.40	2N5830	3.00	74112	80	9309	2.40	8284	8.50	4N27	1.20	XR2207	6.50	4099	3.90
3C150D	4.95	BF494	90	TIP2955	1.90	2N5831	3.00	74113	80	9310	1.50	8286	6.50	4N28	1.20	XR2208	4.90	4104	6.90
3C151D	2.95	BF495	90	TIP3055	1.90	2N5873	1.40	74114	80	9311	2.50	8287	6.50	4N29	1.50	XR2209	5.90	4160	1.25
CI030YY	90	BFW10	1.50	2N301	4.00	2N5874	1.70	74120	1.65	9312	2.50	8288	25.00	4N30	1.60	XR2210	6.90	4161	1.25
CI038	90	BFW11	1.50	2N697	1.00	2N5944	15.50	74121	65	9313	6.00	8289	73.00	4N32	2.50	XR2216	4.90	4162	1.25
CI068	90	BFW16	1.50	2N918	1.00	2N5945	18.50	74122	65	9314	2.40	8291	43.00	4N33	2.50	XR2220	4.90	4163	1.25
CI06D	90	BFY50	1.20	2N1304	1.00	2N5946	19.50	74123	60	9316	1.90	8292	34.50	4N35	2.50	XR2242	4.90	4174	1.25
CI22D	2.50	BFX90	1.50	2N1613	1.20	2N5951	1.90	74125	35	9317	2.60	8293	10	4N37	2.00	XR2243	5.90	4175	1.60
CI22E	2.95	BU126	2.50	2N1202	1.90	2N6027	1.00	74126	60	9318	4.60	8741	57.50	MCT95	2.50	XR8038	6.50	4194	1.95
SC260D	8.50	BU208	3.90	2N2219	1.90	2N6049	1.90	74128	1.80	9319	2.00	8748	23.50	MCT65	6.90	IC71660	12.50	4402	1.00
SC260F	9.50	BU326	3.00	2N2222A	1.00	2N6080	8.50	74132	80	9320	6.90	8749	58.50	MCT2	1.50	95H90	8.50	4404	1.15
2N2646	1.20	BUX80	4.90	2N2369	1.00	2N6083	17.90	74136	55	9321	2.40	8755	33.50	1LD74	5.90	11C90	16.50	4408	6.90
2N2647	2.50	MFE131	2.90	2N2484	1.00	2N6084	22.50	74138	1.80	9322	1.90	2911	26.50	1LD74	6.50	LM7555	1.90	4409	13.50
2N6027	90	MFE3001	9.90	2N2646	1.20	2N6124	1.90	74139	1.00	9324	1.40	2912	27.50	FND357	1.80	MC10116L	1.50	4410	11.50
		MFE3003	6.95	2N2647	2.50	2N6125	1.90	74141	1.10	9328	4.90	2920	239.00	FND500	1.80	LF13741	80	4411	12.60
		MJ413	5.90	2N2894	1.00	2N6130	1.90	74142	1.45	9334	6.00	3205/8205	9.90	FND507	3.80	LF13741-H	1.50	4412	4.5
TRANSISTORS		MJ802	7.50	2N2904	1.10	2N6133	1.90	74143	1.45	9338	5.90	3242	17.50	FND800	1.50	DS75451	60	4415	10.15
AC125	1.20	MJ901	4.50	2N2905	1.10	2N6256	13.50	74144	3.90	9340	9.90	3245	10.90	T1L31A	2.95	DS75452	60	4416	6.0
AC126	1.20	MJ1001	3.90	2N2906	1.10	2N6259	13.50	74145	1.45	9342	5.90	3628	18.50	T1L81C	2.95	DS75491	2.00	4419	3.45
AC128	1.20	MJ1101	3.90	2N2907	1.10	2N6274	29.50	74147	1.95	9368	2.20	8008-1	62.50	T1L306	14.50	DS75492	2.00	4422	9.50
AC187	1.50	MJ1101S	14.50	2N3019	1.90	2N6378	4.90	74148	1.40	9374	3.30	8031-3	29.50	BPW50	2.25	Z126A	41.50	4426	2.35
AC188	1.50	MJ11016	14.50	2N3053	4.50	2N6425	4.50	74150	1.15	9386	2.40	8035	7.50	COY89	1.50	Z126B	42.50	4428	1.75
AC149	3.40	MJ15003	6.50	2N3054	1.90	2N6578	5.90	74151	60	75107	2.50	8039	7.90	MOC3011	2.95	DM2500	16.00	MA4433	13.90
AC161	2.90	MJ15004	6.50	2N3055	1.20	3N201	1.50	74153	65	75110	2.50	FD1771	19.00	MOC3020	2.50	ACC0808	17.00	4435	7.95
AC162	2.90	MJ15024	10.00	2N3096	1.20	2SJ49	7.50	74154	1.15	75154	2.50	FD1791	35.00	MOC3021	2.95	ACC0808	17.00	4435	7.95
AF118	2.90	MJ2955	1.50	2N3109	1.90	2SK134	7.50	74155	8.5	75450	1.50	FD1793	35.00	OC0800	4.50	4441	1.50	4441	1.50
AF126	2.90	MJ3001	6.90	2N3251	1.90	7400	25	74156	1.45	75451	60	FD1795	35.00	LEDS	OC0800	3.50	4443	3.90	
AF127	1.50	MJ4032	12.50	2N3302	1.90	7401	30	74157	60	75452	60	FD1797	35.00	3mm RED	.25	SAK140	9.50	4445	2.65
BC107	5.0	MJ4035	11.90	2N3440	1.80	7402	25	74158	85	75453	60	WD1691	16.50	3mm YELLOW	.30	ZN414	1.95	4446	3.55
BC108	5.0	MJ4502	6.90	2N3441	2.90	7403	35	74160	85	75461	1.50	WD2143	12.50	3mm GREEN	.15	4000	40	4449	1.00
BC109	5.0	MJE340	2.00	2N3442	3.50	7404	30	74161	1.00	75462	1.50	WD1931	22.50	5mm RED	.15	4001	40	4450	3.75
BC159	5.0	MJE350	2.50	2N3563	3.0	7405	35	74162	1.00	75471	3.00	WD1933	34.00	5mm GREEN	.30	4002	40	4451	3.75
BC177	60	MJE371	2.90	2N3564	30	7406	40	74163	1.00	75472	3.00	WD1983	14.75	5mm YELLOW	.30	4006	1.60	4457	5.90
BC178	60	MJE521	2.50	2N3565	30	7407	40	74164	60	75491	2.00	WD1993	59.00	5mm ORANGE	.30	4007	5.00	4458	9.90
BC179	60	MJE700	3.00	2N3566	30	7408	40	74165	60	75492	2.00	WD2123	26.50	RED RECT	.30	4008	1.40	4469	14.90
BC212	30	MJE800	2.90	2N3567	30	7409	35	74166	1.35	75493	3.00	WD2050	3.00	GREEN RECT	.30	4009	6.00	4490	5.90
BC318	30	MJE2801	3.95	2N3568	30	7410	30	74167	2.20	75494	3.00	TR1602	8.50	YELLOW RECT	.30	4010	7.00	4493	3.95
BC320	40	MJE2955	4.90	2N3569	30	7411	35	74174	1.45	8121	4.00	TR1863	8.90	RED CHROME	.40	4011	40	4500	8.90
BC327	30	MJE3055	3.90	2N3638	30	7412	35	74175	8.5	8123	4.00	COM8116	24.00	BEZEL	1.20	4012	5.00	4501	5.0
BC328	30	MJE13005	5.90	2N3640	30	7413	50	74176	1.10	8130	6.00	BR1941	12.50	YELLOW CHROME	.40	4013	75	4502	1.80
BC338	30	MJE13007	7.90	2N3641	30	7414	70	74177	1.10	8131	3.95			BEZEL	1.20	4014	1.50	4503	9.0
BC546	40	MJE13009	12.50	2N3642	30	7415	35	74178	2.15	8135	2.15	8135	4.25	GREEN CHROME	.40	4015	95	4504	2.00
BC547	20	MPP121	2.50	2N3643	30	7416	60	74179	2.15	8136	4.25	74F00	79	BEZEL	1.20	4016	65	4506	7.5
BC548	20	MPP131	2.50	2N3644	30	7417	55	74180	90	8303	5.50	74F02	79			4017	1.20	4507	4.0
BC549	20	MPSA05	1.00	2N3645	30	7420	25	74182	90	8304	5.50	74F04	92	VOLTAGE REGS		4018	1.50	4508	4.50
BC550	40	MPSA06	1.00	2N3646	30	7421	40	74184	1.20	82523	4.50	74F08	79	7805UC	90	4019	60	4510	1.50
BC556	40	MPSA09	1.00	2N3702	1.20	7422	40	74190	1.00	825123	3.90	74F10	79	7805KC	2.00	4020	1.35	4511	1.50
BC557	20	MPSA10	1.00	2N3704	1.40	7423	45	74191	1.45	8311	4.87	74F11	79	7812UC	90	4021	1.10	4512	1.10
BC558	20	MPSA12	1.00	2N3706	1.40	7425	45	74192	1.65	8641	3.83	74F20	79	7812KC	2.00	4022	1.15	4513	2.65
BC559	20	MPSA13	1.00	2N3771	5.50	7426	35	74193	80	8820	4.95	74F22	16.50	7815UC	90	4023	40	4514	2.90
BC635	80	MPSA14	1.00	2N3772	5.70	7427	40	74194	1.10	8830	5.00	74F24	79	7815KC	2.20	4024	1.00	4515	2.90
BC636	80	MPSA20	1.00	2N3773	5.90	7428	40	74195	65	8831	5.00	74F74	89	7818UC	1.00	4025	40	4516	1.45
BC637	80	MPSA42	1.00	2N3792	6.00	7430	35	74196	85	8832	5.00	74F86	1.19	7818KC	2.20	4026	2.00	4517	8.75
BC638	80	MPSA43	1.20	2N3819	1.20	7432	35	74197	1.10	8833	4.90	74F109	99	7824UC	1.00	4027	60	4518	1.50
BC639	50	MPSA55	1.00	2N3866	2.95	7433	55	74198	1.10	8834	5.90	74F138	1.79	7824KC	2.40	4028	90	4519	9.0
BC640	50	MPSA56	1.00	2N3904	1.00	7437	40	74199	1.30	8835	4.00	74F139	1.79	7905UC	1.40	4029	1.20	4520	1.55
BCY70	1.90	MPSA63	1.00	2N3906	1.00	7438	45	74221	90	8836	2.00	74F151	1.79	7905KC	3.00	4030	60	4521	3.90
BCY71	1.90	MPSA65	1.00	2N4032	2.20	7439	70	74240	1.50	1488	1.20	74F153	1.79	7912UC	1.40	4031	2.50	4522	1.90
BD135	1.00	MPSA92	1.00	2N4033	2.20	7440	45	74241	1.50	1489	1.20	74F157	1.79	7912KC	3.00	4032	2.25	4526	1.85
BD136	90	MPSA93	1.20	2N4036	2.50	7442	50	74242	1.50	81S95	2.20	74F158	1.79	7915UC	1.50	4033	2.25	4527	2.65
BD137	90	MPP102	90	2N4121	1.50	7443	1.30	74243	1.50	81S96	2.20	74F175	2.24	7915KC	3.00	4034	3.00	4528	1.15
BD138	90	MPP103	90	2N4123	1.50	7444	1.10	74244	1.75	81S97	2.20	74F181	5.98	7918UC	1.50	4035	1.30	4529	1.80
BD139	90	MPP105	90	2N4236	1.90	7445	1.10	74245	1.75	81S98	2.20	74F182	2.73	7924UC	1.50	4038			



How to make a buzzer

A simple buzzer using junk box parts has often heralded the beginnings of a career in electronics. With a few simple parts, such as a piece of wood, a worn-out hacksaw blade, several bolts and some wire, a very effective buzzer can be made.

by JEFF SKEEN

Many people probably find electronics boring because very little "happens" in your average electronic circuit. There are none of those fantastic electrical explosions seen on TV (haven't they heard of fuses?) and very few robots waving their arms about and running berserk. We've yet to see an authentic ray gun project and a decent space invaders game is a little too complicated to build at home.

This simple buzzer should appeal to beginners as a first project since it moves and makes a noise, is easy and cheap to build, its operation is easily understood, and it will give you a tickle if you get across the coil. The buzzer is so easy to make in fact, that most kids should be able to construct it with little or no supervision. Once built, the buzzer can be modified to try ways to improve its performance, ie, increase its noise.

When power is applied to the circuit, current flows from the power supply, through the switch contacts formed by the hacksaw blade and the screw, through the coil, and back to the power supply. The current flowing through the coil magnetises the steel bolt and the head of this bolt then attracts the steel hacksaw blade.

The end of the hacksaw blade bends toward the bolt but in doing so breaks the electrical path by losing contact with the screw. Current then ceases to flow, as the bolt no longer acts as a magnet, so the blade returns to its original position and hits the screw. The circuit is now completed, current flows again, and the cycle is repeated.

In truth, this simple explanation has omitted to mention any effects which the coil inductance may have. This is done because the frequency of the buzzer is too low for most of these effects to become apparent. One effect which is not frequency dependent, and which can be felt by placing your fingers across the coil terminals, is the ability of the coil to generate a high voltage.

This comes about as the coil dissipates

the energy stored in its magnetic field as the switch contacts open. To understand this we need to examine one of the fundamental equations concerning inductance, $E = L di/dt$.

This formula states that the voltage across a coil is equal to the inductance of the coil (L) times the rate at which the current through the coil is changing (di/dt). Since we are using a switch which breaks the current flow almost instantly, di/dt is very large. Therefore the induced

or the coil will become very hot since it is not intended to dissipate much heat.

Initially the buzzer was constructed with the switch contact at the coil end of the hacksaw blade. This arrangement gave unsatisfactory operation because the screw lost contact with the hacksaw blade too quickly and there was not enough force between the blade and the screw to break through the insulating oxide layer on the blade.

Therefore the switch was moved to its

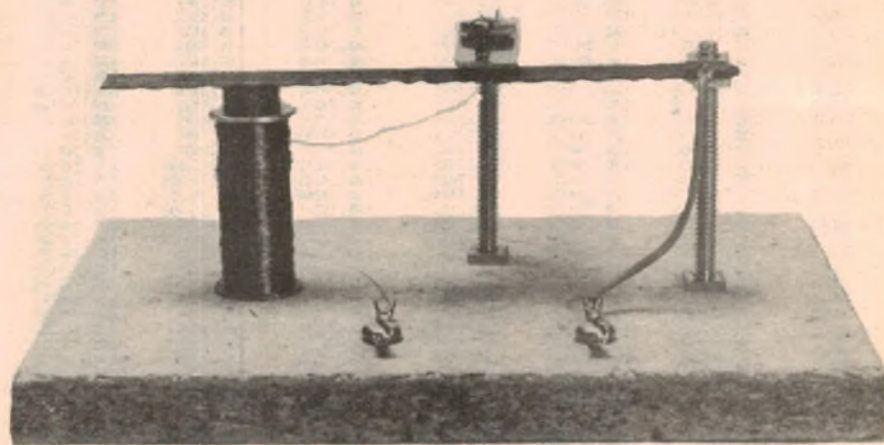

With parts from your junkbox, a very effective buzzer can be made.

voltage (E) is very large, large enough in fact to cause a spark to jump the airgap between the switch contacts. It is in this spark that the stored magnetic field energy is dissipated.

In practice, because the hacksaw blade moves relatively slowly, the airgap between the blade and the screw is quite small and the induced voltage is not great — just enough to tickle your fingers.

OPERATION

The buzzer will operate from DC supply voltages anywhere in the range 12 to 30V. Power is applied via the two front solder lugs and the polarity of the connections is unimportant. Do not operate the buzzer for long at the higher voltages

present location where leverage forces increase the contact pressure between the screw and the blade. Also, the length of time before the blade and the screw lose contact is increased because the blade bends from the end nearest the coil first and so must travel further before breaking contact with the screw. This allows a stronger magnetic field to build up and makes operation at lower voltages feasible.

The buzzer can be "tuned" by adjusting the self tapping screw forming the switch contact. In general, turning the screw clockwise will increase the buzzer frequency while turning the screw anticlockwise will decrease the frequency.

If the bolt around which the coil is

MAKING A BUZZER

wound is made from a magnetically hard material, it is likely that the bolt will remain magnetised (and continue to attract the hacksaw blade) even when no current flows. To stop the hacksaw blade sticking to the head of the bolt stick a piece of electrical tape to the head of the bolt. This effectively places an airgap between the hacksaw blade and the bolt reducing the residual magnetic field to the point where it is not strong enough to hold the bolt and hacksaw blade together.

CONSTRUCTION

The buzzer is constructed on a piece of scrap particle board about 12mm thick. Two mushroom head roof bolts are used to form the support pillars for the hacksaw blade and the switch contact. The bobbin around which the coil is wound is an old steel bolt, with two end-cheeks cut from scrap aluminium.

Aluminium, or some other non-magnetic material is preferred for the end-cheeks since this concentrates the magnetic field in the head of the roof bolt, increasing its pull on the hacksaw blade and making a better buzzer.

Three holes, forming the vertices of a triangle, are drilled in the particle board base for mounting the buzzer parts. Two of the holes are drilled to suit the roof bolts, the third hole is drilled so that the bolt used for the coil bobbin can be screwed directly into the wood. Distances between the vertices for our buzzer were 9.5, 5.5 and 5cm (see photo).

To make the bobbin, first mark and cut out the two end cheeks. The outside diameter of the cheek should be about 20mm, the hole through the centre of

each cheek is drilled to suit the diameter of the bolt being used. Place the end cheeks on the bolt and grip the bolt in the chuck of a hand drill so that there is a gap of 35mm between the two cheeks. Clamp the drill in a vice so that the handle and chuck are free to rotate and you are ready to commence winding the coil.

The wire used for the coil is .125mm diameter enamelled copper winding wire. This is sold by most electronics parts retailers in 25g spools which contain approximately 220m of wire. The content of one spool is required for the buzzer coil.

PARTS LIST

- 2 mushroom head roof bolts, 60 x 5mm and nuts
- 6 solder lugs
- 1 old hacksaw blade (or piece thereof)
- 1 mild steel bolt, about 50 x 6mm
- 1 25g spool of .125mm enamelled winding wire
- 3 10mm self-tapping screws
- 1 piece of aluminium sheet, 100 x 20 x 1mm
- 1 piece of scrap wood (particle board), 190 x 70 x 12mm
- 1 6cm length of hook-up wire

Wind the entire spool of wire evenly onto the bolt between the end cheeks. The wire is quite thin so exercise care while doing this. When finished, screw the bolt assembly into the hole prepared for it in the wooden base. Screw the roof bolts into position in the wooden base and lock them with nuts screwed down against the wood.

To obtain a piece of hacksaw blade the

correct length, (13cm in our case) place the blade in a vice and flex the unwanted section until it breaks off. Use carbon steel hacksaw blades since high speed steel blades do not break cleanly but tend to shatter into a number of pieces when broken.

The hacksaw blade can now be fixed onto the roofing bolt support with the aid of two nuts. The height of the blade should be adjusted so that it clears the head of the bolt by 2mm. If the hole in the hacksaw blade is too small for the roofing bolt, use a reamer or a round file to open the hole slightly. Do not use a drill, for in general, drills are too soft to make holes in hacksaw blades.

The switch contact is constructed by cutting out a small rectangle of aluminium sheet, 30 x 15mm. One end is drilled to fit the roofing bolt, the other end is drilled to suit a 10mm self-tapping screw. The self-tapping screw is located so that it will touch the hacksaw blade when the rectangle of aluminium is mounted on the roofing bolt. (see photo)

Electrical terminations are made via solder lugs. Four of these are fixed with a pair of self tapping screws to the particle board base, two allowing power to be connected to the buzzer and two providing electrical terminations for the buzzer components. Two more solder lugs are used to provide electrical terminations for the switch contacts. These lugs are placed under the top-most nut on each roofing bolt.

The coil is wired to the front left hand side lug and the lug clamped to the small rectangle of aluminium. Before soldering the coil wires, scrape the insulation from the wire ends with knife or razor blade. The front right hand side lug is wired to the lug clamped to the hacksaw blade using a short (6cm) length of hook-up wire. This completes construction.

An introduction to DIGITAL ELECTRONICS

This book can help YOU go right along with it:

Electronic equipment now plays an important role in almost every field of human endeavour. And every day, more and more electronic equipment is "going digital". Even professional engineers and technicians find it hard to keep pace. In order to understand new developments, you need a good grounding in basic digital concepts, and *An Introduction to Digital Electronics* can give you that grounding. Tens of thousands of people — engineers, technicians, students and hobbyists — have used the previous editions of this book to find out what the digital revolutions is all about. The fourth edition has been updated and expanded, to make it of even greater value.

Here are the chapter headings:

- | | | | |
|--------------------------------|---------------------------|---------------------------|------------------------------|
| 1. Signals, circuits and logic | 6. Logic design: practice | 11. Encoding and decoding | 17. Memory: RAMs |
| 2. Basic logic elements | 7. Numbers, data & codes | 12. Basic readout devices | 18. ROMs & PROMs |
| 3. Logic circuit "families" | 8. The flipflop family | 13. Multiplexing | 19. CCD's & magnetic bubbles |
| 4. Logic convention and laws | 9. Flipflops in registers | 14. Binary arithmetic | 20. D-to-A converters |
| 5. Logic design: theory | 10. Flipflops in counters | 15. Arithmetic circuits | 21. A-to-D converters |
| | | 16. Timing & Control | Glossary of terms |

Available from "Electronics Australia", 57 Regent St, Chippendale. PRICE \$4.50 OR by mail order from "Electronics Australia", PO Box 163, Chippendale 2008. PRICE \$5.40.

Add-on board gives increased versatility

Compuvoice for the TRS-80 Model I

Since the publication of our Compuvoice project in the October issue we have received many queries on using the voice synthesiser with the TRS-80 Model I computer. This article should answer those questions.

by PETER VERNON

We connected the Compuvoice to our TRS-80 via the Centronics printer interface circuit published in EA, September 1981. The only circuit change required to use this interface is to ground pin 23, the "Out Of Paper" input of the interface so that the printer driver software of the TRS-80 sees the correct status bits from the circuit.

The voice synthesiser is then wired in place of the printer cable. Power for the interface was originally supplied by the printer on pin 34 of the Centronics connector. We wired the output of the +5V regulator on the Compuvoice board so that the printer interface now draws its power supply from the Compuvoice board.

With these connections made the standard LPRINT statement of Level II Basic can be used to send ASCII codes to the synthesiser. The program in Listing 1 duplicates the function of the Super-80

program published with the first article (in October 1982). It takes a sequence of phoneme codes and displays the ASCII equivalents at the same time sending the ASCII codes to the speech synthesiser so that the user can hear the sound sequence which is entered.

Because of the way in which the printer interface is powered and because of possible conflict between READY signals of a printer and the Compuvoice board, it is not advisable to use a printer while the Compuvoice is connected to the interface. If you want your printer interface to do double duty, you will have to ensure that the Compuvoice can be disconnected when a printer is in use.

Since publication of the original project some readers have reported problems with the timing of the data and STROBE signals to the Compuvoice unit.

The solution is to disconnect the computer STROBE line from pins 3 and 4 of

IC2 and ground these two pins. The STROBE signal from the computer is then connected to pin 5 of IC2.

Construction

Refer to the September 1981 issue for full details of the TRS-80 Centronics printer interface. The printed circuit board wiring diagram in Fig. 1 show the points where connections to the Compuvoice unit are made. Also shown is the point used to ground the Out of Paper input to the computer.

The 34-way solder transition connector used to connect a printer cable is not required for the Compuvoice connections. There are 10 connections to be made; six data lines, A/R, STROBE, GROUND and +5V and these can be soldered directly to the appropriate pads of the Centronics interface board. These pads are numbered from 1 to 34, and Table 1 shows the points to which connections are made.

Note that no connection is made to the UNIT SELECT or FAULT inputs to the printer interface (pins 25 and 28 respectively of a Centronics connector). Both these lines should be high for correct operation of the unit.

The printer interface is a double-sided board without plated through holes. There are a number of "pin throughs" to be made, using short lengths of bare wire soldered to pads on both sides of the board. These are indicated by dots with an oblique stroke on the component overlay of the board (Fig. 1). Some other component leads are also soldered on both sides of the board. Install the pin throughs first, and wherever there is a solder pad on the top of the board solder both sides of the associated component lead.

As already mentioned power for the interface board is derived from the Com-

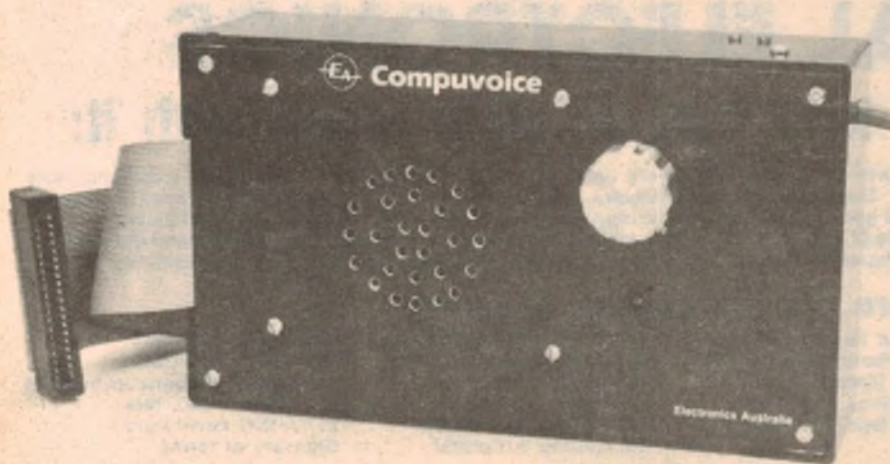

This speech synthesiser for the TRS-80 Model I combines the Compuvoice board (Oct 1982) with the Centronics interface circuit presented in the Sept 1981 issue.

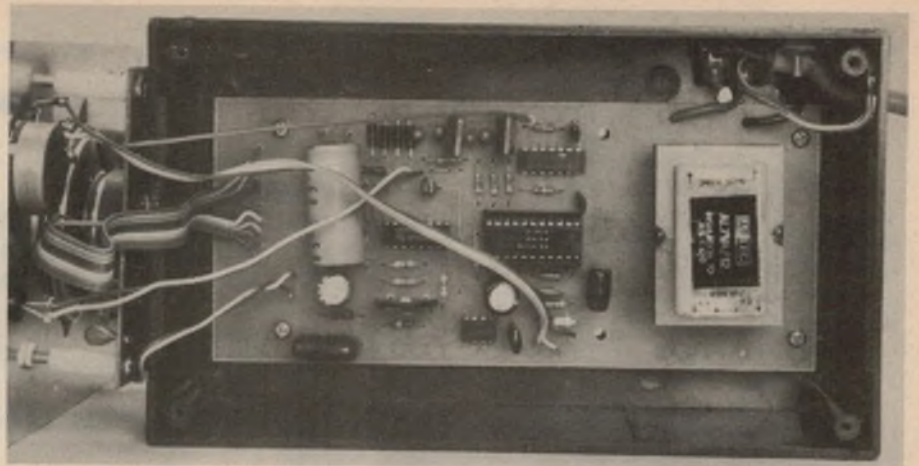
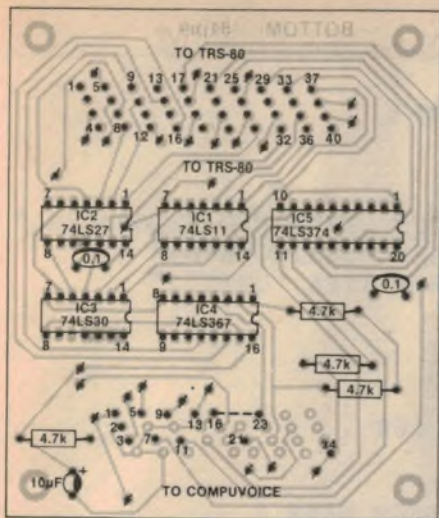

Fig. 1 left, is the overlay of the printer interface board showing connection points to the voice synthesiser unit. Photo above shows the Compuvoice board installed.

puvoice PCB. We drilled an extra hole adjacent to pin 14 of IC2 (on the Compuvoice PCB) to make this connection. Be careful not to drill through the copper track itself in the process. The other end of the power supply connection is made to position 34 of the location formerly occupied by the 34-way solder transition connector on the interface board.

Our prototype TRS-80 voice synthesiser used a printed circuit board supplied by RCS Radio Pty Ltd. This Compuvoice board has been extended to allow mounting of an Arlec 7.5VA PCB-mounting mains transformer at one end. Two insulated wires on the bottom of the board connect the 12VAC output of this transformer to the power supply inputs of the Compuvoice unit, eliminating the need for a plug-pack. This arrangement is by no means mandatory though, and a plug pack power supply is perfectly adequate.

Other suppliers may not be using RCS boards, in which case a plug-pack or an alternative means of mounting a transformer will be required.

The prototype unit is mounted in a plastic utility box measuring 196 x 113 x 60mm. With a transformer, two circuit boards and a loudspeaker installation is a tight fit and requires some care.

The Compuvoice board is mounted on the bottom of the utility box using nylon spacers cut down to 3mm and nylon nuts and bolts (available from Dick Smith Electronics). The Centronics interface board is secured to the aluminium top panel with 20mm nylon spacers, which allows clearance for a 57mm diameter loudspeaker on top of the interface board.

We estimate that the current cost of parts for this project is:

\$150

excluding the cost of a loudspeaker, plugpack supply or case.

If you use a transformer mounted inside the box bring the mains cord in through the side and clamp it securely. Terminate the active and neutral leads to an insulated terminal block and leave the earth lead long enough to connect it to a solder lug underneath a small nut and bolt in the aluminium top of the box.

From the terminal block run the active and neutral connections to the inputs to the PCB mounted transformer, ensuring that no bare wires are exposed.

There is no power switch for the unit. Both the Compuvoice and the interface board will be powered up whenever the unit is connected to the mains. Ensure that the unit is on before switching on the computer to which it is connected, and be certain to pull the plug before doing any work on the circuit, or even opening the box.

As will be seen from the photographs we have mounted the volume control and power indicator LED externally, with connections to the original pads on the

PRINTER INTERFACE
PAD NUMBER

PRINTER INTERFACE PAD NUMBER	COMPUVOICE CONNECTION
1	STROBE
2	GND
3	D0
5	D1
7	D2
9	D3
11	D4
13	D5
21	A/R
23	Connect to GROUND at Pin 8.
34	to +5V from Compuvoice.

Table 1 shows the connections to be made between the Compuvoice board and the TRS-80 printer interface board. Note that pad number 23 on the interface board must be tied to ground. Power for both boards is derived from the Compuvoice supply.

Compuvoice board by short lengths of insulated wire. The frequency control potentiometer could also be mounted externally if required, using the same

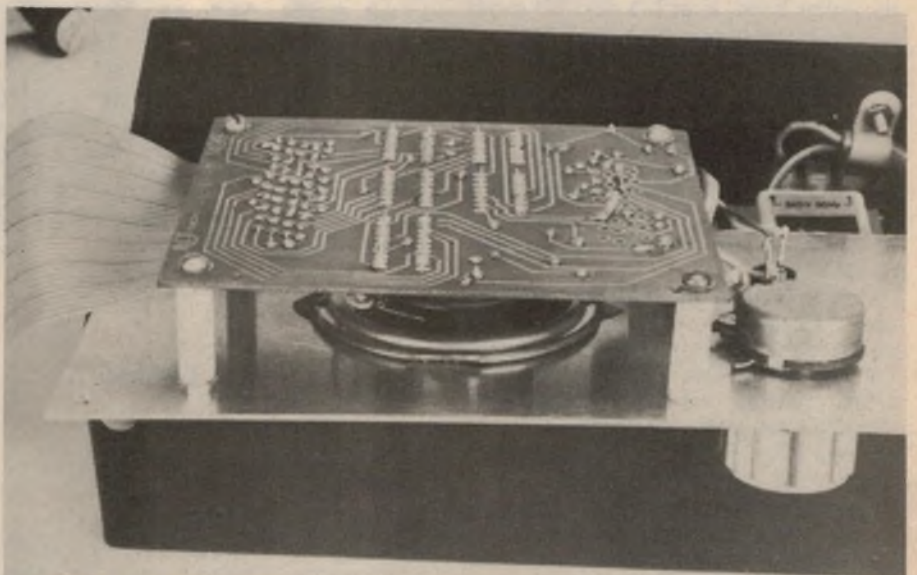

The photograph above shows the underside of the front panel and the method used to mount the parallel interface board. Note the position of the loudspeaker.

Compuvoice for the TRS-80

method. In both cases the potentiometers are 10k Ω linear types.

To reduce the height of the Compuvoice board mount the 1000 μ F 25VW electrolytic capacitor on its side, lying flat on the board. A spot of adhesive will hold it firmly in place. Apart from this alteration and the new power supply arrangements, construction of the Compuvoice unit is as covered in the October, 1982 issue.

The combined voice synthesiser and interface unit is connected to the expansion interface of the TRS-80 Model 1 with a 40-way edge connector and a length of ribbon cable. We clamped the edge connector to the ribbon cable in a vice and soldered the ends of the ribbon cable directly to the printer interface board. The component overlay for the printer interface board shows pin 1 numbered. The remaining connections are made in 10 groups of four each. Group number one runs obliquely down the board, from 1 to 4. The next oblique group are connections 5 to 8, and so on.

To reduce transmission line effects and capacitive loading on the expansion port of the TRS-80, the connecting cable of the unit should be no longer than about 45cm. A slot cut should be cut in the top edge of the right hand side of the utility box to provide an exit point for the ribbon cable.

System-80

The unit as shown will not work for the System-80 for two reasons. Firstly, the printer port of the TRS-80 is at memory location 37E8, and the printer interface board is designed to respond only to this address.

The printer port of the System-80, on the other hand, is at I/O port FD (both addresses are here in hex). The printer interface board, then, will not respond to an LPRINT statement from the System-80. It would respond to a POKE 14312, however, as ASCII characters could be sent by this to the Compuvoice unit by this method, using the ACS ("x") statement of Basic, which returns the ASCII code of the character between the quote marks.

This is where the second problem arises, because the expansion interface connections for the two computers are completely different. The System-80 Users Manual shows the details. Although the unit described here could be connected to the System-80 and the appropriate software changes made, a better solution for System-80 owners is to use the original Compuvoice, connected either to the printer port of the expansion unit or via the "parallel printer cable" (Cat. number X-4013) from Dick Smith Electronics.

Listing 1

```
10 CLEAR 100:CLS
20 DIM B0$(50),B(50)
30 PRINT "ENTER PHONEME CODES SEPARATED BY SPACES."
40 PRINT "PRESS RETURN TO SEE ASCII CODES."
50 PRINT "TO EXIT THE PROGRAM TYPE 'QUIT'."
60 C=0:PRINT
70 INPUT A0$
74 IF A0$="QUIT" THEN END
80 A0$=A0$+" "
90 IF LEN(A0$)=0 THEN GOTO 160
100 C=C+1
110 FOR I=1 TO LEN(A0$)
120 IF MID$(A0$,I,1)<>" " THEN NEXT I
130 B0$(C)=LEFT$(A0$,I-1)
140 A0$=MID$(A0$,I+1,100)
150 GOTO 90
160 REM FIND THE CORRESPONDING ASCII CODE
170 FOR A=1 TO C
180 READ A1$,D
190 IF A1$="OUT" THEN GOTO 600
200 IF A1$<>B0$(A) THEN GOTO 180
210 B(A)=D:RESTORE:NEXT A
220 PRINT "THE ASCII CODES ARE;"
230 FOR A=1 TO C
240 PRINT CHR$(B(A));
250 LPRINT CHR$(B(A));
260 NEXT A
270 LPRINT "?";
280 GOTO 60
600 PRINT "ERROR - NO ";B0$(A);" CODE":END
1000 DATA "EH3",64,"EH2",65,"EH1",66,"PA0",67
1010 DATA "DT",68,"A2",69,"A1",70,"ZH",71
1020 DATA "AH2",72,"I3",73,"I2",74,"I1",75
1030 DATA "M",76,"N",77,"B",78,"V",79
1040 DATA "CH",80,"SH",81,"Z",82,"AW1",83
1050 DATA "NG",84,"AH1",85,"O01",86,"O0",87
1060 DATA "L",88,"K",89,"J",90,"H",91
1070 DATA "G",92,"F",93,"D",94,"S",95
1080 DATA "A",32,"AY",33,"Y1",34,"UH3",35
1090 DATA "AH",36,"P",37,"O",38,"I",39
1100 DATA "U",40,"Y",41,"T",42,"R",43
1110 DATA "E",44,"W",45,"AE",46,"AE1",47
1120 DATA "AW2",48,"UH2",49,"UH1",50,"UH",51
1130 DATA "O2",52,"O1",53,"IU",54,"U1",55
1140 DATA "THV",56,"TH",57,"ER",58,"EH",59
1150 DATA "E1",60,"AW",61,"PA1",62,"STOP",63
1160 DATA "OUT",64
```

Listing 2

```
10 FOR W=0 TO 8
20 READ A$:LPRINT A$;
40 NEXT W
50 LPRINT "???"
100 DATA "9KIRCC","KIRCC",")44+CC"
110 DATA "*(!)","U1:", "BARC"
120 DATA "EE*)CC","R<YET"
130 DATA "CCC[B#X#57"
```

Listing 1, above, is a program to translate Votrax phoneme symbols into ASCII character strings. Listing 2, at left is a demonstration of the possibilities of the speech synthesiser Data statements contain the ASCII codes for the phonemes of "This is your TRS-80 speaking. Hello".

DICK SMITH



NEW ZEALAND

NEW ZEALAND'S MOST POPULAR PERSONAL COMPUTER

THE DICK SMITH SYSTEM 80

It hasn't become Australasia's fastest selling home computer by accident! The System 80 is a complete, ready-to-go computer. You don't have to buy add-ons like cassette recorders or monitors: the System 80 comes with a built-in recorder and modulator, so you can use it with any TV!

Don't be fooled by inferior computers which don't offer you the incredible features of the System 80 (like software compatibility with the world's largest range!) The System 80 is not just affordable: it's usable as well!!!

Compare these features and price with any other computer.

- Flashing Cursor.
- Built-in speaker and amplifier for programs with sound effects.
- Full upper & lower case video display capability.
- Monitor program (suitable for the hobbyist to program in machine language)
- Screen print facility (obtain a printout of any 'page' appearing on the screen)
- Three month guarantee from date of purchase.
- Great expansion capability and flexibility
- No separate tape recorder to buy - it's in-built!
- Cassette level meter and provision for a second cassette.



Cat. X-4005

Was \$1295

now only

\$995

INCLUDES 40% NZ SALES TAX

OVER 10,000 SYSTEM 80's SOLD

Take advantage of this once-in-a-lifetime special offer... Bulk purchase has allowed us to slash the price on this popular computer!!!

"The best value around for a ready built computer..."
(Electronics Aust. Magazine)

BIG SAVINGS ALSO AVAILABLE ON THE 'BUSINESS' VERSION SYSTEM 80 WAS \$1245 NOW \$995
Cat. X-4100

New Zealand's least expensive Business Computer! Use it for Word Processing Accounting, Filing, Invoicing, Stock Control, etc. It has a separate 15-key numeric keypad, plus 4 special function keys. Why pay thousands of dollars more when the Business Computer System 80 MKII does it all? Cat. X-4100

DICK SMITH Electronics

98 Carlton Gore Rd.
Newmarket,
Auckland 1.
Ph: 504 409

MAIL ORDERS:
P&P \$5.00



7 DAY TRIAL OFFER

If you're not completely happy, you can return the System 80 in original condition & packing for a full refund!

Shop by phone.
Use your Bankcard.
Or Visa card

DSE/EA453/JW

Mail Orders: Private Bag, NEWMARKET

PUBLIC ADDRESS AMPLIFIERS

The TPA 100 and TPA 150 professional quality Public Address Amplifiers are designed and built in Australia. They offer the professional installer outstanding performance, features and facilities not found as standard on any other brand. ★ XLR 3-31 connectors ★ Balanced mic inputs with LOW cut filters ★ Booster add on facility ★ 19" Industry Standard Rack Mounting Cabinets ★ Electronic Chime ★ Short Circuit and Overload protected.

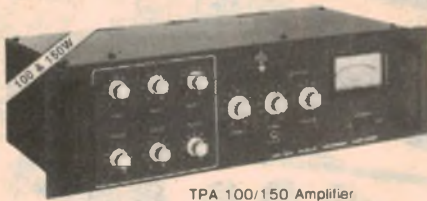

TPA 100/150 Amplifier

Power Output
 TPA 100 100W RMS
 TPA 150 150W RMS
Harmonic Distortion
 Less than 2% at rated output
Frequency Response
 45 to 15000 Hz ± 3 db
Hum and Noise
 Fundamental 80 db
 Microphone 60 db
 Auxiliary 70 db
Tone Controls
 Bass ± 13 db at 100 Hz
 Treble ± 13 db at 10 KHz
Outputs
 4, 8, 50V, 70V, 100V Balanced
Dimensions
 430W x 250D x 138H (mm)
Weight
 TPA 100 12kg
 TPA 150 13.5kg

\$375.00 TPA 100
 \$495.00 TPA 150



PB 150 Booster Amplifier

Power Output
 150W RMS
Harmonic Distortion
 Less than 2% at rated output
Frequency Response
 45 to 15000 Mz
Hum and Noise
 80 db
Input Sensitivity
 1V At 10 K
Outputs
 4, 8, 50V, 70V, 100V Balanced
Dimensions
 430W x 250D x 138H (mm)
Weight
 13kg

\$373.15



TPA 50/70/90 Amplifier

Power Output
 TPA 50 25W RMS
 TPA 70 50W RMS
 TPA 90 70W RMS
Harmonic Distortion
 Less than 1.5% at rated output
Frequency Response
 50 to 15000 Hz ± 3 db
Hum and Noise
 Microphone 60 db
 Auxiliary 70 db
Outputs
 4, 8, 16, 70V, 100V unbalanced
Dimensions
 310W x 230D x 80H (mm)
Weight
 TPA 50 3.8kg
 TPA 70 4.3kg
 TPA 90 5.1kg

\$163.12 TPA 50
 \$281.96 TPA 70
 \$221.25 TPA 90



*All prices are plus 20% sales tax if applicable. Dealer enquiries welcome.

Head Office: 562 Spencer St, West Melbourne 3003. Telephone: (03) 329 7888. Telex 32980.
 Southern Depot: 1103 Dandenong Rd, East Malvern 3145. Telephone: (03) 211 8122.

DISKS FOR YOUR DGOS

APPLIED TECHNOLOGY S100 CARD OWNERS, NOW THERE IS A STANDARD IBM 8-INCH DISK SYSTEM FOR YOUR COMPUTER. TOTALLY ENDORSED BY APPLIED TECHNOLOGY.

Single sided version 1 x 600K Drive	From: \$1370 + Sales Tax
--	--------------------------------

Single sided version 2 x 600K Drive	From: \$2340 + Sales Tax
--	--------------------------------

Double sided version 1 x 1.2 Meg drive	From: \$1804 + Sales Tax
---	--------------------------------

Double sided version 2 x 1.2 Meg drive	From: \$2504 + Sales Tax
---	--------------------------------

CONTROLLER ONLY IS ALSO AVAILABLE

Systems include case, supply, cables, manual, controller, drives, cp/m 2.2 microscope BASIC-80 total software value near \$600.00 free!

ALSO A BROAD RANGE OF OTHER S100 CARDS TO SUIT YOUR SYSTEM.

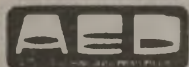

MICROCOMPUTER PRODUCTS

Acoustic Electronic Developments Pty Ltd, Inc in NSW

130 Military Rd., Guildford 2161. Tel: (02) 681 4966 — TLX AA70664

9-5 6 days/week

OFFICIAL SYSTEM SUPPORT ORGANISATION FOR APPLIED TECH S100 SYSTEMS.



Compuvoice for the TRS-80

PARTS LIST

COMPUVOICE BOARD

- 1 Printed circuit board, code 82V510, 105mm x 71mm
- 1 loudspeaker
- 1 15cm length of 10-way ribbon cable
- 1 22-pin socket (see text)

SEMICONDUCTORS

- 1 74SL367 hex bus driver
- 1 74LS121 monostable multivibrator
- 1 SC-01-A speech synthesiser
- 1 LM386 audio amplifier
- 1 BC547 NPN transistor
- 1 7805 +5V voltage regulator
- 1 7812 +12V voltage regulator
- 4 IN4002 diodes
- 1 light emitting diode

CAPACITORS

- 1 1000 μ F/25VW electrolytic
- 1 220 μ F/16VW electrolytic
- 1 100 μ F/25VW electrolytic
- 4 1 μ F tantalum
- 1 0.47 μ F greencap
- 1 0.1 μ F greencap
- 1 .033 μ F greencap
- 2 .01 μ F greencap
- 1 150pF ceramic

- RESISTORS ($\frac{1}{4}$ W, 5% unless stated) 1 x 100k Ω , 1 x 22k Ω , 1 x 10k Ω , 1 x 6.8k Ω ,

- 8 x 4.7k Ω , 1 x 3.9k Ω , 1 x 3.3k Ω , 1 x 1.5 Ω , 1 x 22 Ω , 1 x 10k Ω trimpot, 1 x 10k Ω linear potentiometer.

COMPUTER INTERFACE

- 1 double-sided PC board, coded 81pi9, 85 x 100mm
- 1 40-way mass terminated board edge connector (2.54mm pitch)
- 1 metre 40 way flat cable
- 1 74LS11 triple three-input AND gate
- 1 74LS27 triple three-input NOR gate
- 1 74LS30 8-input NAND gate
- 1 74LS367 hex Tri-state buffer
- 1 74LS374 octal latch
- 4 4.7k Ω $\frac{1}{4}$ W resistors
- 2 0.1 μ F disc ceramic capacitors
- 1 10 μ F 25VW tantalum capacitor

MISCELLANEOUS

- 1 Arlec AL7V/12 PCB mount transformer or 12VAC plugpack (see text)
- 4 20mm nylon spacers
- 4 4mm nylon spacers
- 1 metre mains cord, mains plug, terminal block and solder lug
- 1 Scotchcal panel, 192 x 107mm
- 1 Plastic utility box, 197 x 113 x 59mm
- Nuts and bolts, hook-up wire

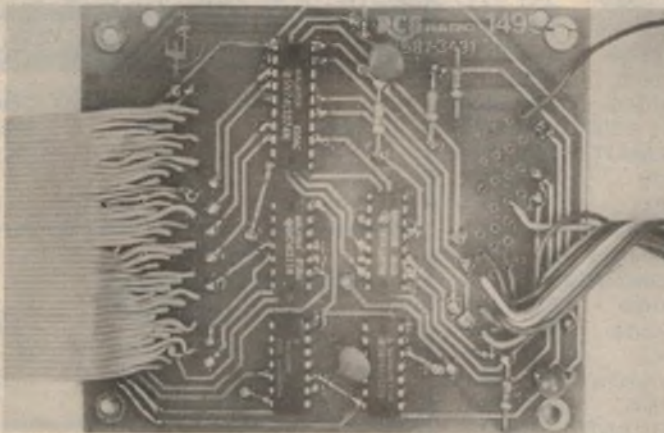

This photograph shows the top side of the parallel interface board. Connection to the TRS-80 is via the 40-way cable at the left of the board.

Software

Listing 1 is a TRS-80 version of the program previously published for the Compuvoice unit. This program accepts Votrax phoneme codes and looks up and displays the corresponding ASCII symbols, sounding the combination of phonemes at the same time.

Listing 2 is a short program which causes the unit to say "This is your TRS-80 speaking". Both programs will run without changes on the System-80 if the Compuvoice unit is connected to the parallel printer cable.

If you have problems getting the speech synthesiser to "shut up", try ex-

ecuting POKE 14312,63.

This statement by-passes the Centronics printer driver used by LPRINT, and ensures that no spurious characters are sent to the speech synthesiser. It may be necessary to repeat the statement as it also by-passes the READY output of the SC-01 chip, so that the data may not be immediately latched.

For the System-80 the equivalent procedure is: OUT 253,63.

That's about all there is to modifying the Compuvoice for use with a TRS-80 Model 1 without an expansion interface. Now at last your computer can talk back!

16K print buffer

only **\$79**

V-SPOOL

Use your computer & printer simultaneously

SAVE VALUABLE TIME Waiting while your computer runs a printer is wasted time. With V-SPOOL you can continue to use the computer while printing a letter, an invoice or other text. V-SPOOL instantly buffers up to 16K in memory - roughly 6 full pages. You retain complete computer control while the buffered text is printed. Using a letter quality printer, you'll save up to a minute a page.

NO HARDWARE COSTS V-SPOOL costs a fraction of a hardware buffer. It requires no power, will never break down, and is in many cases faster. A hardware buffer may take 17 seconds to fill up. V-SPOOL will buffer the text almost instantly.

SIMPLE TO USE One CP/M command activates V-SPOOL. Its operation is foolproof and transparent to your application programmes.

NO INTERFACING V-SPOOL requires no hardware or software modifications. Just CP/M 2.2. It occupies only 1K of memory space plus the size of the print buffer (variable from 2K to 16K).

Software Source

89, Oxford Street, Bondi Junction
(02) 389 8388, PO Box 364
Edgecliff NSW 2027

EA Magazine Holders



The magazine holders are available over the counter from Electronics Australia, 57 Regent Street, Chippendale, 2008 - Price: \$4.50.

Mail orders should be sent to Electronics Australia, PO Box 163, Chippendale, NSW 2008.

Price including postage is:
\$5.50 NSW; \$5.60 other states; or six for \$29.00 NSW; \$31.50 other states, \$A33.00 NZ.



**NOW
36
STORES**

**WE ARE
HERE**

NEW STORE ADDRESS:
Cnr. Bowen & Ruthven Sts.
Toowoomba. Ph 384 300.

Dear Customers,

Quite often the products we advertise are so popular they run out within a few days. Or unforeseen circumstances might hold up shipments so that advertised lines are not in the stores by the time the advert appears. And very occasionally, an error might slip through our checks and appear in the advert (after all we're human too!). Please don't blame the store manager or staff, they cannot solve a dick strike on the other side of the world, or fix an error that's appeared in print. If you're about to drive across town to pick up an advertised line, why not play it safe and give the store a call first - just in case.

Thanks



Dick Smith and Staff



DICK SMITH Electronics

MAIL ORDER CENTRE
PO BOX 321, NORTH RYDE NSW 2113
Telephone orders: (02) 888 3200

STORE LOCATIONS

NSW 145 Parramatta Rd	AUBURN	648 0558
T55 Terrace Level	BANKST. SQ.	707 4888
613 Princes Hwy	BLAKEHURST	546 7744
552 Oxford St	BONDI JCT.	387 1444
818 George St	BROADWAY	211 3777
531 Pittwater Rd	BROOKVALE	93 0441
147 Hume Hwy	CHULLORA	642 8922
162 Pacific Hwy	GORE HILL	439 5311
Elizabeth Dr & Bathurst St	LIVERPOOL	600 9888
396 Lane Cove Rd	NORTH RYDE	88 3855
George & Smith Sts	PARRAMATTA	689 2188
6 Bridge St	SYDNEY	27 5051
125 York St	SYDNEY	290 3377
Tamworth Acde & Kable Ave	TAMWORTH	66 1961
173 Maitland Rd	TIGHES HILL	61 1896
263 Keira St	WOLLONGONG	28 3800
315 Mann St.	GOSFORD	25 0235
ACT 96 Gladstone St	FYSHWICK	80 4944
VIC 260 Sydney Rd	COBURG	383 4455
Ross Smith Av & Nepean Hwy	FRANKSTON	783 9144
205 Melbourne Rd	GEELONG	78 6766
399 Lonsdale St	MELBOURNE	67 9834
Bridge Rd & Coronation Blvd	RICHMOND	428 1614
Springvale & Dandenong Rds	SPRINGVALE	547 0522
QLD 293 Adelaide St	BRISBANE	229 9377
166 Logan Rd	BURANDA	391 6233
Gympie Rd & Hamilton St	CHERMSIDE	59 6255
Cnr. Ingham Rd. & Cowley St.	TOWNSVILLE	72 5722
Cnr. Bowen & Ruthven Sts.	TOOWOOMBA	(TBA)
SA 60 Wright St	ADELAIDE	212 1962
Main South & Flagstaff Rds	DARLINGTON	298 8977
435 Main North Rd	ENFIELD	260 6088
WA Wharf St & Albany Hwy	CANNINGTON	451 8666
414 William St	PERTH	328 6944
Hay St (The Centre Way Acde)	PERTH	321 4357
TAS 25 Barrack St	HOBART	31 0800

POST & PACKING CHARGES

ORDER VALUE	CHARGE	ORDER VALUE	CHARGE
\$5.00-\$9.99	\$1.40	\$50.00-\$99.00	\$4.60
\$10.00-\$24.99	\$2.40	\$100.00 or more	\$6.20
\$25.00-\$49.99	\$3.50		

Charges are for goods sent by post in Australia only — not airmail, overseas or road freight.

SPEEDY PHONE/BANKCARD ORDER SERVICE

Just phone through your order and Bankcard details — it's so simple!

(02) 888 2105



MAJOR RESELLERS

These are our major resellers. However, we cannot guarantee they will have advertised items in stock or at the prices advertised.

Atherton QLD: Jue Sue's Radio Service 55 Main St. 91 1208 ● Bendigo VIC: Sumner Electronics 7 Edward St. 43 1977 ● Ballina NSW: A. Cummings & Co. 91-93 River St. 86 2288 ● Cairns QLD: Thompson Instrument Services 79-81 McLeod St. 51 2404 ● Coffs Harbour NSW: Coffs Harbour Electronics 3 Coffs Plaza Park Ave. 52 5684 ● Darwin N.T. Kani Electronics 42 Stuart Hwy. 81 4749 ● Darwin N.T. Vantronic 24 26 Kavanagh St. ● Danilquin NSW: Dem Electronics 220 Crossy St. 81 3672 ● East Maitland NSW: East Maitland Electronics Cnr. Laws & High Sts. 33 7327 ● Echuca VIC: Webster Electronics 220 Packerham St. ● Geraldton WA: KB Electronics & Marine 361 Main Terrace 21 2176 ● Gladstone QLD: Purely Electronics Shop 2 Cnr. Herbert & Auckland Sts. 72 4321 ● Gosford NSW: Tomorrow's Electronics & Hi-Fi 68 William St. 24 7246 ● Kingstons TAS: Kingstons Electronics Channel Court 29 6802 ● Launceston TAS: Advanced Electronics 5a The Quadrant 31 7075 ● Lismore NSW: Dacia Electric 3A/6-18 Carrington St. Mackay QLD: Stevens Electronics 42 Victoria St. 51 1723 ● Maryborough QLD: Keller Electronics 218 Adelaide St. 21 4559 ● Mt. Gambier SA: Hutchison's Comm 5 Elizabeth St. 25 6404 ● Mildura VIC: McWilliam Electronics 40 Lemon Ave. 23 6410 ● Morwell VIC: Morwell Electronics 128 George St. 34 6133 ● Nambour QLD: Nambour Electronics Shop 4, Lowan House Ann St. 41 1604 ● Orange NSW: MSW Electronics 173 Sumner St. 62 6491 ● Penrith NSW: Accorn Electronics Shop 12 541 High St. 36 1466 ● Port Macquarie NSW: Hall Of Electronics 113 Horton St. 837 440 ● Rockhampton QLD: Purely Electronics 15 East St. 21 058 ● Shepparton VIC: G.V. Electronics Centre 189b Corio St. 21 8866 ● Southport QLD: Amateus Paradise 121 Nerang St. 32 26 44 ● Toowoomba QLD: Hunt's Electronics 18 Neil St. 32 9677 ● Townsville QLD: Tropical TV 49 Fulham Rd. Vincent Village 79 1421 ● Wagga NSW: Wagga Wholesale Electronics 82 Forsyth St. ● Wodonga VIC: A&M Electronics 78a High St. 24 4588 ● Whyalla SA: Mellor Enterprises Shop 2 Forsythe St. 45 4764

STORE HOURS

All Dick Smith stores are open from 9am to 5:30pm (Saturday 9am to 12 noon) except Queensland stores which open and close half hour earlier. Many stores are open for late night trading. Phone your nearest store for details.



Letters to the editor

New opportunities with digital audio

I read the article on the Compact Disc in the February, 1983 issue with considerable interest. I recall recent correspondence in your columns decrying the expected advantages of the new recording medium which was debunked by your pointing out that in listening to broadcast music we have been experiencing a system of sampling for well over a half century without any complaints arising from this aspect of the system.

When I read those adverse comments I was immediately reminded that every new invention has been denigrated and disparaged as inadequate, unnecessary and a dead-end development. When the Wright Brothers had proved the possibility of manned flight (destroying millennia of scoffers in the process) some sage stated that while a man might fly there was little possibility of this developing into a means of mass, long-distance transport.

There used to be a doughnut shop in Sydney which had a slogan on the wall: "As you wander on through life brother,

Whatever be your goal,
Keep your eye upon the doughnut.

And not upon the hole!"

Sound advice you will agree. In keeping with that advice I have speculated on some of the possibilities of digital recording, given that every machine, device or system ever invented has subsequently been improved and has often spawned new developments.

The conversion of sound into a series of binary numbers must lend itself to manipulation of those numbers to enhance or alter the reconstructed sound. An existing analog recording with all its inherent noise and distortion could be converted to digital and the resulting series of binary numbers would lend themselves to analysis by computer and the unwanted noise elements determined and subtracted to produce new distortion-free signals. By simultaneously recording a tenor with a digital system and an old acoustic system and comparing the results in a digital format, useful analogies could be drawn which might make it possible for a recording engineer to someday produce a digital disc titled "Caruso's Greatest Hits" which would be comparable with a current Luciano Pavarotti record.

Misconceptions on amplitude modulation?

Your correspondent D. Dutton in the January 1983 issue is either a born stirrer (in which case I hope someone closes his jaw on the tongue in his cheek) or else extremely naïve.

He states: "It has been said that the amplitude of the carrier varies in accordance with the amplitude of the audio signal. This is not so."

Indeed! Can he then explain the modus operandi of an amplitude modulator without saying that the amplitude of the carrier is varied? Would he also try to tell us that the modulator incorporates a separate RF oscillator for each sideband?

He refers to the different displays on an oscilloscope and a spectrum analyser. Can't he see that one is a real-time representation while the other is a Fourier analysis of the same phenomenon and are not mutually exclusive? Such dualities occur

throughout science, as for example the classic theories of the nature of light (wave theory and quantum theory).

I refuse to buy into the remainder of his implausible arguments, as having started with a one-eyed misconception he has had to follow it through to a totally illogical conclusion.

Let me take this opportunity of saying how much I enjoy reading EA which I find very stimulating, particularly Neville Williams' Forum column. I have been buying it every month since I first had to save up sixpence from my pocket money (around 1944!).

Keep up the stirring, but don't publish too many outrageous letters like D. Dutton's. I don't think my blood pressure could stand it.

D. M. Snowdon SMIREE,
North Rocks, NSW.

The move to digital signals for telecommunications would appear to be inevitable. What are the possibilities for digital broadcasting on FM? As a fringe-area listener I would appreciate the chance to hear superlative reproduction from my radio even though the received signal was of minimal strength.

Perhaps my thoughts may stimulate others to consider the "doughnut" rather than the "hole".

I look forward to your future expositions on the subject.

P. Hanville,
Bellambi, NSW.

Another opinion on "Towards 2000"

The reaction of the Executive Producer of "Towards 2000" to your criticism of that show (Letters to the Editor, January 1983) is exactly in keeping with the show itself — poorly presented and short on thought.

The show is poorly presented by the standards of today, from the print style of the title to the bleep-accompanied computer-like subtitles. You can't even call that juvenile; today's kids are well past it. "Overwhelming" audience response is surely an emotional overstatement. If it is based on an 85% appreciation factor it would have to be accompanied by an indication of how many people actually watch the damn thing before it became a true statement — maybe the staff of the Weather Bureau and a handful more. I certainly wouldn't appear as a statistic as I am not a regular viewer.

Recently I caught a glimpse of, I think, Sonia Humphreys talking about a machine that reports on the lucidity of a particular prose passage and the number of years of education necessary to understand it. The examples chosen for analysis were typical of the superficial approach of the producers — Churchill's spoken words, an extract from a legal document and an extract from James Joyce. Surely our dedicated researchers could have done better than this and provided some "before" and "after" examples as given by Sir Ernest Gowers or similar writers on the subject.

The samples selected did nothing to demonstrate the capability of the equipment. For the machine to report that, I think, 134 years of education would be necessary to understand James Joyce reflects no credit on either Joyce or the machine. If I were the designer I would be furious to think that such unsuitable data was chosen.

"Towards 2000" has a long way to go before it makes an appeal to the layman with an interest in science, which I imagine it is trying to do.

Don Richards,
Ebenezer, NSW.



Books & Literature

Tesla: his life and times



TESLA: MAN OUT OF TIME by Margaret Cheney. Published 1981 by Prentice-Hall, Inc, USA. Hard covers, 160 x 236mm, 320 pages, illustrated with some historical photos. ISBN 0 13 906859 7.

I set out to read this book about the life and times of Nikola Tesla with a high degree of interest as, like most people with a knowledge of electronics and engineering. I knew little of the history of the man whose name has been given to one of the units of magnetism. Incidentally, his first name was Nikola and not Nikolai as is printed in some textbooks.

It turns out that Tesla was a contemporary of Thomas Edison's and he briefly worked for this famous engineer. But whereas everyone knows something of the work of Edison we owe just as much to Tesla. It was Tesla who devised the system of AC power generation and the transformers used for its transmission which was successfully promoted by George Westinghouse. Tesla also invented the induction motor which is the basis for most of the motors used today. Tesla developed and recognised the advantages of the induction motor's "rotating fields" and multiphase power transmission. Tesla signed over the rights for this elegant and complete system of power generation over to Westinghouse for what was a relatively small sum. He did not become really rich by any means.

But while the book is useful for revealing the above truth it is most tedious to read because the author hammers the theme that is implied in the title, that Tesla was a man out of time, that he was

misunderstood, exploited and would be ahead of his time even if he was alive today. Well he was a clever man certainly but he was very much a man of his own time.

He was apparently just as flamboyant, in his own way, as Edison was. He loved to develop and revel in his own mystique and put on many flashy demonstrations of his scientific inventions. But in the way that many inventions come about, it is almost certain that if Tesla had not come up with the idea, some other inventor would soon have discovered the principles of AC power generation and transmission.

In summary, this could have been a more useful book if the biographer had concentrated more on Tesla's science and less on his emotional make-up. (L.D.S.)

Long-wire antennas for amateur radio



73 DIPOLE & LONG-WIRE ANTENNAS by Edward M. Noll W3FQJ. Published 1969 by Editors And Engineers, division Howard W. Sams & Co, Inc Indianapolis. Soft covers, 136 x 217mm, 160 pages. Illustrated with many diagrams and some photos. ISBN 0 672 24006 8. Price \$9.95.

It may be thought from the title of this text that this is in some way connected with the US amateur radio magazine, "73" but this is not so. It is in fact, a col-

lection of 73 antenna designs which could be useful to amateurs working the lower frequency bands.

By definition, a long-wire antenna is many wavelengths long at the frequency of its operation and so in absolute terms it is very long, up to a hundred metres or more, in some cases. This means that anyone wishing to use the published designs will have plenty of room. Unit dwellers can stop reading at this point.

There are eight chapters and eight appendices and the general approach is practical with no theory presented at all. All antenna dimensions are in feet which is a contradiction when it is considered that each band of operation is referred in metres, eg, the 80-metre band.

Chapter headings are as follows: (1) Regular and Modified Dipole Antennas; (2) Inverted-Vee Antennas; (3) Long-Wire Antennas; (4) Vee-Beam Antennas; (5) Long Vee-Beam Antennas; (6) Rhombic Antennas; (7) Very Long-Wire Antennas and (8) Special Vees and Rhombics.

In summary, a useful little book even though the theory side is neglected. Our sample copy came from Jaycar Pty Ltd. (L.D.S.)

Solar Cells and Photocells

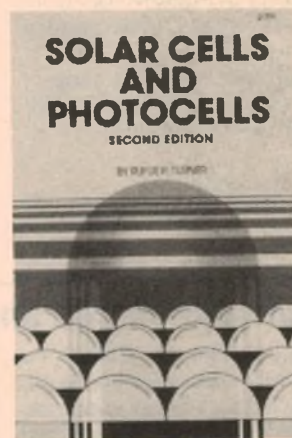

SOLAR CELLS AND PHOTOCELLS by Rufus P. Turner. First Published 1975 by Howard W. Sams, Inc, Indianapolis. Soft covers, 136 x 215mm, 96 pages, illustrated with circuit diagrams. ISBN 0 672 21711 2. \$7.95.

With solar cells and solar power being a topical subject, a book with this title should be useful. Unfortunately, it is a little on the old side and was written at a time before solar cells with outputs approaching an amp or so were readily available at a reasonable price. Consequently, most of the circuits employing solar cells use them as a light detector rather than as source of heavy current.

Similarly, photocells and circuits involv-

ing them can be regarded as fairly old hat these days, especially when they are used in conjunction with the odd germanium transistor.

Having said that, this book does provide a wide range of light sensing and light powered circuits, although some of them are a little contrived.

As might be expected in a slim 96-page text, there is not much emphasis on the theory of operation of the photoconductive and photovoltaic cells featured in the book. However the first chapter does give a useful introduction to the physical operating characteristics and also gives the specific characteristics of the main devices featured, so that substitution of locally made devices is possible.

One small point of interest is that the book reports the expectation that by 1986 improved solar cells will cost around 70 cents per peak watt, in terms of 1980 dollars. We still have quite a way to go, to reach that target.

Our sample copy came from Jaycar Pty Ltd. (L.D.S.)

Apple book for beginners



THE APPLE PERSONAL COMPUTER FOR BEGINNERS: by Seamus Dunn and Valerie Morgan. Published by Prentice-Hall International Inc, 1982. Soft covers, 257 pages, 153 x 227mm. ISBN 13 039131. Price \$20.25.

This book is an introduction to the Apple II and Apple II Plus computers, written for beginners. The emphasis is on "learning by doing" and each concept is illustrated with sample programs and screen response.

Eleven chapters and eight appendices lead the reader from first turning on the Apple to the writing of moderately complex programs, covering graphics, disk techniques and machine language on the way.

Each topic is covered in sufficient detail to provide the reader with a good basis for developing particular areas of interest. Each chapter concludes with a

series of exercises for the reader, with answers provided in an appendix so this book would also be suitable for use in a classroom situation.

The final chapter, in fact, deals with just that, and with the increasing number of Apple computers in schools this book should find a ready market.

Our review copy came from the Technical Book & Magazine Company, 295 Swanston St, Melbourne 3000. (P.V.)

Two-volume source book for ICs



The 1983 international edition of the "IC Master" handbook has been published by Hearst Business Communications. The new edition lists key specifications for 35,000 integrated circuits, microprocessor boards and related products from 225 manufacturers.

Only products currently available worldwide are described in the tables of product data, although new and discontinued devices are shown in an alternate-source directory which lists approximately 55,000 IC substitutes.

The two volume set occupies 3300 pages and is divided into 20 sections covering microprocessors, memories, linear ICs, custom and semicustom products, etc. Listings are arranged so that particular IC functions are grouped together for easy cross comparison. All 64K dynamic memories, for example, are grouped together by manufacturer and then arranged in order of access time.

More than 60 manufacturers including AMD, Fairchild, Intel, Motorola, National Semiconductor and Zilog have supplemented the editorial material and tables in "IC Master" with extensive data sheet sections. Other sections of the publication provide data on advertisers, a part number index, application note directory, alternate sources and a guide to manufacturers' marking schemes.

IC Master is distributed in Australia by A. J. Distributors Pty Ltd, PO Box 71, Prospect, SA, 5082. Phone (08) 269 1244.

NEW BOOKS

NEW — NEW — NEW

Latest editions of some of the most popular books on the subject

The Radio Amateur's Handbook — 1983 Edition. A must for the Radio Amateur and Professional	\$19.95
RSGB Handbook Volume 1	\$21.85
RSGB Handbook Volume 2	\$18.90
Reference Data for Radio Engineers (New Edition) ITT	\$47.25
Radio Handbook — Orr New 22nd Ed	\$42.95

Computer Books

Atari Sound and Graphics — Moore. A self-teaching guide	\$13.95
Computer Reference Guide's Software Handbook — Australian buyers' guide to all types of software products for microcomputers	\$27.65
Fast Basic — Beyond TRS-80tm Basic	\$20.95
TRS-80 Programs and Applications for the Colour Computer — Baker	\$21.95
Computer's first book of Atari	\$19.95
Computer's second book of Atari	\$19.95
Computer's first book of PET/CBM	\$17.20
IBM personal computer — An Introduction to Programming & Applications — Goldstein	\$24.95
IBM's Personal Computer — Que Corp	\$20.95
Microprocessor Circuits Vol. 1 — Noil	\$14.75
Z-80 User's Manual — Carr	\$16.75

Adam Osborne Books

Z80 Programming for Logic Design	\$14.75
6800 Assembly Language Programming	\$26.35
Intro to Microcomputers — Volume 3 Some Real Support Devices	\$21.00
6502 Assembly Language Programming	\$26.35
The 8086 Book	\$23.80
Intro to Microcomputers — Volume 1 Basic Concepts, 2/e	\$22.40
6809 Assembly Language Programming	\$26.35
Z8000 Assembly Language Programming	\$23.95
Interfacing To S 100/IEEE 696 Microcomputers	\$23.25
8089 I/O Processor Handbook	\$ 7.15
68000 Microprocessor Handbook	\$ 7.15
Osborne CP/M User Guide	\$24.75
CRT Controller Handbook	\$15.45
VISICALC Home and Office Companion	\$24.80
Assembly Language Programming for the Apple 11	\$19.50
Some Common Basic Programs — Atari Edition	\$21.00
Some Common Basic Programs — TRS-80/Edition	\$22.40
6502 Assembly Language Subroutines	\$17.80
Intro to Microcomputers — Volume 0, Beginners	\$11.15
Your Atari Computer	\$28.30
Practical Basic Programs — Apple 11 Edition	\$21.00
Practical Basic Programs — TRS-80 Edition	\$20.00
Some Common Basic Programs — Apple 11 Edition	\$19.00
Wordstar Made Easy	\$18.55
Practical Pascal Programs	\$22.40
Discover Forth	\$23.25
6809 Microcomputer Design Guide	\$27.95
CP/M User Guide 2nd Ed	\$18.20
The HP-IL System: An Introductory Guide to the Hewlett-Packard Interface Loop	\$23.80
Practical Basic Programs — IBM PC Ed	\$22.40
Pet Personal Computer Guide	\$23.25
CBM Im Professional Computer Guide	\$23.25

Other Titles

Practical Transformer Design Handbook	\$32.95
Piano Servicing & Tuning & Rebuilding — Arthur Reblitz	\$21.00
Audio Servicing Theory & Practice — Wells	\$22.15
Australia Radio Frequency Handbook — McDonald	\$12.95
Confidential Frequency List — Ferrell	\$14.20
Electronic Design With Off The Shelf Integrated Circuits — Meiksin & Thackray	\$15.50
Understanding DC Power Supplies — Davis	\$10.95
Videocassette Recorders: Theory & Servicing — McGinty	\$21.25

Just a few of the thousands in stock. Call in or write. Prices subject to fluctuation. Correct at time of going to press.

If the book you require is not listed below, it can be ordered from us.

MAIL ORDERS BY RETURN
PLEASE ADD \$1.50 per parcel postage (Vic)
\$2.50 per parcel interstate

TECHNICAL BOOK & MAGAZINE CO.
295-299 Swanston St,
MELBOURNE 3000. Ph. 663 3951

MORE OF THE BEST

MICROSYNTH

COMPACT MUSIC SYNTHESIZER Kit Cat. KJ6002

Equally suited to home, studio or stage use, the Microsynth has resulted from an extensive re-think of what is required from a synthesiser. Its compact and economic design achieves high performance at low cost without sacrificing versatility or musical stability.

A highly efficient switched routing system for signals and/or control voltages is capable of rapid operation for live work, yet unlike other small synthesisers does not restrict the possibilities for complex sound creation. Despite its small size, the Microsynth can produce startlingly rich sounds owing to the number of waveforms available, together with the sub-octave voices. It is capable of advanced effects such as Ring Modulation as well as rhythmic "staircase" or random patterns.

Operates in two modes depending on the configuration of the second oscillator (VCO2), which can either run at audio frequencies or as a voltage controlled low frequency oscillator (LFO). In audio mode, VCO2 will track VCO1 perfectly over its entire range. A Thumbwheel allows manual control of oscillator pitch or filter cut-off frequency, depth of LFO modulation, etc., and internal power amplification will drive headphones or a monitor loudspeaker.

SPECIFICATIONS (BRIEF)

- * Keyboard - 2½ octaves (30 notes) may be stepped through 5 octave range from 16' to 1' using the "Range" switch
- * VCO1 - 10Hz to 10kHz, triangle output to VCA, ramp and square outputs to VCF
- * VCO2/LFO - VCO mode 10Hz to 10kHz, LFO mode 0.1Hz to 30Hz
- * Sub octaves - 2 divide by 2
- * Noise - white noise source with level control
- * Envelope - attack and release times variable 0 to 10 seconds
- * Retrigger - causes the envelope shaper to retrigger itself with a repeat time equal to the sum of the attack and release times
- * Sustain - operates in 3 modes, manual, auto and hold
- * VCF - state variable filter with manual control of roll-off frequency
- * VCA - controls output volume of synthesiser
- * Sample and Hold - analogue memory samples instantaneous output voltage from VCO2/LFO each time envelope ends
- * Sweep - Thumbwheel - Manual level control
- * Power amp - output 2 watts into 8 ohms plus headphone socket
- * Sequencer socket
- * Size: 19½" x 14" x 5½"
- * Weight: 10lb.
- * Power: 240V AC 5W



\$ 399

BAND-BOX Kit

Cat. KJ6604

LIVE PERFORMANCE - Feed in, store, and play complete Music Pad of around 60-100 Backing Scores up to a total of approximately 3,000 Chord changes, each up to eight Beats in length, on more than 120 different chords.

Program Intros, Chorus Repeats, Codas, Key changes and modulations on single or multi-tune sequences. Use simple Playback procedures for live performance, including optional foot operated controls.

PRACTICE SOLOISTS - Instrumental or Vocal Soloists grow to full four piece BAND performance played in any Key, Tempo, and Rhythm style for demanding practice sessions with unlimited, but controlled, Chorus repeats.

ELECTRO MUSIC RECORDING/COMPOSITION - Full Chord sequence and Rhythm programmability for three instrumentalists enables creative Composing and Arranging for both Professional and Amateur applications.

SPECIFICATIONS (BRIEF)

- * Music simulation capacity - three backing instrumentalists. Over 3,000 programmable stored chord changes. 132 different chords plus additional inversions.
- * Chord instrumentalist - four note chords, four waveform options, four envelope options sixteen permutations for piano, organ etc, twenty four programmable rhythm patterns.
- * Bass instrumentalist - four voice/envelope combinations, eight rhythmic figures.
- * Drums - twenty four programmable patterns, eight tracks selecting eleven instrument sounds. Sticks, brushes & Latin American. Sequence operation up to 15 bar repetition.
- * Playback facilities - Keyboard selection of score, display of selected score, variable tempo, switched selection of any key, in-play changes to key, tempo and all instrument voices, rhythmic patterns and levels, bar down beat indicator, all beat indicator, unlimited chorus repeats, Coda key to cancel repeats, automatic stop, manual instant stop, automatic reset to beginning of selected score, measures/beat selectable to match 4 drumming styles.
- * Composition facilities
- * Composition instructions
- * Pre-recorded scores
- * Musical compass - Tuning range - one semitone, use alternative key for gross pitch change. Bass compass - 16 notes, F1 to G2 44Hz to 104Hz, chord instruments - 18 notes E3 to A4 165Hz to 440Hz, automatic chord inversion to fit compass
- * Percussion instruments - Bass drum, low & high tom toms, snare, drum, rim-shot, cymbal, long & short brushes, high bongo, claves, and accent for dynamics
- * Operator interfaces - numerous
- * External sockets - numerous
- * Size: 19" x 11" x 4½"
- * overall Weight: 11lb.
- * Power requirements: 240V 5W.



\$ 699

WHAT A BOO - BOO! For the last 2 months we have been advertising the Band Box. We stated that the Master Rhythm Kit was \$199 on top of the basic kit price. **THIS IS TOTALLY WRONG!** The Band Box kit **DOES** include the Master Rhythm kit at \$699 - a totally different prospect - **WE APOLOGISE FOR THE ERROR.**

ETI 644 direct connect modem

Ref: ETI October 1982

"NEW UPGRADED MODEL FEATURING THE LATEST IMPROVEMENTS AND MODIFICATIONS"

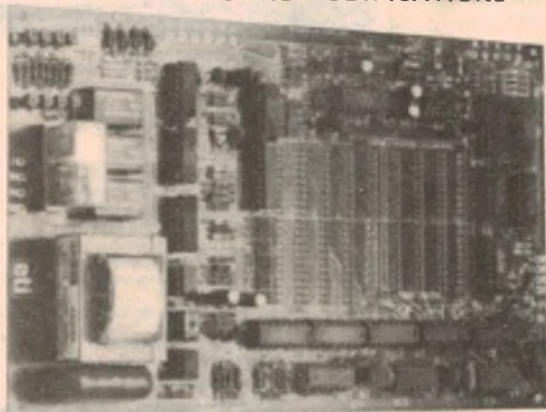

Two models (i) Short form which contains ALL PCB components as specified by ETI (BEWARE!!!) The genuine ETI PCB with plated thru holes, solder mask and component overlay is supplied. We also supply at NO EXTRA CHARGE a full set of quality IC sockets. A must with plated thru PCB's - Remember this when making comparisons (ii) Full kit Includes all of the above plus 12V plug pack, case, front panel, switch and LED bezel and Cannon DB 25 RS 232 connector. Makes a complete stand alone modem. * Capable of a range of Answer/Originate operating modes * Selectable Baud rate * Software controller. * Uses new patented technique * More reliable and faster than most acoustic modems. Arlec transformer as used in this project only \$22.00

SHORTFORM KIT

\$ 169
FULL KIT
\$ 189

Function Generator

Ref: EA April 1982

FREE TILTING
BALL WORTH
\$4.95 included

\$ 99



"Pigeon Pair" companion to the new 500MHz DFM. Low distortion generator of sine, square and triangular waveforms. From below 20Hz to over 160kHz. Inbuilt 4 digit frequency counter in de-luxe Pac-Tec case. Only \$85

JAYCAR EXCLUSIVE - 1% 50ppm metal film resistors used for stability and it's still only \$85!!!

0-30V 1amp power supply

Ref: ETI December 1982

- Fully protected
- Output variable from 0-30V DC
- Selectable current limit
- Both voltage and current metering
- After a multimeter & soldering iron an absolute must for the enthusiast.

You will never own a more useful piece of gear.



\$ 49.50 complete

New Products ...

Product reviews, releases & services

A range of new releases from BWD

A new oscilloscope from Australian company BWD Instruments is claimed to set new standards in cost, economy and performance for applications which require a 50MHz bandwidth.

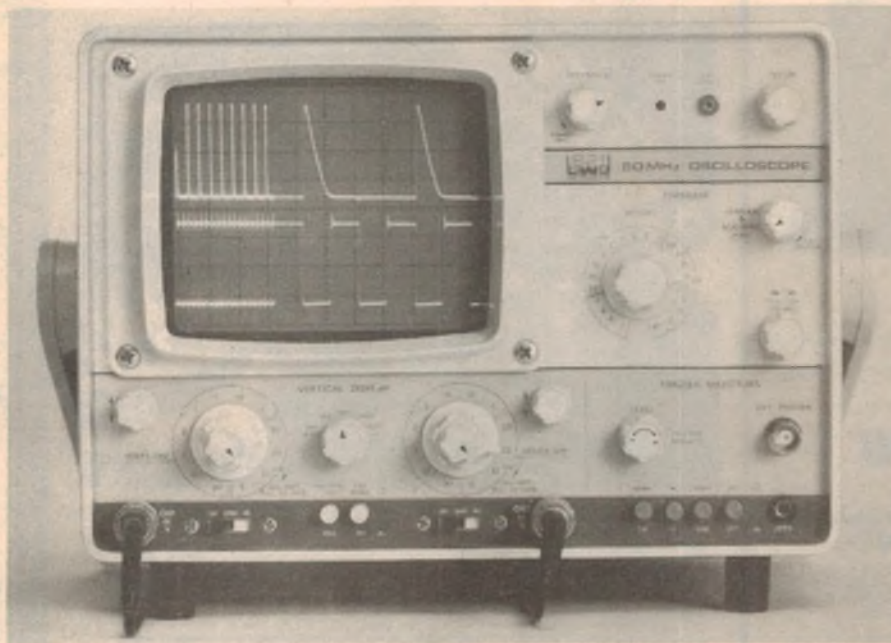

Known as the BWD 821, the oscilloscope provides a number of new features, including a Mix-Mag facility that allows up to 80% of the trace to be magnified X10 in addition to the normal X10 magnification also included, so that overall trace magnification is X100.

Other features of the instrument include sensitivity ranges of 1mV to 20V per division, 20ns per division maximum sweep speed, triggering to 75MHz and television line and frame synchronisation

The new oscilloscope is suitable for a wide range of applications in industry and education, including servicing of computers and other digital equipment with clock speeds to 50MHz. Its high-sensitivity vertical inputs enable low level signals from tape recording heads, pick-ups and microphones to be displayed and measured. The Mix-Mag facility can also be used to magnify each line of a video signal to examine teletext signals, sync pulses and other waveforms

in television receivers and studio equipment.

Also new from BWD is a new low-cost spectrum analyser intended for classroom and instructional use. The main features of the instrument are its relatively low cost and simplicity of operation and front panel control layout.

The BWD 330A spectrum analyser has been designed primarily to support laboratory classes in telecommunications at tertiary levels. By restricting its performance to 1MHz and using a conventional oscilloscope to display the spectrum, the cost of the analyser has been reduced, bringing it in reach of schools.

Specifications of the instrument include a 1MHz bandwidth, 45dB dynamic range, and a resolution of from 200Hz to 8kHz in six steps. Centre frequency and span are entered on a numeric keypad and spectrum information is stored digitally for display on any oscilloscope with X, Y and Z inputs. A video output option is also available to allow a display on a video monitor and a chart recorder output is provided.

Finally, BWD has recently released the Model 1010 pulse generator, a versatile microprocessor controlled instrument specifically designed for testing digital equipment. Pulse widths and amplitude and mark/space ratio are specified via a front panel keypad and all pulses are generated from an internal crystal clock for high accuracy.

For further details on the BWD 821 oscilloscope and other new products contact BWD Instruments Pty Ltd, PO Box 325, Springvale, Vic 3171. Phone (03) 561 2888.

Datel-Intersil parts from Elmeasco Instruments

The ADC-833 from Datel-Intersil is a low power six-bit analog to digital converter able to digitise an analog signal at conversion rates up to 15MHz. Power consumption is 200mW and two of the devices may be connected in parallel to increase the conversion speed to 30MHz.

The device consists of 64 comparators, a resistor ladder network, zener reference diode, a decoder and seven buffer storage registers. The sequential parallel conversion technique makes a

complete conversion possible in one clock cycle. The analog voltage input range is from +2.5V to +10V and all digital inputs and outputs are TTL compatible.

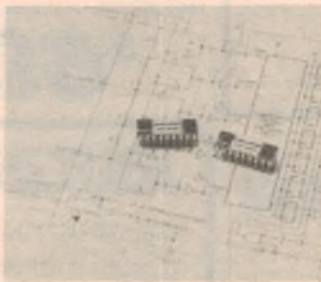

Digital outputs are buffered and can be placed in a high impedance mode. An overflow output is included to allow two units to be cascaded to increase resolution to seven bits.

The ADC-833 is said to be ideal for applications requiring high speed digitisation, including computer graphics, radar signal analysis, motion signature recognition, transient signal analysis and optical character recognition.

Datel-Intersil devices are distributed in Australia by Elmeasco Instruments Pty Ltd, 1 PO Box 30, Concord, NSW, 2137. Phone (02) 736 2888.

Antenna for UHF television covers Channel 28

With the growing interest in UHF TV reception, particularly as an alternative to VHF reception of the ethnic station 0/28, UHF antennas are becoming increasingly important. One of the latest to be brought to our attention is the Wisi model EZ58, manufactured in West Germany.

The model EZ58 is, in fact, available in four different versions, covering four different sections of the UHF TV band. The model submitted to us, and the one likely to be most popular, covers the 21-34 channel segment, thus including channel 28.

The specifications describe it as having a gain of 15.8dB (no reference quoted), a back-to-front ratio of 30dB a horizontal beam width (half power) of 26°, and an overall length of 2.78m. (The Australian agents suggest that, based on experience in the field, the electrical specifications appear to be conservative.) It is suitable for connection to either 300Ω ribbon or, with a balun included, 75Ω coax.

Other versions of EZ58 cover channels 21 to 54, 21 to 60, and 38 to 69. All have similar, though not identical, electrical specifications. Of these the 21 to 54 channel version would seem to be logical choice of those viewers living within the service area of the

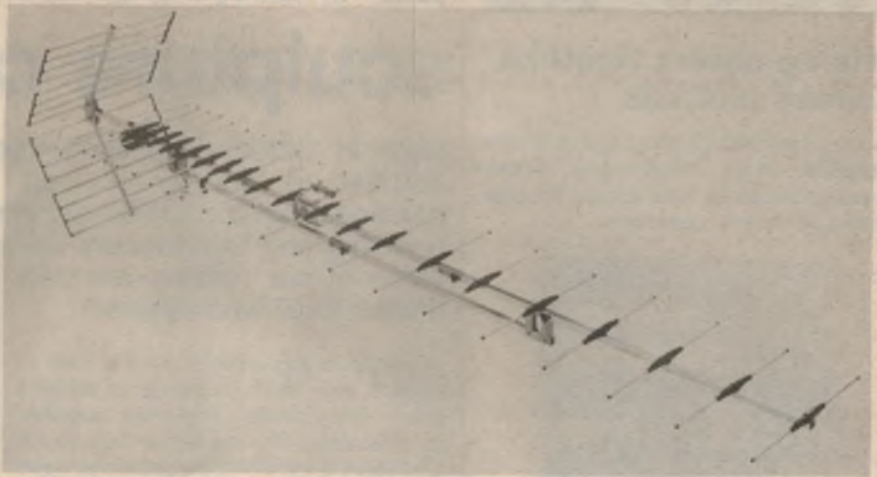

UHF translators at Kings Cross (channels 46, 49, 52). It would also cover channel 28, but there could be an orientation conflict between Gore Hill and Kings Cross in many locations.

The antenna is constructed from square section aluminium tubing for the main boom and support, with a substantial adjustable steel clamp for mounting on the mast. This appears to be designed for large diameter masting, say 50mm or larger. The antenna comes packaged in several sections which are fairly easily assembled, although we found the in-

struction pamphlet barely adequate. Its weight is given as 5.1kg.

The aluminium does not appear to have been given any protective coating but the Australian agents advise that test antennas erected in the seaside suburb of Narrabeen, for over two years, have shown no sign of deterioration.

The price of the EZ58, in any version, is given as \$221.36. Further details may be obtained from the agents, Paul's Antenna Service Pty Ltd, 58 Garden St, Narrabeen, NSW 2101.

Two tape answering machine from Tandy

Tandy Electronics has introduced a new two-tape telephone answering machine at a price claimed to be less than half that of equivalent units.

Two tape answering machines allow the user to record the outgoing message

just once and play the same message to every caller. Users of single tape machines must record the answering message repeatedly, with one for each expected incoming call.

The new Tandy Duo-Fone unit also features a bell adjust which allows the user to set the number of times the phone can ring before the machine

answers, a fast forward for skipping unwanted calls and a call monitor that allows the user to listen to incoming calls before answering personally.

With a built-in electret microphone, side mounted loudspeaker and volume control the unit measures 70 x 222 x 152mm and is priced at \$149.95 from all Tandy stores.

MASTER ELECTRONICS NOW!

The PRACTICAL way!

This new style course will enable anyone to have a real understanding of electronics by a modern, practical and visual method. No previous knowledge is required, no maths, and an absolute minimum of theory.

You learn the practical, way in easy steps mastering all the essentials of your hobby or to start or further a career in electronics or as a self-employed servicing engineer.

All the training can be carried out in the comfort of your own home and at your own pace. A tutor is available to whom you can write personally at any time, for advice or help during your work. A Certificate is given at the end of every course

You will do the following:

- Build a modern oscilloscope
- Recognise and handle current electronic components
- Read, draw and understand circuit diagrams
- Carry out 40 experiments on basic electronic circuits used in modern equipment
- Build and use digital electronic circuits and current solid state 'chips'
- Learn how to test and service every type of electronic device used in industry and commerce today Servicing of radio, T.V., Hi-Fi and microprocessor/computer equipment.

New Job? New Career? New Hobby? Get into **Electronics Now!**

Post coupon now:

The Australian School of Electronics Pty. Ltd.,
(Inc. in Victoria)
PO Box 108, Glen Iris,
Victoria, 3146
A Registered
Correspondence College



FREE
COLOUR BROCHURE

Please send your brochure without any obligation to:

Name _____

Address _____

Post Code _____

EA 4/83

New Products

Catalog covers Heathkit courses and kits

A new Heathkit/Zenith catalog is now available from Warburton Franki covering Heathkit's educational courses, training kits and accessories.



The new catalog outlines a new approach by Heathkit. For additional versatility courses are now available in two formats: a textbook series for classroom and group instruction in which each course is complete with texts, workbooks and instructors guides, training materials and examination papers; and a streamlined self-study format for "on the job" training.

Subjects covered by the Heathkit/Zenith courses include: basic and advanced electronics, digital techniques, microprocessor technology, seminars and exploratory courses, computer systems and computer programming.

The new catalog is available free of charge from your local Warburton Franki office.

Molex connectors from Utilux Pty Ltd

Utilux Pty Ltd now has available the Molex 5295 "Micro Spox" PCB connector, designed for high density wiring applications at currents of up to 1A. The height of the installed connector is 5.7mm and contacts are spaced on 2mm centres. Since it mates directly with the PCB the terminal eliminates the need for a header.

Two to 15 contact types are available, accommodating wire with a maximum outside diameter of 1.5mm. The units are also available with contacts on 2.54mm spacings.

For further information on these and other Molex products contact Utilux Pty Ltd, PO Box 68, Kingsgrove, NSW, (02) 50 0155.

EA/Ellistronics sculpture contest

Back in October we announced the EA/Ellistronics sculpture contest to put a little art into electronics. After much consideration and a final vote amongst the EA staff we've chosen a winner and four runners-up, and come to the conclusion that some of our readers are very imaginative people indeed! Our thanks to all who entered.

First prize was won by Mr Val Starr of Higgins, ACT with his group of athletes titled "The Games". His prize, supplied by Ellistronics Pty Ltd is the Trio Model CS-1560A II oscilloscope shown at right.

The four runners-up are Brian M. Bryne of Indooroopilly, Queensland, Maxwell D. McSundey of Canley Vale, NSW, Mr K. Hennie of Hastings, Victoria and Mr W. A. Fletcher of Mylestom, NSW.

Each runner-up will receive an Ellistronics type 4N breadboard to further assist his electronic artistry. Congratulations to the winners and our thanks to all who entered.

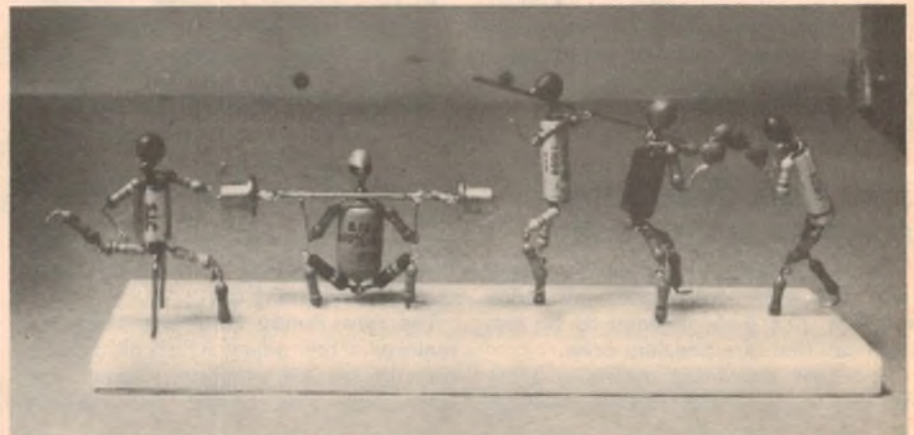

"The Games" by Mr Val Starr won first prize in the EA/Ellistronics sculpture contest.

Mayer Krieg & Co instrument cases

An enclosure for hand-held instruments is now available from Mayer Krieg & Co. The boxes are moulded in two sections from brown or black ABS plastic and measure 76mm x 144mm x 35mm (W x D x H) and have a cut-out for mounting a display.

A separate battery compartment with a snap-on cover is provided at the rear of the case. Screw holes in the base allow the case to be readily assembled and disassembled.

Also available from Mayer Krieg are a new series of shell type cases in a range of sizes with separate battery compartments.

For further information contact Mayer



Krieg & Co Electronic and Electrical Components, GPO Box 1803, Adelaide, South Australia or telephone (08) 223 6766, or their offices in Sydney and Melbourne.



NOW IN STOCK
LUTRON DIGITAL LCD MULTIMETER
 3 1/2 Digit, 5" Display, 10 meg input, Transistor HFE Tester up to 10 amp. DC current, 1% accuracy
\$65.00



\$11.50
 Max Input 1.5 MHz
 Strong Aluminium case
 LEDs HI-LOW-PULSE
 80cm leads
 KEY to LEDs on back of probe
 Input Impedance 300k
 model DLP-1
 Probe Logic



19 INCH RACK BOX (483mm W x 132mm H). Get a professional finish like Namakichi and Technics with your projects.

\$35.00
 PIP \$4.00



WELLER SOLDERING STATION
 A transformer powered soldering station, complete with a low voltage, temperature controlled soldering pencil. The Special Weller features a 'closed loop' which controls maximum tip temperature, thereby protecting temperature sensitive components while the grounded tip protects voltage and current sensitive components. Features: • quick connect/disconnect plug for the soldering iron • extra large wiping sponge • tip tray to store extra tips • 2m flexible 3-wire power cord.

ONLY \$69.75

LOWEST PRICED TOP QUALITY BLACKBOARD
 2N 200 • 640 Holes
\$9.50 each.

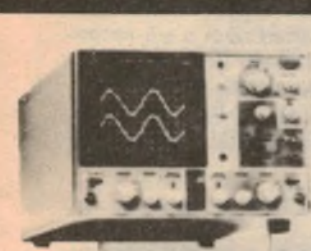

P/P \$10.00
 New Low Price
V152F 15MHz \$520

Dual Trace 15 MHz, 1mV Sensitivity, XY operation, TV sync separator circuit. Sweep times magnifier (10 times) Trace rotation Z Axio Input. Excellent value for money. Supplied to many Government Departments and National TV Service Companies.



\$5.95
S2010 PVC weatherproof re-entrant horn / speaker. Very attractive "off white" colour. 8 ohm 5 Watt RMS. Ideal P.A. use. Individually boxed.
SPECIAL PRICE

S2000 8" (200mm) wide range general purpose. Includes transformer, mounting holes for P.A. and background use. Very smooth over all response 45 Hz-12 KHz. Fitted to a 1.9 cubic ft vented enclosure they sound unbelievable.
 8 Ohm 8 Watt RMS 5.6 oz magnet.
\$6.50ea

LOW PROFILE IC SOCKETS

8 PIN	18
14 PIN	25
16 PIN	28
18 PIN	29
20 PIN	30
22 PIN	33
24 PIN	35
28 PIN	40
40 PIN	60

10 UP LESS 10%

The Name is **JIFFY**
 and that's how long it takes to box your project. Just a JIFFY!

1 9	10 49	50 UP
UB1	2 00	
2	3 00	
3	1 50	
5		1-00

VERO TYPE BOARD

H5614	90 x 80mm	\$1.25
H5602	150 x 90mm	\$2.65
H5116	310 x 100mm	\$3.95

Plated Strips-Alpha Numeric Grid, the most versatile board of the lot. Etched copper strips are pre-drilled and plated for soldering ease. These boards have an Alpha Numeric Grid to facilitate positive Pin identification.

XENON FLASH TUBE
 Trigger Transformer 2-20 80

DUAL LIGHT DEPENDENT RESISTORS
69c

WIRE WRAP TOOL WSU-30
 Wrap-Strip-Unwrap
\$8.85

5" Drive Cases with power supplies
 For 1 Drive \$65.00
 For 2 drives \$79
 P/P \$5.00

REED SWITCH AND COIL
 NOW THRASHED TO RIBBONS
 SWITCH 40 c
 COIL 80 c

COMPUTER COOLING FANS
 4 1/2"
\$13.50

PUSH BUTTON SWITCHES
 Ideal PCB mount. Momentary 2 pole Push-on Positive "click action". Great for alarm equip, intercoms, custom keyboards etc.
PACK OF 4 \$185

DISC DRIVES SPECIALS

MP1B51.....\$295 MP1B52.....\$375
 MP1B91.....\$450 MP1B92.....\$550
 *PHONE FOR BEST PRICES ON MITSUBISHI SLIM LINE DRIVES & POWER SUPPLIES

DIL PCB SWITCHES

4 Pole	\$1.00
6 Pole	\$1.39
8 Pole	\$1.65
10 Pole	\$2.86

New Products

Tecnico Electronics has Belling-Lee components

Tecnico Electronics can now supply Belling-Lee test probe plugs and sockets, intended for use in the construction of insulated test probes. Red, green or black plug and socket units are available with a current rating of 10A and isolation to 1000VAC in accordance with IEC 65 standards.

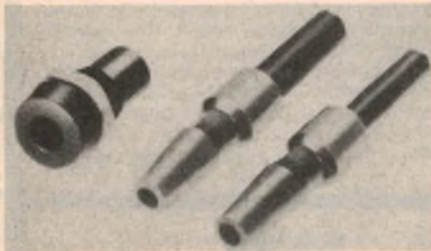

Fuseholders from Belling-Lee are also distributed by Tecnico. The holders are said to meet Australian, British and European safety standards, with all live parts encased in the body of the moulding.

For further information contact Tecnico Electronics, 67 Mars Rd, Lane Cove, NSW, 2066. Phone (02) 427 3444.

Multiplexer converts any CRO to eight channels



A multiplexing device which converts a general purpose single- or dual-channel oscilloscope into an eight-channel instrument has been developed by Global Specialties Corporation. The new Model 800 1 multiplexer functions in the same way as a simple logic analyser without memory and allows simultaneous events on different channels to be compared and displayed in direct relationship to one another.

The instrument allows oscilloscope users to view events occurring synchronously or asynchronously on either all eight channels at once or

one of two four-channel combinations.

Input to the multiplexer is via eight BNC connectors, and the instrument will accept signals of $\pm 5V$ (10V peak-to-peak) with frequency response which is flat to 12MHz and 3dB down at 20MHz. Input impedance is 1M Ω .

Comprehensive trigger facilities are provided and the trigger level can be continuously varied over a ± 5 range.

Global Specialties Corporation is represented in Australia by Vicom International Pty Ltd, PO Box 366, South Melbourne, Vic, 3205. Phone (03) 62 6931.



Think About

SOUND

Have you heard a good film recently? Can you tell a story without words—using only sound effects? Are you interested in the use of sound for FILM & TELEVISION?

If so, you may be one of the creative men or women the

Australian Film and Television School

seeks for its

1984 Fulltime Program Three Year Diploma Course

The course covers all aspects of recording, balancing and mixing dialogue, music and sound effects for film and television. Training is also given in **camera, editing, production management and writing**

Applicants must be . . .

- resident in Australia
- able to submit examples of work work with their application
- socially and culturally aware people

The AFTS is a statutory authority funded by the Federal government.

Full time AFTS students are paid a living allowance while training, plus dependants' allowances where applicable.

All applications must be on the official application form, available from the **Students Officer, AFTS PO Box 126 North Ryde NSW 2113 (02) 887 1666**

Closing date: Wednesday 1 June 1983

Pocket size scanning receiver from Imark

Imark Pty Ltd has released a pocket-sized 10-channel crystal-controlled scanning FM monitor receiver.

The "Pocket Scan" covers three FM bands: 70-90MHz, 146-174MHz, and 430-520MHz. It can operate on either four AAA cells or nickel cadmium batteries.

The scanning facility allows all 10 channels to be scanned continuously and a pass channel feature is provided to allow any number of channels to be bypassed. A manual channel selection switch is also provided and if desired the scanning facility need not be used.

The "Pocket Scan" receiver is supplied complete with nicad batteries, antenna, earpiece, vinyl case with belt strap, operator's manual, and an approved charger.

The "Pocket Scan" uses double conversion superheterodyne circuitry and a crystal filter and a ceramic filter to provide good sensitivity and selectivity. An automatic frequency control circuit adjusts the receiver's local oscillator frequency to compensate for changes in the carrier frequency.

Further information is available from Imark Pty Ltd, 167 Roden Street, West Melbourne, 3003. Phone (03) 329 5433.

Decoupling capacitors mount under ICs

Soanar Electronics Pty Ltd has introduced what it claims is an entirely new concept in decoupling capacitors, the Rogers Micro/Q, designed to reduce transient noise in digital IC circuits.

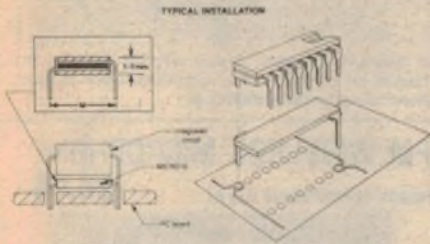

With conventional capacitors inductance can be only slightly reduced by correct printed circuit board layout. Micro/Q capacitors are said to cut lead inductance by an order of magnitude because of their unusual construction.

The capacitors are flat and less than 1.2mm thick, and are designed for use directly under or on top of dual-in-line ICs. They are available in various sizes to suit ICs with from 14 to 64 pins and reduce lead inductance by using wide conducting pins which share the same holes as the IC power supply pins.

Since the capacitors fit directly under the integrated circuit package there is no need to redesign circuit boards.

Further information on Rogers Micro/Q capacitors is available from Soanar Electronics Pty Ltd, 30 Lexton Rd, Box Hill, Vic 3128.

Moulded project cases available from ACE



Moulded high impact ABS plastic project cabinets are now available from ACE Radio. The colour is "battle-ship grey" and the front panel has cut-outs for controls and displays although a blank panel can be easily substituted if required.

Dimensions of the boxes are 350mm x 130mm x 350mm (W x H x D) with 5mm thick sides. Four countersunk plastic screws secure the four sections of the cabinet and the bottom panel is slotted for ventilation and has dimples for the attachment of rubber feet.



For further information on the cabinets and other components contact ACE Radio, 136 Victoria Rd, Marrickville, NSW, 2204. Phone (02) 51 3845.

LIKE TO GET AN AMATEUR RADIO CERTIFICATE? IT'S MUCH EASIER WITH PROFESSIONAL HELP.



If something's worth doing, it's worth doing well. So don't waste your valuable spare time finding your own way through the Amateur Radio maze. Ask Stott's instead. We have top professional instructors, who'll make sure your time is well spent on your way to an operator's certificate. You'll have individual attention, working at your own speed, in the comfort of your own home. Any queries will be answered personally, and promptly.

So don't delay. Mail the coupon for full details. Over and out.

The name to trust in correspondence education

Please send me free, and without obligation, full details of the following courses:

_____ (PLEASE PRINT)

MR MRS MISS _____ AGE _____

ADDRESS _____

_____ POSTCODE _____

Stott's undertake that no sales counsellor will visit you

Melbourne 159 Flinders Lane, 3000 Tel: 63 6212

Sydney 383 George Street 2000 Tel: 29 2445

Brisbane Suite 3 65 Mary Street 4000 Tel: 221 3972

Adelaide 85 Pine Street 5000 Tel: 223 3700

Perth 25 Richardson Street 6005 Tel: 322 5481

Hobart 150 Collins Street 7000 Tel: 34 2399

New Zealand Box No 30 990 Lower Hutt Tel: 670 370

The Stott's range of courses in Amateur Radio is:

- Novice Amateur Operator's Certificate of Proficiency.
- Amateur Operator's Certificate of Proficiency.
- Amateur Operator's Limited Certificate of Proficiency.
- Radio for Amateurs.

ALA/ST4163/EA483

ROD IRVING ELECTRONICS

ETI SERIES 5000



Power Amp \$299.00
Pre Amp \$259.00

CUDLIPP

\$12.00



A fascinating Electronic Cricket with just two ICs. The Cudlipp can be used to bug your Home, Office or Board Room. Great fun. EA February 82

ON SCREEN GRAPHIC ANALYSER \$109.00

The On Screen Graphic Analyser links your hifi to your TV set.

Features:

Six colour bar graph display (Standard PAL receiver).
Ten vertical bars in the display corresponding to the 10 octave bands.
Gives you the best sound quality your system can deliver.

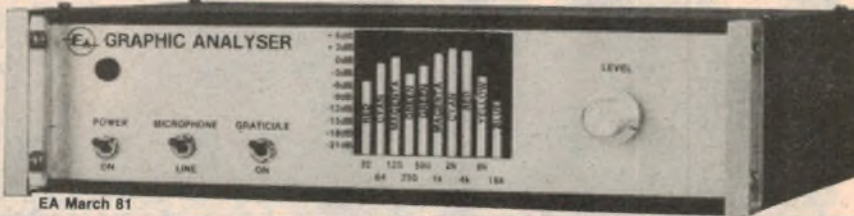

EA March 81

FM WIRELESS MICROPHONE

\$8.50

HOBBY ELECTRONICS May 81



CAR BATTERY MONITOR

\$9.50

Flat Battery! Don't get left out in the rain. Install a voltage monitor which monitors the state of your battery at a glance. EA. October 80.



UNIVERSAL RELAY BOARD

\$13.50

Operating a relay to switch heavy current or mains voltages is a common requirement in electronic control applications. This project permits a relay to be switched in a variety of ways and from a variety of inputs. ETI May 81



LOW FUEL INDICATOR

EA March 81

\$16.50



AM TUNER

\$99.00

ETI 475 September 80



Includes plug pack and punch metal work

\$9.50

MINI DRILL SPEED CONTROLLER

Here's an easy to assemble project for a simple speed regulator for miniature DC electric drills. ETI July 81



ELECTROMYOGRAM

\$89.00

ETI Top Projects Vol 8



SLOT CAR POWER SUPPLY

\$19.50

ETI December 81

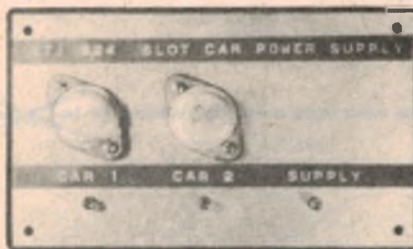

SERIES 4000 SPEAKER KITS

Speakers and crossovers \$450
Speaker boxes \$249
Crossover kits \$189
Complete kit \$679



EPROM PROGRAMMER

EA July 80



Horwood Case Supplied **\$77.50**

HUMIDITY METER. \$22.50

ETI 256



BRIDGING ADAPTER

ETI March 82

\$10.95



SLIDE CROSS FADER \$85.00

EA November 81



425 High Street, Northcote 3070, Melbourne, Victoria. Ph (03) 489 8131. Telex No. 38897

Now open at 18-50 A Beckett Street, Melbourne Ph 347 9251

Shortwave Scene

by Arthur Cushen, MBE



Huge increase in world radio audience

During the past few years there has been a tremendous increase in the number of radio receivers used worldwide and the problem of just what that audience wants to listen to is now being tackled by international broadcasting stations.

Shortwave radio, even though it has audiences running into many millions of listeners, differs from the other mass communication media in that response from listeners is delayed and audience numbers are difficult to assess. Audience surveys of the type carried out by national radio and television stations cannot be applied in the same way to international broadcasting, simply because the cost of carrying out such extensive surveys in each of the target areas served would be prohibitive. Nonetheless Radio Nederland does arrange limited audience surveys, often in conjunction with other international broadcasters. The purpose of these surveys is mainly to ascertain how programs come across to listeners.

The results obtained from such surveys are of great interest in Radio Nederland, but because of the processing of data involved they do not give an immediate reaction. That's why the listener's response, either by mail or by telephone, is so important to the station.

Recent figures issued by the BBC and the Voice of America indicate that their average daily audience is in excess of 100 million listeners. Radio Australia has recently formed an audience survey unit which plans to involve listeners in surveying the type of program which should be broadcast and give some idea of the size of the audience and geographical location of many of the listeners.

The increasing shortwave audience is also reflected in the number of radio receivers now in use throughout the world. Numbers have grown from 237 million in 1955 to 1380 million in 1982. Some of the major increases have occurred in Africa, with a growth from one million to 40 million in 27 years, and in Asia with an increase from 15 million to 279 million receivers in the same period, proving that in the world as a whole radio continues to be the main provider

of news and information, with no sign of a peak being reached.

RED CROSS BROADCASTS

The International Committee of the Red Cross in Geneva continues to carry out test broadcasts each month. A transmission on 7210kHz on Monday, April 25, 0600-0700UTC will be in English for the first 30 minutes and then in French. Other omnidirectional broadcasts are timed at 1130 and 1700UTC.

A special transmission using the facilities of the Swiss Broadcasting Corporation will be beamed to Australia and New Zealand on Tuesday, May 24 at 0945UTC on 9560, 15305, 21520 and 21695kHz. The same facilities will be used in a broadcast to Africa on Thursday, May 26 at 1005UTC on 15430, 17795, 21520, and 25780kHz. These broadcasts will be repeated every second month and the service to the South Pacific at 0945UTC will be heard on July 26, September 27 and November 22.

The omnidirectional broadcasts on 7210kHz at 0600UTC are scheduled for May 23, June 27, July 25, August 29, September 26, October 24, November 21 and December 26.

The Red Cross Broadcasting Service began during the final days of World War Two when the ICRC broadcast lists of prisoners awaiting repatriation and of people missing because of the war. In 1948 the ICRC was granted the use of a frequency for major crises and began test transmissions. It has its own recording studio in Geneva and broadcasting facilities are given free of charge by Swiss Radio International. The program (in English, French, German, Spanish, Portuguese and Arabic) contains news of Red Cross work around the world, and RCBS welcomes reports and questions. IRC's for postage are appreciated while reports are confirmed by verification card from The Red Cross Broadcasting Service, ICRC, 17, avenue de la Paix, CH - 1211 Geneva, Switzerland.

BRAZILIAN SIGNALS

Signals from Brazilian stations during the afternoon continue to be received on the higher frequencies with Radio Guaiba on 11785 heard after 0330UTC, when Deutsche Welle leaves the frequency, and Radio Inconfidencia on 15190kHz heard to 0300UTC with its closing announcement blocked by KYOI Saipan.

Another recent signal is that of Radio Cultura on 17815kHz heard closing at 0500UTC.

CHINA MOVES TO 8MHz

Radio Beijing has appeared on several frequencies around 8MHz and 8425kHz is used to Australia in English at 0830-0925 and 0930-1025UTC with the broadcast also heard on 9860, 11600, 15195 and 15435kHz.

Other frequencies in use in this area of the shortwave bands include 8260kHz at 1100-1130 in Spanish, 8300kHz at 1100-1200 in Cantonese, 8490kHz at 1130-1200UTC in Thai, 8345kHz at 1200-1230UTC in Vietnamese, 8240kHz 1500-1600 in Hindi, 8660kHz 2200-2300 in Spanish and 8450kHz 2230-2300 in Chinese, according to the BBC Monitoring Service.

Notes from readers should be sent to Arthur Cushen, 212 Earn Street, Invercargill NZ. All times are UTC (GMT). Add eight hours for WAST, 10 hours for EAST and 12 hours for NZT. In areas observing daylight time, add a further hour.

DO YOU WANT TO BE A RADIO AMATEUR?

The Wireless Institute of Australia, established in 1910 to further the interests of Amateur Radio, conducts a Correspondence Course for the A.O.C.P. and L.A.O.C.P. Examinations conducted by Telecom. Throughout the Course, your papers are checked and commented upon to lead you to a successful conclusion.

For further information, write to

**THE COURSE SUPERVISOR
W.I.A. (N.S.W. DIVISION)**

P.O. BOX 1066
PARRAMATTA, N.S.W. 2150.

Australia's Most Exciting Personal Computer The Incredible Micro Bee

The Microbee is definitely the most versatile computer now available in Australia. Its ability to run complex software, and its friendliness to the user, have gained the Bee great acceptance, in the home, in small to medium businesses and in schools. In fact the Bee has recently been approved and recommended under contract by the N.S.W. and W.A. Education Departments. Children are growing up with Bee's!

In its basic 16K PLUS form the Bee is capable of playing music through its built-in speaker, high and low resolution graphics, upper and lower case characters, direct connection to printers and has standard features such as battery backup (keep programs in RAM for months), full size QWERTY keyboard, inbuilt in/out ports and basic contained in ROM.

The all Australian designed and developed "Bee" incorporates the most powerful and comprehensive editing facilities of any micro-computer yet released — editing being the single most important operator/programmer facility. With the Bee it's a dream and, incidentally, attracting attention WORLD WIDE!

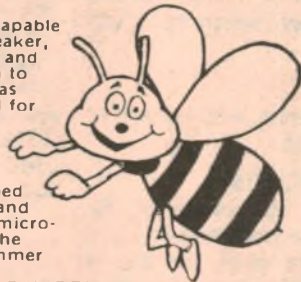

FEATURES OF COMPUTERS COSTING MANY TIMES ITS PRICE

The Bee can be expanded through various stages, (16K-32K, 32K-64K) to a powerful 2.2CP/M Bee with disks capable of word processing and running world class software from machines such as IBM, DEC and HEWLETT PACKARD.

THE VARIOUS BEES AND HARDWARE

COMPUTER

D 1016 Microbee 16K Plus	\$ 449.00
D 1032 Microbee 32K Plus	\$ 549.00
D 1064 Microbee 64K Plus	\$ 699.00
D 1216 16K 16K Plus Conversion Pack	\$ 29.95
D 1232 16K-32K Plus Conversion Pack	\$ 125.00
D 1264 32K-64K Plus Conversion Pack	\$ 175.00
D 1270 S-100 Digitalker	\$ 155.00
D 1275 S-100 Romblaster	\$ 165.00
D 1280 S-100 Desk Top Interface	\$ 299.00
D 1285 Parallel Port inc. DB15 Plug and Hood	\$ 19.95

UPGRADE TO A CP/M2.2 DISK DRIVE SYSTEM

D 1300 Disk Drive with Controller & CP/M2.2	\$ 799.00
D 1305 Add On Disk Drive	\$ 659.00
D 2600 CP/M2.2 Disk	\$ 200.00

SOFTWARE

The Microbee is supported by an ever increasing range of software cassettes and ROM chips.

CASSETTES

D 2520 Space Invaders	\$ 14.95
D 2521 Concentration	\$ 9.95
D 2522 Chess	\$ 9.95
D 2523 Typing/Solitaire	\$ 9.95
D 2524 Target	\$ 9.95
D 2525 Lunar Landing/Hurkle	\$ 9.95
D 2626 Star Shoot/Hangman	\$ 7.95
D 2527 BioRhythm/Calendar	\$ 7.95
D 2528 Eliza	\$ 9.95
D 2529 Kids Games	\$ 9.95
D 2530 Master Mind/Nim	\$ 9.95
D 2531 Chase/Wumpus	\$ 9.95
D 2532 Z Trek	\$ 9.95
D 2533 Educational Pack 1	\$ 24.95
D 2534 Educational Pack 2	\$ 24.95
D 2535 Graphic Games	\$ 9.95
D 2536 Missile Wars	\$ 9.95
D 2537 PCG Tutorials	\$ 9.95
D 2538 Microbee Pilot Educational	\$ 14.95
D 2541 "ESC" Key	\$ 9.95
D 2542 Robot Man	\$ 14.95

ROM

D 2503 Editor/Assembler	\$ 59.50
D 2507 5.1 Basic Upgrade	\$ 20.00
D 2540 Word Bee ROMPack (Word Processor)	\$ 89.50
D 2543 Pascal S+	\$ 299.00



CALL IN FOR A DEMO AT ALTRONICS NEW BEE COMPUTER CENTRE

MICRON 12

Green Phosphor Monitor

Features 12" screen Front controls, on-off, contrast reverse, brightness. Power 240V 50Hz or 12V DC Input RCA type. DC Output Jack 12V 1.1 Amp — power your Micro direct without a power pack. Bandwidth 10Hz to 20MHz the resultant definition is truly amazing for a low cost monitor

Guaranteed by ALTRONICS! Incredible Value.

D 1112 \$199.50



Adjustable Azimuth DATA CASSETTE

At last a Data Cassette Recorder/Player you can afford. The Micron D 1120 is fully adjustable azimuth (absolutely essential in our opinion) and incorporates tailored audio frequency response audio stage together with low distortion.

Now you can save and load software in your Micro with confidence.

Micron D 1120 Data Cassette ONLY \$49.50

D 1140 C10 Data Cassette Tape	\$1.10
D 1141 C20 Data Cassette Tape	\$1.20



EPSON MX80/3 DOT MATRIX PRINTER

All serious programmers require hard copy of program listings and every business needs a printer for stock control, invoicing, monthly balances etc.

The economy-priced MX80 has full graphic capabilities (480 x 8, 960 x 8 dots/line, bit image).

THE QUALITY OF THIS MACHINE'S PRINTING MUST BE SEEN TO BE BELIEVED!

Specifications: Print Rate: 80 char. per sec. Print Direction: Bidirectional logic seeking. Character Set: Full 96 character ASCII with descenders plus 8 international char. sets. Character Structure: 9 x 9 text mode. Character Size: 3.1 (H) x 2.1 (W)mm. Total of 32 Printing Styles: Normal, Normal Enlarged, Condensed, Condensed Enlarged, Emphasized, Programmable. Paper Feed: Adjustable sprocket (4"-10") plus Friction Feed. Interface: Centronics 8 Bit Parallel.

D 1180 MX80 F T (No Graphics)	\$1025.00
D 1183 MX80 3 F T (Graphics)	\$1195.00
D 1188 MX80 Serial Interface Adaptor Board	\$135.00
D 1189 MX80 3 Serial I Face Board w - 2K Buffer	\$249
D 1190 Printer Cable Interface Kit	\$49.95



WILL
YOUR BUDGET PROBABLY WON'T STRETCH TO AFFORD OUR PROFESSIONAL SERIES ALL ALUMINIUM RACK CABINETS
 NOW YOUR PREAMPS, AMPS, CONTROL MODULES MONITOR PANELS ETC. CAN LOOK EVERY BIT AS GOOD AS TECHNICS, NAKAMICHI AND OTHER TOP MANUFACTURERS



INTRODUCTORY PRICES

Cat No.	Finish	A	B	C	PRICE	5 or More
H 0401	Natural	44	34	38	\$42.50	\$39.95
H 0402	Natural	38	57	82	49.95	47.50
H 0403	Natural	132	89	126	55.00	49.95
H 0411	Black	44	34	38	42.50	39.95
H 0412	Black	88	57	82	49.95	47.50
H 0413	Black	132	89	126	55.00	49.95

Beware of other rack boxes that do not conform to international rack sizing.

THE BRILLIANT MARC NR 82 FI

FEATURING: Digital frequency Display, SSB CW, FM AM reception, B.F.O., Double Conversion, Double Super het, crystal controlled (VHF) Local Oscillator, 4 inbuilt antennas and good looks, you will spend hours just learning how to drive it!



See Review in Electronics Australia August 1982

3 Way Power
 Digital Tuning
 HI FI SOUND
 4 Inbuilt Antennae

only \$349 C9484

SPECIFICATIONS:

Semi-conductors: 1-LSI, 4- IC's, 7- FET, 34- Transistors, 42- Diodes
 Frequency range:
 LW 145-360 KHz SW3 9-22 MHz VHF3 88-108 MHz
 MW 525-1600 KHz SW4 22-30 MHz VHF4 108-136 MHz
 SW1 1.6-3.8 MHz VHF1 30-50 MHz VHF5 144-176 MHz
 SW2 3.8-9 MHz VHF2 68-86 MHz UHF 430-470 MHz
 Power supply: AC 240V 50Hz DC 12V (8 x "D" cells), Ext. DC 12V Car/Boat.
 Speaker: 12.5cm Permanent Dynamic Speaker (3.2 ohm)
 Antenna: Ferrite Bar Antenna for LW, MW and SW1
 3 x Telescopic Antenna for SW, VHF and UHF
 Controls: Power ON-OFF switch - Digital display ON-OFF switch - Tape-Radio switch, Wide-Narrow band selector switch, AM band selector (LW/MW/SW1/SW2/SW3/SW4), VHF band selector (VHF1/VHF2/VHF3/VHF4/VHF5/UHF), Ant. Selector (Telescopic ANT./EXT. ANT.), Tuning control (direct gear drive), volume control, Bass control, Treble control, Squelch control, BFO pitch control, RF gain control, Antenna adjustor control, Mode switch (USB-NOR-LSB/CW)
 Terminals: Ext. Speaker/Headphone Jack, Tape IN-OUT jack, VHF/UHF ANT. connector (coaxial), SW EXT. ANT. terminal (Screw), Ext. battery jack
 Meter: Tuning Meter
 Digital Frequency Counter Section:
 Display: LW/MW/SW-1 KHz SW2-4/VHF1-5 MHz
 Control: SW Calibrator Dimensions: 452mm (W) x 288mm (H) x 130mm (D)

ALTRONICS RESELLERS

Please note that resellers may not have all the items advertised in stock, and as resellers have to bear the cost of freight, prices may be slightly higher than advertised. ALTRONICS reseller prices should however represent a considerable saving over our competitors' prices.

NEW SOUTH WALES	QUEENSLAND
CITY	CITY
Radio Dispatch 211 0191	Delsound 229 6155
Electronic Agencies 29 2098	
Jaycar 264 6688	SUBURBAN
SUBURBAN	SALISBURY
LEWISHAM	Colourview Wholesale 275 3188
PraPak Electronics 569 9770	FORTITUDE VALLEY
CONCORD	St Lucia Electronics 52 3547
Electronic Agencies 745 3077	Wholesale Sound Accessories 207 2502
DEE WHY	COUNTRY
David Rivett Electronics 982 7500	CAIRNS
WAITARA	Thompson Instrument Services 51 2404
Applied Technology 487 2711	TOWNSVILLE
MATTRAVILLE	Solex 72 2015
Creative Electronics 666 4000	ROCKHAMPTON
COUNTRY	Purely Electronics 21058
BROKEN HILL	GLADSTONE
Crystal TV 4803	Purely Electronics 72 4321
COPPS HARBOUR	GYMPIE
Copps Harbour Electronics 52 5684	TV and Appliance Services 82 1671
PENRITH	IPSWICH
Acorn Electronics 21 2409	P & P Electronics 281 8001
NEWCASTLE	TOOWOOMBA
D G E Systems 69 1625	Hunts Electronics 32 9677
WINDANG	Down's Radio and TV 32 1044
Madjenk Electronics 96 5066	NAMBOUR
GOSFORD	Namboor Electronics 41 1604
Tomorrows Electronics 24 7246	NT
KURRI KURRI	DARWIN
Kurri Electronics 37 2141	Radio Parts Darwin 81 8508
SOUTH AUSTRALIA	Kent Electronics 81 4749
CITY	Ventronics 81 3491
ADN Electronics 212 5505	ALICE SPRINGS
SUBURBAN	Farmar Electronics 52 2967
PROSPECT	Ascom Electronics 52 1713
Jensen Electronics 269 4744	TASMANIA
ELIZABETH GROVE	HOBART
A E Cooling 255 2249	Beta Electronics 34 8232
CHRISTIES BEACH	KINGSTON
Force Electronics 382 3366	Kingston Electronics 29 6802
KESWICK	AVOCA
Freeway Electric Wholesalers 297 2033	Freemans TV 84 2166
VICTORIA	WEST AUSTRALIA
CITY	ALBANY
All Electronic Components 662 3506	BP Electronics 41 2681
Eliotronics 602 3499	GERALDTON
SUBURBAN	Geraldton TV and Radio 21 2777
HUNTINGDALE	WYALKATCHEM
Stewart Electronics 543 3733	D & J Pease 81 1132
SOUTH CROYDON	MANDURAH
Truscott Electronics 723 3860	Kentronics 35 3227
COUNTRY	ACT
SHEPPARTON	Scientronics 54 8334
GV Electronics 21 8866	Electronic Components 80 4654
MILDURA	
Electronic and Digital Services 23 3380	

RESELLERS WANTED IN ALL AREAS (including WA)

Phone: **STEVE WROBLEWSKI (09) 381 7233** for details

NEW 24 HOUR 7 DAYS P/WEEK PHONE ORDER SERVICE FOR BANKCARD HOLDERS

Take advantage of "off peak" low STD phone rates and phone your order to our new recorded 24 hour order service. Give your name, address with postcode, phone number, bankcard number and expiry date then your order—and presto your order will be processed and back to you in a flash—Please nominate Jetservice if you want overnight delivery.

\$2.50 DELIVERY AUSTRALIA WIDE We process your order the day received and despatch via Australia Post. Allow approx. 7 days from day you post order to when you receive goods. Weight limited 10kgs.

\$4.50 DELIVERY AUSTRALIA WIDE We process your order day received and despatch via Jetservice for delivery next day.

BANKCARD HOLDERS CAN PHONE ORDER UP TO 8PM (EST) FOR NEXT DAY DELIVERY - SOUNDS INCREDIBLE DOESN'T IT? Alright you cynics just try us! Weight limit 3.3kgs. Jetservice cannot deliver to P.O. box numbers (Australia Post would have a fit).

\$10.00 HEAVY HEAVY SERVICE - AUSTRALIA-WIDE All orders over 10kgs must travel on the heavy service, that is - road express. Delivery time 7 days average.

ALTRONICS
 105 STIRLING ST., PERTH
 FOR INSTANT SERVICE
(09) 328 1599

All Mail Orders:
 Box 8280 Stirling St.,
 Perth WA 6000



REVIEWS OF RECENT

Records & Tapes

CLASSICAL • POPULAR • SPECIAL INTEREST

ANTONIO SALIERI: Forgotten tutor of famous pupils

SALIERI — Symphony "The Name Day;" "Venetian Symphony." Variations on the Aria "La Follia di Spagna." London Symphony Orchestra conducted by Zoltan Pesko. CBS Masterworks Analogue Disc CB321.

When Antonio Salieri's name is mentioned today — which is seldom — it is usually linked with Rimsky-Korsakoff's opera, "Mozart and Salieri," a work unknown to the great majority of opera goers. In a legend which is quite untrue, Salieri's motive for "murdering" Mozart was supposed to have been jealousy of his young Viennese rival. (Salieri, although Italian born, spent most of his best years in Vienna.)

The truth is even more unlikely because, at the supposed time of the attempted crime, Salieri was held in much more esteem than Mozart. He was considered great enough to be appointed court musician, and this at a time when Haydn, Mozart, and later Beethoven and Schubert were active.

Salieri's fame spread so widely that he was invited to write a lyric tragedy "Les Danaïdes" for performance in Paris. The production was mounted by Gluck — who put his name to it — though he later gave Salieri full credit for its creation.

Salieri's output was vast and covered every type of composition, including opera, instrumental pieces and much for the church.

It is not an exaggeration to claim that he was the undisputed leader of music in Vienna during the latter part of the 18th century. This was the period of the Mozart rumours. Ironically, Mozart was, for a while, a pupil of Salieri. Many of his pupils won fame for themselves and are not only remembered but played today, while Salieri is almost forgotten. Among them were Beethoven, Schubert and Liszt.

The two symphonies on this disc will give you some idea of one side of Salieri's talent. They are big works, especially when considered against the



musical style of that period. The first, in two movements, is not really a symphony at all in the present meaning of the word. The Sinfonia Veneziana was really the overture to his opera "The School for Jealousy". It was composed in 1778 while the second work on this album, "The Name Day", which is in the classical four movements, was written three years earlier. Their form, which verges on the majestic, will give you

some idea of his fine symphonic style.

Their classical themes are splendidly contrasted and often picturesquely ornamented. The use of changing rhythms was novel at the time of their creation.

The third work is a set of orchestral variations, ingeniously treated but which suffers by remaining for the most part in the same key. As might be expected, this results in allowing the interest to wander.

This disc should be of great value to all students or others interested in 18th century music. Salieri's corpse was exhumed just in time! And you might even have fun with his work in seeing if any of your friends can identify the composer. The playing and engineering are faultless.

P.S. It has just been suggested to me that the lack of key changes in the variations indicate that the work is an exercise in orchestration. (J.R.)

SAINT-SAENS' No. 3: But that organ . . .

Saint-Saens — Symphony No. 3 in C Minor. Berlin Philharmonic Orchestra with Pierre Cochereau at the Notre Dame Organ (Paris) conducted by Herbert von Karajan. On chromium dioxide tape digitally mastered. DGG 3302 045.

Saint-Saens was as chauvinistic a Frenchman as you'll find in a nation as generally chauvinistic as the French. Yet here we hear a German orchestra playing him admirably under a German conductor.

Despite his chauvinism, Saint-Saens had a great respect for German classical music. He was not so keen on the Romantic School and grew to dislike it more and more with age.

Saint-Saens even went to the lengths of forbidding the playing of any German music in France during World War I. But

his admiration for the German classics might well explain the clarity, transparency and all-round technical excellence of his own music. This is dutifully acknowledged by Karajan's sensitive treatment of the first two movements of the symphony under review.

Karajan captures vigour and warmth in the first movement and gives himself up to enjoying the elegant delicacy of the *poco adagio* that follows. Disappointment sets in however when Cochereau lets his organ go full blast in the finale and the result, despite digital recording, is coarse and confused.

As an aside, I might mention what may well be a personal prejudice. It is that I find most of the big organs built during the last century just a mass of noise when playing all out. I enjoy to the full, however, the sweet tones of the average well-built baroque instrument.

Elsewhere, however, the sound is excellent, especially in the daintier

Reviews in this section are by Julian Russell (J.R.), Neville Williams (W.N.W.), Leo Simpson (L.D.S.), Norman Marks (N.J.M.), Greg Swain (G.S.), and Danny Hooper (D.H.).

passages, the whole controlled to perfection by Karajan. Before the Cochereau disaster the Berlin Philharmonic shows just how fine an orchestra it is.

To provide some detail of the playing I must however pick as disappointing the long horn solo in the first adagio. Its tone is certainly not by any means French, though I admit that some French horn players produce a slushy tone rather like a saxophone.

There is great precision in the second movement. No matter your mood, I expect it will carry you along with it, not only its peerless playing but the skilful changes of rhythms and keys in the score.

What, to my ears makes the Cochereau blasting the more offensive is the restraint everywhere shown in the patrician fugue that follows.

All in all, there is so much to admire in this performance that what it lacks in the way of merit is well atoned for. It faces, however, very stiff competition from other labels. (J.R.)

BEETHOVEN: Cello Sonatas One & Two

BEETHOVEN – Cello Sonatas One and Two. Yo-Yo-Ma (cello) with Emanuel Ax (piano). CBS Digital Disc 37251.

These two works written when Beethoven was entering maturity and were called by him, according to the custom of the time, Sonatas for Piano with Cello *Obbligato*. The word *obbligato* has been degraded to mean an additional part written into the accompaniment of a soloist. An example – the deplorable violin solo added to the accompaniment of Strauss' song "Morgen".

In Beethoven's time, the word had two meanings both of which are in the Oxford Dictionary today – "to compel" or "to confer favour". Beethoven used the word in its first meaning. Nowadays, we would call the pieces Cello and Piano Sonatas. True, in the first, the piano has a much more important part than the cello, which supplies, for the most part, a discreet addition.

Moreover it consists of only two movements. The second sonata has four; but the movements in both sonatas are divided into several sections, with the exception of the Finale in both pieces.

The artistry of the two players in both sonatas is admirable. The pianist can produce a run as nimble as anybody playing the instrument today, while the cellist, apart from other expressive merits, can play his instrument as did Paganini his fiddle. And he maintains

MOZART SYMPHONIES

"Ushered in the symphony as we now know it"

MOZART. Symphonies 40, K.550, 41, K.551 "Jupiter". The Los Angeles Chamber Orchestra conducted by Gerard Schwarz. Digital Stereo, DMS Delos, DMS-3012. From P.C. Stereo, P.O. Box 272, MT Gravatt, Qld 4122. Phone (07) 343 1612.

Here's another welcome recording from the baton of the one-time trumpet virtuoso Gerard Schwarz, conducting the chamber orchestra of which he is musical director – one that is rapidly gaining the reputation of being the best chamber orchestra in the USA. This recording can only add to their stature.

Concerning the two symphonies, David Wright's jacket notes put them very well into context. I quote:

"Nobody knows exactly why Mozart composed the two symphonies on this recording. With most of his works it is possible to identify a particular occasion or concert tour for which they were produced – but there is no record of any performance, actual or anticipated of the G-Minor or 'Jupiter' symphonies until years after the composer's death.

"Did this music simply thrust itself upon the desperately poor composer, demanding to be written despite the hopelessness of earning any income from it? It is tempting to think so, for these are the works, if any are, that ushered in the 'symphony' as we now



know it."

Wright carries on with further biographical notes on Mozart, leading into an examination of the structure of both symphonies, with key phrases identified in minutes and seconds from the start.

In addition, there is the usual Delos/Telarc kind of summary of the recording procedures and equipment: microphones, battery powered transformerless console, no panel manipulation, Soundstream digital mastering, disc work by Mobile Fidelity, etc.

In short, the album holds considerable potential interest for the student, as well as pleasure for those who simply want to listen. While the Los Angeles Orchestra is of modest proportions by symphonic standards, it is appropriate to Mozart's original scoring, and is not lacking in body when called for.

More importantly, the sound and surface is very clean and this handsome new album from Delos would make a very worthwhile addition to any collection. (W.N.W.)



BEETHOVEN – Symphony No. 5 in C Minor. Philadelphia Orchestra conducted by Vladimir Ashkenazy. Leonora Overture No. 3. Cassette on chrome dioxide tape. Decca K5XDC 7540.

After the vigorous acclamation that welcomed the recently issued Fifth by Kleber, it must have needed much courage to issue another, even one with Ashkenazy conducting. But the latter performance is so different from its hefty rival that it can hardly fail to excite. It must be admitted, however, that it has its odd sounding moments, too.

There are passages that can only be described as over-expressed. In them you will find little pauses, unexpected accents and other informal details.

The time has long passed, I think, to parse and analyse a Beethoven symphony. I wouldn't dare guess how many times it has been done before.

So I will confine myself to the few remarks that might give you some idea of the whole (and expect your gratitude

absolute clarity no matter what pace he is using.

In the meantime, we must be grateful for the discretion Yo-Yo uses to keep a reasonable balance in the First Interesting as this disc is, it might be prudent to see if the other three sonatas are forth-coming to complete the set so that a useful comparison of improvements can be made.

The digital sound is in every way admirable.

for doing so!) First, despite Ashkenazy's little quirks, his is an attractive performance, very well recorded. Picturesque, perhaps, describes it best.

Some tempos will offend the old school but delight younger listeners. Some will find, for instance, the Finale ultra fast. It exhilarated me. The Scherzo is full of what might be called "new" colour but it sounds fine. Those who find it all adventurous will be those who like it least. But I don't think any experienced musician will be able to ignore it.

Under Ashkenazy, Leonora sounds very luxuriant. More than the usual amount of nuancing makes it all very romantic. For instance, there is what can only be described as an ultra-long pause between the intro and the overture proper.

It was sent to me in cassette form on chrome dioxide tape and I feel it is only fair to all concerned to give it a hearing before dismissing it out of hand. (J.R.)

VIVALDI: Four concertos for guitar and string orchestra. Ernesto Bitetti guitar with Los Solistas de Zagreb. Stereo, Hispavox L-37843. Released through Festival Records.

This album comes as something of a surprise packet. A glance at its contents and the general style of a period pen drawing of St Mark's Square in Venice is strongly suggestive of a World Record Club release. But it isn't. It came to hand through Festival, who are scarcely prominent in the classical field.

In fact, the performance was recorded last year in Madrid, Spain, and comes in what is presumably its original jacket. As a result, while the jacket carries quite lengthy notes on the two concertos, every word is in Spanish and the best a non-Spanish speaker can hope to do is to identify the titles and hazard a guess at the other information.

As listed, the titles are:

● **CONCIERTO EN LA MENOR, Op. 3 No 6.** Para guitarra orquesta, de cuerda y continuo. Allegro 38' 15". Largo 2' 05". Presto 2' 35".

● **CONCIERTO EN MI MAYOR, Op 3, No 12.** Para guitarra, orquesta de cuerday continuo. Allegro 38' 55". Largo 3' 55". Allegro 2' 01".

If my "translation" of the Spanish is correct, both concertos were adapted for string orchestral accompaniment by the solo guitarist Ernesto Bitetti.

From the cover picture, the string orchestra comprises 12 players, although 13 names appear to be listed.

If you know and like the compositions or have a special interest in the classical guitar, the recording will scarcely need further commendation. It is an excellent recording, musically and technically. I don't imagine, what's more, that it would be all that difficult to organise a translation of the jacket notes.

If you are not too sure about the con-

Two Choral Albums

GLORIA. The Mormon Tabernacle Choir and the Columbia Symphony Orchestra, conducted by Jerold Ottley. Digital mastered stereo, CBS Masterworks D-37297, CB-331.

For those to whom this kind of music appeals, this new CBS Masterworks release should represent sheer listening pleasure. The central theme is "Glory to God in the Highest" and the excerpts chosen by the choir range from the baroque, George Frideric Handel (1685-1759) to the 20th century Francis Poulenc (1899-1963). There are 10 excerpts in all:

Gloria (Messa di Gloria) — Giacomo Puccini; See What Love (St Paul) — Felix Mendelssohn; Gloria in Excelcis Deo (Gloria) — Antonia Vivaldi; Sanctus (Requiem) — Gabriel Faure; Laudamuste (Gloria) — Francis Poulenc; Et Resurrexit (Credo, Mass in B-minor) — Johann Sebastian Bach; Sanctus (Mass No 9 in D-minor) Joseph Haydn; Gloria (Mass in C-minor) — Wolfgang Amadeus Mozart; Praise The Lord (Chandos Anthem No 9) — George Frideric Handel; Sanctus (Requiem Mass) — Giuseppe Verdi.

With its long established tradition and its essential understanding of inspirational music, the Mormon Tabernacle Choir under Jerold Ottley performs all these works with authority and will carry you with it if you have a mind to share in the theme: Glory to God in the Highest ... Holy, Holy, Holy, Lord God of Hosts ... That we should be called God's own children!



Technically, the recording ranks high in the current genre. Recorded only last year at the CBS studios in New York, it was digitally mastered on a Soundstream system but committed to disc in West Germany — presumably by Teldec. The surface is quiet, the sound is full and there is little evidence of the "edginess" that so often characterises recordings of massed voices. For the audience for which the album is intended: recommended. (W.N.W.)

NEW AND OLD ...

BLESSED BE THE NAME. Otis Skillings Choir. Stereo, Light LS-5810. From Word Records Aust, 18-26 Canterbury Rd, Heathmont, Vic 3135. Phone (03) 729 3777.

This album comes with a warm commendation from Christian musician Ralph Carmichael, who refers to "the varied selection of titles ... the simple but catchy rhythmic and harmonies ... and the inventive routines."

And that's a pretty good description.

The titles are a mix of new and old — with the old in refreshing arrangements. But "refreshing" doesn't mean way out. The choir has a sufficiently traditional sound to appeal to the older generation but with a rhythmic bass and instrumental accompaniment likely to please younger listeners.

The track titles are: I'll Follow You, Lord — Through The Blood — I'm A Miracle, Lord — Jesus, Please Pray For Me — Near To The Heart Of God — A Perfect Heart — Only Trust Him/'Tis So Sweet To Trust In Jesus — Reach Out To Jesus — Blessed Be The Name / All Hail The Power — While It Is Day.

Tonally, the general balance is good, with the foundational rhythm bass particularly well recorded. If I had any complaint it would be a suspicion of edginess on the loudest choral passages — something you may or may not notice. What I did note personally was a plug on the jacket for the Otis Skillings music book from which these selections came. Having heard them, you may well be tempted to try some of them out in your group of choir. Get them right and they should go over well. (W.N.W.)

tents, I can say without hesitation that they make pleasant listening, in the style of a chamber orchestra, and the sort of music that will stand repeated playing. Well worth a listen! (W.N.W.)

Original film scores

SPELLBOUND. Original Motion Picture score composed by Miklos Rosza and conducted by Ray Heindorf. Stereo, Stanyan POW-4025. (Distributed in Australia by RCA.)

"Spellbound" is probably one of the best remembered dramas of all time and its musical score one of the best known, both in the context of the film and its concert platform adaptations.

The film itself is remembered because it brought together Ingrid Bergman and Gregory Peck under the direction of Alfred Hitchcock, in a story of suspense worthy of their collective talents.

Premiered in 1945, it recounts the plight of an amnesia victim (Gregory Peck) who fears that he has committed a crime but who cannot recall the sequence of events that might help to clear his name and dispel his mental torment.

So, in the company of a beautiful psychiatrist (Ingrid Bergman), he seeks to retrace his steps, physically and mentally, into what becomes a psychological jungle of danger and suspense.

Heightening the tension are dream sequences created by Salvador Dali and an Oscar-winning musical score by Miklos Rosza, a noted musician/composer who created the music for over 80 films, many of them major features.

The music of "Spellbound" is memorable for its other-worldly sound, created in no small measure by the use of the Theremin, an electronic musical instrument played by moving the hands in the vicinity of metal electrodes connected to an electrical oscillator.



In an era when music synthesisers are as common as pop groups, electronically generated music is no longer new. But the Theremin was still a way-out novelty in the '40s and fiendishly difficult to play, let alone to blend into a full-scale orchestra, as happens here.

Like other Stanyan records in this series, this performance uses the original Rosza score. The orchestra is not identified but the technical quality is quite satisfactory. The jacket carries a reproduction of a "Spellbound" poster and, on the back, notes on Miklos Rosza and on the film itself. For a period film music buff it would be a nice piece of nostalgia to have in one's collection. (W.N.W.)

FOR WHOM THE BELL TOLLS. Original motion picture score composed by Victor Young and conducted by Ray Heindorf. Stereo, Stanyan POW-4026. (Distributed in Australia by RCA.)

Premiered in 1943, this film also featured Ingrid Bergman but this time teamed with Gary Cooper and working for Paramount Pictures under the direction of Sam Wood.

The score was composed by Victor Young, whose tally of film scores dwarfs that of Miklos Rosza. According to the jacket notes, between the years



1936-1957, Young wrote, arranged or conducted the background music for over 350 films. As well, he turned out a number of hit tunes and built a reputation as a popular recording artist of Decca Records. A busy man indeed!

"For Whom The Bell Tolls" was shot in the High Sierras in California against backgrounds chosen to resemble the mountainous regions of Spain. It is a story of heroism and sacrifice, set in the Spanish Civil War during 1937. It is a powerful human drama full of action and suspense and that's what comes through in Victor Young's scoring.

Technically, it needs only a few bars to suggest that there is a certain spaciousness about the sound and this is confirmed by a jacket note that tells how Ray Heindorf, himself a one-time arranger and musical director for Warner Brothers, was delighted with the opportunity to present his friend's music in "the new Stanyan surround sound". I'm not sure what that signifies but the quality is indeed excellent.

Here again is another memento of a notable film, with pictures of the leading characters, notes on the music and the story and dramatic theme music that will surely stir memories of those "For Whom The Bell Tolls". (W.N.W.)

★ BRIGHT STAR CRYSTALS

Specifications, Dimensions and data sheets available on request

BULK ORDERS: In addition to our normal range we can supply quantity orders (100 up) at very competitive prices. All we ask is 50% of cost with order balance 30 days.

DELIVERY: 5-6 weeks from receipt of Order. Ring for quote: (03) 546 5076. Telex: AA 36004.

NEW NSW AGENT: APP Master Communications, Sydney (02) 682 5044

BRIGHT STAR CRYSTALS

35 EILEEN RD, CLAYTON, VIC
ALL MAIL TO: PO BOX 42, SPRINGVALE 3171



CRYSTALS

CRYSTAL OVENS AND OVEN OSCILLATOR UNITS

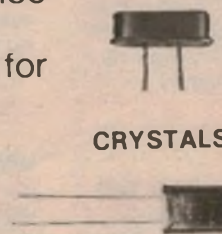

CRYSTAL UNITS FOR QUARTZ CRYSTAL CLOCK

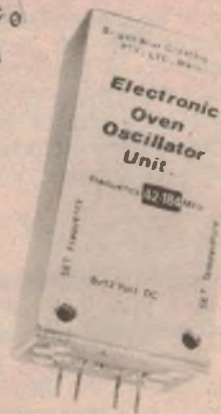

50 & 25 YEARS AGO

"Electronics Australia" is one of the longest running technical publications in the world. We started as "Wireless Weekly" in August 1922 and became "Radio and Hobbies in Australia" in April 1939. The title was changed to "Radio, Television and Hobbies" in February 1955 and finally, to "Electronics Australia" in April 1965. Below we feature some items from past issues.



April 1933

Aircraft radio: The two most modern means of communication — Radio and Aircraft — are closely allied. No regular air service would be a complete organisation without thoroughly efficient radio equipment, and operators of airlines are becoming increasingly aware of this fact. It is pleasing to note that in the Australian Commonwealth contract, for which tenders were recently called, for the air mail connection across the Timor Sea to link with Imperial Airways' Service at Singapore, a modern and efficient radio service was called for.

☆ ☆ ☆

The Radio Exhibition: A special broadcasting medal "for valour" should be struck and awarded to Miss Joy Morgan. She was the only person at the Broadcasting Commission who had the courage to meet listeners face to face, and collect their opinions and hear their views at the recent Radio Exhibition.

☆ ☆ ☆

Popular receiver: The most popular receiver appears to be, at the moment, the five valve and rectifier AC superhet, various forms of which must have been built up in hundreds during the last few months. The numbers of home builders who are converting their sets built from our articles of a year or so ago is a great tribute to the staunch following which we have amongst our readers.

☆ ☆ ☆

Voice on a lightbeam: In New York, where they think of such things, a woman's song was made to modulate a beam of light on top of a skyscraper; the beam of light was caught by a photo-electric cell on the

top of another skyscraper half a mile distant, and this signal was modulated and broadcast. Listeners failed to distinguish between this transmission and the same song direct from the studio, although engineers made the change frequently.

☆ ☆ ☆

AWA on 7 metres: During the past few months the Amalgamated Wireless Co have been conducting tests on seven metres. A crystal-controlled telephony station is used. The transmission has been well received around the suburbs. The signal, due to the excellent depth of modulation and crystal stability, was easily held on a straight regenerative receiver.



April 1958

Future man: Man's appearance would undergo a substantial change within about 65 centuries, according to Jay Savage, an American scientist. He thinks earth's inhabitants of that period will have a hairless head, spindly legs and no toes.

Houses, headgear and umbrellas will have removed the need for hair. Baldness in both sexes is now increasing. Mechanism would mean that we would use our legs a great deal less in the future.

And footwear would make toes unnecessary. Already the human little toe has almost disappeared and has no function.

☆ ☆ ☆

Whistlers: There are signs that IGY (International Geophysical Year) scientists investigating natural radio signals called "whistlers" may hand us a new, reliable long-distance method of point-to-point radio communication. By following the paths which

guide whistlers on round trips through outer space, radio signals could avoid magnetic storms in the ionosphere. Whistlers were first detected 40 years ago and linked to lightning discharges 30 years ago. But until six years ago no basic understanding existed.

L.R.O. Storey postulated in 1952 at Cambridge University, that whistlers follow the earth's lines of magnetic force through ionised gases in the exosphere.

☆ ☆ ☆

Wireless mic: An interesting application of transistors is a wireless microphone operating at a frequency of 460Kc and an effective field too low to cause external interference. It establishes an induction field around the transmitter, and is received by a fixed FM superheterodyne receiver which recovers the audio signal and feeds a public address or speech amplifier. Peak deviation is about 10Kc.

☆ ☆ ☆

Robot trains: New York's vast subway system is to be changed to automation over the next 10 years.

The city's transport authority decided on the change after a strike by train drivers.

The change will mean cutting the staff of 38,000 by half. Drivers will be replaced by electronic brains and gatekeepers by automatic turnstiles.

But there will be no dismissals, the staff has been promised.

☆ ☆ ☆

Electronic vision: Development of a device which "sees" through fog, rain or snow was announced recently by Diamond Antenna and Microwave Corporation of Wakefield, Mass.

"Eyetrone" converts microwaves into visible light, reproducing the vision of the human eye electronically.

☆ ☆ ☆

Longest microwave link: Television station ATN in Sydney performed a remarkable feat on February 25 when it televised the visit of the Queen Mother to Canberra. It covered the inspection of Duntroon Military College in the morning, and the Ball at Government House in the evening. This was done by use of a microwave TV link operating over a total distance of 170 miles. This is believed to be the longest TV link ever attempted by a station using its own facilities.

SO PURE, IT'S WICKED

The ETI 5000 System. Pristine. Pure. Cocaine for the ears. And to think that they are Australian made and designed. They can stand comparison with any kit or ready-built available — anywhere. In fact we still think that they are the world's best amplifiers. We should be justifiably proud of this achievement in Audio.

MAGNUM 200

REF: ETI
JAN/MARCH 1981

NEW! — LOW COST 5000 SERIES AMP

Now we have 2 models of the fabulous 5000 series amplifier. The original "Black Monolith" which is the total no-compromise refinement of this magnificent design. Unfortunately due to massive sales tax increases and cost increases we had to put the price up to \$319 in January. At this price we still felt that it is excellent value for money, however some people claim that they cannot afford to pay this much. So we have a new economy model which we called the "MAGNUM 200".

The Magnum 200 still has such exclusive features as the Super-finish heatsink front panel. It has the following exceptions from our Black Monolith:

- Standard Heatsinks (the original design) on the BF469 470 driver transistors
- No ventilation grilles in the case
- Standard mica washers instead of Beryllium Oxide TO3 washers
- Single 3 pin DIN AC outlet

But that's ALL that you miss out on! So why compromise yourself with the inferior kits when you can now get a superior Jaycar kit for no more!

The Magnum 200, 200 watts of power with IDETICAL performance figures to the Black Monolith is only \$299!

If you still want the Black Monolith it is available for \$319

APRIL SPECIAL! Buy the 5000 "Blueprint" preamp and the Black Monolith this month for ONLY \$599

The Magnum 200 and Super-finish only \$579!



SPECIFICATIONS

POWER OUTPUT Around 100W RMS into 8 ohms
FREQUENCY RESPONSE 8Hz to 20kHz, +0 - 0.4dB
2.8Hz to 65kHz, +0 - 3dB
Note: these figures are determined solely by passive filters

INPUT SENSITIVITY 1V RMS for 100W output
HUM -100dB below full output (flat)
NOISE -116dB below full output (10kHz bandwidth)
2nd HARMONIC DISTORTION <0.001% at 1kHz (0.0007% on prototypes) at 100W output using a *56V supply rated at 4A continuous
3rd HARMONIC DISTORTION <0.003% at 10kHz and 100W
TOTAL HARMONIC DISTORTION <0.003% for all frequencies less than 10kHz and all powers below clipping
INTERMODULATION DISTORTION Determined by 2nd harmonic distortion (see above)
STABILITY <0.003% at 100W (50Hz and 7kHz mixed 4:1)

Unconditional

Cat. KE4200

We regret to advise that among other things, metal work and sales tax increases have forced us to increase our prices slightly. Whilst we could have kept our costs down by using inferior components, we refused to take this course of action.

5000 SERIES GRAPHIC EQUALISERS

Latest addition to the thoroughbred 5000 Series stable! David Tillbrook has once again produced a "No Compromise" design. This new component, a 1/3 octave equaliser, gives you ABSOLUTE CONTROL over the acoustics of your particular listening environment. You get 3 SEPARATE CONTROLS for every octave of audio bandwidth to virtually eliminate the subtle nuances that are particular to your listening area. 1/3 octave equalisers have been used by professional engineers in Recording Studios and Live Concerts for over a decade now. It is no accident that the advent of the 1/3 octave equaliser and studio quality live sound have gone hand in hand. BUT THERE'S A CATCH. One of these equalisers is not enough. You will have to buy 2 (for stereo). Quite a lot of money — but worth it if you want the best. The Jaycar kit includes a fully pre-soldered plated chassis, pre-punched heavy gauge front panel with silkscreened front panel to match the other 5000 components. It is absolutely original. You can purchase the kits one at a time for \$199 each or, for two, \$389 — a \$10 saving. If you are one of the hundreds of happy 5000 users we are convinced that you will be just delighted with this unit.

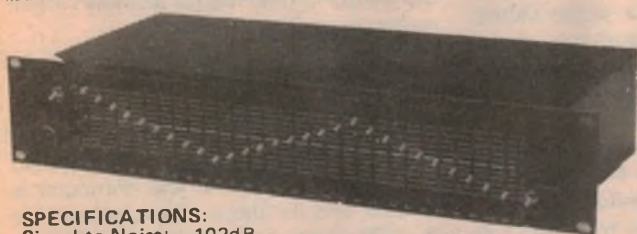

SPECIFICATIONS:
Signal-to-Noise: -102dB with respect to 1 Volt
Frequency Response: 12Hz - 105kHz to -1dB
Boost/Cut: 14dB (28dB total)
Distortion: 100Hz-0.007%
1kHz-0.007%
10kHz-0.008%
(essentially irreplicable of cut or boost)
Current consumption (DC) Approx 100mA @ ±15V (Requires 30VAC CT)
Output short-circuit proof.

\$199

BUY 2 AND SAVE \$10
— ONLY \$389

AUSTRALIAN (NOT HONG KONG) MADE — SPECIAL BUILT RACK CABINET — QUALITY!!!

ALL IC SOCKETS PROVIDED

Cat. KE4204

\$299

Cat. KE4202

"BLUEPRINT"

"One Swallow does not make a spring"
— Neither does a few gold RCA sockets!
Some of our competitors are imitating our "Blueprint" preamp by adding a few bits and pieces, notably gold plated RCA sockets to their standard kits. Unfortunately they have missed the point. We supply gold plated sockets in our "Blueprint" preamp but only where it makes sense to do this, i.e. on the input — NOT the outputs. 16 gold sockets are provided by us. This, however, does not make a "Blueprint". THIS DOES

- Low capacitance screened cable — 12 metres of 11 NDT Taiwanese cable as supplied in other kits. Our cable costs us NEARLY 5 TIMES MORE than the Taiwanese stuff.
- Original ETI designed front panel. Not an "ADAPTATION". Our front panel is by far the nicest.
- Factory pre-tinned PCB's to reduce chances of dry or noisy solder joints.
- Quality LEDs, polished finish, multicoloured display.
- IC sockets on line amp board.
- Special rear panel.
- Special low noise selection 1M394H NDT CH device in M.C. preamp.
- Thermalloy (U.S. made) heatsink on 7805 regulator.
- English Lorlin selector switches.
- Apart from the 16 gold RCA's we throw in a pair of gold plated line RCA plugs — worth \$5.
- Special Nylon rear panel grommets.

So don't "Swallow" the facts before they are properly digested!!
You can't make a silk purse out of a sow's ear. Send SAE for full specs.

- | | | |
|--|---|---|
| <ul style="list-style-type: none"> MOVING COIL INPUT MOVING MAGNET (DYNAMIC) CART INPUTS (2 OFF) TUNER INPUT AUX INPUTS (2 OFF) TAPE INPUTS (2 OFF) INPUT LEVEL CONTROL TAPE OUTPUTS (2 OFF) ROOM CALIBRATION OSCILLATOR LED AVERAGE (VU) & PEAK LEVEL METERS - 40dB TO +6dB | <ul style="list-style-type: none"> MODE SWITCH STEREO BALANCE CONTROL LINE OUT MONITOR OUT MONITOR VOLUME CONTROL | <ul style="list-style-type: none"> LOW NOISE 1.5µm METAL FILM RESISTORS USED TINNED FIBRE GLASS PCB LOW CAPACITANCE SCREENED CABLE USED THROUGHOUT QUALITY IC SOCKETS SPECIAL REAR PANEL MULTICOLOURED RECTANGULAR LED USED |
|--|---|---|

Jaycar NUMBER 1 FOR KITS

125 YORK STREET SYDNEY 2000
PHONE 264 6688 TELEX 72293
NEVILLES CORNER
Cnr CARLINGFORD & PENNANT HILLS ROAD
CARLINGFORD
PHONE 872 4422 or 872 4434
MAIL ORDERS TO BOX K 30 HAYMARKET SYDNEY 2000

Mail Order By BANKCARD
Via Your Phone



Powerful, portable, expandable:

The Sharp PC-1500 pocket computer

The Sharp 1211 pocket computer was introduced two years ago. Since then there have been considerable developments in the microcomputer field and to keep pace Sharp has introduced a new pocket computer, the PC1500, a more powerful and easier-to-use version with some intriguing accessories.

by PETER VERNON

With over 100 different small computers on the market, manufacturers (and the buying public) are becoming more discriminating. Microcomputers no longer attempt to be all things to all people and a number of machines have appeared to suit specialised applications.

The Sharp PC1500 fits neatly into a niche which just 10 years ago was a dream of science fiction writers — the powerful handheld computer. Not much bigger than many calculators at 195 × 86 × 25.5mm (W × D × H) and weighing 375g, the PC1500 really can be held in one hand yet provides powerful computing facilities and an extensive Basic language.

Programs and data are entered via a 65-key keyboard with alphabetic keys arranged in QWERTY fashion. The numeric keys are grouped in a separate area on the right and above the alphabet keys are six programmable "reserved" keys which can be defined by the user to produce commonly used strings of characters. A 26-character liquid crystal display is used for read out of programs and data.

Although the key layout is close to standard the size and spacing of the keys make touch typing impossible — a point which is possibly irrelevant on a pocket computer. Several of the punctuation keys involve use of the SHIFT key, in particular the comma, semi-colon and colon. Considering the

frequency with which these symbols are used, the need to use the shift key is a nuisance.

On the plus side the keyboard does provide single key entry for ten of the most commonly used. Basic statements and the interpreter itself allows abbreviations to be used for most statements, much like Level I Basic of the TRS-80. Lower case letters can also be entered using a key marked "SML" (for Small) — a facility which is unusual in a hand-held machine.

The computer is used in three modes — one for entering and editing programs, one for running programs and a third for defining the functions of the programmable reserved keys. An error message is displayed if an attempt is made to perform an action in the wrong mode and this is the most frequent source of errors until the user becomes accustomed to switching modes.

Switching between modes is by means of successive operations of a single MODE key on the upper right hand side of the keyboard, with the current mode indicated by a small annunciator on the liquid crystal display. Ease of operation of the pocket computer could be improved in this area. It would be convenient, for example, if the computer automatically switched to the programming mode when a syntax error is detected in a program.

Although the LCD readout shows 26 characters at a time program lines can be up to 80 characters long. Cursor control keys are used to scroll longer lines horizontally on the display window and to move up or down within a program. The horizontal cursor control keys have an automatic repeat feature, and with the use of the SHIFT key, activate insert and delete functions for editing program lines.

Characters are formed on a 7 × 5 dot matrix and there are no descenders on lowercase letters. Graphics are also possible, as the display can be treated as a 7 line by 156 dot matrix with each individual dot programmable. Basic statements allow the programmer to define new characters for the display by specifying which points in each column of the display will be illuminated and further statements are provided to control the position at which characters will be displayed.

Unlike the HP45C hand-held computer the Sharp PC-1500 has no provision for an output to a video monitor.

Power for the computer is provided by four AA-size rechargeable batteries, said to be good for 50 hours of continuous operation. If anything, our experience indicates that this figure is conservative. The quoted power consumption for the computer is 130mW and for those who can't put the PC-1500 down, a spare set of batteries is provided.

To conserve battery power the computer automatically switches itself off after about seven minutes without a keyboard entry (provided no program is running, of course). Power to the memory is provided whether the computer is on or off so that it is possible to store programs and data in memory between uses.

Calculator mode

A convenient feature of the PC-1500 is that it can be used as a calculator while in the run mode, without entering a program. All the mathematical functions of

PC-1500 specifications

Processor: Sharp proprietary 8-bit CMOS CPU.

RAM 2.9K standard, 4K and 8K expansion modules can be fitted internally.

ROM: 16K.

Display: 26 character liquid crystal, upper and lower case, programmable as a 156 × 7 point array for graphics.

Keyboard: 65 keys, calculator style.

Special features: Hand held computer, battery powered with non-volatile memory.

Expansion: Four colour printer and cassette interface, RS-232C and parallel port adapter.



The Sharp PC-1500 pocket computer, shown here with the optional printer and cassette interface, provides extensive computing power in a compact package.

Basic are available together with the ability to define and recall variables by name.

Arithmetic is performed to ten significant digits with scientific notation in the range $-9.99999999 \times 10^{99}$ to $9.99999999 \times 10^{99}$.

Individual calculations can be performed by pressing the CLEAR key between each calculation. Calculations can also be carried out serially, with the result of one operation being used in the next, or as compound formulas grouped where necessary with parentheses. Comparison functions are also available in the calculator mode so that the result of two operations can be tested for equality etc.

The full range of editing functions is also available when the computer is used as a calculator, so equations can be altered with the use of the insert and delete functions.

Programming the PC-1500

PC-1500 Basic is similar to Microsoft versions of the language, with extensions to allow for the special features of the hand held computer.

The Basic interpreter resides in 16K of ROM inside the machine. A standard

PC-1500 has 2.9K of usable memory including a fixed memory area for selected variables and a 188 byte area for reserved key definitions.

Internal 4K and 8K memory expansion modules are available, although it appears that there is only room for one such module inside the pocket computer. Maximum possible memory space then is around 11K bytes.

Real number variables may be identified by a single letter or by a letter followed by a second letter or a number, allowing use of over 950 separate variable names. String variables obey the same naming convention with the addition of a \$ sign.

Variables identified by a single letter are stored in a special reserved area of memory which is not cleared when a program is run. By taking advantage of this feature variables from one program can be used as the input to another program or shared between a number of independent programs.

Mathematical and trigonometric functions are perhaps more extensive than other versions of the language. In addition to the standard arctan function, for example, the PC-1500 provides arcsin

and arcos and there are also statements to convert back and forth between decimal degrees and degrees, minutes and seconds.

Natural and base 10 logarithms are provided together with statements to convert between degrees and radians. A STATUS command allows the user to check the amount of memory which has been used. Program testing is assisted by an extensive range of error messages, which unfortunately are identified only by a code number referring to a listing in the instruction manual. ON ERROR GOTO and the trace function TRON/TROFF are also supported.

Statements are provided to execute a program as soon as the machine is switched on and to lock the computer into one mode, so that the programmer can create software for dedicated applications which cannot be crashed by an inexperienced operator.

A full range of string functions is provided, with strings of up to 16 characters long. Longer strings, to a maximum of 80 characters can be created by linking two smaller string variables together. An error message is displayed if the new combined string exceeds 80 characters. Two dimensional arrays are also supported.

The PC-1500 includes an audible sound generator, activated by the BEEP statement. BEEP requires three parameters specifying the number of times the sound is to be repeated, frequency and duration. The volume of the sound is not adjustable but is mercifully low.

Also on board is a timer which once set maintains time and date. One peculiarity of the Basic is that there is no PRINT statement as such. PAUSE (value) is used to display the a value on the LCD readout, holding the display for around .8 of a second.

Sharp PC-1500 Basic statements

RUN, NEW, LIST, CONT, TRON, TROFF, UNLOCK, STATUS, MEM, INPUT, PRINT, GPRINT, CURSOR, PAUSE USING, WAIT, CLS, IF . . . THEN, STOP, GOTO, ON . . . GOTO, GOSUB, ON . . . GOSUB, RETURN, ON ERROR GOTO, FOR . . . TO . . . STEP, NEXT, END, DIM, LET, REM, DATA, READ, RESTORE, BEEP, AREAD, ARUN, CLEAR, RANDOM, DEGREE, RADIAN, GRAD, BEEP ON, BEEP OFF, SIN, COS, TAN, ASN, ACS, ATN, LN, LOG, EXP, DEG, DMS, RND, SQR, SGN, ABS, INT, PI, LEFT\$, RIGHT\$, MID\$, ASC, VAL, LEN, CHR\$, STR\$, POINT, INKEY\$, TIME, LLIST, TEST, LPRINT, TAB, LF, ROTATE, COLOR, USING, GLCURSOR, SORGN, LINE, RLINE, CSIZE, TEXT, GRAPH, CSAVE, CLOAD, CLOAD? MERGE, INPUT#, PRINT#, CHAIN, RMT ON, RMT OFF

The Sharp PC-1500 pocket computer

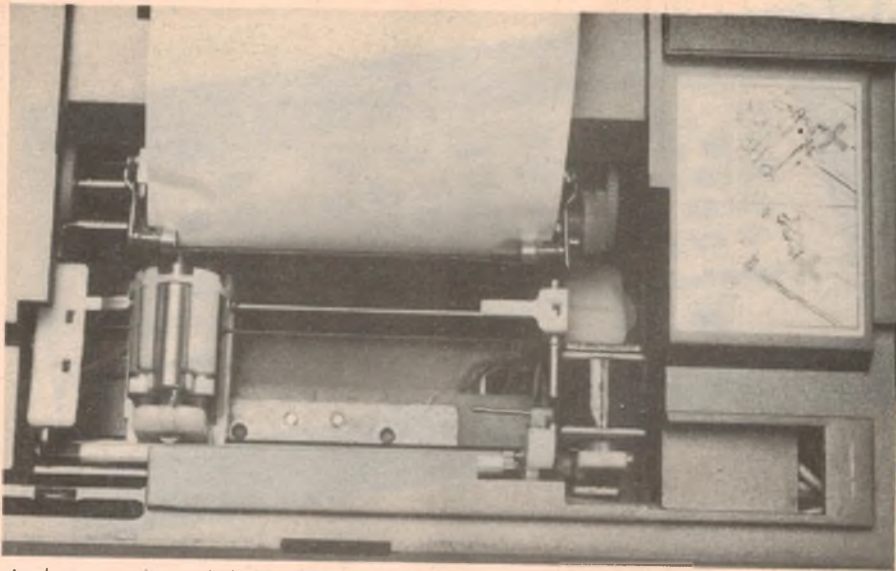

A close-up view of the printer mechanism. Four coloured pens are carried by the rotating drum while the carriage allows forward and reverse movement to print characters and plot graphics.

Also built-in are statements for handling a cassette and printer interface. Although any cassette recorder can be used with the computer, Sharp recommend their own compact model which nicely matches the size and finish of the PC-1500.

Peripherals and expansion

The Sharp CE-150 printer/cassette interface is available as an option. The pocket computer slots in to the interface to form a single unit measuring 330 x 115 x 50mm (W x D x H). The dual cassette/printer interface unit has its own battery power supply and comes with an AC pluggable adapter, cassette cable and a hard vinyl case to store the full system.

Programs can be recorded on the cassette tape (using CSAVE) and then verified by the CLOAD? statement. Data can also be recorded and recalled with PRINT# and INPUT#. Programs on tape can be combined with programs in memory with MERGE which appends the program from tape at the end of the existing program. Line numbers are duplicated by this procedure.

Once a merge is performed no changes are allowed to the program originally in memory. The appended program is identified by a label which allows programs to be linked together by use of a GOTO (label) statement. Several programs can thus be held in memory simultaneously, each called up by a reference to the appropriate label.

The CHAIN instruction can only be used within a program. Programs which are too large to fit in memory at once can be divided into sections with a CHAIN statement at the end of each section. During execution the CHAIN

statement causes the computer to load the next section of the program into memory and run it.

When two cassette recorders are used one is dedicated to recording programs and the other to playing back programs. Editing of programs is simplified by this arrangement, although one cassette recorder can be used for both functions.

One of the most intriguing aspects of the PC-1500 is the compact printer built into the interface unit. The printer uses four ball-point pen tips mounted on a rotating drum to provide text and graphics in four colours. Upper and lower case alphabetic characters can be drawn in various sizes under software control and there is a graphics mode which plots on a Cartesian co-ordinate system with a resolution of 256 x 256 points.

The printer requires standard 58mm wide "tally rolls" as used in many printing calculators and cash registers, not costly metalised paper, and is fascinating to watch in action. Forward and reverse rotations of the carriage are used for vertical plotting while the drum carrying the pens moves horizontally. Colours are selected by rotating the drum carrying the pens with the COLOR statement.

In the text mode the printer produces upper and lower case letters in nine different sizes, ranging from 1.2mm to 10.8mm in height. Letters can also be rotated in increments of 90° to print messages lengthwise along the paper roll or back to front across the paper (this last capability being of limited use).

Graphics mode statements are provided to define the origin of the co-ordinate system, move the pen to any point without drawing and to draw lines bet-



```

10: "A": GRAPH :
    RANDOM
20: GLCURSOR (120,
    -200): SORGN
30: INPUT "NO. OF
    TRIANGLES="; N
40: INPUT "ANGLE="
    ; S
50: INPUT "INCREME
    NT="; K
60: T=-S: R=5
70: FOR I=1 TO N
75: COLOR RND (4)-
    1
80: R=R+K: T=T+S
90: X1=R*SIN T: Y1=
    R*COS T
100: X2=R*SIN (T+60
    ): Y2=R*COS (T+
    60)
110: LINE (0,0)-(X1
    ,Y1)-(X2,Y2)-(
    0,0)
120: NEXT I
130: END
    
```

Both the design shown and the listing that produced it were printed by the PC-1500.

ween two defined points or relative to one point. Eight different types of line are possible, ranging from solid to dashes of various lengths. The addition of "B" to the LINE statement allows plotting of rectangles based on two points which define the diagonal.

A switch on the printer interface module allows the user to make a continuous record of all data and formulas entered in the calculator mode, thus duplicating the function of a printing calculator. While this feature is convenient in some applications, it does use a lot of paper and slows down the operation of the computer.

The lack of speed of the printer may be a drawback for some. Because of the way characters are produced the maximum printing speed is 11 characters per

ROD IRVING ELECTRONICS IS YOUR No. 1 KIT SUPPLIER

STEREO SIMULATOR

EA APRIL 83

\$12

for PCB version.

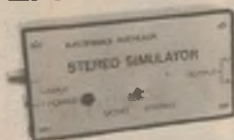

Self-contained version will cost approx **\$20**
(does not include plugpack supply).

EA APRIL 83

TOUCH-LAMP DIMMER

Current cost of parts for this project approximately

\$20

for Touch-lamp Dimmer

and **\$9**

for the remote extension.



ANALOG FUEL CONSUMPTION METER

EA MARCH '83

\$50

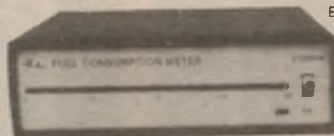

Cost does not include the cost of the fuel and distance sensors.

SELECTALOTT

\$22.00

"Who wants to be a millionaire?" I do. "Selectalott" could help. It will select random numbers without superstition or bias. It could be you. EA December 80

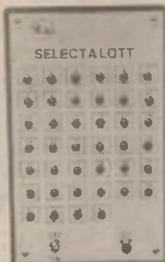

PHOTON TORPEDO GAME

EA September 81

\$24.50



7-SLOT S100 MOTHER BOARD

ETI May 80

\$85.00



FUZZBOX

\$19.90



Simple Fuzz Box for electric guitars. The no fuss, no nonsense Fuzz Box Confused — So are we. Seriously though if you want a sound with a difference, build this project and you can distort the waveform. It produces a sound which is buzzy (like politicians at election time). EA February 81

150W MOSFET POWER AMP

\$79.00

Plus Transformer **\$43.50**
Plus Heatsink Drilled, Tapped and Black Anodised **\$42.50**



A general purpose 150W Mosfet Power Amp Module. Here's a high power, general purpose Power Amplifier Module for guitar and PA applications employing rugged, reliable Mosfets in the output. ETI 499 March 82

CYLON VOICE

EA December 80

\$19.95



Sound like Darth Vader

ANALOGUE AND DIGITAL STORAGE CRO KIT

\$189.00



Store and record non-repetitive Analogue Signals. EA March 81

TV CRO ADAPTOR

\$38.50

Includes Plug Pack. EA August 80



VOICE CANCELLER

\$22.50

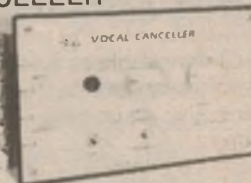

Ever wondered how your voice substituted for your favourite vocalists would sound, well now its possible! You can cancel out the lead vocal on almost any stereo record and substitute your own voice or musical instrument. EA April 82

Oct 82 ETI

ETI'S BRILLIANT NEW DIRECT-CONNECT COMPUTER MODEM

Employs unique 'Commuted Filter' design overcoming virtually all the problems involved with conventional modems. Super flexible unit facilitates communications between computers over cables, the telephone network and radio links. Unit connects to a standard RS 232 interface and is capable of both 1200/75 Baud and 300/300 Baud transmission and reception. ★ Line switching; answer and dialing facilities on board.

EXCLUSIVES: ★ Plated through, double sided PCB ★ Complete set of IC sockets ★ Kit requires 85 IN914 Diodes for programming these are included ★ Ceralock resonator and matching balanced load capacitor used for long life and high accuracy ★ Telecom approved isolating transformer and Reed relays included

Our Price \$169.00



LOUD SPEAKER PROTECTOR

ETI 455 March 80

\$32.50



DIGITAL ENG. ANALYSER

\$48.50



EA August 80

DIGITAL CAPACITANCE METER

\$45.00



Here is an inexpensive Digital Capacitance Meter which measures from 1pF to 99.99uF in just three ranges. It's simple to use and features a big bright four-digit display with automatic updating and decimal points. EA March 80

ELECTRONIC DUMMY LOAD

\$99.00

With this unit you can test power supplies at currents up to 15 Amps and Voltages up to 60 Volts. It can "sink" up to 200 Watts on a static test and you can modulate the load to perform dynamic tests. ETI 147 October 80



ROD IRVING ELECTRONICS IS YOUR No. 1 KIT SUPPLIER

ROD IRVING ELECTRONICS IS YOUR No. 1 KIT SUPPLIER



ROD IRVING ELECTRONICS — YOUR MAIL ORDER SPECIALISTS

General Enquiries: (03) 489 8131

425 HIGH ST, NORTHCOTE, VICTORIA 3070

Mail Order Hot Line (03) 481 1436

MULTIRAIL SWITCHING POWER SUPPLIES

More choice, more performance, more efficiency, more back up and support — at a truly competitive price.

- Single, three & four rail outputs
- 240V/120V AC input
- 3.5kV isolation
- 50KHz switching
- Standard models
- Custom design available

- Output overvoltage shutdown
- Australian design & manufacture
- 5 year guarantee
- Short circuit protected
- Full local technical back up & service
- DCLO signal
- Convenient plug in connectors
- High efficiency
- Fan output
- Compact, rugged, reliable

For complete data, call Scientific Electronics or the distributor in your state.

**Scientific Electronics
The Power Supply
Specialists.**

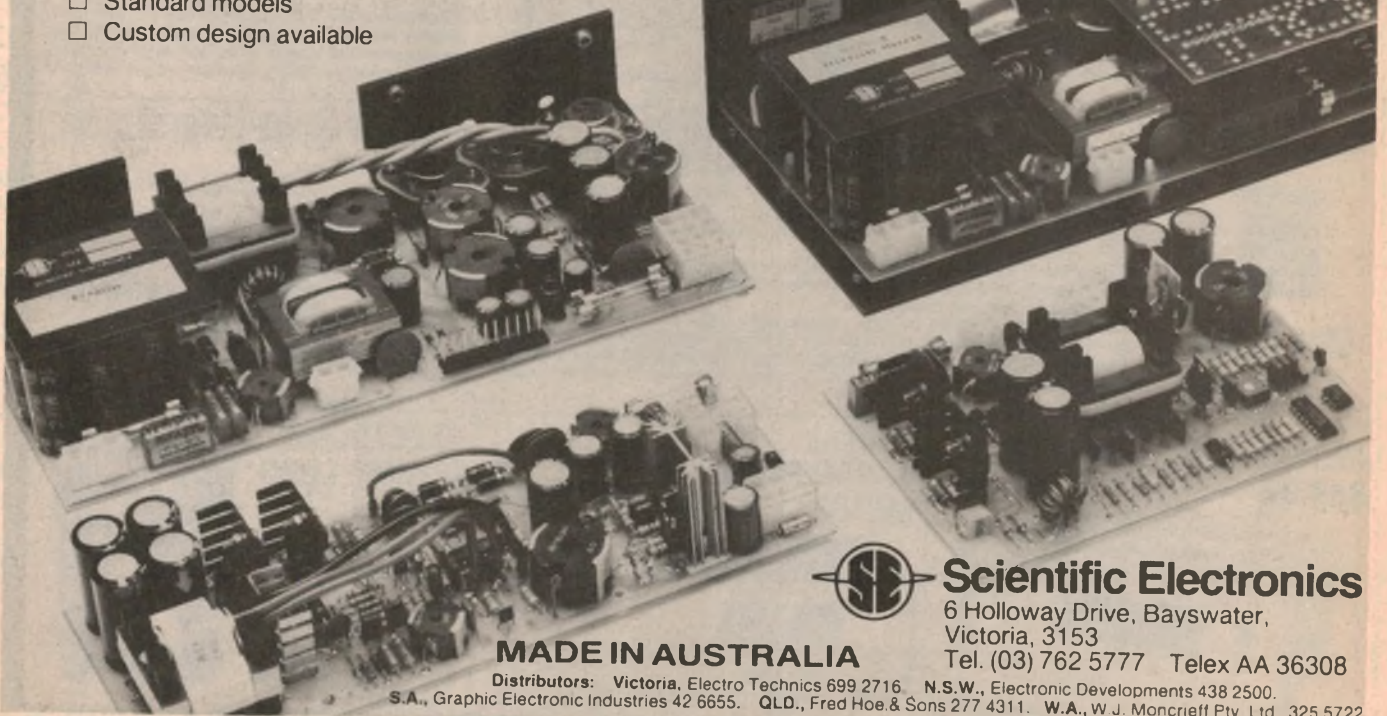

Scientific Electronics

6 Holloway Drive, Bayswater,
Victoria, 3153

Tel. (03) 762 5777 Telex AA 36308

MADE IN AUSTRALIA

Distributors: Victoria, Electro Technics 699 2716 N.S.W., Electronic Developments 438 2500
S.A., Graphic Electronic Industries 42 6655. QLD., Fred Hoe & Sons 277 4311. W.A., W J. Moncrieff Pty. Ltd. 325 5722

The Sharp PC-1500 pocket computer

second, so listings of long programs can occupy some time. Program listings are produced in the default character size (CSIZE 1) which allows a maximum of 26 characters per printed line and results in some oddly truncated words.

Maintenance of the printer in terms of changing paper and pens, is simplicity itself, with each procedure given step-by-step in the instruction booklet which accompanies the printer. A special error message (ERROR 80) indicates that the battery voltage is too low for correct operation. When this occurs the printer will suspend operation until the batteries are changed or recharged.

A combination RS-232C and parallel port adapter is also available for the PC-1500. This unit, the CE-158, allows the pocket computer to communicate with larger machines, either via a modem or a direct connection, or to use a larger printer with either a serial or parallel interface. It too has its own rechargeable battery power supply and is accompanied by a comprehensive manual.

Documentation and applications

The instruction manuals provided with the PC-1500 are extensive and generally

well-written. The instruction manual itself begins with a tutorial and goes on to cover use of the calculator mode, introductory programming and advanced topics, as well as use of the printer and cassette interface. Separate booklets with the interface unit provide mechanical details and connections for each device.

The instruction manual covers each statement of the Basic language and lists the error message codes and their meanings. Unfortunately while the manual is excellent for the beginner some of the more advanced topics are only sketchily covered and can be difficult to locate in the text.

Where the PC-1500 really scores is in the applications manual provided with the computer. This manual provides full listings, instructions and sample print-outs of over 50 programs covering a wide variety of topics including mathematics, engineering, statistics, business and home use. Applications include the solution of quadratic and cubic equations, statistical correlations, loan and depreciation calculations and a "world clock".

Other applications programs appear from time to time in magazines, the most recent being a report in "Australian

Sailing" magazine of a general purpose navigation program for yachtsmen. A range of business and professional programs is also available from Link Computer Systems, including a motor dealer's accounting package, and "electronic diary", professional time and billing program and an income tax instalments calculator. Other applications are under development by Link in conjunction with Sharp Corporation of Australia.

The software available indicates the market that Sharp is aiming at. Engineers, architects, salesmen and others who need portable computing power in a convenient, easy to use package will find the PC-1500 worth a close look.

Prices and availability

The PC-1500 pocket computer has a recommended retail price of \$319, with the printer/cassette interface an additional \$256. The add-on serial and parallel interface retails for \$260, and 4K and 8K memory expansion modules cost \$71.80 and \$175 respectively.

The pocket computer is available from a number of office equipment stores or through Sharp Corporation of Australia Pty Ltd, 64 Seville St, Fairfield, NSW 2165, phone (02) 728 9111. 

An introduction to

DIGITAL ELECTRONICS

This book can help YOU go right along with it:

Electronic equipment now plays an important role in almost every field of human endeavour. And every day, more and more electronic equipment is "going digital". Even professional engineers and technicians find it hard to keep pace. In order to understand new developments, you need a good grounding in basic digital concepts, and *An Introduction to Digital Electronics* can give you that grounding. Tens of thousands of people — engineers, technicians, students and hobbyists — have used the previous editions of this book to find out what the digital revolutions is all about. The fourth edition has been updated and expanded, to make it of even greater value.

Here are the chapter headings:

1. Signals, circuits and logic
2. Basic logic elements
3. Logic circuit "families"
4. Logic convention and laws
5. Logic design: theory
6. Logic design: practice
7. Numbers, data & codes

8. The flipflop family
9. Flipflops in registers
10. Flipflops in counters
11. Encoding and decoding
12. Basic readout devices
13. Multiplexing
14. Binary arithmetic

15. Arithmetic circuits
16. Timing & Control
17. Memory: RAMs
18. ROMs & PROMs
19. CCd's & magnetic bubbles
20. D-to-A converters
21. A-to-D converters
- Glossary of terms

Available from "Electronics Australia", 57 Regent St, Chippendale. **PRICE \$4.50** OR by mail order from "Electronics Australia", PO Box 163, Chippendale 2008. **PRICE \$5.40.**



Motorola evaluation board for the MC68000

Motorola Inc has released an evaluation board for the MC68000 16-bit microprocessor. For those interested in exploring the capabilities of this chip the MEX68KECB (Educational Computer Board) provides a (relatively) low cost 68000 system, needing only a power supply and a serial terminal.

Intended primarily for training and educational use, the Educational Computer Board serves as a comprehensive introduction to systems based on the 68000 microprocessor. The board measures just 264 x 168mm yet provides everything necessary to begin writing and testing machine language programs for the MC68000 16-bit microprocessor.

On the board are a MC68000 processor running at 4MHz, 32K bytes of

selected by jumper blocks and may be any standard rate between 110 and 9600 baud.

So that the ECB can be used immediately, extensive software is included in ROM on the board. Called "Tutor", this software provides the user with a monitor and debugging package, assembler and disassembler and I/O control functions.

The MC68000 microprocessor is often

range of 16 megabytes (16,777,216 bytes). A CHK (Check register against bounds) instruction allows the programmer to create a variety of memory protection/management routines.

Other features of the processor are the ease of single step debugging provided by a trace mode called up by the instruction "TRAP". The processor also makes a distinction between two modes of operation, the "user" and "supervisor" states. The user mode prohibits access to certain of the memory instructions, allowing programs for multi-user systems to be written in such a way so that they will not interfere with each other even in the event of an error.

The 16K "Tutor" software provided with the Educational Computer Board is basically a system monitor which controls communication with the terminal and allows the creation and testing of assembly language programs. The line-by-line assembler does not save the source program but translates each instruction into the correct machine code for storage in memory. Facilities are limited to the specification of operation and operands — line numbers, labels and comments are not allowed.

The disassembler also operates on a line-by-line basis, disassembling the machine code in memory and displaying the instruction mnemonic and operands. No editing facilities are provided other than re-entering the source statement. For other facilities a macro assembler or cross assembler can be run on a host computer, with data communicated to the 68000 board through the second serial port.

In addition to the assembler/disassembler, Tutor provides commands to display and modify memory and registers, commands for executing programs, either continuously or with breakpoints, or in a Trace mode. Other commands allow blocks of memory to be filled, moved or searched for a specified character and there are also commands for controlling the serial communications ports and parallel printer interface and for dumping and loading programs from a cassette recorder.

Documentation provided with the board consists of a 200-page loose leaf manual which covers the set up and

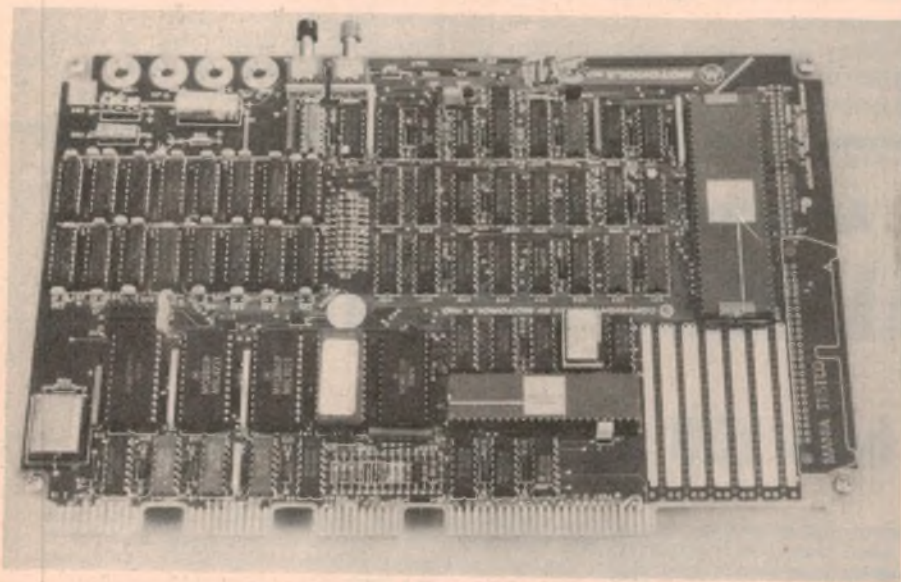

The MEX68KECB board provides 32K of RAM, parallel and serial ports and software.

dynamic RAM arranged as 16K x 16 bit words, two RS232C serial communications ports, a 16-bit parallel input/output port (which can be configured as a Centronics compatible printer port), a cassette tape interface for program storage, a 24-bit programmable timer and Reset and Abort pushbutton switches.

For those wishing to add their own interface circuits a small prototyping area is also provided.

The user must add power supplies of $\pm 1V$ and $\pm 12V$, and a serial terminal. Communications rates for the board are

referred to as a 16/32 bit microprocessor, as it has a 16-bit external data bus but internally is organised around 32-bit registers. In addition to a 32-bit program counter and 16-bit status register, the processor provides 17 32-bit registers. Of these, the first eight may be used for byte, word or "long word" (32-bit) storage while the second group of eight and the 32-bit stack pointer can be used as address registers, for word and long word manipulation and as index registers.

The external address bus is 24-bits wide, providing a direct addressing

operation of the board and describes each instruction in the on-board software as well as providing comprehensive hardware details. In addition, a copy of the MC68000 Microprocessor User's Manual containing a complete description of the instruction set of the processor is included.

In conclusion, the Educational Computer Board provides everything required to put the MC68000 microprocessor to work. It can be used simply for familiarisation with 16-bit processors, as the basis for a more extensive development system or as a powerful programmable controller in its own right. The board deserves to be as popular as Motorola's earlier D2 educational system.

The MC6800 Educational Computer Board is priced at \$750 plus sales tax where applicable and is available from Paris Radio Electronics, Shop 1, 165 Bunnerong Rd, Kingsford, NSW, 2032. Phone (02) 344 9111.

Liberty CRT terminal from PACE Computer

PACE Computer Services in NSW, Archives Computers of Victoria and W. J. Moncrieff Ltd of Western Australia have been chosen by Liberty Electronics USA as distributors of the new Freedom 100 CRT terminal manufactured by Liberty in Taiwan.

The Freedom 100 terminal offers a 30cm green phosphor video display of 80 characters by 24 lines, characters formed on a 7 x 9 dot matrix, ASCII character set and 15 graphics characters. The screen can be tilted back to one of five positions and the detachable keyboard provides a numeric keypad, editing keys and ten special function keys in addition to standard alphanumeric keys. Display modes include half-intensity, inverse video and underline.

RS-232C or 20mA current loop interfaces are available, with data transmission speeds ranging from 110 baud to 19.2 kilobaud.

For more information contact PACE Computer Services, PO Box 36, Leichhardt NSW, 2040, Archives Computers, 163 Clarendon St, South Melbourne, Vic. 3025 or W. J. Moncrieff, 176 Wittenoom Street, Perth.

Seahorse Computers expand the VIC-20

Seahorse Computers has announced an expansion unit for the VIC-20 computer. The unit fits into the VIC-20 expansion connector and provides sockets for up to four memory expansion modules or ROM cartridges and is priced at

SHARP 5 KV. OPTOs



RIGHT 1st TIME!

WHATEVER THE APPLICATION

SHARP's massive range of opto couplers has a product to suit . . . High Gain, High Current, High Voltage, Hybrid Mounting, OPTO FET, ULTRA HIGH SPEED, Single, Double, Triples and Quads, End Stackable or solo

SHARP . . . right, FIRST time



Distributed in Australia by:

daneva australia pty ltd
66 Bay Rd, Sandringham, Vic., 3191.
P.O. Box 114, Sandringham, Vic., 3191.
Telephone: 598-5622. Telex: AA34439.

Sydney: (02) E&M Electronics 51-5880
Adelaide: (08) DC Electronics 223-6946

Perth: (09) Micro Controls 445-2544
Brisbane: (07) Baltec 369-5900

Microcomputer News

\$59.95 plus \$1.50 postage and packing.

Also available from Seahorse is the Corvus hard disk drive in six, 10 and 20 megabyte capacities to suit the Apple II, Apple III, IBM Personal Computer, Xerox 820, Osborne and Atari systems. The Corvus disks, based on proven Winchester technology, now account for 40% of world wide hard disk sales.

A feature of the Corvus range is the optional "Mirror" interface which enables data on the disk to be backed up on a standard video cassette recorder.

For further information contact Seahorse Computers, PO Box 47, Camden, NSW, 2570. Phone (046) 66 6406.

IRD reports on the European micro scene

A research report from International Resource Development Incorporated looks at the European microcomputer scene and makes some interesting predictions.

Currently there are around 1.7 million personal computers installed in European homes and offices, but IRD expects the total to rise to 18 million by the end of 1985. West Germany is expected to emerge as the largest single market although the UK is in the lead at the moment.

Manufacturers in the United States and Japan are not finding the European market an easy one, however. Translation of software and documentation can be a major task. In France, in particular, there is pressure from both government and users for French software.

British and American companies face a fine of \$US14 per word for each English word used in documents submitted to the government, and one French product, the Victor Lambda, is selling at a premium price.

The Lambda is similar to the less-expensive Sinclair "Spectrum" colour computer apart from the fact that it uses French. "Data" is translated as "donnee" and "digital" becomes "numerique". The familiar "FOR...NEXT" construction is "DEPUIS...AUTRE".

IRD forecasts that some European companies will link up with Japanese manufacturers to jointly produce computers for Europe. One predicted partnership is that of BIC (who make the biros) and Sony Corporation.

Will the next breakthrough be a disposable computer?

New enhanced version of the Apple II



The launch of the Apple's Lisa computer has tended to overshadow their introduction of a system that probably will prove to be a bigger seller — the Apple IIe enhancement of the popular Apple II system.

The IIe will sell for slightly less than a comparable Apple II Plus and includes 64K of RAM, expandable to 128K, upper and lower case character display, and an expanded keyboard. An 80-column board from Apple has provided an expanded display and around 80 of the chips in the original design have been replaced by two programmed logic arrays, thus considerably simplifying the internal circuitry.

The two custom LSI devices and the use of 64K RAM chips have reduced the internal parts count from 110 to 31 integrated circuits, providing cooler and more reliable operation and reduced manufacturing and maintenance costs.

S-100 serial I/O board from SME Systems

SME Systems, of Mitcham, Victoria, has released a six channel serial I/O board for use in multi-terminal systems or industrial monitoring applications. Called the MPC-6, the board uses a Z80 processor to provide six independent bi-directional data channels with on-board data buffers totalling 6K of RAM.

Each of the six channels can have in-

All programs written for the Apple II will run on the new version although they make not take advantage of the enhancements, and many software producers are at work adapting existing programs for the new machine. Apple Computers has prepared a user guide, to help the purchaser adapt Apple II and Apple II Plus software to the IIe.

To ensure that the market for the Apple IIe is truly international versions of the Apple IIe are being produced with special power supplies, keyboards in various languages and appropriate built-in colour video circuitry so that the computer can be used with local standard television sets.

Suggested retail price for the basic Apple IIe is \$1625. Apple will also offer a complete "starter system", including 64K Apple IIe computer, floppy disk drive, 30cm video monitor and 80-column card for around \$2500.

dependent data transmission rates set by the control program. The host processor can also redirect data from one channel to another, change baud rates, alter buffer size allocations and select one of two communications protocols (XON-XOFF or DTR-CTS).

The board is compatible with the IEEE 696 S-100 bus standard.

For further information contact SME Systems, 22 Queen St, Mitcham, Vic, 3132. Phone (03) 874 3666.



6809 COMPUTER

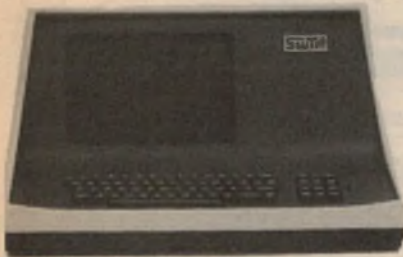

8212 TERMINAL
(ASS. IN AUSTRALIA)

HARDWARE DESCRIPTION

S/09 6809 Computer w/128K Memory
 /09 6809 Computer w/64K Memory
 8212 12" Terminal w/monitor
 DMF 2 Disk System w/2.5m Capacity
 CDS-1 Winchester Hard Disk System
 MP-09A 6809 Process/Board (assem)
 D5-2 double side/double density 720KB
 3809 128K Memory Expansion for S/09
 MP-LA Parallel Interface
 MP-L2 Dual Parallel Interface
 MP-N Calculator Interface
 MP-R Eprom Programmer
 MP-S Serial Interface
 MP-64 Memory board 64K
 MP-S2 Dual Serial Interface
 MP-SX Serial Interface Expansion
 MP-T Interrupt Timer
 S-32 Universal Static Memory Card



DMF DISK SYSTEM 2.5M



**D-5 720k
DT-5 1.3M**

NEW PRODUCTS SOON

SOFTWARE SPECIALIST FOR THE 68XX SERIES

MICROWARE SYSTEM CORP

OS-9 Level 1 Operating System	\$195.00
OS-9 Level 2 Operating System	\$495.00
Basic 09 Programming Language	\$195.00
Pascal OS-9	\$440.00
Macro Text Editor	\$ 95.00
Assembler	\$ 95.00
Debugger	\$ 35.00
Cobol Programming Language	\$995.00
C Programming Language	\$440.00

TECHNICAL SYSTEMS CONSULTANTS

UNIFlex Operating System	\$550.00
UNIFlex Basic	\$200.00
UNIFlex Pascal	\$250.00
UNIFlex Fortran 77	\$350.00
UNIFlex Relocating	
Assembler & Linkage Editor	\$175.00
General Purpose Flex 6809	\$170.00
General Purpose Flex 6800	\$170.00
Exorcisor Flex 6809	\$170.00
SWTPC Flex 6809	\$ 45.00
GIMIX Flex 6809	\$ 99.00
Fortran 77 for Flex	\$425.00
Extended Basic	\$110.00
Utilities	\$ 82.50
Pascal for Flex	\$220.00
68000 Cross Assembler for Flex	\$275.00

Sort Merge Package	\$ 82 50
Text Editor	\$ 55 00
Assembler	\$ 55 00
Debug Package	\$ 82 00
Diagnostics	\$ 82 50
Text Processor	\$ 82 50

FRANK HOGG LABORATORY, INC

XForth	\$165.00
Basic Programmer Tool Kit	\$ 77 00
Extended Use Utilities Pack	\$ 77 00
Password Protection Pack	\$ 99 00
Dynasoft Pascal Flex	\$ 99 00
Bill Payer System	\$185.00
Spell Test	\$220.00
Super Sleuth	\$110.00
Stylograph 2:0 Flex, OS-9	\$325.00
Dynastar Full Screen	
Editor OS-9, Flex	\$ 99.00
CRASMB Cross Assembler, Flex,	
6809, 6800, Z80, 8080, 6502	\$149.00
Dataman + DBM	\$220.00
Plot	\$ 49.00
Tabula Rasa	\$110.00
Job Control Program	\$ 99.00
TRS80C Colour Flex	\$105.00

WASHINGTON COMPUTER SERVICES

6809RMS DBM for Flex	\$220.00
6809 RMS DBM for UNIFlex	\$330.00
6809 RMS DBM for OS-9	\$275.00

UNIVERSAL DATA RESEARCH INC

DBM 2 Flex	\$450.00
DBM 2 UNIFlex	\$550.00
Payroll	\$495.00
Accts Receivable	\$495.00
Accts Payable	\$495.00
General Ledger	\$495.00
Inventory	\$495.00

TALBOT MICROSYSTEMS

tForth	\$ 99.00
tForth+	\$275.00

COMPUTER SYSTEM CENTRE

DYNAMITE Dissassembler	\$ 66.00
DYNACALC	\$220.00

DUGGERS GROWING SYSTEMS

6809 C Compiler ver 2:0	\$130.00
-------------------------	----------

OMEGASOFT PRODUCTS

PCS2 Pascal Compiler Flex,	
OS-9, MDOS	\$490.00
Rall1 Relocatable Assembler &	
Linking Loader	\$150.00

SWTPC

EDIT Word Processing Editor Flex	\$110.00
C Compiler for UNIFlex	\$ POA
* Prices subject to alteration without notice, \$5 handling and packaging plus postage	

ALL PRICES PLUS SALES TAX IF APPLICABLE

AVAILABLE FROM

offices and showroom:

PARIS RADIO ELECTRONICS

SHOP 1 165 BUNNERONG ROAD, KINGSFORD, NSW 2032

Postal address:

PO Box 380 Darlinghurst, NSW 2010. Tel (02) 344 9111. Telex AA22579

FERGUSON TRANSFORMERS
PRINTED CIRCUIT BOARD MOUNTING TRANSFORMERS

PL9/5VA	\$7.95	PL24/5VA	\$7.95	PL18/12VA	\$10.50
PL12/5VA	\$7.95	PL30/5VA	\$7.95	PL24/12VA	\$10.50
PL15/5VA	\$7.95	PL40/5VA	\$7.95	PL30/12VA	\$10.50
PL18/5VA	\$7.95	PL16/15VA	\$10.50		

LOW PROFILE CHASSIS MOUNTING TRANSFORMERS

PL12/20VA	\$14.75	PL12/60VA	\$19.50	PL24/40VA	\$16.50
PL15/20VA	\$14.75	PL15/60VA	\$19.50	PL30/40VA	\$16.50
PL18/20VA	\$14.75	PL18/60VA	\$21.50	PL40/40VA	\$16.50
PL24/20VA	\$14.75	PL24/60VA	\$21.50	PL30/9/40VA	
PL30/20VA	\$14.75	PL12/40VA	\$16.50		\$23.50
PL40/20VA	\$14.75	PL15/40VA	\$16.50	PL30/60VA	\$21.50
PL1.5/18/20VA		PL18/40VA	\$16.50	PL30/9/60VA	\$25.50

CONVENTIONAL CHASSIS MOUNTING TRANSFORMERS

PF3577	\$33.90	PF3993	\$23.90	PF4362	\$57.90
PF3783	\$79.50	PF4244	\$46.50	PF4363	\$57.90
PF3787	\$21.50	PF4354	\$49.50	PF4405	\$44.50
PF3788	\$43.50	PF4361/1	\$49.50		

BELL TRANSFORMERS

PPB4/1000	\$15.50	PPB8/1000	\$15.50	PPB12/500	\$15.50
-----------	---------	-----------	---------	-----------	---------

AUDIO TRANSFORMERS

MT552	\$28.50	OP590	\$46.50	OP592	\$36.90
-------	---------	-------	---------	-------	---------

D.C. POWER SUPPLIES

PPA30C	\$12.90	PPA60C	\$12.90	PPA90C	\$12.90
PPA45C	\$12.90	PPA75C	\$12.90		

TDK
E180 VIDEO
TAPES
10 for
\$148

RITRON COMPUTER GRADE P/S
+5V reg 10A 16V unreg @ 1A
KIT \$79.95 inc
Built and tested \$99.50

ETI636 MOTHERBOARD
7 Slot Motherboard \$90.00
Built and Tested \$120.00
ACTIVELY TESTED

INTERFIL LCD \$38.50
3 1/2 DIGIT PANEL METER KITS

Build a working DPM in 1/2 hour with these complete evaluation kits. Test these new parts for yourself with interfil's low cost prototyping kits complete with A/D converter and LCD display (for the 7106) or LED display (for the 7107). Kits provide all materials including PC board, for a functioning panel meter ICL7106EV (LCD)

P.C. EDGE CONNECTORS



S100 gold plated wire wrap	\$8.50
S100 solder tail	\$7.90
D2 Motorola bus	
43-B6 solder tail	\$8.50

10 TURN POTENTIOMETERS
Stock resistance values

50R 100R 200R	
500R 1K 2K 5K	
10K 20K 50K	
100K	

Spectral model 534 1/4 shaft
Price 1 9
10 + values may be mixed \$10.90

DIP PLUGS
Ideal for use with flat ribbon cable or to mount components on



14 pin	\$1.50
24 pin	\$2.90
40 pins	\$5

POWER TRANSFORMERS
SPECIALLY DESIGNED FOR MICROCOMPUTERS

- Good regulation electrostatic shield
- RI 810 8V @ 10A x 15V @ 1A \$31.00
- RI R20 8V @ 20A 15V @ 1A 15V @ 3A \$37.50

20 TURN CERMET TRIM POT



SPECTROL 43P ACTUAL SIZE

STOCK RESISTANCE VALUES

10R 20R 50R 100R 200R 500R 1K 2K 5K 10K 20K 50K 100K 200K 500K 1M 2M	
1-9	\$1.80
10-99	\$1.60
100	\$1.30

Values may be mixed.

Hexadecimal Keypad \$36.50



19-key pad includes 1-10 keys ABCDEF and 2 optional keys and a shift key

Ideal for dream project

MULTIDIALS



Dials to suit 10 T Pots

Model 21 1 8" dia	\$19.50
Model 16 9" dia	\$14.50
Model 18 1" x 1 75" dia	\$23.50

RS232 & "D" TYPE CONNECTORS

PART NO	DESCRIPTION	1 9	10 25	25 +
DE 9P	9 PIN MALE	\$3.50	\$3.50	\$3.10
DE 9S	9 PIN F MALE	4.50	4.20	3.90
DE 9C	9 PIN COVER	2.20	2.10	1.90
DA 15P	15 PIN MALE	4.50	4.20	3.90
DA 15S	15 PIN F MALE	5.10	4.90	4.70
DA 15C	15 PIN COVER	2.30	2.10	2.00
DB 25P	25 PIN MALE	5.90	5.60	5.10
DB 25S	25 PIN F MALE	6.90	6.60	6.10
DB 25C	1 pc Grey Hood	2.40	2.20	2.00
DB 25C2B	2 pc Black Hood	2.80	2.70	2.50
DB 25C2G	2 pc Grey Hood	2.70	2.50	2.40
DC 37P	37 PIN MALE	7.90	7.50	7.10
DC 37S	37 PIN F MALE	10.90	9.90	9.10
DC 37C	37 PIN COVER	4.90	4.50	4.10
DH S	Hardware set (2 Pairs)	2.10	1.90	1.80

cermet single TURN TRIM POT
Spectral model 63P ACTUAL SIZE



STOCK VALUES

10R 20R 50R 100R 200R 500R 1K 2K 5K 10K 20K 50K 200K 500K 1M 2M	
1-9	\$1.20
10-99	\$1.00
100	\$0.90

Values may be mixed.

DIP SWITCHES SPST

P N	No of Switches	Price
SD3	3	\$1.60
SD4	4	1.70
SD5	5	1.90
SD6	6	2.30
SD7	7	2.40
SD8	8	2.50
SD9	9	2.70
SD10	10	3.00

DIP SWITCHES SPST



TEXT TOOL ZIP* DIP 11 SOCKETS

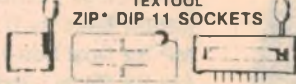

16 Pin Zip* Dip 11	\$11.50
24 Pin Zip* Dip 11	12.50
40 Pin Zip* Dip 11	17.50

*Zero Insertion Pressure

INCREDIBLE MEMORY AND DISC DRIVE PRICES

2708	1 9	10 25	25 +
2716	4.90	4.00	3.90
2732	4.90	4.20	3.90
4136 (200nS)	8.00	7.50	7.00
4164 64K Dynamic	1.95	1.80	1.75
M58725P (2K x 8)	11.00	10.00	9.50
Static	10.00	9.00	8.50

(As used in new 64K Static S100 PCB)
ALL PRICES INCLUDE SALES TAX

MPI DISC DRIVES
(to suit Tandy & System 80 computers)

with Box & Power supplies

1 DRIVE	2 DRIVES
B51 \$295 + tax	\$525 + tax
B52 \$375 + tax	\$650 + tax
B91 \$460 + tax	P.O.A.
B92 \$550 + tax	P.O.A.

CRYSTALS

	Cost
1MHz	9.50
1.8432MHz	7.50
2MHz	5.00
2.3040MHz	5.00
2.4576MHz	5.00
3MHz	4.90
3.5795MHz	3.00
4MHz	4.00
4.194304MHz	4.00
4.44MHz	4.00
4.75MHz	4.00
5MHz	4.00
5.0688MHz	4.00
6MHz	4.00
6.14MHz	4.00
6.6670MHz	4.00
8MHz	4.90
8.867238MHz	4.90
10MHz	4.90
11MHz	4.90
12MHz	4.90
14.31818MHz	4.90
15MHz	4.90
16MHz	4.90
18MHz	4.90
18.432MHz	4.90
20MHz	4.90
24MHz	4.90
27MHz	4.90
32MHz	4.90
36MHz	4.90
48MHz	4.90
100MHz	6.90

BIG BOARD (1) NEWS

Double Density add on.
\$195 + tax (incl. Software & Hardware)

Hard Disc Interface \$195 + tax

HEATSINKS

High Thermal Capacity Black Anodised

	1-4	5-9	10-40	50-99	100-499	500 plus
HS1 - 38mm	1.85	1.75	1.50	1.35	1.00	0.90
HS2 - 75mm	3.00	2.90	2.50	2.00	2.00	1.50
HS3 - 150mm	5.80	5.40	4.90	3.80	2.90	2.70
HS4 - 225mm	8.10	7.60	7.10	5.90	4.50	4.30
HS5 - 300mm	8.90	8.40	7.90	6.50	4.90	4.60

Unanodised

HS11 - 38mm	1.40	1.20	1.00	0.90	0.80	0.70
HS12 - 75mm	2.50	2.20	1.90	1.60	1.25	1.20
HS13 - 150mm	4.90	4.50	4.00	3.20	2.45	2.40

BLANK CASSETTES T.D.K.

TDK ADC60	1 for \$3.60	10 for \$26.00
TDK DC60	1 for \$2.10	10 for \$18.00
TDK DDC60	1 for \$3.50	10 for \$31.00
TDK SAC60	1 for \$3.50	10 for \$31.00
TDK SAXC60	1 for \$5.70	10 for \$46.00
TDK DC90	1 for \$2.40	10 for \$21.00
TDK ADC 90	1 for \$3.50	10 for \$30.00
TDK SAC 90	1 for \$4.20	10 for \$39.00
TDK DDC90	1 for \$4.70	10 for \$45.00
TDK SAXC90	1 for \$5.50	10 for \$49.00
TDK DC120	1 for \$4.50	10 for \$37.00
TDK ADC120	1 for \$5.40	10 for \$46.50

Please debit my Bankcard.
Bankcard No.
Expiry Date.
Name
Signature

Post & Pack \$2.50 small kits, heavier kits add extra postage.
Prices subject to change without notice. Send 60c and SAE for free price list and inclusion on all future mailing lists.
MAIL ORDERS: PO Box 235, Northcote, Vic 3070. Min P & P \$1.00.
Ph: (03) 489 8131. Errors and omissions excepted

ROD IRVING ELECTRONICS

425 HIGH STREET, NORTHCOTE 3070, MELBOURNE, VICTORIA. Ph (03) 489 8131. Telex No. 38897
Most products also available at Ritronics Wholesale at 48-50 A'Beckett Street, Melbourne, right near R.M.I.T. (Please note prices will vary due to Sales Tax laws.)

Microcomputer News

Archives Computers introduces the Morrow



The "Morrow" computer from Morrow Designs

A new high-performance small business computer, the "Morrow", has been released in Australia by Archives Computers. Manufactured by Morrow Designs of the United States, the new machine is claimed to be "the easiest way yet devised for the novice user to enter the computer age".

When the computer is switched on, a menu appears listing all the functions available to the user. All operator errors that could result in loss of data are "trap-

ped" by the software and error messages are displayed in easy to understand language. Automatic hardware diagnostics and protection against accessing non-existent disk drives are also included.

Based on the Z80A microprocessor running at 4MHz, the Morrow runs CP/M 2.2 and is supplied complete with Microsoft Basic-80, BaZic (a language compatible with NorthStar Basic), WordStar word processing software, "Correct-It" spelling checker program, an electronic spreadsheet program and Morrow Designs' own version of Pilot, an elementary programming language for creating educational programs.

The price of the system (around \$3000) also includes a Freedom-100 intelligent terminal with a 30cm green phosphor video monitor and a detachable keyboard. The Morrow also has the ability to read and write floppy disks formatted for the Osborne 1, Xerox 820 and the IBM Personal Computer (under CP/M-86).

For further information contact Archives Computers (Australia), 163 Clarendon St, South Melbourne, Vic 3205, (03) 699 8377; or The Australian Business Solution, 59th Floor, MLC Centre, Martin Place, Sydney, NSW 2000, (02) 235 1151.

Hitachi printer/plotter and chart recorder

Hitachi has introduced a combination plotter, printer and chart recorder for use in scientific and laboratory applications, the Model 661 graphics recorder.

As a plotter, the Model 661 provides a plotting area of 180 x 600mm at speeds of up to 180mm/sec and includes versatile built-in software to facilitate programming.



Hitachi's combination printer/plotter

In the chart recorder mode, the 661 accepts analog inputs between 10mV to 10V in 10 ranges, with 70 selectable chart speeds from 1 to 600mm/min. Specifications for chart speed, signal polarity and type of line drawn (solid or dotted) can be entered on a pressure sensitive keypad.

The recorder also includes a thermal printer capable of producing the full ASCII character set in either 40 or 80 character lines at speeds of up to 40cps.

All functions of the 661 can be remotely controlled by a microcomputer.

For further information contact Datascape International Pty Ltd, 33 Grosvenor St, Neutral Bay, NSW, 2089. Phone (02) 909 1233.

New books from Sybex on CP/M and VisiCalc

New books from Sybex include two titles for users of VisiCalc software.

"Mastering VisiCalc" is a complete guide to the VisiCalc electronic spreadsheet program describing and illustrating each feature and explaining how to use spreadsheets for planning, forecasting and budgeting. Exchange of data between VisiCalc and other programs is also covered in detail.

S-100 Bus, Z80A™ Based System With DMA Transfer and Memory Management on an IEEE Spec 696.1/D2 Board

FEATURES:

- Single or Double Density Floppy Disk controlling up to four 8in or 5 1/4in floppy disk drives in either DMA, interrupt or Programmed I/O mode.
- 64K bytes of onboard Dynamic RAM with Memory Deselect of 4K bytes to 64K bytes under software control.
- Four Channel Direct Memory Access Controller.
- Two Serial I/O channels with one channel programmable in either DMA, Interrupt or Programmed I/O mode.

- Two Parallel I/O channels with one channel programmable in either DMA, Interrupt or Programmed I/O mode.
- Memory Management of 16 Megabytes of system memory
- Eight Vectored Priority Interrupts chained together with I/O Interrupts for use with Z80 Mode 2 Interrupts.
- Provisions for either a 2K byte or 4K byte onboard EPROM. (Monitor in a 2K byte EPROM supplied with board).
- CP/M™ and MP/M™ operating systems available, TurboDOS™ available soon.
- Turbo-Disk™ implementation included.

ALSO:

256K byte Dynamic Memory Board, 16K increments — fully bank selectable compatible with Cromix™, CP/M2.2™, Alpha Micro and other major systems.

ABSOLUTE ELECTRONICS 483 CENTRE ROAD, BENTLEIGH, VIC 3204 Phone (03) 557 3971

WE STOCK: 74LSTTL, Capacitors, CMOS, Connectors, Diodes, Discrete Devices, Kits, LEDs, Linear Devices, OPTO-Isolators, Potentiometers, Rectifiers, Resistors, Sockets, Transformers, Z80/6800 CPU and support ICs, Zener Diodes.

The incredible SORCERER

EXDY SYSTEMS

Australia's most popular micro for the professional is now reduced **\$400!** Now with 48K RAM at no extra charge. Will run CP/M based software.

WAS \$1395

Cat. X-3002

For the serious computer user, this superb machine offers truly out-standing performance – PLUS the ability to run the industry standard CP/M operating system at lower cost than any other computer. Read what one Sorcerer operator has to say:

"I find the Sorcerer's superior graphics excellent for drawing circuit schematics and laying out circuit components. I feel my Sorcerer is far ahead of it's time." C.M.M Computer Technician.



ONLY \$995

FLOPPY DISK SUBSYSTEM

Now there's a disk for the Sorcerer that doesn't need an S-100 expansion interface! And it is designed to plug straight into the back of the computer! What's more it's loaded with extra features such as ★Soft sector Quad Density (308K bytes/disk) – formatted ★Has provision for one or two add-on Disk Drives ★Comes complete with CP/M – industry standard DOS (disk operating system) – Usually extra \$250 worth!

Cat X-3220 **\$995**

MICROPOLIS™ DISK DRIVE

You can have from one to four drives, giving up to 1260K bytes (yes – more than a Megabyte) of storage at the incredibly low cost of under 1c per byte! The Micropolis 1043/1023 system represents third generation state-of-the-art mini floppy disk technology. With the Micropolis you get not only the highest possible disk storage capacity, but outstanding value for money!

Micropolis 1043/mod 2 drive with controller

Cat X-3205 **\$795**

Micropolis 1023/mod 2 add-on Drive

Cat X-3208 **\$620**

S-100 EXPANSION UNIT

Open the way to almost unlimited expansion of your Sorcerer system with the S-100 Expansion Unit. There are S-100 plug-ins available for almost every conceivable avenue of system expansion. And more are being announced all the time, so there is no risk that your Sorcerer system could become obsolete. Supplied with inbuilt power supply, ribbon cable and connector.

Cat X-3010 **\$489**

ROMPACS™

Sorcerer plug-in Rompacs™ give the Sorcerer its incredible versatility! It's a word processor, then a production controller. Or a standard computer running a program. All you do is plug in the Rompac™, the Sorcerer does the rest.

DEVELOPMENT PACK

A powerful dedicated development tool, containing a debug, text editor, linking loader assembler & I/O routines. Complete with 90 page manual.

Cat. X-3090 **\$99**

EPROM PACK

Designed for users who want to use the Sorcerer for a dedicated job and can program their own EPROMs to do it.

Cat X-3095 **\$49**

WORD PROCESSOR PACK

With a suitable printer, cassette recorder and the WORD PROCESSOR PACK™ in your Sorcerer you can have a word processor system that is not only far more powerful than most other systems, it's far cheaper! Features include automatic text wrap-around, automatic checking of drastic commands, a powerful search function and lots more!

Cat X-3085 **\$199**

WORD PROCESSOR KEYTOPS

A special set of red keytops to replace some of the keys on the Sorcerer numeric keypad, for use in word processing applications (these keys take on new meanings when using the Word Processing Pac™ – the keytops explain these meanings.)

Cat X-3086 **\$12⁵⁰**



**BARGAIN PRICES
SORCERER SOFTWARE
SAVE HEAPS!!**

DISK SYSTEM SOFTWARE

	WAS	NOW	
CP/M INC BASIC M/DOS	\$699	\$249	Cat. X-3710
DISK ITOH - HARD	\$155	\$99.00	Cat. X-3725
DISK ITOH - SOFT	\$155	\$99.00	Cat. X-3726
COPY FILE	\$24.50	\$19.95	Cat. X-3714

Disk Based Business Software PRICED TO CLEAR

	WAS
\$29 ⁹⁵	\$250

A/C Payable Cat. X-3702
A/C Receivable Cat. X-3704
General Ledger Cat. X-3700

TAPE SOFTWARE

BELOW COST SAVE UP TO \$48.00

UTILITIES NOW ALL \$9⁹⁵

GAME SOFTWARE NOW ALL \$2⁹⁵

SAVE UP TO \$26.00 Dozens of types available

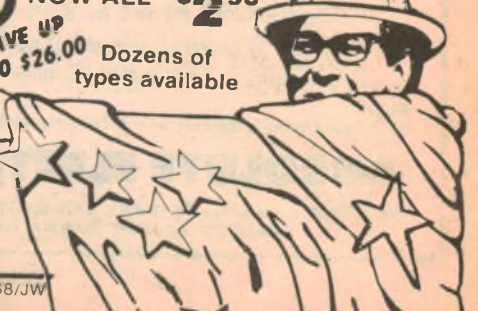

★ ★ **ONLY FROM**
DICK SMITH ELECTRONICS
See Page 98 for address details

Microcomputer News

"Doing Business with VisiCalc" includes over 40 applications of spreadsheets for accounting and management planning, from financial statements to master budgets, pricing models and investment strategies. A complete VisiCalc program for setting up each application is provided.

Programmers using CP/M will be interested in the third new title "Mastering CP/M". The organisation and operation of the BIOS (Basic Input/Output System) and BDOS (Basic Disk Operating System) modules are described in detail, with sample programs and a guide to assembly language programming under CP/M included.

Sybex books are distributed in Australia by the ANZ Book Company Pty Ltd, 10 Aquatic Drive, Frenchs Forest; but try your local technical bookshop first.

AED Supercomputer II for Tonga

The government of Tonga has placed orders for a number of Universe II computers from the Australian company AED Microcomputer Products. The Department of the Treasury, Telephone and Telegraph Department and the Lands Department have each ordered a "Supercomputer" system.

The Universe II computer system, reviewed in EA in March, 1983, includes dual 8085 and 8088 microprocessors on the S-100 bus, fast, high capacity disk drives and a video display terminal of AED's own design.

A variety of operating systems are available for the AED machine, including CP/M and single-user CP/M-86 as well as the multiple-user Multi/OS which is said to be totally compatible with standard CP/M while offering multi-terminal operation.

A variety of standard software is included in the deal including accounting packages, data base management packages and word processing. A multi-user operating system is also specified and it is intended that the government departments will also write their own software using CBASIC under CP/M.

In addition to supplying the three computer systems, AED will also supply a complete spare parts inventory, install the system on site and provide extensive training for operators and maintenance personnel.

For further information on the AED computer system contact AED Microcomputer Products, 130 Military Rd, Guildford, NSW, 2161. Phone (02) 681 4966.

Development system/emulator runs CP/M



The SA-700 development system provides real-time emulation of the Z80 microprocessor, an EPROM programmer and a CP/M based computer system in one convenient package. Programs can be loaded from disk or via an RS232C port from a larger system and run on the emulator in conjunction with the SA-700's testing and debugging facilities.

The emulator is said to be able to accept programs in a variety of disk formats, including MDOS, and provides a full 64K of memory without

the need to relocate programs under test.

Although the machine is primarily intended for use as an emulator and EPROM programmer it can also function as a CP/M computer system, and is claimed to be ideal for development and maintenance of software for dedicated systems.

Versions of the emulator for the 8085 and 8086 microprocessors are currently under development.

For more information contact Alfatron Pty Ltd, 1761 Ferntree Gully Rd, Ferntree Gully, Vic, 3156. Phone (03) 758 9551.

New colour graphics terminal from TCG

A colour graphics terminal developed by a new Japanese company, Nippon Computer Company, is claimed to offer four times the resolution of similar terminals and at \$9500 is "extremely competitive on the local market", according to the TCG Group, who is distributing the terminal in Australia.

The NJC-C1421 terminal provides a 35cm raster scan CRT display able to display 16 colours out of a range of 27. High speed dot and line drawing routines are standard, as is the ability to display any region of a 4096 x 4096 pixel area, with a hardware zoom capability. Graphics resolution of the terminal is 1024 x 780.

As a standard terminal the NJC offers an 86 x 30 line text display with the 128 character ASCII set and 128 special characters with attributes such as inverse video, flashing and underlining. The terminal comes equipped with RS-232C and Centronics parallel interfaces and 274K bytes of memory, and is compatible with

the Tektronix Plot 10 digital plotter. Commands from the host processor allow the user to update the screen, set the graphics display area, set colour and plot straight lines, rectangles, circles and ellipses.

For further information contact Mike Barraclough, TCG, 30 Balfour St, Chippendale, NSW, 2008. Phone (02) 699 9569.

Qume Sprint II daisywheel printer

Anderson Digital Equipment has announced the release of a new Qume Sprint II daisywheel printer, said to be compatible with any standard word processing software. The new printer contains an interchangeable communications module which allows it to interface with applications software and computers from IBM, Hewlett-Packard, Commodore, Tandy, NorthStar, Xerox and others.

Printing speed is said to be up to 40 characters per second and the range will eventually include printers with a 130

Microcomputer News

character printwheel and a new, wide carriage, capable of higher speeds.

The number of mechanical parts in the Qume Sprint II has been reduced by 30% over previous models and a single-board 8085 printer controller has allowed a 50% reduction in the number of electronic components while providing increased reliability.

For further information contact Anderson Digital Equipment, PO Box 422, Clayton, Vic. 3168. Phone (03) 544 3444.

Epson HX-20 portable computer

A new portable computer has been introduced by the Japanese company Epson, previously well known in the industry as a manufacturer of dot matrix printers.

The new HX-20 portable is the first full computer to be made by Epson for export and includes a number of innovative features.

The HX-20 is designed to be used anywhere. It is about the same size as this magazine (although a little thicker) and runs on batteries which provide 40 hours of continuous operation per charge.

16K of memory is provided as standard, with about 12.6K available to the user. RAM can be expanded up to 28.6K. The standard 32K of ROM can be expanded with plug-in cartridges to a total of 72K.

Microsoft compatible Basic is supplied in ROM, with extensions to handle the LCD read-out and the real-time clock



and calendar circuitry of the computer.

The keyboard is a full-size, typewriter style with 10 programmable function keys and programs and data are displayed on a 20 character by four line liquid crystal display. Lines can be up to 255 characters long using horizontal scrolling to display the full text.

Upper and lower case text and graphics can be displayed.

Built in to the HX-20 is a dot matrix printer able to print 24 character lines at a rate of 42 lines per minutes. The printer comes complete with a ribbon cartridge and produces the full ASCII character set.

Full details of the Epson HX-20 can be obtained from the offices of the Australian distributor, Warburton Franki.

New source of software for the MicroBee

M.B. Software is a recently established software house specialising in software for the MicroBee computer. Their first release, "Mine Drop" is a chase game for the standard 16K MicroBee. Written in machine code the interactive program allows the player to control the movement of a tank on the screen and drop mines to foil the pursuing "Bingle".

The game is available on cassette from MicroBee suppliers and from M.B. Software, 248 Brunswick Rd, Brunswick Vic. Phone (03) 380 9805. Price is \$12.95.

Club news

● The Microcomputer Society, Fortitude Valley, Queensland, will hold its next meeting on Friday, April 8 with a lecture on the use of the Motorola 6802 processor in industrial control applications. For details contact the Secretary, PO Box 580, Fortitude Valley, Qld, 4006. Phone (07) 356 6176.

● The NSW Peach Users Club meets each Saturday at 2pm, at Cybernetics Research, 120-122 Lawson St, Redfern, NSW, 2016. Membership is open to all users of Hitachi Peach computers and costs \$10 for each six month period. The fee entitles members to newsletters, access to club software and library and technical advice. For further information contact the club on (02) 698 8286.

● A new club for MicroBee owners has been formed in Sydney. The Northside MicroBee Computer Club meets on the third Saturday of each month from 1pm to 5pm at the McMahons Point Community Centre, Cnr of Lavender St and Blues Point Rd, North Sydney. For more information contact Tony Williams (02) 267 7747 or send an sae to the Club, c/o 6 Tunks St, Waverton, NSW, 2060.

Super-80 Users Groups

Queensland c/- Terry Nunn, 3 Dover St, Wilston, Qld, 4051.

South Australia c/- Mr R. Gillespie, 8 Teusnere Drive, Morphettvale, SA, 5162.

ACT c/- Tom Hays, 11 Mayo St, Weetanger, ACT, 2614.

Victoria c/- Victor Shuttleworth, 17 Stephen Crs, Croydon, Vic, 3136.

NSW The Illawarra Super-80 group meets on 1st Monday of each month at the Government offices, 86 Market St, Wollongong. Ph (042) 202 783.

New Zealand c/- Bruce Stephenson, Peanut Computers, 5 Dundee Pl, Charterwell, Wellington 4, NZ.

ANZCAN — cable to Canada

sealed in a brass cylinder in an atmosphere of dry nitrogen. Finally it is housed in a two metre long steel cylinder with walls 2cm thick.

Each repeater is finished with a cable "tail" emerging from each end. As the cable is loaded into the ship the repeaters are spliced in at the 12km intervals.

Cable signal processing

The cable itself is a single coaxial pair, and quite elaborate electronic systems, including the repeaters, are required to give it such a high channel capacity. The system is a "four wire" circuit, meaning that all voice signals from (say) Sydney to Vancouver go via one circuit, and the reply from Vancouver returns via another. With only one pair of conduc-

tors available, the separation has to be performed electronically.

In accordance with standard telephone carrier operation each voice channel, occupying (say) 3kHz, is stacked one above the other and, on the basis of 1840 channels, these would occupy just under 6MHz. But this is for signals in one direction only and another 1840 channels are required for the opposite direction. These are made to occupy a band between about 7MHz and 13MHz with an adequate guard band between the two channel groups.

From this can be gained some idea of the electronic complexity of the repeaters, which must separate the signals, amplify them in the appropriate direction, equalise them, and send them on their way to the next repeater. Power for the repeaters is fed along the same

coaxial conductors.

As well as the repeaters, which provide a fixed amount of equalisation, adjustable equalisers are fitted into the cable at regular intervals, normally after every 12 repeaters. These are spliced into the cable during loading, but are not finally adjusted until they are about to be submerged. The ship heaves to, the cable is tested, and the data fed to a computer. The computer then calculates the adjustments, which are made to the equaliser in a clean room aboard ship.

At the same time as the cable laying progresses towards Vancouver, another cable ship, starting at Vancouver, will move towards Sydney. The cable is expected to be in full service in mid-1984. By present calculations it should cope with Australia's requirements well into the 21st century.

SAVE \$250

ON DICK SMITH BLUE LABEL SYSTEM 80 COMPUTER NOW ONLY **\$499⁰⁰**

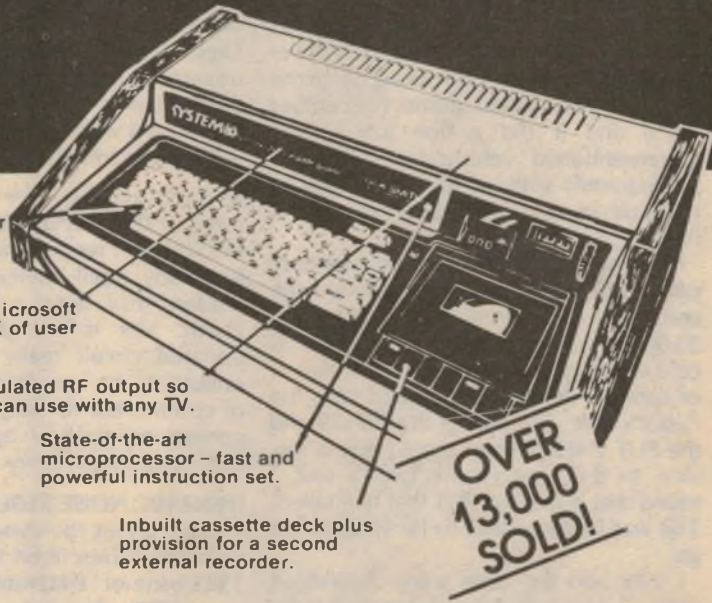

Full 52 key typewriter keyboard.

Powerful 12K Microsoft BASIC plus 16K of user RAM memory.

Modulated RF output so you can use with any TV.

State-of-the-art microprocessor - fast and powerful instruction set.

Inbuilt cassette deck plus provision for a second external recorder.

**OVER
13,000
SOLD!**

Take advantage of this once-in-a-lifetime special offer . . . Bulk purchase has allowed us to slash the price of this popular computer!

Cat X-4005
WAS ~~\$750~~

**NEW MODEL
EXTRA FEATURES!**

The System 80 hasn't become Australia's fastest selling home computer by accident! It was designed to exacting quality control standards to include features of the world's most popular home computers and to be software compatible with Tandy computers so there would always be plenty of programs available to make your computer useful, educational, entertaining and worthwhile.

It's a complete, ready-to-go computer, you don't have to buy any add-ons to make it work. It simply plugs into the aerial socket of your TV and has an inbuilt cassette deck to run your programs.

Compare the Dick Smith Blue Label System 80 Computer with Apple II and/or Tandy Model 3 Computers, and you will know why we have sold over 13,000 in Australia and many thousands worldwide. It's simply more powerful and we believe 10 times better value for money in comparison.

The Blue Label System 80 is not just affordable - it's usable as well!

- Flashing cursor.
- Built in speaker and amplifier for programs with sound effects.
- Full upper and lower case video display capability.
- Monitor program (suitable for the hobbyist to program in machine language.)
- Three month guarantee from date of purchase.
- Screen print facility (obtain a printout of any 'page' appearing on screen.)
- Great expansion capability and flexibility.
- No separate tape recorders to buy as one is inbuilt.
- Cassette level meter and provision for a second cassette recorder.

HFC FINANCE ARRANGED FROM \$11.44 per wk FOR 12 MONTHS. DONT MISS THIS OPPORTUNITY!

HOW CAN WE DO IT?

Simple! The new SYSTEM 80 is cheaper than the original model for two reasons: The massive costs of initially developing this computer have been fully absorbed, and . . . New technology produces better quality components at a much cheaper price! Look at the extra features! Look at the compatible software! LOOK AT THE PRICE!

DICK SMITH ELECTRONICS

See Page 98 for address details

YOU REAP THE BENEFIT!



DSE/A467/PAI



INFORMATION CENTRE

TRANSISTORISED IGNITION SYSTEMS:

May I continue the saga of transistorised ignition systems? My first experience was with the EA CDI and my Passat and never the twain did meet. Then along came the EA transistor-assisted gismo (December 1979) and it did a fine job in the aforementioned vehicle for a while. I subsequently sold my Passat and placed the unit in my daughter's car, also a Passat.

My new car is the Laser and that coped with a TAI unit as well. Lo and woe both units suffered a severe demise at around 20,000 kilometres duty. One failed in cold weather and the other in the heat of of spring. I didn't muck around with the Passat's unit — replacing the BD139 and the PUT 2N6027 soon put it back in service. In the case of the Laser's unit, I found that it was the PUT that had failed. This was replaced and so far systems are go.

I may add the units were assembled with care from Dick Smith kits and were located in the vehicles such that they had plenty of ventilation (cooling drafts of air delicately scented and fan assisted — punkah of course). Can I assume that the PUT is not adequate for the service required of it? Has anyone else had a similar problem?

They, being sensible, have probably confronted DSE about it! Still, it was an EA circuit. In any case can you give me the correct configuration for the PUT. (G. S., Yarralumla, ACT.)

● We are not aware of a problem of inadequate ratings for the PUT or the BD139 for that matter. However, if you suspect that voltage transients are damaging the PUT you could protect it by connecting a 24V zener diode of say, 3W rating, across the main supply of the TAI circuit, ie, from the collector of Q3 to the OV (chassis) line. The revised circuit published last month showed the pinout package configurations for the PUT.

DELTAHET: I have had interest in building the Deltahet communications receiver for some time. The biggest obstacle is obtaining various parts such as the Eddystone dial assembly, tuning capacitors, filters to name a few. I was spurred to write by the interest shown by other readers in issues a couple of months ago. My request is could a list of

suppliers of these parts be published. That is parts other than the parts freely advertised in Altronics, Rod Irving and Dick Smith catalogues and other advertisers in your magazine. An alternative is an updated version be developed with digital readout, PCBs etc — Deltahet MKIII? (K. H., Eaton, WA.)

● Unfortunately, we doubt whether most of the specialised components for the Deltahet receiver would be available from any retail source although some readers may have a few spares lying about. Nor is the publication of an updated circuit really feasible as it is unlikely to be competitive with the cost of commercial receivers using the same general principle of operation, such as the Yaesu FRG7. Sorry.

DYNAMIC NOISE REDUCTION: I wish to enquire about the dynamic noise reduction circuit described in the September 1982 issue of "Electronics Australia" (File No 1/F/15). Since this circuit uses the principle of reducing the high frequency response of the system as the high frequency content of the program decreases in amplitude, could it be pressed into service in a cassette deck to successfully decode pre-recorded Dolby cassettes? I am building a cassette deck and I want the finished article to sound nearly as good as the expensive commercial units available.

If the circuit is suitable, could it, without too much messing around, be adapted so as to work in reverse (through switching) when recording thus enhancing the high-frequency response during passages of low amplitude "highs". This would enable one to make recordings using a format similar to that of the Dolby format. This would then be decoded during playback and the benefits of the noise reduction could be obtained without sacrificing the balance of low and high frequency content contained in the original. (J.P., Wanganui, NZ.)

● The major difference between the function of the Dynamic Noise reduction circuit above and Dolby B noise reduction is that with Dolby, noise reduction only takes place for signals which are below a critical threshold level which is fixed not adjustable. Assuming that you could set up the above circuit to "track" the Dolby characteristic your proposal

would be successful. But that is a big "if". We are inclined to think that you would be better off purchasing Dolby processor ICs as spare parts from one of the major Japanese cassette deck manufacturers and then using conventional circuitry. You would still need a Dolby test tape to set the circuit up though.

SCRATCH ELIMINATOR: Have you ever published a design for a device to delete scratches from records. I have heard of a system which processes the signal through a delay line in a parallel with the normal non-delayed path, and when the gross peak of a scratch noise activates a trigger, the delay line is momentarily used instead of the direct path. Thus the brief period of signal containing the scratch peak is deleted and replaced by a piece of signal (perhaps one millisecond long) taken from immediately before the scratch. If you have no such designs; perhaps you could suggest designs or sources for delay lines which could pass audio signals with reasonable fidelity while introducing delays of a few milliseconds. (R.M., Hamilton, NZ.)

● While we have not published any scratch eliminator circuits perhaps we can add a little clarification of the circuit operation which may be of help in producing such a device. Essentially, as you suggest, the audio signal is passed through a delay line so that there are two signal paths, one direct and one delayed by a millisecond or so.

The undelayed signal is then monitored for the presence of fast transients indicating scratches. In some designs this is done merely by looking for signals with fast rise-times but in better designs, it is achieved by looking for signals with fast decay times. The latter approach is better because normal musical signals have slow decay times. When a scratch signal is detected, the signal from the delay line (which is the one fed to the following amplifier and loudspeakers), is either switched to the OV reference or to a floating reference signal level which was that existing before the scratch came along.

Two bucket-brigade delay devices are currently readily available: The Matsushita MN3001 which we used in our stereo synthesizer published in September 1982 and the Philips TDA1022 used in the Lyrebird piano

published in October, November and December 1981.

Both ICs are available from Jaycar Pty Ltd who advertise in this magazine.

300VA INVERTER: being located in an area without electricity supply, and relying on 12 volt batteries, the recent article on 300VA inverter was of special interest and I am now in the process of constructing one. One point recently came to me after seeing an American made motor generator unit which would switch itself on when a load was connected and then switch itself off when load disconnected. This is a marvellous idea and lends itself to the EA 300VA inverter and 40VA unit as well. There is a lot of time wasted running back and forth to the inverter if located (as necessary) close to the batteries.

Would you please advise if you have a suitable circuit for such a system or if you intend issuing one in your magazine. (R.J.M., Gleniffer via Bellingen, NSW.)

● Indeed, it is possible to make the 300VA self-starting. A suitable circuit to do this was published in the "Circuit & Design Ideas" pages in our February 1981 issue. We plan to re-feature this circuit in a future issue.

12/240V 40 WATT INVERTER: I have the May 1982 issue of your magazine with the 12/240V 40 Watt inverter. Could you tell me if its possible to increase the output to about 70 Watts to run a portable television set. I would appreciate any help you could give me. (A.B., East Doncaster, Vic.)

● As has been noted before in these columns, it is relatively simple to increase the output rating of this inverter circuit. The difficulty lies in obtaining a suitable transformer. One solution may be to connect two 40VA transformers in parallel. Note that we have not tried this.

LE GONG CHIP: Could you let me know where I can obtain the SAB 0600 integrated circuit and the price. (S.H., Para Hills West, SA.)

● That chip was used in our Le Gong project, published in our March 1981 issue (File 3/MS/81). Therefore it should be possible to purchase the kit from any retailer who stocks the Le Gong kit. One such retailer is Rod Irving Electronics of Melbourne.

We suggest you contact them on (03) 489 8131 for details of price and availability. The chip is made by Siemens by the way and makes a jazzy doorbell.

300VA INVERTER: I have read with great interest the excellent articles in the May and June 1982 issues describing the construction of 12V to 240VAC inverters.

Electronics Australia Reader Service

"Electronics Australia" provides the following services:

PHOTOSTAT COPIES: \$3 per project, or \$6 where a project spreads over multiple issues (price includes postage). Requests can be handled more speedily if projects are positively identified, and if not accompanied by technical queries. We reserve the right to supply complete back issues instead of photostats, where these are available.

CHASSIS DIAGRAMS: For the few projects which require a custom metal chassis (as distinct from standard cases) dyeline plans showing dimensions are normally available. \$3 including postage.

PC BOARD PATTERNS: High contrast, actual size transparencies: \$3, including postage. Please specify positive or negative.

PROJECT QUERIES: Members of our technical staff are not normally available to discuss individual projects, either in person at our office, or by telephone.

REPLIES BY POST: Limited to advice concerning projects published within the last three years.

Charge \$3. We cannot provide lengthy answers, undertake special research, or discuss design changes. Nor can we provide any information on commercial equipment.

OTHER QUERIES: Technical queries outside the scope of "Replies by Post" or submitted without fee may be answered in the "Information Centre" pages, at the discretion of the Editor.

COMPONENTS: We do not sell electronic components. Prices and specifications should be sought from advertisers or agents.

BACK ISSUES: Available only until our stocks are exhausted. Within six months of publication, face value plus 90c for post and packing for each issue. Seven months and older, \$3 (includes post and packing and storage fee).

REMITTANCES: Must be negotiable in Australia and made payable to "Electronics Australia". Where the exact charge may be in doubt, we recommend submitting an open cheque endorsed with a suitable limitation.

ADDRESS: All requests to the Assistant Editor, "Electronics Australia", Box 163, Chippendale, 2008.

My problem is that I have a home lighting system which operates from batteries at 48 volt which are are charged by an ex-PMG Dunlite wind-generator. Hence it is 48 volts rather than the more usual 32 volts.

I would like to know how, if possible, either or both of these circuits could be adapted to a 48-volt supply, or if you intend to publish a description of such a circuit in the near future, (D.A., Mt Duneed, Vic.)

● While it would certainly be possible to adapt both circuits to 48VDC operation, the modifications would require upgraded output transistors and different transformers.

Unfortunately, there are no readily available transformers that we can nominate. Even if you were able to arrange for a custom transformer to be made, the expense would probably render the project impractical. A petrol-powered generator may well be cheaper.

VIC-20: I was very interested in your review of Commodore's VIC-20 computer in the July 1982 issue. I was also interested in the news of the coming Commodore 64 model. What was disappointing though was to learn that you are restricted to Commodore's peripherals because of the use of a peculiar bus system.

I thought this was stupid; at least from a user point of view, and I was wondering if there was some way to adapt the machines to standard equipment. Is EA going to publish anything along these lines? (R.C., North Ipswich, Qld.)

● The VIC-20 does include a "user port" providing access to a 6522 VIA ("Versatile Interface Adapter"). With appropriate programming this port could

emulate a standard Centronics parallel interface, while a small amount of additional circuitry would be required to create an RS-232C serial port. We are considering this as a project possibility, so watch future issues.

SUPER-80 PIO: I have recently added a joystick, a Super-80 computer in the spare positions available on the keyboard but have run into difficulty in that three keys cannot be detected at the same time. This means that with a normal switch-type joystick with five switches you cannot use it to move diagonally and fire at the same time as this would involve an up or down switch plus a left or right plus the fire button.

I think the answer to this is to output a value to port FA (the PIO's port B) and receive the value from port F8 (PIO port A) instead of the reverse which normally happens on keyboard scans.

The only problem is that though the PIO is programmable I don't know how to do this. On the circuit diagram of the computer keyboard it shows that two extra ports addresses are available named Control A and Control B. These I suppose are used to program the PIO but I have been unable to find details. Any help would be appreciated. (P.P., Lethbridge Park, NSW.)

● We cannot say whether re-programming the Super-80 PIO will solve your particular problem, but as you have surmised the key is the Control registers A and B, which control the mode of operation of the A and B data ports respectively.

Zilog's PIO (Parallel Input Output) chip is a versatile device, capable of being programmed to operate in one of four different modes. Full details of how to program the chip would occupy too

STOP WASTING TIME TESTING BOARDS

MD will pin-point microtroubles in seconds. Portable and simple to use by non-technical staff in the REPAIR SHOP or on the PRODUCTION LINE. MD tests ROM, RAM & I/O and prints diagnostic reports. MICRODOCTOR can be plugged into an unknown system to perform a general diagnostic and print a MEMORY-MAP.

The ENGINEER may enter sequences of CHECKSUMS and RAMTESTS, READS and WRITES to specific MEMORY and I/O locations. SHORTING tests on DATA and ADDRESS LINES. PRINT-OUTS of memory in ASCII or HEX. These sequences are retained in CONTINUOUS MEMORY, available always at the push of a key.

* FREE Z80 DISASSEMBLER with each MD (other disassemblers soon to be retrofit at low cost). Get a DISASSEMBLER LISTING of ROM in any microsystem!



MICRODOCTOR — \$595.00

Z80 DEVELOPMENT SYSTEM

MENTA puts out a TV PICTURE of memory in hexadecimal. The 40 key keyboard will accept inputs, both in hexadecimal and Z80 mnemonics; there is a quick cassette data storage system, a powerful editor which permits program debugging by showing contents of registers and stack. Also there are 24 bits of I/O for external control! A Z80 disassembler is also available which outputs to any RS232 device such as a printer or terminal. MENTA was designed as a low-budget device for teaching microprocessing in schools. Professional course material is available to teachers together with add-on boards for a variety of control functions and robotic applications.



MENTA — \$249.00

INTELLIGENT EPROM PROGRAMMER

Good tools need not be expensive. SOFTY 2 is the latest version of the engineer's favourite EPROM HANDLER for anybody who uses 2516, 2716, 2532 and 2732 EPROMS. SOFTY will program any of these EPROMS or copy any type into another.

SOFTY puts out a TV picture of memory contents, with many code-manipulating and editing facilities. There is also a fast cassette data storage system. SOFTY is also a ROMULATOR (a lead is supplied which may be inserted into a board under development to emulate the ROM using SOFTY's internal RAM. This procedure can also be used on the single-chipper piggy-back type MPU.) SOFTY is complete in itself as a PRODUCT DEVELOPMENT SYSTEM. Code may be entered in HEXADECIMAL via the keyboard also SERIAL and PARALLEL inputs and outputs allow downloading of object code from your computer or printing EPROM contents on your printer.



SOFTY 2 — \$379.00



ELECTRONICS

P.O. Box 311, Castle Hill NSW 2154. Ph. (02)634 7597.

Coming Next Month * * *

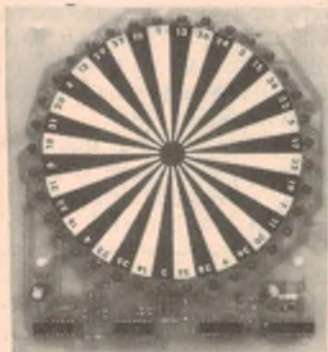

◀ ELECTRONIC ROULETTE WHEEL

Gamble away to your heart's content with our new Electronic Roulette Wheel. Only four inexpensive ICs are used and wheel sound effects are incorporated. Battery powered for mobile gambling if required.

AMPLIFIER OVERLOAD INDICATOR

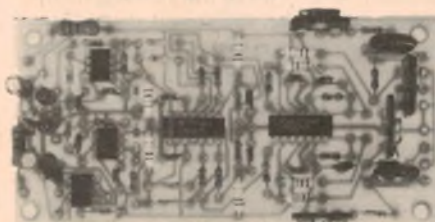

This overload indicator can be connected to any power amplifier and will indicate even the briefest of overloads which cause as little as 0.1% THD. The circuit is independent of the effects of varying supply voltages or load impedance.

**ON SALE:
Monday, May 2nd**

* Our planning for this issue is well advanced but circumstances may change the final content. However, we will make every attempt to include the articles mentioned here.

Trouble-shooting the Large-Screen CRO Adapter

LARGE SCREEN STORAGE CRO ADAPTER: I have built the large screen storage CRO adapter featured in the February '82 issue. The unit does store waveforms but has a few imperfections which spoil what would otherwise be a very adequate performance. The most annoying of these is a tendency to generate spikes at particular voltage levels on the waveforms. I think these spikes are too large to be called "quantising errors".

I have enclosed photographs which show the spikes on a 50Hz ramp and a 1kHz sine wave. It would seem that the fault is in the A/D converter circuit, but all my efforts to eliminate the spike by changing resistor values, adding extra bypass capacitors, shielding the comparator, etc, have made no difference at all. So far I have not changed any of the ICs because it is so difficult to remove them without damaging the printed circuit, but I suspect that IC11 (DAC0800) may be the source of the trouble.

I have also enclosed a photo of a square wave with two large glitches in it. The glitches only appear when the RUN/HOLD switch is in the "hold" position and may take up to 15 seconds to appear. If the waveform is "frozen" by some other means (such as disconnecting the signal the glitches do not occur.

Any advice which you can give me with regard to these problems would be much appreciated. (R.W., Altona Vic).

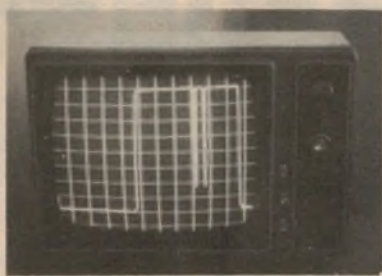

● The spikes which are appearing on the television display are more likely due to a fault in the memory section rather than the DAC. This is evidenced by the fact that the fault does not appear when the CRO is switched to run, which continually updates the display, but does appear when the CRO is switched to hold, which reads the stored waveform from the memory only, with no updating.

The memory is scanned via counters running from a 4MHz clock provided by IC14b. Since incorrect memory addressing by these counters could also be producing your fault, you will need to single step the clock and check the inputs and outputs of the counter and memory ICs. To do this, construct a 555 monostable "stepper" circuit, then break the track leading from pin 9 of IC14b to the clock inputs of IC1 and IC2. Attach the single stepping circuit output to the CRO circuit via a changeover switch (S2) so that either the 4MHz clock or the single step circuit can be selected.

Power for the single stepping circuit can be obtained from the run/hold

switch which has both +5V and ground connected to it. The purpose of the 555 IC in the single stepping circuit is to debounce the switch allowing you to step precisely one memory location at a time.

Now turn the CRO on and with the changeover switch selecting the 4MHz clock, display a square wave as in the photo you provided. Now switch the run/hold switch to hold and wait for the glitches to appear on the square wave display. When they appear note where they are, then switch the changeover switch to the output of the single stepping circuit. The display on the TV should now be a single bright dot on the TV screen. Turn the brightness down on the TV to avoid burning the phosphor then push the single step button.

The dot on the TV should have moved a little to the right. If no dot appears on the screen at first, try pressing the single stepping button a few times. The display is probably slightly larger than the TV screen and the dot is further left or right than you can see. Now step the dot along until it jumps to an incorrect position. The inputs and outputs of the counter, multiplexer and memory ICs can now be examined with a multimeter to see if the addressing is correct and if the correct data was stored in the memory location.

Also check pin 1 of IC5 and IC6; this should be at a high level. A low level means that inputs from IC3 and IC4 are being selected which could cause glitches on the display. 3

much space here but can be found in Zilog's Component Data manual, 1982/83. We obtained a copy from George Brown & Co Pty Ltd, 174 Paramatta Rd, Camperdown, NSW. (02) 519 5855.

LCD TACHO/DWELL METER: I have recently constructed the Tacho/Dwell Meter described in the May, 1982, issue. The meter seems to function properly until the revs go over 1990 then the final three digits go blank, leaving only a "1" as the first digit. Can you suggest what is wrong?

Also, how can a 3½-digit display read up to 12,000 rpm as stated in the article? (S.C., West Preston, Vic.)

● In answer to your first question, there is nothing wrong with the operation of your Tacho/Dwell Meter. The problem lies in your calibration of the meter. The meter was designed to read to the

nearest 10 rpm and is calibrated for a display reading of 150 at 1500 rpm. The meter then displays the first three significant figures of the engine rpm, the fourth figure (assumed to be zero) is mentally added (by you).

We admit that this was not made clear in the article, an oversight for which we apologise.

You have calibrated the meter so that it shows the engine rpm exactly, ie, 1500 at 1500 rpm. This is fine for tuning the engine, but under normal driving conditions the meter will over-range when the engine exceeds 1999 rpm. The over-range meter display is exactly what you have described in your letter, a first digit of "1" with all other digits suppressed. This shows that the meter is working correctly.

By now the answer to your second question should be obvious. Due to the number of digits available on a 3½-digit display the only way to show more than

1999 rpm is to display only the first three significant figures. In this way readings up to 19,990 rpm could be displayed. In this circuit limitations in the meter input circuit set an upper limit of 12,000 rpm on the meter display.

If you wish to keep the more accurate display for low rpm applications such as tuning the car, it would be quite feasible to switch between two calibrated potentiometers, one for each range.

Notes & Errata

SUPER-80 CHUNKY GRAPHICS (Jan 1983, File No. 2/CC/79): The author has advised us of an error in the circuit diagram for the Super-80 graphics modification. The XOR gate, IC4d is intended to operate as an inverter and must have one input connected to +5V for correct operation. Connect either pin 12 or pin 13 to logic 1, but not both.

MARKETPLACE

FOR SALE

NI-CAD BATTERIES. New quality. Cheap. AA; sub C, C and D size at 4 amp. Fast charge. Suit most gear incl flashguns, toys and Big Jim torches, etc. Last for years. Info 557 Merrylands Rd, Merrylands 2160. (02) 636 1592 any time.

RED/ORY LEDS 8MCO National Semi NSL 5754 (New), 8000+, 1000 min Lot. \$60. The Lot \$450. 199 Alexander Drive, Dianella 6062. (09) 276 2725.

OSCILLOSCOPE. Tektronix 2213, mint condition \$1916 duty and tax paid. Sell \$1500. (02) 759 8927.

RAM 4K Static 2114a-4. Intel 200/NS. New price 1-31 \$1.30 ea. 32-up \$1.10 ea. G. Barnes, 217 Victoria Rd, Gladsville, NSW (02) 713 1078.

SUPER 80 SOFTWARE: For free list send SAE to: Megasoftware, 151 Denton Ave, St Albans 3021. Ph (03) 367 1469.

ELECTRONIC VALVES — 3V4, 6AU6, 6BC6, 6AQ4, 6BL8, 6AE8, \$1 ea. 6V6, 6SN7, 6X4, 6SJ7 \$2 ea. EF15, RD12, 6Y9 \$3 ea. CCA — Gold plated pins \$12. A large range of older type valves also available. E80, EB41, EL32, EF12, EF36, EY86, GT1, KT76, VR100, 21A6, 6B4, 6J7, 809 \$1 ea. Special offer 20 mixed valves incl some above \$10. Add \$2 P&P. All above valves are new. Academy TV Service, 9 Coulter St, Newcomb 3219. (052) 48 1621.

TECHNICS SL-Q20 — from p45

The wow and flutter caused by this pulse could also be detected on records with slowly decaying piano notes. So the Technics turntable may have a low figure for wow and flutter but it is audible on certain types of music.

Rumble is specified as -56dB unweighted, and -78dB weighted, a very good figure. We measured turntable rumble as being below -50dB, surface noise on the test record preventing accurate measurements below this. This figure indicates a very good rumble performance.

To sum up, our reaction to this Technics turntable is a little mixed. We think the wow and flutter performance could be improved and the cartridge upgraded. In other respects though, it is a good performer and should give years of satisfaction.

Recommended retail price of the Technics SL-Q20 is \$299 including sales tax. Further information can be obtained from hifi retailers or from the Australian distributors, National Panasonic (Aust) Pty Ltd, 95-99 Epping Road, North Ryde, NSW 2113. (JS)

AMIDON FERROMAGNETIC CORES. Large range for all receiver and transmitter applications. For data and price list send 105x220 SASE to: R.J. & U.S. Imports, PO Box 157, Mortdale, NSW, 2223.

CP/M users group discs \$10 per volume. CPMUG catalogue \$10. 64K S100 CMOS Static RAM cards \$425. 8" Disc drives, New \$450. Discettes 8" \$65, 5" \$53 library box of 10. C.A.E. Electronics, PO Box 62, 1/27 Forge St, Blacktown NSW 2148. (02) 621 4242.

WANTED

NSW RETAIL OUTLETS for range of high quality electronic and associated products — contact Max Scott, (02) 684 1900.

READER SERVICE

REPAIRS to all home, hobby and small business microcomputer systems and peripherals, also all EA & ETI projects. C.A.E. Electronics, 1/27 Forge St, Blacktown 2148. (02) 621 4242.

DISPLAY ADVERTS IN MARKETPLACE are available in sizes from a minimum of 2cm x 1 col rated at \$15 for a col cm.

CLASSIFIED RATES \$3 60 for 40 letters or part thereof per insertion payable in advance. Minimum 80 letters.

CLOSING DATE is six weeks prior to the on-sale date. Issues are on sale the first Wednesday of each month.

FOR HIRE

MICROCOMPUTERS for weekly rental... \$25 per week. Commodore PET systems, with manuals and software tapes. Cassettes include games and self-teaching tutorials in BASIC and 6502 Machine Language. David Bates & Associates, Ph (02) 630 8652.

RCS Radio Pty Ltd
Tel. (02) 587 3491

IS THE ONLY COMPANY
WHICH MANUFACTURES AND
SELLS EVERY PCB & FRONT PANEL
published in EA and ETI

651 Forest Road Bexley 2207
AUSTRALIA

RING FOR INSTANT PRICES
24 HOUR TURNAROUND SERVICE

DID YOU MISS AN ISSUE



JANUARY 1983: The work of the ship's Radio Officer; Scanners and Scanning; Expedition to the Antarctic Pt 2; Laser tests for Loudspeakers; Teac Synthesised AM/FM Tuner review; Remote Infrared TV Sound Control; Battery Saver for personal portables; The LED HEAD Lightchaser, Chunky Graphics for the Super 80; Datum Microprocessor Trainer.



FEBRUARY 1983: The growing peril of Space Debris; Prospects for Cable TV; The Compact Disc; Technics "Way" review; Transistor Assisted Ignition System; Optoelectronic Trigger; Simple Moisture Alarm; Wheatstone Bridge and Decade Box; Microbee Personal Computer; The Otrona 512; Remote Infrared TV Sound Control (to suit DC volume controls).

Available from "Electronics Australia", 57 Regent St, Chippendale.
PRICE: \$2.00 each OR by mail order from "Electronics Australia", PO Box 163, Chippendale 2008. PRICE: \$3.00 each.

ELECTRONICS CENTRE

BARGAIN PRICES • PERSONAL ATTENTION • SLICK MAIL ORDER SERVICE • SATISFACTION



GENUINE FACTORY PRICES ETONE 30cm and 38cm SPEAKER SPECIALS

Rugged top quality Aust made brand new bargains — all with factory warranty.

Model	Size	Cone Type	Vicoil	Reson Hz	Freq Hz	Watts Rms	Price Ea	or	2 for
6110	30cm	Ribbed surround	8/15 Ohms	65	50-8000	30	\$28.50	or	\$49.95
6160	30cm	Twin cone	8 or 15 Ohms	65	50-15000	30	\$29.50	or	\$52.00
6180	30cm	Foam surround	8 Ohms	30	30-4000	60	\$34.95	or	\$64.00
4310	38cm	Straight surround	8-15 Ohms	45	40-6000	60	\$63.00	or	\$120.00
4510	38cm	Straight surround	8-15 Ohms	45	40-6000	100	\$84.00	or	\$156.00
4350	38cm	Hi-Fi	8 15 Ohms	30	30-4000	120	\$63.00	or	\$120.00

Pack — Postage add for one 30cm model. NSW \$3.50. Interstate \$5. For two 30cm models. NSW \$5. Interstate \$7. For one 38cm model. NSW \$4.00. Interstate \$6. For two 38cm models. NSW \$7. Interstate \$8.50.

HIGH GRADE POTTER AND BRUMFIELD RELAY



KU series • 240 VAC 50Hz operation • 3 sets of 240V 10 amp change over contacts • perspex cover and mounting base included • size 50mm x 37mm x 35mm • ex-computer • as new condition. At less than 1/3 of the normal price.

\$3.50 P-P 95c

CABINETS

PROFESSIONAL QUALITY
101 APPLICATIONS



Direct from a manufacturer of sophisticated electronics • Fully moulded, hi-impact, heavy duty ABS plastic • The colour is battleship grey • Detachable U-shape top and bottom, front and back panels • Front panel has cut-outs, and will easily accept a blank panel • 4 jumbo countersunk plastic screws secure the 4 sections • Underside has ample ventilation, and dimples for rubber feet • Dimensions 350mm (W) x 130mm (H) x 350mm (D) material 5mm thick. BRAND NEW PERFECTS.

\$22.95 P.P. NSW \$4.50. V, SA, Q, T \$5.50. WA, NT \$6.50

RECHARGEABLE LEAD ACID BATTERIES

SONNENSCHNEIN
12 VOLT
5.7AH



Fully sealed. Maintenance free. ABS plastic case. 150mm (W) x 90mm (H) x 65mm (D). LIMITED STOCKS.

\$22.95 P-P. NSW. \$2.50
INTERSTATE \$4.50

C-CORE TRANSFORMERS • LOW NOISE • HIGH EFFICIENCY FOR THE COMPUTER • POWER SUPPLY • AND MANY MORE PROJECTS



MODEL	SEC. V.	AMPS
JT266	0-18V	8A
JT235	26-0-26V	2A
JT248	0-10V	10A
JT249	8.5-0-8.5V	4A
	& 15VCT	1A
JT274	0-9.5V	10A
	& 2X 0-12V	1A
JT320	36-0-36V	2A

ONE PRICE
\$29.95 ea

ADD P-POST: NSW \$3.50.
V. Q. SA. T \$4.50.
WA, NT \$5.50

TECNICO STEREO FM FRONT END TUNER

BRAND NEW SUPERIOR GEAR • FULLY CONSTRUCTED ON PCB • UP TO 10.7 MHZ • IF STAGE • IN FULLY SHIELDED METAL BOX 74 x 70 x 42MM • INCLUDES 5 GANG TUNING CAP • 2 RF STAGES • FREQ. 87.5 — 108.5 MHZ • SUPPLY 12V 10MA • CIRCUIT SUPPLIED •
P-P \$1.50 **\$10.95**

500 uA FSD
PANEL METERS

\$3.50
EACH
2
FOR
\$6



2 SIZES. 38 and 45mm. SQ V-U SCALE

KNOBS TO CLEAR

Push on black plastic. For spline shaft. 20 x 20mm.
10 FOR \$3.50

Black plastic with skirt. Imperial shaft. 37 x 24mm
10 FOR \$4.95

Satin aluminium. Knurled body, imp shaft. 26 x 16mm
10 FOR \$6.40

Black plastic. imp shaft. 26 x 15mm.
10 FOR \$4

PP NSW \$1.50. INTERSTATE \$2.30

HEAVY DUTY NI-CAD RECHARGEABLE BATTERIES

SIZE	VOLTS	AH	CHARGE	PRICE EA	PRICE FOR 4	P-POST
D	1.2	4	400ma 14hrs	\$7.50	\$27.00	\$2.75
C	1.2	1.8	180ma 14hrs	\$6.25	\$23.80	\$2.75

PYE BELT-DRIVE STEREO PLAYER

PRO MODEL
TA-10

\$89.95

P-P NSW \$5.50
Q, V, T, SA \$6.50
WA, NT \$7.50



Detachable Headshell
Magnetic Cartridge
Diamond Stylus

Features — Manual Start • Auto Return • Eject Lever • Cue Lever • Full Size. 30cm Heavyweight Aluminium Platter with Anti-static Mat • 2-speed 33-45 rpm • Fully Calibrated Adjustable Counterweight • Anti-Skate • 240 VAC 50Hz 4 Pole. Fully Shielded Motor • Switch Click Suppressor • 3 Core Power Cable. Audio Cable with RCA Plugs • Base Size 40 x 30 5cm •

COMPUTER GRADE ELECTROLYTICS

Famous brands, Siemens, GE, Mallory, Sprague.
Ex-computer stock. Guaranteed perfect. Limited Stocks.

MICRO-FARADS AND WORKING VOLTS • 3500/70 • 5000/55 • 5000/36 • 5800/40V • 6600/25 • 8200/25 • 10,000/30 • 12,000/30 • 16,000/30 • 21,000/15.

\$5.50 ea.

• 180,000/20 • 160,000/10 • 120,000/15 • 71,000/30 • 48,000/30 • 54,000/30 • 34,000/30 • 34,000/55 • 32,000/40 • 24,000/30 • 20,000/75 • 5200/200

\$8.50 EA PP NSW \$2 INTERSTATE \$3

!KEEP IT COOL! WITH EX-COMPUTER FAN MOTORS



Amps • Power Supplies • Electronic Equipment will operate far more efficiently • Imp protected • Excellent condition, perfect order guaranteed 2 sizes — 3" and 4" 2 voltages — 115VAC 50/60HZ and 230VAC 50/60HZ

\$8.95 EA P.P. NSW \$2.50
INTERSTATE \$3.50

☆ SLOW SCAN OSCILLOSCOPES ☆

EX-HOSPITAL CARDIAC MONITORS • MODERN DESIGN • SOLID STATE • 240 VAC 50Hz • EXCELLENT CONDITION • COMPACT

EMI 12" 4 CHANNEL \$175.00
W-V 5 1/2" 2 CHANNEL \$225.00

PP NSW \$6.50 INTERSTATE \$10.50

PUSH-OFF SWITCH

240V 1A. Castel Co Eng. 22 x 12 x 30H mm.

GREAT FOR ALARMS
10 FOR \$7.50 PP \$2.50

PUSH BUTTON TELEPHONE DIALER WITH MEMORY

\$19.95 P-P 90c

Last phone number memory re-call. Busy number redialled by touch of one button. Instant cut-off button. Converts your old fashioned mechanical system into a modern, speedy phone dialer. Easy to install.

EA Magazine Holders



The binders and magazine holders are available over the counter from Electronics Australia, 57 Regent Street, Sydney, NSW — Price: \$5.10 binders, \$4.50 holders.

Mail orders should be sent to Electronics Australia, PO Box 163, Chippendale, NSW 2008.

Prices including postage are:

Holders: \$5.50 NSW; \$5.60 other states; or six for \$29.00 NSW; \$31.50 other states, \$A33.00 NZ.

Binders: \$7.00 NSW; \$8.50 other states; or six for \$33.00 NSW; \$36.00 other states, \$A37.00 NZ.

ADVERTISING INDEX

ADVERTISER	PAGE
Audio Engineers	2
Audio 2000	17
Altronics	22, 23, 26, 66, 67, 114, 115
AWA	39
Audiosound	55
Ampec	IFC, 63
Amtex Electronics	87
Acoustic Electronic Developments	96
Aust School Of Electronics	105
Aust Film & TV School	110
Absolute Electronics	133
ACE Radio	143
Applied Technology	OBC
Bright Star Crystals	119
Bertas International	In Colour Section
Cobo International	33
C&K Electronics	64
Chapman L.E.	70
Castle Electronics	140
Daneva Controls	129
Defence Force Recruiting	In Colour Section
Electronic Agencies	50
Eastern Communications	54, 73
Elmeasco	79
Ferguson Transformers	64
Harman Australia	41
Inca Data Systems	11
Rod Irving Electronics	18, 46, 47, 88, 89, 112, 125, 132
Jaycar	12, 13, 35, 56, 57, 82, 83, 102, 103, 121
Kalextronics	33
MaGrath's	78
National Panasonic	42, 43
Parameters	53
Paris Radio	131
Radio Parts Group	96
Royal Micro Systems	71
RCS Radio	142
Dick Smith Electronics	4, 5, 6, 7, 95, 98, 134, 137
A&R Soanar	70
Software Source	97
Stotts	111
Scientific Electronics	126
Sony Australia	In Colour Section
Truscott Electronics	34
Technical Book & Magazine Co	101
Wireless Institute of Australia	113

EA PC BOARDS AND FRONT PANELS

Some readers have problems obtaining PC boards and front panels for projects. Many of our advertisers sell these items and their advertisements should be checked in the first instance. Failing that, below is a list of firms which produce or sell PC boards and front panels.

NSW

Dick Smith Electronics,
125 York Street,
Sydney, 2000.
Telephone 290 3377
DSE also has branches and resellers throughout Australia.

Electronic Agencies,
115-117 Parramatta Road,
Concord, 2137.
Telephone 745 3077.

117 York Street,
Sydney 2000.
Telephone 29 2098.

Jaycar Pty Ltd,
125 York Street,
Sydney 2000.
Telephone 264 6688.

Radio Despatch Service,
869 George Street,
Sydney 2000.
Telephone 211 0816.

RCS Radio Pty Ltd,
651 Forest Road,
Bexley, NSW 2207.
Telephone: 587 3491

VIC.

Rod Irving Electronics,
425 High Street,
Northcote, 3070.
Telephone 489 8131.

Kalextronics,
101 Burgundy Street,
Heidelberg 3084.
Telephone 743 1011.

Shop 11,
Regional Shopping Centre,
Melton 3338.
Telephone 743 1011.

Sunbury Printed Circuits,
Lot 14, Factory 3,
MacDougal Road,
Sunbury 3429.
Telephone 744 2714

Altronics,

105 Stirling Street,
Perth 6000.
Telephone 328 1599.

Jemal Products,
8/120 Briggs Street,
Welshpool, 6106.

N.Z.

Marday Services,
PO Box 19 189,
Avondale, Auckland.

Mini Tech Manufacturing Co Ltd,
PO Box 9194,
Newmarket.

Printed Circuits Limited,
PO Box 4248,
Christchurch.

SUBSCRIPTION SERVICE



**ELECTRONICS
Australia**

Subscription Rates

\$29.00 per year
within Australia
\$31.00 per year
elsewhere

Make sure you receive every copy of the magazine by ordering it from your newsagent or the publisher. For publisher subscriptions post this coupon, with your remittance to Electronics Australia Subscription Dept. John Fairfax & Sons Ltd, GPO Box 506 Sydney 2001. Subscription will start with first available issue.

Name
Address
Postcode Enclosed is for years

video MAG

A WHOLE NEW ERA IN ENTERTAINMENT



APRIL/MAY ISSUE

Featuring **BLADE RUNNER™**

Models, miniatures, mood and lighting

* **VIDEO GAME SPECIAL**

Plus test of the VIC-20 and software

* **VCR TESTS**

New models from Fisher and AWA Thorn

* **VIDEOTAPE**

What makes it good?



**The name at
everyone's fingertips**



microbee®

For full details of the complete microbee range of personal computers and your nearest stockist phone, write or call in to Applied Technology Pty. Ltd., 1 Pattison Ave., Waitara, N.S.W. 2077. Phone (02) 487 2711. Open 9am to 5pm Mon to Sat.