

**BIG PROJECT CONTEST: \$3500 IN PRIZES!**

Australia's Top Selling Electronics Magazine

# Electronics Australia

SEPTEMBER

1988

Aust\* \$3.95

NZ \$4.95 incl GST

**AUSTRALIA'S EXCITING  
NEW RADIO TELESCOPE**



**SPECIAL CAD FEATURE**

**NEW CHIP FOUNDRY  
OPENS IN SYDNEY**

**PROJECTS TO BUILD:  
MEASURING CURRENT  
SOURCE, STUD FINDER,  
& 30+30W AMPLIFIER  
72-L SPEAKER SYSTEM ►**



# Why Tinker Around When it Comes to Your Communications Testing.

*Internal  
Cellular...  
Trunking...  
Tracking Generator...*

*now available with the **New FM/AM-1200S***



*The FM/AM-1200S is still the most feature intensive of all communications service monitors.*

*See for yourself.* The FM/AM-1200S includes a 1 GHz spectrum analyzer, 1 MHz scope, 2  $\mu$ V receiver, duplex capability, 150 watt power meter, RS-232 interface and numerous programmable functions—all standard in one self-contained, compact and portable unit. With **three new options**, the 1200S can now test cellular mobiles; CLEARCHANNEL LTR<sup>®</sup> compatible mobiles/bases; and duplexers, combiners and isolators.

Think of the advantages of having all these features in one package. With the 1200S cellular option you no longer have to be concerned with what type of test interface the radio has. By connecting a coax between the transceiver and test set you are ready to go. When you need to verify a trunked radio, just connect the RF cable, enter the mobile and system information into the 1200S and execute. This now eliminates the need for "add-on" or accessory units to perform cellular and trunked systems testing.

How many times have you wished for a convenient, inexpensive way to observe the frequency response of a cavity or duplexer? The new 1200S tracking generator option will do just that. By connecting two cables, you can observe the frequency response directly on the 1200S' CRT, providing for instantaneous monitoring of filter characteristics.

Where else can you get all this capability in one communications test set? No where! Compare and you'll agree...the FM/AM-1200S *is* the logical choice.

***Don't tinker around! Buy IFR, the monitors that make the others seem like toys.***



VIC/S&TAS: 4 Meaden Street, SOUTH MELBOURNE, VIC 3705. PH: 690-9399. FAX: 699-3239. TX: AA36935.  
QUEENSLAND PNG: 433 Logan Road, STONES CORNER, QLD 4120. PH: (07) 394-8308. FX: (07) 397-8225. TX: AA36935.  
WA: 25 Hutton Street, OSBORNE PARK, WA 6017. PH: (09) 446-9177. FAX: (09) 446-9110. TX: AA36935.  
NEW ZEALAND: 18 Raroa Road, LOWER HUTT, WELLINGTON, NEW ZEALAND. PH: +64 4 697 625. FAX: +64 4 697 628. TX: NZ3334.  
NSW/NT/FLJ: Suite 803, 8th Floor, GBC Building, 8 West Street, NORTH SYDNEY, NSW 2060. PH: (02) 957-2766. FAX: (02) 957-3821. TX: AA36935.  
OTHER OVERSEAS: 4 Meaden Street, SOUTH MELBOURNE, VIC 3205. AUSTRALIA PH: 690-9399. FAX: 699-3239. TX: AA36935



CLEARCHANNEL LTR<sup>®</sup> is a registered trademark of E F JOHNSON CO.

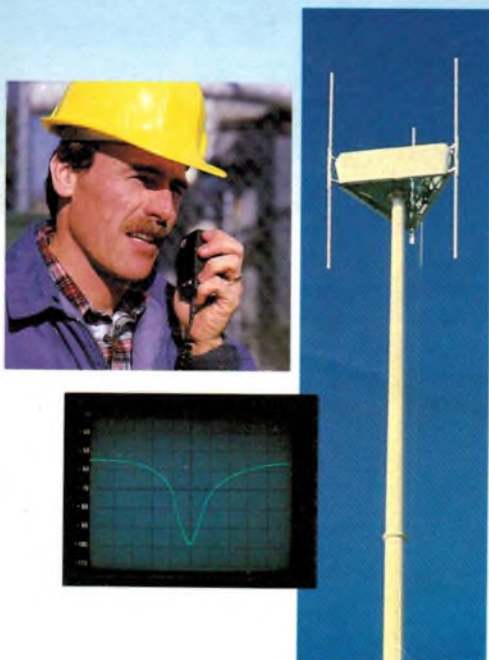

# Bundles of Books

## New Releases . . .

### GETTING THE MOST FROM YOUR MULTIMETER

R.A. Penfold **BP239**  
This book is primarily aimed at beginners and those of limited experience of electronics. Chapter 1 covers the basics of analogue and digital multimeters — the merits and limitations of each. In Chapter 2 various methods of component checking such as transistors, thyristors and diodes are described. Circuit testing is covered in Chapter 3, with subjects such as voltage, current and continuity discussed.  
102 pages **\$11.00**

### AN INTRODUCTION TO SATELLITE TELEVISION

F.A. Wilson **BP195**  
A well written, comprehensive and easy to understand introduction to satellite TV, written for both enthusiast/technician and the interested lay person. Explains how satellite TV works, the equipment needed for reception, how to work out antenna orientation for your location, correct installation and so on. Lots of reference tables, formulas for calculations and a glossary of satellite TV jargon.  
104 pages **\$12.95**

### MORE ADVANCED ELECTRONIC MUSIC PROJECTS

R.A. Penfold **BP0174**  
Intended to complement the first book (BP74) by carrying on where it left off and providing a range of slightly more advanced and complex projects. Included are popular effects units such as flanger, phaser, mini-chorus and ring-modulator units. Some useful percussion synthesisers are also described and together these provide a comprehensive range of effects including drum, cymbal and gong-type sounds.  
96 pages **\$8.50**

### MIDI PROJECTS

R.A. Penfold **BP0182**  
Provides practical details of how to interface many popular home computers with MIDI systems. Also covers interfacing MIDI equipment to analogue and percussion synthesisers.  
112 pages **\$11.00**

### BUILD YOUR OWN SOLID STATE HI-FI AND AUDIO ACCESSORIES

M. H. Babani **BPO220**  
An essential addition to the library of any keen hi-fi and audio enthusiast. The design and construction of many useful projects are covered including: stereo decoder, three-channel stereo mixer, FET pre-amplifier for ceramic PUs, microphone pre-amp with adjustable bass response, stereo dynamic noise filter, loud-speaker protector, voice-operated relay, etc.  
96 pages **\$6.00**

### POWER SUPPLY PROJECTS

R.A. Penfold **BP0076**  
The purpose of this book is to give a number of power supply designs, including simple unregulated types, fixed-voltage types, and variable-voltage stabilised designs, the latter being primarily intended for use as bench supplies for the electronics workshop. The designs provided are all low-voltage types for semiconductor circuits. This book should also help the reader to design his own power supplies.  
96 pages **\$7.50**

### ELECTRONIC HOBBYISTS HANDBOOK

R.A. Penfold **BP233**  
A handy data reference book, written especially for the newcomer to electronics. Provides data on component colour codes, IC families, basic power supply circuits, circuit symbols, op-amp connections, testing transistors and SCRs, basic computer interfaces, morse code and lots more.  
**\$16.00**

### COIL DESIGN AND CONSTRUCTION MANUAL

B. B. Babani **BP0160**  
A complete book for the home constructor on "how to make" RF, IF, audio and power coils, chokes and transformers. Practically every possible type is discussed and calculations necessary are given and explained in detail. All mathematical data is simplified for use by everyone.  
96 pages **\$9.50**

### CHART OF RADIO, ELECTRONIC, SEMICONDUCTOR AND LOGIC SYMBOLS

M. H. Babani B.Sc (Eng) **BP0027**  
Illustrates the common, and many of the non-common, radio, electronic, semiconductor and logic symbols that are used in books, magazines and instruction manuals, etc. in most countries throughout the world.  
Chart **\$4.00**

### HOW TO DESIGN ELECTRONIC PROJECTS

R.A. Penfold **BP0127**  
The aim of this book is to help the reader to put together projects from standard circuit books with a minimum of trial and error, but without resorting to any advanced mathematics. Hints on designing circuit blocks to meet your special requirements where no "stock" design is available are also provided.  
128 pages **\$9.00**

### HOW TO GET YOUR ELECTRONIC PROJECTS WORKING

R. A. Penfold **BP0110**  
The aim of this book is to help the reader overcome problems by indicating how and where to start looking for many of the common faults that can occur when building up projects.  
96 pages **\$8.50**

### AUDIO AMPLIFIER FAULT-FINDING CHART

C.A. Miller **BP120**  
A very useful fold-out chart which will guide almost anyone in tracking down faults in audio amplifiers, systematically and quickly. Includes detailed notes.  
**\$4.00**

### IC 555 PROJECTS

E.A. Parr **BP0044**  
Every so often a device appears that is so useful that one wonders how life went on before without it. The 555 timer is such a device. Included in this book are basic and general circuits, motorcar and model railway circuits, alarms and noise-makers as well as a section on 566, 568 and 569 timers.  
**\$9.50**

### RADIO AND ELECTRONIC COLOUR CODES AND DATA CHART

B. B. Babani **BP0007**  
Covers many colour codes in use throughout the world, for most radio and electronic components. Includes resistors, capacitors, transformers, field costs, fuses, battery leads, speakers, etc.  
Chart **\$4.00**

### ELECTRONIC SYNTHESISER CONSTRUCTION

R.A. Penfold **BP0185**  
Should enable a relative beginner to build, with the minimum of difficulty and at reasonably low cost a worthwhile monophonic synthesiser, and also learn a great deal about electronic music synthesis in the process. This is achieved by considering and building the various individual parts of the circuit that comprise the whole instrument as separate units, which can then be combined together to form the final synthesiser. Printed circuit designs are provided for these main modules. Later chapters deal with sequencing and some effects units.  
112 pages **\$11.00**

### ELECTRONIC CIRCUITS FOR THE COMPUTER CONTROL OF ROBOTS

R.A. Penfold **BP0179**  
Provides information and circuits on computer control of electric motors (including stepper types), plus a range of useful sensors including visible light, infra-red, and ultrasonic types.  
96 pages **\$11.00**

## TO ORDER THESE BOOKS:

Simply fill out the coupon attached and put it in the reply paid envelope supplied. If the coupon and envelope are missing, send your name address, phone number, and a list of book(s) you want, complete with cheque, money order or credit card details (card type, card number, expiry date and signature) to:

**Freeport No.4,  
Electronics Australia Books Offer,  
Federal Publishing Company  
PO Box 227, Waterloo NSW 2017.**

Note: In calculating your remittance, add \$1.50 to the total cost of the books you are ordering to cover package and postage. All orders must be accompanied by a signature — unsigned orders cannot be accepted. As these books are imported, unavoidable delays may occur. Please allow 4 weeks for delivery. If you have any enquiries regarding mail orders, phone (02) 693 9925.

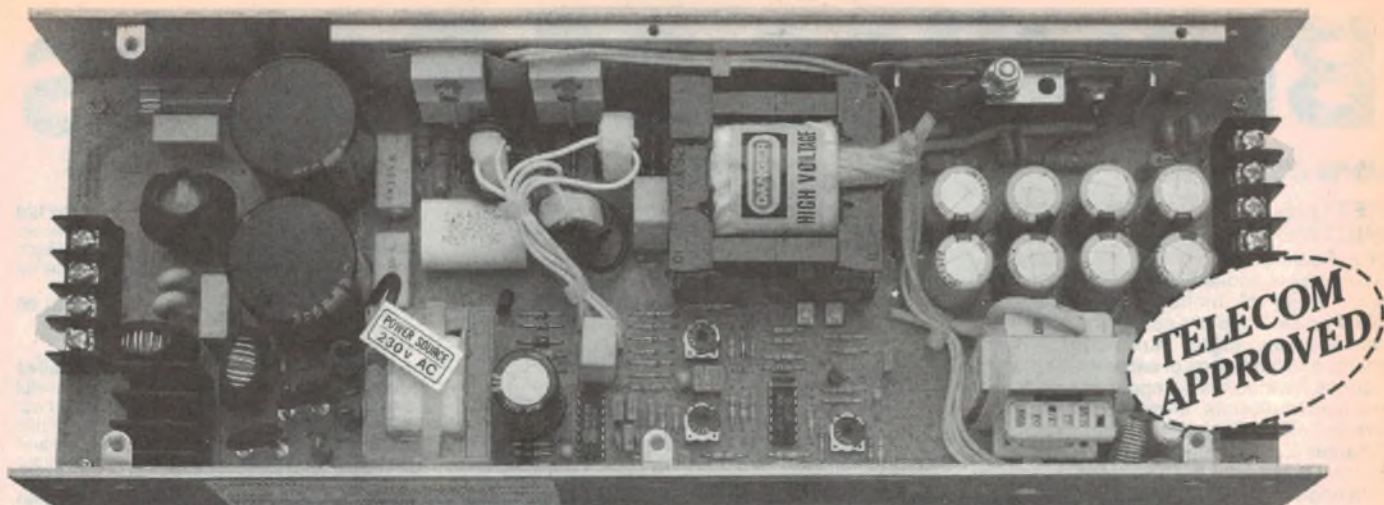

Shown with cover removed

# They've already met tougher specifications than yours. VDE, UL, FCC and CSA.

Our 15-300 watt power supplies meet every important safety and performance standard in the world, including VDE, UL, FCC and CSA.

And some have TELECOM Australia approval, one of the most stringent standards in the world. Surprisingly, the cost of all this quality and performance is very low.

Most needs can be met from our large range of standard models. If you have special needs, we can meet them quickly and easily by custom designing to your specification.

Shown above is model UN1300-48ABC. This is a 300W single output supply with 48V @ 6.5A from a 90-132V/180-264V, 47-440Hz AC input. Full overvoltage, overcurrent, short circuit and thermal protection is built in. It is approved by Telecom (No. RA87/112)



Shown above LP Series DC/DC Converters. Features: • 0.375" max. ht. • 7.7 watts/cub. in. • isolated triple outlets • 25 watt output power • 500kHz MOSFET switching • Surface Mount Technology • high MTBF 300,000 hours • **5 year warranty** • internal  $\pi$  input filter is standard to minimise reflected ripple on input buslines • continuous 6-sided shielding virtually eliminates radiated emissions

If you need DC/DC converters, we can help you there too, with a range of low profile units from 1 to 100 watt ... the compact answer for just about any design need.

Whatever your requirements in power supplies or converters, talk to our engineers. They'll be glad to help you find the simplest, surest, most cost-effective answer.

**SYDNEY:**  
 Centrecourt  
 25-27 Paul Street Nth  
 North Ryde 2113  
 Tel: (02) 888 8777  
 Fax: (02) 887 1283

**MELBOURNE:**  
 1064 Centre Road  
 Oakleigh South 3167  
 Tel: (03) 575 0222  
 Fax: (03) 579 0622

**PERTH:**  
 106 Howe Street  
 Osborne Park 6017  
 Tel: (09) 242 2000  
 Fax: (09) 242 2150

**PARAMETERS**  
 PERFECTION IN MEASUREMENT

# Electronics Australia

Volume 50, No.9

September 1988

AUSTRALIA'S LARGEST SELLING ELECTRONICS MAGAZINE - ESTABLISHED IN 1922

## Australia's newest radio telescope



Australia has always been at the forefront of radio astronomy, and this month sees our scientists take another leap forward with the opening of the massive Australia Telescope. See p12.

## Projects to build

Our construction projects this month include an improved 72-litre 3-way loudspeaker system, - full assembly details for our new Playmaster 30W per channel stereo amplifier (at last!), a simple current source for making very low resistance measurements with your DMM, and a low cost and very easy to build electronic stud finder.

## CAD feature

This month's special feature on computer-aided design includes a story on IBM's new CAD package for PCB design, a run-down on the latest CAD products and a review of a new low-cost CAD package for IBM PCs and compatibles. See p106.

## ON THE COVER

Our main shot this month shows three of the dish antennas for the new Australia Telescope array at Culgoora, in northern NSW. As our feature starting on page 12 explains, the telescope begins operating this month. (Picture courtesy CSIRO).

## Features

- 12 AUSTRALIA'S NEWEST RADIO TELESCOPE *Opens this month!*
- 16 AWA'S NEW WORLD-STANDARD IC FOUNDRY *Now operating...*
- 22 BURNING OFF WITH A LASER *Star Wars in the bush?*
- 43 RECORDING AUSTRALIA'S ORAL HISTORY - Part 5
- 92 THE GRAND AUSSIE HOBBY ELECTRONICS CONTEST *Great prizes!*
- 122 PRODUCT REVIEW: *Hung Chang HC-5050E FET Multimeter*

## Entertainment Electronics

- 8 WHAT'S NEW IN ENTERTAINMENT ELECTRONICS *Video, audio*
- 24 KEEPING THE PHASE WITHIN THE CART *Australian design*
- 28 COMPACT DISC REVIEWS *Tchaikovsky, Bizet, Dvorak*

## Projects and Technical

- 56 THE SERVICEMAN *New and familiar problems with old sets*
- 62 IMPROVED 72L 3-WAY HIFI LOUDSPEAKERS *Great sound!*
- 72 NEW 30W/CHANNEL STEREO AMP - PART 3 *Assembly details*
- 80 LOW COST STUD FINDER *Don't nail into thin air!*
- 84 CIRCUIT & DESIGN IDEAS *Backup alarm control, simple amp*
- 88 CURRENT SOURCE FOR MEASURING LOW R'S *Measure down to .01Ω*
- 100 INTRODUCTION TO HIFI - 20 Loudspeaker systems, part 1
- 106 CAD FEATURE: *Our annual CAD update*
- 111 CAD FEATURE: *New IBM package transforms PCB design*
- 114 CAD FEATURE: *The latest CAD products*
- 118 CAD FEATURE REVIEW: *Low cost "CCS Designer" package*
- 130 SOLID STATE UPDATE *386 compatible chip, 40 amp MOSFET*
- 134 VINTAGE RADIO *Early receiver developments*

## News and Comment

- 6 LETTERS TO THE EDITOR *Electronic typewriters, fax doubt*
- 7 EDITORIAL *How is YOUR hobby project coming along?*
- 30 FORUM *Oxygen-free copper: more than just marketing hype?*
- 34 FRANKLY FRANK *Quit bugging me, will you!*
- 48 NEWS HIGHLIGHTS *Matsushita develops optical disk for HDTV*
- 54 SILICON VALLEY NEWSLETTER *NY enacts first VDT law in US*
- 124 NEW PRODUCTS *Compact 50W switcher, 300MHz digital scope*
- 138 INFORMATION CENTRE *Answers to readers' queries, puzzler*

## Departments

- 3 COMING NEXT MONTH
- 137 BOOK REVIEWS
- 139 NOTES AND ERRATA
- 142 EA CROSSWORD PUZZLE
- 142 50 AND 25 YEARS AGO
- 144 MARKETPLACE
- 145 DIRECTORY OF SUPPLIERS

**MANAGING EDITOR**

Jamieson Rowe, B.A., B.Sc., SMIREE

**PRODUCTION EDITOR**

Angela Pagones

**EDITORIAL STAFF**

Rob Evans, CET (RMIT)

Mark Cheeseman

**CONTRIBUTORS**

Neville Williams, FIREE, VK2XV

Ian Pogson, VK2AZN

Ron Cooper

Jim Lawler, MTETIA

Bryan Maher, M.E., B.Sc.

Ken Pohlmann, M.S., B.S.

**DRAFTING**

Karen Rowlands

**GRAPHIC DESIGNER**

Brian Jones

**ART PRODUCTION**

Alana Horak, Larry Leach

**PRODUCTION**

Kylie Prats

**SECRETARIAL**

Allison Tait

**ADVERTISING PRODUCTION**

Brett Baker, Neville Lawton

**ADVERTISING MANAGER**

Selwyn Sayers

**PUBLISHER**

Michael Hannan

**HEAD OFFICE,****EDITORIAL & ADVERTISING**

180 Bourke Road, Alexandria, NSW 2015

P.O. Box 227, Waterloo 2017.

Phone: (02) 693 6620

Fax number: (02) 693 2842 Telex: AA74488

For reader services see back of magazine.

**INTERSTATE ADVERTISING OFFICES****Melbourne:** 221a Bay Street, Port Melbourne, Vic. 3207. Phone: (03) 646 3111

Fax No: (03) 646 5494, Nikki Roche

**Brisbane:** 26 Chermiside Street, Newstead, Qld 4006. Phone: (07) 854 1119

Fax No: (07) 252 3692, Bernie Summers

**Adelaide:** 98 Jervois Street,

Torrensville, SA 5031.

Phone: (08) 212 1212, Mike Mullins

**Perth:** 48 Clievcen Street, North Perth.

Phone: (09) 444 4426, Des McDonald

**New Zealand:** Rugby Press, 3rd Floor,

Communications House, 12 Heather Street,

Parnell, Auckland New Zealand.

Phone: 796 648 Telex: NZ 63112 'SPORTBY'



**ELECTRONICS AUSTRALIA** is published monthly by Brehmer Fairfax Pty. Ltd., Double Bay Newspapers Pty. Ltd. and General Newspapers Pty. Ltd. trading as Federal Publishing Co., 180 Bourke Road, Alexandria, N.S.W. 2015.

Copyright © 1988 by the Federal Publishing Company, Sydney. All rights reserved. No part of this publication may be reproduced in any way without written permission from the Publisher or Managing Editor.

Typeset and printed by Hannanprint, 140 Bourke Road, Alexandria, NSW for The Federal Publishing Company Pty Ltd. Distributed by Newsagents Direct Distribution Pty Ltd, 17 Doody Street, Alexandria NSW 2015

Registered by Australia Post - publication No. NBP 0240 ISSN 0313-0150

\*Recommended and maximum Australian retail price only.



# Letters to the

## Electronic typewriters

Thanks for printing the letter on "Electronic Typewriters" in the May issue of "E.A.". I hope you open a "can of worms" and receive many dozens of letters regarding these chimes from other users.

I am typing this letter on one such machine. Like your correspondent, it does seem a pity that these lovely little machines are treated with contempt by so many sales-persons. I would guess profit motive would be one factor. One would not have to be a genius to realise that a \$1500+ word processor is much more profitable (for the retailer) than a \$300 "typewriter".

As regards "usability", well-there are more features than the average person would want in ten life-times! Most keys have four different "functions". For instance, the "L" key gives me "l" "L", "β" and "Ω".

There are one or two "negatives" that come with using such a "luxury" machine, though. The machine is mono-cell powered but the consumption is so high (7.6W) that the use of the (optional) mains-adaptor is essential. Also, the ribbon is a "one-time" type in a cassette. These cassettes are both virtually unobtainable and very expensive (\$10). I use my machine rather a lot and a ribbon lasts around 2 months.

All in all, I would be "lost" without this machine. I previously had a manual machine which I used only very occasionally. This machine is used almost every day. It is luxury "par excellence"!

Terry Robinson, VK3DWZ

Woodend, Vic

## Fax for servicemen?

The suggestion raised in your Service-man column regarding a fax users group (May 1988) is a very interesting and worthwhile proposition. However, who will it actually benefit? Are servicemen the only ones able to join in? Admittedly, it would help customers in the long run, due to the fact that servicemen would have an immediate linkup with each other to obtain circuit diagrams and information about parts availability and prices. But how many servicemen have access to fax machines?

What I have wished for in the past is some means by which the public can liaise with servicemen and companies in

order to obtain information. I have been trying to get a circuit diagram for an HMV Braddon 18 television. I received this when buying a second hand computer, and was told that it went in for servicing, but due to the owner not wanting to add to the cost of the computer setup, he included it in the setup for nothing. He said something about a transformer not working. I spent a period of time working for Dixon's TV Service in New Lambton, Newcastle, and in that time I was following circuit diagrams around, locating faults, and doing repairs, and most of them can be easily pinpointed with the aid of a circuit diagram (but not all - you wouldn't have a column to write if they were!). I also have a tape deck at home that needs to have the headphone socket replaced - an easy job if I could just get the part.

Obviously what is needed is some sort of service that could fulfil these purposes. The companies probably wouldn't agree with this saying that it would take away servicing fees from them, and it could result in disaster if an unqualified person was to jump in at the deep end.

I'm not sure how such a system could be set up, perhaps like the Electronics Australia photocopy service; pay a small fee for the relevant information. The next problem would be how to obtain the parts, how does a large company like being asked for one component? Of course, it could be sent to a serviceman with a note attached giving a possible cause. If the diagnosis was correct, it would save a lot in labor costs. Perhaps you could stir a bit of interest in this subject, or let us all know an easy way of obtaining things that have been previously only available to a select few.

Michael Dobbins

Charlestown, NSW

*Comment: Thanks for your response, Michael. A company called JR Publications used to market circuits, but we haven't heard from them for some time.*

## Made in Australia

Because of a lack of the "ready's", I do not buy Electronics Australia every month, but I do manage to get six to eight copies a year. Luckily for me I did get the May 88 issue, because your Editorial Viewpoint was enlightening for me.

# editor

For the past ten years I have been operating a cottage industry in speaker and amplifier making, and although I have never met Peter Stein in person, we are on speaking terms over the phone.

Also, over the past ten years I have on several occasions expressed interest in various installations in the general area in which I live, but have been given the "heave ho".

One chap told me bluntly that unless I wined and dined the people that made money spending decisions, then to forget making any approaches at any time, either now or in the future. After seeing the real world in the audio business especially in the cities, then I can see that this is the norm.

Well, for me it is not to be that way, so I just plod along in my own way, and rely entirely on word of mouth and very satisfied customers.

During my lifetime I have been lucky enough to be privy to the various reasons why things, by things I mean tariffs, taxes, licenses and other things to do with government offices, are done in this country. At the time I was doubt-founded, but it eventually sunk in.

The crux of this letter is to say that I support Peter and any others who wish to thrust the Australian Audio industry into a better understood picture, expressly in the buying public domain.

At one time I almost signed an agreement to purchase compact disc drives and make my own but the outlay, both to the manufacturer & others who could give the go-ahead was too much for me, and so another possible gain was lost, perhaps forever.

G.R. Druery,  
Nambucca Heads, NSW

## Appliance earthing

After rereading your February and April Forums, I conclude that what the SAA and others are trying to say is that the mains earth pin in the household socket (or extension cord) is a highly unreliable source of earth potential and to be avoided where possible. This point, I believe, needs stressing where electronic equipment is involved.

Under leakage or fault conditions the mains earth potential can rise to dangerous levels, and I once received a shock from the earth stake of an old house



## Editorial Viewpoint

### How is YOUR hobby project coming along?

In case you've forgotten, this is the third and final month for entries to our **Grand Aussie Hobby Electronics Competition**. So if you want your pet project to be in the running for one of those beaut prizes donated by Dick Smith Electronics, you'll need to send it in by September 30 (or postmarked no later than that date).

We haven't had too many project entries so far, but I imagine you've all been busy working on them and making sure they perform as intended. On past experience I expect a lot of entries to come in just before the end of the month - three months isn't all that long to develop a worthwhile project, after all.

Don't forget that we have over \$3500 in prizes to be won. First prize in both the newcomer and advanced hobbyists' sections is over \$1500 worth of test gear, in each case the kind of equipment that most hobby enthusiasts can only dream about. And there are runner-up prizes in each section, of DSE Components Vouchers worth \$100 - very handy indeed.

Incidentally if you haven't yet taken advantage of Dick Smith Electronics' offer on a 10% discount for all components purchased to develop your competition project, there's a discount voucher printed again in this issue on page 93. Note that there's no limit to the value of parts you can buy using the voucher, providing you buy them in the one purchase.

We're hoping to announce the winners in the December issue, and publish their designs in the same issue as well. It could be your design!

Changing the subject, we've been working very hard this last month to try and catch up with magazine production after last month's terrible fire. I hope this issue will reach you almost on time, all going well, and by next month we should be back to normal. We're sorry for any inconvenience our unavoidable lateness may have caused.

On the brighter side, it was very cheering this last month to hear from and meet Arthur Mead VK2JM, who has been reading the magazine ever since it began as *Wireless Weekly* back in 1922. As we report in News Highlights, Mr Mead heard that we were looking for very early copies of the magazine, and has generously presented us with bound copies of *Wireless Weekly* Volumes 1 and 3. It was a splendid gesture, and one that was really heartwarming after some of the setbacks we've had lately.

Now there's a reader which any magazine editor would be proud to have, don't you think? I know I am.

Jim Rowe

# What's New In

# Entertainment Electronics

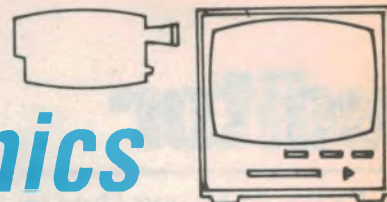

## Boot-mounted car CD player from Pioneer

Pioneer Electronics claims that its new CDX-M100 multi-play compact disc player demonstrates confidence in the future of in-car CD technology, and that it incorporates developments which are a milestone for driver convenience. The CDX-M100 utilises a six disc magazine (JD-M100 supplied with the unit) providing up to six hours of uninterrupted music. The magazine is compatible with Pioneer's multi-play home models and can be easily slipped from the lounge room stereo into the car.

The positioning of the CDX-M100 in the car boot eliminates the need to handle discs while driving, a substantial safety feature. The CDX-M100 mechanism floats on air damper suspension, avoiding potential mis-tracking as a result of rough roads. (This "double float" anti-vibration suspension is similar to that used in buses). Valuable discs are well protected.

The CDX-M100 features AMPS (Auto Magazine Programme Selection) for continuous music selection and other desired functions including Versatile Play modes, track search, track scan, music repeat, programme play, random play, compact three beam laser pick-up and fast forward and reverse.

The pre-programmed six disc music selection loaded into the boot-mounted CD unit is controlled by Pioneer's two new dashboard-mounted command units

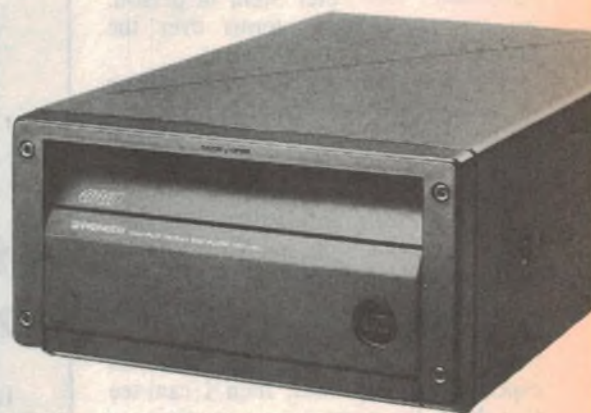
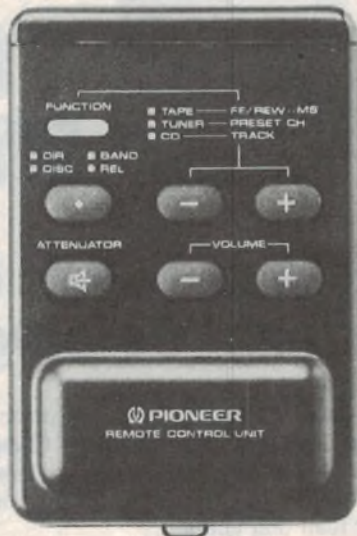

Above is the CDX-M100, which mounts in the boot. Below is the KEX-M700 dash-mounted tuner/cassette/command unit, with the remote control at upper left.



— the KEX-M700 or the DEX-M300.

The KEX-M700, a single DIN-sized unit controlling all three sources is an industry first and offers a high quality cassette deck and Quartz-PLL Super-tuner with an extensive array of desired features.

Alternatively, the DEX-M300 component Quartz-PLL Supertuner may be used to drive the Multi-Play Compact Disc unit. This model also features many of the benefits of the KEX-M700 with the added Detachable Controller facility.

## New graphic equalizers

Two new professional standard graphic equalizers, designed in Australia and manufactured in Taiwan have been released by Sydney based PA specialist,

Freedman Sound.

The Phonic PEQ-3300M and the PEQ-3400S incorporate features generally found on more expensive models

such as low noise, balanced input and output, 6 or 12dB selector switch, high pass filter and EQ by-pass switch. Both are 19" rack mount units.

Specifications are 6Hz to 85Hz frequency response; 0.01% total harmonic distortion; 1V/22k ohms input sensitivity; 1V/600 ohms output. Maximum output is 8.5V RMS and noise-for-band gain set at 0dB is 0.26mV, at -12dB is 0.4mV and at +12dB is 2.2mV. The PEQ-3300M is the mono model with 31 control frequencies between 20Hz and 20kHz. The PEQ-3400S is stereo and has 15 control frequencies between 25Hz and 16kHz on each channel.

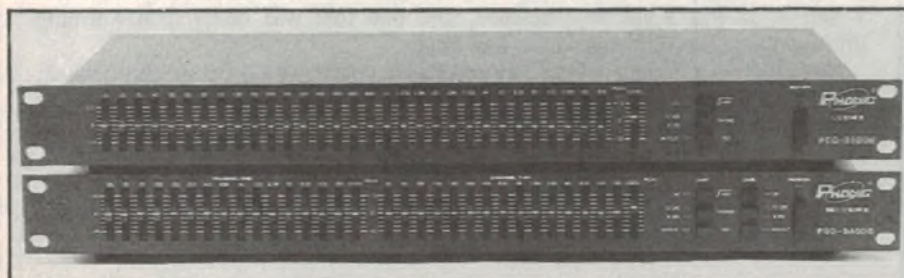



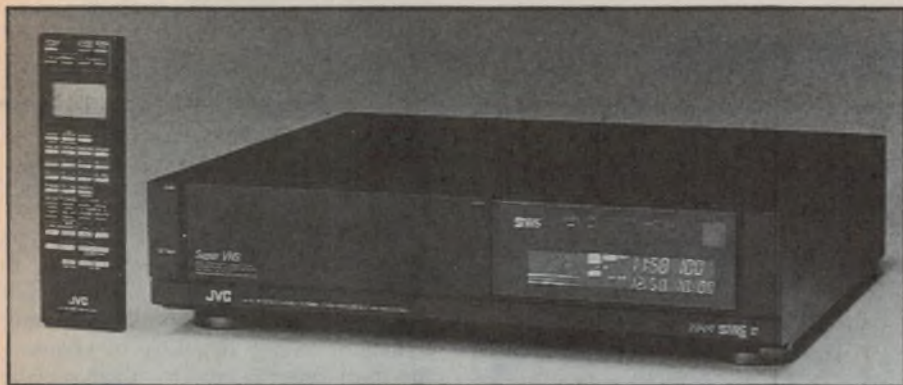

## JVC releases first S-VHS VCR in Australia

Super VHS delivers more than 400 lines of horizontal resolution, a dramatic improvement made possible by recording the luminance signal in a higher and broader carrier frequency band. An equally significant improvement in the S/N ratio has been achieved by expanding the frequency deviation and using a non-linear sub-emphasis system. And, for the best possible colour reproduction, Super VHS incorporates a separate luminance (Y) and chrominance (C) signal processing method to reduce interference between signal components.

The HR-S5000 features an open-out control panel that doubles as a cassette-slot cover and a thick acrylic window to protect the fluorescent display panel.

To ensure that none of the potential Super-VHS quality is lost, the HR-S5000 has a built-in wide bandwidth tuner capable of detecting a much wider range of video signal frequencies than

## DSE selling Sanyo Vision 8

Because most video recorders and players have been basically the same, Dick Smith Electronics has kept clear of the video market altogether until very recently. But now the company is selling the new Sanyo Vision 8 video system.

Weighing in at just 1.27kg and with a very compact design, the Sanyo Vision 8 Camcorder is claimed to be the easiest to handle video camera on the market today.

It provides 1/1500th second electronic shutter speed, giving extra sharp, crystal clear slow and still playback. A new high resolution image sensor allows camera operating illumination to be cut to as low as 9 lux.

With advanced Digital Auto Focus, backlight compensation, auto white balance, 6X zoom, macro that allows focus as near as 5mm, and manual focus se-

lection. And, for the best-possible picture quality in both the SP and the LP modes, a Super Double-Azimuth 4-Head (Super DA-4) combination video head system - based on JVC's tested and proven Double-Azimuth 4-Head (DA-4) system - had been incorporated. First-rate picture quality in VHS recording and playback is also ensured by HQ (High Quality) picture improvement circuits.

For the ideal audio counterpart to its Super VHS picture, the HR-S5000 offers top quality VHS Hi-Fi Stereo sound. Two rotary FM-audio heads combined with an advanced L/R channel independent switching noise reduction circuit provide sound reproduction that is vastly superior to conventional audio tapes.

The HR-S5000 can also function as an editing recorder of near-professional quality, incorporating a flying erase head for precise insert editing and the Zero Frame Editing system for assemble editing. An audio dubbing circuit is also provided.

lection, DSE claims that anyone can get superb quality images without fuss or bother.

To complement the Vision 8 Camcorder, Dick Smith Electronics also stocks the Sanyo Digital Picture VHS remote control video cassette recorder. This allows you to get up to nine frames on the one screen simultaneously, to zoom to a specific frame, add effects such as mosaic and picture paint, or watch the TV in one corner of the screen while a video plays in the rest.

Just to complete the picture, Dick Smith Electronics also carry the Sanyo Simple & Smart monitor look 34cm (14") colour TV.

The Sanyo Vision 8 Camcorder (Cat G-5200) retails for \$2499, the Digital VCR (Cat G-5100) for \$499. All are available through any Dick Smith Electronics store.

# HALF PRICE SEMIS!

What an offer: 6 of the most popular semis - at a HUGE saving. If you're a hobbyist, grab some for the junk box. If you have a service shop or lab, re-stock your parts drawers. You won't get better value than this - anywhere! All these components are brand new, prime spec devices - buy 5 and we'll give you another 5, or buy ten or more and we'll halve the bill. It's a great offer and it's exclusive to all Dick Smith Electronics stores this month only. (Offer also applies through DSXpress Phone or Mail Order Centre).

## 555 TIMERS

Cat Z-6145

60c Each or 10 for \$3.00

## 1N4004 DIODES

Cat Z-3204

10c each or 10 for 50c

## BC547's & 548's

Cat Z-1300

Cat Z-1308

20c Each or 10 for \$1.00

## BC327 TRANSISTORS

Cat Z-2240

35c Each or 10 for \$1.95

## TIP31B TRANSISTORS

Cat Z-2020

\$1.95 Each or 10 for \$9.75

**DICK SMITH**  
ELECTRONICS  
ALL STORES SEPTEMBER ONLY

# Entertainment Electronics

## New video tapes from JVC

JVC has released a new range of video tape claimed to meet a more individual need of users.

For every day use JVC's ER tape is available in five different lengths, ranging from 30 minutes up to four hours of recording. The ER tape has super fine magnetic particles with a BET value of 32m<sup>2</sup>/g and improved cassette mechanism and increased durability.

JVC's Super Pro, according to the company, "raises every performance parameter to previously unattainable levels". Featuring the JVC developed MBV (Multiphase Bari-Fero) emulsion that incorporates barium ferrite, Super Pro tape features perpendicular magnetising of ultra-fine magnetic particles. This is claimed to produce an ideal mix for complex signals used in video recording systems resulting in superior colour expression, improved edge and increased resolution.

Catering for the increase in



audio/video recording, JVC's Super High Grade Hi-Fi tape is said to combine the best in picture and audio reproduction. For those more intent on a superb video reproduction at an affordable price, then Super High Grade video tape, according to JVC, is the answer.

## TDK video tape grading

Choosing one grade of video tape from another is now easier thanks to TDK's new grading system. TDK felt that previously consumers were still finding it rather daunting in choosing the most suitable tape for their specific needs. Price had been the major yardstick in determining their tape selection.

In an effort to change this perception, TDK is endeavouring to raise consumer awareness in the different tape grades, and that the buying decision should not be based purely on price, but on quality and long term value for money.

With the recent release of a new video tape line up, TDK invented a totally new way of judging tape performances more accurately. Called "a Picture Purity Index" a numeric figure shows the differences in such properties as: luminance S/N, chrominance S/N (AM), and chrominance S/N (PM).

## Audio and video test tapes

Sydney audio components specialist Wagner Electronics has released a range of test tapes for both audio and video cassette recorders. The test on the tapes vary in complexity from a simple test of tape speed to everything necessary for the professional to align the record/playback heads.

The AAC9 is an Australian-made audio test tape for the hi-fi enthusiast and audio tradesman. A range of test can be performed without other test equipment or technical knowledge, the most useful one being a test of tape speed. The tradesman user is encouraged to use this tape so as not to risk damage of proper alignment and test cassette tapes. The first six minutes of the tape is a 1kHz sine wave, the next six minutes a 5kHz sine wave, then a 2.5kHz sine wave suppressed for 10 seconds every 10 seconds. Cost is \$19.95.

The LC Engineering range is a more advanced imported range aimed at the audio tradesman. Each tape is a master, not a duplicate, and each is individually produced, tested and numbered. There are six models which test head alignment, tape speed, signal-to-noise ratio and wow and flutter. They are priced from \$36 to \$39.95.

## SPECTACULAR RELEASE



\$799  
PAIR

**vifa**  
NEW SA-100  
SPEAKER KIT

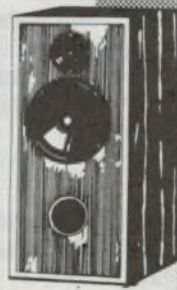

Since the introduction of VIFA speaker kits in Australia in 1985, thousands of speakers have been built with superb results. VIFA is now proud to release four new speaker kits ranging from a mere \$399 to \$1199 per pair including cabinets.

Never before have speaker kits been so popular in Australia than after the heavy devaluation of the dollar. Similar fully imported quality loudspeakers are today typically 2-2½ times more expensive. And these speakers may very well be using Danish VIFA drivers anyway, as VIFA supply more than 50 of the world's most respected loudspeaker manufacturers with drivers.

**But why the big savings?** Because fully imported speakers suffer from 25% import duty, 20-30% freight, 30% sales tax and 28% handling charges (typically). So if you would rather put your money into better quality than in other people's pockets, VIFA speaker kits are the only way to go.

**Are they difficult to build?** No, the kits

are supplied with all parts needed including fully built crossovers and pre-cut flatpack cabinets ready to assemble. No soldering or carpentry skills are needed, just a Phillips head screwdriver, some simple hand tools and a few hours of your leisure time.

**Are they as good as people say?** Read the reviews, listen and compare with any other speakers twice the price or more. Need we say anymore?

**VIFA for the quality conscious audiophile.**

For full details please contact  
Sole Australian Distributor:

**SCAN AUDIO Pty. Ltd.**  
P.O. Box 242, Hawthorn 3122.  
Fax (03) 4299309  
Phone: (03) 4292199 (Melbourne)  
(02) 5225697 (Sydney)  
(07) 3577433 (Brisbane)  
(09) 3224409 (Perth)

Stocked by leading stores throughout Australia

## system

According to TDK the "Picture Purity Index" method is not only more accurate, but the results are more understandable than any other simplified measuring system for consumer video tapes on the market.

To understand the PPI classification the three basic measures of video tape picture quality are thus defined:

1) luminance S/N; a measure of picture brightness and sharpness.

2) chrominance S/N (AM); a measure of video colour saturation and colour vividness.

3) chrominance S/N (PM); a measure of colour trueness and is often referred to as tone fidelity or hue.

The PPI = (1) x (2) x (3) x 100

These measurements are compared to TDK's new reference tape.

From the table you can see that TDK's new HS has a PPI of 119 and its HD-XPRO has a PPI of 266. TDK further claims that at a glance consumers can see the major differences between

### ● "Cubic" Comparison of Picture Purity

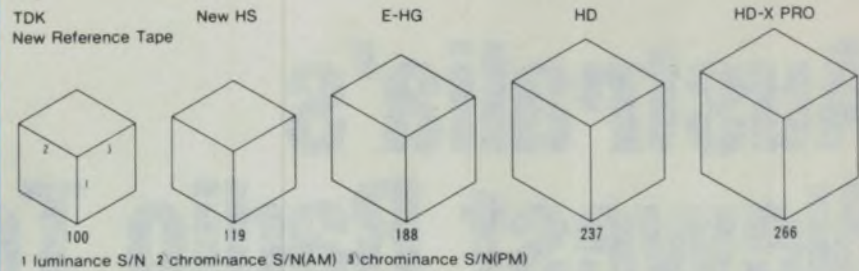

### ● Picture Purity Indexes for TDK Video Cassette Tape

Tape	TDK New Reference Tape	New HS	E-HG	HD	HD-X PRO
Picture purity factor					
factor 1					
luminance S/N (brightness picture sharpness)	0dB (x1.0)	+0.5dB (x1.06)	+2.0dB (x1.26)	+3.0dB (x1.41)	+3.5dB (x1.50)
factor 2					
chrominance S/N(AM) (color saturation vividness)	0dB (x1.0)	+0.5dB (x1.06)	+2.0dB (x1.26)	+2.5dB (x1.33)	+3.0dB (x1.41)
factor 3					
chrominance S/N(PM) (hue tone fidelity)	0dB (x1.0)	+0.5dB (x1.06)	+1.5dB (x1.19)	+2.0dB (x1.26)	+2.0dB (x1.26)
Picture Purity Index 1 x 2 x 3 x 100	100	119	188	237	266

each tape grade. This simplified method of determining the differences in tape grades should help in the choosing of a

tape such as for the recording of a cricket match or the demanding applications as original mastering.

# It takes everything but your pulse.

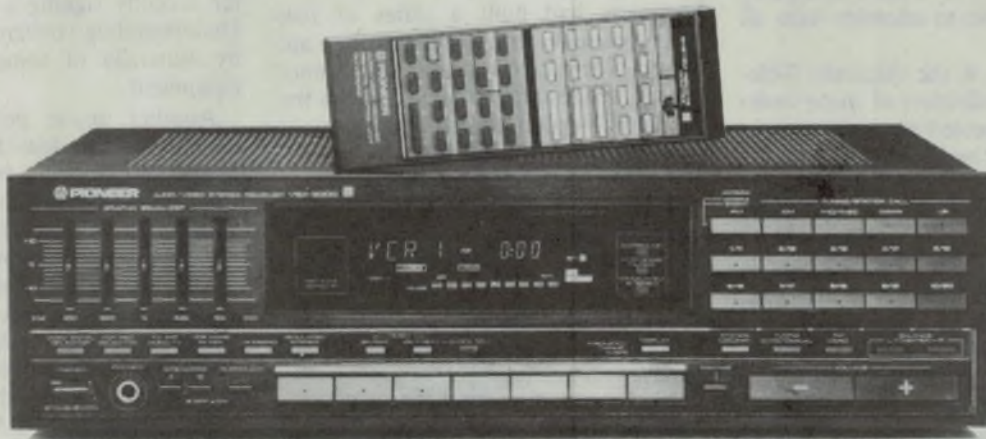

Pioneer  
VSX-3000

And your heart will beat a little faster when you experience the flexibility and performance of the Pioneer VSX-3000.

With inputs for VCR1, VCR2, Video Disc Player or VCR3 (Playback only) Tape Deck, Turntable and CD Player it gives any audio/visual system a new lease of life.

#### Other features include:

- Simulated Surround Sound

- Comprehensive VCR (dubbing) facility
- Sleep Timer
- VCR Noise Filter to reduce tape hiss on Video Playback
- Simulated Stereo for Mono VCR and AM radio reception
- 5 Band Graphic Equalizer
- 20 Station Preset Digital AM/FM Tuner

- Comprehensive Infra-Red Remote Control, including SR Remote for control of other Pioneer Components.

**The Pioneer VSX-3000. It's the perfect heart for a comprehensive audio/visual system.**

**PIONEER®**

**Pioneer VSX-3000 Audio/Video Quartz-Synthesizer Receiver** ● Continuous power output 60W + 60W (8 ohms, 20-20,000 Hz, THD 0.05%) ● Full-function "SR" remote control: Operates Pioneer audio and video equipment with "SR" logo ● 3 video inputs ● 5 band graphic equaliser ● "Matrix" surround sound ● Simulated stereo for mono programs ● Two FM antenna inputs for presetting antenna input (broadcast or cable) for each station ● Audio noise filter ● Video signal selector for independent audio and video switching ● Random preset of 20 FM/AM stations ● Fluorescent display ● Clock, programmable timer, sleep timer.

**Local hi-tech electronics at heart of**

# Australia's Newest Radio Telescope

On September 2nd at the Paul Wild Observatory in the NSW country town of Culgoora, west of Narrabri, the Australia Telescope will be officially declared "open for business". This will usher in a new and exciting era for Australia's radio astronomers, because this \$50 million facility is a radio telescope *par excellence*, designed to satisfy their research needs into the next century. And for its successful operation, the astronomers will rely heavily on hi-tech electronics designed and manufactured locally.

by **DR JOHN B. WHITEOAK**

Australia Telescope Project Secretary

The Federal Government finally approved the Australia Telescope project in November 1983, giving CSIRO Division of Radiophysics the responsibility for its construction. After September the Division will host the telescope, which will operate as a national facility available, on merit, to scientists from all over Australia.

What precisely is the Australia Telescope? It is a collection of eight radio dish antennas, located at three sites in NSW, which will be linked in two basic configurations - the Compact Array (CA) and the Long Baseline Array (LBA). The first, which has risen like a phoenix from the "ashes" of the famous but retired radioheliograph at the Paul Wild Observatory, consists of six new 22-m dish antennas. Five of these can be moved along a 3-km east-west rail-track to any of 35 observing "stations". The sixth antenna is located on a small rail-track with only two stations, a further 3km to the west.

For observation each antenna is set (to an accuracy of a few millimetres) on to one of these stations. By varying the selected stations between observations, the distances between antennas can be varied.

The other configuration, the LBA, is formed by using the CA antennas together with a seventh 22-m antenna constructed at Mopra, a few kilometres

west of Coonabarabran, (and very close to Siding Springs) together with the famous Parkes 64-mm antenna, 320km south of Culgoora.

## Why an array?

During the 1960's Australian radio astronomers had built a series of fine radio telescopes, and although they are still providing useful results they cannot provide images of radio sources with the fine detail needed to solve many current astrophysical problems (such as the nature of the centre of our galaxy).

Generally speaking, the larger an antenna, the finer the detail discerned. A single antenna cannot be built large enough to provide the detail that astronomers now require, but this detail can be achieved using several linked antennas.

Using a technique (called "earth-rotation synthesis") that Australian radio astronomers developed for observations of the Sun during the 1950s, astronomers can produce radio source images with the same detail achievable by a single antenna with a diameter equal to the maximum separation between pairs of antennas in the array. Ideally, the technique requires a large range of spacings between individual antennas, and long periods of observation. The six antennas of the CA provides 15 spacings at any instant, and full simulation

of a 6km antenna requires many changes of antenna positions.

The 6km CA will "see" detail 100 times finer than with the Parkes telescope alone, while detail 50 times finer still will be possible with the LBA. And in the future even finer detail will be observable. The Australia Telescope will be linked with other antennas around Australia, in other countries, and even in orbit, to form giant arrays with maximum spacings of thousands, even tens of thousands, of kilometres.

Test observations combining ground-based and orbiting Tracking and Data Relay Satellite System (TDRSS) antennas have already proved successful, and some time ago the USSR initiated a project, RADIOASTRON, to launch a 10-m antenna into space by 1992. Along with other countries, Australia has joined in the project, the Prime Minister recently signing a Memorandum of Understanding concerning the provision by Australia of some of the antenna equipment.

Another space project, QUASAT, concerning the launch of a 15-m antenna by 1996, is being planned by overseas space agencies, and Australia will play a key role in providing southern hemisphere antennas.

The fine detail achievable with such arrays should provide considerable insight on "black holes", those elusive massive objects believed to dominate the dynamics near the centre of galaxies, and triggering the large distributions of radio emission associated with some objects.

## The new antennas

The CSIRO Division of Radiophysics, working in conjunction with local consultant engineers Macdonald Wagner, produced cost-effective designs for the new 22-m antennas. The Culgoora antennas have a large azimuth slewing ring with widely separated elevation bearings, an intermediate mounting of open



**The five closely-spaced dish antennas at Culgoora, nearing completion. When finished and operational they will be deployed along 3km of tracks, with a sixth dish 3km further west.**

trusswork, a stiff backup structure, and a heavy base equipped with bogeys. For the Mopra antenna, which is not mobile, a simpler "wheel-on-track" design was adopted.

The reflecting surface contains four rings of solid panels and two of perforated panels. The Division developed a simple, low-cost method of panel construction which has produced solid panels accurate to 0.15 mm. The antennas were fabricated and erected by one-time Brisbane shipbuilding firm Evans Deakin Industries, in a \$15 million contract.

The experience gained from the antenna design has already been used to support Australian industry - in the design of two 18-m earth-station antennas that Johns Perry Ltd of Adelaide recently constructed for OTC.

### **Wavelength bands**

The project budget will provide for operation in wavelength bands near 20, 11.6 and 3cm (1.5, 2.7, 5 and 10 GHz). The beamwidth scales with wavelength, and for the Compact Array the smallest (at 3cm) will be 0.8 second of arc. This is about the same as the reso-

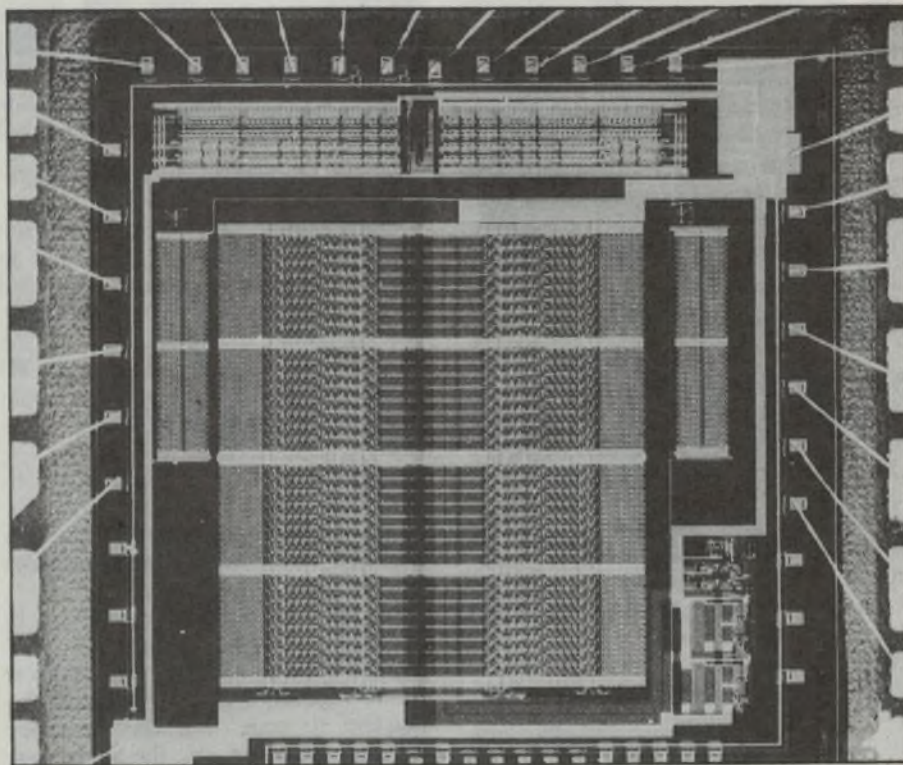

**A close-up of one of the correlator chips used in the Australia Telescope correlator. Thousands of these Australian-made chips are used, each containing nearly 50,000 transistors.**

# Radio telescope

lution of Australian optical telescopes during good observing conditions, and is equivalent to reading a telephone directory from a distance of 200 metres. The wavelength range will be expanded later to include other bands between 90cm and 2.6mm.

The bands were selected not only to enable the "continuum" emission spectrum of radio sources to be sampled at approximately octave intervals, but also to include the discrete, narrowband signals from important atoms and molecules in the interstellar medium.

## Receiving systems

Special wideband feedhorns, also developed at the Division of Radiophysics, enable simultaneous dual-polarization operation at 20 and 13cm, and at 6 and 3cm. Each horn feeds two pairs of low noise FET amplifiers (one pair for each wavelength band) which are housed in a single Dewar and refrigerated, using helium gas, down to  $-263^{\circ}\text{C}$ . The feedhorns and associated amplifiers are set in a rotatable turret, set off-axis near the Cassegrain focus at the centre of the main reflecting surface; an appropriate rotation sets the required system on-axis.

At Culgoora the four outputs per antenna, each of bandwidth 256MHz, will be digitized at 512Mbaud and sent through optical fibres to a control building; use of conventional coaxial cable for this purpose would have degraded the bandwidths. For the more remote antennas the signals will be recorded on special wideband tape recorders and processed after at Culgoora. For a typical observation of four 12-hour periods, the final images will have a low noise level of about  $1.5 \times 10^{-28} \text{ W m}^{-2} \text{ Hz}^{-1}$ .

## Correlators

The IF signals reaching the control building from the antennas will be processed in large correlators. The correlator is the heart of the entire Australia Telescope operation – it not only has to correlate the signals from pairs of antennas, but also must provide outputs with a wide range of resolution in frequency. These requirements imposed considerable constraints on the initial correlator designs, and a successful design was possible only because a suitable Very Large-Scale-Integration (VLSI) chip was developed by the Division of Radiophysics. The chip, a mere 5mm across, contains nearly 50,000 transistors. Several thousand were fabri-

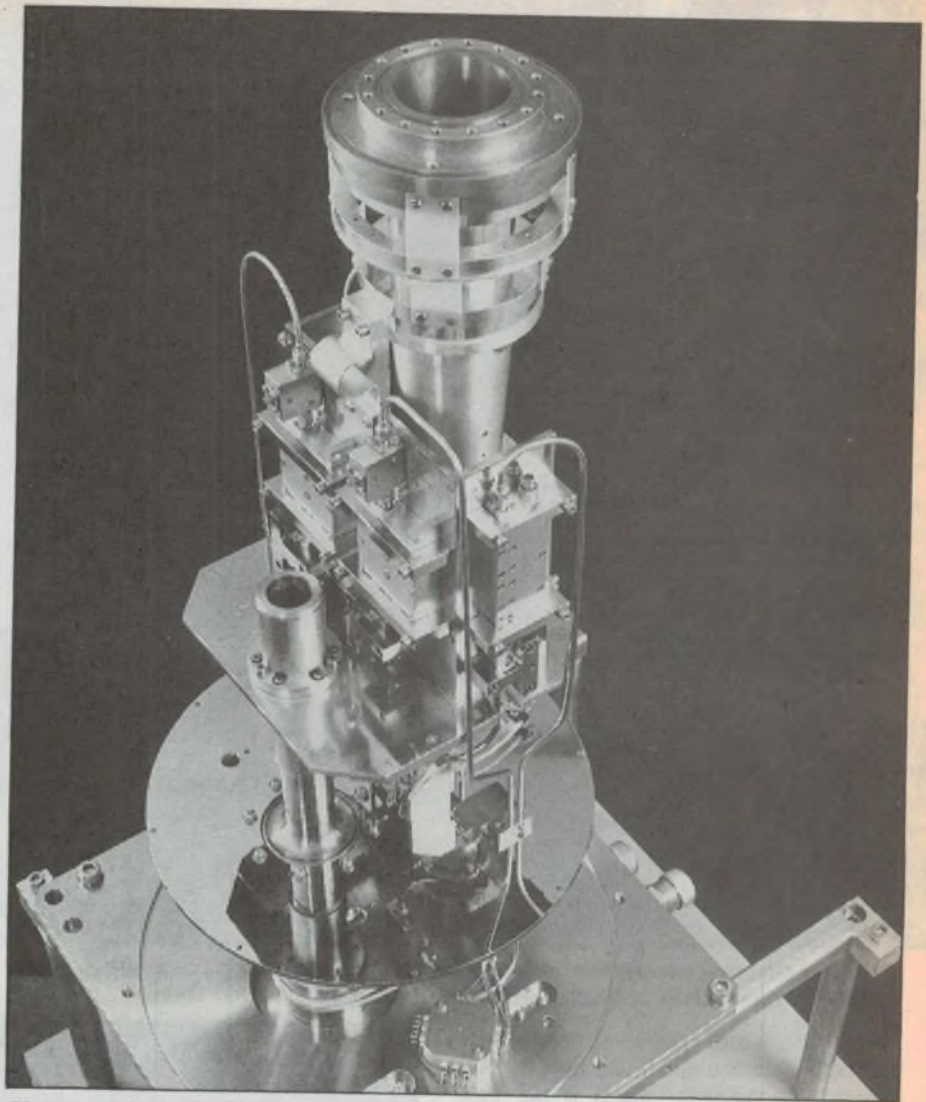

**Above:** a view of the low-noise C/X-band receiver. The wide-band feed horn is at the top. **Right:** sites used for the Australia Telescope.

cated for the project by Austek Microsystems of Adelaide.

Manufactured by the 2.5-micron HMOS process, each chip operates at 16MHz. Correlator boards equipped with 16 chips provide up to 1024 correlator channels, at input rates of 256 megabits per second. More than 300 boards will be needed for five separate correlators – three at Culgoora (one each for CA wideband continuum, CA narrowband spectral-line, and LBA observations) and individual units for Parkes and Mopra to support single-dish operation when these antennas are not required for LBA operation.

The spectral options vary from 18 channels covering 256MHz, to 8192 channels covering 0.5MHz. The smallest channel separation of 60Hz is more than adequate to cope with the frequency structure observed in the narrowest maser spectral lines in the interstellar medium.

## Computer networks

Extensive computer systems are required for the facility. Two VAX 8200 computers are located in the Culgoora control building. One (the "synchronous" computer) is responsible for all tasks synchronised to both the array control and the data sampling as set by the correlators; the other (the "asynchronous" computer) controls the data collection, the preliminary processing, and the data recording on magnetic tape.

An extensive data reduction centre has been developed at the Radiophysics headquarters in Epping, Sydney for production of images and for further image processing activities. The main processor in this network is a CONVEX C-210 mini-supercomputer.

## Summary

The Australia Telescope is a fine tribute to Australian expertise – it was con-

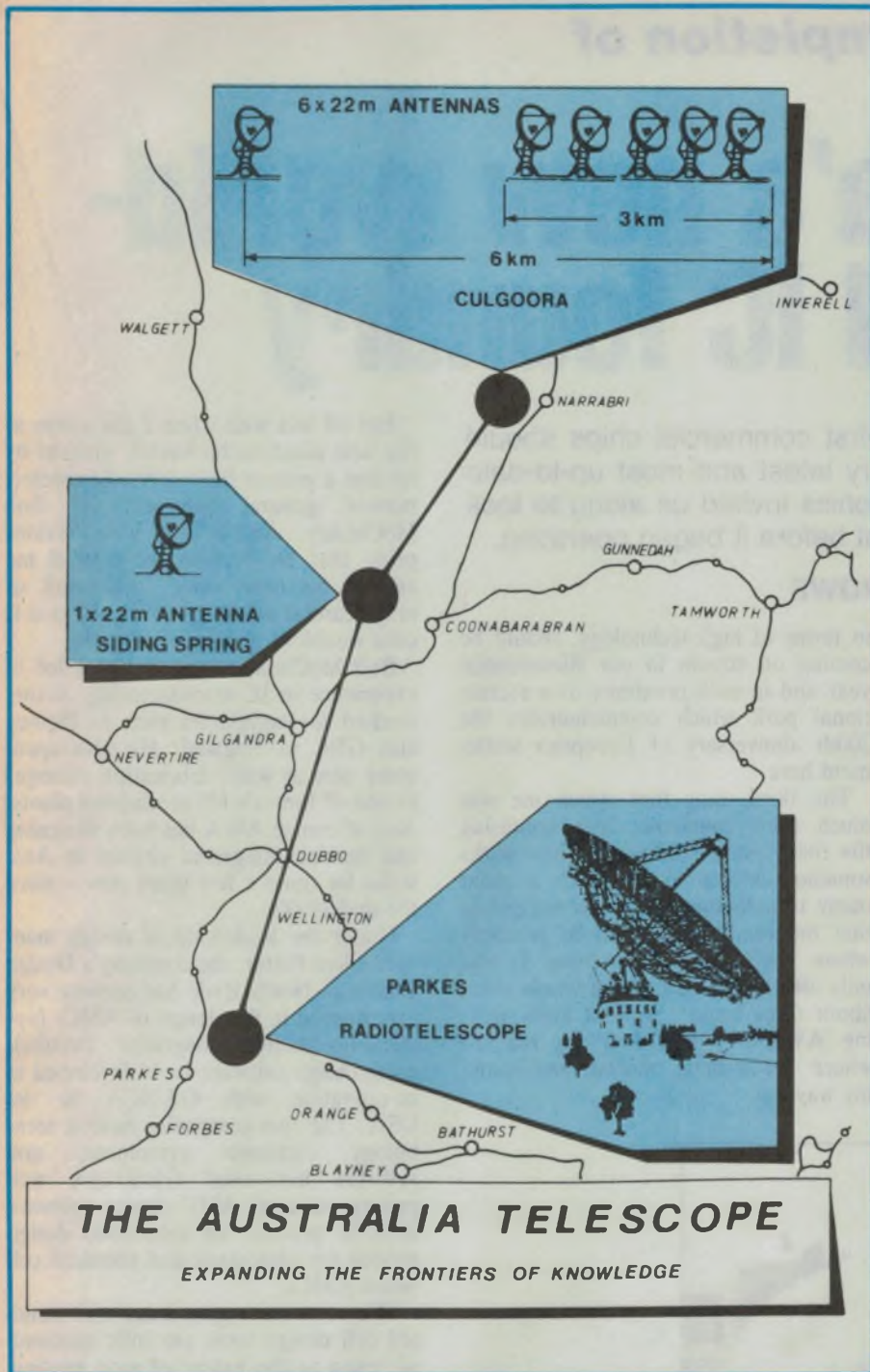

ceived, designed and constructed by Australians, with over 80% local content.

With this instrument Australia's radio astronomers face a rosy future; once again they will be able to compete, on equal or better terms, with overseas radio astronomers. Moreover, their instrument will complement the new generation of telescopes (both orbiting and ground-based) operating at other wavelengths.

Most important of all, the Australia

Telescope is the only instrument of its type in the southern hemisphere. Northern telescopes, no matter how elaborate, cannot reach much of the southern sky, and miss out on many of the unique objects located there.

It will take some time for the Australia Telescope to reach its full potential. However, there is little doubt that this instrument will play a leading role in radio astronomy for many years to come.

## Coming next month in Electronics Australia

### Multi-purpose preamp module

Here's a preamp module with uses limited only by your imagination. You can wire it up as a mic preamp, as a magnetic cartridge preamp, to boost the output from a tape deck, to provide some special equalisation or filtering, as a mixer input channel module – you name it. It's low cost and easy to build, too!

### 16-tune doorbell

Tired of hearing the same old "Ding-Dong" when people press your doorbell? Here's an easy to build electronic doorbell circuit which will play your favourite from a selection of 16 familiar tunes – or come up with a different one at random, every time.

### Using your PC as a function generator

There's no need to panic if you need a signal with a special waveform – use this simple D-to-A adaptor to turn your personal computer into a programmable function generator. It's much simpler and cheaper than a dedicated instrument...

*\*Note: although these articles have been prepared for publication, circumstances may change the final content of the issue.*

**AWA nearing completion of**

# Australia's new world-standard IC foundry

By the time you read this, the first commercial chips should be emerging from Australia's very latest and most up-to-date silicon foundry. AWA Microelectronics invited us along to look over its impressive new plant, just before it began operating.

by **JIM ROWE**

Three things struck me as I neared AWA Microelectronics' brand-new production plant in the western Sydney suburb of Homebush. One was that the new industrial park in which it's located reminded me a lot of Silicon Valley in California, where silicon chips were first produced. Nicely planned, with plenty of trees and parking lots set back from the road to create a pleasant working environment.

The second thing was that the AWAM plant is literally only a stone's throw from the recently dedicated Australian Bicentennial Park. It seems somehow appropriate that this new world-class silicon foundry, signifying in many ways Australia's 'coming of age'

in terms of high technology, should be coming on stream in our Bicentennial year and in such proximity to a recreational park which commemorates the 200th anniversary of European settlement here.

The third thing that struck me was much more mundane: how confusing the road system through the new parks somehow seems to be, with a great many roundabouts and signs suggesting that the road ahead leads to precisely where you've just come from. It was only after going around the whole maze about three times - without even sighting AWAM - that I finally realised where I was being misled, and found my way out.

But all was well when I did arrive at the new plant, to be warmly greeted by no less a person than AWA Microelectronics' general manager, Dr Bob McCluskey. And it was with obvious pride that Dr McCluskey showed me around his new 'baby', the result of much careful planning and based as it is on a wealth of existing experience.

Bob McCluskey himself has a lot of experience in IC manufacturing, having worked for companies such as Plessey and GEC in England. He also spent some time as wafer fabrication manager in one of Inmos's US production plants. And of course AWA has been designing and making integrated circuits in Australia for quite a few years now - since the mid 1960's.

Under the leadership of design manager Clive Potter, the company's Design Centre in North Ryde has become very experienced in the design of ASICs (application-specific integrated circuits), using design software tools developed in co-operation with GE/RCA in the USA. The two companies have a technology exchange agreement, and AWAM has used GE/RCA's well proven suite of ASIC design software tools to produce an automated design service for gate array and standard cell based ASICs.

The company's gate array and standard cell design tools are fully automated, even to the extent of auto routing. They are also capable of coping with very complex architecture, a feature which recently won AWAM an important OTC contract.

The performance of analog circuits and logic cells can be simulated during the design phase with SPICE and RCAP analog circuit simulators, running on AWAM's VAX11/785 computer. Because the simulation software works at the gate level, it is particularly fast and cost effective.

The graphics for chip layout are designed using a Calma GDSII interactive system, which includes design rule

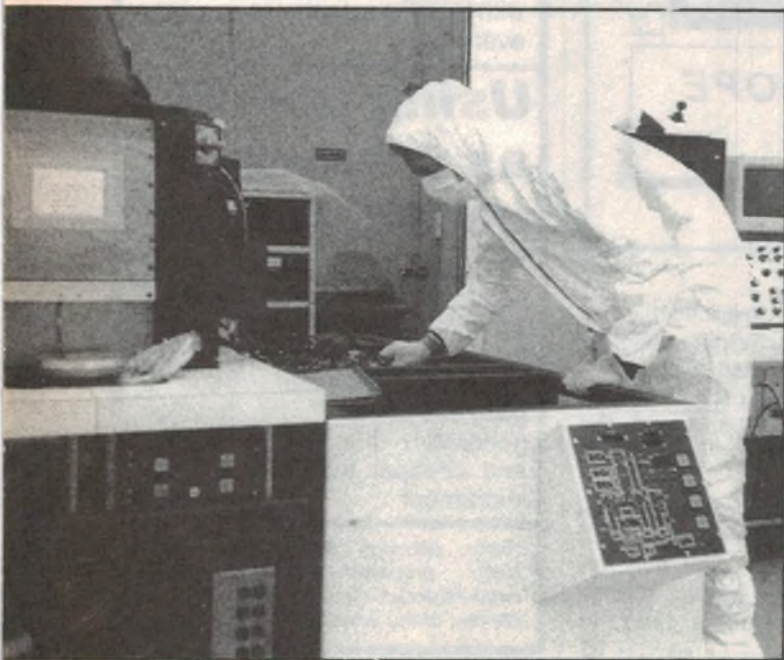

**Assembly and checkout of the Cambridge Instruments EBMF 10.5 electron-beam mask fabricator, capable of writing details down to 0.1 micron.**



checking and pattern generation software.

Similarly AWAM has been fabricating chips and assembling devices for many years at Rydalmere, a few kilometres away, in a plant originally used for valve manufacture and converted for semiconductor fabrication in 1964. Fabrication technologies covered at the Rydalmere plant include bipolar, metal gate and silicon gate CMOS, NMOS and CMOS-bipolar mixed technology, using 3" diameter wafers and 4 micron design rules (0.5 micron registration). Processes available have included ion implantation, epitaxy, diffusion and plasma etching.

The new Homebush facility is for the first time bringing all of AWA Microelectronics' design, fabrication and assembly operations together under the one roof. At the same time it represents a dramatic upgrading of the company's fabrication technology, making it by far the most modern in Australia - and of current world standard.

Actually the new production facility is the result of a joint venture formed in 1987 between AWA, British Aerospace Australia and the New South Wales Investment Corporation, with AWA having the controlling interest. The joint venture partners have initially invested some \$35 million in the plant, while a further \$30 million is to be invested over the next few years.

### Initial impressions

Perhaps the thing that impressed me most initially about the new plant, as Bob McCluskey showed me through, was the air conditioning and filtering system. Someone once said that modern semiconductor plants were basically very large, complex and expensive air conditioning/filtering systems, with a small factory hidden deep inside - and that certainly seems true here again.

As the Homebush plant has been designed with sub-micron fabrication in view, its air conditioning and purification system is designed to meet the highest possible standards achievable with current technology. The specification for the wafer fabrication area called for Class 10 air purity, defined as less than 10 particles of 0.5 micron size per cubic foot of air. The target they were hoping for was even more stringent: less than 10 particles of 0.2 microns.

What is the figure they've *actually* achieved? It was the obvious question, of course. With great delight, Bob McCluskey informed me that the initial figures have turned out to be an amazing 1 particle of only 0.1 micron size per

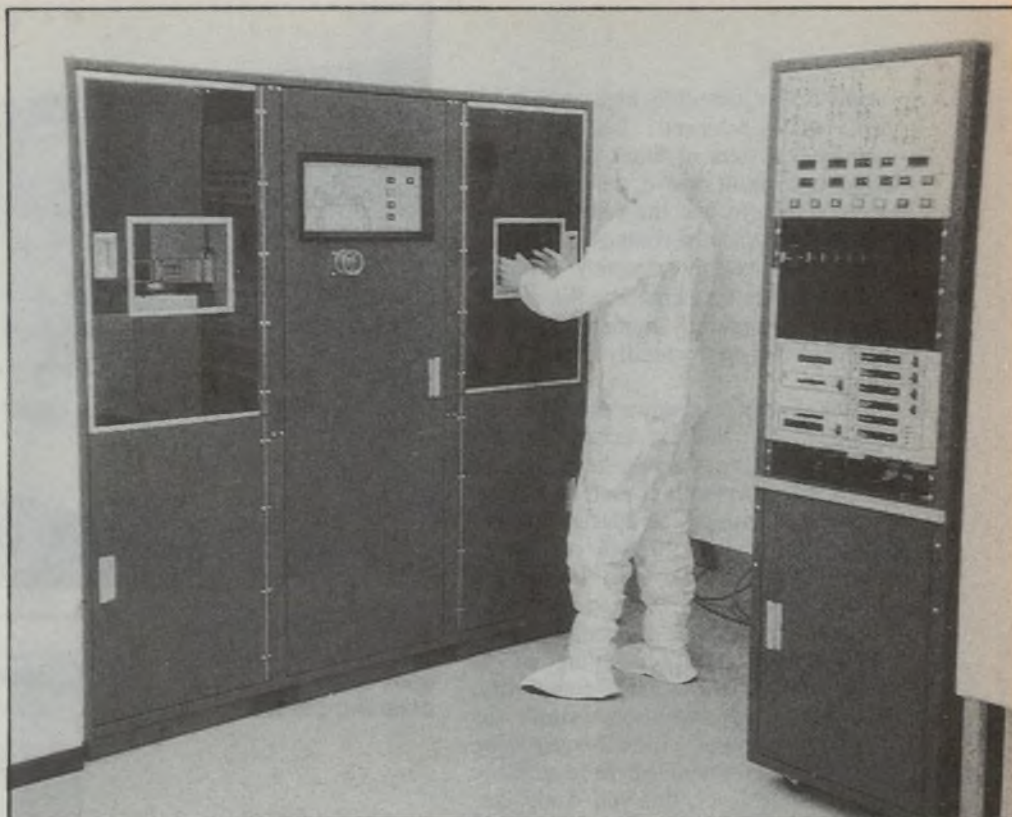

**The operating side of the Eaton 6200 ion implanter, which can operate at current levels up to 2mA (at 200kV) when implanting dopants such as boron into the silicon wafers.**

cubic foot - almost two orders of magnitude better than the specification!

This is particularly impressive when you consider that the size of a typical virus particle is around 0.1 micron. The figure above is also only an initial reading, before all equipment was installed in the clean room and normal control procedures could be adopted. The final

operating figure would normally be expected to be somewhat better again.

For comparison, the now rather outmoded but still functional Rydalmere fabrication facility has an air purity rating of Class 10,000 - meaning 10,000 particles of 0.5 micron size per cubic foot. Positively grubby, by comparison with Homebush!

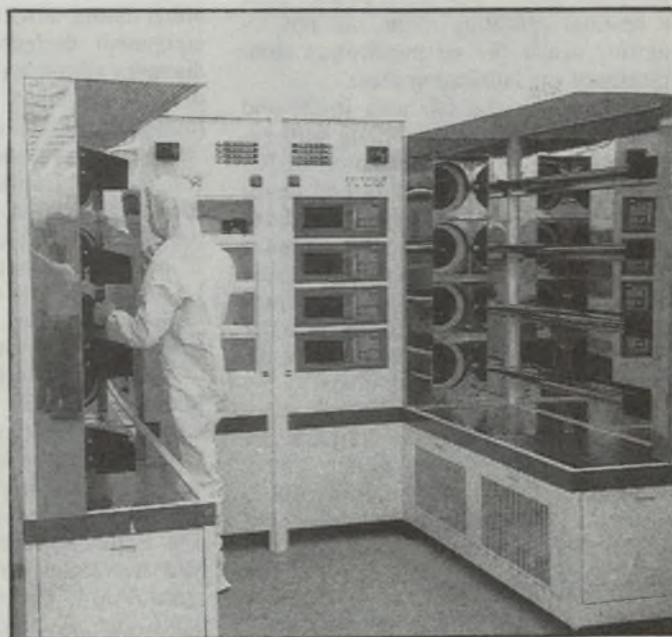

**Two of the diffusion furnace bays being installed. There are three bays in all, each with four compact cylindrical furnaces.**

How is this incredibly high level of air purity being achieved? Basically by a very fancy system of filters and recirculating fans, built above the fabrication area ceilings. In fact the ceilings of this area are completely composed of filter modules, delivering extremely clean air into the rooms concerned at the rate of 90 feet per minute – enough to change the air in the rooms totally every 6 seconds.

After moving downwards from the ceiling filters, the air exits from the rooms via openings along the bottom of the enclosing walls. It is then sucked up by the fans through the spaces between the walls, to pass through pre-filters, cooling coils and back down through the ceiling filters again.

Bob McCluskey took me up into the area above the fab area ceiling, to get an idea of the system's complexity. Most of the fans and filters weren't visible, being enclosed in the 2-metre deep space between where we were and the actual ceiling level, but you could certainly get a good idea of the complexity of the system. I found it very impressive indeed.

Approximate cost of the air conditioning and purification system for the Homebush plant's fab area is around \$3 million – extremely pure air doesn't come cheap! The assembly area of the new plant doesn't need to be nearly as critical as the wafer fab area, by the way, because when the wafers reach this area the chips on them are complete and passivated. The specification calls for Class 1000 – still much cleaner than a hospital operating room, but not requiring nearly the air purification complexity of the fabrication area.

But back to the fab area itself, and other points of interest. Along with extremely pure air, the fabrication of ICs also requires incredibly pure and de-ionised water. So the new Homebush plant also has a very fancy Permutit water purification plant, which takes Sydney's ordinary tap water and processes it at the rate of 20 gallons per minute through a complex system of ordinary and reverse osmosis filters.

The final pure and 'polished' water that emerges has less than 0.5 parts per million of total solid impurities, and a resistivity of 18 megohms. In other words, it's not only extremely pure, but an excellent insulator.

## Fab equipment

What of the hi-tech semiconductor

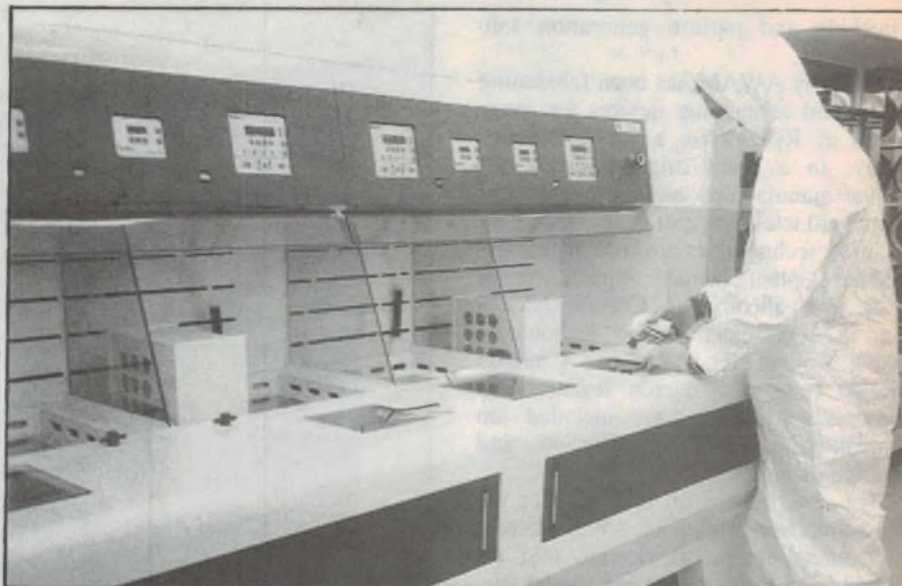

**Above: one of the four Ultra Fab Technology semi-automatic wafer cleaning benches.**

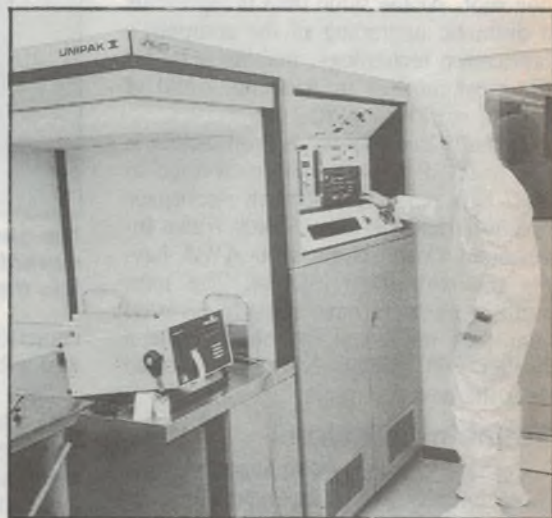

**Right: Setting up the Cambridge Instruments Unipak X epitaxy reactor, which has been modified to take 6-inch wafers.**

fabrication equipment that goes inside this ultra-clean fab area? Well, it's all either brand new, or newly refurbished equipment designed to work with 6" diameter silicon wafers, and to an initial process technology level of 1.5 microns (minimum feature size).

The epitaxy reactor is a Cambridge Instruments Unipak X, with a Hugel 35kW RF generator. This was originally designed to work with multiple rows of 2" wafers, but recently rebuilt in the USA to work with 6" wafers.

There are three Tytan diffusion furnace bays, each with four furnace tubes – a total of 12 separate furnaces. The furnaces are new and very compact units, rather shorter than earlier types.

A single Eaton 6200 ion implanter is being installed initially, with a second unit planned for installation in 1990. The Eaton is a 'medium current' unit, with the ability to run ion beam currents of up to 2mA when implanting dopants such as boron. It uses a 200kV

power supply.

For printing the wafers with the various etching/implantation patterns, there's an ASM (Advanced Semiconductor Manufacturers) PAS 2500/10 printer, the very latest type with the best specs currently available. Heart of the printer is the 5:1 reduction lens used to image onto the wafers from the masks, which is designed to give a resolution down to 0.8 microns. This kind of precision doesn't come cheaply either – the lens itself has a five-figure price tag.

The PAS 2500/10 is also fully computer controlled, with all wafers bar-coded so that they are tracked through the various fabrication steps to avoid errors. Since wafers pass back through the printer a number of times (once for each fabrication process), this is quite important.

The AWAM fab facility is designed so that the wafers are coated with photoresist in very close proximity to the printer. This allows them to be printed

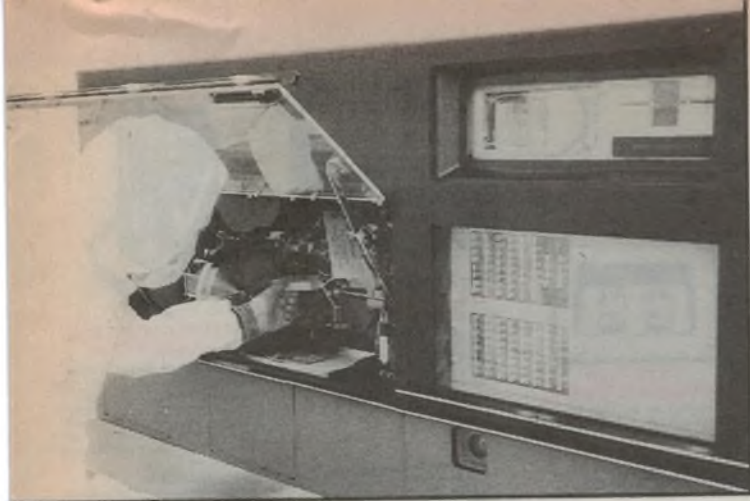

**Left: Operating side of the Varian 3280 metal sputtering unit, used for applying metallisation to the wafers.**

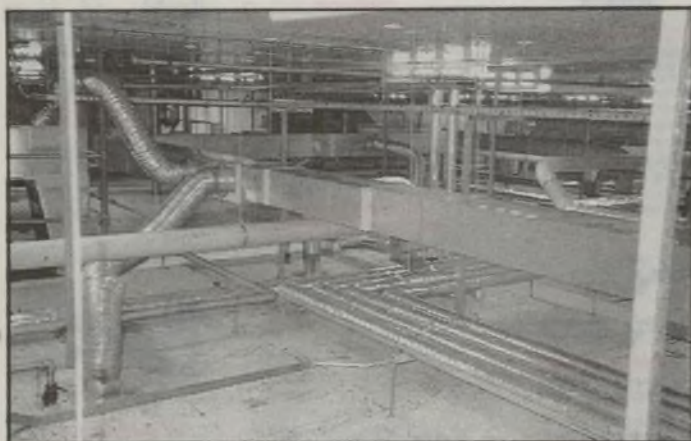

**Right: A view inside the space between the roof and the fan/filter layer, above the fab area – to give an idea of the facility's air conditioning system.**

within 1 hour of coating, to ensure the most controllable results.

The printing masks themselves are made on a Cambridge Instruments EBMF 10.5 (electron beam mask fabricator). This is the very latest type again, and has the ability to write details down to around 0.1 micron. It also has the ability to write directly to wafers, if this is desired in the future or for short runs. Almost as impressive as the performance of the EBMF is its price: over \$3 million!

Other items of interest in the fab area include a Varian 3280 metal sputtering unit, for wafer metallisation, and three LAM Research plasma etchers – dedicated respectively for etching metal, oxide and polysilicon. There are also four Ultra Fab Technology semi-automatic wafer cleaning benches.

Overall design of the new fab facility (including the clean room itself) was carried out by AWAM's own engineers, headed by process technology manager Vladimir Svoboda and wafer fab manager Andrew Brawley.

All in all, the new facility is initially well equipped to produce double metal CMOS wafers with feature sizes down to 1.5 microns, at the rate of around 500 of the 6" wafers per week.



**One of the three LAM Research plasma etchers used in wafer fabrication. One is used for etching metal, the other two for oxide and polysilicon respectively.**

Outside the fab area, wafers will be tested on AWAM's spanking new Trilium "Validmaster" test system. This cost a cool \$2 million, and has two testing heads capable of checking out device performance at a rate of 60MHz. One head will be used for wafer testing and the other for final testing of packaged devices.

From testing they will move into the assembly area, to be sliced into chips and mounted into packages. Wafers will be sawn into chips on a Disco precision wafer saw, and the chips bonded into packages using either three new Kulicke

and Soffa 1419 autobonders or a Mech-EI unit (for ceramic packages).

The K & S bonders each have the ability to handle 600 chips per hour, while the Mech-EI can handle 500 per hour. So the total bonding capacity will be around 2300 chips per hour.

In the case of most of AWAM's products, which are likely to be relatively low-volume ASIC devices, the final package is likely to be of the metal/ceramic type. However the company is also installing a Kras plastic moulding press, and will therefore be able to offer lower-cost plastic packages in the common 14, 16 and 18-leaded DIL formats, as well as the larger 68- and 84-pin PLCC (plastic leadless chip carrier) formats. But the emphasis will still be on small to medium runs. For runs of greater than 10,000 pieces they will generally arrange for assembly and packaging to be done overseas at larger plants (typically Singapore).

This underlines AWAM's overall strategy in planning the new Homebush facility, which has been to produce a world class, state of the art ASIC design and manufacturing centre geared to the needs of the Australian electronics industry. The idea is to concentrate on specialised market areas such as communications, defence and services – the same areas which offer the best opportunities for local equipment makers.

As AWAM's marketing manager Toby Cross stressed, "We're not in the business of making jellybean devices. But for designing and making ASICs and things like proofing of new designs, we can now offer facilities equal to those you'll find anywhere."

When I went through the new plant, installation of its production gear was well advanced. The first runs of commercial silicon should be emerging about the time you read this story, all going well.

What is planned for the existing Rydalmere production facility? Toby Cross explained that this will be run in parallel with the new Homebush facility, until the latter is fully operational and achieving its potential. Then it will be phased down, with existing product lines transferred to Homebush. Current estimates are that this will take place early next year.

Of course all of the existing North Ryde design centre facilities will be transferred to Homebush, as soon as the fabrication plant is operational. The existing VAX11/785 computer will be augmented with a MicroVAX II ma-

*continued on page 141*



**PASSIVE INFRA-RED DETECTOR (WP-800)**

**FEATURES:**

- Walk test LED indicator
- Wall/corner/ceiling mount
- Micro switch tamper proof protection
- 24 detection beams in 3 different ranges
- N.C. silent S.P.S.T. dry relay contact output
- Alarm auto reset approximately 3 seconds after triggered
- Superior RFI immunity protection
- Extremely low power consumption
- Adjustable mounting bracket
- Easy installation - easy adjustment
- Dual element - low noise, high signal to noise ratio pyroelectric
- Detection degree indicator
- D.C. 8-16V power operating

S15079 ..... **\$89.95**



**10W HORN SPEAKERS**

White durable plastic 8 ohms

Cat. C12010 Normally \$11.95  
1-9 ..... **\$7.95**  
10-9 ..... **\$6.95**



**PIR FLOODLIGHT**

A perfect all night security device with dual element Passive Infra Red sensor. All weather outdoor operation. Features off automatic test and manual on at your wall switch. Complete with wall mounting bracket, cable terminations and instructions.

**SPECIFICATIONS:**  
Detecting Range: minimum 6 to 15 metres with variable control.  
Detecting zones: 5 at 15° short 12 at 8° medium 12 at long range  
Preset time: From 1 to 20 minutes with manual override

**Photo cell sensitivity:** Activates circuit at about 2 footcandles: off at about 8 footcandles of light  
**Positioning Adjustment:** 2 ball joints allow free adjustment to suit area

**Relay output:** Up to 500W of incandescent load only  
**Power:** 240V AC 50Hz  
A15597 ..... **\$185**

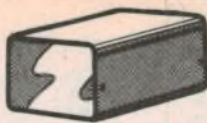

**HORWOOD ALUMINIUM CASES**

H10382	3 x 4 x 2 inches	\$ 5.50
H10383	3 x 4 x 3 inches	\$ 6.50
H10384	3 x 4 x 4 inches	\$ 7.50
H10385	3 x 4 x 5 inches	\$ 7.95
H10386	3 x 4 x 6 inches	\$ 8.50
H10387	3 x 4 x 7 inches	\$ 9.50
H10388	3 x 4 x 8 inches	\$10.50
H10389	3 x 4 x 9 inches	\$10.95
H10390	3 x 4 x 10 inches	\$11.95



**UTILITY BOXES**

Plastic boxes with aluminium tops and available in four sizes. Very popular for projects and very economical!

H10101	150x90x50mm	\$ 3.25
H10102	195x113x60mm	\$ 4.50
H10103	130x68x41mm	\$ 2.75
H10105	83x54x28mm	\$ 1.95
H10110	120x65x38mm	\$ 2.95
H10112	120x65x38mm (Metal top)	\$ 2.95

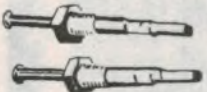

**PIN SWITCHES**

- Self tapping and adjustable
- Suitable for car doors, hoods, trunks
- Single lead hook up
- Easy to use, easy to install
- Length 45mm

S12522 ..... **\$3.95 pair**



**PUSH BUTTON DIALLERS**

Tired of old fashion dialling and re-dialling engaged numbers? These convenient push button diallers include last number radial (up to 16 digits) and instructions for an easy changeover.

Cat. A12030 ..... Normally \$19.95  
**SPECIAL, ONLY \$14.95**  
(Note: Not Telecom approved)



**ARGUS ADJUSTABLE MAGNIFIER WITH LAMP**

Perfect for close up work! Intricate PCB's, projects, etc., will be a breeze under this superb, adjustable magnifying lamp.  
• Magnifies 1.75 times  
• 40 watt incandescent lamp  
• 2 external spring-balanced arms extendable to 800mm  
• Adjustable head for optimum viewing angle  
• Variety of mounting bases available but not included  
Cat T10015 ..... Only **\$99**

**CLAMP BASE**  
To suit above Argus Lamp  
T10016 ..... **\$9.50**

**T-BASE**  
To suit above Argus Lamp  
T10017 ..... **\$17.50**

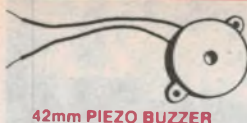

**42mm PIEZO BUZZER**  
S15073 ..... **\$7.95**

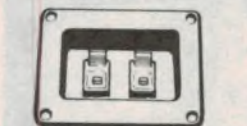

**RECESSED SPEAKER TERMINAL**  
Push button, red and black terminals  
Cat P10248 ..... **\$1.95**



**TRIGGER TRANSFORMERS**  
Cat M10104 ..... **\$1.45**

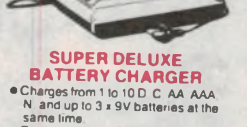

**SUPER DELUXE BATTERY CHARGER**  
• Charges from 1 to 10D C AA AAA N and up to 3 x 9V batteries at the same time  
• Dual colour LED in first three compartments to designate 1.5V or 9V  
• 240V AC/50Hz  
• Approval No: N10637  
Cat M23525 ..... **\$59.95**



**POCKET SIZE BATTERY TESTER**  
• Tests all 9V to 1.5V batteries including button cells  
• Arms extend to various battery sizes  
• Easy to read meter  
• Requires no power source  
M23521 ..... **\$11.95**

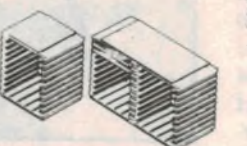

**COMPACT DISC STORAGE UNITS**  
• Holds 10/20 compact discs in their cases  
• Interlocking modular design allows vertical and horizontal interlocking  
• Discs slide into place horizontally making lifing easy to read  
• Wall mount or free standing  
A10031 (10 discs) **\$12.95**  
A10032 (20 discs) **\$19.95**



**CAR BATTERY ISOLATOR**  
Designed for car burglar alarm back-up battery. Allows the back-up battery to be charged from the car battery and isolates the back-up battery by not allowing the back-up battery to drain back to the car battery.  
A12095 ..... **\$3.20**

**JOINABLE PCB MOUNTING SCREW TERMINALS (GREY)**  
2 Way 1-9 10+  
Cat P10520 **\$0.50** **\$0.45**  
3 Way  
Cat P10521 **\$0.75** **\$0.65**



**3 1/2" EXTERNAL DRIVE**

- 720K formatted capacity
- 37 way D type connector fits directly onto drive controller card
- Compatible with IBM PC/XT
- Requires DOS 3.2 or greater
- Size 266(D) x 104(W) x 75(H)mm

only **\$395**



**CD TO CAR CASSETTE STEREO ADAPTOR**

Enables a portable CD player or portable TV to be played through any car speaker system by using the cars cassette player. Reduces the risk of theft. Just plug in when required, and remove when you are finished. Hard wiring not needed.  
A10011 ..... **\$29.95**



**IEC MAINS LEAD**

3 pin mains plug to 3 pin IEC plug 1.8 metres long  
P10252 ..... **\$5.95**



**TELEPHONE INDUCTION COIL**

- For recording or amplification
- 3.5mm plug with 1 metre cord
- Peel-off stick-on adhesive back

A12032 ..... **\$5.95**



**CD PLAYER ADAPTOR**

Many amplifiers have only one auxiliary input. This makes using a compact disc player as well as another auxiliary input inconvenient. Also the majority of CD players have an output voltage of 1.6 or 2 volts whereas the auxiliary input norm is 750mV. This CD adaptor allows dual auxiliary input, and one input has variable gain setting.

**SPECIFICATIONS:**  
• Input 2 sets of 2 x RCA sockets  
• Gain 150, 300, 600mV, 1V and 2V  
• Output 2 x RCA sockets  
A11510 ..... **\$23.95**



**MIDRANGE HORNS**

Use these quality, all metal Piezo tweeters for great top end sound in your band speakers, disco sound system, etc. Rated at 30 watts RMS in a system they will handle over 100 watts RMS.  
**Two sizes to choose from:**  
Size: 4" x 7"  
Impedance 8 ohms  
Rating: 30 watts RMS  
Response: 2kHz - 14 kHz  
Dimensions: 102 x 267 x 177mm  
Cat. C92082 ..... Normally **\$49.95**  
This month only **\$39.95**



**STEREO WIRELESS TRANSMITTER**

This unit was developed to allow portable compact disc players to be used in cars by transmitting the headphone output signal directly to your stereo FM car radio. It will also transmit any mono/stereo signal from any headphone output to any FM receiver.

**SPECIFICATIONS:**

- Input 3.5mm stereo phone plug Impedance 32 ohm
- Mono/stereo switch has plug mounting clip
- FM Transmission approx 90.35MHz (Tunable 89-91MHz)
- Range 15 metres (below 15mV/m at 100 metres)
- Power 1.5V AAA size batteries (100 hours continuous use)
- Size 72 x 38 x 21mm

A16100 ..... **\$69.95**



**MASTER RACK MOUNTING CABINETS**

These superb rack mount cabinets will give your projects a real professional appearance! Just look at these features:

- All dimensions conform to the International Standard
- All aluminium construction
- Choice of black or natural finish
- Deluxe brush finish anodised front panel
- Removeable top and bottom lid
- Ventilated lid
- Horizontal Depth: 254mm  
A - External Front Panel Height mm  
B - Mounting Hole Centres mm  
C - Internal Chassis Height mm  
A B C Finish Cat No. Price  
44 34 38 Natural H10401 \$59.50  
88 57 82 Natural H10402 \$69.50  
132 89 126 Natural H10403 \$79.50  
44 34 38 Black H10411 \$65.00  
88 57 82 Black H10412 \$75.00  
132 89 126 Black H10413 \$85.00



**TELEPHONE EXTENSION BELL**

- 10 metre length extension cord
- Features US type plug
- Use with US/Australian adaptor

Y16043 ..... **\$25.95**



**SPOTLIGHT 12V**

Quartz halogen spotlight. Hand held with moulded plastic grip. Brilliant beam up to 55W, can be seen for miles. Orange lens cover, emergency lighter switch, 3 metre curled cord, cigarette lighter plug and replaceable H3 halogen bulb.  
Cat. A15050 ..... **\$26.95**

Size: 3" x 7"  
Impedance: 8 ohms  
Rating: 30 watts RMS  
Response: 2kHz - 15 kHz  
Dimensions: 76 x 177 x 145mm  
Cat. C92084 ..... Normally **\$29.95**  
This month only **\$24.95**  
Dealers, OEM's, etc., phone (03) 543 2166 for wholesale prices

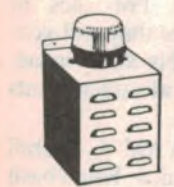

**EXTERNAL SIREN & FLASHING LIGHT**

Housed in a waterproof, metal case, with tamper switch.

**SPECIFICATIONS:**

- Siren:**  
DC 12V, 450 mA  
Impedance 8 ohm  
S.P.L. (dB/W) 110  
Dimensions: 135 x 150mm
- Flashing Light:**  
DC 12V  
100 flashes per minute  
Dimensions: 82 x 100mm

..... **\$89.50**



**MINIATURE HOBBY VICE**

- Lever operated suction grip base for instant mounting and portability
- Mounts on smooth non-porous surfaces
- Ideal for holding components and other small/light objects.

Cat. T12458 ..... only **\$6.45**



**BIG MOUTH CAR ALARM**

**FEATURES:**

- Easy installation
- Automatic on/off
- Loud alarm signal
- Auto reset
- Low Price!

**SPECIFICATIONS:**

- Power: DC 12V battery
- Current Consumption: 10mA at 12V DC
- Dimensions: 139 x 165 x 136mm
- Exit Delay: 60 seconds approx
- Entry Delay: 12 seconds approx
- Auto reset: 90 Seconds approx

S15048 ..... **\$39.95**



**STEP DOWN CONVERTER DC-DC**

Built around a heavy duty heatsink this unit features the latest transistor switching technology to convert 24V DC to 13.8V DC. Finished in matt black with a unique mounting bracket makes it the best in its class.

**SPECIFICATIONS:**  
Input Voltage: 24V DC  
Output Voltage: 13.8V DC  
Primary Current: 4.2A (24V input 4A output)

Output Current: 4 Amp continuous rated (5-5A max.)  
Size: 125(W) x 50(H) x 90(D)mm  
Weight: 450 grams  
A16155 ..... **\$99.95**

**10A STEP DOWN CONVERTER DC-DC**

Built around a heavy duty heatsink this unit features the latest transistor switching technology to convert 24V DC to 13.8V DC. Finished in matt black.

**SPECIFICATIONS:**  
Input Voltage: 24V DC  
Output Voltage: 13.8V DC  
Primary Current: 11A (24V input, 10A output)

Output Current: 8 Amp continuous rated (12A max.)  
Size: 125(W) x 50(H) x 175(D)mm  
Weight: 900 grams  
A16160 ..... **\$119.95**

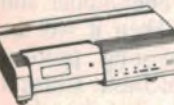

**P.I.R. SENTRY**

**FEATURES:**

- 7 LED indicators
- Passive infra-red detection radium
- Built-in piezo siren
- Rechargeable 12V battery
- Built-in automatic battery charging system
- External siren connections
- Exit/Entry system
- Terminals for external detection devices
- Separate digital panel and main unit
- 3 Function switch: delay/inst/standby
- 3 Adjustable timers
- 24 Hour loop included
- Built-in tamper switch
- Adjustable detection angle
- LED monitor for walk test
- R.F. Protection design

S ..... **\$175**

# EVERYTHING YOU NEED!



### HORWOOD METAL INSTRUMENT CASES (ROUND HANDLES)

H10461	153 x 102 x 203mm	\$18.95
H10462	203 x 102 x 203mm	\$19.50
H10463	254 x 102 x 203mm	\$19.95
H10464	305 x 102 x 203mm	\$22.95

### HORWOOD METAL INSTRUMENT CASES (SQUARE HANDLES)

H10467	153 x 76 x 228mm	\$16.95
H10465	203 x 76 x 228mm	\$17.95
H10466	254 x 76 x 228mm	\$18.95
H10468	305 x 76 x 228mm	\$21.50
H10470	430 x 76 x 228mm	\$29.95



### SUPER HORN TWEETER

- Requires no crossover and handles up to 100W
  - Sensitivity 100dB/0.5m
  - Frequency Response 3kHz-30kHz
  - Impedance 8 OHMS
  - Size 96mm diameter
- Cat. C12102 Normally \$12.95  
**SPECIAL. ONLY \$9.95**

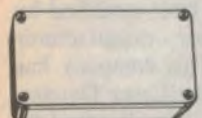

**DIECAST BOXES**  
Diecast boxes are excellent for RF shielding, and strength. Screws are provided with each box.

H11451	100 x 50 x 25mm	\$ 5.95
H11452	110 x 60 x 30mm	\$ 6.50
H11453	120 x 65 x 40mm	\$ 6.95
H11461	120 x 94 x 53mm	\$11.50
H11462	188 x 120 x 78mm	\$13.50
H11464	188 x 188 x 64mm	\$29.50



### K&W METAL INSTRUMENT CASES

Used in many projects, these cases have hammer-tone finish and are both versatile and economical.

H10478	125 x 40 x 65mm	\$ 5.95
H10479	150 x 55 x 95mm	\$ 6.95
H10480	100 x 92 x 130mm	\$ 8.95
H10481	150 x 55 x 100mm	\$ 7.95
H10482	200 x 80 x 130mm	\$ 9.95
H10485	255 x 92 x 155mm	\$14.95
H10487	255 x 165 x 155mm	\$16.95
H10489	305 x 105 x 200mm	\$18.95



**COMPUTER CABLE**  
CIC6 6 conductor computer interface cable. Colour coded with braided shield (to IEC22 specifications). Copper conductor 6 x 7/0 16mm. 1.9 metres 10 + metres

\$1.90/m \$1.70/m

CIC9 100 9 conductor computer interface cable. Colour coded with mylar shielding 9 x 7/0 16mm. 1.9 metres 10 + metres

\$2.50/m \$1.95/m

CIC12 12 conductor computer interface cable. Colour coded with mylar shielding 12 x 7/0 16mm. 1.9 metres 10 + metres

\$2.70/m \$2.50/m

CIC16 16 conductor computer interface cable. Colour coded with mylar shielding 16 x 7/0 16mm. 1.9 metres 10 + metres

\$3.90/m \$3.40/m

CIC25 25 conductor computer interface cable. Colour coded with mylar shielding 25 x 7/0 16mm. 1.9 metres 10 + metres

\$4.90/m \$4.40/m

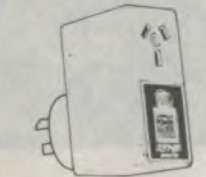

**CPF CONTINUOUS POWER FILTER SPIKE ARRESTOR**  
The Fortron CPF Filtered Electronic Spike Protector provides a protective electronic barrier for microcomputers, printers, telephone systems and moderns electronic typewriters, audio and stereo systems and other sensitive electronic equipment.

The CPF provides protection from dangerous electrical spikes that can cause anything from obvious damage (like immediate equipment failure) to less obvious harm that can drastically shorten a system's life.

CPF's superior circuitry design and semiconducting technology responds instantly to any potentially damaging over-voltage, ensuring safe trouble free operation.

Additionally, CPF's filtering capability helps eliminate troublesome and annoying interference, general hash created by small motors, fluorescent lamps, and the like that threaten the performance and shorten equipment life of unprotected electronic components.

**SPECIFICATIONS:**  
Electrical rating 220-260 volts (AC) 50Hz 10 Amp  
Spike/RFI Protection 4 500 amps for 20ms/second pulses  
Maximum clamping voltage 275V differential mode  
Cat. X10088 \$69.95



### BRAND NEW FANS

Quality, new fans for use in power amps, computers, hotspot cooling etc. Whatever you need plenty of air.

240V 4 5/8"	Cat. T12461	\$14.95
115V 4 5/8"	Cat. T12463	\$14.95
240V 3 1/2"	Cat. T12465	\$14.95
115V 3 1/2"	Cat. T12467	\$14.95

10 + fans (mixed) only \$10 each!

### FAN GUARDS TO SUIT

4 5/8"	Cat. T12471	\$3.95
3 1/2"	Cat. T12475	\$3.95



### HOOK UP WIRE

Cat. No. Description  
W11251 13/ 12 TLD BLK  
W11252 13/ 12 TLD BROWN  
W11253 13/ 12 TLD ORANGE  
W11254 13/ 12 TLD YELLOW  
W11255 13/ 12 TLD GREEN  
W11256 13/ 12 TLD BLUE  
W11257 13/ 12 TLD WHITE

**PRICES PER 100 METRE ROLL**  
1-9 10 +  
\$5.95 \$5.00

W11260 14/ 20 RED  
W11261 14/ 20 BLACK  
W11265 14/ 20 BLUE  
W11268 14/ 20 WHITE  
**PRICES PER 100 METRE ROLL**  
1-9 10 +  
\$12.00 \$10.00

W11270 24/ 20 RED  
W11272 24/ 20 BLACK  
W11274 24/ 20 GREEN  
**PRICES PER 100 METRE ROLL**  
1-9 10 +  
\$14.00 \$12.00

W11280 32/ 2 BROWN  
W11282 32/ 2 BLUE  
**PRICES PER 100 METRE ROLL**  
1-9 10 +  
\$20.00 \$18.00

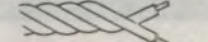

### BELL WIRE

Red and white twisted Conductors, 2 x 1 strand 0.17mm Sheath O.D. 2 x 1.35mm  
Cat. W 10 rolls  
1-9 rolls 10 rolls  
\$19.00/m \$17.50/m

**TAKE 25% OFF THESE BREADBOARDS THIS MONTH ONLY!**

Cat. No.	Description	Price
P11000	100 Holes	\$ 2.75
P11005	640 Holes	\$10.75
P11007	640 + 100 Holes	\$14.95
P11009	640 + 200 Holes	\$17.50
P11010	1280 + 100 Holes	\$26.95
P11011	1280 + 300 Holes	\$32.50
P11012	1280 + 400 Holes	\$39.95
P11015	1920 + 500 Holes	\$59.95
P11018	2560 + 700 Holes	\$69.95



**CAR ANTENNA BOOSTER**  
In-line installation  
12V boosts 100%  
Cat. A12073 \$7.95



### CODE KEY PAD

- Telephone type digital keypad
- Four digit, changeable code
- Over 5000 possible combinations
- Power consumption: 5mA standby 50mA alarm
- Two sector LED and 1 arm LED
- Wrong number lockout
- 12V DC operation
- Relay output
- Panic button
- Normally open tamper switch
- Dimensions: 145 x 100 x 37mm
- AC/PC compatible

Cat. A13014 R.R.P. \$79.95  
**SPECIAL, ONLY \$69.95**

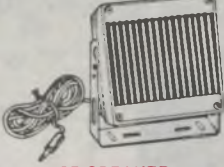

### CB SPEAKER

- 10cm (4") speaker
- 3 metre cord with 3.5mm plug
- Impedance 8 ohms
- Power 5 watts
- Complete with mounting bracket

Cat. A12074 \$24.95



### P.A. SPEAKERS

Low dual cone, wide range 200mm (8in.) Ideal for public address, background music etc. Tremendous Value at these prices!

Cat. C12000 10 +  
\$6.95 \$5.95



### PC BOARD HOLDER

Better than an extra pair of hands! A must for all PCB work.  
Cat. T12444 \$9.95



### CROSSOVER NETWORKS

Crossovers are essential for multiway speaker systems, otherwise your bass will be degraded by inter-modulation distortion and cone break up, and your treble will be distorted by bass components. These crossovers are designed to channel only the frequencies that each driver can properly handle. Read the specifications to choose the correct one for your need.

**2 WAY 60 WATT CROSSOVER NETWORK**  
6dB attenuation  
Cross over point 5,000 Hz  
Impedance 8 ohms  
Cat. A16001 \$4.95

**2 WAY 60 WATT CROSSOVER NETWORK**  
12dB attenuation  
Cross over point 2,300 Hz  
Impedance 8 ohms  
Cat. A16002 \$7.95

**3 WAY 60 WATT CROSSOVER NETWORK**  
6dB attenuation  
Cross over point 800 and 5,000 Hz  
Impedance 8 ohms  
Cat. A16003 \$9.95

**3 WAY 60 WATT CROSSOVER NETWORK**  
12dB attenuation  
Cross over point 800 and 5,000 Hz  
Impedance 8 ohms  
Cat. A16005 \$24.95

**3 WAY 150 WATT CROSSOVER NETWORK**  
1dB attenuation  
Cross over point 350 and 3,000 Hz  
Impedance 8 ohms  
Cat. A16007 \$34.95



### ROTATING LIGHT

Motor driven rotating reflecting mirror with a flash rate of about 150 per minute. Large lens lit right to base making unit weatherproof. Spare globe included.

**SPECIFICATIONS:**  
Available in Blue or Orange  
150 Revolutions per minute (approximately)  
Shock absorbing rubber mounting legs  
Connecting wire fitted through base  
12V DC 750mA  
Base diameter 102mm  
Height 140mm

A15042 Blue \$42.95  
A15043 Orange \$42.95



### FOOT SWITCHES

- Momentary or on/off models to choose from
- Cord length 2.5 metres
- 6.3mm plug

A17000 Momentary operation  
A17005 Push On/Off operation  
each \$19.95

**HEATSINK COMPOUND**  
Heatsink compound is applied to the base and mounting studs of transistors and diodes. It maintains a positive heatsink seal that improves heat transfer from the device to the heatsink, thus increasing overall efficiency.  
Cat. H11800 (10g) \$2.95  
Cat. H11810 (150g) \$17.50



### AUTOMATIC CABLE STRIPPER

- Strips cable with diameter of 1.6 2.6 3.2mm
- Fully automatic action. Squeeze grip will simultaneously strip and eject insulation
- Length 180mm (7")

T11532 \$19.95



### U.S. TO AUSTRALIAN TELEPHONE ADAPTOR

Australian plug to U.S. socket  
Y16008 \$8.95

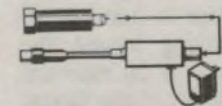

### 10dB IN-LINE COAXIAL AMPLIFIER

Reduces loss from splitters and long cable runs. Suitable for use with antennas, coaxial feed lines and VCR's, A/C adaptor included.

**SPECIFICATIONS:**  
Frequency Range: 5-900MHz  
Gain: 10dB  
Power Requirements: 12V A/C Adaptor (included)  
Input Impedance: 75 ohm  
Output Impedance: 75 ohm  
Cat. L15043 \$39.95

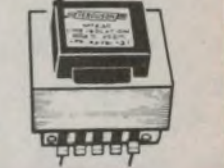

### MODEM TRANSFORMER

PCB pins spacing 25mm, equipment to line 15mm between equipment pins, 25mm between line pins.  
CAT No. 1 9 10 +  
M10230 \$14.95 \$13.95



### GREY FLAT RIBBON CABLE

Cat. No.	Description	\$/Mtr
W12614	14 Way	\$1.90
W12616	16 Way	\$2.20
W12620	20 Way	\$2.50
W12624	24 Way	\$2.90
W12625	25 Way	\$3.20
W12626	26 Way	\$3.60
W12634	34 Way	\$3.90
W12636	36 Way	\$3.90
W12640	40 Way	\$4.90
W12650	50 Way	\$5.90
W12660	60 Way	\$6.90



### Rod Irving Electronics

MELBOURNE: 48 A Beckett St. Phone (03) 663 6151  
NORTHCOTE: 425 High St. Phone (03) 485 8866  
CLAYTON: 56 Renner Rd. Phone (03) 543 7877  
SOUTH AUSTRALIA: Electronic Discounters P/L, 305 Morphett St. ADELAIDE. Phone (08) 212 1799  
NOTE: Prices may vary interstate due to freight costs.

**MAIL ORDER**  
Local Orders (03) 543 7877  
Interstate Orders (08) 33 5757  
All Inquiries: (03) 543 7877

**CORRESPONDENCE**  
P.O. Box 620, CLAYTON 3168  
Telex: AA 151920  
Fax: (03) 543 2648



### MAIL ORDER HOTLINE 008 335757 (TOLL FREE) (STRICTLY ORDERS ONLY)

### LOCAL ORDERS & INQUIRIES (03) 543 7877

**POSTAGE RATES:**

\$1	\$9.99	\$3.00
\$10	\$24.99	\$3.00
\$25	\$49.99	\$4.00
\$50	\$99.99	\$5.00
\$100	\$199.99	\$7.50
\$200	\$499.99	\$10.00
\$500 plus		\$12.50

The above postage rates are for basic postage only. Road Freight bulky and fragile items will be charged at different rates.

All sales tax exempt orders and wholesale inquiries to **TRONICS WHOLESALE**, 56 Renner Rd, Clayton. Ph (03) 543 2168 (3 lines)

Errors and omissions excepted. Prices and specifications subject to change.

IBM, PC, XT, AT are registered trademarks of International Business Machines. Apple is a registered trademark. Donkeys registered trademarks of their respective owners.

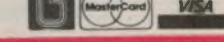

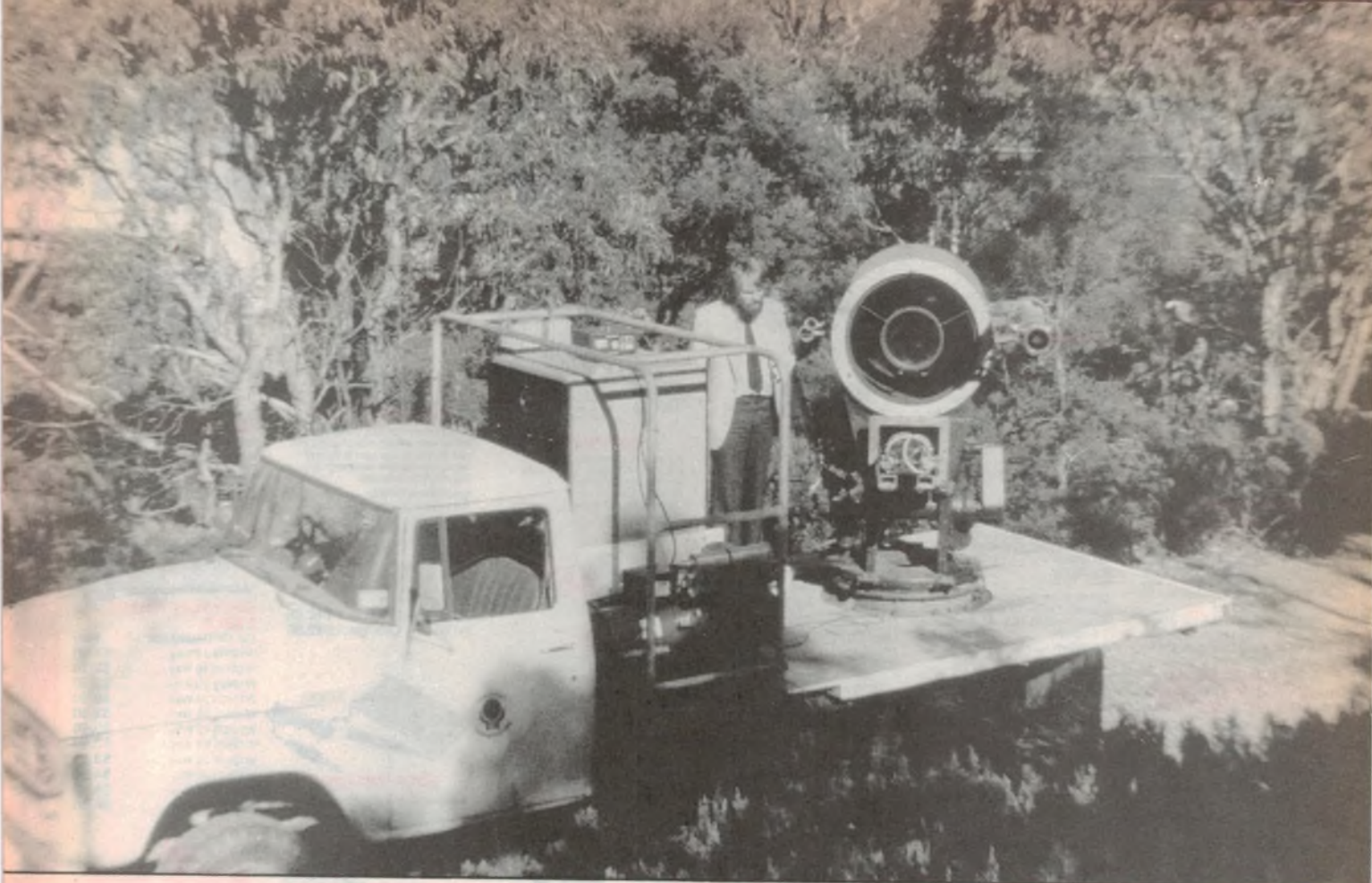

# Burning off with a laser

Environmentalists take heart! Forest regeneration is likely to be enhanced with laser beams in future. World wide interest is currently being shown in Lucifer – an Australian development involving the use of a high-power laser beam as an accurate means of igniting forest waste.

by PETER PHILLIPS

Laser beams have long been associated with the more exotic tasks of brain surgery, holograms, homing beams for nuclear weapons and so on. Using a laser beam to burn off rubbish might seem the height of over-kill, but the advantages are many, particularly if you are the one controlling the burn off.

A particular problem is burning off forest slash after having logged the area. Burning the slash is an essential ingredient to regeneration of the forest, and is a task fraught with dangers for those involved. Traditional methods include ignition with manheld drip torches, electric igniters or "incendiary matches" dropped from aircraft.

Apart from the obvious dangers to personnel, the likelihood of igniting more than was intended is very high, and various fire disasters have occurred over the years as a consequence. For these reasons, the Tasmanian Forestry Commission approached the Physics Department of the University of Tasmania some 10 years ago, with the idea of using a laser beam to light the fires. Although the initial response was "Don't be silly!", it took Dr Michael Waterworth, a Reader in Physics at the university, approximately two weeks to reconsider – and to get the university involved in what was to become an extensive project.

Dr Waterworth originally built a prototype device called "Lucifer", using a 200 watt CO<sub>2</sub> laser, later modified by the Gold Coast laser manufacturer Radiation Research. This company has now been reformed into Laser Dynamics Ltd (LDL) and has been licensed by the University of Tasmania to develop and market Lucifer. To this end, Dr Waterworth has been involved in the project with LDL engineering director John Kavanagh for the last nine years.

The result has been the development of a 750 watt laser ignition device that is to be demonstrated during the 1988 Tasmanian Forestry Commission regenerative burn program. After this, it is proposed to demonstrate the device in North America, where some 200 companies and public authorities have shown interest. In fact, Dr Waterworth has conducted extensive research in North America, and also with various forestry authorities throughout Australia.

The LDL version of Lucifer employs

a 750 watt carbon dioxide fast axial flow laser, a beam expander, range finder and a joystick controlled Cassegrain auto-focussing telescope. The laser beam is first beam expanded, then accurately focussed onto the required point. Collectively, this arrangement can produce a high intensity hot spot of the appropriate size and energy density at the required distance.

Focussing is achieved by adjustment of the beam expanding optics, and the whole device is fully steerable in the horizontal and vertical planes. The laser material is a combination of carbon dioxide, helium and nitrogen. It is claimed that ignition occurs within 2 seconds of application of the hot spot, with the capability of pinpoint accuracy at distances from 10 to 1500 metres with a spot size no more than a few centimetres.

The diagram of Fig.1 shows a block diagram of the system, which is represented essentially by three modules; the laser, the focussing optics and the projection telescope.

The fact that no other country in the world has succeeded in the development of a similar device is testimony to the difficulties involved in such a project. The main problems that had to be overcome were the need for a continuous output from the laser, (up to several hours at a time), the sophisticated optics required, and the need for auto focussing.

The optics problem was an issue somewhat familiar to the Waterworth family, as the company called E.N. Waterworth, (at one time Waterworth - Bessel) had been operating for over 60 years, under the supervision of Dr Michael Waterworth's father. With this type of expertise available "in the family", the solving of the optics problem was possible, with Mr Waterworth senior being able to put into practice the ideas from his son.

Interestingly, it was because of these and other problems that similar research being conducted in the USA was abandoned.

Once operational, however, considerable research was needed in how to make this "hi-tech blow lamp" portable, and then over the terrain typical of a forest.

As shown in the accompanying photo, the device is mounted on the back of a table top truck, on a vibration free base. Considerable effort was required to solve the dichotomy of stump-jumping and laser technology, and much research was needed to make the laser system suitably rugged.

The energy source is also mounted on the truck, behind the cabin, adding up to a total weight of around one tonne. Transportation by ship or helicopter is also possible, allowing it to be used almost anywhere.

One problem, typical of all current high-power lasers is the amount of input power required. For the 750W device here, some 14kVA of input power is required. This means that approximately 13kW of heat must be dissipated, implying the need for an efficient cooling system.

The power supply for Lucifer operates at 18kV, and making such a power source portable was a problem in itself. Because the laser beam may be on for up to several hours at a time, the problems of cooling and power source portability are somewhat enlarged.

Apart from setting fire to scrub, there are many other envisaged uses for Lucifer, as the ability to precisely locate a point of ignition has many advantages. Other applications include precision ignition of oil spills, controlled burning of sugar cane and grain stubble, tree trimming near power lines, avalanche control, breaking of pack ice at sea, de-icing of runways and so on.

An airborne version is planned for early 1989, which will allow the burning of fire breaks in normally inaccessible forest. To enable the device to be used from a helicopter, the system will incorporate gymbal mountings for stability of the beam. This way, precise targetting will still be possible while the 'copter is bumping around in the usual fashion.

Other more esoteric uses include cleaning buildings, paint removal, de-icing TV towers, and various defence applications. Star Wars on a more friendly basis, but hi-tech nonetheless, and another world first for Australian science and technology.

Our thanks to Dr. Michael Waterworth for his assistance in the development of this article. 

## OUR OWN TIME MACHINE!



It may look like a book, but don't let its appearance fool you. There are no whirling dials and control levers; but once you open the cover, it'll take you on an incredible journey backwards in time. You'll find yourself back in the 1920's, when Australia's first new radio stations were just getting established and a typical radio set cost ten weeks' wages. We've chosen a collection of highlights from the 1927 issues of "Wireless Weekly": You'll find some front covers, a few editorials, the best new items, a collection of typical do-it-yourself radio set designs, and some selected pages from the programme listing. Plus a sprinkling of the original advertisements, of course. These are particularly fascinating because they show prices and put everything into proper context. Send today for **The Best of Wireless Weekly in 1927**... A fascinating and nostalgic trip into our radio past.

**Send your order to:**  
**Freepost No.4**  
**Federal Publishing**  
**Book Sales,**  
**P.O. Box 227,**  
**Waterloo NSW 2017**

(no stamp required if posted within Australia)  
Price: \$3.95 plus \$1.00p&p

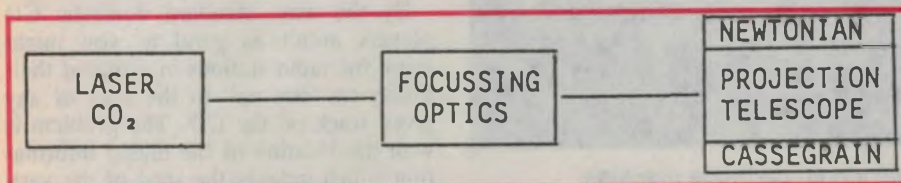

Fig.1: Block diagram of Lucifer's truck-mounted optical system.

**Award-winning Australian development:**

# Keeping the phase within the cart

Melbourne-based Cunningham Consolidated's Autophase 2000 professional stereo tape cartridge machine has won a prestigious award for design innovation, and is meeting with warm acceptance among radio broadcasters both here and overseas. Here's a look at the operation of stereo cart machines, and how the Autophase 2000 solves a previously worrying problem.

by **LANCE MILNE** Chief Engineer, 3EON-FM Melbourne

The Autophase 2000 is a good example of the way we Aussies can show the world the way to go in high-tech industries, if we have the backing. Designed primarily for radio broadcasting, this new stereo cartridge machine incorporates features which won its developer and manufacturer Cunningham Consoli-

dated an Industrial Design Award.

The machine has also won wide acceptance among radio stations, both here in Australia and overseas. In the last 12 months over 300 have been sold, including 135 to Singapore and 50 to Europe.

To understand what is so clever about

the design of the Autophase 2000, we need to take a look at what a cartridge tape machine does and how radio stations use them.

Nearly all radio stations use cartridge (cart) machines fairly heavily. Cartridges themselves are a continuous loop tape, wound on a central hub and enclosed in a two-piece plastic body, very much like the old 8-track cartridge tapes that were all the go in cars some years back.

The main differences are firstly that broadcasting carts run at 19cm/sec (7.5 ips), which is four times the speed of a compact audio cassette and twice as fast as the old 8-track carts. Secondly broadcast carts have a special cut-out hole in the front, for the pinch roller of the deck to come through, whereas the old 8-track variety had the pinch roller built in to the body of the cart - which is a less accurate system.

Both have standard-width 6.3mm specially lubricated tape wound into them, so the continuous loop can roll freely. The diagram of Fig.1 shows how the tape rolls from the outside to the inside of the layers of tape, then out and past the heads from left to right, and then back onto the outside of the spool again. A bit of thought will show you that each layer must slide on its neighbouring layer.

Most commercial stations are reliant on carts to play commercials, jingles and music tracks. There is a fairly obvious advantage in handling rugged cartridges within a studio, which are easily stored and located and just need to be "plugged in" to a cart player, rather than fiddling around with and cueing up tapes, records and compact discs.

By the way, standard domestic CD players aren't as good as you might think for radio stations in terms of their ability to "cue up" to the start of any given track on the CD. The problem is with the location of the digital information which indexes the start of the various tracks on a CD. Index points are



**Developed in Australia, the Autophase 2000 stereo cartridge machine achieves a significant improvement in stereo reproduction.**





**Prime Minister Bob Hawke with Cunningham Consolidated's MD Peter Roberts, at the design award presentation.**

"spot on" the start of audio on some discs, but on others there is one second or more gap between the index mark and the actual start of the audio. Many discs even vary the gap on individual tracks of the same CD!

Some stations have overcome this problem by modifications to the players so that they cue to the index first and then search for audio and wait in the PAUSE mode for the announcer to fire them up. The very latest professional CD players actually have this facility built in.

But back to carts. As mentioned before, cartridges are convenient in a radio station because the operator doesn't have to cue them up to the start of the audio. Obviously this means that there is an automatic cueing system built into the design of the cartridge system, so let's take a look at the format used to record the signals onto the tape.

The track standards for broadcast carts were laid down by the NAB (National Association of Broadcasters) in

the USA over 20 years ago. Originally, there were 2 tracks, the top one being for the audio and the bottom one for the "cue-tones" (which we'll get back to in a minute). Of course, an extra track is needed for stereo audio, so the current standard is 3 tracks, of equal width and equal spacing across the tape.

By looking at the diagrams (Figs 2 and 3), you will notice that unfortunately, this means that stereo-format carts are not compatible with mono ones - which has caused its fair share of troubles within stations as they convert to stereo! The left channel audio goes at the top, right channel in the middle and the cuetones at the bottom.

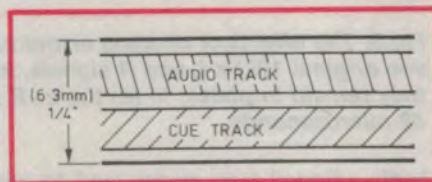

**Fig.2: The standard track format used for mono cartridges.**

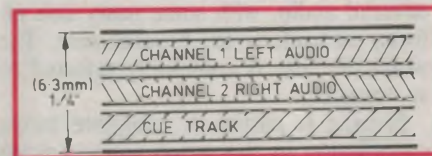

**Fig.3: The standard track format used for stereo cartridges, for comparison.**

You have probably already guessed that the *cuetones*, or tones on the cue track, control the starting and stopping of the cart. Top marks! There are actually 4 cuetones that go on that bottom track, all with quite separate functions.

The primary cuetone is a burst (usually about one second long) of 1kHz sinewave which is recorded simulta-

neously with the commencement of audio. This actually marks the "end" of the tape, because it is a continuous loop.

When the cart is in a playback deck and has played the audio, the transport stops when it detects the 1kHz tone - so the cart is cued ready for its next play. The transport is stopped by pulling the pinch roller away from the capstan shaft, usually by releasing a solenoid or driving a reversing motor.

The second cuetone is again a sine-wave, this time at 150Hz. It is referred to as the end-of-message pulse or EOM tone, and has three functions, concerned with marking the end of audio rather than the end of the tape.

To explain in more practical terms, suppose I wanted to record a piece of music that runs for 3 minutes 48 seconds. Generally, instead of winding tape into a cartridge body that runs for exactly that time, I would pick the nearest "stock" time longer than required, say 4 minutes. The only complication is that this particular music doesn't abruptly stop at 3:48 but starts a slow fade out at 3:42 and is gone by 3:48. How would I describe the finishing point? No problem. The leading edge of the pulse (in other words when the tone commences) marks the "beginning of the end" of the recorded audio (at 3:42) and the "trailing edge" of the tone marks the finish of audio (at 3:48), even though the cart will still be in motion until 4:00. Therefore the 150Hz tone will have 6 seconds duration.

The idea behind all this is that on playback, the leading edge of the EOM pulses will activate a detector in the cart player that will signify to the external world that audio is starting to fade out. This could flash a lamp on an announcer's console, but more often will automatically start another cart machine (or some other source) playing in a studio or automation system, to achieve a nice cross-fade between items. As long as the tone remains (in our example 6 seconds) then the output of the cart machine remains active. At the trailing edge of the tone, the audio output of the player switches off (to avoid tape noise and any other clicks or pops appearing) and the machine will jump into the fast-forward mode, if it is so equipped. This is generally 3 times normal speed, and will naturally raise the frequency of the stop tone to 3kHz. So the EOM pulse is a useful auxiliary tone.

The third cuetone is actually a narrow-band FSK (frequency shift keyed) tone centered on 3.5kHz and modulated

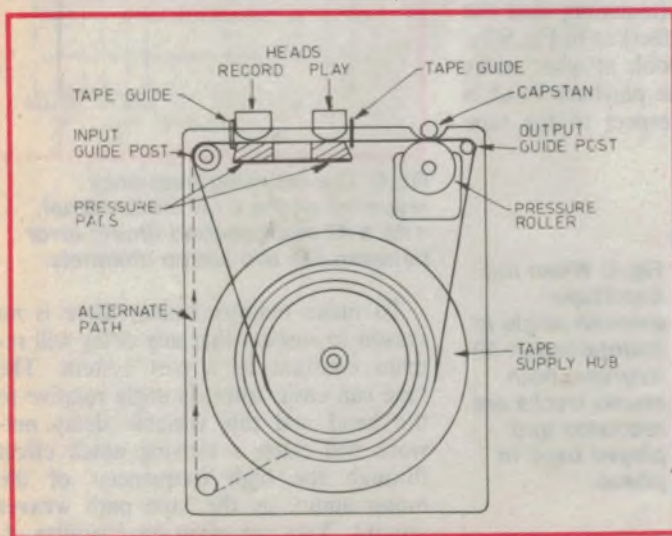

**Fig.1: The general layout of a 1/4" endless tape cartridge as used by broadcasting stations, showing where the heads, capstan and pressure roller meet the tape.**

## Phase Cart

by a data stream at 300 baud that can be used for just about anything. Typically it represents details of the cartridge recording, which can be fed to logging equipment – to tell the station's accounting computer how many times a particular client's commercial was played, in order to send them the bill! This data stream can naturally be recorded at any time on the tape, but is usually started a few seconds after the audio to make sure it fits in neatly with the other cues.

The last cue tone is at 8kHz and is another auxiliary marker tone that can be used as the station requires. As you can see, the cues and the 3-track format of carts make for a very functional system within a radio or TV station.

The system, however, like any other is subject to certain problems and limitations. Since the widespread use of stereo broadcasting, one difficulty in particular has raised its ugly head. The problem is that carts themselves have quite a variation in their ability to accurately maintain the timing between the two audio channels. To understand this, have a look at Fig.4.

Ideally, the recording head should be at an exact right angle to the direction of the tape, so that the maximum amount of magnetic flux variations (corresponding to the recorded audio) can squeeze onto the tape for any given speed (this sets the maximum frequency that can be recorded). This means that any audio information that is common to both left and right channels will be in line with each other, because they have been recorded by the gaps on the recording head which are on top of each other, in line at right angles to the tape direction.

Hopefully this should also be the case with the playback head, but unfortunately variations in the tape path caused by things like moulding variations between cart bodies, erratic head pads and

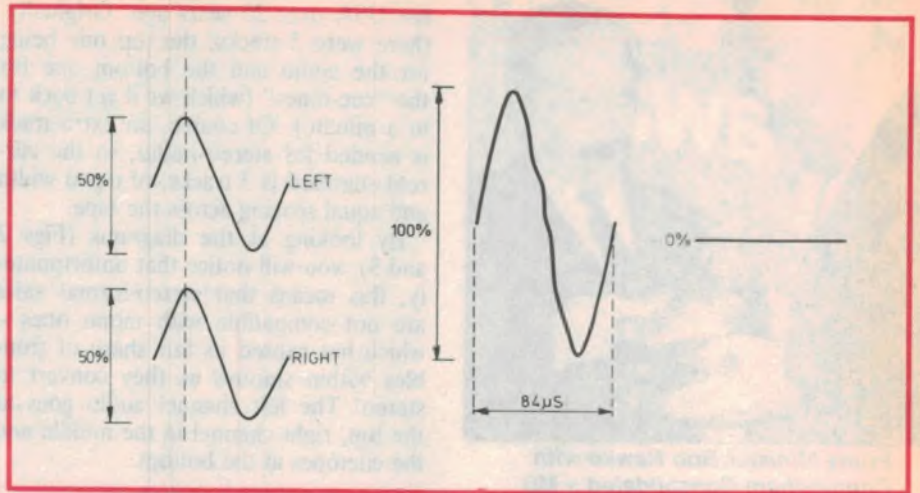

**Fig.5: The effects of phasing errors on the L+R mono component. In (a) we see original 12kHz L and R signals, in phase; in (b), the resultant L+R when they remain in phase; in (c) the L+R signal with one channel delayed by only 42 microseconds.**

badly adjusted tape guides tend to put the tape out of line (azimuth) with the playback head. This causes a time difference between channels of the recovered audio, with some nasty side effects, particularly for broadcasting. The worst of these is commonly referred to as "phasing".

Phasing is partial or complete treble cancellation in the mono sound (mono being the sum of the left and right channels, or L+R) because the two signals do not arrive to be added simultaneously. Let's look at Fig.5(a) and suppose there are two 12kHz signals that were originally recorded in phase on the cart recorder (in other words there was a 12kHz tone in mono or common to both channels). This would be recorded at 50% amplitude in each channel or 6dB down, so that when the channels are recombined the two signals would algebraically add to form the original 100% 12kHz signal (assuming that the tape transfer was perfect) as in Fig.5(b).

Now let's take a look at what really happens. Suppose the playback head is tilted slightly with respect to the tape

(out of azimuth) so that the left channel information arrives slightly before the right channel, as in Fig.5(c). In this case, we'll rig the figures and say that the left channel leads the right by an amazingly small 42us, which corresponds to only 0.008mm or 0.0003 thousands of an inch azimuth error at cartridge speed (190mm/sec).

Now 42 microseconds also happens to correspond to 180° (one half-cycle) at 12kHz. This means that the mono signal (L+R) will be cancelled at 12kHz and be reduced significantly at frequencies right down to 6kHz or so. Sounds bad! Fig.6 shows the resulting frequency response, as the signals would be received on a mono receiver.

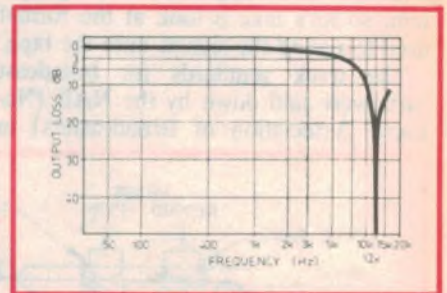

**Fig.6: The resulting frequency response of the L+R mono signal, with a 42 microsecond timing error between the two stereo channels.**

To make matters worse, there is no reason to suspect that any delay will remain constant in a cart system. The tape can easily alter its angle relative to the head and this variable delay network will cause a moving notch effect through the high frequencies of the mono audio, as the tape path weaves around. You can often hear similar ef-

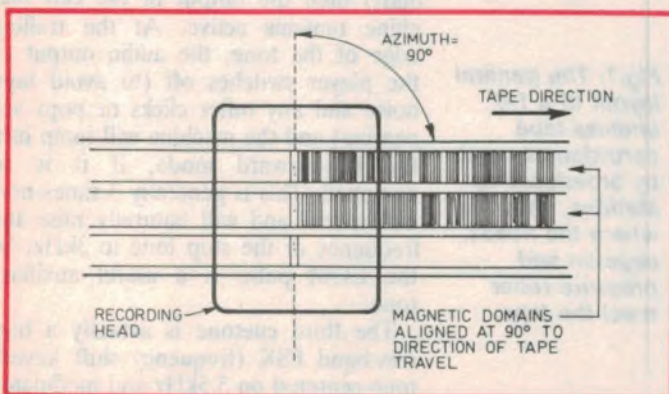

**Fig.4: When the head/tape azimuth angle is maintained at 90 degrees, both stereo tracks are recorded and played back in phase.**

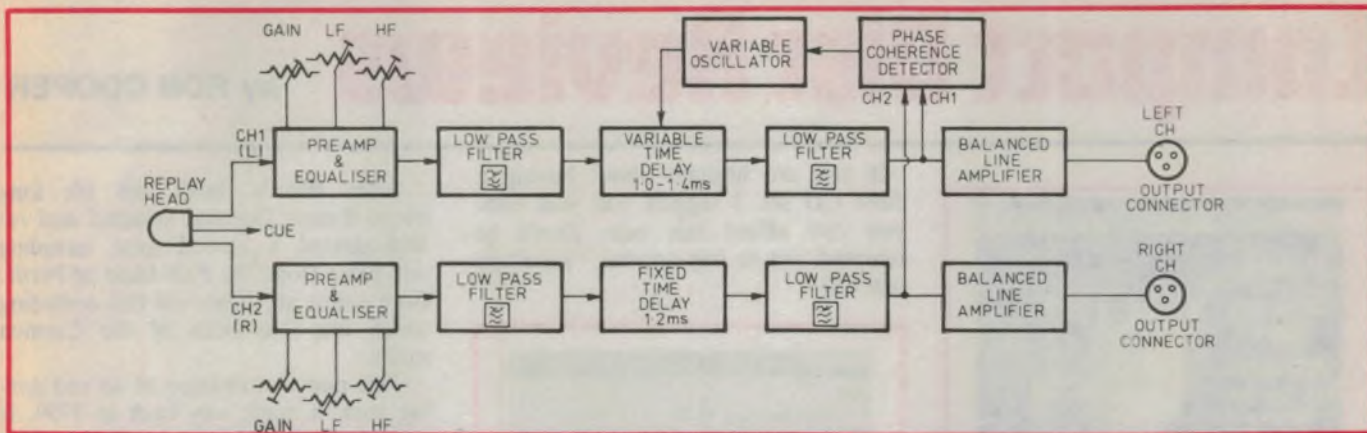

Fig.7: Block diagram of the replay section of the Autophase 2000, showing the phase detector and BBD variable time delay element.

facts when stereo cassettes are played on cheap and nasty mono players.

There are ways to get around these problems, though. One solution is known as matrix format recording. Mono (L+R) is recorded on one track of the tape and the difference (L-R) on the other track. The stereo information is then recovered on playback by dematrixing back to discrete L and R channels. The phasing problem in mono disappears because it now has its own track (rather than the sum of 2 tracks) – but now the azimuth variations result in varying stereo separation. Another problem is that matrix format is not much use if you already have an extensive stereo cart library... it's incompatible and it's too late to change now! However, matrix format recording is used by a number of stations very successfully.

Another possible solution is to use an encoded tone on each channel, so the playback machine can watch the delay between the channels and electronically adjust variable networks accordingly. This system also works well but again suffers incompatibility with normal stereo carts.

Wouldn't it be better to have some kind of processor that would automatically monitor the replayed audio and somehow figure out if it was getting too "phasey" and correct it? That's basically what the boys at Cunningham-Consolidated have in fact developed, and incorporated into the new "Auto-phase 2000" replay machines.

A glance at Fig.7 shows the basic layout of the audio section of the machine in simplified block form. The real heart (or should I say brains?) of the circuit is the phase coherence detector, which we'll look at after a quick overall run through.

The individual L and R signals from the playback head are first pre-amplified and equalised to the machine's internal reference level. Next step is a

low-pass filter to remove any frequencies that could cause aliasing (heterodyne-fold over) products in the following stage, which is a fast analog sampling device with a multi-stage bucket brigade-type delay line. The left channel has a fixed 1.2ms delay due to a fixed oscillator clocking the samples through the bucket brigade.

The right channel follows much the same path, except that in this case the oscillator frequency can be varied to form a variable time delay through its bucket brigade from 1 to 1.4ms. This means that the circuitry has a variation range of + or – 200 microseconds between channels. The outputs of the time delay networks then feed to low-pass filters to remove the out-of-band sampling hash (sidebands around the clock frequency and harmonics) and then to the line output amplifiers.

Now to the brains of the circuit, the automatic phase coherence detector. This device is covered by patent applications and its actual workings are still fairly secret. It takes a sample of each channel and analyses the phase coherence over the whole audio spectrum to about 8kHz, with more weighting on the mid to high frequencies. The output of this device is a DC voltage which varies the frequency of the VCO, thus altering the time delay in the right channel and bringing the two channels back in step again.

Thus the whole design is a servo mechanism, with the phase detector monitoring its own corrective action. A great deal of patient research work has gone into getting the loop response (timing of cause and effect) optimised, otherwise the circuit would "chase its own tail" on one hand, or be too slow and therefore audibly ineffective on the other.

Another interesting fact about this design is that all the filters, delay networks, oscillators and phase coherence detector are physically in a set of three hybrid ICs, made in Melbourne by Hybrid Electronics to Cunningham-Consolidated's specifications. The bucket brigades are actually a DIP package chip from the USA within two of the hybrid chips. Good effort!

The obvious question is: How well does it work... is it any good?

Firstly, the machine itself is a neat package with a nice simple functional front panel, heavy duty chassis and transport including a high-performance pinch roller solenoid and Australian-made DC servo motor, with a hub integrated flywheel. The electronics are all on extendable, removable PC boards with a good switched-mode power supply that doesn't blow up!

All rear panel audio, power, data and control connectors are good quality and well labelled. The audio performance is basically limited by the tape quality, with low noise, distortion and wow and flutter, and high-headroom low-impedance balanced line outputs. I think it's very good. I have purposely recorded all kinds of music and speech in and out of azimuth and on carts of varying stability, and the machine copes well. Occasionally it has been fooled, where there has been high-energy treble predominately in one channel, (especially from CD) but this is a rare occasion and really only obvious from A-B comparisons to the original.

Its real purpose of correcting timing errors of audio from cart is coped with very well, and it's a very clever way of noticeably improving high-quality stereo broadcasting (AM, FM or TV) for the listening audience.

And it's fully Australian!

4

# Compact Disc Reviews

by RON COOPER

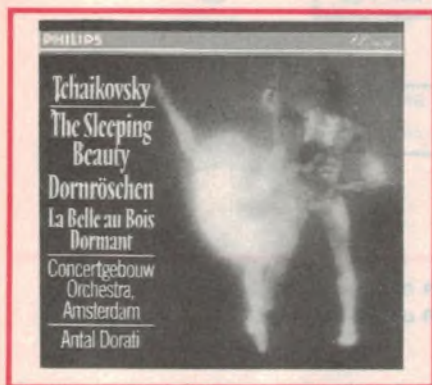

## TCHAIKOVSKY

The Sleeping Beauty  
Dornroschen  
La Belle au Bois  
Dormant

Concertgebouw  
Orchestra

Amsterdam  
Antal Dorati

Classics Disc 1 (420 793-2)

Playing time: 3 Disc set 2 hrs 41 min

### PERFORMANCE

1 2 3 4 5 6 7 8 9 10

### SOUND QUALITY

1 2 3 4 5 6 7 8 9 10

The English conductor/composer Constant Lambert once wrote: 'The Sleeping Beauty is not only one of Tchaikovskys' best works but an unmistakable masterpiece, both musically and theatrically, in which the composer creates a world of timeless beauty that can be compared to the world created by Mozart in such an opera as *The Magic Flute*.'

I think this sums it up pretty well. Certainly the original scenario presented to Tchaikovsky at the time by Vsevolozhsky and Petipa had very good potential, but in craftsmanship alone Tchaikovsky overshadows them. Like the *Nutcracker* and *Swan Lake* the melodies seem to stretch like a golden chain from one end to the other.

The performance and sound of this complete set is excellent in all respects in spite of it being an older analog recording. It has atmosphere and excellent sound balance. The bass is very open and creates the "feel" of the bass drum when played on speakers able to realise this potential.

If you are hesitant about buying a three CD set, I suggest you wait until you can afford this one. Don't be tempted just to buy another "suite" on one CD.



## BIZET

Suites, "Carmen" Nos. 1 & 2  
"L'Arlesienne" Nos. 1 & 2

Orchestre des Concerts Lamoureux  
Igor Markevitch

Silver Line Classics

Playing time: 59 min 32 sec

### PERFORMANCE

1 2 3 4 5 6 7 8 9 10

### SOUND QUALITY

1 2 3 4 5 6 7 8 9 10

Here is perhaps the most famous of classical music ever written – an ever-green if ever there was one! *Carmen* is naturally Bizet's masterpiece and the pinnacle of French Opera Comique.

He commenced writing it around 1873 and the premiere was in March 1875. It was a great pity that it was poorly received at the time, which depressed Bizet and he died exactly 3 months after the first performance on June 3rd 1875. The international success of *Carmen* was strictly a posthumous affair so far as its composer was concerned.

The music for *L'Arlesienne* was written for Daudets' play in just a few weeks in 1872 and was first heard on the 1st of October that year. It is delightful music, has instant appeal and will probably be familiar to most. After the production of the play Bizet arranged five of the orchestral pieces as a suite, increasing the size of the orchestra to symphonic proportions.

After Bizet's death, his life long friend Ernest Guiraud selected and re-orchestrated a second suite including one piece from *The Fair Maid of Perth*. Both suites are heard on this recording which also has both of the *Carmen* suites.

This disc is a re-issue of an old analog version made way back in 1959. It was obviously selected by its excellent performance of these works and not its sound quality, which is even more dated than some other 1959 recordings but on CD at \$19 it is still reasonable value.

However, so far, I am not aware of any other CD releases of these wonderful works.



## DVORAK

Slavonic dances

Royal Philharmonic Orchestra  
Antal Dorati

Decca 417 749-2

Playing time: 70 min 15 sec

### PERFORMANCE

1 2 3 4 5 6 7 8 9 10

### SOUND QUALITY

1 2 3 4 5 6 7 8 9 10

Strangely, it was not until Dvorak was 37 that he achieved a breakthrough in his career as a composer. Although studying at the Prague Organ School equipped him as a church musician, he really was self taught by playing viola in the Provisional Theatre and studying scores as far as symphonic orchestrator was concerned.

The two sets of Slavonic dances here were written in 1878 and 1886 and represent two different periods in his life.

continued on page 141

## Professional Instruments for Professional People

### Digital Storage Scope HM205-2:

This truly innovative feature-packed scope provides digital storage capability with 5 MHz max. sampling rate — all at an incredibly low and unbeatable price. "High-tech" digital storage you can afford!

### Graphic Printer HM8148:

A hardcopy of your stored screen display at the press of a button. In less than 15 seconds! Use it also for automatic data acquisition at programmable times or intervals. The intelligent firmware provides automatic date/time and zoom function, min./max. interpretation, and linear interpolation.

### Modular System HM8000:

A full range of space-saving, interchangeable plug-ins — professional but low in cost! Multimeter, function-, pulse-, sine wave generators, counter/timers, distortion-, milliohm-, LCR-meters, power supply... Plug them in as you need them — and save!

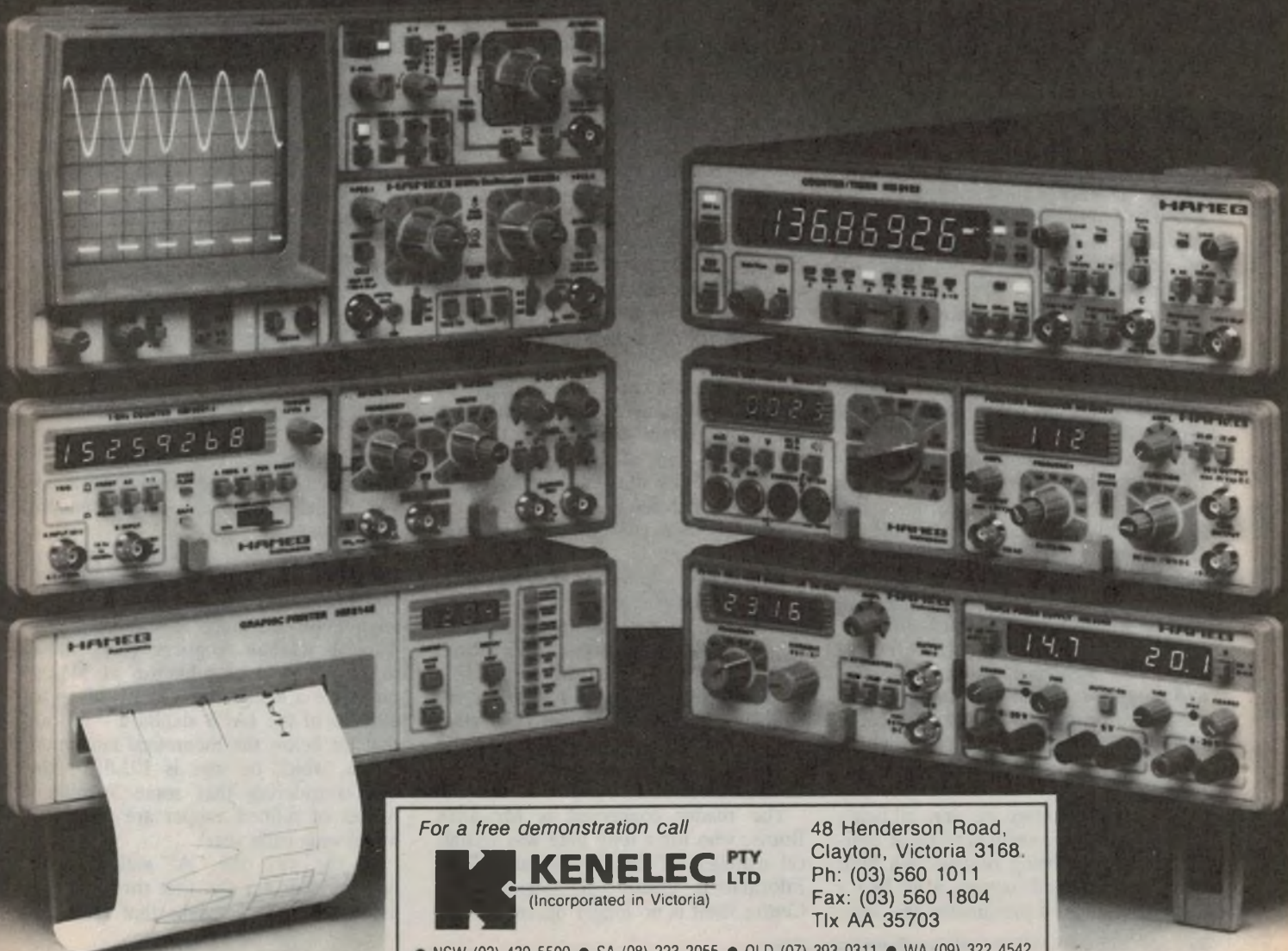

For a free demonstration call

**KENELEC** PTY LTD  
(Incorporated in Victoria)

48 Henderson Road,  
Clayton, Victoria 3168.  
Ph: (03) 560 1011  
Fax: (03) 560 1804  
Tlx AA 35703

• NSW (02) 439 5500 • SA (08) 223 2055 • QLD (07) 393 0311 • WA (09) 322 4542



## Oxygen-free copper: more than just marketing hype?

Increasingly, makers of hifi amplifiers and other equipment are claiming the use of "oxygen-free copper" as a feature of their products. Some amplifiers even use this kind of copper wire for internal wiring. It sounds impressive as a selling feature, but exactly what does it achieve apart from that?

This is actually the second time I'm having to type in this month's column – by sheer bad luck, both the hard disk and floppy disk backup copies of my original file were destroyed by water and soot in our fire. Luckily I had made a "hard copy" of about half of it on paper, which was safely stowed in my bag. So at least I've had that to remind me of what I wrote the first time!

Anyway, here we go again, and I hope it doesn't read too much like a re-hash:

Some months ago, when I was reviewing an advance sample of one of the new DAT recorders, I noted with some bemusement that the manufacturer placed emphasis on the fact that oxygen-free copper or "OFC" was used in various parts of the equipment. This included the winding wire inside the power transformers, some of the internal wiring – and even the metal pillars on the underside of the case, if I remember correctly.

It all sounded suitably plausible, yet I was a bit dubious.

Like many of our readers, no doubt, I'd noticed the recent appearance of OFC among the selling features for hifi and other gear – especially that made in Japan. The term "oxygen-free copper" was obviously meant to imply that the ordinary copper used in other equipment had significant oxygen content, and that this somehow resulted in inferior performance – both electrically, and perhaps mechanically. So that be using OFC, you presumably got a better result.

Somehow the image we were all being invited to imagine seemed to be of ordinary copper as being riddled with little bubbles of trapped oxygen, a bit like a Swiss cheese. And presumably the more

trapped bubbles of oxygen there were, the less of your genuine solid copper metal there would be to provide good electrical conduction and mechanical strength. By using solid copper that was free of those pesky trapped bubbles, you'd obviously be avoiding these troubles.

Mind you, none of this was actually explained in so many words. In fact there was very little overt explanation at all. The use of OFC was simply listed as one of the features, seeming to imply that its benefits were self-evident – or perhaps alternatively, in the hope that we'd draw the above naive inferences.

Now I'm certainly not a metallurgist, but it all sounded a bit glib. I guess I was mildly skeptical – and I'm sure I wasn't the only one.

At the time, I wasn't sufficiently concerned about the matter to pursue it further with the experts. As I suggested in the review concerned, the *benefits* of using OFC might well be open to some conjecture, but at least there didn't seem to be any *disadvantages*. At least judging from the performance of the DAT recorder concerned, which was very impressive.

Since then, though, I've received a fairly long letter from a reader – picking up on the subject and exploring it in depth. And as the reader concerned is quite knowledgeable in this area – he's a chartered engineer and metallurgist, in fact – I thought it might be a good change of topic this month to pass on his comments and explore the topic of OFC further.

The reader concerned is Mr Dick Burns, who for a long time was technical manager of the Copper and Brass Information Centre in Sydney. The Centre itself is no longer operating, but

it gave advice to the local electrical and electronics industries for many years, as well as providing information links with overseas bodies concerned with copper sourcing, refining and supply. So Mr Burns should certainly know his copper.

Now I'm going to have to boil down the content of his letter, because he does go into the subject in detail and at considerable length. But as I understand it, the story seems to be as follows.

Basically, four standard grades or varieties of copper are recognised for electrical/electronic use by our own SAA and similar standards bodies around the world. As defined by the SAA in its Specification 1279-1985, these are summarised as shown in Table 1.

As you can see, despite their somewhat oddball names (which are apparently related to the refining methods used to produce them), they all have remarkably similar electrical characteristics. Each has a rated copper content of 99.9% or better, while all four have virtually the same *maximum* resistivity of 0.15328 ohms per metre at 20°C.

Similarly in each case their *minimum* conductivity relative to the International Annealed Copper Standard or "IACS" is specified at 100% – presumably meaning that they're all equal to or better than the best grade of electrical copper available when the IACS standard was prepared.

Dick Burns notes that most present-day coppers exceed the IACS standard, due to the fact that refining techniques have improved since it was prepared. Typical modern coppers (like those made in our own refineries at Mount Isa) have a conductivity figure of up to 101.5% of the IACS standard – not all that far below the theoretical maximum figure, which he says is 102.5%. Not bad considering that some 7 million tonnes of refined copper are produced world wide each year!

By the way, the "A" suffix in the type number for the first three copper listed in Table 1 means that they are

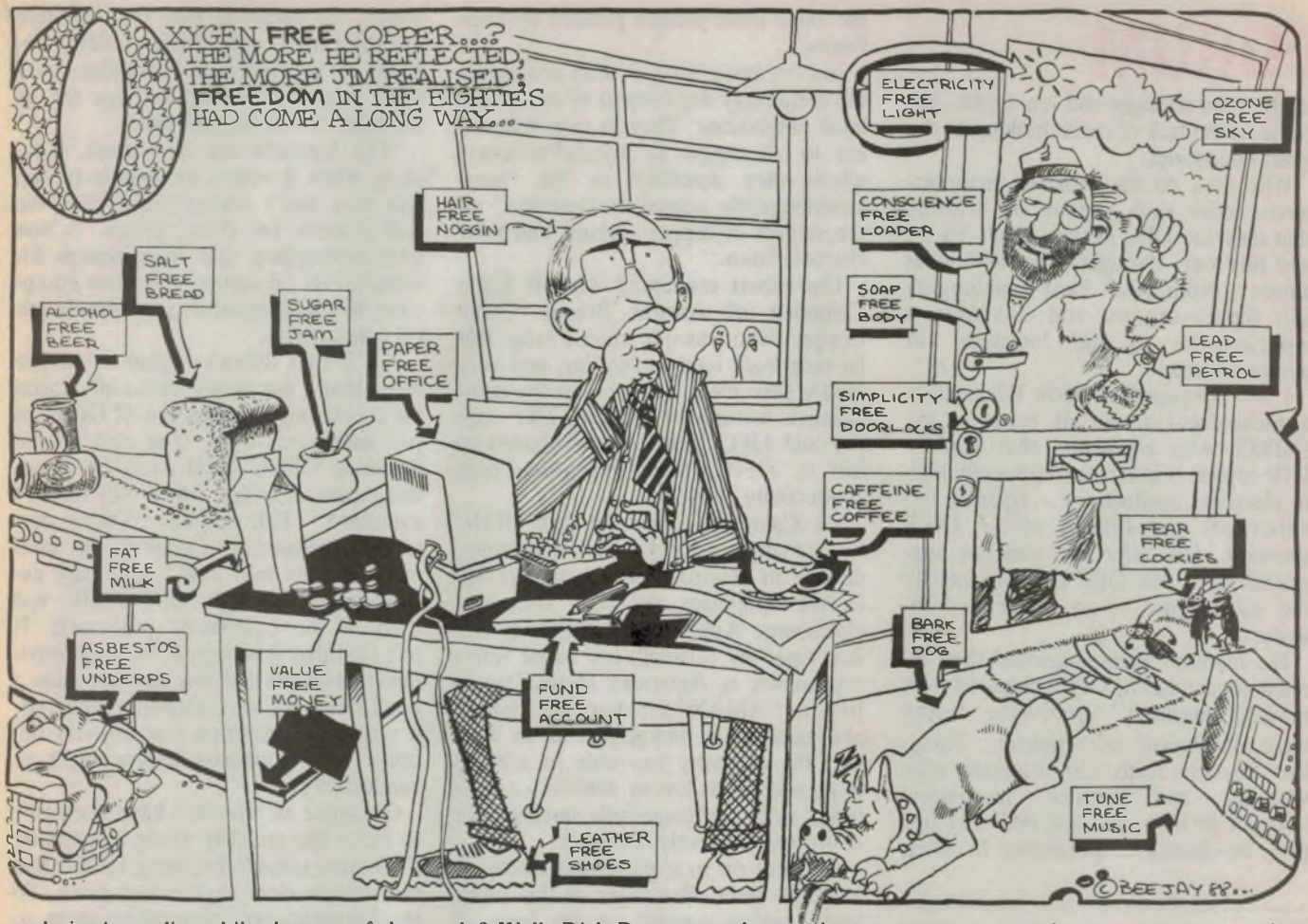

made in Australia, while the rest of the number relates them to the appropriate international specifications.

Apparently oxygen-free copper isn't specified in the SAA specification, and according to Dick Burns this is because it isn't made in Australia. Apparently it requires a special refining process, with the copper surrounded by a vacuum or protective inert gas environment during the final "freezing" into solid copper.

To compare OFC with the coppers shown in Table 1, it is therefore necessary to use data prepared by the Conseil International Pour Le Development Du Cuivre (CIDEC), based in Geneva. And when you do this, according to Dick Burns, it turns out that OFC has virtually the same conductivity range as the type 110A copper shown in Table 1 - from 100% to 101.5% of the IACS standard.

In other words, there doesn't seem to be any significant difference between OFC and say "ordinary" Aussie-made 110A *Electrolytic Tough Pitch* or "ETP" copper, in terms of electrical conductivity at least.

### How much oxygen?

But just how much oxygen is there in ordinary copper, and what else might it

do? Well, Dick Burns says that modern ETP copper has an oxygen content of .05% maximum. Most of this is apparently concentrated at the boundaries of the copper grains, in the form of copper oxides.

According to Mr Burns the main effect of this is to produce a tendency for the copper to become brittle, especially in environments where it will be sub-

jected to high temperatures and/or where reducing gasses will be present. I gather this tends to make OFC preferable to ETP copper for things like lead-in wires for high power thermionic valves, rotor windings for high power motors and alternators, and so on.

So far then, it begins to look as if the main advantages of OFC are mechanical rather than electrical. It looks as if it's

**TABLE 1: STANDARD TYPES OF COPPER**

Code	Name	Copper content min. (%)	Electrical Resistivity (ohms/m) at 20 C	Conductivity % of IACS minimum
110A	Electrolytic Tough Pitch	99.90	0.15328	100
110A	Fire Refined High Conduct.	99.90	0.15328	100
116A	Silver bearing tough Pitch	99.90	0.15328	100
119D	Phosphorised High Conduct.	99.93	0.15328	100

*A table supplied by Mr Burns, comparing four main types of copper. As you can see, there are few differences.*

# FORUM

likely to be stronger and less brittle, because of the lack of oxide buildup at the grain boundaries.

Why then do the Japanese manufacturers make such a point of stressing that they use OFC in their gear? To try and find out, I sought some additional advice – from other local metallurgists and copper experts, and also from a representative of the Japanese hifi manufacturers.

I first contacted Dr John Wilmshurst, a metallurgist friend of mine in the CSIRO, who confirmed that modern ETP copper is indeed exceptionally high in electrical conductivity – typically between 101 and 101.5% of the IACS standard. His reference material suggested again that OFC provides exactly the same range – no better and no worse.

His material again suggested that the main advantages of OFC compared with modern “ordinary” electrolytic copper were mechanical, not electrical. Things like freedom from embrittlement after welding, and greater mechanical strength at both elevated and very low (i.e., cryogenic) temperatures. In short,

the same basic picture painted by Dick Burns.

Just to make sure, I tried contacting the metallurgy department of one of the local universities. They in turn referred me to an expert in private industry, whom they described as the “most knowledgeable person in Australia” on the subject of copper variants and their characteristics.

The expert concerned was Mr Colin Campbell of Austral Bronze Crane Copper, who was out when I rang. But he rang back later in the day, and very kindly gave me a rundown on the comparative features of ordinary ETP copper and OFC – or as he preferred to call it, OFHC (for oxygen-free high conductivity copper).

Mr Campbell explained that OFHC has actually been around for some time, despite its relatively recent appearance in hifi equipment and other consumer electronics. Apparently it was originally developed by a New York based refinery known as American Metal Climax Inc., or “AMAX” for short. By melting and casting the final ingots in an inert gas, the company was able to achieve oxygen levels as low as .0003% – a couple of orders of magnitude smaller than in ordinary electrolytic copper.

He went on to explain that traditionally, the main advantages of this much lower oxygen content (in the form of copper oxides) were mechanical. One was freedom from “hydrogen embrittlement” following welding; another was greater ductility – the ability to be drawn into much finer wires, without breakage or weakening. And thirdly, he noted that an important feature of OFHC is that it has a very tightly bonded layer of oxide on the *outside surface*, presumably because of the lack of oxides inside.

It is this characteristic which apparently makes OFHC particularly suitable for glass-metal seals, such as those required where wires must pass through the glass envelope of a valve.

But what would be the advantage of oxygen-free copper for ordinary electronic components and wiring? Mr Campbell agreed that there is virtually no difference between the electrical conductivity of OFHC and standard electrolytic copper of the type produced at Mount Isa. So that superficially, he too was unable to explain what possible advantage OFHC might have for electronic components, or the wiring inside a hifi amplifier or DAT recorder.

He was cautious about drawing any firm conclusions from this, however. In fact he suggested that we could well be

wrong, in assuming that the Japanese manufacturers were using OFHC because of any electrical advantage over ETP copper. The real reasons for its use might be rather different:

“The Japanese are very smart, especially when it comes to manufacturing. But they don’t always make clear the real reasons for doing things. It was your assumption that their reason for using OFHC in certain electronic equipment was because of its superior electrical conductivity.”

“So if that doesn’t appear to be the case, that’s not really sufficient reason for concluding that this use of OFHC is just marketing hype. The real reason for using OFHC could easily be something quite different, which they haven’t explained.” Fair enough. That’s certainly a possibility. Certainly the sales material I’ve seen didn’t offer any explanation as to *why* OFC/OFHC was used in the equipment concerned. It just said that it was used, with the obvious implication that this was somehow a *good thing*. As Mr Campbell points out, it was our assumption that this was because of a supposed improvement in conductivity.

Of course we wouldn’t have been able to make this possibly wrong assumption if the real reasons for using OFHC had been made clear in the first place. So the manufacturers themselves seem to have contributed to our mistaken inference, if that’s what it is.

## The real reason?

What then is the *real* reason for using OFHC in this equipment, if it isn’t for improved conductivity?

I approached the Australian subsidiary of one of the main Japanese hifi manufacturers, to try and get the answer. The good people there admitted that they didn’t know all of the fine details, but undertook in turn to send a query to Japan, to find out from the design engineers themselves.

Unfortunately by the time I had to send this month’s column away for typesetting, the answer still hadn’t come back from Japan. So I guess we’ll all have to wait until next month, for the definitive answer!

## Tingles and bites

To end up this month, I’ve received a couple of letters already following on from my column in the July issue about double insulated appliances that give you a “tingle” – and how to find out if they’re really dangerous or not.

The first letter was from Phil Allison, a service technician who deals with a lot



Why buy it?  
These valuable projects from *Electronics Australia* will add a new dimension to your workshop! Detailed, step-by-step instructions guide you through the construction of the most useful of electronic workshop test gear. **Never built a project before?** What better way to get started than by building the test instruments needed to begin a workshop? Build it yourself to save and learn at the same time!

Send your order to:  
Freeport No.4,  
Federal Publishing Book Sales,  
P.O. Box 227,  
Waterloo NSW 2017

(no postage stamp required  
if mailed within Australia)

Price: \$3.95



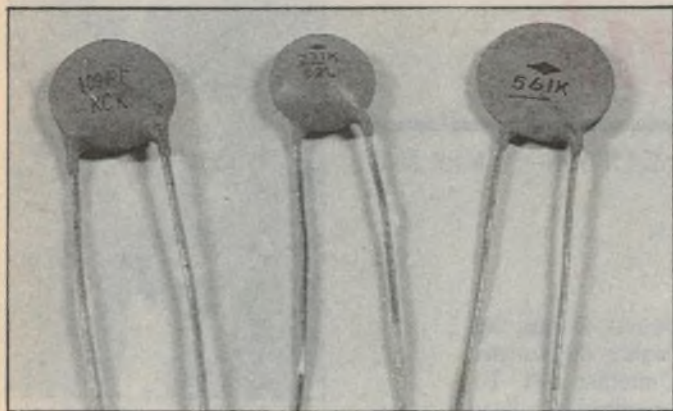

Without wishing to renew the great nanofarad argument(!), I offer these pictures. At left, slightly confusing markings on typical ceramic caps. At right, caps with values given in the "dreaded" nanofarads.

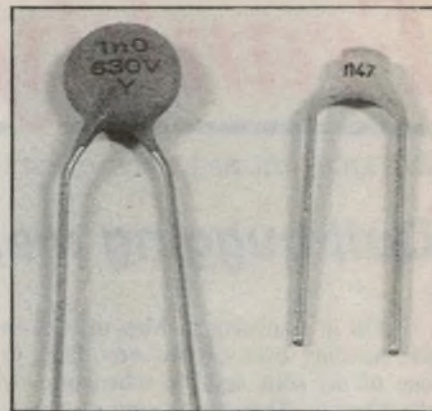

of professional audio gear in the Sydney area. In his letter he describes a situation which is very relevant to the subject of leakage and tingles, even though he didn't experience it directly:

The complaint was that performers in a Sydney Hotel were regularly receiving electric shocks, from the microphones used in the house PA system. An electrician had declared the house wiring OK, and others had attempted to find the cause of the problem - without success.

Those receiving the shocks were usually guitarists, whose instruments would be connected to mains earth - and hence they too would be earthed whenever they were touching the strings. It seemed the microphones must be "live", because the guitarists were getting most unpleasant shocks whenever their lips touched the microphone cases.

The mixer-amplifier employed was of a well-known Japanese make, that uses a two-core power lead - i.e., it is "double insulated". When Phil Allison was asked for advice about the problem (over the 'phone), he guessed that this might be the cause of the problem. Having no mains earth it would be possible for the unit and anything connected to it to "float" at some considerable voltage above earth, as noted recently in Forum.

As a temporary cure only, my advice was to try running a jack lead from a spare input on the mixer to a spare input on one of the normally earthed amplifiers on stage. This would hopefully bring the mixer-amplifier to earth potential.

I was told that this measure completely eliminated the problem. Eventually the mixer-amplifier's two core lead was replaced with a standard three core type, and the double square symbol on the back of the unit effaced as recommended in Forum.

It is likely that the current involved in these shocks was quite small, probably

too small to cause injury. But the problem was very real, and unacceptable to the performers concerned.

My view is that "double insulated" equipment has its place, but that audio equipment, especially PA systems, must be securely tied to mains earth in order to function properly in typical installations.

I should like to hear comment about the above incident from importers of "double insulated" musical equipment, as this would surely not be an isolated case (no pun intended).

A very interesting case Phil, I'm sure other readers will agree. The human lips are a very sensitive part of our anatomy, and I imagine that even supposedly non-dangerous currents applied to them produce a most unpleasant experience. This certainly seems to be a situation where earthing is very desirable, rather than double insulation.

Like Phil Allison, I too would be very interested to hear comments from the equipment importers as to how they can justify continuing to supply this kind of gear with double insulation rather than earthing.

The second letter came from our old mate Jim Lawler of Hobart, also an experienced service technician. Jim's letter brings to light another aspect of double insulation and two-pin power plugs, which I for one hadn't noticed:

My son has just moved house, and he complained to me that none of the power points in the lounge or bedrooms of his new house would work. Only the kitchen socket, where he used the toaster, would accept a plug. All the rest appeared to be blocked in some way, and he couldn't use his hifi, his bedroom clock, or even his electric razor.

I tried several of his appliances in various sockets, but none would accept a plug. But the previous tenants had not complained, so there had to be a simple answer.

When I removed one of the sockets

for a closer look, I soon found what I should have suspected from the beginning. The sockets were fitted with "safety shutters" over the active and neutral openings, which could only be displaced by the earth pin of a normal, three-pin plug. But most modern appliances are "double insulated" and are fitted with two-pin plugs.

So I was faced with the task of either fitting three-pin plugs to 15 or 20 appliances, or removing the shutters from eight sockets. On the basis that there were millions of un-shuttered sockets all over the country, I decided to operate on the sockets rather than chop off and replace 20-odd perfectly good two-pin plugs.

Surely this must be the classic no-win situation. I've done the wrong thing by un-shuttering safety sockets. But otherwise I would have also done the wrong thing by fitting three-pin plugs to double insulated appliances! No matter that the earth pin would not be connected to anything...

As I see the rules, only two-pin plugs can be fitted to double insulated appliances. Like so many rules devised by bureaucrats, the double insulated argument is good in principle, but totally out of touch with reality.

Hmmm. Pretty strong words there Jim, and I'm not sure I'd go that far myself. But there certainly seems to be a clash between the desire to have shuttered power outlets, to prevent children sticking things in, risking electrocution, and the trend towards double insulated appliances with two-pin plugs. The two just aren't compatible.

I think I'd have done what Jim did, in the same situation, and remove the safety shutters. But as Jim himself points out, it seems to be a classic case of "damned if you do, and damned if you don't".

Perhaps someone from the SAA will write in and explain the officially sanctioned solution to that one! ☹

# Frankly Frank

Musings on matters electronic by FRANK LINTON-SIMPKINS



## Quit bugging me, will you!

I was in Canberra in May to witness the handing over of two new flags to one of my sons and his colleagues, by the Queen. There is a sort of family tradition about this flag thing – my wife had been among the spectators when the old flags were handed out by the Queen on a previous visit, and I had often marched around the same parade ground behind a set of flags given by the Queen's father.

As a sort of a secondary event the Queen was in Canberra to open the new semi-submerged Parliament House. I had wanted to personally witness this other event, but since the word was that 1,000,000 people were expected, I was warned off. In the event I needn't have worried, since the TV showed that there was only about one brigade on parade, or around five thousand patriotic horde members of all ranks.

The TV commentators, loyalists to their bootstraps, said that there were 35,000 people and that around 1500 of them were Khoori demonstrators. The true figures were around 500 Khooris and about 4,500 on the terraces. There were probably as many again inside the place. Although I can understand the upset of any people who have had another race move in and take over their country, I suspect the real reason for the Khoori demo was the grossly inaccurate way we pronounce the name of the place. It should really be Camberry after the Bogong Moth, a pre-dawn unsaturated fats delicacy much favoured by the regional tribes before the Europeans came in and renamed the place – firstly "The Limestone Plains" and then "Canberra".

But the Khooris should not lose heart. It took my ancestors 727 years to get rid of the same mob that took over Camberry and still a quarter of the country is gripped hard in the Sassenach fist. I should also point out that 200 years after European settlement began and 87 years after Federation it wasn't an Australian that opened the new house. In the words of a song from my mother's country, "One day we'll all be civilized. Won't old mother England be surprised."

The point of all this was to link the bugs that provided a healthy diet for the Khooris with bugs of another sort. To watch the show at the artificial hill, I sat back five kilometres away and saw the whole thing on TV. There I got a better picture of the new sous terrain and the Firbolgs therein than anyone on the site, except for the men in the security control room. I had a proper CIA view of the event.

In comfort and sipping my Earl Grey's I saw the Queen do her shtick with the keys, saw her wonderfully controlled expression as she undraped a portrait statue of her good-self, in short I saw the whole show. I can't help feeling that the statue was provided in much the same spirit as the slave who was required to ride behind a Roman General during a Triumph and to constantly remind the General that he was mortal.

In a sense, with the aid of several TV channels and with the legal connivance of the Speaker of the House, I had successfully "bugged" the whole show. As I did my bugging and saw the modern Kaaba of the Oz Haj, I was reading of a truly fascinating bit of gear for the Space age peeping Tom US style.

If you are still a relatively gelid spy, a private detective or just curious, this device is for you. It consists of a car radio aerial with a tiny lens at its top. From this lens a fibre optic link comes down to a transmitter/TV camera located in the top of the car's body panelling. The aerial rotates slowly, giving the viewer a panoramic view. The camera transmitter sends the pictures to a remote monitor. The picture provided by the bug is said to be excellent, but then they promised that from SBS – and you all know how poor US colour is.

After reading this I have become unable to pass a parked car without giving its radio aerial a crafty look to see if it is turning. Just before I sat down to write this, having returned from Camelot to Paddington, I had this terrible urge to check how many cars in my street were equipped with TV.

A swift count from behind the front curtains showed that at least six cars in

my vision range had been parked with their aerials up. Considering the nature of the feral patrons from the local pub, to leave your aerial up in Paddington is to tempt fate and the flat 'at mob.

Then I saw a local, one of us, approaching. Doc is a pantheist and talks to trees, even wattles – those wretched wimpish things. Now a discussion of Talmudic intensity with a macho great Moreton Bay fig would not surprise me, but I can't understand wattle tattle.

Doc is a retired cosmetic surgeon who has an order of Australia for services above and beyond the call of duty during the re-location of elderly females' ears, after several face lifts and also for charging fees beyond the dreams of avarice. I went out to greet him. "Doc", I said over the recently installed anti-Mormon fence, "I have been to Canberra to see the Queen". "Why so far Franko?, you could have walked along Oxford Street on late shopping night and seen hundreds", he reasoned. To avoid a conversational dead end I told him about the TV equipped car radio aerials.

Doc then told me that I had nothing further to fear from the seeing-eye aerials as he had a plan, intelligence that filled me with alarm. He reached into his gold initialled calf hide briefcase and removed a roll of surgical sticking plaster, plus a pair of fearsomely clinical scissors. Leaving me he began gracefully wrapping the tops of car radio aerials with the plaster.

Since the day was the one when the local Police collect unpaid parking fines, a young cop and coppette watched in bewilderment as Doc wrapped the aerials of their divisional Magna. We were now safe from observation via car radio aerial TV. Doc had once again earned his right to his Order of Australia, with scalpels, gumleaves and gold Amex cards.

Spy cameras in the aerials of Camirax are bad enough, but for sheer horror I commend to you the old microphone in

the loo down pipe trick. This works best if the people whose words you hang-on have a loo close to where serious matters are discussed. The surface or the water in the bowl vibrates like a microphone diaphragm as people talk nearby. This vibration is transferred up the down pipe to the cisten. The buggers' pickup is located in the cisten. There would have to be a noise overload cut-out to preserve the listeners' hearing.

All things considered I decided I wouldn't tell Doc about the loo bug. Who could say what a desperate man might do with his sticking plaster. I was also concerned for the health of his poor wife, who has only a mere four of five megabucks between her and the pension/meals-on-wheels.

All this talk and thought of bugging etc. reminded me that during a recent committal hearing of charges against the somewhat vocal Mr Grassby, AKA Roy G Biv, it was hinted that the telephone of his legal counsel had been bugged. Like much else about the case it had all been so clumsy and outdated. Couldn't the buggers have used a laser mike on the windows of the learned man's chambers? A bug in his loo? A rifle mike as he and his client walked across the road to lunch at Pomeroy's? Are the National Crime Commissionaires so ill

equipped? Are the doughty men on loan to the NCA from the Feds unable to borrow equipment from the Americans like all our other security community members do?

We all know that the Americans have, for over a quarter of a century, been operating a series of party lines with UK international telephone callers, copying any interesting telexes, fax etc. and with the full permission of UK governments. Since the Americans probably haven't told our governments if they are bugging our local communications as well, they may be able to offer the NCA quite reasonable terms on a comprehensive bugging service.

But in case the Yanks don't trust the NCA here is a partial list of freelance bugging equipment currently on offer in the US and probably on sale in the shops in the transit area at Frankfurt airport if they want to save going to the US. The list, the partial list that is, includes such things as a bug that can pick up and translate typewriter sounds; transmitter bugs that are labelled Telecom or whatever that live permanently in telephone handsets and operate continuously; bugs in handsets that double as small anti-personnel mines in cases where convictions cannot be obtained to judicial or legal interference; microwave

monitoring of computers or word processing units; transmitting bugs that can be stuck on the outside of windows; fibre optic devices; laser mikes to pick up voice vibrations from windows; loo bugs and the favourite one, the telephone infinity bug.

All are illegal to use in Australia, that is they are illegal if used by anyone, but this will only stop civilians, not, as we have seen recently in NSW with the Age Tapes and in other places, the law enforcement authorities.

Doc headed off up the street taping up aerials and the young cop came over to ask me if I knew what it was about. "He's a few sandwiches shy of a picnic", I said, "But totally harmless now he is no longer practising as a doctor". Sometimes it is best not to alarm even our nice young Paddington cops with too much detail.

I went back inside and turned on the SBS test pattern. The music over was Handel's *Messiah* and as I waited for the climax, I wondered who might be listening to me listening to Handel - and who is listening to you turning these pages. The Handel changed: "Why do the nations so furiously rage together? And why do the people imagine a vain thing?"

Welcome to the goldfish bowl. 

## MetaWINDOW

# Power Graphics for your PC!

PC TECH JOURNAL

**"Product of the Month"**  
"... a technological tour de force for fast PC graphics."

**NO ROYALTIES!**

**NEW! - QuickWINDOW/C**  
All the features of MetaWINDOW for Microsoft Quick/C! - **\$346\***

**Unparalleled Performance!**

MetaWINDOW provides an expanded set of graphic drawing functions, plus the added functionality and performance required for designing multi-window desktop applications.

MetaWINDOW comes complete with language bindings for 20 popular C, Pascal and Fortran compilers, plus dynamic runtime support for over 50 graphics adaptors and input devices.

### MetaWINDOW

Advanced Graphics Toolkit  
4 disks, 3260 page manuals -

**\$544\***

### NEW! - TurboWINDOW/Pascal

All the features of MetaWINDOW for Borland Turbo Pascal Ver. 4!

**\$346\***

All prices includes Sales Tax.

**microway**  
SOFTWARE & HARDWARE

292 Chesterville Road, Moorabbin,  
Victoria, 3189.

Telephone: (03) 555 4544

Fax: (03) 555 9871

MicroWay is a registered trademark of Excel Computers P/L  
MetaWINDOW is a trademark of Metagraphics Corp.

- auto-cursor tracking
- pull-down menus
- pop-up windows
- comprehensive graphic functions
- multiple fonts



### Enhanced Features!

- Display multiple bitmap or "filled-outline" fonts.
- Face fonts for bold, italic, underline or strike-out stylings.
- Full "RasterOp" transfer functions for writing, erasing, rubberbanding or dragging: lines, text, icons, bit images and complex objects.
- Create pop-up menus, windows and icons.
- Supports IBM's new PS/2 VGA and MCGA graphics.

# At what age are you co

Allow us to tell you the true story of a SCUBA-diving instructor.

He had a pretty good life.

The small school he operated on the Barrier Reef was doing alright.

There were plenty of tourists who wanted to learn the sport, so the income was reasonable.

All in all the instructor felt he had it made. But after a while, he got to thinking, "What am I going to do when I get older? I can't spend the rest of my life diving."

## Too old for new tricks?

His friends thought he was worried about nothing. "Just about anyone would give their right arm to do what you do," they said. "And besides, you're only 22." Still, the instructor's concern continued, so he looked at a paper to see what was going, and made a few calls.

The enquiries led him to the conclusion he'd suspected; that he

was too old for any worthwhile training or apprenticeship schemes.

Even if he'd been 18, he was told, he'd have been considered a dog too old for new tricks. This story does have a happy ending, however.

## Can you do something about it?

The instructor sent off a coupon not unlike the one you see in the bottom corner, and subsequently found out about the RAAF's Adult Technical Training.

The instructor's plight, in fact, was not unusual. There'd be thousands of men and women who discover some time in their lives that they are dissatisfied with their jobs, and want to start afresh. This is where the RAAF can help.

We can retrain you as an aircraft technician if you're between 17 and 34.

Working with jet engines, navigation systems, armaments and the like, may be something you've never considered.

## Out of your depth?

Indeed, you may feel you'd be completely out of your depth in such a highly technical



# Considered over the hill?

environment. But there's a good chance that this may not be the case.

We could tell you, for instance, the story of the 30-year-old railway ticket collector who can now put a Hercules engine together in his sleep. Or there's the 28-year-old former bricklayer who's now an expert on F/A 18 airframes.

We also have a female clerk from the public service, who at age 22, decided to become an expert on aeronautical instruments. Our SCUBA-diving instructor made ground radars his field of expertise.

## The School of Life?

The point being made is this: The RAAF won't discriminate against you because your further education has been in the School of Life.

In fact, if anything, we feel that your age and experience would make you a more desirable employee for these reasons.

Reflecting this, the Adult Technical Training we'd put you through lasts around

12 months. Apprentices, on the other hand, take four years to gain similar qualifications. When you decide to leave the RAAF, you'll soon discover that, with your skills, you'll be at the top of your field. And that's a far cry from being over the hill.

## Where do you go from here?

Your next step is to fill in the coupon and send it off.

In return, we'll post you all the information on RAAF Adult Technical Training.

You must hold Australian citizenship, and have completed (or be completing) your schooling to year 10 with passes in English, Maths and Science (with a Physics content).

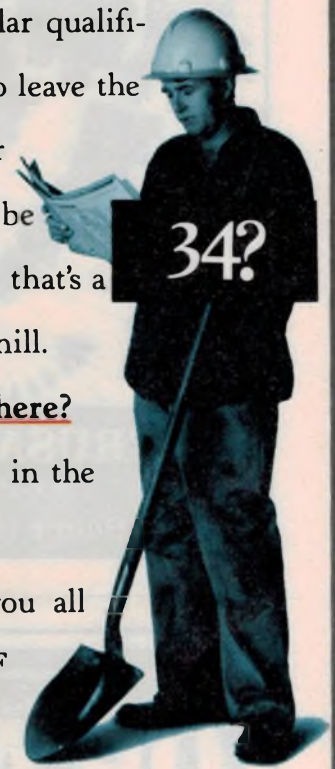

To: RAAF Careers, Freepost 2600AF,  
GPO Box XYZ (in the Capital City nearest you.)

Name \_\_\_\_\_

Address \_\_\_\_\_

Postcode \_\_\_\_\_

Telephone \_\_\_\_\_ Date of Birth \_\_\_\_\_

Highest Educ. level attained or being studied \_\_\_\_\_

Or phone an RAAF Careers Adviser on Adelaide 237 6222. Albury 218277.  
Bendigo 412500. Brisbane 226 2626. Canberra 57 2311. Geelong 211588. Hobart  
34 7077. Launceston 311005. Melbourne 696 2905. Newcastle 26 3011.  
Parramatta 635 1511. Perth 325 6222. Sydney 219 5555. Townsville 72 4566.  
Wollongong 28 1855.

ADULT TECHNICAL TRAINEES  RAAF

# CORNELL DUBILIER

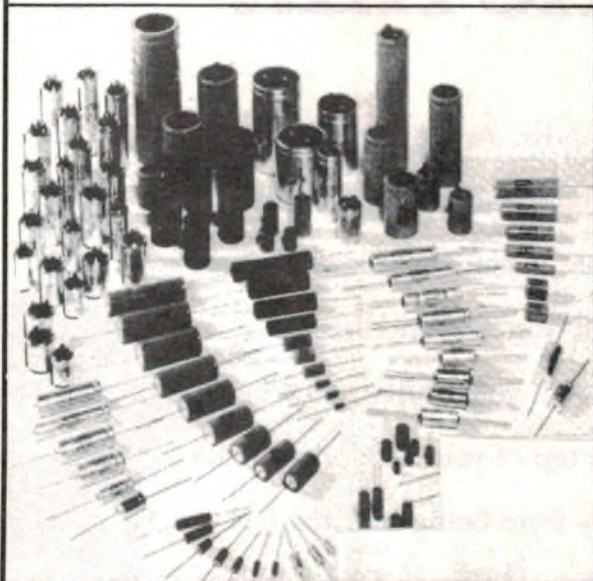

## ALUMINUM ELECTROLYTIC CAPACITORS

**CDE** CORNELL  
DUBILIER



**CRUSADER ELECTRONIC COMPONENTS PTY LTD**

81 Princes Hwy, St Peters, NSW 2044 Fax (02) 517 1189.

Phone (02) 519 5030, 516 3855, 519 6685. Telex 23993 or 123993.

AN ELECTRONICS AUSTRALIA PUBLICATION NZ \$5.95 AUSTRALIA \$4.95

## OP AMPS Explained

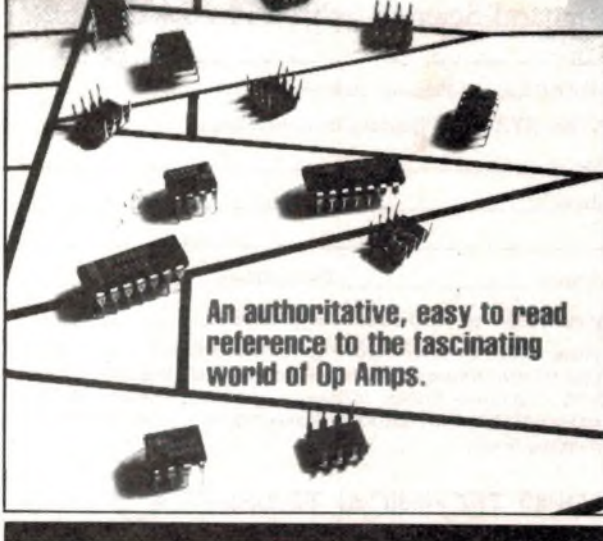

An authoritative, easy to read  
reference to the fascinating  
world of Op Amps.

Look inside almost any piece of modern electronic equipment (even things that are normally "digital") and you're likely to find op amps amplifying, filtering, shaping, clipping, detecting level changes or otherwise processing signals.

Without op amps, we'd still be in the electronic dark ages. And without sound basic understanding of the way they work and the way they're used, you probably won't get very far in today's world of electronics.

This book can be your guide and reference. It is authoritative, but at the same time very accessible and easy to read. The author has really boiled down the concepts of op-amp operation to make them understandable.

Recommended to all interested in linear electronics, operational amplifiers and their applications whether at hobby level or as a serious University or College student.

Send your order to:

Freeport No.4

Federal Publishing Book Sales,  
PO Box 227,

Waterloo NSW 2017

(no stamp required if posted within Australia)

Price: \$4.50 plus \$1.00 p&p

# Yes Yes Yes Yes Yes

## Introducing the "Yes" Service for Passive Components

# Yes Yes Yes Yes Yes

# s Yes Yes Yes

# Yes Yes Yes



In today's competitive production world, engineers need to have supply at their finger tips. The "just in time management" philosophy is proving to be a commercial reality. Philips are prepared.

When you call your component supplier you need some positive answers.

Philips Components promises to

deliver more yes's to your questions because they are leaders in:

- Quality
- Product Range and Stock availability

Not just platitudes but a strong commercial reality as a result of massive research investment, modern systems for efficient production and stock control and that absolutely vital element... top calibre, friendly people.

Apart from being the largest supplier of electronic components in the world, Philips aim to be the friendliest.

If you have a problem right now call the Philips "Componentline" and hear that magic phrase... "Yes, we can do it".

Sydney 439 3322 Melbourne  
235 3677 Adelaide 243 0155  
Perth 277 4199 Brisbane 844 0191.

United Nations 817

## Philips Components



# PHILIPS

SONY®

# Sony revolutionizes the world of radio. Again.



ACTUAL SIZE

We've packed world-band performance into an incredibly small, complete receiver system.

Sony is known for breakthrough radio technology. And for bringing it to you in ever-smaller packages.

But this time, we've really outdone ourselves.

Introducing the Sony ICF-SW1S world-band receiver system.

As you'd expect, it brings you broadcasts from around the world.

What you may not expect is its remarkably small size. Its wealth of features.

And its unique, total system design.

The ICF-SW1 weighs just 230 grams with batteries, yet offers precise 10-key direct access PLL-synthesized tuning. FM stereo, MW, LW and SW bands. Auto-scan and manual tuning.

Memory presets. And a digital clock with alarm and timer.

The ICF-SW1 receiver, by itself, is a world-class performer.

And there's a host of system accessories, starting with an active

antenna, to further enhance its performance.

So don't let the fascinating world of world-band radio go unheard.

Get the Sony ICF-SW1S. And stay forever tuned.

**WORLD-BAND  
RECEIVER**  
ICF-SW1S

For further information contact: Sydney (02)887 6666 Melbourne (03)836 4011 Brisbane (07)844 6554 Adelaide (08)212 2877 Perth (09)323 8646 Launceston (003)4311022 Wollongong (042)715777

SNY078



**"We've got WANs and LANs to troubleshoot. Isn't there a company that can handle both?"**

we never  
stop  
asking

"What if..."

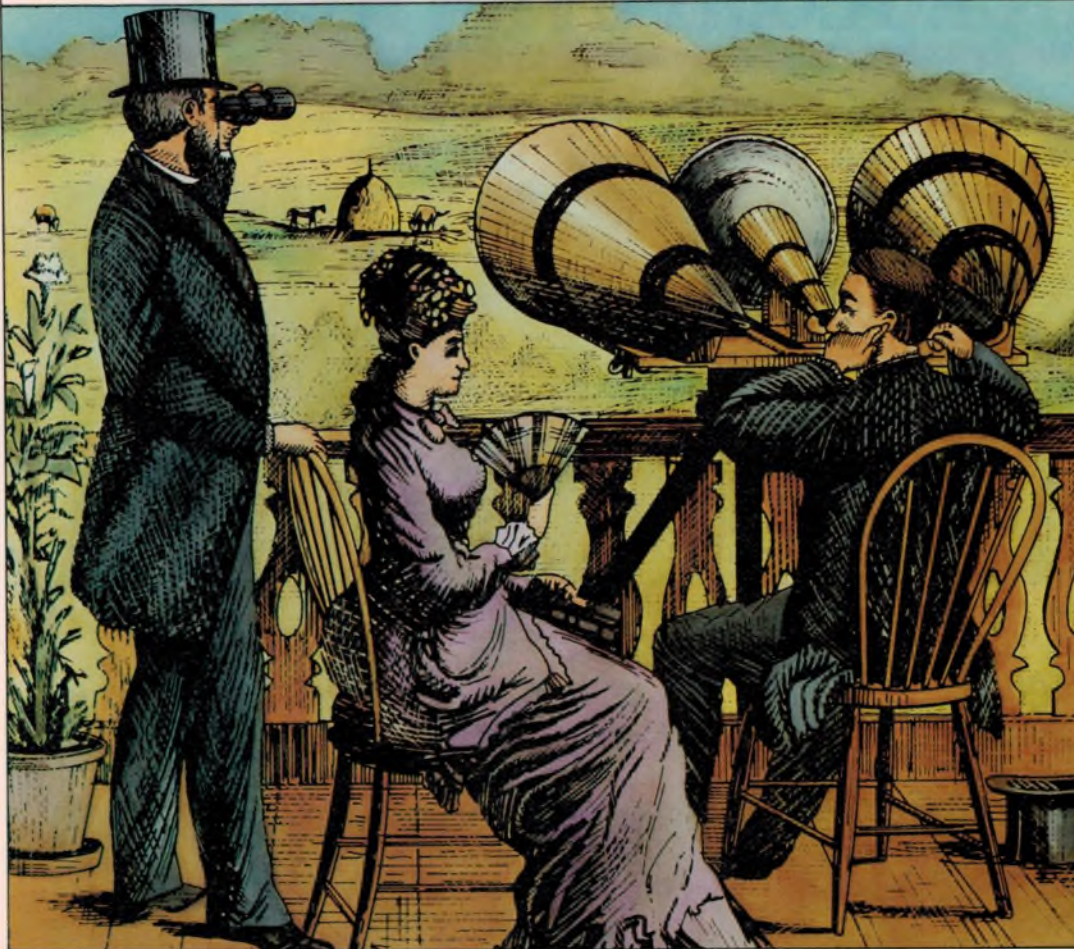

Thomas Edison's megaphone designed to amplify distant sounds. Late 19th Century. "The Bettmann Archive."

## "Hewlett-Packard."

And only Hewlett-Packard.

We have network performance analyzers to help manage and troubleshoot SNA, X.25, Bismync and 802.3/Ethernet.



Monitor performance of important nodes on a LAN with the HP 4972A.

With the same user interface for WAN and LAN protocol analyzers, you

follow the same simple menus whether you're testing Wide Area or Local Area Networks.

Even more important, we have the software to turn your raw data into meaningful information. Fast, accurately and with the kind of reliability you can't manage without. Which makes it easy to analyze, identify and eliminate network problems.

HP's analyzers have the power to grow with you. Even with a thousand nodes in your LAN, our instruments can still handle the peak traffic.

Of course, both kinds of protocol analyzers come with the same kind of service. Hewlett-Packard's. The service and support that's consistently rated among the best in customer polls.

So whether you're troubleshooting LANs, WANs or both, we've got you covered.

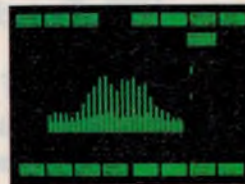

Statistics on performance of an X.25 network with the HP 4954A.

Pick up the phone and call HP's Customer Information Centre STD-free on (008) 033 821 to find out more on HP's WAN and LAN Analyzers.

 **HEWLETT  
PACKARD**

# 3 GENERATIONS TO MEET YOUR 8-BIT MICROCOMPUTER NEEDS.

DEVICE	ON-CHIP MEMORY					I/O			TIMERS	FEATURES
	RAM	ROM	EPROM	DATA EEPROM	PROGRAM EEPROM	BIDIRECTIONAL	OUTPUT	INPUT/SERIAL		
TMS70C20	128	2K	-	-	-	16	8/8	-	1	
TMS70C40	128	4K	-	-	-	16	8/8	-	1	
TMS70C02	256	-	-	-	-	8	0/8	1	1	
TMS70C42	256	4K	-	-	-	24	0/8	1	3	
TMS70C08	256	-	-	-	-	30	0/4	1	3	
TMS70C48	256	4K	-	-	-	46	0/8	1	3	
TMS70C82	256	8K	-	-	-	24	0/8	1	3	
TMS77C82	256	-	8K	-	-	24	0/8	1	3	
TMS77C01	I/O	EXPANDER				24		-	2	
TMS73C41	128	4K	-	-	-	16	0/17	-	2	VF DRIVE, A/D
TMS73C42	128	4K	-	-	-	8	12/1	-	2	LCD DRIVE, A/D
TMS73C43	128	4K	-	-	-	32	0/23	-	3	HIGH SINK OUTPUTS
TMS73C44	256	4K	-	-	-	20	8/5	-	2	LCD, DTMF, CLOCK
TMS73C81	192	8K	-	-	-	28	0/27	-	2	VF DRIVE
TMS370C010	128	4K	-	256	-	21	1/0	1	2	20MHz FREQUENCY
TMS370C310	128	4K	-	-	-	21	1/0	1	2	
TMS370C810	128	-	-	256	4K	21	1/0	1	2	
TMS370C050	256	4K	-	256	-	46	9/0	2	3	A/D, 128K MEMORY
TMS370C350	256	4K	-	-	-	46	9/0	2	3	
TMS370C850	256	-	-	256	4K	46	9/0	2	3	

Texas Instruments now offers three generations of CMOS 8-bit microcomputers with a range of features including EEPROM, LCD Display Drive, EPROM, One-Time-Programmable, and VF Display Drive. So no matter whether you are designing products for Telecommunications, Industrial, Consumer, Automotive, or Computer applications, Texas Instruments has an 8-bit solution for your microcomputer needs in

a selection of DIP, Flatpack and PLCC packages.

The 3 generations of microcomputers are upward software compatible, protecting your valuable software investment, and a full range of development tools are available now.

For additional information on any of the TI 8-bit products, contact VSI Electronics, Australian distributor for Texas Instruments.



THE SOURCE OF  
TEXAS  
INSTRUMENTS   
SEMICONDUCTORS

VSI Electronics (Aust) Pty. Ltd.  
An Electron House Company.  
16 Dickson Ave., Artarmon,  
NSW 2064, Australia.  
Telephone (02) 439 8622.  
Telex AA 22846. Fax (02) 439 6435.

## Recording Australia's Oral History – 5:

# Now you've got it, use it!

*In this last article of his series, the author describes how programmes are actually put together. He explains things to watch if you want to achieve a professional result, and also gives advice on the tricky business of cueing compact cassettes.*

by JIM LAWLER, MTETIA

Telling you how to assemble and use the equipment described in the previous pages can best be done by explaining something of how I want about production work on the Hobart OARTS exercise called "Cobbler's Last".

The first half of this 50-minute programme comprised five short talks of three to five minutes each, linked by a presenter and appropriate theme music. Each of the speakers was a member of OARTS (or Radio 55 as we prefer to call ourselves) and we were talking about our own hobbies or professions. Hence the name "Cobbler's Last".

The second half of the programme was a discussion between a father and son about their respective musical preferences, interspersed among the records they were talking about. (Called "Track for Track", this experimental programme is worthy of development into a fully professional series.)

Three of the five short talks were pre-recorded in my studio. I used a dynamic microphone into the Realistic mixer, then to all four channels of a large AKAI 630D open reel recorder. This gave me, in effect, a mono recording using almost the full width of a quarter inch tape. The other two talks were pre-recorded in the ABC's studio 716 using professional equipment. (I offered a leather medal to any of my colleagues who could tell me which was which. The medal is still unclaimed!)

The links in "Track for Track" were pre-recorded with a professional Shure microphone and a Nagra recorder at the speaker's home. They were presented to me on 5 inch reels, along with the relevant music on discs.

The first half of the program was assembled in the ABC's Studio 716. The presenter played the theme and read the intro from the studio, then I played the pre-recorded talk off tape in the control room. Then more presenter, more pre-recorded talk, and so on until we had completed the script. It was convenient and easy to do this at the ABC, but there was nothing that couldn't have been done at home.

By the time we were ready to do the second half of the programme, we had run out of studio time. I offered to do the rest of the production at home, and

it was when I came to assemble "Track for Track" that the hard work started.

To begin, I cued up the presenter's introduction on the open reel machine (I used a metal tape cassette to record my master copy). I put the intro on the cassette, then paused to reload the open reeler with the first link and to cue the theme music disc. Then it was play the opening music, fade down at the appropriate spot and fade up the link over the music.

Because I only had one of everything, I had to pause the cassette recorder at the end of the first link to cue the next disc and the second link. I had to repeat this sequence over and over until I had all the material assembled. It would have been much easier with two turntables and two recorders, but even so, it worked out quite well.

I made use of my open reel machine simply because I had it. Otherwise I could have just as easily have used a second cassette recorder, although they are not so easy to cue accurately.

Your Oral History tapes will probably



*The author in his home studio. At right is a Akai four-channel open reel recorder, while to the left of the microphone is a Technics dual cassette deck.*

not be as complicated as "Cobbler's Last". It is unlikely that you'll be adding music to your material, and you won't have to assemble tapes from three or four different sources. But you might want to mix in sound effects from disc or tape, and the procedures I have outlined above should give you an idea of how you might go about making your programme.

### The home studio

For the pre-recorded talks that were done at home, the talent was seated at a desk with the microphone on a short stand, about 12" from the mouth. Any closer risks having the speaker's breath popping the mike, and any further away risks reverberation problems. My "studio" was a small workroom that was once a bedroom. It contains a bed and wardrobe, and lots of recording and video equipment. There is no special sound treatment on the walls, so it is moderately "live".

If the recording venue is too "live", echoes and reverberation will distort the speech and make it hard to understand. On the other hand, if the studio is too "dead", the speech sounds the same way. Nothing can be done to save an over-live recording, but in the latter case, the recording can be rescued by adding artificial reverberation using a special effects generator. Doing this properly is a near professional exercise and is beyond the scope of these articles.

The signal was fed to the recorder flat - that is, with equalisation centralised and noise reduction off. Afterwards, the recording quality was checked by playing the tapes back at slightly higher than natural level and a stop watch was used to get an accurate timing. The tape was then clearly labelled and filed for future use.

Playing records was not so easy as my turntable is slow to start, and its on/off switch is incorporated in the pickup rest. Thus, whenever I lifted the pickup to cue a disc, the turntable started to rotate, and it wouldn't stop until I put the pickup back on the rest.

Eventually, I worked out that a ballpoint pen was about the same size as the pickup arm. Putting this in the rest switched off the motor, and pulling it out started the motor. This seems to be a crude way to do things, but it does highlight the differences between amateur and professional equipment.

The motor took two and a half turns to reach full speed, so, although I could cue it accurately enough, it was something of a tossup whether I started

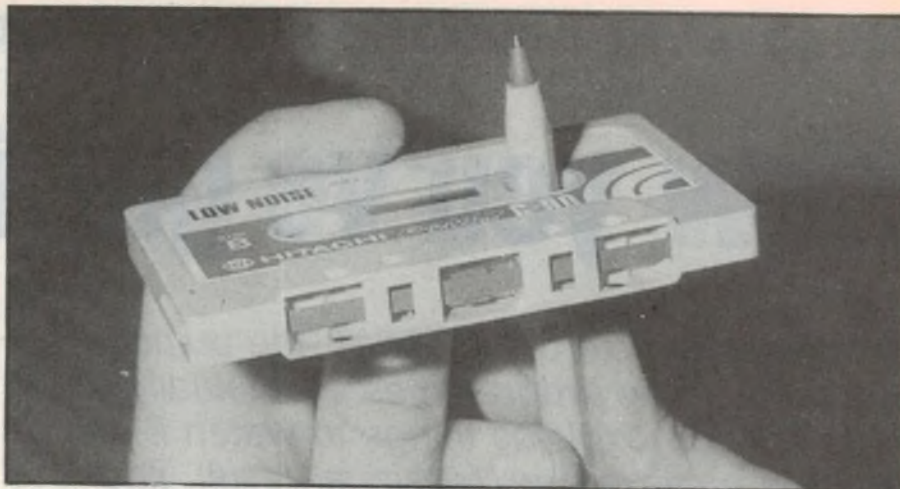

**A hexagonal-shaped ballpoint pen or pencil can be used to rewind a cassette by small and precise amounts.**

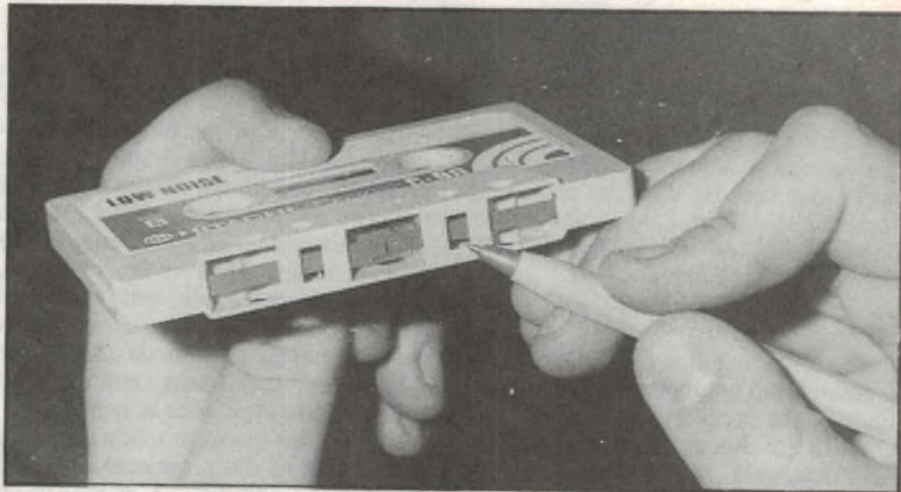

**Here the pen indicates the point to which the tape should generally be rewound (from the middle of the centre head opening) to edit one average word. The author explains this in the text.**

the motor at the precise moment that would allow a smart transition from speaker to music. Our professional training demanded 0.1 second accuracy, so it took a lot of practice and not a few spoiled runs before I got it to what I considered a reasonable production. You probably won't be looking for that kind of precision, but the nearer you get to it, the better your production will sound.

Well, so much for "Cobbler's". Now I'll talk about some other problems, and how I have overcome them.

In one of our Radio 55 exercises, we wanted to record the music of a stage band playing at a fair, with some fairground noises creating atmosphere in the background. I used an ABC Nagra recorder and a Shure microphone, but I was wishing at times that I had my own gear with me.

The Shure mike was an omni-directional unit, of moderate sensitivity. It was a model intended for

close-up interview work but even so, it did a reasonable job of picking up the all-round sounds of the fair. But it flopped badly for the music. I could not get very close to the band so I had to settle for a recording of fairground noises with the band music in the background, instead of the other way round.

A uni-directional or cardioid mike could have given me a better balance. By pointing the mike axis at the band I would have maximised the music and minimised (but not necessarily eliminated) the fairground noises. Oddly enough, I did have a suitable mike with me that day, but I didn't have the right adapter plug to match my mike to the ABC's recorder. See what I mean about standardisation of plugs and sockets?

Earlier in this article I mentioned a programme called "Track for Track", featuring a father and son talking about their kinds of music. On listening to

## Oral History

their pre-recorded links, I felt sure that they had been recorded in different places and probably at different times. Dad could have been in a kitchen or some other very "live" venue, while the son sounded as though he was in the carpeted lounge, with heavy drapes on the walls.

I have been since assured that they were sitting at the same table, at the same time. The sound difference comes about because the father was facing a hard plaster wall several metres or so in front of him. The son, on the other hand, was facing a nearby wall which was draped with medium weight curtains.

If these speakers had turned through 90°, they would have shared equally in the live and dead walls and their sound quality would have been much more uniform. This unfortunate placement is an object lesson to all of us who aspire to record interviews of a uniform high quality.

In the third of these articles, I mentioned special phono discs that can be copied without infringing copyright. These are mostly sound effects made specially for amateur movie buffs, and they are quite suitable for our purposes. However, why not build up your own file of special effects?

I have been doing this for years, and now have a fair sized library of effects, ranging from "cracker night" to "rain on a hot tin roof". There are all kinds of things including aircraft noises, chain saws, thunderstorms, bird calls, trains etc. The only thing I haven't got is a farmyard scene and I need that for a forthcoming "Radio 55" exercise. I suppose I'll have to go out to a farm and put some pigs on tape!

### Cueing cassettes

I have frequently mentioned the difficulty of cueing cassettes. It is not impossible, but it does take care and patience. The following is a description of what I have worked out, and I think it should work for you.

If you look at the front edge of a cassette, you will see five holes, three big ones and two small ones. The centre of the big one in the middle is the spot we are interested in. That is where the record/play head fits and that is where the tape will sit if you stop the machine right at the beginning of the new material you want to record.

Unfortunately, we humans are not fast enough to stop the machine as the first syllable of the wanted word starts.



**The author recording stereo sound effects on location. The two recorders are powered from a pair of 12V batteries via a 300VA inverter.**

Probably the whole word has passed before we react. So we have to "guesstimate" the length of tape occupied by that word and then wind the tape back that far, hopefully to a point just before the start of the word.

Cassette tape runs at 48mm per second (or 1-7/8" per second for us pre-metric types), and a second will hold about three longish words or four average words at normal speaking speeds. So for one average word, we must wind the tape back 12mm - which just happens to be to the near edge of the small hole adjacent to the centre hole.

So, the procedure is this. Play the tape up to the point to be cued. If there is one, note the word immediately ahead of the wanted point. (This will shorten your reaction time so that less tape need be rewound for a proper cue.) In either case, press the stop button as soon as you hear the first word start. The machine should stop as the word finishes.

Then remove the cassette from the recorder and put one of those hexagonal ballpoint pens through the left hand reel hub. You can turn the reel with the pen and so wind back the tape. But now comes the tricky bit.

There are no marks on the tape to show you how far you have wound back. You can guess, or you can make a mark on the tape with a very fine topped felt pen. But beware. The side of the tape you can see and mark is the side that contacts the record/play head. And anything that marks the tape can foul the head, causing poor response and premature wear on tape and heads.

I suggest you use a felt tip pen, but make only the tiniest mark and be prepared to clean the record/play head frequently.

Having wound the tape back to what you imagine to be the beginning of the part you wish to copy on to your new recording, it only remains to record your introduction onto the new tape then press the start button to play the incoming tape. Sounds easy when you say it like that, and it is easy. But you'll chew your fingernails back to the elbows before you get it right.

The only answer is practice - lots and lots of practice. Once you get the feel of how you and your recorder are reacting together, then it starts to come easier. If you do enough work and practice long enough, you'll one day become as adept as those Radio Production Officers at the ABC who seem to press the right button even when their eyes are shut.

And so we come to the end of this series of articles about the home recording of our nation's oral history. Over the last five months we have looked at the reasons why, the equipment for and the techniques by which we can save for all time the historical trivia that shows how we got to be what we are.

Modern cassette recorders allow anyone to be an oral historian. Perhaps in ten years time every library in the country will have its file of local history, recorded and assembled by exponents of this, the newest of all hobbies.

I hope these articles will have provided you with the motivation and knowledge to join in. ✻

# WHY BUY IT?

## BUILD IT YOURSELF & SAVE!

Building your own saves you money - especially at the low, low prices of our amateur & related kits this month (see below). But there's more reasons to "roll your own" than *just* to save money...

- You'll keep (or maybe regain?) those construction skills you had back in the good ol' days - when all there was available was to do it yourself.
- In these days of "black boxes" it's too easy to lose those important - perhaps elementary - skills such as soldering technique, component dress, wiring, even component identification!
- You'll be able to enter those "home brew" competitions that used to be so much a part of our hobby. Today they're all but forgotten in many instances.
- You'll get the piece of gear - test equipment, transceiver, amplifier, whatever, far sooner than having to wait until you've saved for it.
- Perhaps most importantly of all, you'll be proud to say "I built it myself!"



## BIG SAVINGS THIS MONTH ON AMATEUR & RELATED KITS:

### UHF Amateur Transceiver

The ideal way to get onto 70cm.

Cat K-6300 Was \$249.95

**THIS MONTH: \$199**

### 40/80CH Upgrade Kit for UHF Transceiver

Doubles the number of channels you can access. Cat K-6301

Was \$12.95 **THIS MONTH: \$5<sup>95</sup>**

### 70cm Preamp

Not just for the kit transceiver: get a few more dB out of any commercial receiver too - and cheap! Cat K-6306

Was \$21.95 **THIS MONTH: \$9<sup>95</sup>**

### UHF GaAsFET Preamp

When you really want performance, try this beauty! 13dB gain, includes full tx/rx switching. Cat K-6309

Was \$129.00 **THIS MONTH: \$99**

### UHF Power Amp

Extra oomph out, too: 50W ish from 2W drive! Includes carrier detecting switching. Cat K-6307 Was \$279.00

**THIS MONTH: \$199**

### UHF Wattmeter

The inexpensive way to keep your 70cm station up to scratch. Cat K-6312

Was \$49.95 **THIS MONTH: \$39<sup>95</sup>**

### 2m Amateur Transceiver

Why not make a pigeon pair? Covers full 2m band... a great "big time" project for novices (needs fair level of technical skill). Cat K-6308

Was \$249.95 **THIS MONTH: \$199**

### 2m GaAsFET Preamp

Like its 70cm brother, it will put some SIG into your signal! Cat K-6311

Was \$129.00 **THIS MONTH: \$99**

### Need A Supply?

Matching 13.8V power supply for VHF or UHF transceiver. Cat K-6310

Was \$49.95 **THIS MONTH: \$39<sup>95</sup>**

### How About A Linear?

Perfect for the kit - or handheld, etc. 100W out from 15W in (40W from 2W). Cat K-6313

Was \$299 **THIS MONTH: \$249**

### Or A Power Meter?

VHF Wattmeter is easy to build, a must for your 2m station. Cat K-6316

Was \$49.95 **THIS MONTH: \$39<sup>95</sup>**

### And Just In Case You Have Too Much...

Attenuate it! The 50 ohm attenuator kit gives you up to 63dB attenuation in 1dB steps from 50 to 500MHz.

Cat K-6323 Was \$79.95

**THIS MONTH: \$49<sup>95</sup>**

### HF Transceiver Slashed, Too!

Covers 500kHz of HF, with 30W PEP output. As supplied covers 80 metres, upgrade kits below give you other bands. Cat K-6330

Was \$399 **THIS MONTH: \$299**

### Upgrade kits to suit - Half Price:

40 metre K-6332 20 metre K-6333 15 metre K-6334 10 metre K-6335

Were \$39.95 each...

**THIS MONTH: \$19<sup>95</sup> ea.**

### 100W+ Of HF Muscle

10 to 14dB gain on all HF bands - expect around 150W PEP or so from a 5W input on all but 28 (3dB lower). Cat K-6331

Was \$379 **THIS MONTH: \$299**

### 100 W On SIX, Too.

All-mode amp needs only 6W drive for 100W out. Includes carrier operated relay. Cat K-6349

Was \$329 **THIS MONTH: \$279**

### And A Now DIY SW Receiver:

Features 3 bands from 0.48 to 17.12MHz, a great "start-up" kit (great for school projects). Now available in limited quantities in all DSE stores. Cat K-6355



**ONLY \$79<sup>95</sup>**

**HURRY - SOME STOCKS LIMITED!**

LIMITED QUANTITIES OF THESE KITS  
AVAILABLE AT ALL DICK SMITH ELECTRONICS  
STORES... OR PHONE YOUR ORDER DIRECT  
TO TOLL FREE (008) 22 6610  
(SYDNEY AREA 888 2105)

**DSX** PRESS

**DICK SMITH**  
ELECTRONICS

# NEW KITS THIS MONTH!

## ...AND A FEW FROM LAST MONTH

### Vader Voice

Shades of Star Wars! The kids'll have a ball with this one: just speak into it and your voice comes out just like Darth Vader's! Nifty little kit, complete in one zippy box. Cat K-3510

Perfect Beginner's Project!

As seen in 'Silicon Chip'

**\$29<sup>95</sup>**



### Hands-Free Phone

You could spend hundreds of dollars on a hands-free phone. Or you could build this kit. Simple, effective - and cheap! Use in conjunction with existing phone for full two-way hands-free conversation. Cat K-3100

As seen in 'Silicon Chip'

**\$89<sup>95</sup>**



### Studdfinder

If you've ever hammered a nail into a wall - and missed the stud - this one's for you! Easy to build (one night project) is perfect for the home toolbox. (Sorry, it cannot detect the other type of stud!) Cat K-2723

As seen in 'Electronics Australia'

**\$19<sup>95</sup>**

### EA's new 30/30 Amplifier

Remember the twin 25 of a decade ago? We made countless thousands of kits! Here's the up-to-date model: EA's new 30/30 Amplifier. Easy to build, an ideal project for schools, tech colleges, etc - or just the hobbyist who wants a hi-spec kit at a low-spec price.

- 30W per channel
- 0.025% distortion at 30W
- -76dB (phono) and -91dB (line) noise figure



### Guitar Practice Amplifier

Short form kit. (PCB & components only - you decide which case you want to put it in) giving a neat little 8 watt amplifier for guitar and similar practice. Cat K-3548

As seen in 'Australian Electronics Monthly'

**\$19<sup>95</sup>**

### Lab Power Supply

35 volt, 2A supply for the workbench, lab, technician or hobbyist. Fully metered, extremely easy to build and very versatile. Cat K-3461

As seen in 'Australian Electronics Monthly'

**\$109**

### Our Kit Policy ...

Where we advertise a kit from an electronics magazine, it is our firm policy to have that kit in our stores no later than the fifteenth day of the month of issue of the appropriate magazine (usually we do much better than that!)

It's part of our commitment to the hobbyists and enthusiasts of Australia and New Zealand. We want you to have the latest kits, at the best possible prices, and as soon as possible.

Occasionally, we're let down: an oddball component that has to come from the other side of the world; a shipping or dock strike that delays vital parts; perhaps a magazine that changes its mind about the month of publication (or even about the design of the project!).

If we let you down by not having the kit you want in the store when we've promised it, we apologise. We hope you'll understand that we're doing our very best to fix the problem - but they're not always that 'fixable'. Don't forget that there are 'rain checks' available in all stores to ensure that you don't miss out when the stock arrives - you'll get it for the price advertised and written on the rain check.

Dick Smith Electronics.

### Special 'Short Form' Kit:

We've made up a special kit for this amplifier which includes all the "expensive" and hard-to-get bits - the power amplifier IC's, the transformer, the silk-screened & punched front panel and the printed circuit board.

The other components (such as the passive components, pots, etc) are normal stock lines at your nearest Dick Smith Electronics store (or you may even have many of them in your junk box!). Cat K-5100

As seen in 'Electronics Australia'

Short form kit as described above:

**\$99<sup>95</sup>**

### At Last! Recently Released Kits

At time of going to press, there were good stocks of these in our stores. But don't blink ...



### Discolight

Move over, Musicolor: Discolite is here. It's the latest in colour organs, with chaser, audio chaser, etc etc. You want a light show? Discolite is what you want! Cat K-3150

As seen in 'Silicon Chip'

**\$165**

### Strobotuner

Accurately and professionally tune virtually any musical instrument with this fully self-contained and portable kit. If you're into music, get into this! Cat K-3550

**\$54<sup>95</sup>**



As seen in 'Electronics Australia'



### Nicad Charger

Megafast! What you read is what you get - charge 7.2V r/c model type Nicads quickly, but safely: about 15 to 20 minutes, without risk of overcharge. Cat K-3477

As seen in 'Silicon Chip'

**\$45**

### Speaker Protector

Your speakers are in deadly peril every time you turn your amplifier on (or if it goes into amplifucus cactus). Protect your valuable speakers with this easy-to-build and easy-to-fit kit. Cat K-4008

**\$37<sup>95</sup>**

As seen in 'Electronics Australia'



### Chair/Tilt Alarm

Nifty little alarm circuit designed to go off on movement (more precisely, change of angle). It's a great way to protect perambulatory property participating in purloining, pillaging, pilfering, pinching or plundering. Cat K-3248

As seen in 'Australian Electronics Monthly'

**\$11<sup>95</sup>**

### Line Filter/Conditioner

Commercial line filters cost a fortune: build your own for a lot less. Filters out HF noise, spikes, etc and gives over-voltage protection. Cat K-3080

As seen in 'Electronics Australia'

**\$39<sup>95</sup>**

### Budget Power Supply

A low-cost variable supply that's ideal for beginners (no need to mess around with mains - it can be powered from a battery if you wish - or any other AC or DC source). No metering, no frills, but economical! Cat K-3460

As seen in 'Australian Electronics Monthly'

**\$62<sup>50</sup>**

### Relative field Strength Meter

Here's one for the antenna installers, TV techs, etc. Checked out the price of a FSM lately? Build this instead for an xteenth the cost! Gives good relative indication, works on VHF & UHF, and even gives out video signal! Battery/mains operated. Cat K-6329

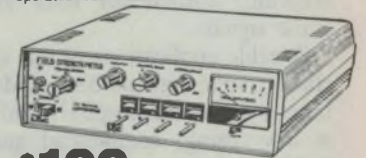

**\$199**

As seen in 'Electronics Australia'

### Mini Mixer

Here's a great beginners project - with specs that make it good enough for serious use. 4 input mixer suits mics, guitar, etc - very simple to make. Cat K-3039



**\$29<sup>95</sup>**

As seen in 'Australian Electronics Monthly'

**DICK SMITH ELECTRONICS**



# News Highlights

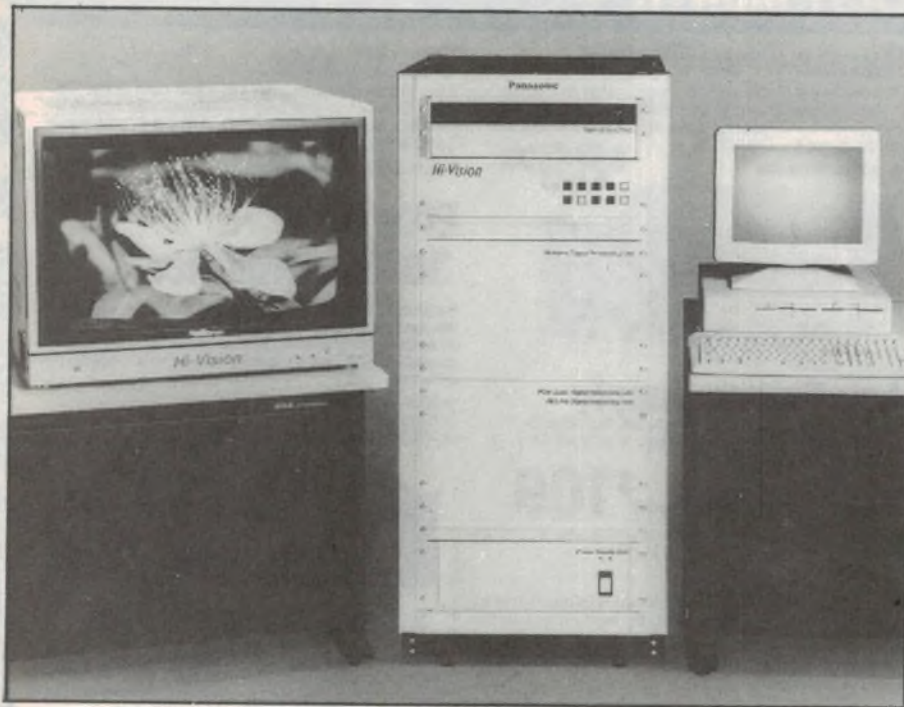

## Matsushita develops first HDTV optical disk

Panasonic Australia's parent company, Matsushita Electric Industrial has announced its development of the world's first high definition digital optical disk recording system, which uses a 12" phase-change write-once optical disk with 2.6 giga bytes of memory capacity per side.

The technology features a fast read and write speed of 18Mbps for recording and playback, as well as a digital recording format for both video and audio signals.

Possible applications of this system include public information guides, video filing systems in hospitals and schools, in advertising, commercial and broadcasting industries.

A maximum of 600 still pictures can be recorded without audio, or 500 still pictures with one hour of stereo sound, can be stored on a removable phase-change type optical disk. Each still video frame can be played back with continuous music reproduction or computer programmed random access playback.

The high definition digital optical disk recording system conforms to high definition SMPTE 240M studio format of ATSC (Advanced TV Systems Committee) and SMPTE (Society of Motion

Picture and Television Engineers). It can also be applied to the current NTSC TV format. In this case, a maximum of 6,000 still pictures can be digitally recorded without audio.

## Australian-made submarine sonar delivered

The first set of Australian-made hydrophone staves for the AN/BQG passive directional sonar array on RAN Oberon class submarines has been delivered to the Royal Australian Navy by the prime contractor, Plessey Australia.

At a handover ceremony in Canberra, Hon Ros Kelly, Minister for Defence Science and Personnel, accepted the first set of staves from Mr Adrian Turnbull, deputy managing director, Plessey Australia, and Mr Harley Tacey, director of marketing.

Mrs Kelly said, "The AN/BQG is a prime example of cost-effective technology development in Australian industry. The cost savings of this design over the previous one will pay for the development of the local expertise."

The rod-shaped hydrophone staves are mounted on the outer hull of the submarine. Each staff is made up of a number of hydrophones, and the staves,

## UK steps up HDTV research

Britain is to increase its backing for plans to develop a high definition television system by 1.7 million to 4.8 million Sterling.

UK Minister of Trade and Industry Mr Kenneth Clarke says the extra money will be used to support the participation in the project by the Quantel company and the British-based Philips Research Laboratories. Quantel will develop a range of high definition editing and image manipulation equipment and Philips Research Laboratories will be making a major contribution to research into picture analysis and coding techniques associated with the transmission and display of high definition signals.

High Definition Television uses approximately twice the number of lines compared with standard definition, to produce and display TV pictures of a quality comparable to that of 35mm film.

The aim of the HDTV project, which involves some 30 European industrial companies, broadcasters and research institutes, is to define a standard for HDTV which is compatible with the MAC (Multiplexed Analogue Components) transmission system being introduced for Direct Broadcasting by Satellite (DBS) services in Europe. The project will develop and demonstrate, by 1990, a complete prototype production and transmission system for MAC-compatible HDTV.

mounted along the length of the hull on both sides, make up the wide aperture distributed array for the submarine's passive ranging system.

The directional arrays currently fitted to the RAN submarines, which the new components will replace as their service lives expire, were developed and manufactured by Unisys in the United States, but the decision was made eight years ago by the RAN in consultation with the then Industry Development Branch to locally develop and manufacture improved staves.

The production cost of the new staves is less than one-third that of the originals. They are more watertight and more explosion resistant than the previous design, and thus more reliable. The new staves have exactly the same acoustic centres as the staves they replace, so the data obtained during years of sea trials is usable without alteration.



## TI and CyberLynx to develop CEBus chips

Texas Instruments and the USA-based communications software firm, CyberLynx, have announced an agreement to develop a family of semiconductor devices based on the Consumer Electronic Bus (CEBus). A low-cost local area network (LAN) protocol that allows electrical appliances used in the home to be controlled by other devices, the CEBus is being proposed as a standard under the sponsorship of the American Electronic Industries Association (EIA).

By adding small integrated circuits, or "chips", that incorporate the CEBus protocol into products, manufacturers will enable users to activate dishwashers, thermostats, air conditioners, phones, TV's, security systems and any other type of home electrical appliance incorporating these chips, in most cases using existing household wiring. As a result, these appliances can be controlled from a common set of commands by a control console, telephone or computer. Future versions of CEBus-based products will allow consumers to link electronic devices into wider networks and information services, including new telephone network services, cable TV systems, public utilities and security monitors.

The CyberLynx trademark, *SmartHome* will be used to designate devices developed under this agreement as well as the end products containing these CEBus devices. The designation *SmartHome* on an end product will indicate that it will be able to communicate on the CEBus LAN in the home. For example, a consumer will be able to purchase a *SmartHome*-compatible dishwasher, put it directly into the existing household wiring, and have it controlled by any other *SmartHome*-compatible products.

John Robinson, Marketing Manager, Semiconductor Division of Texas Instruments Australia Limited stated that, "We believe that this agreement will help the concept of a "smart home" to become a reality, because it ensures that chips to allow creation of CEBus-compatible products will be available from a major semiconductor manufacturer."

"We look forward to hearing from Australian manufacturers who are interested in incorporating CEBus-based integrated circuits into end products."

## Webster provides gateway to Apple Macs

Australian manufacturer Webster Computer Corporation has added a new dimension to its product range with the announcement of Multigate.

Jointly developed by the Department of Computer Science at Melbourne University and Webster Computer Corporation, Multigate has two main applications. One is as a gateway between an Ethernet connected host computer running TCP/IP and up to 4 AppleTalk networks. AppleTalk is the networking protocol used by Apple Macintosh computers. Alternatively, Multigate can connect up to 4 AppleTalk networks without the necessity for connection to Ethernet.

With approximately 65,000 Apple Macintoshes operating in networking environments in Australia, Webster is confident of Multigate's success.

MULTIGATE consists of a motherboard with a connection to the Ethernet, a daughterboard with connections to the AppleTalk networks and a power supply. These are all mounted into a compact, attractive desktop cabinet.

The motherboard contains a 10MHz 68010 CPU chip, 512Kb of 1 wait state dynamic RAM, Ethernet with both transceiver and BNC (thin wire Ethernet) interfaces (only one of which may be active at any one time), two RS232



serial ports, and ancillary devices (EEPROM, PROM, timers, and battery-backed calendar clock).

To overcome potential media incompatibility problems, the Multigate code may be loaded from either the host computer or the Apple Macintosh. The gateway code is distributed as software rather than firmware which allows for easy and economical upgrades, should they be required.

## IEEE seeking the "OzMouse"

The Institute of Electrical and Electronics Engineers will be conducting the inaugural Micromouse Competition at Sydney's Powerhouse Museum, on Saturday 15th October 1988 from 9am to 10pm.

As with other micromouse competitions held in recent years around the world, the goal is to find a self-contained and mobile "intelligent" electronic device which can navigate a large maze and seek out the centre of the maze in the shortest time.

Six groups of enthusiasts from local

university/TAFE backgrounds are currently developing devices to enter in the competition, and the challenge is expected to be an exciting one.

The IEEE MicroMouse Competition is an endorsed Australian Bicentennial activity. Admission to the final will be by ticket, as the seating capacity is limited. Further information is available from David Matters, Chairman MicroMouse Competition, IEEE Computer Society, PO Box 251, Forestville 2087 or phone (02) 451 1256.

## Philips wins award for CCDs

Philips Research Laboratories have won the British Royal Television Society's 1988 Geoffrey Parr Award in recognition of their research and development work on the fram transfer solid-state image sensor, as used in portable and studio CCD colour cameras. These cameras are now in use in Australian broadcast stations.

It is the Society's highest award for engineering.

Mr. Bob Longman, chairman of the Geoffrey Parr Award committee, commented: "This project, which called for high quality development work, is a further step in advancing operational and production flexibility, as the growing use of lightweight and compact solid-state colour cameras is applied to a wide range of program making in the future."

## News Highlights

### Local manufacturing technology for new phone

New manufacturing technology developed in Australia will be used to build Australia's latest standard telephone, the Touchfone 200.

A joint development between Telecom, AWA and Alcatel-STC, the new phone will have many new features including soft touch keypad, 10 stored memory numbers, last number redial and PABX compatibility. Both AWA and Alcatel-STC will be making the phone.

Drawing on its own R & D facilities, AWA designed and constructed computer-controlled assembly and testing equipment.

The AWA assembly line will produce over 3,000 phones per day for the local market with additional capacity for export orders.

The Touchfone 200 is a major advance in telephone design and has considerable export potential, according to AWA Executive General Manager, Communications, Warwick Bishop.

"The Touch fone 200, as a standard phone, is superior in design and features to every other standard phone sold in the world today."

"We used our own skills and technology to design and manufacture both new components for the phone and highly automated assembly methods."

"The very important speech processing circuit, for instance, was designed at AWA's micro circuit design centre and

*The main components inside the new Touchfone 200, which has been designed for minimum assembly time. The soft touch keyboard connects directly to the main PC board. (Courtesy AWA)*

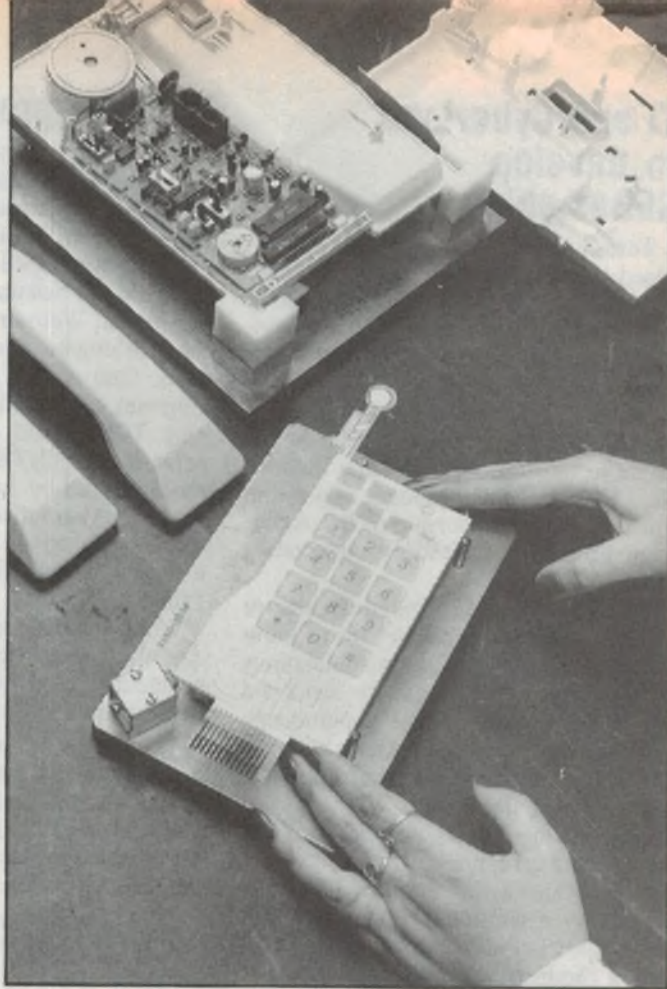

lians, AWA designed and installed a series of quality control testbeds that will be produced at the company's new \$60 million micro circuit plant at Homebush, NSW," Mr Bishop said.

The Telecom developed soft-touch keypad is also regarded as a unique development.

Quality being critical for an item that will eventually be used by most Austra-

lian monitor manufacturing and assembly performance at each step.

Alcatel-STC is also installing a \$300,000 robotic system at its Alexandria factory to automate its assembly of the printed circuit board that is at the heart of the telephone.

Developed by company engineers in conjunction with the Automation and Engineering Applications Centre in Wollongong, OSCAR (Odd-Shaped Component Assembly Robot) will insert a series of five non-uniform components onto the printed circuit board. The remaining non-uniform components will be handled manually. All other components will be automatically inserted.

OSCAR is an AdeptOne four-axis manipulator robot from Adept Technology in San Jose, California. It is powered by an Adept MC Controller that allows several tasks to be performed at once with no degradation of performance. It can, for example, control a conveyor or communicate with an external computer at the same time the robot is fulfilling its primary function.

The AdeptOne is the first commercial robot to employ direct drive technology. This generates high torque at relatively low motor speeds with no loss of mechanical advantage, making cycle speed several times faster than that of conventional robots. E

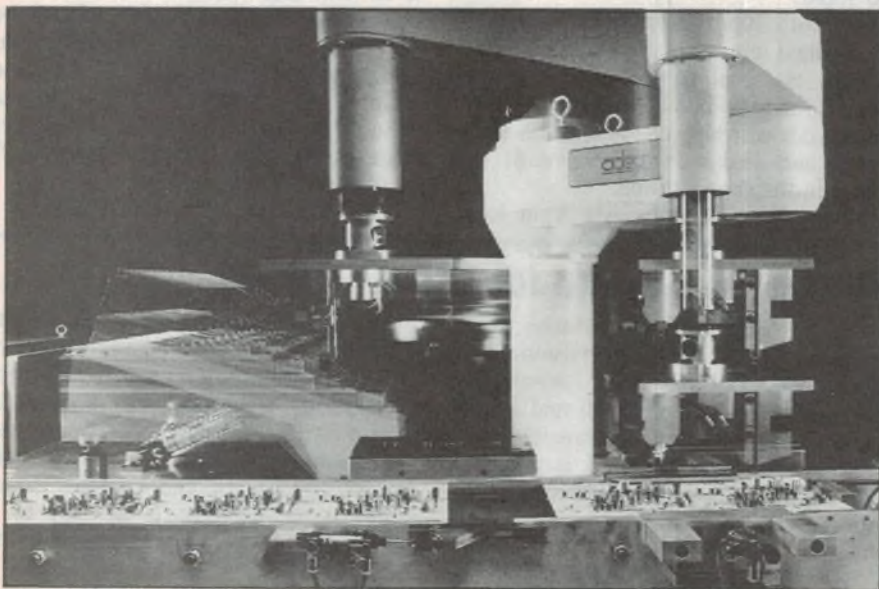

**Alcatel-STC is using a new robotic system called OSCAR (Odd-Shaped Component Assembly Robot) to assemble the Touchfone 200.**

## ISD introduces IC design education program

Integrated Silicon Design (ISD) of Adelaide has introduced an educational program oriented to the Tertiary Education System. The ISD Educational Program is designed to provide its commercial and proprietary Integrated Circuit Computer Aided Design (CAD) Software to tertiary institutions at extremely low cost, to help the education system upgrade technical skills.

Although of commercial grade, the software has the advantage books used in the teaching of integrated circuit design. The authors of the introductory VLSI text are Dr. Douglas Pucknell and Dr. Kamran Eshraghian, both of the University of Adelaide and both of whom are founders of ISD. Thus the company has long had a corporate culture closely concerned with the need and desire to educate the future builders of the Australian electronics industry.

Both the products and services of Integrated Silicon Design are being offered to Australian tertiary institutions at cut rate prices to entice them into taking advantage of the latest technology available. The range includes software products for designing integrated circuits and a fabrication service that will work to university needs in terms of timing and pricing. In this way a university can take advantage of the closely coupled teaching and software interface. Then actual fabrication of completed designs can be realised at a commercial foundry, to complete in every respect a student's introduction to and practical application of the technology.

## Toshiba to adopt Carver's "sonic holography"

Toshiba America and Carver Corporation are jointly developing Carver's "sonic holography" system, which Toshiba plans to incorporate into its larger sized stereo TV receivers.

The sonic holography system uses special signal processing circuits to cancel undesirable crosstalk between the two stereo sound channels, and is said to provide enhanced clarity, depth and stereo focussing. Toshiba is apparently planning to use the system in its new range of up-market 27" and 30" FST (flat square tube) sets, and also its 46" and 50" projection sets.



## Bond Media instals videotape system in PNG

Bond Media has installed a LaKart II Videotape Program Presentation System at its EM TV Studio Centre at Boroko near Port Moresby in New Guinea.

The system is being used to integrate six standard Beta video tape transports with output switching via a Grass X LV/2A audio/video switcher.

Station Manager Gerry Thorley says that the LaKart II System has significantly improved the efficiency of EM TV's program presentation operations. The station is presently investigating the feasibility of extending the system to a second program output channel.

## News Briefs

- US maker of solid state relays and I/O modules Continental Industries has appointed **Amtex Electronics** as its exclusive distributor in Australia.
- **Wormald International (Aust)** has been appointed exclusive agent in Australia for the Sonnenschein range of "Dryfit" sealed lead-acid secondary batteries.
- **TDK (Australia)** has moved to larger premises at 14/39 Herbert Street, St. Leonards 2065. The telephone number is (02) 437 5100, and fax number (02) 439 7151.
- The Barco range of high-quality video monitors is now being exclusively distributed in Australia by **Quantum Pacific**, of Unit B, 5 Skyline Place, Frenchs Forest 2086. Phone (02) 975 1323.
- **Total Electronics**, a unit of Email Limited, has moved to 15-17 Hume Street, Huntingdale, 3166. Phone (03) 544 8244, fax (03) 543 8179.
- David Jacobs, formerly with Sony Australia, has been appointed national sales manager for hi-fi distributor **Scan Audio**. Ian Parnell has also been appointed NSW sales manager, and Ralph Grundl Vic sales representative.
- Major Taiwanese computer maker Acer Incorporated (formerly Multitech) has appointed two Australian distributors for its products. **Dick Smith Electronics** will continue to market the PC-compatible models (500+ and 710), while the "top end" models (910, 1100 and PS/2 compatibles) will be in future marketed by **Remington**, the computer and office automation arm of Natcorp Investments.
- Richard Benfatto, formerly of AWA Microelectronics, has been appointed field sales engineer at **Texas Instruments Australia**.
- US computer hardware maker Bit3 Computer Corporation of Minneapolis has appointed **Mostyn Enterprises** as its sole Australian agent. Mostyn is at 35 Alexander Street, Dundas NSW, phone (02) 871 6279.
- Gordon Jalkemo has been appointed general manager for **Integral Fibre Systems** (IFS), a member of the Andrew Sweeney Electronics Group.
- David Gradwell, formerly of Prime Computers, has been appointed national sales manager of Tektronix affiliate **IDG**.

## News Highlights

### Philips & VLSI sign broad-based ASIC agreement

Philips International of The Netherlands and VLSI Technology of the USA have signed agreement in four key areas to create and produce application-specific integrated circuits (ASICs). The agreement covers CAD design software, foundry services, cell libraries, and gate arrays.

"This agreement lets each company benefit from the strengths of the other," said Cees Krijgsman, Chairman of Philips' Worldwide IC Executive Committee. "Philips has a heavy investment in worldwide production facilities, which will be made available to VLSI. VLSI has a wealth of outstanding IC design software, which will be made available to Philips."

"We are pleased that Philips, after extensive evaluation, selected our IC design software and gate array families, underscoring our belief in the quality and strength of these products," said Alfred J. Stein, VLSI's Chairman and Chief Executive Officer.

Under the terms of the agreement, VLSI will make its IC design software available to Philips for use in Philips' semiconductor operations. VLSI will also license its software to interested Philips customers, including Philips' user divisions. In addition, the agreement calls for Philips to provide foundry services for VLSI, with qualification beginning in the second half of 1988 for 1.5-micron technology.



### NSW-developed pictorial data retrieval system

A pictorial data retrieval system developed by the NSW Government Printing Office for the state's Bicentenary celebrations is to be marketed and developed by a new company set up jointly by the NSWGPO and the Infolink Group.

The videodisc-based system was initially developed by the NSWGPO to provide the public with immediate access to the enormous library of historical photographs, in this Bicentennial year. The initial database in the Bicentennial Archives Project is around 400,000 photographs. The new Video-

disc Pictorial Retrieval System handles the efficient storage of images and associated descriptive text, as well as the ability to rapidly search files and retrieve online both images and text simultaneously.

As marketed by Search Tech, the system includes an analog optical disc containing the images and text, specialised software and a standalone microcomputer connected to a videodisc player. Two software packages are currently available, *Just Imagine* for professional access and *Imagex* for public access.

VLSI will license all elements of its current 1.5-micron ASIC product libraries to Philips, and the companies will also exchange libraries for 1 micron and below on a reciprocal basis. Both parties are committed to design rule compatibility and the adoption of mutually agreed-upon interface formats to facilitate this exchange.

### Electronics 88 exhibition/convention

From 4-6 October at the Adelaide Convention Centre, the Electronics Association of South Australia will present Electronics 88 - a conference and exhibition designed to illustrate recent and potential applications of electronic technology covering computing, communications and micro-electronics.

The exhibition will compliment the conference where topic areas for paper presentations and workshops will include Biomedical engineering, EFT/P-OS, automobile engine management, CAD/CAM, automated testing, devices, machine vision, process control, implanted devices, gallium arsenide, signal processing, digital/data communications, satellites, Viatel/Teletext, cellular radio, CD ROMS, remote sensing, security and broadcasting.

The exhibition will take up the entire Plenary Hall of the Adelaide Convention Centre.

For future information about the conference and exhibition contact Phillip Styles Exhibition Services, 4 Lovell Court, Clarence Gardens, South Australia 5039 or phone (08) 371 1700.

## IBM releases new minicomputer range

A new family of mid-range computers designated the Application System/400 has been released by IBM. The new systems seem destined to ultimately replace existing System/36 and 38 machines.

The new systems are said to offer a 24-fold increase in memory capacity (up to 96Mb as standard), a 48-fold increase in mass storage (up to 27Gb) and a 10-fold increase in speed. They also boast a new operating system, OS/400, which offers software compatibility across the full range of models.

The AS/400 series use 48-bit addressing, which gives a potential memory capacity of 281 terabytes. The largest system (B60) offers 1 second user response with 45,000 transactions per hour.

Other features of the new systems include "self training" applications software, remote on-line hardware fault diagnosis, the ability to upgrade systems and applications software from a remote location via a communications channel, and the use of IBM's densest memory card to date. The latter uses 1MB DRAM chips, and achieves 16 megabytes per card.

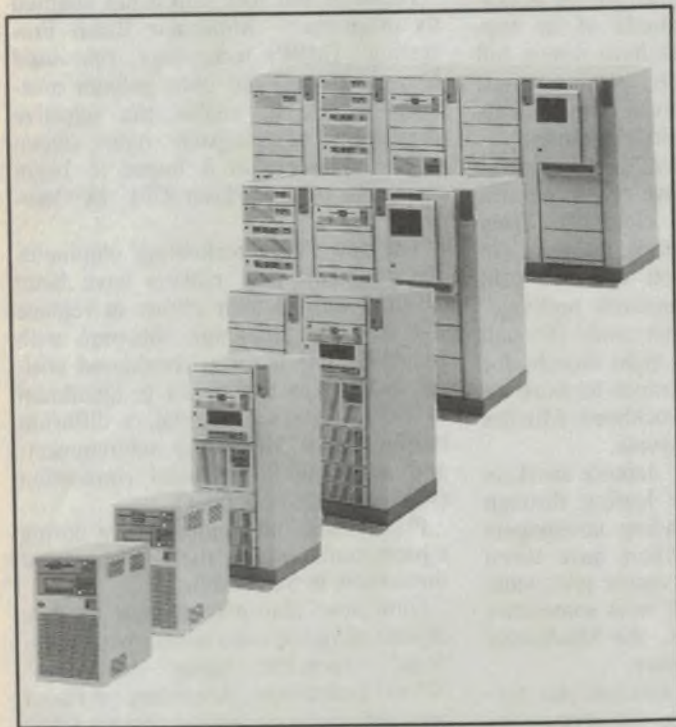

IBM spokespeople described the release of the new AS/400 series as "one of the five most important announcements that IBM has ever made". Systems prices range from around \$65,000 to over \$1 million.

## Long-time reader donates early volumes

Regular readers of the magazine will know that we have been seeking copies of our predecessor publication *Wireless Weekly*, for the years 1922 - 1926. Our own reference copies have only covered the years from 1927 to the present day, leaving a sad gap.

We are therefore delighted to announce that we have now been presented with bound copies of Volumes 1 and 3 of *Wireless Weekly* thanks to the generosity of long-time reader of the magazine, Arthur Mead of Bexley NSW.

Mr Mead is 81 and has been reading the magazine ever since our first issue was published in August 1922 - surely a claim very few could make! He has also been an enthusiastic radio amateur since 1925, currently holding the callsign VK2JM.

An electrical field officer for Telecom over many years (when it was still called the Postmaster-General's Department), Mr Mead is a telephone mechanic and a licensed electrician. He was also very active in motorcycle racing for quite a few years, but says he doesn't have time



to do this nowadays.

The volumes of *Wireless Weekly* presented to us by Mr Mead were originally the property of his late friend and fellow radio amateur, Bill Lewis VK2YB who passed away in 1976.

Our grateful thanks to both Arthur Mead and Bill Lewis for helping us to find an important part of the magazine's history. And if any other readers can help us find other missing copies or (dare we hope) volumes, our editor would be delighted to hear from you.

EA

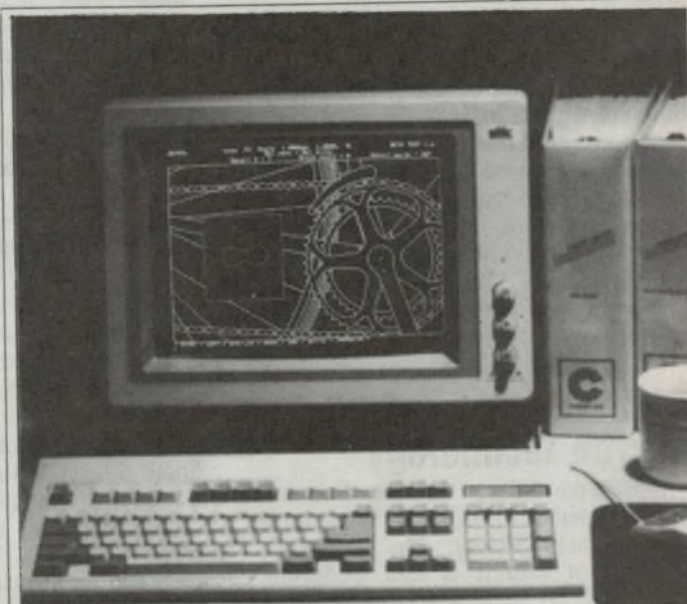

# Anthony Borg & Associates Pty. Ltd.

Telephone: (03) 374 2040  
Fax: (03) 379 3789

# Silicon Valley NEWSLETTER . . .



## NY enacts first VDT law in US

Although widespread in Europe, the use of VDT terminals has never been regulated in the United States until the legislature of Suffolk County in New York overrode a veto of the proposed bill by the County Executive.

The new law affects employers with more than 20 computer terminals and it pertains to any equipment purchased after January 1, 1980.

Under the new law, employers are required to pay for 80% of the cost of annual eye examinations and the cost of eye glasses that might be prescribed as a direct result of the use of VDTs. The law also stipulates that all VDT workstations must be "ergonomically sound," which will force business owners to purchase special adjustable chairs, tables, and desks, as well as install special lighting in VDT terminal areas.

VDT regulations such as the one adopted in Suffolk County are bitterly opposed by the business community. Still more than half of the states currently are considering the introduction, or have introduced legislation regulating the use of VDT-based equipment. Some states, including California, already have adopted voluntary or advisory guidelines for VDT use. But the Suffolk law is the first instance of a mandatory regulation.

## AMD shoots for 0.35 micron technology

Advanced Micro Devices has announced details of its earlier plans for a new research facility. The Sunnyvale chip maker said it is now budgeting some \$US100 million for the facility, which will be built on land AMD owns next to its Headquarters complex.

Earlier this year Intel revealed plans for a \$95 million R&D lab in Santa Clara, and in April, National Semiconductor opened its \$75 million Fairchild Research Centre at its headquarters site.

"Silicon Valley is alive and well," said AMD chairman Jerry Sanders, regard-

ing the huge commitment the valley's biggest chip makers are making to advanced research in the valley.

According to Sanders, the facility will include a 35,000-square-foot super clean room. "This clean room will be 1000 times cleaner than our cleanest to date. A lot of the equipment that will go into it hasn't been invented yet," commented AMD spokesman John Greenagel.

Sanders vowed that research will focus on process technology and designs for components with 0.35 micron features, a size that is even smaller than the 0.5 micron goal set by Sematech, the chip industry's recently formed manufacturing research consortium.

## Hundreds wait up to a year for security clearance

Silicon Valley is known for its workaholic style, but hundreds of its top-secret defence workers have drawn full pay for reading novels, playing tennis and working on trivial assignments while waiting for security clearances.

In interviews, workers and associates describe how they have spent months waiting for high-level clearances from military and intelligence agencies in Washington, DC. "You can get paid very well for doing absolutely nothing," a computer programmer said. He said he has already waited eight months for a "special access" clearance to work on a secret project at Lockheed Missiles and Space Co. in Sunnyvale.

Some Silicon Valley defence workers have passed the time leafing through company manuals, reading newspapers and playing sports. Others have taken classes and performed simple jobs while confined to unclassified areas sometimes known as the Ice Box, the Mushroom Patch or the Leper Colony.

By any name it's a sinkhole for taxpayer's money, defence industry critics say.

The General Accounting Office, an arm of Congress, estimated that defence contractors - and ultimately taxpayers - lost \$US340 million in 1982 because of the time involved in clearing people at

just the low end of the classified scale. A GAO investigator said the situation has improved, but proposed budget cuts might make things worse again.

Wolfgang Demisch, Wall Street defence industry securities analyst, said, "You hire somebody, and if as a kid he went to Eastern Europe on a bike, he's fired. But it takes six to nine months to find out, so in the interim you have him twiddling his thumbs. He's dead time for a year."

## Valley start-up cracks the tungsten problem

In a development that could vastly increase the reliability of sub-micron components, a Silicon Valley equipment start-up announced the development of a new breakthrough process for depositing tungsten on silicon and gallium arsenide wafers.

Plaser in San Jose said it has adapted its proprietary "Molecular Beam Processing" (MBP) technology, first used to deposit tungsten onto gallium arsenide wafers, to enable the selective deposition of tungsten onto silicon wafers. Plaser said it hopes to begin shipments of the "Plaser 8701" by October.

The new Plaser technology eliminates the problems chip makers have been plagued with in their efforts to replace the standard aluminum substrate with tungsten. The latter is considered critical as tungsten is superior to aluminum as both a contact material, a diffusion barrier, as a MOS gate interconnect, and as a multilevel metal connection (via or contact-hole filler).

Plaser made the announcement during a press conference at the Semicon West trade show in San Mateo.

Until now, chip makers have tried to deposit tungsten onto silicon with traditional "chemical vapor deposition" (CVD) technology. According to Plaser president Behrooz Atace, current CVD technology is inadequate for tungsten deposition as it brings along a host of problems, including non-uniformity of deposition, increased resistivity, encroachment, and "worm hole" where tungsten penetrates the substrate in

areas it isn't supposed to.

Instead of exposing the wafer to tungsten vapor that is randomly spread throughout the CVD chamber, Plaser's MBP technology introduces the reactive gases into the chamber in a uniform "beam-like" manner that is spread evenly across the breadth of the wafer, resulting in a uniform deposition in which the thickness at the edges of the circuit closely approaches the thickness at the center.

With the development of the MBP process, for which Plaser has already secured 72 patents worldwide, the company appears poised to quickly acquire a large share of the market for sub-micron CVD processing.

## AEA forms HDTV taskforce

Following its day-long conference on US involvement in the future high-definition television market, the American Electronics Association has announced the formation of a special task force and charged it with helping US electronics firms get into this market - which is projected to grow as large as \$US100 billion in worldwide sales by the turn of the century.

In all, 50 senior executives from leading American high-tech firms attended the conference in Santa Clara. Even NASA and President Reagan's Office of Science & Technology sent representatives to the event.

The message at the conference was clear, as the participants were told in no uncertain terms that failure of the US industry to participate in the HDTV business will cause the US to lose its ability to compete in other high-tech markets as well. This because the new generation of digital TVs will require major advances in key technologies, including semiconductors, signal processing, telecommunications, and display.

The participants agreed that the US should develop an ATV standard that is significantly different from those already developing in Japan and Europe.

## TI makes composite Si/GaAs chip

Texas Instruments has announced the development of the world's first semiconductor featuring both silicon and gallium arsenide on the same chip.

TI officials said during a demonstration of the chip that the combination of silicon and gallium arsenide could lead to components that will be able to take advantage of the high speeds that can

be achieved with gallium arsenide, while making these chips much stronger and thus easier to produce than Ga-As chips which are very brittle.

Also, silicon allows for much greater circuit density than gallium arsenide and has a much lower power requirement.

But the TI officials cautioned that despite being able to demonstrate the feasibility of the combination of the two key materials, it would probably be several more years before the technology can find its way from the lab into commercial production applications.

Putting silicon and gallium arsenide together into one chip was not a simple task, the TI researcher said. During the first phase of the process, a wafer made of only silicon is fabricated, after which gallium arsenide is "grown" on the surface in tiny islands in preselected spots.

## IBM leapfrogs industry into 8-inch wafers

Just when it appeared that any trend towards 8" wafers was all but dead for the time being, IBM stunned many semiconductor manufacturers with the announcement that it has put an 8" wafer, fab into production and is using

the Essex Junction (Virginia) facility to produce the firm's 1 megabit DRAM chips.

IBM made the announcement during the Semicon West trade show recently in San Mateo. It caught many in the industry by surprise, as the evolution from 4" and 5" wafers to the new 6" capacity is still in full swing.

IBM however, has not built any 6" wafer fabs and has apparently decided to leapfrog right on to the 8" wafers, which can produce up to 450 1-megabit chips per platter - three times as many chips as can be printed onto IBM's current 5" wafers.

For many semiconductor manufacturers, the announcement could spell trouble. A commitment to 8" wafers by IBM may well be interpreted as the setting of a new industry standard, as IBM is the world's largest producer of semiconductors.

Companies that have invested tens of millions of dollars during the past three years into new 6" facilities may find themselves forced to change to the 8" capacity much earlier than they had anticipated. Such a costly move would take away considerable resources they may have planned to devote to product and process research and development. 



## Anthony Borg & Associates Pty. Ltd.

Telephone: (03) 374 2040  
Fax: (03) 379 3789

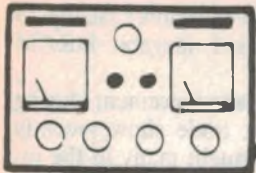

# The Serviceman



## New and familiar problems with old sets

I had a real blast from the past this month, with a job that took me back twenty years to olde worlde valve circuitry. At the same time it hit me with a problem that's just as common with modern solid state equipment. It's very easy to be misled by your test gear, if you're not extremely careful.

I was asked by a customer to repair an old HMV M7 monochrome TV, a valve type set dating from the early sixties. I did my best to convince him that the set wasn't worth fixing, and that my bill would be more than the set was worth.

He was very persistent though, and kept insisting that "it was only a resistor." It's usual to hear customers insisting that it's "only the picture valve", so "only a resistor" seemed to be an easier job and one more worth doing.

In detail, this set was showing a very dark picture which took about half an hour to struggle onto the screen. Now, even without seeing the set, I would be prepared to bet that it had a dud tube. And so it turned out to be. When I put the tester on it, the tube showed not the slightest sign of emission and it is still a puzzle to me that it could show any kind of picture at all.

I told the owner that no resistor on earth could repair that set, and that he would be best served by dumping it on the nearest tip. But he would not be convinced, and kept insisting that a similar fault five years ago only required a resistor to fix. He even pointed out to me the particular resistor involved.

Nothing I could do or say would convince him that his set needed more than one resistor, so to humour him I replaced it. I think he suspected me of fitting a dud one because there was absolutely no improvement in his picture. Try as I might, I couldn't convince him that only replacing the picture tube would cure his set.

Eventually, I had to pack up my tools, push past him to the door and take my leave. As I drove away I made a fervent wish that I would never see that set again. But my wish was not to be granted.

Next day, the customer was back to

ask me if I would try to get a replacement picture tube for his old set. He was desperate to have it working again and was prepared to mortgage his pension to pay for the job. I must admit, I felt a bit sorry for him, yet I wondered why he didn't invest the cost of this job in a newer, second hand colour set. Still, it was his set and his money, so who was I to argue?

When I got the set back to the workshop and had a good look at the picture tube, I began to think that the customer might have got a bit lucky.

Some ten or twelve years ago, a local wholesaler had closed his business and I had bought his stock of regunned black

and white picture tubes at very low prices. Some of them had been sold off at the time, and the rest stowed away under the house and almost forgotten.

Among them was a tube similar to that in the old HMV, still sealed in its original carton, with its twelve month warranty card – and still giving a 100% emission reading!

It took me some time to locate the old B&W picture tube replacement charts, but when I did I realised just how lucky my customer had become. The new tube was not merely a suitable replacement, it was THE recommended replacement for the old one.

To make matters even better, tube replacement in this set could not have been easier. First the cabinet back and the control knobs are removed, then six screws around the base board and two short bolts above the picture tube. After this, the whole cabinet can be lifted off, leaving the tube and chassis sitting naked on the baseboard.

The tube was held in place by a stout rim band, secured by heavy screws at the top and bottom. Loosening these screws allowed the old tube to be lifted

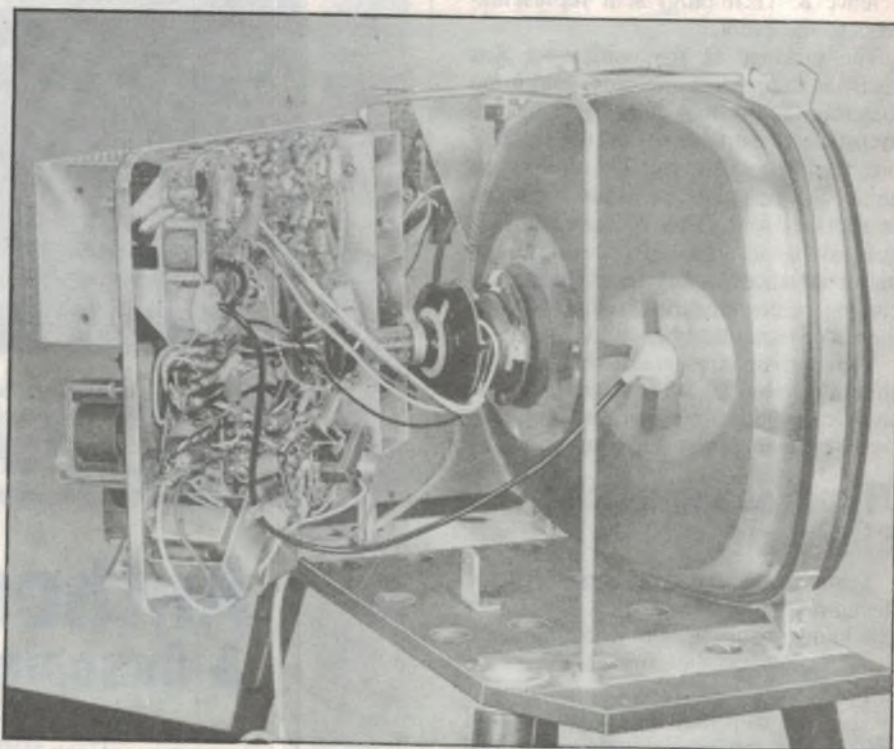

Picture tube replacement was very easy with the early HMV monochrome sets – the cabinet lifted off, and the chassis swung back.



away from the chassis and the new one fitted just as easily. Fifteen minutes and the job was done. (And there were no problems with the convergence, either!)

Unfortunately, when I fired the set up I got a brilliant screen, but no picture. The sound was OK, although a little weak. But if there was any picture, I certainly couldn't see it.

I turned the brightness down and was rewarded with a very faint picture – enough to be recognisable, but quite unsatisfactory for comfortable viewing.

An oscilloscope check at the picture tube base showed that there was only 3V peak to peak of video signal, where there should have been 60 odd volts. And so began a long and frustrating hunt for the reason for the weak video.

The trouble with this set was that it used valves instead of transistors – and I haven't worked with valves for ten years or more. One tends to lose track of old technology when it is not in use day after day. I had to get out my old valve manuals to read up about voltages and currents, in order to make sense of the readings I was getting around this chassis.

An unfortunate aspect of the set was that I couldn't get at the valve bases for measurement while the set was turned on. The chassis could only be swung out far enough for service after the yoke plug and its B+ link had been removed.

So all I could do when the chassis was open was to measure various resistances to either ground or B+. When the chassis was restored and switched on, I could remove the valves and check for voltage at the top of the sockets. But it was difficult, almost impossible, to take any meaningful measurements while the set was working.

Then I remembered a dinkus I had made up twenty years ago for just this purpose. It consisted of a valve socket soldered on the top of a matching plug. The socket pins were splayed outwards to allow access for measurement while the valve was plugged in and working.

I finally found the device in a box of assorted small tools, and soon had most of the measurements that I needed. The set was developing no AGC voltage, which wasn't surprising. But all the anode, screen and cathode voltages that I could get at were about normal.

It wasn't possible to get readings from the valves in the tuner, because they were mounted upside down with deep screening skirts around them. All I could do was to pull the valves and poke a meter probe into the socket to check for voltages.

Everything seemed to be in order, yet

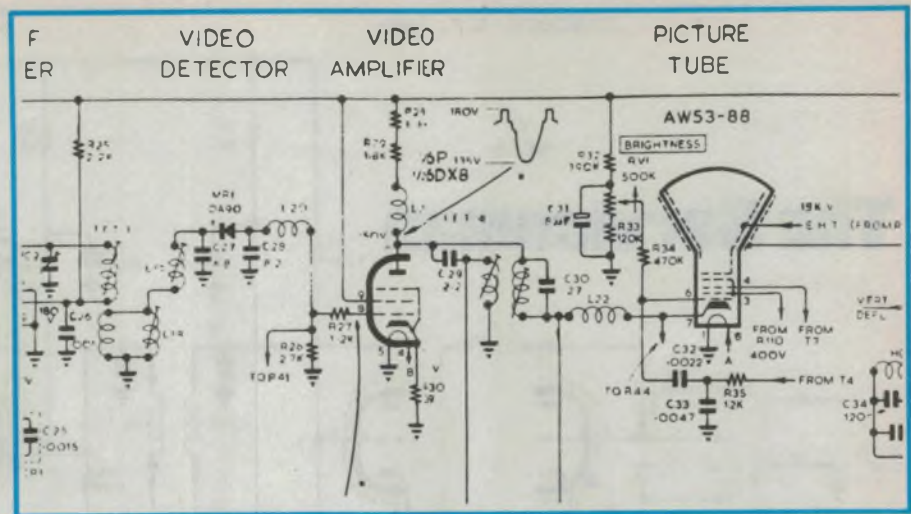

One problem with the old HMV set turned out to be in the video amplifier stage, shown here.

the chassis wasn't doing anything useful with any of the signals I applied. Not even a couple of millivolts applied direct to the tuner antenna terminals could produce any more than a dark, murky picture that disappeared as soon as the brightness was advanced above very dim.

I persevered with resistance measurements in all the old familiar places, and some that were not so familiar. I checked everything I could lay hands (or a meter probe) on. I found a number of the old cracked carbon resistors had gone high, and replaced them with modern metal film types, but all to no avail. There was still no worthwhile picture.

At this point I had to abandon the scientific approach and go in for a more suck-it-and-see type of servicing. Another piece of my useful home made test gear was then pressed into service. This is a small 5" National portable TV, that has been extensively modified.

Among other things, the IF lead from the tuner to the IF strip has been broken and brought out to two RCA sockets in the bottom of the cabinet. In normal use a U-shaped link joins the two sockets, but the link can be removed and the tuner output fed through a suitable lead to another set. Or the output of a suspect tuner can be fed into the test set through the IF input socket.

In this case, I fed the National tuner into the IF amplifier of the old HMV and got a passing-fair picture. It was still lacking good contrast, but at least it was brighter than the earlier effort.

Next, I fed the output of the HMV into the little set – and got a very poor picture as a result. It seemed that I had at least two faults in the big set, one in

the tuner and the other in either the IF strip or the video amplifier.

I decided to get the tuner working properly first. One good thing about old valve tuners is that they are big and robust and pretty easy to work on. First, I pulled out the channel "biscuits" and checked them for damage or dry joints. Then I cleaned and retensioned the spring contacts.

None of this made any worthwhile difference, so I resorted to a more critical assessment of resistances and voltages around the tuner. With the valves out of their sockets, I got readings of HT voltage (180V) at the anode and screen of the converter valve and at the top anode of the RF amplifier valve.

The 6ES8 RF amplifier in this set is run in cascode, where the second anode gets its B+ voltage from the cathode of the top triode. With the valve out of the socket, there can be no voltage – so a resistance check is the only way to make sense of the system.

I checked for continuity from all the external terminals to the various socket pins and found that most of them were very close to the values given in the service manual. But when I came to the feed resistor to the converter screen (R8), it was quite a different story.

Instead of the expected 47k ohms between the 180V terminal on the tuner body and pin 3 in the 6BL8 socket, I found a resistance of some 18 megohms, as read on my modern digital multimeter. And that was it! The resistor was as good as open circuit.

This is yet another example of confusing readings caused by the high impedance of a digital meter. I rechecked the voltage at pin 3 again, first with the digital meter, then with an old analog meter. The digimeter read 178 volts, the

# The Serviceman

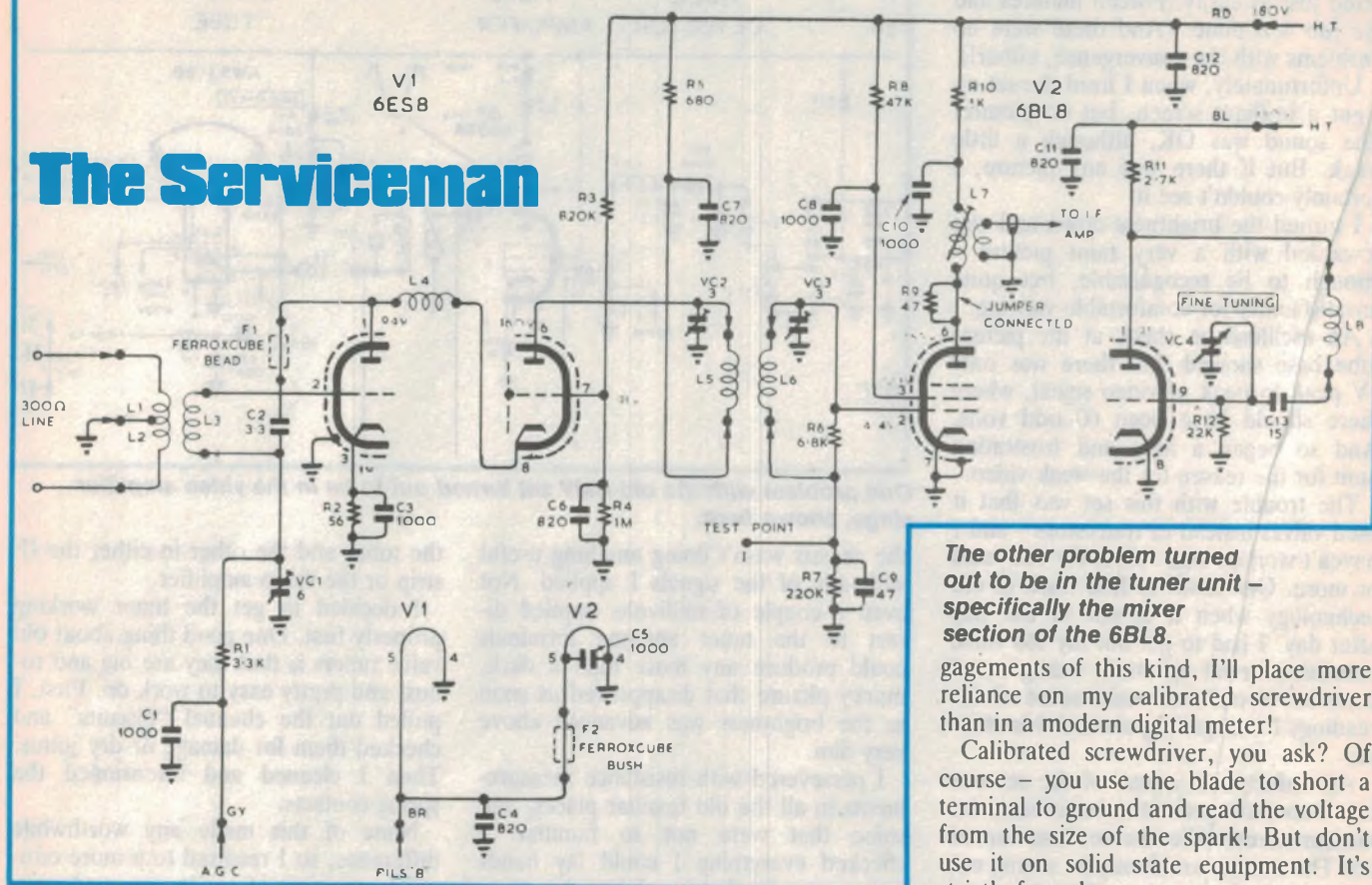

**The other problem turned out to be in the tuner unit – specifically the mixer section of the 6BL8.**

gagements of this kind, I'll place more reliance on my calibrated screwdriver than in a modern digital meter!

Calibrated screwdriver, you ask? Of course – you use the blade to short a terminal to ground and read the voltage from the size of the spark! But don't use it on solid state equipment. It's strictly for valves.

I've also heard of one technician who uses a calibrated finger. He only recognises three voltages – “Yep, it's on!”, “Ouch!”, and “Bloody Hell!!”

Finally this month, a follow-on from my story in the April issue, about the Rank C2205 with very odd symptoms.

Remember the story where the owner used the volume control to adjust the picture?

I said then that I was looking forward to seeing more of those sets, so that I could check just what symptoms appeared in the chassis under other circumstances. Well, several such sets have come in since, and they all experience queer symptoms when C351 is either faulty or removed experimentally. There is a family resemblance to all the symptoms, but there are still big differences between them.

In one set, for instance, removal of the cap showed that channel 6 was perfectly normal over most of the volume control range, although the horizontal sync became unstable at the very lowest setting.

Channel 2, on the other hand, could only be seen with the volume control at either the very bottom or the very top of its range. At every other setting the fine tuning pulled the set right off chan-

analog meter – 0 volts. In this case there was a very high resistance for the digital meter to read through, but I have known them to read voltage on a particular terminal through an impedance that is to all intents and purposes open circuit!

Getting the rotor out of the tuner was a bit fiddly, but I managed and soon had a new resistor in place of the faulty one. With everything back in place, I switched on and was rewarded with quite a good picture. Still a bit darker than one would expect from a new tube, but far better than anything I'd had up to this point.

All that remained was to get the brightness up, and for this my little socket doohicky was invaluable. With the video output valve sitting on the test socket, I was able to determine that a good two volts peak to peak of video was being supplied to the grid of the 6DX8. At its anode there was something over 80 volts of video, considerably more than was called for by the circuit diagram.

The only problem that I could see was that the anode voltage of the video amplifier was a bit higher than specified. This could have been caused by higher than normal resistance in either the

anode or cathode circuits.

The anode resistance was spot on, but the cathode was higher than the manual said it should be, 100 ohms instead of 39 ohms. I hooked a 68 ohm resistor across from the cathode pin to earth and the picture suddenly sprang to life, with brilliant highlights and a good, rich contrast. Indeed, the picture was as good as new.

When I swung the chassis out to replace the faulty resistor, I was surprised to find that it was in fact a 100 ohm unit. It had been in the set since new and had not changed its value. Yet the set clearly needed a 39 ohm resistor to work properly. I don't know how or why, but fitting the correct value resistor has restored the set to perfect operation.

So the customer was nearly right when he told me the trouble was “only a resistor.” It was “only two resistors” (plus a picture tube, of course), although neither of the resistors was the one he pointed out.

He has no idea of how much work I put into repairing his antique. If I charged him the full bit, it would buy him a new colour set. But in a perverse sort of way, I have enjoyed my reunion with the old technology. In future en-

nel - not even the sound was audible. And finally, when switched off, the set gave out with the loudest, rudest Bronx Cheer you've ever heard.

Another Rank, this time with a faulty C351, had yet another set of symptoms. This one had weak sound without distortion, but the sound crackled when the volume control reached the bottom of its travel. A secondary symptom was intermittent total loss of horizontal hold.

There was a moderate herringbone pattern on both channels at the higher volume levels, but the owner claimed never to have noticed this until I pointed it out. It was the horizontal problem that most worried him.

When the faulty cap was removed, but before the new one was fitted, the only other symptom was a squeaky blurt when the set was turned off. A new capacitor produced loud sound, cleared the other symptoms and gave a new life to the old set. (It had been threatened with the "Tip"!)

Quite obviously, C351 is responsible for the bulk of these odd symptoms. However the state of other electros on the 19V rail is a factor in determining the variety and severity of the various symptoms. Who knows? It might just be possible to pinpoint faulty caps by a careful analysis of the secondary symptoms when C351 is removed from circuit!

I have been repairing these Ranks for a good many years, yet it was only a few months ago that I first came across this C351 fault. Since then I have had the same fault in three more sets. How do the electro makers arrange for their products to last exactly 11 years and three months? 

### TETIA Fault of the Month

Philips CP510 (KT3A-2 chassis)

**Symptom:** Intermittent but regular vertical collapse to narrow line at centre screen. Rather like a hiccupping vertical stage.

**Cure:** Q520 (BD233) output transistor breaking down. This fault is heat sensitive and can be tested for with freezer spray. Freezing the transistor will hold off the fault for several minutes.

*This information is supplied by courtesy of the Tasmanian branch of The Electronic Technicians' Institute of Australia. Contributions should be sent to J. Lawler, 16 Adina St, Geilston Bay, Tas 7015.*

# ELECTRONICS

## EXCITING JOBS WITH A FUTURE



## GET YOUR TRAINING NOW AND BE PREPARED FOR THE FUTURE

If you're interested in electronics, a Stott's Home Study Course can make it even more interesting. It could lead to an exciting career in the fast-growing field of electronics.

Stott's electronics courses offer plenty of practical work and 'hands on' experience through custom-designed kits. You'll be skilfully guided by experienced, professional instructors, with individual attention and advice. You study at home, at your own pace.

Choose from Stott's range of electronics courses:  
**Introduction to Electronics, Radio and Television Servicing,  
Radio Receivers, Colour Television,  
Introduction to Micro Computers,  
Digital Electronics for Technicians &  
Servicemen or Industrial Electronics.**

MAKE YOUR MOVE TOWARDS A BRIGHTER  
FUTURE. SEND THE COUPON TODAY.



AN AUSTRALIAN TRADITION

PLEASE SEND ME FREE, AND WITHOUT OBLIGATION,  
FULL DETAILS OF THE FOLLOWING COURSE:

MR. MRS. MISS \_\_\_\_\_ (PLEASE PRINT)  
ADDRESS \_\_\_\_\_ AGE \_\_\_\_\_  
POSTCODE \_\_\_\_\_

Stott's undertake that no sales counselor will visit you  
Melbourne, 140 Finders Street, 3000 Tel. 654 6211  
Sydney, 383 George Street, 2000 Tel. 29 2445  
Brisbane, 65 Mary Street, 4000 Tel. 221 3972

Adelaide, 226 Pulteney Street, 5000 Tel. 223 3700  
West Perth, 25 Richardson Street, 6005 Tel. 322 5481  
Hobart, 2 Davey Street, 7000 Tel. 34 2399  
New Zealand, Box No 30-990 Lower Hutt Tel. 676 592

ALA/ST6439/EA688

## METEX 3800 MULTIMETER

This instrument is a compact, rugged, battery operated, hand held 3 1/2 digit multimeter for measuring DC and AC voltage, DC and AC current, Resistance and Diode, for testing Audible continuity and transistor hFE. The Dual-slope A-D Converter uses C-MOS technology for auto-zeroing, polarity selection and over-range indication. Full overload is provided. It is an ideal instrument for use in the field, laboratory, workshop, hobby and home applications.

- Features**
- Push-button ON/OFF power switch
  - Single 30 position easy to use rotary switch for FUNCTION and RANGE selection
  - 1/2" high contrast LCD
  - Automatic over-range indication with the "1" displayed
  - Automatic polarity indication on DC ranges
  - All ranges fully protected plus Automatic "ZERO" of all ranges without short circuit except 200 ohm Range which shows "000 or 001"
  - High Surge Voltage protection 1.5 KV-3 KV
  - Diode testing with 1 mA fixed current
  - Audible Continuity Test
  - Transistor hFE Test
- SPECIFICATIONS**
- Maximum Display: 1999 counts  
3 1/2 digit type with automatic polarity indication  
Indication Method: LCD display  
Measuring Method: Dual-slope in A-D converter system  
Over-range Indication: "1" Figure only in the display  
Temperature Ranges: Operating 0°C to +40°C  
Power Supply: one 9 volt battery (006P or FC-1 type of equivalent)  
Cat Q91530 Normally \$109  
SPECIAL \$79

## METEX 3530 MULTIMETER

This instrument is a compact rugged, battery operated hand held 3 1/2 digit multimeter for measuring DC and AC voltage, DC and AC Current, Resistance and Diode, Capacitance, Transistor hFE and Continuity Test. The Dual-slope A-D Converter uses C-MOS technology for auto-zeroing, polarity selection and over-range indication. Full overload is provided. It is an ideal instrument for use in the field, laboratory, workshop, hobby and home applications.

- Features**
- Push-button ON/OFF power switch
  - Single 30 position easy to use rotary switch for FUNCTION and RANGE selection
  - 1/2" high contrast LCD
  - Automatic over-range indication with the "1" displayed
  - Automatic polarity indication on DC ranges
  - All ranges fully protected plus Automatic "ZERO" of all ranges without short circuit except 200 ohm Range which shows "000 or 001"
  - High Surge Voltage protection 1.5 KV-3 KV
  - Capacitance measurements to 1pF
  - Diode testing with 1 mA fixed current
  - Audible Continuity Test
  - Transistor hFE Test
- SPECIFICATIONS**
- Maximum Display: 1999 counts  
3 1/2 digit type with automatic polarity indication  
Indication Method: LCD display  
Measuring Method: Dual-slope in A-D converter system  
Over-range Indication: "1" Figure only in the display  
Temperature Ranges: Operating 0°C to +40°C  
Power Supply: one 9 volt battery (006P or FC-1 type of equivalent)  
Cat Q91540 Normally \$139  
SPECIAL \$109

## METEX M-3650 MULTIMETER

20A, 3 1/2 digit frequency counter multimeter with capacitance meter and transistor tester.

This spectacular, rugged and compact DMM has a bright yellow high impact plastic case. It features a frequency counter (to 200kHz) diode and transistor test, continuity (with buzzer), capacitance meter, up to 20 amp current measurement and comprehensive AC/DC voltage current and resistance ranges.

- CHECK THESE FEATURES**
- Push-button ON/OFF switch
  - Audible continuity test
  - Single function, 30 position easy to use rotary switch for FUNCTION and RANGE selection
  - Transistor test
  - Diode test
  - Quality probes
  - 1/2" High contrast LCD
  - Full overload protection
  - 20 Amp
  - Built in tilting ball
  - Capacitance meter
  - Instruction manual
- Q91550 Normally \$165  
Special, only \$129

## METEX 4500H MULTIMETER

10A, 4 1/2 digit multimeter with digital hold, transistor tester and audible continuity tester.

The Metex 4500H is perfect for the technician, engineer or enthusiast who requires the higher accuracy of a 4 1/2 digit multimeter. This meter is exceptionally accurate (just look at the specifications), and yet still retains an exceptionally low price!

The Metex 4500H features digital hold which is normally only found on very expensive multimeters. This enables you take a reading and hold that reading on display even after you have removed the probes simply by pressing the hold button.

- CHECK THESE FEATURES**
- Readout hold
  - Transistor Tester
  - 4 1/2 digit x 1 1/2" (H) LCD
  - Audible continuity tester
  - Push-button ON/OFF switch
  - Quality set of probes
  - Single function, 30 position easy to use rotary switch for FUNCTION and RANGE selection
  - Built in tilting ball
  - Instruction manual
  - Full overload protection
  - hFE test
  - Battery and Spare fuse
  - Diode Tester
  - Vinyl case
- Q91560 Normally \$175  
Special, only \$159

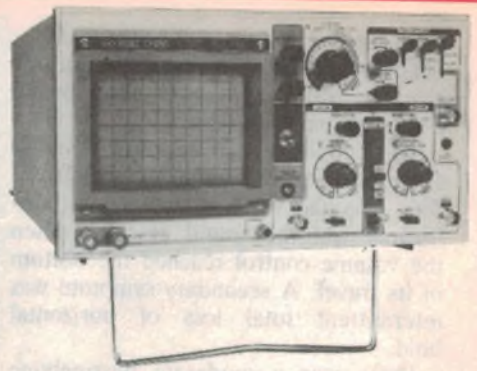

## HUNG CHANG (RITRON) 20 MHz DUAL TRACE OSCILLOSCOPE

- Wide bandwidth and high sensitivity
- Internal graticule rectangular bright CRT
- Built in component tester
- Front panel trace rotator
- TV video sync filter
- Z axis (Intensity modulation)
- High sensitivity X-Y mode
- Very low power consumption
- Regulated power supply circuit

COMPONENT TESTER is the special circuit with which a single component or components in circuit can be easily tested. The display shows faults of components, size of a component value, and characteristics of components. This feature is ideal to troubleshoot solid state circuits and components with no circuit power. Testing signal (AC Max 2 mA) is supplied from the COMPONENT TEST IN terminal and the result of the test is fed back to the scope through the same test lead wire at the same time.

**CRT**  
CRT 6" (150mm) Flat-faced high brightness CRT with Internal Graticule  
Effective display area: 8 x 10 div (1 div = 10 mm)  
Acceleration potential: 2KV

**VERTICAL**  
Operating Modes: CH-A, CH-B, DUAL, ADD (CH-B can be inverted)  
Dual modes: Alter 0.2u/s - 0.5ms/div Chop 1ms - 0.5s/div  
CHOP frequency 200KHz approximately  
Deflection factor: 5mV/div 20V/div +/- 3%, 12 ranges in 1-2-5 step with fine control

Bandwidth: DC-DC: 20MHz (1-3dB) AC: 10Hz - 20MHz (3dB)  
Rise Time: Less than 17ns  
Overshoot: Less than 3%  
Input Impedance: 1M ohm +/- 5%, 20pF +/- 3pF  
Maximum Input Voltage: 600Vp-p or 300V (DC + AC Peak)  
Channel Isolation: Better than 60 dB at 1KHz

**HORIZONTAL**  
Sweep Modes: NORMAL and AUTO  
Time Base: 0.2u/s - 0.5s/div +/- 3%, 20 ranges in 1-2-5 step with fine control  
Sweep Magnifier: 5 times (5X MAG)  
Linearity: 3%

**TRIGGERING**  
Sensitivity: INTERNAL: 1 div or better for 20Hz - 20MHz (Triggerable to more than 30MHz); EXTERNAL: 1Vp-p or better for DC - 20MHz (Triggerable to more than 30MHz)  
Source: INT, CH-A, CH-B, LINE and EXT  
Slope: Positive and Negative, continuously variable with level control PULL AUTO for free-run

Coupling: AC, HF-REJ and TV, TV SYNC Vertical and Horizontal Sync Separator Circuit allows any portion of complex TV video waveform to be synchronized and expanded for viewing TV-H (Line) and TV-V (Frame) are switched automatically by SWEEP TIME-DIV switch  
TV-V: 0.5s/div to 0.1ms/div, TV-H: 50u/s/div to 0.2u/s/div

**X-Y OPERATIONS**  
X-Y Operations: CH-A; Y axis CH-B X axis Highest Sensitivity: 5mV/div

**COMPONENT TESTER**  
Component Tester: Max AC 9V at the terminal with no load; Max current 2mA when the terminal is shorted (internal resistance is 4.7K ohm)

**OTHER SPECIFICATIONS**  
Intensity Modulation: TTL LEVEL (3Vp-p) Positive brighter  
BANDWIDTH: DC - 1MHz; MAXIMUM INPUT VOLTAGE: 50V (DC + AC Peak)  
Calibration Voltage: 0.5Vp-p +/- 5%, 1KHz +/- 5% Square wave  
Trace Rotation: Electrically adjustable on the front panel  
Power Requirements: AC: 100, 120, 220, 240V 20W  
Weight: 7kg approximately  
Size: 162(H) x 294(W) x 352(D)mm

Cat. Q12105 ..... only \$895  
(tax exempt only \$775)

Bulk orders, schools, please phone (03) 543 2166 for special low pricing

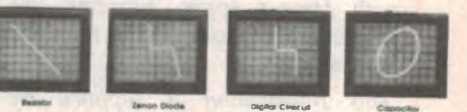

- RS232 WIRING ADAPTOR BOX**
- Male to female
  - 25 Detachable plug on leads
  - 2 mini jumpers
  - Ideal for experimenting or temporary connections
- Cat X15665 Normally \$49.95  
Only \$44.95

## ECONOMY SOLDER SUCKER

- Light weight
  - Sturdy construction
  - Easy to remove tip
  - Excellent value for money!
- Cat T11271 ..... \$11.95

## ECONOMY ANTISTATIC SOLDER SUCKER

- Light weight
  - Sturdy construction
  - Easy to remove tip
  - Excellent value for money!
- Cat T11281 ..... \$13.95

## DESOLDERING BRAID

1.5 metres at direct import prices!

Cat No.	1-9	10+
T11230	\$1.75	\$1.50



**RS232 FAST CABLER**  
Makes RS232 interface configuring fast and simple. 3 slide switches enable line swapping functions, positive and negative voltages are displayed on 6 Incolour LED's

- SPECIFICATIONS**  
Connector: DB25 plug on 100mm cable and DB25 socket on 100mm cable  
Indicators: Tricolour LED's for pins 2(TD), 3(RD), 4(RTS), 5(CTS), 6(DSR), 20(DTR)  
Switches: 3 Slide switches to swap leads  
Power: Interface power  
Enclosure: Black high impact plastic  
Dimensions: 85 x 95 x 30mm  
X15710 ..... \$145



**RS232 BREAK OUT BOX**  
A simple way of monitoring RS232 interface lead activity. Interface powered, pocket size for circuit testing, monitoring and patching. 10 signal powered LED's and 2 spares. 24 switches enables you to break out circuits or reconfigure and patch any or all the 24 active positions.

- SPECIFICATIONS**  
Connectors: DB25 plug on 80mm ribbon cable and DB25 socket indicator: Tricolour LED's for TD, RD, RTS, CTS, DSR, CD, TC, RC, DTR, (E)T  
Jumper Wires: 20 tinned end pieces  
Power: Interface power  
Enclosure: Black high impact plastic  
Dimensions: 85 x 95 x 30mm  
X15700 ..... \$94.95



**POWERFUL MINI DRILL**  
Featuring a powerful 6000 r.p.m. motor, this lightweight (113gm) drill is ideal for many jobs. Perfect for PCB work! Has a 0.8 to 1.2mm chuck and 1mm drill bit. Requires 12V 1 AMP (use with M19010)  
Cat T12302 ..... \$19.95

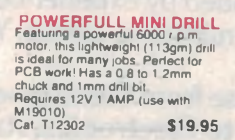

**PORTASOL PROFESSIONAL**  
Four tools in one! Blow Torch, Hot Blow, Hot Knife, No Cords or batteries  
● Heavy duty, tip temperature adjustable up to 400°C  
● Equivalent to 10-60 watts  
● Hard working. Average continuous use 90 minutes  
● Refills in seconds  
● Powered by standard butane gas lighter fuel  
● Range of easily replaceable screw tips included  
● Includes metal stand for the soldering iron when working  
● Cap features built-in mini for igniting Portasol tip  
● Includes snap case for storage  
Cat T12639 ..... \$89.95

## SOLDER ROLLS

Absolutely top quality unlike our opposition!

Cat No	Description	Price
T31000	71mm 250gm	\$8.95
T31002	71mm 500gm	\$15.95
T31010	91mm 250gm	\$7.95
T31012	91mm 500gm	\$14.95
T31020	1.6mm 250gm	\$7.50
T31022	1.6mm 500gm	\$13.95
T31030	71mm 1 metre	\$1.50
T31032	91mm 1 metre	\$1.25
T31034	1.6mm 1 metre	\$1.00



## ARLEC SUPER TOOL

- A versatile 12V electric tool for:
- Sanding
  - Engraving
  - Grinding
  - Polishing
  - Cutting
  - Drilling
  - Milling
  - Erasing, etc.

- Features**  
Operates on safe, low 12 volts from mains electricity via AC adaptor (supplied). Light and easy to handle with lock switch and lock for continuous running. High torque motor, 10,000 R.P.M. Can drill 2mm holes in steel. 2 year guarantee
- Contents**
- 12V Super Tool
  - Plugpack AC adaptor
  - 1 spherical milling cutter
  - 1 wire brush
  - 1 grinding wheel
  - 4 drill bits 0.8 0.8 1.0, 1.2mm
  - Set of 5 chuck collets
  - 6 arser sticks
  - Instruction sheets
- Cat T12300 ..... \$64.95

# COMPONENTS GALORE!

### ULTRASONIC TRANSducers

Designed to transmit at 40kHz (L19990) and receive at 40kHz (L19991) with up to 20V IP on the transmitter. These units can be heard and so are ideal for TV remote controls, water level detectors, burglar alarms, motion detectors and information carriers as they can be either pulsed or used in the continuous wave mode. Full specifications below for design purposes.

**Maximum Input Voltage:** 20V rms  
**Centre Frequency (kHz):** 40 ± 1.0  
**Sound Pressure Level 10V RMS:** 110dB min

**Sensitivity (dB/Vubar) min:** -65 min

**Bandwidth (kHz):**  
Transmit 4.0 (at 100dB)  
Receiver 5.0 (at -73dB)

**Impedance:**  
Transmit 500  
Receiver 5000

Cat. L19990 (Transmitter) \$6.95  
Cat. L19991 (Receiver) \$6.95

### ECONOMY TRANSFORMERS

2155 240V 6-15V 1A  
Cat. M12155 \$3.95 \$8.95

2156 240V 6-15V 2A  
Cat. M12156 \$4.95 \$13.95

2840 240V 9V CT  
Cat. M12840 \$.95 \$4.95

2851 240V 12-6V CT 150mA  
Cat. M12851 \$.95 \$5.50

2860 240V 15V CT 250mA  
Cat. M12860 \$3.95 \$4.95

6672 240V 15-30V 1A tapped  
Cat. M16672 \$14.95 \$13.95

### KEY SWITCHES

Cat. S12500 1-9 Normally \$7.95  
1-9 10+ \$4.95ea \$4.25ea \$3.95ea

### QUALITY 3mm LEDs

Cat. No. Col. 1-9 10+ 100+  
Z10140 Red \$0.15 \$0.12 \$0.10  
Z10141 Grn \$0.20 \$0.15 \$0.12  
Z10143 Ylw \$0.20 \$0.15 \$0.12  
Z10145 Ora \$0.20 \$0.15 \$0.12

### CANNON TYPE CONNECTORS

1-9 10+  
P10960 3 PIN LINE MALE \$3.90  
P10962 3 PIN CHASIS MALE \$3.00  
P10964 3 PIN LINE FEMALE \$4.50  
P10966 3 PIN CHASIS FEMALE \$4.95

### NEW TRANSISTORS

Rod Irving Electronics have two new transistors which will replace a multitude of common hard to get devices.

The PN100 is a NPN general purpose medium power amp and switch with continuous collector current up to 500mA.

The PN200 is a PNP general purpose amp at collector currents to 1 Amp. Both are TO-18 plastic package.

**PN100 REPLACES:**  
PN2221 PN2222 PN2223A  
PN3585 PN3588 PN3589 PN3643  
PN5133 PN2219A PN2222A  
PN4344 PN3415 PN3416 PN3417  
PN3700 PN3704 PN3904 PN4123  
PN4124 PN4401 PN2088 PN5210

**PN200 REPLACES:**  
PN2907 PN2907A PN3638  
PN3638A PN3640 PN3644  
PN4121 PN4143 PN4248 PN4249  
PN4250 PN4355 PN4916 PN4917  
PN5910 PN2905A PN3467  
PN3702 PN2906 PN4125 PN4126  
PN4291 PN4402 PN4403 PN5086  
PN5087 PN5447

PN100 Cat. T90001  
PN200 Cat. T90002

1-9 10+ 100+  
\$0.20 \$0.18 \$0.15

### PANEL METERS GALORE!

We have a great range of panel meters at great prices!

Cat. No. Description Price  
O10500 MU45 0-1mA 12.50  
O10502 MU45 50-0-50uA 12.50  
O10504 MU45 0-100uA 12.50  
O10510 MU45 0-5A 12.50  
O10518 MU45 0-1A 12.50  
O10520 MU45 0-1A 12.50  
O10525 MU45 0-20V 12.50  
O10530 MU52E 0-1A 14.50  
O10533 MU52E 0-5A 14.50  
O10535 MU45 VU PMeter 14.95  
O10538 MU65 0-50uA 16.95  
O10540 MU65 0-1mA 16.95  
O10550 MU65 0-100uA 16.95  
O10560 MU65 0-20V 16.95

### ELECTRET MIC INSERTS

With pins for easy board insertion.  
Cat. C10170  
1-9 10+ 100+  
\$1.20 \$1.00 \$0.90

THIS MONTH ONLY!

### U.V. TUBES

Fits into standard 15W fluoroc holder. Suitable for Scotchkal Eprom erasing etc. As used in ETI Eprom Erasing Kit.

WARNING! Do not look directly into U.V. Tubes.  
Cat. H28600 \$29.95\*

\*If ordering by mail please include an extra \$2 for special packing.

MAIL ORDER HOTLINE  
008 335757  
(TOLL FREE)  
LOCAL: 543 7877

### 10 TURN WIRE WOUND POTENTIOMETER Spectrol Model 534

1/4" shaft.  
Equip (Bourns 3540S, Beckman 7256).  
Dials to suit 16-1-11, 18-1-11, 21-1-11.

R14050	50R	R14100	5K
R14055	100R	R14110	10K
R14060	200R	R14120	20K
R14070	500R	R14130	50K
R14080	1K	R14140	100K
R14090	2K		

1-9 10+  
\$9.95 \$9.50

### SPECTROL 64Y MULTI TURN TRIMPOTS

R14700	10R	\$3.50	\$3.20
R14710	20R	\$3.50	\$3.20
R14720	50R	\$3.50	\$3.20
R14730	100R	\$3.50	\$3.20
R14740	200R	\$3.50	\$3.20
R14750	500R	\$3.50	\$3.20
R14760	1K	\$3.50	\$3.20
R14770	2K	\$3.50	\$3.20
R14780	5K	\$3.50	\$3.20
R14790	10K	\$3.50	\$3.20
R14800	20K	\$3.50	\$3.20
R14810	50K	\$3.50	\$3.20
R14820	100K	\$3.50	\$3.20
R14830	200K	\$3.50	\$3.20
R14840	500K	\$3.50	\$3.20
R14850	1M	\$3.50	\$3.20

### CENTRONICS SOLDER PLUGS SPECIALS!

1-9	10+	100+
\$2.95	\$2.50	\$1.95

### DB25 CONNECTOR SPECIALS!

TYPE	1-9	10+	100+
9P	\$0.70	\$0.60	\$0.50
9S	\$0.70	\$0.60	\$0.50
9C	\$0.60	\$0.50	\$0.40
15P	\$0.70	\$0.65	\$0.60
15S	\$0.70	\$0.65	\$0.60
15C	\$0.70	\$0.60	\$0.50
25P	\$0.70	\$0.60	\$0.50
25S	\$0.75	\$0.65	\$0.60
25C	\$0.70	\$0.60	\$0.50

### DB 25 CRIMP SPECIALS!

Type 1-9 10+ 100+  
Female \$2.95 \$2.50 \$1.95  
Male \$2.95 \$2.50 \$1.95

### QUALITY 5mm LEDs

Cat. No. Col. 1-9 10+ 100+  
Z10150 Red \$0.08 \$0.07 \$0.06  
Z10151 Grn \$0.15 \$0.12 \$0.10  
Z10152 Ylw \$0.15 \$0.12 \$0.10

### NICADS!

Save a fortune on expensive throw away batteries with these quality Nicads and Rechargers!

Size	Desc.	1-9	10+	100+
AA	450 mA H.	\$2.95	\$2.75	\$2.50
C	1.2 A.H.	\$9.95	\$9.50	\$8.95
D	1.2 A.H.	\$9.95	\$9.50	\$8.95

### RELAYS

1-9	10+	100+
\$1.50	\$1.30	\$1.10

S.P.D.T. 3A connectors \$14060  
D.P.D.T. 3A connectors \$14061  
S.P.D.T. 12V Coil 10A 240V \$14114  
\$4.95 \$3.95 \$3.75

### HIGH INTENSITY RED LED BAR GRAPH

Dimensions:  
Overall: 63mm across, 5mm high  
LEDs: 10x5mm x 1mm

Cat. No.	1-9	10+
Z10180	\$2.95	\$2.75

### SPECTROL MULTIDIALS

MODEL 15-1-11  
Number of turns: 10  
Minor Scale Division: 1/500 turn  
Shaft Bore: 6.35mm (1/4")  
Finish: Satin Chrome  
Body Size: 25.4 x 44.45mm (1 x 1 3/4")  
Depth: 25.4mm (1")  
Weight: 45.4g (1.6oz.)  
Cat. R14405 \$45.95  
SPECIAL, \$35.95

### SPECTROL MULTIDIALS

MODEL 16-1-11  
Number of turns: 15  
Minor Scale Division: 1/500 turn  
Shaft Bore: 6.35mm (1/4")  
Finish: Clear Anodize  
Body Size: 22.2mm diameter (875")  
Depth: 22.2mm (875")  
Weight: 19.8g (0.7oz.)  
Cat. R14400 \$26.95  
SPECIAL, \$21.50

### SPECTROL MULTIDIALS

MODEL 21-1-11  
Number of turns: 15  
Minor Scale Division: 1/100 turn  
Shaft Bore: 6.35mm (1/4")  
Finish: Satin Chrome  
Body Size: 46.04mm diameter  
Depth: 35.4mm (1 1/2")  
Weight: 85.9g (3.07oz.)  
Cat. R14410 \$46.95  
SPECIAL, \$37.50

### LOW PROFILE IC SOCKETS

Save a small fortune on these 'Direct Import' low profile IC sockets! PCB mounting solder tail. Dual wire. All tin plated phosphor bronze or beryllium and dual wire for reliability.

Cat. No.	Description	1-9	10+
P10550	8 pin	\$0.20	\$0.15
P10560	14 pin	\$0.25	\$0.20
P10565	16 pin	\$0.35	\$0.20
P10567	18 pin	\$0.40	\$0.30
P10568	20 pin	\$0.40	\$0.30
P10569	22 pin	\$0.40	\$0.30
P10570	24 pin	\$0.40	\$0.30
P10572	28 pin	\$0.50	\$0.40
P10575	40 pin	\$0.50	\$0.40

### GOLD INSERT LOW PROFILE IC SOCKETS

- Gold machined pins
- Extremely high quality
- Anti-wicking
- Ideal for professional use or where field service of components is required.

Cat. No.	Description	1-9	10+
P10620	8 pin	\$1.20	\$1.10
P10624	14 pin	\$1.60	\$1.50
P10626	16 pin	\$1.90	\$1.80
P10628	18 pin	\$2.00	\$1.80
P10630	20 pin	\$2.20	\$2.00
P10632	22 pin	\$2.40	\$2.20
P10634	24 pin	\$2.60	\$2.40
P10640	28 pin	\$2.90	\$2.60
P10644	40 pin	\$3.00	\$2.70

### WIRE WRAP IC SOCKETS

These quality 3 level wire wrap sockets are tin-plated phosphor bronze.

Cat. No.	Description	1-9	10+
P10579	8 pin	\$1.50	\$1.40
P10580	14 pin	\$1.85	\$1.70
P10585	16 pin	\$1.95	\$1.80
P10587	18 pin	\$1.95	\$1.80
P10590	20 pin	\$2.95	\$2.70
P10592	22 pin	\$2.95	\$2.70
P10594	24 pin	\$3.95	\$3.50
P10596	28 pin	\$3.95	\$3.50
P10598	40 pin	\$4.95	\$4.50

### mic

Rod Irving Electronics  
MELBOURNE 48 A Beckett St.  
Phone (03) 863 6151

NORTHCOLE 425 High St.  
Phone (03) 48 8866

CLAYTON 56 Renvar Rd.  
Phone (03) 543 7877

SOUTH AUSTRALIA  
Electronic Discounters P/L  
305 Morphett St. ADELAIDE  
Phone (08) 212 1799

NOTE: Prices vary slightly between the 3 sites.

MAIL ORDER  
Local Orders (03) 543 7877  
Interstate Orders (008) 33 5757  
All Inquiries (03) 543 7877

CORRESPONDENCE  
P.O. Box 620 CLAYTON 3168  
Telex AA 151938  
Fax: (03) 543 2648

MAIL ORDER HOTLINE  
008 335757  
(TOLL FREE)  
(STRICTLY ORDERS ONLY)

LOCAL ORDERS & INQUIRIES  
(03) 543 7877

POSTAGE RATES

\$1	\$9.99	\$2.00
\$10	\$24.99	\$3.00
\$25	\$49.99	\$4.00
\$50	\$99.99	\$5.00
\$100	\$199.99	\$7.50
\$200	\$499.99	\$10.00
\$500 plus		\$12.50

The above postage rates are for basic postage only. Road Freight, bulky and fragile items will be charged at differential rates. All sales tax exempt orders and wholesale enquiries to ITRONICS WHOLESALE, 56 Renvar Rd. CLAYTON Ph. (03) 543 2166 (3 lines)

Errors and omissions excepted. Prices and specifications are subject to change.

SEE PC 41 AT our warehouse (wholesale and international business machines). Apply to a registered trademark licensee, or authorized reseller of their respective products.

MasterCard VISA

### NUMERIC KEYPAD

Unencased keypad 10 digit keys plus two utility keys. Light grey in colour.  
OUTPUT ARRANGEMENT:  
Output Pin No. Symbol  
1 N.A.  
2 Shield plate  
3 Column 2  
4 Row 4  
5 Column 3  
6 Row 1  
7 Column 1  
8 Row 2  
9 Row 3  
10 N.A.

Cat. C19030  
1-9 10+ 100+  
\$2.95 \$2.50 \$1.95

### RECHARGEABLE 12V 1.2AH GEL BATTERY

Leakproof, long service life batteries ideal for security systems, emergency lighting or as a computer backup power supply, etc.

Cat. S15029 Normally \$19.95  
1-9 10+  
\$13.95 \$12.95

### TAG TANTALUM CAPACITORS SPECIALS!

R16124	16V 4.7uF	\$0.48
R16125	16V 10uF	\$0.52
R16126	16V 15uF	\$0.75
R16128	16V 22uF	\$0.85
R16216	25V 2.2uF	\$0.40
R16220	25V 4.7uF	\$0.70
R16222	25V 6.8uF	\$0.70
R16224	25V 10uF	\$0.60
R16228	25V 22uF	\$2.40
R16300	35V 0.1uF	\$0.30
R16302	35V 0.15uF	\$0.30
R16304	35V 0.22uF	\$0.30
R16306	35V 0.33uF	\$0.30
R16308	35V 0.47uF	\$0.30
R16310	35V 0.68uF	\$0.35
R16311	35V 0.82uF	\$0.40
R16312	35V 1.0uF	\$0.30
R16314	35V 1.5uF	\$0.50
R16316	35V 2.2uF	\$0.50
R16318	35V 3.3uF	\$0.35
R16320	35V 4.7uF	\$0.70
R16322	35V 6.8uF	\$0.80
R16324	35V 10uF	\$0.80
R16326	35V 15uF	\$1.40
R16328	35V 22uF	\$3.50

### CHROME LED BEZELS

9mm hole, available 3 colours

Cat. No.	Description	Price
S14030	Red	\$1.20
S14032	Green	\$1.45
S14034	Yellow	\$1.45

## Construction project:

# Improved 72L 3-way hifi loudspeakers

Here are the details of a high quality 72 litre speaker system using the well-known Vifa driver units. The performance of the SA-130 system is comparable with commercial systems costing around \$2500 – but it will cost you less than half this figure, even buying the enclosures in kit form. You can save even more by building these yourself.

by **TOM MANNING** Scan Audio, Melbourne

Loudspeaker construction in the home has never been so popular. Today, commercially available speakers proliferate, and whilst the quality of the many different models available is increasing due to tough competition, the rising labour costs involved in fully built speakers dictate proportionate price increments at the retail end of the production chain. This makes D-I-Y systems particularly attractive, especially considering that the skills involved in construction speakers from proven designs are within the reach of most people with good practical abilities.

This article, describing a large speaker using the now well known Vifa drive units, is loosely based on an earlier and very popular system using similar components. The configuration is reasonably conventional, keeping the construction at a level enabling those with basic woodworking equipment to construct the cabinets from scratch.

To compliment the cheaper designs available in the Vifa kit range, an early design stipulation was that the SA-130 should compete sonically with imported speakers available for around \$2500. To extract this maximum performance we began to look at various permutations available within our projected price of \$1200 for the complete kit.

A speaker of this quality should be capable of bass performance with truly deep extension, clarity and transient ability. Since good bass performance is a function of size (and cost, usually!),

this mandates the use of a relatively large woofer and enclosure. We narrowed down our choice to a few drivers capable of providing us with the desired

performance. After considerable and deliberation, one unit stood out clearly: the Vifa P-25-Wo, a 250mm (10") driver featuring a rigid alloy frame, large magnet and pole piece assembly and a thick magnesium enriched polypropylene cone. When loaded correctly, it promises ideal reproduction of the low registers, with transient ability and power handling to match.

Enclosing the woofer correctly is half the trick. Before making any decisions, we must consider a set of electrical and mechanical parameters which define our options by allowing us to predict, with

*A pair of the new enclosures, one with front cloth fitted and the other "naked" to show its drivers. Each enclosure measures 940 x 300 x 295mm.*



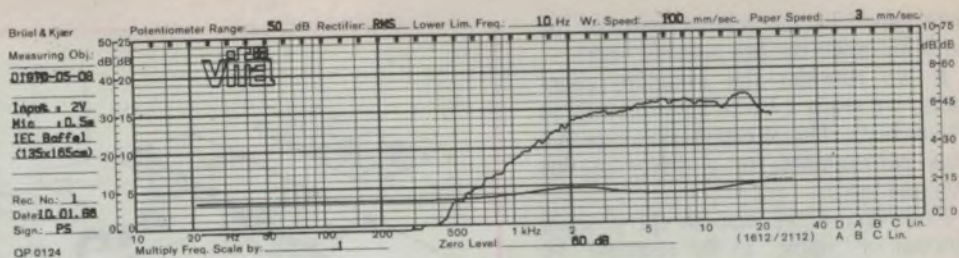

Fig.1: The tweeter used is the Vifa D19TD-05-08, a 19mm dome type with ferrofluid for cooling and damping.

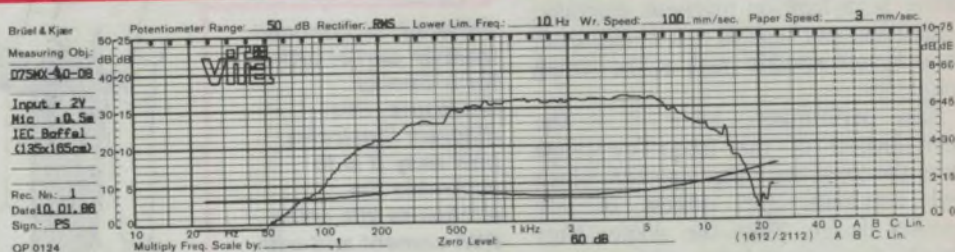

Fig.2: The mid-range driver is the Vifa D75MX-30-08, with a 75mm fabric dome and aluminium voice coil.

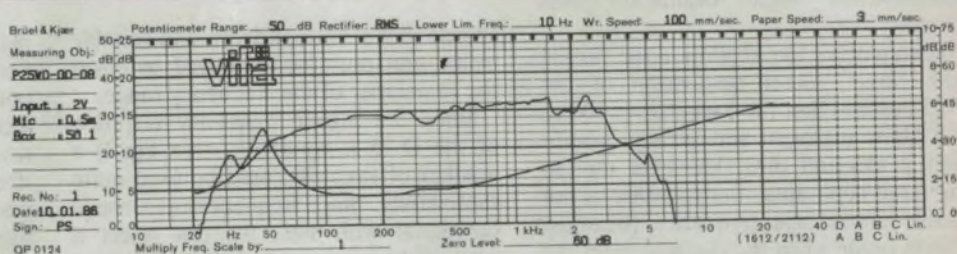

Fig.3: The woofer is Vifa's P25WO-00-08, a 245mm type with magnesium enriched polypropylene cone.

accuracy, the performance of the driver in several cabinet volumes with various bass reflex tuning ratios (alignments). The parameters in question are:

1. The free air resonance ( $F_0$ ), which is the frequency at which the moving system of the driver exhibits the maximum output for the minimum electrical signal.
2. The total Q factor of the driver ( $Q_t$ ), which is the quality factor at resonance and which indicates the combined effects of the driver's electrical and mechanical damping of the moving system at its free air resonance.
3. The VAS, which is the volume of air in litres needed to provide the same restoring force to the cone as does the suspension. Expressed more generally, VAS gives an indication of the "springiness" of the suspension system.

Dictated largely by the  $Q_t$  of the driver, usually just one option is available for the flattest frequency response. But thanks to the large magnet assembly providing high mechanical damping, and subsequent low  $Q_t$  of the P-25, we are afforded some flexibility with our choices for  $V_b$  (cabinet volume) and  $F_b$  (frequency of maximum vent output,

### SPECIFICATION

MODEL:	VIFA SA-130
SYSTEM:	3-way bass reflex
WOOFER:	245mm (10") VIFA P25WO-00-08
MIDRANGE:	75mm textile dome VIFA D75MX-30-08
TWEETER:	19mm dome ferrofluid VIFA D19TD-05-08
RATED POWER:	130 watt Peak
IEC POWER:	90 watt RMS
SENSITIVITY (1W/1m):	90dB
FREQUENCY RESPONSE:	28-20,000Hz
CROSS-OVER FREQ'CY:	800 & 3000Hz
TUNING FREQUENCY:	35Hz
IMPEDANCE:	8 ohms
INTERNAL VOLUME:	72 litres
DIMENSIONS (H x W x D):	94 x 30 x 29.5cm
WEIGHT:	24 kg

determined by the relative mass of the air both inside the box and the vent).

If we consider the optimum alignment, we reach a  $V_b$  of 53 litres with an  $F_b$  of 38Hz. This is clearly unacceptable bass performance for a driver of this size and price.

However, if we can accept a small amount of "ripple" in the response, by increasing  $V_b$  and lowering  $F_b$  somewhat we achieve a far more useful  $F_b$  of 29Hz with a  $V_b$  of 72 litres. Had the driver been light on magnetic damping, a misalignment such as this would result in a distinct audible peak at the tuning frequency.

Bass performance aside, it is the reproduction of the frequency range from the lower midrange upwards which will determine the success of any speaker design. Since the woofer must handle the critical lower midrange region, this must be an equally important consideration when evaluation bass drivers.

Fortunately, the shallow cone profile and "lossy" outer suspension of the P-25 ensures that the range from 100 to 500 Hz is managed without any significant peaks and dips. However due to the large cone area, the response is not usable above this frequency (beaming effects occur when the distance from the centre of the cone to the outside edge equals two wavelengths of the frequency being radiated) and here it becomes necessary to select a midrange unit capable of satisfying a new set of criteria.

The proposed midrange driver must be rugged, it must be compliant enough to handle the excursion necessary under high power at these frequencies, it must be small enough to respond well up into the kilohertz region, it must have clarity and good transient response.

Vifa manufactures several high quality midrange units. The most usable of these is a new 75mm (3") unit, the D75MX-30-08. This circumferentially driven device uses soft fabric for the dome assembly, an aluminium voice coil former and a centrally enclosed magnetic assembly. The open back construction of the driver allows it to "breathe" most efficiently, providing a low free air resonance ( $F_0$ ), of 250Hz.

With these qualities in its favour, it is ideally suited to cross over to the woofer at 500Hz. Furthermore, its low moving mass (3.7g) allows it to respond up to 6kHz where here it is only 3dB down.

But in life, death is unavoidable, and as the mass reactance of the dome becomes dominant with frequency, the re-

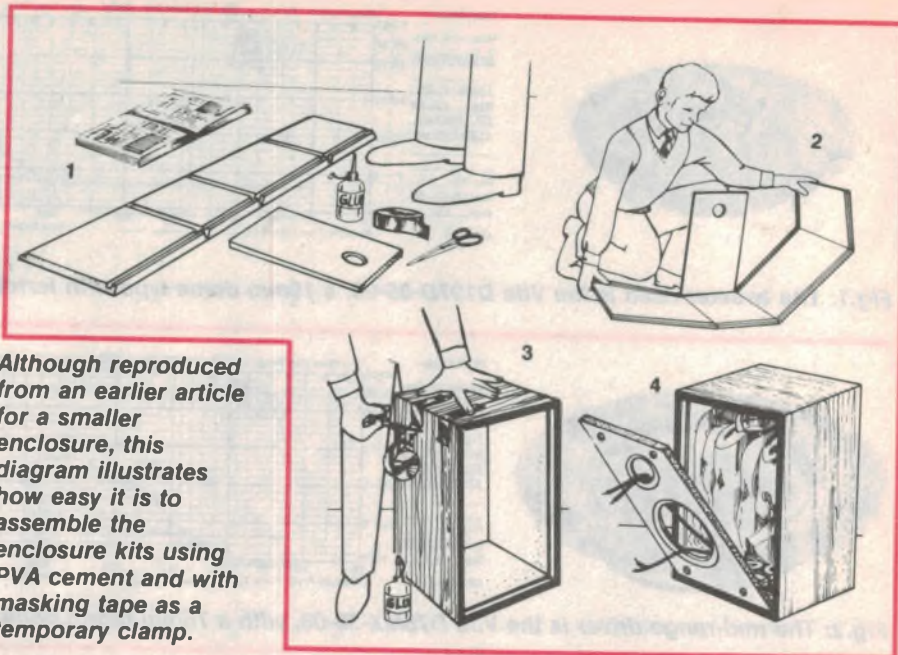

*Although reproduced from an earlier article for a smaller enclosure, this diagram illustrates how easy it is to assemble the enclosure kits using PVA cement and with masking tape as a temporary clamp.*

sponse dies a natural death and suitable treble unit must be employed to cover the remainder of the frequency range.

Since the higher frequency response of the D-75 is so useful, (see Fig.2) a number of tweeters could be used quite successfully. Since frequency response is functional with size, we can select a small diameter tweeter with its excellent high frequency performance, without being concerned about potential reliability problems resulting from operating the unit at or near its natural resonance. (If this were allowed, the excessive excursion under high power will cause fairly prompt failure, ensured by the lack of flexible lead-in wires which are generally not fitted to tweeters of this size.)

The natural selection for the task is the Vifa D-19-TD – a 19mm dome unit of interesting construction. The dome is plastic-polyamide, providing very low

mass with response well past 20kHz. Ferrofluid is used in the magnet gap, both for cooling under high power and mechanical damping of self-generated resonances. The voice coil is constructed from aluminium and the core piece and bottom plate are machined from one solid piece of steel.

With driver decisions completed, the crossover can now be tackled, the most challenging and important aspect of any proposed design. An examination of the circuit, (Fig.4) reveals that it's a mixture of roll off slopes – first, second and third order types being used.

This may seem at first to be an unwise choice, since it's usually desirable to apply symmetrical crossover functions throughout. But loudspeaker drivers are imperfect devices, and before considering any electrical functions, it's necessary to examine the acoustical behaviour of the drivers in question.

Starting with the woofer, L1 and C1 form a second order electrical filter at 500Hz. This, coupled with the driver's natural acoustical roll off provides an overall acoustical attenuation of around 20dB per octave. C2 and R1 are used for impedance compensation, C2 exhibiting a reducing impedance characteristic with rising frequency.

Moving on to the midrange section we must now implement a band pass filter to ensure that the driver copes adequately with its assigned frequency range. C3 forms the high pass section, providing 6dB of electrical attenuation. Together with the natural droop in driver response below 500Hz, the resultant acoustical behaviour is in the region of 24dB per octave.

## KIT PRICE & AVAILABILITY

Kits for the Vifa SA-130 speaker system are available from the Australian importer for Vifa, Scan Audio Pty Ltd of 52, Crown Street, Richmond Victoria 3121.

Complete kits including cabinets (in flat-pack form) are priced at \$1199.00 per pair, while kits complete except for the cabinets are \$929.00 per pair.

Scan Audio can also supply the various drivers units separately, if required.



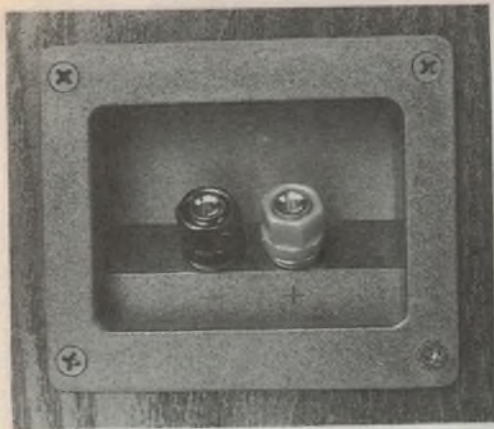

Above: a close-up of the terminal block, fitted to the case rear with screws and sealant.

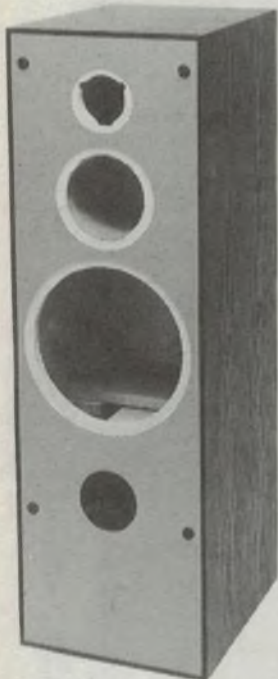

Above: How the assembled enclosures should look before the drivers are fitted.

The low pass section, however, uses a third order filter, comprised of L3, C4 and L4, chosen to avoid operating the driver in the region of 6kHz where its response becomes quite erratic due to break-up modes in the dome assembly. L2 and R3 serve as a step filter, defeating a small rise at 4kHz in the driver's on-axis response. Coupled with R2, the overall sensitivity of the driver is reduced about 2dB to match its output to that of the woofer's.

Lastly, the treble section. Here C5, L5 and C6 are the reactive components, forming a third order filter which provides high power handling by reducing the dome excursion substantially compared with less steep slopes. R4 (3.3 ohms) is used to provide about 3dB of attenuation throughout its operating band.

As a system, the response extends

ONLINE: Vented/35 dB Graph

CASD

ESCAPE: Select Graph

Driver Brand/Model  
VIFA  
P25WO-00-00

Driver Parameters:  
Fs (Hz): 24  
Qts: .28  
Vas (L): 178

Box Parameters:  
Vb (L): 72  
Fb (Hz): 29  
Ql: 7

Filter Parameters:  
Fp (Hz): NONE  
Q: NONE

Cursor (Use F1-F4):  
Hertz: 100  
dB: -.61

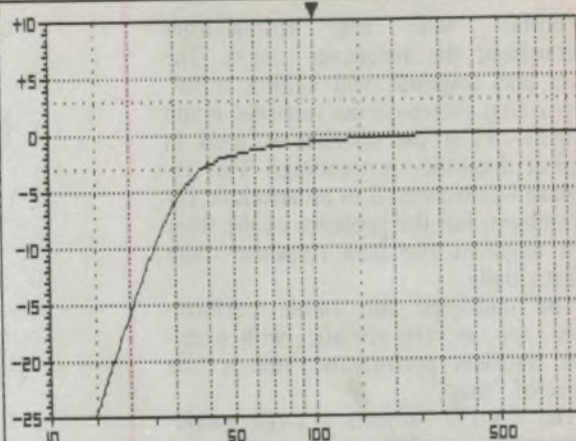

Do you wish to save response graph? (Y/N)

Date: 07-06-1988

(c) SCS

Above: Response of the P25WO woofer in a 72L volume, as plotted.

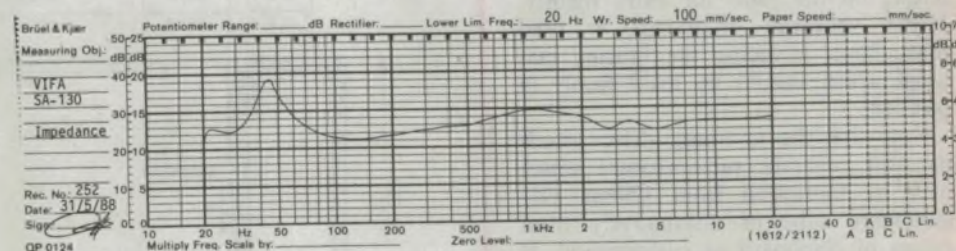
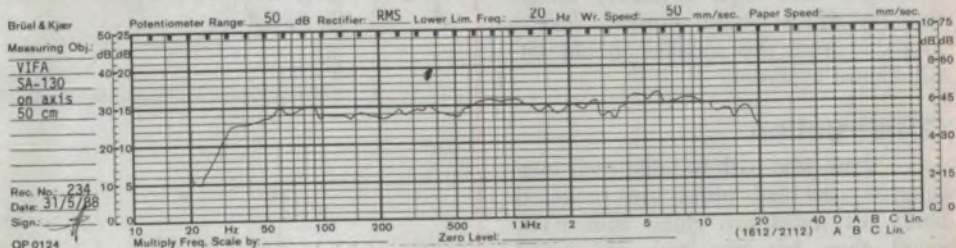

Fig.5: The measured frequency response of the final enclosure (upper curve), and its impedance curve – both measured between 20Hz and 20kHz.

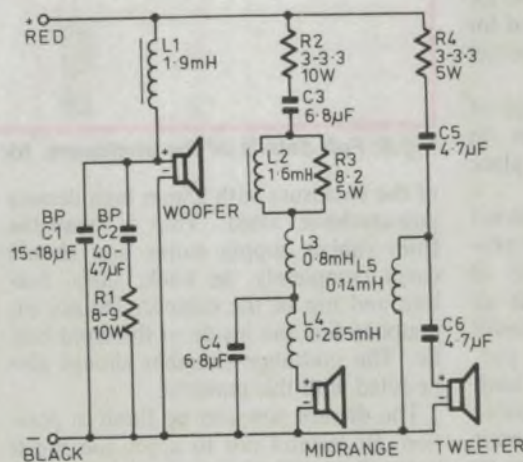

Fig.4: The circuit for the crossover network, together with the parts used.

## CROSSOVER PARTS LIST

- 1 1.9mH ferrite max. 0.45 ohms
- 2 1.6mH air or ferr. max. 1 ohm
- 3 0.8mH air max. 0.4 ohm
- 4 0.265mH air max. 0.3 ohm
- 5 0.14mH air max. 0.5 ohm
- 1 15-18uF bipolar 50 Volt
- 2 40-47uF bipolar 50 Volt
- 3 6.8uF film polyester
- 4 6.8uF bipolar 0 Volt
- 5 4.7uF film polyester
- 6 4.7uF film polyester
- 1 8-9 ohms 10 watt
- 2 3-3.3 ohms 10 watt
- 3 8.2 ohms 5 watt
- 4 3.3 ohms 5 watt

# 3 Way Speaker

smoothly with few irregularities throughout the frequency range. The bass end response will exhibit a lift, above that shown on the response graph (Fig.5), when the speaker is used in typical domestic surroundings. This response was measured in an anechoic environment, but the presence of the floor will augment the bass response quite substantially.

The midrange and treble performance, too, is very realistic, with excellent transient performance and a fine sense of "snap".

The SA-130 projects a large soundstage with the ability to place musical instruments precisely in the soundfield with no signs of "wandering" (usually an indication of poor crossover design). Power handling is very high, and this combined with high efficiency means that the SPL's (sound pressure levels) available from this speaker should satisfy almost everyone!

## Construction

For those who wish to build their own cabinets, detailed plans are provided here. All joints are glued with PVA wood glue, but you may use wood screws on the joins for extra rigidity. 18mm veneered chipboard is used throughout, including the bracing material which should be fixed firmly in position.

Note that the midrange driver needs its own separate sub-enclosure which may be fabricated from 124mm OD cardboard tube or alternatively from scraps of chipboard or customwood. It is absolutely essential that this chamber be completely sealed, to avoid back pressure from the woofer from modulating the midrange dome. Use silicone for this purpose, which can also be used for sealing all inside joints of the cabinet once it's completed.

The bass port is cut from a piece of 90mm PVC sewer pipe, 16mm in length. This should be glued in place with epoxy resin or PVA glue.

For those who intend to construct your own crossovers, a parts list is provided. Hardwire these on a piece of scrap chipboard, making sure that all components are glued securely. Bostik hot melt glue is excellent for this purpose. Secure the crossover to the back of the cabinet, once you have double checked your wiring against the circuit diagram. Pay particular attention to driver phasing.

This done, you should line the inside

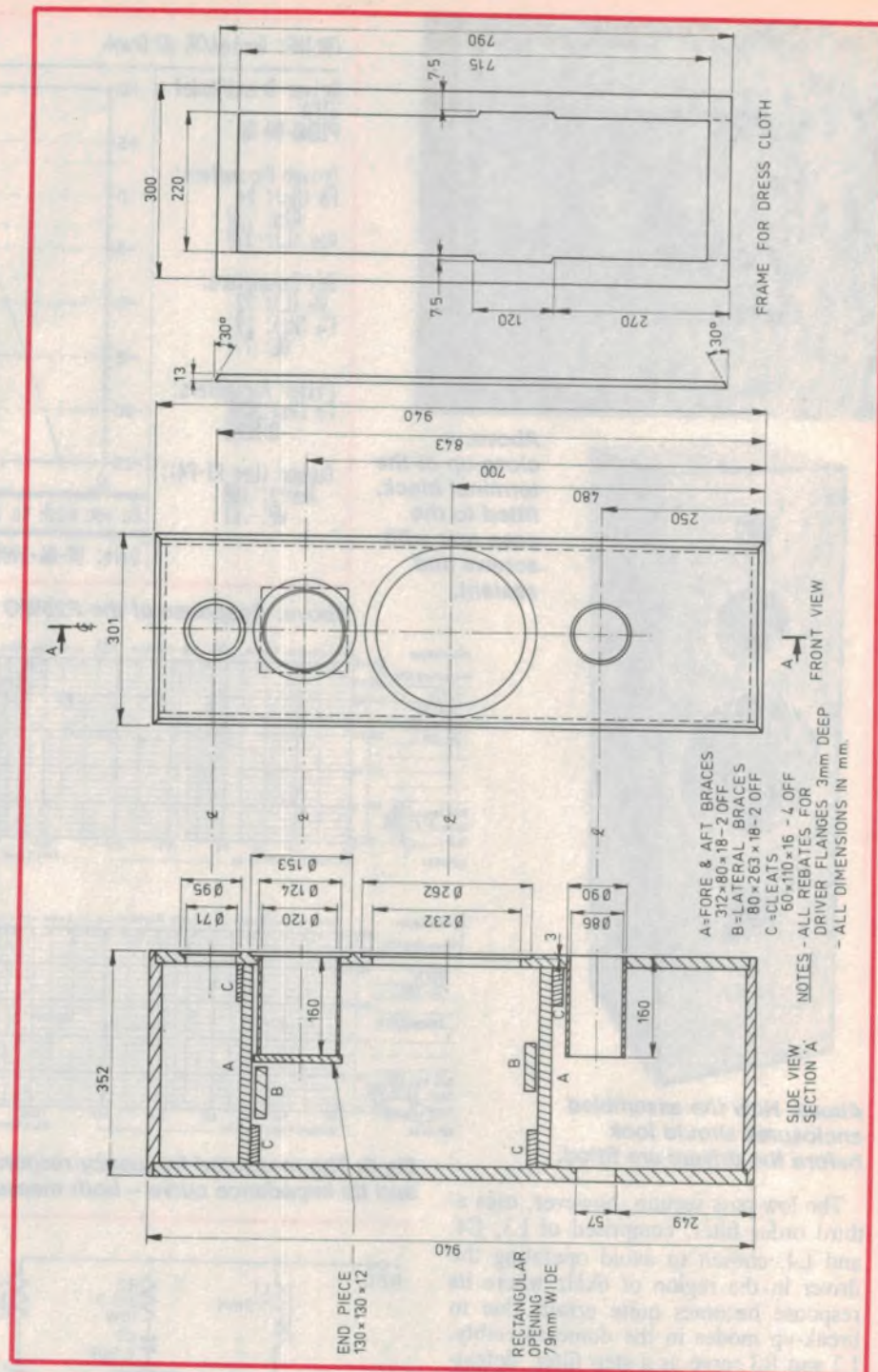

Fig.6: Full details of the enclosure, for "rolling your own".

of the enclosure with 25mm high density polyurethane foam. This is available from rubber supply stores and should cover completely the back, sides, bottom and top of the cabinet. Do not attempt to line the inside of the front baffle. The midrange chamber should also be filled with this material.

The drivers now can be fitted in position. Be careful not to apply too much heat when soldering to the terminals of the tweeter and midrange. (Before mounting the midrange driver, make

sure that the lead in wire to the small chamber is sealed off with silicone or similar sealant).

Now that the system is completed, you should check the bass drivers for phase. Take a 1.5 volt battery, connect positive to positive on the rear terminal and the woofer cone should move out. If it moves in, you have made a wiring error and should re-check all connections. If everything is okay, select a favourite record and settle back to enjoy the sound!



# JAYCAR'S SENSATIONAL

## ALARM EQUIPMENT OFF

# 10%

- Panels
- PIR's
- Keypads
- Stickers
- Sirens



## TV ANTENNAS & ACCESSORIES

# 10% OFF

- Antennas
- Amplifiers
- Wall sockets
- Splitters
- Baluns

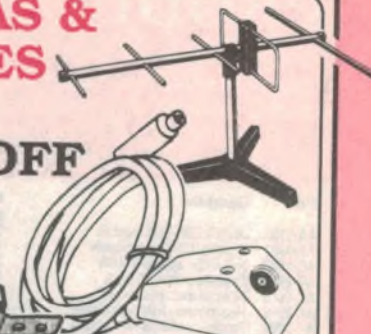

## ILLUMINATED ROCKER SWITCH

• Great for amps • SPDT, 8A, 240V  
 • Illuminated actuator - As used in P/ master 60/60 • Size 21 x 15mm  
 • Panel cutout 13 x 19.5mm  
 Cat. SK-0965  
 Original price \$7.50 ea  
**SPECIAL PRICE \$3.95**

**BARGAIN PRICE FOR SEPT**

**\$1.95 each**



## 25% OFF CROSSOVERS

Take 25% off all the following crossovers.

Cat	X'over	Freq
CX-2611	2 way	2kHz
CX-2612	2 way	3.5kHz
CX-2614	2 way	3.5kHz
CX-2615	3 way	800, 5kHz
CX-2616	3 way	800, 5kHz
CX-2621	3 way	800, 3.5kHz
CX-2619	3 way	600, 3.5kHz

Power	Normal	Sale (ea)
65W rms	18.95	14.21
50W rms	13.95	10.46
40W rms	9.95	7.46
40W rms	15.50	11.62
65W rms	28.95	21.71
200W rms	69.50	52.12
80W rms	32.95	24.71



## DUMMY CAMERA BARGAIN - 25% OFF

We all know that shoplifting and vandalism cost a small fortune every year. It has been demonstrated that television surveillance cameras in the right environment can discourage this activity.

This is where you come in. We have made a great purchase of realistic-looking Dummy TV Cameras.

They are Australian made, are supplied with adjustable swivel mounting bracket, fixing screws, flashing LED circuit board and 2 flashing LEDs. Also supplied is the 2 x D cell nylon battery holder to power the flasher circuit. A fake cable wallplate is also supplied as well as a very conspicuous 210(W) x 160(H) self adhesive sign which says "THESE PREMISES ARE PROTECTED BY TIME-LAPSE ANTI-THEFT CAMERAS" The text of the sign is in orange-red fluorescent ink against a black background.

**BUT HURRY!** We have around 300 only.

Cat. LC-5310

- 1 - 4 pcs **\$37.46**
- WAS \$49.95**
- 5 - 9 pcs **\$32.21**
- WAS \$42.95**
- 10 - 19 pcs **\$29.96**
- WAS \$39.95**
- 20+ pcs **\$28.46 ea**
- WAS \$37.95**



## TWEETY PIE

This incredible little pieza screamer measures 87(L) x 36(H)mm emits a 116dB wail. It's deafening! As used in the screamer car alarm kit. Cat. LA-5255

NORMALLY \$17.95  
**SAVE \$3 ONLY**  
**\$14.95**

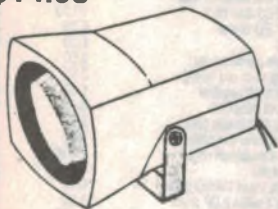

## 8" TWIN CONE SPEAKER BARGAINS

4 ohm 10 watt 8"  
 Cat. CE-2322  
**NORMALLY \$8.95**  
**SALE \$5.95**  
**SAVE \$3**

8 ohm 10 watt 8"  
 Cat. CE-2325  
**NORMALLY \$13.95**  
**SALE \$9.95**  
**SAVE \$4**



## CLOCK MOVEMENT WITH BUILT-IN PENDULUM DRIVER

This module measures 87mm long x 55 wide x 35mm deep and uses 1 x AA battery. Clock movement is supplied with 3 sets of hands, and pendulum is a suspended arm within the module which swings back and forth. A suitable pendulum can be attached to the bottom of the arm. Fit your own custom clock face. Great for novel applications. Cat. XC-0103

**WAS \$22.95**  
**NOW \$16.95**  
**SAVE \$6.00**

**DIRT CHEAP!!**



## UHF TV TUNER Sanyo Model T1087RA

Yet another fabulous scoop purchase. A compact high quality tuner that operates from 526-814MHz (corresponding to channels 28 thru 63). This tuner is designed for Australian standard reception (AS1053 1973), and is offered at a very low price. You can grab one now for the silly price of \$29.95! This price includes circuit diagrams and connection drawing. You can have a photocopy of the complete manual for \$4 but a lot of the info is in Japanese! This is a very cheap way to convert a VHF only TV to UHF! (Some skill may be required). Specs: Power +12V DC nominal @ 14mA. Case neg. Bandwidth 526-814MHz (28-63 ch). AFT +6.5V. Dimensions 150 x 65 x 28mm. Tuning multirotation of 1/4" shaft. Knob not supplied.

Cat. DM-1000  
**NORMALLY \$29.95**  
**NOW \$14.95**  
**SAVE \$15.00**



## AA NiCads \$3.50 each or 4 for \$12.50

Don't waste money. Buy rechargeable NiCads. 450mA. Quality brand.



# SEPTEMBER SALE

## SAVE 30% ON BUG BOXES

Bug boxes are a range of plastic anti-static enclosures basically for IC's. The system is completely modular. You can purchase a single tray or establish a full blown storage and retrieval system from the modules. Refer to our 1988 catalogue for full details.

### BUG BOX

A flat tray with clear locking lid. Will hold 60 x 8 pin or 30 x 14, 16, 18 or 20 pin IC's. Slides into cage described below.

**NORMALLY \$5.95 NOW \$4.15**

Cat. HB-6350

### LSI BUG BOX

Same as Bug Box, but with larger compartments.

**NORMALLY \$7.95 NOW \$5.55**

Cat. HB-6358

### BUG CASE

Moulded cabinet, will accept up to 6 bug boxes.

**NORMALLY \$9.95 NOW \$6.95**

Cat. HB-6366

### BUG CAGE COVER

A clear acrylic door which clips on bug cage and holds boxes in.

**NORMALLY \$6.95 NOW \$4.85**

Cat. HB-6370



LSI BUG BOX

## PLUG & SOCKET TERMINAL STRIP

Brand new product. It's like a standard type 12 way barrier strip or terminal strip but its 2 strips of 12 which can be unplugged from each other. So if you have any number of semi permanent wires from 1 to 12 that you have to unplug, this is the ideal way.

**\$4.95**

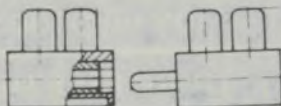

## Computer Leads

### Lower Everyday Prices

	WAS	NOW	Cat. No
• 25D plug - Centronics lead	28.95	18.95	PL-0854
• 25D plug - 25D skt lead	32.95	19.95	PL-0855
• 25D plug - 25D plug lead	30.95	19.95	PL-0856

**DIRT CHEAP!!**



## PUSHBUTTON SWITCH

Quality Japanese made DPDT push on/push off switch rated at 125V 3 amp. Complete with black round knob. These are commonly used as on/off power switches for mains products, and normally cost about \$4 - \$5.

Jaycar has a quantity available for only \$1.95.

Cat. SP-0730

**\$1.95 ea**

**10+ \$1.75 ea**

Knobs available separately:

Cat. HK-7791 **50¢ ea**



## 0.001µF 2KV CERAMIC

High voltage capacitor bargain.

Normally about \$1.50 each

**5 for \$2.50**

Cat. RC-5378



## 75 OHM AIR SPACED COAX

### FOR THE PRICE OF ECONOMY COAX

Yes, for a short time only, you can purchase HIGH QUALITY air spaced 75 ohm coax for the same price as our economy 75 ohm cable.

Normally its \$1.20 per metre, but you can buy it for only 80¢ per metre.

Or, if you buy 50 metres or more, it's only 60¢ per metre.

That's half price!

Cat. WB-2006

**80¢ metre**

**50m or more**

**60¢ metre**



## CAR NEGATIVE ION GENERATOR

Now you can have all the benefits of your home ioniser in your car.

This great new Jaycar direct import is durable, stylish and compact, measuring only 110mm in total length. It simply plugs directly into the cigarette lighter socket in your car. It can generate large amounts of negative ions for purifying air, and some ozone for eliminating odour.

Jaycar's direct importing cuts out the middle man and saves you money.

### SPECIAL INTRODUCTORY OFFER

**ONLY \$34.95**

Cat. YX-2910

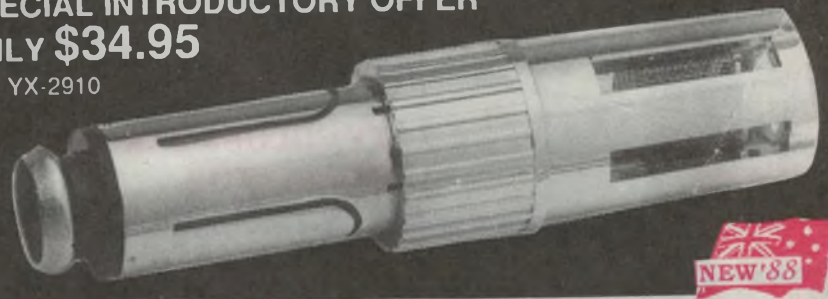

## TRIGGER SWITCH BARGAIN

**\$2.00** Cat. SP-0760

This is a DPST 240V 1.5A switch mechanism that is actuated by a 'trigger' similar to the trigger in a modern electric drill.

We haven't a clue what you could use them for - you work that out!

But this component working-for-an-application is cheap at least. Made in the UK quality. Worth over \$10 but this month only \$2.00!

## Thermal/Magnetic 0.5 Amp Circuit Breakers

Quality made E-T-A German make. Single pole plunger type, 240V AC or 65V DC. Will interrupt when current exceeds 0.5 amp. Has thermal overload (slow current increase) and magnetic overload (fast current increase) for double circuit protection. Has 2 aux contacts (NO & NC) to trigger remote alarms if necessary.

**Normally \$4.50**

**SALE PRICE \$2**

**SAVE \$2.50**

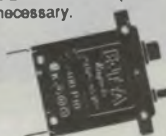

## BNC MALE TO 'N' MALE ADAPTOR

High quality UK made 'Greenpar' brand. Converts BNC male to the type 'N' fitting used in satellite receivers and other microwave gear. 'N' connector has male centre pin. The outer connector is a male threaded fitting. (Not constant impedance).

A rare component and worth collecting at this price.

Cat. PA-3685

**ONLY \$3.00**

**DIRT CHEAP!!**

## ZENER DIODE BARGAINS

**BARGAIN No.1** 12 volt 1 watt Pkt 25  
Cat. ZR-1370

**\$2.95 SAVE \$5.80**

**BARGAIN No.2** 6 volt 500mW Pkt 50  
Cat. ZR-1372

**\$2.50 SAVE \$10**

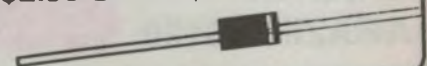

## Flashing LEDs

All 5mm, 3-5 volt operation. Pulse rate 2Hz, 1.2mCd at 3 volts.

Available in 3 colours

RED Cat. ZD-1730

GREEN Cat. ZD-1731

YELLOW Cat. ZD-1732



**\$1.50 ea 10+ \$1.35 ea**

## PC Mount LEDs

Incorporates a 5mm LED in a plastic bezel for PC mounting. 4 colours

RED Cat. ZD-1780

GREEN Cat. ZD-1781

YELLOW Cat. ZD-1782

ORANGE Cat. ZD-1783



**48¢ each 10+ 42¢ each**

## TELEPHONE PLUG BARGAIN

**SAVE 50%**

without the cable grommet. NORMALLY \$3.95 Limited quantity Cat. PP-1400



**ONLY \$1.95 ea**  
10 up \$1.75 each

## DIRECT IMPORT light duty HOOK-UP WIRE ON 25 metre ROLLS

Now all hobbyists can afford to have a roll of each colour hook-up wire by their workbench. Quality 13/0.12 tinned hook-up wire on plastic spools.

Red Cat. WH-3000 Yellow Cat. WH-3004

Black Cat. WH-3001 Green Cat. WH-3005

Brown Cat. WH-3002 Blue Cat. WH-3008

Orange Cat. WH-3003 White Cat. WH-3007

**\$3.95 per reel**

Buy one roll of each colour - 8 rolls in all for only

**\$25.95**

8 pack Cat. WH-3009



## 41256 - 256k RAM 120nS

At the time of going to press we have heaps of these available ex-stock. The price is pretty ridiculous, but we have checked and we are the cheapest supplier of these ex-stock. Unless someone buys the lot (which could easily happen) we will have stock when you read this.

The price... are you sitting down...

**\$25 each 10+ \$23.50 each**

Cat. ZZ-8435

## TELEPHONE DOUBLE ADAPTOR SENSATION

**WAS \$7.95**

**SAVE 47%**

Cat. XT-6020

**\$3.95 ea**



## HIGH VOLTAGE CAPACITOR PACK

This is rare. Attention servicemen. We can offer you a bag of over 175 pcs of both high quality Polycarbonates and ceramic capacitors. Many of these are from current colour TV manufacturers surplus. Limited quantity, and probably will never be repeated. (We rarely see high quality high voltage caps anymore).

Here's what you get:

Polycarbonate

We have many different values in small quantities so most bags will be different. Higher quantities include: 0.0056, 0.047, 0.068, 0.056, 0.1, 0.18, 0.22, 0.27, 0.33, 0.56, in voltages 200V, 400V, 630V, 1.5kV, 1.6kV, 2kV Ceramic:

Include a good range of values. 100pF, 220, 270, 330, 470, 500, 680, 1000, 2200, 4700pF in voltages 400V, 500V, 1kV, 2kV and 3kV.

**DON'T MISS OUT!! LIMITED QUANTITY!! WON'T LAST OVER 175 CAPS FOR \$10.00**

Cat. RG-5200

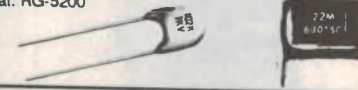

## 6 WAY POWER OUTLET WITH MAINS FILTER

Not only is it a 6 way power board, it incorporates a voltage surge and spike protector and noise rejection filter network. Supplied with two metre cord and mains plug, safety shutters on each outlet, illuminated master on/off switch and even a safety circuit breaker.

Cat. MS-4030

**\$59.95**

NOTE: If you require absolute mains suppression don't forget our Australian made Squeaky Clean Mains Filters.

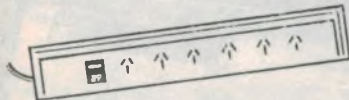

## FUEL CUTOUT SOLENOID

Who needs a noisy car alarm, after you have installed one of these in your vehicle. It's operated from a hidden switch. Simply turn it on when you leave your car, and if your car is stolen, it won't go very far without any petrol. Supplied with instructions, pre-wired switched, hardware and even two alarm stickers. Quality M&D Alarm brand. Add to this our deluxe red light flasher kit - KJ-7000 \$19.95, and who needs an alarm?

Cat. XC-2050

**\$69.95**



## TV COLOUR BAR PATTERN GENERATOR

Ref: EA October 1987

Will provide 8 different patterns and colour bars. Power Pack to suit Cat. MP-3020 \$14.95

Cat. KA-1691 **\$149**



## BARGAIN RF CHOKE PACK

Over 50 pieces supplied!

A pack of 30 brand new RF chokes with at least 14 different values! Popular values include: 1.5, 4.7, 12, 15, 18, 22, 68, 100 & 1000uH. Each choke is resin dipped and colour coded (they look like bead tantalums). A colour coding chart is supplied so that you can decipher the value.

BONUS! Not only do you get 30 useful chokes we will give you at no extra charge at least another 30 more RF chokes! These are genuine chokes but are commonly called 'peaking coils'! They look like a 1/2 watt resistor. (Read the choke value in uH as you would a resistor value).

Cat. RC-5600 **WAS \$10.00 NOW \$5**

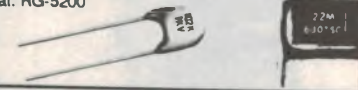

## 8 CHANNEL AUDIO MIXER

Ref: EA April/May 1983

Cat. KJ-6504

**\$595**

Pictured with optional desk console

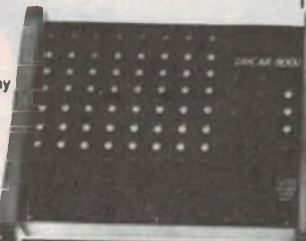

## Micron Amber Monitor Sensation - Below 1/2 Price

At this price one would believe that these Micron Amber 12" monitors fell off the back of a truck! They didn't, but grab one anyway while they last - because at this price they won't be around for long. These are brand new, non-glare Series III 18MHz bandwidth, 900 resolution line quality amber monitors.

See our 1988 catalogue for full details.

Cat. XM-4500

CATALOGUE PRICE \$229.50

**NOW ONLY \$109.50**

SAVE AN

**AMAZING \$120**

**DIRT CHEAP!!**



## TURN YOUR SURPLUS STOCK INTO CASH!!

Jaycar will purchase your surplus stocks of components and equipment. We are continually on the lookout for sources of prime quality merchandise.

**CALL GARY JOHNSTON OR BRUCE ROUTLEY TODAY**

ON (02) 747 2022

**GORE HILL OPEN 'TIL 4 pm SATURDAY**

## NEW KIT FOR SEPTEMBER Speakerphone ONLY \$89

Ref: Silicon Chip Sept. 1988  
High quality hands free telephone adaptor that works extremely well.  
Full kit including box, panel, isolating transformer and all parts.  
Cat. KC-5040

**1/2 PRICE PLUGPACK**  
**6 volts DC 300mA**  
**NORMALLY \$14.95**  
**NOW ONLY \$7.50**

Cat. MP-3008

**DIRT CHEAP!!**



**AT LAST!!**

## Jaycar 12V/300VA SINE WAVE Inverter

**NOW AVAILABLE**

Now you can enjoy SINE WAVE power at AROUND 85% EFFICIENCY for much the same cost as inferior square wave - and this unit gives a genuine 300VA, not less. The Jaycar Sine Wave Inverter has tremendous surge capability. It will, for example, start a small refrigerator.

We are very proud of this Australian made and designed product. The price, however, may have to rise soon, so hurry!  
Cat. MI-5020

**\$399**



**SQUEAKY CLEAN MAINS FILTERS**  
**Fully approved**  
**4 OUTLET**

The MS-4020 will supply up to 4 appliances. Each 240V socket is independently filtered. The filter will suppress interference from RF sources, spikes, transients and lighting, and supply up to 4 outlets with a total load of 4 amps.  
Cat. MS-4020

**NORMALLY \$269**

**SAVE \$40**

**SEPT ONLY**

**\$229**

**2 OUTLET**

The two outlet will handle up to 7.5 amps. The two sockets are not independently filtered although.  
Cat. MS-4025

**NORMALLY \$99 SAVE \$20 NOW \$79**

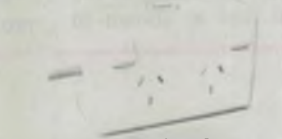

**500MW @ 6V Audio Amplifier** A six transistor 1/2 watt amp for the cost of 2 hamburgers. It has 2 transistor tape preamp which is NAB equalised and a 4 transistor power amp. It has facilities to take 2 line level inputs. The board measures roughly 110(L) x 48(W)mm. Each amp comes with schematic/connection diag. (2 required for stereo. Cat. AA-0290  
**ONLY \$3.95 ea 10+ \$3.50 each**

**FREE SOLDER**

## ADCOLA SOLDERING STATION



Station only \$159.50  
40W iron to suit \$49.95  
80W iron to suit \$55.00

Cat. TS-1475  
Cat. TS-1478  
Cat. TS-1480

Purchase a station and one iron together and receive a FREE 200g roll of solder and a roll of desolderwick - worth \$9.45

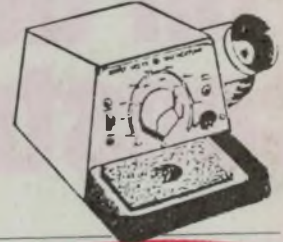
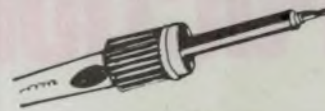

**ADCOLA 240V  
IRONS**

S30 12 watt \$36.95 Cat. TS-1492  
S50 16 watt \$39.95 Cat. TS-1494

Purchase either of these irons and receive a FREE roll of desolderwick - worth \$2.50



**FREE  
DESOLDERWICK**

**TRANSFORMER  
BARGAIN**

This 100VA unit measuring 100(H) x 90(W) x 75(D)mm features a mounting bracket that enables you to mount it vertical or on its side. Primary winding is tapped from 200-240 volts. Secondaries are 1 x 16V, 1 x 12V. Both would be minimum 2 amps.  
Cat. MM-1812

**\$14**

**DIRT  
CHEAP!!**

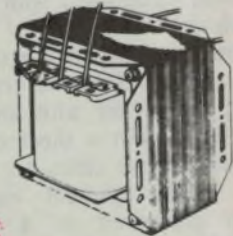

**BARGAIN Electros**

We are hopelessly overstocked and need to move some electros. Brand new, 1st grade quality RT style  
Cat. RE-5905

**470uF 50V RT Normally \$1.90 ea**

**SPECIAL 10 for \$2**

Cat. RE-5880

**100uF 25V RT Normally 55c ea**

**SPECIAL 10 for 60c**

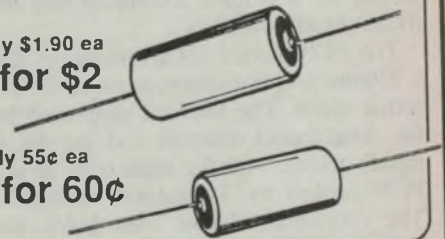

**Jaycar  
ELECTRONICS**

**HEAD OFFICE**  
115 Parramatta Road Concord 2137  
Telephone (02) 747 2022  
Telex 72293  
FACSIMILE (02) 744 0767

**MAIL ORDERS**  
P.O. Box 186 Concord 2137  
**HOTLINE (02) 747 1888**  
**FOR ORDERS ONLY**  
**TOLLFREE (008) 022 888**

**POST & PACKING**  
\$5 \$9.99 \$2.00  
\$10 \$24.99 \$3.75  
\$25 \$49.99 \$4.50  
\$50 \$99.99 \$6.50  
OVER \$100 \$10.00

**MAIL ORDER VIA YOUR ROAD FREIGHT ANYWHERE IN AUSTRALIA \$13.50**



**VISA**



**MasterCard**

**SYDNEY - CITY** 117 York St. (02) 267 1614 -  
Mon-Fri 8.30 - 5.30 Thurs 8.30 pm - Sat 9 - 12

**CARLINGFORD** Cnr. Carlingford & Pennant Hills Rd (02) 872 4444 -  
Mon-Fri 9 - 5.30 Thurs 8.30 pm - Sat 9 - 2pm

**CONCORD** 115 Parramatta Rd (02) 745 3077 -  
Mon-Fri 8.30 - 5.30 - Sat 8.30 - 12

**HURSTVILLE** 121 Forest Rd (02) 570 7000 -  
Mon-Fri 9 - 5.30 Thurs 8.30 pm - Sat 9 - 12

**GORE HILL**

188 Pacific Hwy cnr Bellevue Ave (02) 439 4799 -  
Mon-Fri 9 - 5.30 Sat 9 - 4pm

**BURANDA QLD**

144 Logan Rd (07) 393 0777 -  
Mon-Fri 9 - 5.30 Thurs 8.30 - Sat 9 - 12

**MELBOURNE-CITY**

Shop 2, 45 A'Beckett St. City (03) 663 2030  
Mon-Fri 9 - 5.30 Fri 8.30 - Sat 9 - 12

**SPRINGVALE VIC**

887-889 Springvale Road Mulgrave (03) 547 1022  
Nr Cnr. Dandenong Road Mon-Fri 9 - 5.30 Fri 8.30 - Sat 9 - 12

## New 30W stereo amplifier project - 3

# Full details of construction

This month we'll show you how easy it is to build the new Playmaster 30-30 amplifier. Virtually all of the parts, including the heatsinks, mount on one large printed circuit board.

by **ROB EVANS**

As you may see from the pictures of our prototype, the assembled printed circuit board (PCB) fits neatly into a medium sized case, with very little interwiring.

The case is in fact one of the standard sizes in the "Horwood" range of instrument cases, but with an added front panel cut from a sheet of 1.5mm aluminium. These cases are readily available, and represent excellent value when compared to a suitable rack mounting case for example.

The overall box dimensions are 305 x 228 x 76mm, with a front panel measuring 325 x 80mm; this means the Playmaster 30-30 is quite a compact unit for its power and facilities.

The PCB (coded 88sa8) measures 220 x 220mm and dominates most of the internal space. The board is supported by the front panel controls and the RCA input sockets, with the main body of the PCB carried by 3 insulated standoffs. The remaining chassis area holds the power transformer, mains wiring, and loudspeaker connectors.

### Components

Before discussing the assembly procedure for the Playmaster 30-30, we need to consider a few component choices which will effect the performance and cost of the unit. These choices mainly involve components in the phono pre-amp, so you may wish to consider if records are your prime listening source, or compact discs and other "line" inputs monopolise your listening time.

Naturally, if you rarely use the phono facility, the extra expense of higher quality components is unnecessary; particularly since this stage delivers

quite a credible performance in its standard form. However, if it's even higher performance you are seeking, the changes are simple.

The TL072 op-amp in the phono stage may substituted by an LM833 for example. This is a wide bandwidth low noise device which is pin for pin compatible with most dual op-amps, and will slot directly into the existing circuit. Also, the transistors which form the input differential pair (Q1 and Q2) could be changed for more exotic devices, such as the low noise 2SC2545. However, carefully check the pin configuration of alternative transistors. For example, the 2SC2545 pins happen to be in the reverse order to those of a BC549, and when installed its body must face in the opposite direction to that as shown in

the component overlay.

Another refinement of the phono pre-amp's performance is to include close tolerance components (1% or 2%) in the RIAA feedback network, including R8 to R10 and C5 to C7. This will ensure that the frequency response on the phono input will at least match the accuracy of our prototype, which tracked the RIAA curve within +/- 0.5dB.

At this point you may also wish to consider if the CD attenuating resistors are required. If you have a CD player with a nominal output of around 2 volts, values of 47k and 6.8k for Rx and Ry respectively should match the CD player's output to the amplifiers 250mV rating. Other attenuation levels may be easily calculated using standard voltage divider techniques.

The remaining component considerations involve the question of compatibility, rather than performance. These are the choice of filter capacitors and the power transformer.

The filter capacitors used in our prototype (5600uF 40V), are a neat fit





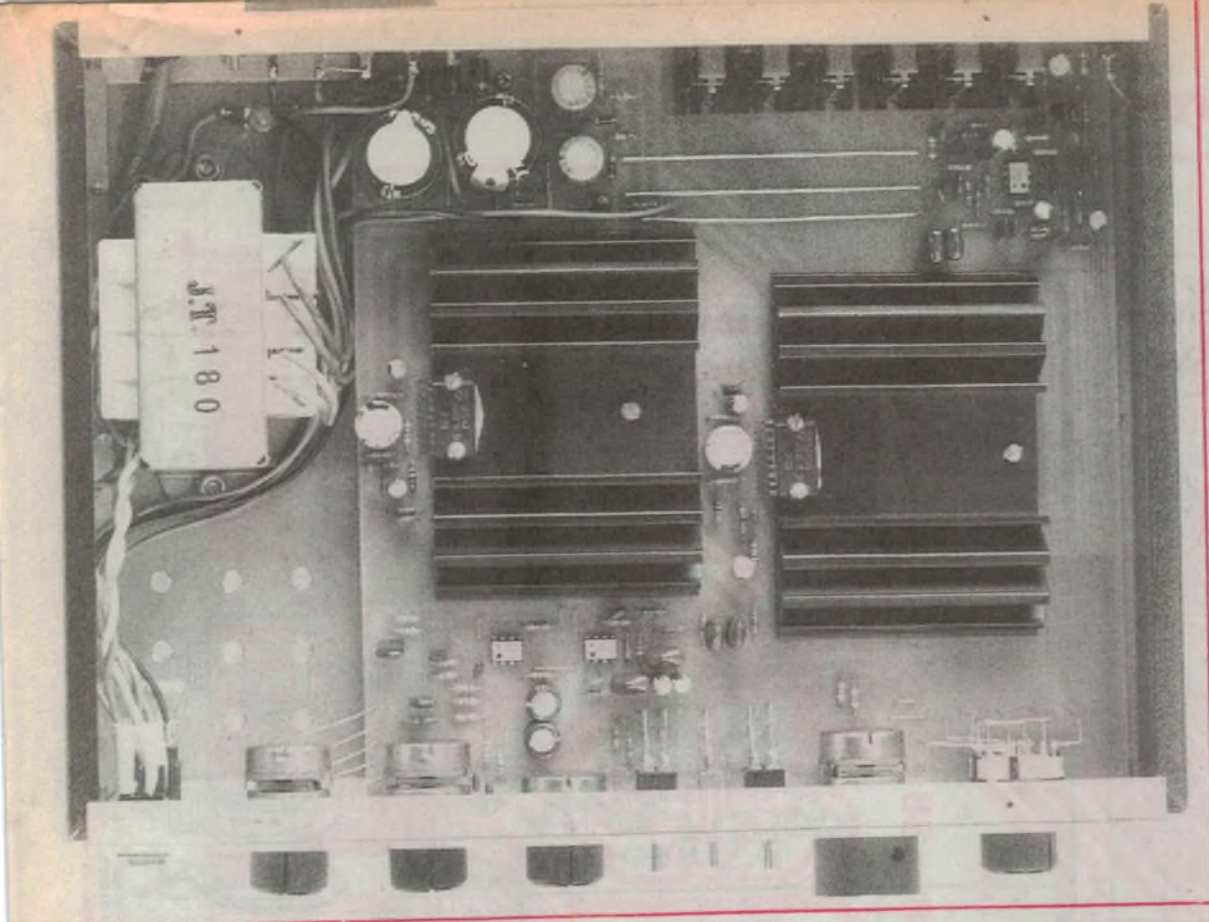

*The neat internal layout and simple construction of the 30-30 amplifier is due to careful PCB design, and the use of integrated power amplifier ICs.*

amongst the other PCB components, leaving little space for units that are physically larger. If capacitors of this size are unavailable, 4700uF 35V types should easily fit, resulting in a slight drop in the amplifier's maximum output power. Alternatively, extra space could be generated by juggling the position of the mounting holes, and physically larger capacitors of the specified value installed.

The power transformer for this amplifier must have a secondary voltage of 22-0-22 volts or less, due to the maximum voltage limitations of the TDA1514A chips. Depending on the rating method of the manufacturer, a 22-0-22 volt transformer may have a secondary voltage as high as 25-0-25 volts when lightly loaded. This would produce supply rails of about +/-35 volts, which significantly exceeds the +/-30 volt maximum rating of TDA1514A chips. The power transformer chosen for the Playmaster 30-30 amplifier *must not* produce supply rails that exceed this +/-30 volt rating, or the power ICs may be damaged.

Fortunately, the suitability of a transformer may be easily tested by measuring its off-load secondary voltage, which should be about 22-0-22 volts or less. In fact, a conservatively rated 20-0-20 volt transformer may be quite appropriate, since its off-load voltage would be

around the required 22-0-22 volts. These voltage levels will depend on the local mains voltage, which should be taken into consideration during these measurements and the initial amplifier testing. Note that the published performance specifications of our prototype were achieved with a 22-0-22 volt, 1.5 amp transformer labeled JT180.

### Wiring the PCB

The first step before installing components on any PCB, is to check the pattern for anomalies such as broken or bridged tracks. Also check the various bolt holes for correct sizing; it's much easier to re-drill them now, rather than dodging components later.

Begin the actual assembly by mounting the lower profile parts first while carefully following the component overlay, noting component positions and polarities (if applicable). Start with the links and work your way through to the larger components. There are 10 links on the PCB, including three long connections between the power supply and the phono stage; these should be constructed from insulated wire which will prevent contact with other components.

All of the resistors may mount flush with the PCB, except those with a higher power rating. These resistors are numbered R28 to R33, and should be

positioned slightly above the board to assist their cooling. The larger capacitors should also mount flush with the PCB to provide maximum mechanical stability (note that the main filter capacitors have a third mounting pin).

Next, carefully install all the semiconductors, with the exception of the power amplifier chips (IC4). These devices should be installed last so that the heatsinks may be aligned as shown in the overlay, while double checking the heatsinks' clearance to the other components.

The best method for installing the TDA1514A chips is to first bend the legs at right angles, about 5mm from the body of the IC. Then smear both the heatsink and IC with thermal grease at their contact points, and bolt both units to the PCB. If you are happy with the alignment, (check that the remaining hole in the heatsink lines up with the matching PCB hole for the standoff) solder the IC legs in place.

In the interests of clarity, the supply bypassing capacitors for the power-amp chips are not shown on the component overlay diagram. Instead, we have provided a picture of those installed in the prototype as a guide to their positioning. These capacitors (C20 and C21 on each IC) must be mounted as close to the IC pads as possible.

Don't forget these capacitors, because

# 30W stereo amplifier

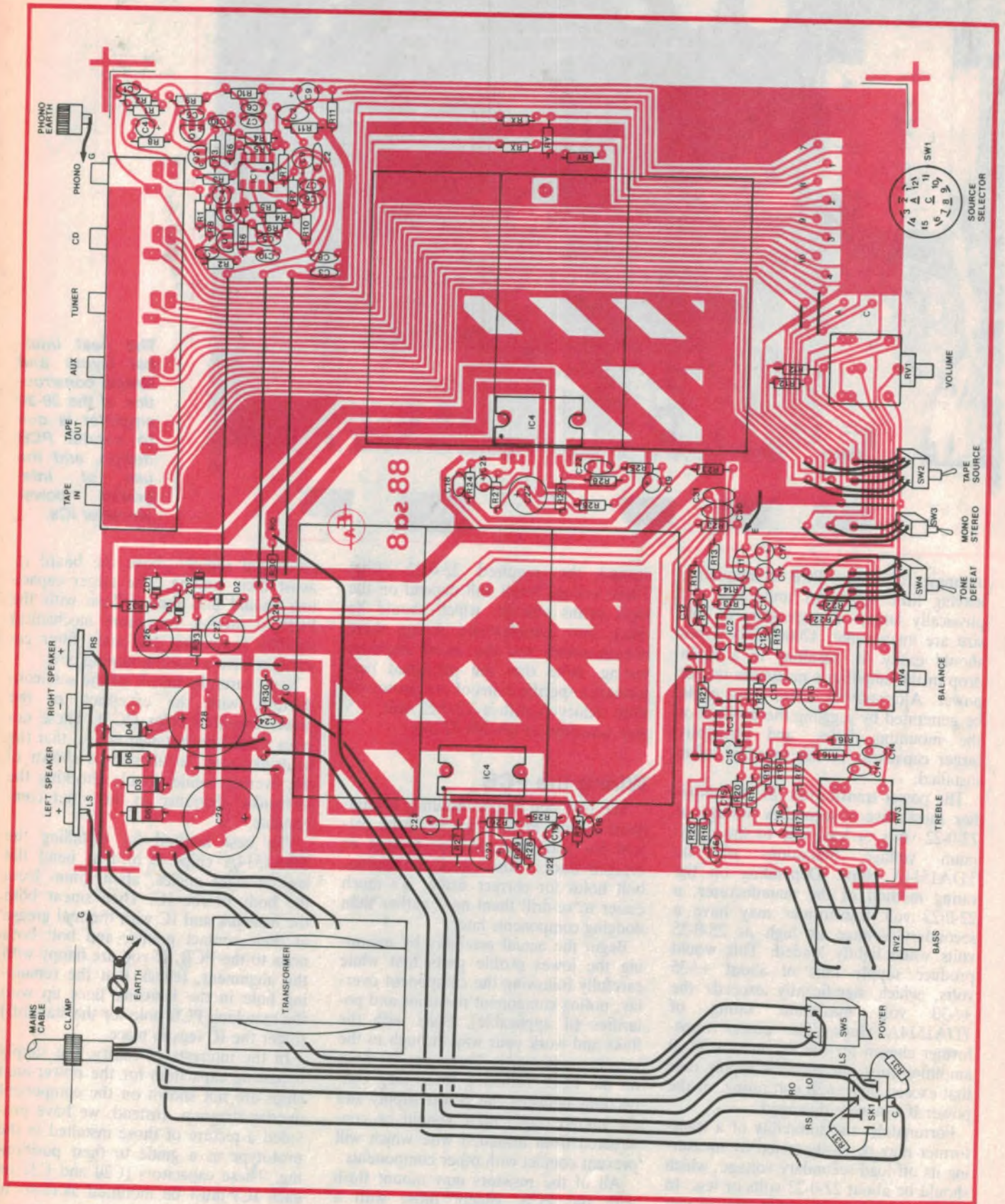

The component overlay and wiring diagram. The PCB pattern and front and rear panel artwork are too large to reproduce on these pages, however copies may be ordered through the EA Reader Services section.

the high bandwidth and slew rate of the TDA1514A chips may induce some instability if they are omitted.

The next step is mounting the potentiometers, switches and RCA sockets, all of which locate the PCB within the box. The pots should be temporarily mounted on the PCB (not soldered in place), so that the mounting points may be compared to the box dimensions, which tend to vary from unit to unit. The PCB has been designed so that the distance between the RCA sockets and the pots threads is slightly shorter than the depth of the specified box. This allows room for adding spacers to the pot shafts, making the whole assembly a neat fit within the box. By measuring the distance on the PCB assembly (in its temporary form), we can decide how many spacers are required or if the pot legs need to be bent either way.

If the pot shaft threads are too short for the required number of spacers, you may need to leave a small gap between the RCA sockets and the rear panel in the final assembly stage. This won't significantly restrict access to the RCA sockets, and prevents the need for any component repositioning. When calculating this spacing, remember to include the small dimension added by the front panel.

Finally, remove the pots and cut the shafts to match the depth of the knobs. Then re-install the pots and solder them in place, while double checking their vertical alignment with a ruler. Install the remaining components, while carefully referring to the component overlay diagram. The switches and bass pot are attached to the PCB by short tinned copper wire stalks, which may be trimmed or aligned after the PCB assembly has been installed in the box.

## Preparing the box

If the "Horwood" style of box is to be used to house the Playmaster 30-30, the front dress panel will need to be at-

tached before installing any electronics. On our prototype, this was located by 4 countersunk bolts to maintain an even surface for the addition of a "Dynamark" (or Scotchcal) panel. The mounting holes in the front and rear panels should be drilled using the panel artwork as a guide, while double checking each component for a neat fit.

Check that the headphone socket has enough thread to clear both the box front panel, and the additional dress panel. If more thread is required to install the locking nut, enlarge the hole in the box front panel only, leaving the threaded bush to penetrate the single thickness of the dress panel.

Next, temporarily install the PCB assembly in the box to serve as a guide for the remaining holes and components. With the bottom panel in place, mark the holes for the transformer, earth lug and PCB supporting spacers. When drilling these holes, take the opportunity to prepare the panel fixing screw holes around its perimeter.

The top and bottom box panels will need to be perforated with a number of holes. This will allow air to flow through the box, cooling the PCB mounted heatsinks. Drill as many holes as your patience will allow - it's better if the heatsinks are over-cooled than under-cooled. However, avoid the transformer mounting area on the bottom panel, as too many holes may cause the metal to flex due to the substantial weight of the transformer.

With the PCB assembly removed, the next step is to attach the front and rear "Dynamark" panels. This can be a little tricky since Dynamark panels must be aligned correctly on the first attempt; they cannot be removed without being damaged.

A successful method for aligning these panels is to first pierce small holes to mark the centre of the panel holes or cutouts. Then tape the panel face down on a smooth flat surface (make sure this surface won't scratch the artwork), with

the protective backing paper removed. The box panel may then be carefully pressed onto the Dynamark panel using the holes as a guide. Then trim the artwork to size with an art knife or scapel.

The PCB assembly may now be permanently installed in the box, but leave the top and bottom panels off for the moment so the final wiring may be completed.

## Final assembly

These final stages are quite straightforward since most of the amplifier's wiring is an integral part of the PCB. The remaining wiring carries the mains power and speaker signals.

Before commencing any wiring, the supporting spacers should be screwed to the PCB with extra washers used to increase their length. This length may be checked with a ruler held where the bottom panel normally lies. Note that these spacers must be of the insulated type, because the mounting face of the power ICs, and therefore the heatsinks, are connected to the negative supply rail. Also, before bolting the mains earth lug in place, its mating surface on the bottom panel should be cleaned with a file or sandpaper to ensure a reliable contact.

Begin the final wiring by connecting generous lengths of heavy gauge hookup wire to the four speaker pads on the PCB. Also connect lengths of wire to the PCB central earthing point (on the underside of the board near C30 and C31) and the phono earthing post. The latter wires may lay under the PCB when finally connected to the chassis earth lug.

Note that one of the two leads coming from the two "common" speaker pads on the PCB connects to the headphone socket, while the other connects to both negative speaker terminals.

To connect the power transformer's secondary leads lay the box on its side, place the transformer loosely inside and solder the wires to the appropriate

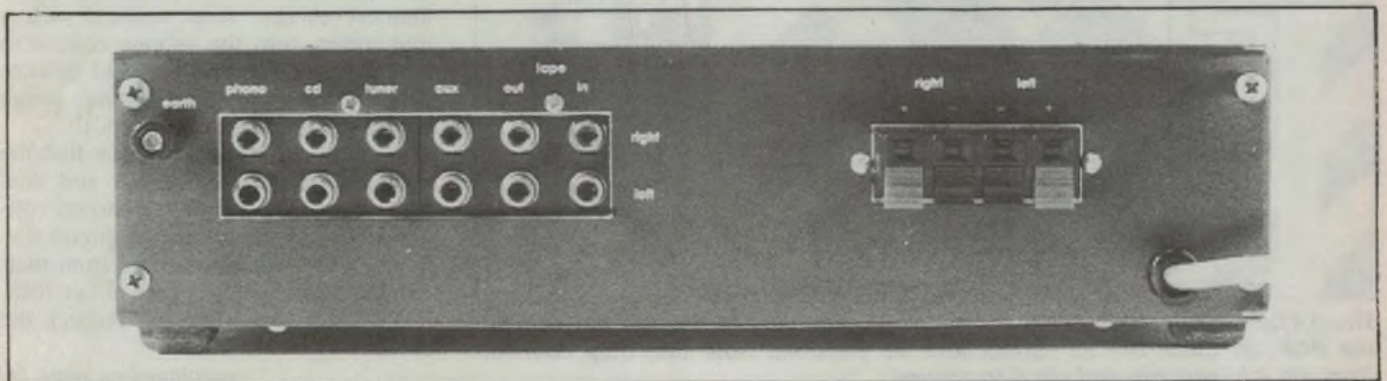

## 30W Stereo

pads. Pay particular attention to these wires; they should be cleaned and carefully soldered so as to avoid dry joints, and the two inner connections taken to the common pads for a centre-tapped configuration.

The bottom panel may now be screwed in place, the transformer secured and the remaining wires connected. Once again, refer to the component overlay for the earth connections, the speaker/headphone wiring and mains connections. Note that the headphone socket must be of the insulated switching type, and the *normally closed* contacts are used.

The mains wiring at the power switch terminals *must be insulated* with protective sleeving, and the cable solidly locked with a cable clamp at the box entry point. Also ensure that the green/yellow lead of the mains cable is connected to the earth lug.

The "Horwood" style box has a metal bottom panel which may tend to vibrate due to the power transformer's electrical influence. This may be cured by inserting a thin rubber or plastic spacer under the transformer's main body, to hold the panel firmly in place. However, make sure the mounting tags remain directly connected to the panel; this will maintain continuity to the transformer's frame and electrical shield. At this stage, it may be worth checking the transformer, pots, switches, and all box panels for continuity to the earth lug.

### The test flight

Now that the amplifier is completed, it's worth spending a few extra minutes to double check the wiring and component orientation against the overlay diagram. Pay particular attention to the orientation of the semiconductors and polarised capacitors.

### PARTS LIST

- 1 printed circuit board, code 88sa8, 220 x 220mm
  - 1 box, 305 x 76 x 228mm
  - 2 heatsinks, 75 x 105mm
  - 1 power transformer, 22-0-22VAC at 1.5A (see text)
  - 1 4-way spring push speaker terminals
  - 2 3 x 2 way PC mount RCA sockets
  - 1 4mm binding post (black)
  - 4 rubber feet
  - 1 stereo insulated 6.5mm socket, with DPDT contacts
  - 1 DPDT illuminated miniature rocker switch (mains rated)
  - 2 DPDT miniature toggle switches
  - 1 SPDT miniature toggle switch
  - 1 2-pole 4-position sealed rotary switch
  - 4 22mm black anodised knobs
  - 1 30mm black anodised knob
  - 1 mains cord clamp
  - 1 mains cord and plug
  - 1 earth lug
  - 3 15mm tapped insulated standoffs
- Semiconductors**
- 2 Philips TDA1514A power-amp ICs
  - 3 TL072 op-amps (see text)
  - 4 BC549 NPN transistors (see text)
  - 2 15V 1W zener diodes
  - 2 1N4002 diodes
  - 4 1N5404 power diodes
- Capacitors**
- 2 5600uF 40V PCB mount electrolytics
  - 2 1000uF 16V PCB mount electrolytics
  - 2 220uF 63V PCB mount electrolytics
  - 4 33uF 16V PCB mount electrolytics
  - 2 10uF 63V PCB mount electrolytics
  - 2 6.8uF 50V PCB mount bipolar electrolytics
  - 4 1uF 16V PCB mount electrolytics
  - 4 0.47uF 100V metallised polyesters
  - 2 0.15uF 100V metallised polyesters
  - 6 82nF 100V metallised polyesters
  - 2 39nF 100V metallised polyesters
  - 4 22nF 100V metallised polyesters
  - 2 4.7nF 100V metallised polyesters
  - 4 3.9nF 100V metallised polyesters
  - 2 3.3nF 100V metallised polyesters
  - 2 1.5nF 100V metallised polyesters
  - 4 1nF 100V metallised polyesters
  - 2 390pF ceramics
  - 2 100pF ceramics
- Resistors (all 0.25W, 5% unless noted)**
- 2 x 820k, 2 x 680k, 2 x 270k, 2 x 150k, 2 x 82k, 2 x 68k, 2 x 56k, 2 x 47k, 6 x 27k, 6 x 15k, 2 x 12k, 2 x 10k, 2 x 5.6k, 2 x 4.7k, 4 x 3.9k, 4 x 2.7k, 2 x 1.2k, 2 x 820 ohms (0.5W), 2 x 680 ohms, 2 x 330 ohms (0.5W), 2 x 220 ohms (0.5W), 2 x 120 ohms, 2 x 47 ohms (0.5W), 2 x 6.8 ohms (0.5W)
- Potentiometers**
- 1 PC mount dual gang 100k linear
  - 1 PC mount dual gang 50k log
  - 1 PC mount dual gang 25k linear
  - 1 PC mount single gang 25k linear
- Miscellaneous**
- hookup wire, nuts and bolts and washers, heatsink compound

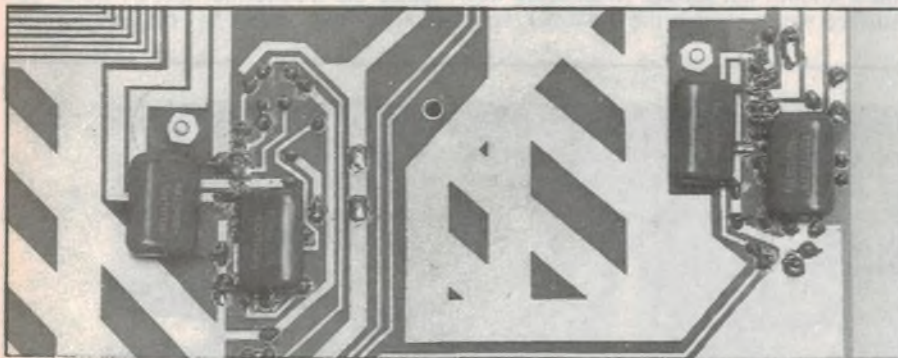

The 0.47uF stability capacitors for the power amplifier ICs mount underneath the PCB, as close the IC connections as possible. Note that they connect from pin 4 to ground, and pin 6 to ground.

If you are satisfied that all is well, it's time to switch the unit on for a few preliminary checks. Arm yourself with a multimeter, turn the volume control to minimum, centre the tone and balance controls, and select the normal switch modes (all toggle switches "up").

Switch on, and quickly check first the main DC power supply rails and then the pre-amp supply for the correct voltage levels, as shown on the circuit diagram. If the readings deviate from their nominal value by more than about 10%, immediately switch off and recheck the circuit.

*continued on page 141*

WOOD FOR CHIPS ... WOOD FOR CHIPS ... WOOD FOR CHIPS ... WOOD FOR CHIPS ... WOOD FOR CHIPS ... WOOD FOR CHIPS ... WOOD FOR CHIPS ... WOOD FOR CHIPS ... WOOD FOR CHIPS ... WOOD FOR CHIPS ...

WOOD FOR CHIPS ... WOOD FOR CHIPS ... WOOD FOR CHIPS ... WOOD FOR CHIPS ... WOOD FOR CHIPS ... WOOD FOR CHIPS ... WOOD FOR CHIPS ... WOOD FOR CHIPS ... WOOD FOR CHIPS ... WOOD FOR CHIPS ...

### Solderless Breadboards

You're far more likely to get that brilliant new design to work if you breadboard it and Geoff has a great range of breadboards for you to choose from. So toss out all those rat's nests and do the job properly!

Tile Points	Term'l Strips	Distrib Strips	Bind'g Posts	Model	Price
840	1	2		B112A	\$18.00
2420	3	5	4	B135	\$50.70
3620	4	7	4	B147	\$69.95
<b>Comp Strips</b>					
<b>Distribution Strips</b>					
540	1	2		B212P	\$22.85
3160	4	8			
plus UC-02 edge plate					
2320	3	4		UIB46	\$92.50
plus UC-02 edge plate					
				UIB34	\$126.50

### UC-Series Universal I/O Strips

These strips simplify interfacing between breadboards and external circuits by providing breadboard connections to connectors

Connector Type	Model	Price
2x32way Card Edge 0.156" pitch	UC01	\$19.05
25way D Sub Male & Female	UC02	\$19.50
60 way straight header	UC03	\$27.55
2x28way Card Edge 0.396mm pitch	UC04	\$28.50
32way DIN41612 - 5.08mm	UC05-3	\$20.65
64way DIN41612 - 2.54mm	UC05-6	\$25.90
96way DIN41612 - 2.54mm	UC05-9	\$31.90
36way Centronics	UC06	\$21.95

### Jumper Wire

Pre-cut multi-strand wire with special hard pin terminations designed for multiple use with breadboards. Pins are the right size to prevent damage to tie points. Pack of ten \$8.95

As above but terminated at one end with a spade lug. Pack of four \$8.20

### Variable Transformers

We have expanded our range to include a more powerful 2kVA model. Ideal for situations where the mains is 'sagging' a little or you want to check out the effects of mains variation on equipment.  
7Amps at up to 270V \$205.25  
5Amps at up to 250V \$175.00

### IC Test Clips

Why risk blowing up an IC with your test prods? Geoff has a whole range of extender clips and they're a worthwhile investment for any technician or serviceman.

C16	16pin	\$7.85
C20	20pin	\$12.20
C24	24pin	\$15.15
C28	28pin	\$17.70
C40	40pin	\$30.30



### PROM Programmer for your IBM PC

Plug-in unit for PC/XT/AT machines. Programs EPROMs 2716A to 27512A NMOS and CMOS types and EEPROMs 2804 to 58064. Over 26 commands to read, write, verify, modify data, check sums and erase. On screen HELP provided plus device pin-outs. Has four zero insertion force sockets. Excellent value at \$309.95.

### Squeaky Clean Mains Filters

Most computers are inadequately protected against mains-borne interference problems. These can include RF interference, voltage spikes and FM modulation. If you've had unexplained errors, program corruptions or other problems you're probably a victim of DIRTY POWER! You need an Australian designed and built Squeaky Clean Mains Filter.

#### Two models

LF-4 10Amp(cont) rated fitted with 4 individually filtered outlets and circuit breaker \$269.00 (\$230.60 ex tax)

LF-2 10Amp(max) rated fitted with 2 single filtered outlets \$99.00 (\$89.20 ex tax)

### Semiconductor Specials

#### LM12CLK

This TO3 amplifier has an unbelievable output of 150W capable of driving +35V at +10A while operating from +40V supplies. Drives a 4Ω load with 0.01% distortion. Power bandwidth is 60kHz. Has extensive protection built-in. \$42.50

#### LM833 Dual Audio Amplifier

As featured in the Silicon Chip Pre-amp project \$1.90

#### LM837 Quad Audio Amplifier \$3.55

#### 4164 Type RAM

64kx1 ceramic pack 150nS Fujitsu MB8264A-150 While stock lasts only \$5.50



### THUMB-WHEEL SWITCHES

These are genuine C&K high quality Available in decimal or BCD format. PCB edge connector or solder leads on directly. Both types are \$6.85 each. End plates are \$3.80 a pair and screws are \$1.40 a pair. They come in sizes depending on number of wafers 1- 3 or 3 to 7. Please specify when ordering

### "COMTEST" RS232/V24 TROUBLESHOOTER



Europe's most popular high quality RS232 tester will save time and trouble because it checks ALL the lines on any RS232 communications equipment.

- \* Tristate monitoring of all 23 signal lines
- \* Breaks and redirects all 25 lines
- \* Ground voltage differential testing between DCE-DTE

- \* Four level bi-directional current loop test
  - \* Simple operation - no batteries required
- Comtest has 25 DIL switches with DTE and DCE interface pins on both sides. Break and patch all 25 lines with switches and jumpers provided. Instructions clearly printed on both sides (and won't wear off) with abbreviation guide to aid identification of connections. All contacts are gold plated. Comes in transport pouch with 8 jumpers. Don't confuse this quality unit with the cheap imitations around. This one is designed in Sweden and compares favourably with testers over \$500. Well worth \$315.00

### Just Released! Low Cost Goldstar Multimeters

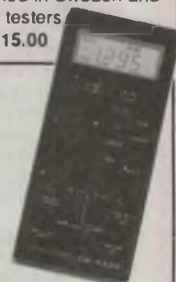

Our latest range of low cost multimeters. High performance with 3 1/2 digit LCD display. Three models  
DM6135 Autoranging 10A ac/dc \$88.80  
DM6235 as above but with Memory function and Range-Hold \$99.60  
DM6335 as above but with Data Hold \$118.80

#### If you really must have the best check our prices on Fluke...

- \* 3200 count digital display
  - \* Analog bar graph
  - \* Instant autoranging
  - \* Range hold in Fluke 75 and 77
  - \* Unique "Touch Hold" in Fluke 77
  - \* 3 year warranty
- |         | Fluke-73 | Fluke-75 | Fluke-77 |
|---------|----------|----------|----------|
| Inc-Tax | \$192    | \$265    | \$339    |



**GEOFF WOOD ELECTRONICS PTY LTD**  
229 Burns Bay Road, (Corner Beatrice St.) INC IN NSW  
Lane Cove West, N.S.W. P.O. Box 671, Lane Cove N.S.W. 2066  
Telephone: (02) 427 1676, Fax: (02) 428 5198.  
8.30am to 5.00pm Monday to Friday, 8.30am to 12 noon Saturday  
Mail Orders add \$5.00 to cover postal charges.  
Next day delivery in Sydney add \$5.00.

All prices INCLUDE sales tax.

Tax exemption certificates accepted if line value exceeds \$10.00.

BANKCARD, MASTERCARD, VISA, CHEQUES OR CASH CHEERFULLY ACCEPTED



# ROD IRVING ELECTRONICS



**JOYSTICK FOR IBM**  
Features Selectable "Spring centring" or "free floating". Electrical trim adjustments on both axis. 360 degree cursor control.  
C14205 ..... **\$39.95**



**APPLE II SERIES COMPATIBLE JOYSTICK**  
These joysticks have adaptor connectors to suit the Apple II, IIC, IIE and II+ computers. Features include selectable "spring centring" or "free floating". Electrical trim adjustments on both axis. 360° cursor control and dual fire buttons.  
C14201 ..... **only \$39.95**

**APPLE COMPATIBLE JOYSTICK**  
Ideal for games or word processing. Fits most 6502 compatible computers.  
Cat. C14200 ..... **\$39.95**



**ROD IRVING ELECTRONICS**  
MELBOURNE: 48 A Beckett St.  
Phone (03) 663 6151  
NORTHCOTE: 425 High St.  
Phone (03) 489 8866  
CLAYTON: 56 Renver Rd.  
Phone (03) 543 7877  
MAIL ORDER & CORRESPONDENCE:  
P.O. Box 620, CLAYTON 3168  
Order Hotline: 008 33 5757  
(Toll free, strictly orders only)  
Inquiries: (03) 543 7877  
Telex: AA 151938  
Fax: (03) 543 2648



**ORDER HOTLINE 008 335757 (TOLL FREE)**  
STRICTLY ORDERS ONLY  
LOCAL ORDERS & INQUIRIES (03) 543 7877

**POSTAGE RATES:**  
\$1 - \$9.99 ..... \$2.00  
\$10 - \$24.99 ..... \$3.00  
\$25 - \$49.99 ..... \$4.00  
\$50 - \$99.99 ..... \$5.00  
\$100 plus ..... \$7.50

The above postage rates are for basic postage only. Road Freight, bulky and fragile items will be charged at different rates.  
All sales tax exempt orders and wholesale inquiries to:  
RITRONICS WHOLESALE,  
56 Renver Road, Clayton  
Phone: (03) 543 2166 (3 lines)  
Fax: (03) 543 2648

Errors and omissions excepted. Prices and specifications subject to change.

IBM, PC, XT, AT are registered trademarks of International Business Machines. Apple is a registered trademark. Denies registered trademarks of their respective owners.



**WITTY MOUSE**  
• Three buttons, user definable. Get the maximum selective features possible by having a third button choice.  
• A specially silicone coated steel ball transfers mouse movement to internal motion encoders without the need of a special surface. Smooth gliding over any hard, even surface.  
• High resolution movement of 195 dots/inch. This means you can work with a smaller table space with less hand movement than a lower resolution mouse.  
• Optical rotary encoder  
• Max. tracking speed 200m/sec  
• Mouse resident firmware  
• Auto repeat key  
• 1.5 metre lead  
• DB25 socket connector  
• Weight 212 grams  
• Size 116 x 66 x 34mm  
Cat X19950 ..... **\$59.00**  
NOTE: HARDWARE ONLY. SOFTWARE NOT INCLUDED

**8087**  
Genuine Intel chips with manual and data sheets packed in boxes!  
8087-3 (4.77MHz) ..... \$195  
8087-2 (8MHz) ..... \$295  
8087-1 (10MHz) ..... \$395  
80287-6 (6MHz) ..... \$349  
80287-8 (8MHz) ..... \$499  
80287-10 ..... \$549  
80387-16 ..... \$899  
80387-20 ..... \$1499  
80387-25 ..... \$1799



**SCHMIDT 123AT MULTI STANDARD MODEM**  
• V21, V22, V23 Multi standard modem (300/300, 1200/1200, 1200/75)  
• Auto dial AT command set (Hayes compatible)  
• Auto answer/auto disconnect  
• Auto answerback (Similar to Telex)  
• Auto or manual control  
• Dial-up or leased line operation  
• Pulse or Tone Dialing  
• Automatic speed ranging  
• Speaker for call progress monitoring  
• Baud-rate converter with 48 character buffer (V23)  
• Synchronous or asynchronous operation  
• Fully self contained power supply  
• Low power operation  
• Metal case (R.F. shielded)  
• Visual monitoring of important interface circuits (7 LED's)  
• Full or half duplex (V23)  
• Double adaptor plug to allow use of standard phone (Mode 1,3,5)  
• Telecom Authorised (C87,37/65)  
..... **\$595**  
\*Hayes is a trademark of Hayes Microcomputer Products Inc.



**TELEPHONE ADAPTOR**  
• Australian plug to U.S. socket  
• Length 10cm  
Cat Y16026 ..... **\$5.95**



**RITRON 2 MONITORS**  
Stylish 20MHz, non-glare 12 inch monitors available in green or amber displays and featuring swivel base that tilts forward and back and swivels right to left!  
Green (X14506) ..... Normally \$179  
Amber (X14508) ..... Normally \$179  
**SPECIAL, ONLY \$149**



**HEAD CLEANER DISKS**  
It only takes a minute amount of dust, dirt or magnetic oxide particles on your drive heads to cause problems: errors, downtime or an expensive service call. Regular use of a head cleaner will keep your drive free of trouble causing dirt and help keep your system up and running. These disk cleaners are simple to use and include a cleaning solution and instructions.  
CAT. No. SIZE PRICE  
C12560 3 1/2" ..... **\$6.95**  
C12555 5 1/4" ..... **\$6.95**



**VERBATIM HARD DISK CARD**  
Available 20 or 30 M-Byte! IBM compatible, plugs straight in to your computers bus connectors!  
X20020 20 M-BYTE ..... **\$695**  
X20030 30 M-BYTE ..... **\$895**

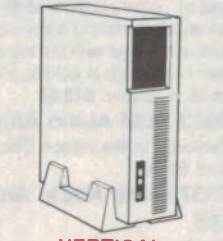

**VERTICAL COMPUTER STAND**  
FREE VALUABLE DESK SPACE OF YOUR PC BY PLACING IT ON ITS SIDE ON THE GROUND!  
• Adjustable width from 115-188mm (4 1/4" - 7 1/4")  
• Accommodates IBM PC XT AT and most compatibles  
• Light weight, durable construction  
C21076 ..... **\$24.95**

**TELECOMMUNICATIONS AUSTRALIAN TO U.S. ADAPTOR CABLE**  
• Australian socket to U.S. plug  
• Length 5 metres  
Cat. Y16017 ..... **\$7.95**



**FUJITSU 5 1/4" 1.2 M-BYTE DISK DRIVE**  
Quality at an affordable price!  
5 1/4" Double sided, double density 1.2 M-Byte unformatted, 720K formatted IBM AT compatible.  
C11906 ..... **ONLY \$249**

**FUJITSU 3 1/2" DISK DRIVE**  
Affordable quality. Double sided double density drive. 1 M-Byte unformatted 640K formatted. Access time 3 m/sec.  
C11905 ..... **ONLY \$255**

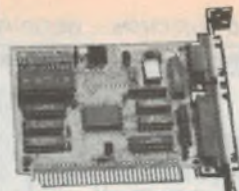

**IBM\* COMPATIBLE CARDS**  
**XT\* 8MHz TURBO MOTHERBOARD**  
X18030 Excluding RAM ..... \$169  
X18031 Including 640 RAM ..... **\$699**  
**XT\* 10MHz TURBO MOTHERBOARD**  
Excluding RAM ..... \$199  
Including RAM ..... **\$749**  
**BABY AT\* MOTHERBOARD**  
X18200 Excluding RAM ..... \$689  
X18201 Including 640 RAM ..... **\$1,299**  
**AT\* 6/10MHz MAINBOARD**  
X18100 Excluding RAM ..... \$689  
**386 MAINBOARD**  
X18101 Excluding RAM ..... **\$2,489**  
X18103 Including 1 M/Byte ..... **\$3,495**  
X18105 Including 2 M/Byte ..... **\$4,495**  
**TTL GRAPHICS CARD**  
X18003 ..... \$139  
**E.G.A. CARD**  
X18070 ..... \$195  
**COLOUR GRAPHICS CARD**  
X18002 ..... \$99  
**COLOUR GRAPHICS & PRINTER CARD**  
X18010 ..... \$99  
**PRINTER CARD**  
X18017 ..... \$29  
**MULTI I/O & DISK CONTROLLER**  
X18040 ..... \$145  
**768K MULTIFUNCTION I/O CARD**  
X18050 Excluding RAM ..... \$194  
**MULTI SERIAL CARD**  
X18154 ..... \$139  
**16 BIT FLOPPY DISK DRIVE CONTROLLER CARD**  
X18005 (2 DRIVES) ..... \$52  
X18006 (4 DRIVES) ..... **\$55**  
**1.2 M-BYTE - 360K FLOPPY DISK DRIVE CONTROLLER**  
X18008 ..... \$124  
**DTC HARD DISK CONTROLLER**  
X18060 (XT\*) ..... \$190  
X18140 (AT\*) ..... **\$290**  
**RS232 & CLOCK CARD**  
X18028 ..... \$89  
**RS232 (SERIAL) CARD**  
X18026 ..... \$49  
**CLOCK CARD**  
X18024 ..... \$55  
**GAMES I/O CARD**  
X18019 ..... \$29  
**I/O PLUS CARD**  
X18045 ..... \$119  
**512K RAM CARD**  
X18013 Without RAM ..... \$99  
X18014 With RAM ..... **\$459**  
**2 M-BYTE RAM CARD**  
X18052 ..... \$194



**150W SWITCH MODE POWER SUPPLY FOR IBM\* PC/XT\* & COMPATIBLE**  
DC OUTPUT: +5/13A -5V/0.5A  
-12V/4.5A -12V/0.5A  
X11096 ..... **\$129**

**200W SWITCH MODE POWER SUPPLY FOR IBM\* AT\* & COMPATIBLE**  
DC OUTPUT: +5.16A -5V/0.5A  
+12V/5A -12V/0.5A  
Cat. X11097 ..... **\$199**

**180W SWITCH MODE POWER SUPPLY FOR BABY AT\* COMPATIBLES**  
Cat. X11098 ..... **\$189**



**IBM\* XT\* COMPATIBLE COMPUTERS FROM \$875**  
Check these features and our prices. We're sure you'll agree they're exceptional value for money!  
• Final assembling and testing in Australia!  
• Fast 8MHz TURBO Motherboard  
• AT\* style keyboard  
• Tested by us for 24 hours prior to delivery!  
• 8 Slot motherboard  
• 12 months warranty!  
• 150W power supply

**\*\$875 COMPATIBLE COMPUTER**  
256K RAM Single Drive, Graphics and Disk Controller Card ..... **\$875**

**256K RAM TURBO COMPATIBLE COMPUTER**  
2 x 360K Disk Drives, Multifunction Card, Colour Graphics, Disk Controller, 1 Parallel Port (Includes Timer Disk) ..... **\$1,045**

**640K RAM TURBO COMPATIBLE COMPUTER**  
2 x 360K Disk Drives, Multifunction Card, Colour Graphics, Disk Controller, 1 Serial Parallel Port (Includes Timer Disk) ..... **\$1,175**

**WITH 20 M-BYTE HARD DISK:**  
& single 360K Disk Drive ..... **\$1,775**  
& dual 360K Disk Drives ..... **\$1,975**

**WITH 40 M-BYTE HARD DISK:**  
& single 360K Disk Drive ..... **\$2,475**  
& dual 360K Disk Drives ..... **\$2,675**

**WITH 80 M-BYTE HARD DISK:**  
& single 360K Disk Drive ..... **\$3,895**  
& dual 360K Disk Drives ..... **\$4,095**



**APPLE\* COMPATIBLE SLIMLINE DISK DRIVE**  
Compatible with Apple 2+  
Cat. X19901 ..... **Only \$179**

**APPLE\* IIC COMPATIBLE DISK DRIVE**  
(including cable ..... **only \$199**  
\*Apple is a registered trade mark.



**20 M-BYTE HARD DISK**  
Tandon, including DTC controller card. 12 month warranty IBM compatible.  
X20010 ..... **ONLY \$549**

**50 M-BYTE HARD DISK**  
Miniscribe. 12 month warranty. IBM compatible. 42 M-Byte formatted.  
Excluding Controller ..... **\$649**

**80 M-BYTE HARD DISK**  
Seagate. 12 month warranty IBM compatible.  
Excluding Controller ..... **\$2,490**



### 386 TOWER PC

The 386 Tower PC is a high performance system that is functionally and mechanically compatible with the IBM AT. However, the 386 Tower PC contains a 80386 microprocessor, 32-bit memory access, and other features, giving it 2.5 times the performance.

#### FEATURES:

- Intel 80386-20MHz microprocessor
- Switchable 8/16/20 MHz
- 8/16/25 MHz, 0 wait state
- One 32 bit memory slot with 0 wait state
- 2 MByte fitted Total memory expandable up to 16 M Bytes
- Up to 2 MByte or 8 MByte RAM modules on system board or on RAM card
- Up to 2M Byte or 8 M Byte RAM chip on system board or on RAM card
- Option for 80287 & 80387 co-processor socket
- Operates in page mode with interleave memory subsystem
- Shadow RAM supported to allow system BIOS to be executed on system memory instead of slower EPROM
- Real time clock with on board rechargeable battery or external battery
- Four 16-bit I/O slot. Three 8-bit I/O slot, and one 32-bit memory slot
- 8042 keyboard controller interface for AT compatible keyboard
- Seven direct memory access (DMA) channels
- 16 interrupts
- Chips and Technology chip set
- AMI 386 BIOS/Phoenix 386 BIOS AWARD 386 BIOS (AMI fitted)
- 50 MByte Miniscribe hard disk Fast access. Formatted to 42 M Byte
- EGA card

\$5,995



### BABY AT\* COMPATIBLE COMPUTER! FROM \$2,295

- Final assembling and testing in Australia!
- 1 MByte Main Board
- Switchable 8/10/12 MHz
- 1.2 MByte Floppy Disk Drive
- 80286 CPU
- Colour Graphics Display Card
- 8 Slots
- Floppy & Hard Disk Controller
- Printer Card and RS232
- Keyboard
- 200W Power Supply
- Manual
- 6 Months Warranty
- Size: 360(W) x 175(H) x 405(D)mm

#### SHORT BABY AT\*

512K RAM \$2,295

#### STANDARD BABY AT\*

640K RAM, hard disk drive  
 & 20 M/BYTE HARD DISK \$3,295  
 & 40 M/BYTE HARD DISK \$3,795  
 & 80 M/BYTE HARD DISK \$4,695



### COPY HOLDER (YU-H33)

- Copy area 9 1/2" x 11"
  - Sliding line guide
  - Flat metal base
- C21060 ..... \$39.95

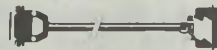

### PRINTER LEAD

- Suits IBM PC/XT compatibles
  - 25 pin "D" plug (computer end) to Centronics 36 pin plug
- P19029 (1.8 metres) \$14.95  
 P19030 (3 metres) \$19.95



### THE BUTTON SPIKE PROTECTOR

Surges and spikes are caused not only by lightning strikes and load switching but also by other equipment being switched on and off, such as fluorescent lights, electric motors, fridge freezers, air conditioners, etc.

For effective protection such spikes must be stopped before they reach your equipment. Simply plug The Button into an outlet and it will protect all equipment plugged into adjacent outlets on the same branch circuit. The Button employs unique metal oxide varistor technology and will dissipate 150 joules of electrical energy, (nearly twice that of comparable surge arresters.)

**SPECIFICATIONS:**  
 Voltage: 240V Nominal  
 Total Energy Rating: 150 joules  
 Response Time: 10ns  
 Protection Level: 350V peak

..... \$34.95

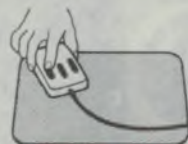

### MOUSE MAT

- A quality mouse mat for accurate and comfortable tracking
  - Anti-static
  - 265 x 225mm
- C21075 ..... \$14.95

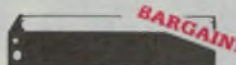

### PRINTER RIBBONS TO SUIT:

CP80, SX80, DP80, BX100  
 MB100 (C22036) 10- \$7.95  
 \$8.95

MX70/80 FX70/80 RX70/80 10- \$7.95  
 1-9 (C22031) \$8.95

MX100, FX100, RX100 10- \$18.95  
 1-9 (C22002) \$19.95

LX80 10- \$8.95  
 1-9 (C22003) \$9.95

LQ1000 10- \$25.00  
 1-9 (C22012) \$27.60



### THOMSON EGA MONITOR

Top quality high resolution EGA monitors with a space-age design.

#### SPECIFICATIONS:

CRT: 14 inch (360mm) diagonal, 90 degree deflection.  
 Display Size: 245(H) x 180(V)mm  
 Phosphor: P22, non glare, tinted screen  
 Dot Pitch: 0.38mm  
 Video Bandwidth: 18 MHz  
 Resolution: 15.75KHz - 640 x 200  
 21.85KHz 640 x 350

#### Input Signals:

1 RGBI - positive, H(+), V(+)  
 2 R/G/B/I - positive, H(+), V(-)  
 Input Impedance: 330 ohms  
 Dual Scanning Frequency:  
 Horizontal: 15.75 KHz or 21.85 KHz  
 Vertical: 50 - 60 Hz

Connector: 9 pin, D-type  
 Size: 312(H) x 363(L) x 380(W)mm  
 Weight: 10.8 Kg (Net!)

X14525 ..... \$695  
 EGA CARD ..... \$195



### Z-DIN 12" TTL MONITOR

X14500 (GREEN) \$139  
 X14502 (AMBER) \$139  
 10 OR MORE \$129 EACH

### Z-DIN 12" 20MHz COMPOSITE MONITOR

X14514 (GREEN) \$119  
 X14516 (AMBER) \$119  
 10 OR MORE \$109 EACH

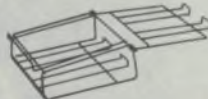

### PRINTER STANDS

- Restores order to your work area.
  - Conveniently stacks paper printout in document tray automatically
  - Made of black plastic coated steel
  - Suitable for most printers (80/132 column)
  - Excellent value at these prices!
- C21054 ..... \$26.95

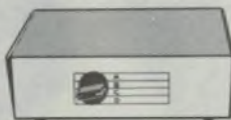

### DATA TRANSFER SWITCHES

If you have two or four compatible devices that need to share a third or fifth, then these inexpensive data transfer switches will save you the time and hassle of constantly changing cables and leads around

- No power required
- Speed and code transparent
- Two/Four position rotary switch on front panel
- Three/Five interface connections on rear panel
- Switch comes standard with female connector

2 WAY RS232 X19120 ONLY \$49  
 4 WAY RS232 X19125 ONLY \$59

2 WAY Centronics X19130 ONLY \$49  
 4 WAY Centronics X19135 ONLY \$59



### VERBATIM DISK SPECIALS!

DESCRIPTION	1-9 boxes	10+ boxes
3 1/2" 1S/2D	\$39.95	\$37.95
3 1/2" 2S/2D	\$46.95	\$43.95
3 1/2" 2S/HD	\$99.00	\$89.00
5 1/4" 1S/2D	\$22.00	\$21.00
5 1/4" 2D/2D	\$26.00	\$24.00
5 1/4" 2S/4D	\$75.00	\$70.00
5 1/4" 2S/HD	\$41.00	\$39.00



### MICRODOT DISKS!

FREE PLASTIC LIBRARY CASE WITH EVERY 10 DISKS!

DESCRIPTION	1-9 boxes	10+ boxes
3 1/2" 2S/2D	\$32.95	\$30.95
5 1/4" 1S/2D	\$11.95	\$10.95
5 1/4" 2S/2D	\$13.95	\$12.95
5 1/4" 2S/HD	\$29.95	\$27.95

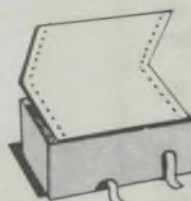

### COMPUTER PAPER

Quality paper at a low price!  
 2,000 sheets of 70 gsm bond paper  
 C21003 11 x 9 1/2" \$39.95  
 C21005 15 x 11" \$67.95



### PANASONIC KX-P1081 DOT MATRIX PRINTER

- 120 C.P.S.
  - Pica or Elite character set
  - Print Modes: NLQ, Dot Graphics, Draft, Proportional Font
  - Reliable and Compact
  - Proportional Printing
  - Logic Seeking
  - 1K Printer Buffer
- C20035 Normally \$595  
 We won't be beaten! only \$379



### DELUXE PRINTER STAND

- Restores order to your work area without occupying extra space
  - Feeds and reloads paper under the printer automatically
  - Adjustable paper deflectors to ensure smooth flow of paper
  - Made of moulded plastic
  - Suitable for most printers
- C21058 80 column \$89.95



### "NO BRAND" DISKS

Now you can buy absolute top quality disks that are probably the cheapest in Australia! They even come with a lifetime warranty! So why pay 2-3 times the price for the same quality?

Packs of 10 2S/2D without boxes or brand name, just their white paper jacket, and index labels (5 1/4" disks includes write protects).

5 1/4" 2S/2D DISKS  
 10-DISKS \$6.95<sup>ea</sup> 100-DISKS \$6.75<sup>ea</sup> 1000-DISKS \$6.50<sup>ea</sup>  
 (ALL PRICES PER 10 DISKS)

5 1/4" HIGH DENSITY (DOUBLE SIDED)  
 10-DISKS \$27.95<sup>ea</sup> 100-DISKS \$26.95<sup>ea</sup> 1000-DISKS \$25.95<sup>ea</sup>  
 (ALL PRICES PER 10 DISKS)

3 1/2" 2S/2D DISKS  
 10-DISKS \$27 \$26 \$24  
 (ALL PRICES PER 10 DISKS)



### 5 1/4" DISK STORAGE (DD100-L)

Efficient and practical. Protect your disks from being damaged or lost!

- Features...**
- 100 x 5 1/4" disk capacity
  - Smoked plastic hinged lid
  - Lockable (2 keys supplied)
  - High impact ABS plastic base
  - Contemporary design

C16020 ..... only \$15.95



### JUMBO 5 1/4" DISK STORAGE (DD120-L)

If you have lots of disks, you'll appreciate the extra capacity of this disk storage unit when it comes to locating a particular disk

- Features...**
- 120 x 5 1/4" disk capacity
  - Smoked plastic hinged lid
  - Lockable (2 keys supplied)
  - High impact plastic base

C16028 ..... only \$19.95

### 5 1/4" DISK STORAGE (DD50-L)

Efficient and practical. Protect your disks from being damaged or lost!

- Features...**
- 50 x 5 1/4" disk capacity
  - Smoked plastic hinged lid
  - Lockable (2 keys supplied)
  - Contemporary Design

C16025 ..... only \$14.95



### 3 1/2" DISK STORAGE (DD80-L)

- Holds up to 80 x 3 1/2" diskettes
- Smoked plastic hinged lid
- Lockable (2 keys supplied)
- High impact plastic base
- Contemporary design

C16038 ..... only \$19.95

ROD IRVING ELECTRONICS

## Construction project:

# Low cost Stud Finder

Here's a very low cost and easy to build little unit that will indicate the position of wooden studs and noggins inside walls clad in the usual gypsum board or fibro. Build it up to take the guesswork out of hanging pictures, or mounting shelves...

How many times have you wanted to hang a picture and found that the hook you hammered into the wall missed the stud behind? Gypsum board and fresh air don't provide a very secure mounting, unfortunately.

The same thing can happen with shelf brackets. You need a solid base for these, even more than with picture hooks. Finding the stud (upright framing members) or noggin (horizontal bracing members) is almost essential, and the old trick of tapping along the board with your cranked finger often isn't accurate enough.

It can also be important to find the positions of the studs and noggins when you want to run electrical wiring – so you can avoid them, or at least arrange your run to minimise the number that will need to be drilled.

Here is the answer. A simple but effective build it yourself tool. It's easy to assemble and can be constructed in a couple of hours.

It provides two forms of indication. A light emitting diode (LED) in the centre position of the sensor changes brightness with variations in the dielectric material beneath. At the same time a piezoelectric transducer produces an audible output that varies from a ticking sound to a constant tone, depending on the density of the material under the sensor head.

In use, the sensitivity control is adjusted with the Stud Finder placed on the wall or other medium to be scanned. Take the following example: We have a plaster or gypsum board wall on which to hang a large picture frame. Two uprights are required to support the hooks. Simply place the Finder on the wall and adjust the control until the transducer just starts to tick. Sweep the finder across the surface and bingo! – there will be a distinct change in sound and LED brightness, reaching a peak over the hidden stud or noggin.

The unit is easy to use, very sensitive and fully adjustable to suit varying materials.

Incidentally this project has been designed by the R&D Department of Dick Smith Electronics, and copyright to the PC board pattern and front panel artwork is held by that company. This means that they cannot be reproduced

commercially. However complete kits for the project will be available from all Dick Smith Electronics stores, and many dealers. The kit is designated with the catalog number K-2723.

### How it works

The sensing system of the Stud Finder is designed to detect changes in the dielectric constant of materials under the sensing head. A sensitivity control allows setting of the detection threshold point for varying materials.

The circuit uses CMOS Schmitt trigger inverters as the active components.





**The circuit for our Stud Finder is deceptively simple. Explaining exactly how it works isn't nearly so easy...**

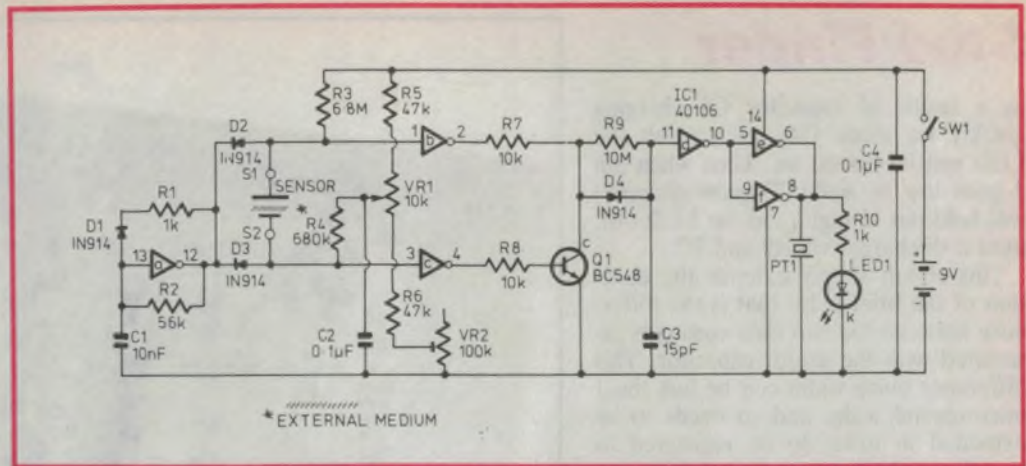

Six inverters are used in all, provided by a single 40106 hex inverter device. This makes for low cost and a simple layout.

The principle of operation is based around the detection of changes in the effective dielectric constant of the medium being scanned (the wall board), caused by the presence of a stud or noggin behind it.

The sensor is actually a two-plate capacitor, with the external wall material as its dielectric or coupling material. The two plates S1 and S2 are actually copper areas of a small PCB, mounted hard up against the bottom of the Stud Finder's case. They are deliberately made of different sizes, with S1 a fairly large solid rectangle and S2 a smaller-area open rectangle around it.

One of the 40106 Schmitt inverter elements IC1(a) is connected as an astable oscillator. This oscillates at about 3kHz, with a very short duty cycle caused by the ratio of R1 and R2. Resistor R1 essentially determines the "pin 12 low" part of the oscillator cycle, while R2 determines the "pin 12 high" part - both in conjunction with capacitor C1. The ratio of high to low times at pin 13 is therefore quite high, with the low time typically only around 6.5 microseconds.

The effect of diodes D2 and D3 is to discharge the S1/S2 sensor capacitor by connecting both plates to the circuit's negative rail, during the brief time that the output of IC1(a) goes low. Then when the output of the oscillator goes high again, D2 and D3 cease conducting. This allows the sensor capacitor to begin charging, via R3 on the S1 side (connected directly to the positive rail) and R4 on the other (connected to an adjustable voltage from VR1, the sensitivity control).

Large plate S1 is connected to pin 1 of inverter IC1(b), while small plate S2 connects to pin 3 of inverter IC1(c). So

when D2 and D3 turn off, the voltages at pins 1 and 3 begin rising up towards the switching thresholds of the two inverters, as the S1/S2 capacitor charges up via R3 and R4.

Operation of this part of the circuit is quite subtle. Because of the difference in size between the two plates S1 and S2, and the different resistor values connected to each, the effect of even quite small changes in their mutual capacitance is to vary the time taken for the

**A look inside the case. Apart from the sensor itself, on the lower PCB, there's only a single IC with one transistor and a handful of parts.**

voltages at pin 1 and pin 3 to rise up to the switching thresholds of IC1(b) and (c), in a differential fashion.

In effect these two inverters form a very sensitive comparator, used to detect very slight changes in the capacitance of the S1/S2 capacitor.

Normally, before the onset of switching or triggering of IC1(b) and (c), both pin 2 and pin 4 will be high. At the point of sensitivity setting just before maximum, VR1 is adjusted so that the triggering of inverter IC1(c) is slightly after that of IC1(b). This means that pin 2 will go low before pin 4. Transistor Q1 is connected to these two points, the base via R8 and the collector via R7.

When pin 4 is high, Q1 is turned on. Its collector is near 0V, therefore inverter IC1(d)'s output pin 10 is high, forcing the outputs of inverters IC1(e) and (f) to go low. As a consequence, the LED will be off.

Now, should pin 4 go low before pin 2, Q1 will be off, so pin 11 will go high

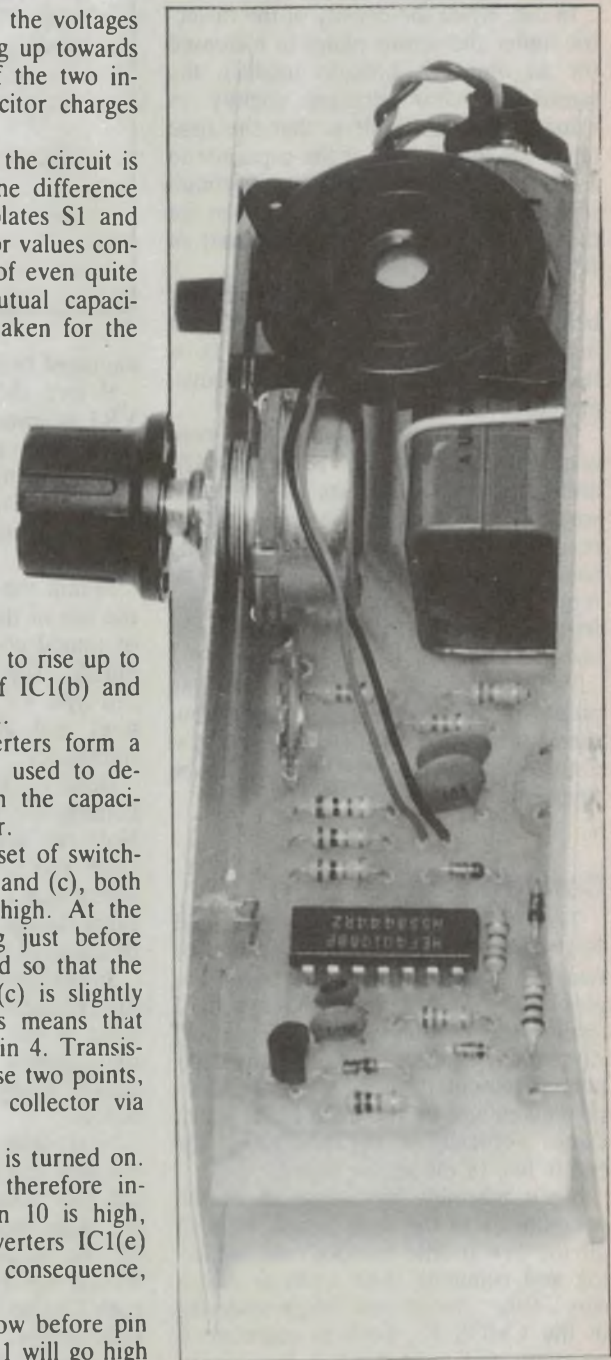

# Stud Finder

as a result of capacitor C3 charging quickly via diode D4. As a result the LED will be turned on. Then when pin 2 goes low as well, C3 (now charged) will hold pin 11 high (and the LED on), until it discharges via R9 and R7.

This circuit simply extends the duration of the brief pulse that is the difference between the two time constants associated with the sensor capacitor. This difference pulse width can be less the 1 microsecond wide, and so needs to be extended in order to be registered as sound or light by the output system.

In use, when the density of the dielectric under the sensor plates is increased (or an object is brought nearer), the sensor capacitor changes slightly in value. The nett result is that the time taken for the S2 side of the capacitor to reach the threshold of IC1(c) becomes slightly shorter than the time taken for the S1 side to reach the threshold of IC1(b).

Because of this pin 4 goes low before pin 2, and Q1 is turned off just before pin 2 goes low. So pin 11 is taken high briefly, as described above, and the LED turns on.

The piezo transducer is also connected to the outputs of IC1(e) and (f), and as a result it reflects in sound the varying conditions of the input. Slight reactions will be heard as short ticking sounds, while larger changes will be represented by a constant tone at the frequency of the astable oscillator - about 3kHz.

Preset pot VR2 adjusts the operating point of the circuit for the different threshold levels of different 40106 ICs. Once set, this pot does not have to be touched in normal operation.

## Construction

The components used in the Stud Finder are mounted on an assembly of two PC boards, mounted at right angles. The sensor board mounts hard against the bottom of the unit's small Zippy box, and does not have any components mounted on it. All of the components mount on the main PCB, which stands vertically in the box along the centre line of the sensor board.

Begin assembly by fitting all of the components to the main board. First fit all the low profile components, soldering and trimming their leads as necessary. Take special care when soldering in the CMOS IC, both to orientate it correctly and to prevent it from being

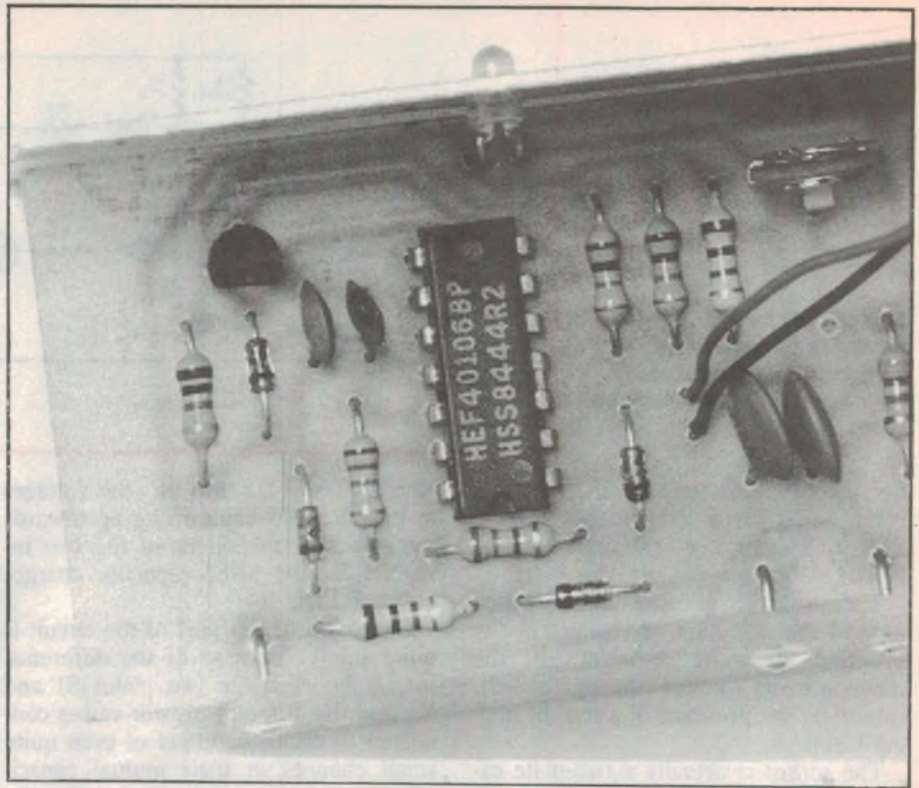

damaged by static electricity.

Before the PC board mounting pot VR1 is installed, it is advisable to cut the shaft to length to fit the knob being used. We cut the prototype 18mm from the body. Fit the pot to the board with the pin shoulders right up to the board surface.

Mount the on-off slider switch flat on the top of the board using three lengths of tinned copper wire through the terminals. Solder in the leads from the 216-type 9V battery snap (red to positive) and also those from the piezo transducer.

Bend the LED pins close to the body, holding the legs with long nose pliers. Note the correct orientation. Push the leads into the PCB holes, but only tack solder one leg at this stage because the exact final position of the LED needs to be adjusted later.

Solder four lengths of copper wire to the connection points along the bottom edge of the main PCB. Bend these at right angles to point away from the board, ready to mate with the sensor board.

Next, take the sensor board and align the four wires from the main board with the four holes down the middle - with the main board on the non-copper side of the sensor board. Push the two boards tightly together and bend over each lead to hold the two in position, at right angles. Then cut off each lead at the edge of the pad and flatten the wire

against the board. Solder each lead, making sure each joint is as low in profile as possible on the copper side. This is to avoid problems when the assembly is mounted in the box (the sensor board needs to be able to mount hard against the bottom of the Zippy box, for maximum sensitivity).

To hold the battery in a stable position, mount it as shown and support with wire straps between the main and sensor board.

The completed assembly should slip into the Zippy box with ease. The edge of the main board should be just below the surface of the box edges, to allow you room to fit the aluminium panel. If it is too high, you may have to reduce the profile of the solder joints on the bottom of the sensor board.

The aluminium front panel has to be drilled to suit the components penetrating its surface. The diagram shows the detail of these cutouts. You can use the label as a template to mark these positions. The pot and LED holes can be carefully drilled, but the switch hole has to be pilot drilled and then filed to the required rectangular shape with a needle file (or cut with a piercing saw).

No holes have been indicated for the switch mount screws. We found they were not necessary in the prototype, but you can add these if you like.

Try the panel for fit before the next step. If necessary, adjust the position of the LED for the best fit with the hole in

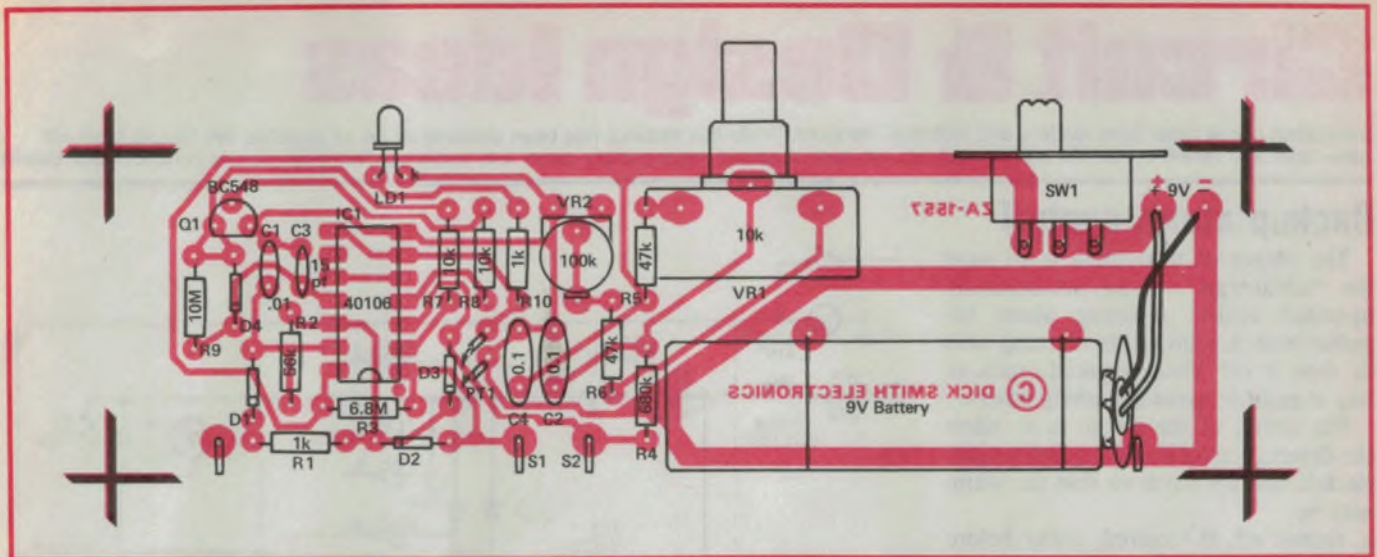

Construction should be easy using this overlay diagram and the picture opposite as a guide.

the front panel. When this is right, solder and trim the leads.

After each hole in the front panel has been dressed and freed from burrs, the self-adhesive label can be applied. Make sure it is correctly aligned before pressing it down on the surface. Then punch or cut out the holes carefully. Use a small scalpel blade or similar to cut to the edge of the switch opening. The drills used for the pot and LED holes can be used to punch through the label from front to rear.

The piezo transducer fits neatly between the battery and the box wall, adjacent to the pot. The front panel holds it in place.

### Setting up

Power up the unit. The LED and transducer may or may not operate at this stage, depending on the position of presets VR1 and VR2.

To set the correct operating point, set sensitivity control VR1 to the mid position and put the PCB assembly in the Zippy box. Make sure the sensor PCB is hard against the bottom of the box. Place the box flat on some wooden surface, and adjust VR2 with a screwdriver until the LED just starts to light. Now fit the box front panel (without screws), along with the knob.

Try the unit on different materials: wood, plaster, plastic, glass etc. The sensitivity control should adjust for varying materials within a third of its full travel, centred around the mid position. Note that these adjustments are made with your fingers around the sides of the box, near the bottom (on-off switch) end. You will notice a slight variation in sensitivity setting as you touch the knob.

After adjustment is complete, the lid can be screwed in position. If you wish to put a nut on the pot, two to three washers may be needed to pack the pot body from the panel. Fit the knob and your Stud Finder is ready to use.

### Using it

Place the Stud Finder flat on the surface to be scanned, holding it with one hand at the bottom end of the box. Adjust the sensitivity control until the transducer just starts to tick, then take your hand from the knob. The ticking should stop. You may need to re-adjust to get the most sensitive setting.

Now run the finder over the wall to get an idea of its operation. The LED at the cross centres indicate the centre of the sensor. Try the unit with known conditions, thickness of panels, types of materials etc.

The Stud Finder is capable of working with a great variety of materials and is sensitive enough to penetrate thick panels.

Remember, it basically detects changes in dielectric. Don't expect it to detect metal through metal – although it is perfectly happy to detect metal studs, pipes or conduits through insulating panels.

With a little operating experience, you can also use it to detect electrical wiring close to the surface. The field around the wires modulates the sound from the transducer.

The Stud Finder will even indicate the direction of grain in a piece of wood when the sensitivity control is set carefully. Even a knot or dense part in the grain structure can be found.

You may well be able to think of other applications for the Stud Finder,

taking advantage of its principle of operation. It could conceivably be used to sense the presence of fluid in a plastic pipe, as a proximity detector, to check for the presence of moisture, or perhaps even as a pH meter. E

### PARTS LIST

- 1 Main PCB, 124 x 36mm, code ZA-1557
- 1 Sensor PCB, 105 x 59mm, code ZA-1558
- 1 Zippy box, 132 x 69 x 42mm
- 1 216-type 9V battery with snap lead
- 1 Piezo transducer
- 1 Mini DPDT slider switch

#### Semiconductors

- 1 40106 CMOS hex Schmitt inverter
- 1 BC548 or similar NPN transistor
- 4 1N914, 1N4148 or similar diode
- 1 3mm red LED

#### Resistors

- 1/4W carbon: 2 x 1k, 2 x 10k, 2 x 47k, 1 x 56k, 1 x 680k, 1 x 6.8M, 1 x 10M
- 1 10k linear PCB mount pot
- 1 100k linear vertical or horizontal PCB mount trimpot

#### Capacitors

- 1 15pF ceramic
- 1 10nF ceramic
- 2 0.1uF ceramic

#### Miscellaneous

Tinned copper wire, knob for pot, insulated hookup wire for mounting battery, etc.

# Circuit & Design Ideas

Interesting circuit ideas from readers and technical literature. While this material has been checked as far as possible, the circuits have not been built and tested by us. As a consequence, we cannot accept responsibility, enter into correspondence or provide constructional details.

## Backup alarm control

The object of this circuit is to have the "advantages" of an automatically operated vehicle reversing alarm together with the advantage of being able to turn it off when required, such as late at night to avoid disturbing others.

The action of the circuit is to allow the driver of a vehicle to control a piezo electric backup alarm so that the alarm may be

- a. turned off, if required, either before or after the vehicle is reversed
- b. maintained in the "off" condition, if set, for approximately 30 seconds after the vehicle is taken out of reverse
- c. turned on again, if required, while the vehicle is being reversed.

Thus, if no action is taken before placing the vehicle into reverse, the alarm will sound. This may be silenced by operating the push button, either after placing the vehicle into reverse or up to 30 seconds before this. The alarm will then not sound while manoeuvring the vehicle in the forward and reverse directions, as when parking, but will sound if the vehicle is placed into reverse after having been left parked or driven forward for more than 30 seconds.

When power is applied via the lead to the back-up lamp, C1 charges to the 12 volt supply voltage via D1 and R1 and this, via C3 to the input of IC1e (Pin 9), causes an earth potential (logical 0) to appear at the output of IC1e (Pin 8). This is applied to Pin 1 of IC1a, which is the clear input of a dual D flip-flop. This pulse lasts for about 10ms, until C3 charges through R5. Hence, the Q output of the flip-flop is set at earth potential (logical 0) and Q1 and Q2 conduct, turning on the alarm via R8, R9 and R10 in parallel. The Q-bar output of IC2a (pin 6) is set to logical 1.

The earth potential via R3 and R2

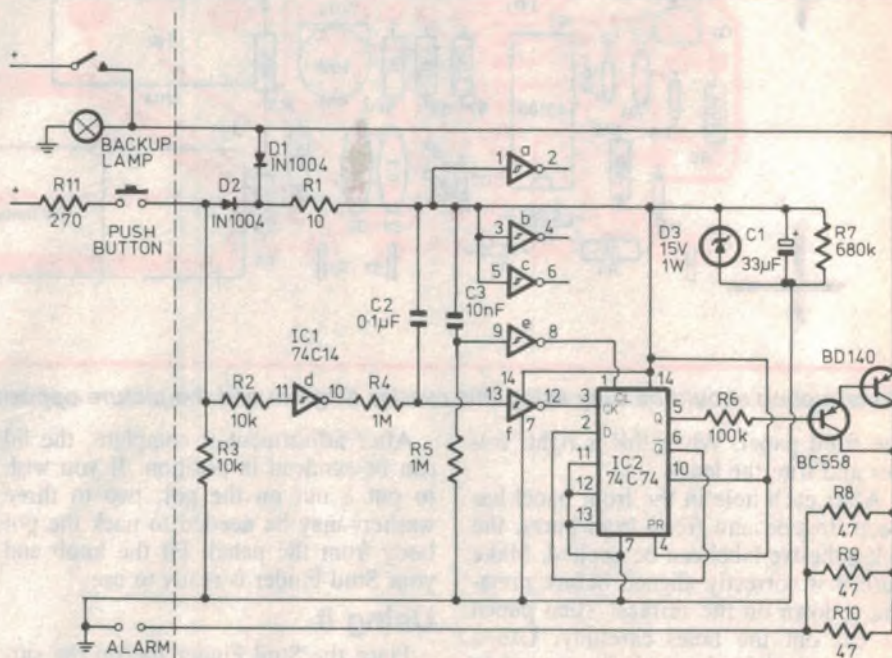

holds the input of IC1d (pin 11) low, causing its output (pin 10) to be high. This holds the input of IC1f (pin 13) high, thus maintaining its output (pin 12) and the Clock input of IC2a (pin 3) low.

If the push button is now operated, almost the full 12 Volt potential is applied via R11 and R2 to the input of IC1d and, after a 100ms delay caused by the charging of C2 via R4, the output of IC1f and the Clock input of IC2a go high. This causes the data at D, which is connected to Q-bar, to be transferred to the Q output of IC2a, turning off Q1 and Q2 and thus stopping the alarm.

If the push button is subsequently operated and released, the flip-flop will toggle each time it is operated; turning the alarm ON or OFF as required.

Because of the low current drain of the CMOS components, the discharge time of C1 is almost entirely dependent

on the current through R7. Thus, if the circuit is set so that Q1 and Q2 are not conducting, this will be "remembered" until C1 is below two thirds of the supply voltage, which takes about 30 seconds. Therefore, once the circuit is set to "OFF", the vehicle can be manoeuvred backwards and forwards without the alarm sounding, so long as any period of forward motion does not exceed 30 seconds.

In addition, if the push button is operated immediately before selecting reverse, C1 will charge via D2 and R1 and the Q output of the flip-flop will be set low by a 10ms pulse via IC1e as before. However, after a further 90ms, a clock pulse will be received via IC1d and IC1f causing the flip-flop to toggle and thus disabling the alarm.

R8, R9, R10 and R11 are not essential to the operation of the circuit. However, R11 prevents a "raw" 12 volt supply being available on the contacts of the dashboard mounted push button switch, and the alarm unit used was found to be somewhat erratic in its period and frequency of operation without a small amount of resistance in series with its supply.

The unused inputs of IC1 (a,b, and c) and IC2 (b) are tied to the 12 Volt or Earth levels as appropriate.

P.B. Taylor,  
Box Hill North, Vic.

**\$50**

## Dreamed up a great idea?

If YOU have developed an interesting circuit or design idea, like those we publish in this column, why not send us in the details? As you can see, we pay for those we publish — not a fortune, perhaps, but surely enough to pay for the effort of drawing out your circuit, jotting down some brief notes and popping the lot in the post (together with your name and address, or course!). Send them to Jim Rowe, Electronics Australia, PO Box 227, Waterloo 2017.

## Simple 3-transistor amplifier

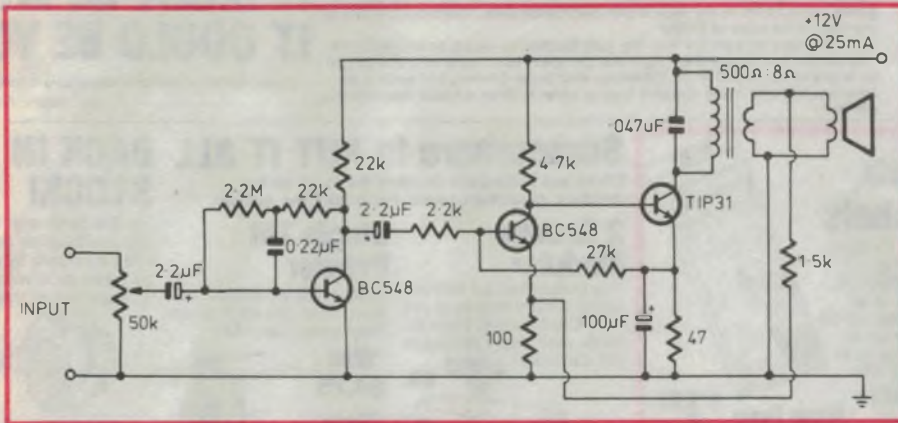

This three transistor amplifier uses a single ended class A output stage which eliminates crossover distortion and does not need any bias adjustments to set it up. The output transformer is sold by Jaycar. Output power is about 80mW. Of course, the speaker should be as large as possible and well baffled to get

maximum efficiency.

Gain is such that a low impedance dynamic microphone as used with tape recorders can drive the amplifier to full output. It would also work well with the regenerative and reflex radios recently described in EA.

Negative feedback is used, which is rare on simple amplifiers, to improve sound quality. Current consumption is about 25mA at 12V.

## Suppressed zero voltmeter

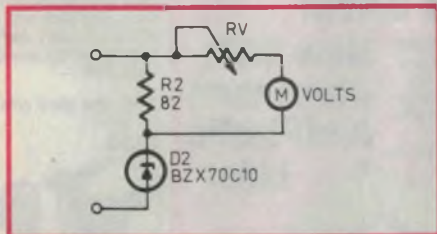

This simple circuit makes an expanded scale type voltmeter from any ordinary meter.

Values and type of parts in the diagram are for 12V car battery monitor. There are three points marked on the scale of the voltmeter: 10.8V for a flat battery, 13.8V for a fully charged battery and 14.4V for correct charging voltage. The fields between these points can be colour distinguished. Voltages outside this range indicate faults, either with the battery or regulator.

Basic rules for design of this voltmeter are: Zener diode determines minimum (zero) voltage. For resistor  $R_z$  use the equation

$$R_z = (V_v - V_z) / I_z$$

where  $V_v$  is average input voltage,  $V_z$  is zener voltage of diode and  $I_z$  is the diode current.

$R_v$  is best set up by trial, otherwise you need to know sensitivity of your voltmeter. This resistor determines the maximum voltage on your scale.

Michal Cedrych,  
Lenah Valley, Tas.

**\$30**

John Hunter,  
Northbridge, NSW

**\$30**

## ELECTRONIC BROKERS AUSTRALASIA TEST EQUIPMENT

Australia's largest range of  
secondhand:

Hewlett Packard

Tektronix

Marconi

Solartron

Boonton

BWD

Bruel & Kjaer

Oscilloscopes, sig gens, spectrum analysers, multi meters. Wide range of valves, coaxial connectors and test accessories. Repairs and service to all makes and models.

All types of equipment bought and sold.

### WE TRADE ALSO!

Calibration facilities available. Screened room and Vibration measurement systems for hire. Communication equipment, Scanners, Mobile Phones and accessories, Ham gear.

Cnr. Barry St. and Brunson St.  
BAYSWATER 3153 VIC.

(enter from Brunson St.)  
TELEPHONE (03) 729 0455  
Mobile Phone 018 312 203

## DON'T SWITCH ON YOUR SCANNER WITHOUT IT!

## THE AUSTRALIAN VHF/UHF FREQUENCY REGISTER ... BY STATE

Compiled from the Department of Communications AMFAR listing, this unique register cover frequencies from 42.500 to 519.925MHz. This exhaustive listing is made on a State by State basis. If you own a scanner this gives you instant information about the frequency you are on.

The sturdy ring-bound volume has over 200 pages of vital scanning information. Please specify State when ordering.

Full price **\$26.50** plus \$5.50 P&P

All States version **\$100.00** plus \$5.50 P&P

Also available: the Australian H.F. Frequency Register  
**\$39.00** plus \$5.50 P&P



28 Parkes Street, Parramatta 2150  
or phone (02) 633 4333 for same day  
delivery. We accept Bankcard, VISA,  
MasterCard. Mail orders our specialty.

# WIN AN OPEN ORDER TO THE VALUE OF \$1000

# IN OUR 1,000,000TH FUN WAY KIT! IT MUST BE WON. IT COULD BE YOU!

We're celebrating the incredible success of our "Fun Way Into Electronics" series, with the one millionth Fun Way kit due to be sold any day! Inside that millionth kit is a surprise: a voucher which can be exchanged for goods worth \$1000 in any Dick Smith Electronics store. That's right: anything you like, to the value of \$1000! It could be any kit from the Fun Way Into Electronics range, or any of the Fun Way packs. And it's out there right now (we don't even know where - it could be in any of our stores or the DSXpress Mail Order Center), just waiting for someone to come along and pick it up or order it. What a bonus that person will get!

Permit numbers applied for at time of going to press in NSW, Victoria, ACT and NT

## STOCK UP THE SHOP!

The workshop, the shack, the toolbox... whatever, with these value plus service aids.

**Cleaning Solvent**  
Non corrosive, low toxicity, idea for all sorts of electronic cleaning applications. Cat N-1040  
**\$6<sup>95</sup>**

**Contact Cleaner/Lub**  
Your switch and relay contacts will love it! Cleans off much, suppresses arcing, reduces wear. Cat N-1042  
**\$7<sup>50</sup>**

**PCB Lacquer**  
Protects pcb's from tarnishing, damage. Solder-through covering makes service easy, too. Cat N-1045  
**\$8<sup>25</sup>**

**Air Duster**  
Give dirt, dust etc a high pressure blast - inert gas won't corrode or damage, great in tight corners! Cat N-1050  
**\$15<sup>95</sup>**

**Permagard**  
Water displacer, penetrates to free stuck nuts & bolts, etc. Also protects against corrosion. Cat N-1065  
**\$7<sup>50</sup>**

**COLOURED INSULATION TAPE, TOO**  
All the colours you need to mark pos/neg, 3 phases, earth, etc. 18 metre rolls, 19mm wide. Colours: Green/Yellow N-1359 Orange N-1360 Red N-1361 Black N-1362 Brown N-1363 Blue N-1364  
**All One Price: 95¢/roll**

**SOLDER ON!**  
Sick of running out of solder: buy in bulk - it lasts and lasts and... You'll save money, too! Two gauges, both 200g rolls. 0.71mm (22g) Cat N-1623  
1.25 (17g) Cat N-1619  
**\$6<sup>95</sup>/roll**

**NEW! WARNING! Bargain Labels**  
Watch out: there are over 80 labels here in just about everything imaginable - warnings, voltage, AC, DC, fuses, etc, etc, all on an adhesive backed mylar base: just cut out the ones you want & stick 'em where you want. And at only \$2.95 that's fantastic value. Cat N-5759  
**Introductory offer: \$1.00 OFF! Now Only \$1<sup>95</sup>**



**Now Hear These...**  
Superb quality hi-fi speakers you'll be proud to own - and hear! 3 way with massive 300mm woofer, 120mm midrange and 65mm tweeter. Overall size 385x300x725mm 65W power handling, attractive teak "wood-grain" finish with black grille. Cat A-9500  
**\$329**

**See The Light?**  
If you need a bezel, look no further. There are some really bright ideas in this lot of quality bezels.  
Mini LED: 2 colours, our most popular. Low drain (20mA @ 2V), high visibility. Red: Cat S-3528 Green: Cat S-3529  
**Both: \$1<sup>50</sup> ea**  
12V Globe: Used in alarms, etc. High brightness, requires 12V DC or AC. Looks great! Red: Cat S-3510 Green: Cat S-3512  
**Both \$1<sup>75</sup> ea**

**No More Birdsnests!**  
Experimentors... circuit developers... engineers... why mess around with the pile of components on the bench; make your prototypes on breadboards - saves a lot of time in the long run! 4 styles to choose from:  
Mini: 80 x 60mm, 58 groups of five connected terminal points. Cat P-4614  
**\$10<sup>95</sup>**  
Giant: As above, but 128 groups. 178 x 67mm. Cat P-4615  
**\$8<sup>95</sup>**

**Save On Phones!**  
Earpieces and Phones at bargain prices. Save \$3 on inside ear mini phones. Quality, yet very tiny. Cat C-4135  
**Were \$9.95 Now \$6.95**  
Save \$5 on lightweight earphones. Complete with on/off switch. Cat C-4145  
**Were \$29.95 Now \$24.95**

## Somewhere to PUT IT ALL

Check out these parts drawers: they're great for resistors, capacitors, semis, fish hooks, etc, etc, etc.

**2 Drawer Modular**  
They're stackable: just keep on adding as many modules as you require. And if you add them this month, you'll save! 2 drawers per unit. Cat H-2580  
**\$3<sup>95</sup> ea.**

**Single Tilt Drawer**  
Similar to left, but this has one drawer on an axle which allows tilting forward. Cat H-2581  
**Was \$4.75 Now \$3<sup>95</sup> ea.**

**And The Big Guns (With Big Savings!)**  
A big 290 x 220 x 45mm case with internal divider containing multiple sections. Cat H-2596  
**Was \$47.95 This month \$29<sup>95</sup>**

## BACK IN STOCK!

The Dick Smith range of quality rotary switches has been a little hard to come by recently... but they're back! We now have good stocks of all styles.



Positions	Poles	Cat No
2	6	S-6302
3	4	S-6303
4	3	S-6304
5	2	S-6305
6	2	S-6306
12	1	S-6312

**Only \$2<sup>25</sup> each!**

## Want POWER?

Here's a handy one: a special scoop purchase so you know you'll save on the normal price! Mains plug-pack with a 6V DC, 400mA secondary - perfect for all those low voltage projects! Cat M-9548

Think what you'd normally pay! Our price:  
**\$6.95**



Other Pluggacks:  
9V @ 200mA (Cat M-9514) **\$11.95**  
3/6/9V @ 200mA (Cat M-9525) **\$16.95**  
3/4.5/6/7.5/9/12V @ 300mA (Cat M-9526) **\$17.95**  
12V AC @ 500mA (Cat M-9555) **\$29.95**  
16V AC @ 900mA (Cat M-9567) **\$14.95**

## QUICK! GRABA ZIPPY BOX AND SAVE!

There's only one genuine Zippy box - it's the one with the deep ribbed sides and the genuine Dick Smith Electronics catalogue number moulded into the bottom. Don't be fooled by cheap imitations: insist on the one, the only genuine Zippy Box - exclusive to Dick Smith Electronics.

**Now With Aluminium And Plastic Lids!**

Small (UB5): 28 x 54 x 83mm Cat H-2855  
**\$2.50 \$1.95**

Large (UB1): 50 x 90 x 150mm Cat H-2855  
**\$2.95 \$3.45**

Medium (UB3): 41 x 68 x 130mm Cat H-2855  
**\$3.50 \$2.95**



## Portasol Pro!

What do you do when you're out of reach of a power point. Use a Portasol, of course - the butane powered gas soldering iron that goes where you go.  
You know the portasol: here's the PRO model! The complete kit includes: • Portasol PRO Gas Iron • Four tips including hot knife and blow torch • Tip Cleaning Sponge • All in a heavy duty plastic case which doubles as an iron stand! Cat T-1374  
Spare tips to suit:  
Standard soldering tip Cat T-1375 **\$12<sup>95</sup>**  
Hot Knife tip (ideal for working in plastics, etc) - simply replaces soldering iron tip. Cat T-1376 **\$12<sup>95</sup>**



Blowtorch tip - for really applying the heat! Good for (carefully!) shrinking heatshrink. Cat T-1377 **\$12<sup>95</sup>**

## WHY WON'T IT SELL?

It would have to be one of the handiest devices anyone working with audio could ever own. It instantly checks cables for go/no go in RCA, Cannon & 6.5mm - without having to worry about meters, etc. But it didn't sell. So we've slashed the price to way below cost to clear 'em out. OK, we lose - but YOU REAP THE BENEFIT of our mistake!  
Cat Q-1532



**SHOULD BE WAY OVER \$60... NOW WAY BELOW COST AT \$19<sup>95</sup>**

Now available at 60 stores:  
• NSW • Albany 21 8399 • Bankstown Square 707 4888 • Blacktown 671 7722 • Bondi Junction 387 1444 • Brookvale (Warringah Mall) 905 0441 • Campbelltown (046)27 2199 • Chatswood Chase 411 1955 • Chullora 642 8922 • Gore Hill 439 5311 • Gosford 25 0235 • Hornsby 477 6633 • Liverpool 600 9888 • Maitland 33 7866 • Miranda 525 2722 • Newcastle 61 1896 • North Ryde 88 3855 • Parramatta 689 2188 • Penrith (047)32 3400 • Railway Square 211 3777 • Sydney City 267 9111 • Tamworth 85 1711 • Wollongong 28 3800 • ACT • Fyshwick 80 4944 • VIC • Ballarat 31 5433 • Essendon 379 7444 • Footscray 689 2055 • Geelong 383 4455 • Dandenong 794 9377 • East Brighton 592 2366 • Richmond 428 1614 • Ringwood 879 5338 • Springvale 547 0522 • QLD • Brisbane City 229 9377 • Buranda 391 6233 • Toowoomba 38 4300 • Townsville 72 5722 • Underwood 341 0844 • SA • Adelaide City 232 1200 • Beverley 347 1900 • St. Marys 277 8977 • Elizabeth 255 6099 • Enfield 260 6088 • WA • Cannington 451 8666 • Fremantle 335 9733 • North Perth 328 6944 • Perth City 481 3261 • TAS • Hobart 31 0800 • NT • Stuart Park 81 1977



**NOW AVAILABLE AT ALL STORES — OR CALL TOLL FREE: (008) 22 6610 FOR HOME DELIVERY!**



## Construction project:

# Current source for measuring low R's

Here's a handy little gadget which can be used to adapt your digital voltmeter for measuring low resistances like speaker voice coils and transformer windings. It costs only a few dollars and can be put together in an hour or two at most.

by **ANDREW PALMER**

The little current source unit to be described is very simple indeed. Like many such devices it was basically put together to fill a personal need.

My DMM is fairly typical, I suspect. It doesn't have 2-ohm or 20-ohm FSR (full-scale reading) resistance ranges; the lowest range is 200 ohms FSR (well, 199 ohms, actually). This gives a resolution of only 1 ohm - not really enough to measure things like speaker voice coils, transformer windings or motor windings with sufficient accuracy for anything more than continuity checking and "ball park" measurements.

On the other hand, the DMM does have 200mV and 2V FSR DC voltage ranges, and these are sensitive enough to measure quite low resistances, provided that you arrange to have a known current of say 100mA flowing through them. This gives effective current ranges of 2 ohms and 20 ohms respectively, with resolutions of .01 ohms and 0.1 ohms - much more useful.

So that's the idea behind this little external current source: to provide a known and accurate constant current of 100mA, to let you measure low resistances using your DMM's low voltage ranges.

Note that a current of 100mA should not be sufficient to cause any damage to most low resistance windings, particularly if it's only applied for the duration of your measurements. Most windings in transformers and motors work at rather higher current levels anyway, while things like speaker voice coils are generally wound from solid enough wire to take this current for a short time without any problems. Still, you should

the resistance of a transformer winding or motor winding accurately also provides a useful way to measure its temperature rise in operation. But more of this a little later.

### How it works

The circuit is extremely simple, as you can see. It's basically just a 6V battery, with a series LM317 three-terminal voltage regulator device connected as a current regulator.

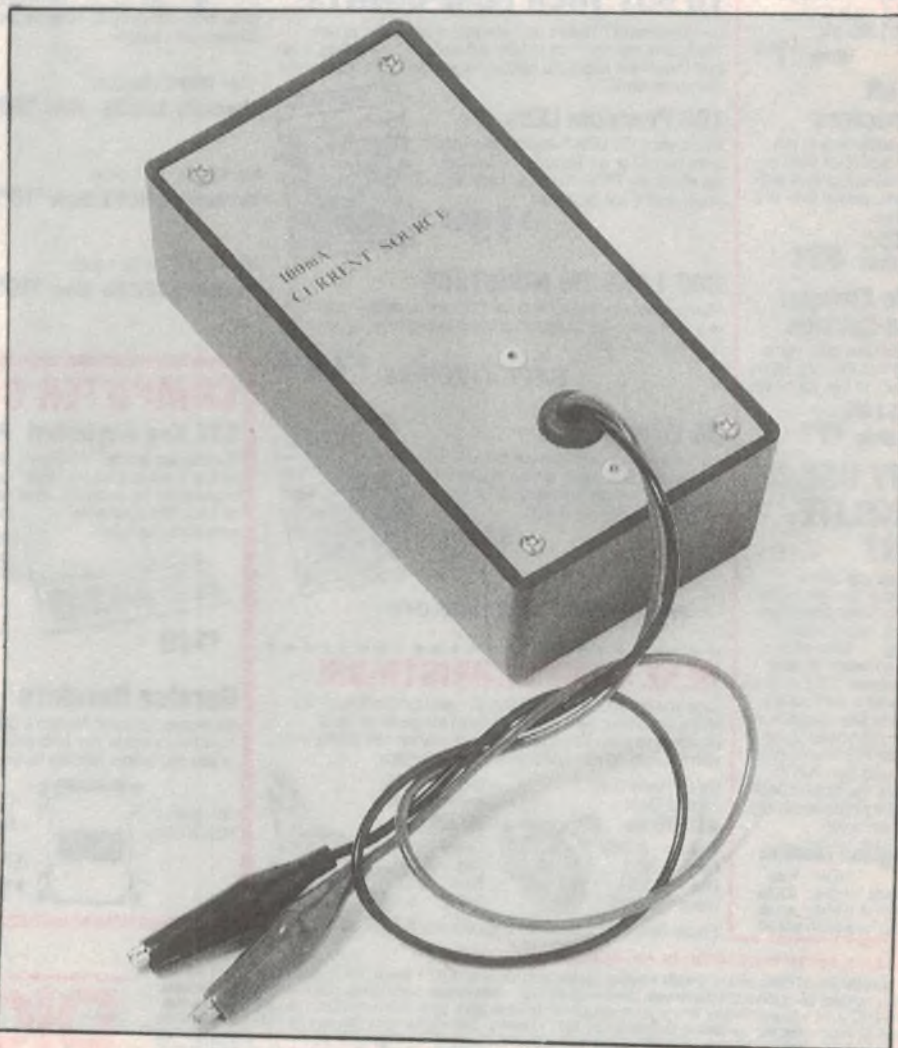



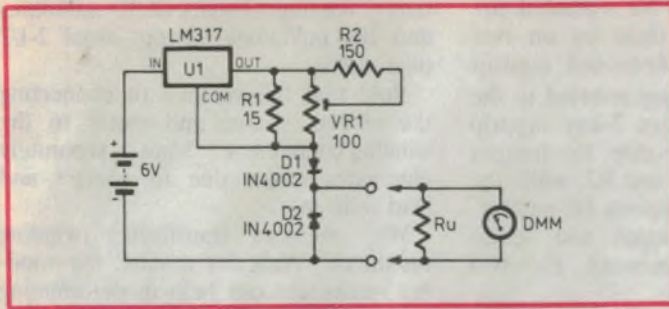

**Left: The circuit is very simple – just a 6V battery and an LM317 connected as a current regulator. Diodes D1 and D2 protect against inductive “kick back”.**

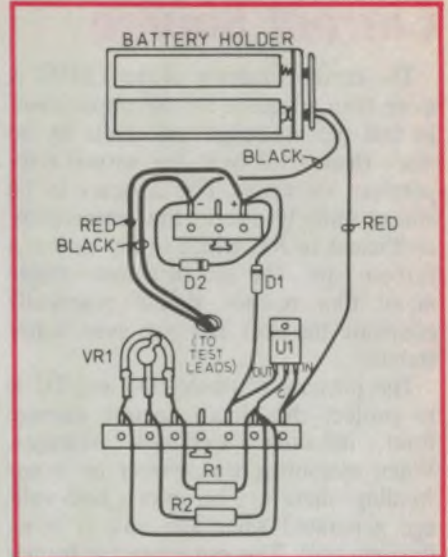

**Above: Wiring up the unit should be easy using this pictorial diagram as a guide.**

How can a voltage regulator chip be used to regulate current? Basically by connecting an appropriate resistance between its output and common pins, and arranging for the chip to develop (or attempt to develop) a known voltage across this resistance.

In this case the resistance connected across the output of the chip is very close to 12.5 ohms, formed mainly by R1 but with R2 and VR1 shunted across it to bring the value down to the final figure. The purpose of VR1 is to allow fine adjustment, in the range 12 - 13 ohms.

The output voltage of the LM317 in this configuration will tend to be that of its internal reference, which is nominally 1.25V but rated to be within the range 1.2 - 1.3V. So that by using VR1, it becomes possible to set the LM317's current level accurately to (1.25/12.5) amps, or 100mA.

Of course this is when a low value load resistor Ru is connected to the circuit; until such a load is connected, no current flows at all. And of course for the LM317 to maintain this 100mA current level accurately, the value of Ru must be low enough to ensure that its voltage drop at this current level is low compared with the 6V battery. Otherwise, the voltage available to the LM317 itself will fall below its “drop-out” level.

With the present circuit, load resistors of just over 20 ohms can be connected before the LM317 “runs out of voltage” and cannot maintain regulation of the 100mA current level. So everything works out rather well.

Why only a little over 20 ohms – surely this would drop only 2V at 100mA? Don't forget that there's also the drop across R1, R2 and RV1, which will drop another 1.25V, and diode D1 which accounts for another 0.65V. So for a 20-ohm external load resistor the voltage available for the LM317 will be (6V - 3.25V - 0.65V), or 2.1V. This is only a little above the device's drop-out level.

Of course this assumes that the battery voltage will remain at 6V with a

drain of 100mA, which is a little optimistic. In practice the circuit will only cope with loads a little over 20 ohms before the current level starts to fall.

Needless to say the output current level must be set as closely as possible to 100mA for accurate resistance measurements. This can be done using the DMM itself. Most DMMs have a current range capable of measuring 100mA quite accurately.

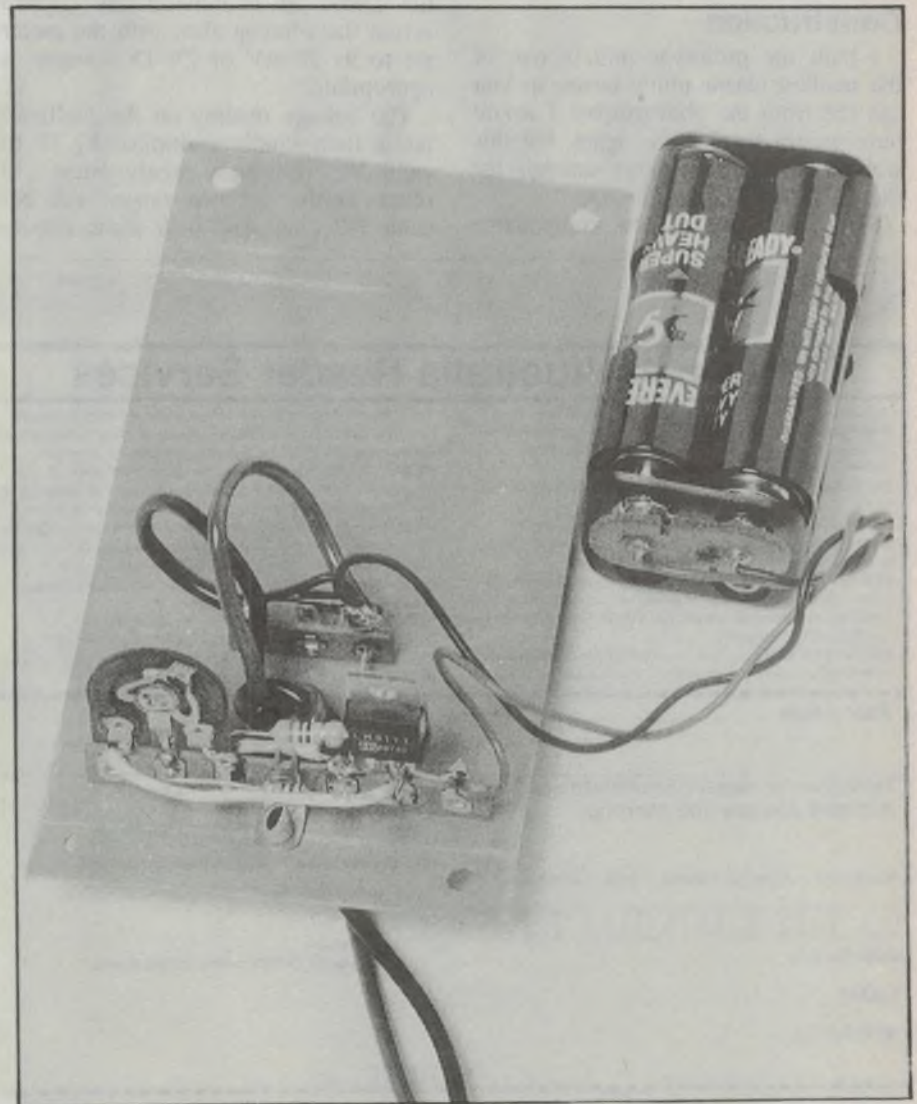

**How the author built up his current source, with the parts supported by two small tagstrips rivetted to the front panel.**

## Current Source

The current stability of the LM317 is more than adequate for this application. In fact the prototype unit drifts by no more than 0.5% over the normal temperature extremes. This appears to be almost entirely due to the temperature coefficient of R1, which in my case is a carbon type. The use of a more stable metal film resistor should practically eliminate the drift and give even better stability.

The purpose of diodes D1 and D2 is to protect the circuit against damage from inductive kick-back voltages. When measuring transformer or motor windings there can be quite a high voltage generated when the unit is being disconnected. This can cause the formation of an arc, in some cases. With D1 and D2 the risk of circuit damage is minimised.

### Construction

I built the prototype unit in one of the smallest plastic utility boxes, as you can see from the photographs. I would have used a smaller box again, but this wouldn't have been large enough for the 4 x AA-cell battery holder.

Since there are so few components

used, there's no need for a printed circuit board. I wired them up on two small lengths of old-fashioned tagstrip (gasp!), which were pop rivetted to the front panel. The larger 7-way tagstrip supports the regulator chip, the trimpot RV1 and resistors R1 and R2, while the smaller 3-way strip supports D2 and terminates the two output test leads. Diode D1 swings between the two strips.

The details are shown in the wiring diagram and inside photo, for those that want to duplicate the original. But the circuit is not at all critical, and you could build it in almost any form you wish.

### Using it

In use, the leads from the unit are simply clipped across the winding or other low-resistance component you wish to measure. Then the leads from the DMM or multimeter are clipped across the winding also, with the meter set to its 200mV or 2V DC ranges as appropriate.

The voltage reading on the multimeter is then simply multiplied by 10 to yield the resistance measurement. In other words, the two ranges will become 0-2 ohms and 0-20 ohms respec-

tively, reading in units of 10 milliohms and 100 milliohms for the usual 2-1/2 digit meter.

Note that this method of connecting the current source and meter to the winding/component leads separately eliminates errors due to contact and lead resistance.

Why measure transformer winding resistance? Well, for a start, the winding resistances can help in determining turns ratio - particularly if the same gauge of wire is used.

It's also a very easy and practical way to measure temperature rise, when the transformer is operating. In this way you can assess whether the transformer is operating within the temperature ratings for its insulating materials.

If the resistance of the windings is measured when the transformer is "cold" (i.e., at ambient temperature), and then measured again after the transformer has been operating at full load for a few hours, the winding temperature can be calculated from the expression:

$$T2 = (Rb/Ra).(235 + T1) - 235$$

where T1 is the "cold" temperature ( $^{\circ}$ C), T2 is the "hot" temperature, and Ra and Rb are the "cold" and "hot" resistance readings respectively.

Note that this expression only applies for copper windings, however.

Normally, if the temperature of the winding has risen by more than about 75 $^{\circ}$ C, you might start to question whether the transformer concerned is adequate for the job. But don't forget that many modern transformers incorporate insulating materials able to withstand considerable higher temperatures.

I hope you find this little measurement aid as useful as I have done. 

## Electronics Australia Reader Services

"Electronics Australia" provides the following services:

**Subscriptions:** All subscription enquiries should be directed to: Subscriptions Department, Federal Publishing Co, PO Box 227, Waterloo 2017. Phone: (02) 693 6666

**BACK ISSUES:** Available only until stocks are exhausted. Price: \$4.50

**PHOTOSTAT COPIES:** When back issues are exhausted, photocopies of articles can be supplied. Price: \$4.50 per project or \$9 where a project spreads over several issues.

**PCB PATTERNS:** High contrast, actual size transparencies for printed circuit boards and front panels are available. Price: \$5 for boards up to 100 square centimetres; \$10 for larger boards. Please specify positive or negative.

**PROJECT QUERIES:** Advice on projects is limited to postal correspondence only, and to projects less than five years old.

Price: \$5. Please note that we cannot undertake special research or advise on project modifications. Members of our technical staff are not available to discuss technical problems by telephone.

**OTHER QUERIES:** Technical queries outside the scope of "Replies by Post", or submitted without fee, may be answered in the "Information Centre" pages at the discretion of the Editor.

**PAYMENT:** Must be negotiable in Australia and made payable to "Electronics Australia". Send cheque, money order or credit card number (American Express, Bankcard, Mastercard, or Visa Card), name and address (see form). All prices include postage within Australia and to New Zealand.

**ADDRESS:** Send all correspondence to The Secretary, "Electronics Australia", PO Box 227, Waterloo, NSW 2017. Please note that we are unable to supply back issues, photocopies or PCB artwork over the counter.

Back Issues .....

Photostat copies .....

Total price of magazines/photocopies, including postage and handling.

No off issues reg ..... x \$4.50 = \$

Cheque  Money Order  Please tick box to indicate method of payment

\*Please make payable to the Federal Publishing Company Pty Ltd

Mastercard  American Express  Visa  Bankcard  Tick

Card Expiry Date

Credit Card No

Signature  
(Unsigned Orders cannot be accepted)

NAME .....

ADDRESS .....

POSTCODE .....

## PARTS LIST

- 1 Utility case, 132 x 68 x 42mm
- 1 4 x AA-cell battery holder
- 1 battery snap lead to suit
- 4 AA cells
- 1 LM317 three-terminal regulator
- 1 100 ohm vertical trimpot
- 1 15 ohm 1/2W resistor (preferably metal film)
- 1 150 ohm 1/4W resistor
- 2 1N4002 or similar silicon power diode
- 1 7-way tagstrip
- 1 3-way tagstrip
- 2 Test leads with insulated clips
- 1 Rubber grommet, 8mm

# THE ELECTRONIC COMPONENTS SHOP

289 Latrobe Street,  
MELBOURNE  
(03) 602 3499

## ARE YOU PAYING TOO MUCH FOR POWER TRANSISTORS?

Compare these prices

2N3055	@ .95c	MJE3055T	@ .70c
MJ2955	@ .98c	MJE2955T	@ .70c
MJ802	@ \$2.50	TIP31C	@ .40c
BUX80	@ \$2.80	TIP32C	@ .40c

## GENERAL PURPOSE TRANSISTORS

BC546	BC556
BC547	BC557
BC548	BC558
BC549	BC559

All Just **10c**

## IC MASTER 1988 3 Vol. Set

A must for all electronic professionals and enthusiasts

**\$215.00**

## IBM™ and OMEGA™ DB CONNECTORS

DB19 Plug	@ \$1.90
DB19 Socket	@ \$2.00
DB19 Backshell	@ \$1.50
DB23 Plug	@ \$1.90
DB23 Socket	@ \$2.00
DB23 Backshell	@ \$1.50

All quality 'Gold Flash' connections

ALL PRICES INCLUDE SALES TAX. TAX EXEMPT AND OEM P.O.A

**Freight:** The prices quoted are ex Store, cost of delivery and the risk of loss in transit fall upon the purchaser. For the convenience of customers, delivery can be arranged through the supplier at the schedule of rates set out below.

- Minimum Charge Only**
1. Local Post \$2.50
  2. Interstate Post \$3.50
  3. Carrier: Melbourne & Metropolitan — \$5 up to 3kg
  4. Carrier: Intrastate — \$8 up to 3kg
- only SMALL ITEMS will be sent by post.

# Don't forget the Electronics Australia – GRAND AUSSIE HOBBY

How good are YOU at designing a really novel and exciting hobby electronics project? Now's your chance to prove what you can do –

The Grand Aussie Hobby Electronics Contest is sponsored by *Electronics Australia*, the country's leading electronics magazine, and leading electronics retailer Dick Smith Electronics. The contest is open to all Australian electronics hobbyists, although entries must be accompanied by the entry form below (or a photocopy if you don't want to cut the magazine).

The idea of the contest is to encourage more Australians to take up electronics as an exciting and rewarding hobby. We're doing this by asking you to design the most novel, exciting, useful and easy to build project you can dream up – provided that the total current retail cost of the parts required to build it is less than \$100.

It can be an electronic game, a test instrument, a radio set, a piece of amateur radio gear, an amplifier, an audio accessory, a useful gadget for use around the home or office or whatever, as long as it meets the above requirements. Now that shouldn't be too hard, should it?

Needless to say, you'll be expected to build up a neat prototype of the project, to make sure that it works properly. And to produce the usual things needed in a good project design to make sure that others can build it up easily: things like a printed circuit board pattern, and so on.

Each project entered in the competi-

tion should also be accompanied by a description of what it is, how it works and how to build it and get it going. In short, the manuscript of an article which could be used to describe it in *Electronics Australia* – complete with neatly drawn circuit and any other diagrams as necessary.

Not surprisingly we'll be awarding points not just for your project design itself, but for the way you've built up the prototype and your description of it as well. In short, for your overall presentation.

Along with the main prizes, there are two runner-up prizes in each category as well. In each case these are Open Vouchers, to purchase components or other products of your choice to the value of \$100, at Dick Smith Electronics.

Rome wasn't designed and built in a day, and neither are good electronics projects. That's why we're giving you three months to prepare your entry. The closing date is September 30, so entries sent to us but postmarked after that date won't be eligible for the competition. The winners will be advised by mail before the end of October, and will be announced in the December issue. If possible we'll also be presenting the winning projects in that issue, as well.

What encouragement is there for you to enter this exciting new competition? Well, for a start there are some great prizes. All up, the total value of prizes

being offered is over \$3500!

To be fair to both newcomers and more experienced hobbyists, we've decided to award not one but TWO main prizes – one for people in each category. The two prizes are of roughly equal value (both more than \$1500), but structured to suit people at different stages of hobby involvement. In each case they provide a mouth-watering collection of the things you've probably always wanted, but couldn't really afford. At the same time they'll provide a tremendous boost to your home workshop, and help you move on to even bigger and better things – what could be more appropriate for a contest designed to encourage hobbyists!

Along with the main prizes, there are two runner-up prizes in each category as well. In each case these are Open Vouchers, to purchase components or other products of your choice to the value of \$100, at Dick Smith Electronics.

In addition to these prizes from Dick Smith Electronics, the winning and runner-up project entries are likely to be published in *Electronics Australia* – the largest selling and most respected electronics magazine in Australasia. How's that for being seen by the largest number of your fellow hobbyists – and having them build YOUR design! When your design is published, you will of course receive the usual contribution



## OFFICIAL ENTRY FORM:

NAME: ..... PHONE NUMBER: .....

ADDRESS: ..... POSTCODE: .....

CATEGORY OF ENTRY: (Tick which one) Newcomer  Advanced

OCCUPATION: .....

MAIN INTEREST IN ELECTRONICS AS A HOBBY: .....

ESTIMATED COST OF PARTS IN YOUR ENTRY: \$ .....

I understand that a condition of entering this contest is that *Electronics Australia* magazine shall have first option on publishing details of my design/project, and that Dick Smith Electronics shall have first option on marketing any kits based on the design/project. I also agree to abide by the decision of the contest judging panel.

SIGNATURE: .....

# Dick Smith Electronics

# ELECTRONICS CONTEST!

whether you're an enthusiastic newcomer, a seasoned old timer or anyone in between. There are great prizes to be won!

fee, as well.

Needless to say Dick Smith Electronics is also going to be interested in producing kits for the winning projects, to make it easy for other readers to build them up. So you'll receive not only fortune but fame as well - what more could you possibly want?

So don't delay - start working on your entry today. Whether you're a keen beginner or an experienced old-timer, you have an equal chance. Put

on your thinking cap, and see if you can come up with a winning design!

A final point. To make it even easier for you to work on your entry, Dick Smith Electronics has decided to offer a special 10% discount on the components you may need to build up your prototype. So if you cut out the voucher on the bottom of this page and take it to your nearest DSE store, it will get you that very handy discount. How's that for being helpful!

Please note, however, that you must use the original voucher from the magazine - photocopies can't be used. The voucher can also be used only to purchase electronic components and associated hardware such as a case, knobs, connectors and PCB materials - not for other products. So write out a list of all the bits you'll need for your project entry, and make sure you get them all at once to take advantage of the 10% discount.

## HERE ARE THE GREAT PRIZES TO BE WON:



### NEW HOBBYISTS' SECTION

#### A. First prize:

Q-1280 6.5MHz Oscilloscope .....	\$399.00
Q-1600 Digital Multimeter .....	\$199.00
T-2000 Solder Station .....	\$129.00
Q-1220 RC Audio Oscillator .....	\$119.00
Q-1335 Transistor Dip Meter .....	\$129.00
N-5700 PCB Etching Kit .....	\$ 99.95
P-4616 Prototyping Breadboard .....	\$ 39.95
PLUS - A DSE Components Voucher for .....	\$400.00

#### A TOTAL PRIZE VALUE OF OVER \$1500!

B. Two runner-up prizes of DSE Components Vouchers, each for the value of .....

### ADVANCED HOBBYISTS' SECTION

#### A. First prize:

Q-1260 20MHz Dual Trace Oscilloscope .....	\$899.00
Q-1666 Precision Digital Multimeter .....	\$249.00
T-2050 Royel "Pro" Soldering Station .....	\$199.00
PLUS - A DSE Components Voucher for .....	\$250.00

#### A TOTAL PRIZE VALUE OF ALMOST \$1600!

B. Two runner-up prizes of DSE Components Vouchers, each for the value of .....

### TOTAL VALUE OF ALL CONTEST PRIZES OVER \$3500!

(All prizes listed above are being donated by Dick Smith Electronics, and further details of each product can be found in the company's latest catalog.)

Prize winning entries and other selected entries may also be published in Electronics Australia, and all entries so published will of course earn an appropriate publication fee, in addition to any prizes awarded.

### SPECIAL DISCOUNT VOUCHER: ►

To make it especially easy for you to enter the Grand Aussie Hobby Electronics Contest, Dick Smith Electronics is offering this special discount voucher. By presenting the voucher at any Dick Smith Electronics store when you're buying the parts to build your project entry, you'll get a very welcome 10% discount!

(Discount only applies to components, etc., and voucher can only be used ONCE)



### COMPONENTS DISCOUNT VOUCHER

I'm building a project for entry in the Electronics Australia - Dick Smith Electronics Grand Aussie Hobby Electronics Contest, and I hereby apply for my 10% discount on the parts I'm buying.

NAME: .....

ADDRESS: .....

P/CODE: .....

PHONE NUMBER: (.....).

CATEGORY (Tick): Newcomer

Advanced

MY MAIN HOBBY INTEREST IS: .....



**Why Waste Your time With Other Suppliers  
Altronics Can Deliver Any Of The Quality Products  
To You Tomorrow — Just Phone Your Order Toll Free  
On 008 999 007**

Jack O'Donnell  
M/Director

Country Clients Please Allow Additional 48-72 Hours

**Microprocessor Controlled Detector  
Clips On To Sunvisor**

Invisible from outside your vehicle - this fantastic high spec Radar Detector Detects X and K Band Radar up to an Amazing 13KM

This super compact "Sunvisor clip on" Microeye Detector is virtually invisible from the outside of most vehicles at normal eye height hence its very unlikely yours would attract the attention of a thief (or the Gendarmes for that matter) However, please remember that use of Radar Detectors is not permitted in some states.

**MICRO EYE VECTOR  
The First Detector With GaAs Diodes**

Until now, GaAs diodes have only been used in sophisticated military radar equipment. The Microeye Vector is the first consumer electronics product equipped with this new technology.

**Why GaAs Diodes Make The Difference**

- Lower threshold allows for a better signal to noise ratio
- Lower signal conversion loss
- Higher barrier reduces noise. Quite simply GaAs diodes increase the sensitivity of the Microeye Vector.
- Using the latest digital processing technology the unit will filter out and ignore emissions from 80% of poorly designed Radar Detectors that emit microwaves.
- Simply plugs into your cigarette lighter socket.
- Clips onto sunvisor
- Detects Mobile Radar Equipment
- Highway/City Modes switch allows monitoring of City or Highway conditions.



A 1530 **\$499**

**Accessories Included:-** Visor bracket • Velcro • Cigarette lighter plug.

21 Day Money Back Guarantee.

**DC Brushless Fan**

120MMx120MMx38MM  
Brushless,  
Electronically  
Commutated DC Motor

**Voltage** 24V DC  
**Current** 330mA  
**Speed** 3100 RPM  
**Air Flow** 23 C.F.M.  
**Noise Level** 32 dbA

Normally **\$29.98**

This Month  
F 1040 **\$24.00**  
6 or More **\$20.00**



**Ultra High Power Capacity  
Polypropylene Bass Drivers**

Save 25% This Month

**12" (300mm) Model**

100 Watts continuous input  
150 Watts intermittent input  
**Impedance** 8 Ohm  
**Sensitivity** 93db  
**Weight** 3620gm

C 3070 **\$99**  
Normally **\$139**



**15" (375mm) Model**

120 Watts continuous input  
200 Watts intermittent input  
**Impedance** 8 Ohm  
**Sensitivity** 92db  
**Weight** 4120 gm

Normally **\$179** C 3075 **\$149**

Our all new "Black" polyprop cone Bass Drivers exhibit quite astonishing low register reproduction. The power ratings quoted are conservative. While they may not be the cheapest around they definitely represent the best value we know of - **Anywhere. The real exciting news is we have the top selling 12 and 15 inch models at low discount prices this month - but be quick stocks are limited.**

These are the Genuine Grain Oriented Toroid Transformers as used in Electronic Australia Projects

**Toroidal Power Transformers**

**Why a Toroid?**

- Smaller size and weight to meet modern "Slimline" requirements
- Low electrically induced noise demanded by compact equipment
- High efficiency enabling conservative rating whilst maintaining size advantages
- Lower operating temperature
- Simple, quick single bolt mounting



**Dimensions and Weight**

160 VA Models 110 Diam. 45mm  
H. 1.8Kgs Leads 200mm

300 VA Models 125 Diam. 45mm  
H. 2.5Kgs Leads 200mm

**160 Watt Models \$65** 10 up **\$62 ea**

**300 Watt Models \$79** 10 up **\$75 ea**

Cat.No.	SEC.V
M 3050	12 + 12
M 3055	18 + 18
M 3060	25 + 25
M 3065	30 + 30
M 3070	35 + 35
M 3075	40 + 40

Cat.No.	SEC.V
M 3085	12 + 12
M 3086	18 + 18
M 3088	25 + 25
M 3090	30 + 30
M 3092	35 + 35
M 3100	40 + 40

**High Performance ALC Wireless Microphone**



Our incredible ALC Mic is one of the most exciting products for '88. Wireless Mics suffer from overmodulation distortion with too higher input sound level making them unsuitable for high grade vocal entertainment use of ALC (Automatic Level compressor) fixes all this.

**SPECIFICATIONS:**

- Cardioid-Uni Directional Pick-up pattern
- Freq.Res.: 30Hz-15KHz
- Carrier Frequency.Adjust Range:

Within +1MHz, 88-108MHz Built-in Antenna

Normally **\$129.00** Amazing Value **\$99.00**

**Super Bargain Save \$50  
Fantastic Negative Ion Generator**

There have been volumes written about the benefits of negative ions combating air pollution, cigarette smoke etc. can be very beneficial to Asthma sufferers. Our great little Rover generates billions of ions per second! Includes tester.



Were **\$79.00**

A 0990

**\$29**

BANKCARD • VISA • MASTERCARD PHONE TOLL FREE 008 999 007 NEXT DAY JETSERVICE DELIVERY

BANKCARD • VISA • MASTERCARD PHONE TOLL FREE 008 999 007 NEXT DAY JETSERVICE DELIVERY

## A Great New Product From Altronics For '88 The Fantastic Pin Point Ultrasonic Cleaner

Clean Computer Connectors,  
PCB's, Switches, Relays,  
Jewellery, Glasses and much  
much more!



ONLY  
**\$199**  
A 0100

### Design Award Winner

Awarded the Good Product Design Award for CETDC in 1987. This fantastic Ultrasonic cleaner can earn its cost a hundred times over in cleaning Computer Connectors, PCB's, Switches, Relays, Jewellery, Glasses, Watches etc.

### How Does It Work?

The Pin Point Ultrasonic Cleaner uses a transducer generator to produce millions of activated microscopic cleansing bubbles, which blow dirt, grease & grime off surfaces, and deep into cracks and holes.

This personal ultrasonic cleaner won't scratch precious jewellery or glass. Comparison studies made by hospitals, commercial businesses and industry show ultrasonic cleaning proves better and safer than any conventional method.

But don't take our word for it. Test the Pin Point Ultrasonic cleaner yourself. Pop your dirty watches, glasses, connectors etc. into the cleaners stainless steel basin, add a cup of tap water, and three minutes later see the difference. The results are instantly revealing.

### SPECIFICATIONS

Power Supply : 240V 50Hz Power Consumption : 300mA Frequency : 40 +/-2KHz Dimensions : 224 x 114 x 124mm Capacity : 570ml Weight : 1kg Body Material: ABS Plastic Tank Material : Stainless Steel (SUS 304) On/Off : 3 Minute Auto Timer.

★ Amazing Price Breakthrough ★

## Free \$50 Probe Set

### Dual Trace 20MHz Oscilloscope

This all new CRO must be the best valued quality Oscilloscope in Australia!

This new model is a 20MHz dual-trace Oscilloscope using a high brightness CRT with an illuminated scale. The vertical amplifiers have high sensitivity 1mV-5V/Div. The unit has LED's to indicate when the controls are in the 'uncal' position, and to indicate if the trace has been triggered. The brilliant triggering circuit will trigger on just about any waveform applied. The highest triggering sweep is 0.2uSec/Div. The Q 0120 also features a 'Hold Off' control for seeing the front end of the input wave form.

**Features:** Large 6" rectangular CRT with internal graticule • High sensitivity: 1mV/Div. • High accuracy: +/- 3% • Stable, low-drift design • 8 divisions of displayed dynamic range and accurate distortion-free waveform measurements • This instrument has a special TV sync separation circuit for quick measurements of video signals • A convenient X-Y operation mode allows phase difference measurements between two waveforms.

### CRO Probe Sets

Q 0175

**\$49.95**

High quality LABTECH Oscilloscope probes. Ideal for use with the Q0120 Oscilloscope. Suits all other brands: 1:1 or 10:1 Attenuation.

Normally \$49.95.

This Month Free with every CRO Sold.

### 1 GHz Frequency Counter

This new addition to the LABTECH range will astound you with its high accuracy and stability. A truly Professional Instrument that will perform brilliantly in the workshop, laboratory, university etc.



Superbly  
Engineered

Q 1530

**\$499**

**Specifications:** The pertinent specifications for the Model Q 1530 are listed as follows:-

**1. Measuring Mode - Frequency Measurements - Channel A** • Range: 10Hz to 10MHz direct counter 10MHz to 100MHz prescaled by 10 • Resolution: Direct counter: 1, 10, 100Hz switch selectable - Prescaled: 10, 100, 1000Hz switch selectable. • Gate time: 0.01S, 0.1S, 1S switch selectable • Accuracy: +/- 1 count +/- time base error x frequency.  
**Channel B** • Range: 100MHz to 1GHz • Resolution: 100Hz, 1KHz, 10KHz switch selectable • Gate time: 0.027S, 0.27S, 2.7S switch selectable • Accuracy: +/- 1 count +/- time base error x frequency.  
**Period Measurements (Channel 1)** • Range: 10Hz to 2.5MHz • Resolution: 10^-7S, 10^-8S switch selectable • Accuracy: +/- 1 count +/- time base error x period. **Totalize measurements (Channel A)** • Range: 10Hz to 10MHz • Resolution: +/- 1 count of input. **General** • Display 8 digits, 7mm red LED display with decimal point, gate, overflow, KHz, MHz and uS indication. • Check: Counts internal 10MHz time base oscillator • Power requirement: Line: 115/230V +/- 15%, 45Hz-70Hz Internal Battery: Option • Temperature: Rated range of use: -5 deg C - +50 deg C - Storage and Transport: -40 deg C - +60 deg C • Humidity: Operating: 10-90% RH. Storage: 5-95% RH.

BANKCARD • VISA • MASTERCARD • DUC 007 NEXT DAY JETSERVICE DELIVERY

BANKCARD • VISA • MASTERCARD • DUC 007 NEXT DAY JETSERVICE DELIVERY

BANKCARD • VISA • MASTERCARD • PHONE TOLL FREE 008 999 007 NEXT DAY JETSERVICE DELIVERY

**Professional Series Rack Cabinets**

Now your preamps, Amps, Control Modules Monitor Panels etc. can look every bit as good as Technics Nakamichi & other top manufacturers.

Save 15% and More This Month

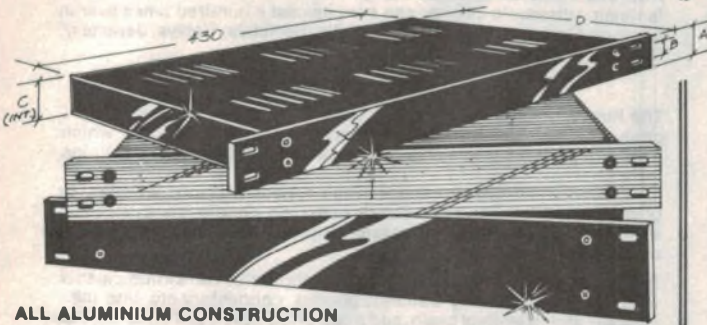

**ALL ALUMINIUM CONSTRUCTION**

**FEATURES:** These beautifully crafted rack cabinet boxes will give your equipment a real 1st class appearance with removable top and bottom cover panels • All dimensioning conforms to the International Standard • Natural or Black finish • Ventilated lid • Deluxe finish front panel • Individually cartoned • Supplied in Flat Pack Form - Easily assembled in minutes - **Side Elevations:** - D=254mm C (Internal Chassis Height) • B (mounting Bolt Centres).

**SIX NATURAL AND BLACK FINISH MODELS** — The Black or Natural finish cabinets are each available in 44mm, 88mm or 132mm high models. Mounting hole centres conform exactly to International Racking Specifications both vertically and horizontally.

Cat. No.	Finish	A	B	C	Were	Now
H 0401	Natural	44	34	38	\$59.95	\$50
H 0402	Natural	88	57	82	\$69.95	\$62
H 0403	Natural	132	89	126	\$85.00	\$79
H 0411	Black	44	34	38	\$59.95	\$52
H 0412	Black	88	57	82	\$79.95	\$70
H 0413	Black	132	89	126	\$89.95	\$80

**Quality Redford Industry Standard 8 Channel Mixer**

This pro quality mixer is yet another fine product from Redford. It like most other Redford series products is made right here in Australia.

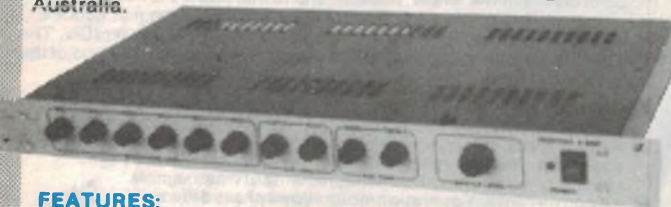

**FEATURES:**

• 6, 200-600 Ohm balanced microphone inputs • 2, 100K auxiliary inputs • Treble and bass on auxiliary inputs • Muting of auxiliary inputs available from microphone input • Balanced 0db 600 Ohm output • Housed in Stylish 1u 19" rack mount chassis.

**SPECIFICATIONS:**

**Inputs** 6 microphone - balanced - 200-600 Ohm. 2 Auxiliary unbalanced 100K Ohm. **Output** 600 Ohm balanced 0dbm. **Sensitivity** Mic 1.25mV -Aux 100mV. **Frequency Res.** Mic 30Hz-15KHz, Aux (Flat) 18Hz-23KHz. **Tone Controls** Bass 100Hz +/- 10db, treble 10KHz +/- 10db. **Signal to Noise** All controls CCW -95db **Distortion** at 1KHz less than 3%.

All measurements measured in respect to 1KHz reference

A 2050 \$399

**Sensational Super Buy On Quality Sampson 12V Rechargeable Batteries**



This Quality 12V 1.2AH Lead Acid Battery Sells Elsewhere for \$30!

Altronic Price?

Just \$15

S 5065



**Passive Infra-Red Lite Guard Floodlight Control**

How often have you thought there could be a prowler outside your door? Install a Lite Guard & (once armed) any "guest" will be floodlit when detected by this highly sensitive Infra-Red Detector.



Please Note Flood-lamps & Holders Not Supplied

\$ 5350 **\$185**

The Lite Guard detects a moving person or vehicle by comparing the background temperature with a rapid change of temperature across the detection beams. So when Lite Guard detects movement across the coverage area, it will turn on the floodlight(s) for 1-20 minutes as pre-adjusted.

**Specifications:** **Detector:** Dual element pyroelectric PIR sensor • Raintight outdoor all weather operation. • Photocell to deactivate sensor during daylight • **Operating Voltage:** 240V AC, 50Hz • **Operation time:** Adjustable 1-20 minutes • **Sensitivity:** Adjustable 20'-50', 30 beams • Aimable desired direction with 2 ball joints • **switching Capability:** 500W max. incandescent. • **Operation Modes:** Off, Auto, Test, Manual Ont.

**Passive Infra Red Movement Detector**



New Model IRD Has Fantastic Range

**Infra Red Movement Detector**

With Two Mode Lens Why Pay \$150 or More

This Month **\$79.00**

**Features:** Lens simply 'snaps' to either **wide angle** (range 40ft.) for normal use or **Normal angle** (range 80ft plus) for corridor applications. • Snazzy integral mounting brackets allows corner 90 deg. mounting as well as normal surface mount. • "Pulse count" circuit to eliminate false triggering. • "tamper" contact. • 12V DC Powered • Built-in test lamp • Alarm output SPDT 30V 1a.

\$ 5301

N.B. These professional detectors use state of the art circuitry to achieve ultra reliability in operation. They are currently specified by several "Name" commercial Security Companies.

**Famous AVTEK Modems**

**Minimodem 11**

**Features:** • Viatel (1200/75 baud rate) and 300/300 full duplex. • Commodore VIC 20 and 64 Versions now available • On 1200 baud (e.g. Viatel) special equalisation is available for improved results on poor phone lines.



Minimodem Inc Power Supply

Minimodem (suit Commodore user port)

D 1225 ~~\$199~~ **\$179**

D 1229 ~~\$295~~ **\$212**

**Megamodem**

These provide complete SM300 and SM2400 compatibility, while also providing a simple to use menu driven mode where suitable software is not available.

**Megamodem 12**

300/300 1200/1200 V21/22

D 1230 ~~\$975~~ **\$340**

• Automatic dial, answer and disconnect • All communications parameters, such as baud rate, parity and number of stop bits are set up automatically by the software and the Megamodem • Auspac compatible • Visual and audio feedback • 12 Months warranty.

**Megamodem 123**

V21/22/23 (inc. automatic speed conversion for Viatel & videotext 1200/75 services)

D 1232 ~~\$449~~ **\$408**



10% Off This Month

BANKCARD • VISA • MASTERCARD PHONE TOLL FREE 008 999 007 NEXT DAY JETSERVICE DELIVERY

BANKCARD • VISA • MASTERCARD PHONE TOLL FREE 008 999 007 NEXT DAY JETSERVICE DELIVERY





Jack O'Donnell  
M/Director

# Great Kit Projects To Build Many Just Released For 1988

## Brilliant Performance Stereo Pre Amp

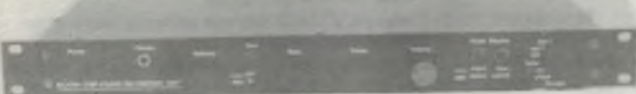

### Studio 200 Stereo Control Unit (Silicon Chip June/July'88)

Out-Performs Commercial Units Costing \$600 Plus

The Studio 200 Stereo Control Unit is companion to the studio 200 stereo power amplifier (or other power amps). It features slim 1u rackmount profile, treble, bass, balance, input selector, tape monitor switch, stereo/mono switch and volume control. Inputs include phono, tuner, CD, VCR and tape loop.

K 5015 **\$229**

Simple PCB Construction  
Virtually No Wiring

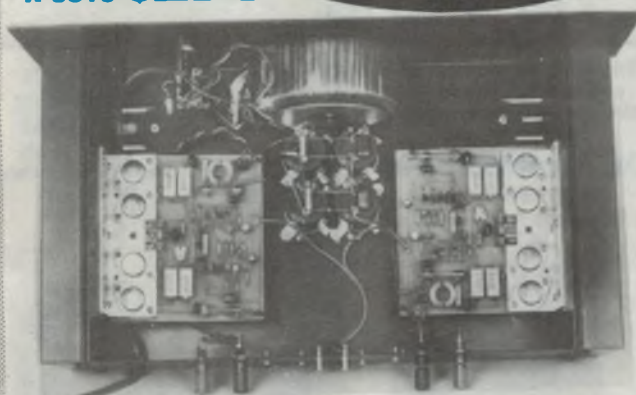

Calling All Audio Purists  
This Great New Amp From Silicon Chip Is For You

### Studio 200 Series 100 Watts Per Channel Power Amplifier

K 5010  
**\$399**

**Features:** • In-Built speaker protection • Toroidal Transformer (low hum) • Black Satin Finish • Low leakage power supply capacitors • Housed in Rugged Custom Chassis.

**Specifications:** • Output Power 100W into 8 Ohms Freq. Res.(at 1W) 20Hz-50KHz + or - 1db Input Sensitivity 870mV Harmonic Distortion (20Hz-20KHz) 0.1% Signal To Noise Ratio 100db or Better Protection 5A fuses plus RDE245A Polyswitch Damping Factor (without Polyswitches) 100 (with Polyswitches) 100. **Stability** Unconditional.

### Discolite

(See Silicon Chip July/Aug'88)  
Add Some Colour To Your Next Party



K 5805  
**\$159.50**

The Discolite Flashes party lights on and off in beat with music from your amplifier.  
• 4 light channels controlled by 4 separate audio channels • Forward, reverse and auto-reversing chaser patterns • Simultaneous strobe on all four channels • Alternating light patterns • Music modulation available on chaser, strobe & alternate patterns • Inbuilt microphone for beat triggering or audio modulation of lights • Direct inputs for beat triggering or audio modulation of lights • Sensitivity control • pre-settable sensitivity levels for each channel • Front panel LEDs mimic light display.  
Great For Parties, Shop displays and special lighting effects.

## Universal High Power Amplifier Module

(See SC Dec'87)

High power rugged reliable design featuring low distortion and inbuilt speaker protection. All components, including output transistors mount on a single PCB. Suitable for high quality guitar amp, public address or in a high fidelity stereo amplifier. Kit includes angled heatsink bracket, main heatsink and unlike other kit suppliers, the in-built Polyswitch for loudspeaker protection.



100W Version **\$69**  
K 5140

150W Version **\$99**  
K 5150

## General Purpose Pre-Amp

This unit contains all necessary components to complete:-  
• A Phono Pre-Amp with RIAA freq. response  
• A tape Pre-amp with NAB response  
• A microphone Pre-amp with either 40 55 or 80db of gain.  
• Or a Pre-amp for just about anything!  
Power 10-40V DC High 100db Ripple Rejection.



K 5510 **\$18.50**

## Active Direct Injection Box

(See EA Oct'87)

Eliminates Annoying Hum Pick up

Converts high impedance unbalanced inputs to low impedance balanced outputs. Used in studios, music, PA industry to convert high impedance devices i.e. electric guitar pickups, synthesizer etc. to low level balanced outputs to be fed over long lines.

**Features:** Professionally screen printed • Earth isolate switch • 15db pad • Phantom powering plus internal 9V bat.



K 5550 **\$45.00**

## High Energy Ignition System

(See Silicon Chip May'88)

Keep Your Car In Top tune

Extends the life of plugs & points, increases power & improves fuel economy. Suits 4.6 & 8 cylinder engines. Install one into your car & start saving \$\$\$ from the very first day.

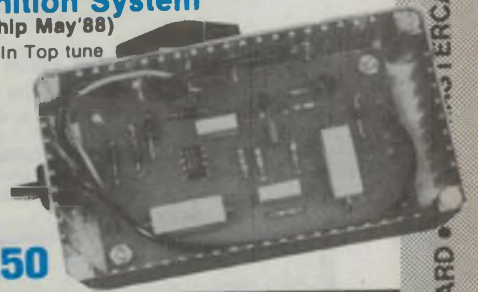

K 4015 **\$43.50**

## Line Filter & Conditioner

(See EA July'88)

Simple, easy to build & low cost too - Helps eliminate those annoying clicks & pops on your stereo & TV when the fridge compressor switches on & off. Helps prevent computer crashes from power spikes & glitches. Altronics customised version housed in strong sturdy Jiffy box nickel sprayed for EMI shielding.



K 6040 **\$39.50**

BANKCARD • VISA • MASTERCARD PHONE TOLL FREE 008 999 007 NEXT DAY JETSERVICE DELIVERY

BANKCARD • MASTERCARD PHONE TOLL FREE 008 999 007 NEXT DAY JETSERVICE

**Go anywhere 240V Mains  
Power from your car or truck  
battery with these fantastic DC  
to AC Inverters**

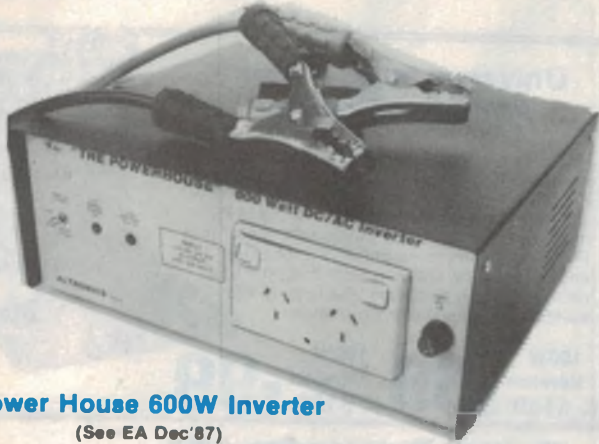

**Power House 600W Inverter**  
(See EA Dec'87)

A must for farming, camping, mining, boating, remote settlements and wherever else 240W power isn't available.

**Features:** Strong custom steel chassis • Industrial grade power coat finish • Can be configured to operate off either 12V and 24V DC • Very little internal wiring • Manual or Auto start facilities • Low battery cut out • Compact Toroid transformer.

Fully Built & Tested

K 6770  
KIT VERSION  
**\$425**

K 6774  
12V INPUT  
**\$525**

K 6775  
24V INPUT  
**\$525**



Complete Kit  
K 6750  
**\$279.00**

Fully Built & Tested  
K 6755  
**\$379.00**

**300 Watt Inverter With Auto Start**  
Operates From 12V Car Battery

**Features:** Auto start draws power from your battery only when appliance is plugged in and "turned on" i.e. battery can be left permanently connected if required. • Voltage regulated • Current Regulated • Current Overload unit self limits — Single PC Board construction — easy to build as there is very little internal wiring.



**40W Inverter For Small Appliances**  
(See EA Aug'85)

**Features:** 2 Modes of operation. Standard 40W Inverter or battery charger. Fixed or variable frequency allows for precision control of frequency dependant devices. Operates from 12v car battery.

K 6705 **\$89.00**



**1GHz Digital Frequency Meter**  
(See SC Nov'87 Jan'88)

This superb 1GHz Frequency Meter will out perform many other instruments twice its price.

**Features:** Professional machined and screen printed red perspex front panel • Easy to assemble and construct • No special tools required • Bright Hewlett Packard 8 digit display • Electronic switch latching • High performance IC's • High Quality Components.

K 2515  
**\$299.00**



**Transistor FET  
Zener Tester**  
(See EA Feb/Mar'88)

New updated circuit incorporates facilities for testing transistor FETs and Zeners etc.

**Features:** • Gain • Leakage • Breakdown Voltages • Zener Voltage • Polarity — NPN/PNP

K 2527 **\$49.95**

This natty service aid allows you to track down short circuits without continually blowing fuses

**DC Electronic Fuse**  
(See EA Nov'87)  
Replaces Any Size Fuse  
Up To 10A



K 2535 **\$39.50**

**Low Ohms  
Adaptor For  
Your DMM**  
(See SC Feb'88)  
Measure Accurately  
Down To 50  
Milli Ohms!



As we all know it's difficult to obtain accurate resistance measurements below 50 Ohms or so with conventional multimeters. This natty little adaptor plugs directly into your DMM via in-built banana plugs enabling quite accurate measurements to 50 Milli Ohms and less. Full instructions provided.

K 2518 **\$24.99**

**8 Way Remote Control**  
(See EA June July'86)

Convert your TV, CD, VCR etc to be operated remotely from the comfort of your armchair. Up to eight separate functions can be switched with this infrared remote control.

Control Your TV  
Or Stereo From  
Your Chair

**Added Facility**

Apart from above - allows for control of On/Off, Mute and volume control.

K 1840  
K 1830 **\$125.00** **\$45.00**

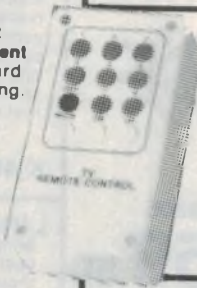

**Telephone Off Hook  
Indication**  
(See SC Nov'87)

Use where 2 or 3 phones are connected on the one line. If one extension is in use a LED will flash in each of the other extensions. Requires no external supply. Runs off the telephone line. One module required for each phone.



K 1400 **\$9.95**

BANKCARD • VISA • MASTERCARD PHONE TOLL FREE 008 999 007 NEXT DAY JETSERVICE DELIVERY

BANKCARD • VISA • MASTERCARD PHONE TOLL FREE 008 999 007 NEXT DAY JETSERVICE DELIVERY



**The Screecher**  
Car Alarm  
(See EA Aug'86)  
Ear Splitting  
110db Modulated Tone

Now our top selling Car Alarm. Two Sensor inputs—Normally open and normally closed enable simple connection to door, bonnet. Boot light, switches etc.

K 4360 \$39.95

Save \$\$\$  
on the cost  
of commercial  
equivalents

**Super Low Price on Famous**  
EA 8 Sector Alarm System Kit  
(See EA Mag. Jan '85)

- Features:**
- Alarm has 8 separate input circuits - 8 sectors can be monitored independently
  - Each input circuit is provided with an indicator LED and a sector On/Off switch.
  - Individual sector isolation allows the user to have some areas of the premises habited while others remain protected e.g. Inside Off/Outside On.
  - Inputs accept both normally closed and normally open sensors.
  - Two inputs provided with an entry delay between 10-75 seconds)
  - Internal trip warning buzzer—alerts owner/occupant of pending alarm operation—great for the "forgetful" amongst us. This buzzer is pre-settable between 5 and 55 seconds prior to Alarm.
  - Unique circuit detects automatically when any N/O or N/C loops are either open circuit or dead short. e.g. someone trying to bridge reed switches etc.
  - Switched output can be used to send a silent alarm through an auto-dialler circuit or similar.

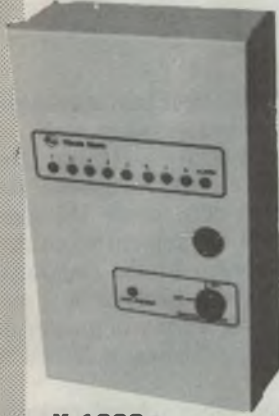

K 1900 (without Back Up Battery) \$149.50  
S 5065 (12V 1.2AH Backup Battery) \$24.95

**24V To 12V DC Converter**  
(Silicon Chip Dec'87)

Enables 12V appliances like stereos, 2 way radios, CB's etc. to operate from a 24V battery.  
• Operates from 18V-30V. Output is 13.6V at 5 amps.



K 3255 \$59.00

**The Protector Car Alarm**

(Silicon Chip Feb'88)  
Save Over \$100 On An  
Equivalent Commercial  
System

- Features:** Internal & External Sirens  
• Dash lamp flasher • Battery back up • Delayed & Non delayed inputs • Ignition killer • Easy to build & install.



K 4370 \$129.00

**Bench Top Power Supply**  
3-30V to 1 amp Max. with  
variable current limit

- FEATURES:**  
• Output 3 to 30V at 1A • Short circuit protected • Load switching • Current limiting • Dual scale meter • Housed in our Deluxe "ABS" instrument case
- SPECIFICATIONS:**  
• Output Voltage - 3 to 30V • Output Current - 0 to 1 amp (fully variable) • Load Regulation - Better than 0.2% from 0 to full load • Output Ripple - Less than 2mV RMS



K 3210 \$79.00

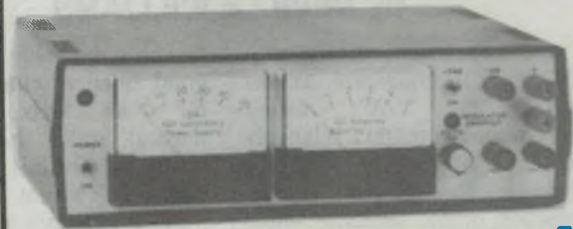

**Laboratory Power Supply** 3-5 Volts at up to 5 Amps

Designed by Electronics Australia, this supply has been one of our most popular kits. Our version incorporates refinements and is now housed in an attractive, tough "ABS" instrument case. This all new compact version has been made possible by the use of a high efficiency Toroid Power Transformer. So you win four ways - less heat, less weight - Greatly enhanced appearance and easier to build - Remember the Altronics Kit is fully drilled and punched.

K 3300 \$195

Manufacturers, Contractors and Bulk Users  
Please Contact Our Wholesale Sales Dept.  
Sydney (NSW Only) Colin Fobister 436 0422  
Perth 09 328 2199

**ALTRONICS**

174 Roe St. Perth W.A. 6000  
PHONE TOLL FREE 008 999 007  
Perth Metro & After Hours (09) 328 1599  
ALL MAIL ORDERS  
P.O. Box 8350 Perth Mail Exchange W.A.6000

**ALTRONICS RESELLERS**

Chances are there is an Altronics Reseller right near you - check this list or phone us for details of the nearest dealer. **Please Note:** Resellers have to pay the cost of freight and insurance and therefore the prices charged by individual Dealers may vary slightly from this Catalogue - in many cases, however, Dealer prices will still represent a significant cost saving from prices charged by Altronics Competitors.  
Don't forget our Express Mail and Phone Order Service - for the cost of a local call, Bankcard, Visa or Mastercard holders can phone order for same day despatch.

- |  |   |  |  |   |  |
|--|---|--|--|---|--|
| <b>WA</b> COUNTRY ALBANY BP Electronics # 412681 | <b>ESPERANCE</b> Esperance Communications 713344        | <b>GERALDTON</b> K.B Electronics & Marine 212176 | <b>KALGOORLIE</b> Todays Electronics # 212777          | <b>KARRATHA</b> Davea Oscitronic 854836                         | <b>MANDURAH</b> Lance Rock                           |
| Retravision 351246                               | <b>WYALKATCHEM</b> D & J Pease 811132                   | <b>NT</b> ALICE SPRINGS Ascot Electronics 548334 | <b>VICTORIA CITY</b> All Electronic Components 6623506 | <b>SOUTH ACT</b> CANBERRA Bennett Commercial Electronics 805359 | <b>SCIENTRONICS</b> 548334                           |
| <b>MELBOURNE</b> Winscott Trading 6995740        | <b>SUBURBAN</b> CHELTENHAM Talking Electronics 5842386  | <b>CROYDEN</b> Truscott Electronics              | <b>BENDIGO</b> KC Johnson # 411411                     | <b>MORWELL</b> Morwell Electronics 346133                       | <b>FORTITUDE VALLEY</b> Economic Electronics 2523762 |
| <b>QUEENSLAND</b> CITY Delsound P/L 8396155      | <b>SUBURBAN</b> BUNDABERG Bob Elkins Electronics 721785 | <b>GLADSTONE</b> Supertronics 724321             | <b>WINDSOR</b> M & E Electronics 775935                | <b>WOLLONGONG</b> Newtek Electronics # 271620                   |  |

Blue Ribbon Dealers are highlighted with a ■. These Dealers generally carry a comprehensive range of Altronic products and kits or will order any required item for you.

BANKCARD • VISA • MASTERCARD PHONE TOLL FREE 008 999 007 NEXT DAY JETSERVICE DELIVERY

BANKCARD • VISA • MASTERCARD PHONE TOLL FREE 008 999 007 NEXT DAY JETSERVICE DELIVERY

## An introduction to hifi – Part 20

# Loudspeaker Systems – 1

Having discussed, in general terms, loudspeakers and their relationship to the amplifier, it now remains to look more closely at some of the matters mentioned and to note how they influence the design parameters for the many loudspeaker systems that are currently on offer in the hifi marketplace.

by NEVILLE WILLIAMS

If we were concerned mainly with median (or speech) frequencies, as was the case in the 1920's, sound propagation would present relatively few difficulties. By simply facing a typical dynamic loudspeaker in the general direction of the audience, most of the listeners would hear most of the frequencies reasonably well. (See Fig.3, Pt.19).

But the lower, or bass, frequencies – particularly those below about 300Hz – pose a special problem as their gradually increasing wavelength becomes comparable to, or greater than, the principal dimensions of the cone. With the cone moving in a given direction for a progressively longer period during each successive half-cycle, air under pressure on one side of the cone has time to flow around the edge of the housing to relieve the partial vacuum on the other side.

As a result, instead of propagating a pattern of low frequency sound waves into the surrounding atmosphere, much of the system energy is wasted in simply pumping air back and forth in the immediate vicinity of the loudspeaker.

### Frequency wavelength

A direct front-to-back path for bass energy is aptly described in technical literature as an "acoustic short circuit". More specifically, it becomes evident at and below the region where a half-wavelength approximates the mean path length from the front to the rear of the cone.

By way of verification, data published by Briggs/Wharfedale around 1950 (Fig.1) indicates that the effect begins

to show up below about 1000Hz for a good quality unmounted 30cm driver. By about 256Hz, or middle-C on the musical scale, the acoustic output is down by 10-12dB, and by 18-20dB an octave below that.

Fig.2 presents this in a generalised form for any comparable moving coil driver. The response is nominally level down to the acoustic short circuit region, where it rolls off into a downward slope equivalent to about 6dB/octave.

The natural resonance of the coil/cone

system is likely to occur part way down the slope, at which point it tends to steepen to 12dB/octave or more. The exact shape of the curve around the resonance region depends on the individual driver and the amount of electrical damping imposed by the associated amplifier, but there is likely to be a plateau, as in Fig.1 or a peak of greater or lesser magnitude, as shown in dashed in Fig.2.

For these and other related reasons, physically large loudspeakers with (normally) a lower frequency cone resonance usually exhibit somewhat better bass response, unmounted, than their smaller counterparts. While it is not normal to use dynamic loudspeakers in this fashion, Yamaha did, at one stage, feature unusually large cones in some of their music systems and electronic organs.

**Fig.1: The free field response of an unmounted 300mm driver, from "Loudspeakers" by G.A.Briggs. The 6dB/octave slope is evident below about 1kHz.**

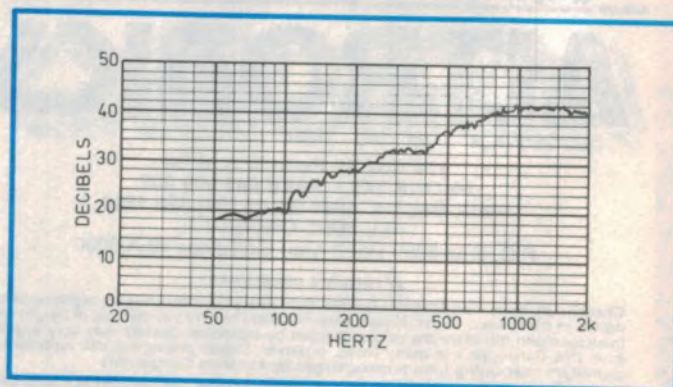

**Fig.2: The behaviour of an unmounted bass-end driver in generalised form, showing the roll-off below the acoustic short-circuit region and the effect of cone resonance.**

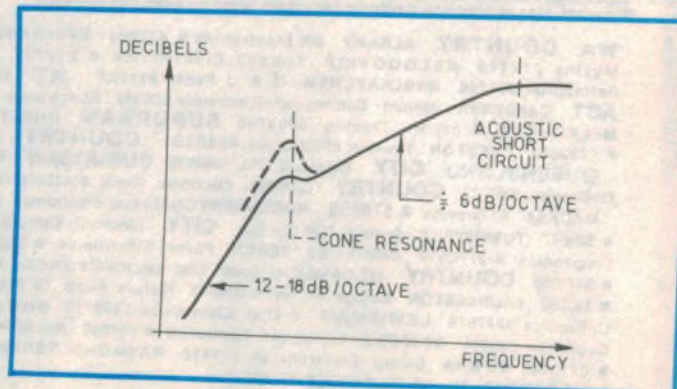

## Role of baffling

However the most meaningful way to push the acoustic short circuit region downwards in frequency is to mount the loudspeaker on a stout baffle board, or in a rugged cabinet of some kind – the larger the better – to ensure a much longer air path from the front to rear of the cone.

The practical result of so doing is to transform the loudspeaker into an item of furniture, which then has to be embellished and accommodated in the listening room – with good grace or otherwise! Apart from a few secondary considerations, it all has to do with the region below about 300Hz, with which this present article is principally concerned.

In the mono era, with only one channel to worry about, the approach favoured by dedicated hifi enthusiasts was to invest in an expensive high efficiency 30-38cm (dia) driver – Wharfedale, Goodmans, Celestion, Rola, American Magnavox, Jensen, etc., – most exhibiting a natural cone resonance of around 45Hz; and then to baffle it as generously as could be arranged.

For some, the ultimate was to install it in a dividing wall, or across an unused fireplace, or in the door of a large built-in cupboard, thereby creating a virtually infinite baffle.

For others, it meant a large, suitably finished baffle board, at least one metre square, free-standing with rear support extensions or fixed across a corner to increase its effectiveness. Still others settled for a heavy wooden rectangular or corner cabinet, variously open, sealed or vented, of around 250 litres (9 cu ft). A few devotees – not this author – even opted for hollow sand-filled panels or brick structures of comparable dimensions!

Most such combinations sounded impressive, because the de-luxe drivers, with their large cones and long-travel voice coils were able to move plenty of air at low frequencies, without obvious distortion. The large magnet system and (normally) a low impedance amplifier ensured good damping, with little or no resonant bass “boom”. Most such baffle arrangements preserved the useful response to below 100Hz, with the natural cone resonance extending it to at least 45Hz, maybe even down towards 30Hz in some cases. It was all very challenging, rewarding – and relatively non-critical!

Unfortunately, the same could not be said for inexpensive look-alikes from the same period. Economy 30cm loud-

**Fig.3: A generously baffled quality driver with a low, well damped resonance can produce an agreeably sustained bass response (solid curve). But poor baffling and a poorly damped resonance at around 70Hz (dashed curve) can produce a “thumping” sound.**

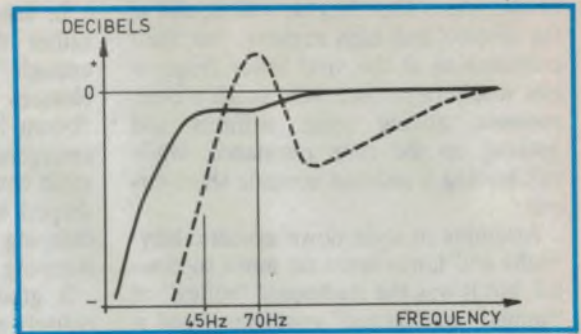

speakers, with limited magnet systems, could not use long-travel voice coils and still retain reasonable sensitivity. In consequence, the suspension had to be fairly stiff to keep cone travel within bounds and that usually meant a cone resonance in the region 65-75Hz, leading to a rather “thumping” or “boomy” low end. The most obvious result was the infamous “one note bass” of many old-style console radiograms.

Fig.3 illustrates the difference between the two situations. The solid curve depicts a high quality driver, with a well damped resonance at 45Hz, generously baffled. The dotted curve is for an inexpensive driver, with a poorly damped 70Hz resonance and limited baffling.

## Changes for stereo

The widespread adoption of stereo completely changed the situation. Hifi devotees might have been prepared to accommodate one generously proportioned loudspeaker system but certainly not two, especially as they had to be placed symmetrically to the front left and right of the listening position. The pressure was on, therefore, to come up with compact, self-contained loudspeaker systems which would offer comparable quality and bass response to that of the familiar mono monsters.

And this is where designers and enthusiasts alike ran into difficulties – and seemingly endless arguments – during the first decade or so of the stereo disc era.

It was clearly not sufficient merely to reduce the size of traditional baffles or open-back structures because, by the time they had been made small enough to be aesthetically acceptable, the acoustic short circuit roll-off had been pushed back up towards 300Hz, with the 30-40Hz region some 20dB down.

Then what about a compact, completely sealed enclosure, misguidedly referred to by some as an “infinite” baffle? While this may indeed contain and isolate back radiation from the cone, it was (and still is) anything but infinite in

its effect on system behaviour.

In particular, the body of air trapped in the enclosure acts as a supplementary spring tending, along with the normal suspension, to return the cone to its median position. The added “stiffness” has the effect of raising both the frequency and the “Q” – or the prominence – of the cone resonance.

In the days of 250-litre enclosures, the end effect was relatively minor. But attempts to mount the same kind of 30cm driver in a scaled down or compact sealed enclosure (around, say, 50 litres) could see the system resonance pushed up into the “boom” region around 75Hz.

Sundry attempts were made to counter the effect by such measures as padding the inside of the enclosure, adding internal absorbent drapes, filling it with wool or synthetic fibre and/or drilling an array of small holes through one or more of the surfaces. While such measures may have helped to reduce internal “standing wave” effects at median and high frequencies, their contribution to the low end performance was small.

## Baffles & labyrinths

An approach that attracted some attention was the so-called “baffle” (Fig.4) which was neither fully sealed nor fully open. Behind the 30cm loudspeaker was a succession of caneite

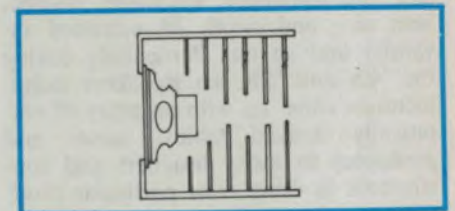

**Fig.4: The so-called “Baffle” system used Caneite panels to break up mid-frequency standing wave effects, but bass performance was a compromise.**

spacers and panels, with circular holes as indicated, which were meant to intercept and absorb radiation from the rear

of the cone. This they doubtless, did in the middle and high register, but their contribution at the vital lower frequencies would have been very much a compromise, adding some stiffness and pushing up the cone resonance, while still leaving a residual acoustic short circuit.

Attempts to scale down acoustic labyrinths and horns were no more successful; but it was the traditional "reflex" or "vented" or "ducted" enclosure – call it what you will – that generated by far the greatest confusion and controversy. The principle dates back at least to the later '30s, when it was taken up by the US Jensen company as an adaptation of the Helmholtz resonator.

The reflex enclosure was/is visually similar to a sealed enclosure except for an extra cutout, usually in the front face, often about the same area as the active cone and sometimes extended inwards to form a short duct or tunnel. The basic idea is to take advantage of the acoustic resonance that occurs between the compliance of the air in the enclosure and the mass of that air in and around the vent.

It transpires that the phase of the energy radiated from the vent is shifted by 180°, relative to the rear of the cone, so that it tends to reinforce rather than to cancel that from the front. And because the radiation from the rear of the cone is utilised rather than absorbed, as in a sealed enclosure, it offers a considerable potential advantage in terms of acoustic low-end efficiency.

By suitably relating enclosure resonance to that of the driver, the overall effect, ideally, is to smooth and extend the low-end response to well below the natural driver resonance while, at the same time, flattening the impedance curve.

For a vented system to function as intended, there must be proper correlation between things like loudspeaker size and resonance, enclosure volume, vent size and depth (if extended inwards) and so on. Particularly during the '40s and '50s, loudspeaker manufacturers came up with an array of empirically derived tables, curves and guidelines to assist designers and constructors in using their particular products.

There were obvious discrepancies in such information but it seemed to work out well enough in practice – while ever the emphasis was on large enclosures. It was when attempts were made to scale down the systems for the stereo market that the empirically derived guidelines really came unstuck.

In less than huge systems – e.g. 150 rather than 250 litres – there were enough "lemons" to earn for reflex enclosures a reputation as potential "boom boxes". This, in turn, saw the emergence of dubious empirically devised corrective measures such as oddly shaped baffle cutouts or ports, internal damping curtains or partitions, and damping applied across the vent.

It gradually became evident that an entirely new approach was necessary to system design, generally. Rather than choose a fancied driver and create an enclosure around it, the designer should first define the desired end product in basic terms: size, bandwidth, power handling, sensitivity, etc. This done, the most promising option could then be targetted – vented, sealed or anything else – and designed as a whole, with the choice of driver becoming an essential part of the design procedure.

### Modern systems

The majority of present-day loudspeaker systems are either vented or sealed, with a wider understanding of the latter being commonly credited to Edgar M. Villchur, founder of AR Inc. Certainly, Gilbert Briggs of Wharfedale recounts an unofficial "contest" at the New York Trade Fair of about 1955, between one of his classical 9 cu ft enclosures and a much smaller AR "acoustic suspension" model. Says Briggs:

"I was surprised at the amount and quality of the extreme bass which came from the AR model (although) the wick had to be turned up to get it".

The essential logic behind the fully sealed, acoustic suspension approach is that the bass-end driver should be initially designed with a long-travel, highly compliant (low stiffness) coil/cone suspension system, having an unusually low (unmounted) resonance frequency – commonly in the region 20-25Hz. Such a driver is totally unsuitable for use in an open-back situation, because of the possibility of distortion and even physical damage due to excessive cone travel.

In a suitable sealed enclosure, however, the stiffness of the entrapped air can add sufficiently to that of the mechanical suspension to raise the fundamental system resonance to an acceptable and convenient 40/55Hz and subject to a carefully selected order of electrical and acoustic damping, in the latter case by internal absorbent padding and/or filling.

There is more to it, however, than just mounting a low resonance driver in

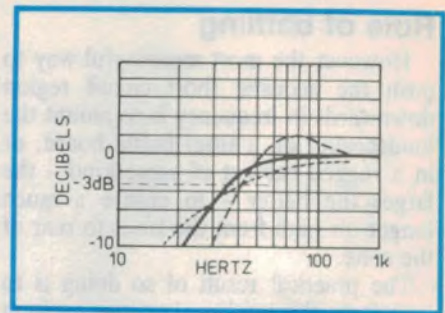

Fig.5: The bass-end response for an optimally designed sealed enclosure (solid curve). The dashed curves show the effect of too small and too large an enclosure.

a likely looking damped enclosure – as emphasised in a paper presented to the 1984 AES Melbourne Convention entitled: "Practical Design of Optimal Sealed-Box Loudspeaker System". In it, Messrs Wiebell and Bywater analyse the relationship between various design considerations such as: available drivers, optimum enclosure volume, system "Q", damping, frequency response and acoustic efficiency.

For example, the solid curve in Fig.5, derived from the paper, shows the bass-end performance of a theoretical, optimally designed acoustic suspension system. The response rolls off smoothly through -3dB at 35Hz – low enough to cope with all normal bass response requirements. The dashed curve, showing the onset of peaking, is symptomatic of a too-small enclosure with too high a "Q". The dotted curve, resulting from an enclosure too large for the particular driver, indicates an actual loss of response over the useful range and reduced protection for the coil/cone system at sub-audible frequencies.

Philips have done much to popularise the fully sealed approach in Australia and elsewhere, in recent years. (e.g., "Building Hi-Fi Loudspeaker Systems" 7th. edition, 1980 by M.D.Hull). Fig. 6 shows the anechoic response of their 3-way System 16 (pp 179-181) using a 30cm woofer with a bass resonance (unmounted) of 25Hz. In the 50-litre sealed enclosure, this rises to around 55Hz, with the response essentially flat down to that point but with still useful output in the 30-40Hz region.

Allowing for timber thickness, the space occupied by the drivers and any internal braces or compartments, a 50-litre (1.8 cu ft) system need be nothing more than a modest free-standing enclosure, with a stereo pair being much less likely to be cited as a reason for divorce than a brace of their 250-litre ancestors!

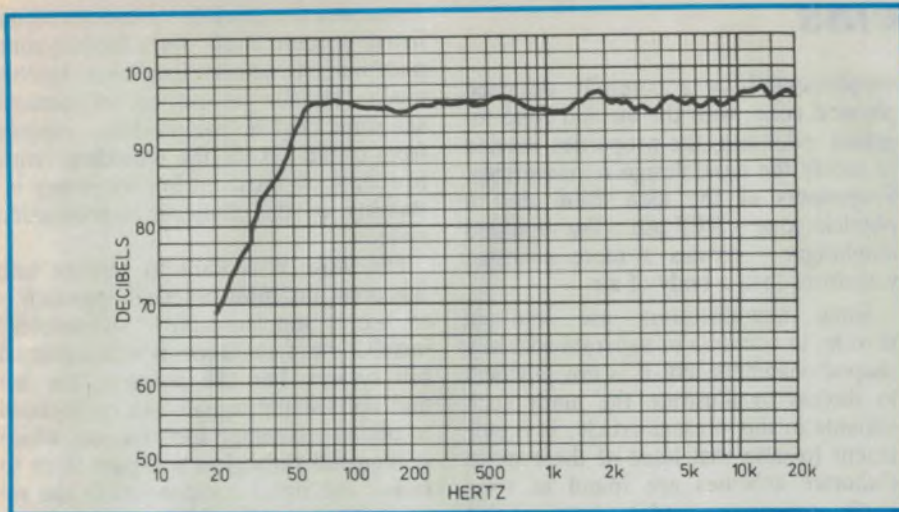

**Fig.6: The frequency response for a modern 3-way 80W sealed system housed in a 5-litre enclosure, designed by Philips.**

### Small sealed enclosures

To meet the inevitable demand for still smaller systems, designers have the logical option of using progressively smaller low resonance bass drivers. Since smaller-area cones exhibit less loading from the entrapped air, it is possible to use them in smaller volume enclosures, while still preserving an acceptably low system resonance and extended bass response.

Nowadays, woofers and/or bass/mid-range drivers are commonplace with nominal diameters of 35, 20, 15 and even 10cm, providing to preserve an acceptable bass response – but at a cumulative price.

As noted earlier, large area cones (30-38cm dia) are able to couple to or “pump” a fair volume of air, to create suitably loud bass sounds. Retaining the pump analogy, smaller area cones need to travel through a proportionately greater distance for equal loudness at low frequencies. Not only does this demand long-travel suspension, but also adequate clearance in the air gap and a very long – or a very short – voice coil, such that a given number of turns will always be present in the magnetic field. (See Fig.7).

The efficiency of physically small drivers must inevitably suffer and if, as normal, they are associated with separate mid/high frequency units, it must be assumed that the sensitivity of these will, in turn, be restricted to preserve proper overall balance. For such reasons, the acoustic efficiency of practical sealed systems tends to diminish with size such that, for a given electrical drive, smaller systems sound progressively less loud than larger ones.

This must be kept in mind when as-

sessing performance specifications. A diminutive system may well be rated for a surprisingly high maximum power input. It may, in fact need it, to provide an adequate peak level in anything but a small room!

In summary, modern sealed, acoustic suspension systems are able to provide excellent low frequency (and overall) sound without needing to be embarrassingly large. But if you have a choice,

and assuming equal design merit, favour a moderately large system rather than one that is needlessly small. Its design will almost certainly have involved less stringent compromises.

### Modern vented systems

The early guidelines adopted for reflex/vented systems needed little skill to interpret, but they were basically flawed because they did not take into account all the operative factors.

Confusion continued until the publication of a landmark paper by Australian engineer Neville Thiele, entitled “Loudspeakers in Vented Boxes” *Proc. IRE (Aust)* Vol.22, No.9, Aug.1961). It was based on the realisation that a reflex or vented system was really a high-pass audio filter, and that it could be analysed and resolved on that basis. His work was subsequently taken up and expanded by others, notably Richard Small, an American engineer then resident in Australia.

As with the sealed system, Thiele showed that it was inappropriate to start off with a fancied bass driver and attempt to design a vented enclosure around it. Many drivers were simply not suitable for the purpose. Not only was the driver an intimate component of the

**Anthony Borg  
& Associates Pty. Ltd.**  
Telephone: (03) 374 2040  
Fax: (03) 379 3789

# Loudspeaker systems

overall design, but driver parameters were involved other than simply cone diameter and resonance. (For a more detailed explanation of the approach, see "Vented Enclosures, The Gospel according to Thiele and Small", by David B. Weems, *Electronics Australia*, Sept. '80.

As it turned out, the up-dated design procedure established by Thiele is more suited to engineers than to hifi hobbyists. More to the point, however, loudspeaker and systems manufacturers have since translated it into computer programs which allow them to investigate and predict the bass-end performance of particular drivers and enclosures with a high order-of accuracy. Largely as a result of all this, reflex enclosures have won back a lot of the support that they were in danger of losing to the (formerly) less ambiguous acoustic suspension concept.

The above methodology holds for all reflex enclosures, from large systems through to the very compact ones based on suitably designed, small diameter drivers. But the same observation applies as for sealed systems, mentioned earlier: given a choice, and assuming equal design merit, favour a larger system rather than one that is needlessly small.

Large or small, it is again important for hifi hobbyists or bargain hunters to understand that there is much more to a reflex enclosure than a polished cabinet with an extra hole in the front and fitted out with likely looking drivers. Whether in the form of plans, a pre-cut assembly kit or the finished item, there needs to be some assurance that the whole project has been professionally designed in accordance with the accepted Thiele procedure or "alignment".

It should also be noted that a number of valid elaborations of the basic vented concept have emerged as, for example, the use of a so-called "passive radiator" (e.g. System 19 in "Building HiFi Speaker Systems"). This involves the use of what appears, at first glance, to be an extra bass driver with a cone which is often quite similar to that of the normal driver. In fact, it turns out to be a passive or "drone" cone, suitably weighted and suspended in a loudspeaker housing in the usual way, but minus a voice coil and magnet system.

The idea is that, instead of using the air in an open vent or duct as one component of the acoustic resonance, it is

supplemented by a carefully designed physical cone, with the air and cone together exhibiting the properties needed to satisfy the basic design requirements. Proponents of the idea claim that a physical cone - KEF use a flat moulded diaphragm - creates a more cohesive wavefront than a body of air.

Some manufacturers use multiple drivers, in common or separate specially shaped chambers; but it is not practical to discuss or illustrate the many such variants in this present article. It is sufficient to note that most of these more elaborate schemes are found in relatively expensive models from major manufacturers and are usually backed by solid research. As such, they can be expected to perform well and it be-

completing the possible limitations of the listening room itself. As a further complication, the source signal must be that much "cleaner" in respect to spurious sub-sonic signal components, ranging from traffic outside the recording venue to rumble or incipient low frequency instability in the domestic reproduction system.

For those who want to venture into this area, the most practical approach is to use a supplementary "sub-woofer" installation in conjunction with a normal hifi system. For the purpose, the left and right stereo signals can be blended to obtain a common mono signal, which is then fed through a low-pass filter to isolate the signal components in the region where the normal loudspeaker are rolling off.

Because these very low frequencies tend to be common to both channels

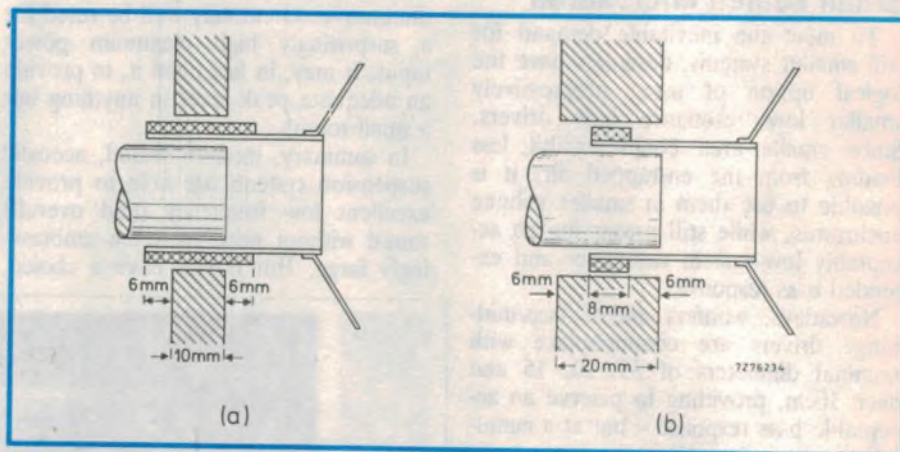

**Fig.7:** As illustrated in M.D.Hull's manual "Building HiFi Speaker Systems" (Philips), long travel voice coils may use either (a) a long coil in a short magnetic field, or (b) a short coil in a long magnetic field, to achieve linearity over the full cone travel.

comes a matter of deciding whether the outlay is justified, based on listening tests and reviews in the technical press.

One other matter warrants brief mention at this point, namely that of sub-woofers. Loudspeaker systems such as those already discussed, which preserve useful output down to about 30Hz, are normally considered adequate for even demanding hifi requirements. Inevitably, however, there are those who are concerned about the occasional sub-octave organ notes and possible sub-harmonics of percussion sounds, all of which tend to be felt rather than heard. Aren't they also part of the music?

Perhaps they are, but the difficulties of extending the response of ordinary systems downwards by another octave are forbidding, when considered against the musical dividend, cost and dimen-

and subjectively non-directional anyway, mono reproduction is entirely adequate. The common signal can therefore be fed to a separate mono amplifier and thence to a special sub-woofer loudspeaker system, hidden or disguised as something else, anywhere in the listening area. The sound level from it can be adjusted to suit the occasion and the program material by simply varying the gain control on the sub-woofer amplifier.

The idea of using a separate mono woofer may also be attractive to music lovers who, while not directly interested in an extra octave, find it difficult to accommodate anything but small main loudspeakers. A separate concealed woofer, able to selectively reinforce frequencies below about 100Hz, can add real "body" to the overall sound.

(To be continued)



# This man isn't a computer expert, yet he chose a UNI-X CompuPak kit - and assembled it in one night!



**\$999**

Including Tax  
At this price

**WHY NOT?**

No, he's not a genius, but he's brilliant at spotting great value. Like many of us, he's realized that a personal computer is invaluable, yet the price tag for a professional unit has always been a little beyond his reach. Until now.

Quite simply the UNI-X CompuPak kit contains all the major components of a top quality Industry standard computer, in an unassembled form. You save the dollars and increase your knowledge, by putting it together yourself.

UNI-X also provide a National Warranty through Honeywell Ltd, a professional network of expert backup and service.

The complete Super 10 kit contains:

- Super — 10 mother board 640K Installed 4.77 / 10MHz, plus V-20 chip (very fast!)
- Colour graphics adaptor card.
- Multi I/O Card-Serial / Parallel Ports, Games Port, Clock, calendar, Floppy Controller.

- Dual Frequency TTL Monitor (Green or Amber) includes tilt and swivel base.
- Top quality Japanese Disk Drive.
- 150 watt switching power supply.
- High tech flip-top case.
- Complete set of accessories.
- AT style keyboard.
- Industry standard — runs all IBM software.
- Assembly manual
- Utility Disk.
- All upgrade options available.

Ring PATRICK SIMONIS (07) 356 7866 right now.

**UNI-X**  **CompuPak**

Phone (07) 356 7866  
Dealer enquiries welcome  
Phone (07) 356 8311

UNI-X CompuPak Division, 16-20 Edmondstone St, Newmarket, Queensland 4051

**Australian Personal Computer**  
LOW COST IBM COMPATIBLE SURVEY - OCTOBER 1987

...and the experts agree with his choice.

Australian Personal Computer have now proved what our customers have known for years

**Processor.**

NEC. The Uni-x contains a NEC V20, manufactured by Sony.

Thus a V20 running at 4.77MHz will outrun an 8086 running at the same clock speed. Machines examined provided a standard PC clock rate of 4.77MHz as a minimum, although the Uni-x delivered higher than standard performance even on the clock rate by virtue of the V20. The Amiga and other machines.

**Performance.**

The Uni-x is fastest overall, providing a 50 per cent boost over the Technogy interface due to the V20.

**Display.**

delivered with a nice INTRA 18"swivel screen. The other.

**Cost Effectiveness.**

As you might expect, the do-it-yourself Uni-x comes up trumps with its low cost and relatively high performance.

**Specifics.**

The Uni-x features a delightfully small motherboard. It has employed a VLSI component to replace the Intel 8253 timer, 8255 PPI, 8247 DMA controller and several other components. This reduced the component count and a simplified motherboard serves to reduce costs.

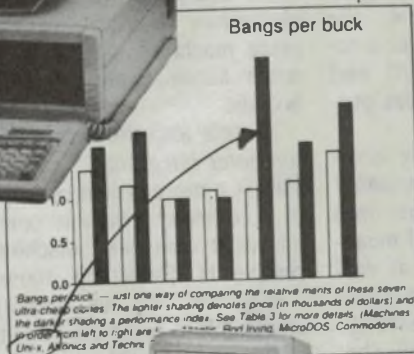

Bangs per buck — just one way of comparing the relative merits of these seven ultra-cheap computers. The lighter shading denotes price (in thousands of dollars) and the darker shading a performance index. See Table 3 for more details. (Machines ordered from left to right are: Uni-x, Amiga and Technogy, Commodore, and IBM.)

see for yourself in the full Report in the October '87 issue, or ring us for a copy.

# Our annual CAD update

It's time again for our annual look at what's happening in the use of computers as tools for design, drafting and related activities. By way of introduction, and for those who haven't looked into this area before, here's a quick rundown on the concepts and terms you'll meet on the following pages.

Originally, the term CAD stood for *computer-aided design* - using a computer running suitable software as a tool for the engineering design of any desired product or system. However in the last few years the term has also acquired the rather narrower meaning of *computer-aided drafting*, where the computer system is used largely as a replacement for a drawing board and drafting machine - for the efficient production of plans and drawings.

Because of this ambiguity, the acronym CAE (standing for *computer-aided engineering*) has tended to come into use, to cover the broader original meaning of a tool to assist in *design* as well as drafting. But the older term CAD still tends to be used for *both* "drafting" and "design" packages, possibly because many CAE packages also perform drafting, as an integral part of their operation.

As a result, it's wise to work on the basis that not all CAD packages are alike. Some are basically just drawing and drafting tools, while others are much more powerful and able to perform things like automatic PCB track routing, circuit analysis and simulation.

Another term you'll come across nowadays is CAM, standing for *computer-aided manufacturing*. This is the use of computer-controlled machine tools and other production equipment. Associated with CAM is the term CNC, short for *computer numerical control*,

used to describe machine tools which accept programs from, or prepared using, a computer. Sometimes CNC is shortened to NC, for *numerically controlled*.

An example of the way CAM and CNC machines are being used in the electronics industry are the pick-and-place machines used to mount components automatically on printed circuit boards.

There's also the term CIM, short for *computer-integrated manufacturing*. This is a more recent concept, where all of a company's process controllers, numerically controlled machine tools and computers (including those used for CAD/CAE and accounting) are integrated into a complete system.

The idea of CIM is that the design for a product can be developed using the engineering department's computer, and drawings prepared. Then the planning department's computer can plan the manufacturing schedule, and the purchasing department's computer can order the parts. The production department's computers can then program the CNC machines to perform the manufacturing, and finally the accounts department computer can prepare the shipping documents and invoices.

It all sounds great in theory, perhaps, but in practice CIM is still some way off.

When CAD software packages were first developed, you needed a fairly

powerful mainframe computer to run them. This still tends to be the case with the most powerful CAD systems, such as those used for the design and simulation of new integrated circuit chips. However quite a lot of lower-level CAD can be performed using packages running on personal computers - such as the IBM PC/AT and compatible machines.

Applications in electronics which can be performed using these PC-level CAD packages include circuit schematic drawing and design, circuit analysis and simulation, PCB design (both manual and automatic routing) and preparation of programs for machine tools and robots such as PCB pick-and-place machines.

Generally the basic hardware requirements for this type of work are a PC-AT level machine with at least 640K bytes of memory, a reasonably fast 20Mb or 40Mb hard disk, an EGA or better graphics adaptor with fairly high-resolution RGB colour monitor, and either a high-resolution dot-matrix (or laser) printer or a plotter. A mouse or graphics tablet can also be very desirable.

A term you'll often find used in connection with the more elaborate CAD/CAE systems used in electronics is *netlist*. This is a data file, usually generated by a *schematic capture* or circuit drawing program, which consists of a shorthand description of the components used in the circuit and their interconnections. The netlist file is the form in which the "circuit" is passed to a circuit analysis or simulation program, for analysis, or to an auto-routing program for generation of the appropriate PCB pattern.

# High Performance In Your Shirt Pocket!

3 1/2 digit LCD Display

Ranges	Max Res	Accuracy
Vdc 200mV-1kV	100µV	0.5% +1dig
Vac 2V-750V	1mV	0.75%+5dig
Adc 200mA	100µA	0.75%+1dig
10A	10mA	1.5%+5dig
Aac 200mA	100µA	1%+5dig
10A	10mA	2%+7dig
Ohms 200Ω-2MΩ	0.1Ω	0.75%+1dig

Actual Size 148x66x23mm

Display also has Low Battery & Over-Range Indication

Memory Function for Relative Readings (DM6235 & DM6335)

Manual Ranging Over-Ride (DM6235 & DM6335)

Hold Reading Function (DM6335)

Overload Protected to 1000Vdc/750Vac

DM6135 Autoranging \$88.80

3 1/2 digit 10A ac/dc  
DM6235 As above \$99.60  
with Memory

function and Range Hold  
DM6335 As above \$118.80  
with Data Hold

Built In Diode Check, Lo-Power Ohms & Continuity Test Beeper

Autoranging

One Year Warranty

10A Range

Automatic Current Limiting

10MΩ Input Impedance

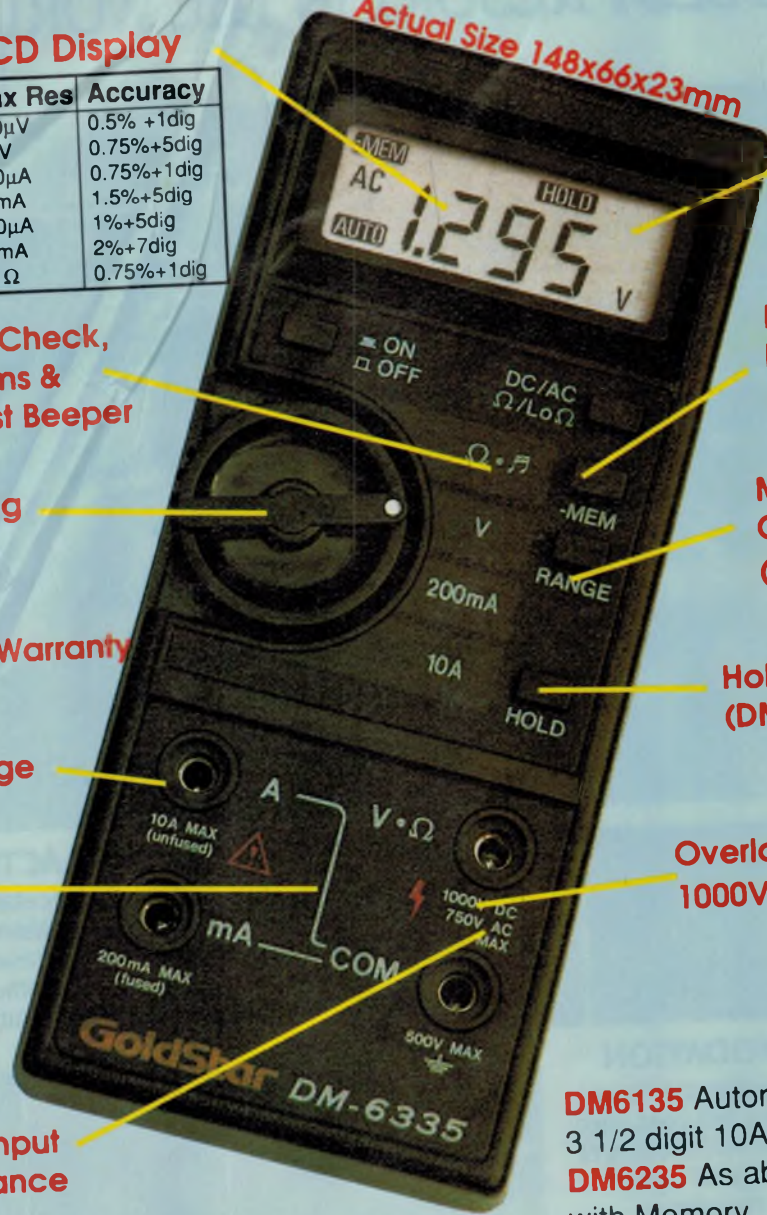

## Look At The Low Prices!

Prices include 9V Battery and High Quality Silicon Rubber Test Leads with Screw-On Alligator Clips

# Gotta Getta GoldStar

Dealer enquiries welcome. Call (02) 736 2243  
Recommended prices only including Sales Tax

You've Gotta Getta Goldstar from :

A.C.T. John Pope Electrical (062) 90 6576 • J Blackwood & Sons (062) 80 5235 • George Brown (062) 80 4355  
 N.S.W. Ames Agency 699 4524 • J Blackwood & Sons • George Brown 519 5855 Newcastle 69 6399  
 • Auto-Catt Industries 526 2222 • D.G.E. Systems (049) 69 1625 • W.F. Dixon (049) 69 5177 • Ebson 707 2111  
 • Macelec (042) 29 1455 • Novacastrian Electronic Supply (049) 62 1358 • Obiat Pty Ltd 698 4776  
 • Petro-Ject 569 9655 • David Reid 267 1385 • Digital 709 6511 • Geoff Wood 427 1676  
 N.TERRITORY J Blackwood & Son (089) 84 4255, 52 1788 • Thew & McCann (089) 84 4999  
 QUEENSLAND Auslec (07) 854 1661 • G. Brown Group (07) 252 3876 • Petro-Ject (075) 91 4199  
 • St Lucia Electronics 52 7466 • Cliff Electronics 341 4655 • L.E. Boughen 369 1277  
 • The Electronics Shop (075) 32 3632  
 • Thompson Instruments (Cairns) (070) 51 2404 • Nortek (Townsville) (077) 79 8600  
 S.AUSTRALIA Protronics 212 3111 • Trio Electrix 212 6235 • Industrial Pyrometers 352 3688  
 • J Blackwood & Sons 46 0391 • Petro-Ject 363 1353  
 TASMANIA George Harvey (003) 31 6533 (002) 34 2233  
 VICTORIA Radio Parts 329 7888 • George Brown Electronics Group 878 8111 • G.B. Telespares 328 4301  
 • A.W.M. Electrical Wholesalers • Petro-Ject 419 9377 • J Blackwood & Sons 542 4321  
 • Factory Controls (052) 78 822 • Mektronics Co 690 4593 • Truscott Electronics 723 3094  
 W.AUSTRALIA Atkins Carlyle 481 1233 • Dobbie Instruments 276 8888 • Protronics 362 1044

# Hamilton Island

GREAT BARRIER REEF • AUSTRALIA

## THE BEST RESORT IN THE WORLD

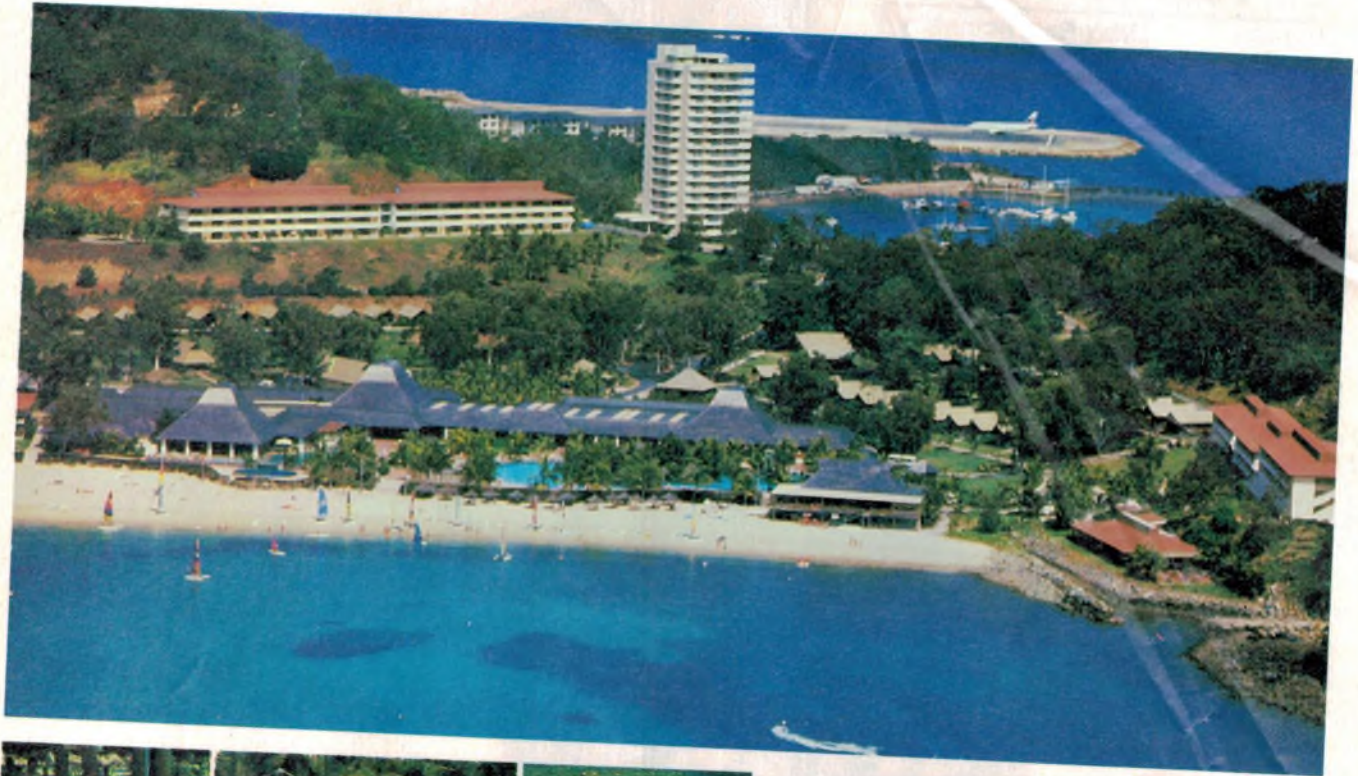

### THE BEST ACTIVITIES

Ride a jet-ski. Hire a catamaran, dinghy, surf ski, canoe or power boat. Water-ski, fish, snorkel or scuba dive. Sailboard, parasail or bushwalk. Try tennis, squash, aerobics or the gym. Or just lie on the beach and soak up the sun.



### THE BEST ACCOMMODATION

There are individual "Polynesian-style" Bures, spacious hotel rooms and luxury, self-contained suites with up to three bedrooms. All have king or queen size beds, ceiling fans and spacious balconies and the views are spectacular.



### THE BEST FAMILY FACILITIES

As well as their own supervised Kids Club (for those under 12), the children will love meeting the kangaroos, emus, koalas, wallabies, deer and birdlife in our mountain-top Fauna Park. And that's on top of all the other island activities.



For reservations see your Travel Agent or Ansett Airlines. For further information call 02-327-1899 or mail this coupon to FREEPOST 14, Hamilton Island Marketing, Suite 609, Eastpoint, 180 Ocean Street, Edgecliff NSW 2027.

Name \_\_\_\_\_  
 Address \_\_\_\_\_  
 Postcode \_\_\_\_\_

### THE BEST VALUE

Currently prices for a week on Hamilton Island are:

SYDNEY	\$879*	CAIRNS	\$699*
MELBOURNE	\$949*	CANBERRA	\$899*
BRISBANE	\$799*	PERTH	\$1249*
ADELAIDE	\$999*	HOBART	\$1069*

\*All prices include return economy airfare and share twin Allamanda or Bure accommodation. Similar savings are available in Bougainvillea hotel rooms and one and two bedroom apartments. These prices are available April 30 to September 18, 1988.

# Introducing MAXX™ for your personal computer. The new way to play your games.



Joystick  
Controllers  
Available for \*IBM  
XT-AT-386  
Up to 16 MHZ

Available for \*IBM  
and \*Apple Computers.

## *Come in for a test flight!*



MAXX™ makes sense. Used as a practice tool, even veteran spray pilots can brush up on operations in controlled air space.



MAXX™ means adventure. Ace pilots can touch and go in a variety of aircraft.



MAXX™ makes it easy. Become a MAXXPilot™ and experience the "real" feel of flight at your personal computer.

*No flight in Britain.*



**HYPEC ELECTRONICS PTY. LTD. (02) 808 3666**  
(INCORPORATED IN N.S.W.) 71 RYEDALE ROAD, WEST RYDE, N.S.W. 2114, AUSTRALIA



\*IBM is a registered trademark.

\*Apple is a registered trademark.

**SIEMENS**

# Surge Arresters

## Gas arresters and metal oxide varistors

There's an explosion of new demands for surge voltage protection.

To keep up, you need instant access to a total protection system. So you need Siemens Gas arresters and metal oxide varistors. Our huge range is available immediately from large local stocks, at competitive prices.

And all components reflect the very essence of Siemens High Technology – premium quality, performance and reliability.

Of particular note is Siemens innovative range of metal oxide varistors – unlimited applications, including the total protection of automotive electronics. Also, space-saving SMD varistors are available, along with our unique heavy duty block types – that's protection up to 100 kA!

We can even customize components to meet your individual requirements.

For more information, contact your nearest Siemens office or distributor.

### **Siemens Ltd.**

#### Sales Offices

Melbourne: 544 Church Street, Richmond, Vic. 3121

Phone: 420 7318

Sydney: 383 Pacific Highway, Artarmon, N.S.W. 2064

Phone: 436 8711

Brisbane: 9 Parkview Street, Milton, Qld. 4064

Phone: 369 9666

Perth: 153 Burswood Road, Victoria Park, W.A. 6100

Phone: 362 0123

New Zealand: Level 9, Marshall House,  
142-146 Wakefield Street, Wellington, N.Z.

Phone: (4) 846 068

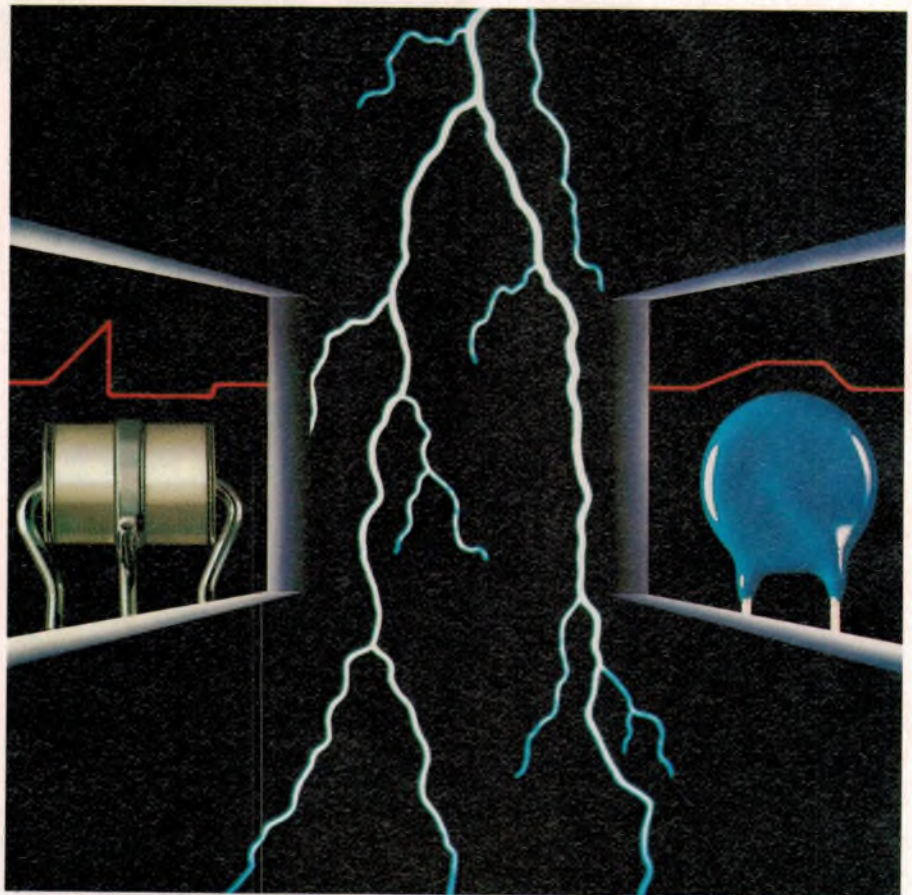

**Siemens. A higher technology**

CSA 3295 SL

## CAD Feature:

# New IBM CAD package transforms PCB design

A new CAD package for PCB design being marketed by IBM for use on a wide range of its computers (including the RT/PC) is claimed to allow a dramatic reduction in the time needed to design complex boards.

In the mid seventies, design of a complex printed circuit board with 70 integrated circuits took about three weeks. Today that same board can take less than a week.

Making this possible is a new package combining CBDS (Circuit Board Design System), developed by Bell-Northern Research of Canada, and CIEDS (Computer Integrated Electrical Design Series Simulators). Marketed internationally by IBM, the recently released CIEDS/CBDS package Version 4 provides powerful, easy to use schematic capture and design entry capabilities plus an object-driven man-machine interface (MMI) for circuit simulation, board layout and routing with on-line documentation and design violation checking.

According to IBM systems engineer Dino Calapai, "With MMI, the user selects the object to be acted upon and then the operation is performed. This leaves the user with the same environment to perform other related functions. More frequently used commands are available through predefined programmed function keys, via IBM's Lighted Programmable Function Keyboard".

Mr Calapai said CIEDS/CBDS Version 4 eliminated the traditional circuit prototyping process. Schematics can be drawn on CIEDS Design Capture, which has a selected component library supporting Texas Instruments, Signetics and National Semiconductor devices.

The CIEDS Analog-Digital Simulator allows for simultaneous simulation of analog sampled data circuits with their digital control logic. Simulation times are minimised through use of piecewise

linear models for all non-linear devices and event driven digital primitives. Results can be evaluated with a display utility provided in CIEDS/Simulation Base.

The CIEDS Design Simulation Base provides a comprehensive and interactive multi-window output display for the designer to view the results of a simulation. Highlights include an easy-to-learn command menu using a mouse to eliminate the need to memorise complex keystroke entry, and the ability to display a chosen portion of a schematic. This allows nets to be selected for viewing in the waveform and tabular display windows.

According to Mr Calapai, "CIEDS re-

places many of the sophisticated instruments used by engineers in the traditional circuit prototyping process. A circuit schematic may be displayed in the CIEDS schematic window, input waveforms are then defined for each input to the schematic. The mouse is used to select circuit nodes to be displayed in the waveform and tabular display windows. Circuit data may be displayed in the time and frequency domain, where node values can be represented in decimal, mnemonic and boolean formats. This feature may functionally replace instruments such as 'scopes, spectrum analysers, logic analysers, phase meters and various development systems."

After a top-down design is completed using approximate delay values, a utility is available for circuit re-verification using actual delay values for the parts that have been selected in the final design.

Another feature is the CIEDS Beha-



IBM systems engineer Dino Calapai uses a mouse to help him review the schematic of a printed circuit board he is designing on CIEDS/CBDS.

vioural Simulator, which allows the designer to start with the design definition of an integrated circuit or printed circuit board, and begin testing parameters at the architectural, register and gate system level.

The CIEDS Logic Simulator is a complementary simulator to the CIEDS Behavioural Simulator. While the latter is used during the "what if" stage of the design process, CIEDS Logic Simulator is used to refine the design and fill in the details.

Switched capacitor networks can be simulated in the time and frequency domains using the CIEDS Switched Capacitor Simulator. This frequency analysis computes amplitude and phase response including sample and hold effects and continuous input/output coupling. In addition it accurately simulates sensitivities to component tolerances and parasitic capacitances, group delay, amplitude slope distortion due to non-linear components and noise density. Time and frequency responses can be evaluated with the display utility provided in the CIEDS Design Simulation Base.

CBDS is basically an interactive graphic design tool that can speed the design and manufacture of printed cir-

cuit boards and thick film hybrid chips. It has a great many available functions, including capability for schematic entry and generation of manufacturing data.

The CBDS system is composed of four modules: a Component Database, a schematic entry module (LOKI), a physical layout subsystem (SPRIG) and a manufacturing data generator (CAM).

Mr Calapai said that designs can be entered through the LOKI schematic capture program or alternatively via the CIEDS/CBDS interface. LOKI can be used as a stand-alone subsystem. Circuit components and their symbols are called up from the predefined component database. Using the IBM 5080 Graphics System as a principal design workstation, CBDS utilises advanced function graphics combined with the MMI to enhance end user productivity.

CBDS offers a starter component database of approximately 10,000 devices. All component data and associated symbols may be centrally created and controlled, for standardisation. Additional components may be defined easily as the need arises.

The SPRIG physical layout subsystem is capable of automatic placement and routing of advanced multilayer PCBs, with high density surface mounted com-

ponents and hybrid packages. SPRIG also offers various optimisation routines and online violation checking for reduction of PCB vias, track length and optimisation of routing to multi-gate IC packages.

CBDS also supports full back-annotation facilities, so that modifications to PCB data are transferred back to the circuit schematic. Design integrity is therefore maintained.

CBDS also offers the CAM module for generation of manufacturing data. CAM is capable of producing all PCB/hybrid artwork including overglaze and silk screen legends, in Gerber photoplotter format and standard pen-plotter format. NC drill tapes and auto-insertion reports are automatically generated, along with a bill of materials report comprising supplier and costing data.

Mr Calapai said that CIEDS/CBDS greatly reduces long lead times usually associated with circuit design, and virtually eliminates traditional prototyping procedures.

CIEDS/CBDS runs under the VM operating system on a range of machines, from the 9370 to the 3090. CBDS is also available on the RT/PC personal computer, under the AIX operating system. EA

# TRONICS 2000

## STEPPING MOTORS SERVO MOTORS

### SANYO DENKI STEPPING MOTORS

Sanyo Denki Stepping Motors are of the efficient, latest design hybrid type. Torque outputs vary from 1 to 150 KgM Cm with speeds up to 3000 rpm. Very economical drive units are available to suit all motors for interfacing to computers for programming under BASIC.

### SANYO DENKI MOTOR FEATURES

- Compact, Lightweight, High out-put
- Excellent Servo Characteristics
- Well matched line-ups and options
- Controller Units available in full line up

### TYPICAL APPLICATION

- Positioning Control of Conveyors
- Industrial Robotics
- Locating and Position Control
- Press Position Control
- Work Position Control
- Simplified NC Machine Retrofitting
- X-Y Table Location Control



DRIVE UNITS AVAILABLE FOR ALL MODELS  
L/R DRIVE UNIT AVAILABLE IN KIT FORM

MELBOURNE: 18-20 Syme St., Brunswick, Ph: (03) 387 0655 Fax: 387 9062  
SYDNEY: 25 Hector St., Sefton, Ph: (02) 644 8133 Fax: 644 3550  
ADELAIDE: A.F. Hay, 116 Gilbert St., Adelaide, Ph: (03) 51 3941

## INTERESTED IN ELECTRONICS?

Right now we have quite a number of vacancies for staff throughout Australia.

### We need:

- **Sales staff** - ambitious self-motivated people who are interested in a retail career.
- **Junior Technicians** - we will train you in the audio, digital, communications, security and video fields.
- **Senior Technicians** - experienced in the RF and digital fields.  
(Technical vacancies particularly in Sydney and Melbourne and from time to time in other capitals.)

### We offer:

- Security (our company is 20 years old)
- Job satisfaction (over 5000 interesting products)
- Opportunity for advancement
- An attractive salary package
- Generous staff discounts

### Give us a call!

Sydney: R Johnson (02) 888 3200  
Perth: P Evans (09) 227 8243  
Melbourne/Adelaide: A McEwin (03) 592 2366  
Brisbane: N Wickson (07) 391 6490

**DICK SMITH**  
ELECTRONICS





# Superior Printed Board Design

CAD Bureau since 1981

## We have installed the RACAL VISULA/APOLLO



interactive design system which offers a 75% reduction in cycle time.

- Schematic
- Netlist
- Parts list
- Auto routing
- Photo plotting

Board layout is consistent with the captured schematic

## ELECTRI-BOARD DESIGNS P/L

PCB DESIGN SINCE 1972

15/31 WATERLOO ROAD, 02-888 6925  
NORTH RYDE NSW 2113. 02-888 3929



# Anthony Borg & Associates Pty. Ltd.

Telephone: (03) 374 2040  
Fax: (03) 379 3789

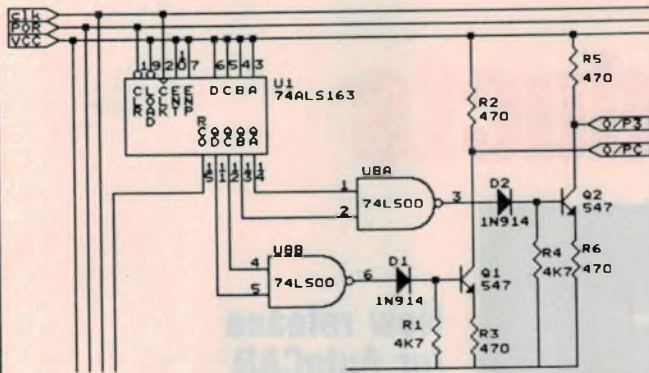

## OrCAD A CUT ABOVE THE BEST

OrCAD/SDT The advanced SCHEMATIC CAPTURE package  
Now combines with OrCAD/VST the DIGITAL SIMULATOR

This powerful combination now gives you the ability to "electronically breadboard" your design on your work desk

### OrCAD/VST Features :-

- 14,000+ Gate capacity
- 50 Channels (signal or buses)
- 10,000 events per second (8MHz AT)
- Selectable sampling times
- Plus many other facilities

### OrCAD/SDT features :-

- Over 3700 unique library parts
- Unlimited level hierarchy
- Powerful Keyboard macros
- Netlisting & post processing utilities
- Variable size Text
- On Line parts browsing
- Graphics entry of library parts

Design and Simulate at your Desk

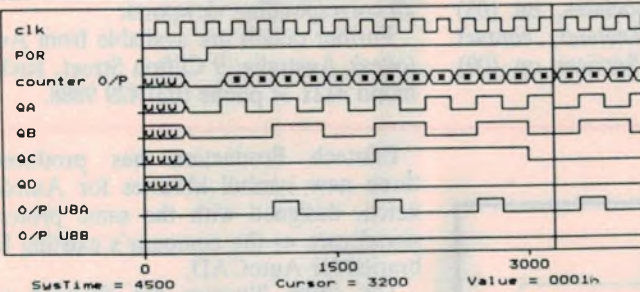

### Cut out and mail Today

We will send you a FREE Demo disk and Literature

Name \_\_\_\_\_  
 Title \_\_\_\_\_  
 Company \_\_\_\_\_  
 Address \_\_\_\_\_  
 Telephone \_\_\_\_\_ Fax \_\_\_\_\_

Prometheus Software Developments Pty Ltd  
260 High Street, Kew, Vic. 3101  
Telephone (03) 862 3666. Fax (03) 862-2092

## CAD Feature:

# New CAD products



### Micro CADAM enhanced

CADAM Inc. has enhanced the functionality of its PC-based CAD system with the release of Micro CADAM Cornerstone 1.3.

The new features supported by Release 1.3 include:

1. Network support, enabling users to share, send and receive design data over a wide variety of DOS and UNIX based LANs.
2. Extended support for input and output devices.
3. Automated installation.
4. Automatic creation of multiple chained offsets, that creates multiple parallel offsets from complex geometric

figures.

5. An optional geometry interface module (GIM) that allows programmers to create FORTRAN application programs.

6. An optional function key box that facilitates the function selection process.

Geometry libraries for mechanical, electrical and architectural design are now also available as options.

Micro CADAM products are available in Australia from the distributor, Anthony Borg & Associates, on (03) 584 5905. In New Zealand, contact Geometric Modelling Services on (09) 39 1402.

### New release for AutoCAD

Autodesk Australia has announced a number of enhancements for its widely used AutoCAD system for personal computers, in the latest Release 10.

AutoCAD now features 3-D wire-frame construction and surface modelling capabilities, together with new drawing, viewing and database features. Also for the first time, this version of the package is available for use on Apple's Macintosh II.

Surface modelling features of Release 10 include 3-D meshes or surface patches, surfaces of revolution, tabulated cylinders and ruled surfaces defined by two boundary curves. Dynamic viewing allows the user to rotate the 3-D model in real time to any orientation. 3-D designs can also be viewed in parallel or perspective projection.

A new multiple viewport feature lets the user display 3-D models in up to four viewports on 16-bit systems and up to 16 viewports with 32-bit systems. Any viewport can be made active, and all changes are automatically updated in all corresponding viewports.

Further details are available from Autodesk Australia, 9 Clifton Street, Richmond 3121 or phone (03) 429 9888.

### AutoSketch symbol libraries

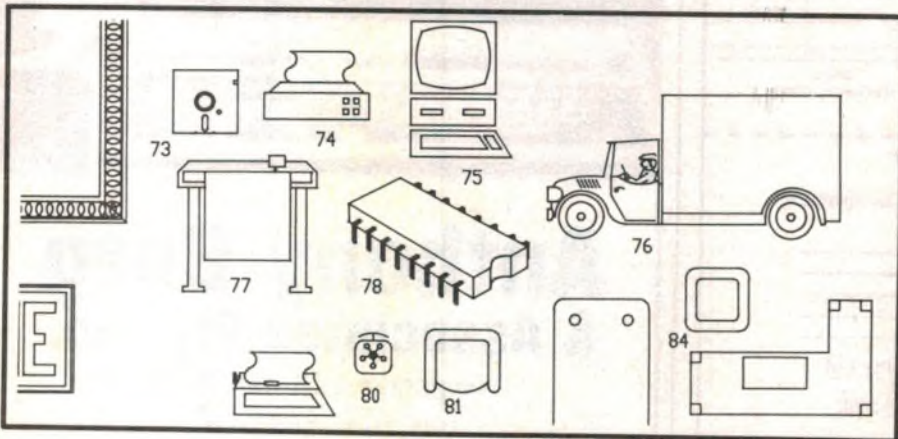

Edutech Production has produced three new symbol libraries for AutoSketch, designed with the same professional care as the company's existing libraries for AutoCAD.

The three libraries are devoted to Clip Art, Electrical & Electronic, and Hydraulic and Pneumatic symbols respectively. The Clip Art symbols are capable of being extracted and uploaded into desktop publishing packages (file.SLD format only).

Each library comes on two 360K IBM formatted 5.25" floppy disks, and costs \$55 plus sales tax.

Further details from Edutech Productions, PO Box 139, Ringwood East, 3135 or phone (03) 720 2488.

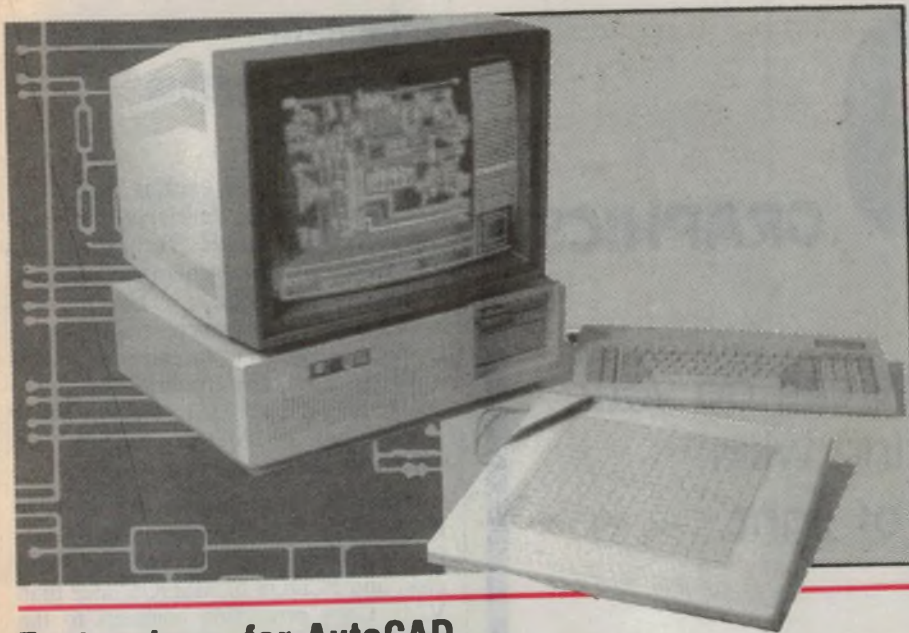

ESP is a very intelligent digital and analog circuit design schematic capture tool, which runs on IBM PC/AT and compatible computers, Digital Equipment VAX systems and Whitechapel workstations.

ESP incorporates a set of interfaces to the more popular simulators and routers. It uses a mouse or puck for data entry and offers full colour and zoom capabilities.

Key features include unlimited levels of hierarchy, automatic symbol status checking and replacement, automatic text location and labelling, and the ability to handle multi-sheet schematics up to A00 size.

Cost of the package is \$8500 and it can be evaluated prior to purchase.

Further details from Parameters, 25-27 Paul Street North, North Ryde 2113 or phone (02) 888 8777.

## Fast redraw for AutoCAD

A new software driver which can redraw an AutoCAD image instantly after pan and zoom has been introduced by Verticom, for its range of colour graphics monitors, distributed in Australia by Sourceware.

The new driver, called Twinfocus, will

also enable AutoCAD users to view two sections, or windows, of an AutoCAD drawing simultaneously, and to draw lines between them.

Sourceware is offering Twinfocus as an option for Verticom's H Series graphics controller cards.

Twinfocus can 'remember' the original AutoCAD drawing before pan or zoom takes place, and return to it instantly once either is complete.

Further details from Sourceware, 586 Pacific Highway, Chatswood 2067, or phone (02) 411 5711.

## PCBreeze

Create PCB artwork quickly and easily.

### Features Include

- \* 50 mil grid, up to 20x20 inches
- \* 25 mil grid, up to 10x10 inches
- \* Variety of Pad & Line sizes
- \* Four Zoom levels & Panning
- \* Autorouting - Single & Double layer, interactive or net-list input
- \* Block operations: Copy, Move, Delete, Save & Load (with rotation)
- \* Trace operations: Copy, Move, Delete, all or part of a trace
- \* Text and Silkscreen layers
- \* High quality output on a plotter
- \* Prototype quality on a dot matrix printer
- \* Automatic component overlay

### Hardware Supported

384K IBM-PC/XT/AT or compatible, CGA, EGA, VGA & Hercules graphics, HP-GL (eg: Hewlett Packard plotters), DM-PL (eg: Houston Instruments plotters), PostScript (eg: Apple laser printers or Linotronic 300 typesetting machines), Epson FX type dot matrix printer, or a compatible output device.

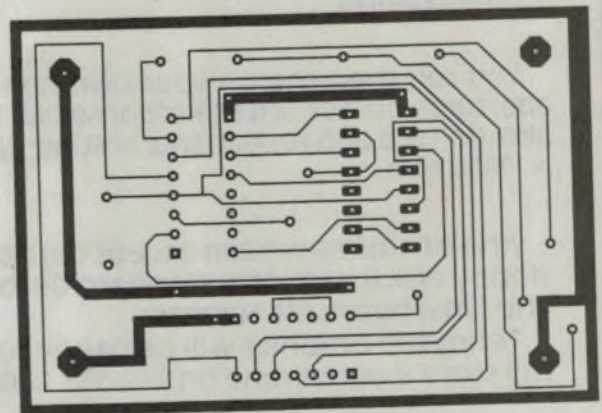

**\$200** (tax exempt)

To order or for further information:

**Kepic** Pty. Ltd.

4 Steinbeck Place, Spearwood 6163,  
Western Australia  
ph: (09) 418 5512

if applicable add 20% sales tax  
prices include shipping  
within Australasia



## TENNYSON GRAPHICS

Tennyson Graphics can do your photoplotting with the speed of light.

Tennyson Graphics are Australia's only company with state of the art laser photoplotting and computer graphics.

So we can photoplot artwork masters of your printed circuit boards with higher speed, higher resolution and higher accuracy than anywhere else in the country.

You can even choose your own non standard apertures on our Scitex Response 280 System. It can also do step-and-repeat and nesting up to 1000 mm x 1850 mm.

And of course we can accept data on tape or floppy disk in industry standard Gerber, Autocad and Smartwork file formats.

Tennyson Graphics will be happy to give you the full story if you phone on (03) 551 8600.

---

TENNYSON GRAPHICS  
A DIVISION OF REPROCART PTY. LTD.

7 PLANE-TREE AVE  
DINGLEY, VIC. 3172  
TELEPHONE (03) 551 8600  
TELEX: 34457  
FAX: (03) 551 8828

## New PCB, schematic design programs from Protel

Building upon its existing highly successful Australian developed PCB design package, Protel Technology has produced a new generation package called Protel-Autotax. This provides many new and enhanced features such as auto component placement and track routing, interactive routing and placement, and the ability to support either through-hole or SMD devices with user-selectable design rule clearances.

Hardware requirements are an IBM PC/XT/AT/PS2 with 640K RAM, two floppy disk drives or one drive and hard disk, and PCDOS or MSDOS later than V2.0. Copy protection connects to the LPT1 or LPT2 printer ports.

Protel-Autotax supports CGA, EGA, VGA, VGA deluxe and Hercules graphics cards. Maximum board size is 813 x 813mm (32" square). It can handle PCBs with up to six signal layers plus power and ground planes, two component overlays, two solder masks, two paste marks and one keep out. Visual or snap grids with 1 to 1000 mils resolution are available, with absolute or relative zero points. Tracks and vias are user definable from 1 to 255 mils.

Protel-Schematic Version 3.0 is the latest version of this low-cost high performance program for creating schematic diagrams of digital and analog circuits. It can be used as a stand-alone package, or in conjunction with Protel-PCB to form part of a powerful PCB design system.

The program now incorporates full pull-down menu operation or can be command driven with optional keyboard macros. Hardware requirements are basically as for Protel-Autotax, with the same copy protection system.

Protel-Schematic is supplied with more than 3000 components in its libraries, with a graphics editor (SLM) to either change existing component symbols or create new ones. A special feature of the program is its text creation ability. Text may be placed with components or freely on a drawing by invoking a word processing function.

Further details are available from Protel Technology, Technopark, Dowsings Point, Glenorchy 7010 or phone (002) 73 0100.

## 3-D design on a PC

CADKEY 3 is claimed to allow the most sophisticated features of 3-D mainframe design to be performed simply on personal computers, at a fraction of the cost.

Cost of CADKEY is \$5500 plus tax, and it will run on hardware costing under \$5000. Minimum requirement is an IBM PC or compatible with 640K of RAM, hard disk, graphics board and screen and a floppy disk drive to load the program. A 286- or 386-based machine with co-processor, EGA and mouse is recommended.

CADKEY produces a 3-D geometric model which acts as an accurate prototype. This can be viewed from any angle and dimensioned according to ANSI or ISO drafting standards. Once a part is created on screen it is managed as a single 3-D model with x, y and z coordinates to seven digits of accuracy. This allows the generation of an unlimited number of views from the 3-D model.

A 'solids synthesis' function automatically produces a 'solid' model from 3-D wire frame geometry and graphically depicts it as a true shaded solid. Up to 356 colours can be plotted at one time.

Further details are available from Advanced Manufacturing Technologies, 31-33 Parramatta Road, Lidcombe 2141 or phone (02) 648 3477. 

# With the V.D.T. ANTI-GLARE USER FRIENDLY has a whole new meaning

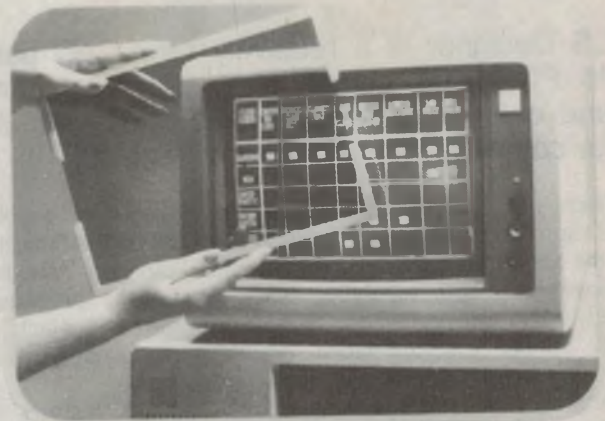

Eyestrain is only one of 24 problems VDT users suffer from. Yet it accounts for a staggering 91% of complaints.

With V.D.T. ANTI-GLARE filters, Video Operators Syndrome is virtually eliminated. Quickly and economically.

- ▶ NO RESOLUTION LOSS
- ▶ REDUCES EYESTRAIN
- ▶ REDUCES GLARE
- ▶ IMPROVES READABILITY
- ▶ EASILY FITTED
- ▶ EASY TO CLEAN
- ▶ RANGE OF SIZES - OVER 7000 MODELS

For improved productivity, less mistakes and reduced downtime, call VDT ANTI-GLARE for your local representative.



## V.D.T. ANTI-GLARE (AUST.) Pty. Ltd.

8 Dowling Avenue, Springvale North, Vic. 3171  
Phone: (03) 548 3485 Fax: (03) 5624858

VDT240 AME

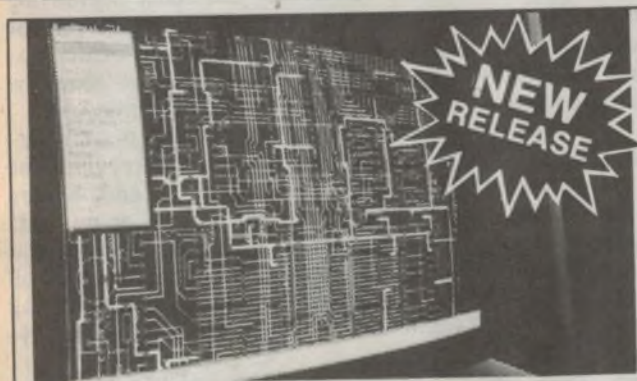

## Top of The Line In PCB Design

\$AUD1395.00

### PROTEL-AUTOTRAX

This product has a host of new features to assist in the design of a PCB whether it is Through-Hole or SMD Technology. Standard features include Automatic Component Placement, Interactive and Autorouting with Design Rule Checking.

AUTOTRAX offers usable definable track widths from 1-255 mil and pads from 1-1000 mil. A multilayer program including power and ground planes plus video drivers for CGA, EGA, VGA, VERGA, Deluxe and Hercules. Outputs include: plotters, printers, N/C Drill and Photoplotter.

Hardware requirements IBM PC/XT/AT/PS2 or compatibles with 640K RAM, 2 floppy disk drives or 1 floppy plus hard disk. PC or MS-DOS version 2.0 or greater. Also supports 4Mb EMS.

Other programs in Protel Family: PROTEL-PCB-SCHEMATIC-ROUTE-TOOLBOX.

### PROTEL TECHNOLOGY PTY LTD

Incorporated in Tasmania

TECHNOPARK DOWSINGS POINT  
HOBART TASMANIA AUSTRALIA 7010

POSTAL G.P.O. BOX 536F HOBART 7001

TELEX AA 58260 CRTEC

PHONE NATIONAL 10021 730100  
INTERNATIONAL +6102 730100  
FACSIMILE NATIONAL 10021 731871  
INTERNATIONAL +6102 731871

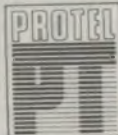

## CAD Product Review:

# Economy CAD package for PC's

CCS Designer is a relatively new CAD package for use on IBM PC's and compatibles. It offers many features often found only on quite expensive packages, yet is currently on offer complete with a mouse for only \$299!

There are now quite a few different CAD software packages available to run on the almost ubiquitous IBM PC's and compatibles – with capabilities varying widely. You can go all the way from fairly simple computer-aided drafting and sketching, through 3-D solid modelling, to full-scale circuit capture/analysis/simulation/auto-routing of the PCB pattern and so on.

Not surprisingly the prices tend to cover a similarly wide range: from a few hundred dollars up to over \$20,000. That's right, just for the software!

Most of the packages down at the bottom end of the price range are fairly spartan, offering very few of the features available on those further up market. But a recent addition to the low end attracted our attention, because it does seem to offer rather more than the others – and at a very impressive price. As noted above it sells for only \$299, complete with operating manual and a mouse. Some mice alone sell for more than this!

The package is called *CCS Designer*, and it comes from a company in California called Complete Computer Services Inc. It's being distributed in Australia by Electronic Solutions.

CCS Designer runs on virtually all normal IBM PC models and compatibles, as long as they have at least 512K bytes of RAM. It can be set up to run on most graphics cards, including the Hercules mono, CGA, EGA and VGA, and also supports a wide range of mice, digitising tablets, printers and plotters. Laser printers are supported as well as a range of dot-matrix types.

By the way, CCS Designer will work quite happily from a normal or ex-

tended PC keyboard. A mouse isn't essential, although it's a little more convenient. Various keys are used to call up the program's range of functions, most of which involve only one keystroke apart from identifying various points.

The features it offers are quite impressive, particularly for a package in this price bracket. For example it will draw 'rubber band' lines and boxes; zoom up and down over a wide range of magnifications; rotate a drawing through any desired angle (2-D); allow section move, copying and mirroring; automatically dimension and scale a drawing; draw arcs and parts of ellipses; draw multiple-segment lines in a single operation; 'fill in' any desired area with a few simple keystrokes; and draw in up to 16 colours (dependant mainly on your computer's graphics card and monitor).

As well as setting a point using the current cursor position, you can define it in terms of either Cartesian (X-Y) or polar co-ordinates, from the last point set.

Drawing things like circles are very easy. You simply define the circle's centre point, then one point on its periphery, and press the 'Draw Circle' key. If you define a third point before hitting the function key, it will draw an ellipse instead of a circle.

Similarly rectangular boxes are drawn simply by defining two diagonal corner points, and then pressing the 'Draw Box' key. The 'Rubber Band Box' function may be used to visualise the box dynamically, as you move the cursor, and before drawing it in permanently. Virtually the same approach is used for

straight or curved lines, with the 'Rubber Band Line' function used to visualise progress.

Sections of a drawing can be saved on disk separately, to become often-used symbols. Alternatively you can draw new symbols separately at a size much larger than they'd be used, to get the best detail, then zoom them down to working size and save them at that size for later use.

Sections of a drawing can also be moved or copied, simply by defining the area concerned and then identifying where you want it to be moved or copied. For repeated moves or duplications there's also a 'Repeat Move or Copy' key, which is quite convenient.

Other interesting features of *CCS Designer* are its provision of three different types of working grid (full grid, border graduations, or dot array), or no grid; optional cursor 'cross hair' lines to allow more convenient alignment; range of line widths and types; and choice of two different text fonts for labelling and titling.

There's also a handy 'help' facility, which lists on the screen all of the available commands whenever you hit the '?' key.

A particularly nice feature is the so-called *Gravity Point* function. This lets you zero the cursor in on the nearest point of your drawing, just by pressing the full-stop key.

The idea behind this is that when drawings are zoomed, rotated, or sections saved and then retrieved, they can end up with various points not exactly lined up with the screen's grid. This can make things tricky, because the cursor normally moves in step increments aligned with the screen grid. So without the gravity point function, it can be impossible to place the cursor on a particular part of the drawing.

What the gravity point function seems to do is shift the reference for cursor in-

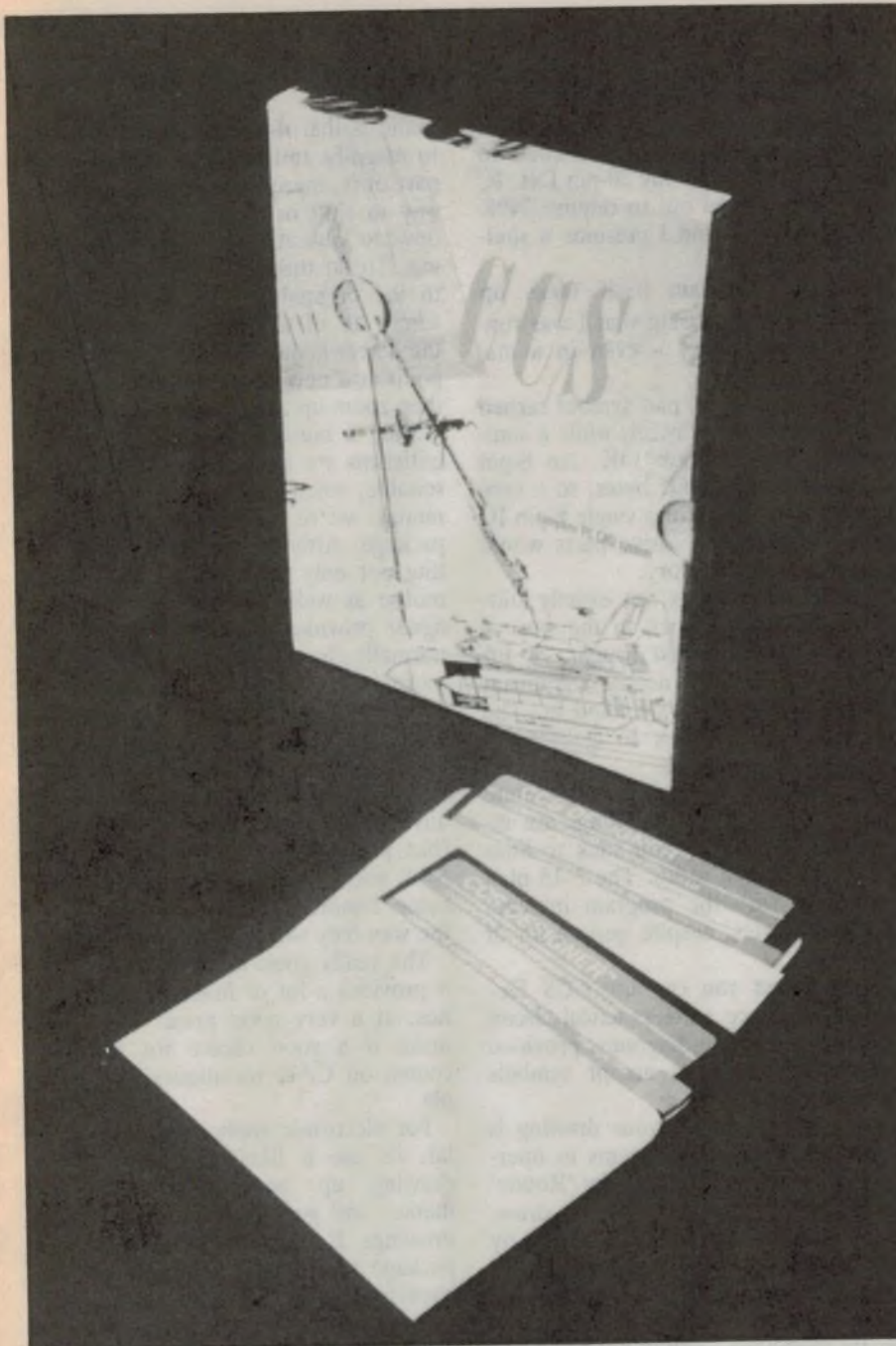

**Our photographers have been working under difficulties this month, but here's roughly what the package looks like without the mouse.**

crementing, so that one of the cursor comes into exact alignment with the nearest point of the drawing. Very nifty!

There's also a similar *Gravity Move* feature which allows you to move symbols retrieved from disk, so that they mate exactly with existing sections of a drawing.

Parts of a drawing can be erased in a number of ways. If you've only just drawn a line or shape, you can erase it again using the 'Undo last drawing command' function key. Alternatively you can use the 'Erase' function, after iden-

tifying key points on the line or shape to be deleted. A third option is to use the 'Section Delete', after defining the borders of the area you want to erase.

If you make a mistake when erasing/deleting, there's also an 'Oops' key to undo the last erasure.

### Trying it out

So much for CCS Designer's features and functions. But how does it work out in practice?

Some CAD packages take a lot of time to get into them, before you're

really able to do much at all. Basically I found *CCS Designer* quite good in this respect; after a couple of hours playing around and studying the manual, I was able to do most basic operations quite easily.

One of the things I discovered fairly early on was that the basic CCS package doesn't come with any existing symbol library. There's just a line drawing of the plan for an F-15 fighter plane, to give you an idea of the package's capabilities.

A symbol library disk is available separately, if you want it. This provides symbols for plumbing, electrical and electronic applications. But the library disk wasn't available at the time of reviewing the package, so it was necessary to try creating my own using the basic package.

This turned out to be relatively easy, and it had the additional benefit of letting me discover more about the package's features – as well as a few of its limitations.

The manual suggests creating your symbols as large as possible on the screen, and then zooming them down for storage and later use. I tried this, finding out along the way that if you used different line widths to create your symbol, these seem to remain at their original widths when you zoom down. So my nicely proportioned bipolar transistor symbol turned into a solid filled-in circle, when I reduced it to working size!

In other words, it seems to be desirable to create your symbols using the basic unit-width lines, so they're still readable when you reduce them.

Another thing I discovered before long was that if you used the 'Paint' function to fill in areas of your drawing/symbol, you soon run out of memory.

For example I first created the symbol for an IC pin pad, for a PCB. Then I saved it, and retrieved it eight times to create the pattern for an 8-pin DIL package. Then after saving this in turn, I added more of the pad symbols to create patterns for a 14-pin package, a 16-pin package and so on – saving each one as I went along.

By the time I had created a 20-pin DIL pattern, the program flashed up a warning: 'Image too big – must save'. So I saved it immediately, but found when I retrieved it that it had been corrupted anyway.

Other experiments along the same lines showed that filling in areas of your drawing or symbol dramatically expands

## DATA ACQUISITION AND CONTROL

**DATATAKER:  
\$2,400 COMPLETE**



46 Analog/8 Digital Inputs  
Matches Common Transducers and Sensors  
Built-in Software/RS-232 Communications

### Portable Dedicated or Stand Alone

The complete solution  
No cards, modules or software to buy  
No programming knowledge required  
Datataker does it all  
Industrial and Field models available

### DATA ELECTRONICS

48 Wadhurst Drive, Boronia, 3155.

Tel (03) 801-1277. Telex 36615. Fax (03) 800-3241

**PROTEL — \$890.00\***

available now from

**R.C.S. DESIGN P/L**

728 Heidelberg Road

Alphington Ph: (03) 49 6404

\*excluding Tax, delivery and training

## Economy CAD package for PC's

the amount of memory area needed, and also the disk file size needed to store it. For example my 20-pin DIL IC pad pattern turned out to require 249K bytes of storage, and I presume a similar memory area.

Since the program itself takes up 135K, it's not surprising that I was running out of memory — even in a machine with 640K.

Even the basic IC pad symbol turned out to require 13.3K bytes, while a similar donut symbol took 14K. An 8-pin DIL pattern took 106K bytes, so a very simple PCB pattern for a single 8-pin IC and a dozen or so passive parts would probably fill the memory.

So *CCS Designer* is not exactly suitable for designing much in the way of PCB patterns, it would appear, or for anything else that needs significant areas of a drawing to be filled in. The filling in really seems to gobble up memory and disk space.

On the other hand it does seem quite economical where line drawings are involved — especially if you stick to lines in the basic single width. The F-15 plan that comes with the program involves only 13.6K bytes, despite quite a lot of linework.

So I suspect you can use *CCS Designer* to produce quite practical circuit schematics and logic diagrams, provided that you're happy to accept symbols with unit-weight lines.

The ability to rotate your drawing is good, and this function seems to operate quite quickly. Note that the 'Rotate' function operates on the complete drawing, as a whole. To rotate a section by itself (to orientate a symbol, for example), you need to move it to the same location, specifying a new angular position by specifying further points. A bit messy, but it can be done. So for circuit schematics you'll probably want to define separate symbols for each component in various orientations: vertical, horizontal, upside down and so on.

Actually it turns out to be a little tricky to move existing screen symbols to a new location, or to position those retrieved from disk, because *CCS Designer* uses the bottom left-hand corner of each symbol as its datum. This complicates matters for electronic circuit schematics, for example, because in most cases you want to position a symbol to line some other part of it up with the existing drawing.

The only other little shortcoming I

found is that if you zoom up a drawing to magnify and fill the screen with one part of it, there doesn't seem to be any way to shift or 'pan' your screen 'window' to look at other parts of the drawing. To do this you have to zoom back to the original size (or at least a size where all of the drawing is visible on the screen), move the cursor and set a point at a new part of the drawing, and then zoom up again.

Still, I must point out all of these criticisms are really being rather unreasonable, when you consider the kind of money we're talking about for this package. After all, for \$299 you're getting not only the basic package, but a mouse as well. It's just that *CCS Designer* provides so many of the features normally found on much larger and more fancy packages, that it's hard to avoid judging it by the same standards!

All in all, it's really a very nice little CAD package indeed. In fact it would make an excellent starter package, for anyone with a PC compatible machine (but preferably an AT-level one, with 640K and a hard disk) who wants to become familiar with CAD systems and the way they work.

The really good thing about it is that it provides a lot of functions and facilities, at a very good price. This would make it a good choice for a college course on CAD techniques, for example.

For electronic applications in particular, its use is likely to be limited to drawing up not-too-elaborate schematics, and perhaps making metalwork drawings. But again it would be a good package to cut your teeth on, perhaps changing over to one of the more elaborate (and expensive) packages when you want to get down to serious work like PCB design.

As already noted, the basic *CCS Designer* package sells for \$299 (RRP), complete with manual and a Dexxa mouse (very similar to the Logitech). Incidentally the basic package comes with two versions of the program, one for computers with the 8087 maths coprocessor chip, and other for those without. An installation/setup program is also included.

The optional Symbols Library disk costs a further \$79, again RRP.

*CCS Designer* is available from Electronic Solutions, of PO Box 426, Gladesville 2111 or phone (02) 427 4422. (J.R.)

②



# Complete CAD Package ... for just the cost of a mouse

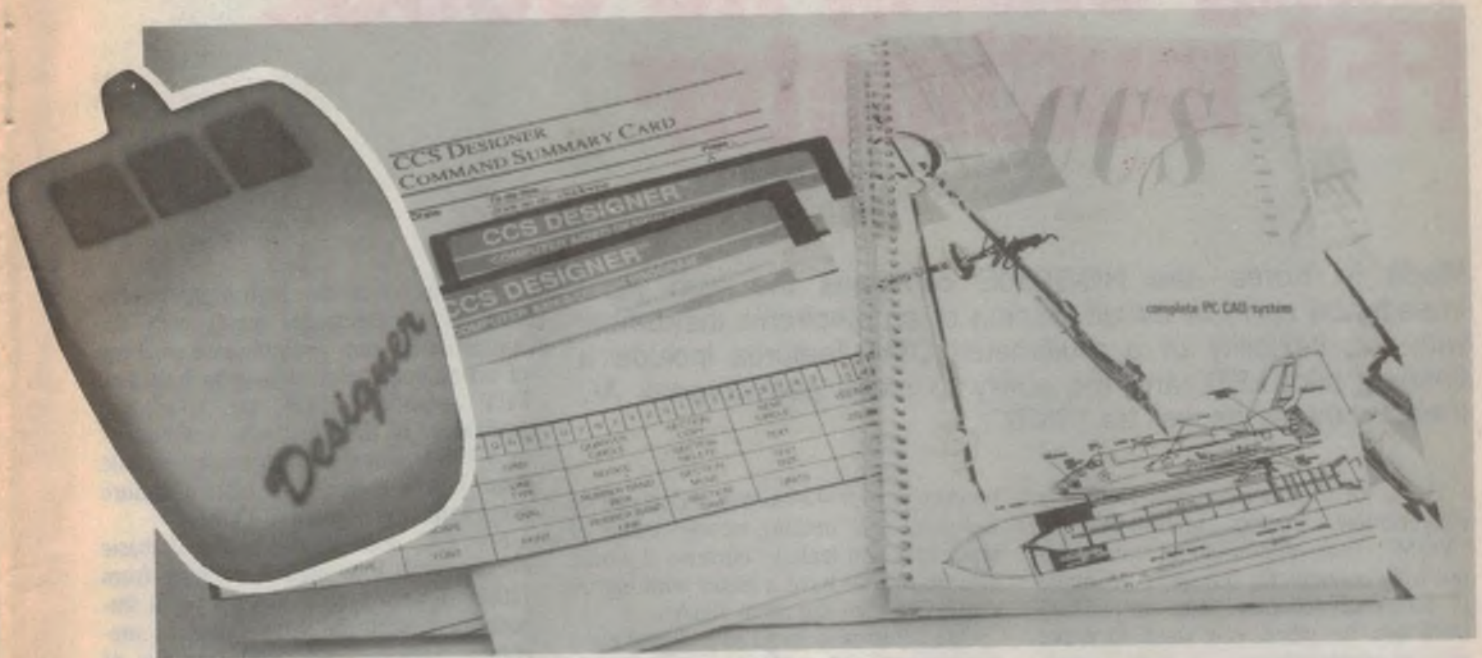

**N**ow you can create detailed, professional quality designs and drawings quickly, easily and inexpensively.

**CCS Designer** comes with many of the same powerful features found in CAD systems costing hundreds, even thousands, of dollars more. All you need is an IBM PC/XT/AT or compatible computer with 512K RAM and you'll be creating designs in less than 30 minutes.

Use it for dozens of applications: Architectural designs, organisational charts, mechanical designs, business graphics, interior designs, landscaping, flow charts, floor plans, schematics - you name it. Built in drivers support 180 mice, 52 input devices, 77 plotters, math co-processors and most display cards.

Use CCS Designer with our Symbol Libraries.

**Symbol Library Volume One:**  
Electrical, Electronic and Plumbing symbols.

**Symbol Library Volume Two:**  
Home design and home furnishing symbols for creating floor plans and designing interiors.

**Symbol Library Volume Three:**  
Flow chart symbols for drawing professional quality flow charts.

## FEATURES

- Enlarge • Rotate • Zoom in and out • Paint/fill • Undo
- Redo • Flip • Move, copy, delete and save sections • Plot to a dot matrix printer • Ares and curves
- Adjustable grid and snap gravity point • Multiple character sets • 8 line types with adjustable thicknesses
- Clearly written manual and on-line help • AutoCAD compatibility available • Create your own symbol libraries • Mouse supported
- Retrieve symbols at any size, angle, or location • 16 colour high resolution display and output • Auto dimensioning and scaling • Single keystroke commands • 8087 Math co-processor support • Point XY command • Point Polar command
- Repeat copy section • Gravity move
- Ortho line • Static zoom

Feature for feature, no other CAD package offers such outstanding performance and value, with a **30 day money back guarantee.**

Send the coupon to receive your CCS Designer with DEXXA mouse.

**CCS Designer and DEXXA Mouse** ..... \$299.00  
**Symbol Libraries** ..... \$79.00 each  
 Plus \$10.00 postage and packing.  
 Prices include sales tax.

Please send me

**CCS Designer & DEXXA Mouse for \$299**

Symbol Library  
 Vol. 1  Vol. 2  Vol. 3  
 \$79.00 each + p&p

\$10.00 p&p

Enclosed is cheque for \$ .....  
 Please debit my credit card \$ .....  
 Bankcard  Visa  Mastercard

Card No. \_\_\_\_\_

Expiry Date \_\_\_\_\_

Signature \_\_\_\_\_

Name \_\_\_\_\_

Address \_\_\_\_\_

\_\_\_\_\_

Postcode \_\_\_\_\_



Send to: Electronic Solutions,  
 P.O. Box 426 Gladesville NSW 2111.  
 Phone (02) 427 4422

## Product review:

# Hung Chang HC-5050E FET multimeter

Made in Korea, the HC-5050E combines the high input impedance and low circuit loading of an electronic instrument with the flexibility of a multimeter. Other features include a flashing pilot LED, and the ability to make peak-to-peak AC measurements as well as "RMS".

For a lot of general circuit testing, a conventional analog multimeter or "VOM" (volt-ohm-milliamp meter) is not only convenient, but quite adequate in terms of accuracy. The only drawback can be when you want to make voltage measurements in high impedance analog circuitry operating from low voltages, where the loading introduced

by even a 20,000 ohm/volt VOM can be too great. For making measurements of input bias and leakage currents it would also be nice to have a meter with higher sensitivity than the usual 50 $\mu$ A.

One solution is to go to a digital electronic meter, but these aren't always the most suitable.

The Hung Chang 5050E electronic

multimeter offers the high input impedance of an electronic meter with the convenience and unambiguous reading of an analog meter. It uses a balanced FET amplifier circuit, the solid-state equivalent of the old "valve voltmeter" or VTVM. But it's much more versatile than just a voltmeter, offering more ranges than most passive VOMs.

For DC voltage there are 7 basic ranges, with FSD figures ranging from 1200V down to 1.2V and an input impedance varying between 9 and 11 megohms. However the most sensitive of the DC current ranges can also be used as an even more sensitive voltage range, with an FSD of 300mV and an input impedance of 3M – quite handy.

The same range can be used as an extremely sensitive current range, with an FSD of 0.1 $\mu$ A. Yes, that's right, 100 picoamps! It's virtually an electronic galvanometer.

The 5 other DC current ranges have more conventional FSD figures varying from 300 $\mu$ A to 300mA in decade steps, and finally 12A.

As an added feature all of the DC voltage and current ranges have the ability to shift the zero up to mid-scale on the meter, to convert them into centre-zero ranges such as  $\pm 6$ V,  $\pm 150\mu$ A and so on. Very flexible, and something you can't do on a passive VOM of course.

There are 6 AC voltage ranges. As the FET amplifier circuit has a very high impedance, the diode detector circuit used for the AC voltage ranges is essentially responding to the peak-to-peak value of the AC, just like the old VTVMs. However for added flexibility the 5050E meter is provided with scales calibrated in terms of both P-P and RMS (assuming a sine wave). So in terms of RMS the six ranges have FSD figures of 3, 12, 30, 120, 300 and 1200V, while for P-P readings they cor-



A close-up of the meter face, a little larger than actual size. Note the provision of both RMS and P-P scales for AC, and the 0-100pA scale second from the bottom.

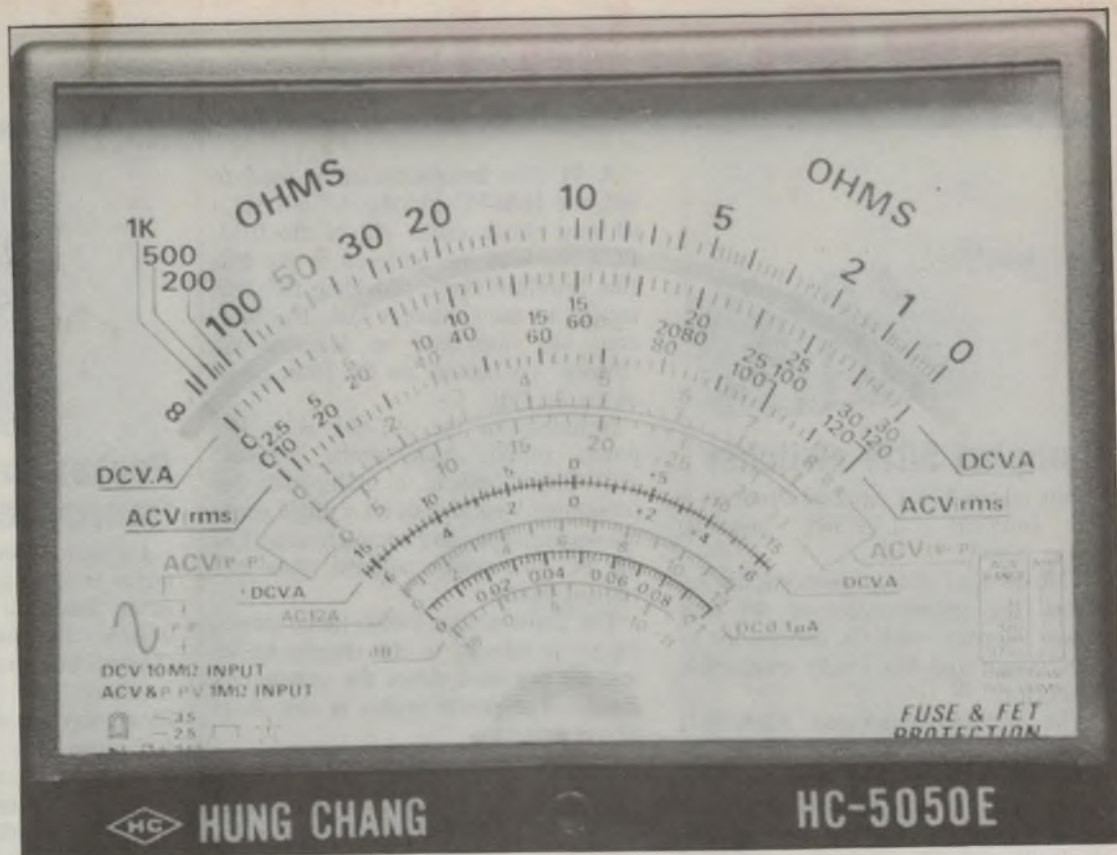

respond to 8.4, 33, 84, 330, 840 and 3300V.

For AC current there is just one range, calibrated separately as 0-12A RMS because of rectifier non-linearity.

The 12A ranges for both DC and AC use a separate input jack, as does the 1200/3300V highest AC voltage range. All of the remaining ranges use the two main input jacks, for convenience. There's also a polarity reversing switch for DC voltage and current measurements, to avoid the need for lead swapping.

Incidentally the input jacks are all recessed to prevent accidental contact, and designed to take guarded banana plugs as fitted to the test leads supplied. The instrument therefore complies with UL1244 and VDE 0411 safety requirements.

For resistance measurement there are 6 ranges, with centre-scale values of 10Ω, 100Ω, 1k, 10k, 100k and 10M respectively. Like the resistance ranges on a conventional analog multimeter, these have zero ohms at full scale and "infinity" at the bottom. However unlike most multimeters and like the old VTVMs, the "+" test lead does indeed become the more positive of the two for resistance measurements. Something you need to remember when checking things like diodes!

From a practical point of view the effective overall range of the resistance ranges is from about 1Ω up to about 100M, with a rough indication down to 0.1Ω and up to 1000M. Quite good for this kind of instrument.

The meter movement fitted to the 5050E is a 133mm (4-1/2") moving coil type with a 90° scale arc. It has a fine knife-edge pointer and mirror-backed scale, for accurate reading. As shown in the pictures it is provided with more than the usual number of scales, but colour coding helps to cut down the clutter to at least some extent. The lowest and least readable scale is for dB measurements, and is probably not going to be of much practical use.

Protection for the dual-FET measuring circuit and meter movement is provided by a further pair of separate FETs, connected as diodes, plus an internal fuse.

The other main point to note about the 5050E is that it has a flashing LED pilot, to remind you when the power is turned on. Power for the basic instrument comes from a 216-type 9V battery, with a pair of AA-size cells used for the ohms ranges source. Average current drain from the main battery is less than 3mA.

On test, the sample unit pictured performed quite creditably. The accuracy

for DC measurements was within the quoted +/- 2.5% of FSD, and for AC it was within the quoted +/- 3.5% of FSD. The ohms ranges also seemed to be within the +/- 2.8% quoted, for all values we were able to try.

Drift appeared to be very low indeed, with a needle movement of less than its width over a 1 hour period from switch on, even on the 1.2V and 300mV/100pA ranges.

In fact there were only three criticisms we could make about the sample meter - all relatively minor and fixable.

One was that its movement did not appear to have been well balanced mechanically, so that the zero would vary for various orientations of the meter. Another was that the ohms adjust pot appeared to be noisy, making it a little difficult to set it for zero ohms (especially on the lower ranges). And the third was that the frontmost of the three internal pillars which receive the back-cover mounting screws had broken off - suggesting that the plastic moulding may not be strong enough.

Otherwise, it seems a very practical little instrument, and good value for money at the quoted price of \$79.95.

The review unit came from Wagner Electronics, of 305 Liverpool Road, Ashfield 2131 or phone (02) 798 9233. (J.R.)

# New Products



## Compact 50W switcher

Just released by Computer Products is the Boschert XL50-7601 switching power supply.

This 50 watt device mechanically replaces the industry-standard 40 watt power supplies, with its dimensions of 100x160mm and has totally compatible connectors.

The compactly-packaged XL50-7601 has a continuous input of 85 to 264 VAC which does away with the need for an external 115/220 VAC switch and cable assembly. Further savings are made through the elimination of failure due to improper input voltage. And since the device is suitable for worldwide application, only one type of power supply need be purchased and stocked.

The XL50-7601 has a minimum switching frequency of 20kHz, is protected against overvoltage and output short-circuit and has a hold-up time of 16msec.

Further information from Amtex Electronics 13 Avon Road North Ryde, NSW 2113 or (02) 805 0844.



## PC Interface design tool

The A-Tek AT-601 is a unique product specifically designed to enable IBM-PC interfaces to be easily designed, evaluated, tested and modified. The breadboard (3060 tie points) is large enough for the complex prototyping that is often necessary in such applications.

A PC-Bus Interface card is used to link the IBM-PC and the AT-601 via a 64 way ribbon cable. All of the IBM-PC's bus lines are buffered by the PC-Bus Interface Card, providing full protection to the computer bus. The buffered bus lines can be accessed via "molex" connectors on the front panel of the AT-601.

Included on the AT-601 is a DC power supply, logic probe adaptor, ALT/CHOP switch, a multiplexer for presenting logic signals on a single channel oscilloscope, and complete access to the PC bus, power, address, data and control signals.

The multi output switch mode power supply is inbuilt, so the circuits under test do not load down the computer's supply. The power supply is also short circuit protected.

Further information from Emona Instruments, 86 Parramatta Road, Campersdown 2050 or (02) 519 3933.



## Plastic dip coating

PDI Plasti Dip is an air-dry liquid plastic dip coating which produces a tough, thick pliable finish for the handles of tools, etc.

The resulting coating is red in colour, virtually impervious to the elements and has good dielectric strength. Multiple coats can be used for increased thickness and protection. Drying time per coat is 4 hours at 70°F.

Jaycar Electronics has Plasti Dip in 473ml (16 fl.oz) cans, for \$24.95. Further details from all Jaycar Electronics sales outlets, or from 115-117 Parramatta Road, Concord 2137 or (02) 747 2022.



## Pocket sized 2m transceiver

Captain Communications of Parramatta is now stocking the micro-sized Icom handheld series – the ICOM u2A/A. The palm-sized transceiver is claimed to represent a breakthrough in 2 metre "go anywhere" technology. Measuring just 4.6" high, 2.3" wide and 1.1" deep, the IC-u2A/A packs more features than some large transceivers.

Features include:

- 10 programmable memories
- Odd offset capability
- LCD readout
- 2.6 watt output
- 32 built-in subaudible tones

In ICOM tradition, the IC-u2A/A has an extensive range of accessories, including rechargeable batteries, carry cases, headsets, and even a vox.

For further information call or fax the Captain: Phone (02) 633 4333, fax (02) 891 2271.

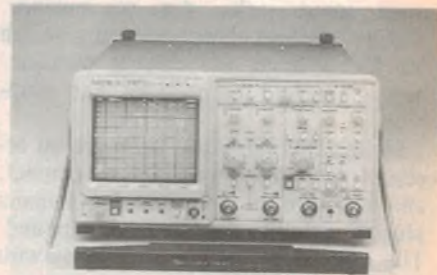

## 300 MHz digital sampling scope

The new Tektronix 300MHz 2440 Digital Oscilloscope combines 8-bit vertical resolution with 500 megasample per second, dual-channel, simultaneous acquisition – the highest sampling rate available in a portable scope. The 2440's combination of high resolution and sampling rate gives users noticeably more horizontal and vertical waveform detail. The result is improved ability to accu-

rately capture very fast single-shot events.

The high performance 2440 offers all the popular built-in automation features pioneered by other 2400 Digital Oscilloscopes – all in a GPIB-compatible unit compact enough to serve as either a system component or standalone test station.

Even unknown signals can be captured and displayed on the 2440 with the push of a single button. This feature automates and simplifies setups for measurements such as rising edge, falling edge, pulse width and period. In addition to the 2440's familiar front-panel controls, set-up and measurement functions can be initiated by an ID button on the head of Tektronix's new P6137 350MHz passive voltage probe.

Further information from Tektronix Australia, 80 Waterloo Road, North Ryde 2113 or (02) 888 7066.



## EMI suppression inductors

Pulse Engineering has developed a complete inductor family to provide a package with guaranteed minimum resonant frequency and leakage inductance limits. These are important parameters to consider when designing on-board filters for high frequency switch-mode power supplies. The wide variety of available component values makes it possible to design a board mounted filter with optimum performance characteristics.

The Inductor Kit has a selection of 31 inductors with rated currents from 1 to 15 amps. All are tested to VDE 0565 part 2 and UL 1278. Dielectric tests are 3750 VAC (winding to winding).

Complete details of the kit are available from Clarke & Severn Electronics, PO Box 129 St Leonards NSW 2065 or (02) 437 4199.

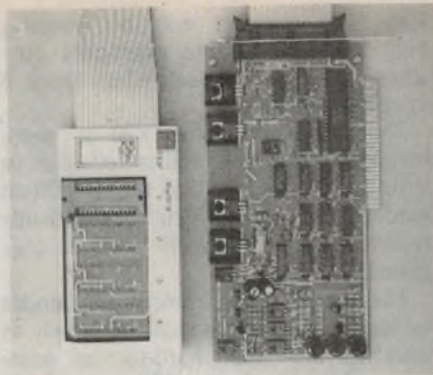

## EPROM burner for PC's

Electronics Solutions has released a powerful EPROM burner with superb "drop down" menu software. Extensive help facilities make EPROM work a snack with the ES Burner. It is suitable for burning most popular EPROMs and comes with a high quality ZIF socket and cabling, with facility to add 3 more sockets if necessary.

Facilities include the ability to read, write, copy, compare and erase the contents of EPROMs. It can also verify data and even combine the data in two smaller EPROMs into a larger one. It is compatible with 2716, 2732, 2764, 27128, 27256, 2804, 2816, 2864, and 58064 devices.

The EPROM burner comes complete with software and user manual. Price is only \$195 including tax and it comes complete with a 14 day money back guarantee.

For further information contact Electronic Solutions, PO Box 426 Gladsville 2111 or (02) 427 4422.



## Fax is OMR-card programmable

The new Toshiba TF-211 facsimile is specifically designed for small to medium sized offices. It is claimed to be particularly "user friendly", with the option to use Optical Mark Reader Cards (OMR) which will automatically access virtually any function of the machine.

for example, when an executive wants

to send documents overseas at a specific time – which because of the time difference, happens to be in the early hours of the morning in Australia – an OMR card can be easily written to perform the task. It dials the number and transmits the information. Even multiple transmissions can be made after hours.

The pre-programmed OMR cards are also ideal for inexperienced operators, eliminating the risk of error; they also release operators for other work, rather than have them supervising the facsimile's operation.

Toshiba's TF-211 has an optical and printing system which will send, and reproduce, up to 16 shades of grey ranging from the softest to the darkest tone. A further benefit is a contrast adjustment which can be fine tuned.

The TF-211 uses internationally recognised G2 and G3 modes for transmission and reception, plus a high-speed mode for communication with other Toshiba models. Voice communication, internal copying of documents and a logical grouping of operating instruction complete the TF-211 lineup.

For further information call Jonathan McQuade, National Sales Manager – Facsimile, Toshiba Copier & Facsimile Division, on (02) 887 6034.

**ON COURSE  
PCB DRILLING  
WITH  
HI DRILL  
ENTRY/BACKING SHEET**

- EQUAL TO LCOA
- LOWER COST

**HI-DAP**



**Pty Limited**

**31 Smith Road  
Springvale Vic. 3170  
Telephone: (03) 547 2477  
Fax: (03) 562 3930**

## New Products

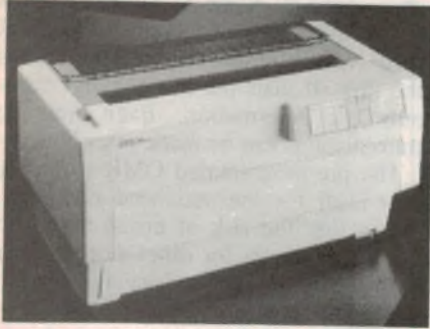

### 533cps line printer

Epson Australia has released the DFX-5000, a high speed, heavy duty printer that has been specifically designed for long print runs in the DP/MIS and office environment.

Filling the gap between high cost line printers and traditional impact dot matrix printers, the DFX-5000 is ideally suited for printing invoices, statements, labels, stock control and continuous report generation where speed and continuous use are of paramount importance.

It prints at 533cps in high speed draft mode, and the long life print head is capable of printing up to 200 million characters.

A dual tractor "Smart Park" function allows the user to switch instantly between two types of continuous paper from the front panel. It prints multi-part stationery up to 6 sheets.

The DFX-5000 can be connected to mini and mainframe computers as an ASCII printer. Optional TWinax and Coax interfaces, which support IBM System 34/36/38 and IBM 3270 respectively, will be also available soon from Epson.

For further information contact Epson sales offices in Sydney on (02) 436 0333 or Melbourne on (03) 543 6455.

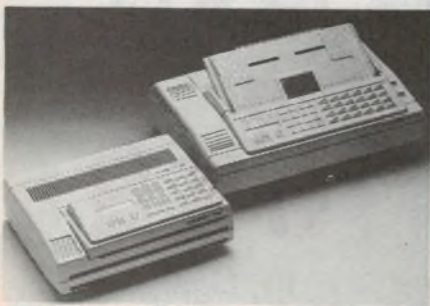

### Portable fax models

Voca Communications has released the new portable Voca-fax F20 and F30 facsimile machines.

The smaller of the two, the Voca-fax

F20, is a compact machine weighing only 4.2 kilos, fitting practically anywhere, even on the wall when space is extremely limited.

The larger Voca-fax F30 is more highly featured and well suited to cope with the demands of any busy, efficient modern office. It even automatically redials engaged numbers twice at programmed intervals.

The F20 has two transmission modes to handle detailed documents, such as drawings and small hard-to-read numbers, while the larger F30 has several transmission modes and can accurately reproduce photographs through its 16 shade greyscale transmission facility.

The F20 and F30 can handle paper up to over 25cm and 28cm wide respectively, automatically reducing documents to the printing capabilities of the receiving unit. The two new models even have a polling feature allowing document retrieval from a remote fax machine. Furthermore, if security or limited access is a high priority, a four-digit passcode can be used to prevent unauthorized polling of sensitive documents.

For further information, contact Voca Communications, 11-29 Eastern Road South Melbourne 3205 or (03) 697 7000.

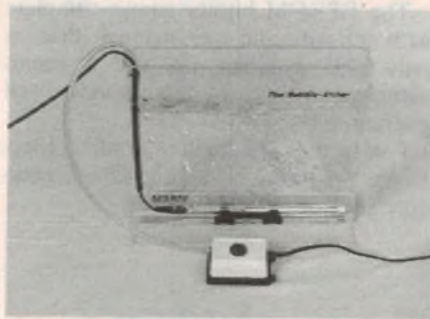

### PCB bubble etcher has heater

Sesame Electronics has added a heater to its PCB Bubble Etcher. Instead of throwing the etchant away after it cools down, you can heat it up again and etch more printed circuit boards.

The Bubble Etcher is a clear acrylic tank, holding the etchant in a narrow, vertical slot. Bubbles are pumped into it by an air pump, and the movement of the fluid plus oxygenation rinses away the dissolved copper, etching the board clean in a few minutes without any stirring.

Using ammonium persulphate allows the progress of the etching to be seen, as it is a clear solution, reducing the risk of over-etching, and consequent undercutting. The Etcher will handle

boards up to 12"x10" (305 x 254mm).

For more information contact Sesame Electronics, PO Box 452, Prahran, 3181 or (03) 527 8807.

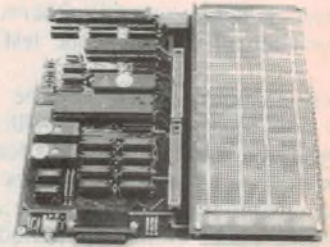

### 68000 Single board computer

The Interrupt Systems 68000 Single Board Computer is a high performance computer system core based on the Motorola 68000 16/32 bit processor. With up to 128K bytes of on-board DRAM, RS232 communications, 68000 buss access and a reusable prototyping area, this computer is intended for a wide range of real-time design applications.

Use is made of ALTERA and AC MOS logic resulting in a very cost-effective system. The 68000 core can be readily accessed from the general purpose prototyping area, thus allowing quick development of the required application. A range of bus signals and additional lines such as pre-decoded chip selects with DTACK implementation are available to suit most prototype designs.

The board is equipped with 128K bytes of 4164 DRAM and 64K bytes of 27256 EPROM. The 68000 processor runs at 12.5MHz and utilises an MC68901 Multi-Function Peripheral Controller providing one RS232 serial port, four timer counters and a general purpose 8 bit I/O Interrupt Controller.

Designed and manufactured in Australia, local hardware and software support is readily available. Software provided includes a monitor/debugger and system software in EPROM. A range of high level compilers is available separately.

Further information from Interrupt Systems, 9 Robinlee Avenue, Burwood East, 3151 or (03) 233 9622.

### Dynamic signal analyzer

Hewlett-Packard Australia has released a fast Fourier transform (FFT)-based analyzer that provides easier test

solutions faster and at lower cost.

The new HP 355660A two-channel dynamic signal analyzer includes many test and automation features that traditionally have required the use of an external computer. It addresses a wide



variety of applications in electronics, mechanical test, acoustics and other low-frequency areas, in both production/process and R&D environments. The HP 35660A provides spectrum analysis from DC to 102.4kHz and network analysis DC to 51.2kHz. The FFT provides 400 lines of resolution in both one - and two-channel modes. Complete alias protection and digital zoom ensure high-resolution measurements with warranted accuracy.

The analyzer has two input channels with 70dB dynamic range and a source that provides signals for stimulus-response testing. It measures linear spectrum, power spectrum, frequency response gain/phase, group delay, time history and power spectral density. A built-in 3.5" disc drive, compatible with HP 9000 Series 200/300 workstations, stores traces, tables and HP Instrument BASIC programs.

Further information from Hewlett Packard Australia, 31-44 Joseph Street, Blackburn 3130 or (03) 895-2895.

## Australian made 240V 200VA inverter

Selectronics has released the latest addition to the Invert-A-Power Series of Australian designed and built inverters.

The new unit, the SPI-200 is available in 12 or 24 volt versions, both of which provide 200VA continuous power and intermittent output power of 425VA and 600VA respectively.

The SPI-200 has been developed in direct response to the demand for a "light-load" model for use in applications such as boating, camping, caravanning, outdoors and weekend holiday homes.



With this new unit, the user can operate a wide variety of domestic 240 volt appliances from a deep cycle 12 or 24 volt lead/acid battery. Typically, items such as TV's, lighting, calculators, computers, mixers, shavers etc. are all within the capacity of the SPI-200.

Weighing only 4.5kg and completely portable, the unit connects to the battery with conventional jumper leads - the appliance is then simply plugged in to the standard switched power point on the inverter. The SPI-200 is equally at home in fixed installations.

For further information contact Selectronic Components, 25 Holloway Drive, Bayswater or (03) 762 4822.

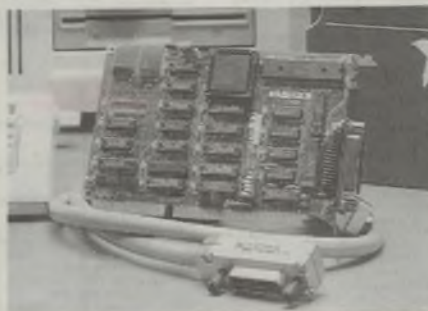

## High speed IEEE-488 interface for PC/ATs

The National Instruments AT-GPIB is a new IEEE-488 interface for the IBM PC/AT and compatible personal computers equipped with 16-bit plug-in slots.

The AT-GPIB is claimed to be the first IEEE-488 interface developed specifically for the high-performance 80386 and 80286 based personal computers. It is a stand-alone, plug-in circuit card providing full-function, high-performance IEEE-488 interface functions. Data can be transferred between a computer equipped with the AT-GPIB and thousands of IEEE-488 cables can connect the AT-GPIB with up to 13 additional devices or instruments (or more using a National Instruments IEEE-488 extender).

A computer configured with the AT-GPIB becomes an IEEE-488 controller that can be used for numerous applica-

MONDOTRONIC

## MP271 EPROM PROGRAMMER FOR IBM™ PC/XT/AT

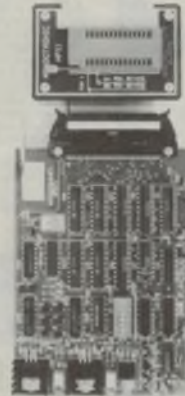

Designed and built in Australia. Supports most 2716 to 27512 eproms including cmos. Hex and binary data formats.

Editing in hex or ascii, copy, move, fill, erase, split, combine, printing, hex-ascii view of buffer disk or eprom. Multiple algorithms, simple menu operation, and much more.

Additional low cost Australian built TTL, relay and opto boards available. Phone or write for additional information from:

**MONDOTRONIC PTY. LTD.**  
P.O. Box 296  
560 Waverley Rd.,  
Glen Waverley Vic. 3150  
Phone: 232 4110

tions in the areas of laboratory testing, production testing, and process monitoring and control.

The NEC UPD7210 GPIB interface controller implements virtually all IEEE-488 functions on the AT-GPIB, including Talker/Listener/Controller (TLC) capabilities.

For further information contact Elmeasco Instruments, 18 Hilly Street, Mortlake 2137 or (02) 736 2888.

# BOOKS



**UNDERSTANDING UNIX**  
-James R. Groff, Paul N. Weinberg  
The exploding popularity of one of the most important trends in computing in the 1980's: UNIX is available on hundreds of different computers ranging from personal computers to mainframes and supercomputers. *Understanding UNIX* offers an overall perspective on UNIX, including a discussion of where UNIX fits in the worlds of computing business, and education. Individual chapters address the UNIX structure file system, multiuser capability, specific applications tools, and more. "A book that balances scope with depth, comprehensiveness with brevity."  
-Alan Kaplan  
Cat B21240 ..... \$44.95

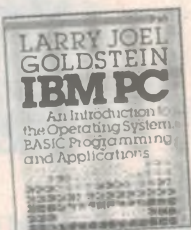

**IBM PC**  
An introduction to the operating system, basic programming, and applications.  
-Larry Joel Goldstein  
This classic and latest edition is the most comprehensive learning tool available for understanding and programming the IBM PC family. Features include a thorough explanation of the MS-DOS and PC-DOS operating systems, a hands-on approach to BASIC programming, chapters on memory printer graphics, file charting, file handling, games, screen graphics and sound.  
B20020 ..... \$39.95



**IBM PC TROUBLESHOOTING & REPAIR GUIDE**  
-Robert C. Brenner  
Keep your IBM PC in top operating condition with this handy reference book. Inside you will find pages of schematics, photos and block diagrams to help you identify problems. Simple instructions tell you what's wrong and how to fix it fast.  
• Make most repairs with few or no tools  
• Quickly zero-in on a malfunctioning component  
• Reduces downtime  
• Pays for itself many times over in repair savings  
• Easy to understand circuit diagrams  
The IBM PC Trouble Shooting and Repair Guide will make even the computer novice feel comfortable with the complex world of electronic trouble shooting. This fully illustrated book is recommended for anyone who uses an IBM PC.  
Cat B20115 ..... \$49.95

## DISKS, FILES AND PRINTERS FOR THE APPLE II

-Brian D. Blackwood  
-George H. Blackwood  
Learn how to create and use text files while running a computer program and to make hard copies of the results on a printer. Covers Apple II // file, and Franklin Microcomputers. You will discover:  
• Using the system includes booting DOS master, initializing disk backup disk, accessing the drives verifying, saving programs and loading programs.  
• DOS commands enable you to operate the disk drives and printer from the keyboard and to change languages (Integer BASIC to Applesoft or vice versa).  
• Sequential files include creating, updating, reading, extending, refining, and multisection.  
• Random access files are faster and take less memory.  
• Executive files can be used to control a series of steps that do not require the operator to make keyboard inputs.  
• Deficiencies of TAB and SPC can be overcome in 80 characters per line printers.  
Cat B20950 ..... \$34.95



**CPM PROGRAMMER'S ENCYCLOPEDIA**  
-Bruce Brigham  
The CPM Programmer's Encyclopedia is a time saving comprehensive reference for serious CPM users. Covering all the commands and syntaxes for CPM 2.4 and CPM 3.0, this encyclopedia gives you the information you need in an easy-to-use format especially designed for programmers. The CPM Programmer's Encyclopedia is the only major compilation of CPM commands and syntaxes. If you use CPM extensively, you should not be without this important reference.  
Cat B21260 ..... \$44.95



**INSIDE THE IBM PC**  
(Revised and expanded edition)  
-Peter Norton  
The widely acclaimed guide to the IBM PC's inner workings. The latest edition now covers every model of the IBM micro PC, XT and AT, and every version of DOS from 1.1 to 3.0.  
B20080 ..... \$44.95

## HARD DISK MANAGEMENT

For IBM PC XT, AT & compatibles  
-Thomas Cain and Nancy Woodard Cain  
Now you can use a hard disk to its fullest advantage with this guide to managing your hardware using DOS batch files, and menu systems. It introduces you to various disk management concepts you need to know while providing step by step techniques for dealing with them. Key topics include partitioning, formatting, the TREE command, sub-directory usage, and file/memory capacity. It also offers extensive information about DOS along the way: how it fits in, and how hard it can work for you.  
B20070 ..... \$39.95



**APPLE II CIRCUIT DESCRIPTION**  
-Winston D. Gayler  
• Covers all Apple II motherboard and keyboard version  
• Helps you learn about microcomputer hardware in general and Apple II hardware in detail  
• Provides you with accurate schematics and verified waveforms to rely on for servicing and repair  
• Explains the advanced concepts of daisy chains, interrupts, direct memory access, and the ready line  
• Gives you many valuable hints for successful interfacing  
• Contains tutorials on video signals, memory IC's and the 6502 microprocessor, as well as full explanations of advanced concepts  
• Each chapter contains an overview for the beginner and a detailed section for the more adventurous  
• Ideal for students, technicians, hobbyists, engineers, and others who need Apple II technical information  
Cat B20960 ..... \$54.95

## INTERFACING TO THE IBM PERSONAL COMPUTER

-Lewis C. Eggebrecht  
This book describes the interfaces, resources, and functions of the Personal Computer. While not presenting specific interface designs or projects, it provides information and techniques that can be used in various projects.  
• Describes the components of the Personal Computer  
• Examines the processor card and its functions  
• Reviews the 8088 microprocessor  
• Discusses fully the PC bus system its signals, its timing, its characteristics  
• Examines the system interrupts and the modes of operation of its timers and counters  
• Looks at the PC memories and describes its methods of data transfer  
• Describes interface signal conditioning and some BASIC interfacing commands  
*Essential reading for everyone who owns or uses an IBM PC!*  
Cat B20075 ..... \$34.95



**PRESENTATION GRAPHICS ON THE IBM PC & COMPATIBLES**  
How to use Microsoft Chart to create dazzling graphics for professional and corporate applications.  
-Steve Lambert  
With Microsoft Chart (version 2), your IBM PC or compatible, and your printer, you have what it takes to produce clear, colourful business charts in a matter of only minutes. Author Steve Lambert shows how you can easily select, create, and modify the chart - column, bar, line pie, high-low, area, scatter or a combination chart, that best communicates your message. And with more than 60 state-of-the-art output devices to choose from. From plotters to slide makers to colour printers, you can create professional quality charts that will give all your presentations dramatic and convincing impact!  
Cat B20000 ..... \$39.95

## PASCAL PRIMER

-Mitchell Waite, David Fox  
If you are learning programming or have dabbled in the popular language BASIC and wish to learn the capabilities of Pascal, this book is definitely written for you. Written and illustrated with a touch of humour, the informative text describes Pascal program structure Pascal variables, Pascal procedures, and many other features. There are chapters on decision making statements, numeric functions, string functions, arrays and sets, and much more. The eight appendices present facts about the advantages and disadvantages of Pascal components of a Pascal system interfacing assembly language routines, and other useful information.  
Cat B21120 ..... \$34.95

## ESSENTIAL APPLICATIONS FOR THE IBM PC AND XT

-Patrick Plemmons  
If you bought your personal computer to streamline just one activity, you're really missing out! This essential volume in the PC World Library demonstrates the amazing breadth and power of the PC, and helps you to take advantage of the computer's potential as a personal and professional tool. It explains the principal categories of application: spreadsheets, word processing, data base management, accounting, graphics, and integrated software, and the major software packages in each category. It tells you how to suit the software task at hand, and how to use the computer most efficiently.  
B20090 ..... \$34.95

## 1-2-3 TIPS, TRICKS & TRAPS

-Dick Anderson, Douglas Cobb  
Contains a collection of valuable techniques to help users of Lotus 1-2-3 get the maximum benefit from this powerful integrated software package. Designed as a quick reference, this book shows you hundreds of shortcuts, offers help with unexpected problems, and suggests techniques for using some of 1-2-3's little known capabilities.  
Cat B20140 ..... \$44.95

## 1-2-3 BUSINESS FORMULA HANDBOOK

An invaluable source of tips and techniques for creating, editing, and using 1-2-3 formulas in a wide range of personal and business applications. To help you use each formula, the Handbook presents all formulas in sample 1-2-3 templates with complete cell listings so that you can easily re-create any formula in the book.  
Cat B20138 ..... \$44.95

## INSIDE MICROSOFT OS/2

-Gordon Lehtin  
A rare and exciting technical examination of the philosophy, key development issues, programming implications, and future of the MS OS/2 operating system. Gordon Lehtin, Chief Architect for MS OS/2, provides a true behind the scenes view of the process of merging Microsoft's vision of an automated office system with the realities of software development. Here is revealing information every MS OS/2 programmer, as well as high tech and office automation specialists, will find invaluable.  
Lehtin discusses:  
• The powerful graphics, true multitasking, hardware and software protection, and program "encapsulation" features that were incorporated into MS OS/2  
• The restrictions of the microprocessor and the constraints of upward and downward MS DOS and MS OS/2 compatibility  
• The software architectural details from a design and programming perspective  
• Central issues for the future: a new MS OS/2 file system, a fully protected environment, and an enhanced network support.  
This book will be a cornerstone book in the library of anyone interested in MS OS/2. You can't get a more "inside view" (352 pages).  
B20720 ..... P.O.A.



**HANDS ON**  
Practical tips and useful programs for IBM PC's and the editors of PC World.  
A collection of the best tips, programs, and routines for IBM computers from the popular "Hands on" and "Columns" columns.  
Covering both hardware and software, the book is organized so that you can quickly find information on virtually everything you need to know.  
B20100 ..... \$34.95



## GETTING STARTED WITH THE IBM PC AND XT

-David Arnold  
An authoritative guide from the PC World Library to using the PC and its more powerful cousin, the XT. If you're new to computing, you'll appreciate their tutorial approach, as you become familiar with keyboard, disks, and operating system (DOS 1.10 and 2.00). You'll learn to set up and handle electronic files, evaluate your software needs, and program in BASIC.  
B20030 ..... \$34.95



**USING PC DOS**  
"Using PC DOS" is the only combination of a beginning tutorial, advanced guide, and lasting reference that gives you ultimate control over your PC's most important software: the operating system! Beginners will learn how to:  
• Prepare your diskettes  
• Manage DOS directories  
• Create, rename, and copy files  
• Print what appears on your screen  
• Avoid disastrous errors  
Advanced users will learn:  
• Master path names  
• Maneuvering through directories  
• Customise DOS  
• Use RAM disks  
• Create AUTOEXEC.BAT files  
Regardless of your level of expertise, you can use the Command Reference section to:  
• Gain quick access to 63 most frequently used DOS commands  
• Recognize valid DOS command phrasing  
• Cope with frustrating DOS error messages.  
Cat B20200 ..... \$49.95

## INTRODUCTION TO BASIC

-Jeffrey B. Morton  
This book is lucidly written and is in two parts. The first teaches BASIC, and the second consists of a dozen carefully constructed projects. These are wide-ranging and set the language into the context of solving real-world problems. Each project is laid out with a set of variables to give the reader insight into the practical applications of the language. Any version of BASIC can be used to solve the projects and the other excellent examples scattered throughout the book.  
Cat B21245 ..... \$16.95

## APPLE II ASSEMBLY LANGUAGE

-Dr. Marvin L. De Jong  
• Teaches assembly language programming at the beginning level - no prior knowledge of 6502 assembly language needed  
• Directs you in hands-on computer exercises and experiments, with both software and hardware  
• Enables you to interface the Apple II to outside devices, eg. aid and dia converters, timers, etc.  
• Provides interfacing circuits and programs that can be used on the Apple II without modification  
• Enhances your power as a programmer in your use of the Apple II  
• Gives you a more general understanding of how microcomputers work than can be obtained by programming in BASIC or any other high-level language  
Cat B20940 ..... \$36.95

## APPLE II CIRCUIT DESCRIPTION

-Jack Purdum  
Learn at your own pace as this self directed study guide takes you through the basics and into advanced areas of the C programming language. The unique format allows you to advance quickly or proceed slowly. The book is divided into two parts.  
**Questions:** of varying degrees of difficulty to guide beginners over the rough spots and to challenge the more experienced C programmers.  
**Answers:** that include many complete programs for testing new functions and for illustrating tips, traps and techniques and short cuts.  
Cat B20690 ..... \$37.95

## THE C PROGRAMMER'S HANDBOOK

-Tom Hogan  
While other books will tell you how to learn C, this one shows you how to use it. It's a literal encyclopedia of the information you'll need to get it to work for you, efficiently and effectively. Handy and well organized, it gives you quick access to the things you need when you need them, plus a clear definition of C language with examples and explanations of restrictions and defaults. You won't find an approach this understandable and objective anywhere else.  
B20120 ..... \$39.95



# SERIES 5000

## INDIVIDUAL COMPONENTS TO MAKE UP A SUPERB HI-FI SYSTEM!

By directly importing and a more technically orientated organisation, ROD IRVING ELECTRONICS can bring you these products at lower prices than their competitors. Enjoy the many other advantages of RIE Series 5000 kits such as "Superb Finish" front panels at no extra cost, top quality components supplied throughout. Over 1,500 sold!

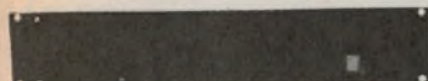

### POWER AMPLIFIER

WHY YOU SHOULD BUY A "ROD IRVING ELECTRONICS" SERIES 5000 POWER AMPLIFIER

1% Metal Film resistors  
**SPECIAL, ONLY \$399**  
**SAVE \$50**

Developed by Rod Irving Electronics and is being supplied to other kit suppliers

**SPECIFICATIONS:** 150 W RMS into 4 ohms (per channel)  
**POWER AMPLIFIER:** 100W RMS into 8 ohms (+/-5V Supply)  
**FREQUENCY RESPONSE:** 8Hz to 20KHz +0/-0.4 dB 20Hz to 65KHz +0/-3 dB. NOTE: These figures are determined solely by passive filters.  
**INPUT SENSITIVITY:** 1 V RMS for 100W output  
**HUM:** 100 dB below full output (flat)  
**NOISE:** 116 dB below full output (flat, 20KHz bandwidth)  
**2nd HARMONIC DISTORTION:** 0.001% at 1 KHz (0.0007% on Prototypes) at 100W output using a +/-56V SUPPLY rated at 4A continues -0.0003% for all frequencies less than 10KHz and all powers below clipping.  
**TOTAL HARMONIC DISTORTION:** Determined by 2nd Harmonic Distortion (see above)  
**INTERMODULATION DISTORTION:** 0.003% at 100W (50Hz and 7KHz mixed 4:1)  
**STABILITY:** Unconditional  
 Cat. K44771 **\$499**  
**Assembled and tested \$599**  
 packing and post \$10

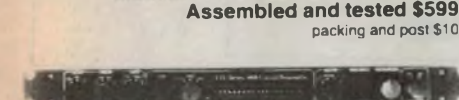

### PREAMPLIFIER

THE ADVANTAGES OF BUYING A "ROD IRVING ELECTRONICS" SERIES PREAMPLIFIER

1% Metal Film resistors  
**SPECIAL, ONLY \$359**  
**SAVE \$40**

Commercial unit available that sounds as

**SPECIFICATIONS:**  
**FREQUENCY RESPONSE:** High level input: 15Hz - 130KHz, +0/-1dB  
 Low Level input: conforms to RIAA equalisation +0/-2dB  
**DISTORTION:** 1KHz -0.003% on all inputs (limit of resolution on measuring equipment due to noise limitation)  
**S/N NOISE:** High Level input: master full, with respect to 300mV input signal at full output (1.2V) -92dB flat -100dB A-weighted. MM input: master full with respect to full output (1.2V) at 5 mV input 50ohms source resistance connected. -86dB flat -92dB A-weighted MC input: master full with respect to full output (1.2V) and 200V input signal: -71dB flat -75dB A-weighted.  
 Cat. K44791 **\$399**  
**Assembled and tested \$699**  
 packing and postage \$10

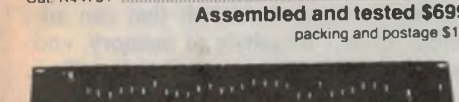

### THIRD OCTAVE GRAPHIC EQUALIZER

**SPECIFICATIONS:**  
**BANDS:** 20 Bands

**SPECIAL, ONLY \$209**  
**SAVE \$30**

1 unit: **\$239**  
 2 units: **\$429**  
 packing and postage \$10



### LAB SUPPLY

Fully variable 0-40V current limited 0.5A supply with both voltage and current metering (two ranges: 0-0.5A/0.5A). This employs a conventional series-pass regulator, not a switchmode type with its attendant problems, but dissipation is reduced by unique relay switching system switching between taps on the transformer secondary. (ETI May 83) ETI 163  
 Cat. K41630 **\$249**

### MUSICOLOR IV

Add excitement to parties, card nights and discos with EAs Musicolor IV light show. This is the latest in the famous line of musicolors and it offers features such as four channel "color organ" plus four channel light chaser, front panel LED display, internal microphone, single sensitivity control plus opto-coupled switching for increased safety. (EA Aug. 81) 81MC8  
 Cat. K81080 **\$114.95**

### DIGITAL CAPACITANCE METER Mk.2

Updated from the EA March '80 issue, this Digital Capacitance Meter checks capacitor values from 1pF to 99.99uF over three ranges. Its main features include a nulling circuit and a bright 4 digit LED display.  
 \*Note: The RIE kit contains quality silk screen printed and prepunched front panel AND an exclusive High Intensity Display!  
 (85cm9a, EA August 85)  
 Cat. K85090 **\$99.95**

### PLAYMASTER 300 WATT AMPLIFIER

This module will deliver up to 200 watts into an 8 ohm load and up to 300 watts into a 4 ohm load. Comprehensive protection is included and a printer circuit board brings it all together in a rugged easy-to-build module. It can be built in either fully-complementary or quasi-complementary versions, so output transistor shortages should be no problem at all. (80PA6) (EA July 80)  
 Cat. K80060 **Normally \$109**  
**SPECIAL, ONLY \$99**  
 (Heatsink not included)

### MULTI SECTOR ALARM STATION

Protect your home and possessions from burglars with this up to the minute burglar alarm system. It's easy to build, costs less than equivalent commercial units, and features eight separate inputs, individual sector control, battery back up and self-test facility.  
**Specifications:**  
 • Eight sectors with LED status indication  
 • Two delayed entry sectors  
 • Variable exit, entry and alarm time settings: entry delay variable between 10 and 75 seconds; exit delay variable between 5 and 45 seconds; alarm time variable between 1 and 15 minutes  
 • Resistive loop sensing, suits both normally open and normally closed alarm sensors  
 • Battery back-up with in-built charger circuit  
 • Built-in siren driver  
 The RIE kit includes a superb printed and prepunched metal case and inside metal work, plus a gell battery! **Unbeatable VALUE!**  
 K85901 without battery backup **\$134**  
**SPECIAL, \$115**  
 K85900 complete kit **only \$159**  
**SPECIAL, \$129**



### 50 W AMPLIFIER MODULE (ETI 480)

Cat. K44880 **Normally \$31.80**  
**SPECIAL, \$21.95**  
 (Heatsink optional extra)

### 100 W AMPLIFIER MODULE (ETI 480)

Cat. K44801 **Normally \$34.80**  
**SPECIAL, \$28.95**  
 (Heatsink optional extra)

### POWER SUPPLY TO SUIT

Without transformer **\$22.95**

# KITS GALORE!



### TRANSISTOR TESTER

Have you ever desoldered a suspect transistor, only to find that it checks OK? Trouble-shooting exercises are often hindered by this type of false alarm, but many of them could be avoided with an "in-circuit" component tester, such as the EA Handy Tester. (EA Sept 83) 83TT8  
 Cat. K83080 **Normally \$18.95**  
**SPECIAL, \$15.95**

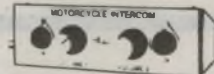

### MOTORCYCLE INTERCOM

OVER 500 SOLD!  
 Motorcycling is fun, but the conversation between rider and passenger is usually just not possible. But build this intercom and you can converse with your passenger at any time while you are on the move. There are no "push-to-talk" buttons, adjustable volume and it's easy to build and make it too.  
 (EA Feb. 84) 84MC2  
 Cat. K84020 **\$49.95**



### 1W AUDIO AMPLIFIER KIT

A low-cost general purpose 1 watt audio amplifier, suitable for increasing your computers audio level etc. (EA Nov 84)  
 Cat. **\$9.95**

### THE SCREECHER CAR BUGLAR ALARM

Here is a low cost car alarm designed with a new deterrent strategy. Instead of using the alarm to try to draw the attention of passers-by to the felony in progress, this alarm sounds inside the car to deter the thief and make it too uncomfortable to proceed with pinching the vehicle!  
 (86a19, EA August 86)  
 Cat. K86081 **\$29.95**

### MUSICOLOR IV

Add excitement to parties, card nights and discos with EAs Musicolor IV light show. This is the latest in the famous line of musicolors and it offers features such as four channel "color organ" plus four channel light chaser, front panel LED display, internal microphone, single sensitivity control plus opto-coupled switching for increased safety. (EA Aug. 81) 81MC8  
 Cat. K81080 **\$114.95**



### HEADPHONE AMPLIFIER PRACTICE WITHOUT ANNOYING THE FAMILY!

If you play any type of electronic instrument this headphone amplifier will surely interest you. It will let you practice for hours without upsetting the household or you can use it to monitor your own instrument in the midst of a rowdy jam session. (EA Feb. 84) 83MA11  
 Cat. K84111 **\$39.95**

### VIDEO AMPLIFIER

Bothered by smeary colours, signal beats and RF interference on your computer display? Throw away that cheap and nasty RF modulator and use a direct video connection instead, it's much better! The Video Amplifier features adjustable gain and provides both normal and inverted outputs. Power is derived from a 12V DC plugback supply. (EA Aug. 83) 83VAB  
 Cat. K83081 **\$18.95**

### CAR IGNITION KILLER

Most car burglar alarms are easily circumvented, but not this cunning "Ignition Killer". This sneaky anti-theft device uses a 555 timer to place an intermittent short circuit across the points. Until disabled by its hidden switch the circuit effectively makes the car undrivable - a sure deterrent to thieves! (EA Feb. 84) 84AU1  
 Cat. K84010 **\$24.95**  
 (Our kit includes the box!)



### AUDIO TEST UNIT KIT

Just about everyone these days who has a stereo system also has a good cassette deck, but not many people are able to get the best performance from it. Our Audio Test Unit allows you to set your cassette recorder's bias for optimum frequency response for a given tape or alternatively, it allows you to find out which tape is best for your recorder. (81A010) (EA Oct. 81)  
 Cat. K81101 **\$59.50**

### LOW-COST BIPOLAR MODEL TRAIN CONTROLLER

Here is a simple model train control for those enthusiasts who desire something better than the usual rheostat control. It provides much improved low speed performance and is fully overload protected, yet contains relatively few components. Best of all, you don't need to be an electronic genius to construct it. (80TC12) (EA Dec. 80)  
 Cat. K80120 **\$39.95**

### ELECTROSTATIC HAZARD DETECTOR KIT

It's called electrostatic hazard and if it, or even its baby brother, jumps on the back of your IC or transistor, then the poor device is never likely to be quite the same again. So out of a very ordinary collection of bits and pieces, ETI has fashioned a black box that will sit quietly on a corner of your bench for years at a time and beep when ever high tension appears. It may save you a lot of trouble, particularly if you ever work with CMOS. (ETI 173 May 86)  
 Cat. K41730 **\$54.95**

### READY-SET-GO LIGHTS

A simple project for starting slot car races, etc. It provides the traditional Red/Amber/Green lights with a random delay between the amber and green. (ETI Oct. 84) ETI 277  
 Cat. **\$24.95**

### EA AM STEREO DECODER

AM stereo is now broadcast in Australia on an experimental basis. This add-on decoder works with the Motorola C-QUAM system. (EA Oct. 84) 84MS10  
 Cat. K84100 **Normally \$26.95**  
**SPECIAL, \$16.95**

### CRYSTAL CONTROLLED TV PATTERN GENERATOR

Anyone wishing to obtain the maximum performance from a colour TV receiver needs a pattern generator. Why not build this superb unit which provides live separate patterns, dot crosshatch, checker board, grey scale and white raster? Note: The RIE kit includes a large ABS type case! (80p6, EA June 80)  
 Cat. K80033 **\$99.95**

### BUZZ BOARD

Test your steadiness of hand with this updated version of an old game of skill. The "Buzz Board" is a sophisticated version of a simple game in which the player attempts to pass a small metallic loop along a bent wire path without making contact with that wire. The "Buzz Board" also features an adjustable time delay unit which means the buzzer will only sound if the metal loop touches longer than the set time. An fun kit to make and even more fun to use! (ETI 048)  
**WAS \$4.50 NOW \$3.25**

### 15V DUAL POWER SUPPLY

This simple project is suitable for most projects requiring a dual voltage. Includes transformer. (ETI 581 June 76)  
 Cat. K45810 **\$34.95**



### Rod Irving Electronics

MELBOURNE: 48 A Beckett St.  
 Phone: (03) 563 6151  
 NORTHCOE: 425 High St.  
 Phone: (03) 489 8866  
 CLAYTON: 56 Renver Rd.  
 Phone: (03) 543 7877  
 SOUTH AUSTRALIA:  
 Electronic Diagnostics P/L  
 305 Morphett St. ADELAIDE  
 Phone: (08) 212 1799  
 NOTE: Prices may vary interstate due to freight costs.  
**MAIL ORDER:**  
 Local Orders: (03) 543 7877  
 Interstate Orders: (08) 33 5757  
 All Inquiries: (03) 543 7877  
**CORRESPONDENCE:**  
 P.O. Box 620, CLAYTON 3168  
 Tel: AA 151938  
 Fax: (03) 543 2648



**MAIL ORDER HOTLINE**  
**(TOLL FREE)**  
**008 335757**  
 (STRICTLY ORDERS ONLY)

### LOCAL ORDERS & INQUIRIES (03) 543 7877

POSTAGE RATES		
\$1	\$9.99	\$2.00
\$10	\$24.99	\$3.00
\$25	\$49.99	\$4.00
\$50	\$99.99	\$5.00
\$100	\$199.99	\$7.50
\$200	\$499.99	\$10.00
\$500 plus		\$12.50

The above postage rates are for basic postage only. Road Freight bulky and fragile items will be charged at different rates.

All sales tax exempt orders and wholesale enquiries to RITRONICS WHOLESALE, 56 Renver Rd. Clayton. Ph: (03) 543 2166 (3 lines)

Errors and omissions excepted. Prices and specifications subject to change.  
 IBM, PC, XT, AT: are registered trademarks of International Business Machines. Apple is a registered trademark.  
 \*Dantele is a registered trademark of their respective owners.

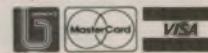

# Solid State Update

KEEPING YOU INFORMED ON THE LATEST DEVELOPMENTS IN SEMICONDUCTOR TECHNOLOGY



## 386 compatible chip

To date, Intel has been the sole source of the immensely popular 32-bit 80386 microprocessor, as the Santa Clara chip maker has resisted all efforts to allow other firms to become alternate sources for the chip. But recently, a Japanese company, VM technology, announced it had developed a new processor that is fully compatible with the 80386 and which will be capable of running application software designed for the Intel processor.

VM Technology is a joint venture between Mitsui, one of the world's largest trading companies, and ASCII Corporation, a Tokyo-based software and trade journal publishing company. The development could have a vast impact on the personal computer market, as the VM chip could force the current high price of the 386 chips to come down and lead to overall price reductions in the cost of 386-based products.

The development also means another major coup for ASCII founder Kay Nishi, who has played a major role in the industry since its formation in the mid seventies. Nishi also played a key role in helping Microsoft become a major force in the industry, as his company successfully marketed Microsoft's early Apple II products in Japan. Later, he also played a key role in the development of MS-DOS. In the early 1980's Nishi tried, and failed, to establish an alternate standard to the IBM PC with his modular and expandable MSX personal computer. While selling relatively well in Japan, MSX never caught on in the US Microsoft's failure to support MSX reportedly caused strains in the relationship between Nishi and Microsoft, where Nishi was vice president, and the two parted ways in 1985.

## 40-amp power MOSFET with current sensing

Motorola has introduced the MTP40N06M power MOSFET, a device with current sensing capabilities and rated at 40 amps, 60 volts with a maximum on-resistance of 40 milliohms. The device is housed in a 5-pin TO-220 package which dissipates 125 watts.

The current sensing capability allows the use of low power sense resistors, re-

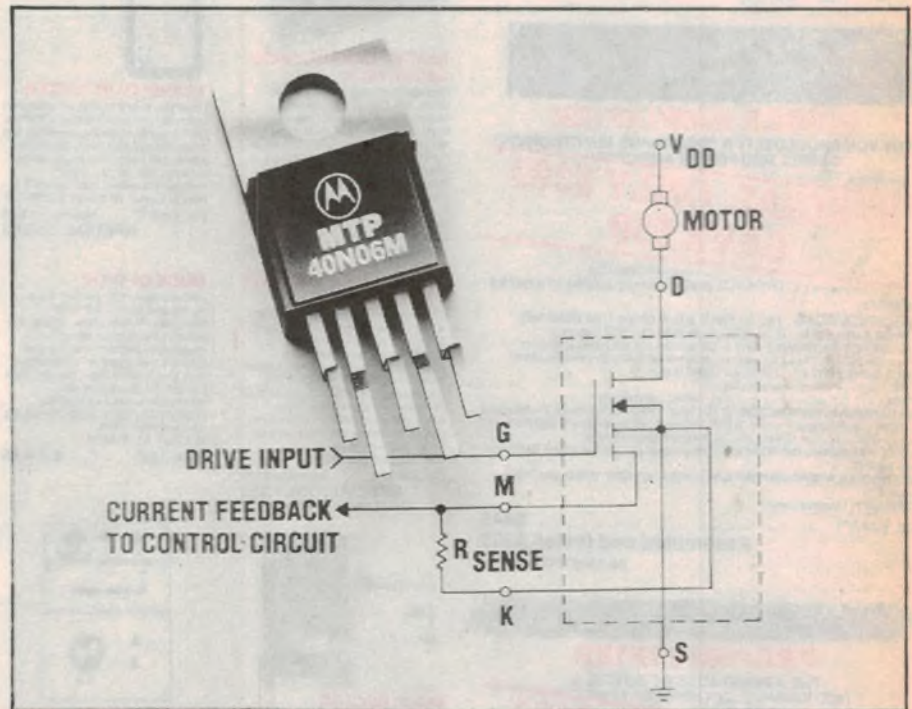

Motorola's new 40-amp power MOSFET can operate at up to 60V and has a maximum on resistance of 40 milliohms.

sulting in increased reliability, less board space and simpler circuitry.

The pinout includes the standard gate, drain and source of the MOSFET and includes a mirror and a Kelvin pin. The Kelvin pin is used to eliminate the voltage drop within the package, which would otherwise cause erroneous sense voltages resulting in an error in the current being sensed. The device mirrors the load current and reduces it by a factor of 900, reducing the power loss in the sense resistor considerably. This is particularly beneficial where large currents are being sensed.

Typical applications for this device are in current mode switching power supplies, both brush and brushless types of motor controls, and automotive applications.

## Enhanced Z80 compatible

Zilog has recently announced the CMOS Z80180, a highly integrated and enhanced version of the 8-bit Z80 microprocessor. Upwardly software-compatible with Z80 code, the Z180 operates at an 8MHz clock frequency and

incorporates key system functions on-chip that raise the performance of this 8-bit processor to 16-bit levels. The Z180 interfaces directly, with no external circuitry, to peripheral circuits designed for the Z80.

The Z180 incorporates an on-chip memory management unit that can address up to 1 megabyte of memory, and supports 64Kb of logical I/O space. Two direct memory access (DMA) channels support memory-to-memory and memory-to-I/O transfers. In addition to supporting the entire Z80 instruction set, the Z180 incorporates seven new high-level instructions including multiply (MLT). Other key features of the highly integrated Z180 include an on-chip wait state generator, a programmable DRAM refresh controller, two full-duplex asynchronous serial communications (UART) channels, clocked serial I/O port, two 16-bit programmable reload timers, and an on-chip clock oscillator and interrupt controller.

For further information contact George Brown Group Marketing Division, 456 Spencer Street, West Melbourne or phone (03) 329 7500.

## 150 MHz FET input op amp

The recently announced National Semiconductor IC type LH4117 is a FET-input wideband amplifier optimized for high speed, low gain applications. It is an ideal alternative to low precision open loop buffers and conventional operational amplifiers and it features a closed loop -3dB unity gain bandwidth in excess of 150MHz. Unlike conventional op-amps, the bandwidth is relatively independent of closed loop gain between 1 and 20. The device features rise and fall times of 3.3ns, a slew rate of 2500V/us (100 ohm load) and a 9ns settling time to 0.2%. A high current output stage is also incorporated, allowing the LH4117 to drive 50 terminated lines directly. This makes it an ideal choice for video distribution applications.

## IBM goes to 8" wafers

IBM is now in volume production on the first manufacturing line in the industry capable of fabricating semiconductor chips on 200mm (8") diameter silicon wafers.

Until recently, the company processed 5" wafers exclusively, each capable of yielding about 150 1 megabit RAM chips. Now it is possible to get up to 400 chips on an 8" wafer in the same amount of time, providing significant increases in cost effectiveness and productivity.

The new manufacturing line is now augmenting production of the company's one-megabit dynamic random access memory (DRAM) chips. The company committed to develop 8" production technology in 1984, requiring the building of a completely new semiconductor production line. IBM was the first to produce one-megabit DRAM chips in large volumes, and also the first to incorporate megabit chips in main-frame computers.

## 12-bit, 20MHz D/A converter

TRW LSI Products Division has added a new low cost D/A converter to its analog product line. The new product, the TDC1012 is a monolithic, 12-bit D/A converter which can convert digital data into analog current at maximum data rates up to 20MHz. Typical settling time is 30ns to within plus or minus 0.012% FSR for a full scale output change.

The TDC1012 on-chip data registers, precisely matched propagation delays and a segmented architecture reduce glitch area to a very low 25pV-sec, eliminating the need for external de-glitcher circuits. The TDC1012 has been

designed for excellent settling time performance when operating into a low impedance resistive load. The complementary 40mA current outputs can produce a 1V full-scale voltage when directly driving a doubly terminated 50 ohm transmission line.

The new 12-bit D/A converter is currently available in two packages; a 24-lead plastic DIP and a 24-lead hermetic ceramic DIP. A 16-page datasheet on the TDC1012 is available for the asking by contacting Email Electronics, 15-17 Hume Street, Huntingdale, 3166. Tel: (03) 544 8244.

## 100MHz operational amplifier

Analog Devices' AD9610 wideband current feedback operational amplifier is now available in a version that conforms to MIL-STD-883B. The hybrid amplifier combines the dynamic per-

formance, the excellent pulse fidelity and the good DC specifications required in military systems. Since the device uses current rather than voltage feedback, bandwidth is relatively independent of gain. The AD9610TH/883B offers a minimum -3dB bandwidth of 80MHz ( $G=-10$ ) unity-gain bandwidth over the full -55 to +125°C temperature range. Military applications include communications, pulse repeaters, and radar signal processing.

Rise and fall times are less than 4.0ns maximum with a 5V step, maximum settling time is <25ns to 0.1% and guaranteed minimum slew rate capability is 3000V/us. The AD9610TH/883B is packaged in a 12-pin TO-8 metal can, operates from  $\pm 15V$  supplies and consumes a maximum 750mW. Further information from Parameters, Centrecourt PO Box 261, North Ryde, NSW or phone (02) 888 8777.

## Hybrid 12-bit ADC guarantees true 1MHz conversion rate

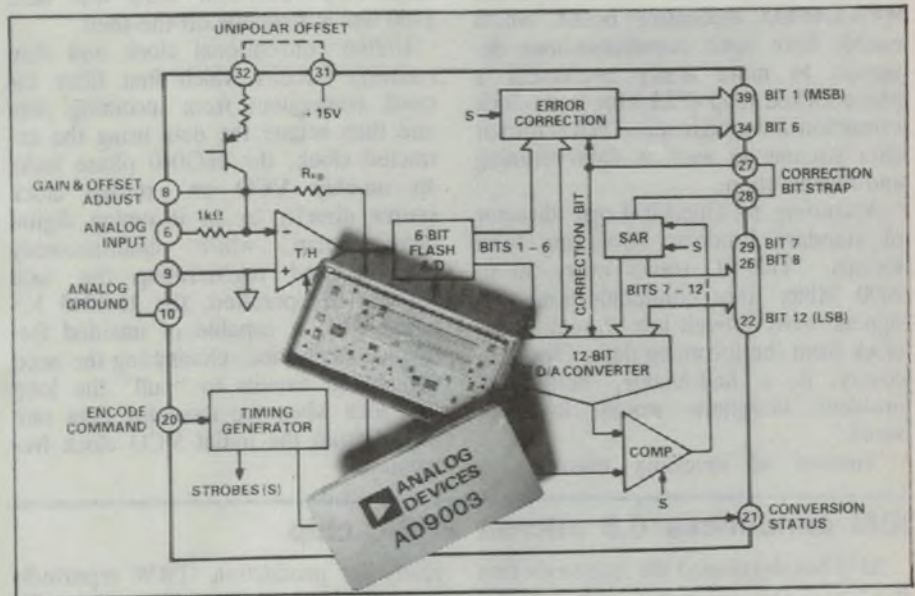

A new hybrid device from Analog Devices combines a 12-bit analog-to-digital converter (ADC) and track-and-hold-amplifier (T/H) in a single package. The AD9003's maximum conversion time of 85ns - including acquisition time - ensures true 1MHz performance. Combining an ADC and T/H in the same package permits complete AC and DC characterisation of the device; the AD9003 guarantees 74dB minimum harmonic distortion, 65dB minimum signal-to-noise ratio, and 87dB typical two-tone intermodulation distortion. Accuracy specifications include:  $\pm 1LSB$  maximum differential nonlinearity,

$\pm 1.5LSB$  maximum integral nonlinearity,  $\pm 0.2\%$  maximum full-scale gain error, and no missing codes over the full operating temperature ranges.

The AD9003 suits applications such as radar systems, digital oscilloscopes, and high-speed data acquisition. The small 40-pin DIP saves board space, especially over competing devices that require a separate external track-and-hold. Typical 2.2W power dissipation reduces cooling requirements in weight-critical avionic applications.

For further information, contact Parameters, 25-27 Paul Street Nth, Nth Ryde 2113 or phone (02) 888 8777.

## Solid State Update

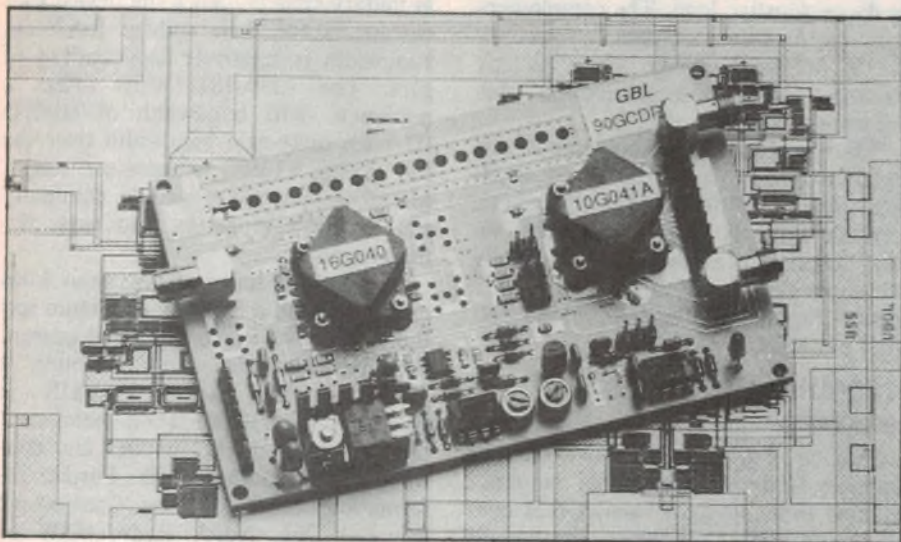

### Clock/data recovery works at 2Gbps

GigaBit Logic in California has announced its 16G040 Clock & Data Recovery (CDR) circuit and companion 90GCDX-DX evaluation board, which enable fibre optic communications designers to more easily implement a phase locked loop (PLL) for both clock extraction from high speed NRZ format data streams as well as data retiming and regeneration.

According to GigaBit Logic director of Standard Products Marketing John Kemps, "This IC solves every 50 to 2000 Mbits fiber communications designers' most difficult job: extracting the clock from the incoming data. Clock recovery is a half-analog, half-digital problem designers would love to avoid."

"Instead of investing massive re-

sources to develop still another complex ASIC or board solution, our low-power, single-chip subsystem costs less than \$100 and is available off-the-shelf."

Unlike conventional clock and data recovery circuits which first filter the clock component from incoming data and then retime the data using the extracted clock, the 16G040 phase locks an on-chip VCO or external clock source directly to an incoming digital data stream, while simultaneously retiming and regenerating the data stream. In operation, the 16G040 IC-based PLL is capable of unaided frequency acquisition, eliminating the need for special circuits to "pull" the loop into lock when the incoming data rate differs from the initial VCO clock frequency.

### IBM announces 0.5 micron VHSIC chip

IBM has developed the industry's first functional semiconductor with features smaller than half a micron.

The revolutionary signal processing chip was developed at IBM's Federal Systems Facility in Manassas, Virginia under the Pentagon's VHSIC (very high-speed integrated circuit) program.

"This is a significant technological milestone for IBM and the US Defence Department," said William Gianopoulos, director of the IBM laboratory in Manassas.

Although other VHSIC contractors have developed components with half-micron features, including TRW and Honeywell, their products are still in the development process. IBM's components, on the other hand are

ready for production. TRW reportedly is targeting a September date for starting production of its "self-healing" VHSIC superchip, which will contain no less than 4 million transistors.

The IBM chip, by comparison, contains about 100,000 transistors and can be used to capture and process high-frequency radar, sonar and other signals.

In the commercial markets, chips with half-micron features are probably still three to five years away, as leading companies like Intel, AMD and others are just now starting to build research labs to handle the development and low-volume production of wafers with such advanced lithography and processing requirements.

### 5-chip AT compatible chip set runs at 16MHz

The Arizona-based Application Specific Logic Products Division of VLSI Technology Inc. (VLSI) has introduced the VL82CPCAT-16, a 16MHz "no wait state", high-integration, five-chip set that greatly reduces the device count on the motherboards of IBM PC/AT-compatible computers. The fully PC/AT-compatible chip set reduces the non-memory device count from 88 industry-standard devices to 15 integrated circuits (ICs), or 83%.

The new 16MHz VL82PCAT-16 set is a significant upgrade of the popular 12MHz VL82PCAT set now in production. It is claimed to provide the system designer with the highest performance possible in standard 16MHz '286-based PC/AT-compatible systems. In addition to the 33% speed improvement, the chip set now allows a significantly faster access to protected memory with an on-chip "hot reset";



on-board clock modulation which permits operations on slower expansion cards in the 16MHz system environment; and a new "shadow RAM" feature which speeds performance further by bypassing ROM access delays.

The five devices in the VL82CPCAT-16 chip set have been designated the VL82C100 PC/AT Peripheral Controller, VL82C201 PC/AT System Controller, VL82C202 PC/AT Memory Controller, VL82C203 PC/AT Address Buffer, and the VL82C204 PC/AT Data Buffer.

Further details are available from Energy Control International, 26 Boron Street, Sumner Park 4074 or (07) 376 2955.

# Dedicated Motion Controllers for Precision Control of DC Servo Motors

Until now, high performance servo motor systems were a slow trial and error process, requiring the expertise of several engineering talents.

However, National's new LM628/629 Dedicated Motion Controllers have changed all that. They eliminate the need for diverse engineering expertise, dramatically reduce software and hardware development efforts down to a few days, plus offer a new level of enhanced motion-control performance and communications with the host system.

The National LM628/629 are the only motion controllers on the market today which incorporate real-time programmable host-interrupt capabilities, trapezoidal velocity profile, and correction for positioning errors.

As National Semiconductor's most experienced distributor, NSD has the stock, expertise and Australia-wide support for the comprehensive range of National and Fairchild products:

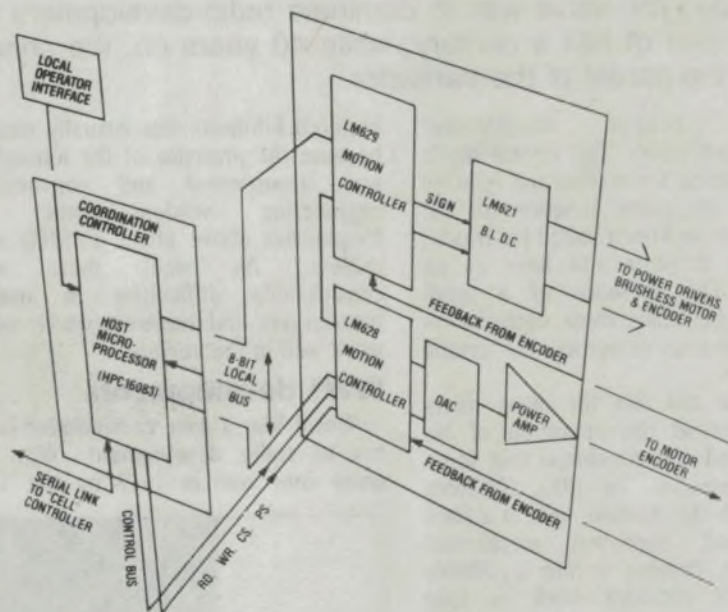

## Other Products

### LINEAR:

- VOLTAGE REGULATORS
- OP AMPS
- VOLTAGE REFERENCE
- COMPARATORS

### MEMORY:

- RAM, EPROM, EEPROM
- GATE ARRAYS
- STANDARD CELLS
- PALS

### MICROPROCESSORS:

- 8-BIT, 6-BIT, 32-BIT
- UARTS
- INTERFACE
- GRAPHICS
- ETHERNET

## DIODES AND TRANSISTORS:

### ALL LOGIC FAMILIES:

- FAST, FACT, S, LS, ALS
- HC, 4000



VIC 205 Middleborough Road, Box Hill, 3128  
 Phone: (03) 890 0970 Fax (03) 899 0819  
 NSW Unit 3, 12 Victoria St. Lidcombe, 2141  
 Phone: (02) 646 5255 Fax (02) 646 5728  
 QLD 62 Doggett Street, Fortitude Valley,  
 4006 Phone: (07) 854 1911  
 SA 108 Gilbert Street, Adelaide, 5000  
 Phone (08) 211 8499 Fax (08) 211 7292  
 NZ 2/4 Cain Rd, Penrose, Auckland  
 Phone 525 1096 Fax 592 493



A MEMBER OF THE  
 ANSIL CORPORATION

MkAdg 1149

# Vintage Radio

by PETER LANKSHEAR



## Early receiver developments

There can be little argument that the two most significant developments in the history of radio were made in 1906, when several crystal detectors were patented and Lee de Forest invented the triode valve by putting a grid into Fleming's diode. The valve was to dominate radio development for the best part of half a century, while 40 years on, the crystal became the parent of the transistor.

Initially, neither development revolutionised radio. The crystal diode was too delicate for marine and military use, whilst the prime functions of the "Audion" as de Forest called his triode, were as a detector and later as an oscillator. The presence of a small amount of gas made these early valves more sensitive as detectors, but erratic as amplifiers.

De Forest did not for many years fully understand the operation of his invention and was convinced that some gas was essential. In 1913, Western Electric took the Audion, gave it a hard vacuum and improved mechanical construction, turning it into a reliable amplifier for repeater work on long distance telephone circuits. These same WE valves made possible the first transcontinental telephone circuit from New York to San Francisco, in 1915. As was often the case, parallel development was taking place in Europe.

It should not be assumed that early radio receiving systems were insensitive. By the use of large and efficient tuned circuits fed from massive aerial systems, quite remarkable performances were possible, even with primitive diodes as detectors. The Audion valve was slow to receive commercial acceptance until 1913, when a student at Columbia University, Edwin Armstrong invented regeneration, or positive feedback around a triode detector. This gave a dramatic increase in sensitivity.

At this time, radio transmissions used what is now the bottom end of the spectrum. The region above a few

hundred kilohertz was virtually unused, because the presence of the ionosphere was unsuspected and conventional engineering wisdom was that frequencies above about 1.5MHz were useless. As well, there were considerable difficulties in making transmitters and receivers which would work well in this region.

## WW1 developments

World War 1 gave considerable impetus to radio development. With the entry into war in 1917 by the USA

Armstrong, who had by now graduated, was given an Army commission and sent to France to carry out research. The Americans were convinced (erroneously, as it turned out) that somehow the Germans were communicating with frequencies around 3000kHz and Armstrong was asked to devise a very sensitive receiver to monitor them.

Existing valves were inefficient at such high frequencies and even his regenerative detector was ineffective. Armstrong's brilliant answer, the superheterodyne, was announced just as the war ended in 1918 and was eventually to have a profound influence on receiver design for all time. The subsequent history of the superheterodyne is an absorbing story which we will cover in the future. It is sufficient to say for the moment that it did not come into its own for another decade.

It was left to another type of receiver, the tuned radio frequency or "TRF" set to be the workhorse of the 1920's and, along with the horn speaker, to become



*The 1925 Freed Eisemann was a typical 5-valve TRF, with 3 tuning controls and 2 filament rheostats for controlling gain. The hinged lid was almost universal at this time.*

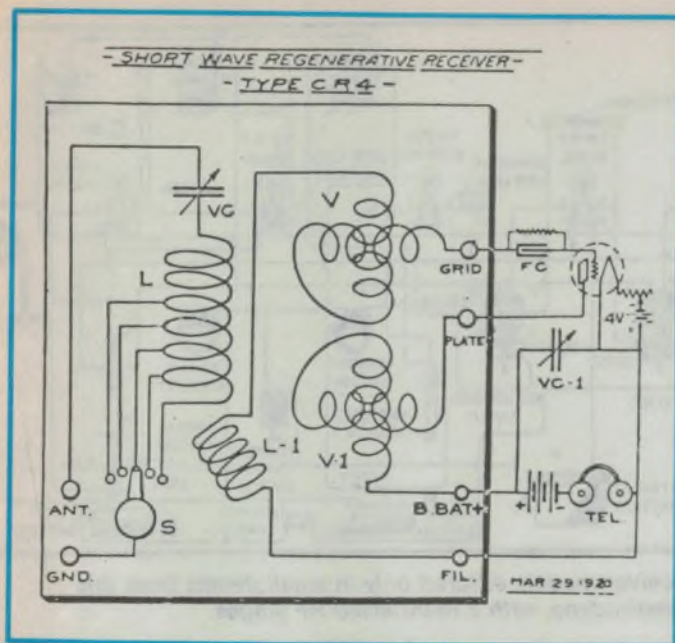

*The circuit for the Grebe CR4 of 1920, typical of pre broadcasting era receivers. The valve was separate from the receiver cabinet. With 2 variable capacitors, two "variometer" variable inductors, a tapped inductor and a filament control it demanded a lot of skill, but results could be impressive.*

the symbol of early broadcasting.

Whilst the US Army was concerned with non-existent German HF transmissions, the Navy was having a real problem. When receiving weak low frequency signals, their receivers were suffering from interference from strong local 500kHz transmissions. The Navy requested L.A. Hazeltine, then Professor of Electrical Engineering at the Stevens Institute of Technology, to design a new receiver. To avoid the interference problem, one of its features was to have minimum capacitive coupling between the aerial and secondary tuned circuits. His remedy was to cancel or neutralise the effect of the capacitance by the use of a separate coil.

A typical amateur receiver of 1920 was the Grebe CR4, the circuit of which is shown in Fig. 1. "Short Wave" indicates that it covered what is now the broadcast band. The variable capacitor VC and coil L tuned the aerial circuit, the main tuning and regeneration being by variable inductors V and V1 called variometers. Note that the detector valve was separate from the receiver. More gain could be provided by adding a two stage audio amplifier.

The controls of a receiver like this all interact, demanding a fair amount of skill to use. A few radio telephone stations were to be heard, but most transmissions were Morse, many still from spark transmitters. By now improved valves, including the UV 201 (shortly to be modified to the famous 201A) had appeared.

In America, radio broadcasting as such began during 1920. Naturally, the "ham" fraternity were involved, often

using home built regenerative receivers. Marconi engineers in Britain were also experimenting with radio broadcasts. There, economics were such that only crystal sets or very simple one or two valve receivers were affordable by the average user. Oscillating regenerative detectors create interference, so their use was discouraged.

By the end of 1923, England was covered by a network of BBC transmitters of reasonable strength, and modest receiver sensitivity was sufficient. Consequently, during the 1920's English receivers were generally simple.

American conditions were different – as they were in Australia and New Zealand when radio came to this part of the world. Away from the cities, long distances from transmitters meant that receivers had to be sensitive and stable. The regenerative detector is remarkably efficient, but its sensitivity falls off rapidly with weak signals, and as mentioned previously, it radiates interference badly if used carelessly. A receiver was required that was stable, sensitive and easily tuned by unskilled users.

Armstrong's superheterodyne was not sufficiently developed. Meanwhile he had discovered super regeneration which initially showed great promise. Capable of phenomenal performance from just two valves, super regeneration was later to be successful at VHF in radar and communications, but for broadcast work, it proved to have inadequate selectivity.

### Different solution

What was needed was amplification prior to detection. Valves that would

amplify at RF were now available, but to achieve a worthwhile amount of gain and to provide a reasonable degree of selectivity, tuned amplifiers would be necessary. However, a valve with tuned circuits at both its grid and anode becomes a healthy oscillator. This occurs because the unavoidable small capacitance between the grid and anode inside the valve feeds sufficient energy back to the grid to cause the valve to oscillate.

One way of preventing this problem would be to cancel the effect of this capacitance. Professor Hazeltine worked on the problem and in 1923 demonstrated a solution based on his Naval work of 1918. In this he "neutralised" the grid plate capacitance by feeding a phase reversed signal from the anode circuit back to the grid via a very small adjustable capacitor. Correctly adjusted, this permitted stable RF amplification and by 1924 the "neutrodyne" tuned radio frequency (TRF) receiver was being sold in increasing numbers.

The TRF was very successful and soon took on a standardised form using 5 valves. There were two tuned RF stages, a grid leak detector generally without regeneration, and two transformer-coupled audio stages feeding a horn loudspeaker. Each RF amplifier and the detector had tuning capacitors with separate knobs which, along with a couple of filament control rheostats, presented a pretty fearsome array to the non technical user.

As a very small boy, I remember my grandfather tuning in Melbourne on a 1925 Federal Neutrodyne. No one else had the confidence to attempt the task. In these receivers, the dials do not track and unless all three are tuned "on the nose" nothing will be heard. Careful tuning in small increments is essential. Naturally, an important part of the operation was to write down or "log" all the settings for future reference!

### Radio takes off

By 1925, America had gone radio mad. Literally dozens of manufacturers were making millions of receivers, the vast majority being the standard "three-knob" TRF.

Many companies resented paying Neutrodyne royalties to Hazeltine, and extensively used alternative ways to stabilise RF amplifiers. One method was to connect resistors of a few hundred ohms in series with the RF amplifier grids. The idea was to introduce sufficient losses to balance the tendency towards positive feedback. Another less elegant method was to return the grids of the RF valves to the positive end of

## Vintage Radio

the filament. This biased the grid positively, causing the valves to load the tuned circuits and again damp down any tendency to oscillate. This was a poor method, leading to short battery and valve life. Amplifiers stabilised by these methods were in no way as effective as well designed neutralised amplifiers.

Here was now a receiver of adequate performance, but with the serious problem of being difficult for the non technical user to operate. Attempts were soon made to couple the tuning controls together, one of the most ingenious coming from Grebe with their "Synchro-phase" receivers whereby the three controls were connected by chain drives and clutches.

A later Grebe used an incredible linkage of "Meccano" parts to couple five capacitors together, whilst Atwater Kent used phosphor-bronze belts.

Two problems arose with "ganging" as it was called. One was wide tolerances between tuning capacitors. The other was that, although RF stages could be made to track well enough, aerial tuning circuits created problems through being affected by the characteristics of individual aerials connected to

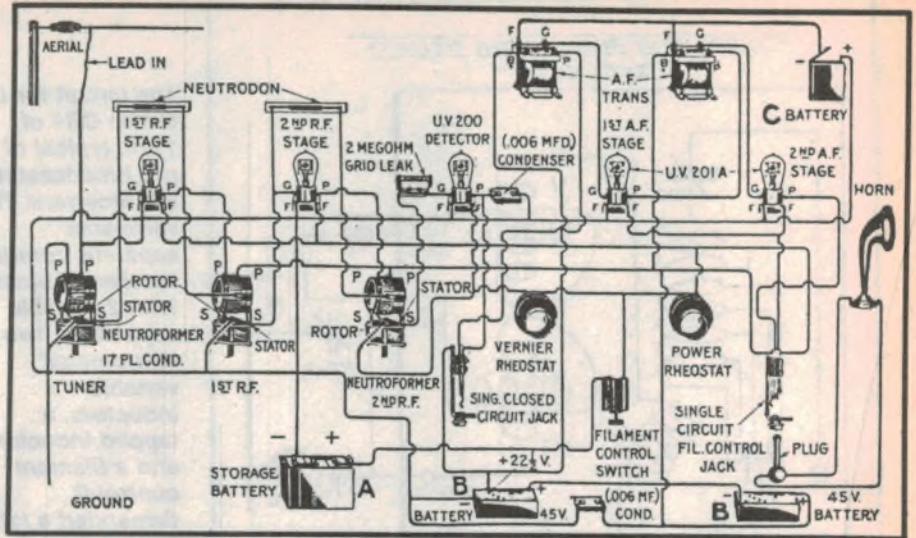

**Dozens of 1925 receiver models differed only in small details from this Standard 5-valve Neutrodyne, with 2 neutralised RF stages.**

them.

One solution was to couple the amplifier and detector stages, but to have separate aerial tuning. This reduced the tuning to a two-handed exercise instead of three! A less satisfactory method was to directly couple the aerial without the benefit of tuning, to the grid of the first valve - leading to problems of cross modulation and harmonics. However,

by 1928, tracking problems had been largely overcome and the TRF had reached the stage of being a reasonably useful and useable receiver.

There were to be two further major developments before the end of the decade. Both were to have a profound influence on radio design and will be described next month. I hope you can join me!

EA



Have you developed a beautiful new circuit or design, and are bursting to tell others about it? Have you written the best article ever on electronics theory or practice? Either way, you're no doubt eager to see your work published as widely as possible.

**Electronics Australia** is by far this country's largest circulation electronics magazine, with more readers than our two nearest competitors combined. This makes us the best possible way to bring your achievements and

## Ever thought of contributing to EA?

knowledge to the largest number of your colleagues and fellow enthusiasts. And our Managing Editor is happy to accept articles for publication, if they're timely and well written.

We also pay top market rates for good, interesting material. It can be either typescript with double line spacing, a word processing file on floppy disk, or you can send us the file via a 'phone modem (enquire for details).

So don't settle for electronics magazines number 2, 3 or 4 — your efforts deserve publication in the biggest and the best!

**Send your articles to Jim Rowe, Managing Editor, at PO Box 227, Waterloo 2017. Or you can fax them to him, on (02) 693 2842.**



# Books & Literature

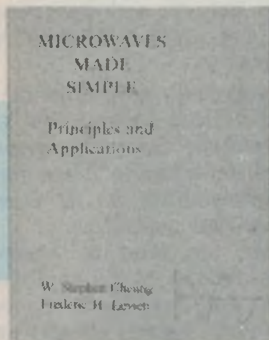

## Microwave text

**MICROWAVES MADE SIMPLE: Principles and Applications**, edited by W. Stephen Cheung and Frederic H. Levisen. Published by Artech House Inc., 1985. Hard covers, 287 x 223mm, 356 pages. ISBN 0 89006 173 4. Also accompanying workbook, ISBN 0 89006 204 8.

Quite an interesting book, this one. It was written to provide an easy to understand basic introduction to the technical side of microwave electronics, for engineers, technicians and others working in the industry. The authors are all staff members of the Microwave Training Institute in Mountain View, California, which was set up by the US electronics industry because it was believed that too many people working in this field didn't have a good enough grasp of the technical concepts and specialised devices used in the microwave area.

As the director of MTI explains in his foreword, conventional microwave textbooks seem to get bogged down in deep maths, and the physical understanding of the devices and techniques is often lost. The idea of *Microwaves Made Simple* was to explain the operation of even the most complicated devices and principles using physical explanations, with only the most basic of maths and the emphasis on practical engineering.

Frankly I think it has achieved this aim exceptionally well. Right from the start the explanations are clear, easy to follow and down to earth, and they remain so all the way through.

The book starts with basic microwave theory and terminology, dealing with the concepts of transmission lines, at-

tenuation, insertion loss and return loss. Then there's an introduction to the Smith chart, allowing it to be used to explain the concepts of matching.

Later chapters then deal with microwave devices (both tubes and solid state), low-noise receivers and antennas. Finally there are chapters discussing the manufacture of devices and the application of microwave systems in radar, satellite communications, electronic warfare, television and health sciences – plus a look at future possibilities.

In short, it's comprehensive in scope as well as highly readable. There's even an optional workbook, for use when the book is used as a college text.

I can't remember having seen a better introduction to this important area of electronics and communications.

The review copy came direct from the publisher in the USA. (J.R.)



## Astronomy guide

**THE SOUTHERN SKY**, by David Reidy and Ken Wallace. Published by Allen & Unwin Australia, 1987. Soft covers, 229 x 179mm, 182 pages. ISBN 0 04 300094 0. Recommended retail price \$19.95.

I'm not sure exactly why this book was sent to *EA* for review. Perhaps the publisher felt that many of our readers are basically interested in many aspects of science, and would therefore have an interest in astronomy as well as subjects more directly related to electronics.

As far as I can judge, it seems to be a well-written and highly readable introduction to the subject, written for people with an interest in astronomy but no prior knowledge. The emphasis is on practical astronomy, the kind of things you'd need to know in order to try it out as a hobby.

I should add that the emphasis is on optical astronomy – there's virtually nothing about radio astronomy, which might well have been of somewhat greater interest to *EA* readers.

The other main point to note is that it has been written in Australia, and therefore discusses the sky and the astronomical scene from the local viewpoint (not all that common, unfortunately). There's even such useful things as a list of astronomical societies in Australia and New Zealand, and latitude/longitude data for many of the larger cities and towns in both countries.

For those with a hankering to spend their evenings peering through a telescope (and don't get me wrong, it can be fascinating!), it should be very worthwhile. I'd just like to see a similar book on elementary radio astronomy for amateurs – after all, Australia has been a leader in this field for many years!

The review copy came from the publisher, but I understand that the book is in stock at all major and technical bookstores. (J.R.)



## Telephone systems

**INTRODUCTION TO TELEPHONES AND TELEPHONE SYSTEMS**, by A. Michael Noll. Published by Artech House, 1986. Soft covers, 230 x 153mm, 177 pages. ISBN 0 89006 203 X.

There always seems to be at least a basic level of interest in telephone systems among electronics people, even though in the past at least these systems haven't involved a great deal of electronics. This book should therefore meet with a good reception, even though it's written from a US viewpoint. The author is a member of the academic staff at the Annenberg School of Communications, at the University of Southern California.

It's by no means a highly academic text, however. Quite the opposite – I would describe it as a very broad and highly readable introduction to the sub-

*continued on page 141*



# Information centre

## Bucket brigade device

The query I have concerns a project which was printed in the June issue 1983 issue, titled "Versatile effects unit for Creative Musicians", by Colin Dawson.

I realise the project is an old one, but on nearing completion I find that one component is unavailable in New Zealand. I am hoping very much if you could tell me where, if possible I could manage to buy some in Australia.

The component in question is the Matsushita MN3001 Bucket Brigade Device (BBD). I would also appreciate it if you could tell me the price (M.D., Auckland NZ)

• *The MN3001 Bucket Brigade IC is listed in the Jaycar catalogue as Cat. No. ZK-8801, at a price of \$24.50. You can order it from Jaycar Pty Ltd at PO Box 185, Concord, NSW 2137 – or use the order form on page 126 of the catalog, which appeared as a supplement to the March 88 issue. The post and packing charges for the IC would be \$3.75.*

## 60-60 Amplifier

I have recently constructed the Ea Sixty-Sixty Stereo Amplifier. After careful assembly and double checking all components wiring etc, I powered the unit up. Everything was OK until it came to setting up the quiescent current, which was very unstable.

Q9, Q10 and Q11 all get hot (both channels) and the quiescent current varies when the above transistors are fanned, even quite lightly. I have checked the components and wiring many times and also had a technician check the above; all was OK. All voltages on the circuit were checked and found to be OK (except of course those associated with the problem). However rail voltage was found to be +55V and -55V – is this too high?

Needless to say I have not attempted to run the amp. Hoping you can shed some light on this problem as I am very keen to get this unit up and running. (R.J., Artarmon NSW)

• *The problems with your amplifier may be due to thermal runaway or supersonic oscillation. These sub-*

*jects were covered in some detail in the May 1987 issue, in an article entitled "Feedback on the Playmaster 60/60 Amplifier". A photocopy is available from this office. See the reader services section in the rear of the magazine.*

*However, the high supply rails are a little unusual and may be compounding your problems. This voltage level would indicate a transformer secondary of 39-0-39 volts AC, or a mains (primary) voltage of about 270 volts AC!*

*Perhaps these voltages should be checked to find the source of the increase. Also, a high secondary may correspond to a similar increase in the 15 volt windings.*

## Quiz Game

I constructed the EA Quiz Game presented in the October 1985 edition, and it works quite well. However, I have not been able to get the chime circuit to operate correctly with a tremolo effect.

Referring to the circuit diagram, the chime circuit is based on two Schmitt oscillators – IC4d providing the basic chime at around 800Hz, and amplitude modulated by a control voltage provided by IC4f at around 1Hz. Associated transistors Q1 and Q2 provide shunting and decay characteristics to the various signals to give the tremolo effect.

My problem is that I am unable to get anything but the basic chime effect (around 400Hz) without any tremolo. Looking at the circuit I cannot understand why this is so. In theory this should mean that the control voltage (1Hz) coming from IC4f is not operating correctly. Frequency measurements however, indicate that it is operating correctly, albeit at around 0.5Hz.

Calculations of the frequencies of the two Schmitt oscillators using the standard formula give 0.3Hz and 368Hz respectively, and this is borne out in practice by actual measurements. This differs from the 1Hz and 800Hz mentioned in the article.

I have even varied the timing components so that in practice each oscillator is actually putting out 1Hz and 800Hz, but this still does not give the tremolo effect. In any event I would doubt that this would have a great effect except to

vary the depth of the tremolo sound.

Can you help me with this – was there a subsequent errata published? (N.A., Canberra ACT)

• *There has been no published errata on the EA Quiz game. This project was developed by the previous EA staff and unfortunately, we have no further information on its operation apart from that published.*

*However, we tend to agree with your calculations of the oscillator frequencies, and suspect the operation of Q2 in your search for the missing tremolo effect. Try lowering the value of the 10uF capacitor at the base of Q2. Its high value may be restraining the oscillator output at the base of Q2, and therefore preventing its conduction. Alternatively, the voltage divider formed by the 100k and 10k resistors may not be allowing enough drive to Q2, particularly if the supply voltage is a little low.*

*It the 800Hz tone has the correct attack and decay characteristics, we may assume that Q1 is operating correctly. If this is not the case, it is also under suspicion and its base drive circuitry should be checked.*

## Philips speakers

I built the Philips 30 W vented 3-speaker system described in your February, 1976 issue. Recently, I noticed that the high frequency performance was lacking. Closer inspection revealed that both tweeters no longer worked.

I contacted the local distributor of Philips speakers, and was advised that the AD0160 was no longer available. The distributor suggested that the AD0140 would be a satisfactory replacement. I am dubious about this recommendation because I seem to recall that the ADO140 was around at the time the speaker system was designed; presumably the designer considered the various Philips tweeters that were available and selected the ADO160 in preference to the ADO140.

I have noticed an advertisement for a Philips AD11610 tweeter and presume from the numbers that it is the replacement for the ADO160. However, unlike the ADO140, the AD11610 is not a drop-in replacement but will require some woodworking. Ideally, I would like to find a source of the ADO160

but, failing that, I would be grateful for your advice in selecting a suitable replacement. Obviously, there are two considerations: a) the ease of replacement, and b) electrical/acoustical suitability.

When I fit the replacement, I would like to avoid a recurrence of the problem and have considered the installation of PTC thermistors. Should I fit a thermistor to each speaker unit (i.e. one for the new tweeter, one for the AD0210 midrange and one for the AD8066 woofer)? Can these be fitted in series with the speakers without affecting the crossover's (ADF600/4000/—B) performance? Will they affect the acoustic performance of the system? Which thermistor should be used for each? (K.L.B., Ringwood Vic)

• *Unfortunately, we do not know a source for the Philips AD0160 tweeters, which appear to have been discontinued. As you have suggested, the AD11610/T8 is probably the most compatible replacement. However, we have not tried this combination and cannot guarantee the results; your ears will be the best judge here.*

*In normal circumstances, the PTC polyswitches exhibit a very low impedance and should not effect the system's general performance. The most economical level of protection is to add a PTC device in series with the tweeter only. Since the tweeter is the most vulnerable unit (as you have experienced), this should significantly increase the protection.*

*The RN3410 device as available from Jaycar Electronics is suitable for this purpose.*

## Fax as scanner?

I am hoping you might be able to help me with a problem I have.

I am trying to find a reasonably simple means of using the output of a Fax to provide the input to a computer (IBM compatible). The prime reason for this is to use the Fax as a scanner to copy material as art work for a simple desktop publisher, however the system would also provide an invaluable (although memory hungry) means of filing documents containing graphics.

Providing the means could be found to provide a screen copy of the Fax signal, a simple program such as Snapshot would provide a usable file for processing. While this would provide a graphics rather than document type file, in some cases this would be advantageous because of extra security from editing.

As most offices are not using both Fax and computers I would have

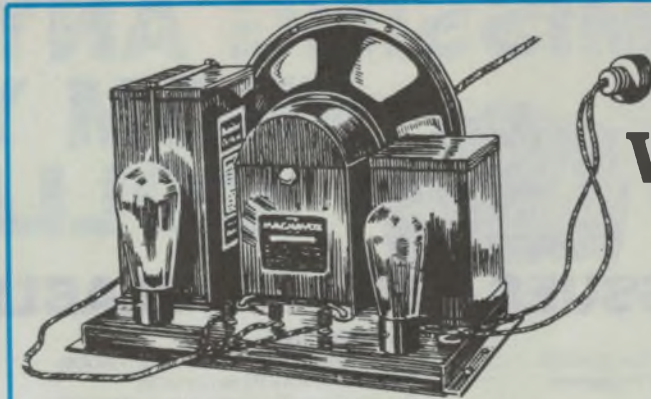

## WHAT WAS IT?

Our mystery object this month is typical of units which appeared on the market in the late 1920's. It came for the then rather princely sum of 45 pounds – not including the two valves visible, which cost an additional 5 pounds. Can you guess what it did? (Answer next month)

### Answer for August:

Last month's mystery item was an audio interstage coupling transformer, used to couple audio signals from the output plate circuit of one valve to the input grid circuit of the next stage – while blocking the DC voltage. The primary side was marked P and B+ (meaning the valve plate and the positive side of the high tension or B battery respectively), while the secondary

side was marked G and C- (meaning the valve grid and the negative side of the bias or C battery).

Later valve circuits used resistance-capacitance coupling between audio amplifier stages, and interstage coupling transformers tended to fall into disuse. However similar but rather smaller transistors were used in the first transistor radios and amplifiers, and are still used in some of the cheaper personal portables.

thought a system to combine both would be available commercially. However this seems not to be the case that I have found, although there are systems that are both over complicated and extremely expensive.

If a system of this type would have sufficient general interest to Ea readers, perhaps it would make the basis for a construction project. In any case I would appreciate any assistance you would provide. (B.K.P., Balya WA)

• *We'll look into it, B.K.P., although it seems a fairly tall order. The modem in a fax machine sends the information in a form which may not be easy to decode.*

## Switch-mode supplies

Please dedicate an article, or series of articles, explaining the fundamentals and design of Switch Mode Power Supplies. Perhaps some inclusion concerning fault finding, dummy loads etc., can be made.

Keep up the good work in producing a very informative magazine. (G.R., Meadowbank NSW)

• *We published quite a comprehensive article on Switcher fundamentals in the February 1988 issue, G.R. That should do for starters. We'll see if we*

*can come up with more on the subject soon.*

## NOTES AND ERRATA

**PLAYMASTER 30-30 AMPLIFIER** (August 1988): The circuit diagram incorrectly shows pin 6 (positive supply) of IC4 connected to the left hand side of R27. Pin 6 should connect directly to the +30V rail on the right hand side of R27. (File: 1/SA/80).

**LINE FILTER & CONDITIONER** (July 1988): We have been advised that the 250VAC rated capacitors specified for this project are not polycarbonate types, but PTFE or PTFE/paper types.

Also with the capacitor values specified, the earth leakage current passed by the filter will exceed the value of 1mA RMS specified in Australian safety standard AS3145 (1979). To reduce the leakage current to an acceptable level, C1 and C2 should be reduced in value to 1nF (rated as before for 250VAC working). As this will tend to reduce the efficiency of the filter, we recommend that when this modification is done, a third and additional 1nF/250-VAC capacitor be connected between the active ends of C1 and C2 (i.e., directly between the A and N input lines). (File No.2/LF/9)



# MISSING ANY COPIES FROM YOUR EA COLLECTION?

## BACK ISSUES STILL AVAILABLE:

### SEPTEMBER 1986

Cool-Down Timer for Turbo Cars (3/AU/50)  
 Upgrading the 1980 EPROM Programmer (2/CC/96)  
 Electronic Melbourne Cup (3/EG/31)  
 FM Wireless Transmitter (3/MS/122)  
 Compact HiFi Loudspeaker (1/SE/66)

### OCTOBER 1986

High Energy Electric Fence (3/MS/123)  
 Power & Antenna For Walkman (2/MS/66)  
 Infrared Remote Control Preamp (1/SC/12)

### NOVEMBER 1986

Build a Microphone (1/PRE/35)  
 High Power HiFi Linear Amplifier (2/TR/63)  
 Low-Cost Dummy Load (7/MS/16)  
 Infrared Remote Control Preamp Pt.2 (1/SC/13)  
 Solar-Powered Bilge Pump (3/MS/125)

### DECEMBER 1986

Low Distortion Audio Oscillator (7/AO/38)  
 Active Antenna for DX Reception (2/AE/41)  
 High-Power HF Linear Amp Pt.2 (2/TR/64)

### JANUARY 1987

Low Distortion Audio Oscillator Pt.2 (7/AO/39)  
 3-Band Shortwave Radio (2/SW/79)  
 Remote Control for Burglar Alarms (3/MS/126)

### FEBRUARY 1987

Dual Tracking Power Supply (2/PS/64)  
 Flashing Lights for Model Railroads (2/MC/23)  
 Digital Sound Store (1/MS/34)

### MARCH 1987

Electronic Rain Gauge (3/MS/127)  
 NiCad Battery Charger (2/BC/12)  
 Masthead Amplifier (6/MS/20)

### APRIL 1987

12/240V Inverter (3/IT/15)  
 Ultrasonic Car Alarm (3/AU/51)  
 Metric Clock (7/CL/37)  
 Crystal Oven (3/MS/128)

### MAY 1987

Low Cost Mini Mixer (1/MX/18)  
 Car Battery Monitor (3/AU/52)  
 Op Amp Tester (7/MS/17)  
 Omega Derived Frequency Standard (7/F/33)



### JUNE 1987

IR Remote Control (2/MC/24)  
 Car Alarm (3/AU/53)  
 VU Meter (1/MS/35)  
 Op Amp Tester Pt.2 (7/MS/18)

### JULY 1987

CD Amplifier (1/SA/78)  
 IR Remote Control Pt.2 (2/MC/25)  
 Phase Difference Meter (7/M/69)  
 Electronics Trainer (3/MS/129)

### AUGUST 1987

Muso Link (1/MS/36)  
 LED Display (7/CL/38)  
 Combination Lock (3/MS/130)  
 Computer Strobe (7/SC/7)

*Back issues are \$4.50 each, including postage. To order copies send cheque, money order or credit card number (American Express, Bankcard, Mastercard or Visa Card) to Electronics Australia, PO Box 227, Waterloo 2017.*

## Do computers play any part in your life?

If they do — or if you just want to find out about them — don't miss each month's issue of

# your computer

A magazine for all computer users and enthusiasts, Your Computer has something for everyone — topical features on all aspects of the computing world, expert reviews of the latest software and hardware, up-to-the-minute information for business people and even games and advice for hobbyists.



Available monthly at your newsagent or subscribe now by phoning (02) 693-9517 or 693-9515.

NEWS  
 REVIEWS  
 PROGRAMS  
 TUTORIALS

## Letters

continued from page 7

being renovated (the active was touching the case of an ironclad switch in the switchbox).

A "functional earth" could fairly be described as an earth connection which functions as an earth, which the mains earth may not always do for DC and low frequency AC and almost never for RF. So that if an installation demands an earth connection, a separate wire to a separate earth stake is the only effective way.

W.A. Jolly,  
Nambucca Heads, NSW

## Info needed

I would be most grateful if you would allow me space in your excellent magazine to ask fellow readers for any service data, circuit diagrams etc., for a National three in one stereo unit MODEL S.G.000A

N.Smith,  
Stanthorpe, Qld.

## 30W Stereo

continued from page 76

If all is well, check the other voltages shown around the power-amp chip (IC4), and the phono pre-amp stage (Q1, Q2 and IC1). When checking voltages around the circuit, don't forget that the heatsinks may be at the negative supply rail potential, and should not be inadvertently grounded. This will depend on the electrical, as opposed to thermal contact between the TDA1514A chips and the heatsink.

That's about it for the preliminary checks of the amplifier; there is no quiescent current to be set, no DC offsets to adjust, or thermal tracking to be checked. However, the TDA1514A chips (and the heatsinks) will normally be quite warm, so the unit should be monitored over a reasonable length of time for any limitations of the box ventilation. Also, the quiescent current of the TDA1514A chips will significantly increase if the power supply rails are beyond the recommended limit, which of course depends on the chosen transformer.

As a final check, connect a suitable input to the RCA sockets and check the controls and switches for their correct operation. After that, you are ready to experience the high performance of your new Playmaster 30-30 amplifier. Ⓔ

## CD Reviews

continued from page 28

In the intervening 8 years he had grown from a relatively inexperienced composer to one with an increasing number of superb works to his credit.

The first set of dance has simple peasant gaiety and freshness, whereas the 2nd set has feelings of deeper emotion. Overall, the music like Bizets *L'Arlesienne* has virtually instant appeal and colourful orchestration.

This recording, which contains both complete sets is a new and dynamic one giving full justice to the composer as well as Dorati's skillful conducting. The balance is first class with good presence and zero noise.

And excellent disc and at mid-price \$19 a real bargain. Ⓔ

## AWA Micro

continued from page 19

chine, and the workstations with a new Apollo DN4000. (A second DN4000 is used for controlling the Trillium test system.)

So there it is - Australia's very latest chip design and manufacturing plant. I don't know about you, but it certainly gives me a warm feeling knowing that we now have the latest chip fabrication technology right here in Australia.

The days of designing them here and then sending them overseas to be made (in due course) should be over. Ⓔ

## Books

continued from page 137

ject, written for almost anyone with a basic understanding of electricity and electronics.

The author follows a largely chronological format, starting with Alexander Graham Bell's momentous invention of the first crude instrument in 1876 and gradually working his way through manual and automatic switching electro-mechanical systems, right through to modern computer-controlled electronic exchanges, cellular radio and data communications. And it's all explained in basic and easy to understand form.

Some of the fine details given to illustrate various concepts are fairly specific to the US scene, but this shouldn't detract from the book's basic value. If you're interested in learning more about telephones, the telecom system and how they developed, I think you'll find it well worth reading.

The review copy came direct from the US publisher. (J.R.) Ⓔ

stamp for list - Hundreds of other items not listed - Send 40c

# L. E. CHAPMAN

122 PITT ROAD, NTH CURL CURL  
MAIL ORDERS BOX 156 DEE WHY, NSW 2099  
TELEPHONE (02) 905-1848

## SUPER SPECIAL

**FM STEREO KITS**  
All three modules supplied are fully assembled and aligned. Circuit diagram supplied.  
**ONLY \$22**

P & P \$2.00  
Antenna \$1 extra

455 KC IF coils for valve radios ..... \$1  
OS coils ..... 75c

**Transistors**  
AD 161-162 ..... \$3 pair  
AD 149 ..... \$2 ea  
1/4 Chrome push-on knobs ..... 10 for \$1  
Slider Pot knobs ..... 10 for \$1

## POTS

1/2 Meg Switch	\$1.00	2 Meg Ganged 1 apped Log	\$1.50
1/2 Meg Single	\$0.50	50K Dual Concentric	\$1.50
25K Dual Ganged Switch	\$1.50	25K TAP 32K	\$1.50
1.5 Meg Single	\$0.50	25K	\$0.50
100K Dual Concentric	\$1.50	1/4 Meg Dual Concentric Linear	\$1.50
1/2 Meg Ganged Log	\$1.50	100K Log Switch	\$1.00
2 Meg Linear Ganged	\$1.00	50K Mini 4 for	\$1.00
10K Dual Concentric	\$1.00	10K Mini 4 for	\$1.00
Double Pole Switch	\$1.50	50 Ohm	\$0.50
25K 4 Gang Linear	\$2.00	0.25 Meg Dual Concentric	\$1.00
20K Linear Single	\$0.50	25K Dual Ganged Switch	\$1.50
1 Meg Log Switch	\$1.00	10K Dual Ganged Switch	\$1.00
1 Meg Dual Ganged Log	\$1.00	250K Dual Ganged Switch	\$1.00
100K Sub Mini	\$0.50	1 Meg 1/2 Meg Dual Concentric	\$1.50
10K Sub Mini	\$0.50	TAP-40K Double Pole Switch	\$1.50
50K Log Switch	\$1.00	300 Ohm Linear	\$0.50
250K Linear	\$0.50	1500 Log	\$0.50
100K Log	\$0.50	0.25 Linear or Log	\$1.50
50K Log	\$0.50		

<b>SPECIAL</b> <b>DUAL VU METERS</b> \$3 pp. \$1	Dynamic microphone Desk Type, HI IMP on/off switch \$4 PP \$1
	TEISCO Ceramic Microphone \$2 PP \$1

5 mixed rotary switches \$2.50	12 mixed switches \$4.50
Touch micro switches 4 for \$1	Micro switches 5 A 250 V 50c
Mixed resistors handy types 100 for \$2	Mixed capacitors handy types 100 for \$2
Stick rectifiers TV 20 sc \$1 each	Transistor ear piece, 4 for \$1 plug & lead

Slider Pots ..... single 50c; dual \$1		
250k dual	25k dual	1 meg dual
250k single	1k dual	2 meg dual
50k single	1/2 meg dual	2 meg single
10k single		

VALVES	6B05	\$7	6BM8	\$6	6K8	\$10	
6V6	\$10	EF86	\$7	6BL8	\$6	6U7	\$7
6K8	\$10	SAS4	\$7	6U7	\$7	6K7	\$7
6B06	\$10	EF86	\$7	6B05	\$7	6A7	\$10
						6V4	\$5

12AX7 \$7

## TUNING CAPACITOR

2 gang covers all Aust. AM bands  
**\$4.75**  
P.P. \$1 for one or two.

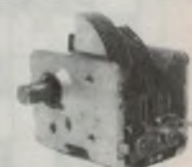

## POWER TRANSFORMER

240V 235 aside 6.3  
**\$10**  
P.P. \$3.50 NSW.  
interstate \$4.40



## VALVE SOCKETS

OCTAL 7 PIN, 9 PIN. 4 FOR \$1

stamp for list - Hundreds of other items not listed - Send 40c

# 50 and 25 years ago..



September 1963

"Electronics Australia" is one of the longest running technical publications in the world. We started as "Wireless Weekly" in August 1922 and became "Radio and Hobbies in Australia" in April 1939. The title was changed to "Radio, Television and Hobbies" in February 1955 and finally, to "Electronics Australia" in April 1965. Below we feature some items from past issues.



September 1938

**Push Buttons Only!**: It must be admitted that, for the non-technical listener who simply wants to hear what is on the air with the least possible trouble, the push-button system of tuning is ideal.

A logical development of this tendency is the dial-less set, with push-button tuning only, which has already firmly established its popularity in America, where most models of this kind are in the midget class.

The local market has already been pioneered along these lines, and now

Slade's Radio has produced the full-sized mantel model illustrated above, tuned by the push-button system and designed for the reception of Sydney broadcasters only.

**A New Radiola:** AWA has announced the release of a further new Fisk Radiola Radio-Gramophone Combination Model 307.

This is a de luxe instrument comprising an electric tuning receiver and an automatic record changing gramophone. Technical features are similar to Radiola 4, with the addition of high-grade record-changing equipment, electrically given turntable and pick-up.

The cabinet of this new instrument is a magnificent console which is a triumph for artist designer and master cabinetmaker. Price, 120 guineas.

**Faulty Insulators:** Faulty insulators on high-voltage transmission lines can cause radio and television interference. Sparks occurring in cavities between metal fittings and the porcelain, between the line and the porcelain, or in cracks in the porcelain, act as primitive radio transmitters. The "signals" they transmit are picked up by receivers along with wanted signals.

An instrument for locating faulty insulators has been developed by Mr L. Medina, of the CSIRO Division of Applied Physics, University Grounds, Sydney, in the course of investigations on discharges in insulating materials. The instrument can distinguish between good and bad insulators two feet apart. Previously only the pole carrying the defective insulator could be identified. It can also be used to determine if a line is live or not.

## SEPTEMBER CROSSWORD

### ACROSS

1. Kind of plug. (5,3)
5. Characteristics of AC supply. (6)
10. Pin number for an octal plug. (5)
11. Scale of Terra! (4,5)
12. Potential unit. (4)
13. Region in junction FET. (5)

14. Conducting system, a twisted ----. (4)
17. What usually draws most from a car battery? (7)
19. Impede current. (6)
22. Air Force's appeal to technicians! (6)
23. Significant magnetic regions. (7)
26. Short electrical units. (4)
27. Household supply. (5)
28. A variable in colour TV. (4)
32. Elastic rule? (6,3)
33. Name of common symbol. (5)
34. Nature of semi-adjustable component. (6)
35. This pioneer had shocking results. (8)

### DOWN

1. Volatge value for vehicle. (6)
2. Massive source of radiation in Orion. (5)
3. Etches. (4)
4. Converter of DC to AC. (8)
6. TV control. (4)
7. Gap seen in low-pressure gas discharge tube. (9)

### AUGUST SOLUTION

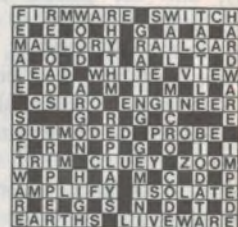

8. Time to effect change between operational limits. (4,4)
9. Satellite's path. (5)
15. Remove data. (5)
16. State a brand of instruments. (5)
18. What's got four feet and a bill? (9)
20. Bigt project by Philips. (8)
21. Zero response tof the calls of 18 down. (2,6)
24. Proponent of exclusion principle. (5)
25. Kind of gauge that may use piezoelectric effect. (6)
29. Said of a theoretically perfect gas. (5)
30. Institution of Electrical & Electronic Engineers. (1,1,1,1)
31. Component of alarm system. (4)

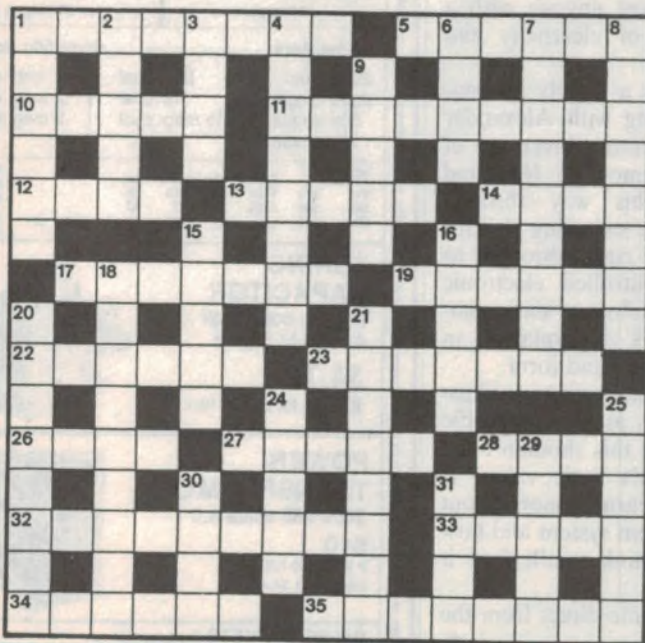

# EA MINI ADS

Rates: One insertion \$195 Six insertions \$180 each Twelve insertions \$170 each  
Send order with remittance to THE ADVERTISING MANAGER, ELECTRONICS AUSTRALIA, P.O. BOX 227, WATERLOO, NSW 2017 by 15th of the month two months prior to issue date.

## KRONE

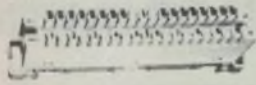

### LSA-Plus

#### TERMINATION SYSTEM FOR DATA APPLICATIONS

Krone LSA-Plus is ideal for the termination of many Multistrand Data Cables.

LSA-Plus offers such facilities as:

- Isolation
- Patching
- Testing
- Over voltage protection

For further information please contact:

**KRONE (AUSTRALIA)  
TECHNIQUE PTY LIMITED**

Telephone (043) 88 4422  
PO Box 335, Wyong, NSW 2259

## DESKS AND BENCHES

Melamine work surface and steel frame.

Suitable for study, computing, ham radio and technician use.

DESKS	— 1200 x 900	\$180
	— 1800 x 900	\$220
	— WITH 900 x 450 RETURN	\$295
BENCHES	— 1200 x 900 & TOP SHELF	\$270
	— 1800 x 900 & TOP SHELF	\$340
PRINTER STANDS FROM		\$45

PLUS FREIGHT COSTS IF APPLICABLE

### LUZER INDUSTRIES

P.O. BOX 213  
ABBOTSFORD 3061  
PH. (03) 592-8348.  
FAX (03) 427-1392

## KRONE



### DiCon

#### OPTICAL FIBRE SWITCHES

Using state of the art moving fibre technology, DiCon switches offer:

- Low insertion loss
- High switching speed
- Range of configurations
- Suitable for multimode fibres

For further information please contact:

**KRONE (AUSTRALIA)  
TECHNIQUE PTY LIMITED**

Telephone (043) 88 4422  
PO Box 335, Wyong, NSW 2259

## Electronic Subcontract Manufacturing:

A new Standard of Professionalism

- Board & Final Assembly
- Component Supply
- Inspect Test & Burn-in
- High Quality; Full Warranty
- Cost competitive in low to medium volumes
- Professional Design Service, Hardware, PCB, Firmware

Microconsultants Pty. Ltd.

72 Derinya Drive, Frankston  
3199. Ph: (03) 787-7700



sale sale sale sale sale sale sale

DISPOSAL  
ELECTRONIC  
EQUIPMENT AND  
TEST GEAR

ELECTRONIC  
BROKERS (Aust.)

Cnr. Barry  
& Brunson Sts.,  
Bayswater, Vic.

(03) 729-0455

sale sale sale sale sale sale sale

## HAS SOMEONE ELSE ALREADY SOLVED YOUR PROBLEM? MS-DOS User Software \$5.00 a disk 1400+ Disks

For your \$40 first year membership of SME Systems Sig and Blue software collection you receive the latest catalog (over 200 pages), monthly catalog updates and newsletters. All disks (with an av. 15 programs) are listed in 26 easy-to-find categories. Our communications category has 73 disks. Databases — 79, General Utilities — 100, Languages — 79, and Graphics/Drawing — 51 disks. Cost per disk:  
5.25" format Self serve \$5.00 Mailorder \$6.00  
3.5" format Self serve \$10.00 Mailorder \$11.00

Ring, write, or fax your membership application today to:

**SME  
SYSTEMS**

S.M.E. PUBLIC  
DOMAIN SOFTWARE  
LIBRARY, 22 Queen  
St., Mitcham, Vic.  
PHONE: (03) 874-3666.  
FAX: (03) 873-4086

## KRONE

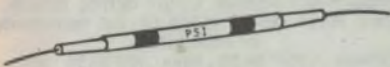

### PSI Lightlinker MECHANICAL FIBRE OPTIC SPLICE

- Low splice loss
- Suits single and multimode
- Utilises patented 4-rod Glass alignment guide
- Lightweight, self contained Splicing kit available

For further information please contact:

**KRONE (AUSTRALIA)  
TECHNIQUE PTY LIMITED**

Telephone (043) 88 4422  
PO Box 335, Wyong, NSW 2259

## CALL US NOW TO RESERVE THIS SPACE

- Free setting
- Over 30,000 audience

Sydney: Call Lyn, 693-9734  
Melbourne: Call Nikki, 646-3111  
Other States: (02) 693-9734

## KRONE

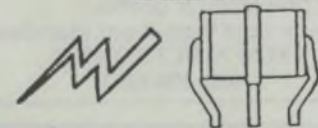

### Sankosha OVER VOLTAGE PROTECTION

A complete range of Protectors to suit:

- Telecommunications
- Data
- Power supplies
- Railway signalling systems
- Programmable logic controllers

For further information please contact:

**KRONE (AUSTRALIA)  
TECHNIQUE PTY LIMITED**

Telephone (043) 88 4422  
PO Box 335, Wyong, NSW 2259

# EA marketplace EA marketplace

## ADVERTISING RATES FOR THIS PAGE

**SMALL ADDS:** The minimum acceptable size of 2 centimetres x one column costs only \$50. Other sizes up to a maximum of 10 centimetres are rated at \$25 a centimetre. **CLASSIFIEDS:** \$4 for 40 letters. Just count the letters divide by 40 and multiply by \$4, ROUND UP TO NEAREST WHOLE NUMBER. **CLOSING DATE:** Ads may be accepted up to the 18th of the month two months prior to issue date. **PAYMENT:** Please enclose payment with your advertisement. Address your letter to THE ADVERTISING MANAGER, ELECTRONICS AUSTRALIA, PO BOX 227, WATERLOO, NSW 2017.

### FOR SALE

**EX-ABC AUDIO TAPES:** 1/4" wide on 10 1/2" Standard metal spool \$6.85. Robust metal spool \$12.85 7" spool \$2.85. 5" spool \$1.25. Post extra. Also in stock 1/2", 1" and 2" tapes. Waltham Dan, 96 Oxford St., Darlinghurst, Sydney. Phone (02) 331-3360.

**ELECTRONICS AUSTRALIA MAGAZINES:** 8/74 to 12/74, 1975, 1976 (except July), 1977 to 1981, 1982 (except April), 1983 to 1986, 1/87 to 9/87. Most in excellent condition. \$20.00 the lot or 20 cents each (minimum 25). John Purcell, 71 Campbell Tce., Alderley, Brisbane. 4051. Phone (07) 356-7062.

**AMIDON FERROMAGNETIC CORES:** Large range for all receiver and transmitter applications. For data and price list and 105X220 SASE to: R. J. & U. S. Imports, P.O. Box 157, Mortdale, N.S.W. 2223. N.S.W: Geoff Wood Electronics, Lane Cove. Webb Electronics, Albury. A.C.T.: Electronic Components, Fyshwick Plaza, Vic.: Truscott Electronics, Croydon. W.A.: Willis Trading Co., Perth.

#### PRINTED CIRCUIT BOARDS

Minimum postage & packaging on all EA & ETI Project PCBs  
Catalogue 1976-85 (inc components) \$2 00  
PCBs made to order — 48 hr prototype service  
Bankcard/Mastercard  
Aetronics PCBs  
112 Robertson Rd. Bass Hill 2197  
(02) 645 1241

#### KIT REPAIRS!!

Repairers of all EA, ETI, AEM and Silicon Chip projects.  
Got a problem! Or queries;  
Ring any time 9 am-9 pm Mon-Sun.  
**EEM ELECTRONICS**  
(03) 401-1393

#### TRANSFORMER REWINDS

ALL TYPES OF TRANSFORMER REWINDS

- REWOUND TO YOUR SPEC
- EXACT REPLACEMENT WINDING
- VINTAGE RADIO A SPECIALITY
- ALL ONE OF TYPES
- ALL QUOTES BY RETURN MAIL
- RAPID SERVICE

For price quote send details showing physical size & number of tappings (or send unit, same will be returned to sender if quote not satisfactory)

**TRANSFORMER REWINDS**  
P.O. Box 438, Singleton NSW 2330  
(065) 76 1291

**NEW 64K-256K PRINTER BUFFER:** design release. VER 4.0 and REV G boards now available. Double sided PCB, EPROM, and instructions \$39.00. Optional additions include 2 by 7 SEG LED front panel display of percentage full, 1 to 99 copies select, 3 polled computer inputs, printer switches, computer switches, and serial converter boards. For a free catalogue send a 37c stamp to Don McKenzie 29 Ellesmere Cres Tullamarine 3043.

**RADFAX2:** Hires radio facsimile morse & rty program for IBM PC/XT on 360K 5.25" floppy + full Doc. Need CGA joystick port SSBhf FSK/Tone decoder. Has re-align auto-start view save print ++. Also "RF2HERC" same as above but suitable for hercules card. Programs are \$30 each + \$3 postage ONLY from M Delahunty 42 Villiers St New Farm 4005 QLD Ph. (07) 358 2785.

**"MAESTRO SUPER COMPUTER:** Fully assembled and tested 6 MIPS Novix based Forth computer. In case with power supply. Attaches to serial port of any IBM/compatible computr. With manuals and software \$950. (075) 39 9055 Ext 14, office hours, (075) 38 8719 after hours."

#### LASER KITS NOW AVAILABLE

HERE is your chance to build a LASER at the lowest possible price. THIS KIT includes everything, tube, p.c. board, all wire pre-cut, holes drilled, finished case, nuts bolts and screws, etc. Price include postage

**YOU WILL SAVE HUNDREDS OF DOLLARS**  
Priced \$395, thats low. Ph (08) 296-7464 till 9, or write to:  
**LASER OPTICS**  
for information, 3 Tarnham Road, Seacombe Heights, SA 5047

**WDELECTRONICS**

**...PCB ARTWORK...**

PHONE  
**(02) 639 1252**

#### 24 HOUR PCB SERVICE

Single Sided ..... 10¢ per cm<sup>2</sup>  
Double Sided ..... 12¢ per cm<sup>2</sup>  
(Minimum 100cm<sup>2</sup>)

DRILLING ..... 3¢ per hole  
Send artwork on Film or transparency P&P \$2.50

**WDELECTRONICS**

P.O. BOX 25, Ermington, NSW 2115  
Phone (02) 639 1252

**PROJECT REPAIRS** Having trouble getting your EA/ETI/SC kit to work? Phone (03) 749 3480 for estimate or send kit to Hunter, 5 Yatama Crt, Werribee 3030.

**ELECTRONIC COMPONENTS NEW \$\$\$\$ WORTH** on circuit boards. Relays, I.C.s, Transistors, Diodes, 2% Resistors, Switches, Inductors, Sockets, etc, etc. \$20 ea. Send \$20 for sample S.A.E. for details. **VIDEO CAMERAS** Sony \$200. **FIBRE OPTIC LEADS** \$10. (09) 349-9413. P.O. Box 368, Mirrabooka, WA 6061

**SAGEM DOT MATRIX:** Teleprinter. Model CX20 in as new condition. Suit hobbyist/enthusiast, complete with punch tape and reader \$350. Phone: (09) 571 8031.

**NEW RADIO VALVES:** For entertainment or industrial use. Waltham Dan, 96 Oxford St., Darlinghurst, Sydney. Phone (02) 331-3360.

### WANTED

**WANTED URGENTLY:** Circuit diagrams & any parts for Dokorder reel to reels. Phone: (053) 821 351 or 825 034 and ask for Steve, or Box 894, Horsham, 3400.

**RETIRED ELECTRONICS TECH:** Required 2-3 days per week for small repair workshop. Contact Martin Griffith. Switchmode Power Supplies, 2 Avon Road, North Ryde, Telephone (02) 888 9371.

**A NEW CONCEPT FOR LOW VOLTAGE PROJECTS**  
**COPPER FOIL TAPE:** thin pure copper tape backed by special hi-tack adhesive. Current carrying capacity, 5 amps, FULLY TESTED at 24V 5A. Not recommended for mains voltage.  
4.75mm ... RRP \$8.03 6mm...RRP\$9.84 8mm ...  
RRP \$13.60 33 metre rolls  
**GIFFORD PRODUCTIONS**  
P.O. Box 62, St. Kilda, Vic. 3182 (03) 534-3462

**RCS RADIO PTY LTD.**

Established 1933  
IS THE ONLY COMPANY  
WHICH MANUFACTURES AND  
SELLS EVERY PCB & FRONT PANEL  
published in EA and ETI  
**651 Forest Road Bexley 2207 AUSTRALIA**  
RING (02) 587 3491 FOR INSTANT PRICES  
24 HOUR TURNAROUND SERVICE



# EA Directory of suppliers

Which of our many advertisers is most likely to be able to sell you that special component, instrument, kit or tool? It's not always easy to decide, because they can't advertise all of their product lines each month. Also some are wholesalers and don't sell to the public. The table below is published as a special service to EA readers, as a guide to the main products sold by our retail advertisers. For address information see the advertisements in this or other recent issues.

Supplier	State	A	B	C	D	E	F	G
All Electronic Components	Vic	•	•	•	•	•		
Altronics	WA,NSW	•	•	•	•	•	•	•
Acetronics	NSW			•				
Chapman, Lance	NSW				•			
Dick Smith Electronics	All	•	•	•	•	•	•	•
Eagle Electronics	SA	•		•	•		•	
Electronic Brokers	Vic						•	
Electronic Component Shop	Vic	•		•	•	•	•	
Emona Instruments	NSW						•	
Geoff Wood Electronics	NSW	•	•	•	•	•	•	•
George Brown Group	All		•		•	•	•	
Jaycar Electronics	Eastern	•	•	•	•	•	•	•
Pre-Pak Electronics	NSW		•		•	•		
Preston Electronics	Vic	•	•	•		•		•
RCS Radio	NSW			•				
Rod Irving Electronics	Vic	•	•	•	•	•	•	•
Scientific Devices	Vic						•	
Sheridan Electronics	NSW		•	•	•	•		
Tandy Electronics	All		•		•	•	•	•

KEY TO CODING:  
 A Kits & modules  
 B Tools  
 C PC boards and supplies  
 D Components  
 E IC chips & semiconductors  
 F Test & measuring instruments  
 G Reference books

Note that the above list is based on our understanding of the products sold by the firms concerned. If there are any errors or omissions, please let us know.

## EA marketplace

### ELECTRONICS ENGINEER/TECHNICIAN

AT&M is a small, smart company looking for a smart (size no object) applications person to assist in developing a range of superior electronics construction kits for the educational and recreation market.

The chosen one will need to have truly diverse experience with audio, RF, Digital Circuitry and be able to write BASIC.

Further desirable skills would be a fluency in PROTEL and AUTOCAD.

We are looking for a "Hands on" worker, letters after your name are nice, but we must have someone with real "Nous" and a free ranging mind (electronically speaking).

We have a well equipped laboratory with some of the most sophisticated test equipment and computers available and will add more as the projects require.

If you really enjoy designing and constructing novel, clever circuitry this is your chance.

AT&M is owned by Clive Chamberlain, formerly Managing Director of PROMARK ELECTRONICS, until I sold it!

So why not call me for an appointment?

**Australian Test & Measurement Pty. Ltd.**  
**Phone Sydney 906 2333**

## ADVERTISING INDEX

Acetronics .....	144
Altronics .....	94-99
Anthony Borg & Associates .....	
.....	53,55,103,113
Captain Communications .....	85
Chapman L.E. ....	141
Crusader .....	52
Data Electronics .....	102
Dick Smith Electronics .....	
.....	9,46-47,86-87,112
EA subscriptions offer.....	146,IBC
EEM Electronics .....	144
Electri Board Designs .....	113
Electronic Brokers .....	85,143
Electronic Component Shop .....	91
Electronic Solutions.....	121
Elmeasco .....	107
Federal Publishing .....	
.....	3,15,23,32,90,136,140
Geoff Wood .....	77
Gifford Productions .....	144
Ginsbury Electronics .....	143
Hamilton Island Marketing .....	108
Hewlett Packard .....	41
Hi Dap .....	125
Hypec Electronics .....	109
Jaycar .....	67-71
JWD Electronics .....	144
Kenelec .....	29
Kepic .....	115
Krone Australia.....	143
Luzer Industries.....	143
Microconsultants .....	143
Microway .....	35
Monodotronic .....	127
N.S.D .....	133
Parameters .....	4
Philips Components .....	39
Pioneer Marketing Services.....	
Prometheus Software Developments .....	
.....	113
Protel Technology .....	117
RAAF Recruiting Australia.....	36-37
Racal Redac.....	OBC
RCS Design .....	120
RCS Radio .....	144
Rod Irving Electronics.....	
.....	20-21,60-61,78-79,128-129
Scan Audio.....	10
Siemens .....	110
SME Systems.....	143
Sony Australia .....	40
Stotts.....	59
Tennyson Graphics .....	116
Transformer Rewinds .....	144
Tronics 2000 .....	112
Unix.....	105
VDT Anti Glare Australia.....	117
Vicom International .....	IFC
VSI Electronics .....	42

This index is provided as an additional service. The publisher does not assume any liability for errors and omissions.

# \$5,000 WORTH OF TEST

## *an EA exclusive*

Here's YOUR chance to win these superb test instruments, valued at over \$5200! All you have to do is subscribe NOW to Electronics Australia, Australia's leading electronics magazine, and you have SIX excellent chances to win!

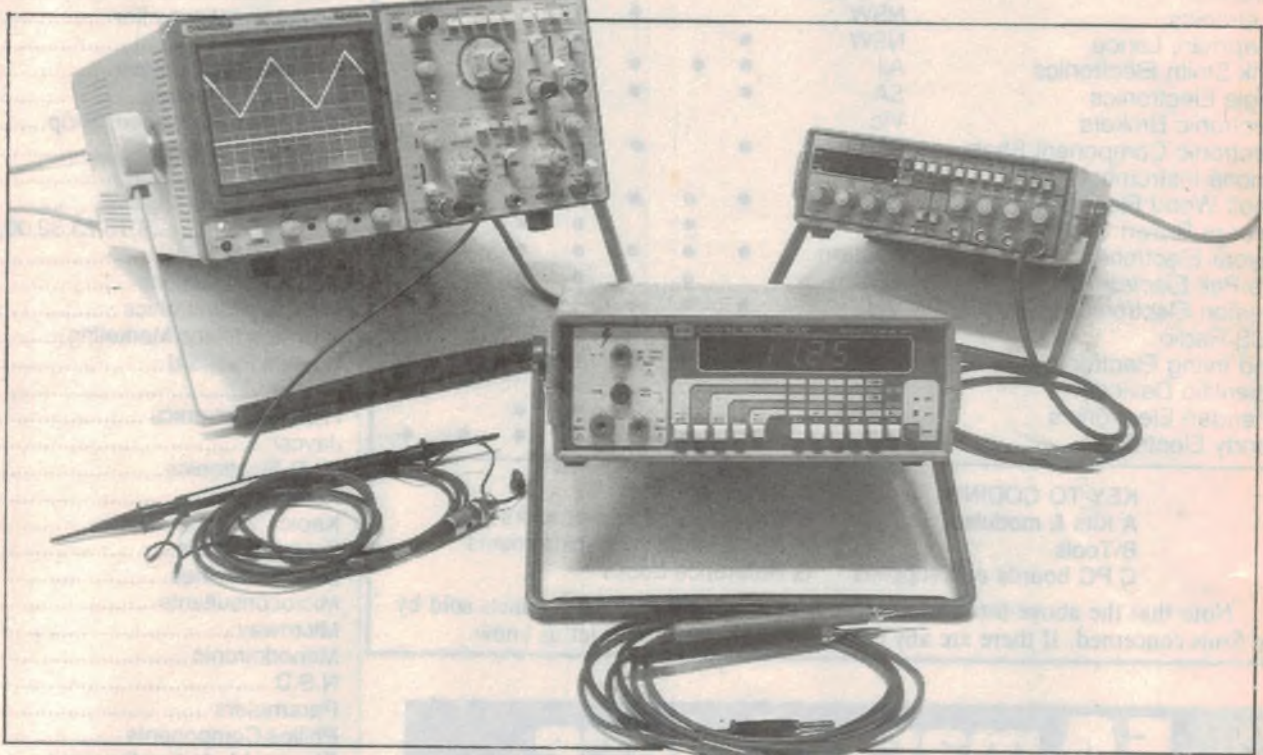

### FIRST PRIZE:

This great set of truly professional-quality test instruments from Emona Instruments will really look good in your home laboratory or workshop. Here's what you get:

- A Kikusui DSS-5020 20MHz dual-trace oscilloscope with inbuilt digital storage facilities, valued at \$3500
- A GW Instruments GFG-8019 multi-function 0.2Hz-2MHz function generator with inbuilt 6-digit 10MHz frequency counter and sweep generator, valued at \$644
- A GW Instruments GDM-8035T high accuracy 28 range 3-1/2 digit digital multimeter, valued at \$400

**TOTAL VALUE OF THIS MAGNIFICENT FIRST PRIZE IS THEREFORE \$4544!**



### 5 CONSOLATION PRIZES!!!

Obviously only one lucky EA subscriber can win this first prize — and it could be YOU. But even if you're not quite that lucky, you could still win one of 5 consolation prizes, each consisting of a top-quality Escort EDM-1122 handheld digital multimeter with 29 ranges PLUS 200kHz frequency counting, capacitance measurements, transistor and diode testing, continuity and logic testing  
EACH CONSOLATION PRIZE VALUED AT.....\$149

# INSTRUMENTS TO BE WON!

## FIRST PRIZE INCLUDES ...



### KIKUSUI DSS-5020A: DUAL TRACE DIGITAL STORAGE SCOPE

Normal mode — Bandwidth DC to 20MHz, 5mV/div to 5V/div — Timebase 50ns/div to is/div  
Storage mode — Bandwidth DC to 400kHz with 1MHz sampling — 8-bit sampling with memory of 1024 words per channel plus 1024 word REF display — 28 dot-div vertical x 100 dot/div horizontal resolution — linear or sinusoidal interpolation — simple pushbutton operation

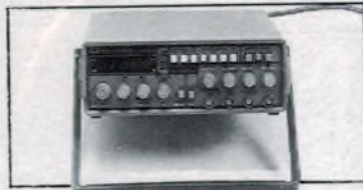

### GW INSTRUMENTS GFG-8019 MULTIFUNCTION GENERATOR

Generator frequency range — 0.2Hz to 2MHz Output waveforms — sine, triangle, square, pulse, ramp. Output level — >20V p-p open circuit, 10V p-p/50 ohms. Frequency counter range — 0.1Hz to 10MHz (6 digits). Counter sensitivity — < 20mV RMS at 10MHz. Sweeping range — 1000:1 ratio. Sweeping modes — Auto/manual, lin/log, 0.5s-30s.



### GW INSTRUMENTS GDM-8035T BENCH-TOP DIGITAL MULTIMETER

3-1/2 digit LED display, all ranges fully protected. Basic accuracy — 0.1%. DC voltage ranges — 199.9mV to 1200V (10M impedance). AC voltage ranges — 199.9mV to 1000V (True RMS). DC current ranges — 199.9uA to 20A. AC current ranges — 199.9uA to 20A. Resistance ranges — 199.9 ohms to 20M (6 ranges)

## ESCORT EDM-122 HANDHELD DIGITAL MULTIMETER/COUNTER

3-1/2 digit LCD display (17mm high digits)  
DC voltage ranges — 200mV to 1000V (5 ranges)  
AC voltage ranges — 200mV to 750V (5 ranges)  
DC current ranges — 200uA to 20A (6 ranges)  
AC current ranges — 200uA to 20A (6 ranges)  
Resistance ranges — 2000 ohms to 2000M (7 ranges)  
Capacitance ranges — 2nF to 20uF (5 ranges)  
Frequency ranges — 2kHz to 200kHz (3 ranges)  
Other ranges — transistor hFE, diode VF, logic levels, audible continuity



(5 TO BE WON AS CONSOLATION PRIZES!)

## SUBSCRIBE NOW AND GET THIS GREAT PAPERWEIGHT/TOOLKIT FREE!



Regardless of whether you win one of those great test instruments, by subscribing now you'll automatically receive one of these intriguing solid brass paperweights — which is also a handy 5-in-1 toolkit!

Outside it's a hammer, but inside the handle there are four screwdrivers (two flat blades, two Phillips). Normal retail value \$14.95!

### TO SUBSCRIBE

Simply fill out the coupon attached and put it in the reply paid envelope supplied — if the coupon and envelope are missing, send your name, address, phone number and cheque, money order or credit card details (card type, card number, expiry date and signature) to Freepost No. 4, Electronics Australia Test Gear Subs Offer, Federal Publishing Company, PO Box 227, Waterloo, NSW 2017. Any enquiries phone (02) 693-9515 or 693-9517. Unsigned orders cannot be accepted.

**HURRY! THIS OFFER CLOSSES 31ST NOVEMBER, 1988**

### CONDITIONS OF ENTRY

1. The competition is open only to Australian Residents authorising a new renewal subscription before last mail Wednesday, November 30. Entries received after closing date will not be included. Employees of the Federal Publishing Company, Emona Instruments and their families are not eligible to enter. To be valid for drawing, subscription must be signed against a nominated valid credit card, or, if paid by cheque, cleared for payment.  
2. South Australian residents need not purchase a subscription to enter, but may enter only once by submitting their name, address, and a hand-draw facsimile of the subscription coupon to The Federal Publishing Company, PO Box 227, Waterloo, NSW 2017.  
3. Prizes are not transferable or exchangeable and may not be converted to cash.  
4. The judges decision is final and no correspondence will be entered in to.  
5. Description of the competition and instructions on how to enter form a part of the competition conditions.  
6. The competition commences on 24 August, 1988 and closes with last mail on 30 November, 1988. The draw will take place in Sydney on 2 December, 1988 and the winner will be notified by telephone and letter. The winner will also be announced in The Australian on Monday, 5 December and a later issue of this magazine.  
7. The prize is: KIKUSUI DSS-5020 20MHz dual trace oscilloscope with inbuilt digital storage facilities; \$3500 GW Instruments GFG-8019 multi-function 0.2 Hz-2 MHz function generator with inbuilt 6 digit 10 MHz frequency counter and sweep generator \$644 & GW Instruments GDM-8035F high accuracy 2 1/2 range 3-1/2 digit digital multimeter \$293. 5 consolation prizes of Escort EDM-1122 handheld digital multimeter \$149 each.  
8. The promoter is The Federal Publishing Company, 180 Bourke Road, Alexandria, NSW 2015. Permit No. TC-88-2324 issued under the Lotteries and Art Unions Act 1901. Raffles and Bingo Permits Board Permit No. 88 1441 issued on 12-8-88, ACT Permit No. TP88-832 issued under the Lotteries Ordinance 1964.

# Heads you win! Tails you win!



*Multi layer... surface mount... fine line routing.  
Whatever your requirements, you win with*

## CADSTAR

The new CADSTAR program is fast... and very cost-effective. It costs much less than you'd expect. And it does more than you ever thought possible.

No wonder. It's brought to you by RACAL-REDAC, the world's leading supplier of CAD systems for PCB design.

CADSTAR is the fast, easy way to work out complex printed circuit boards, including multi layer, fine line routine and surface mounted components... on both sides.

CADSTAR will enable you to design high technology boards, with surface mounted devices, faster than using the old methods with conventional components. Changes are quick, easy, accurate and electronic integrity is maintained throughout.

Your CADSTAR system runs on an IBM PS/2, PC-AT, or compatible. It produces double-sided surface mount designs, with 3,500

connections, resolutions up to one thousandth of an inch and up to 256 pins per component.

CADSTAR uses the power of the new 286/386 based IBM



workstations to provide PCB design facilities which have previously been available only with expensive 32 bit systems.

A single demonstration will prove how much CADSTAR has to offer. To arrange one, please contact any of our authorised distributors.

### MELBOURNE

RCS Designs Pty Ltd  
728 Heidelberg Road  
Alphington VIC 3078  
Telephone: (03) 49 6404/49 6792

### PERTH

Precisions Micro Systems Pty Ltd  
3A, 18 Millford Street  
East Victoria Park WA 6101  
Telephone: (09) 362 4885

### ADELAIDE

Mayer Krieg & Co  
50 Mary Street  
Unley SA 5061  
Telephone: (08) 373 0444

### SYDNEY

Racal Electronics  
47 Talavera Road  
North Ryde NSW 2113  
Telephone: (02) 888 6444

## **RACAL-REDAC**