

WIN
HI-FI GEAR
WORTH \$6000

Australia's Top Selling Electronics Magazine

NDD

Electronics Australia

JANUARY 1989

Aust* \$4.95

NZ \$6.95 incl GST

SPECIAL ANNUAL

DIGEST

**FIVE EXCITING
NEW PROJECTS
TO BUILD!**

- **PC-DRIVEN
FUNCTION GEN**
- **SIMPLE
TOUCH SWITCH**
- **'BEEPO':
MULTI-RANGE
CONTINUITY
TESTER**



- **LOW COST
80/150 WATT
AMP MODULE**
- **COMPACT
UHF REMOTE
CONTROL TX**

100 YEARS OF ELECTRIC STREET LIGHTING IN AUSTRALIA
AUSSIE CHIP BREAKTHROUGH ● **RADIO & TV STATIONS LISTING**
DIGITAL AUDIO BASICS ● **ROBOT ARM HELPS DISABLED**

"I'd settle for a bare bones spectrum analyzer just to have one right on my bench."

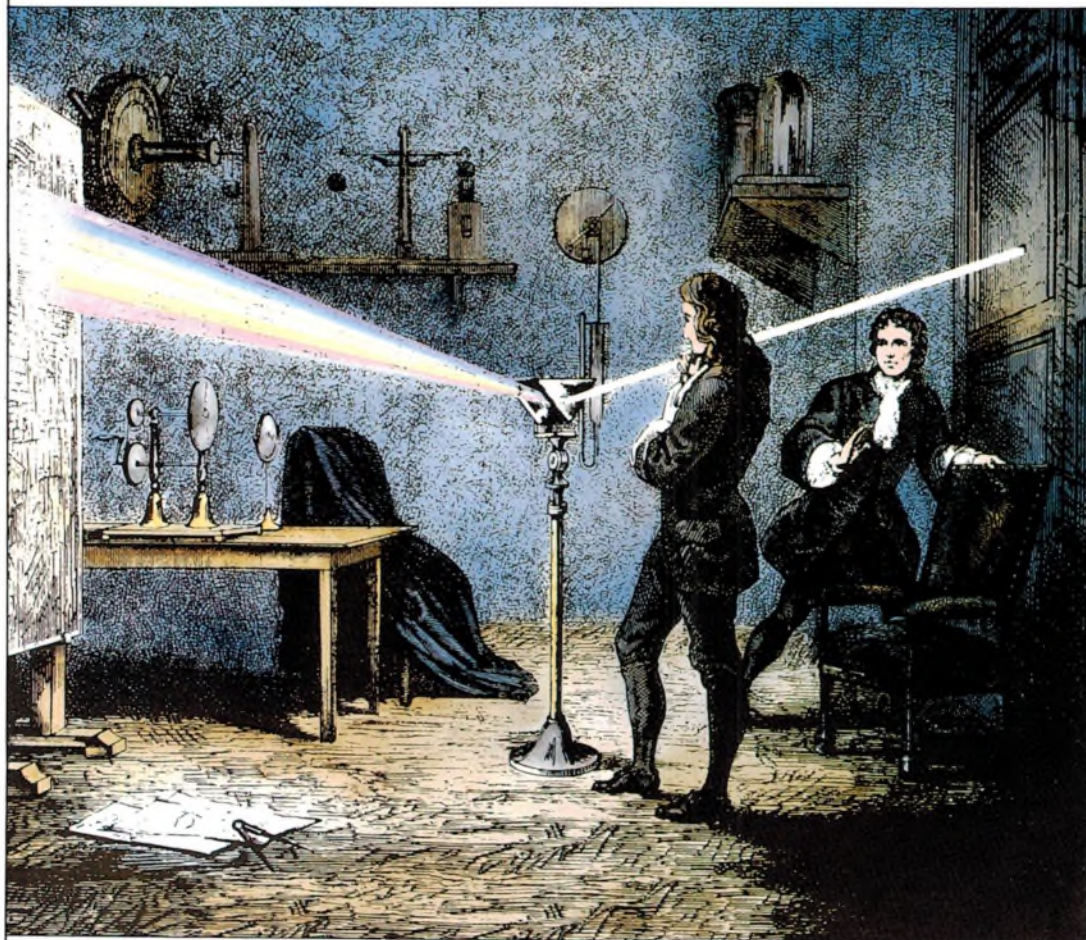

Newton refracts light through a glass prism, circa 1672. "The Bettmann Archive."

we never stop asking "What if..."

"Why settle?" For under \$15,000, the HP 8590A Portable RF Spectrum Analyzer is such a good buy that you can afford one for every bench. Yet it's no stripped down, low-tech model.



HP 8590A
Portable RF Spectrum Analyzer.

It's loaded. You'll find every essential measurement tool in the HP 8590A, plus more of the right bells and whistles than analyzers three times as expensive.

And there's a wide frequency range (10 kHz to 1.5 or 1.8 GHz), large amplitude range (-115 dBm to +30 dBm), plus 50 or 75-ohm input. Frequency accuracy runs \pm (5 MHz + 1% of span).

Take care of the basics with three simply labelled keys: FREQUENCY,

SPAN and AMPLITUDE. The entire keyboard is that easy to understand. There are 14 dedicated keys for common functions plus softkeys for over 80 special tasks.

Three optional digital interfaces make the HP 8590A completely programmable for automated production testing. And you can use just about any desktop or HP hand-held computer to do it.

Use the HP 8590A's briefcase handle to carry it anywhere. It weighs just 13 kgs, slips into all the tight spots, and it's sturdy enough to withstand the rigors of real portability.

Pick up the phone and call HP's Customer Information Centre STD-free on (008) 033 821 to find out more on the HP 8590A Portable RF Spectrum Analyzer.

 **HEWLETT
PACKARD**

PERNA

ELECTRONICS

ELECTRONIC FET LABORATORY METER

This meter breaks new ground for an advanced precision analogue meter of this quality below \$100. It has the advantages of digital multimeters ie: insignificant circuit loading, high accuracy, etc., without the misleading and erroneous readings that DVM's are famous for.

- 10 MEG OHM input
 - 12 AMP DC and AC current ranges.
 - Centre zero pointer adjust for + and - readings.
 - Single range and polarity reversing switch.
 - Power on LED.
 - P-P Calibrated scale.
 - Review EA September '88.
- M10950 RRP.....
\$79.95
SPECIAL.....\$69.95

HI-QUALITY CRYSTALS

- 1 Mhz.....\$8.95
 - 2 Mhz.....\$6.95
 - 2.4576 Mhz...\$4.95
 - 3.57954 Mhz...\$2.95
 - 4 Mhz.....\$2.95
 - 4.9152 Mhz...\$2.95
 - 8 Mhz.....\$2.95
 - 12 Mhz.....\$2.95
 - 24 Mhz.....\$4.95
- Full range available.

ELECTRET MIC INSERTS

Prime quality inserts.
SPECIAL.....\$0.95

POWER HUNGRY?

Build the new VK Powermate 11 ref: EA Oct 88. It delivers a regulated 13.8 V DC at up to a massive 5 AMPS! We supply the complete kit with predrilled panels.
BARGAIN AT \$109.00

18 VOLT 6 AMP

This heavy duty, high current transformer is ideal for CD, amateur computer power supplies and battery charger use. Made in Australia.
T20060 RRP...\$32.95
SPECIAL.....\$29.50

Order by fax: (03) 562 4079

SENSATIONAL SAVINGS ON BRIDGE RECTIFIERS

WO4-400V 1.5 AMP.....	\$0.50
BR64-400V 6 AMP.....	\$1.75
BR104-400V 10 AMP.....	\$2.95
BR108-800V 10 AMP.....	\$3.75
BR254-400V 25 AMP.....	\$4.25
BR354-400V 35 AMP.....	\$4.50
RS404-400V 4 AMP INLINE	\$3.25

We are suppliers of components from NEC, Fairchild, Philips, EMI, Exar, Intel, Rohm, Hewlett-Packard, Motorola, Texas Instruments and others. Call for competitive pricing.

PICK-A-PACK

YOU determine the values of the components in the bulk packs. No more buying unwanted components and junk.

ZENNER DIODES 1 WATT

Choose between 3.3V to 75V pack 50 eg: 10 x 6.8V, 10 x 12V, and 30 x 22V.
SENSATIONAL...\$9.95

FUSES PACKS OF 50

- 3 AG fast action 100ma to 30 AMP. \$6.95
- 2AG fast action 100ma to 6.5 AMP \$6.95

DIODE SPECIAL

IN4004 — 400V 1 AMP pack 100\$5.95
IN448 — 75V 75ma pack 100.....\$4.50



WELLER WTCPS SOLDERING STATION NEW MODEL

From one of the world's leading manufacturers comes this superb new station. It uses an advanced control system which measures temperature. To change temperature simply change the tip. The ultimate for the professional or the serious hobbyist. T12000 Only. \$149.50
Spare tip.....\$9.95
Tip Wiping Sponges\$3.95
Desolder Braid..\$2.95

FREE

With every purchase of Weller WTCPS.



Don't pay full price for Arista products from other suppliers. We have discounted the entire range in the new 1988-89 Arista catalogue — over 3000 items!

ORDER VALUE
(not inc. P&P)

YOUR DISCOUNT OFF RRP

\$25.00 to \$100.00.....	8%
\$100.00 to \$500.00.....	10%
\$500 plus.....	12%

This offer strictly applies to our phone and mail order customers only. Don't have a catalogue? Notify us we will send you one FREE!

THIS OFFER IS LIMITED.

IC EXPRESS

74LS SERIES MISCELLANEOUS IC's

74LS01 ... \$0.50	V20 8Mhz NEC.....\$17.95
74LS03 ... \$0.50	MAX 232 RS232
74LS09 ... \$0.50	TRANS/REC.....\$7.50
74LS10 ... \$0.50	6264 RAM.....\$8.95
74LS48 ... \$1.20	6502 PROCESSOR.....\$7.50
74LS78 ... \$0.80	AY-3-1015D.....\$7.95
74LS83 ... \$1.00	XR2211 PLL.....\$7.50
74LS109 ... \$0.75	ICM7216 FREQ
74LS151 ... \$1.00	DISP/DRIVER.....\$59.50
74LS174 ... \$1.00	NE555 TIMER.....\$0.40
74LS240 ... \$2.25	NE572 STEREO COMPANDOR...\$5.95

All prices this month only. Post and pack \$5.50

Overnight jet service Australia wide for items under 3kg — \$8.00. The above postage rate is for basic postage only. Road freight, bulky and fragile items will be charged at different rates. Sales tax exempt and

wholesale orders welcome. Errors and omissions excepted. Prices and specifications subject to change without notice. IBM, PC, XT, AT are trademarks of International Business Machines.

ORDER BY CREDIT CARD VIA PHONE

(03) 562 4079



PERNA ELECTRONICS, FACTORY 5/22 REGENT AVE, SPRINGVALE 3171
Mail order: P.O. Box 103, CLAYTON, VIC. 3168

Electronics Australia

'89

AUSTRALIA'S LARGEST SELLING ELECTRONICS MAGAZINE – ESTABLISHED IN 1922

100 Years of Electric Lighting



In 1888, the NSW provincial town of Tamworth became the first in Australia to install electric street lighting. To celebrate this historic event, the original power station has been re-created – but it wasn't easy! See page 18...

Australian Radio & TV stations

An up-to-date listing of AM, FM and TV stations (VHF and UHF) throughout the country. Handy reference information – gives callsign, location, frequency and power. See page 150.

State of the Art

Our annual expanded look at new and current components, test instruments, computer peripherals, opto-electronics, RF gear and more.

ON THE COVER

To emphasise that this month's Annual Digest issue has a particularly strong complement of construction projects, as well as reference material, the simplest approach was to simply show you one or two. Our hard-working EA secretary Allison Tait agreed to pose with them, to add warmth and humanity. (Photo by Helmut Mueller)

Features

- 14 **NEW ROBOT ARM HOLDS PROMISE FOR THE DISABLED**
It can feed you, even give you a shave!
- 18 **100 YEARS OF ELECTRIC LIGHTING**
Tamworth recreates its power station – first in Australia
- 24 **A DREAM OF A LIFETIME**
Electronics & computers at the Gold Coast's Dreamworld
- 30 **PROJECT FAULT FINDING**
What to do when your project doesn't work...
- 116 **PRODUCT REVIEW: MINI GAS TORCH, 12V TESTER**
Two handy little tools from Dick Smith Electronics
- 134 **AN ENTHUSIAST'S TREASURE TROVE**
Sheridan Electronics – one of Sydney's few true disposals shops
- 150 **AUSTRALIAN RADIO & TV STATIONS LIST**
Callsigns, frequencies, locations and transmitter power

Entertainment Electronics

- 8 **WHAT'S NEW IN ENTERTAINMENT ELECTRONICS**
Looking back and looking forward in video and audio
- 50 **COMPACT DISC REVIEWS**
First recording of Beethoven's '10th Symphony', plus 3 more...
- 62 **BASICS OF DIGITAL AUDIO**
Sampling, quantisation, brickwall filters and aliasing explained

Projects and Technical

- 36 **THE SERVICEMAN**
One of those cases where nobody wins, and a case of missing colour
- 70 **BEEPO – CONTINUITY TESTER SUPREMO!**
Winner of our Grand Hobby Project Contest, Advanced Section
- 76 **SIMPLE PC-DRIVEN FUNCTION GENERATOR**
Use your personal computer to generate signals with almost any waveform
- 84 **HIGH QUALITY AUDIO POWER AMP MODULE**
Low cost, easy to build, but gives up to 105W into 8-ohm loads
- 96 **CIRCUIT & DESIGN IDEAS**
Serial to parallel interface, logic testers, electrolytic tester, DC-DC converter
- 100 **TOUCH ME!**
Simple but useful beginners' project: a touch switch
- 106 **16-CHANNEL UHF REMOTE CONTROL – 3**
This month: the relay driver module
- 110 **REFERENCE NOTEBOOK**
Capacitor colour codes, Transistor base connections
- 112 **NEW SINGLE-CHANNEL UHF TRANSMITTER**
For remote control use – now even smaller!

ANNUAL DIGEST

- 136 SINGLE CHIP SCSI HOST ADAPTOR FOR PC'S**
New ASIC chip from NCR handles all bus housekeeping
- 142 SOLID STATE UPDATE**
Toshiba makes thin-film superconductors, new Tektronix wafer testing probe, lots more...
- 146 VINTAGE RADIO**
Cabinet restoration part 2: Lacquering techniques

News and Comment

- 6 LETTERS TO THE EDITOR**
Baby monitor, AM/FM tuner, Amplifier 'light show', Vented enclosures
- 7 EDITORIAL COMMENT**
A wealth of informative reading...
- 42 FRANKLY FRANK**
Where have all the neutrinos gone?
- 44 FORUM**
Circuit symbols – your response, and further comments on 'tingles'
- 52 NEWS HIGHLIGHTS**
Breakthrough by local firm Austek: first real single-chip processor for DSP
- 58 SILICON VALLEY NEWSLETTER**
Gene Amdahl bounces back, US distributors freeze out Asian chip makers
- 118 STATE OF THE ART**
Survey of new products, category by category
- 156 INFORMATION CENTRE**
Answers to readers' queries

Departments

- 132 BOOK REVIEWS**
Microprocessor text, antenna tome, computer circuit analysis
- 139 COMING NEXT MONTH**
What's coming in the February issue...
- 149 EA MINI ADS**
Where to spot those new products and services
- 160 EA CROSSWORD PUZZLE**
A little relaxation for that lazy holiday afternoon
- 160 50 AND 25 YEARS AGO**
Nostalgic look back into our past
- 161 MARKETPLACE**
Classifieds and other small advertisements
- 162 DIRECTORY OF SUPPLIERS**
Find out which of our advertisers can sell you that component, instrument or kit...
- 157 NOTES AND ERRATA**
Multi-Purpose Audio Preamplifier (November 1988)

MANY GREAT PROJECTS TO BUILD: Beepo



A very flexible continuity tester design, which was awarded first prize in the Advanced section of our Grand Aussie Hobby Project contest. See page 70.

Touch Me

An ideal project for beginners – a natty little touch switch, to turn things on and off. Very low in cost, too. See page 100.

High quality amplifier module

High quality need not mean high price. Our latest audio amp module is really low in cost, but will deliver over 150W into 4 ohm loads, with less than .05% THD. It's also easy to build and get going – see page 84.

PC-driven function generator

Here it is at last – sorry about the delays! Hook it up to your computer, and use it to produce almost any desired waveform. Gives valuable insights into computer-driven test instruments, too. See page 76.

Single channel UHF R/C Transmitter

A revised version of the UHF radio control transmitter design we presented in 1987. This time it's much smaller and neater – see page 112.

MANAGING EDITOR
Jamieson Rowe, B.A., B.Sc., SMIREE

TECHNICAL EDITOR
Peter Phillips, B.Ed., Dip.Ed., ECC

PRODUCTION EDITOR
Penny Roberts

EDITORIAL STAFF
Rob Evans, CET (RMIT)
Mark Cheeseman

CONTRIBUTORS
Neville Williams, FIREE, VK2XV
Ian Pogson, VK2AZN
Ron Cooper
Jim Lawler, MTETIA
Bryan Maher, M.E., B.Sc.
Ken Pohlmann, M.S., B.S.

DRAFTING
Karen Rowlands

GRAPHIC DESIGNER
Brian Jones

ART PRODUCTION
Alana Horak, Larry Leach

PRODUCTION
Kylie Prats

SECRETARY
Allison Tait

ADVERTISING PRODUCTION
Brett Baker, Neville Lawton

ADVERTISING MANAGER
Selwyn Sayers

PUBLISHER
Michael Hannan

**HEAD OFFICE,
EDITORIAL & ADVERTISING**
180 Bourke Road, Alexandria, NSW 2015
P.O. Box 227, Waterloo 2017.
Phone: (02) 693 6620
Fax number: (02) 693 9935 Telex: AA74488
For reader services see back of magazine.

INTERSTATE ADVERTISING OFFICES
Melbourne: 221a Bay Street, Port Melbourne,
Vic. 3207. Phone: (03) 646 3111
Fax No: (03) 646 5494. Nikki Roche
Brisbane: 26 Chermiside Street, Newstead,
Qld 4006. Phone: (07) 854 1119
Fax No: (07) 252 3692. Bernie Summers
Adelaide: 98 Jervois Street,
Torrensville, SA 5031.
Phone: (08) 212 1212. Mike Mullins
Perth: 48 Clieveden Street, North Perth.
Phone: (09) 444 4426. Des McDonald
New Zealand: Rugby Press, 3rd Floor,
Communications House, 12 Heather Street,
Parnell, Auckland New Zealand.
Phone: 796 648 Telex: NZ 63112 'SPORTBY'

ELECTRONICS AUSTRALIA is published
monthly by Federal Publishing Company Pty
Ltd, 180 Bourke Road, Alexandria, N.S.W.
2015.

Copyright © 1988 by the Federal Publishing
Company Pty Ltd, Sydney. All rights re-
served. No part of this publication may be
reproduced in any way without written per-
mission from the Publisher or Managing Edi-
tor.

Typeset and printed by Hannanprint, 140
Bourke Road, Alexandria, NSW for The Fed-
eral Publishing Company Pty Ltd.
Distributed by Newsagents Direct Distribu-
tion Pty Ltd, 17 Doody Street, Alexandria
NSW 2015

Registered by Australia Post - publication
No. NBP 0240 ISSN 0313-0150

*Recommended and maximum Australian
retail price only.



Letters to the editor

Baby monitor

I have been reading your magazine for a number of years and am very satisfied with it.

One project which I have not seen any electronics magazine tackle to date (correct me if I am wrong) and which, I think, is overdue, is a device to monitor a baby whilst asleep and sound an alarm in the event that it stops breathing. I understand that hospitals have these devices but to my knowledge, they are not available to the man in the street.

As the father of a 6 month old baby who constantly hears of cot deaths in the news, I think that your publishing such a project would go a long way to alleviating my paranoia and that of many others. It would be appreciated, therefore, if you could give this request favourable consideration.

D. Aston
Newtown, NSW.

Comment: We'd be a little hesitant to describe such a project, to be honest. Not because it isn't easy to come up with a really reliable unit. We would hate to have someone's baby die because they built up one of our projects and it didn't work at a crucial moment - for whatever reason.

AM/FM Tuner

Like a number of other constructors I experienced difficulties with the local oscillator of the AM section of the stereo AM/FM tuner. The result was that the AM/FM tuner was placed to one side and the *Electronics Australia*, Notes and Errata column scanned each month in the hope that 'something would turn up'.

When the letter from J S Truelove appeared in April giving an alternative oscillator design I was ready to give his design a go. The alternative oscillator was easy to put together and best of all, it worked. The tuner has now been in operation for several weeks and has proved to be worth the wait. Both the FM and AM sections work well.

I would like to express my appreciation to *Electronics Australia* for publishing the design and to Jaycar.

Jaycar provided a complete kit that matched the original design and also

stocked a full set of replacement parts. This is what I expect of a kit supplier.

There have recently been several letters critical of kit suppliers. I feel these letters are unfair. The kit supplier's role is to provide the required parts and to stock spares for a reasonable length of time. It is up to the constructor to assess the kit and to decide if the kit can be assembled and made to work.

I build kits because I like the thrill of completing something that can be tough and frustrating and has an element of risk. With any kit there is a possibility that you will not be able to get it to work correctly. Building kits may teach a lot about electronics and fault finding but the real pleasure is that it is solely up to you to turn a pile of components into a useful piece of electronic wizardry.

Once again thanks to J S Truelove, *Electronics Australia* and Jaycar for making this kit a success for me.

John Cameron
Chatswood, NSW.

Amplifier 'light show'

We felt obliged to answer the letter from Mr Anonymous in the August issue concerning our AM1600 amplifier. We were glad to see he had an appreciation of the torture the amplifier was subjected to, which was the whole point of the demonstration.

The amplifier was used in bridged mode where into 6 ohms and with music applied, the output will swing between 110-120V RMS, which is what is required to bring the lamp to its full brightness. That is well over 2000 watts and is approximately equivalent to ten 200 watt 100 volt line amplifiers, not bad considering that the AM1600 is physically only slightly larger than just one of them. We wanted to demonstrate the unit's current handling ability and protection features, and show that even in the most adverse conditions it would operate continuously.

Mr Anonymous stated the load at times would be well below 1 ohm, but we must correct him on the amount of current drawn under these circumstances. A load is not some dark dank entity which consumes current at will; it

has to put up with what is available even if it requires more to operate properly. The amount of "in phase current" the AM1600 can supply to a load is approximately 25 amps RMS, which is dictated by various protection circuits.

Though this current is available from each channel the bridging mode is a series circuit and thus no more current than the 25 amps can be drawn, not the 250 amps as proposed. Whether or not in this type of demonstration, the sluggish response of the lamp is antithetic to the signal applied would depend on how well someone can hear through their eyes and whether the source material was Beethoven or Iron Maiden.

Finally, to answer his question there was no light show from within the amplifier and at all the shows that this demonstration was done (AES New York, NAMM Los Angeles, AES Melbourne and AME Sydney) the only failures have been the lamps.

The original unit demonstrated at the two US shows had travelled some 30,000km on ships, planes and trucks to various studios and testing laboratories throughout most of America. It was also used to demonstrate a respected Californian speaker manufacturer's brand new studio monitors at the NAMM show. This amplifier was later sold off the stand and is to this day still going strong.

Ray Bond
Australian Monitor
Gladesville, NSW.

Vented enclosures

I read with interest the article on loudspeakers presented in the September issue of your journal. The chapter on bass reflex speakers repeated the oft-quoted statement that at resonance the air pressure at the back of the speaker cone undergoes a phase inversion before leaving the port, so reinforces the output from the front of the cone.

Explanations of this form have appeared in the texts for over 40 years and have probably remained unchallenged, because it would seem plausible that the acoustic output from cone and vent must be in phase if they are not to

continued on page 159



Editorial Viewpoint

A wealth of interesting reading...

Welcome to our 1989 Annual Digest issue, which is also the first issue in *Electronics Australia's* 67th year of publication.

Even more than in most other areas of science and technology, the state of the electronics art moves at such a rapid rate that it's almost impossible for any of us to keep up. If you're like me, the main chance you get to catch up on your reading is at weekends and during holidays. That's why we try to pack as much useful information as we can into our Annual Digest issues, to help you put your holiday time to good use!

This year you'll find our usual greatly expanded new products sections, designed to give you a better overview of the range of products currently available. And there's also the usual expanded coverage of entertainment electronics and solid state devices, for the same reason.

Among our feature articles, the one I myself particularly enjoyed reading is the story behind Tamworth's celebration of 100 years of electric street lighting in Australia. Ron Greer and his team have done a terrific job of rebuilding an important part of our technical heritage, and I'm sure you'll find it as interesting as I did to read of the many challenges they faced - particularly when it came to re-creating the power station's original dynamos.

On the other hand, our leading news story breaks details of an integrated circuit breakthrough by local chip maker Austek, working in conjunction with the CSIRO. They've come up with a new digital signal processing chip that is at least one, and quite possibly two full years ahead of the overseas competition. A really impressive achievement, especially as the new chip looks as if it might open up almost as many new and exciting applications as the micro-processor. And it's an Aussie development!

In addition we have a particularly strong complement of construction projects, pitched to suit those with a variety of interests and levels of experience. Plus special articles to help you catch up with technology, such as Ken Pohlmann's explanation of Digital Audio, and an up-to-date listing of Australian radio and TV stations.

All in all, then, I'm sure you'll find it packed with informative and helpful holiday reading.

PS: No, we haven't put the cover price of the magazine up permanently, just for this special issue to cover our increased costs. It'll be back to the normal price next month...

What's New In

Entertainment Electronics

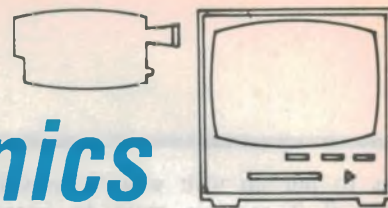

Looking back, and then ahead...

In last year's Annual Digest issue, we made a number of predictions about the developments you could reasonably expect to see in the 12 months ahead. As usual with such forecasts, we turned out to have limited success. Unrepentant, we're having another attempt this year to predict what might happen in 1989...

One of the predictions we made last year was that DAT (digital audio tape) recorders would probably become available to consumers outside Japan, before the middle of the year. We certainly bombed out with that one, because they still haven't been widely released. A few professionals have obtained them, and the US Ford Motor Company has offered DAT *players* (with no recording facility) in some of their 1988 models – but that's about it.

In fact at present, as far as the world consumer market is concerned DAT recorders seem almost as far away as ever, presumably due to pressure from the CD and wider recording industry. This despite the fact that consumer response in Japan itself seems to have been quite good, and manufacturers have been turning out all sorts of new models for home, car and portable use.

So when *will* we see them here? Your guess is as good as ours. DAT still seems likely to turn up sooner or later – although if it takes much longer, there's a danger that it could be still-born. The rather more elegant erasable-CD technology is gradually gaining strength, and could well surge ahead. If this happens DAT could easily end up in the already-bulging category of technologies that 'looked promising, but never made it'.

Another of our predictions that bombed badly was the one that CD-Video or CD-V would also hit the market with a bang, around mid-1988. At the beginning of last year this did indeed seem likely, with both the European and Japanese firms pushing it for all they were worth.

But it wasn't to be. CD-V still hasn't reached the market anywhere, and like DAT it now seems to be as far away as ever. In fact there now seems to be a strong whiff of disaster around CD-V,

and growing rumours that even those firms who were pushing it hardest are quietly bailing out.

CD-V always had the faint air of a technology in search of a non-existent market, and could never quite shake off its links with the earlier unsuccessful videodisc technology. There has also been something of a question mark hanging over CD-V regarding the availability of software.

But what seems to have been the main stumbling-block, from what one can glean, is continuing and apparently quite stubborn manufacturing problems with both the players and the CD-V discs themselves.

Unfortunately the very feature of CD-V that was touted by its promoters as the reason for its likely success (where videodisc had failed) looks like it could well become its downfall. By trying to straddle both CD and videodisc technologies, CD-V seems to have been lumbered with a double dose of technical problems – as well as perhaps being seen by the marketplace as neither audio fish nor video fowl.

It seems likely that unless its problems are sorted out really quickly now, CD-V could well also sink into oblivion.

One of our predictions that did turn out a little closer to the mark was that Super VHS video machines would reach the Australian market later in the year. This has indeed happened, although in a rather low-key fashion.

S-VHS still doesn't seem to have made much impact on the market, despite the dramatic improvement it offers in terms of picture quality. Perhaps its rather higher price is the problem, particularly as you really need a matching high-resolution colour monitor with separate luminance and chrominance

connectors, in order to reap the new system's full benefits.

Pre-recorded S-VHS software doesn't seem to much in evidence as yet, either – which could also be slowing things up.

Perhaps 1989 will turn out to be the year that S-VHS really takes off, after all. In some ways it seems more likely to do so than either DAT or CD-Video.

We also predicted that there would be further growth in the 8mm video format, with more models appearing and prices nudging slowly downwards. That turned out to be fairly true, although the drop in prices has been even smaller and slower than we anticipated – perhaps as a result of the continuing unfavourable exchange rate between the Australian dollar and the Yen.

Certainly the 8mm video system seems to have gained solid market acceptance in the camcorder area, although the VHS-C format has also grown in popularity. At present both seem to have a fairly secure future, so there seems little risk in predicting their continued growth this year.

Another prediction we made was that small personal-portable colour TV sets with LCD screens would probably become available during 1988. And this also happened, although it's true that the small LCD sets haven't made much impact as yet.

Finally, we predicted that high-definition TV (HDTV) probably *wouldn't* appear in 1988, and nor would digital TV – apart from 'quiet' digitisation of various sections inside conventional analog TV sets and VCRs. And again we turned out to be pretty right.

There are now a few sets and VCRs offering 'digital' features such as frame storage, titling and multi-picture display, but no fully digital sets as yet. Both these and HDTV seem to be almost as far away as they did last year, in fact – so we wouldn't suggest holding your breath!

On the whole, then, with last year's predictions we had a few successes and a few failures. But what about the coming year, the last of the 1980's?

Looking ahead

Actually predictions seem a little harder this year, because the consumer electronics industry is going through a quiet phase at present. As the industry moguls are inclined to say, we're going through a period of 'consolidation'.

As noted earlier, DAT seems unlikely to become widely available in the near future, and CD-Video is also having problems in getting to market. It's possible that both may finally get to market this year, although at present the chances look slim.

If we're forced to hazard a guess, we predict that DAT might just make it, but CD-V probably won't. In fact we wouldn't be surprised now if CD-V is a dead duck.

Super VHS video will probably grow, but we suspect its growth will be fairly slow because of the price barrier, the need to use a special monitor or receiver, and the chicken-and-egg situation regarding software. We don't expect prices of S-VHS machines to drop much during 1989, for the same reasons.

The main growth in video seems likely to be in the area of camcorders, with the existing formats of VHS-C and 8mm. Here you can probably expect to see continuing improvement in performance, particularly in terms of picture resolution, as well as a slow but steady reduction in prices.

Where standard home VCRs are concerned, the main developments you're likely to see are in the area of extra features (such as fancier remote controls), and probably again a reduction in prices, as S-VHS and 8mm have more effect.

Will colour LCD's finally start appearing in large-screen sets, bringing in the large picture-on-the-wall sets we've been promised for so long? Frankly we doubt it.

Our impression is that colour LCDs even as large as 300mm diagonal are still struggling to get out of the R&D labs, and you'll be lucky to see sets with even this size of picture hit the market in 1989. It's more likely that even they won't arrive until 1990, with truly large LCD sets a few years further down the track.

If you really do want a large picture, the way to go for the next few years is still likely to be either a projection TV or one of the monster-CRT sets that have started to trickle out of Japan in the last 6 months or so. But take your money with you – both kinds of set tend to carry an equally large price tag.

As noted earlier, HDTV still seems

quite a few years away, so if your current TV or VCR is on its last legs, we wouldn't suggest trying to hang on until HDTV arrives. Current indications are that you could be waiting a long time!

In the area of car electronics, we'll probably see a few more audio systems offering CD players either instead of, or as well as the traditional cassette player and AM/FM radio. Some systems may also start offering decoders for the new 'radio data system' (RDS), which uses supersonic SCA/ACS subcarriers on FM transmissions to transmit program and station ID information – plus traffic information and emergency messages. However this will no doubt only take place if the DOTC authorises local FM stations to broadcast the RDS signals.

The other areas in which you might see new and interesting developments are personal fax machines and cellular radio telephones. But our tip is that here too growth will be fairly modest as well.

In short, we see a fairly quiet year ahead, right across the spectrum of consumer electronics. But we could easily be wrong, so stay tuned!

New Audiosound 30A MKII amplifier



The 30A MKII is a new upgraded version of Audiosound's 30A compact high-performance stereo amplifier. Nominally rated at 30 watts RMS/channel, it offers excellent overall performance. A high capacity toroidal power supply with over 20,000µf of filtering, ensures a very low hum and noise level.

An improved low impedance Baxandall tone control stage with limited range provides good noise performance and square wave flatness in the centre position, with less than 1dB interaction at mid-band with full boost and cut.

The phono pre-amplifier is an optional plug-in unit as many people now prefer not to buy a turntable and this component would therefore be redundant. However, for those requiring excellent record playing facilities a range of high-performance plug-in phono preamps are available to suit a wide range of cartridges and also loudspeakers. Loudspeakers? Yes incorporated in the top line preamps is a high slope 3rd-

order active rumble filter, which can be ordered to match the roll-off of your loudspeakers. This in effect greatly enhances record reproduction, by eliminating rumble and large low frequency cone excursions – which can occur even with very high quality turntables. The result is cleaner record reproduction and much improved power handling from this source.

A wide range of inputs are provided – two for tape (one with monitoring), TV video tuner, CD and phono. Also, a simple surround sound facility is included for video buffs, plus priority loudspeaker switching.

Further information is available from Audiosound Laboratories, 148 Pitt Road, North Curl Curl 2099 or phone (02) 938 2068.

Sanyo camcorder has extra-fast shutter

The Sanyo VM-D5P is a digital 8mm camcorder that puts professional, highly advanced features within the reach of the amateur/home video market.

The unit features a 2/3" CCD (Charge-Coupled Device) image sensor with 480,000 pixels, one of the highest figures of any camcorders on the market, enabling it to take crisp, clear pictures even in light levels as low as 5 lux (roughly the same as candlelight).

A major feature of the VM-D5P is a variable electronic shutter capable of speeds of up to 1/4000th of a second. At this sort of speed, fast action that produces only a blur with lower speed shutter video cameras comes up with crystal clarity and sharpness. Six shutter speeds down to 1/50th of a second are provided, to give maximum flexibility whether shooting fast or slow action, and in all possible light conditions.

Another feature that should prove interesting for the home video market is a Digital Superimposition Function. This allows one to superimpose a still image – a title, message, drawing, in fact any symbol – onto the video picture in a choice of 5 colours (white, red, blue, yellow and black) plus reverse colouring. Aim the camera at the desired image, press the Memory button, and then call it up at any desired time during shooting for permanent recording onto the picture. It can also be superimposed over any pre-recorded video picture during playback or editing.

Other features include a 6-times power zoom – another professional touch; a date imprint function to record the date of shooting; blur-free slow, still

and frame-by-frame special playback; and dual voltage for overseas travel.

A new improved digital auto focus divides the picture into 6 segments and obtains accurate focus every time, even when shooting through glass.

The VMD-5P comes with hard carry case and accessories, and has a recommended retail price of \$3299.00

New Sony camcorder



Sony Australia has announced the release of its latest 8mm video camcorder, the CCD-F330. The release of this unit brings a total of 7 models that are available from Sony.

The CCD-F330 has Auto Focus, 6 x power zoom lens with macro and incorporates two kinds of digital memories for the superimposition of titles during video shooting without going through the editing process. This digital titling process quickly allows the user to title in any language using a choice of eight colours.

The auto iris control gives recordings spot-on exposure by quickly and accurately adjusting for changing light conditions while the back light function compensates for scenes that are strongly backlit. An Auto Linear white balance maintains accurate colour reproduction both indoors and outdoors.

Quick and easy editing is possible on the spot while recording – just flip the Edit Search button back and forth to search for the scene you wish to remove. Re-recording over the desired scene produces noiseless scene transitions every time thanks to the Flying Erase Head.

5.4MHz video signal recording and an RGB colour processing system ensure clean pictures with true-to-life colours. Other features include three hour recording capability; time and date superimpose; LCD tape counter; ear-phone jack.

The CCD-F330 is available now from the Sony dealer network at a suggested retail price of \$3149.00

3-piece CD player

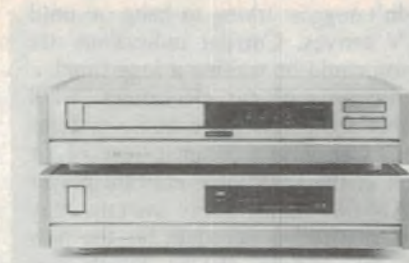

The CD-12, a three piece compact disc player designed in Europe under the leadership of Marantz designer Ken Ishiwata, comprises separate CD drive, digital to analog converter and intelligent table-top remote control.

Marantz claims that the CD-12 sets new standards for digital sound, with special attention having been paid to the elimination of all possible sources of distortion and 'jitter'. In the CD-12, jitter is eliminated by a phased-lock loop driven by a high-accuracy clock beating many millions of times a second.

In the interest of electrical isolation of components, four toroidal low-stray field power transformers are employed: one each for transport, pure digital circuitry, D/A converter box, and analog amplification.

As well as handling the signal from compact disc players and the soon to be released CD Video format, the CD-12 is ready for digital audio tape (DAT) and digital satellite transmission. It automatically switches to the correct sampling frequency – 32, 44.1 or 48kHz – for each sound source.

Marantz claims that the limited edition CD-12, which will sell for about \$5999 is seen by many to be the best CD player in the world today.

New video head cleaners from TDK



Keeping your VCR and camcorder heads in perfect condition will now be much easier thanks to several new head cleaning products recently released by TDK (Australia).

The TDK VHS Dry Type Head Cleaner (TCL-11) replaces the earlier TCL-30, and is designed for VHS and S-VHS VCR's. TDK claim it not only cleans the head, but also regulates the head surface condition (vitaly important owing to the large area of tape scanned by the head). TDK further claim that as an additional benefit, cleaning with the TCL-11 decreases vibration noise which effects the picture image detail considerably.

TDK's TCW-11 Wet Head Cleaner is designed for VHS and S-VHS. It offers an exclusive cleaning of the video heads and also the transport components. The TCW-11 utilises a unique V-type loading, which TDK claim to be safer to the heads because it offers less friction. A third feature is the simplicity of use, by using a fixed volume of liquid per shot thereby avoids damage to the internal mechanism of the VCR.

TDK's VCL-11 Dry Head cleaner is designed for VHS-C video cassette recorders. The VCL-11 offers the same features as the TDK TCL-11. This newly developed non-abrasive cleaning tape both cleans and restores VCR heads to their optimum operating condition.

All three new head cleaners are available from Record Department Stores and TDK Dealers. A TDK audio/video booklet is also available with useful cleaning hints for both audio and video recorders.

'Digital' amplifier from Marantz



Marantz Australia has released a digital amplifier claimed to be capable of achieving and preserving the highest possible sound quality from digital sources.

The amplifier is the PM95 and with direct digital input and a choice of 32, 44.1 and 48kHz sampling frequencies, it is able to accept signals directly from sources such as CD players, DAT recorders and satellite receivers.

In the PM95, digital to analog conversion is performed immediately before

the power amplification stage, eliminating unnecessary stages and ensuring the highest possible sound quality.

Appropriately for an amplifier handling the fastest transient attack and widest dynamic range, the PM95 is capable of delivering high power, even into complex loudspeaker loads. It is conservatively rated at 150 watts, but to give the purest sound at normal listening levels, can be switched to deliver pure linear Class A amplification up to 20 watts.

The PM95 accepts both optical and electronic digital inputs. The DAT circuit also has an optical output for digital tape monitoring.

Borrowing know-how from Marantz's CD players and signal processors, four times over-sampling D-to-A converters are used. Other refinements include a newly developed 9th order digital filter and jitter elimination circuits, as featured in the firm's Reference CD 12 compact disc player.

A Digital Direct switch bypasses the source selector and balance control to give the most direct audio path, eliminating further potential sources of distortion. In keeping with contemporary high-fidelity thinking, there are no tone controls.

It comes with an intelligent table-top remote control pre-programmed for 10 components – and with a memory for 20. The remote control has its own liquid crystal display and has the ability to learn and store up to 150 codes from other audio and video remote control commanders.

The PM95 will sell for about \$6000.00

Parasound all-weather speakers

Parasound, an American company that has been making outdoor hi-fi for the last three years, has just released its range of speaker systems in Australia. The systems combine true hi-fi performance with a totally weatherproof design that lets them be permanently installed outside.

According to the Australian distributor's Doug Osmond, the Parasound range is very well suited to the harsh Australian environment, and carries a two year warranty.

The secret of the Parasound All Weather Speaker is an ingenious technique of using a high density inner enclosure encased in a weatherproof outer shell made from ABS resin. Each speaker driver is also specially constructed to provide long service in the most difficult conditions.

The range comprises three models, including a sub-woofer system to suit the most ardent audiophile. Each model features a carbon fibre reinforced woofer cone, a specially weatherproofed tweeter, and high sensitivity to allow them to work from any amplifier.

Recommended retail prices start at \$450 a pair. Parasound All Weather Speakers are available direct from the distributor, NZ Marketing, 8 Tengah Crescent, Mona Vale 2103 or phone (02) 997 4666.

Akai large-screen TV receivers

Akai's latest large screen television sets, the CT2570 and CT2870, are fully assembled under licence in Germany using the latest CTV (colour television) technology.

John Karbowiak, national marketing manager of Akai Australia, announced that "consumers currently do not accept the validity of true high fidelity from TV, and we intend to dispel this preconception with the new digital stereo sets. These sets have been assembled in Germany under licence incorporating the very latest digital concepts and quality components".

Akai claims that the clean styling of both sets, the 70cm (28") and the 63cm (25") is part of its continuing philosophy to provide colour TV sets that totally integrate into modern lifestyle environments. They use an FST (flatter, squarer tube) type tube, and incorporate a luminance video enhancer and a 'digital transient improver'.

Both the CT2570 and CT2870 incorporate a 20 watt per channel stereo amplifier, feeding two full range, slim line drivers "neatly concealed" behind stylish grills at the lower and right hand sides of the set. Akai has also provided an extra two 8 ohm outputs to drive external loudspeakers for an even more spacious stereo effect.

Both models also incorporate a proprietary spacial sound circuit which converts a monophonic signal into a simulated stereo signal creating an ambience effect (aliveness) to rear speakers if they are connected. Also fitted are separate treble and bass controls and a headphone volume control.

The sets are designed for future satellite and cabled transmissions. Synthesized tuning allows up to direct selection of 200 channels, with 60 programmable pre-set channels. Selection of channels is by infra-red remote control. Both VHF and UHF reception is available.

A SCART connector is provided for

Problems?

...and you
don't have our
new 120 page
electronic parts
and accessories
catalogue...



At last...
a TRADE
catalogue for
the consumer

ARISTA ... Your one-stop
problem solver.

- ...Audio Plugs and Sockets...
- ...Speaker Accessories...
- ...Turntable Belts...
- ...High Quality Monitor PC Cables...
- ...Shielded Audio and Speaker Cables...
- ...Power Supplies for Audio Equipment...
- ...Complete Range of Replacement and Hi Fi Component Speakers...
- ...Audio Crossovers and Attenuators...
- ...Speaker Selector Switching Units...
- ...Bookshelf and Mini Speaker Systems...
- ...Harmony Speaker Systems...
- ...Audio Leads and Plug Adaptors...
- ...Replacement Styli and Carbo Tips...
- ...Earphones and Headphones...
- ...CD Player to Amplifier Adaptors...
- ...Record, CD and Tape Care Accessories...
- ...CD and Cassette Storage Cases...
- ...Mixing Consoles and Stereo Amplifiers...
- ...Graphic Equalisers and Spectrum Analysers...

Just about anything
you want...

Get your catalogue complete with
RECOMMENDED RETAIL PRICES

free from your local ARISTA
dealer or send \$2.50 P & H
and your return address to:

ARISTA
ELECTRONICS PTY LTD

PO BOX 141, LIDCOMBE, NSW, 2141

interconnection to other components. Both models accept PAL B transmissions and also have provision to accept SECAM B, G and NTSC formats.

Built-in Teletext, with Digitext decoder enables a multi-language generator for 7 languages. Therefore, conversion to one of seven languages is possible. Switching to text mode is extremely simple, with menu driven and prompt features, taking you to news, weather or stock market information.

The CT2570 has an RRP of \$1999 and the CT2870 an RRP of \$2199. The sets are covered by Akai's three year warranty and are available at selected Akai dealers and department stores.

New CD player from NAD

A high-end compact disc player at a mid-level price. That's the claim of NAD for its new model 5100 CD player, now released at \$999.

The 5100 is a simplified version of the widely-hailed 5300, NAD's finest CD player. It lacks only the latter's disc-test analyser, ambience enhancer and digital-code output.

Since it shares much of the 5300's high-precision circuitry and its meticulous production-line quality control, the 5100 offers similar sound quality.

What is claimed to separate the NAD 5100 from other CD players in its price range is the attention given to the most important function, reproducing the sound of music with complete fidelity and absolute accuracy.

For instance, in order to provide high-precision decoding over the full dynamic range, the 5100 employs a selected 16-bit decoder, together with two stage digital filtering that operates via four times over-sampling.

And again, in order to guarantee precise linear decoding with the least possible distortion at low levels, the translation level for the "most significant bit" (MSB) in each decoder is fine-tuned by hand during the final testing stage.

Instead of using two less expensive decoders, one for each channel, the 5100 employs a single high-quality digital-to-analog converter to decode the digital signal for both audio channels.

This could produce a time offset as much as 11 microseconds between left and right, causing the two channels to go progressively out of phase at high frequencies. The 4X over-sampling digital filter reduces this offset by a factor of four, and NAD's engineers designed the output filters in the 5100 to produce

opposite delays, neatly cancelling the remaining offset. Result: left and right channels remain in phase at all frequencies.

Further details from Falk Electro-sound, 28 King Street, Rockdale 2216 or phone (02) 597 1111.

Sanyo's VHR-4100 video recorder

Sanyo's VHR-4100 VCR is priced at around \$649.00, yet offers the advanced features found in much more expensive models. It is claimed to provide more auto functions than any other VCR in its price range (such as automatic play upon insertion of tape, automatic rewind and eject tape at end of play, or automatic play upon rewind of tape.)

A feature said to be found in no other video recorder in its price range is a "Lesson Repeat" function. This useful feature allows any section of a tape to be re-played over and over (up to 5 replays at a time) – useful when watching a sports or training video.

The machine also boasts a 5-minute memory back-up, which retains all programmed functions (clock time, program record, etc) for up to 5 minutes in case of a power failure.

New technology in latest Philips car stereo

Inside its latest car radio tuner/cassette player, Philips have included its latest technologies for utmost reliability. A more overt feature of the design is its unique operator multi-function control.

This large, easy to use electronic control operates all major functions such as volume, bass, treble, balance, and fader. You simply push the required function button, then adjust the knob according to personal preference. This 'command' control will then automatically revert to 'volume' two seconds after last use.

Philips ease-of-use philosophy has been carried through to the high-sensitivity digital tuner incorporating large, two-colour liquid crystal display and orange night lighting.

The DC681 has a large capacity EEPROM (Electrically Erasable Programmable Read-Only Memory) memory with a factory encoded four-digit security code. A 14-digit identification number is also etched into each unit's chassis for added theft deterrent. If the DC681 is removed from the vehicle, it will not operate unless the correct coding is re-entered or the chassis identification number is confirmed by the

manufacturer as belonging to the rightful owner. The memory retains all preset stations and other stored information without an electrical power source. This is particularly useful if the optional retractable unit is used allowing the owner to remove the tuner/cassette when leaving the vehicle.

The high-power (2 x 20 watt) amplifier has a four-channel line-out facility for connection to a separate amplifier, or equaliser/amplifier, which provides the basis for building up a complete car entertainment system, including a compact disc player and up to ten speakers.

Pioneer VSA-700 A/V amplifier

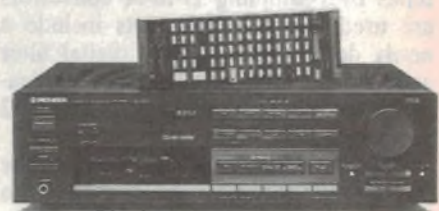

The Pioneer amplifier provides a high level of flexibility to cope with the demands of even the most technically-advanced audio and video home entertainment centre. Combined with a high-fidelity stereo system, VCR and/or Video Laser Disc player, and television monitor/receiver, the VSA-700 forms the vital heart to make all the separate units of your system perform together at optimum level.

The list of features available with the VSA-700 includes a "Surround Sound" processor for Dolby, Stadium and Simulated Surround Sound; a VCR noise filter to remove tape hiss for mono VCR playback; 3-position acoustic memory; and variable fader positions. With four video inputs the opportunity exists for dubbing from a selection of sources.

The amplifier comes with a "smart" remote control which can be programmed to operate almost any other infra-red remote unit (including those supplied by other manufacturers). This 68-key remote control therefore provides the user with total control over all functions of the audio/video system.

Finally, the large multi-function fluorescent display provides at a glance a clear indication of the components in use and the amplifier status at any given time.

With a recommended price tag of \$1299, the Pioneer VSA-700 may be a luxury item – but it could also change the way we live with home entertainment. 

THE ELECTRONIC COMPONENTS SHOP

289 Latrobe Street,
MELBOURNE
PHONE: (03) 602 3499 FAX: 670 6006

METRIX MULTIMETERS



MX41 \$298.80
MX43 \$342.00
MX45 \$534.00
MX47 \$594.00

EUROPE'S LARGEST SELLING
MULTIMETER.
IF YOU WANT A MULTIMETER
THAT'S GUARANTEED TO WORK.

- Measuring rate 2.5/s
- Autoranging or Manual Range Switching.
- 'MEM' function to hold measured value.
- 'MAX' function to hold maximum value.
- True RMS measurement (MX47).
- Temperature measurement with K-Type thermocouple probe (MX47).

IC MEMORY

*Been having trouble sourcing memory?
We have the following ex-stock (as of 1-12-88)*

DRAM	SRAM	EPROM	CMOS EPROM
4116.....\$ 2.50	2114.....\$ 3.00	2708.....\$10.00	27C32.....\$ 8.50
4164.....\$ 6.00	6116.....\$ 7.00	2716.....\$ 8.00	27C64.....\$ 8.00
41256.....\$20.00	6264.....\$18.00	2732.....\$ 7.50	27C128.....\$10.00
411000.....\$60.00	62256.....\$25.00	2764.....\$ 6.50	27C256.....\$12.50
4464.....\$20.00		27128.....\$ 9.50	27C512.....\$22.00
		27256.....\$12.00	
		27512.....\$20.00	

* Due to worldwide shortage on IC Memory, prices shown are valid as of 1-12-88 and may vary at the time of publication.

ALL PRICES INCLUDE SALES TAX. TAX EXEMPT AND OEM P.O.A.

Freight: The prices quoted are ex Store, cost of delivery and the risk of loss in transit fall upon the purchaser. For the convenience of customers, delivery can be arranged through the supplier at the schedule of rates set out below.

- Minimum Charge Only**
1. Local Cost \$2.50
 2. Interstate Post \$3.50
 3. Carrier: Melbourne & Metropolitan — \$5 up to 3kg
 4. Carrier: Interstate — \$8 up to 3kg
- only SMALL ITEMS will be sent by post.

New Robot Arm holds promise for the disabled

At last, robotics technology has reached a stage where it can start to offer real help for people who are physically disabled. A new robot arm system developed by the US Veterans Administration can feed a disabled person, brush their teeth, swap the floppy disks in their computer, and even give them a shave.

by PASCAL ZACHARY

Seated in his wheelchair, Rob Tittle can't reach the shelves above his desk at work and grab the book he needs. "I'm not that good around high objects or really heavy books", he says.

A victim of cerebral palsy, Tittle, 21, is a computer programmer in San Jose, California, and he often finds that the books he needs are either out of reach, too heavy to lift or so large that he can't hold them in his twisted hands. In those situations, he needs someone's help.

For Tittle, that could change soon. Recent advances in electronics are making it possible for thousands of people with limited or no use of their arms and hands to live and work more independently than ever. During the past decade, researchers at the Veterans Administration in Palo Alto have developed a computer-controlled robotic arm that promises to free disabled people from their dependence on costly attendants.

Among other things, the robotic arm can brush a disabled person's teeth, cook his or her lunch, and insert floppy disks into his or her computer. The robot's movements are so precise that it can even shave a person's face.

Late last year, Disabled Programmers Inc, Tittle's employer, became the first company to use the robotic arm on the job. "This is a great idea. I think it's going to help a lot of people", Tittle says.

Justifies cost

The arm isn't commercially available yet, so for the moment Tittle and Jim Hale - a former accountant studying to be a programmer - are the only two workers who are able to use it.

But physical therapists and health-care insurers are keenly interested in

the technology, because it promises to cut the cost of care for the disabled. Many disabled workers now need an attendant by their side while they are on the job, at a cost of more than \$200 a day.

The VA's arm promises to save health insurers - who frequently foot

the bill for innovations in medical and rehabilitative treatment - money by giving a measure of independence to quadriplegics and others with limited use of their arms.

"I'm impressed with the system", says Brian Gould, medical director at Blue Cross of California. "It's not quite a product yet - or insurable yet. But I have no doubt it will be."

The biggest drawback of the system is its cost, which can easily exceed \$US50,000. The robotic arm alone - the VA is using a Puma 260 made by Westinghouse - costs \$US36,000.

Despite the high price tag, at least one Californian firm plans to begin sell-

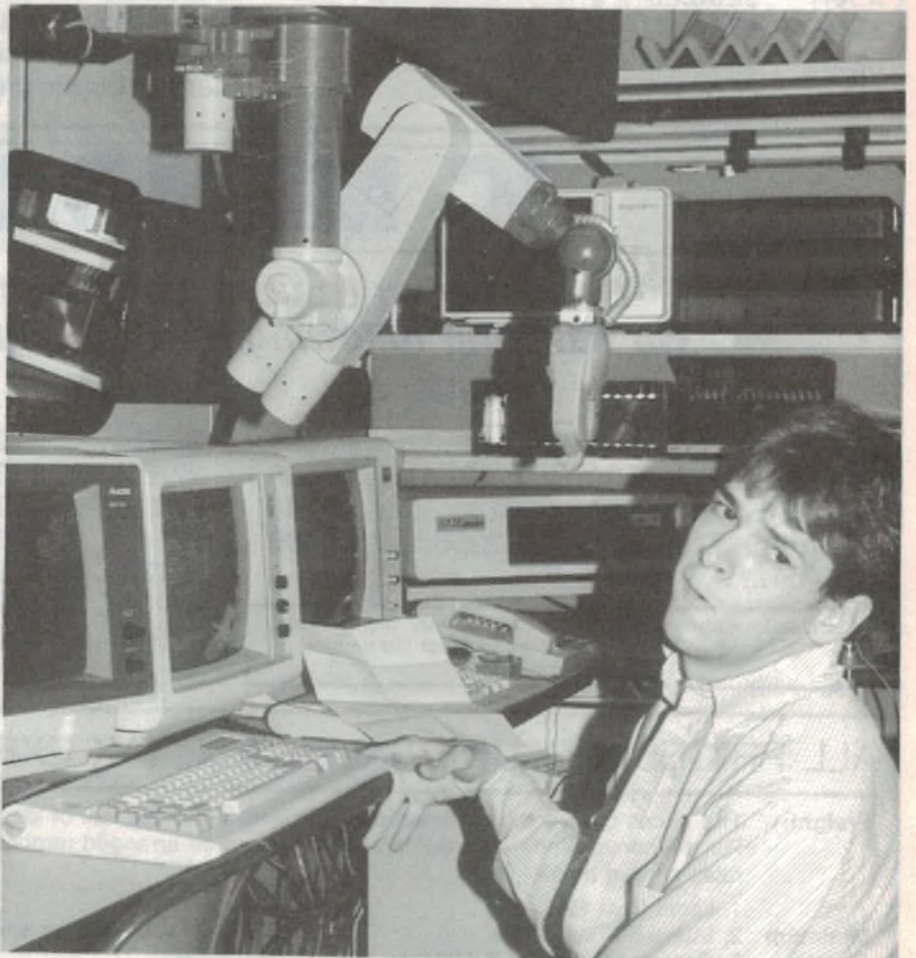

Rob Tittle can verbally command the VA robot to do a variety of tasks, including picking up the phone, getting a drink from the refrigerator or changing the disks in his computers.

ing systems by the middle of the year. Physically Challenged of Clovis is negotiating with the VA, which has funded development of the system, to license the new technology.

Research

The robotic arm is the result of nearly a decade of research by the VA's Clinical Robotics Lab in Palo Alto, with help from professors and graduate students at nearby Stanford University. For the past year, about 25 VA patients, mainly quadriplegics, have tested the system, which can be tailored either to workplace or daily living situations.

The response has been "wonderful", according to Joy Hammel, an occupational therapist at the VA. "Right now, the only alternative for these people is a full-time attendant. This system can give people back their independence, even some privacy."

It also makes economic sense. "Health insurance companies are paying up to \$30 an hour for attendants", Hammel says. "If a robot can replace an attendant for even four hours - half a shift - it's worth it."

The system is simple to use. By issuing spoken commands, a user directs the system to, say, cook a bowl of soup and then spoon it into his or her mouth.

Should the system accidentally spill the soup, the user simply says "stop" to halt the arm.

Delicate touch

Tittle demonstrated how the arm can pick up the telephone and put the receiver to his ear, or open a refrigerator door and bring him a glass of water, without spilling it or breaking the glass.

All the equipment in the VA's system is widely available. This includes an IBM PC and a Votan speech recognition board that recognises up to 60 spoken commands.

What took engineers so long to figure out, however, is how the personal computer communicates with the robotic arm. "That was the toughest challenge", says David Lees, a Stanford graduate engineering student who has worked on the project for the last two years. "How do you teach a robot arm where the microwave oven is?"

To find its way about, the robotic arm requires an immense amount of information. Every 30 seconds, an electronic controller in the robot asks the personal computer for further guidance. The controller stores within its own memory all of its potential positions in space.

For instance, when the user wants the robotic arm to open the microwave and

bring him a cup of soup, he or she says "Soup". When the personal computer delivers the message to the arm, it does so in mathematical terms, describing the exact co-ordinates of the door handle.

"If for some reason the microwave is slightly out of place, you can talk the arm to it by directing it to the right or left, or up and down", says Lees. "You can even tell it to turn in some directions."

The VA's system has enormous potential. From the technical standpoint, the biggest drawback of the current system is that the use must remain stationary when he or she uses it. In the future, however, Stanford engineers hope to design a three-wheel vehicle for quadriplegics that is guided by a computer with a complete floor plan of the user's world, says Michael Van der Loos, a staff researcher in the university's mechanical engineering department.

For now, though, the disabled can only wait and wonder how quickly engineers can advance this new technology.

"Researchers will improve upon it and eventually integrate it into my own system", says Hale, who has a rare birth defect that left his arms and hands virtually useless. "This is only the first stage."

5A

It takes everything but your pulse.



Pioneer
VSX-3000

And your heart will beat a little faster when you experience the flexibility and performance of the Pioneer VSX-3000.

With inputs for VCR1, VCR2, Video Disc Player or VCR3 (Playback only) Tape Deck, Turntable and CD Player it gives any audio/visual system a new lease of life.

Other features include:

- Simulated Surround Sound

- Comprehensive VCR (dubbing) facility
- Sleep Timer
- VCR Noise Filter to reduce tape hiss on Video Playback
- Simulated Stereo for Mono VCR and AM radio reception
- 5 Band Graphic Equalizer
- 20 Station Preset Digital AM/FM Tuner

- Comprehensive Infra-Red Remote Control, including SR Remote for control of other Pioneer Components.

The Pioneer VSX-3000. It's the perfect heart for a comprehensive audio/visual system.

 **PIONEER**[®]

Pioneer VSX-3000 Audio/Video Quartz-Synthesizer Receiver ● Continuous power output 60W + 60W (8 ohms, 20-20,000 Hz, THD 0.05%) ● Full-function "SR" remote control: Operates Pioneer audio and video equipment with "SR" logo ● 3 video inputs ● 5 band graphic equaliser ● "Matrix" surround sound ● Simulated stereo for mono programs ● Two FM antenna inputs for presetting antenna input (broadcast or cable) for each station ● Audio noise filter ● Video signal selector for independent audio and video switching ● Random preset of 20 FM/AM stations ● Fluorescent display ● Clock, programmable timer, sleep timer.

TOOLS

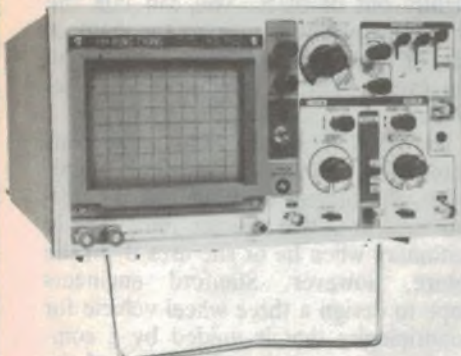

HUNG CHANG (RITRON) 20 MHz DUAL TRACE OSCILLOSCOPE

- Wide bandwidth and high sensitivity
- Internal graticule rectangular bright CRT
- Built in component tester
- Front panel trace rotator
- TV video sync filter
- 2 axis (Intensity modulation)
- High sensitivity X-Y mode
- Very low power consumption
- Regulated power supply circuit

COMPONENT TESTER is the special circuit with which a single component or components in circuit can be easily tested. The display shows faults of components, size of a component value, and characteristics of components. This feature is ideal to troubleshoot solid state circuits and components with no circuit power. Testing signal (AC Max 2 mA) is supplied from the COMPONENT TEST IN terminal and the result of the test is fed back to the scope through the same test lead wire at the same time

CRT
CRT: 6" (150mm) Flat-faced high brightness CRT with Internal Graticule
Effective display area: 8 x 10 div (1 div = 10mm)
Acceleration potential: 2KV

VERTICAL
Operating Modes: CH-A, CH-B DUAL, ADD (CH-B can be inverted)
Dual modes: Alter: 0.2u/s - 0.5ms/div, Chop: 1ms - 0.5s/div
CHOP frequency: 200KHz approximately
Deflection factor: 5mV/div 20V/div - -3% - 12 ranges in 1-2-5 step with line control
Bandwidth: DC, DC - 20MHz (-3dB), AC: 10Hz - 20MHz (-3dB)
Rise Time: Less than 17ns
Overhoot: Less than 3%
Input Impedance: 1M ohm +/- 5% 20pF - -3pF
Maximum Input Voltage: 600Vp-p or 300V (DC - AC Peak)
Channel isolation: Better than 60 dB at 1KHz

HORIZONTAL
Sweep Modes: NORMAL and AUTO
Time Base: 0.2u/s - 0.5s/div - -3% - 20 ranges in 1-2-5 step with line control
Sweep Magnifier: 5 times (5X MAG)
Linearity: 3%

TRIGGERING
Sensitivity: INTERNAL: 1 div or better for 20Hz - 20MHz (Triggerable to more than 30MHz) EXTERNAL: 1Vp-p or better for DC - 20MHz (Triggerable to more than 30MHz)
Source: INT, CH-A, CH-B, LINE and EXT
Slope: Positive and Negative, continuously variable with level control PULL AUTO for freeze
Coupling: AC, HF-REJ and TV, TV SYNC Vertical and Horizontal Sync Separator Circuitry allows any portion of complex TV video waveform to be synchronized and expanded for viewing TV-H (Line) and TV-V (Frame) are switched automatically by SWEEP TIME/DIV switch
TV-V: 0.55div to 0.1ms/div, TV-H: 50u/s div to 0.2u/s/div

X-Y OPERATIONS
X-Y Operations: CH-A, Y axis, CH-B, X axis Highest Sensitivity 5mV/div

COMPONENT TESTER
Component Tester: Max AC 9V at the terminal with no load, Max current 2mA when the terminal is shorted, (Internal resistance is 4.7K ohm)

OTHER SPECIFICATIONS
Intensity Modulation: TTL LEVEL (3Vp-p) Positive brighter
BANDWIDTH: DC - 1MHz MAXIMUM INPUT VOLTAGE: 50V (DC - AC Peak)
Trace Rotation: 0.5Vp-p +/- 5% 1KHz +/- 5% Square wave
Power Requirements: AC: 100 - 120 - 220 240 20W
Weight: 7kg approximately
Size: 162(H) x 294(W) x 352(D)mm

Cat. Q12105 only \$895
(tax exempt only \$775)

Bulk orders, schools, please phone (03) 543 2166 for special low pricing



PORTASOL PROFESSIONAL

- Four tools in one: blow torch, Hot Blow, Hot Knife
- No Cords or batteries
- Heavy duty, tip temperature adjustable up to 400°C
- Equivalent to 10-60 watts
- Hard working. Average continuous use 90 minutes
- Refills in seconds
- Powered by standard butane gas lighter fuel
- Range of easily replaceable screw tips included
- Includes metal stand for the soldering iron when working
- Cap features built-in flint for igniting Portasol tip
- Includes snap case for storage

Cat. T12639 \$89.95



PC BOARD HOLDER
Better than an extra pair of hands! A must for all PCB work
Cat. T12444 \$9.95



ARLEC SUPER TOOL
A versatile 12V electric tool for:

- Sanding
- Engraving
- Grinding
- Polishing
- Curling
- Drilling
- Milling
- Etching, etc.

Features:
Operates on safe, low 12 volts from mains electricity via AC adaptor (supplied). Light and easy to handle with touch switch and lock for continuous running. High torque motor. 10,000 R.P.M. Can drill 2mm holes in steel. 2 year guarantee

Contents:

- 12V Super Tool
- Plugpack AC adaptor
- 1 Spherical milling cutter
- 1 wire brush
- 1 grinding wheel
- 4 drill bits, 0.6 0.8 1.0 1.2mm
- Set of 5 chuck collets
- 6 eraser sticks
- Instruction sheets

Cat. T12300 \$64.95



FREE STANDING, FOLD UP MAGNIFIER
An economically priced 'hands free' magnifier lets you take care of all those tricky fine detailed jobs so often encountered in electronics or any of many other practical uses such as home work, hobbies etc.

Cat. T10020 Normally \$14.95
SPECIAL. ONLY \$12.95



MINIATURE HOBBY VICE

- Lever operated suction grip case for instant mounting and portability
- Mounts on smooth non-porous surfaces
- Ideal for holding components and other small objects

Cat. T12458 only \$6.45



POWERFULL MINI DRILL
Featuring a powerful 6000 r.p.m. motor, this lightweight (113gm) drill is ideal for many jobs. Perfect for PCB work! Has a 0.8 to 1.2mm chuck and 1mm drill bit.

Requires 12V 1 AMP fuse with M1910
Cat. T12302 \$19.95



AUTOMATIC CABLE STRIPPER

- Strips cable with diameter of 1.15 - 2.6 - 3.2mm
- Fully automatic action. Squeeze grip will simultaneously strip and eject insulation
- Length 180mm (7")

T11532 \$19.95



MAIL ORDER HOTLINE
008 335757
(TOLL FREE)
LOCAL: 543 7877

NOW OPEN IN SYDNEY!
74 PARRAMATTA RD, STANMORE
PHONE (02) 519 3134



METEX 3800 MULTIMETER

This instrument is a compact, rugged, battery operated, hand held 3 1/2 digit multimeter for measuring DC and AC voltage, DC and AC current, Resistance and Diode for testing Audible continuity and transistor hFE. The Dual slope A-D Converter uses C-MOS technology for auto-zeroing, polarity selection and over-range indication. Full overload is provided. It is an ideal instrument for use in the field, laboratory workshop, hobby and home applications.

- Features:**
- Push-button ON/OFF power switch
 - Single 30 position easy to use rotary switch for FUNCTION and RANGE selection
 - 1/2" high contrast LCD
 - Automatic over-range indication with the "1" displayed
 - Automatic polarity indication on DC ranges
 - All ranges fully protected plus Automatic "ZERO" of all ranges without short circuit except 200 ohm Range which shows "000 or 001"
 - High Surge Voltage protection 1.5 KV-3 KV
 - Diode testing with 1 mA fixed current
 - Audible Continuity Test
 - Transistor hFE Test

SPECIFICATIONS
Maximum Display: 1999 counts
3 1/2 digit type with automatic polarity indication
Indication Method: LCD display
Measuring Method: Dual-slope in A-D converter system
Over-range Indication: "1" Figure only in the display
Temperature Ranges: Operating DC to +40°C
Power Supply: one 9 volt battery (006P or FC 1 type of equivalent)
Cat. Q91530 Normally \$109
SPECIAL \$79



METEX 3530 MULTIMETER

This instrument is a compact, rugged, battery operated, hand held 3 1/2 digit multimeter for measuring DC and AC voltage, DC and AC current, Resistance and Diode Capacitance, Transistor hFE and Continuity Test. The Dual-slope A-D Converter uses C-MOS technology for auto-zeroing, polarity selection and over-range indication. Full overload is provided. It is an ideal instrument for use in the field, laboratory workshop, hobby and home applications.

- Features:**
- Push-button ON/OFF power switch
 - Single 30 position easy to use rotary switch for FUNCTION and RANGE selection
 - 1/2" high contrast LCD
 - Automatic over-range indication with the "1" displayed
 - Automatic polarity indication on DC ranges
 - All ranges fully protected plus Automatic "ZERO" of all ranges without short circuit except 200 ohm Range which shows "000 or 001"
 - High Surge Voltage protection 1.5 KV-3 KV
 - Capacitance measurements to 1pF
 - Diode testing with 1 mA fixed current
 - Audible Continuity Test
 - Transistor hFE Test

SPECIFICATIONS
Maximum Display: 1999 counts
3 1/2 digit type with automatic polarity indication
Indication Method: LCD display
Measuring Method: Dual-slope in A-D converter system
Over-range Indication: "1" Figure only in the display
Temperature Ranges: Operating DC to +40°C
Power Supply: one 9 volt battery (006P or FC 1 type of equivalent)
Cat. Q91540 Normally \$139
SPECIAL \$109



METEX M-3650 MULTIMETER

20A, 3 1/2 digit frequency counter multimeter with capacitance meter and transistor tester.

This spectacular rugged and compact DMM has a bright yellow high impact plastic case. It features a frequency counter (to 200KHz), diode and transistor test, continuity (with buzzer), capacitance meter, up to 20 amp current measurement and comprehensive AC/DC voltage current and resistance ranges.

- CHECK THESE FEATURES:**
- Push-button ON/OFF switch
 - Audible continuity test
 - Single function, 30 position easy to use rotary switch for FUNCTION and RANGE selection
 - Transistor test
 - Diode test
 - Quality probes
 - 1/2" High contrast LCD
 - Full overload protection
 - 20 Amp
 - Built in fitting ball
 - Capacitance meter
 - Instruction manual
- Q91550 Normally \$165
Special, only \$129



METEX 4500H MULTIMETER

10A, 4 1/2 digit multimeter with digital hold, transistor tester and audible continuity tester.

The Metex 4500H is perfect for the technician, engineer or enthusiast who requires the higher accuracy of a 4 1/2 digit multimeter. This meter is exceptionally accurate, (just look at the specifications), and yet still retains an exceptionally low price!

The Metex 4500H features digital hold which is normally only found on very expensive multimeters. This enables you take a reading and hold that reading on display even after you have removed the probes simply by pressing the hold button.

- CHECK THESE FEATURES:**
- Readout hold
 - Transistor Tester
 - 4 1/2 digit x 1/2" (H) LCD
 - Audible continuity tester
 - Push-button ON/OFF switch
 - Quality set of probes
 - Single function, 30 position easy to use rotary switch for FUNCTION and RANGE selection
 - Built in fitting ball
 - Instruction manual
 - Full overload protection
 - hFE Test
 - Battery and Spare fuse
 - Diode Tester
 - Vinyl case
- Q91560 Normally \$175
Special, only \$159

GET MORE FOR YOUR DOLLAR WITH ROD IRVING ELECTRONICS!

Regardless of where you live in Australia, you can take advantage of Rod Irving Electronics' discount prices either through our Sydney and Melbourne stores or our Mail Order Service. Simply phone your orders through on (008) 33 5757 for the cost of only a local call. (Inquiries and local orders phone (03) 543 7877)

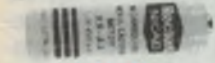

NICA DS1
Save a fortune on expensive throw away batteries with these quality NICA and Rechargers!
Size Desc 1-9 10+ 100+
AA 450 mA H \$2.95 \$2.75 \$2.50
C 1.2 AH \$9.95 \$9.50 \$8.95
D 1.2 AH \$9.95 \$9.50 \$8.95



NEW TRANSISTORS
Rod Irving Electronics have two new transistors which will replace a multitude of common hard to get devices.
The PN100 is a NPN general purpose medium power amp and switch with continuous collector current up to 500mA.
The PN200 is a PNP general purpose amp at collector currents to 1 Amp. Both are TO-18 plastic package.

PN100 REPLACES:
PN2221 PN2222 PN2222A
PN3585 PN3568 PN3569 PN3643
PN5133 2N2219A, 2N2222A,
2N3414 2N3415 2N3418 2N3417,
2N3700 2N3704 2N3904 2N4123
2N4124 2N4401 2N5088 2N5210.

PN200 REPLACES:
PN2907 PN2907A PN3638
PN3638A PN3640 PN3644
PN4121 PN4143 PN4248 PN4249
PN4250 PN4355 PN4916 PN4917
PN5910 2N2905A 2N3467
2N3702 2N3906 2N4125 2N4126
2N4291 2N4402 2N4403 2N5086
2N5087 2N5447.

PN100 Cat. T90001
PN200 Cat. T90002
1-9 10+ 100+
\$0.20 \$0.18 \$0.15

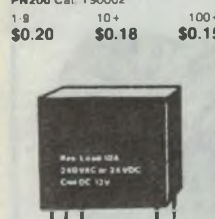

RELAYS
10+ 100+
S P D T 3A connectors \$14.00
\$1.50 \$1.30 \$1.10
D P D T 3A connectors \$14.00
\$1.95 \$1.75 \$1.30
S P D T 12V Coil 10A 240V \$14.14
\$7.95 \$7.50 \$6.95

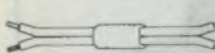

CAR BATTERY ISOLATOR
Designed for car burglar alarm back-up battery. Allows the back-up battery to be charged from the car battery and isolates the back-up battery by not allowing the back-up battery to drain back to the car battery.
A12095 \$3.20

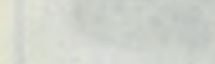

TEXTOL SOCKETS
P17016 16 pin \$14.95
P17024 24 pin \$18.50
P17028 28 pin \$24.95
P17040 40 pin \$29.50

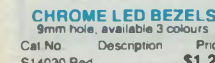

CHROME LED BEZELS
9mm hole, available 3 colours
Cat No Description Price
S14030 Red \$1.20
S14032 Green \$1.45
S14034 Yellow \$1.45

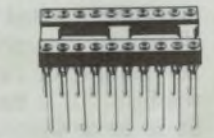

WIRE WRAP IC SOCKETS
These quality 3 level wire wrap sockets are tin-plated phosphor bronze.
Cat No Description 1-9 10+
P10579 8 pin \$1.50 \$1.40
P10580 14 pin \$1.85 \$1.70
P10585 16 pin \$1.95 \$1.80
P10587 18 pin \$1.95 \$1.80
P10590 20 pin \$2.95 \$2.70
P10592 22 pin \$2.95 \$2.70
P10594 24 pin \$3.95 \$3.50
P10596 28 pin \$3.95 \$3.50
P10598 40 pin \$4.95 \$4.50

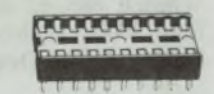

LOW PROFILE IC SOCKETS
Save a small fortune on these "Direct Import" low profile IC sockets! PCB mounting solder tail. Dual wipe. All tin plated phosphor bronze or beryllium and dual wipe for reliability.
Cat No Description 1-9 10+
P10550 8 pin \$0.20 \$0.15
P10560 14 pin \$0.25 \$0.20
P10565 16 pin \$0.35 \$0.20
P10567 18 pin \$0.40 \$0.30
P10568 20 pin \$0.40 \$0.30
P10568 22 pin \$0.40 \$0.30
P10570 24 pin \$0.40 \$0.30
P10572 28 pin \$0.50 \$0.40
P10575 40 pin \$0.50 \$0.40

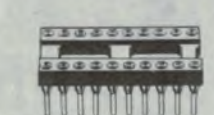

GOLD INSERT LOW PROFILE IC SOCKETS
● Gold machined pins
● Extremely high quality
● Anti-wicking
● Ideal for professional use or where field service of components is required.
Cat No Description 1-9 10+
P10620 8 pin \$1.20 \$1.10
P10624 14 pin \$1.60 \$1.50
P10626 16 pin \$1.90 \$1.80
P10628 18 pin \$2.00 \$1.80
P10630 20 pin \$2.20 \$2.00
P10632 22 pin \$2.40 \$2.20
P10634 24 pin \$2.60 \$2.40
P10640 28 pin \$2.90 \$2.60
P10644 40 pin \$3.00 \$2.70



SPECTROL 64Y MULTI-TURN TRIMPOTS
Cat No Description 1-9 10+
R14700 10R \$3.50 \$3.20
R14710 20R \$3.50 \$3.20
R14720 50R \$3.50 \$3.20
R14730 100R \$3.50 \$3.20
R14740 200R \$3.50 \$3.20
R14750 500R \$3.50 \$3.20
R14760 1K \$3.50 \$3.20
R14770 2K \$3.50 \$3.20
R14780 5K \$3.50 \$3.20
R14790 10K \$3.50 \$3.20
R14800 20K \$3.50 \$3.20
R14810 50K \$3.50 \$3.20
R14820 100K \$3.50 \$3.20
R14830 200K \$3.50 \$3.20
R14840 500K \$3.50 \$3.20
R14850 1M \$3.50 \$3.20



DB25 CONNECTOR SPECIALS!
TYPE 1-9 10+ 100+
9P \$0.70 \$0.60 \$0.50
9S \$0.70 \$0.60 \$0.50
9C \$0.60 \$0.50 \$0.40
15P \$0.70 \$0.65 \$0.60
15S \$0.70 \$0.65 \$0.60
15C \$0.70 \$0.60 \$0.50
25P \$0.70 \$0.60 \$0.50
25S \$0.75 \$0.65 \$0.60
25C \$0.70 \$0.60 \$0.50

DB 25 CRIMP SPECIALS!
Type 1-9 10+ 100+
Female \$2.95 \$2.50 \$1.95
Male \$2.95 \$2.50 \$1.95



P.A. SPEAKERS
Low dual cone, wide range 200mm (8in.). Ideal for public address, background music etc. Tremendous Value at these prices!
Cat C12000
1-9 10+
\$5.95 \$5.50



IC SPECIALS!
WHILE STOCKS LAST
IN QUANTITIES OF 10 ONLY
7404 \$0.50ea
7406 \$0.50ea
7416 \$0.50ea
7445 \$0.60ea
74123 \$0.50ea
74LS162 \$0.50ea
74LS393 \$0.90ea
74M339 \$0.50ea
LM3086 \$0.50ea
5256 \$4.00ea

1 MEG DRAM MCM 511000P-10 \$59.95

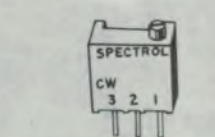

SPECTROL CW 3 2 1

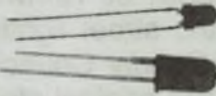

QUALITY 3mm LEDs
Cat No Col. 1-9 10+ 100+
Z10140 Red \$0.15 \$0.12 \$0.10
Z10141 Grn \$0.20 \$0.15 \$0.12
Z10143 Ylw \$0.20 \$0.15 \$0.12
Z10145 Ora \$0.20 \$0.15 \$0.12



QUALITY 5mm LEDs
Cat No Col. 1-9 10+ 100+
Z10150 Red \$0.08 \$0.07 \$0.06
Z10151 Grn \$0.15 \$0.12 \$0.10
Z10152 Ylw \$0.15 \$0.12 \$0.10

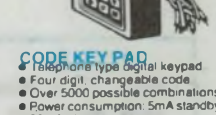

CODE KEY PAD
● Telephone type digital keypad
● Four digit, changeable code
● Over 5000 possible combinations
● Power consumption: 5mA standby 50mA alarm
● Two sector LED and 1 arm LED.
● Wrong number lockout
● 12V DC operation
● Relay output
● Panic button
● Normally open tamper switch.
● Dimensions: 145 x 100 x 37mm
● ACP3 compatible.
Cat A13014 R.R.P. \$79.95
SPECIAL ONLY \$69.95

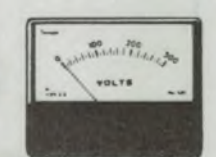

PANEL METERS GALORE!
We have 100 many of the following panel meters, so we're selling them to you at bargain prices. Don't miss out!
Cat No Description Price
O10500 MU45 0-1mA 10.50
O10502 MU45 0-50uA 12.50
O10535 MU45 5VU 10.95
O10533 MU52E 0-5A 14.50

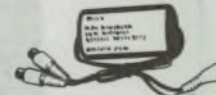

RCA TO RCA ISOLATION TRANSFORMER
● 15A transformer with suppressor isolation transformer
● Designed to eliminate noise in the audio line
● Does not affect the audio signal
● Simply fits inline between car stereo and the separate power amplifier
M10038 \$15.95

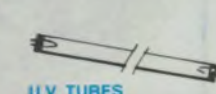

U.V. TUBES
Fits into standard 15W flouro holder. Suitable for Scotchcal, Eprom erasing etc. As used in ETI Eprom Erasing Kit.
WARNING! Do not look directly into UV Tubes.
Cat H28600 \$29.95
If ordering by mail please include an extra \$2 for "special packing"



RCA GOLD PLATED PLUGS AND SOCKETS
For those who need the ultimate in connection. Essential for laser disc players to get that fantastic sound quality.
Plug Cat P10151 \$2.95
Socket Cat P10150 \$2.25

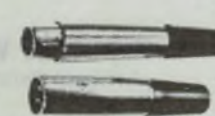

CANNON TYPE CONNECTORS
1-9 10+
P10960 3 PIN LINE MALE \$3.90 \$3.50
P10962 3 PIN CHASIS MALE \$3.00 \$2.50
P10964 3 PIN LINE FEMALE \$4.50 \$3.90
P10966 3 PIN CHASIS FEMALE \$4.95 \$3.95

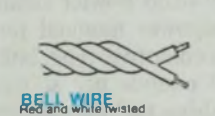

BELL WIRE
Red and white twisted conductors: 2 x 1.1 strand 0.17mm Sheath: 0.2 x 1.35mm
Cat W
1-9 rolls \$19.00/m
10+ rolls \$17.50/m

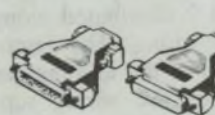

9 PIN TO 25 PIN CONNECTOR ADAPTORS
The perfect solution! Features gold plated pins.
X15668 DB9 Plug to DB25 Socket
X15669 DB9 Socket to DB25 Plug
each \$10.95

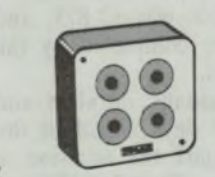

PIEZO SIREN
● 12vzo units in a high impact plastic cabinet
● Input 12V DC - 200mA
● Output 115dB at 1m, dual tone
● Compact size 105 x 85 x 45mm
● Smart design suits interior use
Cat S15071 \$24.95



10 TURN WIRE WOUND POTENTIOMETER Spectrol Model 534
1/4" shaft.
Equiv (Booms 3540S Beckman 7256)
Dials to suit 16-1-11, 18-1-11, 21-1-11
R14050 50R R14100 5K
R14055 100R R14110 10K
R14060 200R R14120 20K
R14070 500R R14130 50K
R14080 1K R14140 100K
R14090 2K
1-9 10+
\$9.95 \$9.50

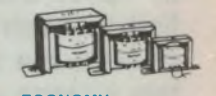

ECONOMY TRANSFORMERS 10+
2155 240V 6-15V 1A
Cat. M12155 \$9.95 \$8.95
2156 240V 6-15V 2A
Cat. M12156 \$14.95 \$13.95
2840 240V 9V CT
Cat. M12840 \$5.95 \$4.95
2851 240V 12-6V CT 150mA
Cat. M12851 \$5.95 \$5.50
2860 240V 15V CT 250mA
Cat. M12860 \$5.95 \$4.95
6672 240V 15-30V 1A tapped
Cat. M16672 \$14.95 \$13.95

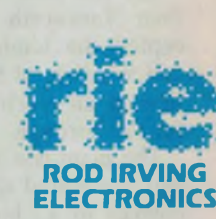

ROD IRVING ELECTRONICS
SYDNEY: 74 Paramatta Rd STANMORE 2048
Phone: (03) 519 3134
Fax: (02) 519 3688
MELBOURNE: 48 A Beckett St
Phone: (03) 663 6151
NORTHCOLE: 425 High St
Phone: (03) 489 8866
CLAYTON: 56 Renver Rd
Phone: (03) 543 7877
SOUTH AUSTRALIA: Electronic Discounters P/L, 305 Morphett St, ADELAIDE
Phone: (08) 212 1799
NOTE: PRICES MAY VARY INTERSTATE DUE TO FREIGHT COSTS

MAIL ORDER:
Local Orders (03) 543 7877
Interstate Orders (008) 33 5757
All Inquiries (03) 543 7877
CORRESPONDENCE:
P.O. Box 620, CLAYTON 3168
Telex: AA 151938
Fax: (03) 543 2648



MAIL ORDER HOTLINE 008 335757
(TOLL FREE STRICTLY ORDERS ONLY)
LOCAL ORDERS & INQUIRIES (03) 543 7877
POSTAGE RATES:
\$1 \$9.99 \$2.00
\$10 \$24.99 \$3.00
\$25 \$49.99 \$4.00
\$50 \$99.99 \$5.00
\$100 \$199.99 \$7.50
\$200 \$499.99 \$10.00
\$500 plus \$12.50

The above postage rates are for basic postage only. Road Freight bulky and fragile items will be charged at different rates.
All wholesale and sales tax exempt inquiries to RITRONICS WHOLESALE, 56 Renver Rd, Clayton Ph: (03) 543 2166 (3 lines)
Errors and omissions excepted. Prices and specifications subject to change.
IBM, PC, XT, AT are registered trademarks of International Business Machines. Apple is a registered trademark. *Denotes registered trademarks of their respective owners.
MasterCard VISA

100 years of Electric Lighting



In 1888, the NSW provincial town of Tamworth became the first in Australia to install electric street lighting. As a special project, the Peel-Cunningham County Council has celebrated this historic event by restoring the original steam-driven power station as a museum, which was successfully opened in November. But restoring the station wasn't as easy as it might sound...

by **RON W. GREER**
Assistant General Manager, PCCC

On the 18th of October, 1887, the then Tamworth Borough Council accepted the tender of Messrs Harrison and Whiffen, of Sydney, for the installation of an electric street lighting plant for the borough.

The plant was to be in duplicate, with two compound semi-fixed Fowler steam engines of 12 horsepower nominal rating running from locomotive type boilers working at 140 pounds per square inch. These would drive two Cromptons Patent No.15 dynamos via flat leather belts, with the electrical outlet fed to some 200 incandescent lamps arranged in groups of 3 and 2 distributed along 15 miles of mains wiring. The lamps were to be mounted in the existing gas lantern fittings, with the wiring supported on the gas lamp posts.

Also included in the tender were the provision of a voltmeter, amp meter, speed indicator, switchboards and three Crompton arc lamps of 3000 candlepower. The quoted price was £2,875, and the work was to be completed by the 18th November 1888.

The plant was actually installed and work completed 10 days ahead of the contract date. To mark the occasion, a banquet was held on Thursday November 8 in the town's Olympic Hall. The contractors decorated the tables with electric lamps in fancy fittings, and the tables groaned with a feast provided by Mrs Smith of the Goldiggers' Arms Hotel: 'A varied cold collation of poultry, hams with hot vegetables, puddings, ices, fruits and other gastronomias inseparable from the festivities of a Britisher.'

At the banquet the Mayor, Alderman W.F. Tribe observed that it was a pity

"there were not more members of parliament present. The lighting of the first town in Australia by electricity was a great epoch in the history of the country."

Mr. W.S. Dowell MLA, in responding, congratulated the Mayor and Council on the enterprise displayed in lighting the town of Tamworth with the electric light. "It is the first town in Australia to be so lighted, and you should be proud of the fact."

The next day was a public holiday in the Colony of NSW, to celebrate the birthday of the then Prince of Wales, and the town's Oval (now the Bicentennial Gardens) was to be opened with a day of sporting events and a bazaar. Electrical contractors Harrison and Whiffen erected at their own expense four 3000 candlepower Crompton arc lamps at the Oval, so that the final

Fig.1: This was the only available reference to Crompton's Patent No.15 Trade Dynamo - a drawing from an old textbook.

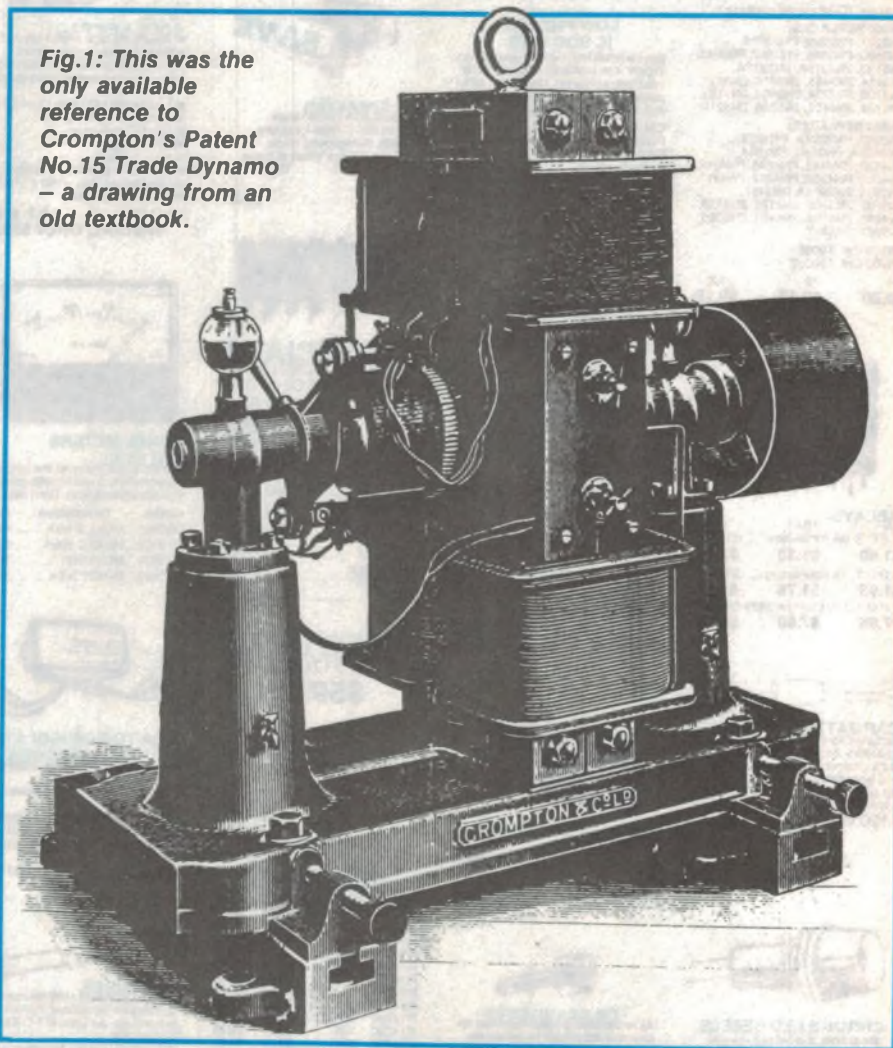

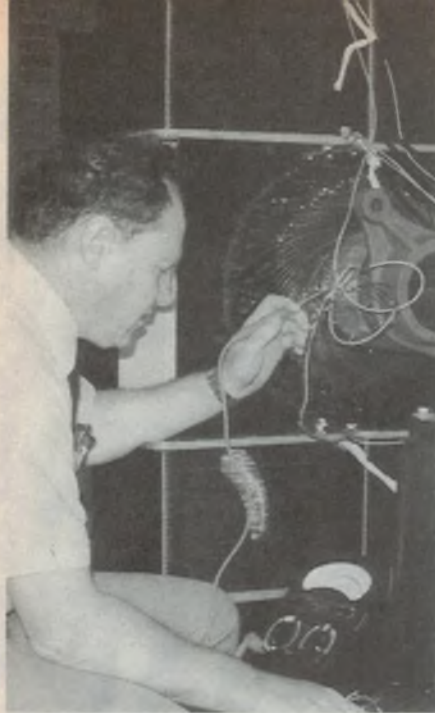

Author Ron Greer checks the resistance of one of the armature windings, on a recreated dynamo.

heats of the sporting events could be run into the night.

At 7.30 in the evening, Mr Dowell MLA and most of the members of the Council, along with a number of other ladies and gentlemen assembled at the electric engine house at 216 Peel Street, to witness the official 'switching on' of the town's electric lights. Mr Alfred

Whiffen set the engines going, and the Mayoress Mrs Elizabeth Piper unlocked the main power switch with a special gold key, turning on the lights of the entire town.

After speeches by the various dignitaries, the crowd gave hearty cheers for the electric lights, the Mayor and Mayoress, the Contractors and Mr Dowell. Champagne was then indulged in, after which all concerned marched up Peel Street behind the Fourth Regiment Band, to the Oval.

The challenge

Coming back nearer the present, it was decided in 1986 by the Peel-Cunningham County Council that an excellent way to celebrate the town's historic inauguration of electric street lighting would be to buy back the old Tamworth Municipal Electric Showroom at 216 Peel Street, refurbish it as the 'Tamworth Powerstation Museum', and rebuild the original 1888 power station behind it as faithfully as possible. (The Showroom had been built in 1907 as an extension to the original plant, housing two additional 50kW dynamos, driven by Bellis and Morcom cross compound high speed steam engines.)

Starting the rebuilding of the old power station wasn't easy, because we had almost no technical information about it. Very little was found in the old Council records, however a long



Tamworth Powerstation Museum curator Ian Simpson with some of the earlier appliances to be displayed.

and tedious search through old local newspapers eventually revealed some information about what had been there.

Harrison and Whiffen of 45 Margaret Street, Sydney were the representatives of R.E. Crompton, of Chelmsford and London. The plant they supplied consisted of two John Fowler double acting cross compound semi-portable under-type steam engines, developing 42 indicated (brake) horsepower at 140rpm. Each was made to drive, by means of a flat leather belt, one of Crompton's Patent No.15 Trade Dynamos of 18kW capacity, producing 78 amps at 230V (DC) "working at the slow speed of 740rpm to minimise wear and tear".

The rest of the plant consisted of Kapp-Crompton 'astatic' potential and current indicators, a speed indicator, a four-circuit switchboard, seven 3000 candlepower arc lights and 140 Swan patent incandescent lamps.

Making a start

With almost all of the Fowler engines manufactured in the UK having been exported, and half of these to Australia, I figured that there *had* to be a few relics still available for us to use in our restoration project. The engines were used extensively for wool scouring, powering sawmills and on the gold-fields.

With the help of local Tamworth steam enthusiasts, the NSW Steam Preservation Society and steam buffs in five states, we finally located two Fowler engines of the right type. One was on a farm in Warrnambool, Victo-

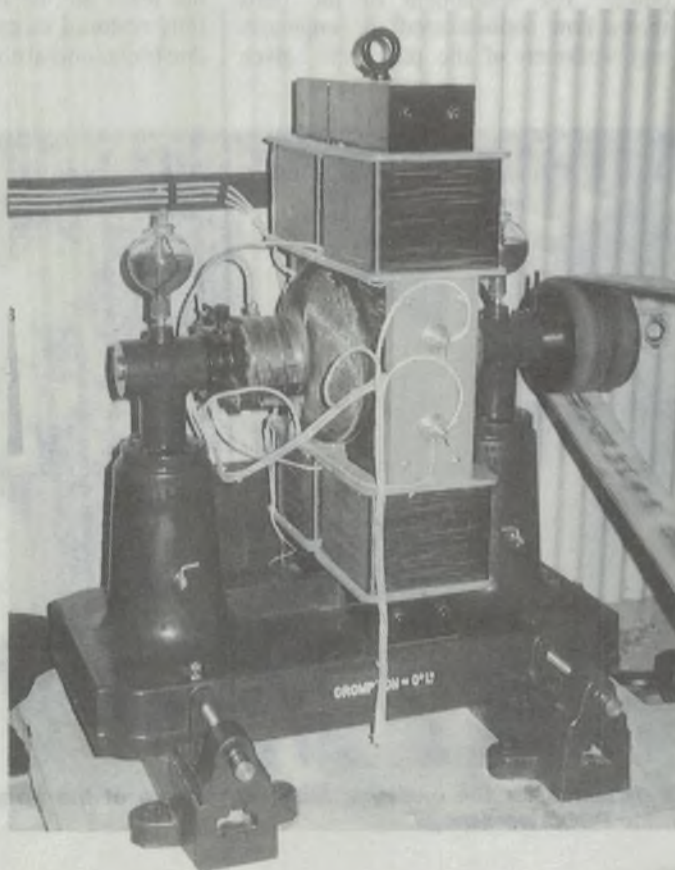

And this is one of the dynamos that Ron Greer and his team recreated from scratch, using the drawing at left as their only guide. They work well – probably better than did the originals.

100 Years ...

ria, and the other on the banks of the Murray River at Mannum in South Australia. PCCC chairman Ald. Ray Walsh MBE, general manager Paul Newman and myself flew to Warrnambool and Mannum to look at the engines and negotiate their purchase. Then we set about moving them to Tamworth and starting the restoration of the engines in the Council's workshop.

There were dozens of items to be manufactured, such as blowdown cocks, safety valves, water-gauge glasses and seemingly countless other pieces. Weeks of work went into drawing up specifications, and then came the job of tracking down industries which were able and prepared to produce the goods. This was quite apart from the business of cleaning and restoring the rusty engines and boilers, bringing them back to original condition after a hundred years of working and weathering.

From April 1988 Arthur Ruttley, the head of the Council's mechanical workshop, together with Kevin Davidson and Malcolm McKenzie put in 100 hours work a week until the opening in November, cleaning out the steam chests, remaking bearings, cranks and a variety of valve and piston gear.

"When we first started work on them we didn't quite know what to expect, from something over 100 years old", said Arthur. "But before we were part way through the job we were very im-

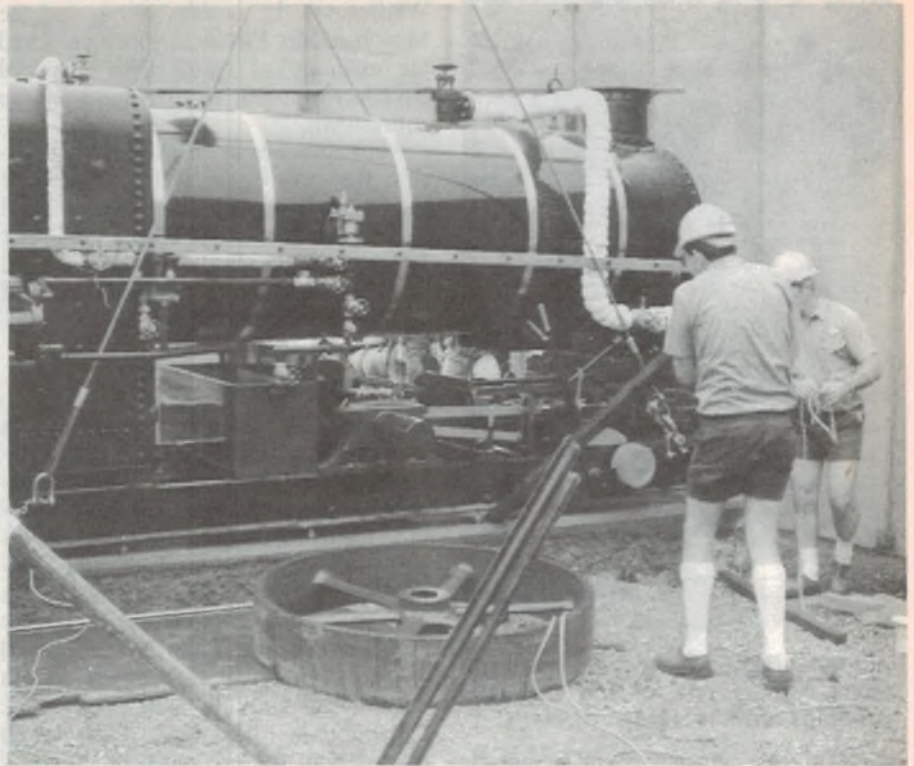

Nearing completion of one of the two Fowler 'semi-portable' steam engines which were restored as part of the powerhouse project.

pressed with the standard of workmanship - it was so refined."

"Everything is so big and cumbersome, but their operation is exceptional, generating an enormous amount of power. The refinement of the parts shows how sophisticated the engineers and workmen of the past were, given

that they had none of today's machinery. Their methods must have required continual refinement of each piece by hand, and a lot of human effort."

The engines restored by Arthur and his team are believed to be the only fully restored examples of their kind in Australia, and are valued at \$200,000.

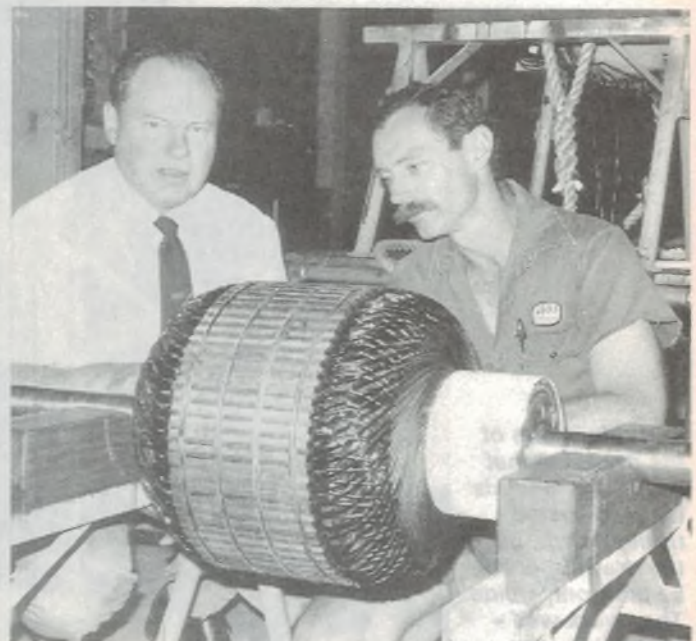

Ron Greer, who designed the recreated dynamos for the museum, looks on as one of the armatures is wound and assembled by mechanic Dick Cooksey in the PCCC workshops.

Dynamo design

When it came to the dynamos for the station, things were even harder. We have not been able to find a single example of anything even like Crompton dynamos of that era in Australia, and enquiries from the UK drew a blank as well. There wasn't even any relevant technical information available – remember that carbon brushes were not introduced until 1896!

There was no option but to make replicas, from scratch.

Our one clue came to me from my former engineering teacher, Professor Sid Prentice, who was able to provide a photocopy of a perspective drawing of Crompton's 'Trade' dynamo, taken from an early textbook called *Electricity in the Service of Man*. In the absence of anything else, this had to become our 'working plan' (Fig.1).

We enlarged it with a photocopier, to get something on which to put dimensions. All we really had to go on for scaling was the fact that the dynamo had produced 18kW at 740rpm.

We knew that the nominal speed of the steam engines was 140rpm, and they had a flywheel diameter of 53 inches. A simple calculation showed that the dynamo pulley must therefore have been 10 inches, giving one clue to the scaling.

A rummage through old textbooks on DC machines turned up a formula relating armature dimensions with power output, knowing the 'output coefficient' achievable at the time. This gave an armature diameter of 15 inches, with a core length of about 7 inches. Note that it was easiest to work in imperial dimensions, in order to stay with the formulas in the old textbooks!

All other dimensions had to be scaled from these, using our one and only sketch of the original machine. For example the commutator looked to be about 8 inches in diameter and 4 inches long.

Using the old textbooks and remembering that Crompton didn't have modern magnetic materials – just 'best charcoal iron sheets' – we came up with what seemed likely to be very close to the original design. It had an armature with 104 slots and a commutator with 52 segments. However prices quoted for the commutators alone quickly put an end to that idea – they would cost \$2000 each.

By now it became clear that the design was going to revolve around the commutators (and their price). Where do you see a commutator about 8 inches in diameter and 4 inches long?

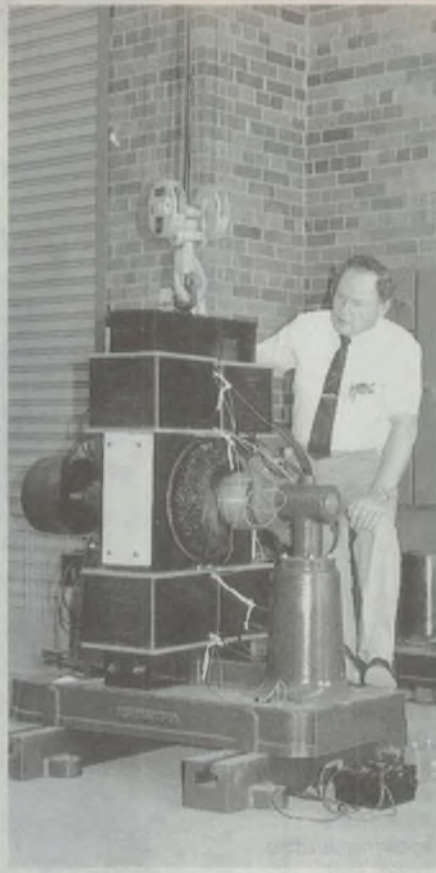

Ron Greer looking with justified pride and satisfaction at one of the recreated dynamos, as it was nearing completion in the PCCC's workshops.

We had an idea. What about those portable engine-driven welding machines? We decided to try Lincoln Electric Company, which turned out to have a machine with a commutator 7 inches in diameter and 4 inches long. It had 73 segments, so it was back to the drawing board and calculator.

Taking advantage of modern winding wires with polyester imide enamel (heaven forbid DCC wire!), we came up with a design for a simplex lap winding with 73 slots each containing the sides of two four-turn windings of 3mm diameter wire. This gives a current density of 5.5A per square mm – a little high, but we won't be working it to full load.

We decided to abandon authenticity with the armature core material, selecting 'Lycore' 230 grade 1.4% silicon steel as it was readily available. I'm sure Crompton would have given his eye teeth for some of this!

The 2-pole field circuit involved four shunt windings, and we calculated that these would need to produce 2583 ampere-turns for each 1/2 of the magnetic circuit. This gave around 1300 turns per coil, for a field current of 1 amp. Using

1mm diameter enamelled winding wire rated at 1.2 amps, each coil turned out to have a resistance of just on 27 ohms, giving a total of 107 ohms for the four windings in series. This left 133 ohms available for the field rheostat, to give 1 amp at 240V.

The field rheostat range has been set at 100 – 230 ohms, to allow regulation of the field current between 0.75 and 1.2A.

We knew that Crompton's original machine was compound wound, with series field windings to give a measure of load regulation. But how to work out the series turns? We decided to do this by trial and error, because it will depend on armature reaction. In any case very few turns are needed, because the flux density of our machine is relatively low.

Now to the point which had us all fooled. In all of the meagre information we could dig out, nowhere was there any mention of the field rheostat. It was while we were making the field coils that the penny dropped...

Look closely at the drawing where the field connections are shown (Fig.1). The top brush wires go to the series (outer) coil, which (it must be deduced) has its other end connected to the top output terminal. The bottom brush wires go to the lower output terminal.

Now look at the shunt field connections. The inner wire to the lower output terminal, the outer end to the top output terminal. Where is the terminal/connection for the field rheostat? The answer is that there WASN'T one!

I'll bet that in 1887, poor old Crompton had only lousy iron with unreliable magnetic properties – and probably his winding wire wasn't much better. He probably went for the 'strongest' magnetic field he could get, to produce the 'best possible' machine. In other words, as many coils with as many turns of wire which would fit into the space available (note the poor shape of the iron circuit and poles).

So the original machine ran at field saturation – there was nothing to regulate!

This was borne out by information we were later sent from England, about the arrangement and wiring of the original street lights.

Shortly after the opening in 1888, a British civil engineer named E.R. Dymond visited Tamworth to see the wondrous new lighting system. Apparently Dymond was a very meticulous man, who made detailed drawings of the power house itself, the street wiring and

100 Years of Lighting...

lamp connection arrangements. On his return to England he presented a paper in early 1890 to the Institution of Civil Engineers, and by chance we learned that a copy of the paper still existed in the Institution's archives. In response to a request, the Institution very kindly sent us a copy of the paper.

It turns out that the street lights nearest the power station were fitted with 3 x 75 volt lamps in series, corresponding to 225 volts. Those further away were fitted with 2 x 110V lamps in series, corresponding to 220V. And those at the very ends of the mains had two 105V lamps in series, showing that the voltage present was by that stage down to 210V.

I must confess that with the new dynamos we're cheating, and using a field regulator. But we do have some old style carbon filament lamps, and we didn't want to risk blowing them up!

Making the dynamos

It was one thing to design the dynamos, and another to make them.

We were fortunate indeed to have the assistance of the pattern shop of the Electricity Commission of NSW. They made all of the patterns to our dimensions.

The eight iron castings for each machine were moulded and cast by our local friends at G & C Foundry in Uralla, north of Tamworth. I went up to Uralla one afternoon, and assisted personally in filling the ladle from the cupola furnace and pouring the molten iron into the moulds.

The castings came out perfect first go, and were machined at the Tamworth Technical College, our own workshops and a couple of other workshops in Tamworth.

The field cores are made from 200 x 12mm mild steel plates, machined on a horizontal borer. The shafts were machined in the Council's workshop, and the commutator and armature laminations fitted. The armatures and fields were wound in the Council's workshop, where they were also dynamically balanced, aligned and assembled.

We had to use some creativity in producing duplicates of the original glass oilers visible in the drawing. Ours are made from flat bottomed chemistry flasks, turned upside down with the bottom cut out and fitted into iso-versenic (oil resistant) rubber stoppers which are drilled to fit a brass tube.

As for the brushes, we had to remem-

Engine restorers Arthur Ruttley, Kevin Davidson and Malcolm McKenzie looking a little tired, but justifiably proud in front of one of the rebuilt Fowler steam engines.

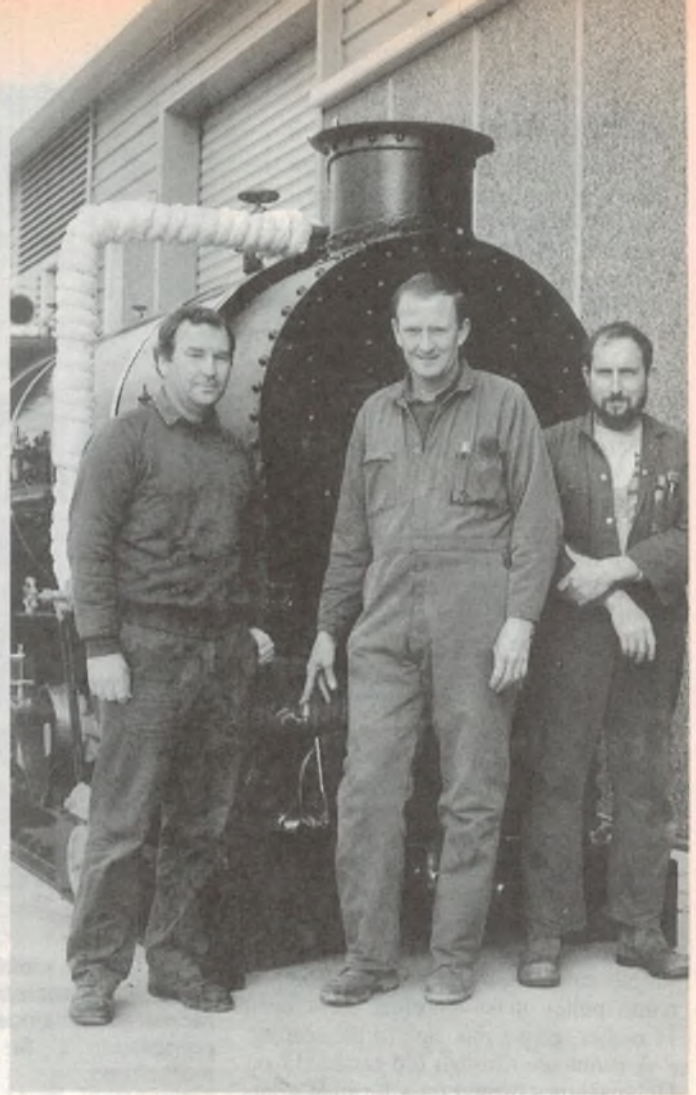

ber that carbon brushes did not come into use until 1896. Instead we have used flat laminated copper strips, and we'll have to wait and see how they last.

The Museum

Opened on November 9th by Mr Frank Brady, former chairman and general manager of the Electricity Commission of NSW, the restored Tamworth Powerstation Museum houses not only the restored power station itself, but a collection of early electrical appliances and reference material. These are housed in the original battery room.

Curator of the collection is Ian Simpson, a self-confessed 'lover of things old and useless', who has lovingly cleaned, restored and collated items collected over the past 10 years by PCCC staff and other Tamworth people. Many were rescued from consignment to scrap metal yards or rubbish dumps.

Ian has catalogued hundreds of electrical objects and equipment, as well as documents, books and journals that relate to the beginning of electricity in the region. These make up an excellent body of information for the educational

and resource centre at the museum, which will serve not only the electricity industry but schools and tertiary institutions.

A highlight of the museum's forecourt area is a faithful reproduction of one of the original Crompton arc lamps, suspended from an 18-foot high pole with a pulley system to allow it to be lowered for changing the carbon rods. Four more reproduction arc lamps have been provided in the Bicentennial Gardens.

If *Electronics Australia* readers have an opportunity to visit Tamworth and our new Powerhouse Museum, I feel sure they'll find it of great interest. We certainly found it very rewarding to rebuild and restore the power station, as a tangible reminder of the city's significance in the development of electrical technology in Australia.

Rookes Crompton was renowned for the quality of his electrical machinery. The restoration project has given all of us on the PCCC's staff a new appreciation of what lay behind the manufacture of electrical machinery 100 years ago. We salute those original engineers and tradesmen, for the ingenuity they displayed.

A Dream of a Lifetime!

Australia's answer to California's famous Disneyland is John Longhurst's Dreamworld, just north of the Gold Coast in Queensland. Here's a look at the way electronics and computers help Dreamworld's dreams come true...

by **THOMAS E. KING**

Greg Weymouth has a menagerie of unusual 'friends'. There's Blue Gum Bill and his Bush Balladeers, a piano loving kangaroo called Honky Tonk; Sunset Sam; M.C. Koala; a Bunyip by the name of 'Mythical', Cousin Grizzly who hails from the American Rocky Mountains and the triplet Koala sisters; Trix, Tootles and Tootsie.

These odd sounding characters are more than just friends, however, as Dreamworld's senior technician has to electronically stimulate them to sing, play and in some cases, dance. Blue Gum Bill, Cousin Grizzly and Tootsie aren't lazy, but like the others in Australia's largest collection of Audio-Animatronics robots they not only require a little computerised encouragement - they also need their relays cleaned and tubes checked once in a while.

State-of-the-art robots that realistically speak and move are the star performers at the 500-seat air conditioned Gum Tree Gully Hall in Dreamworld's Koala Country. During five daily shows, 22 different and larger than life creatures create an Australian Country Jamboree in what's been described as one of the finest fully computerised shows in the world.

In front of the curtain the audience watches and listens to a 20 minute \$2.2 million electronic fantasy staged on several revolving platforms; behind the barrier Greg Weymouth oversees the proceeding to ensure the smooth electronic, electrical and mechanical operations of an entertainment art form not seen on this scale elsewhere in Australia.

Audio-Animatronics - far newer than animation or computers but drawing from both - is an innovative entertainment technique. It was introduced to Australia's only true themed entertain-

ment park in 1982. In the intervening seven years Dreamworld's sole Audio-Animatronics experience has been upgraded and enlarged several times to take advantage of the latest technical advances.

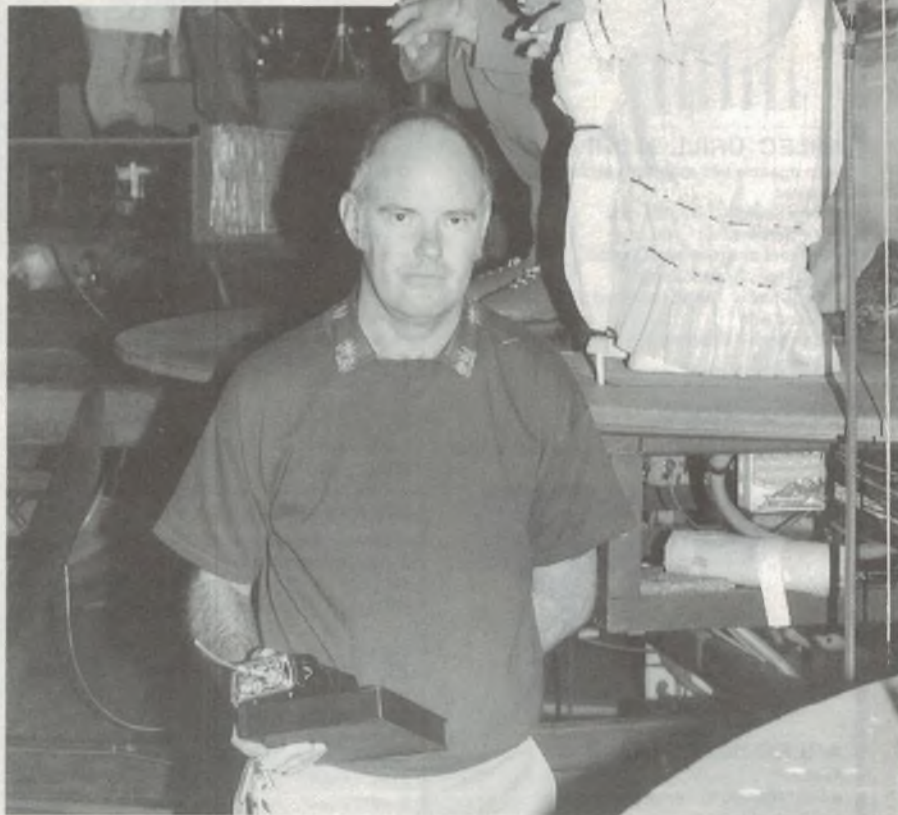

Behind the scenes, senior technician Greg Weymouth checks the relays and tubes that operate the 22 Audio-Animatronics robots at Dreamworld.

Developed in the USA, the entertainment system electronically combines and synchronises voices, music and sound effects. Most notably, Audio-Animatronics is the driving force behind a number of Disneyland's most popular attractions including Pirates of the Caribbean, Country Bear Jamboree,

Tomorrowland's Mission to Mars and Big Thunder Mountain Railroad in Frontierland...

Cam and lever mechanics once in vogue in the States were abandoned a decade or more back in favour of a more sophisticated approach using an electronic/hydraulic pneumatic combina-



The most technically advanced theme park in Australia, Dreamworld has a number of computerised attractions on the drawing boards.

tion. This system used at Dreamworld, means that using computers virtually any object can be programmed – ranging from lifelike humans and animals to birds and flowers. (Dreamworld's Koala Country is novel as no human robot figures are used; the stars are lifelike animals and birds of the Australian bush.)

The feat is accomplished by recording audible and inaudible sound impulses, music and dialogue on magnetic tape. (If a 32-track system is used, as many as 438 separate actions can be controlled.) Playback simultaneously relays music and voices to speakers, while the inaudible sound impulses activate the interior workings of performing figures, control lights and isolate each scene or performance from the following act.

The Audio-Animatronics antics at Gum Tree Gully aren't the only hi-tech wonders of Dreamworld. Using a six storey high screen and super size film the award-winning theme park's Singapore Airlines sponsored IMAX Theatre is an altogether different experience of sight and sound.

IMAX, short for 'Maximum vision' is a cinematographic technique developed by IMAX Systems Corporation, a Canadian company following the success of two multi screen film presentations at EXPO 67 in Montreal. The idea was to develop a single powerful projector to replace the multiple projection system

used at the 1967 exposition.

"The system devised," said John Angilly, engineering services controller, Dreamworld, "not only meets stringent state-of-the-art standards, but while projecting images on the largest screens in cinema history it has a number of interesting technical specifications, as well.

The IMAX 70mm film runs horizontally, and its frame is 10 times the size of a conventional 35mm movie frame – which means the screen can be 10 times the size of a conventional screen. Commonly IMAX screens measure 70 feet high by 90 feet wide.

Dreamworld's 500-seat air conditioned theatre is currently the only one of its

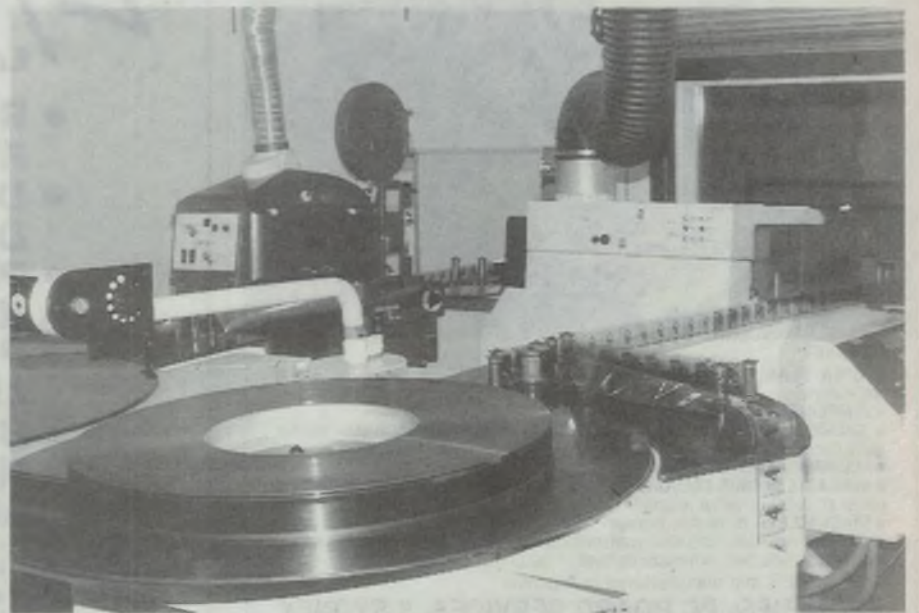

The Singapore Airlines IMAX Theatre at Dreamworld, one of only a small number in Australia, uses 70mm film that has an image 10 times larger than a 35mm frame.

Lifetime dream

kind in the Southern Hemisphere although there are more than 30 IMAX-capable theatres worldwide and two others in Australia, in Townsville and Perth.

Typical cost for a "Standard IMAX package" is around \$1.5 million. This includes just the projector and the screen! The film advances at 48 frames a second horizontally through the projector as opposed to the conventional vertical movement. The sound system at Dreamworld's IMAX theatre is 6-track Dolby, and the projector's shutter transmits one third more light than shutters in conventional projectors. This provides a far brighter image.

Although the IMAX Theatre was opened in 1981 along with a number of other main attractions, it's still a very popular drawcard. "Many visitors find it to be the single most interesting feature of the park, because it is so unique," said Mr Angilly.

Around a million visitors a year now experience Dreamworld, the 'dream' world of creator and owner, John Longhurst. He began it all in 1974 when he purchased 84 hectares of land and commenced building a themed entertain-



Trix, Tottles and Tootsie may operate from computer controlled commands but that doesn't stop Koala Country audiences from enjoying Australia's "loveliest" Audio-Animatronics performers.

ment park which contains many rides and attractions peculiar to Australia.

Situated at Coomera, 15 minutes north of the Gold Coast, the world class complex which is often favorably compared to Disneyland has 27 unprecedented rides, shows and attractions; 23 souvenir and speciality shops and 12

restaurants.

More of everything is planned. Guided by Dreamworld's technical pundits, Mr Longhurst intends to continue introducing new electronic techniques into new consumer attractions. "Dreamworld will never be finished during my lifetime," he said, "and beyond." ☺

P.C. BOARD MATE

PRINTED CIRCUIT BOARD HANDLING RACK

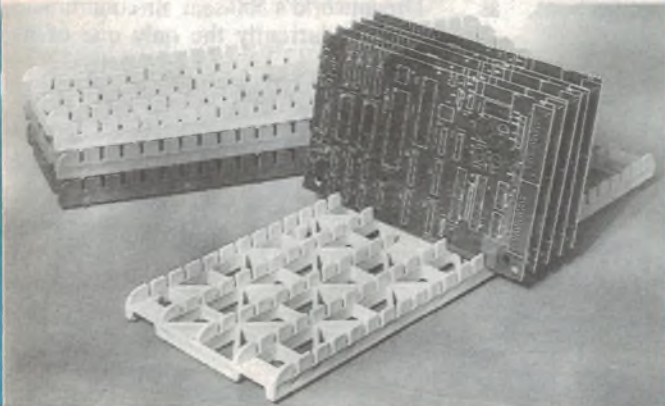

FEATURES

- OPEN PLAN BASE allows excellent ventilation flow for curing or drying applications
- TEMPERATURE TOLERANCE 150°C +
- CHEMICAL RESISTANT constructed from re- reinforced heat stabilised plastic/glass compound
- ACCOMMODATES 26 PANELS
- AVAILABLE IN FOUR COLOURS red, blue, yellow, green. Ideal for process control (other colours on special request)
- STACKABLE nests for easy storage
- DESIGN eliminates chemical contamination and staining problems associated with timber racks and minimises damage to the printed surface
- DESIGNED and manufactured in Australia

ENQUIRIES: PC BOARD SERVICES, 5 SYDNEY ROAD, BAYSWATER, VIC 3153, AUSTRALIA.
PHONE: (03) 720 5433

Looking for inspiration?

Lifestyle

Look no further!

- Restorations & Renovations
- Design & Decorating
- Pools & Spas
- Kitchens
- Pools & Outdoor Living
- Bathrooms
- Home Improvements.

Look for these exciting titles at your newsagent now or subscribe by phoning (02) 693-9517 or 693-9515.

Experience Counts.



EZ-PRO Emulators

Experience quick delivery, easy operation, fast development schedules. EZ-PRO® users reap the benefits of the C language fully integrated with advanced emulation tools, including precedence triggering, Deep Trace™, on-line code revisions, and performance analysis tools.

In addition to IBM® PC-XT/AT, hosts include IBM Personal

System/2,™ Macintosh II,™ VAX,™ MicroVAX,™ and Sun Workstation.®

EZ-PRO users also have the advantage of the best post-sales support in the industry.

They know that their emulators are covered by

American Automation's 5-year limited warranty.

Experience counts. Now with over 10 years experience, American Automation has designed more emulators than anyone. Count on EZ-PRO to provide the most cost/effective development support.

Intel: 8031 8032 8086 8035 8088 8039 80186 8344 80188 8048 80286 8049 8050 8051 8085A 8085A2 8096/97	Motorola: 6800 68B00 68HC11A2 6801 68HC11A8 6802 68B02 146805E2 68008 6803 68010 6808 68B08 6809 6809E 68B09 68B09E	Hitachi: 6301R 6301V1 6301X 6301Y 6303R 6305V 63705 6309 6309E 64180R0 64180R1	Rockwell: 6502 6503 6504 6505 6506 6507 6512 6513 6514 6515	RCA: 1802 1805 1806 CDP6805C4 CDP6805C8 CDP6805D2 CDP6805E3	Zilog: Z80A Z80B Z80H Z180 Z8001 Z8002
				Harris: 80C86 80C88	NEC: V20 V40 V30 V50
				National: NSC800	Signetics: 8X300 8X305

...AND MORE

*Assumes EZ-PRO Development Station connected to MSDOS host.

For a free demonstration call



48 Henderson Road,
Clayton, Victoria 3168.
Ph: (03) 560 1011
Fax: (03) 560 1804
Tlx: AA35703

• NSW (02) 439 5500 • SA (08) 223 2055 • QLD (07) 393 0311 • WA (09) 322 4542

IBM is a registered trademark of International Business Machines. VAX and MicroVAX are registered trademarks of Digital Equipment Corporation. Macintosh is a registered trademark of Apple Computer, Inc. Sun Workstation is a registered trademark of Sun Microsystems, Inc.

**WORLD
EXCLUSIVE TO
DICK SMITH ELECTRONICS**



TELETEXT

for your existing TV set!

- Not a kit — it's ready built and tested. Just plug it in!
- Uses your VCR tuner to save you \$\$\$.
- Hundreds of pages of the latest news, sport, finance, weather, information . . . all free!
- Also receives "subtitles" or closed captions for hearing impaired.
- Easy to use!
- Designed and manufactured in Australia, with full service back-up through Dick Smith Electronics.
- Infra-red remote control INCLUDED at no extra charge!



At last! Now you can receive Teletext — without going to the huge expense of buying a new Teletext TV! Haven't seen Teletext yet? You're missing out on the latest news, stock exchange and financial information, sport results and TAB information, weather reports and forecasts, even recipes, jokes and much, much more. It comes to you absolutely FREE — courtesy of the Australian Television Network.

On a normal TV, it's the little colour flashes you see in the black bars between picture frames when your TV "rolls". Unless you have a Teletext TV or decoder, you don't even know they're there!

And don't forget, most stations transmit popular programmes with subtitles for the hearing impaired. This Teletext decoder will let you see subtitles too!

Until now, you've had to buy a specially equipped TV to receive Teletext.

Now you can buy just the Teletext decoder — and keep your TV set!

It's not a kit — it's ready to go. And because it plugs into your video cassette recorder, costly duplication of the tuner section is eliminated. So you save!

Isn't it time you had the benefit of Teletext in your home?

**WHY BUY A
NEW \$1100
TELETEXT TV?**

ONLY \$579
Cat L-4468
**ONLY AVAILABLE
FROM**

**DICK SMITH
ELECTRONICS**

JUST 2

of the great, money saving reasons
most amateurs shop
at Dick Smith Electronics.

When it comes to selection, price
or sales and service back-up
— there's nowhere else to go!

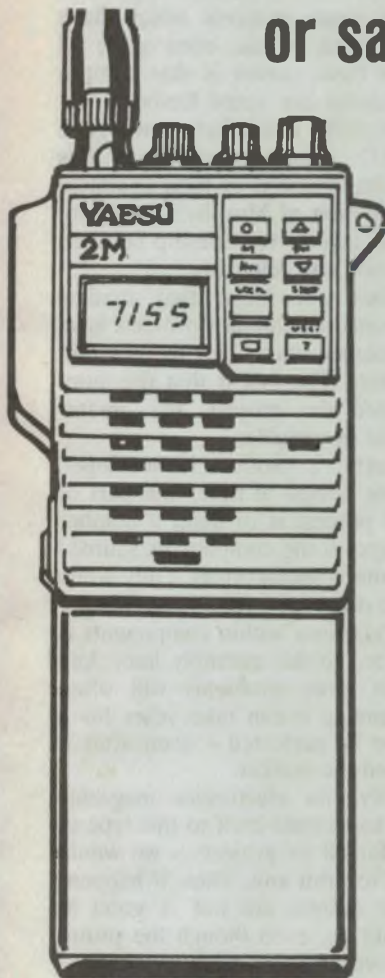

Big Performance From A Tiny Hand-Held!

The ideal 2m for the novice... or anyone wanting the best in hand-held performance. A tiny 55mm x 32mm x 139mm, yet Yaesu's FT23R is packed with all the most advanced features.

— Look! —

- Fully microprocessor controlled
- Covers 144-148MHz
- 10 memories
- Repeater splits
- Busy and priority scanning
- Up to 5 Watts output (With optional 12V supply)
- S/RF Meter, carry case, antenna
- FNB-10 Nicad Battery & more! Cat D-3490

\$469

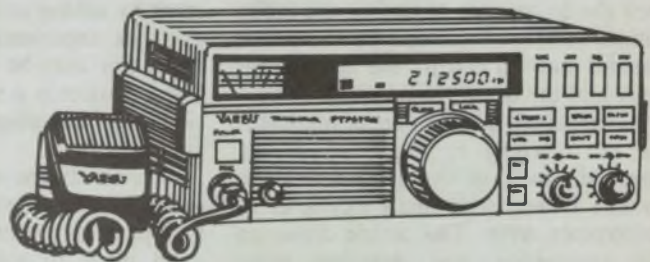

Budget HF Transceiver

Compact and lightweight so you can even use it as a mobile! The incredible Yaesu FT747GX is specially designed for easy operation, high performance and value for your dollar.

Look what you get ...

- All HF bands (160 through 10 including WARC)
- All Mode (with optional FM)
- 100 Watt (CW, AM 25W)
- Just 238 x 93 x 238mm
- Yaesu quality and much more!

\$1395

Cat D-2930

MIC NOT INCLUDED

Now available at 60 stores:

• NSW - Albury 21 8399 • Bankstown Square 707 4888 • Blacktown 671 7722 • Bondi Junction 387 1444 • Brookvale (Warringah Mail) 905 0441 • Campbelltown (046) 27 2199 • Chatswood Chase 411 1955 • Chullora 642 8922 • Gore Hill 439 5371 • Gosford 25 0235 • Hornsby 477 6633 • Liverpool 600 9888 • Maitland 33 7866 • Miranda 525 2722 • Newcastle 61 1896 • North Ryde 88 3855 • Parramatta 689 2188 • Penrith (047) 32 3400 • Railway Square 211 3777 • Sydney City 267 9111 • Tamworth 66 1711 • Wollongong 28 3800 • ACT • Fyshwick 80 4944 • VIC • Ballarat 31 5433 • Bendigo 43 0388 • Box Hill 890 0699 • Coburg 383 4455 • Dandenong 794 9377 • East Brighton 592 2366 • Essendon 379 7444 • Footscray 689 2055 • Frankston 793 9144 • Geelong 43 8804 • Melbourne City 326 6088 • Richmond 428 1614 • Ringwood 879 5330 • Springvale 547 0522 • QLD • Brisbane City 229 9377 • Buranda 391 6233 • Cairns 311 515 • Chermide 359 6255 • Redbank 288 5599 • Rockhampton 27 9644 • Southport 32 9863 • Toowoomba 38 4300 • Townsville 72 5722 • Underwood 341 0844 • SA • Adelaide City 232 1200 • Beverley 347 1900 • St. Marys 277 8977 • Elizabeth 255 6099 • Enfield 260 6088 • WA • Cannington 451 8666 • Fremantle 335 9733 • North Perth 328 6944 • Perth City 481 3261 • TAS • Hobart 31 0800 • NT • Stuart Park 81 1977

DSXpress order line 008 22 6610

DICK SMITH
ELECTRONICS

Project fault finding

Is it our fault or yours? Sometimes it is difficult to tell whether a project has a design error or a constructor error, giving rise to much frustration. Maybe this article will help, particularly if you are ready to quit and take up goat roping instead.

by PETER PHILLIPS

Last month we published an article on the art of tracking down faults in commercially manufactured equipment. We sought to highlight some of the more basic methods that can be used to find both simple and elusive faults. For this reason, the article concentrated on the breakdown type of fault, but we also promised a follow-up article specifically for project fault finding.

Faults in projects can be extremely difficult to analyse, as there are three possibilities that can arise to create the fault. The first, and dare we say, the most common, is constructor error. Next, (now it's your turn to point the finger) is design/presentation error. Finally, there is always the possibility of a faulty component.

The problem, of course, is determining in which of the three categories the fault lies. Because we have already covered the techniques of finding the faulty component (breakdown) type of fault, it remains now to discuss the constructor error and the design error possibilities.

Having spent a large part of my working life teaching in TAFE where the practical aspect of the subject is paramount, I have seen many examples of constructor error. This article draws on this experience, and describes some typical and not so typical constructor-induced faults. Hopefully the examples and hints contained in this article will be useful to those readers with a box full of dead projects.

And there is still the spectre of the design error. This article therefore covers these two fault categories, in the hope we can offer assistance by giving ideas to help you get your project up and running.

Why doesn't it work?

If a project fails to work after its construction, try to determine which of the three categories the fault fits. If this is done prior to fault finding, a lot of time wasting can be avoided.

For example, try to rule out design



error by asking around to see if anyone else has experienced problems. Sometimes this may be difficult, particularly if the project is a new one, and insufficient time has elapsed for the 'word to get around'.

Because design or presentation error is the nastiest one of all, a rundown on how projects are brought into being is a good place to start. By knowing the process involved, you may be able to recognise the source of the error and perhaps come up with a suitable solution. However, as a general comment, where the fault category cannot be determined, assume the error is a constructional one, as it is usually unlikely the components are faulty if they were bought new, and design errors are not as common as you might think.

Project design

Magazine projects are either contributor developed, or are produced by the staff of the particular magazine. Contributor projects represent a fair percentage of the total number, and usually come to the magazine in their completed form. As such, the development

process is unknown, and the contributor's description of the project is usually all that is available.

At EA, contributor projects are always fully reviewed, the specifications checked and the circuit examined carefully. Obviously, it is in our interests to ensure that any published project works as described. Usually, the contributor concerned is known by the magazine, and a fair amount of discussion about the project will have occurred as well.

Staff developed projects are the most common, and again considerable effort is expended to ensure they are bug free, for the same reason. So, if the prototype works, and the magazine is happy, why are there a few projects that still have problems when finally released?

Putting aside printing and circuit re-drawing errors, we acknowledge that there are some projects which have given problems – yes, even some of ours. The basic reason is that component variations can cause havoc in designs that really could have undergone more R&D. Usually, projects of this type are characterised by their complexity – a mutation of Murphy's Law concerning the inverse relationship between sophistication and reliability.

This does not mean that readers should assume all complex projects have these problems, simply that the possibility is greater. The fact is that the more sophisticated the project, the greater the number of variables.

In industry, a product is developed over a long period of time, and part of the R&D process is to build a number of prototypes using components sourced from various manufacturers. Only when the design can cope with all possible parameter variations within components is it committed to the assembly line. And even then more problems will often occur, meaning it can take years for a product to be perfected – even after it has reached the market.

Obviously, no electronics magazine can hope to commit itself to this type of research for all its projects – we would never get to print any. Thus, it happens that some designs are not as good as they should be, even though the prototype may work like a dream.

As an example, we recently discovered a fault in a project by closely examining the photos of the prototype in

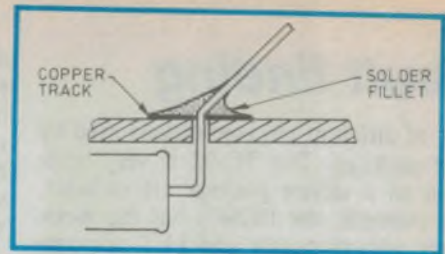

Trim component leads after soldering and check solder connections carefully.

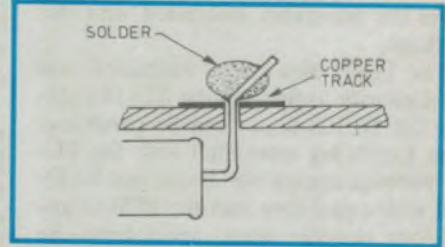

A classic 'bad connection'. Some may not be so obvious.

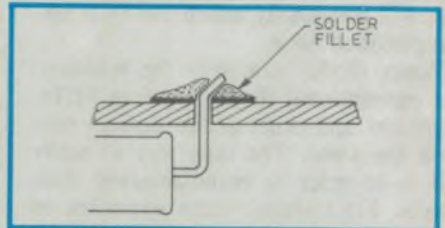

A 'dry joint' in which a oxide layer forms between the solder and the lead.

response to an enquiry. It was discovered that one of the many TTL LS digital ICs used in the prototype was actually a regular TTL type. The parts list specified TTL LS, but, as it turned out, regular TTL was required in one case.

So there is no simple answer. There will always be those projects that turn out to be duds, or that need a bit more attention. At EA we receive many letters from constructors, which often result in the development of an errata file for those projects that need it. We are very sensitive to these types of problems, and do our best to solve them.

We therefore welcome any feedback on our projects, and suggest that all constructors scan the Information Services pages of the magazine, as well as the errata page. But be assured, we are most concerned with quality, and every possible effort within the bounds of practicality is expended to get the bugs out. That's why some projects are often delayed in publication.

Having said that, now lets turn to your side of the operation – the construction.

Construction errors

The adage 'he who never made a mistake never made anything' is always worth quoting – it makes we mortals feel a bit better when things go wrong. The construction error is also not necessarily the province of the amateur, although experience generally helps in minimising these types of problems.

Typical errors in circuit building are faulty soldering, PCB track bridging, incorrect component orientation, use of a wrong component, mixed up wiring to external hardware, and so on. The likelihood of poor soldering decreases with experience, and for this and other obvious reasons, complex projects should only be undertaken after success has been had with simpler exercises.

Because there are so many ways mistakes can be made, we will subdivide them into various categories starting with soldering errors.

Soldering

By far the most likely constructor error is soldering. Here's a short list of some typical nasties which you could check off before proceeding further with the fault finding quest:

- solder bridging tracks.
- connection point not soldered at all.
- wire strand shorting two points.
- earth braid shorting to an adjacent point.
- bad connection.
- overheated and hence broken track.
- overheated and therefore damaged component.
- solder bridge between heatsink and the device on the heatsink.

I always solder each component before cutting off excess lead length. This clearly identifies those components that I may have missed soldering and also helps conduct heat away from the body of the component during the soldering process.

Although not a typical problem, it has happened that some constructors

have used an acid flux (normally only used on guttering and plumbing) on their PCB. As well as being very corrosive, this type of flux also conducts electricity, giving all kinds of problems. Avoid it like the proverbial plague!

Active components

If the project has been purchased as a kit, it is possible that some components, particularly transistors, may have been

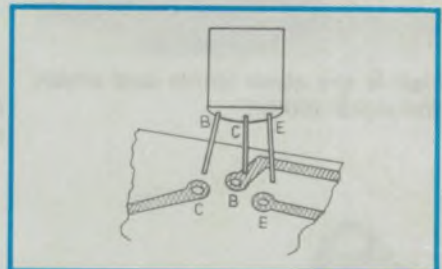

Replacement transistors may not have the same pinout as the original.

substituted with an alternative having a different lead configuration to the original. This is fairly unusual, but could arise with the TO-92 package in particular.

The problem with this package, and the TO-72 package as well, is the num-

Fault finding

ber of different pin connections used by this package. The TO-92 is very common as a device package (it includes, for example, the BC547) but the variations with transistor and FET pin connections have created more than their fair share of hassles. The data sheet at the end of this article may help to unravel the anomalies associated with this package.

The TO-72 also has its variations, and its similarity to the popular TO-18 package (of BC108 fame) can be confusing. The fourth leg associated with the TO-72 package means the device can be fitted with equal ease into the PCB in any of four possible ways, apart from the various pinout configurations. So, don't always assume that the replacement device will necessarily match the PCB layout provided for it.

Zener diodes can often be mistaken for conventional diodes, just as FETs, thyristors and other active devices may look the same. The only way to really tell is to refer to manufacturers' data sheets. Fig.1 shows some examples of quite different devices that look the same.

Sometimes a few tests can be applied to determine the nature of the unknown device, but even this can be unreliable. For example, some transistors are actu-

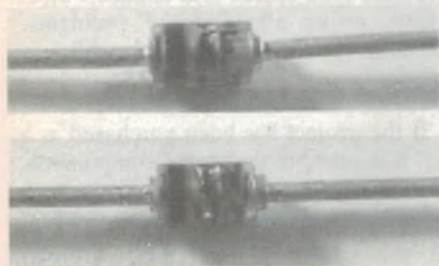

Which is the zener diode and which is the signal diode?

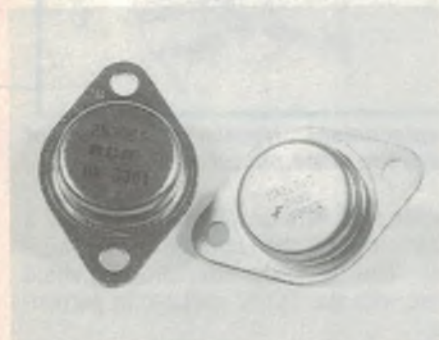

The TO-3 package containing a transistor (left) and a voltage regulator (right).

ally a Darlington pair in a three lead package. Some specialised switching transistors have a diode connected (in reverse polarity) across the collector-emitter terminals. And even worse, some devices will work (in a sort of way) even if connected *back to front*.

I once identified a constructor fault as having all six transistors mounted very neatly with their emitter and collector terminals reversed. The circuit worked, but not as well as it should. The constructor assumed a design error! (I was the designer).

Triacs will often work in reverse, but with reduced efficiency, as will many FETs. Then again, some FETs can have their source and drain terminals interchanged with no effect. Also, check the lead connections for the TO-220 versions of the 7800 and 7900 series of voltage regulators. The two devices have different pinouts in that the 'common' and 'in' terminals are swapped.

The following check list for active devices summarises some of the errors that can easily occur:

- wrong orientation (i.e., back to front)
- wrong type of device (e.g., FET instead of a transistor)
- wrong polarity device (e.g., NPN instead of PNP)
- wrong package outline (e.g., TO-92 variation)

The last three all mean that the device

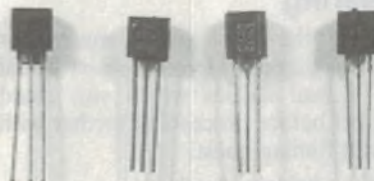

The TO-92 package, containing (l-r) a FET, a voltage regulator, an SCR and a transistor.

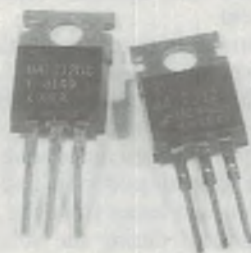

Two TO-220 voltage regulators with different pin connections.

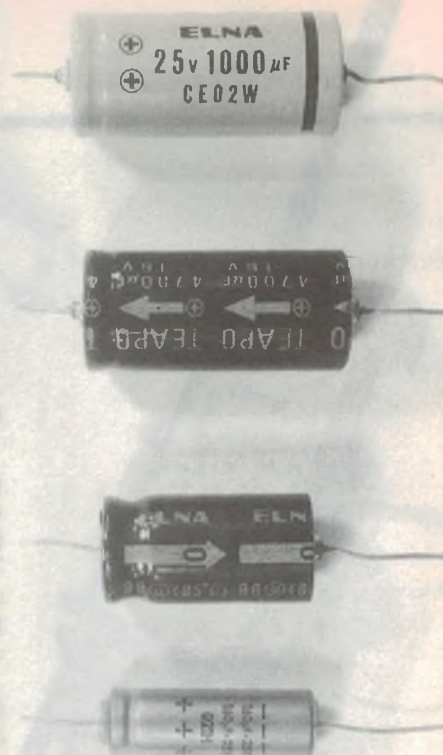

Four different ways of showing the polarity of a capacitor.

actually used will have a different device number to that specified. In other words, check carefully that the device number is correct, and don't assume that because the package is the same, the device is the same as the original.

Passive components

Passive components include capacitors, resistors, diodes and all the other miscellaneous componentry. Some devices are polarised, meaning they must be mounted the correct way round. Electrolytic capacitors and diodes are an example of this.

Often components from several manufacturers may make up the kit, all using different standards to identify the polarisation. Typical of this is the method manufacturers use to show the polarity of an electrolytic capacitor. Some employ an arrow to point to the negative lead, others use the arrow to identify the positive lead, as shown in Fig.2. I always use the foolproof method of noting that the aluminium end is the negative polarity – and ignore the manufacturer's marking.

More insidious is the possibility of confusing the colour code of a resistor. A 12 ohm resistor, coloured brown, red, black can be easily mistaken for a 1k ohm resistor whose code is brown, black, red. Low value resistors using silver or gold as part of the code for the

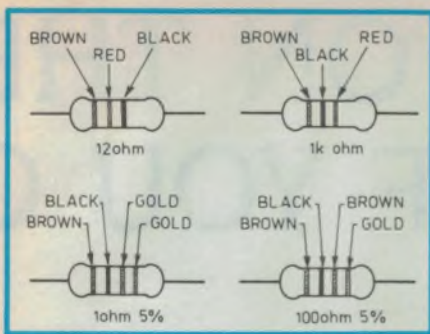

Resistor colour codes that look alike can create problems.

value can be confused with others using these colours for the tolerance band.

Many types of resistors are manufactured, and the construction type is usually denoted by the body colour of the resistor. However, this often makes the colour of the bands hard to decipher, even worse when there are four bands for the value and a fifth for the tolerance. When in doubt, measure it.

Another problem concerns capacitor value markings. It is very easy to mix up the decades, in which, for example, a 10nF capacitor may easily be confused with a 1nF capacitor. The Reference Data sheet in this issue includes conversions between prefixes (nF to uF and so on) and also gives some hints on reading manufacturers codes. The best way round all this, of course, is to build a capacitance meter and measure the values of those you can't figure out.

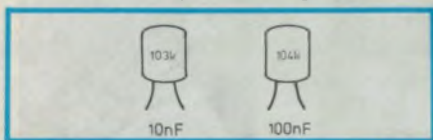

Watch the last figure in a value code, it makes all the difference!

Harking back for a moment to the subject of polarisation, integrated circuit polarising is usually identified with a recess on one end, or maybe with a dot next to pin 1. Some manufacturers mould two recesses in the case, one at either end, with one deeper than the other. The likelihood of inserting it the wrong way round is quite high as a result. To avoid this, use the pin 1 dot as the reference wherever it is provided.

Switch connections are often confusing, and it usually pays to test which terminal is which with an ohmmeter. Also, check that any panel mount potentiometers have the correct taper. Usually, 'A' curve means linear and 'C' curve is logarithmic. To be sure, confirm with an ohmmeter as some manufacturers have been known to use 'A' to denote a non-linear curve.

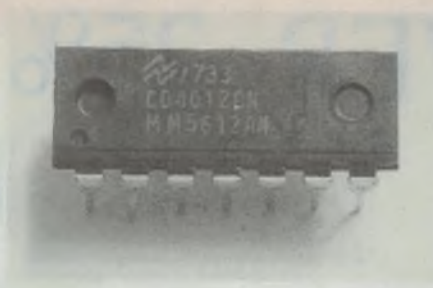

Some ICs can be ambiguous in their pin numbering.

Construction hints

Generally a project kit will include instructions on the best way to go about stocking the PCB, by giving a preferred order of component installation. This is done to prevent the need for component removal to allow the placement of one that may, for instance, be underneath another. Ordinarily, wire links are first, followed by passive components, with active devices being installed last.

To expedite construction, it is usual to insert a number of components, then proceed to solder them in. By trimming the soldered leads after soldering, missed joints can be found as construction proceeds. By methodically doing a section at a time, a constant check can be maintained on the soldering process, with simultaneous checks being made for solder bridges.

The rule is, check as you go, and re-check again and again. A magnifying glass is an excellent way of examining the board. Provide good lighting, and always fix an error as soon as you find it. Look also for strands of wire from multi-stranded cables that may be shorting across to another area. Wire of this type should be tinned before connecting it to the PCB, in order to solder the individual strands together.

Heat-sink/component shorts are very common, as the most imperceptible burrs can pierce thin insulating washers. Always lightly countersink the mounting holes, then rub the heat sink surface with a fine grade of emery paper.

Fault finding

As in all fault finding situations, an organised approach is essential. Try to be open-minded about the fault, as all too often preconceptions can cloud the issue. For example, a component that is too hot on the left side of the board may well mean that the fault is on the opposite side.

How often have servicemen stared at a dead board only to find later that the power plant wasn't turned on? A cassette player that won't record because

the interlock is set, or a silent amplifier because the speaker is disconnected are all common experiences. Or how about the possibility of replacing a good component with a faulty one, thus introducing another fault. The possibilities are endless.

When measuring voltages around an IC, do so at the actual pin of the IC and not the IC socket. ICs can easily be inserted in a socket with a lead bent under it, in such a way that it appears to be properly inserted in the socket. In fact, never assume that a voltage at one end of a piece of wire is necessarily present at the other. Lots of things can happen on the way.

Locating a construction error is similar to finding any fault, except many more possibilities are likely, as already described. Where possible, each section of a board should be proven as construction proceeds, particularly in complex circuits. For example, the power supply can often be constructed first and checked before anything else is built. Fault finding by confirming a section at a time, either during construction or servicing, is often the best means of narrowing down the area containing the problem.

Many constructors when confronted with a problem in a newly built project proceed to strip it down and rebuild it. This is *not* a good idea, as apart from the work involved the chances of reintroducing the fault are high.

If you eventually decide this is the only way around the problem, use all new components if possible, or at least check the old ones. Otherwise, the probability of more faults occurring is greatly enhanced, as by now each component will have undergone a lot of stress, just as the PCB will have received a caning. Unless the original job is of a very poor standard, persevere with the first attempt.

Summary

There is much that can be said on fault finding but space prevents more than this brief review. We cannot hope to get too technical on the subject of fault finding, as this would open a Pandora's Box that could fill volumes. Hopefully this article, its predecessor (*EA* December) and the Reference Data sheet elsewhere in this issue will offer some useful information.

And remember, if you find a fault in any of our designs, please let us know so that we can publish this information. If the fault is yours, be assured that you won't have been the first, nor the last. And that's all part of the fun. Ⓜ

SAVE OVER 25% ON THE IF YOU O



THE COMPLETE SAILING HANDBOOK A beautiful 340 page hardcover book filled with everything you need to know about sailing. Magnificently illustrated with more than 1000 diagrams and photographs. \$29.95 \$21.95 (CACOM24) **SAILING YEAR 1987-1988** An excellent, informative review of the year's sailing racing. Plenty of bright action pictures bring the text alive to capture the interest of the expert and spectator alike. 256 pages beautifully presented in a hard cover. \$29.95 \$21.95 (CASA11) **PACIFIC SAIL** The vast Pacific Ocean has been sailed by ships from the west for many centuries. All these vessels realistically depicted in superb paintings in this 192 page hardcover book. \$39.95 \$29.95 (CAPAC1) **THE SMITHSONIAN BOOK OF FLIGHT** "I can't answer except to assure you that it will be spectacular." (Orville Wright, commenting on the future of aviation) We think you will find this beautiful 288 page history of flight book the same. \$79.95 \$44.95 (TWSM1) **OUTBACK PUBS OF AUSTRALIA** Over 50 beautifully reproduced prints of Rex Newell's paintings. Featuring outback pubs in Australia and the tales connected to them. \$26.95 \$19.95 (CAOUT1) **EXPLORE TROPICAL QUEENSLAND** From the Great Barrier Reef to its vast outback plains, tropical Queensland is full of amazing and colourful contrasts beautifully presented in this 160 page book. \$29.95 \$21.95 (CAEXP2) **DINKUM AUSSIE PICTURE BOOK** Contains over 100 superb photographs which show Australia at its best. Everything from rolling wheat fields to the Sydney Opera House. \$74.95 \$10.95 (CADIN8) **EXPLORE AUSTRALIA'S GREAT INLAND** 160 pages of suggested outback trips, beautifully depicted in full colour photography. Ideal for ideas before you get down to the real planning. \$29.95 \$21.95 (CAEXP1) **THE ENCYCLOPEDIA OF AIRCRAFT** This meticulously researched encyclopedia presents an unrivalled record of over 500 military and civilian aircraft in Australia and New Zealand today. Each entry accompanied by a photograph. \$39.95 \$29.95 (CAILL10) **THE AUSTRALIAN ADVENTURE** This superb 528 page book reflects the best of Australia's travel and adventure destinations. Beautifully presented with glorious colour photography. It would be a valued asset to any library. \$49.95 \$36.95 (CA AUS61) **PRESENTING AUSTRALIA** A land of harsh beauty magically captured in over 400 photographs and engraving. For all Australians and visitors, this book brilliantly reveals the charm and appeal of Australia, past and present. \$26.95 \$19.95 (CA PRE1) **DINKUM AUSSIE ODDITIES** A light hearted look at the weird and wonderful things, mostly man made, but some natural, which makes Australia unique. \$8.95 \$6.70 (CA DIN3) **DINKUM AUSSIE BICENTENARY** Bob Ryan looks at the lighter side of the first fleet and early settlement. He explores the bungsles and bickering, the beer and the beauties, the frolics and fun. \$8.95 \$6.70 (CA DIN5) **DRUNK, INSANE OR AUSTRALIAN** Here it is an Australian publishing first. The first detailed, factual account of the funniest and most bizarre events in recent Australian history. \$8.95 \$6.70 (CA DRU1) **THE OUTDOOR TRAVELLER'S GUIDE TO AUSTRALIA** This is the premier guide to exploring and enjoying the landscape, wildlife, and vegetation of Australia. Superbly presented with 242 colour photographs and 15 full colour maps created especially for this book. \$29.95 \$21.95 (WC 0000000) **ACES HIGH** Fast jet fighter, transport and trainers, all the way from the target tug to top gun itself, modern military air power captured in its element by some of the world's finest aviation photographers. \$29.95 \$21.95 (CA ACE2) **MODERN FIGHTING AIRCRAFT SERIES** Each of these fantastic books has more than 100 full colour photographs on some of the most well known and sophisticated military aircraft. Complete with profiles, cutaway and dozens of explanatory diagrams. The series includes the Harrier, F.A-18 Hornet, F-111, AH-1 Cobra Attack Helicopter, F-16, F-14 Tomcat, F-4 Phantom II, B-1B, A-10 Thunderbolt II and the F-15 Eagle. \$19.95 \$14.95 each (CA FAC) **MIDDLE AGE RAGE AND OTHER MALE INDIGNITIES** At last, an honest hilarious guide to that mysterious and terrifying phenomenon: Male Middle Age. \$9.95 \$7.45 (CA MID1) **FOOD CHEMICAL SENSITIVITY** This book deals with the variety of additives that have been introduced to help food stay fresher longer, maintain its colour, look appealing longer, etc. Many of them can do immeasurable damage to the body. Here is what you can do about them. \$7.95 \$9.70 (WC 063120836) **THE DINKUM AUSSIE DICTIONARY** A list and definitions of all those words and phrases that only an Australian can understand (and some even Australians don't know!). \$8.95 \$6.70 (CADIN1)

SEE MAGNIFICENT BOOKS ORDER NOW!

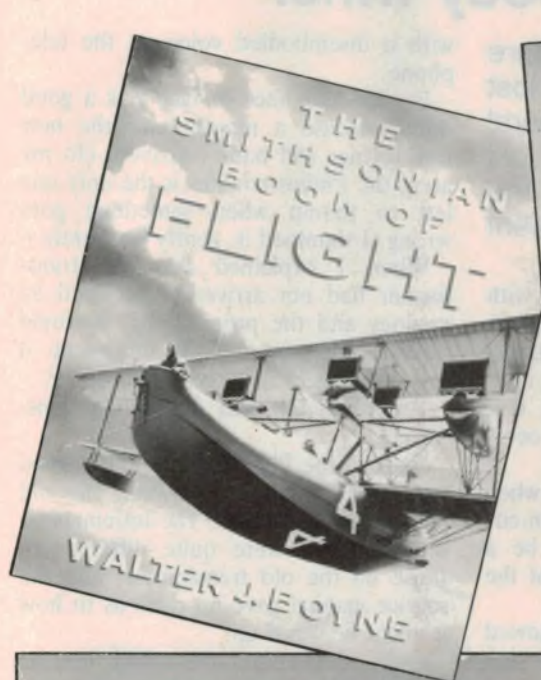

TO ORDER

Simply fill in the coupon remembering to include the code numbers and \$5 postage and handling. If the coupon is missing write down the names, code numbers and prices of the books you require. Include your name, address, telephone number, plus cheque, money order or credit card details (card type, card number, expiry date and signature) and send it all to Federal Publishing book offer, Freeport No 4, PO Box 227, Waterloo, NSW 2017. No stamp required. And don't forget to sign all orders.



PLUS...WIN THIS \$950 COLLECTOR'S ITEM

Orders of books from these pages received before 31st January, 1989 will go into the draw to win this magnificent book. Only 350 copies of this book have been produced. They are numbered and signed and bound in Australian leather and buckram. "The Royal Australian Navy the First Seventy-Five Years" is now in the library of Her Majesty the Queen.

Note: The book can also be ordered for **\$950** (CA ROY7)

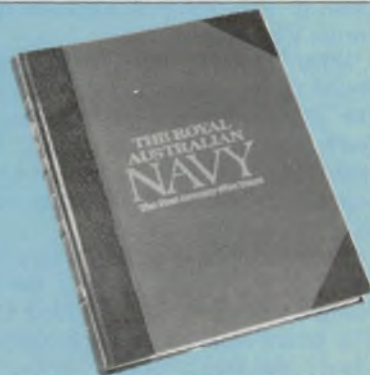

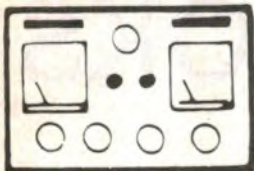

One of those cases where nobody wins!

My first story this month is one of those sorry sagas where everybody does their best, but no one wins. The owner lost out because her set was out of commission for several months and is still not properly fixed. The manufacturer lost out because their communications weren't good enough. And I lost because I was paid for only a fraction of the time I spent on the job...

The set was a Philips KE027, fitted with a KT2A chassis and it belonged to one of my aged customers in a local old folks' home. She had owned the set for some six or seven years, since it was new, and had grown accustomed to its operation.

When the set stopped working, she feared that the picture tube had failed and was most upset at the thought that she might have to get a new set, and learn all over again how to operate it. These problems worry old people, and I do everything in my power to reassure them that their fears are probably groundless.

In this case I was quickly able to set her mind at rest. The set was not going for the simple reason that there was no continuity through the power lead-switch-mains fuses-transformer primary network.

I soon exonerated the lead-switch-fuses combination, which only left the transformer primary as the likely culprit. It didn't take very long to confirm that the primary was indeed open circuit.

At this point I decided to take the set back to the workshop. I had a feeling that there might be a long wait for a new transformer and it was better to keep the set in my storeroom, rather than in the cramped confines of the owner's bed-sitter.

When I got the set on the bench, I found that it was an easy job to remove the transformer for examination. The leads plug into a small 'mains' board and the unit is held in the set by four screws. In two minutes it was on the bench and under scrutiny.

The first thing I noticed when I lifted it out of the cabinet was that the transformer scrunched and crackled loudly. I've heard that sound in the past and it always indicated a cooked tranny.

The sound is associated more with paper-insulated valve radio transformers than with low voltage transistor transformers. But I'll believe anything until proved wrong, and I felt certain that this transformer had been severely overheated.

This feeling was confirmed when closer examination showed the open circuit was in what turned out to be a thermal fuse, buried in the body of the transformer bobbin.

The rest of the transformer showed no open circuits, nor any obvious sign of shorted turns. With the fuse bypassed and the primary fed with low voltage AC, the transformer produced all the expected outputs without any signs of distress.

I went carefully through the chassis, looking for any shorted power diodes, open circuit electrolytics or dry joints that might have overstressed the transformer. I found nothing, and every indication was that the set should work normally, given a good transformer.

As a final test, I reconnected the transformer into the set and gingerly switched on. It was quite an anti-climax, because the set started up and worked quite normally, at least for two or three minutes. But when I switched off and felt the transformer, I knew that there was something very wrong.

The transformer was too hot to touch. It was beginning to smell, and it was making small crackling noises from deep within the windings. So scratch one transformer, and put in an order for a new one.

Fortunately, although the local Philips office carries very few parts, they will accept orders for parts and these are then supplied from the centralised store. In the event of problems, I can at least talk to someone face to face, rather than try to establish communication

with a disembodied voice on the telephone.

In this case, face to face was a good thing because a month later the new transformer still hadn't arrived. (In my area, the Philips counter is the only one left to thump when something goes wrong. I thumped it, gently but firmly.)

When I explained that the transformer had not arrived, I received an apology and the promise that it would be here the next day. In the event, it was a couple of days, but it did arrive.

Except that it was the wrong transformer.

Back at the Philips counter, I showed them the differences between the old and new transformers. The terminals on the new unit were quite different to those on the old transformer, and the service manual gave no clues as to how it might be wired up.

Quite obviously, one could not be used for the other, and I asked if they could get me some more information about the new transformer. I guessed that there were some modification notes somewhere in the system.

At this point one of their staff remembered that there had been two versions of the KT2A chassis. He didn't know what the differences were, but they did involve different power transformers. So the wrong transformer went back, and a 'right' one was ordered, for early delivery.

(You folk who live in the 'big smoke' don't know how lucky you are. If you want something in a hurry, you can go and pick it up yourself. Try that out in the boondocks! We are at the mercy of freight companies, and the 'right' transformer took another two weeks to arrive.)

By this time my elderly customer was most upset about her TV. Her son had rented a replacement set, but she didn't like it because her arthritic fingers could not press the tiny buttons on the remote control. She wanted her own set back, or another one with big buttons that she could manage.

So when the new new transformer arrived, I lost no time in fitting it to the set and setting up a soak test. The set worked, but not very well. There was a

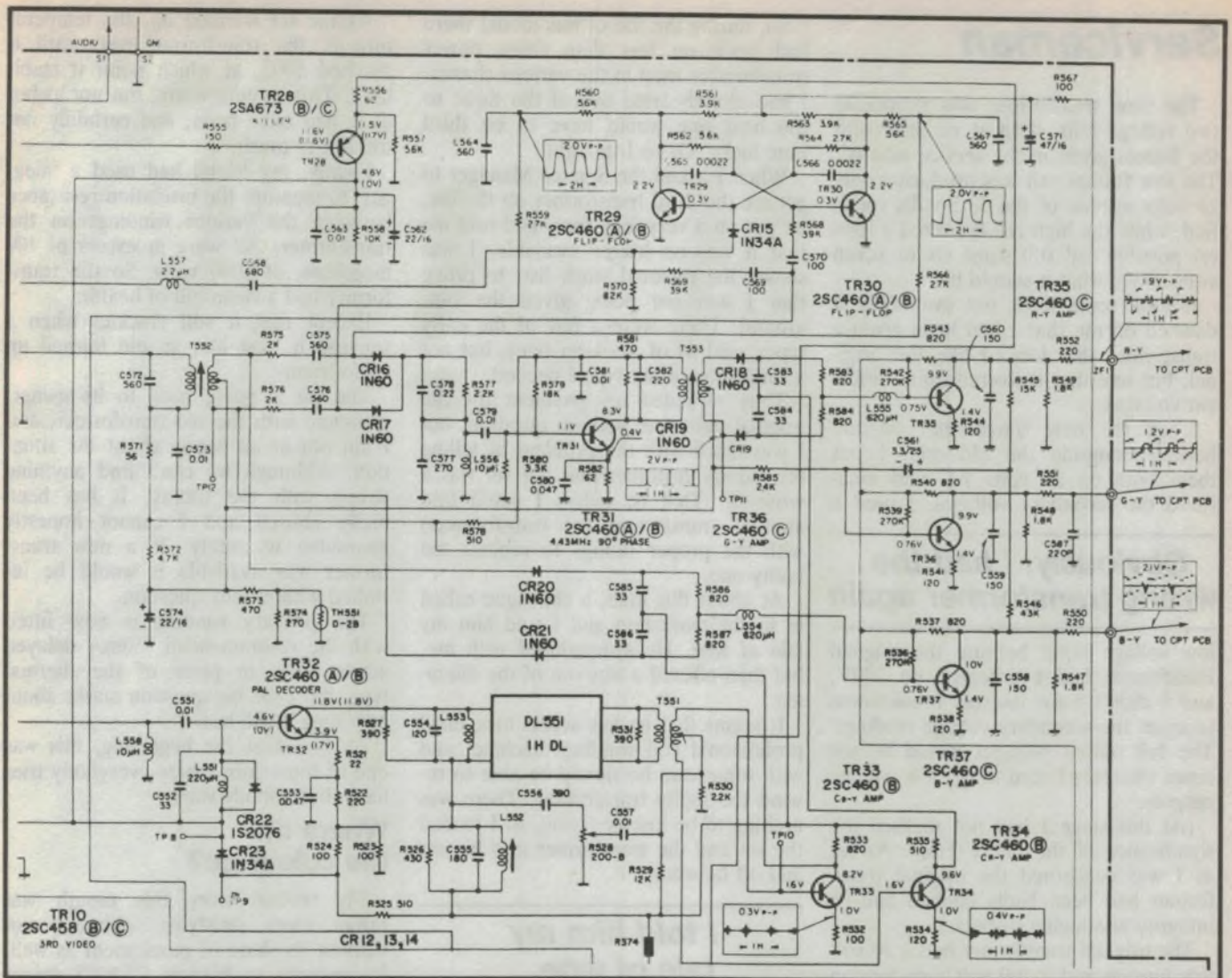

The colour decoding circuitry of an Hitachi CEP288 receiver, which forms the subject of this month's second story. The trouble took quite a while to track down...

very strong buzz coming from the transformer, and the two DC rails were not right.

The 33.5 volt rail was only reading 24 volts, while the 131 volt rail was at about 138 volts at its lowest setting. The adjustment would take the rail up to 150 volts, but nothing I could do would bring it down far enough.

And what is even more significant, the new transformer, after only 10 minutes, was now stinking hot, literally. It was giving off the characteristic smell of hot varnish, and was too hot to touch with the bare hands. So what now?

The only thing that can make a transformer overheat is excessive load, yet that didn't seem to be the problem here. The set was working more or less normally and the total current being drawn from the mains was about right, as far as I could tell with my 6 amp clamp tester.

The only other thing I could think of was unbalanced operation, with DC

flowing in the secondary. This can happen if a bridge diode goes open circuit. The supply goes into half-wave rectification, and double the normal current flows in one direction through the transformer secondary.

I carefully checked the bridge diodes, but they all appeared to be perfect, at least on a multimeter test. Next, I fired up my oscilloscope to have a look at the waveforms. This revealed that, in fact, something very funny was happening around the bridge on the high voltage secondary.

Although all four diodes appeared to be conducting normally, two of them were conducting more heavily than the others. And the input to the regulator transistor TS410 had a very heavy 50Hz ripple on it.

At first, I couldn't imagine where this ripple was coming from. All the diodes were OK and so were the filter capacitors. There was no ripple on the DC output, yet one side of the bridge was

obviously conducting more heavily than the other.

It was only then that I noticed a strange component on the schematic diagram. It looked like a two-way diode, in the negative leg of the high voltage bridge. I must confess I had to go back to my reference books to find out what it was. It was a Triac, a rare component in TV sets, though not all that rare in other power circuits.

The detailed operation of the Philips circuit is not easy to understand, but the Triac shares the regulation function with the series transistor by limiting the current that can flow through the bridge.

It seems that the Triac was switching asymmetrically, allowing more current to flow through one half of the bridge than through the other. A new SC141D cured the problem of ripple current, but did nothing to stop the overheating. And significantly, the voltage adjustment control had no more effect than it did on earlier tests.

Serviceman

The new transformer was producing two voltage rails, both at variance with the figures given in the service manual. The low voltage rail was producing only 24 volts instead of the 33.5 volts specified, while the high rail delivered a lowest possible rail still some six or seven volts above what it should be.

It took some time, but eventually it dawned on me that I had been given a transformer that looked like the original, but one that delivered quite different voltages.

I set the new transformer on the bench, alongside the old one. I put them both on 24 volts AC and measured the secondary voltages. I used a

Obviously, I had the wrong transformer again

low voltage input because the original transformer had overheated on 240V, and I didn't want internal breakdowns to upset the secondary voltage readings. The full output voltages would be ten times whatever I read as the low voltage outputs.

(At this stage I had not realised the significance of the faulty Triac. As far as I was concerned the original transformer had been badly cooked and its integrity was highly suspect.)

The original transformer had a 30 volt low tension and a 100 volt high tension windings. The new transformer could manage only 18 volts on the low winding, and a staggering 230 volts on the high winding. No wonder I couldn't get it down low enough. Obviously, I had the wrong transformer, again, so I had to make another trip over to the Philips office.

Another thump on the counter and it was revealed to me that there were in fact *three* different versions of the KT2A chassis - KT2A-1, KT2A-2 and KT2A-3. And, it seems, there is no clear way to tell which chassis is in the KE027. One must know the differences, then examine the chassis closely to determine which variant it is.

As I understand it, all of the A-1 and some of the A-2 chassis had a chopper type power supply. The rest of the A-2 and all of the A-3 used a series regulator supply. Initially, there were two different power transformers, first a chopper type and then a different one for the series supply. Later, there was a variant of the chopper transformer, just to confuse the issue.

So, during the life of this model there had been no less than three power transformers used in the various chassis. I had already tried two of the three so the next one would have to be third time lucky. Or so I thought.

When I asked the Service Manager to get me the third transformer on the list, he put on a very long face, and told me that it was no longer available. I was shown the national stock list, to prove that I was not being given the run-around. There were a few of the early types, and 64 of the later ones, but not a single one of the type I needed.

They refunded my payment for the original purchase, without question, but I was faced with the problem of telling my elderly customer that her set was a write-off. That is, unless I could find another transformer (or transformers) with the proper ratings to replace the faulty one.

At about this time, a colleague called in to the workshop and I told him my tale of woe. He sympathised with me, but then offered a way out of the dilemma.

It seems that he has access to a small professional coil winding machine, and with some care he should be able to re-wind the faulty transformer. There was nothing to be lost by trying, so I loaded the set and the transformer into his car and off he went.

I told him my tale of woe...

Two days later, he rang me to say that he could find nothing wrong with the transformer. It was consuming the correct current and was not getting as hot as I had implied.

All of this worried me somewhat, because it seemed that I had either neglected some test or misread the tests that I had made. So I hopped on my bike and hot-footed it over to his workshop (to mix a few metaphors).

He had instrumented the set in much the same way as I had done, but he added two other meters that I don't have. One was a power analyser, that can accurately determine the power being consumed by an appliance. The other meter was a temperature probe which he had inserted in the windings, in place of the original thermal fuse.

According to the set's specification plate, the total power consumption is 75 watts. In fact, it only reached this figure at switch on. As the degaussing current fell, the consumption dropped back to 50 watts and settled at that level.

As the set warmed up, the temperature in the transformer rose until it reached 50°C, at which point it stabilised. This is quite warm, but not as hot as it had once been, and certainly not too hot to touch.

Finally, my friend had used a 'megger' to measure the insulation resistance between the various windings on the transformer. All were in excess of 100 megohms, at 1000 volts. So the transformer had a clean bill of health.

Except that it still crackles when I squeeze it, just like an old burned up radio tranny.

The set is going back to its owner, complete with the old transformer, and I am not at all happy about the situation. Although we can't find anything wrong with the tranny, it has been badly abused and I cannot honestly guarantee its safety. If a new transformer was available it would be installed without any question.

The primary winding is now fitted with the recommended 750mA delayed action fuse, in place of the thermal type, but I see big question marks about how long it will last.

As I said at the beginning, this was one of those jobs where everybody tries hard, but nobody wins.

Where did the colour go?

My second story this month was rather more satisfying, although not without its share of puzzlement as well. It concerns an Hitachi CEP288 colour TV, and when I called at the customer's house in response to an urgent call, the lady simply said that "the colour's gone!". She didn't say where it had gone, so it was left to me to find out.

The first thing I noticed was that the set was tuned to channel 1, and there was a National video recorder on the shelf above it. For a moment I thought "Money for jam! All I have to do is to fine tune the set to the video". But it wasn't going to be that easy.

When I asked if the colour was missing from all channels, I was told that there was no colour at all; off-air direct, off-air via the video, or even off video tapes. So that settled it. I would have to delve into the chroma circuits, a part of colour television sets that I have never been totally comfortable with.

When I switched the set on, I had another brief moment of relief. The picture came up very much over-bright, with retrace lines, and for a moment I thought again that I had an easy job.

With many Japanese sets, an over-bright picture and retrace lines means

an open circuit bypass capacitor on the picture tube second anode supply rail. This is usually a 4.7 or 10 microfarad high voltage electrolytic, and they are unreliable beasts.

As it happens, the Hitachi has no equivalent capacitor – but it took me some time to realise that. Before then, I had decided that it wasn't going to be an A2 bypass, because in those cases, there are usually traces of near normal colour, and the brightness controls won't work.

In this Hitachi, the brightness control had a small measure of control over the picture. It was enough to remove the retrace lines, but still left a brilliant picture, with no trace of colour. Inside the set there was a 'sub-brightness' trimpot, and this yielded a little more control over the brightness.

This left the picture just a little brighter than normal, with the main control turned right down. And strangely, there was now a little hint of green in the picture. There was no red or blue, but the yellow bar held a small amount of green which could be turned up or down with the colour control.

I'd be chasing wild geese...

These symptoms were sufficiently different to the bypass capacitor problem to tell me that I'd be chasing wild geese if I went that way.

At this point I decided that the job would be better handled in the workshop. I've found that when faced with a difficult job, there is nothing less conducive to clear thought than to have the set's owner in the near vicinity.

Even if they make a deliberate effort to keep out of the way, they still watch the minutes tick by and brood on the mounting bill. Most come back every five minutes or so with the questions "Have you found it yet?" or "Do you want a cup of tea?". I can concentrate much better, and finish the job much sooner in the privacy of my own workshop.

And so it was with this set, although privacy did little to help sort out the problems.

My first move was to measure the voltages around the picture tube base. These all proved to be close to the values given in the manual, so that didn't help.

Then I went to the colour output transistors, TR15, TR16 and TR17, on the picture tube base board. Again, the

voltages were all about normal, considering the overbright picture.

The next voltage checks were at the colour driver transistors TR35, TR36 and TR37. Here the voltages were considerably out, being 13 volts on the collectors, instead of 9 volts, and only 0.1 volt on the bases, instead of 0.75 volt. Quite obviously, these transistors were not being turned on. The question that I had to answer was 'Why?'

I went carefully over the whole chroma board (incidentally, it's called the Power Board in this set!) and checked the voltages on all the other transistors in the video and chroma sections. All were within a few percent of their assigned values.

I was particularly interested in the voltages around TR28, the colour killer transistor. Any variation here might indicate that the killer was holding the colour off. Unfortunately, the circuit diagram gives two voltages on each element of the killer transistor, and I couldn't find any reference as to which one was which.

I tried to work out from the circuit diagram what would happen at each of the two voltages shown, and came to the opinion that the higher set were for normal operation, and the lower voltages were the killed condition.

If my guess was right, the killer in this set was not tripped and the colour should come through normally, as evidenced by the trace of green mentioned earlier. I shorted out the killer transistor and noticed that this removed the green – which seemed to prove my judgement.

But it was obvious that I wasn't going to find the fault so easily as with a simple voltage check. It was time to get the oscilloscope fired up and look at some of the waveforms.

The circuit diagram for the Hitachi CEP 288 does not carry many waveforms. Those that are shown would probably be enough if one was thoroughly familiar with chroma circuits in general, but I am not thoroughly familiar with them. I've probably been unlucky, in a way, that I've never had

I've probably been unlucky...

many of this kind of colour problem to practise on.

The first thing to look for was chroma at the delay line driver transistor. The waveform here was more or less what I would have expected, about 2 volts

peak to peak, although the normal value was not shown.

Next, following the delay line, the emitters of the B-Y and R-Y amplifiers showed slightly more than the specified voltage. Between these transistors and the colour drivers there were only the chroma demodulators, consisting of four diodes which bring in the sub-carrier from the oscillator on another board.

The scope showed me that the multivibrator that drives the PAL switch was working, and that the ident pulse that synchronises it was also present, at what appeared to be normal amplitude.

The only given waveform that wasn't exactly as per the diagram was that at Test Point 11. This is a sample of the sub-carrier after the 90° switch at the R-Y demodulator, and it was only a tiny fraction of the nominated 2V peak to peak. Yet at the collector of the 90°

It was there, but only just.

switch transistor there was a good, strong waveform of what appeared to be a normal amplitude.

So, if there was sub-carrier and chroma present at the demodulators, there should be a demodulated chroma at the input to the colour output drivers. And sure enough, at the base of the B-Y driver there was a classic on-off-on-off-on-off pattern of the blue colour bar signal.

At the R-Y driver the signal was nowhere near so clear cut. In fact it was barely recognisable as the on-on-off-off-on-on-off-off characteristic of the red signal. It was there, but only just. This was not really surprising, considering the lower than normal waveform at TP11.

If I'd had my brains plugged in properly, I would have found the fault in about two minutes flat from this point. As it happened, I still had an hour of poking about and worrying before I stumbled on the answer.

The one aspect of this whole exercise that had me flummoxed was why the output drivers were not turned on. They are a very conventional transistor amplifier, with un-bypassed emitters. Bias is supplied via 270k ohm resistors between base and collector, a simple system that works like magic in millions of common emitter amplifiers. But it wouldn't work in this set.

In fact, the standing bias on the drivers was only about 0.1 volt, half a volt less than that required to turn on

Serviceman

normal silicon transistors. I considered that the colour signals themselves might have been responsible for the additional bias, but this would have resulted in the loss of the bottom part of the chroma waveforms. Clearly, there had to be some source of bias other than the signals.

As I reflected on the problem with this set, I recalled that conventional transistor amplifiers usually have a pair of resistors forming a voltage divider to feed the base bias. In this circuit there did not seem to be any resistors to hold down the bases. Which meant that the base voltages should have been much closer to the collector voltages.

One thought led to another and I found myself wondering if, perhaps, the bases were returned to earth earlier on, in or near the actual signal source rather than via a separate grounding resistor.

The bias could not come from the R-Y and B-Y amplifiers, because the DC path was blocked by 33pF capacitors adjacent to the demodulator diodes. This meant that any earth return had to be through the diodes themselves.

The diodes, two in each channel,

were connected to opposite sides of the secondaries of the carrier injection transformers, T552 and T553.

The secondary of each transformer was centre-tapped, the taps were tied together and both were returned to the junction of R572 and R573, a voltage divider across the 12 volt rail. Here, then, was the source of some kind of bias for the output drivers. But if so, why was there no actual bias on these drivers – or at least insufficient to turn them on?

The ratio between these two resistors is approximately 10 to 1, so there should be about 1.2 volts on the transformer centre taps. In fact, there was nothing and a resistance check soon showed why. They measured only 9 ohms to earth, whereas the least possible figure should have been about 470 ohms.

At first I guessed that there might be a short in C574, a 22uF 16 volt electro which bypasses the bias supply. But after removing the cap the short was still there.

That was the answer to the whole problem.

The only other path was through the carrier injection transformers, so I removed these one at a time, and checked for the short after each removal. The first one, T552 feeding the B-Y demodulator made no difference to the short. But removing T553 was a different story. The short disappeared from both sides of the transformer and the bias on the B-Y output driver rose to 1.55V, close to the figure shown on the circuit diagram.

I tested the transformer on the bench, by 'ohming' its case to the secondary pins. Sure enough, it was just 9 ohms, the very figure that I had measured earlier on the bias divider.

That was the answer to the whole problem. Replace one tiny transformer and the job should be done. But I couldn't imagine where I was going to get the part. I felt that I would be very lucky to get one from Hitachi. They would be an uncommon spare part, even for a new set – and this one was thirteen years old!

I decided to try to open this one up, to see if the short was obvious enough to repair. I once had a similar short in an audio coil and had found a tiny piece of solder loose inside the can. This could be something similar.

The sides of the can had been

crimped onto the plastic base of the coil and it took considerable pressure to force the core out of the can. I was worried that I might have broken the ferrite core which would have upset the tuning of the coils. But I was lucky, and the core eventually came away.

When I examined the assembly under a high power magnifier, I could see no sign of a short. There were no bare wires and no bits of loose solder. And when I reassembled the transformer, there was no longer any sign of a short between the can and the secondary, either!

I don't know what had caused the trouble but removing the core from the can was enough to cure it.

I replaced the transformer and switched on. The bias on all the output drivers came up to 1.55 volts and I waited for some sort of picture to appear. Then I remembered that I had turned down the sub-brightness control, in an attempt to limit the brightness earlier on. Resetting this control resulted in a near perfect picture.

Just to prove the point, I grounded TP11 and had an instant replay – no colour, overbright picture and retrace lines. Originally, the short must have been on the end of the secondary winding remote from TP11 because there had been a trace of sub-carrier at that point, though not enough to properly demodulate the R-Y signal.

So that was it. I have no idea what it was inside the transformer that caused the short to ground. My guess is a tiny piece of solder, but it might really have been anything. It's certainly gone now and the set should be as good as gold for years to come. E

Available bi-monthly at your newsagent or subscribe now by phoning (02) 693-9517 or 693-9515.

THE MUSIC MAGAZINE

SONICS

f b  **MAGAZINE**
For:

**Musicians, Road Crews,
Recording Engineers,
Lighting People,
Managers, Promoters
and anybody interested
in what goes into
today's music-
making.**

**THE ALL AUSTRALIAN
MUSIC MAKERS'
MAGAZINE**

1 698

TETIA Fault of the Month

Sony KV1300-AS

SYMPTOM: UHF tuner won't work. Screen goes blank white, with no snow. Sound channel is alive but only hash audible.

CURE: Q212 (2SC1364) unserviceable. The transistor is one of five AGC amplifiers in this set and its failure applies excessive AGC to the tuner, effectively turning it off. The transistor checks OK but goes almost short circuit under load.

This information is supplied by courtesy of the Tasmanian branch of The Electronic Technicians' Institute of Australia. Contributions should be sent to J. Lawler, 16 Adina Street, Geilston Bay, Tas 7015.

 **National**
TQ Relay

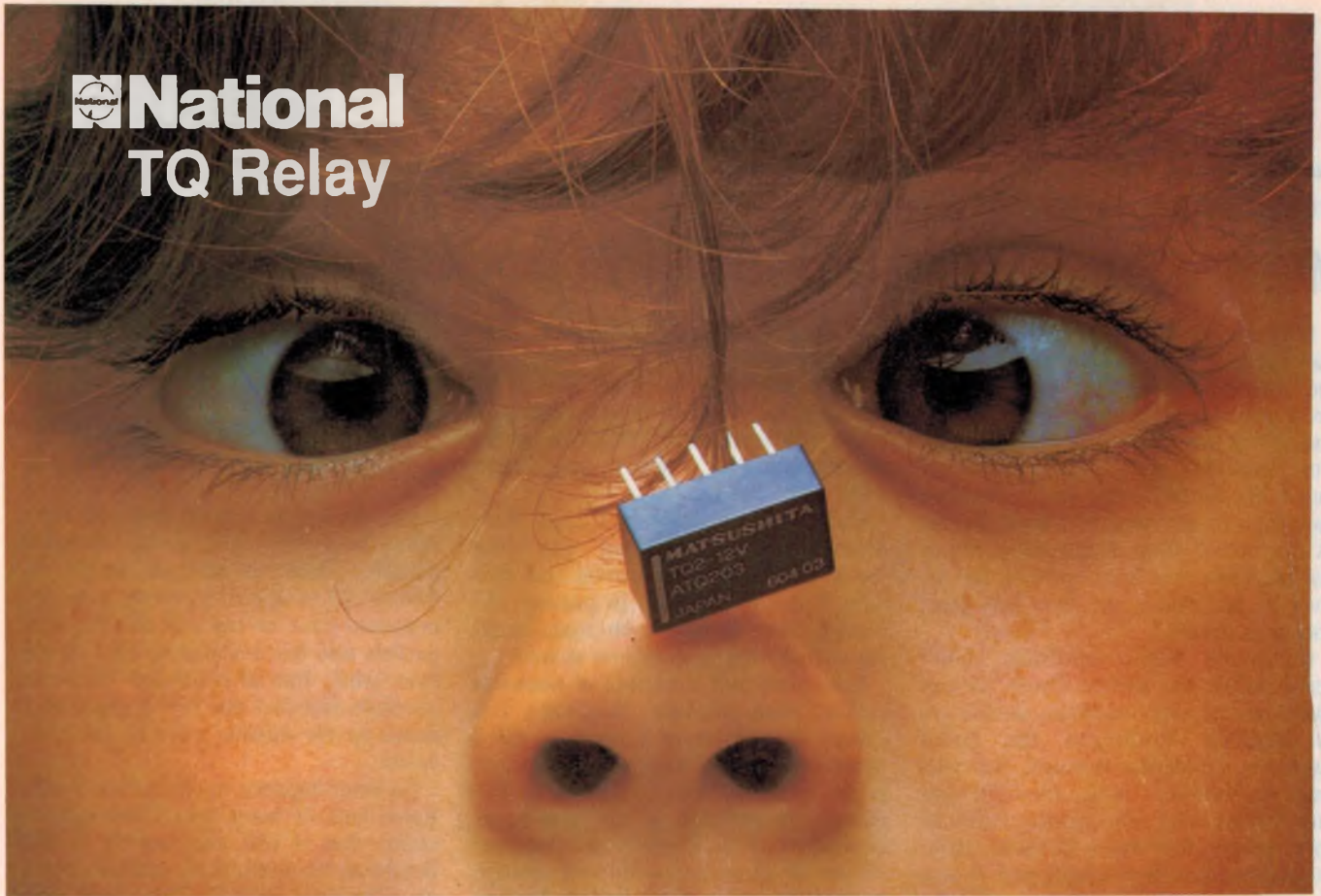

So Tiny....

Is this the world's smallest 2 Form C, sealed, DIL relay in volume production?

Only 5mm. high and weighing 1.5 gram. National's TQ relay sets new standards in small signal switching

Fast! How about 2msec. operate time?

Reliable! TQ's bifurcated gold clad contacts ensure it.

Powerful! 30Watt or 62.5 VA switching puts TQ streets ahead of any DIL reeds.

Sensitive! TQ requires a mere 140 milliwatts drive.

Design Flexibility! Single-side stable, latching, 2 °C/o or 4 °C/o: - DC to 900Mhz, microvolts to 125Volts - Anywhere you need fast, reliable small signal switching TQ is the answer.

Economical! For around \$3.80 ea. at 500 pcs there isn't a relay made that can match TQ spec. for spec., dollar for dollar.

RVB

PRODUCTS PTY LTD

MELBOURNE
242 Huntingdale Road,
Huntingdale Vic. 3166,
Tel: (03) 543 1611
Fax: (03) 543 7747

SYDNEY
Shop 6 SPECTRUM,
220 Pacific Highway,
Crows Nest N.S.W.2065
Tel: (02) 957 6385
Fax: (02) 929 5334

RVB - MORE REASONS TO CALL

Frankly Frank

Musings on matters electronic by FRANK LINTON-SIMPKINS

Where have all the neutrinos gone?

Back in 1604 when the Virgin Queen was coming to the end of her time on the throne of England, one Joachim Frederick was Margrave of Brandenburg and it was still two years until the first European to sight Australia would make his landfall, the last supernova happened in our neighbourhood. So far as we can tell from a diligent search of the literature, no one reported the arrival of neutrinos, not even the great Johannes Kepler.

Good old Kepler probably didn't really accept the ancient Greek idea of the atom, let alone anything smaller, so he possibly overlooked the errant neutrinos wandering through. But perhaps we shouldn't judge the 17th century astronomers too harshly. After all good queen Bess was a devoted visitor to astrologers, often lengthened people in dungeons and passed laws against the practice of witchcraft – as if it existed.

Since good queen Bess's day right down to our own, astronomers and physicists have been without a supernova in the neighbourhood to study. This hasn't stopped them forming theories of many kinds, but recently they have generally come to accept the line that before the final rather exhibitionist flash the supernova's parent first collapses its core to an object only about 20 kilometres across and extremely dense. This emits streams of neutrinos. It is that horrible object a neutron star, so why not?

Then some 19 hours later there is a titanic explosion that emits light. Thus before the light from the explosion reaches us, we really ought to be able to detect a few of the neutrinos.

In the 380 plus years since the last local supernova, the scientists have not been sitting on their hands. No indeed. In both the US and Japan they have built neutrino detectors, to find and count the neutrinos from the next supernova event to occur.

I have few details of the Japanese detector, but the US one involves a tank of water located in an abandoned salt mine near Cleveland, which I think is also abandoned. The water tank isn't small: it weighs 8,960 tonnes, give or take a few kilograms. You could bet

that the Japanese one would be about the same size.

The Italians have a similar sort of detector in an old rail tunnel in the alps, but it has around 100,000 litres of dry cleaning fluid in it and I don't know what it detects.

The problem is that you can't really detect a neutrino, you can only detect the after-effects of its arrival and then only if it hits a proton in passing. Although there is now even some doubt about that form of detection as well.

If all goes well a number of neutrinos collide with protons head-on. This causes the release of a positron and a neutron. You can forget the neutron, it is the positron that is the thing that counts. A positron is the anti-matter equivalent of the electron and it dashes off in all directions with vast energy, causing the water in the tank to become excited and to give off Cerenkov radiations – i.e., a flash of light. And since the sides of the tank are packed with phototubes, these light flashes are detected providing prima facie evidence of the arrival of a neutrino.

After waiting a mere 383 years, the prayers of the more devout astrophysicists were answered on February 23rd in 1987 as the light from Supernova 1987A, a relatively local event, arrived on earth. A search of the records made at the Cleveland water tank yielded the information that some 19 hours earlier, a few neutrinos had in fact arrived at almost the perfect time for the theory. Between them the Japanese and American detectors recorded 19 events that implied the arrival of neutrinos from the Supernova 1987A.

The astrophysicists at first went into total orgasmic withdrawal from the real world, while the rest of us ignored them as usual.

Then various people began to express doubts. There were moves to burn the doubters at the stake in the grounds of the Royal Observatory, but the doubters really seemed to have a point.

It seems that 17 of the neutrino detections seemed to have a directional bias, that neutrinos shouldn't have. It began to look as if the big tanks had found either another strange particle, or the

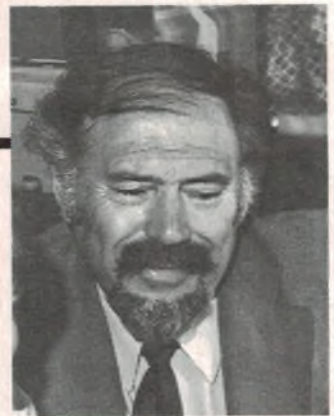

statistical gods had decided to have a joke.

The strange new particle theory currently holds the field, as the detected particles seem to have a weight of 0.00000002 of that of a proton, whereas neutrinos have no mass at all. The new particle also has a charge of 20eV (electron volts). But all is not lost, as some scientists feel that this new particle may make up the missing mass of the Universe.

So what happens to the nearly 9,000-tonne tank of water near Cleveland? It seems that it will wait quietly in the depths of the earth until another supernova happens nearby. This could take 383 years or it could happen tomorrow.

But supposing no supernova happens and sometime around the year 3000 an archeologist, one only hopes he or she is human, comes across the 8,960 tonne tank. Can you imagine them trying to explain what a gigantic container of almost nothing but some totally corroded electronic gear is, and what those funny Clevelanders used it for?

I can hear the conversation now, with perfect clairaudience.

"Hey Ztxyll, mate, come over and look at this ferrous tank thing. What do you make of it, these poor sods must have been driven mad by the pollution!"

"Beats me Zgglyl, I suppose it could have been an underground water cistern in case of attack by strange tribes."

"No Ztxyll, don't take the mickey out of your cousin and commanding officer. See those things jutting out from the walls – they must have been to induce turbulent flow in the fluid it obviously contained. It was obviously a giant massage bath, and from this we can deduce that the ancient inhabitants of Cleveland lived underground and were ten metres long."

Naturally the better archeologists don't go on like that and we can assume

continued on page 159

RAE The Top Performer for Quality and Reliability



seeq

SEEQ'S 512-KBIT FLASH™ EEPROMs

New host-interface features, 12-V programming, and a 1.5µm CMOS process are being combined by SEEQ Technology Inc. to launch a new line of FLASH™ electrically erasable programmable read-only memories.

They offer easy in-system programming and high bit-packing densities. The single-transistor cell-based FLASH memories also erase 30 times faster than conventional EEPROMs.

The 32-pin, 512-Kbit 48F512 becomes the first CMOS FLASH memory tailored for in-circuit programming with 12-V power supplies. It is also now the densest EEPROM chip being sold in a 64-K-by-8-bit organization.

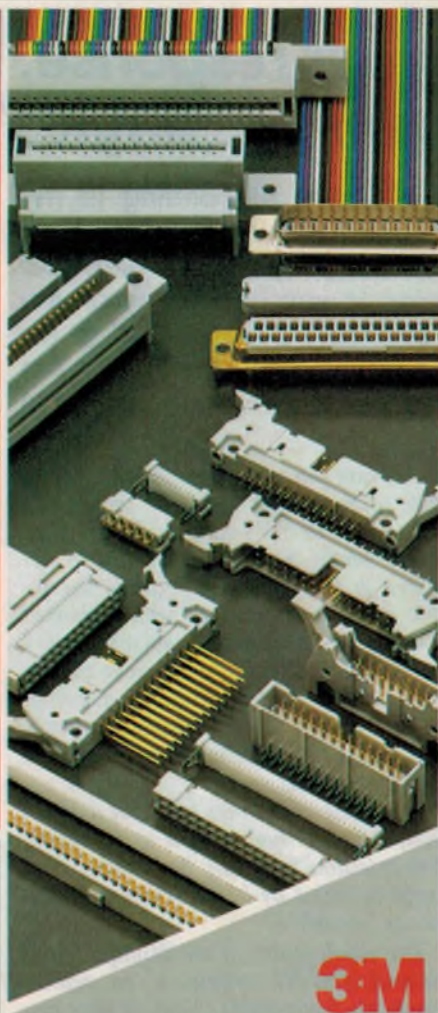

3M

CLICK PLUG CONNECTORS OUTPERFORMS THE OTHERS

Scotchflex Click Plug Connectors provide mating compatibility with Standard socket connectors on 2.54mm x 2.54mm grid spacing. Design applications include use as a T-tap from a cable buss, a splice connector, or I/O interface. Durable sidewall construction adds ruggedness for I/O and external interconnect applications. Use of the Polarizing Key 3518-J and Scotchflex Socket Connectors permits easy polarization without pin sacrifice.

Ejector/Latch Clip is attached to Click Plug Connectors and you can easily withdraw Socket, and locking mechanism is also available. Connectors are available with or without mounting flanges.



micronel

THE NAME FOR MINIATURE FANS

MICRONEL miniature fans are in service all over the world. Mounted in equipment used in space, installed in precision miniature equipment, in medical and optical apparatus MICRONEL miniature fans are demonstrating their dependability. High air delivery with fans of minute dimensions is the result of well designed engineering.

MICRONEL is the only manufacturer in the world with such a complete range of miniature fans (from 24mm diameter up). Twenty years of experience are behind a great programme that includes more than 200 different types; one of them is the answer to your engineering problem.

RAE

NSW: 62 Moore St., Austinmer, N.S.W. 2514 PH: (02) 232 6933, (042) 67 3722 Fax: (042) 67 4791
 NSW: 178 Pacific Highway, St. Leonards, N.S.W. 2065 Ph: (02) 439 7599 Fax: (02) 439 3962
 VIC: Alexander Chambers, 9 Alexander St., Mt. Waverley, Vic. 3149 Ph: (03) 807 4033 Fax: (03) 807 7025
 WA: Suite 1, 6 Leigh St., Victoria Park, W.A. 6100 Ph: (09) 470 2702 Fax: (09) 361 9990



Circuit symbols - your response, and further comment on 'tingles'

Judging by the letters that have rolled in responding to my October column on circuit symbols and our use or misuse of them in *EA*, it's a subject that can certainly arouse plenty of interest. And it's been very gratifying to see how many of you support our position. After those brickbats that seemed to arrive with every second letter for a few months back near the end of last year, it sure is nice to get a few bouquets for a change!

For a while there, the critical letters seemed to be coming in so frequently that I was beginning to feel a bit persecuted. At least, criticism seemed to be becoming the order of the day – like having the mickey taken out of me every month in Bee Jay's cartoons. They were both a bit like having to take medicine: not all that pleasant to take, perhaps, but presumably necessary for the improvement of my character!

When a pile of supportive letters turned up, I have to confess I was a bit nonplussed. Support? Compliments? How do you cope with those? I felt a bit like Walt Disney's Goofy, when for once he wasn't being criticised for clumsiness and awkwardness: all he could do was blush, and mumble 'Gawsh' and 'Shucks'.

To paraphrase that old Russian saying, perhaps there's only one thing harder to take than criticism, and that's being complimented...

Anyway, enough of this blather. Hopefully Bee Jay will bring me well and truly down to earth this month, with an especially cruel cartoon. (Go it mate – I probably deserve it!)

Actually quite a few of the letters raise interesting points, and I'd like to quote from them. But before I do so, I'd better deal with a couple of letters that came in just before those on circuit symbols, in response to an earlier column in the August issue, on electrical appliances that give a 'tingle'.

The first of these was from a Mr Vern Talbot, of Hamilton in New Zealand. And Mr Talbot wasn't at all impressed by some aspects of the column concerned, as you can see for yourself:

I was shocked (sic) to read your Aug-

ust Forum on appliance safety. I can only presume that some of the smoke damage got to EA's editorial brain.

The whole thrust of your article appeared to be that it was perfectly acceptable to have appliances which showed 35V AC on exposed metalwork, and I am finding it difficult to reconcile this attitude with your recent articles questioning the use of 'double insulated' amplifiers in audio applications, which need shielding earths.

Surely the consumers who got a shock from their TV had a right to complain. The question may not be whether they could be killed by it, but whether the device is 'useable'.

The whole point of the Multiple Earth Neutral (MEN) system is to remove potentials from earths, both as user protection and for efficiency in transmission of power. Surely, if a double insulated appliance is going to have exposed metalwork, it should be isolated from anything which develops potentials to earth or can be connected to phase. Your diagram (August Fig.1) provides a direct path to phase via the suppressor capacitors (irrespective of the ability of the capacitors to break down). In MEN terms, an earthed appliance which developed 25V on its earthed case would be losing more than 10% of its useable mains voltage in the cable. I suggest that 25V is far too high a voltage to tolerate on any appliance, double insulated or not.

Imagine the use of appliances with up to 35V AC peak on their cases. A floor polisher with a metal handle, and orbital sander being used to strip a car using wet paper. These devices simply would not be used if their operators were con-

sistently belted, no matter how small the voltage.

The choice of 50k as a 'load' is interesting. Presumably this was chosen as an approximation of the impedance of an average human to earth. Does this mean that if two humans held hands while using an appliance, they could expect to provide half the impedance, and receive twice the belt? The mind boggles.

Perhaps your tongue is firmly in its cheek, but suggesting that consumers should be told to tolerate 'tingles' from their appliances is absolute rubbish.

Cop that! Mr Talbot was mightily displeased with what he read in the column, of that there is little doubt. What isn't so clear is with whom or what he's really arguing.

From the references to smoke damage and the condition of editorial grey matter, it seems likely that he believed he was having a go at me. But I suspect that in many ways he's really having a go at the SAA.

Apart from anything else, his main gripe seems to be with the specification that appliances which produce a leakage voltage of 35V AC peak or less across 50k test resistor are 'safe'. And I certainly didn't dream that specification myself – I was merely quoting from the relevant SAA specification.

Presumably by now, most readers of this column will know that I'm anything but an uncritical apologist for the SAA. Far from it; sometimes I probably go a bit overboard in the opposite direction, because one of my pet hates is authoritarianism. And the good old SAA certainly seems to display generous lashings of that particular quality, from time to time.

From this you might expect that I'd welcome any criticism of an SAA specification, and seek to disassociate myself from it. 'Tain't necessarily so, though, and as it happens not in this particular case. Broadly speaking I find myself in agreement with this particular SAA specification, although there are a few worrying grey areas.

(Jim Rowe actually agreeing with the

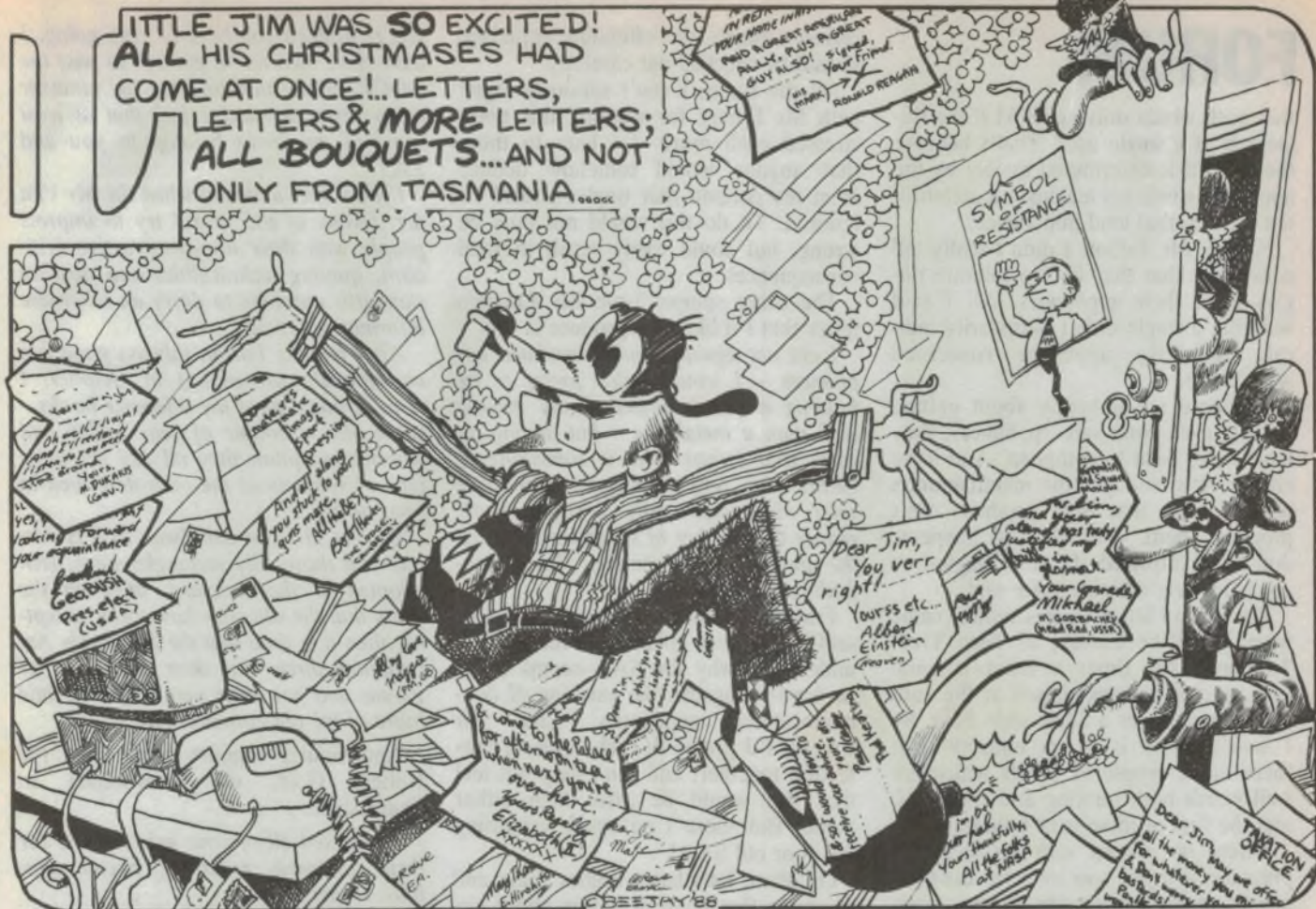

SAA about something? Perhaps Mr Talbot is right – all that smoke might have affected me, after all!)

Basically the thrust of my original piece on this subject was that the exposed metalwork of many double-insulated appliances will produce a 'tingle' under certain circumstances, because of things like internal coupling capacitance. Fact number one. And that this can happen even with appliances that are by all normal criteria perfectly 'safe', in that they can't deliver a leakage current which is capable of causing injury or death in any likely circumstances. Fact number two.

Needless to say, I stressed that any device which delivered a 'tingle' should be tested with all urgency, to ensure that it was indeed safe within the accepted meaning of that term. Because a tingle might well also be a warning that the appliance has developed a dangerous leakage, and is lethal.

Now it happens that if you simply check even a 'safe' appliance with a typical modern high-impedance voltmeter, you'll frequently get a very high voltage reading between the exposed metalwork and mains earth. But that may be just because the meter is presenting an impedance very much

higher than a human body. Fact number three.

So the SAA came up with a way to make the measurement more able to distinguish between 'safe' and 'unsafe' appliances, by using a 50k resistor as a load impedance. And it suggested that if the leakage current able to flow through such a resistor was less than 0.7mA peak or 0.5mA RMS, then the appliance could be regarded as 'safe'. Any more than that figure, and it was 'unsafe'. The alternate voltage figures of 35V peak or 25V RMS were simply derived from the current figures by Ohm's Law.

Perhaps we can argue about the exact current and voltage levels chosen as the borderline between 'safe' and 'unsafe', but apart from that I still don't have any real quibble with the SAA on this point. The idea of using a load resistor seems quite sensible, because it does make the test more meaningful.

What Mr Talbot seems to be saying is that the SAA and I are both wrong to accept 35V peak/25V RMS as an acceptable level for the leakage measurement, because it can still result in a 'tingle' (or as he prefers to call it, a 'belt') being delivered in certain circumstances. Fair enough, I suppose.

It would be nice if no appliance ever delivered even a faint tingle in any circumstances, to be sure. And in a perfect world, I'm sure that would be the case. Tingles are certainly disconcerting and worrying. But I'm not sure that in the real world it's possible to prevent them from occurring, without paying a price that many people might find unacceptable.

By the way, the kinds of appliance that seem to produce most of these tingles in practice are things like TV sets and other home electronic gear, not tools like orbital sanders and drills, or cleaning tools like floor polishers. I fully agree that for the latter to deliver a tingle would be unacceptable, even if they are nominally safe.

Luckily it seems easier to make these appliances 'tingle free' than with much electronic gear. Or is it just that there's greater pressure on the manufacturers to do so?

Where Mr Talbot is a bit off the mark is his suggestion that if two people held hands while using an appliance, they'd receive twice the 'belt' because of the halved load impedance. With a safe appliance, the two load paths in parallel would share the potential leakage current in roughly equal proportions, so

FORUM

that each would only get HALF the tingle/belt of a single user. That's because the current is determined mainly by the appliance's internal leakage capacitance, not the external load impedance.

Finally, Mr Talbot, I didn't really tell consumers that they had to tolerate tingles from their appliances. All I said was that a tingle didn't necessarily indicate that the appliance concerned wasn't safe.

If people are unhappy about getting tingles, even from safe appliances, they have every right to complain. And if we all complain enough, the manufacturers might ensure that their products can't produce them. But if this happens, don't be surprised if those tingle-free products have a higher price tag!

The second letter on this subject came from Mr Mike Emery, of Fern Tree, Tasmania. Mr Emery's letter is quite long, and as he says himself at the end, it does stray over a fairly wide field. So I won't quote it in its entirety. But there are a couple of points which are well worth both quoting and comment, and the first of these is as follows:

I have no quarrel with the facts you presented – a few tens or even hundreds of microamps is not going to cause harm – but I feel very uneasy about promoting the idea that appliances which are fault-free can produce 'tingles' and that it may be reasonable to ignore them. I have come across so many examples of earth wires left disconnected 'because it still works without it', and of home-wired extension cords 'you keep trying connections until they work', not to mention correctly wired appliances that have not been maintained correctly.

If the users of these appliances are unlucky, they're dead. But with a little bit of good fortune, their first warning is a 'tingle' – of one magnitude or another – and that is usually heeded.

I agree completely, Mr Emery. A tingle should never be ignored. It should always be taken as a possible warning that the appliance may be unsafe and dangerous. And the appliance concerned should be tested as soon as possible. But as it happens, I did stress this in the original column.

The main thrust of the column was certainly that even 'safe' appliances can produce tingles, and that they don't necessarily indicate a dangerous leakage. But I pointed out in a number of places that a tingle could equally indicate danger, and right at the end of the column I stressed that if someone re-

ceived a tingle, the offending appliance should be checked out carefully.

All the same, I can't seriously argue with Mr Emery for wanting this point stressed even more. I'd hate to think that anyone would somehow deduce from my column that tingles should be ignored. To do this would not only be wrong, but could easily result in fatal consequences.

The other snippet from Mr Emery's letter that I'd like to reproduce is this:

I am not against double insulated appliances – I would much prefer to be holding a plastic-bodied faulty electric drill than a metal one – but adding an earth lead (when there is something to earth) can only make the appliance safer. More importantly, it would greatly reduce the number of situations in which the public receive 'tingles' from non-faulty appliances.

Frankly I'm inclined to agree. As I've said in previous columns, I really can't understand why the SAA seems to be so dead-set against the earthing of double-insulated appliances. Like Mr Emery, I'd prefer BOTH forms of protection together, and can't help but feel that this would be safer than either alone. But there I go again, criticising the poor old SAA!

OK then, let's leave tingles again and return to that heap of letters about circuit symbols. Not from a desire to wallow in praise and congratulations, but because quite a few of the letters raise aspects which I either didn't think to mention in my own October column, or didn't give sufficient emphasis. Or alternatively because they simply make enjoyable reading...

To set the ball rolling, and in the latter category, here's a very pithy little note from Mr P.W. Bell of Glenorchy, Tasmania:

Regarding 'Forum' in the October 1988 issue, your two complainants should both take a long walk off a short pier. There is nothing wrong with the electrical and electronic symbols used by EA. At least they make sense, which is more than can be said about the SAA symbols.

In similar vein came another letter from Tasmania, from Mr D.C. Logan of Lenah Valley in Hobart:

Let me start by saying thanks to Neville Williams and yourself for the years that you have spent bringing information (in easy to understand language) to people like me. I first got interested in electronics after reading your book 'Basic Electronics' some years ago, and as you once said in an article, once

you're hooked you have to keep going. I have since then learnt enough to pass the AOCPE exam and become an amateur radio operator, and I feel that at least some of the credit belongs to you and EA.

I feel rather annoyed when the Mr Van der Zwans of this world try to impress people with their non-constructive criticism, quoting technicalities and obscure standards numbers to decry an otherwise informative article.

After reading Forum (always good fun and thought provoking) in October, I went through all of my reference books – some only a couple of years old – and without exception they all use the same type of symbols as the ones described in your article.

If what Mr Van der Zwan says is correct and those silly rectangles have been adopted as the standard, after all the years that the old type have been accepted, then it is time that the Standards Association threw out their Mr Van der Zwans and got some people with a little more of the old commonsense.

And similar support came from Mr Robert Gott, of Toowoomba in Queensland:

You asked all of your avid readers for their comments regarding circuit symbols, so here goes.

I am resoundingly in favour of the 'old' symbols as used by EA. In my youth, I taught myself from Newnes publications before entering the RAF as an apprentice in 1952. The 'old' symbols were then – and now – very simple and easy to follow.

In the early 1960's in England I had my first brush (run-in) with circuits in Swedish and German, relating to audio and intercom equipment. I hated them! It took hours to figure out something which would have taken minutes with an English circuit – to the client's ultimate cost!

Since emigrating to Australia in 1970 I have always been impressed by the extreme clarity of EA's circuits. For example the Powermate II circuit on page 67 of the October issue (which I am building) is particularly clear, with no cross-overs. But even the Electronic Doorbell circuit on page 77 is quite clear, thanks to the use of 'loops' where crossovers are involved. With somewhat reduced eyesight I really appreciate these crossover loops.

So don't change anything, please.

The importance of clarity and self-evidence of the symbols used in circuits was also raised by Mr Nathan Littel, of Bellpark in Victoria:



Further to last month's discussion of oxygen-free cable (OFC), I note that Arista Electronics is marketing a broad range of OFC speaker cables. Many are plated in 99.97% pure silver, and they come in various grades and physical configurations.

On the subject of standards for circuit diagrams, I don't know what magazines your two critics have been reading, because every electronics magazine I've ever seen, including EA, uses the so-called 'naughty' symbols to illustrate circuits. Your article on how to read schematics points out that most of the symbols used in EA (perhaps all) relate to what that particular component actually does. I agree that this is most sensible, and will help newcomers to electronics get a grasp on it.

I fail to see how all those rectangles have any relation to electronics at all. Perhaps the person who invented these symbols sits in a square office with a square desk, and therefore has a square outlook?

On a slightly different tack came a letter from design engineer Mr Andrew Pierson, of Salisbury Park in South Australia. As you can see, Mr Pierson makes some interesting points about what makes both a good symbol and a standard:

I'd like you to know that I completely support you in the stand you have taken on circuit symbols.

The first electronic circuit symbols which I encountered were in 'Radio and Hobbies'. They were eminently suitable for the purpose because they clearly represented the FUNCTION of each individual component.

Since then I've drawn an awful lot of circuit diagrams! Whilst I've adapted some ideas from IEC standards, the traditional symbols have stood the test of

time. As you quite correctly point out, most other publishers think so as well.

I can trace the use of IEC-type symbols back as far as 1954 in German literature. If, by the process of 'natural selection', their use hasn't become general in 34 years, there must be a very good reason why!

I don't see why Electronics Australia should be 'blackmailed' into the use of IEC symbols. In recent years, a correspondent wrote to a well-known computing magazine in the US, complaining that their published computer programs were 'unstructured'. As a teacher of computing science, he claimed that this approach was misleading his students, and as a result he was no longer going to recommend the magazine. The magazine's answer was that their approach was fundamentally RECREATIONAL, and that the use of structured programming was unnecessary.

I think the same argument could be used by Electronics Australia. Readers don't want to be saddled with unnecessary 'standards' that don't achieve anything. The argument that students will be confused when they later encounter IEC symbols is pretty weak. If they've learnt anything about electronics at all, most of the substitutions will be quite obvious.

If a genuine mistake has been made in an article, both the author and the editor would want to know about it. I could be wrong, but it seems that nit-picker's names don't appear very often as authors. If these people realised the large amount of work that goes into preparation of even a simple article, and the

high potential for errors that can exist in spite of meticulous checking, they would temper their criticism with the thought that 'There but for the grace of God, go I'. Maybe they too could take some advice from John 8:7!

So keep up the good fight, Jim. I'm sure that most readers feel as I do!

Thanks, Andrew. Your point about the IEC symbols having been around for 34-odd years is a pretty telling one, isn't it? If they're still not all that popular with a large segment of the electronics world (and they're not), this does suggest that they're lacking something as a potential standard. Standards really should be good enough to stand the test of time and practice, after all.

I note that at least someone recognised the significance of my biblical reference, too!

Another interesting letter came from H.J.S. of Ayr, Queensland, who wrote as follows:

I would like to offer my support in regards to your statements made in 'Forum' for October 1988, re circuit symbols. I do not agree with either of the writers in the article, who seem to be stating that because THEY have devised a 'standard' and THEY agree with it, THEY think WE should go along with it!

It does not seem to matter to these gents that their standard may not be very good, i.e., readable, or may not be very popular in either Australia or the USA. A resistor drawn as a zig-zag is instantly

Meter Milestones

Digital Auto-range Multimeter



Only
\$119

The hand held HC779 is a "budget priced DMM that packs in features normally reserved for higher priced meters" – *ETI* August '88.

Electronic Analog FET Multimeter



Only
\$79

The HC5050 is an extra rugged, safety designed, Fuse and FET protected meter with a quick reacting analog dial.

"combines the high input impedance and low circuit loading of an electronic instrument with the flexibility of a multimeter."

Electronics Australia, September '88

Digital Capacitance Meter

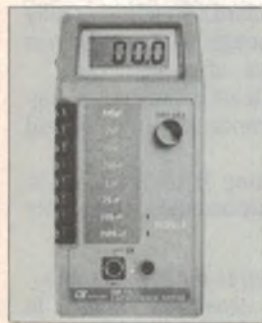

Only
\$149

The DM6023 is an easy to use and highly accurate service instrument designed to measure capacitor values from 0.1pF to 20,000μF

A host of other meters, components, tools, audio and video parts are available from

Wagner Electronics
305 Liverpool Rd
Ashfield, NSW 2131
Ph (02) 798 9233
Fax (02) 799 7051



TRADE ENQUIRIES WELCOME

FORUM

recognisable, as are most of the other symbols used by EA and others. And it is my opinion that a circle around a transistor is an absolute MUST.

The energy expended by these two fellows in arguing that because Telecom and other Australian government departments agree with the European standard, all Australia should too, may be better directed in trying to compel the Europeans to accept Australia's initial standard of symbols as used by EA – instead of meekly adhering to the Europeans!

I don't for a minute think that ALL of EA's symbols are perfect – and I don't think that you, Mr Editor, are dogmatic about it either. However if there is a need for change, let it be for the better, not for the worse. After all, EA changed quite readily when the standard unit for frequency became the 'hertz', instead of 'cycles per second'. I remember quite a few people kicked up a bit of a stink about that, but EA argued FOR, because of the ambiguity of 'cycles'.

I wish there was a universally accepted standard for symbols, and I hope that sometime there will be. But until the people who devise these standards, such as Mr Van der Zwan, realise that a standard must be good, it must be meaningful, and most importantly, it must be ACCEPTABLE by all who use it, it will NOT be a standard.

Putting something in a book and calling it a standard does not make it acceptable. If people don't like it, they won't use it.

I couldn't have put that any better myself, H.J.S. – thanks for your comments. Frankly I'm more than ever inclined to think that the IEC/SAA symbols were decided upon almost entirely by either administrators or draftspeople, not technical electronics people or people who were concerned with the communications ability of the symbols. That quality certainly seems to have been rather low on the list of selection criteria, well below things like 'tidyness' and 'speed of drawing'.

This basic idea was also explored in a letter from our old friend Ian Page, of Mangawhai in New Zealand:

I read your article in the October issue on the subject of standards compliance. International and local standards are useful for manufacturers and suppliers of equipment, to enable them to ensure that their products will meet the requirements of the user, and to enable scientific comparisons to be made internationally.

When it comes to portraying circuitry, surely it is a matter of making certain that diagrams are clear and easily understood by all. As well, there is a certain artistry in producing a diagram which, as well as being easily read, actually brings up a mental image of the components, without having to think about the meaning of the symbol.

The international symbols for electronic components leave a lot to be desired in this respect, and to my mind look horrible. In any case, it is not likely that anyone would be unable to identify easily symbols which have been in use over many years, and moreover – as you point out – are still in use by half the world. Because these symbols ARE able to convey their function.

Standard symbols were produced to reduce the drafting effort and time needed to produce a diagram which would be understandable internationally. But in my opinion they are not as clearly identifiable as those which have been used and understood by most over many years.

As it stands, with the symbols as used by EA and numerous other publications, it is possible to quickly assess the function of the circuit, the type and number of principal components and so on. With the standard symbols it is not so easy, nor so interesting.

I very much hope that you will not be pressured into adopting the standardised system by one or two letters from people who may, for all we know, be closely connected with the SAA.

Thanks, Ian. It certainly does seem that drafting speed and efficiency were major considerations when those 'standard' symbols were chosen. Plus that characteristic of being internationally acceptable – which somehow seems to have resulted in a set of symbols which are so arbitrary and bland as to be equally unhelpful to all people, whichever their country of residence!

To continue, one of the few correspondents to defend the IEC/SAA symbols was another of our old friends, Brian Byrne of Indooroopilly in Queensland. Brian wrote:

Well, here we go again. Let me start by saying you are both right – sort of. Perhaps I could reiterate a statement I wrote to John Moyle, then editor of 'R & H', about 30 years ago. This was to the effect that the R & H (and now EA) draftsmanship and circuit schematicism was among the most understandable (and acceptable) in the world. It still is, so keep up your philosophy as stated in the October issue.

However having said that, I must lean

a bit the other way. As a member of a dozen or so standards committees, I am acutely aware that Standards must be. We live in an era of world trade. Try negotiating without common understanding, and 'caveat emptor' becomes a nightmare. Also, like it or not, Europe and the USA are big brother(s). We do have to follow many of their precepts, or be left out in the trade, economic and technological cold. Time often proves them right, though – remember even little things like adopting 'Hertz' from Europe, instead of 'cycles per second'.

Now, back to the other side (the good guys?). Standards are not infallible, nor are they all correct. Nor are the IEC, the ISO, DIN and the rest always perfect. The current SAA Addendum No.6 (for 1988) lists a couple of hundred new or AMENDED standards! Horse designing committees sure can produce a few camels...

The real determinant of correctness of Standards is the public marketplace, with or without the legislators' backing.

Also SAA committees do not slavishly follow the IEC (or others) at any price, I can assure you. I could list quite a few cases where the Australian scene has dictated otherwise, and rather bitter argument has ensued for months, culminating in the SAA not following the overseas standard.

But let's get back to the graphical symbols business. My impression is that you are in business to survive as a producer of a quality electronics magazine. What do the customers WANT? Among other things, easy to understand circuit representation. You do this now – continue to do it.

A final comment on the subject from me at least. The present graphical symbols were thrust upon us a decade or two ago, with the rationale that they were much cheaper to produce, drafting wise. Even at the time this appeared to me to be a case of the tail wagging the dog.

Now, with scribes (computer-driven drafting pens) and CAD systems generally, there is no cost difference in drawing rectangles, zig-zags or even orthorhombic pinacoids. The inference is – let the marketplace decide.

Thanks for the comments, Brian. Your point about the need for standards to facilitate international trade and understanding is a good one in principle. But the funny thing about the SAA/IEC circuit symbols is that they really aren't used by the countries which lead the world in electronics, like the USA and Japan. Nor by those from which we buy most of our electronics goods, like

Hong Kong, Taiwan and Korea. They're mainly used in countries like Germany and France, from which we buy relatively little electronics.

In fact when you come to think of it, the main countries which are really keen on the SAA/IEC symbols seem to be those which are *not* all that good at manufacturing and exporting electronics, while the countries which are good at electronics seem to avoid them like the plague. Perhaps there's a moral there, somewhere.

Could it be that our 'preposterous' old-fashioned symbols, with their 'naive' representation of component function, might actually help people understand, design, make and export electronics?

To end up this month, the last letter I'd like to quote from is one that gave me a lot of enjoyment when I read it. The letter is from Mr Keith Walters of Brighton in Queensland, and although it's too long to quote fully, here are some edited highlights for your enjoyment:

I really enjoyed reading 'Forum' in the October issue. Your two correspondents are flogging a horse that's not just dead – it's long since been cut up, processed, canned, sold, fed to dogs and now mainly contaminating people's footpaths (hopefully your correspondents').

I can well remember many years ago, somebody else writing to EA and bringing up the very same subject. As I recall he said something like 'The Europeans are WAY AHEAD OF US in circuit drafting techniques...'

Nothing annoys me more than that sort of throwaway statement, completely unsupported and hanging in mid-air like Bondy's blimp. No breathless details of the idyllic lifestyle enjoyed by our European counterparts, made possible by the simple expedient of converting to a lot of incomprehensible rectangles; just a vague implication that they're somehow better off, as we could be too, if we were half as smart as the person making the assertion!

Obviously whoever conducted 'Forum' at the time (I think it was Neville Williams) thought much the same way, as his response was similar to your own.

I had to laugh about your references to 'potty training'. I used to make exactly the same claim about a former colleague who had very rigid ideas about how circuits should be drawn. I firmly supported the idea of little 'bridges' to represent wires crossing but not connected, and 'blobs' to indicate where wires were joined. He claimed that the little 'humps' were obscene (I still wonder what they

symbolised for him...).

When you're presenting circuits for the consumption of enthusiasts who aren't necessarily full-time technical people, it's important that they be drawn as unambiguously as possible – even if it does mean more work for the draftsman! And as far as I'm concerned, anyone with the IQ of a retarded petrol bowser should be able to deduce that a little 'hump' means not connected, while a dot (suggesting a soldered joint) means they're connected. In fact it's hard to imagine that they could be seen to mean anything else, which is not the case with other standards.

Whether people favour one system or the other seems to depend on whether they get more satisfaction out of imparting knowledge, or being seen as knowledgeable. An inscrutable practitioner of the mysterious art of 'black electronics', perhaps?

Of course there are many fields in electronics where people have taken it upon themselves to lay down 'standards' and castigate anyone who disagrees with them. The computer and audio industries are two obvious examples – but I'd be opening a real economy-sized can of worms if I got into a discussion of them.

Basically, standards have a way of finding their own level. They follow the law of survival of the fittest, in a way that Darwin would have approved. Official or not, if a standard is not wanted, it will eventually shrivel up and die. Don't call us, SAA, we'll call you!

Which sums things up pretty well, I think. Thanks for your very entertaining letter. Keith – I really enjoyed it!

And thanks to everyone else who responded to the October column, and basically supported our stand.

Our circuit symbols may not be perfect, to be sure. But they are probably those most widely used throughout the world, even if they aren't the official standard, and they've stood the test of time.

No doubt we will change them from time to time, as circumstances change. But you can rest assured that if we do change any of them, it'll be because we've been convinced that this will improve their ability to communicate circuit functions. It will not be in response to intimidation from self-appointed custodians of international 'truths'.

I hope you'll all join me next month, for another episode. To paraphrase the immortal G & S: I'll try to make it topical, and relevant and logical, and above all slightly comical on matters electronic... ☺

Compact Disc Reviews

by RON COOPER

BEETHOVEN

First recording of *Symphony No.10*
In E Flat, 1st Movement
London Symphony Orchestra
Imp Classics PCD 911 DDD
Playing Time: 48 mins 50 secs

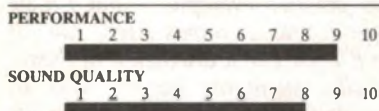

Like myself you may have heard snippets about recent research into many manuscripts relating to Beethoven's unpublished *Symphony No.10*. I was therefore very interested to hear unexpectedly that a recording had just been produced of this work and a review copy was forthcoming.

On examining the copy I felt somewhat let-down, not because of its origin and re-construction, which is first rate, but simply because it is just the 1st movement. Hence my title to this review – not as the CD implies – **Beethoven Symphony No. 10**, then in quite un-highlighted fine print, in E^b, first movement.

The total music playing time is just 20 minutes, with the rest of the CD made up of a lecture by Dr Cooper on its origin. All this is quite fascinating and interesting stuff, especially for students and musical historians but if like me, you are expecting an hour or so of a sequel to the mighty *Erica* or the ninth, you are bound to be disappointed. Incidentally this disc is not expensive at \$14.99.

The movement itself is a little unusual in that it is *Andante-Allegro-Andante* and it was quite enjoyable, yet I had the impression that just maybe if it was Beethoven direct, it probably would

have been more forceful and with a few more repetitions. Without knowing, I would probably have said it sounds like Schuman. The technical side of the recording is very good though Dr Cooper's voice is in mono.

To sum up, in the words of Dr Cooper it is "a kind of artists impression of the first movement". He claims it is fairly close to what Beethoven had in mind, but the real answer will never be known.

MENDELSSOHN

Symphony No.4 in A major "Italian"
Overture and Incidental Music to "A Midsummer Night's Dream"
Orchestra of the Age of Enlightenment
Virgin Classics VC 90725-2 DDD
Playing Time: 63 min 17 secs

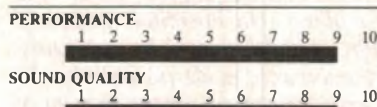

The Italian Symphony is one of those works which has instant appeal – no second or third time listening required. I suspect this could be said about most of Mendelssohn's music, certainly the "Midsummer Night's Dream" also featured on this disc, and his violin concerto.

Even the mighty Beethoven once referred to this piece as Mendelssohn's 'pastoral' symphony. It was inspired by his Italian tour of 1830-31 and while I don't regard it as another Beethoven pastoral, (though there is one work I do), it is a most enjoyable symphony.

The rapid opening tempo is enhanced by all in this recording – very good mixing, virtuoso performers, and excellent

acoustics. The detail in the string parts is extremely clear and although I am not a fan of original instruments, this is one recording which does seem to bring out their best.

The *Midsummer Nights Dream* was composed for a lavish production in Potsdam in 1843, seventeen years after the overture was written. On this recording the clarity is almost exceptional, but this also shows some shortcomings of the original instruments. For example in the scherzo, the flute in the low register does not have the fullness of the modern instrument as with Gallway and the National Philharmonic. This is of only minor consequence though, in a very fine performance such as this. And at \$14.99 it's very good value.

BACH

Bach at Brun Mawr
David Higgs
Organ
Delos D/CD 3048 DDD

Playing Time: 55 min 28 secs

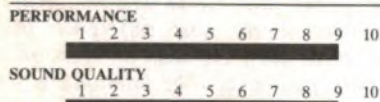
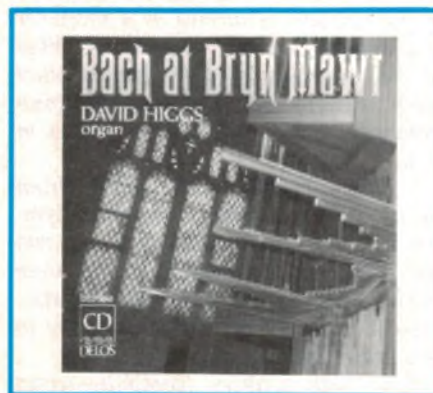

Here is a great recording on a great instrument, representing Bach at his best.

The organ on this disc was built by Rieger Orgelbau of Austria, and dedicated in 1975. It contains tonal resources which allow it to handle the complete range of organ literature. But it is in the works of J.S. Bach that the work principal of tonal designs stands forth. In this principle, each division of

the instrument is conceived as a complete chorus, an "organ within an organ," so to speak, and given its own sub-section in the massive organ case.

The fine dimensions of the Bryn Mawr instrument are arrayed in the rear gallery of the church, beginning with the Brustwerk at the lowest level and Kronpositiv at the top. Pedal registers are located in the side towers of the case.

Key action is mechanical, while stop and combination actions are electric, permitting rapid changes in registration.

The playing by David Higgs is excellent and there is considerable reverberation, which is intended as shown by the technical details on the extensive cover notes. The pieces performed are the Prelude and Fugue in G Major, BWV 541; Concerto in A Minor, BWV 593 (after Vivaldi); Prelude and Fugue in D Major, BWV 532; Trio Sonata No. 5 in C Major, BWV 529; and the Fantasia and Fugue in G Minor, BWV 542.

The clarity of the recording is first class and acoustically you are in a very large church. So with this combination of large organ, church, performer and composer, to really appreciate this disc it should be played LOUD (assuming your woofers can take it!).

In short very enjoyable.

GRIEG

Peer Gynt
Suites No. 1 and 2
Piano Concerto in A minor
London Festival Orchestra
ZYK Classic CLS 4013 DDD
Playing Time: 62 min 44 secs

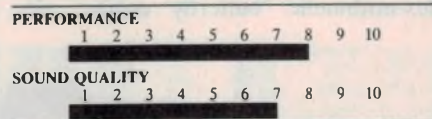

Peer Gynt was written as incidental music to a play by Ibsen, on his commission. After spending some years on the project, Grieg, who felt that it

would not have much merit outside Scandanavia published a concert edition in two suites in 1888 & 1891.

These extremely popular pieces of course have achieved wide appeal. This disc brings you both suites and the A Minor piano concerto as well.

The concerto was first performed in 1869, with Grieg himself as soloist. Unfortunately some regard these works, because of their popularity as hackneyed, yet they are all quite brilliant.

The performance here by Bjorn Lundgren is quite leisurely, enjoyable and enhanced by good acoustics. The single page notes do not refer to the Concerto or the pianist who though unknown to me is 1st class, although I would have preferred a brisker presentation.

The technical quality is in the 'good' category but not outstanding and there is a slight harshness at times. This appears to be a new recording, on a new label which retails for \$9.90. At this price it represents excellent value and although the sound is not in the Philips or Telarc class, I can still highly recommend it.

These discs are available from stores or direct from Active Video, 1306 Yarramalong Road, Yarramalong 2259, phone (043) 56 1077.

Looking for inspiration?

THE *Lifestyle* SERIES

Look no further!

The Lifestyle Series offers you information on ways to improve your home-design a new kitchen or bathroom, plan your outdoor living area, renovate or redecorate your favourite rooms.

- Restorations & Renovations
- Design & Decorating
- Pools & Spas
- Kitchens
- Pools & Outdoor Living
- Bathrooms
- Home Improvements.

Look for these exciting titles at your newsagent now or subscribe by phoning (02) 693-9517 or 693-9515.

IF YOUR NEEDS ARE QUALITY ELECTRONIC ASSEMBLY TRY US

Intertronics assembly offers very **COMPETITIVE** pricing on assembly and manufacture due to our **LOW OVERHEAD** costs, labor saving semi-automated equipment, and **COMPUTERISED** management information systems. Intertronics also provides **100% QUALITY INSPECTION**, thus assuring customers of perfect assemblies, everytime.

INTERTRONICS

Provides customers with:

- ★ circuit board assembly
- ★ wire harness assembly
- ★ flow and hand soldering
- ★ mechanical assembly
- ★ automatic wire cutting and stripping
- ★ wire termination and related services

INTERTRONICS

Unit C1, 23-25 Windsor Road, Northmead, NSW 2152
Telephone (02) 683 5959 or (02) 683 5700 Fax (02) 683 6405

News Highlights

Australian breakthrough: fast single-chip FFT for signal processing

Australian firm Austek Microsystems has announced a new high speed, single-chip fast Fourier transform device which could well be capable of spawning the same kind of revolution in digital signal processing that occurred in computing with the development of the microprocessor. Developed in conjunction with the CSIRO, the new chip appears to be 12-24 months ahead of anything currently available overseas.

Austek has dubbed its new A41102 device a 'frequency domain processor' (FDP). An algorithm-specific, configurable signal processor, it achieves 102 million arithmetic operations per second – in a single device.

"Historically, digital signal processing applications using real-time FFT's have been limited, due to high cost and design-in complexity", said Dr Rob Potter, Austek's general manager. "Austek recognised the enormous potential of applications using DSP devices that integrate high performance, low system cost and design complexity. The A41102 was developed for just such applications."

US-based market research company Dataquest has estimated the worldwide DSP market to have been \$US750 million in 1988, and expects a rise to \$2 billion by 1992. Roughly 30% of this market is estimated to be in the area of high performance processing – the applications for which the A41102 is suited.

Original conception of the A41102 was carried out by a team of DSP scientists and engineers working at the CSIRO Division of Radiophysics, in Epping NSW. Led by Dr John O'Sullivan, the CSIRO team produced a prototype of the chip using NMOS technology. The potential of the development was recognised by Austek, which has close links with CSIRO, and the company entered into an agreement covering its further development and commercial exploitation in the world marketplace. CSIRO scientists were also closely involved in this later development into the final A41102 device, which is fabricated in 1.5-micron CMOS technology.

Key to the team's success in produc-

ing a true single-chip FFT processor was the discovery of a new FFT algorithm which allowed the use of only 7 complex-arithmetic 'butterfly engine' ele-

ments for a basic FFT calculation of a set of 256 data samples. This resulted in a significant simplification in hardware architecture, compared with existing implementations. At the same time, the algorithm-specific nature of the new architecture allowed a dramatic simplification in software programming.

The A41102 provides on a single chip all of the resources necessary to implement *both forward and inverse* transforms for up to 256 complex points – including memory and twiddle factors. Longer transforms can be implemented using either multiple devices, or multiple passes through a single device.

Measuring 8mm x 9mm, the chip contains 167,000 transistors. It operates at 40MHz and dissipates approximately 1 watt, while performing continuous FFTs at input rates of up to 2.5 million complex samples per second.

The Austek FDP chip's high performance and low cost are expected to open up a very wide variety of new DSP ap-



Austek's A41102 FDP chip development team members David McGrath, Peter Ballard and Brian Conolly (L to R).

The major functional blocks inside Austek's new A41102 frequency domain processor.

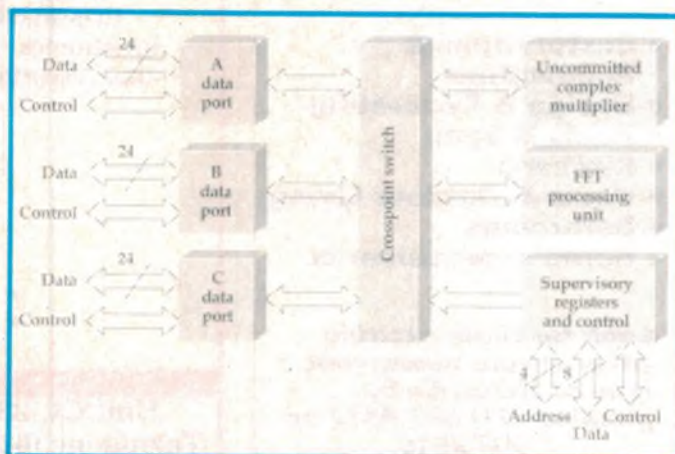

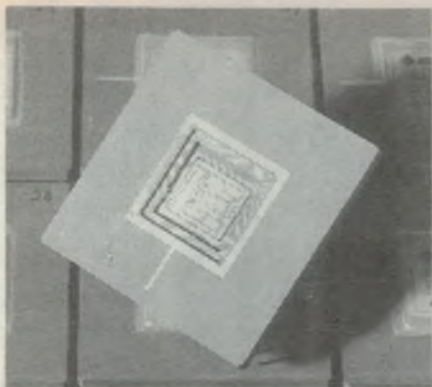

The A41102 FDP chip, sans lid.

plications, in areas such as medicine, industry, military and consumer electronics - including audio and video. Engineering samples are already available, with volume production scheduled before April.

According to Dr Potter, the A41102 gives Austek a 12 - 24 month jump on its competition, which is mainly in the USA. Other firms with high-performance DSP processors include Honeywell and TRW.

Austek is already offering a simulation/design software package for the A41102, called FDPSIM, and available for MS-DOS, VMS, Ultrix and SUNOS environments.

TV by millimetre wave radio

British Telecom's Research Laboratories have successfully demonstrated the use of short-range millimetre-wave radio for delivering programmes into viewers' homes.

If the system were licensed by the Government, it could prove a quick and economic supplement to broadband cable networks. It could bring multichannel TV to millions of homes which are unlikely to be cabled before 2000.

The demonstration, being carried out at Saxmundham, Suffolk, is of a millimetre wave multichannel multipoint video distribution service (M3VDS). It uses radio with a wavelength of about 1 millimetre (corresponding to a frequency of about 30GHz) to beam four satellite TV programs plus the four broadcast services to 10 homes in the town fitted with special antennas capable of receiving the transmission.

M3VDS offers the program base of cable TV at a receiver cost comparable with the equipment required for home reception from just a single satellite. By increasing overall customer base, it could encourage program production, benefitting the broadcasting industry as a whole.

Brain gain

Australian electronics industries are benefiting from a 'brain gain' as overseas specialists are attracted to Australia by new and exciting career opportunities, and by the chance to work with the latest electronics technologies.

AWA Microelectronics has recently announced rapid expansion plans and will soon become the first Australian

company to design and manufacture state-of-the-art Application Specific Integrated Circuits (ASICs) in Australia.

The company has appointed a number of expert personnel - a number of them from overseas. The new people will work at the company's new world-class ASIC design and manufacturing facility at the Australia Centre, Homebush Bay, Sydney when it opens in a few months.

Philips/Signaal computer-controlled gatling gun displayed in Sydney



Representatives of the electronics media in Sydney were recently given a conducted tour of the radar, armament and operational control electronics on the Netherlands Navy frigate HNLMS Witte de With, by courtesy of Netherlands Navy and Philips' defence division Hollandse Signaalapparaten (Signaal). Signaal is involved with both main consortia whose designs are currently under consideration for the ANZAC ship project.

Systems displayed included Signaal's 'STIR' I-band tracking and illumination radar, its 'Vesta' VHF radar transponder and data link systems for reliable positioning and identification of helicopters, and the LW-08 long range D-band radar. However in many ways the star of the tour/display was 'Goalkeeper' - Signaal's completely automatic anti-ship missile defence and anti-air weapon system for ships.

Goalkeeper is a fully autonomous system, integrated on a single mount and designed for 'last ditch' close-in de-

fence. It combines an I-band search radar, a dual I-band/K-band tracking radar and a 7-barrel gatling gun firing 4200 tungsten-tipped 30mm rounds per minute (70 rounds/second). It can detect and assess kill potentials of approaching targets, assign priorities and then lock onto and fire at each target in turn. Firing ceases upon destruction, whereupon the gun is automatically redirected to next-priority targets within seconds.

The system uses electric drive, with a linkless belt ammunition feed system. The search radar uses a 2050 x 280mm linear array antenna rotating at 60rpm, while a 1000mm diameter Cassegrain antenna is used for the tracking radar. Both use a TWT for high output power and 'burn-through' capability, combined with digital FFT (fast Fourier Transform) analysis for rapid and reliable signal processing.

Ammunition capacity for continuous firing is 1190 rounds, while the peak power consumption during gun repositioning is around 136kVA.

News Highlights

Time capsule

The latest Optical Disc Technology donated by computer company, NEC, will store 60,000 signatures in a time capsule, sealed for posterity at the closing ceremony of the World Expo in Brisbane. Fifty percent of the money raised for charity by the venture goes to the Royal Flying Doctor, Australia-wide, and the rest will be divided amongst various Bicentennial groups.

The concept of the Bicentennial time capsule - to be opened at Australia's Tricentennial in 2088 - is part of Brisbane's World Expo.

People have signed scrolls for the time capsule at the World Expo in Brisbane, at local school groups and other Bicentennial groups throughout Queensland.

"In one hundred years, people can come in and get a photocopy of their great grandfather's signature, or they may use it for tracing their family tree," according to Al Ryder, from the Queensland Department of Geographic Information.

Exhibition

The largest electrical and electronics show ever seen in Australia will be staged in March 1989 at Darling Harbour, Sydney. Called ELENEX Australia, the show has been endorsed by the Australian Electrical and Electronic Manufacturers Association and has been extremely well supported by the electrical and electronics industry, with over 90% of the available space already allocated. More than 130 local and overseas exhibitors are expected to take part.

The show is being organised by Australian Exhibition Services Pty Ltd (AES), a specialist in trade shows, and many local and overseas manufacturers and wholesalers will have new and improved products on display.

ELENEX Australia will run from 14-17 March 1989 at the Darling Harbour exhibition complex in Sydney, opening from 10am to 6pm each day. The response to the inaugural show has been so good that AES is already allotting sites for the second exhibition in Melbourne, to be held from 27-30 May 1990. ELENEX will alternate annually between Sydney and Melbourne. Enquiries about either exhibition should be directed to Australian Exhibition Services, on phone (03) 267 4500 or toll free (008) 335 010.



Sensitive heat detectors

Research scientists at AT&T Bell Laboratories have created a new class of heat-detection devices so sensitive that they may make thermal imaging more practical for a number of applications.

The tiny devices, which are potentially cheaper and far easier to make than those now employed, might eventually be used in medical imaging scans for disease diagnoses, factory monitor-

ing and automation, earth resource mapping, environmental heat loss measurements, and night vision applications in aircraft or ground-based vehicles.

Activated by non-visible light given off as heat, the detectors work in the 10-micron infra-red region where room-temperature objects emit the most radiation. The experimental devices are made of gallium arsenide, which is now used to make integrated circuits.

News Briefs

- As from November 1st, **Elmeasco Instruments** and **Tech-Sales** have advised that the two companies are to merge.
- A change of address has been announced by **Electronic Development Sales (EDS)**. Their new address is Unit 2A, 11 Orion Road, Lane Cove NSW 2066, and the new phone number is (02) 418 6999.
- Greg Boot has been appointed managing director of **Ritronics Wholesale** and **Rod Irving Electronics**. Rod Irving has resigned with the intention to 'enjoy life a little more'.
- Ian Wade has joined **Signalling Technology** (Sigtec) as marketing manager. He was previously with Component Resources.
- **Siemens** has appointed John Mason to the newly created position of manager Defence. This job involves the coordination of the defence activities of a number of specialist groups within Siemens.
- John Owens has been appointed to the board of directors of **Hypertec**. Mr Owens will assume the position of national sales director.
- David Taylor of **Austek Microsystems** has been appointed director, digital signal processing (DSP) product line marketing at the company's Mountain View, California office.
- **RCS Design** has changed its name to **RCS Cadcentres**. The name change is in line with the image of the company, who deal in a wide range of CAD software.
- The Services sector of **AWA** has announced the appointments of Garry O'Sullivan to market development manager, Viv Colleran to general manager of Project Services, and Ross Abbott to engineering manager.
- Omron Electronics has appointed **University Paton** as the Australian distributor of its OEM (original equipment manufacturer) products division.



Channel 7 Canberra have recently installed Australian-made Audiosound 8011B monitors for their video edit facilities in the new Parliament House.

ASC wins \$3.6 million Telecom contract

The \$3.6 million contract involves production of about 400km of optical fibre cable, about 10,500 fibre kilometres, at the company's factory in Clayton, Victoria. The cable will be installed in Stage Two of Telecom's inland trunk route between Port Augusta and Brisbane.

Under the contract, ASC will supply

60 per cent of the single-mode optical fibre cable required for the 700km – 18,000 fibre kilometres – Melbourne to Echuca and Clare to Border sections of the route. The successful tender brings the total value of long distance optical fibre cabling contracts from Telecom secured by the company this year to about \$28 million.



New factory

The Premier of Queensland, Mike Ahern, recently opened major extensions to a manufacturing plant in an outer suburb of Brisbane. The factory will be used to produce 70% of all products made in Australia by the international company, Zellweger.

The Australian subsidiary of Zellweger has been manufacturing in Queensland for four years. It produces ripple control systems, used by electric-

ity supply authorities and other large users of electricity to reduce peak demands by controlling the network loads.

Zellweger also produces electrochemical instrumentation and control systems for power generation, water treatment, aluminium smelting, paper manufacturing, iron and steel producers, petrochemical manufacturers and many other industries. It also produces Sieger gas detection equipment.

Electronics Department for hire

Microconsultants Pty Ltd of Frankston, Victoria offers a complete electronics contract design and manufacturing service which will allow non-electronic client companies to acquire an instant electronics capability.

The company's capabilities cover initial analysis and definition, structured system engineering, hardware and software design, production engineering and medium volume high quality manufacture.

The company also offers a contract electronics manufacturing service which is aimed at customers who need small to medium quantities of an item manufactured to a high quality standard at a reasonable price. The manufacturing operation is carried out on a low overhead cottage industry basis, giving the company access to a large pool of highly experienced assemblers who no longer wish to work full time.

Voice Key

MTI Equipment has announced the release of a new biometric access control system called 'Voicekey'. A completely stand alone speech verification system designed for single or multi door access control. The system requires no keys, no cards and no central computer. It is unique in that it offers simplicity of operation to users yet provides managers with better security in a system that costs less than conventional card access control products.

Ecco Inc of Boston Massachusetts, the inventors, have spent 5 years and around \$6 million in the development of the Voicekey and its propriety speech recognition algorithms. The Voicekey requires the user to input via the membrane keypad their personal identification number (pin) and say one word of their choice into the inbuilt microphone, to gain access. The pin and word are administrative only and can be disclosed to others without compromising the system's security.

Units are available with capacities of up to 225 users in the single door configuration or up to 1,800 in the network versions. Standard features include 10 time zones, 3 security levels, duress and forced entry alarms and full audit tracking or events which can be stored internally for later down loading to a printer. Daily fluctuations in voice patterns are used in a process of automatic updating of user speech profiles, thus the ecco system actually improves with usage.

News Highlights

Data network

Prospect Electricity, the second largest electricity distribution authority in New South Wales, has installed a 2 megabit voice and data network based on Datacraft Australia's MegaCraft 3600 system. Located west of Sydney, the Authority services 1.2 million people spread over a vast area of 16,115 square kilometres.

Taking Parramatta as the near-to-Sydney boundary, it provides power for communities as far afield as Lithgow, the Blue Mountains, Mudgee, Wisemans Ferry and St Albans.

In recent years, the authority's resources have been stretched to the limit meeting the needs of nearly 427,000 customers who consume more than \$535 million of electricity a year. The decision was made to upgrade existing computer systems to cater to customer requirements and to plan for future expansion. The authority decided it



needed a 2 megabit data network to handle customer accounts and database, and selected Datacraft's MegaCraft 3600 system.

The authority has purchased six MegaCraft 3600 data systems and 50 modems to carry data between outlying areas.

CD-ROM based software

Hewlett-Packard Australia have announced the local availability of HP LaserRX software package, the industry's first performance-management tool that operates on a CD ROM-based (compact-disc read-only memory) personal-computer workstation.

Designed to monitor HP 3000 business computers, HP LaserRX software runs on HP Vectra or IBM AT personal computers incorporating a 5¼" CD ROM drive and user interface based on MS-Windows.

By using HP LaserRX software, the user can conduct varied performance-management activities, such as identifying and isolating performance bottlenecks, evaluating corrective actions, and balancing system components for maximum efficiency.



Local expertise

Australian industry has the expertise and skills needed to develop flight and ground control software for the ultra-violet telescope due to be launched by the European Space Agency (ESA) in the mid-1990's, according to a report prepared by Computer Sciences of Australia. Local companies are also capable of designing, building and operating an Australian ground station which could control the observatory during its two

year space mission.

The report was prepared by CSA for AUSPACE as part of a study commissioned by the Department of Industry, Technology and Commerce into the feasibility of Australian industry participation in ESA's Project Lyman. Lyman entails ESA launching an Ariane IV rocket which will propel a telescope equipped with ultra-violet energy-detecting instruments into an orbit ranging from 1,000 to 140,000 kilometres around the earth.

See-through mouse

To mark the production of 2 million mice, Logitech are producing a 'Clear Case' mouse which will be available shortly in Australia as a limited edition product through November, December and January.

A transparent case will replace the traditional cream plastic, showing off the technology used by Logitech in their mouse products. The unique opto-mechanical design of the Logitech mouse will be clearly visible for all to see.

Logitech are specially proud of their capabilities to completely design and manufacture, in-house, a line of mouse and other PC peripheral products.

The success of Logitech's operation has resulted in the float of part of the company in a public offering in Switzerland earlier this year.

The clear case mouse will be available in Australia early in November 1988. Suggested retail price is \$260.00 including sales tax. The package includes the clear case mouse, Logitech's PaintShow Plus program and Plus Package software.

Ten million Epson printers

Epson, a pioneer of printer technology, has set a world record for printer sales. The company has sold 10 million dot matrix printers for personal computers in 10 years since its introduction of the TX-Series terminal printers in 1978. In August 1988, the accumulative shipment of Epson dot matrix printers worldwide exceeded 10 million units.

By 1985, shipments had reached 5 million units. The market demand for Epson printers in recent years has accelerated at a rapid rate, and this year's annual shipment is expected to be over 2.5 million units.

Epson developed terminal printers from its experience with precision watch manufacturing, and printer mechanisms for cash registers and desktop calculators, matched with the latest electronics and office computer technology. The latest releases in Epson impact dot matrix printers include the 533 cps DFX-5000 heavy duty printer for DP/MIS; and the top of the range 24 pin printer LQ-2550 with built-in colour and advanced paper handling. Epson also introduced the world's first 48 pin printer, the TLQ-4800. Epson's printer technology extends to other printing methods such as laser and ink jet.

High Performance In Your Shirt Pocket!

3 1/2 digit LCD Display

Ranges	Max Res	Accuracy
Vdc 200mV-1kV	100µV	0.5% +1dig
Vac 2V-750V	1mV	0.75%+5dig
Adc 200mA	100µA	0.75%+1dig
10A	10mA	1.5%+5dig
Aac 200mA	100µA	1%+5dig
10A	10mA	2%+7dig
Ohms 200Ω-2MΩ	0.1Ω	0.75%+1dig

Actual Size 148x66x23mm

Display also has Low Battery & Over-Range Indication

Built In Diode Check, Lo-Power Ohms & Continuity Test Beeper

Memory Function for Relative Readings (DM6235 & DM6335)

Autoranging

Manual Ranging Over-Ride (DM6235 & DM6335)

One Year Warranty

Hold Reading Function (DM6335)

10A Range

Automatic Current Limiting

Overload Protected to 1000Vdc/750Vac

10MΩ Input Impedance

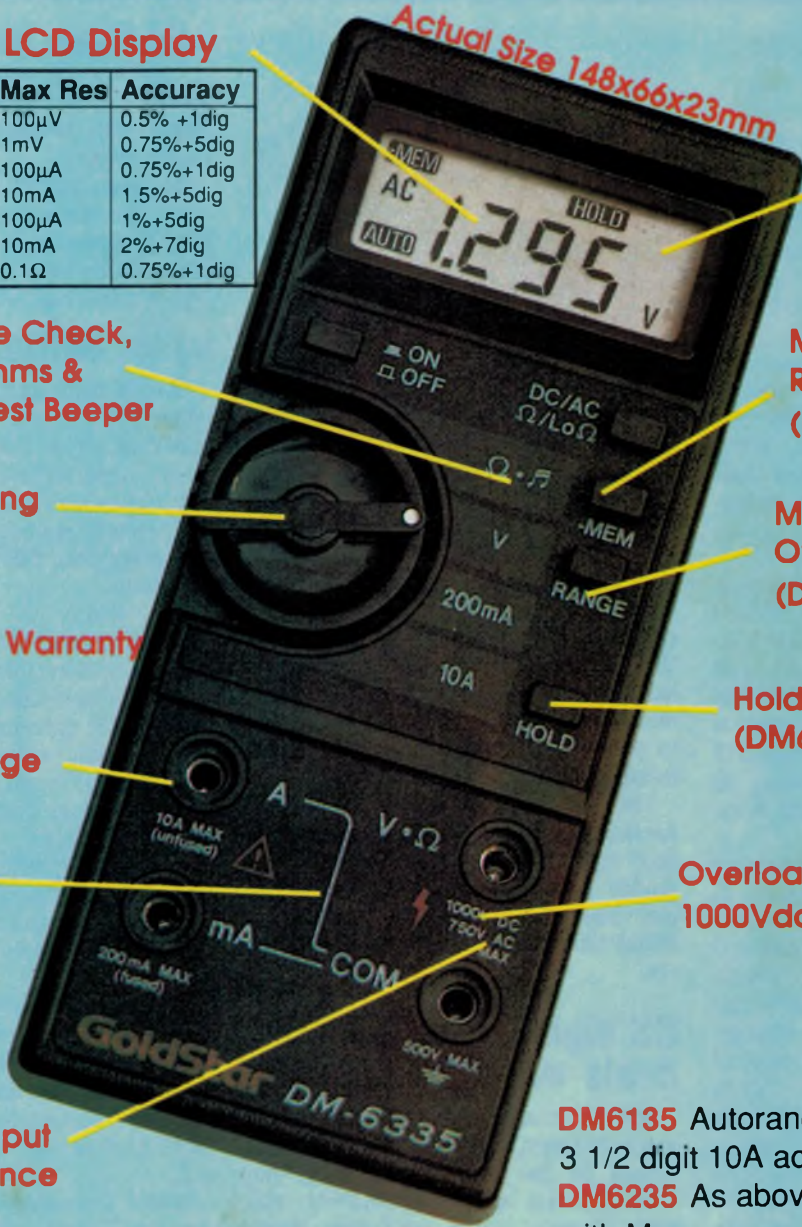

DM6135 Autoranging 3 1/2 digit 10A ac/dc **\$88.80**

DM6235 As above with Memory function and Range Hold **\$99.60**

DM6335 As above with Data Hold **\$118.80**

Look At The Low Prices!

Prices include 9V Battery and High Quality Silicon Rubber Test Leads with Screw-On Alligator Clips

Gotta Getta GoldStar

Supported & Serviced Australia-wide by **Elmeasco Instruments Pty Ltd**
Dealer enquiries welcome. Call (02) 736 2243
Recommended prices only

You've Gotta Getta Goldstar from :

You've Gotta Getta Goldstar from :

A.C.T. John Pope Electrical 80 6576 ● J Blackwood & Sons 80 5235 ● George Brown 80 4355
 N.S.W. George Brown 519 5855 Newcastle 69 6399 ● Ames Agency 699 4524 ● J Blackwood & Sons
 ● Auto-Cart Industries 545 1322 ● D.G.E. Systems (049) 69 1625 ● W.F. Dixon (049) 69 5177 ● Macelec (042) 29 1455
 ● Newtek (042) 27 1620 ● Novacastran Electronic Supply (049) 62 1358 ● Obiat Pty Ltd 698 4776 ● David Reid 267 1385
 ● Digital 709 6511 ● Geoff Wood 427 1676
 N.TERRITORY J Blackwood & Son (089) 84 4255, 52 1788 ● Thew & McCann (089) 84 4999
 QUEENSLAND Auslec 854 1661 ● George Brown 252 3876 ● St Lucia Electronics 52 7466 ● L E Boughen 369 1277
 ● B A S Audiotronics 844 7566 ● Colourview Wholesale 275 3188 ● E.C.O. Electronics 376 5677
 ● The Electronics Shop (075) 32 3632 ● Thompson Instruments (Cairns) (070)51 2404 ● Solex (Townsville)(077) 72 4466
 ● Xanthos Electrical (079) 27 8952
 S.AUSTRALIA George Brown 212 3111 ● J Blackwood & Sons 46 0391
 TASMANIA George Harvey (003) 31 6533 (002) 34 2233
 VICTORIA Radio Parts 329 7888 ● George Brown Electronics Group 878 8111 ● G.B. Telespares 328 4301
 ● J Blackwood & Sons 542 4321 ● The Electronic Components Shop 670 6474 ● Factory Controls (052) 78 8222
 ● Mektronics Co 690 4593 ● Truscott Electronics 723 3094 ● A.W.M. Electrical Wholesalers
 W.AUSTRALIA Atkins Carlyle 481 1233 ● Dobbie Instruments 478 1366 ● George Brown 362 1044
 PAPUA NEW GUINEA T.E. (P.N.G.) Pt Moresby 25 6322 Lae 42 6246

Silicon Valley NEWSLETTER . . .



Gene Amdahl bounces back

Gene Amdahl is sitting in his office in Cupertino with a gleam in his eye. This is the same man whose dream to make a revolutionary mainframe computer went bust four years ago, costing investors in Trilogy about \$US230 million. Some say he has never recovered from the pain.

Still, Amdahl has charged ahead with a new computer venture at the age of 65, and he quickly dismisses critics who say it won't work. After all, many called him crazy when he started Amdahl in 1970, and that went on to become the premier competitor in the IBM-compatible mainframe market.

Amdahl's record against IBM stands at 1-1. He wants to do better, and he's counting on the success of his new venture, Andor Systems, to turn his goal into reality. He keeps chasing the IBM mainframe market because he knows it - and because it's worth more than \$15 billion annually. "If you're going to mine for gold, you might as well mine the mother lode," he says.

This time, though, Amdahl is taking a decidedly different approach. Instead of trying to set a standard for performance at the top end of the IBM mainframe line, he's targeting the low end, specifically the 3090/150E, an 8-10 MIPS machine that costs about \$US1.7 million. He intends to break into the market with a computer that relies on VLSI technology, which has been the key to most of the revolutionary advances in desk-top computing but as yet has been used relatively little in mainframes.

Ostensibly, Amdahl seems to be onto something hot. For starters, his computer will fit into a box that takes up about 2 square feet. The competing IBM model takes up more than 500 square feet. Amdahl's machine will also run on less than 700 watts of power, and could run inside an office; the IBM machine requires an environmentally controlled room and, unlike Trilogy, which tried to invent a giant super chip and peaked at more than 400 employees, Amdahl isn't trying to reinvent the wheel or expand too aggressively.

Perhaps most importantly, the Andor



The famous Gene Amdahl.

system could cost perhaps as low as 10% of the IBM list price, making the hardware end of a customer's investment in a mainframe system secondary to software for the first time in mainframe history.

This time, all Amdahl is really pioneering is a new design philosophy. Motorola will actually build the chips. Andor Systems is a modest venture, too, one with only \$US2.3 million in initial financial backing and 10 employees.

US signs space station deals with 11 countries

Within hours of its re-entry in the space business following the successful launch of the shuttle Discovery, the United States signed agreements with both Canada, Japan, and nine European nations to co-operate in the development and building of a \$US23 billion space station to be fully operational before the end of this century.

The space station, first proposed by President Reagan in 1984 and to be called "Freedom," will be built mostly by the US which will commit 20 shuttle flights between 1995 and 1998 and carry about two-thirds of the overall cost of the project.

According to the building schedule, the Freedom station will be manned permanently as early as 1996, although

the crew would initially consist mostly of construction-oriented personnel assembling the 500-foot structure with components shipped in by the various shuttle flights.

Besides scientific and industrial functions, the space stations will perform a key "stepping stone" role in the possible building of a colony on the Moon and manned flights to Mars.

Laser battle ends

One of the longest licensing battles in industrial history effectively came to an end recently as Spectra-Physics agreed to pay royalties to Patlex, a tiny Southern California firm that invented the laser technology used by Spectra-Physics and more than 300 other firms around the world.

The victory is significant because Spectra is one of the world's largest laser equipment manufacturers, and the last major hold-out against Patlex. As a result of the agreement, Patlex stands to reap in many millions of dollars in future, current, and retroactive royalty payments from companies that use its laser technology.

The development, however, means prices for laser equipment are likely to increase, as manufacturers will try to pass the additional cost on to their customers.

According to George Dies of Spectra, his company decided to settle with Patlex to avoid a potentially expensive legal battle. "We did this to put the entire issue behind us. The decision was very much in the company's best interest".

Under the terms of the deal, Spectra will pay Patlex a 5% royalty on its future sales of instruments covered by the Patlex patents. In addition, the Santa Clara firm said it would pay an undisclosed amount to cover past royalty fees.

The issue of who invented the laser dates back to the 1950s, when George Gould, a student at Columbia University came up with the idea for a gas laser device. When Gould tried to get a patent, Patlex agreed to finance the fight in return for 64% of the licensing income. Last October, the US patent office finally bowed to a series of court

rulings favouring Gould as the inventor of the laser.

At Patlex, chief financial officer Richard Latinen said he is confident most of the remaining 220 or so companies around the world that use its laser technology will end up signing the licensing agreement. "When all the people that sat in the background see the big guys signing, they'll know they might as well get it over with."

US distributors freeze out Asian chipmakers

Korea's Samsung Semiconductor, trying to increase sales of its computer chips in the United States, achieved a major break-through late last year. Arrow Electronics, the US's second-largest distributor of semiconductors, agreed to sell its products.

But the triumph proved short-lived. Two weeks after the deal was announced, Intel of Santa Clara, one of Arrow's major US suppliers, cut back on the amount of business it did with Arrow. Other US suppliers also protested Arrow's agreement with Samsung, according to industry executives.

One month later, citing "changing business conditions," Arrow terminated the agreement.

At a time when US chip manufacturers complain bitterly about being locked out of the Japanese market, the Arrow-Samsung incident indicates that the US market itself has not been completely open either. Indeed, for many years a key part of the US market for chips has been virtually closed to companies from Japan and South Korea.

According to interviews with numerous distributors, the major US semiconductor companies have long had a tacit policy of preventing their distributors from selling products made by Japanese competitors.

The implied threat is that a distributor could lose its US product lines, which are more valuable than the Asian lines, if it takes on as Asian supplier.

US - Japanese 4 megabit DRAM effort announced

Ramtron, a Colorado-based semiconductor maker, announced it has signed an agreement with NMB Semiconductor of Japan to jointly develop 4-megabit DRAM memory chips.

"This co-development and co-licensing agreement has launched our two companies on a program to develop the manufacturing technology and product

designs for an advanced family of high-performance 4-megabit DRAMs," commented Ramtron president Richard Horton.

Horton added that the development program will be based on R&D that is already under way at the two firms and will also be aimed at laying the foundation for development of future 16-megabit chips and beyond. "This partnership will merge Ramtron's design and materials expertise with NMB's advanced CMOS, high-volume production capability for an on going high-density DRAM R&D program."

Under the terms of the agreement, NMB will gain access to Ramtron's memory design technology and advanced materials processing technology for 4-megabit DRAMs. NMB, meanwhile, will provide Ramtron with its semiconductor process technology and automated high-volume manufacturing facilities. Although both firms will own the technology, NMB will have the exclusive rights to the 4MB DRAM chips.

Silicon Systems buys idle Synertek plant

Los Angeles-based Silicon Systems has announced it has purchased the long-idle Synertek chip manufacturing plant in Santa Cruz and hopes to start producing silicon wafers there by year's end. The plant could eventually provide as many as 500 jobs, according to Carmelo Santoro, chief executive and president of Silicon Systems.

Santoro, speaking at a news conference held outside the plant's front door, would not disclose how much his company paid for the plant, which was built in 1981 by Synertek for a reported \$US50 million including equipment.

Doug Elder, who worked for Synertek and who will be director of facilities at the new operation, said Silicon Systems viewed its purchase of the plant as a bargain. It would cost at least \$US80 million to build such a facility from scratch today, not including the cost of equipment, Elder said.

Synertek, a Honeywell subsidiary, operated the plant for four years, closing it in early 1985. The facility was later purchased by AT&T.

AT&T operated it as a chip-making plant with a staff of 60 until January 1986, when it shut down the plant as part of a corporate consolidation. Since then, the plant has been maintained by a skeleton crew of about a dozen people - mostly security guards and maintenance technicians - who kept the equipment in working order.

Another virus shows up in Aldus program

Despite all precautions take by Aldus, the company announced that a new virus has been found in the latest version of its FreeHand drawing program for the Macintosh.

Early last year, Aldus was greatly embarrassed when it turned out that its brand new FreeHand program had been infected by a virus, although the company went to great length to prevent this from happening again in an updated version of the program, a virus has turned up nonetheless. "We don't know where it came from. This is the nature of the virus. You can't really track it," commented Aldus spokeswoman Jane Dauber.

The new virus has been called "nVir," and has so far remained dormant. Dauber also said that so far; "We don't know why it has remained dormant. We don't know what invokes this virus".

Apparently, the virus doesn't automatically get activated when the program is run. Sometimes, it takes several times before it becomes active. The virus was detected by several of a dozen companies around the US that served as beta test sites for the new FreeHand program. So far, Aldus believes at least one East-Coast university computer system has been infected with the nVir virus.

First lithium AA battery announced

In a development that was hailed as a major breakthrough in battery technology, Eveready Battery in New York recently introduced the industry's first lithium battery in the popular AA size.

Already AA batteries account for nearly half of the entire battery market. The new lithium batteries will last twice as long as current leading AA products and have a shelf life of some 10 years.

Until they become less expensive to produce and cheaper to sell through discounting by major retail chains, consumers will not reap in major cost benefits from the new batteries. Eveready said a pair of the new batteries will retail for between \$5 and \$6 when they become available. This compared to \$1.50-\$3.00 for conventional alkaline AA batteries.

Eveready said the new batteries require a complicated manufacturing process for which the company has filed a patent application.



Adilam Electronics

COMPONENT SPECIALIST



ADILAM OFFICES

MELBOURNE Suite 7
145 Parker St
Templestowe VIC 3106
P O BOX
P O Box 131
Bulleen VIC 3105
PH (03) 846 2511 (4 lines)
FAX (03) 846 1467
TELEX AA 151369

SYDNEY Suite 1
Ramsgate Plaza
191 Ramsgate Rd
Sans Souci NSW
PH (02) 529 2277
FAX (02) 529 5893

ADELAIDE
N S Electronics (S A)
59 Wood Ave
Ridleyton SA 5008
Ph (08) 468 531
Fax (08) 340 1456

BRISBANE
St Lucia Electronics
24 Campbell St
Bowen Hills QLD 4006
Ph (07) 252 7466
Fax (07) 522 862

CANBERRA
Electronic Components Pty Ltd
Unit 10
Fyshwick Plaza,
Wollongong St
Fyshwick 2609
Ph (062) 80 4654
Telex 62468

PERTH
Prospect Distributors
Helidon House
31 Adrian St
Welshpool WA 6106
Ph (09) 362 5011
Fax (09) 361 7592

DISTRIBUTORS

Silicon Valley

Packard slams arms procurement system

America's weapons-procurement system is so complex that it operates like "an Iranian bazaar," former Undersecretary of Defense David Packard said at a recent congressional hearing. "One could do just as good a job in awarding the major contracts by putting the names of qualified bidders on the wall and throwing darts, this would also save a lot of time and money," he said in testimony before the Senate Armed Services Committee.

Packard, a founder of Hewlett-Packard of Palo Alto, headed a presidential commission appointed two years ago to recommend reforms in the business practices of the Defense department. Packard, 76, told that panel the weapons-contracting process involves "literally tons of paperwork, describing how the bidder would meet a bunch of 'Mickey Mouse' requirements that have absolutely nothing to do with doing the job right."

The billionaire chairman of Hewlett-Packard also has been asked by Defense Secretary Frank Carlucci to help monitor the unfolding Pentagon fraud and bribery scandal involving weapons buying.

Packard berated a defence industry that he said deliberately underestimates costs and schedules, and said that the 150,000-member Pentagon procurement bureaucracy is so bloated that it should be slashed immediately by 20%. He also chided lawmakers who use taxpayer's dollars to further their own interests.

But Packard reserved some of his harshest criticism for Congress itself, which he said indulged in the "selfish" and "disgraceful" practice of adding funds to the Pentagon's budget for arms that are not wanted.

Toshiba spent heavily to lobby against US sanctions

Toshiba has showed that the millions of dollars it invested in legal and lobbying fees paid off in a big way for the company.

Late in 1987, in the wake of the revelation that Toshiba had sold sensitive computerised milling equipment to the Soviet Union, Toshiba was facing the possibility of losing its ability to sell any product into the United States for a period as long as five years. An out-

raged US Senate and House of Representatives passed several amendments to the new US Trade Act that would have kept most, if not all of Toshiba out of the US market for 2-5 years.

Shortly after the initial tempers had cooled down somewhat, Toshiba embarked on a costly and aggressive lobbying campaign to blunt the effort to impose the import restrictions on its products.

In all, Toshiba paid lawyers and lobbyists between \$US5-9 million to get Congress to reduce or eliminate the sanctions. One law firm alone, received \$US4.3 million in legal fees.

"In all the 21 years I have been in public office, I have never seen a lobbying campaign so orchestrated at so many levels," said Senator Jake Garn of Utah, one of the principal forces behind the move to severely punish Toshiba.

Garn said that during the past year, a steady stream of lobbyist had come to see him to talk about the proposed sanctions. Among them were Japanese cabinet and parliament members, Toshiba executives, and a host of US distributors and customers of Toshiba products. According to Garn, the lobbyists continuously warned members of Congress that as many as 100,000 US workers could be out of a job if severe sanctions against Toshiba were to be imposed.

H-P announces superconductor partnership

In a potentially big boost to bring new high-temperature superconductor products into mainstream markets, Hewlett-Packard announced it has entered into a financial and technical partnership with Conductus, one of the promising US start-ups in the developing area superconductor technology.

Under the terms of the agreement, H-P will acquire a 15% interest in Palo Alto-based Conductus, and will conduct joint research projects aimed at developing superconductor-based semiconductor components and other devices for use by electronics firms like H-P.

Conductus was formed just a year ago by several highly regarded physical scientists from Stanford University and the University of California at Berkeley. To date, Conductus has raised some \$US8 million in start-up capital.

The H-P deal will add another \$US11 million to Conductus' coffers, and the company will also be allowed to borrow equipment H-P has been using in its own superconductivity research labora-

tories. As part of the joint research, engineers from the two companies will be sharing each other's laboratories and other facilities which are just four miles apart.

"I think we are well within the reach of funding that is credible in terms of launching electronic products," commented Peter Canon, chief executive officer of Conductus.

Industry observers noted that the H-P Conductus deal is further evidence of a growing trend at H-P to obtain critical technology through investments in outside organizations. This represents a sharp departure from H-P's tradition of building and selling products based only on in-house R&D.

VLSI Technology's new fab achieves first silicon

VLSI Technology announced that the first runs of production silicon have been completed at its new semiconductor wafer fabrication facility in San Antonio, Texas. "The initial lots of both our fast memory and ASIC products not only produced good die but had yields above the production manufacturing standards," stated VLSI President and Chief Operating Officer, James R. Fiebiger. "This is an important milestone for our world-class fab. We are proceeding on schedule to build up production and have volume production in 1989."

Fiebiger noted that VLSI achieved its first silicon at the site approximately 18 months after the groundbreaking in March of 1987. "Our San Antonio team established a very aggressive schedule and has executed well to this schedule," he said. "Even more impressive is the fact that our San Antonio team got first silicon out in slightly less than three months from the onset of equipment installation. Perry Denning, Director of San Antonio Operations, and his entire team have done a great job. Their competence, enthusiasm and commitment made a tremendous difference and helped us build this facility and produce product on schedule within budget."

VLSI Technology's 250,000 square-foot San Antonio facility, with a 40,000 square-foot "Class 1" clean room (of which a quarter is currently implemented), is one of only a few in the US that will be able to manufacture leading-edge integrated circuits down to as low as 0.25 microns, according to David Ledvina, VLSI's vice president of Wafer Fab. A full three stories high, the new wafer fab uses the top and bottom floors strictly for air handling and utilities.

Basics of Digital Audio

Virtually all of the dramatic improvements that have taken place in the field of audio over the last few years are the result of applying the techniques of digital signal processing and recording. On the domestic scene, compact discs are an excellent example. Here's an up-to-date introduction to the basic concepts of digital audio, to help you grasp what's involved.

by KEN C. POHLMANN

Digital audio technology has transformed the audio industry in areas such as music recording, signal processing, musical instruments, archival storage, and telephone connections. There is simply no question that the future of audio lies in the digital domain. The opportunities presented by the new technology are unprecedented since the birth of audio itself.

Yet many people have taken digital audio for granted, and are missing all the fun (not to mention profit) in really understanding what makes digital audio tick. Let's review some of the basics of digital audio, focusing on its twin cornerstones, sampling and quantisation.

Any look at digital audio must begin with analog concerns. Music, and any other acoustical event perceived at the ears is analog in nature. That is, the key components in the information, amplitude and time, are preserved continuously. From a simple standpoint, analog technology would thus appear to be a good way to record, transmit and reproduce an audio event.

However the practice is more difficult than the theory. Imagine the task of an analog audio chain: The microphone must create a voltage analogous to the acoustical waveform, circuits must amplify and process the voltage faithfully, a record groove or magnetic tape must preserve a signal corresponding to the original, and loudspeakers must reproduce it accurately.

The problem of conveying the original

signal *faithfully* through this chain is considerable. For example, a record groove, a miniature physical replica of the acoustical waveform, encounters dust, dirt, deformations in the vinyl, resonances and reproduction problems from the stylus, and so on. In short, all-too-analog phenomena such as noise and distortion mix with the audio signal, and it is irretrievably degraded.

Digital audio takes an entirely different approach. Instead of attempting to preserve the continuous analog signal, the signal is periodically measured, and those measured values, constituting the waveform's all-important time and amplitude information are preserved.

Thanks to computer technology, binary numbers offer a reliable way of recording and processing that kind of data. The benefits are numerous: mainly, when numbers (instead of a replica) are used to convey waveform, subsequent operations are more precise. For example, a digital recording may be copied by simply duplicating the list of numbers on another medium.

Fundamentally, because numerical data is distinct from the analog noise inherent in any transmission or recording medium, this approach can be superior in terms of fidelity. The degree of fidelity of the technique hinges on two important criteria: How accurately the amplitude of the waveform is measured, and how often. The former is a question of *quantisation*. The latter defines the idea of *discrete time sampling*.

Time sampling

Discrete time sampling theory states that an analog function may be sampled in time, and moreover the sample points can be used to reconstruct the original analog waveform, as shown in Fig.1. The sampling theorem was first proposed in 1926 by Harry Nyquist, an electrical engineer exploring the theory of telegraph transmission.

Nyquist's theorem states that given correct conditions, no information is lost due to sampling as *such* in a digitisation system. The samples contain the same amount of information as the un-sampled signal.

Intuitively, it is difficult to imagine that any finite number of sample points can be used to exactly preserve a con-

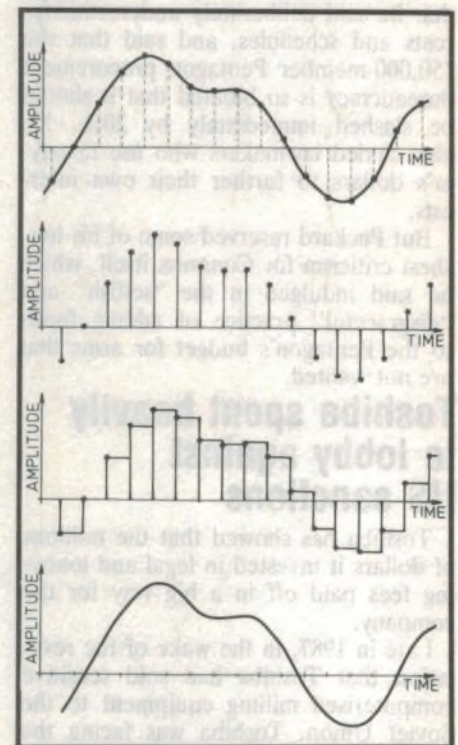

Fig.1: Samples of an analog waveform taken at close intervals can be used to reconstruct it later.

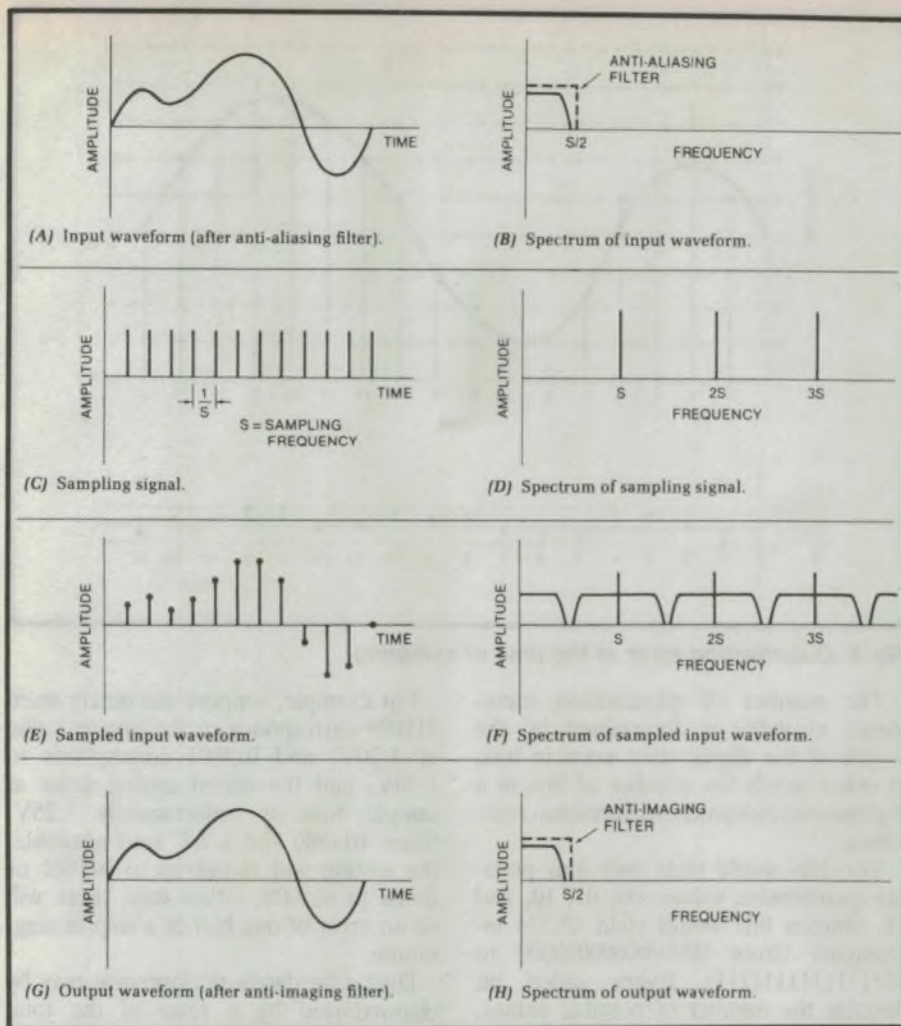

Fig.2: Time and frequency domain descriptions of sampling.

tinuous waveform, yet that is precisely true, given proper conditions. Those conditions limit the bandwidth of the audio signal, for a given sampling rate. In other words, a sampling system can perfectly reproduce audio, up to a certain frequency.

An analogy might help to explain time sampling. Audio sampling may be conceptualized as a process similar to that in a motion picture camera. For sound, the samples correspond to the film frames, the sampling rate corresponds to the frame rate, and the highest signal frequency corresponds to a fast-moving object.

Just as we need some relationship between the frame rate and the speed of moving objects, we need to define the relationship between sampling frequency, and audio frequencies. The Nyquist theorem defines the relationship: if we take samples twice as fast as the highest audio frequency, complete waveform reconstruction can be accomplished.

By definition the samples contain all the information needed to provide complete reconstruction. However bandlim-

iting criteria must be strictly observed; a too-high frequency would not be properly encoded, and would create a kind of distortion called *aliasing*.

To prevent aliasing, the input signal is bandlimited with a low-pass filter, sometimes called the anti-aliasing filter. Its job is to ensure that all frequencies above the half-sampling point are attenuated below the amplitude resolution of the system. To limit the sampling rate required to achieve a given audio bandwidth, we design filters with a very sharp cutoff characteristic – so-called *brickwall* filters.

The choice of sampling frequency determines the frequency response of the digitisation system: quite simply, S samples per second are needed to represent a waveform with a bandwidth of $S/2$ hertz. In other words, the sampling rate must be twice the highest audio frequency.

As the sampled frequencies become higher, the periods are shorter, and there will be fewer samples per period. At the theoretical limiting case of critical sampling, at an audio frequency of

half the sampling frequency, there will be just two samples per period.

Consider a 24kHz input sine wave, sampled at 48kHz. The digitiser would generate two samples, and this would be used at the output to produce a 24kHz square wave. Of course, a square wave is quite unlike a sine wave, which brings us to the final piece of system hardware.

At the output of every digitisation system is another low-pass filter, essentially identical in design to the input low-pass filter. Its job is again to remove all frequencies above the half-sampling frequency, but for a different reason.

We have to filter the output because sampling has generated new, ultrasonic image frequencies above the audio band, placed at multiples of the sampling frequency. This is a natural consequence of sampling, which is inherently a *modulation* process, generating sidebands in the form of these image spectra.

The output filter, sometimes called the *anti-image* filter, removes all the unwanted harmonics above the half-sampling frequency, leaving only the original signal waveform – 24kHz in our example. Viewed in another way, the filter smoothes the reconstructed staircase (that is, removes its high frequency components) leaving the original band-limited waveform.

One more observation. In the above example, our sampler reproduced a 24kHz sine wave. That pleased us, because we started with a 24kHz sine wave. But what if the input to the sampler hadn't been a sine wave?

It had to be a sine wave, because the input low-pass filter would have removed all harmonics from any complex 24kHz waveform, to provide a sine wave to the sampler, in accordance with the Nyquist theorem. Remember – any frequency content, fundamental or otherwise, above the half-sampling frequency is taboo.

That shouldn't bother you: since you're deaf above that frequency, there's no reason for a recording system to try to reproduce it.

Summarising, we must sample at a frequency at least twice that of the highest input frequency we wish to record or reproduce.

In the case of compact discs, the sampling frequency is 44.1kHz, corresponding to a sample every 22.6757 millionths of a second. This permits a theoretically flat frequency response from 0 to 22.05kHz. The input signal must be low-pass filtered to prevent aliasing, and

Digital Audio

the output signal must be low-pass filtered to remove ultrasonic images, artifacts of the sampling process. The filtered signal may be sampled, stored in discrete values, desampled, and reproduced without loss due to sampling.

All this is pictured in Fig.2 – a comprehensive summary of sampling. It shows the signal in its various incarnations, in both the time and frequency domain.

Fig.2A shows the input signal, with its anti-alias low-pass filtered frequency response shown in 2B. Fig.2C shows the sampling signal, and 2D shows the spectrum of the sampling signal, with impulses at multiples of the sampling frequency. Fig.2E shows the sampled waveform, and 2F shows the corresponding ultrasonic images. Finally Fig.2G shows the filtered waveform, identical to the original, and 2H shows how the anti-imaging filter has accomplished this reconstruction.

Quantisation

As we've seen, sampling is a method of periodically taking a measurement. In audio, a measurement is meaningful only if both the time and value of the measurement are stored. Thus sampling represents the time of the measurement, while *quantisation* represents the value of the measurement – or, in the case of audio, the amplitude of the waveform.

Whereas sampling is perfect within its prescribed context, quantisation is imperfect. The problem lies in the quantising of the waveform's amplitude. In the same way that length, an analog quantity, can be measured (e.g., in millimetres), an audio waveform can be measured (e.g., in volts). But in the same way that a measurement of length is prone to error, amplitude quantising is prone to error.

An analog waveform may be divided into a series of samples; the amplitude of each will yield a number which represents the analog value at that instant. By definition, an analog waveform has an infinite number of amplitude values, however quantisation selects from a finite number of digital values. The selected value will be only an approximation to the actual.

Specifically, after sampling, the analog staircase signal is rounded to the numerical value that comes closest to the analog value. The difference between the real values of the signal and values after quantisation appears as error, as shown in Fig.3.

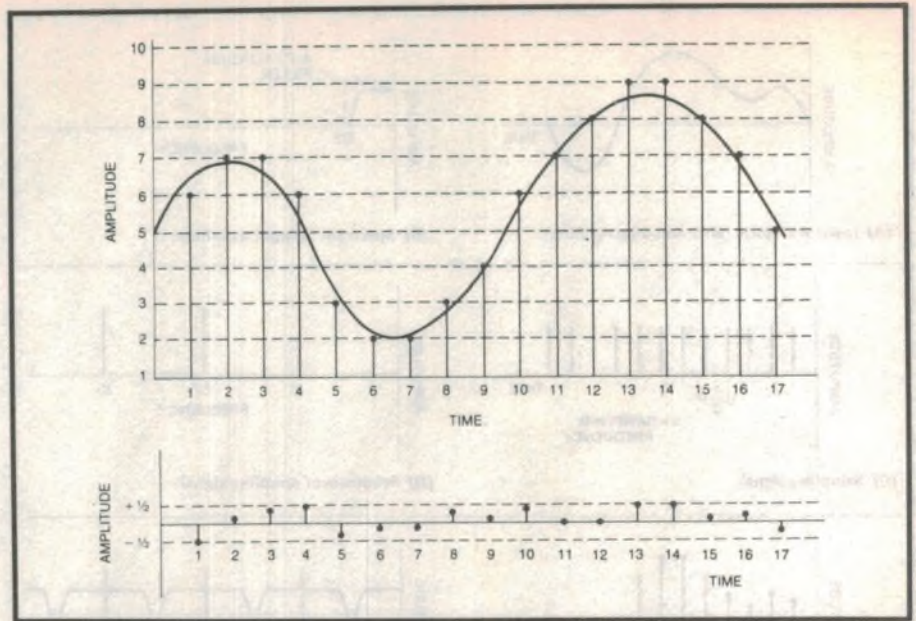

Fig.3: Quantisation error at the time of sampling.

The number of quantisation increments available is determined by the length of the digital data word in bits; in other words the number of bits in a digitisation equipment determines resolution.

Two bits would yield only four possible quantisation values: 00, 01, 10, and 11. Sixteen bits would yield 65,536 increments (from 0000000000000000 to 1111111111111111). Every added bit doubles the number of possible values, as shown in Fig.4. The more bits the better, because they provide more choices, so the steps are smaller, so the magnitude of the error is smaller.

But there will be an error associated with quantisation because the limited number of amplitude choices contained in the binary word can never completely measure an infinite number of analog possibilities.

The accuracy of a quantising system provides an important specification to measure the system's performance. Rarely the selected step will be exactly at the analog value; usually it will not be quite exact. At worst, the input analog level will be one half of a step away, that is, there will be an error of one half the value of the least significant bit of the quantisation word.

For example, suppose the binary word 011000 corresponds to the analog value of 1.20V, and 011001 corresponds to 1.30V, and the actual analog value at sample time is unfortunately 1.25V. Since '011000 and a 1/2' isn't available, the system will round up to 011001 or down to 011000; either way, there will be an error of one half of a step in magnitude.

Digital hardware performance may be characterised by a ratio of the total number of steps covered by a quantisation scheme to the maximum error. This ratio of maximum expressible amplitude to error determines the signal-to-error (S/E) ratio of the digitization system.

In terms of decibels (dB), every added bit yields about a 6dB increase in the system's S/E ratio, because it reduces the quantisation error by a factor of two. The S/E relationship can be expressed in terms of word length as

$$S/E \text{ (dB)} = 6.02n + 1.76$$

where 'n' is the number of bits. Using the formula, a 16-bit system is seen to yield an S/E ratio of about 98dB.

Dither

A purposefully-introduced random noise signal called *dither* is often used

$2^1 = 2$	$2^6 = 64$	$2^{11} = 2048$	$2^{16} = 65536$
$2^2 = 4$	$2^7 = 128$	$2^{12} = 4096$	$2^{17} = 131072$
$2^3 = 8$	$2^8 = 256$	$2^{13} = 8192$	$2^{18} = 262144$
$2^4 = 16$	$2^9 = 512$	$2^{14} = 16384$	$2^{19} = 524288$
$2^5 = 32$	$2^{10} = 1024$	$2^{15} = 32768$	$2^{20} = 1048576$

Fig.4: Every additional bit used in the sampling process doubles the number of quantisation levels.

The Australian Antarctic Division's researchers, and the equipment they depend on, must survive the harshest environment on earth.

Unfortunately, some equipment doesn't survive. And that can put lives at risk.

This is one reason why the Division now uses ICOM radio transceivers in some of the most challenging situations you could imagine.

The helicopters and small craft, which must weather out blizzards and buffeting in

durability that leaves even 'military standard' equipment for dead.

In fact the only time an ICOM radio has been left for dead in the Antarctic, it lived through it.

That was when an IC-MI2 was lost on Heard Island, a base that is always abandoned for the winter. Then twelve months later, the tiny transceiver was found again. And even though it had gone through a full year exposed to rain,



The Ball Partnership ICO 0017

sub-zero temperatures, are fitted with IC-M80 VHF radio telephones, complete with built-in loud hailers.

Research parties, which often travel up to 1000 kilometres inland to remote destinations, take an IC-M700 as their only link with base. And even inside the vehicle, the temperature often drops to -60° celsius.

Then the researchers have to go outside. And naturally, they need a radio they can take with them. So for this job, the IC-MI2 hand-helds were chosen, because they combine practical, easy to use functions with quality and

snow, sleet and seaspray, it worked immediately once a fresh battery was attached.

In that instance, ICOM reliability saved the life of a transceiver. But there have also been plenty of times when it has saved the life of its operators.

Of course, you probably won't be sending your radios to the Antarctic. Or maybe all you'll save is money if you choose the most reliable equipment.

Even so, you need a radio you can count on to be at its best when conditions are at their worst. Call ICOM.

 ICOM

Digital Audio

to remove quantisation error and extend the S/E ratio.

Dither is mixed with the analog input signal, and causes the average quantisation decision to move continuously between levels. Low level signal information is thus preserved in the form of duty cycle modulation. As a result, the resolution of a dithered system may extend below the value of the least significant bit.

With a 16-bit, dithered system, quantisation error is audibly negligible under most conditions. Note that dither must be applied to the signal *before* it is sampled. Any time after that, such as at a CD player, is too late. Professional digital audio recorders are dithered.

Sampling and quantisation are thus the two fundamental design problems for a digitisation system. Sample rate determines bandlimiting and thus frequency response, and word length determines signal-to-error ratio. Although bandlimited sampling is a lossless process, quantising is one of approximation.

In general, a sampling frequency of 44.1 or 48kHz and a word length of 16

bits yields fidelity comparable to, or better than, the best analog systems.

Applications

Using the opportunities, and obeying the limitations of sampling and quantisation, as well as error correction and other recently developed techniques, designers have devised an assortment of digital audio gear.

Recording devices include the Sony F1 family, dBX model 700, and Sony 1610/1630 processors which employ video tape recorders to store the numerical data. Professional, stationary head recorders, both two-track and multi-track, include the Sony and Studer DASH recorders and Mitsubishi PD recorders.

Signal processors have enjoyed a renaissance with the advent of digital audio technology. Digital delay, reverberation, spatial processors, equalisation, compressors and limiters have all been implemented digitally.

Digital mixing consoles are in common use, and almost every professional analog board uses automation, another application of digital techniques. Likewise, music production methods have changed, adapting to the flexibility of

new hardware.

Musical instruments have evolved rapidly over the last few years. At the same time, music composition and performance has been affected by digital audio technology. At the other end of the spectrum, audio test equipment is a far cry from that of the days of analog.

Clearly, digital audio technology has already transformed the audio electronics industry. And yet the biggest changes are perhaps yet to come.

Thus far, digital electronics has essentially been substituted for analog circuitry. Although far from transparent, the shift has been gradual to both help users accommodate the change, and allow digital technology to mature. Now that the technology has developed considerable clout, we'll see entirely new products hitherto impossible to build with analog circuits.

In other words, although things have already changed considerably, the digital audio revolution is yet to come.

Oversampling

While much of digital audio technology is (relatively) straightforward, at least two topics have provided a consensus of audiophiles with considerable perplexity, particularly with reference to

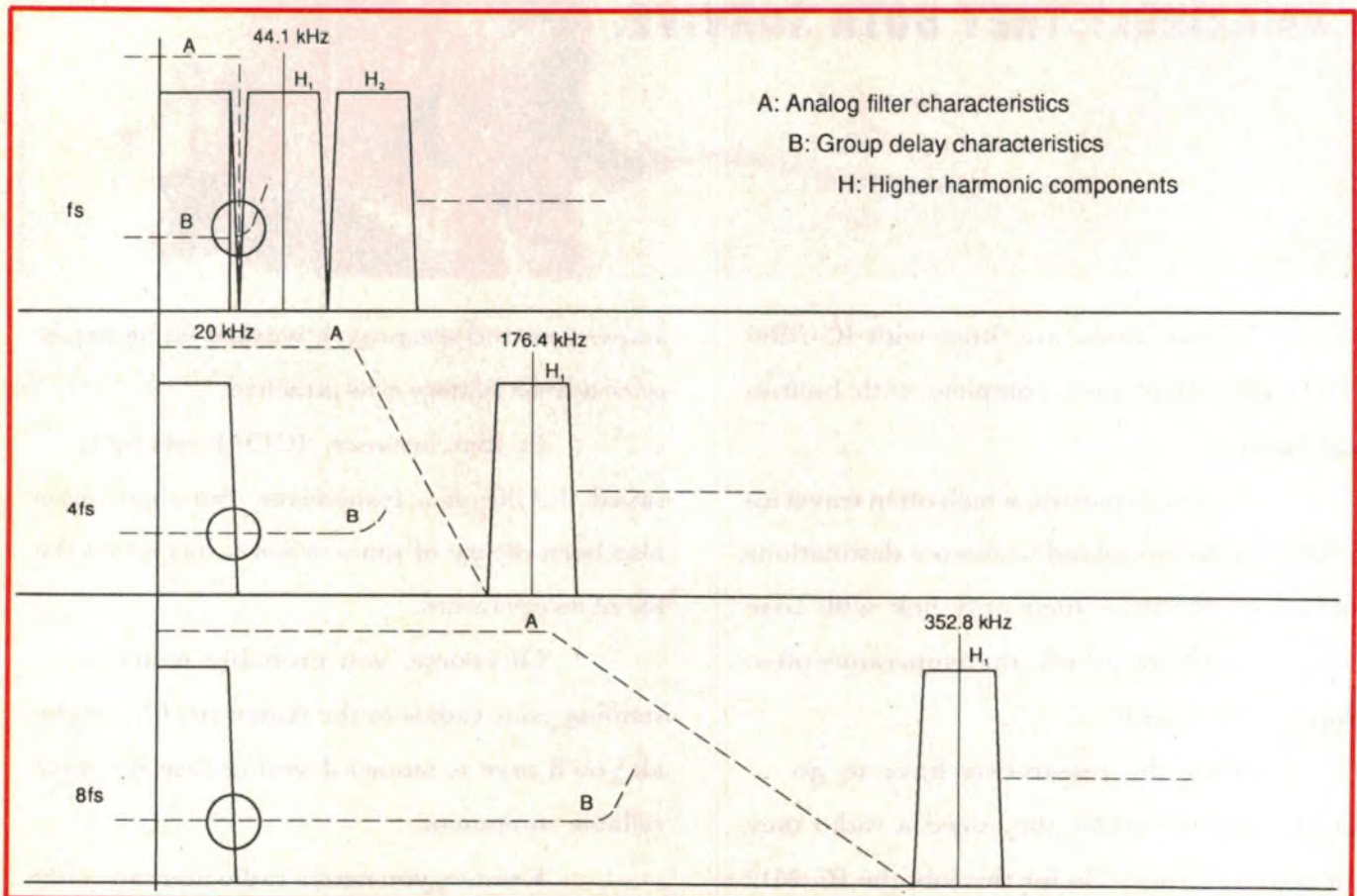

Fig.5: Four-times oversampling shifts the first image of a CD signal to 176.4kHz, and 8-times to 352.8kHz.

CD players. These topics are digital filter oversampling, and 18-bit D/A conversion.

The first problem with digital oversampling filters is that people think they're trickier than they really are. A digital filter does the same job as an analog filter, only it does it with numbers. Numbers come in, are processed, and leave. Because the numbers leaving the filter are different than those entering, and because they are different in a specific way, the signal has been filtered.

In the case of CD players, as we've discussed, we must lowpass filter the output signal.

This is where oversampling comes in: The number of samples leaving the filter is greater (by a multiple of 2, 4, 8, or more times) than the samples entering the filter. To accomplish this, obviously we must generate more samples; specifically we compute additional samples (1, 3, 7, etc. of them) between each original sample.

To do this, we might average the current input sample with the previous input sample by adding the two together, and dividing by two. The exact way in which we do the calculation determines the filter's characteristic. In this case, we shoot for a steep filter characteristic.

The payoff comes when we examine the spectrum of this new signal after D/A conversion. As a result of oversampling, the output image spectra are shifted to the corresponding multiple frequency of the sampling frequency.

For example, 4-times oversampling shifts the first image to 176.4kHz, and 8-times oversampling shifts it to 352.8kHz, as shown in Fig.5. When shifted to such ultrasonic frequency ranges, images may be easily removed by a low order analog filter - which is cheap to build, doesn't drift with temperature, and mainly doesn't suffer from all the problems inherent in analog brickwall filters.

The analog filter is also free of phase distortion. That's the other payoff with oversampling - the digital filter itself is largely free of phase error, and the distortion from the gentle analog low pass filter following it is also negligible.

The bottom line is this: it's easier to do filtering in the digital domain, and it performs better too. For all of these reasons and more, most current CD players use oversampling filters.

But don't be suckered by oversampling rates; that is only a means employed to an end. A higher rate doesn't necessarily mean better performance.

For example, Philips has a 256-times oversampling chip set, but it's only a short-cut to simpler D/A conversion and the chips are intended strictly for low-end to medium fidelity applications.

18-bit conversion

The other perplexing problem is 18-bit conversion. Manufacturers of CD players have introduced 18-bit conversion using both floating 18-bit conversion, or linear 18-bit conversion methods. The question is: How can 18-bit conversion improve playback fidelity for 16-bit CD recordings?

The answer to this lies in understanding the flaws inherent in D/A converters. Except in theory, 16-bit converters cannot fully decode a 16-bit signal without a degree of error. When 18 bits are derived from the stored data and converted through 18-bit conversion, errors can be reduced and reproduction specifications improved.

In short, in order to realise the full potential of audio fidelity for the end user, the signal digitisation and processing steps must have a greater dynamic range than the final recording.

In a perfect world, with perfect 16-bit converters, that's all we would need for CD playback. But the world isn't perfect: 16-bit converters aren't perfect. We need more bits to improve conversion. When correctly done, 18-bit conversion improves the amplitude resolution of the player by ensuring a more linear conversion of the disc's 16-bit signal. In fact, the two extra bits of a linear 18-bit converter would not have to be connected to yield improved 16-bit performance.

But where do those extra 2 bits come from, when there's only 16-bit numbers coming from the compact disc? Here again oversampling solves the dilemma.

When the 44.1kHz, 16-bit signal is oversampled, both the sampling frequency and number of bits are increased - the former because of oversampling, and the latter because of the multiplication which must take place. For example, the output of an oversampling filter may be 352.8kHz and 32 bits. We can use 18 of those, and discard the rest.

Is there any advantage to using more than 18 bits? You bet there is - provided it actually improves the linearity of the 16 bit conversion. Denon has already introduced a 20-bit architecture.

Of course, the number of bits isn't a magic number. Don't shop for players on that basis alone - be sure and compare the most important numbers of all: measured specifications.

YOU DON'T HAVE TO GO TO THE ANTARCTIC TO SEE THE ICOM RANGE.

VICTORIA:

Melbourne. Associated Calibration Lab.

(03) 842 8822. Bairnedale. Bairnedale

Communications. (051) 52 4622. Bendigo.

Bendigo Communications (054) 47 8647.

Warrnambool. Ansonic Electronics.

(055) 62 9688. Wendouree. Wecam

Communication. (053) 39 2808.

NEW SOUTH WALES:

Sydney. Argent Pty. Limited. (02) 671 3333.

Captain Communications. (02) 633 3545.

Master Communications. (02) 682 5044.

Raymond Terrace. Albac Communications

(049) 87 3419. West Gosford. Pacer

Communications. (043) 24 7844. Wollongong.

Macelec. (042) 29 1455.

SOUTH AUSTRALIA:

Adelaide. Jensen Communications.

(08) 269 4744. Transceiver Services.

(08) 42 6666.

QUEENSLAND:

Brisbane. Delsound. (07) 839 6155.

Mobile Communications (Qld). (07) 277 4311.

Mackay. D.S. Marine. (079) 51 1635. Mackay

Communications. (079) 51 3544. Cairns.

Integrated Tech. Services. (070) 51 8400.

Gladstone. Jones Communications.

(079) 72 1116. Townsville. Tradewinds Sailing

School. (077) 72 4021.

WESTERN AUSTRALIA:

South Fremantle. McCorkills Coastal.

(09) 335 5875. Perth. Communication Systems

Aust. (09) 445 1333. Boulder. Hock

Communications. (090) 93 1700.

TASMANIA:

Launceston. Marcom Watson. (003) 31 2711.

Hobart. Marcom Watson. (002) 34 4500.

NORTHERN TERRITORY:

Darwin. Integrated Technical Services.

(089) 81 5411. Alice Springs. Farmer

Electronics. (089) 52 2388.

ICOM AUSTRALIA HEAD OFFICE:

7 Duke Street, Windsor, Victoria. 3181.

Phone: (03) 529 7582.



ROD IRVING ELECTRONICS



IBM* COMPATIBLE CARDS

- EGA CARD only \$330
- 20 M/Byte Hard Disk Card \$695
- PAL/EPROM Prog. Card ... \$245
- 3 M/B RAM CARD
- (AT) Excluding RAM \$239
- Colour Graphics \$99
- Floppy Disk Controllers
- 360 K \$52
- 360K/1.2/1.44MB \$139
- Printer Card \$29
- Multi I/O Card \$145
- Mono Graphics Printer/TTL \$109
- Games Card \$29
- RS232 Card \$55
- RS232 & Clock Card \$65
- Hard Disk Controller Card \$195
- XT 8 MHz Turbo Motherboard excluding RAM \$169
- XT 10 MHz Turbo Motherboard excluding RAM \$199



ROD IRVING ELECTRONICS

SYDNEY: 74 Parramatta Rd
Stanmore 2048
Phone (02) 519 3134
Fax (02) 519 3868

MELBOURNE: 48 A'Beckett St.
Phone (03) 663 6151

NORTHCOLE: 425 High St
Phone (03) 489 8866

CLAYTON: 56 Renver Rd.
Phone (03) 543 7877

MAIL ORDER & CORRESPONDENCE:
P.O. Box 620, CLAYTON 3168
Order Hotline: 008 33 5757
(Toll free, strictly orders only)
Inquiries: (03) 543 7877
Telex: AA 151938
Fax: (03) 543 2648



ORDER HOTLINE
008 335757
(TOLL FREE)

STRICTLY ORDERS ONLY

LOCAL ORDERS & INQUIRIES
(03) 543 7877

POSTAGE RATES:
\$1 - \$9.99 \$2.00
\$10 - \$24.99 \$3.00
\$25 - \$49.99 \$4.00
\$50 - \$99.99 \$5.00
\$100 plus \$7.50

The above postage rates are for basic postage only. Road Freight bulky and fragile items will be charged at different rates.

All sales tax exempt orders and wholesale inquiries to:
RITRONICS WHOLESALE
56 Renver Road, Clayton
Phone: (03) 543 2166 (3 lines)
Fax: (03) 543 2648

Errors and omissions excepted. Prices and specifications subject to change.

IBM*, PC*, XT*, AT* are registered trademarks of International Business Machines. Apple is a registered trademark. Demos are registered trademarks of their respective owners.



BABY AT* COMPATIBLE COMPUTER! \$1,995

- Final assembling and testing in Australia!
- 1 M/Byte Main Board, 640K fitted
- Switchable 8/10/12 MHz
- 1.2 M/Byte Floppy Disk Drive
- 80286 CPU
- Colour Graphics Display Card
- 8 Slots
- Floppy & Hard Disk Controller
- Printer Card and RS232
- Keyboard
- 200W Power Supply
- Manual
- 6 Months Warranty
- Size: 360(W) x 175(H) x 405(D)mm
- With 20 M/Byte Hard Disk \$1,995
- With 40 M/Byte Hard Disk \$2,195
- With 80 M/Byte Hard Disk CALL



IBM* XT* COMPATIBLE COMPUTERS FROM \$895

Check these features and our prices. We're sure you'll agree they're exceptional value for money!

- Final assembling and testing in Australia!
- Fast TURBO Motherboard
- AT* style keyboard
- Tested by us for 24 hours prior to delivery!
- 8 Slot motherboard
- 12 months warranty!
- 150W power supply

*\$895 WORKSTATION COMPATIBLE COMPUTER

256K RAM, Single Drive, Graphics and Disk Controller Card \$895

640K RAM TURBO COMPATIBLE COMPUTER

2 x 360K Disk Drives, Multifunction Card, Colour Graphics, Disk Controller, 1 Serial, Parallel Port (Includes Timer Disk) \$1,095

WITH 20 M/BYTE HARD DISK:
● single 360K Disk Drive \$1,395
● dual 360K Disk Drives \$1,595

WITH 40 M/BYTE HARD DISK:
● single 360K Disk Drive \$1,595
● dual 360K Disk Drives \$1,795



IBM* XT* COMPATIBLE CASE

XT* size and styling. Features security key switch, 8 slots, and mounting accessories.
Size: 490(W) x 390(D) x 140(H)
Cat. X11090 only \$69



8087 CHIPS

Genuine Intel chips with manual and data sheets packed in boxes!

8087-3 (4.77MHz)	\$245
8087-2 (8MHz)	\$350
8087-1 (10MHz)	\$475
80287-6 (6MHz)	\$375
80287-8 (8MHz)	\$555
80287-10 (10MHz)	\$690
80387-16 (16MHz)	\$995
80387-20 (20MHz)	\$1460
80387-25 (25MHz)	\$1860

RAM CHIPS!

Description	1-9	10 plus
4164-12	\$8.95	\$7.95
4164-15	\$7.95	\$7.50
41256-12	\$34.95	\$32.95
41256-15	\$32.95	\$29.95



DUST COVER

Keep your computer and accessories free of dust and grime while not in use.

XT* Cover Set (C21066) \$14.95
AT* Cover Set (C21068) \$16.95

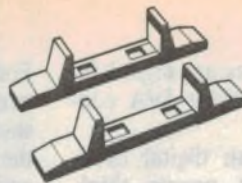

2 PIECE, VERTICAL COMPUTER STAND

SAVE VALUABLE DESK SPACE BY PLACING YOUR PC ON ITS SIDE ON THE GROUND!

- Adjustable width from 119-225mm
- Accommodates IBM*PC/XT/AT and most compatibles
- Stable 2-piece design

C21077 \$24.95



APPLE* COMPATIBLE SLIMLINE DISK DRIVE

Compatible with Apple 2+
Cat. X19901 Only \$179
FREE PACK OF S/S DISKS WITH EACH DRIVE!

APPLE* IIC COMPATIBLE DISK DRIVE

(including cable only \$199
FREE PACK OF S/S DISKS WITH EACH DRIVE!
(*Apple is a registered trade mark.)

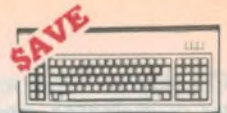

IBM* XT* COMPATIBLE KEYBOARD

- 100% IBM* PC*, XT* compatible
 - Low profile keyboard design
 - Proper placement of shift keys with large key tops to suit professional typists
 - 3 step height/angle adjustment
 - Cherry brand TS-M00001 19mm low profile switches, meet 30mm ergonomic requirement and provides high performance and maximum reliability
 - Curl lead plugs straight into PC
 - 3 Status displays
- Just like the "Real McCoy" only at a fraction of the price!
Cat. X12020 only \$89



RS232 GENDER CHANGERS

- Saves modifying or replacing non-mating RS232 cables.
 - All 25 pins wired straight through
- Cat X15650 Male to Male
Cat X15651 Male to Female
Cat X15652 Female to Female
Normally \$14.95 each
Only \$9.95^{ea}

MONITOR PRICE BREAK-THROUGH!



GOLDSTAR 20MHz COMPOSITE MONITOR
X14516 AMBER only \$89
10 OR MORE \$85 EACH

GOLDSTAR 12" TTL MONITOR
X14500 GREEN only \$99
X14502 AMBER only \$99
10 OR MORE \$95 EACH



DELUXE JOYSTICK

Deluxe micro switch controlled joystick with standard 9 pin connector

- Dual firing buttons contoured for quick response
 - Lightweight design for maximum comfort and playing time
 - Handle is contoured to match your hand
 - Stabilising suction feet
 - Suitable for Atari: 400/800 computers, Commodore* VIC 20/64, Amstrad* CPC464, Sears* games and SV318/328 computers
- C14217 \$34.95



RITRON CGA COLOUR MONITOR
Quality monitors without the exorbitant price tag!
Display Tube: 14 inch 90° deflection 0.39mm Dots trio pitch
Dark face screen
Phosphor: P22
Resolution: 640 dots (horizontal) 240 line (vertical)

..... only \$495



RITRON 2 MONITORS

Stylish 20MHz monitors available in green or amber displays and with built-in swivel and tilt base

SPECIFICATIONS:
CRT Display Size: 12 inches non-glare 90 degree deflection
Input Signal: 1.0 - 2.5V p-p composite video signal
Input Impedance: Normal 75 ohm, high approximately 50K ohm
Input Terminals: RCA phone jack.
Rise and Fall Time: Less than 25 us
Video Bandwidth: 20MHz
Corner: 800 lines
Geometric distortion: 2% or less
Linearity: less than 2%

Controls:
Front: Power On/Off, brightness, contrast
Rear: Vertical hold, Horizontal hold, Vertical line, Vertical size
Green Cat. X14506 \$179
Amber Cat. X14508 \$179
ONLY \$119



RITRON EGA COLOUR MONITOR
Quality monitors without the exorbitant price tag!
Display Tube: 14 inch 90° deflection dot type black matrix.
Standard persistence phosphor
Active Display Area: 240 x 180mm
Resolution:
64 Colour: 720 dots(H) x 350 lines
16 Colour: 640 dots(H) x 200 lines
..... only \$695



RITRON VGA COLOUR MONITOR
Quality monitors without the exorbitant price tag!
Display Tube: 14 inch 90° deflection P22 Non-glare, tint 0.31mm Dot pitch.
Active Display Area: 245 x 185mm
Resolution:
800 dots(H) x 600 lines(V)
Display Colour: TTL input
TTL input: 8/16/64 colours
Analog input: unlimited colours
..... only \$995

BARGAIN!

PRINTER RIBBONS TO SUIT:
CP80, SX80, DP80, BX100 MB100
 1-9 (C22036) 10-
\$8.95 \$7.95



STAR NX1000 PRINTER
 • 144 c.p.s. high speed draft printing
 • 36 c.p.s. NLO printing
 • 8 built-in NLO fonts
 • Proportional printing available in all font styles
 • Convenient push button control panel
 • Paper parking mechanism
 • Tractor and friction feeds standard
 • Standard parallel interface
 • Two emulation modes: IBM Proprinter II, EPSON ESC/P
 C22049 **\$495**

MX70/80 FX70/80 RX70/80
 1-9 (C22031) 10-
\$8.95 \$7.95

MX100, FX100, RX100
 1-9 (C22002) 10+
\$19.95 \$18.95

LX80
 (C22003) 10-
\$9.95 \$8.95

LQ1000
 (C22012) 10+
\$27.60 \$25.00

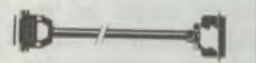

PRINTER LEAD
 • Suits IBM PC/XT, compatibles
 • 25 pin "D" plug (computer end) to Centronics 36 pin plug
 P19029 (1.8 metres) **\$14.95**
 P19030 (3 metres) **\$19.95**
 P19032 (9.5 metres) **\$39.85**



MOUSE MAT
 • A quality mouse mat for accurate and comfortable tracking
 • Anti-static
 • 265 x 225mm
 C21075 **\$9.95**



PANASONIC KX-P1081 DOT MATRIX PRINTER
 • 120 C.P.S.
 • Pica or Elite character set
 • Print Modes: NLO, Dot Graphics, Draft, Proportional Font.
 • Reliable and Compact
 • Proportional Printing
 • Logic Seeking
 • 1K Printer Buffer
 C20035 Normally \$595
 We won't be beaten! **only \$379**

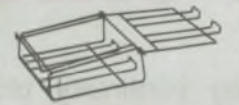

PRINTER STANDS
 • Restores order to your work area
 • Conveniently stacks paper printout in document tray automatically
 • Made of black plastic coated steel
 • Suitable for most printers
 • Excellent value at this price!
 C21056 **\$29.95**



5 1/4" DISK STORAGE (DD100-L)
 Efficient and practical. Protect your disks from being damaged or lost!
Features...
 • 100 x 5 1/4" disk capacity
 • Smoked plastic hinged lid
 • Lockable (2 keys supplied)
 • High impact ABS plastic base
 • Contemporary design
 C18020 **only \$15.95**



"NO BRAND" DISKS!
 Now you can buy absolute top quality disks that are also the cheapest in Australia! They even come with a lifetime warranty, which indicates the quality of these disks. So why pay 2-3 times the price for the same quality?

Packs of 10, D/S D/D without boxes, or brand name, just their white paper jacket, and index labels (5 1/4" disks includes write protects).

5 1/4" 2S/2D "NO BRAND" DISKS
 10+DISKS 100+DISKS 1,000+DISKS
\$6.75^{ea} \$6.50^{ea} \$6.25^{ea}
 ALL PRICES PER 10 DISKS

5 1/4" HIGH DENSITY DISKS (DOUBLE SIDED)
 10+DISKS 100+DISKS 1,000+DISKS
\$21^{ea} \$20^{ea} \$19^{ea}
 ALL PRICES PER 10 DISKS

3 1/2" 2S/2D "NO BRAND" DISKS
 10+DISKS 100+DISKS 1,000+DISKS
\$21 \$20 \$19
 ALL PRICES PER 10 DISKS.



MICRODOT DISKS!

DESCRIPTION	1-9 BOXES	10+ BOXES
3 1/2" 2S/2D	\$32.95	\$30.95
5 1/4" 1S/2D	\$ 9.95	\$ 9.50
5 1/4" 2S/2D	\$11.95	\$10.95
5 1/4" 2S/HD	\$23.95	\$22.95



VERBATIM DISKS!

(ALL PRICES PER BOX OF 10 DISKS)

DESCRIPTION	1-9 BOXES	10+BOXES
3 1/2" 1S/2D ...	\$39.95	\$37.95
3 1/2" 2S/2D ...	\$46.95	\$43.95
3 1/2" 2S/HD ..	\$99.00	\$89.00
5 1/4" 1S/2D ...	\$22.00	\$21.00
5 1/4" 2S/2D ...	\$26.00	\$24.00
5 1/4" 2S/4D ...	\$75.00	\$70.00
5 1/4" 2S/HD ..	\$41.00	\$39.00

NOW OPEN IN SYDNEY!

74 PARRAMATTA RD, STANMORE
 PHONE (02) 519 3134



MITSUBISHI 5 1/4" DRIVE 4851/MF501
 Slimline 5 1/4" disk drive, double sided, double density 500K unformatted, 360K formatted 40 track/side. Steel band drive system.
 Cat. C11901 **\$239**

MITSUBISHI 5 1/4" DRIVE 4854/MF504
 Slimline 5 1/4" disk drive, double sided, high density, 1.6MB unformatted, 1.2MB formatted.
 Cat. C11904 **\$279**

MITSUBISHI 3 1/2" DRIVE MF353C
 Double sided, double density, 1MB unformatted, 720K formatted.
 C11908 **\$239**
 C11909 incl 5 1/4" mount bracket **\$269**

MITSUBISHI 3 1/2" DRIVE MF355
 1.6M unformatted, 1.44M formatted.
 C11910 **\$269**
 C11911 incl 5 1/4" mount bracket **\$299**

5 1/4" MOUNTING BRACKET KIT FOR 3 1/2" DRIVE
 X11050 **\$29**



DIRECT IMPORT 5 1/4" DISK DRIVE!
 Double sided, double density, 500K unformatted, 360K formatted.
 Direct Import price **Only \$139**



THE BUTTON SPIKE PROTECTOR
 Surges and spikes are caused not only by lightning strikes and load switching but also by other equipment being switched on and off, such as fluorescent lights, electric motors, fridge freezers, air conditioners, etc.
 For effective protection such spikes must be stopped before they reach your equipment. Simply plug The Button into an outlet and it will protect all equipment plugged into adjacent outlets on the same branch circuit. The Button employs unique metal oxide varistor technology and will dissipate 150 joules of electrical energy, (nearly twice that of comparable surge arresters.)
SPECIFICATIONS:
 Voltage: 240V Nominal
 Total Energy Rating: 150 joules
 Response Time: 10ns
 Protection Level: 350V peak
 **\$34.95**



3 1/2" DISK STORAGE (DD80-L)
 • Holds up to 80 x 3 1/2" diskettes
 • Smoked plastic hinged lid
 • Lockable (2 keys supplied)
 • High impact plastic base
 • Contemporary design
 C16038 **only \$19.95**

3 1/2" DISK STORAGE
 • Holds up to 40 x 3 1/2" diskettes
 • Lockable (2 keys supplied)
 • High impact plastic lid and base
 C16035 **only \$14.95**



20 M/BYTE HARD DISK
 Tandem drive with controller card. IBM compatible. 12 month warranty.
 X20010 **ONLY \$495**

42 M/BYTE HARD DISK
 MiniScribe drive, IBM compatible. 50 M/Byte unformatted. 12 month warranty.
 Without controller ... **\$595**
 With controller **\$695**

80 M/BYTE HARD DISK
 Seagate drive, IBM compatible. 12 month warranty.
 X20030 **Please call**

Grand Hobby Contest Winner, Advanced Section:

Beepo – Continuity tester supremo!

Meet Beepo, the all singing, all dancing continuity tester design which won the Advanced section of our Grand Aussie Hobby Electronics Contest. It features three tones, operation over six decades of resistance, auto polarity reversal and an ambient current so low that it needs no on/off switch – all in a tiny low-cost package which fits easily into a pocket or toolkit.

by **WEN LIANG SOONG**

An almost classic project in electronic magazines is the audio continuity tester. These range from the simple battery and buzzer type, to ones which can tell the difference between a genuine “dead short” and a forward biased diode junction. This project is the result of combining as many of these features as possible, into the smallest space.

Beepo has three tones, a ‘buzz’ for resistances between one megohm and one kilohm, a ‘beep’ for resistances between one kilohm and one ohm, and an ‘eek’ for resistances below one ohm. Forward biased diode junctions will give a ‘beep’, while only devices which can pass a few mA with a voltage drop of less than a few mV will give an ‘eek’.

To save lead swapping, the polarity of the test voltage changes at a rate of about one hertz. It spends about two thirds of a second in one direction and about one third of a second in the reverse polarity. This allows diodes to be detected, and the polarity determined, by whether the tone consists of short ‘beeps’ or long ‘beeps’.

A side effect of the automatic polarity reversal is that capacitors can be detected and their value roughly determined. As a guide, for 1 μ F a series of ‘buzzes’ is produced, for 100 μ F an alternating series of ‘beeps’ and ‘buzzes’, and for thousands of μ F, almost continuous ‘beeping’.

The maximum output voltage of 3V and current of 3mA is small enough not to damage even the most sensitive circuitry.

All the above features are obtained

from a circuit which fits into the smallest zippy box (only just, mind you!), and has such a low quiescent drain that it does not require an on/off switch.

An audible continuity tester gives ‘ballpark’ resistance indication, while you are keeping your eyes where they belong, on the probes. It also provides a much faster response than that available on digital multimeters. There may not be a lot of difference for small cir-

cuits, but wait till you have to check a computer memory board!

Beepo is particularly useful in ‘in-circuit tests’. Its wide indication range allows you to check for instance, for short circuits on a power supply bus with its multitude of diodes and capacitors. After a bit of practice, a lot of information about the impedance between the probes can be determined just from the tone.

How it works

The circuit of Beepo can be readily split into a number of blocks – refer to the circuit diagram.

In broad terms, low powered CMOS oscillator produces a rectangular output waveform which has an uneven duty cycle. This is fed to the resistance under test via a current limiting resistor. A current sensor detects if the load is drawing any current. If a 1M or less resistor is connected to the output, the current sensor trips, and applies power to the tone generator and the window comparators.

The window comparators detect if the voltage across the test resistor is within

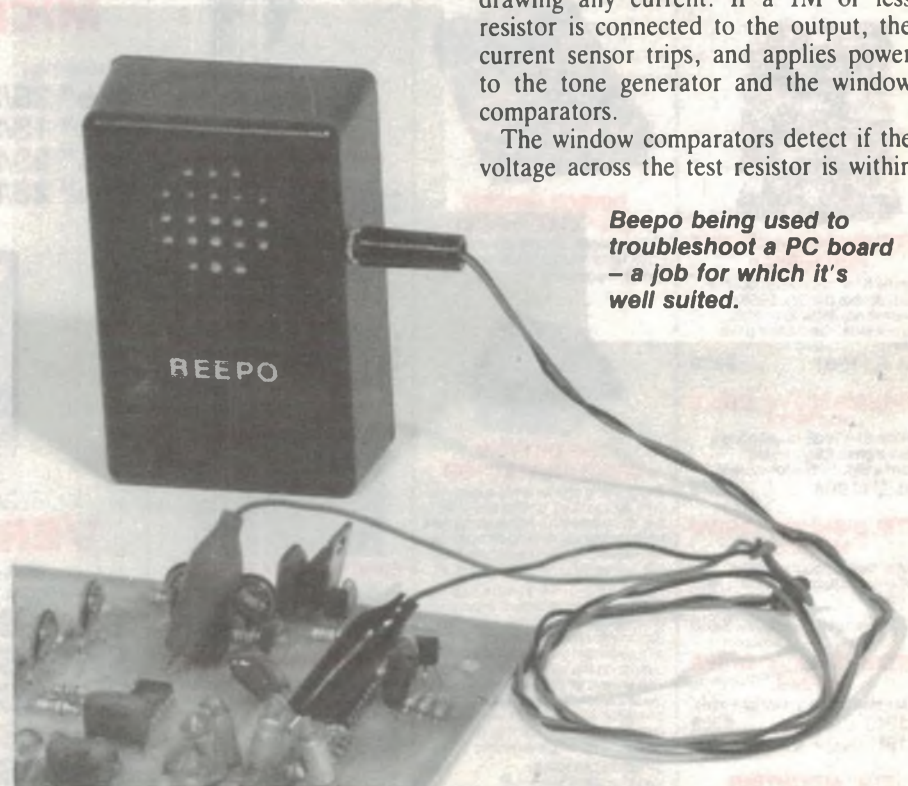

Beepo being used to troubleshoot a PC board – a job for which it's well suited.

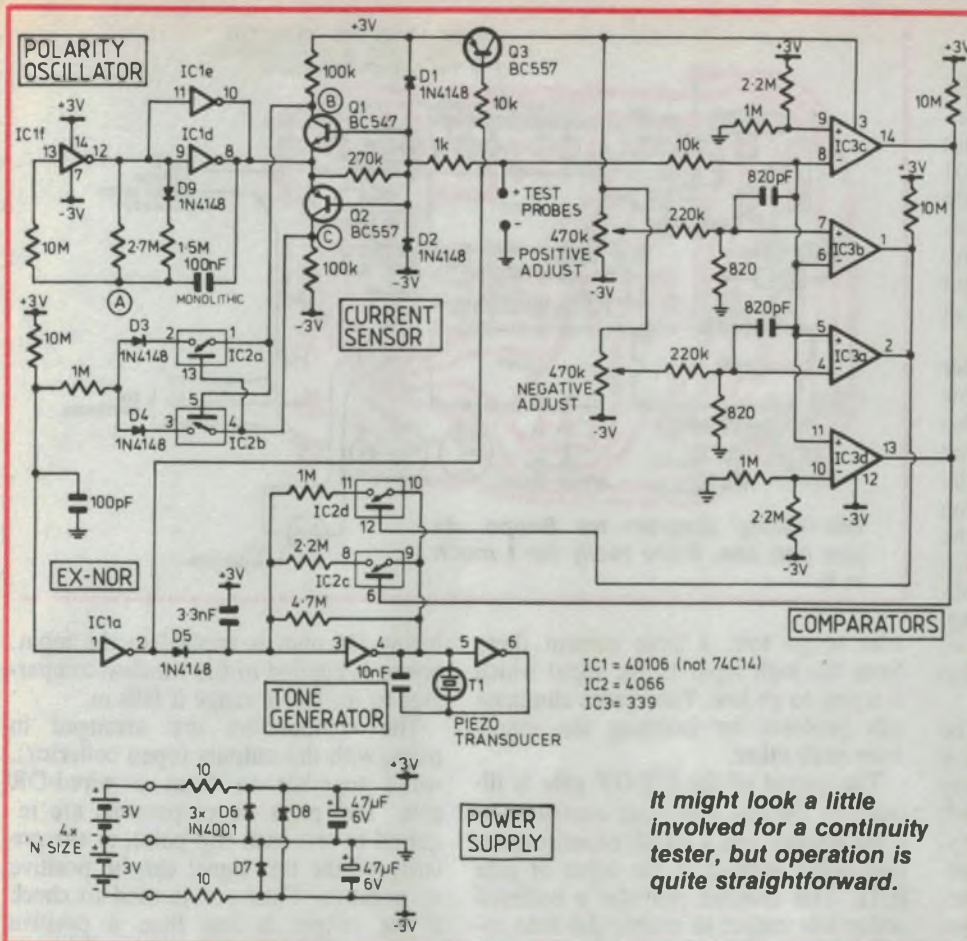

It might look a little involved for a continuity tester, but operation is quite straightforward.

Specifications

External Resistance

less than 1 ohm – high frequency tone 'eekk!'
 between 1ohm and 1k – mid frequency tone 'beep'.
 between 1k and 1M – low frequency tone 'buzz'.

Diodes

forward biased – long beeps
 reverse biased – short beeps.

Capacitors

small valued (1uF) – series of beeps.
 larger valued (100uF) – alternating beeps and buzzes
 very large (10000uF) – almost continuous beeping.

Output characteristics

max current – 3mA
 max voltage – 3V
 can withstand up to about 30V applied to the input for short periods.

Power supply requirements

Uses 4 type "N" size cells
 Quiescent drain is low,
 max40uA

- Life
1. zinc carbon = about 1yr.
 2. alkaline = about 2yrs. (limited by shelf life not capacity).

No on/off switch required.

a set magnitude range. The mid resistance sensor gives an output for voltages less than about a volt, and the low resistance sensor activates if the output is less than a few millivolts. These sensors then activate the appropriate tone.

That's enough of a general description, lets get down to the nitty gritty.

The circuit uses three readily available IC's. IC1 is a 40106 CMOS hex Schmitt trigger, IC2 is a 4066 CMOS analog quad bilateral switch, and IC3 is a 339 single rail quad comparator.

The polarity oscillator forms the heart of the tester. It is named after its job of changing the polarity of the test voltage every second or so. It is the only oscillator which remains active when the circuit is in the quiescent state.

The oscillator is of the standard ring format. This is normally used for non-Schmitt input gates. In this case it was used in preference to the much simpler one resistor and one capacitor oscillator, due to its much lower current drain (10uA compared to 50uA). Note a low current drain is only obtained using a 40106; if a pin for pin compatible 74C14 is used instead, the current drain remains constant for both configurations at 50uA. Thus do not be tempted to use a 74C14.

The reason for the decreased operating current is probably as follows: Schmitt trigger gates draw a lot of current when the input voltage is near the switching point. In the simple oscillator the input voltage remains close to the thresholds at all times and hence there is a high current drain. In the ring oscillator, the voltage swing at the input of the first gate is a lot greater, out of the

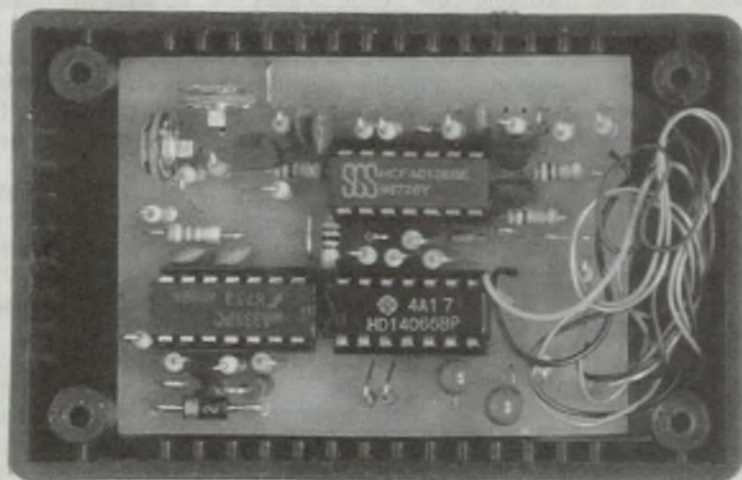

A look inside the case, very close to actual size. the piezo speaker and batteries are under the PC board.

Beepo

The output of the oscillator actually consists of two gates IC1e & d, connected in parallel for a higher output current capability. This is fed into Q1 and Q2, which form a sort of pseudo 'bipolar' common emitter amplifier. This configuration features very low impedance between the input and output terminals, and a high sensitivity to small currents.

To visualise its operation, consider when the output of the oscillator is low (i.e., -3V), this cuts off Q2. It also applies slightly less than -3V to the load (which is connected to ground at the other end). Any current flowing through the load passes through the base/emitter junction of Q1, which forms a sort of common emitter amplifier. If sufficient load current is flowing, Q1 saturates, and its collector goes low. Now as Q2 is cut off, its collector is also low.

A similar chain of events occur if the output of the oscillator is high, except that Q1 is now cut off and the polarity of the levels are inverted. The net result is that if a load of less than 1M is applied to the test terminals, then the output of the collectors will be the same, otherwise they will be different. Thus an Exclusive OR gate is the ideal device to use to test for loads.

The sensitivity of the pair of transistors is so high that it must be trimmed back by placing a resistor in parallel with the bases. This value is chosen so that the current drawn by a 1M resistor is just sufficient to trigger the circuit. That is, it sets the maximum detectable resistance.

The output of the current sensor goes to the output via a 1k current limiting resistor, which sets the maximum current to a safe plus or minus 3V. The two diodes D1 and D2 connected to the bases of the transistors protect them from externally applied voltages.

The operation of the EX-OR gate is as follows. If both inputs are low, then both switches will be off, and the output will go high due to the pull up resistor. If one input is high, it switches the output to the other input. Thus if one is high and one is low, then the output will be low. However if both inputs are high, then the output will be also high. Thus this circuit acts as an Exclusive-OR gate.

To see the necessity of the two diodes D3 and D4 consider the case when both inputs are high. Here the inputs would be effectively shorted together if the diodes were not present. Now if one

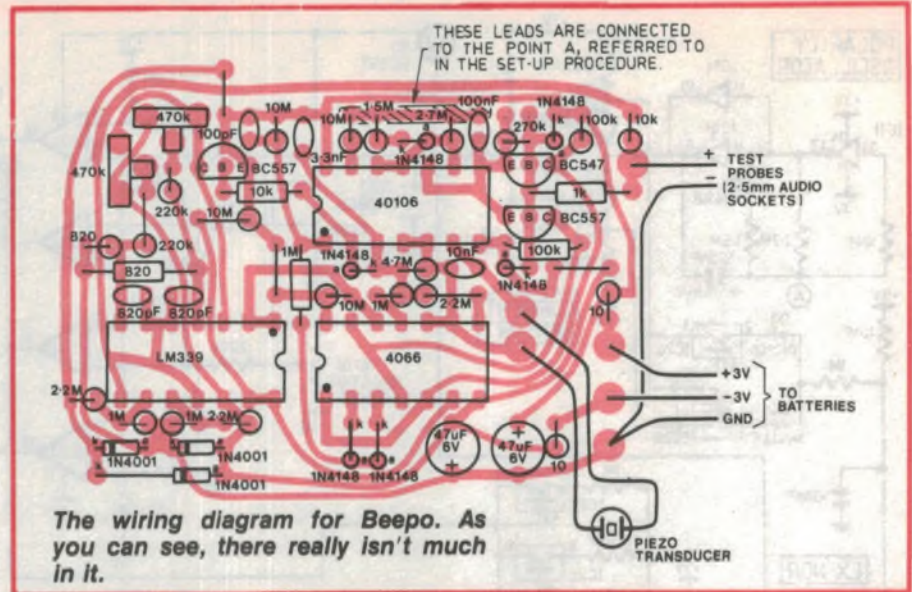

tries to go low, a large current flows from the high input to the input which is trying to go low. The diodes eliminate this problem by isolating the inputs from each other.

The output of the EX-OR gate is filtered by the low pass filter consisting of a 1M resistor and a 100pF capacitor, before being applied to the input of gate IC1a. This inverter provides a buffered active low output to enable the tone oscillator and to apply power to the window comparators.

The tone oscillator generates the three tones. It consists of a simple Schmitt trigger/oscillator IC1b with a switchable resistance component. The switch is done by a pair of analog switches (IC2c and d).

In the quiescent mode, the normally high output of IC1a forces the input of IC1b high via diode D5. However when a low resistance is detected the output of IC1a goes low, allowing the oscillator to start.

The analog switches are controlled by the window detectors. The resistors switched in, in parallel with the fixed 4.7M resistor determines the output tone.

The output of the tone oscillator drives piezo-electric transducer T1 in a bridge configuration, with another inverter IC1c for maximum volume. The element is padded with a 10nF capacitor to modify the sound.

The window comparator uses a 339, which is a low power single rail quad comparator. Even though the comparator is low power, it draws too much current to be left on permanently. Thus it is gated on with PNP transistor Q3, which supplies some of the potential dividers also. Hence when a resistance

below 1M ohm is applied to the input, power is applied to the window comparator to see which range it falls in.

The comparators are arranged in pairs, with the outputs (open collector), wired together to form a wired-OR gate. Two pairs of comparators are required to test each trip point, as the polarity of the test signal can be positive or negative. Thus one is used to check if the output is less than a positive reference level, and the other checks if it is greater than a negative reference level. Together, they determine if the input lies within a set range, a set 'window' hence the term *window comparator*.

The reference level for the 1k trip point is about one volt, however for the one ohm trip point the reference levels are about 3mV. As the offset voltage of the inputs of the comparator are about this magnitude, two pots are used to null these errors.

Note that with the test leads open circuit, the 339 is unpowered, yet the full test signal is applied to the inputs of the comparators. This would be a 'no-no' with most comparators, but not with the 339. This has the special feature that the inputs can be taken up to about thirty volts without them drawing more than the normal bias currents, independent of the supply voltage (even if it is zero).

The small capacitors between the inputs of the 'one ohm' comparators are used to reduce switching oscillations. Their exact value is non critical; any value between 500pF and 1nF would be reasonable.

The four N-size 1.5V cells are arranged to give plus and minus three volt rails, and ground. The three power

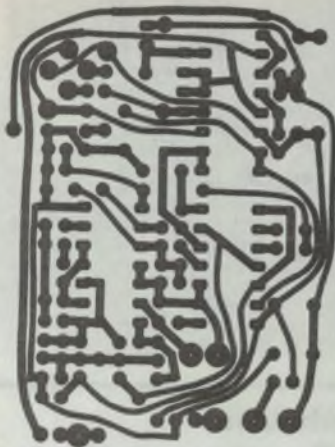

Above: the PCB pattern, actual size. At right: The PCB swung up to reveal the speaker and batteries.

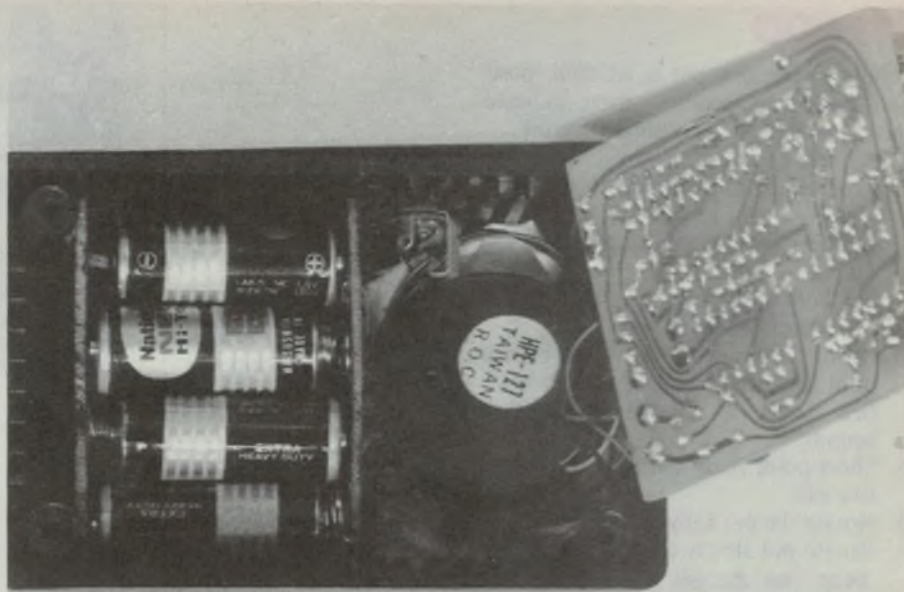

diodes D6 – D8 prevent damage to the circuit due to reverse polarity batteries. The 10 ohm resistors limit the current under fault conditions, and the tantalum capacitors decouple the rails.

Quiescent current drain is about 20uA from the positive rail, and 40uA into the negative rail. This rises to several mA under active operation.

Alkaline batteries are recommended (even if they do cost twice as much) over zinc carbon batteries for their higher reliability and greater capacity.

The output of the circuit can take up to 30V for short periods. This is mainly limited by the power dissipation in the 1k current limiting resistor.

Construction

To achieve fitting the circuit into the smallest zippy box, a very high density, compact PC board was used. Thus it is essential to use a fine tipped (say 1-2mm) soldering iron with preferably a solder sucker or desolder wick on hand to remove the inevitable solder ridges/splashes.

At the start, and at regular intervals during construction, assemble the batteries, printed circuit board and piezo-electric element together in the box to see if they still fit, and to get some idea of the clearances involved.

Start construction with the preparation of the box. Referring to the physical layout, cut two pieces of fibreglass board to form the battery holder. Break the copper surface as indicated and solder on two negative contacts on each board. One possibility for the contacts are the springs found on old battery compartments (AA size), otherwise let your imagination run wild.

With the batteries in position, the space for the audio jack and the piezo should be quite clearly defined. Thus the hole for the jack can be drilled, being careful to allow adequate clearance from the bottom and from the battery compartment. To allow the jack to screw in position, some of the internal ribs of the box will have to be removed with a knife.

A series of holes should be drilled in the 'bottom' of the box to let out the sound from the piezo transducer. One possible arrangement for these is given with the hardware details.

At this point the batteries, piezo element and the jack should rest comfortably in their final positions with nothing sticking out above the level of the batteries.

As noted before, the printed circuit board is quite densely populated, so take care when soldering to avoid 'bridging' tracks. Before construction, check the PCB for shorts or opens. Imagine how much easier this would be if you had Beepo!

The first step is to solder in the three (3) wire links. Next mount the IC sockets, note the different orientation of the 339 comparator compared to the two CMOS devices.

To save PCB space, the majority of resistors and diodes are mounted on end, to give a 0.1" lead spacing. To convert a normal resistor into a single ended component, simply bend over one lead with the fingers until it is parallel to the other one. Note there is a pair of spare holes near the two transistors, and check the polarity of the tantalum capacitors. Some care is required

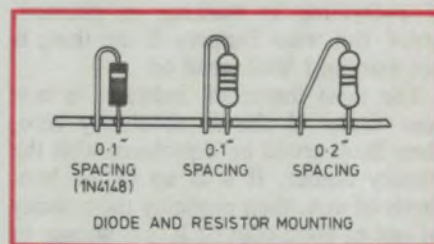

Details of how the resistors and diodes are mounted on end, to save space on the PCB.

during construction, so that no component exceeds the height of the two mini trim pots, otherwise difficulty may be found in fitting everything in the box.

With the above points in mind, mount the resistors and diodes. Finally complete construction by inserting the transistors and the tantalum capacitors, and then the IC's in the correct orientation

Set up & troubleshooting

At this point the jack and the piezo element should be wired in, but the power supply still not connected permanently to allow the rail currents to be easily measured.

The first test is to patch the power supply in and measure the two rail currents. If the currents are within say 50% of 20uA and 40uA for the positive and negative rails respectively, then all bodes well. Using a number of resistors verify that the 1M and 1k trip points are about right (say within -20% and +100% is OK).

The calibration of the 1 ohm trip point requires a one ohm resistor, a fine screwdriver to adjust the two pots and a short piece of wire with two alligator clips at the ends. Note that on the com-

Beepo

ponent layout one pot is labelled 'positive' and one 'negative'; these indicate the polarity of the trip point they set. The procedure is as follows:

1. Short point A on circuit to the positive rail.
2. Connect a one ohm resistor to the output.
3. Set both pots fully clockwise (from the outside of the board).
4. Adjust the +ve pot anticlockwise until the 'beep' changes to an 'eek'. Set it so a reliable 'eek' just sounds.
5. Short point A on circuit to the negative rail.
6. Rotate -ve pot fully anticlockwise.
7. Rotate pot slowly clockwise until the 'beep' just changes to an 'eek' reliably.
8. Remove short.

If everything is working as planned, great! But what happens if the thing is not working? Well, read on ...

The most important indicator is current drain. If this is absolutely zero, then there could be a problem with the battery holder. If it is up in the hundreds of mA, then probably the polarity of one of the diodes or IC's is wrong, or

A closeup of the assembled PCB, to guide you in wiring your own. Refer also to the wiring diagram.

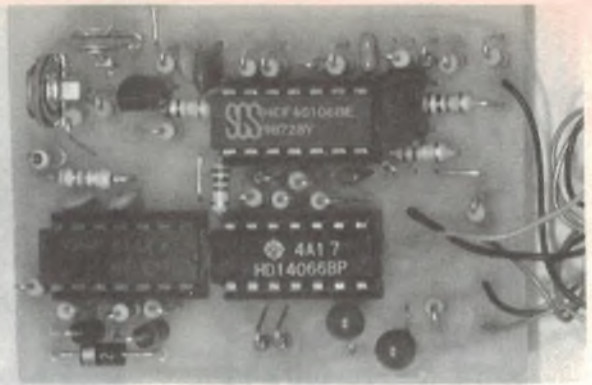

else there is a solder short across one of the tracks.

If there are no apparent symptoms then a more systematic method is required. First check through the entire circuit for wrong polarities, wrong components, solder bridges and bad joints.

In a systematic fashion trace the chain of operation of the circuit from the polarity oscillator via the current sensor, to the comparators. Note, if an oscilloscope is not available, then the polarity oscillator can be frozen by shorting point A to the desired polarity.

Finally, the best way to familiarise yourself with Beepo is to try it out on a pile of components.

Happy Beepoeing!

Parts List

- 1 Zippy box, small, 28 x 54 x 83mm
- 1 PCB, 45 x 60mm
- 1 2.5mm plug & socket
- 2 Alligator clips (black & red), to form test probes
- 4 Size N batteries, zinc carbon or alkaline (see text)
- 1 Piezo electric transducer (without driver) e.g., Dicksmith cat. no. L-7022
- 3 14-pin IC sockets.

Semiconductors

- 1 4066 CMOS quad bilateral switch
- 1 40106 CMOS hex Schmitt trigger inverter (do not use a 74C14)
- 1 339 quad comparator
- 1 BC547 NPN transistor
- 2 BC557 PNP transistors
- 6 1N4148 small signal diodes
- 3 1N4001 power diodes

Capacitors

- 2 47uF, 6V tantalum capacitors
- 1 0.1uF monolith cap, 0.1" lead spacing
- 1 10nF monolithic cap, 0.1" lead spacing
- 1 3.3nF ceramic
- 2 820pF ceramic
- 1 100pF ceramic

Resistors (1/4W, 5%)

- 4 x 10M, 1 x 4.7M, 1 x 2.7M, 4 x 2.2M, 1 x 1.5M, 4 x 1M, 1 x 270k, 2 x 220k, 2 x 100k, 2 x 10k, 1 x 1k, 2 x 820ohms, 2 x 10ohms.

Potentiometers

- 2 470k mini vertical trimpot, linear

Miscellaneous

- hookup wire
- solder
- small pieces of fibreglass printed circuit board
- springs/flexible contact for battery contacts

SPECTACULAR RELEASE



\$799 PAIR

vifa

NEW SA-100
SPEAKER KIT



Since the introduction of VIFA speaker kits in Australia in 1985, thousands of speakers have been built with superb results. VIFA is now proud to release four new speaker kits ranging from a mere \$399 to \$1199 per pair including cabinets.

Never before have speaker kits been so popular in Australia than after the heavy devaluation of the dollar. Similar fully imported quality loudspeakers are today typically 2-2½ times more expensive. And these speakers may very well be using Danish VIFA drivers anyway, as VIFA supply more than 50 of the world's most respected loudspeaker manufacturers with drivers.

But why the big savings? Because fully imported speakers suffer from 25% import duty, 20-30% freight, 30% sales tax and 28% handling charges (typically). So if you would rather put your money into better quality than in other people's pockets, VIFA speaker kits are the only way to go.

Are they difficult to build? No, the kits

are supplied with all parts needed including fully built crossovers and pre-cut flatpack cabinets ready to assemble. No soldering or carpentry skills are needed, just a Phillips head screwdriver, some simple hand tools and a few hours of your leisure time.

Are they as good as people say? Read the reviews, listen and compare with any other speakers twice the price or more. Need we say anymore?

VIFA for the quality conscious audiophile.

For full details please contact
Sole Australian Distributor:

SCAN AUDIO Pty. Ltd.
P.O. Box 242, Hawthorn 3122.
Fax (03) 4299309
Phone: (03) 429 2199 (Melbourne)
(02) 522 5697 (Sydney)
(07) 357 7433 (Brisbane)
(09) 322 4409 (Perth)

Stocked by leading stores throughout Australia

**AT
LAST**

Non-CFC Service Aids for the Australian electronics industry

Top quality, value for money, service aids formulated specifically for the Australian electronics, electrical and computer industries – and they won't harm the environment.

Electronic Freezing Spray

Non-CFC, non-corrosive, safe method of cooling electronic components to detect dry joints and other thermal faults.

Electronic Cleaning Solvent No. 1

Fast drying non-CFC solvent blend for cleaning electronic components and circuit boards.

Printed Circuit Board Lacquer

Specially formulated lacquer designed specifically for protecting circuit boards and components from environmental attack. Can be soldered through for component replacement and acts as a solder flux.

Protek

General purpose maintenance, dewatering and penetrating fluid for protecting, lubricating and rust prevention.

Heat Sink Compound

An efficient, non-toxic paste with excellent thermal conductivity over a wide temperature range.

Available from:

NSW

- Digital Pty Ltd YAGOONA Ph: 796 2888
- W.E.S. Components Pty Ltd ASHFIELD Ph: 797 9866
- Carramar Radio CARRAMAR Ph: 726 3628
- Macelec Pty Ltd WOLLONGONG Ph: 042 291455
- D.J. Coulter Wholesale Pty Ltd MAYFIELD Ph: 049 671455
- Novocastrian Electronic Supplies BROADMEADOW Ph: 049 621358
- Vimcom Pty Ltd WOLLONGONG Ph: 042 284400
- Sheridan Electronics Pty Ltd REDFERN Ph: 888 3200
- N.E.C. Home Electronics Aust Pty Ltd REVESBY Ph: 774 5055
- Altronic Imports CROWS NEST Ph: 436 0422
- Jaycar SYDNEY Ph: 267 1614
- Jaycar GORE HILL Ph: 439 4799
- Jaycar HURSTVILLE Ph: 570 7000
- Jaycar CONCORD Ph: 747 2022
- Jaycar PARRAMATTA 683 3377
- Royston Electronics SILVERWATER 647 1533

Queensland

- A.E.S. Electronics FORTITUDE VALLEY Ph: 07 52 8283
- Selectro Parts Pty Ltd YERONGA Ph: 07 848 8197
- Jaycar BURANDA Ph: 07 393 0777

South Australia

- Protronics Pty Ltd ADELAIDE Ph: 08 212 3111



Victoria

- Royston Electronics NOTTINGHILL Ph: 03 343 5122
- Jaycar MELBOURNE Ph: 03 663 2030
- Jaycar SPRINGVALE Ph: 03 547 1022

W.A.

- Everett International Pty Ltd WEST LEEDERVILLE Ph: 09 381 5500
- Altronic Imports Pty Ltd PERTH Ph: 09 328 2199



RICHARD FOOT PTY. LTD.

26-30 Tepko Road, Terrey Hills, NSW Australia 2084
P.O. Box 245, Terrey Hills, NSW Australia 2084
Fax: (02) 450 2569 Telephone: (02) 450 2133 Telex: AA24777

Construction Project:

Simple PC-driven function generator

Here's a simple and low cost little unit which lets you use your personal computer to generate signals with almost any conceivable waveform. It hooks up to the computer via a standard Centronics-type parallel printer port, making it compatible with almost any kind of computer. Building and using it will also give you valuable insight into the growing trend towards computer-driven test instruments, too!

by JIM ROWE

Generating a signal with a sine or square waveform is not terribly difficult, nor is it hard to produce one with a triangular or sawtooth waveform. But apart from these, things can become a bit messy.

How do you generate a single pulse with a sine-squared waveform, for example – or bursts of 3.5 cycles of a sine-wave tone, separated by long gaps? Or say a sinewave, but with a small 'packet' of oscillation 2/3rds of the way up its positive slopes?

The traditional ways of generating these kinds of waveform have involved either shaping and gating circuits operating on standard waveforms, or 'playing back' what are effectively recordings of the desired waveform. The second of these methods is the one most often used nowadays, as digital electronics has made it relatively easy to 'record' waveform data in a memory chip or chips, and then 'play them back' as desired.

Function generators and 'arbitrary waveform generators' using hard-wired logic to perform these operations have been available for some time, and some have even been described in magazines. However this approach can result in quite a complex and expensive instrument, particularly if it is designed to allow fast and convenient entry of the waveform data into memory. But if it isn't designed to do this, the instrument can be clumsy and tedious to use!

As it happens, there is a simpler and much lower cost alternative – by using software to perform most of the functions, instead of hardware. Just about

all of the functions which need to be performed in such an instrument can be performed by a standard personal computer, running a suitable program. The only exception is the final step of converting the 'played back' waveform data into a varying voltage, which can be performed by a simple and low-cost D/A converter box like that described here.

Now that so many people already have a personal computer, this approach provides a very low cost way of

generating virtually any kind of waveform – no matter how weird. And another important advantage of using software to perform most of the work is that it gives great flexibility. You aren't locked into fixed functions and facilities, as you would be with a hard-wired design.

If you want to add further waveforms, or change the way that special waveform data is fed in and stored in memory, it's simply a matter of changing the program. You can even have a set of different programs to work with the same hardware, to perform alternative jobs.

What can you use the resulting function generator for? To a large extent, that's limited only by your imagination. But here are a few suggestions, which may hopefully get your juices flowing:

- To generate signals with waveforms that would be very difficult to pro-

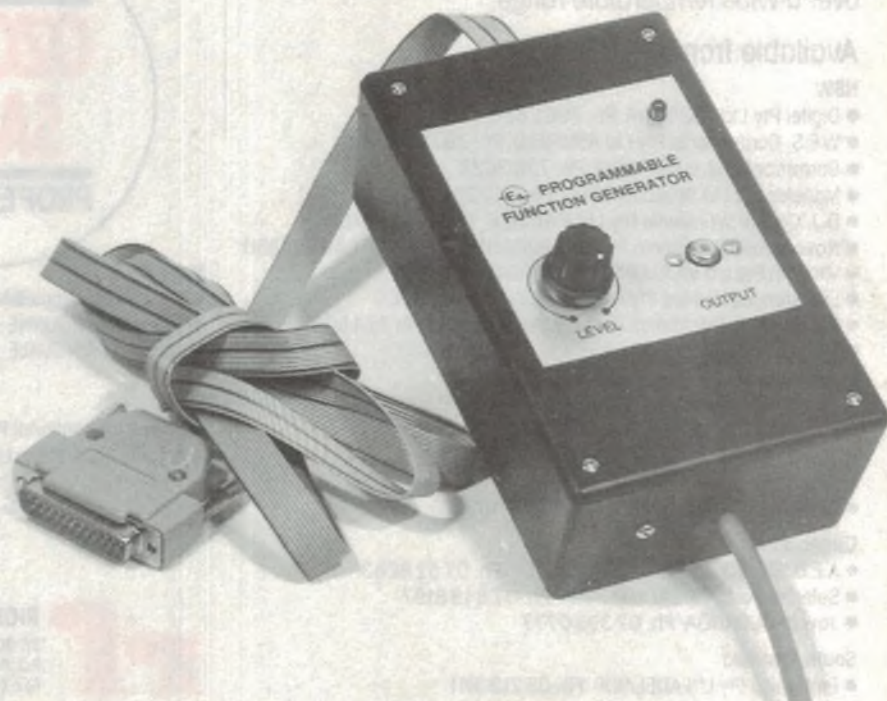

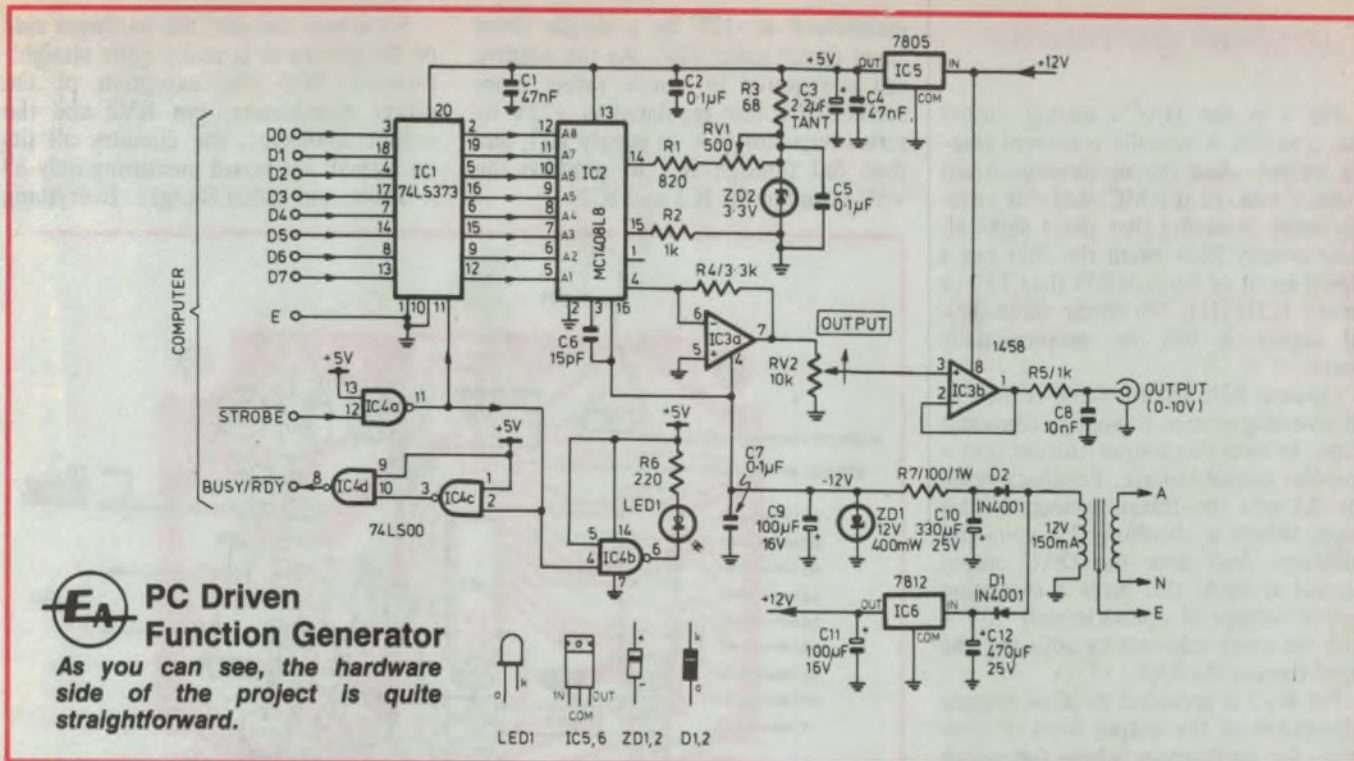

duce by any other means, like a heart's 'QRS' electrocardiogram or ECG waveform, or a frog's 'croak'.

- To demonstrate how complex waveforms like square waves can be synthesised using harmonically-related sinewave signals.
- To experiment with electronic music and speech synthesis.
- To simply generate sinewave or other standard waveform signals, under software control.

In addition, the D/A converter box hardware described can also be used as a programmable DC voltage source, able to produce any of 256 different DC voltage levels between 0V and 10.24V under software control. So it could also be used as a programmable power supply, if you add a DC power amplifier to the output!

How it works

As already noted, the hardware side of the project is quite simple and straightforward, because we're going to rely on the software to do most of the work. All the hardware needs to do is take a string of data bytes from the computer, and use them to reconstruct an analog waveform.

At the heart of the circuit is a low cost 8-bit digital to analog converter chip, the Motorola MC1408L8 (IC2). This is available from at least one of our advertisers (Jaycar) for only \$1.00,

making it the lowest cost DAC currently available.

The MC1408L8 is a *current-multiplying* DAC. This means firstly that its analog reference input and analog output are both currents, and also that its analog output current has a value equal to the *product* of the input reference current applied to pin 14 and the weighted binary value of the digital input bits applied to inputs A1 - A8.

Despite its low cost, the MC1408L8 is

quite a high performance chip. It has an output settling time of typically 300ns, with a slew rate of 4.0mA/us for changes in the reference input. It has an 8-bit conversion accuracy of +/- 0.19%.

In this case the DC reference input current is derived from a 3.3V zener diode ZD2, via R1 and RV1. The latter is used to adjust it over a small range, to allow setting the maximum output voltage of the circuit. The input current level is approximately 3mA.

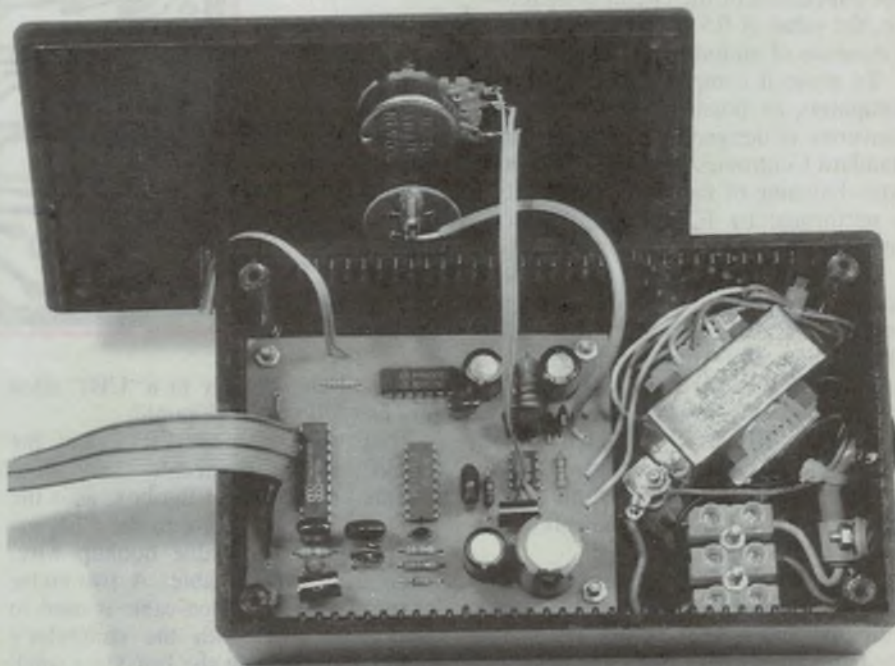

Inside the box.

Function generator

Pin 4 is the DAC's analog output pin, and this is actually a current *sinking* output. And the maximum current transfer ratio of the MC1408L8 is virtually unity, meaning that pin 4 sinks almost exactly 3mA when the chip has a digital input of decimal 255 (hex FF, or binary 11111111). For lower value digital inputs it will be proportionally lower.

Op-amp IC3a (half a 1458) is used as an inverting current-to-voltage converter stage, to turn this output current into a unipolar output voltage. Feedback resistor R4 sets the transresistance of this stage, which is therefore 3.3 volts per milliamp. And since the DAC output current is 3mA, this gives a maximum output voltage of approximately 10V – with the exact value set by adjusting the input current via RV1.

Pot RV2 is provided to allow manual adjustment of the output level or 'volume', for applications where the circuit is used to produce audio signals. It can be left at full setting where the output level is required to vary over the full 10V range, and be controlled only by the digital input.

Buffering of the output voltage is provided by IC3b, the other half of the 1458 device. This is connected as a unity-gain non-inverting stage, to provide a low output impedance. The output is taken from pin 1 via a simple R-C filter formed by R5 and C8, to remove conversion 'glitches'. The effective output impedance of the circuit is therefore 1k, the value of R5 (which also provides a measure of output protection).

To make it compatible with as many computers as possible, the generator/converter is designed to interface via a standard Centronics-type parallel printer port. Latching of the input data for IC2 is performed by IC1, a 74LS373 octal latch device.

IC4a, part of a 74LS00 quad gate is used as an inverter, to allow the printer port's STROBE-bar pulse to be used for enabling IC1 when each new data byte is available. IC4c and d are used to return the same inverted pulse to the computer's BUSY/READY-bar input, with a small delay to ensure reliable handshaking. The fourth section of IC4 is used to drive LED1, to indicate when data is being transferred.

Power for the circuit is provided by a small 12V/150mA power transformer, with two half-wave rectifiers producing positive and negative rails. The negative rail provides only low current, and is

maintained at -12V by a simple shunt zener circuit using ZD1. As the positive rail is required to handle rather more current, it is first regulated to +12V by series regulator IC6, to supply IC3, and then fed through IC5 to produce the +5V required for IC1 and IC2.

So as you can see, the hardware side of the generator is really quite straightforward. With the exception of the power transformer, pot RV2 and the output connector, the circuitry all fits on a small PC board measuring only 89 x 70mm, and coded 88pfg11. Everything

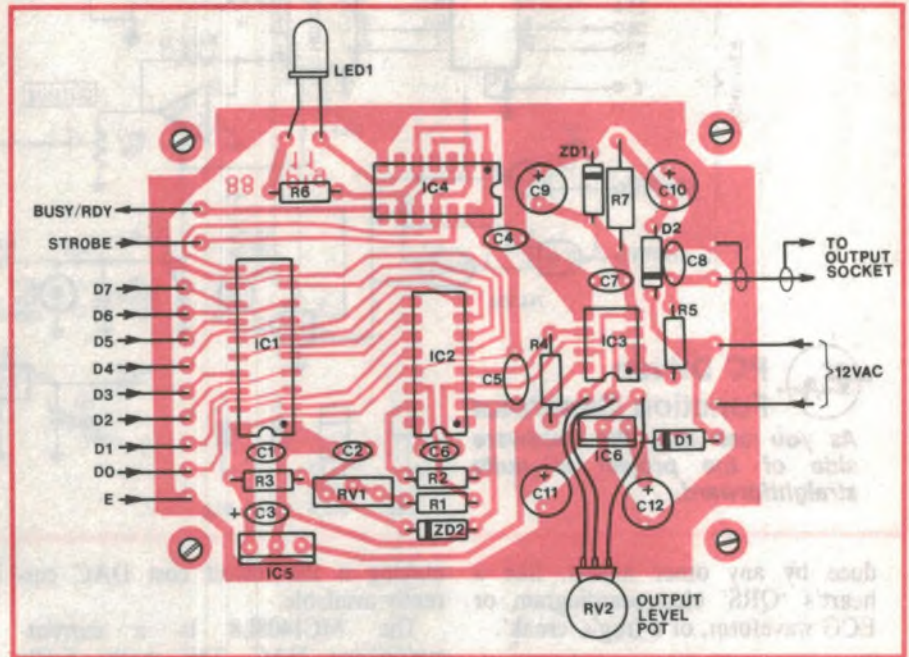

Above: the wiring diagram for the generator's PC board, on which most of the parts are mounted.

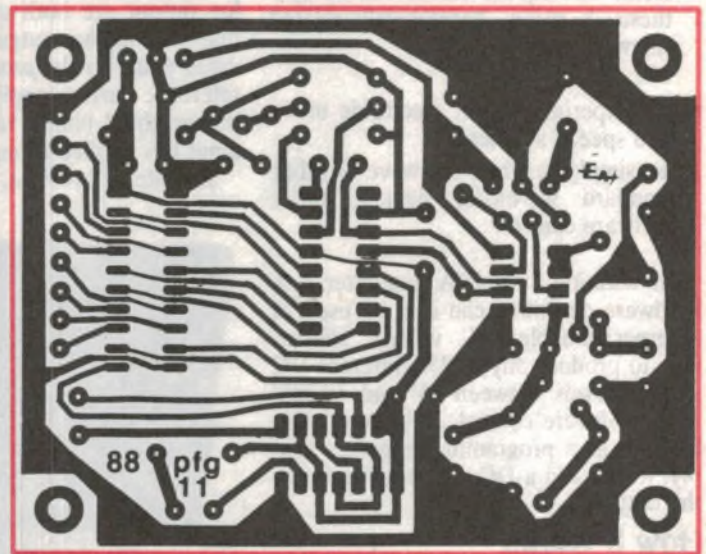

Right: the copper pattern for the PC board, reproduced actual size for those who etch their own.

is housed comfortably in a 'UB1' sized jiffy box (50 x 90 x 150mm).

The output level pot RV2 and the output RCA connector are both mounted on the lid of the box, as is the LED. All three connect to the PCB via short lengths of flexible hookup wire, taken from ribbon cable. A two-metre length of 11-way ribbon cable is used to connect to PCB with the computer's printer port, leaving the box via a small clearance gap cut in the top of the end

nearest the PCB.

The mains cord is brought into the box via a grommet mounted in the centre of the far end. It is then anchored firmly via a nylon P-clamp, after which the three wires are terminated in a three-way 'B-B' connector strip. The transformer is mounted alongside the strip, as may be seen from the internal picture, with its primary wires taken directly to the strip. A short length of green wire is taken from the 'earth' ter-

minimal of the B-B connector to a solder lug fitted under one of the transformer mounting screws, with a 'star' washer used to ensure reliable earthing of the transformer frame.

The location of all of the minor components on the PCB should be clear from the overlay diagram. When assembling the board, watch the orientation of the polarity-sensitive items such as the ICs, diodes, zeners, electrolytics and the LED.

As many readers will no doubt wish to use the unit with an IBM-compatible PC, the connections for a DB-25 plug suitable for this type of printer port are shown in Fig.1. If you plan to use the generator with another brand or model of computer, you'll need to alter the connector and connections to suit.

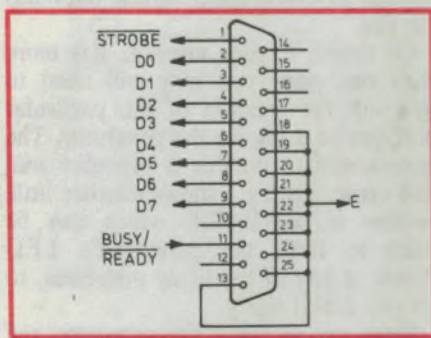

Fig.1: How to wire the generator's ribbon cable to a DB-25 plug, to suit an IBM or compatible PC.

The software side

Obviously all our little hardware unit does is accept data bytes, and produce analog output voltage levels corresponding to the value of these bytes. It is the software running in the computer which determines how these voltage levels are manipulated to produce the desired result.

For example to generate a sinewave signal, the software needs to send out a set of bytes with values calculated to correspond to a sinewave, at a rate which produces the wave at the desired frequency.

How many data bytes are sent for each cycle of the waveform depends upon the *resolution* you need, and to a certain extent on the output frequency you want to produce. The more bytes per cycle, the finer the resolution and the 'smoother' the resulting waveform, but the greater the demands on the computer and software to produce waveforms of higher frequency. It's a bit like any other application of digital sampling.

An example should make this clear. Say you want to generate a very smooth

waveform, and you accordingly elect to send out 360 bytes per cycle (which gives one byte 'sample' for each degree). This means that for every complete cycle generated, your software then needs to send say 360 bytes. And it will have to send out the same 360 bytes for each and every cycle generated.

This means that to generate an analog signal of only 100 hertz, it would need to send 36,000 bytes per second. In other words, the data rate will be 360 times the desired output frequency.

So even quite modest output signal frequencies will call for surprisingly high data rates. To produce a 20kHz signal it would in theory climb to no less than 7.2 megabytes/second, for example!

This is obviously well beyond the capabilities of our little generator/converter circuit. In fact it's also well beyond the capabilities of most normal personal computers and their parallel printer ports, as well.

What this tells us is that unless you only wish to generate very low frequencies, you'll need to accept a rather smaller number of data byte 'samples' per cycle – and the resulting compromise in terms of waveform 'smoothness'.

Obviously the smaller the number of bytes per cycle, the smaller the ratio between the output signal frequency and the data rate needed to produce it. But how few samples can you get away with? It depends upon what you can accept in terms of the waveform.

The limit comes when you have just two samples per signal cycle. Then you can generate the required signal frequency easily, with the data rate only twice the frequency required. But the waveform produced will be nothing more than a square wave – not particularly good if you're after a low-distortion sinewave, or a linear sawtooth!

As few as 10 bytes per cycle can be quite adequate for generating a reasonable approximation of a sinewave, in many applications. This will obviously call for data rates of 10 times the required output frequency, but this still gives reasonably practical data rates, at least for audio signal frequencies.

For somewhat better resolution you could try a figure of 36 bytes per cycle (one sample for every 10 degrees). This gives a temporal resolution roughly equal to that of a CD player reproducing a 1kHz signal, but will of course involve a data rate 36 times that of the frequency to be generated.

If this order of resolution isn't really enough for the kind of signals you want

PARTS LIST

- 1 PC board, 89 x 70mm, code 88pfg11
- 1 Jiffy box, 50 x 90 x 150mm
- 1 Power transformer, 240V to 12V at 150mA
- 1 Mains cord and plug
- 1 2m length of 11-way ribbon cable
- 1 Connector for computer's printer port
- 1 3-section length B-B connector strip
- 1 RCA-type panel socket

Semiconductors

- 1 74LS373 octal latch
- 1 MC1408L8 digital-analog converter
- 1 1458 dual op-amp
- 1 74LS00 quad gate
- 1 7805 5V regulator
- 1 7812 12V regulator
- 1 3.3V 400mW zener
- 1 12V 400mW zener
- 1 5mm red LED
- 2 1N4001 or similar diode

Resistors

- 1/4W 5%: 1 x 68 ohms, 1 x 220 ohms, 1 x 820 ohms, 2 x 1k, 1 x 3.3k
- 1 100 ohms 1W
- 1 500 ohm vertical preset
- 1 10k linear pot

Capacitors

- 1 15pF ceramic
- 1 10nF metallised polyester
- 2 47nF metallised polyester
- 3 0.1uF metallised polyester
- 1 2.2uF tantalum
- 2 100uF 16VW electrolytic
- 1 330uF 25VW electrolytic
- 1 470uF 25VW electrolytic

Miscellaneous

- Nylon P-clamp for mains cord; short lengths of hookup wire for connecting PCB to pot, output connector and LED; screws, nuts and star washers; solder lug for earthing transformer; nylon cable ties to anchor transformer primary leads.

to produce, you'll obviously need to go to even more data bytes per cycle. Just bear in mind that the more bytes per cycle, the higher the ratio between data rate and output frequency. The practical

Function generator

penalty will be a lowering of the maximum output frequency you'll be able to generate.

Apart from this quite basic limitation, you'll be able to generate signals with almost any conceivable waveform. All your software needs to do is store a string of bytes with the appropriate values in the computer's memory, and squirt them out one after the other to the generator/converter via the printer port.

For example if you're a radio amateur, you could use the generator to produce a slow-scan TV signal. Simply store an image in the computer's memory, and then have your software squirt it out to the generator line by line at the appropriate rate, inserting the necessary sync pulses along the way.

The signals you produce don't even have to be of the smoothly varying analog variety. You can generate staircase ramp signals, single pulses or pulse trains – with amplitudes of anywhere between about 40mV and 10V. In fact if you wish, you can generate serial data signals.

Not only this, but as mentioned earlier you can also generate any of 256 different DC voltage levels. To do this your software merely needs to send single data bytes to the generator/converter, with a value corresponding to the required value. For example when the output pot RV2 is set to maximum and preset pot RV1 is set to produce an output voltage of 10.24V for a digital input of 255 decimal (FF hex), the 256 possible output levels will be spaced in 40mV increments. So a byte with a value of decimal 25 will produce an output of 1.00V, one of value decimal 50 an output of 2.00V, and so on.

One more general comment, before I give you a sample program or two to get you started. This is that with most personal computers, the fastest way to squirt data bytes out via the printer port will be to use a program written in machine/assembly language. Higher level languages will generally be very much slower – particularly if they are interpreted languages like many versions of BASIC. And this applies even for machines that are in themselves quite fast – like an AT-level PC running at say 10-12MHz.

So if you're limited to programming in BASIC, don't expect to be able to produce very high frequency signals – particularly if you want to produce

waveforms of high resolution. To get even modest frequencies with such signals, machine or assembly language is virtually essential.

All the same, BASIC can provide a quick way to knock out a program for generating low frequency signals. It's also suitable for producing programs to demonstrate how a PC can be used to 'synthesise' test instruments.

Starter programs

Now let's get down to a few specifics about programming for the generator. First, a word about printer port addresses on IBM PCs and compatibles.

With most other kinds of personal computer, and certainly with earlier types, the printer port is generally at a fixed address in the computer's memory or I/O address space. So usually there's no great problem knowing where the port is located, for programming. But with the PC machines and their compatibles, there are actually a *number* of possible locations for the printer port, as well as the possibility of having a number of ports connected simultaneously.

The three port locations most commonly used are all in the processor's I/O address space:

3BC – 3BE

378 – 37A

278 – 27A

These are all given in hexadecimal, and as you can see, each location actually consists of a group of three adjacent addresses (e.g., 3BC, 3BD and 3BE). The lowest of the three is used for the actual data transfer, while the middle and highest addresses are used for printer status input and printer control output respectively.

How can you tell where your particular port happens to be located – or if the computer has more than one port? How can you tell the location of the

one to which you've connected the generator? It's not too difficult when you know how.

When the computer is first powered up, one of the things its BIOS software does is check to see where the printer port is – and if there are more than one. It actually checks the possible locations in the order given above, and the first one it finds is given the label 'LPT1:'. If it finds any others, these are given the labels 'LPT2:', 'LPT3:' and so on. And more importantly, it stores the base address of the first port it finds, in absolute memory addresses 00408 and 00409H.

So in most cases, it's simply a matter of looking at what's stored at these addresses, to find the location of your port. Listing 1 shows a small program written in GWBASIC, which does this for you.

Of course if your machine has more than one port, you may still need to find out the location of the particular port you're using for the generator. The easiest way to do this is probably trial and error. Listing 2 shows another little routine in GWBASIC which can be used to flash the generator's LED slowly at any of the likely addresses, to let you find it easily.

Once you've found the generator and its port, you're ready to start producing some signals.

Listing 3 shows a simple demo program, again in GWBASIC, which can be used to produce fixed-frequency signals with one of four waveforms – sine, square, triangular or sawtooth. It uses 36 byte 'samples' per signal cycle, and thus produces reasonably smooth waveforms.

Listing 4 shows a very much simpler little routine, to send individual data bytes to the generator. This is for using it as a programmable DC voltage source.

How about custom waveforms? My final offering to you here is Listing 5.

LISTINGS:

1

```
10 'ROUTINE TO FIND PRINTER PORT
20 CLS:DEFINT A,P,X:DEF SEG=0:AD=&H408:PORT=0
30 FOR X=2 TO 0 STEP -1:PORT=PORT+256+PEEK(AD+X):NEXT X
40 DEF SEG:LOCATE 12,12:PRINT"Your primary printer port is located at:"
50 LOCATE 14,12:PRINT"I/O address ";HEX$(PORT);" Hexadecimal."
60 END
```

2

```
10 'ROUTINE TO FLASH FUNCTION GENERATOR LED
20 CLS:DEFINT P,X:PORT=&H378:'OR WHATEVER ADDRESS YOU USE
30 PRINT"FUNCTION GENERATOR TEST ROUTINE"
40 PRINT:PRINT"Board LED should be pulsing..."
50 LOCATE 10,1:PRINT"(Press any key to stop)":
60 OUT PORT,0
70 OUT PORT+2,13:LOCATE 6,12:PRINT"[*]";GOSUB 100
80 OUT PORT+2,0:LOCATE 6,12:PRINT"[ ]";GOSUB 100
90 AS=INKEY$:IF AS="" THEN 70 ELSE END
100 FOR X=1 TO 1000:NEXT X:RETURN
```



```

10 'FUNCTION GENERATOR DEMO PROGRAM
20 DEFINT A-F,P,X,Y:DIM A(35)
30 GOSUB 1400:LOCATE 6,20:PRINT"Waveform Selection:";
40 LOCATE 9,20:PRINT"1. Sine Waveform";
50 LOCATE 11,20:PRINT"2. Square Waveform";
60 LOCATE 13,20:PRINT"3. Triangular Waveform";
70 LOCATE 15,20:PRINT"4. Sawtooth Waveform";
80 LOCATE 20,20:PRINT"(Select 1,2,3, or 4)";
90 GOSUB 1200:ON A GOTO 200,300,400,500
200 GOSUB 700:P1=4*ATN(1)
210 FOR X=0 TO 35:SA=(10*X*PI)/180:A(X)=128+CINT(127*SIN(SA)):NEXT X
220 GOTO 1000
300 GOSUB 700:FOR X=0 TO 17:A(X)=255:NEXT X
310 FOR X=18 TO 35:A(X)=0:NEXT X
320 GOTO 1000
400 GOSUB 700:FOR X=0 TO 17:A(X)=CINT((X*255)/18):NEXT X
410 FOR X=18 TO 35:A(X)=255-CINT((X-18)*255/18):NEXT X
420 GOTO 1000
500 GOSUB 700:FOR X=0 TO 35:A(X)=CINT((255*X)/35):NEXT X
510 GOTO 1000
700 GOSUB 1400:LOCATE 14,20:PRINT"Calculating and storing waveform data";
710 LOCATE 20,20:PRINT"Please wait...":RETURN
1000 GOSUB 1400:LOCATE 6,20:PRINT"Generating waveform now...";
1010 LOCATE 9,20:PRINT"(To stop, press any key)";:PORT=&H378:'OR YOUR PORT...
1020 FOR X=0 TO 35:OUT PORT,A(X):OUT PORT+2,13:OUT PORT+2,0:NEXT X
1030 AS=INKEYS:IF AS="" THEN 1020 ELSE 30
1200 GOSUB 1300:IF AS(">"1" AND AS(">"2" AND AS(">"3" AND AS(">"4" THEN GOTO 1200 ELSE A=VAL(AS):RETURN
1300 AS=INKEYS:IF AS="" THEN 1300 ELSE RETURN
1400 SCREEN 2:WINDOW SCREEN (0,0)-(639,199):CLS:KEY OFF:LINE (0,0)-(639,199),,B
1410 LOCATE 2,12:PRINT"EA PROGRAMMABLE FUNCTION GENERATOR";
1420 LOCATE 2,60:PRINT"MODEL 1.00";
1430 LINE (89,28)-(549,176),,B:LINE (85,26)-(554,178),,B:RETURN

```

3

```

10 'ROUTINE TO SEND SINGLE BYTES TO GENERATOR. FOR DC LEVELS
20 CLS:DEFINT N:PORT=&H378:'OR WHATEVER ADDRESS YOU USE
30 INPUT"Give value to send (Decimal): ";N
40 IF N>255 THEN N=255 ELSE IF N<0 THEN N=0
50 OUT PORT,N:OUT PORT+2,13:OUT PORT+2,0
60 GOTO 30

```

4

```

10 'PROGRAM TO CREATE AND EDIT CUSTOM WAVEFORMS
20 DEFINT A-F,P,X,Y:DIM A(35)
30 GOSUB 900:LOCATE 6,20:PRINT"Select a function:";
40 LOCATE 9,20:PRINT"1. Program new waveform";
50 LOCATE 11,20:PRINT"2. Edit current waveform";
60 LOCATE 13,20:PRINT"3. Send waveform to generator";
70 LOCATE 20,20:PRINT"(Select 1,2, or 3)";
80 GOSUB 800:ON A GOTO 100,500,700
100 GOSUB 900:LOCATE 6,20:PRINT"Waveform Programming:";
110 LOCATE 9,20:PRINT"For each 10-degree step of the wave cycle,";
120 LOCATE 10,20:PRINT"move the cursor up or down to the";
130 LOCATE 11,20:PRINT"desired level using the up and down";
140 LOCATE 12,20:PRINT"arrow keys. Use the left and right";
150 LOCATE 13,20:PRINT"arrow keys to move between sample";
160 LOCATE 14,20:PRINT"columns. When you're happy, press";
170 LOCATE 15,20:PRINT"the [END] key to store the waveform";
180 LOCATE 16,20:PRINT"and proceed,";
190 LOCATE 20,20:PRINT"Press any key to begin...";
200 AS=INKEYS:IF AS="" THEN 200
210 GOSUB 900:GOSUB 380:GOSUB 400:SC=0:GOSUB 450
220 GOSUB 360:IF A=72 THEN 280:'UP ARROW
230 IF A=80 THEN 300:'DOWN ARROW
240 IF A=75 THEN 320:'LEFT ARROW
250 IF A=77 THEN 340:'RIGHT ARROW
260 IF A=79 THEN 30:'END KEY - BACK TO MENU
270 GOTO 220:'NOT A VALID KEY
280 GOSUB 470:IF A(SC)<255 THEN A(SC)=A(SC)+1
290 GOSUB 450:GOSUB 480:GOTO 220
300 GOSUB 470:IF A(SC)>0 THEN A(SC)=A(SC)-1
310 GOSUB 450:GOSUB 480:GOTO 220
320 IF SC>0 THEN SC=SC-1
330 GOSUB 450:GOTO 220
340 IF SC<35 THEN SC=SC+1
350 GOSUB 450:GOTO 220
360 AS=INKEYS:IF AS="" THEN 360 ELSE IF LEN(AS)>2 THEN 360
370 IF ASC(LEFT$(AS,1))<>0 THEN 360 ELSE AS=MID$(AS,2,1):A=ASC(AS):RETURN
380 LINE (140,38)-(500,166),,B
390 FOR X=140 TO 500 STEP 10:LINE (X,38)-(X,166):NEXT X:RETURN
400 LINE (140,102)-(500,102)
410 FOR X=0 TO 35:A(X)=128:NEXT X:RETURN
450 LOCATE 24,12:PRINT"Sample Column: ";SC:LOCATE 24,33:PRINT"(END key to finish)";
460 LOCATE 24,58:PRINT"Value: ";A(SC):RETURN
470 Y=166-(A(SC)/2):Z=SC*10:FOR X=Z+1 TO Z+9:PRESET(140+X,Y):NEXT X:RETURN
480 Y=166-(A(SC)/2):Z=SC*10:FOR X=Z+1 TO Z+9:PSET(140+X,Y):NEXT X:RETURN
500 GOSUB 900:GOSUB 380
510 FOR SC=0 TO 35:GOSUB 480:NEXT SC:'PLOT WAVEFORM
520 SC=0:GOSUB 450:GOTO 220
700 GOSUB 900:GOSUB 380:PORT=&H378:'OR WHATEVER ADDRESS YOU USE
710 FOR SC=0 TO 35:GOSUB 480:NEXT SC:'PLOT WAVEFORM
720 LOCATE 24,12:PRINT"(Press any key to stop)";
730 FOR X=0 TO 35:OUT PORT,A(X):OUT PORT+2,13:OUT PORT+2,0:NEXT X
740 AS=INKEYS:IF AS="" THEN 730 ELSE 30
800 GOSUB 810:IF AS(">"1" AND AS(">"2" AND AS(">"3" THEN GOTO 800 ELSE A=VAL(AS):RETURN
810 AS=INKEYS:IF AS="" THEN 810 ELSE RETURN
900 SCREEN 2:WINDOW SCREEN (0,0)-(639,199):CLS:KEY OFF:LINE (0,0)-(639,199),,B
910 LOCATE 2,12:PRINT"EA PROGRAMMABLE FUNCTION GENERATOR";
920 LOCATE 2,60:PRINT"MODEL 2.00";
930 LINE (89,28)-(549,176),,B:LINE (85,26)-(554,178),,B:RETURN

```

5

This shows another GWBASIC program, which allows you to create and edit a custom waveform on the screen, using the cursor control keys. You can then feed it out to the generator, and while the generator is working the waveform is also displayed on the screen.

I have written a more elaborate version of this program, which also lets you save the custom waveforms on floppy or hard disk, and then re-load them again at a later time. This is a little too long to reproduce the listing here, but I'm happy to supply photocopies of the listing via the EA Reader Service if you are interested. If you send in a formatted 5-1/4" floppy disk (either 360K or 1.2M) I can give you a copy on disk instead, or as well.

But these programs really only scratch the surface of what can be done with this little generator. As noted earlier, for generating higher frequencies and/or smoother waveforms, you really need to use a machine/assembly language routine - at least for the actual squirting of data bytes to the printer port. And of course in most cases there will be the need to vary output frequency, by software timing - either via delay loops, or by using the system's programmable interrupt timers.

What has become quite clear to me, after taking the project this far, is that it's really open-ended. The more you achieve, the more possibilities suggest themselves to you, for further expansion of the system's capabilities.

The hardware may be simple, but the software tends to want to grow ever larger and more complex. So be warned - this project can be addictive!

For example I'm now in the process of making my more elaborate program produce signals of higher frequency, by replacing the 'Send' routine with a suitable machine language routine. This has been a fairly slow process, partly because of my own initial lack of experience with 8086 machine code, and partly because the GWBASIC manual is not particularly clear in its explanation of using the CALL command, which you use to transfer control to a machine code subroutine. But with a little help from my friends, we're getting there...

I'm sure that readers will be much better than I in coming up with a variety of interesting applications, and in producing the software to match. If you come up with something good along these lines, perhaps you could send in the details, so I can make them available to other readers via the magazine.

Over to you!

EA

ONE FOR THE BUSINESS PEOPLE . . .

There are a lot of EA & Silicon Chip readers who have businesses: technicians, electricians, engineers, etc etc. How do you keep in touch? A lost phone call is often a lost customer! Get yourself a Cellular Phone - it goes where you go! But get yourself a good'un - like this superb Audievox. Full hands free operation - so it's legal in those states with strange laws.



Fully installed in your vehicle for under \$2500. That's normally a great price - but you'll also get a special bonus worth \$269! Cat F-7951

\$2495

BONUS!

A top quality GE Telephone Answering Machine - just right for business, for home, for anywhere. Normally \$269. It's yours FREE this month with your Cellular Car Phone.

Bargain Cordless

Cordless Phones are becoming so popular - they're undoubtedly the ultimate in convenience. This one features long range, security code dialling, paging function, built-in charger and more! Cat F-5885



\$179

Top Quality GE

Cordless phone perfection! Famous GE brand, has 10 memories and security code and also doubles as internal intercom! Cat F-7200



\$339

Or TAMS . . .

If you can't take your phone with you, make sure your callers can still leave a message! Our best priced Phone Answering Machine from GE has all the right features! Cat F-8000



\$139

It Does It All!

Everything you'd ever want in a TAMI! Full beepless remote control. Two standard (cheap) tapes for convenience . . . It's a beauty! Cat F-8300



\$269

AM Stereo Saving!



Already got a good car stereo? Why buy a new one just to receive AM Stereo? And why put up with mono any longer? This superb converter gives you great AM stereo with your existing set-up - so you won't have to spend a fortune! And this month, we've slashed the price by another \$10 so you too can hear the superb sound of AM Stereo. Cat A-8030

**WAS \$59.95
NOW \$49.95**

OWN A VIDEO? Try these!

Camera Cleaning Kit

Not just for cameras - it's great for getting into intricate parts in videos, computers, models, etc. Has blower brush, silicon cloth, lens tissue, cleaning fluid and swab. Cat C-7530



\$2.95

Video/Audio Storage

Keep dust (your video's N.1 enemy!) at bay by keeping your tapes stored safely away. Holds up to 24 video tapes or 36 audio tapes safely and securely. Cat C-3058



**\$19.95
SAVE \$5!**

ALARMING NEWS!

You've seen the reports in the newspapers: burglary is on the increase. Don't let your place be next on the list!

Our new Alarm Control Unit is perfect for the home, office, factory . . . anywhere. Fully professional quality (it's actually based on a commercial module) but so simple for the home handyman to install. Do it yourself and save a fortune AND you'll be the only one who knows the details of your own system & wiring!

Heavy duty steel case with inbuilt tamper protection

LED status indicators tell you what's happening

4 individually controllable sectors for maximum versatility

Key-lock switched for maximum security

Inbuilt battery charger for your standby battery (fits inside case)

Mains power supply - included!

Advanced circuitry minimises false alarms, fully complies with noise pollution regulations

Siren oscillator built in - suits standard horn speakers no expensive sirens to buy!

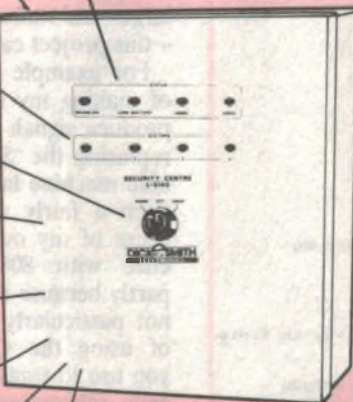

Constant 12V output for PIR's and other accessories PLUS switched 12V (alarm) output for strobes, alarm diallers, etc.

\$199

Cat L-5140

And to complete your system . . .

Magnetic Reed Switches

The most reliable, yet simple form of window/door protection. Surface type (suit aluminium windows etc) Set of magnet and switch L-5210

\$3.00 set



Concealed type (suit wooden doors, frames etc) Magnet & Switch L-5212

\$4.00 set

Individual Switch:

Cat L-5215 **\$2.00**

Individual Magnet: Cat L-5214 **\$1.00**

Special switch set for roller/tilt doors Cat L-5227 **\$5.00**

Window Foil Part of the alarm system - and also a visible deterrent.

32m roll adhesive foil: Cat L-5200

\$14.00 roll



Foil terminal blocks: Cat L-5205

\$1.00 ea



Pressure Mat

Hides under carpet. If it's walked on, it goes off. Put in doorway or hall for optimum protection Cat L-5270

\$24.00



Emergency Button

Just in case! Prowlers, peepers, snowdroppers . . . one push of the button and it scares the daylight out of them! Cat L-5285

\$3.00

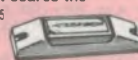

Heat Sensor

Why not make sure you don't burn down? Your alarm can look after that, too with this heat sensor! Triggers at 135 degrees F. Cat L-5254



\$17.00

Horn Speaker

Economy Horn Speaker gives ear-piercing wall to almost wake the dead! Cat C-2705



\$13.00

Horn Cover

With inbuilt tamper protection, stops them disabling your alarm speaker. Cat L-5300



\$24.00

Strobe Lamp

Blue flashing lamp warns if your alarm has been triggered - even after the horn stops. Cat L-6000



\$39.95

Connecting Cable:

Various types to suit every application. 4 Core: Suits detection devices needing power or horn speakers with tamper protection, etc. Cat W-2100 95cm or 100m roll



4 Core Phone Cable:

Similar to above, but small diameter. Suits Permanent installation (not flexible). Cat W-2120 75cm or \$100m roll

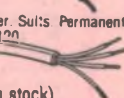

Other types of cable (fig 8, multi core, etc always in stock).

Gell-Cell Batteries

Rechargeable batteries for back-up use. Various sizes available (depending on capacity required) but general purpose 12V, 2.6Ah is ideal for L-5140 panel. Cat S-3320

\$38.95



N.S.W.: BALLINA: Ballina Electronics 86 7022 BOWRAL: F.R.H. Electrical 61 1861 BROKEN HILL: Hobbies & Electronics 86 4098 CHARLESTOWN: Newtronics 43 9800 COFFS HARBOUR: Coffs Harbour Electronics 52 5684 DUBBO: Chris's HI FI 82 8711 FORSTER: Forster Village Electronics 54 5006 GLEN INNES: John Sommerlad Electronics 32 3681 GRAFTON: Repairs and Spares 42 1911 GRIFFITH: Miatronics 82 4534 INVERELL: Lyn Wiling Electronics 22 1821 LISMORE: Decro Electronic Services 21 4137 MOREE: Moree Electronics 52 3458 MURDEE: Headware 72 3895 NOWRA: News Electronics 21 0722 WAGGA WAGGA: Phillips Electronics 21 6558 VIC:MORWELL: Morwell Electronics 34 6133 SHEPPARTON: Phillips Electronics Pty Ltd 21 9497 WARRNAMBOOL: Martronics 62 8870 QLD: BUNDABERG: Bob Elkin Electronics 72 1785 KINGAROO: Holmes Today Electronics 62 1658 MACKAY: Stevens Electronics 61 1723 MARYBOROUGH: Keller Electronics 21 4559 TAS: DEVONPORT: A.I.Electronics 24 8322 BA: LOXTON: G & B Electrical 84 7495 MT GAMBIER: Hutchison's Communication Centre 250400 WA:ALBANY: Micro Electronics 41 2077 SUNSBURY: Micro Electronics 21 6222 GERALDTON: Batavia Lighting & Electrical 21 1966 KARRATHA: Daves Oscitronic 85 4638



NOW AVAILABLE AT ALL STORES - OR CALL TOLL FREE: (008) 22 6610 FOR HOME DELIVERY!

SMITH ELECTRONICS DICK SMITH ELECTRONICS DICK SMITH ELECTRONICS DICK SMITH ELECTRONICS DICK SMITH ELECTRONICS

DICK SMITH ELECTRONICS DICK SMITH ELECTRONICS DICK SMITH ELECTRONICS DICK SMITH ELECTRONICS DICK SMITH ELECTRONICS

Construction project:

High quality audio power amp module

This new amplifier module will produce powers of up to 150 watts at very low distortion, despite its very compact dimensions. It's extremely rugged, simple to build and costs far less than other modules of a similar power.

by **ROB EVANS**

When the need recently arose for a low cost, high quality power amplifier module, a quick scan back through the EA files revealed a distinct lack of suitable projects – clearly an unsatisfactory state of affairs, requiring an immediate remedy!

Fortunately, the large number of Playmaster amplifiers described over the years represent a virtual gold mine of proven high performance circuit designs, making it a simple matter to adapt one of these circuits into a module form. However, before diving headlong into this process, we need to carefully look at the range of applications for such a module.

Perhaps the most obvious use of a power amp module is in the live entertainment area, as either a sound reinforcement 'workhorse' or the power amp section of a guitar/bass amplifier. These applications are not kind to amplifiers. The chance of insufficient cooling, incorrect load impedance (usually too low), gross signal overload, and shorted output terminals tends to increase with the intensity of the performance!

So in this situation, the amplifier's survival is of a much higher priority than the finest edge of performance. The smoldering remains of an amplifier that used to have 0.01% harmonic dis-

ortion are of little use to anyone!

Another, perhaps more refined use of power amp modules is as the basis of a high quality hi-fi amplifier, or as a drop-in replacement to upgrade an existing unit. Naturally, the module must have a reasonable power capability with low noise and distortion performance in order to complement the signals from Compact Disc (CD) players, and other high quality sources.

The other less obvious requirement for this application is the ability of the module to handle a wide range of power supply voltage rails. This is particularly important when the assembly is used as a drop-in replacement, and uses the existing amplifier's power supply. A small printed circuit board (PCB) design is of a further advantage, decreasing the physical complications of installation.

The remaining uses for these modules are wide and varied, and only limited by the user's imagination. They may

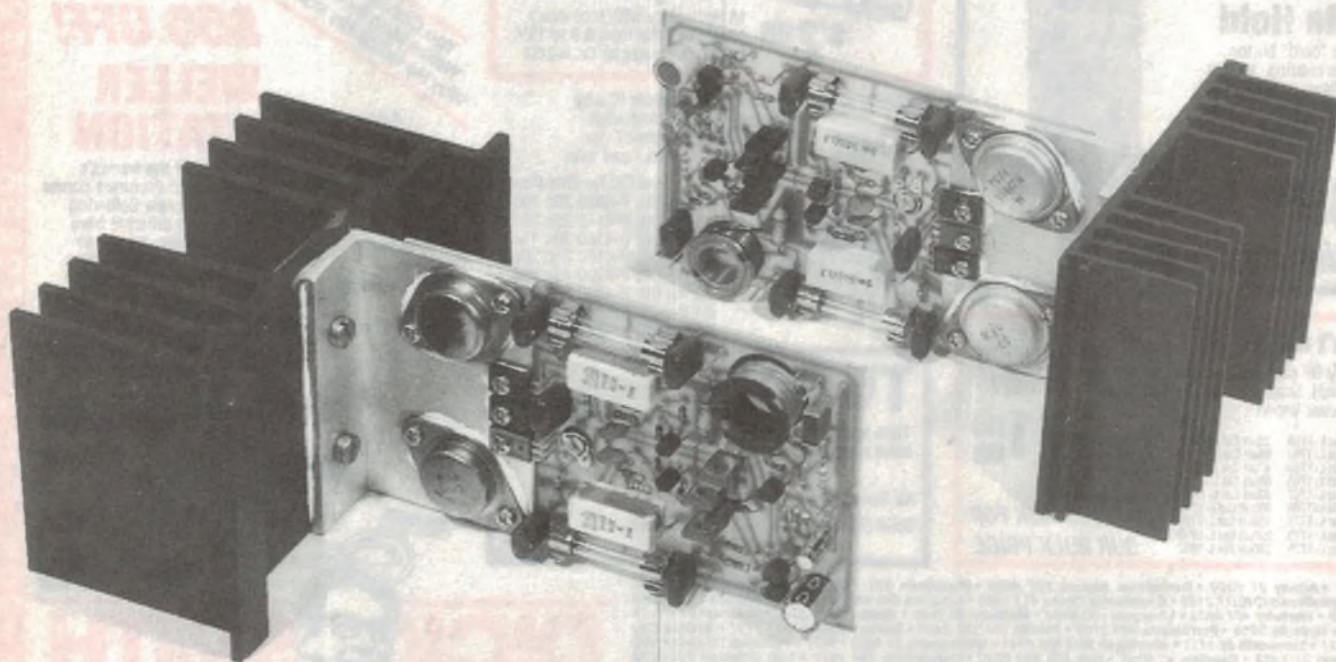

range from simple low power applications such as boosting the output of a TV or portable tape player, to a multiple array of driver amplifiers in an actively crossed over hi-fi or public address (PA) system. Therefore, the final requirement for our design is quite clear – the module must be *low in cost*.

The design

To fulfil the above requirements, we have chosen the basic circuit configuration of the Playmaster 60/60 and 200 amplifiers. This has become quite a standard design in project amplifiers, due to its excellent linearity and resistance to power supply fluctuations. When used with the appropriate semiconductors, this arrangement is capable of producing hundreds of watts of high quality power.

The module presented here however, is shown in two possible configurations – one for supply rails up to about +/- 40 volts, and the other up to about +/- 50 volts. These produce maximum powers of 80 and 150 watts respectively.

Note that these power levels are into a four ohm load, with the figures for an eight ohm load being 50 and 100 watts respectively. It is also worth noting that the 50/100 watt modules that have been presented in the past will only deliver their 100 watts into four ohms, with a maximum power of 50 watts into eight ohms. This means that in hi-fi applications for example, where the load is generally eight ohms, the standard '100 watt amplifier module' will only deliver around 50 watts.

To fill this gap, we have produced a low cost 100 watt module that is ideal for hi-fi applications, as either a drop-in replacement or the basis of a complete system. As a bonus, the unit will produce around 150 watts into four ohms. The final result is about the best value around in high quality watts per dollar.

The main reason for this exceptional value is the use of only a single pair of complementary output transistors, and a compact PCB design (120mm x 75mm). This has been made possible by the careful application of electronic current limiting in the module's output stage, which prevents the driver and output transistors from exceeding their voltage and current ratings.

The actual difference between the two types of module may be seen from the circuit diagram, where the 100/150 watt amplifier's components are shown in brackets. Note that most of the components remain the same, and that both modules use the same PCB.

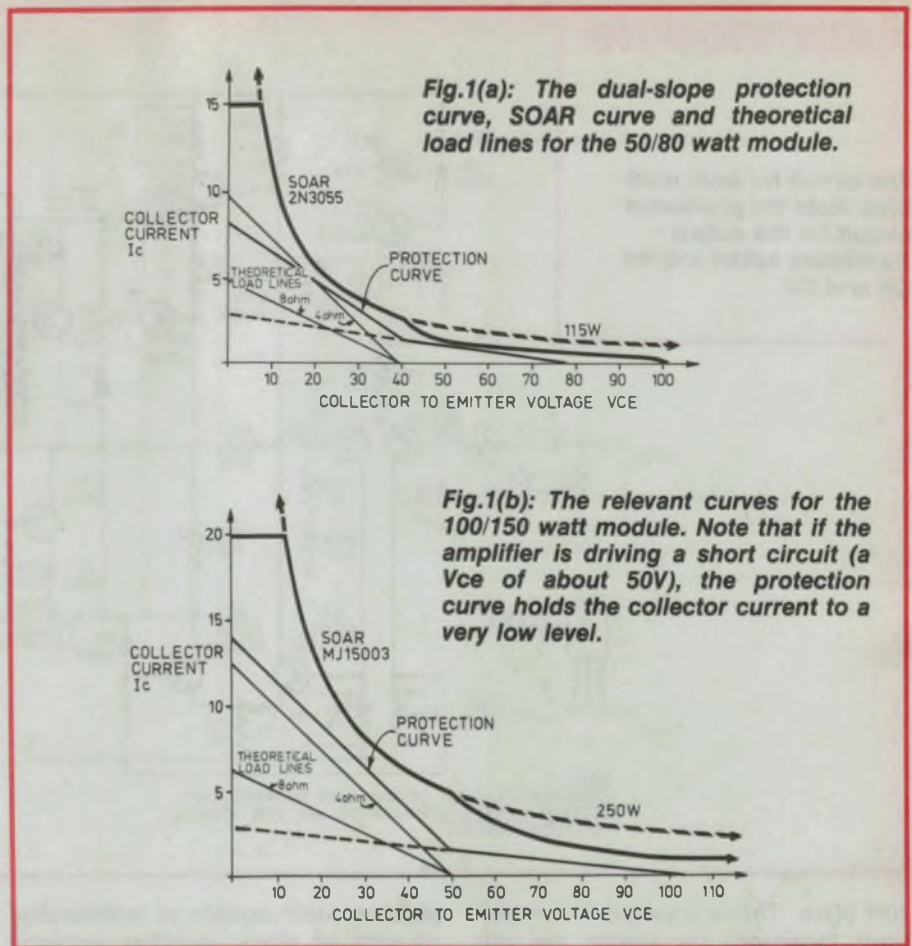

Output protection

As previously mentioned, amplifier modules often have to operate in rather rigorous conditions, placing both the loudspeaker load and the amplifier itself at risk. The essence of this problem is failure of the output devices when their current and voltage relationship exceeds the SOAR curve, as shown in Fig.1.

This curve tends to follow a shape corresponding to the rated power of the device, and dip noticeably above a certain level of Vce due to the effects of secondary breakdown. In the case of a 2N3055, Fig.1(a) shows the SOAR curve following the 115 watt rating for Vce levels below about 40 volts, but above this point the transistor's current capability is considerably reduced.

The diagram also shows the theoretical load lines for a 40V supply and loads of eight and four ohms, which lie safely below the curve. However these are indeed theoretical, and may be radically modified by highly reactive loads, such as electrostatic loudspeakers or very complex crossover networks.

In general, as the load resistance decreases the load lines become increasingly more vertical, rapidly transgressing

the SOAR curve. As you would expect, a short circuit (zero load resistance) across the amplifier's output terminals will produce an almost vertical load line, resulting in the rapid destruction of the output devices.

To avoid this problem fuses may be included in the design, since the transistors are attempting to handle an extremely high current. Unfortunately, by the time the internal fuse wire has failed, the transistors have generally been destroyed already by the large reserve of energy available from the power supply's filter capacitors. Nevertheless, the fuses are a worthwhile addition to prevent further damage to other components.

Other steps may be taken, such as complex sensing circuits driving a relay, which in turn switches out the loudspeaker load when an overload occurs. This method works quite well, but tends to be expensive and does not protect the amplifier against short circuits or very low impedance loads.

The use of electronic current limiting attacks the problem at its source, by preventing the transistor failure in the

Amp module

The circuit for both modules. Note the protection circuit for the output transistors based around Q8 and Q9.

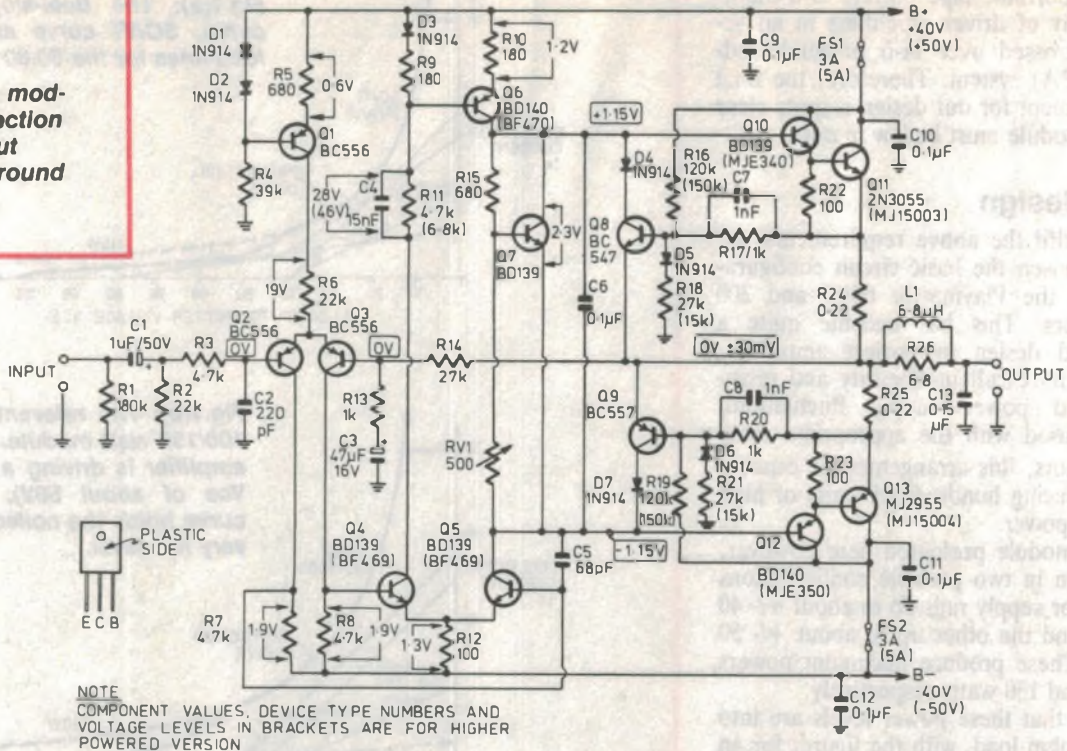

first place. This is achieved by continuously monitoring the voltage and current being handled by the output transistors at any time, and reducing the drive signal if the SOAR limits are exceeded. The actual limiting circuit uses just a few low cost components, and makes the final amplifier virtually indestructible. The two stage protection curves may be seen lying within the SOAR curves shown in Fig.1.

Electronic current limiting must be carefully implemented so as to avoid a marked increase in distortion when the amplifier is operating at high powers. This occurs when the limiting is just starting to operate, and although the amplifier's negative feedback tries to correct the limiting effect, some distortion remains.

The answer here is to arrange the current limiting curve to be quite close to the SOAR curve, so that in normal circumstances the output transistors will be operating well below the selected limiting point. This is achieved by the use of the dual slope curves shown in Fig.1, which makes use of the maximum space under the SOAR curve. Limiting still occurs, but the distortion will increase at an output level only a couple of watts below the point where actual hard limiting is reached.

The final result is a high quality am-

plifier module capable of withstanding all sorts of abuse, including sustained short circuits.

Of course, failures are still possible due to faulty components or extreme overheating, and to prevent loudspeaker damage in this event we would recommend the addition of Polyswitch thermistor protection devices. However, thanks to the current limiting function of this module, transistor failure is extremely unlikely and the addition of Polyswitches might be considered a protection 'overkill'.

The circuit

The actual circuit of our new module is quite similar to the power amp section of the Playmaster 60/60, but with a few minor changes and of course, the additional current limiting components. Only some of the semiconductors, a few resistors and the fuse ratings are changed to produce the lower power module, which uses the same small PCB and heatsink bracket as the higher powered unit.

Naturally, the lower powered module may use the same transistors as the more powerful unit, but the reduced supply rails allow the use of devices with lower voltage ratings, resulting in a considerable cost saving. To check this, try looking up the price difference be-

tween a 2N3055 and a MJ15003 in your favourite components catalogue!

Turning our attention to the actual circuit diagram, we can see the use of a constant current source comprised of D1, D2, Q1, R4 and R5, and a current mirror incorporating Q6, D3, R10 and R9. The advantage of this arrangement is that the currents through the entire circuit are largely independent of the power supply's voltage level, mains ripple and content of signal harmonics. This is quite an asset for a universal amplifier module, since the power supply parameters are far less critical than with other designs.

The constant current circuit maintains a current of around 1mA through the input differential pair (Q2 and Q3) via R6, by virtue of the constant voltage across diodes D1 and D2. This voltage sets the base bias for Q1, and in turn (by emitter follower action) a fixed voltage of around 0.6 volts across R5. Therefore the transistor's emitter current remains at a constant level of 0.9mA (0.6 volts divided by 680 ohms).

This current is then shared equally through the input differential pair, producing a quiescent voltage drop of about 1.9 volts across each of the collector loads, R7 and R8. This voltage then sets the bias for the following differential pair comprised of Q4 and Q5, re-

sulting in a collector current of around 6.5mA in each of these transistors.

The current mirror circuit (around Q6) acts as a collector load for Q4 and Q5, via R11 and the V_{be} multiplier (based around Q7) respectively. The current mirror is effectively a programmable current source, since the current through R9 and D3 sets the base bias for Q6, which as before sets the current through the emitter resistor (R10). Therefore, when the collector current of Q4 modulates the voltage drop across R9, the emitter follower action of Q6 'mirrors' a similar change across R10, duplicating the current change.

The final result of this current mirror action is that Q6 acts as a dynamic, or variable impedance load for Q5 which in turn drives the output stage. By analysing the AC action of this circuit we may see that as Q5 is being turned off, the increasing current in Q4 reflects a higher current through Q6 (increasing its conduction). In this case Q6 represents a lower impedance collector load to Q5, thereby assisting its action (consider Q7 as an AC short circuit for the moment).

Conversely, a raising of the current in Q5 will correspond to less conduction in Q6, representing a higher impedance collector load. This style of dynamic collector load ensures an extremely linear signal is available to drive the following class AB output stage.

R11 appears in the collector load of Q4 to reduce its V_{ce} and quiescent power dissipation to roughly the same level as Q5, whereas Q7 appears in the collector of Q5 as a 'V_{be} multiplier'.

Q7 is effectively self biased by the voltage divider action of R15 and RV1. This induces a fixed voltage across the transistor, which ultimately sets the quiescent current of the output stage. This transistor is mounted on the heat-sink bracket where an increase in temperature will affect its bias (increase its conduction), which in turn reduces its V_{ce} and the quiescent current of the output stage. Thus we have thermal negative feedback, to ensure protection of the output stage against thermal runaway.

The output stage itself is based around a complementary pair of power and driver transistor pairs arranged in a Darlington configuration (Q10 to Q13). These act as emitter followers, providing a high current gain to the output via the resistors R24 and R25. These emitter resistors provide some localised negative feedback, and also a convenient point for monitoring current through the output transistors.

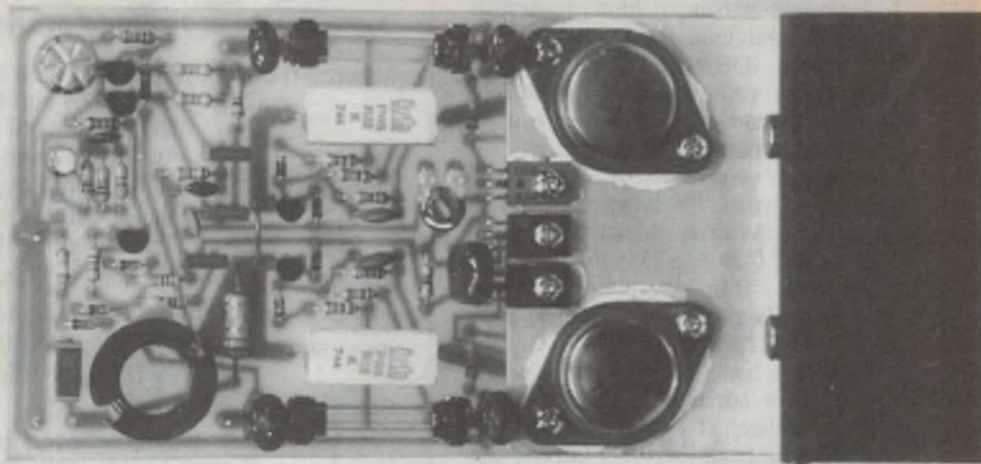

The completed 100/150 watt module. Naturally, it uses a larger heatsink than the lower power version.

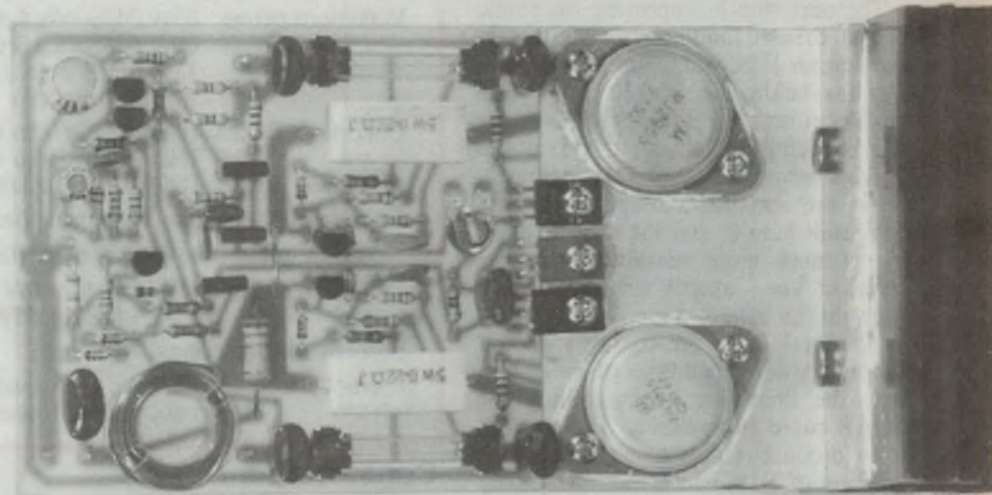

The final 50/80 watt amplifier. Both modules are assembled on a compact PCB measuring 120mm x 75mm.

The actual transfer of a signal to the output stage begins with the the input coupling capacitor C1 and the low-pass filter comprised of R3 and C2, which attenuates signals above about 100kHz. This signal is applied to one half of the input differential pair Q2, while an attenuated version of the output signal is applied to the other half, Q3.

This attenuation sets the amplifier's level of negative feedback, and consequently its overall gain. In this case the voltage division of R13 and R14 sets the AC signal gain to around 28, while the decoupling effect of C3 sets the DC gain to unity. The presence of C3 also defines the amplifier's low frequency response (in conjunction with C1) to about 10Hz.

The balanced drive signal from the input differential pair is then applied to the following pair, Q4 and Q5. These operate as previously described, with

frequency compensation applied by C4 and C5. The resulting drive signal is applied to the output stage with a biasing offset provided by Q7, which is bypassed by C6.

To maintain a high degree of stability into difficult load conditions, an output network comprised of L1, R26 and C13 couples the amplifier to its loudspeaker load. Further stability is provided by the power supply bypassing capacitors C9 to 12.

Current limiting

As may be seen from the circuit diagram, the current limiting circuitry is arranged in two halves; one for sensing the activity in Q10 and Q11, and the other for sensing Q12 and Q13. Since both halves operate in an identical manner, the following description deals with the upper half only.

The simplest form of current limiting

Amp module

is a straight maximum limit, regardless of other conditions. This would be the case if R16, R18 and D5 were omitted, causing the voltage across the current sensing resistor (R24) to be applied directly to the base of Q8 via R17.

When the voltage across R24 rises to about 0.65 volts, Q8 begins to conduct and bleeds the drive current away from the base of Q10 (via D4), limiting output current. This corresponds to a current of about three amps, or 0.65 volts divided by 0.22 ohms.

Referring back to Fig.1, this would appear as a horizontal line across the diagram starting at 3 on the 'Ic' axis. As may be seen from the other curves, this arrangement would not only transgress the SOAR curve, but limit the usable output power.

The next step in improving the shape of the current limiting curve is to add the resistor R16, which produces a sloping line below the SOAR curve. This has the effect of progressively increasing the base/emitter voltage of Q8 as the voltage across Q10 and Q11 increases, or as the amplifier's output falls. The net result here is that the current limiting is much more sensitive for higher levels of Vce - exactly what is required to avoid the SOAR curve.

However, if we are to safely exploit the full power capabilities of the amplifier, the limit line needs to hug the SOAR curve more closely. The solution is to produce a dual slope line by the addition of R18, which due to D5 only comes into play when the output swings in a positive direction.

So for Vce levels of less than half of the total supply rail (about 40V for Fig.1(a) and 50V for Fig.1(b)), progressively more current is made available. This is ideal, since in normal circumstances large output currents from the amplifier correspond to high output voltages, and lower levels of Vce.

A further advantage of the dual slope configuration may be seen in Fig.1 by observing the current limiting point when the amplifier's output is at zero potential, or in the case of Fig.1(a) at a Vce of 40 volts. This is the situation during a short circuit across the amplifier's output terminals, meaning only about 1.5 amps may flow.

So there we have the current limiting, the success of its action clearly showing in the amplifier's specifications. The high powered module for example will cleanly deliver 100 watts into 8 ohms, 150 watts into 4 ohms and yet only 16 watts into 2 ohms!

SPECIFICATIONS

Performance of 100/150W module prototype

Maximum power: 160W RMS into 4 ohms
105W RMS into 8 ohms
16W RMS into 2 ohms (restricted by internal current limiting function)

Distortion: 0.02% THD at 100W into 8 ohms
0.05% THD at 150W into 4 ohms
0.015% THD at normal listening levels

Frequency response: 10Hz to 100kHz +/- 1dB

Signal to noise ratio: better than 100 dB (ref: 1V RMS input)

Input sensitivity: 1V RMS for 100W into 8 ohms
0.9V RMS for 150W into 4 ohms

Stability: unconditional

Protection: full electronic overload and short circuit protection, plus 5 amp supply rail fuses (see text)

Performance of 50/80W module prototype

Maximum power: 85W RMS into 4 ohms
60W RMS into 8 ohms
12W RMS into 2 ohms (restricted by internal current limiting function)

Distortion: 0.05% THD at 50W into 8 ohms
0.09% THD at 80W into 4 ohms
0.03% THD at normal listening levels

Frequency response: 10Hz to 100kHz +/- 2dB

Signal to noise ratio: better than 100dB (ref: 0.7V RMS input)

Input sensitivity: 0.7V RMS for 50W into 8 ohms
0.64V RMS for 80W into 4 ohms

Stability: unconditional

Protection: full electronic overload and short circuit protection, plus 3 amp supply rail fuses (see text)

Construction

Assembling the module is quite a straightforward procedure, the only sections requiring special attention are the coil (L1) construction and the installation of the power transistors.

Before beginning any construction, check the PCB (code 88ma12) for any etching anomalies such as shorts between pads. Also check that the pad holes allow enough space for the component legs and various mounting bolts.

Next, use the PCB as a template for the appropriate holes in the heatsink bracket, and drill these to a large enough diameter for the bolts to be insulated from the bracket. Also drill a few heatsink mounting holes on the other angle of the bracket, and finally remove any sharp edges from around all of the holes with a countersink (or large drill), file and emery paper.

Begin the assembly by installing the lower profile components first, leaving the power transistors and heatsink bracket until last. The 0.22 ohm 5-watt resistors should be mounted clear of the

PCB to allow an unrestricted airflow, as these will get quite hot when the module is run at high continuous levels into 4 ohms.

Take particular care with the polarised components such as the two electrolytic capacitors, and the various transistors and diodes. These should be installed with their polarities arranged exactly as shown in the component overlay diagram.

The coil L1 is wound on an 11mm plastic former using 0.8mm or 1mm enamelled copper wire. The winding should consist of 24.5 turns, with the beginning and end on opposite sides of the coil to match the holes in the PCB. Carefully scrape away the enamel coating from the ends of the wire, and solder the coil in place while double checking the quality of the joint.

To ensure the correct spacing between the fuse clips, attach them to a fuse before they are installed. This also helps to maintain their position while the soldering is completed.

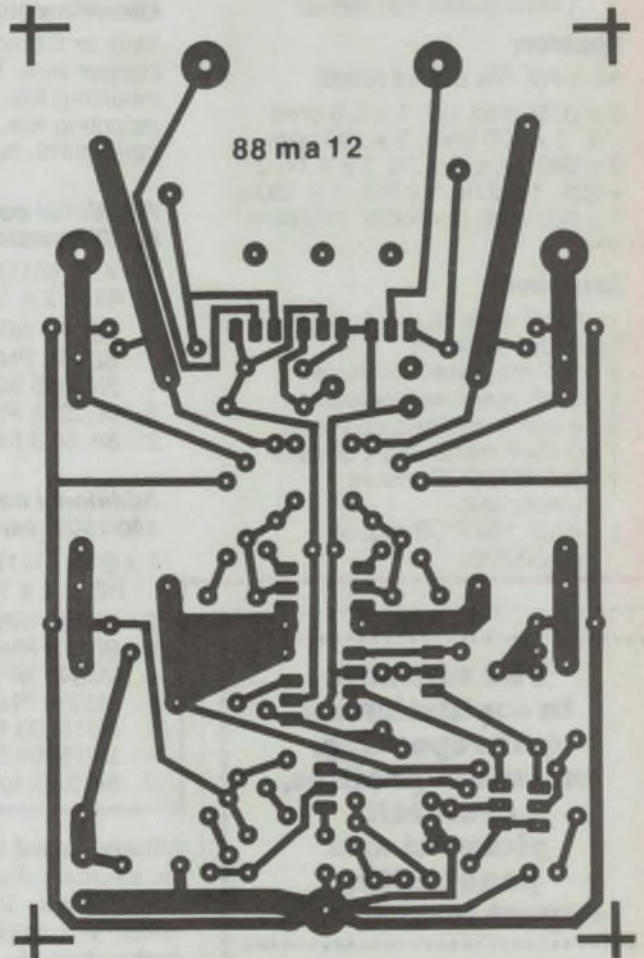
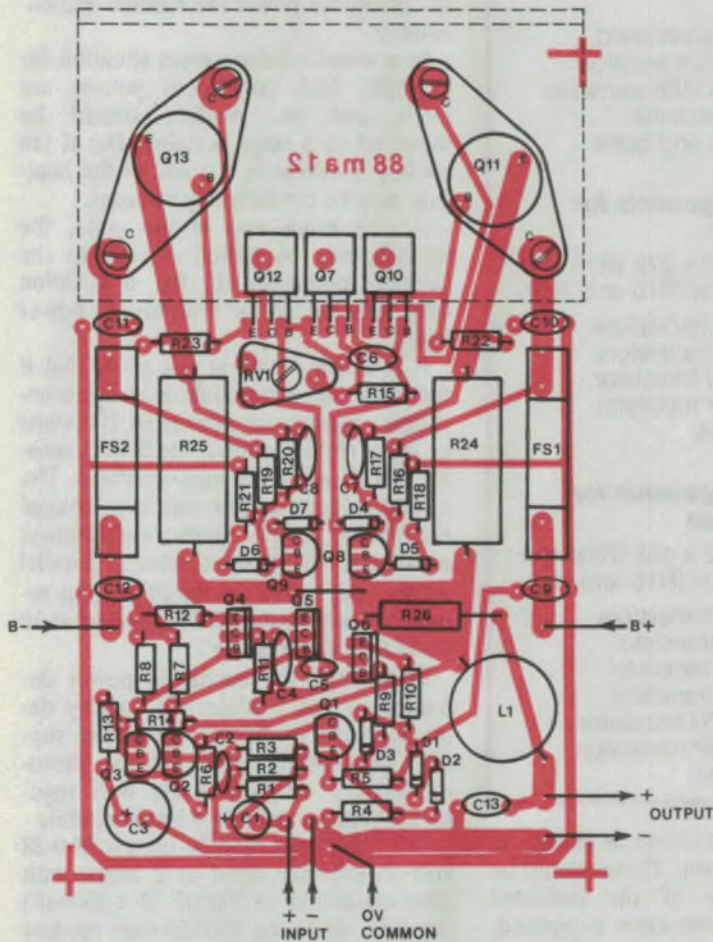
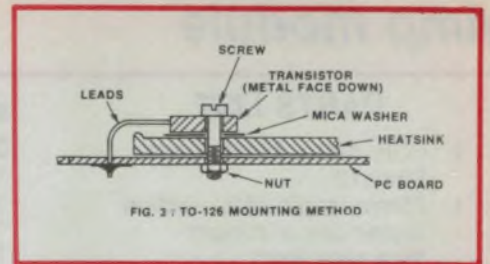
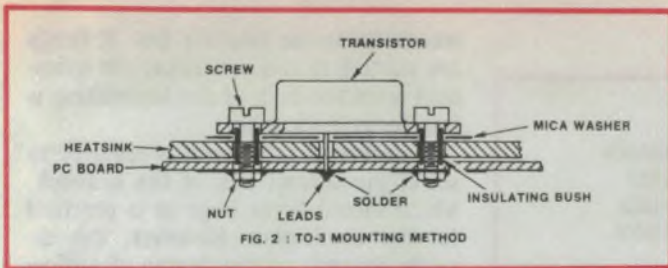

Component overlay diagram. This should be accurately followed when assembling the modules.

An actual size reproduction of the PCB design.

The last steps involve the installation of the power and driver transistors on the PCB, with the heatsink bracket sandwiched between the two. The transistors *must* be electrically isolated from the bracket, yet thermally conducting for effective heat dissipation.

The mounting diagram shown in Fig.2 shows the method for the TO3 style of output transistors. This should be accurately followed and generous amounts of thermal grease applied to both sides of the mica washers. Don't forget to use short lengths of sleeving to insulate the mounting bolts from the bracket, then check the final isolation with the resistance range of a multimeter.

The other 'flatpack' transistors should have their legs bent over to fit the PCB mounting holes in advance, then bolted to the bracket with mica washers for insulation (again, with thermal grease on both sides), and finally soldered in place.

Setting up

Before powering up, the module should be bolted to a free standing heatsink or installed into an existing cabinet/heatsink arrangement. Don't forget to apply thermal grease between the module's bracket and the heatsink. Before installing the fuses, solder a 330 ohm resistor across each fuse holder

from below the PCB, and rotate the trimpot RV1 fully anticlockwise - this corresponds to minimum quiescent current.

Next, apply power to the module and check the output terminals for an offset of less than about +/- 30mV. If all is well, monitor the voltage across one of the 330 ohm resistors and adjust RV1 for a reading of about 6.5V, which corresponds to a quiescent current of 20mA. This reading should be double checked after a few minutes of operation. Note that a load must not be connected during these adjustments and measurements.

As a final check, measure the other

Amp module

PARTS LIST

- 1 PCB, 120 x 75mm, code 88ma12
- 1 75mm length of 'L' section aluminium, minimum thickness 3mm
- 4 3AG fuse mounting clips
- 1 11mm plastic coil former

Resistors

All 1/4W, 5% unless noted:

- 2 x 0.22 ohm 5W, 1 x 6.8 ohm 1W, 3 x 100 ohm, 2 x 180 ohm, 2 x 680 ohm, 3 x 1k, 3 x 4.7k, 2 x 22k, 1 x 27k, 1 x 39k, 1 x 180k, 1 x 500 ohm horizontal miniature trimpot

Capacitors

- 1 68pF ceramic
- 1 220pF ceramic
- 2 1nF metallised polyester
- 1 15nF metallised polyester
- 5 0.1uF metallised polyester
- 1 0.15uF metallised polyester
- 1 1uF 50V PCB mount electrolytic
- 1 47uF 16V PCB mount electrolytic

Semiconductors

- 3 BC556 PNP transistors
- 1 BC547 NPN transistor
- 1 BC557 PNP transistor
- 1 BD139 NPN transistor
- 7 1N914 diodes

Miscellaneous

1mm or 0.8mm enamelled copper wire, TO3 transistor mounting kits, TO126 transistor mounting kits, heatsink compound, nuts and bolts

Additional components for 50/80W version

- 1 x 4.7k (R11), 2 x 27k (R18 and R21), 2 x 120k (R16 and R19)
- 3 BD139 NPN transistors
- 2 BD140 PNP transistors
- 1 2N3055 NPN transistor
- 1 MJ2955 PNP transistor
- 2 3A 3AG fuses

Additional components for 100/150W version

- 1 x 6.8k (R11), 2 x 15k (R18 and R21), 2 x 150k (R16 and R19)
- 2 BF469 NPN transistors
- 1 BF470 PNP transistor
- 1 MJ340 NPN transistor
- 1 MJ350 PNP transistor
- 1 MJ15003 NPN transistor
- 1 MJ15004 PNP transistor
- 2 5A 3AG fuses

transistors to the heatsink fins. If things are starting to run hot, either the quiescent is set too high or the heatsinking is hopelessly inadequate.

A degree of judgement is required to select the correct size of the heatsink, which should be as large as is practical for the application. However, this directly depends on the degree of airflow around the cooling fins, and the amount of continuous power the module will encounter.

In a sound reinforcement situation for example, high continuous powers are likely and the module should be mounted on a large heatsink. But if fan cooling is available, the size of the heatsink may be considerably reduced.

At the other end of the scale, the module may be bolted directly to the cabinet metalwork if the application only calls for low or intermittent power levels.

It is worth noting at this point that if the higher power module is likely to encounter *continuous* powers of 100 watts or more (into 4 ohms), the 5 watt resistors (R24 and R25) may overheat. The easiest solution in this case is to change their value to 0.47 ohms, and connect another set of the same value in parallel on the copper side of the PCB. This results in a total value of 0.235 ohms at 10 watts for each 'resistor'.

In general, the maximum power delivered by the modules will largely depend on the quality of the power supply. The specifications for the prototypes were achieved using well regulated supplies, running a single module.

The 50/80 watt module used a 28-0-28 volt transformer rated at 2 amps, with filter capacitors of 5000uF (2 x 2500uF) per side, while the 100/150 watt module used a 35-0-35 volt 2.5 amp transformer with 6800uF filter capacitors and a 6 amp diode bridge. However, if economic considerations take priority over maximum output power, the transformer's current rating or the main filter capacitors may be reduced in value - this mainly affects the continuous power rating rather than the short term or dynamic power capabilities of the module.

Since the essential design of this module does not rely on a specific power supply voltage, the unit will work on quite happily on a supply as low as say, +/- 20 volts. In this situation, the only change required is dropping R6 to say 10k, and R11 to 2.7k. These values are not critical, and mainly serve to reduce the transistor's power dissipation at higher supply rail voltages.

EA

**The ultimate
in sophisticated
golf reporting,
colourful profiles,
dramatic
pictorial and
penetrating
expert instruction.**

AUSTRALIAN

GOLF!

**COMPULSIVE
READING!**



Available monthly at your
newsagent or subscribe now by
phoning (02) 693-9517 or
693-9515

voltages around the circuit as shown on the schematic diagram. These should be within about 10% of the indicated values. If a significant error is noticed, double check the component values and semiconductor polarities around the area.

Finally...

Now that the soldering iron has cooled down, and the smell of flux has cleared from your nostrils, it's time to use the module for its chosen application.

Remove the 330 ohm resistors (first, turn off the power!) and install fuses of the correct rating. Connect a loud-speaker and re-apply power to the module - there should be barely a whisper of hiss from the speaker under no signal conditions. Now is the time for an input signal.

At normal volume levels, the module and heatsink should remain quite cool, with a gradual transfer of heat from the

This man isn't a computer expert, yet he chose a UNI-X CompuPak kit - and assembled it in one night!



\$999
Including Tax.
At this price **WHY NOT?**

No, he's not a genius, but he's brilliant at spotting great value. Like many of us, he's realized that a personal computer is invaluable, yet the price tag for a professional unit has always been a little beyond his reach. Until now.

Quite simply the UNI-X CompuPak kit contains all the major componentry of a top quality industry standard computer, in an unassembled form. You save the dollars and increase your knowledge, by putting it together yourself.

UNI-X also provide a National Warranty through Honeywell Ltd, a professional network of expert backup and service.

The complete Super 10 kit contains:

- Super — 10 mother board 640K installed 4.77 / 10MHz, plus V-20 chip (very fast!)
- Colour graphics adaptor card.
- Multi I/O Card-Serial/Parallel Ports, Games Port, Clock, calendar, Floppy Controller.

- Dual Frequency TTL Monitor (Green or Amber) includes tilt and swivel base.
- Top quality Japanese Disk Drive.
- 150 watt switching power supply.
- High tech flip-top case.
- Complete set of accessories.
- AT style keyboard.
- Industry standard — runs all IBM software.
- Assembly manual
- Utility Disk.
- All upgrade options available.

Ring PATRICK SIMONIS
(07) 356 7866 right now.

UNI-X  **CompuPak**
Pty Ltd Division

Phone (07) 356 7866
Dealer enquiries welcome
Phone (07) 356 8311

UNI-X CompuPak Division, 18-20 Edmondstone St,
Newmarket, Queensland 4051

Australian Personal Computer
LOW COST AND COMPATIBLE SURVEY - OCTOBER 1987

...and the experts agree with his choice.

Australian Personal Computer have now proved what our customers have known for years

Processor.

NEC. The Uni-x contains a NEC V20, manufactured by Sony.

This is a V20 running at 4.77MHz will outrun an 8086 running at the same clock speed. The Uni-x V20 provides a standard PC clock rate of 4.77MHz as a minimum, although the Uni-x delivered higher than standard performance even on this clock rate by virtue of the V20. The Atlantis and...

Performance.

The Uni-x is fastest overall, providing a 50 per cent boost over the Technology interface due to the V20.

Display.

The Uni-x is delivered with a nice INTRA tilt/swivel amber screen. The other...

Cost Effectiveness.

As you might expect, the do-it-yourself Uni-x comes up trumps with its low cost and relatively high performance.

Specifics.

The Uni-x features a delightfully small motherboard. It has employed a VLSI component to replace the Intel 8253 timer, 8255 PPI, 8237 DMA controller and several other components. This reduced the component count and a simplified motherboard serves to reduce costs.

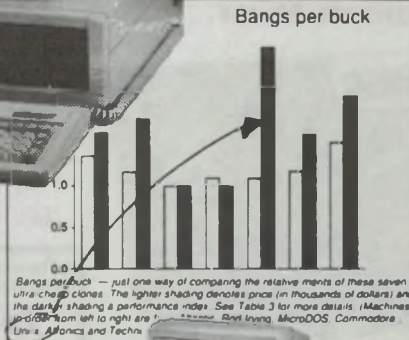

... see for yourself in the full Report in the October '87 issue, or ring us for a copy.



**Why Waste Your time With Other Suppliers
Altronics Can Deliver Any Of The Quality Products
To You Tomorrow — Just Phone Your Order Toll Free
On 008 999 007**

Jack O'Donnell
M/Director

Country Clients Please Allow Additional 48-72 Hours

**Ultra High Power Capacity
Polypropylene Bass Drivers**

Save 25% This Month



12" (300mm) Model

100 Watts continuous input
150 Watts intermittent input
Impedance 8 Ohm
Sensitivity 93db
Weight 3620gm

C 3070 \$99

Normally \$139

15" (375mm) Model

120 Watts continuous input
200 Watts intermittent input
Impedance 8 Ohm
Sensitivity 92db
Weight 4120 gm

C 3075 \$149

Normally \$179

Our all new "Black" polyprop cone Bass Drivers exhibit quite astonishing low register reproduction. The power ratings quoted are conservative. While they may not be the cheapest around they definitely represent the best value we know of - **Anywhere**. The real exciting news is we have the top selling 12 and 15 inch models at low discount prices this month - but be quick stocks are limited.

**Our Top Selling Professional
Stereo Console Mixer**

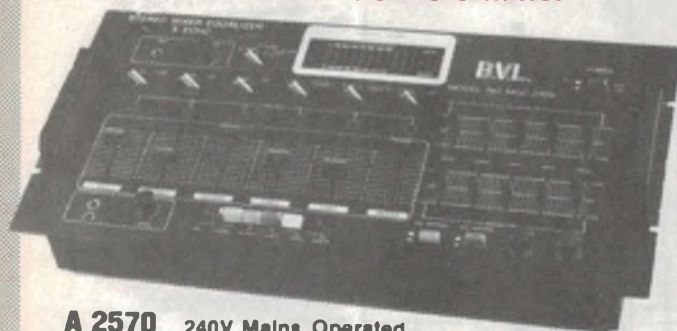

A 2570 240V Mains Operated

Normally \$499 This Month **\$449**
Save \$50 This Month

Our sophisticated "NEW" Audio Mixing Console is ideal for 'live' recording • PA mixing • Fantastic Tape recordings • Even Stereo/Mono VCR recording. A truly professional deck that features separate R/L 5 band graphic equalisers • Echo and Peak LED level indicators • Talkover facility • Separate H/Phone level control • Patch switch bank • Individual microphone, Phono 1 Phono 2, Aux/Line 1, Aux/Line 2, and Master slide level controls. — Blend up to two magnetic or crystal turntables, two tape decks or tuners and two microphones all at once!!

SPECIFICATIONS:

- Input Mic 1—0.5mV 600 Ohms Mic 2—0.5mV 600 Ohms Mic 2—0.5mV 600 Ohms (low imp.) 2.5mV 10K Ohms (low imp.) Phono 1 & 2 (Mag) 3mV 50K Ohms Phono 1 & 2 (Cry) 150mV 100K Ohms Tape/Tuner 1 & 2 150mV 100K Ohms • Equaliser 5 frequency bands—60Hz, 250Hz, 1KHz, 4KHz, 12KHz—Boost Cut range-plus or minus 12db @ Centre frequency. • Output 1.5V/0.775V (Selectable) • Frequency Response 20Hz to 20KHz plus or minus 1db • Distortion Less than 0.05% • S/N Ratio More than 50db
- Headphone Impedance 4—16 Ohms • Echo B B D System • Delay Time 30—200mS • Echo Repeat Control • Delay Time Control • Dimensions 480 (L) x 240 (W) x 110 (H)

**Go Anywhere 240V Mains Power From Your Car or Truck Battery
With These Fantastic DC to AC Inverters**

**300 Watt Inverter
With Auto Start**

Features: Auto start draws power from your battery only when appliance is plugged in and "turned on" i.e. battery can be left permanently connected if required. **Voltage Regulated Current Regulated - Current Overload** unit self limits - single PC Board construction - easy to build as there is very little internal wiring.



Kit

K 6750 \$279

Built & Tested

K 6755 \$379

Power House 600W Inverter

(See EA Dec'87)

A must for farming, camping, mining, boating, remote settlements and wherever else 240V power isn't available.

Features: Strong custom steel chassis • Industrial grade power coat finish • Can be configured to operate off either 12V and 24V DC • Very little internal wiring • Manual or Auto start facilities • Low battery cut out • Compact Toroid transformer.

K 6770
KIT VERSION

\$425



Fully Built & Tested

K 6774
12V INPUT

K 6775
24V INPUT **\$525**

These are the Genuine Grain Oriented Toroid Transformers as used in Electronics Australia and Silicon Chip Magazine Projects.

**Toroidal Power
Transformers**

Why a Toroid?

- Smaller size and weight to meet modern "Slimline" requirements.
- Low electrically induced noise demanded by compact equipment.
- High efficiency enabling conservative rating whilst maintaining size advantages.
- Lower operating temperature
- Simple, quick single bolt mounting



Dimensions and Weight

160 VA Models 110 Diam. 45mm
H. 1.8Kgs Leads 200mm

300 VA Models 125 Diam. 45mm
H. 2.5Kgs Leads 200mm

160 Watt Models \$65 10 up \$62 ea **300 Watt Models \$79 10 up \$75 ea**

Cat.No.	SEC.V
M 3050	12 + 12
M 3055	18 + 18
M 3060	25 + 25
M 3065	30 + 30
M 3070	35 + 35
M 3075	40 + 40

Cat.No.	SEC.V
M 3085	12 + 12
M 3086	18 + 18
M 3088	25 + 25
M 3090	30 + 30
M 3092	35 + 35
M 3100	40 + 40

BANKCARD • VISA • MASTERCARD PHONE TOLL FREE 008 999 007 NEXT DAY JETSERVICE DELIVERY

BANKCARD • VISA • MASTERCARD PHONE TOLL FREE 008 999 007 NEXT DAY JETSERVICE DELIVERY

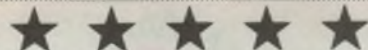

HIGH TECH Company Collapse Brings Fantastic Bargains For Electronic Enthusiast PCB Transformer Scoop

240v to 8, 12 or 20V Quality PCB Mount Type Famous Arlec Brand.

Primary: 240V Pins 1,6 - Secondary 1: 8V @ 1.6 Amps Pins 7,8 - Secondary 2: 12V @ .35 Amps Pins 11, 12 - Secondary 3: 20V @ .35 Amps Pins 7, 12 (join 8, 11)

Cat. ZX 0020

Amazing Price 1 - 47

\$2.50

48 or More (Carton Lots)

\$1.80

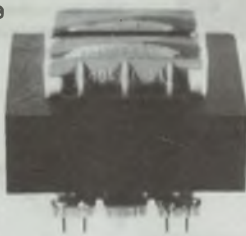

Video Modulators Just \$2

Video into RF Australian Channel 0 - RF Output - Quality ABTEC Brand.



ZX 0090

1-10 **\$3**

10+ **\$2**

Dozens of applications e.g. • Computer to TV • Video Games • Use your TV as remote Video Monitor • Low cost CRO Adaptor for TV • Video Recorder or Camera to TV etc. etc. All self contained in PC mounting shielded case RCA connector output +12V supply (case neg.) Single terminal wire video input.

Fantastic Value

Mylar Stereo Phones With Dynamic Mic

Great For 2-Ways, Intercams P.A.'s & 100 Other Communication uses. Super Comfortable.

Headphone Specs. 20Hz - 20,000Hz, 32 Ohm, 102 db/uW, 3.5mm stereo jack, 8.35mm stereo jack, adaptor. Microphone Specs. dynamic type, 300 Ohm, 100Hz - 15,000Hz, -80 db @ 1KHz, 3.5mm Mono jack.

C 9055

SAVE **\$10.00**

NOW \$29.95

Get One For The Work Bench

2 Amp Regulated Power Supply

Input Voltage: 240V AC-50Hz
Output Voltage: 12V DC
Output Current: 2A
Normally \$69.95

NOW \$45

M 9050



Huge Savings On Top Selling Multipurpose Mains Transformers

Multipurpose 60VA Transformer

Output Two Simple Secondaries, each with just one tap, permit an amazing range of outputs.

240V to 9, 12, 15, 18, 21, 24 volts at 60VA (60W). Use of high grade Silicon steel has enabled surprisingly compact dimensions (70mm x 70mm x 58mm High).

M 2165

Normally **\$26.50**

\$19.00



10 or More **\$15.00 ea**

Multipurpose 120VA Transformer

Another Quality Transformer from Altronics. The M 2175 is wound on expensive grain oriented steel. Look at the size! Just 110mm wide by 85mm High by 65mm Wide. Weight 1.25Kgs. Primary: 240V Secondary: 1 0-12V @ 5A, 15V @ 4A Secondary: 2 0-12V @ 5A, 15V @ 4A.

Normally **\$39.95**

This Month

\$30



10 or More **\$26.00 ea** **M 2175**

RF Signal Generator

SPECIFICATIONS:
Frequency Range: 100KHz - 150MHz In 6 Ranges. RF Output Level: 100mV RMS
Accuracy: +/-3% Modulation: • Internal (30% depth 1KHz • External 50Hz - 20KHz • Crystal Locked Oscillator.

Q 1550

SAVE **\$30**



NOW \$195.00
Limited Stocks Be Quick!

AA Nicad Sensation

New Improved Performance 500MAH

\$ 5020 1-9 \$3.00

10 Up **\$2.50**



Up To Now Similar Lamps Were Selling For \$1000 & More.

Plasma Lamp Display

Fantastic pulsating high voltage Plasma discharge continually changes shape & direction. Mode selectable to either fingertip control or sound activated e.g. from voice or sound system. Provides endless fascination as it sizzles & arcs. Supplied complete with AC Mains Adaptor.

Price Breakthrough For '89

A 0120

\$199



Save Up To 50% On Top Quality D Series Connectors! **Fantastic Value**

D Series Computer Connectors. Gold Plated Professional Series

Items Marked * are 1/2 Price or Less



DB9

WERE NOW

P 3000 Male 9 Pin	2.95	1.47*
P 3010 Female 9 Pin	3.25	1.60*
P 3020 Male PCB R/L	3.75	3.00
P 3030 Female PCB R/L	4.50	3.50
P 3040 Male PCB mnt.	2.95	2.50
P 3050 Female PCB mnt.	3.95	2.25
P 3090 Backshell cover	1.95	.95

DB15

P 3100 Male 15 Pin	3.25	1.60*
P 3110 Female 15 Pin	3.85	1.90*
P 3120 Male PCB R/L	4.35	2.10*
P 3130 Female PCB R/L	5.50	2.70*
P 3140 Male PCB mnt.	3.85	1.90*
P 3150 Female PCB	4.85	2.40*
P 3190 Backshell cover	2.20	1.00*

DB25

P 3200 Male 25 Pin	4.95	2.47*
P 3210 Female 25 Pin	5.50	2.74*
P 3220 Male PCB R/L	4.95	3.50
P 3230 Female PCB R/L	6.90	3.90
P 3240 Male PCB mnt.	4.95	3.00
P 3250 Female PCB mnt.	6.25	3.95
P 3290 Backshell cover	2.20	1.10*

Temperature Adjustable 250 Deg.C to 450 Deg.C

Excellent new Iron, screwdriver temperature adjustable between 250 Deg.C and 450 Deg.C enabling very delicate soldering on low settings with surprising heat energy reserve on maximum setting. Relative temperature is indicated by LED lamp brightness. Much lower cost than a soldering station.

T 2445

Normally **\$37.95** **NOW \$27.95**
\$10.00 OFF

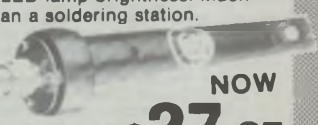

BANKCARD • VISA • MASTERCARD PHONE TOLL FREE 008 999 007 NEXT DAY JETSERVICE DELIVERY

BANKCARD • VISA • MASTERCARD PHONE TOLL FREE 008 999 007 NEXT DAY JETSERVICE DELIVERY

**Superb Redford Wireless Microphone System
Uses Dual Diversity Receivers for long Range,
Noise Free Pure Fidelity Reproduction.**

Now Available
in Australia For
Less Than
\$1,000

Altronic proudly release the Redford
Dual Diversity System - Used Worldwide
by Entertainers i.e. Rolling Stones, Dire
Straites, Tina Turner and 1000's more'

Superb
Microphone
Reproduction
Compares with
Shure, Beyer
and AKG



Unique
Microphone
design completely
Eliminates
"Dangling"
Antenna



Breathtaking performance without signal drop-out or noise interference. The Eleco Wireless Microphone System is virtually the ultimate in an Entertainers Microphone system (or for any roving microphone application for that matter!)

All the annoying wireless microphone characteristics such as "drop out", static and noise are completely eliminated by use of auto switching dual diversity receivers. The output of each receiver is continually monitored, with the strongest and clearest signal always selected. Dynamic Range exceeding 100 db is obtained by employment of a Patented special Parabolic level compressor and Dynamic expander.

The operating range is a minimum of 50 metres (often this can be extended to 200 metres and more in normal circumstances).

Several Frequencies are available to alleviate cross interference when two or more systems are used in proximity.

Brief Specifications Frequency 202.1, 202.5, 203.7MHz (Please specify if you have a preference)

Mic Carrier Power 50mW (Max) Mic Antenna built-in Dynamic Range over 100db S/N Ratio better than 90db Frequency Response 20Hz to 16KHz + or - 3db
Mic Battery 4 x AA cells Battery Life over 24 hours continuous operation Receiver Sensitivity 12db/micro volt for 80db S/N ratio Pre emphasis/De emphasis 50us.
Receiver output unbalanced 6.3mm phone jack and balanced 3 pin cannon type. Output Level (adjustable) Unbalanced 0-2.5V Balanced 0 to + or - .3V into 600 ohms Receiver Power Supply 200 - 260VAC.

Prices

- (A) Dual Diversity Receiver \$729.00
- (B) Entertainment Microphone (hand held type) \$349.00
- (C) Lavalier Type Microphone \$349.00

**Bonus Offer SAVE \$78 Choose Receiver and
Either Microphone For Just \$999**

Please Note 3 different operating frequencies are available (you will need to specifically nominate desired frequency only if the equipment is being used in proximity with other Systems on the 200MHz band.

Frequencies

C 0111	Dual Diversity Receiver	202.1MHz	\$729
C 0113	Dual Diversity Receiver	202.5MHz	\$729
C 0115	Dual Diversity Receiver	203.7MHz	\$729
C 0121	Entertainment Microphone	202.1MHz	\$349
C 0123	Entertainment Microphone	202.5MHz	\$349
C 0131	Lavalier Microphone	202.1MHz	\$349
C 0133	Lavalier Microphone	202.5MHz	\$349
C 0135	Lavalier Microphone	203.7MHz	\$349

**AT LAST Design Quality
Weather Proof Speakers
And Sound Columns By Redford**

- Rugged extruded aluminium construction • Superb powdercoat industrial paint finish • Engineered in Australia • Excellent reproduction • Superior to imports — Yet just a fraction of the price!

Altronic proudly announce the release of the superb Redford Weatherproof Speaker and Sound Column Range. Imagine a wide range speaker system which is highly directional and with efficiency approaching that of reflex horns!

Redford is the solution for high quality sound reproduction outdoors. The Five Models to choose from "Fill the Bill" from applications on boats to high grade paging and music entertainment installations.

RUGGED EXTRUDED CONSTRUCTION

These vibration free enclosures are constructed from die extruded heavy gauge aluminium and finished with incredibly durable industrial powdercoat enamel. The speaker ends are sealed via gaskets and tough moulded "LURAN S" UV resistant end caps. The end result is "Good Looks" together with assured rugged durability for the Australian environment.

EXCELLENT REPRODUCTION

The drivers have been chosen for wide range, low distortion, mid range "presence" (essential for high grade vocal work) and high efficiency in general. Power Capacity for short term use, the drivers will safely handle 150% of rated power. Acoustic wadding is used to dampen Bass resonance. Weather Proof Construction and use of "Doped Cones" Foam plastic and cloth is sandwiched between Baffle and Front Grill to prevent water ingress. A first for Redford is the use of a patented cone moisture repellent process for all models.

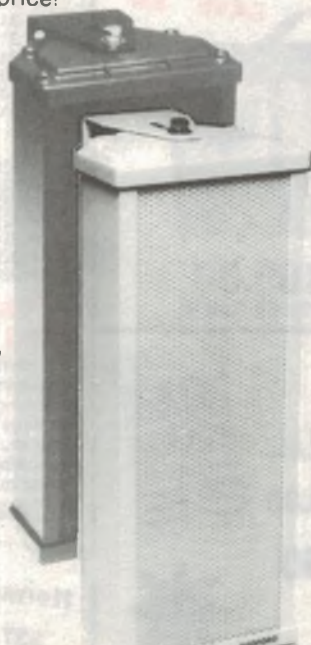

**Wide Range
Weatherproof Extension
Speakers For Your Stereo
System**

**Great For The Back
Patio, Swimming
Pool, Games Room,
Den, Pool Room Etc.**

**Dimensions 260mm wide
x 170mm high x 150mm D.
(Mounting brackets are
included)**

10 Watt 16 Ohm (Max 15 Watt)

Single dual doped cone driver 16 ohm impedance is employed to give a generally correct volume balance with main speakers - an added bonus is your amplifier load is kept to respectable limits! Great for back patio, Den, Boat Deck etc.

- C 0938 White \$99ea \$190 per Pair
- C 0940 Black \$99ea \$190 per Pair

20 Watt 8 Ohm (Max 30 Watt)

Use 2 special dual doped cone drivers for those wanting a bit more umph!

- C 0943 Black \$139ea \$280 per pair
- C 0944 White \$139ea \$280 per pair

**100 Volt Line Models For Use With Professional PA
And Music Systems**

Using a "Doped" wide range drivers and fitted with grain oriented steel line transformer. Output cable allows connection to 10W/5W/2.5W with 10 watt models, 20W/10W/5W with 20 watt models and 40W/20W/10W with the 40 watt versions.

- C 0941 10W/100V line Black \$119ea \$220 per pair
- C 0942 10W/100V line White \$119ea \$220 per pair
- C 0945 20W/100V line Black \$169ea \$299 per pair
- C 0946 20W/100V line White \$169ea \$299 per pair
- C 0950 40W/100V line Black \$225ea \$399 per pair
- C 0955 40W/100V line White \$225ea \$399 per pair

BANKCARD • VISA • MASTERCARD PHONE TOLL FREE 008 999 007 NEXT DAY JETSERVICE DELIVERY

BANKCARD • VISA • MASTERCARD PHONE TOLL FREE 008 999 007 NEXT DAY JETSERVICE DELIVERY

BANKCARD • VISA • MASTERCARD PHONE TOLL FREE 008 999 007 NEXT DAY JETSERVICE DELIVERY

BANKCARD • VISA • MASTERCARD PHONE TOLL FREE 008 999 007 NEXT DAY JETSERVICE DELIVERY

NEW KITS



FM Stereo Transmitter

(See Silicon Chip Oct'88)

Turn Your C.D. Player into a Mini FM Transmitter.

Simply connect your C.D. player to the mini mitter which converts the C.D. signal to an F.M. signal. This FM signal then can be tuned in via your FM walkman or your shed radio. Great for listening to your favorite C.D. while washing the car, mowing the lawn or doing the vacuuming etc. Powered by single 1.5V penlite battery.

K 1120 \$43.50

120W Public Address Amplifier

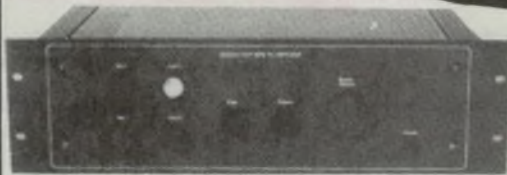

This professional quality public address amplifier offers performance equal to or better than commercial units at about half the price. Ideally suited for halls, churches, clubs and even temporary setups. **Inputs** 2 balanced mic with 3 Pin XLR connectors: 2 auxiliary suitable for direct connection to C.D. tuner etc. **Outputs** 4 Ohm, 8 Ohm or 100V line output configuration.

(See Silicon Chip Nov'88)

K 5020 \$499

Save \$200 Or More On Commercial PA Amps

K 2565 \$12.00

RF Detector Probe
(See EA May'88)

This simple RF probe is ideally suited fault finding and trouble-shooting in AM radios. Feeds directly in the input of an audio amp. Requires external supply. Ideally suited for use with the K 2100 Bench Amp.

Bench Amp Signal Tracer
(See EA April'88)

Test & Fault Find Audio Equipment without Expensive Equipment

This simple but effective bench amplifier is suitable for testing virtually any audio device. **Features:** Input capability from 10mV to 10V • Inbuilt speaker, overload indicator and external speaker socket. • Requires External 9-15V AC supply.

K 2100 \$65.00



Power Transistor Tester

(See EA May'88)

Hand select transistor for power output stages.

This tester has been designed specifically for bipolar transistor with a continuous collector rating of at least one amp. Super simple operation allows for testing of current gain and Vbe of all popular power transistors. Suitable for both N.P.N and P.N.P. types.



K 2532 \$24.95

LED Light The House Number

Identify Your House - Build The LED Light.

(See Silicon Chip Oct'88)

The LED light makes your house easily recognisable at night by illuminating your house number. Great for people visiting, easy for taxis and emergency services to locate you at night. Any number can be configured including Alpha-numeric combinations. Automatic operation works only at night. Automatic switch off approx. 4.5 hrs. 64 LEDS supplied.

K 1960 \$59.95

ALTRONICS

174 Roe St. Perth W.A. 6000
PHONE TOLL FREE 008 999 007
Perth Metro & After Hours (09) 328 1599
ALL MAIL ORDERS
P.O. Box 8350 Perth Mail Exchange W.A.6000

ALTRONICS RESELLERS

Chances are there is an Altronics Reseller right near you - check this list or phone us for details of the nearest dealer. Please Note: Resellers have to pay the cost of freight and insurance and therefore the prices charged by individual Dealers may vary slightly from this Catalogue - in many cases, however, Dealer prices will still represent a significant cost saving from prices charged by Altronics Competitors.

Don't forget our Express Mail and Phone Order Service - for the cost of a local call, Bankcard, Visa or Mastercard holders can phone order for same day despatch.

Manufacturers, Contractors and Bulk Users
Please Contact Our Wholesale Sales Dept.
Sydney (NSW Only) Colin Fobister 437 4077
Perth 09 328 2199

STANDARD DELIVERY & PACKING CHARGE \$4.00 to 1Kg \$7 over 1Kg AUSTRALIA WIDE - We process your order the day received and despatch via Australia Post. Allow approx 7 days from day you post order to when you receive goods

\$7.00 OVERNIGHT JETSERVICE - We process your order the day received and despatch via Overnight JetService Courier for delivery next day Country areas please allow additional 24-48 hours. Weight limit 3Kgs (3Kgs covers 95% of Orders).

\$10.00 HEAVY HEAVY SERVICE - All orders of 10Kgs or more must travel Express Road - Please allow 7 days for delivery.

INSURANCE - As with virtually every other Australian supplier, we send goods at consignees risk. Should you require comprehensive insurance cover against loss or damage please add 1% to order value (minimum charge \$1). When phone ordering please request "Insurance".

TOLL FREE PHONE ORDER - Bankcard, Visa, Mastercard Holders can phone order toll free up to 6pm Eastern Standard Time. Remember with our Overnight JetService we deliver next day.

- WA** COUNTRY ALBANY BP Electronics ■ 412681 **ESPERANCE** Esperance Communications /13344 **GERALDTON** K.B Electronics & Marine 212176 **KALGOORLIE** Todays Electronics ■ 212777 **KARRATHA** Daves Oscitronic 854836 **MANDURAH** Lance Reck Retravision 351246 **WYALKATCHEM** D & J Pease 811132 **NT** ALICE SPRINGS Ascum Electronics 521713 **Farmer Electronics** 522967
- ACT** CANBERRA Bennett Commercial Electronics 805359 **Scientronics** 548334 **VICTORIA** CITY All Electronic Components 6623506 **SOUTH** MELBOURNE Winscott Trading 8995740 **SUBURBAN** CHELTENHAM Talking Electronics 5842386 **CROYDEN** Truscott Electronics ■ 7233860 **PRESTON** Preston Electronics 4840191 **COUNTRY** BENDIGO KC Johnson ■ 411411 **MORWELL** Morwell Electronics 346133
- QUEENSLAND** CITY Delsound P/L 8396155 **SUBURBAN** CAPALABA David Hall Electronics 3902399 **FORTITUDE VALLEY** Economic Electronics 2523762 **WOODRIDGE** David Hall Electronics 8082777 **COUNTRY** CAIRNS Electronic World ■ 518555 **BUNDABERG** Bob Elkins Electronics 721785 **GLADSTONE** Supertronics 724321 **MACKAY** Philtronics ■ 578855 **ROCKHAMPTON** Access Electronics (East St.) 221058 **Electron World** 278988 **TOOWOOMBA** Hunts Electronics ■ 329677 **TOWNSVILLE** Solex ■ 722015 **SA CITY** Electronic Comp & Equip 2125999 **Force Electronic** ■ 2125505 **SUBURBAN** BRIGHTON Force Electronics ■ 3770512 **CHRISTIES BEACH** Force Electronics ■ 3823366 **ENFIELD** Force Electronics ■ 3496340 **FINDON** Force Electronics ■ 3471188 **LONSDALE** Force Electronics ■ 3260901 **COUNTRY** MT.GAMBIER South East Electronics 250034 **WHYLLA** Eyre Electronics ■ 454764 **TASMANIA** HOBART George Harvey ■ 342233 **LAUNCESTON** George Harvey ■ 316533 **Nichols Radio** TV 316171 **NSW** CITY David Reid Electronics ■ 2671385 **CARINGHAH** Hicom Unitronics 5247878 **LEWISHAM** PrePak Electronics 5699770 **SMITHFIELD** Chantronics 6097218 **COUNTRY** COFFS HARBOUR Coffs Harbour Electronics 525684 **NELSON BAY** Nelson Bay Electronics 813685 **NEWCASTLE** Novocastrian Elect Supplies ■ 621358 **NOWRA** Ewing Electronics ■ 218412 **RAYMOND TERRACE** Alback Electronics 873419 **WINDSOR** M & E Electronics 775935 **WOLLONGONG** Newtek Electronics ■ 271620

Blue Ribbon Dealers are highlighted with a ■. These Dealers generally carry a comprehensive range of Altronic products and kits or will order any required item for you.

Circuit & Design Ideas

Interesting circuit ideas from readers and technical literature. While this material has been checked as far as possible, the circuits have not been built or tested by us. As a consequence, we cannot accept responsibility, enter into correspondence or provide construction details.

Serial to parallel interface

This interface was designed to attach a serial keyboard to a computer via a parallel port and can be constructed for around \$10.00.

Using an RC oscillator may seem unconventional, but in practice it works quite well. A couple of kHz either side of the nominal frequency does not seem to upset operation, and it does reduce parts count. Although not tried, other baud rates may be achieved by setting the oscillator to 16 times the required rate. Simply alter the value of the 2.7k resistor and 1500pF capacitor. Some adjustments of these values may be required, depending on the 4049.

The UART (IC1) used was a TR1602, but may be substituted with a TR1863 or TR1865. As these operate on a single +5V supply, pin 2 should not be connected. This will eliminate the -12V supply.

The input, buffered by the 4049 inverter can easily accept 12V, but should not go negative. It is rated at -0.5 to +18V input at a 5V supply. If required, it may be protected from the negative voltage swing in an RS232 signal via a resistor in series, and a diode to ground.

As shown, the setup is for 8-bit word length, 1 stop-bit with no parity. Tie pin 36 (SBS) to +5 for 2 stop-bits. To enable parity, tie pin 35 (PI) to ground instead, then tie pin 39 (EPE) to ground for odd or to +5 for even parity. Word length is set by pins 38 (WLS1) and 37

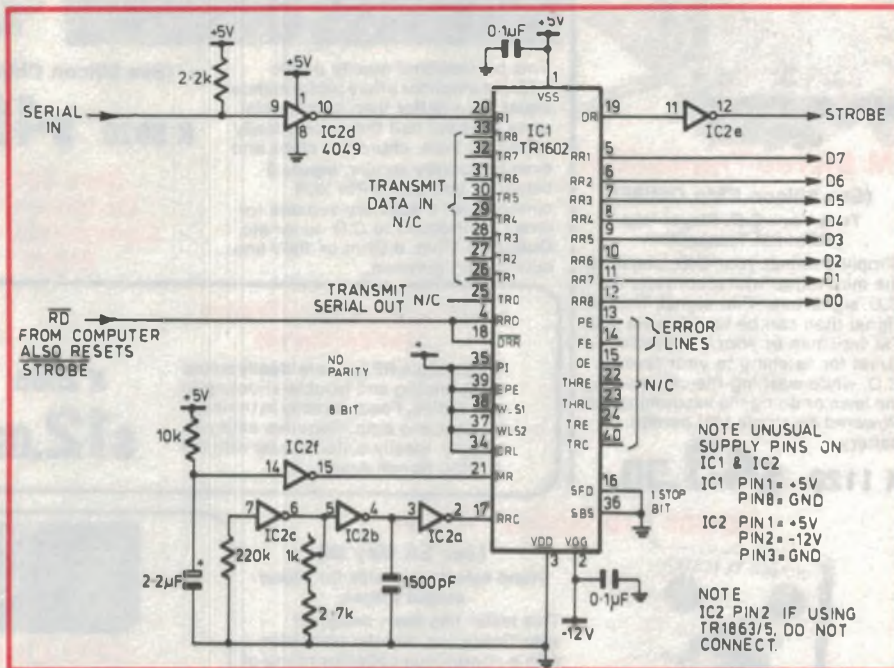

(WLS2); for 7-bit, tie (WLS1) to ground, 6-bit tie (WLS2) to ground, 5-bit tie both to ground.

Note that if a TR1865 is used, input pins are pulled high internally, so any lines tied to +5V may be left floating instead. Alternatively, a DIP switch could be used between these pins and ground.

Error information is available from pins 13 to 15. A high level on pin 13 (PE) indicates a parity error on last character, pin 14 (FE) a framing error (incorrect stop bit), and pin 15 (OE) that a character was missed.

When a character is received, STROBE (output from IC2e) goes low. The computer must then pull RD (input to pins 4 and 18 on IC1) low. This will enable IC1's data lines, which are normally open, to present the character on them, and at the same time reset STROBE (to high).

As the data out lines are three-state they can be connected directly to the computer's data bus. The RD input should be connected to a READ PORT output from the computer.

C.V. Palm
Boulia, Qld

\$60

Logic testers

These two circuits are simple test probes for TTL logic circuits. The first is a logic probe using two transistors and two LEDs. The circuit will consume

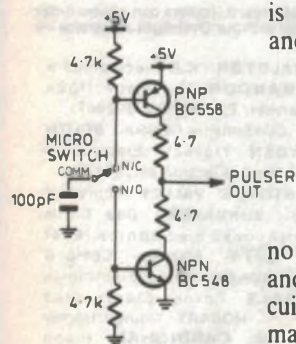

no power until either LED turns on, and has a very low loading on the circuit under test. An accurate idea of the mark-space ratio of pulse trains should be possible with the circuit, due to its symmetry.

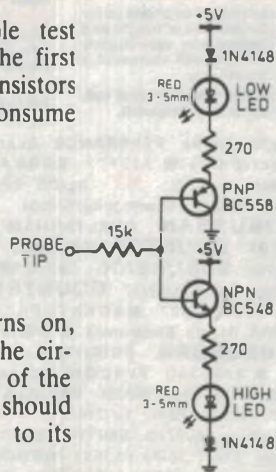

The second circuit is a logic pulser. The circuit operates by depressing or releasing the pushbutton to generate an output pulse that can drive a TTL input (still connected to a TTL output) either low or high. Operating the button will charge or discharge the 100pF capacitor, producing very brief output pulses (approx 100ns) at currents of up to 100mA peak.

Ideally, a logic probe with a 'pulse catcher' indicator should be used with the pulser. This combination can then be used to test TTL ICs, and even for PCB shorts.

Grant Wills
Clarence Park, SA

\$40

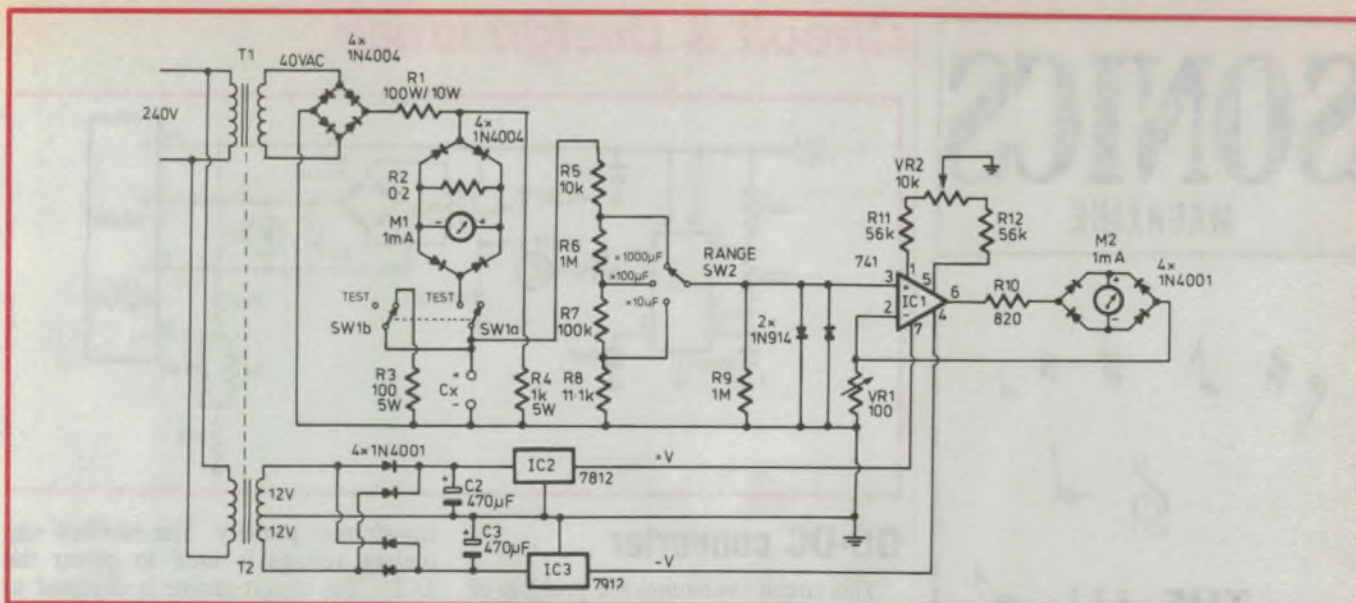

Electrolytic capacitor tester

This circuit is an electrolytic capacitor tester, which, unlike most similar devices, provides an indication of both capacity and leakage. My experience has shown that most electrolytic capacitor failures are caused by the device having either dried up or gone leaky. Both of these faults can be difficult to detect with conventional capacitor testers.

The circuit consists of two sections. The first is a 50V (approximate peak value) power supply that connects in series with an ammeter to the capacitor under test. The bridge circuit around M1 is to ensure the meter can indicate both charging current and discharging current. The 0.2 ohm shunt resistor is set to give a full scale deflection on the meter when the test terminals are shorted.

SW1 is a momentary action pushbutton, which disconnects R4 (discharge resistor) and connects the 50V supply to the test capacitor. When released, the pushbutton will reconnect R4, discharging the capacitor. Thus the ammeter provides an indication of the charge, discharge or leakage currents at a working voltage determined by T1.

The second section is an AC millivoltmeter, to measure the ripple voltage

across the capacitor under test, which will be inversely proportional to the capacitance value. The circuit around IC1 is a voltage to current converter, DC isolated by C1, and supplied by the range switch S2. The AC component of the voltage across the capacitor under test causes meter M2 to deflect proportionally. The bridge around M2 rectifies the AC voltage to give upscale deflection.

VR2 is to null the op amp and give zero deflection of the meter when there is no input signal. VR1 is used to calibrate the circuit when a known value for Cx (100µF or similar) is connected. The power supply for IC1 is derived by the dual polarity supply comprising T2, the bridge rectifier and regulators IC2 and IC3.

The selection of T1 and T2 is not critical (they can be separate transformers or separate windings on the same transformer), providing the peak rectified output of T1 is kept below approximately 60V to allow 63V capacitors to be tested safely.

The meter scale for M1 is a guide only to leakage current, and does not need to be specially calibrated. However, the scale for M2 will need calibra-

tion, as the larger the capacitance value the smaller the deflection. I marked the scale with a '1' for full scale, '2' for half scale, '4' for quarter scale, and so on.

The device can be constructed on Vero-board, or perhaps readers could design and make their own PCB using the suggested layout as a guide.

Ron Wedemeyer
High Wycombe, WA

\$70

MANY QUESTIONS

There are still many questions about the causes of Multiple Sclerosis. More funds means more research and more answers. A cure could be only dollars away.

MS
Multiple Sclerosis.

Dreamed up a great idea?

If YOU have developed an interesting circuit or design idea, like those we publish in this column, why not send us in the details? As you can see, we pay for those we publish — not a fortune, perhaps, but surely enough to pay for the effort of drawing out your circuit, jotting down some brief notes and popping the lot in the post (together with your name and address, or course!). Send them to Jim Rowe, Electronics Australia, PO Box 227, Waterloo 2017.

SONICS

MAGAZINE

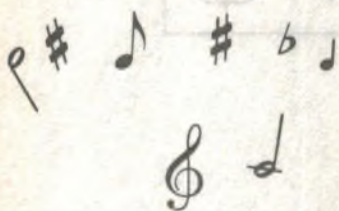

THE ALL AUSTRALIAN MUSIC MAKERS' MAGAZINE

OUT NOW

For: Musicians,
Road Crews,
Recording Engineers,
Lighting People,
Managers, Promoters
and anybody
interested in what
goes into
today's music-making.

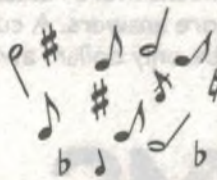

Available bi-monthly at
your newsagent or
subscribe now by phoning
(02) 693-95 17 or 693-95 15.

Circuit & Design Ideas

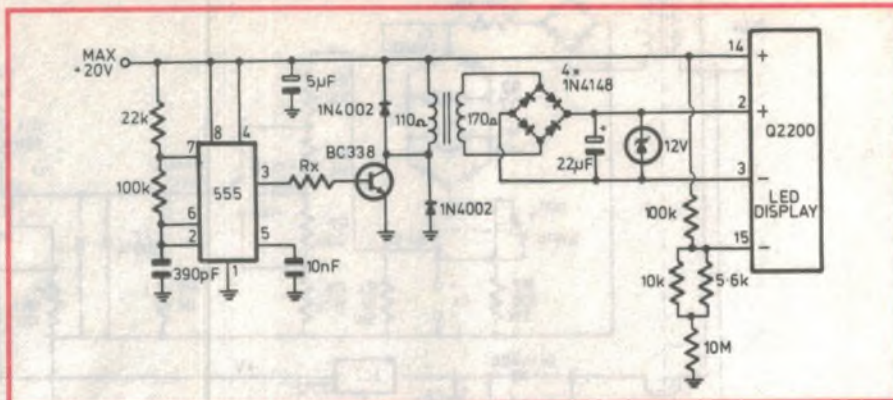

DC-DC converter

This circuit overcomes the problem of powering an LCD voltmeter that needs to read its own power supply. This situation could arise in a car voltmeter application or in an alternative power system in a house. The circuit uses a readily available miniature audio driver transformer, such as those used in transistor push-pull amplifiers. The most efficient frequency was found to be around 10kHz, although this may vary with the transformer. The 555 timer is connected in astable mode to supply a square wave to the BC338 transistor, which switches the DC connected to the

transformer primary. The rectified secondary voltage is used to power the LCD. The circuit shown is designed to work with the LCD panel meter available from DSE (cat Q-2200). The value of Rx (base drive to transistor) determines the current consumption and was set to 56k in the prototype. This established a current of around 45mA (at 16V) and caused the Lo-Bat indication on the display to come on at 11.8V.

Increasing Rx to, say, 220k reduced the supply current to 19mA (at 16V), but made the Lo-Bat indicator stay on all the time.

Rolf Sommerhalder
Mudgee, NSW

\$30

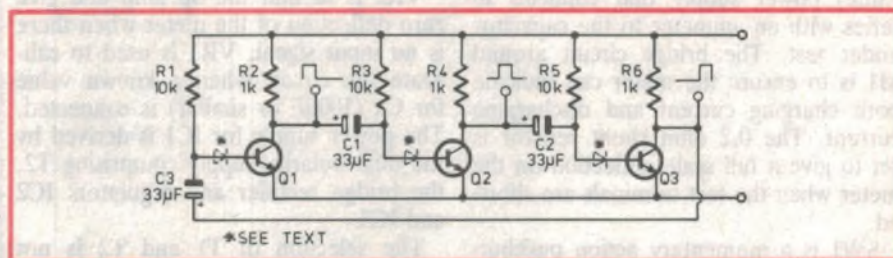

3-phase clock

This circuit is basically an extension of the astable multivibrator, and could have many useful applications. Here's how it works.

At switch on, any two of the three transistors will turn on at random. However, assuming Q2 and Q3 turn on, this will mean the collector of Q3 and the base of Q1 will be at 0V. Capacitor C3 will now charge through R1 until Q1 turns on. When this happens, the falling voltage at the collector of Q1 will turn off Q2, and hold it off until C1 recharges from -Vcc to 0.6V via R2. The negative voltage at the base of Q2 results from C1 having its positive terminal connected to ground through Q2.

Eventually C1 will charge sufficiently positive to forward bias Q2 into conduc-

tion, causing Q3 to turn off. Q3 will be held off by the negative voltage presented to its base terminal by C2, until C2 can recharge via R4. The whole circuit then continues in this mode until the power is interrupted.

Any small signal NPN transistor can be used, providing it has a reasonable current gain. The frequency of operation can be established by altering the values of the coupling capacitors and resistors R1, R3 and R5. If supply voltages greater than 5V are used, it may be necessary to add the diodes (shown dotted) in the circuit to prevent reverse conduction of the base-emitter junctions of the transistors.

Darren Yates
Frenchs Forest NSW

\$30

WORLD TUNER AT4SW

TELESCOPIC ELEMENT
EXTENDS TO 1.2m
UNSCREWS FOR
PORTABILITY.

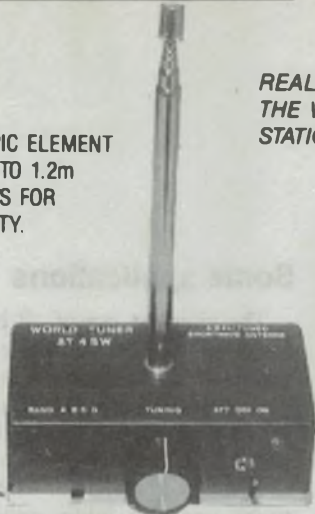

SOLID STEEL
BASE FOR
STABILITY.

REALLY PULLS IN
THE WEAK
STATIONS!

KIT \$49.00
BUILT & TESTED \$79.00
CARRYING CASE \$12.50
P & P \$6.50

A NEW HIGH PERFORMANCE PORTABLE SHORT WAVE ANTENNA

A TAKE ANYWHERE UNIT THAT GIVES
"BIG ANTENNA" PERFORMANCE.
IDEAL IN FIXED LOCATIONS TOO!
"AMPLITUNED" — WITH F.E.T. AMPLIFIER
AND 4 BAND TUNING
3-30 MHz



EVERY
SHORT WAVE
ENTHUSIAST
SHOULD
HAVE ONE!

POWERED BY 2 x AA CELLS (SUPPLIED)
OUTPUT WILL DRIVE 50 Ω OR HIGHER (CABLE SUPPLIED)

NEW ANTENNA TUNER

TUNE YOUR
INDOOR OR
OUTDOOR
WIRE
FOR MAX.
SIGNAL.



ATRX2

Available in
SW SHORT
WAVE
MW MEDIUM
WAVE
LW LONG
WAVE

KIT \$39.00
BUILT & TESTED \$57.00
P & P \$5.50

AT LAST! A SIMPLE TO BUILD
AND EASY TO USE LOW COST
RECEIVER ANTENNA TUNER.
NO COILS TO WIND!

ACTIVE LOOP ANTENNA

TECHNILOOP 3A
200 kHz - 24 MHz
WITH PLUG IN LOOPS

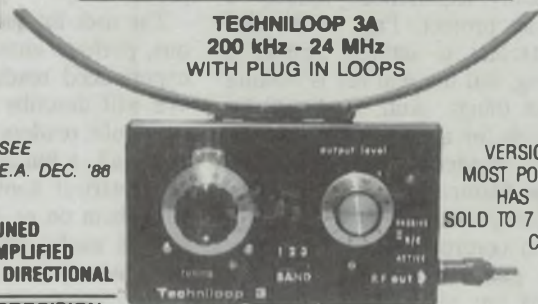

IMPROVED
VERSION OF OUR
MOST POPULAR KIT
HAS NOW BEEN
SOLD TO 7 OVERSEAS
COUNTRIES.

SEE
E.A. DEC. '88

TUNED
AMPLIFIED
& DIRECTIONAL
PRECISION
VERNIER DIAL

KIT \$89.00

P & P \$7.50

NOW SUPPLIED WITH 2 NEW
PLASTIC LOOP FRAMES.
EVERYTHING YOU NEED TO
COVER 200 kHz - 24 MHz.

HI-PERFORMANCE PASSIVE LOOP

TECHNILOOP
PX1

MEDIUM WAVE
TUNEABLE 530 - 1650 kHz
FOR AMAZING LONG
DISTANCE RECEPTION
THE PX1 IS NOW USED
IN MANY REMOTE PARTS
OF AUSTRALIA.

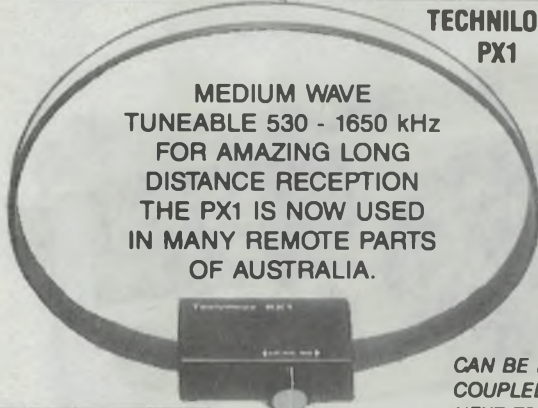

BUILT UP ONLY.
\$69.00
P & P \$5.00

HELPS REDUCE
NOISE IN BAD
LOCATIONS
IDEAL FOR
A.M. STEREO

CAN BE INDUCTIVELY
COUPLED BY STANDING
NEXT TO PORTABLES
OR CONNECTED BY
SUPPLIED CABLE
TO TUNERS, ETC.

FUNCTION GENERATOR PLUS!

SEE SILICON CHIP MAR. '88

IDEAL FOR
STUDENTS
EXPERIMENTERS
COLLEGES
SCHOOLS
AUDIO SERVICE



TECHNILAB 301
SUPER VERSATILE
3 IN 1 FUNCTION
GENERATOR

SINE
SQUARE
TRIANGLE
10 Hz - 100 kHz
AUDIO AMP/SPEAKER

KIT \$79.00

BUILT & TESTED \$109.00 P & P \$8.50

HIGH QUALITY, LOW COST

POWER SUPPLY
±6V ±16V

POTS

DUAL 50k LIN STD \$1.00 each
DUAL 2 M LIN STD \$1.00 each

SLIDER 500k LIN 45mm 10 for \$5.00
P & P \$1.50 PER ORDER

PLEASE NOTE WE ARE A MAIL ORDER BUSINESS.
HOWEVER YOU ARE WELCOME TO CALL IN, BUT PLEASE
TELEPHONE FIRST.

TECHNIKIT
ELECTRONICS

654 Calder Hwy, Keilor, Vic.
3036. Phone (03) 336 7840.

QUALITY KITS THAT PERFORM
AND LOOK PROFESSIONAL

PAYMENT BY CHEQUE, M.O. OR BANKCARD/MASTERCARD

Construction Project:

Touch Me!

Beginners – this is for you! Use this natty little touch switch to turn your radio on and off, operate a bedside light, a relay or whatever. It can operate as a simple touch switch to give on-off operation, or flick a switch and it's a timer. Learn about electronics as you build this useful device, and it will only cost you around \$8.00.

by **BRANCO JUSTIC** and **PETER PHILLIPS**

The idea of this project is to give our less technically experienced readers a useful, cheap project. Part of the fun about electronics is actually getting a project going, but the real fun is making it do useful things. And, it should be cheap enough for anyone to build. So, what is this wonderful project that offers all these features?

The project is a touch switch that allows you to control devices by simply touching a pad. Touch once, and the device turns on; touch the pad again, and it turns off.

Simple enough, you say. So, to make it more versatile, we added a few extra components and a switch to give a time delay function. With the switch set to 'timer', the device will turn on when the pad is touched, and either turn off with

the next touch, or turn off itself after a preset delay.

The uses for such a device are numerous, perhaps enough to make our more experienced readers take note as well. We will describe two applications, but no doubt readers will find many more. After all, a fundamental requirement of all electrical appliances is the need to turn them on or off. And a delay function is useful for many other applications as well.

A word of warning however. This project is not to be used to switch 240V appliances. It is only intended for low voltage use, and could be lethal if used otherwise.

Some applications

The simplest use of all is to switch a torch globe. For example, you might place the touch pad somewhere near your bed, so that it is within reach of a randomly groping hand. Then, in the dark of night, a light is as far away as slapping your hand (or foot etc.) on the touch pad. No fiddly switches to find, just a simple flat surface. If the time function is being used, the light goes out automatically, otherwise it's simply another touch and back to sleep.

Or to get you to sleep, use the switch to operate a bedside radio. In this mode, the timer function is used, set for the time interval you need. Alternatively, the pad can be handy to the bed, and the radio anywhere you like, giving the ultimate in comfort.

We describe both these applications, but there are many other possible uses apart from these. For example, a touch controlled egg timer, a touch activated door bell, a moisture detector; the list is endless. Using conductive foam, the touch pad could be placed under a door mat to act as an alarm. The conductive foam would be placed between the mat



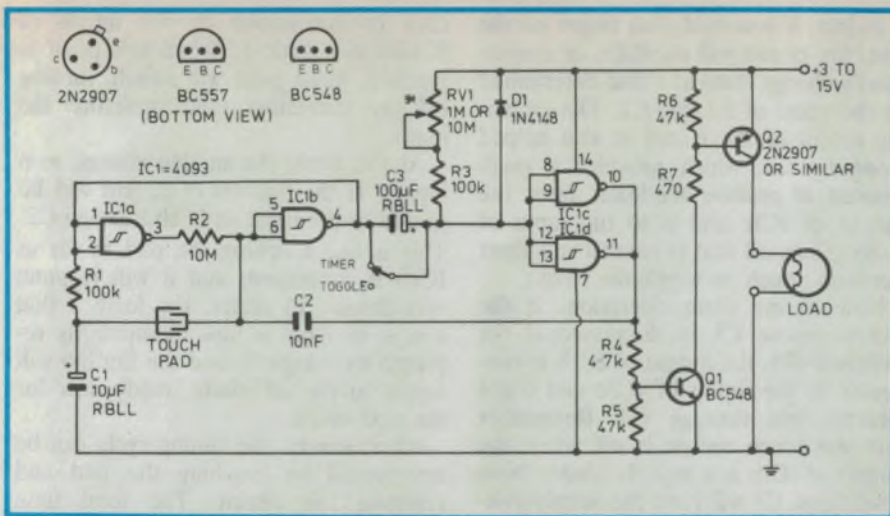

The circuit diagram of Touch Me. The 2N2907 can be replaced with any equivalent PNP transistor, such as a BC557.

and the touch pad, arranged so that the weight of a person is sufficient to trigger the switch. Finally, if the switch is used to operate a relay, any low voltage appliance can be switched.

Having told you what it can do, now to describe how it does it.

How it works

Touch switches work in various ways. One commonly used way is to take advantage of the man made electrical noise that is radiated wherever there is a mains supply. This energy will be picked up by humans in the same way a radio signal is picked up by an antenna. However, the difference between these two is that mains power energy is low frequency, demonstrated if you touch the input lead to an amplifier. If the amplifier has sufficient gain, and presents a *high impedance* (100k ohms or more), a 50Hz hum will be heard through the loud speaker.

This is because the radiating energy will *induce* a small voltage between your hand and earth, which when amplified, becomes audible. A touch switch can take advantage of this voltage, and amplify it enough to trigger a switch. However, this method can be tricky, and may not always work if there is insufficient radiating energy in the vicinity of the switch.

The next method, the one used in this project, utilises the resistance of human skin. The idea is that the normally open circuit offered by the touch pad becomes a resistance value sufficiently low to trigger the circuit when two adjacent sections of the pad are joined by, say, a finger. This method is commonly used in touch controlled TV sets and the like.

Both methods so far described require

that the circuit have a high resistance, as the resistance across a finger tip is many thousands of ohms, depending on contact pressure and how sweaty the finger is. For this reason, touch switches normally use CMOS (Complementary Metal Oxide Silicon) devices, as these have a very high input resistance, meaning a human finger is a low resistance by comparison.

In our circuit, a CMOS NAND gate is used. In fact the IC used has a special feature referred to as *Schmitt trigger* input operation, denoted by the hystere-

sis symbol for each gate. This simply means the input circuits for each of the four gates in the IC have internal feedback that makes them more definite in their switching action. A conventional NAND gate will also work, but the recommended gate performs more reliably.

Apart from the CMOS NAND gate, there are two transistors which are used to supply current to the load. In all, the circuit is very simple, yet surprisingly reliable and versatile. So now to the circuit details.

The circuit

The whole circuit works on the principle that IC1a and IC1b are connected as a *flipflop*, toggled by the touch pad.

A flipflop is any circuit that can be pulsed into one of two possible stable states, usually referred to as either a logic 1 or a logic 0. A conventional light switch is a sort of flipflop; the operator hits the toggle in the required direction and it remains there until the next operation.

Our circuit works like this. Assume for starters that the input of IC1a is at a logic 1, meaning the voltage at the input is actually equal to the supply voltage. Like all four gates in this circuit, IC1a is connected as an inverter, (a gate whose output is the opposite of its input) giving a logic 0 (0V) at its output. This means the input to IC1b is a logic 0

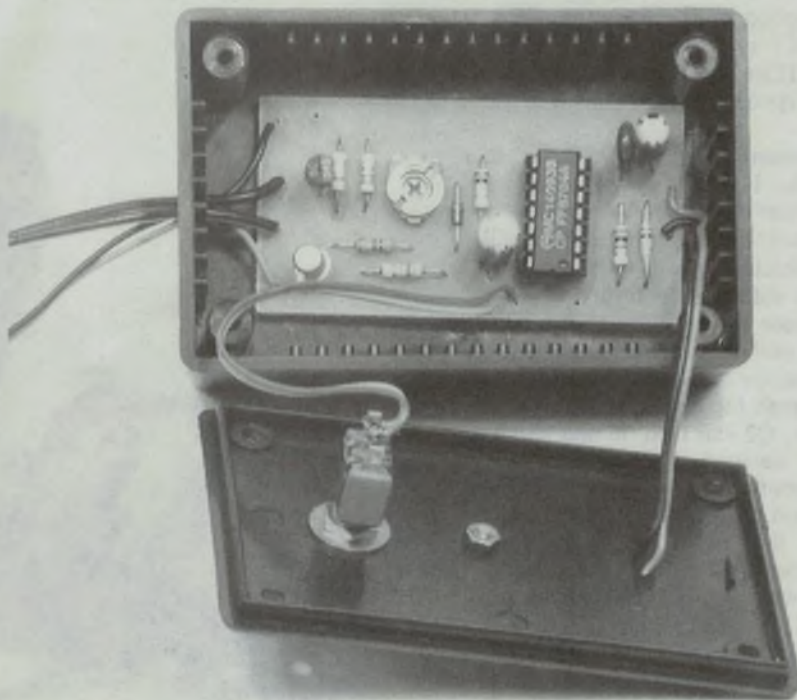

The PCB – less the touchpad section – can fit inside a UB5 jiffy box. Attach the touchpad to the plastic lid and connect it with two wires passed through a hole in the lid.

Touch Me!

also, through R2, causing IC1b to produce a logic 1 (supply voltage) at its output. This all agrees, as the output of IC1b is connected to the input of IC1a.

Under these conditions, C1 will charge to the supply voltage through R1, from the output of IC1b. If the switch was set to 'toggle' mode, the output of IC1b would be fed directly to the input of the parallel pair of gates IC1c and IC1d. As a result, the output of these gates would be a logic 0 (0V) and would therefore not be able to operate Q1, which in turn would cause Q2 to be off. Thus, any load connected to the circuit would also be off.

Now, along comes the famous finger, fair across the touch pad. Remember that C1 is charged to the supply voltage, and that CMOS logic represents a virtual open-circuit at its input. Because of the now low (comparatively speaking) resistance of the previously open-circuit touch pad, the voltage across C1 is applied to the input of IC1b, via the finger.

As a result, IC1b sees a logic 1 at its input (previously a 0) and sends its output to a logic 0. Because the input of IC1a is connected to the output of IC1b, the output of IC1a quickly switches state to become a logic 1. Because the output of IC1a is connected to the input of IC1b via R2, the initial logic 1 supplied by the finger-on-touchpad from C1 is now supported by the output of IC1a. So if you remove the finger, the circuit will now remain in the new state.

Again assuming the switch is set to toggle mode, IC1c and d will receive a logic 0 at their inputs and will produce a logic 1 at their outputs. This voltage will be approximately equal to the supply rail, and is sufficient to turn on Q1 by supplying base current through R4. This will allow current to flow through the collector-emitter junction of Q1 and provide a path for base current for Q2. As a result, Q2 can turn on and supply current to the load. The switch is now in the on position, and will remain there until the next operation.

Because the output of IC1b (and therefore the input to IC1a) is virtually 0V, C1 will be discharged to 0V through R1. Then, when the pad is touched again, the input to IC1b will have 0V applied through the touch pad, replacing the existing logic 1. This will cause all the gates in the circuit to switch back to the other state, in the same manner as already described.

In fact, if you hold your finger on the pad, the circuit will *oscillate*, or continuously change state at a rate determined by the value of R1 and C1. The switching action of the circuit is also helped along by C2, which provides a small amount of *positive feedback* from the output of IC1c and d to the input of IC1b. Thus, all that is needed is a short duration 'touch' to toggle the circuit.

Now to the timer operation. If the switch across C3 is disconnected (or switched off), the output of IC1b is connected to the inputs of IC1c and d not directly, but through C3. Remember that the touch switch is off when the output of IC1b is a logic 1. Under these conditions, C3 will have the supply voltage present at both sides; on one side from the output of IC1b, on the other via RV1 and R3. There is therefore no potential difference across C3, and it remains discharged.

However if the switch is operated, the output of IC1b falls to 0V, effectively connecting the negative side of C3 to ground. Because there is no charge in C3, the inputs of IC1c and d will also be pulled to 0V, and the circuit will switch as previously described.

The difference now is that C3 will charge through the series resistors R3 and RV1. CMOS logic usually recognises any voltage less than half the supply voltage as a logic 0, and any higher as a logic 1. Eventually, C3 will charge to half the supply voltage, which will

then be recognised by the inputs of IC1c/d as a logic 1. When this point is reached, these gates will switch, turning off the transistors (and therefore the load).

At this time, the sudden change to a logic 0 at the outputs of IC1c/d will be passed to the input of IC1b through C2. This is like touching the pad as far as IC1b is concerned, and it will respond accordingly. In effect, the logic 1 that was at its input is now momentarily replaced by a logic 0, and the flipflop will toggle to the off mode, ready now for the next touch.

Alternatively, the timing cycle can be interrupted by touching the pad and resetting the circuit. The total time delay is set by the values of C3 and the series combination of RV1 and R3. In theory if the changeover voltage at the inputs of IC1c/d is exactly half the supply voltage, the time delay is $0.63RC$, where C is C3 and R is the series value of R3 and RV1.

In practice, the time delay is likely to be higher as most electrolytic capacitors have a higher capacitance than their marked value. Also, the changeover voltage could well be higher than half the supply voltage.

As a guide, if C3 is a nominal 100 μ F and RV1 is set to 1M, a delay of nearly 2 minutes is typical. If RV1 is 10M, the delay will be much higher, up around the 15 to 20 minute mark. Oh yes - D1 is there for suppression of any reverse

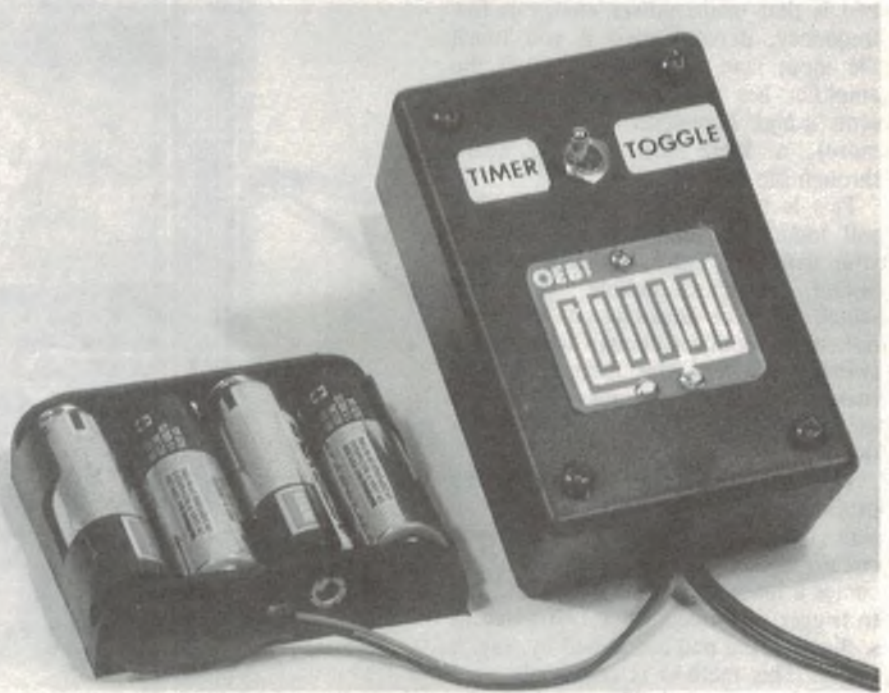

A complete unit, ready for use. The battery pack will power the switch and the device being controlled by the switch.

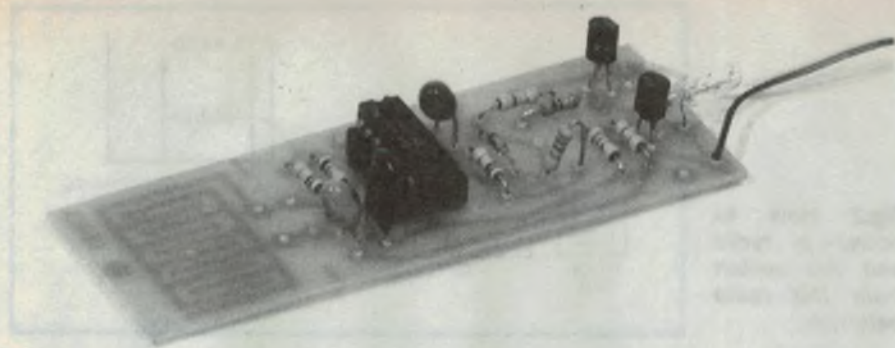
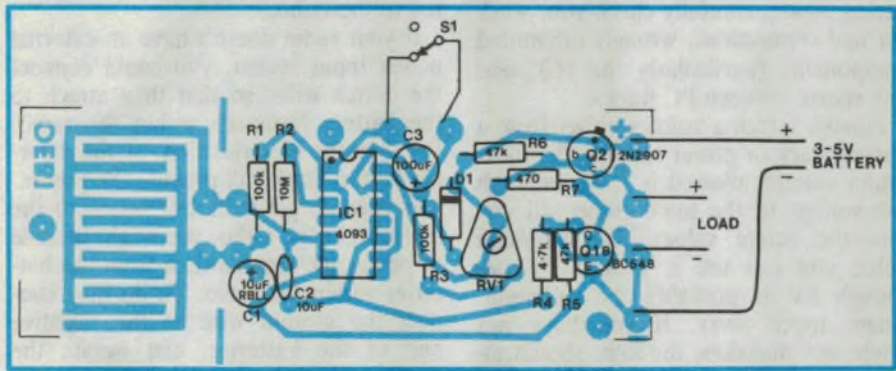
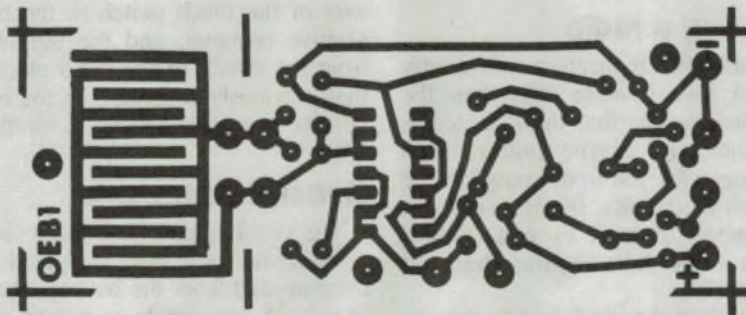

Fig.1 The simplest application for Touch Me. Here a 6V globe (attached to the PCB) is operated by the switch.



The component layout diagram. Check component polarity carefully.



The PCB layout for those who can make their own.

switching transients, and doesn't otherwise affect the circuit operation.

Because the circuit is high impedance, it is important to use low leakage electrolytics for C1 and C3. These can be either tantalum or the cheaper RBLL types specified. C2 can be either a ceramic or a polyester type, depending on what you may have in hand.

Construction

We will describe the two applications separately, although the PCB is obviously common to both uses. You can obtain a complete kit of the components, including the PCB, from Oatley Electronics for \$7.95. See details at the end of this article.

The PCB is designed so that the touch pad can be separated from the main section or left connected. If you are going to separate the sections, do so before installing any components. Either

cut the PCB with a hacksaw or with a guillotine, and file the edges to give a neat appearance. Also, if you intend placing the PCB in a jiffy box, test it for size before proceeding.

To prevent the copper tracks from

Kits of parts for this project are available from:

Oatley Electronics
 5 Lansdowne Parade,
 Oatley West, NSW 2223.
 Phone (02) 579 4985

Postal Address (mail orders):
 PO Box 89, Oatley NSW 2223.

Prices:

Touch switch kit (PCB included).....	\$7.95
4 x AA battery holder	\$0.80
Post & Packing charge.....	\$1.50

PARTS LIST

- 1 PCB 33 x 92mm, code OEB1
- 1 SPDT miniature toggle switch
- 1 Jiffy box, 28 x 54 x 83mm (UB5)

Resistors

all 1/4W, 5%: 1 x 470 ohm, 1 x 4.7k, 2 x 47k, 2 x 100k, 1 x 10M.
 Variable resistor (pot): 1 x 1M or 10M. (see text)

Capacitors

Metallised polyester: 1 x 10nF.
 Tantalum or RBLL: 1 x 10uF, 1 x 100uF (both 16V)

Semiconductors

- 1 BC548 NPN transistor
- 1 2N2907 PNP transistor (or equiv.)
- 1 4093 quad NAND gate Schmitt input.

becoming tarnished with use (after lots of touches), spray the track side with a PCB lacquer. Otherwise, run solder over the tracks to give a tinned coating. The lacquer will still allow the touch pad to sense the resistance of the finger, but go steady on how thickly you apply it.

The touch light

This application is very simple, as everything, including the light is mounted on the PCB. In our prototype, shown in Fig.1, we even left the touch pad attached to the PCB, mainly to show the simplest possible approach. Of course, you can separate the pad and place the light remotely from the board to suit your own situation.

Mount the resistors first, checking carefully that they are the right values. For example, resistors R4 and R5 are next to each other on the board, and have only one colour band different. This is the same for R6 and R7, and also for R1 and R2. The band that differs in all cases is the multiplier, so check carefully.

On our prototype, we elected to mount a fixed value resistor for RV1, and to delete the function selector switch. This way the touch switch is always a timer, with a fixed delay. In fact, unless you really need a variable time delay, the use of a fixed value for RV1 is suggested. Alternatively, you could attach a potentiometer to the board using flying leads, and fit this control so that it is remote to the PCB and therefore more accessible. If you don't want the timer function at all, substitute a wire link for C3 and leave out RV1 and R3.

Touch Me!

Next mount the capacitors, diode and both the transistors. All of these devices (except C2) are polarised, meaning they must be connected the right way round. Follow the PCB layout diagram carefully in this regard.

Note that the specified device for Q2 is transistor type 2N2907. If this device is not available, use any suitable PNP silicon transistor capable of passing the required load current. Even the garden variety BC557 device will work, but only to 100mA.

The last component to mount is the IC, which can either be directly soldered or fitted in an IC socket. Because the IC is CMOS, take care not to inflict it with any static discharges. To this end, solder pins 7 and 14 first, (power connections), and use an earthed soldering iron. These days however, most of the more basic CMOS ICs are internally protected against electrostatic static discharge (ESD), and reasonable ESD precautions are all that are really necessary.

Having soldered in all components, either fit a suitable torch globe directly to the PCB or attach one with flying

Fig.2 How to power a radio and the switch from the radio batteries.

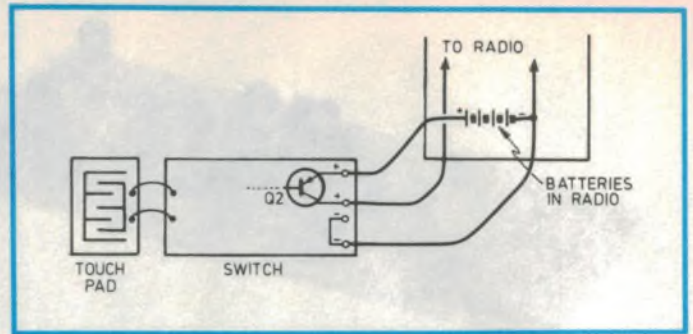

leads. Also, connect two wires for the power supply, colour coded so you can identify the polarity. Before actually applying power, carefully check your work for bad connections, wrongly orientated components (particularly the IC), and any shorts between PC tracks.

Finally, attach a voltage either from a battery pack or power supply. The maximum voltage allowed is 15V, although the voltage of the torch globe will dictate the actual value. The minimum value you can use is around 3V, although 6V is probably the optimum. Then, touch away. If you have not made any mistakes, the light should alternately light and extinguish with each successive pad contact.

Operating a radio

We built this application into a jiffy box, and gave it more frills than the light switcher. The first thing to decide is the enclosure. Maybe your radio is large enough for you to not only include the switch electronics, but to derive the power supply from it as well. Otherwise, do as we did – separate box and battery pack.

We attached the touch pad to the top of the plastic lid of the jiffy box. The wires for the switch come from the underside of the lid through the plastic to the solder lands. A switch to select 'toggle' or 'timer' modes can be fitted if required, as shown in our version.

The PCB construction is the same as for the light application described already, although you might wish to incorporate a preset pot on the PCB to give adjustable delays. Also, attach flying leads to connect to the battery pack and the radio. These can be passed through a suitable hole drilled in the jiffy box.

There are several ways to connect the radio to the touch switch. In our case, we merely plugged into the external supply socket on the radio, and left the radio turned on. Then, when the touch switch is activated, power to the radio is supplied from the external battery pack, through transistor Q2 to the radio. Naturally, make sure the polarity of the

power input to the radio is correct. By the way, there is very little loss across Q2; almost the entire supply voltage is fed to the radio.

If your radio doesn't have an external power input socket, you could connect the switch wires so that they attach to the battery terminals within the radio. Remove the batteries first, as the external battery pack will provide the power.

If you can get sufficient access to the internals of the radio, you might be able to power the touch switch from the batteries within the radio. To do this, connect the ground wire to the negative end of the batteries, and isolate the positive end of the batteries from the radio. Then connect the positive power wire of the touch switch to the battery positive terminal, and the output wire from the switch to the radio electronics that previously connected to the battery positive terminal. See Fig.2 for the details.

General comments

The switch circuit itself takes virtually no current, so it does not need to be disconnected from the battery when not in use. If you decide to power a relay from the output of the switch, connect a diode across the relay as shown in Fig.3.

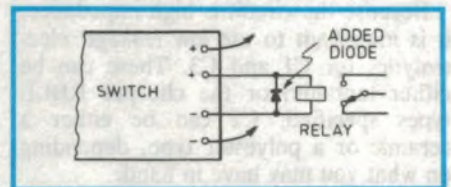

Fig.3 Add a diode as shown when driving a relay. Otherwise the back EMF will 'kill' the transistors.

In fact, many loads can be operated directly by the switch. The limitation is that the load current should not exceed around 200mA. Also, the appliance voltage should be within the limits of 3 to 15V.

No doubt readers can think of other applications, and we would be pleased to hear of those that are particularly unusual.

EA



The World's leading supplier
Racal-Redac
is proud to announce an
exciting new product
CADSTAR.

CADSTAR is another
innovation from *Racal-Redac*
and a major breakthrough
in advanced high-tech
PCB design
CADSTAR gives the capability
of producing very dense
double-sided surface mount
designs.

design right first time'

RCS CADCENTRES

A Division of RCS Design Pty. Ltd. - Incorporated in Victoria

728 Heidelberg Road
Alphington, Victoria 3078
Australia
Tel: (03) 499 6404
Fax: (03) 499 7107

contract pcb assembly

SPECIALISTS OFFERING THE
PRODUCTION FACILITY TO MEET
YOUR MANUFACTURING NEEDS



EAGLE TECHNOLOGIES PTY. LTD. (INC. IN VIC.)

When high performance counts

70 Keys Road, Moorabbin, Vic. Aust. 3189
Phone: (03) 555 0133 Fax: (03) 553 2572



Have you developed an interesting new circuit or design, and are busting to tell others about it? Are you good at explaining electronics concepts, and would like to try your hand at writing?

Electronics Australia is by far this country's largest circulation electronics magazine, with more readers than our two nearest competitors combined. This makes us the best possible medium to present your achievements and knowledge to your colleagues and fellow enthusiasts.

Ever thought of writing for EA?

Our Managing Editor is happy to accept contributed articles for publication, if they're timely and well written. We also pay top market rates for good, interesting material.

So don't settle for smaller electronics magazines – your efforts deserve publication in the biggest and the best!

If you've never written for a magazine before, send an SAE for our FREE writer's guide notes. They'll show you how to do it.

Send your articles to Jim Rowe, Managing Editor, Electronics Australia, PO Box 227, Waterloo 2017.

Construction Project:

16-channel UHF Remote Control – 3

Having already presented the 16 channel transmitter and receiver, now comes the part that does the work – the driver board. This board will control up to four channels, and includes indicators and relays. Next month we also present a 240V appliance driver board for this project.

by BRANCO JUSTIC

Over the last two months we have described a 16 channel UHF transmitter/receiver for use in remote control applications. As previously described, the system has been designed to be as flexible as possible. For example, you can have one transmitter controlling several receivers, or a number of transmitters with one receiver.

However, to actually operate a device, such as an alarm, a garage door opener, a central locking system and so on, a driver stage is required. This month we describe the load interface board, which contains the relays, their electronics and the LED indicators sufficient for 4 channels. The relays are intended to operate low voltage appliances, and up to four boards can be driven by one receiver, giving the full 16 channels. This way, you can simply expand the system to fit your needs.

The board does a simple task, but to make it sufficiently versatile to fit any requirement you may have, it has a number of operating modes, all selected with wire links. Each channel can be separately configured to a particular mode, giving a flexibility that should solve any control situation. But first a look at the block diagram of the board – it has a little more to it than you may at first think.

Block diagram

Fig.1 shows the block diagram for one channel of the board. All four channels are the same, hence the need to only show one of these. As mentioned, there are a number of operating modes possible with each channel, determined by the position of a wire link for each channel.

The first of these is the *pulsed* mode,

selected if link B is connected. This mode means that the output is turned on only for the duration of the input pulse. For example, if channel 1 is set to pulse mode operation and the transmitter sends a code for channel 1, the device will only operate for the time you actually hold down the transmitter button.

The second mode is *toggle* operation. This mode is set by connecting link A, and allows a device to be turned on with one input pulse, and turned off with the next. Thus, you can activate an alarm, go and do your business, then de-activate the alarm – all on the one channel.

Although not supplied in the kit, provision has been included for operating *self-latching* relays. This type of relay has two separate coils and requires alternate application of a DC supply to either one or the other of the coils in order to toggle the relay. Because a permanent magnet holds the relay in its selected state, the relay consumes no power except when actually changing state. This would allow the driver board to operate from batteries, as the current consumption is negligible under static conditions.

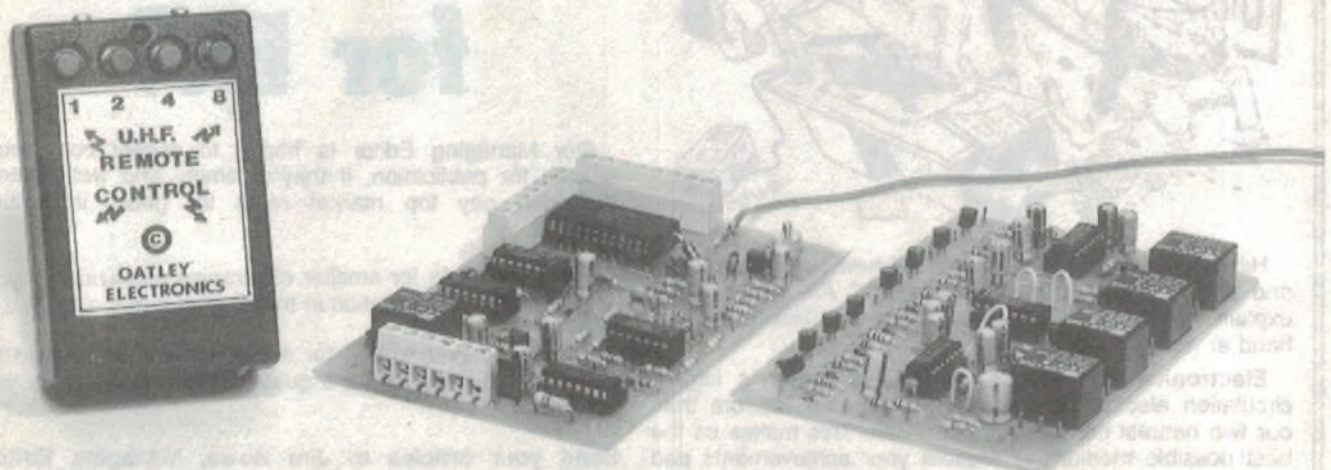

The system so far, showing the transmitter (left), receiver (centre) and the driver board (right) described in this article. It all adds up to a versatile remote control system.

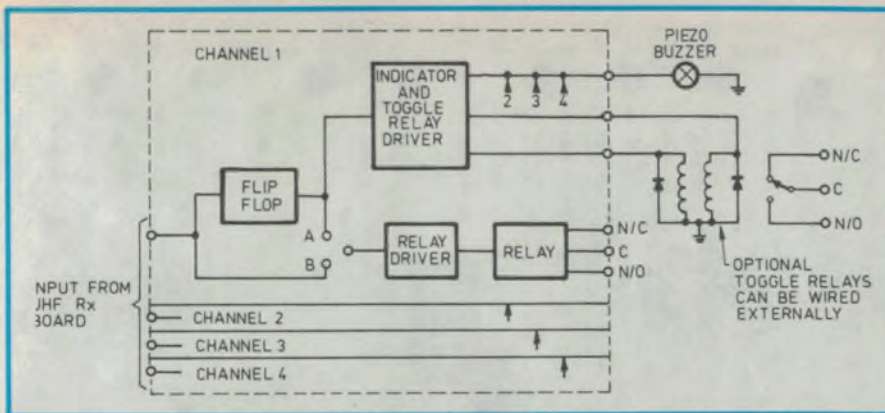

Fig.1. The block diagram of the driver board. All four channels are the same, and all have a link to select toggle or pulsed modes of operation.

The relays used in the project are conventional types that consume around 50mA each when operated. Thus, when these relays are used, an external power supply is required, as battery operation would become impracticable.

The relay board also includes an audio indicator drive circuit which is shared by the four channels. A suitable transducer, such as a piezo buzzer can be connected to this output to indicate if any one of the channels is operated. The circuit is designed to give a short beep to indicate a channel being turned on and a long beep when it is turned off. Thus illegal operation of the system can be monitored, or the buzzer can simply be used as an indicator.

How it works

The individual channel outputs from the UHF receiver board are connected to the chosen inputs on the relay driver board(s). As described last month, these outputs provide pulses only, of a duration depending on how long the transmitter is active. For the description, we will refer to channel 1 only, as all four channels operate the same way. Naturally, the component numbers will be different for each channel.

The pulse output from the UHF receiver board is applied to the input of a flipflop and also to the input of a NAND gate, wired as an inverter. If link 1B is included, a logic 1 input to the relay board will produce a logic 0 at the output of the gate, causing Q1 to turn on via resistor R6, in turn operating the relay. This gives pulsed operation, in which the relay is only on while the transmitter pushbutton(s) is pressed.

The D type flipflop IC1a is connected to function as a toggle or T type flipflop, by having its Q-bar output connected to the D input. Alternate presses of the corresponding transmitter pushbutton(s) will therefore toggle IC1a. The addition of R2 and C1 pre-

vents IC1a from changing state at less than the 3 second intervals, preventing possible double toggling if the transmitter is activated for longer than usual.

To clear the flipflop when power is first applied to the board, C2 and R3 are connected to the 'clear' input of IC1a. This means output Q-bar is set to a logic 1 at power-up. If the channel is configured to toggle mode by link 1A, this output is connected to Q1. However, because Q1 requires a logic 0 (0V) to operate, the relay remains off until an input pulse is received by IC1a. This pulse will toggle the flipflop each time the transmitter (for that channel) is operated, giving the required toggle mode.

PARTS LIST - DRIVER PCB

- 1 85 x 130mm, coded OE8-8RL
- 1 12V piezo buzzer
- 4 12V, 50mA relays
- 3 14 pin IC sockets

Tinned copper wire, hook up wire, screws/nuts/washers

Resistors

- all 1/4W, 5%: 4 x 1k, 4 x 6.8k, 8 x 10k, 4 x 33k, 4 x 47k, 4 x 100k, 4 x 390k, 1 x 1M

Capacitors

- 1 0.1uF disc ceramics
- 12 10uF low leakage electrolytics (RBLL)
- 1 100uF electrolytic

Semiconductors

- 16 1N4148 signal diodes
- 4 1N4004 diodes
- 12 BC559 PNP transistors
- 1 4093 quad Schmitt NAND
- 2 4013 dual D flipflop

When the Q-bar output of IC1a goes low, (operating the relay via Q1), capacitor C5 quickly charges through R7, R9 and the base-emitter junction of Q3. This allows transistor Q3 to turn on for around 0.2 seconds, causing the buzzer to sound as it now receives a DC volt-

Ch. No.	inverter gate			flip flop						IC No.
	inputs	output	IC No.	clock	data	set	reset	Q	Q bar	
1	12,13	11	IC2a	11	9	8	10	13	12	IC1a
2	8,9	10	IC2b	3	5	6	4	1	2	IC1b
3	1,2	3	IC2c	11	9	8	10	13	12	IC3a
4	5,6	4	IC2d	3	5	6	4	1	2	IC3b

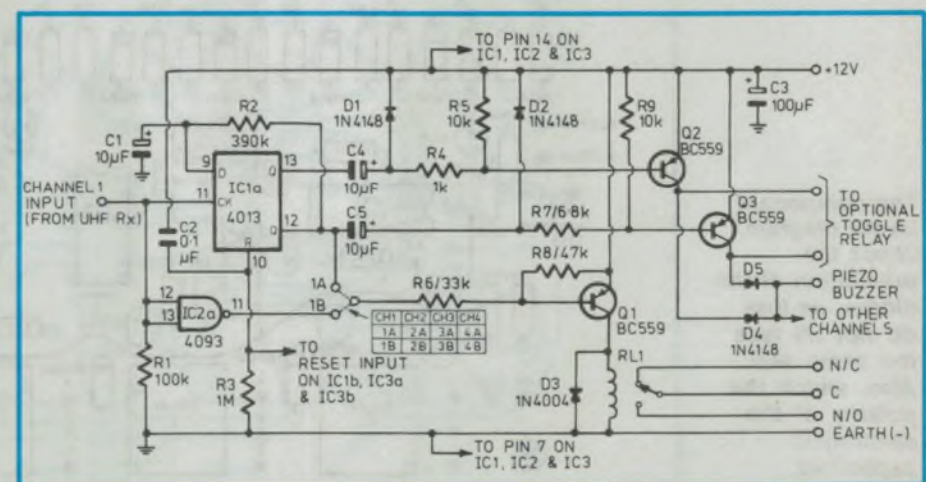

The circuit diagram of the driver board. Table 1 (above) gives the pin numbers for the ICs in each channel. Otherwise, all channels have the same circuit.

Remote control

Kits of parts for this project are available from:

OATLEY ELECTRONICS
5 Lansdowne Pde,
Oatley West NSW 2223
Phone (02) 579 4985

Postal Address (mail orders):

PO Box 89, Oatley NSW 2223

The prices for the kits associated with this project are:

- Complete transmitter kit (battery included).....\$34.95
- Receiver/decoder PCB and components kit.....\$59.95
- Four relay driver/indicator PCB and components kit.....\$37.90
- Four channel mains supply switching unit kit.....TBA
- Post & Packing charge.....\$3.00

NOTE: Each kit only available after publication in Electronics Australia.

The printed circuit artwork copyright for this project is owned by Oatley Electronics and may not be reproduced commercially.

age via isolating diode D5. If an externally connected dual coil self-latching relay was included, it would also receive this voltage, and would toggle to its ON state. Diode D2 is included to quickly discharge C4 when the Q output returns to the high state.

When the Q output of IC1a goes low (Q-bar high - relay OFF), capacitor C4

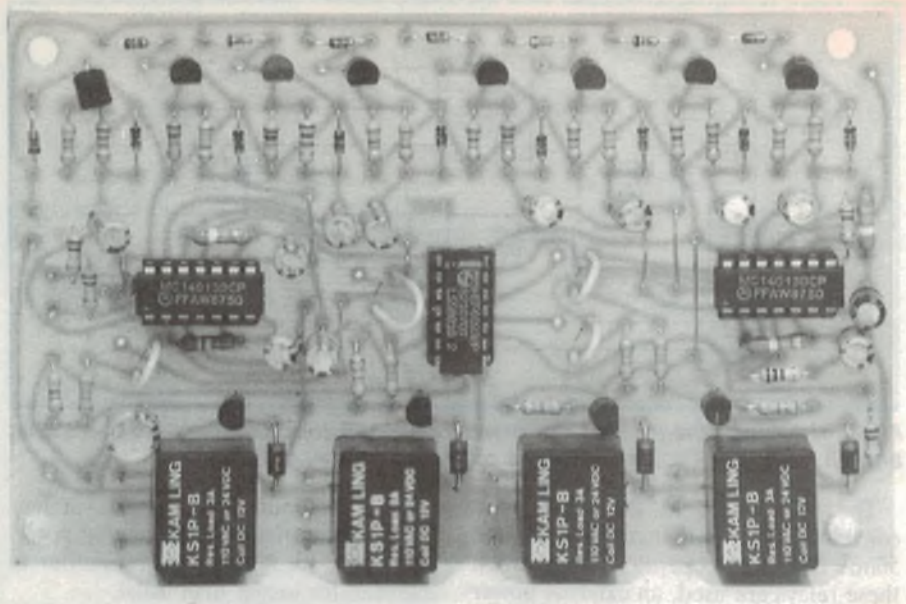

The prototype. Relate this picture to the layout (below) to help during construction. The long link shown in the layout is on the trackside of the prototype.

quickly charges through R4, R5 and the base emitter of Q2. Transistor Q2 therefore turns on for approximately 60ms, again causing the buzzer to sound as a result of the application of a DC voltage via isolating diode D4. If a self-latching relay was being used, it would toggle to the OFF state during this period. Diode D1 is included to quickly discharge C4 when the Q output returns to the high state.

Construction

A kit of parts for this project is available from Oatley Electronics. The kit is

complete (as per prototype photograph) and also includes IC sockets and the relays.

Assemble and solder all the components onto the PCB. Note that there are eight short wire links required on the board, and one rather long link. This link should be of insulated copper wire, and can be connected on either side of the board. The layout diagram shows this link on the component side, but it was fitted to the track side of the prototype. Just be sure to connect the correct points of the PCB. Also, the link to establish the mode of operation (A for

The component layout diagram. Check the orientation of the diodes, as they do not all face the same way. Also, watch the polarity of the electrolytic capacitors.

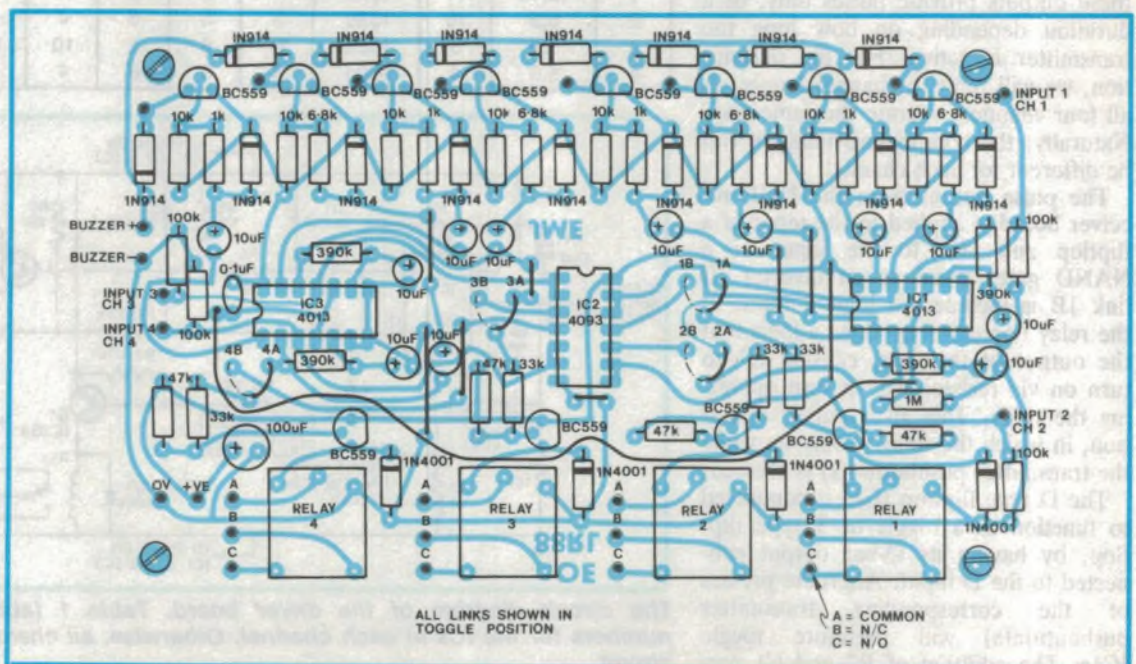

toggle, B for pulsed) will have to be connected for each channel. If this link is not made, the relay for that channel will not operate at all.

Next insert the three ICs into their respective sockets, noting their orientation as shown on the layout diagram. Once all components have been soldered in, double check your work for wrongly orientated components. There are a number of electrolytic capacitors, and it is easy to accidentally put them wrong way round. Also, make sure all the diodes are connected as shown in the layout diagram. As well, examine the track side for any shorts or similar problems.

Once you are convinced the board is finished, it remains to test it. If you intend using the piezo buzzer option, connect it to the board before applying power. Then apply 12V DC to the board, as shown in the layout diagram, and test each channel for correct operation by applying a 12V DC signal to the input of each one. A length of wire from the 12V DC supply can be used for this purpose. Confirm that the selected mode for each channel is functioning correctly, and that everything works as described.

If all is well, the board can now be connected to the output of the receiver. Assuming you have already built and tested the transmitter/receiver modules, the rest is now up to you. Don't try and drive a 240V appliance from these relays, however - use them only for low voltage applications.

Next month we will present a mains control interface board to allow you to operate 240V appliances. This board will also contain a power supply suitable for powering the receiver and the driver boards. Also, we hope to present various electro-mechanical devices that can be used with this project. Ⓔ

SONICS

MAGAZINE

For: Musicians, Road Crews,
Recording Engineers,
Lighting People, Managers,
Promoters and anybody
interested in what goes into
today's music-making.

ELECTRONICS

EXCITING JOBS WITH A FUTURE



GET YOUR TRAINING NOW AND BE PREPARED FOR THE FUTURE

If you're interested in electronics, a Stott's Home Study Course can make it even more interesting. It could lead to an exciting career in the fast-growing field of electronics.

Stott's electronics courses offer plenty of practical work and 'hands on' experience through custom-designed kits. You'll be skilfully guided by experienced, professional instructors, with individual attention and advice. You study at home, at your own pace.

Choose from Stott's range of electronics courses:
**Introduction to Electronics, Radio and Television Servicing,
Radio Receivers, Colour Television,
Introduction to Micro Computers,
Digital Electronics for Technicians &
Servicemen or Industrial Electronics.**

MAKE YOUR MOVE TOWARDS A BRIGHTER
FUTURE. SEND THE COUPON TODAY.



AN AUSTRALIAN TRADITION

PLEASE SEND ME FREE, AND WITHOUT OBLIGATION,
FULL DETAILS OF THE FOLLOWING COURSE:

MR. MRS. MISS _____ (PLEASE PRINT)
ADDRESS _____ AGE _____
POSTCODE _____

Stott's undertake that no sales counsellor will visit you
Melbourne, 140 Finders Street 3000 Tel. 654 6211
Sydney, 383 George Street 2000 Tel. 29 2445
Brisbane, 65 Mary Street 4000 Tel. 221 3972

Adelaide, 226 Pulteney Street 5000 Tel. 223 3700
West Perth, 25 Richardson Street 6005 Tel. 322 5481
Hobart, 2 Davey Street 7000 Tel. 34 2395
New Zealand, Box No. 30-990 Lower Hutt Tel. 676 592

ALA/ST6820/EA189

TRANSISTOR CONNECTIONS

The TO-92 dilemma

The TO-92 package is very common, but has at least six variations on the lead connections and has numerous lead forms. Transistor data books vary in their method of referring to the particular variation of the package, and some data books even leave out the variation altogether, and just state that the transistor is in a TO-92 package. A little like giving your address as 'Australia'.

The package is used for transistors, FETs, SCRs and other devices including regulator ICs, PUTs, UJTs etc. Each

pinout variation is usually shown with the terminals marked for both transistors and FETs, although not all variations have pinouts for both devices.

One variation is known as the standard, but it is not the most common variation. Some transistors come in two variations – for example, the BC182B has a totally different lead configuration to the BC182L, even though both are in a TO-92 package. We have even found variations referred to in data manuals that don't exist, that is, no drawing

showing the lead connections could be found in the manual.

Obviously there is a slight(?) possibility of confusion – perhaps our summary below will help. Each variation that we could find is shown in two ways; as viewed from the bottom and as seen when mounted on a PCB. Next to each drawing is a listing of some transistor types that apply to that variation. We have not included FET example types, although the FET pinouts are included where applicable.

Voltage regulators

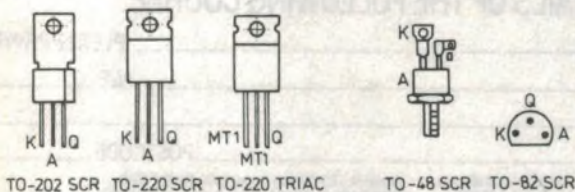
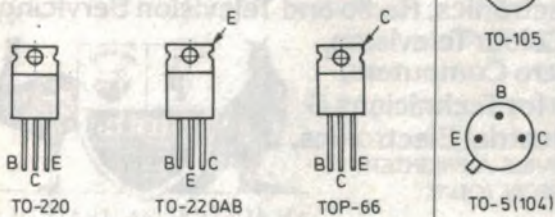
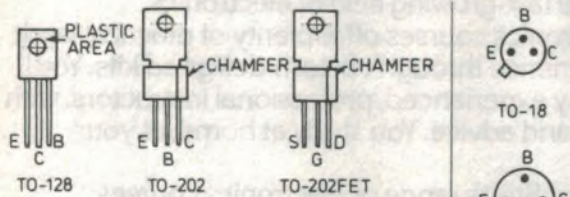
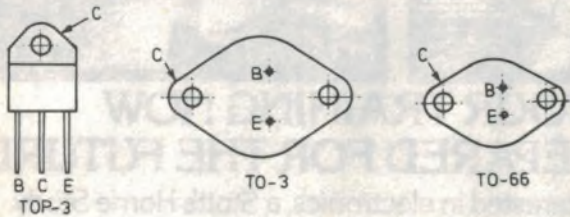
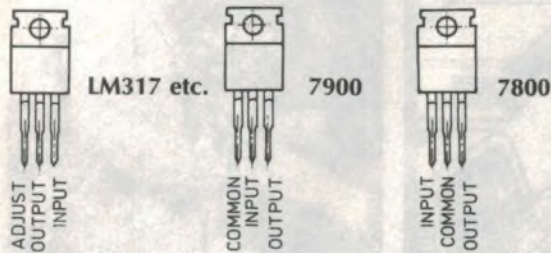

TO-92

Variation 1

Also called variation 71, 96 etc. Includes the following transistor types: MPS6542, '6543, '6546, '6547. MPSH10, '11, '19, '20, '24, '30. PE3100, BF233.

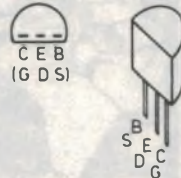

Variation 2

Also called variation 72, 92 etc. Known as the 'standard'. 2N3641, '3642, '3643, '3903, '3904. 2N3905, '3906, '4400, '4403, '5401. BC170, '171, '172, '173, '174, '317.

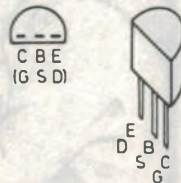

Variation 3

Also called variation 74, 94 etc. T1PP31, '32, '110, 117. BC182L, '183L, '213L, '214L, '257. BC258, '259, '635, '636, '639, '640. 2N3702, '2926.

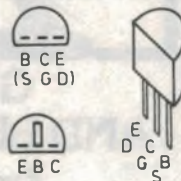

Variation 4

Also called variation 77, 97 etc. The most common type. BC237B, '307B, '327, '328, '337. BC338, '415, '485, '546, '547. BC548, '549, '556, '557, '558. BC559, '560. BF936, '324.

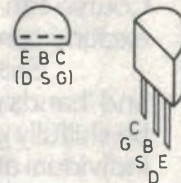

Variation 5

Also called variation 76. 2SC710. Mainly used for FETs.

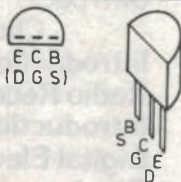

Variation 6

Also called variation 98. BF194, '195, '196, '197, '198, '199. BF237, '238, '240, '241, '254, '255. BF450, '451.

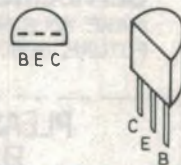

TO-72

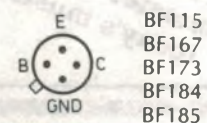
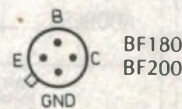

CAPACITOR CODES

This reference sheet is intended to help readers who have problems converting between multipliers for capacitors. It includes the standard we use in the magazine, (conforms to metric standard, by the way), and shows when to use the nanofarad or the millifarad instead of the venerable microfarad.

Although a very difficult area to summarise, due to the number of standards being used, the data sheet also includes information on how to interpret manufacturer's capacitor value codes. The standard used by Philips is reproduced below.

Multiplier ranges

pF	1 →	820
nF	1 →	82
uF	0.1 →	820
mF	1 →	820
F	1 →	inf.

Table 1. The range of capacitance values for each multiplier. The nanofarad range has the least number of values.

Multiplier values

pF	= 10 ⁻¹²
nF	= 10 ⁻⁹
uF	= 10 ⁻⁶
mF	= 10 ⁻³

Table 2. The numerical values for each multiplier. For example, micro (u) means 1 millionth of a farad.

The multiplier

Table 1 shows the range of capacitance values that apply to each multiplier. For example, the value of 1nF is OK, but 100nF is outside the range – instead use the next multiplier and express the value as 0.1uF. Table 2 simply shows the actual value the multiplier represents. For example, the millifarad (mF) is one thousandth of a farad (F).

Table 3 is a conversion table between all the multipliers. For example, a 2.2nF capacitor could also be a 2200pF capacitor or a 0.0022uF capacitor.

Value codes

Capacitor value coding varies, and we include that used by Philips as a guide. Note the use of the multiplier in place of the decimal point. For example, 8.2pF would be written as 8p2.

Another way of expressing a value of a capacitor is to print the first two digits followed by a multiplier digit. This way, 47nF would be expressed as 473, perhaps followed with a letter representing tolerance. To convert the number to a value, write the first two digits, followed by the number of zeros expressed by the third digit. The value obtained is in pF, which can then be converted to nF or uF using Table 3.

Conversions

pF	nF	uF	mF	F
100	0.1	0.0001	—	—
820	0.82	0.00082	—	—
1,000	1	0.001	—	—
8,200	8.2	0.0082	—	—
10,000	10	0.01	—	—
82,000	82	0.082	—	—
100,000	100	0.1	0.0001	—
—	820	0.82	0.00082	—
—	1,000	1	0.001	—
—	8,200	8.2	0.0082	—
—	10,000	10	0.01	—
—	82,000	82	0.082	—
—	100,000	100	0.1	0.0001
—	—	820	0.82	0.00082
—	—	1,000	1	0.001
—	—	8,200	8.2	0.0082
—	—	10,000	10	0.01
—	—	82,000	82	0.082
—	—	100,000	100	0.1
—	—	—	820	0.82
—	—	—	1000	1

Table 3. Conversion reference table. This table should allow conversion between multipliers for most given capacitor values. Numerical values for each decade are from 1 to 8.2.

Letter code

Capacitance (figures & letter)	Tolerance (capital)		Voltage ¹⁾ (lower case)
	≤ 10 pF	> 10 pF	
p 33 0,33 pF	B ± 0,1 pF	—	a 50 V—
3 p 3 3,3 pF	C ± 0,25 pF	—	b 125 V—
33 p 33 pF	D ± 0,5 pF	± 0,5 %	c 160 V—
330 p 330 pF	F ± 1 pF	± 1 %	d 250 V—
n 33 0,33 nF	G ± 2 pF	± 2 %	e 350 V—
3 n 3 3,3 nF	H —	± 2,5 %	g 700 V—
33 n 33 nF	J —	± 5 %	h 1000 V—
330 n 330 nF	K —	± 10 %	u 250 V~
μ 33 0,33 μF	M —	± 20 %	v 350 V~
	P —	+ 100/-0 %	w 500 V~
	R —	+ 30/-20 %	
	S —	+ 50/-20 %	
	Z —	+ 80/-20 %	

¹⁾ No indication is given for 400 V.

Table 4. The value coding used by Philips. The capacitance value is stamped as shown in the left column, followed by two letters. The first letter is the tolerance, the second (in lower case) is the working voltage.

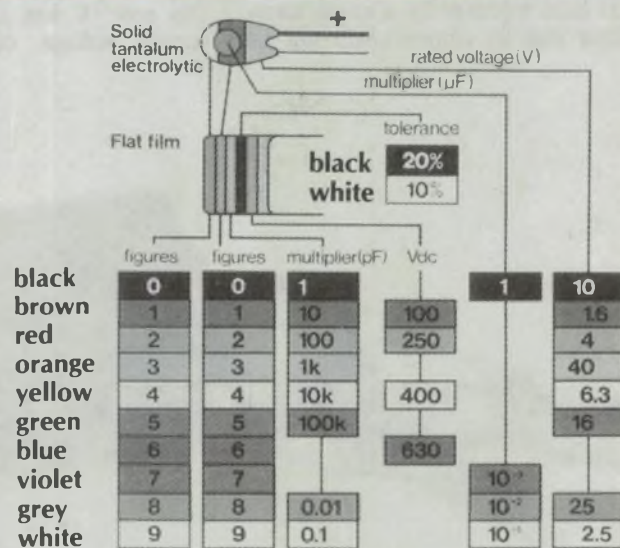

Fig.1. The colour coding used by Philips for their tantalum and flat film capacitors. (Courtesy Philips Components).

New Single-Channel UHF Transmitter

This revised version of the 1987 single channel UHF transmitter uses a new high quality, low profile plastic case. It can be used with the 16 channel remote control project being described currently in EA, (single channel mode only) or with any other 304MHz UHF remote control that uses the Motorola 145026 trinary encoder IC. And all for \$19.99!

by **BRANCO JUSTIC** and **DOMENIC DECARIA**

Readers may recall our January 1987 UHF single channel transmitter/receiver combination. We are currently also describing a 16 channel UHF remote control (see elsewhere in this issue), in a series of articles which commenced with the November issue.

The 1987 version of the single channel transmitter was housed in a small plastic case that was commercially available at that time. Since then, we have been able to source an even smaller and more elegant case. The new case is slimmer, much more rigid and has a pushbutton which is well recessed, to prevent accidental operation. Since the case is held together by a single screw, the case and its contents will not fall

apart even when dropped!

The circuit of the revised transmitter is almost identical to our original and now well proven circuit design. It does however have one main circuit change – the LED is connected in series with the battery that powers the transmitter. This feature is desirable, since it reduces the power supply voltage available to the transmitter by approximately 2 volts as well as providing reverse polarity protection.

The main IC used in the transmitter is the SC41342 trinary encoder, which is now the replacement device for the original IC type MC145026. However, this new IC has a specified maximum supply voltage of 10V, unlike the

MC145026 trinary encoder which could operate up to 15V. Thus, the revised circuit can operate with either of these ICs, as the circuit voltage is now set to around 10V, the LED providing a 2V drop from the 12V battery.

Since the LED is connected in series with the supply line it flashes in synchronism with the transmitted code, and therefore also provides a better indicator of correct transmitter operation.

Construction

A kit of parts (less 12V battery) for this project is available from Oatley Electronics. The kit includes the case and all the necessary components needed to make the transmitter.

Assemble and solder all the components on the PCB provided. Note that the transistor is mounted horizontally, with the flat side facing up. Similarly, the 4.7nF capacitor is fitted horizontally, laying over the 100k resistor and the 1N4148 diode. There is also one insulated wire link used on the component side of the PCB.

The battery holder is made using



The new transmitter is smaller than the previous model and the case is held together with a single screw, giving a more robust arrangement. A recess around the pushbutton (see left picture) will minimise accidental operation.

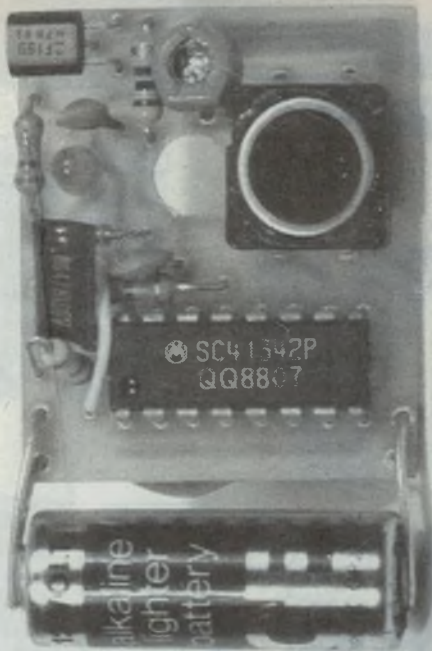

The PCB assembly. Lay C1 over D1 and R1 to allow the assembly to fit in the case.

thick, tinned copper wire at either end of the PCB, formed to make good contact with the battery. Use two wires each end to give a stronger arrangement, although, when combined with the plastic case the holder will be quite strong and provide good support for the battery. A temporary test link using a short length of tinned copper wire is also required for initial testing.

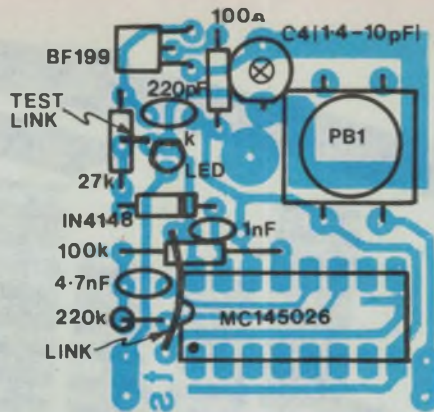

The layout for the transmitter PCB. The link needs to be arranged as shown in the photo (left). Make the battery holder with two lengths (both ends) of thick tinned copper wire.

The frequency of transmission of the finished transmitter should be set to the allocated frequency of 304MHz, although the printed circuit inductor will ensure the frequency is fairly close anyway. To enable the UHF oscillator to run continuously the test link as shown on the circuit diagram will be needed.

To measure the carrier frequency of the transmission a frequency counter should be loosely coupled to the output tank circuit and the trimmer capacitor, C4, adjusted with a non-metallic screwdriver so that the frequency, as read by the counter is 304MHz.

After this adjustment, remove the link to enable the transmitter to transmit the code sequence. Note that a

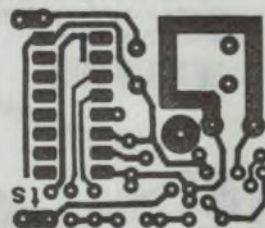
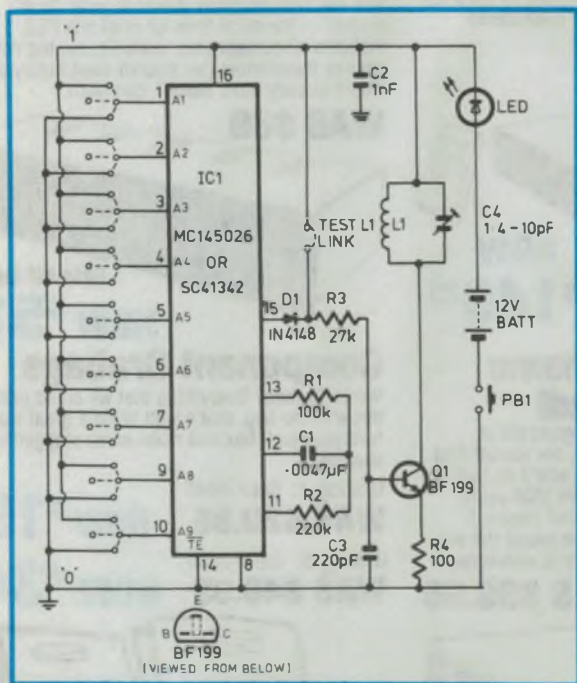

The circuit diagram (left) and the PCB artwork (above). The transmitter circuit is in series with the indicator LED.

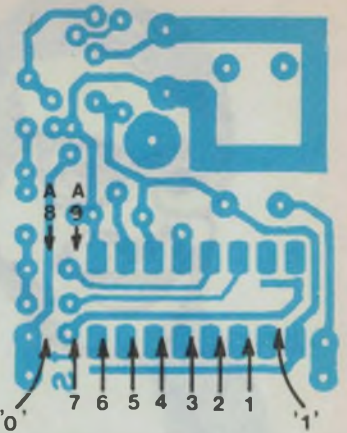

Fig.1 Coding the transmitter requires connecting address pins labelled A1 - A9 to either a logic 0, logic 1 or to be left open-circuit. Two PCB tracks are provided to allow each pin to be connected as required. There are 19,122 possible codes.

functional transmitter should cause interference when placed close to the antenna terminals of a TV set or when it is placed near the ferrite antenna of an AM radio.

Coding the transmitter

This project provides a security code of 19,122 possible codes. The supplied *continued on page 159*

PARTS LIST

- 1 PCB 30 x 34mm
- 1 Plastic case
- 1 Pushbutton switch
- 1 12V battery
- Tinned copper wire and insulated copper wire.

Resistors

All 1/4W, 5%: 1 x 100 ohm, 1 x 27k, 1 x 100k, 1 x 220k.

Capacitors

Disc ceramics: 1 x 220pF, 1 x 1nF
 1 1.4 - 10pF trimmer capacitor
 1 4.7nF metallised polyester

Semiconductors

- 1 1N4148 Si diode
- 1 Red LED (3mm)
- 1 BF199 Si NPN transistor
- 1 MC145026 Trinary encoder IC

Kits of parts for this project are available from:

Oatley Electronics 5 Lansdowne Parade, Oatley West, NSW 2223.
 Phone (02) 579 4985

Postal Address

(mail orders):

PO Box 89, Oatley West

- Transmitter kit (battery not included) .. \$19.99
- 12V Alkaline battery \$2.00
- Receiver (EA January 1987)..... \$34.90
- Post & Packing charge..... \$2.50



JUNKY

In January? OK, so we couldn't wait! Grab a kit bargain now and save **25% AND** six months. **YOU REAP THE BENEFIT!**

Low Cost MOSFET Amplifier Module

Try this one for size: AEM's 60 watt mosfet amplifier module. You can use it for virtually any purpose: P.A., guitar & instrument, even Hi-Fi (yes it's that good). Delightfully easy to build (one PCB construction). Cat K-3441

WAS \$49.95
NOW \$37⁴⁵



IR Remote Control Stereo Preamp

It's much more than a quality stereo preamplifier with full controls: the full controls are by infra-red remote! It matches perfectly with most stereo power amps. Cat K-4003

WAS \$199



NOW \$149²⁵

Low Cost Amplifier Kit Is Now At A Real Low Cost!

The low cost amplifier makes a great "first" project — the short form kit is all one PCB, includes all components, controls, etc but not a case or transformer (we figured most hobbyists would already have those!). CatK-4001

WAS \$69



Case not included
NOW \$51⁷⁵

If It's Real Power You Want . . . 120W

Try double! That's right: 120W of sheer muscle. More than enough for all those "oomph" applications— and if you're really keen, the specs are impressive enough to use a pair for hi-fi use. Wow! 120W per channel!! Cat K-3443

WAS \$59.95
NOW \$44⁹⁵

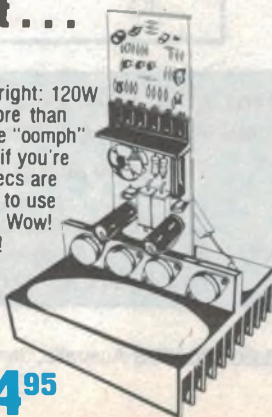

Nice Picture: Shame About The Sound!

Most video recorders do a pretty good job at handling the video signal but, oh, the sound! And when you record off a recording (who'd do that?) it's usually magnified. Fix up crook VCR sound with this processor: gives simulated stereo, 5 band equalizer allows tailoring the sound the way YOU want it, and noise filter virtually eliminates that zzzsh! Cat K-3422

NOW \$29⁹⁵ **WAS \$39.95**



Component Grabbags

Wotsa Grabbag? Everything that we could grab to throw in the bag, that's wot! What a great way to feed your junk box and make some staggering savings!

Grabag 4: Cat K-9040
WAS \$29.95 **NOW \$19⁹⁵**

Grabag 5: Cat K-9050
WAS \$49.95 **NOW \$34⁹⁵**





Appliance Meter

Measures consumption of mains appliances quickly and easily.
Cat K-3453

WAS \$19.95 **NOW \$14.95**

Low Distortion Audio Oscillator.

Cat K-3469
WAS \$44.95 **NOW \$33.70**



Wireless Stereo Headphone Link

With the DSE Infrared Headphone Transmitter/Receiver you can enjoy high quality sound reproduction without messy cables. Relatively easy to build, both the transmitter and receiver have volume controls and a range more than adequate for a larger than average size room.

Receiver:
Cat K-4006

Transmitter:
Cat K-4005

WAS \$49.95 **NOW \$37.45 Ea**

UHF GaAsFET Preamp

When you really want performance, try this beauty! 13dB gain, includes full tx/rx switching.
Cat K-6309

WAS \$109 **NOW \$81.75**

Sound Bender

Great for special effects! Can make voices sound like just about anything of the robot ilk, e.g. Darth Vader, A Cylon... etc. Ideal for electric guitars and other musical instruments. Cat K-3509

WAS \$37.95 **NOW \$28.45**

RF Attenuator Box

The 50 ohm attenuator kit gives you up to 63dB attenuation in 1dB steps from 50 to 500MHz. Cat K-6323

WAS \$69.95 **NOW \$52.45**

AM Stereo Decoder

Can be built inside your tuner!
Cat K-3415

WAS \$19.95 **NOW \$14.95**

Mixer/Module Preamp

Perfect for band use—4 inputs allow virtually unlimited choices: guitar, mic, organ, line, inputs, etc. With each input fully adjustable for gain and impedance. Also includes bass, treble and "presence" control.
Cat K-3036

WAS \$69.95 **NOW \$52.45**

Zener Diode Tester

Essential for the service bench, perfect for the hobbyist too. You'll get a direct readout — in volts — of the Zener voltage of 400mW and 1W Zenors from 3.3 to 50 volts (2 ranges).
Cat K-3051

WAS \$26.95 **NOW \$20.20**

TV Pattern Generator

With just seven IC's you get three patterns: dot, crosshatch and blank raster. Includes deluxe front panel and VHF modulator—operates from plug-pack adaptor (9VDC).
Cat K-3472

WAS \$29.95 **NOW \$22.45**

How About A 2m Linear?

Perfect for the kit — or hand-held, etc. 100W out from 15W in (40W from 2W).
Cat K-6313

WAS \$279 **NOW \$209.25**

Spare Transmitter for Infrared Controller

Just in case you lose yours — or want to give control to more than one person. Cat K-3429

WAS \$9.95 **NOW \$7.45**

STRICTLY WHILE STOCKS LAST

DICK SMITH
ELECTRONICS

Head Office & DSXpress Order Centre: Phone (02) 888 3200

60 Stores Across Australia

- NSW - Albury 21 8399 - Bankstown Square 707 4888 - Blacktown 671 7722 - Bondi Junction 387 1444 - Campbelltown (046) 27 2199 - Chatswood Chase 411 1955 - Chullora 642 8922 - Gore Hill 439 5311 - Gosford 25 0235 - Hornsby 477 6633 - Liverpool 600 9888 - Maitland 373 7866 - Miranda 525 2722 - Newcastle 61 1896 - North Ryde 88 3855 - Parramatta 689 2188 - Penrith (047) 32 3400 - Railway Square 211 3777 - Sydney City 267 9111 - Tamworth 66 1711 - Warringah Mall 905 0441 - Wollongong 28 3800 - ACT - Fyshwick 80 4944 - VIC - Ballarat 31 5433 - Bendigo 43 0388 - Box Hill 890 0699 - Dandenong 794 9377 - East Brighton 592 2386 - Essendon 379 7444 - Footscray 689 2055 - Frankston 783 9144 - Geelong 43 8804 - Melbourne City 326 8088 - Richmond 428 1814 - Ringwood 879 5338 - Springvale 547 0522 - QLD - Brisbane City 229 9377 - Buranda 391 8233 - Calra 311 515 - Chermacle 359 8255 - Redbank 288 5599 - Rockhampton 27 9644 - Southport 32 9883 - Toowoomba 38 4300 - Townsville 72 5722 - Underwood 341 0844 - SA - Adelaide City 232 1200 - Beverley 347 1900 - St. Marys 277 8977 - Elizabeth 255 8099 - ENFIELD 260 8088 - WA - Cannington 451 8666 - Fremantle 335 9733 - North Perth 328 6944 - Perth City 481 3281 - TAB - Hobart 31 0800 - NT - Stuart Park 81 1977

Product Review:

Mini gas torch, handy 12V tester from DSE

Dick Smith Electronics has just released two interesting new additions to its range of tools: a low-cost butane pencil torch for precision brazing and silver soldering, and a neat little hand-held tester for car electrics.

Heating tools using butane gas as the fuel are very convenient, offering true 'cordless' operation combined with the ability to recharge them with fuel very quickly. And they can be made in a very compact size, producing a tool which can not only be slipped into the pocket or toolbox easily, but also manipulated in very confined spaces.

It is for these reasons that gas-powered soldering pencils have recently become popular for electronics work. Some of these also offer a flame torch nozzle as well as a soldering bit, making them suitable for brazing and silver-soldering as well – see our review in the April 1988 issue. With care this type of flame nozzle can also be used for heating plastic 'heat-shrink' tubing.

Unfortunately some of these tools are quite expensive, no doubt because of the multiple nozzles and other accessories supplied. This can make them a little hard to justify if you only want to do a little precision brazing, heat a bit of 'heat-shrink' or bend the odd piece of glass tubing.

For those in this position, Dick Smith Electronics has just released a small tool which is *only* a pencil flame torch: the T-1380. It may seem a little odd that an electronics supplier should release such a tool, when there isn't normally a great deal of brazing or glass bending to be done in electronics as such, but there you are...

The T-1380 is very slim and compact, measuring only 13mm in diameter by 200mm long. As usual the gas tank

forms the handle/body of the torch, with the filler valve at the rear. The nozzle and regulator valve assembly screws into the front end, and in this case the fitting is actually the regulator valve: you screw it down tightly to turn off, and unscrew to light up and adjust the flame.

Unlike other models available, the T-1380 uses all-metal construction. The tank cylinder appears to be of aluminium or alloy, while the nozzle assembly is of brass. It certainly has a nice 'solid' feel, and looks as if it will last.

We checked it out with a few tankfuls of gas, and for continuous heating we obtained between 15 and 35 minutes of operation per filling – depending on how conscientiously we filled it. A quick 5-second 'nominal' refill gave the shorter operating time, while a 20-sec-

ond 'don't be impatient' refill gave the much longer time. Roughly what you'd expect, in fact, and quite practical for most work.

This was with the nozzle adjusted for a typical flame of the size you need for precision brazing or silver-soldering on a small workpiece: the 2mm-diameter blue inner cone was set to about 18mm long.

We did find that it was necessary to re-adjust the regulator valve from time to time, to maintain flame size as the gas pressure dropped. Occasionally it seemed to vary up and down of its own accord, too – as if there were 'lumps' in the butane. This happened particularly with the regulator adjusted for a fairly small and quiet flame, as you might use for heating heat-shrink plastic tubing.

Overall, though, it seems a very nice little pencil torch, the slimline construction making it very easy to manipulate. And the best news about the T-1380 is its price: only \$14.95 retail. This makes it about a fifth the price of many multi-purpose butane tools, and excellent value for money.



The T-1380 gas torch, shown here about half actual size. It features solid all-metal construction.



The handy 12V circuit tester, a little over half size. It's small enough and cheap enough to keep one in the glove box...

12V tester

The other interesting new tool from DSE is the Q-2000 '12V Circuit Tester', a very compact little unit designed to perform basic tests on a car's electrical system.

Measuring only 166mm long and a mere 23 x 12mm in cross-section, the Q-2000 is again very much a pocket-sized item. Yet it can perform both low voltage and high-voltage wiring checks, and offers two extra features: the ability to give an approximate idea of battery charge level, and the ability to identify 'live' 12V wires inside their insulation.

High-voltage indication is via a small neon lamp built into the handle. You simply touch the end of the probe to the coil lead or spark plug terminal, while holding a finger against the head of a 'grounding screw'. (The current level which flows is not sufficient to produce a 'tingle').

For low-voltage testing you need to provide the probe with a reference connection to the chassis, via a short lead and crocodile clip. Three small LEDs built into the handle then indicate voltages below 3V, below 12V and 13V and above – enough to give a reasonable indication of battery charge level.

A neat feature of the Q-2000 is its ability to check if insulated wires are 'live'. It does this by piercing the insulation using a small needle, about the size of the needles used to play old '78' records. The wire of interest is simply slipped into a small hook arrangement near the probe tip, and a small slider pushed along with your thumb until the needle reaches the wire inside the insulation.

It's very quick and convenient, and does virtually no real damage to the wire's insulation – from a practical point of view.

We checked out a sample Q-2000, and found that it worked well. All in all, it seems just the shot for doing quick troubleshooting around a car's electrical system – the kind of things for which a multimeter seems 'overkill'.

And at the price of \$7.95 retail, it again seems excellent value for money. In fact like the T-1380, it would probably make an excellent Christmas giftie for the family's handyperson!

We're advised that both the T-1380 and the Q-2000 are now in stock at all DSE retail outlets, and from many of its dealers. Also available are pressure-pack cans of liquid butane for refilling the T-1380 or other gas torches. (J.R.)



ROTARY ENCODERS

You can count on Allen-Bradley to bring you the best. Our new Rotary Encoder digital output switches

allow you to simplify electronic product design without sacrificing quality, flexibility or economy.

FEATURES:

- 2, 4 & 5 Bit outputs.
- Compact size – 20mm Dia.
- Low contact resistance.
- PCB Mounting.
- Direct digital output.
- Continuous rotation.
- 36 Detents/Revolution.
- Long operating life.
- Types:
 - EV Vertical mounting.
 - EH Horizontal mounting.



APPLICATIONS

2 BIT OUTPUT

- Level controls.
- Cursor controls.
- Frequency controls.
- Temperature controls.
- Time controls.
- Position sensors, etc.

4 & 5 BIT OUTPUTS

- Function selectors.
- Setting selectors.
- Level controls.
- Cursor controls.
- Frequency controls.
- Temperature controls.
- Time controls.



ALLEN-BRADLEY
A ROCKWELL INTERNATIONAL COMPANY

VIC: 37 Chapman Street, Blackburn 3130 Ph: (03) 899 0335
 NSW: 56 Parramatta Road, Lidcombe 2141 Ph: (02) 648 2652
 ACT: P.O. Box 534, Fyshwick 2609 Ph: (062) 80 4654
 QLD: Unit 4 Dennis Court, Springwood 4127 Ph: (07) 208 1044
 SA: 30-40 Hurtle Square, Adelaide 5000 Ph: (08) 232 0001
 WA: 31 Kensington St, East Perth 6000 Ph: (09) 221 2121

State of the Art: New Products Survey

This month, in keeping with our special Digest '89 issue, we've prepared a much broader survey of new products than usual. It's grown so big that we've had to divide it into quite a few sections. The idea is to give you a much better idea of the current state of the electronics art...

Measuring Instruments

Solenoid valve tester

Warsash of Sydney have released a pocket tester for use in checking or repairing control systems incorporating solenoid valves, relays, solenoids, transformers, etc. In use, the OBEL-P Tester is held against the coil housing and by pressing the single button the indicator light will glow if the coil is live, without the risks attendant on removing covers, interfering with electric circuitry, attaching probes, adjusting scales etc.

The instrument has an integral checking function: just press the button and if the instrument and battery are in order, the lamp gives one short flash. Battery life is long as power consumption is minimal. Weighing only 150g, including battery (9V calculator type) the instrument measures 160 x 50 x 35mm.

For further details, contact Warsash Pty Ltd, PO Box 217, Double Bay 2028 or phone (02) 30 6815.

Digital memory scope

A digital memory oscilloscope from Heath/Zenith, now available through Australian Distributor Anitech, can be used for two quite separate purposes: as a PC-based digital storage oscilloscope or as a means of upgrading an existing analog oscilloscope to a dual channel 50MHz storage oscilloscope.

The Heath/Zenith SD-4850, when connected to a personal computer via an RS-232 interface, converts the computer into a full featured digital storage oscilloscope with the programmability, storage and computational capability of the computer. The software supplied



provides control of all oscilloscope functions from the computer keyboard. All waveforms, menus and control settings are displayed on the monitor. Other major advantages of this configuration are the ability to compare live waveforms with those stored on disk, the use of computer-generated cursors to speed measurement taking and signal averaging when making measurements on noisy signals.

For applications where an oscilloscope with a bandwidth greater than 5MHz is available, the SD-4850 will upgrade it to a 50MHz digital storage oscilloscope. By connecting the external trigger and video output of the SD-4850 to the analog oscilloscope, the conversion is complete. The front panel controls on the SD-4850 control all the oscilloscope functions.

For further information contact Anitech, 1-5 Carter Street, Lidcombe 2141, phone (02) 648 1711.

Laboratory scope

Tektronix has introduced a highly accurate laboratory digital storage oscilloscope with 400MHz bandwidth, four acquisition channels and nine bits of vertical resolution. The unit combines laboratory quality measurement perform-



ance with menu-driven touch-screen controls, automatic signal and data processing and live measurement updates.

The 11201 has 9-bit vertical resolution and up to 10K record length, giving it excellent accuracy for both voltage and time measurements. With a combination of up to four acquisition channels and four stored waveforms, up to eight signals can be displayed at the same time. Windows can be used to display a detailed portion of a waveform while simultaneously showing the full waveform.

Touch-screen controls give quick access to the 11201's time, amplitude and area/energy measurements. Up to six alphanumeric measurements can be displayed simultaneously. Buttons located alongside of the screen quickly invoke Waveform, Trigger, Measure, Store/Recall and Utility screen menus. Within these, two more levels of menus give access to all oscilloscope functions.

For further information contact Tektronix, 80 Waterloo Road, North Ryde 2113, or phone (02) 888 7066.



Calibrator

At the launch of the Fluke and Philips Test & Measurement alliance in Australasia on October 5, demonstrations of a new Fluke calibrator were given.

Capable of calibrating the broadest digital multimeter (DMM) workload, the new 5700A multi-function calibrator from Fluke brings expanded performance in both the calibration laboratory and in production environments. It performs many functions automatically, so less experienced technicians can calibrate instruments that normally require the services of a highly trained technician.

Calibration adjustments of all the 5700A's ranges and functions are made using only three artifact standards.

The 5700A provides direct voltage to 1,100 volts and alternating voltage from 220 micro volts to 1,100 at frequencies from 10Hz to 1MHz. Cardinal point resistances range from 1ohm to 100-Mohm. Direct and alternating current are provided to 2.2A and frequencies for alternating current range from 10Hz to 10kHz.

The 5700A is compatible with other Fluke calibration instruments and software, and is now available from Philips.

For more information contact Philips Test & Measurement Group, Centre Court, 25-27 Paul Street North, North Ryde 2113 or phone (02) 888 8222.

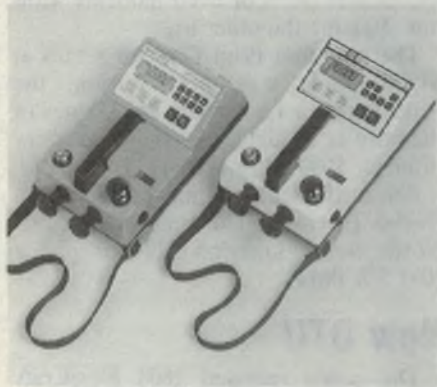

Pressure calibrator

M B & K J Davidson together with Druck Ltd have available a new family of portable, battery-powered digital pressure calibrators.

Introduced as the DPI 601 Series, this new family of compact digital instruments has been developed as a micro-processor-based replacement of the company's established DPI 600 series. The instrument offers 0.05% FS accuracy, and its integral hand pump is capable of 20 bar. Membrane touch controls simplify operation and provide the DPI 601 with a high degree of protection.

Other important features of the pressure calibrator include the ability to power the pressure transmitters or transducers under test, simplified push-button zero control, three pressure scales, the capability to measure current voltage and the provision of a filter which may be manually selected for the measurement of unstable pressures. Options include the display of square root, and other non-linear parameters.

For further information contact Davidson Pty Ltd, 17 Roberna Street, Moorabbin 3189 or phone (03) 555 7277.

Logic Analyser

The TR4726 logic analyser from AWA keeps pace with advanced device technology by enabling timing analysis of even ultra high speed logic circuits using digital signal processors and application-specific ICs as well as microprocessor system state analysis.

For timing analysis, two modules are available – the 300MHz option 75 and the 100MHz option 70. The 300MHz module, with its asynchronous sampling resolution of 3.3ns and its ability to perform synchronous sampling at 100MHz, can handle analysis of ultra high speed logic circuitry and evaluation of high speed A/D converters which require synchronous analysis. And with 64K bits of memory for each channel, a compressed-display view of all data simultaneously is possible.

The TR4726 has a built-in 3.5" floppy disk drive which enables filing of not only analysis results, but of comparison data, measurement conditions and measurement procedures, providing an easy method of automating the analysis process.

For further information contact AWA Distribution, 112-118 Talavera Road, North Ryde 2113 or phone (02) 888 9000.

Audio measurement

The Amber 5200 programmable audio level and frequency meter is a high accuracy, high sensitivity true RMS voltmeter, level meter and noise meter, with a dynamic range of 160dB and 10Hz-500kHz bandwidth.

The unit features 2 channel balanced and unbalanced inputs, and boasts the same wide selection of noise weighting filters as the 5500. As with the other extensions to the 5500, this unit is packaged in a new 2/3rd width instrument enclosure, and uses the same PROMAG plug-in module as the 5500 with similar firmware, but in the smaller chassis.

For further information contact Amber Technology, phone (02) 975 1211.

Powerscope

BWD Precision Instruments Pty Ltd have released the latest version of their unique and successful high voltage oscilloscope, the model 881A Powerscope II. The 881A has a wider bandwidth, new attenuator and time base switches and improved specifications in many areas. It incorporates five vertical amplifiers – four wide band differential channels and a 50MHz single ended



channel. The new differential amplifiers are now direct reading from 20mV to 200V/div on all channels with 30MHz bandwidth from 200mV/div and 20MHz from 20mV to 100mV/div.

The rise time of the combined amplifier and the P91 10:1 probe is typically less than 10ns. This is ideal for switch mode power supplies and, together with the high common mode rejection of the amplifiers, enables direct on-line measurements to be made accurately and safely.

A multiplier can be selected to display CH 1 x CH 2 over the entire sensitivity range with a bandwidth of DC to 12MHz. With voltage applied to one channel and a voltage proportional to current on the other, a direct measurement of instantaneous power is available.

Phase measurement to within 1° can be made from 15Hz to over 2kHz in single or multiphase circuits. The zero reference can be selected from any channel or the input AC, where it is detected to within 1° of zero cross over at line frequency.

For further information contact Parameters, Centre Court, 25-27 Paul Street North, North Ryde 2113, phone (02) 888 8777.

Data logger

Data Electronics has released the Datataker DT200 data logger, which has been designed for industrial monitoring, process control, energy management, research and scientific applications.

The DT200 has 25 differential or 50 single ended analog channels, which can be used in any mix. The ADC has 15 bit resolution, is autocalibrating and autoranges over 4 decades. The DT200 accepts voltage or resistance and directly supports thermocouples, monolithic temperature sensors and strain gauges.

It also has 64 TTL/CMOS compatible digital input channels for state monitoring (bit&byte) and counting (100Hz, 16 bit, presetable). Eight of the digital channels can be used for scanning analog or digital channels on digital or

New Products Survey

counter event, and for conditional scanning. The 25 differential/50 single ended analog channels can also be used as digital inputs, with adjustable threshold.

DT200 has 21 digital output channels, with 8 implemented as changeover relay outputs and 13 as open collector logic outputs.

The unit communicates with the host computer or terminal via an RS232 interface, and all communications are in ASCII. Returned data can be displayed directly on a terminal screen without decoding, and can be input directly into data acquisition and data analysis/reporting software packages such as Lab-Tech Notebook, Lotus 123, Symphony, Asyst, Statpack, etc.

For further information contact Data Electronics (Aust) Pty Ltd, 46 Wadhurst Drive, Boronia 3155, phone (03) 801 1277.

Wide band LCR meter

Hewlett-Packard has announced an LCR meter that it believes is the first with a 20Hz to 1MHz frequency range.

The HP 4284A can test components and materials to commercial and military standards and is a versatile tool for the engineer in R&D, production, quality assurance and incoming inspection. For improved testing efficiency, error-free instrument setups can be quickly loaded from the memory card. The large, easy-to-read LCD display and softkey menus simplify operation.

With a basic accuracy of 0.05%, the new HP LCR meter has a frequency range of 20Hz to 1MHz and six full digits of resolution for all measurement parameters. In addition, the constant test-signal-level feature controls the applied test signal at the device for demanding military tests.

The HP 4284A precision LCR meter is priced at \$15,533.00.

For further information contact Hewlett-Packard Australia, 31-41 Joseph St, Blackburn 3130, phone (03) 895 2644.

Digital Clampmeters

Now available through Australia distributor Anitech are two new high performance digital clampmeters from the Sanwa Electric Instrument Co. of Tokyo. Both have a 3-1/2 digit LCD display. The DCM-20AD model handling both AC and DC, whereas the model DCM-20A is exclusively an AC measuring instrument.

Both clampmeters use a "teardrop" type core for ease of use in any measuring field, and the power ON/OFF switch is conveniently incorporated in the ranging switch. AC current and voltage measurements can be made over a wide frequency range of 40Hz to 1kHz and a low ohm range is incorporated for the convenient measurement of the wound wire of transformers, testing continuity and checking diodes.

The more versatile DCM-20AD has an enhanced current measurement range by virtue of an analog output which can be connected to an instrument or oscilloscope that will indicate true RMS value, or to a recorder.

Both digital clampmeters sample at a rate of 3 times/second and can withstand a voltage of 2500V AC for one minute between circuit and outer case, or circuit and core.

The DCM-20AD has a data function which allows readings to be taken anywhere.

Further information is available from Anitech, 1-5 Carter street, Lidcombe, NSW 2141 or phone (02) 648 1711.

Computer Enhancements

Peripheral Sharer

A new multi-port system released by Data Bridge Communications enables multiple PC users to share common peripherals such as printers, modems and facsimile machines. A unique feature of the system is its ability to enable non-DOS oriented PCs, mainframes and mini-host systems to access the same peripherals.

The product, called Print Director,



was developed by Digital Products, and is distributed in Australia by Data Bridge. It is available in a series of configurations, from six ports to a mixture of 32 serial, parallel and RS422 ports. Print Director enables any type of printer - laser, dot matrix, letter quality - or plotter or facsimile to be accessed by any other PC or other host terminal that is also connected. An in-built buffer acts as a print spooler, freeing up the PC even if the chosen printer is in use.

In a DOS environment the accompanying software provides easy configuration and a further bonus facilitating file sharing or access between each connected user running DOS. As the ports are transparent, users of other systems such as Macintosh can connect freely to the printer ports or even modems without affecting the other users.

The base unit Print Director retails at \$1900, while a six-port version, the Print Director junior with 250K-bytes of memory is available as an introductory offer for \$999.00 (inc. tax).

For further information contact Data Bridge Electronic Communications, 604 North Road, Ormond 3204 or phone (03) 578 0814.

New DTU

The newly released 2608 FlexiCraft V.24/RS232 Octal Data Termination Unit from Datacraft Australia can provide ninety six data circuits on a single 64kb/s.

The 2608 is a statistical multiplexer that provides error protected communications for up to eight asynchronous V.24/RS 232 devices to any of Datacraft's 3600 series primary rate multiplexers.

Non-conditioned, non-loaded, twisted pair telephone wire is the only physical link required between the 2608 and the primary rate multiplexer. This provides a range of up to three kilometres. All operating parameters of the 2608 FlexiCraft are software configurable giving data rates ranging from 300 bps to 19.2 kb/s.

For further information contact Datacraft, PO Box 353, Croydon 3136 or phone (03) 727 9111.

Memory board

Ziatech have released the ZT8825 STD Board that enables up to 1024K bytes of EPROM or RAM (battery backed) to be configured under PC DOS 3.3 either as a Virtual Disk or (E) Extended Memory. For more memory intensive applications multiple boards

may be used up to the 16M byte limit.

The board is provided with a DOS installable driver to enable it to be configured with ease. Larger memory devices than the existing 128K byte chips may be used, when available.

For further information contact Current Solutions, 12a Church Street, Baywater 3153 or phone (03) 720 3298.

High density disks

Rod Irving Electronics & Microdot now market Microdot 5¼" high density diskettes. What makes these disks unusual is their incredibly low retail price. Microdot 5¼" high density disks retail for just \$23.95 per pack of 10 disks. Further to this, they have a lifetime warranty.

Dealer and wholesale enquiries may be made to Ritronics Wholesale, 56 Renver Road, Clayton 3168 or phone (03) 543 2166.

Print spooler

Hypertec has announced Hyperbuffer, a hardware spooler with 256K of memory that allows PC operators to continue using their PC while it is doing print-outs. Hyperbuffer requires no slot but simply connects between computers and printers that use a parallel interface. There is no special setup, switches or software.

The unit measures 1300 x 650 x 400mm and can sit on the desk beside the PC or, with the metre long cable provided, lie on the floor under the desk. Hyperbuffer is useful for memory intensive applications that require large amounts of printing, such as mailing lists, accounting reports and large spreadsheets. It is designed for the IBM PC family, including the PS/2 and compatibles.

There is very little processor usage and because it uses its own memory, no internal memory is required as is necessary for a software spool buffer. Operation is simple - just use the reset switch to clear the buffer at any time. A light indicates when the unit is in operation. The recommended retail price is \$443.00.

For further information contact Hypertec or phone (02) 819 7222.

EPROM burner

The Mondotronic MP271 is a high speed EPROM programmer designed, built and supported in Australia for use in the IBM PC/XT/AT. It is a fully self-contained system including a plug-in short-board, a 28-pin zero-insertion-force module connecting via a flat-rib-

bon cable to the board, and a powerful user friendly software package using conventional or fast algorithms.

The MP271 is capable of programming the 2716 to 27512 and 27C16 to 27C512 EPROMs of most brands available, using programming voltages of 12.5V, 21V and 25V. Typical programming speeds are 10 seconds for the 27C64 and 30 seconds for the 27C256.

The MP271 software contains a powerful screen editor which allows input from keyboard in HEX or ASCII; block-COPY, MOVE, FILL/ERASE; and allowing a mixture of disk, keyboard, memory, and EPROM data to be composed. One of the unique features of the MP271 software allows the display of a 256-byte scrollable window in both HEX and ASCII, which may be used to view the contents of any EPROM plugged into the module, any memory location within the PC or the contents of disk files.

EPROM types are displayed on menu and selected by single keystrokes. Any or all parts of EPROMs may be verified for erasure, or compared to memory. Addresses may be entered from the keyboard, or by pointing the cursor. Most commands are single keystrokes, and displayed in full within on-screen menus. A feature of the COPY com-

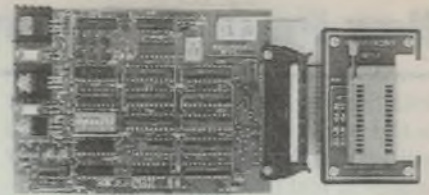

mand allows copying of any memory location within the PC or EPROM to disk. The MP271 is priced at \$330.00 exclusive and \$396.00 including tax.

For further information contact Monotronic, 560 Waverly Road, Glen Waverly 3150 or phone (03) 232 4110.

Image grabber

Primagraphics has announced Virtuoso PC, a new card which extends the company's professional video and image handling capabilities to the users of IBM-PC/At personal computers.

Combining a full 8-bit frame store with an 8-bit video input channel, Virtuoso PC allows the PC user to input images directly from a camera or VCR, and to grab frames in real time at a rate of up to sixty per second. Colour look-up tables are provided, allowing up to 256 grey scale levels or 256 colours to be used on-screen simultaneously, selected from a palette of 16 million. By

TRONICS 2000

STEPPING MOTORS SERVO MOTORS

SANYO DENKI STEPPING MOTORS

Sanyo Denki Stepping Motors are of the efficient, latest design hybrid type. Torque outputs vary from 1 to 150 Kgm Cm with speeds up to 3000 rpm. Very economical drive units are available to suit all motors for interfacing to computers for programming under BASIC.



SANYO DENKI MOTOR FEATURES

- Compact, Lightweight, High out-put
- Excellent Servo Characteristics
- Well matched line-ups and options
- Controller Units available in full line up

TYPICAL APPLICATION

- Positioning Control of Conveyors
- Industrial Robotics
- Locating and Position Control
- Press Position Control
- Work Position Control
- Simplified NC Machine Retrofitting
- X-Y Table Location Control

DRIVE UNITS AVAILABLE FOR ALL MODELS L/R DRIVE UNIT AVAILABLE IN KIT FORM

MELBOURNE: 18-20 Syme St., Brunswick, Ph: (03) 387 0655 Fax: 387 9062
SYDNEY: 25 Hector St., Sefton, Ph: (02) 644 8133 Fax: 644 3550
ADELAIDE: A. F. Hay, 116 Gilbert St., Adelaide, Ph: (03) 51 3941

New Products Survey

installing three cards in the PC, the user can generate a full colour system which will grab and display 24-bit true colour images in real time.

Standard display resolutions provide either 768 x 575 or 768 x 485 pixel interlaced displays at 50 or 60Hz respectively, conforming to European or US broadcast standards. In addition to the standard frame grab and display facilities, a separate overlay plane is provided for text overlays, cursors, and for combining computer-generated images with real time video. This feature also allows keying - viewing part of the active frame through one or more windows (or 'keyholes') in the overlay plane.

A number of software packages will be available for use with Virtuoso PC. These will include an MS-DOS version of the VCS, an easy-to-use, entry level image processing package developed by Vision Dynamics specifically to optimise the frame grabbing and storage facilities offered.

For further information contact Dindima Group, 10 Argent Place, Ringwood 3134 or phone (03) 873 4455.

Computer peripherals



Laser Printer

A new laser printer, the P3400PS from Agfa, boasts a small size with high reliability. Intended for long runs of continuous printing, the new printer

uses a 68020 processor and has 6 MB of memory with a 20 MB hard disk. The unit is delivered with 73 typefaces, and has a 400 dots per inch resolution. This equates to 160,000 dots per square inch.

The printer operates at 12 pages per minute and has generous paper capacity and handling facilities. It is quiet in operation and is therefore suitable for use in an office situation. The printer costs around \$26,000. For further information, contact Seligson and Clare, 52 Queen Street Alexandria 2015 or phone (02) 699 6521.

Modem

The BIT Blitzer 1234E modem from Mike Boorne Electronics is a 300/300, 1200/1200, 1200/75 and 2400/2400 full duplex, synchronous and asynchronous intelligent Hayes modem that conforms to CCITT (V.21/V.22/V.22bis/V.23) and Bell (103/212A) standards.

Its features include auto dialling, auto answer, auto baud rate selection on answer, support for tone and pulse dialling, adjustable carrier detect disconnect time, and so on. The unit is housed in a black anodised aluminium box, and is supplied with an AC plug pack, a telephone line connection cable and a user's manual.

The Blitzer modem family have been designed in Australia and are manufactured in Hong Kong by BIT, a company operated by expatriate Australian David Hartley. The recommended retail price of the modem is \$549. For further information, contact Mike Boorne Electronics, 61A Hill Street, Roseville 2069, or phone (02) 416 9168.

Page scanner

A newly released scanner from Agfa can scan an A4 page with a resolution of up to 800 dots per inch (dpi). The unit allows 13 levels of resolution, from 100 to 800 dpi, and software packages for the IBM or the Apple Mac computers are available.

The scanner can be connected to a computer using various interface standards, including RS232 and Centronics. The unit can respond to 64 grey scale graduations, and there are a number of image enhancements available. Typical scanning speeds are 8 seconds at 100 dpi to 62 seconds for 800 dpi.

The unit is available with software for the Macintosh computer for around \$12,000 and for the IBM (with software) for \$13,000. For further information, contact Seligson and Clare, 52 Queen Street Alexandria 2015 or phone (02) 699 6521.

QUALITY MICROPROCESSORS AT GREAT PRICES

Inc. 80C85B 3-10 MHz
82Cxx Family
Intel Math Co-processors
(8087 to 80387 up to 25MHz)
DRAMs, SRAMs EPROMs ICs

We stock one of Australia's widest ranges of CPUs, PROMs and many specialist chips such as PLDs, FIFO and related ICs.

Call us today for your chip needs.

DCS

DYNAMIC COMPONENT SALES PTY. LTD.
Showroom 1, 17 Heatherdale Road.
RINGWOOD VICTORIA 3134
TEL: (03) 873-4755 FAX: (03) 872-3478

IN STOCK



Removable cartridge hard disk

The SQ555 is the first of a family of new high performance, removable cartridge disk drive products from Sy-Quest. The unit features removable media with reliable Winchester technology. The 5.25" Q-Pak cartridges permit data security as users may remove and lock up sensitive data. At 44 Mb per cartridge, individuals may maintain large independent data bases for shared system applications.

The drive incorporates the industry standard SCSI (Small Computer System Interface), and has an optional host adaptor for the IBM PC/AT bus system. A fully integrated controller minimises system integration cost and expansion slot requirements.

Within ten seconds after cartridge insertion, the SQ555 will have completed

spin-up, self-test diagnostics, and be ready to accept commands. The drive has an average access time of 25ms and a 1:1 interleave capability. Additional special diagnostic tests are provided through the SCSI interface.

For further information, contact Perna Electronics, Fact 5, 22 Regent Ave, Springvale 3171.

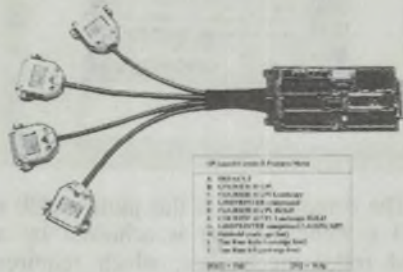

LaserJet sharer

DataBridge Communications has released LaserBoard, a low-cost connection to enable multiple PCs to share a single HP LaserJet series II printer. Consisting of a simple plug-in card and four RS232 connectors, LaserBoard requires virtually no expertise to install, as each connection is made directly to the printer port on each PC. The input ports will also support remote PC access via modems.

The unit is designed to handle concurrent input from all three users and an inbuilt 256K-byte buffer will allocate jobs to the printer according to the user specified priority. Each user may also specify the number of copies required, and multiple copy printing from each user.

LaserBoard retails for \$884.00 (inc. tax).

For further information contact Data-Bridge Communications, 604 North Road, Ormond 3204, phone (03) 578 0814.

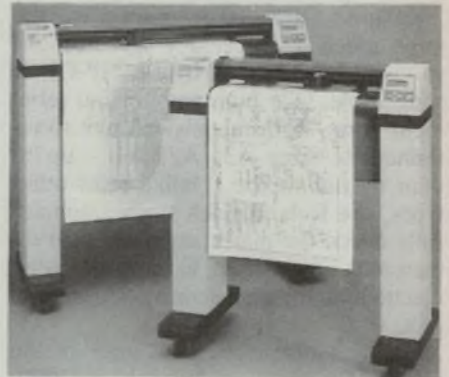

Plotter

Roland DG Australia's newly released GRX 300 and 400 series plotters have been upgraded to incorporate

Data logging for those more interested in production than computers.

Monitor processes, production or energy consumption without the need for complex programming or expensive imported equipment. Datataker will solve your data acquisition problems.

Datataker 200

A new logger with up to 50 analog and 115 digital channels. The ideal unit for process control monitoring and alarms.

Network over 7000 inputs. Over 80,000 data point memory. The new standard for industrial logging. \$4,500 complete.



Datataker 100

46 Analog/8 digital inputs. Matches common transducer and sensors. Built in software/RS232 communications. Portable, dedicated or stand alone.

No cards, modules or software to buy. No programming knowledge required. Datataker does it all.

\$2400 complete.

Talk to the people who designed the logger used by BMW, Volvo, NASA and thousands of engineers in over 26 countries.

Data Electronics 46 Wadhurst Drive, Boronia 3155 Tel (03) 801 1277. Fax: (03) 800 3241.

1Mb memory as standard.

The one megabyte of RAM provides the system with more versatility and ultimately more productivity for the user, says the Managing Director of Roland DG, Mr Adrian Stephens.

The productivity improvements are achieved through the plotters' ability to operate as stand-alone units carrying out plot and re-plots and freeing the host computer for further design work.

Roland's GRX-300 A1 plotter has the same speed and accuracy specifications as the GRX-400, and is also HP-GL II compatible, with both parallel and serial input ports. Both models will plot to intermediate sizes A3, A2, A1 - up to their maximum size. Unlike most other types, the Roland GRX units automatically check the paper alignment and dimensions on start-up to prevent paper ejection and paper tearing during the plot.

The recommended retail price of the GRX 300 unit (excluding tax) is \$9490, and the GRX 400 (ex tax) \$12,956.00.

For further technical information contact Roland DG, 50 Garden Street, South Yarra 3141, phone (03) 241 1254.

Colour plotter

Bell Test & Measurement have released the FPG-316 Imagegraph, A3 plotter, a low cost intelligent six pen colour plotter. It is compact, lightweight and its quiet operation makes it suitable for desktop use in an office or laboratory environment.

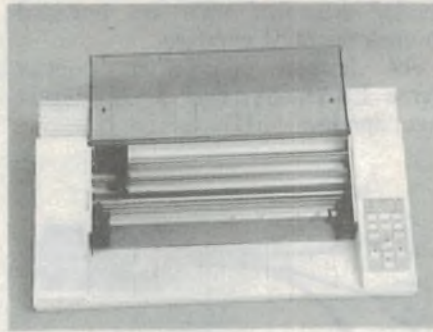

The compact size of this plotter (420 x 260 x 95mm, 4.5kg) is achieved by a grid roller mechanism, which requires half the foot print of an A3 flat bed type. The plotter has a plot speed of 250mm/sec. With a pen up-down cycle time of 10 cycles/sec, a plotting area of 276 x 399mm max. (A3). Six colour pens with water based ballpoint and ink fibre tips and oil based plastic tip pens are available with auto capping to protect pens from drying.

Imagegraph Plotters have the flexibility to interface to most PC systems. The FPG-316-101 has Centronics and RS232 Interfaces, and the FPG316-201 has HP-GL Interface for instruments and scientific computers. The use of HP-GL commands gives compatibility with most popular graphics software. Currently, there are approximately 2000 software packages available.

For further information contact Bell Test & Measurement, 32 Parramatta Road, Lidcombe 2141, phone (02) 648 5455.

CALSOD

CALSOD is a software package for computer-aided loudspeaker system optimisation and design. The program runs on IBM PC/XT and compatible computers with at least 512K bytes of RAM and a graphics card. Included is a 140 page user manual where a number of design examples are explained in detail.

When running CALSOD the designer uses graphical curve-fitting techniques to develop transfer function models of the sound pressure and impedance responses of individual loudspeaker drivers. The user can define a passive crossover network (maximum of 60 components), and CALSOD then numerically optimises the summed acoustic output of the drivers used in a multiway loudspeaker system to achieve a desired target response. Individual driver/filter combinations can also be optimised.

By using CALSOD the speaker designer can create crossover networks in a fraction of the time it would normally take to go through the design and testing cycle. Also, a much more detailed analysis can be carried out at the design stage, resulting in both an improved design and savings in testing time.

The recommended retail price of the package is \$349.00.

For further information contact Audiosoft, 128 Oriel Road, West Heidelberg 3081.

your computer

A magazine for all computer users and enthusiasts, Your Computer has something for everyone — topical features on all aspects of the computing world, expert reviews of the latest software and hardware, up-to-the-minute information for business people and even games and advice for hobbyists.

Available monthly at your newsagent or subscribe now by phoning (02) 693-9517 or 693-9515.

NEWS
REVIEWS
PROGRAMS
TUTORIALS



Power Supplies

Power supply

The TRP275 is an Australian designed and manufactured three rail DC supply intended to power disk drives and other peripheral devices requiring large amounts of well regulated +12 volts. An independently regulated supply of +5 volts is also available which can deliver 10 amps regardless of the load applied to the +12 volt output.

The rated output of 275 watts may include: +12V output at 20A, peak to 30A, regulation +/- 100mV, +5V output at 10A, regulation +/- 50mV, -12V output at 5A, peaks to 8A, regulation +/- 10%.

Input is nominally 230V AC, internally strappable for 115V AC, or alternatively 300V DC. Regulation against +/- 15% change in mains typically yields output variations of less than 0.5%. Hold-up in the event of mains failure is at least 50 milliseconds at 250 watts output.

The TRP275 incorporates a fast acting temperature biased overload shutdown mechanism which protects the supply (and possibly the load) under overload and/or over-temperature conditions. Other features include; 80% efficiency at the +12V output, soft-start circuit to minimise surge currents at switch-on, crowbar over-voltage protection of the output in the event of an internal malfunction and an inbuilt input RFI filter. Dimensions are 335 x 155 x 65mm and the unit weighs 1.9kg.

For further information contact R & D Caruhn, 3 Viscount Way, Forest Hill 3131, phone (03) 233 3595.

Display devices

Touch screen

A touch screen suitable for the Macintosh SE or Mac II computers and the IBM PC series has been released by Microtouch through their Australian agents Rand Walker. The Mac version features mouse driven software with all the usual graphics capabilities of the Mac computer. Hypercard applications are also supported. The device can be retrofitted in most instances, or can be obtained in ready-to-go versions.

For the IBM, a choice of two controllers are available – an ASCII RS-232 version or an IBM bus controller. Most monitor types can be retrofitted and software is also available. The approximate cost of the screen is \$1300.

For further information, contact Rand Walker, 33/47 Neridah Street, Chatswood, phone (02) 419 2088.

Electronic whiteboard

The Sharp model VB-500 electronic whiteboard has five sections selectable with a handheld remote control and features 3-mode reduction copying. The unit is mounted on wheels for portability, and each frame of the whiteboard measures 880 x 1240 mm (usable area).

The surface of the whiteboard is a form of vinyl held between two rollers which move the writing surface as required. Thus, a whole frame or sections of a frame can be brought into view. The VB-500 employs a unique film-roll system to record the images on the writing surface and produces a copy on heat-sensitive paper. Up to four of the five frames can be copied at once, and users can 'copy as they go' to provide ready made lecture notes.

The price of the whiteboard is around \$3000 and is available under state government contract number 735. For further information contact Electroboard, 4th floor, 275 Alfred Street, North Sydney 2060, phone (02) 957 5842.

PC video card

Zenith Data Systems has released the Z-549, a VGA video card that features backwards compatibility. The card is a fully VGA register compatible 16-bit device, which Zenith claim to be the first such card to feature full backwards compatibility at the register level to all the key established graphics standards.

The supported graphics modes are MDA (Monochrome Display Adapter), HGC (Hercules Graphics Controller), CGA (Colour Graphics Adapter), and the EGA (Enhanced Graphics Adapter). The card is compatible with Zenith's Z-150, Z-200 and Z-300 series computers as well as IBM PC, XT and AT computers and their compatibles.

The card includes 256Kb of video memory with digital to analog converter to support colour depth up to 256 colours out of a palette of 256,000. The recommended retail price of the card is \$899. For further information, contact Zenith Data Systems, (02) 417 7999.



Colour LCD Projector

An EGA compatible LCD display for use with overhead projectors and capable of showing up to 8 colours has been announced by Celcast. This is the first of its type, as other such displays operate in monochrome mode, or at best in shades of monochrome. The unit can interface with the IBM computer (and compatibles) using either EGA or CGA video standards, or can be operated by a Macintosh computer, but in 8 shades of blue-grey.

The device is called the Data Projection Panel, model A400SC, and is priced at around \$2500 (ex tax). Celcast also advise that a PS/2 compatible, VGA version of the display panel is likely to be released early in 1989.

For further information, contact Celcast, 5/372 Eastern Valley Way, Chatswood 2067, phone (02) 406 4555

Contract PCB Assembly

Most up-to-date
manufacturing
methods from
prototype to
production

**DUET
ELECTRONICS**

414 St. Georges Road
Thornbury 3071.

(03) 484 4420

New Products Survey

Components

Capacitors

Precision metallised polypropylene capacitors from Arcotronics Italia Spa are supplied to the Australian electronics industry via their Australian agent, Crusader Electronics. Used extensively in a variety of communications equipment, these capacitors fulfil a requirement where long term stability under extreme environmental conditions occur. They are available in radial and axial versions.

As well, Crusader stock the Kemet T491 precision moulded tantalum chip capacitor, which is designed specifically for surface mount applications. Capacitance values range from 0.1uF to 68uF with tolerances of 10% and 20%. These industrial grade capacitors are ideally suited for filtering, bypassing, coupling, blocking and RC timing applications.

In another range, Crusader also stock surface mount metallised polyester chip capacitors, in five international case sizes. These capacitors feature low in-

ductance (5nH) and are available in values ranging from 10nF to 1uF. The nominal voltage is 50V, with tolerances of 5%, 10% and 20%.

For more information contact Crusader Electronics, 73-81 Princes Highway, St Peters, 2044 or phone (02) 516 3855.

Key switches

Two new key operated switches have been released by HPM. The first is a key switch assembly complete with a standard 770 mechanism. This allows it to be interchangeable with other HPM mechanisms. This device occupies the space of two mechanisms and will fit into most 770 series switch plates.

The series includes mechanisms that trap the key in the ON position, another that traps the key in the OFF position, as well as conventional no-trap operation. A master key can be ordered for multiple lock operation.

Designed for the accommodation industry, an expanded range of colours has been applied to the Key Tag Switch range of switches. The range now includes finishes in five metallic colours

and nine vinyl finishes.

For further information, contact HPM, 4 Hill Street, Darlinghurst, 2010, phone (02) 361 9999

IEC power connectors

Arista has just released a range of new power IEC connectors. Their Model Nos. PAC8 to PAC11, are all suitable for use with any 240 volt AC power requirement such as with computers, audio amplifiers, household appliances, etc.

The latest in the Arista range is the PAC8 male chassis socket which is made of a heat resistant plastic and has the ability to filter out electro-magnetic interference (EMI). The PAC9 male chassis socket is also made of a heat resistant plastic and has an inbuilt fuse-holder (240V 6 amp). The PAC10 male 3 pin chassis socket and PAC11 female line plug are also available. The three chassis sockets are fully energy authority approved, allowing them to be used for both domestic and commercial applications throughout Australia.

For further information contact Arista Electronics, 57 Vore St, Silverwater 2141, phone (02) 648 3488.

GOOD SOLDERING REQUIRES GOOD TOOLS!

**BUY THE BEST
BUY AUSTRALIAN MADE.**

ADCOLA

ROYEL

- Rapid, controlled heat for printed circuit boards.
- Lightweight, with industrial reliability.
- ARMCLAD' long-life tips.
- Plugs direct into standard 240V power point.

**WORLD
CLASS
QUALITY**

**LOW
COST.**



ASK YOUR NEAREST
ELECTRONIC PARTS
SUPPLIER!

**USED SUCCESSFULLY
THROUGHOUT
THE WORLD.**

Terminal strips

Samtec square post terminal strips are now Available on .200", .156", .100" and .050" centreline spacings. All Samtec square post terminals are precision drawn phosphor bronze wire for the optimum in mechanical and electrical properties.

The .025" square terminal strips (TSW series) can be supplied on .100" or .200" centres, in single, double and triple row designs. A choice of eleven terminal lengths may be positioned at any point in the insulator body. Plating choices include gold, tin and selective plating.

The larger .045" square terminal strips are available on .156" (FWJ series) and .200" (FWS series) centres. These tin plated terminals are rated to 7 amps at 100V DC. The .156" centre terminal strips are available with a friction lock clip for high vibration applications (FCW series).

The TMS .050" centreline strips feature a coined .018" square terminal and are available in both single and double row designs, with a choice of tin, gold or selective plating.

For more information contact Multi-Contact, 53-55 Whiting Street, Artarmon 2064, phone (02) 438 3600.

Timer

Email Electronics, official distributor of Idec Izumi, have released the Idec-D timer for the simple alternative to complex multi types. Featuring LED indication on both power and output plus a large time display on the preset knobs for easy setting.

The relay is manufactured to suit the standard octal pin socket and has a repeat error as low as +0.2%. Surge and noise resistance characteristics will withstand 5kV impulse voltage test and the timer is available in AC and DC voltages with 9 different time ranges.

For further information contact Email Electronics, 15-17 Hume Street, Huntingdale 3166, phone (03) 544 8244.

Video connectors

ACME Electronics has released a new range of Belden cable and Kings connectors which meet the proposed SMPTE (GBR.) interface standard and are designed specifically for the TV, video, and broadcast industries.

The Belden coaxial cable is the High Resolution Miniature Broadcast/Computer range which consists of two RGB cables for broadcast systems and computer colour monitors. These 75 ohm component cables provide a low loss

video signal in a compact cable which eliminates the need for expensive decoding equipment. They also provide a sharp, clean image.

The new range of Kings Component video connectors and other products now available from ACME Electronics include jack fields, patch cords, 3-circuit connectors, receptacles and crimp BNC plugs, to suit the new Belden cables.

For further information contact ACME Electronics, 205 Middleborough Road, Box Hill 3128, phone (03) 890 0900.

Surge guard

Kambrook has just released their new SG10 Power Surge Guard. The device is designed to protect household electrical items, such as microwave ovens, televisions, computers, refrigerators, Hi-fi equipment and video recorders from power surges.

The surge guard has a red neon indicator light to indicate power on, and is used in the same way as any power point adaptor. The unit sells for around \$24.95 and is available through most retail outlets.

For further information contact Kambrook, 44-60 Fenton Street, Huntingdale 3166, phone (03) 543 2200.

FIBRE OPTICS

PLASTIC FIBRE OPTIC FILAMENTS & CABLES

AVAILABILITY INCLUDES:

- SIZES from 0.25mm to 12.0mm
- SEVERAL TYPES and GRADES
- RETAIL & WHOLESALE: QTY. DISCOUNT FOR OEM
- OVER 1/2 MILLION METERS OF FIBRES IN STOCK

For product listing & pricing send stamped self addressed envelope.

For wholesale & OEM listing enclose business card & letterhead.

FIBRE OPTICS FOR:

DISPLAYS:

SIGNS, DECORATIVE EFFECTS, TRAFFIC SIGNALING.

LIGHT GUIDE:

INDUSTRIAL, MEDICAL ILLUMINATORS

INSTRUMENTS:

ENDOSCOPES, BORESCOPES, SENSORS, CONTROL GEAR

COMMUNICATION:

COMPUTER DATA, VISION & SOUND TRANSMISSION

UNIVERSAL FIBRE OPTICS CORPORATION PTY. LTD.

564 GLENHUNTLY ROAD, ELSTERNWICK 3185
MELBOURNE VICTORIA
Phone (03) 523 5535 Fax: (03) 523 7208

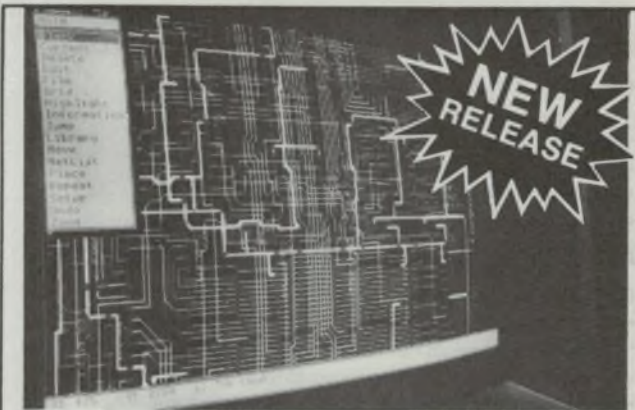

Top of The Line In PCB Design

\$AUD1395.00

PROTEL-AUTOTRAX

This product has a host of new features to assist in the design of a PCB whether it is Through-Hole or SMD Technology. Standard features include Automatic Component Placement, Interactive and Autorouting with Design Rule Checking

AUTOTRAX offers usable definable track widths from 1-255 mil and pads from 1-1000 mil. A multilayer program including power and ground planes plus video drivers for CGA, EGA, VGA, VERGA Deluxe and Hercules. Outputs include, plotters, printers, N/C Drill and Photoplotter. Hardware requirements IBM PC/XT/AT/PS2 or compatibles with 640K RAM, 2 floppy disk drives or 1 floppy plus hard disk. PC or MS-DOS version 2.0 or greater. Also supports 4Mb EMS.

Other programs in Protel Family PROTEL-PCB-SCHEMATIC-ROUTE-TOOLBOX

PROTEL TECHNOLOGY PTY LTD

Incorporated in Tasmania

A Member Company of Critic Corporation

TECHNOPARK DOWSINGS POINT
HOBART TASMANIA AUSTRALIA 7010

PHONE NATIONAL (002) 73 0100

POSTAL G.P.O. BOX 5361, HOBART, 7001

INTERNATIONAL +6102 73 0100

TELEX AA 58260 CRTEC

FACSIMILE NATIONAL (002) 73 1871

INTERNATIONAL +6102 73 1871



OrCAD

Systems Corporation

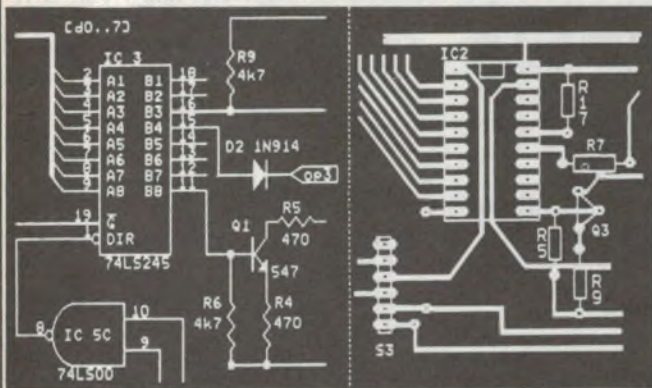

Power and Speed at an affordable price, on your IBM PC.

OrCAD the powerful and easy to use Electronic Design Software now provides complete End to End Design.

First design your circuit using the Schematic Design Tools (SDT).

OrCAD/SDT Features:

- Over 3700 unique library parts and graphic parts editor
- Unlimited levels of hierarchy
- Standard macros supplied and user entry of keyboard macros
- Netlisting to 22 other packages plus other post processing utilities
- Variable size worksheets, text and output

Simulate your design with Verification/Simulation Tools (VST).

OrCAD/VST Features:

- 14,000 gate capacity from up to 50 channels input
- 10,000 events per second (8MHz AT)
- 10 breakpoints, 16 AND/OR signals per breakpoint
- Logic analyser format simplifies data analysis
- Selectable minimum or maximum delays and model library source

Finally produce your design using Printed Circuit Board (PCB).

OrCAD/PCB Features:

- Auto routing up to 32" x 32" with 16 copper layers maximum
- Selectable track, via and isolation from 0.001" to 0.255"
- Square, rectangular, round, oval and SMD pads
- Grid bases of 100, 50, 25, 10, 5 mils. Off grid to 1 mil.
- Ratsnest, force vector for placement optimization

All OrCAD products are fully compatible and include 12 months free updates and support.

CUT OUT AND MAIL TODAY.

We will send you a FREE Demo and Literature.

Name _____
 Title _____
 Company _____
 Address _____
 Telephone _____ Fax _____

Prometheus Software Developments Pty Ltd
 260 high Street Kew. Vic. 3101.
 Telephone: (03) 862 3666.
 Fax: (03) 862 2092.

New Products Survey

RF gear

Microwave detector

Hewlett-Packard Australia have introduced a microwave mixer/detector to provide high-quality, phase-linear down-conversion and video detection of pulse and CW signals from 2 to 18GHz. The new HP 5364A microwave mixer/detector is designed as a companion instrument to the HP 5371A frequency and time-interval analyser. Used together, these instruments represent a new concept in test instrumentation: a microwave modulation-domain analyser.

The recently introduced HP 5371A frequency and time-interval analyser allows the measurement of frequency, phase or time-interval values as a function of time to 500MHz. When compared to time- and frequency-domain measurements done on oscilloscopes and spectrum analysers, the frequency and time-interval analyser allows measurement analysis in the modulation domain. This new domain of measurement now can be achieved at microwave frequencies to 18GHz on the HP 5371A with an HP 5364A and a local oscillator.

Applications in radar, EW, communications and component testing can be handled by this new measurement capability. Direct measurement of spread-spectrum signals, such as agile carriers and chirped pulses, now become possible with a microwave modulation-domain analyser.

The HP 5364A microwave mixer/detector is priced at \$21,174.00 and HP 5371A frequency and time-interval analyser is \$35,013.00.

For further information contact Hewlett Packard, 31-41 Joseph Street, Blackburn 3130, phone (03) 895 2895.



VHF-UHF mobile

The all-new IC-3210A dual band VHF-UHF mobile from Icom is a full duplex transceiver which, allows transmission on one band and simultaneous reception on another band. With a frequency range covering (Tx) 144-148MHz and 430-440MHz, (Rx) 138-174MHz and 430-440MHz, and two sets of 20 memory channels, one for each band, storing frequency, offset and tone data, the IC-3211A is very much two transceivers for the price of one.

The unit has 25 watts of output power on two metres and 70 centimetres, generated by a custom-designed final amplifier power module. Other features include a bright colour LCD display, instant input frequency check via a front-panel switch, programmable priority watch on the call channel memory, any memory channel or even all memory channels in succession even while in operation.

For further information contact Icom Australia, 7 Duke Street, Windsor 3181, phone (03) 529 7582.

Fibre-optics monitor

Ellmax Electronics have just launched the Fibre-Optics Monitor, a new concept in fibre-optics equipment. The Monitor comprises fully portable transmitter and receiver units plus accessories and carrying case, and functions as both test and audio transmission equipment.

Applications of the Monitor include: optical cable/fibre continuity testing, detecting the presence of infra-red radiation, voice communications (especially during cable jointing operations), accurate fibre attenuation measurements (including long-term monitoring), and training in fibre-optics and telecommunications. In testing for optical continuity, the Monitor operates in a similar way to the well known 'buzzer' equipment for electrical continuity testing.

Analog audio signals may be transmitted over optical fibres, and a short distance over free space with the Monitor units. The receiver contains a loud-speaker for directly listening to the received signal, and a microphone for connecting to the transmitter. Connector options include the popular SMA and STRATOS optical connectors, and the equipment operates with all types of multimode fibres, including 50um core graded index fibre.

Each unit operates from a small radio battery, or single external DC supply of +9V to +15V.

For further information contact AWA Distribution, 112-118 Talavera Road, North Ryde 2113 or phone (02) 888 9000.

LCD manufacturer

Email Electronics has announced its entry to the flat panel display market. A major user of liquid crystal displays for many years in their range of petroleum dispensing equipment, Email now intends to market its design and manufacturing capabilities to other Australian companies.

A custom LCD Design Guide has just been released by Email Electronics describing their capabilities and the procedure for developing a new display module. Features include a background to LCD technology, operational specifications, recommended driver IC's and a custom design questionnaire.

For further information contact Email Electronics, 15-17 Hume Street, Huntingdale 3166 or phone (03) 544 8244.



TENNYSON

GRAPHICS

Tennyson Graphics can do your photoplotting with the speed of light.

Tennyson Graphics are Australia's only company with state of the art laser photoplotting and computer graphics.

So we can photoplot artwork masters of your printed circuit boards with higher speed, higher resolution and higher accuracy than anywhere else in the country.

You can even choose your own non standard apertures on our Scitex Response 280 System. It can also do step-and-repeat and nesting up to 1000 mm x 1850 mm.

And of course we can accept data on tape or floppy disk in industry standard Gerber, Autocad and Smartwork file formats.

Tennyson Graphics will be happy to give you the full story if you phone on (03) 551 8600.

TENNYSON GRAPHICS
A DIVISION OF REPROCART PTY. LTD.

7 PLANE-TREE AVE
DINGLEY, VIC. 3172
TELEPHONE (03) 551 8600
TELEX: 34457
FAX: (03) 551 8828

E.A. GIVES YOU THE CHANCE ELECTRONIC

If you win you get to select between
the unbelievable **Tandy** hi-fi pack!
ELECTRONICS

CHOOSE THE COMPUTER PACK WORTH OVER \$6,400
AND THIS IS WHAT YOU'LL WIN!



HIGH PERFORMANCE TANDY 1000 TX. A PROFESSIONAL-CLASS MS-DOS COMPUTER FOR HOME, SCHOOL OR BUSINESS.

- Over six times faster than standard PC XT.
 - Built-in 8.89cm Disk Drive. Stores 720,000 characters.
 - Expandable with a second 8.89cm or 13.3cm Disk Drive.
 - 640,000 characters of memory.
 - IBM PC Compatible.
 - Includes MS-DOS 3.2 and GW-BASIC Software.
 - Includes Personal Desk Mate 2.
- THE CM-11 HIGH-RESOLUTION RGB1 COLOUR MONITOR**, has a 33cm screen displaying 80 x 25 text, 640 x 200 graphics.

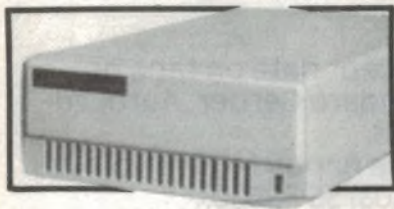

20-MEGABYTE HARD DISK CARD.
For the Tandy 1000, Tandy 3000 HL, IBM PC or PC compatible. Comes with manual and software utilities.

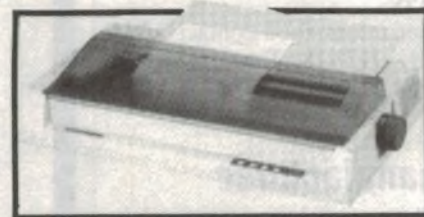

132 COLUMN BUSINESS PRINTER
A superior printer with exceptional speed and quality. Three modes for word processing, data processing and dot-addressable graphics.

PLUS

- Auto Dial Modem.
- All the necessary connection cables.

TO SUBSCRIBE

1 year subscription (12 issues) \$45, 2 year subscription (24 issues) \$88. Simply fill out the coupon attached and put it in the reply paid envelope supplied — if the coupon and envelope are missing, send your name, address, phone number and cheque, money order or credit card details (card type, card number, expiry date and signature) to Freepost No. 4, Electronics Australia Tandy Subs Offer, Federal Publishing Company, PO Box 227, Waterloo, NSW 2017. Any enquiries phone (02) 693-9515 or 693-9517. Unsigned orders cannot be accepted.

CONDITIONS OF ENTRY

1. The competition is open to Australian residents authorising a new renewal subscription before last mail February 28, 1989. Entries received after closing date will not be included. Employees of The Federal Publishing Company-Emons Instruments and their families are not eligible to enter. To be valid for drawing, subscription must be signed against a nominated valid credit card, or if paid by cheque, cleared by payment. 2. South Australian residents need not purchase a subscription to enter, but may enter only once by submitting their name, address and a hand-drawn facsimile of the subscription coupon to The Federal Publishing Company, PO Box 227, Waterloo, NSW 2017. 3. Prizes are not transferable or exchangeable and may not be converted to cash. 4. The judges decision is final and no correspondence will be entered into. 5. Description of the competition and instructions on how to enter form a part of the competition conditions. 6. The competition commences on 28th November, 1988 and closes with last mail on February 28, 1989. The draw will take place in Sydney on March 3, 1989, and the winner will be notified by telephone and letter. The winner will also be announced in the Australian on March 7, 1989 and a later issue of this magazine. 7. The prize is STA-2280 Receiver \$999.95, CD-6000 \$699.95, Mach-2 Speakers x 2 \$1059.90, IMX Equalizer \$299.95, Lab-801 Turntable \$299.95, Vert. Utility cabinet \$179.95, SCT-83 Tape Deck \$429.95, Inv. Handie control \$19.95, Vtd. Sound processor \$199.95, Min-7 speakers x 2 \$279.90, VR-2000 HO VCR \$849.95, CTV-2000 51cm TV \$399.95, OR 1000 TX Computer \$2299, CM-11 monitor \$999, 20 meg. hard disk \$999, RS-232 Cable \$69.95. 8. The promoter is The Federal Publishing Company, 180 Bourke Road, Alexandria, NSW 2015. Permit No. TC88 0000 issued under the Lotteries and Art Unions Act 1901. Raffles and Bingo Permits Board No. 88000 issued on 00.0.88 Act Permit No. TP88000 issued under the Lotteries Ordinance, 1964.

TO ENTER THE DRAW — SUBSCRIBE OR EXTEND

TO WIN IN THE ULTIMATE COMPETITION.

the fabulous **Tandy** ELECTRONICS computer pack or
There can only be one winner!

**CHOOSE THE HI-FI PACK WORTH OVER \$6,400
AND YOU'LL WIN THESE 13 PRIZES**



**HIGH PRECISION FULL
AUTOMATIC BELT DRIVE TURNTABLE.**

This elegant slimline turntable gives you amazing clarity and superb sound. The belt drive system assures smooth rotation constantly and minimizes wow and flutter.



**DELUXE 51cm
COLOUR
TELEVISION**

• Infra-red remote control. • On screen display. • Sleep function. • The CTV-2001 has a slim line and sophisticated design.

PLUS

- A remote control VCR.
- A stereo cassette deck.
- 3-way bass reflex speakers with massive 380mm woofer.



**COMPACT DISC — THE ULTIMATE IN STEREO-CD
PLAYER WITH AUTO CHANGER**

• With remote control for all major functions. • Plays up to 6 discs continuously. • 32 track memory. • Extended repeat mode. • Index search.



**REALISTIC STA-2280, 100 WATTS PER CHANNEL,
MINIMUM RMS INTO 8 OHMS FROM 20-20,000 Hz with
more than 0.05% total harmonic distortion.**

• 11-step bass, treble and balance controls. • Dual tape deck monitoring system. • Memory stores six FM and Six AM stations. • Easily expandable. • FM mute/MPX filter system. • Digital fluorescent frequency display.

- Universal 8-in-one remote control unit.
- Sound processor with surround-sound.
- Equalizer with spectrum analyzer.
- Two minimums-7 mini-speakers.
- Two sturdy, attractive utility cabinets.

“HURRY OFFER ENDS 28th FEBRUARY, 1989”

PLUS EVERYONE WHO SUBSCRIBES OR EXTENDS THEIR CURRENT SUBSCRIPTION NOW RECEIVES THIS GREAT MAGNIFIER ABSOLUTELY FREE. THE WALTEx MAGNIFIER IS NOT A TOY. IT'S A LARGE HIGH MAGNIFICATION MAGNIFIER, WITH AN OPTICAL QUALITY ACRYLIC LENSE. IT'S IDEAL FOR VIEWING SMALL COMPONENTS, STAMP & COIN COLLECTIONS, JEWELLERY AND PHOTOGRAPHS.



YOUR CURRENT SUBSCRIPTION BY 12 MONTHS.

See pages 34 & 35 for your free reply paid envelope & order form.

Books & Literature



Microprocessor text

MICROCOMPUTER ELECTRONICS: A Practical Approach to Hardware, Software, Troubleshooting and Interfacing, by Daniel L. Metzger. Published by Prentice-Hall, 1988. Student edition, soft covers, 235 x 175mm, 674 pages ISBN 0 13580143 5. Recommended retail price \$32.95

Books on microprocessors have become fairly plentiful, as the topic is now firmly entrenched in all but the most basic of courses giving instruction in electronics. This offering by Metzger is different to many, and then much the same. It is different in that it attempts to portray the microprocessor as an IC

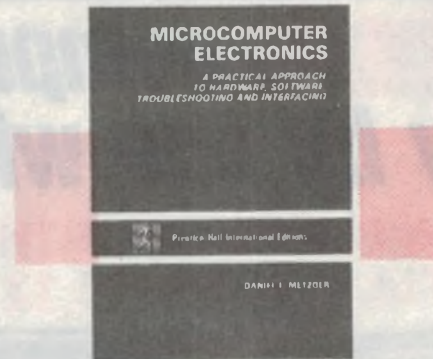

worth only a few dollars, with no real secrets anymore.

However, despite these truisms, a microprocessor is still a complex beastie,

Antenna tome

ANTENNA HANDBOOK: Theory, Applications and Design, edited by Y.T.Lo and S.W.Lee. Published by Van Nostrand Reinhold, 1988. Hard covers, 243 x 198mm. ISBN 0 442 25843 7. Recommended retail price \$285.95.

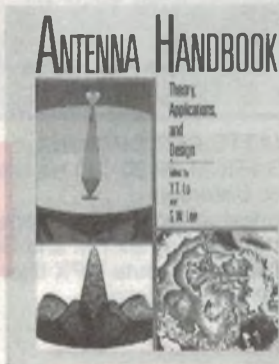

If ever there was a monumental book on antennas, this is it – in both size and price! As with many books designed as reference manuals or handbooks, the pages are not contiguously numbered so I can't quote a single impressive figure. However there are some 33 chapters and 6 data appendices, and despite the use of relatively thin paper stock the overall thickness of the book is no less than 73mm.

The authors are both PhDs, Fellows of the IEEE and professors at the University of Illinois, and said to be two of the world's most distinguished special-

ists on antennas. Their aim in producing the book has been to provide a thoroughly up-to-date and comprehensive handbook, which encompasses all of the advances in antenna technology that have taken place in the last decade. Some 50 different antenna experts from around the world have contributed to the various chapters, making it a work of considerable authority.

The first 4 chapters deal with fundamentals and mathematical techniques, after which the next 12 chapters deal with the theory and design of the various kinds of antennas and antenna arrays. These are followed by a further 11 chapters dealing with various applications of antennas, and finally by 6 chapters covering related topics such as transmission lines, waveguides, propagation and both near- and far-field antenna measurements. Then follow the 6 data appendices, and finally the overall index – which itself occupies no less than 69 pages!

I'm no antenna expert, but from a careful sampling through many of the chapters, it looks to be not only comprehensive in scope but thoroughly professional and up to date as well.

In short, the most impressive reference tome on antennas that I've ever seen. But it's not for everyone, of course. Those who'll find it of most value will be the researcher, design engineer and advanced engineering student.

The review copy came from Thomas Nelson Australia, in Melbourne. (J.R.)

and the next 600 or so pages proceed to unravel the topic. The book deals with the 6802, chosen on the premise that this micro is the least complex of the genre, with the easiest set of instructions. A feature of the book is the presentation of circuits that can be wired on a breadboard to examine certain aspects of the operation of the 6802.

Because the circuits are simple, they are relatively limited in their capabilities, but do allow an immediate 'hands on' approach. The basic circuit which is referred to in many of the programming examples consists of the 6802, some RAM and the necessary switches to input instructions in raw binary. Despite its limitations, this approach certainly removes the mystery; assuming the reader actually either builds or analyses the circuits.

Notwithstanding the apparently simple approach, the book manages to cover a lot of material. In fact, no aspect of the topic has been omitted, it seems. Examples of most of the typical peripheral ICs such as PIAs, ACIAs, RAMs and ROMs are covered. Also, bus standards, communications standards and the

Computer circuit analysis

ANALYSIS AND DESIGN OF ELECTRONIC CIRCUITS USING PCS: By John R. Greenbaum, Les Besser/Brian Biehl, Bruce D. Pollard/Robert Osann. Published by Van Nostrand Reinhold Company, 1988. Hard covers, 235 x 155mm, 278 pages ISBN 0-442-22773-6. Price \$76.95

It is becoming increasingly fashionable for designers to 'dry run' their circuits using a computer program that simulates the circuit then applies various tests to it. This book examines some of the techniques and software packages available for this purpose.

The book by authors various is aimed at design engineers, and assumes the reader has this type of knowledge to at least third/fourth year of a degree. However, there is much to interest anyone involved in this field, and those trained to certificate level will also find it useful.

The book comprises seven chapters, covering topics ranging from general purpose analog simulation analysis programs to the use of programmable logic devices (PLDs). Microwave design is covered fairly extensively in chapter 4, while chapter 6 seems almost out of place in that it concentrates on data acquisition techniques for computers. The

like are included, along with discussion on disk drive interfaces, VDUs and keyboards. The software discussion is excellent, and gives many practical and useful examples.

The book is arranged into four sections, giving a total of 24 chapters. Part 1 presents the basic microcomputer concepts, part 2 software and troubleshooting, part 3 interfacing techniques, and part 4 covers other microprocessors, (in a fairly comprehensive manner), including the Z80 and the 68000.

This book is aimed at those with a basic digital knowledge, and could serve as a teach-yourself book. However, it is intended as a textbook, and will be welcomed by any institution offering a microprocessor course based on the 6802, or who need a general text that follows the 6800 philosophy.

And the price places this book well into the affordable range for anyone, a feature of many of the Prentice-Hall student publications. The review copy supplied was an uncorrected pageproof version, but should be available around December - January. The copy came from Prentice-Hall, Sydney.(P.P.)

**ANALYSIS
AND
DESIGN
OF
ELECTRONIC
CIRCUITS
USING PCs**

John H. Groussmann
Luis Benitez / Brian Botta
Bruce D. Pollard / Howard Osborn

final chapter describes methods and procedures of computer circuit simulation, while presenting examples and code listings for the design and analysis of six different circuits. This chapter is the longest in the book and presents programs written in BASIC that, presumably, can be keyed in and used.

The book describes various software packages currently available, including PSpice, BIAS-D, MICROCAP-II, TOUCHSTONE and others. There are numerous program listings throughout the book, and each chapter is written by one or several of the listed authors.

There is some 'browse' quality to the book, and it would serve well as a general text for those interested in harnessing their PC as a design tool. The review copy was supplied by Thomas Nelson Australia.(P.P.)

ELECTRONIC BROKERS AUSTRALASIA TEST EQUIPMENT

Australia's largest range of
secondhand:

Hewlett Packard
Tektronix
Marconi
Solartron
Boonton
BWD
Bruel & Kjaer

Oscilloscopes, sig gens, spectrum analysers, multi meters. Wide range of valves, coaxial connectors and test accessories. Repairs and service to all makes and models.

All types of equipment bought
and sold.

WE TRADE ALSO!

Agents of T.G.L. spectrum
analysers.

Calabration facilities available.
Screened room and Vibration
measurement systems for hire.

Communication equipment,
Scanners, Mobile Phones and
accessories, Ham gear.

AGENTS FOR ALL ICOM EQUIPMENT

**Cnr. Barry St, and Brunson St,
BAYSWATER, VIC.**

(enter from Brunson St)
TELEPHONE (03) 729 0455
Mobile Phone 018 312 203

An Enthusiasts' Treasure Trove

Mike Sheridan's electronics store in Sydney's inner suburb of Redfern is one of the few remaining with genuine 'disposals' gear as well as new components. A visit is always likely to turn up items of interest, whether you're a newcomer to electronics or an enthusiast of many years' standing – as our editor Jim Rowe recently found...

When I was a teenager just starting to get interested in electronics, back in the 1950's, I didn't have much money to spend on components or test equipment. But this wasn't really a problem, because in those days there were lots of 'disposals' stores around town (usually in the seedier back streets) offering all kinds of ex-services equipment and manufacturer's distress stocks for a tiny fraction of their original value.

I well remember picking up a complete radar display unit, still in its original packing case. After my brother and I lugged it home, I pulled it apart to salvage all of the components. From memory it had about 40 or 50 assorted valves, a cathode ray tube, numerous transformers and filter chokes, and literally hundreds of high-quality resistors, capacitors, connectors and other parts – all brand new. It must have cost the armed forces thousands of pounds, but I think I paid a mere 12 pounds 10 shillings, all saved up from my pocket money. And from all those parts I built a CRO, various amplifiers and even part of my first TV set!

Unfortunately for today's impecunious hobbyists, most of those original disposals stores have now disappeared. Of those that *are* still around, many have turned into pseudo-disposals stores, offering mainly low quality camping gear and fake military-surplus clothing made in Asia.

But in Sydney, at least one of the original type of electronics disposal stores is still to be found: Sheridan Electronics, at 164-166 Redfern Street, Redfern. Run by a genial gentleman of Cockney origin by the name of Mike Sheridan and his young grandson Darren, it offers a veritable treasure trove of bargains for electronics enthusiasts of all ages.

Mike has been in the business for 18 years, and has excellent contacts not only with the services, but throughout the industry. So when disposals gear or manufacturers' distress stock becomes available, he's usually the first to know. And if it's a good bargain, he generally snaps it up quickly for his customers.

As a result, a visit to Mike's store almost always reveals new and interesting 'goodies' – generally at a small fraction of their original price. So if you're a keen enthusiast with an eye for a bargain, regular visits are highly recommended.

There were certainly some interesting things to be found when I visited there

the other day, for example. When I arrived Mike was busy serving a customer, so I had the opportunity to browse around. Very quickly I found some very nice little cassette tape deck mechanisms going cheaply, and not far away some beautiful little whisper-quiet and brand new French-made 240V/2.8W Crouzet synchronous motors with integral reduction gearboxes, producing an output of 60rpm. These were going for only \$5 each – excellent value for such handy little motors.

There was also a large pile of brand-new 12-key keyboards, obviously ex-NCR, of the type used inside banks for customers to enter their PIN number. These are complete with indicator LED, cable and 14-pin DB plug (DB-15 with one pin removed!), plus an A-4 size sheet of plastic stick-on keytop labels including numbers, alphabetic letters, function keys (F1 – F20) and a variety of other symbols including arrow keys and maths operators.

When Mike Sheridan saw me looking



The genial Mike Sheridan and his grandson Darren, behind the counter of their Redfern store. They carry a huge range of electronic goodies, of both the 'new' and 'disposals' variety.

at these keyboards, he showed me inside one that had been opened. It was very nicely made, with a keyswitch assembly and scanning electronics PCB both made by Microswitch in the USA. The electronics consists of a 4049 hex buffer and 74159 4-bit decoder, and looks to be fairly compatible with standard memory-mapped matrix scanning. You could probably use one to add a numeric keypad to an existing computer, or to add editing and special function keys.

And the price of these very nicely made little keyboards is a mere \$9.95, probably less than a tenth of what they originally cost banks!

Mike then showed me one of his latest 'distress stock' acquisitions. This is a large quantity of equipment and components from a firm in Melbourne, which was making a device called 'Typestore' - a word processor adaptor for IBM Wheelwriter electronic typewriters.

For those interested, Mike has the complete microcomputer-based electronics units of the Typestore system (but without video monitor), for \$150. This includes a Mitsumi single-sided 3.5" microfloppy disk drive and a compact KEC KFD25E switch-mode power supply module, both made in Japan.

The disk drive and supply are also available separately, for those who wish to use them to add a 3.5" drive to an existing computer. Mike's price for the pair is only \$90, which seems excellent value.

The disk drive is of quite modern design, with diecast chassis, a direct-drive PCB motor, stepper motor and lead-screw head actuator and VLSI controller chip. The matching power supply has 5V, +12V and -12V outputs, with outputs to drive up to two disk drives. And Mike can even supply the cables to connect the two together.

That's just a sampling of the bargains that were on display when I called in to Sheridan Electronics. Along with these there was a very wide range of new semiconductors and other components, many of them at significantly lower prices than you'll find elsewhere. You can buy them either singly, or in bargain packs.

If you live anywhere within range of Redfern, I'd recommend a personal visit to see the range for yourself. Failing that, keep your eyes peeled for bargains in Mike's regular advertisements - but don't delay in sending in your mail orders when you do see them, because he tells me that the bargains often go quite fast!

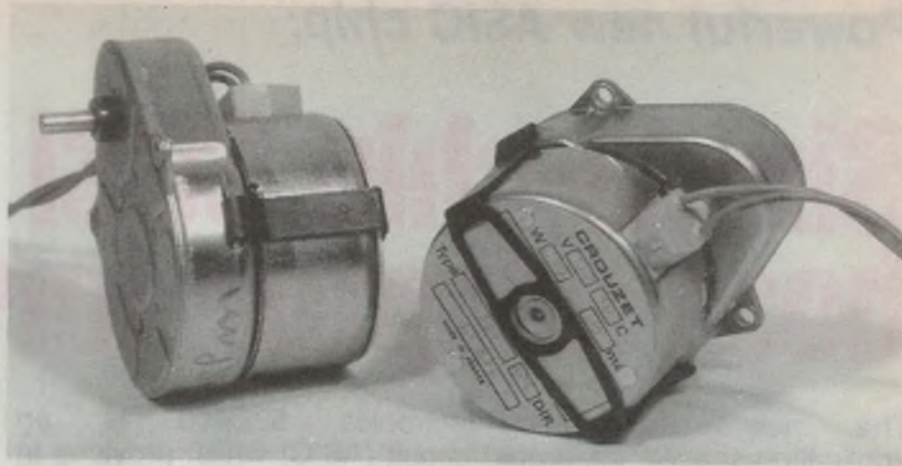

Above: Samples of the little Crouzet synchronous motors, with integral 60rpm gearbox.



Right: Mike also has these 12-key keyboards, complete with scanning circuitry and a sheet of legends.

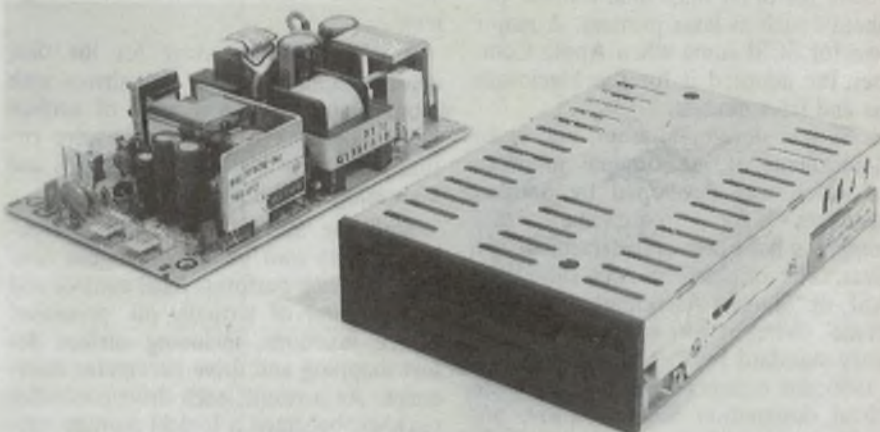

Above: The Mitsumi single-sided 3.5" floppy drive with matching power supply.

Right: An outside view of the Sheridan Electronics shop.

For those who want to save time, you can send your orders by fax; the number is (02) 698 3694, while the normal 'phone numbers are (02) 699 5922 or 699 6912.

But to discover the real bargains, you really need to drop in and browse around. Mike's address at 164-166 Redfern Street is only about 300 metres' walk from Redfern station, making it very accessible. Why not see for yourself?



EA

Powerful new ASIC chip:

Single-chip SCSI host adaptor for PC's

The new NCR Microelectronics 53C400 is an application-specific integrated circuit (ASIC) which provides in a single 68-pin PLCC package virtually all of the circuitry necessary to interface IBM PC's and compatibles to the Small Computer Systems Interface (SCSI) bus, now being widely used for hard disks and other peripherals.

by JIM ROWE

In the last few years, the Small Computer Systems Interface or 'SCSI' (pronounced 'skuzzy') bus has quickly gained acceptance internationally as the standard way to interface hard disk drives and other mass storage peripherals to microcomputer systems. It is also suitable for other mass-data-transfer peripherals such as laser printers. A major boost for SCSI came when Apple Computer Inc adopted it for the Macintosh Plus and later models.

SCSI was developed from, and is an enhancement of, an original interface bus which was developed by Shugart Associates for interfacing that company's hard disk and streaming-tape drives. The original bus was called the SASI, or 'Shugart Associates System Interface'. When it was adopted as an industry standard by the American ANSI in 1986, the enhanced bus was given the official designation X3T9.2/86-109, but is still most widely known as the SCSI bus.

Apart from the added flexibility in interfacing that it offers, there is also a cost and system overhead saving with SCSI compared with the earlier approach to interfacing disk drives.

Traditionally, the disk drive was fitted with only low-level electronics, interfaced to the host computer via an intelligent controller which handled all of the primitive drive control functions – under the direction of the disk operating system software. Because the two were separated, it was not possible to rationalise overall hardware and achieve a further increase in cost effectiveness.

Equally importantly, since only

'dumb' electronics was built into the drive, no provision could be made for automatic internal mapping of surface defects. Instead the host computer's controller and disk operating system had to perform virtually all mapping and disk drive management, maintaining system overheads at a relatively high level.

A further disadvantage for the disk drive manufacturer was that drives with more than a very low level of surface defects on their storage media were virtually unusable – giving lower yields and increasing overall product cost.

With the SCSI system, each peripheral has its own inbuilt intelligent controller, which performs local control and management of virtually all 'primitive' device functions, including surface defect mapping and drive parameter tolerances. As a result, each drive/controller package becomes a logical storage subsystem, with all 'housekeeping' handled

transparently by the internal controller.

This not only gives a significant reduction in system overheads in the host computer, but also allows the disk drive manufacturer to achieve higher production yields because of the custom integration of drive and controller. So overall drive cost tends to be lower as well.

When the SCSI bus is used for disk and tape drive interfacing to the host computer, the latter no longer requires the traditional disk drive controller. Instead it has a 'SCSI Host Adaptor' or 'Host Interface Controller', which as these names suggest is used essentially to manage the computer's end of bus transfer protocol (Fig.1). For further basic details of the SCSI bus system, see the data box headed 'SCSI Bus Basics'.

The first SCSI host adaptors were PC boards with a considerable number of lower-level ICs. However as with early disk drive controllers, the chip count has steadily fallen as VLSI technology has allowed integration of more and more functions.

NCR Microelectronics apparently introduced the first available monolithic SCSI bus controller chip, the 5385. This came in 1983, and was followed in 1986 by the 5380 – which offered on-chip bus transceivers. It is the 5380 that is used in Apple's Macintosh Plus, SE and II models.

The 5380 is essentially little more than

Fig.1: A typical SCSI bus configuration. The host computer interfaces via a host adaptor, while the peripherals each have intelligent controllers.

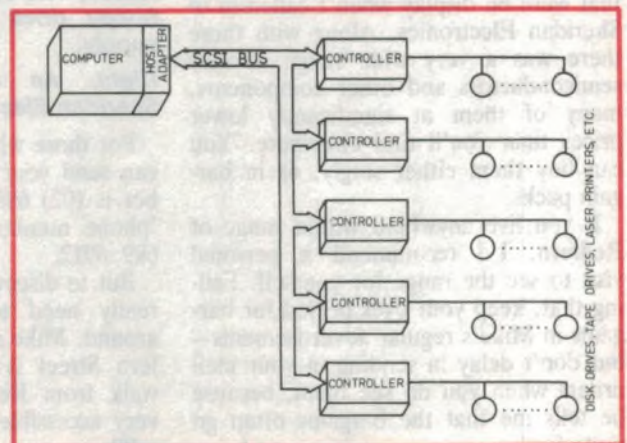

a pair of high-speed parallel ports for the SCSI bus data and control lines, plus handshaking logic and high-current output drivers. It includes logic to implement basic bus handshaking and physical control of data transfer phases, but doesn't implement any of the SCSI logical protocol. This means that all protocol and bus phase sequencing must be performed by the host computer and software – again adding to system overheads.

Balancing this disadvantage, there is the advantage that variations in protocol can be easily implemented by changes to software. As a result, many system designers still prefer to use this level of controller chip, and firms like NCR have produced enhanced versions such as the 5386 and the CMOS 53C80.

To cope with the demand for controllers requiring less system overhead, NCR and other firms have developed more sophisticated SCSI protocol controller chips, such as the 53C90 which appeared in 1987. This has internal state-machine wired logic which very efficiently handles most of the SCSI bus transfer protocol, relieving the host computer of most aspects of bus management.

More recently, NCR has introduced the 53C400, a single-chip VLSI ASIC device designed specifically to provide virtually all of the functions required for a high performance SCSI host adaptor

SCSI Bus Basics

The Small Computer Interface (SCSI) bus is now an internationally accepted standard interface for connecting hard disk drives and other mass storage devices to microcomputers. It is essentially a local-area interface, designed to transfer data in parallel byte-wide form at rates of up to 4 megabytes/second, between as many as 8 different devices (including the host computer).

Unlike earlier disk drive interfaces such as the ST-506, the SCSI bus requires all devices connected to it to have their own intelligent controllers. These perform local control of all 'primitive' device functions, behaving externally as logical subsystems capable of sending and receiving blocks of data.

The SCSI specification provides for both single-ended and balanced differential electrical transmission of bus signals, the latter allowing cable lengths of up to 25m. However to date most SCSI bus implementations have used the simpler single-ended unbalanced approach. If active terminations are used this gives high speed operation over distances of up to about 6m.

Electrically the SCSI bus uses 50-way flat ribbon or twisted-wire cable, and ID (insulation displacement) connectors having two rows of 25 pins on 0.1" (2.54mm) centres, with the two rows spaced the same distance apart. All devices are connected to the bus in daisy-chain fashion, with all signals common to all devices and the signal lines terminated actively at both ends.

Normally there is a single 'Talker' or 'Initiator' device, which initiates the data transactions on the bus. The rest of the devices are 'Listeners' or 'Target' devices, which basically respond to commands from the Initiator. Usually the host computer is the Initiator, with the disk drives or other peripherals forming the Targets. However the SCSI standard specifies an arbitration option, which if implemented allows multiple Initiators.

The SCSI interface provides eight data lines DB(0-7), plus a ninth bit DB(P) used for parity. There are also nine status and control lines, and one power supply line for the active terminations. All other lines are earthed, except in balanced systems where all data and control lines have matching return lines.

Negative or 'active low' logic polarity is used throughout, with the buslines driven by open-collector or tristate driver outputs. Logic 'true' or 1 corresponds to a voltage of less than 0.4V, while 'false' or 0 corresponds to a voltage between 2.5V and 5.25V.

Information transfers on the SCSI bus are generally *asynchronous*, although synchronous transfer is an optional enhancement. Data is transferred byte by byte, with handshaking via the REQ/ACK control lines. However an extended command set capability allows up to 65,535 data blocks to be transferred in response to a single command. The logical addressing capability is up to 32 bits, allowing data blocks of up to 2³² bytes in length.

Each of the up to eight devices connected to the bus is assigned a fixed identification or 'address' code (0-7), designated directly by the bits of the bus addressing byte. The codes are preset in terms of arbitration priority for bus control; the device with code 7 has the highest priority, and that with code 0 the lowest.

Typical SCSI bus data transfers consist of three main *phases*, the first two of which are selected by the Initiator and the third by the designated Target.

First the Initiator looks for a 'bus free' condition, and then makes a bid to capture control of the bus. This is called the *arbitration* phase.

If no device with higher priority bids, the Initiator gains bus control and enters the *selection* phase by flagging up the Target device with which it desires to communicate.

The third, or *information transfer* phase, is entered when the selected Target device responds, and indicates the type of transfer it is able/prepared to engage in. These include Data In or Data Out, Command Request, Status Acknowledge, Message In or Message Out.

Typically the speed of SCSI bus data transfers is limited by the data transfer rate of the disk drive concerned. Most current hard disk drives are limited to around 625K bytes/second (5M bits/second), with the fastest running at about 1.25MB/second. The SCSI bus is quite capable of coping with this rate, even when relatively slow SCSI controller chips are used.

The SCSI bus transfer rate of 1.5 – 4MB/second is also very suitable for transferring data to laser printers, another application where the use of the bus is growing rapidly.

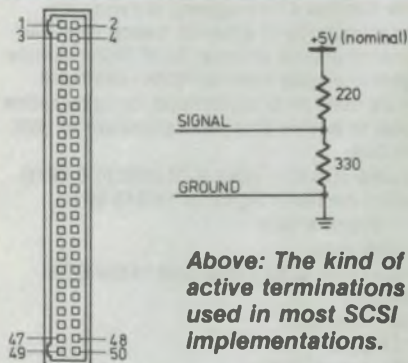

Above left: The SCSI bus uses a 50-pin physical connector.

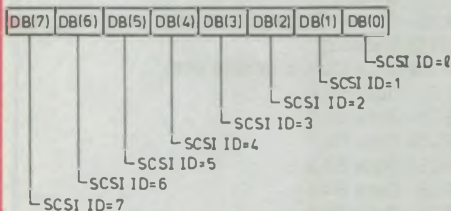

Each device on the SCSI bus is assigned a fixed address and priority level.

SONICS MAGAZINE

For: Musicians, Road Crews,
Recording Engineers, Lighting
People, Managers, Promoters and
anybody interested in what goes
into today's music-making.

THE ALL
AUSTRALIAN
MUSIC MAKERS' MAGAZINE

MONDOTRONIC

MP271 EPROM PROGRAMMER FOR IBM™ PC/XT/AT



Designed and built in Australia. Supports most 2716 to 27512 eproms including cmos. Hex and binary data formats. Editing in hex or ascii, copy, move, fill, erase, split, combine, printing, hex-ascii view of buffer disk or eprom. Multiple algorithms, simple menu operation, and much more. Additional low cost Australian built TTL, relay and opto boards available. Phone or write for additional information from:

MONDOTRONIC PTY. LTD.
P.O. Box 296
560 Waverley Rd.,
Glen Waverley Vic. 3150
Phone: 232 4110

SCSI chip

for the IBM PC/XT/AT family of micro-computers.

The 53C400 was developed jointly with a major West Coast (US) manufacturer of peripherals, and was designed to provide a minimum parts-count and versatile SCSI adaptor for use with that company's disk drives. It is a CMOS

device, fabricated in 2-micron geometry using NCR's library of standard cells - including a 'Supercell' version of the 53C80.

In addition to the 53C80 dual ports, bus control and handshaking logic, the 53C400 features two 128-byte rotating (FIFO) RAM data buffers for matching the speeds of the SCSI and host data busses - making it capable of SCSI-bus data burst rates up to 2 megabytes/sec-

TABLE 1:

SIGNAL	TYPE	PIN #	DESCRIPTION
A0 - A19	I	26 - 45	Host address bus bits 0 through 19
D2 - D0	I/O	20 - 22	Host data bus bits 0 through 2 with internal pull-ups
D7 - D3	I/O	14 - 17, 19	Host data bus bits 3 through 7
AEN	I	25	Host address enable - asserting this signal de-gates the 53C400 from the host bus, while the host DMA takes over
IOW/	I	48	Host IOW/ signal - used by the host to issue a global rearm of the interrupt request in the interrupt-sharing host computers
SMEMR/	I	46	Host SMEMR/ signal - asserting this signal instructs the chip to place data onto the data bus
SMEMW/	I	47	Host SMEMW/ signal - asserting this signal instructs the chip to read data from the data bus
RESET	I	24	Host RESET_DRV signal is used to reset the chip. This pin has a Schmitt-trigger input.
IRQ	I/O	4	Interrupt request signal. During normal interrupt mode this pin has an active pull-up output. In the shared interrupt mode this pin has an open-drain output and a Schmitt-trigger input.
ØWS	O	5	When this pin is low the microprocessor is instructed not to insert any additional wait cycles
ASEL0 - ASEL2	I	10 - 12	Base address select pins with internal pullup - see Section 4 for mapping of segments
SW_SEL/	O	8	Signal to strobe in external Switch Register
ROM_SEL/	O	9	Signal to enable external BIOS ROM module
RAM_SEL/	O	6	Signal to enable external RAM - this RAM can be used as a scratchpad for calculations
DRV_SEL/	O	7	Signal to enable external transceiver to host data bus
CLK	I	23	Variable system clock (4.77 MHz to 8 MHz)
OSC	I	49	System oscillator signal of 14.318 MHz
VDD		13	+5 V power supply
VSS		18	Ground pins
SCSI_VSS		1,64, 58,52	Ground pins to be connected to the SCSI connector
SATN/	I/O	60	SCSI Attention
SBSY/	I/O	59	SCSI Busy
SACK/	I/O	57	SCSI Acknowledge
SRST/	I/O	56	SCSI Reset
SMSG/	I/O	55	SCSI Message (phase line)
SSEL/	I/O	54	SCSI Select
SC/D	I/O	53	SCSI Control/Data (phase line)
SREQ/	I/O	51	SCSI Request
SI/O/	I/O	50	SCSI Input/Output (phase line)
SDB0/	I/O	3	SCSI Data Bit 0
SDB1/	I/O	2	SCSI Data Bit 1
SDB2/	I/O	68	SCSI Data Bit 2
SDB3/	I/O	67	SCSI Data Bit 3
SDB4/	I/O	66	SCSI Data Bit 4
SDB5/	I/O	65	SCSI Data Bit 5
SDB6/	I/O	63	SCSI Data Bit 6
SDB7/	I/O	62	SCSI Data Bit 7 - has highest priority during the Arbitration Phase
SDBP/	I/O	61	SCSI Data Parity - odd parity is used

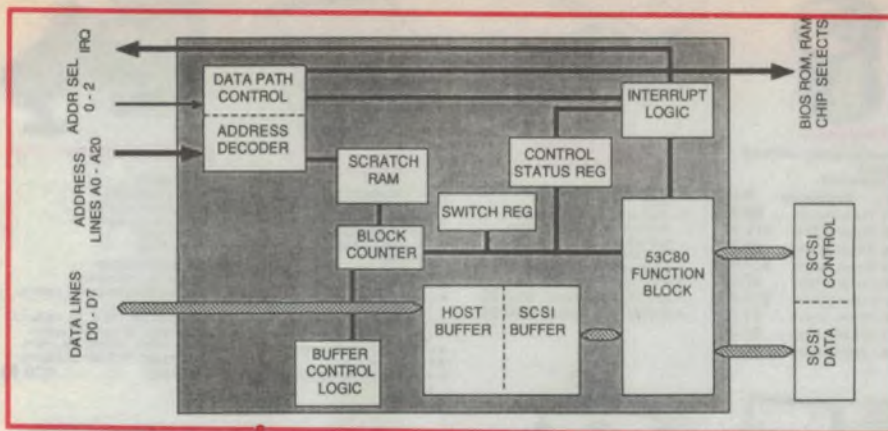

Fig.2: Inside the new NCR 53C400 single-chip SCSI host adaptor chip.

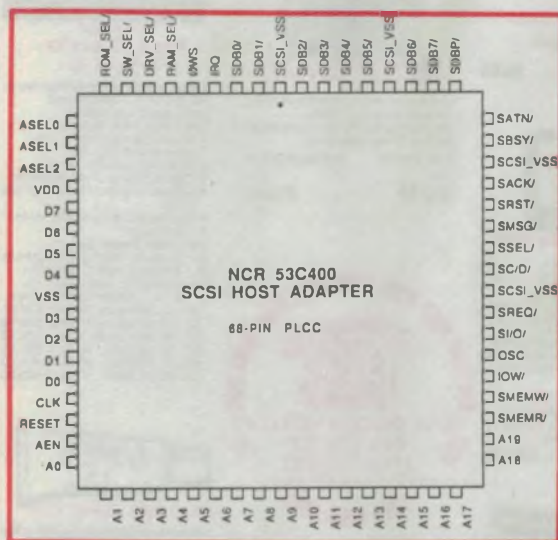

Fig.3: Pin connections for the 53C400's 68-pin PLCC package.

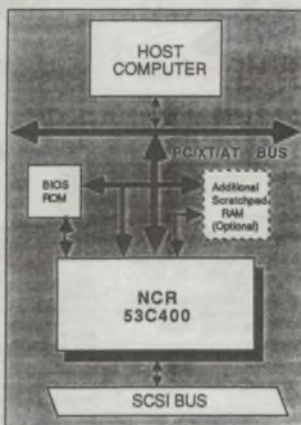

Fig.4: In most cases, the 53C400 performs all SCSI adaptor functions. All that is needed is the appropriate BIOS ROM.

ond, and host-bus bursts of up to 1Mb/sec. It also includes an internal 64-byte scratchpad RAM for storage of BIOS tables or calculations, high-current single-ended bus transceivers, programmable interrupt levels (6 choices, for compatibility with PC, XT and AT systems), interrupt sharing (for PS/2 system compatibility), memory mapped host addressing with 6 choices of base address and PIO (Programmed Input/Output)/block counting circuitry to allow the use of block move instructions for faster bulk transfer of data into host memory than is possible with DMA.

The internal block diagram of the 53C400 is shown in Fig.2, with the connections for its 68-pin PLCC (plastic leadless chip carrier) package shown in Fig.3. The functions of the various device pins are identified in Table 1.

The 53C400 can operate in either 'Initiator' or 'Target' SCSI modes, and fully supports the low level SCSI bus arbitration protocol. Its on-chip single-ended bus transceivers include special high-

current output drivers capable of sinking 48mA at 0.5V, for direct connection to the SCSI bus.

On the software side, the 53C400 is fully software compatible with the earlier 5380/C80 SCSI chips, allowing the use of existing and proven BIOS routines.

Apart from the 53C400 chip itself, virtually only one other chip is needed to implement a complete SCSI host adaptor for PC/XT/AT computers: a 2732 or similar ROM for the adaptor BIOS (Fig.4). In some cases an octal data buffer chip may also be required for data bus buffering.

In a following article, we will be describing a low-cost SCSI host adaptor card for PCs using the 53C400 chip, developed by NCR Microelectronics. Complete kits for the card will be available from the Australian distributor for NCR, Energy Control International, based at 26 Boron Street, Sumner Park, Brisbane 4074. Energy Control's phone number is (07) 376 2955, and its fax number (07) 376 3286. ④

Coming next month in Electronics Australia

Simple Shorts Locator for PCBs

Tracking down short circuits on complex printed circuit boards can be quite tricky. This easy to build shorts locator lets you 'home in' on the short easily, using an audio tone. It's much lower in cost than commercial shorts locators, too.

Build an old-time induction coil

Induction coils were an essential part of early radio transmitters, right from the days of Hertz and Marconi. Here's an article which shows how to build one for yourself. Use it to re-create early radio equipment, or just to have fun experimenting with high voltage AC!

Low distortion audio oscillator

It's taken a little while to bring to the stage where we could publish it, but at last it's ready. Low in distortion, much simpler and easier to get going than earlier designs, it also offers a choice of two methods of amplitude stabilisation - fast and slow. You'll find it's worth the wait!

Note: Although these articles are being prepared for publication, circumstances may change the final content of the issue.



UTILITY BOXES

Plastic boxes with aluminium tops and available in four sizes. Very popular for projects and very economical!

H10101 150x90x50mm	\$ 3.25
H10102 195x113x60mm	\$ 4.50
H10103 130x68x41mm	\$ 2.75
H10105 83x54x28mm	\$ 1.95
H10110 120x65x38mm	\$ 2.95
H10112 120x65x38mm (Metal top)	\$ 2.95



"SNAP TOGETHER" PLASTIC CASE

Top and bottom simply snap together (no screws required), removable front and back panels. Size: 186(W) x 125(D) x 50(H)mm
Cat. H10116 \$7.95



ECONOMY 19" RACK CASE

Save with this quality rack mount-case complete with vents, handles and assembly screws! Tremendous value!
Dimensions: 480 x 134 x 250mm
Cat. H10415 \$44.95



COMPUTER CABLE

CIC8 8 conductor computer interface cable. Colour coded with braided shield. (to IE422 specifications)
Copper conductor 8 x 7/0 16mm
1-9 metres \$1.90/m
10+ metres \$1.70/m

CIC9 100 9 conductor computer interface cable. Colour coded with mylar shielding 9 x 7/0 16mm
1-9 metres \$2.50/m
10+ metres \$1.95/m

CIC12 12 conductor computer interface cable. Colour coded with mylar shielding 12 x 7/0 16mm
1-9 metres \$2.70/m
10+ metres \$2.50/m

CIC16 16 conductor computer interface cable. Colour coded with mylar shielding 16 x 7/0 16mm
1-9 metres \$3.90/m
10+ metres \$3.40/m

CIC25 25 conductor computer interface cable. Colour coded with mylar shielding 25 x 7/0 16mm
1-9 metres \$4.90/m
10+ metres \$4.40/m



DIECAST BOXES

Diecast boxes are excellent for RF shielding, and strength. Screws are provided with each box.
H11451 100 x 50 x 25mm \$ 5.95
H11452 110 x 60 x 30mm \$ 6.50
H11453 120 x 65 x 40mm \$ 6.95
H11481 120 x 84 x 53mm \$11.50
H11462 188 x 120 x 78mm \$13.50
H11464 188 x 188 x 64mm \$29.50



MAGNETIC BULK ERASER

The best and by far the quickest way to erase tapes, cassettes and computer disks! Reduces noise levels below recorders own erase head level. On/Off switch located in handle 240V AC operation.
Cat. C14950 Normally \$34.95
SPECIAL, ONLY \$29.95



HOOK UP WIRE

Cat. No.	Description	Price
W11251	13/12 TND BLK	
W11252	13/12 TLD BROWN	
W11253	13/12 TLD ORANGE	
W11254	13/12 TLD YELLOW	
W11255	13/12 TLD GREEN	
W11256	13/12 TLD BLUE	
W11257	13/12 TLD WHITE	
PRICES PER 100 METRE ROLL		
1-9		\$5.95
10+		\$10.00

Cat. No.	Description	Price
W11260	14/20 RED	
W11261	14/20 BLACK	
W11262	14/20 BLUE	
W11268	14/20 WHITE	
PRICES PER 100 METRE ROLL		
1-9		\$12.00
10+		\$10.00

Cat. No.	Description	Price
W11270	24/20 RED	
W11272	24/20 BLACK	
W11274	24/20 GREEN	
PRICES PER 100 METRE ROLL		
1-9		\$14.00
10+		\$12.00

Cat. No.	Description	Price
W11280	32/2 BROWN	
W11282	32/2 BLUE	
PRICES PER 100 METRE ROLL		
1-9		\$20.00
10+		\$18.00

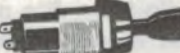

KEY SWITCHES

Cat.	1-9	10+
S12500	Normally \$7.95	
	1-9	25+
	\$4.95ea	\$3.25ea
	\$4.25ea	\$3.95ea



SOLDER BRAID

1.5 metres of specially treated braid for removing solder from PCB's etc. Simply place the braid against the solder and apply the soldering iron. The melted solder is drawn up into the braid.
T11320 1.5 metres \$1.95



VIDEO RF MODULATOR

At an unbelievable price! Our RF modulators are channel selectable either Channel 0 or Channel 1.
Cat. S16040
1-9 \$3.95
10+ \$2.95



CPF CONTINUOUS POWER FILTER SPIKE ARRESTOR

The Fortron CPF Filtered Electronic Spike Protector provides a protective electronic barrier for microcomputers, printers, telephone systems and modems, electronic typewriters, audio and stereo systems and other sensitive electronic equipment.
The CPF provides protection from dangerous electrical spikes that can cause anything from obvious damage (like immediate equipment failure) to less obvious harm that can drastically shorten a system's life.
CPF's superior circuitry design and semi-conductor technology responds instantly to any potentially damaging over-voltage, ensuring safe trouble free operation.
Additionally, CPF's filtering capability helps eliminate troublesome and annoying interference, general hash created by small motors, fluorescent lamps, and the like that threaten the performance and shorten equipment life of unprotected electronic components.

SPECIFICATIONS:
Electrical rating: 220-260 volts (AC) 50Hz 10 Amp
Spike/RFI Protection: 4,500 amps for 20microsecond pulses.
Maximum clamping voltage: 275V differential mode.
Cat. X10088 \$89.95



SOLDER ROLLS

Absolutely top quality, unlike our opposition!
60/40 Resin cored

Cat. No.	Description	Price
T31000	71mm 250gm	\$8.95
T31002	71mm 500gm	\$15.95
T31010	91mm 250gm	\$7.95
T31012	91mm 500gm	\$14.95
T31020	1.6mm 250gm	\$7.50
T31022	1.6mm 500gm	\$13.95
T31030	71mm 1 metre	\$1.50
T31032	91mm 1 metre	\$1.25
T31034	1.6mm 1 metre	\$1.00



RS232 BREAK OUT BOX

A simple way of monitoring RS232 interface lead activity. Interface powered, pocket size for circuit testing, monitoring and patching. 10 signal powered LED's and 2 spares. 24 switches enables you to break out circuits or reconfigure and patch any or all the 24 active positions.

SPECIFICATIONS:
Connectors: DB25 plug on 80mm ribbon cable and DB25 socket
Indicators: Tricolour LED's for TD, RD, RTS, CTS, DSR, CD, TX, RC, DTR, (E)TC.
Jumper Wires: 20 tinned end pieces.
Power: Interface power
Enclosure: Black, high impact plastic.
Dimensions: 85 x 95 x 30mm
X15700 \$94.95



12 WAY TERMINAL BLOCKS

P18050	240V 10AMP	\$1.95
P18052	240V 15AMP	\$1.95



SUPER HORN

Wide dispersion tweeter, handles up to 100W
● Sensitivity 105dB/0.5m
● Frequency Response: 3kHz-30kHz
● Impedance: 8 OHMS
● Size: 145x54mm
Cat. C12103 Normally \$12.95
SPECIAL, ONLY \$9.95



ULTRASOUND TRANSDUCERS

Designed to transmit at 40kHz (L19990) and receive at 40kHz (L19991) with up to 20W I/P on the transmitter. These units can't be heard and so are ideal for TV remote controls, water level detectors, burglar alarms, motion detectors and information carriers as they can be either pulsed or used in the continuous wave mode.
Full specifications below for design purposes
Maximum Input Voltage: 20V rms
Centre Frequency (kHz): 40 ± 1.0
Sound Pressure Level: 10V RMS - 110dB min.
Sensitivity (dB/ubar) min.: -65 min.
Bandwidth (kHz):
Transmit: 4.0 (at 100dB)
Receiver: 5.0 (at 73dB)
Impedance:
Transmit: 500
Receiver: 5000
Cat. L19990 (Transmitter) \$6.95
Cat. L19991 (Receiver) \$6.95

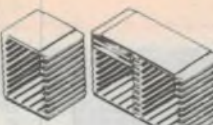

COMPACT DISC STORAGE UNITS

- Holds 10/20 compact discs in their cases
- Interlocking modular design allows vertical and horizontal interlocking
- Discs slide into place horizontally making titles easy to read
- Wall mount or free standing

A10031 (10 discs) \$12.95
A10032 (20 discs) \$19.95



COMPACT DISC CASES

Two standard replacement compact disc cases
A10030 \$6.95



CD PLAYER ADAPTOR

Many amplifiers have only one auxiliary input. This makes using a compact disc player as well as another auxiliary input inconvenient. Also the majority of CD players have an output voltage of 1.6 or 2 volts whereas the auxiliary input norm is 750mV. This CD adaptor allows dual auxiliary input, and one input has variable gain setting.

SPECIFICATIONS:
● Input 2 sets of 2 x RCA sockets
● Gain 150, 300, 600mV, 1V and 2V
● Output 2 x RCA sockets
A11510 \$23.95



OMNI-DIRECTIONAL WIRELESS MICROPHONE

Tunable: 92 - 104MHz
Freq Response: 50 - 15kHz
Range: Over 300 feet in open field.
Modulation: FM
Power Source: 9V Battery
Type: Electrical Condenser
Dimensions: 185 x 27 x 38mm
Weight: 180 grams
Cat. A10450 \$19.95



HORWOOD ALUMINIUM CASES

H10382	3 x 4 x 2 inches	\$ 5.50
H10383	3 x 4 x 3 inches	\$ 6.50
H10384	3 x 4 x 4 inches	\$ 7.50
H10385	3 x 4 x 5 inches	\$ 7.95
H10386	3 x 4 x 6 inches	\$ 8.50
H10387	3 x 4 x 7 inches	\$ 9.50
H10388	3 x 4 x 8 inches	\$10.50
H10389	3 x 4 x 9 inches	\$10.95
H10390	3 x 4 x 10 inches	\$11.95



GREY FLAT RIBBON CABLE

Cat No	Description	\$/Mtr
W12614	14 Way	\$1.90
W12616	16 Way	\$2.20
W12620	20 Way	\$2.50
W12624	24 Way	\$2.90
W12625	25 Way	\$3.20
W12626	26 Way	\$3.60
W12634	34 Way	\$3.90
W12636	36 Way	\$3.90
W12640	40 Way	\$4.90
W12650	50 Way	\$5.90
W12690	60 Way	\$6.90



4A REGULATED POWER PACK

- 240V AC input to 13.8V DC regulated 1A outlet
- Ideal for CB, ham radio, and other high power applications
- Fully overload and short circuit protected
- Will handle up to 6A surge current
- Ripple less than 10mV peak to peak
- Large heatsink and vent system for cooling
- Outputs screw terminals or 4mm banana sockets
- Illuminated on/off switch
- Fuse protected
- Approved by the Department of Energy

M19032 \$139



RECHARGEABLE 12V 1.2AH GELL BATTERY

Leakproof long service life batteries ideal for security systems, emergency lighting or as a computer backup power supply, etc.
Cat. S15029 Normally \$19.95
1-9 \$13.95
10+ \$12.95



MAIL ORDER HOTLINE
008 335757 (TOLL FREE)
LOCAL: 543 7877



BIG MOUTH CAR ALARM

FEATURES.....
● Easy installation
● Automatic on/off
● Loud alarm signal
● Auto reset
● Low Price!

SPECIFICATIONS:
Power: DC 12V battery
Current Consumption: 10mA at 12V DC
Dimensions: 139 x 165 x 136mm
Exit Delay: 60 seconds approx
Entry Delay: 12 seconds approx
Auto reset: 90 seconds approx
S15048 \$39.95



MASTER RACK MOUNTING CABINETS

These superb rack mount cabinets will give your projects a real professional appearance! Just look at these features:
● All dimensions conform to the International Standard
● All aluminium construction
● Choice of black or natural finish
● Deluxe brush finish anodised front panel
● Removable top and bottom lid
● Ventilated lid

Horizontal Depth: 254mm
A = External Front Panel Height mm
B = Mounting Hole Centres mm
C = Internal Chassis Height mm
A B C Finish Cat.No Price
44 34 38 Natural H10401 \$59.50
88 57 82 Natural H10402 \$69.50
132 89 126 Natural H10403 \$79.50
44 34 38 Black H10411 \$65.00
88 57 82 Black H10412 \$75.00
132 89 126 Black H10413 \$85.00



HEATSINK COMPOUND

Heatsink compound is applied to the base and mounting studs of transistors and diodes. It maintains a positive heatsink seal that improves heat transfer from the device to the heatsink, thus increasing overall efficiency.
Cat. H11800 (100g) \$2.95
Cat. H11810 (150g) \$17.50

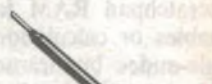

ROYEL QUOTEMP SOLDERING IRONS

The QUOTEMP range are designed to idle with a normal tip temperature of 360°C, without its button depressed. In this mode they are ideal for delicate work such as printed circuit boards. With the button depressed, the power is doubled, allowing much heavier work to be completed, or a rapid temperature recovery from larger joints. (Note: This mode cannot be used continuously.) A range of 6 long-life tips are available.

ROYEL DR-30 (21 WATT)
● 3mm tip
● 240V operation, no transformer required
● Safety Standards Approved
● 6 months warranty
Cat. T12640 \$39.50

ROYEL DR-50 (30 WATT)
● 5mm tip
● 240V operation, no transformer required
● Safety Standards Approved
● 6 months warranty
Cat. T12645 \$44.50

ROYEL DR-60 (40 WATT)
● 6.5mm tip
● 240V operation, no transformer required
● Safety Standards Approved
● 6 months warranty
Cat. T12650 \$49.50.

ELECTRONIC WATT METER

This unit will measure the power consumption of any mains appliance with a rating up to 3 kilowatts. It makes use of a special op amp called an 'output transconductance amp' or OTA. For short (EA Sept 83) 83WMB
Cat. K83082

\$89.95
SPECIAL \$59.95

BZZZ BOARD

Test your steadiness of hand with this updated version of an old game of skill. The 'Buzz Board' is a sophisticated version of a simple game in which the player attempts to pass a small metallic loop along a bent wire path without making contact with that wire. The 'Buzz Board' also features an adjustable time delay unit which means the buzzer will only sound if the metal loop touches longer than the set time. An fun kit to make and even more fun to use! (ETI 048)

K40480 \$4.50
SPECIAL \$3.25

BIT PATTERN GENERATOR KIT

In applications where you are required to look for a particular byte of information in a serial or parallel data path, short of a logic analyser or a storage oscilloscope, there is not a lot to help you. However, this Bit Pattern Generator gives you a simple and economical way to detect and display specific bytes of data. It may be used on both parallel and serial data paths. (ETI 172, May 86)

Cat. K41720 \$54.95
SPECIAL \$39.95
(Serial/Parallel Kit)

READY-SET-GO LIGHTS

A simple project for starting slot car races, etc. It provides the traditional Red/Amber/Green lights with a random delay between the amber and green. (ETI Oct '84) ETI 277
Cat. K42770

\$24.95
SPECIAL \$22.95

PHONE MINDER

Dubbed the Phone Minder, this handy gadget functions as both a bell extender and paging unit, or it can perform either function separately. (EA Feb. 84) 84TP2
Cat. K84021

\$27.50
SPECIAL \$21.95

EXPANDED SCALE LED VOLTMETER

One of the most useful monitors of battery condition is an expanded scale voltmeter. This novel, but none the less useful project should find applications in vehicles, battery chargers etc. (ETI 326, September 80)

Cat. K43280 \$15.95
SPECIAL \$9.95



PH METER KIT

Build this pH meter for use with swimming pools to fish tanks to gardening. This pH meter has many applications around the home. This unit features a large 3 1/2 digit liquid crystal display and resolution to 0.1 pH units, making it suitable for use in the laboratory as well. (EA Dec. 82) 82PH12
Cat. K82123

\$199
SPECIAL \$139



EA SUPER SIREN

Ever wanted to build an earsplitting alarm which would be compact and not draw much current? This is just the circuit for you. It uses a piezo electric tweeter in a pulsed mode to form an arresting and very efficient alarm. (EA Nov '82) 82AL11
Cat. K82111

\$28.95
SPECIAL \$19.95
(battery extra)

PICTURE PLUCKER FACSIMILE DECODER

Print your own weather maps with your Microbee. This project allows you to decode the signals of shortwave stations transmitting 'radio facsimile' weather maps and satellite pictures and then reproduce them on your dot-matrix printer. (ETI 736, ETI Sept 83)
Cat. K47360

\$29.95
SPECIAL \$24.95

AUTO TESTER

Just the thing to keep in the glovebox or toolkit to find those nasty electrical bugaboos that occur at awkward times. Simple to build, simple to use. (ETI Jan 83) ETI-344
Cat. K43340

\$17.00
SPECIAL \$14.95



PREAMP FOR PAGING AMP

A versatile preamp with separate bass, treble and volume. (ETI 1421)
Cat. K54210

\$24.95
SPECIAL \$11.95



LOW OHMS METER

How many times have you cursed your Multimeter when you had to measure a low-value resistance? Well with the 'Low Ohms Meter' you can solve those old problems and in fact measure resistance from 100 Ohms down to 0.005 Ohms. (ETI Nov. 81) ETI 158
Cat. K41580

Normally \$44.95
SPECIAL \$39.95

15V DUAL POWER SUPPLY

This simple project is suitable for most projects requiring a dual voltage. Includes transformer. (ETI 581, June 78)
Cat. K45810

\$34.95
SPECIAL \$19.95

KIT CLEARANCE!!

WHILE STOCKS LAST, SO BE QUICK!!

THE BRILLIANT SERIES 5000 INDIVIDUAL COMPONENTS TO MAKE UP A SUPERB HI-FI SYSTEM!



POWER AMPLIFIER

150 W RMS INTO 4 OHMS PER CHANNEL!!

WHY YOU SHOULD BUY A "ROD IRVING ELECTRONICS" SERIES 5000 POWER AMPLIFIER...

- 1% Metal Film resistors are used where possible.
- Aluminium case as per the original article
- All components are top quality
- Over 1,500 of these kits now sold
- Super Finish front panel supplied at no extra cost

Please note that the Heatsink for the Power Amplifier was designed and developed by ROD IRVING ELECTRONICS

Cat. K44771 Normally \$449
Packing & Post \$10 **SPECIAL, ONLY \$399**



PREAMPLIFIER

THE ADVANTAGES OF BUYING A "ROD IRVING ELECTRONICS" SERIES 5000 PREAMPLIFIER KIT ARE...

- 1% Metal Film Resistors are supplied
- 14 Metres of Low Capacitance Shielded Cable are supplied (a bit extra in case of mistakes)
- English "Lorlin" switches as supplied (no substitutes here)
- Specially imported black anodised aluminium knobs

Cat. K44791 Normally \$399
Packing & Postage \$10 **Special, only \$359**



THIRD OCTAVE GRAPHIC EQUALIZER

Cat. K44590 1 unit: \$239
2 units: \$429
Packing & Postage \$10

MORE KITS TO CLEAR!!

- CAR ALARM K43300 (ETI) \$32.95
- METAL DETECTOR K45610 (ETI) \$19.95
- LEDS & LADDERS K80070 (EA) \$9.95
- GUITAR BOOSTER K82060 (EA) \$14.95
- POWER UP K82110 (EA) \$19.95
- BOGGLE GOGGLES K82124 (EA) \$4.95
- BROWN OUT K83031 (EA) \$14.95
- VCR PROCESSOR K84040 (EA) \$34.95
- ULTRASONIC DETECTOR K84060 (EA) \$49.95
- PLUG PACK REGULATOR K83013 (EA) \$7.50
- TV PATTERN GENERATOR K83700 (EA) \$19.95
- LEVEL INDICATOR K42720 (ETI) \$7.50
- SPEED REGULATOR K42580 (ETI) \$7.50

VIDEO AMPLIFIER

Bothered by smeary colours, signal beats and RF interference on your computer display? Throw away that cheap and nasty RF modulator and use a direct video connection instead. It's much better! The Video Amplifier features adjustable gain and provides both normal and inverted outputs. Power is derived from a 12V DC plugpack supply. (EA Aug. 83) 83VA8
Cat. K83081

\$18.95



HUMIDITY METER

This project can be built to give a readout of relative humidity either on a LED dot-mode display or a conventional meter. In addition it can be used with another project as a controller to turn on and off a water mist spray in a hothouse, for example. (ETI May 81) ETI-256 (Includes humidity sensor \$18.50)
Cat. K42560

\$61.45



SAVE \$150 COMPLETE KIT \$649

VIFA/AEM 2 WAY SPEAKER KIT!

This exciting new speaker kit, designed by David Fillbrook (a name synonymous with brilliant design and performance) uses VIFA's high performance drivers from Denmark. You will save around \$300 when you hear what you get from this system when compared to something you buy off the shelf with similar characteristics. Call in personally and compare for yourself!

The system comprises:
2 x P21 Polycos 8" woofers
2 x D25T Ferrofluid cooled dome tweeters with Polymer diaphragms
2 pre-built quality crossovers
The cabinet kit consists of 2 knock-down boxes in beautiful black grain look with silver baffles, speaker cloth, in-rand, grill clips, speaker terminals, screws and ports.

D25T SPEAKER SPECIFICATIONS
Nominal impedance: 6 ohms
Frequency Range: 2 - 24kHz
Free Air Resonance: 1500Hz
Operating Power: 3.2 watts
Sensitivity (1W at 1m): 90dB
Nominal Power: 90 Watts
Voice Coil Diameter: 25mm
Air Gap Height: 2mm
Voice Coil Resistance: 4.7ohms
Moving Mass: 0.3 grams
Weight: 0.53kg

P21 WOOFER SPECIFICATIONS
Nominal impedance: 8 ohms
Frequency Range: 26 - 4,000Hz
Free Air Resonance: 33Hz
Operating Power: 2.5 watts
Sensitivity (1W at 1m): 92dB
Nominal Power: 60 Watts
Voice Coil Diameter: 40mm
Voice Coil Resistance: 5.8ohms
Moving Mass: 20 grams
Thiele-Small Parameters
Qm: 2.4
Qs: 0.41
Qts: 0.35
Vas: 80 l

Weight: 1.65kg
Complete Kit Cat. K16020 \$799
Speaker Kit Cat. K16021 \$649
Cabinet Kit Cat. K16022 \$209

LOW BATTERY VOLTAGE INDICATOR

Knowing your batteries are about to give up on you could save many an embarrassing situation. This simple low cost project will give you an early warning of power failure, and makes a handy beginner's project. (ETI 280, March 85)
Cat. K42800

\$9.95

SLIDE CROSS-FADER

Want to put on really professional slide show? This slide cross-fader can provide smooth dissolves from one projector to another, initiate slide changing automatically from an in-built variable timer, and synchronise slide changes to pre-recorded commentary or music on a tape recorder. All this at a cost far less than comparable commercial units. (EA Nov. 81) 81SS11
Cat. K81110

Normally \$99.00
SPECIAL, \$89.00



GENERAL PURPOSE AMPLIFIER CLASS B

One of the handiest tools for the electronics experimenter is a genuine purpose audio amp. This module will work from a wide range of supply voltages, has good sensitivity, is robust and reliable - easy to build too! (ETI 453)
(ETI April 80)
Cat. K44530

\$16.95



FAIR DINKUM RS232 FOR MICROBEE

The Microbee, among other home computers, has a 'soft' of RS232 port in that it doesn't implement negative-going portion of its output signal (TxD). Most peripherals with an RS232 input can cope with that, but inevitably there are those that can't. This project fixes that. (ETI 676, ETI FEB 84)
Cat. K46780

\$39.50

ROD IRVING ELECTRONICS

SYDNEY: 74 Parramatta Rd. STANMORE 2048
Phone: (02) 519 3134
Fax: (02) 519 3868

MELBOURNE: 48 A Beckett St. Phone: (03) 663 6151

NORTHCOTE: 425 High St. Phone: (03) 489 8866

CLAYTON: 56 Renver Rd. Phone: (03) 543 7877

SOUTH AUSTRALIA: Electronic Discounters P/L, 305 Morphett St. ADELAIDE Phone: (08) 212 1799
NOTE: PRICES MAY VARY INTER-STATE DUE TO FREIGHT COSTS

MAIL ORDER: Local Orders: (03) 543 7877
Interstate Orders: (008) 33 5757
All Inquiries: (03) 543 7877

CORRESPONDENCE: P O Box 620, CLAYTON 3168
Telex: AA 151938
Fax: (03) 543 2648



MAIL ORDER HOTLINE 008 335757

(TOLL FREE, STRICTLY ORDERS ONLY)

LOCAL ORDERS & INQUIRIES (03) 543 7877

POSTAGE RATES:
\$1 - \$9.99 \$2.00
\$10 - \$24.99 \$3.00
\$25 - \$49.99 \$4.00
\$50 - \$99.99 \$5.00
\$100 - \$199 \$7.50
\$200 - \$499 \$10.00
\$500 plus \$12.50

The above postage rates are for basic postage only. Road Freight, bulky and fragile items will be charged at different rates.

All wholesale and sales tax exempt inquiries to: ITRONICS WHOLESALE, 56 Renver Rd. Clayton, Ph. (03) 543 2166 (3 lines)

Errors and omissions excepted. Prices and specifications subject to change.

IBM, PC, XT, AT: are registered trademarks of International Business Machines. Apple is a registered trademark. *Denotes registered trademarks of their respective owners.





33MHz maths coprocessor

Motorola's 68882 (882), its second-generation 32-bit floating-point maths coprocessor, is now available at a speed of 33 MHz. The 33 MHz chip enhances system performance by increasing the processing speed of mathematical operations that are crucial to business and engineering environments.

The 882 coprocessor is a high-performance single chip used with Motorola's 68000 family that includes the 68000, 68010, 68020 and 68030 microprocessors. The 882 conforms to the IEEE Standard for Binary Floating Point Arithmetic and offers software and pin compatibility with its predecessor, the 68881 (881).

The 33MHz 882 is claimed to be the first single chip to break the two million Whetstone barrier. (The Whetstone is a standard benchmark that tests processor's ability to perform mathematical operations.) The 68881, the 882's predecessor, was the first single chip floating-point coprocessor to break the one million Whetstone barrier. System users can simply unplug the 881 and replace it with an 882 chip, gaining a 50% performance increase.

CMOS for radio

Siemens has begun mass production of the TBB 200 PLL chip for processor-controlled frequency synthesis. This CMOS circuit is intended for the RF section of two-way radios operating in the mobile frequency ranges, upwards of 900MHz and typical current consumption is 2mA.

The SAB 80C51 single-chip processor is ideally suited to point operation with the TBB 200 PLL chip, because both circuits have I²C interfaces.

An SMD version will be marketed as the TBB 200G. A complement to the TBB 200 is the TBB 202 bipolar circuit; this is a divider chip operating up to 1Ghz with a division rate of 128/129 and typical current consumption of 7mA. Samples are available.

Further information is available from the Electronics Components Department of Siemens, at 544 Church Street, Richmond 3121 or phone (03) 420 7314.

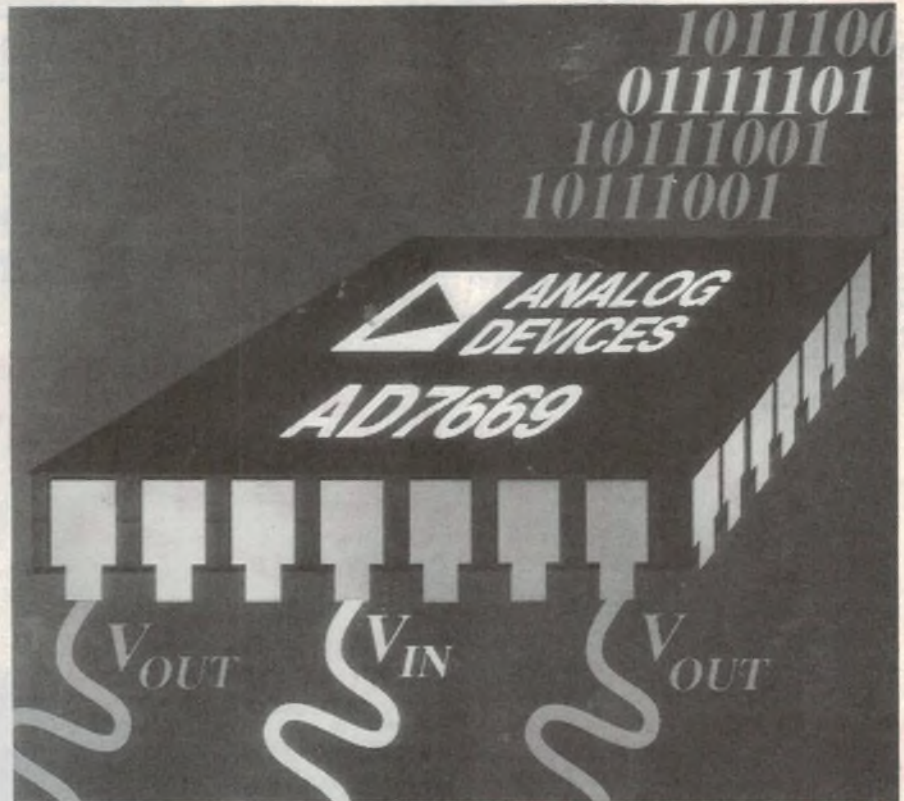

Analog I/O port combines 8-bit ADC, two 8-bit DAC

A new 'analog I/O port' from Analog Devices combines an 8-bit analog-to-digital converter (ADC), two 8-bit digital-to-analog converters (DACs), a 200kHz track-and-hold (T/H) amplifier, two buffer amplifiers, and a voltage reference on a single chip. This level of integration permits designers to replace up to 8 separate ICs with a single device.

The on-ship ADC guarantees a 2 μ s maximum conversion time to $\pm 1/2$ LSB; each DAC is buffered by an on-chip amplifier to deliver a maximum 2 μ s voltage-settling time to $\pm 1/2$ LSB.

Applications such as disk drives, where the drive monitors head position with the ADC and controls positioning with the DACs can benefit from the AD7669's design. In microstepping drives, one DAC can supply sine phase information, while the other provides cosine phase signal. Designers can also use the I/O port in control applications that require the generation of multiple analog outputs.

The AD7669 is tested and specified

for both static and dynamic performance. It guarantees ± 2 LSB maximum total unadjusted error, ± 1 LSB relative accuracy, and ± 1 LSB differential nonlinearity. Maximum full-scale error match of the two DACs is ± 2.5 LSB. Dynamic specifications include a 44dB signal-to-noise ratio, -48dB total harmonic distortion, and -55dB intermodulation distortion.

Since all the necessary conversion circuitry is on the chip, the AD7669 simplifies logic timing; a single command generates a hold signal for the track-and-hold, delays an A/D conversion until the T/H has acquired the signal, and initiates the conversion. With a bus access time of 75ns and write pulse width less than 80ns, the fast logic interface is compatible with all high-speed uPs and DSPs.

The AD7669 is available in a 28-pin plastic DIP or 28-terminal PLCC.

For further information contact Parameters, 25-27 Paul Street North, North Ryde 2113.

Toshiba makes thin-film superconductors

The most fundamental and important challenge in applying superconductors to electronics is to make flat and uniform thin films, and join them with other materials. However, there are many problems with present high-temperature superconductors processed into thin films, such as an uneven surface, heat required during the production stage, and surface deterioration. These problems have led to partial and total loss of superconductivity, and constituted major bottlenecks in the quest to achieve applications in electronics.

As a step towards the future application of superconductors in electronics, Toshiba researchers in Japan have recently achieved three breakthroughs:

- (1) a new technology to make a flat and uniform layer of superconductor thin film without annealing;
- (2) a solution to the problem of deteriorating surface of superconductor thin film; and
- (3) an experimental junction of insulator and lead on the surface of superconductor thin films, through which a superconducting tunnel effect has been observed - an important phenomenon that could be used to realise high-speed switching capability.

Until now, superconducting thin films have been made using an annealing process, which reaches a temperature of approximately 900°C, and results in a rough surface that is difficult to join to other thin film materials. In addition, the superconducting properties of the surface of the film deteriorate due to contact with air and moisture.

Toshiba researchers have developed a new fabrication method, called multi-target reactive sputtering, which alleviates the need for annealing. In this method, yttrium, ceramic materials of barium and copper, and metallic copper are targets that are bombarded with an argon-oxygen gas mixture. The argon ions are excited by electrical energy, which strikes atoms from the target and forms layers of thin film up to 700 millionths of a millimetre onto substrates preheated to 560°C.

By controlling the energy of argon ions, the method can accurately control the amount of atoms of yttrium, barium and copper in the proportions of 1:2:3 to form the optimum compound. Because of the optimum proportionality, the newly formed material requires no annealing to acquire superconductivity,



Experimental circuit exhibiting tunnel junction phenomenon.

and is thus preserved from the damage which frequently results during annealing. The material's surface is as flat as a mirror.

In order to prevent the surface of the thin film from losing its superconducting properties and thus making the junction with other materials possible, the researchers added a layer of silver to the surface for stability.

The silver layer was formed on the superconducting thin film through vacuum evaporation, after which it was annealed at 500°C while being supplied with oxygen. This creates an oxidised silver layer that prevents oxygen from escaping from the thin film and prevents the effect of water vapor in the air.

Moreover, researchers have discovered that the silver layer on the film also exhibits superconductivity, although silver is not a superconductor itself. This effect is called proximity effect, and the two materials in conjunction can work as a single superconductor.

As the third breakthrough, using this superconducting thin film and lead (another superconducting material), Toshiba researchers have successfully fabricated an experimental tunnel junction, which showed superconducting tunnel effect.

When two superconductors (in the

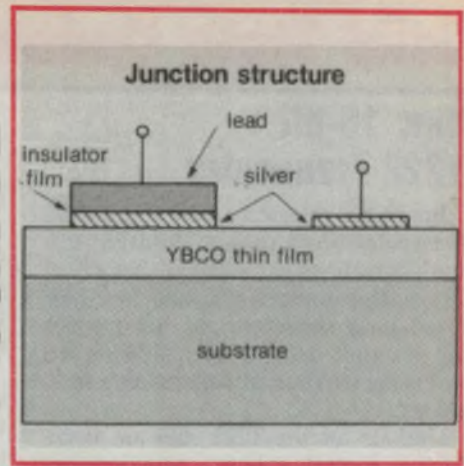

Superconductive thin film coated with silver.

form of thin films) are joined with an insulator between them (tunnel junction), there is a flow of electric current through the layers in spite of the insulator. This is called the superconducting tunnel effect, a phenomenon peculiar to superconductors. The most prominent characteristic of this tunnel effect is that, when electric current flows beyond a certain level, a large resistance suddenly appears, generating electric voltage; on the contrary, if the electric current decreases, the resistance gradually diminishes to zero, losing voltage. This characteristic can be used as a switch. As electrons can move much faster in the superconductors, unhindered by resistance, the switching function is expected to work 10 to 100 times faster than that of present silicon or gallium arsenide semiconductors.

Although the junction is still an experimental one, using lead, which is a low-temperature superconductor, and requiring liquid helium to obtain the necessary low temperature, the achievement will surely expand the prospects of superconductor application and contribute much to the overall progress of superconductor technology.

For further information contact Toshiba Corporation, 1-1-1 Shibaura, Minato-Ku, Tokyo or TLX J22587.

Video speed CMOS FIR filter

The TMC2243 from TRW LSI is a monolithic video speed (20MHz), three stage, 10 x 10-bit Finite Impulse Response (FIR) filter integrated circuit. It comprises three registered multiplier-adders concatenated into a one-dimensional systolic array.

Features include 20MHz data input and computation rate; 10 x 10-bit multiplication with 23-bit Extended Precision

Sum of Products; 16-bit Sum-In and Sum-Out ports for cascading; and internal 1/2 LSB rounding.

All inputs and outputs are registered, and the TMC2243 operates from a single +5V power supply. It is available in a 68 Pin Grid Array (PGA) package.

For further information contact Email Electronics, 15-17 Hume Street, Huntingdale, 3166 or phone (03) 544 8244.

New 16-bit T222 Transputer

Inmos has released a new 16 bit T222 Transputer which runs at 10 MIPS (million instructions per second), has 4K of fast on-chip static RAM, and four high speed links similar to the T800 which can transmit data at over 40Mbits/second using overlapped data sending technology.

Markets for the T222 chip are in industrial control, robotics, telecommunications, motor vehicles, and as a message router in large or small Transputer arrays.

Inmos has also released an upgraded T414 Transputer, called the T425. This chip is basically similar to the T800 with 4K of on chip memory, and with the faster overlapped 40Mbits/second communication link speeds. The T425 runs at 10 MIPS scalar performance but has no Floating Point Unit on the chip - unlike the T800 which has a 64 bit FPU which runs at 1.5 Mflops.

Inmos is releasing faster Transputers, with the T800 now available in 17Mhz, 20Mhz, 25Mhz and 30Mhz versions. The last of these runs at up to 2.25 Mflops per 84 pin chip.

For further information contact Hawk Electronics, 203 New South Head Road, Edgecliff 2027 or phone (02) 32 5530.

Improved Schottky chips

Hewlett-Packard has improved specifications for its HSMS-0002/0012 Schottky diode chips by cutting maximum reverse leakage current (I_r) in half - from 100nA to 50nA at 15 volts.

This characteristic is important in automatic-test-equipment applications and for other applications requiring mixing, detecting, switching, gating, sampling and wave shaping.

The HSMS-0002 chip is offset with a Schottky junction designed specifically to allow for thermosonic or thermocompression wire-bonding techniques. The gold-bottom metalisation is suitable for epoxy or eutectic die-attach methods.

The HSMS-0012, a batch-matched version of the HSMS-0002, is tested at 1 milliamp forward current (IF) for forward-voltage (VF) batch variation of no more than 15 millivolts.

For further information contact, VSI Electronics (Australia), 16 Dickson Avenue, Artarmon 2064 or phone (02) 439 4655.

12-bit, 1 μ s A/D converter

Datel's ADC-511 utilises an advanced hybrid design to provide a high speed 12-bit A/D converter with reduced power, cost and size. The device dissipates only 925mW of power and needs just 1 microsecond for the 12-bit conversion process.

The ADC-511's performance is based on a digitally-corrected subranging architecture, enhanced by utilising a proprietary custom chip and unique laser trimming schemes.

Functionally complete, the ADC-511 contains an internal clock, and an internal reference that is capable of supplying +10 volts at 1.5mA externally. All digital inputs and three-state outputs are CMOS/TTL compatible. The output coding can be in Straight Binary/Offset Binary or Complementary Binary/Complementary Offset Binary. A pin-programmable feature allows the selection

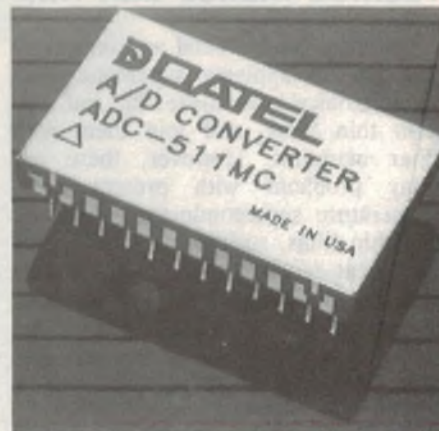

of either unipolar analog inputs from 0 to +10 volts or bipolar analog inputs from -5 to +5 volts. Typical applications include spectrum, transient, vibration, and waveform analysis.

For further information contact Elmeasco Instruments, PO Box 30, concord 2137 or phone (02) 736 2888.

'Super bright' LEDs

Crusader has released Super bright LED indicator lights.

The basic advantage of these new units is their practically unlimited life. Although brightness and illumination are equivalent to conventional indicator lights, the usual requirement for bulb replacement after 1000-2000 hours operating hours is eliminated.

The Super bright LED indicators are executed in the 16.2, 22.3 and 30.5mm fitting hole ranges, in accordance with DIN EN 50007 to meet industrial requirements for machines and plant construction. This constructional form also

makes a large illumination area possible and in addition the spherically domed lens design gives good sideways-on vision with uniform illumination.

For high brightness, special multi-LEDs are used, which are built into the unit in a fully encapsulated construction form. This construction provides the further advantages of increased shock and vibration resistance.

For further information contact Crusader Electronic Components, 73-81 Princes Highway, St Peters 2044 or phone (02) 516 3855.

125MHz fibre-optic receiver

Hewlett-Packard has announced a fibre-optic receiver with preamplifier that expands the digital-transmission capability of HP's 820nm components to 150Mbps.

The new HFBR-24X6 fibre-optic component is designed for cost-sensitive digital applications including CPU to disk links, PBX links and digitised video. Its 125MHz bandwidth also makes the HFBR-24X6 suitable for analog video applications including workstation links and security-transaction links.

This new receiver contains a PIN photodiode, preamplifier integrated circuit and a lens. Because the PIN photodiode and the preamplifier are con-

tained in the same package, the photodiode is shielded from external noise.

With a dynamic range of 24dB, the HFBR-24X6 enables users to operate over a wide range of link distances, typically from 1 metre to 3 kilometres at 35Mbits per second.

The HFBR-24X6 is available with either an SMA- or an ST(R)-connector port. This receiver is fully compatible with HP's existing HFBR-14XX transmitters, and it is fully specified for use with 62.5/125, 100/140 and 50/125 micrometre multimode fibre.

For further information contact VSI Electronics (Australia), 16 Dickson Avenue, Artarmon 2064 or phone (02) 439 4655.

Tektronix develops thin-film wafer testing probe

Tektronix is introducing a radically new wafer probing technology that replaces conventional mechanical probing systems, and opens the way for AC testing at the die level on very high-density integrated circuits with 360 to 500 pins.

Incorporating this new thin-film technology is the Tektronix P6521 Wafer Probe Card, which uses bumps or pads to make contact with the wafer instead of the needles and blades used in conventional cards.

The P6521 which possesses up to 360 test contacts and has the potential for more than 500 contacts, is designed for

testing high-density, high-performance ICs such as gate array and semi- and full-custom ASICs (Application specific ICs).

The P6521's 2.5GHz bandwidth ensures maximum signal integrity and accurate measurements. Such high bandwidth requires strip lines with controlled impedance to the contact point. This high level of performance does not compromise the performance of the VLSI tester or the device under test.

For further information contact Tektronix Australia, 80 Waterloo Road, North Ryde or phone (02) 888 7066.

1K x 9 FIFO chip

A high-performance, low-power 1K x 9 FIFO (first-in,first-out) memory support chip that is the first drop-in replacement for the popular IDT7202S/L is now available from Texas Instruments. Fabricated in one-micron CMOS technology, the SN74ACT7202 is pin- and function- compatible with its predecessor, yet it dissipates less power.

Like the IDT7202S/L, the zero-fall-through 'ACT7202 is available with access times of 35 and 50 nanoseconds maximum. The 35-nanosecond version, the 'ACT7202-35, dissipates 20% less power than the IDT7202S/L-35 in active mode, 47% less in standby mode and 90% less in power-down mode.

The 'ACT7202-35 has a maximum operating frequency of 22MHz while the 'ACT7202-50 has a maximum operating frequency of 15MHz. The 1,024-word by nine-bit device is fully expandable in

width and depth, and its nine-bit word width supports the use of control or parity bits. "Full" and "empty" flags help users avoid data overflow and underflow conditions.

The 'ACT7202 can be used in a variety of applications requiring a wide, deep, zero-fall-through FIFO.

TI's EPIC technology, used in fabricating the FIFO's, is a twin-well silicon-gate process based on the one-micron CMOS process developed for the high-volume production of one-megabit DRAMs. Devices fabricated in EPIC technology combine the performance of advanced bipolar processes with the low power consumption typical of CMOS.

For further information contact the Semiconductor Division of Texas Instruments Australia, 6-10 Talavera Road, North Ryde 2113 or phone (02) 887 1122.

600V depletion type MOSFET

With its BSS 135, Siemens is marketing a MOSFET which offers a maximum reverse voltage of 600V, more than twice the previous level. The Sipmos depletion transistor for proximity switches, auxiliary power supplies or constant current sources now joins the range of small-signal transistors BSS 129/229 (also depletion types) available so far for 240V.

The BSS 135 is rated for a continuous drain current of 70mA. Together with the increase to 600V, the chip dimensions were optimised for assembly of the BSS 135 in the very popular TO92 package.

Depletion transistors like the new BSS 135 have a channel whose conductivity onset is at negative gate voltages;

with no voltage at the gate, it is permanently maintained (self-conducting) and only ends when the gate voltage drops below a particular negative limit. The new transistor is therefore suitable for all applications primarily requiring negative control-voltage switching, whilst enhancement types only respond above the zero line.

The BSS 135 for 600V is rated at 50mA drain current, 1 watt power dissipation and 100 ohms turn-on resistance (maximum values); the threshold voltage is -1V.

Further information is available from the Electronic Components Department of Siemens at 544 Church Street, Richmond 3121 or phone (03) 420 7314.

Lower resistance MOS transistors

Siemens is now extending its range of Sipmos small-signal transistors with three BSS types whose maximum turn-on resistance values $R_{DS(on)}$ are only 0.3 ohm (BSS 295), 0.8 ohm (BSS 296) and 2.0 ohms (BSS 297). The previous minimum was 3.5 ohms (BSS 98). The reduced resistance values decrease the power dissipation of the Sipmos chips, allowing a drain current of up to 1.3A (BSS 295).

The new N channel transistors of the enhancement type already operate from a threshold voltage of 0.8 to 2.0V, and can thus be directly driven with CMOS or TTL levels. Additional level converters are superfluous. The so called current yield also exhibits an improvement, as can be seen in a comparison between the two 50V transistors, BSS 295/298: at a battery voltage of 4.5V (V_{GS}) the limiting current of the new BSS 295 is 2A, whilst the BSS 98 allows a maximum of 0.4A.

Further information is available from the Electronic Components department of Siemens at 544 Church Street, Richmond 3121 or phone (03) 420 7315.

Fastest single chip DSP

First samples are available in the US of AT&T Microelectronics' WER DSP16A microchip - claimed to process data faster than any other single chip digital signal processor on the market.

The DSP16A microchip executes 30 million instructions per second (MIPS), and processes an add-and-multiply instruction in 33 nanoseconds (ns).

Designed by AT&T Bell Laboratories, the DSP16A is the first AT&T DSP to be implemented in advanced, 0.75-micron, double level CMOS (complementary metal oxide semiconductor) technology. This technology makes possible the 33ns instruction cycle time.

The DSP16A also has increased memory capacity, which enables customers to perform applications on a single chip that normally would require two or three chips. The DSP16A is said to be particularly well suited for telecommunications and computer applications - such as modems, PBX's, digital cellular phones, laser printers and optical character recognisers.

For additional information about AT&T Microelectronics' DSPs write to AT&T Microelectronics, 555 Union Boulevard, Department 51AL230230, Allentown, PA, 18103. 

Vintage Radio

by PETER LANKSHEAR



Cabinet lacquering

Sooner or later the problem of cabinet refinishing has to be faced. Whilst retention of the original finish is to be preferred, some cabinets are in such a state that they just *have* to be stripped and repolished. Last month we dealt with the preparation of a 1940's mantel cabinet in readiness for relacquering.

I cannot overstate the importance of adequate preparation. Properly applied lacquer enhances the beauty of wooden cabinets – but by the same token, it mercilessly emphasises flaws such as scratches, roughness or stains. Once lacquering is commenced, correction of these problems is very difficult.

Make sure that in the removal of the old finish, dents and scratches and the subsequent sanding leave no room for criticism. If you have used a stripping paste, let the cabinet ventilate for a few days to allow the active gas to disperse. This gas permeates the wood and can do strange things to new lacquer!

There is a common misconception that many cabinets were French polished, but this was not normally so. The cost would have been prohibitive and anyway, French polish is extremely vulnerable to water and alcohol. French polishing requires shellac which is difficult to find today, but if you have some and can do this kind of polishing, the result is beautiful – although with a slightly orange tinge.

Lacquer or polyurethane?

The traditional finish employed on radio cabinets was clear cellulose, which is closely related to celluloid and provides a deep lustrous and hard wearing finish. Aging tends to give it a greenish opaqueness, which can hide some of the figuring of the wood grain.

Sticklers for originality insist that only refinishing with cellulose is acceptable, but it cannot be brushed on. If you are adept at spraying, or know a good car painter who still works with traditional finishes, your problems are over. Most of us however, have to do things the

hard way, and settle for a finish that can be applied by hand.

Today the standard finish for wood is polyurethane. This is colourless, hardwearing, is available in various grades, and can be applied by spray or brush. Some may argue that it is a 'synthetic', but so is cellulose anyway. Had polyurethane been available at the time, the old radio manufacturers would surely have used it for preference.

The technique

Make sure that all blemishes have been removed, the cabinet can't be sanded any smoother, and that the co-

lour is right. If you have access to a spray gun and the skills, apply two or three coats of clear lacquer, sanding between applications, and the job will be done.

You may be able to achieve good results with an aerosol can of lacquer, but in my own experience, the delivery from these is too erratic and application too critical to be satisfactory.

For most of us brushing is the only method. The best finish is clear polyurethane, which, with care and patience, produces excellent results. There are various grades available, the easiest to apply being satin. This gives a dull sheen which many restorers consider to be most appropriate for old cabinets. More like the original finish in most cases, but requiring greater care in application, is gloss polyurethane.

All important is the correct equipment. *Never* use a brush that has been used previously for general painting. No matter how well cleaned, it will have little flecks of dried paint which will be all too obvious embedded in the lacquer. Purchase the best quality 25mm brush



The final result. Not only are all of the blemishes gone, but the attractive figured wood grains are again bright. It can now take its place in the household or collection.

with the longest bristles available.

Other items needed will be a litre of mineral turpentine and a couple of sheets of 400 grade waterproof carborundum paper, and, if you are going to use the high gloss lacquer, a can of 'Brasso' or similar metal polish.

Choose a well lit, dust free, warm place for applying the lacquer. These finishes have a remarkable attraction for lint and dust, and are easiest to apply at temperatures above 20°C.

The cabinet should be given a thorough dusting. Unfinished timber is very absorbent and traditionally, the pores were first filled with a sealer, which was often a preparation that was rubbed into the wood to choke up the pores. However, the polyurethane lacquer itself can be used as a sealer.

Never shake the tin of polyurethane. This will fill it with air bubbles which are likely to survive the brushing process and create pits in the surface. Gentle stirring is all that is necessary. Dip the brush no more than 1 centimetre into the lacquer and brush it on with long regular strokes.

There is an optimum thickness to apply. Too much and there will be 'runs'. Too thin and the surface will drag. Try and *flow* it on. A bit of practice should give you the feel of it. When completed, put the cabinet in a dust free area for at least 24 hours.

Brush care essential

At this stage many handymen pop the brush into a tin of water and call it a day. This may be OK for house paint, but it is disastrous for brushes to be used on fine work. Despite the water, the polyurethane hardens and leaves particles to ruin later coats.

Instead, spend a couple of minutes cleaning the brush thoroughly. Put a quarter cup or so of the turpentine into a container and then work the lacquer out of the brush. Change the turpentine and repeat a couple of times. Now you will appreciate avoiding getting the lacquer into the roots of the bristles, by using only the tip of the brush.

When the brush is really clean, work up a good lather into the bristles with a cake of soap. If they feel at all sticky, more cleaning with turpentine is needed. When you are satisfied that the brush is really free of lacquer and turpentine, rinse it well in warm water and hang it up to dry. Treated this way, a brush will last a long time.

Don't expect too much of the sealer coat. Much of it will have soaked into the wood and the surface will be rough.



Peter Lankshear, the author of this monthly column, is a well-known authority and international writer on vintage radio. A long-time employee of the Broadcasting Corporation of New Zealand, he is currently that organisation's Transmission Superintendent for Southland.

Allow 24 hours for hardening and then carefully sand it smooth with a worn piece of sandpaper. A second coat can now be applied and, again, clean the brush thoroughly. When this coat has hardened, you will have a fair idea of how the cabinet will finally look. However, there are likely to be brush marks, pits and dust specks. Carefully rub down with wet 400 grade waterproof paper until there is an overall even matt finish. Now very carefully apply a third coat. If your preparation has been

meticulous and you have chosen a satin lacquer, the result should be a first class finish which will require no further attention.

Polishing

Gloss finishes are less tolerant of imperfections, brush marks and specks, but we can use one of the traditional finishing techniques of cutting the surface down to a smooth finish and polishing with fine pumice powder. Pumice is an aerated form of volcanic glass which, when crushed, produces extremely fine and sharp particles.

The metal polish 'Brasso' is a convenient and readily available form of pumice powder. Rub down the third coat of lacquer with 400 grade waterproof paper and be prepared if necessary to apply a fourth coat, again rubbing down to a fine flawless surface. As final polishing with pumice requires the surface to be thoroughly hardened, put the cabinet in a warm place for a week or so for complete curing and to drive off residual solvents.

When the cabinet is ready, fold some soft cotton cloth into a pad, shake the container of Brasso thoroughly and sprinkle some of the contents onto the cabinet. Some vigorous rubbing will bring up the gloss in a surprisingly short time. The resulting finish does not have an extreme glass-like glitter, which can look unnaturally bright, but a very convincing and hardwearing shine. Carefully remove all traces of polish as any residue will leave white deposits.

This method of using a metal polish also works wonders with original finishes that are still sound. The cutting ac-

Vintage Radio Societies in Australia and NZ

If you're interested in joining a vintage radio society or club, here are those we know about at present:

Historical Radio Society of Australia

c/- Rex Wales,
24 Park Lanes, Mt. Waverley, Vic. 3149

Early Wireless & Sound Society of Aust.

c/- John Murt, PO Box 623, Lane Cove NSW 2066

Vintage Wireless & Gramophone Club of WA,

c/- Barry Jenkins, 8 Philip Street, East Fremantle, WA 6158

New Zealand Vintage Radio Society,

c/- Bryan Marsh, 20 Rimu Road, Mangare Bridge, Auckland

Club secretaries please note: If you would like your organisation's name and address given in future listings, please send the details to the Editor. We plan to update this listing on a regular basis.

LISTEN TO THE WORLD

Captain Communications has Australia's best range of shortwave listening equipment, scanners and frequency registers. Our expert technical staff will help you to select the right equipment for your needs.

Frequency Registers:

Find out what you're listening to! We stock a complete range of these exhaustive listings.

Buy with confidence.

Our technicians service and repair everything we sell.



OPEN 7 DAYS

28 Parkes St., Parramatta,
NSW 2151

Phone 633 4333,

Fax 891 2271

Bankcard, VISA, Mastercard, AGC, Diners,
Leasing, Cash and Layby.



ICOM IC-R71 100kHz - 30 MHz
IC-R7000 25MHz - 1300 MHz



KENWOOD RZ1 500kHz - 905MHz



KENWOOD R5000 100kHz - 30MHz



SANGEAN ATS803 150kHz - 30MHz plus FM



KENWOOD

SANGEAN

The Best of Australia's Wireless Weekly

It may look like a book, but don't let its appearance fool you. There are no whirling dials and control levers; but once you open the cover, it'll take you on an incredible journey backwards in time. You'll find yourself back in the 1920's, when Australia's first new radio stations were just getting established and typical radio set cost ten weeks' wages. We've chosen a collection of highlights from the 1927 issues of "Wireless Weekly".

Send your order to:

Freeport No.4,

Federal Publishing Book Sales

PO Box 227

Waterloo NSW 2017

(No postage stamp required if mailed within Australia)

Price: \$3.95
plus \$1.00
p&p

Vintage Radio

tion removes surface deposits and small scratches and will often restore a cabinet that would otherwise need refinishing.

The speaker cloth

The remaining major part of the project is the speaker grill cloth, which should be reglued in position behind the grille with a careful application of PVA glue.

Unless you are very fortunate, the original cloth will be damaged, faded, or at the least in need of laundering, which is frequently a failure anyway. Renewal has generally to be faced and it is unfortunate that the traditional cotton and rayon materials are no longer made. However, alternatives are available.

Speaker grill cloth has several requirements. It must be reasonably loosely woven so that there is minimal impedance to sound, but not so loose as to be seen through. The weave should also be elastic, so that in service it retains its tension. This requirement renders a lot of fabrics unsatisfactory. Finally, the colour and pattern must be appropriate. If you have ever seen a dignified cabinet resplendent with a bright floral replacement grill cloth you will know what I mean!

Cabinets of the 1940's generally had brown fabrics, with either mild geometric patterning or no patterning at all.

Some of the modern plastic fabrics for hifi systems can be effective. The cabinet in the illustration has been fitted with a dark brown cloth of this type. Many of these modern materials have a useful 'heat shrink' feature.

Fit the cloth, making sure that any pattern lines up with the opening. Don't be too concerned about tautness. When the glue is dry, carefully direct a portable electric heater at the cloth, which will readily shrink to size with a good tight finish.

It now remains to reassemble the cabinet, and replace the speaker and the chassis. One final problem though - as like as not, there will be one or more of the original knobs missing. Most manufacturers had their own distinctive style and it is worth while putting a fair degree of effort into locating a correct replacement. This is where membership of a society can pay dividends by using the buy, swap and sell columns in the newsletters and magazines.

EA MINI ADS

Rates: One insertion \$195 Six insertions \$180 each. Twelve insertions \$170 each
Send order with remittance to THE ADVERTISING MANAGER.
ELECTRONICS AUSTRALIA, P.O. BOX 227, WATERLOO, NSW 2017 by 15th of the month two months prior to issue date.

KITS THAT WORK!! (If properly assembled)

• **EVERPOPULAR — UHF REMOTE CONTROL KEY** (EA Jan 87)
Complete transmitter kit (Even the battery) plus the receiver PCB and all board components kit..... **ONLY: \$49.95**

• **ULTRASONIC BURGLAR ALARM** (SC May 88)
Bonnet, boot, ultrasonics, back-up battery, flashing light, Xtal controlled..... **ONLY \$39.90**
40 Khz tanducers \$14.50 pr extra

• **EVER POPULAR MINI PIEZO SCREAMER** AT THE **BEST PRICE: \$16.50**

• **LIMITED QUANTITY OF AA (Panlite) NICAD BATTERIES**
BELOW WHOLESALE PRICE: NORMALLY \$4.90
NOW ONLY \$2.00

• **FOR A REAL BARGAIN! QUALITY EX-TELECOM POWER SUPPLIES:**
See review in Oct 88 SC... **CLEARANCE AT ONLY \$20.00 ea**
P+P \$3 — POWER SUPPLIES P + RAIL FREIGHT APPROX \$6

OATLEY ELECTRONICS

MAIL: P.O. Box 89, Oatley, NSW 2223
SHOP: 5 Lansdowne Parade, OATLEY WEST
PHONE: (02) 579-4985

Bankcard, Mastercard and Visa Card Accepted With Phone Orders.

BRIGHT STAR CRYSTALS PTY LTD

From our new manufacturing facility at:

1/9 Hi-Tech Place,
Rowville Vic 3178,

we offer a full range of **CUSTOM STOCK** crystals and hybrid packaged oscillators, all with **FAST** delivery available.

Phone: (03) 764 1311

Fax: (03) 764 1602

Mailing address:

P.O. Box 335
Vermont Vic 3133

CALL US NOW TO RESERVE THIS SPACE

- Free setting
- Over 30,000 audience

Sydney: Call Lyn, 693-9734

Melbourne: Call Nikki, 646-3111

Other States: (02) 693-9734

SONICS

MAGAZINE

For: Musicians, Road Crews,
Recording Engineers, Lighting People,
Managers, Promoters and anybody
interested in what goes into
today's music-making.

**THE ALL AUSTRALIAN
MUSIC MAKERS' MAGAZINE**

sale sale sale sale sale sale sale sale
DISPOSAL
ELECTRONIC
EQUIPMENT AND
TEST GEAR
**ELECTRONIC
BROKERS (Aust.)**
Cnr. Barry
& Brunson Sts.,
Bayswater, Vic.
(03) 729-0455
sale sale sale sale sale sale sale sale

HARDWARE AT DISCOUNT PRICES

MINISCRIBE HARD DISKS	
20 MB WITH CONTROLLER	\$455
30 MB WITH CONTROLLER	\$510
40 MB WITH CONTROLLER	\$590
80 MB VOICE CELL	\$1050
EGA CARD	\$250
VGA CARD	\$360
FAX CARD	\$795
386 MOTHERBOARD (20 MHZ)	\$1995
AT MOTHERBOARD (12 MHZ)	\$500
XT MOTHERBOARD (10 MHZ)	\$140
AT 2 SERIAL PRINTER	\$85
EGA MONITOR	\$610
MULTISYNC MONITOR	\$840
CGA MONITOR	\$450
ETHERNET CARD	\$380

FREE CATALOGUE

COMPANION COMPUTERS

Factory 3/12 Florence St, Burwood, 3125.
Ph: (03) 288 3835. Fax: (03) 288 8116

Contract PCB Assembly

Most up-to-date
manufacturing
methods from
prototype to
production

DUET ELECTRONICS

414 St. Georges Road
Thornbury 3071.

(03) 484 4420

PRECISION METALWORK

For the quality electronics
manufacturer • CNC punching

NAMEPLATES

Screened • Etched • Panels &
Stickers

CIRCUIT BOARDS

Single & Double sided

DESIGN • PROTOTYPES •
ASSEMBLY • SERVICE

Installing Quality Assurance to AS1822.

**ELECTRONIC RESEARCHES
AUSTRALIA P/L**
22 FINSBURY STREET,
NEWMARKET

PH (07) 356 1668

FAX (07) 856 4729

B&C PROM PROGRAMMERS

DOS-MAC-CPM-UNIX
2716 TO 275 12 EPROMS
27011 128 K BYTE EPROMS
SINGLE CHIP MICRO'S
RS232 PORT DRIVEN

FROM \$441 TAX FREE

CURRENT SOLUTIONS

PH: (03) 720 3298

FAX: (03) 720 4967

RADIO & TV

Call	Location	Freq. (kHz)	Power Watts	Call	Location	Freq. (kHz)	Power Watts	Call	Location	Freq. (kHz)	Power Watts
COMMERCIAL RADIO - AM				NT				TAS			
ACT				8DN	Darwin	1242	2000	7HO	Hobart	864	2000
2CA	Canberra	1053	5000	8DN/T	Katherine	765	250	7HT	Hobart	1080	5000
2CC	Canberra	1206	5000	8HA	Alice Springs	900	2000	7AD	Devonport	900	2000
NSW				QLD				7BU	Burnie	558	2000
2CS	Coffs Harbour	639	5000	4LM	Mt Isa	666	2000	7EX	Launceston	1008	5000
2CH	Sydney	1170	5000	4LM/T	Cloncurry	1458	100	7LA	Launceston	1098	5000
2GB	Sydney	873	5000	4BC	Brisbane	1116	5000	7QT	Queenstown	837	500
2KY	Sydney	1017	5000	4BH	Brisbane	882	5000	7SD	Scottsdale	540	5000
2SM	Sydney	1269	5000	4BK	Brisbane	1296	5000	VIC			
2UE	Sydney	954	5000	4IO	Brisbane	1008	5000	3AK	Melbourne	1503	5000
2UW	Sydney	1107	5000	4KQ	Brisbane	693	5000	3AW	Melbourne	1278	5000
2WS	Sydney	1224	5000	4AK	Oakey	1242	2000	3CR	Melbourne	855	1000
2AD	Armidale	1134	2000	4AM	Atherton	558	5000	3TT	Melbourne	1026	5000
2AY	Albury	1494	2000	4RR	Townsville	891	5000	3KZ	Melbourne	1179	5000
2EC	Bega	765	3500	4BU	Bundaberg	1332	5000	3MP	Melbourne	1377	5000
2EC/T	Moruya	765	500	4CA	Cairns	846	5000	3UZ	Melbourne	927	5000
2EC/T	Narooma	1584	200	4CA/T	Gordonvale	954	350	3XY	Melbourne	1422	5000
2BH	Broken Hill	567	500	4CC	Gladstone	927	5000	3BA	Ballarat	1314	5000
2BS	Bathurst	1503	5000	4CC/T	Biloela	927	100	3BO	Bendigo	945	2000
2DU	Dubbo	1251	2000	4GC	Charters Tow.	828	500	3CS	Colac	1134	5000
2DU/T	Cobar	972	300	4GC/T	Hughenden	765	500	3CV	Maryborough	1071	5000
2GF	Grafton	1206	5000	4GG	Gold Coast	1197	5000	3GL	Geelong	1341	5000
2GN	Goulburn	1368	2000	4GR	Toowoomba	864	2000	3HA	Hamilton	981	2000
2GO	Gosford	801	5000	4GY	Gympie	558	5000	3MA	Mildura	1467	2000
2GZ	Orange	1089	5000	4HI	Emerald	1143	5000	3NE	Wangaratta	1566	5000
2HD	Newcastle	1143	2000	4HI/T	Moranbah	1215	250	3SH	Swan Hill	1332	2000
2KA	Katoomba	783	2000	4HI/T	Dysart	945	1000	3SR	Shepparton	1260	2000
2KA/T	Penrith	1476	500	4KZ	Innisfail	531	5000	3TR	Sale	1242	5000
2KO	Newcastle	1413	5000	4KZ/T	Tully	693	500	3UL	Warragul	531	5000
2LF	Young	1350	5000	4LG	Longreach	1098	2000	3WN	Horsham	1089	5000
2LM	Lismore	900	5000	4MB	Maryborough	1161	2000	WA			
2LT	Lithgow	900	5000	4MK	Mackay	1026	5000	6MM	Mandurah	1116	2000
2MC	Kempsey	531	5000	4RO	Rockhampton	990	5000	6IX	Perth	1080	2000
2MG	Mudgee	1449	5000	4SB	Kingaroy	1071	2000	6KY	Perth	1206	2000
2MO	Gunnedah	1080	2000	4SS	Nambour	828	5000	6PM	Perth	990	2000
2MW	Murwillumbah	972	5000	4TO	Townsville	774	5000	6PR	Perth	882	2000
2NM	Muswellbrook	981	5000	4VL	Charleville	918	2000	6AM	Northam	864	2000
2NX	Newcastle	1341	5000	4VL	Cunnamulla	1584	200	6BY	Bridgetown	900	2000
2NZ	Inverell	1188	2000	4WK	Warwick	963	5000	6CI	Collie	1134	2000
2OO	Wollongong	1575	5000	4ZR	Roma	1476	2000	6GE	Geraldton	1008	2000
2PK	Parkes	1404	2000	SA				6KA	Karratha	1260	1000
2QN	Deniliquin	1521	2000	5CC	Port Lincoln	765	5000	6KA/T	Mt Tom Price	765	100
2RE	Taree	1557	2000	5AA	Adelaide	1386	5000	6KA/T	Paraburdoo	765	100
2RG	Griffith	963	5000	5AD	Adelaide	1323	2000	6KG	Kalgoorlie	981	2000
2ST	Nowra	999	5000	5DN	Adelaide	972	2000	6LN	Carnarvon	666	1000
2ST/T	Bowral	1215	350	5KA	Adelaide	1197	2000	6LN/T	Exmouth	747	1000
2TM	Tamworth	1287	2000	5AU	Port Augusta	1242	2000	6MD	Merredin	1098	2000
2VM	Moree	1530	2000	5MU	Murray Bridge	458	2000	6NA	Narrogin	918	2000
2WG	Wagga Wagga	1152	2000	5CS	Port Pirie	1044	2000	6NW	Port Hedland	1026	2000
2WL	Wollongong	1314	5000	5RM	Renmark	801	2000	6SE	Esperance	747	5000
2XL	Cooma	918	2000	5SE	Mt Gambier	963	5000	6TZ	Bunbury	963	2000
								6VA	Albany	783	2000
								6WB	Katanning	1071	2000

Broadcasting Services Around Australia

Compiled with the
co-operation of
the Department of
Transport and
Communications

Call	Location	Freq. (kHz)	Power Watts	Call	Location	Freq. (kHz)	Power Watts	Call	Location	Freq. (kHz)	Power Watts				
COMMERCIAL RADIO – FM															
ACT															
2KIX	Canberra	106.3	10000	8ABCRN	Groote Eylandt	103.9	100	7ABCFM	Hobart	93.9	27000				
2RO C	Canberra	104.7	10000	QLD								7QNT	Queenstown	104.7	600
NSW															
2DAY	Sydney	104.1	35000	6ABCRN	Tambo	107.5	25	7QNT	Rosebery	106.3	300				
2MMM	Sydney	104.9	35000	6ABCRN	Normanton	107.5	25	7QNT	Savage River	104.1	200				
2ST/T	Ulladulla	106.1	500	6ABCRN	Karumba	107.7	25	7QNT	Strahan	107.9	200				
NT															
8HA/T	Yulara	100.5	200	4ABCRN	Croydon	102.9	25	7QNT	Queenstown	107.5	30				
QLD															
4MK/T	Airlie Beach	91.5	100	4ABCRN	Wandoan	107.5	25	VIC							
4MMM	Brisbane	104.1	6000	4ABCRN	Quilpie	100.9	50	3ABCFM	Upper Murray	104.3	50000				
SA															
5SSA	Adelaide	107.5	5000	4ABCRN	Pentland	107.7	25	3ABCFM	Ballarat	105.5	50000				
TAS															
7QT/T	Rosebery	107.1	300	4ABCRN	Injune	105.1	100	3ABCFM	Bendigo	106.3	100000				
VIC															
3EON	Melbourne	92.3	10000	4ABCRN	Greenvale	107.5	25	3ABCFM	Melbourne	105.9	50000				
3FOX	Melbourne	101.9	10000	4ABCRN	Bedourie	107.7	25	3ABCFM	Mildura	102.3	100000				
WA															
6NOW	Perth	96.1	10000	4ABCRN	Birdsville	100.9	25	3ABCFM	West Victoria	107.5	70000				
ABC RADIO – FM															
ACT															
2ABCFM	Canberra	101.9	50000	4ABCFM	Clermont	104.5	50	3ABCFM	Murray Valley	105.9	50000				
NSW															
2ABCFM	Broken Hill	103.7	2500	4ABCRN	Cloncurry	103.3	50	WA							
2ABCFM	Murrumbidgee	107.5	50000	6ABCRN	Hughenden	107.5	25	6ABCRN	Marble Bar	97.3	25				
2ABCFM	Newcastle	106.1	25000	4ABCRN	Charters Tow.	97.7	50	6ABCRN	Halls Creek	103.5	100				
2ABCFM	Cnt. Tablelands	93.1	10000	4ABCRN	Barcardine	107.5	25	6ABCRN	Ravensthorpe	100.9	25				
2JJJ	Sydney	105.7	10000	4ABCRN	Blackall	92.3	50	6ABCRN	Meekatharra	98.3	25				
2ABCFM	Sydney	92.9	50000	4ABCRN	Clermont	107.7	50	6ABCRN	Fitzroy Cross.	107.7	50				
2ABCFM	Wagga Wagga	105.7	50000	4ABCRN	Muttaborra	105.5	25	6ABCRN	Fitzroy Cross.	106.1	50				
2ABCFM	Illawarra	107.9	25000	4ABCRN	Longreach	100.7	500	6ABCRN	Port Hedland	95.7	1000				
2ABCFM	Bega/Cooma	105.7	100000	4ABCRN	Richmond	105.3	50	6ABCRN	Meekatharra	99.9	25				
2ABCFM	Manning River	107.9	50000	4ABCRN	Capella	107.3	25	6ABCRN	Karratha	101.7	100				
2ABCFM	Cen/Wst. Slope	93.5	50000	4ABCRN	Alpha	101.3	50	6ABCRN	Dampier	88.1	50				
NT															
8ABCRN	Groote Eylandt	104.7	100	4ABCRN	Jericho	107.7	200	6ABCRN	Pannawonica	95.1	25				
8ABCFM	Darwin	105.7	10000	8ABCRN	Tambo	105.9	25	6ABCRN	Kununurra	92.1	50				
8ABCRN	Nhulunbuy	103.7	50	4ABCRN	Isisford	107.7	25	6ABCRN	Newman	96.9	50				
8ABCRN	Borroloola	103.7	50	4ABCRN	Aramac	105.1	50	6ABCRN	Exmouth	88.7	25				
8ABCRN	Galiwinku	103.5	5	4ABCRN	Corfield	107.3	200	6ABCRN	Broome	102.9	100				
8ABCRN	Galiwinku	105.1	5	6ABCRN	Julia Creek	107.5	25	6ABCRN	Derby	94.9	100				
8ABCRN	Borroloola	105.3	25	4ABCRN	Pentland	106.1	25	6ABCRN	Wyndham	99.3	50				
SA															
5ABCFM	Adelaide	92.1	10000	4ABCFM	Mt Isa	101.7	300	6ABCRN	Tom Price	98.5	50				
5ABCFM	Loxton	105.1	95000	4ABCFM	Brisbane	106.1	50000	6ABCRN	Paraburdoo	93.7	50				
5ABCFM	Mt Gambier	104.1	150000	4ABCFM	Wide Bay	92.5	50000	6ABCRN	Halls Creek	101.9	100				
TAS															
7ABCFM	Nth/East Tas	93.3	120000	4ABCFM	Rockhampton	93.7	50000	6ABCRN	Argyle	101.7	50				
VIC															
6ABCFM	Hobart	93.9	27000	4ABCFM	Darling Downs	107.9	50000	6ABCRN	Onslow	94.9	25				
7QNT	Queenstown	104.7	600	4ABCFM	Townsville	101.5	65000	6ABCRN	Marble Bar	98.9	50				
7QNT	Rosebery	106.3	300	4ABCFM	Cairns	105.9	50000	6ABCRN	Koolan Island	104.1	50				
7QNT	Savage River	104.1	200	4ABCRN	Injune	104.3	100	6ABCFM	Bunbury	93.3	60000				
7QNT	Strahan	107.9	200	4ABCRN	Greenvale	105.9	25	6ABCFM	Geraldton	95.1	5000				
7QNT	Queenstown	107.5	30	4ABCRN	Quilpie	100.1	50	6ABCFM	Kalgoorlie	95.5	1500				
WA															
6ABCRN	Marble Bar	97.3	25	8ABCRN	Normanton	105.7	25	6ABCFM	Mawson	98.9	50000				
6ABCRN	Halls Creek	103.5	100	8ABCRN	Karumba	106.1	25	6ABCFM	Perth	97.5	50000				
6ABCRN	Ravensthorpe	100.9	25	4ABCRN	Bedourie	106.1	25	6ABCFM	Sth. Agricult.	94.5	50000				
6ABCRN	Meekatharra	98.3	25	4ABCRN	Birdsville	100.1	25	6ABCRN	Ravensthorpe	100.1	25				
6ABCRN	Fitzroy Cross.	107.7	50	4ABCRN	Croydon	102.1	25	6ABCRN	Laverton	100.3	25				
6ABCRN	Fitzroy Cross.	106.1	50	4ABCRN	Wandoan	105.9	25	6ABCRN	Mt Magnet	99.9	25				
6ABCRN	Port Hedland	95.7	1000	4ABCRN	Alpha	102.1	25	6ABCRN	Yalgoo	100.3	50				
6ABCRN	Meekatharra	99.9	25	SA											
6ABCRN	Karratha	101.7	100	5ABCFM	Adelaide	92.1	10000	6ABCRN	Cue	100.3	125				
6ABCRN	Dampier	88.1	50	5ABCFM	Loxton	105.1	95000	6ABCRN	Argyle	104.9	40				
6ABCRN	Pannawonica	95.1	25	5ABCFM	Mt Gambier	104.1	150000	6ABCRN	Leonora	102.3	50				
6ABCRN	Kununurra	92.1	50	TAS											
6ABCRN	Newman	96.9	50	7ABCFM	Nth/East Tas	93.3	120000	6ABCRN	Menzies	94.9	25				
6ABCRN	Exmouth	88.7	25	VIC											
6ABCRN	Broome	102.9	100	3ABCFM	Upper Murray	104.3	50000	6ABCRN	Denham	102.1	50				
6ABCRN	Derby	94.9	100	3ABCFM	Ballarat	105.5	50000	6ABCRN	Kalbarri	101.7	25				
6ABCRN	Wyndham	99.3	50	3ABCFM	Bendigo	106.3	100000	6ABCRN	Koolan Island	105.7	50				
6ABCRN	Tom Price	98.5	50	3ABCFM	Melbourne	105.9	50000								
6ABCRN	Paraburdoo	93.7	50	3ABCFM	Mildura	102.3	100000								
6ABCRN	Halls Creek	101.9	100	3ABCFM	West Victoria	107.5	70000								
6ABCRN	Argyle	101.7	50	3ABCFM	Murray Valley	105.9	50000								
6ABCRN	Onslow	94.9	25												
6ABCRN	Marble Bar	98.9	50												
6ABCRN	Koolan Island	104.1	50												
6ABCFM	Bunbury	93.3	60000												
6ABCFM	Geraldton	95.1	5000												
6ABCFM	Kalgoorlie	95.5	1500												
6ABCFM	Mawson	98.9	50000												
6ABCFM	Perth	97.5	50000												
6ABCFM	Sth. Agricult.	94.5	50000												
6ABCRN	Ravensthorpe	100.1	25												
6ABCRN	Laverton	100.3	25												
6ABCRN	Mt Magnet	99.9	25												
6ABCRN	Yalgoo	100.3	50												
6ABCRN	Cue	100.3	125												
6ABCRN	Argyle	104.9	40												
6ABCRN	Leonora	102.3	50												
6ABCRN	Menzies	94.9	25												
6ABCRN	Denham	102.1	50												
6ABCRN	Kalbarri	101.7	25												
6ABCRN	Koolan Island	105.7	50												

Call	Location	Freq. (kHz)	Power Watts	Call	Location	Freq. (kHz)	Power Watts	Call	Location	Freq. (kHz)	Power Watts
ABC RADIO - AM				5PA	Naracoorte	1161	10000	2NBC	Narwee	90.1	100
ACT				5SY	Streaky Bay	693	2000	2NCR	Lismore	92.5	3000
2CN	Canberra	666	2000	5WN	Woomera	1584	50	2NSB	Chatswood	91.5	80
2CY	Canberra	846	10000					2NUR	Newcastle	103.7	3000
NSW				TAS				2RDJ	Burwood	88.1	50
2GU	Goulburn	1098	200	7ZL	Hobart	585	10000	2REM	Albury	107.9	300
2BL	Sydney	702	50000	7ZR	Hobart	936	10000	2RES	Waverley	89.7	100
2FC	Sydney	576	50000	7FG	Fingal	1161	1000	2RRR	Ryde	88.5	50
2AN	Armidale	720	50	7NT	Launceston	711	10000	2RSR	Sydney	88.9	40
2BA	Bega	810	10000	7QN	Queenstown	630	400	2SER	Sydney	107.5	4000
2BY	Byrock	657	10000	7SH	St Helens	1584	100	2VTR	Windsor	89.7	20
2CO	Corowa	657	10000	VIC				2YOU	Tamworth	95.5	20
2CP	Cooma	1602	50	3WA	Wangaratta	756	10000	2MCE	Bathurst	92.3	1000
2CR	Cumnock	549	50000	3AB	Albury/Wodonga	990	250	2MCE/T	Orange	94.7	500
2GL	Glen Innes	819	10000	3AR	Melbourne	621	50000	2GCR	Goulburn	103.3	100
2KP	Kempsey	684	10000	3AL	Melbourne	774	50000	2RPH	Concord West	1.629	500
2LG	Lithgow	1395	200	3GI	Sale	828	10000	2WEB	Bourke	.576	2000
2ML	Murwillumbah	720	400	3MT	Ormeo	720	2000	NT			
2NA	Newcastle	1512	10000	3WL	Warrnambool	1602	250	8CCC	Alice Springs	102.1	250
2NB	Broken Hill	999	2000	3WV	Horsham	594	50000	8TOP	Darwin	104.1	10000
2NC	Newcastle	1233	10000	WA				8KIN	Alice Springs	100.5	400
2NR	Grafton	738	50000	6KP	Karratha	702	10000	8KIN/T	Ali-Curung	103.7	20
2NU	Tamworth	648	10000	6WF	Perth	720	50000	8KIN/T	Hermannsburg	103.7	225
2TR	Taree	756	2000	6WN	Perth	810	10000	8KIN/T	Santa Teresa	103.7	20
2UH	Muswellbrook	1044	1000	6AL	Albany	630	400	QLD			
2WA	Wilcannia	1584	100	6BE	Broome	675	50	4CCR	Cairns	89.1	3000
2WN	Wollongong	1431	2000	6BR	Bridgetown	1044	1000	4CRB	Gold Coast	89.3	16000
NT				6BS	Busselton	684	4000	4DDB	Toowoomba	102.7	2000
8DR	Darwin	657	2000	6CA	Carnarvon	846	200	4MBS	Brisbane	103.3	7500
8AL	Alice Springs	783	2000	6DB	Derby	873	2000	4TTT	Townsville	103.9	50
8GO	Nhulunbuy	990	500	6DL	Dalwallinu	531	10000	4RPH	Fig Tree Pock.	1.620	500
8JB	Jabiru	747	100	6ED	Esperance	837	1000	4EB	Brisbane	1.053	500
8KN	Katherine	639	2000	6GF	Kalgoorlie	648	2000	SA			
8TC	Tennant Creek	684	1000	6GN	Geraldton	828	2000	5YY	Whyalla	106.9	100
QLD				6KW	Kununurra	756	100	5PBA	Elizabeth	89.7	250
4CH	Charleville	603	10000	6MJ	Manjimup	738	5000	5TCB	Bordertown	106.1	1000
4QG	Brisbane	792	10000	6MN	Mt Newman	567	100	5EBI	Adelaide	92.9	4000
4QR	Brisbane	612	50000	6NM	Northam	612	200	5GTR	Mount Gambier	105.7	250
4AT	Atherton	720	4000	6PH	Port Hedland	603	2000	5MMM	Adelaide	93.7	4000
4GM	Gympie	1566	200	6PN	Pannawonica	567	100	5RRR	Woomera	107.3	30
4HU	Hughenden	1485	50	6PU	Paraburdoo	567	100	5UV	Adelaide	.531	500
4JK	Julia Creek	567	10000	6TP	Tom Price	567	100	TAS			
4MI	Mt Isa	1080	200	6WA	Wagin	558	50000	7HFC	Hobart	103.3	1500
4MS	Mossman	639	1000	6WH	Wyndham	1017	100	7RGY	Geeveston	95.3	10
4QA	Mackay	756	2000	6XM	Exmouth	1188	2000	7THE	Hobart	92.1	3000
4QB	Pialba	855	10000	ACT				7RPH	Hobart	1.620	500
4QD	Emerald	1548	50000	2SSS	Canberra	103.9	10000	7LTN	Launceston	103.7	2000
4QL	Longreach	540	10000	1PHR	Canberra	1.620	500	7WAY	Launceston	105.3	2000
4QN	Townsville	630	50000	2XX	Canberra	1.008	300	VIC			
4QO	Eidsvold	855	10000	NSW				3BBB	Ballarat	97.5	200
4QS	Toowoomba	747	10000	2GLA	Forster	101.5	5000	3MFM	Leongatha	106.1	1000
4QW	St George	711	10000	2WKT	Bowral	107.1	200	3RPP	Mornington	94.3	500
4QY	Cairns	801	2000	2EAR	Moruya	106.5	800	3RIM	Melton	95.5	200
4RK	Rockhampton	837	10000	2EAR/T	Narooma	102.9	160	3CCC	Castlemaine	103.9	2000
4SO	Southport	1593	200	2BOB	Taree	104.5	1500	3GCR	Churchill	103.5	50
4TI	Thursday Is.	1062	2000	2TEN	Tenterfield	107.5	100	3MBR	Murrayville	103.5	500
4WP	Weipa	1044	500	2AAA	Wagga Wagga	107.1	200	3MBS	Melbourne	103.5	10000
SA				2ARM	Armidale	92.3	1000	3PBS	Melbourne	106.7	10000
5AN	Adelaide	891	50000	2BBB	Bellingen	107.3	100	3RPC	Portland	106.7	2000
5CL	Adelaide	729	50000	2BBB/T	Dorrigo	90.5	400	3RRR	Melbourne	102.7	10000
5CK	Port Pirie	639	10000	2BCR	Bankstown	88.7	100	3RPH	Collingwood	1.629	500
5LC	Leigh Creek S	1602	100	2CBA	Sydney	103.2	5000	WA			
5LN	Port Lincoln	1485	200	2CHY	Coffs Harbour	104.1	1000	6SON	Perth	98.5	20000
5MG	Mt Gambier	1584	200	2GLF	Liverpool	89.3	50	6RKR	Rockingham	101.7	200
5MV	Renmark	1593	2000	2MBS	Sydney	102.5	5000	6NEW	Newman	92.9	250
				2MWM/T	Manly	92.1	25	6UVS	Perth	92.1	5000
								6NR	Perth	.927	2000

PUBLIC RADIO

Call	Location	Freq. (MHz)	Power Watts	Call	Location	Freq. (MHz)	Power Watts	Call	Location	Freq. (MHz)	Power Watts
COMMERCIAL TV											
ATC				NT				TAS			
CTC7	Canberra	182.258	100kW	NTD8	Darwin	189.250	20kW	TVT6	Hobart	175.258	100kW
CTC10	Canberra	209.258	100W	GEMR9	Groote Eylandt	196.250	200W	TVT8	Maydena	189.250	5W
NWS				QLD				VIC			
CTC2	Bombala	64.252	2kW	RTN55	Gold Coast	716.250	50kW	ATV10	Melbourne	209.250	100kW
CTC10	Cooma	209.260	50kW	BTQ7	Brisbane	182.250	100kW	ATV55	Marysville	716.250	10W
CTC10	Goulburn	209.240	100W	BTQ52	Gold Coast	695.250	50kW	ATV48	Upwey	667.224	160W
CTC66	Jindabyne	793.224	200W	QTQ9	Brisbane	196.250	100kW	ATV55	Warburton	716.250	150W
ATN7	Sydney	182.250	100kW	QTQ58	Gold Coast	737.250	50kW	ATV65	Ferntree Gully	786.224	350W
ATN49	Sydney	674.250	1kW	TVQ0	Brisbane	46.172	100kW	ATV66	Selby	793.198	500W
ATN49	Gosford	674.224	200W	TVQ46	Gold Coast	653.250	50kW	GTV9	Melbourne	196.250	100kW
TCN9	Sydney	196.250	100kW	DDQ10	Darling Downs	209.260	200kW	GTV52	Marysville	695.250	10W
TCN52	Sydney	695.250	1kW	DDQ5A	Toowoomba	138.260	900W	GTV45	Upwey	646.224	160W
TCN52	Gosford	695.224	200W	TNQ10	Cairns	209.250	100kW	GTV52	Warburton	695.250	150W
TEN10	Sydney	209.250	100kW	TNQ5A	Herberton	138.250	20W	GTV62	Ferntree Gully	765.224	350W
TEN55	Sydney	716.250	1kW	TNQ5A	Cairns	138.260	2kW	GTV63	Selby	772.198	500W
TEN55	Gosford	716.224	200W	TNQ5A	Mission Beach	138.240	100W	GTV52	Mount Martha	695.250	100W
BKN7	Broken Hill	182.250	7.5kW	TNQ6	Babinda	175.260	300W	HSV7	Melbourne	182.250	100kW
CBN8	Can. Tablelands	189.258	100kW	TNQ6	Mareeba	175.240	16W	HSV42	Upwey	626.250	160W
CBN11	Bathurst	216.240	200W	TNQ11	Ravenshoe	216.260	12W	HSV49	Marysville	674.250	10W
CBN68	Condobolin	807.224	40W	TNQ11	Tully	216.250	1kW	HSV49	Warburton	674.250	150W
CBN10	Kandos	209.250	20W	TNQ55	Cardstone	716.250	20W	HSV59	Ferntree Gully	144.224	350W
CBN4	Portland	95.260	100W	TNQ65	Atherton	783.250	50W	HSV60	Selby	751.198	500W
CBN6	Lithgow	174.250	30W	TNQ7	Townsville	182.250	100kW	HSV49	Mount Martha	674.250	100W
CBN50	Lithgow	681.198	100W	TNQ5A	Townsville	138.250	20W	AMV4	Upper Murray	95.260	100kW
CWN6	Can/Wes Slopes	175.260	200kW	TNQ68	Stuart	807.250	100W	AMV11	Bright	216.260	10W
CWN9	Mudgee	196.260	10W	TNQ1	Bowen	57.250	5kW	AMV10	Corryong	209.260	100W
CWN10	Cobar	209.250	50W	TNQ69	Bowen	814.250	2.5kW	AMV9	Myrtleford	196.260	20W
CWN66	Nyngan	793.250	100W	ITQ8	Mt Isa	189.250	500W	AMV48	Tawonga South	667.224	25W
MTN9	Mur. Irrig. Area	196.240	100kW	MVQ6	Mackay	175.250	180kW	AMV62	Mt Stanley	766.260	280W
MTN5A	Hay	138.250	1.4kW	MVQ6	Dysart	175.260	610W	BCV8	Bendigo	189.250	125kW
NBN3	Newcastle/Hun.	86.250	100kW	MVQ8	Clermont	189.260	30W	BCV11	Swan Hill	216.250	20kW
NBN69	Dungog	814.250	50W	MVQ8	Nebo	189.250	100W	BCV64	Gredgwin	780.250	100W
NBN10	Merriwa	209.260	50W	MVQ10	Middlemount	209.248	25W	BTV6	Ballarat	175.248	100kW
NBN1	Murrurundi	57.258	50W	MVQ11	Collinsville	216.250	20W	BTV7	Nhill	182.240	20kW
NBN10	Scone	209.240	1.5kW	MVQ11	Moranbah	216.240	2kW	BTV11	Portland	216.260	3.5kW
NBN40	Gosford	611.224	200W	MVQ32	Glenden	555.250	20W	BTV10	West. Victoria	209.240	30kW
NBN68	East Rossgole	807.250	800W	RTQ7	Rockhampton	182.260	100kW	BTV9	Warrnambool	196.258	1.3kW
NEN9	Upper Namoi	196.240	200kW	RTQ69	Boyne Island	814.250	50W	BTV62	Mt Arapiles	766.250	200W
NEN0	Tamworth	46.260	1kW	RTQ6	Emerald	175.240	1kW	BTV68	Warrnambool	807.250	2.5kW
NEN1	Walcha	57.240	100W	RTQ9	Capella	196.242	100W	GLV8	Latrobe Valley	189.260	100kW
NEN3	Glen Innes	86.278	10W	RTQ10	Blackwater	209.240	500W	GLV6	Foster	175.240	250W
NEN11	Quirindi	216.240	500W	RTQ10	Gladstone	209.250	10W	GLV7	Orbost	182.240	200W
NEN10	Armidale	209.240	50W	RTQ10	Springsure	209.260	250W	GLV11	Lakes Entrance	216.260	100W
NEN10	Ashford	209.250	15W	SDQ4	Southern Downs	95.240	200kW	GLV64	Latrobe Valley	783.250	1kW
NEN10	Inverell	209.240	25W	SEQ8	Wide Bay	189.240	150kW	GMV6	Goulburn V.	175.256	110kW
NEN69	Lightning Rdge	814.240	8W	SEQ1	Gympie	57.240	3kW				
NEN8	Manning River	189.250	200kW	SEQ5	Monto	102.250	1.2kW				
NEN11	Gloucester	216.250	200W	SEQ10	Nambour	209.268	3kW				
NEN47	Laurieton	660.250	500W	SA							
NRN11	Grafton/Kemps.	216.260	200kW	ADS10	Adelaide	209.250	100kW				
NRN63	Coffs Harbour	772.224	150W	ADS55	Adelaide	716.250	2kW				
RTN8	Richmond/Twd.	189.260	100kW	NWS9	Adelaide	196.260	100kW				
RTN5	Bonalbo	102.240	5W	NWS52	Adelaide	695.250	2kW				
RTN5	Kyogle	102.250	5W	SAS7	Adelaide	182.260	100kW				
RTN5	Murwillumbah	102.260	25W	SAS49	Adelaide	674.250	2kW				
RVN2	S/W Slopes	64.260	100kW	GTS4	Spencer Gulf N	95.250	100kW				
RVN6	Young	175.250	50W	GTS8	Powell	189.250	2kW				
RVN11	Wagga Wagga	216.250	25W	GTS5	Port Lincoln	102.250	1kW				
RVN69	Tumbarumba	814.250	8W	RTS5A	Renmark/Loxton	138.260	80kW				
WIN4	Illawarra	95.250	200kW								
WIN3	Wollongong	86.260	5kW								
WIN3	Eden	86.250	50W								
WIN3	Narooma	86.260	500W								
WIN6	Bega	175.250	1kW								
WIN11	Batemans Bay	216.250	1kW								
WIN39	Stanwell Park	604.224	20W								
WIN62	Wollongong	766.250	300W								

Call	Location	Freq. (MHz)	Power Watts	Call	Location	Freq. (MHz)	Power Watts	Call	Location	Freq. (MHz)	Power Watts
Commercial TV continued				ABC TV				NT			
GMV3	Eildon	86.250	50W	ACT				ABD6	Darwin	175.250	30k
GMV11	Alexandra	216.260	3kW	ABC3	Canberra	86.240	100k	ABAD7	Alice Springs	182.250	250
GMV48	Mansfield	667.198	1kW	ABC/9	Tuggeranong	196.258	100k	ABKD7	Katherine	182.250	30
GMV61	Bonnie Doon	758.250	75W	NSW				ABTD9	Tennant Creek	196.250	1k
GMV62	Yea	765.250	25W	ABC/0	Goulburn	46.250	50	ABTD/10	Warrego Mine	209.250	100
STV8	Mildura	189.270	50kW	ABN2	Sydney	64.250	100k	ABD/11	Adelaide River	216.250	20
WA				ABN/46	Kings Cross	653.250	1k	ABD/11	Bathurst Is.	216.250	150
STW9	Perth	196.250	100kW	ABN/46	Gosford	653.224	200	ABD/6	Borruloola	175.250	200
TVW7	Perth	182.250	100kW	ABCN1	Central Tab.	57.258	100k	ABD/10	Daly River	209.250	125
BTW3	Bunbury	86.240	50kW	ABCN/6	Bathurst	175.250	200	ABD/8	Galiwinku	189.250	30
BTW10	Katanning	209.250	400W	ABCN/5	Lithgow	102.258	5	ABD/7	Groote Eylandt	182.250	100
BTW11	Mawson	216.224	100kW	ABCN/0	Kandos	46.258	15	ABD/8	Jabiru	189.250	10
BTW60	Narrogin	751.198	5kW	ABCN/0	Portland/Wall.	46.258	100	ABD/8	Mataranka	189.250	30
BTW59	Northam	744.250	50W	ABDN2	Grafton/Kemp.	64.260	100k	ABD/8	Nwcas. Wtrs	189.250	100
BTW6	Wagin	175.240	60kW	ABDN/60	Coffs Harbour	751.224	150	ABD/11	Nhulunbuy	216.250	150
BTW66	Kojonup	793.250	50W	ABGN7	Murrumbidgee	182.240	100k	ABD/10	Pine Creek	209.260	10
GSW9	Sth Agricult.	196.240	50kW	ABGN/65	Argoon/Jerild.	786.250	200	ABW/45	Bayulu	646.250	2
GSW10	Albany	209.260	50W	ABGN/11	Jerilderie	216.240	7k	ABD	Central Aust.	2693.0	30
GTW11	Geraldton	216.250	100kW	ABGN/69	Jerilderie	814.250	500	QLD			
GTW63	Mullewa	772.224	200W	ABGN/9	Deniliquin	196.260	1k	ABQ2	Brisbane	64.240	100k
GTW30	Morawa	541.250	60kW	ABGN/10	Hay	209.240	2.5k	ABQ/49	Gold Coast	674.250	50k
GTW62	Mingenew	765.224	200W	ABHN/8	Scone	189.240	1.5k	ABAAQ1 1	Augathella	216.250	13
VEW8	Kalgoorlie	189.250	8kW	ABHN/65	East Rossgole	783.250	1.5k	ABAQ8	Alpha	189.250	13
VEW50	York	681.250	5kW	ABHN/8	Merriwa	189.250	50	ABBQ10	Barcardine	209.250	13
VEW6	Koolyanobbing	175.240	1W	ABLN2	Broken Hill	64.250	2.5k	ABBQ9	Blackall	196.250	100
VEW6	Merredin	75.250	15W	ABLN/68	Menindee	807.250	200	ABCAQ1 0	Cunnamulla	209.250	13
VEW69	Tammin	814.250	15kW	ABLN/9	Menindee	196.250	100	ABCEQ9	Charleville	196.250	130
VEW9	Esperance	196.260	500W	ABMN0	S/Wes. Slopes	46.240	100k	ABCLQ7	Cloncurry	182.240	100
VEW9	Norseman	196.250	40W	ABMN/11	Young	216.240	50	ABCTQ1 0	Clermont	209.250	50
VEW10	Southern Cross	209.250	250W	ABQN5	C/Wes. Slopes	102.240	100k	ABDIQ7	Dirranbandi	182.250	10
VEW3	Baandee	86.248	500W	ABQN/11	Mudgee	216.240	10	ABDQ3	Darling Downs	86.252	100k
VEW3	Kambalda	86.250	10W	ABRN6	Richmond/Twd	175.260	100k	ABEQ11	Emerald	216.250	1k
VEW63	Meckering	772.250	5kW	ABRN/3	Bonalbo	86.250	5	ABGQ6	Goondiwindi	175.250	250
WAW	West.Australia	2661.000	30W	ABRN/3	Kyogle	86.250	5	ABHQ9	Hughenden	196.260	100
WAW7	Kununurra	182.250	100W	ABRN/29	Tenterfield	534.198	200	ABIQ6	Mt Isa	175.260	1.25k
WAW57	Karratha	729.250	500W	ABSN8	Bega/Cooma	189.240	100k	ABJQ10	Julia Creek	209.260	100
WAW6	Roebourne	175.260	1kW	ABSN/0	Cooma	46.240	35	ABLQ6	Longreach	175.250	650
WAW10	Port Hedland	209.242	300W	ABSN/1	Eden	57.240	50	ABMQ4	Mackay	95.250	100k
WAW32	Dampier	555.250	50W	ABSN/60	Jindabyne	751.224	200	ABMQ/2	Shute Harbour	64.260	160
WAW8	Pannaawonica	189.198	30W	ABTN1	Manning River	57.250	100k	ABMQ/49	Airlie Beach	674.250	300
WAW11	Exmouth	216.240	75W	ABTN/6	Gloucester	175.240	200	ABMQ/8	Collinsville	189.250	30
WAW11	Derby	216.224	100W	ABUN7	Upper Namoi	182.240	100k	ABMQ/0	Nebo	46.250	100
WAW11	Broome	216.198	1kW	ABUN/10	Mungindi	209.250	50	ABMQ/5A	Moranbah	138.240	2k
WAW57	Moora	730.250	20kW	ABUN/5A	Ashford	138.250	15	ABMQ/2	Dysart	64.260	250
WAW10	Carnarvon	209.224	250W	ABUN/0	Glen Innes	46.240	25	ABMLQ6	Mitchell	175.250	100
WAW8	Wyndham	189.250	50W	ABUN/2	Inverell	64.250	25	ABMNQ7	Morven	182.250	50
WAW9	Goldsworthy	196.242	250W	ABWN5A	Illawarra	138.250	100k	ABMSQ9	Miles	196.250	160
WAW9	Shay Gap	196.250	250W	ABWN/50	Wollgng Nth	681.198	2.5k	ABNQ9	Cairns	196.240	100k
WAW63	Newdegate	772.224	4W	ABWN/9	Batemans Bay	196.260	1k	ABNQ/1	Babinda	57.260	300
WAW34	Mukinbudin	569.198	10W	ABWN/0	Narooma	46.240	500	ABNQ/52	Cardstone	695.250	20
WAW34	Kulini	569.224	4W	ABN/4	Brke/Brewar.	95.250	1k	ABNQ/46	Dimbulah	653.250	800
WAW32	Hyden	555.224	8W	ABN/2	Cobar	64.250	60	ABNQ/0	Gordonvale	46.250	500
WAW8	Koolan Island	189.250	50W	ABN/8	Goodooga	189.250	10	ABNQ/4	Herberton	95.250	20
WAW11	Paraburdoo	216.250	200W	ABN/6	Ivanhoe	175.250	100	ABNQ/68	Atherton/Mare.	107.250	50
WAW7	Tom Price	182.250	50W	ABN/10	Lightn. Ridge	209.240	125	ABNQ/2	Mission Beach	64.240	100
WAW9	Newman	196.250	50W	ABN/6	Murrurundi	175.240	50	ABNQ/4	Cairns North	95.240	2k
WAW63	Argyle	772.250	100W	ABN/3	Nyngan	86.250	10	ABNQ/4	Crns N/Moss.	95.240	500
WAW65	Hearson Cove	786.224	4W	ABN/10	Tottenham	209.250	100	ABNQ/8	Mossman	189.240	1k
WAW9	Mt Nameless	196.250	2.5kW	ABN/11	Walgett	216.250	100	ABNQ/8	Ravenshoe	189.250	12
WAW64	Lagrange	779.224	50W	ABN/8	Wilcannia	189.250	100	ABNQ/46	Tully Falls	653.250	35
WAW45	Lake Grace	646.198	20W	ABN/5A	Quirindi	138.250	500	ABNQ/1	Mareeba	57.250	16
WAW62	Westonia	765.198	20W	ABN/2	Tamworth	64.240	1k	ABRAQ7	Roma	182.250	1k
WAW55	Koorda	716.250	10W	ABN/68	Tamw./Moonbi	807.250	1k	ABRQ3	Rockhampton	86.260	100k
WAW68	Hopetown	807.250	4W	ABN/60	Mnbi/Walcha	751.250	2.5k	ABRQ/5	Gladstone	102.260	10
WAW66	Bremer Bay	793.224	10W	ABN/60	Mnbi/Armdl.	751.250	4k	ABRDQ6	Richmond	175.240	100
WAW66	Jerramungup	793.198	50W	ABN/6	Walcha	175.250	100	ABSEQ9	SpringSURE	196.250	250
WAW6	Denham	175.250	10W	ABN/5A	Armidade	138.240	50	ABSGQ8	St George	189.250	65
WAW6	Mt Magnet	175.250	15W	ABN/29	Collarenebri	534.250	250	ABSQ1	South. Dwns	57.260	100k
WAW53	Nullagine	702.198	4W	ABN	SE Australia	2661.0	30	ABSQ/11	Texas	216.250	20
WAW6	Marble Bar	175.250	20W					ABTQ3	Townsville	87.270	100k
WAW66	Trayning	793.250	8W					ABTQ/1	Townsville Nth	57.240	10

Call	Location	Freq. (MHz)	Power Watts	Call	Location	Freq. (MHz)	Power Watts	Call	Location	Freq. (MHz)	Power Watts
ABC TV				ABT/4	Bicheno	95.250	500	ABCW5A	Cent. Agricult.	138.250	100k
ABTQ/66	Inkerman/Bwn	791.250	2.5k	ABKT11	King Island	216.240	2k	ABCMW8	Morawa	189.260	1k
ABTQ/5A	Bowen	138.260	5k	ABNT3	NE Tasmania	86.200	300k	ABCNW7	Carnarvon	182.250	100
ABQ/8	Winton	189.250	1k	ABNT/1	St Marys	57.240	100	ABEW10	Esperance	209.240	1k
ABWQ6	Wide Bay	175.240	150k	ABNT/0	St Helens	46.240	30	ABEW/6	Cond./Howick	175.250	200
ABWQ/4	Gympie	95.260	3k	ABNT/4	Burnie	95.469	500	ABGW6	Geraldton	175.240	10k
ABWQ/11	Miriam Vale	216.250	100	ABNT/48	E Devonprt	667.250	800	ABGW/8	Northampton	189.240	10
ABWQ/1	Monto	58.350	1.2k	ABNT/8	Lileah	189.240	2k	ABGW/9	Mullewa	196.240	40
ABWQ/5A	Nambour	138.250	3k	ABNT/2	Waratah	64.250	800	ABKAW7	Karratha	182.260	25
ABQ/11	Aramac	216.250	100	ABNT/4	Smithton	95.260	100	ABDW10	Dampier	209.250	20
ABQ/7	Bedourie	182.250	10	ABNT/1	Lncestn Sth	57.250	30	ABKW6	Port Hedland	175.250	8k
ABQ/8	Birdsville	189.250	100	ABNT/4	Savage River	95.260	100	ABKW/5	Kambalda	102.240	10
ABQ/8	Blackwater	189.260	500	ABNT/1	Wynyard	57.100	1k	ABW/60	Moora	751.250	60k
ABQ/8	Boulia	189.250	100	ABNT/59	Ulverstone	744.224	100	ABNW7	Norseman	182.240	40
ABQ/8	Camooowal	189.250	300	ABNT/60	Penguin	751.224	100	ABPHW7	Port Hedland	182.250	340
ABQ/5A	Capella	138.250	100	ABNT/60	Montumana	751.250	4k	ABRBW9	Roebourne	196.250	1k
ABQ/8	Coen	189.250	30	ABNT/60	Mont./Lileah	751.250	1k	ABSW5	Bunbury	102.250	100k
ABQ/8	Cooktown	189.260	12	ABNT/60	Mont./Smthtn	751.250	2k	ABSBW9	South. Cross	196.260	1k
ABQ/10	Corfield	209.250	100	ABNT/60	Mont./Wynrd	751.250	400W	ABSBW/1			
ABQ/8	Croydon	189.250	12	ABNT/48	Devonport/Ulv	667.250	200W	1	Kolyning	216.260	10
ABQ/7	Georgetown	182.250	10	VIC				ABW/69	Argyle	814.250	150
ABQ/8	Greenvale	189.250	10	ABV2	Melbourne	64.250	100k	ABW/8	Broome	189.250	1k
ABQ/7	Isisford	182.250	100	ABV/46	Warburton	653.250	150	ABW/10	Cue	209.250	20
ABQ/7	Jericho	182.250	250	ABV/46	Marysville	653.250	10	ABW/8	Denham	189.250	100
ABQ/6	Karumba	175.250	10	ABV/57	Selby	730.198	500	ABW/8	Derby	189.260	100
ABQ/8	Laura	189.250	10	ABV/39	Upwey	604.250	160	ABW/8	Exmouth	189.240	75
ABQ/7	Mt Molloy	182.250	150	ABV/56	Ferntree Gully	723.224	350	ABW/46	Eneabba	653.250	40
ABQ/8	Muttaborra	189.250	100	ABAV1	Upper Murray	57.250	100k	ABW/8	Halls Creek	189.250	20
ABQ/8	Normanton	189.250	10	ABAV/9	Corryong	196.250	100	ABW/55	Jurien	716.198	2k
ABQ/8	Pentland	189.250	100	ABEV1	Bendigo	57.260	100k	ABW/46	Cervantes	653.198	5
ABQ/8	Quilpie	189.250	100	ABGV3	Goulburn Val.	86.230	100k	ABW/9	Kalbarri	196.250	12
ABQ/11	Surat	216.250	100	ABGV/5A	Alexandra	138.250	3k	ABW/7	Katanning	182.260	400
ABQ/6	Tambo	175.250	100	ABGV/1	Eildon	57.240	5	ABW/6	Koolan Island	175.250	50
ABQ/11	Taroom	216.250	100	ABGV/2	Myrtleford	64.230	25	ABW/9	K./Cock. Is.	175.250	50
ABQ/8	Thursday Is.	189.250	10	ABGV/45	Mansfield	646.198	1k	ABW/9	Cockatoo Is.	196.250	4
ABQ/5A	Wandoan	138.250	100	ABGV/58	Bonnie Doon	737.250	75	ABW/9	Kununurra	196.250	60
ABQ/7	Weipa	182.250	300	ABGV/69	Myrtleford	814.250	200	ABW/10	Laverton	209.260	100
ABQ/58	Gympie Town	737.224	100	ABLV4	Latrobe V.	95.240	100k	ABW/5A	Leeman	138.250	60
ABQ/44	Chrtws Twrs	639.198	50	ABLV/11	Foster	216.250	250	ABW/10	Linster	209.250	10
ABQ/8	Tully	189.260	1k	ABLV/46	Bairnsdale	653.198	5k	ABW/8	Leonora	189.250	400
ABQ	NE Australia	2629.000	30	ABLV/2	Orbost	64.260	150	ABW/8	Marble Bar	189.250	20
SA				ABLV/2	Orbst/Cnn R.	64.260	200	ABW/8	Meekatharra	189.250	10
ABS2	Adelaide	64.260	100k	ABLV/11	Cann River	216.240	1.6k	ABW/10	Menzies	209.250	10
ABS/46	Adelaide Foot.	653.250	2k	ABMV4	Mildura	95.270	100k	ABW/8	Merredin	189.250	35
ABGS1	South East	57.250	100k	ABRV3	Ballarat	86.238	100k	ABW/8	Mt Magnet	189.250	15
ABNS1	Spencer Gulf	57.250	100k	ABRV/8	Cobden	189.250	500	ABW/57	Narrogin	730.198	5k
ABNS/6	Cowell	175.238	2k	ABRV/5A	Colac	138.250	1k	ABW/7	Newman	182.250	50
ABNS/48	Hawker	667.250	200	ABS2	Murray Valley	64.260	100k	ABW/8	Onslow	189.250	30
ABNS/3	Port Lincoln	86.258	1k	ABWV5A	West. Victoria	138.250	66k	ABW/11	Pannawonica	216.250	30
ABNS/47	Quorn	660.250	1.8k	ABWV/3	Casterton	86.250	50	ABW/6	Paraburdoo	175.250	200
ABRS3	Rnmrk/Lxton	86.248	150k	ABWV/2	Coleraine	64.250	50	ABW/11	Ravensthorpe	216.250	20
ABWS7	Woomera	182.250	10	ABWV/4	Portland	95.270	2k	ABW/8	Salmon Gums	189.250	300
ABS/8	Andamooka	189.260	30	ABWV/2	Warrnambool	64.250	2k	ABW/9	Teutonic Bore	196.250	20
ABS/2	Bordertown	64.240	500	ABWV/69	Mt Ara./Nhill	814.250	200	ABW/10	Tom Price	209.250	125
ABS/9	Cedna/Smoky	196.240	1k	ABWV/9	Nhill	196.240	20k	ABW/8	Wagin	189.240	60k
ABS/8	Cooper Pedy	189.250	10	WA				ABW/10	Wyndham	209.250	100
ABS/9	Leigh Creek	196.250	20	ABW2	Perth	64.250	100k	ABW/10	Yalgoo	209.250	10
ABS/7	Leigh Creek	182.250	50	ABAW2	S Agricultural	64.240	100k	ABW/46	Dalwallinu	653.250	10k
ABS/8	Marree	189.250	30	ABAW/7	Albany	182.240	50	ABW/6	Wongan Hills	175.260	300
ABS/8	Wirrulla	189.240	1k					ABW/58	Fitzroy Cross.	737.198	50
ABS/45	Coffin Bay	646.250	10					ABW	West. Aust.	2725.000	30
ABS/30	Wudinna	541.250	100k								
ABS	Central Aust.	2501.000	12								
TAS											
ABT2	Hobart	64.240	100k								
ABT/4	Queenstown	95.250	100								
ABT/1	Rosebery	57.260	50								
ABT/10	Strahan	209.260	10								
ABT/5	Strathgordon	102.250	50								

AUSTRALIAN VHF TELEVISION CHANNELS					
Channel	Vision(MHz)	Sound(MHz)	Channel	Vision(MHz)	Sound(MHz)
0	46.25	51.75	6	175.25	180.75
1	57.25	62.75	7	182.25	187.75
2	64.25	69.75	8	189.25	194.75
3	86.25	91.75	9	196.25	201.75
4	95.25	100.75	10	209.25	214.75
5	102.25	107.75	11	216.25	221.75
5A	138.25	143.75			

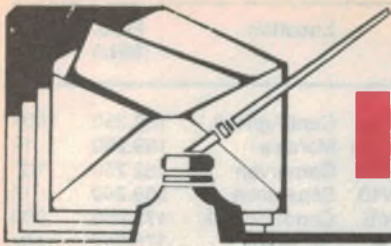

Information centre

Conducted by Peter Phillips

Expanding the horizons

It's amazing how many letters we get asking our advice on matters both electronic and.. weell.. not so electronic. Because we like to be responsive to our readers, we have decided to expand this section into one catering for all; not just those with project queries.

From now on we will widen the horizons and attempt to answer questions of any sort. If we can't supply the answers, we will print the question and ask for replies. Naturally, questions concerning projects will still form the central part of these pages, but general questions will now be included. And to warm things up we may even enter into a little bit of technical discourse concerning readers' comments. No, it's not another Forum, just a clearing house for both world shattering and trivial technical matters. We also intend to include a few teasers of our own – of the question now, answer next month variety.

There will also be a bit of humour thrown in, as technical matters can get rather serious at times. If you have any humorous items you think readers may enjoy, let's 'ave 'em.

So, if you have any questions you think we, or other readers can answer, write to our usual address, but mark your letter as attention EA Information Centre, and we will do the rest.

Our lead time is at least six to eight weeks, so don't expect instant response – it 'just ain't possible'. We will have to reserve the right both to edit letters and publish only those we think other readers will want to read – the usual kind of thing all publications have to do.

OK, so on with this months' lot. The first letter is actually a compilation of two, which collectively raise some interesting points.

Differential amplifiers

I write concerning the project titled Multi-purpose preamp board (EA Nov). The idea is fine and most circuits seem workable. However the balanced mic pre-amp seems to have taken Rob Evans off the rails somewhat. This is an area dear to my heart and several

claims for the circuit don't ring true.

For example, the equation on page 65 appears out of nowhere and might well be returned there immediately. The resistance looking into the negative input is 1.8k. To balance the input loads to ground a resistor of about 1.8k should be used for R8, and not the suggested 1k. But then, as most microphones these days have a floating input anyway – that is, they are not even referenced to ground (see Fig. 1b), it seems Rob's discussion is irrelevant.

My next point concerns the quoted noise level. Rob states a value of -92dB below the 100mV reference level. This reference is not appropriate as an input level (I assume he means this is the input level – not the output level) as such an input would imply a sound level

at the microphone of at least 130dB SPL(!). A 100mV level is OK for an auxiliary input perhaps, but not a mic input. The correct noise level is -68dB, a figure I have verified both by experiment and computation based on material contained in my article 'Estimating noise in op amps' (EA April 87).

Finally, the CMRR figure quoted is possible, but fortuitous. A worst case analysis for 5% resistors gives a figure of only -32dB, while a practical figure is more likely to be around -50 to -60dB, not the -85dB given. This latter figure would require resistors with a tolerance of 0.05% (reference IC Op amp Cookbook, 2nd Ed. p.21).

Possibly a small correction could be printed in the interests of technical accuracy, though I realise no-one's life is in danger. (P.A., Summer Hill, NSW)

• **Whoops! It seems we may have sacrificed accuracy for space with this one. I raised the issue with Rob, the project's designer, and our discussions on this circuit led us into op amp theory in no uncertain terms. So let's take P.A.'s points last to first, as the first one is possibly the most contentious.**

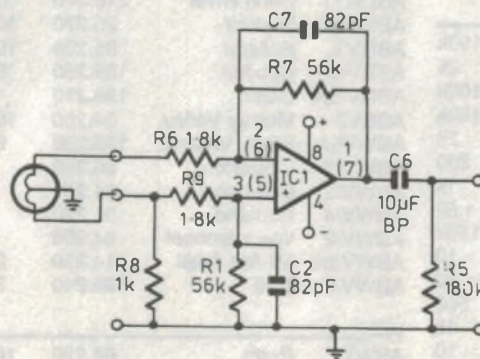
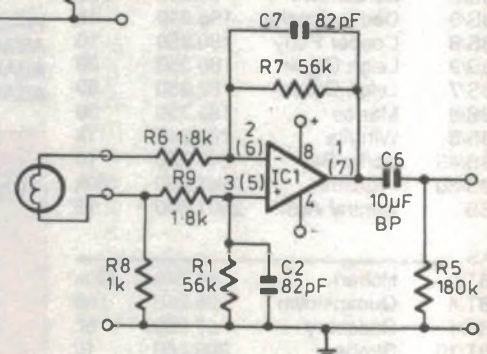

Fig.1(a) – (left). The differential amplifier circuit under discussion being driven by a balanced input source. What is the correct value for R8?

Fig.1(b) – (right). A floating input signal source for the differential amplifier; the usual thing these days. Is R8 necessary at all?



The circuit in question is shown in Fig.1, which readers will recognise as a differential amplifier. As P.A. points out, the CMRR (common mode rejection ratio) is dependent on the exact match between R9-R1 and R6-R7. Because resistors these days are usually very close to their marked value, it was probably this fact rather than good design that the quoted figure of -85dB was realised. The correct procedure should perhaps have been either to specify 1% resistors and to quote a theoretical figure for CMRR, or make R1 adjustable. Our mistake.

The next point concerns noise level. We admit here that the article is misleading. Rob intended to state 'referenced to 100mV in/3.1V out', which was how the original figure was obtained. Somehow it got screwed up to suggest a 100mV output level.

By the way, some 'musicians' have been known to present a sound level of 130dB SPL to the microphone they are nearly swallowing, giving the perhaps unlikely input voltage of 100mV. We agree that this figure was somewhat unrealistic as a reference level for a mic input.

Now to the first point concerning balancing the resistances of both inputs of the amplifier. There are two ways of looking at this; when using a balanced input signal as shown in Fig.1(a) or when the input (as suggested by our correspondent) is floating as shown in Fig.1(b). To be fair here, P.A. has since agreed in later correspondence that the equation in the article is correct, but because most microphone inputs are floating, he argues the explanation is irrelevant. Let's see how it works out.

When the input is balanced, meaning the input voltages are equally referenced to the common line, P.A. previously suggested that a resistance of 1.8k for R8 is required to give an equal input resistance at both inputs.

This is a reasonable thing to say, particularly when it is supported by the usually reliable IC Op Amp Cookbook (1st Ed. by W.G.Jung), which states that the input resistance at the inverting input of a differential amplifier (op amp type) is simply R6 (for Fig.1). In fact, this is true if the non-inverting input is connected to ground, which makes the differential amplifier somewhat redundant anyway. But for a balanced input, it is more complicated, as Rob Evans points out in the text for the project.

According to my figuring, and to Deboo and Burrous in their book In-

tegrated Circuits & Semiconductor Devices (1971), the effect of a phase-reversed input signal simultaneously applied to the non-inverting input mucks things up a bit.

To prove the point, readers may like to do a 'paper simulation'. Apply 1V to the inverting input, -1V at the non-inverting input (both with respect to common) and go through the mathematics. The voltage at the op-amp's non-inverting input will be -0.96885131V, which therefore becomes the voltage at the inverting terminal of the op amp, due to the feedback.

Then use Ohm's law to find the current in R6 (1.093810073mA), and then the input resistance at the inverting terminal - by dividing the input voltage (1V) by the current in R6. It equals 914 ohms, exactly as Rob said.

The input resistance at the non-inverting input (and here we all agree) is the sum of R9 and R1, giving 57.8k. To get this value down to 914 ohms, a resistance of 928.6 ohms is needed for R8, or 1k as suggested.

However, as our correspondent states, this is all pretty irrelevant anyway when a floating input is used, as is normally the case these days. Here the value of R8 doesn't matter, as the input circuit is not referenced to earth. But I suggest that because common mode (noise) signals will be referenced to earth, both terminals should still offer the same input impedance, to ensure the same amplitude common mode signal. This should give the best noise rejection figures. Therefore we stand by the stated value of R8.

So, we lose two and kind of win one. Nonetheless, we welcome letters that take us to task, as it keeps us honest. Now, moving right along...

Greenhouse effect?

Would you please give me information regarding the following;

(1) If the Earth's weather depends on its rotation around the sun, giving winter when it leans away from the sun, because the sun's rays are lengthened, and summer then the Earth is closer to the sun, would it be possible to control the weather by means of lengthening or shortening the sun's rays electronically, perhaps in the upper atmosphere?

(2) Could the above be used to control the 'greenhouse effect'? (D.B., Darwin NT.)

• OK readers - answer that one. D.B. is surely correct in his assumptions

December's Mystery Item:

Last month's historic puzzler was a General Radio type 358 wavemeter, used in the late 1920's to check the frequency/wavelength of transmitters. It covered from 14 to 240 metres (21.4MHz - 1.25MHz), using four coils, and came complete with a calibration chart. The radio department of David Jones' store in Sydney advertised it in 1929 for the sum of 5 pounds.

General Radio went on to become world famous as a US maker of high quality electronic test equipment.

concerning the seasons and their relationship to the length of the sun's rays. It seems reasonable to me, anyway. The main problem, as I see it, is how to 'electronically' control the length of the rays. Any ideas?

No MIDI software

In recent issues of EA there have been two MIDI projects, one for any computer, (but really an IBM), and another for the Apple. That's fine, but what about the software? How can I use these projects without a program, as no commercial programs will work with them. I like the projects, but I'm not much good at programming. (F.G., Mogo NSW.)

• Work is under way in this regard. We hope to be able to offer software for both these projects shortly. As the developer of the Apple Interface, I intend to develop software myself, making it available to readers through our normal services. The MIDI-out device for the IBM etc., is another matter, but big things are happening here as well. Just stay tuned (pardon the pun) to these pages.

Burglar alarm

Would it be possible to adapt the car burglar alarm described in the 1985 publication 'Easy to build electronics projects for your car' to a home situation? Obviously the entry and exit delays would need to be altered.

As well, could the ultrasonic movement detector also described in this publication be connected to the alarm? If so, what sort of range could I expect? (L.B., Dudley NSW.) ▶

Information Centre

• When confronted with this question, technical staff member Mark Cheeseman reached for the coffee pot, studied it (and the question) and came to the following conclusion.

'There is no reason why the car burglar alarm system cannot be used to protect a home, provided that a suitable power supply could be constructed.' However, Mark also pointed out that a home burglar alarm was described in EA January-February 1985, which incorporates its own power supply.

The ultrasonic movement detector questions are a bit more difficult to answer, as the author of the article has since left the magazine. All we can suggest is that you study the article carefully.

However, in forthcoming issues we plan to present an infra-red movement detector, which may offer more reliable operation than the ultrasonic device. I hope that helps a little, anyway.

Disillusioned student

Since reading your helpful article on 'Careers in Electronics', I am writing to ask your advice concerning the degree I am currently undertaking. I am a 2nd year student at Newcastle University, and gained a HSC aggregate of 334, allowing me to undertake studies in my chosen field of electronics and computers.

I was told that because my aggregate was below 350, I would have to work hard, but because I am interested in computers, I felt this degree to be the best choice for my future. The problem is, most of the course so far is on subjects I am not interested in.

I realise that any engineering degree has subjects of a general nature, but I am not even sure if the subjects I will be offered in the final years of the degree will be attractive to me. It seems the university offers the subjects it wants to, and doesn't concern itself with what students might want.

Maybe TAFE or a CAE have courses that are better suited to the field I wish to follow. So far, out of the 11 subjects I have completed, only four have been in the area I am interested in. I am finding it very difficult, as having to study all the unrelated subjects is making this degree an arduous task that, even if completed, may not give me what I want. (C.O., Merewether, NSW.)

• I wonder how many readers will re-

late to this problem. I can see our correspondent's difficulty from two sides; as a student and as a lecturer. In my student days I was required to learn, for example, the distillation process of petrol and the stress factors in a hip roof. Awesomely boring to someone with a passion for electronics!

As a lecturer I have often sympathised with students following my diatribe on the vagaries of the AC equivalent circuit of a transistor. However, I have also spent a lot of time developing the content of a number of courses, and have had to weigh up arguments from students, employers and other lecturers.

In short, education of any sort is hard work. Very few students find a course of study, whether a degree or an apprenticeship, totally enjoyable. However, C.O. is concerned about the ultimate outcome - will his degree get him where he wants to go? My answer here is yes and no. Yes, because it will open doors for him by giving him opportunities for employment he could not otherwise obtain.

No, because a degree in itself is not the whole answer anyway. Education is a continuing process - it doesn't stop at graduation. My advice here, for what it may be worth, is complete the degree then seek the field you really want. The degree will have prepared you better than you might think. It may not have given you the nitty gritty you really wanted, but that will come.

Of course, it may be that different institutions can offer subjects more closely related to those you want. I would suggest you contact other universities, for example the University of NSW, the University of Sydney, Macquarie University and the University of Technology. All of these institutions offer engineering degrees, and may give subjects more in line with your expectations. However, watch out that you don't lose the points already gained towards the degree by transferring to another institution.

My experience has been that most students become disillusioned at some stage in their course, some more than others, and that all universities require study in subjects that are apparently unrelated.

The real school is industry itself, where you survive and eventually prosper by using the degree or other qualification as a platform to gain the knowledge essential to your chosen field. My article mentioned that a degree was hard work - you had better believe it. However, on the positive

side, once completed, the real learning begins and life becomes a whole lot better. And remember this, an engineering degree is held by only around 5% of the population. The other 95% either didn't try for one, or couldn't hack it. Hang in there C.O., - you won't be sorry.

Quick quiz

We have encountered the following terms in technical literature. Circle the response you think best describes the term and mail the answers to your grandmother.

1. *Printergration* means:

- (a) the act of incinerating a printer.
- (b) a tossed salad containing grated printers.
- (c) a problem for some printers in South Africa.
- (d) a happy printer (grateful - get it?).

2. A *zero fall-through FIFO* means:

- (a) a dog with good balance.
- (b) a shift register with a problem.
- (c) a brand of weed killer.
- (d) a high-tech open circuit.

3. A *vertical systolic array* is:

- (a) a lump on an aneroid barometer.
- (b) a yuppy with kidney failure.
- (c) a ladder made of systolite.
- (d) the IC's annual orgy.

Why??

Everyone knows (or should know) that in a series RC circuit, the product of R (in ohms) and C (in farads) gives a time value (in seconds). The units *ohm* and *farad* are both named after two men who established basic laws concerning the components concerned.

Why is it that the product of these terms (basically the surnames of two venerable gentlemen) ends up as a value of time? In other words, show mathematically why $RC = \text{time in seconds}$.

NOTES AND ERRATA

MULTI-PURPOSE PREAMP

(November 88): The captions beneath the circuit diagrams of the NAB preamp and the unbalanced mic preamp are transposed. The circuit in the centre column of page 65 is the unbalanced mic preamp, whereas the first schematic on page 66 is the NAB preamp. Also, The parts list for power supply 3 should not include the two 22 ohm resistors. (File: 1/PRE/36) ④

UHF Transmitter

continued from page 113

circuit board has all the address lines left open circuit, and the required code must be applied by adding links.

The final code you select is programmed into the transmitter by the chosen states of the address pins A1-A9 on IC1. These address pins can be left open circuit, connected to supply ('1') or to ground ('0'). The code is implemented by connecting each address pin to the selected logic level, using short lengths of tinned copper wire.

Obviously, the transmitter code needs to match the code used in the receiver. Fig.1 shows how to apply the code. For further information you might like to refer back to EA, January 1987. As well, because this transmitter can be used with the remote control system currently being described (low security channel only), reference to this set of articles may also be useful. ③

Frankly Frank

continued from page 42

that those who arrive here to check on what happened to us and where we went would have some inkling of what a neutrino was or is. (In their time that famous particle, the Higgs Boson might have returned.) Besides, the entrance to the abandoned salt mine would have been long buried – although our colleagues in the military electronic field have made it possible to readily find underground objects, wells, cisterns, etc.

In an attempt to locate those famous Viet Cong tunnels in Vietnam, the Americans built an underground microwave radar system. Sadly it didn't work too well in wet ground, but in the middle east where it isn't often too wet, the system is working wonderfully. At a place near the Gaza Strip, not a place of numerous streakers, but one hotly disputed by various people for these last four of five millenia, the microwave radar was used at Tell Halif.

Now it is true that in a place that lies between the Gaza Strip and the Dead Sea, no person of reasonable sanity would seek to stay long. Archeologists are not people who fall into this category of sane people. Anyway, at Tell Halif a team of American archeologists have used microwave underground radar to locate a vast buried water supply cistern. Naturally it now has no water in it and the radar worked admirably.

So when our future archeologists,

Zgglyl and his/her/its assistant, Ztxyll arrive from Barnard's star to find out all about us, it is safe to assume that they will have microwave ground search radar to help them locate the Cleveland neutrino detector's remains. If that object might confuse them a bit, imagine what they would make of the partially melted Opera House or the Giant Gippsland Earthworm museum!

This will all be a mite academic should the next supernova be located right in our near neighbourhood. Should Proxima Centauri decide to go supernova, or anything within about ten or twelve light years, then our friends from Bernard's star might just as well stay home. Not even that three kilometre wide feature on Mars, the one that looks like some upper house member's head, would survive. Perhaps Jupiter, the planet described as a 'failed' sun, might reverse its failure and the whole thing start again in four or five thousand million years... ②

Letters

continued from page 7

cancel each other.

Rigorous mathematical models describing the behaviour of a vented speaker have been around for almost thirty years, but apparently no-one has put the old explanation to the test.

An examination of the electrical equivalent circuit, or the mathematical expression derived from it reveals that, taking the high frequency acoustic output as reference, at resonance the cone output leads 90° and the vent output leads 180°. Thus for a traditional B4 alignment the driver and box resonance are coincident and there is a 90° difference between the phase of the cone and port outputs. Also the cone output is seen to be almost zero.

Readers having a mechanical bent may recognise the similarity to the harmonic balancer, where the primary and secondary masses are displaced 90° and the primary mass has almost zero motion.

That the output from cone and port are not in phase is of no consequence as the cone output is negligible compared to that of the port. What may be of interest is the phase reversal of the acoustic output as the program frequency is swept down towards the speaker resonance. Those concerned with phase linearity may care to examine this effect.

Peter H. Row, Manager
Technico Supplies & Services
Ashburton, VIC.

'Soft start' relay

Thank you for publishing the circuit of my soft start spotlight relay, in the October 1988 issue.

As mentioned in the text, there is about a 1/2-second delay before the filaments begin to glow. A 10uF/50V non-polarised capacitor across D1 (1N4004) solves this problem, without losing the soft-start characteristic. It forms a capacitive voltage divider network with C1, allowing for the effects of R2. When Hi Beam is switched on, C1 is immediately charged to Vthreshold, at which point the normal soft start feature of the circuit takes over.

When switching to Lo Beam, there is a slight negative voltage across the added capacitor, as allowed by D1. Thus it must be a non-polarised type.

I hope this further information will be of assistance to builders of the relay.

Ron McGregor,
Belconnen, ACT.

Vintage Valves

I noticed an article in your August 1988 edition by Mr Peter Lankshear – perhaps you could pass this enquiry on to him.

I would like to know if there is a market for vintage valves. I have a few but have never seen anyone who wants to buy.

I remember being given a box of 60 battery-set valves which I used for air-gun target practice!

E.J. Spain
Hongkong

Comment: We thought it would be better to publish your letter, Mr Spain. If we get any enquiries, we'll forward the letters on to you.

Circuit symbols

Re your Forum of October 88, it seems to me that rectangular boxes could have been seen as a solution to neat, quick drawing for draftsmen. But I still prefer to see the traditional wiggly lines for resistors. Computer aided drafting makes those boxes obsolete, and we can now surely revert to symbols providing clarity of understanding.

Resist, by all means, introducing the bland and confusing boxes for logic symbols instead of the simple and more informative curved ones.

G Cutter
Bentleigh, Vic

Comment: Thanks for your support, Mr Cutter. We have no intention of changing our logic symbols, rest assured! ④

50 and 25 years ago..

"Electronics Australia" is one of the longest running technical publications in the world. We started as "Wireless Weekly" in August 1922 and became "Radio and Hobbies in Australia" in April 1939. The title was changed to "Radio, Television and Hobbies" in February 1955 and finally, to "Electronics Australia" in April 1965. Below we feature some items from past issues.



January 1964

Prefixes for standard units: Expanding electronic technology, particularly in the generation of higher and higher frequencies, has created a need for a whole new range of prefixes ahead of standard unit terms. In 1959, the US National Bureau of Standards published a set of prefixes recommended by the International Committee of Weights and Measures, and in February 1963 the National Bureau of Standard's Bulletin published an amended list with the

Multiples and Submultiples	Prefixes	Symbols
10^{12}	tera	T
10^9	giga	G
10^6	mega	M
10^3	kilo	k
10^2	hecto	h
10	deka*	da
10^{-1}	deci	d
10^{-2}	centi	c
10^{-3}	milli	m
10^{-6}	micro	μ
10^{-9}	nano	n
10^{-12}	pico	p
10^{-15}	femto	f
10^{-18}	atto	a

addition of two new prefixes (see Table 1).

The following explanatory comment is taken from the same NBS Bulletin,

Apology

Unfortunately for the next three months we will only be able to bring you articles from 'Radio Television and Hobbies' (25 years ago), as the issues from January 1939 to March 1939 of Wireless Weekly are missing from our library. If anyone does have copies of these issues we would be pleased to here from you, particularly with a view to updating or completing our library.

referring to the single asterisk in the table.

"The official French spelling for the prefix representing the multiple ten is 'deca.' This prefix has long been spelled 'deka' in the US, Great Britain, Germany, and a few other countries. The continued use of this spelling is consistent with our use of 'gram' for the French 'gramme' and 'meter' for 'metre'.

The symbol, however, should be universal and even though 'dk' has long been used in the US for the symbol for 'deka', NBS will from now on adhere to the official international symbol 'da' for the prefix representing the multiple of ten".

ACROSS

- Information exchange. (13)
- UV radiations are sometimes called ---- rays. (7)
- Change from locked state. (7)
- Printed replica. (4)
- TV and radio are part of the electronic ----. (5)
- Subdue loudness. (4)
- Periods of increased electrical activity in the brain. (6)
- Naturalness in reproduced sound. (7)

CROSSWORD

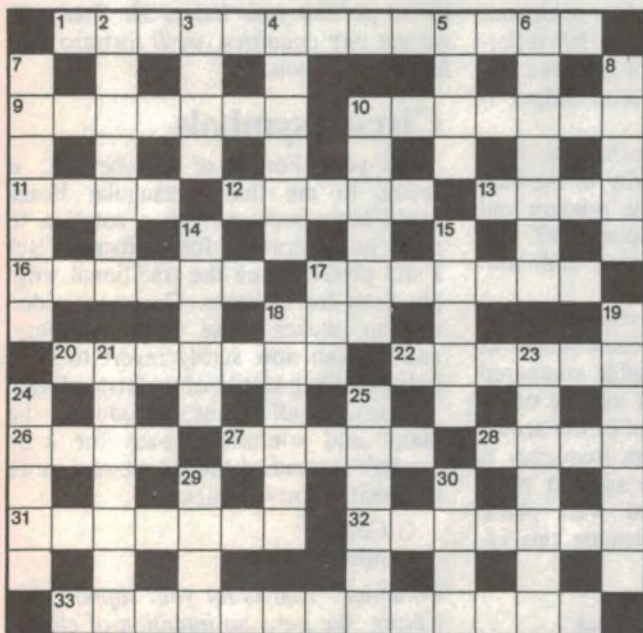

- Standard of quality and uniformity. (3)
- Type of publishing. (4-3)
- American inventor. (6)
- Forerunner of calculators in timber industry? (4)
- Displayed options on computer terminals. (5)
- Information section of data for message. (4)
- Instruments often amplified electrically. (7)
- Non-ferrous alloy applied with iron. (4-3)
- Regular department of EA. (3,10)

DOWN

- Eightfold quantity. (7)
- Magnetic weapon. (4)
- Metal often used in electroplating. (6)
- Trunk call charge in US. (4)
- Terminals providing power, signals, etc. (7)
- Information for optical scanning. (3,4)
- Such is the power of the cube. (5)
- Maker of the Sea Wasp radio. (6)
- Drawback in testing situation. (5)
- A basic rheostat is the ---- wire potentiometer. (5)
- Current going in waves. (3)
- Dry joints? (6)
- Kind of replay. (7)
- Language in international aviation. (7)
- Ranges of frequencies. (7)
- Connectors. (5)
- Sources of some electromagnetic radiation. (6)
- Matter that's attractive to physicists. (4)
- Summon. (4)

DECEMBER SOLUTION

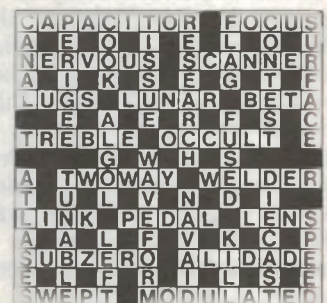

EA marketplace EA marketplace

ADVERTISING RATES FOR THIS PAGE

SMALL ADDS: The minimum acceptable size of 2 centimetres x one column costs only \$50. Other sizes up to a maximum of 10 centimetres are rated at \$25 a centimetre. CLASSIFIEDS: \$4 for 40 letters. Just count the letters divide by 40 and multiply by \$4, ROUND UP TO NEAREST WHOLE NUMBER. CLOSING DATE: Ads may be accepted up to the 18th of the month two months prior to issue date. PAYMENT: Please enclose payment with your advertisement. Address your letter to THE ADVERTISING MANAGER, ELECTRONICS AUSTRALIA, PO BOX 227, WATERLOO, NSW 2017.

FOR SALE

AMIDON FERROMAGNETIC CORES: Large range for all receiver and transmitter applications. For data and price list and 105X220 SASE to: R. J. & U. S. Imports, P.O. Box 157, Mortdale, N.S.W. 2223. N.S.W: Geoff Wood Electronics, Lane Cove. Webb Electronics, Albury. A.C.T.: Electronic Components, Fyshwick Plaza, Vic.: Truscott Electronics, Croydon. W.A.: Willis Trading Co., Perth.

NEW RADIO VALVES: For entertainment or industrial use. Waltham Dan, 96 Oxford St., Darlinghurst, Sydney. Phone (02) 331-3360.

EX-ABC AUDIO TAPES: 1/4" wide on 10 1/2" Standard metal spool \$6.85. Robust metal spool \$12.85 7" spool \$2.85. 5" spool \$1.25. Post extra. Also in stock 1/2", 1" and 2" tapes. Waltham Dan, 96 Oxford St., Darlinghurst, Sydney. Phone (02) 331-3360.

BUILD YOUR OWN LED: Moving Message board. \$75 for a 4 character display experimenters short form kit and \$150 for 16 characters. Include PC boards Eprom and full instructions to complete project to a professional standard. Loaded from Centronics printer port, or PC/XT keyboard. Equip commercial units start at around \$1000. For more info send a 39c stamp to Don McKenzie 29 Ellesmere Crescent, Tullamarine 3034.

A NEW CONCEPT FOR LOW VOLTAGE PROJECTS
COPPER FOIL TAPE: thin pure copper tape backed by special hi-tack adhesive. Current carrying capacity, 5 amps, FULLY TESTED at 24V 5A. Not recommended for mains voltage.
4.75mm ... RRP \$8.03 6mm...RRP\$9.84 8mm ... RRP \$13.60 33 metre rolls
GIFFORD PRODUCTIONS
P.O. Box 62, St. Kilda, Vic. 3182 (03) 534-3462

RCS.RADIO PTY. LTD.
Established 1933
IS THE ONLY COMPANY
WHICH MANUFACTURES AND
SELLS EVERY PCB & FRONT PANEL
published in EA and ETI
651 Forest Road Bexley 2207
AUSTRALIA
RING (02) 587 3491 FOR INSTANT PRICES
24 HOUR TURNAROUND SERVICE

RADFAX2: Hi-Res radio facsimile morse and rty program for IBM PC/XT on 360K 5.25" floppy + full Doc. Need CGA, SSBhf, FSK/Tone decoder. Has re-align auto-start view save print. Also "RF2HERC" same as above but suitable for hercules card, and "RF2EGA" for EGA card (640X350 mode). Programs are \$30 each + \$3 postage ONLY from M. Delahunty, 42 Villiers Street, New Farm 4005, QLD. Phone: (07) 358-2785.

F.M. BUGS: Various models, fully assembled. 488 Sandgate Road, Clayfield, Brisbane, QLD 4011.

PLASMA BALLS, JARS, ETC: From \$80. Balls from 250ml up to 450 litres, with or without power supplies. All designed, built in Australia. Custom Special Effects. Phone Studio of Arts and Sciences (02) 319-2427.

PRINTED CIRCUIT BOARDS
Minimum postage & packaging on all EA & ETI Project PCBs.

PCBs made to order — 48 hr prototype service
Bankcard/Mastercard.
Acetronics PCBs
112 Robertson Rd. Bass Hill 2197
(02) 645 1241

MAGNETRON TESTING

By Return Mail
All domestic and commercial oven magnetrons to 1000 watts. Result sheet provided. Tag with return address, pack securely.
Include cheque or money order for \$14 test fee plus \$7 post and handling.

Mail to:
Service Electronics, 2 Provost Street,
North Melbourne 3051

Phone: (03) 326-6220
Replacements for faulty units post free
from stock at competitive prices ...

WANTED

ELECTRONICS TECHNICIAN: Required 2-3 days per week for small repair workshop. Contact Martin Griffith. Switchmode Power Supplies. 2 Avon Road, North Ryde. Telephone (02) 888-9371.

LASER OPTICS

Build yourself a Laser and Save Big Bucks. Kit Includes, Laser Tube, Transformer, Board, Wiring, Case, Caps, Resistors, Transistors. Many Uses — Discos, Relay Activation 300 Metres, Levelling, Security Effects, Alignment.

Buy Now and Save Hundreds.
Price \$435 Includes Postage Phone (08) 296-7464
Till 9 p.m., Or Send For an Info Pack to
LASER OPTICS.
3 Tarnham Road, Seacombe Heights S.A. 5047.

KIT REPAIRS!

Repairers of all EA, ETI,
AEM and Silicon Chip projects.
Got a problem! Or queries;
Ring any time 9 am-9 pm Mon-Sun

EEM ELECTRONICS
10 Bouverie Place, Epping 3076
(03) 401-1393

SLOW SCAN TELEVISION FOR RADIO AMATEURS

Construct A High Resolution Colour Pal Or NTSC Fast To Slow Scan Television Converter In Your Home, As An Off-Campus Student At Wodonga College Of Tafe At Wodonga Institute Of Tertiary Education.

Full Documentation, Photographs, Schematics And Components. Includes Technical Assistance And Aid In Fault Finding After Instruction.

**FOR FURTHER DETAILS AND BROCHURE
PLEASE CONTACT JOHN WILSON,
(VK3LM) DEPUTY DIRECTOR WODONGA
COLLEGE OF TAPE
P.O. BOX 963 WODONGA, VIC., 369C
PHONE: (060) 56-1122.
FAX: (060) 56-1030**

your computer

A magazine for all computer users and enthusiasts, Your Computer has something for everyone

TUTORIALS
REVIEWS
NEWS
PROGRAMS

EA Directory of suppliers

Which of our many advertisers is most likely to be able to sell you that special component, instrument, kit or tool? It's not always easy to decide, because they can't advertise all of their product lines each month. Also some are wholesalers and don't sell to the public. The table below is published as a special service to EA readers, as a guide to the main products sold by our retail advertisers. For address information see the advertisements in this or other recent issues.

Supplier	State	A	B	C	D	E	F	G
All Electronic Components	Vic	•	•	•	•	•		
Altronics	WA,NSW	•	•	•	•	•	•	•
Acetronics	NSW			•				
Chapman, Lance	NSW	•			•			
Dick Smith Electronics	All	•	•	•	•	•	•	•
Eagle Electronics	SA	•		•	•		•	
Electronic Brokers	Vic						•	
Electronic Component Shop	Vic	•		•	•	•	•	
Emona Instruments	NSW						•	
Geoff Wood Electronics	NSW	•	•	•	•	•	•	
George Brown Group	All		•		•	•	•	
Jaycar Electronics	Eastern	•	•	•	•	•	•	•
Pernea Electronics	Vic				•	•		
Pre-Pak Electronics	NSW		•		•	•		
Preston Electronics	Vic	•	•	•		•		•
RCS Radio	NSW			•				
Rod Irving Electronics	Vic	•	•	•	•	•	•	•
Scientific Devices	Vic						•	
Sheridan Electronics	NSW		•	•	•	•		
Tandy Electronics	All		•		•	•	•	•
Wagner Electronics	NSW		•		•	•	•	

KEY TO CODING

A Kits & modules

B Tools

C PC boards and supplies

D Components

E IC chips & semiconductors

F Test & measuring instruments

G Reference books

Note that the above list is based on our understanding of the products sold by the firms concerned. If there are any errors or omissions, please let us know.

Electronics Australia Reader Services

"Electronics Australia" provides the following services:

Subscriptions: All subscription enquiries should be directed to: Subscriptions Department, Federal Publishing Co, PO Box 227, Waterloo 2017. Phone: (02) 693 6666

BACK ISSUES: Available only until stocks are exhausted. Price: \$4.50

PHOTOSTAT COPIES: When back issues are exhausted, photocopies of articles can be supplied. Price: \$4.50 per project or \$9 where a project spreads over several issues.

PCB PATTERNS: High contrast, actual size transparencies for printed circuit boards and front panels are available. Price: \$5 for boards up to 100 square centimetres; \$10 for larger boards. Please specify positive or negative.

PROJECT QUERIES: Advice on projects is limited to postal correspondence only, and to projects less than five years old.

Price: \$5. Please note that we cannot undertake special research or advise on project modifications. Members of our technical staff are not available to discuss technical problems by telephone.

OTHER QUERIES: Technical queries outside the scope of "Replies by Post", or submitted without fee, may be answered in the "Information Centre" pages at the discretion of the Editor.

PAYMENT: Must be negotiable in Australia and made payable to "Electronics Australia". Send cheque, money order or credit card number (American Express, Bankcard, Mastercard, or Visa Card), name and address (see form). All prices include postage within Australia and to New Zealand.

ADDRESS: Send all correspondence to The Secretary, "Electronics Australia", PO Box 227, Waterloo NSW 2017. Please note that we are unable to supply back issues, photocopies or PCB artwork over the counter.

Back Issues

Photostat copies

Total price of magazines/photocopies, including postage and handling

No off issues reg x \$4.50 = \$

Cheque Money Order Please tick box to indicate method of payment

Please make payable to the Federal Publishing Company Pty Ltd

Mastercard American Express Visa Bankcard Tick

Card Expiry Date

Credit Card No

Signature

(Unsigned Orders cannot be accepted)

NAME

ADDRESS

POSTCODE

ADVERTISING INDEX

Allen-Bradley	117
Altronics	92-95
Arista Electronics	11
Bright Star Crystals	149
Captain Communications	148
Companion Computers	149
Current Solutions	149
Data Electronics	123
Dick Smith Electronics	28-29,82-83,114-115
Duet Electronics	125,149
Eagle Technologies	105
EA subscriptions offer	130-131
Electronic Broker Aust	133,149
Electronic Components Shop	13
Electronic Researchers	149
Elmeasco	57
Federal Publishing	34-35,IBC
Geoff Wood Electronics	23
Gifford Productions	161
Hewlett Packard	IFC
Icom Australia	65,67
Intertronics	51
Kenelec	27
Laser Optics	161
Mondotronic	138
Oatley Electronics	149
PC Board Services	26
Perna Electronics	3
Pioneer	15
Prometheus Software	128
Protel Technology	127
Royston Electronics	126
RCS Design	125
RCS Radio	161
Richard Foot	75
Rod Irving Electronics	16-17,68-69,140-141
RAE	43
RVB Products	41
Scan Audio	74
STC/Anritsu	OBC
Stotts	109
Tennyson Graphics	129
Technikit Electronics	99
Tronics 2000	121
Universal Fibre Optics	127
Uni-X	91
WES Components	48

This index is provided as an additional service. The publisher does not assume any liability for errors or omissions.

WIN A YEAR'S SUPPLY OF BEER!

*5 people will each collect a case of
Labatt's beer per week for a
whole year.*

CANADA'S No 1 LAGER

To enter simply send in the entry form in The Australian Beer Guide! (It even comes with its own envelope)

IT'S THAT EASY!



ON SALE
AT YOUR
NEWSAGENT
NOW!

PLUS 100 great Labatt's caps to be won.



**CANADA'S TRUE
BLUE LAGER!**



ANRITSU CREATES NEW POSSIBILITIES WITH INTELLIGENT PEAK SEARCH

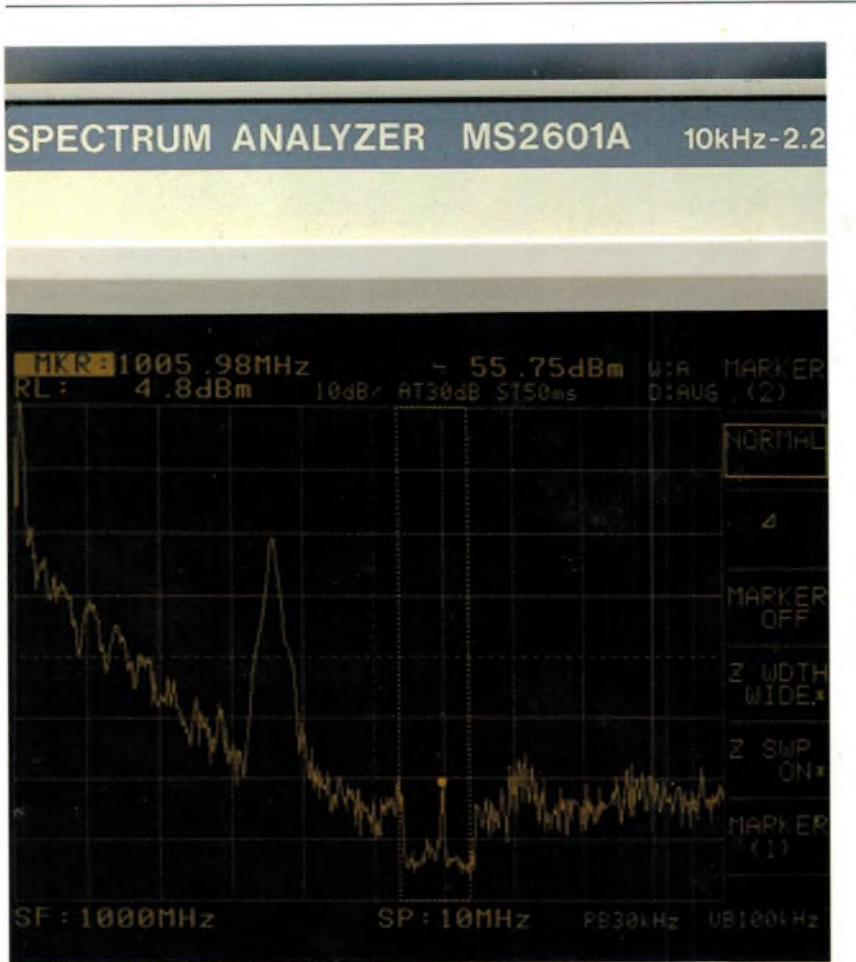

The all-new spectrum analyzer smartly pinpoints signals with more precise results.

*Now you can do it all with the new MS2601A Spectrum Analyzer: locate the signal peak instantly in a user-specified range even in crowded spectra with the world's first **zone marker**, track the signal through repeated sweeping within the zone, and average the levels of the zone. The detected peak is digitally displayed with 0.05dB resolution and in optimum RBW. You'll agree—the analysis is simpler, faster and more precise than ever.*

*The MS2601A offers highly accurate signal analysis up to 30Hz RBW and automatic calibration guarantees **1dB total level accuracy**. A new scroll function shows the spectrum beyond the screen, smoothly moving up to two divisions each way.*

*What's more, advanced digital processing enables faster measurement and display menus simplify operation. Plus, new **Plug-in Memory Cards** make complex operations easy and fast by storing up to 48 sets of data. The compact, portable MS2601A has a range of 10kHz to 2.2GHz at -130 to +20 dBm (dynamic range of 75dB).*

Choose the smart spectrum analyzer with greater cost-performance — choose the Anritsu MS2601A.



MS2601A Spectrum Analyzer

Anritsu

ALCATEL

STC AUSTRALIA

MELBOURNE — 58 QUEENSBIDGE STREET
SOUTH MELBOURNE, VICTORIA 3205
TELEPHONE: (03) 615-6677
FAX: (03) 615-6667
TELEX: AA30878
SYDNEY — TELEPHONE: (02) 6632283