

★ WIN  
TEK TESTGEAR  
WORTH \$4800!

CAD FEATURE: NEW AUSSIE PACKAGE FOR PCB DESIGN

Australia's Top Selling Electronics Magazine

# Electronics Australia

SEPTEMBER  
1989

Aust\* \$4.50

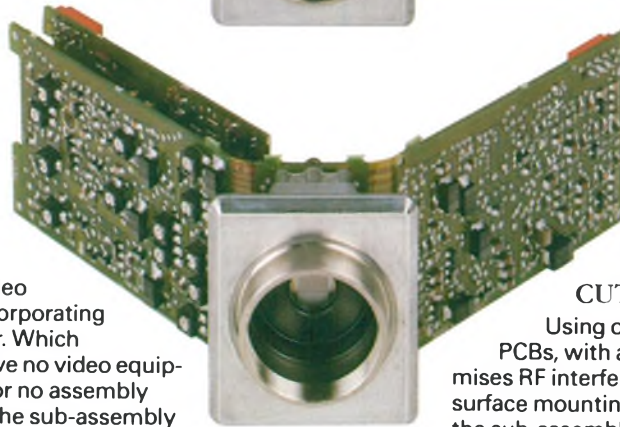
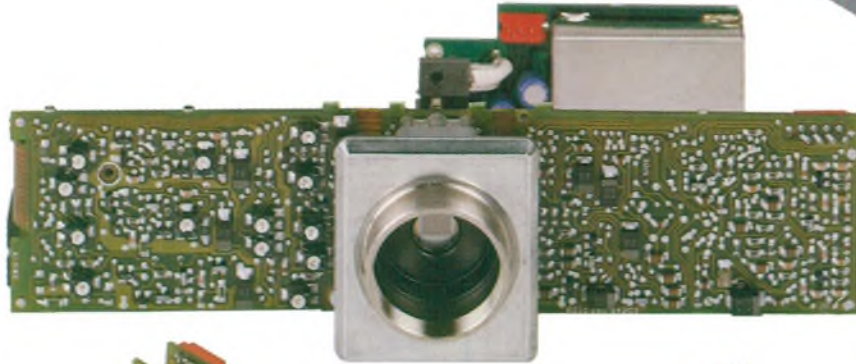
NZ \$5.95 <sup>incl</sup> GST

BUILD  
OUR  
'MUSOLIGHT'  
FUN  
MACHINE!

**LOW COST SUB-WOOFERS ADD BASS TO YOUR HIFI SYSTEM**  
**50MHZ ACTIVE PROBE FOR SCOPES • DISCHARGER FOR NICAD**  
**BATTERIES • FIX COMPUTERS WITH OUR MINI LOGIC ANALYSER**

# MAKE YOUR OWN VIDEO CAMERA – NO EXPERIENCE NECESSARY!

ALSO  
IN COLOUR



Philips brings you a video camera sub-assembly incorporating a solid-state image sensor. Which means that even if you have no video equipment design experience, or no assembly facilities, you can now fit the sub-assembly module quickly and easily into any vision system. (Naturally, Philips will provide you with information support).

## JUST ADD LENS

The imaging module requires only a chassis and a standard lens to form a complete monochrome video camera, for use in machine vision or surveillance.

Or connect the module to a computer and you have an industrial inspection and control system. Ideal for extreme low light conditions, such as a gloomy factory, the SSIS used in the module works in an ambient light level of below 1 lux.

## CUT THE SPACE

Using only five small flex/rigid PCBs, with a unique layout that minimises RF interference, Philips' advanced surface mounting techniques mean that the sub-assembly can be folded to an area just 89 x 40 x 45 mm or extended to 37 x 170 x 45 mm.

## CUT THE COSTS

Why accept a lesser name than Philips when you don't have to? You can have a Philips Imaging Module for less than you think, from \$560 (plus sales tax) for one off purchases. There are ten modules in the range to suit your needs. Find out how little it can cost to have the highest standards of resolution and sensitivity for your application. Call Philips Components on 439 3322 in Sydney, 235 3677 in Melbourne, 348 5222 in Adelaide, 277 4199 in Perth, or 844 0191 in Brisbane.

United Nations 1811

**Philips Components**



**PHILIPS**

# Electronics Australia

Volume 51, No.9

September 1989

AUSTRALIA'S LARGEST SELLING ELECTRONICS MAGAZINE – ESTABLISHED IN 1922

## Mini logic analyser to build



One of our FIVE construction projects this month is this easy to build unit, which gives you many of the features of a fancy logic analyser, but at a tiny fraction of the cost. Invaluable for tracking down those elusive faults in PCs and other computer systems! (See page 88)

## Sub-woofers

Another great project is a pair of low cost sub-woofer speaker enclosures, each designed to add extra 'oomph' to many of today's compact hifi systems. Unlike other sub-woofers, these won't cost you an arm or a leg... (See page 104)

## On the cover

This month's special project for beginners is Branco Justic's exciting new Musolight, a low cost and SAFE 'light show' unit to add fun to your music listening. Shown here with the prototype are Branco's daughters Melissa (L) and Angela, who think dad's latest creation is just great!

## Features

- 10 ELECTRONIC 'SUN' BURSTS INTO LIFE *Hi-tech liner*
- 14 SCIENCE OR BUSINESS: *Which would YOU study?*
- 16 ROBOTS' FUTURE IS IN A VACUUM *Say the experts...*
- 26 WHEN I THINK BACK... *John Murray Moyle – 1*
- 30 7TH AES CONFERENCE *Focus on digital audio*
- 50 ELECTRONICS IN INDUSTRY – 2 *Sensors and how they're used*
- 80 HAM TALK: *Dick Norman, VK2BDN*

## Entertainment Electronics

- 6 WHAT'S NEW IN ENTERTAINMENT ELECTRONICS *Video, audio*
- 84 PRODUCT REVIEW: *Siemens FS 940 digital TV set*

## Projects and Technical

- 64 THE SERVICEMAN *Flashes of horror, and a customer I was happy to lose*
- 68 CIRCUIT & DESIGN IDEAS *Test message generator, low noise preamp*
- 74 50MHz ACTIVE PROBE FOR OSCILLOSCOPES
- 88 LOW COST 'MINI LOGIC ANALYSER' *Very handy for servicing*
- 104 COMPACT SUB-WOOFER ENCLOSURES *Enhance your hifi bass!*
- 110 MUSOLIGHT *A low cost fun machine*
- 116 NICAD DISCHARGER *Mates with our new charger*
- 128 SOLID STATE UPDATE: *World's fastest 1Mb DRAM...*
- 132 CAD FEATURE: *Protel's new Autotrax package (Review)*
- 138 CAD FEATURE: *New CAD products*
- 140 CAD FEATURE: *Racal-Redac's new Cadstar 386*
- 148 BASICS OF RADIO – 9 *Double-change superhets, demodulators & AGC*
- 152 VINTAGE RADIO *The Kolster-Brandes 930 amplifier*

## News and Comment

- 4 LETTERS TO THE EDITOR *Dream designer, industry malaise*
- 5 EDITORIAL *Projects and features for almost everyone*
- 38 FORUM *Surely ham radio can't be dead – look at all these plurry letters!*
- 42 SILICON VALLEY NEWSLETTER *Sematech boss blasts Japan*
- 58 NEWS HIGHLIGHTS *Most powerful SEM in Australia at UNSW*
- 122 NEW PRODUCTS *EPROM programmer, low cost 100MHz scope*
- 144 SPECTRUM *Communications news & comment*
- 155 AMATEUR RADIO NEWS *China's hams back on the air*
- 156 INFORMATION CENTRE *Answers to readers' queries, puzzlers*

## Departments

- 126 BOOK REVIEWS
- 160 EA CROSSWORD PUZZLE
- 160 50 AND 25 YEARS AGO
- 161 MARKETPLACE
- 162 DIRECTORY OF SUPPLIERS
- 162 ADVERTISING INDEX
- NOTES AND ERRATA



# Letters to the editor

## MANAGING EDITOR

Jamieson Rowe, B.A., B.Sc.,  
SMIREE, VK2ZLO

## TECHNICAL EDITOR

Peter Phillips, B.Ed., Dip.Ed., ECC

## PRODUCTION CO-ORDINATOR

Anne Toogood

## EDITORIAL STAFF

Rob Evans, CET (RMIT)

Mark Cheeseman

Dewald de Lange, B.Eng.

## READER SERVICES

Milli Godden

## ADVERTISING MANAGER

Selwyn Sayers

## CONTRIBUTORS

Neville Williams, FIREE, VK2XV

Ian Pogson, VK2AZN

Ron Cooper

Jim Lawler, MTETIA

Bryan Maher, M.E., B.Sc.

Ken Pohlmann, M.S., B.S.

## DRAFTING

Karen Rowlands

## GRAPHICS DESIGNER

Brian Jones

## ART PRODUCTION

Alana Horak, Larry Leach, Ray Eirth,

Ron Farrell

## PRODUCTION

Tracy Douglas

## ADVERTISING PRODUCTION

Brett Baker, Inga Tettmann

## CIRCULATION MANAGER

Michael Prior

## PUBLISHER

Michael Hannan

## HEAD OFFICE,

## EDITORIAL & ADVERTISING

180 Bourke Road, Alexandria, NSW 2015

P.O. Box 227, Waterloo 2017.

Phone: (02) 693 6620

Fax number: (02) 693 6613

For reader services see back of magazine.

## INTERSTATE ADVERTISING OFFICES

**Melbourne:** 221a Bay Street, Port Melbourne,

Vic. 3207. Phone: (03) 646 3111

Fax No: (03) 646 5494, Nikki Roche

**Brisbane:** 26 Chermside Street, Newstead,

Qld 4006. Phone: (07) 854 1119

Fax No: (07) 252 3692, Bernie Summers

**Adelaide:** 98 Jervois Street, Torrensville,

SA 5031. Phone: (08) 352 8666

Fax No: (08) 352 6033, Mike Mullins

**Perth:** 48 Clieveden Street, North Perth.

Phone: (09) 444 4426.

Fax No: (09) 381 3115, Des McDonald

**New Zealand:** 63-73 View Road, Auckland,

New Zealand. Phone: (09) 443 0250.

Fax No: (09) 443 0249, Gordon Marr

**ELECTRONICS AUSTRALIA** is published

monthly by Federal Publishing Company Pty.

Ltd. Incorporated in NSW, 180 Bourke Road,

Alexandria, NSW 2015.

Copyright © 1989 by the Federal Publishing  
Company Pty Ltd, Sydney. All rights reserved.

No part of this publication may be reproduced  
in any way without written permission from the  
Publisher or Managing Editor.

Typeset and printed by Hannanprint, 140

Bourke Road, Alexandria, NSW for the

Federal Publishing Company Pty Ltd.

Distributed by Newsagents Direct Distribution

Pty Ltd, 150 Bourke Road, Alexandria

NSW 2015, (02) 693 4141.

ISSN 0313-0150

\*Recommended and maximum Australian re-  
tail price only.

## Dream designer

I write with a friendly jibe about the article 'The Dream Computer 10 years on', by Tom Moffat, published in the June *EA*. You gave it three pages and yet made no mention of Michael Bauer, who created the thing.

Michael wrote the articles that captured Tom Moffat's imagination back in 1979, but he did not write the sub-heading 'Designed especially for beginners'. It wasn't designed especially for beginners, and unfortunately many beginners built a Dream but were never able to get it debugged.

In the early eighties, I spread the word where Michael worked that he was THE Michael Bauer of 'Dream' fame, and several non-working Dreams were brought in for the laying-on of Bauer hands!

If Tom Moffat purchased a Dream kit soon after the first article, then it didn't have a 6802 in it. If he bought one with a 6802, then it isn't a 'genuine' Dream.

Unlike the 6800 which Michael used in the Dream, the 6802 does not have tri-state buffers on the address outputs. This feature is an absolute requirement on the Dream as the address bus is seized periodically by the video scanning circuitry.

Just after the Dream articles were published, the Australian stocks of the 6875 clock generator IC dried up. Michael did some interesting investigations into driving the 6800 with a clock circuit made from SSI, the result of which was published in *EA*. Meantime one of the kit suppliers, less enlightened than Michael, solved the shortage problem by substituting the 6802 processor — which does not need an external clock circuit.

Tom Moffat and many others like him should be grateful that the good old 6802's are gracious enough to keep on working, even though their address outputs were being overridden every screen write. It's hardly the way to treat a good IC though!

To look back on the Dream phenomenon is a good idea, but why not consult Bauer and get the authentic story?

Richard Schurmann,  
Ausmode Power Systems  
Eltham, Victoria

*Comment: There was no conscious rejection of any reference to Mr Bauer, Richard — just an unfortunate omission. Undoubtedly your letter will remedy this.*

## Makeshift inductor

If, in a pinch, you ever need a 2.2uH inductor, we have found the metal springwork of a wooden clothes peg able to provide just such a value.

D. Thompson,  
Relay Lab, SECV  
Richmond, Victoria

*Comment: Thanks for the tip, Mr. Thompson. Judging by the spiral element in a lot of 1-watt carbon resistors, they probably contain an inductor of around 30nH. How's that for a fair exchange of trivia?*

## Industry malaise

I read with considerable interest your recent editorial regarding the demise of Australia's technology based industries. Your observations struck a particularly strong note, as I have recently had to close our Sydney Office since the effort produced no meaningful result — in fact, the revenue generated did not even pay the rent.

As you are aware RCS Cadcentres provides one of the leading PCB design and documentation services in Australia, with considerable expertise in new techniques. The company also sells and supports a range of dedicated software tools for electronic engineering and design. Because of our exposure to the industry we speak with most firms at one stage or another. We have observed in many cases acceptance of the mediocre level of business opportunity and an overall attitude of depression and gloom.

A substantial number of companies that we would have considered potential customers during the past 12 months are no longer in business, or facing liquidation and bankruptcy.

Surely Mr. Keating's tax policies are not to blame — or are they? I have given the question considerable thought and I suppose it would be too easy to blame the government, but a great deal can be laid at their doorstep. In spite of the efforts of a few courageous ministers (such as Messrs. Button and Jones), who are attempting in vain to stimulate

the manufacturing and technology sectors, their efforts are cancelled out if their colleagues do not direct their respective departments to buy Australian and be totally committed to Australian enterprise.

From what I understand of the Partnership program, little, if anything, has spun off for the small to medium manufacturers who make up the bulk of the high technology employers in this country.

Is there sufficient incentive for Australian firms to invest in new technology? How can Aussie firms compete with overseas operations, who enjoy huge tax respite for investing in new equipment and processes? One doesn't have to look very far for direct comparisons. Singapore sets just one example of how Government can assist.

There is no doubt that this is a very complex issue, with many conflicting requirements.

There are many company's like RCS suffering through what is to me quite clearly a recession. While the whole country may not be experiencing the effects, our industry definitely is. It is not enough for some observers to recommend that the best solution is continued investment. The banks are simply not interested in lending without bricks and mortar security, and other funding is either not available, or too expensive or both.

When a company cannot even get an adequate market share in the local market, which is essential before export is considered, further investment would be considered foolhardy.

Eventually, the greatest share of the Australian market is controlled by Government expenditure, as indeed it is in most developed countries. The solution therefore would appear to be in the hands of those we have elected. Senator Button is wasting his breath talking to 'industry'. We are already convinced; he needs to talk very sternly to his fellow ministers.

In the meantime, I personally am not holding my breath for a quick remedy. I tried it once and it doesn't work!

Ray Smith, Managing Director  
RCS Cadcentres  
Alphington, Victoria

### DROP US A LINE!

Feel free to send us a Letter to the Editor if there's a something you believe that EA's readers should know. If we agree we'll publish it, but we do reserve the right to edit those that are too long, or potentially libellous.



# Editorial Viewpoint

## Projects and features for almost everyone

We have a very solid issue for you this month, with enough reading to keep you busy for quite a while. It's certainly taken quite an effort on our part, to put it all together!

I'm happy to tell you that there are no less than FIVE construction projects, for example. There's a new high input-impedance active probe for oscilloscopes, with better than 50MHz bandwidth and much lower circuit loading than the usual 10:1 divider probes. There's also a mini logic analyser, which allows a normal scope to perform many of the functions of a full-scale analyser – triggering on a specific address/control line combination, and even displaying the data bus state, either at the time or after an adjustable delay. Just the shot for tracking down those elusive faults in a microprocessor-based computer system!

One of the other projects is a pair of low cost sub-woofer speaker enclosure designs, either of which you can use to extend the bass response of many of today's smaller hifi systems. There's also an automatic NiCad battery discharger, to match the auto charger described in our July issue. And finally but by no means least there's the Musolight, a low cost 'light show' project designed especially for beginners. This adds all sorts of intriguing light effects to your music, but unlike most other designs is based entirely on low-voltage circuitry – making it completely safe.

Other features in the issue are part 2 of Peter Phillips' short series on Electronics in Industry, discussing the many different kinds of sensors and their uses; our review of the new Siemens FS 940 'digital' TV receiver, with its impressive 'freeze frame' facility, 100Hz scanning and other refinements; and a double-barrelled review of Protel Autotrax, the new Australian developed PCB design package.

If that isn't enough to please you, there's also Tom King's look at the hi-tech gear on the new Scandinavian luxury cruise ship, the *Royal Viking Sun*, and another story on the development of industrial robots capable of working in a vacuum – the working environment of the future, according to some experts.

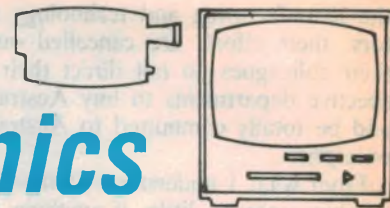
But there's one other article I'd encourage you to read as well: the one on pages 14 and 15, written by Professor Barry Ninham of the Australian National University. Professor Ninham makes some important points about the continuing low status of science in Australia, and he makes them in a particularly frank – not to say provocative – fashion.

Of course you'd find just about all of our regular features and departments inside, too. So one way and another, you should find quite a bit to interest you this month – regardless of your particular interests.

*Jim Rowe*

# What's New In

# Entertainment Electronics



## New Akai VCR has 'digital tracking'

Akai has introduced the VS-53 'digital tracking' HQ VCR. The VS-53 utilises Akai's proprietary DX4 head system, a double azimuth crystal ferrite head which the company claims offers unprecedented hardness and smoothness – ensuring years of noise-free service.

The novel in-built 'Digital Tracking

Control' continually monitors head alignment, ensuring it is optimised and automatically adjusts to each tape, thus doing away with bothersome manual adjustments.

A choice of either high quality SP or economical LP modes allow up to eight hours of recording on a single E-240

tape. The HQ (High Quality) enhanced video system offers cleaner and sharper outlines, and a novel noise cancelling circuit utilising a CCD reduces picture noise, while at the same time retaining fine picture quality.

Special affects include: slow motion, still picture, frame by frame advance, double speed playback, Quicker Finder – which allows scanning up to five times faster than normal speed for SP mode, and high-speed cue/review which allows zeroing in on an exact location on a tape up to five times faster in SP mode than normal speed.

The VS-53 is covered by Akai's three year warranty (except heads – one year) and is available at Akai's state offices or selected dealers. It has an RRP of \$849.



## Home movies/video transfer service

Many people have treasured family history recorded on home movie film, and would like it transferred to videotape for more convenient viewing. Needless to say, this must be done very carefully in order to achieve optimum results.

A new company has recently been formed in Sydney to provide professional video transfers of movie films, slides, negatives and prints. The proprietor of 'All Home Movies onto Video' is Warren Wood, who has over 30 years of experience in the operation and preservation of 8mm, Super 8, 9.5mm, 16mm and 35mm motion picture film and equipment. Warren is well known in the industry, having managed a leading film library, rental and retail firm for over 20 years.

All transfers are done using Fuji HQ Beridox fine grain tape, and the equipment used is adjusted for optimum performance with this tape to ensure the best possible results. All transfers in-

clude free background music if desired, and a selection of high quality artist-drawn Movietitles. All movie films are also cleaned and checked before transfer, with minor repairs carried out free of charge. Splicing together of small reels is charged at the rate of 50 cents per splice plus the cost of any reels and cans required. Tapes are packed in a free presentation library case with multi-coloured indexed jacket.

Transfer charging for movies is at the rate of \$1.00 per minute, with a minimum charge of \$30.00. This includes tape. Transfers of slides, negatives or photographs cost \$39.00, which covers the first 50 slides or negatives, or the first 25 photographs. Additional slides or negatives cost 60c each, while additional photographs are 70c each.

Further details from All Home Movies onto Video, PO Box 101, Strawberry Hills 2012 or phone (02) 698 1470.



## New videotape lineup from TDK

TDK (Australia) has released a new range of VHS video tape.

Designated the 'Super Avilyn Technology Plus' range, the new tape comes in four grades starting with the new HS (High Standard), new E-HG (Extra – High Grade), new Hi-Fi (High Fidelity) and new HD-XPRO (High Definition – Excellent).

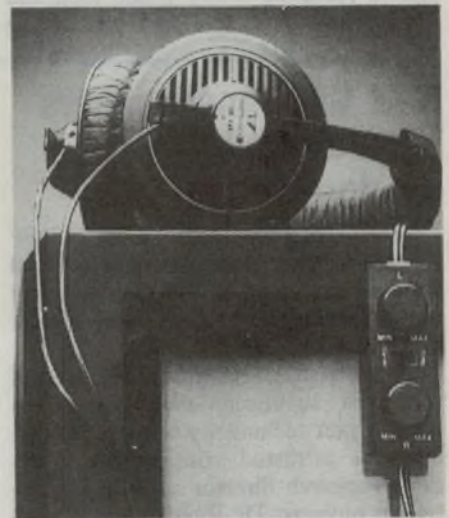
The 'new' prefix indicates the latest formulation upgrade. Also the previous HD (High Definition) grade has been replaced by the new Hi-Fi; this is primarily to indicate the new Hi-Fi grade is specifically designed for hifi stereo applications.

## TV headphones include volume control

Releasing the viewer from the tiresome necessity of having to leave his chair to adjust TV volume, two models in the extensive range of high performance headphones from Beyerdynamic incorporate an in-line volume control.

The DT 340 TVs, which are designed for use with today's advanced new stereo televisions, allow the viewer to enjoy the full fidelity of these sets without disturbing others. The headphones are lightweight and their comfortable circumaural design employs an advanced new transducer that provides clear, natural reproduction and fast transient response. A seven-metre long flat cable gives maximum accessibility and twin, clearly-marked rotary controls allow fully independent left and right channel volume adjustment from the comfort of the viewer's chair.

Weighing only 66 grams, the 'phones have a wideband frequency response of 20-20,000Hz.



## Midi system has twin CD player

Pioneer's new Prologue shelf system features a twin CD player component, which allows two compact discs to be loaded and played in sequence, giving versatility to the listener's music program and the flexibility of changing discs without breaks in the music.

Pioneer first led the development of CD multiplay some five years ago, when it released the award winning PDM6 with its 6-disc magazine, and has continued to broaden its appeal with the inclusion of the Double CD player in the Prologue.

The twin player allows the listener to choose to play one disc after another in a normal manner, random play with the machine selecting at will from both discs, or playing according to a pre-set program of up to 24 tracks from the two discs.

The Prologue includes a 22-watt amplifier with five band equaliser and remote control volume. Its twin cassette gives a double or normal speed dubbing facility and both decks are operated by soft touch controls. The tuner has 6 presets each for FM and AM, giving easy and convenient selection.

The system is equipped with 2-way bookshelf speakers comprising a 16cm woofer and 6cm tweeter in each, and all components are easily accessed by a convenient cordless remote control which allows the user to power on or off, mute sound for breaks, adjust volume, change functions and scan preset stations.

The Pioneer Prologue has a recommended retail price of \$999 and is available throughout Australia.

## Mid-price CD players offer many features

The new Marantz CD6511 and CD7511 CD players sell in Australia for a recommended \$599 and \$699 respectively, yet they contain features normally found only in players costing more than \$1000 – and in some cases much more – according to Marantz Australia's National Manager, Mr Kym Biddell.

These include three separate power supplies for mechanical, digital and analog audio stages; a fully floating diecast mechanism with single-beam laser, able to track dirty or damaged compact discs

which result in errors in most machines; and gold-plated electronic digital output. The CD7511 also has an additional optical-fibre connection.

Both the CD6511 and CD7511 use 16-bit four-times oversampling for improved sound quality with precise stereo imaging and focus. Marantz tests have

shown that 16-bit four-times oversampling techniques result in superior sound to so-called 18-bit eight-times oversampling systems, according to Mr Biddell.

The CD6511 has a remote control with 10-key direct access to 99 tracks. A 20-step memory can program by track, index point or time.



## Entertainment Electronics

### Sanyo midi systems have 'trapezoid'

Sanyo has launched a new range of portable sound systems which incorporates 'trapezoid' – claimed as a breakthrough in sound technology. Developed by Sanyo, 'trapezoid' is said to deliver a superior sound through trapezoidally shaped speaker boxes.

The new Sanyo trapezoid systems include the MW242F, which incorporates a 5-band graphic equaliser, FM stereo MW radio, condenser microphone, surround sound system, high speed and synchronised dubbing and one-touch recording and 30 watt (PMPO) output. Also available is the MW232F, which incorporates an FM Stereo MW radio, high speed and synchronised dubbing, 3 band graphic equaliser and 2-way 4 speaker sound system with built-in condenser microphone.

Released at the same time is the DJ-1, a new generation, fashionable sound system featuring a new round look and a fully automatic hifi digital recording



system with CD and programme edit, twin 7-band spectrum analyser with graphic equaliser.

The DJ-1 also has a 48-key remote control that provides access to all necessary operations, along with a one key

CD tape playback. Recording is fully automatic whether it is from CD to tape, tuner to tape or tape to tape. The built-in fully automatic computer system FCRS lets you record with just a touch of a button.

### New KEF loudspeakers have unified woofer/tweeter

British speaker manufacturer KEF Electronics has released a new range of systems employing a 'radical' new driver unit – effectively a combined woofer and tweeter in the same chassis.

The system is claimed to be one of the most significant developments in loudspeaker technology for many years, and has attracted considerable attention. Research director of KEF is Australian physicist Dr Richard Small, well known for his work on enclosure design theory in conjunction with fellow Australian Neville Thiele.

Development of the integrated 'Uni-Q' driver used in the new systems is said to have been dependent on the use of a recently discovered high-efficiency magnetic alloy, neodymium-iron-boron. This has allowed the fabrication of the dome tweeter system within the central pole of the woofer, and in the same vertical plane – unlike earlier designs. This gives a truly co-axial and co-planar relationship between the woofer and tweeter, so that the sounds produced by each effectively emanate from a single common point.

As a result, there are no relative phase differences or time delays. This

### Improved phono connector

Two basic shortcomings of many phono connectors are that they 'make' the signal connection before the ground, and break ground before signal; and the poor quality of the cable strain and stress relief.

Neutrik claims to have solved these two basic problems with its NF2C/2 ('Profi') phono connector.

The NF2C/2 makes ground contact before signal contact, and breaks the signal before the ground – eliminating noise and the risk of broken speaker cones. It is also furnished with the well proven Neutrik chuck-principle cable protection.

The ground before signal function is accomplished by a special shell element which protrudes, under spring load, out of the shell around the pin. This pro-



protects the pin from undesirable contacts with foreign potentials, and provides a safe ground connection before the pin-contact is closed.


The NF2C/2 has a nickel housing and gold plated contacts, and comes in a pair of two (black and red) phono plugs.

For further information contact Amber Technology, PO Box 942, Brookvale 2100 or phone (02) 975 1211.

gives cleaner, balanced sound at virtually all angles and distances from the driver, rather than only at a single 'sweet spot'.

Four of the new KEF systems incorporate the new Uni-Q driver: the C95, C75, C55 and C35. This series is the first range to spring from the Eureka Research Programme, a \$3 million

three-year European Community project undertaken by KEF and the Danish firm Bang & Olufsen, with the aim of developing speaker systems that will adapt to the acoustics of any room.

Further details are available from KEF's Australian distributor, Falk Electrosound Group of 28 King Street, Rockdale 2216 or phone (02) 597 1111. 



CMOS EPROMs  
 512K from \$7.99 each  
 256K from \$2.99 each

Offer ends  
 October 31  
 1989



## Our prices are on the board

We want you to know that you don't have to pay more to get the Philips name or the famed Philips back-up. See for yourself.

Philips CMOS EPROMs are industry pin-compatible and are available in UV-ERASABLE, OTP\* plastic and SMD packaging with a range of access times from a low 45ns.

For more information on how you can take advantage of this offer on the range of Philips CMOS EPROMs, please contact:

- Soanar Electronics (all states)
- CL Burton Assoc. (Adelaide)

or, Philips Components direct - Sydney 439 3322; Melbourne 881 3677; Brisbane 844 0191; Adelaide 348 5222; Perth 277 4199.

**Take a closer look.**

United Nations 2043

	Type	Price Each	Minimum Qty
27c 64A-25FA	250ns UV-ERASABLE	\$2.99	min 100pcs
27c256 -25FA	250ns UV-ERASABLE	\$3.89	min 100pcs
-20FA	200ns UV-ERASABLE	\$3.99	min 100pcs
-20N	200ns OTP*	\$2.99	min 100pcs
27c512 -20FA	200ns UV-ERASABLE	\$9.99	min 100pcs
-20N	200ns OTP*	\$7.99	min 100pcs

\*OTP = ONE-TIME Programmable

### Philips Components



# PHILIPS

# The Electronic Sun bursts into life

Ocean cruise liners maintain the grand tradition of leisurely sea travel, while nowadays taking full advantage of the latest hi-tech navigation and communications gear. Here's a look at the setup on the very latest vessel, the *Royal Viking Sun*.

by **THOMAS E. KING**

Late last year, a massive ship was commissioned at the Turku Shipyard in Finland. Instead of quietly beginning its working life as a cruise liner, the launch of super ship the *Royal Viking Sun* was headlined in much of the world press and shown in prime time newscasts in many countries. No ship in recent times had received such publicity.

Media reports focused on innovative public-pleasing features like individual butlers for suite-sited guests, private verandas, floor-to-ceiling windows, walk-in closets and gold plated fittings in selected staterooms. As well, statistics were often quoted: "glass covers more than a quarter of the Sun's outer surface" and "all 740 passengers can be ac-

commodated for dinner in a single sitting."

Figures revealing size and performance were presented, to show the outstanding credentials for this flagship of a new generation of ocean-going luxury cruisers. But virtually nothing was broadcast or printed about the level of sophisticated technical and electronic inclusions which help to make the *Royal Viking Sun* the jewel in the crown of 21st-century ocean vessels.

The *Royal Viking Sun*, for starters, makes extensive use of satellite communication facilities for entertainment, navigation and communication purposes.



*Royal Viking Sun's* Captain Ola Harsheim pauses before his state of the art navigation system during the ship's 100-day inaugural world cruise.



**Well above the Sun's entertainment and pool deck and near the stern funnel is a radome-enclosed Intelsat dish, one of three satellite dishes on the elegant vessel.**

Satellites positioned over the Atlantic, Pacific and Indian oceans and a host of Coast Earth Stations constitute the backbone of the INMARSAT maritime satellite telecommunications system, in use on the *Sun*. With the touch of a single button one of the ship's three radio officers can send a 20-watt signal into a 25dB gain antenna to instantly access a geosynchronous INMARSAT satellite orbiting some 36,000km overhead.

There's always one satellite that can be accessed with the ship's Magnavox MX2400 Integrated Satcom Terminal. In some instances where coverage overlaps, such as in the Southeast Asian region, two satellites can be contacted - with either used for telephone, telex, FAX and data transmission and reception.

During the five weeks I was onboard the *Sun*, I made a number of live satellite broadcasts back to 2GB in Sydney for my weekly 'Travel by Radio' program. As these first-ever Pacific Ocean-

**INMARSAT system maps like this example for the Indian Ocean show the footprint for a communications satellite used by many of the world's maritime operators.**

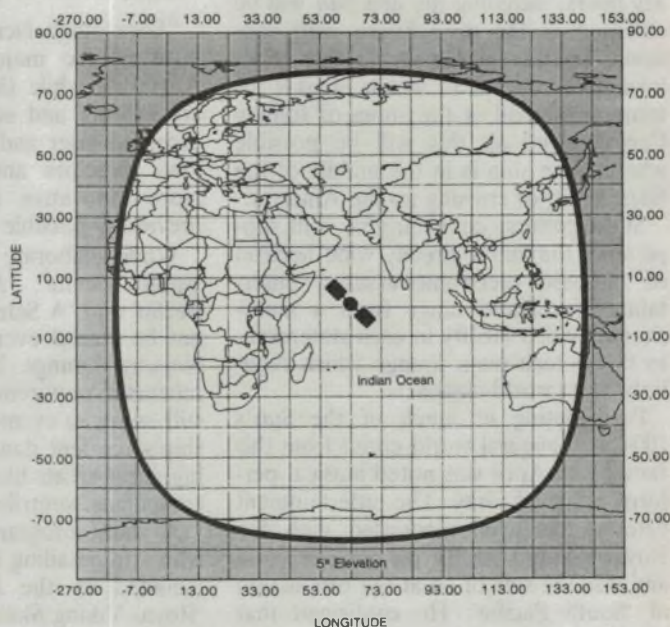
sited ship to Australia-sited radio station satellite transmissions were only made in Australian and Southeast Asian waters, we used the INMARSAT over the Pacific Ocean.

Generally the subsequent satellite telephone call went through the Singapore Coast Earth Station, but on one occasion we had to use the Tokyo CES as the level of telecommunications traffic through the Southeast Asian gateway city was saturated. Had both Singapore and Tokyo Coast Earth Stations been unable to handle the call, then a third option would have involved the use of the Santa Paula CES in Alameda, California.

Another Coast Earth Station for the Pacific region is expected to come on line soon in Moscow. (The selected name is Nakhodka). As yet no CES has been established in Australia!

For the Indian Ocean region, satellite telecommunications traffic can be sent via Coast Earth Stations located in Tokyo, Japan; Stavanger, Norway; Thermopylae, Greece; Gydnia, Poland and Moscow, USSR (the code name for this latter station will be Odessa). Another maritime satellite station is anticipated for Jeddah, Saudi Arabia.

The number of Coast Earth Stations within the footprint of the Atlantic Ocean-positioned satellite reflects the amount of maritime traffic in the region. No less than eight stations are operational: New York; Falmouth, England; Rome, Italy; Moscow, USSR; Gydnia, Poland; Etel, France and Rio de Janeiro, Brazil with two others planned.



## Electronic sun

In 1991 a new satellite with an expanded footprint is to be launched. This new generation satellite will be accessible to ships sailing along the USA West Coast, those in the mid Atlantic as well as liners cruising Western European waters.

INMARSAT may be invaluable for navigation and communications, but it's not the only satellite used by the world's most elegant cruise vessel.

The Oceansat system (not related or linked to the INMARSAT system) uses two satellites. These, located over the Atlantic and Pacific Oceans, provide a visual-only information service to subscribers in the region. Financial information, news, weather and sports highlights are the mainstay of the regularly updated teletex-type formatted service, designed primarily for ship passengers.

Oceansat is a relative newcomer on the maritime satellite scene. In July 1987 a sister ship of the *Royal Viking Sun*, the *Royal Viking Sea*, was the first pleasure liner to make the information service available to its leisure-orientated passengers. Extending the service to the Indian Ocean (a procedure which would involve the launch of another satellite or fulltime lease of a transponder) would provide round-the-world cruise passengers and other maritime subscribers with a much needed information service.

While such an outlet over the Indian Ocean is not yet available, satellite TV using INTELSAT is a reality. Electronic pundits of the Royal Viking Line forecast that all four of the company's luxury liners, including the new *Sun* will be outfitted in the near future with consumer satellite hardware capable of allowing passengers to watch Sunday afternoon football or the antics of Johnny Carson. And all this will be possible whether the ship is in the middle of the Bass Strait, or cruising up the Amazon.

Such 'cultural contributions' will supplement the *Sun's* already wide horizon of onboard electronics-assisted entertainments. These range from a multi-channel video facility in each stateroom, to the hi-tech main lounge which regularly hosts world-class acts.

Participating in much of the *Sun's* 100-day inaugural world cruise from this January to April was noted musical performer, David Gray. The entertainment veteran has been associated with the Royal Viking Line for the past six years and was the star of an at-sea production of 'South Pacific'. He confirmed that "the best of everything" was on board.



**Knut Norheim, one of the *Sun's* Chief Radio Officers, with the impressive communications gear at his disposal.**

"Back stage facilities are as good as most of the major cabaret rooms in Australia, while the ship's state-of-the-art lighting and sound system with its excellent laser and visuals capability allows directors and performers to be more innovative than has ever been previously possible at sea".

While elaborate productions such as 'South Pacific', 'A Tribute to Irving Berlin' and 'A Salute to Broadway' cannot be staged every night in the *Sun's* Norway Lounge because of extensive rehearsal requirements, passengers can still enjoy an evening of variety with the ship's resident dance company or rotating guest artists like magicians, jugglers, comedians, ventriloquists and vocalists.

A daily programme profiling who's who and detailing venues and times was included in the *Royal Viking Sun's* 'Royal Viking Skald'. This four to eight page computer composed and laser

printed tabloid also contained a complete schedule of the day's other events and activities. These varied from 'enrichment' lectures such as my own illustrated series on travel photography in Asia, and team Trivial Pursuit, to weekly Bible readings and golf simulator tee times.

(This novel invention allows sports people to electronically golf at championship courses around the world. Enthusiasts tee up a conventional golf ball and drive as normal. The ball hits a translucent screen just metres away, which is rear projected with panoramic views of a selected course. The golfer plays a round with a computer keeping score. All this is done within the space of an executive office!)

Not only was a summary of the day's activities printed in the 'Skald', they were also covered every morning in a live TV production, 'Sunrise'. This one-

hour program, seen on colour monitors in various public areas and on all 370 state room sets, featured interviews with performers and even the occasional passenger as well as informative discussions with on-air personalities Carole Klein, Social Hostess for the inaugural cruise of the *Sun* and Paul McFarland, the Cruise Director.

The many talents of resident video wizard Frank Coccaro were frequently called upon to capture the essence of shore excursions. Frank would then edit hours of material into compact visual reminders of a day's outing on Bali or in Goa, for instance. Most of the ship-board activities were also videotaped, edited in the 'Penthouse Production Suite' and either made available for continuous viewing over one channel of the closed circuit television system or included in 'Sunrise'.

This very popular program, which went to air each day the cruise vessel was at sea, was part of a visual feast which passengers could enjoy 24 hours a day in the comfort of their luxurious and serene staterooms. Staterooms, considerably quieter than those on board most cruise ships because of a high degree of sound proofing and rubber mounted engines, featured the latest model colour TVs, video cassette players and a centralised video library with hundreds of current titles.

In addition to the video library and the regular breakfast show was a series of continuously broadcast destination documentaries. Sightseeing lectures and shipping talks on ports still to be visited were also telecast. One channel featured a video tape of nothing but a blazing log fire. Accompanying classical music, I discovered, created the perfect

setting for a romantic in-room dinner of lobster and wine.

Another video channel simply showed the sea for much of the time. A video camera positioned high atop the ship in the panoramic bridge was fixed to gaze ahead and show the passing parade: the occasional tanker, another cruise liner, a frolicking dolphin (whales are sometimes seen) or frequent low flying birds. Attention to this channel and its accompanying popular music sound track was heightened during the impending docking of the *Sun* at one of the nearly three dozen ports visited on the inaugural world cruise.

On the screen passengers could only see the massive ship inching nearer and nearer to the prepared wharf. The activity in the bridge or the vast amount of highly sophisticated navigation equipment used in docking was never visible. Only during specially organised tours to the bridge were passengers ever allowed to see the 'inner sanctum' brain of the 673 foot, 38,999 tonne giant. While the very latest radar system took pride of place, I was fascinated to see an age-old sextant still within an arm's reach of CAD equipment.

Even on a hi-tech, ocean-spanning pleasure vessel like the *Sun*, lo-tech navigation and telecommunications equipment still has its place. Despite a 'black box' used to access an orbiting satellite at the mere push of a button, the radio room of the *Sun* is also equipped with an envious assortment of more conventional radio equipment. Set in racks along one wall are four HF transmitters, eight receivers and four VHF transceivers.

Almost everything is of Scandinavian origin. 'AS' receivers in use on the *Sun* come from Denmark while 'Standard' is a well known brand of Swedish communications equipment. Some of the antennas were manufactured in Norway.

HF still serves maritime communications users well. In American waters the *Sun* and other cruise liners use all the allocated marine HF bands (4, 6, 8, 12, 16 and 22MHz) for relay of traffic. As well, the emergency frequency of 500kHz is constantly monitored.

And what about Morse? Even on such a sophisticated ship as the *Royal Viking Sun* all radio officers must be proficient with Morse. It seems that not only is the Morse code still used for weather reports, but in some areas of the world the universal code system is also employed by some coastal stations with telegrams for passing boats and



The *Sun's* resident video expert Frank Coccaro preparing a tape for broadcast, following much the same procedure as in a metropolitan TV station.

(Continued on page 159)

# Science or business: which would YOU study?

In view of the current debate over the state of science and technology in Australia, this short but provocative piece by the head of Applied Mathematics in the Research School of Physical Sciences at the Australian National University in Canberra seems particularly appropriate.

by PROFESSOR BARRY NINHAM

My Department is called Applied Mathematics. It does research. It's one of eleven in our Research School of Physical Sciences, which is one of seven in the ANU. Sounds pretty boring, physics and mathematics, but it isn't.

Last year the Director of Science Policy Studies at Griffith University gave a talk on Robyn Williams' Science Show. These policy people are what Professor Manning Clark calls 'measurers with no soul'. The Director had a go at the cossetted academics in our Research School of Physical Sciences. He did the statistics, and reckoned we weren't working. He said we were publishing fewer research papers in physics than our mates in the State Universities who have heavy teaching loads. If that were true, it would be cause for alarm.

But he got it wrong, badly wrong, which illustrates the dangers of non-professional managers – efficiency experts – setting science policy.

You see, my Department does experimental and theoretical research, pure and applied, basic and development work, but not mathematics or physics of the textbook kind.

We do fundamental work that relates to enhanced oil recovery, fibre optics, neurophysiology, membrane biology, immunology, materials science, and colloid and surface science. In fact, in that last field we lead the world, which is why we have so many people from France, Sweden, Japan, America, China, and other places who keep coming to work with us. The research we do underlies soil science and many industrial processes such as metal extraction, paper making, paint production, thin-film techniques, and so on.

It also relates to medicine. With the John Curtin School of Medical Research we have found some remarkable new

immunosuppressant properties of household detergents. These findings may eventually be useful for the organ transplant business.

Our Department manufactures and sells (at \$130,000 a time) to overseas industry and universities a unique apparatus, developed here, for measuring molecular surface forces.

And so, of the 50 or so research papers we publish each year, virtually none appear in core physical science journals. Most turn up in core journals of chemistry, biochemistry, biology and engineering. This may be confusing to science policy economists, but not to scientists.

Each year members of my Department deliver eight or nine invited lectures at major international conferences, nearly all funded by overseas institutions.

Thirteen of our fellows have gone on to full professorships in Australia and

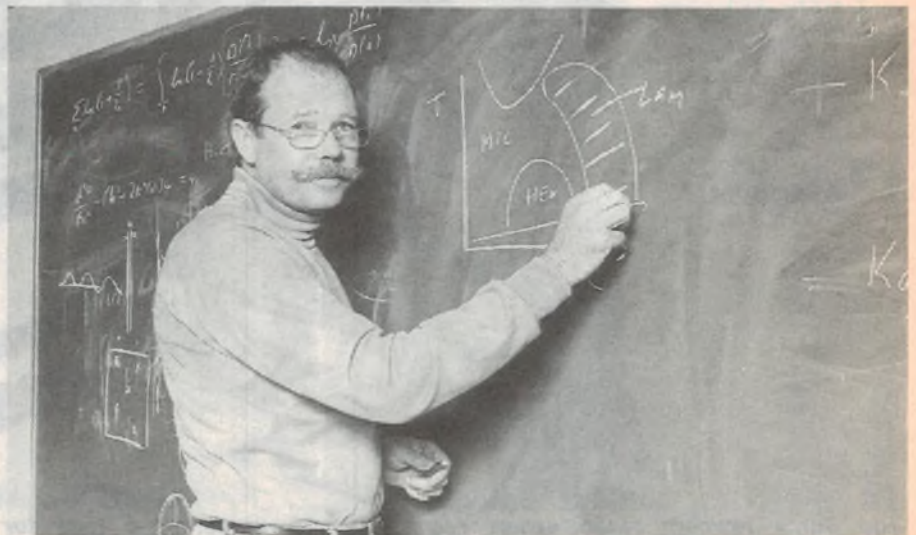
overseas. Like other ANU scientists, these days we do much applied research with diverse industrial partners – as do all the good academic places like Caltech, Harvard, and the like.

We're not stuck in an academic groove. New avenues of research at the moment involve new approaches to drug delivery and making novel metal alloys for the aircraft industry. If you try to label our research as pure or applied, strategic or mission oriented – to put everything in boxes as the economists or efficiency experts long to do – it doesn't work. You can't assess scientific productivity like that.

We may be wimps, but we love our work. We're exploring new frontiers all the time, and can only feel sorry for the poor devils who have been persuaded to do dull things like business.

The University of Arizona State has 40,000 students and is the sixth largest in the USA. This year it has 5000 students in business and administration and 5000 in law. But only 30 in chemistry. Exactly 30! The impact of that on future American high technology, and its economy, is appalling. One could say that a business course is a licence to print money, but what happens if the printing press breaks down?

Who cares that nobody can dress up a



Professor Barry Ninham is head of the Department of Applied Mathematics in the Research School of Physical Sciences, ANU. (Picture by Marie Colvill)

piece of timber with a Stanley plane any more, or sharpen a blade, or build a clinker boat and rivet it? They might care when there are no craftsmen left, and when the public learns how dangerous some of the new fibreglass materials can be to long-term health.

The unions know and keep quiet. So do some people in government, but it is too hot to handle. Scientists get called 'greenies' or 'stirrers' if they tell all they know. Very anti-business.

We wouldn't do that in Australia would we? The hell we wouldn't. Something like 18,000 students applied to Queensland Institute of Technology to do business studies this year. There were 8000 places. Next year probably 26,000 will apply. The cut-off for entry will be higher than medicine. It is the same for the University of Sydney West at Hawkesbury. It is all a matter of market forces, they say.

But who will all these people manage when they finish? They won't manage scientists or engineers, because there'll be none of them left. Maybe these new managers will all be financial whizzes trading share options on the stock market with their MicroVax computers, a sort of giant Yuppie TAB.

Our approach to science funding and teaching in Australia reminds me of the old Harry Secombe song from *The Goon Show*: 'I'm Walking Backwards for Christmas, across the Irish Sea'. Why is funding for science deemed so unimportant?

Remember that the education of most of the people who now make decisions at senior levels in politics, industry, or the work force stopped at secondary level. In the 1950s, Australia was like what we now call a Third World country and, for the majority, secondary education was about all there was. School was it, and social contacts and expectations made there formed the basis of lifelong attitudes.

We have made some progress in education, but our decision-makers still see the need for universal secondary education, whereas post-industrial countries require universal tertiary education.

In 1800 Napoleon recruited France's best scientists, mathematicians, and engineers to set up the tertiary Ecole Normale Supérieure colleges. They are still the source of France's economic strength. In the 1850s Japan and Germany instituted massive tertiary programs in engineering and science, the source of their present economic vigour.

Professionalism is the key. Australia

persists in its old-fashioned amateur attitude of muddling through. Outside this country, funding cuts to science, research, and CSIRO (not to mention the graduate tax) are viewed with incredulity.

Australia's amateurism derives in good measure from the men of the '40s and '50s who run the country. Among our political, industrial, and government decision-makers, there are few scientists or engineers of world stature who know what research is all about. Research funding is decided by managers, accountants, and economists who understand nothing of science except saving dollars. Yet those savings are illusory. We have to invest to produce.

There is a key difference between Australian industry's attitude to research and that of overseas industry. Large companies in the US, West Germany or Japan give their researchers complete freedom to work on ideas — pure research — in close contact with the best university scientists. Australian industry has a few scientists working on tied research.

Americans pick out, and promote to senior management, talented young researchers at a time when they are still technologically competent and up-to-date. Our administrators are yesterday's

men, whose exposure to science stopped too early and too long ago.

Why not go into the business stream, when a top honours science graduate here gets a miserable \$8000 (taxed) per year, about the level of the dole, to do a PhD? And young scientists with PhDs, five years' research experience and international reputations are offered jobs at \$30,000 for three years, with a heavy teaching load. Hardly an incentive to even the most patriotic Australian who, overseas, can double this salary with minimal teaching duties.

The picture is gloomy, but ignorance is bliss to Australian politicians, our '50s men who devalue the intelligence of the Australian people. The country needs a Marshall Plan to recoup the losses and redress the balance. We have the brains, but sadly no General Marshall, and no Napoleon. A massive injection of money — the CSIRO needs \$200 million — would have a real return of at least 50% per annum.

Can we afford it? No way. After all, it represents a tax of about one middy per week on Australia's drinking population.

*Reprinted by permission from 'Advance', the newsletter of the Research School of Physical Sciences, ANU.* ☐

# TRONICS 2000

## STEPPING MOTORS SERVO MOTORS

### SANYO DENKI STEPPING MOTORS

Sanyo Denki Stepping Motors are of the efficient, latest design hybrid type. Torque outputs vary from 1 to 150 KgM Cm with speeds up to 3000 rpm. Very economical drive units are available to suit all motors for interfacing to computers for programming under BASIC.



### SANYO DENKI MOTOR FEATURES

- Compact, Lightweight, High out-put
- Excellent Servo Characteristics
- Well matched line-ups and options
- Controller Units available in full line up

### TYPICAL APPLICATION

- Positioning Control of Conveyors
- Industrial Robotics
- Locating and Position Control
- Press Position Control
- Work Position Control
- Simplified NC Machine Retrofitting
- X-Y Table Location Control

### DRIVE UNITS AVAILABLE FOR ALL MODELS L/R DRIVE UNIT AVAILABLE IN KIT FORM

MELBOURNE: 18-20 Syme St., Brunswick. Ph: (03) 387 0655 Fax: 387 9062  
SYDNEY: 25 Hector St., Seltou. Ph: (02) 644 8133 Fax: 644 3550  
ADELAIDE: A.F. Hay, 116 Gilbert St., Adelaide. Ph: (03) 51 3941  
BRISBANE: P.O. Box 627, Springwood, 4121. Ph: (018) 75 4816

# Robots' future is in a vacuum

Many of tomorrow's robots will be working in a vacuum — either in vacuum chambers here on Earth or in the vacuum of outer space, according to experts at UC Santa Barbara's Centre for Robotic Systems in Microelectronics (CRSM).

"On the one hand", says Gerardo Beni, co-ordinator of CRSM, "people in the microelectronics industry are increasingly recognising that vacuum manufacturing is an effective way to reduce defects that result from airborne contamination. On the other hand, increasing space exploration should create growing use for vacuum-compatible robots".

"On Earth, we create bubbles of vacuum in an ocean of atmosphere. As a result, it appears to be a very strange and exotic environment. When we go beyond Earth, however, you see that our world is a bubble of atmosphere surrounded by a vast sea of vacuum. So, vacuum becomes the normal environment," says Beni.

UCSB's robotics centre is one of a handful of academic organisations specialising in the design of computer-controlled mechanisms compatible with vacuum, a field known as *vacuum mechatronics*.

Earlier this year CRSM hosted a two-day workshop on the subject. The gathering brought together more than 50 experts from Japan, Europe and the United States, to share information on how to design robots for use in vacuum chambers and in outer space.

Specialised research and development is needed, because most mechanical devices, including robots, will not function properly without air. For example, in a vacuum common lubricants evaporate, causing bearing surfaces to freeze. Without air to carry away excess heat, ordinary electric motors rapidly overheat. And many common plastics become brittle in a vacuum.

The need to reduce airborne contamination is behind the microelectronic industry's growing interest in vacuum processing. As the size of features on integrated circuits continues to shrink,

contact with smaller and smaller particles during the manufacturing process can cause them to malfunction.

In the past, semiconductor manufacturers have used extensive air cleaning systems to create 'clean rooms', where the number of airborne particles is kept below the level which causes problems.

Today, the size of individual transistors on state-of-the-art integrated circuits is one micron, one twenty-fifth the width of a human hair. As a result, contact with even minute particles in the air can cause such chips to malfunction, and current clean room technology is being pushed to its limits.

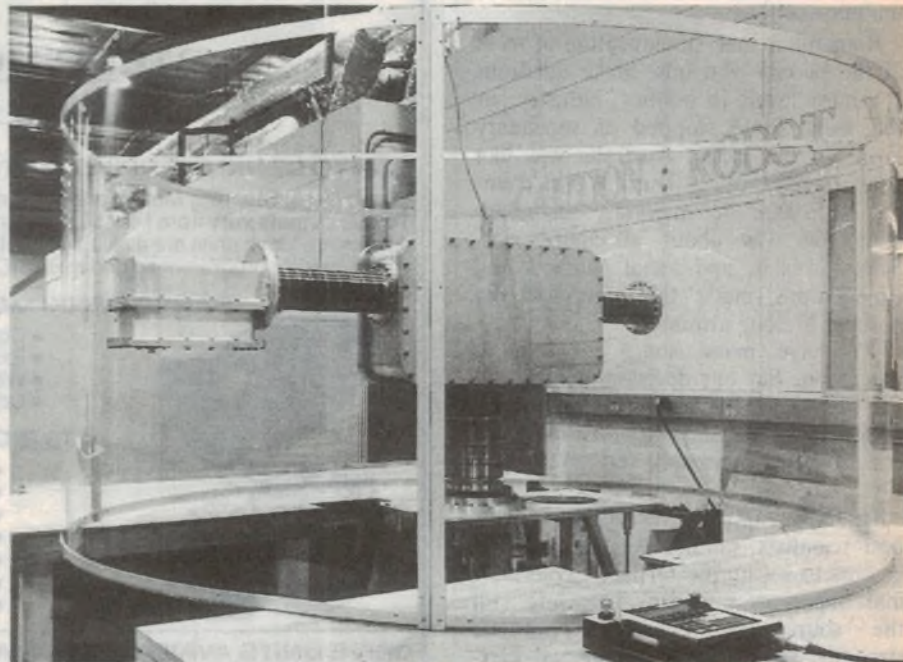
"Recent studies have shown that vacuum chambers are much cleaner

(than clean rooms). They indicate that, when the size of features on integrated circuits drops below a micron, switching to a vacuum environment becomes desirable economically," says Beni.

Already there are signs that research on vacuum robots will have valuable applications.

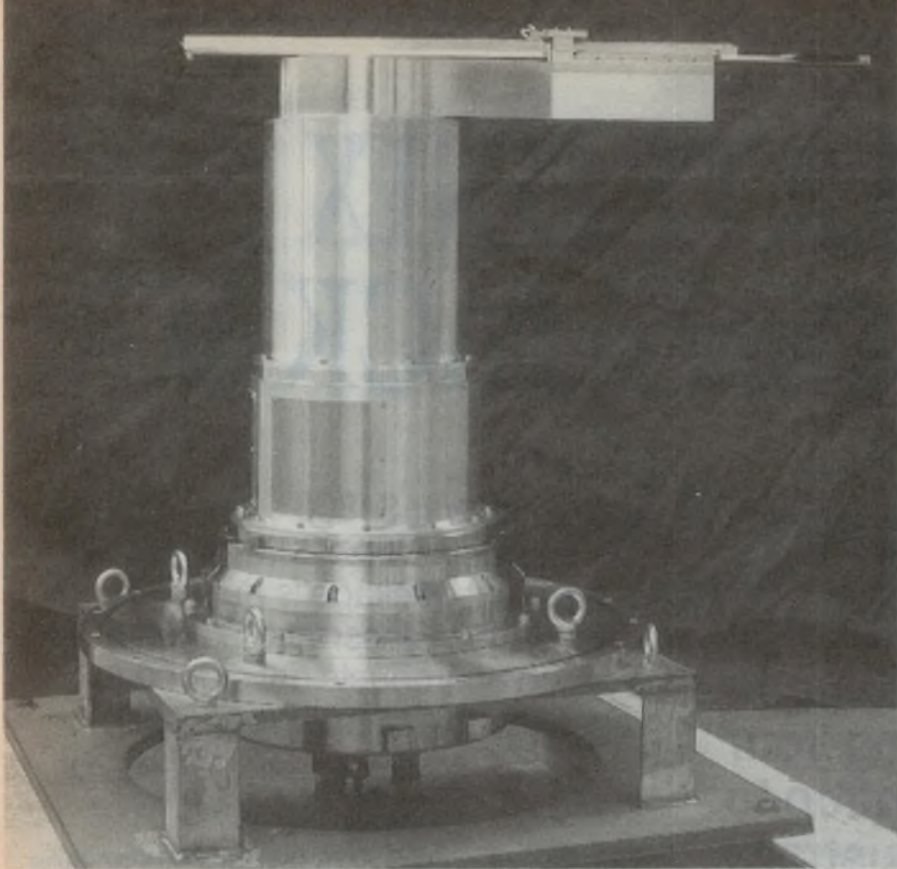
A large Japanese company has recently developed a magnetic levitation system for manufacturing integrated circuits in vacuum. A company in Silicon Valley recently completed a total vacuum system for producing optical disks. IBM was recently granted a patent on a vacuum manufacturing system design. And the US Department of Defense is supporting a large project to develop a vacuum manufacturing system.

Once robots that work in vacuum have been developed, they could find a variety of applications, CRSM researchers speculate. For example, they might be put to work in conjunction with



**A conventional robot arm modified by UC Santa Barbara's CRSM to work in a vacuum environment. Its original casing was replaced by a 'space suit' of heavy aluminium plate, with stainless-steel bellows and rotary seals. (Picture: Jeff Brouws, UCSB)**





**A special robot arm designed from scratch jointly by CRSM and Yaskawa Electric of Japan, for automated vacuum manufacturing of semiconductor chips. The 1-metre high cylindrical arm is the first such device with vacuum-compatible electric motors. (Picture: Jeff Brouws, UCSB)**

vacuum processes currently used in biomedicine, food processing and materials processing.

### Robot's 'space suit'

The first vacuum-compatible robot developed by the faculty and students at CRSM started with a commercial robot arm of the type used in large factories.

In 1985 engineers from the Delco Systems Business Unit of the Delco Electronics Corporation began a two-year project with CRSM. The object was to develop a robot capable of assembling a complex instrument in a vacuum chamber.

The UCSB research team decided that it was more practical to adapt a commercial robot arm, so that it could operate in a vacuum, than to pursue the much more costly course of designing and building a vacuum-capable robot from scratch.

To allow the industrial robot arm to operate in a vacuum, CRSM researchers and students designed a 200-pound vacuum suit out of thick aluminium plate, with stainless-steel bellows and special rotary seals. The suit allows the robot's motors and internal components to operate at normal atmospheric pressure when it is inside a vacuum cham-

ber.

When operating in a vacuum the buoyancy of the air-filled suit just about offsets the weight of all the additional armour, says UCSB's Welcome Bender, who directed the project with CRSM engineers Steve Belinski and Majid Shirazi.

The robot suit has a bellows that allows its arm to extend and retract. But it also has a second, matching bellows that retracts when the arm extends and extends when the arm retracts. "Without a second bellows, the pressure from the air inside the suit would be continually pushing outward on the arm with a force of 450 pounds, and the robot's motors are not built to cope with that much force," explains Bender.

Despite all the modifications that were made, the performance of the vacuum-suited robot arm was essentially unchanged. CRSM tests have shown that it still operates with a precision of half a thousandth of an inch, when subjected to the equivalent of vacuum conditions.

The US\$170,000 project was completed successfully. "I think UCSB's group did a very good job of overall tasking and a good job of responding to the changes that we required," says Art

Voros, who oversaw the project for Delco.

### New motors

In the past year, CRSM researchers have built a vacuum-compatible robot arm from the ground up, one which is specially designed to automate the process of making computer chips in a vacuum environment.

The project is a collaboration with Yaskawa Electric Company, the largest of half-a-dozen Japanese companies that have begun specialising in vacuum-compatible motors and machinery.

In 1988 CRSM project engineer Steve Belinski spent seven months in Japan, working at Yaskawa's research laboratory. While there, he and Takeo Suzuki of Yaskawa designed the specialised vacuum robot.

"The traditional approach to providing mechanical power in a vacuum chamber is to mount the electric motors outside the chamber. They are linked to a shaft that passes through a rotating seal to drive the mechanisms inside the chamber," Belinski explains. "With our new robot, electricity is the only thing transmitted into the vacuum chamber. This substantially reduces the likelihood that air will leak into the chamber."

The CRSM/Yaskawa robot is a shiny, stainless steel cylinder that stands about one metre high. In place of the normal arm and gripper, it has a track-like arm that extends in and out and is equipped with an end effector that can pick up and hold silicon wafers from which computer chips are made.

According to its designers, the new robot has a number of advanced features, including:

- Motors that are completely vacuum-compatible and equipped with vacuum-compatible electronic circuits which are required to precisely measure and control their operation.
- An advanced electronic controller that directs the robot's arm motion with a precision of one hundredth of an inch.
- A special dry lubricant that is chemically bonded to its seals and bearings, and works well in vacuum conditions.

The robot was specifically designed to fit into an experimental vacuum chamber at CRSM, where it will be used as part of a project called the Self-Contained Automated Robotic Factory (SCARF). The vacuum chamber, which is 50 inches in diameter, is specifically designed as a test bed for developing a completely automated system for manufacturing advanced microelectronic chips in a vacuum. Ⓜ

# WIN A TEKTRONIX INSTRUMENT PACKAGE

**You could win the superb  
Tektronix CRS2225  
Instrument Package  
simply by subscribing to  
or extending your  
existing subscription to  
Electronics Australia  
\$45 — 12 months,  
\$88 — 24 months**

*Hurry — this  
offer closes  
30 September, 1989*

Electronics Australia is Australia's top selling electronics magazine and in 1989 is celebrating its 50th year of publication. Don't miss a single issue — subscribe and have it home delivered.

For further information on Tektronix products  
phone toll free 008 023 342.

Valued at over \$4800 the Tektronix CRS2225 Instrument package is part of the new Tek Classroom Series, a group of products developed in response to educator requests.

The Tektronix CRS2225 Instrument Package consists of

- 50 MHz Dual Trace Oscilloscope
- Digital Multimeter
- Power Supply
- Function Generator
- Frequency Counter
- Instructional Material

## Conditions of Entry

1. The competition is open only to Australian residents authorising a new/renewal subscription before last mail October 31, 1989. Entries received after closing date will not be included. Employees of the Federal Publishing Company, Tektronix Pty Ltd and their families are not eligible to enter. To be valid for drawing, subscription must be signed against a nominated valid credit card, or, if paid by cheque, cleared for payment.
2. South Australian residents need not purchase a subscription to enter, but may enter only once by submitting their name, address, and a hand-drawn facsimile of the subscription coupon to The Federal Publishing Company, P.O. Box 227, Waterloo NSW 2107.
3. Prizes are not transferable or exchangeable and may not be converted to cash.
4. The judges decision is final and no correspondence will be entered into.
5. Description of the competition and instructions on how to enter form a part of the competition conditions.
6. The competition commences on 23 June, 1989 and closes with last mail on October 31, 1989. The draw will take place in Sydney on November 3, 1989 and the winner will be notified by telephone and letter. The winner will also be announced in The Australian on November 7, 1989 and a later issue of this magazine.
7. The prize is:  
A Tektronix CRS2225 Instrumentation Package valued at \$4,827.00.
8. The promoter is The Federal Publishing Company, 180 Bourke Road, Alexandria NSW 2015. Permit no. TC 89/000 issued under the Lotteries and Art Unions Act 1901; Raffles and Bingo Permit Board Permit No. 89/000 issued on 00/05/89; ACT Permit No. Tp89/000 issued under the Lotteries Ordinance, 1964.

The perfect measure of economy plus performance in a 50 MHz package for the beginning or intermediate lab. With Tek's CRS2225 Instrumentation Package you can economically equip lab stations for analog circuit work, signal analysis and digital logic applications. Well-suited for digital troubleshooting this scope is an ideal choice for service training. It includes the following lab station units — packaged together.

The **50 MHz Tek 2225 Dual Trace Oscilloscope** offers features you'd expect to find only in more expensive instruments, including 500 uV/div sensitivity, alternate magnifications of X5, X10 and X50, front panel Z-axis input and HF/LF Reject trigger filtering. Rugged, X10 probes are included.

The **CPS250 Triple Output Power Supply** is a versatile instrument with two 0 to 20 V, 0.5 A variable outputs and fixed 5V, 2 A output top meet the needs of semiconductor and digital lab experiments, which can be performed easily and with minimal training. Three sets of test leads are included.

The **CMD250 Digital Multimeter** measures voltage up to 500 V, ac or dc; current to 10A; and resistance to 20M on a 3½-digit LED display. The unit comes complete with UL listing and circuit test leads.

## Plus

everyone who subscribes or extends receives absolutely free the Australian designed storage innovation **Hangaway™** — worth \$8.95.

The Hangaway™ is a versatile and efficient adjustable hanging system with hundreds of applications around the home, garage or workshop.



The **CFG250 2 MHz Function Generator** featuring variable amplitude and dc offset produces sine, square and triangle waves and TTL signals for applications including testing of amplifiers, filters and digital circuits.

The **CFC250 100 MHz Frequency Counter** counts the signal frequency of sine, square and triangle waves from 5 Hz to 100 MHz at input levels from 80mV to 42V peak for use in many of the same applications as the CFG250.

To subscribe one year year subscription (12 issues) \$45, two years (24 issues) \$88. Simply fill out the coupon attached and put it in the reply paid envelope supplied — if the coupon is missing, send your name, address, phone number and cheque, money order or credit card details (card type, card number, expiry date and signature) to Freepost No. 4, Electronics Australia Tek Subs Offer, Federal Publishing Company, P.O. Box 227, Waterloo, NSW 2017. Any enquiries phone (02) 693-6666. Unsigned orders cannot be accepted.

Proven design and rugged construction offer reliability at its best. And the Tektronix reputation for meeting rigid environmental requirements means confidence in your measurements — and in knowing this scope is built to last.

Fast, accurate horizontal magnification lets you choose any of three expansion levels.

Sweep speeds to 5 ns/div are fast enough for accurate pulse and timing measurement on most digital logic families, with good resolution.

Complete, versatile feature set for a variety of applications

Low-pass filter feature prevents high-frequency interference for signals below 100 kHz

Easily learned, easy-to-use functions help make the most of student lab time.

Variable and fixed outputs for analog circuit and digital logic applications.

**Tektronix**  
COMMITTED TO EXCELLENCE

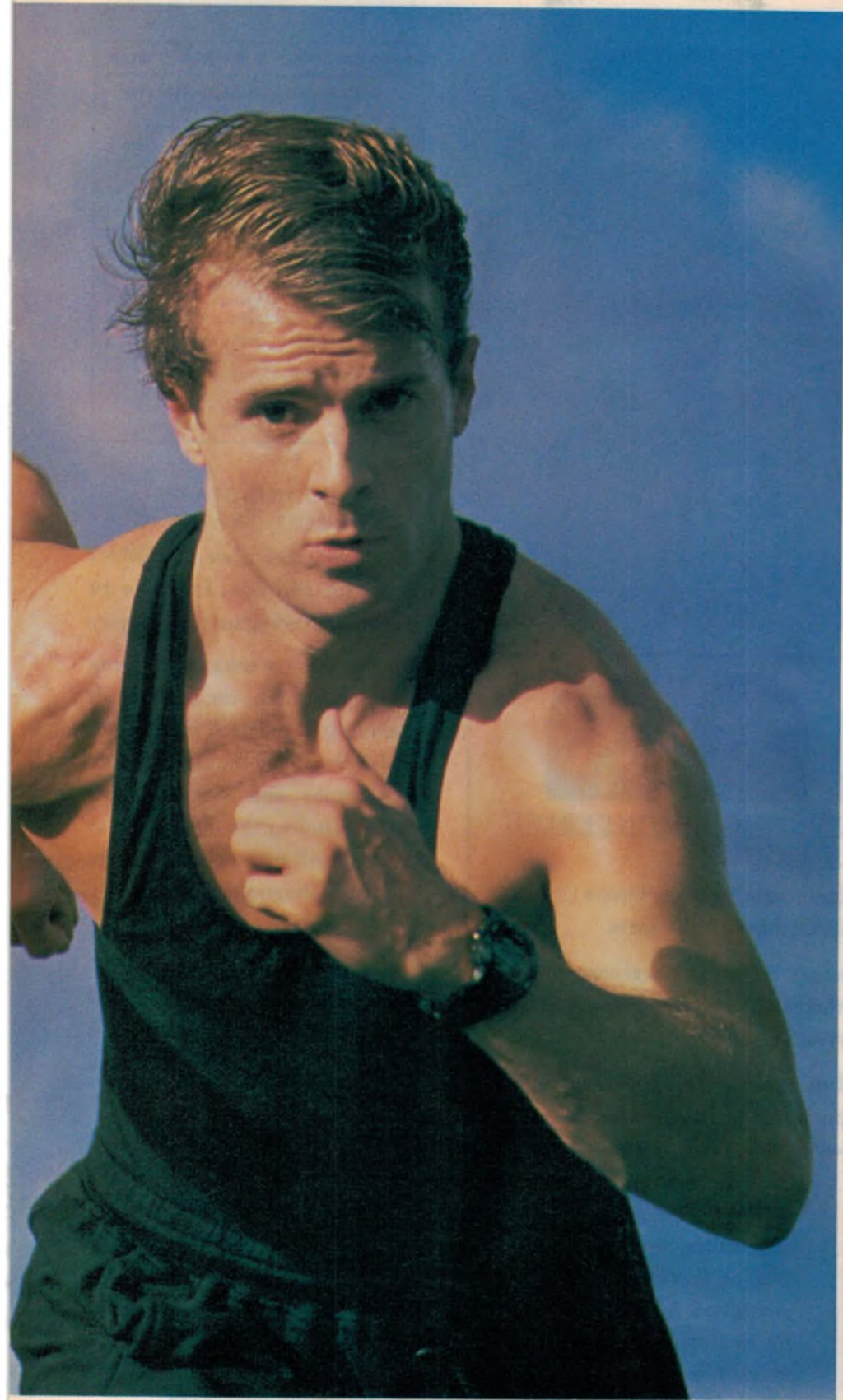


**SPARKS**

Authorised by Dept. of Defence

*Getting a charge  
from working out after  
working on highly  
sophisticated equipment.*

*A feeling  
every sailor knows.*



**FLY**





NAVY CATEGORY	JOB SPECIFICATION
*ETW. Electrical technical weapons.	Hydraulic, electrical and underwater weapons systems.
ETP. Electrical technical power.	Power generation AC-DC motors, generators, hand appliances.
*ETS. Electronic technical systems.	Radars - sonar navigational aids weapon control systems
ETC. Electronic Technical Communications	Radio-teletype satellite navigation cryptographic direction finding internal/external communications

### SECOND STAGE CIRCUIT TRAINING

This also takes place at HMAS Cerberus and runs for 12 to 14 weeks, depending on the category.

During these weeks each young sailor gets to take the back off all the Navy's high tech equipment. Radar, Sonar and the complex communications and weapons gear that is vital to the operations of the fleet of modern warships in the Royal Australian Navy.

Understanding and working on the intricate and delicate circuits inside the Navy's sophisticated electronic equipment requires a good brain, a keen eye and a steady hand.

Printed circuits and wiring that once resembled a bowl of highly colourful spaghetti, within a few weeks will be amazingly clear and easy to understand.

Don't worry. You don't need any special educational qualifications to apply. The Navy will give you all the training you need.



### ELECTRICAL & ELECTRONIC ENGINEERING INITIAL TRAINING.

All Electrical and Electronic Engineering recruits have a 12 week basic training period at HMAS Cerberus in Victoria.

This course incorporates general orientation in Naval customs and practices. All recruits develop their skills in leadership, armed and unarmed drill, safety and survival at sea.

Young recruits are encouraged to increase their fitness levels by participating in all kinds of sports and physical activities.

#### THE FIRST STAGE OF YOUR WORK-OUT

Young ETs begin their specialist training with a 14 week course understanding the theory, practical and organisational requirements of all the Navy's modern electrical equipment.

This covers all the hydraulic systems, mechanical equipment, generators, amplified communications systems and the theory of applied AC and DC currents. At this stage each ET sailor is assigned to their specialist branch categories.

★ Navy Electrical Technicians work with up-to-the-minute technology. You might say it's very current. ★



**THE VERY LATEST  
ELECTRONIC  
EQUIPMENT  
THAT GOES BANG  
AGAIN AND AGAIN.**

**NAVY**

THE PRIDE OF THE FLEET IS YOU.

Authorised by Dept. of Defence NET 24 5PC 69/2

## GET YOUR CAREER OFF TO A GOOD START WITH SOME HIGH QUALITY CIRCUIT TRAINING.

If you want to get to know your way around the Navy's highly sophisticated circuits  
you'll have to be eligible for Australian citizenship.

It is not necessary to have any specific educational qualifications. But the Navy will give  
you a short questionnaire to complete, to assess your aptitudes in Maths, English and  
Comprehension. This is not used in any PASS or FAIL context but more as a guide for the  
Careers Officer to understand better what it is that sets your sparks flying.

**Fill in the information sheet below and send to Navy Careers Advisor, Freepost 2600N,  
P.O. Box XYZ in your capital city, or contact your nearest Navy recruiting office.**

Name \_\_\_\_\_

Address \_\_\_\_\_

Postcode \_\_\_\_\_

Previous school or place of work \_\_\_\_\_

Category of your choice \_\_\_\_\_

Favourite sport \_\_\_\_\_

Date of birth \_\_\_\_\_

I am interested in     \*Electrical Technical Weapons     Electrical Technical Power  
                                  \*Electronic Technical Systems     Electronic Technical Communications

**Sydney (02) 219 5549 (008) 422 177 Melbourne (03) 696 2677 (008) 333 243**

**Brisbane (07) 226 2626 (008) 777 531 Townsville (077) 72 4566 (008) 015 150**

**Adelaide (08) 237 6222 (008) 888 554 Hobart (002) 34 7077 Canberra**

**(062) 57 2311 Perth (09) 325 6222 (008) 199 018 Darwin (008) 888 554**

\*Females cannot be employed in combat or combat related duties.

EA/SEP



# NAVY

THE PRIDE OF THE FLEET IS YOU

Authorised by Dept. of Defence NET 24 SPC 69/3



# Protect Your Electronic Equipment

& Valuable Data Files from a

## PowerSurge!



With

## COMPUTER PROTECTOR

A definite must for all electronic office equipment



Available in the following Current Ratings:  
1 Amp, 3 Amp, 6 Amp, & 10 Amps



**WESTINGHOUSE BRAKE & SIGNAL COMPANY (AUSTRALIA) LIMITED**  
SIGNAL DIVISION

80-86 Douglas Pde, Williamstown, Victoria.  
(P.O. Box 267, Williamstown, Victoria, 3016)  
Phone (03) 397 1033. Fax: (03) 397 1861  
Telex: 37 477 Wessys

Vic: (03) 397 1033, NSW: (02) 545 1322, Qld: (07) 275 3188  
SA: (08) 212 3161, WA: (09) 446 8844 COM/1

**BEAT THE NEW LAWS**

Legislation is being introduced to limit CFC products in all states during 1989

## Non-CFC Service Aids

**MADE IN AUSTRALIA FOR AUSTRALIAN CONDITIONS**

### Electronic Freezing Spray

Non-CFC, non-corrosive, safe method of cooling electronic components to detect dry joints and other thermal faults.

### Electronic Cleaning Solvent No. 1

Fast drying non-CFC solvent blend for cleaning electronic components and circuit boards.

### Printed Circuit Board Lacquer

Specially formulated lacquer designed specifically for protecting circuit boards and components from environmental attack. Can be soldered through for component replacement and acts as a solder flux.

### Protect

General purpose maintenance, dewatering and penetrating fluid for protecting, lubricating and rust prevention.

### Heat Sink Compound

An efficient, not-toxic paste with excellent thermal conductivity over a wide temperature range.

### NSW

- Carramar Radio CARRAMAR Ph 726 3628
- D J Coulter Wholesale Pty Ltd MAYFIELD Ph (049) 67 1455
- Digital Pty Ltd YAGOONA Ph 796 2888 Fax 707 4780
- George Brown Group CAMPERDOWN Ph 519 5855
- George Brown Group NEWCASTLE WEST Ph (049) 696 399
- Jaycar SYDNEY Ph 267 1614
- Jaycar GORE HILL Ph 439 4799
- Jaycar CONCORD Ph 747 2033
- Jaycar PARRAMATTA Ph 683 3377
- Macelec Pty Ltd WOLLONGONG Ph (042) 29 1455
- NEC Home Electronics Aust Pty Ltd REVESBY Ph 774 5122
- Novocastrian Electronic Supplier BROADMEADOW Ph (049) 62 1358
- Royston Electronics SILVERWATER Ph 647 1533 Fax 648 5922
- Sheridan Electronics Pty Ltd REDFERN Ph 699 5922
- Vimcom Pty Ltd WOLLONGONG Ph (042) 28 4400 Fax (042) 226 1857
- WES Components Pty Ltd ASHFIELD Ph 797 9866

### ACT

- George Brown Group FYSHWICK Ph (062) 804 355
- Queensland**
- AES Electronics FORTITUDE VALLEY Ph (07) 252 8233
  - George Brown Group SPRING HILL Ph (07) 252 3876
  - Jaycar BURANDA Ph (07) 393 0777
  - Selectro Parts Pty Ltd YERONGA Ph (07) 848 8197
  - St Lucia Electronics BOWEN HILLS Ph (07) 252 3762
  - St Lucia Electronics GOLD COAST Ph (075) 32 3632
  - Dudley Marshall Agencies GARBUTT PH (077) 79 3855

### South Australia

- Force Electronics ADELAIDE Ph (08) 212 5505
- George Brown Group HILTON Ph (08) 353 2222

### Northern Territory

- AES Electronics DARWIN Ph (089) 81 6602

### Victoria

- Electronic Engineering Supplies BRAESIDE Ph (03) 587 3888



- George Brown Group BLACKBURN Ph (03) 878 8111
  - Jaycar MELBOURNE Ph (03) 663 2030
  - Jaycar SPRINGVALE Ph (03) 547 1022
  - Radio Parts EAST MALVERN Ph (03) 211 8122
  - Radio Parts ALBURY Ph (06) 21 8177
  - Radio Parts W MELBOURNE Ph (03) 329 7888
  - Royston Electronics NOTTINGHILL Ph (03) 343 5122
- W.A.**
- Everett International Pty Ltd WEST LEEDERVILLE Ph (09) 381 5500
  - George Brown Group VICTORIA PARK Ph (09) 362 1044
- Tasmania**
- George Harvey Electric Pty Ltd LAUNGESTON Ph (003) 31 6533
  - George Harvey Electric Pty Ltd HOBART Ph (002) 34 2233

**rf**

**RICHARD FOOT PTY LTD**  
Telephone (02) 450 2133  
Fax (02) 450 2569  
Telex AA24777



# When I Think Back...

by Neville Williams

## John Murray Moyle — engineer, editor, music and art lover

A great many people knew 'Johnny' Moyle, having met him personally, or on-air as a radio amateur, or as an editor/writer for many years in technical magazines. Few realised, however, that over and above his preoccupation with electronics, John was a man with a natural flair for poetry, painting and music. He was also an informed debater on a wide range of subjects.

Having worked alongside John, or been in close contact with him for twenty-odd years, I got to know him better than most. Many long hours were spent over innumerable cups of coffee discussing all manner of subjects, from equipment design to the hereafter. I sat in on dozens of arguments with Julian Russell about musical interpretation, and caught the backwash of many others he had with Jim Corbin over Wireless Institute politics.

Sadly, I also witnessed his final confrontation — with terminal cancer.

John Murray Moyle was born in Malvern, Victoria in February 1908 and, from an early age, displayed an unusual blend of literary, musical and 'mechanical' talents, which were evident throughout his entire working life.

He attended Scotch College, Melbourne, from 1923 to 1926, and emerged with an impressive student record. He won prizes for poems which he contributed to the school magazine *The Scotch Collegian* and — shades of things to come — was appointed editor of that magazine during his final year. In that same year he wrote the Colcough Prize song and, as a member of the debating team, won the school debating award.

His school testimonial was both perceptive and prophetic: 'John Moyle has a marked literary facility and, if he finds scope for his powers in the field, may be relied upon to do his utmost to bring distinction to himself and his employer'.

After leaving Scotch, John continued to find outlets for his literary talents, some of his poems and short stories

being published in the daily press and magazines, including *The Sydney Morning Herald*, *The Sun Pictorial*, the *New Triad* and *The Argosy* — a literary publication no longer in existence.

These facets of John Moyle's personality may come as a surprise to some of his industry contacts in later life, who may well have seen him as a single-minded man, completely committed to

the theory and practice of electronics.

I, for one, knew nothing of his penchant for poetry until in late 1941, on the eve of his joining the the RAAF, John sought the urgent assistance of Frank Cull, *Radio & Hobbies* foreman printer, in the production of a small book: *Forty Poems*. I still have the copy that he gave me at the time — almost diffidently, it seemed.

The poems and sonnets are not dated or otherwise identified, but they provide intimate glimpses of a man sensitive to many things beyond the realm of multimeters, soldering irons and typewriters. I quote just one, written decades before environmental awareness became fashionable (see box).

In Melbourne, during the late 1920s, John's first job was in the commercial advertising section of radio station 3DB. Later, during the depression years, he took on the editorship of a farming weekly: *The Gippsland and Northern*. It



John Moyle and his wife Alice on a picnic in the Blue Mountains, in the mid 1930's. John was also testing some amateur radio gear, while they were there. (Courtesy Mrs Olga Bell)



A portrait of John Moyle taken before the second World War.



During the war, John Moyle served in the RAAF and rose to the rank of Squadron Leader.



A whimsical John Moyle, snapped at the stereo hifi demonstration at Sydney's Conservatorium in 1959.

was scarcely in accord with his predominantly technical aspirations, but it provided valuable journalistic experience and helped pay the bills.

One aspect of the job that did appeal to him was road testing late model cars. Deputising for his rural readers, he drove them personally along selected routes to and through the Dandenongs, and commented on their performance.

Already a lover of classical music, John taught himself to paint, about this time, using both water colours and oils. Later, when he came to work in Sydney, he was to take every opportunity to broaden his knowledge and appreciation in these areas.

### Joins 'Wireless Weekly'

But while John's roots were in Melbourne, it was Sydney that, in 1932 gave him the break he wanted when he gained a position on the staff of *Wireless Weekly*. Ross Hull had returned to the USA a few months previously (See our February 1989 issue, p.24) and while Ross's brother 'Braith had taken over as editor, the magazine was clearly in need of another enthusiast in the Ross Hull mould.

John Moyle, at 24, was just such a person - sharing Ross Hull's wide-ranging interests and writing skills, plus a useful background in radio.

Bitten by the 'bug' at school, John had maintained a hobby interest in wireless/radio, along with his other activities. By the late 1920s, he had become an enthusiastic experimenter and radio amateur, writing occasional technical articles for the Victorian journal *Listener In*.

When he moved to Sydney, he changed his callsign to VK2JU, which was too close to VK3JU - Ross Hull's callsign - to be a coincidence. '2JU' was later to be associated with a string of amateur radio projects featured in *Radio & Hobbies*, but more of that later.

By coincidence, John's first job on *Wireless Weekly* paralleled that of Ross Hull when he had joined *QST* in 1926 - that of answering technical queries addressed to the magazine. Both became assistants to the technical editor and both were later promoted to technical editor in their own right.

In 1933, John married a Melbourne lass, Alice Brown, whom he had known since his schooldays. An accomplished cellist, Alice shared his interest in classical music and this, along with John's involvement with hifi receivers and amplifiers, ensured that the family home in Chatswood, Sydney, would re-echo to the sound of new record releases - 78rpm style. It was into this environment that their two daughters were subsequently born: Josephine and Carolyn.

John prepared regular record reviews for *Wireless Weekly*, while Alice also provided articles on the music scene, writing under her maiden name. In those days, *Wireless Weekly* appeared to have a 'thing' about too many by-lined articles by any one writer, let alone too many articles by a married couple!

It was perhaps not surprising that John should also turn up on Sydney radio 2UE which, like *Wireless Weekly*, was a subsidiary of Associated Newspapers Ltd. In off-the-cuff talk sessions,

he would answer technical questions on behalf of the magazine but, on Sunday evenings, he would turn his attention to the classics in 'Serenade to Music' - a session which became associated with the Sydney Recorded Music Society, of which John was a foundation member

### Landmark years

1933 was a landmark year for *Wireless Weekly*, highlighted by a receiver design competition that produced the famous '1933 Standard' - an ambitious project that signalled a new era in home receiver construction. It was followed in 1934 by the 'Champion', another receiver that clearly outclassed contemporary commercial models.

What input John had to the series is difficult to define at this remote date, but the style is very much his. Certainly, in the years that followed, John's diligence at both workbench and typewriter is evidenced by the number of projects that carry his byline.

Those listed in our recent 50th Anniversary issue were a mere sampling of

### The Leaves

The leaves are falling on my garden path,  
One by wistful one, they flutter down,  
Born on the wings of every little breeze,  
Red, gold and brown.

Each day I needs must tread them underfoot;  
Softly I take each single step, lest they  
Should think that I, in passing, could forget  
Their sun-sweet day.

One of John Moyle's poems. He was a man of diverse talents.

## John Moyle

designs published in the latter part of 1938: 'Little Jim' for bedside listening, May 27; 'Stereoscopic Six' receiver, Sept 2; 'Stereoscopic Amplifier', Oct 7; 'Stereoscopic Eight', Nov 18; 'Stereoscopic Nine', Dec 16; and so on.

The Stereoscopic Nine would have been a major undertaking for any do-it-yourself publication. The separate tuner featured dual-wave coverage, with an RF stage, combined dial and push-button (lever) tuning and a 2-position selectivity switch. The amplifier used push-pull 2A3 output triodes, driven by an Australian made full-range transformer and feeding multiple Australian Rola loudspeakers.

The job of conceiving, building, testing and writing about a succession of such projects for years on end could never have been fitted into a regulation 40-hour week. But John Moyle didn't live by the clock; his day began when he got up and finished long after everyone else had gone to bed. Like Ross Hull before him, once possessed by an idea he had to pursue it to a conclusion, grudging the time lost to meals and sleep.

For sure, he did manage to grab the odd weekend away from workbench and typewriter – often to pursue another obsession: tearing around the countryside with mobile 6-metre (50MHz) amateur radio gear, talking back to fellow 'hams' from remote mountain bluffs around Sydney – some the best part of 200km away. This interest had a sequel in the immediate postwar years.

### 'Radio & Hobbies'

Having recently celebrated what is effectively this journal's golden anniversary as a monthly (see our April 1989 issue), the story of *Radio & Hobbies* (et seq.) is sufficiently well known not to warrant recounting in detail. It warrants mention, however, primarily for the sake of continuity.

Sufficient to say that projects like the Stereoscopic Nine really clamoured for presentation in a monthly technical magazine, rather than being jammed into a threepenny weekly, along with throwaway programmes and gossip about radio station personalities.

The result was just such a monthly, entitled *Radio & Hobbies in Australia* – the last two words in small type. It was an immediate success, such that Associated Newspapers had to load the first issue (April 1939) back on to their presses for a second run – which also sold out.



July 1949: Back in mufti after the war, and surrounded by the newly reconstituted staff, editor John Moyle presents Maurice Findlay with a 21st birthday present. (Courtesy Dr Alice Moyle)

But the much heralded team of editor A.G. ('Braith) Hull and technical editor John Moyle proved less enduring. Within 12 months, John Moyle had taken over as editor and 'Braith Hull

had disappeared, to re-surface almost immediately as editor and publisher of the existing and rival monthly *Australasian Radio World*.

Feelings ran high between the two



Complete with pipe and micrometer, John is pictured here with his crystal-grinding paraphernalia spread out on the table: frequency meter (top right), a slab of rigid very flat glass and (foreground) his test oscillator. In those days, crystals were large enough to handle – gingerly! (Courtesy Dr Alice Moyle)

magazines, or rather the people running them. Busier than the proverbial one-armed paper-hanger, John Moyle set about assembling a group of regular contributors. This is where I first became involved with *R&H*, subsequently accepting the position of technical editor towards the end of 1941.

It was about then that John joined the RAAF with a view to becoming a radar instructor. Involved in the group were a number of other well known radio engineers, amateurs and industry executives – all likely candidates for a crash course in the new and highly secret technology.

John served in the RAAF from 1941 to 1946, based mainly in Melbourne. He rose to the rank of squadron-leader and, fittingly, was made responsible for the production of all radar manuals at the Melbourne headquarters.

### Back at the office

During this period, John used to call in to the *R&H* office during his periodic visits to Sydney but, while obviously interested in the well being of the magazine, he never sought to interfere in its affairs.

I must confess, however, to some personal misgivings as to how it would work out when he moved back into the editor's chair. While I also devoted many extra hours to the job in hand, I preferred to work by the clock: 9.00am start, 5.30pm finish, and a structured day in between. John's routine, I knew, would be to turn up when he had recovered from the exhaustion of the previous day, cope with tasks and diversions on a needs-must basis, then work through the evening until once again exhausted!

In fact – and fortunately – our different approaches turned out to be complementary rather than a source of conflict, when he did return. My own routine fitted in with the everyday requirements of staff and office administration. It left John free to work the way he wanted to with never any doubt, on the part of other staff, as to his flair, his enthusiasm or the fact that he was 'pulling his weight'.

He took over the record review section that had been maintained by popular science contributor Calvin Walters, building it into one that had a unique reputation for combining keen musical appreciation with informed technical appraisal.

It was in this period that morning tea sessions were frequently dominated by arguments with Julian Russell, himself a

former professional pianist and conductor and, at the time, adjudicator and music critic for the *Sydney Sun*.

One such argument took the three of us into an inner sanctum at Associated Newspapers, where there happened to be a piano. No stranger to the instrument himself, John had maintained that it was essentially a mechanical device in which the percussive qualities could be expressed ultimately as a function of the velocity imparted to the hammer by the player, irrespective of their technique.

Julian was unimpressed by this 'mechanical' analysis. He was determined to demonstrate the subtleties of wrist and finger action and the tonal differences resulting from variously striking, stroking or merely pressing the keys. Arguments like that were always so entertaining and/or informative that, if they didn't commence spontaneously, they were well worth starting!

It wasn't that there was lack of discussion, debate or argument between John and myself – or other members of the staff – on other subjects. Seldom, if ever, was it acrimonious and it usually served a very useful purpose. With somebody always ready to act as the 'devil's advocate', strongly held views were challenged and tested before ever they appeared in print.

### Back on the air

For obvious reasons amateur radio had been silenced during the war, but was given the okay again following the cessation of hostilities. Amateurs were keen to get back on the air, keen to apply techniques picked up from war-time communications, and keen to get their hands on war surplus equipment and oddments which began to turn up in disposals stores.

Squadron leader John Moyle may only just have relinquished his commission and resumed his role as editor of *Radio & Hobbies*, but he had as much boyish fun as any of us jostling for 'two bob' bargains at Prices' Radio in Angel Place (Sydney), or searching through piles of equipment at Ace Radio and elsewhere for sought after items that others may have overlooked.

One such unit that he found, a battery powered frequency meter, complete with calibration book, enabled him to re-grind ex-disposals quartz crystals at a time when new made-to-order crystals were dauntingly expensive. Other amateurs on the staff inherited free crystals as John refined his touch with paste, talcum powder and hydro-fluoric acid. But that was only half the story, which I'll continue next time. ☺

# SPECTACULAR RELEASE



**\$799  
PAIR**

## vifa

NEW SA-100  
SPEAKER KIT

Since the introduction of VIFA speaker kits in Australia in 1985, thousands of speakers have been built with superb results. VIFA is now proud to release four new speaker kits ranging from a mere \$399 to \$1199 per pair including cabinets.

Never before have speaker kits been so popular in Australia than after the heavy devaluation of the dollar. Similar fully imported quality loudspeakers are today typically 2-2½ times more expensive. And these speakers may very well be using Danish VIFA drivers anyway, as VIFA supply more than 50 of the world's most respected loudspeaker manufacturers with drivers.

**But why the big savings?** Because fully imported speakers suffer from 25% import duty, 20-30% freight, 30% sales tax and 28% handling charges (typically). So if you would rather put your money into better quality than in other people's pockets, VIFA speaker kits are the only way to go.

**Are they difficult to build?** No, the kits are supplied with all parts needed including fully built crossovers and pre-cut flatpack cabinets ready to assemble. No soldering or carpentry skills are needed, just a Phillips head screwdriver, some simple hand tools and a few hours of your leisure time.

**Are they as good as people say?** Read the reviews, listen and compare with any other speakers twice the price or more. Need we say anymore?

**VIFA for the quality conscious audiophile.**

For full details please contact  
Sole Australian Distributor:

**SCAN AUDIO Pty. Ltd.**  
P.O. Box 242, Hawthorn 3122.  
Fax (03) 429 9309  
Phone: (03) 429 2199 (Melbourne)  
(02) 522 5697 (Sydney)  
(07) 357 7433 (Brisbane)  
(09) 322 4409 (Perth)

Stocked by leading stores throughout Australia

# 7th AES Conference focuses on digital audio

The main topic of discussion at the Audio Engineering Society's seventh International Conference in Toronto, Canada a few weeks ago was no less than the future of audio: 'Audio in Digital Times'. Here's a report on what the experts saw when they looked into the crystal ball...

by JAYANT DATTA

'The city of the future', Toronto, Canada played host to the 7th Audio Engineering Society (AES) International Conference. The three and half day conference consisted of nine sessions, during which all technical aspects of digital audio were covered. An authority on digital audio, Ken Pohlmann — a man who has written a number of books on digital audio in addition to contributing many columns to magazines, was quite aptly the Conference Chairman.

The first time digital audio was treated as a separate topic was during the premiere AES conference, held in June 1982. During this time it has grown tremendously in importance, and now it is indeed very difficult to find facets of audio that have not been invaded by the digital age. Of course, the initial input and final output of the audio chain, which have to interface with human beings, have to be and will always remain analog, but the intermediate processing seems to be shifting to digital.

Some of the main reasons for preferring digital to analog technology are the facts that (a) recordings can be made essentially independent of the medium characteristics, (b) repeated playback without deterioration is possible and (c) many generations of editing, dubbing etc., can be done without serious loss. In addition, signal processing is often easier to implement and more versatile in the digital domain.

## Digital tutorial

The first day was planned to gradually ease people into the digital frame of mind. A paper from a company that has many achievements in the digital audio field, Denon, traced its history. The real tutorial, however, came from

Lipshitz and Vanderkooy, who discussed and illustrated both visually and aurally the fundamentals of digital audio in a unique demonstration.

In order to enter the digital domain, the analog sound must go through an analog-to-digital converter (ADC). In order to increase the resolution, the pursuit is on for ADCs with more than the normal 16 bits in use presently. A 1x, 2x or 4x oversampling dual 18-bit ADC has been developed by Burr-Brown Corporation, employing the switched capacitor architecture to provide co-phase sample/hold operation for each channel. Robert Adams presented a 2-chip 20-bit high-resolution ADC that consists of a front-end IC to implement noise-shaping and a digital decimator IC to reduce the sampling rate.

Increasing the resolution to 20 bits, where we take into account 1 part in a million, has its price to pay, as Remy Fourre pointed out. At such levels, many normally ignored problems play an important role. In order to test a dual 20-bit 200kHz digital-to-analog converter (DAC) he had to use an ultra-accurate programmable clock, a proper ground scheme to prevent contamination of the sensitive analog section by digital noise, and high-quality output filters.

## Adding noise

The very act of digitising sound can create distortions unless care is exercised, the most common ones encountered being *aliasing* and *quantization distortion*. The former may be eliminated by band-limiting the signal, and the latter, strangely enough by the addition of low-level analog noise called *dither*!

Lipshitz and Vanderkooy showed that even after using analog dither, however,

certain digital processes can re-introduce quantization distortion and limit-cycle oscillations, if appropriate digital dithering is not employed before final truncation. This results in a more linear transfer function and reduction in the noise modulation.

## How many bits?

It seems no one is sure just how good digital sound is today. Most laymen, it may be argued, have been brainwashed by the media into believing the superiority of digital sound, but the seasoned professionals, who earn their daily bread by working in studios have varied opinions about it. This was the result of a survey conducted by Bob Ludwig, who has many gold and platinum discs to his credit. The opposing views presented by these veterans makes one wonder just how audible these differences really are.

Most people respect the 16-bit, 98dB dynamic range that is available on today's CD as more than adequate. In fact, it is treated as a kind of yardstick to measure other performances. Louis Fielder, after taking measurements of live performances, concludes that while 16 bits might be enough for the consumer, it is certainly not enough for the professional — who needs to work with more realistic levels of 122dB or 20 bits.

## Interactions

Advances in diverse fields such as recording media, signal processing, encoding techniques and semiconductor technology, all affect digital audio. The only way to harness all these advances in a cost-effective way is to use application specific ICs (ASICs). Naturally, as in any rapidly advancing field, marketing strategy is important but the way to go is to take the advantages of the technical advances.

A casual glance might show that digital audio alone stands to gain from the other fields. A closer look, however, will reveal that the stringent requirements of digital audio in turn gives these industries the direction in which to proceed in the future.

Digital signal processing (DSP), a tool

introduced initially exclusively for professional use, avoids many problems introduced by using analog components besides providing enhanced control of signal parameters. The benefits of these DSP chips are now becoming more and more accessible to consumers.

Sony uses a pair of proprietary chips that allow elaborate tone control, ambience control and dynamic range compression/expansion. Yamaha has already moved to its second generation of digital soundfield processors, through which different architectural settings can be recreated using extra amplifiers and speakers.

Keeping in view the goal of providing digital sources to the consumer, an efficient algorithm called SuperSound has been developed for digital transmission. This maintains the fidelity of the CD at a reduced data bandwidth from the source to the consumers' digital tuner/decoder.

An erasable prototype digital audio recorder/player was demonstrated by Nakamichi. It uses a 3.5" magneto-optic (MO) disc that uses the advantages of both the magnetic and optical media. The same data format as the CD is retained and digital inputs allow direct copying from a digital source. The prototype has a maximum length of 20 minutes.

## Film & broadcasting

Most formats that have something to do with sound are increasingly using digital audio. This increasing popularity reflects the numerous advantages of the digital format. In post-production film work, digital techniques can be used to do the entire processing in much less time with improved quality and versatility at each stage, making this an indispensable tool.

In addition to improved sound quality, digital audio provides playback speed accuracy, stereo phase stability, high storage densities, greater cost-effectiveness relative to broadcast quality analog equipment – advantages inherent in the system. These are invaluable secondary benefits for the radio broad-

caster.

A very flexible digital broadcasting centre in Bern, Switzerland, consisting of three transmission suites, is just being completed. The advanced facilities feature elaborate converters to ensure compatibility, extensive processors, manual or automated operation, even analog transmission while all the internal processing remains digital.

A new 4-channel sound system for HDTV was proposed by Eiichi Miyasaka. It is claimed to maintain better coincidence between the picture direction and the sound localisation for off-axis observers. Compatibility with movie sound reproduction systems has been taken into account. A new coding scheme was also proposed, to provide 4 channels of digital sound transmission for the HDTV format.

It is not possible for digital audio to fit hand in glove into every application. B. Lilly of Sony discussed the practical considerations in the video environment with respect to editing, digital signal routing and distribution, bit rate conversion and audio delay relative to video. The author felt that the extra care that needs to be taken is rewarded by the superior quality of the finished product.

Kodak has felt that the sound quality of film should be improved for a long time. They found that it is possible to record several channels of high-quality digital audio in the normal sound recording area. At the moment, SMPTE is considering providing at least three channels behind the screen: one reduced bandwidth subwoofer channel and two surround channels with a bandwidth of 20kHz and a dynamic range comparable to the CD to the moviegoer.

## Expected trends

The future of digital audio looks both promising and exciting. One common feeling at the Conference was that the CD is here to stay, for some time at least. Due to a variety of reasons it was felt that no single format of storage can dominate digital audio and it is important to strike a balance between the right formats for each application, and

at the same time keep in mind the concept of the system.

Techniques of dithering, noise-shaping, pre- and post-emphasis in combination with a better understanding of human auditory capabilities should yield further improvements in sound quality in the future.

There exists a branch of audio engineers who believe in a tapeless studio, and progress is being made in this direction too.

Disc performance is getting better and it has been predicted that in the future a 2" disc will be capable of holding one hour of information. It is felt that the next generation of rewritable optical discs could be used with digital audio recorders and digital work stations.

## Summary

The digitisation of audio has led to a closer association being formed between the audio industry and other industries. This has served to broaden the perspective of the audio engineer who, in the past, thought himself to belong to a unique group with unique requirements. Now he can make use of results from other fields and apply them to audio, thus reducing his burden.

Digital audio technology has matured a lot over the years. Everyone realises its benefits and it has created inroads into all aspects of audio technology. The sound quality prevalent at present is already very good, but the finicky and dedicated audio engineers, who are never satisfied, seem to treat this as merely a coarse adjustment. They are now in the process of fine-tuning the system, ironing out the smallest anomalies that are often inaudible under normal circumstances. As an end-user one certainly can't complain.

This conference was certainly one worth attending. The wide array of papers presented covered all aspects of digital audio – right from its theoretical roots to commercial applications. The Conference Committee are to be congratulated for providing this opportunity to bring people up to date with the latest in digital audio. ☺

### The MAESTRO 2400XR

Here's a fully-featured, Hayes compatible 1200 & 2400 bps full duplex modem for just

**\$299 (incl. tax).**

This modem uses the LATEST in DSP chip Set Technology and microprocessor control, bringing you the future Today.



Super price on a super V.22/V.22 bis Modem!

### The MAESTRO 2400 ZXR

4 Speed Version **\$399 (incl. tax).**

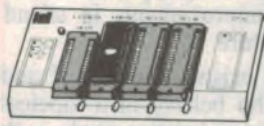
Don't Wait! RING NOW (043) 68 2277 or 68 2278

### Maestro Distributors

Calool St. South Kincumber, NSW 2256

## NEW NEW NEW NEW NEW NEW

### MULTI-CHIP PROGRAMMER CARD



- Model LP-A1
  - Module: Multi-Chip
  - Good for programming SRAM TEST 6116-62256
  - EPROM 8 BIT ICs
  - 2716-27512, 2716A-27512A, 27012-27012, 27C16-27C512, 2804-5, 8064, 28256-52813
  - EPROM 16 BIT ICs
  - 271024, 27102, 27210
  - MCS-48 series of ICs
  - 8741-8750, 8748-8748H, 8749-8749H
  - MCS-51 series of ICs
  - 8751-8752
- X18020.....Only \$575

### MIDI INTERFACE CARD - DS/401

The MIDI DS-401 Card is the PC standard MIDI interface that runs most popular PC music programs for sequencing, recording, composing, music printing, patch editing, music instruction and many other applications.

- Run all programs designed for the Roland MPU-401 architecture

- Socketed EPROM for easy user replacement
  - 1/3 length (short) card will fit in any computer accepting standard expansion card, including laptops
  - Including "Y" cable, external connector box to transport is unnecessary
- X18164.....\$195

### MOTHERBOARDS



#### 10 MHz XT\* TURBO MOTHERBOARD

Increase the performance of your sluggish XT\* approximately four times with this super fast motherboard.

- 8088-2 running at 10 MHz, no wait state
- Turbo/ Normal selectable
- 640K
- 8 Expansion slots
- 4 Channel DMA
- Keyboard port

Excluding RAM  
X18032.....\$199  
Including RAM  
X18033.....\$570

#### BABY AT\* MOTHERBOARD (WITHOUT MEMORY)

- 6/12 MHz system clock with zero wait state. 12 MHz, 1 wait state
- 80286-12 Microprocessor
- Hardware and software switchable
- Socket for 80287 numeric data co-processor
- 64K ROM
- Phoenix BIOS or Award
- 8 Expansion slots

Excluding Ram  
X18202.....\$575  
Including 2M/Byte Ram  
X18201.....\$1,250

#### 386 MAIN BOARD

- Intel 80386 CPU (20 MHz)
- Socket for 80387 Math co-processor
- 32 bit Memory BUS system
- Built-in speaker attachment
- Battery backup for CMOS configuration table and real time clock
- Keyboard controller and attachment
- 7 Channel DMA
- 16 Level interrupts
- 3 Programmable timers
- 8 System expansion I/O slots: 5 with a 36 pin and a 62 pin expansion slots / 2 with only the 62 pin expansion slot / 1 with two 62 pin expansion slots (32 bit BUS)

Without RAM  
X18103.....\$1,232  
Including 2 M/Byte RAM  
X18107.....\$2,300

### IBM\* CARDS

- G7 CGA/ MGP**  
X18007.....\$139
- MGP**  
X18003.....\$99
- HEGA**  
X18070.....\$295
- VGA**  
X18071.....\$595
- VGA 512k**  
X18072.....\$795
- RS232**  
X18026.....\$39
- RS232 & Clock**  
X18028.....\$59
- Clock**  
X18024.....\$49
- Printer**  
X18017.....\$29
- Games**  
X18019.....\$29

**Multi-function**  
X18040.....\$99

**Multi I/O**  
X18045.....\$115

**2 M/Byte Ram**  
X18052.....\$225

**3 M/Byte Ram**  
X18056.....\$275

**Serial /Parallel /Games**  
X18151.....\$115

**Floppy Disk Drive**  
X18005.....\$52

**4 Way Drive Controller - 360K/ 720K/ 1.2M/ 1.44**  
X18006.....\$129

**XT\* Hard Disk Controller**  
X18060.....\$129

**AT\* Hard Disk Controller**  
X18140.....\$195

### DRIVES

**COPAL 3.5" 1.44/ 1.2/ 720 DRIVE**  
C11911.....\$225

**COPAL 5 1/4"360 DRIVE**  
C11901.....\$175

**COPAL 5 1/4"1.2 DRIVE**  
C11906.....\$225

### RAM

#### SUPER FAST DYNAMIC RAM

- 4164-120ns
- U20832.....\$5.50
- 4464-100ns
- U20842.....\$17.85
- 41256-80ns
- U48262.....\$18.95
- 41256-100ns
- U48260.....\$14.95
- 1MB-100ns
- U48265.....\$43.95

### TEST CARD



#### POSTCARD DIAGNOSTIC MODULE

Pinpointing component problems in IBM\* compatible motherboards can take hours. Usually the whole system has to be working to isolate the troubled area. But not so with the new Postcard Diagnostic Module. So no other cards are necessary to test a bare motherboard.

"It now only takes seconds."

- Simplified debugging for:
- Field service- for on-site repairs or maintenance depot work
  - Manufacturing test- for burn in test flaws and to do quality control
  - Inspection- Postcard simplifies incoming and outgoing test processes on stand

X18048.....\$849

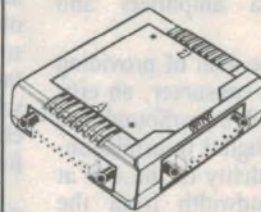
### EXTENSION CARD

#### IBM\* PC/AT\* DECODED I/O CARD

This card is designed for the IBM\* PC/AT\* expansion slot and includes data buffering and address selection. The wire wrap area features plated through holes. Extremely useful for R&D, it's address range is 0280H to 72 F7H. + -5V, + -12V fuse protection and has location for D type 37 pin or D type 25 pin connector.

H19125.....\$99

### I/O ACCESSORIES

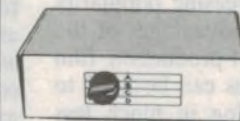


#### POCKET AUTO AB SWITCHES

- Pocket size, auto-scanning
  - Allows 2 PC's to share one laser
  - Serial model: MS-201 - Host-powered
- X19150.....\$79.95

#### POCKET AUTO AB SWITCHES

- Pocket size, auto-scanning
  - Allows 2 PC's to share one laser
  - Parallel model: MP-201 - Protocol transparent
- X19155.....\$89.95



#### DATA TRANSFER SWITCHES

If you have two or four compatible devices that need to share a third or fifth, then these inexpensive data transfer switches will save you the time and hassle of constantly changing cables and leads around.

- No power required
- Speed and code transparent
- Two/Four position rotary switch on front panel
- Three/Five interface connections on rear panel
- Switch comes standard with female connector

2 Way RS232  
X19120.....\$69

4 Way RS232  
X19125.....\$79

2 Way Centronics  
X19130.....\$69

4 Way Centronics  
X19135.....\$79

RS232 2 X 2 Crossover  
X19140.....\$79

Centronics 2 x 2 Crossover  
X19145.....\$79

### CASES

#### XT\* Cases Now Back in Stock

**XT\*/ AT\* STYLE CASE**  
X119091.....\$99

**BABY AT\* CASE**  
X119093.....\$99

### P.C ACCESSORIES



#### GRIP CLIP COPY HOLDER

- Attaches to the top of your monitor
  - Put your copy right where you need it spring clip to hold paper
  - Velcro at mount for easy removal
- C21065.....\$14.95



#### MINI VACUUM CLEANER

- Use it to clean:
- Computer keyboards
  - Printers
  - Video recorders
  - Computer circuit boards
- C21087.....\$14.95



#### MAGIC STAGE

- A working bench for your Mouse.
- High quality ABS plastic and anti-static rubberised top
  - Stationary holder
  - Includes pull-out shelf for Mouse
  - Dimensions: 280 x 260 x 25mm
  - Fits over keyboard
- C21080.....\$24.95



### REMOVABLE CARTRIDGE HARD DISK

Ricoh R260 20 M/Byte Removable Hard Disk is a sub-system for AT or 386 systems. Extra 20 M/Byte cartridges are available. To enable the end user to build a library that can be safely locked away. Or taken to another site that is using the same sub-system. It's the ultimate in hard disk back up systems or for transport ability of data.

Includes a cartridge  
X20022.....\$1,274

Extra 5 1/4" 20 M/Byte cartridge for disk (Ricoh RH5260)  
X20024.....\$220



### "NO BRAND" DISKS

Now you can buy absolute top quality disks that are also the cheapest in Australia! They even come with a lifetime warranty, which indicates the quality of these disks. So why pay 2-3 times the price for the same quality?

Packs of 10, D/S D/D without boxes, or brand name, just their whitepaper jacket, and index label. (5 1/4" disks includes write protects)

#### 5 1/4" 2S/2D "NO BRAND" DISKS

10+ DISKS	100+ DISKS	1,000+ DISKS
\$6.00ea	\$5.75ea	\$5.50ea

#### 5 1/4" HIGH DENSITY DISKS

10+ DISKS	(DOUBLE SIDED) 100+ DISKS	1,000+ DISKS
\$23ea	\$22ea	\$21ea

#### 3 1/2" 2S/2D "NO BRAND" DISKS

Suitable for IBM, PS/2, Macintosh, Atari, etc.

\$21

(ALL PRICES PER 10 DISKS)



#### VERBATIM DISKS

(ALL PRICES PER BOX OF 10 DISKS)

DESCRIPTION	1-9 BOXES	10+ BOXES
3 1/2" 1S/2D.....	\$39.95	\$37.95
3 1/2" 2S/2D.....	\$42.95	\$39.95
3 1/2" 2S/HD.....	\$89.00	\$85.00
5 1/4" 1S/2D.....	\$22.00	\$21.00
5 1/4" 2S/2D.....	\$26.00	\$24.00
5 1/4" 2S/4D.....	\$75.00	\$70.00
5 1/4" 2S/HD.....	\$41.00	\$39.95

## NEW DISKS

### VERBATIM DATALIFE PLUS Teflon\* Coated

(ALL PRICES PER BOX OF 10 DISKS)

#### 5 1/4" DS/DD

C12522.....\$34

#### 5 1/4" High Density

C12523.....\$64.95

### DISK BOXES

#### DISK STORAGE UNITS

- 80 x 3 1/2" - Lockable  
C16038.....\$16.95
- 40 x 3 1/2" - Lockable  
C16035.....\$14.95
- 40 x 3 1/2" "Eclipse"  
C16040.....\$8.99
- 120 x 3 1/2" - Lockable  
C16039.....\$21.95
- 50 x 5 1/4" - Lockable  
C16025.....\$14.95
- 100 x 5 1/4" "Eclipse"  
C16042.....\$9.95
- 100 x 5 1/4" - Lockable  
C16020.....\$15.95
- 120 x 5 1/4" - Lockable  
C16028.....\$19.95

# rie

## ROD IRVING ELECTRONICS

All sales tax exempt orders and wholesale inquiries to:

**SYDNEY:** 74 Parramatta Rd. Stanmore 2048  
Phone: (02) 519 3134  
Fax: (02) 519 3868

**MELBOURNE:** 48 A'Beckett St  
Phone: (03) 663 6151

**NORTHCOTE:** 425 High St.  
Phone: (03) 489 8866

#### MAIL ORDER & CORRESPONDENCE:

P.O. Box 620, CLAYTON 3168  
Order Hotline: 008 33 5757  
(Toll free, strictly orders only)  
Inquiries: (03) 543 7877  
Telex: AA 151938  
Fax: (03) 543 2648

#### RITRONICS WHOLESALE:

56 Renver Road, Clayton  
Phone: (03) 543 2166 (3 lines)  
Fax: (03) 543 2648

#### ORDER HOTLINE 008 33 5757 (TOLL FREE)

STRICTLY ORDERS ONLY

LOCAL ORDERS & INQUIRES  
(03) 543 7877

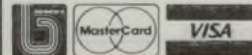
#### POSTAGE RATES:

\$1 - \$9.99 .....	\$2.00
\$10 - \$24.99 .....	\$3.00
\$25 - \$49.99 .....	\$4.00
\$50 - \$99.99 .....	\$5.00
\$100 + .....	\$7.50

The above postage rates are for basic postage only. Road Freight, bulky and fragile items will be charged at different rates.

Errors and omissions excepted. Prices and specifications subject to change.

IBM, PC, XT, AT are registered trademarks of International Business Machines. Apple is a registered trademark. Teflon is a registered trademark of Dupont. Denon is registered trademarks of their respective owners.



### COMPUTERS & ACCESSORIES

#### IBM\* XT\* 640K RAM TURBO COMPATIBLE COMPUTER

Check these features and our prices. We're sure you'll agree they're exceptional value for money!

- Final assembling and testing in Australia!
- Fast TURBO Motherboard
- AT\* style keyboard
- Tested by us for 24 hours prior to delivery!
- 8 Slot motherboard
- 12 months warranty!
- 150W power supply



#### 386 TOWER PC

The 386 Tower PC is a high performance system that's IBM\* AT\* compatible. However, the 386 Tower PC gives you 2-5 times the performance.

#### FEATURES:

- Intel 80386-16MHz microprocessor
- Switchable 16/20 MHz
- 2 M/Byte fitted. Total memory expandable up to 16 M/Byte
- Up to 2 M/Byte or 8 M/Byte RAM modules on a system board or on RAM card
- Option for 80287 & 80387 co-processor socket
- Operates in page mode with interleaved memory subsystem
- Shadow RAM supported to allow system BIOS to be executed on system memory instead of slower EPROM
- Four 16-bit I/O slot. Three 8-bit I/O slot, and one 32-bit memory slot
- 8042 keyboard controller interface for AT\* compatible keyboard
- Seven direct memory access (DMA) channels
- Chips and Technology chip set
- AMI 386 BIOS/ Phoenix 386 BIOS/ AWARD 386 BIOS (AMI fitted)
- 50 M/Byte hard disk. 42 M/Byte formatted. VC
- EGA card
- 3 1/2" drive 1.44 M/Byte

X20070.....\$5,995

#### TOWER COMPUTER CASING

Remount your computer to give it that professional look.

- Accepts XT, AT, Baby AT and 386 boards
- Horizontal full height hard disk drive mounting
- Room for 2 x 3 1/2" and 2 x 5 1/4" floppy drives
- Full height HDD plus fan mount
- Size: 165(W) x 600(H) x 500(D)

X11105.....\$250

#### 640K RAM TURBO COMPATIBLE COMPUTER

2 x 360K Disk Drives, Multi-function Card, Colour Graphics, Disk Controller, 1 Serial, Parallel Port (Clock).....\$1,050

**WITH 20 M/BYTE HARD DISK:**  
& single 360K Disk Drive...\$1,450  
& dual 360K Disk Drives...\$1,600

**WITH 40 M/BYTE HARD DISK:**  
& single 360K V.C. H.D.....\$1,775  
& dual 360K V.C. H.D.....\$1,925



#### BABY AT\* COMPATIBLE COMPUTER!

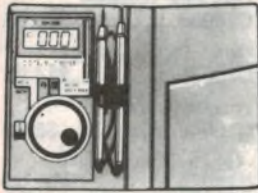
#### 2M/B RAM \$2,195

- Final assembling and testing in Australia!
- 4 M/Byte Main Board, 2 M/Byte fitted
- Switchable 8/10/12 MHz
- 1.2 M/Byte Floppy Disk Drive
- 80286 CPU
- Colour Graphics Display Card
- 8 Slots
- Floppy & Hard Disk Controller
- Printer Card and RS232
- Keyboard
- 200W Power Supply
- Manual
- 6 Months Warranty
- Size:  
360(W) x 175(H) x 405(D)mm

With 20 M/Byte Hard Disk \$2,195  
With 40 M/Byte V.C. H.D....\$2,395  
With 80 M/Byte Hard Disk...CALL

# ROD IRVING ELECTRONICS

## TEST EQUIPMENT



### MULTIMETER (YF-100)

- Autoranging for DCV, ACV, OHM & continuity measurement
  - 10mm thickness & 80g light weight for easy operation
  - Dimension & weight = 108 x 54 x 8mm and 60g approx
- Q11264.....\$69



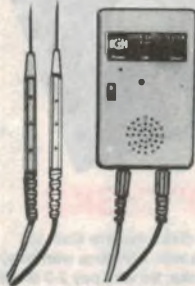
### MULTIMETER (YF-2100)

- Large display 4 1/2 dgt 0.5" height LCD with maximum reading of 19999
  - Automatic polarity "-" display for negative input
  - High over-load protection for all ranges
  - Over load display, the highest digit "1" or "-1" alone glows
  - Power consumption 20mW approx.
  - Dimension & weight = 162 x 86 x 28mm and 200g approx
- Q11266.....\$199



### MULTIMETER (YF-3000)

- Large display 3 1/2 digit 0.5" height LCD for easy readout
  - Auto/manual range select easy to operate
  - Automatic low battery "-" display for battery indication
  - Memory-comparative function available for allowance within  $\pm 5\%$
  - Warning sound for overload and conductance
  - Dimension & Weight = 170 x 80 x 33mm, 260gram approx
  - Data hold function for easy readout
- Q11268.....\$110



### SHORT TESTER

- Instantly shows the open/short position of PCB
  - It can test whether PCB or solid wire open/short by Buzzer
- Q11276.....\$22.95



### LOGIC PULSER (LP-540H)

- Can be used directly to inject a signal into logic circuits without removing IC
  - Compatible with TTL, DTL, RTL HTL, MOS and CMOS
- Q11274.....\$42.95



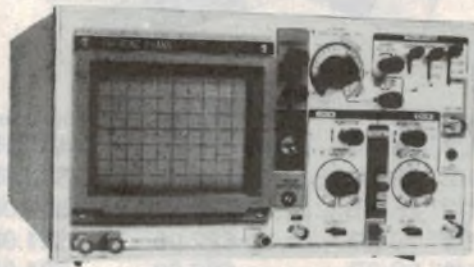
### LOGIC PROBE (LP-2800)

- Useful for TTL or CMOS has high and low indicator leds and also with pulse memory.
  - This is a very handy tool for the hobbyist or serious technician for tracing those hard to find faults on logic boards.
- Q11272.....\$34.95



### DIGITAL METER (YF-120)

- Autoranging operation
  - Data-hold for easy readout
  - Full range protection
  - 0-500 volts AC-DC
  - 0-20 M $\Omega$
  - Dimension & weight = 133 x 29 x 17mm and 60g approx
- Q11270.....\$98.95



### HUNG CHANG (RITRON) 20 MHz DUAL TRACE OSCILLOSCOPE

- Wide bandwidth and high sensitivity
- Internal graticule rectangular bright CRT
- Built in component tester
- Front panel trace rotator
- TV video sync filter
- Z axis (Intensity modulation)
- High sensitivity X-Y mode
- Very low power consumption
- Regulated power supply circuit

Component tester is the special circuit with which a single component or components in circuit can be easily tested. The display shows faults of components, size of a component value, and characteristics of components. This feature is ideal to trouble shoot solid state circuits and components with nbo circuit power. Testing signal (AC Max 2 mA) is supplied from the component test in terminal and the result of the test is fed back to the scope through the same test lead wire at the same time.

Q12105.....\$695

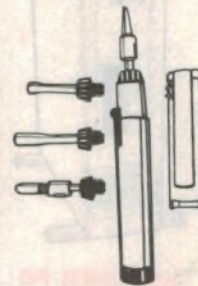
## GENERAL TOOLS

### ROYAL SOLDERING STATION

The all solid-state heat sensor and control unit allows the selection of the appropriate soldering tip idling temperature. The very high-powered element (relative to the size of the tool) will replenish heat drained from the tip during each soldering operation and will recover the tip temperature moments after the tip is lifted.



- Zero voltage switching
  - Zero tip potential
  - Aux ground connection
  - For soldering irons-CT6 (3mm Tip), CT7 (5mm Tip)
- T12570.....\$195



### BESWICK 88100 PROBE SET

CONTAINS: Compensated probe lead with...

- Detachable 6 inch earth lead
- Retractable hook
- IC test tip
- Tip insulator
- BNC adaptor
- Trimming tool

#### SPECIFICATIONS:

Bandwidth: 10:1 position

:250MHz at -3dB into 20pF

Rise Time: 10:1 position less

than 1.4ns nominal

Switch Function:

(a) 10:1 attenuation +/-1%, with oscilloscope of 1Mohm input resistance

(b) 1:1 attenuation with bandwidth of 10 MHz approx.

(c) Reference position, tip grounded via 9 Mohm, oscilloscope input grounded

Input Capacitance: 16pF typical depending upon oscilloscope input capacitance

Compensation Range:

Oscilloscopes of 15 to 60 pF input capacitance

Working Voltage: 600V DC or peak AC

Q12200.....\$49.95

### PORTASOL PROFESSIONAL

- Four tools in one: Blow torch, Hot Blow or Hot Knife
  - No Cords or batteries
  - Heavy duty, tip temperature adjustable up to 400°C
  - Equivalent to 10-60 watts
  - Hard working. Average continuous use 90 minutes
  - Refills in seconds
  - Powered by standard butane gas lighter fuel
  - Range of easily replaceable screw tips included
  - Includes metal stand for the soldering iron when working
  - Cap features bully-in flint for igniting Portasol tip
  - Includes snap case for storage
- T12639.....\$89.95

### PORTASOL PROFESSIONAL TIPS

- 4.8mm (T12610).....\$12.50
- 3.2mm (T12612).....\$12.50
- 2.4mm (T12614).....\$12.50
- 1.0mm (T12616).....\$12.50

### PORTASOL SOLDERING IRON

T12637.....\$39.95



### ECONOMY ANTISTATIC SOLDER SUCKER

- Light Weight
  - Sturdy construction
  - Easy to remove tip
  - Excellent value for money
- T11281.....\$13.95



### SOLDER ROLLS

• 60/40 Resin cored

• 0.71mm, 250gm  
T31000.....\$8.95

• 0.71mm, 500gm  
T31002.....\$15.95

• 0.91mm, 250gm  
T31010.....\$7.95

• 0.91mm, 500gm  
T31012.....\$14.95

• 1.6mm, 250gm  
T31020.....\$7.50

• 1.6mm, 500gm  
T31022.....\$13.95



**HANDS FREE SPEAKERPHONE**

Here's a hands-free telephone that anyone can afford. With the speakerphone you can have relaxing conversations without the need to hold the phone to your ear. And if you are put on "hold" you can continue with you work while you wait. (SC SEP 88)  
**K88130.....\$89**



**DISCOLIGHT SC**

These days when you go to hear your favourite band or disco there is always a top light show. Now you can have many of these exciting light show effects - with the Discolight (SC AUG 88)  
**K88125.....\$159**



**PC DRIVEN FUNCTION GENERATOR**

Here's a simple and low cost little unit which lets you use your personal computer to generate signals with almost any conceivable waveform. It hooks up to the computer via a standard Centronics-type parallel printer port, making it compatible with almost any kind of computer. Building and using it will also give you valuable insight into the growing trend towards computer-driven test instruments, too! Software included. (EA JAN 89)  
**K88111.....\$49.95**



**CAPACITANCE ADAPTOR FOR YOUR DMM**

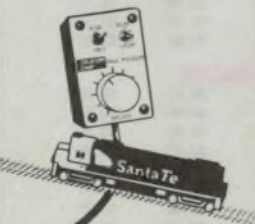
This clever adaptor circuit plugs into your digital multimeter and can measure capacitance up to 2.2 microfarads. (SC NOV 87)  
**K88119.....\$24.99**

**PRINTER BUFFER**

This external printer buffer will allow two computers to share one printer without the bother of swapping cables. Without dynamic ram (ETI 1620 FEB 89)  
**K56012.....\$139.95**  
 Dynamic Ram (extra).....\$150

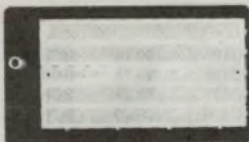
**PCB SHORTS LOCATOR**

Here is a simple circuit to help you locate shorted tracks on printed circuit boards, by means of a varying audio tone. It is easily built and will cost you a lot less than equivalent commercial units. (EA FEB 89)  
**K88015.....\$22.95**



**WALK-AROUND THROTTLE FOR MODEL**

This walk around throttle offers a host of features including pulse power, inertia (momentum), braking and full overload protection. (SC APRIL 88)  
**K88122.....\$89**

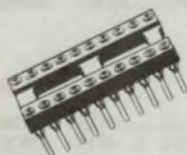


**BREAD BOARDS**

This inexpensive range of modular interlocking units enables a quick, easy way of experimenting with new circuits and ideas. There are two main units consisting of a terminal strip or distribution and a Central plug-in unit.  
 • 100 holes  
**P11000.....\$2.75**  
 • 640 + 100 holes  
**P11007.....\$14.95**  
 • 1280 + 100 holes  
**P11010.....\$26.95**  
 • 2560 + 700 holes  
**P11018.....\$69.95**

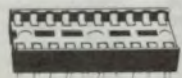
**HEAT SHRINK TUBING**

• Price per metre  
 PHS 25 25mm.....\$6.95  
 PHS 20 20mm.....\$5.00  
 PHS 16 16mm.....\$3.60  
 PHS 13 13mm.....\$3.30  
 PHS 10 10mm.....\$2.65  
 PHS 7 7mm.....\$2.15  
 PHS 5.5 5mm.....\$1.85  
 PHS 3.5 3.5mm.....\$1.70  
 PHS 2.5 2.5mm.....\$1.50  
 PHS 1.5 1.5mm.....\$1.30



**GOLD INSERT LOW PROFILE IC SOCKETS**

• Gold machined pins  
 • Extremely high quality  
 • Anti-wicking  
 • Ideal for professional use or where field service components is required.  
 Cat.no. Description 1-9 10+  
**P10620 8 pin \$1.20 \$1.10**  
**P10624 14 pin \$1.60 \$1.40**  
**P10626 16 pin \$1.90 \$1.80**  
**P10628 18 pin \$2.00 \$1.90**  
**P10630 20 pin \$2.20 \$2.00**  
**P10632 22 pin \$2.40 \$2.20**  
**P10634 24 pin \$2.60 \$2.40**  
**P10640 28 pin \$2.90 \$2.70**  
**P10644 40 pin \$2.95 \$2.75**



**LOW PROFILE IC SOCKETS**

Save a small fortune on these "Direct Import" low profile IC sockets! PCB mounting solder tall. All tin plated phosphor bronze or beryllium and dual wipe for reliability.

Cat. No. Description 1-9 10+  
**P10550 8 pin \$0.20 \$0.15**  
**P10560 14 pin \$0.25 \$0.20**  
**P10565 16 pin \$0.35 \$0.20**  
**P10567 18 pin \$0.40 \$0.30**  
**P10568 20 pin \$0.40 \$0.30**  
**P10569 22 pin \$0.40 \$0.30**  
**P10570 24 pin \$0.40 \$0.30**  
**P10572 28 pin \$0.50 \$0.40**



**CANNON TYPE CONNECTORS AT SPECIAL PRICES !!**

Cat. no. Description Price  
**P10960 3 pin line male \$2.90**  
**P10962 3 pin chassis male \$3.25**  
**P10964 3 pin line female \$3.50**  
**P10966 3 pin chassis female \$3.75**



**ROYAL DUOTEMP SOLDERING IRONS**

The DUOTEMP range are designed to idle with a normal tip temperature of 360°C, without its button depressed. In this mode they are ideal for delicate work such as printed circuit boards. With the button depressed, the power is doubled, allowing much heavier work to be completed, or a rapid temperature recovery from larger joints. A range of 6 long-life tips are available.  
 Note: This mode cannot be used continuously.

**ROYAL DR-30: 21 WATT**

• 3mm tip  
 • 240V operation, no transformer required  
 • Safety Standards Approved  
 • 6 months Warranty  
**T12640.....\$58.50**

**ROYAL DR-50: 30 WATT**

• 5mm tip  
 • 240V operation, no transformer required  
 • Safety Standards Approved  
 • 6 months warranty  
**T12645.....\$59.95**

**ROYAL DR-60: 60 WATT**

• 6.5mm tip  
 • 240V operation, no transformer required  
 • Safety Standards Approved  
 • 6 months warranty  
**T12650.....\$62.50**



**12V DC FANS**

80 x 80 x 25.4mm  
 12V DC, 1.7 Watt, 0.14 Amps  
**T12469.....\$12.95**  
**10+ fans only \$11.95 each**

**BALL BEARING FANS**

Quality, fans for use in power amps, computers, hotpot cooling etc. Anywhere you need plenty of air.  
**240V 4 5/8" T12461...\$14.95**  
**115V 4 5/8" T12463...\$14.95**  
**240V 3 1/2" T12465...\$14.95**  
**115V 3 1/2" T12467...\$14.95**  
**10+ fans (mixed) only \$13.95 each**



**WIRE WRAP IC SOCKETS**

These quality 3 level wire wrap sockets are tin-plated phosphor bronze  
 Cat. no. Description 1-9 10+  
**P10579 8 pin \$1.50 \$1.20**  
**P10580 14 pin \$2.50 \$2.25**  
**P10585 16 pin \$2.50 \$2.25**  
**P10587 18 pin \$2.95 \$2.75**  
**P10590 20 pin \$3.25 \$2.95**  
**P10592 22 pin \$3.25 \$2.95**  
**P10594 24 pin \$3.95 \$3.65**  
**P10596 28 pin \$4.50 \$4.25**  
**P10598 40 pin \$6.95 \$6.50**



**ROD IRVING ELECTRONICS**

All sales tax exempt orders and wholesale inquiries to:  
**SYDNEY:** 74 Parramatta Rd. Stanmore 2048  
 Phone: (02) 519 3134  
 Fax: (02) 519 3868  
**MELBOURNE:** 48 A'Beckett St  
 Phone: (03) 663 6151

**NORTHCOTE:** 425 High St.  
 Phone: (03) 489 8866

**MAIL ORDER & CORRESPONDENCE:**  
 P.O. Box 620, CLAYTON 3168  
 Order Hotline: 008 33 5757  
 (Toll free, strictly orders only)  
 Inquiries: (03) 543 7877  
 Telex: AA 151938  
 Fax: (03) 543 2648

**IRTRONICS WHOLESALE:**  
 56 Renver Road, Clayton.  
 Phone: (03) 543 2166 (3 lines)  
 Fax: (03) 543 2648

**ORDER HOTLINE 008 33 5757 (TOLL FREE)**

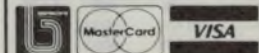
STRICTLY ORDERS ONLY  
**LOCAL ORDERS & INQUIRES (03) 543 7877**

**POSTAGE RATES:**  
**\$1 - \$9.99 .....\$2.00**  
**\$10 - \$24.99 .....\$3.00**  
**\$25 - \$49.99 .....\$4.00**  
**\$50 - \$99.99 .....\$5.00**  
**\$100 + .....\$7.50**

The above postage rates are for basic postage only Road Freight, bulky and fragile items will be charged at different rates.

Errors and omissions excepted. Prices and specifications subject to change.

IBM, PC, XT, AT, are registered trademarks of International Business Machines. Apple is a registered trademark. Teflon is a registered trademark of Dupont. Denon is registered trademarks of their respective owners.



## SEMICONDUCTORS

### SEMICONDUCTORS 74LS SERIES

74LS00 \$0.75	74LS112 \$0.70	74LS244 \$2.50
74LS01 \$0.60	74LS113 \$0.70	74LS245 \$2.95
74LS02 \$0.60	74LS114 \$0.80	74LS247 \$1.30
74LS03 \$0.60	74LS122 \$1.30	74LS248 \$1.40
74LS04 \$0.75	74LS123 \$1.30	74LS249 \$1.50
74LS05 \$0.75	74LS125 \$1.00	74LS251 \$1.50
74LS08 \$0.60	74LS126 \$1.00	74LS253 \$1.35
74LS09 \$0.80	74LS132 \$1.00	74LS257 \$1.20
74LS10 \$0.60	74LS133 \$0.90	74LS258 \$1.20
74LS11 \$0.75	74LS136 \$1.20	74LS259 \$2.25
74LS12 \$0.80	74LS138 \$1.20	74LS261 \$2.50
74LS13 \$0.90	74LS139 \$1.00	74LS266 \$0.70
74LS14 \$0.80	74LS145 \$1.50	74LS273 \$1.95
74LS15 \$0.80	74LS147 \$2.50	74LS275 \$6.80
74LS20 \$0.60	74LS148 \$1.90	74LS279 \$0.80
74LS21 \$0.90	74LS151 \$1.20	74LS280 \$2.60
74LS22 \$0.90	74LS152 \$1.95	74LS283 \$1.20
74LS26 \$0.90	74LS153 \$1.00	74LS290 \$1.20
74LS27 \$0.90	74LS154 \$3.80	74LS293 \$1.10
74LS28 \$0.90	74LS155 \$1.50	74LS295 \$1.50
74LS30 \$0.60	74LS156 \$1.50	74LS299 \$3.90
74LS32 \$0.60	74LS157 \$1.20	74LS323 \$6.50
74LS33 \$0.60	74LS158 \$1.00	74LS324 \$2.20
74LS37 \$0.70	74LS160 \$1.50	74LS352 \$2.20
74LS38 \$0.80	74LS161 \$1.00	74LS365 \$1.00
74LS40 \$0.80	74LS162 \$1.50	74LS366 \$1.00
74LS42 \$1.20	74LS163 \$1.10	74LS367 \$1.00
74LS47 \$1.80	74LS164 \$1.40	74LS368 \$1.00
74LS48 \$1.80	74LS165 \$1.20	74LS373 \$2.00
74LS49 \$1.80	74LS166 \$2.55	74LS374 \$2.00
74LS51 \$0.70	74LS169 \$2.95	74LS375 \$1.00
74LS54 \$0.80	74LS173 \$1.20	74LS377 \$2.15
74LS55 \$0.80	74LS174 \$1.20	74LS378 \$1.20
74LS73 \$0.60	74LS175 \$1.00	74LS379 \$1.90
74LS74 \$1.00	74LS181 \$4.00	74LS386 \$1.00
74LS75 \$1.00	74LS190 \$1.50	74LS390 \$1.80
74LS76 \$1.00	74LS191 \$1.20	74LS393 \$1.80
74LS83 \$1.20	74LS192 \$1.20	74LS395 \$2.00
74LS85 \$0.85	74LS193 \$1.20	74LS424 \$5.50
74LS86 \$0.60	74LS194 \$1.20	74LS490 \$3.20
74LS90 \$1.20	74LS195 \$1.00	74LS540 \$2.95
74LS91 \$1.20	74LS196 \$1.20	74LS541 \$3.50
74LS92 \$1.20	74LS197 \$1.35	74LS574 \$4.90
74LS93 \$1.50	74LS221 \$2.00	74LS601 \$5.90
74LS95 \$1.20	74LS240 \$2.40	74LS629 \$5.95
74LS96 \$1.20	74LS241 \$2.40	74LS640 \$3.95
74LS107 \$0.90	74LS242 \$2.40	74LS642 \$2.75
74LS109 \$0.90	74LS243 \$2.10	74LS645 \$2.75

### TRANSISTORS

BC107 \$0.75	BC558 \$0.20	BU326 \$3.90
BC108 \$0.75	BC559 \$0.20	BUX80 \$4.90
BC327 \$0.25	BC639 \$0.50	2N2222A \$1.00
BC328 \$0.28	BC640 \$0.50	2N2907 \$1.10
BC337 \$0.25	BD139 \$0.75	2N3055 \$1.50
BC338 \$0.25	BD140 \$0.75	2N3904 \$1.00
BC546 \$0.40	BD237 \$0.90	2N3906 \$1.00
BC547 \$0.20	BD238 \$0.90	2N6027 \$1.00
BC548 \$0.20	BD681 \$2.00	2SJ49 \$9.95
BC549 \$0.20	BD682 \$2.00	2SK134 \$9.95
BC550 \$0.40	BF199 \$0.60	INS16450 \$26.95
BC556 \$0.40	BU126 \$3.95	
BC557 \$0.20	BU208 \$4.90	

### SEMICONDUCTORS

LF347 \$2.60	MC1489 \$1.20	WD8250 \$29.50
LM301 \$1.20	EM2907-14 \$3.90	NE5534AN \$3.50
LM308 \$1.00	CA3130E \$3.90	XR2206 \$8.95
NE555 \$1.00	CA3140E \$2.20	XR2211 \$7.95
NE556 \$1.65	6502 \$15.00	ICL7660 \$6.90
LM723 \$1.00	Z80ACPU \$6.75	2SK134 \$9.95
LM741 \$0.80	AD590 \$9.50	2SJ49 \$9.95
MC1488 \$1.20	MSM5832 \$16.50	

### VOLTAGE REGULATORS

78L05 \$0.80	79L05 \$1.20	LM317T \$2.50
7805UC \$0.60	7905UC \$1.90	LM317K \$4.95
7805KC \$2.50	7905KC \$3.00	LM350T \$6.80
78L12 \$0.80	79L12 \$1.20	LM337T \$2.90
7812UC \$1.20	7912UC \$1.90	LM338K \$10.50
7812KC \$2.50	7912KC \$2.50	

### DIODES

IN4002 \$0.10	IN4007 \$0.20	IN5408 \$0.40
IN4004 \$0.10	IN5404 \$0.30	IN5401 \$0.40

### EPROMS

2716 \$12.50	27128 \$9.95	27C128 \$12.50
2732 \$8.95	27512 \$19.95	27C256 \$15.95
2764 \$8.95	27C64 \$8.95	

### TAG TANTALUM CAPACITORS

#### 6.3V TAG TANTALUMS

R16032 47uF \$1.00	\$0.80	\$0.70
R16036 100uF \$2.50	\$2.20	\$1.90

#### 16V TAG TANTALUMS

R16124 4.7uF \$0.50	\$0.45	\$0.40
R16125 10uF \$0.60	\$0.55	\$0.50
R16126 15uF \$0.80	\$0.70	\$0.60
R16128 22uF \$1.20	\$1.00	\$0.80
R16130 33uF \$1.75	\$1.50	\$1.25
R16132 47uF \$2.50	\$2.20	\$1.90
R16034 68uF \$4.95	\$3.95	\$2.95

#### 25V TAG TANTALUMS

R16216 2.2uF \$0.60	\$0.50	\$0.40
R16218 3.3uF \$0.60	\$0.50	\$0.40
R16220 4.7uF \$0.60	\$0.50	\$0.40
R16222 6.8uF \$0.70	\$0.60	\$0.50
R16224 10uF \$0.70	\$0.60	\$0.50
R16228 22uF \$2.50	\$2.00	\$1.50
R16229 33uF \$4.50	\$4.00	\$3.50

#### 35V TAG TANTALUMS

R16300 0.1uF \$0.50	\$0.40	\$0.30
R16302 0.15uF \$0.50	\$0.40	\$0.30
R16304 22uF \$0.50	\$0.40	\$0.30
R16306 33uF \$0.50	\$0.40	\$0.30
R16308 47uF \$0.50	\$0.40	\$0.30
R16310 0.68uF \$0.50	\$0.40	\$0.30
R16312 1.0uF \$0.50	\$0.40	\$0.30
R16314 1.5uF \$0.60	\$0.50	\$0.40
R16316 2.2uF \$0.60	\$0.50	\$0.40
R16318 3.3uF \$0.60	\$0.50	\$0.40
R16320 4.7uF \$0.70	\$0.60	\$0.50
R16322 6.8uF \$0.70	\$0.60	\$0.50
R16324 10uF \$0.80	\$0.70	\$0.60
R16326 15uF \$1.75	\$1.50	\$1.25
R16328 22uF \$3.50	\$3.00	\$2.50
R16330 33uF \$4.50	\$3.95	\$3.60
R16332 47uF \$4.95	\$4.00	\$3.70

## GENERAL COMPONENTS



### JUMP WIRE KIT (KS-350)

Contains:  
14 kinds of length from 0.1" to 5" with different colors  
Q11278.....\$19.95

### WIRE WRAP WIRE

- Pack of 100
- Pre-cut wire
- W19002 Blue 3.0" \$4.75
- W19022 Red 3.0" \$4.75
- W19042 Yellow 3.0" \$4.75
- W19062 Black 3.0" \$4.75
- W12784 Green 3.0" \$4.75
- W19026 Red 5.0" \$5.95
- W19046 Yellow 5.0" \$5.95
- W19066 Black 5.0" \$5.95
- W12790 Green 5.0" \$5.95
- W19006 Blue 5.0" \$5.95
- W19016 Blue 10.0" \$10.50
- W19036 Red 10.0" \$10.50
- W19056 Yellow 10.0" \$10.50
- W19076 Black 10.0" \$10.50
- W12796 Green 10.0" \$10.50

- Spool wire
- W19390 Green 50ft \$8.00
- W19400 Blue 50ft \$8.00
- W19406 Purple 50ft \$8.00
- W19407 White 50ft \$8.00
- W19408 Orange 50ft \$8.00
- W19410 Yellow 50ft \$8.00
- W19415 Black 50ft \$8.00
- W19416 Green 100ft \$10.75
- W19417 Brown 100ft \$10.75
- W19420 Blue 100ft \$10.75
- W19425 Red 100ft \$10.75
- W19426 Purple 100ft \$10.75
- W19427 White 100ft \$10.75
- W19428 Orange 100ft \$10.75
- W19430 Yellow 100ft \$10.75
- W19435 Black 100ft \$10.75
- W19460 Blue 500ft \$33.75
- W19461 Green 500ft \$33.75
- W19465 Red 500ft \$33.75
- W19475 Black 500ft \$33.75



### FLASHING LEDS

- Red, 5mm
- 1-10 10+
- Z10159 \$1.10 \$1.00

### SUPER BRIGHT LEDS

- Red.....Z10146
- Green.....Z10147
- Yellow.....Z10148
- 1-9 10+
- \$1.00 \$0.90

### QUALITY LEDS

Cat. no.	Description	Price
Z10140	3mm Red.....	\$0.15
Z10141	3mm Green.....	\$0.20
Z10143	3mm Yellow.....	\$0.20
Z10145	3mm Orange.....	\$0.20
Z10150	5mm Red.....	\$0.10
Z10151	5mm Green.....	\$0.15
Z10152	5mm Orange.....	\$0.15
Z10155	10mm Red.....	\$1.00
Z10156	10mm Green.....	\$1.00
Z10157	10mm Yellow.....	\$1.00

## GREAT SAVINGS AT R.I.E

Ring Now Toll Free 008 33 5757

### SEMICONDUCTORS 74 SERIES

7400 \$0.50	7416 \$0.50	74123 \$0.70
7404 \$0.50	7437 \$0.50	74154 \$2.00
7406 \$0.50	7445 \$0.80	
7407 \$0.50	7474 \$0.60	

### SEMICONDUCTORS SERIES 4000

4000 \$0.75	4027 \$0.85	4054 \$3.90	4096 \$2.40
4001 \$0.45	4028 \$1.15	4055 \$3.90	4097 \$6.50
4002 \$0.45	4029 \$1.50	4056 \$4.20	4098 \$2.90
4006 \$1.55	4030 \$1.50	4060 \$2.50	4099 \$3.90
4007 \$0.45	4031 \$2.95	4063 \$2.00	40194 \$2.50
4008 \$1.70	4032 \$2.30	4066 \$0.80	4510 \$1.40
4009 \$0.90	4033 \$2.75	4067 \$9.90	4511 \$1.45
4010 \$0.90	4034 \$3.10	4068 \$0.50	4512 \$1.40
4011 \$0.45	4035 \$1.80	4069 \$0.50	4513 \$2.65
4012 \$0.45	4038 \$2.25	4070 \$0.50	4514 \$2.60
4013 \$0.70	4040 \$1.20	4071 \$0.50	4515 \$2.90
4014 \$1.45	4041 \$1.50	4072 \$0.50	4516 \$1.60
4015 \$1.45	4042 \$1.50	4073 \$0.50	4517 \$4.80
4016 \$0.70	4043 \$1.20	4075 \$0.50	4518 \$1.50
4017 \$1.35	4044 \$1.25	4076 \$1.90	4519 \$0.90
4018 \$1.50	4045 \$4.90	4077 \$0.50	4520 \$1.50
4019 \$0.80	4046 \$1.90	4078 \$0.50	4521 \$3.40
4020 \$1.40	4047 \$1.90	4081 \$0.50	4522 \$1.90
4021 \$1.50	4048 \$1.20	4082 \$0.75	4526 \$1.90
4022 \$1.45	4049 \$0.60	4085 \$2.20	4527 \$1.90
4023 \$1.45	4050 \$0.60	4086 \$2.30	4528 \$1.95
4024 \$1.30	4051 \$1.20	4093 \$0.80	4558 \$2.25
4025 \$0.45	4052 \$1.20	4094 \$3.35	4584 \$0.90
4026 \$2.40	4053 \$1.20	4095 \$2.40	4585 \$2.10

## CABLES

### PRINTER LEAD

- Suits IBM PC/XT, compatibles
- 25 pin "D" plug (computer end) to Centronics 36 pin plug
- 1.8 metres
- P19029.....\$14.95
- 3 metres
- P19030.....\$19.95
- 10 metres
- P19034.....\$39.95



### FLAT GREY RIBBON CABLE

- Flat cable for IDC connectors
- m = metre
- 14 way W12614
- 1-9 m 10+ m 100+ m
- \$1.90m \$1.80m \$1.20m
- 16 way W12616
- 1-9 m 10+ m 100+ m
- \$1.90m \$1.80m \$1.20m
- 20 way W12620
- 1-9 m 10+ m 100+ m
- \$2.50m \$2.20m \$1.50m
- 24 way W12624
- 1-9 m 10+ m 100+ m
- \$2.90m \$2.70m \$1.70m
- 26 way W12626
- 1-9 m 10+ m 100+ m
- \$3.60m \$3.30m \$2.20m
- 34 way W12634
- 1-9 m 10+ m 100+ m
- \$3.90m \$3.60m \$2.30m
- 36 way W12636
- 1-9 m 10+ m 100+ m
- \$4.50m \$3.80m \$2.50m
- 40 way W12640
- 1-9 m 10+ m 100+ m
- \$4.90m \$4.00m \$2.80m
- 50 way W12650
- 1-9 m 10+ m 100+ m
- \$5.50m \$4.90m \$2.90m



### COMPUTER CABLE

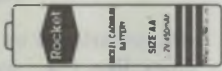
- Six conductor shielded computer interface cable
- m = metre
- CIC6 W12670
- 1-9 m 10+ m 100+ m
- \$1.30m \$1.10m \$1.00m
- CIC9 W12672
- 1-9 m 10+ m 100+ m
- \$1.60m \$1.50m \$1.20m
- CIC12 W12674
- 1-9 m 10+ m 100+ m
- \$2.50m \$2.20m \$1.90m
- CIC16 W12676
- 1-9 m 10+ m 100+ m
- \$3.50m \$3.20m \$2.50m
- CIC25 W12678
- 1-9 m 10+ m 100+ m
- \$3.90m \$3.40m \$3.00m

## GENERAL ACCESSORIES



### AAA SIZE NICAD (2 PACK)

Nominal Voltage: 1.2V 180mAh  
S15026  
1-9 10+  
\$11.95/Pk \$10.95/Pk



### AA SIZE NICAD

Nominal Voltage: 1.2V 450mAh  
S15020  
1-9 10+ 100+  
\$2.45 \$2.35 \$2.00



### C SIZE NICAD

Nominal Voltage: 1.2V 1,200mAh  
S15021  
1-9 10+  
\$9.95 \$8.95

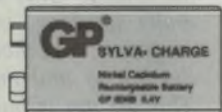


### D SIZE NICAD

Nominal Voltage: 1.2V 1,200mAh  
S15022  
1-9 10+  
\$10.95 \$9.95

### NR-N SIZE NICAD (2 PACK)

Nominal Voltage: 1.2V 150mAh  
S15027  
1-9 10+  
\$11.95/Pk \$10.95/Pk



### 9V SQUARE TYPE NICAD

Nominal Voltage: 9V 100mAh  
S15023  
1-9 10+  
\$11.95 \$10.95

### NBC3 SUPER DELUXE BATTERY CHARGER

- Standard charges up to ten-UM3, UM4 and UM5 NiCad with "NM4/5" charging modules
- Slow charges up to ten-UM1 and UM2 NiCad batteries
- Also charges up to three-006P 8.4 volt NiCads
- 240V AC operated
- Approval No. N/10637
- Automatic current ranging
- Dual colour LED Indicators
- M23525.....\$54.95

### NBC1 UNIVERSAL BATTERY CHARGER/TESTER

NiCad battery charger complete with tester

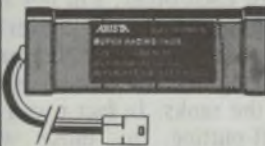
- Will standard charge UM3, UM4, UM5, 006P NiCad batteries
- Slow charge UM1 and UM2 NiCad batteries
- Automatic current ranging from 20 to 70mA
- LED indicators and voltage level meter
- Supplied with 240V AC adaptor
- Approval No. N/1499
- M23519.....\$39.95



### NBC5 RACING PACK BATTERY QUICK CHARGER

Fast charger for 7.2V Nickel Cadmium batteries

- Input: 12V DC cigarette lighter - fuse protected
- Output: standard racing pack lead and terminal to suit "NCRP72" and Tamiya 7.2V batteries
- 0 to 30 minute timer - standard fast charge is 15 minutes for "NCRP72" and other 7.2V batteries
- M23528.....\$39.95



### NRP72 7.2V NICAD RACING PACK BATTERY

Suits most Tamiya and other brand remote control cars, toys and models

Voltage: 7.3 volts  
Charging Current: 130mA  
Nominal Capacity: 1300mAh  
Charging Time: 15 hours  
S15025.....\$39.95

### CRYSTALS

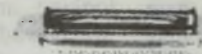
- |        |            |         |
|--------|------------|---------|
| Y11000 | 1MHz       | \$11.50 |
| Y11003 | 1.8432MHz  | \$7.50  |
| Y11005 | 2MHz       | \$6.90  |
| Y11007 | 2.3040 MHz | \$6.50  |
| Y11008 | 2.4576 MHz | \$6.50  |
| Y11009 | 2.7648 MHz | \$4.90  |
| Y11010 | 3MHz       | \$4.90  |
| Y11015 | 3.57954MHz | \$3.00  |
| Y11018 | 3.93216MHz | \$4.90  |
| Y11020 | 4.00 MHz   | \$4.90  |
| Y11022 | 4.19430MHz | \$3.90  |
| Y11023 | 4.33618MHz | \$4.90  |
| Y11024 | 4.44 MHz   | \$4.90  |
| Y11025 | 4.75 MHz   | \$4.90  |
| Y11026 | 4.9152 MHz | \$6.90  |
| Y11027 | 4.9562 MHz | \$4.90  |
| Y11030 | 5MHz       | \$4.90  |
| Y11033 | 5.0688MHz  | \$4.90  |
| Y11042 | 6.144 MHz  | \$4.90  |
| Y11050 | 8.00 MHz   | \$4.90  |
| Y11055 | 8.86723MHz | \$4.90  |
| Y11070 | 12.00 MHz  | \$4.90  |
| Y11072 | 14.318 MHz | \$4.90  |
| Y11080 | 16.00 MHz  | \$4.90  |
| Y11085 | 18.432 MHz | \$4.90  |
| Y11090 | 20.00 MHz  | \$4.90  |

## PLUGS AND SOCKETS



### D TYPE SOLDER PLUGS

- |        |        |        |
|--------|--------|--------|
| DE9P   | P10880 |        |
| 1-9    | 10+    | 100+   |
| \$1.55 | \$1.50 | \$0.80 |
| DA15P  | P10890 |        |
| 1-8.5  | \$1.55 | \$0.90 |
| DB25P  | P10900 |        |
| 1-9.5  | \$1.60 | \$0.90 |
| DC37P  | P10910 |        |
| 3-9.5  | \$3.75 | \$3.50 |
| DF50P  | P10920 |        |
| 5-9.5  | \$5.75 | \$4.95 |



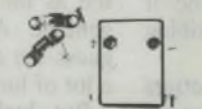
### D TYPE SOLDER SOCKETS

- |        |        |        |
|--------|--------|--------|
| DE9S   | P10881 |        |
| 1-9    | 10+    | 100+   |
| \$1.95 | \$1.75 | \$0.80 |
| DA15S  | P10891 |        |
| 1-9.5  | \$1.75 | \$0.90 |
| DB25S  | P10901 |        |
| 1-9.5  | \$1.75 | \$1.00 |
| DC37S  | P10911 |        |
| 3-9.0  | \$2.90 | \$2.70 |
| DF50S  | P10921 |        |
| 6-9.0  | \$5.90 | \$4.90 |



### D TYPE IDC SOCKETS

- |        |        |        |
|--------|--------|--------|
| DE9S   | 1-9    | 10+    |
| P12167 | \$7.50 | \$7.00 |
| DA15S  |        |        |
| P12169 | \$7.75 | \$7.25 |
| DB25S  |        |        |
| P12171 | \$7.95 | \$7.50 |



### D TYPE SOLDER COVERS

- |        |        |        |
|--------|--------|--------|
| DE9C   | 1-9    | 10+    |
| P10882 | \$1.20 | \$1.00 |
| DA15C  |        |        |
| P1089  | \$1.25 | \$1.10 |
| DB25C  |        |        |
| P10902 | \$1.25 | \$1.10 |
| DC37C  |        |        |
| P10912 | \$5.50 | \$4.95 |
| DF50C  |        |        |
| P10922 | \$6.50 | \$5.95 |
| DE9C   |        |        |
| P10882 | \$1.20 | \$1.00 |



### CARD EDGE CONNECTORS 1" SPACING

- |        |        |               |
|--------|--------|---------------|
|        | 10+    | 100+          |
| P12060 | 10 pin | \$3.95 \$3.50 |
| P12062 | 20 pin | \$4.25 \$3.75 |
| P12064 | 26 pin | \$4.50 \$3.95 |
| P12066 | 34 pin | \$4.95 \$3.95 |
| P12068 | 40 pin | \$5.95 \$4.95 |
| P12070 | 50 pin | \$6.95 \$5.95 |

## SAVING DOLLARS AT

# ROD IRVING ELECTRONICS

All sales tax exempt orders and wholesale inquiries to:

**SYDNEY:** 74 Parramatta Rd Stanmore 2048  
Phone: (02) 519 3134  
Fax: (02) 519 3868

**MELBOURNE:** 48 A Beckett St  
Phone: (03) 663 6151

**NORTHCOLE:** 425 High St  
Phone (03) 489 8866

**MAIL ORDER & CORRESPONDENCE:**  
P.O. Box 620, CLAYTON 3168  
Order Hotline: 008 33 5757 (Toll free, strictly orders only)  
Inquiries: (03) 543 7877  
Telex: AA 151938  
Fax: (03) 543 2648

**RITRONICS WHOLESALE:**  
56 Renver Road, Clayton.  
Phone: (03) 543 2166 (3 lines)  
Fax: (03) 543 2648

**ORDER HOTLINE 008 33 5757 (TOLL FREE)**

STRICTLY ORDERS ONLY  
LOCAL ORDERS & INQUIRES (03) 543 7877

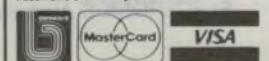
**POSTAGE RATES:**

\$1 - \$9.99	\$2.00
\$10 - \$24.99	\$3.00
\$25 - \$49.99	\$4.00
\$50 - \$99.99	\$5.00
\$100 +	\$7.50

The above postage rates are for basic postage only. Road Freight, bulky and fragile items will be charged at different rates.

Errors and omissions excepted. Prices and specifications subject to change

IBM, PC, XT, AT, are registered trademarks of International Business Machines. Apple is a registered trademark. Teflon is a registered trademark of Dupont. Danontes registered trademarks of their respective owners.



president and chief executive officer. Wilf Corrigan, chairman of LSI Logic, has been appointed as chairman of US Memories' board of directors.

Although Kane is possibly the most qualified man in the US to pull off a high-risk venture such as this, the key to the potential success of US Memories clearly has to be the willingness of IBM to license its leading-edge DRAM technology to the new company.

The founding of US Memories is the outcome of a program initiated by the Semiconductor Industry Association. Earlier this year, the SIA established a board-level committee to recommend collective efforts that could lead to the return of large scale DRAM production to the United States.

SIA president Andy Procassini emphasised that US Memories is not another industry consortium, but a new start-up company that merely depends on its equity partners for funding. Added Sematech chairman Robert Noyce, jokingly: "Consortia like Sematech are for non-profit. We certainly hope that this one is not."

## Motorola introduces 12-ounce cellular phone

Remember how 'special agent' Maxwell Smart on the popular 1960s television series 'Get Smart' used to have a portable telephone built into his left shoe? Motorola has now introduced a cellular telephone unit small enough to turn this Hollywood make-believe into reality.

Motorola said its engineers spent five years developing the US\$2,995 hand held phone, which weighs just 12.3 ounces and measures only 13 cubic inches in volume. The wallet-size phone is small enough to fit in a coat pocket or average lady's purse.

Most of the research involved reducing the size and number of components the unit is made out of, particularly the oscillator and duplexer which allow callers to listen and talk at the same time.

In all, the Motorola phone contains just 220 components, 1/10th the number of parts used to build the company's first portable telephone 10 years ago. The battery-powered phone provides enough power for 75 minutes of continuous use, compared to about 2.5 hours for most standard, bulkier portable phones.

Motorola said the phone was designed to survive the company's 'drop test' in which the unit is dropped onto a hard surface from a height of four feet (1.3m).

## First HDTV contracts from Pentagon

The Pentagon has issued the first five of a series of research grants for high-definition TV, including two to Silicon Valley electronics companies.

The grants were issued by the Defense Advanced Research Projects Agency, which oversees the most advanced research being conducted on supercomputing, Star Wars, and other advanced technological projects.

Earlier this year, the Pentagon announced it had set aside US\$30 million to fund HDTV-related research projects. The Pentagon believes it is essential for US national security that the United States plays a major role in the future market for HDTV products. Most of these products will be based on leading-edge technology that will have applications in defence-related areas.

One of the areas the Pentagon is particularly interested in is new display technology. Not surprisingly, all five initial contracts went to projects dealing with HDTV display technology.

Three of the five companies that were selected - NewCo of San Jose, Texas Instruments, and Projectavision of New York - were chosen for development of projection-related display technology in which television pictures are projected much like film projection. Raychem of Menlo Park and Photonics Technology of Ohio were chosen to develop flat-panel display technology.

## Tracking system puts car thieves out of business

A piece of Star Wars-like technology is being spun off into the commercial world, where it may make it all but impossible for car thieves to steal automobiles and not be caught by the police. Prevent-A-Theft International, which is located in Irvine, California, has announced the development of a tracking system that uses communications satellites to spot and track stolen vehicles.

The so-called 'Locator Satellite Vehicle Tracking & Recovery System' uses a small homing device that can be installed randomly in almost any part of a vehicle. To enter and start a car, the owner must enter a secret code in a small electronic box attached to the keyring. The homing device is triggered as soon as someone enters the vehicle through other means, or tries to 'hot-wire' the ignition.

At that point the homing device starts sending messages to a satellite, giving details about its location. The satellite

relays the information, including a detailed description of the car, to the nearest police authority. The vehicle is tracked every 15 minutes and is accurate to within just a couple of feet.

"The beauty of the system is that the car, in effect, reports itself stolen, instead of waiting until someone discovers the theft. Often cars are stolen while the owners are in a restaurant, shopping mall or on vacation, and the thieves get a big head start," commented John Jansen of Prevent-A-Theft.

He said that the system, introduced in January at the National Automobile Dealers Association, was particularly well received by the insurance and financing industries. Jansen said a number of major carriers and financial institutions have expressed interest in requiring their customers to install the system, which costs about US\$500 per vehicle. The system would also make it much simpler for banks to repossess cars if the owners become delinquent on their monthly payments.

## Tape giant buys Silicon Systems

TDK, the world's largest manufacturer of audio and video tapes, has agreed to acquire Silicon Systems, a Southern California-based chip maker that specialises in circuits for the automotive, computer, and telecommunications markets, including hard-disk and modem controller chips.

The deal is valued at US\$200 million, as TDK agreed to buy up all of Silicon Systems' 10 million outstanding shares. In addition, TDK has agreed to invest another US\$200 million into the Tustin-based company, money that will be used for new product development and expanding production capacity.

"This means I can be more concerned with our goals of building a US\$1.3 billion company by 1998, rather than whether the per-share profit next quarter is going to be 21 cents or 24 cents", said company president Carmello Santoro, referring to the often-cited shortsightedness of American businesses which sacrifice long-term oriented investments for short-term profits.

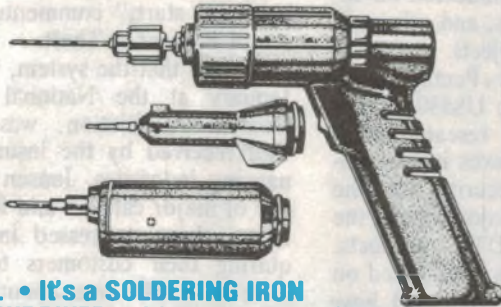
For TDK, the deal with Silicon Systems means the company instantly will be able to enter the semiconductor market without going through a lengthy and costly start-up phase. "We have been looking at semiconductors for many years. Now we are finally going to be making them", commented Ken Aoshimo at the US headquarters of the company. ④

# THE BEST PLACE TO BUY!

## The Amazing 3-In-1 Modular Tool....

The Best Price Around

Just \$99



- It's a DRILL • It's a SOLDERING IRON
- It's a SCREWDRIVER • It's totally PORTABLE
- And it's RECHARGEABLE!

This has to be one of the smartest tools for hobbyist, handyman and tradesman alike. Modular components fix to a rechargeable battery pack (handle) and in seconds you can switch from a soldering iron to a drill, from a drill to a reversible screwdriver, etc. etc.

It's easy to handle and the pistol grip action leaves one hand free to make working a breeze! Comes complete with assorted drills, screwdrivers, solder accessories and charger. Check out our great price...it's the best around. Cat T-5712

## SSB CB For Under \$200!

89/90 Catalogue Price \$229

Now \$199

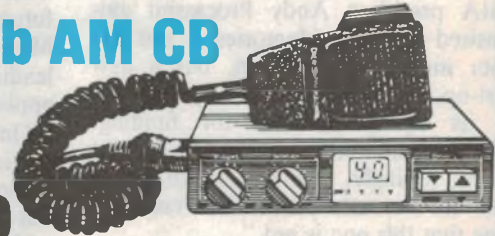


The sensation Super Tomcat AM SSB CB mobile at an incredible low price! An outstanding buy with maximum legal power on both AM and SSB, all 40 channels, the extra range and performance SSB offers.... and, with optional power supply, it can even double as a base station! Comes complete with mounting hardware, microphone and full instructions.

Cat D-1713

## Superb AM CB

Pushbutton Channel Selection



Just \$89

You won't find a better deal! The DSE 40 AM CB gives you high quality mobile communication without the hefty price tag. Its amazingly compact, beautifully styled and features all 40 AM channels, pushbutton channel tuning and maximum legal power. Comes with Mic and mounting hardware! Cat D-1200

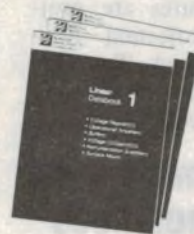
## Three Volumes!

### National Linear Databook

This has to be the most comprehensive Databook ever! 3 complete volumes from National Semiconductor. Covers everything - Voltage regulators, operational amps, active filters, analogue switches, audio/radio/video circuits, etc. etc. An absolute must for the library.

Cat B-5001

\$49<sup>95</sup>



### Linear Applications Databook

Over 1200 pages of detailed reference! A fully indexed and cross referenced collection of linear integrated circuit applications using both monolithic and hybrid circuits from National Semiconductor.

Cat B-5504

\$24<sup>95</sup>



### Electronic Test Instruments

Robert Witte - 261 pages

A comprehensive sourcebook which simplifies the internal workings of test instruments through easy to understand circuit models and conceptual block diagrams. An excellent supplement to instrument operating manuals.

Cat B-4999

\$29<sup>95</sup>



## Maths Co-Processors

Just what's needed for heavy duty mathematical calculations - and it saves time as well! A maths co-processor can perform high speed and highly accurate arithmetic, logarithmic and trigonometric operations while leaving your microprocessor free to perform other functions. Ideal for working in Auto CAD and most major spreadsheet programs such as Lotus 1-2-3, Symphony, Multiplan, etc. etc. Just plugs into your co-processor socket.

### For AT's And Compatibles

80287-6 6MHz Co-processor.

Cat Z-9106

Limited Stocks!

\$399

### For XT's And Compatibles

8087-1 10MHz

Cat Z-9107

Limited Stocks!

\$499

## Need More Memory?

### Dram Memory Chips

Building your own computer or extending the memory of your existing system? You'll do it in minutes with these great value DRAM memory chips. They just plug into the motherboard or extension memory card.

### 256K Chip 41256-12

Was \$29.95

A zippy 120NS, 256K x 1Bit chip at a fantastic low price.

Cat Z-9313

### 1Mb Chip 511000p-80

Now \$19<sup>95</sup>

Here's the way to go for those big memory machines like our AT Mother Board and many other powerful computers fast 80NS, 1MB x 1 Bit.

NEW!

Just \$59<sup>95</sup>

**N.S.W.:** • BALLINA: Ballina Electronics 867022 • BOWRAL: F. R. H. Electrical 611061 • BROKEN HILL: Hobbies & Electronics 884098 • CHARLESTOWN: Newtronic 439800 • COFFS HARBOUR: Coffs Harbour Electronics 525684 • DUBBO: Chris's H. F. 828711 • FORSTER: Forster Village Electronics 545008 • GLEN INNES: John Sommerlad Electronics 323861 • GRAFTON: Repairs and Spares 421911 • GRIFFITH: Miatronics 624534 • INVERELL: Inverell Electronics 221821 • LEETON: Leeton Audio/Video 532800 • LISMORE: Dacro Electronic Services 214137 • MOREE: Moree Electronics 523458 • MUDGEE: Headware 723895 • ORANGE: Central West Electronics 826481 • NOWRA: Nowra Electronics 210722 • PARKES: Strad Music Centre 623308 • WAGGA WAGGA: Philips Electronics 218558 • VIC: MORWELL: Morwell Electronics 348133 • SHEPPARTON: Phillips Electronics Pty Ltd 219487 • WARRNAMBOOL: Martronic 828870 • QLD: • BUNDABERG: Bob Elkin Electronics 721785 • MACKAY: Stevens Electronics 511723 • MARYBOROUGH: Keller Electronics 214559 • TAB: • DEVONPORT: A. I. Electronics 248322 • BA: • LOXTON: G. S. Electrical 847485 • MT GAMBIER: Hultchesson's Communication Centre 250400 • WA: ALBANY: Micro Electronics 412077 • BUNBURY: Micro Electronics 216222 • GERALDTON: Batavia Lighting & Electrical 211966 • KARRATHA: Daves Oacitron 854836





## Surely ham radio can't be dead — look at all these plurry letters!

Yes folks, it's the third hearing of our inquest into the death of experimental ham radio. Or is it? I'll let you be the judge, after you've seen some more of the letters that have been steadily lobbing in from amateurs over the last few months, following my 'stir' in the April issue.

When I presented the first batch of responses to my April piece on ham radio, in the July column, you may remember that I expressed the hope that these would be followed by many more — including some which *didn't* agree with me. Well, that's certainly happened, as you'll see shortly. There have been quite a few more letters, and a significant number have been fairly critical. And that's good. If everyone agreed with everything I wrote here, it'd soon get extremely boring.

All the same, the other hope I expressed in both the April and July columns was that there would arrive not only letters *telling* me that experimental ham radio wasn't dead, or castigating me for suggesting that it was, but also a flood of articles describing down-to-earth ham radio projects — to *prove* that it isn't dead. In that respect I have been disappointed, because there's been barely a sausage.

A few hams did send in articles for me to look at for possible publication, and in one or two cases I've been able to accept them for publication soon. My thanks to these people for their initiative, and I hope others decide to take their lead. But to date virtually none of these submitted articles were describing true ham radio gear.

In fact I received a couple of letters from hams who *are* active in building up home-brew gear, basically telling me that they wouldn't send me details of their projects, because they felt duty-bound to offer them to the dedicated amateur radio magazines such as the WIA's *Amateur Radio*, or Chris Edmondson's *Amateur Radio Action*, rather than to a general-interest electronics magazine like *EA*.

Fair enough, I suppose. But what this does suggest is that although experimental amateur radio may not be dead, it

might well have become very *inward-looking* and anti-social. Perhaps hams are nowadays only interested in talking amongst themselves and sharing their knowledge and achievements within their own ranks, to the exclusion of outsiders?

The funny thing is that I seem to read quite frequently in amateur radio magazines that the overall number of hams is slowly shrinking, and the average age is gradually getting older and older. In other words, that amateur radio isn't really attracting too many young people and newcomers nowadays.

If they're mainly talking to each other and writing for each other, I'm not surprised. Preaching only to the converted and slapping each other on the back may be satisfying and less hassle, but it rarely swells the ranks. In fact it can be positively off-putting, to those who might otherwise be attracted to the hobby. One of this month's correspondents makes mention of this, in fact.

There has always been a cliquy side of ham radio, of course, with some hams taking great delight in ignoring or 'freezing out' any newcomers that don't seem to them to possess whatever they see as the 'right' qualifications to be a genuine Amateur Radio Operator. I guess the same sort of thing happens in a lot of human organisations.

But luckily this nasty side of ham radio has been more than balanced, most of the time, by a strong spirit of technical altruism — the desire to help newcomers as much as possible, and to further the achievements of amateur radio as a whole.

If the amateur radio movement is really concerned about the lack of newcomers, then, perhaps it should look to becoming a bit more outward looking. And this would presumably include encouraging hams to send construction

project articles to general-interest magazines like *EA*, instead of just offering them to the amateur radio magazines where they'll be read by the same bunch of people...

Anyway, that's enough preamble from me. Let's look at some of those letters that have come in. There are quite a few, so I won't be able to quote them all in their entirety. But here's my attempt to pick out the bones and other tasty bits.

First off, I *am* going to quote a fair bit from one of the more hard-hitting letters, which came from New Zealand amateur Andy McFarlane ZL3JL, of Ashburton:

*As one who had at one time a leg in both camps, I question the validity of your inference that the radio amateur is solely an 'appliance' operator.*

*The radio amateur has as much in common with the CB operator as the licentiate pianoforte exponent has with the Grade VIII certificate holder, or the IREE member with the 6th form maths student. One through his/her efforts has made that extra effort to become in essence a 'professional' compared with the purely amateur.*

*With the complexity of the amateur radio scene today, on must of necessity specialise in some particular aspect(s) of the hobby. Only one such aspect, generally speaking, is catered for by your magazine, and that basically is the introduction to and the art of construction. This art too is but a shadow of its former self.*

*Where, for example, are the video tutorials on basic construction techniques, that your firm could be producing, to widen your readership base with the young or inexperienced? Where are the articles on interfacing television, video recorders, video cameras and home computers with amateur radio 'appliances'?*

*No, you say, this is outside the scope of the magazine, better left to a dedicated magazine or organisation.*

*It appears obvious, from this side of the pond, that your respected magazine*



Don  
Huttons  
Presto  
Meapro  
Tancrod  
Dandy  
Melosi  
Primo  
M&N  
Grubb  
Burgomaster  
Mayfair  
Silber

Calling VKHAM, calling VKHAM..." Again Jim Jim stirred the flames of forum, faithfully fostering feedback; in quest of an answer... Is Hamateur radio dead or...



— fodder to me since the 1940's — cannot cope physically with the breadth of electronics as it exists today, and of necessity must have certain limitations in scope and outlook. Similar, perhaps, to the financial and other constraints that limit amateur radio construction?

An 'appliance' such as the transceiver, after all is but a tool, as is the ubiquitous multimeter. One would no more consider building a multimeter today than a transceiver, unless of course it was a limited version for a specific purpose.

It would assist, if you require amateur radio related articles, to regularly publish up-to-date details of the magazine requirements. The bottom line is that you will only get what you are prepared to pay for. Bluntly put, we 'appliance' operators are not running an 'Electronics Australia' charity, and would prefer — if the rewards are limited — to support our local societies before a commercial organisation, as much as we might respect that organisation.

Having said that, may I now express the wish that your ALMOST exemplary magazine, together with CBers, amateur radio operators, listeners and all other electronics nuts — be they of professional or amateur persuasion — work together in harmony over the next 50 years, to

promote this glorious Kaleidoscope that is electronics.

Well — where do I start, with that one? First of all by thanking Andy for his considered comments, I guess, and then by admitting that much of what he says about electronics in general, and the things we could be doing, are true.

I'm not sure, though, whether I can go along with his initial assertions about the degree of difference between hams and CBers. He doesn't really seem to present much evidence to support the case, except perhaps by saying that 'appliance operator' hams are somehow more 'professional' than CBers because they have passed an exam and have chosen to specialise in operating rather than the more technical aspects. I don't find that argument too convincing.

Yes, I agree that we could indeed be producing the kind of video tutorials Andy suggests, and I guess we'd be the ideal people to do it. I'll certainly look into it, although sometimes it's hard enough to produce the magazine itself — let alone other things as well.

I'm inclined to think that Andy's other dig, about hams not wanting to 'run EA as a charity', supports my earlier suggestion that amateurs have become rather inward-looking. What

Andy seems to be saying, in so many words, is that 'unless there's a buck in it, we'd rather just talk amongst ourselves.'

As it happens, EA is anything but a charity. We do pay for all contributed material published, so there's no suggestion that we're asking hams to regard us as a charity. Quite the contrary, in fact, and I'm puzzled that Andy somehow got the wrong impression.

Anyway, let's pass on to the next letter, which came from W.B. Weiby VK2AZW, of Boat Harbour, NSW. Mr Weiby writes:

Many of your comments on 'appliance operators' and the lack of design/construction activities are quite valid, but the hobby is still not a terminal case.

The tremendous advances in electronics in recent years have overawed many would-be designers and constructors, while at the same time the lower relative price of commercial equipment has reduced the incentive to 'roll your own'. Lately higher prices exacerbated by the falling dollar have rekindled interest, but some major difficulties arise.

Firstly, while a basic circuit design may be relatively straightforward, redesign around available components can be both time consuming and frustrating.

## Forum

*Secondly the relative design rigidity of printed circuit techniques makes prototypes difficult and expensive to modify. And thirdly some essential components are now difficult if not impossible to obtain, even after detailed circuits and descriptions of designs have been published in local magazines and handbooks.*

*To overcome these difficulties, kits may be the means of reviving interest, particularly if a modular design is used.*

*The need to justify amateur radio by means of experiments, discoveries, training, national service and general excellence is extraordinarily persistent among its adherents. Amateur golfers, fishermen, woodworkers and others are untroubled by these ideas, and rightly pursue their hobby for various personal reasons.*

*I enjoy the intellectual stimulation, the satisfaction of an experiment or project, and the on-air social contact which the hobby provides – especially now in my retirement. The term 'ham' is one which I am prepared to accept with good humour, and some pride.*

Thanks for your comments too, Mr Weiby, and I'm sure that some of the factors you note have been responsible for the decline in experimental work. Your suggestion about modular projects and kits is very appropriate also, and as it happens we're already working on a few projects along these lines.

I note your comment about hams seeming to be obsessed with the idea of justifying themselves, as well. Over the years I've noticed that myself – they can get a bit tedious about it sometimes, with this apparent need to prove that amateur radio is absolutely essential to the whole fabric of western civilisation.

I guess the reason behind it is that unlike most other hobbies, ham radio does make use of a relatively finite natural resource – the radio frequency spectrum – and ever since the hobby began, hams have been worried about losing some of their allocations. It's not an unreal fear, either, because this has happened from time to time.

But one way and another, the fear itself seems to have given amateur radio a kind of paranoia, whereby it must always justify everything it does to some kind of 'Big Brother' who is always watching. It's sad, and I suspect that it may have prevented a lot of people from learning of the enjoyable side of ham radio.

It's also noticeable that this need to

justify amateur radio as a 'professional' hobby has also grown more intense, as more and more hams have found themselves turning into appliance operators.

Another letter with a rather different slant came from Peter Parker VK6BWI, of Witchcliffe WA. Aged 17, Peter has held a licence since late 1985 – so although young, at the same time he has a good knowledge and experience of amateur radio. Here's some of the main points from his letter:

*There is no piece of equipment in my shack which was intended for the amateur market – mainly for financial reasons. Because I could not spare \$1300-plus for a new rig, I built or converted much of my equipment, so I would sit squarely in the 'second rank' of amateurs.*

*Frankly, though, there is no class structure in amateur radio as you describe it. I think that in many ways, the experimenter is in front. The AOCPEX exam becomes fairly easy for the Novice who has built most of his gear, particularly CW equipment.*

*One important aspect is our future as a hobby. At the stroke of a pen, amateur radio could be made illegal. Now that governments around the world are talking about 'user pays', 'cost recovery' and 'spectrum pricing', amateurs need to get their act together. Our spectrum, if allocated to other users, could net the government millions of dollars a year – a very tempting option for a government struggling with debt.*

*Amateurs, being ordinary people, have to prove themselves to the DOTC that we are not a glorified CB service. In order to do this we need to get back to our original aims and activities: 1. To carry out technical investigation; 2. To communicate; and 3. To train ourselves continually for activities 1 and 2.*

*In much of the above we are performing poorly, and our image with others involved in the electronics field, be they hobbyists or engineers, is as a bunch of senile old men gossiping into microphones and doing precious little experimenting. We must correct this image by correcting ourselves – doing more experimenting as you outline in your column.*

*With regard to the availability of parts, yes it is hard. But we should be more inventive. A fellow member of the CW Operators' QRP Club, frustrated at the lack of variable capacitors for VFO's, devised a variable inductance tuning system costing only a few dollars to build. This has been incorporated into a successful 80m QRP CW transmitter kit.*

Thanks very much for your comments, Peter – I couldn't have made the points better myself. How about getting your friend to send me an article on his tuning scheme and QRP transmitter, so we can share the good news with a lot more people outside your Club? Don't forget, articles that are published earn an appropriate fee – which will no doubt help swell Club funds.

Moving right along, another letter with a different angle again came from Greg Matheson of Nimbin in NSW. Here's an interesting extract:

*I tend to agree that amateur radio does seem dead. Very few of my contemporaries see the value in DX competitions and many of the other pursuits of the amateur radio fraternity.*

*Perhaps some reason for the perceived demise of popularity and investigative zeal of amateur radio is due in part to the huge attraction of modern hobbyists to the computer sphere. The parallels between hackers and the early radio hobbyists are many. Radio was a black art in the early days, with the parameters for the broadening science being broadened every day, and much excitement to be gained by being at the cutting edge of a brand new technology.*

*The situation we have now is that all young people have heard a radio play from the day they were born. If they want to transmit themselves, they can buy a CB. There is no longer an innovative thrill in constructing a machine capable of linking people over distance – or not in radio, anyway. But if we look at computing we see a very different picture, with BBS's set up in most corners of the country and linking the world, with a choice of text, graphics, codes to operate machines and any number of levels of interaction possible.*

*I am just about to embark on my Radio Operator's Certificates, so that I can pursue my interests in communications in the digital sphere – where I can be assured that I am participating in the cutting edge of both radio and computing. I would like to think that in time, as more hackers realise the freedom that the air waves can provide for low cost communications, that there will be an upsurge in the amateur radio world.*

Thanks for your comments too, Greg. Perhaps you're right, that digital communications may well produce a renewed interest in amateur radio.

I certainly agree that there are a lot of parallels between the early days of radio and the recent 'hacking' era in personal computers, with a lot of the

zeal and enthusiasm that was evident in the former being present in the latter – and no doubt for the reason you suggest. So with a bit of luck, joining the two together will re-infuse some of that enthusiasm back into ham radio. Like you, I hope so.

Another letter which also makes reference to computing came from Matthew Sandow, of Sydney, who also has a less than happy tale of trying to get into ham radio. Here's what Matthew has to say:

*I have been involved in electronics for about three years, and any knowledge I have has been gained from magazines such as yours. After building the Bicentenary radio and the three-band SW radio, I got hooked on the idea of amateur radio.*

*The obvious step was to approach several of the organisations involved in the field, for information, contacts and instruction about equipment and licensing, etc. I wrote to these, even including a stamped, self-addressed envelope for reply. After waiting patiently, I received only ONE reply – from the WIA in Victoria, detailing their correspondence courses but giving no other information. My only conclusion is that perhaps amateur radio clubs collect stamps, as well as QSL cards from weird places!*

*My next step was to give up on the amateurs, and try the 'professionals' – the dedicated ham radio retailers. But what did I find? Heaps of flashy, all singing and dancing equipment costing an arm and a leg, but the attitude of "Look mate, get your licence and come back then".*

*In frustration I built a simple modem, hooked it up to my el cheapo computer and dialled up a computer bulletin board. It was the smartest thing I have ever done, because that's where the new generation of amateurs are – all tapping away happily on their keyboards sending messages to each other, exchanging information and developing techniques to extend the limits of their respective machines.*

*Since then I have made many new friends, learned a lot and had a heap of fun – which oddly enough is supposed to be the idea behind amateur radio. Like a lot of others I am now in the process of building my own you-beaut computer, from components and cards available as kits. The interesting thing is that anyone needing help or advice is given it freely and quickly, from the enormous pool of talent and experience – again just like amateur radio USED to be.*

*As you have rightly observed, amateur*

*radio has lost young and enthusiastic people to computers. In my view, the reasons are simple. It has placed itself above the general population with its high cost and elitist attitude; there is no real facility for low power, simple and cheap entry level radio; and council regulations regarding antennas make it impossible for inner city dwellers such as myself.*

*The answers are perhaps simplistic, but fairly obvious:*

- 1. Amateur radio needs to get out of its ivory tower of self righteousness and recognise that to survive, it needs new blood.*
- 2. A special CW licence should be created on a separate band, as per the USA. Limit the power to say 5 watts, and use this licence as a basis for higher ratings.*
- 3. Release kits or plans for simple receivers, transmitters and antennas for those without big budgets and bigger backyards.*
- 4. Talk to people. If amateur radio can't be bothered to correspond with outsiders, then it is a closed society preaching to the converted.*

*Perhaps as a final note, it's not so much a matter of breathing life into a Frankenstein monster, but more a case of a phoenix either rising from the ashes, or lying there to die.*

Hmmm – some pretty strong words there, Matthew, but your reaction is quite understandable considering your experience. It's interesting that you've found the computer hacking fraternity so much more friendly and helpful than the radio amateurs – yet I suspect you'd still be interested in getting into ham radio, given half a chance and despite the difficulties you've encountered.

Your suggestions regarding the action that should be taken to help the phoenix arise again also seem pretty constructive.

There have been lots of other letters, but space is tending to run out. To end up for the moment, I'd like to give just a couple of further snippets, extracted from letters that were either very long, or mainly going over the same ground as those already quoted.

The letter from George Compton of Kalgoorlie, WA made the following interesting comment:

*Your figure of 'perhaps only 5%', for the proportion of amateurs directing their efforts to the frontiers of knowledge, is possibly nothing very new. All amateur activities in any field of endea-*

*your cover ranges of competence and interest, from the cosmetic to the social to the erudite, and yet the amateurs generally do advance the utility of their fields of activity. I doubt that 'only 5%' will indicate that further amateur advances are unlikely.*

Fair enough, too. But I'd like to give the final words, this round, to Mr R.M. Daniell of Masterton, New Zealand. Here's the way he summarised his fairly long and detailed letter:

*But where are we going? We cannot as amateurs compete any longer with the marvels of technology. What are the outlets for inventiveness, skill and ingenuity for the rest of us, if technology (frequently Asian) supplies everything 'to go' – short-order cooking at the hamburger stand, colour prints processed while the party is still going on, computers in our vehicles to identify what is wrong, digital audio, music put together by a sequencer and so on.*

*What is left for the artist, the craftsman or woman, the handyman or woman? And without these outlets for his/her skill, what happens to our society?*

*Do we all sink to the level of uncomplaining consumers of the technological marvels, mostly devised overseas, by technicians working for a world wide market. Do not our nations vitally need the ingenuity, skill and expertise developed by the electronics hobbyist?*

*What is to stop us from becoming couch potatoes? Which way is forward?*

Frankly I don't think things are quite that bleak, Mr Daniell, but I agree that there is cause for concern. Of course some of the aspects you raise are rather wider than amateur radio – we can't expect the hams to solve all of our problems in grappling with technology. Industry has to get its act together too, and that's a much harder problem to solve.

Perhaps I am an optimist (after all!), but I still think there's plenty of room for the skilled artisan and amateur enthusiast – and plenty of chances for them to make an important contribution. In fact I suspect it's essential.

In some areas, of course, you can't achieve much nowadays without fairly high tech gear. But when you consider how many of our most important breakthroughs in science and technology were essentially happy accidents, achieved with the simplest of equipment, it makes you realise that almost anything is possible – with energy, enthusiasm and persistence.

What's holding you back, fellas? ②

# Silicon Valley NEWSLETTER . . .



## Noyce blasts Japan, urges tough sanctions

'Warning! Purchasing this product may cause loss of American jobs'.

If Sematech boss Robert Noyce has his way, labels with this warning will be printed on Japanese telecommunications products sold in the US. It is just one of a number of punitive actions Noyce said the US government should undertake, in retaliation for Japan's unfair trade practices in the area of telecommunications.

Noyce made his unusually bold recommendations while delivering a keynote address at the Semicon West trade show. He spoke on behalf of Semi/Sematech, the group of US equipment firms that are helping Sematech build next-generation chip manufacturing technology and equipment.

It is widely expected that the Bush Administration will place a number of Japanese semiconductor lithography, automatic test, and other equipment on a list of products that will be subject to severe tariff penalties. Those sanctions are the result of the government's recent determination that Japan has unfairly locked American suppliers out of its telecommunications market.

Noyce and Semi/Sematech are opposed to sanctions against Japanese chip equipment, because that could actually end up hurting US-based chip makers who depend on the equipment for the production of their most advanced chips. Instead, the sanctions should be targeted at Japanese telecommunications products and vendors, Noyce believes.

## US Electronics 'must lift its game'

With its dominance in global high-technology markets a fading memory, the US electronics industry faces further decline unless problems of capital access, inadequate schools and a disjointed government trade policy are resolved. That's the view of Richard Iverson, president of the powerful American Electronics Association in Santa Clara.

"US high technology is at a critical



**Richard Iverson, AEA President.**

point in its evolution", Iverson said. "The past decade has seen a dramatic shrinkage of America's share of the global market for electronics products and services. Immediate action by both industry and the federal government has become mandatory."

Iverson was speaking before a gathering of technology executives and political figures at Intel's Folsom plant, near Sacramento.

He charged that the US Government has failed to recognise the importance of high technology when it comes to shoring up America's standing in the world market-place. Despite the dollar's decline against the yen, Japan has actually extended its market advantage over the United States in high-tech trade, Iverson said.

Unlike Japan, the United States has no cohesive government strategy to support American high-tech firms in developing and commercialising a new generation of products and to broaden markets, Iverson said. The national debt also has hurt the industry by driving up the cost of borrowing money. US companies face real capital costs four times those of Japanese companies, Iverson said.

The current kindergarten-through-12th-grade school system is not doing an adequate job of providing the maths and science skills necessary for the

workforce of the future, Iverson said. At the university level, there is a chronic shortage of technical and scientific faculty, which will only get worse when professors hired in the 1960s retire in the 1990s.

## Industry majors form new DRAM maker

In what will easily qualify as the most ambitious start-up in US high-technology history, seven leading US semiconductor and computer manufacturers, with the support of the SIA and AEA, jointly announced the formation of US Memories Inc. The company hopes to start production of 4-megabit DRAMs, to be based on technology licensed from IBM, as early as 1991. The group also said it has lured IBM's top semiconductor technology executive to head the new company.

During a press conference in Santa Clara, IBM, Hewlett-Packard, Digital Equipment, Intel, National Semiconductor, Advanced Micro devices, and LSI Logic said they have agreed to provide the seed money for getting US Memories started. They have committed large funds that will be part of the estimated US\$500 million-to-\$1 billion worth of investment, needed to develop US Memories into a major DRAM supplier over the next five years. The group said they expect a number of other major US chip and system houses to join as equity partners in US Memories.

In addition to putting up large funds for the new company, the member system houses are also committing themselves to buy up as much as 50% of US Memories' DRAM output. This requirement will protect the start-up against the traditional violent price and demand swings in the DRAM market. At the same time, the member firms will be guaranteed a certain percentage of the company's DRAM output, at relatively low prices in times of shortages.

US Memories will be headed by Sanford 'Sandy' Kane, currently vice president of industry operations for IBM's General Technology Division, which includes the giant company's semiconductor operations.

Kane, a 27-year IBM veteran, became

president and chief executive officer. Wilf Corrigan, chairman of LSI Logic, has been appointed as chairman of US Memories' board of directors.

Although Kane is possibly the most qualified man in the US to pull off a high-risk venture such as this, the key to the potential success of US Memories clearly has to be the willingness of IBM to license its leading-edge DRAM technology to the new company.

The founding of US Memories is the outcome of a program initiated by the Semiconductor Industry Association. Earlier this year, the SIA established a board-level committee to recommend collective efforts that could lead to the return of large scale DRAM production to the United States.

SIA president Andy Procassini emphasised that US Memories is not another industry consortium, but a new start-up company that merely depends on its equity partners for funding. Added Sematech chairman Robert Noyce, jokingly: "Consortia like Sematech are for non-profit. We certainly hope that this one is not."

## Motorola introduces 12-ounce cellular phone

Remember how 'special agent' Maxwell Smart on the popular 1960s television series 'Get Smart' used to have a portable telephone built into his left shoe? Motorola has now introduced a cellular telephone unit small enough to turn this Hollywood make-believe into reality.

Motorola said its engineers spent five years developing the US\$2,995 hand held phone, which weighs just 12.3 ounces and measures only 13 cubic inches in volume. The wallet-size phone is small enough to fit in a coat pocket or average lady's purse.

Most of the research involved reducing the size and number of components the unit is made out of, particularly the oscillator and duplexer which allow callers to listen and talk at the same time.

In all, the Motorola phone contains just 220 components, 1/10th the number of parts used to build the company's first portable telephone 10 years ago. The battery-powered phone provides enough power for 75 minutes of continuous use, compared to about 2.5 hours for most standard, bulkier portable phones.

Motorola said the phone was designed to survive the company's 'drop test' in which the unit is dropped onto a hard surface from a height of four feet (1.3m).

## First HDTV contracts from Pentagon

The Pentagon has issued the first five of a series of research grants for high-definition TV, including two to Silicon Valley electronics companies.

The grants were issued by the Defense Advanced Research Projects Agency, which oversees the most advanced research being conducted on supercomputing, Star Wars, and other advanced technological projects.

Earlier this year, the Pentagon announced it had set aside US\$30 million to fund HDTV-related research projects. The Pentagon believes it is essential for US national security that the United States plays a major role in the future market for HDTV products. Most of these products will be based on leading-edge technology that will have applications in defence-related areas.

One of the areas the Pentagon is particularly interested in is new display technology. Not surprisingly, all five initial contracts went to projects dealing with HDTV display technology.

Three of the five companies that were selected - NewCo of San Jose, Texas Instruments, and Projectavision of New York - were chosen for development of projection-related display technology in which television pictures are projected much like film projection. Raychem of Menlo Park and Photonics Technology of Ohio were chosen to develop flat-panel display technology.

## Tracking system puts car thieves out of business

A piece of Star Wars-like technology is being spun off into the commercial world, where it may make it all but impossible for car thieves to steal automobiles and not be caught by the police. Prevent-A-Theft International, which is located in Irvine, California, has announced the development of a tracking system that uses communications satellites to spot and track stolen vehicles.

The so-called 'Locator Satellite Vehicle Tracking & Recovery System' uses a small homing device that can be installed randomly in almost any part of a vehicle. To enter and start a car, the owner must enter a secret code in a small electronic box attached to the keyring. The homing device is triggered as soon as someone enters the vehicle through other means, or tries to 'hot-wire' the ignition.

At that point the homing device starts sending messages to a satellite, giving details about its location. The satellite

relays the information, including a detailed description of the car, to the nearest police authority. The vehicle is tracked every 15 minutes and is accurate to within just a couple of feet.

"The beauty of the system is that the car, in effect, reports itself stolen, instead of waiting until someone discovers the theft. Often cars are stolen while the owners are in a restaurant, shopping mall or on vacation, and the thieves get a big head start," commented John Jansen of Prevent-A-Theft.

He said that the system, introduced in January at the National Automobile Dealers Association, was particularly well received by the insurance and financing industries. Jansen said a number of major carriers and financial institutions have expressed interest in requiring their customers to install the system, which costs about US\$500 per vehicle. The system would also make it much simpler for banks to repossess cars if the owners become delinquent on their monthly payments.

## Tape giant buys Silicon Systems

TDK, the world's largest manufacturer of audio and video tapes, has agreed to acquire Silicon Systems, a Southern California-based chip maker that specialises in circuits for the automotive, computer, and telecommunications markets, including hard-disk and modem controller chips.

The deal is valued at US\$200 million, as TDK agreed to buy up all of Silicon Systems' 10 million outstanding shares. In addition, TDK has agreed to invest another US\$200 million into the Tustin-based company, money that will be used for new product development and expanding production capacity.

"This means I can be more concerned with our goals of building a US\$1.3 billion company by 1998, rather than whether the per-share profit next quarter is going to be 21 cents or 24 cents", said company president Carmello Santoro, referring to the often-cited shortsightedness of American businesses which sacrifice long-term oriented investments for short-term profits.

For TDK, the deal with Silicon Systems means the company instantly will be able to enter the semiconductor market without going through a lengthy and costly start-up phase. "We have been looking at semiconductors for many years. Now we are finally going to be making them", commented Ken Aoshimo at the US headquarters of the company. ②

# THE BEST PLACE TO BUY!

## The Amazing 3-In-1 Modular Tool....

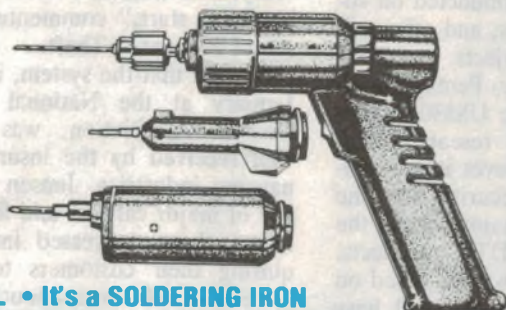
The Best Price Around

Just \$99

- It's a DRILL • It's a SOLDERING IRON
- It's a SCREWDRIVER • It's totally PORTABLE
- And it's RECHARGEABLE!

This has to be one of the smartest tools for hobbyist, handyman and tradesman alike. Modular components fix to a rechargeable battery pack (handle) and in seconds you can switch from a soldering iron to a drill, from a drill to a reversible screwdriver, etc., etc.

It's easy to handle and the pistol grip action leaves one hand free to make working a breeze! Comes complete with assorted drills, screwdrivers, solder accessories and charger. Check out our great price...it's the best around. Cat T-5712



## SSB CB For Under \$200!

89/90 Catalogue Price \$229

Now \$199



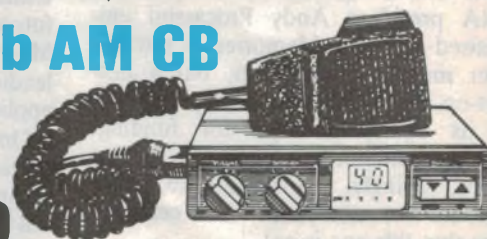
The sensation Super Tomcat AM SSB CB mobile at an incredible low price! An outstanding buy with maximum legal power on both AM and SSB, all 40 channels, the extra range and performance SSB offers.... and, with optional power supply, it can even double as a base station! Comes complete with mounting hardware, microphone and full instructions.

Cat D-1713

## Superb AM CB

Pushbutton Channel Selection

Just \$89



You won't find a better deal! The DSE 40 AM CB gives you high quality mobile communication without the hefty price tag. Its amazingly compact, beautifully styled and features all 40 AM channels, pushbutton channel tuning and maximum legal power. Comes with Mic and mounting hardware! Cat D-1200

## Three Volumes! National Linear Databook

This has to be the most comprehensive Databook ever! 3 complete volumes from National Semiconductor. Covers everything - Voltage regulators, operational amps, active filters, analogue switches, audio/radio/video circuits, etc. etc. An absolute must for the library.

Cat B-5001

\$49<sup>95</sup>

## Linear Applications Databook

Over 1200 pages of detailed reference! A fully indexed and cross referenced collection of linear integrated circuit applications using both monolithic and hybrid circuits from National Semiconductor.

Cat B-5504

\$24<sup>95</sup>

## Electronic Test Instruments

Robert Witte - 261 pages  
A comprehensive sourcebook which simplifies the internal workings of test instruments through easy to understand circuit models and conceptual block diagrams. An excellent supplement to instrument operating manuals.

Cat B-4999

\$29<sup>95</sup>



## Maths Co-Processors

Just what's needed for heavy duty mathematical calculations - and it saves time as well! A maths co-processor can perform high speed and highly accurate arithmetic, logarithmic and trigonometric operations while leaving your microprocessor free to perform other functions. Ideal for working in Auto CAD and most major spreadsheet programs such as Lotus 1-2-3, Symphony, Multiplan, etc. etc. Just plugs into your co-processor socket.

### For AT's And Compatibles

80287-6 6MHz Co-processor.

Limited Stocks!

\$399

Cat Z-9106

### For XT's And Compatibles

8087-1 10MHz

Cat Z-9107

Limited Stocks!

\$499

Need More Memory?

## Dram Memory Chips

Building your own computer or extending the memory of your existing system? You'll do it in minutes with these great value DRAM memory chips. They just plug into the motherboard or extension memory card.

### 256K Chip 41256-12

Was \$29.95

A zippy 120NS, 256K x 1Bit chip at a fantastic low price.

Cat Z-9313

### 1Mb Chip 511000p-80

Now \$19<sup>95</sup>

Here's the way to go for those big memory machines like our AT Mother Board and many other powerful computers fast 80NS, 1MB x 1 Bit.

NEW!

Just \$59<sup>95</sup>

**N.S.W.:** • BALLINA: Ballina Electronics 887022 • BOWRAL: F R M Electrical 811861 • BROKEN HILL: Hobbies & Electronics 884098 • CHARLESTOWN: Newtronic 439800 • COFFS HARBOUR: Coffs Harbour Electronics 525884 • DUBBO: Chris's Hi Fi 828711 • FORSTER: Forster Village Electronics 545008 • GLEN INNES: John Sommerlad Electronics 323861 • GRAFTON: Repairs and Spares 421811 • GRIFFITH: Miatronics 624534 • INVERELL: Inverell Electronics 221821 • LEETON: Leeton Audiotronic 532800 • LISMORE: Decro Electronic Services 214137 • MOREE: Moree Electronics 523458 • MUDGEE: Headware 723895 • ORANGE: Central West Electronics 826481 • NOWRA: Nowra Electronics 210722 • PARKES: Strad Music Centre 823368 • WAGGA WAGGA: Philips Electronics 218558 • VIC: MORWELL: Morwell Electronics 348133 • SHEPPARTON: Philips Electronics Pty Ltd 219487 • WARRNAMBOOL: Mairronics 828870 QLD: • BUNDABERG: Bob Elkin Electronics 721785 • MACKAY: Stevens Electronics 511723 • MARYBOROUGH: Keller Electronics 214559 • TAB: DEVONPORT: A.I. Electronics 248322 SA: • LOXTON: G & S Electrical 847495 • MT GAMBIER: Hutchesson's Communication Centre 250400 WA: ALBANY: Micro Electronics 412077 • BUNBURY: Micro Electronics 218222 • GERALDTON: Batavia Lighting & Electrical 211966 KARRATHA: Daves Oscitronic 854836

**DICK SMITH**  
ELECTRONICS

# Best Value in Sight & Sound!

## New Voice Activated Modell Expandable FM Wireless Intercom

Perfect for the office, factory or home. Can take up to 6 stations allowing 3 simultaneous (and Private) conversations. There's no wiring, it's mains operated, gives crisp, sharp sound and can also be used as a monitor system.  
Cat F-1250

**\$99**



## New Release! Stereo Cassette With Auto Reverse

Look sgreat, sounds great and has an amazing array of features for the price! The new Digitor stereo cassette with auto reverse and tape direction selector. Fast forward and rewind makes track selection easy. Comes with stereo headphones, belt clip and DC jack. Cat A-4091

**NEW!**  
**\$49<sup>95</sup>**



## New Release! Portable Stereo Cassette

A bargain price for a stereo cassette with lightweight headphones, belt clip, auto stop and Super Bass Boost — superb, realistic sound! With DC jack so you can save on battery power when you're at home.  
Cat A-4090

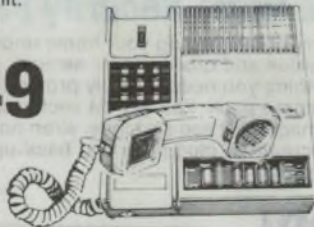
**NEW!**  
**\$29<sup>95</sup>**



## Two In One! Bargain Telephone/ Answering Machine

Sensational value and it saves space too! A modern pushbutton phone with all the usual features including selectable tone/pulse dialling, last number redial, etc. etc. . . plus a single tape answering machine in one compact unit.  
Cat F-6140

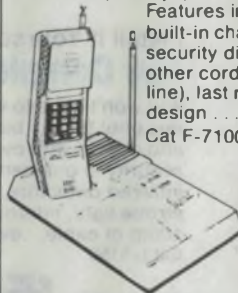
**\$249**



## Engineered For Australia! Cordless With Double Adaptor

Built, from the ground up, for Australian conditions this cordless phone offers exceptional value for your money, wall or desk mount capability, plus cordless convenience.

Features include maximum range, built-in charger, paging facility, security dialling code (prevents other cordless phones using your line), last number redial, compact design . . . the lot!  
Cat F-7100



**\$199**

## With 10 Memories! Stylish Two-Tone Phone

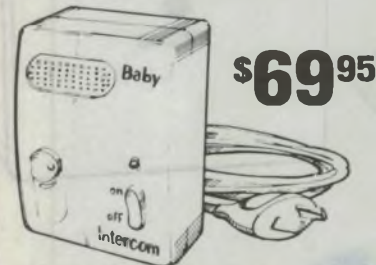
A great looking phone with performance to match! Features 10 memories including last number redial! In two-colour finish with large rubber pushbuttons for mistake-proof dialling, pause button, tone/pulse selection, ringer on/off and much more. Cat F-5505/9

**\$69<sup>95</sup>**



## Wireless! Monitor System

Simply plugs into the mains — so there are no batteries or wiring to worry about. Monitor has adjustable Voice Activated sensitivity and the master can be moved from room to room . . . anywhere you are. Cat F-1400



**\$69<sup>95</sup>**

## It's Incredible! Pocket sized LCD Full 'Colour' TV

It's the most amazing thing! A full colour TV that you can fit in your pocket. The 2" LCD screen gives a suprisingly clear picture and you get great reception inside and out. Comes with an inbuilt stand so you can get the right viewing angle, has earphone supplied with the TV so you can listen without disturbing those around you.  
Cat G-5520

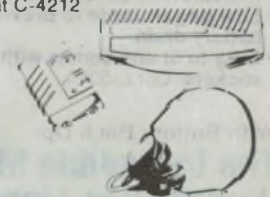


**\$329**

## Cordless Remote Headphone System

Cordless Remote Stereo Headphones — so there's no wires to get tangled in. Just plug the transmitter into your stereo, TV, VCR, radio or whatever and clip the receiver to your belt. There's a volume control on both receiver and transmitter and the unit comes with adaptor plugs, mains adaptor and quality stereo headphones. Cat C-4212

**\$129**



**DS XPRESS**

ORDER BY PHONE - 008 22 6610 (LOCAL CALL FEE) OUTSIDE SYDNEY  
SYDNEY AND ENQUIRIES - (02) 888 2105 FAX: (02) 805 1986  
OR WRITE TO DS XPRESS, PO BOX 321 N/RYPDE NSW 2113  
ALL MAJOR CREDIT CARDS ACCEPTED. O/NITE COURIER AVAILABLE.  
24 HOUR DESPATCH OF ALL ORDERS

**DICK SMITH**  
**ELECTRONICS**

# EASY WAYS TO SECURE YOUR HOME AND CAR!

## Remote Switched Car Alarm

Here's a the inexpensive to protect your car against theft! A current sensing car alarm that you can easily install yourself! Features instant boot/bonnet trigger, ignition cut off, battery back up capability and manual override capability.

Comes complete with....

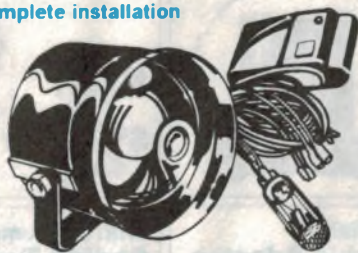
- Transmitter key
- Boot/bonnet switch
- Dash warning light
- Mounting hardware and complete installation instructions.

Cat L-5069

Priced to clear!

Was \$129

Now Only **\$99**



## Ultrasonic Interior Protection

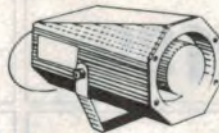
A great addition to your Moss car alarm! The MS701 Ultrasonic Volumetric Sensor is easy to fit to the dashboard or parcel shelf and detects any movement inside the vehicle. It's great for soft tops or cars with a sunroof! Plugs directly into the MS700/705/720 alarm systems. Cat L-5072



**\$99**

## MOSS MS700 Keyless Alarm

Now it's better value than ever. The Moss MS700 keyless car alarm is one of the easiest car alarm to use. Simply turn the ignition 'off'...and the alarm comes 'on'. Features automatic arming, bonnet and boot protection hidden valet switch and more. Installation is a breeze. Cat L-5070

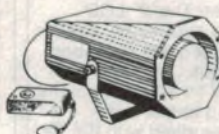


**\$99**

## MS705 Remote

Instantly arm/alarm before you get into the car! Comes with TWO remote keyswitches that can be attached to your keyring.

- Instant remote arm/disarm
- Indicators flash for arm/disarm
- Low power usage to prevent battery drain
- Easy to fit and comes with window stickers Cat L-5071



**\$245**

With Battery Back Up!

## The Incredible MS720 Remote Car Alarm

It's approved by most major insurance companies! Truly professional quality security for your car. Features key override, completely immobilizes the ignition, shock sensing, security circuit, battery back up, water and steam resistant...the list goes on. Comes with TWO remote switches. Cat L-5073



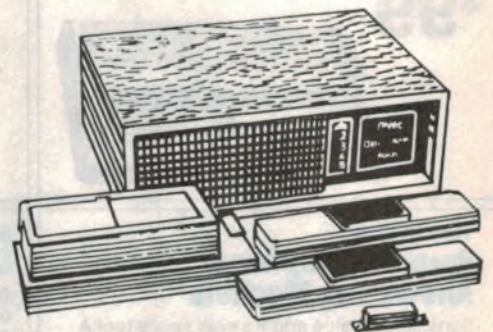
**\$399**

So Easy To Install!

## Complete Wireless Home Alarm

Five zone protection for your home and it can be installed in no time - Without Wiring! Simply plug it in, set the code and you've got instant protection. Features instant/delay modes, five zones of protection, built-in speaker and provision for external speaker. Ideal for units, flats or anywhere wiring presents difficulties. Comes with remote control, remote Reed switch, infrared sensor and mains adaptor - it's a complete system! Cat L-5125

**\$399**



Install It Yourself!

## The Complete Home Security Pack

You won't have to worry about leaving your home unprotected with this one! It's the best value and quality home security system around and comes with everything you need for truly professional quality security in one carry-home pack. You get a 4 sector control panel, 2 infrared detectors, 2 magnetic reed switches, siren horn and cover, strobe light, internal screamer, plug pack and back-up battery, 100m of cable...everything! Cat L-5150

All For Only **\$599!**



**DICK SMITH**  
ELECTRONICS



# THE AMAZING ATARI ST

Now the world's favourite home entertainment/computer system comes with the astounding ATARI POWER PACK! That's 20 of the most popular software titles, including such all time favourites as 'Double Dragon'. Nearly \$1000 worth of software - and it's FREE!

Of course you still get all the superb features of the powerful ATARI ST. High speed, superb sound, amazing power (up to an incredible 1Mb memory), standard features that most others call options... and graphics so good, you won't believe your eyes!

PLUS we'll give you as an EXTRA BONUS the amazing Partner ST. It's a complete desktop utility with appointment calendar, memo pad, phone list and auto dialler, full function calculator and more!

## Just Plug It In!

The ATARI ST plugs straight into your existing TV and comes with mouse, 720K 3 1/2" disk drive, fast 8MHz clock speed, Centronics port, RS-232 port, joystick port, and musical instrument digital interface.

Now With The Atari "POWER PACK"



Nearly \$1000 worth of software, Free!

• PLUS EXTRA BONUS -  
valued at \$99!



## Great Range Of Software!

BATTLEZONE	Cat X-6120	\$24.95
STAR RAIDERS	Cat X-6121	\$24.95
JOUST	Cat X-6122	\$24.95
MOON PATROL	Cat X-6123	\$24.95
BORODINO	Cat X-6124	\$24.95
GO MOKU	Cat X-6125	\$24.95
CRYSTAL CASTLE	Cat X-6126	\$24.95
DRILLER	Cat X-6127	\$49.95
STARQUAKE	Cat X-6128	\$49.95
CAPTAIN BLOOD	Cat X-6130	\$69.95
SPACE RACER	Cat X-6131	\$49.95
HOSTAGES	Cat X-6132	\$69.95
LOMBARD RALLY	Cat X-6133	\$59.95
MORTVILLE MANOR	Cat X-6134	\$49.95
FLIPPIT	Cat X-6136	\$29.95
G'NIUS	Cat X-6137	\$49.95
EQUATION BUILDER	Cat X-6210	\$19.95
MAGICAL MATH 1	Cat X-6211	\$19.95
SPELLING BEE	Cat X-6215	\$19.95
MAGICAL ANAGRAM	Cat X-6216	\$19.95
PC DITTO	Cat X-6270	\$169.00
FLASH	Cat X-6275	\$79.00
TIMWORKS PUBLISHER	Cat X-6250	\$199.00
WORD WRITER	Cat X-6260	\$99.00
DATA MANAGER	Cat X-6261	\$99.00
PARTNER ST	Cat X-6263	\$99.00

**ATARI 520ST \$799**

With 512K memory and all the incredible ATARI features. Cat X-6000

**ATARI 1040ST \$1099**

With an amazing 1Mb memory plus all the ATARI features! Cat X-6005

## Colour Monitor

A superb colour monitor with high resolution and vivid colours. Gets all your fantastic games and graphics software looking good! With front mounted controls so it's easy to use, and inbuilt speaker for sound.

**\$649**



# Everything To Make Your Computer System Perform!

## RS-232 Serial 9 Line Tester

An easy to use tester with 25 pin male and 25 pin female connectors. 18 bright LED's monitor the lines so you'll know immediately where the problem lies. A great time and headache saver! Cat X-2650

**\$19<sup>95</sup>**



## RS-232 Quick Tester

An in-line tester which has both 25 pin male and 25 pin female connectors. Three switches and 6 LED's allow quick selection for the most popular RS-232 configurations. You simply set the switch to select the connection you need. Cat X-2652

**\$39<sup>95</sup>**



## RS-232 25 Pin to 9 Pin Adaptor

In-line adaptor with DB25 pin female connector one end and DE9 male at the other. Cat X-2661

**\$9<sup>95</sup>**



## RS-232 9 Pin to 25 Pin Adaptor

In-line adaptor with DE9 female connector one end and DB25 male at the other. Cat X-2660

**\$9<sup>95</sup>**



## RS-232 Null Modem

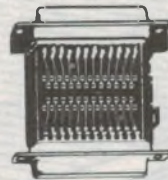
With Female DB25 connectors at each end. Wired for full handshaking. Allows the connection of two computers 'back to back'. Cat X-2664

**\$9<sup>95</sup>**

## RS-232 Serial Jumper Box

25 pin male and 25 pin female connectors. With jumper pads and wires which allow permanent soldering for RS-232 connections. Cat X-3569

**\$9<sup>95</sup>**



## RS-232 Serial Breakout Box

A complete in-line tester/adaptor which makes complex and time consuming Serial connections a breeze. Comes with 25 pin male connector at one end and 25 pin female connector at the other. With jumper pads and wires, as well as 24 in-line switches, for quick selection for any RS-232 configuration. The tester itself has 8 bi-colour LED's which monitor the lines and tell you at a glance when you've got it right. Cat X-2654

**\$49<sup>95</sup>**



## 3-Way Switch Boxes

A great idea! The switch box allows the switching of a common input to any one of three other devices. All lines are switched. Ideal for sharing a printer or modem with more than one computer or connecting several printers to one Centronics port. 25 Pin with DB25 Connectors. Cat X-3575  
36 Pin with Centronics Connectors. Cat X-3576

**\$49<sup>95</sup> ea**

## XT Prototype Card

A veroboard on an XT compatible expansion card. Complete with interrupt and memory addressing circuits already installed to enable easier construction of more advanced project ideas. With comprehensive manual. Cat X-2034

**\$149**



## Anti Static Wrist Strap

A must for when installing expansion cards or changing memory chips. Stray static charges can destroy chips in an instant. With adjustable fastening, coiled ground lead and high value series resistor for added safety. Eliminates the risk! Cat X-2042

**\$9<sup>95</sup>**

## Disk Drive Power Splitter Cable

A great idea! This 'Y' adaptor allows you to connect two disk drives to one power connector. Splits a 4-line Molex male into two females. Cat X-2604

**\$6<sup>95</sup>**



## Floppy IDC Universal Data Cable

A floppy drive data cable which is fitted with both Edge and DIL socket connectors. Facilitates the easy fitting of both 5.25" and 3.5" floppy disk drives. Cat X-2606

**\$19<sup>95</sup>**



**DICK SMITH**  
ELECTRONICS

# KITS | KITS | KITS

# KITS | KITS



## Touch Lamp Dimmer

This unit can turn your light on and off or dim them just by touching the decorative plate. Unit is intended for dimming incandescent lamps rated from 25 watts up to a total of 300 watts.  
Cat K-3001

**\$34<sup>95</sup>** As described in Silicon Chip June '89

## Extension For Touch Lamp

Do you have a two-way switch in your home and would like them replaced with touch dimmers? We have just the thing for you. An extension touch plate is connected in parallel to the K-3001 main unit, so that you can switch your lights on and off or dim them remotely.  
Cat K-3002

As described in Silicon Chip July '89

**\$12<sup>95</sup>**

## Passive Infrared Detector



Small in size, simple to construct and it comes at less than half the cost of commercial units! Has 10 metre range and can be used in conjunction with your existing alarm system or with optional interface (Cat K-8201) you can use it as the basis for a complete new system for your home, etc. Comes with white filter so it can be used in the daytime (not direct sunlight).  
K-8200

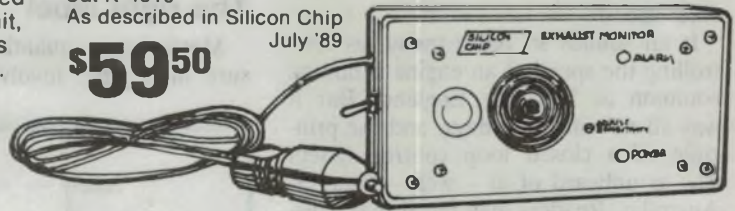
**\$39<sup>95</sup>** As described in EA May '89

## Vehicle Exhaust Monitor

This unit can be installed in your vehicle and will detect any carbon monoxide gases which may seep through into the cabin from your vehicles exhaust. Driver will be alerted either by a flashing led or an audible alarm.  
Cat K-4610

As described in Silicon Chip July '89

**\$59<sup>50</sup>**



**EXCITING NEW KIT SOON TO BE RELEASED! • EXCLUSIVE TO DICK SMITH ELECTRONICS!**

*Sophisticated Security For Your Home Alarm!*

## Alarm Phone Dialler

Designed by Dick Smith Electronics research and development department! Phone diallers are a great idea but, until now, they've been prohibitively expensive.

So here it is! The phone dialler that is not only inexpensive and easy to install but can be fitted to just about any home alarm system with a 5V-25V output (bell/strobe output).

Look what it does...

All you do is program a telephone number into the Phone and it rings you (and emits a tone) to tell you your alarm has been triggered.

If you're away from home (on holidays, etc.), you can phone home and the Alarm Dialler will tell if your alarm has sounded. That means peace of mind no matter where you are. Cat K-8300

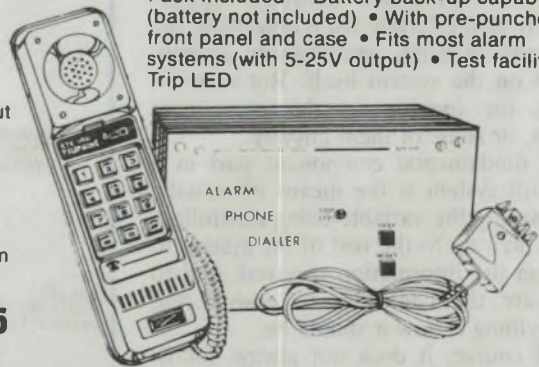
*Easily Affordable!*

As described in Silicon Chip Sept '89

**\$79<sup>95</sup>**

### Features

- Comes with pushbutton Telephone
- Plug Pack included
- Battery back-up capability (battery not included)
- With pre-punched front panel and case
- Fits most alarm systems (with 5-25V output)
- Test facility
- Trip LED



• NSW • Albury 21 8399 • Bankstown Square 707 4888 • Blacktown 871 7722 • Campbelltown (046) 27 2199  
 • Chatswood Chase 411 1955 • Chudlers 642 8922 • Core Hill 439 5311 • Gosford 25 0235 • Hornsby 477 8633  
 • Hurstville 580 8622 • Liverpool 600 9888 • Maitland 33 7866 • Miranda 525 2722 • Newcastle 61 1896 • North Ryde  
 88 3855 • Paramatta 689 2188 • Penrith (047) 32 3400 • Railway Square 211 3777 • Sydney City 267 9111  
 • Tamworth 66 1711 • Warringah Mall 905 0441 • Wollongong 28 3800 • ACT • Fyshwick 80 4944 • VIC • Ballarat  
 31 5433 • Bendigo 43 0388 • Box Hill 890 0699 • Coburg (03) 383 4455 • Dandenong 794 9377 • East Brighton  
 592 2386 • Essendon 379 7444 • Footscray 889 2055 • Frankston 783 9144 • Geelong 43 8804 • Melbourne City  
 326 6088 • Richmond 428 1814 • Ringwood 879 5338 • Springvale 547 0522 • QLD • Brisbane City 279 9377  
 • Buranda 391 6233 • Cairns 311 515 • Chermside 359 8255 • Redbank 288 5599 • Rockhampton 27 9644  
 • Southport 32 9863 • Toowoomba 38 4300 • Townsville 72 5722 • Underwood 341 0844 • SA • Adelaide City  
 232 1200 • Beverley 347 1900 • St. Marys 277 8977 • Elizabeth 255 6099 • Enfield 260 6088 • WA • Cannington  
 451 8666 • Fremantle 335 9733 • North Perth 328 6944 • Perth City 481 3261 • Midland 250 1480 • TAS • Hobart  
 31 0800 • NT • Stuart Park 81 1977

**DICK SMITH**  
ELECTRONICS

## How sensors and transducers are used:

# Electronics in Industry – 2

Some of the cleverest examples of man's ingenuity occur in the science of measurement. Today it is accepted practice to measure stresses amounting to thousands of tonnes or to separate eggs into their weight categories, in both cases using the same technology. We examine how these and other measurement tasks are achieved in this article about sensors and how they are used in industry.

by PETER PHILLIPS

The industrial revolution started in the 18th century, and some historians cite the Boulton and Watt steam engine as the beginnings of a 'system incorporating feedback'. This incredible engine, circa 1785, and now a centrepiece of the Sydney PowerHouse museum, was one of the first engines that used a closed loop control system to control a variable: speed.

It all sounds so *passé* today, as controlling the speed of an engine is now as common as flying to England. But it was all new in those days, and the principle of a closed loop control system was as unheard of as – well – flying to Australia. Readers may recall that I discussed the principles of a closed loop control system last month, in the first of these articles.

In that previous article the control system itself was described, mainly to show the principles involved. I purposely steered away from describing the component parts, preferring to concentrate on the system itself. But now it's time for looking at the component parts, or some of them anyway.

A fundamental component part in a control system is the means of actually *measuring* the variable being controlled. It is then up to the rest of the system to act on the information received, and to activate the controller to ensure that everything is how it should be.

Of course, it does not always follow that measuring something implies controlling it as well. Measuring the weight of a bag of bananas or the oil temperature of a motor car is simply that – measurement.

So the topic of measurement is very broad, and can become rather involved. This article therefore looks at *some* of the devices used to measure a quantity, be it a variable or not. In other words, it examines sensing devices, and then only those that output an electrical signal.

### The right label

Measuring a quantity, say the pressure in a pipe, involves a device that

needs to output an electrical signal proportional to the pressure. Depending on who you talk to, the device itself may be called a sensor, a converter or a *transducer*.

By definition, a transducer is a device that converts a quantity from one form to another. It can also be argued that a *converter* does the same thing – it converts just as the transducer converts. However, a converter often implies a specific device, such as a rotary converter to convert DC to AC.

A sensor is a device that produces a predictable variation in response to the presence of a quantity, such as mercury expanding in a capillary tube in response to temperature. If the resulting change is an electrical characteristic, then the sensor is itself a converter/transducer. For example, a thermocouple produces an electrical voltage proportional to temperature, meaning it fits

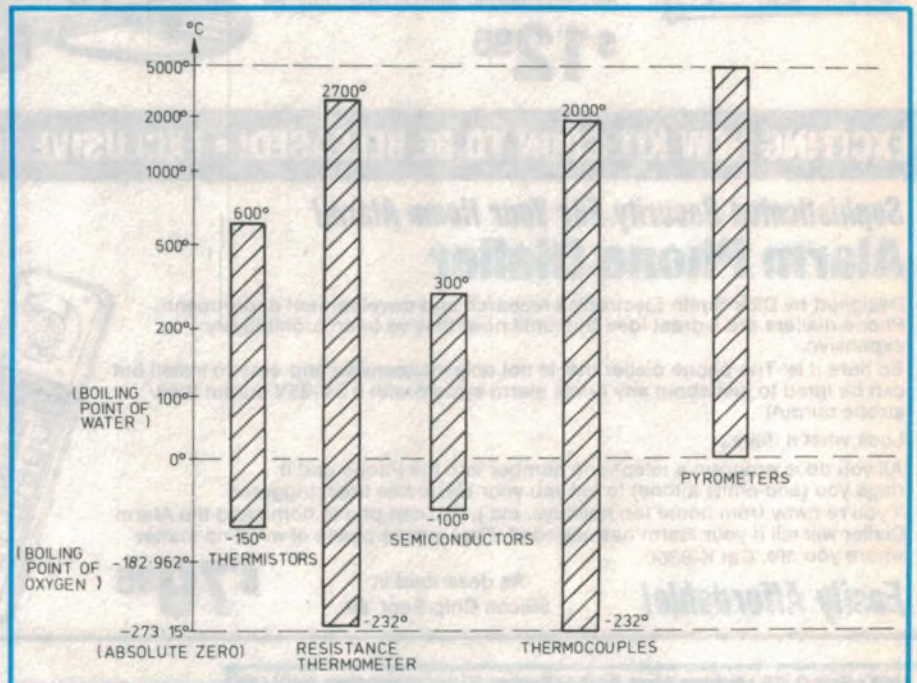


Fig.1: Graph showing the range of temperatures that apply to temperature sensors. The resistance thermometer has the greatest range, but is usually physically larger, more expensive and more fragile than the thermocouple.

the definition of a transducer – that is, converting heat to voltage. But it also fits the description of a sensor.

So, for the purposes of this article, I will use the term transducer or sensor for those measuring devices that respond in an electrical sense to the quantity being measured. However, it can be argued that transducers are used in applications other than measurement. A loudspeaker is a transducer, in which an electrical signal is converted to air pressure, which we hear as sound. An electric motor is also a transducer, converting electrical power to mechanical power.

Complicated? Well not really, providing we stick to the definitions. Now to the devices themselves.

## Temperature sensing

Of all the variables requiring measurement, temperature is probably the most common. Like most measuring devices, a temperature measuring device can be electrical or mechanical. Our concern is only for electrical types, which is fortunate as the list would otherwise go on for ever.

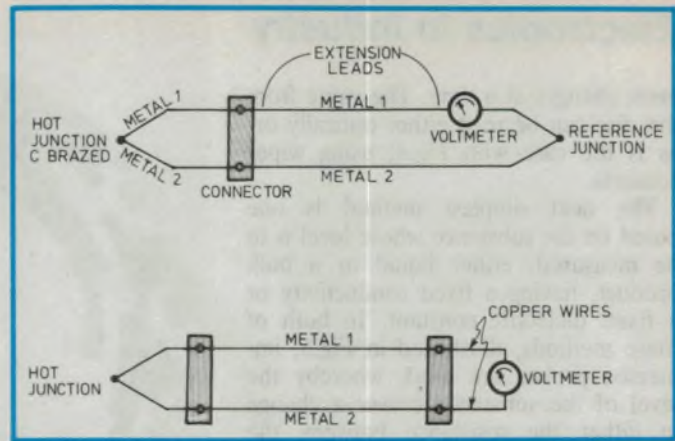
Temperature measuring transducers fall roughly into the categories of resistance thermometers (including thermistors), semiconductors, thermocouples and pyrometers. Fig.1 gives an idea of the range of temperatures each category of device can measure, although a single device within that category will only cover a section of that range.

For example, a platinum resistance thermometer can only cope with the range from  $-232^{\circ}\text{C}$  to around  $1000^{\circ}\text{C}$ , while a tungsten type is good for the range  $-40^{\circ}\text{C}$  to  $2700^{\circ}\text{C}$ . Similarly, an iron/Constantan (type J) thermocouple will handle temperatures from  $0^{\circ}\text{C}$  to around  $700^{\circ}\text{C}$ , and the more exotic Chromel/Constantan (type E) device can extend from  $-232^{\circ}\text{C}$  to over  $900^{\circ}\text{C}$ .

The voltage produced by a thermocouple is a function of the metals used and the temperature difference between its two junctions. Generally, one of the junctions, called the *reference* junction will be held at a constant temperature, usually ambient of  $27^{\circ}\text{C}$ . Fig.2 shows how two ways of connecting a thermocouple to a voltmeter, depending on the degree of accuracy required.

There are standard tables that list the voltage output for each type of thermocouple, and industry generally identifies a thermocouple by a letter, such as type J for the iron/Constantan type. Fig.3 shows the voltage versus temperature curves for some representative types of thermocouples.

**Fig.2: In (a), a thermocouple is connected so that it has a reference junction that could be maintained at a constant temperature. If this accuracy is not required, (b) is used.**



The thermocouple is an interesting device, discovered in 1821 by Seebeck, who found that an electric current flowed in a closed circuit of dissimilar metals when their junction points were at different temperatures. Perhaps not widely known is the fact that causing a current to flow in a thermocouple creates the reverse action, in which one junction becomes hot and the other cold. This principle, known as the Peltier effect, is used in some types of 'solid state' refrigerators.

Resistance thermometers are simply a spiral of metal wire wound on a heat resisting former. A pure metal exhibits a fairly linear *positive temperature coefficient*, meaning its resistance rises with temperature, and the metal is selected on the basis of its ability to withstand the temperatures involved. Because of the linear relationship, the resistance of the wire can be used as a means of measuring temperature. Usually, the resistance thermometer will form one leg of a Wheatstone bridge circuit, which is then connected to the indicating instrument, often after some form of amplification.

The thermistor is a device made of a metal oxide, and may have a positive or

negative temperature coefficient of resistance. They generally have a non-linear relationship to temperature, and are only useful over small changes of temperature. However, the change in resistance is very high per unit of temperature change, making them ideal for applications such as sensing the temperature of a motor winding.

Solid state temperature sensors use the fact that the voltage across a silicon PN junction drops at a rate of  $-2\text{mV}/^{\circ}\text{C}$ . This drop is linear over a fairly small range, but allows devices such as a conventional diode to be used to measure temperature.

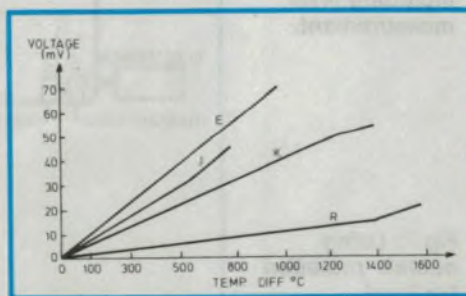
The optical pyrometer is used when temperatures exceed around  $2200^{\circ}\text{C}$ , as other devices simply cook up with the heat. The optical pyrometer is based on the principle that a hot body radiates light concentrated around a specific colour, depending on its temperature, and requires the user to adjust the glow of a filament within the instrument until its colour matches that of the hot body being observed. The current used by the filament is measured and used to calculate the temperature.

## Level sensing

Measuring the level of a liquid may seem simple enough – until the realities of acidity, flammability, toxicity and viscosity of the liquid are considered.

Perhaps the simplest method of level measurement is a 'float' attached to a line that causes some form of encoded disk to rotate as the level alters. The photo of Fig.4 shows such a system, in which two encoded discs, one disc driven from the other, are used. The resolution with this system is very high, in which disc 1 gives a particular numerical value, while disc 2 gives the fractional position between each value.

Those up with digital techniques may notice that the discs use the Grey code format, in which only one bit per seg-



**Fig.3: The voltage versus temperature curves for various thermocouples – type E (Chromel-Constantan), J (Iron-Constantan), K (Chromel-Alumel) and R (87% platinum/13% rhodium-pure platinum).**

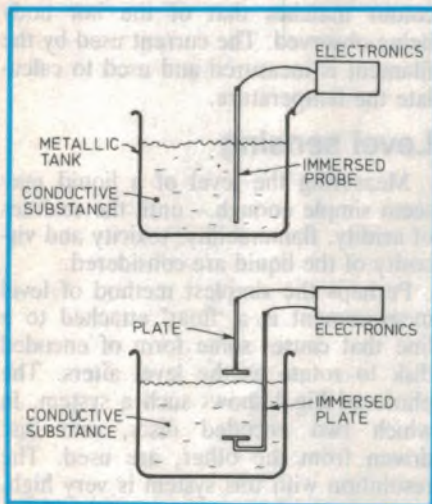
## Electronics in Industry

ment changes at a time. The value from the disc can be read either optically or, as is the case with Fig.4, using wiper contacts.

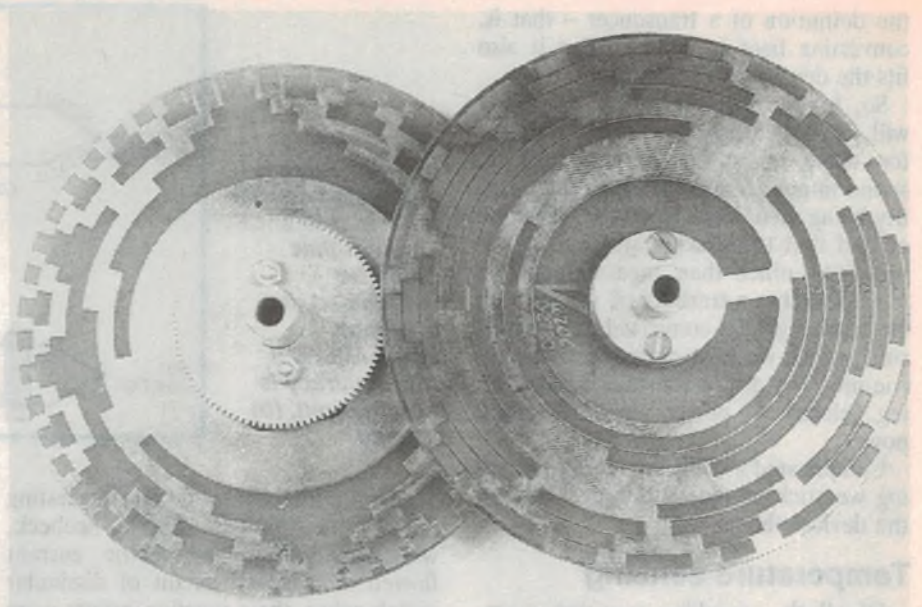
The next simplest method is one based on the substance whose level is to be measured, either liquid or a bulk product, having a fixed conductivity or a fixed dielectric constant. In both of these methods, illustrated in Fig.5, immersed probes are used, whereby the level of the substance causes a change in either the resistance between the probes or the capacity presented by the probes. The capacitive effect can also be used if the product has a high conductivity, providing one probe, in the form of a plate, is held above the product, while the other is immersed.

As many fishermen will know, the 'sonic echo' technique can be used to measure level. This is often referred to as *non-contact* level monitoring, and uses either sonar, sonic or ultrasonic devices. Sonar (an acronym for Sound Navigation And Ranging) measures the time taken to receive the reflection of a transmitted pulse of a sound signal, after its reflection from the surface being measured, and can use either sonic (audible) or ultrasonic (inaudible) pulses.

*Sonic* level measurement uses a continuous sound frequency ranging from around 7kHz to 10kHz, and ultrasonic measurement uses frequencies up to 600kHz. In principle, a transmitter is used to produce the signal (either sonic or ultrasonic) and a receiver is posi-



**Fig.5:** Measuring the level of a substance having a fixed conductivity, using resistance (a), or a fixed dielectric constant using capacitance (b).



**Fig.4:** These Gray-encoded discs were originally used to measure the level of petrol in a storage tank at a refinery, to within a few millimetres.

tioned to pick up the reflected signal.

The attenuation of the received signal compared to the transmitted signal will depend on the substance and the distance travelled by the wave. Assuming the properties of the substance are constant, the attenuation of the received signal will be proportional to the distance travelled by the wave, giving a means of level measurement.

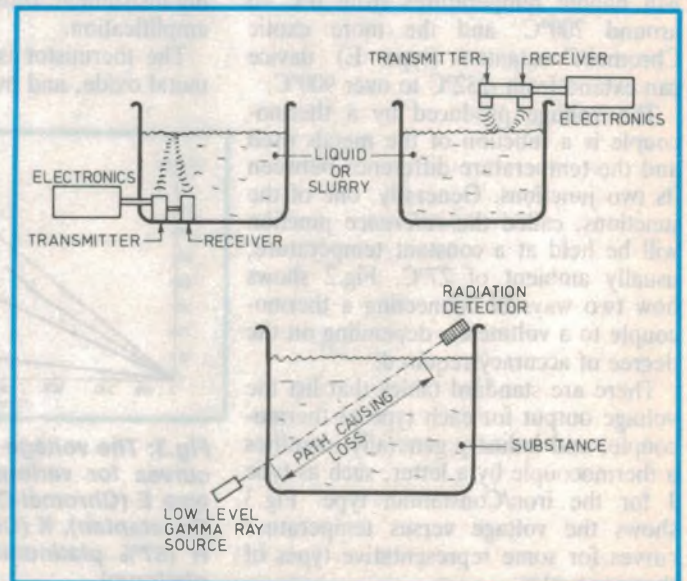
As shown in Fig.6, the transducer elements can be either above or below the surface being monitored. The transducers are often piezoelectric devices, one acting as the transmitter, the other as the receiver.

Level measurement using microwaves is based on the premise that different materials attenuate a microwave beam

depending on the conductivity of the material. For example, air offers very little loss to a microwave transmission, while sea water causes considerable losses. Like the ultrasonic system, the received signal strength in a microwave system can give a measurement of the level of the substance through which the wave has passed. If the tank holding the substance is made of metal, a 'window' that is transparent to the microwave transmission must be provided.

There are numerous other methods, such as the use of nucleonics, optical systems, even resistance *tape*. Nucleonics has the advantage of being able to measure the level of a wide range of substances, without having to install the system inside the container. The nuclear

**Fig.6:** Ultrasonics has a lot of applications in industry, including level measurement.



**Fig.7:** Using nuclear radiation for level measurement. The attenuation of the detected gamma radiation is directly related to material level.

radiation source is usually a low level gamma ray source, and the sensor measures the radiation level after it has passed through the substance. The lower the level of received radiation, the longer the attenuating path and the higher the level. The set up required is shown in Fig.7.

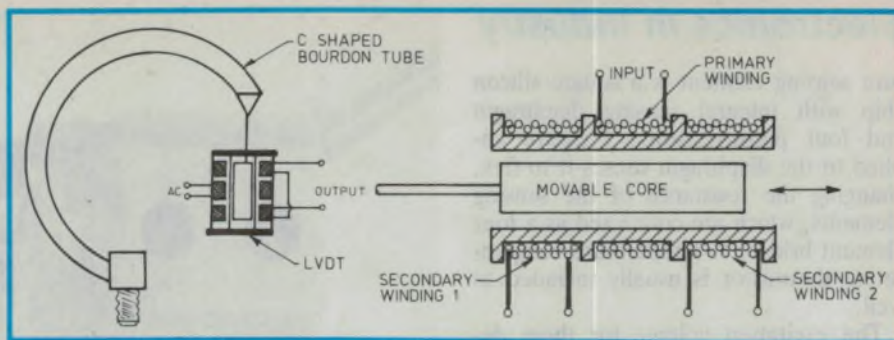
## Pressure sensing

Using electronic devices to measure pressure may seem somewhat obscure. For years mechanical methods such as the Bourdon tube pressure gauge, the spring balance and other such devices have reigned supreme. However this is no longer the case, as any shopper will know. These days the family fruit order is weighed electronically, and the weight converted directly to dollars and cents.

One of the earliest methods of pressure measurement involving a mechanical to electrical conversion is probably the Bourdon tube connected to a potentiometer. In this simple system, the flexing action of a Bourdon tube is mechanically connected to the wiper of a potentiometer, allowing the resistance value to be used as an indication of pressure.

A slightly more robust variation on the Bourdon tube/potentiometer device is shown in Fig.8(a). As shown, a *linear variable differential transformer* (LVDT) is connected with a linkage to a Bourdon tube. When pressure is applied, the Bourdon tube will straighten, somewhat like a balloon during inflation, moving the core of the LVDT.

The LVDT is shown diagrammatically in Fig.8(b), and an actual device in

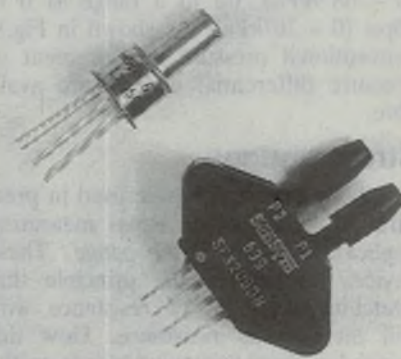


**Fig.8(a):** Pressure measurement using a Bourdon tube connected to an LVDT. **(b):** Inside the LVDT, showing the core almost centred.

Fig.9. Like any transformer, it has primary and secondary windings, in this case arranged as shown in Fig.8(b). If the movable core is centred, the secondary windings will receive equal flux coupling from the primary, and produce equal output voltages. If the core is moved, one secondary winding will receive more flux than the other, giving a higher output from one secondary and a lower output from the other.

In a measuring application, the windings are connected in series opposition (start of one winding to the start of the other), giving a zero output voltage if the core is centred. Moving the core will produce an output that will either be in or out of phase with the primary, depending on which direction the core has moved, with a value proportional to how much it has moved.

The LVDT is useful in a number of measuring applications, including position, such as measuring the expansion



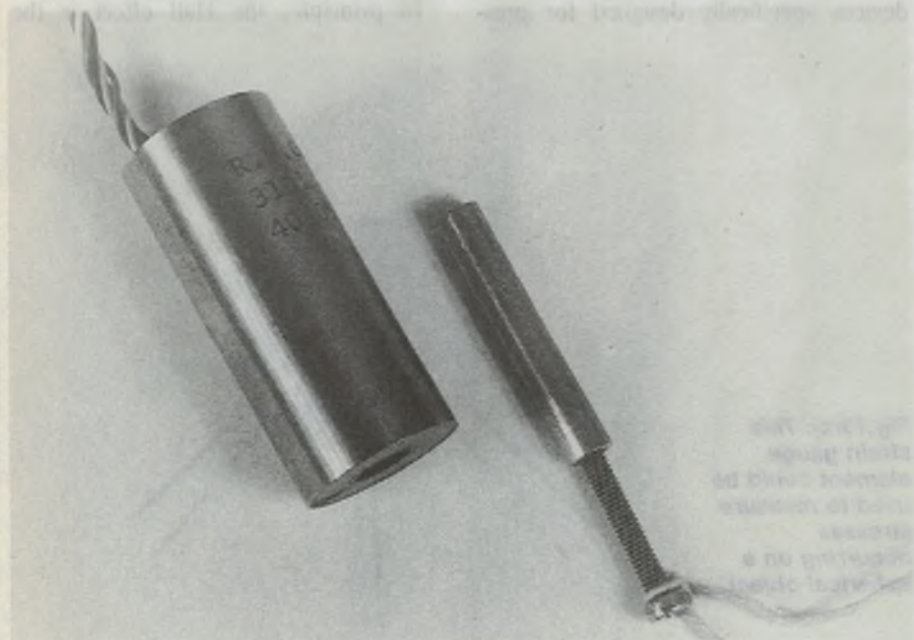
**Fig.10:** Pressure sensors in an IC package. Four piezo-resistors are used, in a bridge configuration.

of a turbine during initial warming up. The usual displacement range is around 25mm, and the primary voltage in the order of 10V AC. The output voltage range is typically 0 to 10V AC, (for an input of 10V).

Another type of pressure transducer uses a diaphragm system to create a variation in capacitance. In this type of transducer, pressure is applied to one side of the unit, and any movement is arranged to cause a variation in the capacitance value of a specially constructed pair of plates internal to the mechanism. Typically, silicone oil is forced between the plates with an increase in pressure, causing both plates to separate, thereby decreasing the capacitance value represented by the plates.

The piezoelectric effect of a crystal can be used in pressure measurement, by mechanically linking the crystal with a diaphragm. This type of transducer is useful for dynamic pressure measurement, such as in shock testing.

A smaller type of solid-state pressure transducer is one using piezo-resistors coupled to a diaphragm. This device often looks like an IC with a tube attached, as shown in Fig.10. The pres-



**Fig.9:** An actual LVDT. The core can move up to 25mm, allowing the device to also measure position.

## Electronics in Industry

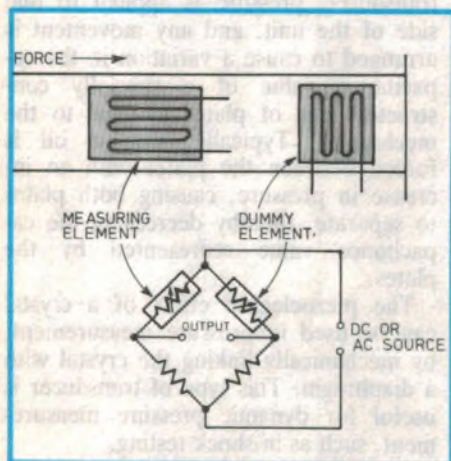
sure sensing element is a square silicon chip with integral sensing diaphragm and four piezo-resistors. Pressure applied to the diaphragm causes it to flex, changing the resistance of the sensing elements, which are connected as a four element bridge. A temperature compensating thermistor is usually included as well.

The excitation voltage for these devices is usually around 10V DC, and the output voltage from the bridge in the order of 5mV/psi (0.725mV/kPa). Typical pressure ranges vary from 0 to 10psi (0 - 68.9kPa), up to a range of 0 to 30psi (0 - 207kPa). As shown in Fig.8, conventional pressure measurement or pressure differential devices are available.

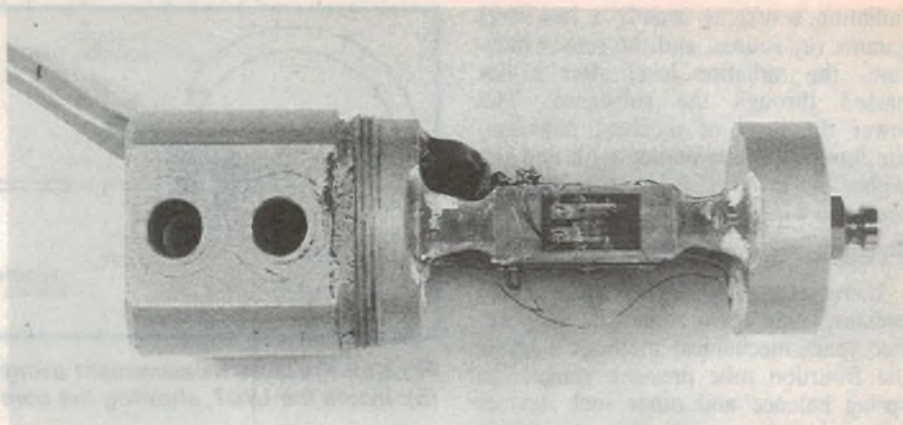
### Strain gauges

A fairly common device used in pressure measurement or stress measuring applications is the *strain gauge*. These devices operate on the principle that stretching a length of resistance wire will increase its resistance. How this principle is implemented depends on the task, and more particularly the forces involved.

As shown in the accompanying photographs, strain gauge elements come in various shapes and sizes. Usually, at least two resistive elements are mounted on some form of backing, which can then be cemented to a surface receiving the force. If stresses in a structure are being monitored, a number of strain gauges will usually be fitted at various points around the structure and connected to the measuring instrumentation.



**Fig.11:** The strain gauge, showing how two elements are used in a bridge, and cemented to the body receiving the force, as shown.



**Fig.12:** This device, fitted with a strain gauge, originally formed part of a mechanism used to separate eggs on the basis of weight.

Because the change in resistance is fairly small, usually around 2% for a 1% change in the length of the resistive element, it is normal practice to connect both elements into a bridge circuit as shown in Fig.11. In this arrangement, one element is placed in line with the force, and the other across the force. This way, any variations in resistance due to temperature and ageing are balanced out.

If a small pressure is to be measured with a strain gauge, the element can be supported between a fixed plate and a movable plate that is in contact with the force. Because of the low pressures being sensed, the strain gauge is often attached to an elastic strip that can stretch as the movable plate changes position with the applied force.

All kinds of arrangements are possible with strain gauges, including mechanical devices specifically designed for pres-

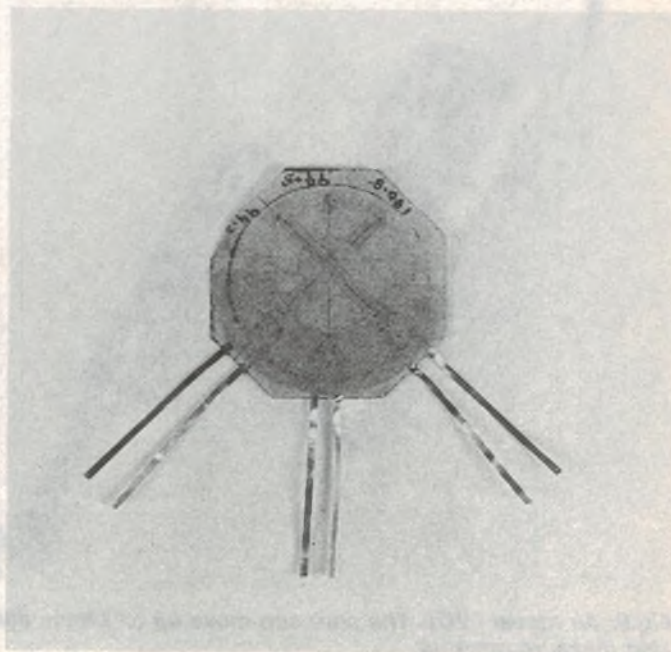
sure measurement. The photo of Fig.12 shows a strain gauge attached to a mechanism originally used to measure the weight of an egg. The strain gauge element of Fig.13(a) could be placed on a spherical surface to measure stresses or deformation of the surface due to pressure.

### The Hall effect

So far, nucleonic, microwave and ultrasonic measuring techniques along with a range of other sensors with differing principles of operation have been described. But how about magnetism?

The Hall effect, discovered in 1879, is one based on magnetism, and finds many applications in industry. However, useful Hall effect devices require more than just the effect itself, and these types of transducers are really an IC integral with the actual Hall effect device.

In principle, the Hall effect is the



**Fig.13(a):** This strain gauge element could be used to measure stresses occurring on a spherical object.



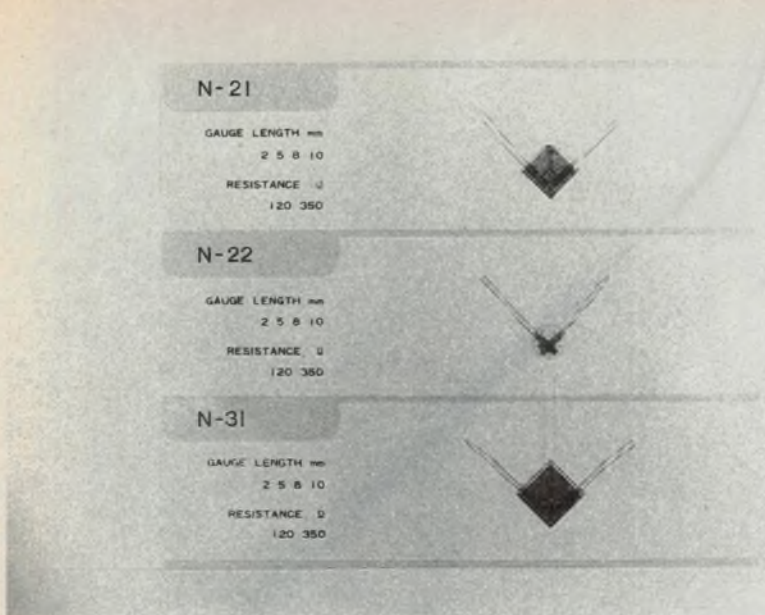


Fig.13(b): Typical strain gauge elements with their specifications.

phenomenon by which charge carriers moving through a magnetic field are forced to one side of the conducting medium. In other words, if a current is passing through a metal plate surrounded by a magnetic field, a potential difference will be developed across the plate, mutually perpendicular to the direction of the current and the magnetic field as shown in Fig.14(a).

Because the Hall voltage is very small, an amplifier stage integral with

the Hall element is required. The material used for the Hall element is usually Indium or Antimonide, and the whole package is typically around the size of a small signal transistor.

The classic use of a Hall effect device is as a *proximity* detector, in which a magnet attached to the movable object is used to trigger the Hall sensor when the object is in range.

Another industrial application of the Hall effect is in measuring flow. This works only if the liquid contains *ions*, which are a form of mobile charge carrier, like the electrons responsible for a

normal electric current in a wire, only the corresponding form within a liquid.

To use the Hall effect with this kind of liquid, a section of plastic pipe (non-magnetic and non-conducting) is mounted in a magnetic field, and the liquid passed through the pipe. As shown in Fig.14(b) two plates are installed within the pipe, and the Hall voltage developed across them will be proportional to the rate of flow and the degree of ionisation of the liquid.

## The whole scene

So far we have only looked at temperature, level, pressure and flow sensors. There are many other quantities that need measuring, such as acceleration, speed, rpm, humidity, pH, dissolved oxygen in water, free oxygen in a gas, vibration, physical dimensions of a product and so on.

Some of these sensors are fairly specialised, and unlikely to be of general interest. In any case, space constraints prevent describing them, and we will have to simply state that they exist and leave it at that.

An integral part of today's industrial technology is the computer. While some industries still use pneumatic systems for measurement and control, it is general practice to computerise everything, requiring the sensors to be connected to the computer.

If the sensors are pneumatic, some form of conversion of the pneumatic signal to an electrical signal is required, allowing them to be used in a computer

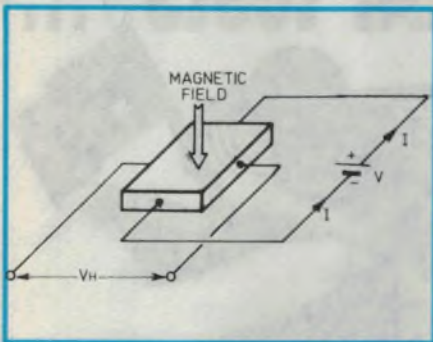
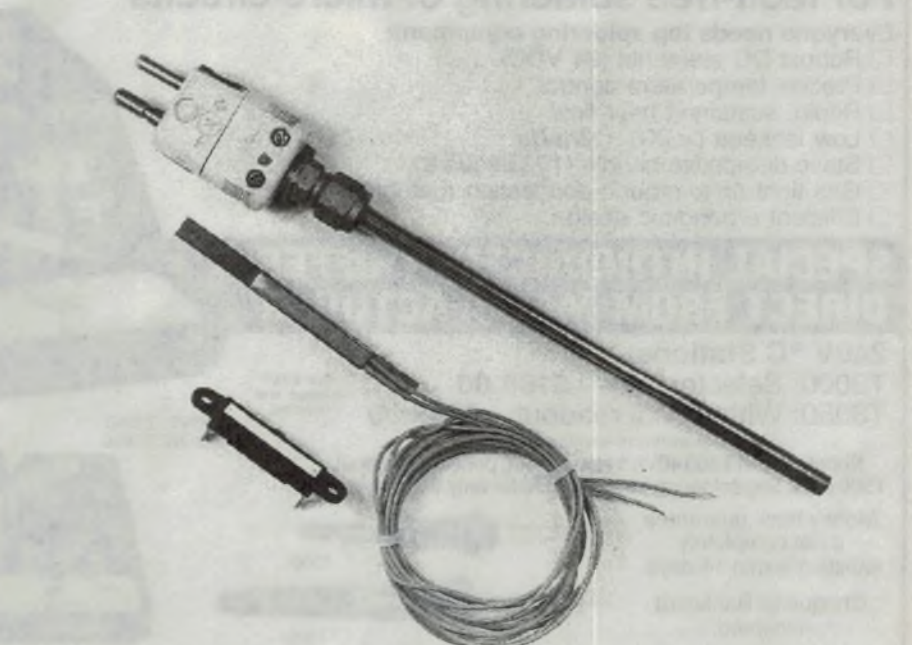
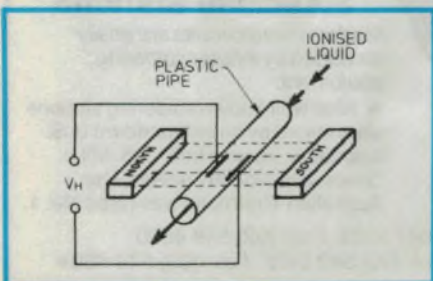


Fig 14: (a) The Hall effect phenomenon, in which a voltage is developed across a current carrying conductor in a magnetic field. In (b) below, the effect is used to measure flow in an ionised liquid.



Temperature sensors, showing a thermocouple (top) and two resistance thermometers.

## Electronics in Industry

controlled system. However, a problem that has to be overcome is actually connecting the sensors to the computer. A typical industrial complex may require sensors up to several kilometres away from the central computer, in an environment thick with electrical noise.


Optical fibres are becoming popular in transmitting sensor information, either in digital or analog form. The more usual method simply uses wires, although transmission using microwave links is another technique. Regardless of the method, if an analog sensor has to be interfaced to a computer, an analog to digital converter (ADC) is required.

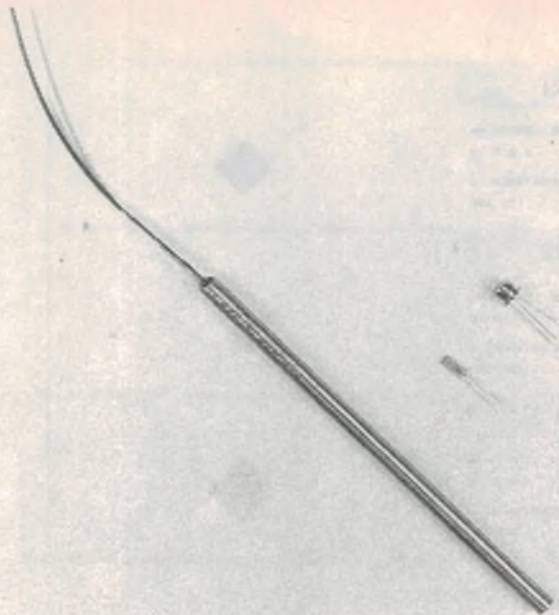
Where conventional instrumentation is used, the output voltage of the sensor will need amplification, and a range of instrument amplifiers are available for this purpose. These amplifiers are actually a buffered differential amplifier, sometimes with a converter stage to change the incoming DC signal to an AC signal prior to amplification.

And so the story goes on. Sensors, instrumentation, computers, amplifiers, controllers and so on. They all keep the

**Solid state temperature sensors, showing the devices and a complete assembly. The devices are simply a PN junction in a suitable housing.**

wheels of industry turning, 24 hours a day in many instances, with engineers continuously striving to perfect the methods used in all aspects of the pro-

cess. Just how the technology will progress in the future is anyone's guess, but it seems things are pretty interesting right now. 



# ROYEL rated No. 1 in U.S.A. tests

## For fault-free soldering of micro circuits

Everyone needs top soldering equipment:

- Robust DC elements (24 VDC).
- Precise temperature control.
- Rapid, sustained heat flow.
- Low leakage (<math>< 2\Omega</math>, <math>< 2\text{mV}</math>).
- Static dissipative handle ( $10^7\Omega/\text{square}$ ).
- Gas tight tip-to-ground connection (patent pending).
- Efficient ergonomic design.

## SPECIAL INTRODUCTORY OFFER DIRECT FROM MANUFACTURER

### 240V °C Stations:

T3000: Selector only – \$160.00

T3050: With digital readout – \$185.00

Complete technical literature supplied.

Supplied with T300 40W, 14g soldering pencil (additional T500 60W, 50g soldering iron available for only \$40.00 extra).

Money back guarantee if not completely satisfied within 14 days.

Cheque or Bankcard accepted.



Plus \$3.00 postage and handling

ABOVE: T3050  
BELOW: T3000



### SOLDERING STATIONS

Modern micro circuits are easily damaged by inferior soldering equipment.

★ Nine well-known soldering stations were tested by an independent U.S. laboratory, against both U.S. Mil. Specs. and industry needs. The Australian Thermatic was rated No. 1.

**ROYEL INTERNATIONAL**

T8905

SYDNEY: P.O. Box 21, Ermington, NSW 2115. Tel: (02) 647 1533. Fax: (02) 648 4620

MELBOURNE: P.O. Box 328, Mt. Waverley, Vic. 3149. Tel: (03) 543 5122. Fax: (03) 544 4894

# THE ELECTRONIC COMPONENTS SHOP

289 Latrobe Street,  
**MELBOURNE**  
 PHONE: (03) 602 3499 FAX: 670 6006  
 SYDNEY (Office Only): (02) 906 2411

## FREE PRICE LIST

Just write to us and we'll mail one to you or come down to the shop and pick one up.

### KYNAR WIRE WRAP WIRE

**10 COLOURS:** BLACK, RED, BLUE, YELLOW, GREEN, VOILET, ORANGE, WHITE, BROWN, GREY.

**SPECIFICATIONS:** CONDUCTOR: 30 Guage Silverplated Copper  
 TEMP RATING: 105°C, UL1423, CSA Approved.  
 HEAT RESISTANCE: 135°C Max Rate.  
 INSULATION: Kynar .1 mm thick

**6 SIZES:** 15cm/50ft @ 6.65 152m/500ft @ 27.30  
 30.5m/100ft @ 8.74 304m/1000ft @ 45.50  
 76m/250ft @ 14.69 3048m/10,000ft @ 315.00

### WIRE WRAP SOCKETS

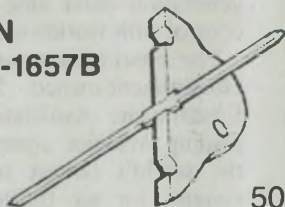
Machine Pin Gold Contact 3 Level Wire Wrap Sockets at our 500 plus price\*.

\* MARCH-APRIL ONLY

8 Pin	@	1.20
14 Pin	@	1.60
16 Pin	@	1.70
18 Pin	@	2.00
20 Pin	@	2.20
24 Pin	@	2.95
28 Pin	@	3.10
40 Pin	@	4.20

### WIRE WRAP PINS

VERO PIN  
 TYPE: 18-1657B



1	@	.25
50	@	9.84
500	@	63.00

### WIRE WRAP TOOL

OK INDUSTRIES INC.

**WSU-30m**

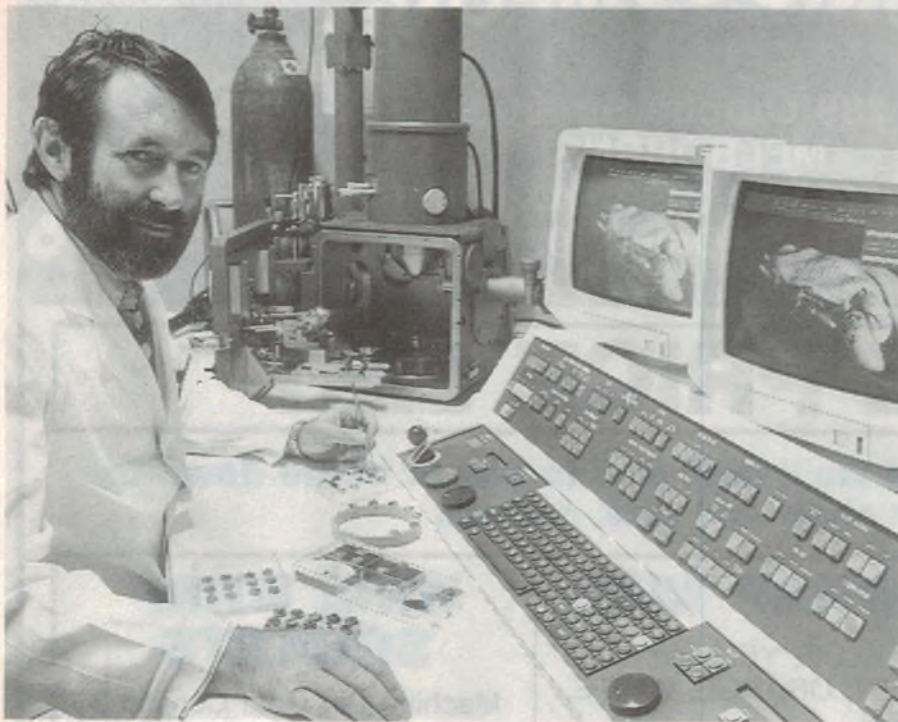
**\$27.50**

ALL PRICES INCLUDE SALES TAX. TAX EXEMPT & OEM P.O.A.

**Freight:** The prices quoted are ex Store, cost of delivery and the risk of loss in transit fall upon the purchaser. For the convenience of customers, delivery can be arranged through the supplier at the schedule of rates set out below.

<b>Minimum Charge Only</b>	1. Local Cost \$2.50	<b>only SMALL ITEMS will be sent by post.</b>
	2. Interstate Post \$3.50	
	3. Carrier: Melbourne & Metropolitan — \$5 up 3kg	
	4. Carrier: Interstate — \$10 up to 3kg	

# News Highlights



## Most powerful SEM in Australia

The University of NSW has just installed the most powerful scanning electron microscope (SEM) in Australia.

The microscope is capable of magnifying specimens from 5 to 500,000 times,

giving a whole new perspective on anything from the common housebrick to the common house fly.

"With the installation of this new system, we can contemplate doing research

work which was not possible before", said Dr Mel Dickson, Director of the Biomedical Electron Microscope Unit.

"We can now compete with overseas teaching institutions and attract academics to our University. Similarly, our own researchers are not forced to leave the country to carry on with their work."

"Suddenly we have a world class facility. My ambition is to maintain our position by continually updating our equipment. We don't want to fall back."

The electron microscope has a multitude of uses. So far it has been used to study such things as asbestos cement roof weathering, the effects of drug treatment on cells, the development of sense organs in crayfish larvae and membrane filtration. But, said Dr Dickson, the system could be used to examine almost anything.

Most of the microscope's functions are controlled by a central computer so that optimal performance is obtained by even inexperienced users. The computer retains images in a large store and images fed into the store can be manipulated until they are ideal. Images can be displayed and photographed in colour for later analysis.

"The computer allows us to use more sophisticated techniques and it also makes the microscope very easy to use", said Dr. Dickson. "With the use of colour, we can highlight what we want and add impact to the visual message."



## 'Lucky Draw' for soldering station

Like to own a top of the range soldering station? Here's your chance to win Scope's impressive ETC60L, featuring infinite temperature adjustment between 200 - 470°C, zero voltage switching, illuminated temperature readout, and a host of other features.

All Electronic Components and Scope Laboratories are pleased to announce the staging of a 'Lucky Draw', to be run between 1st September and 20th October, 1989.



To enter, simply visit or write to All Electronic Components of 118 Lonsdale Street, Melbourne, 3000 and request to be included in the draw. It's that easy.

The draw for the station - worth around \$220 - will be conducted by Nikki Roche from *Electronics Australia's* Melbourne office, at 12 noon 20th October, 1989.

The winner will be notified by mail, with the result also published in *Electronics Australia* for January, 1990.

## Interscan wins Italian radar antenna contract

Interscan International Limited, the all-Australian manufacturer of air navigation equipment, has been awarded a \$2 million contract to develop a new generation radar antenna for air traffic control with worldwide export potential.

The contract was awarded by Italian Government-owned Selenia Industrie Elettrotecniche Associate SpA, Europe's leading avionics company and one of the world's largest suppliers of radar systems for air traffic control outside the United States.

The new planar array primary radar antenna will make a significant contribution to international air traffic control. A particularly beneficial feature will be its ability to discriminate against 'clutter', the name given to the problem of a radar confusing aircraft with objects on the ground.

Primarily destined for customers overseas, the new antennas could earn Australia more than \$15 million in export revenue over the next 10 years.



## Navy refit awarded to Australian firm

Australia's growing defence electronics expertise has been recognised by the awarding of a major ship communications refit to an Australian company.

The contract, let by Australian Shipbuilding Industries (WA), was won by the recently listed electronics firm, Stanilite Pacific. Stanilite will completely refit the communications hard-

ware on the Royal Australian Navy destroyer escort, HMAS Swan.

The refit will include a major modification and update to the ship's external communications systems and repair to the internal communications system. In addition, Stanilite has tendered for the repair of the radar and weapons systems equipment.

## News Briefs

- Switchgear and connector maker **Utilux** is opening a 600 square metre warehouse and sales office complex at Bowen Hills in Queensland, ending 30 years of representation in the state by R.A. Venn. Gary Mole will be manager of the new complex.
- New Zealand's 28th national electronics conference, **NELCON 89**, is being held this month (September 19-21 inclusive) in Wellington at the Plaza International Hotel. Over 40 exhibitors are likely to take part in the associated trade exhibition. Further details are available from Ben Furby, 11/127 Evaline Street, Campsie 2194 or phone (02) 787 1353.
- Switzerland has become the 56th member of international satellite consortium **Inmarsat**, only the second land-locked country to do so. Inmarsat operates a global system of satellites for communications services to shipping, aircraft and land mobile users.
- Swedish hi-tech manufacturer **Asea Brown Boveri** (ABB) and Japanese giant **Matsushita Electric Industrial** (MEI) have signed a co-operation agreement in the field of robot-based factory automation. MEI will now sell and distribute ABB Robotics' products in the Japanese market. ABB makes some 17 different robot models, and has so far delivered over 16,000 world wide.
- UK-based **Racal-Redac** has acquired New Jersey logic simulation and test automation maker HHB Systems from its US parent Daisy/Cadnetix. HHB has been supplying simulation equipment on an OEM basis to Racal-Redac, Data I/O, Calay, Harris Semiconductor, Schlumberger, Fujitsu and NCR.
- **Toshiba** and **Digital Equipment Corporation** have signed a technology exchange agreement to ensure that Toshiba's popular laptop computers are integrated into DEC's Network Application Support (NAS) program. The agreement provides for the exchange of hardware and software product specifications.
- UK instrument maker **Marconi Instruments**, a subsidiary of GEC, has acquired the instruments and automation business of **Racal Electronics**. The deal includes US subsidiaries Racal-Dana Instruments and Racal Automation. Marconi MD Dr Colin Gaskell noted that Racal's instruments were complementary to those of Marconi, and would integrate well. Racal-Dana's US facilities will also give the company a strong manufacturing base there.
- **Automate Australia**, the International Robotics and Industrial Automation Exhibition, will be held next year from 3-6 June at the Royal Exhibition Building in Melbourne.
- CCTV specialist **Javelin Video Surveillance Systems** has opened a sales and service centre in Brisbane, completing its national network. Manager for Queensland and the Northern regions is Paul Leslie.
- **MM Cables** has appointed Bob Smith as NSW state manager - wholesalers. Tony Milroy has also been appointed to the corresponding position for Queensland and NT, based in Eagle Farm.

## Queensland police using satellite data links

Police in some of the most remote parts of the state will soon have instant access to the complete computer resources of the Queensland Police Department, through Queensland's only private satellite service, Q-NET.

The service will provide police in country centres with access to central criminal records, emergency and information bulletins as well as administrative records via a computer terminal in their specific location.

General Manager of Q-NET, Mr Geoff Johnson said that police from 20 regional centres including Weipa, Julia Creek, Cardwell and Mornington Island would soon have access to the information service.

"The service will not only help officers in routine administrative procedures, but will provide information which is often vital in emergency situations and in the apprehension of criminals", he said.



## WSRL orders advanced sonar processor

Scientists and engineers at the Weapons Systems Research Laboratory (WSRL) at Salisbury in South Australia will soon be able to accurately compare results from their research into advanced signal processing techniques with the Royal Australian Navy's precise requirements for sonar systems.

This advance in defence research will result from a contract awarded by WSRL to Computer Sciences of Australia, for the design and development of a signal processing system.

The system will process data captured by sonar sensors and will be used to develop advanced methods for analysing data from sonar and sonobuoy hydrophone arrays.

Under the contract, CSA will complete the detailed system design, procure the sophisticated hardware from various suppliers, develop applications software and integrate and test the complete system at the company's Technology Park premises in Adelaide.



### HP-41C calculator has 10th birthday

In a world where many electronic products fall by the wayside in a year or two – victims of advancing technology and consumer whims – the 10-year life span of Hewlett-Packard's HP-41C handheld calculator is testimony to the machines' advanced engineering.

The HP-41C was not just any run-of-the-mill calculator. Introduced in 1979, it was the first calculator that could display alphabetic characters as well as numbers. But more importantly, it was fully programmable and expandable.

For many people, the HP-41C was their introduction to computer programming. It was less expensive than personal computers and – through the HP Interface Loop (HP-IL) – it could be hooked up to printers, plotters and mass-storage devices.

In 1980, Dennis Conner used an HP-41C onboard the 12-metre yacht, *Freedom*, to help him win the America's Cup. The calculator continually computed *Freedom's* distance ahead of and behind the competition. Conner chose the HP-41C for its handheld size and durability. The HP-41CX also saw action in the last two America's Cup races.

On April 12, 1981, two HP-41Cs were sent into space aboard the first space shuttle, *Columbia*. Each calculator contained its own critical program, one dedicated to the acquisition of signals and the other to the center of gravity.

Each program was loaded prior to launch and both calculators were stored in a special pouch in the flight suit of astronaut Robert Crippen.

Beginning simultaneously with launch, the signal acquisition program began to run. The HP-41C told the *Columbia* the next ground station to contact, when contact would be made, for how long, and which frequency could be used.

On the way back to Earth, the center-of-gravity program enabled the astronauts to determine the proper balance for the space shuttle. The HP-41C calculated *Columbia's* pre-entry centre of gravity and the amount of fuel that would have to be burned from each tank, to establish the center of gravity for re-entry.

Thousands of programs have been written for the HP-41 by users around the world. Shortly after the HP-41C was introduced, users discovered some interesting quirks in the machine.

For instance, HP had programmed the HP-41C to show a goose flying across the display, while the machine is working on a long problem. By using unpublicised instructions, one HP-41C fanatic figured out how to make the goose fly backwards. He then turned it into a string of nine geese, and got them to collide with the factory-programmed goose. The new flock of fowl provided much amusement for user-group members.

### New site for Qantas computers

Qantek, the Qantas information technology subsidiary, has acquired more than five hectares of land at Arncliffe in Sydney, to build a new back-up computer centre.

The new centre, to be operational early in 1991, will provide development and back-up facilities for the main Qantas reservations and communications system, Qantam, located in the basement of the Qantas International Centre in downtown Sydney.

The land, on Princes' Highway and fronting the Cooks River, is the site of Tempe House, built for a Sydney merchant more than 150 years ago and a former home for women run by the Sisters of the Good Samaritan – who acquired the historic house in 1885. Tempe House and those parts of the complex deemed historically significant, will be renovated and returned to their original splendor.



### ECI – Yamaha link up

Pictured are a jubilant Ken Curry, Managing Director of Energy Control International Pty Ltd, and Mr Vic Amana, General Manager of the Yamaha Semiconductor Division in Hamamatsu, Japan, shortly after the signing of a contract for Energy Control International to represent and distribute the Yamaha Electronic Systems Division in Australia and New Zealand.

Yamaha Electronics Systems Division manufactures an advanced range of electronic devices for digital audio, data communications and graphics applications.

## Low cost 1500dpi gray-scale scanner



A new 8-bit, gray-scale, flatbed scanner now available from Hewlett-Packard Australia dealers, provides higher-quality image and text input for only \$170 more than HP's original 4-bit scanner.

The HP ScanJet Plus scanner, plus an IBM PC/compatible or Macintosh interface kit, is \$3886, plus sales tax if applicable.

The HP ScanJet Plus scanner allows people to add high-quality reproductions of photographs, line art or illustrations to most PC and Macintosh desktop-publishing and word-processing software packages.

It provides 256 levels of gray – which exceeds the gray-scale range a human eye sees – compared to 16 available with a 4-bit scanner. The wide range of gray levels provides greater image contrast and intensity control.

The flatbed design of the scanner accommodates bound documents, such as books or magazines, and single pages. An optional 20-page sheet feeder allows users to perform unattended scans of up to 20 pages of text.

## CSIRO robot vision system for NASA space shuttle

The extremely rapid 'blob feature recognition and analysis' capability provided by the APA 512 MX high-speed machine vision processor module, developed by the CSIRO Division of Manufacturing Technology in collaboration with Vision Systems Ltd of Adelaide, has led to its incorporation by NASA as an integral component in the Space Shuttle Robot Vision Guidance system recently installed by the US company Adaptive Automation Inc., at the Kennedy Space Center at Cape Canaveral in Florida. The installation also includes a massive ASEA IRB-90 robot arm on the Space Shuttle launch pad, a range of Datacube image processing equipment, and three separate computers.

Functions of the robot arm include a requirement to insert and unplug various umbilical lines that give the Shuttle its life support from the ground, including connections for power, fuel, remote control, internal environment control, etc.

Although the robot arm is affixed to the umbilical tower, the Shuttle is primarily free standing, and when influenced by the prevailing ocean breeze it can sway back and forth on the pad. At its height of over 30 metres, the launch pad itself can also move slightly in the breeze. Thus to achieve accurately positioned umbilical line connections, it is necessary for the robot arm to continuously monitor the Shuttle's movement and compensate for any misalignment,

tracking its target to an exacting six degrees of freedom – represented by the x, y and z and pitch, yaw and roll co-ordinates.

The intelligent vision sensor system (which digitises the image that is produced from a camera mounted on the robot arm) keeps a watch on a small target – a pattern of white circular (25.4mm diameter) dots on a black background – at short range, and facilitates the reporting of the target's position to the central (MicroVax II) computer at the rate of 30 times per second.

## French place largest D2 MAC order


The French Telecom has ordered 750,000 D2 MAC decoder/descramblers from La Radiotechnique Portenseigne, part of the French Philips organisation.

The order, worth more than \$200 million – the largest ever placed for ground equipment hardware in the European cable and satellite industry – is for direct supply to French Telecom. Deliveries will be completed by the end of 1991.

The equipment will be used to descramble the signals from the recently-launched TDF1 direct broadcast satel-

lite, four of whose five channels will be pay-TV channels. One of these channels will be broadcast on the TDF1 satellite to Germany.

"Because D2 MAC is a first step towards HDTV, this order is a definitive commitment," said Mr R.L. van Oostenbrugge, MAC/HDTV marketing manager within Philips' Consumer Electronics group.

The contract specifies Eurocrypt (in which Philips has been heavily involved) as a conditional access norm, using the French CCETT standard. 

### VIDEO RECORDER PARTS

- MANUALS
- BELTS
- GEARS
- IDLER WHEELS
- PINCH ROLLERS
- VIDEO HEADS
- SEMICONDUCTORS

OPEN SATURDAY MORNINGS

### TELEVISION REPLACEMENTS



134A AYR ST  
DONCASTER  
VICTORIA 3108  
AUSTRALIA  
FAX (03) 850 4843

# Sheridan Electronics P/L

164-166 Redfern Street, Redfern NSW 2016  
 Ph: (02) 699 5922 or (02) 699 6912 Fax: (02) 698 3694  
**Mail Orders to:** PO Box 229 Redfern NSW 2016  
**Mail Charges:**

\$15.00-\$19.95.....\$ 5.00 **Trading Hours:**  
 \$20.00-\$39.95.....\$ 7.00 Mon-Fri..... 9am-5.30pm  
 \$40.00-\$69.00.....\$ 8.00 Sat ..... 9.30am-1pm  
 \$70.00-\$99.00.....\$10.00 Large or overweight articles  
 \$100 & over .....\$15.00 sent Skyroad Freight Forward.

STOP PRESS!! Our New Address, from first week of September will be: 286 Cleveland Street, Surry Hills 2010. Phone and Fax numbers remain the same.

## End of Lease Massive Clearance

LOOK OUT FOR OUR NEW ADDRESS SHORTLY  
 LOTS BELOW COST — Special prices for bulk purchases

NOTE: We accept Bankcard and Visacard. However we cannot give quantity discounts on credit card purchases or account orders. Minimum for account orders is \$50.00. Non account minimum order is \$25 exclusive of postage and packing. All prices include Sales Tax.

**All prices quoted are for September only or until stocks last.**



Sheridan's prices are coming down

### DEFINITELY - BUT DEFINITELY THE CHEAPEST IN AUSTRALIA COMPUTER CABLE LEADS

Pt. No.	Description	Price
930346	15 way 'D' male to 15 way - 'D' female 15 metres - only <b>\$9.95</b>	
7909	5 pin male 'DIN' to 5 pin male 'DIN' 2 metres - only <b>\$5.50</b> 5 metres - only <b>\$7.50</b> 9 metres - only <b>\$9.50</b>	
Cheaper than the price of the cable		
AP012	'Amiga' centronics male 36 way to DB25 female	<b>\$6.50</b>
IP002	IBM printer cable, 'centronics' 36 way male to DB25 male	<b>\$9.95</b>
CC001	'Centronics' 36 way male to 36 way male	<b>\$9.50</b>
SC102	Serial Cable, DB25 male to DB25 male	<b>\$5.00</b>
SC101	Serial Cable, (Pins, 1-8, 12-20-22 wired)	<b>\$5.00</b>
MC004	Modem cable DB25 male to DB25 female	<b>\$5.00</b>
MC003	Modem cable DB25 male to DB25 female	<b>\$5.00</b>



### NOVELTY FOOTBALL PHONE

Makes an excellent second phone for the kitchen, rumpus room or even bathroom. A good gift for a good friend.  
 Features: Decorator design one-piece desk phone and pulse dialing with last number redial

FCC registered  
**ONLY \$15 each (limited stocks)**

### 74LS & 74S Price 'Massacre' Lowest in Australia!!

Part No.	Quantity	Price
<b>74LS Series</b>		
74LS02	10 for	<b>\$ 2.50</b>
74LS04	10 for	<b>\$ 3.00</b>
74LS27	10 for	<b>\$ 3.50</b>
74LS32	10 for	<b>\$ 3.00</b>
74LS38	10 for	<b>\$ 3.50</b>
74LS51	10 for	<b>\$ 3.00</b>
74LS75	10 for	<b>\$ 3.00</b>
74LS83	10 for	<b>\$ 4.00</b>
74LS86	10 for	<b>\$ 3.75</b>
74LS92	10 for	<b>\$ 3.75</b>
74LS113	10 for	<b>\$ 3.00</b>
74LS114	10 for	<b>\$ 3.00</b>
74LS123	10 for	<b>\$ 4.00</b>
74LS157	10 for	<b>\$ 4.00</b>
74LS161	10 for	<b>\$ 4.20</b>
74LS163	10 for	<b>\$ 4.00</b>
74LS169	10 for	<b>\$ 6.00</b>
74LS175	10 for	<b>\$ 4.20</b>
74LS221	10 for	<b>\$ 4.50</b>
74LS241	10 for	<b>\$ 4.00</b>
74LS367	10 for	<b>\$ 4.00</b>

Part No.	Quantity	Price
<b>74S Series</b>		
74S03	10 for	<b>\$ 3.00</b>
74S04	10 for	<b>\$ 3.00</b>
74S05	10 for	<b>\$ 3.00</b>
74S11	10 for	<b>\$ 3.00</b>
74S22	10 for	<b>\$ 3.50</b>
74S51	10 for	<b>\$ 3.00</b>
74S64	10 for	<b>\$ 3.00</b>
74S112	10 for	<b>\$ 4.00</b>
74S138	10 for	<b>\$ 4.00</b>
74S140	10 for	<b>\$ 3.75</b>
74S158	10 for	<b>\$ 4.25</b>
74S174	10 for	<b>\$ 4.75</b>
74S175	10 for	<b>\$ 4.25</b>
74S182	10 for	<b>\$ 13.00</b>
74S188	10 for	<b>\$ 13.00</b>
74S241	10 for	<b>\$ 12.00</b>

Please note: Special prices for quantities of 100 and over.

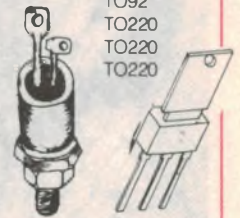


### Triacs & SCR's at Rock Bottom Prices.

Pt. No.	Description	Case
Q400IL4	Triac, 400V 16A	TO220
Q4006L4	Triac, 400V 6A	TO220
S2003MSC	S.C.R. 200V 3A	TO220
S4003L	S.C.R. 400V 3A	TO220
Q400\$	Triac 400V 4A	TO220
S2010L	S.C.R. 200V 10A	TO220
EC103Y	S.C.R. 30V 4A	TO92
EC106AI	S.C.R. 100V 6A	TO220
TO106DI	S.C.R. 200V 4A	TO220
TO106BI	S.C.R. 200V 4A	TO220

All above only \$1.00 each

buy 10 assorted for **\$9.00**  
 GT-32 Diac 35-45V 2.00A  
 30 cents each or **10 for \$2.50**  
 HT-40 Diac 45-55V 2.00A  
 35 cents each or **10 for \$3.50**



### SHERIDAN GOES "POTTY" ON RIBBON, RAINBOW, COMPUTER CABLE PRICES

Description	Price per mtr
9 way ribbon, flat rainbow, loom wiring	1.50
14way ribbon, flat rainbow, loom wiring	1.70
15way ribbon, flat rainbow, loom wiring	1.95
16way ribbon, twisted, white, grey, red wiring	2.25
20way ribbon, flat, grey, IDC connection	1.35
26way ribbon, flat, grey, IDC connection	1.50
26way ribbon, twisted, white grey red.	2.50
60way ribbon, flat rainbow, loom wiring	3.95
64way ribbon, flat grey, IDC connection	2.95

### JACKETED COMPUTER CABLE from HITACHI

**Top quality UL style**  
 Easy termination to 0.050" IDC connectors  
 Black protective outer jacket  
 EMI/RFI shielding via aluminium foil inner jacket  
 2 drain wires with tin overcoating for added reliability  
 Capacitance 40pF/ft  
 Characteristic impedance 60 ohms  
 Crosstalk 1.1 - 2.7%/10ft (10nS rise time pulse)  
 Propagation delay 1.53nS/ft

40 Way	3.00 per metre
34 way	2.50 per metre

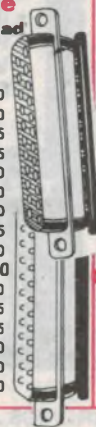


### Connector Clearance

Massive savings with our mad, mad prices

#### 'D' Type connectors:

9 way male (metal body)	\$1.00
9 way female (metal body)	\$1.10
9 way backshell	\$0.75
9 way male, right angle (moulded body)	\$0.75
9 way female, right angle (moulded body)	\$1.00
15 way male (metal body)	\$1.10
15 way female (metal body)	\$1.20
15 way backshell	\$0.75
15 way male, right angle (moulded body)	\$1.00
15 way female, right angle (moulded body)	\$1.10
25 way male (metal body)	\$1.20
25 way female (metal body)	\$1.35
25 way backshell	\$0.95
25 way male (right angle) moulded body	\$0.50
37 way male & female (metal body) pair	\$2.00
50 way male & female (metal body) pair	\$1.00



### Gorman-Rupp(USA) DISPENSING PUMP

The 2-1/2" bellows pump has the ability to discharge in a pressurised system. However, system or discharge pressure over 5 PSI may cause damage to the bellows or gear box, pump is designed for use up to approx 49°C(120°F).  
 Bellows pump size (2-1/2") is the outside diameter of the bellows. Pump operates on an adjustable stroke, positive displacement principle (operates on 115VAC 50-60)

**ONLY \$75 EACH**



All new and cartoned with instructions.  
**Super-duper 'special' scoop purchase on "Varta"**

'AA' Nicads - 500 MA rating  
**only 4 for \$9.95!!! Lowest ever**  
 SAFT 'C' nicads, 180MA-  
**2 for \$10.00**

### Another 'killing' on plug packs and only from us. AC Adapters

Input 220 OVAC 50/60HZ Output 9VDC 0.9AMP

**ONLY \$9.95 EACH ONLY TILL THEY LAST**



### Sony 3 1/2" Single Sided Disk Drive

Low Profile 40K. Scoop purchase, once gone, not repeatable.  
**Was \$35.00 NOW \$22.50**



### MAD! MAD!! MAD !!! CRAZIEST PRICES EVER PRICES ON SEMI-CONDUCTORS - MASSIVE BELOW COST CLEARANCE

6800P	\$2.50 ea
6809P	\$2.50 ea
6812P	\$2.50 ea
2114P-30	\$1.50 ea
2114P-20	\$2.00 ea
BD680	10 for \$1.00 (TO220)
BD679	10 for \$1.00
2708(Ex)	\$1.50 ea
BUX48A	\$1.50ea (TO3)
2N2905	10 for \$1.75(TO5)
2N3733	10 for \$1.75
2N 3739	\$1.00 ea (TO66)
2N6213	10 for \$1.75(TO66)
LM348	10 for \$0.50
TR1865(Disc Cant)	\$2.00 ea or 10 for \$17.50
WD2795A(Disc Cant)	\$2.00 ea or 10 for \$17.50
TIP29B	10 for \$1.00
68000 BMHz	CPU \$8.00
4049	10 for \$2.50
74188	10 for \$2.00
7476	10 for \$2.00
74156	10 for \$2.00
7404	10 for \$1.80
7410	10 for \$2.00
7408	10 for \$2.00
7400	10 for \$2.50
75451	10 for \$2.00
8205	10 for \$1.00



### Callers only - (No mail orders)

Ex-IBM "QWERTY" keyboards - removed from printers but still in excellent condition - has lots of uses -  
**Only \$5.00 each to clear**

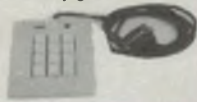




### 12 Key Keypads (NCR)

Another scoop purchase by us. Type used in banks to enter PIN numbers. complete with indicator LED, DB15 "D" cable and plastic stick-on keypad labels for function keys (F1-F20). Were going for only \$9.95, but now out they go:

**ONLY \$7.00 each**



### NOW LOOK AT THIS!!

ONLY FROM US - Interface boards, 2 wire for 'Telecom' commander T210 (value \$250 approx.) All new in sealed cartons. Each Board has 10 x 12 VDC mini relays, 10 useful I.C.'s, two 40 way female transition connectors, 6 transformers and lots of caps, resistors etc.

**ONLY \$19.95 the lot**



### ANOTHER SCOOP PURCHASE!!!

8 digit 5v Dotmatrix (8 X 5) alphanumeric display (with data sheet) Dimensions: 60 X 33mm (overall). 1/3 normal price!!

**ONLY \$5.75 EACH**



### Axial fans at 'blowaway' prices

- A 80 x 80 x 30 (4 1/2" x 4 1/2" x 1 1/2") 230VAC 22/21w **\$18.00**
- B 80 x 80 x 30 (3" x 3" x 1 1/8") 230VAC 0.06A **\$15.00**
- (imped. protected)
- C (Ex-Equipt) 3" x 3" x 1 1/8" AC-115VAC **\$2.95**
- D (Ex-Equipt) 7" x 7" x 4 1/2" 230VAC 50-60Hz **\$20.00**



### Price crash on Suhner subminiature 50Ω

#### RF and microwave connectors 4 GHz connectors

- 11SMB 50-2-4c/111 snap-on cable receptacle **\$2.50**
- 16SMB 50-2-4c/111 snap-on angle cable plug **\$3.00**
- 24SMB 50-2-4c/111 snap-on cable entry bulkhead jack **\$2.50**
- 27SMB 50-0-1/111 snap-on angle bulkhead receptacle **\$3.00**
- 82SMB 50-0-1/111 snap-on receptacle for P.C.'s **\$2.25**

#### 18GHz connector

- 25 SMA-2-15/111 screw on square flange receptacle **\$2.75**

#### 10 GHz connector

- 83 SMC-0-2-2/111 cable receptacle for P.C.'s **\$2.50**



### Toroidal Transformers

Type: 350-208k Pri: 240VAC Sec: 12V&15V 2-3Amp 50VA **only \$19.95**

Type: 351-307-2 Pri: 240VAC Sec: 15V 2-3Amp 50VA **only \$15.00**

### Price massacre on mini-switches

2/3rds off normal cost

- STMIA DPDT centre off lock spring return, solder spill 10 for \$7.00
- 7201 DPDT ON/ON, flatted toggle, solder spill 10 for \$9.95
- 7101 SPDT ON/ON flatted toggle, solder spill 10 for \$8.85
- 7101 SPDT ON/ON rocker, rt angle mounting PCB 10 for \$8.50
- 8012 DPDT ON/OFF/ON rocker, rt angle mounting PCB 10 for \$7.00
- 7201 DPDT ON/ON large toggle type solder spill 10 for \$9.95
- PW 2013 SPDT ON/OFF/ON bezel MTD lever handle s/s solder spill 10 for \$6.00
- PW 2022 DPDT ON/OFF, Bezel mounted lever handles/s 10 for \$6.50

### SPECIAL! SPECIAL!

#### Plug-in power pack to Telecom specifications.

Model No: PS-T105-HFTS  
Input: 240V 50Hz  
Output: 33VDC 130mA(NOM)  
Complete with lead and terminating to 2.1mm plug

**ONLY \$3.95 each**



### LAST OPPORTUNITY TO BUY AT 'ROCK-BOTTOM' PRICES COMPUTER GRADE ELECTRO'S

CAPACITY	VOLTS	MAKE	DIA	HT	PRICE
470	180	NICHICON	30	40	\$3.00
8,700	40	SPRAGUE	35	110	\$4.00
10,000	40	SPRAGUE	50	90	\$4.50
14,000	25	SPRAGUE	50	85	\$4.00
14,000	40	SPRAGUE	50	110	\$6.00
20,000	25	SANGAMO	45	110	\$6.00
22,000	10	PHILIPS	35	117	\$4.00
22,000	25	SIEMANS	50	85	\$5.00
30,000	25	SANGAMO	65	85	\$6.00
33,000	16	PHILIPS	50	120	\$7.00
39,000	16	PHILIPS	50	120	\$7.00
39,000	30	SPRAGUE	50	145	\$7.50
43,000	25	MALLORY	75	150	\$7.00
47,000	10	PHILIPS	50	120	\$5.50
47,000	25	PHILIPS	65	120	\$6.50
88,000	10	SPRAGUE	50	145	\$6.50
100,000	10	PHILIPS	65	110	\$7.50
100,000	16	SEIMANS	65	110	\$8.00
150,000	6.3	PHILIPS	65	113	\$6.00
200,000	3	SANGAMO	65	135	\$5.50

Mtg clips and hardware to suit 50¢ each

### "Matsumi" 3 1/2 Single Sided Disk Drive.

Model D351, double Density, 360K. Size: L: 155mm, W: 100mm, D: 30mm. We were selling these for \$60.00.

**Now reduced to \$30.00**



### Telephone Mike Inserts

A 'Scoop' Purchase  
Purchase for our customers or can be used as a mini speaker.  
**ONLY \$1.50 each**



\$19.95

### STK NO Z152 PHILIPS Mains Filters

The BEST there is.  
Model No: 9390 253 30142. 250VAC 2.4AMP. Dim: 80 x 63 x 45 mm

Reduced from \$15  
**Now only \$12**  
Only a few left



### 'Scoop-purchase'

Motorsised paper tape assembly with powerful 30 VDC motor (works beautifully on 12 VDC) Ideal for the model maker - This must have cost 100's of \$'s - belt driven and has lots of gears, spindles and activator & ball races.

**Only \$19.95 each**  
new not ex-equip  
Only limited quantities



### 12VDC Powerful Solenoids

Made by HARTING. Has 7mm Thrust. Dia: 50mm. Ht. 60mm

**ONLY \$5.00 EACH**

WORTH TREBLE!!



### Scoop Purchase

Powerful 12VDC motor with take-up drive and geared to off-set common spindle - bags of torque beautifully engineered.

**A bargain at \$12.50 each**

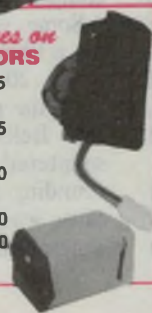
**Only Limited quantities**

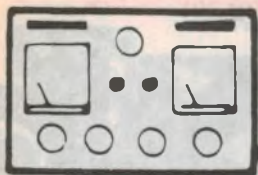
- all new not ex-equipment



### The very best prices on I.E.C. CONNECTORS

- A 3pin chassis socket **\$1.95**
- B 3pin chassis plug with 2amp filter and fuse-holder **\$8.75**
- C 3pin chassis plug with switch and fuse-holder **\$4.50**
- D 2m lead with 3pin socket and 2pin plug **\$2.00**
- E 3pin chassis plug **\$1.50**





# The Serviceman



## Flashes of horror, and a customer I was happy to lose – finally

This month I have two stories for you, the first where I was lucky not to have to give the customer bad news about his set. In the other, I was unlucky enough to have a customer who was the bad news. In both cases I came out on top, though not without some trouble and tribulation.

The first job gave me the fright of my life – and the cause of my fright nearly cost my customer his 26" picture tube.

Destroying a picture tube is usually considered as a mechanical problem. If you hit the faceplate with a hammer, or lean too heavily on the neck, you can expect the tube to have a very short life.

On the other hand, destruction by electrical means is not so easy to imagine. Putting 200V across the 6.3V heater is about the only method that comes quickly to mind.

There is another means, though, and it can be dramatic and spectacular. The subject of this story was fortunately neither of these, yet it was just a whisker away from one or the other.

The set was a Philips KH654, fitted with a K9 chassis. It came in last week, when the owner noticed a bright flash from the vicinity of the on/off switch. He didn't try it again, but brought the set straight to me.

I tried the switch, but couldn't duplicate his experience. So I lowered the convergence panel to get a good look at the works as I turned the set on and off. As contact was made there was indeed a bright flash from the contacts and I lost no time in removing the switch for a closer examination.

In fact, I found very little to explain the cause of the flashing. The switch action worked cleanly and made good contact when it was closed. The only difference between this switch and the new one which I eventually fitted was that the moving contacts on the old switch were deeply grooved, where repeated sparking had burned away the metal.

With a new switch in place, I felt confident to leave the power on for long enough to check the rest of the set and its operation. This showed up what I

might have noticed earlier if I had not been so preoccupied with the switch – the set was hiccupping.

In a Philips, this often means a faulty tripler; and so it was in this case. Disconnecting the lead between the output transformer overwind and the tripler brought up the sound and all the expected functions, except the picture.

A new switch and tripler, plus my time, made this a moderately expensive repair for my customer. But he was happy enough to have his set back in working order.

So I was surprised, to say the least, when the set was back again within a week. The owner said it had stopped after only two nights, but he hadn't heard what I could hear – a slow tick, tick, tick of a hiccupping power supply.

My first worry was that the new tripler had failed, but that care was soon dispelled when disconnecting the input

*...there was a terrific 'splat' from the ultor cap...*

to the tripler left the set still hiccupping as before.

Next, I checked for a short circuit between the collector of the line output transistor (TS455) and ground. This shows up collector/emitter leakage, which is another fairly common cause of hiccupping.

This test showed only 50 ohms to ground from the collector, so it was out with the old and in with a new one. I checked the various components around the base circuit of the output transistor, as faults here are a common cause of transistor failure.

(As a matter of interest, the transistor fitted here was a BU108, an old fashioned 500V line transistor once common

in monochrome TV. This shouldn't have lasted a day in this set, yet it had been there for years and only now had given up the ghost. I might have saved myself a lot of trouble if I had checked in the manual for the correct replacement. Instead, I fitted a BU326, a more modern and gutsy 900V version of the BU108.)

There was nothing obviously wrong around the drive circuits, so I switched on and got no more than a one second burst of sound before the set shut down and began hiccupping, just as before.

My multimeter showed that the new transistor was now also leaky. Not quite shorted, but quite unserviceable nonetheless. The failure in short order of no less than two line output transistors had to be explained.

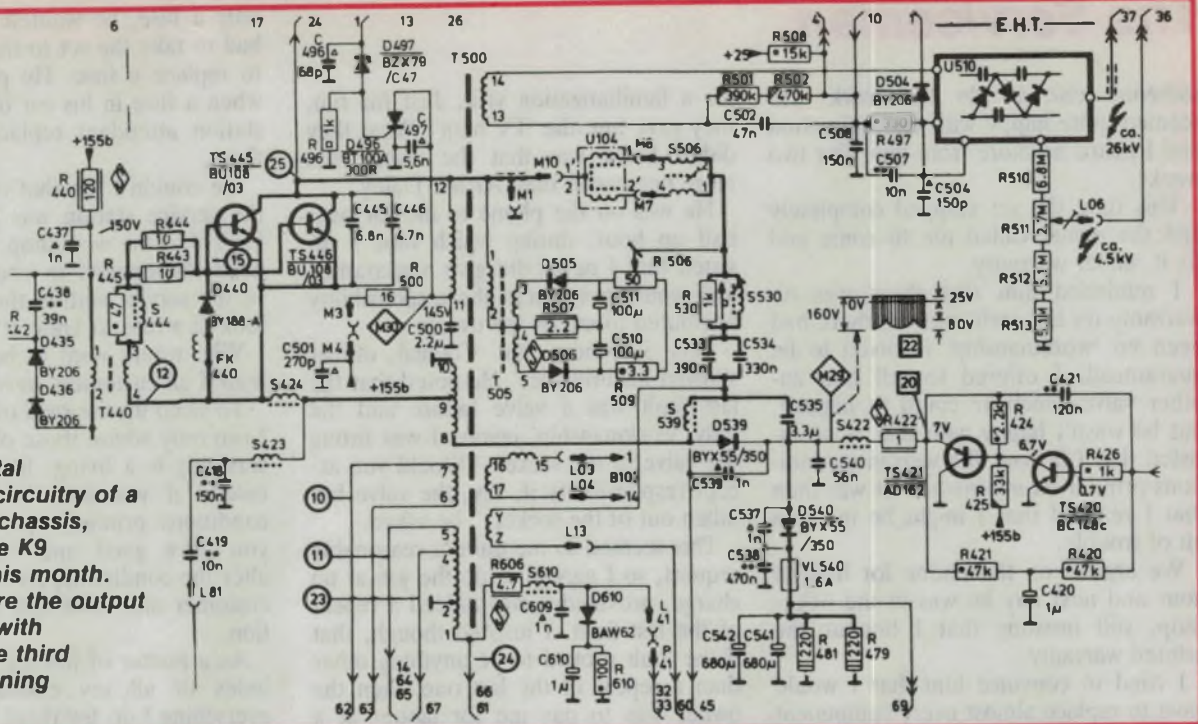
But try as I might, I could find no likely culprits around the output stage. There were no shorted diodes or leaky caps that I could find, so I was forced to the conclusion that it had to be sheer bad luck that I had got a bad BU326. But as luck would have it, that was the last one in my stock.

At this stage I was faced with the need to find a replacement for the BU326, so I did what I should have done first up – go to the service manual. Here I found the correct replacement was a 2SD350. I had a number of these on hand, so it took no time at all to fit one and switch on to check everything out.

Except that this time, as the power supply started up, there was a terrific 'splat' from the ultor cap on the tube and a brilliant flashing display from the spark gaps around the tube base board. It took me only half a second to realise what was going on and exactly which component was faulty.

Some years ago a colleague showed me a Philips K9 with a neat round hole, about 20cm in diameter, punched up from the particle board top of the cabinet. Below this was the charred and splintered remains of the yoke, surrounding the shattered tube neck. The cause was a fault which had allowed the generation of extremely high EHT, far

**The horizontal output/EHT circuitry of a Philips K9A chassis, similar to the K9 discussed this month. TS445/446 are the output transistors, with C445/446 the third harmonic tuning capacitors.**



in excess of the normal 26kV. It was estimated that in this set the EHT must have gone up to 80 – 100kV, in order to blast the top out of the cabinet.

This was an extreme example of a fault that is fairly well documented, if not all that common. What happens is that the third harmonic tuning capacitor (C446), across the line output transistor, loses capacity and the 1200V pulse normally present on the collector of the transistor increases dramatically.

Of course, this is reflected in an increase in the 8kV input to the tripler, which then outputs a much higher than normal EHT.

Personally I have only ever seen the fault where a small loss of capacity in the capacitor results in an EHT of 30 – 40kV. This causes a very 'stiff' beam, due to the much higher acceleration of electrons, and normal deflection currents can only scan a small picture.

Further loss of capacity can result in EHT of 50 – 60kV, and this can puncture the picture tube, usually underneath the yoke on the top surface of the neck.

When I got the capacitor out of this set I measured it at 370pF, quite a long way short of the required 11nF. It would be interesting to know how high the EHT had gone, but there was no way I was going to restore the set to measure it.

The faulty capacitor also explains why the BU326 transistor lasted no time at all, earlier in this exercise. At only 900V it would have been overstressed

by the 1200V pulse in a normal set. In this case, even the 1.5kV 2SD350 might have failed soon, if I hadn't switched off in a hurry. But nothing explains why the original BU108 lasted so long in normal service!

I don't know how one could normally combat this kind of trouble. Only when there's a *small* loss of capacitance is there any clear symptom – a notably smaller picture. At higher levels of loss there is absolutely no sign of a faulty component, and it's not until you have a hole in the tube that you know you have a problem.

Then again, if the loss of capacity was progressive, the owner would surely complain about the smaller picture, before the loss becomes great enough to damage the tube. I imagine that the breakdown inside the capacitor is usually sudden, giving us no chance to salvage the situation before disaster strikes.

In this case I was lucky that dust under the ultor cap and around the tube base spark gaps allowed the discharge of excess EHT without damage to the tube. I can't think what I'd have said to the owner if it had been otherwise.

### The HMV revisited

The second customer this month is not new to these pages. Those readers who have been following the saga of the old valve-era HMV television in this column will be sorry to hear that the story is now finished.

You might remember that the tale

opened when I fitted a regunned picture tube, then continued with EHT rectifier trouble. In between times there were several small, unreported, not particularly noteworthy faults, all of which were repaired without fuss.

Every time the owner called me, I repeated the argument that the set was too old and not worth fixing, and every time the owner insisted in going on with the job. Each time I returned the set, I told him that I was giving no guarantee about its reliability and that only the workmanship in the present repair was warranted.

(Those of you who know the difference between a car and a television set might get a giggle from his comparisons. He told me he has an old car – a 1972 model Toyota or something – and he can always get it fixed at the garage. When I pointed out that his TV was thirteen years OLDER than his car, he couldn't see the point and reiterated that if a motor mechanic could fix an old car, I should be able to fix an old TV!)

The owner accepted the warranty restriction and fortunately, each breakdown came at intervals of a few months or so, and the question of warranty never came up – until this time.

A few weeks ago the set suffered a minor hiccup – another valve had failed. It was replaced with a new valve, of which I still have a stock, and the owner was advised that this was to be the very last time I would service his set. In future, he would have to find

# The Serviceman

someone else to do the work. He seemed quite happy with this ultimatum and I heard no more from him. For two weeks.

This time the set stopped completely and the owner called me to come and fix it, under warranty.

I reminded him that there was no warranty on the earlier job as there had been no 'workmanship' involved to be guaranteed. I offered to sell him another valve which he could fit himself, but he wasn't happy with that — he insisted that I honour the warranty conditions printed on my invoice. It was then that I realised that I might be in for a bit of trouble.

We argued on the phone for half an hour and next day he was in the workshop, still insisting that I honour the printed warranty.

I tried to convince him that I would have to replace almost every component if the set before I could give a guarantee on it — that's why I had insisted each time that there was no guarantee. Not surprisingly, he couldn't remember me ever saying that the printed warranty was cancelled.

I eventually got him out of my workshop, and over the next week or so managed to forget the whole incident. But then I got a letter from the Consumer Protection Council, asking me why I was not prepared to honour the warranty printed on my invoice.

I wrote out a two page report on the matter, and enclosed a copy of the original story from this magazine. The following day I had a call from the Council, with the next best thing to an apology for having to trouble me. The Council officer explained that they were obliged to follow up complaints, even when they found that the complaints were unjustified.

The officer said that they'd had several sessions with the owner and had found it just as difficult to explain to him the facts of life as I had done. I was told the file was closed, as far as the Council was concerned, but they felt that the owner might press on with other processes.

And press on he did! Not through the courts, as the Council had expected, but through the Council itself. It seems that he was back every second day, each time buttonholing a different Council officer, monotonously trying to get them to make me honour the warranty.

A few weeks later the Council had one of its officers from another city, in

for a familiarization visit. Just for fun, they gave him the 'TV man'. What they didn't know was that the visitor was more persuasive than Arthur Daley.

He was on the phone to me for over half an hour, during which time I insisted that I never did give a guarantee and would not accept the responsibility attributed to me by the owner.

This is where the Council officer showed his brilliance. He noted that the last fault was a valve failure and the only 'workmanship' involved was fitting the valve to the socket. "Would you accept responsibility if, say, the valve has fallen out of the socket?" he asked.

This seemed to me quite a reasonable request, so I agreed to do the job at no charge, provided it was indeed a repeat of the last fault. I insisted though, that if the fault proved to be anything other than a repeat of the last one, then the owner was to pay me for labour at a concession rate, plus any parts used. (I had offered the concession on my labour as a goodwill gesture, and the point was not lost on the Council officer.)

In either event, the owner was to pay my service fee, or he could get a taxi-truck to bring the job over to my workshop. Needless to say he chose to pay my fee.

And finally, the owner was to agree not to ask me to repair this particular set ever again. This was to be definitely the last time.

The Council officer suggested that I write down the conditions we had agreed upon, and get the owner to sign a copy of it before I did any work. The owner was agreeable enough at the Council office, but he might decide to change his mind later. Hence the suggestion about the signed statement.

I collected the set and soon found that there really was no connection with the original fault. This time the set was quite dead, although all the valve heaters were alight.

My calibrated screwdriver told me that there was no voltage on the anode cap of the line output valve. This could have meant a faulty damper diode, but I took a gamble that it was the HT fuse in the power supply.

I wasn't wrong, and a new 500mA slow-blow fuse had the set back to first class working order. I elected not to charge the customer anything, other than the service fee. I was just relieved to get rid of the job once and for all.

When I told the owner that it was

only a fuse, he wanted to know why I had to take the set to the workshop just to replace a fuse. He pointed out that when a fuse in his car blew, the service station attendant replaced it then and there.


He couldn't see that taking his car to the service station was just like taking his TV to the workshop. And why did I need instruments to check a TV fuse? In the service station they only have to look at a fuse to know it's blown.

Who would want to be a TV serviceman if all customers were like that?

To wrap up the saga of the old HMV, I can only advise those of you for whom servicing is a living, like myself, to be careful if you ever have to vary the conditions printed on your invoice. If you have good and valid reasons to alter the conditions, do it in front of the customer and have him sign the alteration.

As a matter of interest, I keep a card index of all my customers, detailing everything I do for them. It's invaluable in cases like this one, where a detailed record can rebut the customer's half-remembered facts. You know the situation, where the customer says it was only three months ago, but the card shows that it was early last year! I commend the idea to all who have dealings with the public.

Oh — by the way! It's nice to know that the Consumer Protection Council is not all fire and brimstone. If you are fair with your customers, the Council will bend over backwards to be fair to you.

Bye for now. See you again next month? 

## Fault of the month

### Philips K9

**SYMPTOM:** Bad East-West pincushion distortion, with very little adjustment available. Set goes into hiccapping mode if width is made wider, but works normally if adjusted for narrower pix. TS421 runs abnormally hot.

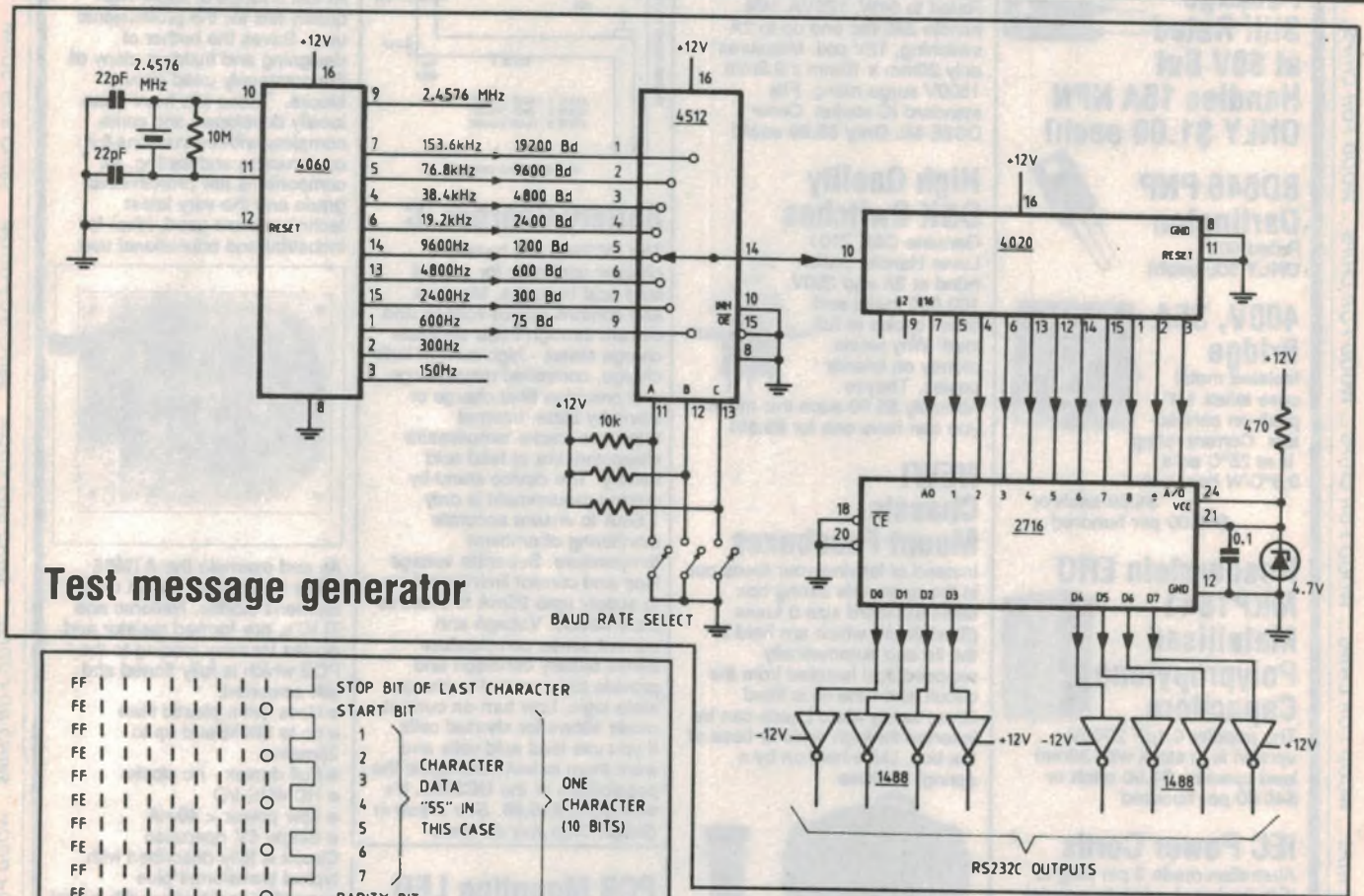
**CURE:** D540 (BYX55/350) leaky. R422 (1 ohm fusible) should open to protect TS421, but may not open soon enough to protect the transistor from damage. Check TS421 for leakage after replacing the diode.

*This information is supplied by courtesy of the Tasmanian Branch of The Electronic Technicians' Institute of Australia (TETIA). Contributions should be sent to J. Lawler, 16 Adina Street, Geilston Bay, Tasmania 7015.*

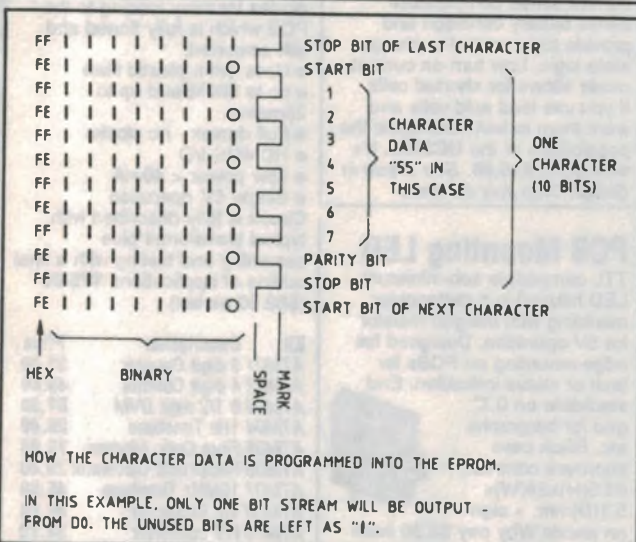


# Circuit & Design Ideas

Interesting circuit ideas from readers and technical literature. While this material has been checked as far as possible for feasibility, the circuits have not been built and tested by us. As a consequence, we cannot accept responsibility, enter into correspondence or provide constructional details.



**Test message generator**



When working with data communications equipment and networks it is sometimes useful to have a source of data to check if a terminal or printer is responding, or to track down transmission faults in a network. If the data source has switchable baud rates and parity it can also be used to determine the operating parameters of other equipment.

This test message generator could be constructed as a stand-alone instrument or incorporated into some other test instrument such as a deluxe 'breakout-box'.

The 4060 is a 14-stage binary ripple-

counter which incorporates a crystal oscillator. The 2.4576MHz crystal is an easily obtainable 'baud-rate' crystal. The outputs of the 4060 are 16 times the final baud rate. One of these outputs is selected by the 4512 and fed to the clock input of the 4020, which is another ripple counter whose outputs sequentially address a 2716 EPROM.

Now for the tricky bit. Each address in the 2716 represents one BIT of each of the eight messages. Suppose we only want one message and it is to output from D0; we would program the EPROM with FE for a '0' and FF for a '1'. If we assume 10 bits per character

(start bit, 7 data bits, parity bit, stop bit) this gives us a maximum message length of 204 characters (the 2716 has 2048 locations) - see Fig.2.

In fact, it would be wasteful to have only Bit 0 programmed, because the EPROM could be generating eight different messages simultaneously! This may not seem very useful but a good idea would be to program say four messages, each with different treatment of the parity bit (always 0, always 1, even parity, odd parity).

Programming the EPROM is the big problem. You could do it the hard way by generating a listing on graph paper by marking the 1's and 0's for each location, translating the binary to hex and keying it into a computer, but this could get a bit tedious! Better to whip up a 'Mickey Mouse' program on your computer to do it all.

Using the 4512 to select baud rates is only one way to do it. You could use a rotary switch if you like.

Henry Choke,  
Ringwood, Vic.

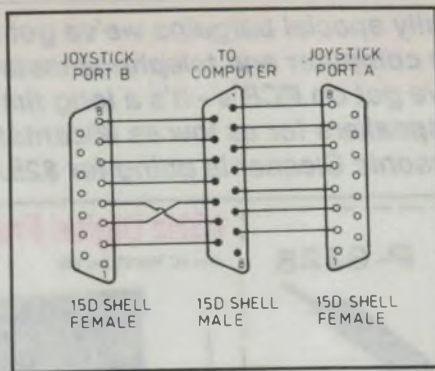
**\$40**

## Low cost joystick for IBM compatibles

Joysticks for the IBM and compatible computers are expensive to say the least. For a 'cheap' free-floating one you'll pay around \$40. A self-centring joystick will set you back about \$45. And if you really want to go deluxe and have a joystick which is both, be prepared to fork up around \$50.

To make your own joystick you will need only a joystick pot with 100k linear pots (self centre or free float); a 15D shell connector (male); a box; two momentary pushbuttons; and some cable.

To assemble your joystick, solder a



wire from pin 1 of the connector to an outside pin of each pot on the joystick pot. Next solder a wire from pin three to the centre pin on the X co-ordinate pot. Then solder a wire from pin 6 to

the centre pin of the Y co-ordinate pot.

Connecting the buttons is next. Solder wires from pins 2 and 4 to button number 1, and pins 5 and 7 to button number 2.

The joystick can now be mounted in a box and is then ready for use. If the joystick is dis-orientated, change the wire soldered between pin 1 and the pot which needs changing to the other outside pin the particular pot.

If all is well, the joystick should work the same as any commercial unit costing much more. The joystick will operate with a Y adaptor, so you will be able to have two joysticks operating at once.

Brett Wood,  
Bellbird Park, Qld

**\$25**

## Neater wire joints

Sometimes it becomes necessary to extend a wire, or make a joint, in 'mid-air' and in-line. Here is a very neat method.

Use some brass sheet as thin, or thinner, than the wall thickness of the insulation on the wire you wish to join. Rub with steel wool, to make it very clean and bright. Cut a narrow strip - about two wire diameters in width and say about two centimetres long.

Select a suitable mandrel (a small nail, a pin, sewing needle, etc.) with a

diameter a little bigger than the wire. Wind the strip on the mandrel, using fine pliers, to form an open helical sleeve - see illustration (a little practice will help you find the appropriate angle at which to start winding). Square off



and smooth the ends by filing.

Slide onto one of the wires a piece of fairly neat-fitting plastic tubing about

twice as long as the jointing sleeve. Bare back the ends of the two wires, each a little less than half the length of the sleeve, and tin the ends very lightly. Insert the wire ends into the sleeve, support them so that they stay put, and tin the whole sleeved joint - use very little solder, and work very quickly to avoid swelling the wire insulation. When cool, slide the plastic tube over the joint to cover it fully.

H C Harrison,  
Brighton, Vic

**\$25**

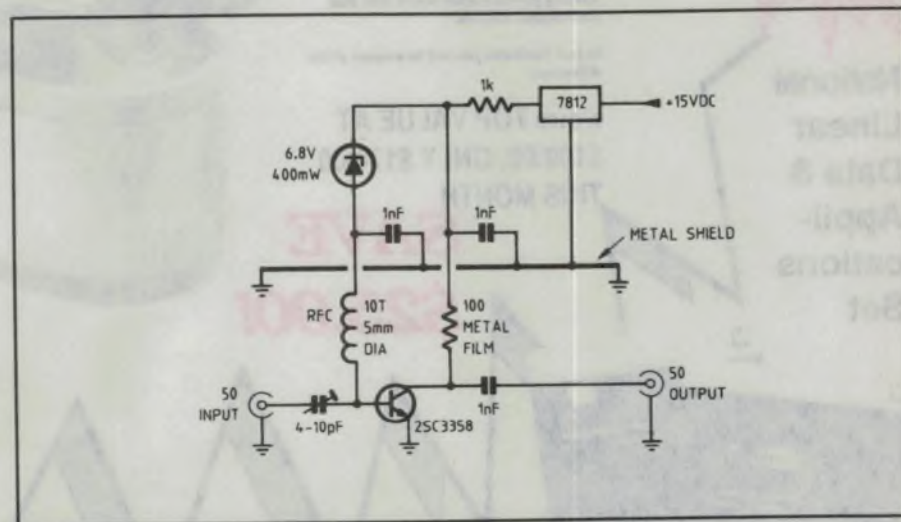
## UHF low noise preamp

This circuit is suitable for the 420-450MHz amateur band and UHF television use. It provides a gain of approx 15dB and a very low noise figure of 1-1.5dB. This excellent noise figure is due to the use of a 2SC3358 transistor, which has a noise figure of 1dB at 500MHz and an Ft of 7GHz!

The 2SC3358 is biased by a 6.8 volt zener diode, 7812 voltage regulator, 100 ohm and 1k resistors. Although this arrangement may seem strange, it gives a stable bias of 5mA flowing through the collector of the transistor for optimum noise figure.

The base of the transistor is fed via an RF choke consisting of 10 turns of wire around a 5mm former. These dimensions are not critical, nor is the wire diameter. The 100 ohm resistor should preferably be metal film, for better performance at high frequency.

A 4-10pF trimmer is used to adjust the amplifier for lowest noise figure. If no equipment for doing this is available, substitute a 6.8pF ceramic, which will give almost as good performance over the 400-700MHz range. The output



needs no tuning and consists solely of a 1nF capacitor to block DC. Other 1nF ceramics are used throughout the circuit as RF bypasses.

The preamplifier should be constructed on unetched PCB to act as a ground plane. A metal shield around 2cm high along the length of the board

should be used to separate bias and RF components. The RF choke, 100 ohm resistor, 2SC3358 and capacitors should be on one side of the shield and other components on the other, as shown on the circuit diagram.

Jeffrey Harrison,  
Mt. Waverley, Vic.

**\$35**



Look at the really special bargains we've got this month - the wire specials alone will save computer and telephone installers a fortune. And look at the great deal we've got on PCB's - it's a long time since they were this price. Then there're speakers for as low as 99cents! You've waited for it - the fabulous Ultrasonic Cleaner is going for \$25.00 less this month only.

**STOP PRESS!** P-8328

**IEC MAINS LINE PLUG.**  
\$9.95 EACH  
10 UP \$9.50 EACH



**1GHz Digital Frequency Meter**

(See SC Nov '87 Jan '88)



**SAVE \$30.00**

**Specifications**  
Operational Modes: Period Freq. to 100MHz Freq. to 1GHz Freq.  
Range: 100Hz-1GHz (1.7GHz typ.) in frequency mode; 10Hz-  
2.5MHz (5MHz typ.) in period mode.  
Gating times: 0.01, 0.1 and 10 seconds (10MHz & 100MHz  
range); 0.128, 1.28, 12.8 & 128 sec. (1GHz range).  
**K 2515 was \$299.00 NOW \$269.00**

P-0522  
**PLUG SCART 21 PIN EUROPEAN STANDARD VIDEO INPUT PLUG.**  
\$3.95 EA.  
10 UP \$3.60 EA.

**● NEXT DAY JETSERVICE DELIVERY**  
Country clients please allow an additional 48-72 hrs

Will even clean your teeth!  
Earns its cost hundreds of times over in cleaning connectors, PCB's, switches, jewellery, glasses, watches, drafting pens, etc.  
Awarded the Good Product Design Award for CETDC in 1987

Won't scratch or damage - uses ordinary tap water and creates millions of super-penetrating bubbles. Hospital tests show that Ultrasonic cleaning produces better results safer than conventional methods.

In just 3 minutes you will be amazed at the difference!

A 0100 TOP VALUE AT \$199.00, ONLY \$174.00 THIS MONTH

**SAVE \$25.00!**

**Pin Point ULTRASONIC CLEANER**



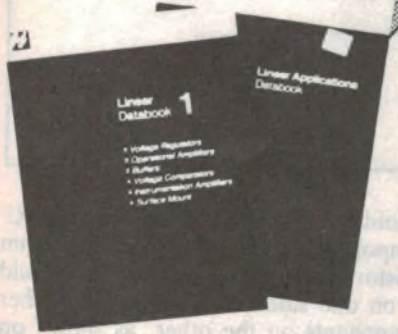
**TOLL FREE 008 999 007**



**BANKCARD**



**National Linear Data & Applications Set**



You get Vols. 1, 2, & 3 and the, EXTREMELY DIFFICULT TO OBTAIN, latest printing of National semiconductor Linear Applications. (Please note that the Linear Applications can't be sold separately)  
**4 books normally \$24.00 each - \$96.00 Value for only \$79.95 the set of 4.**

**Fantastic!**  
**6 1/2" Polypropylene 30 Watt RMS 50W Max.**

(See Electronics Australia's amazing new sub-woofer project Aug/Sep '89)  
8 Ohm Impedance  
Frequency response 0 - 3000Hz  
Resonant Frequency 36Hz (+/-5Hz)  
Sensitivity 1M/1 Watt 87db (+/-2db)  
Voice Coil 25mm

C 3055 **\$29.95 Top Value**



PHONEORDER TOLL FREE ALTRONICS 008 999 007

PHONEORDER TOLL FREE ALTRONICS 008 999 007



# RACK CASES

## FEATURES:

*Put your projects on display in a really professional setting*

- Beautifully crafted to give your equipment a really first class appearance.
- Aluminium construction with removable top and bottom steel cover panels.
- All dimensions conform to the International Standard
- Subtle Grey or Handsome Black finish.
- Ventilated lid
- Deluxe finish front panel
- Individually cartoned
- Supplied in flat pack form - easily assembled in minutes

Dimensions: A = Front depth, B = Mounting bolt centres, C = Internal chassis depth, D = 254mm in all cases.

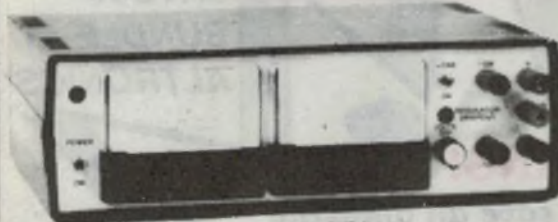
Cat. No.	Finish	A	B	C	NORMALLY	THIS MONTH	SAVE
H 0401	GREY	44	34	38	\$59.95	\$55.00	\$4.95
H 0402	GREY	88	57	82	\$69.95	\$65.00	\$4.95
H 0403	GRBY	132	89	126	\$85.00	\$80.00	\$5.00
H 0411	BLACK	44	34	38	\$59.95	\$55.00	\$4.95
H 0412	BLACK	88	57	82	\$79.95	\$75.00	\$4.95
H 0413	BLACK	132	89	126	\$89.95	\$85.00	\$4.95



## BLANK RACK PANELS EXCELLENT VALUE

GREY FINISH			BLACK FINISH		
	NORMALLY	THIS MONTH		NORMALLY	THIS MONTH
H 0421 44mm	\$11.95	\$10.99	H 0426 44mm	\$11.95	\$10.95
H 0422 88mm	\$14.95	\$13.50	H 0427 88mm	\$21.95	\$19.95
H 0423 132mm	\$18.95	\$17.50	H 0428 132mm	\$29.95	\$27.50

## LABORATORY POWER SUPPLY



3 - 50 Volts at up to 5 Amps ( Ea May '85)

- Specs: 1 Output Voltage - 3.50 Volts
- Output Current up to 5 Amps (max. 175W)
- Floating outputs isolated from ground
- Ripple less than 90mV p-p at max.
- Employs Dual Meters - no switching from one to the other.

K 3300 **\$195.00 TOP VALUE**

### OPTIONS

10 Turn Output Voltage Control  
(K 3300 is normally supplied with standard pot.)

K 3301 **\$29.50**

Auxiliary + AND - 12V Output Terminals  
Fixed outputs independent of variable main output

K 3302 **\$14.50**

**KIT BUILDERS AND ENTHUSIASTS**

## MEGGER METER



See EA April/May 89  
Checks electrical wiring and appliances for insulation breakdown  
Insulation breakdown can be determined by the use of this dual range megohm meter.  
Ideally suited for checking breakdown in electrical wiring, appliances transformers, automotive generators and alternators etc.  
Breakdown can be measured at either 500V or 1000V depending on the required situation.  
*Would suit electricians or technicians work van, tool box or work bench.*

**REAL VALUE \$79.00**  
K 2555

## 50 MHz DIGITAL FREQUENCY METER (EA May '88)

Fit this into your toolbox for only **\$99.00!**

50MHz in 5 ranges  
Features high input impedance, overflow LED indicator, kHz and MHz LED indicators.

**K 2510 \$99.00**



## SCOOP PURCHASE!

### ON BLANK PCB MATERIAL

Calling all PCB Makers

We have just purchased a truckload of blank phenolic PCB board, both single-sided and double-sided.

Typical sizes are 150mm x 400mm to 200mm x 500mm

### ALL BRAND NEW STOCK

Single-sided PCB	1-9	10up
Size 1 310x185mm	\$2.00	\$1.70
Size 2 405x170mm	\$2.00	\$1.70
Size 3 505x90mm	\$1.70	\$1.50

Double-sided PCB	1-9	10up
Size 505x205mm	\$3.50	\$3.00

## BE QUICK....



**LED Light**  
**The House Number**  
Identify Your House - Build The LED Light.

(See Silicon Chip Oct'88)

The LED light makes your house easily recognisable at night by illuminating your house number. Great for people visiting, easy for taxis and emergency services to locate you at night. Any number can be configured including Alpha-numeric combinations. Automatic operation works only at night. Automatic switch off approx. 4.5 hrs. 64 LEDs supplied.

K 1960

**\$25.00**

## INVERTERS INVERTERS INVERTERS INVERTERS INVERTERS

Get 240V AC Mains Power from your battery with these handy inverter kit sets  
Many combinations to choose from:

### POWERHOUSE 600W INVERTER

(See BA Dec'87)

This inverter has the capacity to produce 600 watts of mains power which will run a fantastic array of appliances. Ideally suited to running power tools, lighting (including fluores) electric motors and much more. It can be used either as a portable or a permanent fixture.

- Manual or Auto Start facilities
- Low battery cut-out.

Kit version K 6770 **\$425.00**

Fully built and tested

12V Input K 6774 **\$525.00**

24V Input K 6775 **\$525.00**



**100'S OF USES AT HOME AND AWAY**

### 300 WATT INVERTER

#### WITH AUTO START

Operates from 12V Car Battery  
1 Auto Start draws power from your battery only when appliance is plugged in and "turned on" i.e. battery can be left permanently connected if required. ● Voltage Regulated ● Current Regulated  
Current Overload unit self limits

Complete Kit

K 6750 **\$279.00**

Fully built

and tested

K 6755 **\$379.00**

PHONEORDER TOLL FREE ALTRONICS 008 999 007

PHONEORDER TOLL FREE ALTRONICS 008 999 007

**TOP TRANSFORMER BARGAINS! - THE POWER BE WITH YOU**



**Multipurpose 120VA**

This transformer is wound on expensive, grain oriented steel to make it super-efficient! And look at the size! Just 110mm x 65mm x 65mm High, wieght 1.25kgs  
 Primary: 240V  
 Secondary: 12V - 10A, 15V - 8A, 24V - 5A, 27V - 4.4A, 30V - 4A

**M 2175 Normally \$39.95, This month 1-9 \$30.00ea**

**10 up \$25.00each.**

**SAVE UP TO \$14.95 EACH**

**Mini Speaker Price Sensation!**



**Mini 57mm (2.25") 200 mW 8 Ohm**  
 with LARGE ferrite magnet from an incredibly low 99cents!  
**C 0610 Normally \$2.30 ea but look at this!**  
**1-9 only \$1.25 ea**  
**10 up 99 cents ea**

**Save over 40%**

**Multipurpose 60VA Very Versatile**

Output - Two tapped secondaries give: 240V to 3,6,9,12,15,18,21&24Volts at 60VA (60W)  
 Use of high grade silicon steel has enabled surprisingly compact dimensions of 70mm x 70mm x 58mm high.

**M 2165 Normally \$26.50 each this month only**

**\$22.00**

**SAVE \$4.50 EACH**

**UP TO 50% OFF!**

**SAVE A BUNDLE AT ALTRONICS**

**WIRE BARGAINS!**

**Buy these by the ROLL and save an amazing 50% or more!**

**100% Screened Computer Cable**

W 0705 4 wire usually \$1.40/M NOW \$79.00per 100M  
 W 0710 6 wire usually \$1.80/M NOW \$90.00per 100M  
 W 0715 9 wire usually \$2.30/M NOW \$125.00per 100M

**Telephone Type Cable**

W 0302 4 wire usually 60cents/M NOW \$70.00per 200M  
 W 0303 6 wire usually 80cents/M NOW \$90.00per 200M  
 W 0310 20 wire usually \$2.40cents/M NOW \$295.00per 200M

See our Catalogue for full specifications on all products.

**AC Adaptor Bargain!**

240V to 15V AC to 100mA M 9009  
**Boggins of uses!**  
 Reduced to clear at \$7.00ea or \$6.00 each 5 or more.

**Calling all PA Techs! Telephone Line Isolation Units**

**All Telecom Approved**

Type 1 - Designed to interface paging output of PABX or Commander phone systems to Public Address Amplifier. Connects to Aux. input  
**A 0610 \$99.00**

Type 2 - Provides "Music On Hold" (MOH) to your Commander phone system. Program input can be, radio, tape deck, landline etc.  
 Max. output 800mV P-P.  
**A 0615 \$99.00**

Type 3 - Similar to type 2 (A 0615) except max. output is 2.8V P-P/  
**A 0620 \$99.00**

**ONLY \$99 each**

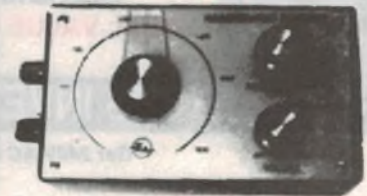
**STROBE SIGNAL LAMPS**

Uses Xenon Strobe tube for High Energy strobe flash at output rate of approx. 1 per second.  
 Amazing light energy output for the small amount of power used -  
 DC input 12V 320mA  
 Dimensions: 97mm Diam. x 90mm High

**Save \$5.00 each this month!**

**S 5455 Blue S 5450 Red Normally \$27.50 this month \$22.50ea**

**BARGAIN! SAVE \$19.00**



**Regenerative Radio (See EA Jan 88)**

Step back in time and build this simple regenerative radio receiver. Using only 3 transistors, its not only fun to build, but uses Varicap tuning

**K 1150**

**\$20.00**

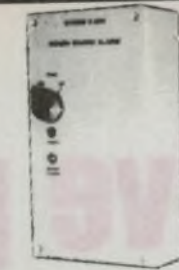
**GUARD YOUR HOME!  
NEW! NEW! NEW!  
HOUSE GUARD ALARM SYSTEM**

Burglaries are on the increase! Doesn't it make sense to protect your home and its contents?

This easy-to-build kit assembles on a single PC and INCLUDES 12V 1.2AH inbuilt lead calcium back-up battery.

- Features include: ● Entry and exit delay ● Panic alarm input  
● Battery back-up ● Line monitoring ● Soft alarm start ● Lamp test/line output  
● Auxiliary relay for external siren etc. ● Key switch operation ● Uses almost any type of sensor.

"Schroecher Siren" 110db SPL S 5170 \$17.95



Small Business people - protect your premises and equipment!

KIT WITHOUT SIREN

K 1910 \$89.00

**MULTI SECTOR  
BURGLAR ALARM**

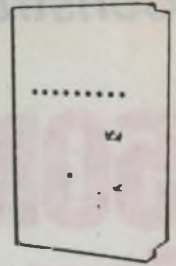
Protect your Home or Business from intruders with this "State of the Art" Burglar Alarm System

Over the last few years, House Break-Ins have increased dramatically. The recovery rate of stolen goods is very low. Now more than ever before, it makes extremely good sense to build and install this ingenious Multi-Sector System. This unique Alarm System incorporates the features of the more expensive commercial models - at a fraction of the price.

Features: (See EA Jan/Feb '85 or our 1989 Catalogue for full features)

Kit (Less Battery Back Up) K 1900 \$149.50

Back Up Battery 12V 1.2AH S 5065 \$29.95



**Passive Infra-Red  
Lite Guard  
Floodlight Control**



How often have you thought there could be a prowler outside your door? Install a Lite Guard & (once armed) any "guest" will be flooded when detected by this highly sensitive Infra-Red Detector.

- Specifications: ● Raintight, outdoor, all weather operation ● Operation Time: Adjustable 1-20 mins ● Sensitivity: Adjustable 20 - 50, 30 beams ● Aimable to desired direction with 2 ball joints ● Switching Capability: 500W max. incandescent ● Operation Modes: OFF, AUTO, TEST, MANUAL ON.

S 5350 Was \$135.00 SPECIAL  
ONLY \$99.00 SAVE \$36.00

**SECURITY**

**Infra Red  
Movement  
Detector**

Pulse Count Type  
Our 1989 model IRD now includes pulse count circuitry with a specific time delay between pulse sensing. Three pulses of IR radiation are required to trigger the detector.  
Features: Lens - wide angle & narrow angle | 12V DC Powered.

S 5301 \$79 (3) for \$180



K-2530  
SAVE  
\$7-50

ONLY \$10.00

FEATURES:  
● Tests both NPN and PNP transistors in circuit at the touch of a switch ● Tests Diodes and SCR's as well ● No need to switch between NPN and PNP - its automatic. Two LED indicators are used to show condition of device being tested.  
Altronics Kit Feature - "ABS" jiffy box and test leads supplied. Cal K 2530

● BANKCARD ● VISA ● MASTERCARD ● PHONE TOLL FREE 008 999 007  
● NEXT DAY JETSERVICE DELIVERY  
Country clients please allow an additional 48-72 hours

**ALTRONICS**

174 Roe St. Perth W A 6000  
PHONE TOLL FREE 008 999 007  
Perth Metro & After Hours (09) 328 1599  
ALL MAIL ORDERS  
P.O. Box 8350 Perth Mail Exchange W A 6000  
ALTRONICS RESELLERS

Chances are there is an Altronics Reseller right near you - check this list or phone us for details of the nearest dealer. **Please Note:** Resellers have to pay the cost of freight and insurance and therefore the prices charged by individual Dealers may vary slightly from this Catalogue - in many cases, however, Dealer prices will still represent a significant cost saving from prices charged by Altronics Competitors.

Don't forget our Express Mail and Phone Order Service - for the cost of a local call, Bankcard, Visa or Mastercard holders can phone order for same day despatch. Blue Ribbon Dealers are highlighted with a ■ These Dealers generally carry a comprehensive range of Altronics products & kits or will order any required item for you.

- WA COUNTRY** ALBANY BP Electronics ■ 412681 **ESPERANCE** Esperance Communications 713344 **GERALDTON** K B Electronics & Marine 212176 **KALGOORLIE** Today's Electronics ■ 212777 **KARRATHA** Daves Oscitronic 854836 **MANDURAH** Lance Rock Retravision 351246 **PORT HEADLAND** Ivan Tomek Electronics 732531 **WYALKATCHEM** D & J Pease 811132 **NT ALICE SPRINGS** Ascum Electronics 521713 **FARMER** Electronics 522967 **ACT CANBERRA** Bennett Commercial Electronics 805359 **SCIENTRONICS** 548334 **VICTORIA CITY** All Electronic Components 6623506 **SOUTH MELBOURNE** Winscott Trading 6995740 **SUBURBAN CHELTENHAM** Talking Electronics 5842386 **CROYDEN** Truscott Electronics ■ 7233860 **PRESTON** Preston Electronics 4840191 **COUNTRY BENDIGO** KC Johnson ■ 411411 **MORWELL** Truscott Electronics 346133 **QUEENSLAND CITY** Delsound P/L 8396155 **SUBURBAN CAPALABA** David Hall Electronics 3902399 **FORTITUDE VALLEY** Economic Electronics 2523762 **WOODRIDGE** David Hall Electronics 8082777 **COUNTRY CAIRNS** Electronic World ■ 518555 **BUNDBERG** Bob Eikins Electronics 721785 **GLADSTONE** Supertronics 724321 **MACKAY** Philtronics ■ 578855 **ROCKHAMPTON** Access Electronics (East St) 221058 **XANTHOS** Electronics 278952 **TOOWOOMBA** Hunts Electronics ■ 329677 **TOWNSVILLE** Solex ■ 722015 **SA CITY** Force Electronic ■ 2125505 **SUBURBAN BRIGHTON** Force Electronics ■ 3770512 **CHRISTIES BEACH** Force Electronics ■ 3823366 **ENFIELD** Force Electronics ■ 3496340 **FINDON** Force Electronics ■ 3471188 **LONSDALE** Force Electronics ■ 3260901 **COUNTRY MT. GAMBIE** South East Electronics 250034 **WHYALLA** Eyre Electronics ■ 454764 **TASMANIA HOBART** George Harvey ■ 342233 **LAUNCESTON** George Harvey ■ 316533 **Nichols Radio** TV 316171 **NSW CITY** David Reid Electronics ■ 2671385 **CARINGHAM** Hicom Unitronics 5247878 **COUNTRY COPPS HARBOUR** Coffs Harbour Electronics 525684 **GOSFORD** Tomorrow's Electronics 247246 **GRAFTON** East Coast Electronic 431250 **NELSON BAY** Nelson Bay Electronics 813685 **NEWCASTLE** Novocastrian Elect Supplies ■ 621358 **NOWRA** Ewing Electronics ■ 218412 **RAYMOND TERRACE** Alback Electronics 873419 **WINDSOR** M & E Electronics 775935 **WOLLONGONG** Newtek Electronics ■ 271620 **VIMCOM** Electronics 284400

Manufacturers, Contractors and Bulk Users  
Please Contact Our Wholesale Sales Dept  
Sydney (NSW Only) Colin Fobister (02) 437 4077  
Melbourne (Vic/Tas Only) Brian Sorensen (03) 811 9967  
Perth (W.A., S.A., QLD., N.T.) (09) 328 2199

**STANDARD DELIVERY & PACKING CHARGE \$4.00 to 1Kg \$7 over 1Kg AUSTRALIA WIDE** - We process your order the day received and despatch via Australia Post. Allow approx 7 days from day you post order to when you receive goods.  
**\$7.00 OVERNIGHT JETSERVICE** - We process your order the day received and despatch via **Overnight JetService Courier** for delivery next day. Country areas please allow additional 24-48 hours. Weight limit 3Kgs (3Kgs covers 95% of Orders).  
**\$10.00 HEAVY HEAVY SERVICE** - All orders of 10Kgs or more must travel Express Road. Please allow 7 days for delivery.  
**INSURANCE** - As with virtually every other Australian supplier, we send goods at consignee risk. Should you require comprehensive insurance cover against loss or damage please add 1% to order value (minimum charge \$1). When phone ordering please request Insurance.  
**TOLL FREE PHONE ORDER** - Bankcard, Visa, Mastercard Holders can phone order toll free up to 6pm Eastern Standard Time. Remember with our **Overnight JetService** we deliver next day.

PHONEORDER TOLL FREE ALTRONICS 008 999 007

PHONEORDER TOLL FREE ALTRONICS 008 999 007

## Construction project:

# 50MHz active probe for oscilloscopes

The loading introduced by a normal passive oscilloscope probe can significantly alter the operation of a circuit under test. This low cost unit will overcome most of these problems.

by DEWALD DE LANGE

Whilst following the operation of an RF circuit, have you ever considered the effect of the probe on your measurements? A probe impedance comparable to that of the circuit will not only give incorrect amplitude levels, but can also change the operating frequency of the circuit. At higher frequencies, the probe input capacitance also has to be considered, in addition to the resistance.

An oscilloscope has a typical input resistance of 1Mohm in parallel with a capacitance of 20 to 30pF. The capacitance of the connecting cable can range from 100pF/m for a standard 50-ohm cable to 33pF/m for a low capacitance 125-ohm cable.

The resistance of 1Mohm is high enough not to load most circuitry. However, to determine the effect of the capacitance, consider a circuit operating at an impedance level of 1000 ohm. Such a source impedance, when loaded by say a 100pF, would limit the useful bandwidth of the oscilloscope (and possibly the circuit!) to 1.6MHz.

### Passive probes

These large capacitance values are reduced in the familiar passive 10X probe by sacrificing signal strength. A simple compensation scheme for such a probe is illustrated in Fig.1. A 9M resistor in the probe head gives a division ratio of 10, with the 1M input of the oscilloscope. The same impedance division is used for the cable capacitance and oscilloscope input capacitance. Because reactance is inversely proportional to capacitance, this gives a smaller 13pF input capacitance for the probe itself. The 15pF trimmer capacitor allows the

probe to be used with a variety of oscilloscope capacitances. This trimmer is adjusted when the probe is calibrated with a low frequency square-wave, to set the capacitance division ratio equal to the resistance ratio and give a 'flat' response.

### Reflections

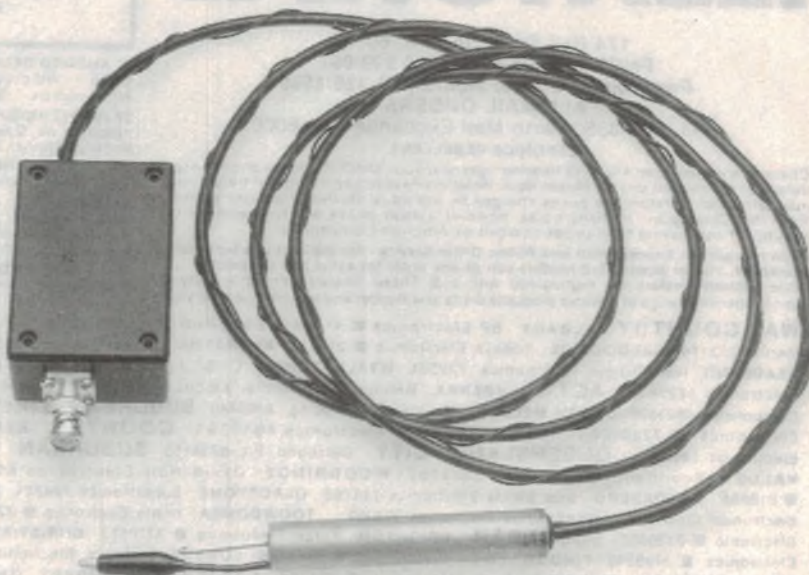
The finite time it takes for a signal to travel through the probe cable creates another problem. If the cable isn't terminated into its characteristic impedance, echoes will appear on the oscilloscope display.

A signal measured with a 50-ohm cable is largely reflected at the oscilloscope input, because of its 1M impedance. It travels back to the source and

will be reflected again if the source impedance isn't 50 ohms. Thus a second signal is added to the original, delayed by the time it has taken to propagate forwards and backwards along the cable. The process is of course repeated and on the oscilloscope a series of echoes will appear.

This can easily be demonstrated by looking at the response to a step input. Fig.2 shows the oscilloscope display when a 3MHz square wave is measured through a 2m long mismatched co-axial cable. Fig.2a is with a source impedance higher than that of the cable, giving in-phase reflections. About 20ns after the first rising edge, a reflected signal adds to the original square wave. The process continues with the reflections weakening each time. In Fig.2b a low source impedance gives out of phase reflections, producing a typical 'ringing' waveform.

In commercial passive probes this effect is reduced by using resistive wire as the inner conductor of the co-axial cable. This is illustrated in Fig.1 by a



distributed resistance. The resistance would be in the order of 250 ohm for a 2m cable.

With the distributed capacitance between the inner conductor and outer braiding and the oscilloscope capacitance, the reflected signal is sufficiently reduced not to be visible. However, for wideband probes, the attenuation caused at higher frequencies has to be cancelled with an equalising circuit in the compensation box.

In our active probe design cable reflections are prevented by terminating one end of the co-axial cable into a matched load.

### Active probe

After that background information on the difficulties involved in getting signals to an oscilloscope, let's look at the construction project itself.

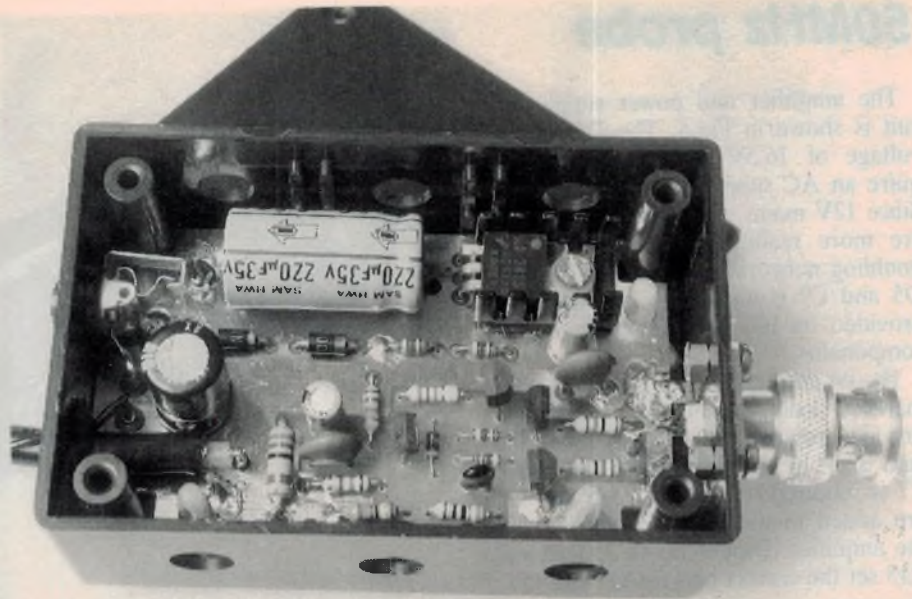
The block diagram of Fig. 3 illustrates the basic operation of the active probe. The buffer gives the probe a high input impedance. The signal is then attenuated to a level at which a 50-ohm cable can be driven. At the end of the probe cable the signal level is restored by amplification. The latter unit plugs straight into the oscilloscope. Power is supplied by a mains plug-pack and regulated in the amplifier unit.

### Circuit operation

The circuit used in the probe head is shown in Fig.4. The input signal passes through resistor R1, which is required for stability under short circuit conditions. R2 and R3 set the bias for the source follower stage of Q1.

To keep the probe capacitance down, a MOSFET with low input and feedback capacitance is used for Q1. It is protected against voltage spikes by internal back-to-back diodes. R4, R5 and C2 keep the unused second gate forward biased.

Additional buffering is provided by Q2, connected as an emitter follower. The signal is then attenuated by the ratio of R7 and 50 ohms, the latter being the input impedance of a 50-ohm coax cable terminated by a matching load.



A look inside the amplifier and regulator case, with its captive BNC plug to connect to the 'scope.

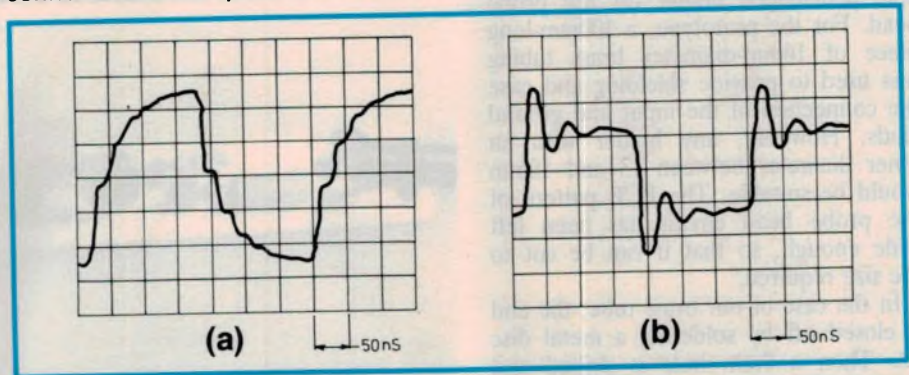


Fig.2: The effect on a square-wave signal of a mismatched cable with (a) a high source impedance (b) a low source impedance.

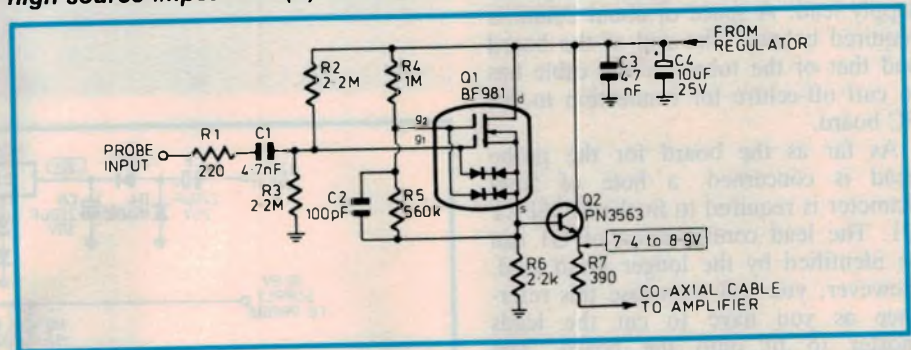


Fig.4: The schematic for the input buffer and attenuation section of the circuit, in the probe head itself.

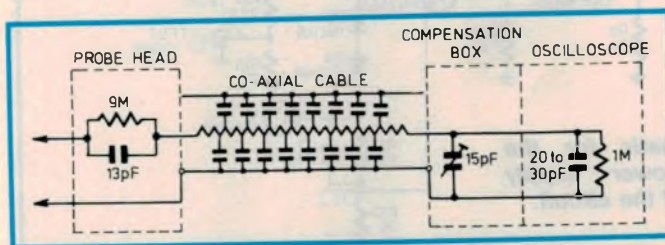


Fig.1: The equivalent circuit for a conventional 10x passive probe.

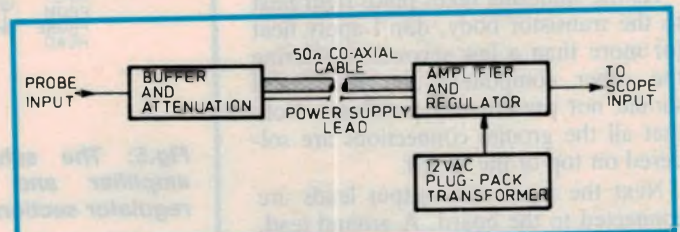


Fig.3: A block diagram of the complete active probe project.

# 50MHz probe

The amplifier and power supply circuit is shown in Fig.5. The DC supply voltage of 16.5V would normally require an AC supply of more than 16V. Since 12V mains plug-pack transformers are more readily available, a voltage doubling network consisting of C8, D4, D5 and C9 is employed. Regulation is provided by IC1 and its accompanying components.

The co-axial cable is terminated into a matched load, namely R8. Amplification is provided by Q3 and Q4. The gain is set by the ratio of R12 and R13. C7 is required for stability. Q5 and Q6 are added to improve the slew rate of the amplifier. Diodes D1 to 3, R14 and R15 set the correct bias for Q5 and Q6.

## Construction details

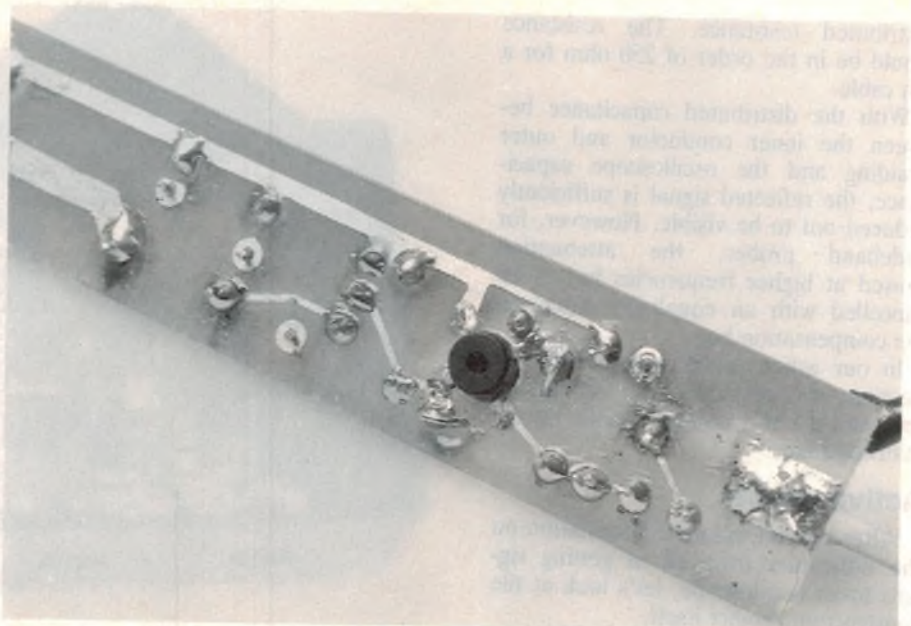
First of all, you have to find a suitable pen-shaped holder for the probe head. For the prototype, a 100mm-long piece of 16mm-diameter brass tubing was used to provide shielding and ease the connection of the input and ground leads. However, any holder with an inner diameter between 13 and 18mm would be suitable. The PCB pattern of the probe head circuit has been left wide enough, so that it can be cut to the size required.

In the case of our brass tube, the end is closed off by soldering a metal disc on. Then a 9mm hole is drilled and reamed into its centre. A 6mm grommet is fitted for the co-axial cable and power supply lead. A space of about 20mm is required between the end of the board and that of the tube, for the cable has to curl off-centre for connection to the PC board.

As far as the board for the probe head is concerned, a hole of 5mm diameter is required to fit the MOSFET Q1. The lead configuration of Q1 can be identified by the longer drain lead. However, you will soon lose this reference as you have to cut the leads shorter to fit onto the board. The source lead can still be recognised by its having a wider protrusion at its base.

As the soldering takes place right next to the transistor body, don't apply heat for more than a few seconds. Soldering the other components on the board should not present any problems. Note that all the ground connections are soldered on top of the board.

Next the input and output leads are connected to the board. A ground lead, with an alligator clip, is soldered to the ground plane on top of the board. We



The photo below shows a top view of the probe head PCB. The MOSFET Q1 soldered underneath the board, as shown in the closeup above.

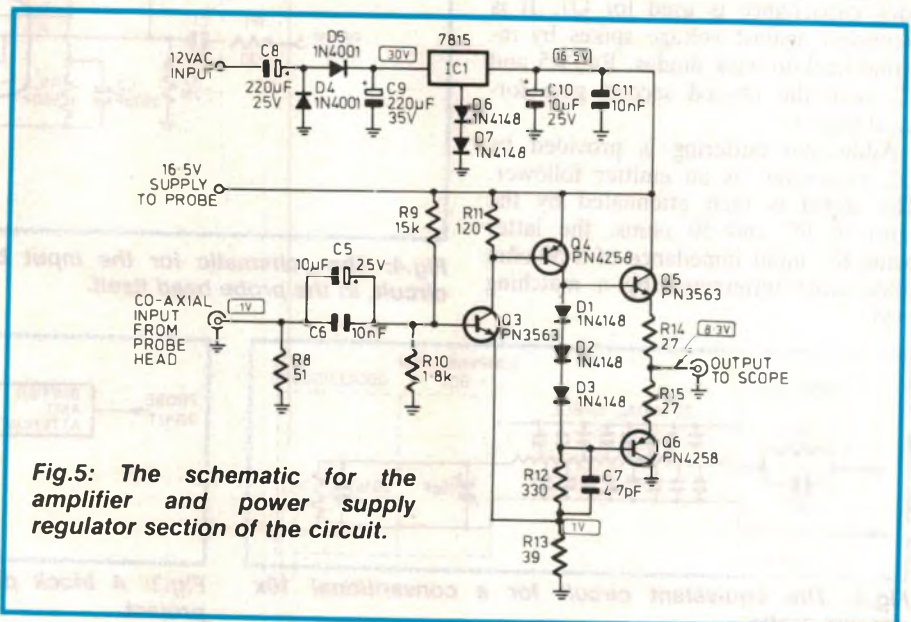
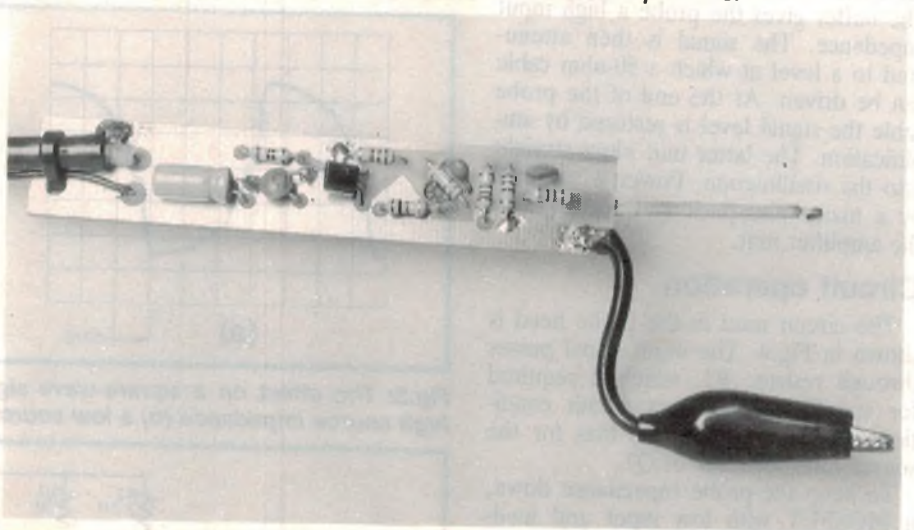


Fig.5: The schematic for the amplifier and power supply regulator section of the circuit.

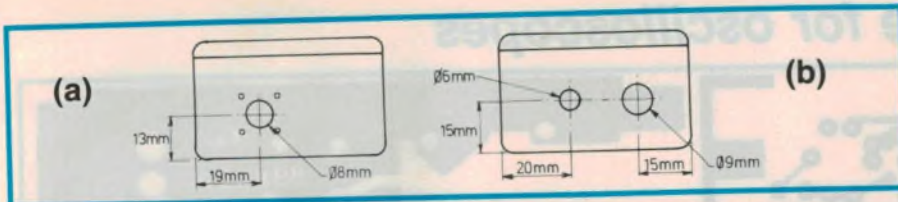
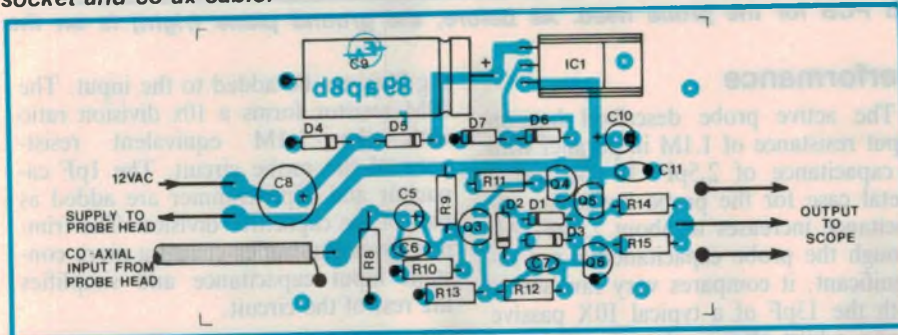


Fig. 6: The holes required in the case for (a) the BNC panel plug (b) the phone socket and co-ax cable.



The component overlay for the amplifier.

used the inside of a test clip as a flexible probe tip.

A length of standard 50 ohm co-axial cable connects the probe head to the amplifier and can be any length – 2m is convenient. The outer braiding of the cable is soldered to the ground plane. The cable is secured to the board with a cable tie. The power supply lead is kept in place by twisting it around the co-axial cable.

The amplifier and regulator is housed in a 83 x 54 x 28mm plastic utility box. For the board to fit, it must be sawn and filed to the inside of the lines marking the edges. The rectangular blocks marked out on the corners are removed.

All the components are subsequently soldered in, making sure that ground connections are soldered to the copper layer on the component side. IC1 requires a miniature 19 x 13 x 9 mm heat-sink, and is mounted to the board via a mica washer. The four external connections will be made on top of the board, therefore PCB pins are soldered in these positions.

The holes required for the BNC panel plug are shown in Fig. 6a. It is advisable to use a reamer for holes bigger than about 5mm, as larger drill bits tend to draw the plastic in.

On the opposite side of the box the holes for the phone socket and co-axial cable are made according to Fig. 6b. Another three holes of 8mm diameter are required in each the longer sides, to assist cooling by providing some airflow. With one in the centre, the other two are made about 18mm from the edges of the box. For the standoff, first drill holes into the PC board and use these to mark the hole positions inside the box.

Start assembly of the amplifier unit by pushing the PCB standoffs into the box. Next the BNC panel plug is held in position by loosely fitting the two bottom bolts and nuts only. These bottom screws should be short enough, so as not to protrude from the nuts when tightened.

The PC board is then slid in underneath the BNC connector's centre pin (shortened if necessary) and pressed

onto the standoffs. The bottom nuts of the BNC connector are soldered to the board's ground plane. Don't apply heat for too long, as the plastic case may start melting.

The BNC connector is secured further with the remaining screws. Remember to solder the connector's centre pin to the appropriate PCB pin.

On the other side of the case, a 6mm grommet is fitted into the 9mm hole, before the co-ax cable and power supply lead are pushed through. A 3.5mm phone socket is placed into the 6mm hole, so that the outer lead can be soldered to the ground plane and the inner connection can be soldered directly to the 12V AC input pin.

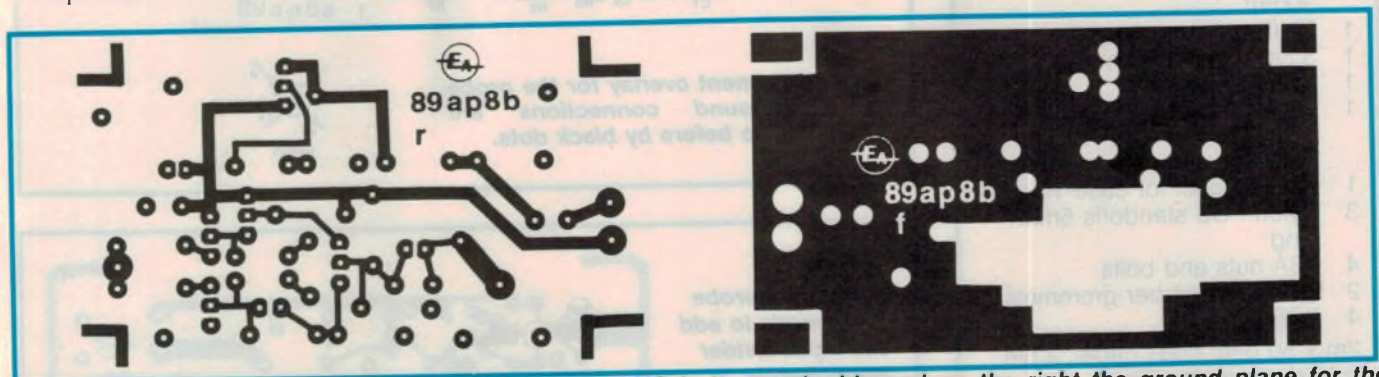
## Operating

With the assembly completed, the active probe can be tested. Plug the amplifier unit into an oscilloscope's input and set the oscilloscope to AC coupling. Plug the 12V AC supply into its socket. With the probe leads shorted together, there should be no signal appearing on the oscilloscope.

If a large 100Hz signal is present, the problem is either with the regulator circuit or the rest of the unit is drawing too large a current. If you used the correct capacitor values for C8 and C9 and the regulator IC1 is operating correctly, a large current drain is the probable cause.

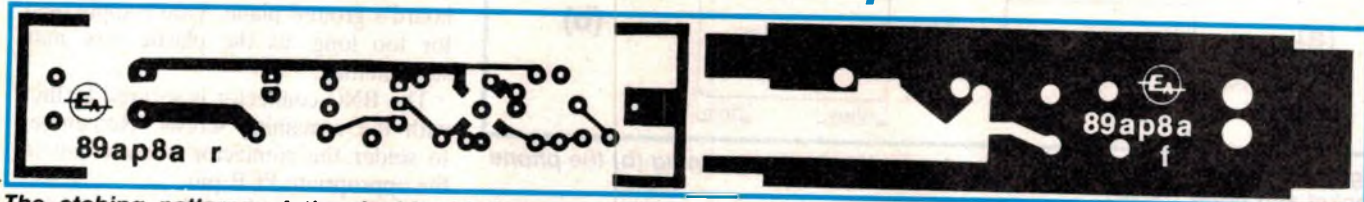
In that case, unplug the 12V AC supply and make sure all the connections have been made, especially those on top of the board. Otherwise you may have to check the condition of the transistors in the amplifier.

Assuming there is no signal displayed on the oscilloscope, use the probe to measure a known signal source. If it appears distorted or has an incorrect amplitude, go through the circuit, using the DC voltages shown in Figs. 4 and 5 as a guide.



The PCB etching patterns for the amplifier. On the left is the track side and on the right the ground plane for the component side.

# 50MHz active probe for oscilloscopes



The etching patterns of the double-sided PCB for the probe head. As before, the ground plane (right) is on the component side.

## PARTS LIST

### Semiconductors

- 1 BF981 dual gate MOSFET (Farnell order code BF981 or Radio Spares stock no. 296-289)
- 3 PN3563 NPN transistors
- 2 PN4258 PNP transistors
- 1 7815 voltage regulator
- 2 2N4001 diodes
- 5 2N4148 diodes

### Capacitors

- 1 4.7pF ceramic
- 1 100pF ceramic
- 2 4.7nF ceramic
- 2 10nF ceramic
- 3 10uF 25V electrolytic radial
- 1 220uF 25V electrolytic radial
- 1 220uF 35V electrolytic axial

### Resistors

- 5% carbon film 1/4W: 2 X 27 ohm, 1 X 120 ohm, 1 X 220 ohm, 1 X 1.8k, 1 X 2.2k, 1 X 15k, 1 X 560k, 1 X 1M, 2 X 2.2M
- 2% metal film 1/4W: 1 X 39 ohm, 1 X 51 ohm, 1 X 330 ohm, 1 X 390 ohm

### Miscellaneous

- 1 PCB 85 x 18mm, code 89ap8a
- 1 PCB 75 x 44mm, code 89ap8b
- 1 Plug-pack transformer 12V 300mA AC
- 1 ABS plastic box 83 X 54 X 30mm
- 1 BNC panel plug
- 1 3.5mm phone panel socket
- 1 Mini alligator clip
- 1 Miniature heatsink 19(L) X 13(W) X 9(H)mm (Rod Irving H10606)
- 1 Insulating kit for case TO-220
- 3 Nylon PCB standoffs 5mm long
- 4 6BA nuts and bolts
- 2 5 or 6mm rubber grommets
- 4 PCB pins
- 2m x 50 ohm coax cable, 2.5m light duty single wire.

## Performance

The active probe described has an input resistance of 1.1M in parallel with a capacitance of 2.5pF. If you use a metal case for the probe head, the capacitance increases to about 2.7pF. Although the probe capacitance is not insignificant, it compares very favourably with the 13pF of a typical 10X passive probe, whilst offering the advantages of a 1X probe.

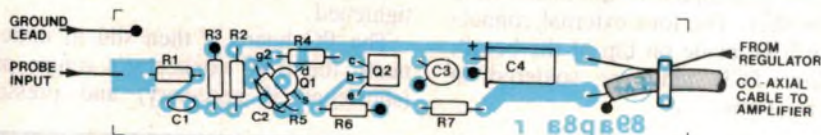
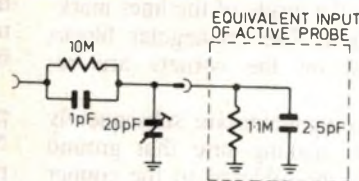
Dynamic range is limited to 10V peak-to-peak. At this full power level, the slew rate required to drive the oscilloscope input capacitance limits the probe bandwidth to about 50MHz. For smaller signals the response approaches -3dB at 110MHz, but does not actually reach that level until about 140MHz. The low frequency cut-off occurs at 20Hz.

To increase the dynamic range of the probe, the dividing network shown in

Fig.7(a) can be added to the input. The 10M resistor forms a 10x division ratio with the 1.1M equivalent resistance of the probe circuit. The 1pF capacitor and 20pF trimmer are added as part of the capacitive division. The trimmer gives the buffer circuit a more constant input capacitance and simplifies the rest of the circuit.

A possible modification to the probe PCB is shown in Fig.7b. R1 is replaced by the 10M resistor, with the 1pF capacitor added underneath the board. The trimmer is also soldered underneath, in shunt with R3. The trimmer is set in the usual manner by connecting the probe to a 1kHz square wave and adjusting for sharp edges without overshoot. The overall input impedance of the probe will now consist of a resistance greater than 10M, in parallel with 1pF. But of course there will now be an overall 10X division, as well. Ⓜ

Fig.7(a): A 10x passive attenuator circuit may be added to the input of the probe, to increase dynamic range and further reduce its loading capacitance.



The component overlay for the probe head. Ground connections are indicated as before by black dots.



Fig.7(b): Suggested probe head mods to add the input divider permanently.





"How can I check this Disk Drive?"

"How do you know which Chip is blown on this SCSI board?"

"What's wrong with this Printer?"

"Is this Modem working O.K.?"

"How do I connect to this Comms Port?"

**"EASY!"**



With the ElectroTest MT1000 and MT500 simulation based functional testers it's easy to troubleshoot each part of a PC system and many PC peripherals. And it's inexpensive because you only buy the test pods you need.

**MT1000** tests Floppy Disk Drives, Hard Disk Drives, SCSI Devices, Printers (including laser), Plotters, Modems, Microprocessor Boards, Comms Ports, Cables etc.

**MT500** SCSI Tester for Direct Access and Sequential Access Devices, Supports vendor unique commands, built-in Break Out Panel, Set-Up, Diagnostic and Command Modes.

*Arrange a demo through your local Elmeasco Office*

## **ELMEASCO** Instruments Pty. Ltd.

Incorporated in N.S.W.

### **NEW SOUTH WALES**

18 Hilly Street,  
MORTLAKE  
P.O. Box 30, CONCORD  
NSW 2137  
Tel : (02) 736 2888  
Telex : AA25887  
Fax : (02) 736 3005

### **VICTORIA**

12 Maroondah Highway,  
RINGWOOD  
P.O. Box 623, RINGWOOD  
VIC 3134  
Tel : (03) 879 2322  
Telex : AA30418  
Fax : (03) 879 4310

### **QUEENSLAND**

192 Evans Road,  
SALISBURY  
P.O. Box 274 SALISBURY  
QLD 4107  
Tel : (07) 875 1444  
Telex : AA44062  
Fax : (07) 277 3753

### **SOUTH AUSTRALIA**

241 Churchill Road,  
PROSPECT  
P.O. Box 154 PROSPECT  
SA 5082  
Tel : (08) 344 9000  
Telex : AA87519  
Fax : (08) 269 6411

### **W. AUSTRALIA**

32 Teddington Road,  
VICTORIA PARK,  
W.A. 6100  
Tel: (09) 470 1855  
Fax: (09) 470 3173

# Ham Talk



## Dick Norman, VK2BDN

Dick Norman must be one of the best-known Australian amateurs working on the VHF-UHF and microwave bands. He's been pioneering on these bands since the 1950's, and in that time has chalked up quite a few 'firsts' – including the first trans-Tasman contact on 1296MHz.

When I asked Dick Norman how he first got started in amateur radio, his reply wasn't quite what I expected. With disarming frankness, he explained that he'd started operating in the 1940's as a 'pirate' – using the callsign of a local amateur (2JT) who wasn't very active. The reason for this subterfuge was that although he had mastered the technical side of the art, for some years he just couldn't pass the Morse code test.

Eventually the code-free 'Z' calls were introduced, of course, and that allowed him to become legal without needing the Morse. In fact he was one of the first Z-calls to be licensed, with the callsign VK2ZCF. Later on he did manage to bring his Morse up to scratch, and get a full ticket – gaining his present callsign VK2BDN. But I'm jumping the gun a bit, because he had first become interested in radio soon after leaving school, before the war.

Having grown up in suburban Croydon, in the house where he still lives, he had to leave school at the age of 13. It was the depression, and family finances wouldn't allow further schooling.

After an initial spell working at Pauls' hardware and tool store in Sydney, he found himself working at Slade's Radio, in Croydon. His first work was drawing up meter scales for 'Calstan' meter movements, but because this didn't keep him busy enough he was also set to work on a lathe, turning up pup-jacks and similar small metal items. The boss of the company was Charlie Slade, one of Sydney's first radio hams, with the callsign 2SX. Other hams also worked there as well, and it was here that Dick first became aware of ham radio.

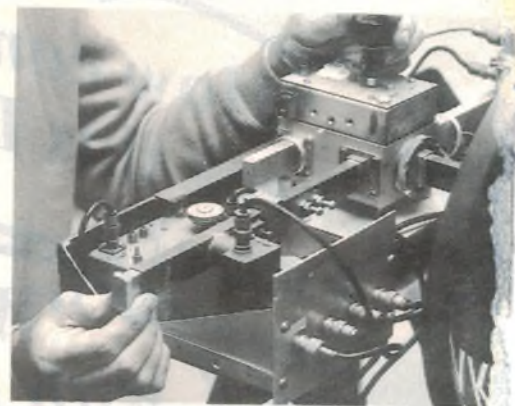
When the war broke out, Dick joined the AIF. After doing training courses in both radar and electrician training, he was shipped up to Moritai with the 2/11 AGH, and among other things spent part of his service running a mobile

cinema, with a 35mm projection plant they built into the back of an old 'Arnotts Biscuits' truck.

After the war, he found a job as maintenance engineer with GEC, and soon became active in ham radio. All of the initial gear he built up himself – often from designs published in *Radio & Hobbies*, and like most amateurs making use of parts salvaged from disposals equipment.

Like many other enthusiasts Dick was also interested in other areas of electronics, besides ham radio. When home disc recording was popular he built a recording setup, using an American 'Green Flyer' lathe at first, and subsequently a more professional overhead leadscrew type. Then when home tape recording became feasible, he built up his own deck – with an amplifier again based on an *R & H* design. Later on in the 1950's he was also to build the *R & H* 5" and 17" TV receivers.

Right from the start with ham radio



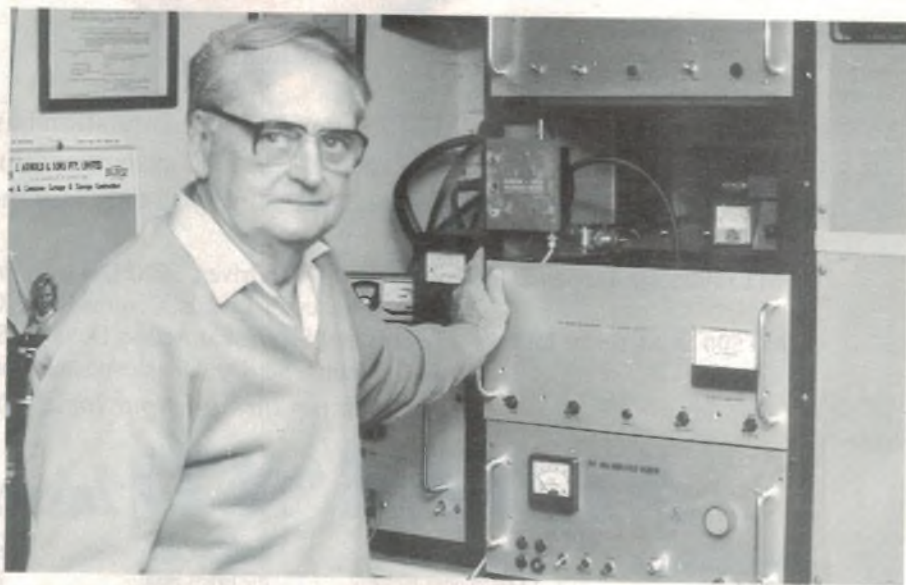
Dick is currently working on this crystal-locked transceiver for 10GHz.

he was interested in the VHF and UHF bands, partly because these were at the time 'the great unknown', and partly in response to the apparent snobbery of some of the older 'full call' hams towards the new 'limited' call people.

"When I first went on the air as VK2ZCF, there was a kind of stigma attached to being a limited call", he recalls. "I remember that on 'scrambles', many of the full-call hams wouldn't ever come back to you – they pretended you just didn't exist."

Unpleasant and childish though it was, perhaps it was all for the best, because it made Dick Norman for one determined to 'show them', by pioneering in the use of the still largely uncharted VHF and UHF bands. And pioneer he did.

Initially he worked on the then-available 288MHz and 576MHz bands, building on the simple designs published in *Radio & Hobbies* by John Moyle VK2JU, Neville Williams VK2XV and



Dick Norman VK2BDN with some of his home-brew transmitters for 144MHz, 432MHz and 1296MHz. He was the first to contact New Zealand on 1296MHz.

Maurice Findlay. Then he progressed to more elaborate designs for 144MHz, and later the 432MHz and 1296MHz bands when these became available.

"I remember saving up my lunch money to buy my first QOE0-6/40 output valve, so I could put out more power on 2 metres", he told me. "This allowed me to work my friend Hugo, VK2WH at Forbes - quite a good 'DX' contact for 2 metres, at the time."

But before long he was working ZL1AUM in New Zealand on 2 metres - the first confirmed contact from Sydney, he thinks. This was just before the band 'opened up'.

At the same time he built up gear to work on the 6-metre band, and during the sunspot peak in the 1950's he was one of the first to work Japanese hams during the band openings.

He remembers being 'a bit of a maverick' at the time, always willing to try doing things a different way, despite commonly accepted 'wisdom'. For example he was one of the first to try using co-axial cable on the UHF bands, and found it quite good - despite accepted wisdom that it had unacceptably high losses compared with twin open line. Similarly he used the low-cost Belling-Lee connectors (largely to save money) at 1296MHz, even though these were held to be very poor compared with the much more costly and harder to get type 'N' connectors.

It can't have done too much harm, because he gradually collected a string of 'firsts'. The one he's still most proud of is the first contact between Australia and New Zealand on 1296MHz: "Without a doubt, that was the biggest thrill of the lot!"

Some of Dick's antennas for 1296MHz, 144MHz, 432MHz and HF.

Of course, there are always new fields to conquer. Right now, his goals are to span the Tasman on 2.3GHz and 10GHz - even though many say this is 'impossible'. But to Dick Norman, that's just the motivation he needs to give it a go...

Currently under development is a full crystal-locked transceiving system for 10GHz, built in compact form so that it can be transported by car and set up on a tripod in the field (or rather, on a suitable hill or mountain!). When finished it will have an RF output of 20 milliwatts, but with the high antenna gain possible at these frequencies (about 35dB) this will translate into quite a solid ERP. It's shaping up very nicely, and Dick is confident that when finished it will fill the bill.

Dick's other current interest is community FM radio. He has been involved with local station 2RDJ in Burwood for some 10 years now, looking after the station's technical equipment and producing some programs as well. It

gives him a lot of satisfaction, as he has always had an interest in 'show biz'. Even when he's home in the shack, there's always a radio in the background monitoring the 2RDJ programme.

Did he have any advice for new hams, or people considering taking up the hobby?

"Well, I still believe that amateur radio can be a tremendously satisfying hobby. Perhaps it isn't as easy to achieve the same results nowadays, with so much RF tending to fill up the bands and the 'frontiers' moving ever upward in frequency. Some of the special parts you need for UHF and microwave rigs are becoming harder to get, and very expensive when you *can* get them."

"But all this just adds to the challenge - and to the satisfaction, when you overcome the difficulties. There's still an enormous feeling of achievement when you hear a signal coming out of the noise from somewhere, with gear you've built yourself. And the feeling you get when you've made a contact with someone who is further away than either you, or anyone else, has contacted before on that band - what a thrill!"

"Of course what you do need is a good mate at the other end. Someone who will listen for your signal, and help you achieve the best results - in return for you doing the same for them. I've been lucky to have good mates like this, and no doubt that's why I've been able to set a few records."

Good advice, I think. It also shows that despite his achievements, Dick Norman is still a pretty modest kind of bloke. (J.R.)



# SOLID STATE RELAYS

## NOW EVEN BETTER!

### RELAY FEATURES:

- High surge current capabilities
- Zero voltage switching for low RFI
- Opto isolated input/output terminals increased to 4KV rms
- Inbuilt snubber
- Industry standard packaged format
- Logic level control signals
- Type A-B BASEEFA approved for hazardous applications
- Meet UL flammability standards
- Chassis mount and PCB mount
- Phase control option.



### LOAD CURRENT:

- Type A-BM 3-4 amps (Irms) Vertical mount
- Type A-BP 3-4 amps (Irms) Horizontal mount
- Type A-B 10-45 amps (Irms) Vertical mount

### INPUT VOLTAGES:

- Types A-BM, A-BP, A-B(D) 3-32V DC
- Type A-B(A) 90-280V AC

### LOAD VOLTAGES:

- New high voltages 24-480 (Vrms)

**ALLEN-BRADLEY, WORLD KNOWN FOR CONSISTENT QUALITY.**

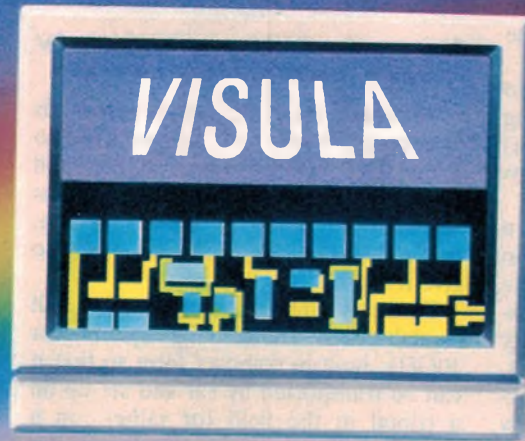


**ALLEN-BRADLEY**  
A ROCKWELL INTERNATIONAL COMPANY

VIC: 37 Chapman Street, Blackburn 3130 Ph (03) 899 0335  
NSW: 56 Parramatta Road, Lidcombe 2141 Ph (02) 648 2652  
ACT: P.O. Box 534, Fyshwick 2609 Ph (062) 80 4554

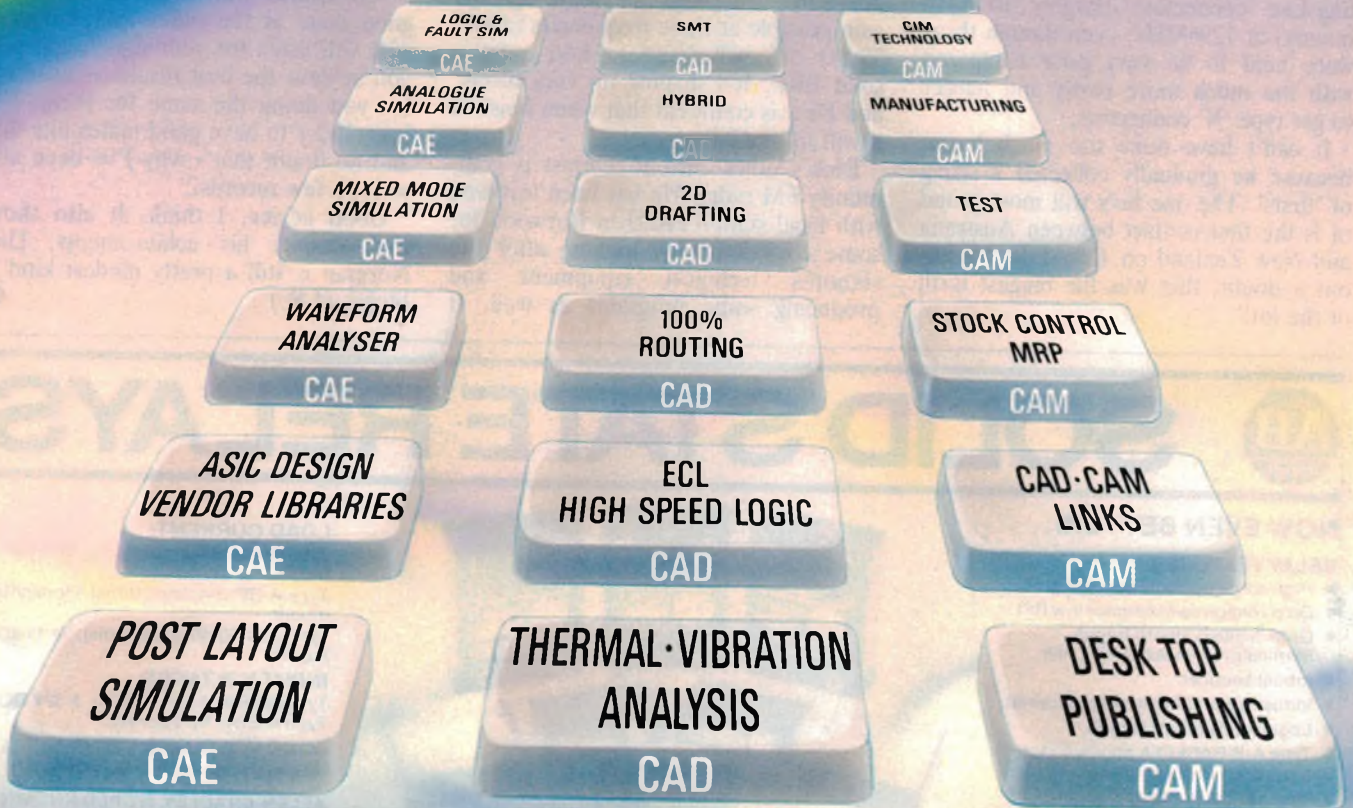
QLD: Unit 4 Dennis Court, Springwood 4127 Ph (07) 208 1044  
SA: 30-40 Hurtle Square, Adelaide 5000 Ph (08) 232 0001  
WA: 31 Kensington St, East Perth 6000 Ph (09) 221 2121

# FOLLOW THE



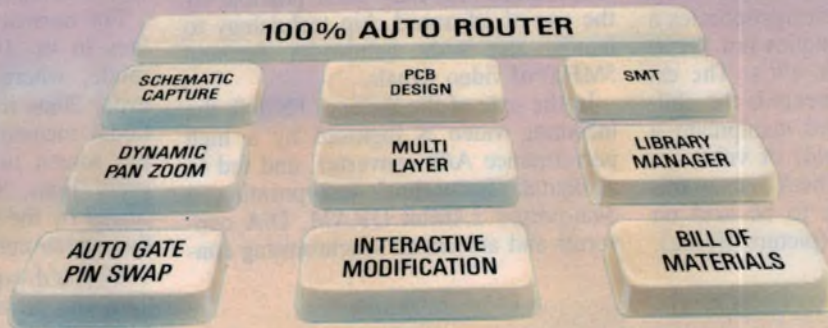
◀ COMPONENT  
LOW COST  
◀ COMP  
◀ ANALOGUE AND  
◀ MORE COMPUTING PO

## COMMON RELATIONAL DATABASE



# E R A I N B O W

LIBRARY TRANSFER ▶  
DESIGN SEATS ▶  
COMPATIBILITY ▶  
DIGITAL SIMULATION  
WEB AND APPLICATIONS



*Protect your investment in component libraries. Racal-Redac unites the PC and workstation CAD environments. Now CADSTAR libraries, together with schematic capture and PCB design data, can be transferred to VISULA, or VISULA libraries can be transferred to CADSTAR. Racal-Redac offers compatibility between CAE simulation libraries and PCB libraries. With 10,000 CAE parts and 6000 PCB parts, it's one of the most comprehensive libraries available. Combine the power and versatility of your VISULA workstation-based CIM environment with the cost benefits of the CADSTAR PC-based CAD system.*

**RACAL-REDAC RACAL**

RACAL-REDAC Pty. Ltd., 3rd Floor, Chubb House, 64 Clarence Street, Sydney 2000, N.S.W., Australia. Tel: (02) 262 5466. Fax: 262 5418.

Product review:

# Siemens FS 940 'high-tech' TV receiver

The flagship of Siemens' new television range reflects the leading edge of current TV technology. It offers an almost overwhelming range of features, including full digital processing of the video information.

While the release of a new range of television receivers is generally associated with liberal amounts of fanfare and razzmatazz, it's rarely heard in the *Electronics Australia* office. However when such a release coincides with significant use of the latest technology, our hearing tends to improve.

Such is the case with this new product line from Siemens, which incorporates a number of digital techniques not previously found in domestic TV's. The essence of these developments is the ability to digitally store and manipulate a complete screen (or field) of video information. In the practical sense, this allows a selected frame to be held on the screen indefinitely (picture freeze),

or repeated so as to double the effective scan rate – producing a 'flickerless' image.

## Digital pictures

While the actual process of converting real-time analog signals to a digital format is hardly new, its entry into the video arena has only been possible by the use of advanced chip technology to handle the wide bandwidth (around 5MHz) of video signals.

In the case of the Siemens FS 940, the incoming video is digitised by a high performance A/D converter, and fed to a digital 'featurebox' incorporating a dual-ported 2.4Mbit DRAM, D/A converter and associated synchronising con-

trollers. Here each 'digital picture frame' is both stored and subject to some level of Digital Signal Processing (DSP) – such as noise reduction for increased picture quality. This treated signal is then restored to an analog (RGB) form via the D/A converter, under the control of a main system microprocessor.

It's this system logic that determines the manner in which the stored frames are sent to the screen for the double scanning, picture freeze and 'cinema' modes of operation.

For normal viewing the FS 940 operates in its '100Hz' or double scanning mode, where the memory is updated every 20ms in response to the conventional incoming field, but read out to the screen *twice* as often – that is, every 10ms. So every vertical field received by the set becomes two consecutive screen updates, at a 100Hz rate.

As you'd expect from the freeze function, the picture is captured by terminating the memory's update process in response to a 'freeze' command. Then the static contents of the memory are simply sent to the screen in a continuous manner, at the 100Hz 'flickerless' rate.

Alternatively, the 'cinema' function only updates the memory with the information from every *second* incoming field (every 40ms), yet still 'writes' to the screen at the 100Hz rate.

In fact this cinema mode is rather interesting. The process often used to transmit cinema film first involves a slight speed change to convert the original shutter rate (1/24th of a second) to half of the television vertical scan rate – or in effect from 42ms to 40ms. Each film image is then sent twice during this period, so as to update the television picture at the expected 20ms rate.

Now, if the device (a 'flying spot scanner' comes to mind) generates the repeated image by optically re-reading the film, one would expect this second



The FS 940 displaying its menu page for the user programming functions.

### TV Transmitter Table

Prog	Chan	Station	Prog	Chan	Station	
1	C	28	ARD	11	S	20
2	C	08	ZDF	12	C	40
3	C	14	PR 3	13	C	76
4	C	06	PR 4	14	C	27
5	C	08	PR 5	15	C	29
6	C	14	PR 6	16	C	60
7	C	05	PR 7	17	C	17
8	C	12	PR 8	18	C	18
9	S	02	PR 9	19	S	20
10	S	03	PR10	20	C	12

P^ Pv    Prog + -  
 <- +>    Prog 41-49, AV/21-40  
 OK        Edit

The set allows remote programming of the station ID and channel tuning.

scan to be slightly different from the first – these slight errors will cause some flickering of the image. So the answer from the FS 940 is to only read every alternate field (that is, each new film image) at 40ms intervals, and generate its own digitally accurate copies every 10ms. Apparently this alternate-scan mode also improves the picture quality produced by a VCR operating in its pause mode, where once again, the repeated image is rather inconsistent.

### Digital control

We've come to expect a reasonable level of 'digital' features in the latest generation of domestic televisions, ranging from the simple multiplexing functions of a hand held remote control, to storage and processing of Teletext information. In this respect the Siemens FS 940 has taken a couple of further strides down the technology road.

The actual level of microprocessor control here includes the receiver tuning with the aid of frequency synthesis, the complete menu-driven operation of user features, use of an internal self-diagnostic program and access to an on-board database of alignment information – whew!

The search capability of the synthesised tuner enables the unit to effectively operate as a TV scanner. With a couple of stabs at the remote control, the user can search through the complete spectrum, including the satellite and cable frequencies. Also, the menu of user features allows remote program-

ming of an 80-page Teletext memory, TV channel and satellite call signs and frequencies, a dual function alarm, the choice between five languages for the text generator, and a 'features demonstration' mode.

If that's not enough, a number of functions are fully automatic, including the unit's ability to lock onto and decode virtually any of the available transmission standards ('multinorm' in Sie-

menspeak), such as PAL, SECAM, NTSC etc. This is achieved by the use of a universal decoder under the main system control.

So this, coupled with the set's satellite, cable, and multi-language capabilities must make the FS 940 the first true 'world' television. While this may seem of little interest on our own remote island, the increasing availability of satellite broadcasts means that such a set can easily decode the variety of international programs supplied by a service such as Intelsat. Also remember that the manufacturing cost of any item is escalated by the number of versions that must be produced to satisfy world conditions – that is, one for Europe, one for America and so on. Presumably, a universal product *must* be less expensive in the long run.

### Even more features

Although not quite as ground breaking as digital image processing or universal standard capabilities, the features list for the Siemens FS 940 rolls on. It includes full stereo reproduction through 35W per channel amplifiers and two-way loudspeakers, with selectable expansion and bi-lingual modes – even monophonic signals may be enhanced with a 'spatial' facility.

The set kindly switches to standby mode about 10 minutes after the transmission has ceased – no more waking up at 3AM to roaring snow, after you

### Alarm Time Setting

Alarm Time 1	12:30
Alarm Time 2	17:35

P^ Pv    1-2  
 0-2     Edit  
 =■     Clear

The 'Alarm Time' page: At the selected time, the time is displayed on the TV screen. This occurs daily unless the times are cleared or re-programmed.

# Siemens FS 940 TV receiver

have dozed off while watching a riveting documentary on the mating habits of sea slugs! Also, an array of 'pop-up' information is available at the perimeters of the screen. This includes a clock, station identification and program number, Teletext information (such as a news-flash) and the status of the remote's continuously variable controls (treble, bass, volume, contrast etc).

Not surprisingly, the remote control has total command of the set's range of functions including Teletext and external connections (hi-fi etc). It even doubles as a remote control for your VCR - providing it's part of this new Siemens range.

As far as external connections are concerned, the FS 940 is similarly well endowed. The rear panel contains the usual antenna connection, a pair of two-pin DIN connectors for external loudspeakers, stereo line output via RCA sockets, and two 21-way SCART (or Euro) connectors which offer almost any in/out facility you may need, including direct RGB inputs. Lastly, a standard stereo headphone socket hides in the front panel moulding.

At this point we couldn't resist the

temptation to remove the rear panel for a peek inside. As expected, the unit is a neat arrangement of a few highly populated boards, with widespread use of LSI technology. The only unusual aspect of the construction was in the relatively low-tech area of loudspeakers, where the piezo-electric tweeters are simply attached to the front grill, and the bass drivers occupy elaborate moulded plastic enclosures.

## In use

Compared to its dazzling range of hi-tech features, the physical appearance of the FS 940 is rather unassuming. The clean frontal lines of the cabinet neatly surround the large 70cm screen, and offer no (visible) user controls except the mains on/off switch. This appears to be labeled '10', but is intended to imply a 'one' for ON, and a 'zero' for OFF - very digital...

The upper right-hand corner holds a 3-digit LED read-out for the program number and general tuning information, while the space immediately below is occupied by the infra-red receiving device and a hidden control panel for manual tuning and memory functions. The lower areas on either side of the screen contain the loudspeaker 'enclosures', with the treble units facing forward and the bass drivers radiating from the sides of the cabinet. While this arrangement appears to add little to the set's overall dimensions, it is not a small unit - with measurements of 79cm wide, 54cm high and 46cm deep, it's bound to take a commanding position in anyone's lounge room. Also, your favourite television table may need a few structural checks, since the FS 940 weighs in at a hefty 43kg.

Once it's installed, the set is very easy to tune and program. The scanning nature of the receiver allows each station to be easily captured, and assigned to the desired memory position. The menu system is a little confusing until you manage to find the 'language' page and program the text generator to display English instructions, since the unit is sent from the factory in 'Deutsch' (German) mode.

Although the 46-button remote control may look a little frightening, with the help of the icons printed on the buttons and a little experimentation the unit can be mastered in a short time. Of course, the manual is quite clear on all of these points.

In the more subjective sense, we found the quality of the '100 Hz' or

double scanned pictures quite exceptional. Even at close viewing, which is hardly required from such a large screen, the images were sharp and rock solid. To put it simply, the 100Hz feature really does improve the effectiveness of the picture, which is completely devoid of any of the usual scanning flicker. In fact after using this set for the review period, we found that the flickering effects of a conventional 50Hz television became rather obvious.

If you're used to the image generated by the 'pause' function of a standard VCR, you will find the FS 940's picture in the freeze mode quite uncanny by comparison. It does just that - freezes. There is absolutely no loss of picture quality or stability, since the internal memory's update process is simply interrupted by the toggling action of the picture freeze button.

Similarly, although a little unexpected, the 'cinema' mode worked quite well. After a quick session with the midday movie, we found that this function reduced the edge flicker effects, and generally improved Clark Gable's image (pun intended). Under this alternative processing, the actual figures on the screen stopped jittering in sympathy with the frames as when they were repeated in the conventional manner. This was particularly noticeable with any close-up images that were in a static position on the screen - such as Mr Gable grinding out his lines.

The sound was also quite satisfying, with a generous frequency response and little evidence of cabinet resonances, which is a common problem with many sets. The actual amplifier power seemed more than adequate, although it could be driven into clipping by the combination of a high volume setting and excessive bass-boost. However if this is your inclination, we would suggest connecting a more powerful stereo system to the set's line-out sockets.

So all in all, the Siemens FS 940 is a delight to use and a pleasure watch. And how much will this enjoyment set you back? According to the Australian distributors, the unit retails for \$3649, including tax. Not cheap by any standards, but you're dealing with the upper echelon of television receivers where like luxury cars, the purchase price may not be a prime consideration - the question is, will it fit into the back seat of your Porsche for the trip home?

The review set was supplied by the national distributor of Siemens audio and video products, Branbery Pty Ltd, P.O. Box 1082, Windsor 3181, who can be contacted on (03) 529 3557. (R.E.)

## SPECIALS

FLASH A/D/D/A		85 SERIES	
MP7684JN 8 Bit CMOS Flash ADC	\$22.86	G655C92P-2 8 Bit Micro	\$3.96
MP7685JD 11 Bit CMOS Flash ADC	\$39.60	G655C22P-2 Via	\$3.82
MP7682JN 8 Bit CMOS DAC	\$11.43	G655C51P-2 Uart	\$3.85
MP7614JN 10 Bit CMOS DAC	\$22.86	CRYSTALS	
MP7682JN 11 Bit CMOS DAC	\$9.78	XL08 0000 MHz HC18/49	\$ 74
HDAC 7543ACB 12 Bit CMOS DAC	SPECIAL \$7.50	XL04 0000 MHz HC18/49	\$ 72
MP7596JN 16 Ch Mux	\$10.58	XL04 9132 MHz HC18/49	\$ 87
MPREF01DP 10V Pwr Ref	\$2.65	XL11 381350 MHz HC18/49	\$1.05
Wide range of A/D D/A as stock		32.768 MHz 3 x 8mm Round	\$ 47
VLSI LOGIC & SRAM		XICO MAG CARD	
VL82C50 Uart	\$6.30	READER/ENCODER	
VL18C450-PC Uart	\$8.50	INSERTION READER	
3001200 Modem Kit	\$60.00	7202SA	\$154.80
VT7132-90 Dual Port Ram 90NS	\$20.00	INSERTION ENCODER 7702SA	\$531.80
VL82C37A DMA Controller	\$7.00	COMPUTER CABLE	
VL8288-35PC 18K x 4 SRAM	\$17.00	PRINTERCABLE 1.8M	\$7.66
VT20C1B-35PC 2K x 8 SRAM	\$12.85	RS232 CABLE 1.8M	\$7.66
EPROM		CONNECTORS	
AT27C256-15DC Eprom 150NS	\$7.65	DB25F SI	\$ 52
AT27C512-15DC Eprom 150NS	\$13.95	DB25M R + PCB	\$1.52
AT27C010-20DC 1 Meg Eprom 200NS	\$30.00	DB25M SI	\$ 48
VT27C04-25DC Eprom 250NS	\$3.50	DB9F R + PCB	\$1.24
		DB9F SI	\$ 44
		DB9M SI	\$ 40
		MULTIMETER MM8810	
		3% DIGIT DC AC OHM PUSH BUTTON SELECT	\$49.95
		ALL PRICES TAX INC PRE-PAID OEM PRICING WELCOME	
		Min order	\$20.00
		P&P	\$6.50
		Q/Night Serv inc packing	\$10.00
		No Rain Checks	

26 Boron St, Sumner Pk,  
Brisbane Qld 4704.  
Phone: (07) 376 2955  
Fax: (07) 376 3286  
WELLINGTON, NZ:  
Ph: (04) 85 8742  
Fax: (04) 82 8850

Ken Curry  
Managing  
Director



energy  
CONTROL



# SIEMENS

## VISIBLY BETTER Twice As GOOD

DIGITAL 100Hz STEREO COLOUR TELEVISION  
WITH FULL FRAME STILL PICTURE



**TWICE AS GOOD?** Normal televisions refresh the viewed picture 50 times a second in two stages giving a complete picture every 1/25th of a second. This technique often leads to a perceived flicker which is both distracting and tiring. The **Siemens FS 940** does all the above but **TWICE** as fast. End result **HIGH DEFINITION, NO MORE EYE STRAIN, NO MORE FLICKER.**

**FREEZE FRAME.** Full digital circuitry means remote control of all functions and the ability to **FREEZE** the picture. You can stop action at any point to examine the detail or savour the moment.

**SOUND QUALITY** from the FS 940 is quite simply unsurpassed for a television. Hi-Fi stereo from an **enclosed 4** speaker system driven by a forceful 140 watt amplifier.

Other features such as Teletext and multi system operation are standard additions to this premier model.

# SIEMENS

Distributed by

## BRANBERY PTY LTD

1A Windsor Place, Windsor. Vic. 3181. Phone: (03) 529 3557 Fax: (03) 521 1325

# Low cost 'mini logic analyser'

Here's a project that should be of ideal for anyone who needs to service digital equipment. It allows you to trigger a CRO when any combination of address and control lines reaches a certain pre-determined state. It operates with a wide variety of 8- and 16-bit computers, and also captures the data on the data bus and displays this on a front-panel display.

by **MARK CHEESEMAN**

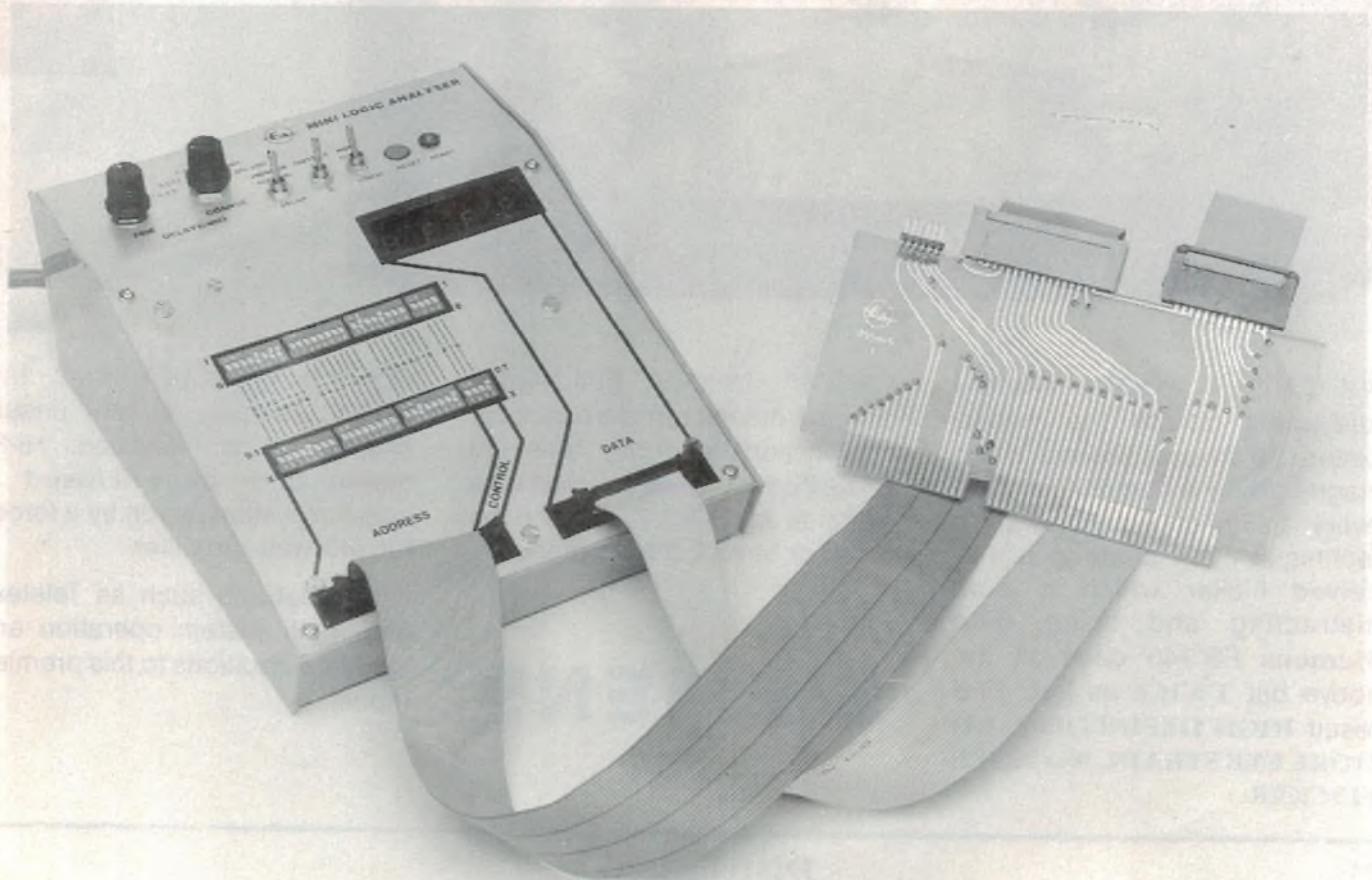
Analysis of computers and other complex digital circuits is not easy with an ordinary CRO, regardless of the number of input channels that the instrument has. The difficulty in using a CRO is related not only to how many discrete

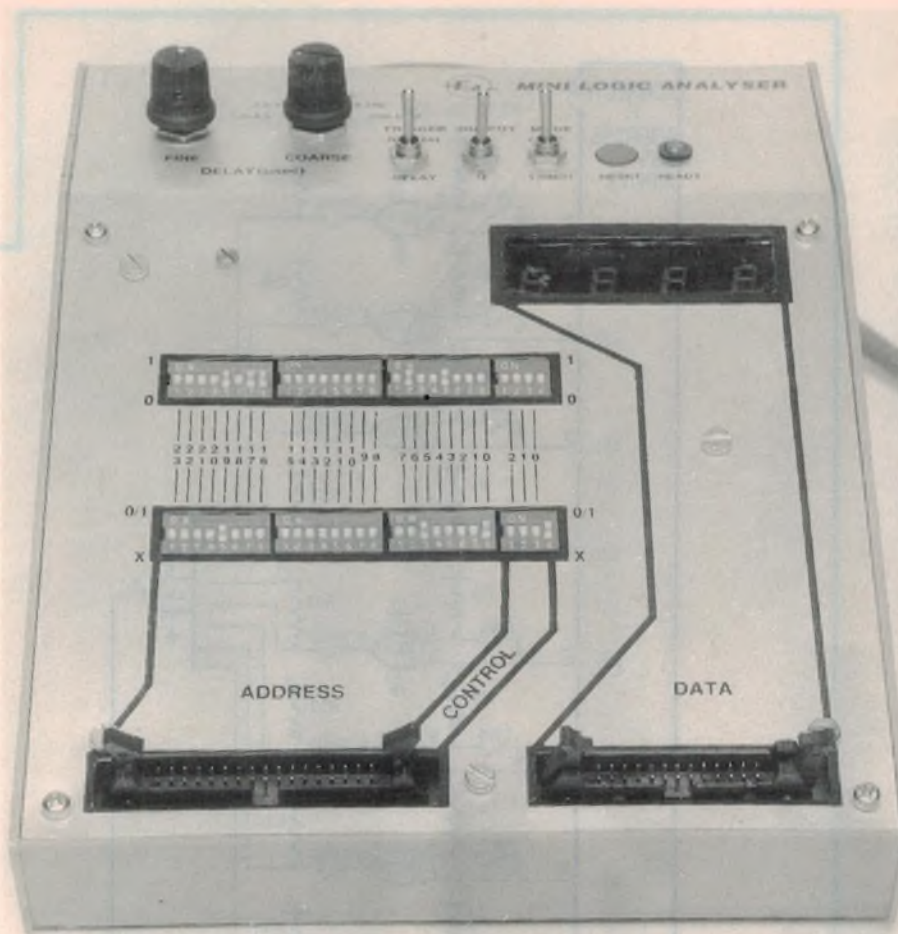
signals can be displayed simultaneously on the screen, but also on how the CRO is triggered.

The most common method of triggering a CRO is to use one of the signals which are actually being displayed to

begin each sweep of the electron beam. This is fine when the signal being monitored conforms to a simple regular pattern, as are usually found in analog circuits. Even the external trigger input on most CROs is not much help, as either method can only monitor one signal at a time.

However, in many digital circuits (such as computers), an event (such as a memory read or write) will only occur when a certain combination of logic levels is present on the address and control lines. Unfortunately the external trigger input of the CRO can only monitor one of these at a time, making





the display of the desired waveform on the CRO at best a hit-and-miss affair.

In some cases it may be possible to find a single line which can be used alone to trigger the CRO, but in many cases this is simply not possible, especially if this line is under suspicion for some reason, or not working at all. In these cases, some form of logic comparator circuit is required to monitor the status of several lines at once, and to trigger the CRO when a pre-set combination of lines are high or low, as appropriate.

Probably the most common place to connect such a device is to the address bus of a computer system. The analyser is then programmed, via front-panel switches, to trigger the connected CRO when a certain address appears on the bus. It is also useful to be able to monitor a few of the computer's control signals, such as a read/write line or a line indicating that a valid memory address is present on the line, to further narrow down the conditions under which the CRO is triggered.

The EA Mini Logic Analyser is designed to be used in conjunction with virtually any 8- or 16-bit computer,

which account for almost all personal computers currently in use. Up to 24 address lines and three control lines can be monitored simultaneously by the analyser. If the system which you are testing has less than 24 address lines, then the unused address inputs can be used to monitor additional control lines, or simply ignored by setting the switches to the 'don't care' position.

In addition to triggering a CRO when the analyser detects the correct combination of address and control lines, a set of internal latches also 'captures' the data on the data bus at the same time. This makes it easy to monitor the entire data bus without having to observe one or two channels at a time on a CRO screen. In fact, there are times when this is all that is required of the analyser, and connection of a CRO is not needed.

One other feature of the present design is a variable delay facility, which optionally allows the CRO and internal data latches to be triggered a pre-determined time *after* the correct address and control signal combination appears. This occurs irrespective of whether the address and control signals remain

stable for this period of time or not.

If the event being observed occurs repetitively at a fast enough rate, you can actually use this facility to look at the state of the data lines apparently *before* the desired event has occurred.

Each address input has two switches on the front panel associated with it. One of these determines whether or not that address line will be monitored or not (don't care). The other switch tells the analyser whether to check for a 0 or 1 on that particular address line.

## Circuit details

While there are quite a large number of ICs in the circuit, there is a lot of repetition involved, and the operation of the whole logic analyser is reasonably straightforward. Each of the 24 address lines is connected to an exclusive-OR (XOR) gate (IC1 - 6), each of which compares that address line with the corresponding DIP switch on the front panel.

An XOR gate's output assumes a 'high' logic level if the two inputs are different, and a 'low' level if they are the same. However, we really want it to be the other way around. That is, we want the output of the XOR gate to be high when the address line matches the DIP switch, and low otherwise. Fortunately, this is easily achieved by simply reversing the switch labels on the front-panel.

Thus, when the switch is closed, that input of the gate is low, so the output of the gate will go high when the corresponding address line is high, which is what we want. The output of each XOR gate goes via a switch (SW28-52) and pull-up resistor to an input of one of the three NAND gates.

If this switch is closed, then the input of the NAND gate will be driven by the output of the XOR gate. However, if the switch is open, then the input of the NAND gate will be pulled high by the resistor, and the state of that address input line will not have any bearing on the output of the logic analyser.

The outputs of the 24 XOR gates are then grouped into three sets of eight (via the above-mentioned switches), and NAND-ed together by ICs 8 to 10. Thus, the output of each NAND gate will be low only if the relevant eight address lines match their corresponding switches.

The three control lines are handled similarly, except that the switches operate the opposite way around. That is, when the switch is closed, the corresponding input to the XOR gate is pulled high, so that the outputs of these

# Logic analyser

three gates are effectively active-low, not active high as for the address lines.

These three gates are then connected to the inputs of a 3-input NOR gate (IC11b), the output of which goes high when all of the control signals match their appropriate front-panel switches. The outputs of the three main NAND gates (IC8 - 10) are fed to another NOR gate (IC11a), the output of which also goes high when all 24 address lines have the desired logic levels present on them.

When the outputs of these two gates are high simultaneously, then the output of IC18a goes low, triggering the rest of the circuit - either directly, or via the delay circuit based around IC19a.

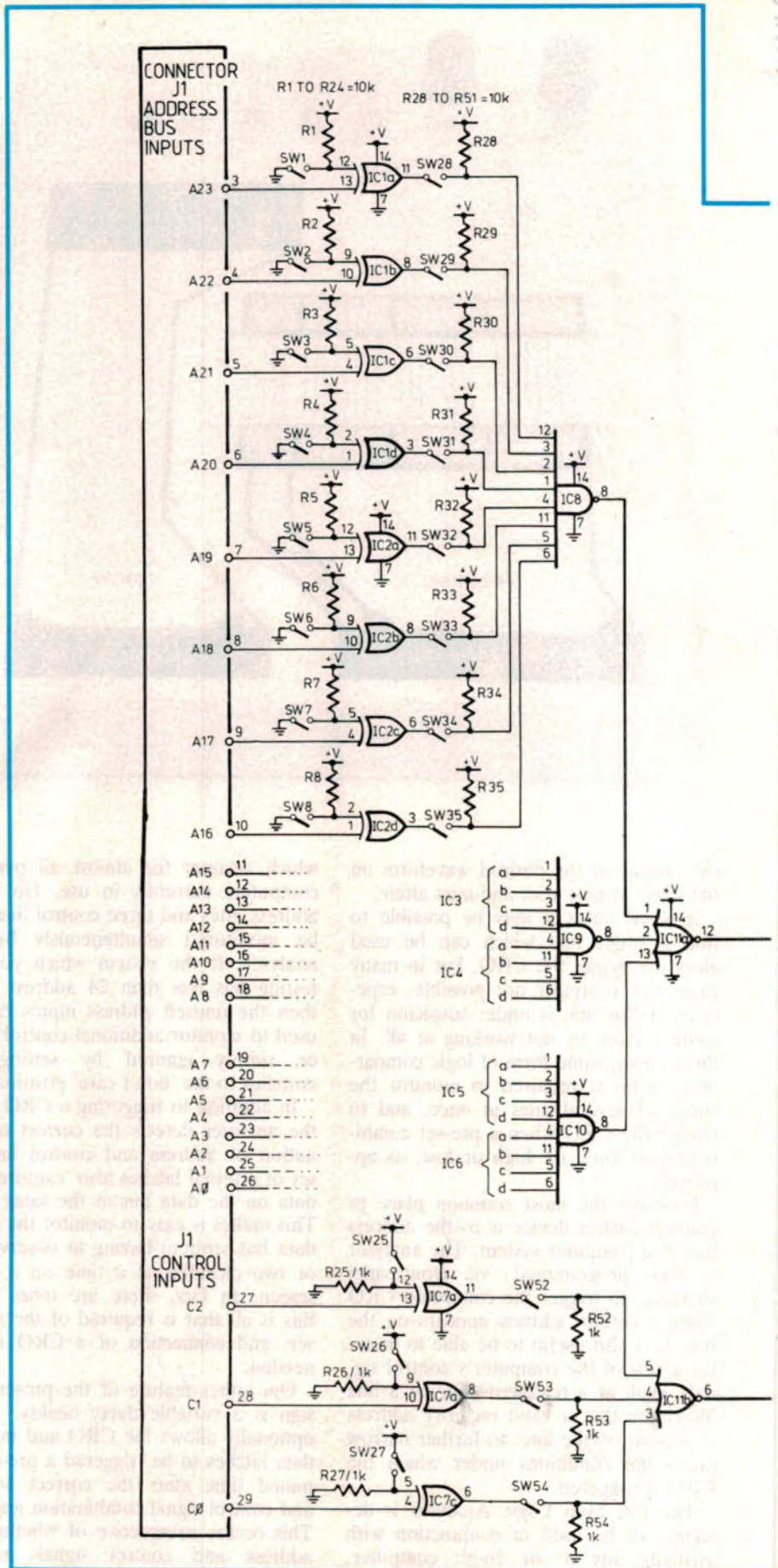
IC19 is a 74LS123 dual monostable, half of which is used to generate the delay for the delayed trigger function, while the other half generates the trigger pulse for the CRO and data latches. The delay time for IC19a is determined by the capacitor selected by SW55 (C1-6), and the series combination of R55 and RV1. SW56 allows the delayed-trigger function of the analyser to be bypassed if desired.

C7, R56 and R57 cause IC19b to be triggered by the falling edge of either IC19a or IC18a, depending on the position of SW56. This generates a pulse of length 0.8 $\mu$ s, which is passed to the CRO output in either inverted or non-inverted form.

If the analyser is in one-shot mode, then the falling edge on pin 4 of this IC also triggers the flip-flop composed of IC18c and d. This applies a low level to pin 2 of IC19, preventing further triggering until the flip-flop is reset by momentarily closing SW59. The combination of R59 and C10 ensure that the flip-flop is reset on power-up.

In addition to triggering the CRO, the Q output of IC19b also triggers the two data latches, IC12 and 13. Each of these latches eight bits of data from the data bus, and the state of these latches is displayed on the seven segment displays (LED1-4) by IC14-17, which are 9368 binary-to-seven segment HEX display drivers. While these drivers also have input latches in them, we elected to use external LS TTL latches, as the 9368s are standard TTL devices, and will load the bus much more than necessary, due to their higher input current requirements.

Power for the circuit is derived from the mains via a 9.5V/1A transformer and a full-wave bridge rectifier. IC20 regulates the output of the rectifier/filter



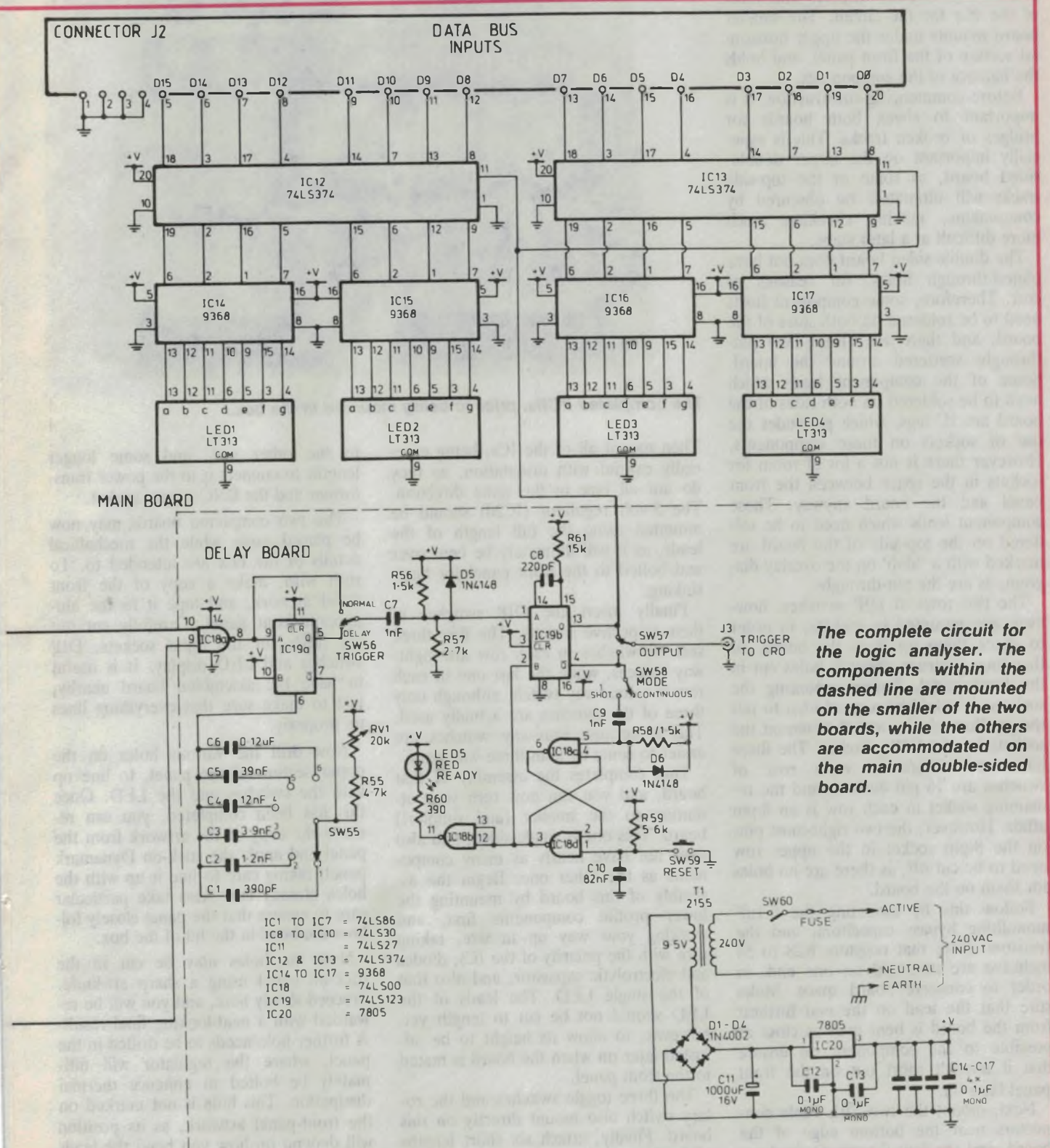
combination down to the 5 volts required by the rest of the circuit. The current drain of the circuit is quite high, owing to the pre-set 20mA current in each segment of the 7-segment displays. With all segments on, the total current drain of the circuit can easily exceed 750mA.

### Construction

The logic analyser is housed in a sloping front plastic and aluminium box, which was the only readily-obtainable box that we could find with suitable front-panel dimensions, and is available from Jaycar Electronics stores. The en-

tire circuit (with the exception of the power transformer and delay potentiometer) is accommodated on two printed circuit boards, which are mounted behind the aluminium front panel.

The larger of the two, coded 891a6a,



The complete circuit for the logic analyser. The components within the dashed line are mounted on the smaller of the two boards, while the others are accommodated on the main double-sided board.

## Logic analyser

is a double-sided board, due to the large number of interconnections involved. This board mounts behind the large sloping surface of the front panel, and accommodates the input sockets, DIP switches, LED displays and most of the ICs for the circuit. The smaller board mounts under the upper horizontal section of the front panel, and holds the balance of the components.

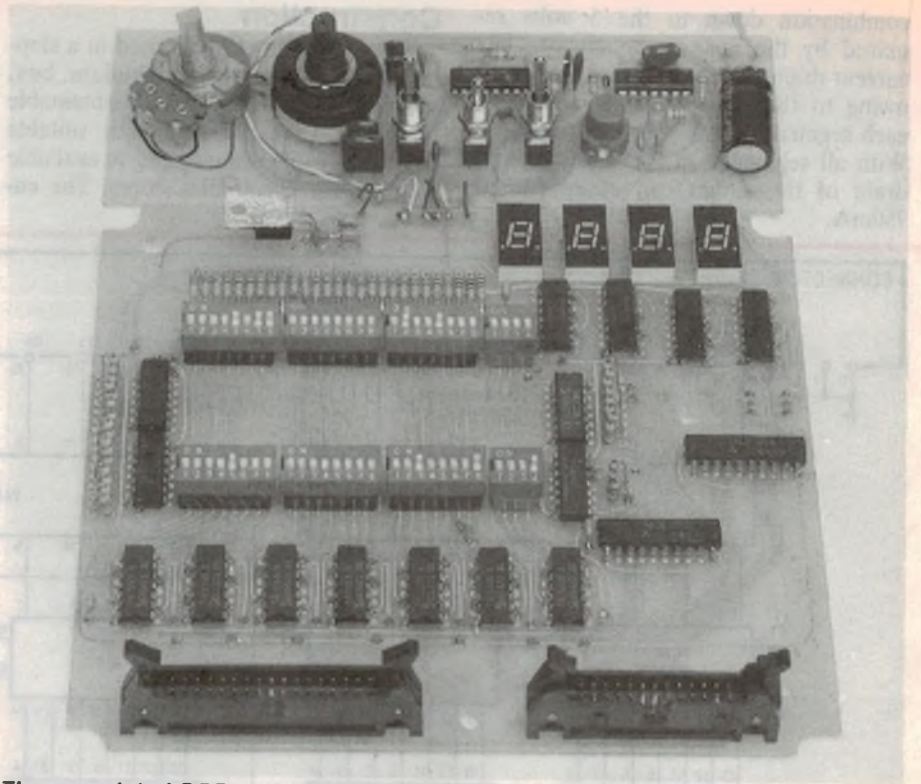
Before commencing construction, it is important to check both boards for bridges or broken tracks. This is especially important on the larger double-sided board, as some of the top-side tracks will ultimately be obscured by components, making checking much more difficult at a later stage.

The double-sided board does not have plated-through holes, for reasons of cost. Therefore, some component leads need to be soldered on both sides of the board, and there are also a few pin-throughs scattered around the board. Some of the component leads which need to be soldered on both sides of the board are IC legs, which precludes the use of sockets on these components. However there is not a lot of room for sockets in the space between the front panel and the board anyway. Those component leads which need to be soldered on the top-side of the board are marked with a 'blob' on the overlay diagram, as are the pin-throughs.

The two rows of DIP switches, however, are mounted in sockets, in order to space them up from the board, so that they protrude through holes cut in the front panel. Before mounting the sockets, it would be a good idea to put the pin-throughs in, and then mount the sockets for the DIP switches. The three left-most sockets in each row of switches are 16 pin devices, and the remaining socket in each row is an 8-pin affair. However, the two right-most pins on the 8-pin socket in the upper row need to be cut off, as there are no holes for them on the board.

Follow this by mounting the 0.1 $\mu$ F monolithic bypass capacitors, and the resistors. Note that resistors R28 to 54 inclusive are mounted on one end, in order to conserve board space. Make sure that the lead on the end furthest from the board is bent over as close as possible to the component, to ensure that it doesn't short out on the front panel later on.

Next, mount the two DIL cable connectors near the bottom edge of the board, and the four 7-segment displays.



The completed PCBs, prior to being mounted in the box.

Then mount all of the ICs, being especially careful with orientation, as they do not all face in the same direction. The 5-volt regulator (IC20) should be mounted using the full length of the leads, as it will ultimately be bent over and bolted to the front panel for heat-sinking.

Finally insert the DIP switches in their respective sockets. The first three sets of switches in each row are eight-way devices, while the last one in each row is a four-way switch, although only three of the switches are actually used. This is because four-way switches are easier to come by than three-way ones.

That completes the assembly of that board, and you can now turn your attention to the smaller (and simpler!) board. This one is single-sided, and also does not have nearly as many components as the other one. Begin the assembly of this board by mounting the lower profile components first, and working your way up in size, taking care with the polarity of the ICs, diodes and electrolytic capacitor, and also that of the single LED. The leads of the LED should not be cut to length yet, however, to allow its height to be adjusted later on when the board is mated to the front panel.

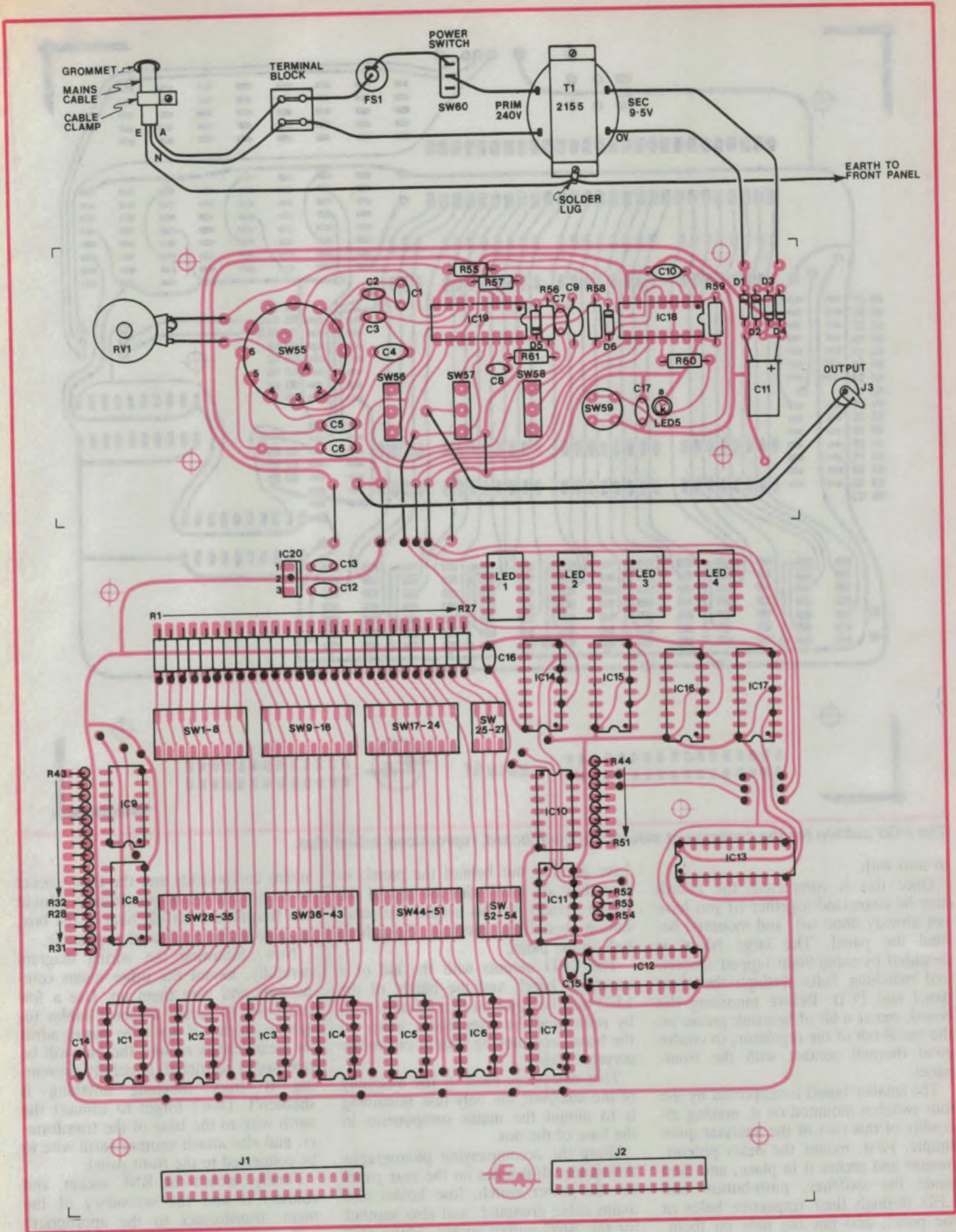
The three toggle switches and the rotary switch also mount directly on this board. Finally, attach six short lengths of hook-up wire to connect this board

to the other one, and some longer lengths to connect it to the power transformer and the BNC output socket.

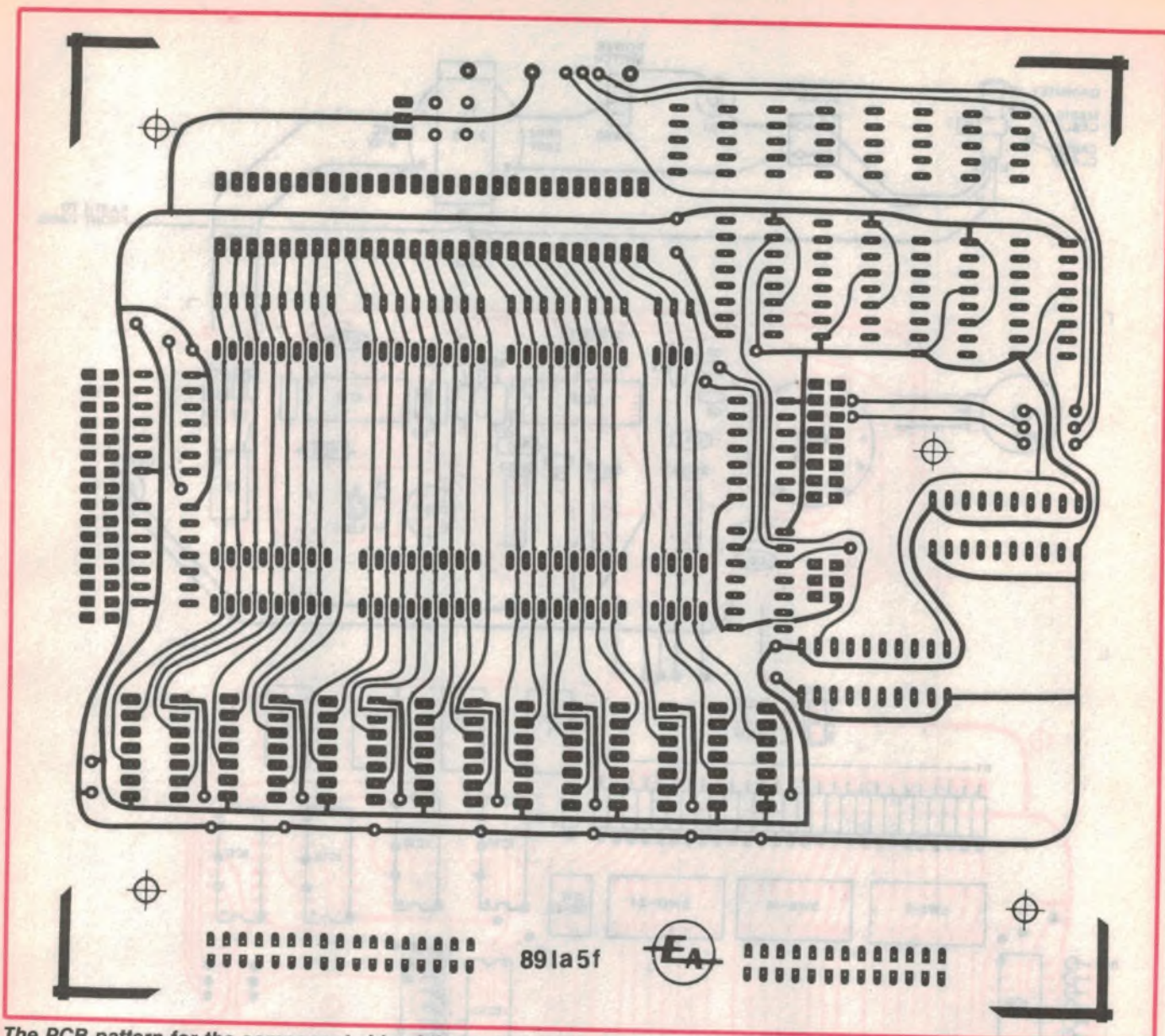
The two completed boards may now be placed aside while the mechanical details of the box are attended to. To start with, make a copy of the front panel artwork, and tape it to the aluminium front panel. Carefully cut out the holes for the input sockets, DIP switches and LED display. It is useful to have the assembled board nearby, just to make sure that everything lines up properly.

Now drill the various holes on the upper section of the panel, to line up with the switches and the LED. Once this has been completed, you can remove the copy of the artwork from the panel and apply the stick-on Dynamark panel, taking care to line it up with the holes already cut. Also take particular care to ensure that the panel closely follows the bend in the lid of the box.

Now the holes may be cut in the stick-on panel using a sharp art-knife. Proceed slowly here, and you will be rewarded with a neat-looking final result. A further hole needs to be drilled in the panel, where the regulator will ultimately be bolted to enhance thermal dissipation. This hole is not marked on the front-panel artwork, as its position will depend on how you bend the leads of the regulator, and how long they are



The overlay diagrams for both PCBs, also showing the overall wiring for the analyser.



The PCB pattern for the component side of the main board, reproduced actual size.

to start with.

Once this is completed, the boards may be connected together (if you have not already done so), and mounted behind the panel. The large board is mounted by using 9mm tapped spacers, and matching bolts through the front panel and PCB. Before mounting the board, smear a bit of heatsink grease on the metal tab of the regulator, to ensure good thermal contact with the front-panel.

The smaller board is supported by the four switches mounted on it, making assembly of this part of the analyser quite simple. First, mount the delay potentiometer and secure it in place, and then guide the switches, push-button and LED through their respective holes in the panel, and put the nuts on them. The three toggle switches should each

have another nut behind the panel, so that they are level with the top of the rotary switch. At this height, the push-button should just protrude through its hole in the panel.

The LED mounts with the aid of a mounting bezel, and the height of the LED may be adjusted to a suitable level by re-heating the appropriate joints on the board and moving it in or out to the correct height.

That completes most of the assembly of the analyser; the only task remaining is to mount the mains components in the base of the box.

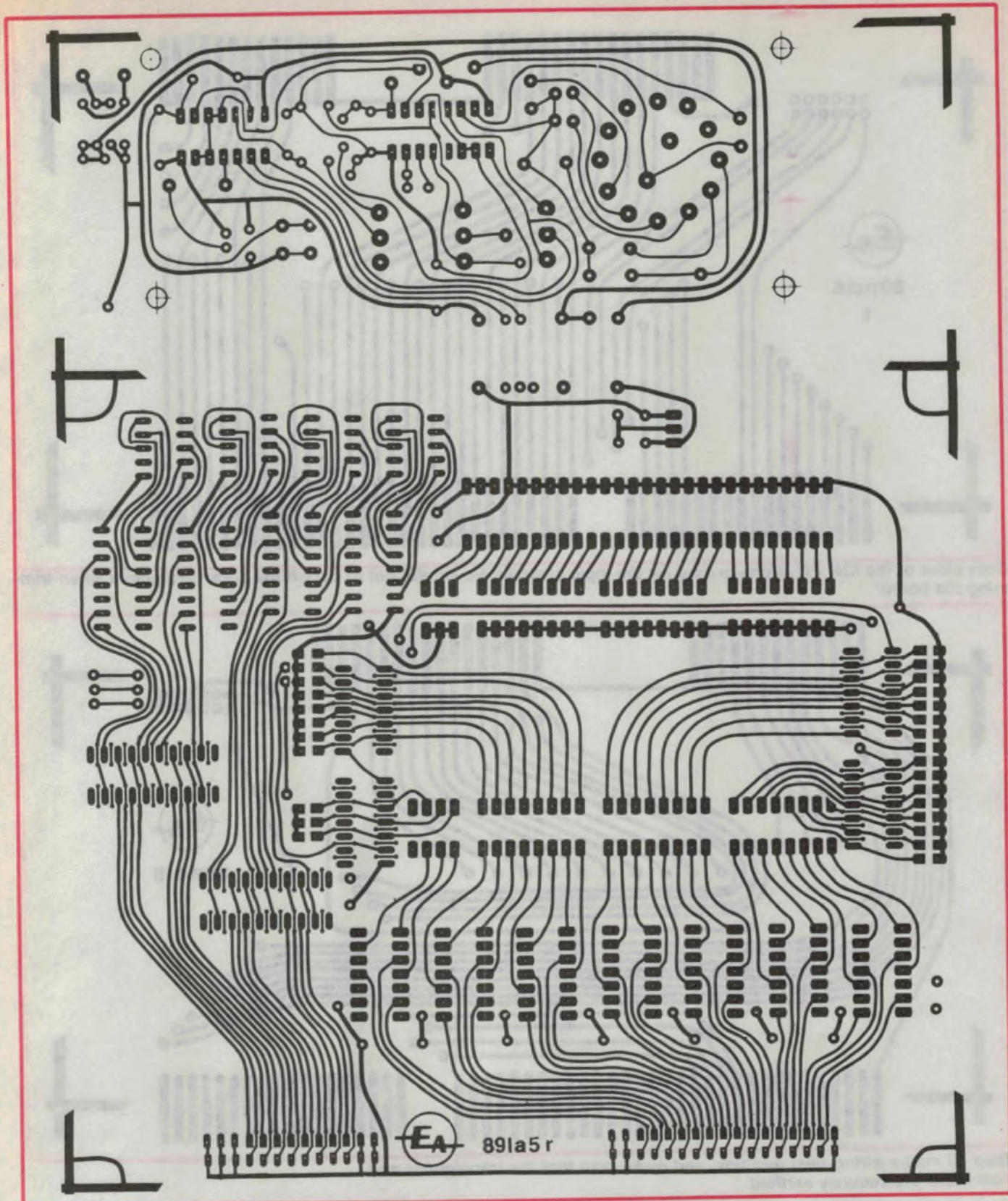
Using the accompanying photographs as a guide, drill holes on the rear panel for the power switch, fuse holder and mains cable grommet, and also another for the BNC output socket. Make sure you allow enough room between the

mains components and the BNC socket to mount the mains transformer. Mount the transformer on the base of the box, as close to the rear panel as possible.

Now, following the wiring diagram carefully, mount the other mains components and wire them up. Use a few cable ties to secure adjacent cables together, so that if one wire comes adrift its meanderings around the box will be reasonably restricted, hopefully preventing it from touching anything it shouldn't. Don't forget to connect the earth wire to the base of the transformer, and also attach another earth wire to be connected to the front panel.

Finally, mount the BNC socket, and connect it and the secondary of the mains transformer to the appropriate pads on the small PCB. The AC supply to the board connects to the 0V and





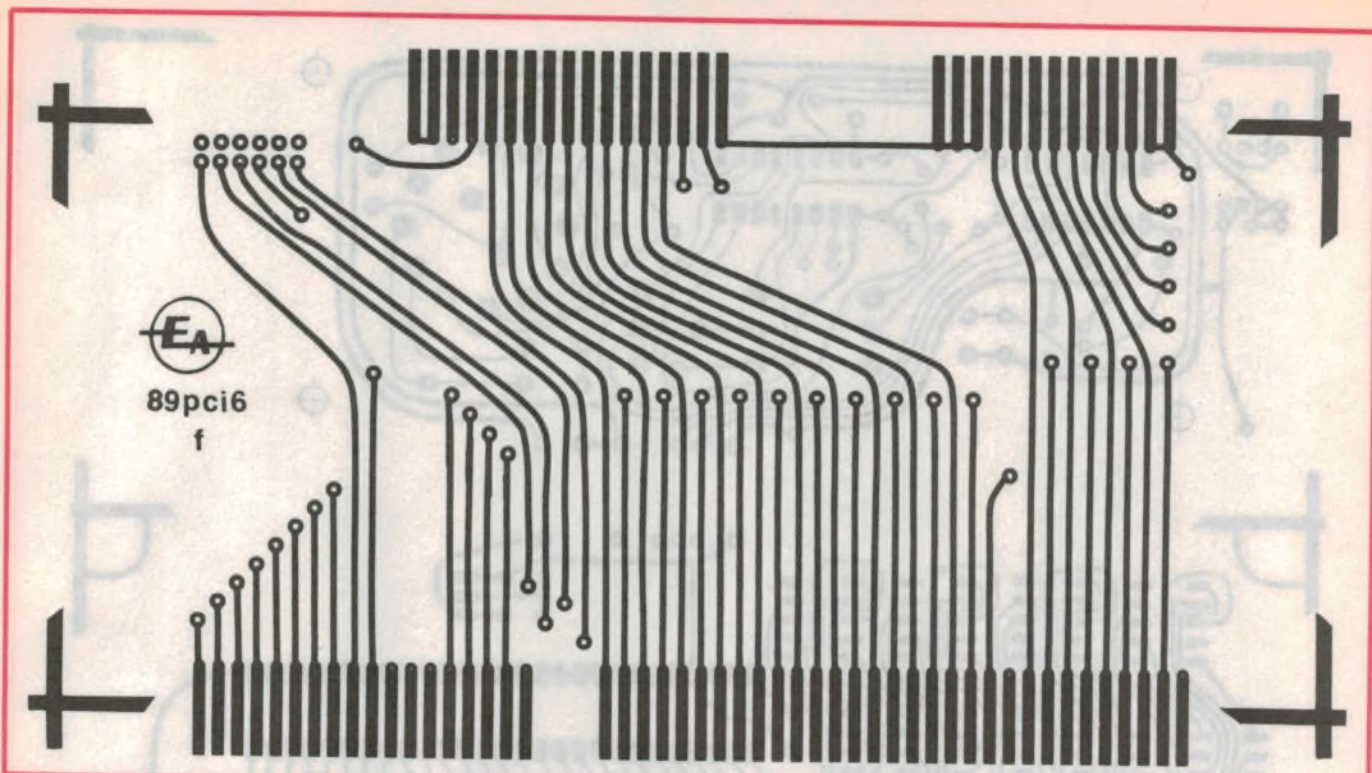
The PCB patterns for the solder side of the main board and also for the delay board.

9.5V taps on the transformer, all of the other terminals remaining unconnected. That completes the assembly of the logic analyser, except for finally screwing the lid of the box in place.

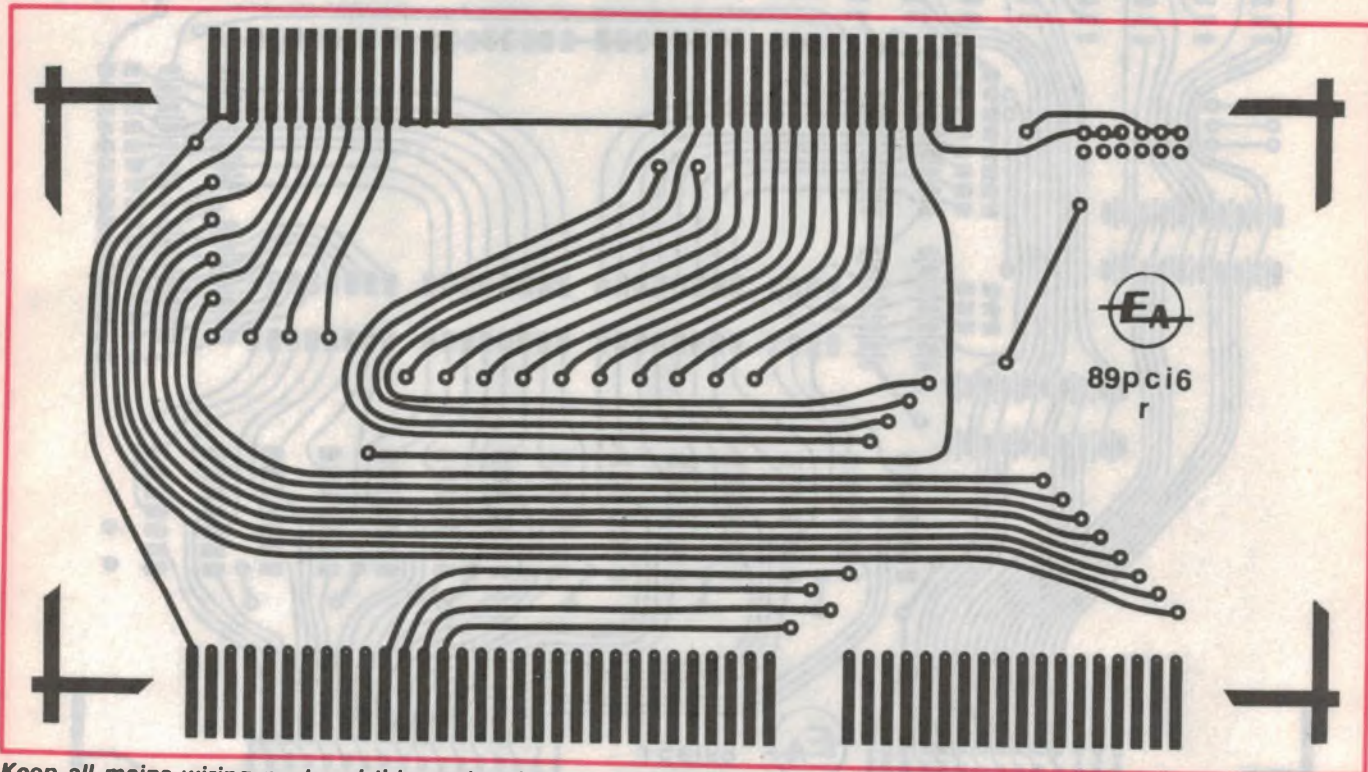
### Analysing logic

Connecting the logic analyser up to the computer requires a little thought, with the ultimate configuration depending on which computer's logic you in-

tend to analyse. One possible solution would be to make up a cable with an IC test clip at one end and a couple of plugs to connect to the logic analyser at the other. The test clip can then be



Both sides of the IBM PC interface card for the logic analyser. Be careful not to cut off the edge-connectors when trimming the board!



Keep all mains wiring neat and tidy, and make sure that the transformer and front-panel are securely earthed.

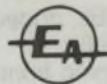
piggy-backed onto the processor chip itself for testing.

However, there are two potential problems with this approach. One is that the output drive capabilities of the processor may not be equal to the task

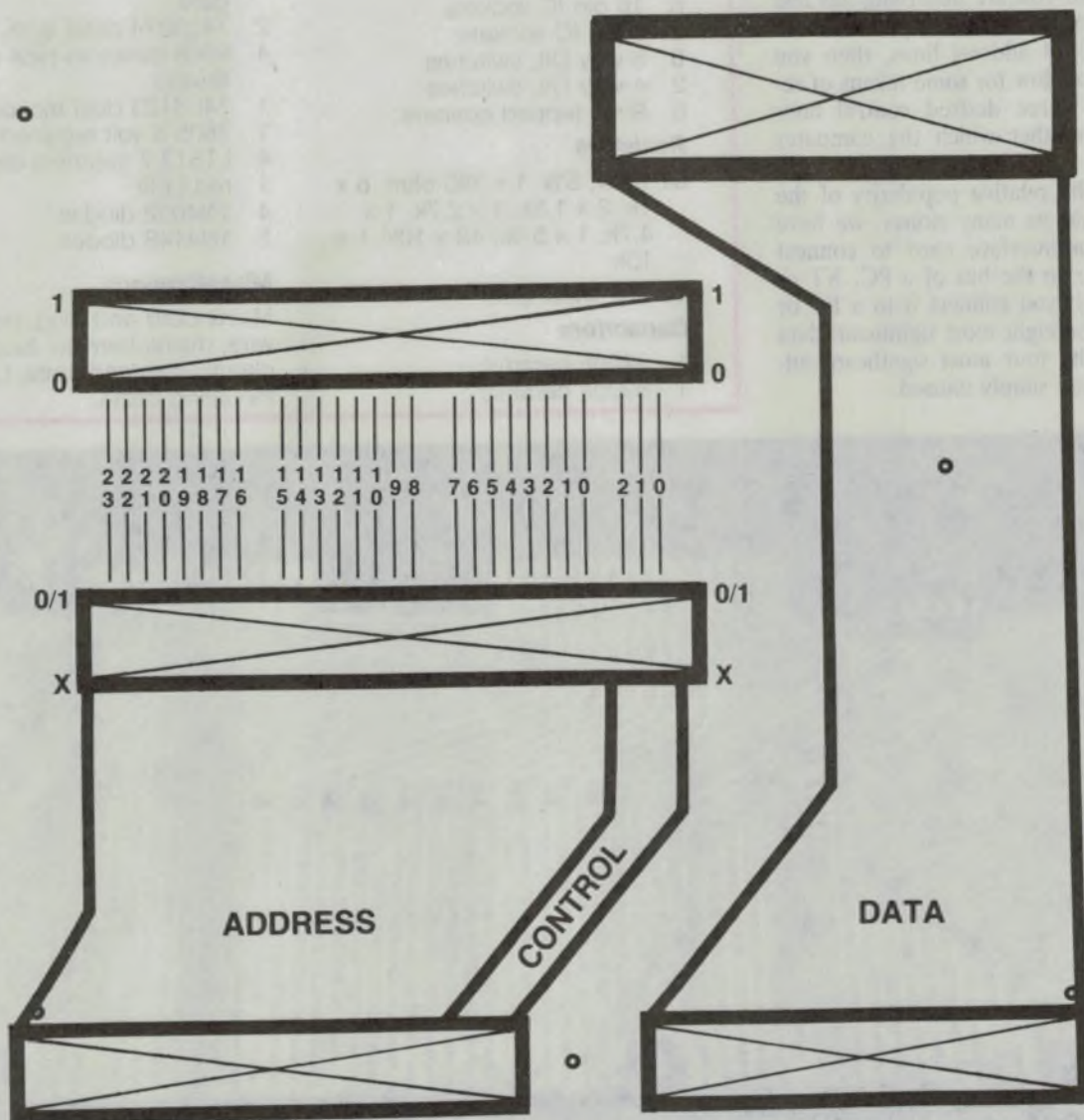
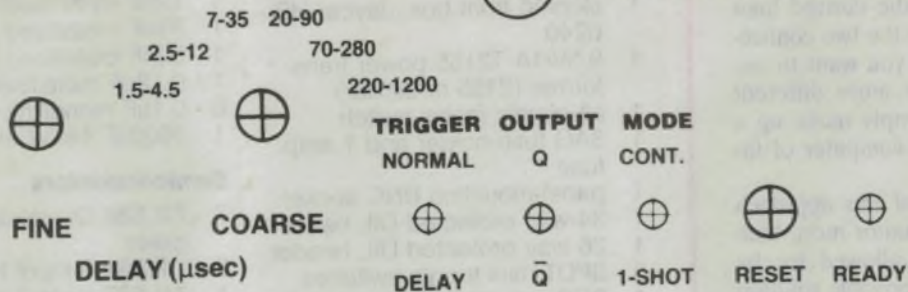
of driving the long cables to the analyser, especially at high clock speeds, due to the capacitance of the cable.

The other problem is that some processors multiplex two different signals on to some of their pins, in order to reduce

the pin-count of the chip. For example, the 8086/8088 have a multiplexed address and data bus, and the 8080 multiplexes some of its control signals with the data bus. In these cases, the lines are usually de-multiplexed by external



# MINI LOGIC ANALYSER



latches. Since this logic analyser does not incorporate such de-multiplexing circuitry (as it would need to be different for each processor), it has to be connected to the computer at a point where these signals are already de-mul-

tiplexed.

The best place to pick up all of the desired signals is probably the expansion bus connector on the relevant computer, assuming it has one. The signals at this point are usually well buffered,

and are also de-multiplexed. For those computers which don't have such a connector, other arrangements will of course need to be made.

If the expansion bus connector on the computer is a socket of some descrip-

## Logic analyser

tion, then all you need to do is to make up a cable to connect the desired lines on the expansion bus to the two connectors on the analyser. If you want to use the analyser on two or more different computers, then you simply make up a separate cable for each computer of interest.

The main limitation of this approach arises if you want to monitor more than the three control lines allowed for by the logic analyser. One possible solution is to use some of the unused address lines as extra control inputs, if the processor which you are observing has less than 24 address lines. If you need to monitor all 24 address lines, then you will need to allow for some means of selecting the three desired control lines from the number which the computer uses.

Due to the relative popularity of the IBM PC and its many clones, we have designed an interface card to connect the analyser to the bus of a PC, XT or AT clone. If you connect it to a PC or XT, then the eight most significant data lines and the four most significant address lines are simply unused.

### PARTS LIST

- 2 PCBs, coded 89la6a and 98la6b
- 1 sloping front box, Jaycar HB-6240
- 1 9.5V/1A T2155 power transformer (2155 or similar)
- 1 all-plastic mains switch
- 1 3AG fuse-holder and 1 amp fuse
- 1 panel-mounting BNC socket
- 1 34-way protected DIL header
- 1 26 way protected DIL header
- 3 SPDT mini toggle switches
- 1 PCB-mounting single pole 6 position rotary switch
- 2 small knobs
- 6 16 pin IC sockets
- 2 8 pin IC sockets
- 6 8-way DIL switches
- 2 4-way DIL switches
- 5 9mm tapped spacers

### Resistors

- all 1/4W, 5%: 1 x 390 ohm, 6 x 1k, 2 x 1.5k, 1 x 2.7k, 1 x 4.7k, 1 x 5.6k, 48 x 10k, 1 x 15k

- 1 20k linear pot.

### Capacitors

- 1 220pF ceramic
- 1 390pF ceramic

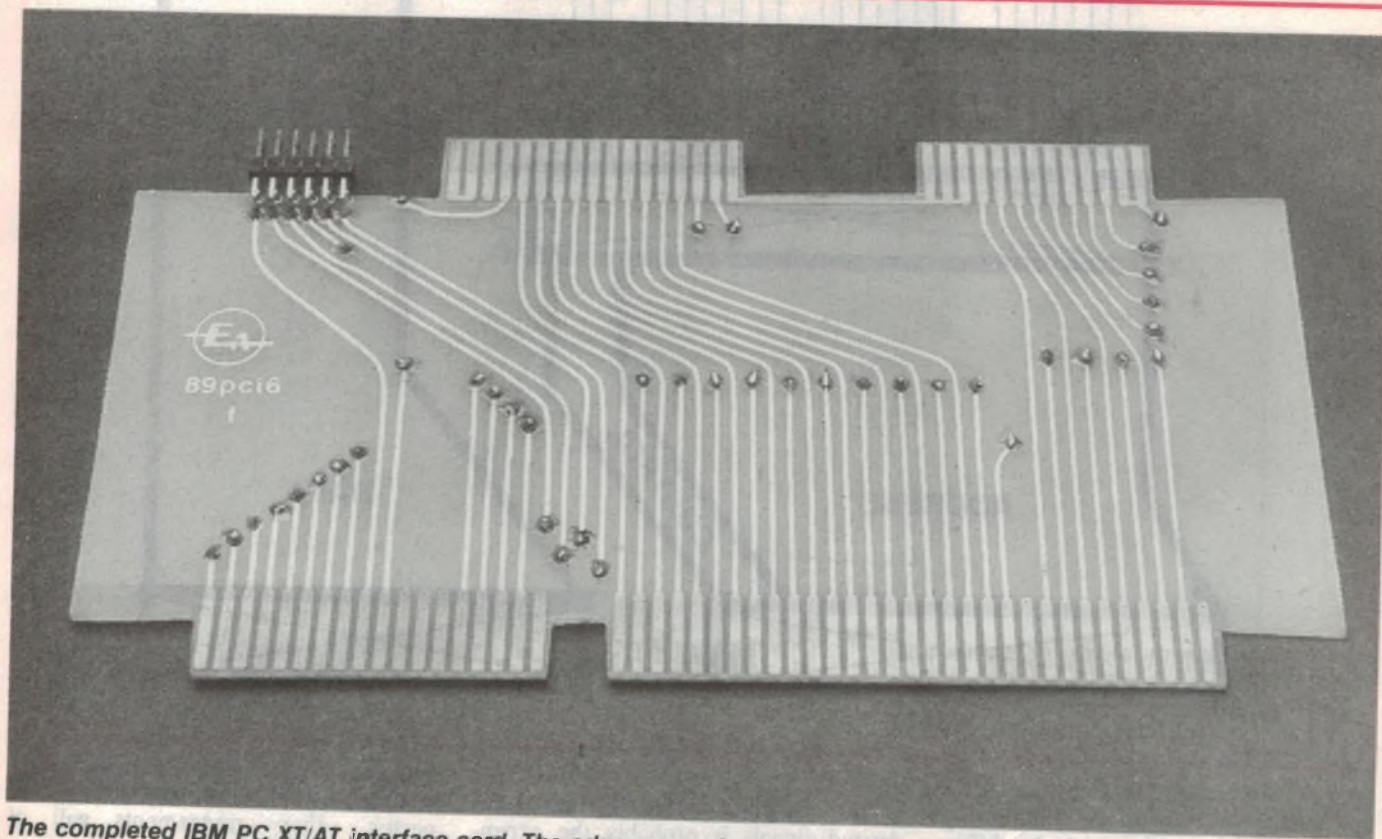
- 2 1nF metallised polyester
- 1 1.2nF metallised polyester
- 1 3.9nF metallised polyester
- 1 12nF metallised polyester
- 1 39nF metallised polyester
- 1 82nF metallised polyester
- 1 0.12uF metallised polyester
- 6 0.1uF monolithic
- 1 1000uF 16VW electrolytic

### Semiconductors

- 7 74LS86 Quad exclusive-OR gates
- 3 74LS30 8-input NAND gates
- 1 74LS27 triple 3-input NOR gate
- 1 74LS00 quad 2-input NAND gate
- 2 74LS374 octal latch
- 4 9368 binary-to-HEX display drivers
- 1 74LS123 dual monostable
- 1 7805 5 volt regulator
- 4 LT313 7 segment displays
- 1 red LED
- 4 1N4002 diodes
- 2 1N4148 diodes

### Miscellaneous

Mains cord and plug, hookup wire, mains terminal block, cable clamp, nuts and bolts, LED mounting bezel.

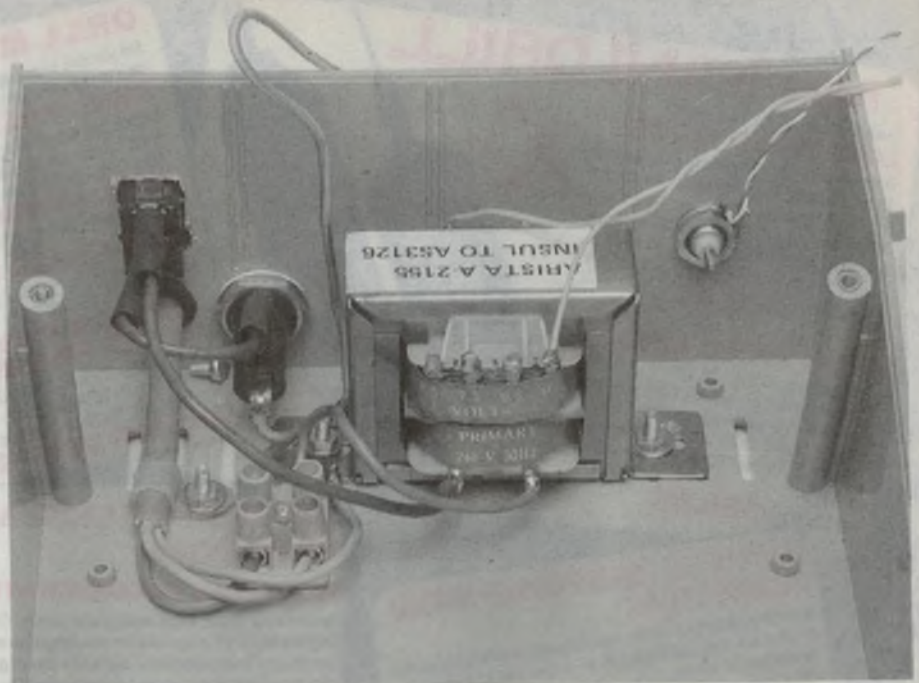


The completed IBM PC XT/AT interface card. The edge connectors at the top have the same pin-outs as the address and data input sockets on the analyser. The jumper block near the upper left corner selects which control signals are sent to the analyser - the row of pins furthest from the top edge need to be soldered on the top side of the board. All other pads on the board are for pin-through connections.

The *Address Enable* (AEN) signal is permanently connected to one of the control lines to the analyser. The other two lines may each be connected to one of three control lines on the bus. One line can be selected to monitor the I/O read line (IOR), or one of two memory read lines (MEMR and SMEMR). SMEMR is active when a read operation is performed from the lowest megabyte of the AT's address space, and is the only memory read line in a PC or XT machine. MEMR is active whenever a memory access is made anywhere in the address space of the 80286.

The other control input to the analyser can monitor one of IOW, SMEMW and MEMW. The functions of these signals are similar to the other three mentioned above, except they apply to write operations rather than reads.

The usual way to use the logic analyser is to trace the operation of a program of some description. This could be a program which is not operating correctly, and you are using the analyser to see whether the processor is doing what you think it should be doing. On the other hand, the program may be a special diagnostic utility, which performs certain operations so that you can check the workings of the computer with the



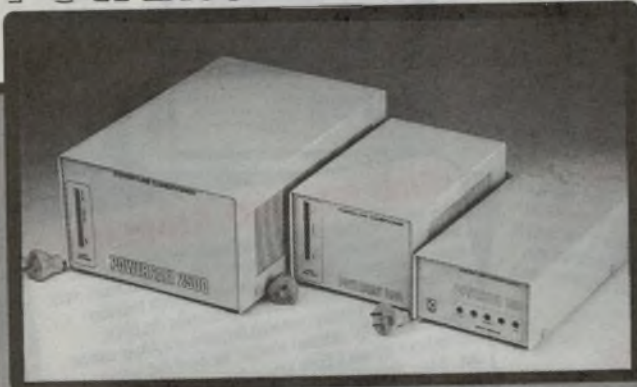
The completed PC interface card. The 12 way right-angle jumper strip is visible near the top-left corner of the board.

logic analyser.

One final point to bear in mind is to make sure that the length of the cables connecting the logic analyser to the computer are kept as short as possible.

This is because the capacitance of the cable will load the bus down, and prevent the signals on the bus from reaching the correct voltage levels in the time required. <sup>(2)</sup>

## POWERSAFE = SAFE POWER



Your 240 volt power requirements are guaranteed to  $\pm 4\%$  or  $5\%$  depending on the model.....

**500 VA, 1000VA or 2500VA.**

All units are equipped with superior CRITEC surge filter protection.

**CRITEC**

VIC (03) 419 4477  
TAS (002) 73 0066  
ACT (062) 515 467

QLD (07) 391 8222  
WA (09) 293 2000  
NSW (02) 688 4528  
SA (08) 352 2577  
VIC (03) 555 6777  
SA (08) 234 2033  
NT (089) 410 322

AUCKLAND NZ (9) 392 464  
WELLINGTON NZ (4) 694 129

CRITEC P/L (Incorporating Component Resources P/L) Technopark Hobart

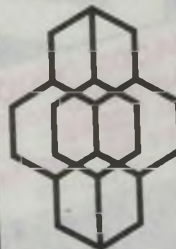
# IBM\* PC/XT/AT compatible Universal Cross Assembler

**8-bit is still alive**

- Quality conditional macro assembler.
- Supports Z80, Z8, 8051, 6811 and all other 6800 family microprocessors.
- 15 day turnaround for any other 8-bit micro.
- Many other features included.

**FROM \$200**

(ex tax)



**Coherent Electronic Systems**  
GPO Box 2597W  
Melbourne Vic 3001  
Telephone: (03) 367 8799

\*Registered trade name.

## TORAS MINI DRILL

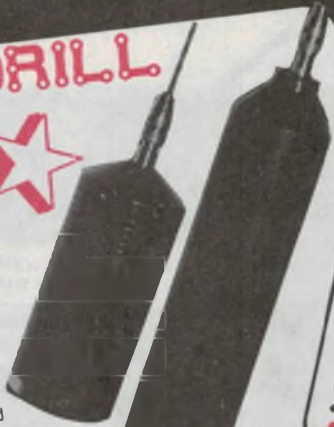
Available once again. Two models.

### LOW SPEED MODEL

Operates on 4 - AA batteries or DC voltage 6 - 12 volts 1 AMP. Supplied with three chucks 1 x 0.4 - 1.5mm, 1 x 1.7 - 2.9mm, 1 x 2.8 x 3.4mm and three drill bits, spanner and tommy bar. Two speed 1100 RPM and 550 RPM. Torque 900gm/cm. Dimensions 43 x 230mm.  
Cat TD-2470 **\$39.95**

### HIGH SPEED MODEL

Operated from 6 VDC - 35 VDC 1 - 1.5 AMP. Supplied with 3 chucks and 3 drill bits, spanner and tommy bar (same as supplied in Low Speed Model). Speed 3500 - 30,000 RPM depending of voltage. Torque 150-600gm. Dimensions 42 x 105mm.  
Cat TD-2475 **\$29.95**



## DRILL MADNESS

Are you sick of paying high prices for mini PCB drill bits? We were. Now you don't have to pay outrageous prices anymore. Jaycar's direct imports save you money.

### DRILL PACK

Includes all those common ones.

- 1 x 3.5mm - for PC supports, relays • 2 x 1.2mm - for PC pins, hookup wire
- 3 x 1mm - for resistors, capacitors etc • 4 x 0.8mm - IC's etc.

**TOTAL 10 DRILLS FOR ONLY \$12.95**  
Cat. TD-2400 - WERE SELLING FOR \$24

**MINI DRILLS IN PKTS OF 10**  
• 0.8mm x 10 (Cat. TD-2420) • 1mm x 10 (Cat. TD-2421)

**ANY PACK ONLY \$9.95**  
**LOWER PRICES ON SINGLE BUYS**

- 0.8mm Cat. TD-2408 SAVE 70¢
- 1mm Cat. TD-2410 SAVE 90¢
- 1.2mm Cat. TD-2412 SAVE 90¢

**ANY ONE ONLY \$1.50**



## UTILUX UX HIGH POWER AUDIO CONNECTORS

Another surplus buy. Utilux now only supply these connectors in black but, they had a quantity of chrome plated ones and Jaycar bought the lot.

Utilux have developed this revolutionary connector system for the professional audio industry. But now you can afford to use these at home.

There are two connectors, one line and one panel type. The line connectors are hermaphroditic, which means they can be plugged into themselves for a line connection. Fits our jumbo each for these.

Specs:

- Mechanical: cable clamp withstands a cable pull out force of 30 Newtons. ■ Material contacts: copper iron alloy silver plated.
- Body Shell: zinc alloy die casting chrome plated. ■

Electrical: Rated at 30 Amps continuous at 100V maximum  
**LINE CONNECTOR \$2.95 10+ \$2.50**

Cat PP-1080

**PANEL CONNECTOR \$2.95 10+ \$2.50**

Cat PP-1082



## EXIDE RECHARGEABLE BATTERY MADNESS.....

### EXPENSIVE RECOMBINATION ELECTRODE TYPE

Another surplus buy which saves you a fortune. This time we have 12 volt Gel-type batteries. They are high-tech recombination electrolyte batteries (a spin off of the space program) which can be used in any orientation and which do not gas, spill, leak or need top up. We are able to offer these batteries at about 1/2 trade price. These are not "cheap" batteries, they are high quality and are made in Japan.

PLEASE NOTE - TRADE NOT SUPPLIED

THREE SIZES AVAILABLE

1.9 amp/hour Exide No. RE 12-1.9

**ONLY \$14.95** 10+ \$13.95 ea

Cat. SB-2482 (Trade price \$30)

2.6 amp/hour Exide No. RE 12-2.6

**ONLY \$19.95** 10+ \$18.95 ea

Cat. SB-2484 (Trade price \$35)

15 amp/hour Exide No. RE 12-15

**ONLY \$79** 10+ \$95 ea

Cat. SB-2490

Size

178mm x 34 x 67 LWH inc connector (1.9)

134mm x 67 x 67 LWH inc connector (2.6)

181mm x 76 x 167 LWH inc connector (15)

Mail order customers in WA and NT please add on extra \$2 for 1.9 and 2.6 batteries for extra mail charges due to weight, and \$10 extra for 15A.



## 1.5V BATTERY TESTERS

The latest in battery testers. Consists of a very flexible piece of plastic with a conductive strip on the rear. Simply place over the battery terminals and the indicator will show if the battery is good, reasonable or bad. Re-usable. Every desk drawer, workshop, toolbox needs at least one. And at the price - who cares.

5 different designs available.

**ONLY 65 cents each**  
**or 4 for \$2.**



## MINI STEREO AMPLIFIER

This amplifier was originally supplied with a pair of 5 watt walkman speakers. We believe this amplifier has much more merit on its own rather than accompanied with two very ordinary speakers, which effectively doubles the price. The amplifier is battery operated (requires 4 x AA) or can be used with a DC 6V external source. Its input and output connections are via 3.5mm stereo sockets. One for in, one for out. It has 3 leds for each channel to monitor output, a high pass and low pass filter switch and an on/off switch with LED indicator. Size 150 L x 70 D x 25 H mm. Ideal for walkmans, or anywhere a low power, battery operated amplifier is required.

Output  
Input & Imp  
Band Width  
Voltage Gain  
Input voltage  
mw



0.5 watt per channel 8 ohms  
600 ohm  
120 H2 - 20 Kh2 - 3 dB  
8 dB +/- 1 dB (walkman only)  
250 mw + power output 50 (walkman)

Cat. AA-0350  
**\$29.95**

## REED RELAY BARGAIN

This time a 5 volt S.P. reed Relay. It will fit into a 14 Pin IC socket. These normally cost \$5 each. Grab a few while you can.

1 - 9  
10 - 99  
100+

**\$1.95**  
**\$1.65**  
**\$1.50**

NORMALLY OPEN  
Cat SY-4040  
NORMALLY CLOSED  
Cat SY-4041



## IN4003 DIODES

**1 Amp 300 volts**  
**Save \$\$\$\$**  
**50 for \$3 100 for \$5**  
STOCK UP NOW Cat ZR-1003



### PLEASE NOTE

All these NEW products are due into stock early September. These ads were written on the 13th of July, so we cannot account for wharfies strikes etc. Please check first before driving across town. Jaycar and Staff.

## ELECTRONIC SENTRY

A complete burglar alarm in a PIR. What a great idea. Basically, it looks like a standard PIR but, it has a keyswitch on the front. It's completely self contained and needs no installation. Can be wall mounted or free standing. Incorporates a built in sound maker giving a scream in excess of 95 dB. Battery operated. Ideal simple burglar alarm for homes, units, caravans, garages, boats, shops, offices, etc.

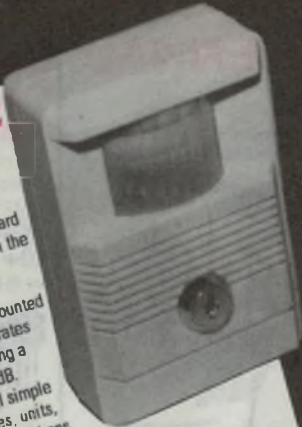
### SPECIFICATIONS

Installation  
Operation  
Normal Operating Height  
Operation Power Requirement  
Standby Arming Delay  
Entry Delay  
Alarm Period  
Siren Volume  
Reset and Rearm  
Low Battery Indication

Free standing or wall mount  
By key  
0.5 - 2 metres  
9V Alkaline battery  
2 minutes  
15 seconds  
1 minute  
In excess of 95 dB  
Automatic  
Short 'Beep' at 10 seconds interval

**\$99.95**

Cat LA-5015



## 3 IN 1 ALARM CHRONOGRAPH

Incorporates  
- Hand held stop watch  
- Clip stop watch  
- Alarm chronograph wrist watch  
- Whistle

Features  
- Quartz accuracy  
- 1/100 second chronograph with lat time  
- Display hours, minutes, seconds, month, date and day flag  
- Alarm and hourly chime function  
- Battery included



## COLOUR BAR PATTERN GENERATOR

See catalogue for full specs  
Normally \$249 **Save \$50**  
**ONLY \$199**

Cat QT-2325



## METRONOME

A must for people learning music. Fully self contained electronic style. Tempo is variable from 40 to 208 beats or times per minute. Switchable between audio sound and a Red LED. Supplied with an earphone for private use. Battery operated. Size 60 x 106 x 30mm.

Cat QM-7240  
**\$39.95**



## C & K SWITCH BARGAIN

C & K Brand 7103 SPOT Centre Off PC Mount. Another surplus stock buy. As pictured, but with longer actuator. Actuator length, 12mm. Switches vertically. These are normally worth over \$4 each. Save a bundle.

**STOCK UP NOW**  
1-9  
10-99  
100+  
Cat ST-0563

**\$1.95 ea**  
**\$1.65 ea**  
**\$1.50 ea**



## JUMBO LCD CLOCK

Huge, easy to read 20mm high digits. Unit measures 57 x 32 x 11mm and is supplied with a slip in bracket and double sided tape for easy mounting. Complete with light for night reading, and battery. Ideal for cars, homes, boats, virtually anywhere.



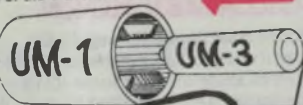
**ONLY \$7.95**

CAT XC-0220

## NiCad BATTERY ADAPTORS

Why buy expensive C and D size NiCads when these adaptors allow you to use low cost AA NiCads instead. These adaptors look like a normal battery except that they are hollow, and on AA NiCad can be inserted inside. These can then be used in place of the C or D NiCads.

C Size Pkt of 4 **\$4.95** Cat. SB-2462  
D Size Pkt of 4 **\$4.95** Cat. SB-2464  
AA NiCads 500mA/hr \$3.50 ea  
**4 for \$12.50** Cat. SB-2452



## PERFORMANCE COMPUROBOT II

This highly sophisticated robot has it all. The robot is programmed via a wireless infra-red hand held controller with a 25 key keypad. A very comprehensive 30 page instruction manual is also provided. Up to 64 program steps can be accommodated in the robot memory. The unit will go in any direction as well as make a number of different noises, flash lights, etc. It beeps every time a key entry has been entered so that it verifies entry. The robot has two (non-motorsised) mechanical arms to actually carry a payload. A crayon attachment is also provided to enable the robot to 'draw'. When the IR controller is not in use the robot has a holder to carry it about. Another very valuable feature is an auto-turn-off facility, which conserves battery life. A highly recommended product. Measures 230 (H) x 210 (W) x 176 (D) mm. Rugged ABS plastic case. Uses Japanese quality Mabuchi motors. Batteries required 4 x C (for robot), 4 x AA (for controller).



Cat XR-1026  
NORMALLY \$129.95  
**SELL OUT PRICE \$89.95 SAVE \$40**

## VIFA SA100

Speakers & cabinets  
8", 2 way 70W rms  
**SAVE \$100**  
**ONLY \$699pr**



Cat. CS-2460/  
CS-2462



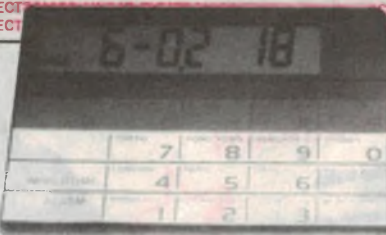
**Jaycar** No. 1  
ELECTRONICS  
**FOR NEW PRODUCTS AND BARGAINS**

## WORLD TIME

Pre-programmed with 12 times\* for different cities including Tokyo, Hong Kong, Bangkok, Sydney, London, Paris, Cairo, Moscow, Honolulu, Los Angeles, Chicago, New York and one spare zone for another city. The times are displayed immediately after touching the button.

Also incorporated is a calculator as well as the date and an alarm. Credit card size.  
\*Once one time zone is programmed in, the other zones are automatically calculated by the unit.

Cat. QM-7210  
**ONLY \$19.95**



## Turn Your Surplus Stock Into Cash!!

Jaycar will purchase your surplus stocks of components and equipment  
**CALL GARY JOHNSTON OR BRUCE ROUTLEY**  
**(02) 747 2022**

## SAVE \$\$\$ ON SPEAKERS POLYPROPYLENE WOOFERS

See 1989 Catalogue for full details

**12" 80W rms**

Cat. CW-2130

Normally \$69.95  
**SAVE \$15**  
**ONLY \$54.95**

**10" 70W rms**

Cat. CW-2116

Normally \$52.50  
**SAVE \$12.55**  
**ONLY \$39.95**

**8" 60W rms**

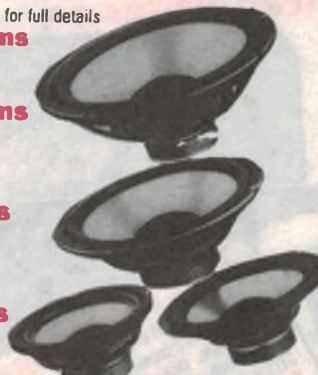
Cat. CW-2114

Normally \$39.95  
**SAVE \$10**  
**ONLY \$29.95**

**6" 30W rms**

Cat. CW-2108

Normally \$29.50  
**SAVE \$8**  
**ONLY \$21.50**



## WHITE CONE MIDRANGE

80W rms system power (not polypropylene)

Cat. CM-2000

Normally \$22.50

**SAVE \$7.50**  
**ONLY \$15.00**



## ELECTRONIC PEDOMETER

### FEATURES

- Measures distance travelled in miles and kilometres.
- Counts steps taken
- Tally counter, to count numbers by hand
- Calculator function

Easy to read LCD display, clips on belt, battery lasts for years. Size 50x56x17mm

Cat. QM-7220 **\$29.95**



## MONITOR MADNESS

Another distress stock purchase!

This time a quantity of Samsung brand 12" Green composite computer monitors.

**SEE LAST MONTHS ADS FOR FULL SPECIFICATIONS**

**LIMITED STOCK - BE QUICK**  
**GREEN Cat. XC-3000**

**ONLY**  
**\$99.50**  
**SAVE**  
**\$50**



## UHF ANTENNAS

### 91 Element

Receives all band 4 and 5 channels through 21 to 69. Ideal for fringe areas. Includes balun for 75Ω cable. Max gain 16dB  
Cat. LT-3182

**\$139**

### 43 Element

Suits both bands 4 and 5. Ideal for medium signal reception areas. Includes balun. Max gain 13dB  
Cat. LT-3181

**\$75**

### 11 Element

The baby. Again bands 4 and 5. Includes balun. 8dB gain  
Cat. LT-3178

**\$39.95**

## EASY TO INSTALL

Simply mount above or below your existing VHF aerial and connect to existing cable with a diplexer.  
Cat. LT-3014 **\$12.95**



## Wire Wrap Machine Pin IC Socket Strips

Snap off to any length to make IC sockets. Quality machine pin wire wraps pins.

**\$6.95 per length**  
**10+ \$6.50 per/l**

Cat. PI-6472



## DIGITAL HYGRO-THERMOMETER

Measures temperature AND humidity at the same time!

This compact battery operated unit has two bright LCD readouts. One for temperature (down to -25°C) and the other for humidity (20 - 95%).

Can be used in the car or home/office etc.

Cat. QM-7230

**\$69.50**



## SIREN MADNESS

Another distress stock purchase which saves you lots of money. This time two sirens.

### SCREAMER BARGAIN

Don't miss out. Grey in colour. Made in Italy. Unbearable sound. Save \$5 over normal unit. Size: 57L x 33Hmm. Operates on 12 volt. Ideal for burglar alarms inside car and houses.

Cat. LA-5254

**ONLY \$12.95 10+ \$11.95 ea**

### SCREAMER HORN

We used to sell this unit years ago for \$35. Today, it would cost about double that. Ideal for car alarms and home burglar alarms. It's very loud, the specs say 112dB, but we think it's louder than that. It has a nylon case and the noisemaker is a nylon 4" speaker. It's weatherproof and operates from 6-12 volts. Current drain 2 amps and the frequency is 1200-1500Hz oscillating. Supplied with mounting bracket. Size: 110 x 100mm

**GIVEAWAY PRICE -**  
**ONLY \$25 ea**

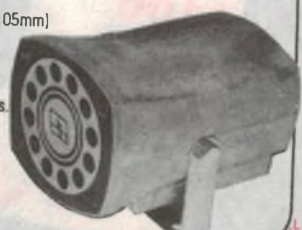
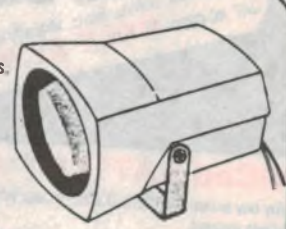
Cat. LA-5262

### LARGE PIEZO SCREAMER

Not unlike our tweety pie, this unit is larger (80 x 105mm) and is housed in a zinc die cast body. This is rare, as most these days are plastic. Sound level is 124dB. Operating voltage 6-12 volts, current drain 350mA. Ideal for car and home burglar alarms. Normally worth about \$39. A bargain at \$25.

Cat. LA-5265

**ONLY \$25**







## Construction project:

# Low cost, compact Sub-woofer enclosures

These inexpensive sub-woofers are ideal for extending the bass response of small to medium sized stereo systems. The cabinet may be built in single or double driver formats, using simple construction techniques and standard materials.

by **ROB EVANS**

In the May '89 issue of *Electronics Australia* we presented a simple box of tricks called a 'Versatile Sub-woofer adaptor', which enables a sub-woofer to be easily added to almost any hifi system. This unit sums and attenuates the signals from an amplifier's output terminals, and filters the resulting 'sum' signal to remove frequencies above a selectable crossover point. The low-frequency information is then applied to a suitable amplifier and loudspeaker combination, to enhance the main system's bass response.

This arrangement has proven to be so effective, we've undertaken the design of a dedicated sub-woofer enclosure to eliminate the weakest link in the chain – the low-frequency loudspeaker itself. Happily, our efforts were well rewarded by the resulting sub-woofer system, which offers very compact cabinet dimensions and a controlled, extended low-frequency response.

### Design aspects

To *literally* live up to its name, a sub-woofer should be able to reproduce sub-sonic frequencies (say below 30Hz), when available from the signal source. However such systems are rather rare, being generally both very large and prohibitively expensive. In practice the expression 'sub-woofer' is more of a generic term, and tends to include any free-standing low frequency speaker system. So for the sake of this discussion, consider a sub-woofer as a separate speaker system that extends the low frequency response of an existing system.

The type of speaker system that will benefit the most from this sub-woofer technique is one using the commonly found 'bookshelf' units. Once again a

generic expression, these speakers may be defined as any small system designed to be physically compact – despite the fact that they may not actually fit into a bookshelf itself. The point here is that these units generally have a limited acoustic output below 100Hz due to the restricted cabinet volume, and the use of a modestly sized bass driver (typically less than 200mm).

So to complement this type of speaker system we require a sub-woofer with compact dimensions, reasonable power handling, and a frequency response down to say 40Hz. However these conditions are a little contradictory, since such a response from a small cabi-

net volume can only be achieved with an equally small driver. In turn, the speaker must be capable of large cone excursions in order to produce the equivalent acoustic output of a larger driver.

Fortunately, a low-cost 150mm (6") speaker with almost ideal specifications for the task is available from Altronic Components, under catalogue number C3055. This imported driver is equipped with a long throw voice-coil, polypropylene cone, offers a nominal power rating of 30W RMS and a free-air resonance of around 38Hz. In a vented enclosure with optimum tuning, this excellent little speaker can deliver a smooth frequency response down to about 35Hz.

So the remaining challenge was to establish a small, but effective design for the vented enclosure. The danger here is that while a vented system provides lower distortion, extended frequency response and higher power handling than an equivalent sealed enclosure, it is far less tolerant of design errors. In practice, a misalignment in the driver-to-enclosure relationship will tend to cause a lumpy frequency response and excessive cone travel.

However, we are lucky enough to have access to Chris Strahm's LEAP (Loudspeaker Enclosure Analysis Pro-



**The prototype enclosures in unfinished particle board. Both versions offer a smooth response down to about 35Hz.**

gram) computer software, which quickly completes the relevant calculations and displays or prints the results – see our review in the May '89 issue of *EA*. This elegant program removes the tedium of manual number crunching, and consequently allows a wide variety of enclosure volumes and tuning relationships to be compared with ease.

As a result, the optimum enclosure for the above driver was found to have quite a small volume of 25 litres, and a cabinet/vent tuning of 38Hz. This produced a smooth low-frequency response down to a -3dB point of about 35Hz, and quite an astonishing acoustic output – especially considering the small dimensions of both the cabinet and driver.

Further to this, we then constructed a second enclosure to accommodate two drivers, which simply requires double the original cabinet volume and an increased port area. The benefit here is increased power handling (from 30W to 60W) – and less obviously, a slight improvement in the low frequency extension due to mutual coupling between the drivers.

The actual power handling of both the single and double driver sub-woofers will depend upon signal content, to some degree. However on a typical music signals, amplifier powers of around 50 watts and 100 watts respectively are quite suitable. In fact many amplifiers rated at 50 watts (into 8 ohms) will deliver about 80 watts into a 4 ohm load, which is appropriate for either sub-woofer arrangement. Of course, the two drivers in the larger cabinet will present a 4 ohm load to the amplifier, when wired in parallel.

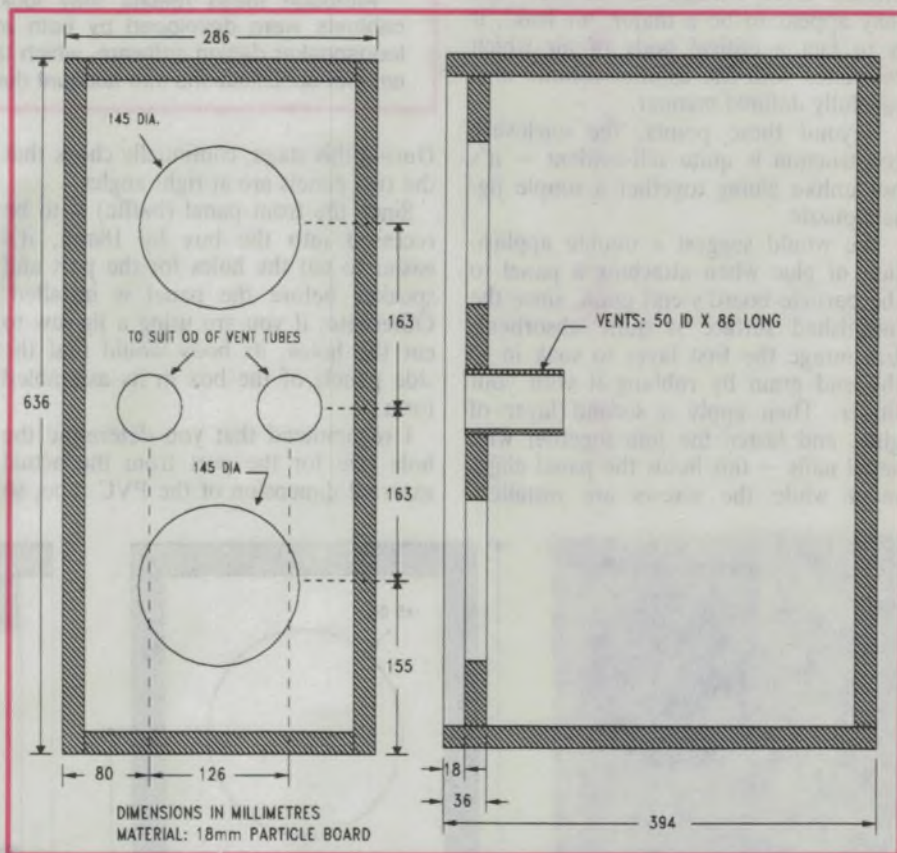
## The enclosure

The prototype cabinets for both configurations were constructed from 18mm (3/4") particle board using simple butt joints, without extra cleats or bracing. This technique proved to be more than adequate for the task, and made the actual assembly a very straightforward process. Similarly, we chose standard PVC tubing for the vent material since it's readily available, rigid and easy to work.

The slightly odd shape of the prototype cabinets was considered to be the most versatile arrangement for most living areas, since this low profile format has the ability to fit under or between (when standing on its end) the surrounding furniture. Nevertheless, this may not suit some constructors who (for example) take pleasure in startling their guests with cup-rattling coffee tables or



*The two-driver unit packs quite a wallop.*



*The dimensions for the larger enclosure. These may be altered, provided the internal volume remains the same.*

the odd 'sensurround' sofa – indeed, the physical options are vast.

However this is not a problem, since the actual box dimensions may be varied from that of the prototype without suffering a performance penalty, as long as the internal volume remains as specified. When calculating an alternative shape, avoid very narrow internal dimensions (say less than 200mm), particularly for the spacing between the baffle board and the rear panel. Also avoid internal dimensions which fall into

ratios of 1:1, 2:1, 3:1 and so on, for these may promote severe standing waves within the cabinet.

## Construction

While the basic butt-joint style of construction makes the box assembly a simple task, particular care should be taken in the following couple of key areas. In fact, they apply to the construction of *any* speaker cabinet.

Firstly, how well the box fits together and its general appearance will depend upon the accuracy of the panel cuts.

## Sub-woofers

These edges must be clean and straight, and at 90° to the main panel face. If you don't have the facilities to produce reasonably accurate results, your friendly timber merchant may be able to help. As well as selling you the particle board, the staff are often willing (for a small fee) to cut the sheet into the required panel sizes.

The other main point of concern is the sealing of the completed enclosure. All timber joints and box to component connections must be thoroughly air tight, since the passing of air through a poor seal will produce audible harmonic effects. Even though the cabinet vent may appear to be a major 'air leak', it is in fact a critical body of air which resonates with the cabinet volume in a carefully defined manner.

Beyond these points, the enclosure construction is quite self-evident – it's not unlike gluing together a simple jig-saw puzzle.

We would suggest a double application of glue when attaching a panel to the particle board's end grain, since the unfinished surface is quite absorbent. Encourage the first layer to soak in to the end grain by rubbing it with your finger. Then apply a second layer of glue, and fasten the join together with small nails – this holds the panel alignment while the screws are installed.

## Alternative drivers

While the combination of the Altronics driver (Cat: C 3055) and the described cabinets provide excellent results, other (nominally) 150mm units may be used. Of course, any alternate speaker will exhibit different characteristics from the above driver, and its parameters must be known in order to recalculate the optimum vent tuning and/or enclosure volume.

For example, detailed testing of the 162mm unit available from DSE stores (Cat: C 2042) indicated that a port length of 56mm is required for a smooth response from the 25 litre cabinet, and two 52mm long ports suit the 50 litre (double driver) enclosure. However the low-frequency response is a little restricted (a -3dB point of 42Hz) when compared to the prototype, which extends down to 35Hz.

Similarly, we also analysed a comparable unit with a white 'poly' cone which is available from Jaycar stores (Cat: CW 2108). In this case, a reasonably smooth and extended response (a -3dB point of 40Hz) is obtained with a cabinet of *twice* the original volume – that is, about 50 litres for a single driver. For the appropriate tuning, two ports are required, each with a length of 55mm.

Although these results may look rather simple, all of the suggested cabinets were developed by both extensive practical tests and the LEAP loudspeaker design software, which takes some 15 driver parameters and 12 cabinet specifications into account during its analysis routine.

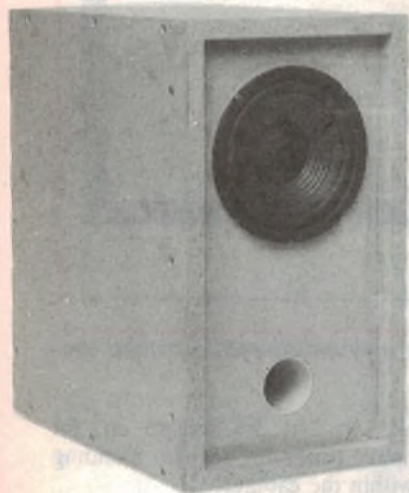
During this stage, continually check that the two panels are at right angles.

Since the front panel (baffle) is to be recessed into the box by 18mm, it's easier to cut the holes for the port and speaker before the panel is installed. Otherwise, if you are using a jig-saw to cut the holes, its body would foul the side panels of the box in its assembled form.

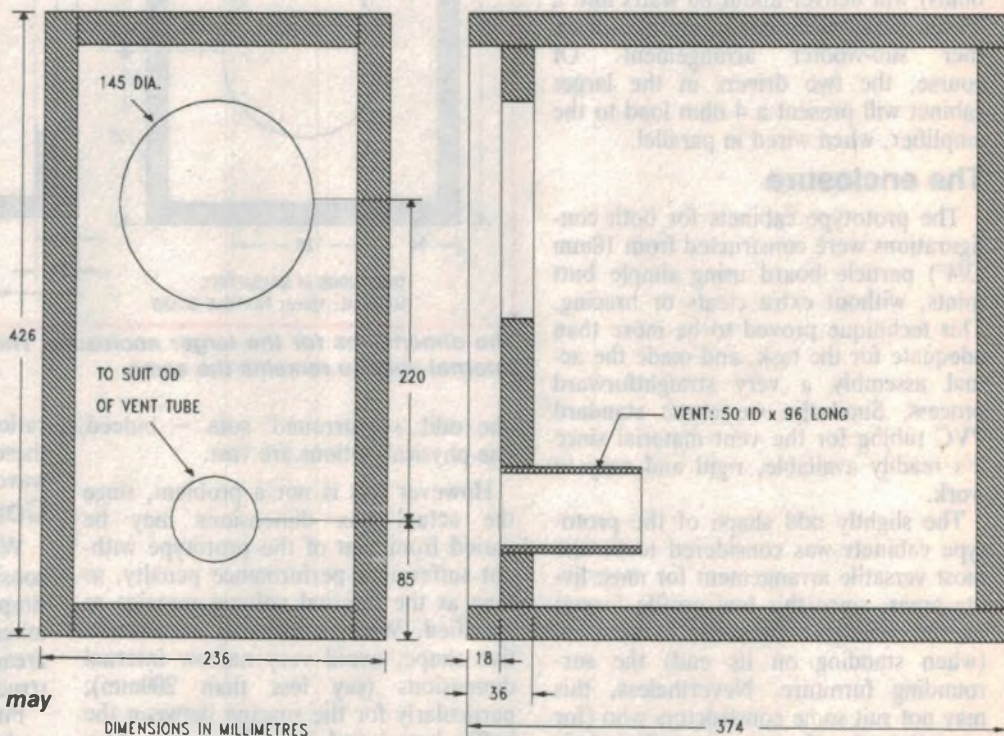
I recommend that you determine the hole size for the port from the actual external dimension of the PVC tube, so

as to ensure a neat fit when it's finally installed. A simple way of ensuring a complete air seal in the cabinet wood-work is by running a bead of glue along all of the inside joints, and smoothing it in place with your finger.

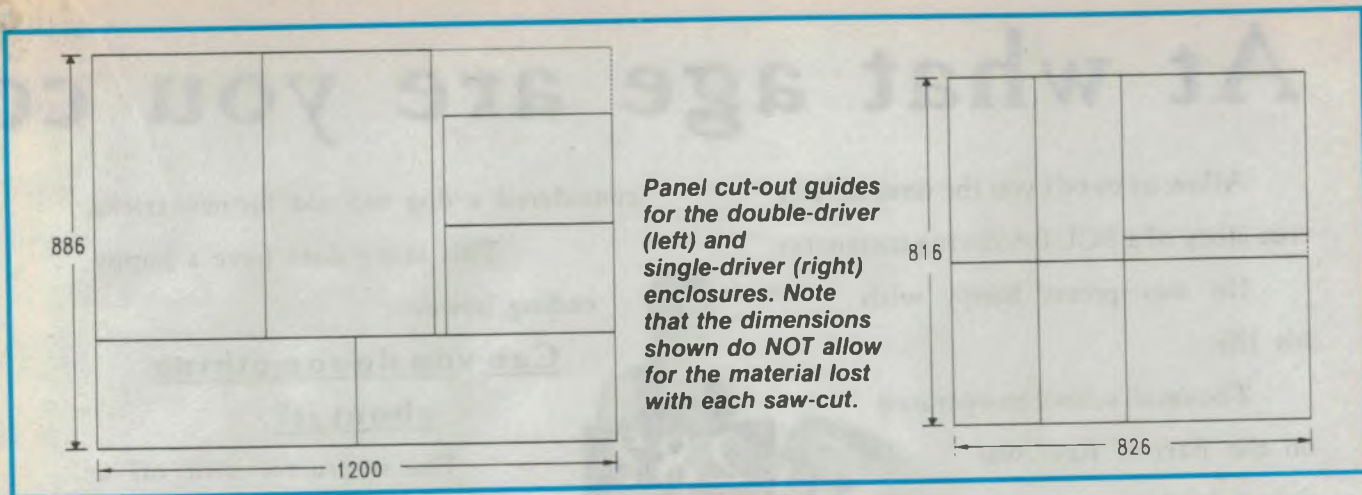
When you are happy with the cabinet construction and finish, it's time to install the driver and the various hardware components. First, mount the connector for the speaker cable to a suitable position on the rear panel, together with generous lengths of heavy-duty



**Above: The smaller sub-woofer is able to fit into the nooks and crannies of a typical listening room.**



**Right: The dimensions for the single-driver cabinet. Again, they may be varied to suit different requirements, provided the internal volume remains constant.**



hookup wire for later connection to the driver. Once again, the connector must be sealed to the box to prevent air leaks.

After that, place a layer of Innerbond (or an equivalent acoustic lining) loosely within the cabinet, so as to cover the rear and side panels. Then attach a circle of door or window sealing tape (the water-proof type is best) around the inside perimeter of the speaker frame, and connect the hookup wires to the driver's terminals – bringing them out through the speaker mounting hole.

The speaker may then be installed into the baffle (from the front, of course), and held in place with large self-tapping screws. In this final assembly stage, make sure that the internal wiring does not foul the speaker cone.

Finally, the vent tube may be installed. When cut to length, the PVC tube may be neatly finished by scraping the end surfaces with a metal ruler or knife. The tube should be a firm fit within its baffle hole, and sealed to the panel with glue or a general-purpose sealant.

An audio oscillator and amplifier may be used to test the integrity of the final cabinet seal – its 'air worthiness', so to speak. First, drive the sub-woofer with a test tone of 10 to 20Hz at sufficient level to produce about 5mm (peak) of cone travel. Then block off the vent with a smooth flat surface, and listen for the telltale 'chuffing' noises produced by air leaks. Check all of the box joints, the driver to baffle seal and around the speaker cable connector.

If required, the front grill cover should be constructed using a reasonably open weave cloth stretched tightly across a suitable frame. The frame may be constructed from wooden slats, or a duplicate front panel (baffle) with over-size cut-outs. Remember that the air velocity from the speaker and port can be

quite high, causing the grill cloth to flap dramatically and produce audible overtones. In fact, when driven hard with a transient signal (such as a bass drum), the air movement generated by the prototype's port could extinguish a burning match held at a distance of 250mm!

### Setting up

If the sub-woofer is to be driven with signals derived from the EA Sub-woofer Adaptor, refer to the May '89 article for a number of adjustment procedures. However the subjective method (your ears!) is as quick as any other, and can be quite an enlightening exercise.

Nevertheless, the results will be quite unsatisfactory if the phase relationship of the entire system is not preserved. This starts with the phasing of the speakers themselves. Both the sub-woofer and the main speakers should be tested by connecting a low voltage battery (say a 1.5V cell) to their terminals, and observing the driver's cone movement – a positive voltage on the positive speaker terminal (usually red) should force the cone in an outwards direction.

Although usually not a problem, the phase consistency of the amplifiers should also be considered. Once you are confident of the speaker phasing, the amps may be checked by a simple overall listening test.

With both the sub-woofer and main speakers operating, carefully listen at the position where you hear a combined output from both systems. Then invert the phase of the sub-woofer by swapping over the speaker cable connections, and listen again – the two arrangements should sound quite different. When the systems are in-phase the results should sound coherent, with this combined signal appearing between the speakers. However the out-of-phase

situation will sound quite diffuse, with the signal source being difficult to locate. However if the results are inconclusive on normal source material, try a sine wave signal set to around the cross-over frequency (say 80Hz).

Alternatively, a rather 'bombastic' approach to testing a system's phase is to use a very low-frequency square wave (less than 1Hz), and watch the cone movement of the various speakers, which should move in unison if the phase is correct. *But beware* – if the power level is too high, such a signal source could easily damage the tweeters in the main system.

With any phasing anomalies out of the way, you're ready for the satisfying listening available from a system with a truly extended bass response. Ironically, once you're used to a correctly set up sub-woofer, you often forget that it's there until it's turned off – then you wonder how you ever enjoyed listening without it!

### PARTS LIST

- 1 150mm woofer (Altronics cat: C 3055)
  - 1 96mm length of PVC pipe (50mm diameter)
  - 1 2-way spring loaded speaker connector
  - 1 Sheet 18mm particle board 850 x 850mm for single-driver enclosure, 1250 x 900mm for two-driver enclosure
- Innerbond or similar damping material (300mm x 600mm), speaker cable, screws, draught sealing tape, wood glue etc.

#### Note:

The double driver configuration requires two 50mm ports, each with a length of 86mm. Obviously two speakers are required, and roughly double the amount of Innerbond.

# At what age are you co

Allow us to tell you the unusual but true story of a SCUBA-diving instructor.

He was pretty happy with his life.

The small school he operated on the Barrier Reef was doing alright.

There were plenty of tourists who wanted to learn the sport, so the income was reasonable.

All in all the instructor felt he had it made. But after a while, he got to thinking, "What am I going to do when I get older? I can't spend the rest of my life diving".

## Too old for new tricks?

His friends thought he was worried about nothing. "Just about anyone would give their right arm to do what you do," they said. "And besides, you're only 22." Still, the instructor's concern continued, so he looked at a paper to see what was going, and made a few calls.

The enquiries led him to the conclusion he'd suspected; that he was too old for any worthwhile training or apprenticeship schemes. Even if he'd been 18, he was told, he'd have been

considered a dog too old for new tricks.

This story does have a happy ending, however.

## Can you do something about it?

The instructor sent off a coupon not unlike the one you see in the bottom corner, and subsequently found out about the RAAF's Adult Technical Training.

The instructor's plight, in fact, was not unusual. There'd be thousands of men and women who discover some time in their lives that they are dissatisfied with their jobs, and want to start afresh. This is where the RAAF can help.

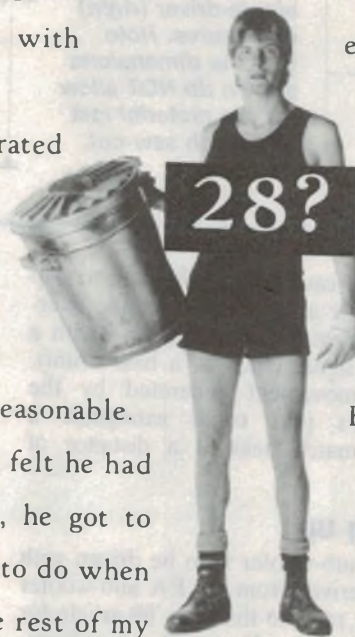
We can retrain you as an aircraft technician if you're between 17 and 34.

Working with jet engines, navigation systems, armaments and the like, may be something you've never considered.

## Out of your depth?

Indeed, you may feel you'd be completely out of your depth in such a highly technical environment. But there's a good chance that this may not be the case.

We could tell you, for instance, the story of the 30-year-old railway ticket collector who can now put a Hercules engine together in his sleep. Or there's



# nsidered over the hill?

the 28-year-old former bricklayer who's now an expert on F/A 18 airframes.

We also have a female clerk from the public service, who at age 22, decided to become an expert on aeronautical instruments. Our SCUBA-diving instructor made ground radars his field of expertise.

## The School of Life?

The point being made is this: The RAAF won't discriminate against you because your further education has been in the School of Life.

In fact, if anything, we feel that your age and experience would make you a more desirable employee for these reasons.

Reflecting this, the Adult Technical Training we'd put you through lasts around 12 months. Apprentices, on the other hand, take four years to gain similar qualifications.

When you decide to leave the RAAF, you'll soon discover that, with your newly acquired skills, you'll be right at the top of your chosen field.

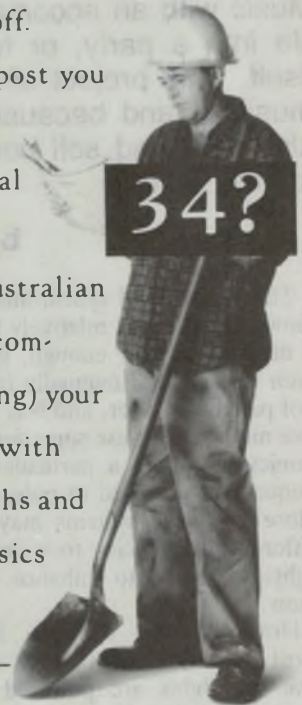
And that's a far cry from being over the hill.

## Where do you go from here?

Your next step is to fill in the coupon and send it off.

In return, we'll post you all the information on RAAF Adult Technical Training.

You must hold Australian citizenship, and have completed (or be completing) your schooling to year 10 with passes in English, Maths and Science (with a Physics content).



Yes, I'm interested in becoming one of the most highly trained people in the country. Please rush me more information on Adult Technical Trades Trainees with the RAAF

Name \_\_\_\_\_

Address \_\_\_\_\_


Postcode \_\_\_\_\_

Telephone \_\_\_\_\_ Date of birth \_\_\_\_\_

Highest education level attained or being studied \_\_\_\_\_

Send to: RAAF Careers, Freepost 2600AF, GPO Box XYZ (in the capital city nearest you). Or phone an RAAF Careers Adviser on Adelaide 237 6222, (008) 888 554 Albury 21 8277 Bendigo 41 2500 Brisbane 226 2626, (008) 777 531 Canberra 57 2311 Geelong 21 1588 Hobart 34 7077 Launceston 31 1005 Melbourne 697 9755, (008) 333 243 Newcastle 26 3011 Parramatta 635 1511 Perth 325 6222, (008) 199 018 Sydney 219 5555, (008) 422 177 Townsville 72 4566, (008) 015 150 Wollongong 28 1855

ADULT TECHNICAL TRAINEES

 RAAF

## Construction Project:

# Musolight: a fun machine

Music with an accompanying light show is a great way to put life into a party, or to get more satisfaction from the music itself. This project is an inexpensive way of lighting up your music – and because it is powered from a low voltage, it's also safe and self contained. Build it and beam yourself into fantasy land...

by BRANCO JUSTIC

The principle of synchronising a light show with music is relatively simple and if the beat is slow enough, lights could even be operated manually from a control panel. A better, and less user-intensive method is to use some form of electronics, in which a particular range of frequencies are used to pulse the lights. More advanced systems may even use different frequencies to pulse different lights, coloured to enhance the whole show.

However, one common feature of most electronic light show systems is that the lights are powered from the mains, and the electronics needs to be interfaced accordingly. Such a system is therefore usually fairly expensive and suitable mainly for stage work.

But how about in the home? Having 240 volt lights strung everywhere is both messy and possibly hazardous, as well as being an example of kaleidoscopic overkill.

The Musolight, our answer to a musical light show, is a compact unit that produces a bright, colourful and totally random light display that pulses in time with the music. And when the music stops it can even be made to automatically revert to its own pulsating random display. The unit makes a great addition to disco equipment, the home hifi or any music making system.

Because it has an inbuilt microphone, all you need do is place the unit near the sound source, then sit back and enjoy the show. And the best news is that the basic kit of parts for the unit only costs \$25.90!

The Musolight uses low voltage incandescent lamps, placed behind a diffused plastic screen with coloured transparent

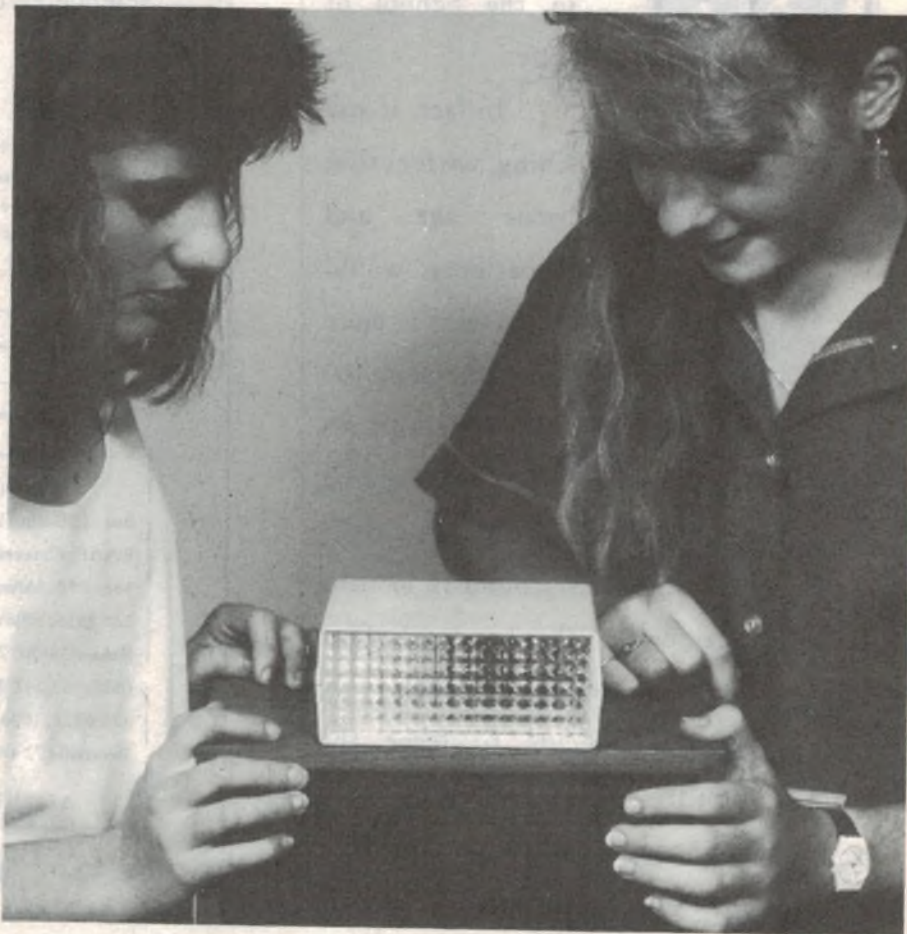
material between the lights and the screen. This produces four coloured sections that are surprisingly bright when illuminated.

Like most devices of this type, the bass frequencies are used to trigger the unit. But unlike many such systems, each bass 'beat' triggers a random display *sequence* involving all four lights,

rather than merely triggering one light. The effect is very entertaining and non-repetitive in form, due to the random nature of each individual sequence.

As already mentioned, the unit can be prewired so that it keeps up a light show even when there is no music. Again a random series of display sequences will occur, this time pulsing at a preset rate. When the sound starts up again, the sequences will revert to being in sync with the music. This feature can be selected or de-selected during construction as required.

The Musolight can be triggered either from an external sound source by direct connection to the speaker or 'line level' signal, or, as in the prototype, triggered from the unit's internal electret micro-





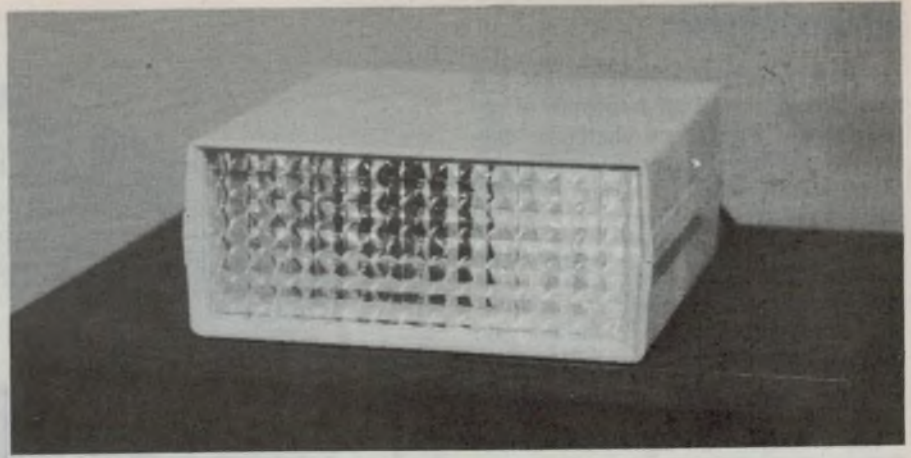
phone element.

The system can be powered by supplies with a voltage range from about 8-35 volts. The voltage supply will depend on the lamps being used, although the lamp driver transistors will necessarily limit the allowable current rating of the lamps. The lamps used in the prototype were 12V/250mA types, and produce a very high light output. These lamps will be the type supplied by Oatley Electronics in the kit for this project.

We expect that most readers will make the unit for 12V operation as per our prototype unit. In this case, if one lamp is used in each display, the average current required will be 500mA and the peak current will be around 1 amp. This arrangement will allow the unit to be powered with an inexpensive 12V/1A, DC plug-pack.

If two lamps are used in parallel for each of the four coloured displays, the current requirement will double to 1A average and 2A peak. It is therefore important that the current rating of the power supply or plug-pack being used be checked, to ensure that it can handle this type of load.

It is also possible to connect two lamps in series in each of the four dis-



**Add life to your music with our Musolight – a safe, easy to build music driven light show. It's also low in cost...**

plays. If the same lamps are used as in our prototype, a 24V DC power supply with a peak current capability of 1A would be required.

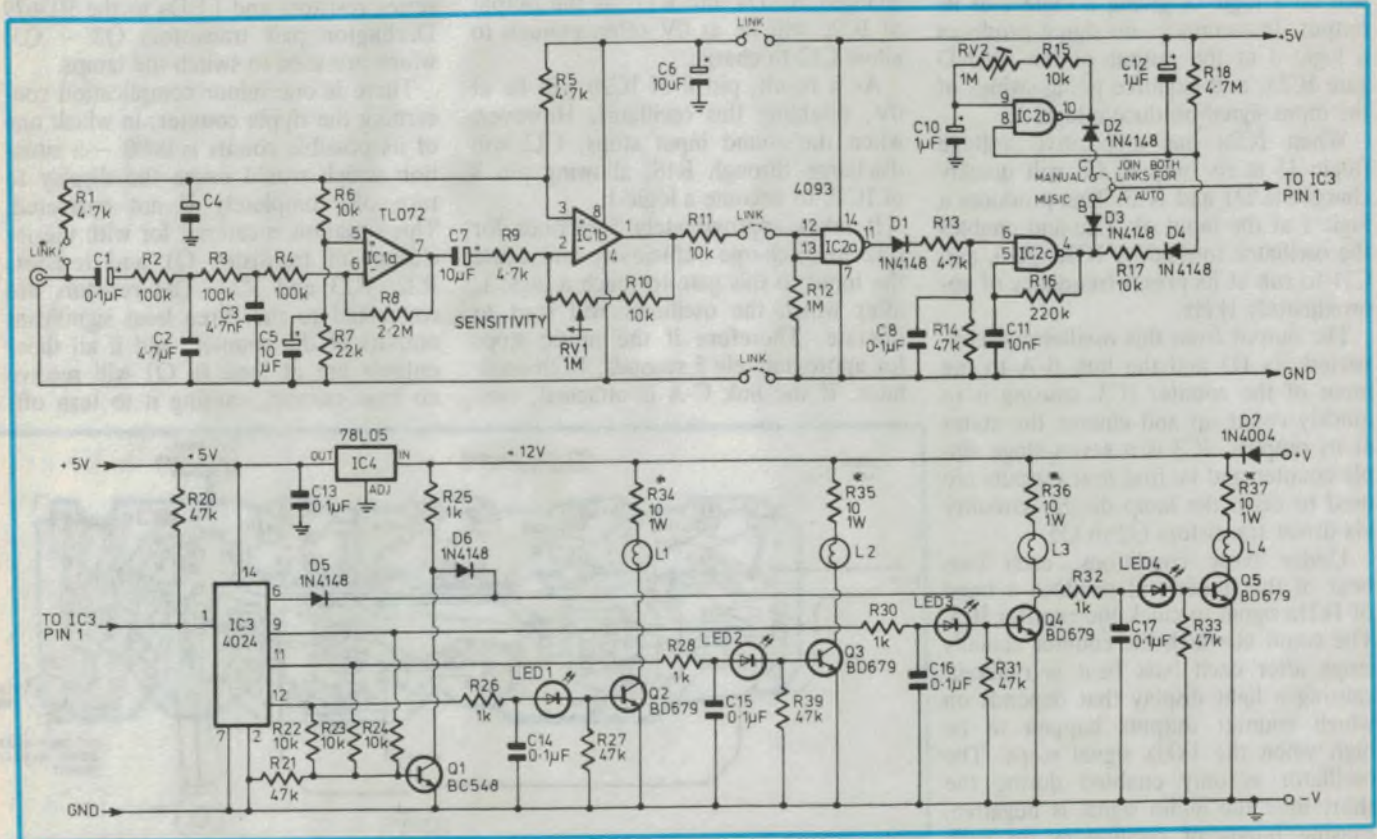
### How it works

The circuit contains three sections: the input signal processing block, the sequence generator and the lamp drivers. The input signal processing section comprises a filter and amplifier stage, built around IC1.

If the link between resistor R1 and

the input terminal is connected, a positive DC voltage will be applied to the input terminal, allowing an electret microphone element to be used as the signal pickup. This voltage is necessary to supply power to the FET amplifier stage within the microphone assembly, and the link is only required if an electret microphone insert is to be used.

The audio signal from the input terminal is applied via the coupling capacitor C1 and a low pass filter made up of R2, C2, R3 and C3 to the inverting ampli-



**Fig.1: The circuit diagram. Bass frequencies are amplified by IC1, which gates the oscillator formed by IC2c. This in turn clocks the counter IC3, which drives the lights. Link A-B is for normal operation, link A-C gives auto operation. Add either or both links as required.**

# Musolight

fier stage associated with IC1a. The low pass filter has a cut-off frequency of approximately 300Hz and therefore only couples the low frequency components (bass) to the amplifier. This amplifier has a gain of approximately 7, and its output is connected via C7 to the inverting amplifier stage around IC1b. The gain of this second amplifier is adjustable by the setting of RV1, and the gain can be varied from around 2 to over 250. RV1 becomes the Musolight's 'sensitivity' control.

The quiescent (no signal) DC output voltage from IC1b is set to approximately 4.3V by the resistor divider network formed by R5 and the series connected resistors R6 and R7. Under these conditions, the voltage at the inputs of the NAND gate IC2a will be a logic 1, and the output of the gate will be a logic 0.

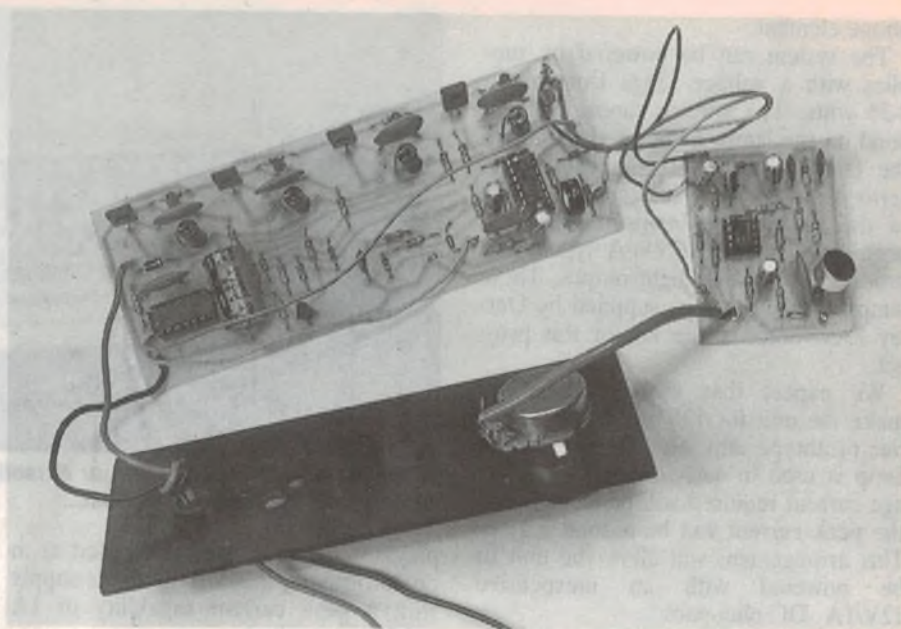
When an audio signal occurs, the output of IC1b will vary around the quiescent 4.3V, going either more positive to a maximum of 5V for positive excursions of the input signal, or as low as zero for negative swings of the input. When the input voltage is sufficiently negative, the input to the NAND gate will be a logic 0, giving a logic 1 at its output. In summary, no signal produces a logic 0 at the output of the NAND gate IC2a, and negative going swings of the input signal produce a logic 1.

When IC2a has a positive voltage (logic 1) at its output, C8 will quickly charge via D1 and R13. This produces a logic 1 at the input of IC2c and enables the oscillator formed by IC2c, R16, and C11 to run at its preset frequency of approximately 1kHz.

The output from this oscillator is connected via D3 and the link B-A to the input of the counter IC3, causing it to quickly count up and change the states at its outputs. IC3 is a seven stage ripple counter and its first four outputs are used to drive the lamp display circuitry via driver transistors Q2 to Q5.

Under these conditions, each bass beat of the music will produce a burst of 1kHz signal to clock the counter IC3. The count at which the counter actually stops after each bass beat is random, causing a light display that depends on which counter outputs happen to be high when the 1kHz signal stops. The oscillator is only enabled during the short time the audio signal is negative, causing bursts of oscillations on each bass beat, giving a new light display on each beat.

The circuit configuration around IC2b



The main PCB contains everything except the pre-amplifier. Note the wire links used to select the mode of operation and the connections required between both PCBs.

is similar to that around IC2c, again forming an oscillator. The frequency of this oscillator is adjustable, and is used to clock the counter in the absence of an audio input signal. However, when an audio signal is present, C12 will be charged via D4 and R17, as the output of IC2c will be at 0V often enough to allow C12 to charge.

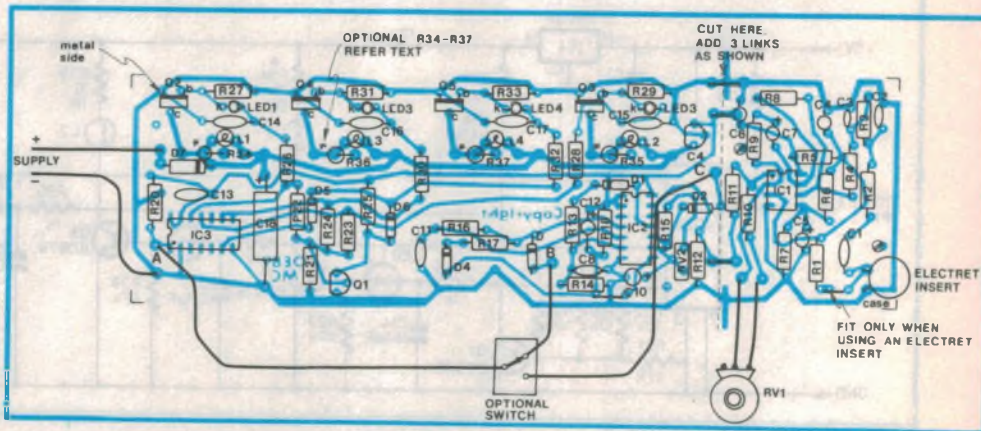
As a result, pin 8 of IC2b will be at 0V, disabling this oscillator. However, when the sound input stops, C12 will discharge through R18, allowing pin 8 of IC2b to become a logic 1.

It takes approximately 5 seconds for C12 to discharge sufficiently and cause the input to this gate to reach a logic 1, after which the oscillator will start to operate. Therefore if the music stops for approximately 5 seconds, IC2b oscillates. If the link C-A is attached, con-

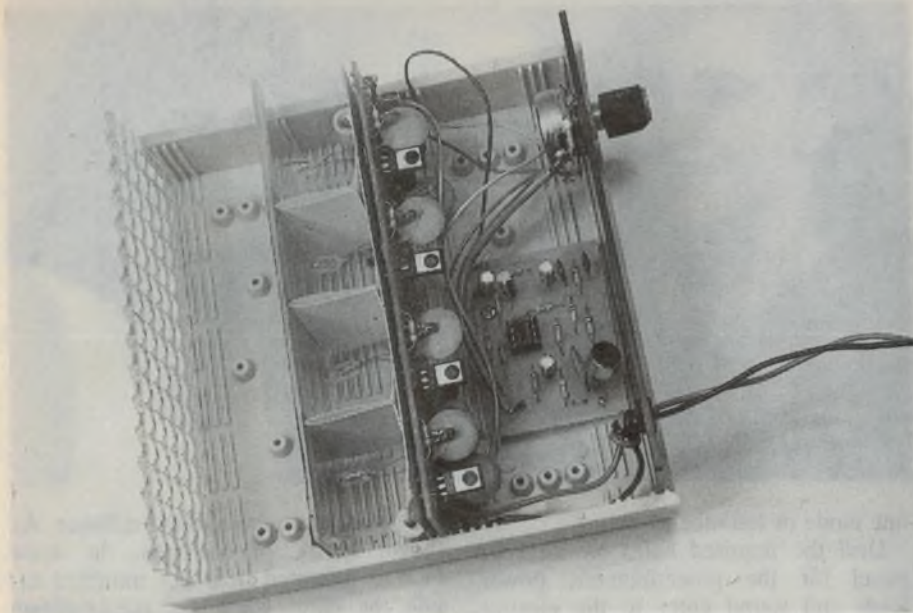
necting the output of IC2b to the counter, the unit will automatically generate its own display sequences at a rate determined by the setting of RV2.

The four least significant outputs from the ripple counter IC3 are connected via series resistors and LEDs to the BD679 Darlington pair transistors Q2 - Q5, which are used to switch the lamps.

There is one minor complication concerning the ripple counter, in which one of its possible counts is 0000 - a situation which would cause the display to turn off completely if not corrected. This situation is catered for with the inclusion of transistor Q1 and resistors R22, R23 and R24. The resistors are connected to the three least significant outputs of the counter, and if all these outputs are at logic 0, Q1 will receive no base current, causing it to turn off.



The layout diagram. Cut the PCB as shown if you intend making the unit as per the prototype. The optional switch can be mounted on the back panel to select the mode of operation. Otherwise connect the links directly.



**This photo shows how everything is placed in the instrument case. The internal slots make fitting the main PCB and the screens very easy.**

As a result, its collector voltage will be at rail voltage, allowing Q5 to turn on, driven by the base current supplied through R25 and the isolating diode D6.

If Q5 is already on, due to the counter output driving it being at a logic 1, then nothing further happens. However, if this output is also a logic 0, Q5 will now be turned on, giving one lamp on for a counter output of all zeros. This means the same lamp display can occur for two counter output codes, but the randomness of the output codes hides this effect anyway.

### Construction & testing

Kits of parts for this project are available from Oatley Electronics. The basic kit includes a screen-printed circuit board, all the components, an electret microphone element and the lamps.

If you decide to make your unit the same as the prototype, the printed circuit board will need to be cut as shown in the layout diagram, to separate the preamplifier from the rest of the circuitry. If the board is cut, the larger section of the PCB will slot into the case used

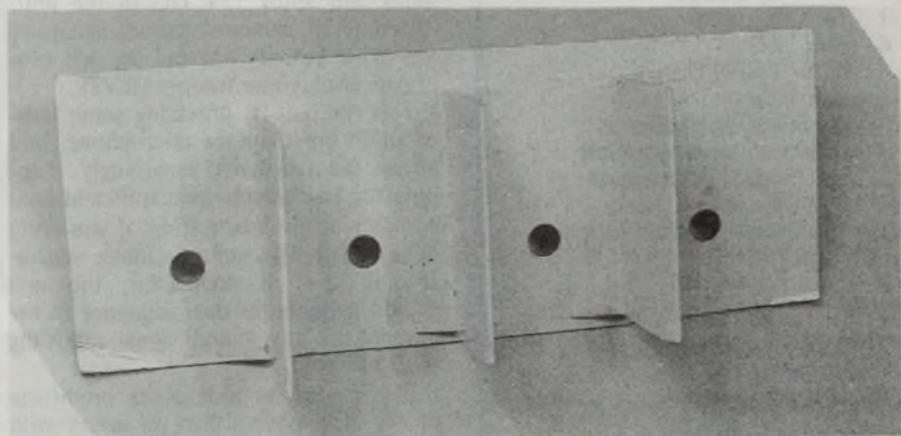
in the prototype. This unit, a plastic instrument case, has the dimensions of 160(d) x 155(w) x 65mm(h), giving internal dimensions of 145(w) x 58(h). Although it is possible to make several different versions of the Musolight, the following construction procedure refers to the prototype unit as shown in the

photographs. After cutting the PCB on the line indicated, assemble and solder all the components onto the PCB. Watch the orientation of all the polarised components. Note that the lamps are mounted and soldered on the copper side of the PCB, with their full lead lengths.

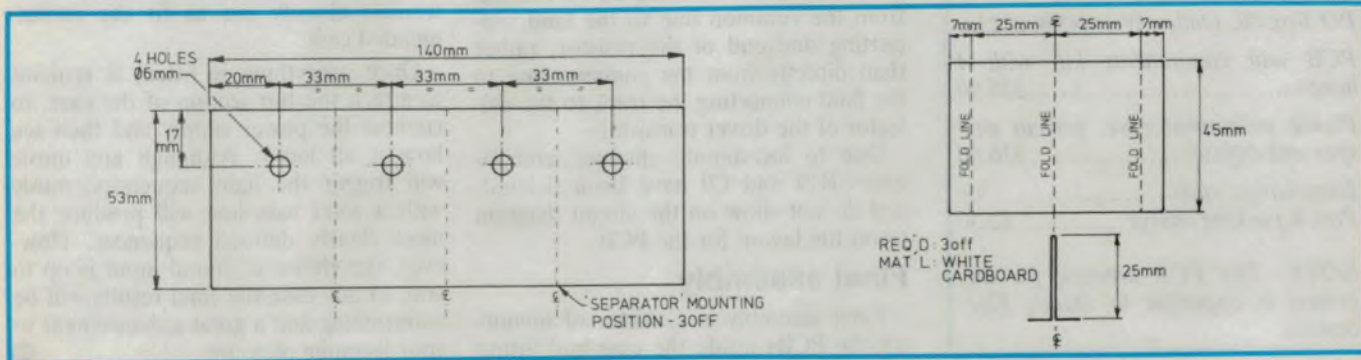
The electret microphone insert, if used, is mounted at the input terminals, with the case of the insert connected to the earth terminal. Also, the link connecting R1 to the insert needs to be included, to provide the necessary DC voltage to the internal FET amplifier.

As already mentioned, provision is made for two insulated wire links (A-B & A-C), in which link A-C allows the unit to automatically revert to its own generated internal display when the music stops. However the display can be made to trigger from music only, by including the link from A-B only.

Alternatively by including the link from A-C only, the unit will produce its own internal display only, without the need for any music. You might want this just for show, in which case you don't even require the preamplifier section. If required, a switch could also be included on the rear panel to enable you to switch between these two different modes of operation, that is, either



**Fig.2: The reflector units for the lights can be made using white cardboard. Cut pieces of cardboard to the sizes shown and glue or tape the separators to the reflector.**



## PARTS LIST

- 1 Silk screened PCB, coded OE89MC
- 1 plastic instrument case - 155 x 65 x 160mm
- 4 6.3V, 250mA pigtail mount lamps
- 1 Electret microphone insert

### Resistors

- All 1/4W, 5%: 5 x 1k, 4 x 4.7k, 9 x 10k, 1 x 22k, 6 x 47k, 3 x 100k, 1 x 220k, 1 x 1M, 1 x 2.2M, 1 x 4.7M.
- 4 10 ohm 1W (optional - see text)

### Potentiometers

- 1 1M vertical mount trimpot
- 1 1M, panel mount

### Capacitors

- 2 4.7nF polyester
- 1 10nF disc ceramic
- 7 0.1uF disc ceramics
- 2 1uF 35V low leakage electrolytic
- 4 10uF 16V low leakage electrolytic
- 1 470uF 25V electrolytic

### Semiconductors

- 6 1N4148 diodes
- 1 1N4004 diode
- 4 Red LEDs
- 4 BD679 NPN Darlington transistors
- 1 BC548 NPN transistor
- 1 78L05 voltage regulator
- 1 TL072 dual operational amplifier IC
- 1 4093 quad Schmitt trigger NAND IC
- 1 4024 counter IC

*Kits of parts for this project are available from:*

*Oatley Electronics  
5 Lansdowne Parade,  
Oatley West, NSW 2223.  
Phone (02) 579 4985*

*Postal address (mail orders):*

*PO Box 89, Oatley West NSW 2223.*

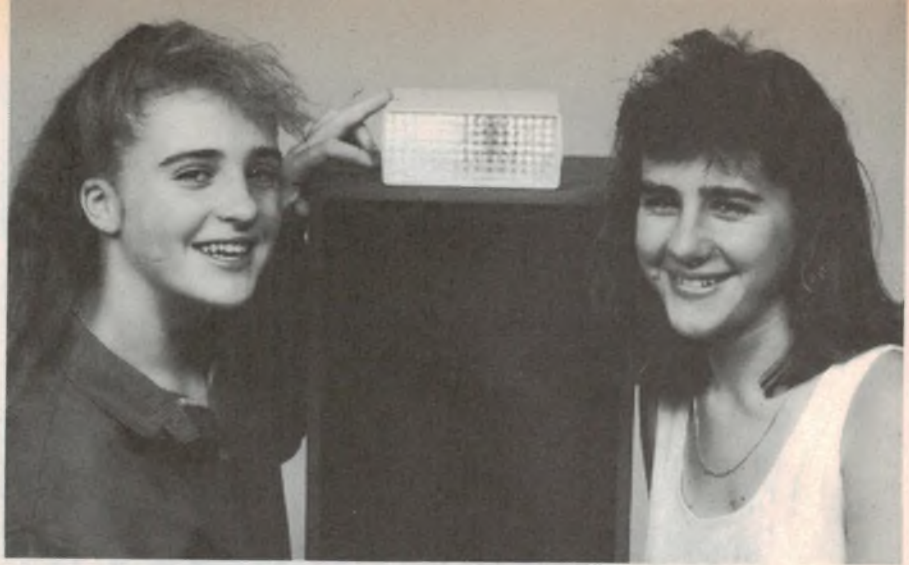
*PCB and components kit, with 4 lamps ..... \$25.90*

*Plastic instrument case, pre-cut perspex and diffuser ..... \$16.00*

*Extra lamps, each ..... 50c*

*Post & packing charge ..... \$2.50*

*NOTE: The PCB artwork for this project is copyright to Oatley Electronics.*



one mode or the other.

Drill the required holes on the rear panel for the potentiometer, power leads and sound entry to the electret microphone. Drill the sound entry holes close to the electret microphone. As well, the four LEDs could be mounted on the rear panel to provide a monitor of the display being generated, perhaps as a check for correct operation.

Finally, connect the various leads between the two PCBs and the sensitivity pot, then connect two leads to supply power. Double check your work, including the orientation of all the components and apply 12V DC to the unit. The only adjustments that are necessary are the sensitivity pot and the self generated display rate trimpot (RV2).

Test the unit by providing some form of audio input for the microphone, and adjust the sensitivity accordingly. Tapping the case should give sufficient bass component to allow testing, if you don't have access to a suitable music source. If link A-C is connected, the unit should produce its own sequence in the absence of any sound signal, allowing RV2 to be set.

If you want to reduce the brightness of the display, resistors in series with the lamps can be added. Provision is made on the PCB to add these resistors, shown as R34 to R37, although the lamps will now be soldered to connect from the common line to the land supporting one end of the resistor, rather than directly from the common line to the land connecting the track to the collector of the driver transistor.

Due to last-minute changes, components R19 and C9 have been deleted, and do not show on the circuit diagram or on the layout for the PCB.

## Final assembly

Final assembly is a matter of mounting the PCBs inside the case and fitting

the coloured screen and the diffuser. As shown in the photographs, the main PCB is mounted in a slot moulded inside the case, while the pre-amplifier PCB is attached to a mounting post near the rear of the case.

To separate each light, and to provide the highest light output, a reflector made from thin white cardboard is required. This is made by cutting a piece of cardboard the same size as the main PCB, and attaching three 25mm deep, vertically mounted sections of cardboard to act as separators between each light. The holes for the lamps can be punched using a paper hole-punch and the three separators can be secured with adhesive tape. Refer to Fig.2 for details.

The colour screen is made by carefully attaching sections of coloured cellophane to a small sheet of clear perspex, using sticky tape. The colours used in the prototype were blue, red, green and yellow, purchased as gift wrapping material from the local newsagent. This screen should be mounted about 30mm from the main PCB, so that the edge of the separators of the reflector unit are close to the screen.

The diffuser screen used in the prototype is a plastic material similar to that used with fluorescent lights. The clear perspex and diffused plastic screens required are available from Oatley Electronics, already cut to fit the recommended case.

Once everything is fitted, it remains to attach the top section of the case, to connect the power supply and then see how it all looks. Although any music will trigger the light sequences, music with a solid bass line will produce the most clearly defined sequences. However, the choice of sound input is up to you; in any case the final results will be entertaining and a great enhancement to your listening pleasure. E

# OBIAT<sup>PTY LTD</sup> YOUR ONE STOP DISTRIBUTOR OF TEST & MEASURING INSTRUMENTS

With 2 multifunction displays and 16 different measurement capabilities, the Fluke 45 does virtually everything you want a meter to do... at a suprisingly affordable price from \$1190 ex tax



- Five digit 100,000 count
- Closed Case Calibration
- Dual Display
- True rms voltage and current including ac+dc
- 0.02% basic dc voltage accuracy
- 0.05% basic dc current accuracy
- 1MHz frequency counter
- RS-232 Interface standard
- dB with 21 reference impedances and audio power calculations
- Compare and Relative functions
- Min/Max and Touch-Hold™ functions
- Optional PC software for RS-232 applications
- Optional IEEE-488.2 interface, battery pack

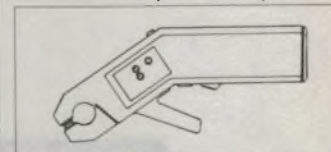
## Full Range of Multimeter Accessories Available

Here are some of the Fluke range of accessories which are compatible with most brands of multimeter

### Current Probes

#### Y8101

1 to 150A ac clamp-on current probe



#### Y8100

Dual range 10A/200A Hall Effect clamp-on current probe

#### 80i-400

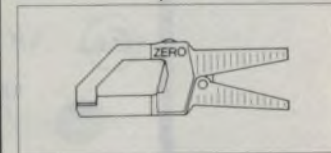
1 to 400A ac clamp-on current probe

#### 80i-410

5 to 400A Hall Effect ac/dc clamp-on current probe

#### 80i-600

1 to 600A ac clamp-on current probe



#### 80i-1010

1 to 1000A Hall Effect ac/dc clamp-on current probe

### High Voltage Probes

#### 80k6

6000V dc or peak ac voltage probe

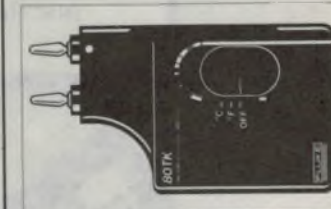
#### 80k-40

40kV dc or 28kV rms ac voltage probe

### RF Probes

#### 85RF

AC voltage probe from 100kHz to 500MHz



### Temperature

#### 80T-150U

Universal temperature probe. -50°C to +150°C. Uses P-N Junction to give ±1°C accuracy

#### 80TK

Type K thermocouple module for use with interchangeable probes. Basic accuracy is 0.5°C. Use with any 10MΩ input multimeter having banana sockets.

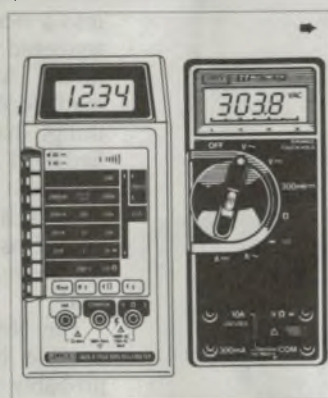
Also ask us about a case to protect your investment!

Express delivery throughout Australia and South Pacific

## Fluke 8060A Hand Held Multimeter

- 0.04% basic accuracy
- 19999 count display
- True rms ac volts and current
- Continuity & diode test
- Frequency measurement
- dBm, relative dB
- Relative reference
- One year calibration cycle and Warranty

\$895 inc tax \$778 ex tax



## Fluke 8062A

- 0.05% basic dc accuracy
- True rms ac voltage and current
- Continuity and diode test
- Relative reference
- One year calibration cycle and Warranty

\$757 inc tax \$658 ex tax

## Fluke 8050A

- 4 1/2 digit bench model with 0.03% basic dc accuracy
- True rms ac to 50kHz
- Rechargeable battery option
- dB function with 16 selectable impedances (8Ω to 1200Ω)
- Relative Reference & Conductance

\$987 inc tax \$858 ex tax

## Fluke 70Series Multimeters

73 \$161 inc tax \$140 ex tax

- Analog Bar Graph
- 3200 count Display
- 0.7% basic dc accuracy
- 10A range
- Autoranging only
- 3 year warranty

75 \$262 inc tax \$227 ex tax

- 0.5% accuracy
- Autoranging with range hold
- 10A + autoranged mA ranges
- Continuity & diode test beeper

77 \$352 inc tax \$306 ex tax

- 0.3% accuracy
- Touch Hold™ function

## Fluke 20 Series Multimeters

21 \$264 inc tax \$229 ex tax

- Safety Yellow case
- Fluke 75 features but less 10A range

23 \$357 inc tax \$310 ex tax

- Safety Yellow case
- Fluke 77 features + fused 10A input

25 \$478 inc tax \$415 ex tax

- Water and dust-proof, fully sealed
- Charcoal or yellow case
- Analog/Digital display
- 0.1% basic dc accuracy
- 100μV to 1000V ac & dc
- 0.1μA to 10A all fused
- -15°C to +55°C operation
- Touch Hold™ function
- Two year warranty

27 \$603 inc tax \$524 ex tax

- As 25 but adds
- Relative (difference) mode
- Min/Max recording mode

# FLUKE

Manufactured in USA

## NEW 80 Series Multimeters

- Min/Max/Average recording stores highest, lowest and true average of all readings
- Selectable response time to record turn-on surges or drift etc
- 1ms peak Min/Max hold on 87 to capture elusive transients or half-sine surges to 400Hz
- Audible Min/Max Alert™ signals readings above or below previous limits

83 \$428 inc tax \$372 ex tax

- Volts, Amps, Ohms, diode test, continuity, frequency and duty cycle, capacitance, Touch Hold™, relative, protective holster
- 0.3% basic dc accuracy
- 5kHz Vac
- Analog bargraph with zoom
- 3 year warranty

85 \$504 inc tax \$438 ex tax

- 0.1% accuracy
- 20kHz Vac

87 \$604 inc tax \$525 ex tax

- High resolution analog pointer
- True rms ac
- 1ms peak Min/Max
- 4 1/2 digit mode
- Back lit display

Detailed brochures and specifications available. We are factory trained to advise on your requirements for general purpose Test & Measuring Instruments

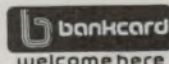
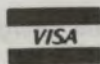
# OBIAT PTY. LTD.

(Incorporated in N.S.W.)

129 Queen Street, Beaconsfield

P.O.Box 37 Beaconsfield NSW 2014

Tel : (02) 698 4776 Telex : AA71958 Fax : (02) 699 9170



## Construction project:

# NiCad discharger

Combine our automatic Nicad discharger with our equally automatic charger and rejuvenate your NiCad batteries. It's amazing how they'll respond to the discharge/charge treatment – you could add years to the life of your re-chargeables.

by PETER PHILLIPS

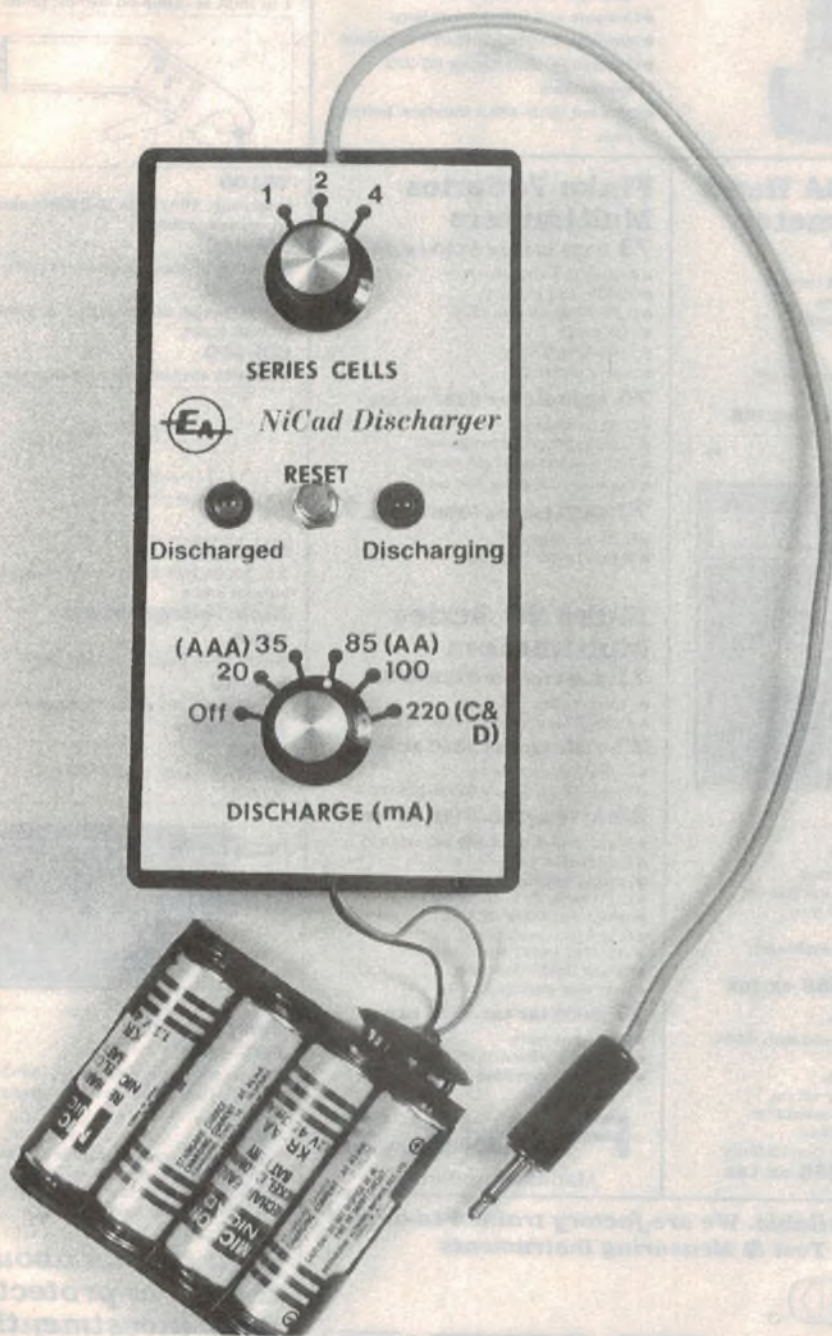
Although I'm not a fanatic, at least as far as NiCad batteries are concerned anyway, I have to admit that they will respond to the right sort of treatment. I recently noticed for example, that my battery-powered drill could no longer 'last the distance' it used to when it was new. In fact it was becoming downright infuriating – 'dying' when the drill bit was halfway through a brick wall and all that sort of thing.

So, encouraged by the suggestion that the NiCad batteries would respond to a total discharge followed by recharging, I decided to give it a go. I locked the drill into a vice so that the on-off trigger was squeezed on, and left it run for a few hours. After recharging, I then went madly drilling brick walls to see whether things had improved. They certainly had, so I repeated the exercise. There is no doubt about it, the cells have been dramatically improved, and the drill is almost as good as new. Pity about all the holes in the wall, but it was the best test!

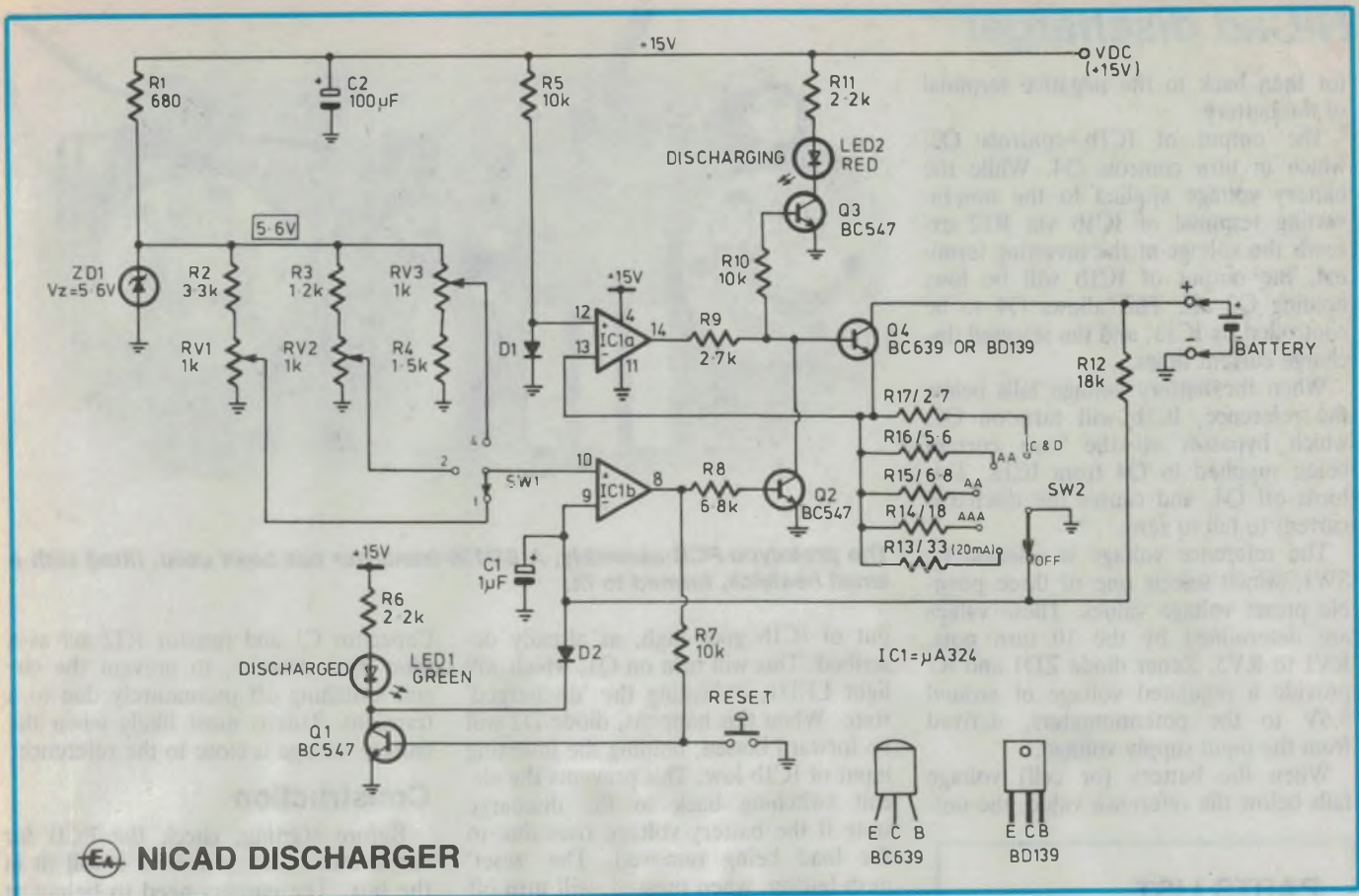
The NiCads in the drill are only accessible by dismantling the drill, so I probably wouldn't use this nifty little discharger to do the job; but I have lots of other NiCads to service. There's all the kid's toys, the rechargeable torch, the radio, the battery vacuum cleaner, and a miscellany of other useful and useless appliances that rely on NiCads for their power. I had already designed the charger, (described separately) but for the purposes of coaxing the cells into longevity, I now knew a discharger was necessary.

Like the charger circuit, I wanted it to be versatile, have total automation, and above all, be simple. The final result is a device that has the capability of discharging a single cell, two cells in series, or four cells in series. It will turn off when a predetermined cell voltage has been reached, and remain in this condition until reset.

The discharge current is set by a se-



**The discharger.** A simple little unit that mates with the charger to give a complete servicing station for all your NiCads.



The circuit has a constant voltage regulator switched by IC1a. The discharge current is selected with SW2 and the threshold voltage with SW1.

lector switch, with its settings matched to the Ah capacity of the most popular sizes of cells. LED indicators show the status of the circuit, one LED to indicate that discharge is occurring, the other to show that no discharge current is flowing. An open circuit will be duly indicated by the 'no current' LED, meaning the LEDs show the true status of the external conditions.

The discharger can therefore handle any of the popular sizes of NiCad cells, in packs of two or four, or as single cells. Power to the unit is supplied by the companion charger, or you can apply your own external DC supply if you don't build the charger. It all fits into a small jiffy box, and everything is on the PCB, making construction a breeze.

### Discharging NiCads

The topic of how best to discharge a NiCad may seem somewhat irrelevant, and perhaps you might even be thinking that a device to do this for you is verging on overkill. What's wrong with simply leaving the appliance turned on until the power runs out, I hear you saying?

The idea behind this project - combined with the charger - is to provide a

complete NiCad servicing station. For starters, discharging a series pack of NiCad cells beyond a certain point can cause one or more of the cells to undergo a polarity reversal, because these cells discharged completely before the others. Also, discharging a cell to its absolute limits is not really a good idea. A NiCad cell is generally regarded as being discharged when its terminal voltage falls to around 1.1V, and going any lower is likely to shorten its life.

As this is 'Be Kind to Your Nicads' month, we would therefore be remiss if we only presented a charger and left the discharging to take care of itself. With this little project, every contingency is covered. Being a separate module, you have the choice of building the duo, or building either one. Then you can be sure that the NiCads are correctly discharged with a suitable load current and only as far as is necessary.

The discharge current chosen for each battery type is around twice the normal charge current. This means it should take approximately five to seven hours to totally discharge a fully charged cell. You might also be able to determine the quality of a cell by timing its discharge, to determine if that cell should

be discarded. Of course, you could speed things up a bit by selecting a discharge current higher than the five hour rate, if you wanted to give the cell a good old purge.

Having described why you can't live without a NiCad battery discharger, now to the circuit itself.

### How it works

There is not a lot to say about this simple circuit. In block diagram form, it comprises a discharge load, a voltage reference and the LED driving circuitry.

The load for the battery is Q4 and the emitter resistor selected by SW2. IC1a works in conjunction with Q4 to keep the discharge current absolutely constant. The op amp will produce sufficient output voltage to keep the voltage across the selected resistor (R13 to R17) equal to the voltage across D1. This will be around 0.6V, and the circuit provides a remarkably constant discharge current, even when the cell voltage falls to the 1.1V value.

The current is determined by the value of emitter resistor (R) selected by SW2, in which the current equals  $0.6/R$ . The current path is from the battery positive, through Q4, the selected resis-

## NiCad discharger

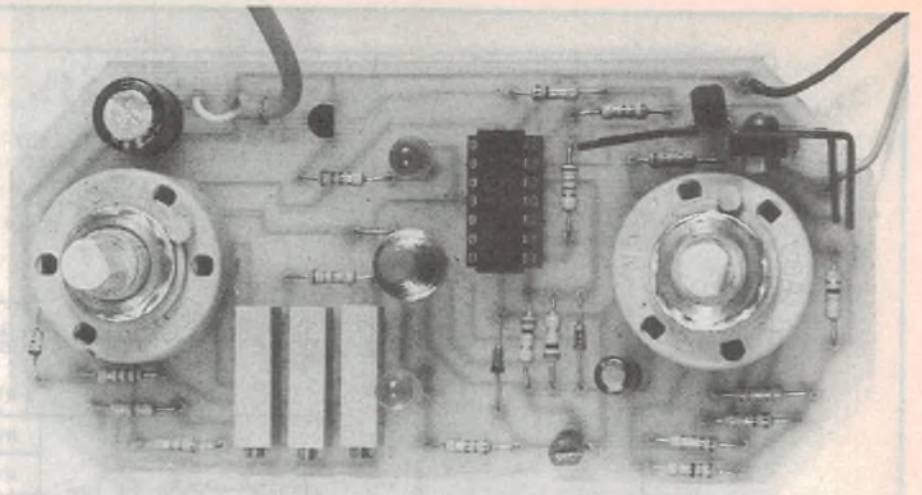
tor then back to the negative terminal of the battery.

The output of IC1b controls Q2, which in turn controls Q4. While the battery voltage applied to the non-inverting terminal of IC1b via R12 exceeds the voltage at the inverting terminal, the output of IC1b will be low, holding Q2 off. This allows Q4 to be controlled by IC1a, and the selected discharge current flows.

When the battery voltage falls below the reference, IC1b will turn on Q2, which bypasses all the base current being supplied to Q4 from IC1a. This turns off Q4, and causes the discharge current to fall to zero.

The reference voltage is selected by SW1, which selects one of three possible preset voltage values. These values are determined by the 10 turn pots, RV1 to RV3. Zener diode ZD1 and R1 provide a regulated voltage of around 5.6V to the potentiometers, derived from the input supply voltage.

When the battery (or cell) voltage falls below the reference value, the out-



*The prototype PCB assembly. A BD139 transistor has been used, fitted with a small heatsink, formed to fit.*

put of IC1b goes high, as already described. This will turn on Q1, which will light LED1, indicating the 'discharged' state. When this happens, diode D2 will be forward biased, holding the inverting input of IC1b low. This prevents the circuit switching back to the discharge state if the battery voltage rises due to the load being removed. The 'reset' push-button, when pressed, will turn off Q1, and allow the circuit to reset to the discharge state, assuming the battery voltage exceeds the reference voltage.

During discharge, the voltage present at the output of IC1a will operate Q3, lighting LED 2 to indicate that discharge is in progress. If the battery is disconnected, or if SW2 is set to the OFF position, the inverting input of IC1b will be 0V, setting its output high. This will cause the circuit to latch into the 'discharged' state, as already described.

This means LED2 will only light if the battery is actually connected, giving a true indication of the circuit conditions.

Capacitor C1 and resistor R12 act as a filter against noise, to prevent the circuit switching off prematurely due to a transient. This is most likely when the battery voltage is close to the reference.

### Construction

Before starting, check the PCB for any defects, then trim it so it will fit in the box. The corners need to be cut at 45° to allow the PCB to fit, and it should be trimmed to give 2 to 3mm of clearance all round. Also check that the switch mounting holes in the PCB are the correct size.

Once the PCB is ready, install the one wire link, the resistors and the two capacitors. As vertical space is limited, use capacitors that are no more than around 17mm high. Check also that the capacitors are installed the correct way round, as shown on the layout diagram. Next solder in the two diodes and the zener diode, checking they are correctly orientated. Leave the LEDs until last.

The two selector switches can now be

### PARTS LIST

- 1 PCB 60 x 120mm, code 89di5
- 2 2 pole 6-position PCB mount selector switches
  - 1 14 pin IC socket.
  - 3 1k, 10 turn potentiometers

#### Resistors

All 1/4W, 5%: 1 x 2.7, 1 x 5.6, 1 x 6.8, 1 x 18, 1 x 33, 1 x 680, 1 x 1.2k, 1 x 1.5k, 2 x 2.2k, 1 x 2.7k, 1 x 3.3k, 1 x 6.8k, 3 x 10k, 1 x 18k.

#### Capacitors

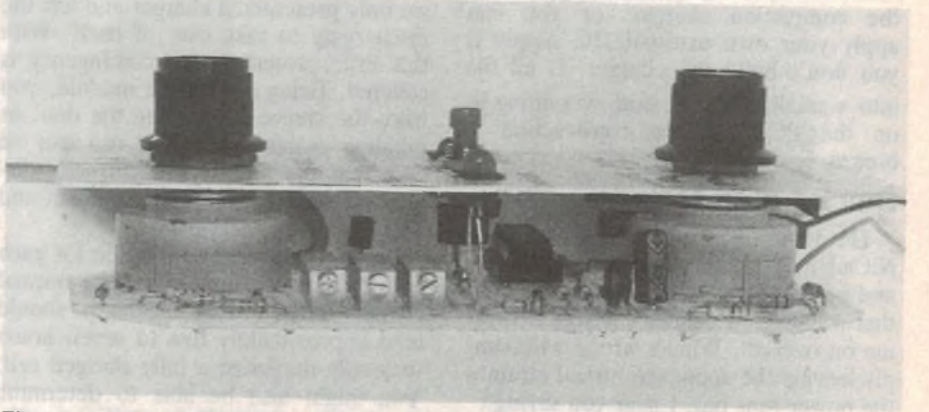
Electrolytics, 25VW, PCB mount: 1 x 1uF, 1 x 100uF

#### Semiconductors

- 2 1N914 signal diodes
- 2 5mm LEDs, red and green
- 1 5.6V 400mW zener diode
- 1 BC639 or BD139 NPN 1 amp transistor
- 3 BC547 NPN transistor
- 1 LM/uA324 quad op amp

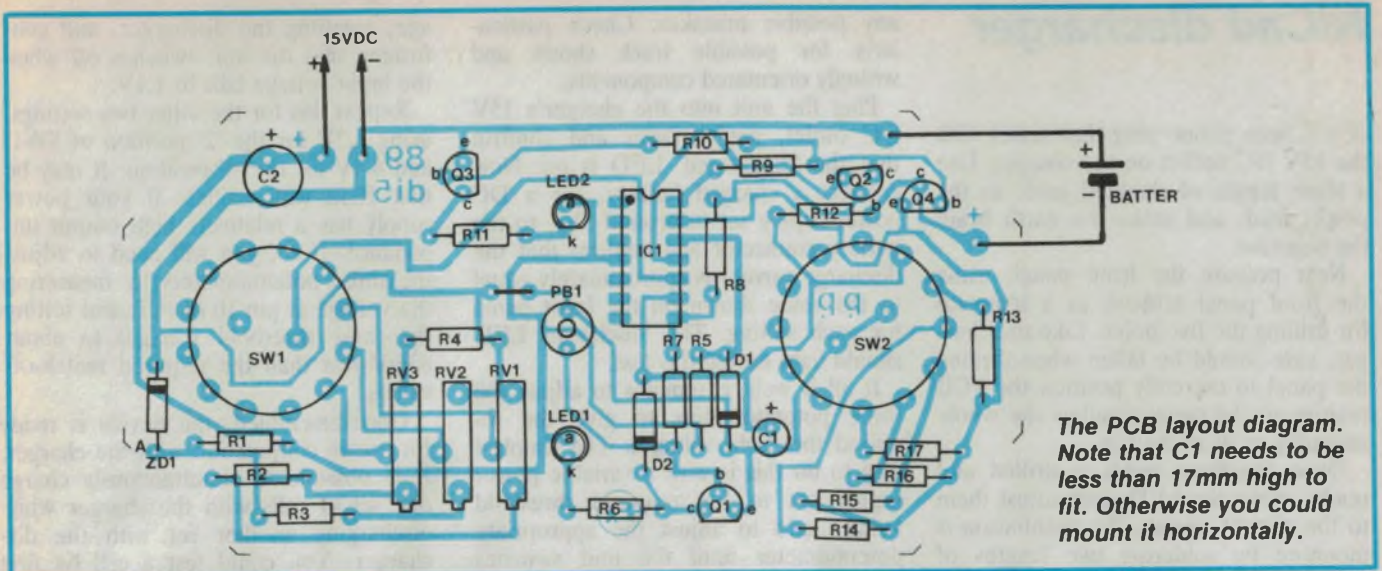
#### Miscellaneous

- 1 x 3.5mm phono plug, zippy box, size UB3, 41 x 68 x 130mm,
- 2 x 20mm dia knobs to suit switches, battery pack connector to suit, LED mounting bezels, TO220 heatsink.



*The complete assembly, showing how the front panel and the PCB are attached together.*



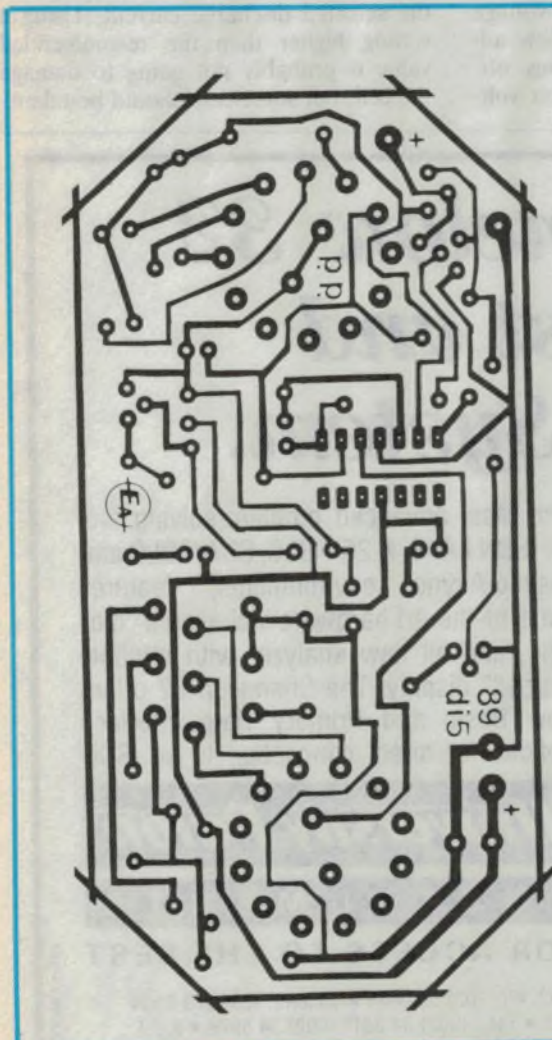


The PCB layout diagram. Note that C1 needs to be less than 17mm high to fit. Otherwise you could mount it horizontally.

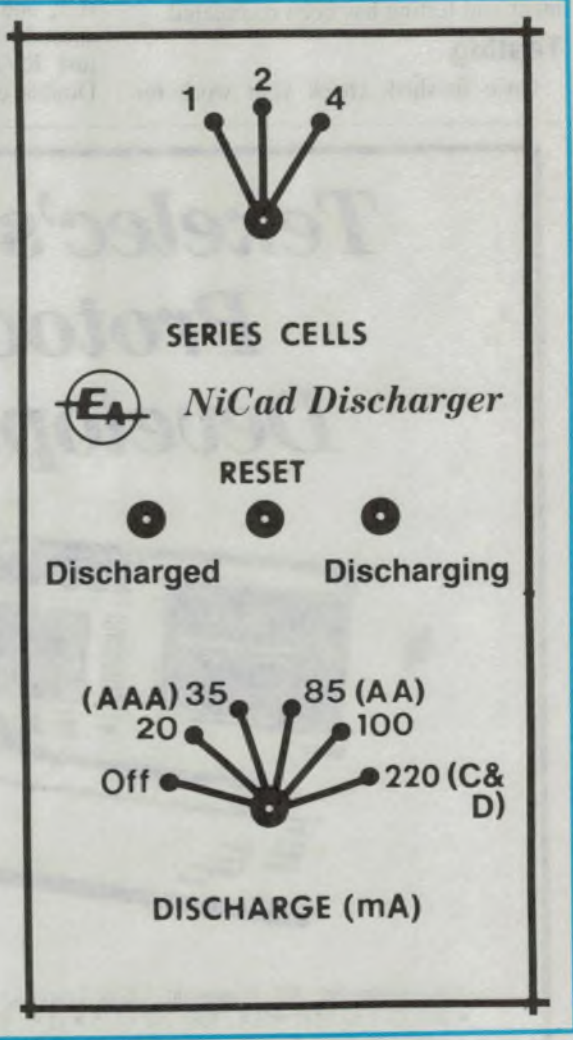
soldered in place. The PCB artwork is designed for the PCB mount 'Alpha' rotary switches sold by Jaycar and others. The artwork is also designed so that the pointer of the recommended knob will align with the front panel artwork. Therefore check that the switches are

correctly orientated so that the flat on the shaft is facing the correct way. The transistors and the IC (socketted if you wish) can now be fitted. Transistor Q4 can be either a BC639 or a BD139, depending on the sort of load you envisage. If you intend discharging

a 6V pack of C or D cells, use the BD139, with a small heatsink, as the 1.2W dissipation can cause Q4 to become fairly warm. The 10-turn pots should now be fitted, and the leads connected. Power to the unit is supplied by way



The PCB artwork and the front panel artwork are both reproduced full size. Use the front panel artwork to assist in marking out the front panel for drilling.



## NiCad discharger

of a 3.5mm phono plug that mates with the 15V DC socket on the charger. Use a short length of shielded cable as the power lead, and make the earth braid the negative.

Next prepare the front panel, using the front panel artwork as a template for drilling the five holes. Like the charger, care should be taken when drilling the panel to correctly position the PCB relative to the panel to allow the whole assembly to fit in the box.

Once the front panel is drilled and ready, insert the LEDs and adjust them to the correct height. The pushbutton is mounted by soldering two lengths of tinned copper wire to the terminals of the switch. These wires can then insert into the PCB, and the height of the switch adjusted to suit.

Lastly, file two slots in the top of the box as exit points for the battery holder and power supply leads. Leave the PCB separate from the panel until adjustment and testing has been completed.

### Testing

Once finished, check your work for

any possible mistakes. Check particularly for possible track shorts and wrongly orientated components.

Plug the unit into the charger's 15V DC outlet, apply power and confirm that the 'discharged' LED is on. Now connect a charged battery, (or a DC power supply set to around 5V), to the battery connector and confirm that the discharge current is approximately equal to the value shown on the front panel for each setting. The 'discharge' LED should light during this test.

If all is well, it remains to adjust the three potentiometers to give the required threshold voltages. The simplest way to do this is with a variable power supply set to the required threshold voltage and to adjust the appropriate potentiometer until the unit switches off.

The order is unimportant, as there is no interaction between settings. For example, select 1 cell with SW1, adjust the input voltage from the power supply to 1.1V and press RESET to cause the unit to switch into discharge mode. If it won't, measure the voltage at pin 10 of IC1, and adjust RV1 until this voltage exceeds 1.1V, and try again. Now adjust RV1 until the unit switches off. Double check by raising the input volt-

age, resetting the discharger, and confirming that the unit switches off when the input voltage falls to 1.1V.

Repeat this for the other two settings, using 2.2V for the '2' position of SW1, and 4.4V for the '4' position. It may be that IC1a will oscillate if your power supply has a relatively high output impedance. If so, you will need to adjust the three potentiometers by measuring the voltage at pin 10 of IC1, and setting the three threshold voltages to about 80mV less than the required switch-off values.

Once assembled, the device is ready for use in conjunction with the charger. It is possible to simultaneously charge one set of cells with the charger while discharging another set with the discharger. You could test a cell by first discharging it, then fully recharging it, followed by a timed discharge. If the discharge time is much less than half the charge time, it would seem that cell should be written off.

The discharger allows various discharge rates, although the front panel shows the cell type that corresponds to the selected discharge current. Using a setting higher than the recommended value is probably not going to damage the cell, but some care should be taken. ②

# Tekelec's Chamelon™ 32 Protocol Test and Development System.



The most advanced problem-solving tool for ISDN LAPD, X.25/HDLC, SNA/SDLC and Bisync/Async environments, features state-of-the-art hardware including a color CRT, and all new analyzer with multiple "paged" display. The Chamelon 32 offers new Basic and Primary Rate Interface options for direct connection to an ISDN

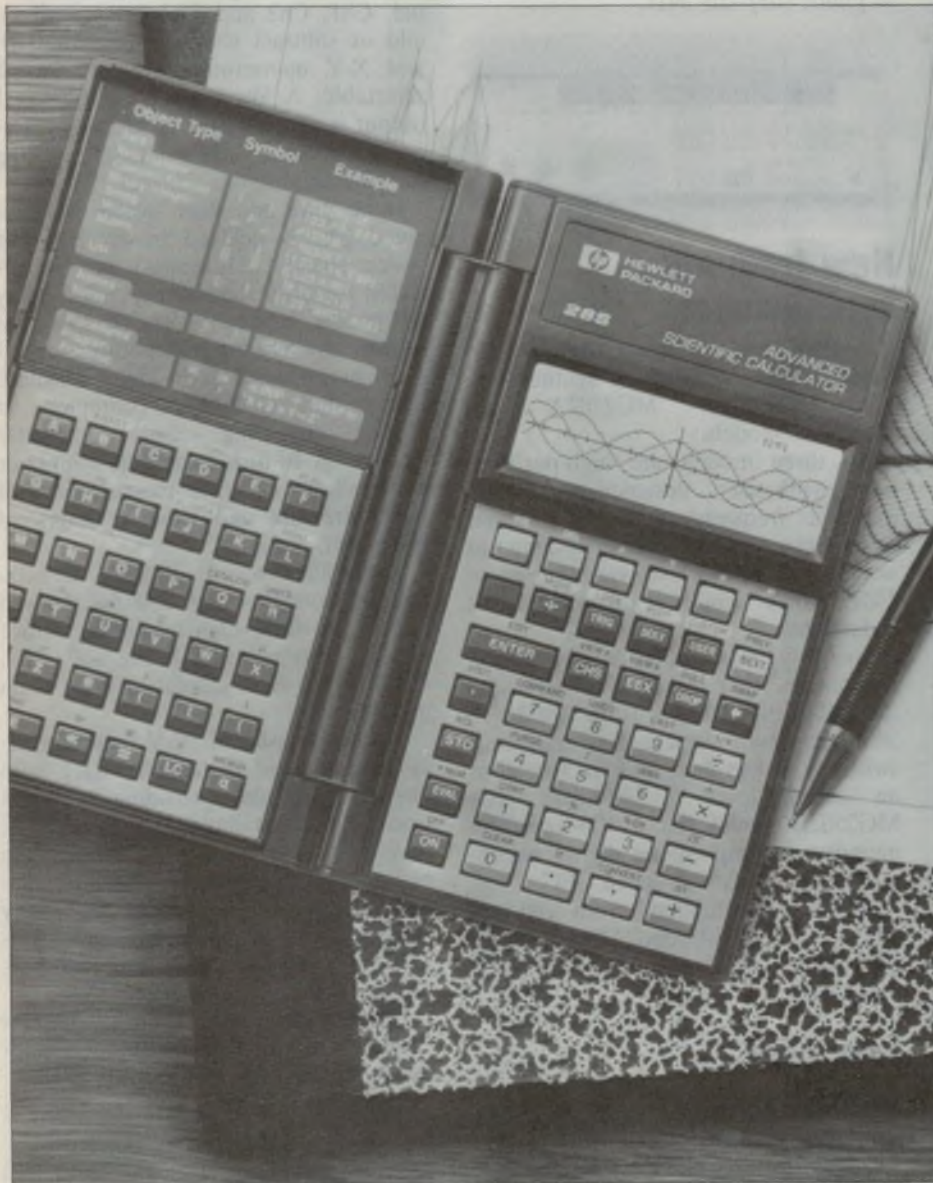
**University Paton**

**INSTRUMENTS**

**FOR ACCESS TO THE BEST**

106 Belmore Rd., Nth. Riverwood, N.S.W. Telex: AA 121398. Fax.: (02) 534 4002. Ph.: (02) 53 0644 ■ Victoria: (03) 370 5994  
■ Qld: (07) 52 9611 ■ S.A.: (08) 212 6235 ■ W.A.: (09) 244 2777 (09) 381 6422 ■ Tas.: (002) 34 2811 (002) 34 5978 ■ A.C.T.:  
(062) 80 6576 ■ Hunter: (049) 69 5177 (049) 69 3122 ■ Illawarra Dist: (042) 71 3844 ■ N.Z.: (09) 46 3048 (09) 59 4481

# According to current calculations Hewlett-Packard is still the most advanced in the industry.



Ask any professional in the field of science or engineering to name the most advanced calculators and they'll all give you the same answer. Hewlett-Packard.

Our comprehensive range starts with the HP-20S, which gives you fundamental math functions plus a programme library of extended functions.

Our most advanced model is the HP-28S, offering you symbolic and numeric solutions, a hefty 32k bytes of RAM and a combination of graphic capabilities, symbolic algebra and calculus.

Each calculator is designed and manufactured with precision engineering. And after being put through the most rigorous and exacting tests, reliability and durability are guaranteed.

So, no matter how basic or complex your technical problems are, there is a Hewlett-Packard calculator to solve them.

But according to our calculations, you probably knew all that anyway.

To find out more about the range of Hewlett-Packard calculators call (008) 03 3821.

 **HEWLETT  
PACKARD**

1230P9036 JWT

# New Products



## Cushion handle flushcutters

A new range of cushion handle flushcutters has been released by Scope Laboratories.

The manufacturer claims that a blade bypass feature that 'shears' leads combines to reduce hand fatigue by as much as 35%. A low profile allows trimming in tight areas. Heavy duty and long life cutters are included in the range, as well as safety models featuring a clip designed to hold the offcut – thus eliminating the hazards of flying leads. A narrow long nose plier compliments the range.

For further information contact Scope Laboratories, 3 Walton Street, Airport West 3042 or phone (03) 338 1566.

## Economy EPROM programmer

The PROM8900 stand-alone EPROM programmer is specifically targeted to those users that employ high capacity devices but cannot afford to upgrade more expensive existing systems. It is also suitable for users just starting to work with EPROMs, as its very low cost does not require major investment to get a project under way.

Despite being very price competitive the 8900 currently programs devices from 32K bit to 1M bit and is designed to upgrade all the way to 8M bit devices. It can program a 256K bit device in just four seconds, using the latest fast programming algorithms. At this speed it can offer greater yield than many production programming systems.

The 8900 is extremely compact and weighs only 1.5kg. It has a master and slave socket, three push buttons and an LCD alphanumeric display on its front panel. Control is effected with the push buttons using a menu system on the display. An integral parallel interface is a standard feature for connecting to a host computer.

For further information contact Alfafron, 5/14 Jersey Road, Bayswater 3153 or phone (03) 720 5411.



## New frequency synthesizers

Anritsu has launched three high-speed frequency switching synthesizers, the MG2501A, MG2502A and MG2502B models.

All three models are high-performance synthesizers designed to accomplish 5 $\mu$ s frequency switching (8 times faster than previous Anritsu systems) as well as continuous level variation up to 20dB, while achieving significant cost reductions.

The MG2502A model covers output frequencies from 1MHz to 600MHz and the MG2501A covers from 1MHz to 300MHz. Both achieve 5 $\mu$ s frequency switching at less than 100kHz as well as an output level of +19dBm. The MG2502B model has a 100-waveform memory and high-speed digital sweeping, thanks to its high-speed CPU.

Further information from Alcatel STC, 58 Queensbridge Street, South Melbourne 3205 or phone (03) 615 6666.

## Low cost 100MHz scope

A new high-performance, low cost, 3-channel 8-trace 100MHz oscilloscope Model COS5100, has been released by Kikusui of Japan.

The scope has a frequency range of DC to 100MHz (-3dB) and maximum sensitivities of 5mV/div (full bandwidth) and 1mV/div (20MHz). Temperature compensated, DC amplifier circuits en-



sure a very low drift and low noise of the base line. Single channel, dual channel, Ch1, Ch2 and Ch3 (trigger view), add or subtract channels (differential), and X-Y operation modes are switch selectable. A low impedance channel 1 output is provided for connecting a frequency counter or a voltmeter – using the Ch1 amplifier as a buffer.

Delay line and dual sweep are provided (A, A delayed by B, B). The sweep speeds (23 ranges) can be selected for both the main (A) and delay (B) sweeps between 0.5sec/div and 20nsec/div. At x10 magnification, a maximum sweep speed of 2ns/div is reached. Push-button selection of continuous or delayed triggering ensures low-jitter viewing. A 10-turn delay time multiplier knob allows accurate measurement of time intervals and time relations of waveform.

'Alternate sweep' displays simultaneously both the main and the delayed sweep, providing high resolution 8-trace viewing of waveforms. (Ch1, Ch2, Ch3, Ch1+/-Ch2, each displayed both main and delayed).

The scope uses an 18kV high acceleration voltage 6" rectangular CRT with internal graticule, providing a bright trace and a parallax-free measurement of waveform characteristics even at the highest sweep speeds. Made of aluminium diecast, the oscilloscope is very compact and light but sturdy, being suitable for both laboratory and field service use.

Further information from Emona Instruments, 86 Parramatta Road, Campersdown 2050 or phone (02) 519 3933.

## Fused power filter

Latest addition to the Belling Lee (UK) power filter range is an extra safe version with a retained double fuseholder, for applications where both the live and neutral lines are to be fused.

By incorporating an integral double

fuse-holder, the filter greatly reduces the number of panel cut-outs required. Double fusing is commonly required in instruments, and instruments likely to be used out of doors or in damp environments. The fuse-holder is attached to the filter, to prevent loss. For maximum safety, the fuse-holder cannot be accessed until the mains connector has been withdrawn.

Available in 2A, 4A or 6A versions, the filters are equipped with an IEC fixed socket with twin 20mm x 5mm fuse-holder. A low earth leakage current version for medical applications is also available, with a maximum earth leakage of 4uA. Connections are by quick connect or solder tags.

For further information contact Tecnico Electronics, 11 Waltham Street, Artarmon 2064 or phone (02) 439 2200.



## Precision wire stripper

OK Industries has introduced a new adjustable precision wire stripper designated the ST-500.

The ST-500 quickly and accurately strips 20 to 30 AWG (0.25 to 0.8mm) wire. The precision tool also has 4 specially hardened blades that easily strip all types of wire insulations, including Teflon.

This lightweight (less than 1 oz.) tool effortlessly strips all wire by turning the adjustment wheel to the appropriate wire diameter, putting the wire through the hole, squeezing the handle and turning the tool slightly to withdraw the wire.

The ST-500 also includes an adjustable wire stop which ensures consistent wire strip lengths.

Further information from Electronic Development Sales, 2A/11-13 Orion Road, Lane Cove or phone (02) 418 6999.

## Slim, compact short-Leq meter

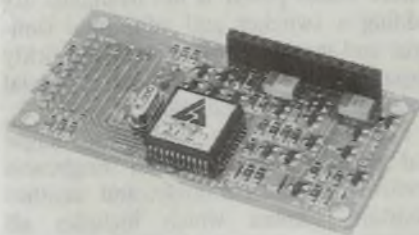
Cirrus Research has commissioned a new technology analog meter only 12.5mm thick, allowing the construction of a super slim sound level instrument only 23mm deep – truly pocket sized.

The performance of the CRL 2.22 is

claimed to be exceptional, particularly for the low price. Both Leq and sound level can be measured over a full 53dB span and the maximum Leq time is more than 8 hours, allowing use over a full working day. The accuracy is to the full specification of BS5969 or IEC651 Grade 2, and the CRL 2.22 also meets the new IEC804 specification of Integrating Meters. Sound exposure level is fitted as standard, so that the noise dose of individual workers can be measured on a direct energy-related scale.

Although the CRL 2.22 is a normal hand-held unit, one of the most powerful features is 'Short Leq'. With a microcomputer plugged into the 'computer' output, to provide memory, the CRL 2.22 becomes a powerful data acquisition unit. Any Leq period from one second upwards can be used as a data base.

For further information contact M.B. & K.J. Davidson, 17 Roberna Street, Moorabbin 3189 or phone (03) 555 7277.



## Selective calling module for FM620

The GSA2112 is a 5 or 6 tone sequential encoder/decoder, providing full professional features that until now have not been available for the popular Philips FM620 UHF CB transceiver.

By providing a set of switch contacts, the 6th tone can be used to indicate status conditions of the vehicle. An emergency alert is a common use. Because the output from the GSA2112 is in BCD format, indicating up to 10 conditions is a relatively simple task.

Complete international standard 5-tone signalling sets and tone periods are programmable using a solder matrix. Other features are also provided, including automatic knowledge and automatic number identification.

The GSA2112 is of very rugged construction, employing CMOS surface mount construction and is most competitively priced.

For further information contact GSA Technology, 1 Hall Street, Hawthorn 3122 or phone (03) 822 7858.

## Comms & data acquisition cards

Qua Tech has available a range of data acquisition and industrial control products, communications boards, waveform synthesiser boards, IEEE 488 GPIB boards and power controls for IBM PCs and compatibles, including IBM PS/2.

The products include analog to digital (A/D), digital to analog (D/A) and digital input/output (I/O) capability. Both 8- and 12-bit resolution converters are available. Labstar, a powerful assembly language driver with an array of commands callable from BASIC, C, Fortran and Turbo Pascal is included with each module.

The communications boards are developed to meet asynchronous and synchronous, serial and parallel data communication requirements. Communication over the interface protocols of IEEE-488, RS-232, RS-422, RS-485 and current loop are available.

The WSB-10 waveform synthesiser board is a self-contained analog waveform synthesiser which produces user definable signals. The user programs the shape and repetition rate of the waveform, and the WSB-10 automatically synthesises the desired waveform continuously without further support from the host computer.

For further information contact Interworld Electronics and Computers, 55 Wellington Street, Windsor 3181 or phone (03) 521 2952.

## PC-based generator, scope/logic analyser

Orion Instruments of Redwood City, California has released the OmniLab 9200 series, a unique set of no-compromise tools which totally integrates analog and digital functions.

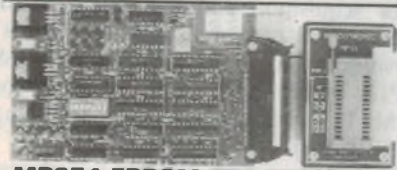
The system combines a 100MHz digital oscilloscope with a time-aligned 200MS/s 48-channel logic analyser. With synchronised analog and digital stimulus generators and a new triggering system, the 9200 series is designed to speed analog and digital test and measurement and so shorten the time between concept and product.

The 9200 series is based on an innovative architecture that merges high-speed hardware and integrated software to provide a wide array of powerful functions.

Further details from Anitech, 1-5 Carter Street Lidcombe 2141 or phone (02) 648 1711.

**MONDOTRONIC**

FOR YOUR PC/XT/AT



### MP271 EPROM PROGRAMMER

High speed programming of 2716-27512 eproms. Screen editor in the HEX or ASCII, copy, move fill-erase. File handling of S1-S9, hex or binary formats. User friendly. Demo disk available.



### MD230 TTL I/O BOARD

Professional 8255 based design. 48 TTL I/O signals. High noise immunity connections. Supports hardware interrupts 2-7. Multiple board addressing.



### MD120 OPTO/RELAY ISOLATOR BOARD

64 Opto coupled inputs connect directly 5V-25V DC/AC. 4 Relays with 2A contacts. Supports hardware interrupts 2-7. Multiple board addressing allows large number of inputs. Ideal for PC control applications from factory floor to home.



### MD100 OPTO/RELAY ISOLATOR BOARD

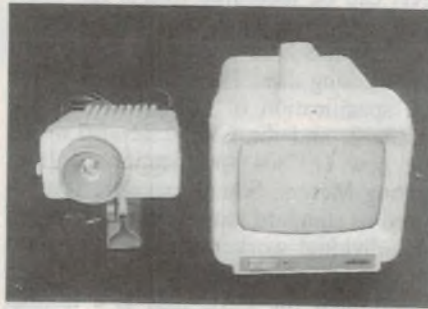
16 Opto coupled inputs connect directly 5V-25V DC/AC. 8 Relays with 2A contacts. Supports hardware interrupts 2-7. Multiple board addressing. Easy programming, as with all Mondotronic boards.

Mondotronic products are designed build and supported in Australia. For more information please write or call:

#### MONDOTRONIC PTY. LTD.

560 Waverley Road Glen Waverley  
3150 P.O. Box 296 Fax (03) 233 0376  
Phone (03) 232 4110

## New Products



### Video monitoring system

Captain Communications is now distributing the low cost OnSight video monitoring system. This compact system is complete, with camera and monitor. Easy to install and operate, it is small and light enough to fit even cramped locations.

The use of 13.8V power (via a mains adaptor) makes the OnSight suitable for battery backup and use in situations where mains power is not available. By adding a switcher and additional cameras and monitors, the system is quickly expandable. For use outdoors, a special weather shield is available.

Features include a compact 6" diagonal monitor; contrast and brightness controls; an ultra compact and weather resistant camera which includes all mounting hardware; and 70 feet of wire included for installation flexibility.

For further information contact Captain Communications, 26-28 Parkes Street, Parramatta 2150 or phone (02) 633 4333.

### Fast logic analyser

Thurlby Electronics has introduced the first self-contained full-performance logic analyser to cost less than \$3000. The LA3200 is a 32-channel analyser with a high-resolution screen that can operate at acquisition speeds up to 100MHz. Also available is the LA4800, which has an identical specification but with 48 channels.

The LA3200 and LA4800 are fully featured logic analysers incorporating a large high-resolution LCD display. They differ from conventional logic analysers in being smaller, lighter and considerably less expensive. Because of this, they are ideally suited to the 'personal' logic-analyser market in product development, training and education.

The maximum acquisition speed is 25MHz in synchronous mode and

100MHz in asynchronous when using data pods, and the memory depth is 8K words per channel. Glitch capture is available when using appropriate pods.

The trigger facilities are very sophisticated, and include multi-level triggering with 'if/then/else' sequencing and multiple delays via event or clock counts. Data qualification is equally sophisticated with full width 'start/stop' trace words being provided.

Further information from Parameters, 25-27 Paul Street North, North Ryde 2113 or phone (02) 888 8777.



### 12MHz PC/AT \$500

Electronic Solutions has released a 12MHz zero wait-state PC/AT computer - complete (except for a video card) and built right onto a 'baby-sized' mother board only 8.5" x 13".

Not only does the board give superior performance (with video and disk running at processor speed), but it works out around half the price you'd pay for the same thing 'in pieces'.

Features include 12MHz zero wait-state performance - equivalent to 16MHz on most ATs; DISC (dynamic I/O speed control) which provides superior compatibility with add-on cards; the ability to fit up to 4MB on the motherboard - no need for memory expansion cards. (Uses 256K or 1MB chips); two serial ports and one parallel port on-board; and an on-board floppy drive disk controller for both 5 1/4" and 3 1/2" drives.

For further information call, write or fax Electronic Solutions, Box 426, Gladesville 2111 or phone (02) 427 4422, fax (02) 427 2542.

### 40GHz sweep oscillator

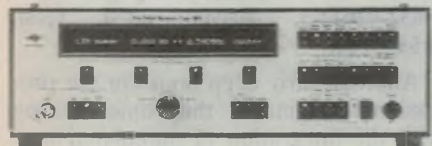
Tech-Rentals has recently expanded its inventory to include the Hewlett-Packard Sweep Oscillator. The 8350B is a versatile broadband sweep oscillator, covering the frequency range 10MHz to 40GHz and having extensive applications in the microwave region including millimetre mixer and noise figure measurements.

The unit comprises a mainframe ac-



cepting either the HP83500 or HP86200 series plug-ins, which provides control and display of various functions such as sweep limit frequencies, sweep time and power output. The 8350B features high output power, up to 20mV, low harmonics typically less than -36dBc and five frequency markers.

For further information on the HP8350B sweep oscillator contact your nearest Tech-Rentals office, on Melbourne (03) 879 2266; Sydney (02) 736 2066; Brisbane (07) 875 1077; Perth (09) 470 3644; Adelaide (08) 344 6999; and Canberra (062) 57 4938.




## Sine/noise generator

Bruel & Kjaer's new high performance Sine/noise generator type 1054 offers signal purity and accuracy over a .01Hz to 2.54MHz frequency range, with a frequency resolution of 10mHz. For single, repetitive or continuous sweeps, the sweep rate is adjustable from .001Hz/s to 2.54MHz/s for linear sweeps or .001 udec/s to 4,000 dec/s for logarithmic sweeps.

Output levels from 1mV to 5V are selectable with better than -60dB harmonic distortion. The generator has an amplitude linearity of +/-0.1dB in the 20Hz to 20kHz range. A built-in compressor provides 118dB of 'live' amplitude regulation, which is continuously displayed on the generator's front panel.

For frequently repeated tests, the generator stores nine complete sets of control panel settings internally for instant recall.

Additional features of the type 1054 include outputs providing narrow-band, white and pink noise. The generator also provides a 5MHz crystal clock which can be used as a test system master-clock or synchronised with an external clock.

Further information is available from Bruel & Kjaer Australia, 24 Tepko Road, Terry Hills 2084 or phone (02) 450 2066. 

## COMPUTER

80286-12 Microprocessor 512 KB Ram @ 100ns access time. 1.2MB 5 1/4" floppy disk drive Baby Case with flip top lid. 200 watt power supply. 101 key de-luxe extended keyboard. Dual Serial & Centronics port card. Colour Graphics Monochrome Adapter Card Floppy Disk drive controller card



**\$1,499**

## MOTHERBOARD

80286-12 microprocessor 12 MHz with 0 wait state 6 16-bit expansion slots 2.8-bit expansion slots. Sockets for up to 4 MB of RAM socket for 80287 co-processor. Award Bios. Size 22x33 cm



**\$489**

## FLOPPY DRIVE

5 1/4" floppy drive. Encoding FM & MFM. Read and Write to 1.2 MB high density diskettes. Read and Write to 360K double density diskettes. Wide variety of user options



**\$155**

## HARD DISK DRIVE

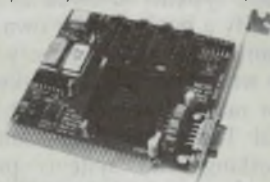
5 1/4" Hard Disk Drive. 41mm half height size. 20 MB formatted capacity. Complete data protection against vibration and shock during transportation



**\$320**

## CGMA CARD

Ideal for driving a wide range of monitors. MONOCHROME HERCULES, CGA, MULTISYNC. Dual scan high definition mode for multi sync monitors. Bios compatibility switch sockets to all chips.



**\$134**

## CONTROLLER CARD HARD/FLOPPY DRIVE

PC/AT compatible MFM/ST506/412 compatible 5 MB transfer rate. Supports 16 heads and 2048 cylinders. Sector buffer.



**\$210**

## CASE & POWER SUPPLY

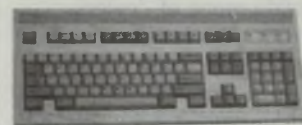
Baby AT Case with flip top lid. 360mm wide x 408mm deep x 165mm high. Space for three half height drives. 200 watt power supply installed.



**\$181**

## KEYBOARD

Switchable XT/AT type 101 key de-luxe extended keyboard. Separate cursor keys. Separate numeric keypad. 12 function keys. Double injection key/caps.



**\$78**

## DISKETTES:

5 1/4" DSDD \$5.49 } Pk. 10 inc. tax  
3 1/2" DSDD \$18.99 } LIFETIME GUARANTEE

26 Boron St, Sumner Pk,  
Brisbane Qld 4704.  
Phone: (07) 376 2955  
Fax: (07) 376 3286.  
WELLINGTON, NZ:  
Ph: (04) 85 8742.  
Fax: (04) 82 8850.

Ken Curry  
Managing  
Director



energy  
CONTROL



# Books & Literature

## Device indices

**INTERNATIONAL INTEGRATED CIRCUITS INDEX**, 6th Edition by Semicon Indexes Ltd. Published by Tech Publications, 1987. Soft covers, 220 x 154 x 24mm. ISBN 9971-84-873-2

**INTERNATIONAL DIODE & SCR INDEX**, by Semicon Indexes Ltd. Published by Tech Publications, 1987. Soft covers, 220 x 154mm, 27mm thick. ISBN 9971-84-875-9

With such a huge number of semiconductor devices having been used – and still being used – in electronic equipment, indexing and cross-referencing information is almost mandatory for anyone such as a service technician who must service or maintain a range of equipment. The Semicon indices have been around for a while now (these are the current editions) and their longevity must surely testify to their utility.

Although the original Semicon indices are compiled in the UK, these editions are in fact economy reprints produced in Singapore – apparently by arrangement. Although printed on rather thin paper, they appear to be quite well bound and durable.

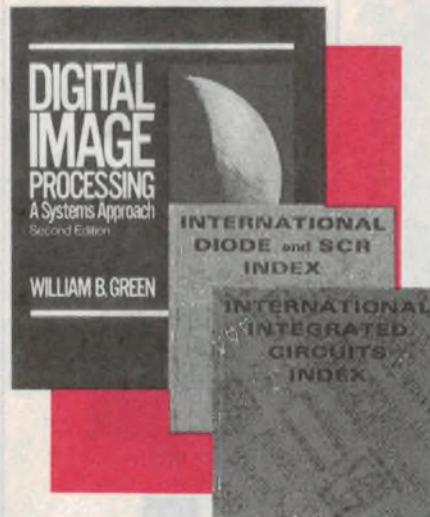
As with the previous editions they provide basic identification and pinout information, plus details of manufacturer, etc. The diode/SCR volume also gives basic functional and performance data, as well. In both cases they cover an extremely wide range of devices.

Do they cover all possible devices? Probably no single volumes can, because the range is so immense. However with these on your reference shelf, you'll at least have a fighting chance of being able to identify an unknown device and either obtain a replacement or work out a substitute.

The review samples came from Jaycar Electronics, which stocks them in its stores under the catalog numbers BM4562 and BM4560 respectively. Each sells for \$29.95. (J.R.)

## Image processing

**DIGITAL IMAGE PROCESSING, A SYSTEMS APPROACH**, by William B. Green. Second Edition, published by Van Nostrand Reinhold, 1989. Hard covers, 288 x 225mm, 251 pages. ISBN 0-442-23052-4. Recommended retail price \$115.50



Digital processing of images is now such an important and widespread activity, in so many fields of endeavour, that the techniques and hardware/software systems involved in it more than justify a book of their own. And the author of this volume is very well qualified to write one, having worked in the field for many years. He spent some time at Cal Tech's Jet Propulsion Laboratory, working with systems processing the images sent back by NASA's Mariner 9 and 10, Viking and Voyager spacecraft. He has also worked in the image processing section of Unisys Defense Systems, processing reconnaissance images, and lectured on image processing at Harvard University.

This book is essentially a general reference work on the subject as a whole, with the emphasis on giving a broad understanding of the concepts and techniques, rather than a lot of maths and theory. There are plenty of illustrations, including quite a few very interesting colour plates of LANDSAT images, images from spacecraft and so on.

There are nine chapters in all, the first giving a basic introduction to digital image processing concepts. The later chapters then go into the various aspects in more detail – image acquisition, subjective and quantitative processing techniques, image display, processing software design, image database management, binary image processing and image processing on PCs. The last of these has been added especially, as part of the revision for the book's second edition. Three appendices at the

end then give useful data sources, data on LANDSAT receiving stations and distribution centres, and a bibliography and list of further information.

All in all, I found it a very readable and informative book, and one that gives an authoritative insight into this important field. The cover price is a bit steep, perhaps, but it would make an excellent reference on the subject. (J.R.)

## Integrated testing

**COMPUTER INTEGRATED TESTING**, edited by Allen Buckroyd. Published by BSP Professional Books, 1989. Hard covers, 162 x 242mm, 394 pages. ISBN 0-632-02042-3. Recommended retail price \$144.

Another fairly deep book for the professional engineer, this time dealing with the integration of automated testing into an overall computer-controlled manufacturing environment. In other words, the computer-integrated testing or 'CIT' part of *CIM* – computer integrated manufacturing – as opposed to the other essential parts such as CAE, CAD, MRP and CAM (engineering design, drawing, resource planning and manufacture itself). The editor is a project manager at Marconi Communication Systems in the UK, and the other contributors are all from the UK or the Netherlands.

The contents are divided into four basic parts, the first of which gives an introduction to the basics of CIM, testing in general and automated testing in particular. Then part 2 deals with CAE and CAD, with particular emphasis to simulators and emulators.

Part 3 then provides some five practical case studies, designed to illustrate the professional approach to CIT in practice. Finally part 4 deals with aspects such as designing products for testability, collecting shop floor data and maintaining statistics, and likely future trends.

The text is clear and concise, and although the overall treatment seems a little slanted towards the European scene, I suspect that Australian engineers will find a lot in it of value and relevance.

The review copy came from Blackwell Scientific Publications, of 107 Barry Street, Carlton 3053. (J.R.)





**NEW**

# AT&M

**ELECTRONIC PRODUCTS FOR INDUSTRY & EDUCATION**

**AUSTRALIAN TEST AND MEASUREMENT**  
Pty. Ltd. 28 Hotham Parade, Artarmon, NSW. 2064  
Phone 906 2333 FAX 438 4219



**Professional  
Quality  
Electronic Kits**

## AT&M DISTRIBUTORS

*Australian Test And Measurement now has a network of stocking distributors for our high technology self assembly kits to make it easier for you to select from our range of functional modules. Our range of kits is constantly expanding and our distributors will keep you up to date with the latest developments.*

### NEW SOUTH WALES

**Geoff Wood Electronics**  
229 Burns Bay Rd. Lane Cove West  
Phone 02-4271676 FAX 02-4285198

**Davred Electronics**  
127 York St. Sydney  
Phone 02-2671385

**DGE Systems Pty. Ltd.**  
103 Broadmeadow Rd. Broadmeadow  
Phone 049-691625 FAX 049-695067

### VICTORIA

**Stewart Electronics Pty. Ltd.**  
44 Stafford St. Huntingdale  
Phone 03-5433733 FAX 03-5437238

**The Electronic Components Shop**  
289 LaTrobe St. Melbourne  
Phone 03-6706474 FAX 03-6706006

### QUEENSLAND

**St. Lucia Electronics**  
24 Campbell St. Bowen Hills QLD  
Phone 07-2527466 FAX 07-2522862

**Southport Electronics Shop,**  
Shop 1, 10 Welch St. Southport QLD  
Phone 075-323632

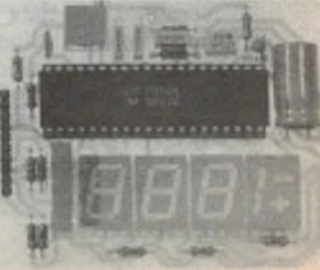
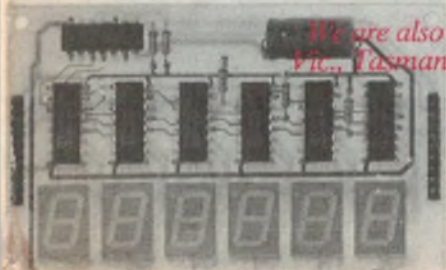
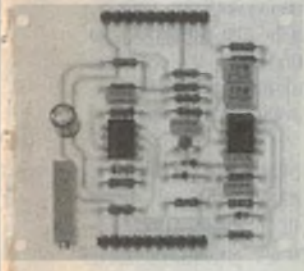
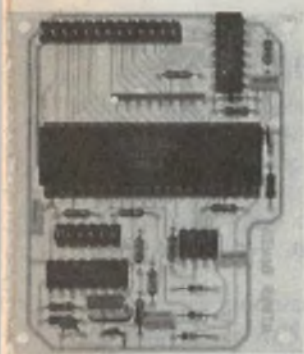
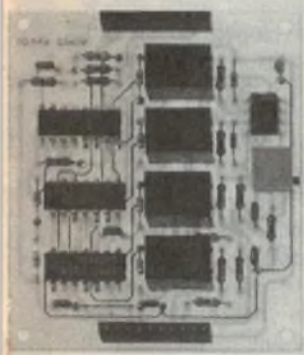
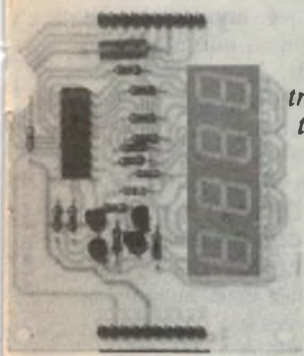
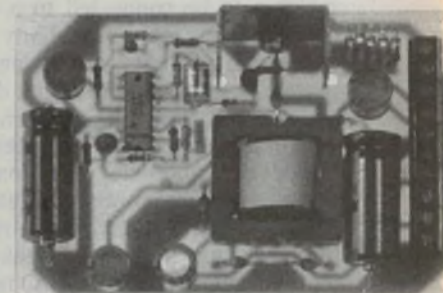
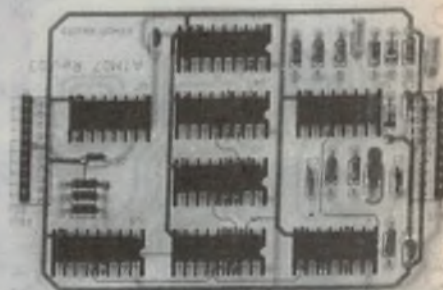
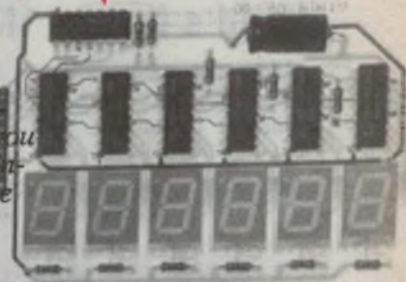
### SOUTH AUSTRALIA

**Electronic Components & Equipment Pty. Ltd.**  
30-40 Hurtle Sq. Adelaide  
Phone 08-2320001 FAX 08-2320670

### AUSTRALIAN CAPITAL TERRITORY

**Electronic Components Pty. Ltd.**  
10 Fyshwick Plaza, Wollongong St. Fyshwick ACT  
Phone 062-804654 FAX 062-804654

*We are also seeking distributors in Sydney West, Country NSW, Country Vic., Tasmania, Western Australia, Northern Territory and New Zealand.*



# Solid State Update



KEEPING YOU INFORMED ON THE LATEST DEVELOPMENTS IN SEMICONDUCTOR TECHNOLOGY

## World's fastest 1Mb DRAM

IBM researchers claim to have made the world's fastest one-megabit dynamic memory computer chip, at the

company's Yasu, Japan, manufacturing plant.

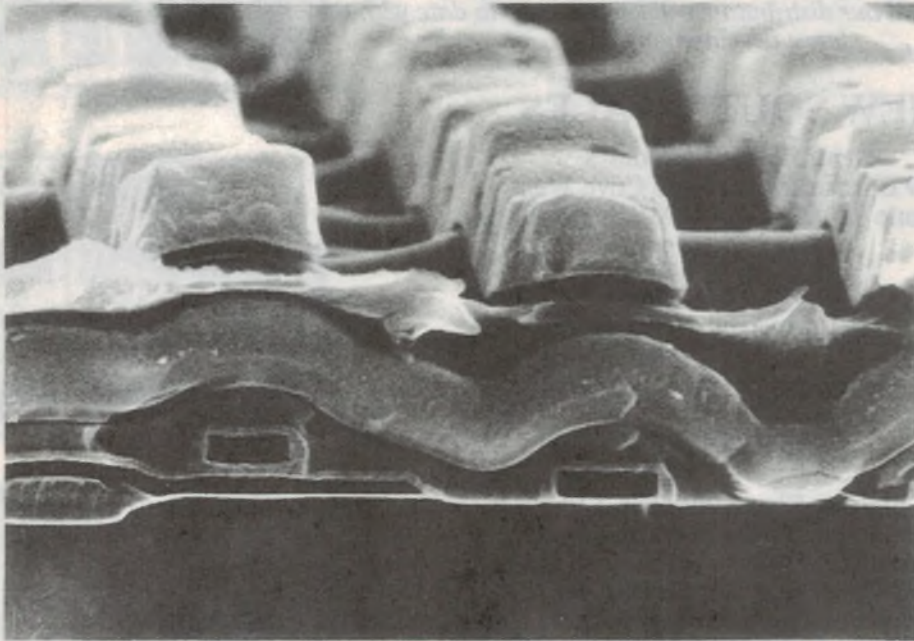
The experimental IBM DRAM oper-

ates two to three times faster than the current generation of one-million bit chips, retrieving a bit of information in just 22 nanoseconds. It can store the equivalent of about 100 pages of double-spaced typewritten text.

The chip provides an unprecedented combination of high speed and density. Manufacturing the DRAM on an existing production line demonstrates its volume production potential and heralds the advent of very fast main memory in supercomputers, personal computers and desktop workstations.

The chip was fabricated using a new CMOS process developed at IBM's Technical Applications Laboratory in Yasu. Two layers of polycrystalline silicon and two layers of metal were used for the chip's wiring. This composition allows greater density and higher speed.

In addition to its high-speed performance, the CMOS technology allows substantially cooler operation of its circuits than other types of technology. The chip dissipates only 500 milliwatts of power during operation — very low in view of its three times faster speed than today's production chips.

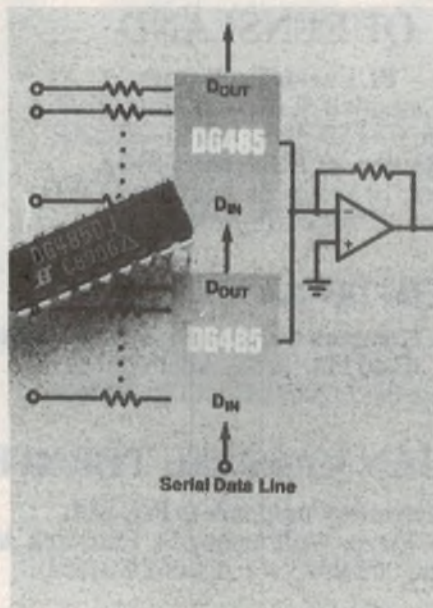


## Analog switch array

Just released by Siliconix is the DG485, an analog switch array that combines the features of the company's silicon gate DG4XX family with a new serial-controlled switch architecture.

The DG485 has a serial input control that allows any combination of the eight switches to be connected to a common output line, a novel capability that reduces wiring, parts counts and board space. It also simplifies the design of signal-conditioning circuits such as summing-node mixers, microprocessor-controlled gain and filter selection circuits and analog signal routing circuits.

The DG485 offers low on-resistance (85 ohms max.) and low leakage currents for improved signal throughput accuracy. Fast switching ( $t_{on}$  less than 200ns) is well suited for high-speed operations in data acquisition, communication and avionics applications. Its low power dissipation (105uW) is ideally suited to battery operated systems that require very low power consumption.



Further information from Anitech, 1-5 Carter Street, Lidcombe 2114, or phone (02) 648 4088.

## Peltier coolers

Lastek has been appointed Australian distributor for the MELCOR range of solid state thermo-electric coolers.

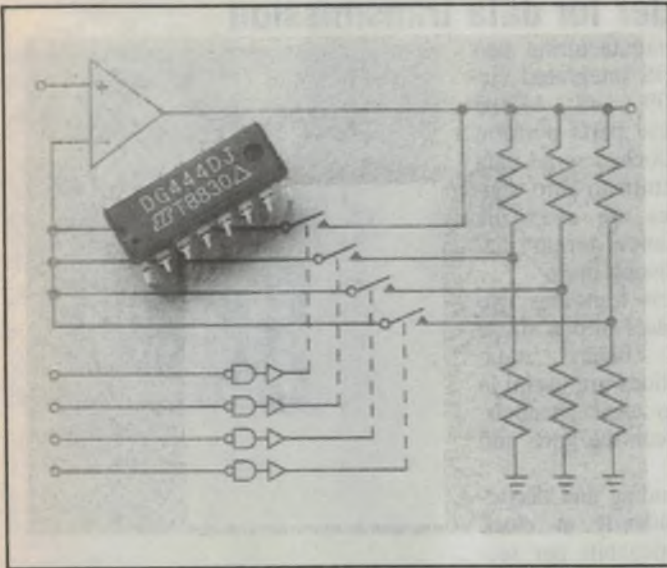
These solid state heat pumps can generate a temperature differential in the order of 70°C and greater, between the hot and cold plates.

The devices are based on thermocouples constructed of N & P elements of highest grade bismuth telluride, in the form of oriented polycrystalline ingots. The ends of the ingots are soldered to copper bus bars interfaced to ceramic plates providing good mechanical integrity, high dielectric strength and thermal conduction.

The operating temperature range is -150°C to 80°C. Special stacked modules are available for temperature differentials of over 70°C. Standard sizes range from 1.8 x 3.4mm up to 55 x 55mm, with cooling factors of 220mW to 125W.

For further details contact Lastek, GPO Box 2212, Adelaide 5001 or phone (08) 231 2155.

## Silicon-gate analog switches



The recently released DG441/2/4 and DG445 silicon-gate analog switches from Siliconix provide high-performance pin-for-pin replacements for the popular metal-gate DG201A/202/211 and DG212, respectively. Offering significantly lower on-resistance (85 $\mu$ m) and lower leakage currents, the new DG400 family of silicon-gate switches have faster transition times (250ns) than the older metal-gate parts.

The improved specifications allow designers to greatly reduce system errors and improve system performance, as the pin-to-pin compatibility with frequently used industry-standard parts enables advantage to be taken of the high performance specifications. These new ICs have reduced sensitivity to electrostatic discharge and have the ability to withstand more than  $\pm 4000$ V on all pins (with respect to ground), making them easier to handle in the manufacturing environment.

The DG441 and DG442 are available in 16-pin plastic and ceramic dual-in-line packages (DIPs), as well as small-outline (SO) packages for automated assembly. The DG444 and the DG445 come in 16-pin plastic DIPs and SO packages.

For further information contact Anitech, 1-5 Carter Street, Lidcombe 2141 or phone (02) 648 4088.

## DC-DC converter

Rohm has introduced its new BP5000 series PWM type DC-DC converter.

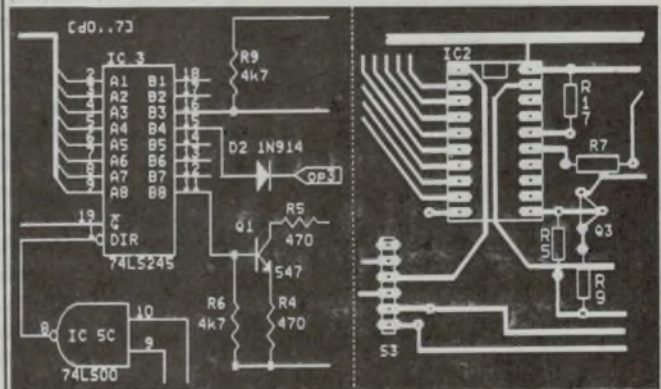
The BP5000 series' wide input voltage range and high conversion efficiency make them ideal as local power supplies, enabling stable power to be provided from a main power supply where the supply voltage varies greatly. There is no need for a heatsink and the device comes in a light and compact 9-pin SIP package.

There are six models available, to suit the desired output voltage and output current.

For further information contact Fairmont Marketing at Suite 3, 208 Whitehorse Road, Blackburn Vic 3130, or phone (03) 877 5444.

# OrCAD

Systems Corporation



Power and Speed at an affordable price, on your IBM PC.

OrCAD the powerful and easy to use Electronic Design Software now provides complete End to End Design.

**First design your circuit using the Schematic Design Tools (SDT).**

**OrCAD/SDT Features:**

- Over 3700 unique library parts and graphic parts editor
- Unlimited levels of hierarchy
- Standard macros supplied and user entry of keyboard macros
- Netlisting to 22 other packages plus other post processing utilities
- Variable size worksheets, text and output

**Simulate your design with Verification/Simulation Tools (VST).**

**OrCAD/VST Features:**

- 14,000 gate capacity from up to 50 channels input
- 10,000 events per second (8MHz AT)
- 10 breakpoints, 16 AND/OR signals per breakpoint
- Logic analyser format simplifies data analysis
- Selectable minimum or maximum delays and model library source

**Finally produce your design using Printed Circuit Board (PCB).**

**OrCAD/PCB Features:**

- Auto routing up to 32" x 32" with 16 copper layers maximum
- Selectable track, via and isolation from 0.001" to 0.255"
- Square, rectangular, round, oval and SMD pads
- Grid bases of 100, 50, 25, 10, 5 mils. Off grid to 1 mil.
- Ratsnest, force vector for placement optimization

All OrCAD products are fully compatible and include 12 months free updates and support.

**CUT OUT AND MAIL TODAY.**

We will send you a FREE Demo and Literature.

Name \_\_\_\_\_  
 Title \_\_\_\_\_  
 Company \_\_\_\_\_  
 Address \_\_\_\_\_  
 Telephone \_\_\_\_\_ Fax \_\_\_\_\_

Prometheus Software Developments Pty Ltd  
 260 High Street Kew, Vic. 3101.  
 Telephone: (03) 862 3666.  
 Fax: (03) 862 2092.

## We will burn your PROMS

- Any number
- All popular device technology
- Guaranteed results
- Competitively priced



Alfatron Pty Ltd

Tel (03) 720 5411

Fax (03) 720 5383



The Electronic Technicians Institute of Australia is an organisation established to protect and promote the professional status of technicians working in all branches of the electronics industry.

Membership enquiries should be directed in the first instance to The Federal Secretary, TETIA, PO Box 148, Riverwood, NSW 2210.

## ?CAD?

■ Want to talk with an experienced user?

We use  
**PROTEL Autotrax**  
 for PCB layout  
**PROTEL Schematic**  
 for Schematics

Advice and Sales

**McCUBBIN ELECTRONICS**

PH (03) 584-5330

FAX (03) 584-5330

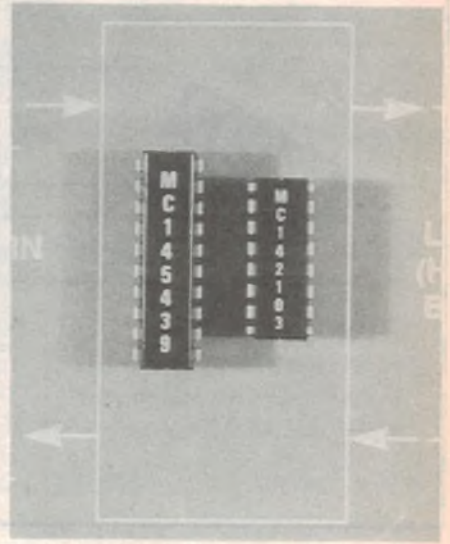
## Solid State

### Encoder/decoder for data transmission

Motorola is now manufacturing two new high speed CMOS integrated circuits, the MC145439 and 142103 Encoder/Decoder. These parts perform coding translation of clocked serial data into two streams of return to zero digital pulses. The pulses are externally mixed to form a selection of ternary signals for driving transmission lines.

Reversing the process translates two streams of clocked pulses into a single stream of clocked binary data. Encoder/Decoder functions are useful in converting TI links to clear channels. Slight differences between the parts add design-in flexibility.

The parts perform coding and decoding functions independently at clock rates from DC to 9 megabits per second. Also featured are loopback and error monitoring functions. Both parts perform HDB3 coding and decoding



functions within CCITT G.703 guidelines.

### V.35 receiver/transmitter

Exar has released a CCITT V.35 compliant chip set, consisting of two bipolar devices. One performs a receive function, the other a transmit function, according to the specification requirements laid down in Appendix 11 of the V.35 CCITT recommendation and Bell 306 modem interface specification.

Typical applications require three transmit and receive pairs to establish the link between distant DTE's at data rates ranging from 48kbps to 10Mbps. To conserve power (especially in the case of the transmitter, which requires approximately 22mA for each output stage) and to meet CCITT specifications, power-down functions are included in both devices, allowing any of

the three receive/transmit circuits to be disabled. All inputs and outputs are TTL compatible and designed to offer maximum versatility and performance.

Both the transmitter and receiver require termination resistors external to each device, to meet the V.35 specification tolerance. Hybrid parts are also available from Exar, which include the termination resistors on top of a ceramic substrate.

The XR-T3588/T3589 are available now in 18 and 14 pin dual-in-line ceramic packages.

For more information contact 1/407 Highett Road, Highett 3190 or phone (03) 555 6777.

### P-channel JFET

Three ranges of P-channel silicon junction field-effect transistors for insertion or surface mounting are now available from Philips Components. The new devices are plug-in replacements for well-known industry-standard types. They are suitable for analog switches, choppers, and commutators, with switching speeds in the low nanosecond range. They can also be used in digital switching in, for example, data transmission systems.

There are 12 twelve devices in all. The devices are symmetrical, having interchangeable drain and source connections which facilitates assembly, and have maximum gate-source and drain-

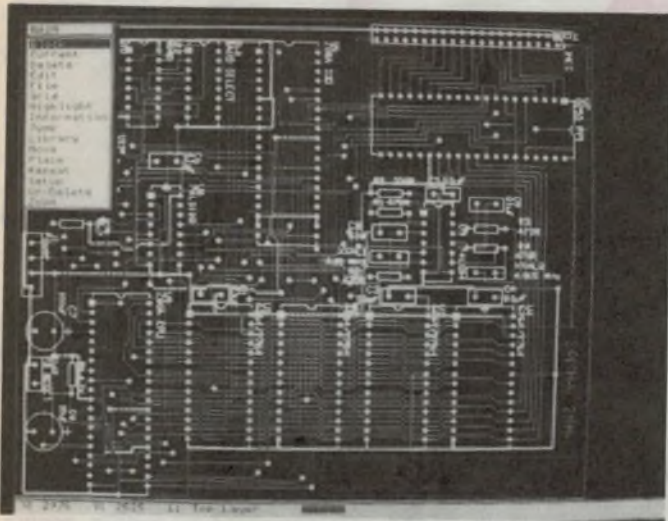
source voltages of 30V. They are complementary with N-channel equivalents, which leads to less components overall at the system level.

The BSJ174, BSR174, and PMBFJ174 have the highest switching capacity in their respective ranges, carrying maximum drain currents of 135mA. The drain-source on-resistance for the 174 types is a low 85 ohms. These are also the fastest devices in the range, with turn-on turn-off times of 7 and 15ns respectively.

For further information contact Philips Components, 11 Waltham Street, Artarmon 2064 or phone (02) 439 3322.

# PROTEL-EASYTRAX®

Outstanding value in  
Printed Circuit Board/CAD



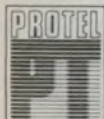
PROTEL-EASYTRAX, is a new, low-cost design package for PC users that includes everything required to produce professional-quality Printed Circuit Board artwork.

Our easy-to-learn menu-driven design system breaks the 'expert barrier' – you'll be designing in minutes, not hours. Our comprehensive tutorials guide you through the program's extensive features that take the tedium out of board lay-out.

When we say professional – we mean through-hole component boards to 32 x 32 inches with 6 signal layers plus ground and power planes. A fully-independent print/plot program is included which supports most plotters, dot matrix and laser printers, Gerber® photoplotting and N/C drill tapes.

EASYTRAX is a 100% Australian product ... and user support is only a phone call away.

**NOW \$295**



**Professional by design**

PROTEL TECHNOLOGY PTY LTD

GPO Box 536F HOBART TAS 7001

Telephone (002) 73 0100 Facsimile (002) 73 1871



## A Service Monitor recognised for its reliability and performance.

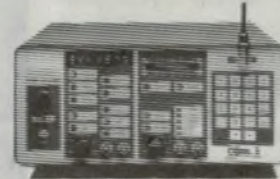
It's not surprising why the RAMSEY COM-3 COMMUNICATIONS SERVICE MONITOR has been so roundly applauded by its peers.

That's because the COM-3 can Generate, Receive, measure Deviation and Frequency of all transceivers over the entire 100 KHz to 1000 MHz range.

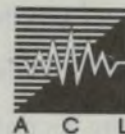
COM-3's internal microprocessor control with direct keyboard features a programmable memory capable of storing and recalling up to 10 commonly used test set-ups.

But what they really like about the COM-3 is its price - less than half that of other communications service monitors.

**The RAMSEY COM-3 Communications Service Monitor**



Yet another star performer from ACL



ACL SPECIAL INSTRUMENTS  
27 Rosella St, East Doncaster, 3109  
Victoria, Australia.  
Tel: (613) 842 8822  
Fax: (613) 842 5730

A member of the Lamplam Group of Companies

A.C.L. 890532 (A) AD Inc

## CAD Feature: software review

# Protel's new 'Autotrax' PCB router

Tasmanian based Protel Technology has recently added Autotrax, a full-blown auto-routing PCB design package, to its line-up of 'all Australian' CAD software. Because of its likely interest to our readers, we decided to ask two different people to review it: staff member Mark Cheeseman, and our contributing technical editor Peter Phillips – both of them familiar with other PCB design packages.

**First of all, here's what Peter Phillips had to say:**

To begin with, a few general observations. Computers have revolutionised many aspects of our lives, particularly in the areas of wordprocessing, data crunching and CAD-CAM. The IBM range of PCs in particular have created the means of bringing very high power versions of all these applications into everyday use, and it is sometimes possible to lose sight of just when the application is useful or just 'nice to have'.

For example, writing a letter to Aunt Maude is really best done with a pen and notepad; it's quicker and less formal. Similarly, keeping all your phone numbers in a computer data base is overkill, as a flip-file is much more accessible. But what about CAD-CAM? In particular, is a computer program to design a PCB layout more efficient than traditional methods?

For starters, any decent CAD program is likely to be expensive, both in terms of the software and the hardware. Unlike most other applications, which can operate effectively with a \$300 dot-matrix printer, a plotter or laser printer becomes an essential component to effectively use CAD software, and that usually spells big money. If you buy a cheap plotter, which will set you back around \$1500 anyway, the printed results may not be good enough, particularly for a PCB artwork master.

Many CAD programs have dot matrix printer drivers, which, for PCB design work at least, allow the user to produce a taped master by using the printout as a guide. This may suit small PCB lay-

outs, but whether this is faster than doing the design with tape from the start is questionable. However, if the package has auto-routing, then considerable time savings can result.

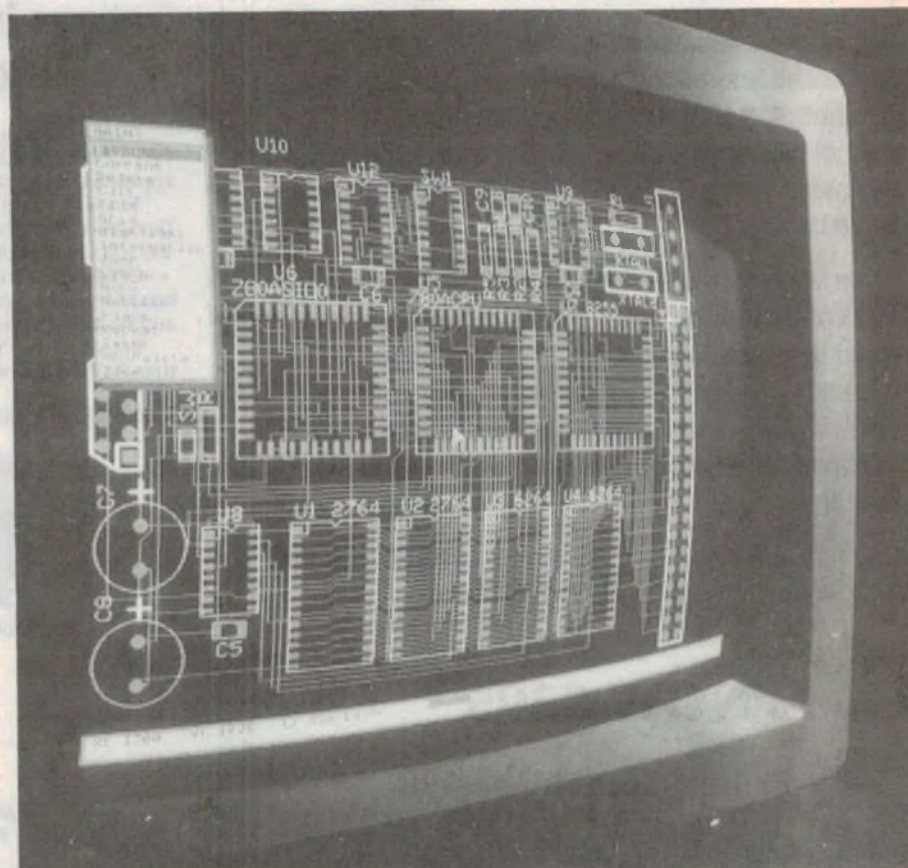
Protel-Autotrax has all these functions, and quite a few more as well. After using the package and getting to

know it, I have to admit it's a significant advance on its forerunner – Protel-PCB.

### Protel-PCB

There have been various PCB design programs written over the years, and the most popular are those for the Apple Macintosh and the IBM computers. Mac users will generally claim that the Mac interface (mouse, pull down menus) makes software easier to learn and use, compared to similar applications for the rather less sophisticated IBM with its DOS an' all. In all fairness, users of Protel-PCB would probably have to agree.

As a devotee of Protel-PCB, I found



*Pull-down menus make Protel Autotrax much easier to use than before.*

it necessary to have a command summary pinned to the wall every time I sat down to a bit of design work, and remembering more than half of the available commands was about all I could ever achieve. But then, as an irregular user, I suppose it could be argued that I would find things easier if I used the program more frequently.

This is not to say I didn't like the program; in fact I found it excellent and was able to do all I ever wanted to. But it is good to be able to compare the new version to the old, if only to see how many improvements have been made. As it turns out, Protel-Autotrax is now more like a Mac application, which makes things easier to start with.

However, I used to wonder at times when designing a board layout with Protel-PCB whether I could do the job more quickly with tape, and I was anxious to see if the new version was any faster. Here's what I found.

### Protel-Autotrax

The software package comes on four 360K disks, and only includes the PCB design and PLOT functions. This contrasts to the four modules of the old version, which included the PCB design, Schematic, Auto-routing and Plot packages. Like the old version, the new has a hardware 'key' or 'dongle' to prevent unauthorised use — better known as pirating. The key plugs into any of the parallel output ports of the IBM, and the software continually polls the port to see if the key is still in place.

Personally, I find this a pain, as I work with a number of computers at various locations, and the need to transport a 'dongle' is a nuisance, let alone having to fit it each time. For the price one pays for this package, I suggest the suppliers should include at least two dongles, as I know I'm going to lose this one. Anyway, that's the minus side to the program; everything else is good.

After copying the four disks onto the hard disk of my AT compatible, I then booted up, and opened the manual as I started my first look at the program. The manual is first class, and is somewhat similar to the Protel-PCB manual in its tutorial approach. The style is easy to understand, professional and the whole thing is generally well laid out.

The first thing that impressed me is the use of pull-down menus, which are accessible with the mouse or from the keyboard. Some users may argue that pull-down menus are for kids and amateurs, and I have previously experienced software (Apple and IBM alike) that is made more difficult by this type of in-

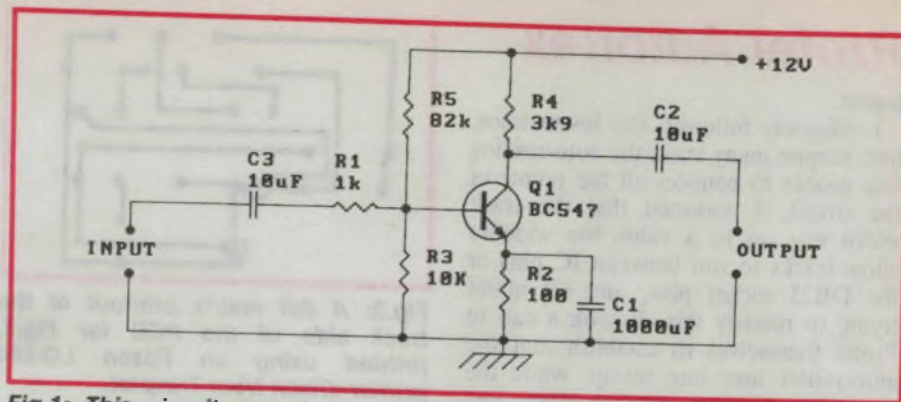


Fig.1: This circuit was drawn with Protel Schematic, and a netlist of the connections for use in Autotrax developed with the utility Post.Com.

terface. But not Protel-Autotrax. For example, you can be anywhere on the screen with the cursor, and gain access to the main menu simply by pressing the left mouse button. Once at the main menu, further selection is a matter of more mouse movement and button pressing, until you reach the desired function.

For dedicated keyboardists, every function can be accessed by pressing a letter key as well. For example, if you wish to quit the program you can select FILE with the mouse, then QUIT from the FILE menu. Alternatively, pressing F (for file) and Q (for quit), achieves the same thing. The software developers have retained compatibility with the old 'PCB' commands as well, which makes previous familiarity a bonus, enhancing the learning process.

Another nice feature is that the PCB pattern can be moved around by 'pushing' it with the cursor. Previously, you had to position the cursor then press F10 to move the desired section of the pattern into view. Zooming is done either through the menus or the PageUp and PageDown keys, rather than F5 and F6 (which still work as well). Similarly, HOME will centre the pattern around the cursor, and END will refresh the screen to clean up the graphics. Swapping between layers is simply a matter of pressing the asterisk (\*) key; much simpler than Control-L as before.

There are many more nice features, such as the 'jump' function which will position the cursor over a nominated component. Once at the component, you can then call up a window to tell you about it. Similarly, it is easy to find out how many components you have placed on the design, or look at the library list to see what you have available, and so on.

### Designing a PCB

The true test, of course, is how easy is it to design a PCB layout compared

to either tape or Protel-PCB. There are three ways a board pattern can be developed with Autotrax: manually, auto-routing and from a previously drawn schematic from Protel-Schematic.

Manual plotting requires the components to be laid out on the board, then drawing in the tracks using the mouse. This is fairly tedious, and much the same as the old program. It is reasonably easy to draw a track for a double sided board, where the track run occupies both sides, but all the usual fiddling about is still necessary.

Auto-routing is the next step up from the manual method, and is selected by pressing N (Netlist), R (Route) and P (Pad to pad), or by using the mouse to select these options from the pull-down menus. Once invoked, this option invites you to select the first pad, then the second. Once done, the program will draw a track between the two points automatically. It will use both sides or only one side of the board, depending on the settings that control all this.

One problem I found was in the tutorial exercise described in the manual. This exercise develops a layout for an RS-232 interface, and first teaches you how to place the required components from the library onto the screen. This is easy enough, and the next step is to have the auto-router complete the track

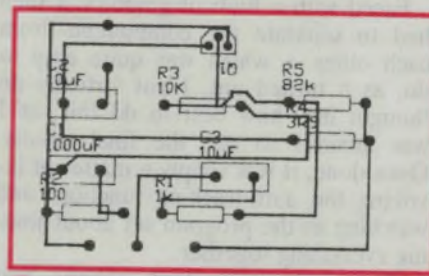


Fig.2: The PCB layout developed by Protel Autotrax for Fig.1. The transistor and its tracks had to be added manually, but apart from positioning the other components, everything else was done automatically.

## Protel Autotrax

layout.

I diligently followed the instructions, but, despite many tries, the auto-routing was unable to connect all the points of the circuit. I reasoned that the track width was set to a value too wide to allow tracks to run between IC pins or the DB25 socket pins, and set about trying to remedy this. It took a call to Protel themselves to establish that the auto-router uses one set-up, while the manual router uses another. Once discovered, I had no further problems, but it would have been nice for this information to have been included with the tutorial.

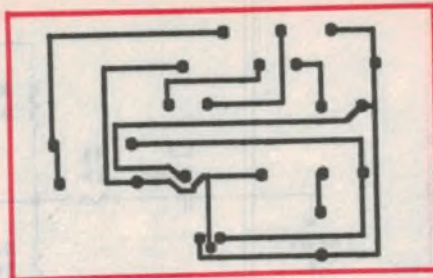
The real power comes with the facility of taking a circuit drawing, done in Protel-Schematic, and seeing a board developed as you sit back and have a cup of coffee. The circuit I drew for this exercise is shown in Fig.1, which is obviously a very simple example. Once drawn, a 'Netlist' for the circuit needs to be developed, by running the program call POST.COM. This routine is present in all versions of Protel-Schematic, and produces a listing of the interconnections of the circuit.

The next step is to return to the Autotrax program and to select Netlist from the main menu, then Autoplace from the Netlist menu. Once the file name for the already generated netlist has been loaded, the components making up the circuit can then be placed on the grid. In the case of my example, two strange things happened.

Firstly, all the components were placed on top of each other (!), and secondly, the transistor was omitted. The manual does say that small PCBs may produce peculiar results, and I have to agree. I tried various tricks to get the transistor to come with the netlist, but finally put this down to some peculiarity of my version of 'Schematic', which dates back to Version 1.

Faced with a blob of graphics, I then had to separate the components from each other — which was quite easy to do, as it turned out. I put virtually no thought into how best to do this, as I was anxious to see the final results. Once done, it was simply a matter of invoking the auto-tracking function, and watching as the program set about joining everything together.

The whole thing took around two minutes, and I completed the exercise by adding a transistor manually then using the pad to pad auto-router to complete the exercise. The end result is shown in Fig.2. If I had chosen to fiddle



**Fig.3: A dot matrix printout of the track side of the PCB for Fig.2, printed using an Epson LQ-800 printer driven from Traxplot.**

about some more, I could easily have produced a smaller, more professional looking layout.

### Professional users

Protel-Autotrax is clearly aimed at professional users, and my example is hardly a true test of the program. Opinions vary amongst those working in the field as to the merits of auto-tracking PCB design programs, as often the end results are, at worst, useless and, at best, in need of considerable human intervention. Whether this package is any better than previous auto-routing programs is beyond the scope of this review, but it would seem that it has the potential to be so.

At no stage does the manual claim that perfect results will be obtained from the auto-router. Rather, it draws attention to the facilities available to allow the user to ensure good results. In fact, the manual states that there is no guarantee that the layout will even be completed; a fact of life in any auto-router, including those costing very much more.

### CAM utilities

A strong feature of any CAD-CAM package is the 'CAM' (Computer Aided Manufacturing) section. CAD (Computer Aided Design) is only half the story, and any serious package should be able to produce a database to assist in actually making the end product.

For example, industrial standard PCB design software packages can usually generate data to control the pick and place machine that stocks the board. As well, the data to establish the required testing procedures of the end product may well come from the design package, as will the shopping list (and costs) for the components. Naturally, this type of software is usually far more expensive than Protel-Autotrax, and is of limited use outside the industry for which it is written.

There are several utilities supplied with the Autotrax package that fall into

the 'CAM' definition. The 'Traxplot' program is typical, and drivers are provided to produce printouts on a range of ink plotters, a Gerber-compatible photo plotter and even various dot matrix printers. The HP Laserjet II printer is also supported.

The Traxplot program is separate from the design section, and is entered through a DOS command. The program is more sophisticated than the old PLOT program, again features pull-down menus, and has various added functions such as automatic centering of the printout on a dot matrix printer.

It is also possible to have the program control an Excellon format N/C drill, even to the extent of changing drill sizes. Not having access to such a machine, I could not try this rather excellent utility, but it would seem to be a nice bonus.

### Summing up

Space prevents a more detailed description of this package, which has many more functions other than those described. However, the important question is whether Protel-Autotrax is worth the asking price of \$1395.

Certainly it is a great program, and I am convinced that it makes PCB design much easier than ever before. I used to find Protel-PCB agonising at times, particularly in the clean up stages. The auto-routing facility of Autotrax is great, and the expanded library, the pull down menus and the general feel of the program puts this package into a whole new class.

I could not justify purchasing this program myself; it is a bit too expensive for my limited needs. However, I am convinced that people involved in the field of PCB design work will find that the time saved more than offsets the cost of the package. Because it is an Australian product, support is as close as a phone call, and I predict Protel-Autotrax will become an Australian PCB design standard.

### Mark's findings:

As you can see, Peter's reaction to Autotrax was quite positive. As it happens, Mark Cheeseman was also quite impressed:

Protel is Protel Technology's new, high-end CAD package for printed circuit board design. It can be seen as a much revised and enhanced version of the earlier program, Protel-PCB, however the power of the new package leaves little resemblance to its predecessor. A lower-powered manual package, Easytrax, is now available for people



who do not require the more advanced features of Autotrax.

Facilities such as auto-routing of tracks and net-list capture from its com-

panion schematic designing package, Protel-Schematic, place Autotrax firmly in the 'big-league' of PCB CAD software. However while offering features

usually found only in packages costing many times the price, it is nevertheless flexible and easy to use.

Autotrax runs on IBM PCs and compatibles, and consists of two main programs (the editor, *Traxedit*, and the plotting program, *Traxplot*), a set of drivers and library files, and some utilities for converting library and drawing files from Protel-PCB, making the upgrade path easier for users of the older program. Accompanying the software itself is a 200-odd page ring-bound manual, and a 'dongle'.

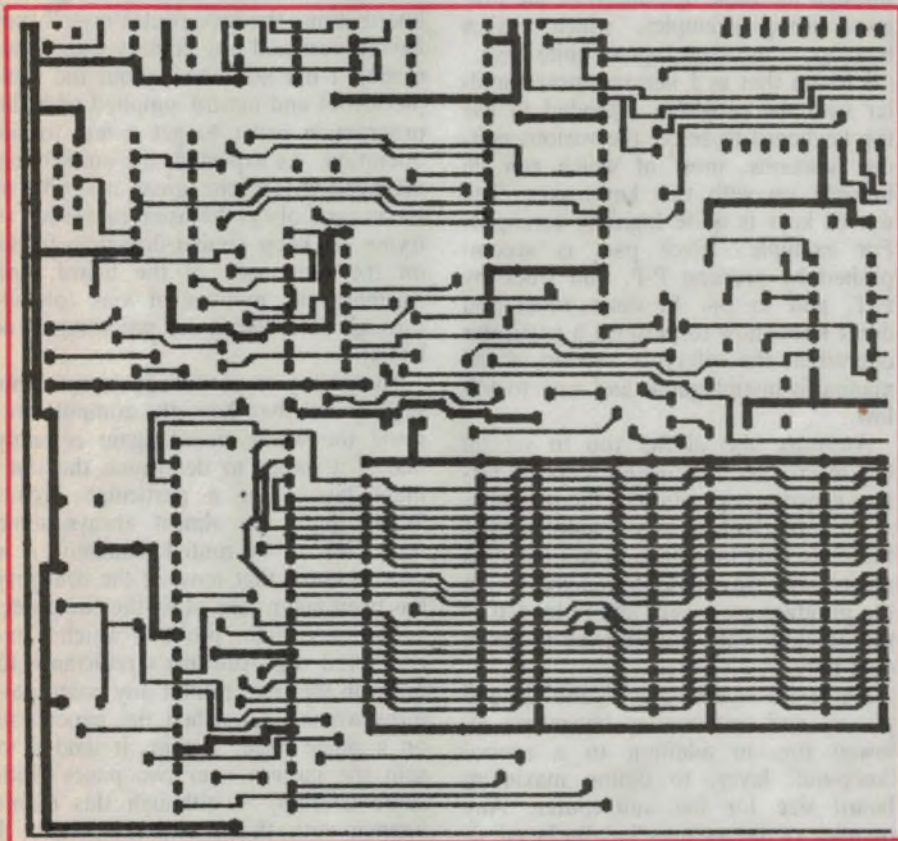
The dongle (more properly called a hardware lock) must be plugged into one of the parallel ports on the computer in order for the program to operate. It is transparent to normal printer operations, so that the printer may be simply plugged into the other end of the dongle.

Normally I dislike copy-protection on programs, as it can often leave you without any copy of the program if, for example, your hard disk crashes. The expense of recovering from such a disastrous situation is often quite high, in terms of both money and time, without having to go out and purchase new copies of software as well. Thankfully, the dongle approach means that you can make as many backups of the original disks as you like, and even install the software on several computers, provided that you only use it on one computer at a time.

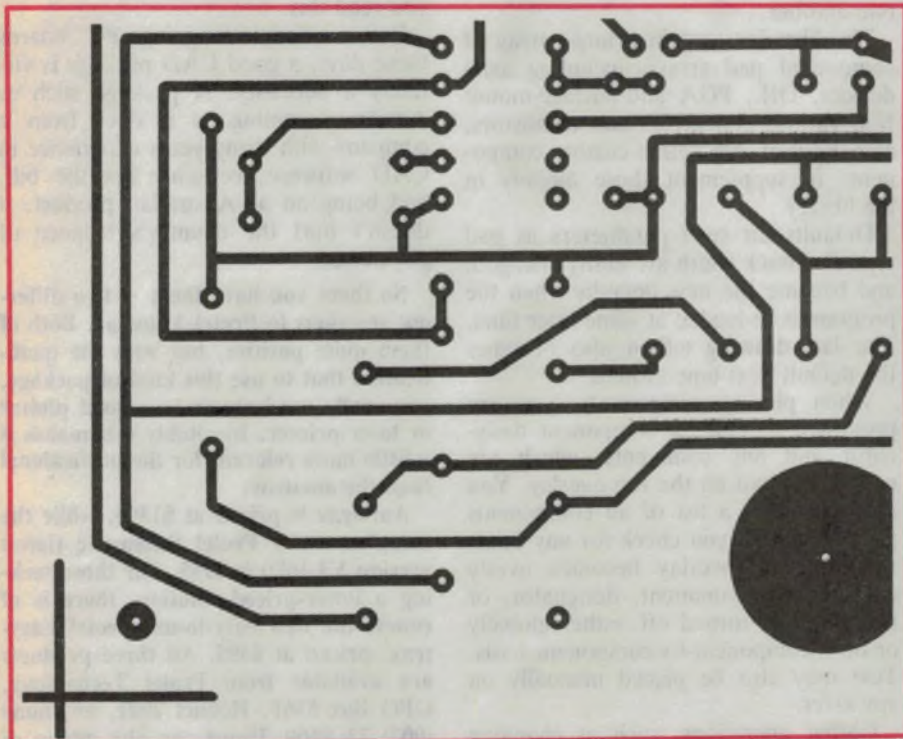
Installation of the software is easily accomplished by copying the contents of the four distribution disks into a sub-directory of the computer's hard disk. While operation on a dual-floppy machine is possible, a hard disk is certainly preferable for the usual speed and capacity reasons. Expanded memory (conforming to the LIM EMS specification) is also supported, to enable editing of large drawings.

A wide range of video standards are supported, and selection is achieved by executing a batch file before starting *Traxedit* for the first time. The batch file copies the relevant driver to a file called 'GRAPH.DRV', which *Traxedit* loads in when started. All of the standard PC graphics formats are supported (CGA, EGA, VGA and Hercules), in addition to an 800 x 600 pixel mode on Paradise VGA cards and 640 x 480, 800 x 600 and 912 x 350 pixel modes on Genoa EGA cards. The Genoa 800 x 600 mode also works with that manufacturer's extended VGA cards.

The plotting program, which is separate from the main editing program sup-



A typical PCB pattern developed by Protel Autotrax. This plot was done on a relatively cheap plotter, and is the solder side of the Demo.PCB file supplied with the software package.



An example of the kind of output produced by Autotrax using a laser printer.

## Protel Autotrax

ports a wide range of plotters, in addition to Epson-compatible dot matrix printers and the HP Laserjet plus (and compatibles), which provides an output resolution of up to 300 dots per inch. Files to drive a Gerber photoplotter and NC drill can also be generated from the drawing file by the plot program.

A mouse, while not absolutely necessary, is certainly very useful for moving around the board and selecting options from menus. The mouse interfaces with Autotrax via the driver supplied with the mouse. The two buttons on the mouse mimic the operation of the return and escape keys on the keyboard. In this way, the program can be driven without having to use the keyboard much at all.

The main editing program, Traxedit, is fully menu driven. Menus may be pulled down by pressing the first letter in the name of the menu, for example, 'F' for the file menu. If you do not know the name of the menu which you want, simply hitting the return key will bring down the main menu, from which all other menus may be selected. This is great for newcomers to the program, and this extra step can be bypassed

when the user becomes more familiar with the operation of Autotrax.

Part of the manual consists of a series of tutorials, which guide the novice through the basic operations of the program using examples, which makes learning to use the program quite easy.

I found that as I became more familiar with the program, I tended to use the keyboard to select the various editing functions, most of which can be brought up with two keystrokes. The use of keys is quite logically arranged. For example, 'place pad' is accomplished by pressing P-P, edit track by E-T, and so on. In cases when you don't know how to perform a particular operation, the reference section of the manual is unambiguous and easy to follow.

Autotrax also allows you to set up key macros on the function keys, to further speed-up operation of the program. A default set of macros is supplied, but these are easy to change to suit personal preference. Any options changed within the program are saved, and re-loaded as the defaults when you run the program next time.

Six track layers, power and ground planes, and two overlay layers are allowed for, in addition to a special 'keep-out' layer, to define maximum board size for the auto-router. Any number of layers may be displayed simultaneously, and a colour display is a decided advantage to help distinguish the contents of the various layers from one another.

The libraries contain a large array of component pad arrays, including axial devices, DIL, PGA and surface-mount ICs, various connectors and transistors, and the user can define custom components to supplement those already in the library.

Defaults for such parameters as pad type and track width are easily changed, and become the new defaults when the program is re-loaded at some later time. The last drawing edited also becomes the default next time around.

When placing components, you are prompted to enter a component designator and any comments, which are usually entered on the top overlay. You can also show a list of all components placed, to help you check for any omissions. If the overlay becomes overly cluttered, the comment, designator, or both may be turned off: either globally or on a component-by-component basis. Text may also be placed manually on any layer.

Global operations, such as changing the sizes of all tracks or pads on the

board, are easily accomplished by performing the operation on a single item and then selecting the global option when it is presented.

While I did not actually design any boards using the auto-router myself (not having designed any circuits with Schematic), I did however try out the sample layout and net-list supplied with the program in order to get a feel for its operation. As expected, the auto-router managed to lay the great majority of tracks, and obeys the usual rules such as trying to keep similar-direction tracks on the same side of the board, and minimise the number of vias (plated-through holes which are not component holes).

The ability to re-arrange components slightly and then have the computer re-route the whole board again certainly makes it easier to determine the optimum layout for a particular circuit. While there are almost always some tracks left to be routed manually, it is nice to know that most of the drudgery has been taken care of by the computer.

The only minor problem which I encountered was Autotrax's reluctance to print on the laser printer any board patterns which approached the paper size on a single page. Rather, it tended to split the pattern over two pages (with some overlap) - although this didn't happen with the dot-matrix printer. I phoned Protel about the problem, and they said they were working on it, so hopefully it will be fixed by the time you read this.

For anybody designing PC boards these days, a good CAD package is virtually a necessity. A package such as Autotrax, coming as it does from a company with many years experience in CAD software, certainly fits the bill, and being an all-Australian product, it doesn't hurt the country's balance of payments.

So there you have them - two different reactions to Protel-Autotrax. Both of them quite positive, but with the qualification that to use this kind of package, you really need access to a good plotter or laser printer. Inevitably this makes it a little more relevant for the professional than the amateur.

Autotrax is priced at \$1395, while the complementary Protel Schematic (latest version V3.16D) is \$995. For those seeking a lower-priced solution, there is of course the new easy-to-use Protel Easytrax, priced at \$495. All three products are available from Protel Technology, GPO Box 536F, Hobart 7001, or phone (002) 73 0100. Protel can also advise of distributors and suppliers in each state. ☐

### — RACAL-REDAC —

CADSTAR INTERACTIVE \$1650  
including Cadstar Schematic  
CADSTAR ADVANCED  
RIP-UP AUTOROUTER P.O.A.

### — PC-CADAT —

ADVANCED SIMULATION \$6000

### — PSPICE —

ANALOGUE  
SIMULATION from \$1295

### — ORCAD —

SCHEMATIC \$1290  
DIGITAL SIMULATION from \$1900

### — PROTEL —

AUTOTRAX \$1290  
SCHEMATIC \$890

available now from

**RCS CADCENTRES**

phone 03 499 6404 or  
fax 03 499 7107

# SAVE TIME WITH HI-TECH C

## HI-TECH C

is a high level language ideally suited to both hosted (e.g. DOS, Unix) and embedded applications. A C program can be written and debugged up to 5 or 10 times faster than the same program in assembler code. HI-TECH C is the optimum choice in C compilers for all the common microprocessor families. With more features, better diagnostics and smaller, faster code HI-TECH C will save you time in completing your project. Act now! Join the thousands of programmers world-wide who have discovered the benefits of HI-TECH C.

### NEW FEATURES IN VERSION 5

- |   |  |
|---|--|
| <input type="checkbox"/> Source Level Debuggers | <input type="checkbox"/> Far data                |
| <input type="checkbox"/> Interrupt Functions    | <input type="checkbox"/> Global Optimization     |
| <input type="checkbox"/> I/O Port Variables     | <input type="checkbox"/> Smaller Faster Code     |
| <input type="checkbox"/> Absolute Variables     | <input type="checkbox"/> Parameters in Registers |
| <input type="checkbox"/> Far and Near Pointers  |  |
| <input type="checkbox"/> Automatic Prototyping  |  |

### FEATURES

- ANSI Standard C
- Compact Fast Code
- Complete Library
- Macro Assembler
- Linker and Librarian
- Cross Reference
- Full Library Source
- Execution Profiling
- Interrupt Support
- Floating Point Arithmetic
- Mathematical Functions
- Comprehensive Local Support
- 12 Months Free Updates

### HOST OPERATING SYSTEMS

MS-DOS/PC-DOS  
CP/M-86  
SCO XENIX

ATARI ST  
APPLIX 1616

**GUARANTEED  
TO SAVE YOU TIME  
OR  
YOUR MONEY BACK**

### APPLICATIONS

- Robotics
- Remote Control
- Telemetry
- Process Control
- Lift Control
- Monitoring
- Space Applications
- Bionics

### SUPPORTED PROCESSOR FAMILIES

8086/186/286  
Z80/64180  
68000/010/020  
8096/80C196  
8051/8031  
6800/6801/68HC11/6301/6303  
6809

### NATIVE C COMPILERS

CPM-80	\$195
MS-DOS	\$300
CP-M 86	\$300
ATARI ST	\$250
APPLIX 1616	\$250

### CROSS C COMPILERS

\$495 - \$895  
DEPENDENT ON TARGET  
AND HOST



*The Cutting Edge*

All prices are in Australian dollars  
and exclude sales tax and delivery.

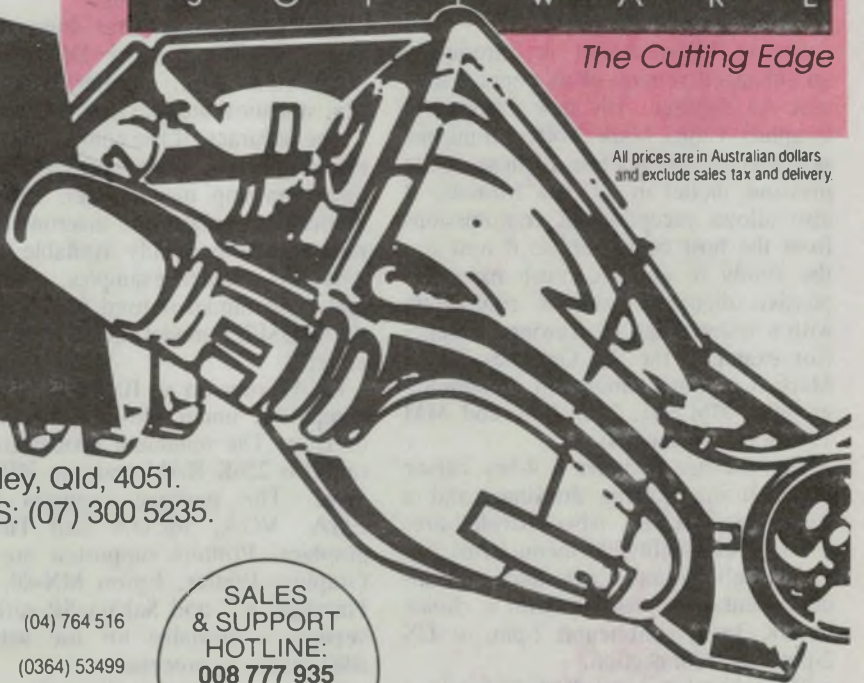
HI-TECH Software, P.O. Box 103, Alderley, Qld, 4051.  
Ph: (07) 300 5011 Fax: (07) 300 5246 BBS: (07) 300 5235.  
E-Mail: hitech@hitech.oz

#### AUTHORIZED DEALERS

**AUSTRALIA:**  
Baltec Systems (07) 369 5900  
Macrodynamics (03) 720 2399  
BJE Enterprises (02) 858 5611  
Esis Pty. Ltd. (02) 467 2032  
Program Development Systems (03) 793 4698

**NEW ZEALAND:**  
R.A. Bell Inst. (04) 764 516  
**UNITED KINGDOM:**  
Greymatter (0364) 53499  
**U.S.A.:**  
Z-World (916) 753 3722  
**JAPAN**  
Southern Pacific (043) 314 9514

**SALES  
& SUPPORT  
HOTLINE:  
008 777 935  
OR  
(07) 300 5011**



## CAD Feature:

# CAD News & Products



### Upgraded digitising tablet

Cherry Mikroschalter is introducing an enhanced version of its popular low-cost A3 digitiser. The new Cherry A3 Graphics Tablet Mark 3 offers transmission speeds twice as fast as those of the previous model in all data formats. It also allows reception of transmissions from the host computer, so it now has the ability to emulate much more expensive digitisers, and is compatible with a wider range of drawing packages (for example, the A3 Graphics Tablet Mark 3 supports emulation of Summagraphics MM 961, MM 1201 and MM 1812 software drivers).

The package includes a 4-key cursor for digitising existing drawings, and a stylus for sketching. Also provided are: a set of user-definable menu strips, interface cabling, and a calculator-style independent power supply with a choice of UK 3-pin, continental 2-pin, or US 2-pin mains connection.

The tablet has a standard A3 working area of 384mm x 260mm which can be increased to 384mm x 290mm if the

menu strip is not being used. Resolution is 0.1mm, and accuracy better than  $\pm 0.5$ mm. It supports RS 232 serial, and serial or parallel TTL interfaces – all with optional handshaking – and offers a choice of ASCII or fast, packed binary formats. Selectable baud rates of 300, 1200, 2400, 4800, 9600 and 19200 are available in point, stream or switch-stream modes.

Further information from Swann Electronics Group, 5 Dunlop Road, Mulgrave, 3170 or phone (03) 560 7555

### Circuit simulation, analysis program

Emona Instruments has released ENAP 3.03, a PC-based electronic circuit simulation and analysis program written in Australia.

ENAP is a fully integrated, menu-driven package that analyses complex circuits with ease, producing tabular and high resolution graphical outputs on the screen or on a printer. ENAP quickly answers 'what if' questions without the need for trial-and-error breadboarding, and offers improved accuracy and efficiency of electronic design.

The program features four analysis functions. These cover DC operating point calculation, transfer characteristics, statistical analysis and AC analysis.

The accuracy of the component model is all-important. ENAP uses a fully non-linear op-amp macromodel, and automatically calculates the macromodel parameters from readily available catalog data. As further examples, the Gummel-Poon model is used for BJTs, and the MOSFET model includes the 'body effect'.

ENAP runs on an IBM PC/XT/AT or compatible under MS-DOS version 2.0 or later. The minimum system configuration is 256K RAM and one 360K disc drive. The package supports CGA, EGA, VGA, MCGA and Hercules graphics. Printers supported are IBM Graphics Printer, Epson MX-80, NEC Pinwriter P7, and Sakata SP series. A version is available for use with the 8087 maths co-processor.

Further information from Emona Instruments, 86 Parramatta Road, Campdown 2050 or phone (02) 519 3933.



### Speech recognition system for PCs

The new VoiceScribe 1000 speech recognition system from Cherry Electrical Products lets users of IBM XT and AT-compatible computers input commands or data using natural language rather than hands-on devices such as keyboard, mouse, touch-screen, etc. The system is capable of recognising up to 1000 words in any language.

VoiceScribe 1000 features include: word recognition accuracy of 99.3%; dedicated and custom software drivers; the ability to edit vocabulary without leaving an application; online, dynamic menu selection; close to real-time response to spoken words and phrases; speaker dependent or independent operation; and fast retraining of the system to recognise a new user's voice.

The system comprises a card that installs in any vacant full-size slot on the XT and AT backplane, a high quality Shure noise-cancelling headset microphone, operating software, and full documentation. Also included in the package are software drivers for MS-DOS 3.1 and several popular programs including Lotus 123, Multiplan, dBase, and Displaywrite. A compiler feature is provided for the creation of custom drivers.

Further information from Swann Electronics Group, 5 Dunlop Road, Mulgrave 3170 or phone (03) 560 7555.

## Improved SCHEMA

The SCHEMA range of advanced automation software has recently been enhanced by Texas-based designer Omatron, to become SCHEMA 11+. This provides added ease of use, such as fast, smooth real-time panning to allow review of an entire worksheet with speed and efficiency.

A combined mouse/keyboard support gives the flexibility to select the best method to execute any command or function. Rapid continuous drawing can be achieved by a user-configured automatic step and repeat function.

SCHEMA 11+ has more than 10 libraries, on-line parts browsing, sophisticated library management routines and a special re-entrant object editor and multiple software configurations.

Two new additions have been launched for SCHEMA 11+. SCHEMA PCB, which is fully integrated with the SCHEMA 11 Schematic Capture program, allows a schematic to be entered using Schematic 11, then processed with SCHEMA-PCB into a finished printed circuit card, from start to finish in one easy step.

The second new development is SCHEMA-ROUTE, an optional autorouter supplement for SCHEMA-PCB.


Further information from Anitech, 1-5 Carter Street, Lidcombe, 2141 or phone (02) 648 1711.

## Racal Redac now in Sydney

Racal Redac has established a marketing and support centre in Sydney, to provide both pre- and post-sales support and training for the company's Cadstar and Visula product lines.

Cadstar, launched as a migration upgrade to the highly successful RedCAD package, offers PC-based schematic capture, bill of materials, automatic and interactive design aids for PCB layout and interfaces to manufacturing. It can also be linked to mechanical CAD packages, PC-Spice and PC-Cadat simulation analysis.

Visula is the firm's flagship EDA solution, available on industry standard unmodified Apollo, DEC and Sun workstations. It has no data size or resolution limits, and can work with metric and imperial units, so that even a board of 5m square can be designed at 1/100 micron resolution.

For further information contact Racal Redac, 3rd Floor Chubb House, 64 Clarence Street, Sydney 2000 or phone (02) 262 5466. 



# TENNYSON

# GRAPHICS

Tennyson Graphics can do your photoplotting with the speed of light.

Tennyson Graphics are Australia's only company with state of the art laser photoplotting and computer graphics.

So we can photoplot artwork masters of your printed circuit boards with higher speed, higher resolution and higher accuracy than anywhere else in the country.

You can even choose your own non standard apertures on our Scitex Response 280 System. It can also do step-and-repeat and nesting up to 1000 mm x 1850 mm.

And of course we can accept data on tape or floppy disk in industry standard Gerber, Autocad and Smartwork file formats.

Tennyson Graphics will be happy to give you the full story if you phone on (03) 551 8600.

---

**TENNYSON GRAPHICS**  
A DIVISION OF REPROCART PTY. LTD.

7 PLANE-TREE AVE  
DINGLEY, VIC. 3172  
TELEPHONE (03) 551 8600  
TELEX: 34457  
FAX: (03) 551 8828

## CAD Feature:

# Cadstar 386 PC-based PCB design package

Racal Redac has released the latest version of its top of the range products – Cadstar 386 – and describes it as the 'most sophisticated PC-based PCB design tool available on the market today'.

### by RAY SMITH

Managing Director, RCS Cadcentres

As well as incorporating the main features of its predecessor, i.e., SMD technology, 1-thou grid resolution, true electrical connectivity and multilayer capability, Cadstar 386 is now said to offer more in terms of functionality and performance. Features such as an automatic router, new interactive routines and dynamic pan and zoom have been incorporated as standard items.

### Hardware

Cadstar 386 has been designed to run on the same hardware configuration as its predecessor, namely an IBM PC-AT or compatible computer with at least 640K bytes of memory and capable of running DOS operating system 3.0 or later. Other necessary items include a serial communications port, an IBM EGA and a suitable colour monitor.

The EGA needs to be fitted with Graphics Memory Expansion Cards for 640 x 360 pixel resolution. The range of cards supported includes the Matrox PG640, the Metheus Omega 1104/1004/1008, and the Vermont IM1024/IM640. The above configuration is needed with an 80287 or 80387 Math coprocessor. The package also runs on PS/2 machines, including models 50, 60 and 80.

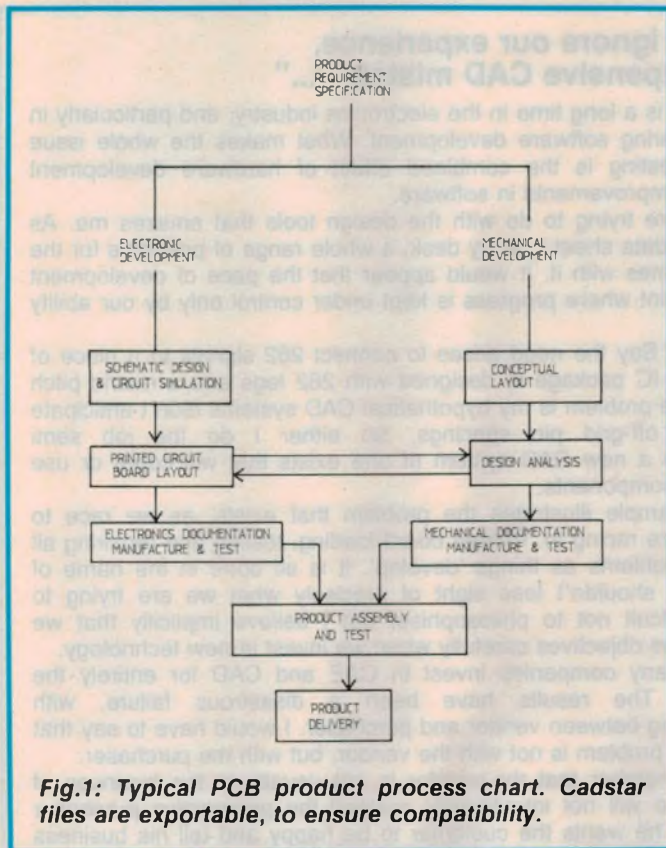
### Documentation

The documentation that is contained with the software package is comprehensive. A self-study guide is included, along with an in-depth reference manual, as well as a full listing of the command sequences involved in creating a particular item. These step by step instructions are very clearly laid out and should enable the first time user to grasp the fundamentals of the system relatively quickly.

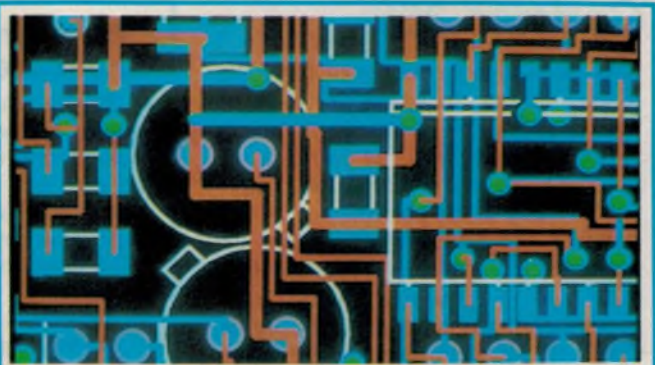
### Components library

Listings of a parts and components library are also included in the documentation. The components library supplied on the diskettes contains the graphical descriptions of the parts contained in the parts library. The descriptions include the outlines, the pads, position of component, name, copper, and text. The actual components contained include dual in line packages, single in line packages, surface mount capacitors and resistors and small outline IC's. A designer can use the parts and components in order to produce 8 alternative true outline shapes per component, with up to 256 pins for customised circuit boards.

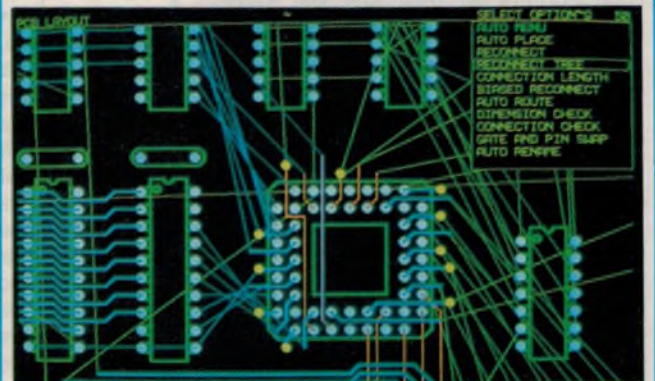




**Fig.1: Typical PCB product process chart. Cadstar files are exportable, to ensure compatibility.**



**A gridless algorithm allows dense auto-routing.**



**Powerful interactive routines give great flexibility.**

## Auto place & routing

Cadstar 386 contains a new automatic placement routine which allows components to be placed on both sides of the board. Functions include creation and modification of placement matrices. Automatic rotation of components is also offered. The side of the board that the components are placed on is selected by the use of a simply operated automatic mirror feature. The possibility of confusion is eliminated by the system's inversion of text when one is



**Author Ray Smith is MD of RCS Cadcentres in Melbourne.**

working on the reverse side.

Another improvement on the previous package is an enhanced built-in autorouter. This gives the designer an alternative to the manual router and can be used in single segment mode with a variety of segments as required by a designer. This is an extremely useful device which leaves the designer in full control of the rate at which the board is created. Other new features are automatic routing of partial routes and interrupt autorouting capabilities.

## Connections

Improvements have also been made in the connection of components. Cadstar 386 has the ability to dynamically reconnect a component and to reconnect a specified connection tree. Particular trees can be highlighted and then reconnected to components after replacement.

As connections are being made around the board, yet another new feature can be used to assist the designer. A board status report of the number and length of connections etc., can be displayed. This report is also of use when gate swapping operations are carried out, as any errors in the procedures can be listed.

Further very useful aids to design are the display options and attributes tables. These two features were also included

on the original Cadstar package, with access achieved by typing in the relevant abbreviation on the keyboard. The display options menu can then be used to switch on/off connections, routes, vias and components if necessary. The attributes tables enable pad and track sizes to be altered in order to accommodate manufacturing changes required for SMD designs.

The two tables can be used to change the working environment and then, by selecting the redraw facility, return immediately to the previous layout without having to store it as a file, change the environment and then retrieve the amended file as in other packages. This is one of the most obvious examples of the user-friendliness of 386.

## Autorouter

Launched along with the 386 package is the Cadstar 386 Autorouter, which also runs on the Compaq 386/30 PC or compatible. Utilising the Xenix operating system, this package has been specifically designed to complete the Cadstar 386. The Autorouter is controlled from any 386 design station on the network via a Router Monitor Control System (RMCS), in order to free the PCB design station for further auto-interactive work during the routing process.

The multipass, gridless, 'rip up and

## Cadstar 386

retry' Autorouter is designed for 100% routing success, based on an algorithm unique to Racal Redac. It is usually necessary for the designer to run a single pass mode first to access the component viability of the placement.

Before the Autorouter rips up and retries routes, it pushes aside tracks already laid to allow new routes on the next iteration. This feature has been designed to prevent blockages created from previous routed connections. On completion of the final pass, the Autorouter selects the routing result produced which will give the minimum number of individual violations.

In cases where the Autorouter has difficulty in finding a way to route a tree, it can push existing routes and vias aside to make more room.

After completion of the design, a number of smoothing passes can be made in order to make the board easier for manufacture. As a first priority, the operation reduces the number of route segments rather than contour following. This approach can, in certain designs where vias have to be removed, increase the route length but make the board more manufacturable.

A post-processing option on the Cadstar 386 packages enables the design data to drive a pen plotter, photoplotter and an NC drill machine.

### True CAE

Having had a close look at the Cadstar 386 we should now have a look at where Cadstar can fit into the overall CAE/CAD cycle. Computer aided engineering implies that we capture the engineering data for a particular job in the form of a schematic circuit. Once we have that information we have the means for a totally integrated design verification solution for all levels of system design.

Files for output to simulation packages such as PSPICE and PC-CADAT enable fairly comprehensive testing and debugging of your circuit design. One should bear in mind that in some instances the DOS environment can be restrictive, and OS/2 or UNIX/XENIX environments should be considered. However since most programs such as PC-Cadat use the same input files as standard CADAT, circuit and stimulus files which are created locally on the PC can be uploaded in a communications link to a mainframe system running CADAT at any time.

Fig.1 represents a typical product process chart. All PCB's involve some me-

### "Many firms ignore our experience, and make expensive CAD mistakes..."

Twelve months is a long time in the electronics industry, and particularly in regard to engineering software development. What makes the whole issue even more interesting is the combined effect of hardware development coupled with the improvements in software.

It is what we are trying to do with the design tools that amazes me. As each new device data sheet hits my desk, a whole range of problems for the PCB designer comes with it. It would appear that the pace of development has reached a point where progress is kept under control only by our ability to implement it.

Let me explain. Say the need arises to connect 262 signals to a piece of silicon, so a new IC package is designed with 262 legs and a metric pitch between pins. The problem is my hypothetical CAD systems didn't anticipate huge IC's with off-grid pin spacings. So either I do the job semi automatically, buy a new CAD system (if one exists that will cope) or use older technology components.

This simple example illustrates the problem that exists, as we race to wherever it is we're racing to. Printed board loading, testing and repairing all present similar problems as things 'develop'. It is all done in the name of progress, but we shouldn't lose sight of precisely what we are trying to achieve. It is difficult not to philosophise, but I believe implicitly that we should examine the objectives carefully when we invest in new technology.

I have seen many companies invest in CAE and CAD for entirely the wrong reasons. The results have been a disastrous failure, with recriminations flying between vendor and purchaser. I would have to say that in most cases the problem is not with the vendor, but with the purchaser.

One has to remember that the vendor is not usually in the business of selling lemons. He will not intentionally mislead the prospective purchaser because after all, he wants the customer to be happy and tell his business associates — even if they are competitors (in most cases).

The point I wish to make is that the purchaser *must* understand what the objectives are, what the limitations will be, and if there is sufficient knowledge and experience within their own company to actually use the equipment or software effectively.

RCS Cadcentres sells software and hardware for printed circuit board design and documentation. We also use the software we sell, in our bureau. I have personally been involved in drafting and PCB design for 17 years. My staff are experienced and capable, but it is amazing to me how many people still choose to ignore our advice and recommendations.

There have been many comments in the trade press over recent months about the lack of training and experience available in Australia, or the fact that we have to go offshore to get it. I have to say that for a great many R & D organisations out there, they have a lot to learn locally before it will be necessary to go offshore to top up. The sorry part is that most of the information is available here already — free.


It comes in the form of product support from companies such as RCS Cadcentres.

***These comments come from Ray Smith, Managing Director of RCS Cadcentres, a PCB design bureau and CAD software vendor based in Melbourne.***

chanical design as part of a products' development. Since Cadstar 386 supports an output file in DXF format, PCB outlines and component placement drawings can be exported to a 2D and 3D drafting system such as AutoCAD. This ensures that all component parts of product will go together at the assembly and test stage.

This also gives the documentation manager additional information to complete a full product description and user manual.

In summary, with Cadstar 386 the product engineering team has available all the tools to improve the productivity and quality of design and development. This ensured that design to product marketing spans a minimum time and the design is right the first time — of course, provided the design rules and concepts are correctly applied.

Further information in Cadstar 386 is available from RCS Cadcentres, 728 Heidelberg Road, Alphington 3078 or phone (03) 499 6404. 



Two more exciting CHERRY Products available through:

## Swann Electronics Group Limited



### VOICESCRIBE 1000

This SPEECH RECOGNITION SYSTEM enables the owners of IBM PC/XT, PC-AT and compatible systems to access, edit & file data by VERBAL COMMAND, virtually HANDS FREE. Comprised of a card to fit a full sized expansion slot on the XT & AT backplane, 1×Shure microphone headset, operating software, and full documentation. Also included are drivers for MS-DOS 3.1, Lotus 123, dBase, and a compiler feature for the creation of custom drivers.

### A3 GRAPHIC TABLET MKIII

This advanced version of their popular low cost A3 Digitiser is twice as fast and more compatible. With a working area of 384 mm×260 mm (or up to 384×290 if menu strip is not in use) resolution is 0.1 mm, and accuracy is better than ±0.5 mm. It supports RS 232 serial, and serial or parallel TTL interfaces — all with optional handshaking. With its ability to receive transmissions from the host computer, it also has a self diagnostic feature, and a request mode that outputs co-ordinates only when triggered to do so by the host.

For further information please contact —  
**SWANN ELECTRONICS GROUP LIMITED,**  
Dunlop Rd, Mulgrave, Victoria, 3170  
Telephone (03) 560 7555

## COAXIAL CABLE STRIPPER

PROUDLY  
AUSTRALIAN  
MADE



**\$215** Excluding  
Sales Tax

#### FEATURES:

- Simple operation
- Rotary blade cutting action
- Extra long life blades
- Unique cable locking handle
- Quick release lever
- Cast alloy construction
- Cable guide rollers
- Multiple stripping facilities
- Easy access cutter cassettes
- Non slip pivot handle
- Fast stripping times
- Suitable for use on production, or one off basis

**POSTAGE FREE  
WITHIN AUSTRALIA**



**MIJELL ENTERPRISES PTY. LTD.** Inc. in Vic.

5 BARRIE DALE GROVE, FRANKSTON VICTORIA 3199  
Telephone: (059) 71 1853 Fax: (059) 71 3523

FLUKE AND PHILIPS - THE GLOBAL ALLIANCE IN TEST & MEASUREMENT



## PHILIPS



With 2 multifunction displays and 16 different measurement capabilities, the Fluke 45 gives you more data, more easily. For example both the Vdc output and Ac ripple of a power supply. Or both the amplitude and frequency of an AC signal. All from a single test connection!

The Fluke 45 offers true RMS measurements, 5-digit resolution on both displays, and basic accuracies of 0.02% for DC voltages and 0.05% for DC currents.

An RS-232 interface is standard, for connection to PCs, printers and modems, while an IEEE-488.2 interface is available as an option.

For further information please contact: Philips Test & Measurement NSW (02) 888 0416, Brisbane (07) 844 0191, Melbourne (03) 235 3666, Adelaide (08) 348 2888, Perth (09) 277 4199, Auckland (09) 894 160, Wellington (04) 889 788.

# Introducing the first Dual Read Out DMM: The Fluke 45

**THE MEASURE  
OF QUALITY**



## Optical link nears completion

October should see the completion of the first optical fibre cable link between Adelaide and Perth – with the second already under way!

The cable follows the route of the Transcontinental Railway, and was planned some three years ago. But the demand had outgrown it before completion, says Mr John Cooper, project manager of Telecom's Optical Fibre Group.

A base camp has been established at Ceduna to house up to 40 Telecom workers, with additional mobile camps at Wirrulla, Wudinna, Lock and Cleve. The second cable will have 26 fibres, and more than twice the capacity of the first cable, carrying telephone, fax and television signals from OTC's Ceduna Earth Station into the national Telecom network.

The second cable is expected to be completed by early 1992, at which time the current microwave link to the west will remain as only a back-up service.

## Coming soon to NZ: UHF TV, Pay-TV & more

It may be less than six months before Auckland TV viewers move from famine to feast, with the announcement that the first course – the introduction of private network TV3 – is set to commence in November.

The network will join New Zealand's existing two-channel government broadcaster TVNZ as the last of the VHF TV stations, with expectations to reach 70% of the NZ market initially and some 90% by November 1990.

But for the viewers the best is still to come – a three-channel pay-TV service and possibly a chain of regional stations, all of which will be on UHF.

Sky Network (no connection with Alan Bond's pub-TV network of the same name) will begin broadcasting in early 1990, offering three channels of sport, news and light entertainment. These will be transmitted on UHF, the first NZ television signals on this band, and will be encoded.

Signals will be received by a UHF aerial and then fed to a decoder/VHF

downconverter leased from Sky Channel for an estimated \$A200 start-up fee and an additional \$A10 per week for all three channels.

This high level of subscriber funding will make Sky less reliant on advertising for income, and so it is likely that pay TV in NZ will have rather less advertising than TVNZ and TV3. Sky has already committed \$A16 million to the project and expects the final cost to approach \$A50 million, although this is seen as an investment in capturing their share of the lucrative New Zealand video hire market, believed to be worth some \$100 million a year.

Another possibility is a series of regional UHF TV stations backed by TVNZ. However under their new business-like direction this will only be considered if it appears profitable.

## Rural Watch on UHF CB

The UHF CBRS, which already established itself as a 'community radio service' in country towns, is becoming a vital part of the Rural Watch program.

Rural Watch is similar to the very successful Neighbourhood Watch project, and aims at preventing stock and goods thefts in rural areas.

One of the best examples of the role of 477MHz CB in Rural Watch is found in and around Deniliquin, towards the southern border of NSW. The Rural Watch groups of Deniliquin and the neighbouring shires of Conargo, Windouran and Murray have had local police stations and stock squad vehicles outfitted with UHF CB, through which locals can directly report suspicious activity or even pass emergency messages.

The range of 477MHz in the flat country regions is an extremely reliable 50km, although 100km is by no means unusual. But even if a caller is out of range of the police units, they can still pass on their message to a nearby UHF user for relay by telephone.

## New ABC radio, TV transmitters

Radio listeners in the remote northern NSW towns of Goodooga and Lightning Ridge now have a better

choice of ABC radio programs, thanks to two new FM transmitters which have just been installed in each town. Frequencies used in Goodooga are 99.3MHz (Regional) and 100.9MHz (National), while those in Lightning Ridge are 92.1MHz (Regional) and 93.7MHz (National).

New ABC television transmitters/translators have also been commissioned in Condobolin, NSW (channel 65) on Hospital Hill; in Khancoban, NSW (channel 60); in Eidsvold, Moura and Theodore, Queensland (channels 57, 54 and 58); in Horsham and Dimboola, Victoria (channel 45) on Mt Araphiles; and in Bridgetown and Pemberton, WA (channels 56 and 33), from Suttons Lookout and adjacent to the Forestry Commission offices respectively.

Viewers wanting advice on UHF television, tuning and antenna installation should ring the Department of Transport and Communications 'UHF Hotline', which can be called from anywhere in Australia for the cost of a local call. The number is (008) 077361.

## A second cellular network?

One of the keenly-awaited projects by new telecommunications regulator Austel is its investigation into the case for a second cellular operator. However Telecom seems to fear that in this instance the 'regulator' may turn out to be a *deregulator*.

Although reportedly resigned to foregoing its sole-carrier monopoly if the proposed CT2 system (currently under trial) is given the go-ahead, Telecom is not as passive when it comes to the cellular mobile telephone service – as evidenced by their 350-plus page submission to Austel on the issue.

(As one senior Telecom wit remarked, "We wouldn't be so paranoid if everyone wasn't out to get us!")

There are a host of aggressive would-be CMTS licensees, one of the keenest being Link Telecommunications. They are small, dynamic and boast one of Australia's largest private telecommunications networks. They also have Ross Ramsay, former First Assistant Secretary with the Dept. of Communications – a smooth operator who has, as Link's

slogan trumpets, 'All the right connections'.

Ramsay argues that neither the issues of quality of service, a 'natural' CMTS monopoly or the socio-economic 'cross-subsidisation' argument have any weight against a second cellular carrier.

In particular he points out that the American AMPS and UK TACS systems, the largest and most successful CMTS markets, are both 'duopoly' systems - designed so that the allocated radio frequency spectrum can be used efficiently with two operators. Further to this, even France and Germany, previously strong supporters of the cellular monopoly, have now authorised second networks, and even New Zealand is preparing for the same according to Ramsay.

Cross-subsidisation is also a non-issue he says, with only a few hundred thousand cellular phones out of a total fixed base of some 7.2 million being unlikely to seriously affect the cross-subsidy. In fact, he argues, the additional mobile phones of a second carrier would be "more likely to bring extra profitable traffic into Telecom's fixed network".

If Austel does open the way for a second network, Link would certainly be a front-runner. Its national 'Linknet' already includes voice mail, telephone answering, paging, data and computer-based communications, and the addition of a cellular system would create perhaps Australia's first turn-key communications supplier.

## Millionth radio licence issued

Queensland fisherman Mr Terry Hansen has taken out the one millionth radio communications licence on issue in Australia.

The licence and a commemorative certificate were presented to Mr Hansen by the Minister for Telecommunications and Aviation Support, Ms Ros Kelly, at his Bundaberg home.

Ms Kelly said the issue of the millionth licence was an indicator of the strong growth of radio communications in Australia, which is growing at a rate of 15% per year.

The licences themselves cover a diverse range of business and private activities, including aviation and shipping, the rural industry, emergency services, CB and amateur radio.

Companies or organisations with communications news items which they believe would interest our readers can send them directly to David Flynn, PO Box E160, St James 2000.

# ELECTRONICS

## EXCITING JOBS WITH A FUTURE



## GET YOUR TRAINING NOW AND BE PREPARED FOR THE FUTURE

If you're interested in electronics, a Stott's Home Study Course can make it even more interesting. It could lead to an exciting career in the fast-growing field of electronics.

Stott's electronics courses offer plenty of practical work and 'hands on' experience through custom-designed kits. You'll be skilfully guided by experienced, professional instructors, with individual attention and advice. You study at home, at your own pace.

Choose from Stott's range of electronics courses:  
**Introduction to Electronics, Radio and Television Servicing,  
 Radio Receivers, Colour Television,  
 Introduction to Micro Computers,  
 Digital Electronics for Technicians &  
 Servicemen or Industrial Electronics.**

MAKE YOUR MOVE TOWARDS A BRIGHTER  
FUTURE. SEND THE COUPON TODAY.



AN AUSTRALIAN TRADITION

PLEASE SEND ME FREE, AND WITHOUT OBLIGATION,  
FULL DETAILS OF THE FOLLOWING COURSE:

MR. MRS. MISS \_\_\_\_\_ (PLEASE PRINT)  
 ADDRESS \_\_\_\_\_ AGE \_\_\_\_\_  
 POSTCODE \_\_\_\_\_

Stott's undertake that no sales counsellor will visit you.  
 Melbourne: 140 Flinders Street, 3000. Tel: 654 6211  
 Sydney: 383 George Street, 2000. Tel: 29 2445  
 Brisbane: 65 Mary Street, 4000. Tel: 221 3972

Adelaide: 226 Pulteney Street, 5000. Tel: 223 3700  
 West Perth: 52 Kings Road, 6005. Tel: 322 5481  
 Hobart: 2 Davey Street, 7000. Tel: 34 2339  
 New Zealand: Box No. 30-990 Lower Hut. Tel: 676 592

ALA/ST6820/EA589

# Electronics Australia

You can now purchase any of these specially selected books from the easy to order Electronics Australia Bookshop.

Titles cover a wide range of electronic, scientific, and technical books and will be updated regularly to keep you abreast of the latest trends.

**Superconductivity — The Threshold of a New Technology:** Jonathan L Mayo

Written for the general science reader, this book explains the discoveries, explores the applications and examines the implications of the most exciting physical breakthrough since electricity. 160 pp HEA001 **\$26.95**

**Experiments in CMOS Technology:** Dave Pronchnow

**Experiments in Gallium Arsenide Technology:** D. J. Branning

These books provide readers with everything they need: each project is complete with an accurate schematic diagram, parts list, and PCB template (where applicable) HEA002 HEA003 **\$34.95**

**50 CMOS IC Projects:** Delton Horn

This book is a collection of 50 interesting and practical digital electronics projects based on the extremely popular CMOS ICs for electronics experimenters with intermediate or higher skills. 240pp HEA005 **\$34.95**

**Delton T Horn's All-Time Favorite Electronic Projects:** Delton T Horn

Horn has garnered countless favourable reviews over the years — Back Stage: "Delton T Horn offers expert advice on achieving top performance for minimum price," and Hands-On Electronics: "Horn has avoided the temptation to become overly theoretical in his presentation. Instead, he has provided easy-to-follow explanations, supported by generous doses of drawings, diagrams and schematics." 96 pp HEA006 **\$15.95**

**The Encyclopedia of Electronic Circuits:** Rudolf F Graf

Includes more than 1,300 designs. "An invaluable reference tool for every hobbyist, technician, student and design professional" 768pp HEA007 **\$59.95**

**The Giant Book of Easy-To-Build Electronic Projects:** Editors of Elementary Electronics

A huge variety of projects designed to be put together in only a few hours and at a minimal cost. 325pp HEA008 **\$29.95**

**The Illustrated Dictionary of Electronics — 4th Edition:** Rufus P Turner and Stan Gibilisco

This handy guide defines more than 27,000 vital electronics terms, acronyms, and abbreviations — more than any other electronics reference. 656pp HEA009 **\$45.95**

**Master Handbook of 1001 Practical Electronic Circuits.** Solid State Edition Kendall Webster Sessions. "An ideal source book for the engineer, technician or hobbyist" (Electronics Today International) Thoroughly indexed, with more than 1,000 illustrations. 420pp HEA010 **\$42.95**

**25 Fun-to-build Projects for Learning Electronics Theory:** The Editors of Elementary Electronics.

Even elusive concepts are simple to understand and apply when they are incorporated in interesting projects such as these 210 pp HEA011 **\$15.95**

**Servicing Radio Hi-Fi and TV Equipment Third Edition:** Gordon J King

"Thoroughly recommended" Electrical and Electronic Trader 'A long standing favorite' Electronics Monthly HEA012 **\$31.95**

**Communication Satellites — The Technology of Space Communications:** Larry Blonstein

A technical introduction to communication satellites that explains, giving dates and worked examples, how satellites work, how they are constructed and used, and optimization of space communications systems. HEA013 **\$34.95**

**LSI Interfacing:** Mike James

A guide to the use of standard LSI interface chips. It examines general principles of data transfer and connecting devices to microprocessor buses. It covers a range of devices by presenting block diagrams, pinouts and their software aspects together with a discussion of programming methods. 216pp HEA015 **\$34.95**

# BOOK SHOP

BACK BY  
POPULAR DEMAND

**Oscilloscopes Revised Second Edition:** Ian Hickman

This revised edition has been updated and enlarged to cover new instruments. Illustrated with diagrams and photographs of many more instruments, the book will appeal to everyone who wants to know about oscilloscopes, from the school student to the graduate, from the hobbyist to the technician. HEA016 **\$17.95**

**Practical Design of Digital Circuits:** Ian Kampel

"This is a book which the reader will refer to repeatedly as a source of instruction and inspiration", Whats New in Electronics HEA017 **\$36.95**

**110 IC Timer Projects for the Home Constructors:** Jukes H. Gilder HEA029 **\$21.95**

**Beginners Guide to Digital Electronics** Ian R. Sinclair  
HEA018 **\$14.95**

**Beginners Guide to Electronics — Fourth Edition:** Owen Bishop

An essential and often reprinted book for the newcomer to electronics. The subject is treated with the minimum of mathematics. HEA019 **\$19.95**

**Beginners Guide to Integrated Circuits:** Ian R. Sinclair

"As before Ian Sinclair has managed to produce an outstanding book for the beginner to electronics." Everyday Electronics, Reviewing first edition. HEA020 **\$14.95**

**Newnes Audio and Hi-Fi Engineers Pocket Book:** Vivian Capel HEA021 **\$29.95**

**Newnes Radio and Electronics Engineer's Pocket Book:** Seventeenth Edition Keith Brindley

An invaluable compendium of facts, figures and formulae which is indispensable to the designer, student, service engineer and all those interested in radio and electronics. HEA023 **\$19.95**

**Newnes Television and Video Engineer's Pocket Book:** Eugene Trundle

"A thoroughly up-to-date reference book on domestic TV/Video systems is very welcome and this book fulfils its aims admirably . . ." Television "a gem of a book" . . . can be used by service engineers throughout the world" Elektor Electronics HEA024 **\$29.95**

**Newnes Computer Engineer's Pocket Book:** Michael Tooley

"A very full and useful compendium . . . very practical . . . good value" NATFHE Journal HEA025 **\$29.95**

**Newnes Engineering Science Pocket Book:** J. O. Bird

"A wealth of information which will be most useful to students and engineers alike" Elektor Electronics HEA026 **\$29.95**

**Newnes Electronics Pocket Book:** E. A. Parr

"An excellent and useful book for daily use that is unreservedly recommended to anyone with an interest in electronics" Elektor Electronics HEA027 **\$29.95**

**Newnes Physical Science Pocket Book for Engineer's** J. O. Bird and P. Chivers

"The selection of material is sensible and balanced" Times Educational Supplement HEA028 **\$29.95**

To order simply fill in the coupon, remembering to include the code numbers and \$5.00 postage and handling. If the coupon is missing, write down the names, code numbers and prices of the books you require. Include your name, address, telephone number, plus cheque, money order or credit card details (card type, card number, expiry date and signature) and send it all to: Federal Publishing, Freepost No. 4, P.O. Box 227, Waterloo NSW 2017. No stamp required. And don't forget to sign all orders.

# Double Change Superhets, Demodulators and Improved AGC

In this chapter of our series we look at 'double change' superheterodynes, which use both high and low intermediate frequencies in sequence, to obtain the advantages of both. We also look at demodulators and achieving more efficient AGC action.

by BRYAN MAHER

Whereas receivers designed for reception of music and voice material from local broadcast stations give good results using two or three tuned IF transformers tuned to 455kHz, as we saw in the last of these chapters that this is not good enough for communications receivers – whether intended for commercial or amateur use.

When the received signal is down in the microvolt region and partly buried in electromagnetic interference (EMI, i.e. 'static') and/or unwanted interfering stations, we noted last time that narrow bandwidth is mandatory to reject interferences and enable the wanted transmission to be copied. And we saw that either crystal filters, electromechanical filters or very low frequency tuned IF transformers can be used to achieve this narrow bandwidth.

Crystal filters may be expensive, and were so particularly in the past, leading to a widespread use in good quality receivers of electromechanical filters and/or tuned IF transformers, operating on a low IF from 60kHz to 455kHz.

We saw last time that a low IF on its own is not satisfactory, because of the severe image reception problems ('phantoms' or 'double spots') which follow any use of a low IF – because images are separated from the wanted frequency by twice the IF.

Clearly we really need the advantages of both a high IF (to cure imaging) and a low IF (to achieve narrow bandwidth). Lest any gentle reader should burst into a tirade of uncomplimentary remarks at the hide of the working class

(that's us) wanting our cake and eating it too, let us hasten to proclaim our voracity, as radio receivers are in fact already made and sold using two intermediate frequencies, one high and one low!

## Double changing

Such receivers are called *double change superheterodynes*, and commonly use a first IF at 10.7MHz (or sometimes much higher) followed by a second IF at some low choice between 50kHz and 455kHz. Mechanical filters are common in the second IF section.

By now readers hopefully are familiar with the *mixer* stage of every superheterodyne, which beats (mixes) the incoming station signal at frequency  $f_1$  with a tunable local oscillator generating frequency  $f_2$ , to produce a third frequency, the intermediate frequency  $IF_1$ . Usually  $IF_1$  is the difference between the two, i.e.  $IF_1 = (f_2 - f_1)$ , although sometimes it is the sum – e.g.  $IF_1 = (f_2 + f_1)$ .

Well, in a double change superhet the

same idea is repeated again in a second mixer, as in Fig.1 where after tuned amplification the first (high) intermediate frequency  $IF_1$  is mixed with the signal  $f_4$  from a second local oscillator  $LO_2$ , to produce a second lower intermediate frequency  $IF_2$ . Here  $f_4$  is generally on the high side of  $IF_1$ , and  $IF_2 = (f_4 - IF_1)$ .

## Second LO

The second local oscillator generates a fixed sinewave RF signal  $f_4$  at a suitable frequency, depending on the choice of frequency  $IF_1$  and  $IF_2$ . If  $IF_1$  is chosen nice and high, at say 10.7MHz, to give excellent freedom from unwanted image reception, and if  $IF_2$  is selected quite low, say 455kHz using an electromechanical IF filter, then the second local oscillator frequency  $f_4$  must be such that:

$$\begin{aligned} IF_2 &= (f_4 - IF_1) \\ 455\text{kHz} &= f_4 - 10700\text{kHz} \\ f_4 &= (10,700 + 455)\text{kHz} \\ f_4 &= 11,155\text{kHz} = 11.155\text{MHz} \end{aligned}$$

Notice that as both  $IF_1$  and  $IF_2$  are constant frequencies (any intermediate frequency is a constant), it follows that their sum, the second local oscillator frequency  $f_4$  must stay accurately constant and must not drift with time or temperature change – otherwise the receiver's intermediate frequency sections would become misaligned.

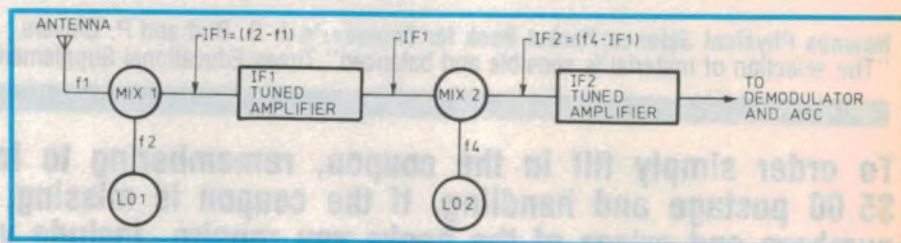
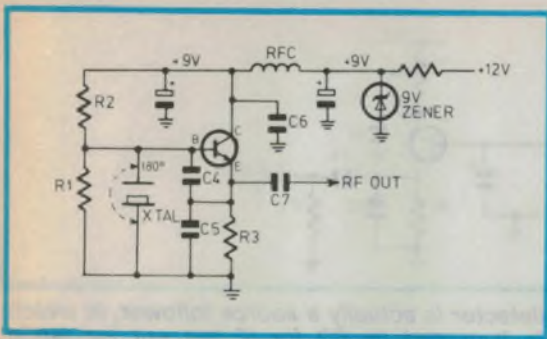


Fig.1: The double change superhet principle uses two intermediate frequencies  $IF_1$  and  $IF_2$ , and two local oscillators. The high first IF gives good image rejection, while the low second IF ensures high gain and narrow bandwidth.



**Fig.2: The Colpitts crystal oscillator uses a tapped capacitive divider C4/C5 to provide positive feedback in conjunction with the inherent 180° phase change across the crystal.**

Therefore it is common practice in double change superhet receivers to use a crystal oscillator circuit for the second local oscillator f4.

As remarked previously, in part 8, the electromechanical effects of crystal shape distortion and relaxation, associated with applied and generated RF voltage, can only occur at one frequency. This frequency is determined by the axis along which the crystal was cleaved in manufacture and the thickness of the crystal, thinner crystals resonating at a higher frequency.

Any change in temperature changes crystal dimensions slightly (by expansion/contraction), which naturally causes a very small change in frequency.

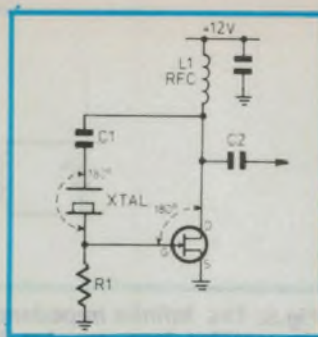
## Crystal oscillators

Fig.2 shows a crystal oscillator circuit of the Colpitts or tapped capacitor type, while Fig.3 shows a variation on the Pierce type.

In Fig.2 the capacitive voltage divider using C4 and C5 should be silver mica types for good RF performance and temperature stability. The ratio of resistors R1 and R2 sets the forward bias for starting, while the capacitor ratio C4/C5 sets the amount of positive feedback to continue the oscillations. RF output is taken from the lowest impedance feed point available, the emitter.

In Fig.3 the small capacitor in series with the crystal can be used to 'pull' the crystal frequency slightly (i.e., change the crystal frequency by a few hertz) if necessary.

In this circuit the crystal, being electrically a high Q tuned circuit, produces a 180° phase change across itself, and this added to the 180° phase shift inherently between drain and gate of every FET results in a total shift of 360°. So there is 'in phase' or positive feedback from drain to gate, which sustains the oscillations. The gate leak resistor R1 and the capacitance of the crystal with



**Fig.3: The Pierce oscillator, probably the simplest of all crystal oscillators. The stability is decided mostly by the crystal itself, but the circuit also produces many harmonics.**

C1 develop the class C bias. Inductor L1 is untuned but serves to isolate the RF output from the positive rail, which is bypassed to ground for radio frequencies.

## The benefits

Compared to a single change superhet receiver the double change superhet has all the advantage of both high and low IF frequencies, i.e. lower image response (high IF) and also narrow bandwidth and high gain (low IF). However the extra complication does persuade many constructors to steer away from this approach.

At a glance it would seem that a single high frequency IF (between say 10.7MHz and 35MHz), together with a high frequency crystal filter to narrow the bandwidth, would be the cleanest, simplest solution. Some constructors do follow this view, but care must be taken to eliminate filter input/output stray capacitance, as such stray coupling tends to negate the effectiveness of the filter. And, furthermore, the higher the frequency of any filter the more difficult is the required input/output isolation.

Some builders of communications receivers actually choose an intermediate frequency higher than the incoming sta-

tion frequency, IF's as high as 120MHz being sometimes used to get rid of the image problem in HF reception. This 'up conversion' method may be used either for a single conversion receiver employing a VHF crystal filter, or as the first IF of a double conversion receiver.

In addition to image reception, if any local oscillator RF output contains significant distortion harmonics, such harmonics can beat with a higher frequency station to produce an accepted IF signal, causing confusion. Double change superhet receivers, having two local oscillators, do have more chance of experiencing such problems than do single change superhets.

## AM demodulation

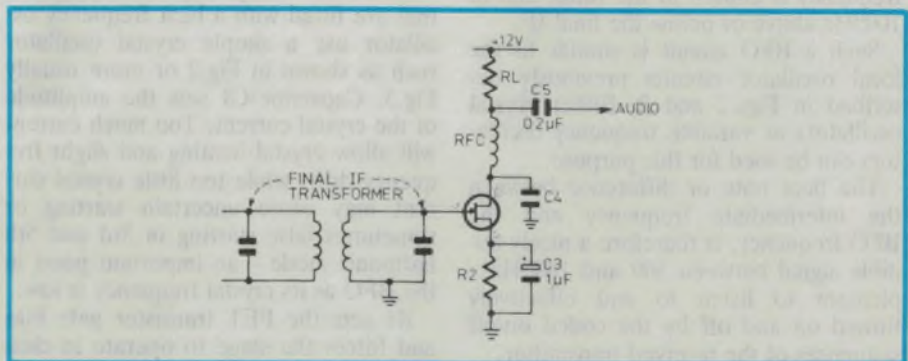
Simple AM demodulators or 'diode detectors' were described in part 5 of this series. Although the diode detector is quite satisfactory in its simplicity and its ability to cope with strong signals, the low impedance of the diode does load the tuned circuit which feeds it, lowering the Q and broadening the bandwidth.

One improvement is to arrange a detector circuit which has much higher input impedance. One such, known by its generic name 'plate detector' (due to its initial use of vacuum tubes) is shown in Fig.4. The source resistor and its bypass capacitor form a fairly long time constant, and hold the drain almost at the current cut-off point because of the large negative bias developed.

Therefore the gate causes drain current flow on positive IF voltage excursions only, effectively rectifying the applied IF signal at the drain to recover the AM modulation.

For most of the IF voltage cycle, as the JFET is not conducting, this type detector does not load the final IF tuned circuit and does not reduce its Q, so narrow bandwidth is preserved.

An extension of the low loading idea is shown in Fig.5, an AM demodulator



**Fig.4: 'Plate detector' is the name still given to this very old circuit now applied to modern solid state JFETs. It is a high performance AM demodulator.**

## Basics of radio

known as an 'infinite impedance detector'. The main difference between Figs.4 and 5 is that in the infinite impedance detector the source resistor  $R_L$  is of much higher value and is bypassed only for high frequencies by the short time constant  $C_2 R_L$ , using a small value  $C_2$ .

Therefore in this circuit the FET appears as almost a source follower circuit at audio frequencies, and the extremely high gate impedance of a source follower (the so-called infinite impedance) imposes very little loading on the final IF tuned circuit, so narrow bandwidth is maintained. This circuit is capable of following weak or strong signals with low distortion.

### Code reception

Many communications receivers are intended for reception of Morse code, in the form of so-called 'continuous wave' or CW, in addition to AM. An ordinary AM detector does not give satisfactory reception of CW code transmissions, giving rather a muffled distorted sound output in response to the simplest code transmitters – which merely switch their carrier on/off in the Morse code pattern, rather than employ any modulation.

What is needed is an extra small oscillator circuit, to beat with the final IF signal to give forth an audible beat note at some convenient audio frequency.

Such a *beat frequency oscillator* or 'BFO' is mixed with the final IF signal in a *product detector* circuit, which is essentially similar to an RF mixer, as the principle of each is the same.

Fig.6 shows one type of product detector using a JFET, but passive double-balanced diode product detectors are also widely used.  $R_1$  is a low valued resistor at the source, to which is fed a fairly large signal from a BFO – whose frequency is chosen in the range 500 to 1000Hz above or below the final IF.

Such a BFO circuit is similar to the local oscillator circuits previously described in Figs.2 and 3. Either crystal oscillators or variable frequency oscillators can be used for this purpose.

The beat note or difference between the intermediate frequency and the BFO frequency, is therefore a nicely audible signal between 500 and 1000Hz – pleasant to listen to and effectively turned on and off by the coded on/off sequences of the received transmitter.

### Crystal BFO?

Perhaps readers of searching mind

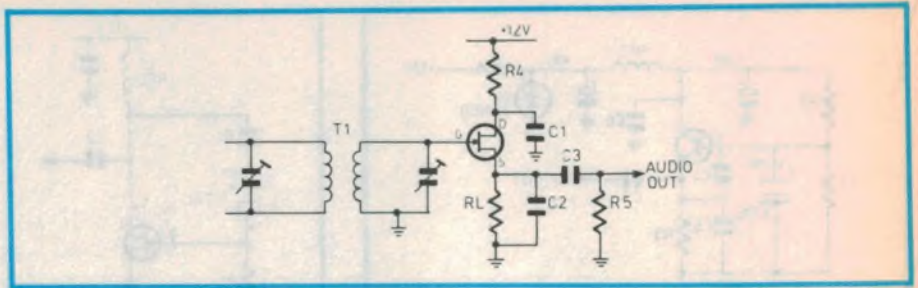


Fig.5: The 'infinite impedance' detector is actually a source follower, in which the emitter load resistor  $R_L$  is bypassed by  $C_2$  for IF but not for audio frequencies.

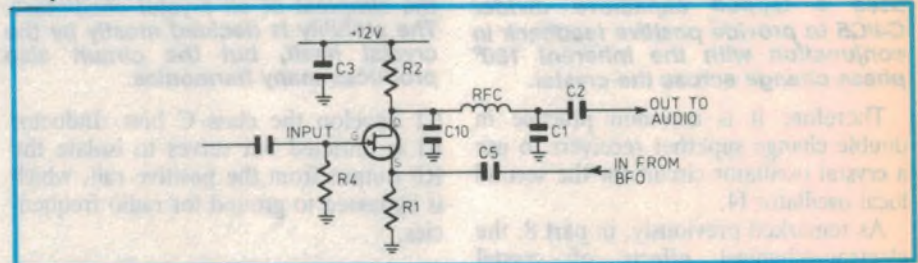


Fig.6: A product detector for reception of Morse code. The input from the final IF stage beats with the BFO to produce an audible note.

may wonder why a little BFO circuit should be so fancy as to use crystal stability?

Some figures may show the need. Say the final IF is 455kHz and the BFO frequency is 455.5kHz, giving a difference or 'beat' frequency of 0.5kHz or 500Hz. Now if the BFO is not crystal controlled and therefore drifts in frequency as much as 1% with hourly temperature change, the conditions would be:

Final IF frequency: 455kHz  
BFO (= 455.5 + 1%): 460kHz  
Difference beat note: 5kHz

So a quite small percentage change in BFO frequency results in the audible beat note heard by the operator changing from 500Hz to 5000Hz – by a factor of 10. Enough to spoil the operator's day, making listening a somewhat painful experience.

Therefore many superhet receivers that are fitted with a beat frequency oscillator use a simple crystal oscillator such as shown in Fig.2 or more usually Fig.3. Capacitor  $C_1$  sets the amplitude of the crystal current. Too much current will allow crystal heating and slight frequency drift, while too little crystal current may cause uncertain starting or sometimes false starting in 3rd and 5th harmonic mode – an important point in the BFO as its crystal frequency is low.

$R_1$  sets the FET transistor gate bias and forces the stage to operate in class C, while  $C_2$  is a quite small capacitor to ensure low loading on the oscillator by the circuit being driven.

### Improving AGC

Automatic gain control (AGC), also known as automatic volume control (AVC), has as its aim the maintaining of constant output volume despite the inevitable fading and ups and downs in carrier strength of long distance reception.

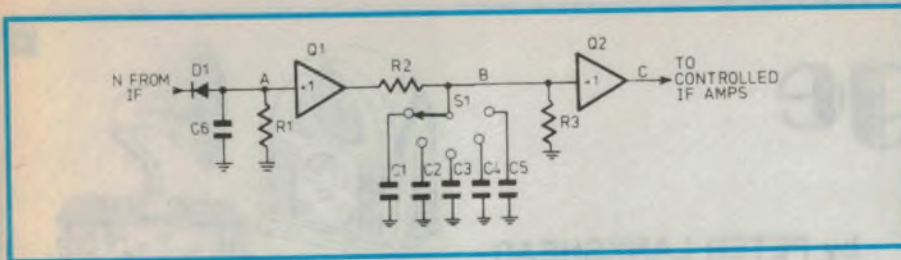
Simple methods of achieving AGC were discussed and illustrated in part 6 of this series. While such simple schemes are perfectly adequate for local reception, they leave much to be desired in high gain communications receivers. Hopefully you'll remember that the AGC system should adjust the gain of the IF stage in inverse ratio to received signal strength.

Firstly, in high frequency reception conditions over long distances you are likely to experience a received carrier strength varying very slowly (waving up and down), or fading up and down at any speed up to a fast fluttering action. This can be complicated again in the reception of simple Morse code transmitters, which send their code sequences by simply turning their carrier on and off. Reception of such a transmission can fool the receiver AGC system, as it will try to turn receiver gain down and up – trying to follow the on/off excursions in carrier strength.

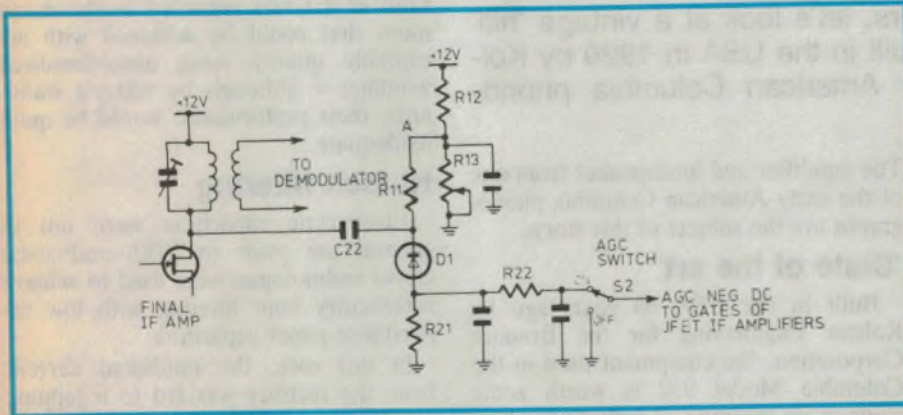
Furthermore simple AGC systems, if applied to high gain receivers, may turn the gain down on received atmospheric and receiver noise in between stations, so that you miss hearing a weak transmitter.

Without succumbing to the horrors of





**Fig.7: Scheme for variable AGC time constants. D1, R1 and C6 form the basic AGC detector, while S1 selects one of capacitors C1 through C5. This with R2 forms the AGC time constant chosen. For further gain in AGC action, Q1 can be changed to a non-inverting operational amplifier with the desired DC gain.**



**Fig.8: Delayed AGC is achieved by biasing the AGC detector diode D1 off until the received signal is large enough to equal the noise. Potentiometer R13 adjusts the holdoff bias, and hence the signal level at which AGC action begins.**

pedantry, let us just say that to cope with reception of signals of different fading rate the ideal would be to have front panel control of the AGC rectifier's *time constant*. The outline of such a scheme is shown in Fig.7, where C1 to C5 are various sizes of capacitor which, selected by front panel switch S1 and in combination with series resistor R2, give the AGC time constant chosen by you, the listener.

### Delayed AGC

Now how will we cope with the action of simple AGC systems which see atmospheric and front-end receiver noise as just another signal, so obediently turn down the receiver gain?

Electronic systems which can pick the difference between a noise signal (which you don't want) and a real wanted signal are not simple, though they have been built for other applications (ref. Maher: *Proc. IREE*, Dec. 1979).

But wishing to keep it simple, why don't we just instruct the AGC system to not come into effect on small signals (including noise), but to begin turning down the receiver gain only when the received signal is stronger than some chosen value. In other words we need to give the AGC system a 'threshold', below which it is inactive.

Such a desired system is easy to implement, by biasing the AGC diode off until the negative half cycle of the IF signal to the AGC diode exceeds the bias, set at some chosen value. We call this 'delayed' AGC - although we should note that this is a *voltage* delay, and not (as erroneously supposed by some) a time delay.

The delay has nothing to do with time, because the AGC action is almost instantaneous when we tune to a strong station. That is, it will be 'instantaneous' within the limits of the AGC time constant, of course.

Fig.8 shows the idea, in which AGC detector diode D1 is returned via R11 to a small positive voltage at A, adjustable via R13. This voltage biases the diode out of conduction unless the IF signal is large enough that its negative peak value exceeds the positive voltage at A.

Thus no AGC negative DC is fed to the control gates of the FET IF amplifiers unless a moderately large carrier is received, allowing the receiver to operate at full gain on small signals, despite some noise.

### Amplified AGC

The extent of AGC control over the gain is naturally higher when higher

gain IF stages are used. But there is a limit to the IF gain permissible, otherwise instability will overcome the whole receiver.

Many designers of modern communications receivers would like more AGC action, but as an alternative to using higher IF gain, the additional gain is achieved by amplifying the negative DC AGC signal itself.

The essence of the idea is that the negative DC voltage derived from the AGC diode is passed through one or two simple low bandwidth DC amplifiers, and thence to the controlled gates of all IF amplifier FETs. A DC gain control is often added, to allow the action to be regulated by the user. To achieve DC gain just replace the voltage follower Q1 in Fig.7 with an operational amplifier with the desired value of DC gain.

With all these niceties added, the final communications receiver is a sophisticated high performance machine. Now that you understand how it works, perhaps you may now be inspired to study the design of high class high frequency receivers further - or even build one!

In the next instalment of this series we delve into the wonders of frequency modulation. E



The Electronic Technicians Institute of Australia is an organisation established to protect and promote the professional status of technicians working in all branches of the electronics industry.

Membership is open to all qualified technicians and is graded to reflect training and experience.

Membership enquiries should be directed in the first instance to The Federal Secretary, TETIA, PO Box 148, Riverwood, NSW 2210.

# Vintage Radio

by PETER LANKSHEAR



## The Kolster-Brandes 930 amplifier

As a change from radio receivers, let's look at a vintage 'hifi' amplifier. The model 930 was built in the USA in 1929 by Kolster Engineering, and used in American Columbia phonographs of the day.

In 1888, Emile Berliner patented the flat, laterally cut gramophone recording, which, unlike the earlier Edison cylinder, could be readily mass produced. Subsequent development of the gramophone has seen steady progress interspersed with significant improvements, each one regarded as a major step towards 'ultimate' reproduction. These landmarks include exponential horns, electrical recording and reproduction, magnetic tape mastering, microgroove, stereo and now digital recording and compact discs.

### Important development

Radio broadcasting, the wonder of the 1920's, had serious repercussions on the recording industry. However, the same electronic technology which created broadcasting was used by the recording companies to mount a counter attack. The result, electrical recording, was a most important event in the evolution of disc recording.

For nearly 50 years following Edison's original patents, recordings were cut by the direct action of sound on a diaphragm and stylus. Reproduction was a reverse process. These acoustic recordings were very restricted in frequency response and full of resonant peaks. But by 1924, electronic recording was being successfully demonstrated and in 1925 the Bell Telephone Laboratories introduced the Western Electric system which, with a frequency response of 50Hz to 5kHz, was quickly adopted by many recording companies.

Initially, domestic users of the new 'electric' recordings continued to play them back on acoustic gramophones, but the introduction of mains powered amplifiers enabled major companies like HMV, Columbia, Brunswick and Victor to market gramophones incorporating amplifier driven moving coil speakers.

The amplifier and loudspeaker from one of the early American Columbia phonographs are the subject of this story.

### 'State of the art'

Built in the USA 60 years ago by Kolster Engineering for the Brandes Corporation, the equipment used in the Columbia Model 930 is worth some study as an example of early technology in audio design.

The two-stage amplifier used transformer input coupling to a type '27 triode, itself transformer coupled to a pair of '45 output valves.

Three audio transformers for a two stage amplifier may seem a bit much, but as the amplification factor of a '27 valve was only 9 and that of the '45 a mere 3.5, much of the necessary gain, demanded by the pickup output of

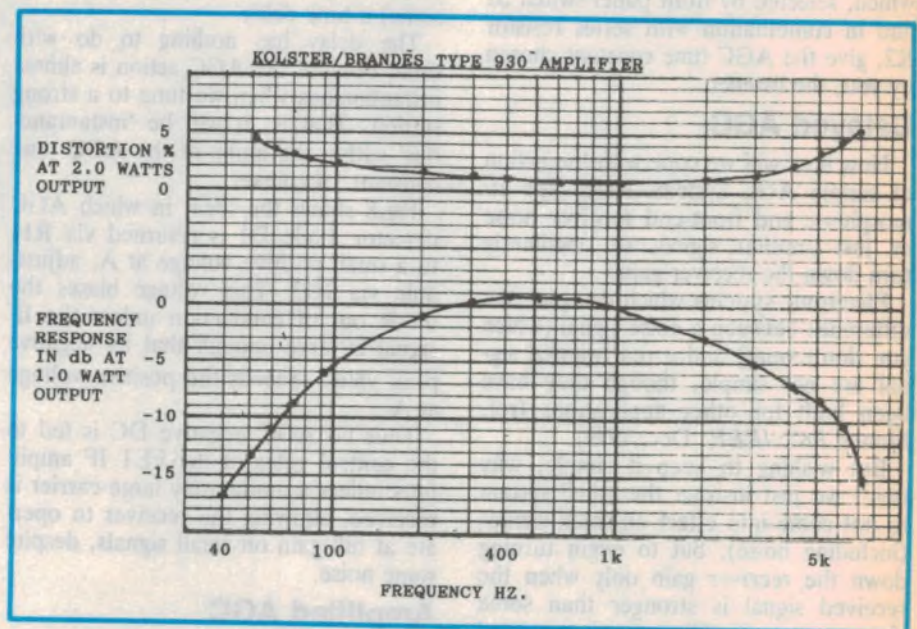
about a volt, came from the input and interstage transformers. Their turns ratio of 4:1 was regarded as the maximum that could be achieved with acceptable quality using unsectionalised windings – although by today's standards, their performance would be quite inadequate.

### Hi tech filtering

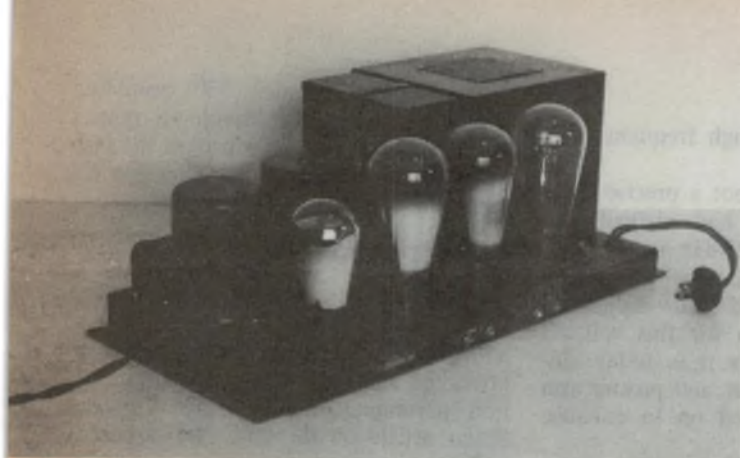
Electrolytic capacitors were not in general use prior to 1930, and some clever technologies were used to achieve satisfactory hum filtering with low capacitance paper capacitors.

In this case, the unfiltered current from the rectifier was fed to a tapping on the filter choke, with the main portion of the winding acting as a conventional filter. The remaining section of the winding was connected to earth via a 2.0uF capacitor – to form a series tuned circuit, resonant at the hum frequency of 120Hz (for a 60Hz mains supply). This induced a magnetic flux that had a 'bucking' effect on the hum component in the main winding.

Despite the main filter capacitor being only another 2.0uF unit, the hum level



The author's measurements revealed these performance curves – good for the time. Note that there was no overall negative feedback.



With only the wiring and two small resistors underneath, the amplifier needed only a very shallow chassis. All capacitors were in the smaller rectangular box.

For its day, the 12" loudspeaker was progressive, with the centring 'spider' behind the zinc sputtered cone. Note the output transformer on the side.

at about -50dB was quite satisfactory by the standards of the day. Some American mains supplies were 25Hz at the time, and the choke was tapped to allow for this.

### Advanced speaker

Loudspeakers in high grade record reproducing equipment have always been 'state of the art' and the Kolster 12-inch moving coil unit is no exception. The first practical moving coil loudspeaker had been introduced by RCA in 1925, but it had only a 6-inch cone. As steels capable of providing sufficient flux for permanent magnet fields did not exist, the use of electromagnets was standard. However the inclusion of field windings in the HT supply for hum fil-

tering of the output stage was not common before 1930.

Instead, it was general for the field to form part of the voltage divider and bleeder system. In the Kolster amplifier the field winding, along with a 0.5uF capacitor, does provide some filtering of the HT supply to the '27 amplifier stage.

The speaker cone is interesting, being made from zinc sprayed fabric. Early centring 'spiders' were normally in the front of the cone. Kolster were advanced in using the more compliant rear mounted spider, but it is unusual in that it was made of thin brass. Modern suspensions are, of course, made of plasticised fabric, the open spider having long since given way to a corrugated disc.

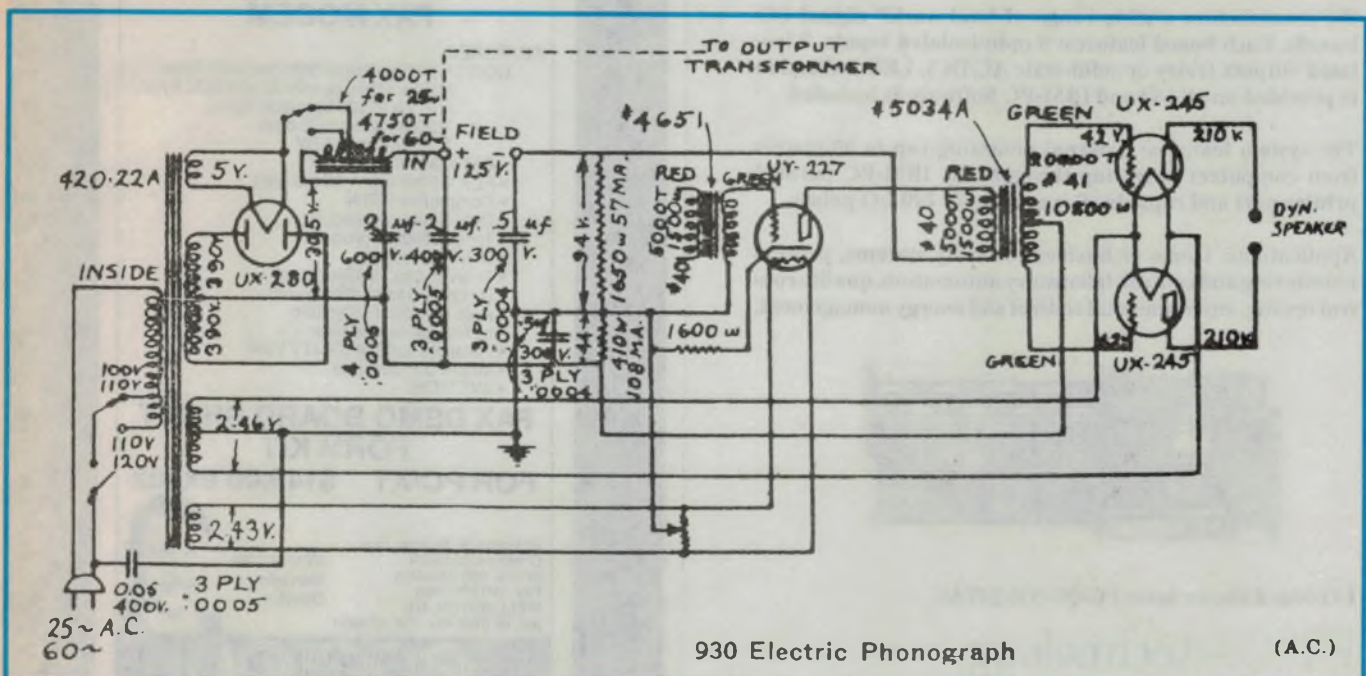
### Novel features

An uncommon feature of the circuit diagram is the listing of 'plies' for the capacitors.

At the time, the working voltages of paper capacitors were governed by the number of plies or layers of dielectric paper. Each ply of .0005" was rated at about 200 volts DC, but as paper is liable to have random pinholes, an extra ply was included for safety.

Note also that resistance values are shown using what appears to be a 'w' symbol. This is an obsolete use of the lower case Greek letter Omega ( $\omega$ ) instead of the modern use of the upper case symbol ( $\Omega$ ).

The 1600 ohm cathode bias resistor for the '27 would have needed at least



930 Electric Phonograph

(A.C.)

Copied from an elderly manual, the circuit is rather rough but shows how the valves were used. Note the 'ply' ratings for the capacitors, and the novel series-resonant filtering system.

## Vintage Radio

5.0uF of capacitance for satisfactory bypassing. This would have been expensive, so bypassing was ignored, with the result that the valve gain was halved to a modest 5 times!

### Performance tests

Although by the 1950's, amplifier performance curves were frequently available, very little has been published about the characteristics of earlier equipment. It was, therefore with considerable interest that I measured the performance of the 930. Measurements were made with an AWA self-zeroing Distortion & Noise Meter, connected across a 6 ohm resistor replacing the speaker voice coil. Signal source was an AWA Audio Oscillator connected through a 10k series resistor.

The poor frequency response results from the use of simple winding configurations in the audio transformers. Later valve amplifier designs incorporated elaborate transformer winding configurations and resistance coupling.

There was no point in extending the response above the recorder limit of 5kHz. In fact, the high noise level of shellac recordings and pickup reso-

nances made some high frequency roll off desirable.

The bass end was not a precise area. Acoustic recordings had virtually no output below about 250Hz and to limit groove excursions, electrically recorded discs have always had a low frequency roll off. Equalisation for this roll off was not electronic as it is today. Instead, cabinet, speaker and pickup arm resonances were relied on to enhance the bass response.

### Low distortion

Recordings, pickup and loudspeaker would each have created more distortion than the amplifier, a situation that exists to this day. My measured power output of 2 watts at less than 1% distortion into the load resistor is a very good performance and corresponds closely to the theoretical maximum for push-pull class A operation of a pair of '45's.

Note that this amplifier was produced before the use of overall negative feedback for flattening frequency response and reducing distortion and noise.

For reference, at 210 volts HT a single '45 was rated to produce 1.0 watt at 5% distortion to the primary of the out-

put transformer.

The Kolster/Brandes 930 amplifier shows clearly that gramophone reproduction has come a long way in the last 60 years. Who knows what the next 60 years will bring?

### Welcome feedback

I am indebted to well known radio historian Mr Winston Muscio, who was an STC Engineer from 1933 to 1980, for providing me with additional information pertaining to the April *Vintage Radio* article on the STC 506 portable radio.

In July 1939, the 506 was in fact superseded by a 1.4 volt portable, the 510, using British made Brimar rather than Australian or Raytheon valves.

The 510 was featured and very favourably reviewed in *Australasian Radio World* for July/August 1939. Pictures show a cabinet much in the style of the 506, but about half the height (and with it a very youthful Winston Muscio).

Thanks again for that further information, Mr Muscio. And if other readers have additional information on any of the equipment discussed in this column, please don't hesitate to write to me, care of EA.

EA

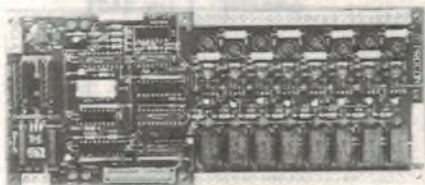


**IN ANYONE'S LANGUAGE\***  
**PROCON TECHNOLOGY**  
**LETS YOU TAKE CONTROL!**

We manufacture a wide range of 'real-world' digital I/O boards. Each board features: 8 opto-isolated inputs, 8 isolated outputs (relay or solid-state AC/DC), LED indication is provided on all I/O and IBM-PC Software is included.

The system features: External mounting (up to 30 metres from computer) operating through any IBM-PC parallel printer port and capable of expanding to 240 I/O points.

Applications: Home or business security systems, process monitoring and control, laboratory automation, quality control testing, environmental control and energy management.



I/O board shown here: PC-IO-NR-24VAC

**PROCON**technology

P.O. Box 43, Essendon, VIC., 3040 TEL: (03) 3364956

\* Yes! High-speed drivers are provided for GWBASIC, QuickBASIC, TurboBASIC, QuickC, TurboC and TurboPascal. Our file I/O driver also allows many other programs and languages to be used. E.g. DBASE, Clipper, COBOL, FORTRAN, MODULA-2 etc.

## YAMAHA L Si YM7109 FAX MODEM

### FEATURES:

- CCITT V.29 (9600 bps/7200 bps) IIDX Sync.
- V.27ter (4800 bps/2400 bps) IIDX Sync.
- V.21 ch 2 (300 bps) IIDX Sync.
- V.23 Backward (75 bps)
- V.21 (300 bps) FDX
- Bell 103 (300 bps) FDX
- FDX V.27ter and V.23 (75 bps)
- Compatible PSTN
- Dual tone orig. prog. fn.
- Tone detection prog. fn.
- DTMF detection
- Tx level: 0 to 15 dBm (prog)
- Rx level: 0 to 43 dBm (prog)
- Auto equalizer sub/cable
- built-in bandpass filter
- Parallel interface (CCITT V.24)
- 40 pin DIP package
- 5VCMOS

**FAX DEMO BOARD SHORT  
FORM KIT  
FOR PC/XT \$149.00 ex tax**

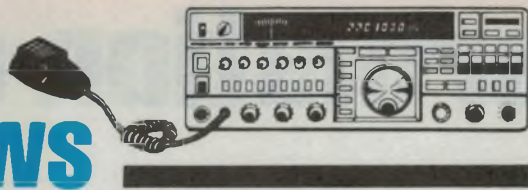
26 Boron St, Sumner Park  
Brisbane, Qld 4074  
Phone: (07) 376 2955  
Fax: (07) 376 3286  
WELLINGTON, NZ:  
(04) 85 8742 Fax: (04) 82 8850

**KEN CURRY**  
Managing  
Director



**energy  
CONTROL**

# Amateur Radio News



## Customs tariff: correction

Following our item in these columns for July, concerning customs tariff for amateur radio transceivers, WIA General Manager and Secretary Bill Roper VK3ARZ has advised that we got the story a bit garbled.

Amateur radio transceivers are exempt from Customs duty as long as the importer or manufacturer is in possession of an Exemption Certificate issued by the WIA, and such an Exemption will only be granted where certain conditions are met concerning the capability of the equipment to operate outside allocated amateur bands. Details of these conditions were given in the May 1989 issue of *Amateur Radio*.

The decreasing levels of Customs duty given in our July column apply to all forms of radio transceiver, and are part of a general reduction of such duties introduced by the Government some time ago. As such, presumably they would only apply to amateur radio gear if an exemption was not applied for, or granted.

Our thanks to Bill Roper for this correction.

## Silent key

We have been advised of the passing of Ernie Kinscher VK2ADL, of Baulkham Hills, on June 20. Our sympathies to his family and friends.

## Hornsby ARC packet repeater

Hornsby & Districts Amateur Radio Club has changed the frequency of its 2m packet radio repeater to 144.900MHz. This is part of the changes planned for networking of the packet repeaters on the 2m band, coincident with the linking of repeaters on UHF. Club meetings are now held at the Normanhurst Boys' High School.

## Sunspot peak in December

TNX Worldradio reports that the 11-year sunspot cycle is shaping up for a peak this December, and researchers predict that it will be one of the most

violent for 250 years.

According to researchers at the National Oceanic and Atmospheric Administration (NOAA), the average number of solar flares (51.3 per month over a 13-month period) is greater than that observed (40.7) over a similar period in the strongest cycle previously recorded, in 1957. The NOAA researchers predict that the present cycle will peak at close to 200 sunspots per month.

Disturbances to radio communications are expected to continue during this period.

## WIA closes Keylink BBS

After some months of trials, the WIA has discontinued its national telephone bulletin board service. The service was only used by a small percentage of WIA members, and as a result its cost in terms of both money and time to maintain the currency of the news information could not be justified.

WIA Federal President Peter Gamble VK3YRP commented that the need to bring members up to date via Keylink was less pressing nowadays, because of the shorter lead time for *Amateur Radio* magazine.

## China's hams back on the air

According to the International Amateur Radio Club (IARC), hams in the Peoples' Republic of China came back on the air in late June, after a month of enforced silence during what were described as "troubles".

Some 60 Chinese have apparently passed the country's new 'BZ' private ham licence exams, and were allowed to set up private stations after August 6th. Previously only club licences were allowed.

China's Director for the International Amateur Radio Network is Zhou BY4AA, of Shanghai, who will be visiting Australia shortly for 6 months to study English and as a guest of the IARN. Hams willing to host BY4AA during his stay are asked to contact IARN Director Sam Voron VK2BVS, on (02) 407 1066.

## AMATEUR RADIO

Hobbyists communicating world wide using state-of-the-art electronics.

### CBers!

Bands too crowded?

Like to work DX around the world?

Why not upgrade to the amateur bands?

Want to know more?

Join the WIA - the oldest and most experienced radio society in the world - always at the forefront of radio communications for hobbyists.

Receive AMATEUR RADIO, the monthly magazine for members of the WIA, full of news of DX, clubs, satellites, technical articles and lots more.

Other WIA services include:

- A world wide QSL card service
- Weekly news broadcasts
- Classes for all grades of amateur licences
- Correspondence lessons available
- Meetings, contests, field days
- Representation for radio amateurs at Government level

Learn more about the WIA and Amateur Radio

Forward this coupon, or write to:

WIA EXECUTIVE OFFICE  
P.O. BOX 300  
CAULFIELD SOUTH  
VICTORIA 3162

Registered address: 3/105 Hawthorn Road  
Caulfield North, 3161

Please send a WIA information package to:

NAME: .....

ADDRESS: .....

..... POSTCODE .....

E004A



# Information centre

Conducted by Peter Phillips



## Doing the right thing...

The word illegal crops up several times this month, prompting my heading, and we get involved in a discussion of the SAA wiring rules. As well I offer a point of view about listening in to radio transmissions. Touchy areas sometimes, but well worth getting into. We even have suggestions from a reader about our September 1985 Ignition Killer, which is a simple device to prevent those intent on NOT doing the right thing – with your car!

As you may have noticed, I try to establish a theme each month that, however vaguely, ties each letter together. For this reason, I may hold a particular enquiry over for the next month, resulting in delays that will be noticed mainly by the writer of the particular letter.

But there is another reason for delays that I would like to mention, as I currently have a pile of letters that I cannot possibly answer. Quite simply, the letters either don't give me enough information or I can't understand them. For example, one request concerns a house alarm we apparently published. The letter gives me no details on the date of publication or even the title of the project, except to say that we have made lots of mistakes.

Yet another asks technical questions about a suitable power supply for an amplifier the correspondent wants to build. Unfortunately, I am not sure whether the voltages being referred to are AC or DC. While I think I can guess, I would rather know for sure before trying to answer the question.

I also have letters in my 'can't understand' file that have other problems. Some of these are handwritten and are difficult to read because of the lousy writing (not that mine is much better); while others, though typed, don't seem to make any sense. It seems that some correspondents, in their attempt to provide a readable letter (thank you), miss out on getting the message across due to their manner of expression.

I have to make these points in the hope all letters will be of the usual high standard, so that I can at least evaluate

every one I receive for possible inclusion.

Having said all that, we move into the first letter which takes me to task about my assertion in a previous article that fixed mains wiring connections should, ideally, be both soldered and fitted with a BP style connector.

## Making connections

Readers may recall an article I wrote titled 'Electrical Fires', published in the May 1989 edition of *EA*. In this article I stated that all power wiring connections should be soldered and also fitted with a screw connector, if the risk of a bad connection was to be minimised. The following letter disagrees with this statement, and I am pleased to be able to air different opinions on this most important topic.

The correspondent is known to me, and while I disagree with some of his opinions, I respect his experience and knowledge in this area. Hopefully other readers will contribute their views as well, as it would be good to establish the safest procedure for connecting fixed mains wiring. The letter is as follows:

*With reference to your article 'Electrical Fires', I would like to make the following points:*

*Firstly, it is illegal (and dangerous) for anyone other than a licensed electrician to install or maintain fixed wiring in an installation.*

*Secondly, regarding your suggestion that one should 'solder all connections', it must be remembered that the SAA*

*Wiring Rules (rule 3.9.1) specifically bans the tinning (and therefore soldering) of the conductors used in crimp and compression joints in fixed wiring. This type of connection is extensively used in appliances for both earth and mains connections, which is not classed as fixed wiring, but for which I would apply the same rules.*

*Screwed connections are another classification and from experience I have found these should not be soldered either. When the screw is tightened, it bites into the soft solder readily but with time and vibration the connection is much more likely to come loose than if it were not soldered – one of the reasons why soldered connections are not used in vehicles.*

*Another important reason is that once the soldered joint does become loose, it develops into a high resistance joint which creates heat, resulting in the solder melting and running out of the connection. This molten solder can do a great deal of damage and has the potential for disaster if it comes into contact with other materials.*

*When a connection is soldered, extra conductor insulation must be removed and the remaining insulation can be damaged. The SAA Wiring Rules (rule 3.9.4) require the insulation level of any connection to be at least equal to that of the rest of the cable – obviously some sort of replacement insulation must be added.*

*As well, the possibility of the wire breaking off just past the connection is greater with a soldered joint, as a definite weak point is created as a result of the heat necessary for soldering, the damage to the remaining insulation and the rigid point at which the solder finishes.*

*Your summary in the article was 'solder all connections'. Mine would be 'give consideration to not soldering connections, especially where the joint is subject to vibration and never solder or tin the conductors where the connection is of the crimp or compression type.' (P.G., Kiama Downs NSW)*

Following receipt of this letter, I asked a few colleagues their opinion on the matter. They referred me to the SAA rule book, and I quote the following to support my original suggestion. In section 3.9, headed 'Joints in Cables', the following points are made:

Rule 3.9.1 states that 'joints in cables and conductors shall be made at terminals or by means of connectors, soldering, crimping, approved compression fittings, or by other approved means.' Note that soldering is mentioned.

Rule 3.9.3, (in summary) states that soft-soldered joints shall not be used in any part of an installation where the temperature exceeds 120°C, or where the connections are subject to tension. OK, that's the SAA's limitations on soldering, apart from those applied to a crimped connection as referred to by our correspondent.

But the interesting one concerns joints in the earth wire, covered in section 5.5.5. Here it is stated that connections shall comply with the requirements already referred to, as well as: 'Any joint in a main earthing conductor of cross-sectional area not more than 16mm<sup>2</sup> shall be soldered in accordance with rule 5.5.5.3.'

Rule 5.5.5.3 goes on to say 'Soldered joints shall be made so that the earthing conductors are retained in position by approved means, independently of the solder'. The rules then give examples of 'acceptable means', including enclosure in a suitable metal ferrule, binding, twisting and so on. I regard the earth wire as the most important one of all, and here we have the SAA specifying that it must be soldered.

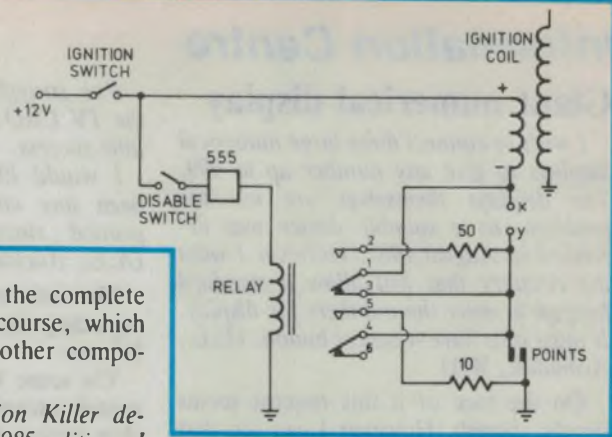
However the correspondent is particularly concerned with my assertion that a soldered connection should also be terminated with a screw type connector, such as the BP connector. I agree that the screw will bite into the solder and possibly become loose after time. Perhaps I should have made it clearer that the purpose of the screw type connector is to provide suitable insulation for the connection.

There is one point that I fully agree with - fixed mains wiring is the province of the licensed electrician. But I still prefer the connections to be soldered, regardless of who does it. What do you think?

## Ignition killer

The next letter refers to a project published in the September 1985 issue of EA. The writer has implemented some modifications, as shown in the cir-

**Fig.1: Our correspondent's modified version of the September 1985 Ignition Killer - see text.**



cuit of Fig.1. This is not the complete circuit of the project of course, which includes a 555 timer and other components. I'll let him explain:

*After building the Ignition Killer described in the September 1985 edition, I found that using the specified 15-ohm resistor across the distributor contacts still allowed the motor to run, albeit rather roughly. My car is a Sigma SE with electronic ignition, meaning it has no distributor points as such. I fitted a 10-ohm resistor instead, which did effectively 'kill' the engine.*

*Inspired by a previous correspondent who advised that a stalled motor will never stop on the compression stroke, meaning the points will be closed at stall, I also added a 50-ohm resistor in series with the coil. The idea is to prevent excessive current flowing through the coil should a would-be thief leave his jumper lead connected, after giving up in frustration. This resistor is connected in series with the relay contacts. (B.F., Glenroy Vic)*

## Scanner frequencies

Scanning the air waves is a popular hobby with many people, and our next correspondent offers some frequencies he has picked up around the Proserpine area. His question may also be of interest for those into scanning...

*I have a Pro 33 scanner, and am purchasing a Pro 34 scanner which should allow me to listen in and program even more frequencies. I currently have a book called Australian Scanners World, but I would like to obtain more information. I am mainly interested in those frequencies around the Proserpine area, and I wonder if you either know of any frequencies, or if you can tell me how I might find further information.*

*The following frequencies are a few that I have logged, which other readers may be interested in: Mackay Electricity Board, 79.045MHz; Proserpine Taxi Service, 77.912MHz; Queensland Railways, 168.520MHz; Proserpine Council, 70.237MHz; Marine Shute Harbour, 161.675MHz and 157.075MHz. (E.H., Proserpine Qld)*

It is reasonably predictable that we

can't supply much in the way of frequencies pertinent to the Proserpine area, as we are based at Sydney. Also, none of our staff is into scanners anyway. However, there are two avenues I can find that may provide the information sought. The first is a book sold by Dick Smith Electronics, called *Australian Radio Frequency Handbook*. This book is not listed in the current DSE catalogue, but copies are likely to still be available in many stores.

The second source is the Department of Communications (DOC). While I am not sure of the procedure, it is likely that the information required can be supplied by this body, possibly for a service fee.

One point worth noting, of course, is that while it is perfectly legal to listen to any broadcast, it is not legal to use the information so obtained. As a friend of mine put it, if you find out by listening in to a frequency that your next door neighbour is about to be raided, you are not legally permitted to warn him. But then you might not like him anyway!

## Printer?

My thanks to Apple Australia for supplying the following story:

It seems the Apple technical department received a call from a seven year old would-be whiz kid, who was having difficulty printing out his homework assignment. "It sort of doesn't act right" replied the caller, in response to prompting as to what the problem was.

After further questioning, it was established that the required homework wasn't printing out. "OK. Now tell me if the printer was working before."

Silence...

"Hello?"

"Printer? I don't think I have one of those."

"Yeah, well..."

"So does that mean I haven't broken the computer and I won't get in trouble when Dad comes home?"

## Information Centre

### Giant numerical display

*I wish to connect three large numerical displays to give any number up to 999. The displays themselves are not the problem, as a suitable device was described in August 1987. However I want the circuitry that will allow a standard keypad to enter the numbers for display. It must also have a cancel button. (E.L., Armadale, WA)*

On the face of it this request seems simple enough. However I can see that it will involve quite a few ICs, including latches, decoder/drivers and a means of converting a key press to a code that will generate the desired numbers. Perhaps there is an LSI chip capable of performing this, or a similar role, but I am unaware of it. Could be difficult to implement, E.L., but we'll see if a reader has found the solution already.

### TV CRO adaptor

Although this project is a few years old, (May 1980), it seems it is still popular with constructors. The following letter typifies the requests we get from readers, and the answer may assist those having problems with this project.

*I've struggled for many hours to get the TV CRO adaptor working, but with little success.*

*I would like to know if there have been any circuit alterations or errata printed since its initial publication. (A.E., Auckland NZ)*

The only notes and errata published regarding the TV CRO adaptor are as follows:

'On some kits, the range of the horizontal control may be insufficient to enable horizontal locking of the picture. This can be overcome by changing the horizontal control to 47k ohms and also increasing the value of the associated 47k resistor to 82k. It may also be necessary to alter the bias around the BC549 to centre the picture. To do this, increase the 10k trimpot to 20k and reduce the associated 180k resistor to 120k.'

However, Rob Evans advises that if the unit is not delivering any picture at all, the RF modulator should be suspected. To confirm this, try connecting a suitable video monitor (or VCR) to the direct video output. If it works, the modulator may be faulty or incompatible.

### What??

Here's a simple little question for those into Z80 machine language programming. What's the simplest single byte instruction that will clear the Z80 accumulator to zero?

### Answer to last month's What??

The answer to last month's question concerning the gain of a two stage RC coupled transistor amplifier is 40. Here's how it can be calculated:

(1) The voltage across R4 = the input voltage ( $V_{in}$ ), by emitter follower action.

(2) The voltage across R10 equals R10 x the current in R4, i.e.  $R10 \times (V_{in}/R4)$ .

(3) The output voltage ( $V_o$ ), equals the sum of the voltage drops across R4 and R10.

Putting this together,  $V_o = V_{in} + ((V_{in}/R4) \times R10)$  as per (1) and (2). Rearranging this equation to get  $V_{in}$  to the left hand side gives the equation  $V_o/V_{in} = \text{gain} = 1 + (R10/R4) = 40$ .

In other words, the feedback network formed by R10 and R4 determines the gain of the circuit. This is true if the gain without feedback is relatively high, and applies to any such circuit.  $\text{\textcircled{Z}}$



## Miss out on our 50th Anniversary Issue?

Don't despair if you missed out on our special 260-page 50th Anniversary Issue, with its 76-page Souvenir of the complete April 1939 issue. Copies are still available, for \$5.95 including post & packing. Send your cheque to EA Reader Information Service, PO Box 227, Waterloo 2017.

# SONICS

## MAGAZINE

For: Musicians, Road Crews,  
Recording Engineers, Lighting People,  
Managers, Promoters and anybody  
interested in what goes into  
today's music-making.

# THE ALL AUSTRALIAN MUSIC MAKERS' MAGAZINE



## Electronic sun

(Continued from page 13)

ships. The cost of a Morse key and headphones is totally insignificant when compared to the estimated \$630,000 spent on glowing dials and buttons in the *Sun's* radio room.

Such an investment has provided the *Royal Viking Sun* with telecommunications and navigation equipment second to none. Virtually nothing that is currently available on the market is missing from the ship's inventory, although new technology will soon be responsible for adding a revolutionary concept in maritime life saving techniques.

Known as Sarsat, the system involves the installation of radio beacons in life boats. A series of positioned satellites will instantly pinpoint the exact location of the life boats and alert rescue teams located in selected regions of the world.

The probability that such a system will actually have to be used is exceptionally low. But the adoption of Sarsat by the Royal Viking Line is indicative of the company's forward-looking attitude of incorporating 21st century technology while pursuing the grand tradition of classic sea travel.



Passenger Kay King (L) was a TV star during the *Sun's* daily breakfast programme 'Sunrise'.

# Considered a career in electronics writing?

Australia's leading electronics magazine requires a project designer/writer for its editorial staff. This position involves the design and development of hobby electronics projects, and then writing about them for the magazine.

You'll need a sound knowledge of electronics theory and practice, and lots of **enthusiasm**. You'll also need to be able to express yourself clearly, in writing. But apart from that, we have no preconceived ideas about your background. You might be a student, a technician, a fully qualified engineer or just a keen enthusiast.

**If you believe you're the person we're looking for, ring Jim Rowe on (02) 693 6620, or send your resume to him at Electronics Australia, Federal Publishing Company, 180 Bourke Road, Alexandria 2015.**

# 50 and 25 years ago..

"Electronics Australia" is one of the longest running technical publications in the world. We started as "Wireless Weekly" in August 1922 and became "Radio and Hobbies in Australia" in April 1939. The title was changed to "Radio, Television and Hobbies" in February 1955 and finally, to "Electronics Australia" in April 1965. Below we feature some items from past issues.



## September 1939

**New multi-purpose valve:** The development of the 1.4 volt series of valves has already had a marked effect on battery set design, setting new standards of economy. This new valve, type number 1D8-GT is actually three valves in one envelope.

It has first of all, a diode plate for detection, next a triode section with an

amplification factor of 25, and finally an output pentode section with an output of 200 milliwatts at 90 volts high tension. Thus it can replace two valves — the 1H5G and the 1C5G.



## September 1964

**Orbiter to photograph the Moon:** America's recent success with the Ranger 7 moon probe has focussed attention on the next phase of Moon exploration — a

photographic satellite which will orbit the Moon and produce strip maps of its surface. From these, scientists will be able to select areas suitable or unsuitable for ultimate landing.

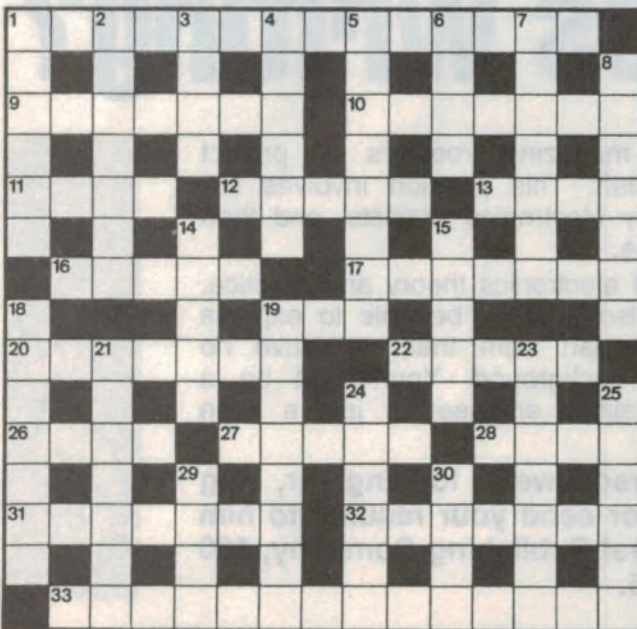
The 800-pound Lunar Orbiter, to be built for the National Aeronautics and Space Administration, will fly around the Moon and take sharp, close-up pictures of the lunar surface. The photographic package will be composed of a camera, film, processor and readout equipment designed by Eastman Kodak. Film will be processed automatically to produce a high-quality negative. Information on the film will be converted into electrical signals and flashed to receiving stations in the Deep Space Network, where they will be converted back to photographs. Radio Corporation of America will provide the Orbiter's power and communications subsystem.

In addition to its cameras, the Orbiter spacecraft will carry four solar panels, a three-foot parabolic dish antenna and an omni-directional antenna, which will pop out after the craft is safely through the Earth's atmosphere and into the frictionless realm of space.

# EA CROSSWORD

## ACROSS

1. Astronomical device at Culgoora. (5,9)
9. Instruction books. (7)
10. Desk with keyboards, panels, etc. (7)
11. Fundamental physical concept. (4)
12. Strontium is an example of this. (5)
13. Drive for record player. (4)
16. Divisions on dial. (5)



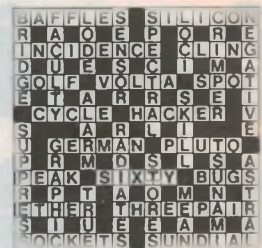
17. Town with stations 2NR and 2GF. (7)

19. Tone fidelity in TV. (3)
20. Able to be heard. (7)
22. Distribution of readings. (5)
26. Outlets in a transformer. (4)
27. Item counted by a counter. (5)
28. Diminish in loudness. (4)
31. Amount of video tape used in camcorder. (7)
32. Melting (of a fuse). (7)
33. Device for reproducing sound. (8,6)

## DOWN

1. Nature of modern TV control. (6)
2. Opposite to static. (7)
3. Type of history that's recorded, by the sound of it. (4)
4. Less difficult. (6)
5. Telephone system's control point. (8)
6. Light-sensitive cell in retina. (4)
7. Undertaking by an EA hobbyist. (7)

## AUGUST SOLUTION



8. Position of a control knob. (7)
14. Light source in a lamp. (5)
15. Pioneer's home. (5)
18. Throw away (because of colour problem?). (4,3)
19. Said of object with the greatest weight. (8)
21. Qualification at tertiary level. (7)
23. Example of a force field. (7)
24. Allow system to operate. (6)
25. Type of radiation counter. (6)
29. Electrical devices producing currents in air. (4)
30. Open-air auditorium. (4)

# EA marketplace EA marketplace

## ADVERTISING RATES FOR THIS PAGE

**SMALL ADDS:** The minimum acceptable size of 2 centimetres x one column costs only \$50. Other sizes up to a maximum of 10 centimetres are rated at \$25 a centimetre. **CLASSIFIEDS:** \$4 for 40 letters. Just count the letters divide by 40 and multiply by \$4, **ROUND UP TO NEAREST WHOLE NUMBER.** **CLOSING DATE:** Ads may be accepted up to the 18th of the month two months prior to issue date. **PAYMENT:** Please enclose payment with your advertisement. Address your letter to THE ADVERTISING MANAGER, ELECTRONICS AUSTRALIA, PO BOX 227, WATERLOO, NSW 2017.

## FOR SALE

**AC Voltage stabilizer:** 240V 6kVA Mag Amp type. New in crate. Replacement cost over \$5,000. Urgent sale best offer (02) 648 1117.

**EX-ABC AUDIO TAPES:** 1/4" wide on 10 1/2" Standard metal spool \$6.85. Robust metal spool \$12.85 7" spool \$2.85. 5" spool \$1.25. Post extra. Also in stock 1/2", 1" and 2" tapes. Waltham Dan, 96 Oxford St., Darlinghurst, Sydney. Phone (02) 331-3360.

**VERY OLD RADIO SETS:** Valves, Books, Spares etc Max, 41 Willmington St, Newmarket 4051. Tel (07) 356 6052.

## FIX-A-KIT

**\$15 PER HOUR LABOUR**  
No charge for kits that can't be repaired.  
3 months warranty on repairs.  
Construction available.

### HYCAL INSTRUMENTS

Design, manufacture, repair of electronic equipment

**(02) 633 5897**

## PRINTED CIRCUIT BOARDS

Minimum postage & packaging on all EA & ETI Project PCBs.  
PCBs made to order — 48 hr prototype service.

Bankcard/Mastercard  
**ACETRONICS PCBs**

112 Robertson Rd, Bass Hill 2197  
(02) 645 1241

## RCS RADIO PTY LTD

Established 1933

IS THE ONLY COMPANY  
WHICH MANUFACTURES AND  
SELLS EVERY PCB & FRONT PANEL  
published in EA ETI & Silicon Chip

651 Forest Road Bexley 2207  
AUSTRALIA

RING (02) 587 3491 FOR INSTANT PRICES  
24 HOUR TURNAROUND SERVICE

## RF TRANSISTORS

ACRIAN, TRW, CTC, MOTOROLA  
We can quote most RF Semiconductor Spares.  
Contact Mike Ryan  
AVISUN P/L

TEL (02) 438 3900, FAX (02) 438 2564

**NEW RADIO VALVES:** For entertainment or industrial use. Waltham Dan, 96 Oxford St., Darlinghurst, Sydney. Phone (02) 331-3360.

**BRAND NEW AVO:** Universal Measuring Bridge type I made in England 1/4 normal price Phone (042) 94 1151.

**NEW AND USED:** Electronic components and equipment from retired business: thousands of items very cheap. Send S.A.E. for list: W. Kluenner, P.O. Box 97, Kallista 3791.

**CADMAX:** pcb layout programme for PC/XT/AT. Reviewed EA July 88, p76. With user manual, tech manual, newsletters, latest SMD library disc. \$150. Ian Cousins, 22 Ward St, Eudunda, SA 5375. Phone (085) 81 1484, fax (085) 81 1656.

**1 MEG PRINTER BUFFER KIT:** REV H boards now available. Supports 8K to 1MEG. \$39 kit consists of Double sided PCB, EPROM, and instructions. Optional additions include 2 by 7 SEG LED front panel display of percentage full, 1 to 99 copies select, 3 polled computer inputs, printers switches, computer switches, and serial converter boards. For a free catalogue send a 39c stamp to Don McKenzie, 39 Ellesmere Cres, Tullamarine 3043.

**SATFAX:** weath satellite picture receiving program for IBM XT/AT. Displays in 64 colours. Needs EGA colour monitor and card, AM demodulator and ADC interface. \$45 + \$3 postage. RADFAX2: HF weather fax, morse and RTTY receiving program for IBM XT/AT. Needs CGA, SSBHG, FSK/Tone decoder. Also "RF2HERC" and "RF2EGA", same as RADFAX2 but suitable for Hercules and EGA cards respectively. \$35 + \$3 postage. All programs are on 5.25", 360K floppy + full documentation. ONLY from M. Delahunty, 42 Villiers St, New Farm 4005 QLD Phone (07) 358 2785.

ELECTRON TUBES MAGNETRONS  
KLYSTRONS IGNITRONS  
HYDROGEN THYRATRONS  
Contact Mike Ryan  
AVISUN P/L

TEL: (02) 438 3900. FAX: (02) 438 2564

**AMIDON FERROMAGNETIC CORES:** Large range for all receiver and transmitter applications. For data and price list and 105x220 SASE to: R.J. & U. S. Imports, P.O. Box 157, Mortdale, N.S.W. 2223. N.S.W. Geoff Wood Electronics, Lane Cove. Webb Electronics, Albury. A.C.T.: Electronic Components, Fyshwick Plaza, Vic.: Truscott Electronics, Croydon. W.A.: Willis Trading Co., Perth.

## WANTED

**HUMIDY METER KIT:** ETI-256 with humidity sensor, built up or not. Please ring (076) 229 340 or (076) 222 257 AH.

**NEW CASSETTE/RIBBON:** PN G32-00107367-002, for KEL 3080 printer, Phone (066) 24 1474.

**TANNOY SPEAKERS:** Pair of 1960's "Monitor Reds" (or older) wanted by enthusiast. Steve Spicer, (03) 560 9883.

## TRANSFORMER REWINDS

ALL TYPES OF TRANSFORMER REWINDS

- REWOUND TO YOUR SPEC
- EXACT REPLACEMENT WINDING
- VINTAGE RADIO A SPECIALITY
- ALL ONE OF TYPES
- ALL QUOTES BY RETURN MAIL
- RAPID SERVICE

For price quote send details showing physical size & number of windings (or send unit, same will be returned to sender if quote not satisfactory)

### TRANSFORMER REWINDS

FREEPOST NO 7, PO Box 438, Single ton, NSW 2330. Ph: (065) 76 1291.

# SONICS

MAGAZINE

For: Musicians, Road Crews,  
Recording Engineers,  
Lighting People, Managers,  
Promoters and anybody  
interested in what goes into  
today's music-making.

# EA Directory of suppliers

Which of our many advertisers is most likely to be able to sell you that special component, instrument, kit or tool? It's not always easy to decide, because they can't advertise all of their product lines each month. Also some are wholesalers and don't sell to the public. The table below is published as a special service to EA readers, as a guide to the main products sold by our retail advertisers. For address information see the advertisements in this or other recent issues.

Supplier	State	A	B	C	D	E	F	G
All Electronic Components	Vic	•	•	•	•	•		
Altronics	WA,NSW	•	•	•	•	•	•	•
Acetronics	NSW			•				
Chapman, Lance	NSW	•			•			
Dick Smith Electronics	All	•	•	•	•	•	•	•
Eagle Electronics	SA	•		•	•			
Electronic Brokers	Vic						•	
Electronic Component Shop	Vic	•		•	•	•	•	
Emona Instruments	NSW							•
Geoff Wood Electronics	NSW	•	•	•	•	•	•	•
George Brown Group	All		•		•	•	•	
Jaycar Electronics	Eastern	•	•	•	•	•	•	•
Pre-Pak Electronics	NSW		•		•	•		
Preston Electronics	Vic	•	•	•		•		•
RCS Radio	NSW			•				
Rod Irving Electronics	Vic	•	•	•	•	•	•	•
Scientific Devices	Vic						•	
Sheridan Electronics	NSW			•	•	•		
Tandy Electronics	All		•		•	•	•	•
Wagner Electronics	NSW		•		•	•	•	

## KEY TO CODING

A Kits & modules

B Tools

C PC boards and supplies

D Components

E IC chips & semiconductors

F Test & measuring instruments

G Reference books

Note that the above list is based on our understanding of the products sold by the firms concerned. If there are any errors or omissions, please let us know.

## Electronics Australia Reader Services

Electronics Australia provides the following services:

**Subscriptions:** All subscription enquiries should be directed to: Subscriptions Department, Federal Publishing Co, PO Box 227, Waterloo 2017. Phone: (02) 693 6666

**BACK ISSUES:** Available only until stocks are exhausted. Price: \$4.50

**PHOTOSTAT COPIES:** When back issues are exhausted, photocopies of articles can be supplied. Price: \$4.50 per project or \$9 where a project spreads over several issues.

**PCB PATTERNS:** High contrast, actual size transparencies for printed circuit boards and front panels are available. Price: \$5 for boards up to 100 square centimetres; \$10 for larger boards. Please specify positive or negative.

**PROJECT QUERIES:** Advice on projects is limited to postal correspondence only, and to projects less than five years old.

Price: \$5. Please note that we cannot undertake special research or advise on project modifications. Members of our technical staff are not available to discuss technical problems by telephone.

**OTHER QUERIES:** Technical queries outside the scope of "Replies by Post", or submitted without fee, may be answered in the "Information Centre" pages at the discretion of the Editor.

**PAYMENT:** Must be negotiable in Australia and made payable to "Electronics Australia". Send cheque, money order or credit card number (American Express, Bankcard, Mastercard, or Visa Card), name and address (see form). All prices include postage within Australia and to New Zealand.

**ADDRESS:** Send all correspondence to The Secretary, "Electronics Australia", PO Box 227, Waterloo, NSW 2017.

Please note that we are unable to supply back issues, photocopies or PCB artwork over the counter.

Back Issues .....

Photostat copies .....

Total price of magazines/photocopies, including postage and handling.

No off issues reg ..... x \$4.50 = \$ .....

Cheque  Money Order  Please tick box to indicate method of payment

\*Please make payable to the Federal Publishing Company Pty Ltd.

Mastercard  American Express  Visa  Bankcard  Tick

Card Expiry Date

Credit Card No

Signature  
(Unsigned Orders cannot be accepted)

NAME .....

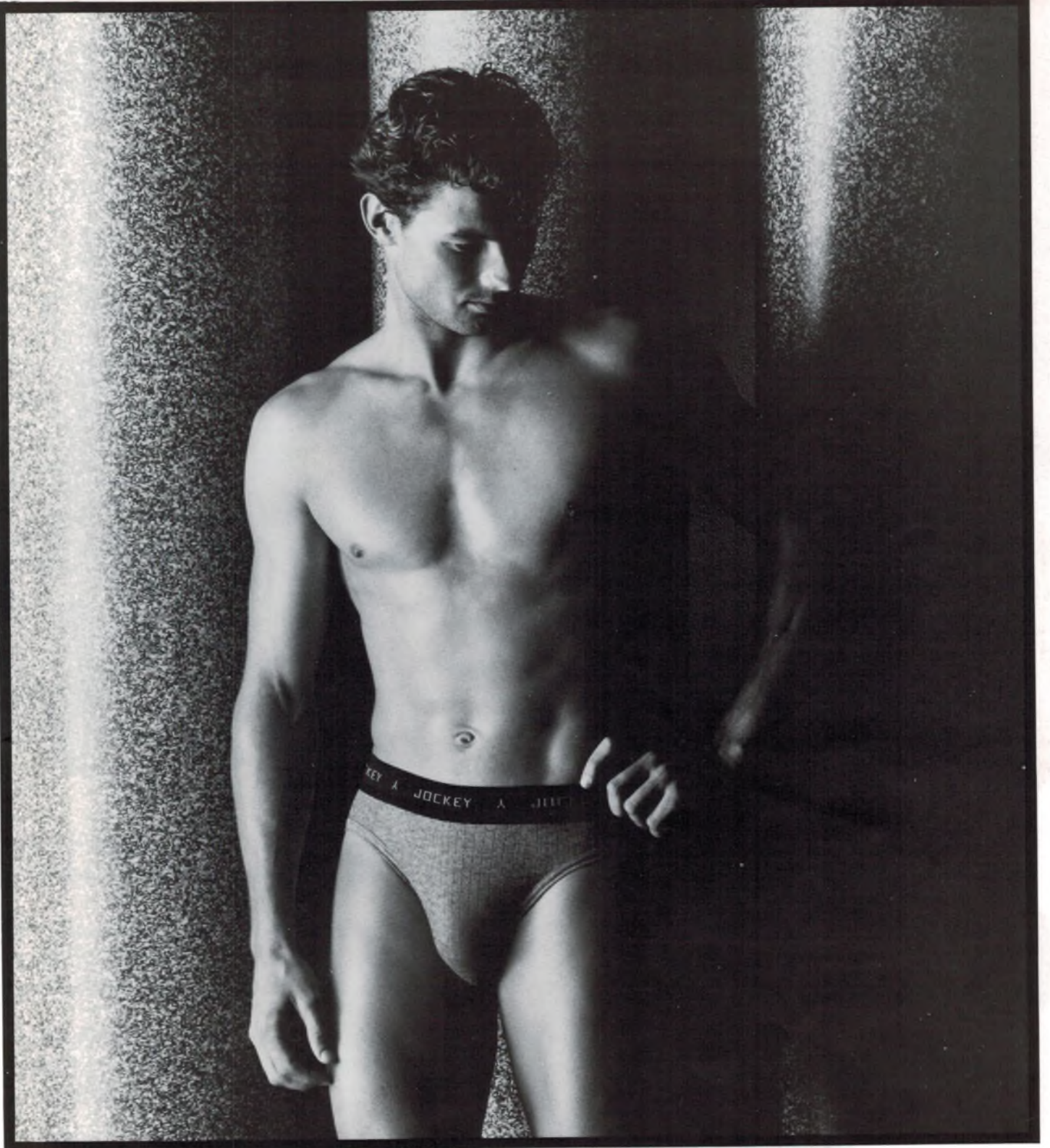
ADDRESS: .....

POSTCODE .....

## ADVERTISING INDEX

Acetronics .....	161
Alfatron .....	130
Allen-Bradley .....	81
Altronics .....	70-73
Assoc. Cal. Labs .....	131
Aust. Test & Measurement .....	127
Branbery .....	87
Coherent Elect. Systems .....	99
Critec .....	99
Department of Defence .....	20-24
Dick Smith Electronics .....	44-49
EA subscriptions offer .....	18-19
EEM Electronics .....	161
Electronic Components Shop .....	57
Elmeasco .....	79
Energy Control Int. ....	86,125,154
Federal Publishing .....	146-147,158,159
Geoff Wood Electronics .....	67
Gifford Productions .....	161
Hewlett-Packard .....	121
Hi-Tech Software .....	137
Hycal Instruments .....	161
Instr. & Computer Rentals .....	130
Jaycar .....	100-103
Jockey .....	IBC
Llew Griffiths & Assoc. ....	151
Maestro Distributors .....	31
McCubbin Electronics .....	130
Mijell .....	143
Mondotronics .....	124
Obiat .....	115
Philips Components .....	9, IFC
Philips Scientific & Industrial .....	143
Procon Technology .....	154
Prometheus Software .....	129
Protel Technology .....	131
RAAF .....	108-109
Racal-Redac .....	82-83
RCS Design .....	136
RCS Radio .....	161
Richard Foot .....	25
Rod Irving Electronics .....	32-37
Royal Electronics .....	56
RVB Products .....	OBC
Scan Audio .....	29
Sheridan Electronics .....	62-63
Stotts Correspondence .....	145
Swann Electronics .....	143
Tennyson Graphics .....	139
Transformer Rewinds .....	161
Tronics 2000 .....	15
TV Replacements .....	61
University Paton .....	120
Westinghouse Systems .....	25
Wireless Institute of Aust. ....	155

This index is provided as an additional service. The publisher does not assume any liability for errors or omissions.



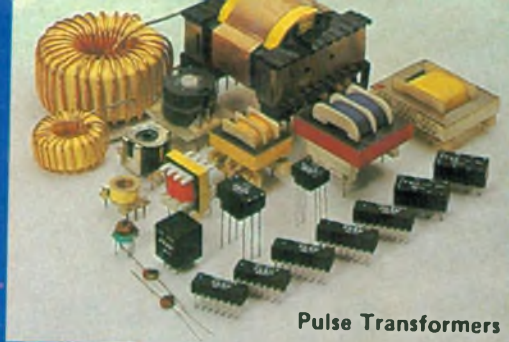
MARL BIKINI 100% COTTON

*Another famous Australian jockey.*

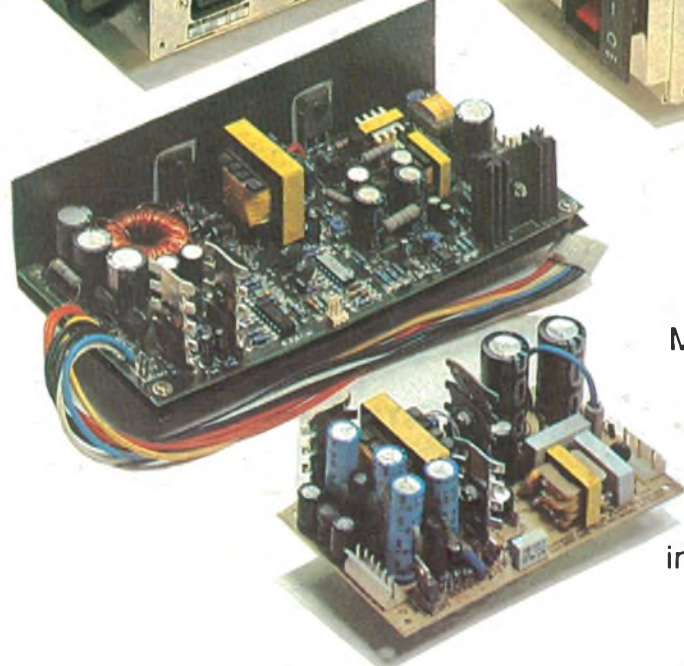
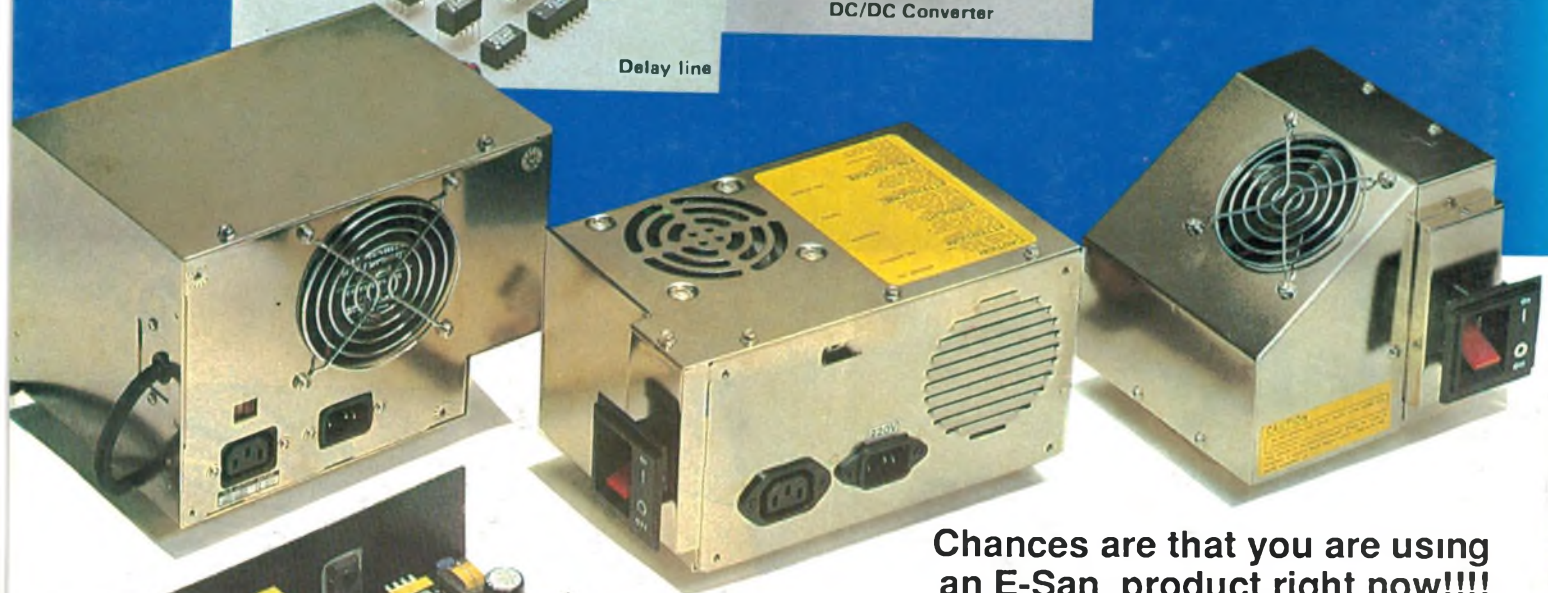
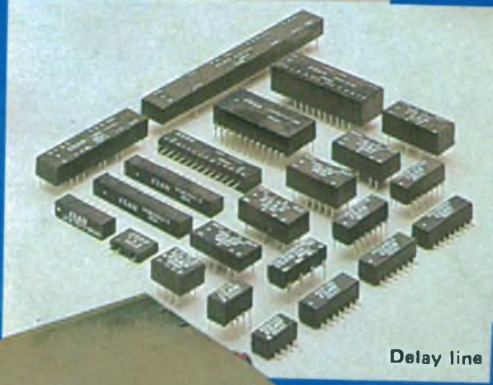
THE  
BOTTOM  
LINE IS  
**JOCKEY.**

JOC 0010

**E-SAN**  
ELECTRONIC



# PULSE TRANSFORMERS DC-DC CONVERTERS POWER SUPPLIES DELAY LINES



**Chances are that you are using an E-San product right now!!!!**

E-San Electronics Ltd. are a major source of active and passive digital delay lines, pulse transformers, DC-DC converters and switchmode power supplies.

Many of E-San's products are the industry's first choice, marketed under the most respected brand names in the components market.

You will find them in memory boards, instrumentation, communications circuits, personal computers, and industrial controllers from manufacturers the world over.

**E-San.... your No. 1 second source.**



Distributors in Australia  
**RVB PRODUCTS PTY. LTD.**

**MELBOURNE :** 23 Dehavilland Road, Braeside, Victoria, 3195. Tel: (03) 580 0688. Fax. (03) 587 3532  
**SYDNEY :** S/6 220 Pacific Highway, Crows Nest, N.S.W. 2065. Tel: (02) 957 6385 Fax: (02) 929 5334