

REVIEW OF SONY'S NEW CORDLESS 'PHONES

WIN  
A \$2100  
ACER COMPUTER!

Australia's Top Selling Electronics Magazine

# Electronics Australia WITH **eti**

NDD

JULY 1990

Aust\* \$4.50

NZ \$5.95 incl GST

**GRAND PRIX  
TELECAST:  
BEHIND THE  
SCENES**

**BUILD THIS  
LOW COST  
GAS LASER!**



**'SMART' DIGITAL VIDEO SECURITY SYSTEM ★ VHF TEST  
METER FOR RADIO AMATEURS ★ SSTV SCANCONVERTER**



**FLUKE**



**PHILIPS**



# Great Choice.

**More professionals in more industries make Fluke their first choice in multimeters.**

Fluke DMMs. Reliable. Accurate. Powerful. Tough. Versatile. Easy to use and simple to operate. Backed by the longest, most comprehensive warranty in the business. In short, Fluke makes meters you can bet your reputation on.

**More choice.** No matter what the job, there's a Fluke to handle it.

There's the new 80 Series—the most powerful, most complete test and measurement system available in a handheld package.

The popular 70 Series—simply put, the most requested DMM in the world, with nearly 2 million units in service since 1984. And the Fluke 21 and 23—70 Series simplicity in high-visibility yellow.

The Fluke 25 and 27—the most rugged meters ever built, totally sealed against water, dust and other contaminants.

And the precise 8060 Series—with the versatility of a test lab, the accuracy of a bench instrument, and the convenience of a handheld.

**Smart choice.** Compare Fluke DMMs with any other handheld. No one else gives you as much meter for your money. And no other meter costs less to own.

**Your choice.**

---

FROM THE WORLD LEADER  
IN DIGITAL MULTIMETERS

---

**PHILIPS**

**Available from the following Philips Test & Measurement distributors:**

- ALL STATES:** George Brown Group, Dobbie Instruments, Petro Ject.  
**NSW:** Obiat, Ames Agency, Ebson, David Reid, DGE Systems, W F Dixon, Novocastrian Electronic supply, Macalec, Vincom, Blackwoods, Emcorp, Tecnico.  
**ACT:** John Pope Electrical, Aeromotive Maintenance Services.  
**VIC:** Radio Parts Group, Mektronics, Factory Controls, Blackwoods, Emcorp, Tecnico

- QLD:** St Lucia Electronics, L E Boughen, Colourview Electronics, Auslec, Thomson Instruments, Nortek, Emcorp.  
**SA:** Electronic Components & Equipment, AWM  
**NT:** Blackwoods, Thew & McCann.  
**WA:** Atkins Carlyle, Leda  
**TAS:** George Harvey Electric **NEW ZEALAND:** Control Tech, David Reid

# Electronics Australia

Volume 52, No.7

July 1990

AUSTRALIA'S LARGEST SELLING ELECTRONICS MAGAZINE - ESTABLISHED IN 1922

## Grand Prix: behind the scenes



Were you impressed by this year's Grand Prix telecast from Phillip Island? Here's the story of how it was done... (Page 20)

# eti

This month's ETI is again in the centre of the book, starting opposite page 68. Highlights include an explanation of extended, expanded and enhanced memory systems for PC's, by Stewart Fist; Les Cardilini's look at Pioneer's new KEH-M5000QR mobile stereo hifi rig; and the second part of Louis Challis's report on this year's Las Vegas Consumer Electronics Show.

## On the cover

Angela Justic demonstrates her father's latest project, a new low cost 'build it yourself' helium-neon gas laser for experimenters. Peter Phillips describes Branco's laser in our story starting on page 112.

## Features

- 10 INTELLIGENT VIDEO SYSTEMS *Aussie development!*
- 16 OBITUARY: DR JOHN ERNEST BENSON, D.Sc.Eng.
- 20 NINE WINS AT PHILLIP ISLAND *Grand Prix telecast*
- 32 SYNTONY & SPARK - 1 *The first attempts at tuning*
- 44 WHEN I THINK BACK... *Major Edwin Armstrong - 1*
- 176 TEST INSTRUMENT REVIEW: *Voltech's TF 2000 gain phase analyser*

## Entertainment Electronics

- 6 WHAT'S NEW IN HOME ELECTRONICS *Latest audio, video products*
- 66 HIFI EQUIPMENT REVIEW: *Sony's MDR-1F5 cordless stereo 'phones*

## Projects and Technical

- 58 THE SERVICEMAN *Lots of time & effort, but not much excitement!*
- 112 LOW COST HELIUM-NEON LASER *Easy to build, too...*
- 120 CIRCUIT & DESIGN IDEAS *Quiz game circuit, LED 'scanner' display*
- 126 VHF POWERMATCH MK2 *Popular design updated*
- 132 IMPROVED RS-232C DATA LINK ANALYSER *Mini project*
- 138 SSTV TRANSMIT SCANCONVERTER - 1 *For amateur TV*
- 150 VINTAGE RADIO *The Williamson amplifier*
- 166 SURFACE MOUNT FEATURE: *Picking the right SMT rework machine*
- 168 SURFACE MOUNT FEATURE: *PCB design for manufacture - 2*
- 172 SURFACE MOUNT FEATURE: *New SMT products*

## News and Comment

- 4 LETTERS TO THE EDITOR *Noumea cable, Telecom debate*
- 5 EDITORIAL VIEWPOINT *Confusion reigns in CD-ROMs, satellite TV*
- 28 NEWS HIGHLIGHTS *PM opens Alcatel TCC optical cable plant*
- 38 SPECTRUM *Communications news and new products*
- 48 FORUM *Digital multimeter accuracy, calibration woes, headphone driving*
- 62 SILICON VALLEY NEWSLETTER *SIA wants Japan on 'unfair' list*
- 144 NEW PRODUCTS *Video generator, benchtop coil winding machine*
- 157 AMATEUR RADIO NEWS *Aussie VHF, UHF & SHF records*
- 158 INFORMATION CENTRE *Questions answered, puzzlers, new kits*
- 164 SOLID STATE UPDATE *Sony GaAs chip for 12GHz PLLs*

## Departments

- 156 EA CROSSWORD PUZZLE
- 156 50 AND 25 YEARS AGO
- 161 MARKETPLACE
- 178 DIRECTORY OF SUPPLIERS
- 178 ADVERTISING INDEX
- 160 NOTES AND ERRATA

**MANAGING EDITOR**  
Jamieson Rowe, B.A., B.Sc.,  
SMIREE, VK2ZLO

**NEWS EDITOR**  
Winifred Vincent, MSEE, MS.Phys

**TECHNICAL EDITOR**  
Peter Phillips, B.Ed., Dip.Ed., ECC

**PRODUCTION CO-ORDINATOR**  
Milli Godden

**EDITORIAL STAFF**  
Rob Evans, CET (RMIT)

**SECRETARY**  
Karen Muggleton

**ADVERTISING MANAGER**  
Selwyn Sayers

**CONTRIBUTORS**  
Neville Williams, FIREE, VK2XV  
Jim Lawler, MTETIA

**DRAFTING**  
Karen Rowlands

**GRAPHICS DESIGNER**  
Brian Jones

**ART PRODUCTION**  
Alana Horak, Ray Eirth, Michael Riley

**PRODUCTION**  
Tracy Douglas

**ADVERTISING PRODUCTION**  
Brett Baker, Inga Tcittmann

**CIRCULATION MANAGER**  
Michael Prior

**DISTRIBUTION MANAGER**  
Helen Petersen

**PUBLISHER**  
Michael Hannan  
**HEAD OFFICE,  
EDITORIAL & ADVERTISING**

180 Bourke Road, Alexandria, NSW 2015  
P.O. Box 227, Waterloo 2017.  
Phone: (02) 693 6620

Fax number: (02) 693 6613

For reader services, see last page

For subscription enquiries, phone 693 9517

**INTERSTATE ADVERTISING OFFICES**  
**Melbourne:** 221a Bay Street, Port Melbourne,  
Vic 3207. Phone: (03) 646 3111.

Fax No: (03) 646 5494, Nikki Roche

**Brisbane:** 26 Chermiside Street, Newstead,  
Qld 4006. Phone: (07) 854 1119.

Fax No: (07) 252 3692, Bernie Summers

**Adelaide:** 98 Jervois Street, Torrensville, SA  
5031. Phone: (08) 352 8666.

Fax No: (08) 352 6033, Mike Mullins

**Perth:** 118 Forrest Street, Cottesloe, WA  
6011. Phone: (09) 385 3332.

Fax (09) 385 3700, Estelle de San Miguel

**New Zealand:** 63-73 View Road, Auckland.

Phone: (09) 443 0954.

Fax No: (09) 443 1326, Gordon Marr

**United Kingdom:** John Fairfax & Sons (Aust)  
Ltd, 12 Norwich Street, London, EC4A 1BH.  
Phone: (01) 353 9321. Fax: (09) 593 0348

**ELECTRONICS AUSTRALIA** is published  
monthly by Federal Publishing Company Pty.  
Ltd. Incorporated in NSW, 180 Bourke  
Road, Alexandria, NSW 2015.

Copyright © 1989 by the Federal Publishing  
Company Pty Ltd, Sydney. All rights  
reserved. No part of this publication may be  
reproduced in any way without written per-  
mission from the Publisher or Managing Editor.

Typeset and printed by Hannanprint, 140  
Bourke Road, Alexandria, NSW for the  
Federal Publishing Company Pty Ltd.  
Distributed by Newsagents Direct Distribu-  
tion Pty Ltd, 150 Bourke Road, Alexandria  
NSW 2015, (02) 693 4141.

ISSN 0313-0150

\*Recommended and maximum Australian  
retail price only.

# LETTERS TO THE EDITOR



## Noumea cable

Mr Kerry Adams, Manager, OTC Doonside has requested that I reply to a letter appearing on page five of the March edition of *Electronics Australia*. The letter from Mr Neville Williams, asks for information on the severing of the Australia-Noumea (New Caledonia) cable.

The OTC Limited Archive has considerable information on cable history and I have searched our collection for information on this cable. I am pleased to forward to you the attached history of the cable and ask that you please pass this on to Neville Williams.

Your readers may be interested to know that the following reference books contain information on the Queensland-New Caledonia cable: *Cable Ships and Submarine Cables* by K.R. Haigh; *Taming the Tyrant* by Edgar Harcourt; *What Hath God Wrought* by P.J. Gribble.

The OTC Limited Archive is located at 363 Oxford Street, Paddington and provides a public reference service, Mondays to Fridays 9.30 am to 4.30 pm. To visit the Archive, please contact the Archive Coordinator, telephone (02) 339 3954, to make an appointment.

Kimberly O'Sullivan,  
Archives Coordinator, OTC,  
Paddington, NSW.

*Comment: Thanks for the information, Kimberly. As requested, we've passed the other information on to Neville Williams.*

## Telecom debate

First of all let me say that I couldn't agree more with Jim Rowe's Editorial in the February EA. It is a somewhat rare sight to hear anybody say something positive about Telecom these days. Telecom 'bashing' seems to have become one of the nation's favourite pastimes - sometimes we deserve it, most times we don't.

It has been shown that if allowed to (without continual interference from the government and other interested parties), Telecom CAN provide a very good service and also quite innovative products. An organisation the size of

ours will always have some problems - shortcomings of the system are being changed or corrected wherever possible. (Shortcomings of the management are another story!)

On the issue of privatisation (not necessarily Telecom), the main interests to be served are ALWAYS big companies, who can only see dollar signs as their motivation. A network the size of Telecom cannot be gutted and also be expected to run efficiently as well.

Of course some people will say that it is in our interest to have a second carrier "because Telecom would have to compete and be more efficient." Of course, there is no evidence to support this; one only has to look at BT (British Telecom) and Mercury to see what a mess can be created. Also you only get one chance, as the network will never recover from this process of cream-skimming. These private companies only want profitable areas of course, and Telecom gets left holding the bag.

I suppose one could also mention that certain companies at the moment are setting themselves up in the areas that they believe our beloved politicians will give them either directly (for instance the cellular network) or indirectly (the very fast train project).

What has an Intercity train link got to do with communications? On the surface not much at all. However, if the railway link was to use a proposed fibre optic link for its communications, and that link just happened to go between Sydney and Melbourne and had quite a lot of spare capacity, this would really be quite convenient, particularly if a company is interested in bypassing our STD network and carrying third party traffic as well. It sort of puts things in a different light, doesn't it?

Name supplied,  
Sydney.

## Commercials by force?

This letter is prompted by Peter Phillips' article 'Commercials by Force' in April's EA. As I see it the current problems with TV stem from the fact that there are too many stations, and not enough good programmes.

In the early days of TV, we had two stations - the ABC and a commercia

— which, because they had differing philosophies, were not directly competitive and were in some ways complementary. Both stations (as I remember it) provided a good range of programmes. From an advertising point of view, this one commercial station was at a distinct advantage, but it did have to compete with the already established print and radio media for its advertising, and with the ABC for its viewers.

Then came the second commercial channel and the available advertising had to be shared between two stations — with an inevitable loss of advertising revenue. Today we have three commercial stations competing for both viewers and the advertising dollar, with a result that most TV networks are finding it difficult to keep their revenue ahead of their costs.

The current popularity of VCRs and video movies is adding to the woes of the commercial stations.

From the viewer's point of view the outlook is not much better. Any increase in the number of commercial stations can only reduce the advertising income received by each station, and without adequate advertising revenue, they cannot hope to buy better programmes.

What is often overlooked is that there are only a limited number of really good programmes produced each year, and the introduction of more TV stations is unlikely in itself to make more good programmes available to viewers.

J. Emery,  
Bullcreek, WA.

*Comment: Thanks for your comments, Mr Emery. Peter's article was intended as a joke, of course...*

## Birthday edition

Thank you to all the staff concerned in producing the 50th Anniversary Edition of Electronics Australia, as it helped me a lot in my science project on the history of electronics, for which I received an A+.

I am a 12 year old boy and very interested in electronics and I am hoping to have a career in this field when I grow up.

Alexander White,  
Hazelmere, WA.

*Comment: We're glad you liked it, Alexander, and it's nice to know that it helped you with your science project.*

Feel free to send a letter to the Editor if there's something you believe that EA's readers should know. If we agree we'll publish it, but we do reserve the right to edit those that are too long, or potentially libellous.

# EDITORIAL VIEWPOINT



## Confusion reigns yet again, in CD-ROMs and satellite TV

Why do the technical decision makers in so many of the world's major electronics firms seem to make the same old mistakes over and over again? I suppose the obvious answer is that they're only human; but all the same it's hard to understand why people who are obviously so very capable, when it comes to running most aspects of a large business enterprise, can make such crazy decisions when it comes to the actual technology.

What I'm beefing about is standardisation — or rather, the lack of it. Somehow, the electronics industry seems to be particularly prone to the tendency for every engineer and firm to 'do it *my way*', presumably in the belief that this will automatically be better than the way everyone else is doing it.

We've seen this so many times in the past — think of the old fight over 45rpm and 33.3rpm long-playing records; the three main colour TV systems (NTSC/PAL/SECAM), with their umpteen mutations; the Philips/Beta/VHS (and now VHS/Video 8) videotape battle; the many different videodisc systems; the numerous and incompatible processor/operating system combinations for PC's; and the total shemozzle over quadrasonic sound. At best, the lack of agreement on technical standards has fragmented markets and retarded growth; at worst, it has caused complete failure of what might have been useful technologies.

Of course there are a few notable exceptions, such as audio compact cassettes and the audio CD standard established by Philips and Sony. But it's pretty obvious now that two NEW technological disasters are developing: one in the area of satellite TV broadcasting, and the other with CD-ROM disks for computer data storage.

A recent report by Tom Ivall in *Electronics World + Wireless World* points out that although European viewers now have a choice between programmes from five different satellites, these use three quite different (and incompatible) video coding/scrambling systems. So viewers would need to buy or rent three different receiver/descramblers, in order to take advantage of these additional programmes. No wonder most viewers are showing a decided lack of interest!

Another report by Barry Fox in *New Scientist* describes the CD-ROM scene as one with 'an absurd confusion of technical standards'. It seems that virtually every different maker of CD-ROM drive/software systems has adopted their own hardware interfacing, driver software, and management/indexing software for accessing disc data. The nett result is that despite the vast potential of CD-ROMs for database storage and access, the technology is growing much more slowly than it should.

Here we go again, shooting ourselves in the feet. When is our industry ever going to learn from its past mistakes?

*Jim Rowe*

# What's New In HOME ELECTRONICS



## New Akai VCR has 'quick start' feature

Akai's latest addition to its VCR range is the VS-765, an HQ two-speed wireless remote control VCR. Using the firm's latest DX4 head technology, the VS-765 is claimed to offer exceptional picture clarity and detail even in LP (half speed) mode. The VS-765 uses the HQ system, employing a CCD (com-

mon charge device) noise cancelling circuit that is said to aid picture quality detail.

To maintain optimised tracking the twin digital auto tracking control automatically monitors and adjusts for optimum head to tape contact.

Akai has designed the VS-765 to be

'user friendly', and its proprietary Quick Response feature goes a long way in accomplishing that goal. The feature includes Quick Start which enables starting in less than 1.2 seconds. Quick Index Search also enables the user to quickly find a pre-recorded programme. By placing an index signal on the tape at the beginning of a programme you wish to record, you can then go back to that programme by simply fast forwarding or reversing.

All features are available through the cordless remote control which has a built-in LCD panel. Programming timer information can be checked at a glance, and then pointed at the VCR to automatically program it.

The VS-765 is covered by a one year parts and labour warranty and has a recommended retail price of \$749. It is available through Akai dealers or selected department stores.

## Wireless microphone system

Shure L series Wireless Microphone Systems are based on the new L2 transmitter, the new L series receivers and a choice of interchangeable microphone heads.

The L2 transmitter is a 100% Shure-developed and manufactured single-frequency, crystal-controlled compact handheld unit with 50mW output. It has a totally enclosed loop antenna which is individually tuned and not affected by hand position.

The L3 non-diversity receiver features double-tuned RF stages, dual ceramic IC filters and a three-pole Chebyshev audio low pass filter. A detachable, quarter-wave whip antenna with a UHF-type connector can be remote located for rack installations and for difficult pickup situations.

The L4 Marcad diversity receiver employs the signals received by two antennas and, similar to a 'switching' system these antennas operate into separate radios. It uses smart circuitry to constantly monitor the signals from both

radios, determine when each radio is providing a usable signal and then add the signals accordingly.

Two systems suitable for guitars and instruments are the System LS13, with an L3 non-diversity receiver, and the System LS14, with an L4 Marcad diversity receiver. Both include the L1 body-pack transmitter and the WA-300 instrument adaptor cable.

Compatible and interchangeable mi-

crophone heads available are the Beta 58 for its supercardoid pickup pattern; the SM58 for classic sound; the SM96 condenser element for extended frequency response; and the 839W wireless lavalier condenser microphone.

L series Wireless Microphone Systems range in price from \$959 to \$1999.

For further information contact Audio Engineers, 342 Kent Street, Sydney 2000 or phone (02) 29 6731.



## Single-chip CCD camera for S-VHS

Panasonic's new WVP-F15 2/3" single chip CCD camera offers 460 lines of horizontal luminance resolution, a Y/C output for S-VHS recording and a choice of five electronic speeds from 1/120 up to 1/2000 sec.

The WVP-F15 is designed to deliver optimum picture quality to a portable S-VHS or composite input VCR, for full electronic field production (EFP). It also features remarkably low power consumption: only 9.48W, including the optional WVP-KT115 camera kit containing a 1" electronic viewfinder.

The portable camera kit includes a stereo microphone, shoulder pad/grip, cheek pad, VTR cable and camera



strap. Additional kits are available for ENG or studio production and include a genlock adaptor and rack mount remote control unit. A portable remote controller also provides local adjustment of the camera's standard operational parameters.

For further information contact GEC Video Systems Division, 2 Giffnock Avenue, North Ryde 2113 or phone (02) 887 6222.

## High quality audio preamps

Gryphon, a Danish company which started six years ago manufacturing one product, a Head-amp, now markets a headamp and a preamp which can be figured for MC and MM cartridges.

All products are of true 'dual mono' design, including dual power supplies that are even provided with separate AC power cords. The products use military and professional grade components throughout, even to the extent that some components are custom made regardless of expense - including C-core transformers.

The circuit topology of the pre-amp is

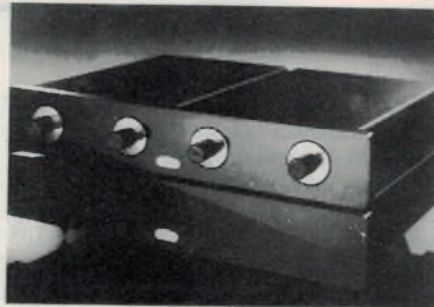

a class A dual mono directly coupled design, with a triple-stage power supply that contains a 28,000uF capacitor bank with very stable regulation, which Gryphon claims would be larger than most 60 watt power amplifiers. The phono section incorporates a wholly passive



## Portable sound unit features 'super woofer'

Hitachi's model CXW700 is claimed to produce a sound quality that matches its 'space age' design. The big difference with this new design being the incorporation of three separate sealed speaker enclosures. Both left and right channels are now virtually free from reverse phase cancellation, with the addition of an effective surround sound system to further emphasise clear channel separation.

The third enclosure houses the 'acoustic super woofer', which in effect is similar in design to a component hifi sub-woofer box, incorporating a tuned port to pump out the sub bass frequen-

cies down to an impressive 50Hz.

The CXW700 also incorporates features such as a four band tuner, programmable CD player and twin tape decks with full auto stop function, high speed dub and auto reverse playback. Personal alignment of the three band graphic equaliser will provide even greater control of output sound quality. The provision of CD line out and microphone mixing virtually turns the CXW700 into a complete home recording system.

For further information, contact Hitachi Sales Australia, on (03) 555 8722.

RIAA network.

Other quality features include Swiss 24-position switched resistor volume controls, fully discrete construction, non-resonant, non-magnetic chassis, star earthing and zero negative feedback.

The preamplifier provides precision engineered WBT sockets for phone, CD, tuner, auxiliary and tape, plus two main outputs (for bi-amping or running two systems).

The Gryphon product range has a starting price from \$2495 for the headamp and \$9995 for the linestage.

For further information contact Audio Connection, Shop 44, Old Town Centre Plaza, Bankstown 2200 or phone (02) 708 4388.

## Bose 'Freestyle' speaker system

The new Bose Freestyle speaker system proves that you don't have to sacrifice style or flexibility to enjoy excellent sound. The name 'Freestyle' refers not only to its sculptured and free-flowing lines, but to its versatility as well.

At the heart of the Freestyle speaker system is the Bose helical voice coil driver. The same type of driver was first used in the famous 901 direct/reflecting speaker, world-renowned for its accuracy, power handling and reliability. But this is a new version of the HVC driver designed especially for the Freestyle system, providing exceptional power handling and extended high frequency performance.

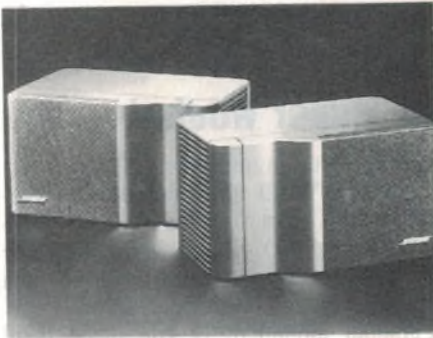

While almost anyone can afford the Freestyle, its performance is claimed to impress even the most discriminating listener.

The system includes two 4-1/2" (11cm) helical voice coil drivers; with copper-clad polepieces, rates for use with receivers/amplifiers from 10 to 100 watts per channel. The finish is black polymer, painted.

The dimensions are 24.1 x 15.2 x 3.9cm and the recommended retail price is \$599.

Further information from Bose Australia, 11 Muriel Avenue, Rydalmere 2116 or phone (02) 684 1255.

## Fax/phone switch

The Faxteller-105 allows one phone line to be shared by a fax machine (or Faxcard) and a telephone. It is compatible with Group 3 and Group 2 fax machines and Group 3 Faxcards.

The switch can recognise an incoming call within five seconds. If the call is a fax, the switch will automatically route the call to the fax machine or Faxcard.



Sony Australia has released the TA-E1000ESD digital signal processing control pre-amplifier, a 'state of the art' control centre that incorporates the latest digital technology - allowing all signals to be processed in the digital domain.

Through the efforts of Sony engineers, new large scale integrated circuits capable of high speed, high density digital processing (previously available only in the most sophisticated professional studio equipment) are now being incorporated in this new ES series component.

The TA-E1000ESD provides a 3-band parametric equaliser, adjustable in 0.1dB steps up to 12dB change. The EQ slope is selectable between three positions showing 1/3 octave increments. Up to 10EQ settings can be stored and recalled.

One of the benefits of digital audio has been the great increase in dynamic range, but sometimes wide dynamic range cannot be appreciated due to high ambient noise conditions. Low level signals are lost in the increased noise level. To restore the full fidelity of the music,

the TA-E1000ESD offers selectable digital dynamic compression, which can effectively raise the quiet passages above the noise floor without negatively effecting peak dynamic performance.

Many analog sources are compressed at recording or at point of broadcast. Fidelity from those sources can often be described as dull or lacking in realism. With the TA-E1000ESD's dynamic expansion control, several selectable expansion levels can be called upon to add 'life' to dull sources.

The TA-E1000ESD establishes a new reference for soundfield control. Not only is digital Dolby prologic surround sound available, but nine additional environment may be summoned. Hall 1, Hall 2, Opera, Church, Jazz Club, Disco, Stadium, Live Concert and Theatre are preprogrammed into memory. Each soundfield selection will contain main and sub parameters including room size, wall condition, reverb time, spread and seating position which allows selection of 10,225 different listening positions!

Further details of the TA-E1000ESD are available from selected Sony stockists.

If the call is from a phone, it will route the call to the telephone.

This invention means that large and small businesses, as well as those of us using fax devices from home, can save the costs of installing and renting an extra phone line. Even if you already have a dedicated fax line the Faxteller-105 will allow you to use it for both incoming and outgoing phone calls.

Faxteller-105 will disconnect the phone line after transmission is finished, after the parties have finished talking and hung up the receivers, or after 40 seconds of unanswered ringing. The caller does not have to push any buttons to identify the type of call, and will not

hear a fax tone for a voice call.

The triangular switch measures only 112 x 26mm. One edge of the case has three modular jacks - for phone line in, fax machine (or Faxcard) and the phone set. The top of the case has LEDs for power on, fax and phone. The switch consumes less than one watt of 9 volt DC power at 200mA, supplied by an AC converter.

The sample price is \$149, and the manufacturer is looking for distributors, dealers and/or re-sellers.

For further information contact Diamond Technology Products, 419 Gardeners Road, Rosebery 2018 or phone (02) 667 4068.



# SIEMENS

## Launch into the future with Siemens electro-mechanical components



Siemens is a world leader and innovator in electro-mechanical components; relays for automotive, power, industrial, consumer and entertainment electronics applications; various economical switches, including dual-in-line switches; and DIN connectors (41612).

No matter how specialised your application is, we can meet it

quickly from our existing range or custom design it for you. In fact, Siemens now manufacture DIN connectors (41612) in Australia.

Naturally, all components are industry standard and future-proof, and backed by Siemens proven reliability and technical support.

So why keep yourself grounded . . . when you can launch into the future with Siemens.

### Siemens Ltd.

Melbourne: 544 Church Street, Richmond, Vic. 3121  
Phone: (03) 420 7318 Fax: (03) 420 7275  
Sydney: 383 Pacific Highway, Artarmon, N.S.W. 2064  
Phone: (02) 436 8730 Fax: (02) 436 8644  
Wellington: Level 9, Marshall House,  
142-146 Wakefield Street, Wellington.  
Phone: (4) 846 068 Fax: (4) 846 066

Hi-tech from Siemens –  
into the future together

**Australian development:**

# INTELLIGENT VIDEO SYSTEMS

After three years of development work, a local company has succeeded in producing an 'intelligent' digital video system which can transmit pictures around the world – over the phone lines. Now patented in 39 countries, it looks set to generate a lot of export business...

by **BARRIE SMITH**

**Scenario One:** You're sitting in your rooftop suite at the Kathmandu Hilton, sipping your third gin and yak's milk, when thoughts turn to home. You pick up the phone, dial the codes – out of the country, into Oz, area code, home town, then finally your home number. Ring, ring...

Turning a quarter circle to your right, there's a laptop video receiver, perched precariously on top of the Gideon's on the bedside table. The blank, black screen now fires up: a jigsawed image appears – a 'block picture' – looking something like a parquet floor. Fifteen seconds later, the picture changes – aha! – home.

You're now peering at a well-constructed, sharp monochrome picture of your own living room. Punch button 2: the hall. Button 3: the sunroom.

What? The maid hasn't changed the flowers, the TV's on, and the dog is in the house.

'Alice!', you call into the phone. A few seconds later a face appears in the parquet, and gradually clarifies into a living, breathing replica of your maid.

A visual and aural altercation ensues – with one difference: *you* can see *her*, yet she – poor, downtrodden employee – can only hear her master's voice, so far away on top of a mountain or two.

**Scenario Two:** Secreted away in an unmarked location in Sydney, a guard sits quietly before an array of monitors – all screens blank.

Alarm! Screen number 80 fires up. First parquetry – the familiar, short-hand picture of Acme Foods' liquor warehouse – but there's something different in the scene. In a little over ten seconds up comes a clearer version: a still picture of two figures in dark clothes hacking away at a wire cage, stacked ceiling high with bottled spirits. As each second ticks away the story unfolds – a truck is seen backing in through the main doorway, and another man appears.

A prompt phone call to the police. The intrusion is notified. A minute and five seconds has passed. And a patrol car nearby is on its way to the scene.

A little bit of the George Orwell's, you may say. However the Kathmandu scenario is already here – although for Alice's peace of mind, hearing her master's voice is a few months away in development.

Scenario Two is already up and running, and running so well one client discovered an intruder who, fortunately, turned out to be his own wife.

Claimed to be the world's first intelligent digital video camera, Zone Technology's IDV is unique in that it acquires, digitises and transmits video pictures along ordinary copper telephone lines to a remote receiving point, with no limitation of distance – Kathmandu to Kogarah, Koo-Wee-Rup to Kalgoorlie. Now patented in 39 countries, the



**The master camera, equipped with an 85° coverage Fujinon lens. Note the two cables at rear: the thick co-ax is for satellite camera inputs, while the thin line is for phone output.**

device is the result of over three solid years of development.

And, like many technological innovations, the Intelligent Video camera was a tangible creation well before focus was applied to viable and commercial applications.

Managing Director, Bill Nolan described the company's search for a market:

"This firm has something a lot don't have — a very strong marketing base. We went out and surveyed industry generally — three years ago — and asked ourselves what do we do with a relatively unique, relatively inexpensive image acquisition system?"

"We found there were three main markets — videophone; the medical industry — the transmission of X-rays and patient data over phone lines — we could see a radiographer being able to transmit to a GP; and the other area was image processing in industry, production lines, etc."

"You could program a camera to look at geometric patterns and shapes, and for it to carry out a specific strategy when it sees something odd in the production line. A printed circuit manufacturer — you could take a camera looking at a production line, if it's out of the reference the system reacts. Monitoring furnaces, cold stores — currently they are all monitored by alarms, which go off and say 'we're down'; but it would be very nice to say what is the problem, and to say we're down because the meter is at zero, because there's no gas going through the pipes — and we can see the dials."

"But to cover the investment neces-



**Two 'slave' or satellite cameras maintaining surveillance. Their pictures are passed on to the master camera.**

sary to get to a mature product we had to have three criteria: the industry had to be about \$500 million a year in Australia, it had to have a growth rate of about 10%, and it had to be based on pretty old technology. Consequently the security industry was the one that screamed out at us."

"It's in fact worth, under various estimates, \$1 billion a year — and growing at 16.7% pa on the electronics side. And the electronics side is based on infra-red sensors which go back to the Vietnam war: that's basically what the whole security industry is based on."

"The other thing is that it had to be of world proportions. In Australia, be-

lieve it or not, the security industry electronically is probably one of the leaders in the world compared to Europe and the US. So that's what led to our decision to develop a base system."

"We know what kind of income to make from the product, we know the base, and we can make some assumptions of the volume we can expect from that market. And thus the significant investment in technology is basically protected by the knowledge that we can expect a certain return out of that industry."

Bill Nolan has already built two technology businesses — one of which was the company who developed the software for the world's most successful airline reservation system. He and a partner were approached by two young engineers who had this idea and wanted finance and backing. A team was hired, and the company formed three years ago.

The IDV camera could be described as a video fax. But it does more: a fully digital, intelligent CCD camera with a harness of interlinked circuits that allow communication with other cameras, sensors and computers capable of receiving digital information, plus two way audio links.

The system can be configured in a variety of dimensions and complexity: from a simple one-camera installation sending to a sole monitor, or a major one capable of monitoring 5000 cameras. The base station can be made capable of processing the incoming signal so that the features of the image can be enhanced, magnified, displayed in



**The receiver console, which can remotely control camera operation.**

## Intelligent Video

multiples, then stored on videotape, floppy disk or printed out on paper for evidential purposes.

The camera is normally in a mute, passive state. But, once activated, it captures a picture within 1/50th of a second – or after a set 'wait' period of a few seconds. This image is held in memory, embellished with data of time, date and site number; the composite signal is then digitised, encoded and sent to a sequence of pre-set phone numbers – security room, police, proprietor.

The number having been dialled, an image appears on the monitor in just one second – normally these monitors are inactive until an alarm is triggered.

The picture displayed is of simple quality – a broad, rapidly painted digital picture. At this point "we can see what's happening. But if we want to take a full evidential shot for legal reasons it takes 40 seconds."

This high quality image is called up by the guard, and compares with that produced by a conventional closed circuit video system. In fact, the IDV can be operated in that role – full motion, black and white – but the camera-monitor link must be the normal coaxial cable.

"The camera can be configured to give normal closed circuit TV, remote monitoring at the same time. So if you put this system into a building you get CCTV for no cost."

After the initial picture is viewed updates can be requested, and motion at

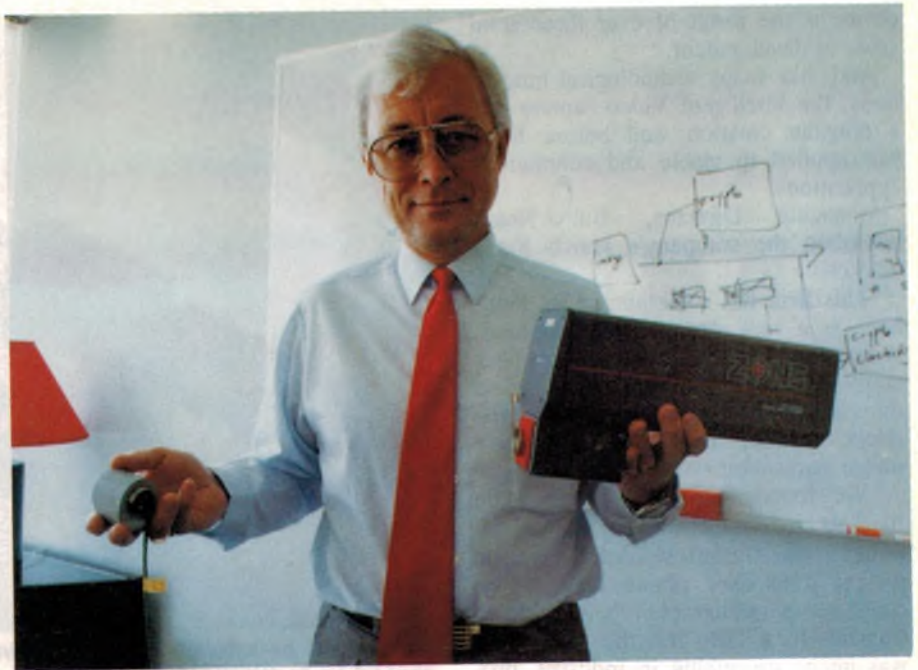

**Zone MD Bill Nolan with IDV master camera on right and Fujinon lens at left.**

three frames a second reproduced on the monitor. The display speed is "variable – it can be tuned to give whatever speed we want. We think we can get much higher frame rates. But, the critical factor is to get an alarm through quickly."

The frame rate is dependent on the link employed. Fibre optic links offer one answer, ISDN another. By 1991, almost all of Australia's capital cities will be linked by fibre networks. Sydney's 130 telephone exchanges will be linked by fibre in the same year.

Says Nolan: "To use fibre optics the

output stage has to be altered. At this point we have three outputs – phone output, which plugs straight into a phone point, RS232 output, and a co-ax output." The latter is for a conventional closed circuit picture.

The inputs can cope with literally hundreds of sensor circuits: smoke, infra red, audio and so on. These circuits are linked into the camera's activation circuits.

"The sensor picks up the alert, immediately tells the camera – the camera's got an onboard processor. This is programmed how to react to these



**A typical warehouse installation showing how well the security camera can be concealed: the camera is at centre of picture directly above the car's spare wheel.**



**Closeup of the warehouse satellite camera.**

### The bottom line:

Zone Technology has constructed the world's first remote IDV base station, manned and monitored 24 hours a day, 7 days a week. A camera, or cameras, can be connected to this base station — from any point on the globe.

A four camera installation, plugged in, cabled up, ready to pump out pictures will set a customer back just under \$5500; on top of this he has only to pay another \$50 a week for the monitoring service, depending on the level of scrutiny.

According to Bill Nolan, most prefer to rent and take advantage of no-cost technology up-dates as they happen: The same outfit, including monitoring, can be rented for less than \$150 a week.

Further details are available from Zone technology, Unit 6, Teac Centre, 175 James Ruse Drive, Rosehill NSW 2142 or phone (02) 891 4200.

alarms.”

“The industry states that 96% of alarms are false — the biggest bugbear of the industry. This device will verify a false alarm.”

Physically, the master camera is a little larger than current closed circuit units — but the satellite units, which can be operated in chain, are much smaller.

“Remote pan and tilt is possible but cost is against it, plus load on circuits and need for control. We believe it's more cost effective to put in more cameras. Plus the base station operator has only to push a button for each camera, rather than work pan/tilt/zoom controls.”

Evident at the rear of the camera is the umbilical input cable which carries sensors, power and the signals from satellite cameras. Next to it is a thinner wire — the outgoing phone line.

Lens choice depends on location. Most common is an auto iris 85° Fujinon, although one customer uses a 600mm for up-tight coverage of a small sensitive area.

In security applications the camera CCD has the appropriate high IR sensitivity for totally dark locations, and the ability to operate in light levels ranging from full sunlight to as low 0.05 lux — approximately that of moonlight.

The picture is 256 x 256 pixels at 64 grey levels, but the final picture is better than this because of signal processing circuitry. Storage memory is in three banks of 256 x 256 x 64.

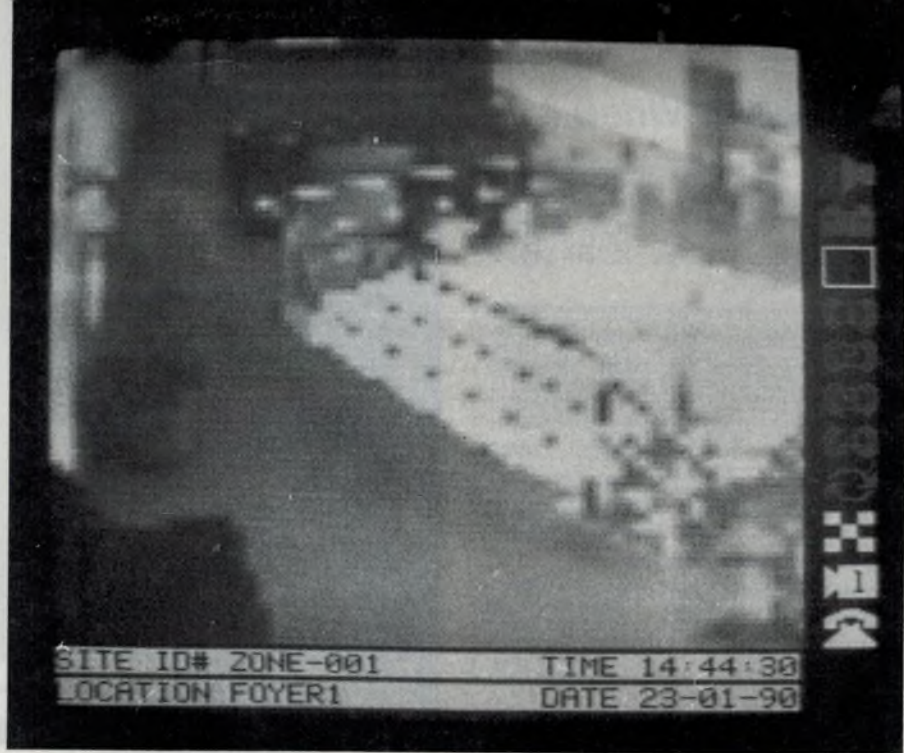

**Typical office foyer: represented is initial low resolution scan, as emitted by camera as part of alarm triggering.**

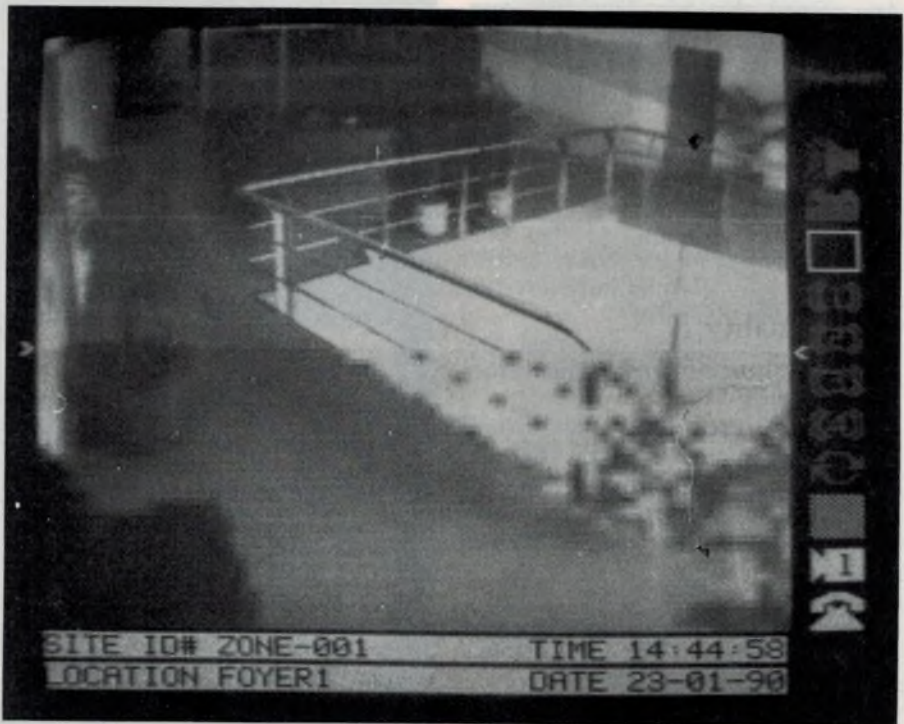

**Office foyer: here the low resolution initial scan is being replaced by a high quality image.**

The main camera allows control of up to three satellites — these four outputs can be sampled in sequence at the receiving point. Image output can be delivered in any one of four levels of resolution and quality.

“Also going down the line is full military type encoded signal. If someone taps into our phone line they can't pre-record something and pump it in.”

Components: the boards are sourced

locally, the camera housings made in Australia, the CCDs off shore. The hardware and software and final assembly are all local, resulting in very high local content.

The metal casing itself was thought important enough to see tens of thousands of dollars paid to an industrial designer for the shape of the housing.

Zone have “just delivered systems to the RTA. They're being put on subur-

## Intelligent Video

ban and city corners to follow traffic flow. Although there is already a very extensive system of video cameras across the city, the cost (of IDV) is substantially cheaper."

"What you have in Sydney is a real-time system, running on fibre-optic cable. Plus there are some slow scan boxes sitting on certain intersections. We can place four cameras for less than the price of one conventional camera. These cameras feed back to the central monitoring station in Oxford Street, and to a new one in the Western Suburbs. They're very excited about it."

Nolan contends that "closed circuit installations don't work. Industrial psychologists say the average attention span on a B&W TV screen is 12 minutes."

Nolan stressed the down to earth approach to their product: "The thing is we are going to use the public phone network, and you'll get a crossed line. Any system that you buy, like scan video, once they hit a crossed line they drop off. This (the IDV) has a very tenacious modem - once it links in, it will stay."

He demonstrated this by picking up the phone on the video receiver in the midst of a picture being 'written'.

"Should I cut across the line with voice, it will wait for me to take breath, and it will start to go again. Every line of picture sent is verified."

"And each system has its unique fingerprint. So your system cannot cross over into mine."

"With full fibre optics, this system will run full motion in colour. But not everyone has fibre optics, not everyone has ISDN yet. We are after the normal consumer, to use it in a factory or house."

And down the line?

"Videophone is certainly on the horizon. We looked at videophones before, and wanted to get into it."

"But I think, until you can get a full motion picture colour phone, it's a bit of a gimmick. Or B&W full motion - then you've got yourself a videophone. At the moment there's only slow scan and I believe it's too much of a gimmick. Sony, Mitsubishi, NHK - they've all got them, but they're not sweeping the world. So I think our gut feel three years ago, when we started, was pretty right."

And Kathmandu?

The company's laptop receiver - fitting into a briefcase - is designed for the casual monitoring client 'on the

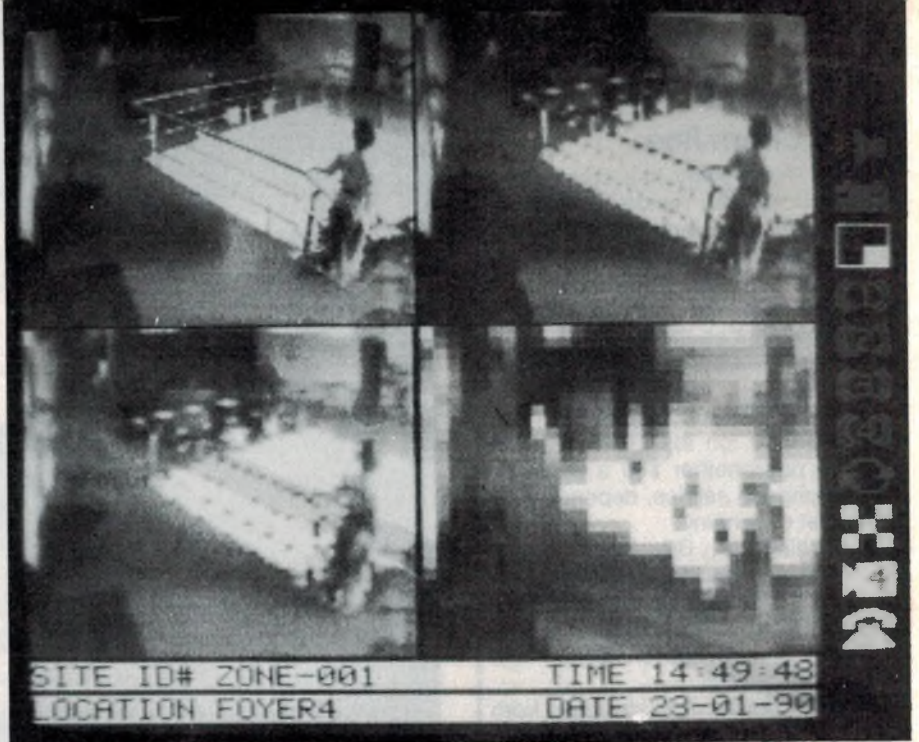

Foyer scene as depicted in four degrees of resolution.



Typical company installation, as covered by four cameras at maximum resolution. Note icons at right of screen, each depicting functions available.

move'. The unit plugs into the phone with one wire, and a normal RF output fits into a TV set or monitor with the other. Once connected the mobile client can dial up the IDV camera (in Kogarah?) using the inbuilt keypad. Once linked, the user can instruct the system to hold images, store, sequence through the slave cameras, and conduct two-way communication.

"Hello, Alice."

"Yes, Boss?"

The communication can be in the form of audio; or, if Alice is a little recalcitrant, you can even switch off the TV. From any telephone point in the world.

Changing the flowers? And evicting Rover? Maybe the 1991 model will acquire the capability.

# OBIAT PTY LTD YOUR ONE STOP DISTRIBUTOR OF TEST & MEASURING INSTRUMENTS

**80 Series - rapidly becoming the most popular Multimeter ever made by Fluke...**

...It's a digital multimeter, an analog meter, a frequency counter, a recorder, a capacitance meter and a whole lot more!

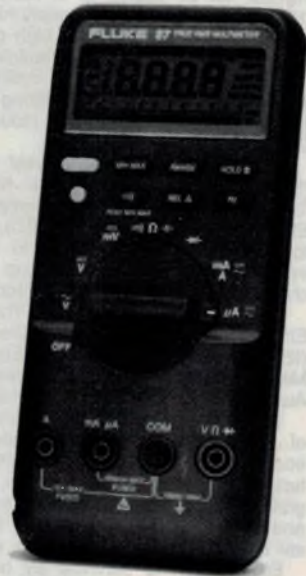

The Fluke 80 series is the first multimeter that can be truly called "multi". It offers not only standard features, but special functions usually limited to dedicated instruments, plus innovations only Fluke can bring you. Like duty cycle measurement; or automatically store the highest, lowest and true average (mean) of readings for a few seconds or up to 36 hours; or record maximums and minimums for days; or the audible, MIN MAX Alert™ that beeps for new highs or lows.

**ADDED BONUS - FREE Softcase worth \$45 with orders this month ONLY**

**FLUKE**  
Made in U.S.A.

- Min/Max/Average recording stores highest, lowest and true average of all readings
- Selectable response time to record turn on surges or drift etc
- 1ms peak Min/Max hold on 87 to capture elusive transients or half sine surges to 400Hz
- Audible Min/Max Alert™ signals readings above or below previous limits
- Splash and dust proof and impact resistant case

**83 \$399 ex tax \$468 inc tax**

- Volts, Amps, Ohms, diode test, continuity, frequency and duty cycle, capacitance, Touch Hold™, relative, protective holster
- 0.3% basic dc accuracy
- 5kHz Vac
- Analog bargraph with zoom
- 3 year warranty

**85 \$480 ex tax \$560 inc tax**

- 0.1% accuracy
- 20kHz Vac

**87 \$580 ex tax \$676 inc tax**

- High resolution analog pointer
- True rms ac
- 1ms peak Min/Max
- 4 1/2 digit mode
- Back lit display

**We Stock A Full Range of Fluke Multimeters from \$150 and Accessories**

## Black★Star

**Quality British Made Instruments... 2308 RS232C I/O Interface**  
...at Very Affordable Prices



### 1502 Battery Oscilloscope

- DC-15MHz
  - Dual Trace
  - Mains/Rechargeable Battery
  - Fits in a Briefcase
  - Full Range of Functions
  - 10mV/div to 50V/div
  - 0.5s to 0.1µs Timebase
- \$1050 ex tax (inc probes)**  
**\$1208 inc tax (inc probes)**

### Orion PAL TV/ Video Pattern Generator

- Tests TV, VCR, Monitors etc
  - PAL B, D, G, H, I, K
  - RF, Composite Video and IRGB Outputs
  - Colour Bars, Greyscale, Crosshatch, Dots, Lines, Focus, Purity etc.
  - Separate or Mixed Syncs
  - 1V or TTL IRGB
  - 5.5, 6.0 and 6.5MHz Sound Carriers
  - Internal/External Sound
  - Trigger Output
  - Mains Operated
- \$685 (ex tax) \$785 (inc tax)**

- Complete with software for IBM compatible PC's
  - Ideal for simple logging and control applications
  - 8 channel 12bit analog input
  - 4 ch. 12bit analog output
  - 8 opt-coupled digital inputs
  - 8 mains rated relays
  - Non-volatile data logging memory
  - High limit detection
  - Simple command language
- \$795 ex tax \$911 inc tax**



### Now distributing SILVERTRONIC Test Leads and Scope Probes

If you're looking for high quality, here's the answer - **Universal Deluxe Multimeter Lead Kit** has croc clips, spring hooks, spade terminals etc **\$40 (ex tax) \$48 (inc tax)**  
**100MHz Scope Probe Kit** x1/x10 switched **\$43 (ex tax) \$50 (inc tax)**  
**250MHz Scope Probe Kit** x1/x10 switched **\$48 (ex tax) \$56 (inc tax)**  
**Just Released...**  
**Safety Fused Test Lead Set** Fuse holder in each lead. Includes insulated croc clips. **\$65 (ex tax) \$75 (inc Tax)**



Queensland enquiries for Blackstar Products to:  
**CLIFF ELECTRONICS (AUST) P/L**  
TEL: (07) 252 3178  
FAX: (07) 252 3165

Special account facilities available for Education and Government Departments  
Express delivery throughout Australia and South Pacific

Detailed brochures and specifications available. We are factory trained to advise on your requirements for general purpose Test & Measuring Instruments

**OBIAT PTY. LTD.**

Ask for our FREE 16 page Shortform Catalogue

129 Queen Street, Beaconsfield P.O. Box 37 Beaconsfield NSW 2014  
Tel: (02) 698 4776 Telex: AA71958 Fax: (02) 699 9170  
QLD: Electro Technical Systems Qld, Tel (07) 356 2699, Fax (07) 356 0456  
W.A.: Leda Electronics, Tel (09) 361 7821, Fax (09) 470 4641





## OBITUARY: DR JOHN ERNEST BENSON

On 2nd August 1989, Dr J.E. Benson, known affectionately to his friends as 'Ern', passed away at the age of 78. His loss is felt by a wide circle of friends and colleagues, among them the electroacoustics community where he was continuing to contribute to our understanding, of loudspeakers especially, to the moment of his death. We are grateful to have had his friendship, encouragement and advice for so long, but our deep sense of personal loss is compounded with regret for what he might have achieved even further.

Ern Benson was born in 1911 and educated at Sydney Technical High School and Sydney University, graduating Bachelor of Science (B.Sc.) in 1932 and Bachelor of Engineering (B.E.) with First Class Honours in 1934. Little engineering work being available then in the Great Depression, he took up a Teachers' College Scholarship and obtained a Diploma of Education (Dip.Ed.) from Sydney University. When a position became available at the end of 1934, he joined the Research Laboratories of Amalgamated Wireless Australasia (AWA) Ltd., where he tested the carrier frequencies of MF broadcasting stations.

When crystal control of these frequencies became mandatory, he specialised in the study of piezoelectric crystals. Ten published papers resulting from his work in this field led to a Master of Engineering (M.E.) degree from Sydney University, with First Class Honours and the University Medal, in 1945.

Ern's life was permeated by his Christian belief and his devotion to the Anglican Church, as a Sunday School teacher, a member of Synod and of the World Council of Churches. That devotion led him eventually to applying the art of electroacoustics to the service of the Church.

In 1939/40, with the assistance of his wife Mavis, he constructed an electric organ following the Hammond principle that had been patented in 1936, in which the tones are produced by steel wheels rotating under magnetic pickup coils. In 1944 he built for St. Anne's Church, Ryde, NSW the first model of a new musical instrument, a keyboard operated carillon, in which sounds produced by tubular bells were amplified and radiated by loudspeakers from the bell tower.

AWA commercialised the design and installed a number of chime carillons in churches throughout the country in the late forties.

From 1947, when AWA inaugurated a television section at its Ashfield plant, Ern was involved in television. In particular, his paper 'A Survey of the Methods and Colorimetric Principles of Colour Television', in the *Proc. IRE (Aust)* for July and August 1951 was a landmark, both for the novelty of the material it presented and for the clarity of its exposition. It became for at least one younger author a lifelong model for writing a technical paper. He continued this involvement, with a number of clearly presented demonstrations and lectures throughout the fifties and sixties.

In the late 1950's Ernest had been involved in designing loudspeakers, in particular a stereophonic system for the large auditorium of Sydney Town Hall.

In 1960, when AWA submitted a tender for Electroacoustics and Signalling Systems for the Sydney Opera House, which was then in the long process of being built, the fine performance of the Sydney Town Hall installation was a deciding factor in acceptance of AWA's tender by the Sydney Opera House Trust. When the Opera House opened in October 1973, the fidelity of reproduction of his electrically tapered column loudspeakers was an outstanding feature and one of the contributions to the Opera House installation for which AWA as an organisation and Ern personally had received a Duke of Edinburgh prize for industrial design in 1972.

Ern published papers on the 'Theory and Design of Loudspeaker Enclosures', in three parts in the *Proc. IREE, Aust.* and the *AWA Technical Review* between 1969 and 1972. These were followed by 'An Introduction to the Design of Filtered Loudspeaker Systems', first published in the *AWA Technical Review* in 1973, and reprinted in

1975 in the *Proc. IREE* and *Journal of the Audio Engineering Society*, and followed again by more detailed work on loudspeaker systems incorporating electrical filters in the *AWA Review* in 1974 and 1975. These seven papers constitute some of the most important work published on loudspeaker design. Because of their wealth of detail, new insights and clarity of presentation, they are still repaying study 15 to 20 years later. They constituted, along with his earlier work on piezoelectric crystals and television, the basis of an award of Doctor of Science in Engineering (D.Sc.Eng) by Sydney University in 1975.

Besides his highly innovative engineering work and his devotion to many aspects of the Anglican Church, Ern edited the *AWA Technical Review* for 27 years, up to his retirement from AWA in 1975. From 1975 on, he continued to apply his expertise in electroacoustics to the design of loudspeakers for high quality sound reproduction, in homes and for a number of large buildings, halls and churches - including St. Andrew's Cathedral in Sydney. He was also a consultant for loudspeaker design, incorporating his electrically tapered columns, in the new national Parliament House in Canberra that was opened in October 1988.

He also took a keen interest in the work of Standards Australia (SA) on electroacoustics. He had chaired the relevant committee TE/24 (later TE/8), which complements TC84 of the International Electrotechnical Committee (IEC), from 1968 to 1980, and continued to make solid contributions to its work in setting Australian and international standards right up to the day of his death, always characterised by his usual care for detail and clarity of exposition.

Dr Benson was a Fellow of The Institution of Radio and Electronics Engineers Australia (IREE), the Institution of Electrical Engineers (IEE) and the Institution of Engineers Australia (IE Aust), and a Member of the Audio Engineering Society Inc. (AES) and the Australian Acoustical Society (AAS).

Those of us who knew him and worked with him are deeply aware of the contribution he has made to our lives, by his example, his encouragement, his diligence, his kindness, his generosity and his fund of wisdom on all matters, including electroacoustics. We are grateful for the great contributions he made to society during his life and cannot suppress a pang for the loss of contributions that he might still have made, was still making, when he passed from us.

Ern Benson is survived by his wife Mavis, whose support in all things he continually acknowledged, and their two sons Ronald Ernest and David John.

We will remember him gratefully as long as we have memory.

### Postscript:

Dr. Benson's electrical tapering provides an elegant solution to the problem of maintain the directivity of a column loudspeaker over a wide range of frequencies. A loudspeaker in which a number of driver units are mounted in a vertical column confines the sound to a wedge that is narrow in the vertical direction, but wide horizontally. However it does this best over a comparatively narrow range of frequencies. Ern's solution to the problem was to effectively reduce the height of the column progressively with increasing frequency, by feeding the drivers through a series of low-pass filters.

At the highest frequencies, the signal is carried by the central driver alone. At a suitable lower frequency the first low-pass filter allows signal to pass also to the drivers immediately above and below the centre, and contribute through them to the sound output. At a lower frequency again, the next low-pass filter allows the next pair of drivers immediately above and below to contribute also to the sound output, and so on.

The success of the method will be well remembered by those who saw the long single shining column and heard it delivering wonderfully clear and natural speech in the Concert Hall of the Sydney Opera House, during its first few years. However in later years, the need for high level amplification for some concerts has been given as a reason for abandoning its use altogether.

In the new Federal Parliament House in Canberra, sets of Ern's columns, with a microphone switching system, are capable of delivering clean, clear speech throughout chambers which, without electroacoustic assistance, are quite impossible for debate. The debater's voice can not only be heard clearly, but it also appears to emanate from his direction - through use of the Haas effect. However due to a set of political factors, appropriate perhaps to our centre of national politics, the system is not allowed to function as Ern intended - sheer loudness being preferred to mere intelligibility.

Ern described some of the principles of these electrically-tapered columns in a paper that he delivered at IRECON 75, but the space available in the Convention Digest was insufficient to do it full justice. He was working on a complete paper at the time of his untimely death.

(Main Obituary reprinted from *IREE Monitor*, by permission of the IREE Australia.)





## Metrix 50 Series

- Comprehensive Display with Analog Bar-Graph
- 5000 Count Digital Display
- Patented Live-Trend™ Mode Shows Instant Values
- Storage of Up To 5 Different Readings
- Surveillance Mode
- Models with dBs and Frequency to 500kHz

**Now with  
Holster  
from \$310**

**metrix**



## Metrix 40 Series

- Exceptional All-Weather Performance
- Four Year Warranty
- 4000 Count Resolution
- Autoranging with Manual Override
- Hold & Peak Functions
- True RMS AC or AC+DC
- Safe to IEC348 Class 11

**from \$220**

**metrix**

**From the home of the Mercedes Benz and BMW comes  
Metrix — Europe's Favourite Multimeters**



## Metrix MX573

- True Analog and Digital
- True RMS ac
- 25kHz Bandwidth for Vac
- Auto-Polarity Switching
- Taut Band Linear Scale Analog Movement
- 2000 Count Digital LCD Display

**\$650**

**metrix**



## Metrix MX1200S & MX200 Clamp-On

- Power Measurements
- Current Ranges to 200A/100A
- Frequency to 1kHz
- Resolution as low as 10mA
- Analog Output

**\$875**

**metrix**

**Also ask about the MX545 Series and MX579 Benchtop Multimeters and a Wide Range of Probes & Accessories**

**ELMEASCO Instruments Pty. Ltd.**

**Australia's Leading Test & Measuring Instrument Company**

### NEW SOUTH WALES

18 Hilly Street,  
MORTLAKE  
P.O. Box 30, CONCORD  
NSW 2137  
Tel: (02) 736 2888  
Telex: AA25887  
Fax: (02) 736 3005

### VICTORIA

12 Maroondah Highway,  
RINGWOOD  
P.O. Box 623, RINGWOOD  
VIC 3134  
Tel: (03) 879 2322  
Telex: AA30418  
Fax: (03) 879 4310

### QUEENSLAND

192 Evans Road,  
SALISBURY  
P.O. Box 274 SALISBURY  
QLD 4107  
Tel: (07) 875 1444  
Fax: (07) 277 3753

### SOUTH AUSTRALIA

241 Churchill Road,  
PROSPECT  
P.O. Box 154 PROSPECT  
SA 5082  
Tel: (08) 344 9000  
Telex: AA87519  
Fax: (08) 269 6411

### W. AUSTRALIA

32 Teddington Road,  
VICTORIA PARK,  
W.A. 6100  
Tel: (09) 470 1855  
Fax: (09) 470 3173

Prices quoted do not include  
Sales Tax and are subject to  
change without notice

**READER INFO No. 4**



# Get into computing, with this complete ACER 500+ system

The ACER 500+ is made by one of the world's largest and most experienced manufacturers of personal computers, and is 100% quality control tested to ensure top performance and reliability. It is designed to provide the most affordable starter system for serious home and business computing.

The ACER 500+ gives you both MGA and CGA video graphics support as standard, allowing you to run both colour or graphics software on the paper-white monitor without the need for expensive add-on boards or colour monitors. It also comes fitted with

both serial, parallel and games ports as standard, so that you can connect a printer and modem directly – again without any expensive adaptors. So whether you're a beginner or a serious professional user, the ACER 500+ is a great starter system.

Features include V20 processor with selectable 4.77MHz or 8MHz clock speeds; a real time clock; full 640K of memory; dual 5.25" disk drives; 8087-2 co-processor socket; separate 84-key keyboard; MS-DOS operating system with GW-BASIC; and 12 months warranty.

The ACER 500+ system pictured above includes computer (X-8061), paper-white 30cm monitor (X-2400), 9-pin 135cps dot matrix printer (X-3225), Bit Blitzer 12E 300/300bps and 1200/1200bps communication modem (X-3306), and the Better Working Eight-in-One integrated software package (X-9402). These come complete with all interconnecting cables (X-8614, X-8007) plus a bonus box of 5.25" diskettes (X-3501), a printer stand (X-3814) and printer paper (X-1185), to produce a full 'ready to run' system – for an amazingly low price:

**ONLY \$ 1995**

## UNBEATABLE VALUE!

The above system can be ordered from your nearest Dick Smith Electronics store or dealer, or ordered direct by phoning (008) 22 6610. Sydney callers phone 888 2105, or fax (02) 805 1986.



# THAT'S RIGHT, by arrangement with Dick Smith Electronics

we have THREE of these superb ACER 500+ computer systems – each worth \$1995 – to be won over the next three months by lucky *Electronics Australia* with ETI subscribers.

Each system includes ACER 500+ computer (X-8061), 30cm monitor (X-2400), 9-pin 135cps dot matrix printer (X-3225), Bit Blitzer 12E 300/300bps and 1200/1200bps communications modem (X-3306), all necessary cables, MS-DOS operating system, the 'Better Working Eight-in-One' integrated software package (X-9402), a bonus box of 5.25" DSDD diskettes, a printer stand and pack of printer paper – a package valued at \$1995.

How do YOU have a chance of winning one of these superb systems? It's easy. Simply subscribe to *Electronics Australia* with ETI, or extend your current subscription for a further 12 months, between NOW and September 28, 1990. All new/renewing/extending subscriptions received during each month (July, August and September) will be registered, and one lucky subscriber from each month's group will win one of the three computer systems.

**So subscribe, or renew/extend your subscription NOW!**

**ONLY \$47 FOR  
12 MONTHS  
(12 ISSUES) incl. postage  
SAVE OVER 12%**

# Electronics Australia with **eti**

Australia's biggest, brightest and top selling electronics magazine – have it home delivered each month



**BONUS:** EVERYONE who subscribes, renews or extends will receive absolutely FREE this economy pencil blow torch – great for heat shrink work, silver soldering, brazing, glass work, etc. It fits easily in the pocket and is powered by butane gas (the same as used in cigarette lighters, etc.). Incredibly handy and normally sells for \$15.95 – but yours free!

# NOT ONE, BUT THREE OF THESE SUPERB COMPUTERS TO BE WON!

**BUT HURRY – THIS OFFER ENDS September 28, 1990!**

To enter simply fill out the coupon attached and place it in the reply paid envelope supplied – if the coupon and the envelope are missing, send your name, address, phone number, cheque, money order or credit card details (card type, card number, expiry date and signature) to: Federal Publishing Company, Freepost No.4, P.O. Box 227, Waterloo NSW 2017. Any enquiries can be made by phoning (02) 693-6666. Unsigned orders cannot be accepted.

1. The competition is open only to Australian residents authorising a new/renewal subscription before last mail 28.09.90. Entries received after closing date will not be included. Employees of the Federal Publishing Company Pty Ltd and Dick Smith Electronics and their families are not eligible to enter. To be valid for drawing, the sub-

scription must be signed against a nominated valid credit card or if paid by cheque, cleared for payment.

2. South Australian residents need not purchase a magazine to enter, but may enter only once by submitting their name, address and a hand-drawn facsimile of the subscription coupon to Federal Publishing Company Pty Ltd, P.O. Box 227, Waterloo NSW 2017.

3. Prizes are not transferrable or exchangeable and may not be converted to cash.

4. The judges decision is final and no correspondence will be entered into.

5. Description of the competition and instructions on how to enter form a part of the competition conditions.

6. The competition commences on 25.06.90 and closes with last mail on 28.09.90. The draw will take place in Sydney on 03.10.90 and the winners will be notified by telephone and letter. The winners will also be announced in *The Australian* on 06.10.90 and a later issue of *Electronics Australia*.

7. The prizes are: Three Acer 500+ computer systems – each valued at \$1995 – total value \$5985.00.

8. The promoter is Federal Publishing Company Pty Ltd, 180 Bourke Road, Alexandria NSW 2015. Permit No. TC90/0000 issued under the Lotteries and Art Unions Act 1901; Raffles and Bingo Permit Board Permit No.90/0000 issued on 00/00/90; ACT Permit No.TP90/0000 issued under the Lotteries Ordinance, 1964.

**Behind the Grand Prix telecast:**

# Nine wins at Phillip Island

Several hundred million people around the world were able to watch a virtually flawless telecast of the first Australian Motorcycle Grand Prix, thanks to the considerable preparation and effort put in by the Nine Network technical and production team. Here's a glimpse behind the scenes.

by GERARD KNAPP

The inaugural Australian Motorcycle Grand Prix was not only a triumph for local hero Wayne Gardner, but also for the 150 staff who produced possibly the finest coverage of any motorcycle GP in the world.

At Phillip Island, no less than 24 cameras covered the action around and above the track, while two helicopters buzzed overhead. One was for aerial camera-work, while the other acted exclusively as a signal repeater for the 500cc bikes and sidecars fitted with tiny camera/microwave line packages.

It's unlikely any other broadcaster would devote so much time, money and effort, but in Australia we should expect nothing less as our local networks have proved to be second to none when it comes to covering motor racing.

The Nine Network, being host broadcaster of the motorcycle GP, poured almost \$1.5 million into covering the event, including sub-contracting out the ABC's extraordinary Mini Cam. That's about \$170,000 per hour of broadcast television, which is serious money for what was once considered a minority sport in Australia. But it was also in the Bond Corp's interests, as Nine's sister company, Swan Premium, was the principal sponsor of the event.

Along with this strong corporate backing, Australian electronics companies played a part behind the scenes by providing several key pieces of broadcast hardware.

Nine has already won international awards for its coverage of the Australian Formula One GP in Adelaide, so it used the same approach to cover the ac-

tion at Phillip Island. But being a new track and location for the network, the broadcast required months of planning.

Kilometres of video and stereo audio cables were laid around the track, while scaffolding was erected for most camera locations. Thirteen cameras were stationed around the 4.45km circuit, which allowed the director, Brian Morelli, to

switch camera sources smoothly without losing the main subjects.

Due to the size of the broadcast and its inherent commitment to some 30 overseas broadcasters – who in turn, relayed the programme onto an estimated world audience of several hundred million – Nine divided its production into three basic levels.

**Scott Field survived four days of carrying this 22kg package of batteries, cables and microwave link equipment through the hectic pit and grid area.**





**Director Brian Morelli (centre in focus) directed the action coverage from a specially constructed hut called WART - Wreck-air-Race Terminal.**

Firstly, there was Race Cover, directed by Mr Morelli, whose primary task was to direct the coverage of the on-track action. With up to 19 cameras to choose from, it was a difficult task. The output was fed to World Cover, where other video sources such as pre-recorded segments and interviews were added to bring the coverage up to the standard format for international broadcasters. In fact, four countries even sent their own commentators, who were accommodated by Nine with separate commentary booths above the track.

The third level was for the domestic coverage, where further video and audio sources were mixed in to bring the coverage up to Nine's stringent in-house standard for Wide World of Sports.

Australian-made video and audio equipment played a big role in production control. For example, the key vision switcher, used by Mr Morelli, was made by a Melbourne company headed by engineer Joe Talia. This piece of equipment has the ability to monitor and control up to 30 separate video sources.

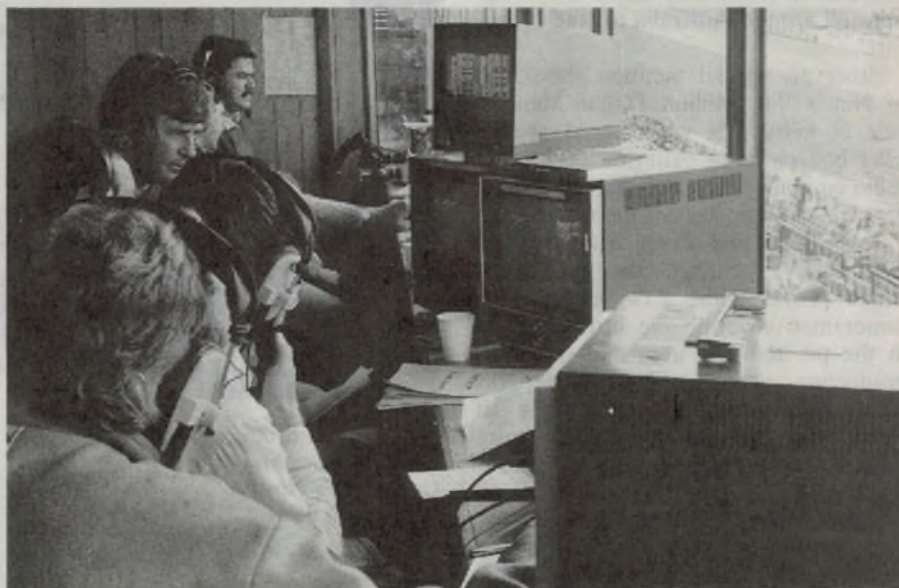

**In the commentary booth above the track.**

To centralise all its production control activities, Nine built a trackside production compound - a village of portable buildings, OB vans and tents - that approximated the size of a regional television station.

Keeping track of all the video and stereo audio sources throughout Nine's compound was another key piece of equipment, dubbed 'Deep Thort' by Nine's technicians. "It tells us what to do and where everything is," joked one



**Capturing the action at one of the trackside camera positions...**

engineer. The device, made by local firm Practel, is actually a 40 x 50 stereo-follow-video routing switcher and was the main signal distribution point within the compound.

As could be seen on race day, Nine's coverage was virtually flawless — a credit to the planning efforts of Nine's production crew, who came from stations all around Australia for the broadcast.

However, special mention should go to Nine's 'Six Million Dollar Men,' a pair of hefty lads who lugged around 22kg bodypacks of batteries, cables and radio equipment through the frenetic pit area for the four days of the meeting.

Scott Field and Peter Maisey, both from GTV9, carried the equipment which provided the link between the cameramen covering the furious action in the pit and grid area and the main production control. Their bodypacks were so large they could hardly sit down, while they also carried two-metre poles which doubled as wave guides for the 13GHz horn antennas mounted on top. They had to point these antennas at tennis-ball size receiver targets just below the bridge (otherwise the signal would drop out), keep up with the cameramen in the pits and not get run over in the process. Remarkably, they survived unscathed.

But it was effort like this which ensured the success of a remarkable television event in Australia, one which seems sure to be repeated in 1990.

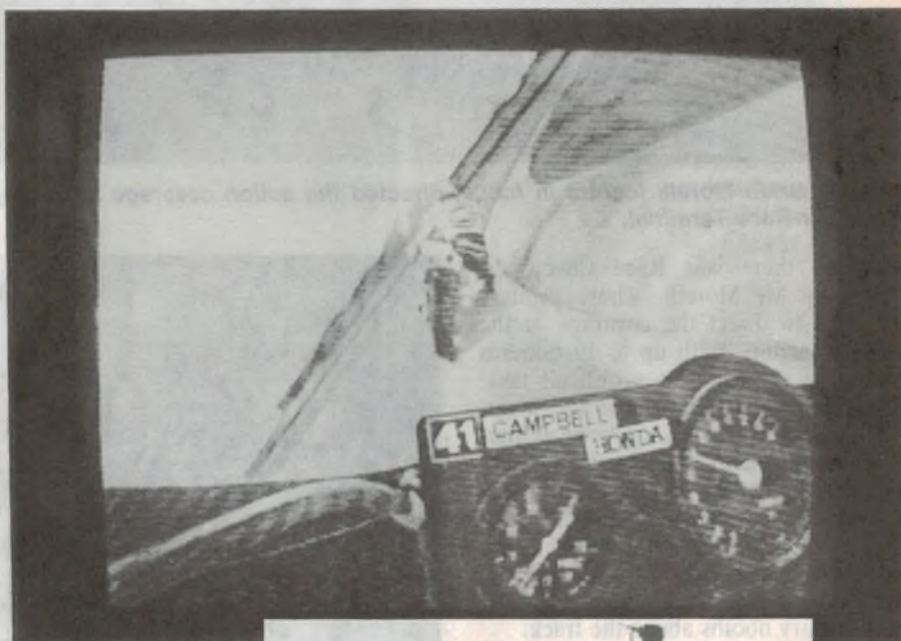

**(Above) A monitor shot of Malcolm Campbell's Honda fitted with Mini Cam.**

**One of the camera cranes, used to provide high-angle shots.**



# 4 inches high, 1000 MHz wide puts the world in your pocket

## The New IC-R1 handheld receiver



### Versatile Mobile

#### The New IC-R100 wideband brings the world to your car

The IC-R100, with an ultra-wide band width of 500 kHz to 1800 MHz, was born of the technologically marvellous IC-R9000 (Icom's and the world's most sophisticated receiver). Operating from 13.8V DC with a built-in 15dB pre-amp to enhance weak signals (50 to 905 MHz), the IC-R100 is invaluable

Icom, leading the way again in communications technology and miniaturisation with the world's smallest wide band receiver.

It's so small you could carry it in the palm of your hand or the pocket of your shirt.

Yes, an FM/AM and FM/W wide-band receiver that continuously covers 2 MHz - 905 MHz (Guaranteed specifications) and yet is small enough to carry anywhere.

Weighing in at a mere 280 g (9.9 oz) this tiny package features **MULTI-SCAN FUNCTIONS** including programmed, memory,

selected mode and auto memory write with a capacity for **100 MEMORY CHANNELS**. Electronic locking of tuning control and keyboard prevents accidental frequency change, 2-way frequency selection, a built-in clock and timer functions - all running off an internal Nicad battery. The IC-R1 is equipped for high performance and is a "must have" item for any one on the move who is keeping up with the world and technology.

Find out more about the IC-R1 and the optional extras available - send in or phone for a free brochure - **BUT HURRY** - the R1 is selling fast!

as a mobile and for base station use. Other features, such as an enormous **121 channel memory, built-in clock/timer** and, of course, **multi-mode scanning** functions for VHF/UHF/MW/HF make this a most desirable receiver.

Compact, economical and easy to operate as a scanning radio, it's no wonder the IC-R100 is stimulating great interest. By satisfying the demands of shortwave and broadcast listeners, scanner enthusiasts as well



as business and professional users, Icom again leads the way. Contact us by Freepost or phone for the name of your stockist, colour brochures on the IC-R1, R100 and the complete range of Icom receivers - IC-R9000, IC-R7000, and IC-R71A.

For further information call Icom free on 008 338 915

Melbourne callers (03) 529 7582 Icom Australia Pty. Ltd., 7 Duke Street, Windsor 3181.

Icom Australia's warranty is only applicable to products purchased from their authorised Australian Dealers.

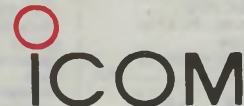
  
**ICOM**

■ AMATEUR ■ MARINE ■ LAND-MOBILE ■ AVIATION ■ CB ■ AMATEUR ■ MARINE ■ LAND-MOBILE ■ AVIATION ■ CB ■ AMATEUR ■ MARINE ■ LAND-MOBILE ■

Please rush to me your brochure on the  IC-R1,  IC-R100 and the name of my nearest Icom stockist.

SEND TO: Freepost 15, Icom Australia Pty Ltd, Windsor, 3181 (no stamp required).

Mr., Mrs., Ms. .... Company ..... Title .....

Address ..... Suburb .....

City ..... Post Code ..... Phone No. .... NCAA 4672 ETI

■ AMATEUR ■ MARINE ■ LAND-MOBILE ■ AVIATION ■ CB ■ AMATEUR ■ MARINE ■ LAND-MOBILE ■ AVIATION ■ CB ■ AMATEUR ■ MARINE ■ LAND-MOBILE ■

# LOOK...NEW PRODUCTS



### AIR IONS GENERATOR

No need for air fresheners with our Negative Air Ions Generator. Just plug it into the cars cigarette lighter and it releases negative air ions into the vehicle...making a fresh driving environment. Odors, smoke and dust are eliminated and a fresh feeling prevails. The product is also good for the respiratory and blood systems.

A15072.....\$49.95

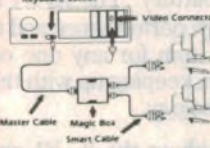

### PC-SHARE

The PC-SHARE Magic Box enables two user workstations (monitor & keyboard) to be connected to one PC.

**SPECIFICATIONS:**

- Magic box - 20mm X 100mm X 20mm
- Master cable - 500mm
- Smart cable - 2, 4, 10, 40 mt.
- Maximum distance between desks - 80 metres
- Power supply - none required
- Compatible computers - PC, PC-XT,
- PC-AT 286, PC-AT 386, PS/2 Model 25,
- PS/2 Model 30
- Compatible operating systems - Supports MS-DOS, OS-2, MS-WINDOW, UNIX, PICK etc
- Monitors - monochrome, CGA, EGA, RGB
- Keyboards - PC-XT or PC-AT type.
- Leads sold separately.

X19088.....\$299



### PRINTER BUFFER

PB - 42P PRINTER BUFFER The printer buffer is for offices or schools which have high volume data to process. It's a time saver. It accepts data from your computer and stores the data in its memory, then feeds the data to your printer at its own speed so that your computer is free for other work.

256K FITTED CAN TAKE UP TO 1 MEG OF RAM  
X19160.....\$595



### TOUCH MOUSE

A STATIONARY BREAK THROUGH !!!  
Now you can use your fingers instead of your mouse.  
MODELS: ATM-110 Touch Mouse for IBM PC/XT/AT and compatible's. Operates under Microsoft / mouse system mode.  
FEATURES:  
- User's finger movements on the 58 X 48mm front panel of the touch mouse control the on screen cursor movement.  
- With no ball, the touch mouse requires no desk space for movement.  
- No pad to get dirty and take up desk space.  
- One finger can do all the users drawing.  
- Compatible with all existing mouse software.  
- RS-232 serial port - Especially suitable for laptops, the touch mouse saves on desk space.  
X19960.....\$149.00



### TRIPOD VIDEO CAMERA STAND

Collapsible three legged floor stand for video and 35mm camera's with centre leg to prevent sudden camera drop. The platform can be tilted sideways or angled to the front or the back and has a securing bolt and locking pin for keeping the camera secure. It is also easily removed so it can be permanently secured to the video camera. When it is needed it can be speedily re-attached to the stand with the aid of a quick release lever system.  
- Removable panning arm  
- Fully geared elevator system  
- Quick release snap leg locks  
- Rubber feet screw up to reveal spikes for usage on soft surfaces  
- Black semi gloss aluminium frame.  
A15598.....\$199.95



### 10 AMP CAR NOISE SUPPRESSOR

Heavy duty automotive electrical noise filter.  
- Reduces alternator whine and impulse noise.  
- Will take up to 40 amps.  
- Used for stereos, and equalisers, CB's, etc.  
A12102.....\$19.95



### CONSUMER PREMISES EQUIPMENT PROTECTOR

USE:  
For protection for fax's, computers, computer's with modem connections, telephones, telephone answering machines.  
PROTECTION:  
- The unit uses a combination of both M.O.V.s and gas arrestor circuitry to prevent damage to home and office machinery which can amount to several hundred dollars costly repairs and down time.  
- Approved by the Australian Dept of Minerals and energy.  
- Approval # N11361  
X10089.....\$64.95



### 240VAC MAINS SURGE PROTECTOR

Atmospheric discharges that cause power spikes and surges often occur in the IC's mains reticulation system sometimes causing severe damage to appliances, computers, Hi-Fi systems etc. Protection of any device can be achieved by simply inserting the PAC15 into the power point and plugging the appliance into the front of the PAC15. Built in MOV circuitry absorbs any spikes or surges that enter the PAC15 through the AC power system before they reach the appliance.  
An amber light shows you that the unit is in proper working order. If a surge or spike enters the MOV it will break the circuit and the amber light will not appear.  
This means that the PAC15 has prevented the appliance from being damaged.  
X10091.....\$29.95

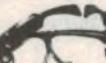

### MAGIC EYES

(HANDS FREE LIGHT) You don't have to take your glasses off. Great for checking circuit boards. Inside dark placar, motor cycle repairs, camping, flashing. Anywhere you need your hands to be free.  
A15062.....\$19.95

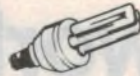

S14049 7W BC.....\$34.95  
S14051 11W BC.....\$34.95  
S14052 15W BC.....\$34.95



S14053 12W BC.....\$42.95  
S14054 18W BC.....\$44.95

### FLUORO GLOBES!

DID YOU KNOW THAT SOME AUTHORITIES IN AMERICA NOW SUPPLY FLUORO GLOBES FREE OF CHARGE?  
IT IS CHEAPER TO GIVE AWAY THE GLOBES THAN FACE THE POLLUTION AND FINANCIAL COST TO BUILD NEW POWER STATIONS.  
IF THE SUPPLY AUTHORITIES RECKON THEY CAN SAVE MONEY THEN SO SHOULD YOU.  
HOW?  
EACH FLURO GLOBE PRODUCES 5 TIMES THE LIGHT OF A NORMAL GLOBE. SO YOU NEED ONLY BUY A 20 WATT FLURO TO REPLACE THAT 100 WATT GLOBE. YOU SAVE MONEY BY USING POWER AT ONLY 20% OF THE PREVIOUS RATE.  
IMAGINE CUTTING YOUR LIGHTING BILL BY 80%!  
THOSE CHEAP GLOBES POP ALL THE TIME AND THEY APPEAR TO COST MORE EVERY TIME YOU BUY THEM. WHEN YOU HAVE TO CLIMB ON CHAIRS OR UNDO FITTINGS TO CHANGE THEM YOU REALISE THE COST IS NOT JUST AT THE CHECK-OUT.  
THE FLURO GLOBES LAST AT LEAST 8 TIMES AS LONG AS YOUR NORMAL GLOBE. YOUR TRIPS UP THE LADDER AND THE CALLS FROM YOUR CHILDREN OR ELDERLY PARENTS WILL COME LESS FREQUENTLY.  
BUT PERHAPS THE BIGGEST SAVINGS IS IN OUR FUTURE. IF WE ALL USE LESS POWER, WE NEED DIG LESS COAL, USE LESS WATER WASHING IT, AND LESS ENERGY TRANSPORTING IT AND ULTIMATELY LESS DESTRUCTION OF OUR ENVIRONMENT.  
SO NOW YOU CAN SAVE ON YOUR LIGHTING BILLS AND BE LIKE EVERYONE ELSE AND CARE A LITTLE MORE FOR YOUR ENVIRONMENT.  
TAKE YOUR STAND NOW AND INSIST ON FLUROGLOBES FROM ROD IRVING AND TELL YOUR POLITICIANS WHAT YOU ARE DOING AND WHY. PERHAPS THE MESSAGE WILL GET THROUGH AND THEY WILL ALSO SEE THE LIGHT....

S14049 7W BC.....\$34.95  
S14051 11W BC.....\$34.95  
S14052 15W BC.....\$34.95

S14053 12W BC.....\$42.95  
S14054 18W BC.....\$44.95

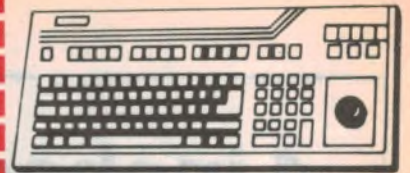

### 101 KEY TRACKBALL KEYBOARD

The Trackball keyboard is a palm driven mouse which is built into your NEW keyboard. Above the ball is 3 keys- which allow you, your selections and zooming in and out on work. The Trackball allows you to keep the feel of your work in the centre of your palm.

- Advantages of the Trackball mouse:
- It is more accurate than other cursor controls
  - It has more flexibility than other devices.
  - It is so responsive that you can move your cursor across the screen in a split second and continue working in another area.
  - Distortion free drawing ability.
  - Compedability with other major mouse systems
  - Dynamic resolution.

Specifications:  
- Microsoft serial mouse and PC mouse compatible  
- Tracking speed- 900mm/sec.  
- Resolution- 200 dpi (dots per inch)  
- Dynamic resolution- 100-1200 dpi  
- Opto mechanical encoder.  
X12030.....\$169.95



### SPECTROL MULTIDIALS

MODEL 15-1-11  
Number of turns: 10  
Minor Scale Division: 1.500 turn  
Shaft Bore: 6.35mm (1/4")  
Finish: Satin Chrome  
Body Size: 25.4 x 44.45mm  
Depth: 25.4mm (1")  
Weight: 45.4g (1.6oz)  
Cal.R14405.....\$45.95  
SPECIAL, \$35.95

MODEL 16-1-11  
Number of turns: 15  
Minor Scale Division: 1.50 turn  
Shaft Bore: 6.35mm (1/4")  
Finish: Clear Anodize  
Body Size: 22.2mm diameter (875)  
Depth: 22.2mm (875)  
Weight: 19.8g (0.7oz)  
Cal.R14400.....\$26.95  
SPECIAL, \$21.50

MODEL 21-1-11  
Number of turns: 15  
Minor Scale Division: 1.100 turn  
Shaft Bore: 6.35mm (1/4")  
Finish: Satin Chrome  
Body Size: 46.04mm diameter  
Depth: 25.4mm (1")  
Weight: 85.9g (3oz)  
Cal.R14410.....\$46.95  
SPECIAL, \$37.50



### IBM PC TROUBLESHOOTING & REPAIR GUIDE

- Robert C. Brenner  
Keep your IBM PC in top operating condition with this handy reference book. Inside you will find pages of schematics, photos and block diagrams to help you identify problems. Simple instructions tell you what's wrong and how to fix it fast.  
B20115.....\$49.95



### INSIDE MICROSOFT OS/2

- Gordon Letwin  
A rare and exciting technical examination of the physical, key development issues, programming implications, and future of the MS OS/2 operating system. Gordon Letwin, Chief Architect for MS OS/2 provides a true behind the scenes view of the process of merging Microsoft's vision of an automated office system with the realities of software development. Here is revealing information every MS OS/2 programmer, as well as high-tech and office automation specialists, will find invaluable.  
Letwin discusses:  
- The powerful graphics, true multitasking, hardware and software protection, and program "encapsulation" features that were incorporated into MS OS/2  
- The restrictions of the microprocessor and the constraints of upward and downward MS DOS and MS OS/2 compatibility  
- The software architectural details from a design and programming perspective  
- Central issues for the future  
- A new MS OS/2 file system, a fully protected environment, and an enhanced network support.  
This book will be a cornerstone book in the library of anyone interested in MS OS/2. You can't get a more "inside" view (352 pages)  
B20720.....\$39.95

### ROD IRVING ELECTRONICS

MELBOURNE: 48 A Beckett St,  
Phone: (03) 663 8181  
OR: (03) 663 4760

NORTHCOOTE: 425 High St,  
Melb Phone: (03) 489 8866

SYDNEY: 74 Parramatta Rd,  
Stammore, NSW.  
Phone: (02) 519 3134

CLAYTON MAIL ORDER  
86 Renner Rd,  
Phone: (03) 543 7877  
Hotline: 008 5757  
Fax: (03) 543 2648

E & O Accepted  
IBM, PC, XT, AT, are registered trademarks of International Business Machines. Apple is a registered trademark of Apple corporation.



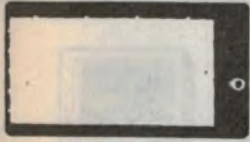

### BREAD BOARDS

This inexpensive range of modular interlocking units enables a quick, easy way of experimenting with new circuits and ideas. There are two main units consisting of a terminal strip or distribution and a Central plug-in unit.

• 100 holes  
P11000.....\$2.75

• 640 + 100 holes  
P11007.....\$14.95

• 1280 + 100 holes  
P11010.....\$26.95

• 2560 + 700 holes  
P11018.....\$69.95

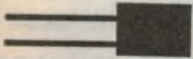

### RECTANGULAR LEDS

	1-9	10-99	100+
RED	20c	15c	12c
GREEN	20c	15c	12c
YELLOW	20c	15c	12c
ORANGE	20c	15c	12c

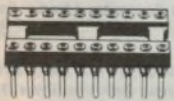

### GOLD INSERT LOW PROFILE IC SOCKETS

- Gold machined pins
- Extremely high quality
- Anti-wicking
- Ideal for professional use or where field service components is required.

Cat no.	Description	1-9	10+
P10620	8 pin	\$1.20	\$1.10
P10624	14 pin	\$1.60	\$1.40
P10626	16 pin	\$1.90	\$1.80
P10628	18 pin	\$2.00	\$1.90
P10630	20 pin	\$2.20	\$2.00
P10632	22 pin	\$2.40	\$2.20
P10634	24 pin	\$2.60	\$2.40
P10640	28 pin	\$2.90	\$2.70
P10644	40 pin	\$2.95	\$2.75



### LOW PROFILE IC SOCKETS

Save a small fortune on these "Direct Import" low profile IC sockets! PCB mounting solder trail. All tin plated phosphor bronze or beryllium and dual wipe for reliability.

Cat. No.	Description	1-9	10+
P10550	8 pin	\$0.20	\$0.18
P10560	14 pin	\$0.25	\$0.20
P10565	16 pin	\$0.25	\$0.20
P10567	18 pin	\$0.40	\$0.35
P10568	20 pin	\$0.40	\$0.35
P10569	22 pin	\$0.40	\$0.30
P10570	24 pin	\$0.40	\$0.30
P10572	28 pin	\$0.50	\$0.40
P10575	40 pin	\$0.50	\$0.40



### INSIDE THE IBM PC

(Revised and expanded edition)  
Peter Norton  
The widely acclaimed guide to the IBM PC's inner workings. The latest edition now covers every model of the IBM micro PC XT and AT and every version of DOS from 1.1 to 3.0  
B20080 .....\$44.95



### 12V DC FANS

80 x 80 x 25.4mm  
12V DC, 1.7 Watt, 0.14 Amps  
T12469.....\$12.95  
10+ fans only \$11.95 each

### MICE



### QUICK MOUSE

MICROSOFT™ COMPATIBLE!  
• Auto-selection and auto-transfer between mouse system system PC mouse mode and Microsoft serial mouse mode  
• Microsoft Serial Mouse and Mouse System compatible  
• Super high tracking speed: 600mm/sec  
• Super high resolution: 200 D.P.I. (0.12mm/dot)  
• Silicon rubber coated ball  
• Optical rotary encoder  
X19952.....\$79.00



### WITTY MOUSE

• Three buttons, user definable  
• Silicone coated steel ball  
• High resolution movement of 195 dots/inch Smaller table space and less hand movement required  
• Optical rotary encoder  
• Max tracking speed: 200m/sec  
• Mouse resident firmware  
• Size: 116 x 66 x 34mm  
• Mouse Driver Software included, allowing you to install with all popular software packages. Also included is the handy Pop-up menu software that allows the user to integrate the mouse with the keyboard, DOS, and other popular software packages  
X19950.....\$59

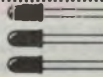

### FLASHING LEADS

• Red, 5mm  
1-10 10+  
Z10159 \$1.10 \$1.00



### THIS MONTHS INCREDIBLE IC'S SPECIALS

4002	1-9	10+
4007	29c	25c
4012	20c	18c
4014	20c	18c
4018	75c	70c
4022	75c	65c
4028	35c	30c
4034	1.30	1.10
4035	75c	60c
4040	60c	50c
4047	65c	60c
4071	25c	20c
4075	25c	20c
4081	25c	22c
4098	60c	50c
4510	70c	60c
4511	75c	70c
4515	80c	70c
4516	80c	70c
4518	75c	70c
4520	75c	70c
4528	80c	70c
4536	2.50	2.00
4556	50c	40c
MM5369	2.50	2.20
40175	50c	40c
7402	50c	40c
7405	50c	40c
7409	40c	35c
7410	45c	40c
7425	50c	40c
7426	30c	25c
7427	50c	40c
7430	50c	40c
7437	60c	55c
7438	30c	25c
7448	50c	45c
7447	50c	45c
7473	60c	55c
7475	60c	55c
7478	60c	55c
7493	50c	45c
7495	65c	60c
7497	1.20	1.00
74125	60c	55c
74126	60c	55c
74145	75c	70c
74150	1.00	90c
74155	80c	55c
74157	60c	55c
74161	60c	55c
74164	60c	55c
74174	60c	55c
74175	50c	45c
74283	75c	70c
74290	50c	45c
74100	30c	25c
74F32	30c	25c
74F109	42c	35c
74F153	25c	20c
74F157	80c	70c
74F181	2.50	2.20
74F194	1.00	80c

OFFER VALID TILL JULY 30, 1990

### CRYSTALS

Y11000	1MHz	\$11.50
Y11003	1.8432MHz	\$7.50
Y11005	2MHz	\$6.90
Y11007	2.3040 MHz	\$6.50
Y11008	2.4576 MHz	\$6.50
Y11009	2.7648 MHz	\$9.00
Y11010	3MHz	\$9.00
Y11015	3.5795 MHz	\$9.00
Y11018	3.9 MHz	\$9.00
Y11020	4.1 MHz	\$9.00
Y11022	4.2 MHz	\$3.90
Y11023	4.5 MHz	\$4.90
Y11025	4.75 MHz	\$4.90
Y11027	4.9152 MHz	\$6.90
Y11028	4.9562 MHz	\$4.90
Y11030	5MHz	\$4.90
Y11033	5.0688MHz	\$4.90
Y11042	6.144 MHz	\$4.90
Y11050	8.00 MHz	\$4.90
Y11055	8.86723MHz	\$4.90
Y11070	12.00 MHz	\$4.90
Y11072	14.318 MHz	\$4.90
Y11080	16.00 MHz	\$4.90
Y11085	18.432 MHz	\$4.90
Y11090	20.00 MHz	\$4.90



### PRINTER LEAD

- Suits IBM® PC/XT, compatibles
- 25 pin "D" plug (computer end) to Centronics 36 pin plug
- 1.8 metres

P19029.....\$14.95

• 3 metres  
P19030.....\$19.95

• 10 metres  
P19034.....\$39.95

### CABLES



### FLAT GREY RIBBON CABLE

- Flat cable for IDC connectors
- m = metre

W12614 - 14 way  
1-9m 10+m 100+m  
\$1.90m \$1.80m \$1.20m

W12616 - 16 way  
\$1.90m \$1.80m \$1.20m

W12620 - 20 way  
\$2.50m \$2.20m \$1.50m

W12624 - 24 way  
\$2.90m \$2.70m \$1.70m

W12626 - 26 way  
\$3.60m \$3.30m \$2.20m

W12634 - 34 way  
\$3.90m \$3.60m \$2.30m

W12636 - 36 way  
\$1.90m \$1.80m \$1.20m

W12640 - 40 way  
\$4.90m \$4.00m \$2.80m

W12650 - 50 way  
\$5.50m \$4.90m \$2.90m

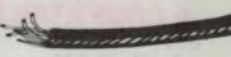

### COMPUTER CABLE

- Six conductor shielded computer interface cable
- m = metre

W12670 - CIC6  
1-9 m 10+ m 100+ m  
\$1.30m \$1.10m \$1.00m

W12672 - CIC9  
1-9 m 10+ m 100+ m  
\$1.60m \$1.50m \$1.20m

W12674 - CIC12  
1-9 m 10+ m 100+ m  
\$2.50m \$2.20m \$1.90m

W12676 - CIC16  
1-9 m 10+ m 100+ m  
\$3.50m \$3.20m \$2.50m

W12678 - CIC25  
1-9 m 10+ m 100+ m  
\$3.90m \$3.40m \$3.00m



### METEX M-3650 MULTIMETER

20A, 3 1/2 digit frequency counter multimeter with capacitance meter and transistor tester.

This spectacular rugged and compact DMM has a bright yellow high-impact plastic case. It features a frequency counter (to 200kHz), diode and transistor test, continuity (with buzzer), capacitance meter, up to 20 amp current measurement and comprehensive AC/DC voltage current and resistance ranges.

#### CHECK THESE FEATURES

- Push-button ON/OFF switch
  - Audible continuity test
  - Single function 30 position easy to use rotary switch for FUNCTION and RANGE selection
  - Transistor test
  - Diode test
  - Quality probes
  - 1/2" High contrast LCD
  - Full overload protection
  - 20 Amp
  - Built-in lifting bail
  - Capacitance meter
  - Instruction manual
- Cat. No. O91550 ..... Normally \$165  
Special, only \$129

### FREE

100 PAGE CATALOGUE  
PLEASE CALL IN AND PICK ONE UP



### METEX 3530 MULTIMETER

Compact, rugged, battery operated, hand held 3 1/2 digit multimeter.

**Features:**

- 1/2" high contrast LCD
- Automatic over-range indication with the "1" displayed
- Automatic polarity indication on DC ranges
- Capacitance measurements to 20uF
- Diode testing with 1 mA fixed current
- Audible Continuity Test
- Transistor hFE Test

**SPECIFICATIONS**  
Maximum Display: 1999 counts  
3 1/2 digit type with automatic polarity indication  
Indication Method: LCD display  
Measuring Method: Dual-slope in A-D converter system  
Over-range Indication: "1" Figure only in the display  
Temperature Ranges: Operating 0°C to +40°C  
Power Supply: one 9 volt battery (006P or FC 1 type of equivalent)  
Cat. O91540 ..... Normally \$139  
SPECIAL \$99

# ROD IRVING ELECTRONICS

## AUSTRALIA'S CHEAPEST DISKS!

FREE  
PACK & POST  
ON ORDERS  
OVER \$100!

OVER 10,000,000 SOLD!!!

MAIL ORDER  
HOTLINE  
008 33 5757

### "NO BRAND" DISKS

Now you can buy absolute top quality disks that are also the cheapest in Australia! They even come with a lifetime warranty, which indicates the quality of these disks. So why pay 2-3 times the price for the same quality?

Packs of 10, D/S D/D without boxes, or brand name, just their whitepaper jacket, and index label. (5 1/4" disks includes write protect)

(ALL PRICES PER 10 DISKS)

	1-9	10+	50+	100+
5 1/4" DS/DD	\$5.20	\$4.90	\$4.80	\$4.60

5 1/4" DS/HD	\$12.75	\$11.50	\$11.00	\$9.80
--------------	---------	---------	---------	--------

	1-9	10+	50+	100
3 1/2" DS/DD	\$12.75	\$11.50	\$10.75	\$9.80

3 1/2" DS/HD	\$32.50	\$29.50	\$29.00	\$28.50
--------------	---------	---------	---------	---------

### HS-3000 HANDY SCANNER



- WIDE 4.13" (105mm) scan width
- 100/200/300/400 switchable DPI resolution
- Four encoding modes: B/W and three half-tone patterns.
- Thirty-two shades of gray
- Built-in scanner view window for accurate scanner placement
- Yellow-green LED scan light
- Visible LED light to monitor scanning speed
- Bundled with ZSoft's PC Paintbrush Plus, DFI's Scan Utility and Image Tools
- Database and high-level language support
- Support for over 150 printers/plotters
- Support for over 225 display adapters

### NEW MODEMS

#### THE XITEL XM-12E MODEM

The XM-12E is designed for applications that require high speed, full duplex data communications such as data base access, file transfer and electronic mail (e.g. Auspac and Keylink) as well as direct communications and other CCITT and Bell systems.

#### KEY FEATURES:

- 1200 bps Asynchronous (CCITT V.22 B1) or Bell 212A)
- 300 bps Asynchronous (CCITT V.21 or Bell-103)
- Full Duplex data communications on a standard Telecom PSTN 2 wire circuit
- Auto-Dial, Auto-Answer and Auto-Disconnect (CCITT V.25 or Bell)
- Automatic data rate selection in both Originate and Auto-Answer modes
- Compatible with the Industry Standard Hayes AT Command Set
- Tone or Pulse Dialling with Call Progress Monitoring and Internal Speaker

.....\$249

#### BBM 1234E

- Auto V21, V22, V23, V22bis
- Bell 103 212A
- Async/Synchronous External

.....\$499

### POWER SUPPLIES

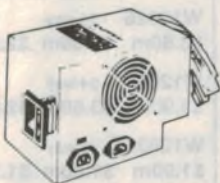

### 150W SWITCH MODE POWER SUPPLY FOR IBM\* PC/ XT\* & COMPATIBLES

DC OUTPUT  
+5 13A -5V 0.5A  
+12V 4.5 - 12V 0.5A  
X11096 ..... \$129

### 200W SWITCH MODE POWER SUPPLY FOR IBM\* AT\* & COMPATIBLES

DEC OUTPUT  
+5 16A -5V 0.5A  
+12V 5A -12V 0.5A  
X11097 ..... \$199

### PRINTERS



LX-400	\$349
LQ-400	\$595
LX-850	\$495
LQ-850	\$995
LQ-1050	\$1,295
NX1000	\$475
SUPER 5 KXP 1081	\$369
PANASONIC 24 PIN	\$775
STAR NX2410	\$970



### FAX SWITCH

- Lets you connect a normal telephone handset and a fax to the same telephone line
- Detects whether an incoming call is for the phone or the fax and automatically puts it through to the correct unit
- It automatically switches when you pick up the phone or use the fax to make an out going call
- Lets you override the automatic switching and connect the line to either the phone or the fax as you wish
- It is protected against lightning strikes- your fax switch has built in protection against power surges, created by lightning striking telephone lines.

X19090 .....\$289

### IBM\* CARDS



GAMES.....\$29  
AT S/P GAMES.....\$59  
4 WAY FDD CONT.  
(360-1.44M).....\$129  
2 WAY FDD CONT.  
(360-1.44M).....\$80  
CLOCK CARD.....\$39



VOICE MAIL.....\$245  
PRINTER CARD.....\$29  
EGA CARD.....\$199  
2 WAY FDD CONT.  
(360K).....\$39  
RS232 SERIAL/  
CARD.....\$39



RS232/ SERIAL/  
CLOCK.....\$49  
MONO/ COLOUR CARD...\$95  
MULTI I/O.....\$99  
512K RAM.....\$59  
DIAGNOSTIC.....\$750  
TTL/ PRINTER.....\$89



4 PORT SERIAL.....\$89  
VGA 256K.....\$299  
VGA 512K.....\$399



### JOYSTICK FOR IBM\*

Features selectable "spring centring" or "free floating". Electrical trim adjustments on both axis. 360 degree cursor control  
C14205.....\$39.95

### APPLE\* COMPATIBLE

Ideal for games or word processing. Fits most 6502 "compatible" computers  
C14200.....\$39.95

### APPLE\* IIE & IIC SERIES COMPATIBLE

These joysticks have adaptor connectors to suit the Apple II, Iic, Iie and Iic+ computers. Features include selectable "spring centring" or "free floating". Electrical trim adjustments on both axis. 360 degree cursor control and dual fire buttons  
C14201.....\$39.95



### RITRON MULTISYNC VGA COLOUR MONITOR

Quality Auto VGA, EGA, CGA monitor without the excessive price tag!  
Display Tube: 14 inch 90° deflection P22 Non-glare, Int 0.13mm dot pitch  
Active Display Area: 245 x 185mm  
Resolution:  
800 dots(H) x 600 lines(V)  
Display Colour:  
TTL Input: 8/16/64 colours  
Analog Input: unlimited colours  
X14528.....\$895



### RITRON CGA COLOUR MONITORS

Quality monitors without the exorbitant price tag!  
Display Tube: 14 inch 90° deflection 0.39mm Dots trio pitch. Dark face screen.  
Phosphor: P22  
Resolution: 640 dots (horizontal) 240 line (vertical)  
X14526.....\$395



### RITRON EGA COLOUR MONITORS

Display Tube: 14 inch 90° deflection dot type black matrix. Standard persistence phosphor.  
Active Display Area: 240mm x 180mm  
Resolution:  
64 Colour: 720dots(H) x 350 lines  
16 Colour: 640dots(H) x 200 lines  
X14527.....\$595

## COMPUTERS



### IBM\* XT\* 640K RAM TURBO COMPATIBLE COMPUTER

Check these features and our prices. We're sure you'll agree they're exceptional value for money!

- Final assembling and testing in Australia!
- Fast TURBO Motherboard
- AT\* style keyboard
- Tested by us for 24 hours prior to delivery!
- 8 Slot motherboard
- 12 months warranty!
- 150W power supply

### 640K RAM TURBO COMPATIBLE COMPUTER

2 x 360K Disk Drives, Multi-function Card, Colour Graphics, Disk Controller, 1 Serial, Parallel Port (Clock).....\$895

WITH 20 M/BYTE HARD DISK:  
& single 360K Disk Drive...\$1,195  
& dual 360K Disk Drives...\$1,395

WITH 40 M/BYTE HARD DISK:  
& single 360K V.C. H.D.....\$1,575  
& dual 360K V.C. H.D.....\$1,725



### BABY AT\* COMPATIBLE COMPUTER!

2M/B RAM \$1,695

- Final assembling and testing in Australia!
- 4 M/Byte Main Board, 2 M/Byte fitted
- Switchable 8/10/12 MHz
- 1.2 M/Byte Floppy Disk Drive
- 80286 CPU
- Colour Graphics Display Card
- 8 Slots
- Floppy & Hard Disk Controller
- Printer Card and RS232
- Keyboard
- 200W Power Supply
- Manual
- 6 Months Warranty
- Size:  
360(W) x 175(H) x 405(D)mm

With 20 M/Byte Hard Disk \$1,995  
With 40 M/Byte V.C. H.D... \$2,195  
With 80 M/Byte Hard Disk \$2,795

## TEST EQUIPMENT

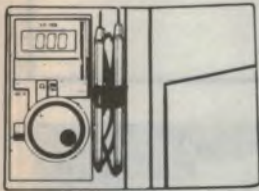

### MULTIMETER (YF-100)

- Autoranging for DCV, ACV, OHM & continuity measurement
- AC DC 0 - 500 Volts
- 10mm thickness & 80g light weight for easy operation
- Dimension & weight = 108 x 54 x 8mm and 60g approx

Q11264.....\$69

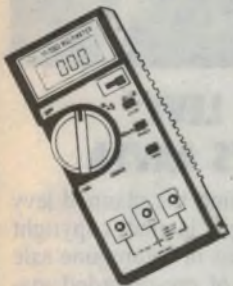

### MULTIMETER (YF-3000)

- Large display 3 1/2 digit 0.5" height LCD for easy readout
- AC DC 0 - 1000 Volts
- Auto/manual range select easy to operate
- Automatic low battery " - + " display for battery indication
- Memory-comparative function available for allowance within  $\pm 5\%$  f.s
- Warning sound for overload and conductance
- Dimension & Weight = 170 x 80 x 33mm, 260gram approx
- Data hold function for easy readout

Q11268.....\$110

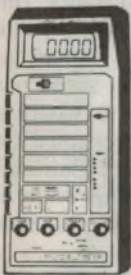

### MULTIMETER (YF-2100)

- Large display 4 1/2 digit 0.5" height LCD with maximum reading of 19999
- AC DC 0 - 1000 Volts
- Automatic polarity " - " display for negative input
- High over-load protection for all ranges
- Over load display, the highest digit "1" or "-1" alone glows
- Power consumption 20mW approx.
- Dimension & weight = 162 x 86 x 28mm and 200g approx

Q11266.....\$199

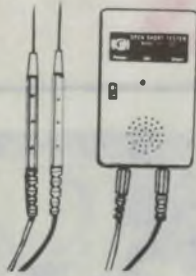

### SHORT TESTER

- Instantly shows the open/short position of PCB
- It can test whether PCB or solid wire open/short by Buzzer

Q11276.....\$22.95



### LOGIC PULSER (LP-540H)

- Can be used directly to inject a signal into logic circuits without removing IC
- Compatible with TTL, DTL, RTL, HTL, MOS and CMOS

Q11274.....\$42.95



### DIGITAL METER (YF-120)

- Autoranging operation
- Data-hold for easy readout
- Full range protection
- 0-500 volts AC-DC
- 0-20 M $\Omega$
- Dimension & weight = 133 x 29 x 17mm and 60g approx

Q11270.....\$98.95



### LOGIC PROBE (LP-2800)

- Useful for TTL or CMOS has high and low indicator leds and also with pulse memory.
- This is a very handy tool for the hobbyist or serious technician for tracing those hard to find faults on logic boards.

Q11272..... \$19.95

## NEW CRO'S

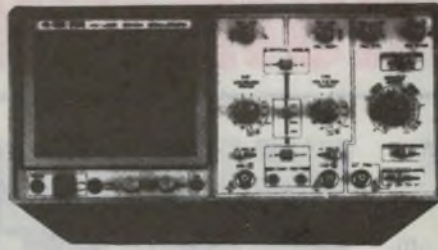

### 20MHZ DUAL TRACE OSCILLOSCOPE

- CRT DISPLAY
- 150mm rectangular

#### VERTICAL DEFLECTION

- Deflection Factor: 5mV to 20V/ Div on 12 ranges in 1-2-5 step with fine control
- Bandwidth DC: DC to 20MHz (-3dB)  
AC: 10Hz to 20MHz (-3dB)
- Operating Modes: CH-A, CH-B, DUAL and ADD (ALT/CHOP L202 only)
- Chop Frequency: 200KHz Approx
- Channel Separation: Better than 60dB at 1KHz

#### TIME BASE

- Type: Automatic and normal triggered in automatic mode, sweep is obtained without input signal
- Sweep Time: 0.2 $\mu$  Sec to 0.5 Sec/ Div on 20 ranges in 1-2-5 step with fine control and X-Y
- Magnifier: X5 at all ranges

#### TRIGGERING

- Sensitivity Int: 1 Div or more  
Ext: 1Vp-p or more
- Source: INT, CH-B, LINE or EXT
- Triggering Level: Positive and Negative, continuously variable level; Pull for Auto
- Sync: AC, HF Rej, TV (each + or -) at TV Sync, TV-H (line) and TV-V (Frame) sync. are switched automatically by SWEEP TIME/Div switch.

#### HORIZONTAL DEFLECTION

- Deflection factor: 5mV to 20V/ Div on 12 ranges in 1-2-5 step with fine control
- Frequency Response: DC to MHz (-3dB)
- Max Input Voltage: 300V DC + AC Peak of 600Vp-p
- X-Y Operation: X-Y mode is selected by SWEEP TIME/ Div switch
- Intensity Modulation Z Axis: TTL Level (3Vp-p-50V) + bright, - dark

#### OTHER SPECIFICATIONS

- Weight: 7Kg Approx
- Dimensions: 162(H) x 294(W) x 352(D) mm

Q12105.....\$750

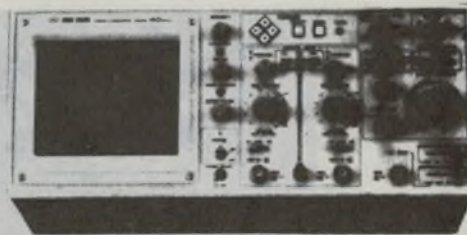

### 40MHZ READ-OUT OSCILLOSCOPE

- CRT DISPLAY
- 150mm rectangular

#### VERTICAL AMPLIFIER (CH1 and CH2 Identical)

- Operational Modes: CH1, CH2, ADD, DUAL, ALT, CHOP
- Sensitivity: 5mV-5V/ Div 3% in 1-2-5 steps  
1mV-1V/ Div x5% x5MAG
- Bandwidth DC: DC to 40MHz (-3dB)  
AC: 5Hz to 40MHz (-3dB)
- Rise Time: Less than 87ns

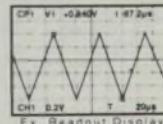

#### HORIZONTAL AMPLIFIER

- Operating Modes: X-Y operation CH1-X axis, CH2-Y axis
- Sensitivity: 5mV-5V/ Div 3% in 1-2-5 steps
- Input Impedance: 1M $\Omega$   $\pm$  2%, 25pF  $\pm$  3%
- Bandwidth DC: DC to 1MHz (-3dB)  
AC: 5Hz to 1MHz (-3dB)

#### TIME BASE

- Sweep Method: AUTO, NORM, SINGLE
- Sweep Time (A): 0.2 $\mu$ s-0.5S; Div  $\pm$  3% in 1-2-5 steps (X1 only)  
(B): 0.2; S-0.5mS; Div  $\pm$  3% in 1-2-5 steps (X1 only)
- Magnified Sweep: 10 times  $\pm$  5%, Max 20ns
- Linearity:  $\pm$  3% or better

Q12107.....\$1,695

## CASES

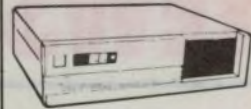

### IBM\* XT COMPATIBLE CASE WITH AT\* STYLING

- Features security key switch, 8 slots, and mounting accessories
- Size: 490(W) x 145(H) x 400(D)

X11091.....\$99

### BABY AT\* STYLE COMPUTER CASING

- Small footprint. Features security key switch, 8 slots and mounting accessories
- Size: 360(W) x 175(H) x 405(D)mm

X11093.....\$99



## ROD IRVING ELECTRONICS

SYDNEY: 74 Parramatta Rd. Stanmore 2048  
Phone: (02) 519 3134  
Fax: (02) 519 3868

MELBOURNE: 48 A'Beckett St  
Phone: (03) 663 6151

NORTHCOTE: 425 High St.  
Phone: (03) 489 8866

MAIL ORDER & CORRESPONDENCE:  
P.O. Box 620, CLAYTON 3168  
Order Hotline: 008 33 5757  
(Toll free, strictly orders only)  
Inquiries: (03) 543 7877  
Telex: AA 151938  
Fax: (03) 543 2648

All sales tax exempt orders and wholesale inquiries to -  
RITRONICS WHOLESALE:  
56 Renver Road, Clayton.  
Phone: (03) 543 2166 (3 lines)  
Fax: (03) 543 2648

### ORDER HOTLINE 008 33 5757 (TOLL FREE)

STRICTLY ORDERS ONLY

LOCAL ORDERS & INQUIRES (03) 543 7877

#### RATES

\$1 - \$9.99	\$3.00
\$10 - \$24.99	\$3.50
\$25 - \$49.99	\$4.50
\$50 - \$99.99	\$6.00
\$100 - \$199	\$6.00
\$200 - \$500	FREE
\$500 PLUS	FREE

The above postage rates are for basic postage only. Road Freight, bulky and fragile items will be charged at different rates.

Errors and omissions excepted. Prices and specifications subject to change.

IBM, PC, XT, AT are registered trademarks of International Business Machines. Apple is a registered trademark. Teflon is a registered trademark of Dupont. Danonites registered trademarks of their respective owners.



# ROD IRVING ELECTRONICS

# NEWS HIGHLIGHTS

## PM OPENS ALCATEL-TCC OPTICAL CABLE PLANT

Prime Minister Bob Hawke has officially opened Alcatel TCC's state of the art \$100 million submarine optical cable factory at Port Botany, just south of Sydney.

The Port Botany plant was built initially to produce the Sydney-Auckland TASMAN 2 cable, as reported in our March issue. However the plant already represents some 50% of Alcatel's worldwide manufacturing resources for submarine optical fibre cables, and is strategically placed to become a prime supplier for the Asia-Pacific region. The market in this region is expected to be worth some US\$5 billion in the next 10 years, and the Port Botany plant is expected to generate around A\$100 million/year in export business.

Present at the opening ceremony was Mr Pierre Suard, Chairman of the parent company Alcatel NV, which has an annual turnover of A\$20 billion and claims to be world leader in both communications and power cables. Mr Suard jointly hosted the ceremonies with Mr Bill Page-Hanify, Chairman of Alcatel TCC and Chairman-MD of Alcatel STC. Alcatel TCC is a joint ven-

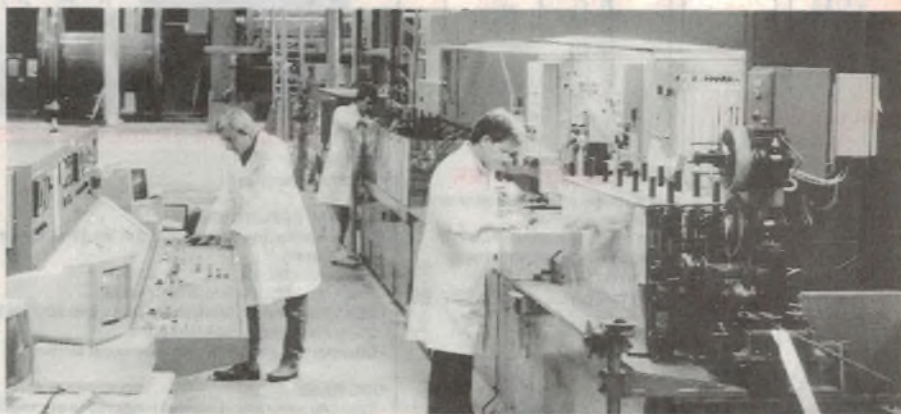

ture of Alcatel STC, Alcatel CIT and Cables de Lyon, of France.

Also present for the opening were Mr Claude Bovis, President and GM of Cables de Lyon, Mr Jean Devos, MD of Alcatel Submarcom, and Mr Jacques Imbert, President of Alcatel Radiocommunications, Space and Defence.

The new Port Botany factory employs 180 people at present, and has the capacity to produce around 12,000km of submarine optical cable per year. It is now operating continuously 24 hours per day and 365 days per year, and is already being expanded to increase its capabilities. The TASMAN 2 cable is planned to be laid before April 1991.

## BLANK TAPE LEVY UNFAIR, SAYS AAVTA

The rationale behind the planned levy on blank audio tape is that copyright owners suffer the loss of a foregone sale every time a piece of pre-recorded material is taped, and this is an incorrect assumption, says the Australian Audio Video Tape Association. According to AAVTA Secretary Ian Prosser, authorities in the UK and USA have acknowledged that such a levy would be both wrong in principle and unworkable in practice – yet Australian legislators are pushing on regardless.

Mr Prosser says that slapping a levy on all blank tapes presumes that all tapes will be used to copy pre-recorded material – i.e., that all users are guilty of copyright violation, and must therefore pay the levy in advance (unless they are prepared to submit a statutory declaration, in order to obtain a refund). Yet the Australian scene is very similar to that in the USA, where a recent survey by the Congressional Office of Technology Assessment showed that only 6% of home recordings were made to avoid purchasing a commercial recording.

The same survey apparently showed that 81% of taped selections and 64% of complete album recordings were made from recordings purchased legitimately by the user or their family.

Mr Prosser also noted that as there is no reciprocal arrangement between copyright owners in Australia and those in the UK or USA, no levy should be payable when recordings are made of music produced in these countries.

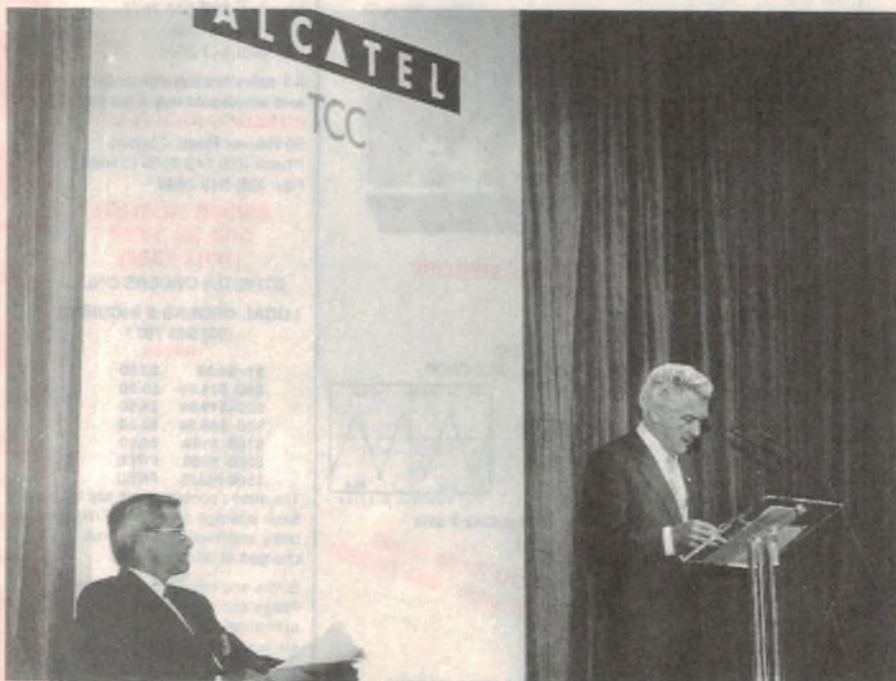

## LOCAL FIRM TO DEVELOP SPEECH SYNTHESIS CHIP

Syrinx Speech Systems, recently formed in response to the growing demand for commercial R&D services, has just reached agreement with OTC on the development of advanced speech synthesis technology. The preliminary agreement precedes a contract worth quarter of a million dollars (\$254,000) to design and develop an advanced speech synthesis chip based largely on the work of two respected electrical engineers.

Professor Trevor Cole, Professor of Electrical Engineering at the University of Sydney and Dr Clive Summerfield, a former Research Fellow there, see Syrinx providing a vital first step in the development of speech synthesis technologies primarily for financial, banking and telecommunications services. The team has a fine track record, with Dr Summerfield's earlier work in speech technology having been commercially applied in Europe, the United States, Australia and Japan.

According to Syrinx Managing Director, Dr Summerfield, the world potential for speech synthesis is put at a figure in excess of \$250 million by 1992.

## TELECOM FUNDS PRODUCTIVITY RESEARCH

Would office workers like to send a ten page fax in less than a second, and would business executives like to conduct interstate video conferences through their desk-top PCs? And what about doctors and bankers? Would they like to examine X-ray photographs or cheques that are located half a continent away?

Telecom Australia thinks they would, and a collaborative research effort between Telecom Research Laboratories and the University of Wollongong has been established to forge these and other telecommunications scenarios into reality.

Telecom has provided the University with \$1.1M to establish a Centre of Expertise in switched networks research. Telecom's funding will fully support the Centre's research activities for an initial three years.

The work of the new Centre will complement and extend core research already well established at Telecom Research Laboratories. The research will also involve members of the University of Technology, Sydney, thus enhancing the synergy of the project by creating a

powerful three-way partnership between institutions which are internationally renowned for their research expertise.

Heading the Centre's research will be Professor Hugh Bradlow. Under the general guidance of Telecom researchers Mr Jim Park and Dr Paul Kirton, Prof Bradlow and his team will explore key aspects of intelligent networking and fast packet switching technologies.

"The work of this Centre will lower the costs of doing business in Australia because it will make business communications cheaper, more versatile and more effective," said Harry wragge, head of Telecom Research Laboratories. "For example, businesses will be able to transmit data and very high resolution images at extremely fast speeds, and will be able to individually configure their use of the Telecom network to manage changing market forces."

## PROTEL CAD SOFTWARE LAUNCHED INTO JAPAN

Protel Technology, the Australian producer of Protel CAD software for printed circuit board design, has reached a formal agreement with the Nissho Iwai Systec Corporation, a subsidiary of Nissho Iwai Corporation in Tokyo, for them to market the full range of Protel software in Japan as sole distributor.

Nissho Iwai Systec is working closely with Protel to make sure that the software is localised to include Japanese text reference manuals plus other important specifications, such as metrication and Japanese component libraries.

Protel software is now marketed in over 25 countries, including the USA, where Protel Technology operates its own company, providing marketing and technical support facilities for both North and South America, from its office in San Jose, California.

## PROGRESS IN HDTV STANDARDISATION

During a recent meeting of the CCIR in Atlanta (United States), the Eureka EU-95 HDTV consortium (led by Philips, Thomson, Nokia and Bosch and with 35 other European companies as members) and most European administrations achieved world-wide support for the proposal of a further study programme to define and enhance a number of important parameters for an HDTV world production standard.

During this CCIR meeting, a recom-

mendation was adopted which defines a number of parameters for an interim HDTV standard and expresses the need for an improved final single world standard for HDTV production. The European countries, as well as the Eureka EU-95 HDTV consortium, concluded that the number of now-agreed parameters is too limited to develop a single HDTV world production standard. Therefore, it was agreed to have a further study period of four years (1990-1994) to define the missing parameters and improve the set of existing parameters.

## NEW INSTRUMENT CONTROL LANGUAGE

A new instrumentation language has been established to standardise commands and responses for control of test and measurement (T&M) instruments, while enhancing existing standards such as IEC 625-1 (IEEE-488) and VXIbus. The Standard Commands for Programmable Instruments (SCPI) addresses customers' needs for a common command set among T&M instruments.

SCPI is the result of months of technical and administrative efforts by a worldwide consortium of nine major T&M equipment manufacturers, who worked together to refine the Test and Measurement Systems Language (TMSL) originally developed within Hewlett-Packard, and the Analog Data Interchange Format (ADIF) from Tektronix. The SCPI Consortium will initially include Bruel & Kjaer, John Fluke Mfg Co, Hewlett-Packard, Keithley Instruments, National Instruments, Philips Test & Measurement, Racal-Dana, Tektronix and Wavetek.

SCPI expands the limited command set of IEEE-488.2, which clearly defined some generalised commands, but left the naming of the commands that do the actual testing and measuring to individual manufacturers. The new language provides a comprehensive, easy-to-remember, 'plain-English' command set. To measure voltage, for example,

The standardisation of the language among a number of manufacturers means that customers no longer need to spend long hours relearning command sets to operate a number of different instruments. SCPI also improves the likelihood that products will be interchangeable. For example, ':MEAS.FREQ?' returns a frequency measurement from an oscilloscope or a counter, despite the great differences in the internal hardware of the instruments.

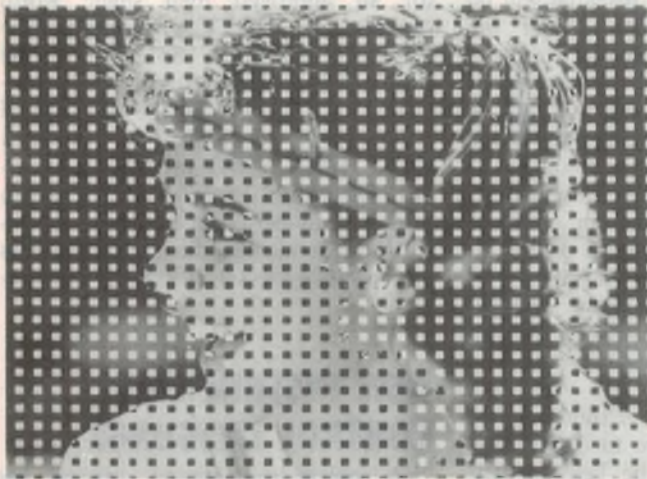

## TECHNIQUE FIXES GROSS ERRORS IN VIDEO, AUDIO

At the Philips Research Laboratories in Eindhoven (Holland), Raymond Veldhuis has developed a method which allows even large errors in signals, such as speech, music or images, to be restored. For this he makes use of the regularity present in almost every signal. By analysing the error's environment it is possible to correct the error in such a way that there is no longer any perceptible dissonance or picture

disturbance.

Veldhuis bases his restoration method on the fact that speech, music or picture signals all have a certain regularity, characterised by the signal spectrum. This regularity can be measured in the environment of the error. With the information gained in this way, it is possible to replace the missing numbers in the series so that the restored part of the signal shows as far as possible the

same regularity as the environment.

In the (future) transmission of digitised pictures, for example, groups of 8 x 8 pixels will be transmitted. If there is a transmission error then an entire 8 x 8 area can suddenly disappear and this is seen as a picture fault. Restoration can again take place in the manner indicated: determine the regularity in the brightness distribution in the area's surroundings and from this, calculate the brightness of the missing picture elements (see photo).

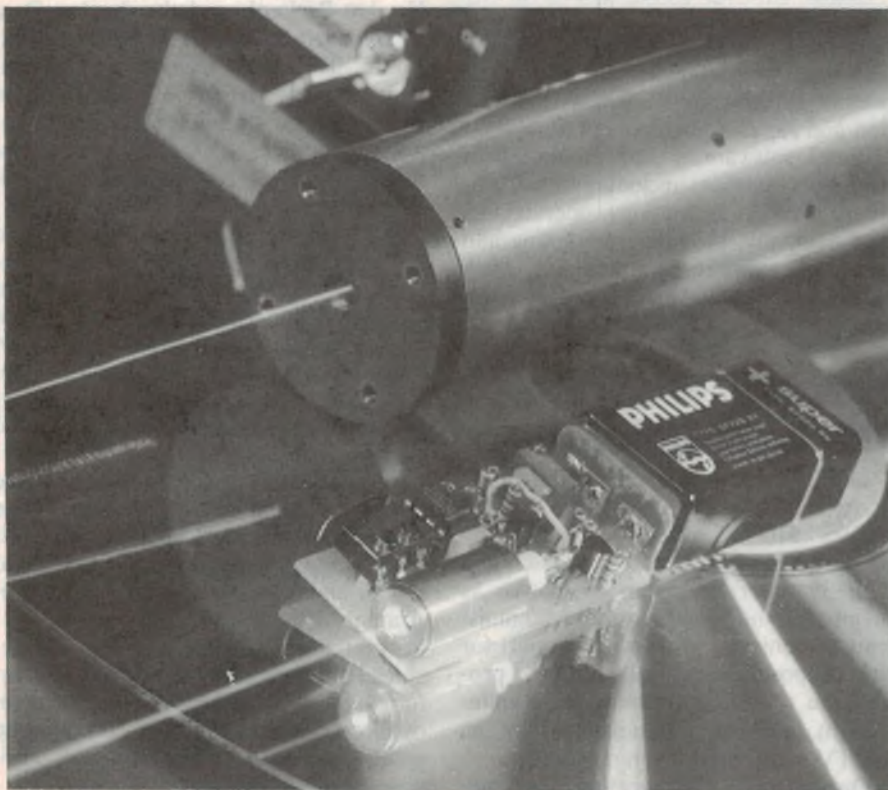

## PHILIPS DEVELOPS FIRST SEMI LASER WITH 633nm OUTPUT

Staff at the Philips Research Laboratories in Eindhoven have achieved a world first: they have succeeded in creating a semiconductor laser for practical use which emits light with the same light red colour as the widely-used helium/neon gas laser (a wavelength of 633 nanometres).

At present, applications for semiconductor lasers include glass fibre communications and optical recording and playback, such as the reading of CDs. The semiconductor lasers produced so far emit light with a 'colour' between invisible infrared and barely-visible dark red (670nm). The new laser is the first semiconductor laser to emit light which is clearly visible to the human eye. The wavelength is exactly the same as that of the helium/neon gas laser, which is used widely in laser printers and bar-code readers. Previously, this wavelength could not be achieved with semi-

conductor lasers for practical use, since it resulted in excessive losses in the material. Now Philips has succeeded in reducing these losses to such an extent that a semiconductor laser is quite feasible with a wavelength of 633nm.

Replacing the helium/neon laser with the new semiconductor laser is an attractive prospect, on account of the very small dimensions (the laser length has been reduced from 300mm to 0.3mm), the high operational safety, and high efficiency — which means that a simple battery is sufficient to power the laser. The production of the new laser is based primarily on familiar semiconductor technologies, allowing it to be produced reliably in large numbers.

The light-emitting heart of the new laser is formed by a number of extremely thin layers of a compound crystal of the elements gallium, indium and phosphorus. These layers are grown from the gaseous state on a gallium arsenide base layer, giving them a perfect structure.

The new laser differs from dark-red-emitting semiconductor lasers in the thickness of these layers. Each layer is ten thousand times thinner than a human hair (the thickness equals a few nanometres, or a few tens of atoms). Philips claims to be the first to have succeeded in using such thin layers in a completely controlled manner and in understanding their behaviour, which has been of vital importance in achieving the above results.

As yet, the results described here relate only to laboratory research, they do not imply the manufacture or marketing of new products.

## AUSSIE DEBUT FOR GROUP 4 FAX

Group 4 fax transmission had its first public demonstration in Australia recently at the ATUG '90 Conference in Melbourne, between the Philips and Telecom stands. Capable of sending data at 64kbps through ISDN, Group 4 can send an A4 page in less than 3 seconds.

## HUBBLE SPACE 'SCOPE LAUNCHED

The Hubble Space Telescope has been successfully launched and placed in orbit, to begin its 15-year search of the heavens for answers to the questions that have frustrated astronomers for decades. The telescope is 13.1m long, and has a mass of 11,000kg — more than three times larger and heavier than any

unmanned satellite ever previously launched by NASA.

At the heart of the telescope's 270kg Wide Field/Planetary Camera (WF/PC) are eight CCD image sensor chips, each less than 25mm square, which were developed especially for the mission by scientists at Texas Instruments' Central research Laboratory in Dallas, Texas. Similar TI chips were used on the European Space Agency's Giotto mission to photograph Halley's Comet, while others are currently on JPL's mission to Jupiter.

Each of the TI CCD chips has an 800 x 800 array of 15µm square silicon photodetectors. The four sensor chips in each mode of the WF/PC are combined to produce an image of 1600 x 1600 pixels. Each chip is coated with a phosphor which converts ultraviolet light into visible photons.

## FIRST ISDN MICROLINK EQUIPMENT DELIVERED

Alcatel STC has delivered its first batch of ISDN basic access multiplexers (BMUX) to Telecom Australia. Deliveries were made on time, after an inten-

sive two year development program at Alcatel's Sydney research and development laboratories.

The BMUX and associated network terminations will provide Telecom with the equipment needed to introduce the second phase of its ISDN network — the basic access MICROLINK service — this month.

Network Terminations (NT1) are mounted in small neat boxes and link the customers' telephones, computers and/or fax machines with Telecom's local loop cable. These network terminations act as the bridge between the internal four-wire ISDN s-bus and the standard twisted pair telephone cables.

The new BMUX will be located in a number of exchanges where it will allow the extension of ISDN (Integrated Services Digital Network) into Australian homes and small businesses. The advantage of this service is that dual voice/data channels can be provided without the need to rewire the network.

The BMUX connects to the standard twisted pair telephone cable running out to customer premises. Each twisted pair carries the basic access 2B + D (144-kbps) digital stream between the BMUX and the network termination unit located in the customer premises.

## NEWS BRIEFS

- Jurgen Heinsen has been appointed Managing Director of **BASF Australia**, following the retirement of Hugh Grayson, who held the position for the past 10 years.
- **Procon Technology** has a new postal address: PO Box 655, Mt. Waverley 3149 or phone (03) 807 5660.
- Maxim Integrated Products, a leading international supplier of analog ICs for data acquisition and control systems, has leased Saratoga Semiconductor's Class 10 wafer fabrication facility and purchased equipment and assets for \$5.3M. The Australian distributor for Maxim is **Veltek**, 22 Harker Street, Burwood 3125 or phone (02) 713 4100.
- **George Brown Group** has been appointed Australian and New Zealand stocking representative for Waferscale Integration of California, and also as a distributor in Australia for the French company Thomson LCC.
- The eighth annual Australasian conference and exhibition on computer graphics, **Ausgraph 90**, will be held on September 10-14, 1990, at the World Congress Centre, Melbourne. Inquiries to Ausgraph 90 Secretariat, PO Box 29, Parkville 3052 or phone (03) 387 9955.
- **Malcolm Kerr**, managing director of Hewlett-Packard Australia from 1985 until March 1989, passed away on 18 April 1990 after a long illness.
- Melbourne based datacommunications specialist, **Datacraft Computer Protocol**, has opened a branch office in the Canberra suburb of Fyshwick.
- French video wall and visual display specialist, Synelec, has restructured its Australian operations into a new company, **Vision Display (Australia)**, based in the Sydney suburb of Ryde.
- **Elmeasco Instruments** has been appointed as the Australian Distributor and Service Agent for Kenwood TMI products.
- Jan Sander of The Netherlands has been elected Chairman of the **Inmarsat Council** for the coming year. Inmarsat, with 59 member countries, operates a global system of eight satellites to provide mobile communications for maritime, aeronautical and land mobile customers worldwide.

# Syntony & Spark — 1

In this first of two further articles dealing with the early development of 'wireless' transmission and reception, the author describes Marconi's development of tuning — leading to the Jigger and the Multiple Tuner.

by PETER R. JENSEN VK2AQJ

In 1903, 'wireless' was still the great scientific novelty of the Victorian era and crowds of people would flock to hear anyone who had the qualifications and the ability to explain and demonstrate what it could do.

It was at just such a gathering, early in 1903, that Dr J. Ambrose Fleming, senior scientific adviser to the fledgling Marconi Company, was to present a lecture designed to show off the work of his employer. However, despite careful preparations for his presentation, things soon began to go wrong in a completely unexpected fashion.

Reading Dr. Fleming's later scientific treatises on the subject of wireless, when he had become a Professor, there has to be more than a small suspicion that he was a serious minded and rather humourless fellow. What was to happen in that lecture would have taxed the sense of humour of even a seasoned politician, let alone a single-minded and determined scientist, bent on establishing his reputation.

The introduction was over and Fleming was just about to turn to the receiving apparatus that had been set up. His

assistant stood ready to receive messages from the two Marconi stations at Chelmsford and Poldhu, when the altogether unexpected happened. Suddenly the Morse printer started to chatter and as the paper tape ran out and Fleming was able to read it, he realised that something was seriously wrong. With, at first puzzlement, and then mounting fury, he read the word, 'Rats' and then a poem that began, 'There was a young man from Italy, who diddle the public so prettily'.

As one might have expected, the source of the messages was a business rival of Marconi, a gentleman called Maskelyne, who had set out to discredit the Marconi system.

However apart from the fine row that this action caused and which, in a letter to the newspapers, Fleming was to describe as, 'scientific hooliganism', the question that had to be answered was how had Maskelyne been able to have his messages printed out by the Marconi system. The answer was ridiculously simple.

The apparatus that Fleming was using had minimal provision for 'tuning' to a

particular frequency. All that Maskelyne had to do was to set up an untuned transmitter close enough for his signals to be received by the rather indiscriminating detector of Fleming, and the embarrassing episode described was the inevitable result. If Marconi had not already fully appreciated the fallibility of untuned wireless communication, this would have been enough to convince him that a solution was essential if a fully effective system was to be achieved.

However for the start of the story of 'tuning', one must go back fully 14 years to the first experiments of Hertz.

## Hertz lucky

In the research that Heinrich Hertz undertook during 1888, and in the results that he achieved, while his scientific skill was clearly evident there is no doubt that good luck was also on his side. With the benefit of scientific hindsight, it is now clear that he was fortunate in more than one respect.

Firstly his work was conducted in a large laboratory with a limited number of metal reflecting surfaces to disturb the radio frequency waves. Secondly the physical dimensions of the apparatus Hertz used resulted in the radio frequency energy being confined to a part of the spectrum where it would exhibit behaviour more like that of light than would have been the case at lower frequencies. Lastly the relatively small di-

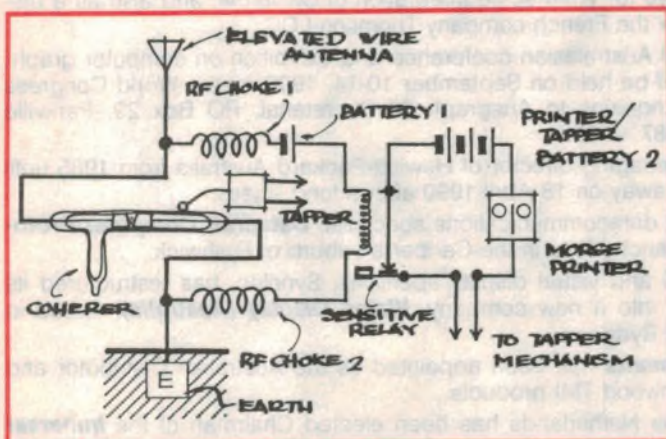

The schematic of a Marconi receiver of 1897. As you can see the RF circuit consists only of the antenna, coherer (detector) and earth, with no attempt at any kind of tuning.

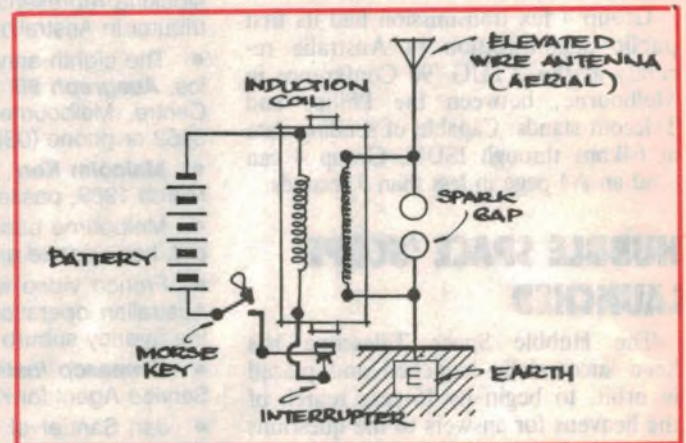

A matching Marconi transmitter, also from 1897. Here too there is no attention to tuning the oscillating system formed from the coil secondary and antenna system.



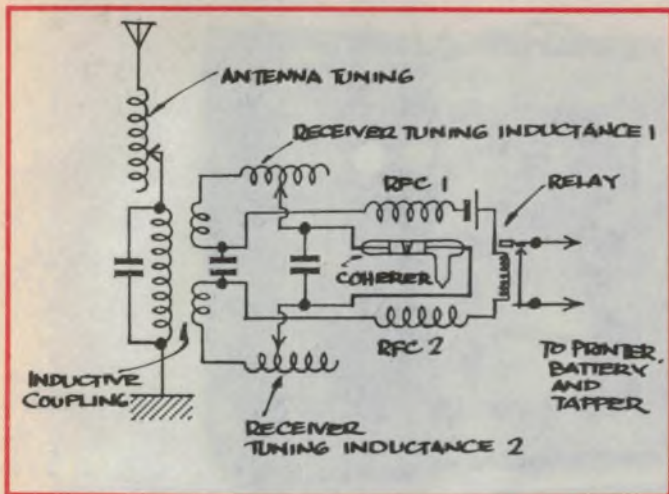

In contrast, here is a Marconi receiver of 1900. Now there are a number of variable inductors and capacitors, used to tune both the antenna and detector circuits.

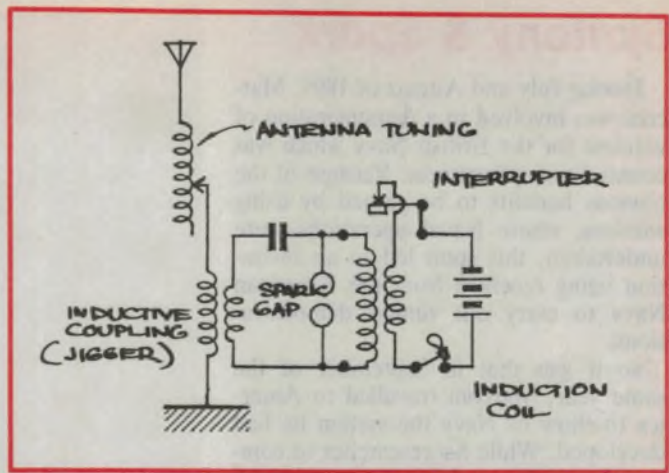

And antenna tuning has now been added to this transmitter, of the same vintage. The capacitor also formed an RF oscillatory circuit, with the spark gap and 'jigger' primary.

mensions of the radiating elements of the transmitting and receiving system allowed them to be brought into tune with each other.

Not surprisingly, with such a new field of research, Hertz seemed to have been generally unaware of his good fortune and particularly that of bringing the two parts of his transmitting and receiving apparatus into resonance. It was not until 1894, after Hertz's tragically early death in 1892 at the age of 37, that the theory of tuning was clearly demonstrated by Oliver Lodge. However Lodge did not call it tuning but *syntony*, a word more reminiscent of the theory of musical harmony than of radio science.

Very soon after Hertz had died and his obituary had been read by the youthful Marconi, the first successful radio communication was to be undertaken at the Villa Grifone, the Marconi residence, near Bologna. However this was not with a 'syntonic' or tuned system. That was a subtlety that evaded Marconi for several years to come and was to bring him into a heated dispute with Oliver Lodge, a dispute that smouldered for well over 10 years.

The dispute was not finally resolved until 1910 when, after a threatened Court action, a financial settlement was agreed to by Lodge. He received an undisclosed sum of money and beyond that was made a scientific advisor to the Marconi Company — a rather ironic victory in the light of the acrimony that had existed for so long between the warring parties.

So what was this subtle issue which caused so much bitterness and argument between the great men of radio communication?

### Basic need

These days it is the most elementary part of a radio communication system and one of the matters that any engineer or radio amateur learns about first. In simple terms it is the means by which a signal can be established in one part or other of the radio frequency spectrum, which stretches from the top of the audio frequency band all the way up through light and on to gamma radiation. It is the ability to *tune*, or in the old language of wireless to 'syntonize', that allows the myriad of communications, that occur at all times by radio, to take place without overlap or mutual interference.

While it is the most elementary of skills these days to place a transmitter and a receiver at the same place in the

spectrum that stretches over such a great range of frequencies, in many respects it proved to be the most elusive of the early elements of radio to discover and define.

Without tuning what would be the result? In a word, 'Bedlam' and after 1895 it did not take Marconi very long to realise that his system would remain simply a scientific novelty of very little commercial value — without some means of separating the signals that fell upon the indiscriminating particles of metal in his detector, the coherer.

To emphasize the vulnerability of the untuned system pioneered by Marconi, it is only necessary to give one further example which caused the young entrepreneur considerable difficulty at the time.

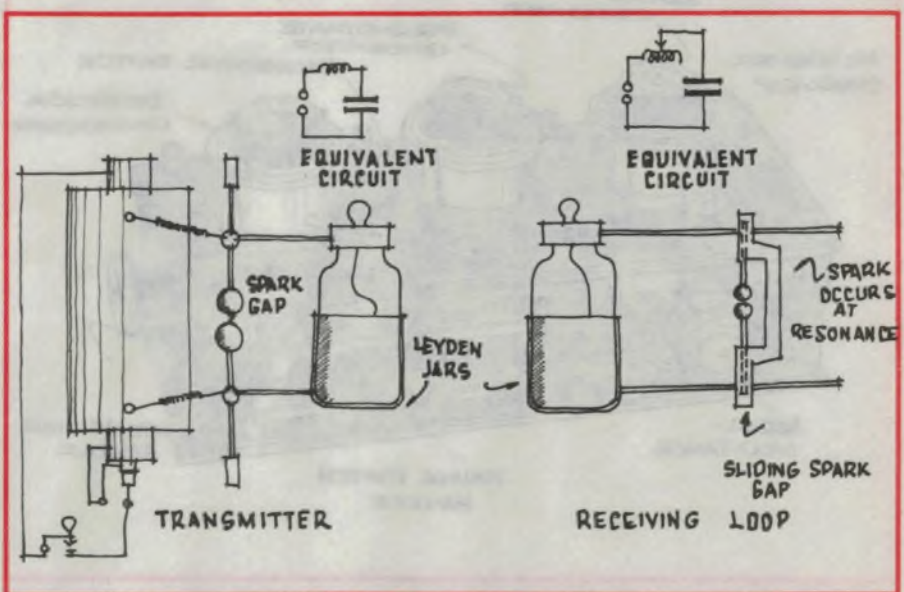

The principle of tuning, or 'syntony' as it was first called, was first demonstrated by Sir Oliver Lodge with these experiments.

## Syntony & Spark

During July and August of 1899, Marconi was involved in a demonstration of wireless for the British Navy which was counted a major success. Because of the obvious benefits to be gained by using wireless, where Naval operations were undertaken, this soon led to an invitation being received from the American Navy to carry out similar demonstrations.

So it was that in September of the same year, Marconi travelled to America to show its Navy the system he had developed. While his researches to combat the problem of interference caused by lack of tuning were well advanced at this stage, nevertheless the equipment that was to be reviewed was not tuned.

When the American Navy required a test which an untuned system of transmission and reception was incapable of passing, Marconi was forced to admit that his apparatus could not comply. However he did inform the Navy that he was in the process of patenting a method by which he could successfully respond to their demands at a later stage.

What the Naval Authorities required was that two receivers and transmitters be operated simultaneously and remain intelligible during the process. This test, as Marconi was undoubtedly aware, was one that his system, as it then stood, could not comply with. The inevitable

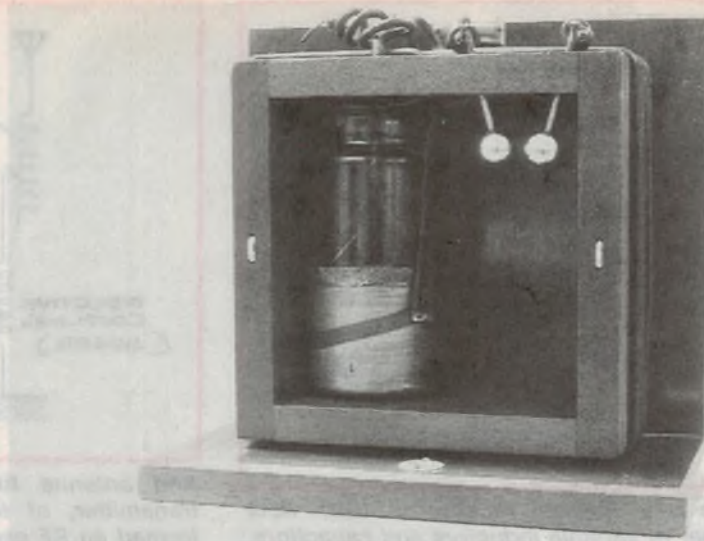

**Marconi's 'Jigger', a combination of a spark gap and what we would now call an inductively coupled RF transformer.**

results, no doubt as anticipated, were 'garbled' messages due to the overlapping of the frequencies used by the two sets of receiving and transmitting apparatus.

In rather guarded terms, Marconi wrote to the Naval Authorities saying that he was in the process of developing a device that would entirely overcome the problem of jamming and interference but was unable at this stage to reveal its method of operation. His reasons for concern are now clear enough; no patent protection had at that stage been obtained for the new system of

tuning, and obviously Marconi was afraid that his ideas would be stolen by commercial rivals. Industrial espionage is by no means a new phenomenon!

Having reached an impasse with the Americans, Marconi left the United States in November of 1899, having successfully resisted all the 'media' efforts to get him to reveal his intended method of interference protection.

### Famous patent

What he had been developing during the previous two years was made clear in the Patent application of 1900, now known as the famous Patent Number 7777. This patent describes the method of tuning both transmitter and receiver to a common frequency, allowing simultaneous operation of various transmitting and receiving links and ensuring the absence of interference.

As happened on many an occasion, Marconi was then accused of poaching and developing the ideas of other scientists and, in this instance, particularly those of Doctor Oliver Lodge who had earlier developed the idea of 'syntonic' or tuned oscillating circuits.

However the circuits developed by Lodge had not been demonstrated with the idea of transmission and reception in mind. Where the requirement for an efficient transfer of energy from one tuned circuit to another transmission or receiving circuit had to be accommodated, the limitations of Lodge's work became all too clear.

In this context, the observations of Marconi, made in 1902 make interesting reading. As he said:

*It was soon, however, realised that so long as it was possible to work only two*

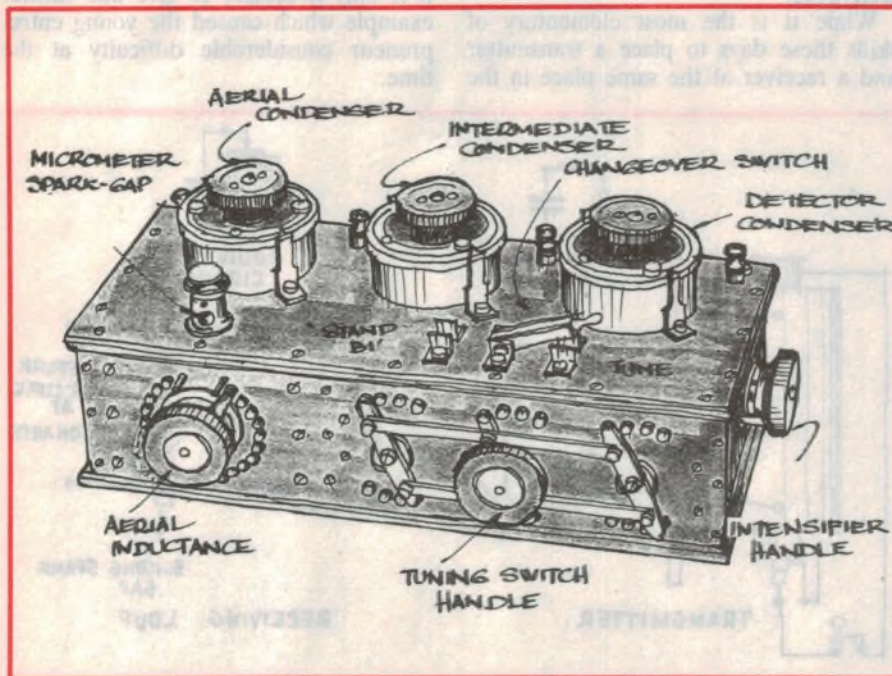

**Developed for receiver tuning, Marconi's 'Multiple Tuner' provided quite an array of controls and adjustments to optimise reception.**

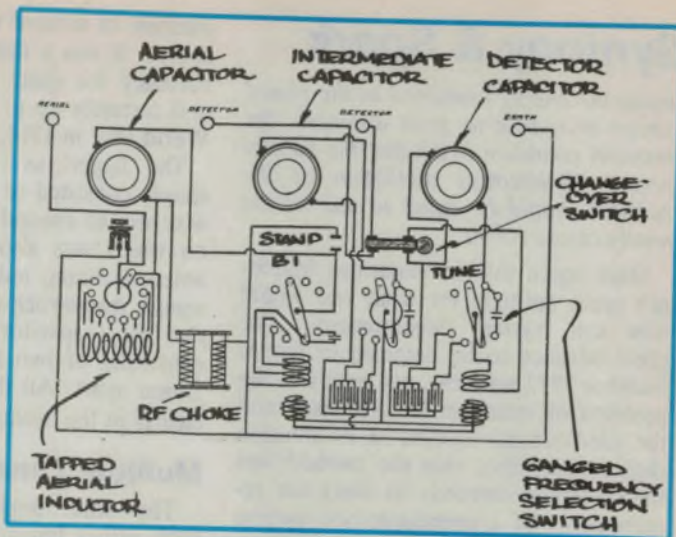

Above: The schematic for the Multiple Tuner, which as you can see included bandswitching.

stated that in order to make the tuning more marked, a condenser is placed across the coherer. This condenser increases the capacity of the secondary resonating circuit of the transformer, and in the case of a large series of comparatively feeble but properly timed electrical oscillations being received, the effect of the same is summed up until the EMF at the terminals of the coherer is sufficient to break down its insulation and cause a signal to be recorded.

In order that the two systems, transmitter and receiver should be in tune it is necessary (if we assume the resistance to be very small or negligible) that the product of capacity and inductors in all four circuits should be equal.

In a later discussion of the phenomena of tuning, Marconi referred to the earlier experiments of Sir Oliver Lodge, and again perceptively pointed to the need for what we would now describe as 'loose coupling', in order to obtain a proper transfer of energy to an antenna system. As he said in presenting his work to the Royal Institution in 1905:

An arrangement consisting of a circuit containing a condenser and a spark gap, Figure 8, constitutes a very persistent oscillator. Sir Oliver Lodge has shown that by placing it near to another similar circuit it is possible to demonstrate effects of tuning. The experiment is usually referred to as 'Lodge's Syntonic Jars' and is extremely interesting, but as Lodge himself points out in his book, 'The work of Hertz', a closed circuit such as this is, 'A feeble radiator and a feeble absorber, so that it is not adapted for action at a distance'.

If however such an oscillating circuit is inductively associated with one of the author's elevated radiators, it is possible to

Left: The configuration of the Multiple Tuner varied for each of the four frequency ranges, as shown.

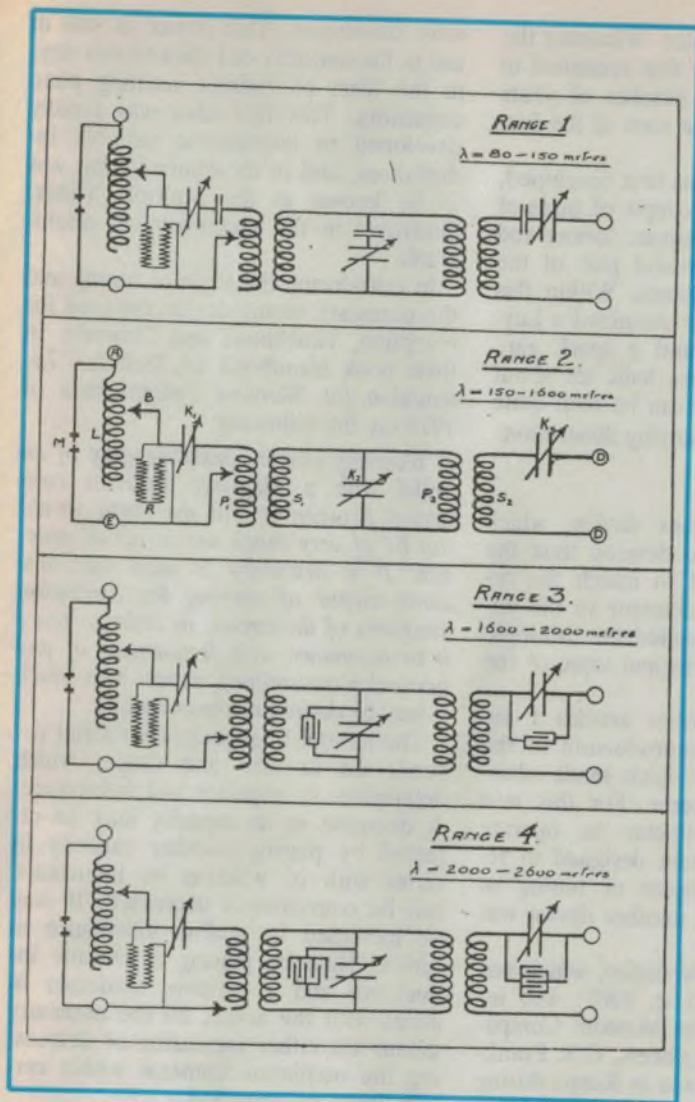

installations within what I may call their sphere of influence, a very important limit to the practical utilisation of the system was imposed. Without some practical method of tuning the stations it would have been impossible to work a number in the vicinity of each other at the same time without interference caused by the mixing of messages...

My first trials with this system were not successful, in consequence of the fact that I had not recognised the necessity of attempting to tune to the same period of electrical oscillation (or octaves), the two electrical circuits of the transmitting arrangement (these circuits being the circuit consisting of the condenser and primary of the transformer and the aerial or radiating conductor and secondary of the transformer). Unless this condition is fulfilled the different periods of the two conductors create oscillations of a different frequency and phase in each circuit, with the result that the effects obtained are feeble and unsatisfactory on a tuned receiver.

The syntonised transmitter is shown in Figure 1. The period of oscillation of the vertical conductor (a) can be increased by introducing turns of wire or decreased by diminishing their number, or by introducing a condenser in series with it. The condenser in the primary circuit is constructed in such a manner as to render it possible to vary its electrical capacity.

The receiving station's arrangements are shown in Figure 2. Here we have a vertical conductor connected to earth through the primary of a transformer, the secondary circuit of which is joined to the coherer or detector. In order to make the tuning more marked, I placed an adjustable condenser across the coherer in Figure 3.

Now in order to obtain best results, it is necessary that the free period of electrical oscillation in the vertical wire primary of the transformer and earth connection should be in electrical resonance with the secondary circuit of the transformer, which includes the condenser. I

## Syntony & Spark

*cause the energy contained in the closed circuit to radiate to great distances, the essential condition being that the natural period of electrical oscillation of the radiator should be equal to that of the nearly closed circuit.*

Once again this demonstrates Marconi's great aptitude for what one would now call 'system development'. The great advance to be detected in Patent Number 7777 was that, not only was the problem of interference recognised and the fundamental method of its solution defined but, also, that the method was then adapted correctly to meet the requirements of a communication system involving an antenna.

Having seen the development of Marconi's appreciation of the need for tuning, on the one hand, and the need for coupling to an antenna system on the other, it will come as no surprise that two important new elements of wireless were soon to make their appearance.

### The 'Jigger'

The first of these, involving the tuning and coupling of the radio frequency energy produced in the closed spark circuit to the open antenna circuit, was what we would now call an *inductively coupled radio frequency transformer*. What Marconi called it was a 'Jigger'.

Where this quaint name came from is not at all clear, although it has been suggested that it might be seen as deriving from the physical action of adding a strong shot of spirits to the weaker

medium of aerated water. Whatever the source, it was a name that remained in currency for quite a number of years and certainly up to the start of the first World War in 1914.

The 'Jigger', as it was first developed, simply consisted of a couple of turns of wire wound around a square former and on which was also wound part of the antenna tuning inductance. Within this square framework was contained a Leyden jar (capacitor) and a spark gap, consisting of two brass balls set about 25mm apart. All this can be seen quite clearly in the accompanying illustration.

### Multiple Tuner

The other important device, which took rather longer to develop than the Jigger, was designed to match the receiving circuits and detector to the antenna. It was to be called the 'Multiple Tuner' and is the principal topic of the following article.

In one of my earlier articles I described in detail a reproduction of the Magnetic Detector, which made obsolete the earlier coherer. For this new radio frequency detector to operate effectively, in a system designed to respond to the principles of tuning as defined by Marconi, another device was now required.

This important new device, which was to receive a Patent in 1907, was invented by one of the Marconi Company's most prolific engineers, C.S. Franklin. It was while he was in Russia during the Russo-Japanese war of 1904 that his first ideas for a form of disc capacitor

were developed. This device is still in use in the majority of radios to this day, in the form of variable rotating plate capacitors. This first idea was rapidly developed to incorporate variable inductances, and in its ultimate form was to be known as the Multiple Tuner, illustrated in the accompanying photograph.

In introducing the topic of tuning and the necessary tuning device required for reception, Hawkhead and Dowsett, in their book *Handbook of Technical Instruction for Wireless Telegraphists* of 1915 say the following:

*A receiving circuit consisting only of an aerial with a Magnetic Detector connected between it and the earth would not be of very much use in actual practice. It is necessary to also introduce some means of varying the oscillation constants of the circuit, in order to place it in resonance with frequencies of any particular transmitting station with which it may be desired to communicate.*

The natural frequency of an aerial depends on its size and shape, which determines its capacity and inductance. A decrease in its capacity may be effected by placing another capacity in series with it, whereas its inductance can be conveniently decreased. It may be increased by adding inductance in series. Thus by placing a variable inductance and a variable condenser in series with the aerial, all the necessary means for either increasing or decreasing the oscillation constant within certain limits are provided...

Such a circuit would not only respond

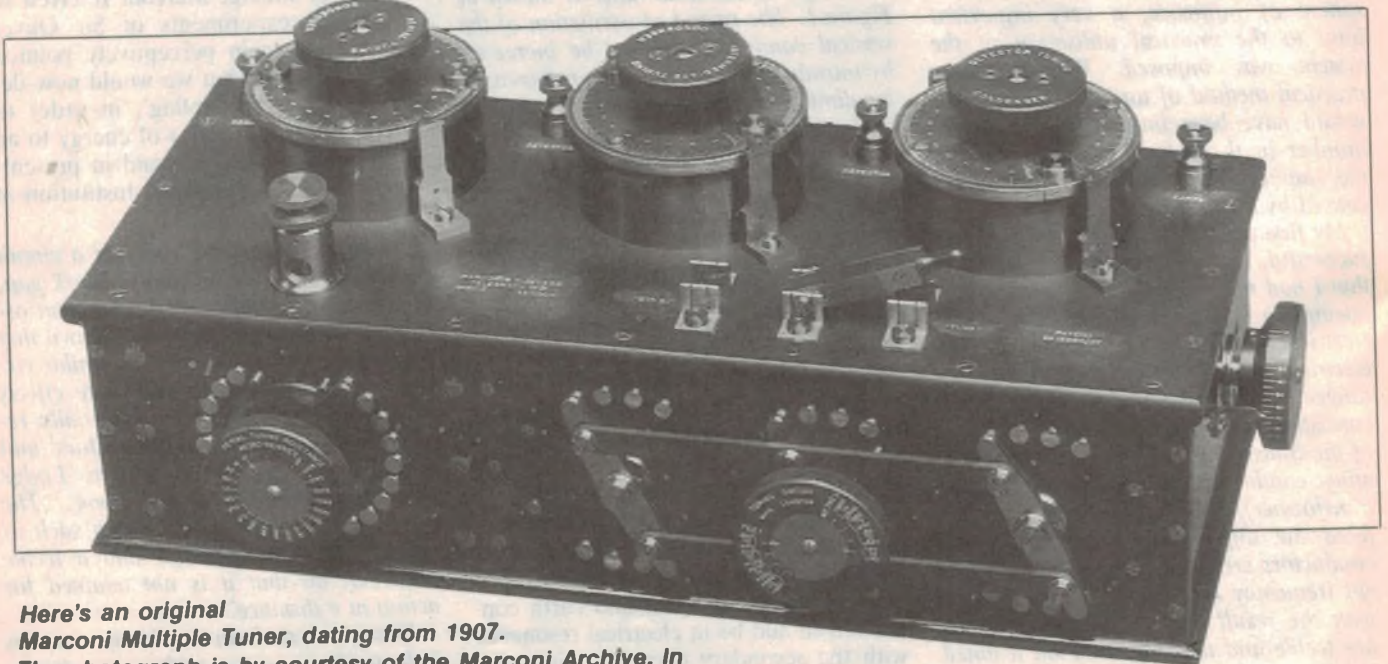

**Here's an original Marconi Multiple Tuner, dating from 1907. The photograph is by courtesy of the Marconi Archive. In the second of these articles the author explains how to build a replica.**

to oscillations of its own frequency, although such oscillations would reduce the maximum effect in it, but oscillations with frequencies of one third, one fifth or one seventh of its natural frequency, known as harmonics, could also be set up in it...

Oscillations of all kinds are more readily set up in an open circuit of the aerial type than in a closed circuit. Consequently the primary of an oscillation transformer is often made part of the open receiving circuit, while the secondary of the transformer forms part of the closed circuit containing the receiving apparatus...

This closed circuit not responding so well to the harmonics of its fundamental frequency and being more difficult to impulse by out of tune waves, is then better adapted to the elimination of all waves other than the fundamental wave required. Such an arrangement of two circuits is shown in figure 81. The second circuit must of course be supplied with means of tuning it to the open circuit and a variable condenser is used for this purpose...

It has been said that a closed circuit is better adapted to the elimination of all waves other than the one required. An extra intermediate oscillating circuit is therefore very often interposed between the aerial circuit and a third circuit containing the Detector... The variable capacities and inductances for the three circuits are all contained in an instrument called a Multiple Tuner.

Later in this same reference is a detailed description to the Multiple Tuner. As this is very helpful in carrying out the construction, to be described later, it is reproduced as follows.

*This instrument contains the variable inductance and capacity for the aerial receiving circuit, the whole of an intermediate circuit and the variable inductance and capacity for the detector tuning circuit.*

*The inductance coils are contained in a teak box with an ebonite top and front. On the top are three disc condensers, one for each circuit. Also a two-way change-over switch, and a micrometer spark-gap.*

*To the left-hand side of the front of the instrument is an ebonite handle carrying a brass arm, capable of rotation over a set of brass studs set in the form of a circle, which enables the inductance in the aerial circuit to be adjusted. To the right of this handle is another, which is so connected by means of ebonite coupling strips to three brass arms, that these arms may be moved simultaneously over three sets of brass stops, thus enabling*

*proportionate adjustments to be made in each of the three circuits with a single movement. This is called the Tuning Switch.*

*Each of the two handles is calibrated, the aerial inductance being marked in microhenrys, and the tuning switch showing the limits of the receivable wave lengths on the respective stops. On the right-hand end of the instrument a third ebonite handle is mounted, called the intensifier handle, marked in degrees through one quadrant on its periphery. This handle is used to vary the relative positions of the inductances in the intermediate circuit, with respect to the inductances in the aerial and detector circuits, or, as already explained, to vary the coupling between the circuits.*

Accompanying this description are a series of schematic diagrams, the first showing all the internal connections for the Multiple Tuner. The other four diagrams show the arrangement of internal connections for various frequencies of operation. From this it will be apparent that the Tuner was designed to work between wavelengths of 80 metres, or 3.5 megahertz, being one of the lower bands now used by radio amateurs, and 2600 metres in wavelength. This longer wavelength is these days used only for long range navigational aids rather than for communication purposes, with the possible exception of secret submarine communication systems employed by the United States.

### Break-in operation

One particularly interesting feature of the tuner is the spark arrester, which is designed to allow what radio amateurs would these days call 'full break-in' operation. This is the ability to alert the sender's attention, even between dots and dashes by having the receiver capable of receiving during these short breaks.

After the days of the Multiple Tuner it was not for many years that reliable 'break-in' was available using valves. Even with modern transceivers it is considered something of a luxury, with most sets offering only partial 'break-in' facilities where the receiver is activated during breaks between words.

In the second of these articles, the physical form of the Multiple Tuner will be described, based on direct observation and photographs provided by the Marconi Archives and the Victorian State Museum in Melbourne. Dimensions and detailed information for any intending constructor will also be provided. 

(To be continued)

## AUDIO TELEX

# Sound REINFORCEMENT

## Is Our Number 1 Business!

That is why our products meet the needs of most Australian Sound Contractors

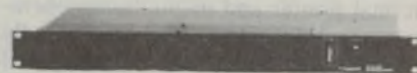

### TX8000

Eight Channel Mic/Line Mixer with separate tone EQ per channel.

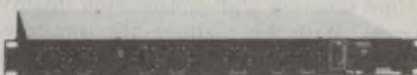

TX30 - Low Profile Mixer Amplifier 100v line two mic and two aux inputs.



8383 - 8 Channel Powered Mixer Amplifier Three Amplifiers six mic/line and two aux inputs inbuilt reverb.

CALL US FOR A FREE 24 PAGE COLOUR CATALOGUE!

AUDIO TELEX

COMMUNICATIONS PTY. LTD. SYDNEY

Phone: (02) 647 1411 Fax: (02) 648 3698

MELBOURNE

Phone: (03) 562 8566 Fax: (03) 562 8781

BRISBANE

Phone: (09) 249 2977 Fax: (09) 249 2978

PERTH

Phone: (07) 852 1312 Fax: (07) 252 1237

ADELAIDE

Phone: (08) 231 6955 Fax: (08) 231 6062

AUCKLAND

Phone: (09) 867 032 Fax: (09) 894 588

READER INFO No. 6

# SPECTRUM

Communications News & Comment



## DIGITAL COMMS TESTER

The new Siemens K4400 demultiplexer/analyser is said to be the first unit of its kind to monitor digital transmission systems in operation, at bit rates of 140Mb to 64kb. Private and public network users thus have at their disposal a handy service unit for operation and maintenance. Errors in bit streams can be located and analysed down to the individual 64kb channel. A large illuminated LCD screen, a built-in thermal printer and menu-driven operator control are part of the user friendly concept. The K4400 can be integrated into a computer-controlled network, using an IEEE bus and a V.24 (RS-232-e) interface.

There are numerous problems in modern digital communications networks that can only be solved with measurement methods that can perform online function and transmission quality checks. With this method, the transmission quality from alignment words can be checked, allowing conclusions to be drawn on the transmission quality of the entire information the K4400 is capable of displaying, the bit errors thus recognised in the form of bit error rates, bit error numbers or as specified in CCITT recommendation G.821.



For monitoring the operation state, the service bits can be evaluated in all frames from 2 to 140Mb. A built-in thermal printer can record all changes to the service bits, programmable thresholds of burst errors and error rates, deviations in the stuffing ratio or the frequency and also A/S and frame loss with the particular time and date.

The realtime clock, calendar and one memory (RAM) have battery backup to protect measurement parameters and results in the event of power failure.

Further information on the K4400 is available from the Communication Network Department of Siemens, 544 Church Street, Richmond 3121 or phone (03) 420 7640.

## MOBILE SCANNING RECEIVER

The Saiko SC-8000 features direct entry of any frequency within the assigned bands. The Saiko SC-8000 operates on HF (26-29.995MHz), VHF low band (68-88MHz), air band (118-138MHz), VHF high bands (138-176MHz) and UHF (380-512MHz) bands. Any 50 frequencies within these frequency ranges can be entered into memory.

A microprocessor is used to control the PLL and the operational functions. These functions include manual channel change, scanning, memory scanning, search, delay, auto AM/FM selection and channel lockout. Other features include adjustable squelch, tone, volume and on/off controls.

The Saiko SC-8000 is supplied complete with telescopic antenna, mobile



mounting brackets and an operator's manual.

For further information, contact

Imark Communications, 75 Mark Street, North Melbourne 3051 or phone (03) 329 5433.



## RESCUED SATELLITES RE-LAUNCHED

Two communications satellites stalled in space after launch six years ago and dramatically rescued from orbit by space shuttle astronauts were re-launched recently.

In February 1984 Westar VI and Palapa B2, two communications satellites built by Hughes Aircraft Company for Western Union and Indonesia respectively, were launched on the same shuttle mission. Shortly after launch, however, motors which should have propelled them into a higher orbit malfunctioned and the two spacecraft became stranded in space.

After nine months of exhaustive rescue planning and engineering efforts by a Hughes-NASA team, another shuttle crew retrieved both satellites in an extraordinary rescue mission which involved one of the astronauts using a rocket-propelled backpack to fire himself towards the satellites so that he could attach himself to them and drag

them back to the shuttle.

Both satellites have now been completely refurbished and were due to be re-launched a few days' apart from opposite ends of the earth and by different launch vehicles.

Westar VI, now re-named Asiasat 1, was due to be fired into space on a Chinese Long March 3 rocket from Xi-chang in south-west China, on Saturday, April 7th.

Observers in Australia were particularly interested in this launch, as Long March is the vehicle contracted to launch Assat's second generation of communications satellites - also being manufactured by Hughes Aircraft Company - in 1992.

Palapa B2, now called Palapa B2R, was scheduled for launch by McDonnell Douglas Commercial Delta rocket from Cape Canaveral, Florida on Monday 9th April.

## HAND-HELD GPS POSITION RECEIVER

Just about to hit the Australian market is the Transpak, a compact hand-held receiver which uses the US Navy's Global Positioning System (GPS) to provide a three-dimensional location fix (latitude, longitude and altitude) anywhere on earth, accurate to within 15 metres. Just the thing for explorers, serious boating and gliding enthusiasts, mountain climbers or those who enjoy trekking across the Simpson desert!

The GPS system uses a constellation of 21 orbiting satellites, whose signals are used in combination by receivers such as the Transpak to locate their position on land, sea and in the air.

Transpak is manufactured by Trimble Navigation, of California, and will be distributed by Sydney-based Navlink, of PO Box 387, Kensington 2033. Further details are available from Tony Vaccarella, on (02) 662 2257.

## DARWIN RADIO HIT BY 'STRIKE'

In one of the worst electrical storms in living memory, earlier this year, a lightning bolt hit OTC Maritime's Darwin Radio and almost totally destroyed the equipment at the station.

The lightning struck both the main MF/HF mast and VHF antennae at the microwave shack, incinerating the circuitry and transceivers and immediately putting the station off air.

In a graphic account of the scene, Darwin Radio Manager Herman Willemssen said the station was in total darkness because the lightning also knocked out the control-board for the emergency power unit.

Fortunately, with the help of OTC technicians Jeff Daly and Allan Lane, services were quickly restored with back-up equipment and spares.

And, as is often the case in times of trouble, there were some humorous asides. When initial repairs had been completed, Darwin Radio operator Dianne Hick announced on the first sked that they were back on the air after a lightning strike but that Radphone and Seaphone services would be out until further notice. Soon afterwards, a small ship called the station and asked Dianne if it was possible to send a Seagram, "or was the strike still on?"

Dianne had to explain that it was not an industrial strike but a lightning strike that had caused their problems.

## FAX MARKET SLOWING DOWN

According to Paul McNicholl, GM of Voca Communications, import clearances of facsimile machines for the 12 months to January this year indicated a strong initial growth in the market during the first half of 1989, with a levelling off in the second half and a downward swing in December. Recent figures suggest that the overall 35% market growth for the year may well be followed by a reduction in total volume during 1990.

January saw a total of 5045 machines cleared through customs, 37.9% down on the 8136 imported during January last year. This bears out the trend noticed in the September and December quarters, where imports fell from the June figure of 36,132 down to 25,796 and 21,830 respectively.

So it looks as though Australia's fax boom may have passed its peak. However as Mr McNicholl points out, the figures should be put into perspective by noting that fax machine placements grew by around 900% between 1983 and 1989.

Meantime, Canon Australia's national sales and marketing manager for fax products Richard Dennis has blasted Austel, for its delays in granting approvals for new machines. Dennis says that there have been delays of up to six months since deregulation, due to the bottleneck created by having Comtest as the only approved testing laboratory. This has retarded the flow of product technology and cramped marketers' competitive positions, according to Dennis.

"In other large world markets, approvals are processed in about 10 days - why can't Austel do the same?", he added.

Dennis claims that Austel has also failed to police its own ban on unapproved products, with the result that the market has been flooded with unapproved cheap products, which have been blatantly marketed without Austel's intervention.

Perhaps the market slowdown will help Austel catch up with its approvals, if nothing else.

## OTC TO UPGRADE KIRIBATI TELECOMMS

Australia's OTC International has signed a memorandum of understanding with the Government of Kiribati to upgrade the Pacific Island nation's telecommunications network.

Minister for Telecommunications and Aviation Support Ros Kelly, announced that Kiribati had approved in principle a joint venture with OTC International for the efficient running of the international and domestic telecommunications network for the next 15 years. It had a land area of 746 square kilometres and is spread over a territorial zone of more than three million square kilometres of ocean.

Since April 1988, OTC International has assisted in the improvement of the Kiribati network under a joint management contract.

Mrs Kelly said that under the proposed joint venture Kiribati would be integrated into the Pacific Ocean Cooperative Telecommunications (PACT) network for international telecommunications. OTC International has developed the PACT network, which comes into operation in early 1990, to provide affordable satellite communications for Pacific Island nations.

## OTC'S PACT TO LINK PACIFIC

An agreement linking island communities in the South Pacific with a state-of-the-art satellite telecommunications system has been signed in Fiji.

The agreement saw five member nations of the South Pacific Forum become the first to join the Pacific Area Cooperative Telecommunications (PACT) network. They are: Cook Islands, Kiribati, Marshall Islands, Nauru and Australia. Other nations are expected to sign shortly.

PACT is a custom designed Australian solution to the problems of linking the widely dispersed island nations with their neighbours, their own remote communities and the rest of the world. The network has been developed by OTC International, the overseas operations and marketing subsidiary of OTC Limited, Australia's worldwide communications company.

Group Manager of Network and Carrier Projects for OTC International, Mr Rod Masterton, said the signing ceremony in Fiji followed three years of negotiations between members of the Forum and OTC International.

"The establishment of the PACT network has been made possible by OTC International's adaptation of Demand Assigned Multiple Access (DAMA) technology in a way never previously used anywhere in the world."

The DAMA system is claimed to be the most advanced in the world, allowing a mix of earth stations with antenna sizes from 4.5m to 32m to interconnect with each other in an effective manner regardless of their location in the Pacific.

## NEW MODEL TOUCHPHONE

Alcatel STC is apparently readying a new version of the Australian made Touchphone, to be known as the 200S Executive, for delivery to Telecom.

The new phone has a visual day/time/date display, an alarm, a built-in mike and speaker for hands-free operation, 16 one-touch memory buttons and up to 99 abbreviated dialing memories. It also provides an automatic call duration timer and PIN lock security, plus a choice of using either a plug-in AC adaptor or three AA cells to maintain the clock and memory facilities.

The result of an intensive design program, the Touchphone 200S Executive is destined to replace the Versatel model supplied to Telecom since 1987. It is also expected to generate considerable export business.

## CELLULAR RADIO REFERENCE BOOKS

Available exclusively through DNA from the publisher (Quantum, USA) at the publisher's prices. These books are easily the most authoritative cellular publications available anywhere in the world. If you are in the cellular business you cannot afford to be without a copy.

### 1. The Cellular Installation Handbook. Quantum Publishing.

This book is written for the mobile telephone dealer and reveals a wealth of experience in the supply and installation of mobile telephones. Poor installations account for more than 50% of customer complaints. It is a must for all mobile telephone dealers.

Price \$75

### 2. The Cellular Radio Handbook. Quantum Publishing.

This book is written for cellular radio system operators and engineers or others seeking an understanding of cellular radio at a professional level. Just published, in 35 chapters it deals with all aspects of designing, installing and operating a cellular radio network. It covers both the theory and practice of cellular operations. In all, over 500 pages of information, most of which is not available elsewhere at any price. Contains details of cellular operations worldwide as well as a detailed look at digital cellular.

Price \$260

### 3. The Asia/Pacific Mobile Phone User's Guide.

This book will be released soon and will be a mobile user's guide covering in detail the use of a mobile phone in the Asia/Pacific region where roaming between networks is now widely practised.

For a FREE listing in the Asia/Pacific Guide, cellular dealers (particularly in Australia and NZ) should please write giving the following details:

- A. Business Name  
B. Address/Phone/Fax  
C. Products carried

Note: Prices include postage in Australia/NZ.

Reply to **DNA**  
PO Box 69 Phone  
Broadway (07) 862 1929  
Brisbane 4006 or  
Fax (07) 262-6593 (075) 91 4956

## READER INFO No. 7



## Professional Instruments for Professional People

### Digital Storage Scope HM205-3:

This truly innovative feature-packed scope provides digital storage capability with 20 MHz max. sampling rate — all at an incredibly low and unbeatable price. "High-tech" digital storage you can afford!

### Graphic Printer HM8148:

A hardcopy of your stored screen display at the press of a button. In less than 15 seconds! Use it also for automatic data acquisition at programmable times or intervals. The intelligent firmware provides automatic date/time and zoom function, min./max. interpretation, and linear interpolation.

### Modular System HM8000:

A full range of space-saving, interchangeable plug-ins — professional but low in cost! Multimeter, function-, pulse-, sine wave generators, counter/timers, distortion-, milliohm-, LCR-meters, power supply... Plug them in as you need them — and save!

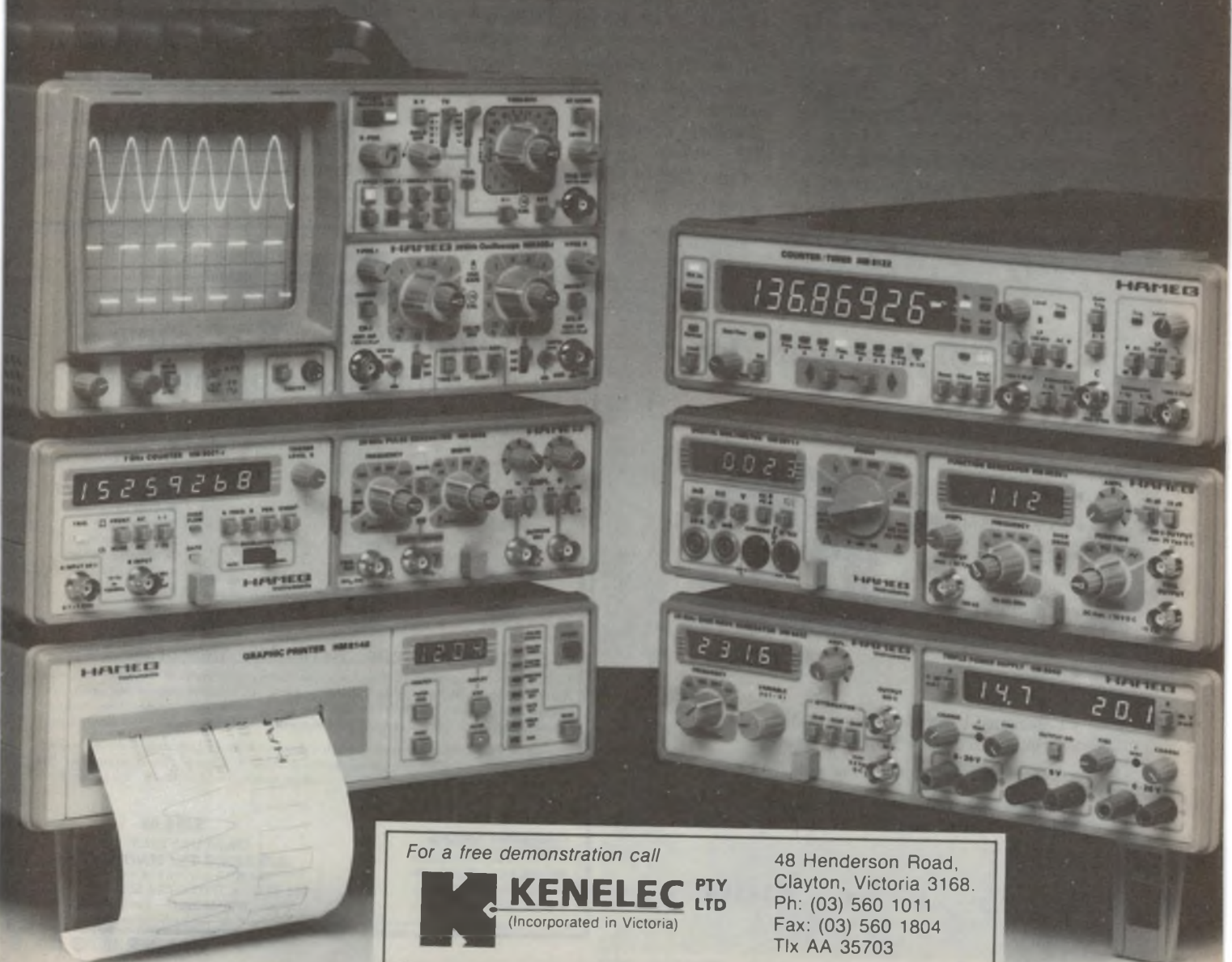

For a free demonstration call

**KENELEC** PTY LTD  
(Incorporated in Victoria)

48 Henderson Road,  
Clayton, Victoria 3168.  
Ph: (03) 560 1011  
Fax: (03) 560 1804  
Tlx AA 35703

• NSW (02) 439 5500 • SA (08) 223 2055 • QLD (07) 274 2377 • WA (09) 322 4542

READER INFO No. 10

## RADIO MODEM

If you have a need for 8-bit error corrected data communications to remote or mobile sites, GFS Electronics of Mitcham Victoria, claims it has the answer in the form of the new smart Radio Modem, model CPU-100 version 5.0.

The new modem is apparently optimised for use on long haul HF SSB radio systems, by virtue of its digital signal processing front end. However, it

may be also user selected (with the change of an internal DIP switch) to its VHF/UHF FM mode, where it is equally at home in line-of-sight applications.

On HF, where multipath propagation will normally cause major problems to data transmission, GFS claims that the CPU-100 exhibits impressive performance. Running 600 baud over the radio system, it will see no reduction in its error free throughput, for multipath conditions, where the delayed signal is

3dB down on the primary, over delay periods from 0 to 20 milliseconds. Above 20 milliseconds, throughput gradually drops as blocks of errored data are automatically re-sent, however, only correct data is output to the modem's DTE.

Another problem which can occur with HF SSB data transmission is the possibility of a frequency offset between the transmitter at one end of the link and the receiver at the other. GFS claims that the CPU-100's performance under such conditions is very good. For a frequency error of plus or minus 110Hz (total 220Hz) the Smart Radio Modem continues to provide 100% error free throughput, without the need for block re-sends.

Over the past few years the CPU-100 Smart Radio Modem has gone into applications throughout the world on all continents, as well as on the oceans. The innovative design approach, GFS claims, has made the CPU-100 a considerably better performer than the X.25 or TOR type radio modems, used by data communications operators in the past.

Additional information is available from GFS Electronics at PO Box 97 Mitcham 3132 or phone (03) 873 3777. ☺

## TINY RECEIVER FOR SATELLITE TV

Melbourne firm MMT Australia now has available a satellite TV receiver the size of a paperback book, said to provide outstanding performance for Australian PAL and other world standard satellite TV signals.

The Nexus SR-5.1 is said to be one of the world's smallest commercial satellite receivers. Three of the receivers occupy only 40 x 480mm of pack space 1U high. It has a coverage of 950-1750MHz, for use as an IF with standard block down-converters. Audio and video controls are continuously tuneable for maximum flexibility, and there is a range of optional audio bandwidth modules. The receiver is said to be very

suitable for professional receiving sites, being compatible with BMAC and EPAL transmission standards.

MMT is the Australian distributor for both MASPRO and NEXUS products, and can supply LNB's for both Ku and C band, amplifiers for the 950-1750MHz band, diplexers, splitters, directional couplers and other distribution components. It can also supply a range of both FM and AM optical fibre transmission systems, for distribution of video and audio signals over both long and short distances.

Further details are available from MMT Australia, 124 Boronia Road, Boronia 3155 or phone (03) 762 6455.

$\int_0^n 80C51 .dx = \text{smart chip}$

- 8K Bytes EPROM.
- 256 Bytes RAM.
- 10-bit ADC with 8 I/Ps.
- 2 x 8-bit PWM O/Ps.
- I<sup>2</sup>C Bus.
- Full Duplex UART.
- Watch-Dog Timer.
- 5 x 8-bit I/O parts.
- 2 Standard 16-bit timer/counters.
- 1 Additional 16-bit timer/counter with 4 capture latches and 3 compare registers.
- Available from Stock in Window and OTP Packaging.



87C552

Philips Components



PHILIPS

READER INFO NO. 8

United Nations 2303D

NEW!

# LEAP

## Loudspeaker Enclosure Analysis Program

**Graphics Features**

- ◀ Semilog Graphs
- ◀ Absolute Scales
- ◀ Auto Scale Set
- ◀ Display 3 Designs
- ◀ Solid/Dot/Dash Line
- ◀ Fast Graphic Paging
- ◀ Disk Graph Storage
- ◀ EGA Color Graphs
- ◀ Cursor Measurements
- ◀ Hardcopy Printout

**Output Graphs**

- ▶ Acou. On-Axis SPL
- ▶ Acou. On-Axis Phase
- ▶ Acou. Power SPL
- ▶ Acou. Power Phase
- ▶ Cone Excursion
- ▶ Group Delay
- ▶ Impedance Mag.
- ▶ Impedance Phase
- ▶ Current Mag.
- ▶ Current Phase

**Advanced Analysis...Beyond the State of the Art!**

Comprehensive true general system model/ Small-Large signal analysis/ Frequency dependent acoustic elements/ Multiple speakers and ports in box/ Full mutual coupling analysis/ Passive radiators/ Parasitic elements: Port loss, Box loss, Lining loss/ Any Power level/ Array Analysis/ Frequency dependent VC resistance/ VC temperature/ Cable resistance/ SPL at any Distance.

**PROGRAM FEATURES:** Unlimited Speaker, Cabinet, and Design Libraries/ Computer assisted parameter entry and checking/ Library Searches/ Metric or English Cabinet units/ Over 100 Speakers already in library from 3" to 30", JBL to Audax, Pro. Car, HI-FI, Easy operation!

**Computer System**

PC/AT/386 and Compatibles  
MS-DOS 2.x/3.x. 512K RAM  
Math Coprocessor Suggested  
Graphics: EGA/CGA/HGA/VGA

**\$499.00**

Demo Disk \$29.00 p.p.

**SPEAKER TECHNOLOGIES**  
*(an ME Sound Pty. Ltd. subsidiary)*

P.O. BOX 50, DYERS CROSSING NSW 2429  
Phone (065) 50 2254 — Fax (065) 50 2341

READER INFO NO. 9

# THE ELECTRONIC COMPONENTS SHOP

289 Latrobe Street,  
MELBOURNE  
PHONE: (03) 602 3499 FAX: (03) 670 6006  
SYDNEY (Office only): (02) 906 2411

## FREE WHOLESALE PRICE LIST

(SEND BUSINESS CARD)

## ON OUR COMPLETE RANGE OF PRODUCTS

### DIODES & OPTOS

1N914.....	0.04
1N4148.....	0.03
1N4004.....	0.04
1N4007.....	0.06
1N5404.....	0.14
1N5408.....	0.16
W04.....	0.35
BR64.....	1.00
BR104.....	2.00
RS404.....	1.20
C103B.....	0.65
C106D.....	0.85
BT136-500.....	1.20
BT137-500.....	1.50
BT138-500.....	2.00
BT139-500.....	2.50
3mm LED RED.....	0.10
3mm LED GRN.....	0.12
3mm LED YLW.....	0.12
5mm LED RED.....	0.08
5mm LED GRN.....	0.14
5mm LED YLW.....	0.14
REC LED RED.....	0.20
REC LED GRN.....	0.28
REC LED YLW.....	0.28
HDSP7301.....	1.50
HDSP7303.....	1.50
HDSP5301.....	2.00
HDSP5303.....	2.00
4N28.....	0.75
4N33.....	0.90
4N35.....	0.90
4N38.....	0.90
6N138.....	3.80
MOC3021.....	1.20
MOC3041.....	1.65

### TRANSISTORS

BC107.....	0.35
BC108.....	0.35
BC109.....	0.35
BC177.....	0.35
BC178.....	0.35
BC179.....	0.35
BC327.....	0.12
BC328.....	0.12
BC337.....	0.12
BC338.....	0.12
BC546.....	0.07
BC547.....	0.07
BC548.....	0.07
BC549.....	0.07
BC556.....	0.07
BC557.....	0.07
BC558.....	0.07
BC559.....	0.07
BD139.....	0.35
BD140.....	0.35
BU126A.....	2.00
BU208A.....	2.50
BU326A.....	2.10
BU406D.....	1.90
BU407D.....	1.75
BUX80.....	3.50
MJ2955.....	1.10
MJE13007.....	1.95
MJE2955T.....	0.85
MJE3055T.....	0.85
TIP31C.....	0.65
TIP32C.....	0.65
2N3055.....	1.20
2N6123.....	0.80
2SJ56.....	8.50
2SK176.....	9.00

### MICRO'S

63B09P.....	17.50
64180R1P8.....	18.50
65C02.....	6.00
65C22.....	8.50
68B09P.....	12.75
68B21.....	5.00
68B50.....	6.00
68000P-10.....	14.50
8031.....	5.60
8039.....	8.00
80C39.....	8.50
8250.....	14.00
82C50.....	15.50
8255.....	4.00
82C55.....	5.00
8279.....	3.75
Z80A CPU.....	3.00
Z80B CPU.....	5.50
Z80C CPU.....	6.00
Z80H CPU.....	12.00
Z80A PIO.....	3.00
Z80B PIO.....	5.50
Z80C PIO.....	6.00
Z80H PIO.....	10.00
Z80A SIO.....	8.50
Z80B SIO.....	10.00
Z80C SIO.....	12.00

FOR ALL OTHER IC'S NOT IN THIS LIST, E.G. DIGITAL IC'S, LINEAR IC'S, KEEP LOOKING FOR OUR AD IN FUTURE ISSUES OF THIS MAGAZINE OR PLEASE CONTACT US.

## ALL PRICES INCLUDE SALES TAX. TAX EXEMPT AND OEM P.O.A.

**Freight:** The prices quoted are ex Store, cost of delivery and the risk of loss in transport fall upon the purchaser. For the convenience of customers, delivery can be arranged through the supplier at the schedule of rates set out below.

Minimum Charge ONLY	1. Local Post \$2.50
	2. Interstate Post \$3.50
	3. Carrier, Melbourne & Metropolitan — \$5 up to 3kg.
	4. Carrier: Interstate — \$10 up to 3kg.

Only SMALL ITEMS will be sent by post



# When I Think Back...

by Neville Williams

## Major Edwin Howard Armstrong MIEE: a genius who lost the will to live - 1

Enthusiast, amateur, US Army officer and graduate engineer, Edwin Howard Armstrong could well qualify as one of the most inventive of all the pioneers in the history of electronics. But sadly, he is also one of its most tragic figures who, in a mood of despair, ended his own life a few years back at age 64.

The outlook must surely have been much more promising when an obviously young Major Edwin Armstrong was pictured on the cover of *The Australasian Wireless Review* in March 1923. It was one of a series of picture/stories featuring scientists and innovators such as Senatore Guglielmo Marconi, Professor Michael I. Pupin, John Henry, Dr Alexander Graham Bell, Sir Oliver Lodge and Sir Joseph J. Thompson.

Explaining his decision to include the 32-year old Armstrong in such auspicious company, the *AWR* editor offered this opinion: 'Major Edward H. Armstrong is a comparatively young man, but there is probably no other single individual who has accomplished so much in the radio field'.

At this early point in his career, he had been a keen radio amateur, prominent in the historic trans-Atlantic tests of 1921, was associated with the Institute of Radio Engineers, President of the Radio Club of America and held a position as a professor at Columbia University.

According to the accompanying one-page biography, he had been born on December 18, 1890, the son of an American representative of a British book publisher. His favourite reading as a lad was *The Boy's Book of Inventions*.

At age 15, while still at high school, Armstrong developed a keen interest in radio, which continued to claim his attention at Columbia University, from which he graduated in 1913 as an Electrical Engineer. He had set up receiving – later, transmitting – equipment in his bedroom, where he pursued his youthful experiments employing the primitive techniques of the period. Armstrong

later described it as "The age of darkness; the 'hit or miss' years of radio".

High technology in those days was exemplified by the Fleming diode; but in 1911, Armstrong went one better when he acquired an 'audion' three-element valve made by Dr Lee De Forest. Not content to experiment blindly, he sought out every text he could find on the basics of radio, especially anything that might have a bearing on the operation of the audion triode.

Armstrong was fortunate that, during his student years, the Professor of Electro-mechanics at Columbia was the celebrated Michael Idvorsky Pupin PhD (Hon) DSc, DLI. A world authority on matters electrical, Pupin had himself devoted considerable attention to wireless communication.

### Regeneration

In 1912, it occurred to Armstrong to try tuning the plate circuit of the audion

**Armstrong as pictured on the front cover of the 'Australasian Wireless Review' for March 1923. Still a young man, he had already earned a high reputation for his contribution to wireless/radio.**



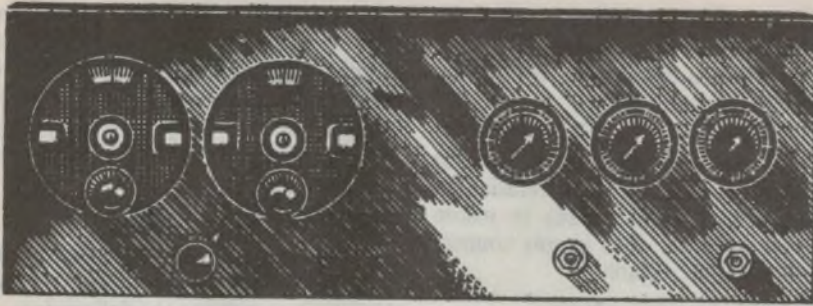

**The front panel of an 8-valve build-it-yourself superhet described in 'Wireless Weekly' for July 29, 1927. The main controls are (L to R) oscillator tuning, loop aerial tuning, IF amplifier filament current and bias, and detector filament current.**

triode, as well as the customary grid circuit. He was rewarded by a substantial increase in the loudness of the incoming signals, although any attempt to increase the gain of the detector beyond a certain point resulted in a 'raspy' degradation of the audio content, with the signal ultimately becoming almost 'indistinguishable'.

With hindsight, Armstrong had stumbled upon the configuration of what later became known as the TPTG (tuned plate, tuned grid) oscillator, in which a valve may sustain oscillation by reason of its internal grid/plate capacitance, when the plate circuit is brought to near-resonance with the grid circuit.

In the case of a triode valve being used as a detector, Armstrong's experiment set up a situation whereby bringing the plate and grid circuits towards a common resonance resulted in positive feedback – later to become known as *regeneration* or *reaction* – thereby substantially increasing detector gain or sensitivity.

On the verge of instability, the audio content of the incoming signal tended to become distorted, being ultimately swamped by the detector's own self-generated signal when oscillating strongly. In the years that followed, countless experimenters with small regenerative receivers had to contend with these very same effects.

At first, Armstrong did not understand why the circuit should behave in this manner but, in early 1913, he felt that he had worked out a logical explanation. His technical friends were not convinced that he had uncovered an important circuit principle but, following the advice of a canny uncle, he took the precaution of having a copy of his circuit witnessed by a notary public.

## Patent litigation

By way of interest, ARW's picture/story on Professor Pupin, in their April 1923 issue, mentions that on

the patent application for the so-called 'Armstrong Regenerative Circuit', Pupin's name is coupled with that of Armstrong as joint applicant. To quote from the article:

*It is hard to say what part was actually played in the invention of the regenerative circuit by Professor Pupin, but it is certain that Major Armstrong had the benefit of the Professor's mature experience in wireless research matters to aid and guide him.*

In due course, the original notarised circuit proved to be a key document when the concept of feedback and the audion oscillator became the subject of litigation involving Armstrong, De Forest and others. Indeed, the patent litigation between Armstrong and De Forest is said to have been the most protracted ever in wireless history.

Armstrong won the first round in 1917, after which De Forest assigned his patent interests – past, present and future – to AT&T. In that same year, Armstrong was awarded the IRE Medal in recognition of his discovery. The court verdict was effectively reversed some time later but, in the eyes of contemporary engineers, Armstrong was thereby unjustly denied his rights.

Historically, he is still seen as the father of the two related concepts – regeneration and the valve oscillator – both of which were further developed by other designers during the 1920s.

This view is supported by an article in the UK paper *Electronics Weekly* for January 30, 1963. I quote:

*It is no disparagement to the parallel work of of De Forest, Langmuir, Meissner and our own Captain H.J. Round to point out that even though the US Supreme Court – in the face of the bulk of engineering opinion – twice refused him the credit for the discovery of regeneration, there can be little doubt that Armstrong was the first to realise its practical importance and to benefit from it in actual receiving practice.*



**THE RADIOLA STANDARD 6**

A 6 Valve Superheterodyne Receiver housed in a handsome Laminated Maple Cabinet. Complete with all accessories, including Amplion Loud Speaker, £45.

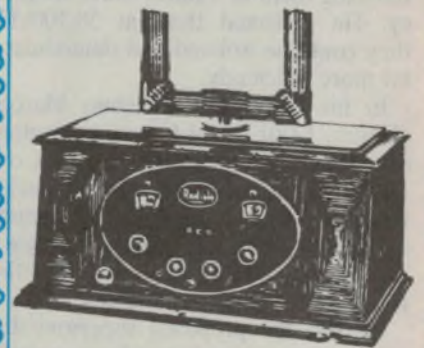

**THE RADIOLA SENIOR 6**

A 6 Valve Superheterodyne Receiver complete with all accessories, including Amplion Loud Speaker, £65.



**THE RADIO SUPER 8**

A magnificent 8 Valve Superheterodyne Receiver with concealed loop and enclosed Amplion Loud Speaker.

**AWA followed RCA's lead by introducing an Australian series of AWA Radiola superheterodynes. The Standard 6, Senior 6 and Super 8 were advertised in 'Wireless Weekly' for November 18, 1927.**

## WHEN I THINK BACK

### The 'superhet'

In 1917, Armstrong was commissioned into the Signal Corps of the AEF (American Expeditionary Force) and sent to Paris – there to investigate the possibility of intercepting messages being exchanged by German low-power trench wireless sets. It was an assignment that called for unusually sensitive receivers, capable of working from directional loop aerials concealed behind the allied front-line trenches.

As a possible answer, Armstrong came up with the idea of a receiver with a built-in oscillator that would beat with or 'heterodyne' the wanted signals, reducing them to a much lower frequency. He reasoned that, at 50-100kHz, they could be isolated and demodulated far more efficiently.

In his book on Guglielmo Marconi (Heron, 1970) David Gunstan mentions, *inter alia*, that Armstrong had his own dream about a further role for such a receiver: that it might be sensitive enough to sense the ignition systems of approaching enemy aircraft before they could be discerned acoustically.

In fact, the proposed superheterodyne or *superheterodyne* receiver emerged too late to find much practical application in World War I. But Armstrong's research earned him the rank of Major in the American Army, and a citation by the French as Chevalier of the Legion of Honour.

But, as if on-going litigation about his earlier work was not sufficient, his responsibility for the superheterodyne principle was also questioned – as would have been apparent to readers who have followed the 'Letters to the Editor' columns of *Electronics Australia* over the past year or so.

In response to an article by Peter Lankshear in the September 1988 issue, letters in the November '88 and February '89 issues from both the author and retired STC engineer Winston Muscio drew attention to the fact that the first

superhet receiver patent was filed in Paris by Lucien Levy on August 4, 1917 – some eighteen months ahead of Armstrong's American patent.

The Levy patent was subsequently assigned to Western Electric of London (June, 1924) and, for Australasia, to STC of Sydney (June, 1926) to whom the relevant licence fees in this country had thus become payable.

### Possible explanation

Commenting on this in the October 1989 issue, a former patents examiner (wireless) G.H. Rance BSc, says that the US Patents Office is unlikely to have deliberately ignored Levy's claim; a more logical explanation being that a wartime patent issued in Paris may simply not have been circulated to it. In any case, he says, in terms of novelty, US law at the time allowed a US citizen's patent to date back to the actual time of the invention.

Seeking to explain the apparent conflict, Winston Muscio suggested a likely course of events in the February 1990 issue of *EA*. It is well known, he said, that Armstrong and Levy worked closely together during World War I on the problem of achieving higher receiver gain using then-available triodes. It is entirely possible that they reached the same conclusion together or simultaneously. At this point, Levy may well have pressed on with the paperwork, with Armstrong putting it off until he had clarified his thinking about another concept that he was pursuing, namely *superregeneration*.

Quite obviously, Armstrong's contribution was recognised by the US military and the French Government and endorsed by the US Patents Office by the issue of patent No. 1,342,885, filed on February 8, 1919 and issued on June 8, 1920.

As it happens, I have on hand an original article on the superheterodyne receiver written by Edwin Armstrong. Entitled 'A New System of Short-Wave Amplification', it was published in the Australian magazine *Sea, Land and Air* for September 1, 1921.

It should be noted that, in those days, the term 'short wave' signified wavelengths below (shorter than) about 600 metres (500kHz), and would therefore include the whole of our present-day AM broadcast band, which we now describe as 'medium wave'.

### Armstrong's article

Reviewing the design options for a high sensitivity 'short wave' receiver, Armstrong mentions the following:

1. *Amplification of the audio frequency current after rectification.* The limitations of this approach lie in the diminishing efficiency of available detectors with decreasing wavelength, and the noise problems with high-gain audio amplifiers working from too small a recovered signal.
2. *Amplification of the radio frequency current before detection.* A difficult approach on short waves, because resistance-coupled RF stages yield very limited gain and tuned systems are prone to self-oscillation. In passing, Armstrong acknowledges a notable contribution in this area by Round in England and Latour in France, with special low-capacitance valves and what we would now define as high L/C, low-Q resonant coupling circuits.
3. *Application of the heterodyne principle to increase the efficiency of rectification.* The reference is unclear, but rather suggests the direct conversion or 'homodyne' principle. Armstrong rejects it for use at wavelengths below 600 metres, because of instability of the beat tone – which results in distortion in the case of telephony and the loss of 'clear tone' and 'individuality' with spark signals.

Armstrong then proceeds to introduce and explain an 'expedient' approach "evolved at the Division of Research and Inspection of the Signal Corps, American Expeditionary Force".

As depicted in Fig.1, the incoming signals are intercepted by loop L, which is rendered broadly resonant in conjunction with the secondary winding of transformer H and variable capacitor C.

Transformer H provides a means of introducing to the input circuit a second signal, from an external tuneable oscillator. A signal rectifier D1, in the role of 'first detector', feeds to resonant transformer T1 the original input and the local oscillator signals, plus their sum and difference resultants.

### Typical figures

By way of example, Armstrong assumes that circuit LC is tuned to select

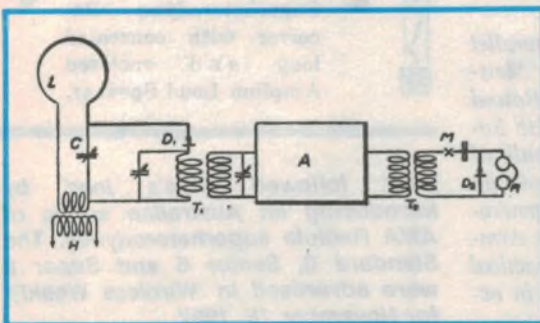

**Fig.1: From Armstrong's own paper published in Australia in September 1921, the basic concept of a superhet receiver. Early superhets commonly used loop aerials to minimise objectionable signal radiation from their heterodyne oscillator.**

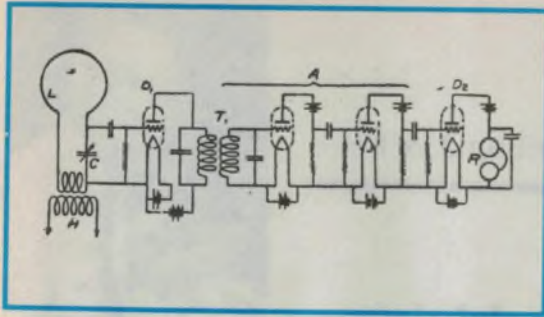

**Fig.2: More elaborate than Fig.1, this suggests the use of a resistance coupled IF amplifier (bracketed 'A') which, in practice could involve up to six separate stages. Note the use of triodes as the first and second detectors.**

a wanted signal at 3,000,000 cycles (Hz) and that T1 has been pre-tuned to what we would now describe as an 'intermediate' frequency of 100,000 cycles. If the external heterodyne oscillator is now set to either 3,100,000 or 2,900,000 cycles, the heterodyne process will produce a difference resultant of 100,000 cycles, which will be passed on to amplifier A, the original source frequencies being rejected.

In effect, the original 3,000,000Hz signal, together with any superimposed modulation will have been 'shifted down' to 100kHz. Further filtering is possible by output transformer T2, which can also be tuned to 100kHz. A signal rectifier D2 serves to isolate the modulation, to drive the headphones or for further amplification by an audio amplifier.

Although expressed without the benefit of present-day jargon, this is pure superheterodyne theory. Armstrong even mentions the option of double frequency changing, with the idea of achieving still higher overall gain with minimal risk of interstage feedback and instability. For example, to receive signals in the vicinity of 5MHz, it may well prove worthwhile to use double frequency shift to 500kHz and then 50kHz before final detection.

He also mentions the possibility of simplifying the overall circuitry by exploiting self-oscillation – presumably a self-oscillating mixer – although he recommends separate heterodyne oscillators by reason of their superior frequency stability, particularly at the higher frequencies.

Fig.2 is another of the six diagrams used to illustrate other points in Armstrong's paper. One is the use of a triode valve as a combined signal amplifier and first detector, ahead of the tuned transformer T1. This not only provides gain, but also opens the way for the introduction of input circuit regeneration.

Next is the use of resistance coupling in the intermediate frequency amplifier, bracketed as 'A'. The point is made that two such stages may be needed,

just to compensate for the signal loss in frequency changing, and that as many as six IF stages may be considered desirable in a high performance receiver.

At the time, limited selectivity was scarcely a problem because of the relatively few transmitters on air and the poor frequency stability of those that were. Perhaps significantly, Fig.2 omits the output coupling transformer T2 and features another triode as the second detector, for extra gain.

(Intended mainly to illustrate principles, Fig.2 shows each stage with its own separate filament and plate supply batteries. Normal practice would be to use common A- and B-batteries for all stages).

## Superhet development

In view of the earlier debate about the origin of the superhet, the final paragraph in Armstrong's article is interesting, having in mind that it must have been written shortly after the patent documents had been issued:

*While the fundamental idea of this method of reception is relatively simple, the production of the present form of the apparatus was a task of the greatest difficulty for reasons known only too well to those familiar with multi-stage amplifiers; and to Lieutenant W.A. MacDonal, Master Signal Electricians J. Pressby and H.W. Lewis and Sergeant H. Houck, all of the Division of Research and Inspection, Signal Corps, A.E.F., I wish to give full credit for its accomplishment.*

*Hartley Research Laboratory, Columbia University, New York City.*

According to the article in the UK journal *Electronics Weekly* (January 30, 1963), that same H. (Harry) Houck assisted Armstrong to adapt the design for domestic broadcast band reception – a project that worked out so well that Armstrong offered it to RCA in February 1923.

At a time when outdoor antennas were mandatory, Armstrong turned up at RCA Chairman David Sarnoff's

apartment carrying a radio playing at full blast. Sarnoff was so impressed that the receiver became the basis of the RCA 'Radiola' for 1924, setting new performance standards in a market that was otherwise locked into the TRF-plus-reaction format.

In that same year, at a more personal level, Armstrong 'acquired' one of Sarnoff's secretaries, who became his wife!

It took a while for industry as a whole to face up to the challenge of the superhet circuit, but more or less coincident with the design revolution that accompanied the switch from battery to mains operation in the late 1920s, superhets took over and TRFs virtually disappeared.

Superhets are still with us, even if rendered functionally unrecognisable by solid-state digital technology. Gone are the accoutrements that were once necessary to make it all happen. Whether in a domestic AM/FM radio, a TV receiver or high-tech communications equipment, you simply press a button and built-in logic circuitry does the rest. Yet Armstrong's basic explanation, as above, still applies.

We'll look at Armstrong's other achievements and the unhappy circumstances associated with the end of his life, in the second half of this story. ☺

### BLISTERING

80286 Motherboards	
16MHz-Landmark 21MHz	\$429
20MHz-Landmark 27MHz	\$495
386/25/33C Also Available	\$call

### GREAT SAVINGS ON DRAM ...

512 Kit 18 x 256k x 1-100	\$98
2M Kit 18 x 1M x 1-100	\$299
256K x 4, 64K x 4, SIMM, SIP avail	\$call

### MORE LOW PRICES ...

XT-1000 12MHz V20 M/Board	\$127
AT-4000 12MHz 286 System 512k	\$999
AT-4000 M/Board ETI Aug/Sep/Oct	\$299
EC-FAX G3 9600bps Int with sw	\$399
EC-2400S V22 bis Extern Modem	\$299
EC-2400P V22 bis Intern Modem	\$299
Monitor VGA 0.31 for 1024 x 768	\$699
Keyboard 101 Deluxe	\$79
CGA/HERC card with LPT port	\$99
EC452B 2S + IP + G	\$49
Award Post Card	\$802
EC-FDD 5 1/4 / 3 1/2 Card w / Cable	\$98
HDFDC AT FDD/HDD Controller 1:1	\$195
Slotless Clock for XT / AT	\$49

### SAVE \$\$\$'s ON QUALITY DISKETTES

5.25" DSDD	\$5.99	5.25" DSHD	\$11.99
3.5" DSDD	\$12.99	3.5" DSHD	\$33.00

Pkt 10 inc tax. 100% error free  
L/time guarantee. Quantity discounts available.  
ALL PRICES SUBJECT TO CHANGE WITHOUT NOTICE.

26 Boron St, Sumner Pk,  
Brisbane Qld 4704.  
Phone: (07) 376 2955  
Fax: (07) 376 3286

KEN CURRY  
Managing  
Director



energy  
CONTROL

READER INFO No. 12



## Digital multimeter accuracy, calibration woes and headphone driving

We've had quite a few letters about the item in the April column on DVM accuracy – including one that points out a rather embarrassing error in my explanation. There's also a letter from former *R,TV & H* staffer Maurie Findlay, with an amusing account of a similar 'misleading meters' situation back in the pre-DVM days. We end up with a few words about driving headphones, and another warning about dud power transistors...

Among the letters that arrived following the April discussion of DVM accuracy, there was one nice follow-up note from the reader who originally brought up the subject, Mr Bert Heinemann of Fairfield in NSW.

As well as thanking us for throwing open the subject for discussion, Mr Heinemann raises the further question of DVM reliability. He notes that among a small group of three friends and himself, they've had three DMM's fail in fairly short order – two completely, and one with its decimal point indication having gone awry. This seems to indicate rather poorer reliability than with earlier analog instruments, he suggests, and asks if other readers have experienced similar problems.

He also offers some further information about his Metex 3650 instrument, which read 40% low on the 200 ohm resistance range, when the battery voltage had fallen to 8.3V. It turns out that when he tried a NiCad battery with the same nominal voltage of 8.3V, the meter read normally – suggesting that it wasn't so much a problem of the battery's voltage, but its internal resistance.

This is an interesting point, and one that again backs up his point that we should check a DVM/DMM's tolerance to battery voltage/internal resistance changes, when we test them for review. If other readers have any experiences similar to Mr Heinemann's, perhaps they'd give us all the benefit of hearing about them too.

Another letter on the DVM topic came from Mr Phil Denniss, of the Department of Plasma Physics at Sydney University, who like Mr Heinemann has written to us in the past. Mr Denniss' letter draws attention to an error in my April explanation of DVM accuracy specs, where what I wrote turned out to

be rather misleading:

*I would like to say first up that I find 'Forum' very entertaining and thought provoking, and that I would contribute more often, but I do not get around to it. In fact I have an unfinished letter concerning audio cables, and an experiment or two we tried to see any nonlinearities in ordinary wires, just waiting to be written up and posted off. This effort should be much shorter, and therefore quicker.*

*Near the top of page 48 you point out the problems of measuring voltages just above the limit of one range of the meter, so you have to go to the next highest range to measure the voltage – and thereby lose resolution. I think you are in error in suggesting that the accuracy is '0.8% of 20V', or '+/-160mV'. The accuracy of meters is usually given as a percentage of the reading, and not as a percentage of full scale – plus one or two digits or a percentage of full scale, for digital meters.*

*This is certainly the case for Philips and Fluke, although other dealers and manufacturers are often much more reticent to publish full and complete specifications for their meters.*

*This means that for the meter you discuss, the accuracy is (or should be) 0.8% of reading, plus one digit (say), so the error in reading a voltage of about 2V should be +/-16mV, regardless of the range used – plus some uncertainty caused by the digital nature of the meter, and depending upon the range used.*

*Well, having dumped that on you, I would like to thank you for bringing this topic into focus. As I said above, many manufacturers do not publish very useful nor unambiguous specs for their meters. Most well-known and respected manufacturers do, but meters that come from SE Asian manufacturers with strange names that you've never heard of before,*

*just do not seem equipped with reliable or believable specs, although the meters themselves often appear to be quite serviceable.*

*Some of the blame for this lack of relevant information must be laid on the Australian distributors, and I believe that simple ignorance and a dash of laziness are the real causes. Quite often the accuracy quoted is the best that the meter can achieve, and is usually only that for DC volts, as you state in the article.*

*I have noticed other strange behaviour in various meters, in my time. One trap that I've discovered is the specified input impedance. One meter we have has the specified 10M ohms only on the ranges 20V and above, and this occasionally causes problems with high voltage probes (for example), which rely on a known load resistance for accuracy reading.*

*Some meters I have used actually output some signals via the test prods, that can upset some circuits – although the more modern meters don't seem to do this. Some digital meters give misleading readings with some inputs, usually when measuring DC values that have AC signals impressed upon them. In fact I seem to remember an incidence of this published in EA in the past few years, in relation to a project that worked at radio frequencies (a transceiver or linear amp).*

*I think that the buyer or user of a DMM must beware, and it is in this context that journals such as EA have an important role to play. By educating the readership (in Forum, for example) on the perils and pitfalls involved, hopefully they can be avoided. Generally I think that most journals do make a significant and worthwhile contribution to this process. What remains, though, is for the user to know what they are doing, and how their equipment performs.*





Thanks indeed for those comments, Mr Denniss, and you're quite right to draw attention to my gaff. It's perfectly true that with the better class of DMM, the accuracy is specified as a percentage of actual reading, rather than a percentage of full-scale reading (FSR). Obviously I forgot this when I was writing the piece, in my haste to warn readers that this mightn't be the case with meters from less reputable makers.

Clearly what I *should* have written was that although the accuracy should normally be specified as a percentage of the actual reading, this can't be taken for granted, as some of the meters from 'unknown' manufacturers seem to be specified in terms of a percentage of FSR. And that if the latter is the case, the working accuracy can turn out to be a lot poorer than you'd expect.

I tried to explain this more clearly in the article headed 'Choosing a DMM', published in last month's issue.

Actually I've noticed that many of the advertisements and catalogs offering what we might call 'generic' DMMs don't even specify an accuracy figure at all. They seem to talk exclusively about *resolution* – presumably in the hope

that most potential buyers won't know the difference, and will assume that high resolution is either the same as high accuracy, or at least implies it!

But anyway, Mr Denniss is quite right to correct my error, and to prevent any misunderstandings. His other comments are also very appropriate, and will no doubt add to everyone's awareness of the potential pitfalls. Thanks again, Phil, and on behalf of our other readers I'd urge you to complete that other letter about your experiments on audio cables – it sounds as if it too will make interesting reading...

Another letter on the topic of DVMs came from a reader in Edensor Park, NSW. I can't be too sure of his name, though, because the signature is rather difficult to decipher; it looks like B. Daity. But whatever the name, he has some interesting comments about using DVMs:

*I have been an avid reader of EA for 18 years, and have read just about every article printed in the magazine. After all, I do have a month to get through each issue!*

*Regarding DVMs, I am a technician who has used and still use both types.*

*There are two areas where a DVM can let you down: voltage measurements and diode/transistor junctions.*

*The typical input impedance for a DVM is 10M or more. If you have a wiring loom, where a cable is effectively open circuit and you are trying to trace it through, the DVM can tell you there is voltage present when there really is not – by reading a signal fed through by capacitive or leakage coupling. Under such circumstances I either switch to an analog multimeter, or load the DVM down with a 10k resistor in parallel with the input.*

*The other problem is with regard to reading diode and transistor junctions, on the resistance ranges. Some DVMs don't use a high enough test voltage, so that the junctions don't conduct, and hence appear as an open circuit. This can be a problem especially with auto-ranging DVMs. In fact I have even experienced the problem with a DVM having a built-in 'Diode' test range – but perhaps a low battery voltage might have been to blame.*

*Yet with my trusty analog meter, I know that the x1 ohms range has sufficient voltage to make the junctions con-*

## FORUM

duct, and it always works reliably. I have also used it in conjunction with a power supply, resistor and separate meter as a transistor beta tester.

I'm not condemning DVMs, as in CMOS and high impedance circuitry they are essential for accurate measurements. But they can certainly be tricked, and a good technician knows the shortcomings of his tools.

Fair comment, Mr Daity. With its high input resistance, the DVM is great for making measurements in high impedance circuits, but the same characteristic can indeed lead you astray at times – especially when you're trying to track down a normally low resistance that may not have gone truly 'open', but only risen to a somewhat higher level. It's a characteristic it shares with the old valve voltmeter or 'VTVM', and with the latter's successor the analog 'solid state VOM'.

I guess you can't have it both ways. The very feature that gives the DVM an advantage in some situations, can be a source of problems in others – unless you're careful. So as Mr Daity says, a good technician needs to be aware of the shortcomings of his tools, and work around them when necessary. And Mr Daity's solution, that of shunting the DVM input with a suitable low-value resistor, seems as good as any when you don't want to be misled in low resistance circuits.

Incidentally, some DMMs can have a particularly high input impedance on their lowest (basic) DC voltage range – as high as 2000 megohms. This can make them even more susceptible to giving what look like sensible readings, even when things are very much abnormal in the circuit you're testing.

Mr Daity's other comment, about the driving voltage used for resistance measurements is also quite relevant, although I think nowadays both users and manufacturers are rather more aware of this one. All of the current DMM models that I've seen seem to be provided with ranges suitable for testing all common semiconductor junctions. In some cases there are also other ranges, specifically designated as having a driving voltage below the threshold for junction conduction, and meant to allow in-circuit testing of resistors and other components. So you can have the best of both 'worlds'!

### Memories...

And so to the letter which came in

from Mr Maurie Findlay, who was a staff member of the magazine back in the days of Editor John Moyle, when it was called *Radio, TV & Hobbies*. Maurie left to try his hand at other things just before I joined myself in 1960, so we never actually worked together. But we've met at various times since then, and corresponded a few times, so it almost feels like we worked together.

In any case we certainly share the experience of working with various other former *R, TV & H/EA* staff members – even though it wasn't at the same time!

Anyway, here's Maurie's letter, and I think you'll find it as amusing as I did:

*First of all, I read with interest your article on the very high quality Sony headphones, in the February issue. Mind you in view of the price, my interest is academic only!*

*You remarked that headphone manufacturers appear not to specify the feed conditions for their products. I suspect that other readers as well as myself would be interested to hear more about this subject. I have a couple of pairs of good quality phones from a respected manufacturer, and as far as I know their construction is similar to that of a moving coil speaker. Speakers are normally fed from an amplifier which behaves as a low source resistance, and yet the headphone jack on the commercial amplifier I have provides a high resistance source.*

*Changing the subject, your discussion of DVM accuracy reminds me of an amusing incident from the magazine's past. A journalised version appeared some years ago, with the names thinly disguised and the facts distorted, I feel, for a laugh at my expense. But it's worth telling again, I believe – this time straight:*

*While a member of the staff of *R, TV & H*, probably around 1955, I was given a project by the then Editor John Moyle, to work on a high power VHF transmitter for the two-way radio system we were building for 'The Sun' newspaper. Both the transmitter and the *R, TV & H* office were high up in what is now the 'Sydney Morning Herald' building, in Broadway, Sydney. As an (almost) professional engineer at the time, I was concerned that a first-class job be done.*

*The RF power amplifier of the transmitter used a pair of vacuum tubes with thoriated tungsten filaments. Technical advice from Eimac, the makers of the tubes, indicated that the filament voltage of the tubes was critical, and that great care should be taken to ensure that it was within their stated tolerances.*

*The magazine's laboratory had six or seven multimeters at the time, and I was supposed to use the magazine's facilities to get the transmitter into operation. The problem was that they all gave widely different readings, and it was anybody's guess which one – if any – was correct.*

*Pleadings with the 'powers that be', to purchase just one reasonably accurate multimeter, were fruitless.*

*I brooded over the situation for some days, and finally rationalised that as a fledgling engineer, I could justify a moderately good quality multimeter for my own personal use. Checking on those available at the time, I decided on an AVO Model 7, at £40. This was not an inconsiderable sum at the time, considering I was paid about £22 a week as a member of the magazine's editorial staff.*

*To be absolutely sure of the new instrument, I prevailed upon a fellow student who worked at a standards laboratory, to provide me with a set of correction data for the AVO. He carefully set out both scale shape and full-scale corrections for each range, using his very accurate standards. It turned out that the Model 7 was well within the makers' specification, but with the corrections provided by my friend, it would be easy to set up the Eimac tubes correctly.*

*Armed with the new and freshly calibrated AVO, I thought that I would also solve the magazine's multimeter problem, by using it to correct the other multimeters in the lab. So late one night, and probably after a lecture at what was then the nearby University of NSW, I returned to the lab with my AVO and connected it up in parallel with the other meters to a variable power supply, with the idea of correcting their errors. At hand was a bundle of resistors, to place either in series or in parallel with their multipliers as required.*

*To begin with, I tried checking all of the ranges. All of the 'R, TV & H' instruments consistently gave near enough to the same reading – but it was always widely different from that shown on the AVO!*

*Was I going bonkers? Was the renowned AVO unreliable after all? Should I toss it out of the window and down the 12 floors to Jones Street? I went home that night in a disturbed state.*

*But there was a logical explanation.*

*Another member of the staff, Phil Watson, had also been concerned about the multimeter problem. He reasoned that if he averaged the multimeter readings and made them all read that figure, the net result would be an improvement. So unknown to me, he had gone to the*

lab the night before, set the meters up and gone to a great deal of trouble to make them all read the same!

My faith in the world of radio and electronics was restored.

I still have the AVO Model 7, bearing the marking below the mirror scale 'Accuracy B.S.1 No.57354-A-655'. It still looks almost new, and checked against a modern very accurate digital multimeter, is well within the makers' original tolerance.

Thanks indeed for that story, Maurie. It certainly goes to show that just because a bunch of meters may give the same reading, this doesn't necessarily rule out the possibility that they're all wrong!

Maurie's comments about headphone driving impedance are also interesting. You may have noticed that there was a response by Sony to the comments I made on this subject in the February review, by a Mr Terazawa, which we published in last month's 'Letters to the Editor' columns. Basically he seemed to be suggesting that although the MDRR10 headphones perform well regardless of the driving impedance, Sony engineers agree that "the possibility of getting better performance is higher when a low impedance headphone jack is used".

Which is what one would expect from basic principles of electromagnetic transducer operation, of course. As Maurie Findlay points out, and I suggested in the review itself, moving-coil headphone drivers are basically very much like small speakers, and like speakers you'd expect them to give best results when driven from a low impedance source. In other words, when the electrical drive is 'stiff', with as little

decoupling as possible between the amplifier's drive signal and the headphone's back EMF. Or looking at it in another way, when the 'phones are receiving maximum electrical damping.

Presumably in the case of Sony's yobaut MDRR10 phones, they are so well damped internally that the external electrical damping isn't too important. Although judging from Mr Terazawa's reply, it looks as if Sony believes they'd rather have the extra damping than not, if there's a choice!

Fair enough, I suppose. My main point in the review was that having gone to such lengths with the MDRR10's, to ensure an extremely high standard of reproduction - bordering on perfection, in fact - it seemed strange that Sony didn't even bother to make mention of driving impedance considerations, in the MDRR10 user manual. And having read Mr Terazawa's admission that low driving impedance is likely to give the best results, I guess I'm still puzzled.

If low driving impedance is the way to achieve the best possible results, from what are almost certainly the world's best headphones, why not recommend this to the user?

And that's about all for this month, except for another warning from Sydney electronics technician Phil Allison, that counterfeit Motorola MJ15003 and MJ15004 power transistors again seem to have surfaced, in at least one Sydney retail outlet.

For legal reasons we can't name the outlet concerned, but Phil suggests that we republish the details on identifying the dud product, so that readers can check for themselves. You'll find this information in the box panel.

## WARNING: COUNTERFEIT MJ15003/4 TRANSISTORS

Back in the June and July 1988 issues, we warned readers that illegally re-labelled TO-3 power transistors had been discovered in Australia. We have now been advised that the same devices are again being offered for sale, by at least one retail electronics outlet in Sydney.

The devices are represented as Motorola MJ15003 and MJ15004 types, but in reality they appear to be somewhat lower power devices which have been relabelled. Cut open, they are found to contain a much smaller chip than true MJ15003/4 devices, and with much lighter internal bonding wires.

The counterfeit devices can be identified as follows: they are in aluminium TO-3 cases, rather than steel, and with inked date codes of '8713' or '8715'. Readers with devices matching this description are advised to return them to the supplier from which they were purchased, asking for either a refund or replacement with a guaranteed genuine product.

Please note that according to Motorola Australia, the best way to ensure obtaining genuine products is to source them from the company's official Australian distributors, VSI Electronics and Soanar Electronics, or their nominated resellers.

# Audio & Video spare parts

## Japanese Semiconductors

Including AN, BA, HA, LA, LM, MB, STK, UPC, 2SC, 2SB and 2SD. Many others.



### READER INFO NO. 13

We stock thousands of different European and Japanese transistors and ICs. Try us for that hard-to-find semiconductor.

## Video Heads



To suit Hitachi, JVC, National, Sanyo, Sharp, Sony, Toshiba and many others.

High quality DAI-ICHI video heads are available for all these brands at sensational low prices.

### READER INFO NO. 14

## Drive Belts

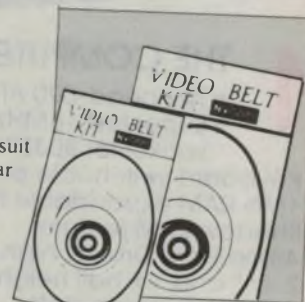

Belt kits to suit most popular VCRs.

### READER INFO NO. 15

Also, square section belts for tape recorders and flat section belts for most audio applications including turntables. Other video and tape recorder parts are stocked.

## Wagner Electronics

305 Liverpool Road  
Ashfield, NSW 2131  
Ph (02) 798 9233  
Fax (02) 799 7051



TRADE ENQUIRIES WELCOME

# Look To The Future

HERE ARE 4 GOOD REASONS WHY  
YOU'LL BUY YOUR FUTURE  
COMPUTER FROM DICK SMITH  
ELECTRONICS....



## 1 THE COMPUTER

- Twinhead -590 AT compatible
- Super fast 16MHz 80386SX processor with socket for 80387SX Maths co-processor
- Keyboard switchable processor speeds
- 1Mb RAM expandable to 5Mb on board
- Shadow RAM feature
- 40Mb Hard Drive & high density 5 1/4" Drive
- 2 x 1" and 1 x half height drive bays
- 4 free expansion slots
- MS.DOS 4.01 Operating System
- 2 serial & 1 parallel port
- Paradise VGA graphics adaptor with 256k (expandable to 512k) Graphics Memory
- VGA monochrome Monitor

**DICK SMITH**  
ELECTRONICS

## WITH A 386SX FROM

# Twinhead

32 Bit Computing Power without The 5 digit Price Tag!



## 2 THE QUALITY

Twinhead computers are constructed using the latest surface mount technology for improved reliability. All controls are conveniently located on the front panel and the AT keyboard has a smooth, bounce-free design to keep up with the fastest typists. Your SuperSet-590 Computer has undergone extensive testing before it leaves the factory. To ensure it has arrived safely, our own Quality Control Department then puts EVERY Twinhead computer through 24 hours of rigorous testing and has given your new computer a 100% diagnostic test... even formatted and tested your Hard Drive. Yes, you can trust your business to the computer you buy from Dick Smith Electronics!



## 3 THE SUPPORT

Think of a computer question and our support staff will know the answer! If you have a problem using any of our computers or software, or just need some good advice, our support staff are waiting for your call. Computer Service Hotline 888 2002 SERVICE TOO! Service is not a problem with a computer you buy from Dick Smith Electronics. We have a computer service plan to suit YOUR needs-

- Take your computer to the nearest Dick Smith Electronics Store and we'll rush it to our Service Department.
- For a small fee, your 12 months warranty can become a 24 month warranty.
- Enquire about a Field Service Contract. Available nationally, a Field Service Technician will come to you and in most cases your computer will be repaired on the spot!
- We can even turn your 12 or 24 month warranty into a Field Service Warranty for just a little extra!

## 4 THE PRICE Only \$2995

including VGA Monochrome Monitor  
Add \$500 for VGA Colour Monitor

# Enhance Your Computer

## 20MHz Neat AT Motherboard

Faster, and more versatile, the 286 NEAT motherboard represents a significant advance over conventional 80286 designs. The NEAT (New Enhanced AT) chip set enables the user to control the relationship between microprocessor, expansion bus, and on-board memory, giving greater flexibility than ever before.

The NEAT Motherboard suits any IBM compatible case from AT to tower and runs at 8, 10, 12, 16 or 20MHz with any version of MS-DOS above 3.0. It has onboard support for Lotus-Intel-Microsoft (LIM) Expanded Memory Spec. Version 4.0.

Using the ROM based setup program provided, you can set CPU, BUS, and DMA speeds, memory wait states, even install custom hard drive specs. Comes socketed for the 80287 Math co-processor and three 8-bit plus five 16-bit expansion slots, as well as the capacity to hold 8 megabytes of memory (DIP and SIP memory modules).  
0k memory supplied. Cat X-1003

Only **\$699**

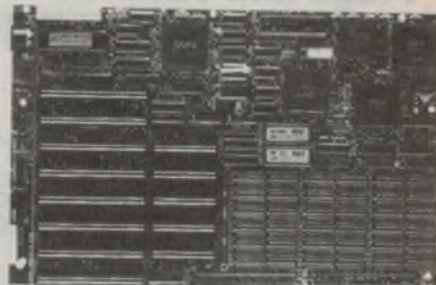

## More Colours! More Options! VGA Graphics Adaptor!

More colours, higher resolution and more options are just some of the outstanding features of our VGA Graphics Adaptor!

Fits into any IBM compatible (XT or AT) and comes with 256K RAM on board that's easily expandable to 512K for even more amazing colour and graphic capabilities. Super VGA is supplied with utilities which allow emulation of EGA, Hercules, and CGA. Supplied with software drivers and comprehensive manual.

**8 Bit Version. \$249**      **16 Bit Version \$299**

Cat X-2018

Cat X-2019

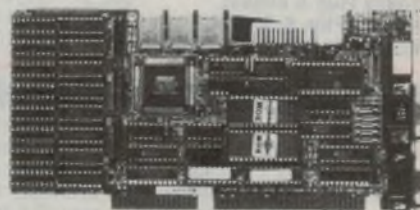

## 8MB Memory Board

This 8MB IBM compatible memory board can grow with your needs. Start out with just 2MB then expand it in lots of 2MB up to a full 8MB as your memory needs grow. It uses standard 1MB RAM chips and can be configured as expanded or extended memory. EMS version 4.0 drivers come with the board along with user selectable I/O ports for page selection. 0k RAM on board.

Cat X-1020

**\$299**



## Twin Port Game Card

Want a friend to share the fun of your computer games? This card will allow you to fit two joysticks to your IBM compatible computer for twice the action!

Cat X-2040

**\$39<sup>95</sup>**

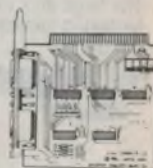

## RS-232 Quick Tester

An in-line tester with 25 pin male and 25 pin female connectors. 3 switches and 6 LED's allow quick selection of the most popular RS-232 configurations. Simply set the switches to select the connection you need

Cat X-2652

**\$39<sup>95</sup>**

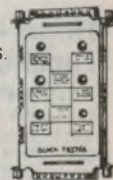

## 3.5" Disk Drives

These 720K and 1.44Mb disk drives come complete with 5 1/4" mounting kit, hardware, manuals, power and 34 pin adaptors, bezels... the lot!

**1.44Mb Version. \$219**

Needs DOS 3.3 or higher.

Cat X-2221

**720K Version. \$199**

Needs DOS 3.2 or higher.

Cat X-2220

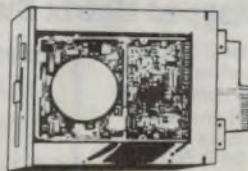

## Co-Resident Floppy Controller

Allows you to add a third and fourth floppy disk drive to your IBM compatible. Designed to co-exist with your current floppy controller card.

Cat X-2025

**\$99**

## RS-232 Serial Breakout Box

A complete in-line tester/adaptor which makes complex and time consuming serial connections a breeze! Comes with 25 pin male and female connectors. Also comes with jumper pads and wires, as well as 24 in-line switches for quick selection for any RS-232 configuration. The tester has 8 bi-colour LED's which monitor the lines and tell you at a glance when you've got it right!

Cat X-2654

**\$49<sup>95</sup>**



B982/TL1

**DICK SMITH**  
**ELECTRONICS**

# Things

# & Stuff

## Plugs and Sockets

Nylon plugs and sockets in various configurations suitable for automotive, radio control applications, etc. Quality connectors from Molex complete with pins.



2-Way Plug & Socket.	P-5102	\$1.95
3-Way Plug & Socket.	P-5103	\$2.75
4-Way Plug & Socket.	P-5105	\$2.95
6-Way Plug & Socket.	P-5106	\$3.75
9-Way Plug & Socket.	P-5109	\$4.50
12-Way Plug & Socket.	P-5112	\$4.75
Spare Pins to suit. Pk of 6M & 6F	P-5100	\$2.95

## Bench Voltmeter

An ideal bench-top Voltmeter. More convenient than a multimeter, this meter is perfect for the classroom as well as the work bench. It measures voltage in two ranges - 0 to 10Vdc and 0 to 20Vdc at ~2.5% accuracy. The large 80 x 80mm scale is perfect for taking measurements in vehicles. Cat Q-2140

**\$29<sup>95</sup>**



## Bench Ammeter

The perfect partner for your Bench-top Voltmeter. This Bench Ammeter measures current in two ranges - 0 to 5Adc and 0 to 10Adc. The easy to read 80 x 80mm scale is great for demonstration work while the 4mm banana terminals make connections a breeze. Cat Q-2130

**\$29<sup>95</sup>**



## Tuning Meter With Centre Zero

Just what you need for Tuner or Receiver projects to give accurate tuning indication. The meter scale is 35mm x 15mm, impedance is 1k, and the straw coloured meter face looks great mounted with a back-lit display. Cat Q-2095

**\$2<sup>95</sup>**



## Moving Iron Meter

Ideal for Hobbyists and enthusiasts. AC/DC movement iron meter in oval style case measuring approx. 55mm wide x 58mm long. Note - moving iron meters are not highly accurate but give good relative indication. Cat Q-2080

0-20V (AC & DC)

**\$19<sup>95</sup>**



## Finger-Proof Fuseholders

These fuseholders are designed to keep 240V connections safely out of reach of roaming fingers! Cat P-7914 suits M205 fuses Cat P-7916 suits 3AG fuses

**\$3<sup>95</sup>**



## Bayonet Fuseholder

These easy access fuseholders are ideal for use in test equipment or any low voltage device. They accept 3AG fuses and require a 13mm mounting hole. Cat P-7902

**\$1<sup>30</sup>**



## Square Fuseholder

Attractive 18mm square faced fuseholder with black casing and coloured insert. Accepts standard 3AG fuses. Cat P-7900

**\$1<sup>95</sup>**

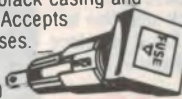

## In-Line Fuseholder

The right fuseholder for car accessories... radios, CBs, etc. Takes 3AG fuses and comes with 600mm of cable attached. Cat P-7912

**\$1<sup>10</sup>**

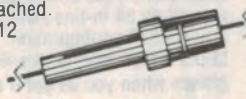

## PCB Mount Fuseholders

Easy to mount fuseholders in both popular sizes. Cat P-7910 M205

**\$1<sup>20</sup>**

Cat P-7908 3AG **95<sup>c</sup>**



## Keypad Matrix Switch

Use it for electronic locking devices or numeric input for any digital device. Cat P-7804

**\$3<sup>95</sup>**

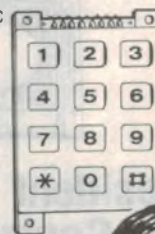

## Miniature Led Bezel

A low current drain, highly visible LED in a chrome bezel. Available in red and green. Cat P-8104 Red **\$1<sup>50</sup>** Cat P-8106 Green



## 12V Mes Bezel

Attractive bezels with bright, flat topped lenses for a smart, modern appearance. Available in red or green. Cat P-8100 Red **\$2<sup>50</sup>** Cat P-8102 Green



## Dual Colour Led Bezel

Ideal for two-state indication especially in logic circuits. Mounted in a chrome plated bezel. Cat P-8108 **\$4<sup>95</sup>**



### MAJOR DICK SMITH AUTHORISED STOCKISTS:

**NSW:** ARMIDALE: New England Electronics 711655 BALLINA: Ballina Electronics 867022 BOWRAL: F.R.H. Electrical 611861 BROKEN HILL: Hobbies & Electronics 884096 COOTAMUNDRA: Cootamundra Music & Lite 422561 COFFS HARBOUR: Coles Harbour Electronics 525584 DENILIQUIN: Dem Electronics 813672 DUBBO: Chris's Hi-Fi 828711 FORSTER: Forster Village Electronics 545006 GLEN INNES: John Sommerlad Electronics 323661 GRAFTON: Repairs and Spares 421911 GRIFFITH: Miatronics 624534 INVERELL: Inverell Electronics 221821 LEETON: Leeton Audiomatic 532800 LIGHTNING RIDGE: Cycle & Sound 290579 LITHGOW: Douroy Photographics 513173 LISMORE: Deero Electronic Services 214137 MOREE: Moree Electronics 522091 MUDGEE: Headware 723895 NARRABRI: Namoi Computer Service 923274 NELSON BAY: Nelson Bay Elect & Hobbies 813685 NOWRA: Nowra Electronics 210722 ORANGE: Central West Electronics 626491 PARKES: Strad Music Centre 623366 PORT MACQUARIE: Hastings Computer Service 834574 TARIEE: Brads Electronics 526603 WAGGA WAGGA: Phillips Electronics 216558 YASS: Warrington Electrical 261116 YOUNG: Keith Donges Electronics 821279 **VIC:** BAIRNSDALE: LH & LM Crawford 525677 COLAC: Coiac Electronics 312847 MILDURA: Pullman Auto Pro 232882 MORWELL: Morwell Electronics 346133 SHEPPARTON: Andrew Guyatt Electronics 219497 SWAN HILL: Nyah District TV Service 325003 WARRAGUL: Roylelaine 234255 WARRNAMBOOL: Korrisi Elec Services 627417 **QLD:** AYR: Delta Electria 831566 BUNDABERG: Bob Elkin Electronics 721785 CALOUNDRA: Electro-man 918533 DYSART: Dysart Videotronics 582107 INGHAM: Masons Electronics 763188 MACKAY: Stevens Electronics 511723 MARYBOROUGH: Keller Electronics 214559 NAMBOUR: Nambour Electronics Shop 411604 PIALBA: Keller Electronics 283749 **TAS:** BURNIE: Electronic City 314760 DEVONPORT: A.I. Electronics 748322 **SA:** MT GAMBIER: Hulsehousen's Communication Centre 250400 PORT LINCOLN: Basshams TV & Comp World 822188 WHYALLA: Eyre Electronics 454754 **WA:** ALBANY: Micro Electronics 412077 BUNBURY: Micro Electronics 216222 GERALDTON: Batavia Lighting & Electrical 211966 KARRATHA: Oaves Osciltronics 854836 MANDRAM: Micro Electronics 5812206 PORT HEDLAND: Ivan Tomek the Elect 732531

# DICK SMITH ELECTRONICS

# NEW KITS SOON TO BE RELEASED

Secure Start

## 2 Sector Alarm Control Module

The basis of an effective 2 sector home burglar system. Just add an arm/disarm keyswitch, horn speaker, sensors and a 12V DC power supply and you are in business, not the thieves!

Supplied in shortform — components and PCB only.  
Cat K-8401

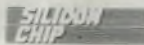

JUNE '90

**\$39<sup>95</sup>**

Need more sectors?

## 2 Sector Module

By adding these modules to K-8401 you can expand your system to secure your entire house or business. Shortform kit - PCB and components only.

Cat K-8400

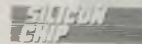

JUNE '90

**\$12<sup>95</sup>**

## 4 Digit Capacitance Meter

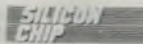

MAY '90

Measures capacitance from 1pF up to 9999uF in 7 ranges. Accuracy better than +/- 1% +/- 1 digit. Supplied with all components, hardware, PCB, pre-punched silk screened front panel and case.

**\$129**

Cat K-7500

# KIT CLEARANCE — HURRY! LIMITED STOCKS!

Batteries tired?

## Nicad Fast Charger

No more flat batteries with this Mains powered fast charger. Complete with all components, case and PCB. It can't overcharge (if set correctly) and you'll save money!  
Cat K-3476



**\$69<sup>95</sup>**

## Remote Alert/Doorbell

Eliminates the need for unsightly wiring, pleasant two tone chime. Ideal for the sickroom and elderly. Complete with Transmitter  
Cat K-2730



**\$59<sup>95</sup>**



So Easy To Build!

## Bookshelf Speakers

Low cost compact Bookshelf Speaker Kit uses a Magnavox 6MV 15cm driver and 3AC Tweeter. Buy the complete kit and SAVE!

Cat K-4000 Sleeves, baffles x-overs etc.

**\$126 Pair**

Cat K-3999 Speaker Woofer 6MV **\$29.75 ea.**

Cat K-3998 Speaker Tweeter 3AC **\$6.75 ea.**

## Tilt Alarm

Got a leaning towards this 'go anywhere alarm' which sounds when it's tilted? Ideal as an alarm for bikes!  
Short Form - Case not supplied.  
Cat K-3248

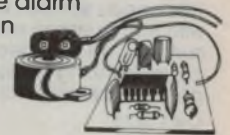

**\$9<sup>95</sup>**

Revive Your Old TV

## UHF to VHF Converter

See UHF channels 28 to 63 including SBS, with this easy to build low cost converter. Complete with pre-punched case.

Cat K- 3236



**\$69<sup>95</sup>**

## Brake Lamp Monitor

A low cost, easy to build project that warns you if your vehicle brake lights aren't working. Complete with all components and case.  
Cat K-4500

**\$19<sup>95</sup>**



Low Cost!

## Battery Power Supply

Variable supply - ideal for beginners. No messing with Mains, can be powered from a battery. Includes all components, hardware and case. No metering, no frills, but economical.  
Cat K-3460

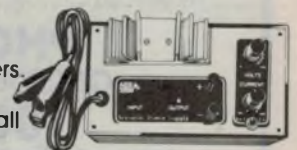

**\$49<sup>95</sup>**

Due to limited stocks some stores may not carry all of these items. We can arrange transfer to your nearest store, please phone ahead to check availability.

# TOOLS

## LOW VOLTAGE IRONS



### Quality Spring Loaded Pliers/Nippers

High quality handtools help make work easier! Specially selected for project work they're all high carbon steel, drop forged, hardened and tempered with insulated handles.

- 127mm Needle Nose. Cat T-3290
- 115mm Diagonal Nipper. Cat T-3291
- 115mm Long Nose. Cat T-3292
- 153mm Needle Nose. Cat T-3293
- 125mm Flat Nose. Cat T-3596
- 125mm Bent Nose. Cat T-3297
- 115mm End Nipper. Cat T-3298

**\$8<sup>95</sup>** each

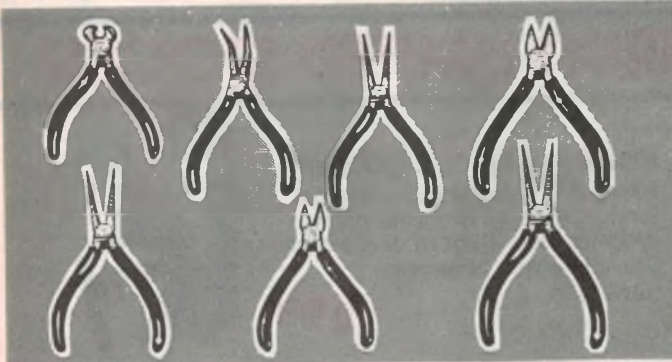

### 4 Blade Scraper 'G' Clamp Set

This handy scraper has a blade with four purpose designed surfaces on it for deburring and countersinking holes as well as general finishing work.  
Cat T-3625

**\$3<sup>95</sup>**



Three handy 'G' Clamps that are perfect for most hobby work, etc. All fit the 30mm (diam.) magnetic base supplied. Sizes include 40mm x 35mm, 30mm x 30mm & 20mm x 25mm.  
Cat T-4755



**\$5<sup>95</sup>**

### 'F' Clamp Set

Three sizes: 20 x 120mm, 20 x 80mm & 20 x 40mm. All fit to the 38mm magnetic base included in pack.  
Cat T-4750

**\$5<sup>95</sup>**



### 10-70 Watt Miniscope

Lightweight, fingertip control gives precise temperature. Requires 3.3V @ 30A. Comes with spare tip & element pack. Cat T-1660

Fast Heating  
30-150W  
12 Volt

**\$79<sup>95</sup>**



Connects to your car battery & heats in 3 secs. Comes with 6m (20ft) lead with clips. Current drain 45A. Cat T-1635

### 3.3V@30A (Int) Transformer

Low Voltage transformer for scope irons with electronic shield for extra protection.  
Cat T-1692

**\$79<sup>95</sup>**



**\$69**

Spare Tip & Element Pack Cat T-1601

### 150 Watts! Superscope.

Select temp. Heats to required in 6 secs! Requires 3.3V @ 30A. Comes with spare tip & element. Cat T-1605

**\$59**

Spare Tip & Element Pack Cat T-1603



### Hobby Mini Vice

Sturdy, lightweight & portable. Fits easily to workbench, table, etc (anything up to about 40mm thick). Jaws are 60mm wide and they open to 50mm.  
Cat T-4747

**\$15<sup>95</sup>**



#### Store Locations

• **NSW** • Albury 21 8399 • Bankstown Square 707 4888 • Belconnen (06) 253 1785 • Blacktown 671 7722 • Brookvale 905 0441 • Bondi 387 1444 • Campbelltown 27 2199 • Chatswood Chase 411 1955 • Chullora 642 8922 • Gore Hill 439 5311 • Gosford 25 0235 • Hornsby 477 6633 • Hurstville 580 8622 • Kolara 56 2092 • Liverpool 600 9888 • Maitland 33 7866 • Miranda 525 2722 • Newcastle 61 1896 • North Ryde 878 3855 • Parramatta 689 2188 • Penrith 32 3400 • Railway Square 211 3777 • Sydney City 267 9111 • Tamworth 66 1711 • Wollongong 28 3800 • **ACT** • Fyshwick 80 4944 • **VIC** • Ballarat 31 5433 • Belmont 43 8522 • Bendigo 43 0388 • Box Hill 890 0699 • Coburg 383 4455 • Dandenong 794 9377 • East Brighton 592 2366 • Essendon 379 7444 • Footscray 689 2055 • Frankston 783 9144 • Geelong 232 7111 • Melbourne City 399 Elizabeth St 326 6088 and 246 Bourke St 639 0396 • Richmond 428 1614 • Ringwood 879 5338 • Springvale 547 0522 • **QLD** • Brisbane City 229 9377 • Buranda 391 6233 • Cairns 311 515 • Chermside 359 6255 • Redbank 288 5599 • Rockhampton 27 9644 • Southport 32 9033 • Toowoomba 38 4300 • Townsville 72 5722 • Underwood 341 0844 • **SA** • Adelaide City 223 4122 • Beverley 347 1900 • Elizabeth 255 6099 • Enfield 260 6088 • St. Marys 277 8977 • **WA** • Cannington 451 8666 • Fremantle 335 9733 • Perth City 481 3261 • Midland 250 1460 • Northbridge 328 6944 • **TAS** • Hobart 31 0800 • **NT** • Stuart Park 81 1977

### PHONE ORDERS OUTSIDE SYDNEY — FREECALL

**(008) 22 6610**

Sydney Customers and Enquiries: (02) 888 2105  
Fax: (02) 805 1986. MAIL ORDERS: DS XPRESS,  
Freepost 100, P.O. Box 321  
North Ryde NSW 2113





# A CASE

## FOR EVERY OCCASION

### METAL CABINETS

Beautifully made cabinets to suit a huge range of projects, especially those with meters and controls which need to be panel mounted. They consist of an aluminium base, metal sides with cooling slots, and self-tapping screws. All in an attractive two-tone finish.

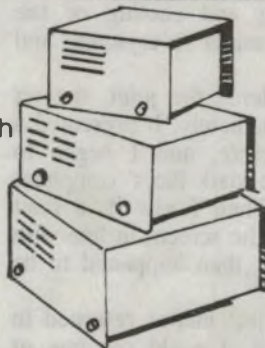

102 x 56 x 83mm  
150 x 61 x 103mm  
150 x 76 x 134mm  
185 x 70 x 160mm

Cat H-2741 \$6.95  
Cat H-2742 \$8.95  
Cat H-2743 \$9.95  
Cat H-2744 \$11.95

### ALUMINIUM BOXES

Just the thing for those weekend projects that get left lying around! These boxes come in two pieces which slide together and come complete with screws. Versatile and in a wide range of sizes. Natural finish.

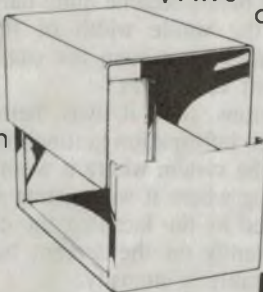

110 x 51 x 70mm  
104 x 60 x 46mm  
127 x 102 x 76mm  
133 x 76 x 54mm  
152 x 132 x 103mm  
180 x 158 x 118mm

Cat H-2300 \$5.95  
Cat H-2305 \$4.95  
Cat H-2320 \$6.95  
Cat H-2325 \$5.95  
Cat H-2330 \$8.95  
Cat H-2335 \$10.35

### EXTRUDED CASES

Ultra strong, ultra reliable cases based on a specially made 18 gauge aluminium extrusion. The extrusion measures 76 x 102 x 102mm and is available in three different lengths each with four slots for insertion of PCBs without the need for screw mounts.

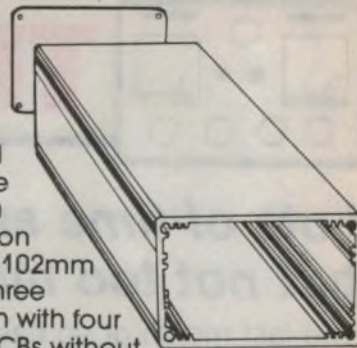

76mm Cat H-2420 \$22.95  
102mm Cat H-2425 \$25.95  
153mm Cat H-2430 \$29.95

### ZIPPY BOXES

The box most preferred by electronics magazines because of its quality and versatility! With Dick Smith Electronics Zippy Boxes you get a better finish with a tight fitting plastic and recessed aluminium lid. Yes, two lids with every box!

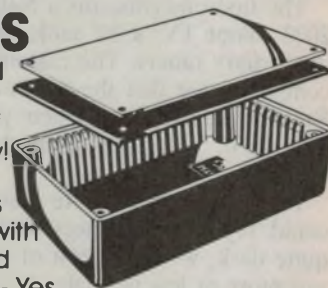

28 x 54 x 83mm Cat H-2855 \$2.95  
41 x 68 x 130mm Cat H-2853 \$3.95  
50 x 90 x 150mm Cat H-2851 \$4.95  
60 x 113 x 196mm Cat H-2852 \$6.95

### RACK MOUNTING CASES

Just what your equipment needs for space efficient storage and that clean, professional look. All cases are 430mm wide and 554mm deep (international standard), and have a black anodised finish.

Key:  
A=Front Panel height (mm)  
B=Mounting Hole centres (mm)  
C=Internal Case Height (mm)

A	B	C		
44	34	38	Cat H-2483	\$69
88	57	82	Cat H-2485	\$89
132	89	126	Cat H-2487	\$99



### RACK MOUNTING BLANK PANELS

Designed to bolt directly onto your rack system and neatly fill the spaces between equipment. They come with predrilled mounting holes and black anodised finish.

44mm Cat H-2482 \$15.95  
88mm Cat H-2484 \$25.95  
132mm Cat H-2486 \$29.95

**DICK SMITH**  
ELECTRONICS

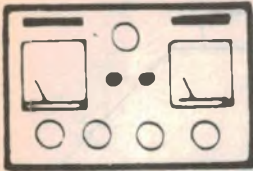

# The Serviceman



## Lots of time and effort, but not too much excitement!

The last month or so has been a rather uninteresting time in my workshop. There's been plenty of work coming through, but very little of it has been spectacular enough to make it onto these pages. Unfortunately, the Editor doesn't like blank pages in his magazine, so I've had to make the most out of some essentially routine stories. See how you like this batch!

The first one concerns a National TC-2002 colour TV, a 20" table model with dual rotary tuners. The customer's main complaint was that the set wouldn't go. But she added that "when you've got that fixed, you might look at the dark faces!"

When pressed for more detail, all she could say was that faces tended to go quite dark, while the rest of the picture was more or less normal.

I wasn't impressed with that description of the fault. It sounded like nothing I've ever heard of, and I couldn't even imagine what it would look like. Obviously I'd have to wait until I could see it for myself.

As it happens, the set was very easy to get going. The power supply is protected by a heavy duty spring resistor. This 20 watt resistor has two contacts mounted on the side of the casing. One contact is of spring metal and is normally soldered to the other.

In the event of an overload, the resistor heats up and melts the solder holding the contacts together. They then

spring apart and break the power circuit into the set. This is a rather primitive system, but it does away with the need to keep replacing fuses when chasing difficult overload problems.

In this case there was no overload – the solder joint had broken spontaneously. This sometimes happens, because repeated heating and cooling of the joint causes the solder to crystallise and become weak.

Once I re-soldered the joint, the set came to life immediately. It presented a near perfect picture, and I began to wonder what the 'dark faces' complaint was all about. Then I saw it: a faint dark line across the screen, in line with a title which just then happened to be showing.

When the subject matter returned to program material, I could see one or more faint dark bands moving about across the screen, in time with the movement of bright parts of the picture. Sometimes the bands became quite dark and covered the whole width of the screen. This must have been the cause of the complaint 'dark faces'!

It was obvious that it was being caused by video information getting into some part of the system where it wasn't wanted. Finding where it was getting in was complicated by the fact that the effect was constantly on the screen, but varied considerably in intensity.

I have seen something similar to this before. Then it was a smearing of video information caused by a faulty bypass capacitor on one of the supply rails feeding the video amplifier.

The present fault was not quite the same, but was similar enough to prompt a search for the electrolytic capacitors bypassing the 160 volt, 24 volt and 12 volt rails – all of which have a bearing on the final picture on screen.

Unfortunately, not even replacing all of the relevant electros produced the slightest sign of improvement. The fault

was obviously not the same as the smearing mentioned earlier, but was something else which merely produced a similar result.

At this point I switched on my trusty PM5544 pattern generator, intending to look for distorted waveforms with the oscilloscope. However, that idea was soon scotched because there was not the slightest sign of trouble on the generator channel. But turning back to channel 2 restored the fault.

Next I turned to channel 28, where the SBS was broadcasting its usual test pattern. This produced an interesting effect, one that was kind of halfway between the wandering bands on live program and the absence of bands evident on the generator pattern.

The PM5544 pattern showed a bright bar across the centre of the circle, shading to dark at the top and bottom. And it was perfectly static. It didn't move at all and provided a stable signal to look at with the CRO.

Unfortunately, the scope showed absolutely nothing that might indicate what was going on. Whatever the fault was, its effect on waveforms was so slight as to be invisible. With no help from the high-tech tools, I was clearly on my own – and not too happy about it at all.

Then I had a lucky break. I remembered that among a box of old TV parts, there were some panels from junked Nationals, and one of them was a chroma board from this very model. It had been cannibalised for its PAL switch IC, but that should only stop the colour. In this case I was more concerned with the luminance.

In next to no time I had the junk board in the set, and was watching a perfect black and white picture. There was no trace of the dark lines, either on test pattern or on program material.

So it was obvious that the trouble lay in the luminance circuits on the set's

## Cut The Guesswork!

SADELTA TC400

Television signal  
level meter.

Ask your aerial  
supplier for  
a brochure  
today!

Under  
\$700+tax



Peter C. Lacey Services Pty. Ltd.  
74 Fulton Rd. Mt. Eliza 3930 — Fax: 03 787 3460

READER INFO NO. 17

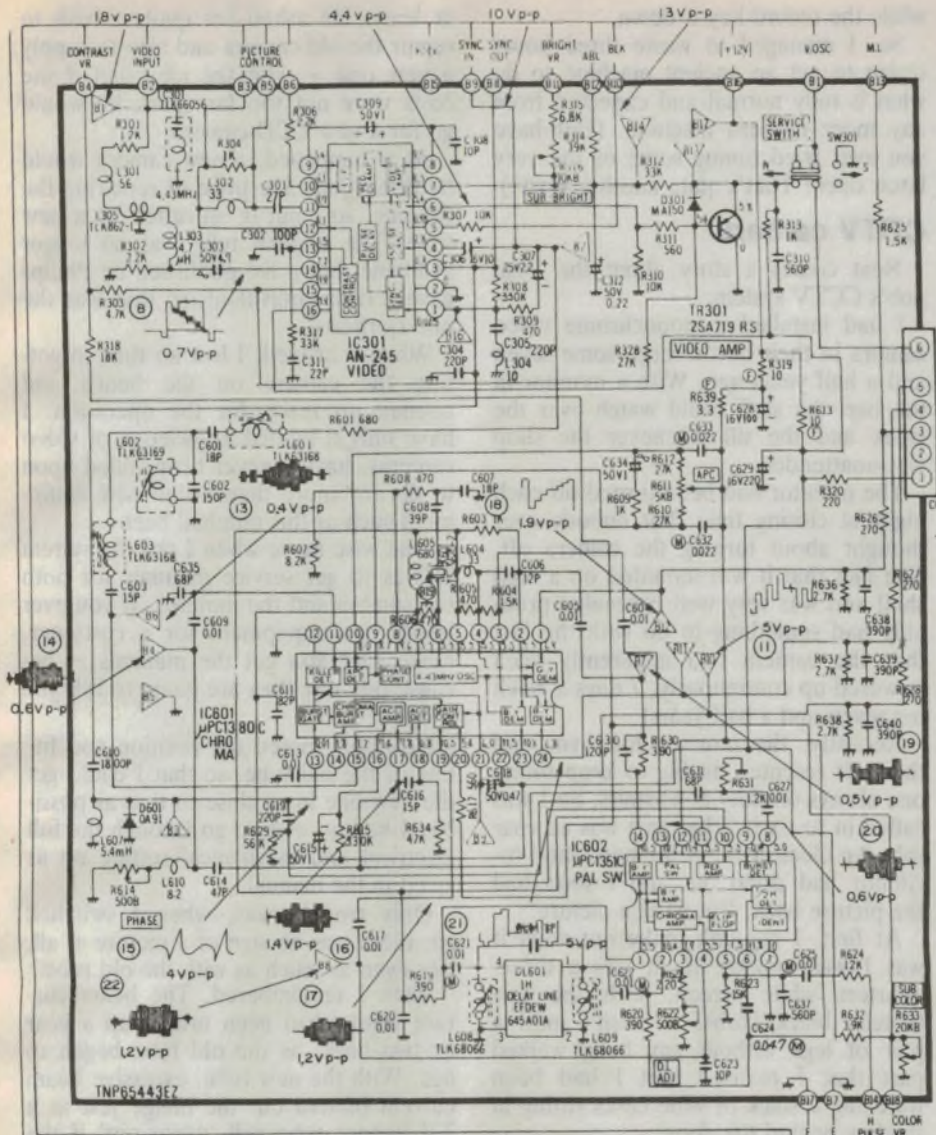

**The top part of the chroma board schematic for a National TC2002. As can be seen, there is very little luminance processing on the board, but in this month's first story it still created big trouble.**

own chroma board. There was very little luminance on that board, and what there was seemed to be concentrated in IC301, an AN-245 video processor.

I didn't have a spare AN-245 in the IC box, but I did have a good one on the junk board. It took less than five minutes to swap them over, and the point was proved. The junk board was now showing smeary dark bars wandering all over the screen, while the set's own board was as good as new.

So it wasn't a capacitor after all, although I would have bet anything that it had to be some kind of cap trouble.

I only wish that IC's would break down completely, instead of just going 'funny'. Some IC's make their distress painfully obvious. I know, but those that don't lead us on some merry dances before they are finally revealed.

### Intermittent sound

Then I had a Thorn 18" table model in recently, for intermittent sound. The audio level was supposed to go up and down, with a slight click as it changed level.

I had to wait several hours before it started to play up, but then the symptoms were exactly as the customer had described.

Giving the chassis a solid bump would start several minutes of variations, while the next bump would stop the changes. The bumps themselves didn't seem to be causing the trouble, but were simply aggravating whatever was really the problem.

Eventually I found that gentle pressure on a bundle of wires at the left-hand end of the chassis would raise the volume, and releasing the pressure

would drop it again.

I couldn't tell which wire was responsible, so I unwrapped the bundle and moved each wire in turn. Finally, I found one that turned the sound on and off quite emphatically.

This wire led to the speaker terminals, mounted underneath the speaker and behind the rather large power transformer (Murphy's Law!).

When I removed the speaker for a closer look, I found that the suspect wire was completely loose. It had been hooked through an eyehole on the terminal strip, but had never been soldered nor even clinched in place.

The set is a model 9136, about five years old. It had only started to play up in the past 12 months, but the potential for trouble has been there since the set was new!

### Read the manual!

The next story is one I can tell against myself.

I had a Rank Arena RV320 video recorder in for service, one of the original 'piano key' types. All it seemed to need initially was a new cassette lamp and a good clean up. After that it was playing perfectly.

To complete the job, I set out to test the Record function — but I couldn't get any interest from the machine at all. It seemed to me that the tuner/IF section was either totally out of tune, or completely dead. There wasn't a station to be seen.

I made sure that the antenna was properly connected, but there was no off-air image at all. There were no settings of the controls or switches that would produce the slightest sign of life on the monitor.

I poked around on the tuner board and the Y/C board for some sign of video, but without the manual I wasn't really surprised when I got nowhere.

The Rank Arena machine was not so common around my area, and none of my colleagues had a manual for it either. However, it was actually made by JVC, so I guessed that a JVC manual for a similar model might be of some help.

This approach led me to the HR3330 manual, which seemed to be very close to the Rank model. In fact, as far as I can tell only on the audio/servo board is there much difference between the two models.

Unfortunately, I neglected to read the first few pages in the manual, which covered the operating instructions (an omission for which I kicked myself later). Instead I proceeded straight to

## THE SERVICEMAN

the tuner board, where I found no 12V rail.

I spent the next two hours tracing the rail all over the place, trying to find where it was and where it wasn't. All that I learned was that there was no 12V anywhere on the tuner or IF strip.

There was a 12V rail on the audio/servo board, but it disappeared at a terminal on a multi-contact switch. Oddly enough, a lead from the tuner board ended at an adjacent contact on the same switch.

I wondered what would happen if those contacts were shorted, and a small screwdriver soon supplied the answer. I was lucky that I had not twiddled the tuning wheels too far, because the shorted contacts immediately provided a picture on the monitor.

Next, I unscrewed the audio/servo board and turned it over. On the other side were two of those long change-over slider switches that used to be common on audio recorders. I pressed both switches into the record position and got both picture and sound from the monitor.

In their normal position, the switches were operated by a linkage from the front panel Record key. But I felt certain that there must be some other way to operate them – otherwise how could the user ever pretune the machine to the local TV channels?

I went over and over both the machine and the manual, trying to find the link that I felt sure must be there somewhere. But eventually I came to the conclusion that there was no such linkage! Yet some way had to be provided so that the user could ready the machine for off-air recording.

It was then that I turned to the 'User Manual' pages in the front of the Service manual. Here I found the detail that I needed.

With this (and similar) early machines there is no provision for 'E to E' viewing as on more modern machines. In standby mode the screen is blank, and the user must use his TV set tuner to change channels. In order to adjust the recorder tuner, the user is instructed to insert a cassette with the record protection tab intact, and then press the Record key.

This then provides 12V to the tuner and the result can be seen on the appropriate video channel. In this way the recorder tuner can be set up for any required local channels. The cassette can be ejected while in this set-up mode, but a screen image will only appear

while the record key is down.

So, I managed to waste three hours trying to get an ancient machine to do what is only normal and expected from any more modern machine. (But have you ever tried tuning some of the very latest ones? That's quite another story!)

### CCTV camera

Next comes a story about the local pub's CCTV system.

I had installed a monochrome video camera in their bottle shop, some seven and a half years ago. With a monitor in the bar, the staff could watch over the stock and the till whenever the shop was unattended.

The monitor had been turned off each night at closing time, but nobody ever thought about turning the camera off. The fact that it was mounted on a high shelf and was very well concealed probably had something to do with the fact that the camera had apparently been powered up continuously, 7 days a week for seven and a half years!

Recently, the monitor lost sync and the staff resented having to keep someone always on duty downstairs. So I was called in to fix it. That part was an easy job. An electrolytic in the horizontal oscillator had dried out and I soon had the picture back. But what a picture!

At first, I couldn't make out what it was I was looking at. It was a three-quarters white screen, with the rest blotchy black blobs! It wasn't until a pair of legs without any body walked past that I realised that I had been watching a stack of wine casks sitting in shadow behind the door.

The camera tube had deteriorated so badly that it was only capable of registering a minimum amount of shadow detail. The highlights were completely washed out.

I told the manager his camera was unservicable and would need a new tube,

at least. He asked for quotes, both to repair the old camera and also to supply a new one – with the idea that if the costs were not too far apart, he would go for a new CCD camera.

As it happened, a new camera would be three times the price of repairing the old one, so I put in an order for a new tube. The original tube was no longer available, but a list published by Philips gave a near equivalent, so that was the one I ordered.

When it arrived, I lost no time in getting the camera on the bench and opened up ready for the operation. I have only a limited knowledge of video cameras, having never been called upon to do any more than install new equipment such as this one had been.

One wise move when I put the system in was to get service manuals for both the camera and the monitor. If you ever install new equipment for a customer, make sure you get the manuals – because one day they are going to ask you to fix it!

I carefully noted the position and fitting of the old tube, so that I could get the new one in as close to that as possible. I had no wish to go through the full electrical and mechanical setting up as given in the manual.

Only trouble was, when I switched on, there was no sign of a picture at all. Not even as much as with the old tube.

Then I remembered. The beam current setting had been turned up a year or two back, as the old tube began to age. With the new tube, excessive beam current blotted out the image just as a TV picture tube will 'white out' if the screen voltage is too high.

With the setting adjusted to normal for the new tube, I had a picture of sorts on the monitor. It was grossly out of focus, and the focus range on the lens was nowhere near enough to clean up the image.

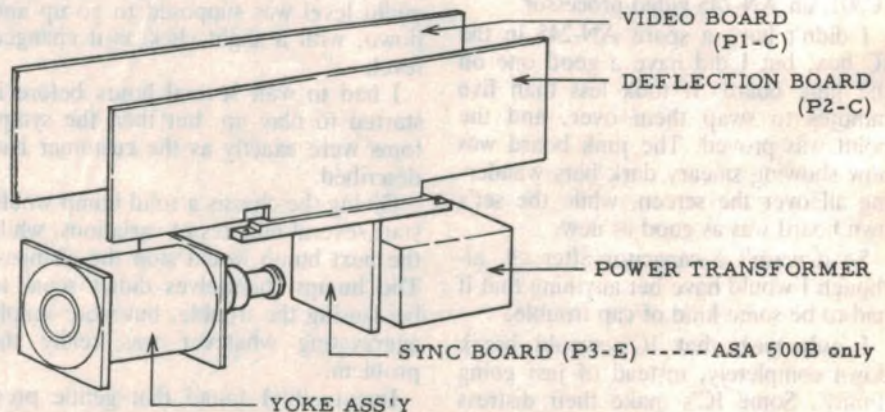

**Mechanical layout for a typical monochrome CCTV camera, like that in our fourth story. The tube mounts inside the focus and deflection coils, unlike a television set where the deflection coils mount on the tube neck.**

Most CCTV cameras have two focus systems, one electrical and the other mechanical. The mechanical system is used to set up the camera when used with a fixed focus lens, and makes allowance for differing dimensions between lens mounts and camera tubes.

When a focusing lens mount is fitted, the camera effectively has two mechanical systems and the rear focus has to be adjusted with the lens set to infinity. The rear focus has to be set first, and this is where I found the problem with this camera. In fact, the tube had to be moved about two millimetres forward to get good focus.

I'm sure that I put the new tube in exactly the same position as the old one had been, so I can only assume that the difference lies in the thickness of the faceplate. I have no technical literature on the various camera tubes, so I can't be sure of the reason. But moving the new tube forward fixed the problem.

With the camera back in place amid the 'top shelf' bottles, the bar staff can see everything that goes on between the door and the till, so the Manager thinks it's been money well spent.

### Computer monitor

The next story came from a colleague and was intended for the TETIA Newsletter, but I think it's important enough to get a wider reading. It's about an IBM computer monitor, model 12HP55T and the story goes thus:

*The symptoms were 'intermittent everything - any time'. Sometimes the raster would get a bit wider and picture edges took on a 100Hz wobble - making it look like a power supply fault. Then sometimes the raster size would change, getting larger but at other times smaller!*

*Sometimes there'd be a drive line (folded over horizontal raster). Then sometimes the picture would fade away to nothing, or at other times collapse to a spot. We tried everything at one time or another but the fault was neither consistent nor obvious.*

*We eventually found the trouble, although we can't imagine why this isn't more widely known. There must be hundreds of these monitors in service, each with the potential to suffer this selfsame fault.*

*The cause is a totally inadequate focus adjustment pot and the circuit design around it. We found a 2M focus pot and a 0.1 watt 220k resistor in series. Neither appear to be high voltage types, but in any case the 0.1W resistor with 650V across it is badly underrated for resistor in a focus control circuit.*

*Sometimes the 2M pot would get hot*

*and start sparking, the arcing overloading the power supply and causing thermal shutdown. At other times it would fall in resistance, loading the line output transformer and causing horizontal fold-over.*

*Now and again it would just go open, again causing the picture to fade out.*

*We rebuilt the circuit, replacing the 2M pot and 220k resistor with a 1M resistor + 1M pot + 1M resistor in series - each rated at 0.5 watt. There's been no more trouble.*

Faulty IC's, dodgy wiring, old videos, CCTV cameras, computer monitors - what else can we find for this month? One thing I do know, servicing electronic equipment is never boring! There's always something different to be done.

Finally, I would like to thank all those readers who have taken the trouble to write to me in recent months. There have been so many letters that I am unable to answer every one of them.

Those who included contributions or good suggestions have been or soon will be answered. For the rest, please accept these words as grateful thanks for your interest.

One thing I would like to ask of all contributors is this: please type your material if at all possible, and whether typed or handwritten, please use double line spacing. Double spaced copy is much easier and faster to transcribe, and that process is the most tedious part of getting your contribution onto these pages.

That's all for this month. I'll be back again next time with more exciting stories from the workbench. ☺

### Fault of the Month

National TC-2002  
(M7/M8 chassis)

**SYMPTOM:** Variable bands of dark or light shading across the screen. The bands followed the video content, with dark bands following light subjects and vice versa. Replacing all of the likely bypass capacitors made no difference.

**CURE:** IC301 (AN-245) was faulty. This video detector-cum-video processor chip includes the contrast control stage, and logic suggests that the fault lay in this section of the chip.

*This information is supplied by courtesy of the Tasmanian Branch of The Electronic Technicians' Institute of Australia (TETIA). Contributions should be sent to J. Lawler, 16 Adina Street, Geilston Bay, Tasmania 7015.*

MONDOTRONIC

FOR YOUR PC/XT/AT



### MP271 EPROM PROGRAMMER

High speed programming of 2716-27512 eeproms. Screen editor in the HEX or ASCII, copy, move fill-erase. File handling of S1-S9, hex or binary formats. User friendly. Demo disk available.



### MD230 TTL I/O BOARD

Professional 8255 based design. 48 TTL I/O signals. High noise immunity connections. Supports hardware interrupts 2-7. Multiple board addressing.



### MD120 OPTO/RELAY ISOLATOR BOARD

64 Opto coupled inputs connect directly 5V-25V DC/AC. 4 Relays with 2A contacts. Supports hardware interrupts 2-7. Multiple board addressing allows large number of inputs. Ideal for PC control applications from factory floor to home.



### MD100 OPTO/RELAY ISOLATOR BOARD

16 Opto coupled inputs connect directly 5V-25V.DC/AC. 8 Relays with 2A contacts. Supports hardware interrupts 2-7. Multiple board addressing. Easy programming, as with all Mondotronic boards.

Mondotronic products are designed build and supported in Australia. For more information please write or call:

### MONDOTRONIC PTY. LTD.

560 Waverley Road Glen Waverley  
3150 P.O. Box 296 Fax [03] 233 0376  
Phone [03] 232 4110

READER INFO No. 18

# Silicon Valley NEWSLETTER



## Superconductor outlook improves

How well will new high-temperature superconductor materials perform in space? A group of US scientists hope to be able to answer that question when an experimental scientific satellite they are building using a number of electronic circuits made with new high-temperature superconductor material, will be launched next year.

Extensive use of superconductors in satellite systems has the potential of vastly reducing the weight of electronic systems, allowing engineers to make satellites smaller and, consequently, much less expensive to launch. And because of the vast performance advantages of superconductors, such compact satellites could also become far more powerful than current systems.

One particular advantage of using superconductors in space is that as long as the components remain shielded from the sun, no cooling will be needed for most of today's high-temperature superconductors.

The announcement of the expected satellite program was made at the annual meeting of the American Association for the Advancement of Science. Speakers at the one-day event said that most experts in the field are currently far more optimistic regarding the prospects for commercial applications of new high-temperature superconductors than they were a year ago. In fact, the first such applications may appear on the market in as little as three to five years.

The US scientists also agreed that, contrary to popular belief, the Japanese have not taken the lead in the refinement of superconductor technology and the path towards commercialisation.

## SIA wants Japan on 'unfair' list

American chip makers, through their Semiconductor Industry Association trade group, have appealed directly to the White House to crack down on Japan for alleged violations of the 1986 US-Japanese semiconductor trade



*Currently Intel is the sole source of its latest 80386 and 80486 microprocessors, but Nexgen Microsystems of San Jose is one of two recent start-up firms said to be working on 'clones' of these chips. Compaq is reported to have invested around US\$5-10 million in Nexgen.*

agreement.

In a petition to US Trade Representative Carla Hills, the SIA is demanding that Japan be placed on this year's 'Super 301' list of countries violating fair trade laws. Last year, Japan was put on this list for unfair trade policies in the areas of telecommunications, supercomputers, and satellites. The US and Japan have since negotiated for abolition of trade barriers in two of those product areas (supercomputers and telecommunications).

In the petition, the SIA says that recent figures show that the US share of the Japanese market has once again fallen below 10% after reaching 12% late last year. The new level is about the same as when the agreement went into effect in August 1986, and about the same as the historic 10% level US companies have maintained in Japan since the industry was in its infancy.

Under the terms of the agreement, the US share was supposed to increase to 20% by the end of 1991. Although there is still some 18 months left in the lifespan of the agreement, the SIA contends that it will be impossible to get anywhere near the agreed upon 20%

level and that new market figures show that Japan has done little to change its prohibiting trade barriers.

In Washington, the Electronics Industry Association of Japan immediately filed an official protest with the Administration asking Hills to deny the SIA petition. EIAJ officials said their petition will state that Japan is indeed complying with the agreement and that there are no longer any barriers to the import of American chips. Also, they expect to show that Japanese purchases of American products have increased since the agreement went into effect.

## Unfortunate choice of date

There are 365 days in a year, but only one is of particular significance in US-Japanese historic relations: December 7, a day that will 'live in infamy' as President Roosevelt announced in 1945 following the bombing of Pearl Harbour.

For yet unexplained reasons, no one involved in the process of writing and editing the English edition of the instruction manual for Sony's new SLV-50 VCR remembered that. Several times

throughout the booklet, examples for setting the time and date, or for preprogramming the machine for the recording of certain television programs, use the December 7, 1988 date.

It didn't take long for the phones at Sony's US headquarters to start ringing off the hook. Tokyo-based Deputy President of Sony, Ken Iwaki said his company is offering its "deepest apology for this unfortunate misunderstanding."

## IBM endorses SCSI

IBM has given a powerful endorsement to the SCSI (pronounced 'skuzzy') interface adaptor which allows up to seven peripheral devices to be hooked up to a single PC expansion slot. IBM has also launched several other key personal computer-related products, including a low-cost laser printer and a CD-ROM disk drive.

The SCSI interface was pioneered by Apple Computer when it launched the Macintosh Plus system in 1986. The new interface showed up in the six new PS/2a file server systems IBM has just launched. It also introduced an SCSI adaptor board for older PS/2 models.

Meanwhile, the company appears determined to become a major vendor of low-cost laser printers with the launch of a new model that carries a price tag of just \$1495, about the same as the suggested retail price of the industry's leading printer from Hewlett-Packard. IBM however, claims its printer works about 25% faster than the H-P competitor. The company also said it will offer PS/2 users a \$490 Postscript option that will allow the printer to handle Adobe typefonts.

## Weapons lab to study parallelism

Lawrence Livermore laboratory, the US's premier nuclear weapons development laboratory located 30 miles east of Silicon Valley, has announced one of the most ambitious massively parallel supercomputer development projects to date in an effort to determine the prospects of the still controversial technology.

As part of the program, no less than 50 of the lab's computer scientists will be working for three years to evaluate massively parallel processing technology, including the development of experimental application software.

The move is significant because the laboratory has played a critical role in the development and advancement of

earlier generations of conventional single processor-based supercomputers. When Cray Research shipped its first supercomputers in 1976, the lab was its first customer and also helped write the operating system for the machine.

Massively parallel computing architectures use hundreds, sometimes thousands, of smaller processors to create systems that have the potential of processing huge quantities of data. The main obstacle has been the development of operating systems and application software that takes adequate advantage of the machines' potential power.

For their experiments, Lawrence Lab announced it will be using a massively parallel supercomputer system developed by BBN Advanced Computers in Massachusetts, a subsidiary of Intel. The US\$4.5 million machine contains 126 processors.

## Three Australian hackers arrested

A two-year investigation into the break-in of the Internet computer network in the United States and elsewhere has resulted in the arrest of three Australians. The three young men, using their computers and ordinary modems, allegedly broke into the Internet network that connects universities, independent research centres and unclassified Defense Department research facilities across the United States and other countries, including Australia.

The three, who range in age between 18 and 21, were charged with breaking into government computers and damaging data files, which are criminal offences under Australian law with a maximum penalty of 10 years in gaol.

The first break-in of the system by the three occurred back in 1988 when Citicorp reported its system and data banks had been broken into.

Industry security experts said the most troubling aspect of the case is the fact that individuals were able to break into computers and damage data files from half a world away. This could open the door to increased international computer terrorism by representatives from unfriendly nations, or individuals in a host of Western-oriented countries where tampering with computers does not break any laws.

Australian authorities said they had been aware of the acts by the three men since 1988, but they deliberately delayed pursuing their investigation until a new Australian law prohibiting computer tampering became effective last July.

## AMD sells Texas plant to Sony

In a deal said to be the first of a kind, Advanced Micro Devices of Sunnyvale has agreed to sell its San Antonio chip plant, including the facility's 650 workers, to Japan's Sony. In return, Sony will pay AMD US\$55 million and provide the company with crucial advanced manufacturing technology. AMD hopes to be able to use the technology to increase its own overall productivity and chip yields on current and future semiconductor products.

Besides getting a much-welcomed cash influx and manufacturing technology, the deal will also sharply reduce AMD's excess manufacturing capacity, a problem that has been a major drag on the firm's financial performance in past quarters.

AMD chairman Jerry Sanders said the transfer of manufacturing technology represents perhaps the most critical part of the deal for AMD. "It is like learning how to cook. You have to work alongside a master chef in order to learn. You cannot succeed in this business unless you are in control of your production process."

With the acquisition of the AMD facility, which is Sony's first chip facility in the US, the company will now have eight manufacturing sites in the United States, producing everything from televisions to disk drives.

## Pentagon clears low-end exports

With the threat of a military conflict between the United States and the Soviet Union sharply diminished, the Pentagon has adopted a much softer policy towards the export of high-tech equipment to the USSR and other Eastern European nations.

Under the new guidelines issued by the Defense Department, American and other CoCom nations will be allowed to sell a variety of high-tech products that were previously banned. Included were low-end mainframes, such as the IBM4300 series, and medical systems such as CAT Scanners, MRI imaging systems and cancer-treatment equipment.

According to officials at the US Commerce Department, while the level of restricted products remains the same, the new procedures will make it much easier for companies to do business with the East, as the Pentagon will no longer exercise its right to block exports of low-level technology products. ④







SAVE \$20

### ENCLOSED PRINTER STAND

- Transparent cover makes it easy to check on paper supply
  - Paper can be fed from the centre or the rear according to the design of the printer
  - Removable drawer which allows paper to be changed without moving the printer
  - Retractable rear basket makes print-out collection fast and convenient
  - Suitable for most printers
- C21055.....\$29.95

## AN EXTRA 5% OFF ALL OUR SYDNEY STORE'S PRICES ON TUESDAY

(SIMPLY BRING THIS AD IN WITH YOU)  
74 PARRAMATTA RD,  
STANMORE. 2048.  
(02) 519 3134



### APPLE COMPATIBLE SLIMLINE DISK DRIVE

Compatible with Apple 2+  
Cat. X19901 Only \$179  
FREE PACK OF S/S DISKS WITH EACH DRIVE!

### APPLE IIC COMPATIBLE DISK DRIVE

(including cable) only \$189  
FREE PACK OF S/S DISKS WITH EACH DRIVE!  
\*Apple is a registered trade mark.



### POSTCARD DIAGNOSTIC MODULE

Pinpointing component problems in IBM compatible motherboards can take hours. Usually the whole system has to be working to isolate the troubled area. But not so with the new Postcard Diagnostic Module. So no other cards are necessary to test a bare motherboard.

- "It now only takes seconds." Simplified debugging for:
  - Field service- for on-site repairs or maintenance depot work
  - Manufacturing test- for burn in test flaws and to do quality control
  - Inspection- Postcard simplifies incoming and outgoing test processes on stand
- X18048.....\$849

### 386SX 16MHz MOTHERBOARD

- Processor: 80386SX-16MHz (0/1 wait state)
- Co-processor: 80387SX-16 (optional)
- CHIPS & TECH NEAT chipsets
- (SMT) Surface Mount Technology for chipsets & CPU
- Supports up to 2MB on board, (Sixteen 44256 and Eight 41256 sockets)
- Three 8-BIT slots
- Five 16 BIT slots
- Memory Expansion Slot
- Optional 2-8MB memory card
- Supports LOTUS-INTEL-MICROSOFT (LIM) Expanded Memory Spec. (EMS) version 4.0
- Supports Page Interleave Mode using 100NS DRAM
- BIOS: AMI or PHOENIX
- Turbo Light and Hardware Reset connector
- Keyboard or Hardware Reset connector
- Power Good Signal on board
- Baby size main board

X18094.....\$900

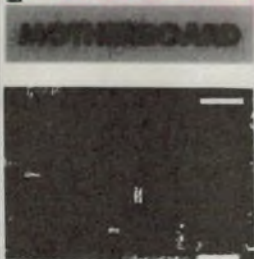

### 10 MHz XT TURBO MOTHERBOARD

Increase the performance of your sluggish XT\* approximately four times with this super fast motherboard.

- 8088-2 running at 10 MHz, no wait state
- Turbo/ Normal selectable
- 640K
- 8 Expansion slots
- 4 Channel DMA
- Keyboard port

Excluding RAM  
X18032.....\$179  
Including RAM  
X18033.....\$350

### BABY AT MOTHERBOARD (WITHOUT MEMORY)

- 6/12 MHz system clock with zero wait state. 12 MHz, 1 wait state
- 80286-12 Microprocessor
- Hardware and software switchable
- Socket for 80287 numeric data co-processor
- 64K ROM
- Phoenix BIOS or Award
- 8 Expansion slots

Excluding Ram  
X18202.....\$375  
Including 2M/Byte Ram  
X18201.....\$795

### 386 MAIN BOARD

- Intel 80386 CPU (20 MHz)
- Socket for 80387 Math co-processor
- 32 bit Memory BUS system
- Built-in speaker attachment
- Battery backup for CMOS configuration table and real time clock
- Keyboard controller and attachment
- 7 Channel DMA
- 16 Level Interrupts
- 3 Programmable Timers
- 8 System expansion I/O slots: 5 with a 36 pin and a 62 pin expansion slots / 2 with only the 62 pin expansion slot / 1 with two 62 pin expansion slots (32 bit BUS)

Without RAM  
X18103.....\$1,195  
Including 2 M/Byte RAM  
X18107.....\$1,625



### QUALITY JAPANESE DRIVES!!

5 1/4" 500K DRIVE  
• 360K formatted  
• IBM XT\* compatible  
Cat C11901 .....\$175

5 1/4" 1 2 M/BYTE DRIVE  
• 720K formatted  
• IBM AT\* compatible  
Cat C11906 .....\$225

3 1/2" 1 M/BYTE DRIVE  
• 720K formatted  
• Double sided, double density  
• 5 1/4" mounted  
Cat C11909 .....\$269

3 1/2" 2 M/BYTE DRIVE  
• 1.44 M/Byte formatted  
• Double sided, double density  
• 5 1/4" mounted  
Cat. C11911 .....\$299



20 M/BYTE HARD DISK  
• Drive with controller card. IBM compatible. 3 month warranty  
X20010.....only \$499

40 M/BYTE VOICE COIL HARD DISK  
• IBM compatible. 28 msec access. 3 month warranty  
Without controller...\$895

80 M/BYTE VOICE COIL HARD DISK  
• IBM compatible. 25 msec access. 3 month warranty  
Without controller...\$1,495  
330 M/BYTE VOICE COIL HARD DISK  
• IBM compatible. 18 msec access. ESDI. 3 month warranty  
Without controller...\$2,995

### 286 NEAT MOTHERBOARD

- Processor: 80286-12, -16MHz or -20MHz (0/1 wait state)
  - Co-processor: 80287 (optional)
  - CHIPS & TECH NEAT chipsets
  - 1-4MB dual RAM socket
  - 1-4MB module RAM socket on board
  - 640KB-384KB memory relocation
  - Three 8 BIT expansion slots
  - Five 16 BIT expansion slots
  - Memory expansion to 8MB
  - Supports EMS 4.0
  - Page Interleave Technology
  - BIOS: AMI or PHOENIX
  - Hardware and keyboard switchable Clock Speed
  - LED speed display
  - Power Good Signal on board
  - Baby size main board
- 16MHz  
X18090.....\$695  
• 20MHz  
X18092.....\$895

### I/O ACCESSORY



### THE BUTTON SPIKE PROTECTOR

Simply plug the button into an outlet and it will protect all equipment plugged into adjacent outlets on the same branch circuit.  
SPECIFICATIONS:  
Voltage: 240V Nominal  
Total Energy Rating: 150 Joules  
Response Time: 10ns  
Protection Level: 350V peak  
X10087.....\$39.95

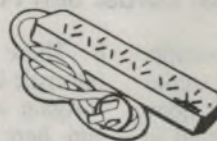

### CLICK SURGE BUSTER

6 PROTECTED POWER OUTLETS  
Ideal for protecting personal computers, video equipment, colour TVs, amplifiers, tuners, graphic equalisers, CD players etc.  
SPECIFICATIONS:  
• Electrical rating: 240V AC, 50Hz, 10A  
• 3 x Metal Oxide Varistors (MOV)  
• Maximum clamping Voltage: each MOV: 710 volts at 50 amps  
• Response time: Less than 25 Nanoseconds.  
X10086.....\$69.95

### PC ACCESSORY

### 386 TOWER PC

The 386 Tower PC is a high performance system that's IBM AT\* compatible. However, the 386 Tower PC gives you 2-5 times the performance.

- FEATURES:
- Intel 80386-16MHz microprocessor
  - Switchable 16/20 MHz
  - 2 M/Byte fitted. Total memory expandable up to 16 M/Byte
  - Up to 2 M/Byte or 8 M/Byte
  - Option for 80287 & 80387 co-processor socket
  - Chips and Technology chip set
  - AMI Phoenix 386 BIOS
  - 50 M/Byte hard disk. 42 M/Byte formatted. Fast access
  - EGA card
  - 3 1/2" drive 1.44 M/Byte
- X20070.....\$5,995

### EXTENSION CARD

### IBM PC/AT\* DECODED I/O CARD

This card is designed for the IBM PC/AT\* expansion slot and includes data buffering and address selection. The wire wrap area features plated through holes. Extremely useful for R&D. It's address range is 0280H to 72 F7H. +5V, +12V fuse protection and has location for D type 37 pin or D type 25 pin connector.  
H19125.....\$99

## FOR GREAT SAVINGS GO TO



### ROD IRVING ELECTRONICS

All sales tax exempt orders and wholesale inquiries to:  
SYDNEY: 74 Parramatta Rd Stanmore 2048  
Phone: (02) 519 3134  
Fax: (02) 519 3868  
MELBOURNE: 48 A'Beckett St  
Phone: (03) 663 6151  
NORTHCOTE: 425 High St.  
Phone: (03) 489 8866

MAIL ORDER & CORRESPONDENCE:  
PO Box 620, CLAYTON 3168  
Order Hotline: 008 33 5757  
(Toll free, strictly orders only)  
Inquiries (03) 543 7877  
Telex: AA 151938  
Fax: (03) 543 2648

RITRONICS WHOLESALE:  
56 Renner Road, Clayton.  
Phone: (03) 543 2166 (3 lines)  
Fax: (03) 543 2648

ORDER HOTLINE  
008 33 5757  
(TOLL FREE)  
STRICTLY ORDERS ONLY

LOCAL ORDERS & INQUIRES  
(03) 543 7877

POSTAGE RATES:  
\$1 - \$9.99 .....\$3.00  
\$10 - \$24.99 .....\$3.50  
\$25 - \$49.99 .....\$4.50  
\$50 - \$99.99 .....\$6.00  
\$100 + .....FREE

The above postage rates are for basic postage only. Road Freight, bulky and fragile items will be charged at different rates.

Errors and omissions excepted. Prices and specifications subject to change.

IBM, PC, XT, AT\* are registered trademarks of International Business Machines. Apple is a registered trademark. Telfon is a registered trademark of Dupont. Denotes registered trademarks of their respective owners.

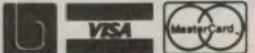

# ROD IRVING ELECTRONICS

# Sony's new IR cordless 'phones

Looking like something brought back from the future by a time traveller, the new Sony MDR-IF5 cordless stereo headphones allow you to listen to your favourite music in private, without getting tangled in the usual cords. Jim Rowe has been trying them out...

"We've just received the first sample of our new infra-red cordless stereo headphones", said the man from Sony Australia. "Would you be interested in borrowing them for a few days, to try them out?" The question was a formality, of course; no magazine editor on this side of the grave would answer it in the negative; we're all born stickybeaks.

The sample MDR-IF5 system arrived the next day, and that night I hooked it up to my CD player. It took only a few minutes, and soon I was tapping away as usual at the word processor – while enjoying a pleasant musical accompaniment, also as usual. But this time the headphones I was wearing were decidedly *unusual*.

Before long my daughter came into the room, and asked if I would help her find something. She was rather surprised when I simply rose from the chair and walked off, without taking off those compact and elegant-looking 'phones. Where were the cords?

Needless to say I had to let her try them out too, and the response was immediate. Her eyes lit up, and I was immediately advised of a sudden change to her Christmas wish list. Those boffins at Sony have a lot to answer for.

An hour or so later my 'better half' came in, to drag me away from the keyboard for a welcome cuppa. Her eyes didn't so much notice the 'phones on my head; after all, at first sight they look fairly normal. But she *did* spot the transmitter unit perched on a nearby bookshelf. What on earth was *that*?

Not an unreasonable question, I guess, because said transmitter does look a little like a small impressionist version of those large stone heads on Easter Island. Apart from the column of glowing LEDs down the front, that

is. These do tend to give it a rather futuristic look...

Again a quick demo was called for, and here too the response was very positive. Such clear sound – and such a comfortable and lightweight little pair of 'phones, without any heavy cords dragging them down. My dear wife is not an avid worshipper of modern technology, but I had the distinct impression that she found the MDR-IF5 system far from unattractive.

I too found the system quite impressive, I have to confess. So from this quick mini market survey, it looks as if Sony's MDR-IF5 is likely to meet with a warm reception. But I'm jumping the gun; sorry! Let's proceed a little more logically, by first looking at how the system works.

### IR link

The idea of using an infra-red link to convey stereo audio signals to headphones is hardly new; we've even described a similar system in the magazine, back in the January 1988 issue. As with other such systems Sony's new unit modulates the light beam with two subcarriers, each of which is frequency modulated by the signals from one of the two stereo channels.

However the MDR-IF5 takes the basic concept rather further than before, in a couple of ways. One is by raising the subcarrier frequencies into the megahertz region: 2.3MHz and 2.8MHz respectively. This gives the potential for rather lower distortion, flatter frequency response and higher signal to noise ratio.

But Sony's second achievement, and in many ways the more impressive, has been to do away with the usual pocket-sized receiver unit – by shrinking all of

the receiver circuitry and fitting it *inside* the actual phones and headband.

It's only when you see and try on the 'phones that you realise the magnitude (microtude?) of this feat. In contrast with what you might expect, they're slim, elegant and light (98g); very comparable, in fact, with normal 'mini' lightweight 'phones. Yet tucked away inside that quite slim band and pair of earpieces are a complete IR receiver and stereo demodulator circuit, plus a rechargeable battery.

Initially the only things you notice about the headset, as clues to its 'special' nature, are the absence of cords – plus a small 'hump' at the top centre of the band. This is actually a dome of smoked plastic, enclosing the main IR receiving sensor and a small LED used to indicate that the headset is 'alive'.

There are two further supplementary IR sensors on the underside of each 'phone, although these are rather less obvious. There's also a tiny volume control for each 'phone, located on the side of the band just above the 'phones themselves, plus an equally tiny on-off slider switch at the rear of the top hump.

On the other hand the transmitter unit is somewhat distinctive, as noted earlier. With its 'mini monolith' shape and column of faintly glowing LEDs down the front, it really can't be ignored – despite the design effort that has obviously gone into making it as elegant and unobtrusive as possible.

Of course it isn't *just* an infra-red transmitter and modulator, but also a recharging unit for the headset's inbuilt battery. And Sony's designers have tackled the recharging function by making the unit also act as a storage stand for the 'phones, when you're not actu-



ally wearing them.

At the top of the unit is a small cradle, with two small spring-loaded pins. When the headset is placed in the cradle, the pins protrude into a pair of matching holes on the underside of the headband hump, completing the charging circuit. A small green LED built into the top of the transmitter unit indicates when charging is taking place.

There are only two connections to be made for the transmitter unit. It re-

ceives 9V DC power from a small plug-pack power unit, whose lead plugs into a standard connector at the rear. Needless to say, the power is normally left on all the time, or at least until the headset is recharged after use.

The other connection is a captive lead for the audio signal input, with a 3.5mm stereo plug designed to connect to the normal 'phones' output of an amplifier, cassette deck or CD player. So hooking the MDR-IF5 system into an existing

stereo setup is very straightforward indeed.

Incidentally the transmitter unit has a novel 'auto sleep' function, whereby it automatically turns off if there are no incoming audio input signals for more than 3 minutes. It also has the ability to pivot on the base, so that you can mount it on a wall if desired.

## Performance

Sony specifies the effective range of the MDR-IF5 system as 'up to 7m (23ft)', and lists its frequency response as 18Hz - 22kHz. No figure is given for signal to noise ratio, but the distortion is rated at 'less than 1% at 1kHz'.

This figure may seem rather high, but in practice distortion doesn't seem to be a problem. In fact the reproduction from the MDR-IF5 'phones sounds at least as clean as from all but the very highest quality corded 'phones (such as the incredible MDR-R10's I reviewed back in February).

It wasn't really practical to perform electrical measurements of overall system performance, though, because of the integrated nature of the headset. But again the frequency response sounded very wide and smooth; my only qualification is that as with many small 'open air' headsets, you need to fit the pads quite carefully into your outer ears in order to get a balanced bass response.

In practice I found that the maximum distance between the transmitter unit and the headset, for acceptable signal to noise ratio, seemed to be rather less than the quoted 7m - unless you have the transmitter unit directly in front of you, and ideally facing downwards from a height of about 2m.

If you can't conveniently mount the transmitter in this position, the maximum range for best results seems to be not much more than 3 - 4m. This still means that you can generally get quite good results almost anywhere in a normal lounge/living room, although turning away from the transmitter or bending down to pick up something from the floor can produce a noticeable increase in background noise.

Of course you must expect *some* degradation in both distortion and signal to noise ratio, from any system such as this. It's inevitable that any additional FM-optical modulation/optical link/optical-FM demodulation processing of the signal must introduce more degradation than a pair of short copper leads. That's something that even Sony's brilliant bof-fins can't avoid.

Incidentally while trying out the  
*Continued on page 148*

# To Choose The Best In Sound Quality, Be Guided By The Critics



"It was clear and detailed with a crisp and attractively positive presentation. Dynamic range was wide and the player produced vivid stereo with clearly localised images."

JIMMY HUGHES, HI FI ANSWERS MAGAZINE (U.K.) ON THE PD91 REFERENCE SERIES C.D. PLAYER

"I am forced to note that the sheer goodness of the Pioneer revealed starkly the inconsistent engineering standards at the BBC and other broadcast organisations."

ALVIN GOLD, WHAT HI FI MAGAZINE (U.K.) ON THE F91 REFERENCE SERIES AM/FM TUNER

"The fidelity, lack of distortion and even the low frequency performance belied the size of the speakers, their cost and their miniscule proportions. The quality of sound was right on par with my reference speakers and I was more than impressed."

LOUIS CHALLIS, ETI (ELECTRONICS TODAY INTERNATIONAL) ON S55T LOUSPEAKERS.

"I used it to fill a restaurant with sound for a lively office party and accepted accolades on the sound quality all night."

PAT HAYES, ETI (ELECTRONICS TODAY INTERNATIONAL) MAGAZINE OF THE Z770 'MIDI' SIZE HI FI SYSTEM

"Pioneer's Z990 should be on the short list of anyone looking for a midi system."

CHRIS GREEN, AUSTRALIAN HI FI MAGAZINE, ON THE Z990 MIDI SIZE HI FI SYSTEM

"I see it appealing both to the audiophile wanting a good "purist" machine for sound quality reasons, as well as to the more general user."

JIMMY HUGHES, HI FI ANSWERS MAGAZINE (U.K.) ON THE PD9300 (PD71 IN AUSTRALIA) REFERENCE SERIES C.D. PLAYER

"This player is a high quality example of the genre. Build and finish are first rate, and the lab performance was superb. Impressive in many ways, it can be recommended with confidence."

MARTIN COLLOMS, WHAT HI FI MAGAZINE (U.K.) ON THE PD6300 C.D. PLAYER

"Given that it's a good idea having two trays, Pioneer has achieved this enhancement very elegantly and with surprisingly little additional hardware."

JIM ROWE, ELECTRONICS AUSTRALIA MAGAZINE ON THE AWARD-WINNING PDZ72T TWIN TRAY C.D. PLAYER

## HIGH COMMENDATION - DIGITAL AUDIO CATEGORY

C.E.S.A. (AUSTRALIA) AWARD TO THE PDZ72T TWIN TRAY C.D. PLAYER

"Replay of PAL encoded discs gave superb results. It was virtually impossible to tell it from a normal broadcast picture and was miles better than standard VHS tape."

RICH MAYBURY, WHAT HI FI MAGAZINE ON THE CLD1400/CLD1450 COMBINATION C.D./C.D. VIDEO PLAYER

"Many people will be surprised that it is a cassette based machine at all, so nearly is it in danger of transcending the natural limitations, and so authoritative is its style of delivery."

HI FI CHOICE MAGAZINE (U.K.) ON THE CT91A CASSETTE DECK

"The CT656 is a distinguished entrant in the market for budget three head designs. It can be confidently recommended."

HI FI CHOICE MAGAZINE (U.K.) ON THE CT656 CASSETTE DECK

"Pioneer have just launched a player which sets a standard by which others will be judged."

GRAHAM S. MAYOR, WHICH COMPACT DISC? MAGAZINE (U.K.) ON THE PD91 REFERENCE SERIES C.D. PLAYER

"Pioneer have done well to put together such a package for this price and the only real problem is to find good enough programming to exercise its virtues."

CHRIS BRYANT, HI FI CHOICE MAGAZINE (U.K.) ON THE F91 REFERENCE SERIES AM/FM DIGITAL TUNER

"This tuner was free of digital nasties and benefitted from a pleasantly quiet background."

PAUL MILLER, WHAT HI FI MAGAZINE (U.K.) ON THE F225L AM/FM DIGITAL TUNER

"The Pioneer's impressive specification and build were confirmed by the listening tests."

WHAT HI FI MAGAZINE (U.K.) ON THE CT335 CASSETTE DECK

 **PIONEER®**

**BUT DON'T JUST TAKE THEIR WORD. HEAR FOR YOURSELF. - FOR YOUR NEAREST PIONEER DEALER PHONE**

Melbourne (03) 580 9911 Toll Free 008 338 179 Sydney (02) 152 1988 Toll Free 008 251 510

Graphic Influence A1549

# ETI

ELECTRONICS TODAY  
INTERNATIONAL



**PIONEER'S NEW  
KEH-M5000QR/CDX-M70  
MOBILE STEREO COMBO**

## JULY CONTENTS

### ELECTRONICS

ETI-339 Headlights & Parkers Alarm.....	2
Building Blocks of Electronics – 10.....	5

### WORKSTATION

Extended/Expanded/Enhanced PC Memory .....	12
Computer News & New Products .....	18
ETI-1630 RISC Computer Card – 2.....	25

### SOUND INSIGHTS

Cardilini on Pioneer's Mobile Stereo combo.....	36
Challis visits the Winter CES – 2 .....	39

# HEADLIGHTS AND PARKERS ALARM

Have you ever been caught with a flat battery because you inadvertently left your headlights and/or parking lights on? We've all done it at one time or another. Install this simple project and you'll never be caught out again, says Will Kennedy.

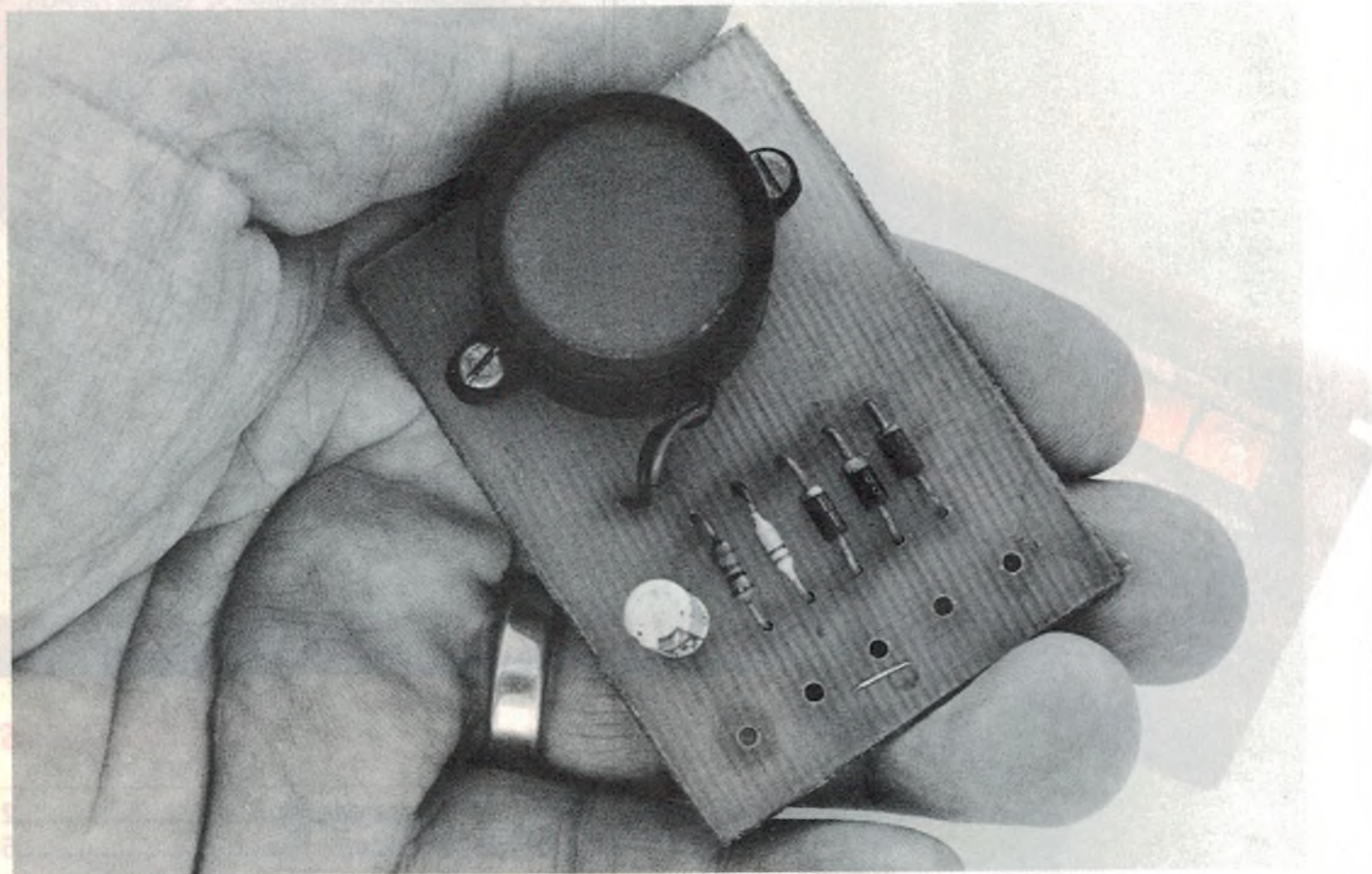

*This simple little project will save you from a flat battery the next time you leave your headlights or parking lights on.*



**I**f you leave your headlights or parking lights on, this project will cause a warning alarm or buzzer to sound when you turn off the ignition switch. The project is remarkably simple, yet effective. It uses common off-the-shelf components and can be installed in a trice. It's an ideal project for anyone who is a newcomer to electronics.

Many late model vehicles now include a warning if you leave the headlights on when you park the car. But there are more older model cars on the road that don't have such a feature.

It is usual to turn on the headlights when driving in rain to improve your vehicle's visibility. Having the headlights on also improves your visibility to other traffic when driving in the early morning hours

ELECTRONICS  
E T I - 3 3 9

ETI JULY '90

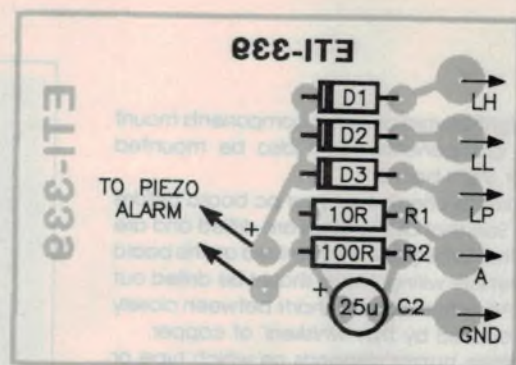
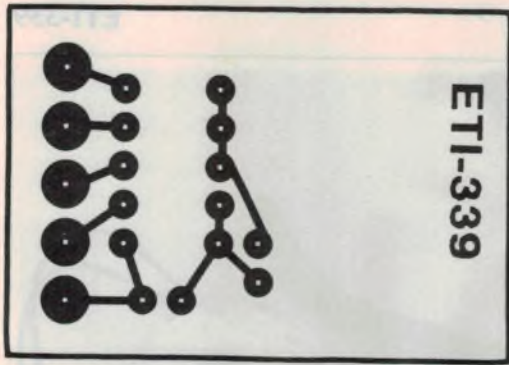

Full-size reproduction of the printed circuit artwork.

Component overlay for the printed circuit board showing the positions and orientation of the components.

after dawn, when the headlights don't actually illuminate much. But, in both situations, there's the possibility of leaving the lights on when you park the car.

Parking lights are only meant to be left on when you're in the car or nearby and intend to return in a short space of time. Turning on the parking lights makes the vehicle visible to others. But if you get out of the car and leave the parking lights on, you'll return to a car with a dead battery!

**Circuitry**

The simplicity of the circuit shown in Figure 1 is due to the use of a circuit known as a diode OR gate. To explain what it's for and what it does, you first need to see what happens when you leave your headlights or parking lights on and leave the car. The possibilities are these:

- a) You could remember to switch off all the lights. Great!
- b) You could leave the parking lights on
- c) You could leave the headlights on at low beam

**PARTS LIST ETI-339**

Resistors.....	all 1/4 W, 5%
R1.....	10R
R2.....	100R
Capacitor	
C1.....	.25u/25 V RB electro.
Semiconductors	
D1, D2, D3.....	1N4004, 1000 V power diodes
Miscellaneous	
ETI-339 pc board; piezo alarm (see text); hookup wire.	
Approximate cost: \$14-\$19	

- d) You could leave the headlights on at high beam
- e) You could do a combination of these.

So what you want is a warning alarm to sound if (b), (c), (d), or (e) occurs when you switch off the ignition. Now you see why an OR gate is used.

However, you don't want the alarm to sound if you have the ignition switch turned on the accessories position, which allows you to leave the lights on while the motor is off and you're in the car. So some means of disabling the alarm in these circumstances is necessary.

Now let's see how the circuit works in detail. Three inputs are provided from the lighting circuits for the diode OR gate made up from diodes D1 to D3. These provide isolation between the three lighting circuits. More diodes could be added to provide warnings for door, boot or other lights, as shown by the dashed circuit section.

The input from the ignition/accessories switch is applied to the negative end of a piezo audio alarm via a filter which consists of R1 and C1. These components filter out any noise impulses which may be present on the vehicle's supply.

When the lights are off and the ignition switch set to the accessories position, the negative side of the alarm is at +12 V. Thus the alarm does not sound. It is protected against reverse current by the diodes D1 to D3.

When the lights are on and the ignition switch set to accessories, the voltage on both the positive and negative terminals are nearly the same and the alarm does not sound.

However, when the lights are left on and the ignition switch off, the negative terminal of the alarm is at 0 V (chassis potential) and the positive terminal is at +12 V, and the alarm goes off.

The resistor R2 is in series with the alarm, reducing the current through it and therefore the sound output (but not greatly). This resistor can be selected to suit, but if you use a value less than 100 Ohms you may have to reduce the value of R1 to mute the alarm when the lights and the ignition/accessories are both on.

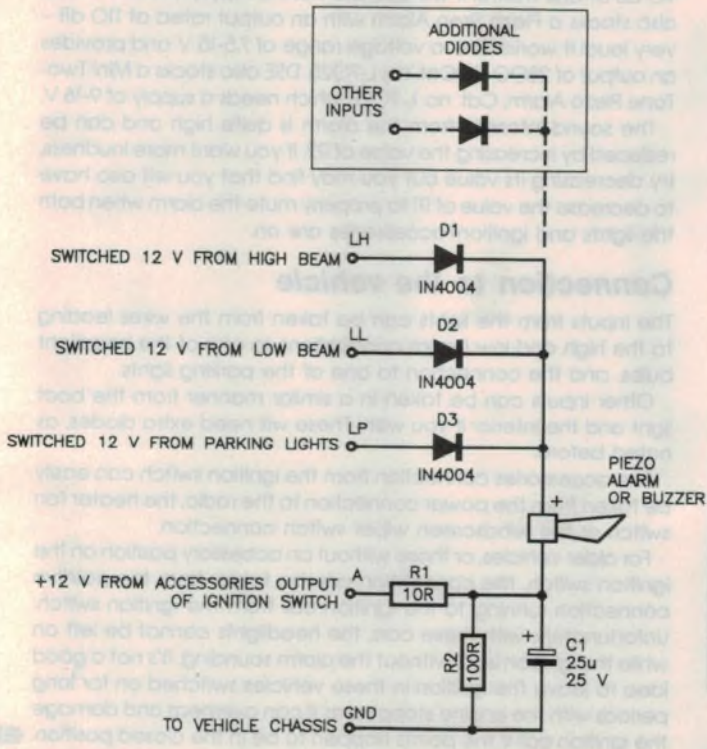

Figure 1. Circuit of the alarm — simplicity plus!

## Building it

Construction is quite straightforward as all the components mount on the pc board. The components could also be mounted successfully on matrix or Vero board.

It's always good practice to check over your pc board before commencing assembly. See that all the holes are drilled and are the right diameter. Note that large pads are provided on this board for connections to the vehicle wiring. These should be drilled out to 1.6 or 2 mm diameter. Also check for any shorts between closely spaced tracks or pads caused by thin 'whiskers' of copper.

Mounting the piezo alarm buzzer depends on which type or model you buy, so arrange to drill the large blank area to suit your alarm's mounting. The alarm should be mounted to the board after all the other components have been soldered in place.

You can solder the components to the board in any order. However, watch out for the orientation of the diodes and the electrolytic capacitor, C1. Note that the diodes must be 1000 V types as specified, to guard against possible destruction from high voltage spikes which are often present in automotive electrical systems. Lower voltage types may be prone to breaking down.

I used a commonly available piezo alarm which mounts conveniently on the pc board. A variety of alarm types are available, some pulsed and some not, some having two-tone output. All will work successfully with this circuit. Some larger types, which will not fit directly on the pc board, have to be mounted separately. Note that the flying leads from the alarm will be colour-coded red and black. The red lead is positive (marked with a + on the circuit and component overlay diagram). Make sure you get the connections right.

The available alarms have titles including: Piezo Alarm, Piezo Alarm Buzzer and Local Siren Alarm. All feature an in-built driver circuit with a piezo transducer and can be operated from a wide-ranging supply voltage, from as low as 3 V to a maximum of 30 V. These alarms produce quite a loud output - typically 90-110 dB at one metre, pitched in the vicinity of 3 kHz; which all means they're real attention-getters. Most are single tone (screeee), but

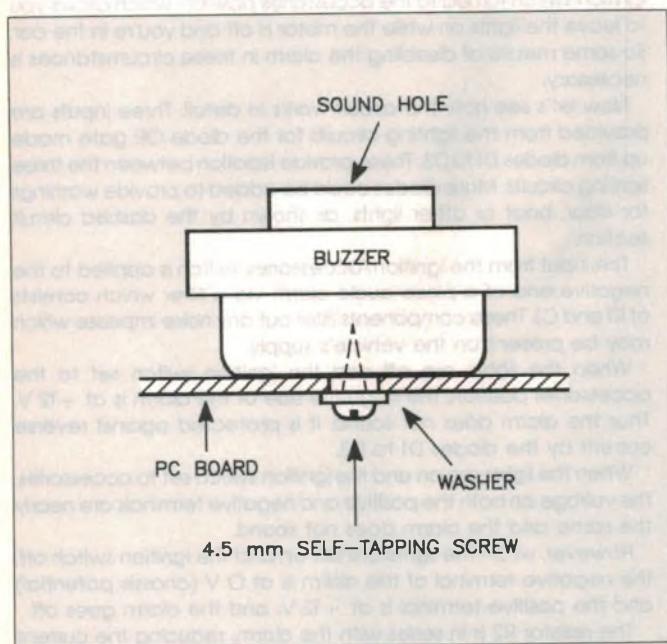
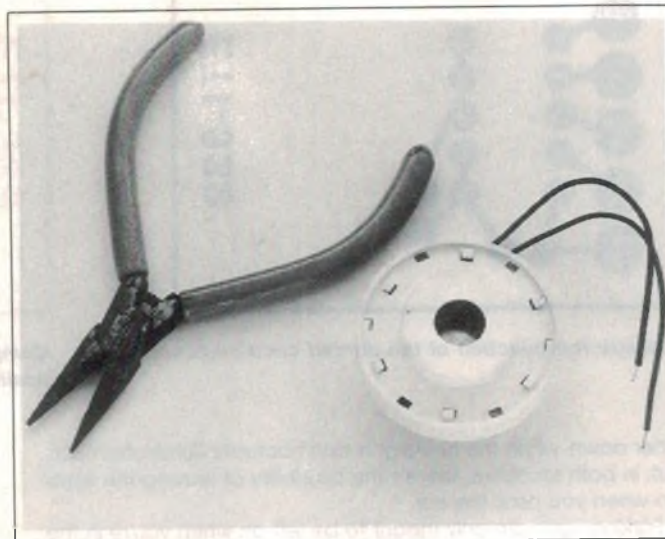

Figure 2. This shows how to mount an Arista AB-3 type piezo alarm to the pc board. It's secured by a No.8 self-tapping screw, 4.5 mm (3/16 inch) long.



Another type of piezo alarm buzzer that may be used with this project. This is the Arista AB-3, stocked by a number of retailers. See the 'Shoparound' page in this issue.

some have a dual tone output (eee-aaw/eee-aaw).

Many electronics retailers stock a suitable type distributed by Arista, the AB-3 Alarm Buzzer, shown in the accompanying photograph. Figure 2 shows how to mount it to the project's pc board.

The AB-3 operates from a supply voltage ranging between 5 V and 15 V and features an output level of 90 dB at one metre, pitched at about 3 kHz. Rod Irving Electronics lists it as Cat. no. S15O66.

Dick Smith Electronics stocks a Slim Piezo Alarm, Cat. no. L-7O24. Its output is pitched at around 3600 Hz, with an output level of 90 dB at one metre. It will operate from a supply of 3-30 V. DSE also stocks a Piezo Siren Alarm with an output rated at 110 dB - very loud! It works over a voltage range of 7.5-15 V and provides an output of 2800 Hz; Cat. no. L-7O25. DSE also stocks a Mini Two-Tone Piezo Alarm, Cat. no. L-7O27, which needs a supply of 9-16 V.

The sound intensity from the alarm is quite high and can be reduced by increasing the value of R2. If you want more loudness, try decreasing its value but you may find that you will also have to decrease the value of R1 to properly mute the alarm when both the lights and ignition/accessories are on.

## Connection to the vehicle

The inputs from the lights can be taken from the wires leading to the high and low beam connections to one of the headlight bulbs, and the connection to one of the parking lights.

Other inputs can be taken in a similar manner from the boot light and the interior if you wish. These will need extra diodes, as noted before.

The accessories connection from the ignition switch can easily be taken from the power connection to the radio, the heater fan switch or the windscreen wiper switch connection.

For older vehicles, or those without an accessory position on the ignition switch, the connection can be taken from the positive connection running to the ignition coil from the ignition switch. Unfortunately, with these cars, the headlights cannot be left on while the ignition is off without the alarm sounding. It's not a good idea to leave the ignition in these vehicles switched on for long periods with the engine stopped as it can overheat and damage the ignition coil if the points happen to be in the closed position.



Contributed by The Apogee Group



# BUILDING BLOCKS OF ELECTRONICS

## Oscillators and frequency changers

Radio receivers of the superhet type all employ oscillators and frequency changers. By Jack Middlehurst.

**T**he superhets of 40 years ago and the solid state hi-fi tuners of today have two things in common - RF oscillators and frequency changers. They are at the heart of every superhet receiver's front end. Oscillators are also widely used in test equipment for both audio and RF applications.

### Valve oscillators

Some circuits of valve oscillators of the kind found in valve broadcast receivers are shown in Figure 10.1. In each case, an increase in plate current causes the grid to go more positive, which increases the plate current further, and so on. Once the plate

current can increase no further, the 'ringing' of the tuned circuit makes the grid voltage decrease. This reduces the plate current, which makes the grid voltage go more negative, which decreases the plate current further, and so on. With a tuned circuit having a Q of 10 or more, quite a reasonable sine wave is produced.

In frequency changers, it is common to use a multiple valve such as a triode-pentode or triode-heptode. The idea is to make the triode into the oscillator, and to make the characteristics of the other valve as non-linear as possible. This gives maximum frequency-mixing efficiency. Because of this, it is unwise to try and redesign the circuit by substituting different values of components.

Typical valves of this kind are the 6K8, 6J8, ECH81, and 6BE6.

Doing dc tests on oscillators while they are working can be a surprising experience - depending on the type of meter you have. If the meter has a simple rectifier on its ac range, and you measure the plate voltage of the second circuit using the 1000 Vdc range (as you should), it is possible for the RF to be capacitively coupled to the ac connections within your meter and for the meter to read, say, 1000 V. This can come as a bit of a shock if  $V_{plus}$  is only 250 V.

There is no 1 kV in the oscillator; the meter is simply acting as an ac current meter and will indicate full scale on any range. This effect can be removed by putting a 100k

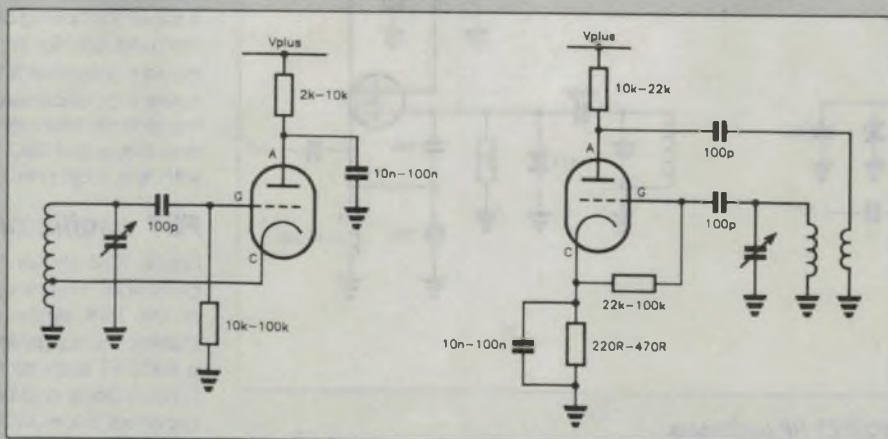

Figure 10.1. Two valve RF oscillators.

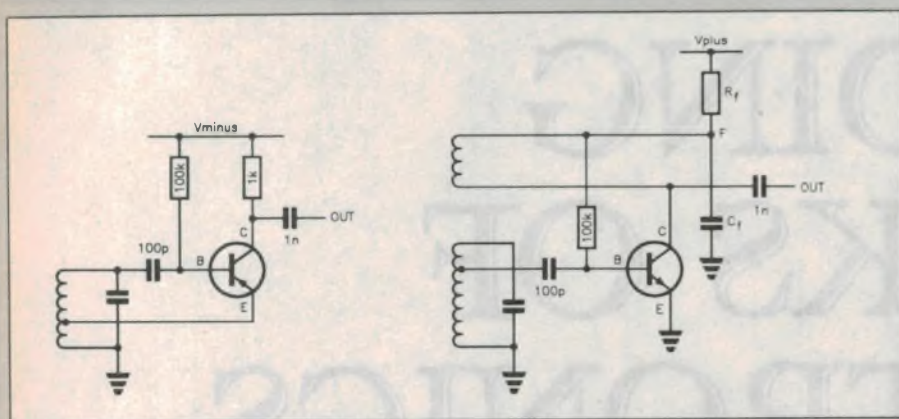

Figure 10.2. Two forms of transistor RF oscillator.

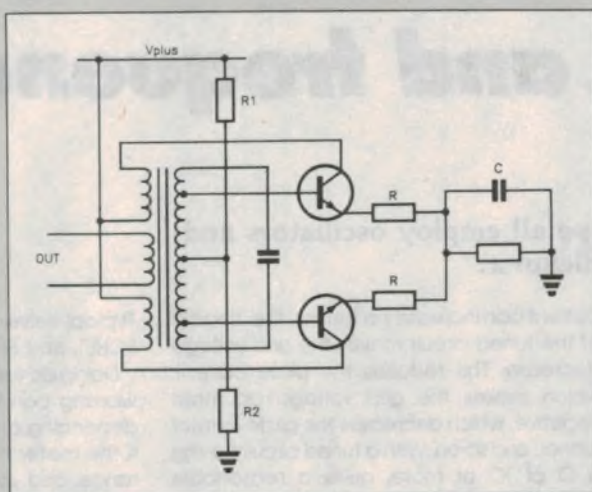

Figure 10.3. Low distortion oscillator for tape recorder.

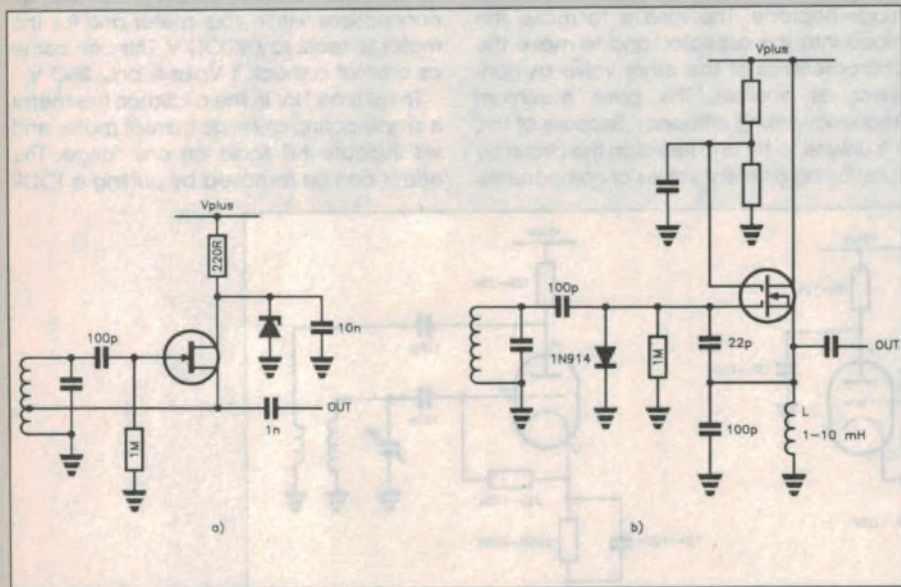

Figure 10.4. JFET and MOSFET RF oscillators.

series resistor and 1 nF capacitor to earth to form an RC filter on the input of your dc meter. The added resistor will make the meter read somewhat low.  $V_a$  should be 10 to 30 V less than  $V_{plus}$ . If you measure the dc voltage at the grid, using a high input resistance meter,  $V_g$  should be 5 to 20 V negative. If it is, the oscillator is working. If not, check  $V_a$ , the dc resistance of the transformer grid winding, and the values of all the  $R_s$  and  $C_s$ . If all are correct and there is still no oscillation, the valve is faulty. Of course the oscillator can oscillate at the wrong frequency if the transformer or the tuning capacitor is faulty.

## Transistor oscillators

Figure 10.2 shows typical RF transistor oscillators. Each of these has a 'starting' resistor feeding the base from  $V_{minus}$  (for PNP) or  $V_{plus}$  (for NPN). Almost any small signal transistor will work in these circuits. While adequate for transistor radio purposes, neither of these oscillators is particularly stable. For the better class of FM receiver, frequency synthesis based on a crystal oscillator is used. Such oscillators are usually based on FETs. The dc testing of transistor oscillators is similar to that of valve oscillators.

Figure 10.3 shows the type of oscillator used in high quality tape recorders. Since both the overall noise and the audio distortion of tape recorders are increased by distortion of the bias waveform, a fully symmetrical arrangement is used. The circuit values depend critically on the design of the particular transformer, so no values are given. The value of  $C$  is particularly critical (usually about 2  $\mu F$ ), so do not attempt to alter it.

The two resistors marked  $R$  must be well matched for lowest distortion. The resistors marked  $R_1$  and  $R_2$  provide the startup bias, and their junction must not be bypassed. With fast transistors, putting a capacitor of a few  $\mu F$  on this junction will blow the transistors' internal base connections on startup. Even though the tuned transformer is shown as having an iron core, ferrite cores are used, and for the lowest distortion an air-cored transformer is best (in a suitable metal screening enclosure). With an air-cored transformer and high impedance heads, it is possible to get 280 Vac output at 100 kHz with less than one per cent distortion.

## FET oscillators

Figure 10.4 shows the circuits of two FET oscillators, the first using a JFET, such as one of the MPF series, with a zener diode to stabilise the supply line, and the second using a MOSFET such as the 40673. In the latter case, a diode and bleed resistor have to be provided since MOSFETs are not efficient rectifiers of RF and so cannot develop their

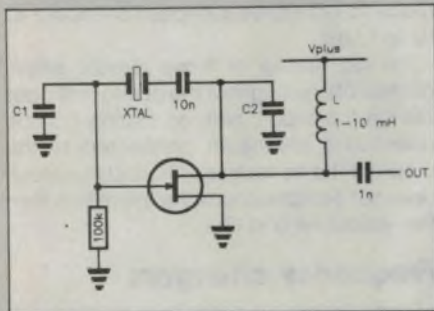

Figure 10.5. FET crystal oscillator.

own bias in the way that transistors and JFETs can.

The inductor marked L is a radio frequency choke that provides a dc return path for the source current but presents a high impedance to RF. The values of the other components depend on the frequency and the particular MOSFET used. One of many forms of FET crystal oscillator is shown in Figure 10.5. Capacitors C1 and C2 are about 150 pF each and their ratio controls the strength of oscillation. If you have to change the crystal in this form of oscillator, you will need to experiment with the values of the capacitors. The inductor L is a radio frequency choke appropriate to the frequency.

### IC oscillators

ICs are used as oscillators in the audio frequency range to produce sinewaves. The standard Wien bridge oscillator is shown in Figure 10.6. There are many variations on this circuit, particularly in the way the amplitude

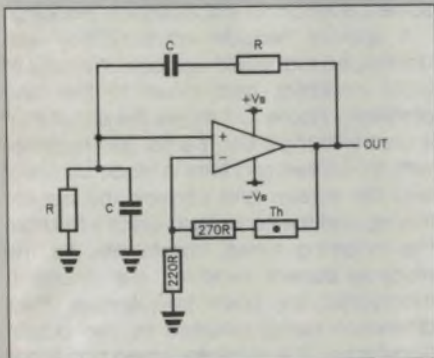
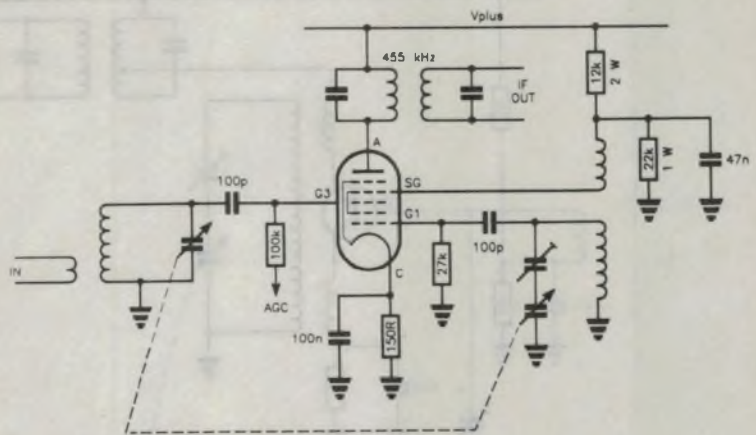

Figure 10.6. IC Wien bridge oscillator.

is controlled. The circuit shown uses a thermistor as the controlling element, but a zener diode bridge or a miniature lamp works in a similar way.

Positive feedback is applied via the Wien bridge and negative feedback via the limiting element. For tuning, either the two resistors marked R or the two capacitors marked C have to be varied simultaneously using ganged controls. The circuit can be



Vplus = 250 V

V <sub>A</sub>	250 V
V <sub>SG</sub>	100 V
V <sub>G1</sub>	-12 V
V <sub>G2</sub>	-2 TO -30 V
V <sub>C</sub>	1.5 - 0.5 V
GAIN	5 - 0
GAIN	$\frac{E_{out} (455 \text{ kHz})}{E_{in} (1 \text{ MHz})}$

Figure 10.7. Circuit for 6BE6 frequency changer (mixer).

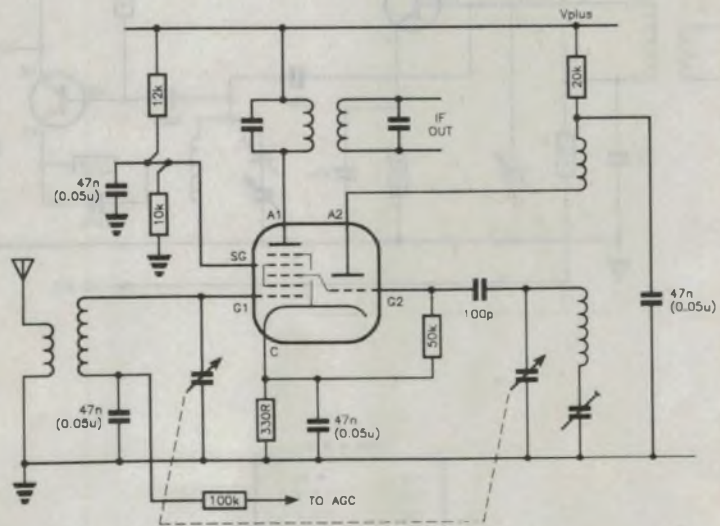

Vplus = 250 V

V <sub>A1</sub>	250 V
V <sub>SG</sub>	100 V
V <sub>A2</sub>	100 V
V <sub>G2</sub>	-20 V
V <sub>G1</sub>	0 TO -20 V
V <sub>C</sub>	3 - 1.5 V
GAIN	4 - 0

Figure 10.8. Circuit for 6J8 low noise frequency changer.

## Oscillators and frequency changers

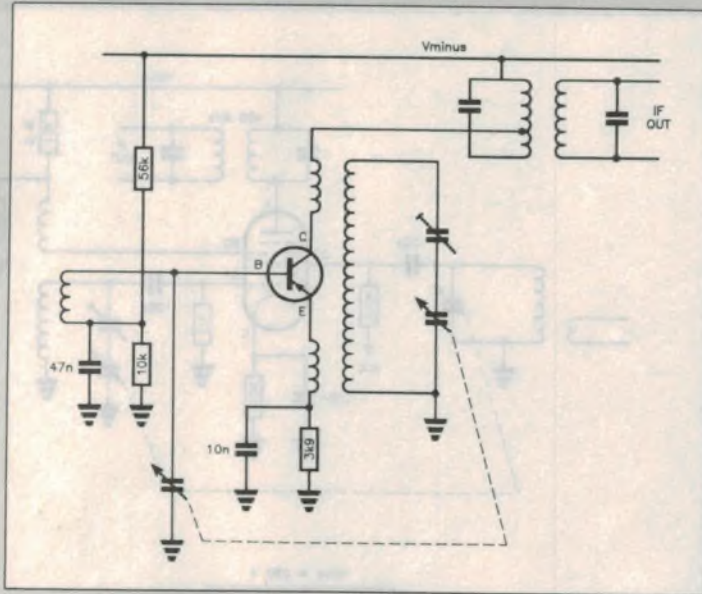

Figure 10.9. PNP self-oscillating mixer.

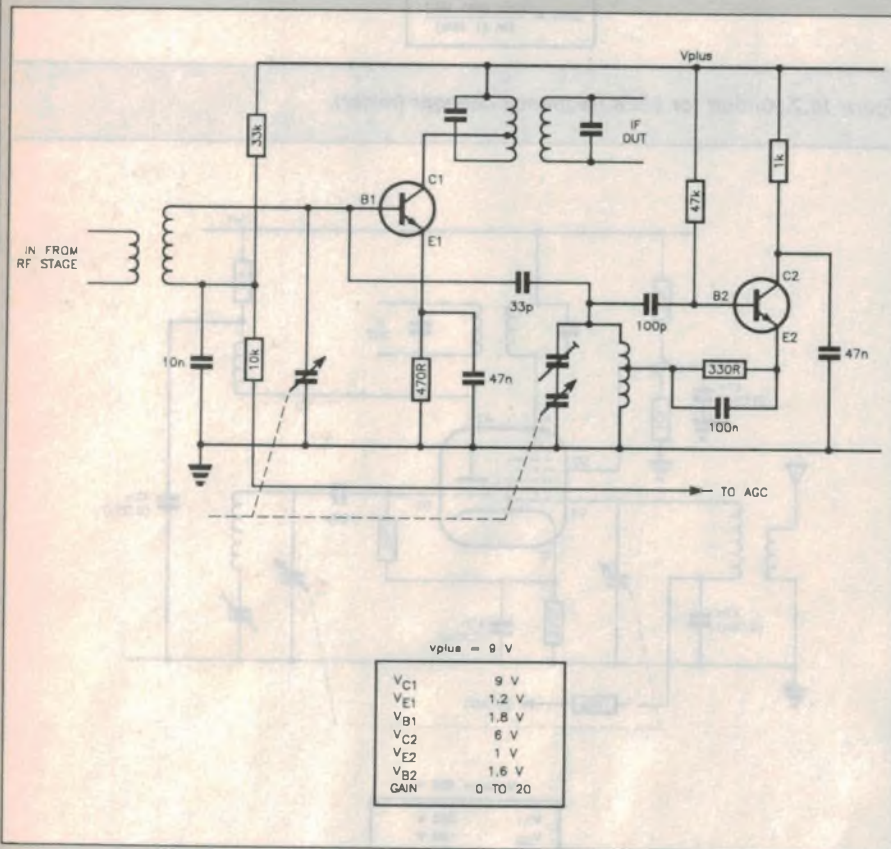

Figure 10.10. Two transistor mixer.

made to work at frequencies from about 10 Hz to 1 MHz.

The dc testing of these circuits simply consists of ensuring that the correct voltages are on the supply pins. ac testing can be done using the tracer connected to the output. If the dc tests are OK, and the circuit does not oscillate, check the thermistor, then the various Rs and Cs.

### Frequency changers

All superheterodyne receivers must have a frequency changer to change the incoming frequency to a fixed intermediate frequency (IF), usually 450, 455 or 465 kHz. This frequency changer is commonly called a mixer, and should not be confused with an audio mixer that does something quite different.

In a frequency changer, a local oscillator generates a sine wave that is mixed with the incoming frequency in a mixing device that is decidedly non-linear. This produces, at the output, the two original frequencies together with some output at both the sum of the incoming frequencies and their difference.

For example, if a radio is tuned to 1.000 MHz and the local oscillator is at 1.455 MHz, the output will contain 1.000 MHz, 1.455 MHz,  $1.455 + 1.000 = 2.455$  MHz and  $1.455 - 1.000 = 455$  kHz. By putting a transformer tuned to 455 kHz in the output circuit, the other three frequencies are eliminated.

Clearly, for the output frequency to remain at 455 kHz independent of the incoming frequency, the local oscillator frequency has to follow the incoming frequency. This is achieved by using ganged capacitors and some clever circuit-capacitance 'padding'.

A special hexode valve (6BE6) was developed that could combine the tasks of local oscillator and mixer in the one envelope. Figure 10.7 shows the circuit that is used with the 6BE6. The first grid together with the screen grid form a triode oscillator and the screen grid controls the current flowing past the control grid which is fed from the incoming tuned transformer. So the electron current reaching the anode is modulated by both frequencies, their difference being selected by the output transformer. The oscillator tuned circuit has a pre-set padder capacitor of about 425 pF. If ganged tuning capacitors of 40-400 pF are used.

A considerable decrease in noise level is achieved by using triode-hexode valves such as the 6K8 or particularly a triode-heptode such as the 6J8. In addition, these valves have particularly smooth automatic gain control (AGC) characteristics.

The circuit of Figure 10.8 shows a typical circuit for the 6J8. In some circuits the oscillator anode coil is connected to the 100

V supply to the screen grid rather than using its own 20 k dropping resistor. Even though the gain is slightly lower than that achievable with a 6BE6 or 6K8, the superior noise performance of the 6J8 means that a tuned RF stage ahead of the mixer gives little improvement in signal-to-noise ratio on the broadcast band. Consequently the 6J8 became popular as the input stage in many Australian broadcast band radios.

Apart from the obvious dc voltage checks, measuring the negative voltage on the grid of the triode will determine whether it is oscillating. If this is so and the circuit does not work, short the AGC voltage to earth and try again. If it now works, the trouble is in the AGC system. If there is still no output, one of the tuned circuits is faulty.

Transistor-based mixers usually have a separate oscillator, particularly in AM/FM radios, although early AM radios and some cheaper AM/FM sets use a self-oscillating mixer. The latter is shown in Figure 10.9. The PNP transistor uses collector-to-emitter feedback via the tuned circuit to produce the oscillation, and the incoming frequency is applied to the base.

This form of the circuit feeds very little voltage at the oscillator frequency into the input tuned circuit. The output transformer has to have a fairly high Q to filter out the oscillation frequency since the collector has a large voltage swing at this frequency. The noise performance of this circuit is not particularly good, so once transistors became cheap, a separate oscillator was used.

A two-transistor mixer circuit using a separate oscillator is shown in Figure 10.10. In all such circuits, there is a critical level of oscillator power needed at the input to the mixer transistor. It is therefore unwise to alter the values of the components around such a mixer. Because the oscillator current is injected directly into the base of the mixer transistor, radios using this type of mixer always have an RF stage before the mixer to prevent radiation of the oscillator frequency from the aerial. If only a two-gang capacitor is available, the RF stage need not have a tuned input.

Similar circuits are used for JFET mixers. Once MOSFETs became relatively cheap, their superior isolation between the input and oscillator signals made them popular, particularly for BC/SW and FM receivers. A circuit of such a mixer is shown in Figure 10.11, in which the incoming signal is applied to G1 and the oscillator signal is applied to G2. The noise performance of this circuit, particularly above the broadcast band, is hard to beat.

Another advantage of the MOSFET is that it is not particularly susceptible to cross-modulation effects when it is tuned to a

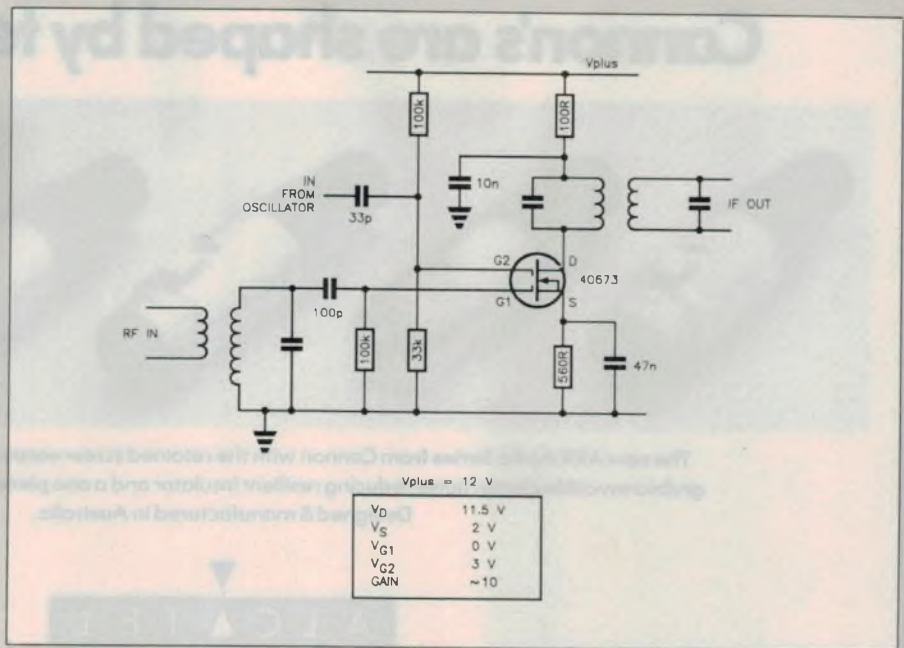

Figure 10.11. MOSFET mixer.

weak station on a frequency close to that of a strong station.

The CA3028A is an IC whose many uses include acting as a mixer. The circuit is shown in Figure 10.12. The internal circuit of the CA3028A will be given later; its main advantage as a mixer is its excellent inherent cancellation of the oscillator frequency at its output. This considerably eases the difficulty of the IF transformer design. Since the IC is relatively expensive, its use is restricted to

frequency synthesizers, frequency meters, high quality FM receivers and similar equipment.

Again, dc testing will usually establish whether any of these circuits should work. If all the voltages are correct and there is no output, the most likely problem is incorrect oscillator frequency caused by failure of one of the oscillator tuning components.

Contributed by The Apogee Group

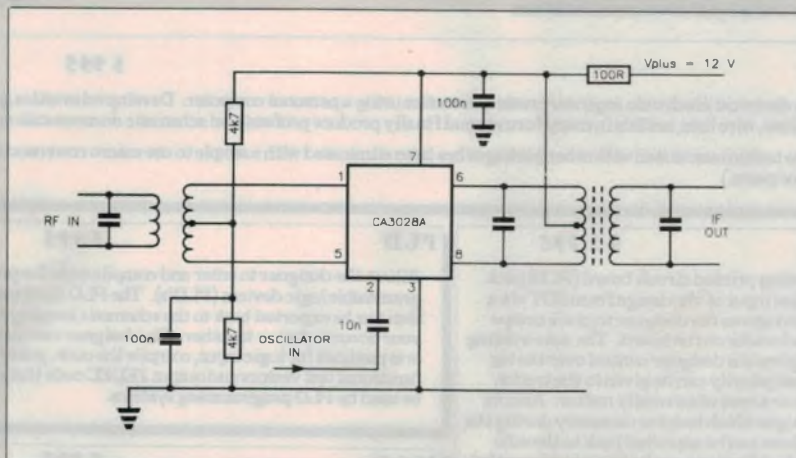
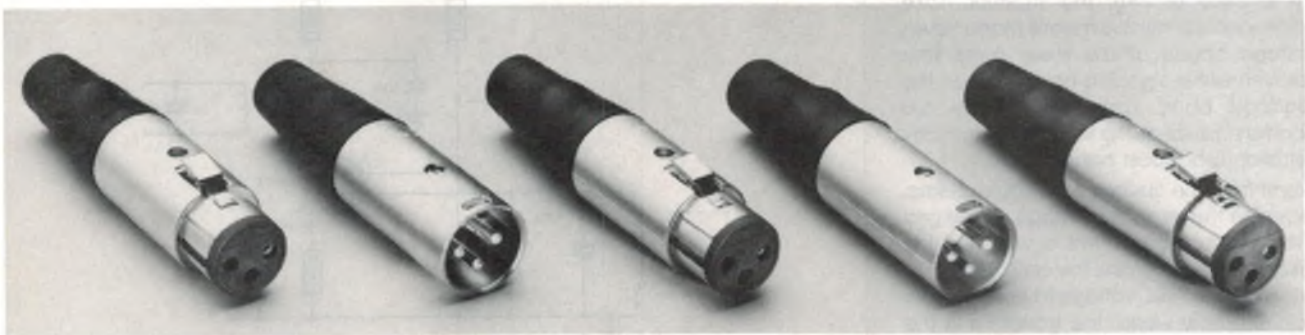

Figure 10.12. IC mixer.

# Connectors come in many forms Canon's are shaped by technology



The new AXR Audio Series from Cannon with the retained screw version offers a rugged internal grub screw cable clamp, noise reducing resilient insulator and a one piece diecast zinc alloy housing. Designed & manufactured in Australia.



COMPONENTS

248 Wickham Road, Moorabbin. Vic. 3189

Phone (03) 555 1566 Fax: (03) 553 3801 Telex: 30877

Sydney (02) 663 2283 Adelaide (08) 363 0055 Brisbane (07) 832 5511

## READER INFO No. 20

Fully integrated PC based electrical and electronic design tools.

With almost any PC hardware you can generate quality documentation and schematics, design programmable logic devices, computer model your PLD's, simulate the entire design (including PLD's) and finally produce PCB layouts.

All without the delays, inaccuracies and cost of outside services.

Five standalone packages that are hard to equal and unbeatable when combined. All having the same easy to learn and use pull down menu interface.

**OrCAD**  <sup>®</sup>  
Systems Corporation

### SDT

\$ 995

To help the electrical/electronic engineer create schematics using a personal computer. Develop schematics, produce check prints, check standard design rules, produce parts lists, wire lists, netlists in many formats and finally produce professional schematic documentation.

Much of the tedium associated with other packages has been eliminated with a simple to use macro command structure and a comprehensive library of parts (over 6,000 unique parts.)

### PCB

\$ 2,995

Autorouting printed circuit board (PCB) package. Takes input of the design from SDT via a netlist and allows the designer to place components and tracks on the board. The auto-routing facility gives the designer control over the layout so that priority can be given to the tracks, modules or zones which really matter. Annotation changes which become necessary during the layout phase can be exported back to the schematic. Modifications can be imported from the schematic without the need to completely redesign the PCB. Complex designs up to 16 copper layers can be accommodated, surface mount components can be used and an optimizer routine is provided to reduce the number of pinthroughs and track length in the layout.

### PLD

\$ 995

Allows the designer to enter and compile code for programmable logic devices (PLD's). The PLD documentation can be exported back to the schematic keeping all your documentation together. The designer can use several methods for logic input, compile the code, generate functional test vectors and output JEDEC code that can be used by PLD programming systems.

### MOD

\$ 995

Converts JEDEC fuse map input files into timing based computer models of PLD's. These are used by OrCAD VST to simulate an entire design - including the PLD's.

### VST

\$1,985

A digital simulator which allows the designer to simulate an entire design developed with SDT and PLD.

The package has an oscilloscope-like output on the screen and results can be printed to assist with documentation. Designs can be simulated not only for logic functionality but also for timing constraints - eliminating much of the need for repeated bread-boarding of the circuit.

**PROMETHEUS**

SOFTWARE DEVELOPMENTS PTY LTD

Tel: (03) 862 3666  
Tel: (02) 809 7255

Fax: (03) 862 2092  
Fax: (02) 808 3570

**BULK PURCHASE  
DISCOUNTS  
PHONE NOW**

# WORKSTATION



EA/ETI'S COMPUTING SUPPLEMENT

**EXPANDING  
YOUR PC'S  
MEMORY**

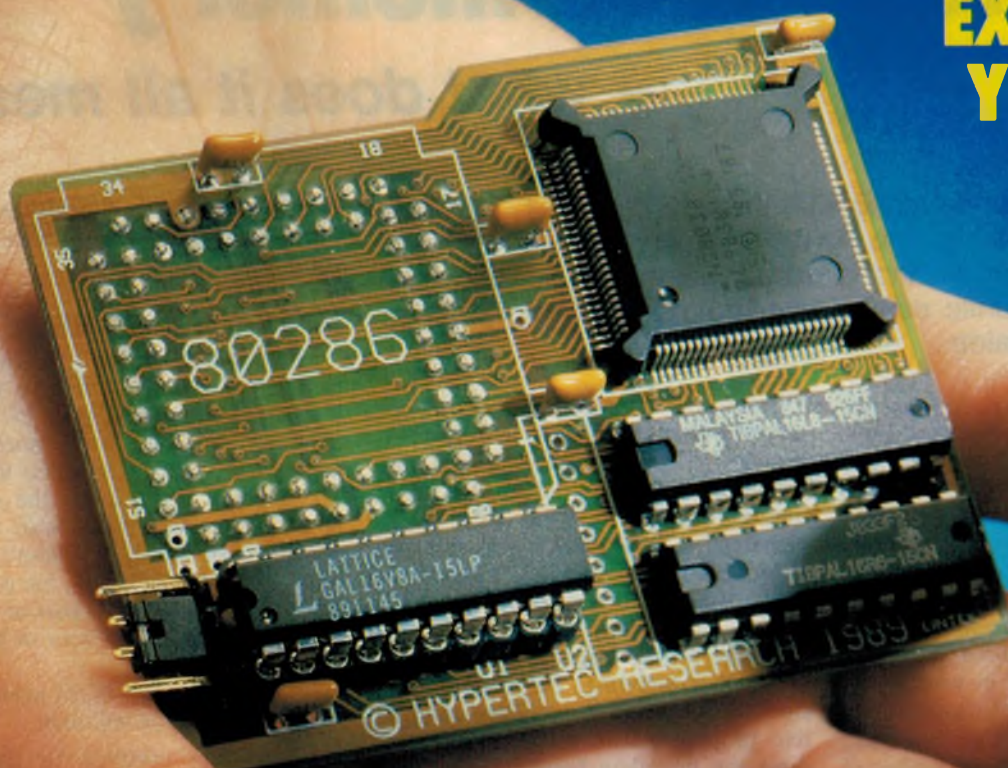

**HYPERTEC'S 386SX  
UPGRADE BOARD**

**BUILDING A RISC COMPUTER - 2**

## Understanding your IBM-compatible PC:

# Extended memory, Expanded memory, Enhanced EMS memory

## — what does it all mean?

Are you still staggering along with that old PC or XT, regularly dreaming of breaking the 640K memory barrier? Plug-in memory expansion is the obvious answer — if you can decipher the semantic confusion surrounding memory cards. Stewart Fist translates...

What is the difference between *extended* and *expanded* memory? And which of these (if either) does 'memory extension' refer to? And why would you use one technique and not the other? Can both be used together? And where does EMS and Enhanced EMS come into all this?

If you don't know the answers, and aren't even too sure about the questions, you are not alone in your confusion. A few months ago, I was researching an article on accelerator cards and I talked to technicians from a number of card suppliers. Half of them didn't have a clue about the reason behind the PC's original 640K limit, or how extended and expanded memory differed — and the other half thought they knew, but had it wrong.

So let's get hard-nosed about this, and dispel some of the myths.

First of all, MS-DOS *doesn't* have a 640K limit to the memory size — this myth results from an architectural decision made by IBM when they designed their first 8088-based PC. It carried on in the 8086-based XT range, and then into the 80286 and '386 machines when they are running in 'real' mode. IBM's reason was simple: they wanted to have a firm, fixed location for their video RAM and, as the stalker said to the magistrate, 'It seemed like a good idea at the time' to place this in the address space starting at 640K.

If you want proof that this *wasn't* Microsoft's fault, check out the old DEC Rainbow. This was an MS-DOS machine that came out about the same time as the first PCs, but DEC set its demarcation point much higher — as did a couple of supposed IBM-compatibles (which weren't too compatible, as their owners discovered). Since IBM's PC hardware set the standard for all future MS-DOS computing, the decision has stuck if you want to use IBM compatible programs. The 640K point represents the boundary between free read-write RAM space (below), and system space (above).

Memory in a computer is best visualised as a single stack with addresses that extend from zero to the highest possible with the available processing chip — see Fig.1. And the Intel 8086 processor, which spawned the 8088 variation that IBM chose to use in the original PC, has a 20-bit address bus. So the memory limit can be calculated as two raised to the power of 20, which is 1MB (or 1,048,576 bytes, if you want to be pedantic).

Now, a computer can't make all of its addressable memory space available just for use by operating systems, applications software and data. It also needs *some* space for mapping the video for the screen, and for other housekeeping functions usually stored in ROM. The video memory map obviously needs its

own RAM, because it holds the current image of the screen — which changes constantly.

### Memory addresses

The point of all this is to clarify the fact that if you want to have 640K of usable RAM space in your PC or XT, then you need to have more RAM memory to support the video mapping. These chips may be on the motherboard, on an expansion card, or on a plug-in video card; it doesn't matter where they are physically, the computer will still address them as part of one single address map, from zero to the 1MB limit.

So in the upper 384K of memory addresses in a PC you will find:

- RAM chips reserved for the video mapping;
- ROMs which control the hard disks and EGA displays;
- A BIOS ROM;
- Some free space; and
- In the uppermost 64K (F segment), the BASIC language in ROM (if you have an original IBM PC).

When someone attempts to sell you a '640K PC', you need to ask whether the machine has the full 640K of free read-write RAM space (for use by DOS and the programs) — or is the figure just a count of the number of RAM chips on board? Some retailers include the video memory RAM in with the count, so there's some variation in what you actually get with '640K compatibles'. Be warned!

According to IBM, the correct term for this bottom 640K of read-write user



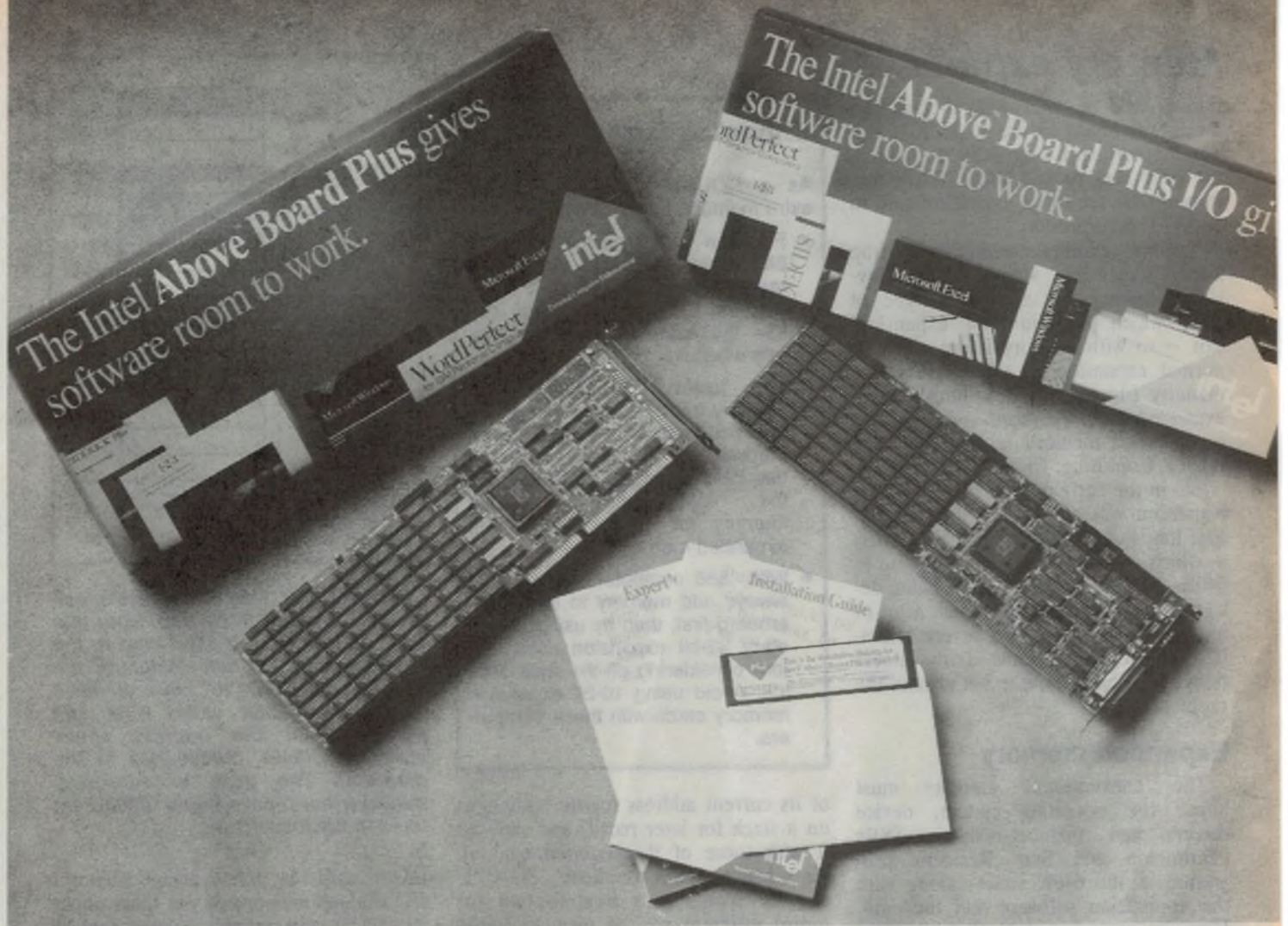

**Intel's 'Above Board Plus' can be configured as conventional, extended or expanded memory.**

RAM is *conventional* memory, and it needs to be in a continuous (contiguous) run of addresses. But despite this, it is not treated simply as a single chunk.

To make it easier to work with memory, software programmers divide the total 1MB of mapped space into 16 segments, each of 64K bytes. These are numbered from Seg 0 to Seg 9 for the first 10 segments (which makes up the total 640K of 'conventional' RAM space), then Seg A to Seg F, for the uppermost six segments used for video RAM and ROM, up to the 1Mb limit.

At this stage I'd like to emphasise one point: this 'system' space isn't totally occupied. There is usually at least one segment (64K) of free address space available, which can be used for expanded memory control.

Don't forget that the original PCs were released with only 64K of user memory, with four rows ('banks') of RAM, each row containing 16K with a parity bit. Later, 256K memory chips were used instead of the 16K ones, and

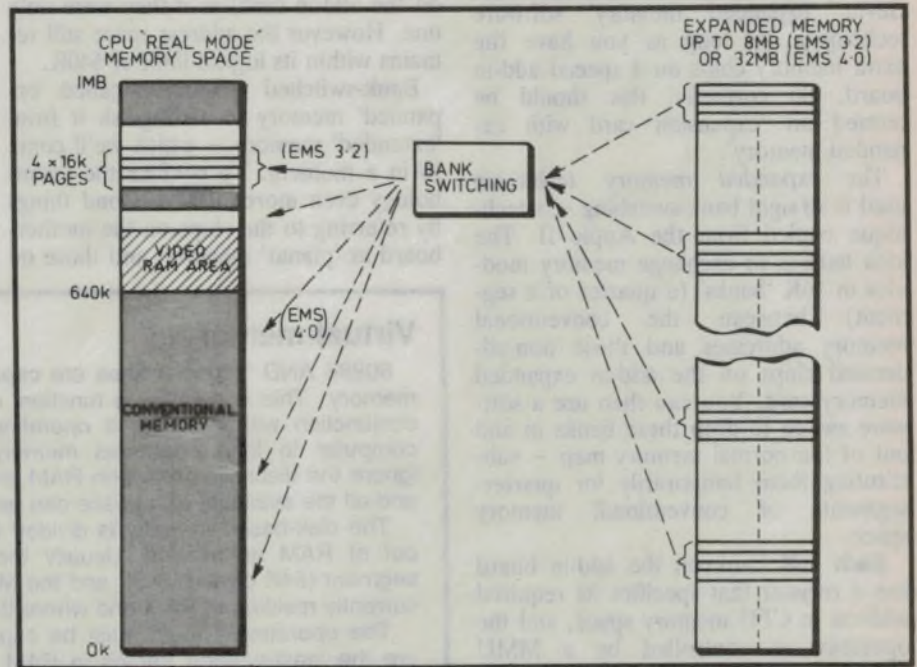

**Fig.1: EMS 'expanded' memory systems swap 'pages' of memory in and out of four 16K pages of system memory (above the 640K limit) - EMS 3.2 supported 8MB of expanded memory, while version 4.0 supports 32MB.**

## Memory expansion

this allowed the maximum memory on the motherboard to rise to 256K. Once the motherboard was fully populated, the only way to add more RAM was through the use of an expansion card in an I/O expansion slot.

There's another terminology trap here. 'Expansion' simply means anything (memory or any other type of card) which plugs into an 'expansion' slot – so with memory it can apply to normal expansion of the conventional memory (up to the 640K limit), or to expanded memory (bank-switched), or to extended memory (above the 1MB range). Confusing, isn't it?

So, in the early days of PCs and XT's, expansion was still within the addressable limits of the processing chip (1MB) – which meant user memory only up to 640K. At the time the PC was being designed, 640K sounded like such a lot of memory, but now it is a severe limitation. Fortunately, some fairly clever things have been done to get around the problem.

### Expanded memory

The 'conventional' memory must house the operating system, device drivers and memory-resident TSRs (Terminate and Stay Resident programs) in the 640K space, along with the application software and the data. However, you can fool the processor into using more than this through some clever 'expanded memory' software techniques, as long as you have the extra memory chips on a special add-in board. So correctly, this should be termed an 'expansion card with expanded memory'.

The *expanded memory* technique used is straight bank-switching – a technique copied from the Apple II. The idea here is to exchange memory modules in 16K 'banks' (a quarter of a segment) between the conventional memory addresses and those non-addressed chips on the add-in expanded memory card. You can then use a software switch to drop these banks in and out of the normal memory map – substituting them temporarily for quarter-segments of conventional memory space.

Each 16K bank on the add-in board has a register that specifies its required address in CPU memory space, and the operation is controlled by a MMU (Memory Management Unit) on the memory expansion card.

When the program needs to use this expanded memory, it clears the contents

### Choosing extra memory:

As a ROUGH guide to choosing extra memory, follow these rules:

- For slow speed machines (below 8MHz) on the bottom end of the range (PCs, XT's and slow AT's), buy an EMS add-in board and use the expanded memory system whenever possible.
- With faster AT's, always build memory into the motherboard before you consider adding EMS on hardware. It is always faster to use EMS emulation software and the motherboard extended memory for EMS, than add-in expanded memory.
- With '386 computers you should always add memory to the motherboard first, then by using proprietary 32-bit expansion units, before considering off-the-shelf add-ins. Avoid using 16-bit expansion memory cards with these computers.

of its current address register (saving it on a stack for later recall) and replaces it with those of the required bank(s). As a result of this 'duplicity', the CPU can be fooled into treating two (or more) different sets of memory banks (one on the motherboard and the others on the add-in card) as if they were only one. However the address space still remains within its logical limit of 640K.

Bank-switched memory is called 'expanded' memory to distinguish it from 'extended' memory – which we'll come to in a moment. To confuse the terminology even more, IBM becloud things by referring to the chips on the motherboard as 'planar' memory, and those on

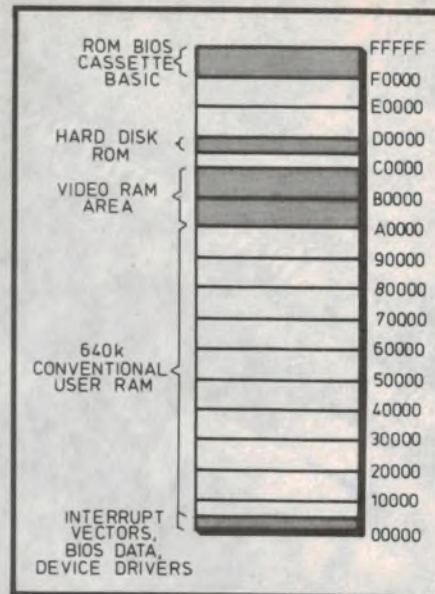

**Fig.2: How the 1MB of address space is used in Intel's 8088 chip. Note that DOS doesn't have a 640K limit to the memory size – when designing the XT, IBM wanted to have a fixed location for their video RAM and placed it in the address RAM space starting at 640K (A0000 hex in the diagram). The gaps in addresses between the blocks below A0000 are used in bank-switching.**

add-in cards as 'I/O channel' memory. I/O channel memory (if you think about it) can be conventional memory (extensions), or expanded memory, or extended memory.

*(Editor's Note: Another source of confusion is that some makers of PC compatibles seem to use the terms 'expanded memory' and 'extended memory' in the opposite way to everyone else. An example is Epson, as I discovered the hard way when I added an expanded memory card to my Epson AX-2.)*

They really go out of their way to

### Virtual memory

80286 AND '386 machines are capable of supporting gigabytes of 'virtual memory'. This is a software function, made possible by the MMU working in conjunction with a modified operating system. Virtual memory allows the computer to fake enormous memory capacity, by allowing programs to ignore the distinction between RAM and disk storage. All the available RAM, and all the available disk space can be written to, and read from, at will.

The disk-based memory is divided into 'frames', that are swapped in and out of RAM as needed. Usually the frame will be the same size as a segment (64K on the '286), and the MMU will keep track of what frames are currently residing in RAM and where the others are on the disk.

The operating system must be capable of making decisions as to which are the least-needed frames in RAM, and instructing that these be copied back to disk to make room for new frames that are needed. Often these decisions are made on the basis of 'clock algorithms', which drop a RAM frame if it hasn't been used for some time.

make computers difficult to learn about, don't they?

To round out this historic picture of 'expanded' memory: note that software can only take advantage of bank-switching and expanded memory when it has been written with this possibility in mind. And since there are many ways of implementing bank-switching, the software needs to be matched to the requirements of the add-in memory board. These boards are not cheap because they need costly MMUs in addition to the memory chips.

Before the days of a recognised single standard for bank switching for IBM compatibles, few software publishers were willing to gamble on writing software with requirements larger than the 640K limit – because they couldn't be sure which add-in memory boards could be used. As a consequence, the hardware manufacturers didn't have software that would use their product, so it was a confused form of egg-and-poultry stalemate.

Then, when the popularity of TSR programs reached the point where a 100K of RAM was being permanently occupied by these accessories, the problem reached a crisis point.

Lotus and Intel both decided that they had to do something about bank-switching standardisation. Lotus was having to write multiple versions of their software to feed the growing hordes of expanded memory cards, and Intel liked the idea of selling more chips – it was in the DRAM business in those days.

The result of their collaboration was EMS (Expanded Memory Specification) which allows up to 8MB of memory.

Microsoft was quick to realise the advantages of EMS, and from DOS 3.2 on, it ensured that the operating system was compatible. So with Lotus, Intel and Microsoft behind it, LIM (Lotus, Intel, Microsoft) EMS had enough clout to become established as the *de facto* industry standard. But it wasn't without its challengers: there was a later AST 'super-set' version from AST, Quadram and Ashton-Tate.

The LIM EMS specification assumes that at least one segment (64K) of memory space is free in the memory map of a PC or XT, between the normal 640K conventional memory limit, and the 1MB upper processing limit. Not all this space is occupied by video RAM and the ROM chips, you may recall.

This spare 'window' page-frame can hold four 'pages' of memory, each of 16K. These pages can each hold

## Memories are made of...

To help sort out the confusion in terminology, here are brief definitions of the commonly used expressions:

**EEMS:** Enhanced Expanded Memory System – AST's super-set of EMS. It allows 64 pages of bank-switching, rather than the four available with EMS 3.2. The two were combined into AST/LIM 4.0, which allows pages to be switched in both above and below the 640K barrier (see Expanded memory).

**E/EMS:** Expanded/Enhanced Memory System – a general expression for all standardised forms of DOS memory management.

**EMS:** Expanded Memory Specification – the Lotus, Intel, Microsoft (LIM) collaboration which allows up to 8MB of memory.

**XMS:** eXtended Memory System – devised by AST Research, Intel and Microsoft, to allow DOS to use 64K of extended (not expanded) memory for a total of 704K. Windows/286 was the first program to recognise XMS.

**Expanded memory:** Originally a general term for a number of bank-switching techniques, but now it is applied almost exclusively to EMS. The LIM group devised this standard way of expanding the 640K limit. EMS systems swap 'pages' of memory in and out of four 16K pages of system memory (above the 640K limit). Not every program can use EMS, because its sophisticated form of bank switching requires the hardware and software to work together. EMS 3.2 supported 8MB of expanded memory, while the enhanced version 4.0 supports 32MB.

**Expansion memory:** A very general term which merely refers to chips on an adapter card, without defining whether these are being used in the expanded or extended state.

**Extended memory:** The extra memory above DOS's 1MB limit; it is straightforward additional memory for 80286 (AT-class) and 386 machines. Only a few DOS programs can use it; the most common examples are utilities and disk caches (however, see XMS, above). This memory space is primarily available for the likes of OS/2 and Unix, with the processor running in protected mode.

switched pages from the expanded memory on the card. The EMS scheme allows the software to shunt data or applications in 16K page amounts into this addressable space, from an add-in memory card under the control of a Memory Management Unit – and ultimately, device drivers in the software.

The card can hold (and the software can use) a couple of megabytes of this expanded memory, which are simply called in as required; the switching is virtually instantaneous.

The memory area on the card itself is outside the normal 640K, so DOS is unable to access it without special code being written; similarly TSR programs can't use this space.

While switched into the addressable memory space, the pages are treated as extensions to the conventional 640K. So any processor, from the 8088 up, can access and use these pages only if the operating system and software allow access to this system space – the CONFIG.SYS file is used to set up this function.

I must also mention AST's super-set of the EMS standard, known officially as – would you believe? – *Enhanced Expanded Memory Specification*

(EEMS). This was promoted to take the bank-switching idea to new heights – to 64 pages rather than the four available with EMS 3.2.

Luckily, the two groups eventually got together, and the result is LIM 4.0, which incorporated some of the best AST ideas into the one EMS standard.

The AST/LIM 4.0 enhancement did not limit the number of pages available for bank-switching in the addressable space to only those four original 16K pages. It allowed a much greater number to be dynamically assigned by the software, and to exist in any part of the processor's 1MB addressable space.

This meant that these pages could be switched in both above and below the 640K barrier, making the system far more efficient and flexible, especially for multi-tasking and multi-user systems.

Finally, the combined set of expanded and enhanced-expanded standards for memory are now known as E/EMS, just to add to the confusion.

Expanded memory boards come with software drivers – usually called 'EMS managers' – which provide the interface between the board and application programs designed to use EMS. The

## Memory expansion

drivers take care of 'mapping' the available banks of memory on the board into the EMS page-frame (a 64K contiguous block of memory in the address space accessible to DOS - see Fig.2).

So much for expanded and enhanced-expanded memory systems, which are all based around the limitations of the old 8088 chip with its 20 address bus lines giving a maximum of 1MB address space. The next subject in this cognitive web of semantic confusion is the *extended memory* system, which came about because later Intel chips that evolved were able to address more than a single megabyte.

### Extended memory

When the IBM AT made its appearance (powered by Intel's 80286 chip), the IBM PC family jumped from 20 to 24 address bus lines, and therefore the memory limit rose to a maximum of 16MB (two raised to the power of 24). What is more, the AT's microprocessor was able to operate in two modes: the 'real' mode which imitated the standard PC and ran conventional MS-DOS and DOS-based applications, and a new 'protected' mode.

It was only in this new mode that the chip was effectively able to use the full 24 address bits and address 16MB. However, for a long time there were no applications written specifically for the '286's protected mode - except if you were interested in Xenix - so most ATs have always been employed as 'super' DOS PCs in the real mode.

In these '286 machines, the memory space above the old 1MB limit became known as 'extended memory' (which it was from the real mode's point of view - but not really from that of the protected mode).

If you intend to use your machine to run OS/2 or programs such as Oracle (which have been specifically written for the protected mode), then this 'extended memory' is simply treated as a continuation of the first megabyte.

In the real mode/DOS-emulation environment, any read-write RAM above the normal 640K limit (but with addresses above the 1MB range) could only be used as a print or disk spooler, or as a RAM disk. It was a cache area, into which data was put when it wasn't actually needed by the processor.

There is one seeming exception to this: the XMS (eXtended Memory Specification) devised by AST, Intel, Microsoft and Lotus, which allowed DOS to use 64K of 'high-memory'

(above 1Mb) extended space as 'an extended read-write area, for a total of 704K. Windows/286 seems to be the only current program to recognise this extension, but it is available for others.

The XMS extended memory specification is a complex piece of memory map manipulation, which allows addresses above the top end of the normal PC range to wrap around and appear at the bottom of the memory map, but 'only on machines having an A20 address line', I am told. (I believe them!)

The difference between *expanded* and *extended* memory is supposed to be that the former does not have specific memory addresses. Expanded memory gets added to the system page by page, and assumes the address of the page-slot into which it is added. Extended memory has its own specific addresses above the 1MB limit.

I don't understand XMS, and it isn't important anyway, so I won't go any further. It appears to me to be a complex form of bank-switching, but Microsoft insist that it is extended memory - and who am I to argue?

Whatever! The software needs to be able to handle this rule-breaking if it is to take advantage of these rather minor extensions. You may wonder whether it was worth the bother, but it was at the time.

Are you still with me? Unfortunately, it gets a trifle more complex yet!

The point is that '286 and '386 machines can have addressable memory above the 1MB limit, but if they are running DOS and standard DOS applications in their 'real' modes (or in the 'virtual 8086' mode of the '386), the DOS can't 'see' or use more than the 1MB.

Extended memory with '286-based computers can go as high as 16MB, and with the '386, as high as 4 gigabytes. And both '286 and '386 computers can use both their extended memories and the old bank-switched expanded memories, if the application has been written to take account of this.

This is what makes it all so confusing. An add-in *expanded* (bank-switched) memory card can also double as a normal extension of memory in these later computers (although you are wasting the MMU chip) - but with the exception of the disk and print spooling noted above (and XMS), you can't use this extended space in the 'real' mode. It is not for standard DOS applications.

Well, now! Suppose you have a '286 or '386 machine with a couple of mega-

bytes, and you always use it for DOS applications. Since you've got all this extra memory unused on the motherboard in the 'real' mode, why should we need to add a special memory card to run the bank-switching expanded memory system? Why add new chips when we've got some sitting idle?

The answer is that you need a MMU (Memory Management Unit) to handle the bank-switching. The '286 doesn't have one that can handle this operation, unless it is specifically provided on the add-in card; but fortunately, the '386 has such an MMU built-in.

The '386 microprocessor can change the address of any bank of memory in the system. Therefore, with the right software drivers and DOS, the extended memory of a '386 sitting unused above the old 1MB limit, can now be made available for bank-switched expanded memory. Now extended memory is also expanded memory!

The way it does this is to temporarily switch the processor from real mode to protected mode, using routines contained in the AT's BIOS chip. The device drivers used in the E/EMS expanded memory system must also be modified to perform this function. You can get 'Above Disk' and several other drivers for this purpose.

Both Above Disk and a software developer's product called '386/VMM' allow programs to use extended RAM even greater than the four gigabyte limit, by swapping into a virtual memory mode when it senses the end of RAM addresses, and using the hard disk as a natural extension.

Got that?

Just a final point. With '286 and '386 machines, when we talk about memory, we recognise that it exists in three blocks. The '1MB' machine you buy from your local retailer will have the normal conventional memory in the address space extending upwards from zero to 640K. Then the next 384K of address space (up to the 1MB point) will be reserved for the standard video and ROM functions, and finally, there will be 384K (to make up the 1MB of user RAM) of 'hi-mem' extended memory occupying addresses from 1MB up to about 1.4MB.

However, you've got to be careful here. Some of the AT-clones, and many '386 systems, reserve for themselves some system space within this top 384K (supposedly 'extended memory'), so you won't get your full 1MB of usable RAM.

Now, you are allowed to go away and quietly beat your head against a wall! ☹



Are these some

of the judges

who judged

the judges

who judged

Steinlager

the best beer

in the world?



**Judge for yourself**

SWH&P SL2078B APB11797-A

**READER INFO No. 39**

# Computer News and New Products

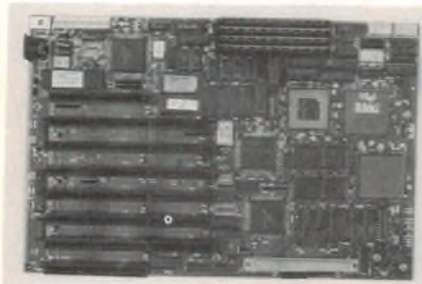

## 33MHz 80386 Motherboard

Electronic Solutions' high performance 33MHz 80386 based motherboard is a suitable platform for high speed file server and graphics workstation use. It will fit into any PC/XT or AT case.

Its features include: clock speed of 33MHz using an Intel 80386-33 with 80385 cache controller support; single board approach with 4MB DRAM and 32KB cache memory; phoenix BIOS; built-in disk caching and EMS driver; and 32-bit FastSlot expansion memory to 12MB, running at the same speed as on-board memory.

For further information, contact Electronic Solutions, PO Box 426, Gladesville 2111 or phone (02)906 6666.

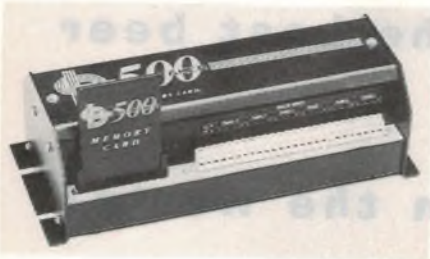

## Remote data logger

Data Electronics has released the Datataker 500 data logger, designed for long term local and unattended remote

data logging applications, including industrial, scientific, meteorological, environmental and pollution monitoring and research.

The Datataker 500 has 10 differential or 20 single ended analog input channels, which can be used in any mix. The analog to digital converter has 15 bit resolution (1uV), is auto-calibrating and auto-ranges over 3 decades.

It also has 4 TTL/CMOS compatible bidirectional digital channels. These can be used as inputs for state monitoring (bit and byte), low speed counting (10Hz, 16 bit, presettable), and to trigger scanning of any input channels on digital or counter events and condition of digital status.

The Datataker 500 is wholly designed and manufactured in Australia, and is backed by a 12 month full factory warranty.

For further information, contact Data Electronics, 46 Wadhurst Drive, Boronia 3155 or phone (03) 801 1277.

## Universal line isolator

Pascom has announced the release of its new telecom line isolator, code named REDBACK. The device provides manufacturers and end users alike with the ability to ensure their products meet with the relevant Telecom authority standards for connection to line, anywhere in the world.

The REDBACK passes all the current Austel standards for connection to line, including the recently revised insertion loss requirements and is believed to be the first of its kind in the world.

In its final form the device will have a footprint of about 2.7cm sq and stand about 1cm high. In this form the device will find application either as a stand-

alone device or as an integrated component, completely replacing conventional means of line isolation.

The REDBACK is the subject of a number of international patent applications.

For further information, contact Pascom, 5 Cochrane Street, Mitcham 3132 or phone (03) 874 2233.

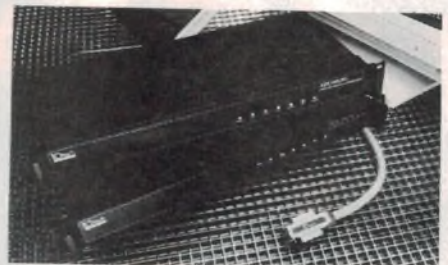

## New IEEE digitisers

US Company, IOtech has introduced two new high resolution IEEE-488 based digitisers which outperform board-level products and are strong price-performance alternatives to digital oscilloscopes and waveform digitisers. Both products provide 16-bit resolution with 100kHz maximum sample rates.

The ADC488/16 supports 16 single-ended or 8 differential analog channels; the ADC488/8S supports 8 differential analog inputs and features independent sample and hold circuits reducing inter-channel time skew to only 10ns.

Variable channel sequences are programmable, and 20 scan rates from 10us to 50s can be specified in 1-2-5-10 sequence. All analog circuitry is optically isolated from the digital control logic, the IEEE bus, and the AC power line by up to 250V common mode.

For further information, contact Scientific Devices, 2 Jacks Road, South Oakleigh 3167 or phone (03) 579 3622.

## A SHORT MESSAGE ABOUT THE ALLDATA RANGE OF HI-TECH QUALITY PRINTERS - FROM ONLY \$299

Complete range to suit your particular application. From high speed 9 pin, to 24 pin to multi head, draft/letter quality options and more.

**ALLDATA**

ALL DATA AUSTRALIA: 27 RHUR STREET DANDENONG VIC 3175. PH: (03) 794 5799 FAX: (03) 794 0668

READER INFO No. 24



ALL463-2AME



## IBM PC AT backplane

A new IBM PC AT multilayer backplane is available from Anitech BICC-VERO division. This four-layer backplane uses stripline construction, so minimising crosstalk and maximising protection against external radiated noise.

The 8-slot backplane is supplied with 6 PC AT and 2 PC XT connectors fitted. It also has decoupling capacitors for on-board supply voltages, a 5-way DIN connector for keyboard input, a 10-way header for keyboard output and a supply input connector.

Facilities for additional decoupling and pull-up resistors have been provided.

For further information, contact Anitech, 1-5 Carter Street, Lidcombe 2141 or phone (02) 648 4088.

## Windows-based waveform software

Users of Tektronix arbitrary waveform generators (AWGs), VXI digitisers, and 2400 series oscilloscopes now have the opportunity to create and modify waveforms in a Microsoft Windows based environment.

The new WaveWriter software is the first Windows-based waveform-generation software for AWGs and Tek oscilloscopes with the save-on-delta features. It runs on the IBM PC/AT or compatible computers. Because it operates in a Windows environment, it allows users to generate, edit, or import waveforms with speed and ease.

The new software supports the following Tektronix instruments: 5101/5501 Arbitrary Function Generators, VXI

VX5790 Arbitrary Waveform Generator and 2400 series Portable Oscilloscopes.

Once the user defines the target instrument, whether it be a waveform generator or oscilloscope, WaveWriter automatically sets input parameters such as record length and vertical resolution, saving the user considerable time and effort, and only allows creation of waveforms that can actually be generated by the target instrument.

For further information, contact Tektronix Australia, 80 Waterloo Road, North Ryde 2113 or phone (02) 888 7066.

## Australian genlock for computers

The Acre Industries' B1-01 Genlocker is designed to turn an Amiga or Atari personal computer into a highly versatile video production tool. Designed and manufactured in Australia, the B1-01 provides computer genlocking to any stable camera or VCR video source.

By using the B1-01 with the appropriate software it is possible to add a wide range of professional touches to video productions. They include 2D and 3D computer titles and graphics, as well as full animation sequencing. The computer can now be used as a video paint box with full colour palette to create spectacular animations for corporate presentations or educational demonstrations.

The main features of the B1-01 include: digital key to black or white; in-built background colour generator with infinite shading; inbuilt colour bar generator for accurate graphic and text alignment; vertical, horizontal and corner hardware wipe controls; and vertical interval switching on all key and wipe controls.

The B1-01 Genlocker also offers ten production test patterns, a seven segment LED display for quick pattern identification - all housed in a durable and attractive mild steel case with enamel baked surface.

For further information contact GEC Video Systems Division, 2 Giffnock Avenue, North Ryde 2113 or phone (02) 887 6222.

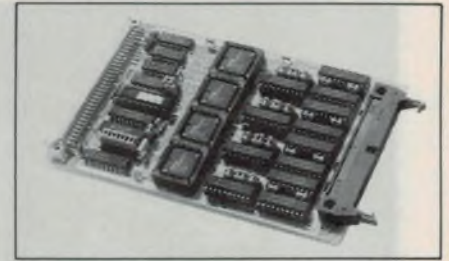

## High density STEbus I/O

Users of STEbus computer systems can now have 80 lines of buffered digital I/O on a single 3U Eurocard. Manufactured by DSP Design of London, the SP800 is just one of a growing range of cards for the IEEE1000 STEbus.

The high density capability is due to the use of the Zilog 8536 CIO chips. Each CIO has three 16-bit counter/timers, giving the design engineer a wide range of options on how to gain the maximum flexibility from the system.

Vectored and non-vectored interrupts are supported by the SP800 and comply fully with IEEE1000 STEbus specification.

For further information, contact DGE Systems, 103 Broadmeadow Road, Broadmeadow 2292 or phone (049) 69 4242.

## PC SOFTWARE 25,000 PROGRAMS

The best of the world's public domain software and shareware for IBM PC and compatible computers, catalogued into Australia's most comprehensive and up-to-date collection.

Membership \$45 pa includes:

- Monthly updates & member's program reviews.
- \$5 per disk (5.25" format) \$6 mail order.
- 200 page catalogue.

**Also 500  
Mac  
Disk  
Library**

Open Mon-Thurs 9-5, Fri 9-9, Sat 9-1.

**SME**  
PUBLIC DOMAIN

22 QUEEN STREET,  
MITCHAM VIC. 3132  
TEL: (03) 874 3666.  
FAX: (03) 873 4086

SME/EA/8-90



### A SHORT MESSAGE ABOUT TOP PERFORMING ARROW COMPUTERS RANGE - FROM ONLY \$790.00

At last a powerful executive range of quality computers ranging from XT, to AT and the super fast 386 models at prices to knock you off your feet.

**ALLDATA**

**ARROW**

ALL DATA AUSTRALIA: 27 RHUR STREET DANDENONG VIC 3175. PH: (03) 794 5799 FAX: (03) 794 0668

ALL483-3AME

**READER INFO No. 25**

# IEEE-Z

Our Personal488™ IEEE (GPIB) interfaces for PC/AT/386 & PS/2s are packed with these easy-to-use features:

- DOS device driver loads at power-on
- Hewlett-Packard style commands
- Automatic error indication
- BASIC ON SRQ GOSUB capability
- DMA transfers over 300K bytes/s
- Up to four IEEE boards/computer
- NEC-7210 compatible software
- Serial/Parallel/IEEE port redirection
- DMA and interrupt channel sharing
- Compatible with popular languages (no extras to buy), including BASICA, GWBASIC, Quick BASIC, Compiled BASIC, Turbo BASIC, True BASIC, TBASIC, Turbo Pascal, Microsoft Pascal, Turbo C, Microsoft C, Aztec C, Lattice C, Microsoft Fortran, Lotus 1-2-3/Symphony/Measure, ASYST, DADISP, Test Windows, AutoCAD, and many more.

LOtech



SCIENTIFIC DEVICES AUSTRALIA PTY. LTD.

Melbourne (03) 579 3622  
 Fax (03) 579 0971  
 Sydney: (02) 344 5200  
 Fax (02) 349 2602  
 Adelaide (08) 281 3788  
 Fax (08) 281 4194

READER INFO No. 27

## COMPUTER NEWS & NEW PRODUCTS

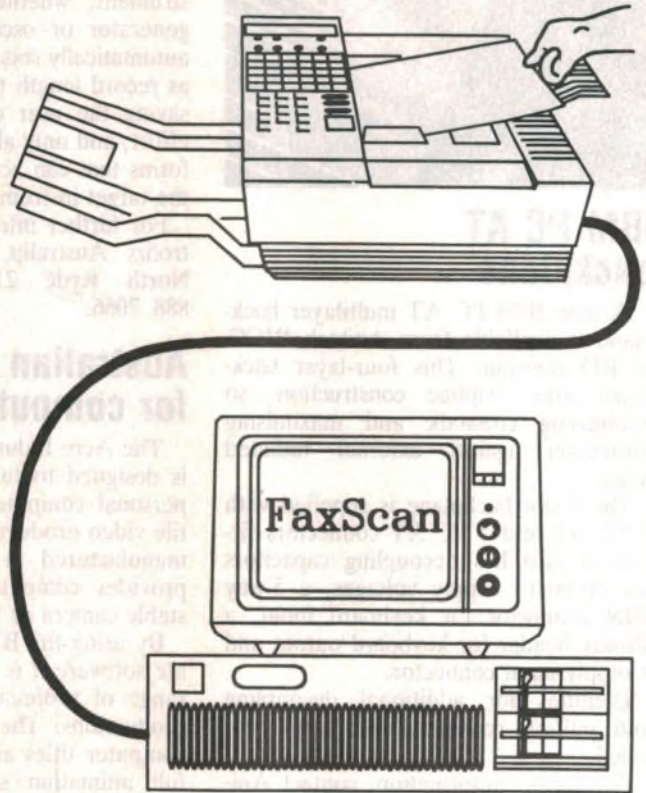

### ELECTRONIC CAD

#### PROTEL

- EASYTRAX, LOW COST PCB \$260
- AUTOTRAX, PCB WITH SMD \$1290
- SCHEMATIC, WITH PCB INTERFACE \$890
- TRAXSTAR CALL
- TRAXVIEW CALL
- EVALUATION PACKAGES CALL

#### OrCAD

- OrCAD/SDT III, SCHEMATIC/CAPTURE CAD \$950
- OrCAD/VST, DIGITAL LOGIC SIMULATOR \$1800
- OrCAD/PCB, PCB WITH SMD \$2600
- OrCAD/MOD, PLD SIMULATION MODELING \$950
- OrCAD/PLD, PROGRAMMABLE LOGIC DESIGN \$950

#### PSPICE

- ANALOG CIRCUIT SIMULATION \$1200
- DELUXE DOS VERSION, WITH OPTIONS \$3000
- DELUXE VERSION FOR OS/2 \$4600
- DELUXE VERSION FOR OS/2 INCLUDING NEW DIGITAL LOGIC SIMULATION \$6000
- DIGITAL FILE OPTION FOR DOS VERSION \$450
- ALSO AVAILABLE FOR MAC, NEC, DEC, SUN & APOLLO CALL

#### SPECTRUM

- MICRO-CAP III, ELECTRONIC CIRCUIT ANALYSIS \$2150
- MICRO-LOGIC II, ELECTRONIC DRAFTING & SIMULATION \$1450



Technical Imports Australia  
 P.O. Box 927 Crows Nest 2065  
 Tel: (02) 954 0248 Fax: (02) 925 0311



## Computer scan from fax

Designed and manufactured in Australia by Advanced Solutions, Faxscan is an interface between certain models of fax machines and a PC, turning the fax machine into a full page scanner.

Applicable fax machines come fitted with an RS-232 serial connector, and have in-built communications firmware to download scanned data. The initial Faxscan (Model 0) suits Okifax models OF-10, 17, 23, 27, 38 and 110.

Faxscan scans a full page (up to A3 size on some fax machines) in a single, machine-controlled pass without any alignment or distortion problems at all resolutions available on the fax machine and handles photos as well. It produces 'industry-standard' TIFF files, accepted by all good desk-top publishing, good 'draw' and 'paint' programs.

Faxscan also works with low-cost OCR programs (not included with the package) to produce standard (ASCII) text from scanned documents, for use in a word processor.

While connected to the computer, the fax machine still performs its normal send/receive/copy functions.

For further information, contact Advanced Solutions, 47 Karril Avenue, Beecroft 2119 or phone (02) 872 1981.



## Intelligent disk head cleaner

Headmax can be an intelligent cleaning disk for the office, or a complete diagnostic tool for the repairman. When a cleaning cycle is initiated from the on-screen menu, the signal level is measured automatically from the calibration information on the disk. The heads are then placed over the cleaning material on the same disk and vibrated in a lateral manner.

The Headmax interfaces directly with the floppy controller chip to produce this extremely efficient cleaning movement. After this, the heads are then placed over the calibration area. If there has been an improvement in amplitude then the cycle is repeated. If there is no significant improvement then the cycle is stopped, so it is impossible to damage the heads!

## Protect Your Computer & Office Equipment from POWER SURGE with COMPUTER PROTECTOR

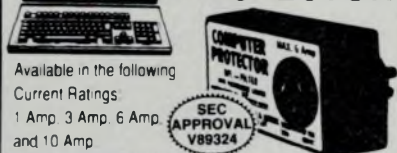

Available in the following Current Ratings:  
1 Amp, 3 Amp, 6 Amp, and 10 Amp

SEC APPROVAL V89324



WESTINGHOUSE  
BRAKE & SIGNAL COMPANY  
AUSTRALIA LIMITED  
PHONE (03) 397 1033  
FAX (03) 397 1861

READER INFO No. 30

The professional user can utilise the calibration data direct and using solely Headmax, a rapid functional test can be performed and printed. This makes it useful for diagnostics and inspection.

For further information contact Westinghouse Brake & Signal, 80-86 Douglas Parade, Williamstown 3016 or phone (03) 397 1033.

## VersaCAD Professional CAD for the Macintosh

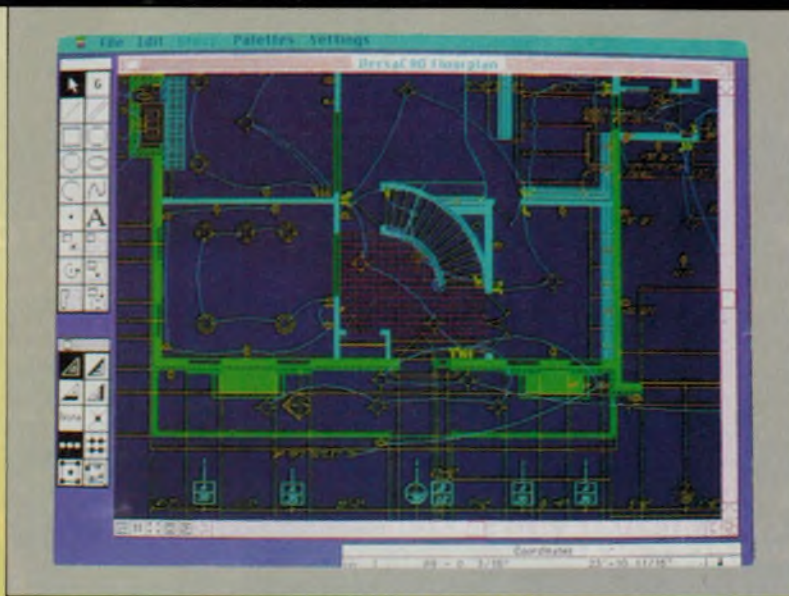

Contact: Prime Personal CAD Business Unit  
Phone: (02) 968 9251

# The Power! The Performance!



**BRISTOL**  
RESEARCH

Bristol Research from Alldata Australia. Powerful 386 Series compatibles that raise the benchmark in standards for Australian computer technology.

The speed, the power, the economy. Bristol computers are Australian built to meet industry's most demanding performance requirements regardless of application - be it CAD/CAM/CAE, Desktop Publishing, or Office management - in single or multi user situations.

Bristol Research — powerful performance, competitive in price.

## **BRISTOL 386SX**

16 Mhz (19.6 Mhz Landmark) desktop series, 2 Meg RAM, 0 Wait, high speed RAM interleave technology, configurable to suit your floppy and hard disk requirements, with tactile response feedback 101 key enhanced keyboard

## **BRISTOL 386/25**

25 Mhz (43.5 Mhz Landmark) tower series, 4 Meg RAM, 0 Wait, high speed RAM interleave technology, configurable to suit your floppy and hard disk requirements, with tactile response feedback 101 key enhanced keyboard.

## **BRISTOL 386/33**

33 Mhz (59.2 Mhz Landmark) tower series, 4 Meg RAM, 0 Wait, high speed RAM interleave technology, configurable to suit your floppy and hard disk requirements, with tactile response feedback 101 key enhanced keyboard

**FOR MORE INFORMATION ON THE POWERFUL  
BRISTOL 386 SERIES CALL ALLDATA AUSTRALIA  
FOR YOUR NEAREST DEALER**

Manufactured and Distributed in Australia by:

**ALLDATA**

27 RHUR STREET, DANDENONG, VIC. 3175  
PHONE: (03) 794 5799 FAX: (03) 794 0668

CALL FOR YOUR NEAREST DEALER. DEALER ENQUIRIES WELCOME

READER INFO No. 31



ALL483-1AME

# The *Printed Word* has never looked so good!

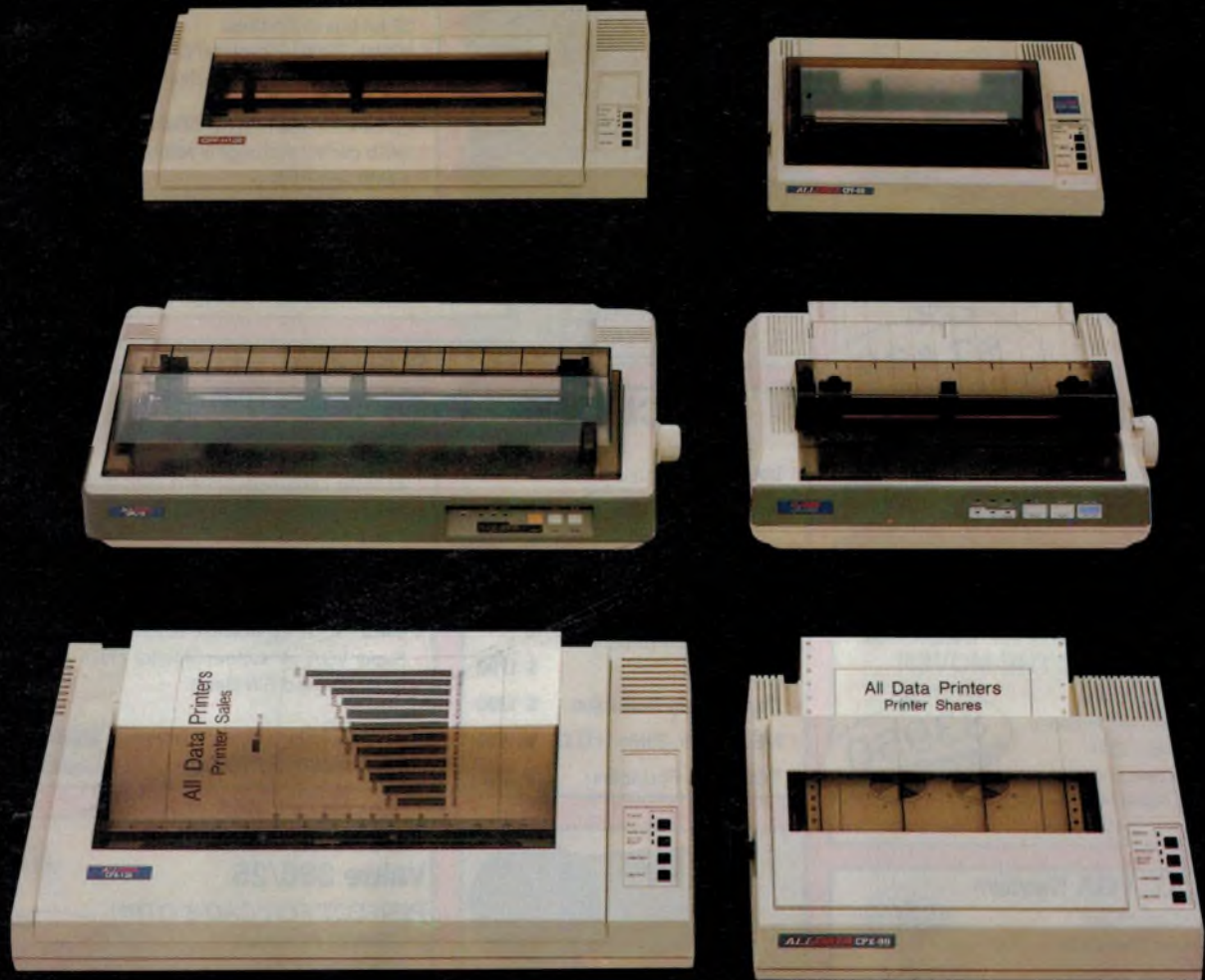

In true Alldata tradition, here is a top quality line up of some of the finest printers available. Alldata printers are built to a standard, not just a price. Yet it's comforting to know they're also probably the most attractively priced as well.

Whatever your needs, there's a quality Alldata printer to suit. Whether it's the budget priced CPF series, the advanced CPL series or even the multi head line printing CPX series, 10", 15", 9 or 24 pin, you'll find they're all meticulously designed for precise and impressive performance.

Before making a decision on your next printer, make sure you check the Alldata range on performance and price - we know you'll be pleasantly surprised.

**ALLDATA**

ALL DATA AUSTRALIA PTY. LTD.  
27 RHUR STREET, DANDENONG VIC. 3175  
PHONE: (03) 794 6714 FAX: (03) 794 0668

CALL FOR YOUR NEAREST DEALER. DEALER ENQUIRIES WELCOME.

READER INFO No. 32

RETURN COUPON NOW FOR SPECIAL INTRODUCTORY OFFER!  
PLEASE RUSH ME DETAILS ON THE RANGE OF ALLDATA PRINTERS!  
NAME \_\_\_\_\_ ADDRESS \_\_\_\_\_  
PHONE \_\_\_\_\_ P/CODE \_\_\_\_\_

ALL451M

"FOR INDEPENDENT ADVICE ON AUSTRALIA'S  
BEST VALUE PC'S, PRINTERS AND SOFTWARE"

**CALL (03) 525 2622**  
**FAX (03) 525 2940**

618 ST. KILDA ROAD, MELBOURNE  
3004



**CAPITAL**  
COMPUTER  
EQUIPMENT

**NOW**  
**TOLL FREE**  
**AUSTRALIA WIDE**  
**008 335833**



**MAJOR CARDS WELCOME**

**Blinding Speed 59.2Mhz LANDMARK  
386/33 System with disk caching and**

- ★ 80386/33 Processor
- ★ 33Mhz Zero Wait State
- ★ 32 bit bus (8 i/o slots)
- ★ 105Mb ESDI Voicecoil H.D.D.
- ★ 4Mb RAM (8ons) Upgradable to 16Mb
- ★ Super VGA, 16 Bit Card (1024 x 768 res.) 512Kb DRAM
- ★ 64Kb cache; thoroughly reliable
- ★ 1.2Mb 5/25" F.D.D.
- ★ Super VGA 14" Colour Monitor (1024 x 786 res.)
- ★ DOS 4.01 and GW Basic

Only  
**\$9,990**  
SAVE \$5,900

**18 Months Warranty**



**SUPERFAST 43.5Mhz LANDMARK  
386/25 SYSTEM**

- ★ 43.5Mhz Landmark (25Mhz Zero Wait State)
- ★ 150Mb ESDI Voicecoil H.D.D.
- ★ 1.2Mb 5.25" F.D.D.
- ★ 4Mb RAM (8ons) to 16Mb
- ★ Super VGA, 16 Bit Card (1024 x 786 res.) 512Kb DRAM
- ★ 64Kb cache, expandable to 256Kb
- ★ Super VGA 14" Colour Monitor (1024 x 786 res.)
- ★ DOS 4.01 and GW Basic

Only  
**\$7990**  
SAVE \$2300

**18 Months Warranty**



**Australia's Best  
Value 386/25**

**PERFECT FOR CAD & DTP!!!**

- ★ 80386/25 Processor
- ★ 4Mb RAM (8ons)
- ★ 25Mhz Zero Wait State
- ★ 64Mb Voicecoil H.D.D.
- ★ Super VGA Card, 16 Bit (1024 x 786 res.) 512Kb DRAM
- ★ 14" VGA Colour Monitor (1024 x 786 res.)
- ★ DOS 4.01 GW Basic

Only  
**\$4990**  
SAVE \$1400

**BULLETIN  
BOARD**

**WORLD'S FASTEST VGA BOARD!**  
**THE NEW ATI VGA WONDER-BOARD**

- ★ High Speed. Perfect for 286 & 386
- ★ 132 Column Text Available
- ★ 100% Register Compatible in ALL MODELS! VGA, EGA, CGA, MDA, Hercules and 8514/A
- ★ 256Kb and 512Kb Versions

From  
**\$590**

**PLUS MORE!!!**

**READER INFO No. 13**

**NEC MultiSync 3D**

- ★ 14" screen
- ★ 0.28 dot pitch
- ★ 1024 x 768 res
- ★ Analog & TTL

Only  
**\$975**

**WORLD'S FIRST RENARD**  
Your business cunning

**BATTERY POWERED 20Mhz 386 LAPTOP**

- ★ 40Mb Voicecoil H.D.D.
- ★ Battery/mains power
- ★ 20Mhz 80386 CPU
- ★ 2Mb of RAM (upto 8Mb)
- ★ 3.5" 1.44Mb F.D.D.
- ★ VGA Card (640 x 480 res)
- ★ Detachable keyboard
- ★ 5.25" 1.2Mb F.D.D.

Only  
**\$7,490**  
120Mb \$8290

CALL for full Renard range

**"LAP V"** CHENDAI  
YOUR BUSINESS CUNNING

**THE FULLY BLOWN AT DESKTOP  
FOR PEOPLE ON THE MOVE!!!**

- ★ 80286/12 Processor
- ★ EGA Screen resolution
- ★ 5.25" 1.2Mb F.D.D.
- ★ 2 Full length expansion slots
- ★ 30, 48 or 60Mb Hard Disk Drives
- ★ DOS O/S and Carry Bag

Only  
**\$3950**  
TAX INC.

**Arrow AT, VGA System**

- ★ 80286/12 processor
- ★ 20Mb Hard Disk Drive
- ★ VGA Card and Monitor
- ★ 1.2Mb 5.25" F.D.D.
- ★ 1Mb RAM (8ons)
- ★ 12 Months Warranty

Includes Tax  
**\$2490**  
AND MUCH MORE!!!

**ARROW 386/SX**

- ★ 80386 SX/16 Processor
- ★ 40Mb Voicecoil Hard Disk Drive
- ★ Super VGA Card (1024 x 768 res.)
- ★ Super VGA 14" Colour Monitor
- ★ 0.28 Dot Pitch (1024 x 768 res.)
- ★ 18 Months Warranty!!!

**386 PERFORMANCE AT 286 PRICE!!!**

Only  
**\$3590**  
TAX INC.

**ULTRA AT 286 PLUS, 16Mhz**

- ★ 2 Year Warranty
- ★ EGA Card & Monitor
- ★ 40Mb Hard Disk Drive
- ★ LOTUS & DBASE 4 included!!!

Only  
**\$3690**  
SAVE \$1600



CALL FOR YOUR PERSONAL CONFIGURATION

**SPECIALS!!!**

- ★ Lotus 123 \$ CALL
- ★ 80Mb HardCard \$ 1490
- ★ Epson LX400 \$ 345
- ★ Bondwell Mouse with Dr. Halo \$ 95
- ★ Fax/Copier/Printer 3-in-One!!! \$ 1790
- ★ Dual Floppy Portables \$ 1390
- ★ NEC 40Mb, 20Ms H.D.D. \$ 599
- ★ TOSHIBA Portables \$ CALL



CALL FOR YOUR PERSONAL CONFIGURATION

**Super VGA Monitors**

- ★ 14" Screen
- ★ 0.28 Dot pitch
- ★ 1024 x 768 resolution
- ★ 12 Months Warranty

**SUPERB VALUE**

Only  
**\$690**

**CORPORATES: FAX OUR "QUICK QUOTE" SERVICE FOR ALL YOUR PC REQUIREMENTS.  
GOVERNMENT DEPARTMENTS: PLEASE CALL OR FAX FOR ALL GOVERNMENT PRICES.**

# THE 'BLUE STREAK' RISC COMPUTER CARD



ELECTRONICS  
E T I - 1 6 3 0

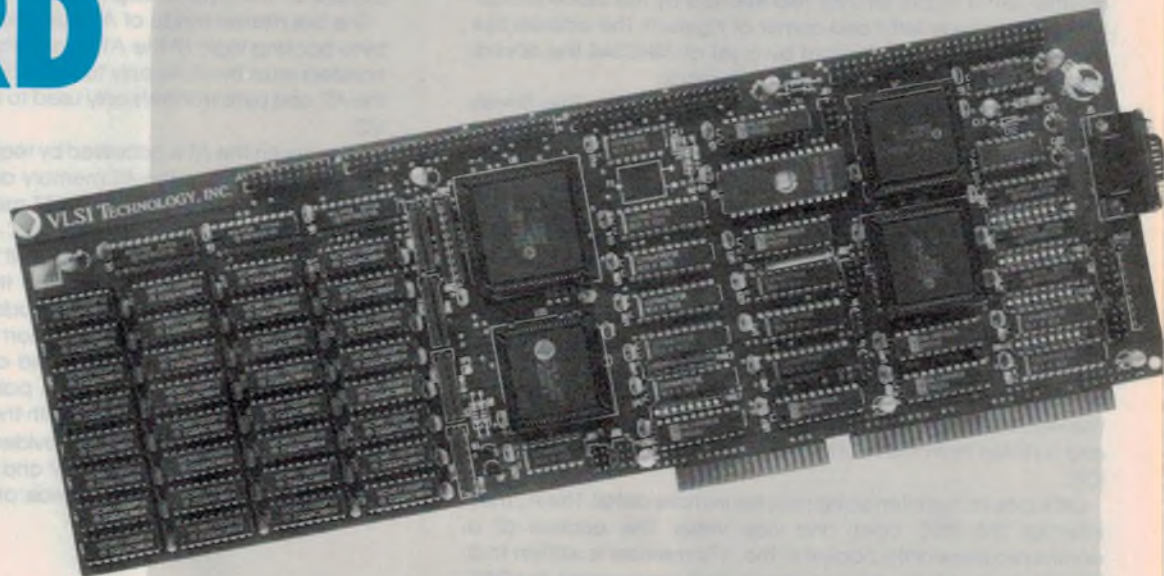

*The Blue Streak RISC board. Its features are detailed in the text.*

**In the second part of our exploration of RISC technology, Roger Harrison gives an overview of the card's design, highlights of the circuit and constructional details. This will be followed in the concluding part, next issue, by firing-up your card.**

**T**he Blue Streak project is housed on a full-length AT card – just – as is apparent from the photograph. The card uses the PC/AT as a terminal, also deriving its power from the AT's bus. The Blue Streak has been designed around the VL86C010 RISC processor, VL86C110 memory controller and VL86C410 input/output (I/O) controller. A video controller is not used in the system, to keep the cost and complexity down; all that is handled by the PC/AT. The basic memory configuration is 1M, using 256 Kbit DRAMs, the minimum recommended, 4M can be installed instead, using 1 Mbit DRAMs. Dual-footprint 16/18-pin sockets accommodate either DRAM type.

An expansion bus is provided by a 96-pin DIN connector on-board. This allows the attachment of external hardware for prototype development. An RS232C port allows down-loading of code to other systems.

Provision has been made on-board for an SCSI interface, but implementation of this is optional and not supported by software provided with the Blue Streak. The controller chip for this interface is not included in kits or built-up units unless ordered.

A row of four LEDs at the top rear of the board provides a diagnostic display. A fifth LED nearby indicates interface activity. The push-button in the top right hand corner of the board is the

RISC system reset switch.

Two floppy disks are provided with the Blue Streak RISC card. One contains a demonstration routine plus a monitor. The other contains 'CASM' – a compiling assembler, about which I will have more to say later.

## **The system up close**

Figure 9 shows the general system diagram of the project. It is easier to get an idea of its structure and features from this diagram than from poring over the circuits. The heart of the system is the 86C110 memory manager (MEMC) (on the left of Figure 9) and not the 86C010 RISC processor (CPU) on the MEMC's left, as explained in Part 1. To the right of the MEMC is the memory subsystem, which comprises a minimum 1M of 32-bit DRAMs. An on-board jumper selects which memory set is installed. The memory is arranged in four planes of eight DRAMs per plane.

A boot ROM is included, access to which is managed by the MEMC. This ROM can be either 128K, 256K or 512K size (jumper selected). On the right of Figure 9, you'll see the 86C410 input/output controller (IOC).

The Blue Streak card performs as a bus master on the PC/AT's expansion bus. This gives the card direct access to the AT's

## RISC computer card

memory and I/O space. For communications between the Blue Streak and the AT, a simple 'mail box' register is used to indicate the need for a transaction. The VL86C010 CPU accesses the PC bus under programmed I/O to simulate a high-speed direct memory access (DMA) channel.

Down the centre of Figure 9 are sets of 74HC573 tri-state D-type latches. One set, at the bottom, sits between the upper and lower bytes of the AT's data bus and the CPU's data bus, isolating the two. The upper set isolates the CPU's and the IOC's data buses.

The CPU's address bus is interfaced to the rest of the circuit via another set of HC573 latches, represented by the 'ADDR LATCH' block in the lower left-hand corner of Figure 9. The address bus interface to the AT is effected by a set of 74HC244 line drivers, seen to the right of the address latch block.

The IOC manages communications between the Blue Streak RISC card and the PC/AT, as mentioned above, in conjunction with a number of PALs which are part of the 'glue' logic. These PALs look after AT port decoding, data bus contentions, timing, address space qualification and so on. A 74HC574 tri-state octal D-type flip-flop (seen immediately below the IOC in Figure 9) serves as an interface control register and LED display driver. The IOC sets the HC574 when it wants to take control of the AT.

Of the five LEDs on board, four provide a user-programmable display and the fifth shows interface activity. The four-LED display is provided as a convenience in the initial debugging of system-mode programs. These LEDs are turned on by appropriate bits in the RISC's bus control I/O port. The fifth LED is labelled BUS BUSY and is driven from the PC-DACK\ line, CO output of the 86C410 IOC.

Let's look at the interfacing process in more detail. The AT may interrupt the RISC card, and vice versa. The address of a communications data packet in the AT's memory is written to a 16-bit slave port in the AT's I/O space. Upon an interrupt, the RISC card reads the packet from the AT's memory and interprets it. The RISC card may read and write AT memory, but the AT may only write to that slave port in the card.

To the PC/AT, the RISC card is located at a specific port address, which can be jumper selected (JB9 jumper block, see the circuit and component overlay). Selecting the appropriate pin pair with a jumper selects a given address, as shown in Figure 10.

The card acts as a bus master on the AT system bus and takes over the AT's bus during transfers between the RISC card and the AT's memory or I/O areas. Both word- and byte-mode transfers

are supported by the card.

This bus master mode is a similar operation to DMA. The RISC supplies the address and reads or writes the data. It gives up control of the bus at 10 microsecond intervals to allow the AT to refresh its memory. This interval is a transaction limit controlled by the firmware aboard the RISC card.

In a word-mode access to the AT's memory, a transfer of 16 bits to or from a RISC register and the AT takes place. In a byte-mode access, a single byte is transferred between the lowest byte of a RISC register and the AT. On reads from the AT, the RISC will barrel-shift the byte to align it properly in the register.

The bus master mode of AT operation disables the automatic byte-backing logic of the AT's backplane. Because of this, word transfers must be done only to word-oriented memory or I/O on the AT, and byte transfers only used to byte-oriented memory or I/O.

Memory on the AT is accessed by requesting control of the bus, reading or writing to the AT memory and then giving up control of the bus. The lowest 1M of PC/AT memory is mapped into an otherwise unused upper area of RISC memory.

It should come as no surprise that I/O ports in the AT are accessed in an identical manner to the memory accesses just described; except that a different addressing range is used by the RISC; the AT has a 10-bit I/O port addressing range.

The RS232C serial port, mentioned above as one of the Blue Streak card's features, provides a pair of standard handshake control lines (RTS and CTS) along with the usual XMT (transmit) and RCV (receive) lines. A MAX231 provides full-standard RS232 level interfacing between the +3-25 V and -3-25 V RS232 line signal excursions and the 5 V/0 V signals of the IOC.

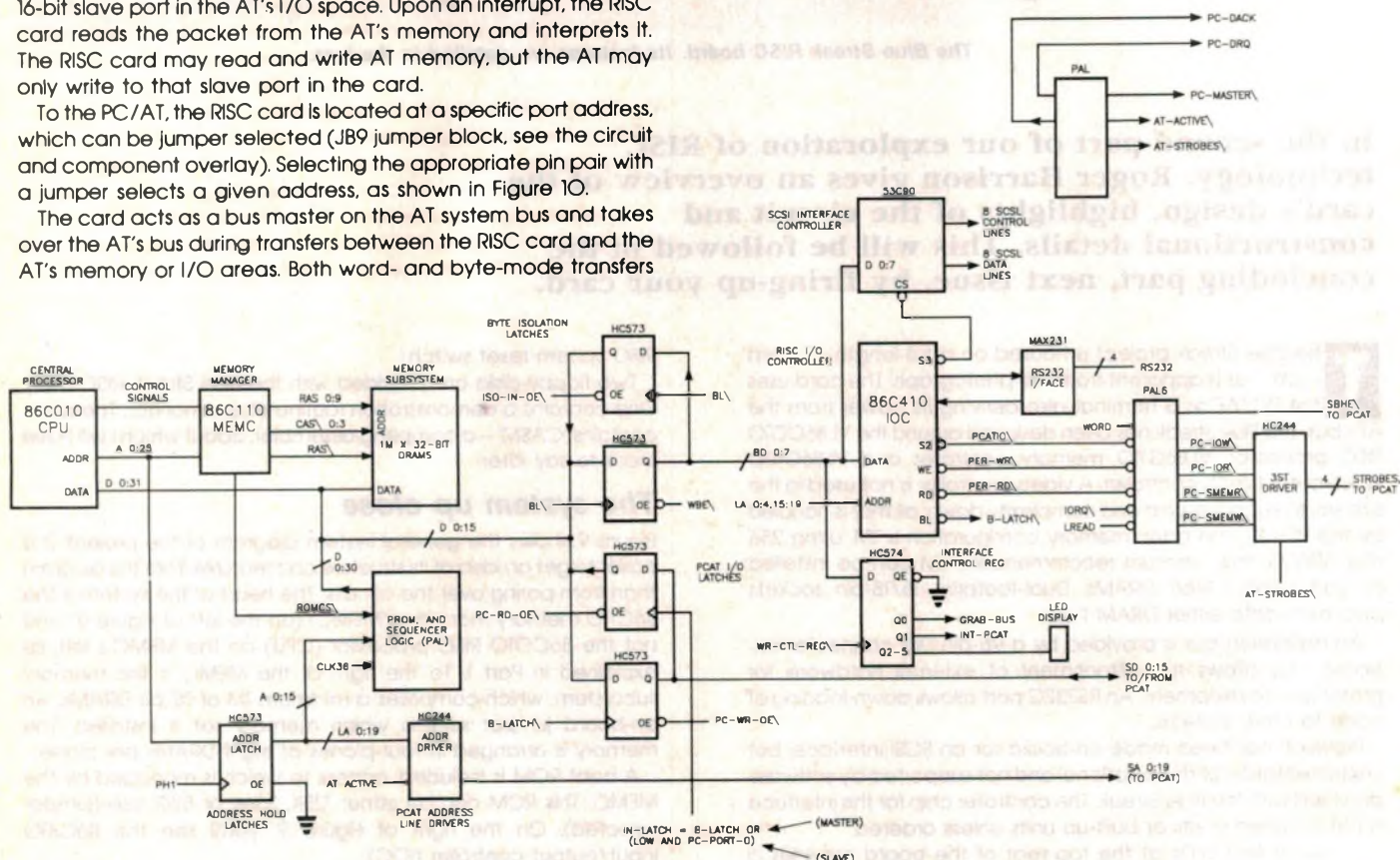

Figure 9. Showing the general system diagram of the project.



## RISC computer card

or restrict. The high level of control within CASM macros removes macro usage from the simple realm of statement expansion into the realm of compiled code generation.

### Construction

In the photograph, you can see that the left-hand third of the board is taken up by the 32 DRAM chips. Immediately to the right, you can see the 68-pin MEMC (VL86C110) and CPU (VL86CO10) ICs. These devices are in plastic, leaded chip carrier, or PLCC packages. Located in the top centre area of the board, beneath the 96-pin expansion bus socket, is the boot ROM, and to its right, the 24 MHz clock crystal.

On the right-hand end of the board, you can see another 68-pin PLCC chip. This is the VL86C410 IOC. Just to its right and immediately below the 9-pin D-sub serial port socket is the MAX231 serial interface chip. Above the IOC is the location for the SCSI controller. The other chips on board comprise the interface and glue logic. Note that all the ICs are socketed.

The four-LED display is located to the right of the 96-pin DIN

socket; below and to the right is the fifth LED, the bus interface indicator.

The pc board is a 6-layer type. The component overlay here (Figure 12; see page 91) shows only one of the track layers for the sake of clarity. The component side of the board is silk-screened which makes for ease of component location during assembly. Study this before you start assembling the board, to familiarise yourself with the positions of at least the major components.

You will need a fine-tipped, temperature controlled soldering iron and thin (22g) gauge resin-cored solder. Work methodically, in a pattern, and you're less likely to make errors or omissions.

You could proceed from the top left-hand corner of the board, working across and down - just as you read a page in a magazine.

Your first step is to solder all the passive components to the board. Set them well down on the board and check the orientation of polarised components, such as the SIP resistors and tantalum capacitors, before soldering. A hint here - you'll find it easier to leave all the 100n (0.1u) monolithic ceramic bypass capacitors till last in this stage.

### PARTS LIST ETI-1630 BLUE STREAK RISC CARD

#### Semiconductors

CR1, CR2	1N914
LED1-LED5	3 mm red LEDs, T1 case
Q1, Q2	2N4126
U1, U2, U3	74HC574
U4-7, U13-16, U20-23, U27-30, U35-38, U44-47 U53-56, U62-65	P21256-10 256K/100 ns DRAMs, or MCM511000PIO 1M/100 ns DRAMs
U8	VL86CO10
U9	27256
U10	74HCO4N
U11	53C90 (optional)
U12	74F74
U17	74HCT573
U18	PAL16R4BCN
U19	74HC574
U24	74HCT573
U25	PAL16L8BCNS
U26	74HCT573
U31	74HCT573
U32	PAL16L8BCNS
U33	74HCT573
U34	VL86C410
U39	VL86C110
U40	PAL16RP4ACN
U41	PAL16L8BCNS
U42	not used
U43	MAX231
U48, U49	not used
U50	74HCT244
U51	PAL18P8BPC
U57, U58	not used
U59, U60	74HCT244
U61	PAL16L8BCNS
U66	74HCO4

#### Resistors

	all 1/4 W, 5% unless noted
R1-R3	not used

R4	100k
R5	220R
R6	22R
R7	100k
R8, R9	330R
R10, R11	4k7
RN1	220R x 7 SIP
RN2, RN3	470R x 4 SIP
RN4	4k7 x 7 SIP
RN5, RN6	470R x 4 SIP
RN7	4k7 x 9 SIP
RN8	680R x 4 SIP
RN9, RN10	470R x 4 SIP
RN11	4k7 x 9 SIP
RN12	2k2 x 7 SIP
RN13, 14, 15	680R x 4 SIP
RN16	2k2 x 9 SIP
RN17, RN18	470R x 4 SIP
RN19, RN20	680R x 4 SIP

#### Capacitors

C1, 5, 7, 8, 24, 80, 81	15u/10 V tant.
C22	15p ceramic
C43	10u/10 V ceramic
The rest	68 x 100n monolithic ceramic

#### Miscellaneous

Y1.....24 MHz HC36/U crystal  
pc board; pc-mount momentary action pushbutton switch;  
PC/AT card slot bracket with 9-pin D cutout; 32 x 16/18-pin  
dual-footprint IC sockets; 4 x 14-pin DIP sockets; 23 x 20-pin  
DIP sockets; 1 x 28-pin DIP socket; 3 x 68-pin PLCC sockets; 1  
x 84-pin PLCC socket; 29 x DIP header pairs (jumpers);  
jumper clips; 1 x 50-way DIP header (optional, for SCSI  
interface); 1 x 96-pin DIN socket; 9-pin D-sub male connector,  
right-angle pc-mount type; nuts and bolts to suit D-sub.

Short-form kits comprising the pc board plus EPROM, CPU,  
MEMC and IOC chips and 24 MHz crystal, or fully built units,  
are obtainable from Energy Control International, 26 Boron St,  
Sumner Park Qld 4074. ☎ (07)376-2955.



**FUNCTIONAL PIN DIAGRAM**

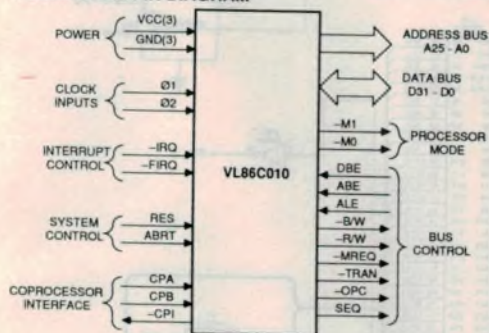

**PIN DIAGRAM  
PLASTIC LEADED CHIP CARRIER (PLCC)**

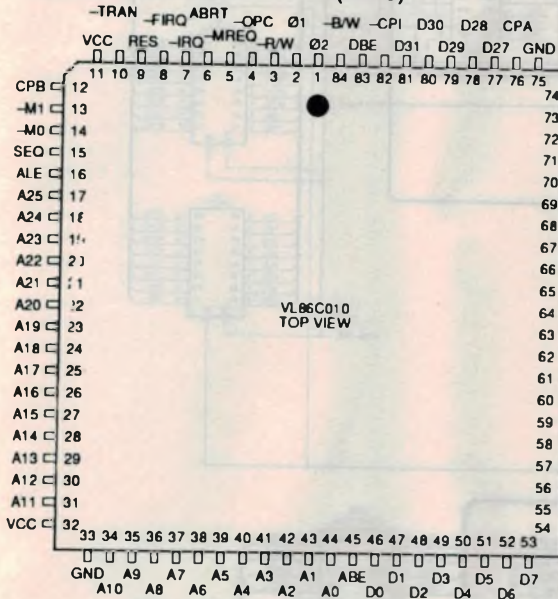

VL86C010  
TOP VIEW

**SIGNAL DESCRIPTIONS**

Signal Name	Pin Number	Signal Description															
Ø1, Ø2	2, 1	Processor Clock Ø1 and Ø2 Inputs - These two inputs provide the clock to the processor. In order to minimize clock skew, these inputs are not buffered internally and therefore must swing monotonically between GND and VCC without overshoot. The clocks must be non-overlapping and should be driven directly by 74HCXX outputs. A typical circuit is shown on the following page. The VL86C110 (MEMC) will normally drive these inputs directly.															
-IRQ	7	Interrupt Request Input - This is the normal interrupt request pin. It may be asserted asynchronously to cause the processor to be interrupted. It is active low.															
-FIRQ	8	Fast Interrupt Request Input - This interrupt request line has a higher priority than IRQ, but otherwise is the same. It too is active low.															
RES	9	Reset Input - This is the reset signal for the processor. While active, the processor executes no-ops (with -MREQ and SEQ both held active) until the RES signal goes inactive, from which point execution starts at the reset exception vector location. This signal is active high.															
ABRT	6	Abort Input - The signal can be used to abort the current bus cycle being executed by the processor. Typically, it is connected to a memory management unit, such as the VL86C110, to control accesses for protection purposes. The abort signal is active high and requires a two clock minimum pulse to insure the reset operation will occur.															
D31 - D0	81 - 77, 74 - 56, 46 - 53	Data31 - Data0 - This is the 32 bit bidirectional data bus used to transfer data to and from the memory. These lines are tri-state and active high.															
DBE	83	Data Bus Enable Input - This is the asynchronous tri-state control signal for controlling the drivers of the data bus. When asserted the data bus is enabled and when low the data bus drivers are forced into the high impedance state. During read operations the bus drivers are in the high impedance state as well. This signal is active high. Systems that do not require the data bus for DMA or similar activities may tie this signal high.															
-B/W	84	Not Byte / Word Output - This pipeline (note 1) signal indicates to the memory system that the current memory cycle is a byte rather than a word operation. It is asserted (low) the last portion of the cycle preceding the byte operation. When asserted (low) the memory system should deal with bytes by decoding the A1, A0 address lines. It is active low.															
-M1, -M0	13, 14	Mode 1,0 Outputs - These two signals are used to indicate the current operating mode of the processor. They can be used as address space modifiers to increase the address space, or to assist a memory management unit in offering various protection modes. The lines are active low and the inverse of bits 1, 0 of the processor status register.  <table border="1" style="margin-left: 20px;"> <tr> <td>-M1</td> <td>-M0</td> <td>MODE</td> </tr> <tr> <td>0</td> <td>0</td> <td>Supervisor</td> </tr> <tr> <td>0</td> <td>1</td> <td>IRQ</td> </tr> <tr> <td>1</td> <td>0</td> <td>FIRQ</td> </tr> <tr> <td>1</td> <td>1</td> <td>USER</td> </tr> </table>	-M1	-M0	MODE	0	0	Supervisor	0	1	IRQ	1	0	FIRQ	1	1	USER
-M1	-M0	MODE															
0	0	Supervisor															
0	1	IRQ															
1	0	FIRQ															
1	1	USER															
A25 - A0	17 - 31, 34 - 44	Address 25 - Address 0 Outputs - These are the 26 address lines. A1 and A0 are byte addresses and should be ignored except during byte memory cycles. During word transfers, the current mode value appears on these signals. The address lines are tri-state and active high.															
ABE	45	Address Bus Enable Input - This is the asynchronous three-state control signal for controlling the drivers of the address bus. When asserted the address bus is enabled. The signal is active high.															
ALE	16	Address Latch Enable Input - This signal is used to control internal transparent latches on the address outputs. When ALE is high the address outputs change during Ø2 to the value required for the next cycle. Direct interfacing to ROMs requires address lines to be stable until the end of Ø2. Holding ALE low until the end of Ø2 will latch the address outputs for ROM cycles. Systems that do not directly interface to ROMs may tie ALE high.															
<b>Note:</b>																	
1. Pipeline signals are asserted during the last portion of the cycle preceding the cycle for which they will be used.																	
-R/W	3	Not Read/Write Output - This is the read / write signal from the processor. When asserted (low), it indicates that the processor is performing a read operation. When negated (high), the processor is performing a write operation. This signal is a pipeline (note 2) signal and is active low.															
-MREQ	5	Next Memory Cycle Start Output - This is an pipeline (note 2) indicator that is asserted before the processor will start a memory cycle during the next clock phase. This signal is active low. During the reset condition this signal is held active as the processor executes no-ops.															
-TRAN	10	Translate Enable Output - This signal, when asserted by the processor tells a memory management unit that translation should be done on the current address. When negated, it indicates that the address should pass through untranslated. This signal is active-low.															
-OPC	4	Instruction Fetch Output - This pipeline (note 2) signal when asserted indicates that the current bus cycle is an instruction fetch. This signal is active-low.															
SEQ	15	Next Address Sequential Output - This pipeline (note 2) signal is asserted when the processor will generate a sequential address during the next memory cycle. It may be used to control fast memory access modes. This signal is active-high. During the reset condition this signal is held active as the processor executes no-ops.															
-CPI	82	Coprocessor Instruction (CMOS level output) - When the VL86C010 executes a coprocessor instruction, this output is driven low and the processor will wait for a response from an attached coprocessor device. The action taken is dependent upon the coprocessor response signalled on the CPA and CPB inputs.															
CPB	12	Coprocessor Busy (TTL level input) - An attached coprocessor that is capable of performing the operation which the VL86C010 is requesting (by asserting the -CPI), but cannot begin immediately, should indicate the busy condition by driving this signal high. When the coprocessor is ready to start it should bring the CPB signal low. The VL86C010 samples this signal on the falling edge of the Ø1 clock while the -CPI is active (low).															
CPA	76	Coprocessor Absent (TTL level input) - A coprocessor capable of executing the operation currently requested by the VL86C010 (-CPI active) should bring the CPA low immediately. If the CPA is high on the falling edge of the Ø1 clock, the processor will abort the coprocessor handshake and take the undefined instruction trap. If the CPA is low and remains low during the -CPI active time, then the VL86C010 will busy wait until the CPB signal becomes low and complete the coprocessor instruction.															

**VL86C010 RISC processor pinout diagram and pin functions table.**

Now solder all the DIP headers in place, including the 50-way SCSI header, if you're implementing this option. Next, solder the two transistors, two diodes, the 24 MHz crystal and five LEDs in place. Take care with the orientation of the semiconductors.

Mounting the IC sockets comes next. In this operation, the importance of getting the orientation of each and every socket correct should be apparent. This is comparatively easy since, with the exception of the 86C410 PLCC socket, all the sockets are located with pin 1 facing the left hand (front-facing) end of the board. The overlay shows the orientation of the PLCC sockets. With all these in place, solder the 96-pin expansion bus socket to the

**The MAESTRO 2400XR**

Here's a fully-featured, Hayes compatible 1200 & 2400 bps full duplex modem for just

**\$299 (incl. tax).**

This modem uses the LATEST in DSP chip Set Technology and microprocessor control, bringing you the future Today.



Super price on a super V.22/V.22 bis Modem!

**The MAESTRO 2400 ZXR**

**4 Speed Version \$399 (incl. tax).**

Don't Wait! RING NOW (043) 68 2277 or 68 2278

**Maestro Distributors**

Calool St. South Kinumber, NSW 2256

**READER INFO NO. 34**

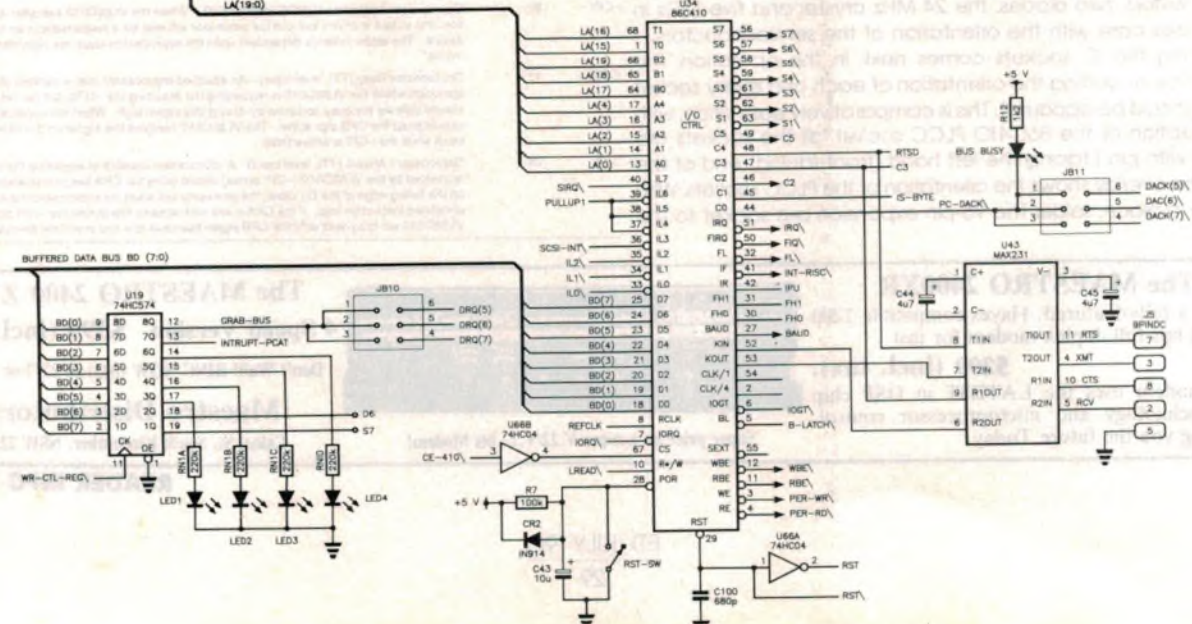
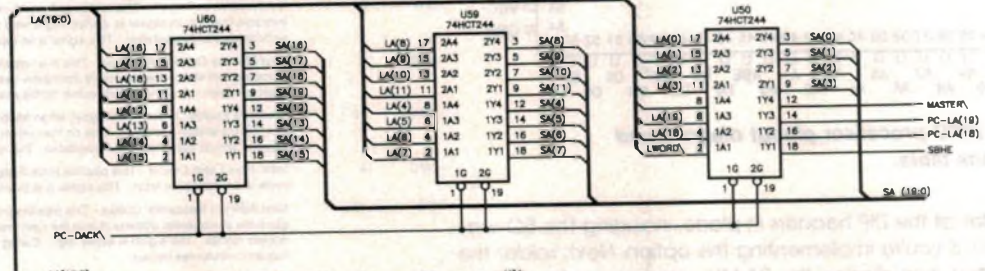
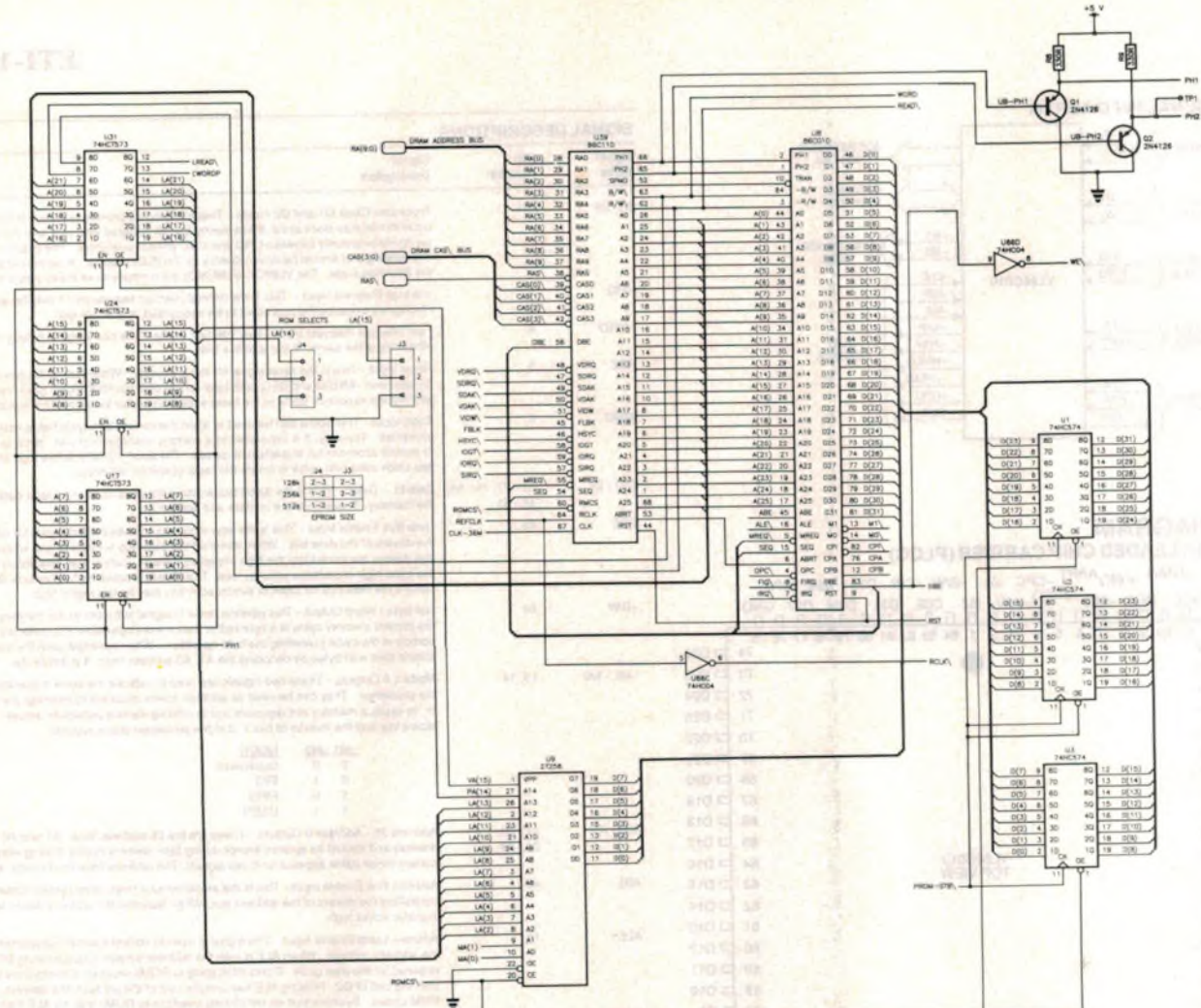

FUNCTIONAL PIN DIAGRAM

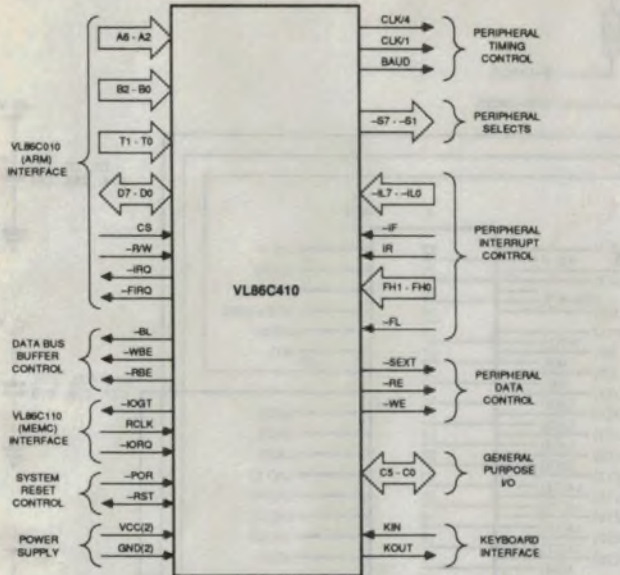

SIGNAL DESCRIPTIONS

Signal Name	Pin Number	Signal Description
RCLK	8	Reference Clock (CMOS level input) - The main reference clock for bus transactions between different devices. RCLK is in phase with the 02 processor clock.
CLK/1	54	Buffered System Clock (CMOS level output) - Provides timing for external peripherals. This is RCLK buffered and inverted.
CLK/4	2	Peripheral Timing Clock (CMOS level output) - Is the RCLK input divided by four. This signal is used to generate latch timing for external peripheral controllers.
-BL	5	External Data Bus Latch Control (CMOS level output, open-drain) - This signal remains high, making the external data latches transparent, for internal register accesses and when CS is low. It is taken low during a write to latch the processor data, and during a read to latch the peripheral data.
D7-D0	25-18	Processor data bus (CMOS level input/output) - This is the 8-bit bidirectional three-state data bus used to transfer data to/from the attached processor. Normally these lines would be connected to one byte of the 32-bit VL86C010 data bus through a transparent latch.
-IORQ	7	Input/Output Cycle Request (CMOS level input) - Determines whether the current cycle is a memory or an I/O reference and is usually connected to the corresponding signal of the VL86C110 Memory Controller. When asserted (low), the MEMC has detected an I/O address and the proper I/O control should respond. When negated (high), the current cycle is a memory reference or internal processor cycle that does not require the attention of the I/O controllers.
-IOGT	6	Input/Output Cycle Grant (CMOS level output, open-drain) - Determines when the current I/O cycle will terminate. When asserted (low), the VL86C410 is signalling that the current I/O cycle will complete on the next falling edge of the RCLK. An I/O cycle completion is determined when -IOGT and -IORQ are both low on a rising edge of RCLK.
T1-T0	68, 1	Cycle Type 1, 0 (CMOS level inputs) - These signals indicate the type of I/O cycle to be performed; 0 = slow, 1 = medium, 2 = fast, 3 = synchronous.
-RW	10	Not Read/Write (CMOS level input) - This signal normally is generated by the VL86C010 and determines cycle direction. The signal is low for read or high for write.
-SEXT	55	External Peripheral Select (CMOS level output) - This signal is used to enable an external data buffer. It is active for any I/O external peripheral access. This allows the I/O and any other -IORQ/-IOGT devices to be isolated from the external peripherals.
-S7-S1	56-59, 61-63	Peripheral Selects (CMOS level outputs) - Indicate address and write data are valid on the bus. The B2-B0 lines are decoded to determine the active select output.
B2-B0	66-64	Bank Select Lines (CMOS level inputs) - Are decoded to determine the I/O access device. A zero value on these lines indicates an access to VL86C410 internal registers. Any other value will decode to one of the external peripheral select outputs.
CS	67	Chip Select (CMOS level input) - When high the I/O will perform either an internal register or external peripheral access cycle. Even when low, the VL86C410 controls the -RBE and -WBE outputs.
A6-A2	17-13	Register Select Lines (CMOS level inputs) - These signals are decoded to determine which internal register to select. Normally these signals are a latched version of the address outputs from the VL86C010 processor.
-RBE	11	Read Buffer Enable (CMOS level output) - Is taken low during a read of any -IORQ/-IOGT device including the I/O.
-WBE	12	Write Buffer Enable (CMOS level output) - Is taken low during a write of any IORQ/IOGT device including the I/O.
-RE	4	Read Enable (CMOS level output) - Provides the external peripheral timing strobe. This signal is used to time peripheral read access cycles.
-WE	3	Write Enable (CMOS level output) - Provides the external peripheral timing strobe. This signal is used to time the peripheral write access cycles.
-RST	29	Reset (CMOS level open-drain input/output) - Is driven (active) low whenever the -POR input is low to provide the system with a power on reset pulse during cold restart. Once the -POR is inactive, the VL86C410 will monitor the -RST as an input to detect a warm system restart condition.
-POR	28	Power On Reset (Schmitt trigger, active low input) - Is used to generate a reset pulse during power on conditions and to differentiate cold restart from subsequent causes of the reset condition. This signal is usually connected to an RC network.
-IL7--IL0	40-33	Interrupt (TTL level inputs) - These signals are the IRQ interrupt active low inputs. These signals are level sensitive.
-IF	41	Interrupt (TTL level input) - This signal provides an edge-sensitive IRQ interrupt source. An interrupt condition is generated on a falling edge of this input.
IR	42	Interrupt (TTL level input) - This signal provides an edge-sensitive IRQ interrupt source. An interrupt condition is generated when a rising edge is detected on this input.
FH1-FH0	31-30	Fast interrupt (TTL level inputs) - These lines provide FIRQ interrupt sources. An interrupt condition is generated whenever the input is high.
-FL	32	Fast interrupt (TTL level input) - Provides a source of FIRQ interrupt. An interrupt condition is generated whenever this input is low.
CS-C0	49-44	Control (Bidirectional open-drain) - These signals provide six lines of general purpose programmable I/O. The direction of these signals is determined by bits in the Control Register. The outputs can be forced low by programming the Control Register. Otherwise the pins can be treated as inputs.
-IRO	51	Interrupt Request (CMOS level open-drain) - Provides the interrupt signal to the system processor. When used with the VL86C010, this signal is tied directly to the -IRQ input of the processor.
-FIRQ	50	Fast Interrupt Request (CMOS level open-drain) - Signals the system processor with the fast interrupt condition within the system. When used with the VL86C010, this signal is tied directly to the -FIRQ input of the processor.
BAUD	27	Baud Clock (CMOS level output) - This signal is generated by the Timer 2. The output level is toggled by the reload event on the counter. The frequency of the BAUD clock is determined by the equation: $f(\text{baud}) = 1/(\text{latch} + 1) \text{ MHz}$ (if the RCLK frequency is 8 MHz) $f(\text{baud}) \text{ max is obtained when the latch value equals one providing a maximum value of 500 KHz.}$
KIN	52	Keyboard serial data input signal (TTL level input) - Is connected to the keyboard input controller. A clock of 18 times the data rate is used by the receiver to clock keyboard data into the KART section from this line. The data should be input as LSB first on this pin.
KOUT	53	Keyboard serial data Output (CMOS level output) - This output provides serial data transmission to the keyboard. The data is transmitted with a fixed format of eight bits per character with one start bit and two stop bits. The data appears on this pin with LSB first.

PIN DIAGRAM PLASTIC LEADED CHIP CARRIER (PLCC)

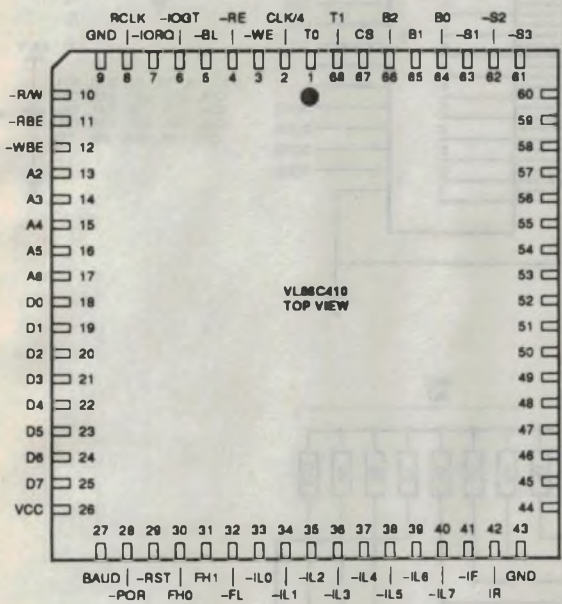

VL86C410 RISC I/O controller pinout diagram and pin functions table.

board with row C uppermost (top edge of the board). Bolt the 9-pin D-sub male connector to the board and then solder the pins. Screw the slot bracket to it. Solder the pushbutton reset switch in place; it's located in the top right-hand corner of the board. Now - check everything. Using a multimeter, check the supply rails at the PC/AT bus pins for shorts. Locate and clear any problems. Now you can load the ICs. Remember that except for the 86C410 IOC chip, all the ICs have pin 1 facing the left-hand end of the board. Once again, check everything! You are now ready to try out your board, which will be detailed in the concluding part, next issue.

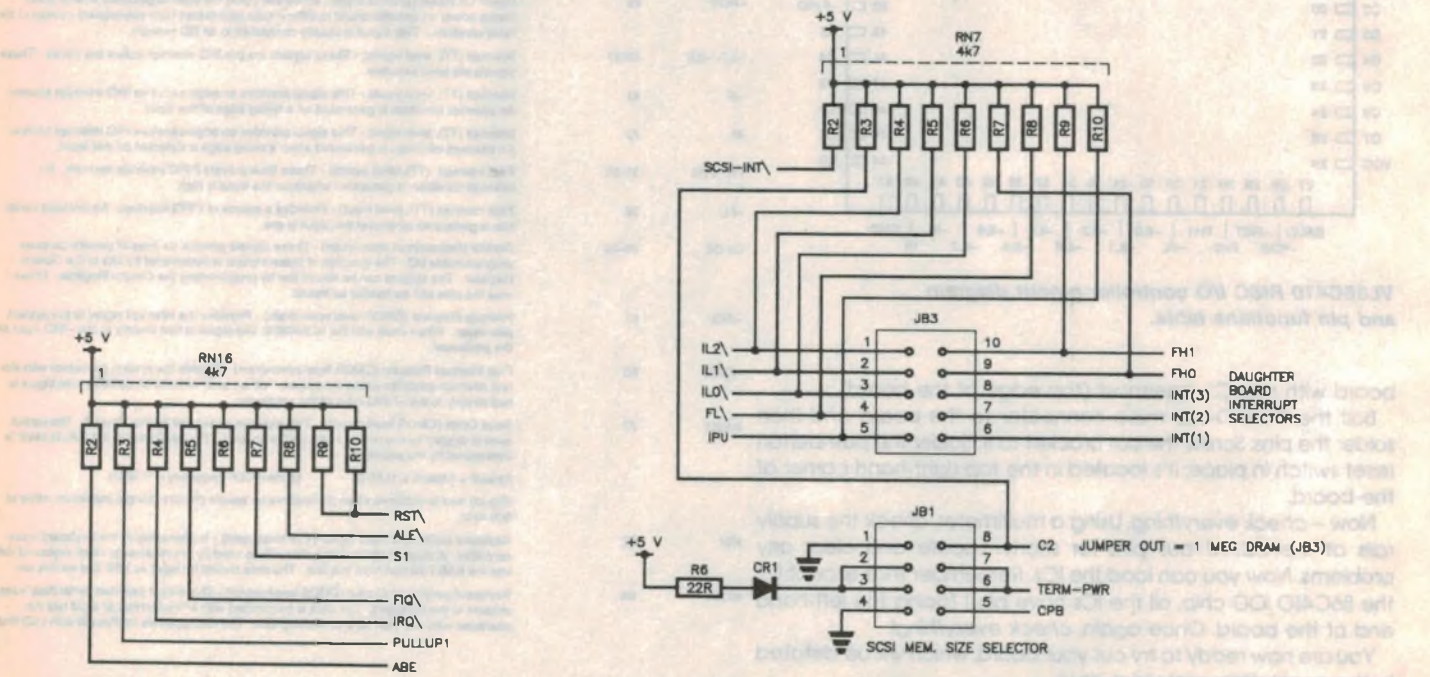
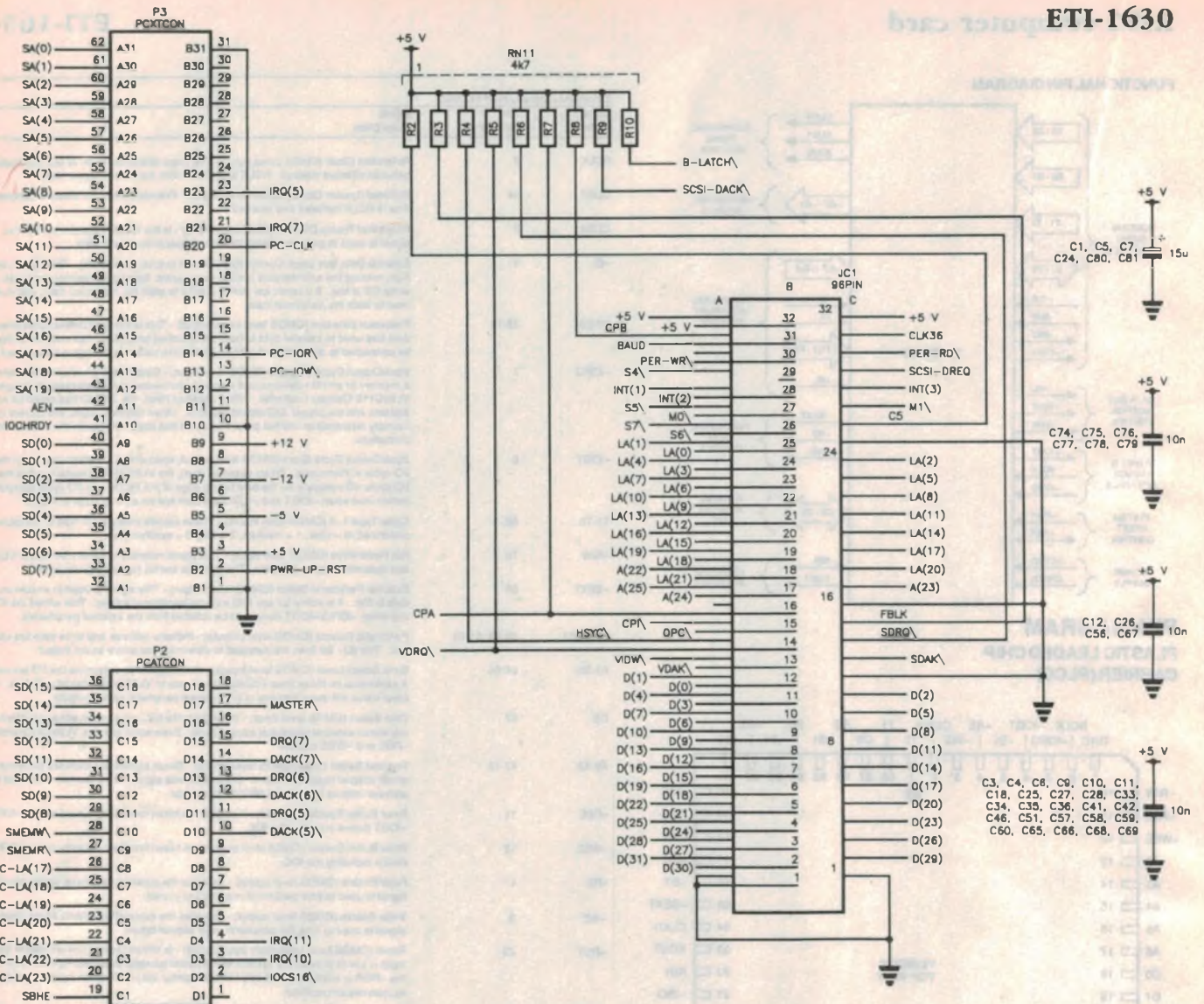

# RISC computer card

## PIN DIAGRAM PLASTIC LEADED CHIP CARRIER (PLCC)

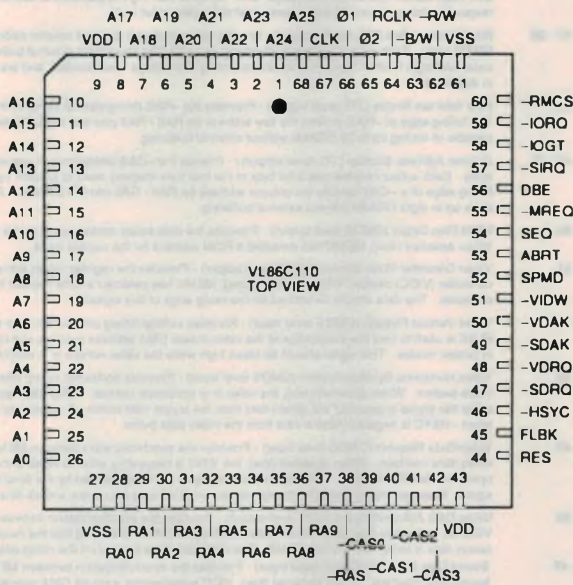

### SIGNAL DESCRIPTIONS

Signal Name	Pin Number	Signal Description
A25 - A0	68.1 - 8, 10 - 26	Address 25 - Address 0 (CMOS level inputs) - These are the 26 processor address lines that contain the address of the memory reference. When Ø2 is low these signals should contain the address of the current memory reference. When Ø2 goes high, these address pins should be changed to the value for the next cycle. A1 and A0 are byte addresses and are ignored during word transfer cycles. A3 and A2 are decoded to determine sequential access boundaries.
-RW	62	Not-Read/Write (CMOS level input) - Determines the direction of data flow during the current memory access. When asserted (low) the memory cycle will be a read operation, and if negated, (high) a memory write will be performed.
-B/W	63	Not-Byte/Word (CMOS level input) - Determines the size of the data transfer of the memory access (Note 2). When asserted (low) the transfer is byte-wide (8-bits) or negated (high) word-wide (32-bits). When transferring bytes the A1 and A0 address inputs are decoded to determine which 8-bit field is to be referenced. Word transfers are always aligned on word boundaries (A1 = A0 = 0) because A1 and A0 are ignored during word operations.
-MREQ	55	Processor Memory Request (CMOS level input) - Determines whether a memory cycle will be performed during the next access time. When asserted (low) this line indicates that the processor will require either a memory (Note 1) or I/O access during the next cycle time (Note 2). If negated (high), no cycle is required because the ARM will perform an internal cycle. This input must be valid well before the falling edge of the Ø2 clock signal. Under special circumstances, this signal may affect operation of the current memory cycle. When both -MREQ and SEQ are asserted during a processor internal cycle, MEMC begins a DRAM non-sequential cycle immediately which effectively overlaps the internal cycle with the first half of the non-sequential access time.
SEQ	54	Processor Sequential Access (CMOS level input) - Determines whether the next memory cycle will be a two clock non-sequential (N-cycle) or a one clock sequential (S-cycle) access (Note 2). The ARM processor asserts this signal whenever the address for the next cycle is sequential (current address + 4) to the address presently on the bus. When asserted (high), MEMC performs a S-cycle (page mode) by removing -CAS while retaining -RAS active. This keeps the row address latched in the DRAMs and loads in the new column address. In general, the page-mode access time of most DRAM devices is one-half the random access time. When negated (low), the next memory cycle will be a two clock N-cycle. MEMC removes both -RAS and -CAS at the end of the current cycle, allows the memory to properly precharge, and performs a random-access cycle. This signal must be setup well before the falling edge of the Ø2 clock signal for the same reasons as the -MREQ.
SPMD	52	Supervisor Mode Select (CMOS level input) - When low, the processor is restricted from access to certain areas of the memory map and will be aborted if illegal access attempts are made. SPMD is generally connected to the -TRAN output of the VL86C010 processor.
Ø1, Ø2	66, 65	Processor Clocks (CMOS level outputs) - These signals drive the two phase, non-overlapping clock inputs of the ARM processor. The frequency of these clocks is the master clock (CLK input) frequency divided by three. The Ø2 clock is in phase with the reference clock (RCLK output).
DBE	56	Processor Data Bus Enable (CMOS level output) - Determines when the data bus drivers inside the ARM processor are enabled. When asserted (high) the processor is driving the data bus during a write cycle. This signal should be inverted externally to provide an active low write enable for the Dynamic RAMs to prevent three-state driver contention on the data bus.
ABRT	53	Processor Abort (CMOS level output) - Determines whether the current memory cycle will terminate abnormally. When asserted (high) MEMC has detected either an attempted access to a higher privileged area or a non-existent logical page. Both these conditions will cause an abort of the current memory cycle and exception processing to be invoked by the processor to determine error recovery procedures. When negated the current cycle will terminate normally and processing flow continue under program control.
Notes:	1	The word memory in this context refers to any device mapped into the processor's address space.
	2	Some of the processor signals are asserted in the processor cycle preceding that in which they are used.
-IORQ	59	Input/Output Cycle Request (CMOS level output) - Determines whether the current cycle is a memory or an I/O reference. When asserted (low), MEMC has detected an I/O address and the proper I/O controller should respond. When negated (high), the current cycle is a memory reference.



## Reader Information Card

On the reverse of this page you will find the Reader Information Card. This is a service EA with ETI provides free to readers who want more information about products advertised or otherwise mentioned in the magazine. At the bottom of the article or advert you find a RI number. Just circle that number on the card and send the card to us. We will pass on your address to our contacts, either the advertiser or our source for the story, who will then inundate you with literature on the product of your choice. Another feature: to the right, there is a blank space. Why not use it to drop us a line, and let us know what you think of the magazine. We are particularly interested in ideas from readers on how we can improve things.

### Note to the Editor:

.....

.....

.....

.....

.....

.....

.....

.....

.....

.....

### For publication! Yes/NO

Name: .....

Address: .....

.....

Postcode: .....

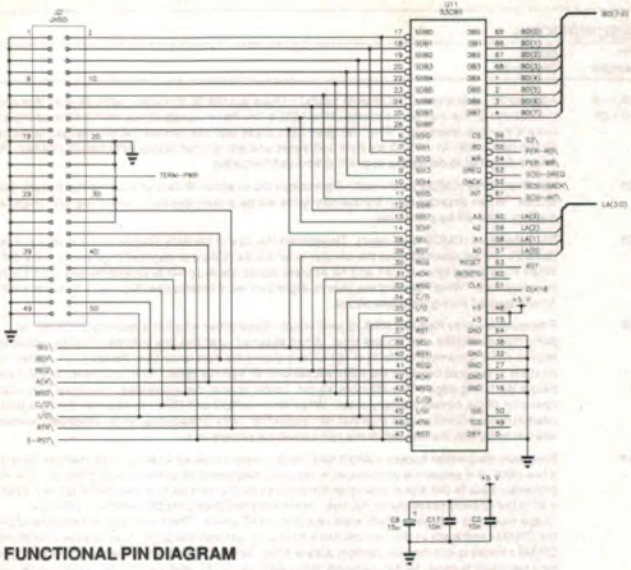

FUNCTIONAL PIN DIAGRAM

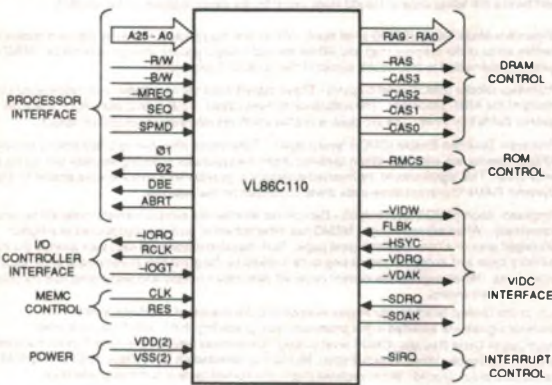

- IOGT 58 Input/Output Cycle Grant (CMOS level input) - Determines when the current I/O access cycle will terminate. When asserted (low), the selected I/O controller is signaling that the current I/O cycle will end on the next falling edge of the RCLK clock if the -IOGT is still low.
- CLK 67 Clock (CMOS level input) - Master input clock used to derive all system timing functions. The input signal should be approximately a 50% duty cycle with full CMOS levels. This clock is divided down internally to obtain the two-phase processor clocks, system reference clock, and the DRAM refresh clock.
- RCLK 64 Reference Clock (CMOS level output) - Provides the main reference clock for bus transactions between different devices. RCLK clock is in phase with the @2 clock of the processor.
- RES 44 Reset (CMOS level input) - Places the MEMC in a known initial state. When asserted (high), MEMC is forced into the following modes: ROM is continually selected with an access time of 450 ns, DRAM page size is 4K bytes, operating system mode disabled, sound DMA operations disabled, -SIRO set low, video/cursor operations unaffected, and -IORQ is held high to prevent I/O controllers from responding to spurious addresses generated during the reset state.
- RA9 - RA0 37 - 28 RAM Address Bus (TTL level output) - Provide the multiplexed row and column addressing lines to the DRAM array. Each output is capable of driving up to 32 DRAMs without external buffering. The bit order and logic level of these pins varies according to the page size selected, and are shown in detail in Appendix A.
- RAS 38 Row Address Strobe (TTL level output) - Provides the -RAS timing/control signal to the DRAM array. The falling edge of -RAS strobes the row address on RA9 - RA0 pins into the DRAMs. This signal is capable of driving up to 32 DRAMs without external buffering.
- CAS3 - CAS0 42 - 39 Column Address Strobes (TTL level outputs) - Provide the -CAS timing/control signals to the DRAM array. Each output controls one 8-bit byte of the four byte memory word to support byte writes. The falling edge of a -CAS strobes the column address on RA9 - RA0 into the DRAMs. Each signal will drive up to eight DRAMs without external buffering.
- RMCS 60 ROM Chip Select (CMOS level output) - Provides the chip select control signal to the ROM devices. When asserted (low), MEMC has detected a ROM address for the current cycle.
- VIDW 51 Video Controller Write Strobe (CMOS level output) - Provides the register select signal to the video controller (VIDC) device. When asserted (low), MEMC has detected a write request to the video controller. The data should be latched on the rising edge of this signal.
- FLBK 45 Video Vertical Flyback (CMOS level input) - Provides vertical timing information from the video section. FLBK is used to time the initialization of the video/cursor DMA address pointers and for refresh control in certain modes. This signal should be taken high while the video retrace is in progress.
- HSYC 46 Video Horizontal Synchronization (CMOS level input) - Provides horizontal timing information from the video section. When asserted (low), the video is in horizontal retrace. Video data requests made while this signal is asserted will obtain data from the cursor data buffer. A video data request made when -HSYC is negated obtains data from the video data buffer.
- VDRQ 48 Video Data Request (CMOS level input) - Provides the synchronization between MEMC and VIDC for video data interface. When asserted (low), the VIDC is requesting either a video or cursor DMA operation for video refresh. Video and cursor requests are distinguished by the level of the -HSYC signal. Requests made during horizontal retrace (-HSYC low) are cursor and all others video.
- VDAK 50 Video Data Acknowledge (CMOS level output) - Provides the synchronization between MEMC and VIDC for video data interface. When asserted (low), MEMC is indicating that the requested video/cursor data is being latched from RAM. The data should be latched on the rising edge of -VDAK.
- SDRO 47 Sound Data Request (CMOS level input) - Provides the synchronization between MEMC and VIDC for sound data interface. When asserted (low), VIDC is requesting a sound DMA operation.
- SDAK 49 Sound Data Acknowledge (CMOS level output) - Provides the synchronization between MEMC and VIDC for sound data interface. When asserted (low), MEMC is indicating that the requested sound data is being latched from RAM. The data should be latched on the rising edge of -SDAK.
- SIRO 57 Sound Interrupt Request (CMOS level output) - Provides the synchronization between MEMC and the processor for sound data interface. When asserted (low), MEMC is requesting a sound service operation by the processor. The sound DMA address generators interact with interrupt driver software to implement the sound system. -SIRO is set low on reset.
- VSS 61, 27 Digital ground. The digital ground power supply.
- VDD 43, 9 Digital power. The digital + 5.0 volt power supply.



**Electronics Australia**      **READER INFORMATION SERVICE COUPON**      **eti**

**READER INFORMATION SERVICE**

To find out more about the products and services in this issue, note the Reader Service Number from the advertisement or article, and circle the corresponding number in this coupon. Enclose it in an envelope and send to:

**FREE POST No. 4**  
**The Federal Publishing Company**  
**P.O. Box 227, Waterloo, N.S.W. 2017**  
No stamp required if posted in Australia.

- A. Engineer/Designer
- B. Technical Officer
- C. Technician
- D. Programmer/Analyst
- E. Manager
- F. Teacher/Lecturer
- G. Student
- H. Interested Consumer
- I. Other (please state)

Please ✓ the box that best fits you.

Name.....  
 Company.....  
 Address.....  
 Telephone ( ).....

1	26	51	76	101	126	151	176	201	226	251	276	301	326
2	27	52	77	102	127	152	177	202	227	252	277	302	327
3	28	53	78	103	128	153	178	203	228	253	278	303	328
4	29	54	79	104	129	154	179	204	229	254	279	304	329
5	30	55	80	105	130	155	180	205	230	255	280	305	330
6	31	56	81	106	131	156	181	206	231	256	281	306	331
7	32	57	82	107	132	157	182	207	232	257	282	307	332
8	33	58	83	108	133	158	183	208	233	258	283	308	333
9	34	59	84	109	134	159	184	209	234	259	284	309	334
10	35	60	85	110	135	160	185	210	235	260	285	310	335
11	36	61	86	111	136	161	186	211	236	261	286	311	336
12	37	62	87	112	137	162	187	212	237	262	287	312	337
13	38	63	88	113	138	163	188	213	238	263	288	313	338
14	39	64	89	114	139	164	189	214	239	264	289	314	339
15	40	65	90	115	140	165	190	215	240	265	290	315	340
16	41	66	91	116	141	166	191	216	241	266	291	316	341
17	42	67	92	117	142	167	192	217	242	267	292	317	342
18	43	68	93	118	143	168	193	218	243	268	293	318	343
19	44	69	94	119	144	169	194	219	244	269	294	319	344
20	45	70	95	120	145	170	195	220	245	270	295	320	345
21	46	71	96	121	146	171	196	221	246	271	296	321	346
22	47	72	97	122	147	172	197	222	247	272	297	322	347
23	48	73	98	123	148	173	198	223	248	273	298	323	348
24	49	74	99	124	149	174	199	224	249	274	299	324	349
25	50	75	100	125	150	175	200	225	250	275	300	325	350

For a prompt reply

**POST TODAY**



**POST TODAY**



**POST TODAY**

JUL '90

# Fujitsu Hard Disks

## 600 MB ESDI or SCSI

**5  
Year  
Warranty.**

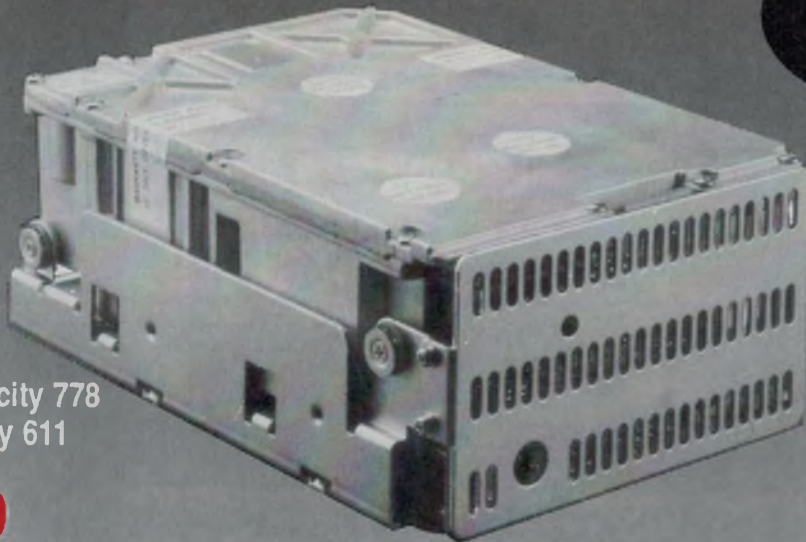

Cylinder 1658  
Head 15  
Unformatted Capacity 778  
Formatted Capacity 611

**ONLY \$5,900**

3 1/2" 180MB Fujitsu AT-BUS Hard Disk with Controller only \$1,750  
3 1/2" 180MB Fujitsu SCSI Hard Disk with Controller only \$1,950

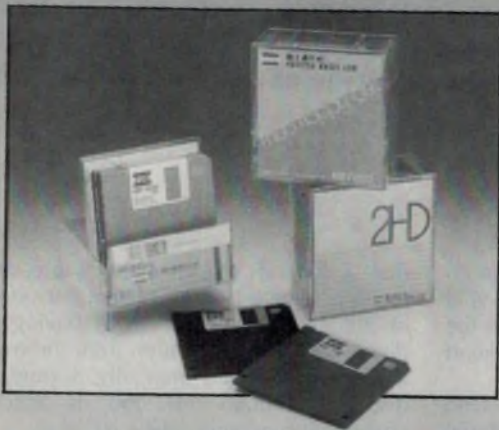

## Fujitsu Floppy Diskettes

(Boxes of 10 diskettes)

**Normally**

**Special Price**

	Normally	1 - 9	10 plus
3 1/2" DS/High Density	\$85	\$45	\$42
3 1/2" DS/Double Density	\$38	\$26	\$23

# HI-COM UNITRONICS

363 Port Hacking Rd., Caringbah, NSW. 2229  
Tel: (02) 524 7878 Fax: (02) 525 8686  
Dealer Enquiries (02) 525 8318

ORDER FORM	Quantity	Unit Price	Total	Mail Orders:
600 MB Fujitsu Hard Disk ESDI or SCSI		\$5,900		Mail Order ..... Postage
3 1/2" 180MB Fujitsu AT-BUS Hard Disk with controller		\$1,750		under \$50 ..... \$4.50
3 1/2" 180MB Fujitsu SCSI Hard Disk with controller		\$1,950		\$50-\$99 ..... \$5.50
Fujitsu Floppy Diskettes 3 1/2" DS/High Density (Boxes of 10 diskettes)		\$45.00		\$100-\$250 ..... \$7
Fujitsu Floppy Diskettes 3 1/2" DS/Double Density (Boxes of 10 diskettes)		\$25.00		above \$250 .... \$10
I enclose my <input type="checkbox"/> Cheque <input type="checkbox"/> Money Order (please tick appropriate box)			<b>TOTAL</b>	Add 1% on Total for Insurance
Please Debt my <input type="checkbox"/> Visa <input type="checkbox"/> BankCard <input type="checkbox"/> Mastercard				All prices including tax.
Card No. <input type="checkbox"/> <input type="checkbox"/> <input type="checkbox"/> <input type="checkbox"/> <input type="checkbox"/> <input type="checkbox"/> <input type="checkbox"/> <input type="checkbox"/> <input type="checkbox"/> <input type="checkbox"/> <input type="checkbox"/> <input type="checkbox"/> <input type="checkbox"/> <input type="checkbox"/> <input type="checkbox"/> <input type="checkbox"/>			Name .....	
Expiry Date .....			Address .....	
Signature .....			P/C .....	

**Fax to: (02) 525 8686 or Post to: P.O. box 626, Caringbah, NSW. 2229. Australia**

# PIONEER'S MOBILE STEREO HIFI COMBO



Having recently taken Pioneer's new KEH-M5000QR FM/AM Tuner Deck Amplifier with matching CDX-M70 Multi-disc CD player on a test drive from Melbourne to southern New South Wales, Les Cardilini reports that it was hifi stereo all the way. With the choice of AM or FM stereo radio, cassette tape or compact disc, your options are just as wide as at home — and with no sacrifice in quality, either.

Trying out the new Pioneer KEH-M5000QR car stereo system certainly made my trip a very pleasant musical experience. In need of an hourly news fix, however, I was tempted to switch back to the AM band occasionally and was surprised to find that I could still tune in and listen to Melbourne radio station 3AW, while motoring along the Murray Valley highway in the mid afternoon.

And the total absence of interference from the vehicle's electrical and ignition system in the presence of the weaker radio signals, indeed on all program sources, was also most impressive — testimony no doubt to the effectiveness of the noise filter in the power lead on this model.

That kind of reception on the AM band might be considered par for the course after sunset, but in daylight hours it is fairly commendable.

All round, the powerful Pioneer system comprising the dash mounted KEH-M5000QR Tuner-Stereo Cassette

Deck, with four onboard 25 watt audio amplifiers plus optional CDX-M70 Multi-CD Player installed securely in the boot made driving on the weekend round trip very relaxing.

The loading magazine supplied with the Pioneer Multi-CD Player Model CDX-M70 will accommodate from one to six compact discs — up to seven hours of your favorite music — and can be controlled via either the KEH-M5000QR head unit in the dash or its infrared remote control. The removable magazine may also be used in compatible Pioneer home compact disc players, thus enabling compact discs to be taken from home to car and back again without leaving the protection of the six-pack magazine.

Separate discs and tracks can be played either sequentially in order of disc and track number, or by individual selection in this Pioneer system. And for those occasions when you are not sure where you might find the required piece of music on a disc, you can audition the

first 10 seconds of each track by pressing the appropriate (SCAN) button just once, on the head unit. This saves having to divert the driver's attention from the road ahead to sequence manually through a disc — although this, too, is accomplished with relative safety and ease.

Of course, there is also the RANDOM PLAY mode, where I discovered that the CDX-M70's computer creates an air of anticipation by selecting and playing discs and tracks for you — at random. Between changes there is just enough time for passengers to guess the next disc and track numbers and wait for them to appear, like lotto numbers, in the illuminated display — doubtless a fun application the system designers hardly intended, but nonetheless one which proved to be entertaining!

The CDX-M70 uses 3-beam laser tracking and features audible fast forward and reverse for cueing. The display on the KEH-M5000QR can be switched to show either track number or playing time in minutes and seconds,





general direction of the sensor in the KEH-M5000QR, a positive response to its signals is virtually assured. Acceptance of the remote control signals whenever one of the eight buttons on the hand operated unit is pressed is confirmed by a comforting 'beep' from the head unit. Again, little or no visual contact with the controller unit by the driver is necessary, to verify that the required adjustment took place. Similar acknowledgments are voiced when keys are pressed on the dash unit. (The set even beeps politely when you turn on the power.)

The remote control can also be used to change AM and Stereo FM radio stations, compact discs and track selection, and to switch between forward and reverse while a cassette is playing. It will even switch the system on and off. Most operations in the KEH-M5000QR system can be performed using the remote control, without taking your eyes from the road — another significant 'plus' for driving safety.

An attenuator which reduces the volume by 20 decibels at the touch of a button on the remote control is another safety feature, which can be used when approaching rail crossings and intersections, while conversing with passengers or blowing into bags at unscheduled stops. The display flashes while the attenuator is activated, and regular volume level is restored by a second press of the same button.

There are just eight buttons on the diminutive remote control. The buttons are shaped for feel and orientation and the current function of each button is determined by which program source is selected: Tuner, Tape Deck or Compact Disc Player. Such a small complement of pushbuttons gives the remote control a pleasingly simple appearance and ease of operation, despite its multiplicity of functions. Pushbuttons on the KEH-M5000QR head unit itself are similarly multi-functional.

Pushbutton selectors for program source and overall volume are grouped together at the top right hand corner of the KEH-M5000QR in the dash. With a little practice these can be readily located — without having to sight them — by first feeling for the top corner of the set and then moving the index finger onto the appropriate button. A reassuring beep will signal that the adjustment has taken place. Similarly, the SCAN and BSM keys are located near the diagonally opposite corner of the front panel, for ready access in scanning the tuning memory or searching for new stations.

The two UP-DOWN keys used for volume adjustment are also multi-functional, controlling channel balance, front to rear speaker fading and bass and treble tone control.

The Tuning Memory in the KEH-M5000QR will store up to 18 FM and six AM stations, 24 in all, in four bands. In the scanning mode the set tunes in to each preset station for approximately eight seconds and continues to do so until the scan key is again operated — when, say, a suitable program is tuned in, or when another band or program source is selected. The LOCAL/DX switch enables weaker stations to be ignored if only stronger stations are preferred. Pioneer's Super Tuner technology is used to maintain the best possible listening quality of program sound on weaker stereo radio signals.

In addition to its manual and preset pushbutton tuning, the KEH-M5000QR also has a Best Stations Memory (BSM) function which can be activated at the press of a button. This automatically searches for up to six radio stations in an unfamiliar locality or town, for example. In a matter of only several seconds the strongest six stations received are then 'stored' in the Best Stations Memory. When less than six stations are available some will be duplicated on otherwise 'spare' tuning pushbuttons, for convenience and to prevent the selection of noisy vacant channels. Once stored of course it is a simple matter to scan that selection for the program which most appeals.

Requiring only a single key press, the BSM process relieves the driver of the chore of tuning along the band to find and then store new stations — and freed to keep his or her mind on the road.

Despite its host of features, the KEH-M5000QR sits conservatively in the dash and with its quick-release carrying handle can be removed conveniently in seconds, from its dash housing, for safe-keeping whenever the vehicle is to be left unattended.

An internal calculator-type backup battery keeps the tuning memory active and retains the current program source selection and control settings — such as volume, tone and balance; in fact, the system status generally — while the set is out of its cradle. The status prevailing when the set is switched off or taken from its cradle is restored when the set is again plugged into its housing in the dash. Optional amber or green dash lighting to match existing illumination on the vehicle's instrument panel is switchable on the unit.

The auto-reversing stereo cassette deck in the KEH-M5000QR has automatic tape selection from NORMAL up to Metal (IEC IV) position, and Dolby B Noise Reduction.

Periods of silence while cassettes are being rewind or fast-forwarded are avoided in the KEH-M5000QR by switching to Radio Intercept. With Radio Intercept active the radio will play

and the player remains cued to the track which was playing when the player was last switched off. Vehicle vibration did not seem to worry the CDX-M70, as I cannot recall the player mis-tracking at all, on the entire trip.

The small shirt-pocket size infrared remote control is perhaps the major driving safety feature of the system. It comes with self-adhesive Velcro patches for fixing anywhere within easy reach, without having to drill holes in the host vehicle's interior panels. The remote can be attached to the steering wheel or an armrest, for example, and gives the driver instant access (no fiddling around the seats and under lolly bags) and virtually eyes-free control over the system's main functions. This includes switching the KEH-M5000QR on and off, and changing between AM-FM Tuner, Auto-Reverse Stereo Cassette Deck and the CDX-M70 Multi-CD Player.

The remote control has an exceptionally wide angle of sensitivity, and provided the unit is aimed in the

**UV MATERIALS**  
**3M Scotchcal Photosensitive**

	Pack Price 250x300mm	Pack Price 300x800mm
8001 Red/Alum.	86.00	98.00
8003 Black/Alum. 12mm	95.00	106.00
8005 Black/Alum.	86.00	98.00
8009 Blue/Alum.	86.00	98.00
8130 Black/Gold	109.00	130.00
8006 Red/Transp.	77.00	88.00
8010 Green/Transp.	77.00	88.00
8011 Red/White	77.00	88.00
8012 Black/Transp.	77.00	88.00
8013 Black/Yellow	77.00	88.00
8014 Blue/Transp.	77.00	88.00
8015 Black/White	77.00	88.00
8016 Blue/White	77.00	88.00
8018 Green/White	77.00	88.00
8060 Black/Silver	77.00	88.00

**ACCESSORY FILMS:**

8007 Reversal Film	47.00	63.00
--------------------	-------	-------

**RISTON 3400 PCB MATERIAL**

SIZE INCHES	SINGLE SIDED	DOUBLE SIDED
36 x 24	\$96.00	\$124.00
24 x 18	\$48.00	\$ 62.00
18 x 12	\$24.00	\$ 31.00
12 x 12	\$16.00	\$ 20.80
12 x 6	\$ 8.00	\$ 11.00

**KALEX UV LIGHT BOX**  
**KALEX ETCH TANK**

All prices plus sales tax if applicable

**KALEX** 40 Wallis Ave  
 East Ivanhoe 3079  
 (03) 497 3422  
 497 3034  
 Fax (03) 499 2381  
**ELECTRONIC COMPONENTS & ACCESSORIES**  
 • SPECIALIST SCHOOL SUPPLIERS

READER INFO NO. 36

**— RACAL-REDAC —**

CADSTAR PCB DESIGN  
 (including Schematics)

STANDARD CADSTAR(V3)	\$3700
ADVANCED CADSTAR	P.O.A.
PROFESSIONAL CADSTAR	P.O.A.

**NEW!**

TRANSPUTER RIPUP AUTO ROUTER  
 (32 bit performance on PC-AT)

**— PSPICE —**

ANALOGUE SIMULATION from \$1290

**— ORCAD —**

SCHEMATIC STD III	\$995
PCB II	\$2995

**— PROTEL —**

SCHEMATIC	\$945
AUTOTRAX	\$1345
EASY TRAX	\$295

Contact us for PCGERBER/GPLOT  
 available now from

**RCS CADCENTRES**

phone 03 499 6404 or  
 fax 03 499 7107

READER INFO NO. 37

**Pioneer's Mobile Stereo Hifi**



whenever the deck is spooling. As well, pressing the Fast Forward or Rewind buttons twice in succession enables the Music Search feature, for more convenient accessing of taped music selections. Music Search automatically senses the beginning of each recorded section on the tape and returns the deck to the Play mode from its faster spooling speed in either direction.

Another, reassuring feature in the KEH-M5000QR cassette deck is that the rubber pinch roller and capstan are automatically disengaged whenever the power to the set is switched off. Releasing the mechanism prevents the rubber pinch wheel from being deformed by prolonged stationary contact with the capstan. A deformed pinch roller would almost certainly cause unpleasant wow and flutter distortion. Tapes too are protected from accidental damage, which might otherwise occur due to prolonged pinching between the stationary capstan and pinch roller in the event that the vehicle's ignition-accessory switch is turned off, or the set is removed from its cradle, with a cassette loaded in the playing position.

With its four high power amplifiers already on board for stereo front and rear speaker systems, together with the inbuilt tuner and cassette deck, the Pioneer KEH-M5000QR can be installed as a

straight stereo system with as few as two speakers at first. Later it can be expanded to include additional speakers and the Multi-Play CD Player, as budgets permit and if desired.

In fact, the physical profile of the KEH-M5000QR for mounting in the standard aperture, and its system expandability make this Pioneer head a sound foundation for a top end, comprehensive car hifi stereo system. And if you already have a compatible Pioneer multi-play compact disc player in your home hifi system, you might be able to exchange magazines between it and the CDX-M70 and program the car unit using the infra-red remote from the hifi unit.

Recommended retail price is \$899 for the KEH-M5000QR High Power Receiver with Multi-Play CD Controller. The CDX-M70 Multi-Play Compact Disc Player is also priced at \$899 RRP. Multi-lingual handbooks included with each set also have system connections and installation diagrams. Loudspeakers are not included in the prices listed, though. All Pioneer car sound products carry a 12 months warranty and are supported by 317 accredited service centres around Australia.

Further information is available from Pioneer Electronics (Australia) Pty Ltd, 178-184 Boundary Road, Braeside 3195, or phone (03) 580 9911.

ETI JULY '90

# CHALLIS THROUGH THE LOOKING GLASS

**Invisible speakers and artificial volcanoes continue to haunt Louis, as he makes his way around the 1990 Winter CES. The second part of his first-hand account...**

Las Vegas is possibly one of the most forgettable places in America, yet the entrepreneurs go out of their way to make visual impressions with which film producers could have a field day.

The newest hotel/casino in Las Vegas is the Mirage, a bizarre building which Christopher Skase could have created. There is a large indoor jungle in the middle of the hotel, each of whose plants has its own 'micro spray' to keep it well watered. Three white tigers in a glass fronted cage draw top crowds day and night. An outdoor 'artificial volcano' gushes forth smoke and flames at precisely quarter past and quarter to the hour. And the long corridors outside each of the guest suites have jungle printed wallpaper. I was intrigued by the wonderful optical illusions, particularly after a few drinks, when the corridors seemed to extend to infinity.

I was in the Mirage to attend the media release of the new Dolby S-type recording process mentioned in the first of these articles (April issue), but warranting expansion as the single most important technical release at the Winter CES. I was intrigued to discover that Dolby Laboratories had aligned themselves with Sony of Japan to develop the new IC set on which the 'S' type system is based.

At the demonstration, Dolby Laboratories used conventional cassette

decks incorporating Dolby 'B' so that we could aurally compare the sound with a prototype Pioneer cassette deck fitted with the new Dolby 'S' system.

The Dolby 'S' system is a simplified version of the Dolby Spectral Recording (SR) system developed four years ago for professional recording, broadcast and cinema systems. Three years after it was introduced, there were more than 30,000 channels of Dolby SR in use, a positive statement of its industry acceptance and status in the film and broadcast fields.

The Dolby 'S' system is based on a number of the basic design principles of the SR system and claims to provide an economical and simple format specifically optimised for consumer cassette recording.

Complementary noise reduction systems work on the principle of boosting low-level signals during recording and then reducing them — along with added tape noise — during playback. The high-level signals are not normally boosted, as this avoids tape saturation and overload problems.

To prevent nasty audible side effects such as noise modulation during recording, the ideal NR system would apply constant gain wherever there are no high level signals, even in the presence of such signals elsewhere in the audible spectrum. This is called the

principle of 'least treatment'. Dolby S-type conforms more closely to this principle than did any of the previous (Dolby) consumer noise reduction systems.

As a result of this stratagem, high-level signals have little effect on low-level signals. This contributes to a general freedom from audible side effects, and it also reduces susceptibility to decoding errors, such as those introduced by using a tape formulation for which the recorder has not been optimised. In addition, S-type recordings heard after playing with a Dolby B-type decoder, or even with no decoding, will be free of obvious dynamic flaws such as 'pumping'.

The Dolby S-type system provides more than 20dB of noise reduction at higher frequencies. Providing that much noise reduction by means of conventional techniques would subject low-level signals to an unduly high compression ratio. To avoid this problem with the Dolby S-type noise reduction, compression is provided in two staggered stages which operate at different signal levels with comparatively gentle compression ratios. This technique was pioneered in the Dolby C-type system and further refined in the Dolby SR system.

The system also incorporates anti-saturation circuits to provide

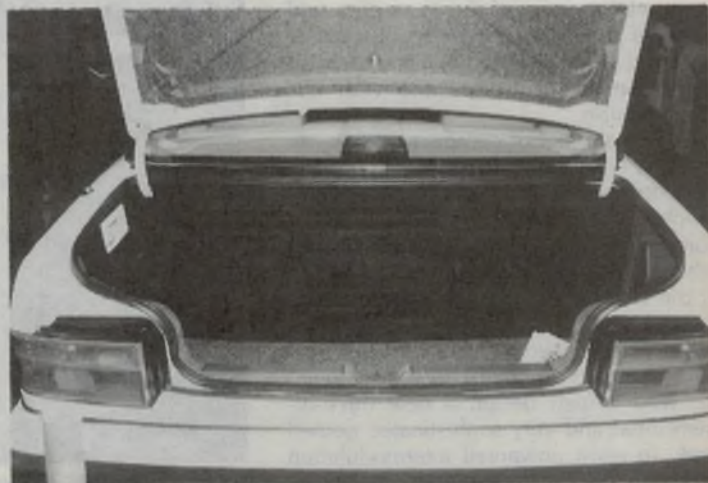

**On display were the latest car stereo systems from Cerwin Vega (above) and Sony (right).**

increased headroom and lower distortion than any of the previous consumer noise reduction systems. To do this, it uses anti-saturation at low frequencies as well as at the more conventional 'highs'. This ensures a positive reduction in the level of low frequency distortion, a common problem in cassette recorders because of the significant low frequency signal level boost created by the equalisation process.

The 'S-type' system encoding process has two staggered action compressors, one a low level high frequency fixed band, the other a high frequency sliding band. The encoder output is filtered and fed back to the control paths of each compressor to control the compressors' action by a technique described as 'modulation control'.

An 'S-type' encoder adapts its characteristics to the input signal to provide maximum boost at all times, especially for frequencies lower or higher than the dominant signal. The overshoot suppression (O/S) circuits used are also designed to allow maximum boost from the compressor. The 'least treatment' is thus given to the signal at all times, which results in a relatively stable output with a low dynamic action. When the signal is decoded on replay, the maximum amount of noise reduction is obtained in the presence of signals, ensuring low noise modulation and a high degree of tolerance for errors in the transmission chain. The system provides up to 24dB of noise reduction at high frequencies and unlike Dolby 'B' or 'C', in excess of 10dB at low frequencies.

The high level stage is active for signal levels in the range from -25dB to Dolby level, and provides up to 12dB of boost at frequencies above 400Hz and 10dB of boost at frequencies below 200Hz.

## Revolutionary Potential

The major advantage of the Dolby 'S' noise reduction system is its potential to revolutionise the compact cassette field by providing most of the low noise and some of the wider range advantages of the latest generation of DAT recorders, at a fraction of their price and with less complication.

On the subject of compact cassette recorders, some new and exciting compact cassette tapes have been released by a number of manufacturers. The Japanese company Taijo Yuden (That's Tape), which released the first recordable CD's at the CES last year, has released an advanced version of its SUONO tape cassette. These were produced with the help of Italian designer Giorgetto Giugiaro, who helped design a new three-dimensional and very sophisticated domed body to resist unwanted intermodulation vibration effects in the body shell. The

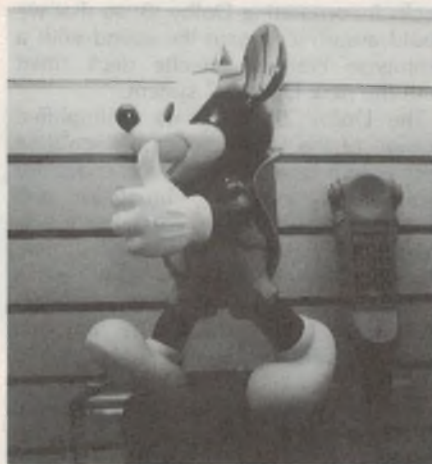
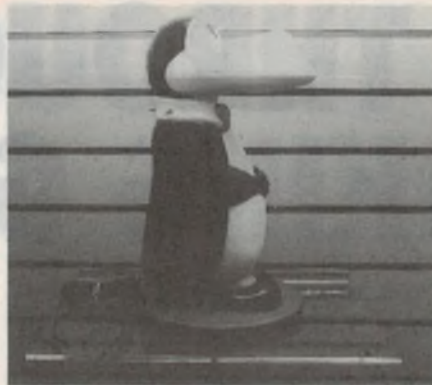

**Novelty phones were still in evidence, including the penguin and Mickey Mouse.**

resulting shell certainly resists some of the vibration effects that can be generated, but at a significant increase in the manufacturing — and consequently, retail price.

The best of the That's Tape is their metal formulation, and with the SUONO cassette their product offers very impressive performance.

TDK was again at the forefront of tape releases, with its new MA-XG metal dual

layer audio cassette tape, which offers the lowest noise (-59dB) and highest output (+7.5dBA @ 315Hz) of any cassette tape currently in manufacture. It is 25 years since TDK came onto the American market with the first of their 'SD' cassette tapes, and they were proud to have been consistently the leaders in most aspects of magnetic tape technology.

BASF, market leaders in the magnetic tape field in Europe, released improved formulations of their 'Chrome Extra II' audio cassettes which they claim is now the world's best-selling genuine chrome audio cassette, and which was selling for only US\$2.99 for a C90 cassette (before discounting).

Their 'Chrome Maxima II' audio cassette now features an improved dual-layer coating technique, a (10%) thicker base carrier film, a substantially reduced print-through and a much improved bass and treble response.

At the TDK stand, I heard about a recording company in San Francisco called Reference Recordings, who have added a twist to the 'Direct to Disc' recording process. Their latest disc 'Dick Hyman Plays Fats Waller' was apparently played on a Bosendorfer SE, which stores its keystrokes and nuances on a computer disc.

The magnetic disc is replayed on another Bosendorfer SE surrounded by microphones which pick up the sound signals and transmit them by microwave links to the CD mastering plant, where they are fed into the mastering equipment without tape, or any of the normal editing processes.

All that trouble just to avoid a tape record and re-play process! But then, some people will go to any lengths to make their product different from the next, especially in the USA...

When it comes to being different, the recorded messages on telephone answering machines show up the differences

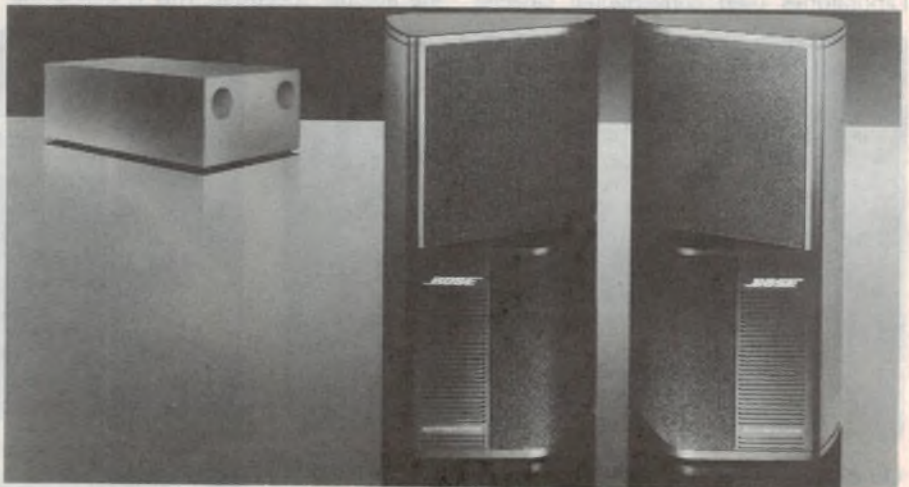

**Bose's new SE5 direct/reflecting system, with Acoustimass subwoofer.**

## 1990 Winter Consumer Electronics Show...

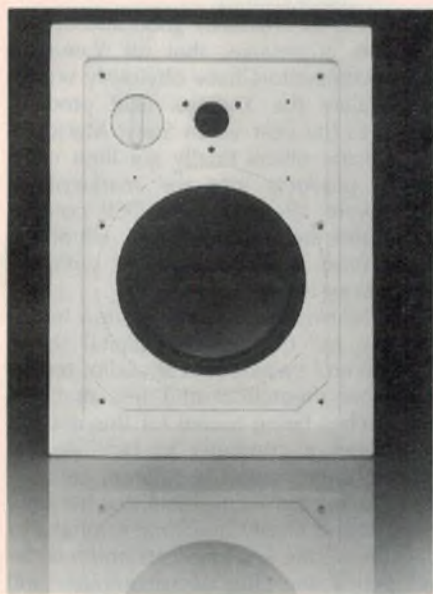

**The Sonance 40 in-wall speaker system, typical of the new breed.**

between individual's imaginations. A lot of people would like to have cute or original messages on their machines, but don't quite know how to do it. You guessed it! Somebody realised there's a new market to be tapped, and a firm called 'Novel Notions' has prepared two cassettes, each with 12 clever messages for your phone answering machine. One is a 'Chain Message', which threatens that "if you don't leave at least another five chain messages on other phone answering machines in the next 48 hours, then woe and betide you!"

### Camcorder cassettes

The most important tape development released at the CES was the new 'Hi 8' video cassettes, a new generation of sophisticated metal evaporation-deposited coatings. These are applied as triple layer coatings to achieve an unusually high frequency output, coupled with ultra smooth running characteristics for the latest generation of 'Hi 8' camcorders.

The 'Hi 8' camcorders are lightweight and miniature, with improved video definition. With more than 400 lines of horizontal resolution, they are now giving the S-VHS-C format camcorders a tough time, as they play for three times as long (up to 120 minutes).

The 'Hi 8' offers some technical breakthroughs. The luminance signal is boosted from 4.2MHz to 5.7MHz for sync peak signals and from 5.4MHz to 7.7MHz for white peak signals. This results in higher resolution and sharper colour reproduction than previous 8mm video camcorders could achieve.

The three dominant suppliers of 'Hi 8'

camcorders at the CES were Sanyo with the VEM-GI, Sony with their Video 'Hi 8' cam, and Canon with their A1, whose superlative new optical system appears to give it the edge over the competition.

The outstanding new TDK Hi 8 tape uses an exciting manufacturing process in which three layers of vapour deposited metal are applied on an ultra stable backing system housed in a sealed cassette shell. I saw some demonstration NTSC field recordings on a large projection monitor and they were exceptionally good.

Another group of consumer products which caught my eye were the latest economy models of combined home fax/telephone machines. They can automatically detect whether you are being rung by a telephone or a fax machine and respond to the source of the call, so you only need one machine and one telephone line to fulfill both requirements.

The lowest priced unit was the Murata 'Double Header', a conventional 'group 3' machine with a 20 number memory, on-hook dialling and a price of only US\$498. The Sharp machine was US\$598 and the Ricoh fax telephone was US\$698. The Panasonic Fax automatic telephone fax machine (with all the features of my existing Panasonic fax machine) also doubles as a photo copier and was on sale at only US\$998.

One closely aligned product group at the CES which attracted considerable interest was the new combined calculator pocket diallers, on which you enter the name and telephone number of your friends, relatives or clients. When you key in the first one to three letters of a person's name, up comes their number. It may require an extra keystroke or two, if there are a number of similar names.



On command (by pressing the dial key), the dialler emits a series of voice frequency dial tones to ring the number. If you place the active portion of the unit over your telephone mouthpiece, (assuming your phone and the exchange use DTMF-tone dialling), you'll be rapidly connected to the desired number.

Public telephones in the large US cities all use DTMF dialling. Australian public telephones, however, don't. So these pocket diallers are only really usable at your office or in homes connected to DTMF dialling exchanges. With a memory capacity of more than 400 telephone numbers, plus a conventional calculator, and typical prices between US\$40 to \$50, they are among the most attractive and economical 'executive toys' on display. The Texas Instrument 'Pocket Diallers' were some of the best configured examples, while Sharp and Casio offered attractively priced models.

### Invisible speakers

I have already reviewed the high powered loudspeakers displayed at the CES, but most readers will be more interested in the consumer orientated home speakers which were released as well.

The most significant trend was the number of manufacturers displaying 'build-in loud speakers' for incorporation in ceiling spaces or in stud wall construction. Two of the most prominent displays were those of Boston Acoustics, who were selling the concept of high fidelity in 'impossible places' with their model 360 and model 350 - two way systems.

Their model 360 system features a 160mm diameter woofer, while the model 350 incorporates a 130mm diameter woofer. Both use a CFT-4 dome tweeter. All build-in speaker systems are easy to install, unobtrusive and have better sound quality than the garden variety public address loudspeaker systems common in airline terminals and



**Above: the 'Lego Phone'. Left: The Acoustic AMP 560, described as 'the largest, most powerful car audio amp in the universe'.**

public halls. The Boston acoustic systems are sensibly fitted with waterproof diaphragms so that they can be installed in bathrooms, kitchens, or boats — a new and growing market, in both the USA and Australia.

The KEF Custom series two-way CR 200F is marketed as being the least obtrusive and having the smoothest frequency response of all of the speakers developed for this market. The innovative design team at KEF has also developed what they claim is the first built-in subwoofer that fits into a standard wall. Model CR 250SW extends the bass response down by at least an octave, to approximately 32Hz.

I listened to this subwoofer system, working in a dummy wall in conjunction with a pair of CR 160R wall speakers, and was so impressed that I decided we would just have to review them in the magazine. (Editor's Note: Coming soon...)

At least another eight manufacturers were also offering innovative wall mounted louspeakers, including Cerwin Vega, Fosgate, Sony, Sonance, and the well received Yamaha AST. There is an obvious market demand, particularly in new houses where owners want not only more discrete installations, but also bet-

ter performance, and are prepared to pay for it.

Over the last three years, there has been a growing trend to release new subwoofers at the CES, and if we ignore the monsters that I saw in the back of cars, vans and trucks, this was more evident than ever. Yamaha has released an impressive expanded AST range, Sony released its Mega Bass SRS-57 and 67, and Bose released two new direct reflecting speaker systems to which the acoustimass subwoofer system is added.

The Bose subwoofer system is stil the most outstanding, the smallest and (I believe) the most innovative of those on offer, although other manufacturers are now hot on their heels with a range of competing units, some of which produce higher power levels with lower distortion.

The latest speaker technology satisfies the demands of yuppies in American, European and Japanese apartments, who want to be able to reproduce the peak sound levels of orchestral drums, without the need for huge bass reflex speakers.

When Yamaha released their Digital Sound Processors three years ago, they really set the competition back. The product was outstanding, its technology the result of many years research. The

product is so obviously good and the results so impressive, that all Yamaha's major competitors have obviously set out to emulate the Yamaha DSP product. This was the year when Sony, Matsushita, and the others finally got their competing products into the marketplace. They were offering major DSP components and, rather surprisingly, simplified DSP components to compete with the Yamaha systems.

The Matsushita Communication Industrial Co has developed a digital sound field control system for car audio, one of the more theoretical and less practical approaches being touted for this market. It requires a computer to facilitate the multi-channel sound generation capability. The company considers that the tight bass, sound clarity and dimensional dispersion are the key elements and has developed a one chip microcomputer and LCD (or fluorescent display) with control buttons on the car's dashboard. Their miniaturised automotive system appears to be at least two years from practical implementation. Once that system is available, however, I believe that DSP will advance one stage further on its way to becoming one of the most outstanding electro-acoustic advances of the last decade.



## AVO ELECTRONIC SYSTEMS PTY LIMITED

188-192 Pacific Hwy. (Cnr Bellevue Ave.) St. Leonards. N.S.W. 2065

Tel: (02) 906-2655 Fax (02) 906-2735

Training, installation and problem solving specialist

Reliable repair and service by qualified engineer

Full 12 months parts and labour warranty

### DTP Special Package

- \* 386 20 MHz
- \* 80 MB HDD
- \* 2 MB RAM
- \* 1.2 & 1.4 FDD
- \* VENTURA SOFTWARE & TRAINING
- \* 1024 X 768 14" NEC MON
- \* TI LASER — HF Laserjet III Compatible and upgradeable to Postscript!!!!

RRP ~~\$12,600~~ NOW \$9999

### PC XT

12 MHz CPU  
360KB FDD  
20 MB HDD  
101 KEYS KB

MONO \$1250  
CGA \$1553  
EGA \$1838

### PC AT

80286 CPU  
12 mHz 0 WS  
1.2 MB FDD  
20 MB HDD

MONO \$1615  
EGA \$2202  
VGA \$2290

### PC SX

80386 SX  
1024 KB RAM  
42 MB HDD  
LM = 26 MHz

MONO \$2451  
EGA \$3038  
NEC3D \$3674

### PC 386

80386 — 33 MHz  
1 MB RAM  
80 MB HDD  
LM = 59 MHz

MONO \$4442  
EGA \$5029  
NEC3D \$5665

STORAGE	DISPLAY	PRINTER	ACCESSORIES
20 MB Harddisk & card \$465.00	Mono & CGA (dual) card \$75.00	Panasonic 9 pins \$330.00	12" x 12" Digitiser \$590.00
42 MB VC HDD & card \$825.00	EGA card \$185.00	Epson 10" 9 pins \$380.00	Mouse with software \$85.00
70 MB VC Harddisk \$1100.00	VGA card (16 bits) \$250.00	Epson 10" 24 pins \$585.00	Keyboard draw \$75.00
100 MB VC Harddisk \$1450.00	Dual mode monitor \$188.00	Star 15" 9 pins \$680.00	Joystick \$30.00
150 MB ESDI Harddisk \$2180.00	EGA monitor \$600.00	Epson 15" 24 pins \$1280.00	Printer stand \$25.00
330 MB ESDI Harddisk \$2490.00	VGA monitor \$630.00	Printers switch box \$45.00	Diskette Storage Box \$18.00
360 KB Floppy disk drive \$135.00	NEC 2A Super VGA \$720.00	Printer cable \$12.00	360 KB DDSD Diskette/10 \$10.00
1.2 MB Floppy disk drive \$165.00	NEC 3D Multi-sync \$1080.00	Printer stand \$25.00	1.2 MB DSHD Diskette/10 \$25.00
1.4 MB Floppy disk drive \$195.00	NEC 4D 16" \$2180.00	TI Laser \$2180.00	1.4 MB DSHD Diskette/10 \$50.00
AT HDD/FDD controller \$185.00	NEC SD 20" \$3630.00	HP Laser \$3630.00	call Co-processor from \$250.00

# Yamaha brings you the most innovative entertainment technology since moving pictures...

## Moving sound.

Prepare yourself for a very special audio and video experience.

With Yamaha's innovative Digital Sound Field Processor technology, you can recreate the excitement of actual live performance venues and cinema sound, right in your own living room.

Digital Sound Field Processing precisely recreates the special ambiance of these environments, for a breathtaking listening experience.

At the touch of a button you can have the acoustic characteristics of a European concert hall, a Jazz club, an open air Rock venue, a Disco, a Church or even an Opera house.

When watching video, just select DOLBY® PRO-LOGIC SURROUND to recreate the magic of the cinema.

For example, when a movie shows a gun being fired, you'll hear the bullet ricochet around the room. When a plane prepares to land, you'll hear it soar over you from behind and touchdown at the front of the room - that's just how life-like this system sounds! All functions are

fully managed by a learning remote control which completely integrates and operates your TV, video and audio system.

To experience the excitement of 'MOVING SOUND' and to find out just how easy this system is to operate and install in your living room, see your local YAMAHA HI-FI Specialist now.

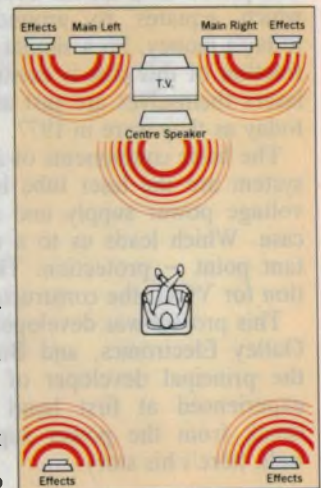

Multi-dimensional sound imaging created with a 7-speaker DSP-Dolby Pro Logic surround system.



Yamaha's exciting 'Moving Sound' system: The DSP-A700 amplifier and its companion AVS-700 selector, centre speaker, main speakers and the smaller effects speakers.



\*Dolby Pro Logic Surround is a trademark of Dolby Laboratories

## Construction Project:

# New low cost Helium-Neon Laser

If you thought a gas laser project was too expensive, try this one for size. For less than \$240 you can construct our new helium-neon laser, which features a single PCB contained in a neat plastic case. It's simple to build and requires no adjustments. Build it and explore the fascinating world of the laser!

by PETER PHILLIPS

When low-power gas laser tubes first became generally available some 20 years ago, a number of laser projects were published in various magazines, including *EA*. Our first such project was described in August 1969, for example.

The interesting feature of all these projects was their cost. The laser project published by *EA* in October 1977 was priced as a kit for \$180 (plus tax), which equates to around \$1000 in today's money. So a similar project at a fraction of this cost is exciting news, as lasers themselves are just as fascinating today as they were in 1977.

The basic components of any gas laser system are the laser tube itself, a high voltage power supply and a protective case. Which leads us to a most important point — protection. That's protection for YOU, the constructor.

This project was developed by staff at Oatley Electronics, and Branco Justic, the principal developer of the project experienced at first hand an electric shock from the power supply that — well, here's his story:

### It nearly killed me!

*"The power supply used to operate a laser tube develops very high DC voltages and is capable of delivering currents that are potentially lethal. Anybody who has survived an electric shock from a high voltage DC supply will tell you it is most frightening."*

*"I experienced an incredible shock from the high voltage DC section of this unit during its development, and if someone else had not turned off the power, this might have been my last, and unfinished, project. A DC voltage paralyses, unlike AC which tends to throw you away, and the burns to my hand are still healing."*

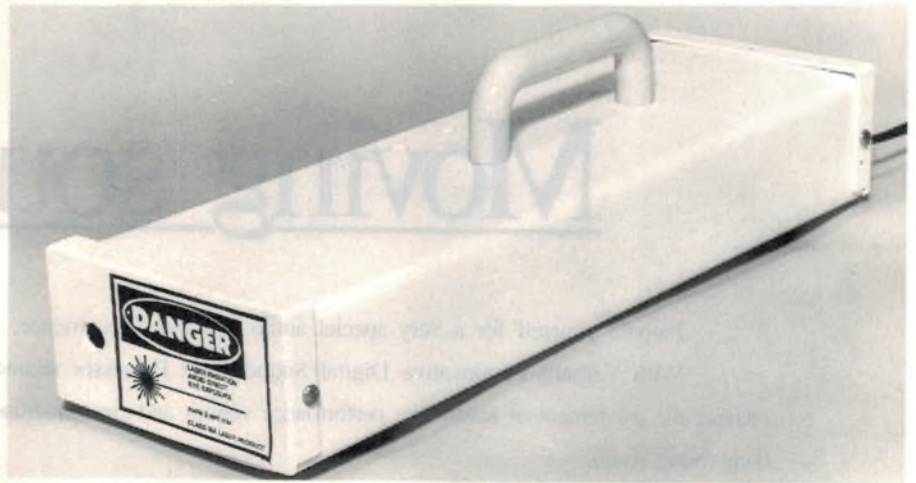

Get into laser technology with this inexpensive project. The unit features a 0.8mW helium-neon laser tube and single PCB construction.

As a result of this event, Oatley Electronics re-designed the PCB and the case, and have asked us to print the following warnings, with which we thoroughly agree. This is a potentially dangerous project, and to protect constructors, Oatley Electronics, the suppliers of the kit, may request intending purchasers to offer proof of their age. They have decided to restrict sales to those over the age of 18 years and will possibly ask you to sign to the effect that you have read the warnings. The warnings are simple enough, and we at *EA* totally agree that they should be followed by all constructors.

### Warnings

1. Looking directly at the laser beam close to the laser tube could damage your eyes.
2. The power supply of this project is POTENTIALLY LETHAL.

Therefore, while you are working on the exposed PCB, have someone else

present who can switch off the power in case of accidents. And remember, the capacitors in the power supply can hold a charge after the power is switched off. Placing a short circuit across the tube will discharge all the capacitors, assuming the circuit is correctly wired and free of faults. As a final test, to confirm no residual charge remains, measure the voltage across each capacitor with a meter fitted with suitably insulated probes.

Finally, tell anyone using the laser of these hazards, and attach a warning label inside and on the outside of the case. A suitable label is included in the article for this purpose.

Having explained the dangers of a laser, we can now look at what the laser is all about.

### Laser recap

The word 'laser' is an acronym for Light Amplification by Stimulated Emission of Radiation, and the first



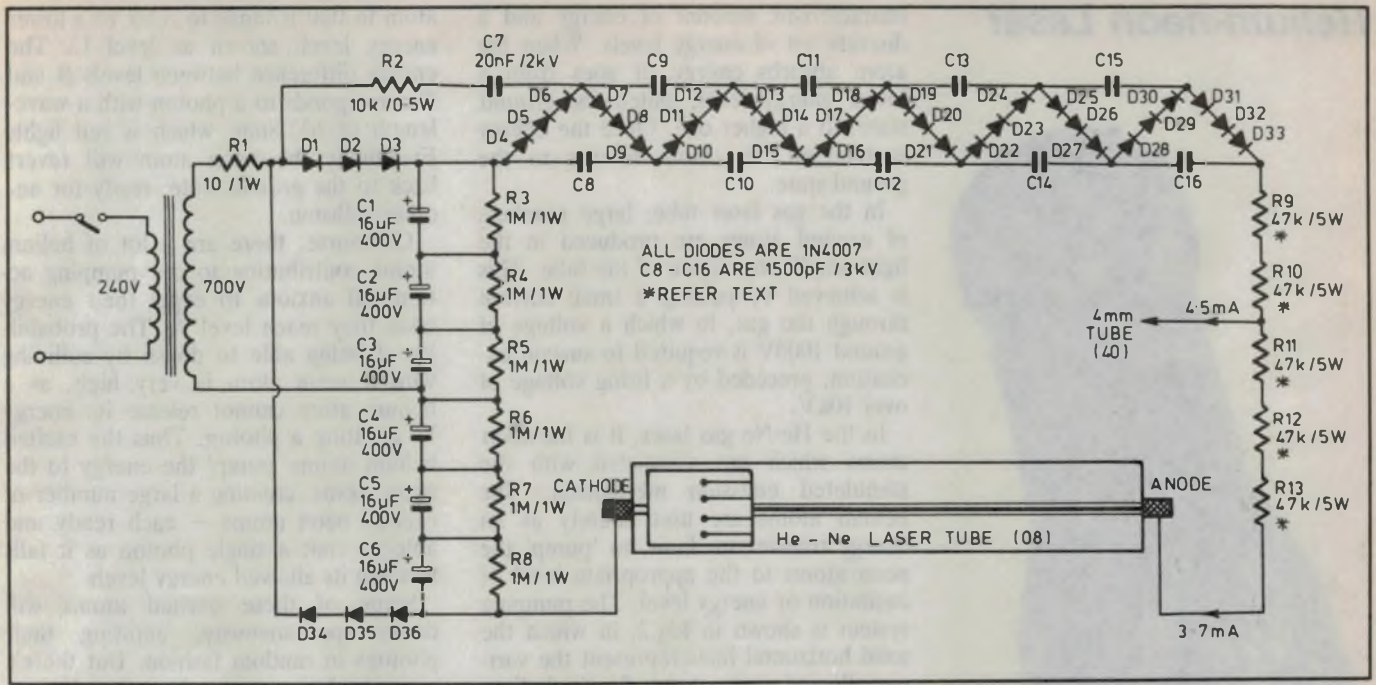

**The circuit diagram. The circuit comprises a voltage doubler supplied with 700V AC, a multistage voltage doubler to trigger the laser tube and a ballast resistor consisting of R9 to R13. It's all high voltage stuff, with enough punch to kill. Be careful!**

operational laser was developed in 1960 by Theodore Maiman. The Maiman laser used a synthetic ruby crystal as the active material, and emitted a red beam of light (see Fig.1). Since then, other 'lasing' materials have been developed, along with a range of techniques to produce the lasing action.

The three main categories of lasers are the optically pumped (solid, liquid or gas), the discharge excited gas, and the electron injection (or semiconductor) type. The optically pumped laser tube uses a high intensity light source, such as a xenon flash tube, to excite the atoms in the laser material, and this type can produce tremendous output energy (5 billion watts peak power). The other two systems are directly excited by electricity, but have an output much less than the optically pumped type, usually to a maximum of several kilowatts.

The semiconductor laser is the most efficient of all the types, (around 50%), while the optically pumped type is less at 4%. Most gas lasers are very inefficient, usually less than 0.2%. The semiconductor laser is also very compact, (1mm cube), but needs cooling to keep the efficiency high. The most common semiconductor laser material is gallium arsenide, although other types are being developed.

Lasers can also be designed to operate in either pulsed or continuous wave mode, and the pulsed type can produce

higher peak outputs than the continuous wave. Most lasers produce red or infrared light, but other colours can be produced by the discharge excited gas types by mixing different gases.

### The He-Ne laser

The helium-neon (He-Ne) laser is the most common type of discharge excited gas laser. It emits a bright, deep red beam, at a wavelength of around 633nm (nanometres). The glass body of the laser tube is filled with approximately 10 parts helium and one part neon, to a pressure of around 1mm Hg. Electrodes are placed at either end of the tube to allow a high voltage to ionise the gas, thereby exciting the helium and neon atoms.

Mirrors mounted at either end of the tube form an optical resonator (known as a Fabry-Perot resonator). Usually, one mirror is totally reflective and the other only partially reflective, the latter forming the output of the tube. The mirrors are fused in place during manufacture, and adjustment is therefore impossible. Earlier tubes designed for experimental purposes sometimes had external adjustments for the mirrors, but this is now fairly uncommon.

The He-Ne laser tube actually comprises two tubes; an outer plasma tube that contains the gas, and a shorter and smaller inner capillary tube, where the actual lasing action takes place. This smaller tube is attached at one end of the outside tube, and the other, free

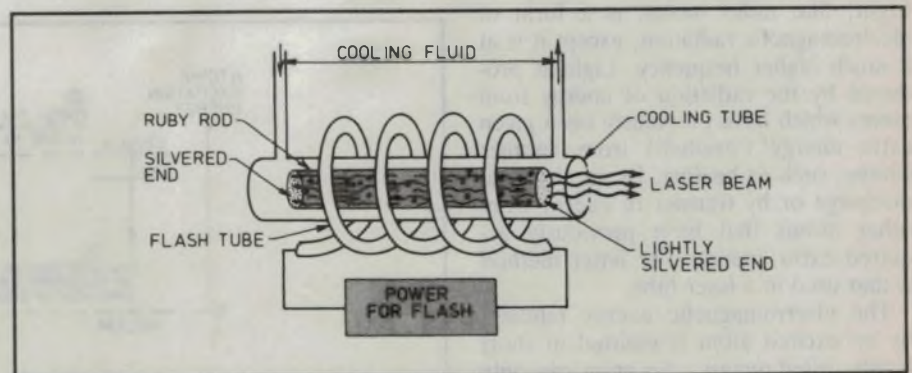

**Fig.1: The ruby laser, similar to that used by Maiman in 1960, consists of a cylindrical ruby rod with mirrored ends, a cooling tube and a flash tube to invoke the lasing action.**

## Helium-neon Laser

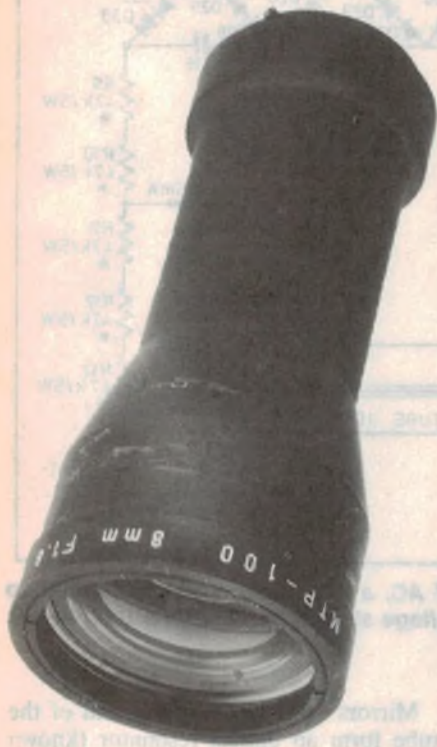

A collimator such as that shown in this photo is used to focus the laser beam into a narrow point source. The collimator is simply a glass lens, and the beam enters at the wide end. Positioning of the collimator is not critical, but it will need to be fixed firmly in place.

(and open) end faces the partially reflective output mirror. The capillary tube is usually held in place by a metal spider.

### Light generation

The lasing action of the Ne-He gas laser tube is fairly complex and falls into the science of Quantum Physics. Light, like radio waves, is a form of electromagnetic radiation, except it is at a much higher frequency. Light is produced by the radiation of energy from atoms which have previously been given extra energy ('excited') from another source, such as heating, by an electrical discharge or by transfer of energy from other atoms that have previously acquired extra energy. The latter method is that used in a laser tube.

The electromagnetic energy released by an excited atom is emitted in short bursts called *quanta*. An atom can only emit a single quantum, after which it needs to absorb extra energy before repeating the discharge. Each atom has a

characteristic amount of energy and a discrete set of energy levels. When the atom absorbs energy, it goes from a lower energy level, called the *ground* state, to a higher one. Once the energy is released, the atom returns to the ground state.

In the gas laser tube, large numbers of excited atoms are produced in the light amplifying region of the tube. This is achieved by passing a small current through the gas, in which a voltage of around 1000V is required to sustain excitation, preceded by a firing voltage of over 10kV.

In the He-Ne gas laser, it is the *neon* atoms which are associated with the stimulated emission mechanism. The helium atoms are used merely as an energy transfer medium, to 'pump' the neon atoms to the appropriate level of excitation or energy level. The pumping system is shown in Fig.2, in which the solid horizontal lines represent the various allowed energy levels for the helium atoms (left) and neon atoms (right). The so-called 'ground' state is shown at the bottom of the diagram.

When an electric current is passed through the gas, the combination of the high temperature and the electric field existing in the discharge plasma causes helium atoms to be ionised and accelerated, thereby exciting them to energy levels above the ground state.

One of the allowed energy levels for helium corresponds to a number of closely spaced energy levels for the neon atom (shown on the right of the diagram). Because of this level equivalency, a collision between a helium atom and a neon atom will result in a total transfer of energy from the helium atom to the neon atom. The helium atom will now fall back to the ground level, leaving the neon atom with an energy level shown as point B on the diagram.

The neon atom is unlike the helium

atom in that it tends to relax to a lower energy level, shown as level C. The energy difference between levels B and C corresponds to a photon with a wavelength of 632.8nm, which is red light. Eventually the neon atom will revert back to the ground state, ready for another collision.

Of course, there are a lot of helium atoms contributing to the pumping action, all anxious to expel their energy once they reach level A. The probability of being able to do so by colliding with a neon atom is very high, as a helium atom cannot release its energy by emitting a photon. Thus the excited helium atoms 'pump' the energy to the neon atoms, creating a large number of excited neon atoms – each ready and able to emit a single photon as it falls through its allowed energy levels.

Some of these excited atoms will decay spontaneously, emitting their photons in random fashion. But there's more to laser action than this; in fact here's where the actual *lasing* takes place.

As it happens, an excited atom can actually be 'stimulated' into decaying and emitting its photon, by the influence of another photon passing close by. This is the effect known as *stimulated emission*. And an important feature of the effect is that the newly emitted photon turns out to be precisely *in phase* with the one that stimulated its emission.

So the first photon effectively causes the creation of an exact 'clone' of itself, without being effected. In fact both the original photon and its newly emitted clone can continue on – to have the same stimulating action on other excited neon atoms.

In this way each photon can actually stimulate the emission of a large number of clones, all identical in phase to it. So we have a mechanism of light *amplification*, arising directly from the stimu-

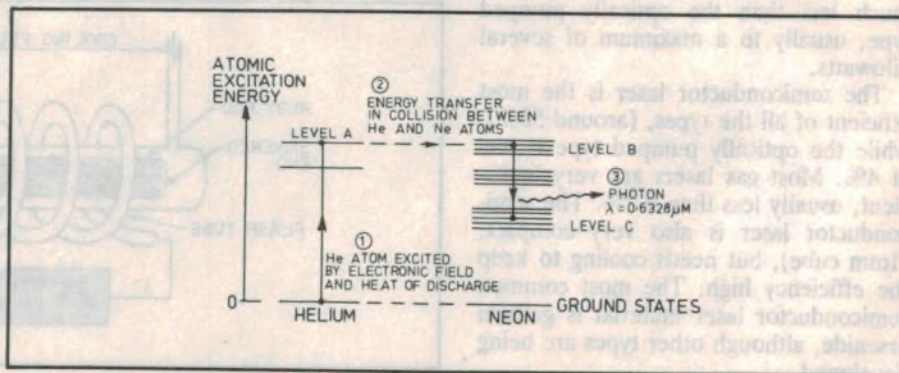

Fig.2: At (1), the helium atoms are raised to energy level A, where they transfer their energy to neon atoms during collision (2). When the neon atoms fall from energy level B to C, (3) they emit a photon of red light.



**This photo shows a 4mW He-Ne laser tube that can be used instead of the 0.8mW tube described in the article. It's larger and much brighter.**

lated emission process.

In the gas laser we ensure that this lasing action operates continuously by squeezing the excited atoms into a long, narrow capillary tube. This allows photons that are emitted along the axis of the tube to pass by many other excited atoms, to stimulate the production of clones. By providing accurately aligned mirrors at each end we also force the photons to bounce back and forth along the axis, so that the lasing action continues to build up.

It's rather like turning an amplifier into an oscillator, by applying positive feedback.

### Laser light

Laser light differs from that emitted by conventional sources such as a tungsten filament lamp. The first difference is that because all of the photons are in phase, laser light is *spatially coherent*. This means the crests and troughs of each light wave in the beam coincide, reinforcing each other, unlike all other light sources which are *incoherent*.

Laser light also tends to be highly *collimated*. That is, the rays are nearly parallel to one another, and diverge only slightly as they travel. This allows a pinpoint of light to be displayed on a target, even though the beam may have travelled many kilometres.

The other important feature of laser light is that it is *monochromatic*, or a pure single colour. This is because all the light waves in the beam have the same wavelength, unlike most other sources of light. In fact, white light such as that from the sun is made up of light

waves with a mixture of wavelengths, combining to give the appearance of white. A few conventional light sources, such as low-pressure sodium vapour lamps, emit light that is almost monochromatic, but the light output is neither coherent nor intense.

### Uses

Lasers are now fairly common as a tool, particularly in the areas of measurement, medicine, metal welding and so on. The compact disc player uses a low power laser as the means of reading the surface of the disc, while laser light shows are a feature of most pop music concerts. Another use is as a communications channel.

Theoretically a single laser beam can be modulated to carry thousands of radio, television and telephone messages simultaneously. The advantage is that security is high, as the beam is rather like a wire link, instead of an antenna radiating the signals everywhere. The use of laser communications in space was first applied in the manned Gemini flights in 1966, and subsequent forays into space have used the laser for communications between earth and the spacecraft.

A problem with using a laser as the communications link is its inability to pass through dust, clouds and other similar obstructions. Also, the complexity of the equipment tends to make it less attractive than conventional communication techniques.

The laser is also useful at creating holograms, in which a three dimensional picture appears to be suspended in

space. This technique uses special photographic processes that require the specific properties of laser light (monochromaticity and coherence).

Powerful lasers capable of welding or cutting metals are used where conventional methods are incompatible with the metals being used. In fact, the use of lasers in industry is widespread, and most resistors made today are 'laser trimmed' to get the required value. By using special lenses, a laser beam can be focused to give a pinpoint of light suitable for welding ceramics or for cutting tiny holes in metal. The nozzle in the ink cartridge of an inkjet printer has some 40 holes, drilled by a laser beam. And of course, the laser printer uses the beam itself to create an image on a photoconductor drum for subsequent transfer to the printed page.

Another popular use of a laser is in eye surgery, where detached retinas can be rejoined by burning the tissues at the point of detachment. The resulting scar tissues effectively reconnect the retina, preventing blindness. Similarly, burst blood vessels in the retina can be sealed with a laser, preventing partial or even complete blindness. Bloodless surgery is also performed with lasers, in which a laser is used as the cutting implement instead of the scalpel. The laser cauterises the blood vessels as it cuts, preventing bleeding at the incision.

So that's a brief look at lasers in general, which hopefully has removed some of the mystery as well as showing that the laser is far from being a novelty. Of course, the power output of a laser is the key to its capabilities, and the laser in this project is not going to be a substitute for a welding machine or a knife. It's basically for experimental and demonstration work.

We'll present some uses for this project after describing the circuit diagram and how to build it.

### Circuit details

As already described, the main components of this project are the laser tube, a high voltage DC power supply and the plastic case which contains everything. Although the power supply can operate different types of He-Ne laser tubes, some component changes are needed for higher power tubes.

The recommended tube for this project is one with a rated output of 0.5 to 0.8mW, and the values shown on the circuit diagram are compatible with this type of tube. The specified tube requires approximately 3.7mA of operating current, with a voltage drop across the tube of 1010V. This represents a

## Helium-neon Laser

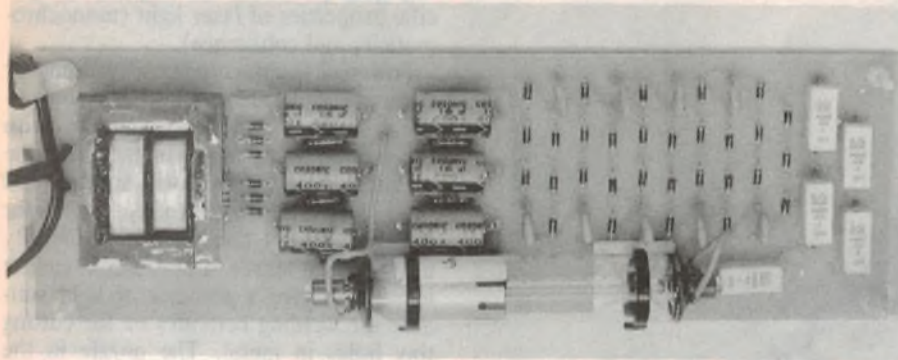

This photo shows the prototype PCB. The laser tube is held on the board with two adhesive bases, attached to the tube with cable ties.

total power input to the tube of 3.737W, which for a 0.8mW output gives an efficiency of 0.021%. Not a high efficiency by any means, but 0.8mW of laser light is amazingly bright, and reflections off low flying clouds, adjacent hills and so on will be clearly visible.

The light output is the characteristic red beam, with a wavelength of 632.8nm. The tube requires a firing voltage of around 8kV, and the recommended ballast (or series) resistor is 75k. The ballast resistor effectively converts the circuit into a constant current source, and different tubes require different values of ballast resistors. Oatley Electronics will supply these resistors and the necessary information for tubes other than that described in this article, such as the 4mW type shown photographed and referred to in the price list at the end of this article.

The circuit is really very simple, although the number of series connected components suggests otherwise. The series strings are needed to accommo-

date the high voltages, and if suitably rated components were available, the schematic could have been simplified to that shown in Fig.3.

The circuit consists of a custom made 240V/700V PCB mount transformer, a voltage doubler, a multistage voltage multiplier and the series-connected ballast resistors. The transformer drives the voltage doubler through overload protection resistor R1, and the output of the doubler will be around 2kV at no load. The doubler circuit consists of diodes D1, D2, D3, D34, D35, D36, capacitors C1 to C6 and the bleed resistors R3 to R8.

The bleed resistors discharge the capacitors when the power is turned off, and also help to equalise the voltages across the capacitors C1 to C6. Note that 1W resistors are specified for these resistors, as the higher wattage rating also gives the necessary voltage rating for the resistors.

The voltage multiplier is used to provide the 'kick-start' voltage for the tube, and is driven by the output of the volt-

age doubler. When power is first applied, the 2kV output of the voltage doubler will be boosted by the voltage multiplier to somewhere in excess of 10kV. Once the tube fires, the multiplier circuit will be unable to supply current, and the tube will be driven by the voltage doubler via the series connected diodes in the multiplier (D4 to D33). Thus the positive potential appears at the cathode of D33, and the negative end is at the anode of D36.

The ballast resistor is made up of the series-connected resistors R9 to R13. These resistors are all 47k, 5W wire-wound types, and provide a total resistance of 235k – well in excess of the recommended minimum of 75k. Thus, the current is maintained at a constant value, as the impedance of the circuit is very high. The total voltage drop across the ballast resistors is around 870V (174V across each resistor), and the total power dissipation in the resistors is approximately 3.3W (0.66W in each resistor).

All diodes in the circuit have a 1kV PIV rating, and the capacitors in the voltage multiplier are 1.5nF/3kV ceramic types. The electrolytic capacitors (C1 to C6) are conventional 400V/16uF capacitors, but with a smaller physical size than similar capacitors were in the days of valve equipment.

### Construction

Before we start, another warning needs to be made. A kit of parts for this project is available from Oatley Electronics, who have spent considerable effort to ensure the supplied components are suitable and correctly rated.

The transformer is custom made and insulated with baked enamel for highest

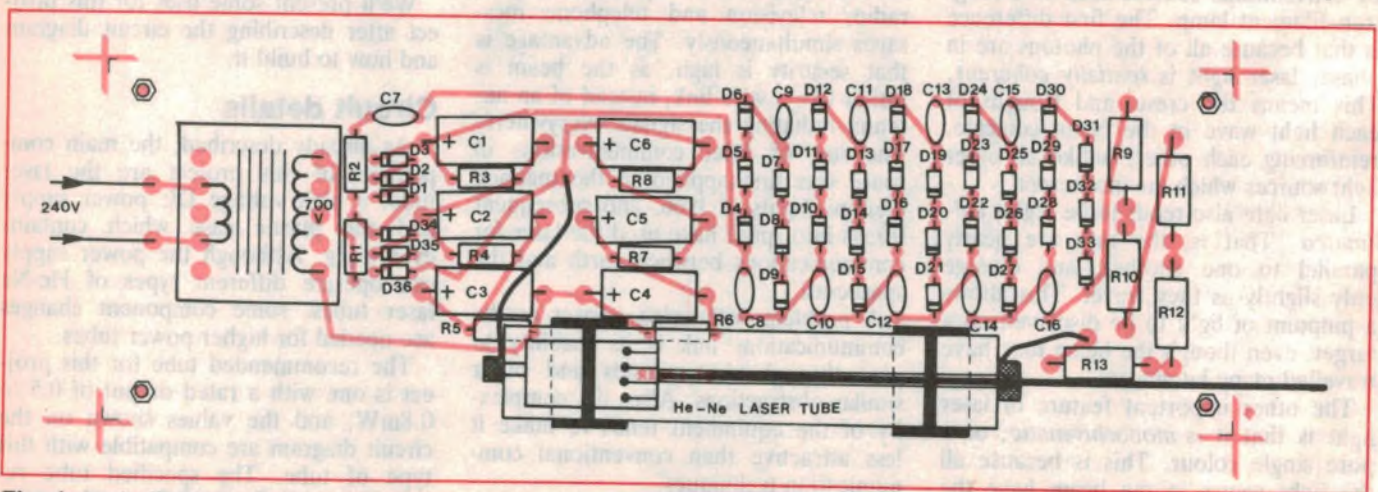

The layout diagram. Take special care with the orientation of the diodes, the transformer, the laser tube and the electrolytic capacitors. The tube is mounted so that the internal metal spider is at the transformer end. When the PCB is completed, but before the tube is fitted, spray the track side with PCB lacquer.

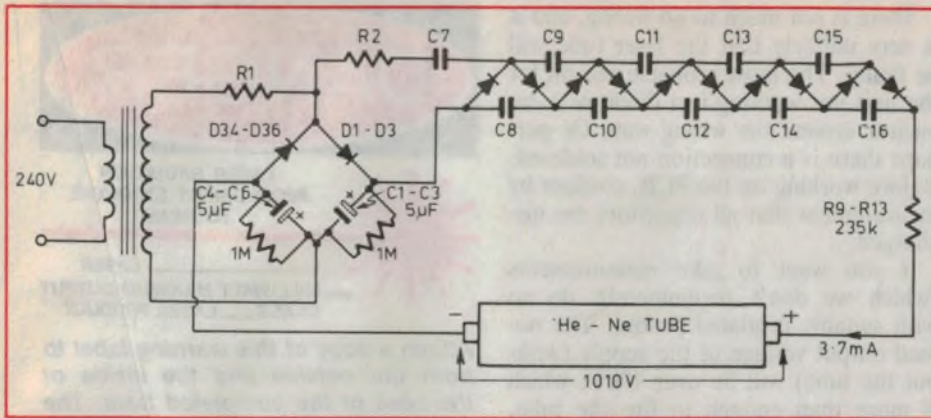

**Fig.3:** When simplified, the circuit for the laser looks like this. The voltage doubler supplies the tube under normal operation, and the voltage multiplier provides the firing voltage for the tube.

## PARTS LIST

- 1 PCB coded OELASER
- 1 Model 05 laser tube
- 1 Insulated mains switch
- 1 240V/700V transformer
- 1 360mm length of 50 x 100 square section plastic moulding for case
- 2 Plastic end caps to suit moulding
- 1 Plastic sheet, 320 x 95 x 1mm
- 1 Plastic handle
- 2 Warning labels
- 1 Length of 2-core mains flex and plug
- 4 Adhesive rubber feet
- 2 Cable ties and stick on bases to hold laser tube; self-tapping screws; nylon nuts and bolts, grommet, cable clamp and hook up wire

### Resistors

1 x 10 ohm 1W, 1 x 10k 1/2W, 6 x 1M 1W, 5 x 47k 5W (see text if different tube used).

### Capacitors

9 1.5nF 3kV disc ceramic  
1 0.02µF 2kV disc ceramic  
6 16µF 400V electrolytic

### Semiconductors

36 1N4007 1kV 1 amp diodes

*Kits of parts for this project are available from:*

*Oatley Electronics  
5 Lansdowne Parade,  
Oatley West, NSW 2223.  
Phone (02) 579 4985*

*Postal address (mail orders):  
PO Box 89, Oatley West NSW 2223.*

*Complete kits with 0.8mW laser tube ...*  
..... \$239.90

*Complete kit with 4mW laser tube*  
*(see text)..... \$349.50*

*Post and packing (certified) ..... \$10.00*

*Note that the PCB artwork for this project is copyright to Oatley Electronics.*

possible isolation. The 1.5nF/3kV capacitors are special types, and other similarly rated capacitors may not perform correctly in their place. In other words, if you want to try and source your own components, be it at your own risk. At best, the project may not work, and the inherent dangers of the power supply make faultfinding very hazardous.

It's particularly important not to try substituting lower wattage resistors for the ballast resistors R9-R13. We have used 5W types not for their power rating, but in order to achieve a safe margin in terms of *voltage* rating.

Construction of the kit is very simple, as everything mounts on the one PCB. Start by carefully checking the PCB for any manufacturing errors. Because later faultfinding is likely to be hazardous, making continuous checks of your work is essential to ensure the circuit works first up. Once you're convinced that the PCB has no problems, it becomes a matter of loading and soldering the components, with the laser tube being the *last* thing to be fitted in place.

Before any components are fixed in place, the case mounting holes should be drilled using the blank PCB as a guide. A piece of grey plastic is provided as an insulator for the track side of the PCB, and this and the case will need to be drilled with a 4mm drill at the four mounting points of the PCB.

The layout has been designed to make component orientation easy to follow. For example, diodes D4 to D33 are arranged in 10 strings of three diodes. Each string has the diodes facing the same way within the string, while each alternate string has the group facing opposite ways. Similarly, the diodes next to the transformer all face the same way.

Using the layout diagram as a guide,

solder all the diodes in place and check their orientation before continuing, perhaps even using a meter as a double check.

The electrolytic capacitors C1 to C6 again all face the same way, and these along with the 1M resistors can now be installed followed by the remaining capacitors and resistors. The transformer is designed to mount directly onto the PCB, although residual lacquer may need to be scraped off the pins. Note that the transformer can be mounted either of two ways, and the correct way can be seen by noting that the winding terminations match the PCB pads. No harm will result if you mount the transformer backwards, as power won't make it to the transformer; the project simply won't work!

The 240V lead can now be attached, and as shown in the photographs, the lead should be secured with a clamp held by one of the mounting screws. Note that because the unit is double insulated, an earth wire should *not* be used. Drill holes in the end cap to hold the switch and as an exit point for the power lead, before attaching the lead itself.

Before fitting the tube, carefully compare your PCB to the layout diagram and check for any errors. Sorry if we sound a bit repetitive, but the circuit won't work if a component is in backwards, or if something is left out – and because of the high voltages, a fault may be rather unforgiving. Once the PCB is complete, spray PCB lacquer on the track side to minimise the possibility of corona discharge. Most PCB lacquers are resistant to high voltages, and several layers will give the best protection.

Finally, the tube can be fixed in place. First solder two leads to the connection points of the tube. Do the soldering carefully and quickly to avoid

damaging the tube, then attach the supplied plastic mounts to either end of the tube with plastic ties wrapped around the body of the tube. The mounts are fixed to the PCB with adhesive tape (already on the mounts), and the tube should be orientated with the internal

## Helium-neon Laser

metal spider of the tube at the transformer end of the PCB. Attach the wires from the tube to the PCB points shown on the layout diagram.

The remaining tasks are to fit the handle to the case and to drill a hole in the front end cap, for the laser beam to pass through. To attach the handle, drill two holes in the bottom of the case for screwdriver access, and drill holes for the screws attaching the handle in the top of the case. We also drilled three 6mm holes in the top of the case above the tube, for ventilation and to give a bird's eye view of the tube.

We recommend you fit the PCB into the case before testing, as the chances of it not working are fairly unlikely. The grey plastic sheet is fitted between the PCB and the bottom of the case, and the whole assembly is attached to the case with four nylon nuts and bolts. A few nylon washers between the PCB and the grey plastic will give clearance for the projecting soldered joints of the PCB. Fig.4 shows how the unit is assembled into the case and how the case fits together.

Then it's simply a matter of applying power to the unit.

### Testing

We stress again: test the unit inside its plastic case. If you have to work on it outside the case, leave the grey plastic sheet attached and clear a wide area on the workbench.

If the laser tube doesn't immediately greet you with an output when power is applied, switch off the power. Remove the plug from the power point, wait a while for the capacitors to discharge then remove the PCB from the case.

There is not much to go wrong, and it is very unlikely that the laser tube will be faulty. The most probable reason for the unit not working is a diode or a capacitor around the wrong way. Or perhaps there is a connection not soldered. Before working on the PCB, confirm by measurement that all capacitors are discharged.

If you want to take measurements (which we *don't* recommend), do so with suitably insulated probes. The no-load output voltage of the supply (without the tube) will be over 10kV, which is more than enough to fire the tube, regardless of its age and other factors.

### Using the laser

We intend to publish application projects for the laser, but it has a range of uses as it stands. The most typical use is as a light show, and shining the laser through smoke, a glass of water or off a reflective surface will all enhance the display. Bouncing the beam off low level clouds (best in the evening) is a sure way to attract attention.

Because the beam is narrow and intense, a laser can be used as a substitute for a string level. Amaze your neighbours the next time you build a fence, or undertake any construction that needs a level reference. Just watch that you don't hit it with a hammer or drop it on the ground! Surveyors often use lasers, although a collimator is generally required for best accuracy.

Teachers will find a laser beam an excellent way to demonstrate the properties of light. The laser beam can be passed through a range of lenses, or it can be used to prove that the angle of incidence equals the angle of reflection. The laser beam's monochromatic qualities can be shown with a glass prism,



LASER RADIATION  
AVOID DIRECT EXPOSURE  
TO BEAM



— LASER  
— MILLIWATT MAXIMUM OUTPUT  
CLASS — LASER PRODUCT

**Attach a copy of this warning label to both the outside and the inside of the case of the completed laser. The label should state that the unit has a Helium-Neon laser of 0.8mW output and that the device is a Class II laser product.**

and the collimated qualities of the beam can be demonstrated by bouncing it off a distant building.

Another exciting application is to create shapes with the beam. This is fairly complex, as it requires a mechanical system to move the beam. However, random shapes that change with music can be created by attaching a reflective film to a speaker and driving the speaker with an audio signal. The mirror needs to be curved for this to be effective, and two speakers, each with a reflective surface can create some very fancy shapes. With a bit of ingenuity, it would be possible to actually trace a wave shape by using one speaker driven with a sawtooth waveform (the X axis) and the other with the signal itself (Y axis).

So there it is, an inexpensive laser project that should be suitable for many applications, limited only by your imagination. Oh yes — you did fit the warning labels as described, didn't you? 

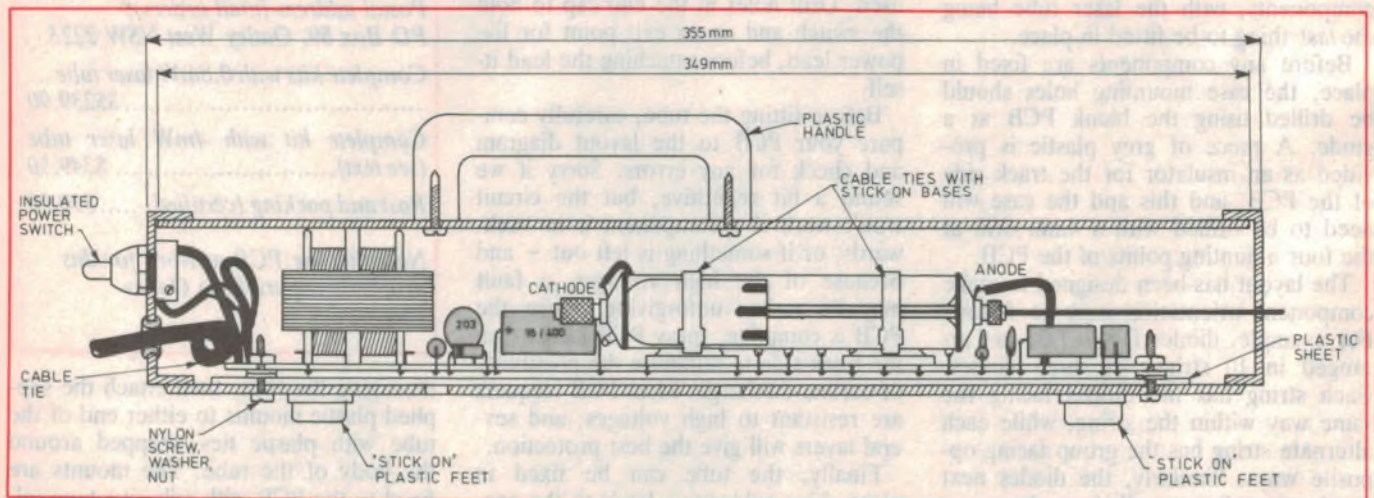

**Fig.4: The final assembly looks like this, in which the PCB attaches to the case with four nylon screws and nuts, with the plastic sheet between the PCB and the case. Note how the mains lead is secured with a plastic clamp.**

# AT&M

AUSTRALIAN TEST AND MEASUREMENT Pty. Ltd.

28 HOTHAM PARADE ARTARMON NSW P.O. BOX 732, 2064 PHONE 02-9062333 FAX 02-4384219

## BEAT THE RECESSION!!! SAVE MONEY WITH AT&M

**DO IT YOURSELF INSTRUMENTATION FOR PROCESS CONTROL, LAB WORK AND RESEARCH.**

Our kits are proudly **AUSTRALIAN MADE** for high performance and **UNBEATABLE VALUE** with industrial grade components and comprehensive assembly & application manuals. We have over 30 High Quality Kits ready for hard work.

*WRITE, PHONE OR FAX FOR OUR NEW CATALOGUE & PRICE LIST.*

**ALL PRICES FOB ARTARMON, PLUS 20% SALES TAX IF APPLICABLE, FREIGHT \$8.50 PER ORDER**



**ATM13** Universal 4 Digit 4MHz Counter, bright Orange 1/2" Displays, Reset & Latch 5V 50mA ..... **\$54.50**



**ATM28** 3 1/2 Digit LED DVM ±199.9mV or 1.999VDC Jumper Sel. Bright Orange 1/2" Disp. .... **\$56.00**

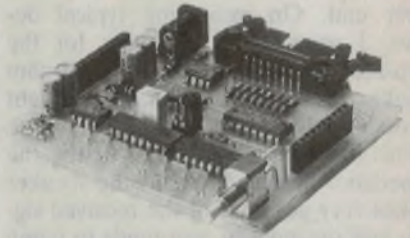

**ATM27** 8 Channel Temperature Meter uses "K" Thermo wire pairs for -75°C to +350°C Plugs into ATM28 ..... **\$85.00** "K" PTFE Clad.... **\$4.00/M**



**ATM15** Stopwatch/timer connects to ATM13 1, 1/10 or 1/100Sec at 9999 counts. Crystal controlled operated by switch, opto beam break (ATM20) ..... **\$44.50**

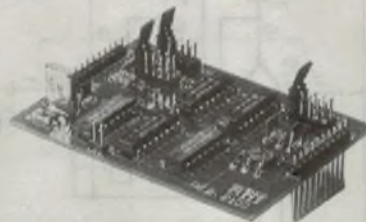

**ATM21** 80MHz Dig. Freq. Meter connects to ATM13, 4 ranges CMOS/TTL input ..... **\$38.50**

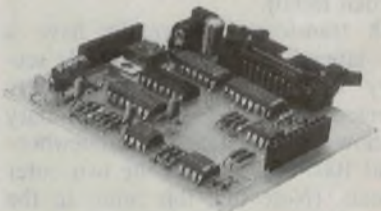

**ATM29** Plug in Autoranger for ATM28, ±200mV, 2V, 20V, 200VDC ..... **\$64.50**



**ATM26** Digital Amphometer (CAR SPEED METER) as per April EA complete W/Sensing Cables, case and connectors. Opto beam break kit ATM20 \$48.50 ea- 2 needed. .... **\$175.00**

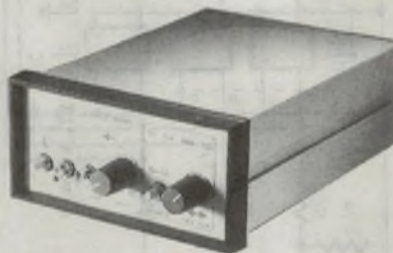

**ATM17** Digital Storage Adaptor for Oscilloscopes 200 to 200K Samp./Sec as Per Dec. '89EA ..... **\$185.00** (Complete W/Case)

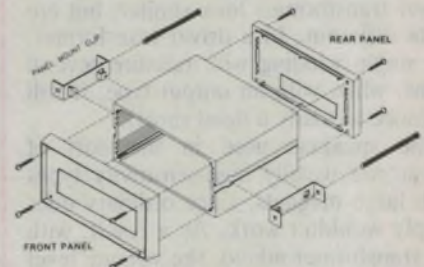

**HWK/UB70** Universal extruded Al. Panel Mtg. case w/Bezels & Filter **FOR ALL ABOVE KITS** ..... **\$35.50**

# Circuit & Design Ideas

Interesting circuit ideas from readers and technical literature. While this material has been checked as far as possible for feasibility, the circuits have not been built and tested by us. We therefore cannot accept responsibility, enter into correspondence or provide further information.

## Improving a low cost phone

Many of the 'el Cheapo' one-piece phones available these days tend to suffer from very low volume, both in their own earpiece and as received on the other end. On examining typical devices, I soon found out why: for the earpiece they usually have an eight-ohm speaker connected virtually straight across the phone line!

This has two nasty effects: firstly, the impedance mismatch means the speaker makes very poor use of the received signal; and secondly, it also tends to damp the audio generated by the unit's own microphone, thus killing the volume at the other end.

An enormous improvement can be had by fitting a small transistor radio type audio output transformer to the speaker. (These are available from Dick Smith Electronics for a couple of dollars, or you could salvage one from a discarded radio).

Such transformers normally have a centre-tapped primary and a single secondary winding. With the secondary connected to the speaker, the primary will show an impedance of somewhere around 1000 ohms across the two outer terminals. (Note that this refers to the AC impedance – the DC resistance will be only a few ohms).

I have found that using this connection, (ignoring the centre tap), gives the best results. You simply solder these wires to where the speaker was originally connected. Normally, the transformer can be left supported by its own connecting wires.

(Make sure you get the right type – driver transformers look similar, but are quite different. In a driver transformer, the single winding will measure several ohms, while with an output type, it will measure virtually a dead short).

The speakers used in this sort of phone are usually high-sensitivity types with large magnets, since ordinary ones simply wouldn't work. As a result, with the transformer added, the volume level is often superior to that from much more expensive phones.

Keith Walters,  
Lane Cove, NSW

**\$40**

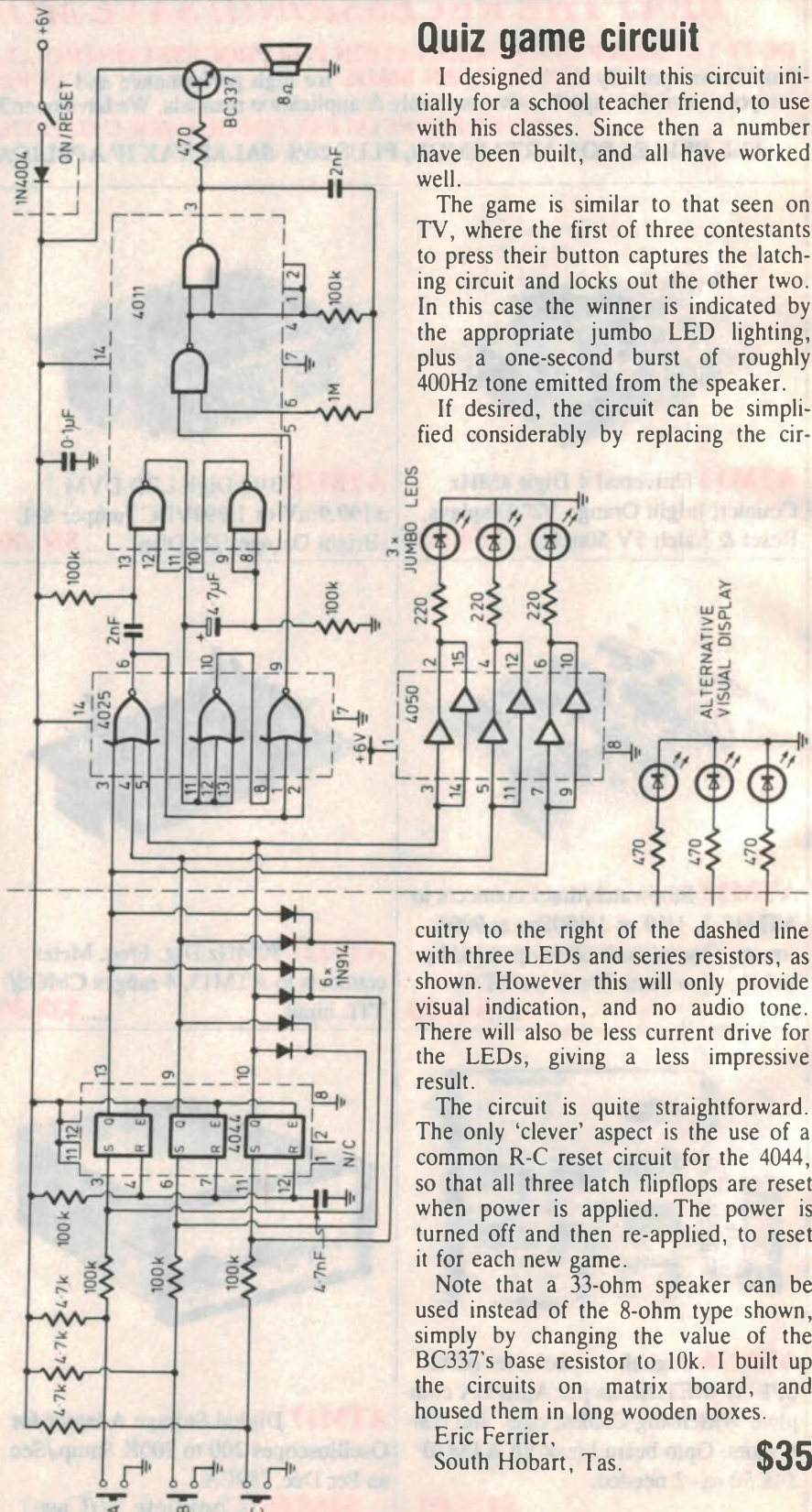

## Quiz game circuit

I designed and built this circuit initially for a school teacher friend, to use with his classes. Since then a number have been built, and all have worked well.

The game is similar to that seen on TV, where the first of three contestants to press their button captures the latching circuit and locks out the other two. In this case the winner is indicated by the appropriate jumbo LED lighting, plus a one-second burst of roughly 400Hz tone emitted from the speaker.

If desired, the circuit can be simplified considerably by replacing the cir-

cuitry to the right of the dashed line with three LEDs and series resistors, as shown. However this will only provide visual indication, and no audio tone. There will also be less current drive for the LEDs, giving a less impressive result.

The circuit is quite straightforward. The only 'clever' aspect is the use of a common R-C reset circuit for the 4044, so that all three latch flipflops are reset when power is applied. The power is turned off and then re-applied, to reset it for each new game.

Note that a 33-ohm speaker can be used instead of the 8-ohm type shown, simply by changing the value of the BC337's base resistor to 10k. I built up the circuits on matrix board, and housed them in long wooden boxes.

Eric Ferrier,  
South Hobart, Tas.

**\$35**



## 24 more channels for ICOM 22S

In the early days of 2-metre working in this country, it was a convention to refer to frequencies by 'channels' spaced 50kHz apart; 146.000MHz was 'channel 40' - 146.500MHz was 'channel 50' and so on.

Repeater output frequencies for FM operations started at 146.650 (repeater 1) and initially went to 147.000 (repeater 8). The repeater input frequencies were 600kHz down.

Subsequently, repeaters have been installed with frequencies about 147.000MHz with the repeater input frequencies 600kHz up. More recently frequencies have been allocated 'in-the-gaps' i.e., with 25kHz spacings, with repeater outputs from 146.525 to 147.375MHz.

Very many operators have the ICOM 22S, which features a frequency synthesiser programmed via a diode-matrix. Output lines 0 to 7 are each connected to a logic gate and the frequency selected depends on these gates being 'high' or 'low' depending on which diodes are switched in.

Normally the 0 output as supplied has no diodes connected, and to produce an

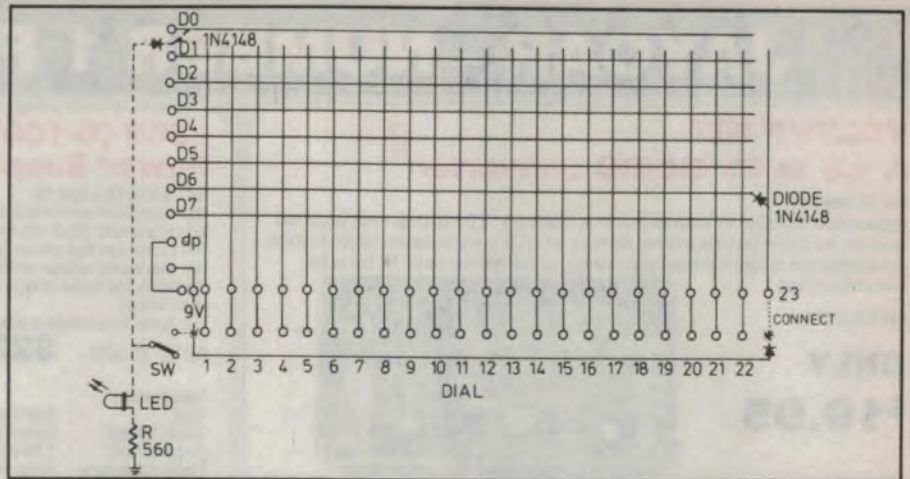

increase of 25kHz on each frequency requires only one diode and an on-off switch - see diagram. Please note that with repeater operation the matrix must be programmed for the lower of the two frequencies.

Many rigs came from the factory programmed for 8 repeaters and two or three simplex frequencies, of which 'channel 40' was one; generally this was found in dial position 9. There is a vacant position on the dial which could be connected to row 23 of the matrix (with a jumper wire), and one diode in the appropriate position will provide for

146.000MHz in its proper order.

At the same time add diodes in their correct places to the existing row 9 to provide for the next frequency which you wish to use, e.g., 146.450MHz (channel 49) and so on.

If you feel that it would be an advantage to know when the 'up 25' function is operating, then all that is required additionally is (typically) a 560 ohm resistor and a LED to earth, as shown on the diagram.

Hal Moors VK3KYE, and  
Malc Moors VK3CWM,  
Bendigo, Vic.

**\$30**

## LED 'scanner' VU display

The attached circuit provides an eye-catching display, which can be described

as either a 'time-scanned LED VU meter', or a low-resolution solid state audio scope. It accepts audio signals from a radio, amplifier, CD or tape player, and gives a repetitive time plot

of either a 'dot mode' or 'bar mode' representation of the signal's level, as desired.

The incoming audio is fed to input pin 5 of a standard LM3916 dot/bar display driver. However instead of driving the usual set of only 10 LEDs, in this case the outputs are connected to a matrix of 100 LEDs, in 10 column sets. Each column set is driven by a separate output of the 4017 Johnson decade counter/decoder, so that only one column set can operate at any particular instant. The 4017 is then driven by the 555 timer chip, connected as an asynchronous oscillator, so that the column drive outputs cycle 'on' continuously. In effect, the 555 and 4017 together act as a simple 'timebase'.

The 15k pot connected from pins 6 and 7 of the LM3916 to earth acts as a brightness control for the LED display. The 200k pot between pins 2/6 and 7 of the 555 varies the oscillator frequency, and hence the scanning rate.

The circuit as shown produces a 'dot mode' display, rather like a normal oscilloscope. For an alternative 'bar mode' display, pin 9 of the LM3916 should be connected to pin 3 and +12V.

Steve Goebel,  
Picnic Point, NSW

**\$45**

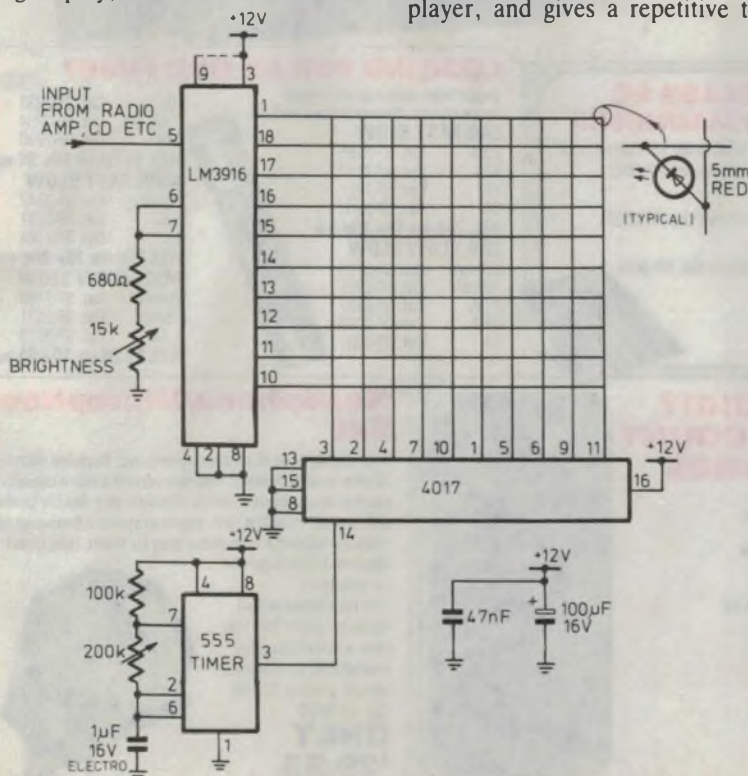

# JAYCAR - NUMBER 1 FOR KITS

## VOLTUP KIT A 1.5 to 9V DC/DC converter

Ref: EA May 1990  
Replace those expensive 9V batteries with an economical 1.5V D cell. Lasts much longer and saves you the cost of the kit in no time. Shortform kit - PCB, potcores, battery holder, heatsink and all electronic components supplied (excluding optional receiver parts). No box or box hardware supplied.

Cat. KA-1724

**ONLY  
\$19.95**



## Non First Syllable Dropped Off VOX Relay Kit

Ref: Silicon Chip April '90. At last a VOX (Voice Operated Relay) that does not cut off the first bit of speech! This clever project uses an acoustic delay to prevent the common fault in all but the most expensive VOX circuits - the 10ms or so of that is lost by relay operating time. It may not sound much but it is very annoying and a long time in speech terms. This kit is supplied by Jaycar in a short form, i.e. without case, front panel, plug adaptor etc. This saves you over \$20 on the price otherwise, as we believe most of these projects will be built into other equipment anyway. All other parts (including all PCB parts) included.

**Only \$59.95** Cat. KC-5074

Specifications Signal delay: 16.4 milliseconds • Clock frequency: 15.7kHz • Frequency response: 100Hz to 43kHz within (pm) 3dB • Maximum output signal: 800mV RMS • Maximum input sensitivity: 0.7mV RMS (to actuate relay) • Harmonic Distortion: <0.5% at 250mV and 1kHz <1.5% at 800mV and 1kHz • Signal to noise ratio: (ms) 66dB unweighted with respect to 500mV RMS at the output



## PRO SERIES 1 POWER AMP - 140 WATTS RMS PER CHANNEL

Ref: EA Dec 1989/Jan 1990  
NEW - upgraded design - now gives 140W rms channel into 8 ohms  
Dual toroidal transformers supplied.  
Cat. KA-1725

**\$599**



## BARGAIN LED PACK

100 assorted LED's 5mm, 3mm, rectangular plus others  
Normal value about \$35

Cat. ZD-1696

**ONLY \$8.95**

**ADELAIDE STORE  
NOW OPEN  
190 Wright Street  
Ph: (08) 231 7355**

## FIBREGLASS PC BOARD MADNESS!!

Stock up now. Well under 1/2 normal price.

SIZE 1 505 x 205mm Cat. HP-9522

**\$4.50**

SIZE 2 400 x 170mm Cat. HP-9523

**\$3.00**

SIZE 3 500 x 90mm Cat. HP-9524

**\$2.00**



## LOOKING FOR AN ODD FUSE?

Jaycar now stocks an increased range of fuse. New additions include:

### 3AG FAST BLOW

2.5A Cat. SF-2195

4A Cat. SF-2197

7A Cat. SF-2201

8A Cat. SF-2203

**ALL 25c ea 10+ 20c ea**

### 3AG SLOW BLOW

250mA Cat. SF-2223

750mA Cat. SF-2225

1.5A Cat. SF-2227

2.5A Cat. SF-2229

4A Cat. SF-2231

6A Cat. SF-2233

7.5A Cat. SF-2234

10A Cat. SF-2236

**ALL \$1.20 ea 10+ \$1 ea**

### M205 FAST BLOW

50mA Cat. SF-2147

1.6A Cat. SF-2161

4A Cat. SF-2164

**ALL 25c ea 10+ 20c ea**

### M205 SLOW BLOW

200mA Cat. SF-2169

250mA Cat. SF-2171

1.5A Cat. SF-2173

**ALL \$1.20 ea 10+ \$1 ea**



## EXPERIMENTERS PLUG PACK BARGAIN

Don't miss this one  
Primary - 220V 50Hz (will work OK on 240V) lead length 1.8mt  
long - bare ends (no 240V plug supplied)  
Secondaries - 16V AC at 800mA  
- 9V AC at 1.5AMP  
Lead length 1.7mt long terminated in a  
strange plug

Supplied in a maxi box style. Measures 75 (W) x 85 (L) x 60 (H)mm

1-9 **\$5.95**  
10-49 **\$5.50**  
50-99 **\$4.95**  
100 + **\$4.50**



Cat No. MA 2618

**NOTE! This item is sold strictly  
for parts only. It is not approved  
for connection to the electricity  
grid.**

## 3.75 DIGIT 4000 COUNT 39 RANGE

- Inductance
- Capacitance
- Frequency
- Temperature
- Peak hold
- Logic

See catalogue for  
full details

Cat. QM-1475

**\$179**



## Headphone/Microphone Set

High quality headphone/microphone set. Supplied with a pair of 32 ohm quality dynamic headphones and a noise cancelling electret microphone. Insert is mounted on a flexible boom with windscreen. Supplied with separate stereo 3.5mm plug for headphones and 3.5mm mono plug for insert. (Mic insert requires 3-5 volts power for operation.)

This headphone would easily be worth \$50. We have a limited quantity available at the absolute bargain price of \$29.95

Cat. AA-2022  
**ONLY  
\$29.95**



### Low Noise Universal Pre Amp Kit

Refer Silicon Chip June 90  
Ideal for a magnetic cartridge, tape player or microphones. Shortform kit, includes PCB switch, cable and all electronic components  
No box front panel or panel hardware supplied



Cat. KC-5077  
**\$32.95**

### Power Supply Load Protection Kit

Refer Silicon Chip June 90  
This add-on board prevents dangerous voltages from being delivered to a load by any dual tracking power supply when it is turned on or off  
Short form kit. Includes PCB, relay and all specified components



Cat. KC-5078 **\$17.95**

### Ferguson Transformer Bargains

#### PF-4725

A large transformer ideally suited to computer power supplies. Size 115 (L) x 10 (W) x 86 (H) mm.  
Primary  
2 x 120 V 50hz (240 V)  
1 x 110 V  
Secondary  
16 V Regulated to +12V DC 5A  
16 V Regulated to -12 V DC 5A  
9.3V Regulated to 5 V DC 5.7A



These transformers would normally cost about \$80 each. We have a limited quantity available for only \$30 each.

#### A bargain at \$30 each

Cat. MM-2040

Due to huge weight mail order customers add \$8 extra to normal P & P charges.

#### PF-4766

A medium size transformer measuring 96 (L) x 96 (W) x 80 (H) mm.  
Primary  
2 x 120 V 50hz (240 V)  
1 x 110 V  
Secondary  
10.5V 3A  
16V 3A

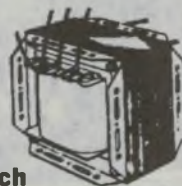

#### Normally \$70 each

Limited quantity available

#### Only \$20 each

Mail orders add \$4 extra P & P.  
Cat. MM-2045

### TURN YOUR SURPLUS STOCK INTO CASH!!

Jaycar will purchase your surplus stocks of components and equipment. We are continually on the lookout for sources of prime quality merchandise.

### CALL BRUCE ROUTLEY OR MARK HARRIS NOW ON

(02) 747 2022

### Guitar Speakers

Full range available

10" 65W RMS	Cat. CG-2376	\$59.50
12" 65W RMS	Cat. CG-2379	\$59.50
12" 100W RMS	Cat. CG-2380	\$89.50
12" 200W RMS	Cat. CG-2381	\$159.00
15" 150W RMS	Cat. CG-2832	\$129.00



### VARTA BATTERY MADNESS VARTA 2.4 V 100mA/H Ni-CAD

These batteries are encased in a black plastic housing which measures 30 (L) x 16 (W) x 19 (H) mm. They were removed from printed circuit boards by simply cutting of the PC terminals so to use you would need to break open the plastic case. Inside are two 1.2 V cells. So purchase 4 of these, remove 1 cell and you have an 8.2 V (9V 216 type) battery for only \$4, not about \$20

Ideal for Hobbyists, experimenters, etc.  
To buy these today they would cost about \$13 ea

**ONLY \$1 each**  
**10+ .90¢ each**  
**100+ .75¢ each**

Cat. SB-2470



### 5mm 3000 MCD LED

An amazing 3000 MCD of brightness in a LED! Lights up red, clear to look at.

**ONLY \$3.95** 10+ \$3.65 Cat. ZD-1796



### 1pF - 9999uF Capacitance Meter Kit

Refer Silicon Chip May 90

This attractive 4 digit capacitance meter kit is designed for workshop, laboratory or serious hobbyists. It can measure capacitance from 1pf up to 9999uf in seven ranges with an accuracy of better than +/- 1% +/- 1 digit. Kit is complete with all components required to finish construction.

Cat. KC-5075

**\$109**



### Philips Computer Capacitor Bargain

15,000uF 40V Can

Normally about \$25 ea

Cat. RU-6714



**THIS LOT ONLY**

**\$12.95 ea**

10+ \$11.50 ea

### 84 Pin PLCC Socket SALE

Texas brand, save a fortune on normal prices

1-9 **\$2.95 ea**

10 - 99 **\$2.50 ea**

100 up **\$2.00 ea**

Cat. PI-6300



### High Energy Ignition for Cars with Reluctor Distributors

Refer silicon Chip May 90

Designed for cars with Reluctor distributors, this ignition kit features improved protection for the coil and main switching transistor.

Kit includes PCB, die cast box and all components to finish the kit.

KC-5076

**\$46.95**



### High Quality Electricians Pliers Sale

Importers distress, your gain!  
220mm long, yellow handles, super high quality. Normal trade price is \$35.04 including tax.  
Cat. TH-1875

**GRAB A PAIR FOR YOUR TOOL BOX ONLY \$12.95**

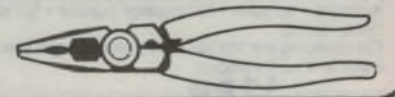

## Magnavox 8MV 8/30 Replacement

Update your 8/30 woofers - today! The old 8/30's handled 30 watts these 120 watts rms. No need to buy new cabinets - the 8MV mounts in the same hole. High quality and high performance woofer for most applications

Power Handling	120 watts rms
Resonant Freq.	31Hz
Freq. Range	fo - 4kHz
Voice Coil Dia.	38mm
Magnet Weight	510 grams
Oms	1.73
Qes	0.47
Qto	0.37
Vas	80L
Cat. CW-2110	

**WAS \$99.50**  
**NOW \$59.50**  
**SAVE \$40**



## Magnavox 12MV

The 12MV is a high power high fidelity woofer utilising a 38mm diameter long throw voice coil wound on an aluminium former and high compliance suspension with a polyurethane foam roll surround, resulting in excellent linearity at very high input powers.

Power Handling	150 watts rms
Resonant Freq.	19Hz
Freq. Range	fo - 9kHz
Sensitivity	96dB
Magnet Weight	510 grams
Oms	3.76
Qes	0.58
Qto	0.49
Vas	580L
Cat. CW-2125	

**WAS \$119.50**  
**NOW \$79.50**  
**SAVE \$40**



## Magnavox 8W Woofer

The 8W Mk 6 is a high fidelity woofer utilising a 25mm diameter long throw voice coil wound on an aluminium former and a high compliance suspension with a polyurethane foam roll surround, resulting in excellent linearity at high power.

Power Handling	65 watts rms
Resonant Freq.	39.5Hz
Freq. range	39.5Hz - 5kHz
Sensitivity	96dB/1w/1mt
Voice Coil Dia.	25mm
QMS	2.317753
QES	0.5470474
QTS	0.4425861
VAS	3.241097
Cat. CW-2109	

**WAS \$39.50 NOW \$24.50**  
**SAVE \$15**



## pH CHLORINE METER

### Unbelievable Distress Stock Purchase

These were included in our 1987 Catalogue and were selling for \$39.95 each. We have purchased the entire quantity from the importer who was told to clear all stocks at any price!

The unit is not the most accurate in the world, but it will give you some idea of the pH and Chlorine levels. The two probes are inserted in to the water to be tested. An instant reading of the Chlorine level and pH value is given on the panel meter display.

We emphasise that this offer is more a bargain for the parts. The meter for example, is worth \$10 alone. The case/probe could be used for all sorts of things!

Cat. QM-6135 **WAS \$39.95 each**

**NOW ONLY \$9.95**

**SAVE 75%**



## Probe Type Digital Multimeter 3 1/2 Digits - Manual or Auto Range with Logic Probe

This fantastic 3 1/2 digit meter is actually easier to use than a conventional hand-held unit. The readout is in the body of the 'probe' itself so you don't have to avert your eyes to get a circuit reading. The unit has most of the features of conventional meters as well! Logic Probe Bonus. This TTL/CMOS compatible feature will test logic 'HI' or logic 'LO'. The circuit is protected to 250V. All electrical symbols are shown in the large (42mm x 18mm) window.

Cat. QM-1420

**\$59.95**



## CODE-A-PHONE REMOTE ANSWERING MACHINE

The Code-A-Phone is a top quality remote control answering machine which is simple to use. It features Digital Recording whereby your voice is recorded on a microchip.

Special features include:

- dual recording • personal greeting • call screening • personal memo record • one touch playback
- digital message counter • answer only/message limit • ring selector • tape saver • automatic on
- fast forward and rewind • easy to replace microcassette • expanded message length • REMOTE CONTROL FEATURES: 13 function beeperless remote control • remote on • personal 3 digit security code • fast forward/rewind • greeting change • greeting breakthrough • save messages • cancel messages • toll saver • last message indicator • full tape retrieval • repeat playback • personal - memo - record.

This answering machine has every feature that you will ever require in an answering service. One year warranty. A quality product.

Cat. YT-7032 **\$289**

## SWITCHMODE POWER SUPPLY

### Unbelievably cheap but there's a catch!

We have obtained a quantity of new (removed new from brand new equipment) computer switchmode type power supplies. They have outputs of +5V 2A, +12V 30mA, -12V 30mA, & 12V 2A. The problem is that they are 110V powered and NOT 240V. You can use them for parts at this bargain price. Cat. MP-3000

**\$9.95**



## IC SOCKET MADNESS

### Solder Type

20 Pin normally 48¢ each	
Now 16 for \$2	Save \$5.68
Cat No. PI 6504	
28 Pin normally 70¢ each	
Now 14 for \$2	Save \$7.80
Cat No. PI 6507	
40 Pin normally 70¢ each	
Now 10 for \$2	Save \$5
Cat No. PI 6508	

### Machine Pin Type

16 Pin normally \$1.50 each	
Now 3 for \$2	Save \$2.50
Cat No. PI 6456	
18 Pin normally \$1.65 each	
Now 4 for \$2	Save \$4.60
Cat No. PI 6458	
20 Pin normally \$1.90 each	
Now 3 for \$2	Save \$3.70
Cat No. PI 6460	
22 Pin normally \$2 each	
Now 4 for \$2	Save \$6
Cat No. PI 6462	
24 Pin normally \$2.30 each	
Now 3 for \$2	Save \$4.90
Cat No. PI 6464	
28 Pin normally \$2.60 each	
Now 4 for \$2	Save \$8.40
Cat No. PI 6466	
40 Pin normally \$3.25 each	
Now 3 for \$2	Save \$7.75
Cat No. PI 6468	

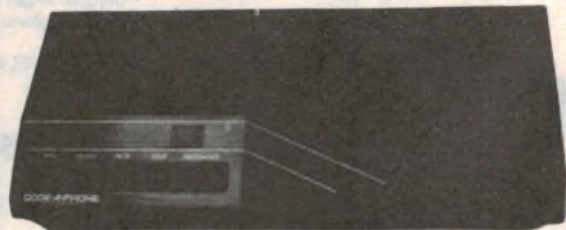



## Construction Project for Radio Amateurs:

# VHF Powermatch Mk2

In response to many requests, here's an updated version of a multi-purpose RF test instrument design we published back in 1971, and which proved very popular. Based on a simple multi-range electronic voltmeter, it allows measurement of RF voltage and power, SWR and impedance well into the UHF region.

by JIM ROWE

Way back in the February, April and June 1971 issues of *EA*, I described a simple RF measuring system for radio amateurs – the 'VHF Powermatch'. It was based on a low cost passive metering circuit, combined with a dummy load and detector circuit for measuring RF power up to 30W. A switching system and series of plug-in modules extended its capabilities, allowing measurements of SWR, RF voltage and impedance, approximate frequency and signal strength up to around 450MHz.

The design proved to be quite a popular one, with many hundreds being built and used over the following years by amateurs and other people working in the VHF communications area. But like all designs it dated. Some of the parts became difficult to get, such as the special non-inductive metal film resistors used in the dummy load, the moulded-track carbon pot used in the RF impedance bridge module, and the tuning capacitor used in the absorption wavemeter. As a result, interest in the design gradually waned.

Since my return to the magazine a few years ago, though, many of our readers with an interest in amateur radio have asked me to publish an updated version of the design – using components that are available nowadays, and likely to remain so for at least a while. As a result of these requests I've spent quite a lot of time working on a new design, and things have now progressed to the point where it can be presented.

I should note, though, that some aspects of the new design are still not solved entirely to my satisfaction. This is certainly the case regarding the provision of a suitable RF dummy load,

capable of giving reliable operation into the UHF region.

The special non-inductive metal film power resistors used in the original design were made by IRH in Australia, and gave good results up to at least 450MHz. However these don't seem to be made anymore, and I've had great difficulty in finding any really satisfactory equivalents.

So far I've made up sample dummy loads using about five different kinds of currently available resistors that are at least *nominally* non-inductive, using the usual construction methods to ensure minimum overall reactance. However in all cases the results have been quite disappointing, with all kinds of undesirable reactive effects by the time you get to 432MHz.

Essentially I'm still looking for the answer, as far as this problem is concerned. But rather than delay publication of the rest of the design, I've modified the original concept so that it now *doesn't* hinge around a special inbuilt dummy load and detector combination.

Instead, the new design uses a separate external dummy load, which for the present at least will not be described. The assumption I'll make is that you'll either be using an existing load, or buying one of those available commercially. This may seem something of a cop-out, but it's one that seems to me justified at present, in view of the difficulties.

Along with this change to an external load, the design now also uses a separate detector system for the RF power measurements. This is designed to be fitted into the RF line, as close as possible to the dummy load. It is designed to introduce as little line disturbance as possible, to allow this to be done.

This approach involves compromises of its own, including a limitation of the maximum power level to 12W for direct measurement, due to the PIV rating for the Schottky-barrier detector diode.



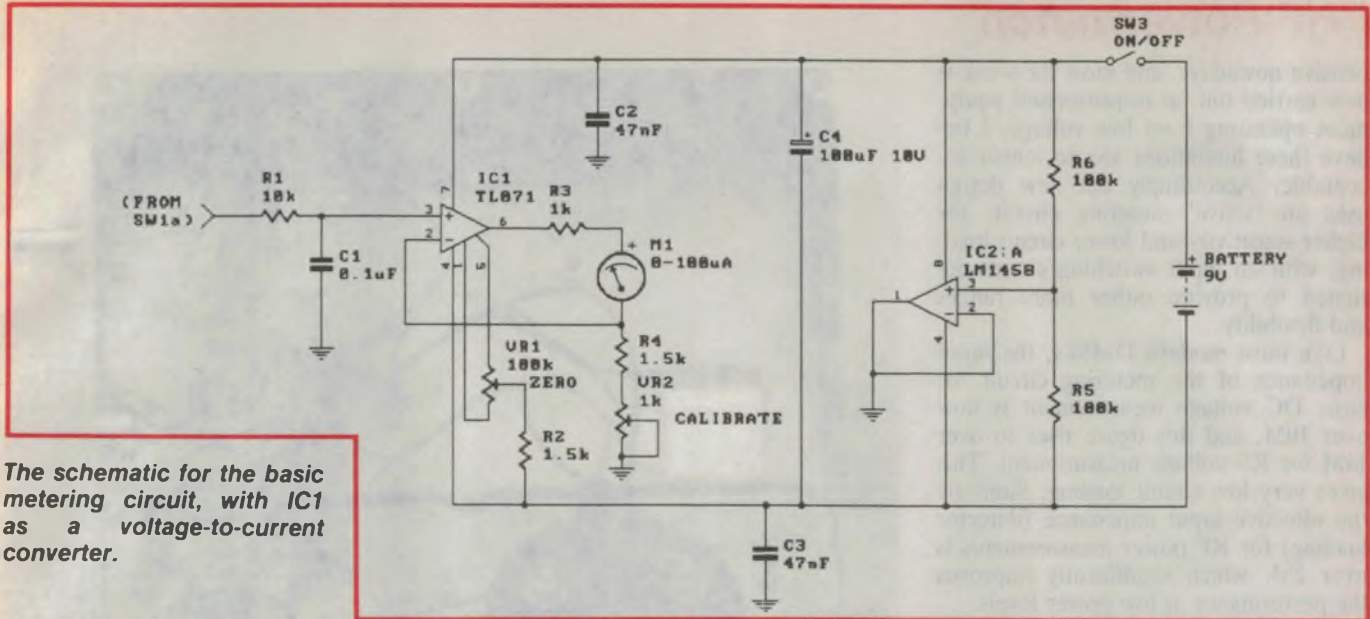

The schematic for the basic metering circuit, with IC1 as a voltage-to-current converter.

However this limitation can be obviated – in principle at least – using attenuator pads, so that it's not a major hurdle.

On the whole, the separate dummy load and detector system seems a rather more practical and more flexible one than that originally used. It also seems to have more potential for extending the system's operation beyond the original limit of 450MHz – and hopefully as far as 1300MHz, in view of the increased activity on 23cm nowadays. But this still remains to be seen...

Another problem area I still haven't been able to resolve, as yet, is the absorption wavemeter. As noted earlier, the 50pF air dielectric tuning capacitor

used in the original wavemeter is no longer available, and even similar units are extremely scarce. This makes things very difficult, as the usual alternative tuning schemes – such as a varicap diode – do not lend themselves to automatic calibration. But I'm still working on this one, and with a little luck we'll end up finding a satisfactory solution.

There are still a few loose ends, then, and due largely to the current difficulty in obtaining certain parts that were quite readily available back in 1971. But enough of the new design has been 'firmed in', I believe, to make it of interest and value to readers. So away we go!

### Basic philosophy

The original unit had a passive metering system, using a small 50uA meter movement. This was simple and straightforward, and seemed to work fairly well, but with the benefit of hindsight it had quite a few limitations – most of which were the result of its modest sensitivity. The reliability of RF power readings was quite poor below about 100mW, for example, while it was not really feasible to provide RF or DC voltage measurement ranges less than 10V FSD due to excessive circuit loading and/or detector nonlinearity.

Since meter movements are quite ex-

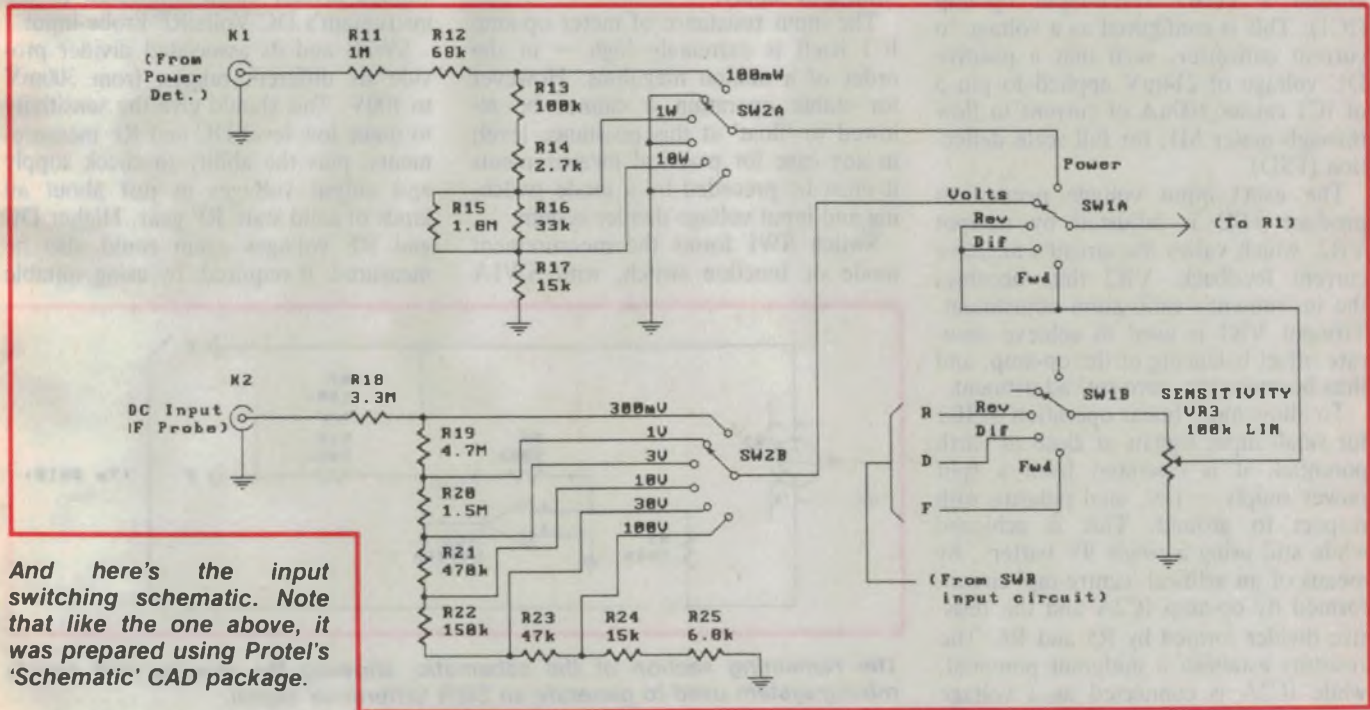

And here's the input switching schematic. Note that like the one above, it was prepared using Protel's 'Schematic' CAD package.

## VHF Powermatch

pensive nowadays, and most RF work is now carried out on transistorised equipment operating from low voltage. I believe these limitations are no longer acceptable. Accordingly the new design uses an 'active' metering circuit, for higher sensitivity and lower circuit loading, with an input switching circuit designed to provide rather more ranges and flexibility.

Like most modern DMM's, the input impedance of the metering circuit for basic DC voltage measurement is now over 10M, and this figure rises to over 14M for RF voltage measurement. This gives very low circuit loading. Similarly the effective input impedance (detector loading) for RF power measurements is over 2M, which significantly improves the performance at low power levels.

A small complication arising from the use of an active metering circuit is that it has been a little harder to provide a 'difference' range, for convenient SWR minimisation and correct operation of the RF impedance bridge. However this has been achieved, using an additional op-amp inverting stage.

Apart from these changes, the design is essentially just an updated version of the original, using currently available parts. As you'd expect it's also based much more on the use of PC boards, in line with current practice and also to make it easier to build and get going.

### Circuit description

The basic metering circuit is based around a TL071 JFET-input op-amp (IC1). This is configured as a voltage to current converter, such that a positive DC voltage of 214mV applied to pin 3 of IC1 causes 100µA of current to flow through meter M1, for full scale deflection (FSD).

The exact input voltage needed to produce FSD is adjusted by trimpot VR2, which varies the circuit's negative current feedback. VR2 thus becomes the instrument's calibration adjustment. Trimptot VR1 is used to achieve accurate offset balancing of the op-amp, and thus becomes the 'zero set' adjustment.

To allow more linear operation of IC1 for small input signals at close to earth potential, it is operated from a split power supply - i.e., dual polarity with respect to ground. This is achieved while still using a single 9V battery, by means of an artificial 'centre-tap' circuit, formed by op-amp IC2A and the resistive divider formed by R5 and R6. The resistors establish a midpoint potential, while IC2A is connected as a voltage

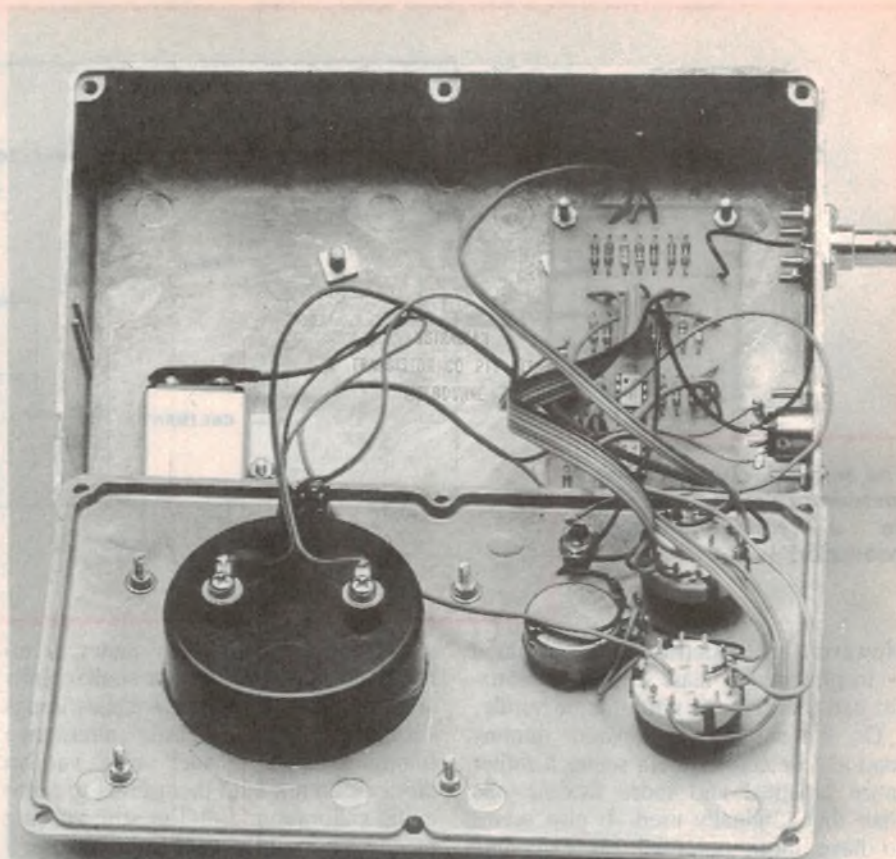

*A look inside the case, showing how little wiring is involved. All of the components used are readily available...*

follower to ensure that the centre tap has a suitably low impedance, without wasting battery current. The output of IC2A is grounded, to achieve the desired split supply.

The input resistance of meter op-amp IC1 itself is extremely high - in the order of a million megohms. However for stable operation it cannot be allowed to 'float' at this resistance level; in any case for practical measurements it must be preceded by a mode switching and input voltage divider system.

Switch SW1 forms the measurement mode or function switch, with SW1A

making the primary selection between power, volts or SWR measurements. In the 'Volts' position it transfers control to SW2B, which selects tappings on a voltage divider chain connected to the instrument's DC Volts/RF Probe input.

SW2B and its associated divider provide six different ranges, from 300mV to 100V. This should give the sensitivity to make low level DC and RF measurements, plus the ability to check supply and output voltages in just about all kinds of solid state RF gear. Higher DC and RF voltages again could also be measured, if required, by using suitable

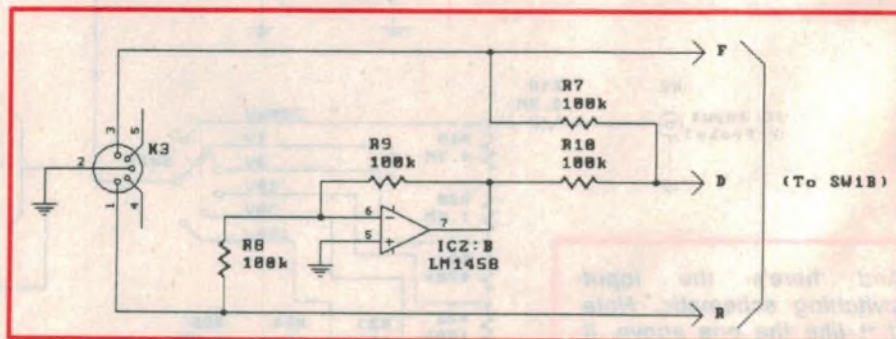

*The remaining section of the schematic, showing the inverter and simple mixing system used to generate an SWR 'difference' signal.*



divider probes.

The voltage divider ratios and the corresponding meter scales have been chosen to ensure uniform 10dB steps between ranges, for minimum reading errors. Incidentally the reason for limit-

**The PCB overlay diagram, which also shows the connections between the board and the other major components.**

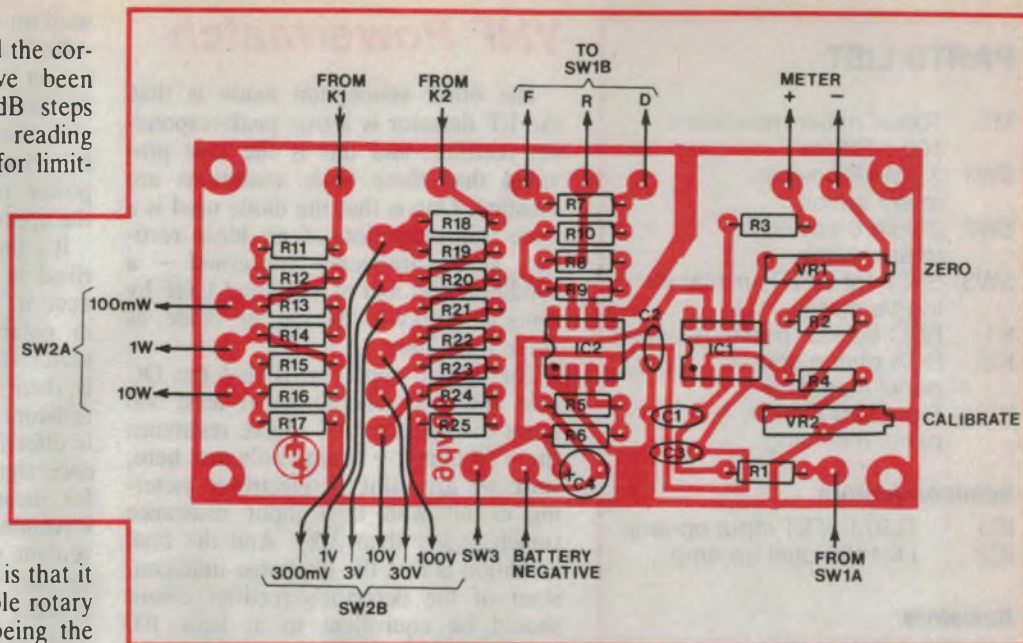

ing the number of ranges to six is that it allows the use of readily available rotary switches – a 6-position type being the largest 2-pole switch now stocked by most suppliers!

The 'second half' or A section of SW2 becomes operative in the 'Power' position, and again selects tapplings on an input voltage divider chain. This time the divider is connected to the instrument's Power Detector input, though, and it provides only three division ratios. These give power ranges of 100mW, 1W and 10W FSD respectively, again in 10dB steps.

Note that the RF signal whose power is being measured is not fed directly to the Power Detector input. This input merely connects to a small power detector module (to be described later), which rectifies the RF voltage present on the RF line when terminated in a known dummy load.

The main assumption made here, as with the first VHF Powermatch, is that a simple peak-responding rectifier con-

nected to the correctly terminated line will give an output DC voltage directly related to the square root of the RF power level. In practice this is quite a reasonable assumption, because it mainly depends upon the RF signal being a pure sinewave – i.e., having a very low harmonic and/or spurious content. And if this isn't true, you have a far more urgent problem than measuring power output!

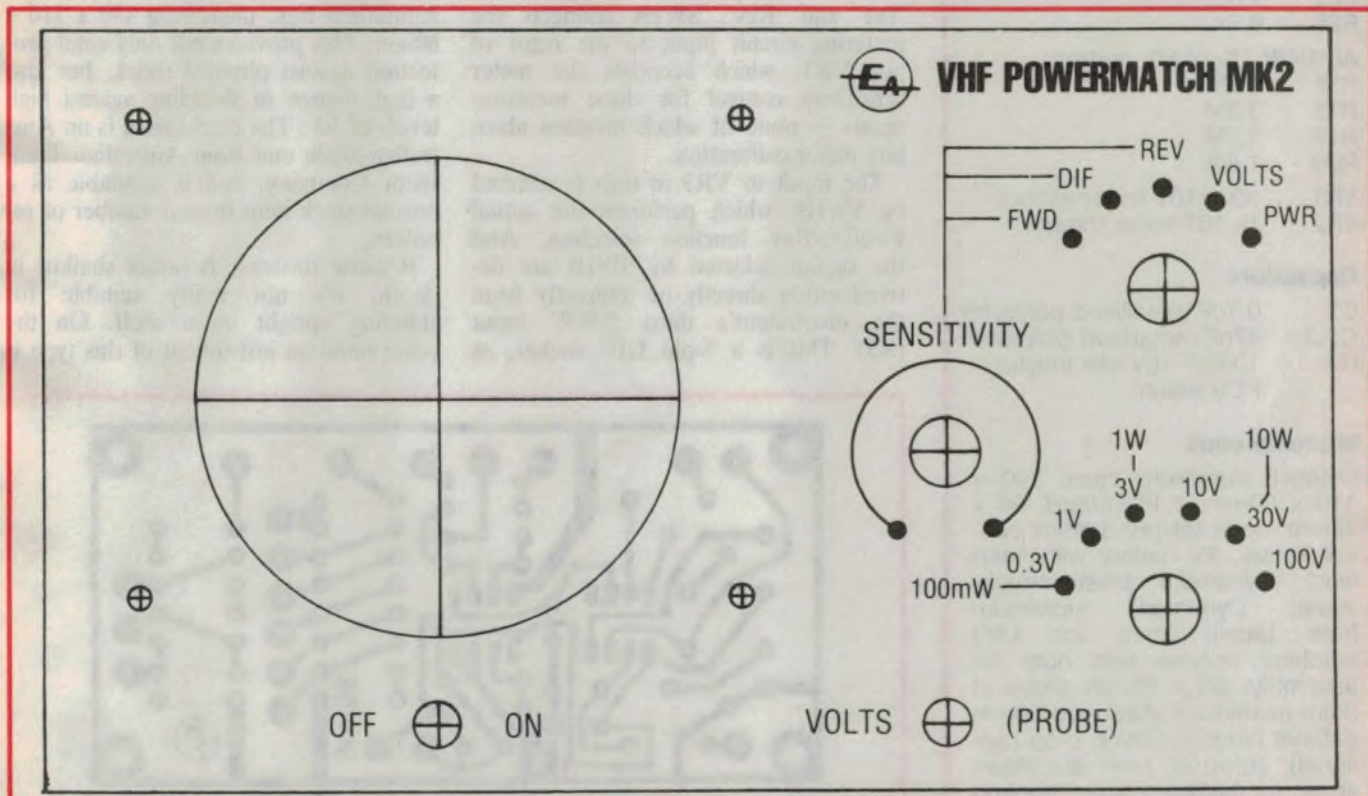

Here's the artwork for the front panel, reproduced actual size to allow convenient copying.

## PARTS LIST

M1	100uA meter movement, 100 x 82mm
SW1	2 pole 5 position rotary switch
SW2	2 pole 6 position rotary switch
SW3	SPST (or DPDT) miniature toggle switch
K1	BNC socket, panel mounting
K2	RCA phono socket, panel mounting
K3	5-pin DIN socket, panel mounting

### Semiconductors

IC1	TL071 JFET input op-amp
IC2	LM1458 dual op-amp

### Resistors

All 1/4W 1% metal film:

R1	10k
R2,4	1.5k
R3	1k
R5,6,7,8,	
9,10,13	100k
R11	1M
R12	68k
R14	2.7k
R16	33k
R17,24	15k
R21	470k
R22	150k
R23	47k
R25	6.8k

All 1/4W 1% or 5% carbon:

R15	1.8M
R18	3.3M
R19	4.7M
R20	1.5M
VR1	100k 10T linear trimpot
VR2	1k 10T linear trimpot

### Capacitors

C1	0.1uF metallised polyester
C2,3	47nF metallised polyester
C4	10 0uF 10V electrolytic, PCB mount

### Miscellaneous

Diecast aluminium case, 190 x 110 x 60mm; 1 PC board, 96 x 48mm, code 90vp6; 3 small control knobs; 9V battery with snap lead; 'Dynamark' plastic meter scale; 'Dynamark' aluminium front panel; 3mm (or 1/8") machine screws and nuts for assembly; 85 x 85mm piece of 3mm aluminium sheet and 50mm cabinet hinge for tilting prop (optional); scrap of 1mm aluminium sheet for battery clamp; hookup wire, solder etc.

## VHF Powermatch

The other assumption made is that the RF detector is a true peak-responding rectifier, and this is the case provided that three basic conditions are satisfied. One is that the diode used is a close approximation of an ideal rectifier, at the frequency concerned – a condition best met at VHF and UHF by using a Schottky or 'hot carrier' diode, as we're using here.

The second condition is that the DC load resistance should be at least 500 times the effective AC source resistance (here 50 ohms) – again easily met here, since we are using an electronic metering circuit with high input resistance (much higher than 25k). And the final condition is that the discharge time-constant of the detector's rectifier circuit should be equivalent to at least 100 periods of the lowest frequency to be measured, and preferably much longer; again a relatively easy condition to meet here. In fact with the values chosen, the discharge time-constant is about 200us, which would allow reasonably accurate measurements down to well below 10MHz.

The three remaining positions of mode switch SW1 are essentially used to select functions for SWR, impedance and wavemeter measurements. In all three of these positions, marked 'Fwd', 'Dif' and 'Rev', SW1A connects the metering circuit input to the rotor of pot VR3, which becomes the meter sensitivity control for these measurements – none of which involves absolute meter calibration.

The input to VR3 in turn is selected by SW1B, which performs the actual Fwd/Dif/Rev function selection. And the signals selected by SW1B are derived either directly or indirectly from the instrument's third 'SWR' input (K3). This is a 5-pin DIN socket, as

used on the original design.

Both the 'Fwd' and 'Rev' signals are in fact taken directly from K3. Hence in the case of the SWR reflectometer module, the meter is simply connected to the output from either the 'forward power' or 'reverse power' detectors, for the appropriate readings.

It's the third, 'Dif' signal that is derived in a more indirect way. To produce it, the Rev signal is first reversed in polarity, by means of op-amp inverter stage IC2B. This inverted signal is then 'added' to the Fwd signal via resistors R7 and R10, to produce what is effectively a (Fwd – Rev) or *difference* signal. It is this signal that is used for measurements with the absorption wavemeter module, and it is also a convenient one to use when adjusting an antenna system for minimum SWR – because it reaches a *maximum* when SWR is a minimum. In other words, it becomes a good indicator 'matching efficiency'.

So that, then, is the basic Powermatch II metering unit, which forms the heart of the system. To it are connected the various measuring modules, which will be described in following articles. For the present, though, let's look at the physical side of the metering unit.

## Construction

The unit is housed in a sturdy diecast aluminium box, measuring 190 x 110 x 60mm. This provides not only solid protection against physical shock, but also a high degree of shielding against high levels of RF. The case I used is an Australian-made unit from Australian Transistor Company, and is available as a normal stock item from a number of retailers.

Because this case is rather shallow in depth, it's not really suitable for standing upright on a shelf. On the other hand an instrument of this type is

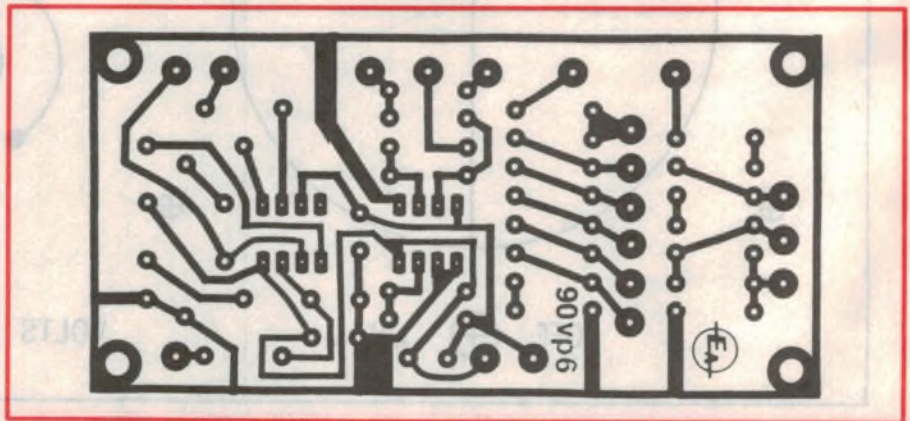

This PCB etching pattern is also reproduced actual size...

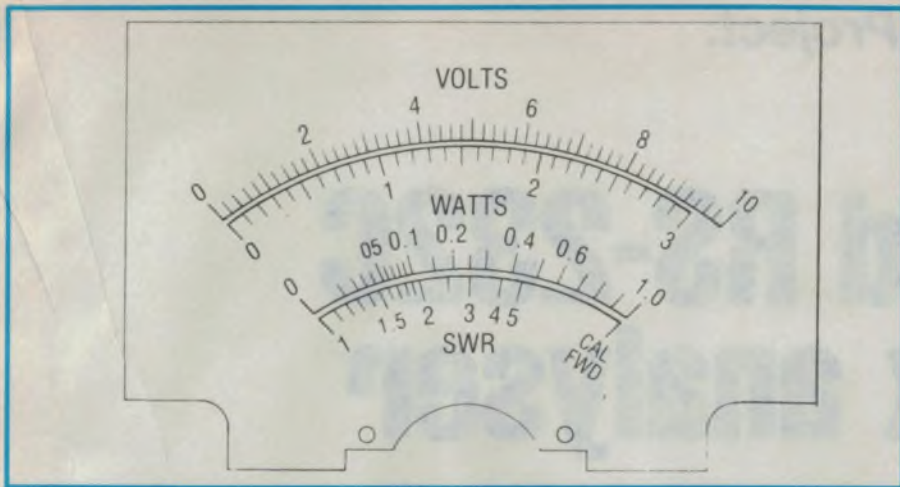

...As is this reproduction of the replacement meter scale art.

not all that easy to use when lying flat on its back, on the bench.

To make things more convenient, I decided to add a small tilting prop at the back. This is attached via a hinge, so that it folds back flat against the rear of the case for storage. When swung out, it allows the case to sit very stably on the bench at about 45° – as shown in the photo.

A fairly large 100 x 82mm (4") meter movement is used. This size of meter is not exactly cheap (around \$22), but nowadays even the smaller size isn't much cheaper. The longer scale length of the larger movement is really worth having, because it makes accurate readings significantly easier.

The actual meter I used came from DSE, which sells it under the catalog number Q-2065. However Jaycar and Altronics both have an almost identical unit, listed as number QP-5042 and Q-0550 respectively. It's also called type MU65, and other suppliers may have it under that number.

The 0-100uA meter scale supplied with the meter needs to be replaced for this project, with one having the appropriate voltage, power and SWR scales. As part of developing the project I have produced the artwork for these scales, and this is reproduced on these pages actual size. One approach would be to photocopy this from the magazine, and cement the photocopy onto the rear of the meter's original scale plate – after carefully removing it from the movement, of course!

This should give a reasonable looking result, but if you're prepared to go to a little more trouble, there is a better way. This is to produce a positive image on 3M's 'Dynamark' photosensitised plastic sheet, which can then be applied to the meter scale plate using its own adhesive backing layer. The meter

scales on the prototype were produced in exactly this way.

For those who would like to do this, our Reader Services department will be able to supply actual-size duplicate negatives of the artwork for a fee of \$10.

Incidentally Dynamark sensitised aluminium sheet was used to produce the prototype's front panel, again from custom artwork and using a film negative. If you'd like to duplicate this panel also, actual-size duplicate negatives will also be available from EA Reader Services for a fee of \$10, or a total of \$15 if you want both the meter and front panel negs.

As with the meter scale artwork, the front panel art is also reproduced on these pages for those who are happy using a photocopy instead.

With the exception of the front panel switches and pot, the various input connectors, the meter and the battery, the remainder of the circuitry and components are mounted on a small PC board. This measures 96 x 48mm, and is coded 90vp6. For those who like to etch their own boards, an actual-size artwork is again reproduced on these pages.

The positions of the components on the PCB are shown quite clearly in the overlay diagram, which also shows the various connections running from the PCB to the switches and other items. Wiring up the unit should thus be fairly straightforward, by referring to both this diagram and the photo showing the inside of the case.

I suggest you wire up the PCB itself first, fitting the fixed resistors and capacitors before the other parts. Then add the two 10-turn trim pots, and finally the two ICs – making sure that these are orientated correctly.

After checking against the overlay diagram, you can then add the various

connection leads, leaving these all about 180-200mm long to allow them to reach to their respective controls, etc. The board assembly will now be finished, and you can put it aside while you prepare the case.

This will involve cutting the various holes in the case lid/front panel, a large one 64mm in diameter for the meter's barrel and smaller 9mm holes for the three controls. There are also two 6mm holes for the on/off switch SW3 and the Volts/Probe socket, which is of the RCA 'phono' type, and four 3mm holes for the meter mounting studs.

Probably the easiest way to locate all of these holes is by making a photocopy of the front panel artwork, cutting this to size and taping it to the front of the case lid. Then you can easily use a centre punch to transfer the centre locations through the paper into the metal.

There's probably no really easy way to make the large meter hole. For the prototype I drilled a circle of close-together 7mm holes through the panel, just inside the required diameter; then I used a metal-cutting 'drill file' in the bench drill, to remove the metal between the holes. The resulting serrated hole was then tidied up with a half-round file – and a fair amount of 'elbow grease'.

An alternative would be to use a metal-cutting 'holesaw' of the appropriate diameter. But to do this safely, you'd need to do it in a drill press, and have the case lid firmly clamped down. Otherwise it can easily 'take off', and cause damage to either itself, the drill press or you!

There are also a few holes to be made in the case itself. These are mainly in the right-hand end, to mount the 'SWR' DIN socket K3 and the 'Power Detector' BNC socket K1. The exact sizes and locations of these holes will depend upon the sockets you use, and I'll leave them to you.

The remaining holes are mainly in the rear of the case, and are in the main of 3mm diameter. These are to take 3mm or 1/8" mounting screws, for the PC board and the battery clamp. If you decide to copy the prototype and add a tilting prop, you'll also need a couple of holes to mount the prop's hinge. I used a 50mm brass cupboard-door type hinge, which required 5mm holes for the mounting screws.

To locate the four holes for the PCB mounting screws, I suggest that you make a photocopy of the PCB artwork. This can then be taped to the rear of the case, and again used as a guide for centre-popping. The exact location of

Continued on page 148

## Mini Construction Project:

# Improved RS-232C data-link analyser

Although originally sent in as a contribution to 'Circuit & Design Ideas', we decided that this design justified a little more space. Those involved in troubleshooting data communications systems should find very interesting.

by 'HENRY CHOKE'

The ubiquitous RS-232 'breakout box' is an essential tool for anyone involved in data communications, but most breakout boxes are less than user-friendly. Some common problems are:

1. A captive socket on one side and a plug, on a very short cable, on the other side. These often turn out to be the wrong sex (when you have a fixed male connector on the back of a terminal for example). In any case you really need cables long enough to bring the box out where you can work comfortably – not crouched behind a terminal or under a desk!
2. Signal-powered indicator LEDs. These sometimes cause loading problems on the signals you are trying to observe, and just the act of monitoring a line can pull it high (or low).
3. LEDs which are physically located on one side of the switches may be electrically located on the other side. This can be confusing, even when you know about it.
4. Special adaptors are generally required for the increasingly popular 9-pin standard.

The frustration caused by these problems led this author to design and construct his own breakout box ('Data-link Analyser' might be a better name). It provides the following facilities:

- Four high-impedance indicators which show +ve, -ve or nothing.
- Long connecting cables, each equipped with male and female 25-pin connectors and male and female 9-pin connectors.

- Existing cables can be checked for opens, shorts etc.
  - Unknown cables can be analysed to see what is connected to what.
  - A source of 'data' which can be used to check if a terminal or printer is responding.
  - Local sources of positive and negative voltage.
- The conditions on a straight-through connection can be monitored.
- A custom cable for linking any pieces of equipment can be quickly set up.

Fig.1 shows how easily this is done. The two interface cables each come to

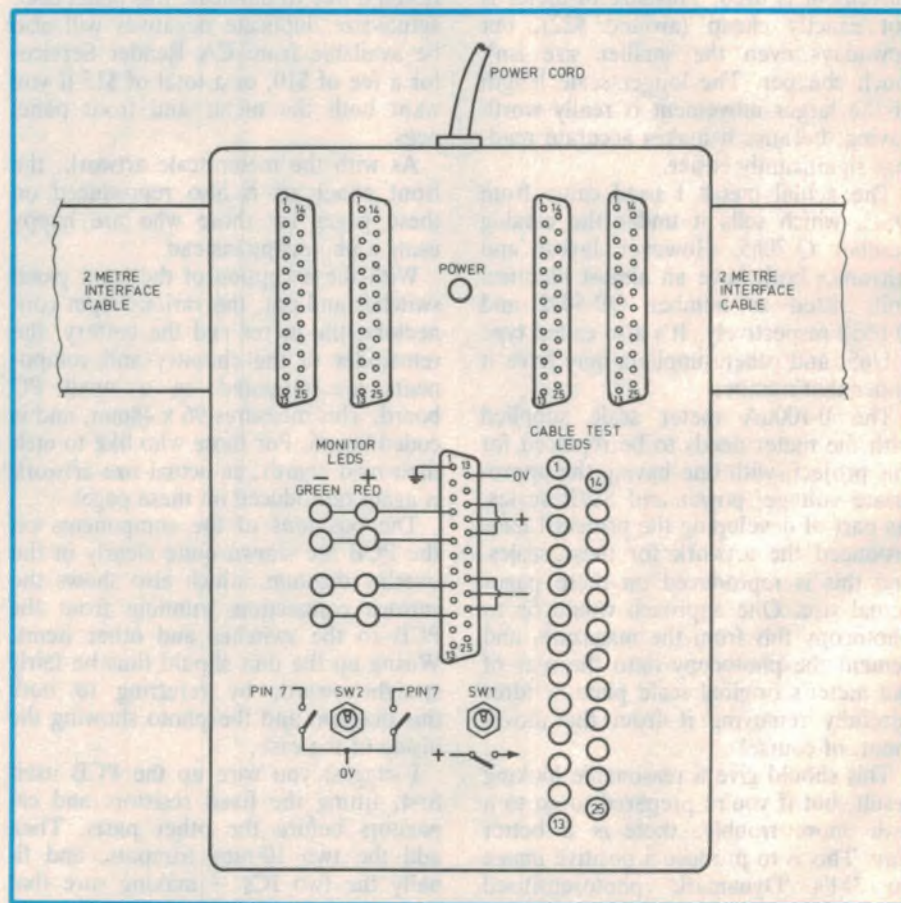

The physical layout used for the author's prototype. The five DB25 sockets allow very flexible patching of connections.

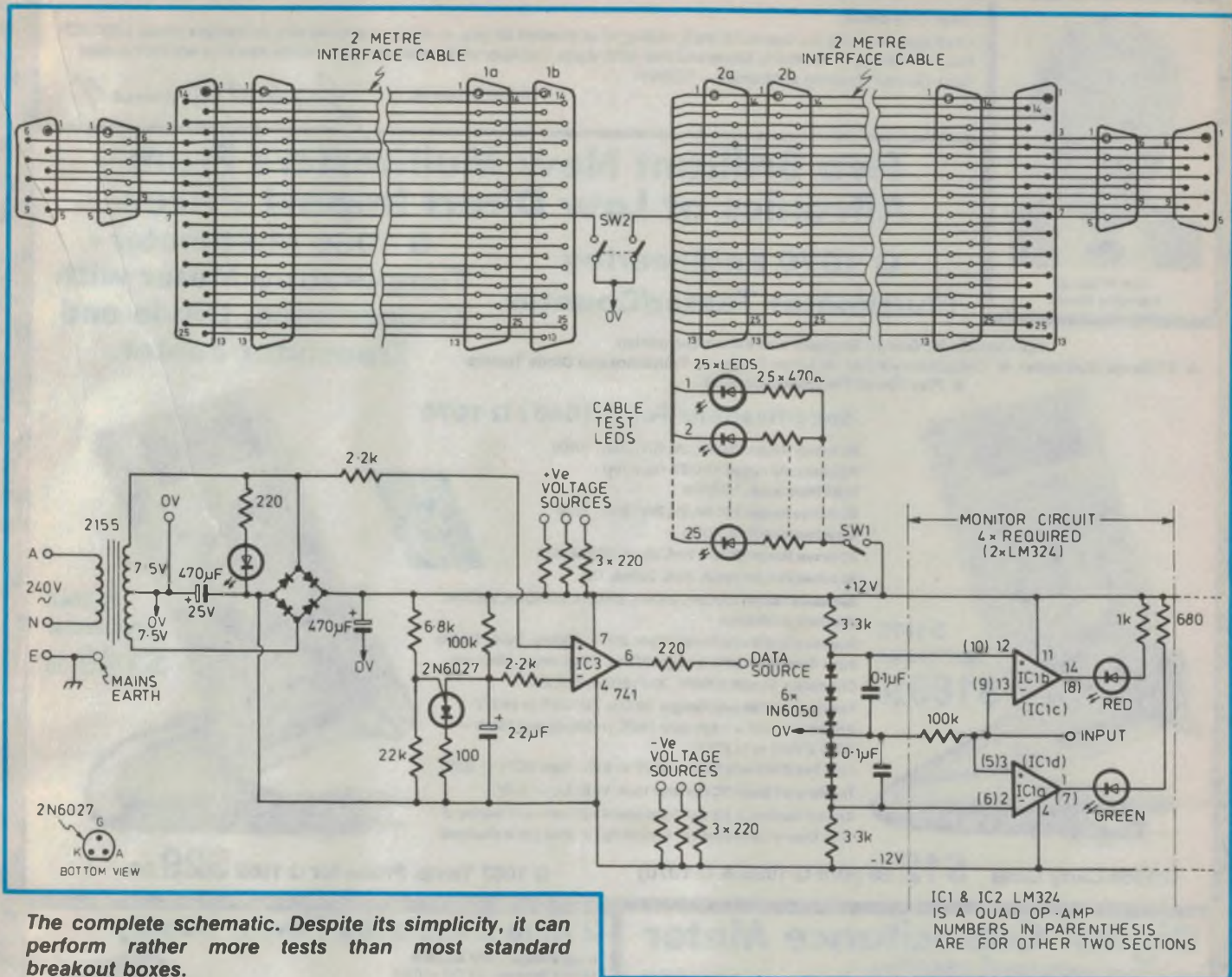

**The complete schematic. Despite its simplicity, it can perform rather more tests than most standard breakout boxes.**

two female connectors on the box. These are used for patching. On one side we also have 25 LEDs for cable testing; these can be isolated from the power by SW1.

To test or analyse a cable, it is connected between the two interface cables, SW1 is operated to put +12V behind all the LEDs, a jumper wire is plugged into OV and touched on each pin of socket 1a. The LEDs indicate continuity, opens or shorts.

Another female connector is used to patch in the monitor circuits, the data source, the positive and negative voltage sources, OV and mains earth.

Jumper leads can be made by soldering a small nail to each end of some hookup wire and insulating the joints with heat-shrink tubing. The nails should be chosen to be a neat fit in the sockets. Alternatively you can dismantle a DB-25 plug, and use the pins from it instead of the nails.

The monitor circuits each involve two comparators, which light the red LED for voltages above +2V and light the green LED for voltages below -2V. Neither LED is illuminated if the input is in the undefined zone between -2V and +2V. Four such circuits have proved to be adequate.

To use this facility, the OV reference from the box must be tied to 'signal ground' of the circuit under test. This is done by operating SW2, which connects OV to pin 7 of both interface cables. The connectors are crimped onto the ribbon cables in such a way that pin 7 of the 25-pin connectors corresponds to pin 5 of the 9-pin connectors.

The 'data' source is provided by IC3, which compares a 50Hz sine wave with a slow ramp function generated by the PUT oscillator. The result is a 50Hz pulse train with a varying mark/space ratio. This may not seem very useful, but in practice it will produce some sort

of response from a terminal or printer regardless of baud rate, number of bits or parity - enough to verify that it's working.

If you're really keen you could include a test message generator with switchable baud rates.

Mains power is not as inconvenient as might be thought. When working with computers, terminals, printers and modems, a power point is never too far away.

The prototype was built in a 185 x 115 x 50mm diecast box, arranged as in Fig.2. Since ribbon cable is used for the interfaces, it is a simple matter to crimp on two female connectors for the box ends and male & female, 25 and 9-pin connectors for the far ends.

It is a good idea to make up a short male-to-male ribbon cable to bridge sockets 1b and 2b, so that the 'straight-through' condition can be quickly set up. 2



Jack O'Donnell  
Managing Director

Dear Customer,

Once again we have put together a really exciting lot of products for you. — And look at these very competitive prices! LABTECH has produced a terrific 40MHz Scope and their NEW Audio Oscillator will be a winner. Don't waste your time and hard earned cash. Do your shopping at Altronics — TODAY!

With kind regards,

*Jack O'Donnell*

## Two Brilliant New Multitesters From Altronics at Low Direct Import Prices

**Q 1070 Engineering Multimeter Tester/Counter**

**Q 1066 Multimeter - Temperature Meter with Capacitance, Diode and Transistor Tester.**

The Ultimate for Design Engineer and Bench Technician

- 27 Range Multimeter ● Capacitance Meter ● Logic Tester ● Transistor and Diode Testers
- Five Range Frequency Counter.

### Specifications For Q 1066 / Q 1070

DC Voltage Range: 200mV, 2V, 20V, 200V, 1000V  
 Accuracy: All ranges +/- 0.5% rdg + 1dgt  
 Input Impedance: 10M $\Omega$   
 AC Voltage Range: 200mV, 2V, 20V, 200V, 750V  
 Input Impedance: 10M $\Omega$   
 DC Current Range: 200 $\mu$ A, 2mA, 20mA, 200mA, 10A  
 AC Current Range: 200 $\mu$ A, 2mA, 200mA, 10A  
 Resistance Range: 200 $\Omega$ , 2k $\Omega$ , 20k $\Omega$ , 200k $\Omega$ , 2M $\Omega$ , 20M $\Omega$ , 200M $\Omega$   
 Frequency (Q 1070 only) Range: 2kHz, 20kHz, 200kHz, 2MHz, 20MHz  
 Input Sensitivity: 20MHz range 1V rms. Other ranges 35mV rms.  
 Capacitance Range: 2000PF, 20nF, 200nF, 2 $\mu$ F, 20 $\mu$ F  
 Temperature (Q1066 only) Range: -20°C to 750°C 0°F to 1400°F  
 Accuracy: +/- (3 + 1 dgt) up to 150°C +/- 3% rdg over 150°C +/- (15 + 2 dgt) up to 225°F  
 Logic Test (Q1070 only) Logic 1: 2.4V +/- 0.2V, Logic 0: 0.07V +/- 0.2V  
 Transistor hFE Base DC Current: 10 $\mu$ A, VCE: 2.8 +/- 0.4V  
 General: Display: 3 1/2 digit liquid crystal with maximum reading of 1999  
 Overrange Indication: Highest digit of (1) or (-1) is displayed



Q 1070  
Multimeter  
**\$189.00**



Q 1066  
Multimeter  
**\$149.00**

**NEW  
IN  
'90**

Q 1068 Carry Case **\$12.50** (suit Q 1066 & Q 1070)

Q 1067 Temp. Probe for Q 1066 **\$29.95**

## Digital Capacitance Meter



**NEW  
IN  
'90**

K 2524 **\$109.00**

"Silicon Chip" May '90

- Capacitance 1pF to 9999 $\mu$ F in seven ranges ● Accuracy +/- 1%, +/- 1 digit ● Mains powered
- Designed for laboratory and workshop use

## 2 Amp Regulated Power Supply

Input Voltage: 240V AC-50Hz  
 Output Voltage: 12V DC +/-0.5V  
 Output Current: 2A DC  
 Dimensions: 84 x 68 x 200mm  
 Weight: 1.2kgs  
 M 9050



Normally **\$69.95**  
**This month only**  
**\$59.95 SAVE \$10.00**

The Days Of Tape Decks Are Numbered

This Digital Recorder delivers astonishing reproduction of voice and/or music without one single moving part!

## Digital Voice Recorder

(Silicon Chip Dec'89)

Here is a digital voice recorder that can store 4 different signals, voice, sound or a music source of up to 30 seconds each or one recording of up to 2 minutes.

This new digital voice recorder uses a special voice recorder/playback IC and 7 other IC's making it both simple to construct and incredibly economical.

Separate 256K Ram chips are used for each channel. These memories can be ganged to provide a total of 2 minutes of message time. There are 4 trigger inputs so that a message can be stored when a certain condition occurs.

Battery backup is provided so that the messages are retained when main power is off.

Typical applications include:

- Alarm system messages ● Sales messages for customers put "on hold" ● Experimental telephone answering machine ● Door station announcer ● Talking displays for shops ● Emergency warning message announcement
- Operation instructor for machinery etc.

K 9550 Kit complete - PCB Format **\$129.00**

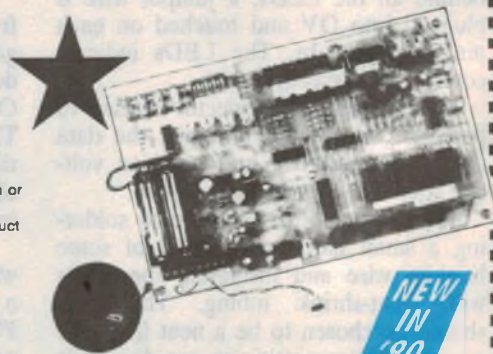

**NEW  
IN  
'90**

For those who want a professional appearance - stand alone product, we can supply with our Deluxe H 0483 Instrument case and fully punched and screen printed front panel.

K 9555 Kit complete - with Inst. case **\$149.00**

## 40MHz Dual Trace Oscilloscope

- CRT Display 150mm rectangular, domed mesh and 12kV post accelerator type.
- Vertical Amplifier (CH1 and CH2 identical) Operational Modes: CH1, CH2, ADD, DUAL, ALT, CHOP Sensitivity: 5mV - 5V/Div 3% in 1-2-5 steps, 1mV - 1V/Div 5% X5 Mag
- Horizontal Amplifier Operating Modes: X-Y operation CH1-X axis, CH-2 Y axis Sensitivity: 5mV - 5V/Div +/- 3% in 1-2-5 steps
- Input Impedance: 1MOhm +/- 2%, 25pF +/- 3%
- Time Base Sweep Method: AUTO, NORM, SINGLE Magnified Sweep: 10 times +/- 5%, Max 20nS Delay Method: Continuous delay and adjustment
- Synchronization A, B, B Triggered, Internal V-MODE, CH1, CH2, LINE, EXT
- Trigger Coupling: AC, DC, HF Rej, TV-H (Line), TV-V (Frame) Triggering Sensitivity: INT. DC - 20MHz 1.0 Div, 20MHz - 40MHz 2.0 Div, EXT. DC - 20MHz 150mVp-p, 20MHz - 40MHz 300mVp-p
- Vertical Amplifier Signal Output: 50 mV/Div. - 50 Ohm
- Intensity Modulation Z Axis Bandwidth: DC - 1MHz, Sensitivity: 3Vp-p
- Probe Calibrator Output : 1 kHz square wave 1V

Highly recommended for  
Service Workbench, Design Laboratory, Manufacturers,  
Universities and the dedicated Enthusiast.

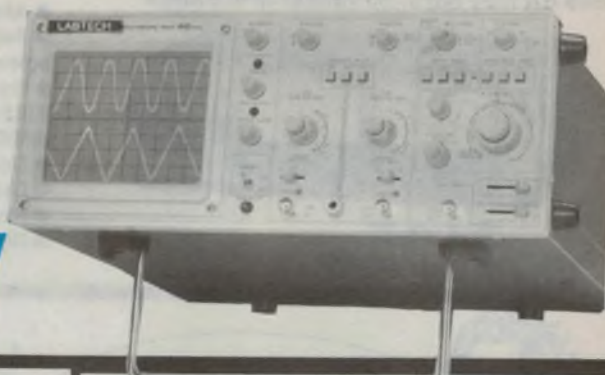

Q 0160 **\$1495.00** Price includes TWO X1/X10 Probes worth \$100.00!

**NEW IN '90**

## DUAL TRACKING POWER SUPPLY +/- 50V DC AT 1.0AMP

SILICON CHIP APRIL '90

- Voltage output: 0 to +/-50V or 0 to 100V
- Current output: 1.7A from 0 to 87V (+/-43.5V)
- 1A from 0 to 100V (+/-50V)
- Load regulation, better than 500mV at +/-50V, 1A
- Drop out indicator (5mV of ripple)
- Short circuit protection
- Load switch - no need to switch off when switching load.



K 3380 **\$229.00**

**NEW IN '90**

## Laboratory Series Audio Oscillator

**NEW IN '90**



Q 1547 **\$480**

- Frequency Range: 20Hz to 200kHz in 4 ranges
- Sine Wave Characteristics: Output voltage: 5V RMS or more at no load Distortion factor (at max output) 0.5% or less Output impedance: 600 Ohms +/-10% Output attenuator: 0 to greater than 50dB continuously variable.
- External Synchronisation Characteristics Input impedance: approx. 10kOhms Max. allowable input voltage: 10V RMS
- Reading Accuracy 0.01%, +/-1 count
- Frequency Counter Characteristics Display: 4 digits, 7mm red LED display Frequency range: 10Hz—1Mhz (square wave) Sensitivity: 25mV RMS Max. input: 150V p-p Input impedance: 1MOhm Square Wave Characteristics (TTL Out) Overshoot: 2% or less (at 1kHz) Rise/fall time: 200n sec or less
- Power requirements: 100/120/220V +/-10% 240V +5%, -10%, 48-86Hz

## 17 Range Digital Multimeter

with Overload Protection  
Australia's best value, less than \$50

- Specification:
- DC Voltage Range: 2V, 20V, 200V, 2000V
  - AC Voltage Range: 200V, 500V
  - DC Current Range: 200mA, 20 mA, 2mA, 10A
  - Resistance Range: 200Ohm, 2kOhm, 20kOhm, 200kOhm, 2MOhm
  - Diode Test
  - Test Current: 1.0 +/- 0mA
  - Test Voltage: 3.2V Max.
  - Battery Test Range: 1.5V, 9V

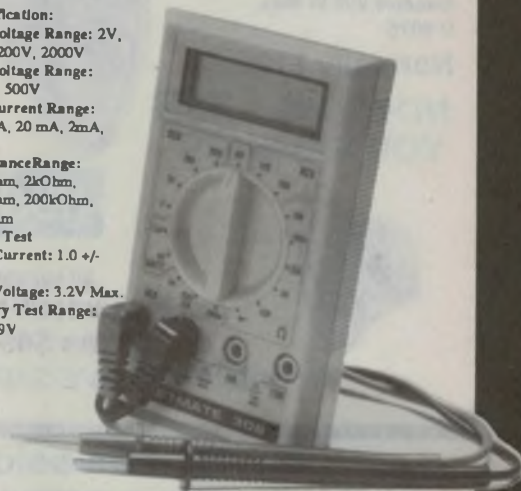

Q 1056 **\$49.95**

Another Altronics Direct Import Price Breakthrough

Carry Case Q 1057 **\$12.50**

# INVERTERS INVERTERS INVERTERS INVERTERS INVERTERS

Get 240V AC Mains Power from your battery with these handy inverter kit sets  
Many combinations to choose from:

## POWERHOUSE 600W INVERTER

(See EA Dec 87)

This inverter has the capacity to produce 600 watts of mains power which will run a fantastic array of appliances. Ideally suited to running power tools, lighting (including fluores) electric motors and much more. It can be used either as a portable or a permanent fixture.

- Manual or Auto Start facilities
- Low battery cut-out.

Kit version

K 6770 **\$425.00**

Fully built and tested

12V Input K 6774 **\$525.00**

24V Input K 6775 **\$525.00**



## 300 WATT INVERTER WITH AUTO START

- Operates from 12V Car Battery
- Auto Start draws power from your battery only when appliance is plugged in and "turned on" i.e. battery can be left permanently connected if required.
- Voltage Regulated
- Current Regulated
- Current Overload unit self limits

Complete Kit

K 6750 **\$279.00**

Fully built and tested

K 6755 **\$379.00**

**100's OF USES AT HOME AND AWAY**

## Laboratory Power Supply

(See EA May '85) 3 - 50 Volts at up to 5 Amps



K 3300 **\$195.00**

- Single printed circuit board construction
- Deluxe instrument case
- Attractive silk screened front panel
- Fully drilled and punched chassis - No holes to drill
- Front panel supplied to accommodate K 3302 option if required

**SPECIFICATION:**

- Output Voltage - 3 to 50 volts
- Output current up to 5 Amps (max. 175W)
- Floating outputs isolated from ground
- Ripple less than 90mV p-p at max.

**10 TURN OUTPUT VOLTAGE CONTROL OPTION.** (K 3300 is normally supplied with standard pot) **K 3301 \$29.50**

**AUXILIARY + AND - 12V OUTPUT TERMINALS OPTION** Fixed Outputs Independent of Variable Main Output

**K 3302 \$14.50**



**Pssst...! Listen to this!**

The really exciting news is that all of these speakers are available at such a low discount price for this month - but be quick - stocks are limited.

## Ultra High Power Capacity Polypropylene Bass Drivers

Our ALL NEW "Black" polyprop cone Bass Drivers exhibit quite astonishing low register reproduction. Power ratings quoted are conservative. Not the cheapest but definitely the BEST VALUE we know of - ANYWHERE.

**15" (375mm) WOOFER**  
Huge 120 Watts RMS  
Massive 200 W Max.  
C 3075

Normally \$129

**NOW ONLY \$99**  
YOU SAVE \$30



**12" (300mm) WOOFER**  
100Watt RMS 150W Max.  
C 3070

Normally \$99

**NOW ONLY \$89**



**10" WOOFER**  
60Watt RMS  
100W Max.  
C 3065

Was \$69.00

**NOW ONLY \$49.00**



## HUGE SAVINGS ON SPEAKERS



**8" WOOFER**  
60Watt RMS 100W Max.  
C 3060 Was \$49.95

**Now \$39.95 SAVE \$10.00**



**6 1/2" WOOFER/Midrange**  
30Watt RMS 50W Max.  
C 3055 WAS \$29.95

**NOW ONLY \$24.00**



**6 1/2" Mid Range**  
30Watt RMS 50W Max.  
with sealed frame

C 3045 Was \$27.50

**NOW YOU SAVE AT \$22.00**

## Multiple De-soldering Tool

Ideal for service technician and hobbyist alike.  
Can also be used as a soldering iron.

1 240V AC 50Hz | SEC Approval W/2228 | Easy, single-handed action | Earthed | Simple cleaning action.

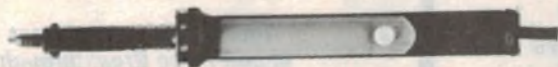

T1250 Normally \$59.95 **This month \$49.95 SAVE \$10.00**

Replacement Tip T 1255 1.5mm \$4.95 Spare Tip T 1252 1.2mm \$4.95

## TO 3 HEATSINK GIVE-AWAY FROM 50 cents each!

H 0503 50c EACH

10 UP 40c EACH

NORMALLY \$1.50 EACH



**TOP VALUE**

## HEADPHONES



Why pay \$400 or more for a David Clark set?  
**AVIATORS HEADSET WITH OIL FILLED EAR CUSHIONS**

- High performance, noise attenuating earphones.
- Noise cancelling microphone
- Cushioned head pad
- Super sturdy
- Great performance
- Superb, professional pilot's headset will last a lifetime with reasonable treatment.
- Includes standard aircraft jacks.

C 9070 **ONLY \$189.00**

Now available from Altronics Dealers **VALUE**

OUR DIRECT IMPORT PRICE LESS THAN \$100!



## Pocket Sized Personal Audio Signal Generator

Quite the finest portabel audio oscillator we have ever seen. Range switch and multiply enable selection to 46 preset frequencies from 20Hz to 150kHz, eg 20Hz, 28Hz, 32Hz, etc.

Sine Wave and Square Wave output.

Output control -20db to 0db  
Internal 9V battery

Q 1542 Oscillator

**\$99.00**

Q 1544 Protective Carry Case \$12.50





## Harris Four Channel Digital Recorder/Announcer

Designed around the TMS 3477 digital recorder IC, this brilliant Australian made recorder has no moving parts and will play indefinitely.

- The Harris A2100 provides 4 channels of natural speech recording and play-back.
- Record time for each channel is internally selectable to 10, 15, 20 or 30 seconds.
- Channels can be used separately or linked to provide one long recording/announcement.

### Facilities/Features

- Microphone Input - balanced line, low Z, Input 5 PIN DIN socket (mates with Redford C 0372 desk mic)
- Auxilliary Input - 100KOhm 0.2V sensitivity, e.g. for CD, tape deck, Tuner, BGM line.
- Timer Switch - automatically initiates the play back of the selected channel. Intervals are 10, 20, 30 seconds, 3, 6, 12 and 30 minutes and off.
- Line In/Line Out - zero gain circuit enables you to 'pipe' a music source such as BGM or tuner, cassette deck etc through the recorder. This line will interrupt with the recorded announce-

ments as desired.

### Literally dozens of applications

- Music on Hold Adviser - Over 50% of phone calls are placed on hold - use this time to promote your business or products.
- Information Guide - Great for displays, trade shows, self guided tours and even art galleries.
- PA System Feedback Eliminator - With the Harris Announcer, feedback is eliminated. Just operate on 'instant replay' mode and once the announcement is recorded it will automatically page. Self resets ready for the next message.
- Emergency Signals - and/or security warnings can be generated automatically or at the push of a button.
- Advertisement Announcer for Retail Stores - Either record your own ads or have them commercially produced - play through your PA/BGM system as often as desired with

NEW IN '90



Literally hundreds of applications. Dead easy to use.

A 2100 Great Value

**\$799.00**

## 50MHz Logic Probe with Logic Pulser

### LOGIC PULSER (Model Q 1280)

Synch input impedance	1MOhm
Pulse rate	0.5/400Hz
Pulse width	10uS
Output current	100mA sink/source
Square wave output current	5mA sink/source
Power supply range	5 - 15V DC
Power supply protection	20V DC (30seconds max.)
Synch input protection	120V DC (30 seconds max.)
Test point protection	35V DC (30 seconds max.)

Maximum input signal frequency	50MHz
Input impedance	120kOhm
Operating supply range	18V DC maximum
TTL: Logic '1' (HI LED)	> 3.0+/-0.25V
Logic '0' (LO LED)	< 0.75+/-0.25V
CMOS: Logic '1' (HI LED)	> 60% Vcc+/-5%
Logic '0' (LO LED)	< 15% Vcc+/-5%
Minimum detectable pulse width	10 Nanoseconds
Maximum signal input protection	+/-70V AC/DC (for15seconds)
Power supply protection	+/-20V DC

NEW IN '90

Q 1280 **\$54.95**

## Bench Top Power Supply

(See EA Jan '85)



- Short circuit protection
- Load switching
- Current limiting fully variable-twin selectable ranges-dual scale meter
- Separate earth terminal provided
- Housed in our Deluxe "ABS" instrument case

### SPECIFICATIONS:

- Output Voltage - 3 to 30V
- Output Current 0 to 1 amp (fully variable)
- Load Regulation - Better than 0.2% from 0 to full load
- Output Ripple - Less than 2mV RMS

**VALUE**

3-30V to 1 Amp Max. With Variable Current Limit.

K 3210 **\$90.00**

● BANKCARD ● VISA ● MASTERCARD ● PHONE TOLL FREE 008 999 007

● NEXT DAY JETSERVICE DELIVERY

Country clients please allow an additional 48-72 hours

# ALTRONICS

174 Roe St. Perth W.A. 6000  
PHONE TOLL FREE 008 999 007  
Perth Metro (09) 328 1599  
ALL MAIL ORDERS

P.O. Box 8350 Stirling Street Exchange Perth W.A.6000

### ALTRONICS RESELLERS

Chances are there is an Altronics Reseller right near you - check this list or phone us for details of the nearest dealer. **Please Note:** Resellers have to pay the cost of freight and insurance and therefore the prices charged by individual Dealers may vary slightly from this Catalogue - in many cases, however, Dealer prices will still represent a significant cost saving from prices charged by Altronics Competitors.

Don't forget our Express Mail and Phone Order Service - for the cost of a local call, Bankcard, Visa or Mastercard holders can phone order for same day despatch.

Blue Ribbon Dealers are highlighted with a ■. These Dealers generally carry a comprehensive range of Altronic products and kits or will order any required item for you.

**WA COUNTRY** ALBANY BP Electronics ■ 412681 **ESPERANCE** Esperance Communications 713344 **GERALDTON** Bird Electronics 841831 **KALGOORLIE** Today's Electronics ■ 212777 **KARRATHA** Daves Oscitronic 854838 **PORT HEADLAND** Ivan Tomek Electronics 732531 **WYALKATCHEM** D & J Pease 811132 **NT ALICE SPRINGS** Ascot Electronics 521500 **Farmer Electronics** 522388 **DARWIN** Ventronics 853822 **ACT CANTERRA** Bennett Commercial Electronics 805359 **VICTORIA CITY** All Electronic Components 6823508 **SUBURBAN CHELTENHAM** Talking Electronics 5842386 **CROYDEN** Truscott Electronics ■ 7233860 **PRESTON** Preston Electronics 4840181 **COUNTRY BENDIGO** KC Johnson ■ 411411 **MORWELL** Morwell Electronics 348133 **Tattersall Sounds** 8212892 **QUEENSLAND CITY** Delsound P/L 8396155 **SUBURBAN CAPALABAI** Kingway Electronics 3902399 **WOODRIDGE** David Hall Electronics 8082777 **COUNTRY BUNDABERG** Bob Elkins Electronics 721785 **GLADSTONE** Supertronics 724459 **MACKAY** Philtronics ■ 578855 **ROCKHAMPTON** Access Electronics (East St.) 221058 **TOOWOOMBA** Hunts Electronics ■ 329877 **TOWNSVILLE** Solex ■ 7724486 **MAROOCHYDORE** Mala Electronics 436119 **SA CITY** Force Electronic ■ 2125505 **SUBURBAN BRIGHTON** Force Electronics ■ 3770512 **CHRISTIES BEACH** Force Electronics ■ 3823366 **ENFIELD** Force Electronics ■ 3496340 **FINDON** Force Electronics ■ 3471188 **LONSDALE** Force Electronics ■ 3280901 **COUNTRY MT.GAMBIER** South East Electronics 250034 **WHYALLA** Eyre Electronics ■ 454784 **TASMANIA HOBART** George Harvey ■ 342233 **LAUNCESTON** George Harvey ■ 318533 **NSW CITY** David Reid Electronics ■ 2671385 **CARINGHAM** Hicom Unltronic 5247878 **BLACKTOWN** Sheridan Electronics 821 1494 **COUNTRY COFFS HARBOUR** Coffe Harbour Electronics 525684 **GOSFORD** Tomorrows Electronics 247248 **GRAFTON** East Coast Electronic 431250 **NEWCASTLE** Novocastrian Elect Supplies 821358 **RAYMOND TERRACE** Albac Electronic 873419 **WINDSOR** M & E Electronics 775935 **WOLLONGONG** Newtek Electronics ■ 271620 **Vimcom Electronics** 284400 **WAGGA WAGGA** Phillips Electronics 216558

### MORE ALTRONICS DEALERS WANTED

If you have a Retail Shop, you could increase your income significantly by becoming an Altronics Dealer, Phone Chris Campbell (09) 328 2199 for Details.

**STANDARD DELIVERY & PACKING CHARGE \$5.50 to 1Kg \$8 over 1Kg AUSTRALIA WIDE** - We process your order the day received and despatch via Australia Post. Allow approx 9 days from day you post order to when you receive goods

**OVERNIGHT JETSERVICE** Up to 3Kg is \$8.00 - 3Kg to 5Kg is \$20.00 - We process your order the day received and despatch via Overnight JetService Courier for delivery next day Country areas please allow additional 24-48 hours

**HEAVY HEAVY SERVICE** - All orders of 10Kgs or more must travel Express Road - Please allow 7 days for delivery. \$12.00 to 10Kgs, \$15.00 over 10Kgs

**INSURANCE** - As with virtually every other Australian supplier, we send goods at consignees risk. Should you require comprehensive insurance cover against loss or damage please add 1% to order value (minimum charge \$1). When phone ordering please request "insurance".

**TOLL FREE PHONE ORDER** - Bankcard, Visa, Mastercard Holders can phone order toll free up to 6pm Eastern Standard Time. Remember with our Overnight JetService we deliver next day.

## Construction Project:

# SSTV Transmit Scanconverter - 1

For many years, radio amateurs have been sending and receiving slow-scan television (SSTV) pictures around the world. Perhaps you're interested in this fascinating mode of communication, and have built or purchased a receive-only scanconverter to 'look in' on the action. Here's a low cost transmit scanconverter design that will allow you to join in, and send your own pictures.

by LEON WILLIAMS, VK2DOB



My interest in slow scan television started about 10 years ago, when I met a fellow amateur who lived nearby. When I heard the tones coming from his transceiver and appearing as pictures on his converted black and white television, I was hooked.

From that moment on, I began building my own scanconverter. Not being very familiar with the concepts I did a lot of reading, searching, asking, building and rebuilding until the day came when my homebrew scanconverter received its first pictures. On a personal level it was a truly momentous occasion.

The limiting factor was then and has always been the cost and availability of memory chips and analog to digital converters. As these devices became cheaper and obtainable, scanconverters obtained higher levels of sophistication. Today scanconverters are microprocessor controlled and can hold many high

definition colour pictures, and rival personal computers in their graphics capability. There is a problem with this situation, however: the complexity of these units is very high. They contain many IC's, some costly and specialised. This unfortunately has prevented a lot of amateurs from home brewing their own.

The project presented here will not equal these units in performance, but will still allow those on a budget to experience the thrill of operating SSTV.

This scanconverter accepts a standard 1V p-p negative sync fast-scan video signal. During the period of one fast scan frame, a portion of 128 lines – which is every second line in a field of 256 lines – is sampled and digitised. This data is written into random access memory (RAM) where it is stored and read out at a slow scan rate. The data is converted to tones and combined with sync pulses to allow correct reception at the

distant end.

The unit can store two pictures independently, transmit single frames or transmit continuously, has instant picture 'snatch', camera controls, and as it has its own memory your receive unit can hold pictures while you transmit others.

Inexpensive, easily obtained parts are used and assembly is on two printed circuit boards housed in an inexpensive case. Dangerous voltages are avoided by using a plug pack for the power supply. Construction and alignment are straightforward, needing only basic instruments.

Interested? Well read on, and before long you too, will be sending your own pictures around the world.

### SSTV standard

There have been many standards set up over the years for the transmission of SSTV pictures. This unit conforms to

the recognised standard for eight second black and white transmission:

**Format:** 128 dots (pixels) x 128 lines  
**Shades:** 64 (including black and white).

**White frequency:** 2300Hz

**Black frequency:** 1500Hz

**Horizontal sync:** 1200Hz 5ms

**Vertical sync:** 1200Hz 50ms

**Line period:** 60ms (55ms active picture plus 5ms horizontal sync).

**Frame period:** 7.73s (128 line periods plus 50ms vertical sync).

## Circuit description

Fig.1 shows the circuit of the fast-scan video amplifier, sync separator and analog to digital converter (ADC) sections. Transistor Q1 is a common emitter input amplifier, with dual supply biasing to allow a large peak to peak signal at its collector. The gain of this stage is about three and the signal is inverted at the collector, with the sync tips being positive going.

The signal is then split into two directions, to Q4 which is the sync separator and also to Q2. Due to the action of C5 and the biasing of Q4, the signal is clamped at such a level that Q4 only conducts on the sync tips and the rest of the signal is ignored. Transistor Q5 is used to buffer and invert the signal so that the horizontal sync signal is a series of positive going pulses. To obtain the vertical sync pulses only, it is necessary to pass the composite signal through an integrator. This is formed with R17 and C13, the resulting vertical sync pulses being buffered and inverted by Q6.

Transistor Q2 has two functions. It is used to amplify the signal by about three times and also to invert the signal so that it is in phase with the input signal. Transistor Q3 follows Q2 and is configured as an emitter follower, with variable biasing provided by the brightness control VR2.

The ADC chip U1 is wired to require an input voltage of 0V for black and +5V for peak white. The job of both the contrast and brightness controls is to adjust the signal to fall within these limits. D1 and D2 are used for protection against excursions of input voltage outside the safe range of the ADC.

The ADC used here is an RCA CA3306. It is a 'flash' type, requiring an external clock, has tristate outputs and resolution to six bits. It is perfect for this job and is very reasonably priced.

The input signal is applied to pin 11 and with an input voltage of 0V the data outputs D0-D5 will be all low, while with an input voltage of +5V the data outputs will be all high. The data is

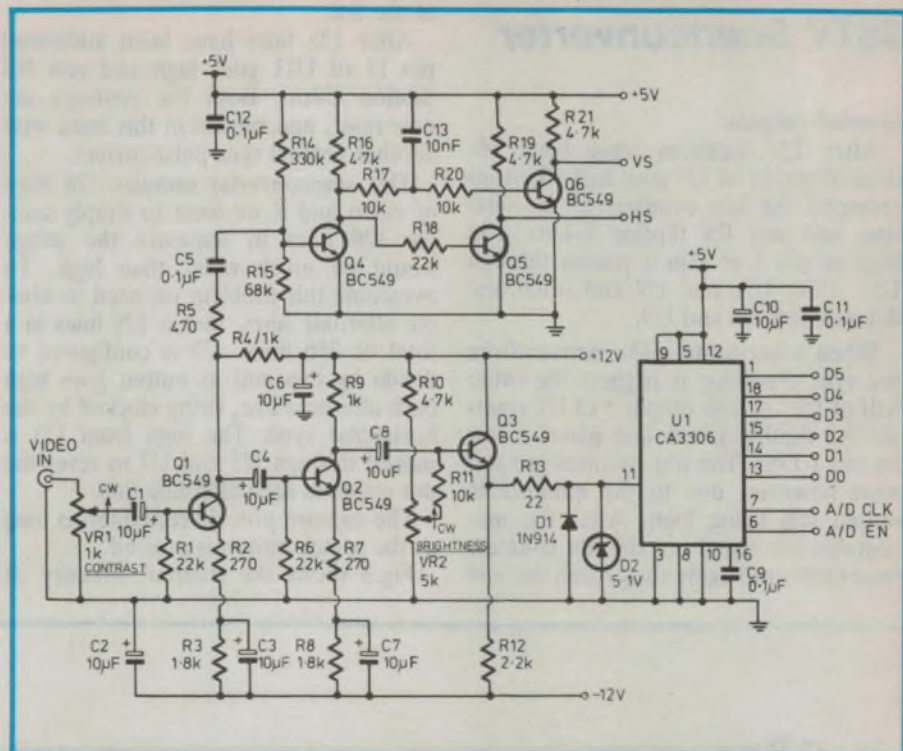

**Fig.1:** The schematic for the input fast-scan video amplifier, sync separator and analog-to-digital converter sections of the circuit.

passed to the tristate output latches on the negative transition of the clock signal at pin 7, while the data outputs are enabled when pin 6 is taken low.

Fig.2 shows the circuit of the memory, address, counters, and control logic section. U12 is the picture storage RAM; a 62256 or a 43256 device is used, which is configured as 32K by 8 bits. A slow scan picture is 16K, so that we can store two pictures. Pin 21 is used to select the half required and effectively becomes the most significant address bit.

You may have noticed that the ADC has a resolution of only six bits and therefore one quarter of the RAM IC is unused. While this is wasteful, it is much easier to employ this scheme than to use six dynamic RAM IC's and the refresh circuits they would require. U8 and U9 are the dot counters and keep track of the dots in a line. U10 and U11 are the line counters. Both dot and line counters can address a maximum of 128 locations.

U6 is the fast scan clock source. The crystal chosen is a common type and as a bonus results in a near 1:1 aspect picture. U7, a 74LS158, is effectively a four pole double throw switch. In the snatch mode it selects the counter resets, clock and memory write pulses from the control circuit. In the transmit mode it selects counter resets and clock from the transmit circuit. U2 is a dual

monostable which is used to delay the digitising process from the top and left of the frame, to centre the sampling 'window' in the fast-scan frame.

The operation of the control circuitry may not be obvious at first, so let's have a closer look. Once the snatch button has been pushed, U7 selects the control circuit signals. Upon a vertical sync pulse arriving from the sync separator it triggers one half of U2. This causes the Q output at pin 13 to go high, resetting the RS flipflop U4c/d and placing a low on pin 9 of U5d. Pin 8 of U5d is held high however by U2 pin 13 still being high. The high is passed through U5b, U5a and U7 to reset the dot counters, U8 and U9, and by pin 11 U7 to reset the line counters U10 and U11. We have therefore all counters reset, addressing the first dot in the first line after a delay following a vertical sync pulse.

Once the vertical sync delay has ended pin 8 U5d goes low, allowing the dot counters to increment. The crystal clock source is used to clock the dot counters and the ADC on the negative transition. The memory is placed in write mode and the ADC tristate outputs are enabled when the clock is in the low state.

In the transmit mode the ADC's outputs are placed in a high impedance state and the memory is placed in permanent read mode. Note that U7 has

# SSTV Scanconverter

inverted outputs.

After 128 locations have been addressed pin 11 of U9 goes high. This increments the line counters to the next line, and sets RS flipflop U4a/b. The high on pin 1 of U4a is passed through U5c, U5b, U5a and U7 and resets the dot counters U8 and U9.

When a horizontal pulse arrives from the sync separator it triggers the other half of U2. A high on pin 5 of U2 resets the RS flipflop U4a/b and places a low on pin 1 U4a. The dot counters are still reset however, due to the monostable output still being high. After the monostable has timed out the dot counters increment until again they reach the end

of the line.

After 128 lines have been addressed pin 11 of U11 goes high and sets RS flipflop U4c/d. Both the counters are now reset, and remain in this state until another vertical sync pulse arrives.

This scanconverter samples 128 lines of video and if we were to simply sample 128 lines in sequence the image would be much wider than high. To overcome this problem we need to sample alternate lines, that is 128 lines in a total of 256 lines. U3 is configured to divide by two and its output goes high every alternate line, being clocked by the horizontal sync. The high from U3 is passed through U5 and U7 to reset the dot counters each alternate line.

The capture process continues as long as the snatch button is pressed.

Fig.3 shows the transmit circuitry. It

can be broken into two separate parts, the sync generator and the digital to frequency converter.

Firstly to the sync generator. At the end of a line one half of U13 is triggered at pin 10 to produce a 5ms horizontal sync pulse at pin 5, which resets the dot counters via U14c and U14d. At the end of a frame the other half of U13 is triggered at pin 2, to produce a 50ms vertical sync pulse at pin 13 which resets the line counters directly and the dot counters via U14c and U14d. Either sync pulse produces a low on U14c pin 13 to reset the slow-scan clock generator U15.

A 555 is used here in the astable mode, with pin 4 used as a reset. The clock is reset during sync pulses to ensure that it is in the same phase at the start of each line. The clock generator is

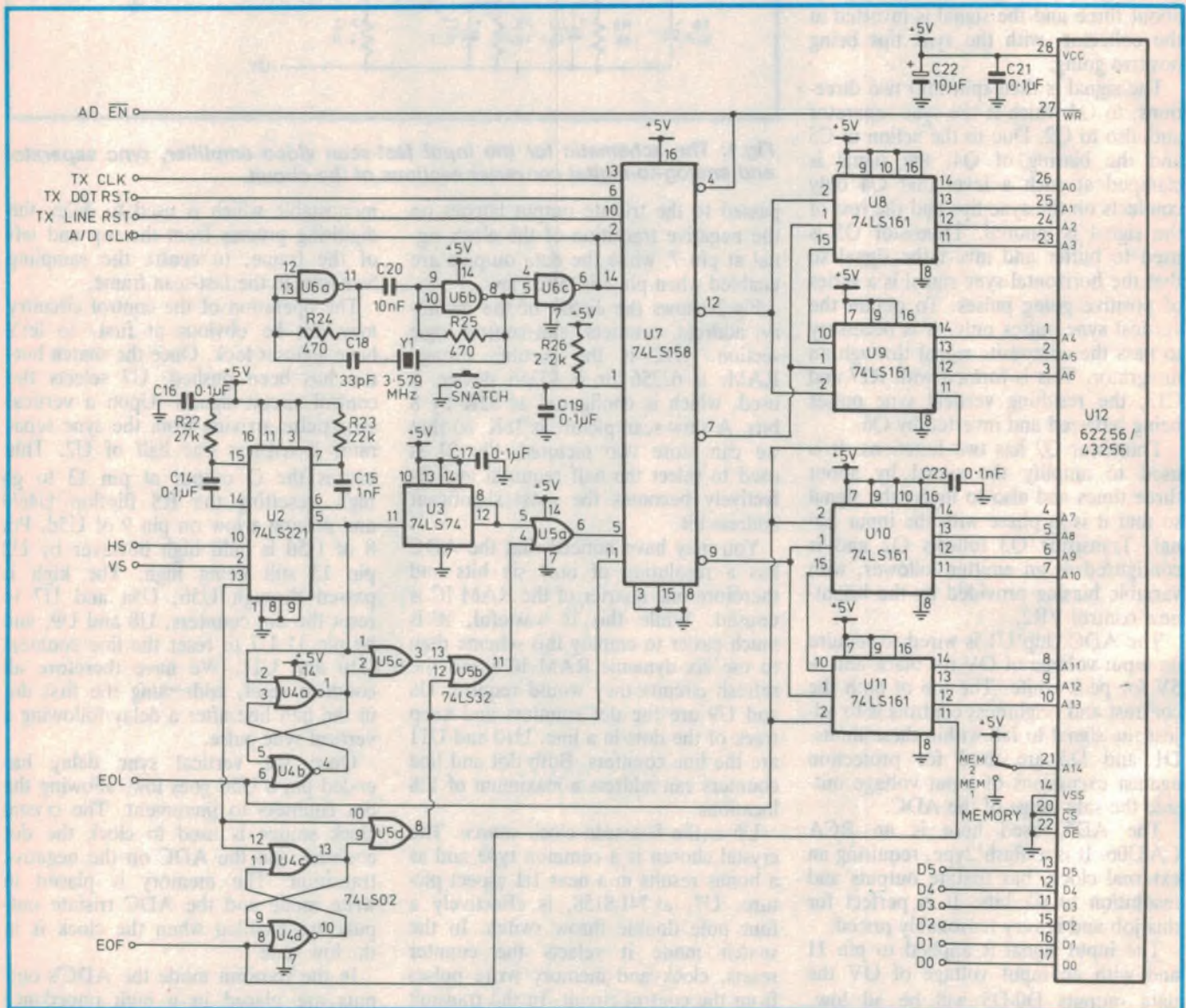
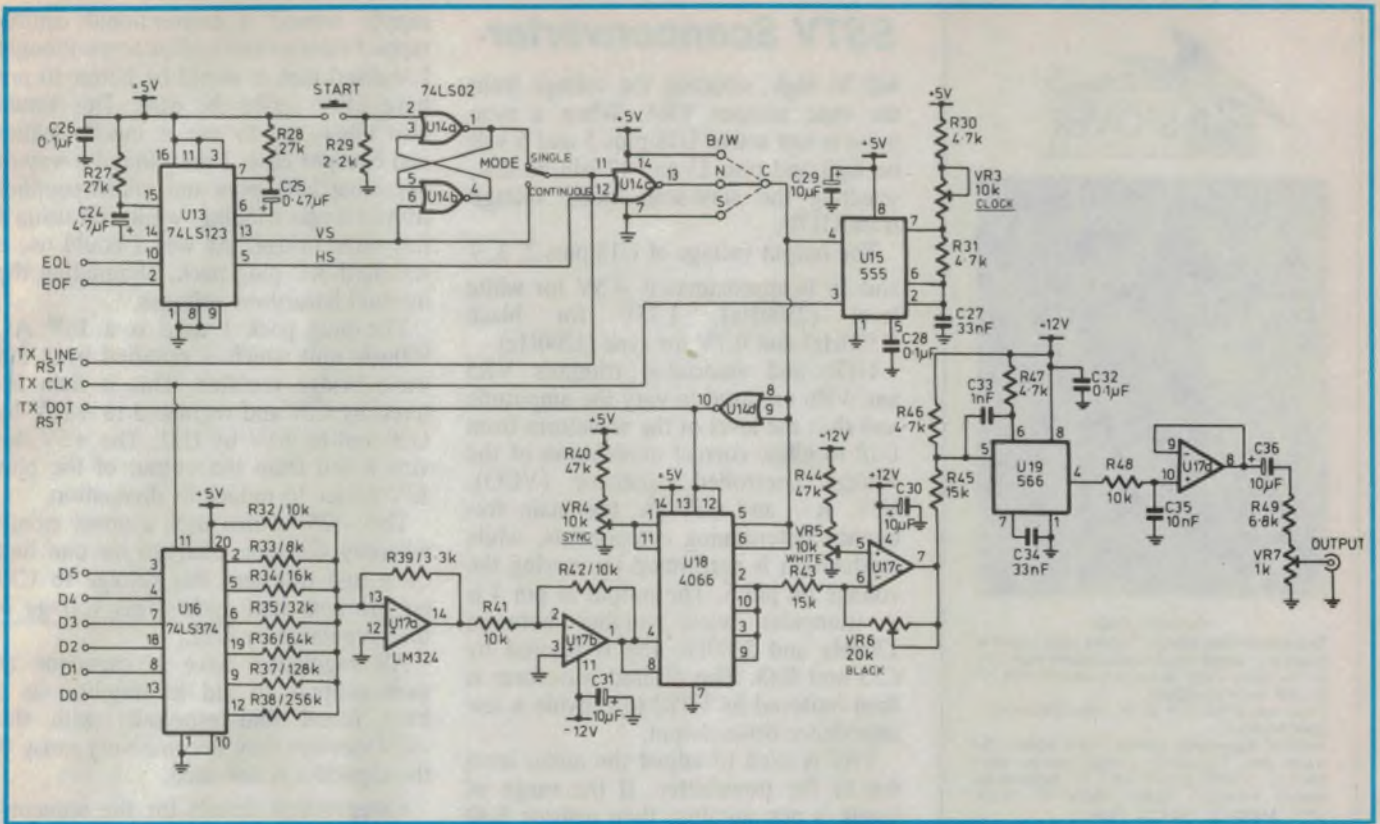

Fig.2: The schematic for the memory, address, counters and control logic circuits.



**Fig.3: The slow-scan transmit circuitry. U15 is the slow scan clock generator, U16 with its resistors perform D to A conversion, and U19 the audio frequency modulation.**

adjusted for a frequency of approximately 2327Hz. This is calculated by dividing the active line period of 55ms by 128 dots. The output at pin 3 is used to increment the dot counters on the negative transition and latch the data by U16 on the positive transition.

With the single/continuous (mode) switch in the single position, a vertical sync pulse will set the RS flipflop formed by U14a/b, to produce a high on pin 1 U14a. This high on pin 11 U14c causes a permanent transmission of 1200Hz sync tone. When the start switch is pressed the flipflop is reset and picture transmission commences from the top of the frame. At the end of the frame another vertical sync pulse again sets the flipflop and only sync tone is transmitted.

With the switch in the continuous position, the start switch is not used, and when the bottom of the frame is reached a vertical sync pulse is transmitted and the picture continues from the top of the frame and repeats indefinitely.

U13 is a retriggerable monostable and is used because during snatch periods the EOL and EOF lines will be pulsing. If we used a non-retriggerable monostable the outputs of U13 would not be in

a permanent state and would cause spurious signals to be transmitted.

If a picture is being transmitted and the snatch button is pressed, the transmission will stop and a permanent 1200Hz will be sent with the mode switch in the single position. With the switch in the continuous position, pushing the snatch button during transmission will cause 1200Hz to be sent while the button is pressed and the frame will start from the top again after the button is released.

Now we will look at the digital to frequency converter. As the memory ad-

dress counters are incremented, the corresponding memory data will appear at the inputs of U16, which is used here as a six-bit latch. A 74LS374 was selected because of its high output drive capability, and so its tristate outputs are permanently enabled. A digital to analog converter is formed with U16, a set of binary weighted resistors, U17a and U17b.

R32 is used to bias the output voltage of U17b above 0V. U18 is wired as a single pole double throw analog switch. When a sync pulse is active U18 pins 5 and 6 will be low, and pins 12 and 13

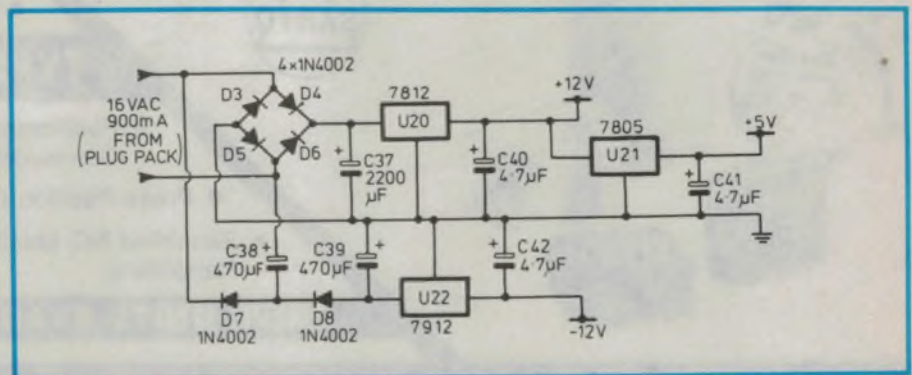

**Fig.4: The power supply section, which produces the necessary +12V, -12V and +5V from an external 16V AC plug pack.**



#### DUMMY LOAD

This inexpensive reliable Dummy Load cased in heavy duty turned copper was designed especially for the field service technician, working with HF to UHF communications.

Fitted with either UHF or 'N' type connectors. Specifications:

Nominal impedance 50ohm Input power 150 watts (int) Frequency range greater than 500mhz VSWR @ 499mhz 1.15 Dimensions overall 140mm x 55mm Model DL 150/1 UHF Model DL 150/2 'N' Type

Price \$235.00 plus sales tax if applicable plus \$7.50 cost & packing  
175 Bunda Street, Cairns, QLD, Australia 4870  
Phone: (070) 513530 Fax (070) 53 6700

READER INFO No. 41

## SSTV Scanconverter

will be high, selecting the voltage from the sync trimpot VR4. When a sync pulse is not active U18 pins 5 and 6 will be high and pins 13 and 12 will be low, selecting the slow-scan video voltage from U17b.

The output voltage of U18 pins 2, 3, 9 and 10 is approximately 4.5V for white level (2300Hz), 1.75V for black (1500Hz) and 0.7V for sync (1200Hz).

U17c and associated trimpots VR5 and VR6 are used to vary the amplitude and shift the level of the waveform from U18 to allow correct modulation of the voltage controlled oscillator (VCO), U19. R47 and C34 are the main frequency determining components, while modulation is performed by varying the voltage on pin 5. The output at pin 4 is a triangular wave varying between 1200Hz and 2300Hz and is filtered by C35 and R48. The filtered waveform is then buffered by U17d to provide a low impedance drive output.

VR7 is used to adjust the audio level fed to the transmitter. If the range of levels is not suitable, then resistor R49 should be adjusted to suit.

The power supply circuit is shown in Fig.4. I originally designed the power

supply around a conventional centre-tapped transformer. After some thought I realised that it would be better to not have 240V inside the case. This would also allow me to use a much smaller and cheaper case. I then found a way of obtaining both plus and minus supplies from a single winding, while still using a full wave bridge. As well I could use a standard AC plug pack, eliminating the internal hazardous voltages.

The plug pack I used is a 16V AC 900mA unit which is rectified by a full wave bridge rectifier. This is then filtered by C37 and regulated to +12V by U20 and to +5V by U21. The +5V device is fed from the output of the plus 12V device to reduce its dissipation.

The -12V source uses a novel circuit whereby C38 gets charged on one half cycle and transfers this voltage to C39 on the next half cycle. This voltage is then regulated by U22.

All regulators have a capacitor at their outputs to aid in stability, as I have found that especially with the -12V devices they become very noisy if the capacitor is not used.

Construction details for the scanconverter will be given in the second of these articles, along with its testing and alignment. EA

# STEPPING AND SERVO MOTORS



## FEATURES

- High out-put
- Compact, Lightweight
- Excellent Servo Characteristics
- Well matched line-ups and options
- Controller Units available in full line up

## TYPICAL APPLICATIONS

- Positioning Control of Conveyors
- Industrial Robotics
- Press Position Control
- Work Position Control
- Simplified NC Machine Retrofitting
- X-Y Table Location Control
- Locating and Position Control

## DRIVE UNITS AVAILABLE FOR ALL MODELS

# TRONICS 2000

**MELB:** 22-24 SYME ST, BRUNSWICK, 3056  
PH (03) 387-6100 FAX (03) 387-5919  
**SYDNEY:** 25 HECTOR ST., SEFTON, 2162  
PH: (02) 644-8133 FAX: (02) 644 3550  
**ADELAIDE:** ARNOLD F. HAY, 116 GILBERT ST.,  
ADELAIDE 5000. PH: (08) 231-394  
**BRISBANE:** P.O. BOX 627, SPRINGWOOD, 4121  
PH: (018) 75-4816 FAX (075) 521 677



### NEW Digital Engine Analyser

The APPA23 gives you 8 functions - dwell, tacho, duty cycle, continuity, volts, amps, ohms and diode testing. Huge 20mm high contrast 3 1/2 digit LCD readout. Auto-power-off to save battery life. Large rotary switch to simplify function selection. Case is drop-proof and water resistant.

#### Brief Specs

DC Voltage : 200mV to 200V  
Tacho : 0 to 10000rpm and 0 to 2000rpm  
Duty Cycle : 0 to 100%  
Dwell : 0 to 90° (4cyl)  
Resistance : 20 $\Omega$  to 20M $\Omega$   
DC Current : 15A

Great value at **\$119.00** inc tax  
(**\$99.00** ex tax)

### Emtek E-301 Logic Probe

- Level Detector
- Pulse Detector
- Pulse Memory
- Hi/Low/Pulse Leads
- Suits TTL/CMOS/HTL etc
- Operates from 4.5 to 20Vdc

Specifications  
Max Input Frequency 17MHz  
Min Pulse Width 30nS  
Input Impedance 1M $\Omega$   
Over-Voltage Protection 220Vac  
Pulse LED flash time 500ms

**\$31.50**

### HCK Stackable 4mm Test Leads

Proven the best under all conditions from -100°C to +300°C. Laminated cage springs on solid brass pin to ensure virtually non-resistive contact. Sliding action is self cleaning. Soldering irons won't burn them. Highest quality and flexibility. Another must for professionals. 16A rating. Available in black, red, blue, yellow, green and violet and in lengths of 500mm **\$6.85**, 1000mm **\$8.70**, 1500mm **\$10.45**



### Fluke 80 Series... Top of the line Multimeters

The Fluke 80 series offers a huge range of extra features like a 200kHz frequency counter, capacitance meter, combined analog and digital scales plus the ability to automatically record max/min and average readings and store them for up to 36 hours!

#### 80 Series Features

- 4 3/4 digit 4000 count resolution
- Digital Display updates 4 times/s
- 87 has analog pointer
- 83/85 have analog bargraph with zoom mode. Analog display updates 40 times/sec
- 0.5Hz to 200kHz Counter with duty cycle from 0.1% to 99.9%
- 10pF to 5 $\mu$ F Capacitance range
- Input alert warns of incorrect connections
- 87 is a true rms 1ms Peak Min Max hold with backlit display
- Touch Hold and Relative modes

**83 \$478.80 (\$399 ex tax)**  
**85 \$576.00 (\$480 ex tax)**  
**87 \$696.00 (\$580 ex tax)**

#### Also...

**Fluke 23 Multimeter**  
Protected 10A range plus 6kV line surge protection to IEEE-587 Cat B Touch Hold Analog Bar Graph Yellow Industrial ABS Case. **\$393.60 (\$328.00 ex tax)**

### Weller WTCPS Soldering Iron Station

Transformer powered low voltage features Weller closed-loop method of controlling maximum tip temperature to protect temperature sensitive components

- 48W stainless steel heater
- Non-burning silicon rubber cord
- 15 tip sizes - 0.8mm to 6.00mm
- 11secs to recover for 37°C drop
- Choice of tip temperatures 315°C/600°F, 370°C/70°F, 430°C/800°F

Weller WTCPS **\$137.00**

Weller EC3001D Electronic Controlled Solder Station **\$325.00**  
Weller EC1001D Electronic Controlled Solder Station **\$195.00**  
Replacement Tips **\$8.95**

We have a huge range of irons to suit every requirement

### Witte Screwdriver Set

This set is for the professionals. Rated to 1000V. Fully insulated right through to the tip in a single hard moulding. Contains 4 flat blades, 6.5, 5.5, 4, 2.5mm and No 1 and No 2 Philips head plus a pocket mains testing screwdriver. Made in Germany with a 5 year guarantee and VDE approved.

A must for electricians **\$49.50**  
Individual screwdrivers available  
Flat : 2.5mm **\$4.20**, 4mm **\$5.40**, 5.5mm **\$7.80**, 6.5mm **\$10.50**  
Philips Head : No 1 **\$6.40**, No 2 **\$8.40**

### Wire Wrap

We carry extensive stocks of wire and tools.

Wire Wrap comes in two pre-cut lengths - 10.16cm and 12.7cm 30AWG at **\$4.80** and **\$5.60** per 100 lengths. Also on spools of 30m for **\$9.95**

We also have a wire kit consisting of 200x 6.25cm, 250x7.62cm, 100x8.89cm, 100x10.16cm, 100x11.43cm and 100x13.97cm. All 30AWG and colour coded for **\$34.80**

#### Tools

The OK M8T hand wrap tool is just **\$19.50**  
The OK Cutter and Stripper is **\$28.50**

Enquire about wire wrap sockets. Our range is too extensive to list here.

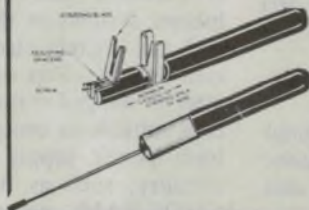

### AT&M KITS

We carry the full range of the great kits. Why develop your own circuits when these building blocks are already available?

Kit	Description	Price
ATM01	3 digit Counter	\$33.60
ATM02	4 digit Counter	50.40
ATM03	3 1/2 digit DVM	59.40
ATM04	1Hz Timebase	22.40
ATM05	Fibre Optic Modem	75.00
ATM06	Reciprocal Calculator	29.40
ATM07	10MHz Timebase	45.60
ATM08	V/F Converter	42.60
ATM09	F/V converter	42.60
ATM10	Quad Power Supply	60.60
ATM11	10 Minute Controller	46.20
ATM12	6 dig Batch Counter	75.00
ATM13	3 Digit Counter	65.40
ATM14	3 1/2 digit LCD DVM	42.60
ATM16	10kV Isolator	70.80
ATM17	Storage Adaptor	193.80
ATM18	8 bit UART	66.00
ATM19	6 dig Up/Dn Counter	69.60
ATM20	IR Transceiver	39.60
ATM21	Multi-Timebase	42.60
ATM22	16Ch Transmitter	77.40
ATM23	16Ch Receiver	77.40
ATM24	22/3 Comms PCB	34.80
ATM25	22/3 Radio Modem	66.60

### Cables

#### All 2m long

D9 plug to D915 socket (that's the triple row 15 pin in a 9 shell) **\$29.95**  
D9 socket to D25 Plug **\$19.95**  
D9 plug to 8 pin Mini-DIN **\$15.00**  
D9 Plug to D9 Plug **\$19.95**  
D9 Socket to D9 Socket **\$19.95**  
D9 Plug to D9 Socket **\$19.95**

#### AMIGA Users

We have the D23 Plug to D23 Socket you're looking for! **\$29.95**

Another Problem Solver  
Our 4 way, 2metre adaptor.

Consists of Male and Female D25 to Male and Female D25. Ideal for service technicians and installation people. A very versatile piece of cable! **\$34.00**

### NEW 2-Way Automatic Data Switch

Now two PC's can share one printer automatically. The printer (or other peripheral) is allocated on a first-come-first-served basis. LED indication tells you which PC is connected. No external power and can be easily attached to any surface using velcro pads supplied. Suits any PC and Printer with parallel (Centronics) connections using DB25 connectors **\$99.50**

#### Manual Data Switches

Total flexibility at very modest cost.  
**2 Way** Serial (RS232) **\$45.00**  
Parallel (Centronics) **\$55.00**  
**4 Way** Serial (RS232) **\$70.00**  
Parallel (Centronics) **\$80.00**

### NEW APPA76 Meterplus

You can't really call this one a multimeter! Does everything your multimeter doesn't - tests resistors, capacitors, trimmers, VRs, diodes, LEDs, transistors, SCRs, batteries. We call it a component tester because it has none of the conventional multimeter functions.

#### Brief Specs

Capacitance : 200pF to 20 $\mu$ F  
Resistance : 200 $\Omega$  to 20M $\Omega$   
Transistor hfe and Iceo Test : 0 to 1000hfe (PNP or NPN)  
Iceo from 10nA to 20.00 $\mu$ A  
Diode : displays Vf at 1mA  
LED : displays Vf at 2mA and 10mA  
Battery : Tests 9V and 1.5V cells under load  
SCR : Pass/Fail

Another great instrument at **\$138.00** (inc tax), **\$115.00** (ex tax)

### GEOFF WOOD ELECTRONICS PTY LTD

229 Burns Bay Road, (Corner Beatrice St.) INC IN NSW  
Lane Cove West, N.S.W. P.O. Box 671, Lane Cove N.S.W. 2066

Telephone: (02) 428 4111 Fax: (02) 428 5198.

8.30am to 5.00pm Monday to Friday, 8.30am to 12 noon Saturday.

Mail Orders add \$5.00 to cover postal charges.

Next day delivery in Sydney add \$5.00.

All prices INCLUDE sales tax.

Tax exemption certificates accepted if line value exceeds \$10.00.

**BANKCARD, MASTERCARD, VISA, CHEQUES OR CASH CHEERFULLY ACCEPTED**



# NEW PRODUCTS

## Laser modules for optical fibre

Philips Components has launched a range of laser and PIN diodes in a low-cost flexible coupling module which matches with all standard connectors currently used in the fibre-optics industry – such as FC, SMA, STC, DIN, and pigtailed. Dubbed the 'receptacle', it

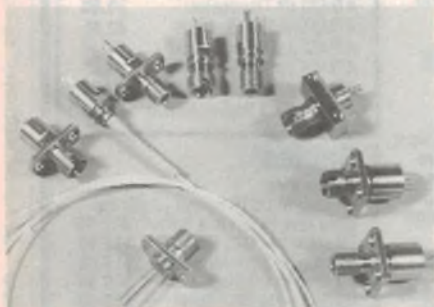

is designed mainly for use in short haul – but also for long haul – optical communications systems such as LANs, ISDN and data links up to 2km.

The receptacle accommodates all semiconductor lasers, from such diverse areas as lasers originally designed for compact disc through to quaternary double-channel heterojunction types. Philips also offers its proven proprietary ranges of off-the-shelf lasers with wavelengths of 780 to 875 and 1300nm in the receptacle. Laser power level can be adapted to customer requirement. PIN-diodes matching the emitting parts in the receptacle execution are also available.

For further information contact Philips Components, 11 Waltham Street, Artarmon 2064 or phone (02) 439 3322.

## Video generator

Grundig's VG1100 multi functional PAL/NTSC video generator has options for SECAM, YUV (and RGB), and teletext.

Featured as standard is a wide range of full-field and vertical interval test signals, including the standard Philips and FuBK test patterns.

The software-generated-pattern philosophy adopted in the VG1100 allows for easier implementation of specific customer requirements, as well as allow-

ing text insertion and on-screen real-time clock.

Text messages are stored in non-volatile RAM, in conjunction with specific test patterns – allowing for test pattern source identification.

Other standard features include – external synchronisation; control over SC/H phase, independent control over the sync, burst, chroma, luminance or composite signal; control over multi-burst level in either VITS or the full-field; Y/C outputs for S-VHS; and so on. An optional IEEE-488 interface allows computer control for automated testing in production.

For further information contact Rohde & Schwarz, 35 Doody Street, Alexandria 2015 or phone (02) 744-1044.



## High reliability Lithium/CrO cells

Varta ER series lithium/chromium dioxide cells present one of the highest practical energy densities available on the market – approximately 1000mWh/cm<sup>3</sup>. Discharge performance is excellent and compared to other lithium systems of the same cell shape, with an organic electrolyte, no significant voltage drop can be noticed even after prolonged storage. This makes the cells suitable as energy sources for long-term power supply of microelectronic circuitry, such as backup supplies for CMOS RAMs and realtime clocks.

Nominal voltage is 3.0V, with an open circuit voltage of 3.8V when fresh, and a self discharge rate of less than 1% pa.

Type ER cells are cylindrical and are available with welded tags for PCB mounting. They have an operational life of up to 10 years.

Varta also has available nickel-cadmium mass type batteries for memory backup and similar applications, again fitted with welded tags for PCB mounting. Examples are the 3/60DK, with a terminal voltage of 3.6V and a nominal capacity of 60mAh, and the 3/100DKO 'Safetronic' with a terminal voltage of 3.6V and nominal capacity of 100mAh. These batteries are completely sealed, can be safely wave-soldered in the fully charged state, have no memory effect – so that they are suitable for long term trickle charge operation – and are protected against damage from overcharging and over voltage.

Further details from the Australian distributor Adeal, of 148-150 Buckhurst Street, South Melbourne 3205 or phone (03) 690 4911.

## Metallised film capacitors

Arcotronics series MKT160.60 metallised plastic film capacitors have been approved to specification RJA379 and DIN44122. These capacitors conform also to IEC Publ.202 category 40/85/56, as well as the more specific requirements demanded by this specification.

Available in a range of capacitances from 4700pF to 10uF in voltage ratings 63V-630V DC, the capacitors are available in tolerances of +/- 5%, +/- 10%, +/- 20%. They are supplied marked with capacitance, tolerance, DC nominal voltage, manufacturers logo, series, climatic category and date code.

Depending on the body size (4), the capacitors come in four mounting pitch sizes (P) 10, 15, 22.5 and 27.5mm.

For further information contact Crusader Electronic Components, 73-81 Princes Highway, St Peters 2044 or phone (02) 516 3855.

## Automatic insertion machine

Both DIP's and axial leaded components can be automatically inserted into circuit boards with the remarkable model CS-302 system together with the CS-80, developed by the US-based Contact Systems organisation.

The machine accepts DIPs from six to 24 pin and reel-fed axial leaded compo-



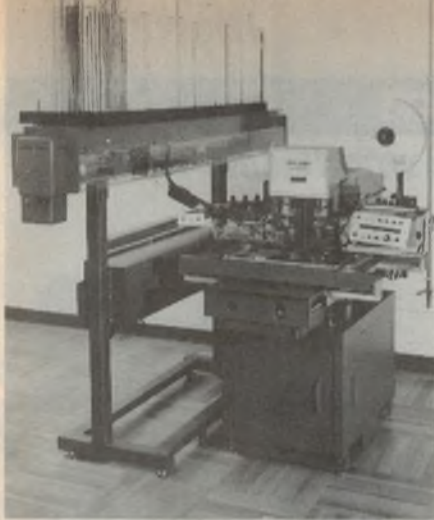

nents, inserting them at speeds of around 2000 per hour. The retractable keyboard provides for generation or duplication of programmes, and the simple, user-friendly programming procedure can be mastered within a few hours.

For further information contact Royston Electronics, 28 Vore Street, Silverwater 2141 or phone (02) 647 1533.

## Intensified CCD cameras

Panasonic WV-BD900 Nite Hawk II series of low-light intensified CCD cameras are useful where both night and daylight operation is essential. Even in moonlight, Nite Hawk cameras deliver usable video pictures for all surveillance applications by incorporating a highly sensitive 2/3" CCD pick-up image sensor and fibre optic plate, attached to a first generation image intensifier.

The WV-BD900 and WB-BD904 (for 24V operation) cameras also feature standard EIA RS-170 sync circuitry: automatic control circuits for high-quality, adjustment-free pictures; gen-lock capability through composite sync or a composite video signal; line-lock capability;



and AGC gain circuitries for clear, accurate pictures, even in poor contrast situations.

Automatic internal/external sync switching and built-in protection circuitry for the image intensifier are additional electronic features, while a rug-

ged die-cast chassis protects the camera against the normally rough treatment which CCTV cameras endure.

For further information contact GEC Video Systems Division, 2 Giffnock Avenue, North Ryde 2113 or phone (02) 887 6222.

## High precision 5.5 digit DMM

The analogic data precision DP100 is not an ordinary digital multimeter but a versatile, ultra-precise, 5-1/2 digit portable and laboratory multifunction meter claimed to challenge the market leaders. Available at a lower cost than previously available 5-1/2 digit meters, it is equivalent to three instruments in the one package.

Weighing only 1.6kg, the DP100 is said to deliver more measurement versatility and performance than any other 5-1/2 digit instrument in its price range. With excellent DC accuracy and sensitivity it also has the ability to measure true RMS AC voltage and current and 2 or 4 wire resistance measurements.

The built-in rechargeable batteries provide over 10 hours of portable operation. The instrument has a rugged single board construction and is housed in an ABS plastic case. A large, high-contrast LCD display allows for easy use even in adverse lighting conditions. The DP100 also has "closed case" calibrations and an RS232 interface to permit printout or external control. It can be used as a data logger and uses the 4-wire technique for measurement of temperature using external RTD sensors.

For further information contact Keneltec, 48 Henderson Road, Clayton 3168 or phone (03) 560 1011.

## Pulse generator operates at 5Gbps

Anritsu has released the world's highest performance pulse pattern generator, the MP1608A. Operating up to 5Gbps, it meets worldwide demand for use in high-speed digital communications and ISDN systems.

The MP1608A generates high purity signals without jitter and sharp waveforms at up to 5GHz, thanks to a built-in synthesiser and Anritsu's own newly developed hybrid ICs and LSIs. PRBS patterns are available in seven types, with maximum 2.1 gigabit length pattern sequence. A large random programmable pattern capacity of 512kbits makes pattern setting of one synchro-



nous transfer mode (STM)-16 (2.4Gbps) frame possible. Thus, this generator far exceeds conventional 5Gbps generators in function and performance.

For further information contact Alcatel STC Anritsu, 58 Queensbridge Street, South Melbourne 3205 or phone (03) 615 6677.

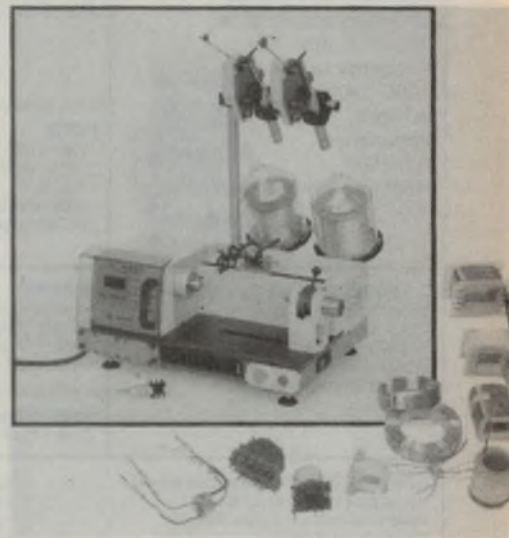

## Benchtop coil winding machine

The Marsilli WM06L is a bench multi-programme layer winding machine where all winding parameters are controlled by a microprocessor.

The following functions can be programmed: number of turns - winding direction - acceleration/deceleration - number of turns/layers - winding speed - slow turn of winding/end and layer/end - pyramidal winding - wire guide positioning - spindle indexing - opening and closing sub-routines - waiting time between operation and many other features.

This therefore makes it a very cost effective and versatile machine for coil winding at entry level.

Wire range is from 0.02 - 2mm. Distance between centres is 250mm, winding width is 130mm and the maximum coil diameter is 130mm.

For further information contact Suba Engineering, 6/150 Canterbury Road, Bankstown 2200 or phone (02) 790 0900.

# L.E. CHAPMAN

## SUPER SPECIAL

**FM Stereo Kits** with circuit diagram  
All three modules supplied are fully assembled and aligned only \$22 pp \$2.10

Antenna supplied

## Tuning Capacitor

2 gang covers all Aust. AM bands  
\$4.75 pp \$1.20 for one or two.

## SPECIAL

### Cellular Horn Tweeter

Mounting specification  
12.5 x 7.1 cm  
frequency range  
2000-20,000HZ  
30 watts, impedance  
8 OHMS  
RRP was \$49.50  
105 Db

## Car Radio Suppressors 4 for \$2

Valve Sockets 9 Pin 4 for \$2  
Octal 4 for \$2  
Stick Rectifiers TV20SC \$2  
Transistors AD 161-162 pair \$3  
AD 149 \$2 each

## SUPER SPECIALS

Gramo Motor and Pickup 4 speed includes cartridge and stylus mono or stereo. Ideal for recording 78 records to tape \$18 pp NSW \$3.80 (Interstate \$4.60)

## SPECIAL

### Dual VU Meters

\$3 pp \$1  
For 1 or 2

## POTS

1/2 MEG \$1.50  
1/2 MEG Switch \$2  
1 MEG \$1.50  
1 MEG Switch \$2  
25K Dual Ganged \$2

Dual 2 MEG Ganged Lin \$2  
Dual 1 MEG Ganged Lin \$2  
Dual 1 MEG Ganged Log \$1  
Dual 1 OK Ganged Log \$2  
50 OHM Single 50c

## Slide Pots

1/2 MEG Dual \$1  
1 MEG Dual \$2  
2 MEG Dual \$2  
1K Dual \$1

25K Dual \$2  
5K Single 50c  
250K Single 50c  
10K Single 50c

## AM/FM Tuning Capacitors

Gear Drive \$10

Chrome 1/4 push on knobs RRP \$1.20 ea 10 for \$1  
Mixed Capacitors fresh stock 100 for \$2  
Mixed Resistors all handy values 100 for \$2  
Slide pot Knobs 10 for \$1  
IFS 455K for Valve radios \$2 ea  
Oscillator Coils \$1 ea  
Dynamic Microphone Desk type HI IMD on/off switch \$4 pp \$1  
Teisco Microphone Ceramic \$2 pp \$1

Touch micro switches as used on colour TV sets 4 for \$1  
Transistor ear pieces plug and lead 4 for \$2  
Push button switches 4 pos 50 cents

1 C Sockets 28 pin 4 for \$1, 18 pin 4 for \$1, 24 pin 4 for \$1

2 way speaker crossover networks \$2

Jack Plug Sockets 2.5MM 4 for \$1, 3.5MM 4 for \$1, 6.5MM 4 for \$1

Push Button switch 5 position \$2

**Rotary Switches**  
2 POS \$1  
4 POS \$1.50

**Valves**  
EF 50 \$5  
GK 7 \$7  
EF 86 \$8  
6K8 \$10  
6V4 \$5  
1S5 \$7  
GAL3 \$6

6 BM8 \$7  
6 BL8 \$5  
5 AS4 \$6  
12 AU7 \$7  
6 U7 \$10  
1T4 \$7

## TV Tuners

46 300.5  
11 Volts \$10

**Speaker Transformers**  
7000 to 15/OHM 5W \$7  
7000 to 3.5 OHM 15W \$10  
5000 to 3.5 OHM \$7

**Speakers**  
5x7 \$5 6x4 \$4

## Capacitors

6N8 1500V 50c  
1000UF 16V 50c  
1000UF 50V ea \$1  
0.0039 UF 1500V 50c  
0.0068 250V 10 for \$1  
47 UF 63V ea \$1  
47 UF 160V 3 for \$1  
470 UF 16V 3 for \$1  
47 UF 200V ea \$1  
0.1 UF 250V 5 for \$1  
680 UF 40V 3 for \$1  
0.027 250V 4 for \$1  
10 UF 25V 10 for \$1  
22 UF 160V 5 for \$1

## Electros

50 MFD 350V \$1.50

Dual 20 MFD 10 MFD 450V \$1.50  
Inline fuse holders 4 for \$1  
Shielded leads 7ft 3.5 to 3.5 \$1  
3.5 to 6.5 \$1  
6.5 to 7 ft 75c

Inline Bay not Plugs & Sockets 4 for \$1

**Shielded Cable** 20 cents a metre

**Record Player Cabinets** solid timber base, perspex top \$20 pp NSW \$4, \$7 interstate

## Speaker Cabinet Cloth

\$10 per metre width 5ft. Send postage stamp for samples

122 PITT ROAD, NORTH CURL CURL,  
NSW 2099. PHONE 905 1848

## NEW PRODUCTS

### Mains switch with remote control

Schadow's NE20B represents a new design for a mains switch, with snap action in combination with an appliance coupler.

A double pole mains switch with 10 amp rated current (6 amp for inductive loads) is integrated in a three-pole appliance coupler with earth contact. The mains switch is operated by a plastic 'snap-in' panel mounting actuator, connected by a Bowden cable - which may vary in length between 150mm and 500mm.

This new concept offers the possibility of switching the current from the front panel of the equipment and clearly indicating the 'on' or 'off' status while leaving the power circuit at the rear panel.

The NE20B is recommended for EDP equipment, monitors, terminals, instrumentation, oscilloscopes and signal analysers.

For further information contact Alcatel STC-Cannon, 248 Wickham Road, Moorabbin 3189 or phone (03) 555 1566.



### Power monitoring

Designed for solving computer electrical power problems quickly, the T2400 power line monitor can be used in situations requiring continuous site monitoring, power evaluation prior to installation of systems, during start-up/software development to differentiate power glitches from software bugs, and to establish the need for power conditions or UPS systems. It only needs access to an AC mains socket.

The parameters of the T2400 are pre-set at industry standard acceptable levels, determined after years of research in the business of solving computer power problems, and through the compilation of data in the evaluation of thousands of computer sites with various power related equipment problems.

An economical yet effective monitor, the T2400 is sufficiently low in cost to warrant holding more than one, so that the monitor may be left on-site for several days when dealing with an intermittent fault.

Further information from Anitech, 52/2 Railway Parade, Lidcombe 2141 or phone (02) 749 1244.

## COMPUTER POWER DIAGNOSTIC INSTRUMENT

<p>LINE TO NEUTRAL</p> <p>HIGH TRUE RMS VOLTAGE &gt;247 V</p> <p>ACCEPTABLE</p> <p>LOW TRUE RMS VOLTAGE &lt;195 V</p> <p>&gt;1/4 HZ DROP OUT (NOTCH)</p> <p>&gt;2 HZ POWER FAIL</p> <p>&gt;5 V PEAK HIGH FREQUENCY NOISE</p> <p>&gt;400 V SPIKE</p>	<p>NEUTRAL TO GROUND</p> <p>≥ 3 VOLTS AC AVG</p> <p>≥ 5 VOLTS AVG</p> <p>&lt; 5 VOLTS AVG (ACCEPTABLE)</p> <p>&gt; 3 V PEAK HIGH FREQUENCY NOISE</p> <p>&gt;100 V SPIKE</p> <p>WIRING CHECK</p> <p>LINE TO NEUTRAL REVERSED</p> <p>NO GROUND</p>
---	--

DIAGNOSIS

- ALL TESTS OK
- A LOW IMPEDANCE TRANSFORMER BASED POWER CONDITIONER REQUIRED
- A TRANSFORMER BASED UPS OR SPS REQUIRED
- A LICENSED ELECTRICIAN REQUIRED

PUSH TO RESET

TLC S.E. INC.

MODEL T2400

## Expandable security system

An expandable single detector security system suitable for domestic and commercial premises is now available. 'Security Guard' can be readily expanded into a multi-detector system monitoring several areas.

The unit can be switched on in either 'instant' or 'delay/silent entry' modes. It can also be supplied with a 24 hour panic facility. Should an intruder be detected when the system is turned 'off', the operator can still operate the alarm(s) by just pushing a button to summon assistance.

An optional memory facility notifies the operator that the system has been triggered in their absence. Notification can be by way of strobe lights, buzzers or LEDs.

The Security Guard system can easily be customised by incorporating a range of additional accessories. These include diallers - for automatic telephone contact when the alarm is triggered; key-pads - for pushbutton 'no key' operation; PIR detectors for extra patrolled areas; and reed switches for doorway control.

Security Guard features a convenient delay, allowing the operator to exit the premises after setting the system, and internal 12 volt battery back-up ensur-

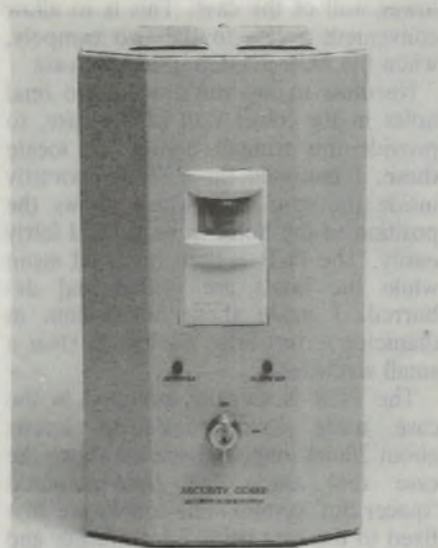

ing continuity of surveillance even in the event of mains power failure.

For further information contact Steer Engineering, 218 Grange Road, Thornbury 3071 or phone (03) 497 1844.

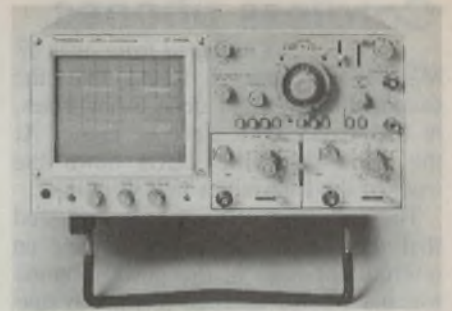

## 60MHz, 40MHz scopes

National Panasonic has released two new oscilloscopes, the VP-5564A and VP-5566A.

The VP-5566A has a bandwidth of 60MHz, three channels and six traces, whilst the VP-5564A has 40MHz bandwidth, two channels and four traces with a sensitivity of 5mV/div.

Both instruments feature the novel 'autofix' triggering with the addition of DC, TV, AC and norm modes. Main A sweep and delayed B sweep are included with time base setting down to 50ns/div.

For further information contact Scientific Devices Australia, 2 Jacks Road, South Oakleigh 3167 or phone (03) 579 3622. 

# A DISPLAY FORCE YOU CANNOT IGNORE

*or forget*

The largest selection of displays backed by unrivalled application expertise - that's DENSTRON. When you're faced with a display choice our sales consultants, with in-depth technical knowledge and design experience, can help solve your problem. It's worth remembering.

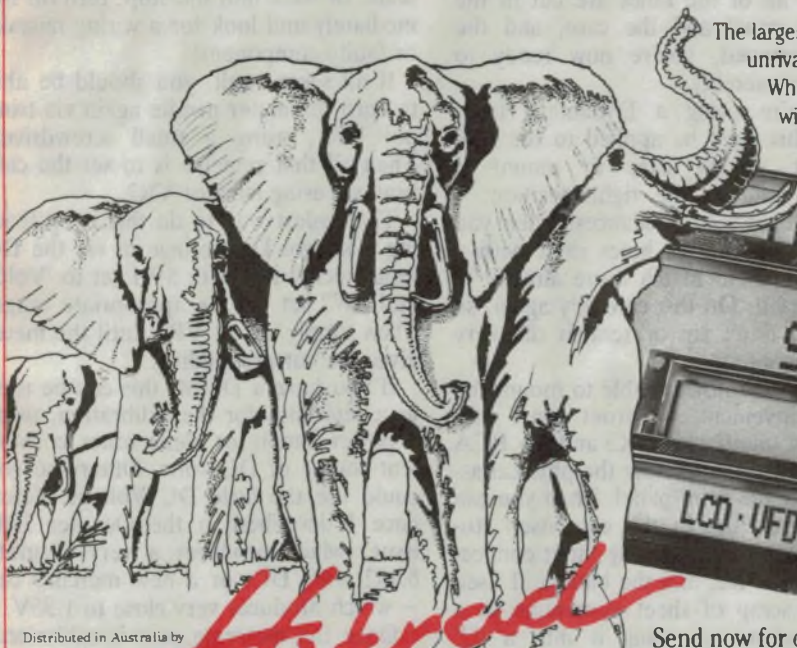

Your Message - Our Technology

Send now for our product brochure

P.O. Box 57, Crows Nest, NSW 2605 Tel: (02) 436 0422 Fax: (02) 439 2157

Displays by DENSTRON

## Cordless phones

*Continued from page 67*

MDR-IF5 system, I found that the sound suddenly went dead a few times, in the middle of a piece of music. At the same time, the LEDs down the front of the transmitter unit went dark.

The darkening of the LEDs suggested that the sample system might have an intermittent fault in the power connector, but when I checked this it was fine. Then I twigged – each time the problem had surfaced, I had been listening to a fairly quiet passage in the music. The transmitter unit's 'auto sleep' function had apparently decided that there had been no signal for the specified three minutes, and closed things down!

Obviously I had set the headphone level output control on my CD player too low, so that the level for quiet passages was below the transmitter unit's signal sensing threshold. Simply turning the control up a bit solved the problem completely. A trap for unwary players!

In fact it seems a good idea to set the input signal to the transmitter as high as possible, to a point just before distortion becomes audible on signal peaks. This gives the best overall signal to noise performance, as well as preventing the automatic turnoff circuit from closing everything down in the middle of a *pianissimo* passage.

I'm not too sure *why* the transmitter is provided with this auto turnoff function, actually. After all, it isn't powered from batteries, but from the mains. And in any case when the transmitter unit itself turns off, the plug-pack still remains connected to the mains. The headset still remains on too, until you turn it off manually via the slider switch. So the rationale behind the auto turnoff function isn't all that obvious.

Still, it isn't really a problem either – provided that you set the headphone signal level high enough.

On the whole, the Sony MDR-IF5 cordless phones are very impressive. The performance is fine, and they're both compact and convenient.

Sony's achievement in fitting the complete receiver system inside the headset has certainly produced an elegant solution to the traditional tangled cords problem. At the quoted retail price of \$299 they also seem to represent good value for money.

By the time you read this, the MDR-IF5 should be available in all of the usual Sony outlets. However if you have any difficulty, Sony Australia can no doubt help. The address is 33-39 Talavera Road, North Ryde 2113, or phone (02) 887 6666. ②

## VHF Powermatch

*Continued from page 131*

the PCB is not unduly critical, but it needs to be roughly below the front panel controls and fairly close to the lower wall of the case. This is to allow convenient access to the two trim pots, when the PCB is fitted inside the case.

Needless to say you'll need two final holes in the lower wall of the case, to provide this trim pot access. To locate these, I mounted the PCB temporarily inside the case first, which allows the position of the holes to be gauged fairly easily. The PCB is then removed again while the holes are drilled and deburred. I made these holes 4mm in diameter – just large enough to clear a small screwdriver.

The PCB is actually mounted in the case using countersunk-head screws about 20mm long, and spaced above the case rear using the time-honoured 'spacer nut' system. The screws are first fixed to the case using a lockwasher and nut on each; then a further nut is added to each screw, and these are spun down so that they are uniformly spaced at about 13mm from the case rear. The PCB is then added, so that it sits on these 'spacer' nuts; and finally a further set of lockwashers and nuts are added to hold it in position.

Of course the two holes cut in the lower wall of the case are located such that they are level with the trim pot adjustment slots, when the PCB is mounted in this position.

When all of the holes are cut in the lid/front panel and the case, and the burrs removed, you're now ready to continue assembly.

If you're using a Dynamark front panel, this must be applied to the case lid first, taking care to mount it squarely and in the right position – there are no second chances! Then you can cut the various holes in it with a hobby knife, to match those already in the lid itself. Do this carefully again, so that you don't rip or scratch the very thin aluminium.

You should now be able to mount the meter movement, the front panel controls, the on/off switch K3 and the RCA input socket, completing the physical assembly of the front panel. Then you can mount the PCB in the case itself, together with the remaining input connectors K1 and K2, and the battery. I used a small scrap of sheet aluminium as a battery clamp, bending it into a 'U' shape with a mounting lip on one side.

You may also wish to attach the hinged tilting prop to the rear of the case at this stage, if you're using one. I

made it from a scrap of 3mm aluminium sheet, about 85mm square, and mounted its hinge centrally about 20mm from the top of the case rear.

The final step in assembling the unit is to connect the various PCB leads to the front panel switches, the meter and the input connectors, using the overlay diagram again as a guide. You'll find there are also a few additional wires to add, from K3 to switch SW1B and between VR3 and the two halves of SW1.

Don't forget to run wires to link the earthy sides of the three input connectors (and the bottom of VR3) to the PCB earth line. It's also a good idea to earth the unused intermediate-position lugs on SW2A, as shown in the circuit schematic.

## Setting it up

There's very little involved in setting the metering unit up when it's completed.

The first thing to do is check that the meter pointer is correctly positioned at zero, before power is applied. If not, this can be corrected using the adjustment screw on the front.

Then turn on the power, after carefully checking all of your connections against the overlay diagram and photographs. And while you're turning it on, watch the meter needle carefully; it will probably move rapidly away from the zero point in one direction or the other, but hopefully neither very far, nor with great force. If it slams hard over to full scale, or back into the stop, turn off immediately and look for a wiring mistake or faulty component!

If all seems well, you should be able to zero the meter needle again via trim pot VR1, using a small screwdriver. Then all that remains is to set the calibration, using trim pot VR2.

The easiest way to do this is by feeding a known DC voltage in via the DC input socket K2, with SW1 set to 'Volts' and SW2 set for the appropriate range. Then simply adjust VR2 until the meter gives the correct reading.

If you have a DMM, this can be used as a reference for the calibration, using a power supply or some other convenient source of DC volts. Otherwise you could use the little DC Voltage Reference I described in the October 1989 issue, which produces a very accurate 8.192 volts DC, or a new mercury cell – which produces very close to 1.35V.

Once the metering unit is calibrated, you're ready to turn your attention to the matching measurement modules. But we'll start looking at these in the second article. ④

# Do computers play any part in your life?

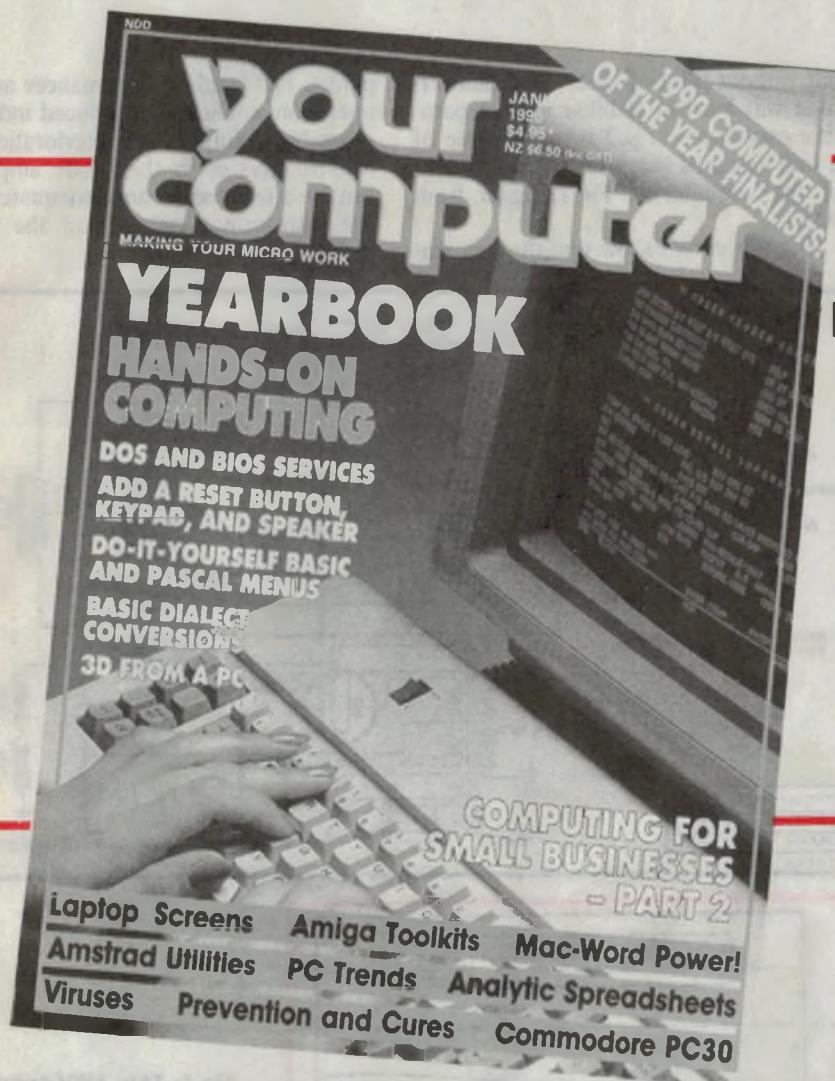

If they do — or if you just want to find out about them — don't miss each month's issue of **YOUR COMPUTER**

*A magazine for all computer users, **YOUR COMPUTER** has something for everyone — topical features on all aspects of the computing world, expert reviews of the latest software and hardware, up-to-the-minute information for business people.*

# Vintage Radio

by PETER LANKSHEAR



## The Williamson amplifier

Experimental audio amplifiers were first made about 75 years ago. Since then, a vast amount of work and research has gone into improvements. A major advance came in 1947, when a new design that raised standards of performance considerably was described in the British magazine *Wireless World*.

Although during the period prior to 1950, there were luxury receivers using elaborate audio systems, few qualified as being genuinely 'High Fidelity'. As professional equipment was neither affordable nor readily available to the private user, enthusiasts and small manufacturers usually 'rolled their own', often using designs that appeared in *Wireless Weekly* and later *Radio & Hobbies*, A.W.'s *Radiotronics*, *Wireless World* from the UK and numerous American magazines.

### Two philosophies

Pentode and beam tetrode output valves with their advantages of high sensitivity and efficiency had become standard in receivers, but they had the serious shortcomings of high distortion and the inability to damp down bass resonances in loudspeakers, due to high output resistance.

Quality conscious enthusiasts continued to insist on triode output stages, the ultimate valves being the American 2A3 and its British equivalents. A pair of these could provide around 10 watts, but required upwards of 100 volts drive between grids. Interstage driver transformers were strongly recommended, but suitable types required complicated winding configurations and were very expensive. One solution was to use a large driver valve, as in the A.W.V. circuit in Fig.1.

### Tetrodes suspect

Multiple grid output valves simplified design considerably. Their grid drive requirements were less demanding than those of triodes and they were more efficient. By using negative feedback, amplifier performance could be made to be equivalent to a good triode amplifier,

but without a lot of care, the beam tetrode was hard to stabilise against parasitic oscillations. Fig.2 is an example of a well designed beam tetrode equivalent of the amplifier in Fig.1, again from A.W.V.

The test curves show that the two am-

plifiers had similar performances and in operation would have produced indistinguishable results. The deterioration at low frequencies in the triode amplifier can be attributed to an inadequate output transformer rather than the basic design.

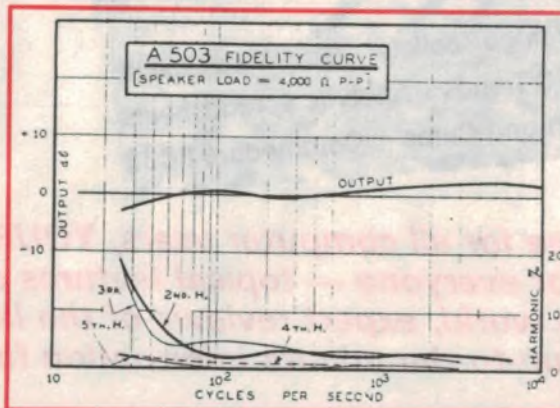
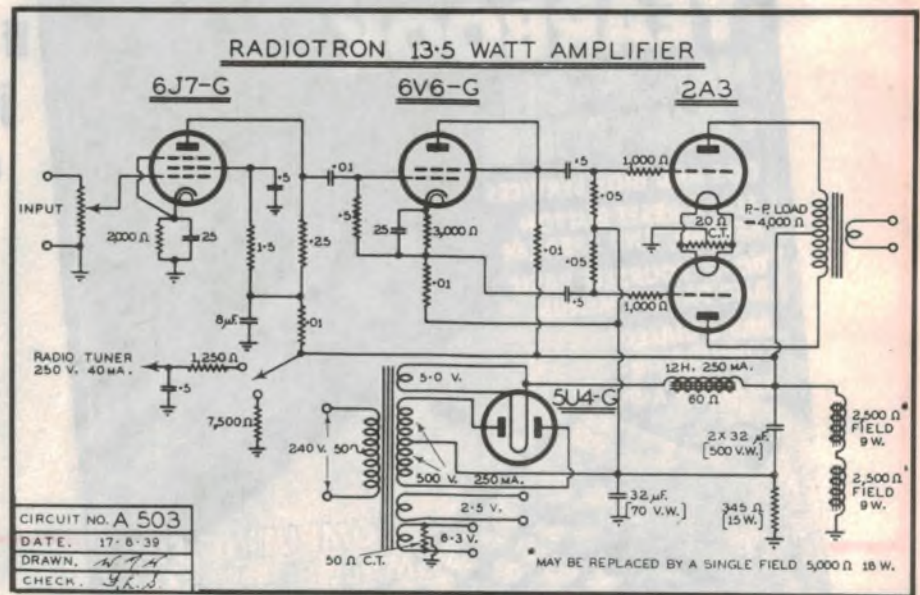

**Fig.1:** This A.W.V. triode amplifier circuit of 1939 shows the performance achievable without negative feedback. Note that the circuit was drawn by Neville Williams, and checked by F. Langford-Smith.

## Two factions

Sound reproduction technologies have a history of attracting opposing opinions, and recent arguments in *EA* show that this spirit is still alive. The triode versus tetrode debate became quite heated, so much so that early in 1946, the redoubtable Australian authority, F. Langford-Smith took a hand and wrote an article in *Radiotronics* putting the whole thing into perspective. He reported on the work done by the American authority J.K. Hilliard, whose conclusions were that beam power valves could deliver the same audio power as triodes with the same or less distortion.

## New standards

By 1947, a typical high quality amplifier would have had a frequency response varying by no more than 1.0dB from 40Hz to 10kHz and, above 100Hz, harmonic distortion at 10 watts output of between 1% and 2.0%. With the 78rpm shellac records and radio transmissions then available as programme sources, these specifications were adequate, but improved methods were forecast.

Wartime developments had been incorporated in Decca's 'FFRR' recordings, improved pickups and speakers were becoming available, FM transmissions were planned and German developments in tape recording were being revealed. It was time to improve amplifier performance.

One solution was obvious. If negative feedback improved beam tetrode amplifiers, it should make a good triode amplifier even better. However in practice it was not quite this simple.

## Transformer problem

In the amplifier of Fig.2, feedback is taken from the anode of the upper output valve to the screen of the input valve. but it was not sufficient simply to substitute low mu power triodes for the 6L6G's. Apart from there now being insufficient gain, some distortion could be produced by the output transformer. Furthermore, it may be seen from Fig.2 that because feedback came from the upper output anode only, any incomplete coupling between the two primary sections would result in there being a smaller feedback component from the lower output valve.

For there to be any worthwhile progress, the entire amplifier including the output transformer would have to be included in the feedback chain. This had been tried often enough, but the problem was that serious limitations were imposed by conventional output trans-

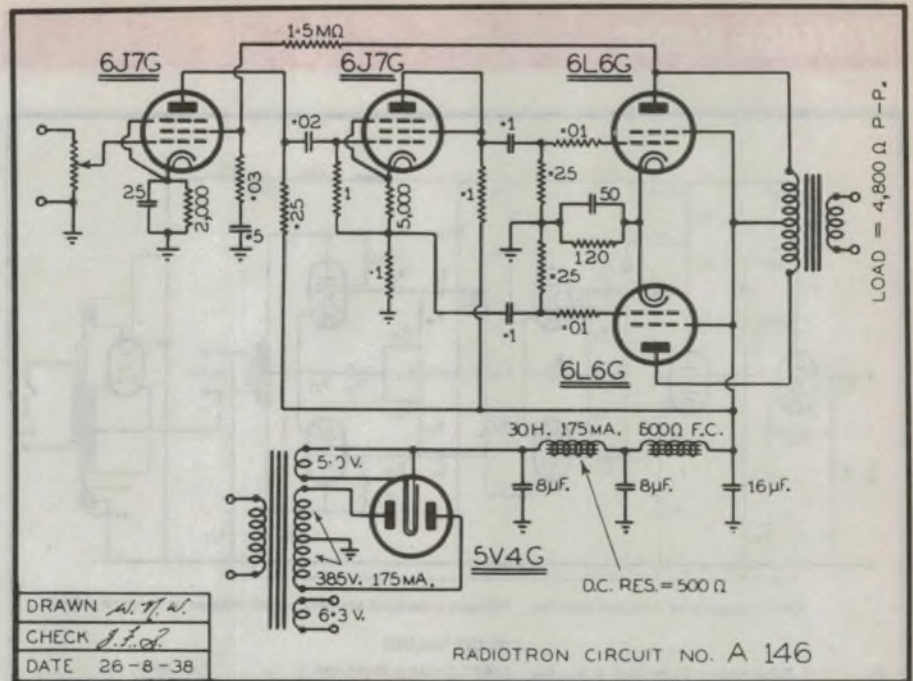

**Fig.2: The tetrode equivalent of Fig.1, also from AWV, with negative feedback taken from the anode of the upper 6L6G to the screen grid of the first valve.**

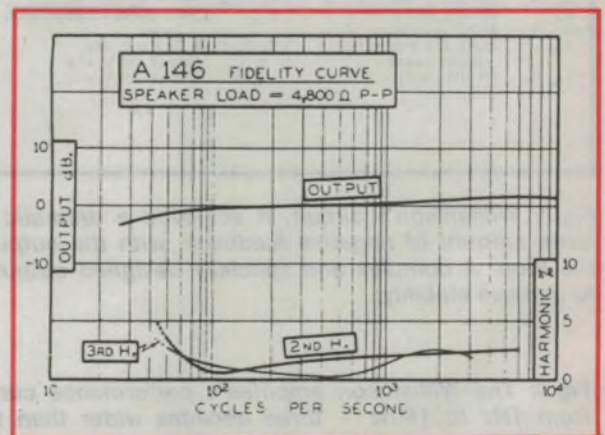

formers, causing the amplifier to become unstable before a worthwhile amount of negative feedback could be applied.

Low frequency transformer response could be degraded by insufficient primary inductance, as the graph in Fig.1 shows, whilst the high frequency end was restricted by inadequate coupling between windings. These limitations introduced sufficient phase shift at each end of the audio spectrum for the feedback to become positive, with disastrous results.

To avoid instability with a worthwhile amount of feedback, a transformer would need to have a frequency response wider than that of its associated amplifier. Without careful design, adding extra voltage amplifier stages to compensate for the loss of gain could also increase the phase shift problems.

## Williamson's answer

In articles published in the April and May 1947 issues of *Wireless World*, D.T.N. Williamson of the Marconi Osram Valve Company dealt at length with these problems and their solutions. He concluded by giving constructional details of an amplifier which produced 15 watts with 0.1% distortion, and a frequency response that was absolutely flat between 10Hz and 100kHz, a remarkable standard of performance.

Williamson tackled the transformer problem head on. He produced a design that permitted its inclusion within the feedback loop operating with a 10 times (20dB) gain reduction, with a stability margin of a further 10dB.

The lack of inductance was countered by the use of no less than 4400 turns of wire for the primary, on a core as big as

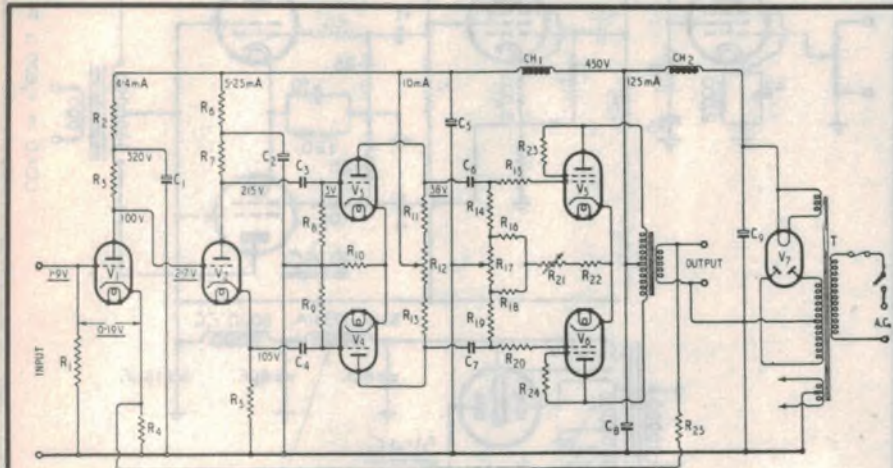

Circuit diagram of complete amplifier. Voltages underlined are peak signal voltages at 15 watts output.

### CIRCUIT VALUES

R <sub>1</sub>	1 MΩ ½ watt ± 20 per cent	R <sub>16</sub> , R <sub>20</sub>	1,000 Ω ½ watt ± 20 per cent	C <sub>8</sub>	8 μF 650 V, wkg
R <sub>2</sub>	33,000 Ω 1 watt ± 20 "	R <sub>16</sub> , R <sub>18</sub>	100 Ω 1 watt ± 20 "	C <sub>9</sub>	8 μF 600 V, wkg
R <sub>3</sub>	47,000 Ω 1 watt ± 20 "	R <sub>17</sub> , R <sub>21</sub>	100 Ω 2 watt wire-wound variable	CH <sub>1</sub>	30 H at 20 mA (min.)
R <sub>4</sub>	470 Ω ½ watt ± 10 "	R <sub>23</sub> , R <sub>24</sub>	100 Ω ½ watt ± 20 "	CH <sub>2</sub>	10 H at 150 mA (min.)
R <sub>5</sub>	470 Ω ½ watt ± 10 "	R <sub>26</sub>	1,200 √speech coil impedance, ½ watt	T	Power transformer.
R <sub>6</sub> , R <sub>7</sub>	22,000 Ω 1 watt ± 10 "				Secondary 425-0-425 V
R <sub>8</sub> , R <sub>9</sub>	0.47 MΩ ½ watt ± 20 "				150 mA (min) 5 V, 3A, 6.
R <sub>10</sub>	390 Ω ½ watt ± 10 "				V 4A, c.t.
R <sub>11</sub> , R <sub>13</sub>	39,000 Ω 2 watt ± 10 "			V <sub>1</sub> to V <sub>4</sub>	1.63
R <sub>12</sub>	25,000 Ω 1 watt wire-wound variable			V <sub>5</sub> , V <sub>6</sub>	KT66
R <sub>14</sub> , R <sub>19</sub>	0.1 MΩ ½ watt ± 20 "			V <sub>7</sub>	U52

13

**Fig.3: Williamson's circuit.** It achieved a dramatic improvement by using a large amount of negative feedback, with the output transformer included in the loop. A complex and specially designed output transformer was needed to achieve stability.

**Fig.4: The Williamson amplifier's performance curves.** Note that they cover from 1Hz to 1MHz – three decades wider than those for the earlier AWW amplifiers.

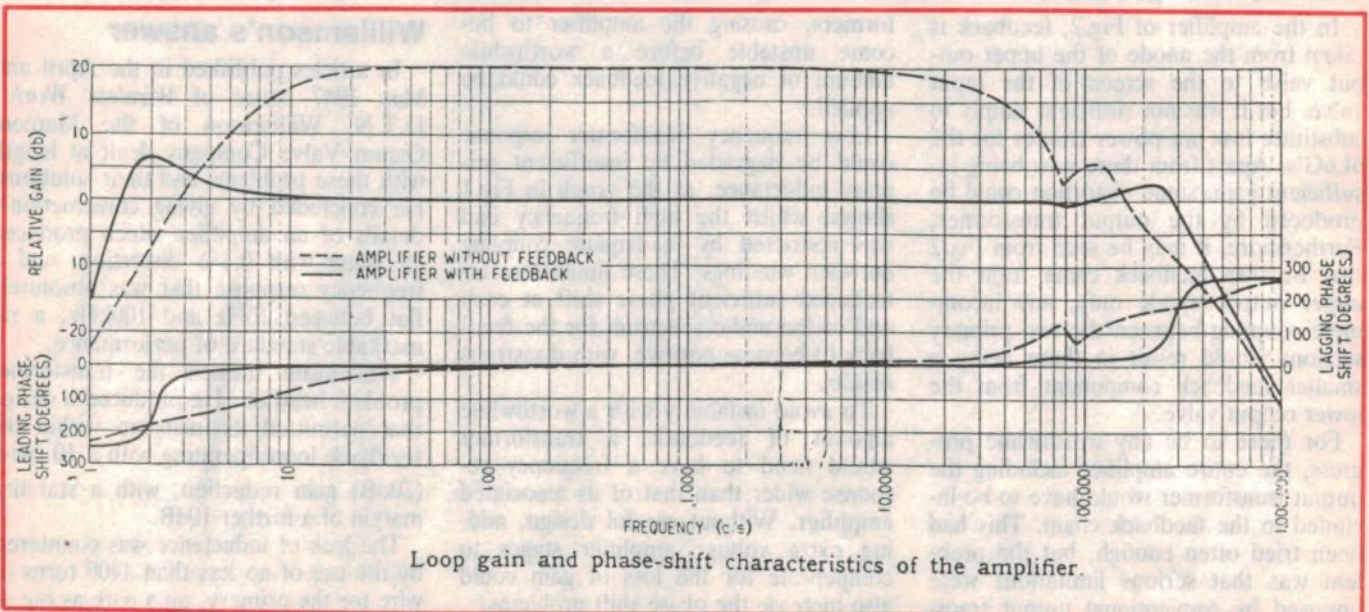

Loop gain and phase-shift characteristics of the amplifier.

that of a large power transformer – providing a minimum of 100 henries inductance. To overcome the high frequency coupling problem, the windings were divided into no less than 10 primary and 8 secondary sections, all interleaved in two balanced halves.

## Simple amplifier

No tricks were employed in the amplifier circuit itself. Just as in the circuit of Fig.1 there was a voltage amplifier (V1) and phase splitter (V2), but to provide the additional gain needed, there followed a push pull driver stage (V3/4). To minimise low frequency phase shifts, the voltage amplifier stage was direct coupled to the phase splitter and there were no cathode bypass capacitors.

The output stage used triode connected KT66 beam tetrodes. These needed about half the drive of 2A3 triodes, but required a greater HT voltage. KT66 valves were similar to the American and Australian 6L6G and 807, but had much higher screen voltage ratings. The L63 general purpose triodes used for the amplifier stages were identical to the 6J5 or one half of a 6SN7GT.

## Instant success

Within a very short while, Williamson amplifiers were being built by enthusiasts world wide. Many with lots of patience wound their own transformers, but manufacturers soon produced them, admittedly at a price.

In Australia, AWV adapted it to their own valve types and F. Langford-Smith himself published a very full report in the October 1947 edition of *Radiotron*.



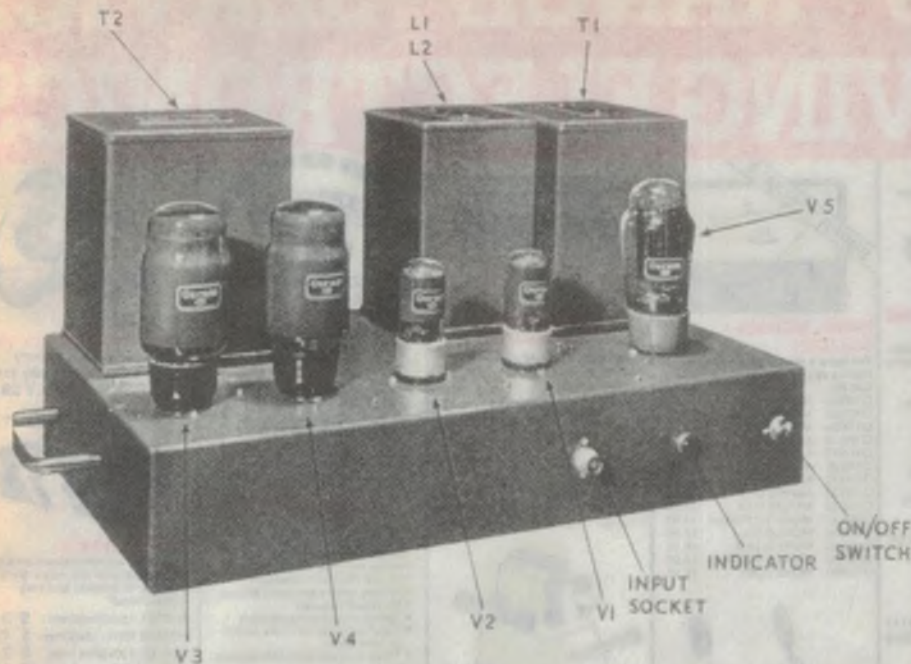

**Fig.5:** This version of the Williamson design was made by GEC. Note that the output transformer T2 was at least as large as the power transformer T1. Valves V1 and V2 were here B65 (6SN7) double triodes, replacing the original L63 single triodes. V5 is the rectifier.

ics. Although they were themselves leaders in amplifier design, it is to their considerable credit that AWV were unstinting in their praise of the Williamson design. The report summed up their opinion by stating "This amplifier is by far the best we have ever tested. It not only gives extraordinary linearity and lack of harmonic or intermodulation distortion, but is comparatively simple and involves no special problems except the choice of output transformer."

### Upated 807

A possible problem with the Australian version was that the 807 had a rated maximum screen voltage rating of only 270 volts. AWV found that triode connected, it could with cope the 425 volts of the Williamson amplifier without distress, and placed some samples on long term test. Some months later they reported that there had been no problems, and the ratings of the 807 were officially increased.

*Radio and Hobbies* reprinted the AWV report in full in its January 1948 issue, and gave complete constructional details in the March issue, using locally made transformers – but strangely, without any reference to Mr. Williamson as the originator. Ferguson and Red Line advertised their versions of the output transformer at six pounds, which is more than \$120 at today's values. In New Zealand, Beacon Radio made a very respectable transformer.

### Americans impressed

Traditionally, American constructors had tended to favour their own home grown designs, but they adopted the Williamson design with enthusiasm. Some even took the unprecedented action of importing transformers and KT66 valves! It can be said that the Williamson amplifier revealed to many Americans the quality of British equipment and opened the market for a range of British high fidelity products.

During the 1950's, American manufacturing of high fidelity equipment boomed. Each edition of the magazine *Audio* carried reviews of commercially available amplifiers, and a significant number used the Williamson circuit. I doubt if D.T.N. Williamson gained any financial benefit from this development, but he did achieve immortality with his landmark design. Amplifiers that followed, such as Quad, Leak, Mullard, Baxendall and the R&H 'Playmaster' series showed that with the use of large amounts of stable negative feedback, similar results were possible with other configurations.

The real importance of Williamson's work was that he demonstrated that extremely low distortion was achievable by using plenty of negative feedback, combined with carefully designed output transformers. His design set a standard of performance that is still acceptable today. After 43 years, that's a pretty good record.

**PCB ARTWORK A PROBLEM?  
DO YOU HAVE SCHEMATICS THAT  
NEED TO BE DRAWN OR UPDATED?**

IF SO CONTACT

## CIRCUITWORKS

- \* ALL TYPES OF ANALOGUE & DIGITAL BOARDS.
- \* GENERAL ELECTRONIC DRAFTING.
- \* WE CATER FOR THE HOME HOBBYISTS & PROFESSIONAL WORK CENTRES.
- \* CIRCUIT BOARD PRODUCTION IF REQUIRED.
- \* PROMPT SERVICE.

PHONE: (07) 359 1285  
65 EVANS STREET, KEDRON, QLD.

READER INFO No. 48

## ELECTRONIC PROJECTS

YOU SHOULD SEE  
US NOW  
**BIG RANGE**  
**BIG NEW STORE**  
SO COME ON IN

## DAVID HALL ELECTRONICS

3/376 KINGSTON RD,  
SLACKS CREEK 4127  
Ph (07) 808 2777  
Fax (07) 209 2623

READER INFO No. 49

## ?CAD?

Want to talk with  
an experienced user?

We use

PROTEL Autotrax  
for PCB layout

PROTEL Schematic  
for Schematics

Advice and Sales

**McCUBBIN ELECTRONICS**

PH (03) 585 0905

FAX (03) 584 5330

READER INFO No. 50





# 50 and 25 years ago..

'Electronics Australia' is one of the longest running technical publications in the world. We started as 'Wireless Weekly' in August 1922 and became 'Radio and Hobbies in Australia' in April 1939. The title was changed to 'Radio, Television and Hobbies' in February 1955 and finally, to 'Electronics Australia' in April 1965. Below we feature some items from past issues.

## July 1940

### Secrecy of Radio:

From now on, it is an offence to repeat information heard over the air from Australian or foreign stations. Newspapers may not print such information, apart from news released through official channels.

In addition, the identity of all radio commentators must be announced before and after their broadcasts. This will ensure that the opinions expressed will be given their true value according to the knowledge and experience of the commentator, and reduce the spreading of irresponsible or damaging statements.

### Sizzling telephones:

The Postmaster-General (Mr Thorby) was recently asked how he proposed to act should the new regulation, which prohibits the use of foreign languages in

telephone conversations, be broken.

"We have special machines," he is reported to have said, "which will sizzle if any language other than English is spoken."

We have known the phone to sizzle when spoken to in the King's English before today, Mr Thorby, and it hasn't always been the wife, either.

The ban concerning languages does not apply to Allied and neutral consuls, it is learned.

## July 1965:

### Satellite dish refit:

To operate to best advantage with the 'Early Bird' satellite, 22,000 miles above the South Atlantic, Britain's Goonhilly Downs tracking station has recently undergone a half million pounds refit.

The 'dish' has been re-surfaced with a

central paraboloid 25 feet across, surrounded by 24 stainless steel "petals," which can be individually adjusted to provide maximum accuracy.

Transmitting power is 8kW, highest in the world, while masers can amplify incoming signals ranging in strength as small as one ten millionth part of a watt.

The station will take its turn with other European installations handling traffic from 'Early Bird'.

### Symposium on careers electronics:

Dr H.R. Bailey, MB, BS, DPM (Univ. of Sydney), spoke on the revolution that electronics is causing in medicine. He explained how a radioactive substance introduced into a patient's bloodstream could be traced through the body and demonstrated a piece of equipment used for that purpose.

Modern electronic equipment, such as the electro-encephalograph - used for recording small electrical pulses generated in the brain - electro-cardiographs, and pace makers to stimulate the function of the heart, were among the electronic aids now available to medical science.

Also mentioned was electrical therapy which induces sleep and the laser beam for the treatment of detached retina in the eye.

# EA CROSSWORD

## Across

1. Doyen of Australian electronics publishing. (7,8)
8. Capability of a versatile photocopier. (9)
10. Region near electric fence! (5)

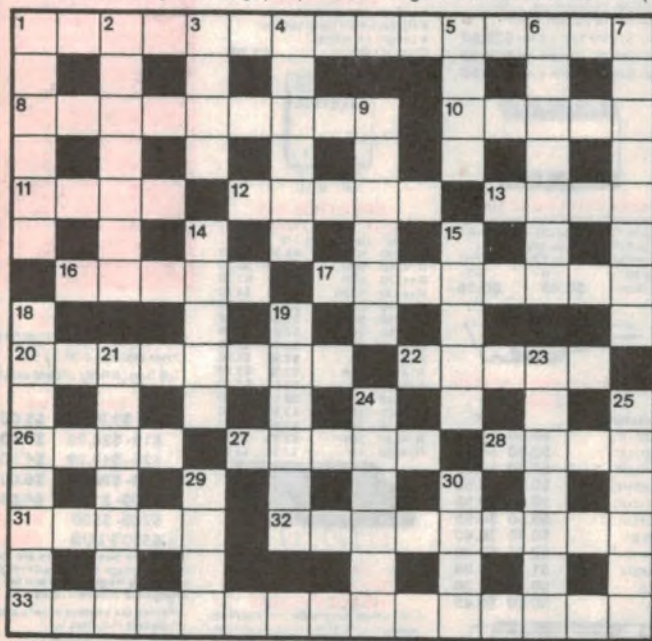

11. Kind of wave. (4)
12. An atom is mostly ---- space. (5)
13. The first atomic ---- was detonated in the USA. (4)
16. Transmission line support. (5)
17. Relieve load on system. (8)
20. Separation into components. (8)
22. Region in space, the ---- hole. (5)
26. This one is flash. (4)
27. Fundamental facts, or ---- principles. (5)
28. Metric prefix. (4)
31. Groups of linked devices. (5)
32. Semiconducting element. (9)
33. Senior position at EA. (9,6)

## Down

1. Stylus. (6)
2. Combining factor. (7)
3. Title of Kelvin. (4)
4. German electric encrypting machine. (6)
5. Computer jargon for "last in, first out". (4)
6. Kind of barometer. (7)
7. Region associated with modulated carrier wave.

## JUNE SOLUTION

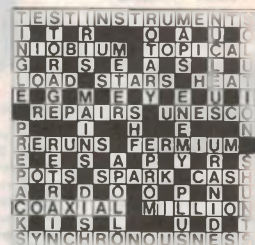

- (4,4)
9. Function of electronic clock. (6)
14. City with electronics base. (5)
15. Assemble parts of a kit. (5)
18. Forerunner of electric lamp. (8)
19. Circuit conductors. (6)
21. Pertaining to negative particle. (7)
23. Faraday was both a physicist and a ----. (7)
24. Concerned with stars. (6)
25. Common electric device. (6)
29. Abbreviation for a structured organisation. (4)
30. High-vacuum tubes are termed as such. (4)

# Amateur Radio News

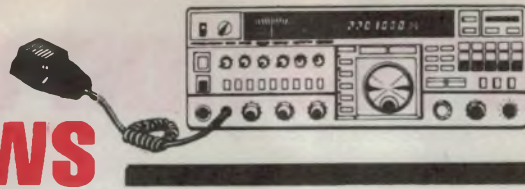

## Australian VHF, UHF and SHF records

John Martin VK3ZJC, Acting Chairman of the WIA's Federal Technical Advisory Committee (FTAC) has kindly sent us details of the current (April 1990) records for both state and national contacts on the amateur VHF, UHF and SHF bands - with the idea that we might like to publish them, as an incentive for other amateurs to 'have a go'. That sounds like a good idea, so the listing is shown below.

The 'N' code shows a national record, while the 'W' code indicates both a national and world record. The asterisk (\*) indicates a new record made since the list was last published. Where a band is not listed, there is no current record claimed.

Next month we'll try to publish details of the current world records on these bands, for terrestrial and EME, ATV, Mobile and Digital category contacts.

### Home/Portable Category

VK1	144MHz	VK1RH	to	VK1ZJR	01/03/87	16.3km
VK2	50MHz	VK2ASZ	to	VE1ASJ	06/04/81	16654.4km
	144MHz	VK2ZRU	to	VK6AOM	13/12/86	2697.9km
	432MHz	VK2ZAB	to	ZL1AKW	13/01/88	2299.8km
	576MHz	VK4ZRF/2	to	VK4ZSH/4	11/12/81	255.4km
	1296MHz	VK2BDN	to	ZL1AVZ	09/12/82	2132.7km
	2300MHz	VK2ZAC/2	to	VK2BDN/2	19/05/73	159.9km
	3300MHz	VK2AHC/2	to	VK2SB/2	16/01/77	114.1km (1)
	5650MHz	VK2AHC/2	to	VK2SB/2ZND/2	12/04/75	114.1km (1)
	10GHz	VK2AHC/2	to	VK2SB/2ZND/2	12/04/75	114.1km (1)
VK3	50MHz *	VK3OT	to	F6HWM	19/10/89	16887.8km
	144MHz	VK3YLR/3	to	VK6KZ/6	23/01/80	2784.4km (2)
	432MHz N	VK3ZBJ	to	VK6KZ/6	23/01/80	2715.9km
	576MHz W	VK3ZBJ	to	VK3KAJ/5	25/02/89	382.9km
	1296MHz N	VK3ZBJ	to	VK6WG	18/03/88	2449.3km
	2300MHz	VK3ZHP	to	VK7HL	12/01/85	427.3km
	3300MHz	VK3KAJ/3	to	VK3ZBJ	25/01/86	244.3km
	10GHz N	VK3KAJ/3	to	VK3ZBJ/3	08/02/86	252.1km
VK4	50MHz	VK4AYX	to	DL3ZM/YV5	18/03/81	15582.0km
	144MHz N	VK4ZSH/4	to	JA70XL	24/04/83	6616.9km
	432MHz *	VK4ZSH/4	to	ZL2TPY	13/01/88	2401.9km
	576MHz	VK4ZRF/4	to	VK4ZSH/4	07/12/81	377.6km
	1296MHz	AX4NO/4	to	AX4ZT/2	12/04/70	402.0km
	10GHz	VK4ZNC/4	to	VK4ZSH/4	09/11/81	170.6km
VK5	50MHz	VK5KK	to	XE1GE	09/04/79	14078.0km
	144MHz	VK5ZEE	to	ZL1HH	15/01/86	3458.8km
	432MHz	VK5NY	to	VK7JG	21/05/85	995.0km
	576MHz	VK3KAJ/5	to	VK3ZBJ	25/02/89	382.9km
	1296MHz	VK5MC	to	VK6KZ/6	23/01/80	2289.4km
	2300MHz W	VK5QR	to	VK6WG	17/02/78	1885.5km
	3300MHz W	VK5QR	to	VK6WG	25/01/86	1885.5km
	5650MHz N	VK5NT	to	VK5ZO/5	12/11/89	176.4km
	10GHz	VK5CU/5	to	VK5MW/5	30/12/71	95.7km
VK6	50MHz	VK6BE	to	JA8BP	30/10/58	8833.0km
	144MHz	VK6KZ/6	to	VK3YLR/3	23/01/80	2784.2km (2)
	432MHz N	VK6KZ/6	to	VK3ZBJ	23/01/80	2715.9km
	576MHz	VK6KZ/6	to	VK6HK	16/01/83	196.4km
	1296MHz N	VK6WG	to	VK3ZBJ	18/03/88	2449.3km
	2300MHz W	VK6WG	to	VK5QR	17/02/78	1885.5km
	3300MHz W	VK6WG	to	VK5QR	25/01/86	1885.5km
VK7	50MHz	VK7JG	to	W5FF	17/04/82	13765.0km
	144MHz	VK7ZAH	to	VK4ZAZ	01/01/67	1910.0km
	432MHz	VK7JG	to	VK5NY	21/05/85	995.0km
	1296MHz	VK7ZAH	to	VK3AKC	17/02/71	439.0km
	2300MHz	VK7HL	to	VK3ZHP	12/01/85	427.3km
VK8	50MHz N	VK8GB	to	9Y4LL	10/04/82	18665.4km
	144MHz	VK4ZSH/8	to	JA70XL	24/10/82	6460.9km

NOTES: (1) VK2AHC now licensed as VK5ZO  
(2) VK3YLR now licensed as VK3KAW

## AMATEUR RADIO

Hobbyists communicating world wide using state-of-the-art electronics.

Are you  
a radio amateur but not a  
member of the WIA?  
Do you know what you are  
missing?  
Do you like using VHF/  
UHF repeaters?  
Enjoy working DX?

Want to preserve your  
bands?

Join the WIA - the oldest and most  
experienced radio society in the  
world - always at the forefront of  
radio communications for hobbyists.

Receive AMATEUR RADIO, the  
monthly magazine for members of  
the WIA, full of news of DX, clubs,  
satellites, technical articles  
and lots more.

Other WIA services include:

- A world wide QSL card service
- Weekly news broadcasts
- Classes for all grades of amateur licences
- Correspondence lessons available
- Meetings, contests, field days
- Representation for radio amateurs at Government level

Learn more about the WIA and  
Amateur Radio

Forward this coupon, or write to:

WIA EXECUTIVE OFFICE

P.O. BOX 300

CAULFIELD SOUTH

VICTORIA 3162

Registered address: 3/105 Hawthorn Road  
Caulfield North, 3161

Please send a WIA information package to:

NAME: .....

ADDRESS: .....

..... POSTCODE .....

E003A

READER INFO No. 51



# Information centre

Conducted by Peter Phillips



## In April, things can happen in EA

As winter grips us in its icy blast, we reflect on events that happened in April. Almost seems like a cue for a song – but rather it's a cue for this month's content. Ah April! when the sun was shining and jokes were in the air...

There are many traditions that have vague origins and little purpose. The song 'Tradition' from *Fiddler on the Roof* has the memorable line '...it's tradition' as the reason for 'why'. And 'why not' is another good reason.

April Fool's Day is one of the traditions that EA has helped keep alive for as long as I can remember, with discussions on 'metric time' and the like causing angst among those who forgot the date.

Sometimes an April Fool's article can be so convincing that readers become alarmed and write to us with obvious anxiety. Our article on Metrication (April 1989) drew a few responses, though I am surprised anyone could take that one seriously, as it lapsed into absolute stupidity towards the end. To the best of my knowledge, the government has no plans for a revised metric system as that article suggested, despite those letters wishing this might be the case. But that's another story.

The April Fool's article for 1990, (for which I claim limited responsibility!) has also drawn a response, though so far no one from the TV industry has threatened legal action. And fortunately, no one has asked for technical details of the IC referred to in this article – which is just as well, as a reader has now found out that this IC has problems. What a shame!

April also saw the usual What? question, which has prompted several replies. We'll start with this one, as some interesting circuits have resulted.

### Dual supply

In the April 1990 edition, I posed the question of how to produce a dual polarity supply from a single 9V battery. My answer, published in May showed a

simple circuit using diodes to generate the negative supply. Several contributors took up my challenge and sent me their solutions to the question. The one that I liked best had several solutions, including the diodes I suggested, and was sent by W.S. from Fullarton, SA.

Basically, according to this contributor, the diodes would give a regulation of 21% for the currents specified in the problem. Several alternatives to the diodes are suggested by W.S., including a LED (10% regulation), an LM336 regulator 'diode' (0.1%) and the three circuits of Fig.1, which give regulations

Fig.1

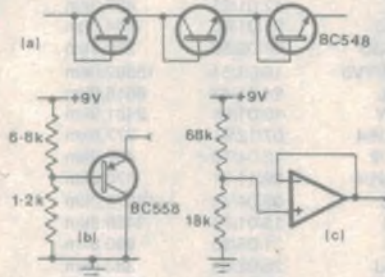

of (a) 12%, (b) 6.7% and (c) 0.1%. So take your pick.

All of these regulation figures are improved by the addition of a shunt resistor around the load in the 7V positive side, which should be selected to make the change in load current a smaller percentage of the total (shunt plus load) current. Thank you for these circuits W.S., you win the grand prize of... Well, you win, anyway.

### The AF9014

The IC that can detect commercials (April 1990) has problems it seems, as the following letter from a most serious

reader points out:

*The manufacturer of the IC that can detect commercials has reported that the chip (which has one leg, by the way) is suffering a virus. Rather than lock the volume, it is now reducing the sound level of advertisements by 90dB, and invites the viewer to search for a 'non-ad' program.*

*The chip is also now oblivious to having its leg pulled, and cannot fuse, regardless of which way it is plugged in. The operation of this leg was succinctly described by the explanation of the extra PCMQBSPTSS signal required, which of course any truly technical person will thoroughly understand(!)*

*Another feature of the virus ridden chip is the built-in but unintended 'P' trap. This characteristic allows 'P'arents to program the TV set to play dead, enabling children to be coaxed to the dining table. Oh yes! The part number of the IC is the AF9014.*

*Oh well! May I thank you for your humour. Please keep up the good work and I will look forward to next April. (R.S., North Melbourne Vic.)*

The writer also referred to 'a certain game' that seems to drive Victorians to a frenzy. Apparently if a well known professor of law is near a TV set fitted with the AF9014, and Collingwood is being thrashed, that TV set will turn on automatically!

Don't know what you mean about 'next April', R.S., the article was dead set true – honest.

### Spectrum analyser

The next letter wants help on two audio type projects.

*Have you ever published a project for a one third octave spectrum analyser?*

Maybe something that could plug into a television set or a monitor and show a bar graph display. If not, would this be a feasible idea for a project? Or perhaps there is something like this available commercially that is computer software based.

Lastly, I wonder if you or any readers have any ideas on how to modify the April 1982 Function Generator so that the frequency can be swept and so that it produces a DC output that is proportional to frequency. (S.V., Greenslopes Qld).

The nearest thing to a suitable spectrum analyser we can find is the 'On-screen Graphic Analyser', published in the March 1981 issue on page 42. (File number 1/SC/11). This project displays 10 bar graphs, but it only covers full octaves ranging from 32Hz to 16kHz.

There are several possibilities I can offer about how to produce a DC output voltage that is proportional to frequency. The first method is one that I employed in a project I designed for ETI in June 1987, on page 74. (Yes, I've been around a bit!) This project is an analog frequency meter that uses a moving coil meter to display frequency, and should be suitable in the application you are enquiring about.

The circuit is based on an op amp, a 555 timer, and a few transistors. I researched this project using books like the *TTL Cookbook* by Don Lancaster, and another called *IC Timer Cookbook*, by Walter Jung (see page 192). Both books are Sams publications, and are probably still available.

In fact, a frequency to voltage (f/v) converter is a fairly common circuit, and most electronic tachometers that use a meter movement have some type of f/v converter. Hope that helps you, S.V.

## Nicad charger

Over the past few months, several readers have described two problems with the Nicad Charger, published in July 1989. The following letter will be of interest to anyone having these problems with this project, which supports my theory that not all 339 quad comparators are born equal. The good news is the letter solves the problems.

After constructing the Nicad Charger, the problems outlined in *Information Centre* (January 1990) initially plagued the one I built.

The most obvious fault was that of LED 3 (charge indicator) not completely extinguishing when the charger entered the trickle charge mode. Replacing the

uA339 quad comparator with another from the same manufacturer corrected this fault.

Not so obvious was finding that the charge mode changed over to trickle mode at half the time indicated by the 'time' switch. I was using a Dick Smith 12.6V/150mA transformer (M-2851) to power the circuit, which was set to recharge a 9V battery.

Close examination of the DC output from the bridge rectifier revealed a spike of some 8us duration on the waveform used to clock the counter. Soldering a 0.015uF polyester capacitor (greencap) across R18 (IC3b, pin 7 to ground) completely removed the spike, and also eliminated the timing problem.

Trust this information will be useful to you and to constructors of this fine project. (M.L. Boondall, Qld).

As the designer of this project, it is most gratifying to read of a solution to the two problems that have been mentioned previously in these columns. Over the years I have found that ICs from different manufacturers are likely to have different characteristics. But it is unusual to have differences between ICs from the same manufacturer.

I recall discovering quite incredible differences between various brands of 555 timers, and some variations between makes of 324 quad op amp ICs. From now on, I'll add the 339 to my list of ICs to stay away from when designing projects!

The addition of a small value de-spiking capacitor to the supply rail is one that I referred to in the May edition, and this letter supports my theory. I'm glad you think well of the project M.L., despite the problems.

## Videos on electronics

The following letter comes from a contributor who spends his Saturday mornings with a class of young people learning electronics at Christ's College in Christchurch, New Zealand. His letter is too long to reprint in full, but the essence of it is simple. Help!

I am anxious to find a source of suitable training videos that cover radio and general electronics. As the class comprises boys from 3rd form to 6th form, I am particularly anxious to purchase videos that describe how to make projects rather than those that contain a lot of theory.

A project I am keen to get started is one where the boys construct an amateur radio station. They are already building a shortwave receiving station with a digital readout and an active antenna. As I

would also like the class to sit for the amateur licence, a video on this topic would be of great assistance.

I have tried various sources including the Christchurch Polytechnic, Canterbury University and the New Zealand National Library. If you could print this letter in your columns, perhaps EA readers may be able to help. If so, please write to Derek Rout, 4/54 Rolleston Ave, Christchurch, New Zealand, or phone (03) 795 570.

We're very pleased to print your letter Derek, in the hope someone can assist you. Videos of this type may be difficult to obtain, but there are a number of private educational suppliers who may just have what you want. Over my time in education, I have seen videos that describe soldering techniques, those that discuss resistors and others that cover the principles of radio. The Dick Smith Electronics organisation also markets a video on assembling its 'Fun Way Into Electronics' kits, which may be worth looking at.

The type of videos you want do exist, I'm sure - all we have to do is find them. Over to you, folks.

## Active CRO probe

The next letter asks for help on two projects; the active CRO probe and the good old EA frequency counter.

I am having trouble locating a BF981 transistor for the Active CRO probe described in the September issue of EA. None of the major parts suppliers lists these, and the suggested supplier (Radio Spares) states that the component is not available. Is there an alternative device, or can you suggest another source? Also, can I use 1N4002 diodes instead of the specified 1N4001 diodes, and rather than use an expensive panel mount BNC plug, is it OK to use a standard BNC line plug with a few centimetres of coax?

Finally, several months ago I wrote about my EA Frequency Counter, although as yet I have not seen anything appear in your columns answering my query. Trusting you can find a few lines to help me. (R.D., Yass NSW)

Concerning the frequency counter, I replied in detail in the March edition of these pages. Remember that our lead time plus preparation time totals around three months, and we don't usually reply personally to reader letters unless the \$5.00 fee is included with the letter.

On reading about the difficulties of sourcing a BF981 dual gate MOSFET, I contacted the alternative supplier, Farnell, mentioned in the parts list for the Active CRO Probe. They currently

**SUPER JUNE-AUGUST 90 SPECIAL  
VHF REMOTE CONTROL — EA April 89**

With our latest VHF transmitter • Proven reliable unit • Complete Tx kit and PCB with components for Rx kit. Tx battery included

**UNBEATABLE PRICE  
\$49.90 for the pair  
EXTRA Tx \$17.20**



**PIR MOVEMENT DETECTOR/ALARM  
EA May 89**

Now supplied with a commercial case lens swivel base assembly. The optional interface kit lets you use it as a stand alone alarm, auto light control, auto door opener, etc.

**SUPER VALUE AT  
\$39.95 for PIR kit  
\$7.95 for interface  
components.**

*We can hold this price only for a limited time.*



**PIR DETECTOR/LENS KIT**

High quality DUAL ELEMENT pyroelectrical detector and small wide angle lens

**For JUNE/AUGUST only  
\$17.90 the set.**

*Stock up now!  
THAT'S MORE THAN 30% OFF*



**EHT POWER SUPPLIES**

Slightly used but tested professional units. Fully regulated. Two types. 24VDC 3.5kV DC at 5mA and 24VDC 15kV DC at 500mA. Both will work at reduced outputs down to 6VDC. Use for CROs, high voltage testing, night vision tubes, experimenting, etc.

**\$39.75 — 3.5kV unit  
\$44.90 — 15kV unit**

*Limited stocks at these  
SPECIAL prices*



**LASER TUBES AT BARGAIN PRICES**

See our ads in Silicon Chip April 90 and EA May 90. We now also stock a collimator lens assembly which is used to maintain small beam diameter at long distances. **\$79.00**

**HIGH ENERGY IGNITION SYSTEM  
SC May 88**

Uses high energy ignition IC made by Motorola. Proven reliable performer. Short form kit includes PCB and all semiconductors with instructions.

**ONLY \$29.90**

**MAINS MUZZLER — SC Jan 89**

Filters mains and protects against high voltage spikes. Includes 40 joule varistor and AC capacitors. For all electronic equipment. Short form kit includes PCB and all components as shown.

**SUPER PRICE  
\$12.90**

*Why not buy two just in case?*



**SERVICEMAN'S SPECIAL  
10kV Diodes — \$2.50  
Late model TV tripler — \$12.90**

**OATLEY  
ELECTRONICS**

PO BOX 89 OATLEY, NSW 2223  
Telephone: (02) 579 4985

MAJOR CREDIT CARDS ACCEPTED

Certified p&p \$4 \$6 Aust; NZ add \$2

Distributors: Slightly higher prices may apply

MELBOURNE: ELECTRONICS WORLD — (03) 723 3860  
BRISBANE: KINGSWAY ELECTRONICS — (07) 390 2399

**INFORMATION CENTRE**

have these components, at a one-off price of \$1.82, and can be contacted on (02) 645 8888. And yes, the 1N4002 diodes can certainly be used instead of the 1N4001 diodes. In fact, because the 1N4002 devices have a higher reverse voltage (100V instead of 50V for the 1N4001), they are probably superior.

I can see no problems in using a BNC line plug, providing good quality shielded cable is used — perhaps a piece of the cable prescribed in the parts list. I would recommend using as short a length of cable as possible, mainly to keep losses to a minimum.

**Baluns and SWR readings**

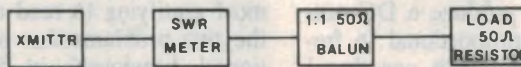

The next letter asks us about baluns and their effect on an SWR reading. The connection referred to by the contributor is shown in Fig.2.

*Would you tell me whether there is any difference between a 1:1, 75 ohm balun and a 1:1, 50 ohm balun. Also, if the SWR meter in the block diagram (Fig.2) showed anything other than 1:1, is this due to power losses in the balun? (D.A., Findon SA)*

**NOTES & ERRATA**

**Voltup** (May 1990): In Fig.5, on page 101, the battery legend should read '3 x 1.5V New Alkaline D Cells'. In other words, the total battery voltage should be 4.5V — not 13.5V.

**What??**

This month's question is supplied by Mr Don Law from Tumblong, NSW. It may seem simple, but appearances can be deceptive. Don asks: Determine the values of two resistors that give 100 ohms when connected in series, and 21 ohms when connected in parallel.

**Answer to last month's What??**

Last month's What?? question asked for the function of a two-transistor circuit, supplied by contributor Mr Peter van Schaik. Answer: it's a Schmitt trigger. Mr van Schaik did not supply an analysis, but it's simple enough. If the input signal is zero, Q1 is off, Q2 is biased on via R2 and R3 and the current in R5 is around 5mA (5V/1k), giving a voltage across R5 of approximately 0.5V.

When the input signal rises to around 1.1V (assuming Vbe equals 0.6V), Q1 conducts, turning off Q2. When this happens, the current in R5 drops to nearly half (5V/1.8k), causing the voltage across R5 to drop to around 0.28V. This is a form of positive feedback, and Q1 conducts even harder, until the input voltage falls to less than 0.88V. When this happens, Q1 switches off, assisted by the rising voltage across R5 and we are back to the original condition. The waveforms may make it more obvious. My thanks to Mr van Schaik, and I trust my analysis is correct.

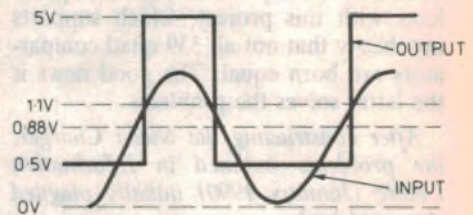
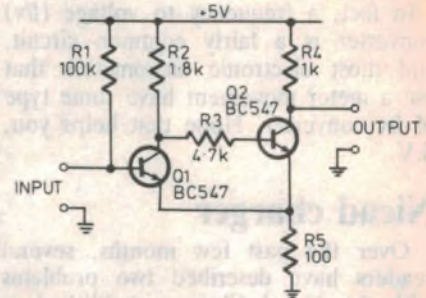



# EA with ETI marketplace

## ADVERTISING RATES FOR THIS PAGE

**SMALL ADDS:** The minimum acceptable size of 2 centimetres x one column costs only \$50. Other sizes up to a maximum of 10 centimetres are rated at \$25 a centimetre. **CLASSIFIEDS:** \$4 for 40 letters. Just count the letters divide by 40 and multiply by 4, **ROUND UP TO NEAREST WHOLE NUMBER.** **CLOSING DATE:** Ads may be accepted up to the 15th of the month two months prior to issue date. **PAYMENT:** Please enclose payment with your advertisement. Address your letter to THE ADVERTISING PRODUCTION MANAGER, ELECTRONICS AUSTRALIA, PO BOX 227, WATERLOO, NSW 2017.

### FOR SALE

**EPSON P80: portable battery:** rechargeable 80 column printer serial interface very compact and light. 1.1 kg uses normal or thermal paper. \$175. IMPORT TECHNOLOGIES 07-3725138

**WHOOPS!** My Z80 based PBUFF printer buffer just doubled its memory capacity again. Over 3000 kits now sold. Combinations of DIP/SIPP/SIMM DRAMs in 9 memory sizes up to 2Mb. Rev J Board, Ver 4.2 EPROM and instructions \$39. Cable board \$9. P&P \$3. Serial board and many other options available. Send a 41c stamp for a free catalogue to Don McKenzie 29 Ellesmere Cres, Tullamarine 3043.

**SWITCH MODE POWER SUPPLY REPAIRS:** Any type, fast turnaround Ph: 256-2706 A.h.: 252-4594

**BUILD AT LOW COST:** Z80 micro-controller development system. Uses any PC/XT/AT/386 or Z80 system as the host computer. Fast PC machine language cross assembler included. Super fast load to target system via parallel printer port. EG: - 8K rom file in three seconds on standard 4.77 mhz PC. Battery back-up on target system. For more information sent a 41c stamp to Don McKenzie, 29 Ellesmere Crescent, Tullamarine 3043.

**CB RADIOS:** \$59 to \$199, business, amateur, marine, outback, world wide radios, scanners, power supplies, aerials, walkie talkies, amplifiers, test gear, microphones, HF, VHF, UHF, different gear weekly. We buy, sell, trade in and repair. Enquire about hobby radio and computer club activities for beginners. Sam Voron, VK2BVS 24 hour, 7 day number, (02) 407 1066.

## SONICS

MAGAZINE

For: Musicians, Road Crews,  
Recording Engineers,  
Lighting People, Managers,  
Promoters and anybody  
interested in what goes into  
today's music-making.

### AMIDON FERROMAGNETIC CORES:

For all transmitter and receiver applications. Send DL size SASE for data/price to: RJ & US Imports, PO Box 157, Mortdale, NSW 2223. Agencies at: Geoff Wood Electronics, Sydney; Webb Electronics, Albury; Electronic Components, ACT; Truscott's Electronics, Melbourne; S. Willis, Perth; Assoc TV Service.

**ETI 466 300W "BRUTE AMP":** The "Brute" develops 300W into 4 ohms or 200W into 8 ohms at 20-20K response kit \$85 + \$7 P&P. Pre-built and tested \$130 + \$7 P&P. (Transformer and heat sink not included.) Send to E.D. Electronics, 493 Mitcham Road, Mitcham 3132.

**WEATHER FAX:** programs for IBM XT/AT's \*\*\* "RADFAX2" is a high resolution, shortwave weather fax, morse & RTTY receiving program, Needs CGA, SSBhf radio & RADFAX decoder. Also "RF2HERC", "RF2EGA" & "RF2VGA", same as RSADFAX2 but suitable for Hercules, EGA, & VGA cards respectively. \$35 \*\*\* "SATFAX" is a NOAA, Meteor & GMS weather, satellite picture receiving program. Displays in 64 colors Needs EGA color monitor and card, + "WEATHER FAX" PC card. \$45 \*\* All programs are on 5.25" OR 3.5" disks (state which) + documentation, add \$3 postage. ONLY from M. Delahunty, 42 Villiers St., New Farm 4005, QLD. Ph. (07) 3582785.

### ELECTRONIC DRAFTING SERVICES

- \* Drafting for the home hobbyist.
- \* Support for professional schematics.
- \* Improve diagrams, reports and presentations.

Phone: (02) 606-6752

**TOSHIBA LCD:** Screen originally to suit T1500 desktop 240 mm x 180 mm (640 x 200) pixels uses 5v supply & TTL drive signals suit experimenter. \$150.

IMPORT TECHNOLOGIES 07-3725138

**TOSHIBA T3100:** co-processor kit. This piggy-back board enables the fitting of a 80287-8 to the early T3100. Two types available, solder in and plug in. Solder ver. \$190 plug ver. \$335  
IMPORT TECHNOLOGIES 07-3725138

**REMOTE CONTROL SYSTEM:** Used for garage doors or alarms or anything to be controlled by remote 12V or 24V supply. System is crystal locked on the 27 meg band, 5 amp relay with momentum or flip flop action. Range 200 metres. Complete system \$120 + \$7 P&P. 10 only. Send to E.D. Electronics, 493 Mitcham Road, Mitcham 3132.

### RCS RADIO PTY LTD

Established 1933  
IS THE ONLY COMPANY WHICH  
MANUFACTURES & SELLS EVERY PCB  
& FRONT PANEL  
published in EA & Silicon Chip.  
651 Forest Road, Bexley 2207  
AUSTRALIA  
RING (02) 587 3491 FOR INSTANT PRICES.

### TRANSFORMER REWINDS

ALL TYPES OF TRANSFORMER REWINDS

- \* REWOUND TO YOUR SPEC
- \* EXACT REPLACEMENT WINDING
- \* VINTAGE RADIO A SPECIALITY
- \* ALL ONE OF TYPES
- \* ALL QUOTES BY RETURN MAIL
- \* RAPID SERVICE

For price quote send details showing physical size & number of windings (or send unit, same will be returned to sender if quote not satisfactory)

**TRANSFORMER REWINDS**  
FREEPOST NO 7, PO Box 438, Single  
ton, NSW 2330. Ph: (065) 76 1291.

Good news for the fans of Quadraphony  
New 4-channel productions are available

quadrOsound

on discrete 4-channel tape and cassette  
Info from P.B. 610411, 2000 Hamburg 61  
West - Germany

### KIT REPAIRS!!

Repairers of kits from all magazines.  
Computer equipment sales/repairs.  
Got a problem? Or queries?

Ring anytime 9am-9pm Mon-Sun.

**EEM ELECTRONICS**  
10 Bouverie Place, Epping, Vic.  
(03) 401-1393

**LOGIC ANALYSER GOULD INSTRUMENTS:** K40 Stand alone analyser 8 nonvolatile memories 7" crt 4 x 2k sample memories 2 x 16 channel probes up to 100MHZ asynchronous capture. Weighs 7.7 kg. \$975.  
IMPORT TECHNOLOGIES 07-3725138.

### FIX-A-KIT

**\$20 PER HOUR LABOUR**

No charge for kits that can't be repaired.  
3 months warranty on repairs.  
Construction available.

**HYCAL INSTRUMENTS**  
Design, manufacture, repair of electronic equipment  
(02) 633 5897

# Electronics Australia

You can now purchase any of these specially selected books from the easy to order Electronics Australia Bookshop.

Titles cover a wide range of electronic, scientific, and technical books and will be updated regularly to keep you abreast of the latest trends.

Simple Tropical and MW Band Aerials	BP-145	\$6.00
Test Equipment Construction	BP-248	\$11.00
An Introduction to Satellite Television	BP-195	\$12.95
Computer Music Projects	BP-173	\$11.00
How to Get Your Computer Programs Running	BP-169	\$11.00
The Simple Electronic Circuit & Components (Elements of Electronics — Book 1)	BP-062	\$14.00
Chart of Radio, Electronics, Semiconductor and Logic Symbols	BP-027	\$4.00
Electronic Music Projects	BP-074	\$9.50
How to Design Electronics Projects	BP-127	\$9.00
25 Simple Amateur Band Aerials	BP-125	\$6.50
25 Simple SW Broadcast Aerials	BP-132	\$6.50
An Introduction to Z80 Machine Code	BP-152	\$10.00
Radio & Electronic Colour Codes Data Chart	BP-007	\$4.00
50 Projects Using Relays, SCRs and TRIACs	BP-037	\$8.50
50 Simple LED Circuits	BP-042	\$6.00
Popular Electronics Projects	BP-049	\$9.50
Practical Electronics Calculations and Formulae	BP-053	\$16.00
Your Electronic Calculator & Your Money	BP-054	\$5.00
Electronics Security Devices	BP-056	\$9.50
Choosing and Using Your Hi-Fi	BP-068	\$6.00
Transistor Radio Fault-Finding Chart	BP-070	\$4.00
Power Supply Projects	BP-076	\$7.50
How to Use Op-amps	BP-088	\$11.00
Communications (Elements of Electronics — Book 5)	BP-089	\$11.00
Audio Projects	BP-090	\$8.50
Model Railway Projects	BP-095	\$8.50
IC Projects for Beginners	BP-097	\$8.50
Mini-Matrix Board Projects	BP-099	\$6.50
Aerial Projects	BP-105	\$8.50
30 Solderless Breadboard Projects — Book 1	BP-107	\$11.00
Audio Enthusiasts Handbook	BP-214	\$3.00
Build Your Own Solid State Hi-Fi and Audio Accessories	BP-220	\$6.00
Beginners Guide To Building Electronic Projects	BP-227	\$8.50

**BABANI BOOKS  
— BACK BY  
POPULAR DEMAND**

# BOOK SHOP

The Art of Programming the 1K ZX81	BP-109	\$8.50
How to Get Your Electronic Projects Working	BP-110	\$8.50
Remote Control Handbook	BP-240	\$13.00
A Z-80 Workshop Manual	BP-112	\$12.00
30 Solderless Breadboard Projects — Book 2	BP-113	\$10.00
The Pre-Computer Book	BP-115	\$8.50
Practical Elec. Building Blocks — Book 1	BP-117	\$8.50
Practical Elec. Building Blocks — Book 2	BP-118	\$8.50
Audio Amplifier Fault-Finding Chart	BP-120	\$4.00
How to Design and Make Your Own PCB's	BP-121	\$6.50
Audio Amplifier Construction	BP-122	\$9.50
25 Simple Indoor and Window Aerials	BP-136	\$6.00
An Introduction to Programming the BBC Model B Micro	BP-139	\$8.50
Digital IC Equivalents & Pin Connections	BP-140	\$18.00
Linear IC Equivalents & Pin Connections	BP-141	\$18.00
Further Practical Electronics Calculations and Formulae	BP-144	\$16.00
The Pre-BASIC Book	BP-146	\$11.00
An Introduction to 6502 Machine Code	BP-147	\$9.50
An Introduction to Computer Peripherals	BP-170	\$10.00
More Advanced Electronic Music Projects	BP-174	\$8.50
An Introduction to Computer Communications	BP-177	\$11.00
Electronics Circuits for the Computer Control of Robots	BP-179	\$11.00
Electronic Circuits for the Computer Control of Model Railways	BP-180	\$18.00
MIDI Projects	BP-182	\$11.00
Electronic Synthesiser Construction	BP-185	\$11.00
Using Your Amstrad CPC Disc Drives	BP-189	\$11.00
LOGO for Beginners	BP-193	\$11.00
Electronic Hobbyist Handbook	BP-233	\$16.00
Getting the Most from Your Multimeter	BP-239	\$11.00
International Radio Station Guide	BP-255	\$16.00
Digital Audio Projects	BP-245	\$11.00
More Advanced Test Equipment Construction	BP-249	\$12.00
From Atoms To Amperes	BP-254	\$12.00
How To Use Oscilloscopes and Other Test Equipment	BP-267	\$12.00
An Introduction To Loudspeaker and Enclosure Design	BP-256	\$11.00

**To order, simply fill in the coupon, remembering to include the code numbers and \$5.00 postage and handling. If the coupon is missing, write down the names, code numbers and prices of the books you require. Include your name, address, telephone number, plus cheque, money order or credit card details (card type, card number, expiry date and signature) and send it all to: Federal Publishing, Freepost No. 4, P.O. Box 227, Waterloo, NSW 2017. No stamp required. And don't forget to sign all orders.**

# Solid State Update

KEEPING YOU INFORMED ON THE LATEST DEVELOPMENTS IN SEMICONDUCTOR TECHNOLOGY



## Three-phase bridge rectifier matrix

A new matrix series of three-phase bridge rectifier power modules of 1000, 1200, 1400 and 1600V each have continuous current selections of 90, 110, 130 and 160A.

The series from International Rectifier is intended for general purpose, heavy duty applications, being particularly suited for use as the input supply bridge for single and three-phase bridges in motor drive and uninterruptible power supply systems.

Compactness, high thermal conductivity, electrical insulation, and excellent power volume ratio are features of the INT-A-pack modules which are 94mm long, 34mm wide and 30mm high and



weigh 225g. Mounting hardware is two standard M5 pan-head screws with captive disk springs.

For further information, contact NSD Australia, 205 Middleborough Road, Box Hill 3128 or phone (008) 33 5623.

## Sony GaAs chip for 12GHz PLLs

A new GaAs frequency divider chip capable of operating at 12GHz has been developed by Sony, for use in satellite communications receivers. The chip can divide by either 256 or 258 times and integrates some 400 JFET active devices, each with an active length of 0.5µm.

The use of JFETs instead of Schottky-junction MESFETs is said to be the key to achieving 12GHz operation.

## Transistor has 29ps gate delay

NEC Corporation recently announced the world's highest-frequency bipolar transistor with 29-picosecond gate delay.

The new bipolar transistor will find application in ICs for next-generation supercomputers and ISDN (Integrated Services Digital Network) equipment.

With NEC's proprietary 'BSA' techniques, a 50nm thick base layer is formed 100nm below the silicon substrate. The bipolar transistor uses a col-

lector structure with graded impurity distribution, and a layer of tungsten deposited by selective chemical vapour deposition for the emitter electrode.

The BSA technique makes possible a 40GHz cutoff frequency, and a 29-picosecond ECL gate delay time. The 0.3mA gate current and 1.6mW dissipated power are also lower than previous parts. Using a 0.8µm ultra-fine processing technique, the transistor occupies only 57 square microns.

## 512K x 8 CMOS SRAM module

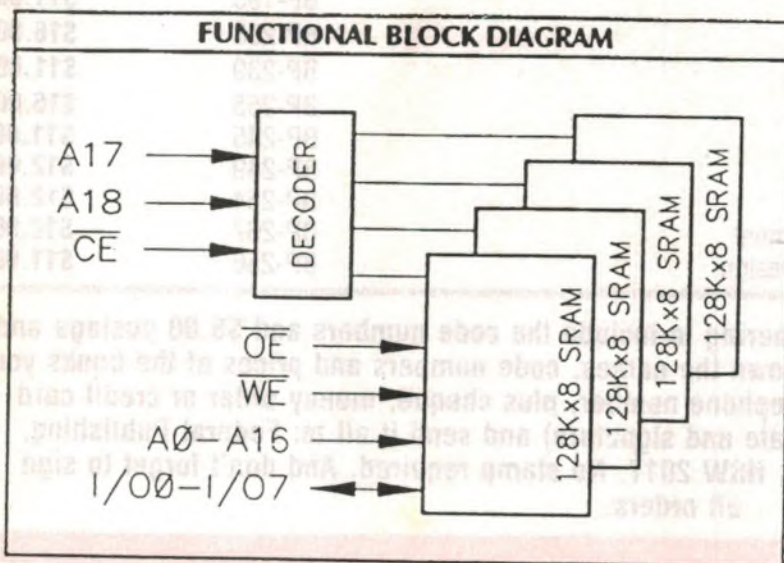

The DPS512S8 is a 512K x 8 high-density low-power static RAM module comprising four 128K x 8 monolithic SRAM's, an advanced high-speed CMOS decoder and decoupling capacitors, surface mounted on a co-fired ceramic substrate having side-brazed leads.

The DPS512S8 is available in a 600-mil-wide, 32-pin dual-in-line package that conforms to the same JEDEC standard pin configuration as the future four-megabit monolithics.

The DPS512S8 operates from a single +5V supply and all input and output pins are completely TTL-compatible. The low standby power dissipation of 40µW makes it suitable for battery-backed applications.

For further information contact A.J. Distributors, 44 Prospect Road, Prospect 5082 or phone (08) 269 1244.

## Surface-emitting lasers

Researchers at the University of California, Santa Barbara, have produced the world's most miserly surface-emitting lasers, requiring little more than a milliamp to operate.

The tiny devices – half the width of a human hair – have broken a major barrier that has kept this type of laser from being used to link integrated circuits by means of light rather than electrical wires.

Surface-emitting lasers, or SELs, project light perpendicular to the surface of the semiconductor chips that they are created on, as opposed to the current state-of-the-art 'in plane' lasers that produce light which shines from the edge of a chip. Because of its basic geometry, an SEL chip with hundreds of individual lasers can be connected directly to an integrated circuit. By contrast, chips with in-plane lasers must be cut into individual, salt-grain-sized lasers that are individually mounted and attached.

The UCSB micro-lasers are made from a mixture of indium, gallium, aluminium and arsenic. The active region of each tiny laser is a structure called a quantum well. It consists of an ultra-thin layer of indium-gallium-arsenide, sandwiched between thicker layers of gallium-arsenide.

The quantum well is so thin that it forces electrons within it to behave like waves rather than particles. In the process, its electrical and optical properties are substantially altered. In addition, the structure is placed under considerable mechanical strain. The strain and the quantum effects combine to create

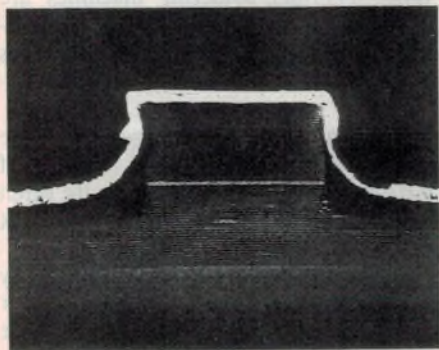

an optical amplification ten times greater than that of the gallium-arsenide layers, the researchers report.

The devices are not very efficient as yet; only 4% of the electrical energy pumped into the laser comes out as light. However, the researchers do not see any fundamental obstacles preventing them from correcting these shortcomings.

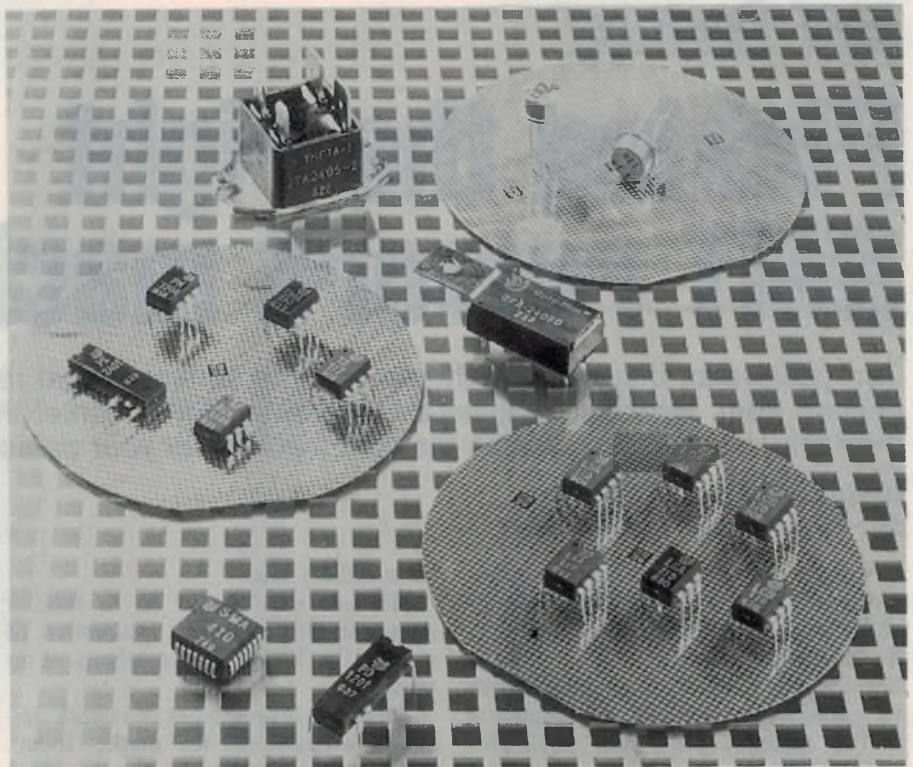

## Miniature industrial solid-state relays

Using advanced thick-film hybrid technology, the OFA, OFB and OFC offer the optimum space usage through multi-function integration.

Total solid state circuitry offers reliability and long-life with added benefit of TTL control of high power systems. Typical applications include control of heaters, motors, solenoids, lighting systems, larger relays, and contractors.

The OF series is UL recognised and CSA, VDE compatible and has high noise immunity. It offers a comprehensive range of blocking voltages from 400

to 600V peak and output ratings of 1.5A, 3A, 5A and 10A at 120V, 240V and 280V RMS. Input control current to operate is only 15mA max and input control voltage is 8, 16 or 28V DC max.

The devices are available in two packages. The 1A and 3A series are PCB mounted and the 5A and 10A heatsink flange mounting, with either QC or PC pins.

For further information contact IRH Components, 32 Parramatta Road, Lidcombe 2141 or phone (02) 648 5455.

## 'FREDFETs' reduce commutation losses

Philips has released a range of 13 FREDFETs, displaying commutation losses between five and ten times lower than standard MOSFETs, coupled with excellent dv/dt behaviour. Aimed at half-bridge and full-bridge applications, each of the Philips' BUK600 family devices has an integral fast-reverse epitaxial diode which offers significant advantages at frequencies up to 50Hz in circuits for motor control, inverters and uninterruptible power supplies.

By doping the epitaxial layer of a standard MOSFET, a FREDFET eliminates the inherently slow parasitic reverse diode between the MOSFET's source and drain. This reduces the device's stored charge by a factor of five, and hence cuts the reverse-recovery

time by a factor of five or more in a practical circuit – to as low as 125ns for a 500V device at a 25°C junction temperature, rising to only 190ns for the same device at 100°C.

FREDFETs are particularly useful in bridge legs, where the parasitic diode is forced into conduction: here, the FREDFETs are less susceptible to dv/dt turn-on, and has lower losses. The heavy-metal doping keeps leakage currents and drain-source on-resistances down to those of other PowerMOS devices.

For further information contact Philips Components, 11 Waltham Street, Artarmon 2064 or phone (02) 439 3322.

## SMT Feature:

# Picking the right SMT rework machine

Ten years ago, there were only two or three surface-mount rework machines on the market to choose from. However in today's fast-growing SMT market there are more than 20 machines available. How do you choose the right machine for *your* particular SMT application?

by **MICHAEL J. BRUNO**

SMT Product Manager, OK Industries, NY

Surface mount technology is becoming more and more prevalent in today's electronics manufacturing process. Technological advances are making SMT boards more complex and difficult to manufacture than ever. Choosing the correct equipment for your SMT production line is a critical step towards achieving your desired results. Unfortunately, most of a manufacturer's time and energy are spent sourcing SMT line components such as screen printers, pick and place systems, production reflow machines and cleaning machines.

A rework machine is hardly ever considered when an SMT line is being initially installed. Often manufacturers are already doing production of SMT boards before they even look at their first rework machine. Ultimately, the purchase of a rework machine is often driven by the fact that a manufacturer has a stack of surface-mount boards that need to be repaired. One of the problems is that SMT manufacturers usually don't have the time to evaluate many different rework machines before they decide on a purchase.

It becomes very important that the manufacturer knows what type of machine he needs, and what features he wants in that machine. A manufacturer must define his needs by looking at the types of boards and components he will be working with. He must then look at the different types of rework machines, and ultimately decide which type will be most suitable. This is the first step toward getting the right equipment for the application.

Once the choice is made, the manufacturer should then decide which features of that type of machine are most important to him. It should then be easier to narrow down the number of vendors that have something that will fit

his specific needs.

The last step should be to have a demonstration and an evaluation of each of the SMT rework machines of interest.

There are several types of rework machines available on the market today. These are categorised by the way each performs solder reflow. The four most popular types are: conductive reflow; convective reflow; thermal soldering reflow; and infra-red reflow machines.

### **Conductive reflow machines**

Conductive reflow or conductive soldering is usually how most manufacturers start in SMT rework. Conductive soldering is performed using a soldering iron on the lead of an SMT part. The soldering iron actually touches the solder, physically conducting heat to the solder joint which reflows the solder.

Conductive solder reflow is practical and effective when working on discrete SMT parts, because these parts are very small and only have two or three leads. Conductive soldering is also very useful when doing 'touch up' work on multi-leaded parts; however, conductive reflow soldering is not practical or effective when trying to remove or replace high lead-count devices. A good guideline would be to only use conductive reflow soldering on devices with no more than 16 leads.

The reason for not using conductive soldering on high lead-count components is that it is very difficult to reflow all the leads at the same time. Alternate methods must be used to effectively reflow such components.

### **Convective reflow soldering**

Convective reflow soldering is the process which uses hot air or hot gas

(nitrogen) to solder or desolder a multi-leaded SMT component. This process involves a machine which directs hot air or hot gas, usually by some type of air nozzle, towards the leads of one specific SMT component. Because of the ease of use and the effectiveness of convective soldering, it has become the industry standard for performing rework of multi-leaded SMT components. Since convective soldering is so prevalent in today's SMT market, convective soldering machines will be focused on after this overview.

### **Thermal soldering**

Thermal soldering, often referred to as 'hot bar' soldering, is a technique that uses thermally conductive bars to perform the actual solder reflow. These bars lie across the leads of a component, reflowing an entire side at one time. Thermal soldering machines are available with one, two or four soldering heads, since one soldering head is required for each side of the component.

'Hot bar' machines are very effective on components with lead centres of 0.020" or less. These machines are often categorised as 'fine pitch' SMT rework machines.

'Hot bar' machines are typically very expensive as compared to hot air or convective soldering machines. These machines are also very maintenance-intensive, since maintaining the coplanarity of the reflow bars is extremely important.

### **Infra-red reflow soldering**

Infra-red reflow soldering is very new to the SMT rework area. IR rework machines usually use a simple quartz IR lamp focused by a combination of glass lenses. The IR 'beam' encompasses the

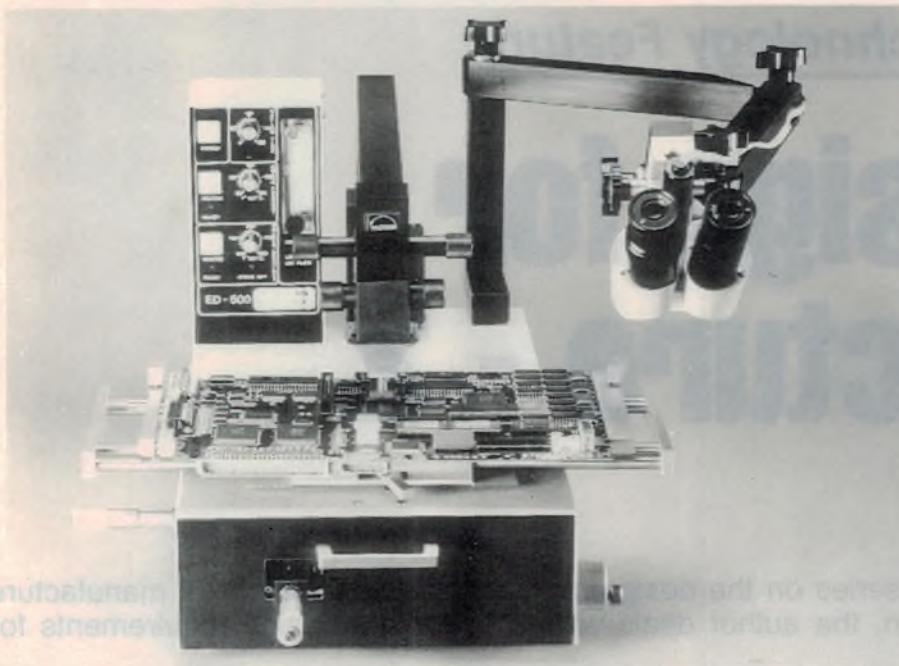

**OK Industries' ED500 Hot Air SMT Rework Machine.**

entire SMT component and performs the actual solder reflow. Once the solder is molten, the part must be manually removed or replaced using tweezers.

Although IR reflow for SMT rework is very new and not yet widely used, it may be a very viable SMT rework solution in the 1990s.

### Features of the rework machine

Since convective reflow soldering seems to be an industry standard for reworking SMT components at the present time, let's look at this category more closely. Many of the features of such machines may also hold true for the other types of SMT rework machines.

It would be virtually impossible to discuss all the features of every convective or hot air rework machine on the market in one article; however, there are some extremely important features — temperature controllability, mechanical movements and ease of use.

#### Temperature controllability:

Temperature control is probably the most important single feature to look for in a rework machine. The ability to control the amount of heat directed at a component and at a board is obviously extremely critical; the temperature control mechanism (thermocouple) should be as close to the actual work surface as possible. The system should be closed-loop with a constant feedback to an accurate control board. Temperature control is not only the ability to maintain a

set temperature, but also the ability to maintain a uniform temperature on all sides of the SMT component.

Some SMT rework machines will heat to a very high temperature (800°F or more), simply to remove a component. These systems only control the amount of time spent heating the device rather than controlling the actual temperature of the device.

You would probably not use an uncontrolled temperature technique when using a soldering iron on through-hole devices, so you should certainly not use it for SMT rework.

#### Mechanical movements:

Virtually all SMT rework machines have manually controlled mechanical movements. These movements are important when it is time to place a component back on the board. All machines can remove components; however, the real task is placing the parts back down.

Placing an SMT component requires a certain degree of operator technique, and a good SMT rework machine will provide an operator with the mechanical movements necessary to perfect their techniques. A rework machine should have the ability to move the component and/or the board in the X, Y, Z and theta axes. The machine should also have true micrometer adjustment of each axis.

One extremely beneficial movement is the ability to finely control the movement of the board in the Z, or up and down, axis. This feature will allow the operator to precisely set the component on the board without applying too much

pressure to the component's leads. It is a more controllable process for the operator to raise the board up to the part rather than dropping the part to the board.

When the SMT rework machine has more mechanical features, operator technique ultimately becomes less critical when it comes to removing or replacing the SMT component.

#### Ease of use;

The important thing to remember when beginning with SMT rework is that you are teaching your operators not only about a new machine, but also a new technology. The rework machine should be simple enough that any operator can use it rather than limiting it to one or two dedicated technicians. The machine should not appear to be intimidating or overbearing to the operators, or they will never be comfortable with it. A good SMT rework machine should be functional, simple, and easy to use.

### Getting demonstrations

Features, benefits and ease of use will help you to narrow down the number of rework machines that seem to fit your needs. The last step should be to have a demonstration of each piece of equipment. Such a demonstration should be in your facility, with your boards (if available), and this will let you see exactly how the machine will work for your application.

If the demonstration does not answer all your questions about the rework machine, then ask the manufacturer for an evaluation unit to keep and use for a few days. This will absolutely eliminate any concerns you may have about the machine.

Define your needs and choose the type of rework machine needed for your application. Investigate the features and benefits of each SMT rework machine. And be sure to ask each supplier to give you a demonstration and an evaluation of their rework machine. If you follow these procedures, you'll make the right choice. □

### Footnote

*The foregoing article is reprinted with permission from the publisher of 'Atlantic-Tech'. Further information on the SMT rework machines and other tools and equipment manufactured by OK Industries is available from the firm's Australian distributor, Electronic Development Sales, of 11 Orion Road, Lane Cove 2066 or phone (02) 418 6999.*

## Surface Mount Technology Feature:

# PCB design for manufacture - 2

by **RAY SMITH**

Managing Director, RCS Cadcentres\*

In this second part of his short series on the design of PC boards for successful manufacture and reliable equipment operation, the author deals with some of the design requirements for surface mount technology.

In the first of these articles, I reminded you of the people or groups who have an interest in the PCB that is subsequently designed by you. I have to reiterate the importance of consulting with these people whenever a new design is proposed, because materials and processes are constantly changing. This should be done even if you have gone to the trouble of preparing your design guide for PCB documentation and design.

Having determined what performance class (1, 2, 3) and what productibility level (A, B, C) you wish to comply with, appropriate tolerances can be set for manufacture and assembly.

For example, communications equipment with reasonably complex trackwork might be set at Class 2, Level B, which would result in the following typical manufacturing tolerances (Ref. IPC-D-949):

- Maximum number of layers:** 12
- Maximum board thickness:** 3.8mm + .18mm
- Minimum conductor width:**
  - Internal .2mm (0.008")
  - External .25mm (0.010")
- Master pattern accuracy up to 300mm:** 0.08mm (0.003")
- Minimum conductor spacing:** .2mm (0.008")
- Minimum annular ring:**
  - Internal .13mm (0.005")
  - External .20mm (.008")

There are tolerances for a lot of other important features but these are what we most often look at. Such a specification would describe what would be an 'above average' PCB in Australia, however, it is only midway on our chart. The important issue here is that if you know what to specify, i.e., Class 1, Level A or whatever, all those concerned in the fabrication of the PCB should know what is expected of them, with no confusion.

The board tolerance will have a bearing on the assembly techniques and this will in turn, be considered during design.

### Component Technology

Since PCB's are designed to carry and interconnect components, the component technology is of fundamental importance. For years, designers have been able to get away with all sorts of bad practice, because leaded components had broad tolerances for assembly. They had built in stress relief in most areas, leaders could be reshaped to fit wayward holes and there was always somewhere to hang a test probe.

Unfortunately for some, modern component packaging is such that most of these advantages are being designed out of the components. Things such as fine pitch (0.50"), DIP IC's and surface mount components are presenting us with enormous headaches.

No longer can we assume that some-

how it will all hang together. Deliberate thought must be given for test points, matching the thermal coefficients of components with that of the printed circuit board, soldering stress and so on.

During the process of designing 'conventional' double sided (DS), plated-through-hole (PTH) printed circuits with leaded components, in general the larger the pad the better off everyone is, especially our field service technician with his plumber's soldering iron.

So long as the pad was big enough, almost anything could be plugged in.

Unfortunately with SMT, bigger is not better. Refer to Fig.1 and you will understand that very strict tolerances need to be applied to the size and shape of component pads. In fact components need to be ordered according to the machinery used to load them and the size of the pads designed to accommodate them.

Even without the complexity of SMT, component selection is difficult enough. Cermet trim pots are a good example of this. They all have the same value and similar specification, but not one is pin compatible - refer Fig.2. Should your purchasing department get all excited and buy a container load because they are cheap, you may end up with a container load of useless pots or a truck load of useless PCB's. Communication is vital, and so is the documentation, specifying the exact components for which the PCB has been designed.

RCS Cadcentres is one of Australia's leading PCB design service bureaus, with experience in fine line multilayer board design, documentation and artwork generation. These articles are adapted from a paper presented by Ray Smith to the CIMA seminars on PCB Manufacture, in March 1990.



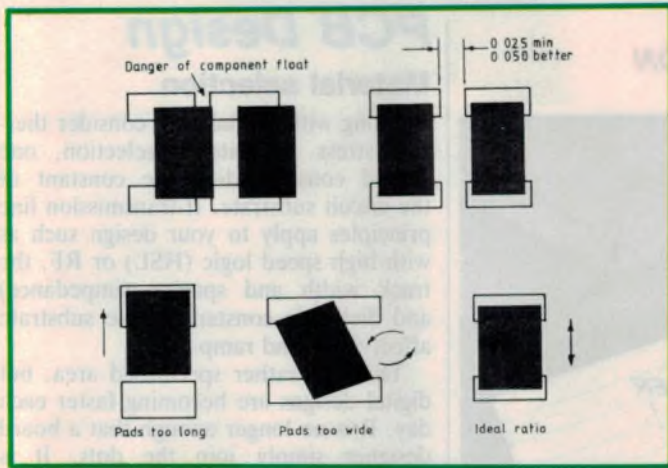

**Fig.1:** PCB pads for SMT chip components need to conform to much tighter tolerances than those for leaded components, as illustrated here.

**Fig.2:** Even leaded components pose PCB design problems, as illustrated by the many different – and incompatible – types of cermet trimpot shown here.

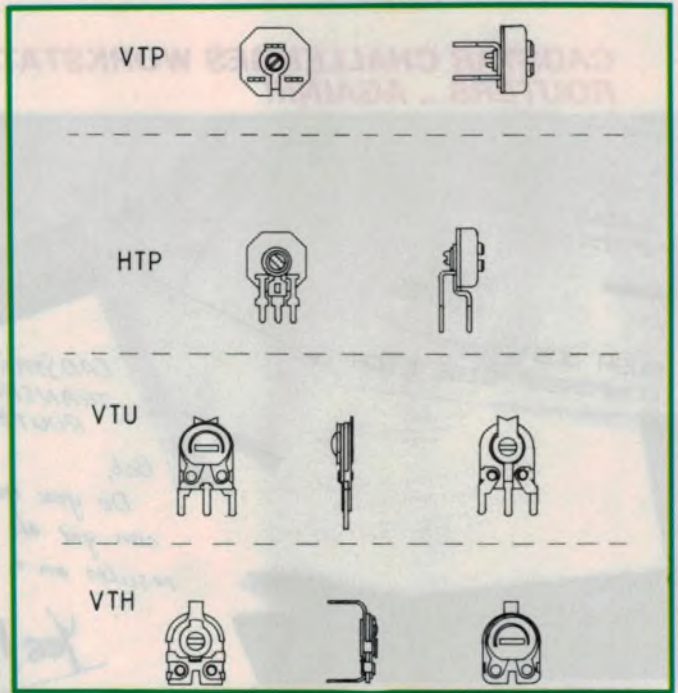

## Thermal and mechanical stress

As has been mentioned, a great many variations could be accommodated within the flexibility of a component lead. However, if the components have no leads as such, we must consider other aspects like mechanical and thermal stress. Certainly with SMT components the centre of gravity is much lower, but on the other hand, they are perfectly rigid. This forces any vibration to be transmitted to the next weakest point, which can be the component substrate or the solder joint.

The more significant problem is likely to be that of thermal stress. Since the surface mounted component is usually a relatively stable material such as ceramic, the thermal coefficient of expansion is considerably less than that of the usual PCB material based upon fibreglass and epoxy resin. This results in different rates of expansion between the component and the circuit board, which could cause failure in the solder joint after fewer thermal cycles than for a leaded component. Refer Fig.3.

For high reliability equipment, a more stable PCB dielectric needs to be considered such as teflon nylon or even

ceramic.

There are also stresses on components caused by solder flow, during the actual reflow process used for SMT boards. Here again the design of PCB tracks and pads can be critical – see Fig.4.

While on the subject of mechanical stress, a great deal of vibration can be reduced by effectively mounting the circuit board assembly, determined of course, by the environment into which it is expected to operate. An extra mounting hole in the centre of a larger board is a whole lot cheaper than servicing warranty returns on your product!

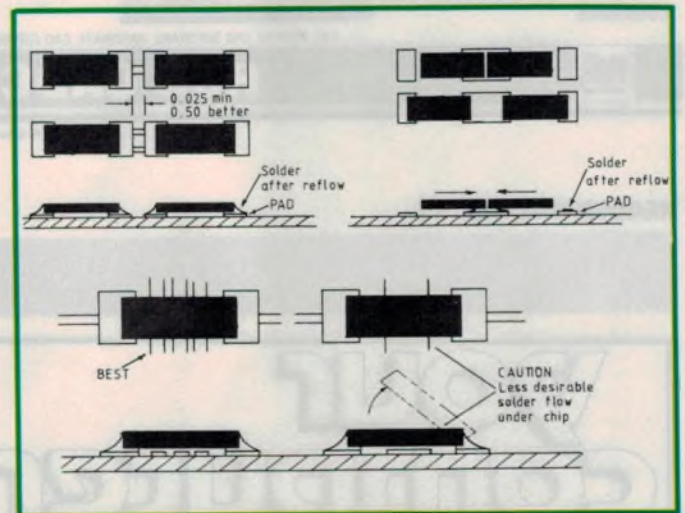
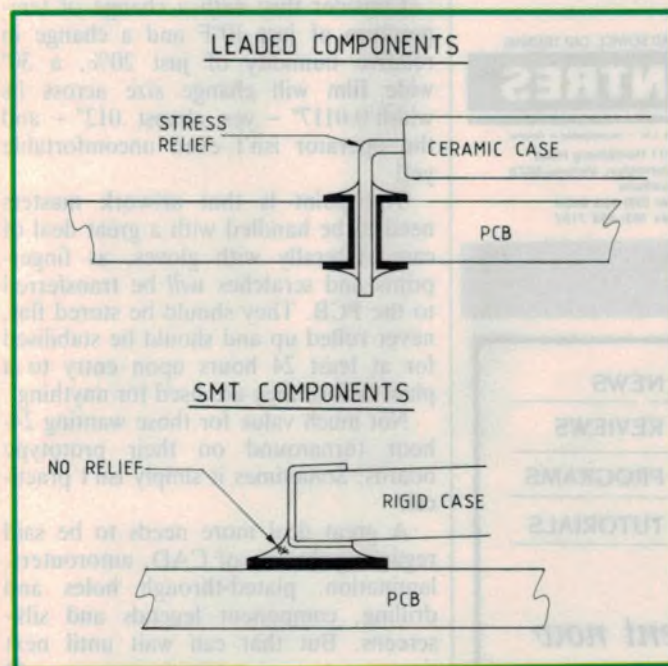

**Fig.4:** (Above) Another aspect of PCB design for SMT is pad and track design for minimising problems during solder reflow.

**Fig.3:** (Left) Thermal stress is more of a problem with SMT, as chip parts have no lead to provide stress relief.

## CADSTAR CHALLENGES WORKSTATION ROUTERS... AGAIN!!!



### ...WITH SPEED

The CADSTAR Transputer Router adds a new dimension to PC based PCB design. The Racal-Redac Advanced autorouter has been ported to run on a Transputer co-processor card under the Helios operating system, which allows it to be installed in any IBM PC-AT/386 compatible system and meets the requirements of new and existing PC-AT customers who wish to run the advanced autorouter on the same hardware as their CADSTAR PCB software.

### ...PERFORMANCE

CADSTAR PC based Design and Layout software is the best mid-range CAD systems in the industry. It enables you to perform 95% of all the interactive and automatic capabilities of high-end "workstations". You'll be able to handle today's most sophisticated boards with high density, multilayer and surface mount components.



CAD BUREAU, CAD SOFTWARE, HARDWARE, CAD SUPPORT, CAD SERVICE, CAD TRAINING

### AND PRICE!

CADSTAR meets the challenge. It combines the best in PCB CAD software with our CADSTAR Transputer Router. Buy this package for a fraction of the cost of workstation systems.

Call RCS Cadcentres for complete details.

ORDER TODAY!

# CADSTAR

from

**RACAL-REDAC**



## RCS CADCENTRES

A Division of RCS Design Pty Ltd - Incorporated in Victoria

731 Heidelberg Road  
Alphington, Victoria 3078  
Australia  
Tel: (03) 499 6404  
Fax: (03) 499 7107

READER INFO No. 53

# your computer

NEWS

REVIEWS

PROGRAMS

TUTORIALS

— at your newsagent now

## PCB Design

### Material selection

Along with the need to consider thermal stress in material selection, one should consider dielectric constant of the circuit substrate. If transmission line principles apply to your design such as with high speed logic (HSL) or RF, the track width and spacing (impedance) and dielectric constant of the substrate affect delay and ramp times.

This is a rather specialised area, but digital designs are becoming faster each day. It is no longer enough that a board designer simply join the dots. It is becoming quite a science to design a PCB and one should be a good student to be successful at it.

### CAD output

As each design becomes more complex, the number of layers increase and tracks and spacings go finer, the method of producing our artwork master becomes important too.

With hand-taped artwork a good operator on a good day could produce work with  $\pm 0.005"$  (1:1) accuracy, without too much concentration. However now we have to consider the accuracy of the media as well!

If you are involved in multilayer, fine line PCB design and you are not photo-plotting your artwork masters, give up. We are rapidly approaching the point where the only way to guarantee reliable yield in fabrication is in fact, to have the output plotted, where the boards will be fabricated and in a controlled environment.

Consider this: with a change of temperature of just 10°F and a change in relative humidity of just 20%, a 30" wide film will change size across its width 0.0117" — yes, almost .012" — and the operator isn't even uncomfortable yet!

The point is that artwork masters need to be handled with a great deal of care. Literally with gloves, as fingerprints and scratches *will* be transferred to the PCB. They should be stored flat, never rolled up and should be stabilised for at least 24 hours upon entry to a plant before they are used for anything.

Not much value for those wanting 24-hour turnaround on their prototype boards! Sometimes it simply isn't practical.

A great deal more needs to be said regarding the use of CAD, autorouters, lamination, plated-through holes and drilling, component legends and silk-screens. But that can wait until next time.



# EXTRA FAST DELIVERY



- Chip Resistors
- Surface Attachable Resistor Array (SARA)
- SOJ Lead Dipped Networks
- SIP Networks

# SURFACE MOUNT TECHNOLOGY

Allen-Bradley is one of the world leaders in SMT design and manufacture and offers a full range of support services to facilitate the use of any Allen-Bradley SMT product.

In Australia your Allen-Bradley Components Service Centre is just waiting for your call with the promise of extra fast delivery to all metropolitan areas – and of course the guarantee of Allen-Bradley quality.

Surface Mount technology is more than an exercise in optimising area utilization – to Allen-Bradley it is design in ease and speed of manufacture, automation, testing, inspection and rework. Allen-Bradley – the best way to think SMT.

Call us today to discuss your Surface Mount requirements.



**ALLEN-BRADLEY**  
A ROCKWELL INTERNATIONAL COMPANY

VIC: 37 Chapman Street, Blackburn 3130 Ph: (03) 899 0335  
 NSW: 56 Parramatta Road, Lidcombe 2141 Ph: (02) 748 2652  
 ACT: P.O. Box 534, Fyshwick 2609 Ph: (062) 80 4654  
 QLD: Unit 4 Dennis Court, Springwood 4127 Ph: (07) 208 1044  
 SA: 30-40 Hurtle Square, Adelaide 5000 Ph: (08) 232 0001  
 WA: 31 Kensington St., East Perth 6000 Ph: (09) 221 2121

READER INFO No. 54

## Advanced Design for Efficiency & Flexibility

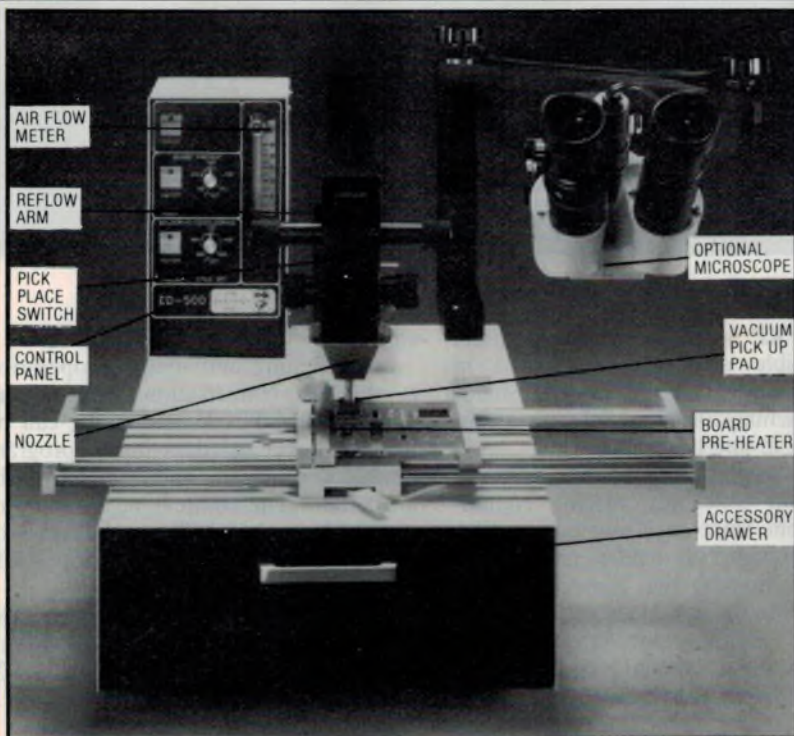

## SMD REWORK STATION

- Greater component protection
- IC Body not heated – legs only heated
- Non-dedicated nozzles and pads
- All devices easily handled
- Visibility during rework cycle
- K type closed loop – thermocouple control
- C.C.T.V. vision system option
- Micro adjustable board holder

Incorporates Industry Standard hot gas reflow techniques with State of the Art thermocouple control.



from  
**ELECTRONIC DEVELOPMENT  
SALES PTY LIMITED**

- 2A/11-13 Orion Road, Lane Cove, N.S.W. 2066
- P.O. Box 822, Lane Cove, 2066
- Tel: (02) 418 6999 ● Fax: (02) 418 6550
- VIC. (03) 587 3888 ● S.A. (08) 365 1000
- QLD. (07) 376 5677

READER INFO No. 55

**SMT Feature:**

# NEW SMT PRODUCTS



## SMT thru-hole repair system

Pace Inc has introduced its new MBT 250E, a three channel, microprocessor controlled SMT/Thru-hole assembly and repair system which can proportionally power up to three 60-watt handpieces simultaneously.

An easy-to-use key array allows quick entry of idle tip temperature, tip temperature offset and temperature range for each channel into a non-volatile memory. Set values and real-time operating temperatures for the indicated channel are clearly displayed on a LED readout. Any re-calibration is quickly and easily performed right on the front panel.

The standard system features 'Snap-Vac' desoldering for safe and effective through-hole component removal and SMT land preparation. ThermoTweez high-heat-output tweezers, a high-capacity surface mount reflow iron and a Thermojet focused hot gas reflow handpiece provide a wide range of SMD capability.

A Thermopic hot bar flatpack iron and a wide variety of SMD and standard tips are optionally available for added versatility. Highly responsive, Sensatemp control provides consistent, accurate tip temperatures for all handpieces.

For further information contact Coltronic, 6 Stanley Street, Auburn 2144 or phone (02) 647 1566.

## Debugging surface mounted PLCC

Most emulators come with a pod that directly plugs into the socket where the device to be emulated resides. When the device is soldered to the PC board as with an SMD, this is not possible. To overcome this problem, Emulation Technology has released a new line of adaptors called an Adapt-a-Clip.

The Adapt-a-Clip comprises two adaptors. The first part is a quad-clip

which connects over the surface mounted PLCC and brings all the pins out of the top of the clip. The quad-clip is suitable for debugging purposes using logic analysers and oscilloscopes.

The second adaptor clips onto the pins at the top of the quad-clip and converts them into a specific connector to suit the emulator pod. These include male DIP, PGA, PLCC or LCC.

For further information contact Current Solutions, 12A Church street, Baywater 3153 or phone (03) 720 3977.

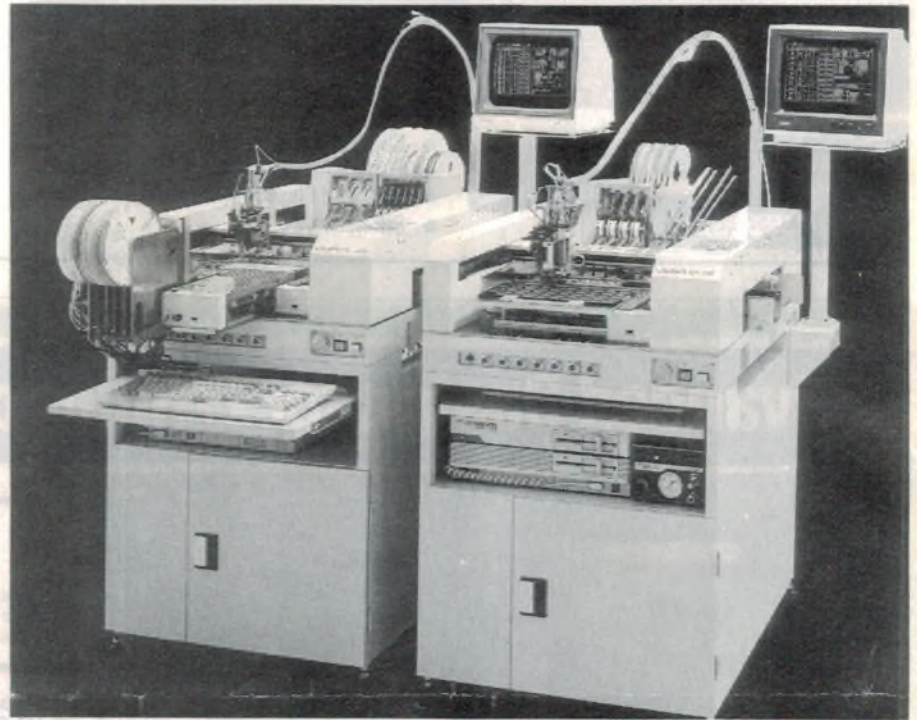

## Range of chip mounters

Juki's KP series of SMD mounters are flexible machines constructed in modular design. They can be stand-alone machines or equipped with a conveyor for in-line production.

The mounters are capable of accurately and efficiently placing components from 8mm to 32mm tapes, from sticks, through bulk feeders and IC tray units. To handle the wide variety of components the machines are equipped with all the important automatic tool change systems, which guarantees the right nozzle size for each component at

all times.

Programming and machine operation is through conversation mode menu with an IBM PC. Programming can be through keyboard data input, program download or speedy and accurate teach-in method. The component data library with its huge data collection makes programming an easy task and possible without specialised knowledge.

For further information contact Suba Engineering, 6/150 Canterbury Road, Bankstown 2200 or phone (02) 790 0900.

## Hot air rework system

Scope Laboratories has released a hot air desoldering/soldering system. Designed Hozan HS600, the non-contact desoldering unit directs hot air at IC pins through an array of pipes in each clip-on nozzle. The needle pipes are curved in some nozzles to direct hot air beneath LCC chip carriers. An interchangeable nozzle is available for each SMD IC package, including PGA, PLCC, SOP, QFP, SIP and others.

A desoldering time of around seven seconds is typical. Control of air flow and air temperature between 100°C and 390°C is provided.

For further information contact Scope Laboratories, 3 Walton Street, Airport West 3042 or phone (03) 338 1566.

## Chip trimmer capacitors

Murata Manufacturing of Japan has released the TZB04 series of miniature surface mount trimcaps with external dimensions of 4.0 x 4.5 x 3.0mm. Capacitance ranges available cover from 1.4 – 3.0pF through to 7.0 – 50pF, with a minimum Q at 1MHz of 300.



The TZB04 series is designed to be machine placed, and is available in both sealed and unsealed versions, on tape, in magazines and bulk. The sealed version may be both flow and reflow soldered, may be immersed in flux and is machine washable by organic solvents.

The TZB04 case is a solid thermosetting resin structure that allows for adhesive attachment to the PCB along with other components in the normal manner, and provides heat resistance during adhesive curing and soldering.

For further information contact IRH Components, 32 Parramatta Road Lidcombe 2141 or phone (02) 648 5455.

## Thin chip capacitor

The new version of ceramic chip capacitors from Siemens is only 0.6mm high. This allows them to be accommodated in a space-saving arrangement under the integrated circuits on the printed circuit board. Batch quantities are now available.

The type 1206 chip, in particular, with a capacitance value of 100nF +/- 20%, has become established as a decoupling capacitor for memory chips. Its capacitance makes it suitable for all generations of memories, including the 4-megabit memory.

The capacitor meets the Z5U characteristic and is available with silver-nickel-tin contacts for reflow and flow soldering. As an alternative, a silver-palladium version is available for conductive adhesion. Other ceramic material (COG, X7R) in various types (0805, 1206 and 1210) can be obtained on request.

For further information contact the Communications Equipment Department of Siemens, 544 Church Street, Richmond 3121 or phone (03) 420 7313.

## Why do so many companies Australia-wide use MMT products?

Because we are Australia's leading distributors of CATV, MATV & Broadband Equipment; TV & FM Transmitters and RF Test Equipment in co-ax and fibre.



7 AMSTED RD, BAYSWATER VIC 3153 PH: (03) 762 6455 FAX: (03) 762 6818

READER INFO No. 56

The choice is crystal clear

“THE AUSTRALIAN COMPANY” — the choice is crystal clear

### Hy-Q International

Be it a Jumbo Jet or a local courier Hy-Q appreciate that stand down time represents lost revenue — so we have tailored our operation for efficient, fast service as a world leader in crystal technology with our bases on four continents — in Australia, Singapore, Great Britain, USA — we have the resources and technology to unequivocally guarantee our quality and service. Hy-Q also manufacture and stock Crystal Filters, DiI Oscillators, MPU Crystals, Clock Crystals, SPXO and TCXO Oscillators etc.

**EXPRESS!!!**

Our special emergency service slips into overdrive to despatch within \*six hours in special circumstances — 24 hours for others.

Normal despatch for custom quality crystals is ten working days.

\*Providing order received before 10am.

**1 ROSELLA STREET, FRANKSTON, VICTORIA 3139**  
 (PO BOX 256, FRANKSTON)  
**TELEPHONE: (03) 783 9611**  
**FAX: (03) 783 9703**

READER INFO NO. 57

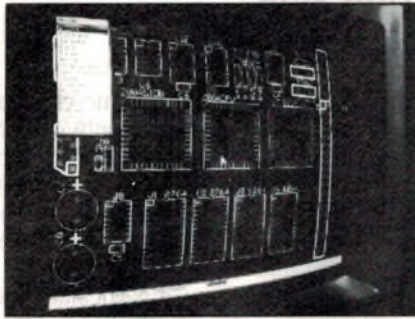

**TOP  
OF THE  
LINE  
IN PCB  
DESIGN**

**PROTEL-AUTOTRAX™ \$1595**

Full-featured professional PCB layout for both through-hole and SMD designs. Auto component placement from Netlists. Interactive and Full Autorouting. Support for popular printing/plotting formats including Gerber format photoplots.



**QUICK  
START  
CIRCUIT  
DESIGN**

**PROTEL-SCHEMATIC™ \$995**

Flexible, easy-to-use schematic capture program for both digital and analog circuit designs. Netlist transfer to PROTEL-AUTOTRAX completes a powerful end-to-end circuit board design system.

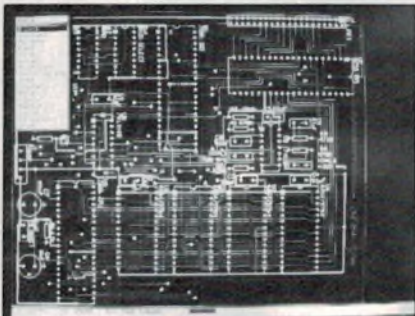

**EASY,  
LOW-  
COST  
PCB  
DESIGN**

**PROTEL-EASYTRAX™ \$295**

Easy to learn, easy to use manual PCB design package. Capable of producing professional artwork for multi-layer, through-hole boards to 32 x 32 inches. Host of powerful editing features make efficient PCB lay-out a breeze. Gerber and NC Drill output.

**PROTEL PHOTOPLOTTING** We now offer complete photoplotting and board manufacturing services. Phone David Warren for details.

**PROTEL TECHNOLOGY PTY LTD**  
Incorporated in Tasmania A Member of CRITEC CORPORATION



G.P.O. Box 536F Hobart TAS 7001  
Telephone (002) 73 0100 International +6102 73 0100  
Facsimile (002) 73 1871 International +6102 73 1871

# This IBM AT/XT™ keyboard only feels expensive



**FUJITSU**

Just **\$88.00** each (1-9) FKB4700-101

plus sales tax if applicable and \$7.00 delivery or  
**only \$84.00 ea** (Qty 10+ plus sales tax and Free delivery)

If you work with PC's or workstations, you know how users like the crisp clean feel of a tactile keyboard. But you also know that it's hard to justify the extra cost.

Now there's a way - and you save money too - when you choose the new FKB4700 keyboard from Japanese giant Fujitsu.

**Unique Switch Makes The Difference**

Only Fujitsu FKB4700 keyboards incorporate the unique coil spring, rubber dome switch. This design combines the simplicity of a membrane keyboard with a full 20-gram tactile response.

**Compatible with Industry Standards**

FKB4700 keyboards have the popular 101 key layout and are approved to UL478, CSA220 and FCC standards.

**Specifications**

Number of Keys	101
Configuration	Suits IBM/AT and XT or compatibles
Tactile	20gram typ
Keystroke/Force	3.8±0.5mm ±20g typ
Key Top	Rectangular cylindrical step sculpture
Tilt	7°/12°

*Distributor enquiries welcome*

™ IBM AT/XT Trade Mark of International Business Machines Corp

**ihh**  
**COMPONENTS**

**SEND FOR DATA TO -**

**SYDNEY** : 32 Parramatta Road, Lidcombe, N.S.W. 2141. Phone: (02) 648 5455. Fax: (02) 647 1545. Telex: AA24949  
**MELBOURNE** : Unit 7, 72-74 Chifley Drive, Preston, VIC 3072. Phone: (03) 484 5021. Fax: (03) 480 2772. Toll Free Enquiries 008 25 2731



MasterCard

## SMT Products

### Cylindrical power chip resistors

Expanded resistance values and tighter TC and tolerances are now available on IRC's CHP series surface mount resistors.

The CHP's are available in 1/8W to 2W power ratings and are now available in resistance values from 0.2 ohm to 2.2M with tolerances to  $\pm 0.25\%$  and temperature coefficient to  $\pm 50\text{ppm}/^\circ\text{C}$ .

A major advantage of the CHP design is its excellent solderability. The nickel contacts are completely silver-free, are hot solder dipped, and provide maximum assurance of reliable solder connections without problems of leaching or de-wetting. End caps are not used.

The CHP series has been developed from the RG product family of precision resistors, which has been in production for over 20 years. It is available either bulk pack or tape and reeled for automatic insertion.

For additional information contact Email Electronics, 15-17 Hume Street, Huntingdale 3166 or phone (03) 544 8244.

### Automatic chip placer

Heeb's HM-60 automatic chip placer has an automatic tool change system for up to eight tools, and is suitable to place a wide variety of SMD components from small 1608 chips right up to PLCC's. The detachable component feeder wagon cuts loading down-time between production runs significantly.

The software, with component library and program optimisation, allows for easy programming on or off line, with incorporated keyboard, joystick, digitiser and PC.

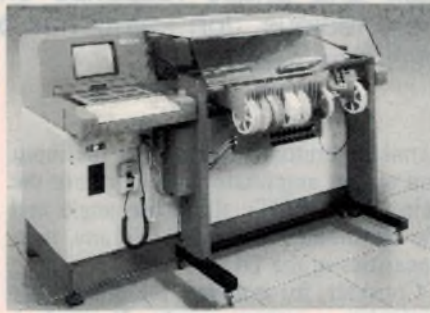

The versatile HM-60 can be used as a stand alone or as an integral part of an

in-line system, with board loader and reflow oven.

For further information contact Suba Engineering, 6/150 Canterbury Road, Bankstown 2200 or phone (02) 790 0900.

### Quarter watt chip resistor

Allen-Bradley's existing series of type AC 1/10W and type BC 1/8W surface mount chip resistors has now been expanded to include a new series of type CC 1/4W.

The standard size is 3.20 x 1.60 x .06mm (1206). Ohmic values range from 10 ohm - 1M ( $\pm 2\%$ ), 4.7 ohm - 1M ( $\pm 5\%$  200ppm) and 4.7 ohm - 15M ( $\pm 5\%$  300ppm); zero ohm jumper chips are also available.

The resistors are suitable for wave or reflow soldering, consisting of a high purity alumina substrate, thick film resistance element, wrap-around terminations and inner electrode protection. Standard packaging is tape and reel.

For further information contact Allen Bradley, 56-60 Parramatta Road, Lidcombe 214 or phone (02) 748 2652. 

# Voltech TF2000 Frequency Response Analyzer

The TF2000 is built for precision gain-phase measurement in electrical and mechanical systems.

By combining the best of digital and analog technology, Voltech have produced another unique instrument offering outstanding value, performance and ease of use.

- Frequency range — 10 mHz to 100 kHz
- True Fourier analysis — accurate with noisy or distorted signals
- Harmonic analysis to 39th harmonic
- Easy to use
- Fully autoranging — 3  $\mu\text{V}$  to 300 V rms
- Inbuilt sinewave generator for single or swept frequency analysis
- Serial and parallel output ports
- Low in cost

Many other features included

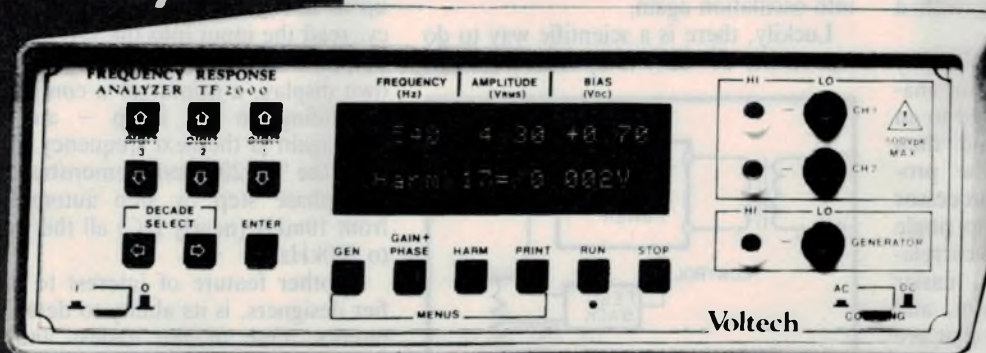

**WESTINGHOUSE BRAKE & SIGNAL COMPANY (AUSTRALIA) LIMITED**  
Incorporated in New South Wales  
80-86 Douglas Parade,  
Williamstown, Victoria

**Postal Address:**  
P.O. Box 267,  
Williamstown, Vic. 3016  
Phone: (03) 397 1033  
Fax: (03) 397 1861

Qld.: (07) 275 3188 N.S.W.: (02) 545 1322  
Fax: (07) 275 3238 Fax: (02) 545 1324

# The Voltech TF 2000 Gain/Phase Analyser

Making measurements of the gain and phase response characteristics of an amplifier or feedback control system can be very tedious. Jon Fairall has been trying out a new instrument which can make this kind of analysis a lot easier...

A good deal of design and repair work is based on the measurement of a system's output signal, relative to its input, over a range of frequencies. Measurement of the amplitude, frequency, and phase can reveal a good deal about what is happening – or not happening – inside a 'black box'.

Typically, getting this information requires a number of different bits of equipment, a profusion of wires, much complaining and a lot of patience. Many bench technicians regard it as their lot in life; a necessary chore to define the stability of closed-loop feedback systems, determine the bandwidth of amplifiers, characterise linear and non-linear systems, and do harmonic analysis on waveforms.

Design engineers at Voltech, a small instrument company just north of London, decided to use 'smart' digital technology to make life easier. They came up with a small box containing a digital signal generator and analyser, with outputs to drive a computer and printer, and controlled the whole thing with a built-in Z80 microprocessor.

Detecting the signals is controlled by software. The signal comes onto an analog interface board, where it is fed to an analog to digital converter and then through an opto-coupler to the processor (now digital). On the processor board, the waveform is subject to single sine fourier analysis, a type of correlation technique. It's faster and easier than a full fast fourier transform, and yields results in this application that are just as good.

The result is a gain-phase analyser, or *measurement made easy*. Excite the device under test (DUT) with the inbuilt

signal generator, and read out the input and output amplitude (and therefore the gain of the DUT), the phase angle and the harmonics generated by any non-linearities in the DUT.

Consider, for instance, the problem of designing a power supply. It needs a feedback loop on its output in order to achieve good regulation and fast response to dynamic loads on the supply. Good regulation and fast response, however, can also lead to oscillation; and a power supply is not expected to be an oscillator. In fact, oscillation could have disastrous consequences.

The way practical power supplies are generally designed by practical people is to bodgy up some old thing you think might work, and then fiddle with capacitors and resistors until a compromise is reached between oscillation and regulation. This method, while widely practised, has the disadvantage that as soon as you alter the load or supply conditions, the entire house of cards can fall to pieces, with the circuit bursting into oscillation again.

Luckily, there is a scientific way to do it, and the TF 2000 is optimised for this

approach. Consider the circuit in Fig.1, a block diagram of a power supply. Inside the power block, the AC is rectified and adjusted to a level set by the control signal. The output level is detected and fed into the feedback loop, where it is compared with the reference voltage. If the output is below the reference, the control signal drives the power stage harder, until the two are equal.

An axiom well known to power supply gurus says that if the loop gain of the power stage is unity, the phase change between input and output must be less than  $360^\circ$  (ideally less than  $315^\circ$ ) or we are in the oscillator business.

More generally, in-phase inputs and output are undesirable while there is any gain in the system. The scientific way of demonstrating that this is not the case is to obtain a transfer function, a map of gain and phase at any frequency (see Fig.2).

Voltech has optimised the TF 2000 for this sort of task. The unit can be set up to start at a predetermined frequency, read the input into the DUT and the output from it, send the results to its own display, a printer or a computer – depending on the setup – and then start again at the next frequency. In this way, the TF 2000 can demonstrate gain and phase step by step automatically from 10mHz (nearly DC) all the way up to 100kHz.

Another feature of interest to amplifier designers, is its ability to detect harmonics. One of the easiest and best tests of an amplifier is to determine whether it distorts the signal into it. If you feed in a pure sine wave, you should get a pure sine wave out.

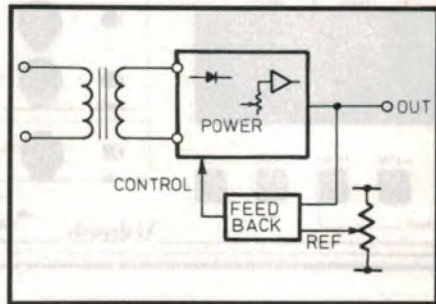
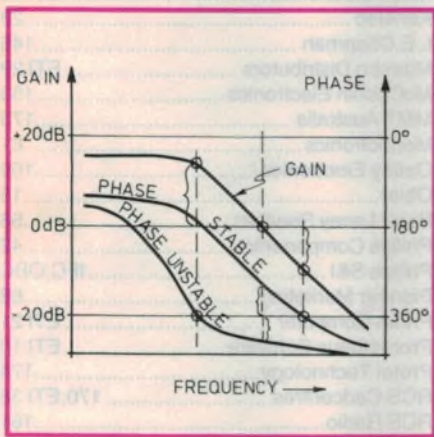
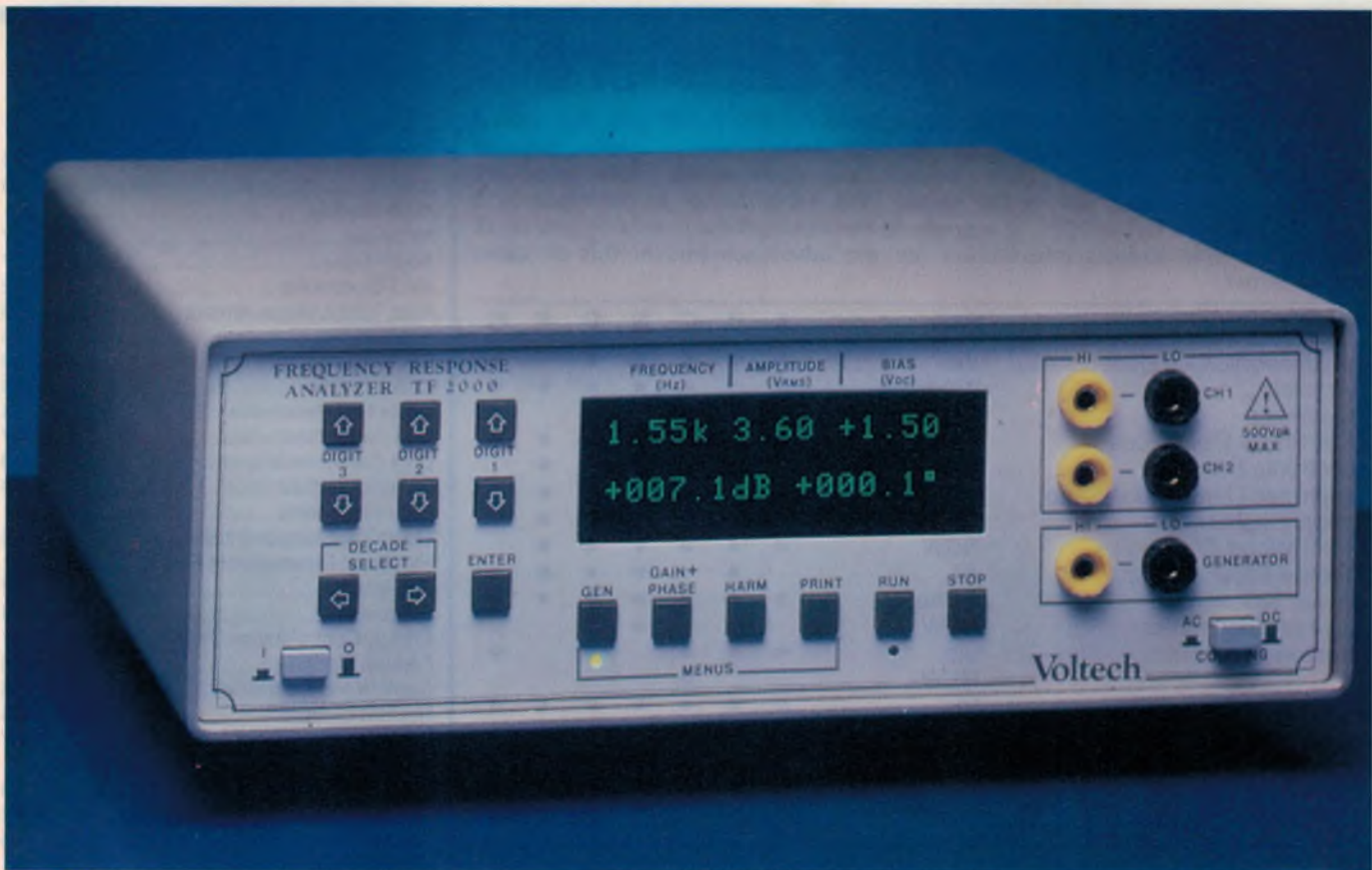

Fig.1: A typical power supply with a feedback control system.





**Fig.2:** A transfer function showing a stable and unstable phase relationship. The brackets show the gain and phase margins.

The Voltech allows you to do this. It will detect everything up to the 39th harmonic of the input. It analyses the input, looking for the fundamental signal, then allows you to determine which harmonics you want to look at. It displays the voltage value of the fundamental, then the value of each harmonic as a percentage of the fundamental.

The TF 2000 is ideal for establishing the frequency response. I tried it on my ETI type 5000 amplifier and discovered that even after all these years (and all

those modifications), it's still giving a pretty good response down to about 20Hz. Admittedly, there is some funny stuff going on at 25kHz, but you can't have everything!

There are two modes for all the functions on the TF 2000. In the self-excited mode, the internal generator puts the signal into the DUT, and the two signal analysis channels compare their signals to yield gain and phase. In the harmonic mode, of course, only one channel is necessary.

But it's not necessary to rely on the internal generator. In many applications, the DUT can excite itself; in fact, it may be a significant part of the test that it should. In this instance, the two channels compare signals without reference to the local generator.

If you wish to use the harmonic analyser in this mode, you need to supply a synchronising signal to the other channel for accurate measurement. This can usually be achieved simply by connecting the two sets of inputs, although I would have thought a switch would be a slightly more elegant solution.

Using the TF 2000 is simplicity itself. All that's needed is a brief glance through the manual to understand the logic of the keys on the front panel. It uses a simple menu system, that allows you to select firstly, the function (e.g.,

gain, harmonics) and then the parameters that need to be supplied – such as the frequency, amplitude and DC bias. These are all displayed on the front panel during operation.

It is also possible to operate the Voltech over an RS232 link. Like everything else on the unit, it is simple to set up and operate. On the TF 2000, you simply change a switch in the menu; on the computer, you load a disc supplied with the unit.

All of the standard controls are accessible using a PC's function keys (F1-F10) in a series of menus. One extra function exists in the logging screen, and allows you to set up automated testing, which might be required during a manufacturing process. It's possible to save both the setup of the instrument to a file, and the output from it.

In summary, the Voltech TF 2000 is a nice little unit. It's smaller, lighter and easier to use than the competition, and at less than \$4000, also much cheaper.

I would have liked to see it fitted with an IEEE 488 interface – it's an industry standard and should really be obligatory on any serious test equipment, but that is my only real reservation.

For further information, contact Westinghouse Brake and Signal Company, 80-86 Douglas Parade, Williamstown 3016 or phone (03) 397 1033.

# EA Directory of suppliers

Which of our many advertisers is most likely to be able to sell you that special component, instrument, kit or tool? It's not always easy to decide, because they can't advertise all of their product lines each month. Also some are wholesalers and don't sell to the public. The table below is published as a special service to EA readers, as a guide to the main products sold by our retail advertisers. For address information see the advertisements in this or other recent issues.

Supplier	State	A	B	C	D	E	F	G
All Electronic Components	Vic	•	•	•	•	•		
Altronics	WA,NSW	•	•	•	•	•	•	•
Acetronics	NSW			•				
Dick Smith Electronics	All	•	•	•	•	•	•	•
Electronic Brokers	Vic						•	
Electronic Component Shop	Vic	•		•	•	•	•	
Emona Instruments	NSW						•	
Geoff Wood Electronics	NSW	•	•	•	•	•	•	
George Brown Group	All		•		•	•	•	
Jaycar Electronics	Eastern	•	•	•	•	•	•	•
Pre-Pak Electronics	NSW		•		•	•		
Preston Electronics	Vic	•	•	•		•		•
RCS Radio	NSW			•				
Rod Irving Electronics	Vic	•	•	•	•	•	•	•
Scientific Devices	Vic						•	
Sheridan Electronics	NSW		•	•	•	•		
Tandy Electronics	All		•		•	•	•	•
Wagner Electronics	NSW		•		•	•	•	

### KEY TO CODING

A Kits & modules

B Tools

C PC boards and supplies

D Components

E IC chips & semiconductors

F Test & measuring instruments

G Reference books

Note that the above list is based on our understanding of the products sold by the firms concerned. If there are any errors or omissions, please let us know.

## ADVERTISING INDEX

Adilam Electronics	IBC
Alldata	ETI 18,19,22-23
Allen Bradley	171
Altronics	134-137
Audio Telex	37
AVO Electronics	ETI 42
Aust. Test & Measurement	119
Bell IRH	174
Capital Computers	ETI 24
Circuit Works	153
David Hall Electronics	153
Dick Smith Electronics	52-57
DNA Communications	40
EA subscriptions offer	18-19
EEM Electronics	161
Electronic Component Shop	43
Electronic Development Sales	171
Elmeasco	17
Emtronics	149
Energy Control International	47
Federal Marketing	162-163
Geoff Wood Electronics	143
Hi-Com Unitronics	ETI 35
Hitrad	147
Hycal Instruments	161
Hy-Q International	173
Icom Australia	41
Jaycar	122-125
John Ferella	161
Kalex Electronics	ETI 38
Kenelec	23
L.E.Chapman	146
Maestro Distributors	ETI 29
McCubbin Electronics	153
MMT Australia	173
Mondotronics	61
Oatley Electronics	160
Obiat	15
Peter Lacey Services	58
Philips Components	42
Philips S&I	IFC,OBC
Pioneer Marketing	68
Prime Computer	ETI 21
Prometheus Software	ETI 10
Protel Technology	174
RCS Cadcentres	170,ETI 38
RCS Radio	161
Rod Irving Electronics	24-27,64-65,154-155
Scientific Devices	ETI 20
Siemens	9
SME Systems	ETI 19
Speaker Technologies	42
STC Cannon	ETI 10
Steinlager	85
Stover Electronics	142
Technical Imports	ETI 20
Transformer Rewinds	161
Tronics 2000	142
WEST Components/Wagner	51
Westinghouse Systems	175,ETI 21
Wireless Institute of Aust.	157
Yamaha	111

This index is provided as an additional service. The publisher does not assume any liability for errors or omissions.

## Electronics Australia Reader Services

Electronics Australia provides the following services:  
**Subscriptions:** All subscription enquiries should be directed to: Subscriptions Department, Federal Publishing Co. PO Box 227, Waterloo 2017. Phone: (02) 693 6666

**BACK ISSUES:** Available only until stocks are exhausted. Price \$4.50

**PHOTOSTAT COPIES:** When back issues are exhausted, photocopies of articles can be supplied. Price: \$4.50 per project or \$9 where a project spreads over several issues.

**PCB PATTERNS:** High contrast, actual size transparencies for printed circuit boards and front panels are available. Price: \$5 for boards up to 100 square centimetres; \$10 for larger boards. Please specify positive or negative.

**PROJECT QUERIES:** Advice on projects is limited to postal correspondence only, and to projects less than five years old

Price: \$5. Please note that we cannot undertake special research or advise on project modifications. Members of our technical staff are not available to discuss technical problems by telephone.

**OTHER QUERIES:** Technical queries outside the scope of "Replies by Post" or submitted without fee, may be answered in the "Information Centre" pages at the discretion of the Editor.

**PAYMENT:** Must be negotiable in Australia and made payable to "Electronics Australia". Send cheque, money order or credit card number (American Express, Bankcard, Mastercard, or Visa Card), name and address (see form). All prices include postage within Australia and to New Zealand.

**ADDRESS:** Send all correspondence to The Secretary,

"Electronics Australia", PO Box 227, Waterloo, NSW 2017.

Please note that we are unable to supply back issues, photocopies or PCB artwork over the counter.

Back Issues

Photostat copies

Total price of magazines/photocopies, including postage and handling.

No off issues reg. x \$4.50 = \$

Cheque\* Money Order  Please tick box to indicate method of payment

\*Please make payable to the Federal Publishing Company Pty Ltd

Mastercard American Express Visa Bankcard  Tick

Card Expiry Date

Credit Card No

Signature  
(Unsigned Orders cannot be accepted)

NAME

ADDRESS

POSTCODE

# Papst; proven technology & reliability available from Adilam

Papst manufacturer the largest range of equipment fans in the world providing the most efficient and versatile solutions to problems in both AC and DC applications.

In addition to model in sleeve bearings (proven in millions of installations) Papst offers ball bearing versions for high environmental temperatures, enhanced performance models for increased airflow and quiet types with particularly favourable air-flow/noise characteristics for sensitive audibility requirements.

Papst are continually introducing new models to their range, the more recent being miniature 40mm 12VDC fans and a range of 48VDC fans for use in telecommunications equipment with alarm circuit and speed sensor options.

Fan housing sizes include 40, 60, 80, 92, 119mm square and 150, 172mm round units.

Available voltages are 12, 24, 115 240VAC and 12, 24, 48VDC.



**Papst first for Reliability-Versatility - Availability.**

READER INFO No. 61



**Adilam  
Electronics** Pty.  
Ltd.  
*The Component Specialists*

**MELBOURNE-**  
Suite 7, 145 Parker Street,  
Templestowe 3106  
PO Box 131, Bulleen 3105  
Telephone: (03) 848 2511  
Facsimile: (03) 846 1467

**SYDNEY-**  
Suite 1, Ramsgate Plaza,  
191 Ramsgate Road,  
Sans Souci 2219  
Telephone: (02) 529 2277  
Facsimile: (02) 529 5893

DISTRIBUTORS:

ADELAIDE: N.S. Electronics  
Ph: (08) 46 8531 Fax: (08) 340 1456

BRISBANE: St Lucia Electronics  
Ph: (07) 252 7466 Fax: (07) 252 2862

PERTH: Pro-spec Distributors  
Ph: (09) 362 5011 Fax: (09) 341 7582



PHILIPS

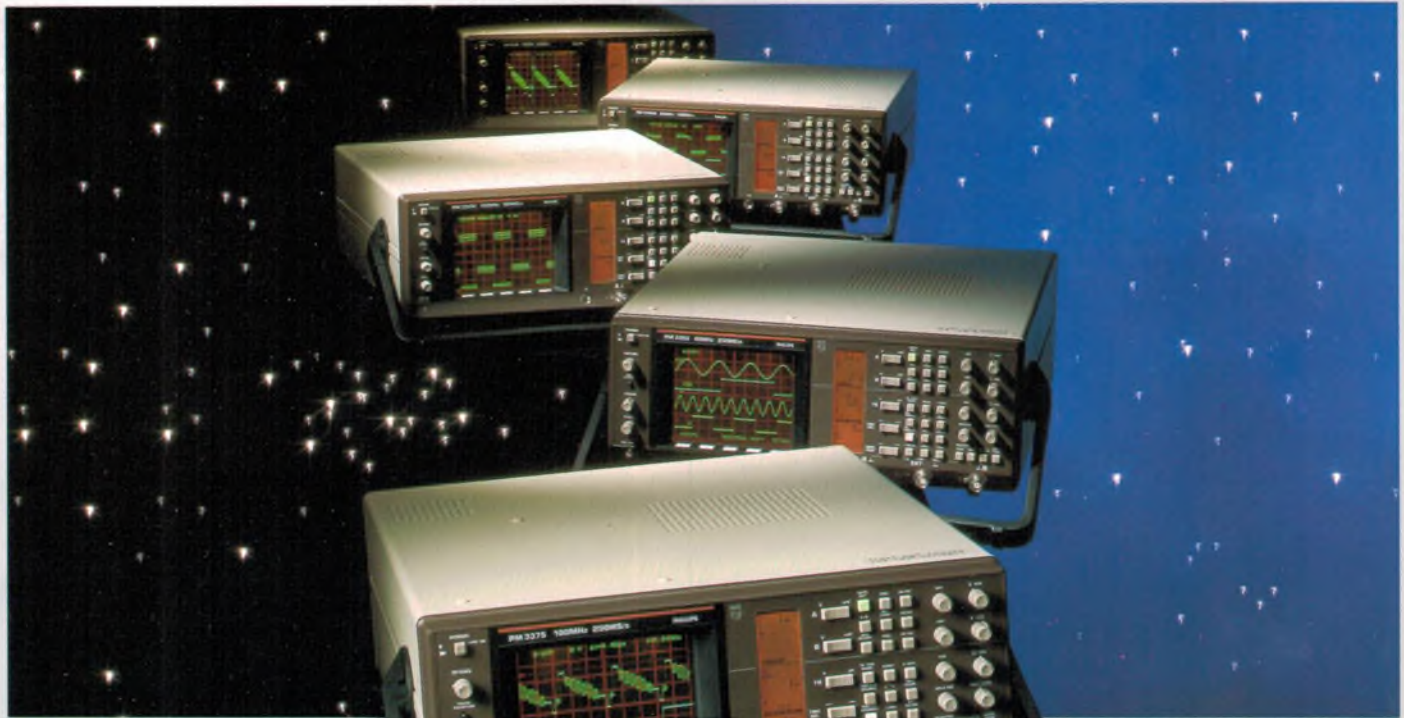

# Power packed DSO choices upto 250 MS/s.

Now, Philips offers you more power packed choices in mid-frequency digital storage oscilloscopes. With a new range of five models, from entry-level to advanced.

Each one is a breakthrough in performance and ease of operation. And each one is priced to give you unexpected economy.

Operation is simple and intuitive - just like a conventional analog instrument. With full analog functionality for real-time signal display and measurements.

But just select 'digital memory' to get powerful DSO facilities. Letting you capture, compare and analyze both single-shot and repetitive signals.

So check the features and performance of these power packed instruments. And see for yourself why they add up to unbeatable value in digital storage.

- 20 MS/s - 60 MHz
- 100 MS/s - 60 MHz
- 100 MS/s - 100 MHz
- 250 MS/s - 60 MHz
- 250 MS/s - 100 MHz

■ **PM 3335** 20 MS/s sampling rate, large 8 K deep memory, 60 MHz analog bandwidth, full cursor measurements, combined GPIB/IEEE-488 - RS232-C interface option.

■ **PM 3350A** 100 MS/s sampling simultaneously on both channels, 60 MHz analog bandwidth, 4 memory registers, fast-action 'intelligent cursors', Digitally Delayed Timebase, GPIB/IEEE-488 or RS232-C interface options.

■ **PM 3365A** 100 MS/s sampling simultaneously on both channels, plus repetitive sampling at up to 100 MHz, 100 MHz analog bandwidth, 4 memory registers, extra signal-processing modes, Digitally Delayed Timebase, GPIB/IEEE-488 or RS232-C interface options.

■ **PM 3355** Fast 250 MS/s sampling simultaneously on both channels, 60 MHz analog bandwidth, 4 memory registers, fast-action 'intelligent cursors', Digitally Delayed Timebase, GPIB/IEEE-488 or RS232-C interface options.

■ **PM 3375** Fast 250 MS/s sampling simultaneously on both channels, plus repetitive sampling at up to 100 MHz, 100 MHz analog bandwidth, 4 memory registers, fast-action 'intelligent cursors', Digitally Delayed Timebase, GPIB/IEEE-488 or RS232-C interface options.

For further information please contact your local Philips Test & Measurement Organisation:

<b>SYDNEY</b> (02) 888 0416	<b>BRISBANE</b> (07) 844 0191
<b>MELBOURNE</b> (03) 881 3666	<b>ADELAIDE</b> (08) 348 2888
<b>PERTH</b> (09) 277 4199	<b>AUCKLAND</b> (09) 89 4160
<b>WELLINGTON</b> (04) 88 9788	

**READER INFO No. 62**

ADVANCED TECHNOLOGY  
MADE TO MEASURE