

NDD

Electronics

AUSTRALIA WITH Professional Electronics & ETI

NOVEMBER 1996 \$5.50
NZ \$7.20 incl GST

**TEK'S NEW
TDS 220
LOW COST
100MHZ
SCOPE,
WITH
1GS/S
REAL-TIME
SAMPLING**



*Review
inside...*

**'MIRACLE' ANTENNA
FOR AM RECEPTION**



**ADAPTOR LETS
YOU SAFELY VIEW
MAINS CURRENTS** ➔



Print Post Approved PP255003/01056

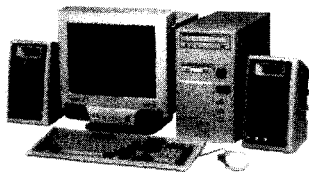

TECS Pentium Systems

Picture for illustration purpose only. Actual unit may vary.

Configuration:

Genuine Intel Pentium CPU, GigaByte PCI bus motherboard with 256K pipeline burst cache, on-board dual channel enhanced IDE and floppy controller, on-board 1 x enhanced parallel and 2 x 16550 UART fast serial ports, 1.2G mode 4 HDD, 16M EDO RAM, 1.44M FDD, 2M S3 Trio64V+ video card, 8X speed CD-ROM drive, Sound Blaster 16 Plug and Play, pair of speakers, MS mouse and pad, Windows 95 keyboard, choice of desk-top or mini-tower case plus following software pre-loaded:
Windows 95, MS Encarta 96, MS Works 4.0, MS Money, MS Golf, MS Dangerous Creatures and VET 9.0 antivirus software.

2 year parts, unlimited labour warranty.

1 year on-site warranty, delivery and setup.*

*Limited to Melbourne metropolitan areas only. Conditions apply.

100MHz

With 14" monitor

\$2090

With 15" monitor

\$2240

133MHz

With 14" monitor

\$2320

With 15" monitor

\$2470

Upgrade options:

512K pipeline cache in lieu of 256K add \$50
Latest Triton II HX chipset in lieu of FX add \$50

Under \$2000!!

6x86-100MHz P-120 computer system
Configuration as above with 14" monitor

Excellent value for money at

\$1995

Enhanced IDE hard drives



850M	\$259	2.1G	\$419
1.2G	\$289	2.5G	\$539
1.7G	\$329		

Essential item to connect you to the exciting world of Internet!



Banksia MyFastModem
V34 28,800bps

Internal **\$339**

External **\$399**

PCMCIA **\$525**

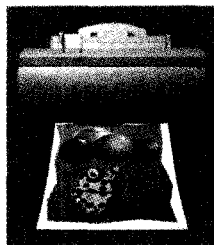

Canon BJC-210

The new low cost bubblejet printer with three colour process without sacrificing the quality. No more "bluish-green mud" substitute instead of black. For high speed black & white printing, the BJC-210 accepts the optional black cartridge, giving you up to 3.4ppm. The standard resolution is 360 x 360 dpi. In addition, BJC-210 offers a special 720 x 360 dpi smoothing function for sharp, laser-like text using the optional 64-nozzle black cartridge.

\$319

IBM 6x86-100MHz CPU & motherboard

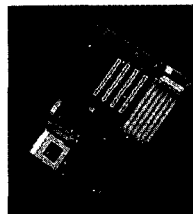

- 256K p/line cache.
- 4 x PCI slots.
- 4 x 72pin SIM sockets.
- on-board dual channel E-IDE controller.
- on-board floppy controller.
- 2 x on-board 16550 UART serial ports.
- on-board ECP/EPP parallel port.

\$369

CAM WIZ digital camera

Ideal for still images
or video conferencing!



KEY FEATURES:

- for use with desktop and notebook computers
- adjustable focus lens for portrait and distance shots
- manual and automatic controls including: shutter speed, scan mode, brightness, white balance, colour saturation and gain
- 256 grey scale and 16 million colour modes
- 640 x 480, 320 x 240, and 160 x 120 image resolution modes
- requires no video capture card, external power or additional hardware
- connected through parallel port and powered from keyboard
- compatible with EPP bi-directional or uni-directional parallel ports

\$449

Goldstar monitors

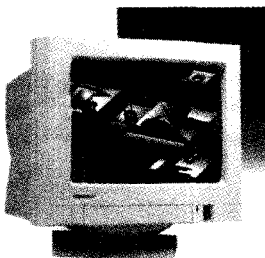

14" Model 1468	\$395
14" Model 44m	\$445
15" Model 1505s	\$515
15" Model 56i	\$560
15" Model 56m	\$599
17" Model 76i	\$1069

i - digital control
m - digital with speakers built-in

High performance video cards

Hercules Terminator 64 2M DRAM	\$195
Hercules Terminator 64 2M EDO	
with hardware MPEG	\$465
Hercules Dynamite 128 2M	\$379
Diamond Stealth 64 2M DRAM	\$149
Diamond Stealth 64 2M VRAM	\$445



THE ELECTRONIC & COMPUTER STORES

City: 305 Latrobe Street, Melbourne, Vic. 3000 Ph:(03)9602-3499 Fax:(03)9642-8551
Clayton: Cnr. Blackburn & Wellington Rds., Vic. 3168 Ph:(03)9562-9501 Fax:(03)9562-9261
Trade: TECS Imports P/L, 88 South Pde., Blackburn, Vic. 3130 Ph:(03)9877-7071 Fax:(03)9877-7081

Electronics

Volume 58, No.11
November 1996

AUSTRALIA WITH Professional Electronics & ETI

AUSTRALIA'S LARGEST SELLING ELECTRONICS MAGAZINE — ESTABLISHED IN 1922

No ordinary CD player



This month Louis Challis has been testing the new Onkyo Integra DX-7911 high-end CD player, which incorporates technology claimed to eliminate jitter and offer dramatically improved tracking. His test results confirm that this is indeed no ordinary CD player — see Louis' review, which starts on page 12.

An eye for your PC...

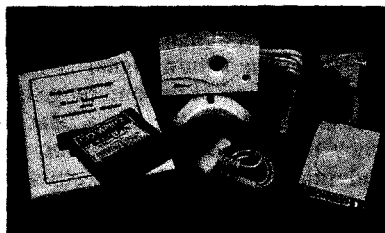

The new Compro D-Cam digital camera is relatively low in cost, and hooks up very easily to your PC via the Centronics printer port — so there's none of the usual hassles with IRQ's, DMA's or I/O address conflicts. It takes quite respectable 640 x 480 pixel colour images, too, as Graham Cattley found when he tried one out this month. You'll find his review starting on page 18...

On the cover

The new Tektronix TDS 220 and its 60MHz sibling the TDS 210 look set to woo many low-end scope buyers away from traditional analog models, as Tek has effectively halved the price of DSOs while simultaneously upping performance and reducing size by about 75%. See our review on page 77. (Photo by Phil Aynsley)

Video and Audio

- 8 CONSUMER VIDEO IS GOING DIGITAL *With a big jump in performance!*
- 12 THE CHALLIS REPORT *Onkyo's impressive Integra DX-7911 CD Player*
- 24 WHAT'S NEW IN VIDEO & AUDIO *LCD projector has 800 x 600 resolution*

Features

- 6 MOFFAT'S MADHOUSE *Happy birthday, Windows 95!*
- 18 COMPRO'S D-CAM DIGITAL CAMERA *Hooks up easily to your PC...*
- 20 HFC NETWORKS & BROADBAND COMMS - 1 *Start of a new series*
- 26 DEEP SPACE PABX *Australia's Tidbinbilla Tracking Station*
- 30 THE NEW RPI MODEMS: A CAUTIONARY TALE *You'll need a fast PC!*
- 38 WHEN I THINK BACK... *Maxwell Howden, pioneer & crystal expert (1)*

Projects and Technical

- 34 AUTOMOTIVE ELECTRONICS *The CIE 8088 handheld Automotive Meter*
- 42 THE SERVICEMAN *Biggest repair and reconditioning job of all time?*
- 47 EXPERIMENTING WITH ELECTRONICS *Exploring CMOS gates (2)*
- 56 CIRCUIT & DESIGN IDEAS *ADC supports 256 inputs; battery charger cutoff*
- 58 'MIRACLE' AM ANTENNA *Listen to distant stations with this low cost unit*
- 62 HIGH ISOLATION CURRENT ADAPTOR *Uses new Hall-effect sensor...*
- 70 IMPROVED 24-LINE I/O CARD FOR PC'S *Revamp of a popular design*
- 77 REVIEW: TEK'S NEW TDS 220 SCOPE *Low cost, tiny but high performance*
- 80 A PC-BASED 32CH LOGIC ANALYSER - 2 *Construction, testing & use*
- 86 VINTAGE RADIO *The Astor 'Mickey Mouse' and its descendants*

Columns and Comments

- 4 LETTERS TO THE EDITOR *Optical Doppler, memories of Ferris Bros*
- 5 EDITORIAL VIEWPOINT *New series starting, on HFC networks & broadband*
- 51 SHORTWAVE LISTENING *Satellites ahead of many listeners...*
- 92 INFORMATION CENTRE *Keeping you informed on hassles with a laptop*

Departments

- | | |
|-----------------------------|----------------------------|
| 33 BOOK REVIEWS | 130 DIRECTORY OF SUPPLIERS |
| 96 MARKETPLACE | 130 ADVERTISING INDEX |
| 98 EA HISTORY, CROSSWORD | 115 EA SUBSCRIPTIONS OFFER |
| 22 NEW KITS FOR EA PROJECTS | 7,97 NOTES & ERRATA |

Professional Electronics

- 100 NEWS HIGHLIGHTS *Philips shows new 42" flat-screen TV at CeBIT Home*
- 104 SOLID STATE UPDATE *16Mb SDRAM for PC graphics; SM power MOSFETS*
- 106 SILICON VALLEY NEWSLETTER *Toshiba laser writes 15GB on a DVD side*
- 108 SHORT HISTORY OF PACKAGED POWER SUPPLIES *As told by Kepco...*
- 111 POWER SUPPLY & CONDITIONING PRODUCTS *Some recent releases*
- 112 NEW PRODUCTS *CCD camera on a fibre cable; handheld GPS navigator*
- 116 QUEENSLAND FEATURE: *Another good year for Griffith University's IAP*
- 120 QUEENSLAND FEATURE: *The latest products & services, supplier listing*
- 126 COMPUTER NEWS & NEW PRODUCTS *Half-sized Pentium CPU card*

MANAGING EDITOR

Jamieson Rowe, B.A., B.Sc., SMIREE, VK2ZLO

TECHNICAL EDITOR

Rob Evans, CET (RMIT)

PROJECT DESIGNER/WRI-TER

Graham Cattley

PRODUCTION EDITOR

Witold Budzynski, B.Sc.

CONTRIBUTORS

Louis Challis

Arthur Cushen, MBE

Roger Johnson

Jim Lawler, MTETIA

Jon Loughron, Assoc. Dip. Elect.

Tom Moffat, VK7TM

Peter Phillips, B.Ed., Dip Ed., ECC

Nick de Vries, MIAME, AMSAE

Neville Williams, FIREE, VK2XV

READER SERVICES CO-ORDINATOR

Ana Marie Zamora; phone (02) 9353 0620

DRAFTING

Drawquick Computer Graphics

COVER DESIGNER

Clive Davis

ADVERTISING MANAGER

Selwyn Sayers

Phone (02) 9353 0734; fax (02) 9353 0613

ADVERTISING PRODUCTION

Tim Cooney; phone (02) 9353 0740

PRODUCTION

Ray Eirth

CIRCULATION MANAGER

Michael Prior

HEAD OFFICE - EDITORIAL

PO Box 199, Alexandria 2015.

180 Bourke Road, Alexandria 2015.

Phone (02) 9353 0620; fax (02) 9353 0613

E-mail: electaus@magna.com.au

Subscriptions Enquiries:

phone (02) 9353 9992; fax (02) 9353 0967.

Book Shop Enquiries: phone (02) 9353 9944**Computer Bulletin Board:** (02) 9353 0627**INTERSTATE ADVERTISING SALES****MELBOURNE:** Pilar Misa, 504 Princes Highway, Noble Park, 3174.

Phone (03) 9213 3222; fax (03) 9701 1534.

BRISBANE: Graham Smith, 26 Chermide Street, Newstead 4006.

Phone (07) 3854 1119; fax (07) 3252 3692.

ADELAIDE: Sue Bowshall, 98 Jervois Street, Torrensville, 5031.

Phone (08) 352 7937; fax (08) 352 6033.

ELECTRONICS AUSTRALIA is published by

Federal Publishing Company, a division of

Eastern Suburbs Newspapers Partnership,

which is owned by

General Newspapers Pty Ltd.

A.C.N.000 117 322.

Double Bay Newspapers Pty Ltd.

A.C.N.000 237 598, and

Brehmer Fairfax Pty Ltd.

A.C.N.008 629 767.

180 Bourke Road, Alexandria, NSW 2015.

Copyright © 1996 by Federal Publishing Company, Sydney. All rights reserved. No part of this publication may be reproduced in any way without written permission from the Publisher or the Managing Editor.

Printed by Macquarie Print, 51 - 59 Wheelers Lane, Dubbo 2830. Phone (068) 843 444.

Distributed by Newsagents Direct Distribution Pty Ltd, 150 Bourke Rd, Alexandria 2015; phone (02) 9353 9911.

ISSN 1036-0212

*Recommended and maximum Australian retail price.

LETTERS TO THE EDITOR

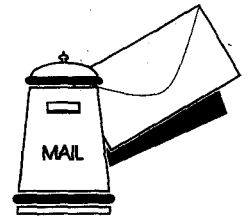

Liked cartoon

I really liked the 'Forum' cartoon in *Electronics Australia* for August '96 (EMI & the pacemaker escort).

As a hospital biomedical engineer, I am involved a little with this issue of EMI in patient treatment areas. Your cartoon is an apt statement of where a little too much of our regulation is headed.

Ron Coleman,
Rivett, ACT.

More information

In the September 96 issue of *EA* you published my MIDI interface circuit for the Macintosh, in 'Circuit and Design Ideas'. Thank you.

It may interest your readers to know that this information is also available on the World Wide Web and includes not only the schematic, but also the design of the stripboard among other things. This would naturally save anyone wishing to build the circuit a lot of time designing the board themselves. The URL of the page is <http://www.usyd.edu.au/su/anaes/lectures/midi.html>.

All the best.

John Loadman,
Stanmore, NSW.

Memories of Ferris

I read with great interest your piece on Ferris Bros in the August issue of *Electronics Australia*, as I am an old employee of that firm having joined them in 1957. It was the era of the metal cabinet C17 TV. I was initially employed as a technician on the test line, so I am familiar with that particular TV. I graduated to the development lab and in fact was involved in the development of the 21" set you referred to. But about that time I hankered for a warmer climate and was transferred to the Brisbane office of Ferris Bros.

After a time I left Ferris Bros, only to rejoin them later at the time they became involved in HF marine communications. I was employed then as a non-graduate engineer in the lab working on the development of HF transceivers. I remember well the many trips out in *Tempest*, Chum's cruiser which he kept moored at Cottage Point, whilst checking out prototypes.

Working for Ferris was like being paid to indulge in my favourite hobby — i.e., messing around with electronics. I have many fond memories of my time with the old firm, and it was a pity to see it go the same way that so many of our home-grown radio enterprises went.

Stewart B. McGregor, VK4ZSB
Carina, Qld.

Optical Doppler

David Horsfall seems to doubt the application of Doppler Shift to the measurement of automobile speeds. Actually Microwave speed detectors use the Doppler shift, and so are not a RADAR in a really formal sense, in that they do not use ranging information. (RADAR = Radio Detection and Ranging)

I have not seen the innards of an optical one, but the same principle should be applicable. Doppler shift does not only occur at relativistic speeds, although the higher the speed the greater the shift.

To use Doppler shift to measure an objects speed, a signal is bounced from the object. The return signal is mixed with a proportion of the outgoing signal in the detector. This gives a beat frequency in the audio range for conventional microwave speed detectors and normal automotive speeds.

It is of course far easier to measure this frequency than it would be to detect a small change in the received frequency directly. It is also probably more accurate than attempting to measure the range over a period of time and then calculate the speed from that. It is necessary for the transmitted frequency to remain reasonably accurate.

The received frequency is given by:

$$Fr = F * c / (c - v)$$

where F is the transmitted frequency, c is the speed of light and v is the speed of the object — positive if approaching and negative if receding. For audio frequency doppler effects the speed of sound should be used.

Astronomers are of course not able to bounce light from distance stars, but are able to determine the radiated frequency by analysis of the spectroscopic lines characteristic of the materials in the star, such as hydrogen. This can then be compared to the actual frequency received.

The position of the spectral lines is not affected by passing through any dust or material in space, even if the perceived colour is changed in any way.

John Olsen, B.E.
Whitireia Comm. Polytechnic, NZ.

Power response

I have no wish to needlessly prolong the exchange of letters between Rex Callaghan of DSE and myself (*EA* Sept 96) regarding the Power Response and Frequency Response of an audio power amplifier. However I am concerned that the response from Rex will continue to confuse and misinform your readers.

First of all there are international standards such as IEC 268 or its local equivalent AS 1127, which prescribe methods of test that are in line with the points made in my original letter. I served on the Standards Australia committee under the chairmanship of Neville Thiele to develop AS1127.

No audio power amplifier can produce its rated power output over an infinite bandwidth. There is an upper and a lower frequency outside of which the power output will be greatly reduced. This is especially true for amplifiers that have an output transformer, e.g., public address amplifiers and audio amplifiers that are required to have a floating output.

So the Power Response is the frequency range within which the amplifier can produce its rated power output. This is not to be confused with Frequency Response, which is the voltage gain of the amplifier with respect to frequency.

Obviously if a measurement of frequency response is to be accurate it is essential that the amplifier is not overloaded or clipped at any measuring frequency. This is why the frequency response needs to be measured at a low level.

So the practice of measuring frequency response at low power levels does not yield 'better' figures. It simply yields accurate figures.

Neil McCrae,
East Hawthorn, Vic.

Why that name...

That article about 'Iridium' (September 1996) was most informative, but I find it strange that it failed to mention the origin of the name. Since there were initially going to be 77 satellites in orbit, it was named after the element Iridium ('Ir'), whose atomic number is 77. However, financial cutbacks meant there are now 66 satellites, and I guess 'Dysprosium' didn't have quite the same ring to it...

David I. Horsfall,
Wahroonga, NSW. ♦

EDITORIAL VIEWPOINT

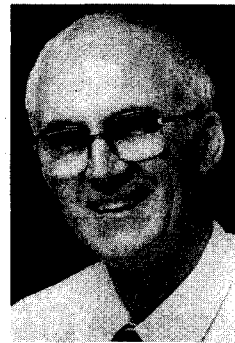

New series starting, on an important topic: HFC networks...

One of our feature articles this month is the first in a new series on HFC Networks and Broadband Communications, which is being specially written for *EA* and its readers by the engineering staff of Scientific-Atlanta. I feel sure that many readers will find these articles of great interest, because a lot of the technology involved in Australia's new cable networks is quite unfamiliar to most of us, yet it's going to play an important role in our futures.

As most regular readers of *EA* will already realise, those cables that are being rolled by Optus Vision and Telstra are going to carry far more than Pay TV's endless choice of sports programmes and recycled movies. Soon they'll be providing an alternative high performance network for telephony as well, plus the opportunity to use cable modems for dramatically faster data communications than most of us have ever experienced before. This will not only allow much faster Internet/Web access, but also open the door to a plethora of exciting new interactive services.

In short, HFC networks are a very significant development, and Australia's new networks are going to be at the leading edge of this important technology. So most of us are going to need at least a good basic understanding of the way it all works. And that's the idea behind this new series of articles.

Although you may still think of Scientific-Atlanta in terms of its expertise in satellite and digital video technology, it is in fact one of the world leaders in HFC technology, and has a great deal of experience in this area as well. Many of its new-generation HFC network components are being used by Optus Vision, and its engineers in the USA have been closely involved in building and upgrading cable networks over there. So SA engineers certainly have the expertise in this area, and I'm delighted that they were prepared to spend the time and effort to share some of this knowledge with us.

So if you're keen to get a good grounding in this exciting and fast-moving technology, I strongly suggest that you read the first introductory article (it starts on page 20), and in the following months make a point of not missing its successors. I'm certainly going to be following them myself!

Of course there are lots of other interesting and informative articles in this issue, as you'd expect. There's a review of the exciting new Tektronix TDS 220 low cost two-channel 100MHz DSO, for example, with 1GS/s sampling and a 'footprint' only 25% that of traditional benchtop scopes. There's also a report by Barrie Smith on the new breed of consumer video products based on digital technology — and why the video professionals are even more interested in them than consumers, as yet.

There's a good selection of interesting construction project designs, too, and Neville Williams has recovered his strength sufficiently to restore his When I Think Back column. But I'm afraid one thing that *is* missing this time is Forum; I had a health problem myself this month, and as a result I wasn't able to prepare it in time. Sorry about that, but Forum should be back next month.

Jim Rowe

Moffat's Madhouse...

by TOM MOFFAT

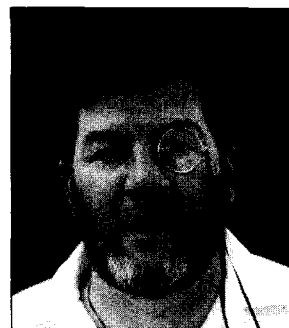

Happy Birthday, Windows 95!

A little over 12 months ago from when this is being written, in August 1995, Microsoft's Windows 95 was unleashed on an unsuspecting public. The operating system had been promised in '93, and then in '94, but nothing had happened. Then, in what was probably the biggest marketing exercise ever undertaken for any product, Windows 95 became a reality.

At 12:01 on the morning of August 24, television cameras were standing by to transmit live pictures of the first people rushing the doors to buy Windows 95. A few did rush, maybe to get on TV, but many stayed away in droves. But you don't want to hear about all that again — it was covered in all its gory detail in Moffat's Madhouse a year ago.

A few months on, computer users were still forgetting to buy Windows 95. But that was no problem, because it became pretty well impossible to buy a new IBM-PC *without* Windows 95. Want it or not, you got it — although some clever computer manufacturers arranged things so the older Windows 3.1 existed alongside Windows 95 in compressed form. If the new owner wasn't quite ready to experience Windows 95, he could press a couple of keys and it would be gone, replaced with the more familiar, and some say much more stable, Windows 3.1.

During the past year I purchased a new laptop computer set up in this way, but in my case Windows 95 was allowed to stay (Windows 3.1 still lurks in the machine as a 60 megabyte .ZIP file, just in case...). This was primarily because I got a new job in which Windows 95 was required, and I had to buy the new computer to get something large enough to accommodate the enormous Windows 95 operating system.

What I was hired as was a Windows 95 'guru', to assist new Internet users in getting Windows tamed and civilised so that they could use it to go online. Trouble is, I'd never even touched Win 95 until after I'd been hired. So some

study was required, real fast. I got some new books — *Peter Norton's Complete Guide to Windows 95* and another book almost made for the purpose: *Windows 95 Communication and Online Secrets*.

I must say I was a little disappointed in the Norton book. I've been following this guy's work since the days of the IBM-XT computer, watching him grow older and older in the inevitable photos that adorn his book covers. I used his first MS-DOS book so much the covers eventually fell off. But Peter the Great seemed a little bamboozled by Windows 95, just like the rest of us. He said a lot, but most of it was stuff available 'officially' from Microsoft anyway.

So now I'm an experienced Windows 95 user of some six months standing, spending several hours a day seated at my laptop, headset firmly in place, staring at that familiar Windows screen and trying to help some poor soul on the other end of the phone to understand the many quirks of Win95. It ain't easy, folks, but at least it's interesting. And I've managed to gather some information, and impressions, which you probably won't read about in the mainstream computer press.

First, a statement, and this comes from a DOS diehard who slings off at Windows at every opportunity. This is the same guy who got in heaps of trouble after publishing an article entitled 'GUI — Foey!' Here (gulp) goes: I rather like Windows 95. There, I said it. I'm eating my words...

Are you all back up on your feet again? Good. Yes, this Windows thing does look rather yummy on the nice colour screen of my trusty Travelmate. There they are, all these little gadgets that look rounded, smooth, almost three-dimensional. When you open a window (and that's what Windows is all about, after all), they are nicely framed, nicely presented in appropriately muted colours.

As for the screen itself — the back-

ground which is known as 'wallpaper' — I have learned how to replace the boring old default blue colour with photos I've scrounged from the Internet. I've got heaps of them stashed away on my hard disk, and I change them once a week or so, or whenever the whim takes me. This week the screen is decorated with a vintage Cascade beer label. Last week it displayed a label from a 1950's Tasmanian apple crate; 'Beautiful Isle' apples.

I sometimes use sci-fi and horror movie posters from the fifties. The one for *Invasion of the Body Snatchers* is a particularly lurid one, and of course there has to be *Dracula*. Other impressive images come from satellite photos and side-looking radar images of Mother Earth, and some truly spectacular stuff is being handed around by NASA, straight from the Hubble Space Telescope. My favorite is a towering intergalactic dust cloud.

If you're a Windows user, you should try this. It's good fun making your own ever-changing art gallery, especially if you're stuck in front of the same old computer every day.

Remember that part of the Windows 95 hype which told us that "MS-DOS is no longer required — Windows 95 is a stand-alone operating system in its own right"? Well, that statement was, shall we say, slightly incomplete...

Hidden DOS

There is, in fact, an MS-DOS running beneath Windows 95 in the conventional way. Microsoft has just hidden it from us, covering the DOS boot-up messages with a Microsoft logo. With some fiddling and twiddling, you can arrange things so DOS is once again visible (thank you, Peter Norton, for that one...).

You can also make the boot sequence stop in its tracks before Windows 95 ever comes into the picture, leaving the computer sitting there

with the good old MS-DOS 'C:>' prompt. DOS is still my method of choice for 'industrial-strength' work, such as remote Unix-hacking of our big Web server via a VT-100 terminal. And every one of my magazine articles is still written under MS-DOS.

The DOS beneath Windows 95 is officially known as "MS-DOS Version 7.0", and this is the way it reports under Microsoft's own DOS diagnostics program. I have found it to be a good solid MS-DOS version, and so far it hasn't pulled one dirty trick on me — unlike that Windows behemoth that rides on its shoulders. It seems to me that since DOS Version 3, the odd numbered versions have been the best ones, and the even numbers were troublesome. You may remember MS-DOS 6 was a little buggy until replaced by Version 6.2, and MS-DOS Version 4 was an absolute disaster.

The only thing really wrong with DOS 7 is its size, yet another victim of software bloat. It is possible, in the usual DOS way, to prepare a DOS 7 boot disk which will run quite happily on a computer that doesn't even have Windows 95 installed. But the DOS is so large, several hundred K, that there's little room left on the floppy for anything useful. It's likely that a good part of Windows 95's low-level functionality is buried in DOS 7, even if it's not being used under MS-DOS.

Plug and Play

What about the much ballyhooed 'Plug and Play', which cynical people refer to as "plug and pray"? Here you are supposed to be able to connect something like a modem or a printer to your computer, and Windows does all the configuration for you — it's goodbye to DIP switches and arcane command-line settings. Well, Plug and Play works most of the time, sometimes too well.

For instance, I had a Megahertz PC-Card modem which I wanted to use under Windows 95. After much study and experimentation, I have come up with certain settings which I like my modems to use. But when I plugged my modem into the Travelmate, Windows 95 announced it had found a new modem and was installing same. It didn't give me any choice about HOW it was installed; it just went Wham-Bam-Thankyou-Ma'am, and the deed was done. Take it or leave it; and you, the stupid user, don't deserve to know what settings the modem is using.

I later learned it is possible to delve into Windows 95's secrets by the

process of 'hacking the registry'; the registry being a couple of obscure files where Windows keeps important operating information. It's a pity though that you have to go through the trouble, and danger, of hacking the registry just to see what your computer is doing on your behalf. It's dangerous because the registry is a real minefield, and any improper changes you make here can bring the computer to its knees in an instant.

Only this week I bought a new Hayes modem, since my work now requires me to test the Web server's modems at 28,800Kb/s and the Megahertz was a 14,400kb/s model. So here was a chance to see if Plug and Play was really plug and play. I pulled out the Megahertz modem and installed the snazzy little Hayes number, right out of the box, ignoring the somewhat complicated installation routines suggested by Hayes.

When I turned on the computer, it beeped and then announced that it had found a new modem and was installing same. We'd been here before; so far so good. When everything settled down I tested the modem by clicking the mouse on the Dial-Up Networking thing that Windows 95 uses to connect to the Internet. And guess what? No go! The Dial-Up Networking couldn't find the modem...

It turned out that it was still looking for a Megahertz modem, and was it was only being offered a Hayes. It seems Plug and Play had neglected to tell Microsoft's own modem-using software that Plug and Play had made some vital changes. Well, I guess we can't all be perfect...

What about Windows 95 reliability? Many commentators feel it is more stable than Windows 3.1, although experience would suggest that stability comes at a price: heaps of memory. In the early Win95 days, it was suggested that 8MB of RAM was needed to run Windows 95 successfully. And almost every new PC you buy comes with Win95 pre-loaded, and 8MB to run it in.

However many users quickly learn that Windows 95 seems to have a built-in schedule of daily crashes; sometimes two or three a day. My own computer obliges regularly. One co-worker running a Gateway 2000 computer with 8MB reported that Windows 95's daily crashes increased in frequency over time, to the extent that the machine became almost unusable.

I had recently upgraded my own laptop from eight to 16MB, with the

result that there was a lot less thrashing of the hard disk, and everything seemed to run a little smoother. But the crashes still occurred on a regular basis. So the co-worker decided to upgrade her memory too, but she went a little overboard. Memory was very cheap at the time, so she went wholehog and ended up with a whopping 40MB of instant-access RAM. Needless to say, the computer really flies now — and more importantly, the crashes have stopped altogether.

All along through the Windows 95 saga, Microsoft has been recommending 32MB as a suitable amount of RAM for Windows 95. It looks like they were right, but why? Whatever could Windows be doing with *thirty-two million* bytes of memory? The very biggest programs we use for our work on OlympusNet, things like Netscape and Claris Works, surely consume no more than three or four megs. Put two or three of them in together and maybe you need 10 megs.

Where does the memory go? Why does Windows 95 crash when you refuse to satiate this greedy hunger? I guess this remains one of life's unfathomable questions; you just learn to live with it and accept it as fact. Meanwhile Windows 3.1 continues to cruise along quite happily with four or 8MB.

As this is being written, both Netscape and Microsoft have released 'Version Threes' of their web browsers. And, according to an article in the *Seattle Times*, each of them is at least twice as large as their previous versions. Software bloat is alive and well!

What's the next Windows going to look like? I guess when we find out we'll discover we have to double our memory, yet again. I sometimes think I should be in the memory business... ♦

NOTES & ERRATA

PC Bus Sleuth (October 1996): The component overlay diagram shows U1 to U10 as LS series ICs. For reliable operation with some motherboards, these should be HC series as shown in the circuit diagram and parts list.

50W/Channel Stereo Amplifier (June/July 1996): Capacitors C404 and C504 (22uF) are shown with reversed polarity in the PCB overlay diagram on page 74, July issue. The schematic is correct.

More notes and errata on page 97 ♦

CONSUMER VIDEO IS GOING DIGITAL

Consumer video equipment is about to follow audio, and move into the digital domain — with dramatic improvements in performance. In fact the image quality delivered by the 'next generation' of consumer video gear is so good that professional users are jumping aboard as well, which is causing some complications for manufacturers. We may be in for a re-run of the DAT marketing kerfuffle, it seems...

by **BARRIE SMITH**

From the manufacturers' view, it seemed as though home video had come to the end of its analog road as 1995 approached. Sales of VHS/VHS-C/Video 8/Hi8 camcorders are stagnant, and development of these consumer formats had reached its logical end.

Obviously, digital was the way to go. Even so, it was perhaps a surprise to witness the haste with which a new format — Digital Video (DV) — came to market. It was only in 1994 that agreement was reached by a group of companies on a 1/4" (6.35mm) digital video format. In September 1995 confirmation arrived that a Sony digital Handycam had appeared on the Japanese and US markets — in NTSC. Two PAL versions arrived in Australia just one month later.

The companies initially involved in agreeing to the standard were Sony, Philips, Thomson and Matsushita, followed by Hitachi, Toshiba, Sharp, Mitsubishi, Sanyo and JVC. Virtually all of the others are now likely to follow.

Which is all very fine for the home

Mini DV versus DVCPRO		
Parameter	Mini DV	DVCPRO
Tape width	6.35mm	6.35mm
Cassette sizes	66x78x14.6mm (270mins)	97.5x64.5x14.6mm (63mins)
	125x78x14.6mm (60mins)	125x78x14.6mm (123mins)
Tape type	Advanced ME	Advanced MP
Max Rec time	270mins	123mins
Horiz Res	App 500 lines	App 750 lines
Compression rate	5:1 intraframe	ditto
Track layout	12 tracks/frame	ditto
Track pitch	10 micron	18 micron
Head drum diameter	21.7mm	21.7mm
Head drum speed	9000rpm	ditto
Video data rate	29.948Mb/s	ditto
Record data rate	41.85Mb/s	ditto
Tape speed	18.797mm/sec	33.813mm/sec
(Note that the Mini DV format provides for a larger 270 mins cassette size, with an eye on its suitability for a digital VCR)		

video maker. But there are two streams of DV: amateur (Mini DV) and 'pro' (DVCPRO). And there the problems begin...

Panasonic's pro approach to small gauge digital was shown at the SMPTE Convention in Sydney, mid 1995. According to a company spokesman, DVCPRO's "primary aim is for digital acquisition — news, ENG and EFP — delivering quality level with that of D1, D5 and Digital Betacam, and definitely better than SP Betacam."

On working demonstration were a camera, VCR and edit suite, a compact field recorder and a camera ('Journocam') weighing 2.5kg.

As this story is written a consumer version — the Panasonic DX1 — is on sale in this country. This year JVC has also launched its 450g mini Cybercam, the DV1.

Panasonic is about to launch its pro model in PAL, the EZ1. It is apparent the internals of the pro EZ1 and DX1



Sony's VX1000 camcorder, a three-CCD model using the Mini DV format. A digital output is provided, but as yet there's no means of accessing the signal.

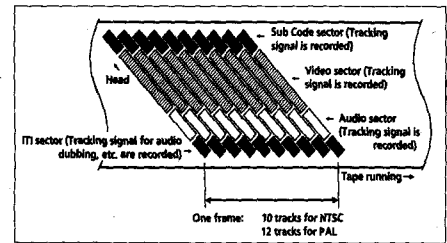
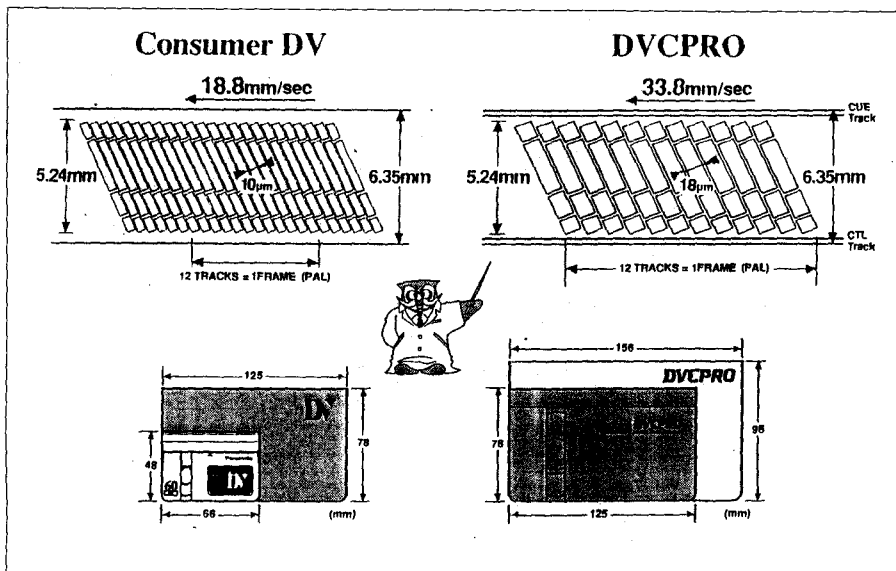

Above: The track pattern used for the DV format. (Courtesy Sony)

Left: A Panasonic diagram comparing the consumer DV and DVCPRO formats. Note the two different linear tape speeds.

are identical, so the specs and performance match exactly — except that the pro EZ1 model is some hundreds of dollars dearer. The company claims that superior grade components are used in the pro version. But how would a purchaser tell?

Anyway, what is the furore all about? Basically, it's about cost and quality. Sony's Mini DV camcorders cost \$8499 retail for the three-CCD VX1000 model, while the single-chip VX700 model gets to \$4999. The professional tax free price drops to \$6400 and \$3800 respectively. By comparison a digital Betacam camcorder costs tens of thousands of dollars more.

The two Sony cameras have analog and digital outputs but, as at this writing, there is still no way of extracting the digital signal. Nor is there a digital VCR to accept it. A communication cable called Firewire is the answer,

developed by Apple — but it has not yet surfaced as a sale item.

The self-made 'problem' with DV is that it is so good that many broadcast and programme makers are falling over themselves to take up the DV models.

The agency for Sussan fashion shops shot their recent TV commercials with a bundle of the new Sony DV camcorders. One TV station has requested 50 cameras. Another buyer is the seemingly immortal underwater programme maker, Ben Cropp. Ben now owns a three-chip Sony camcorder and a pro Panasonic AJ-D700, which uses the higher speed DVCPRO version of the standard.

The consumer (and pro clone) Panasonic camcorder is hobbled by excluding any form of digital output — composite AV and S-video analog only. JVC's Cybercam offers a proprietary digital output format called JLIP (Joint



Level Interface Protocol), but as yet there is no hardware (or cabling) to accept the signal. The company is promoting JLIP as an industry standard.

Current information is that there is unlikely to be a Mini DV VCR in the short term. Undoubtedly one or more exist in the research lab, but US concerns about copyright are preventing any marketing plans from being formulated.

If this all sounds like a rerun of the DAT fiasco, you may be right. The engineers develop a top quality, no quality loss recording format, then when the matter of copyright is raised the lawyers move in and slam the door...

Superb quality

The specified performance of Mini DV is simply superb. For instance, the Sony three-chip camera is able to resolve 500 lines of horizontal resolution (compared to 400+ lines with S-

		DV	8mm	VHS
Diameter		 ø 21.7	 ø 40.0	 ø 62.0
Relative speed	NTSC	Approx. 9.9 m/s	Approx. 3.8 m/s	Approx. 5.8 m/s
	PAL		Approx. 3.1 m/s	Approx. 4.9 m/s
Rotating speed	NTSC	9000 rpm	1800 rpm	1800 rpm
	PAL		1500 rpm	1500 rpm
Track pitch		10 µm	20.5 µm (SP)	58.0 µm (SP)

Above: A Sony diagram comparing the head drum specs for DV, 8mm and VHS. Right: JVC's new mini DV format Cybercam. Smaller than a paperback book, it offers digital recording and four-track digital PCM sound.

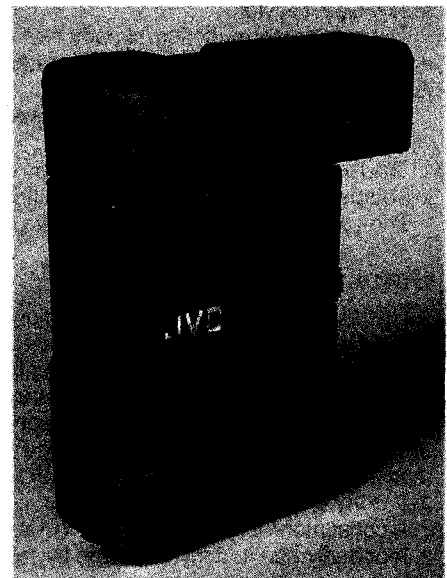

Digital Video

Right: Panasonic's DX1 consumer recorder, using the Mini DV format. Virtually the same model is sold professionally as the EZ1. There is no digital output on the camcorder.

Below: The construction of the metal evaporated tape developed for the DV format. (Courtesy Sony)

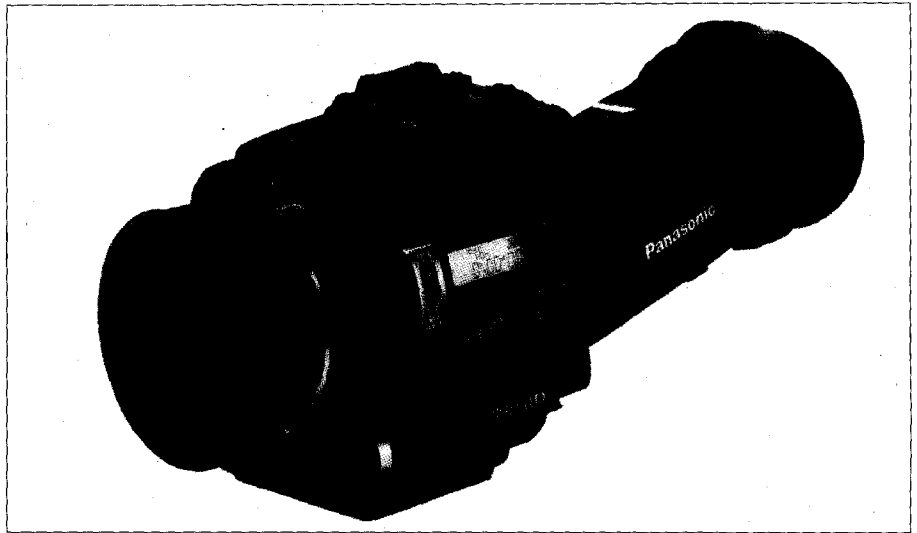
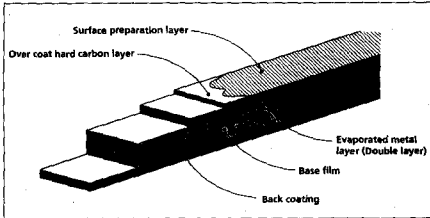

Digital-S

Expected before the end of 1996 is JVC's backwards-compatible Digital-S, based on the 'prosumer' S-VHS format. Predicted to come in at half the cost of Digital Betacam, the new format will still share 'many of the same subjective features'.

Interframe compression is deployed, along with metal particle tape; a VHS size cassette should contain 105 minutes of recording.

Appearing at first will be an editing recorder/player (able to replay S-VHS) and a docking recorder, with a dockable camera expected within 12 months.

Cybercam

JVC's tiny new Cybercam — about half the size of a VHS cassette — has internals which house two six-layered PCBs, laser drilled to enable high packing densities. The weight is 520g with battery; the cassette weighs a mere 35g.

The camcorder delivers a video signal in excess of 400 lines of horizontal resolution. The audio side has a two-channel PCM stereo signal, sampled at 48kHz/16 bits — or four channels of PCM audio at 32kHz/12 bits. The zoom is a 10X optical (imaging to a 1/3" CCD with 670,000 pixels), boosted by a 100X digital boost.

The price is around \$4000 retail.

Panasonic's DX1 (and EZ1)

These new digital video camcorders are 320,000 pixel three-CCD models, with similar audio specs and capability to the JVC. Internally they are interesting in their use of five digital video LSIs, equivalent to 2.5 million transistors. Part of the system is an image stabiliser and a TBC (timebase corrector). The zoom is a 10X optical boosted by a 20X digital system.

There is some muttering already that these cameras don't offer a digital output — and, more annoyingly for shaky amateur handholders — that the image stabiliser reduces the image field size.

The Mini DV tapes from both camcorders can be replayed in DVCPRO VCR decks with the use of an adaptor.

The bad news is that early purchasers are having to put up with a disappointing analog output (even in S Video), while waiting for dedicated VCR equipment.

The consumer unit is likely to retail for under \$5000.

Sony's DV models

It would appear that Sony's professional division is not launching equipment in DV. It apparently has enough on its hands — what with the superb, but pricey, Digital Betacam, its cheaper clone SX, analog Betacam SP plus a sprinkling of cameras and peripherals in analog Hi8 — four formats.

The company's consumer division reports brisk sales of the two Mini DV camcorders, but there is a reported hesitancy within the company as to which direction subsequent models should follow — the populist JVC approach or the heavyweight, high ticket path that Sony is already treading.

A consumer VCR was promised in May this year. However as yet there's no sign of it, reportedly due to copyright fears by record and movie interests.

Video), accompanied by PCM sound.

Oddly, the sound input is at 12-bit quality, sampled at 32kHz, so its top frequency is at around 16kHz. However the output is 16 bits, sampled at 48kHz, topping 24kHz — so you can replay CD quality stereo audio, but you can't record it. Do we detect the strong hand of the recording companies?

No-one, especially Sony (they do make a few CDs!), is going to allow a consumer device onto the market which will allow CD quality in/output. In the US the cameras are configured for a digital signal input — but not in PAL countries.

Tiny cassette

The 30- and 60-minute Mini DV cassettes are tiny (66 x 48 x 12.2mm), a little bigger than a micro audio cassette. An analog 8mm cassette is 2.3 times larger in volume, a VHS cassette 12.5 times. The digital video SD specification includes another cassette size (125 x 78 x 14.6mm), capable of recording for 270 minutes. Metal evaporated coating is used in the tape, in a dual layer construction to offer a low error rate — essential for digital recording.

Sony's Mini DV cassettes have an inbuilt 500 bytes of IC memory, providing a memory function which offers the ability to store such data as the recording date and time. This cassette memory function aids scene searching.

Other camcorder manufacturers are using cassettes without the IC chip, thereby holding down tape costs.

As a point of interest, the tiny digital video heads spin at 9000rpm (for comparison, the 8mm format head speed is 1500rpm). This allows them to write the information to tape at the rate of 41.85Mb/s (megabits per second), in a track width of 10 microns.

Messy situation

As 1996 rolls to an end, it seems as though the early players in digital video — Sony, Panasonic and JVC — are wrestling with a metaphorical gorilla. The problem for these three companies is that they have a considerable presence in both consumer and professional fields.

In the consumer market, there's only a tiny proportion of enthusiasts willing to shell out the \$4-8000 for an upmarket, high quality camcorder, capable of superb pictures and sound. So, at this stage the digital video format will have only limited sales at consumer level.

But in pro terms, the format (if you can lump together Mini DV and DVCPRO as one format) is capable of unseating not only the far more expensive Digital Betacam format for many uses, but pushing aside the older analog Betacam SP and putting some more nails into the coffin of 16mm film as a programming format.

However, the wise and wary pro and semi-pro are likely to buy consumer camcorder models for original capture, adding only pro VCRs and edit controllers for post production. Comparative durability of the hard-

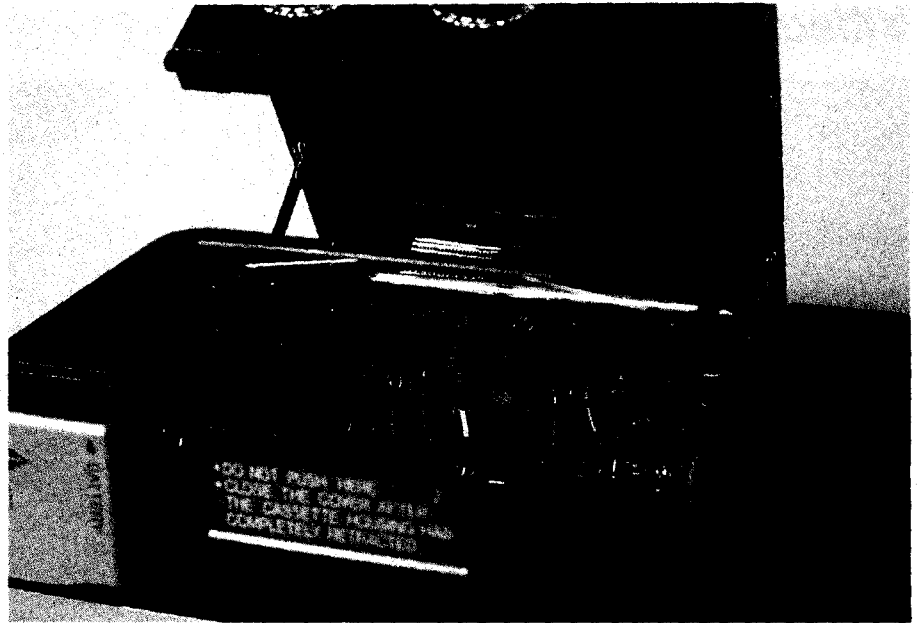

Inside the JVC Cybercam's tape well. A head drum speed of 9000rpm demands a hard wearing tape coating.

ware would be the only limiting factor for professionals.

At the launch of Sony's two digital models, the company promised continuing support for the 8mm amateur format. Panasonic, while it launches another twelve analog models onto the

market in 1996, offers no such promise. JVC expresses awareness that digital video may mean the end of S-VHS for the amateur market — the price points are dead level.

Are we likely to get a rerun of the DAT tangle? It sure looks like it! ♦

Hy-Q International

Frequency

Control

Products

- Crystals • Filters •
- Oscillators •

Quartz & Ceramic

Hy-Q manufacture and stock an extensive range of Quartz Crystals, Filters and Oscillators, including TCXO and VCXO.

We also supply a full range of high quality Ceramic devices at competitive prices.

Hy-Q specialises in quality, service and delivery.

17 Winterton Road, Clayton,
Victoria 3168 Australia
(Private Bag 100, RMDC
Clayton Victoria 3169)
Telephone (03) 9562 8222
Facsimile (03) 9562 9009

We sell speakers.

We sell famous Danish speakers - Vifa, Peerless and Dynaudio, including six speaker kits. We have the biggest range and we are always the cheapest. Always.

vifa **Peerless** **DYNAUDIO**

We have magnetically shielded drivers for Surround-sound and multi-media, woofers up to 12", lots of different tweeters and heaps of parts. We sell crossovers, Bennic and Solen capacitors, inductors, grill clips, flared speaker ports, gold-plated terminals and U.K made Deflex damping materials. Phone, write or fax for free information including price list, specials list and specs on all our drivers. Or send \$10 cheque, money order or phone/fax with credit card details for our 80 page catalogue of complete engineering data sheets on every speaker driver we sell. (Price includes air mail postage anywhere in Aus. and N.Z.)



P.O. Box 242 Hawthorn 3122
Phone: (03) 9429 2199
Fax: (03) 9429 9309

READER INFO NO. 2

SPEAKER PARTS DIRECT

READER INFO NO. 3

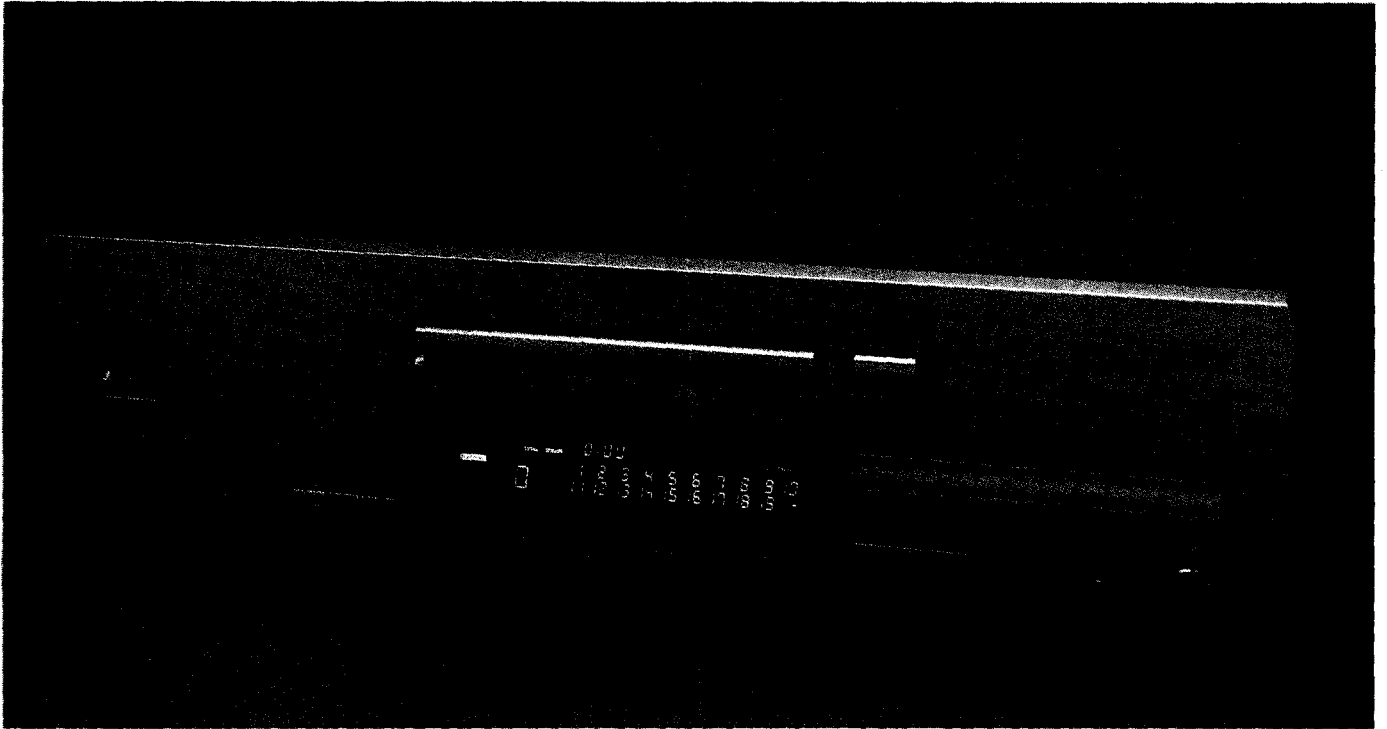

THE ONKYO INTEGRA DX-7911 CD PLAYER

This month our reviewer Louis Challis had the opportunity to test Onkyo's new high-end DX-7911 CD Player, which incorporates technology claimed to eliminate jitter and offer dramatically improved tracking. As well as substantially confirming these claims, his testing also revealed other aspects of the player which are quite impressive.

The archaic translation of 'Onkyo' from Japanese to English would have been 'reverberant sound'. Its more modern translation is 'sound', and the modern translation fits in far better with Onkyo's marketing strategy and long term aims.

Whilst the Onkyo brand, and more particularly its 'Integra' series of products have been prominent in Japan for more than 25 years, their impact on the Australian market has been far less obvious or consistent.

Twenty-five years ago, the company set up a design team which was given free reign to develop a new and outstanding range of hifi products. In the ensuing period, Onkyo produced some of the most powerful and outstanding amplifiers on the Japanese market. Their amplifiers rapidly assumed the reputation as being the 'market pacesetters', and were duly copied by a legion of 'look-alikes' from Japanese, Taiwanese and other manufacturers.

Whilst Onkyo were unquestionably amongst the foremost market leaders in

terms of amplifier design, their development of CD players has tended to lag slightly behind some of the other well-known names. Thus by way of example, when the first of the single bit CD players hit the market in the late 1980s, Onkyo's literature claimed that a conventional 16-bit D-A converter with multiple oversampling was technically superior. That position changed of course, when Onkyo's R&D division developed its own advanced single bit D-A converters. We then saw the start of a new stream of 'top-of-the-line' CD players, which could equal, or more importantly, could outperform the bulk of their competitors' best products.

The new DX-7911

The new Onkyo Integra DX-7911 CD Player is an attractive and impressive piece of equipment. The choice of a gold brushed satin front fascia would grace any living room. Onkyo's rejection of the 'black is beautiful' concept is a positive statement that Sol Marantz pioneered on

the American market, more than 40 years ago, and is equally valid today.

With a recommended retail price of just under \$2000, this is the type of equipment that only well heeled, or very dedicated audio-files would purchase as a fundamental element in a new or existing hifi system.

When a single item of hifi equipment costs \$2000, I am duty-bound to find out why it cost that much. That assessment has a priority, to identify in what way its performance parameters are superior to the products with which it must be compared, and with which it will ultimately compete.

The underlying design philosophy of the Integra DX-7911 CD player is sensible and pragmatic. Onkyo set its R&D team the task of identifying the primary functional electronic and electro-mechanical limitations which degrade a CD player's audible characteristics. Having identified the nature and the technical significance of those limitations, they then proceeded into the development of a range of innov-

ative practical solutions. Whether the solutions were also cost-effective was apparently of lesser significance.

Manufacturers' glossy literature all too frequently make claims which the consumer is unable to verify. All too often they are unable to judge the objectivity and merits of those claims. In this particular case, Onkyo's literature makes multiple claims, which you may well believe because of the price of the product, even though you still remain sceptical as to the real merits of those claims.

Now the first problem which they cite as degrading the quality of low level signals is 'jitter'. Of course when the jitter problem was originally identified more than a decade ago, some manufacturers and many purchasers believed that its stated impact was very much overrated.

In hindsight, and following A-B testing of large numbers of CD players with and without jitter control, let me assure you that jitter can be a very insidious problem. Of course Onkyo's ambit claim is that they have not just reduced the problem of jitter, but more significantly, that they have eliminated it!

Now jitter occurs as a result of minuscule variations in the frequency, and to a lesser extent the amplitude of a CD player's basic reference oscillator.

The source of the jitter is also frequently traced to minute variations in the power supply voltage. More frequently however, it is generated by limitations in the basic design of the reference oscillator circuit.

Other common causes of jitter are associated with the performance of the servo circuitry which controls the laser focusing, the tracking coils and even the constancy and speed stability of the spindle motor. Each of these elements is subject to significant fluctuations in the absolute level of supply current, whilst fulfilling their role of maintaining the appropriate rotational speed and correct position of the interacting elements in the laser pickup system.

Onkyo's literature claims that the significant currents required in the various elements of the feedback loop circuitry reflect themselves as significant noise-related fluctuations in the system's supply voltages. Needless to say, any voltage or current fluctuation in the system must manifest itself as a potential adverse impact on the stability and operation of all other system components.

The jitter ultimately manifests itself as an increase in playback noise (which is only likely to be detected if you have a keen ear) and the program content is readily audible with signals as low as -60dB to -90dB (relative to peak level). The jitter most frequently produces identifiable spurious intermodulation products. The key frequency component in those intermodulation products occur at the clock oscillator frequency, or at a multiple, or submultiple thereof.

Onkyo's subjective and objective assessments confirmed that the primary adverse effect of jitter noise manifests itself at mid-

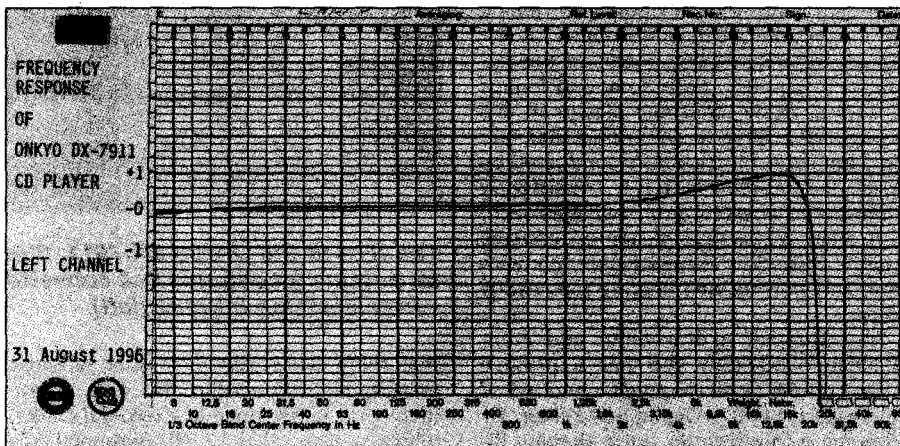
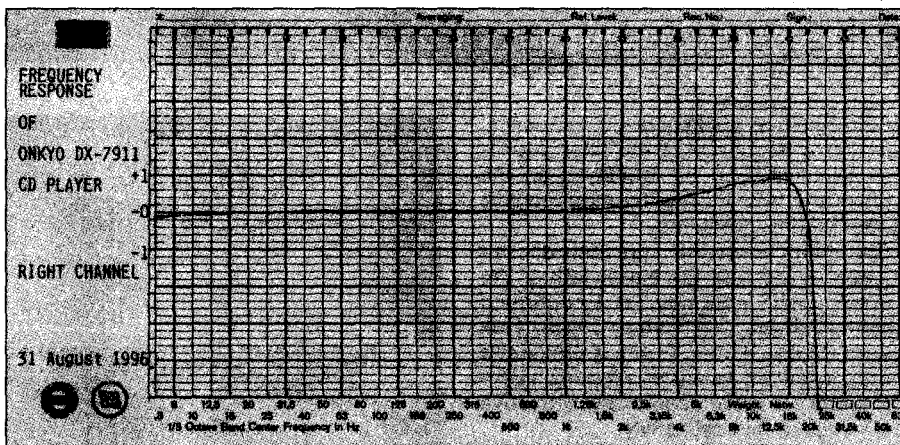

The measured replay frequency plots for the right and left channels. Arguably preferable to the 'ruler flat' response of some CD players, the modest 1dB peak around 16kHz is inaudible and is one consequence of the low-pass filter's characteristic. Another is a relatively gentle roll-off above 20kHz, with less phase shift.

dle and high frequencies, rather than at the low frequency end of the spectrum. The affected signal is most frequently identified as a degradation of sound transparency. Onkyo also claims that it frequently impinges on your ability to

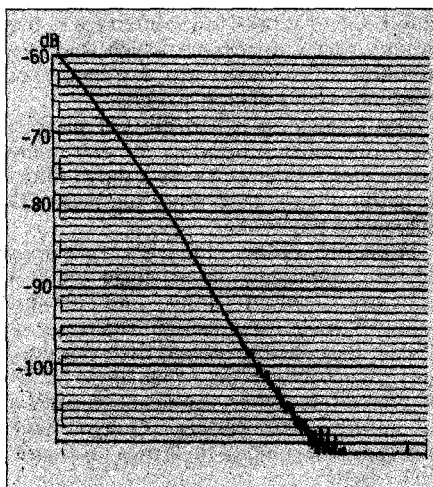

The measured 'fade to noise' performance, below -60dB; a small amount of nonlinearity, but very little jitter or dither thanks to Onkyo's refinements.

achieve optimum sound localisation. Whilst I have no difficulty in accepting the proposition that jitter will adversely impinge on both of those parameters, my own investigations lead me to believe that the magnitude of the impact is not necessarily quite as serious as Onkyo's literature would have us believe.

The digital signal processing in the DX-7911 CD player occurs at 16.9344MHz, which is 384 times the original 44.1kHz sampling frequency. To eliminate the jitter associated with external factors, the sampling frequency is converted to 52.083kHz, and the critical section of the sampling rate converter is then controlled by a 20.0000MHz clock frequency.

Onkyo claims that by completely isolating the two separate clock oscillators, i.e., the D-A converter's clock from the main system control clock, any adverse external effects associated with the clock oscillator are eliminated. Onkyo claims that this positively obviates the primary cause of jitter.

There are of course other technical advantages associated with adopting a higher sampling frequency. By increasing the sampling frequency from 44.1kHz to 52.083kHz, it became possible to re-define the low pass filter's skirt selectivity. This would otherwise have been defined

THE CHALLIS REPORT

by the nominal 20kHz cut-off frequency. The cutoff frequency of the filter and its skirt selectivity can be redefined on the basis of the less demanding requirements of the 23.6kHz frequency.

The adoption of this approach doesn't necessarily increase the bandwidth of the audible signal. However, as I confirmed when reviewing the Pioneer Legato Link system (EA December 1992), it provides a most convenient means of adopting a gentler and a far more acoustically attractive and effective skirt selectivity.

The most tangible advantage of that approach is this system's ability to reduce the magnitude of phase distortion for the highest frequency components in the signal. As it happens, both Sony and Philips as well as many other key players in this market have already confirmed that factor. Multiple subjective tests conducted by those manufacturers have consistently confirmed the viability of that approach, as it offers a practical means of reducing audible distortion — which listeners with keen and well attuned hearing can readily detect.

The adoption of the wider and more effective bandwidth also has a positive impact on the noise shaping technology of the single-bit DAC's digital noise filter. By adopting a fourth-order noise shaping filter, there is a significant reduction of quantisation noise within the normal auditory range. This of course is only achievable where the designer is capable of adopting a more gently sloping low pass filter, supplemented by improvements in the conversion linearity of the D-A converter.

The Onkyo DX-7911 CD player also uses a new generation of linear motor actuators. This new system achieves significant improvement in terms of its positioning accuracy, with similar improvements in its pickup response time. The improvement in its tracking ability is achieved even when the face of the disc is masked or blanked by dirt, dots, finger marks or scratches.

These electronic advances are underpinned by the addition of a very effective electronic screening system. Surprisingly, Onkyo makes no mention of this feature in its literature. The enhanced screening reduces interaction between the laser head electronics and the separately packaged and screened power supply on one side of the chassis, and the digital to analog converter and related output amplifier sections on the other side of the chassis.

A look inside

On opening the cabinet, the first thing that catches your eye is the 'Twin-Core AEI Transformer'. AEI is an abbreviation for 'anti electromagnetic interference'. Whilst I have no doubt that the transformer achieves what is claimed, I noted

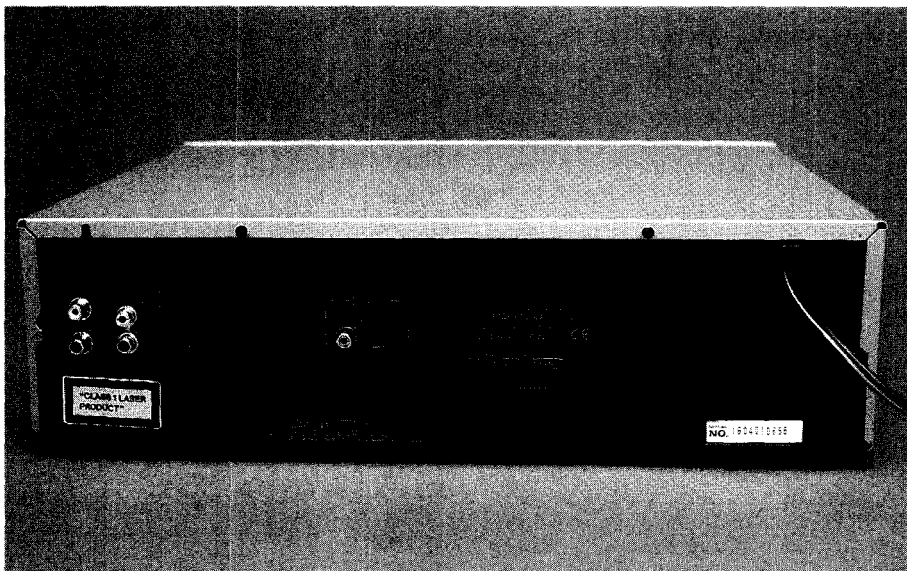

The rear of the Onkyo DX-7911. It provides both optical and electrical digital outputs for external D-A converters (centre), together with both fixed and variable analog outputs (left).

that there were also a number of other unsung features within the unit. These included the presence of a toroidal choke, which suppresses the high frequency currents in the mains power lead. There are additional mains suppression units, in the form of voltage dependent transient suppressors and filter capacitors, whose effectiveness we confirmed.

The two large electrolytic capacitors in the power supply are rigidly clamped together by a very solid plastic bracing assembly. This ensures that there is no movement of the capacitors, as a result of extraneous vibration. On closer examination I also discovered that all of the electrolytic capacitors have been carefully glue-bonded at their lower interface to the printed circuit boards on which they are installed. This apparently also improves their vibration isolation stability.

The chassis on which the CD player's electronics is supported is extremely heavy and strong, as it uses a much thicker grade of steel than other top-flight CD players on the market.

Notwithstanding Onkyo's previous adverse comments about single bit D-A converters when Sony and Philips released theirs, the design engineers at Onkyo have clearly revised their position, and have now accepted that single bit D-A converters offer significant technical advantages. Admittedly, Onkyo have incorporated some of their own 'in-house' new technology to eliminate vibration, which ensures a cleaner and superior signal, even when exposed to high, or what I classify as totally unacceptable levels of extraneous vibration...

Some of the additional features which

this CD player provides include the following:

- The provision of a 'peak-level search' button, which allows the user to automatically scan a disc and locate the highest peak levels. With that information the ideal recording level may be set for a compact cassette recorder connected to the system. The function may also be used to provide the ideal listening level when setting your amplifier's volume control.
- A 'TIME EDIT' function, through which you can automatically calculate and select the most appropriate combination of tracks on the CD in order to optimally fill the side of the cassette tape that you wish to record.
- The provision of both 'FIXED LEVEL' and 'VARIABLE OUTPUT LEVEL' RCA coaxial sockets. These offer the advantage of being able to adjust the volume by means of your CD player's remote control, or should you prefer, through the amplifier's volume control as desired.
- Separate OPTICAL and COAXIAL DIGITAL OUTPUTS. These provide the ability to achieve superior quality copying of your disc with a MiniDisc recorder, a DCC recorder or a DAT recorder.

The other attributes and features claimed include a superior signal-to-noise ratio, a more effective reduction of distortion, and superior channel separation.

Objective testing

My objective assessment of the DX-7911 CD Player's performance characteristics proved to be rewarding, as the manufacturer's primary claims of enhanced performance were all confirmed.

The first parameter confirmed was the

replay frequency response, which is flat to 1kHz, and then gently rises by just under 1dB to a plateau in the 12-16kHz region. The curve then gently rolls over, as you will note on the graphs.

Unlike most other recent CD players which tend to provide an almost 'ruler flat' response, this lack of flatness is intentional and most deliberate. It results from the designer's choice of the low pass filter, and must in these circumstances be viewed as an attribute, rather than a liability.

A 1dB rise in the frequency response at 16kHz is inaudible, particularly as most loudspeakers or headphones are far less uniform and/or flat than you may have realised, in that particular frequency region.

The frequency roll-off above 20kHz is extremely smooth and gentle, and extends all the way out to 23.6kHz and beyond.

The shape of the replay frequency curve is quite different to that which I have become reconciled in recent years. The only real exceptions are Pioneer's CD players incorporating the Legato Link circuitry. As I discovered during my listening tests, this is a very positive attribute, but I will comment about that later in the review.

The digital to analog converter's (D-A) linearity response is smooth and precise all the way down to -50dB. With a signal in the -60dB range, a minuscule degree of non-linearity is observable. That non-linearity is still observable at -70dB, but becomes more significant at -80dB. Once the signal level drops below -90dB, the non-linearity is readily measurable. This characteristic was confirmed in the fade-to-noise test, which covers the range -60dB to -110dB (see graph attached), and provides a graphic picture of the system's low signal linearity.

As that curve shows, between -80dB and -100dB the slope of the curve changes perceptibly. Below -100dB the additional energy of residual noise reads just the slope of the curve.

Unlike most other top-line CD players which I have evaluated and reviewed, the jitter and dither characteristics in the -90dB to -110dB region are unusually low. This is a most positive confirmation of the improvements achieved by the CD player's electronic design. The fade-to-noise test graph lends considerable weight to the manufacturer's claim that they have effectively reduced, even eliminated, low level jitter.

The channel separation is also extremely good at all four test frequencies. At 100Hz it is better than -126dB between either channel, which appears to be better than any other CD player I have yet reviewed. At 1kHz the separation is better than -114.9dB between either channel. At 10kHz the separation is better than -95.5dB, whilst at 20kHz it is still remarkably good at -89.8dB.

The distortion figures at 1kHz are extremely good all the way down to -60dB, below which the level of distortion climbs very rapidly. Irrespective of what type of electronic circuitry is used, the

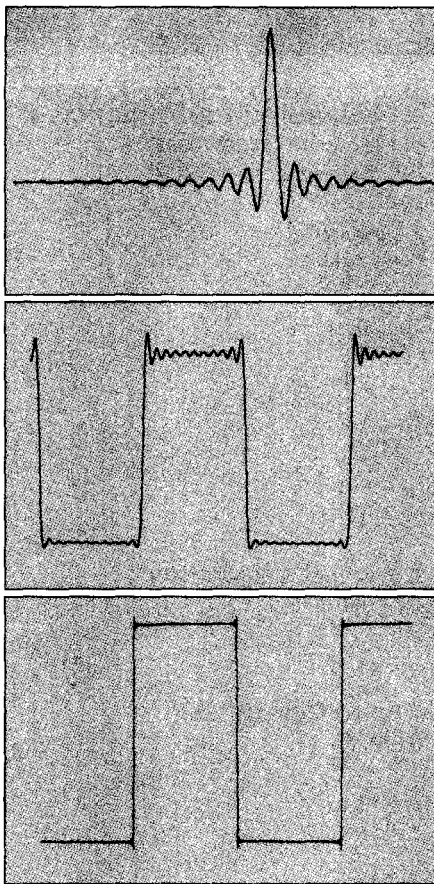

The Onkyo's measured impulse response (top), plus the square wave response at 1kHz (centre) and 100Hz (bottom). All are particularly well controlled, testifying to the careful design of the player's post-conversion filtering. An exceptional result!

ability to maintain the low level distortion is determined by the number of effective bits that you have to play with. When you don't have those critical extra bits, then you must expect that you will have a proportional increase in the level of simple harmonic distortion.

The measured signal to noise ratio, both with and without emphasis, is exceptionally good. Its unweighted response is better than 103dB, whilst its A-weighted response is better than 107dB(A). The frequency accuracy is good, with a deviation of only 0.14Hz for a nominal 20kHz test signal.

Dirty disc test

One test which can separate the CD player 'men from the boys', is the Dirty Test Record test. This test provides interruptions in the information layer, with black dots and wedges on the read-out side which completely obliterate the information layer.

As I conducted this test and viewed the results, I realised that Onkyo have achieved meritorious results. With all standard obscuration signals, and even with a 3mm wide wedge, the DX-7911

CD Player took all of these impediments within its stride. It did not display the slightest measurable or audible trace of imperfections in the output signal, or in its sound quality.

Now you may not appreciate that a 3mm wide wedge is a really awesome signal interruption. Over the last 14 years, I have only seen one other CD player that could cope with that test, and that CD player was more than twice the price of this unit.

Vibration test

Onkyo boldly claims that the DX-7911 CD Player is designed to resist vibration. Their glossy literature simply exudes confidence about how well the CD player performs, and how much design effort has gone into providing resistance to its destructive characteristics.

I duly placed the DX-7911 on our large shaker table, and slowly raised the acceleration level until the vibration level had risen to 0.5G RMS (at which point the peak levels are 1.4 times higher). That was the highest level of acceleration that I was prepared to impose, and is significantly higher than I have ever imposed on any CD player which we have tested.

Throughout this exercise I monitored the output signal on my real time analyser. Even with a 0.5G RMS shaker signal, I was unable to detect even the faintest trace or suggestion of either harmonically related, or non-harmonically related (noise) signals — at even the lowest threshold level displayed by the real time analyser. Even with the fundamental of the output signal notched, and when looking for signals which were more than -100dB down, there was still no trace of detectable harmonics or noise in the output.

Well, I have to acknowledge that I was impressed. That performance is exceptional by any standards, and I have to acknowledge that Onkyo's design engineers have achieved a most meritorious result.

I progressed to an evaluation of the square-wave and impulse responses. As you will observe, each of those was remarkably clean and uniform. They confirmed that there are no unusual non-linearities in the dynamic performance of the CD player.

Subjective testing

By this time, I had realised that I couldn't fault the DX-7911's objective performance. So I proceeded with a subjective evaluation, using a range of test discs in my listening room.

In view of the claims that they had completely removed the problem of dither, I started with a special demonstration disc manufactured by Sony entitled 'Super Bit Mapping Demonstration Disc' (SBM 1). Two of the tracks on that disc incorporate low level signals whose peaks fall below -60dB to -80dB. With test signals as low as that, one should be able to readily assess the signal processing quality of this CD player when referenced against a more conventional (and previous generation), of

THE CHALLIS REPORT

quality CD player.

Whilst the differences in signal quality are not outstanding, they are however, readily evident, and the DX-7911 comes out clearly in front.

I progressed to another new disc, with Wynton Marsalis 'In Gabriel's Garden' (Sony SK66 244). In my opinion, Wynton Marsalis is one of the finest trumpeters in the world, and his rendition of a range of music from Bach, Purcell and Torelli with the English Chamber Orchestra, is absolutely stunning. Sitting in my listening room with the CD's player output fed to a Yamaha M400 amplifier and a pair of B&W 801M loudspeakers, and with my eyes shut, I could swear that I was in the same room as the orchestra and Wynton Marsalis. The stereo localisation was exceptionally good, and I could pinpoint precisely where the trumpeter stood at all times.

I progressed to a different genre of pre-recorded music with a very topical disc entitled 'Summon the Heroes', featuring John Williams with the Boston Pops Orchestra. This is the first disc that I have featuring John Williams with the Boston Pops Orchestra, and both the music and his cooperative involvement are unusually good. There are differing styles of music on the disc, but without exception all of the music is stirring. More significantly, it is intended to be played at loud levels.

I played it in the manner intended, and hoped that my neighbours would not object. I compared the results with my current (but older) quality CD player. Unlike the low level signals where the differences in quality were clearly perceptible, at high listening levels, those differences were no longer identifiable.

Summarising

The Onkyo DX-7911 CD Player is an exceptionally well designed piece of equipment. Its price reflects its quality, and its marketing is clearly directed towards people who crave, and can afford the best.

If you were thinking of buying this CD player to play rock music, then forget it! This is not the CD player for you. If however, you intend to play classical, orchestral, symphony or operatic music encompassing the fullest and widest spectrum of sound, and a frequency range to match, then this CD player has much to offer.

There are many other CD players which offer some of the attributes of the Onkyo DX-7911. However I am not aware of any other CD players that offer all of the attributes that it provides.

The DX-7911 measures 435 x 365 x 131mm (W x D x H), and weighs 10.5kg. As noted earlier it carries an RRP of \$1999. For further information contact the Australian distributor Amber Technology, of Unit B, 5 Skyline Place, Frenchs Forest 2086; phone (02) 9975 1211, or fax (02) 9975 1368. ♦

Measured Performance of the DX-7911 Onkyo CD Player

(Serial No. 1004010685)

1. FREQUENCY RESPONSE

20Hz to 20kHz +1/-0dB
5Hz to 22.05kHz +1/-0dB

2. LINEARITY

Nominal Level 0dB	L Output	R Output
0.0	0.0	0.0
-1.0	-1.0	-1.0
-3.0	-3.0	-3.0
-6.0	-6.0	-6.0
-10.0	-10.0	-10.0
-20.0	-21.0	-20.0
-30.0	-30.0	-30.0
-40.0	-40.0	-40.0
-50.0	-50.0	-50.0
-60.0	-60.1	-60.1
-70.0	-70.1	-70.1
-80.0	-80.3	-80.2
-90.0	-89.5	-89.5

3. CHANNEL SEPARATION

Frequency	Right Into Left, dB	Left Into Right, dB
100Hz	-129.4	-126.4
1kHz	-114.9	-116.9
10kHz	-95.5	-97.5
20kHz	-89.8	-91.6

4. DISTORTION (@ 1kHz)

Level 0dB	2nd	3rd	4th	5th	THD(%)
-1.0	-100.1	-	-91.4	-	0.0036
-3.0	-100.6	-	-98.3	-	0.002
-6.0	-95.7	-	-105.9	-	0.0016
-10.0	-	-	-96.3	-	0.0015
-20.0	-99.2	-	-102.9	-	0.0018
-30.0	-91.7	-90.2	-92.1	-96.2	0.0097
-40.0	-83.0	-81.1	-85.3	-87.7	0.025
-50.0	-72.2	-69.1	-74.5	-77.8	0.09
-60.0	-70.0	-66.0	-68.6	-68.1	0.16
-70.0	-54.1	-49.9	-58.8	-55.7	0.79
-80.0	-44.0	-40.2	-45.8	-44.6	2.0
-90.0	-33.7	-29.0	-37.3	-30.8	9.8
	-27.9	-21.0	-28.5	-14.4	35.7

Distortion at 100Hz:

Level 0dB	2nd	3rd	4th	5th	THD(%)
-20.0	-101.8	-110.5	-95.8	-101.4	0.0036
-40.0	-97.7	-94.8	-98.4	-	0.004
-60.0	-82.7	-74.0	-76.4	-85.4	0.047
	-57.3	-52.5	-54.1	-63.0	0.064

Distortion at 6.3kHz:

0dB	-108.0	-107.0	-104.3	-	0.0015
-----	--------	--------	--------	---	--------

5. EMPHASIS

Frequency	Recorded Level	Output Level (L)	Output Level (R)
1kHz	-0.37dB	-0.34	-0.37
5kHz	-4.53dB	-4.50	-4.54
16kHz	-9.0dB	-9.3	-9.4

6. SIGNAL TO NOISE RATIO

Without Emphasis (track 23)	-103.3 (Lin)	-107.2dB(A)
With Emphasis (track 24)	-103.2 (Lin)	-107.1dB(A)

7. FREQUENCY ACCURACY

Input signal	19.999kHz
Measured Output	19.99914kHz

8. SQUARE WAVE RESPONSE @100Hz and 1kHz

See X-Y plots appended

9. IMPULSE TEST

See X-Y plot appended

10. DIRTY RECORD TEST (Sony/CBS Test Disc)

In Information Layer:

Passed all levels up to and including 3000 micrometers

Black dot at readout side:

Passed all test levels

Black stripe test:

Passed all test levels

11. VIBRATION OR DISPLACEMENT TEST

Acceleration Level 0.5G RMS:

Faultless performance

12. OUTPUT IMPEDANCE OF HEADPHONE AMPLIFIER

110 ohms

For people who listen



Do you have a keen ear for music? And have you been meaning to upgrade your current sound equipment to a better quality, better performing system? Well here's a range of top quality hi-fi that's been impressing the buffs for over 49 years. No image pretensions here - Onkyo's dozens of international awards speak for themselves.

Onkyo is built for people who actually listen. There are outstanding individual components or cleverly simple integrated systems. Thoroughly individual. Inspiring sound clarity. Quality at a price you can afford. And a unique *5-year* warranty.

Visit an authorised Onkyo consultant to hear the difference and you'll wonder why you've waited until now to pamper your ears. Call us to set up a personal presentation at a time to suit you. It's worth the listen.

ONKYO®

For a personal introduction phone

Sydney (02) 9975 1211 or Toll Free 008 251 367 Australia-wide.

COMPRO'S D-CAM DIGITAL CAMERA

If you thought that connecting a video camera to your computer system would require expensive video cards, a lot of money, and a good reason to go into desktop video, you might take a look at the new Compro D-Cam digital camera, available from Rod Irving Electronics. Priced at \$399, it is a remarkably simple and inexpensive way to capture high quality images for use on your system.

by **GRAHAM CATTLEY**

With computers nowadays becoming far more graphically orientated, the need to get images into a digital form is rapidly becoming a necessity. In the 1980s, clip art was the way to go, but with the advent of the World Wide Web and the multimedia PC, full colour video images have come to be expected everywhere.

Unfortunately, the only means that most people have to acquire images is to either photograph an object and scan it in with a reasonable quality scanner, or to use a camcorder to record the subject on videotape, and then use a frame grabber on the PC to capture a likely looking image.

Both of these methods tend to be unsatisfactory, and expensive.

So what is the answer? A dedicated digital camera connected to the computer would seem to be the obvious solution, but few people would consider this to be a viable option. Mention digital cameras to most people, and they tend to think of expensive photographic equipment, rather than another computer peripheral.

Enter D-Cam

What the world needs is a simple camera that doesn't require internal cards, six hours of fiddling with settings and jumpers, or converting your humble desktop into a dedicated imaging workstation.

In my opinion, the Compro D-Cam fills these requirements very well, and is probably one of the few peripherals I've come across that you can take out of the box and have up and running in less than five minutes. As the D-Cam plugs into your printer port, installing the camera is as simple as installing a new mouse. No hassles with IRQs and DMAs, and no need to take the lid off your computer...

The Compro D-Cam consists of three main parts: The camera itself, looking just like an everyday point-and-click camera, a similarly sized interface box, and the driver software.

The camera plugs into the interface box via a generous two-metre cable, and the box in turn plugs directly into the parallel port of your PC. The camera

takes its power from the computer's keyboard, via an ingenious T-piece that plugs in series with the keyboard's cable. The whole interface system sits out of sight at the back of your computer, and the interface box even provides a parallel port feed-through connector so that you don't need to switch plugs in order to use your printer. A standard fitting on the bottom of the camera allows it to be mounted on a tripod, or on the little adjustable stand provided.

Impressive software

When reviewing computer products, I make it a policy not to read the software manual unless absolutely necessary. I am happy to say that the D-Viewer software supplied with the camera was so intuitive that I didn't need to refer to the manual at all. A few clicks with the mouse was all that was required to get a 640x480 image on screen in 24-bit colour.

The system requirements for the software are surprisingly small; a 286 with 4MB RAM and Windows 3.1 is all that

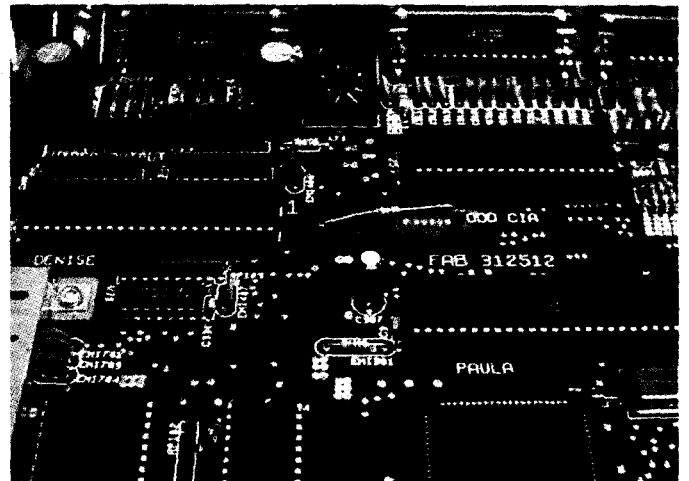
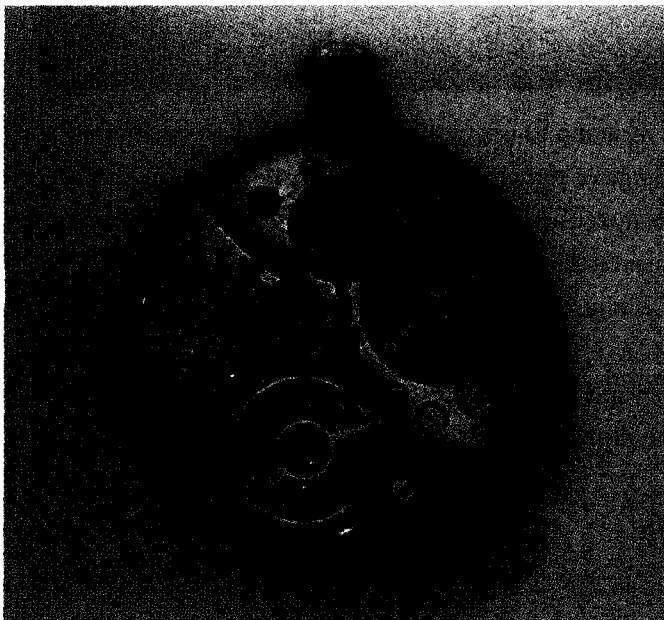

These two photos show the output from the D-Cam, with the image on the left taken at the distance of around 150mm. The above shot of the computer motherboard was sharpened using one of the many image processing features in the D-Cam software. (Both images are 640x480, with 24-bit colour.)

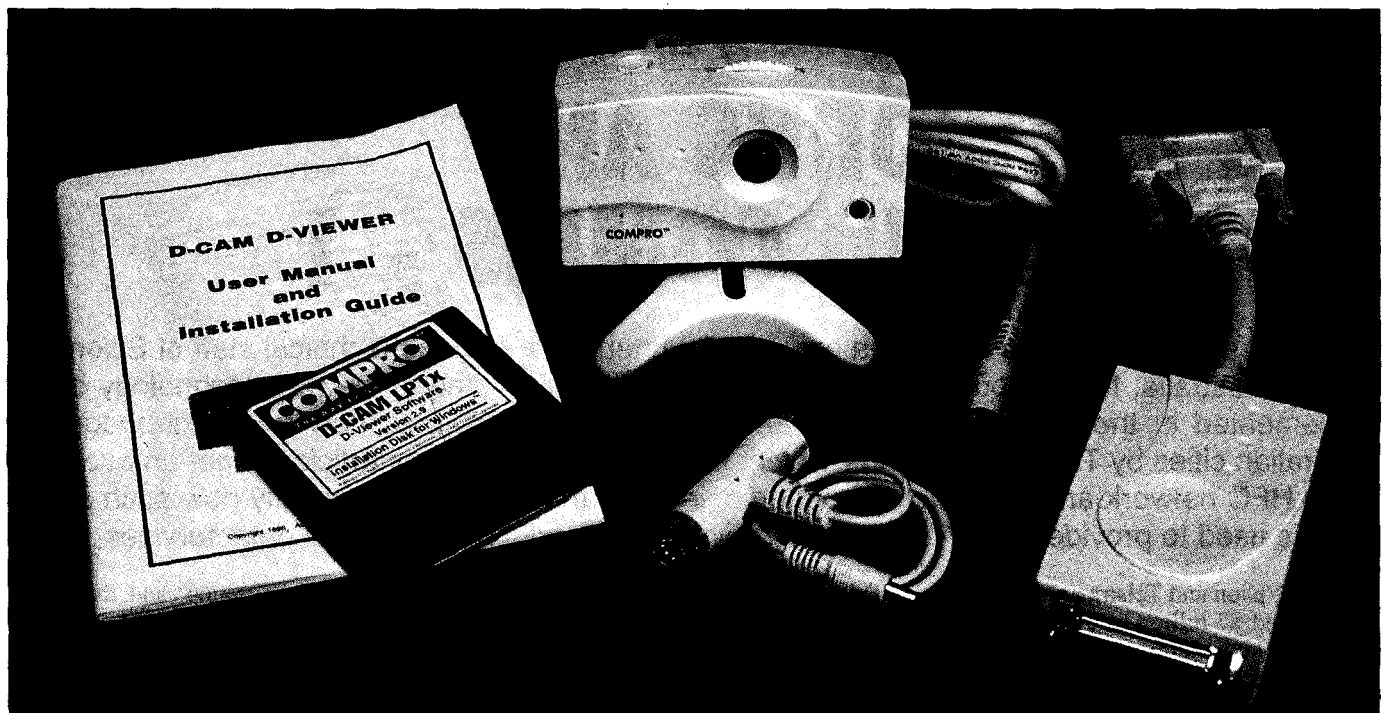

is needed to get you up and running. Although the system requirements are tiny, the program itself is fully featured, and supports a whole raft of import and export file formats, image enhancement features, and other image processing options — including the usual smooth, sharpen, emboss and outline, along with image scaling and full colour control. In fact, this program's image processing capabilities alone are quite impressive, making for a very professional package indeed.

Trying it out

The instructions supplied with the camera were highly detailed, and left no doubt as to how the unit should be installed. After plugging everything together, switching on the computer, and running the usual Windows install program, the software quickly decompressed and set up a program group for itself.

When I ran the D-Viewer program, it automatically detected which port the D-Cam was connected to, and initialised the camera. This reflects the level of user friendliness of the whole system; with no hardware settings to worry about, the user is protected from the usual PC hardware rigmarole that plagues the installation of most peripherals.

A row of buttons along the top of the main window allow the user to perform the most common functions with a single mouse click. By clicking on the Capture Frame button, the camera captures an image, which is then displayed on the screen in one of the three set resolutions (160 x 120, 320 x 240 or 640 x 480 pix-

els). While 160 x 120 pixels sounds awfully small, the 24-bit colour used makes for quite a respectable image.

The Preview Mode button triggers the camera to capture a new image as soon as the last one has been displayed. This results in a moving display, which at the lowest resolution runs at about eight frames per second. In the higher resolution modes, the frame rate drops quite significantly, with a 640 x 480 image taking about five seconds to update. This comparatively slow frame rate is due to the bottleneck experienced when trying to pass data through the computer's parallel port.

It is important to emphasise here that the D-Cam is designed for single image capture, and is not intended for full motion video, so it is best to see the preview mode as just that: a preview of the final shot.

There is provision for a 256-level greyscale image capture, which when combined with the smallest image size results in the highest frame rate. This mode is useful when focusing the camera, allowing you to quickly zero in on the best focus — which brings me to the only aspect of the D-Cam that I felt could be improved.

Focusing is achieved by turning the edge of a toothed wheel that protrudes through the top of the camera. This wheel is directly connected to the camera's simple lens assembly, and being a bit loose, it tends to drift out of focus if the camera is moved between shots. It also gives an undeservedly cheap feel to the camera, as the wheel rattles against the housing whenever the camera is handled.

Pressing the small recessed shutter button situated on the top of the camera has the same effect as clicking on the Capture Frame button with the mouse; that is, a single frame is recorded just like a real camera. Unlike a real camera, however, there is no viewfinder — so if you point and click, you'll probably miss. A minor point, but irritating nonetheless.

Extra software

Bundled along with the Compro D-Cam is CallWiz Plus, a teleconferencing software package that operates over the Internet, modem or local area network. It allows users to employ such tools as virtual whiteboards, audio conferencing, and, of course, video conferencing using the D-Cam.

Unfortunately we only had one D-Cam for review, and thus we couldn't test this package fully. But judging from the well set-out user manual, it looks to be an ideal companion for this excellent camera.

Having played with this camera for a few hours (and I do mean played; it really is quite addictive after a while), I could definitely recommend the Compro D-Cam to anyone working with computer images, whether you're laying out a Web page, sending snapshots over the Internet, or just want to set your own face as Windows wallpaper. All in all, thoroughly recommended.

The Compro D-Cam is available from Rod Irving Electronics (Cat. No. X26000), for \$399. This includes the CallWiz Plus teleconferencing software bundled in the package. ♦

HFC NETWORKS AND BROADBAND COMMS - 1

Here is the first in a series of articles especially written for *EA* by the technical staff of Scientific-Atlanta Australia, to help our readers get a good basic grounding in the new technology being implemented in the new hybrid fibre/coax or 'HFC' cable networks now being introduced in Australian cities by Telstra and Optus Vision. In this short introductory article we get an overview of an HFC network and its basic components; in later articles we'll see exactly how such a network is used to provide Pay TV, cable telephony and broadband/interactive data services.

Optus Vision and Telstra are spending a combined \$7 billion to establish rival broadband communication systems in Australia. Within the next two years, more than four million households will have access to an array of new products and services including pay TV, cable telephony, high-speed internet access and interactive services.

This infrastructure investment is a far cry from the cable industry's more humble beginning. The industry began in the United States in 1948, when simple cable networks were first used to deliver commercial television signals into communities shielded from normal terrestrial broadcasts by hills and other natural obstructions. An antenna would be

set up on high ground, and the signal distributed to individual homes by cable. These systems were commonly called Community Antenna Television (CATV).

Many engineers and technicians still use the term CATV to describe a cable network, however the term broadband communication system has become popular in recent years. Today's sophisticated networks evolved from commercial cable-only networks that began appearing in the early 1970s.

Network components

In its most basic form, a broadband system collects commercial programming from large 'off air' television antennas, a satellite receiving station, or a local broadcasting centre, and then distributes these signals to individual subscribers via fibre optics or coaxial cable. The collected signals require processing before distribution to subscribers — a job accomplished in a central electronic hub known as the *headend*.

Once processed, the signals are combined and routed to the subscriber through a fibre and coaxial cable 'trunk' to a local feeder system, which in turn provides signals to individual homes.

On the coaxial cable part of the network, the various signals are generally carried in the form of modulated RF carriers, in the HF-VHF-UHF spectrum. As a result, broadband systems are most often identified by their upper frequency limit. Most systems in the US to date are built to 550MHz while systems in Europe generally extend to 860MHz. In Australia, both cable operators are building 750MHz networks. These differences reflect regional variations in the average age of the installed equipment base — and to a lesser extent, the spectrum allocated for terrestrial broadcasting.



Installing aerial broadband cable in Longueville, a harbour suburb of Sydney. Optus Vision is using SA transmission products including amplifiers, line extenders and multimedia taps. Visible in the background is Sydney harbour and the city skyline. (Courtesy Scientific Atlanta)

Forward & reverse path

A broadband system can be further categorised according to its configuration and use. A 'forward-only' system only carries signals in one direction — from the headend towards the home. This system is most common when a network's sole use is for subscriber entertainment services. In this system, program information is collected at the headend and distributed through trunk and feeder cables to the subscriber.

A 'reverse-path' system is used when more advanced applications on the network require signals to be carried to and from a subscriber's home. The signals to the home travel via a forward path, while return signals use a reverse path. Typical applications include telephony, interactive services and security systems such as fire, theft or medical alert.

Reverse path networks are considerably more complex and expensive to build and maintain, as weaker signals carried on the reverse path are susceptible to noise ingress. Poor cable installation and inadequate shielding introduce a host of unwanted signals that swamp reverse signals being transmitted back to the headend.

Hybrid fibre/coax

Optus Vision and Telstra are both building reverse-path systems using a hybrid fibre/coax (HFC) architecture called fibre-to-the-serving area (FSA). This type of network uses fibre optic cables to transport high-quality digital signals from the headend to a local node known as the *servicing area*. At this point, digital signals are converted to RF analog signals for delivery along a coaxial cable network.

The FSA architecture being used in Australia follows an FSA-star design (see Fig.1). In this design, pockets of homes are served by an AM fibre node. AM modulation is used as it allows for simple interfacing to a coaxial cable system. Optus Vision is building nodes that typically serve 2000 homes, while Telstra's build supports 500 homes.

From each FSA node, signals are transported to individual homes by coaxial feeders radiating out from the node in a star-like pattern. As the signal travels away from the node it is boosted by a series of amplifiers.

Generally, a feeder cable's maximum length is determined by the designers' specified end-of-line noise and distortion requirements. In a typical 750MHz system, like those in Australia, the signals are boosted by two to six amplifiers before becoming unacceptably distort-



A typical broadband system headend, in this case manufactured by Scientific-Atlanta. The racks of electronics manage the distribution of signals to the HFC network. (Courtesy Scientific-Atlanta)

ed. This means the last home on a single feed cannot be more than few kilometres from the original node.

Advantages of fibre

Fibre optics offer the best solution for improving distortion and noise performance on broadband systems. A fibre optic link, depending on the format used, can virtually eliminate any picture quality degradation.

An HFC network that takes fibre as

deep as individual streets is called a fibre-to-the-curb (FTTC) architecture. As yet few broadband systems are built this way, as the electronics for optical fibre are considerably more expensive. Operators typically try to establish a more cost-effective balance between the number of RF and fibre components by using an FSA architecture.

As the price of fibre-optic cable and fibre electronics continues to fall, some operators have begun to design networks using fibre-to-the-street. In effect, fibre can now be cost-effectively used to reach as few as 50 homes.

In the next of these articles we'll take a closer look at the HFC architecture being deployed in Australia, and explain some of local conditions that have affected network design. In the meantime, here's a glossary of basic terms used in HFC broadband communications.

Glossary of terms

Broadband: Broadband refers to a communications system able to carry extremely large amounts of data. Data can take the form of video, text or voice signals.

CATV: Community Antenna Television is the historical name given to broadband systems.

HFC: Hybrid fibre/coax is a network architecture that uses fibre-optic and coaxial cable technology to transmit and deliver communications signals.

About Scientific-Atlanta

Scientific-Atlanta provides a broad range of communications delivery systems to the converging cable TV, telephone and computer industries. The company has divisions and offices throughout the United States and operates seven international subsidiaries with representatives in more than 75 countries.

Scientific-Atlanta's Australian office was established in March 1985. For more than 10 years, its Sydney office has provided sales and technical support for customers in Australia, New Zealand and the South Pacific. Its customers include Optus Vision, the Department of Social Security, the Australian Broadcasting Commission, Network Ten, Sky Channel and Telecom New Zealand.

HFC Networks and Broadband Comms

FSA: Fibre-to-the-Serving Area is an HFC architecture that uses fibre to carry signals to one or more distribution nodes. Each node supports between 125 and 2000 homes. Signals from the node to each home are carried via coaxial cable.

FTTC: Fibre-to-the-curb is a network architecture that uses fibre to deliver signals to individual homes.

Forward-only: A broadband system that only carries signals in one direction — usually towards the home, as in the first CATV cable systems.

Reverse-path: A broadband system that carries signals in both directions, as required for cable telephony, broadband data communications and interactive services. This is also the term given to the part of the network carrying signals away from the home.

Trunk: A fibre-optic or coaxial cable link that delivers high-quality signals to one or more distribution nodes in a network. To maintain signal quality this link has a limited number of external connections.

Feeder: A coaxial cable that carries signals from a distribution node to individual homes. This link usually has a large number of external connections or 'taps'. ♦

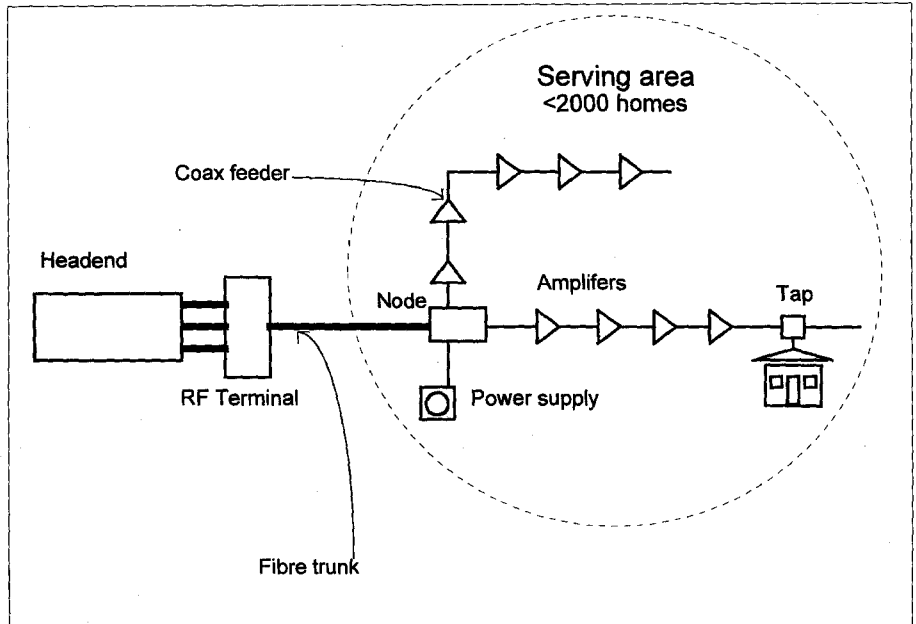
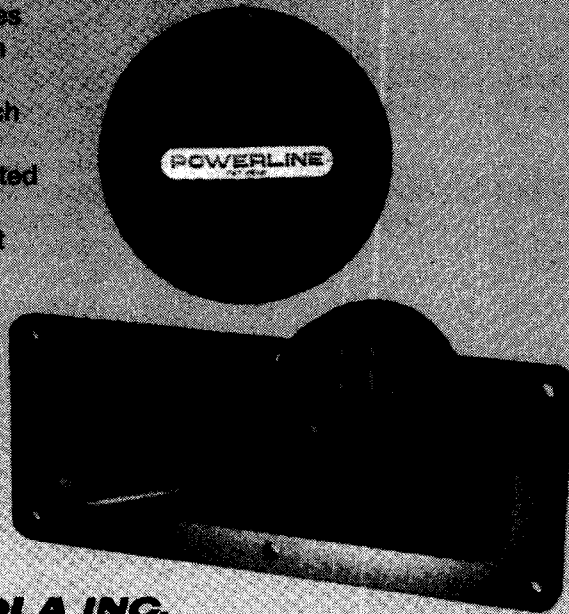

Fig.1: The main components of a hybrid fibre/coax (HFC) broadband network. The signals travel from the headend and the RF terminal via a fibre-optic trunk to each area node, from which they are distributed via co-axial cable feeders. Amplifiers boost levels and maintain signal quality in the coax, and taps split off the individual subscriber drops. Australia's new HFC networks have an RF bandwidth of 750MHz, compared with 550MHz in the USA and 860MHz in Europe.

2x6 Wide Dispersion Horn

Model KSN 1141A

The new Powerline series of Motorola's 2kHz Horn speakers incorporate protection circuitry which allows them to be used safely with amplifiers rated as high as 400 watts. This results in a product that is practically blowout proof. Based upon extensive testing, Motorola is offering a 36 month money back guarantee on this product should it burn out



MOTOROLA INC.

Available @ DICK SMITH, JAYCAR, AVICO, ALTRONICS & OTHER GOOD AUDIO SUPPLIERS
Imported and distributed by FREEDMAN ELECTRONICS PTY LTD.
283 Victoria Rd, Rydalmere NSW 2116. Phone: 02 9638 6666

NEW KITS FOR EA PROJECTS

From Dick Smith Electronics:

10/20MHz Comb Generator (October 1996): The DSE kit is of the 'short form' type, with the PCB and all components including BNC socket, pushbutton switch and battery clip lead. Listed as Cat. No. K-7623, it is priced at \$18.70.

From Jaycar Electronics:

Improved 24-Line I/O Card for PCs (November 1996): The Jaycar kit includes double-sided PCB plus all specified components. IDC launcher plugs for PCB, matching IDC sockets and IC sockets are also included. Listed as Cat.No. KA-1789, it is priced at \$42.50.

From Rod Irving Electronics:

High Isolation Current Adaptor (November 1996): The Rod Irving kit is complete with all components as specified, including the case and Hall sensor. Listed as Cat. No. K-10810, it is priced at \$59.95.

This information is published in good faith, from advice provided by the firms concerned, and as a service to readers. Electronics Australia cannot accept responsibility for errors or omissions. ♦

UNIVERSAL TEMPERATURE CONTROLLER

This kit controls temperature by switching power on and off to a heater or a cooler. Useful for incubators, aquariums, air conditioning etc. Has a thermistor to sense ambient temperature and switches a MOSFET that can handle up to 10A 50V DC directly. Use a relay for isolation if necessary. Includes status indicator LEDs, operates from 11 to 25V DC. Use a rewound jug element for a cheap heater element. PCB and all on-board components: **\$19**

LASER POINTERS

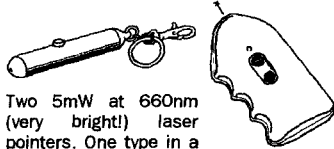

Two 5mW at 660nm (very bright!) laser pointers. One type in a small flat plastic case, the other in a small metal cylindrical case fitted with a keychain. Both powered by 3 LR44 batteries and APC driver circuitry. Greatly reduced prices: **\$55 ea.**

UV MONEY DETECTOR

Portable UV source. Has two AA batteries and an inverter to step up the voltage to power a 50mm long, cold cathode UV tube. Simple circuit. Inverter can dimly light a 4W fluoro tube. Takes about 250mA. Case 82 x 46 x 21mm: **\$5 ea or 5 for \$19**

GEIGER COUNTER KIT

PRICE BREAKTHROUGH!

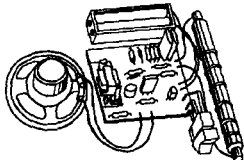

Based on a Russian Geiger tube, has traditional 'click' to indicate each count. Kit includes PCB, all onboard components, a Money Detector (see above), speaker and YES, the Geiger tube is included. **\$30**

12V - 2.5W SOLAR PANEL KIT

US amorphous glass solar panels only need terminating and weather proofing. Includes clips and backing glass. Very easy to complete. Size: 305 x 228mm, Voc 18-20V, Isc 250mA. **\$22 ea, 4 for \$70**

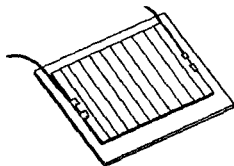

Efficient switching regulator kit also available: suits 12-24V batteries, 0.1-1.6A panels, **\$27**. Also available, simple shunt regulator kit **\$5**

PIR MOVEMENT DETECTOR

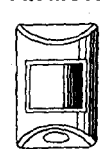

Commercial quality 10-15M range PIR movement detectors. Second hand, tested and guaranteed, have relay contact outputs, a tamper switch and operate from 12V DC. Compatible with standard alarm systems. Includes circuit. **\$10 ea. or 4 for \$32**

PIR CASE FOR CCD

Used cases from PIR movement detectors, with Fresnel lens and PCB. Ideal as a case to conceal a CCD camera. **\$2.50 ea or 4 for \$8**

PLASMA EFFECTS SPECIAL

Ref: EA Jan '94. Produces a fascinating colourful high voltage discharge in a domestic light bulb, or light up an old fluoro tube or any gas filled bulb. The EHT circuit is powered from a 12V to 15V supply and draws a low 0.7A. Output is about 10kV AC peak. PCB and all on-board components (flyback transformer included), and instructions: **\$28** (cat K16) Hint: connect the AC output to one of the pins of a non-functional but gassed laser tube, amazing results! The special? We supply a low power functional laser tube for an additional **\$14**, but only if purchased with the plasma kit. Total price: **\$42** (Includes instructions on getting the laser tube to produce a laser beam!)

FOG MACHINE

Mains operated fog machine: 700W, 3000 cubic meter per minute capacity, remote operation with lead supplied. Great for light shows and lasers! Low introductory price: **\$300**

RARE EARTH MAGNETS

Very strong!!! Zinc coated. Cylindrical: 7 x 3mm, **\$2** (G37) 10 x 3mm: **\$4** (G38), toroidal 50mm outer, 35mm inner, 5mm thick: **\$9.50** (G39)

NOV4SALE!

Our annual sale day is on again at our new premises:

Saturday 9th November
9am to 3pm

68 Lorraine Street,
Peakhurst.

A list of items will be available from November 4th. Poll our fax on (02) 9579 3955, or see our Web site. Mail orders will be accepted up to November 16. Phone/fax orders accepted from Nov 4 to Nov 8.

LED FLASHER KIT

3V operated 3-pin IC that flashes 1 or 2 high intensity LEDs. Very bright and efficient. IC, two high intensity LEDs and small PCB: **\$1.50 ea, 10 for \$12**

SIMPLE MUSIC KIT

3V, 3-pin IC plays a single tune. Two ICs that play different tunes, speaker and small PCB: **\$3 or 10 for \$25**

MAGNIFIERS - LOUPES

Four types (see review S.C. May 96). Small jewellers eyepiece with plastic lens: **\$3**. Others in the range have two glass lenses, used where the loupe is placed close to the object being magnified. Focal point just below base of the loupe. Loupe with 50mm dia viewing area, 10 x mag: **\$8**, 75mm: **\$12**, 110mm **\$15**.

SECURE IR SWITCH

Toggles a relay from an IR transmitter. Coded transmitter and receiver so a number can be used in the same area. Includes commercial one button transmitter, receiver PCB and parts to operate a relay (not supplied): **\$22**

VISIBLE LASER DIODE KIT

We have redesigned our 5mW 660nm visible laser diode kit so the PCB fits neatly into a new hand held case (supplied). Complete pointer kit (with case) at a REDUCED PRICE of **\$35**. A similar kit with a 5mW 635nm laser diode: **less than \$100**

STEPPER MOTOR PACK

Pack of seven stepper motors. Save 50%! Includes 3 x M17, 2 x M18, 2 x M35, all new: **\$36**

VIDEO TRANSMITTER

Low power UHF TV transmitter with adjustable level audio and video inputs, power switch and power in socket. Needs 10 to 14V DC at 10mA. Set to Ch 31, can be altered. Video input accepts standard composite video (eg CCD camera), comes in small metal box and built-in telescopic antenna. Range typically 7 to 10cm for internal TV antenna: **\$25**

WEB ADDRESS

See our web site for our latest catalog and list of items at

<http://www.ozemail.com.au/~oatley>

MINIATURE FM TRANSMITTER

Very small ready-made FM transmitter in a small black metal case. Powered by a 1.5V watch battery (included), has an in-built electret microphone. Tuning range: 88 to 108MHz (adjustable). Range approx 50m: **\$32**

3-STAGE TUBE CLEARANCE

SC Nov. 95. 25mm 3-stage fibre optic night vision tube, works in starlight EHT supply kit and eyepiece. **\$200**

IR REMOTE CONTROL TESTER

Kit includes a blemished fibre optic coupled IR converter tube with either 25 or 40mm diameter window, and our night vision HT power supply kit. The tube responds to IR and visible light, and can 'see' the output of an IR remote control. **\$30**

SOLID STATE Peltier DEVICES

12V 4.4A, can be used to make a thermoelectric cooler - heater. Basic info included. **\$25** 12V DC fan **\$8**

IR REPEATER KIT

Extend the range of existing remote controls up to 15m and/or control equipment in other rooms: **\$18**

VISIBLE LASER DIODE MODULE

Industrial quality 5mW/670nm laser diode module. Dimensions: 12mm dia x 43mm long. Includes visible laser diode, diode housing, APC driver circuit and collimation lens all factory assembled in one small module. Has superior collimating optic, divergence angle less than 1 milliradian: **\$65**

POWER MOSFETS

IRFZ44 N-channel MOSFETs at a realistic price for hobbyists. 60V (max), 0.028 ohm on-resistance, 50A (max). T0220AB package. **\$4 ea, 10 for \$30**

ALCOHOL BREATH TESTER KIT

Has high quality Japanese thick-film alcohol sensor. Kit includes PCB, all components, meter movement: **\$30**

ARGON-ION HEADS

Used Argon-Ion heads with 30-100mW output in the blue - green spectrum. Head only supplied. Needs 3V/15A AC (for filament) and approx 100V/10A DC for the inbuilt driver circuitry. We provide a circuit for a suitable power supply. Dimensions: 35x16x16cm, weight 6.0kg. 1 year guarantee on head. Needs a 1kW transformer, available elsewhere for about **\$170**. Argon head only: **\$300**

HIGH VOLTAGE AC DRIVER

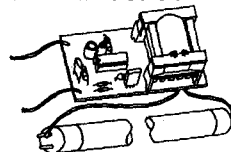

Produces a high frequency, high voltage AC for ionising most gas-filled tubes up to 1.2m long. It can partially light a standard 36W fluoro tube with two connections, taking less than 200mA from a 12V battery. Heat the tube filaments to get about 6W of light output. Includes PCB, small fluoro tube and components. **\$18**

CCD CAMERA - TIME LAPSE VCR RECORDING SYSTEM

Includes PIR movement detector and control kit, plus learning remote control. Combination can trigger any domestic IR remote controlled VCR to start recording when movement is detected, and stop recording a few minutes after movement stops: **\$90**

CCD CAMERA BONUS SPECIAL

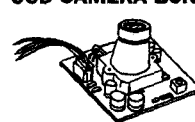

Tiny (38 x 38 x 27mm) PCB CCD camera, 0.1 lux, IR responsive

(works in total dark with IR illumination). Connects to any standard video input or via a modulator to aerial input. SPECIAL pack 1: standard or pinhole camera with bonus VHF modulator OR regulated 10.4V plugpack. REDUCED PRICE **\$140**
SPECIAL pack 2: pack 1 PLUS video transmitter: **\$155**

LOW COST IR ILLUMINATOR KIT

Allows a CCD camera or a night viewer to see in the dark. Adjustable power, 10 to 15V operation at 600mA (max). Has 42 IR 880nm LEDs: REDUCED PRICE **\$30**

400x128 LCD MODULE

New Hitachi LM215 400 X 128 dot matrix LCDs in an attractive silver grey housing measuring 340 x 125 x 30mm. Driver ICs fitted but needs external controller. Effective display size 65 x 235mm. Basic data also provided. New and unused. **\$25 ea or 3 for \$60**

OATLEY ELECTRONICS

PO Box 89, Oatley NSW 2223

Phone (02) 9579 4985

Fax (02) 9570 7910 or 9579 3955

orders by e-mail: oatley@world.net

major cards with phone and fax orders. P&P typically \$6.

READER INFO NO. 7

What's New In VIDEO and AUDIO

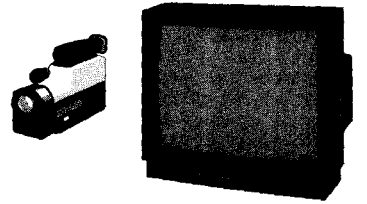

Economy hi-fi speakers from Bose

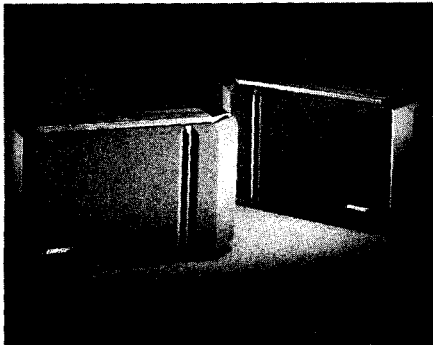

The new model Bose 301 Series IV and 201 Series IV Direct/Reflecting speaker systems are claimed to create lifelike sound that conventional speakers cannot match, and are intended to enhance the performance of existing stereo systems.

Bose claims the 201 and 301 speakers can also be very effective for home theatre applications.

The 201 speaker can be used with amplifiers from 10 to 120 watts per channel while the 301 can be used with amplifiers from 10 to 150 watts per channel, making both systems compatible with virtually all home-use stereo systems. Like all Bose products the speakers are simple to install.

The speakers now offer two complementary high-sensitivity tweeters for optimised sound delivery. The magnetic-fluid-cooled 2" Stereo Targeting tweeter directs the mid and high frequencies to a wide, stable area between the speakers. This creates balanced stereo sound throughout the listening area and a focused, stable centre image. Meanwhile, the rear-firing 3" Direct/Reflecting tweeter sends sound from the back and side of

the speaker to recreate a natural balance of reflected and direct sound energy.

The new 301 speaker also features a proprietary multiple frequency crossover network for clear, natural voices and midrange instruments.

In the bass, a long-excursion six and a half inch woofer combines with a new, turbulence-reducing, flared-port design for clean low frequencies at high volumes.

The 301 Series IV speakers, which come in black or rosewood, will retail at \$749 per pair. Also available in black or rosewood, the new 201 Series IV speakers retail at \$529 per pair.

Bose 301 Series IV and 201 Series IV speaker systems are available from authorised Bose dealers throughout Australia. For information about Bose stockists circle 140 on the reader service card or call Bose toll-free on 1800 816 774.

Compact A-V systems from Kenwood

Kenwood's powerful new audio visual entertainment systems — the UD-755CRS and UD505CRS — are said to provide a high level of realism for home cinema presentations. The systems provide Dolby Pro Logic Surround and also Dolby 3 Stereo, which lets you enjoy a wider, more expansive sound with clear, easy to hear dialogue when using only three front speakers.

Turning either of the Kenwood UD systems into a complete A-V home entertainment system is simply a matter of hooking them up to your VCR, Laserdisc player and TV.

The UD-755CRS features ASP (Acoustic Sound Processor), which recreates the ambience of a choice of performance venues, like Arena, Stadium and Jazz Club. A four-channel amplifier provides stereo 60W x 2; surround mode 60W x 2 (front left and right), 15W centre, and 10W x 2 rear. The UD755CRS also includes a 6-disc CD player which enables you to change any of the discs while one is playing.

The UD-505CRS features a three-disc Carousel CD player, which allows you to change up to two discs respectively while

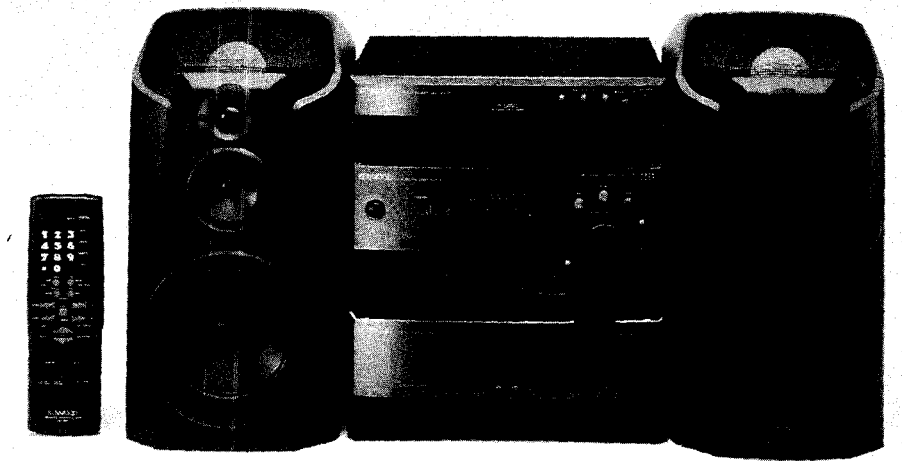

a disc is playing. It also provides the SRS (Sound Retrieval System) 3D Sound system, which provides a synthetic surround sound effect from only two front speakers.

Both UD systems feature Low Level Control, which instantly returns the volume to a previously set level; Dolby HX-Pro Headroom Expansion, producing great recording results by adjusting bias during recording and expanding the dynamic range; and One Touch Edit, the simple way to create

your own tapes from multiple CDs. Both models also have the option of the SW-500 powered subwoofer and P-100 turntable.

The UD-755CRS has an RRP of \$1649, while the UD-505CRS has an RRP of \$1099. Kenwood's UD systems are covered by a 24 month warranty and are available at selected Kenwood audio dealers. For further information circle 141 on the reader service card or call Kenwood on (02) 9746 2688.

Constant phase monitor speaker from Audiosound

Audiosound Laboratories has released its Minuet 8033 AB, a high-performance monitor loudspeaker system for small studios and control rooms where wide range accuracy and phase coherence with extended low frequency performance are of prime importance over sheer power ability.

Whilst claimed to offer exemplary music detail, the new system is also said to be excellent for critical assessment of audiophile amplifiers (both solid state and valve), compact disc players, D to A converters and esoteric analog audio, etc. Further, they are claimed to be an excellent tool for evaluating microphone technique and phasing, as well as comparison of recordings in critical audio/studio appli-

cations. Near-field lobing is said to be virtually eliminated with the 8033 AB.

This special, AB version in the 8033 series incorporates a recently developed Thiele/Linkwitz 24dB/octave constant phase crossover system. Audiosound's Ron Cooper says is the culmination of over 20 years of refinements on the original 8033 loudspeaker system. In 1991 the Minuet 8033A Mk III received an Australian Design Award.

The 8033 AB is priced at \$2690 and is available in black, walnut and jarrah with matching stands or a one-metre high dual-support professional rigid metal stand.

For further information circle 144 on the reader service card or contact Audiosound Laboratories at 148 Pitt Road, North Curl Curl 2099; phone/fax (02) 9938 2068.

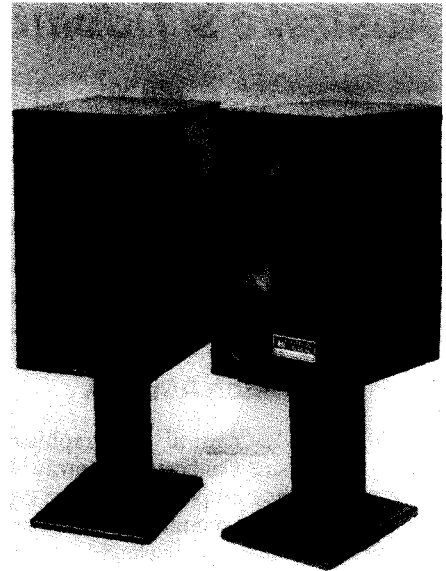

Big screen CTV from Goldstar

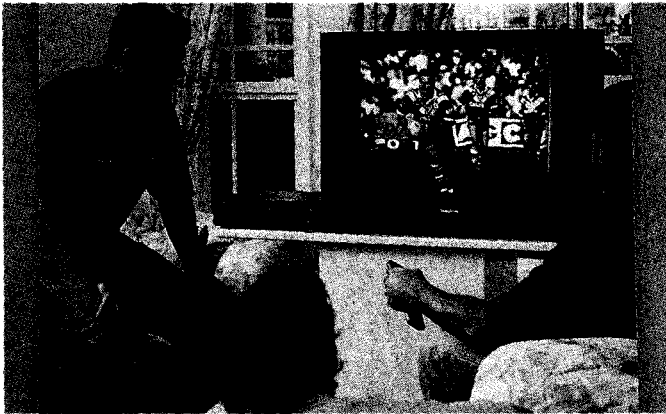

Aware of the current interest in home theatre, Goldstar has released a 68cm stereo model colour TV that is claimed to offer great value.

The new model CF-29C44XM has a stylish cabinet design with teak trim, and offers a host of quality features, starting with a 'super flat' picture tube to deliver clearer pictures with less distortion and reflection. Also a real bonus in this price

range is the PIP (picture in picture) function, with two tuners giving you the opportunity to watch the main TV screen with a sub screen showing the broadcast from another channel or video recorder.

The inbuilt Super Woofer reproduces deep bass sounds, resulting in clear, stereo sound. Total audio output is a powerful 44 watts, directed through five speakers in all.

Other features include:

- Teletext — the service which gives you a wide variety of information from the weather to stock market reports, racing results and news;
- Multi system capability, making the TV compatible with most broadcasting systems in the world;
- Front AV (audio video) connections;
- Full function on-screen display;
- A unified remote control; and
- A child lock.

Goldstar also backs its commitment to these receivers with a three-year warranty. The 68cm CF-29C44XM receiver has an RRP of \$1999.

Goldstar television receivers are available at David Jones, Betta stores and selected Harvey Norman outlets nationally. For further information circle 142 on the reader service coupon of contact Goldstar on (02) 9888 1311.

LCD projector offers 800 x 600 resolution

Fujitsu General has released the fully featured General LPF-3200 LCD colour video projector, a compact and elegant unit claimed to be ideally suited for both computer graphics and video cinema because of its high image resolution of 800 x 600 pixels (SVGA).

Measuring only 340 x 410 x 172mm (W x D x H) and weighing only 11kg, the LPF-3200 is fully compatible with all colour TV systems (NTSC/PAL/SECAM/M-PAL/N-PAL/4.43 NTSC). It uses a 250W metal halide lamp, together with three 1.3" polysilicon TFT LCD panels with a high aperture ratio, and provides a light output

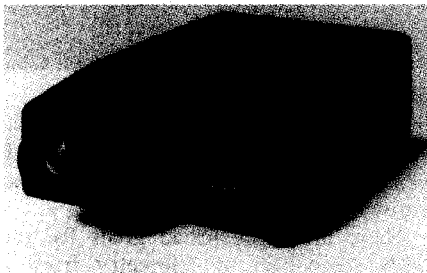

of 350 ANSI lumens. Each panel provides a resolution of 832 x 624 pixels, for a total image resolution of 1,557,504 pixels. The single projection lens (F2.8 - F3.3) offers 3X power zoom, power focus and power shift, and allows adjustment of image size from 500mm — 7.6m (diagonal), with

a typical size of 2.5m at a screen distance of 3.4m. Colour temperature is 6000 - 7500K.

Horizontal resolution is rated at over 450 TV lines. In addition to the various TV standards, the projector also accepts SVGA (800 x 600) computer graphics signals with horizontal scan rates of 35, 37, 47 and 49kHz, and VGA (640 x 480) signals with horizontal rates of 15, 24, 31, 35, 37 and 30kHz. It also accepts S-Video inputs as well as composite video.

The General LPF-3200 includes a 2W audio amplifier and inbuilt mono speaker. It will be available in Australia later this year, with an RRP of under \$9000.

For further information circle 143 on the reader service card or contact Fujitsu General (Aust.) on (02) 9638 5199. ♦

Australia's Tidbinbilla Tracking Station:

DEEP SPACE PABX

The Tidbinbilla Tracking Station near Canberra is one of only three in NASA's worldwide Deep Space Network, and its collection of dish antennas and associated equipment plays a crucial role in controlling and communicating with ongoing deep space missions such as Galileo. Geoff McNamara was able to tour the station recently, and here's what he discovered.

by GEOFF McNAMARA

Nestled in a natural geographical depression outside Canberra is an array of large radio dishes, all pointing toward the sky. Surrounded by mountains, the dishes are protected from increasingly severe interference that 'lights up' the radio sky. This isolation from mainstream radio communication is necessary if the dishes are to accomplish their task: tracking and communicating with spacecraft in deep space. Welcome to the Canberra Deep Space Communication Complex.

The majority of spacecraft are launched for Earth-related activities, such as communications and monitoring terrestrial phenomena such as the weather. A few, however, have a different role: exploring outer space. But as these interplanetary pioneers voyage deeper into space their signals get weaker. To be able to communicate with a spacecraft billions of kilometres away calls for some special skills. The fact that some of them can be heard at all is a technological achievement in many ways greater than that which sent them on their way.

Situated in the Tidbinbilla valley outside Canberra, the complex is more commonly referred to as 'Tidbinbilla', or simply 'Tid'. Tid is one of three deep space tracking stations established by NASA to maintain communication with its spacecraft; the others are at Madrid in Spain and Goldstone in the USA.

Collectively called the Deep Space Network (DSN), the three stations are essentially identical. A technician from Tid could walk into either the Madrid or Goldstone stations, pull up a chair and, if it weren't for someone else's coffee cup on the desk, think he was at his usual station back in Australia.

Tid's Director is Peter Churchill, a friendly fellow who has come up through the ranks. Starting out as a digital systems engineer, he decided that after 13 years "...it was time to let somebody else play with the screwdrivers and for me to tell others what to do", he laughed. Peter became Deputy Director

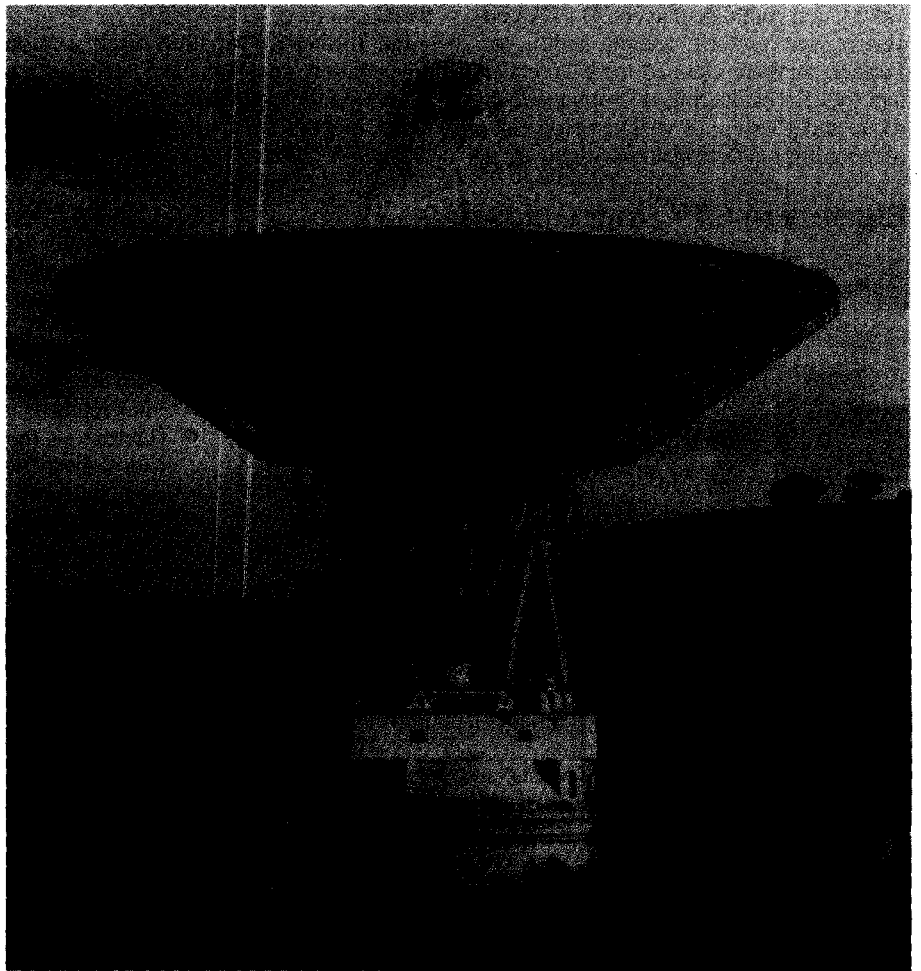

in 1990 and then Director in 1994. "Come November I'll have been here 20 years", he noted. There are few who know this game better.

There are three broad goals for the DSN: reception of telemetry from a spacecraft, transmission of commands, and tracking the spacecraft as it moves through space.

"This is all performed under unique telecommunications conditions", Churchill explained. "We're communicating by radio with another entity at an enormous distance from us, that is itself transmitting to us a relatively low-pow-

ered signal. In order to communicate with typical interplanetary spacecraft you need rather special equipment on the ground."

Microwave window

Communicating with spacecraft a long way from Earth constrains the DSN to certain parts of the electromagnetic spectrum. Specifically, the frequencies used are those which can penetrate the Earth's ionosphere. These bands are collectively called the *microwave window* — the same window through which radio astronomers

look. At these wavelengths, the radiation has optical characteristics, which in turn dictate the kind of receiving equipment needed on the ground. This means parabolic reflectors, similar to those found in optical telescopes, only larger. Much, much larger...

Yet the story of keeping tabs on interplanetary spacecraft begins much closer to home. Spacecraft begin their journeys from NASA's launch site in Florida. Shortly after that, Tid begins its job of tracking the spacecraft. "By the time the spacecraft is free of the launch vehicle, it's coming over Tid's western horizon," Churchill explained.

At that point, a 26-metre Earth Orbit Support antenna locks on to the spacecraft. The 26-metre dish uses two smaller wide-angle 'acquisition dishes' mounted on its edges to help find the fast-moving spacecraft. The main dish then swings toward the spacecraft and tracks it as it flies overhead.

The initial acquisition is performed by the relatively small 26-metre dish for two reasons. Firstly, the signal from a spacecraft still in Earth orbit is so strong that a larger dish isn't necessary; secondly, larger dishes can't move fast enough to track the spacecraft as it flies overhead. And so the 26-metre dish begins the process of tracking an interplanetary probe — a job that may last decades.

As well as keeping an eye on the spacecraft operations, the antenna is also providing navigation data. "While we track it, we're generating data derived from encoders on the antenna's

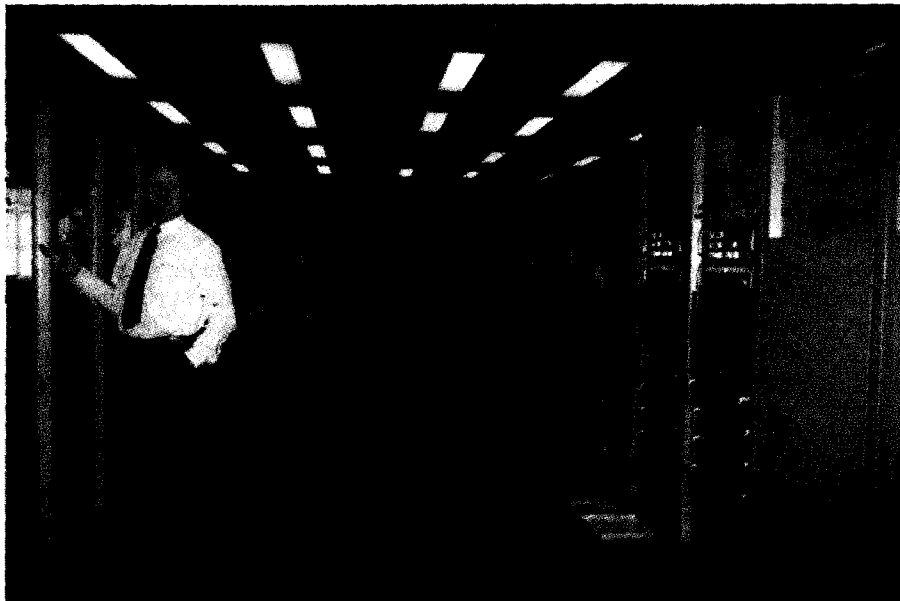

CDSCC Director Peter Churchill with some of the station's control equipment. "It's not state-of-the-art, but the staff make up for it." (Photo by Brenda McNamara)

axes," explained Churchill. The data on where the spacecraft is headed is provided to that mission's navigation team, to improve their estimate of the spacecraft's trajectory. The new estimates are used to improve the precision of the trajectory model that resides in the computer at the mission control centre.

While the spacecraft is nearby its trajectory is expressed as an *inter-range vector*, which is used to produce altitude and azimuth information for pointing the antennas on the ground. Once the spacecraft is on its way, however, it 'becomes' a celestial object. Its position

is then expressed in terms of astronomical 'Right Ascension' and 'Declination' — the equivalent of longitude and latitude projected onto the sky. The third factor needed to plot its course is time.

No matter how accurate the prediction of the spacecraft's trajectory, however, Tid has to keep monitoring where the spacecraft is for comparison with those predictions. Once the spacecraft is well beyond Earth one of the deep space antennas, the largest being 70 metres across, is swung into action. These giant antennas use a beam width of approximately two arc-minutes to track spacecraft with milli-degree accuracy. But because of the tremendous distances involved, even small errors in positioning can have drastic effects on Tid's ability to locate and lock on to the spacecraft signal.

Conscan technique

This necessitates some clever navigation techniques. "On specified occasions we perform a special function to determine exactly where the spacecraft is", Churchill said. "The function is called 'conscan' — short for *conical scanning*."

The conscan technique is used to help refine the position of the spacecraft for navigation purposes. During a conscan run, the dish tracking the spacecraft is instructed to trace out a tiny circle on the sky, in effect carving out a narrow cone in space. The signal will be strongest when the dish is aimed closest to the spacecraft and correspondingly weakest at the edge of the circle farthest from the spacecraft. By comparing the relative signal strength with the direction of the

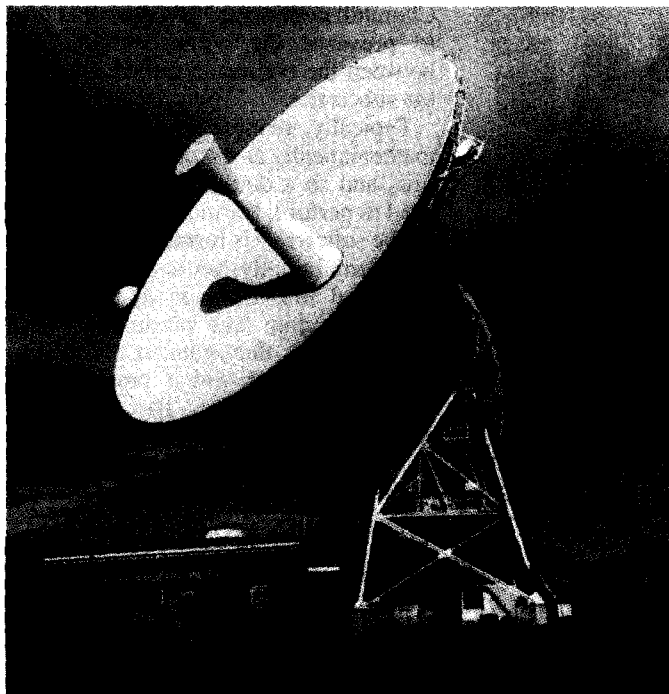

The 26-metre 'Earth Orbit Support' antenna, used for communications with spacecraft when they're still quite close to the Earth. It can swing around faster than the main 70m dish, and is therefore more suitable for close-range working. (Photo by Brenda McNamara)

Deep Space PABX

antenna, the tracking team can pinpoint the spacecraft with amazing accuracy.

How often the conscan manoeuvre has to be carried out depends on the precision required for navigation, for that part of the spacecraft's trajectory. If it's approaching a trajectory correction manoeuvre (TCM) or a planet, then the procedure may be carried out every couple of days. On the other hand, during interplanetary cruises it may only be needed every month or so. "Nevertheless, the process is used whenever the opportunity arises. We always like to gather navigation data", added Churchill.

But there's more to tracking a spacecraft than simply plotting its position on the sky. Its velocity through space has to be determined, usually using the phenomenon known as Doppler shift (the same technique used by police to catch speeding drivers).

Finally, the spacecraft's distance from Earth is determined using a *ranging code* — a special message sent to the spacecraft telling it to relay the same message back to Earth. How long it takes the message to get out to the spacecraft and back again — travelling at the speed of light — tells the navigation team how far away the spacecraft is.

The precision achieved is remarkable. In the most recent example, the Galileo spacecraft was to fly past Jupiter's moon Io at an altitude of 1000 kilometres. It passed within 80 kilometres of

the targeted point; not bad for a spacecraft 934 million kilometres from Earth!

Churchill points out that this is typical of the accuracy attained by the Network: "If we're given a prediction of where a spacecraft is going to be and we move the antenna to that point at the beginning of a tracking pass, it's almost certain that we will locate the spacecraft. The reason it's that good is because these measurements have been made over a long period of time. Combined with various tricks of the trade, we can precisely determine the spacecraft's position in the sky."

Communication with a spacecraft is planned in minute detail well ahead of schedule. The mission team decide what they want the spacecraft to do and when. "Even that's a long process, with lots of meetings!" said Churchill.

With so many vested interests — scientists who have devoted their lives to particular experiments carried by the spacecraft — there is inevitably heated debate over which operation is carried out first and if others are done at all. The spacecraft can't necessarily do everything at once, simply because two instruments might be mounted on the same scan platform on the spacecraft.

Once decisions have been made it's time to tell the spacecraft. The instructions are compiled into a 'command file', with several command files constituting a command sequence. This command sequence is relayed from JPL to the relevant station via satellite (see

box), and then sent on to the spacecraft.

Risk of disaster

Because of the consequences of giving the spacecraft a wrong command — such as happened with the Russian Phobos mission, when the spacecraft was erroneously told to point its high-gain antenna away from the Earth, permanently severing communication — many checks on the commands are made before they're sent.

The commands can be sent in two modes: 'throughput commanding' and 'store-and-forward commanding'. Throughput commanding means the instructions are received from JPL, shuffled around a bit before being sent straight on to the spacecraft. Store-and-forward commanding is when the commands are received from JPL, and stored in the command processor for transmission at a later, specified time. The decision on which mode to use is based on the mission parameters and requirements.

Either way, the basic process is the same. "We use command elements to modulate a subcarrier", explained Churchill, "Our main transmitter, which sits up in the antenna, is transmitting a radio frequency that the spacecraft receives and that's the main carrier. We modulate the main carrier with a subcarrier, in other words another much lower frequency. It's this subcarrier that contains the command information."

"This is a fully digital process", Churchill continued, "It's done this way to preserve the phase relationships between the command information and the subcarrier."

Typically, modulation is represented mathematically as a multiplication function, and so a digital multiplier chip is used to perform the modulation process.

The subcarrier is represented in a digital form initially, as is the incoming command file. Both go to the digital multiplier chip. The product of these two quantities then goes to a digital to analog converter which produces the modulated subcarrier. The modulated subcarrier is then sent to the main transmitter and modulates the main carrier being transmitted to the spacecraft.

Two power levels

Transmission of commands to a spacecraft hundreds of millions of kilometres away calls for a powerful signal. There are two power levels available at Tid — 'low power', at 20kW, and 'high



The Link Control Monitor consoles at Tidbinbilla, used to supervise the various tracking, control and telemetry functions when a spacecraft is being tracked. (Photo by Brenda McNamara)

power' ranging from 100kW to 400kW. "If we do transmit at high power — and at the moment the threshold is anything over 125kW — we have to coordinate the event with Air Services Australia," said Churchill. ASA then diverts aircraft away from the vicinity at the time of transmission. Although very slight, the danger isn't to pilots or passengers, but rather to the aircraft's avionics which may be disturbed by Tid's transmission.

High-powered transmissions are made on a regular basis, usually when Tid sends commands to the Pioneer 10 spacecraft which is the furthest from Earth. For some critical phases of the Galileo mission Tid has been on standby to transmit at very high power of around 300kW, and there may be a dozen or more times a year where such transmissions are needed.

With such powerful transmission capabilities, the spacecraft's reception doesn't need to be that sensitive. Not so the other way around. The data collected by a spacecraft — measurements, photographs and so on — along with information of how the spacecraft is performing, is collectively known as telemetry. Reception of this data is one of the most important and difficult tasks of a deep space tracking station, especially considering that spacecraft transmissions are typically around 20 watts. By the time the signal reaches Earth, it has faded to less than a whisper. For example, the amount of signal collected by the 70-metre antenna from Pioneer 10 is about 10^{-20} watts!

In order to recover such a faint signal special receivers are required, starting with a low-noise amplifier mounted at the focus of the antenna. This amplifier is cooled by a helium refrigerator to 4 Kelvins (-269°C), so that its self-generated noise is almost non-existent. The amplified signal is fed into a special receiver that is fully digital in operation. This receiver uses phase-lock loop principles to detect and lock onto the carrier and telemetry subcarrier, and to demodulate the 'baseband' telemetry.

In addition, to enhance the signal-to-noise ratio and so maximise the likelihood that what is received is what was actually sent, the telemetry is encoded by the spacecraft as a stream of *symbols*. The baseband telemetry comprises this 'symbol stream', which is just a string of 1's and 0's.

One function that the receiving system performs is to *synchronise* the symbol stream. That is, the receiver has to determine where the end of one symbol and the start of the next occurs. A 'local clock' — just a square wave, but

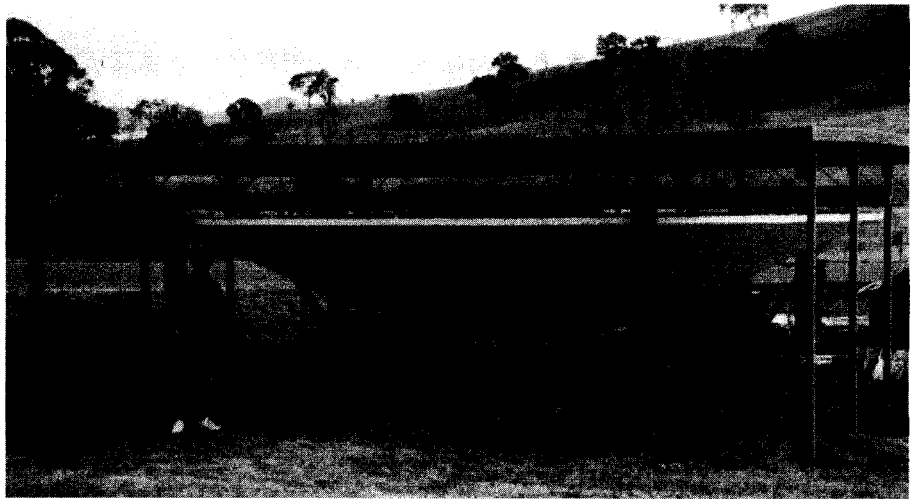

Author Geoff McNamara standing next to a spare sub-reflector for the 70m antenna, to help emphasise the scale of that antenna. (Photo by Brenda McNamara)

derived from a very stable hydrogen maser clock — is synchronised with the symbol stream and provides the reference for determining the best estimate of where the symbol edges occur.

Once synchronised, the symbol stream is processed by a decoder to recover the original telemetry data. The decoder provides a data stream that has the 'maximum likelihood' of being the same as that which entered the spacecraft encoder in the first place. "That is a fairly sophisticated mathematical process", comments Churchill. "Suffice it to say that this encoding process at the spacecraft and then the decoding process at the tracking station in the telemetry processor enhances the signal-to-noise performance of the telemetry reception process."

All of these processes — the tracking, commanding, reception of telemetry, and so on — all need very careful monitoring. The 'monitor and control' function is performed at a special console in Tid's control room.

"The various systems that we have on the station all communicate on a local area network", Churchill explained. "Specific units from these systems can be collected and configured into what we call a 'link'."

'Specific units' might be a telemetry or command processor, or a receiver and transmitter. Information provided by these systems, for example receiver signal strength and phase-lock loop status, or the current data rate of the symbol stream and the telemetry signal-to-noise ratio, are available to the operator and appear as displays on computer screens. Similar features can be called up for the command system. In this way, the operator can monitor and control the configuration of the systems during any tracking pass.

At the same time, the operator has a keyboard for instructing all the systems on the site to perform the appropriate functions for each tracking pass.

"When you first bring the link up, you have to tell the various systems which spacecraft is being tracked," Churchill said. The system has to know which spacecraft is being tracked, so it can load the appropriate standards and limits tables for the various parameters particular to that spacecraft.

All of the interaction between the operator and the rest of the system passes through a computer known as the monitor and control processor. "The operator is concerned with the performance of the various systems on the station to make sure they're performing within expected tolerances and to make sure the telecommunications link is performing as expected."

Despite popular belief, the staff at Tid don't see the results of all that data streaming in from the spacecraft. "People expect to see a picture of Jupiter on the screen — it's not like that at all", said Churchill. Converting the data into useful images is done only at the Jet Propulsion Laboratory in Pasadena by the mission science team.

"In some respects, a deep space station is like a sophisticated post office. We don't read the mail, we just make sure it's packaged and addressed correctly, and forward it on," says Churchill.

Churchill made a surprising comment, which made Tid seem even more impressive: many things on the station are not state-of-the-art. Despite the magnificent achievements of the deep space programme — seeing detailed images of planets thousands of millions

Continued on page 32

The new RPI modems: a cautionary tale

Some of the latest generation of low cost modems are based on the Rockwell RPI chipset, which off-loads a significant amount of the signal processing back on the host PC. And as Tom Moffat reports here, many US computer users are finding that their new low-cost 'multimedia PC' simply isn't capable of coping with the extra workload — especially when hooked up to the World Wide Web. Australian computer and modem buyers should perhaps take note...

by TOM MOFFAT

In a recent issue of a Seattle newspaper, the column 'Computer Corner' reviewed the latest modem from US Robotics, known as the Winmodem. This modem was considerably cheaper than most other models, from both US Robotics and other manufacturers.

The Winmodem worked fine in a Gateway 2000 DX2-66 computer running Windows 95. But there were a couple of surprises for the writers. Unlike previous modem models, the Winmodem required a special driver to be installed for it to work under Windows. And it wouldn't work at all under MS-DOS...

What these writers hadn't realised is that they were dealing with an RPI modem. RPI stands for Rockwell Protocol Interface. Rockwell is probably the most prolific supplier of chipsets for modems, although they don't manufacture modems themselves. They're more into making things like Space Shuttles (for which they've recently teamed up with Boeing).

But what's so different about their new RPI chips, and the modems that use them? Well, to understand that we need a bit of background.

As well as sending and receiving straight computer data, any modem worth its salt must be able to do error checking on the incoming data, and ask for it to be resent if it's faulty. It must also do data compression and decompression on the fly, to the extent that a decent modem can squash some kinds of data to 1/4 its size, send it, and then expand it out again at the other end. This gives an effective data speed of four times the 'line speed'; in other words a 28.8Kb/s modem can whizz along at 115,200b/s, given the right conditions.

Traditional modems use on-board hardware to do error correction and data compression/decompression. This

involves lots of software activity, so these modems contain microprocessors, EPROMs and some RAM chips to use as stacks and scratchpad storage. This stuff is totally transparent to the host computer, and what comes out the end of the modem is a string of eight-bit bytes, sometimes over 11,000 of them a second. The host computer then has to handle these bytes, assembling them into a text file or a nice graphics image. If it can't do this 11,000 times a second, there's big trouble.

RPI takes a very different approach. There's no longer a special micro, or ROM, or memory on the modem board; all their functions have been transferred to the host computer. That's the purpose of the special driver file.

So now the *host computer* (e.g., your PC) must handle data coming in from the modem at 28,800b/s. Each byte is part of a compression scheme, so decompression must take place in conjunction with past bytes and future bytes. And the results must be made available to the rest of the host computer at 11,000 bytes each second.

As well, incoming data must be checksummed and compared with what was supposed to be sent; and if there's a problem, the dud data must be resent. And if the connection is full duplex, the computer must compress outgoing data and arrange error checking with the other end. Once all this work is done, the computer must then process the data into text or graphics or whatever, just as it did before RPI ever came along.

But that's not all. Apparently the communications software is expected to chip in with some help as well, and only a few comms packages are able to work correctly with RPI. For software which is not RPI-aware, error correction and data compression are disabled, leaving a very mediocre modem performance indeed.

The bottom line

Why subject a poor innocent computer to all this stress? PRICE, that's why. A dedicated micro and its memory chips cost money, and if you can keep them out of the modem, you have a much cheaper modem.

Modems are routinely included in new computers, particularly those 'multimedia' computers destined for home markets and sold through big discount chains. In this market, price competition is absolutely furious, with brand new 'all bells and whistles' computers selling in the US down near the \$1000 mark. The difference between an RPI modem and a non-RPI modem may be as little as \$50, but that \$50 on the overall computer price may sway the buyer toward your machine and away from someone else's.

This philosophy is spelled out in a document released by Rockwell: 'Today's PC marketplace is characterized by price wars, which continually force vendors to lower costs while providing increased feature sets. The modem, as an increasingly popular PC peripheral, is not exempt from the same market pressures. Modem vendors at both the silicon level and the board level who can effectively reduce costs and add features will dominate the increasingly cost-competitive marketplace.'

Beware RPI!

It appears at this stage that the introduction of RPI has been a disaster. US Robotics' Winmodem seems to be OK; that company has a reputation for quality and they've never released a dud modem yet. And in the review above, it was tested in a decent-quality computer from Gateway 2000, although the processor seemed a little weak for the job.

But since the whole thrust of RPI is as a cost-cutting measure, RPI modems are mostly turning up in the very bottom-

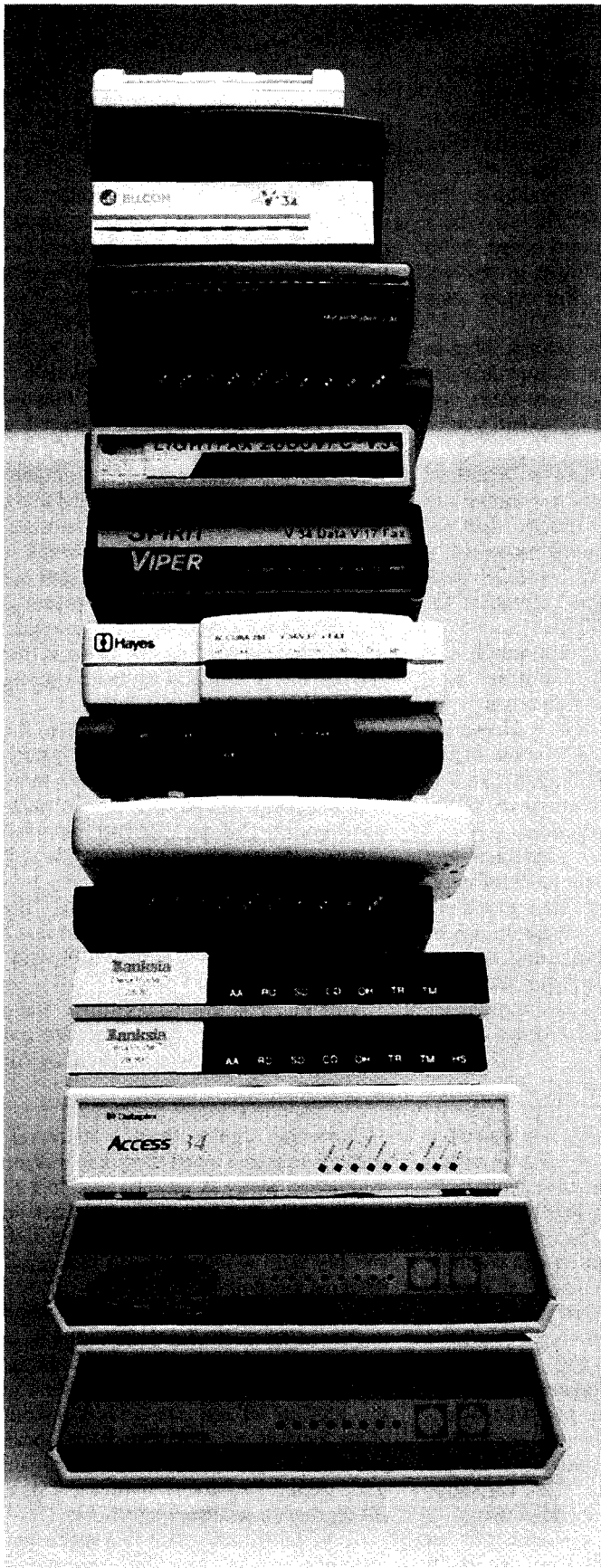

As far as we know, none of these modems is of the new RPI type. But the huge of modems available makes it all the more important to exercise caution — especially when buying one for an existing computer.

end computers. These are the machines in which every other corner has been cut, as well as the modem. They might have a fancy high-speed Pentium, but maybe the memory isn't the best quality and it can't keep up with the processor — especially under the barrage of activity demanded by an RPI modem connection.

I spend much of my time nowadays working the technical support hotline for the big Internet service provider Olympus.Net. When some new member is trying to get connected and they run into trouble, it's often me they end up talking to.

There are common complaints: the modem rings the number, and within seconds of the other modem answering, the connection hangs up. Or maybe the connection does last long enough to get to the username/password stage. Then the server rejects the user, even though we know the username and password are correct. (As a test, I can log in successfully using their username and password, but *their* computer simply can't do it.) Maybe once they get connected, the modem unexpectedly hangs up. Or maybe the data transmission is excruciatingly slo-o-o-o-w.

Reports of these symptoms always ring alarm bells: RPI Modem! We can't expect the user to know about RPI; all they know is they just bought this brand new computer and now it won't work on the Internet. The computer may be a popular brand, or unbranded, and most times the modem is definitely 'Brand-X', with no identification on it at all.

So we try to explain a little about the RPI problem, and then suggest they go out and buy a new modem. We usually recommend a US Robotics 'Sportster' model, because they are known good performers and easy to come by — and we send our users to a store that has a '30-day unconditional money-back guarantee'. In other words, if the new modem doesn't fix their problem, then they can return it for a full refund.

But replacement modems seldom go back; a new Sportster almost ALWAYS solves their problems...

Many RPI modems seem to handle simple terminal connections all right, such as to a bulletin board or online service such as Compuserve. But when they try to handle the 'PPP' Internet protocol, they drop their bundle. This is because during PPP, the computer is itself part of the Internet, and it has to do lots of fancy software shuffling in addition to just sending and receiving bytes.

Lots of debate

Here in the USA there's been a lot of publicity and debate about RPI, both online and in various magazines and newspapers. Take for instance these snippets from the *Albuquerque Journal*:

Bob Broen of Minneapolis, Minnesota, is an example of a user who learned this lesson in modem design the hard way. The Minneapolis Compuserve node he uses regularly is fuzzy enough so that it won't work unless he has error correction enabled. But unfortunately, he can't enable error correction because his modem contains an RPI chipset, and his Compuserve navigation software doesn't support RPI.

Karen Whitman of England adds, "I have a Zoltrix 14,400b/s modem which uses an RPI chipset and boy am I having problems with it! It's really hit and miss whether I can send messages on Compuserve. I really feel strongly that this modem is not 'fit for the purpose' (UK legal term relating to Sale of Goods), but the shop I bought it from won't give a refund."

"You need to avoid the RPI like the plague", advises Art Mercier on Compuserve, "but don't automatically write off any modem that claims to use the Rockwell chipset. If you do, you'll be ignoring some mighty fine equipment — most of the PPI modems, for instance."

We certainly don't intend to imply here that there is any-

New RPI Modems

thing dishonest or underhanded going on. But sometimes things could be better stated in advertising. That modem advertising that says 'Specially suited to Windows' may really mean 'works only with Windows' — in other words, RPI.

By the way never, since this whole business began, have I ever seen an advert owning up to an 'RPI modem'.

If you are going to pay a rock-bottom price for a computer, you can't expect it to be as good as a brand-name machine at twice the price. The cheapest computers have the cheapest parts, and despite glowing specs, it's pretty clear that some computers just aren't up to the task of handling RPI. And these El-Cheapo's are the very machines RPI modems are being supplied with. It's the worst possible situation!

As mentioned above, many of these computers experience a miraculous recovery when the RPI modem is replaced with non-RPI. So why not try to buy it that way in the first place — do a deal with the computer shop to upgrade the modem as part of the original sale. You pay a few bucks more, and you get a modem that works well on the Internet. Here in the USA, stores I spoke with weren't keen on the idea, but they indicated they might do a modem swap if the sale depended on it...

I also noticed, on first approach, that the average salesperson has never *heard* of RPI — or if they have, they won't admit it. So it's really up to you, the buyer, to figure out if the modem in question is RPI. You probably can't tell by just looking, because many cheap modems don't carry any labelling at all — no brand name, no nothing. However

there are some software tests you can use that are fairly foolproof.

One trick I've learned is to prepare a floppy disk with a DOS-based communications program on it, and carry it around from store to store. Ask the sales counselor (yep, that's what they're called here!) to get the machine into MS-DOS mode for you. This may be a little tricky, because many store demo units carry special software to prevent you exiting Windows. But every sales counselor has the key...

When you see the `C>` prompt, plug in the floppy and start your communications program. If it can't find the modem, you can be certain it's an RPI modem you're dealing with.

Another way is to get a Windows communications program running so you can communicate directly with the modem. This is happening successfully if you can type AT and receive OK back as a response. Then send a request for modem information, AT+I3.

Most modems will announce the name of their manufacturer, and sometimes this identification will include the term RPI. However Rockwell is known to use some of the same code in different chipsets, so it is possible AT+I3 will announce 'RPI' when it's not an RPI modem.

Some modems do not send back any manufacturer name, or protocol information, or anything useful. They just don't speak English; all you see are strings of undecipherable numbers and letters. Although not mentioned specifically in the known literature, local experience indicates this behaviour is always associated with RPI modems.

Apparently a special command

exists in RPI modems — and only RPI modems — which will disable error correction and data compression. If you send the command AT+H to a non-RPI modem, you will get an ERROR response. So ERROR means your modem is *not* RPI.

If you already own an RPI modem and it is giving you trouble, you can put the command AT+H0 into your modem initialisation string to manually disable error correction and data compression. This might be enough of a fix to get your system working until you can look at replacing the modem with a non-RPI model.

There is light on the horizon, however. Rockwell has recently released a new version of the Windows RPI drivers, one for Windows 3.1 and another for Windows 95. They are claimed to fix many previous problems and substantially improve performance — which is a roundabout way of admitting that the problems did exist in the first place. If you have an RPI modem, and troubles, it's worth downloading one of these free drivers and giving it a try before going out and buying a new modem.

It will be interesting to see where the RPI matter will stand a year from now. Will Rockwell decide the whole thing was a mistake, and go back to fully hardware modem chipsets? Or will improved software drivers allow RPI to work as it was intended?

Maybe the performance of El-Cheapo computers will improve enough that they can handle RPI without problems. Who knows?

All I know is that many times when I'm trying to type 'RPI' it comes out as 'RIP'. Maybe that's a prophecy for the future... ♦

Deep Space PABX

Continued from page 29

of kilometres away — it's all done on a tight budget. Far from using 'space-age technology', deep space trackers are forced to make do with some outdated equipment.

Walking through the room which contains most of the hardware that drives Tid, Churchill pointed out that most of the equipment is 'old technology'. However, the old equipment is gradually being replaced with current technology. The digital receivers, for example, are state-of-the-art, but much of the older equipment is very bulky.

Churchill explained: "Until NASA was hit with this recent budget crunch, there was a long term program to construct four

more antennas here. This room would not have needed enlarging because we would have supported those antennas with technology occupying much less space."

So while it's true that Tid's success as a deep space tracking station is a result of technology, it's also a result of knowledge, experience and dedication. It is literally a case of what the machines can't do, the people make up for.

The staff are the subject of another popular misconception: just who works at Tid? Far from eccentric caricature academics in white coats, the people behind the antennas are casually-dressed engineers and technicians.

"There are no scientists at Tidbinbilla!" Churchill emphasised. "I wish I could get that across to the general media. Reporters keep saying '...a scientist at Tidbinbilla said...' We're not scientists, we're engineers!"

Capturing signals from a spacecraft perhaps four and a half thousand million kilometres away is an amazing feat of engineering. But when those images do hit the media, it's thanks to Churchill and his team as much as the spacecraft designers and manufacturers.

The last word, however, should go to Peter Churchill. He defines the mission of Tidbinbilla in simple terms, but the skill and complexity behind the goal is all too easily overlooked: "Our part is to keep track of these spacecraft out there and communicate with them. Twenty four hours a day, seven days a week..."

Geoff McNamara is a freelance science writer who contributes to several Australian and international magazines. He thanks Peter Churchill, Director of the Tid, for his time and lucid explanations. ♦

NEW BOOKS



Microphones, in depth

MICROPHONE ENGINEERING HANDBOOK, edited by Michael Gayford. Published by Focal Press (Butterworth-Heinemann), 1994. Hard covers, 241 x 170mm, 449 pages. ISBN 0-7506-1199-5. RRP \$160.00.

An in-depth and comprehensive book on the design and use of microphones, intended mainly for audio engineers and technicians but also likely to be of interest to anyone involved in the design, manufacture or even use of almost any kind of microphone. The editor has been professionally involved in the design of mikes and audio systems in the UK for many years, and was apparently responsible for the design and manufacture of the famous STC range of broadcast-quality mikes. He is also the UK representative on the IEC committee on Microphone Standards.

There are 11 chapters in all, with the first introductory chapter on microphone techniques written by the editor himself. Then follow chapters covering precision mikes and measurements, optical mikes, high quality RF condenser mikes, radio mikes and infra-red systems, microphone testing, ribbon mikes, microphone preamps and transformers, stereo mikes, microphone standards and finally a glossary. The authors of these chapters are all experts in their fields, and include well-known names like Peter Baxandall, Torben Neilsen and Gunter Rosen. Most chapters end with a list of references.

The treatment throughout is uniformly thorough, comprehensive and up to date, while at the same time concise and readable. The text is complemented by many diagrams, photos and tables.

In short, then, an authoritative and very satisfying reference on just about every aspect of microphone technology.

The review copy came from Butterworth-Heinemann Australia, PO Box 5577, West Chatswood 2057. (J.R.)

Appliance repair

TROUBLESHOOTING & REPAIRING MAJOR APPLIANCES, by Eric Kleinert. Published by McGraw-Hill, 1995. Soft covers, 185 x 263, 417 pages. ISBN 0-07-035079-5. Australian RRP \$69.95.

This two-part book covers selection, servicing and repair of most of today's home appliances including dishwashers, stoves, garbage disposers, washing machines, dryers, water heaters, refrigerators, freezers and automatic ice makers — but not microwave ovens, or anything electronic such as TV, radio or sound systems.

The author starts by describing appliance selection and installation. Subsequent chapters explain the safety precautions and tools needed for installation and repair, basic troubleshooting techniques and the basics of electricity. This latter chapter introduces circuit components, Ohm's law, electrical quantities and use of a multimeter.

Part two has a chapter devoted to each of the main appliances. There are lots of diagrams to illustrate each aspect of repair and service, particularly where a mechanical fault is involved. Included also are troubleshooting flow charts, tables and thorough descriptions of how to locate and remove particular parts.

Each chapter provides a comprehensive description of each aspect of appliance repair and servicing, rather than a

general overview that is often useless. Being a US publication, the section that describes warranties and energy guide information is not relevant here, but overall I believe it will still be very useful. It has a friendly, no-nonsense writing style, and gives a full coverage on the assumption the reader knows little about the topic. The measurement units used are imperial.

The review copy came from McGraw-Hill, PO Box 239, Roseville 2069. (P.P.)

Photodiode amps

PHOTODIODE AMPLIFIERS — OP AMP SOLUTIONS, by Jerald Graeme. Published by McGraw-Hill, 1995. Hard covers, 236 x 158mm, 253 pages. ISBN 0-07-024247-X. Australian RRP \$89.95.

Photodiodes are now used in many different areas of electronics, but often need special design techniques to achieve the best performance. Although there have been a reasonable number of articles in magazines like *EDN* (many written by Mr Graeme) covering these techniques, there have been few books pulling it all together. Until this one, that is.

Jerald Graeme is of course a well known US engineer and technical author, and also an acknowledged expert in both this field and the application of op-amps. He spent nearly 30 years working at Burr-Brown, holds eight US patents, and has written over 100 published technical articles and three books. Nowadays he's principal engineer at Gain Technology, where he designs high speed amplifier ICs. So there's no doubt at all that he's eminently qualified to write this book...

There are 10 chapters in all, progressing from an examination of photodiodes and their behaviour through the various kinds of amplifiers and their performance (including noise performance), to areas such as power supply filtering, shielding and so on. In all a very thorough and informative treatment, and written in Mr Graeme's usual concise but friendly style.

For anyone who needs to design circuits using photodiodes, it should be a most valuable reference.

The review copy came from McGraw-Hill Australia, of PO Box 239, Roseville 2069. (J.R.) ♦

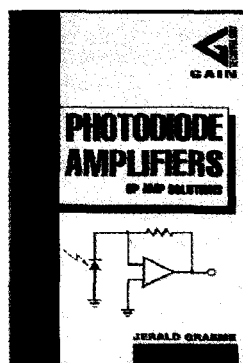
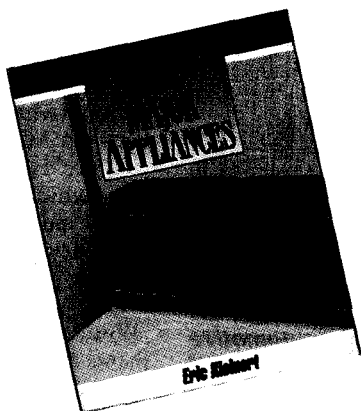
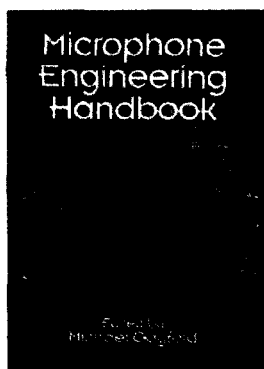

AUTOMOTIVE ELECTRONICS

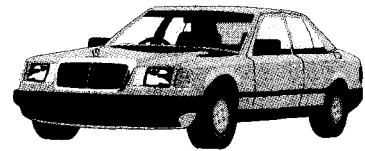

with JON LOUGHRON Assoc. Dip. Electronics

The CIE 8088 handheld Automotive Meter

This month we're looking at a portable test instrument that may look superficially like a standard digital multimeter, but in reality offers a lot of very useful features for automotive testing. The CIE 8088 allows you to measure duty cycle, temperature, RPM, dwell angle, pulse width and more.

Well, another month has gone by and it is again time to sit in front of the laptop and try to inform you about the weird and wonderful world of automotive electronics. This month I've decided to 'road test' a new handheld automotive meter, the CIE 8088.

Handheld or portable automotive test equipment is now more reliable, and definitely more affordable. Portable scopes have entered the market in a big way, but for the untrained can still be quite intimidating — a drawback that doesn't apply with a multi-function type automotive meter like the 8088.

Using a scope is not a totally new experience for the automotive technician, because engine analysers have been around for quite some time. But normally analysers have had fixed time-base and vertical amplitude settings, because they were dedicated mainly to testing and viewing of the primary and secondary ignition patterns. As a result they've been relatively easy to use once the tangle of leads was sorted out.

As technology progressed, the analysers incorporated more features such as special patterns (for checking injection times etc.), four gas analysers, power balance testing and ECM fault code presentation. The new automotive scopes such as the Bosch FSA 560 (Fig.1) are a very impressive machines indeed. They interface to the new DFI ignition systems, talk to the gas analyser, test and capture all sorts of waveforms and signals, provide help screens and include all the bells and whistles. Basically if the new Bosch unit doesn't test it, it ain't worth testin'!

This is all very nice for a workshop environment, but most of the Tunescopes are quite large and portability is a problem. Also if somebody is using the scope to do a service or adjustment, another technician would have to wait in line so that he can use the

machine. It would be nice if we could have one auto scope per technician, but this becomes a little expensive.

So there will always be a place in the workshop for extra, lower cost testing equipment. And I do mean 'extra', because there is no way that the 8088 (that number brings back fond memories of the 8/16 bit micro days, doesn't it?) or other portable test gear is meant to *replace* the dedicated automotive tunescope. But it is a handy device to have for doing adjustments when, as mentioned above, the main scope is tied up or when you may have to attend an on-site vehicle with a problem.

Knob & buttons

The 8088 meter has the standard rotary dial and also 10 menu buttons to select subfunctions such as

celsius/fahrenheit, cylinder number, etc. It comes with an assortment of 4mm insulated probes, grabbers, a temperature sensor and an RPM pickup. It has a rugged outer boot, which is designed to protect the meter against accidental damage and also provide a convenient method for storing the meter probes (see Fig.2, a and b).

The LCD display has four main digits and includes both an analog bar graph and symbols to indicate the various modes and functions. When a function is selected the appropriate symbol will be displayed to verify selection.

The rotary switch turns the meter on and off, and selects modes. If there is no activity for 30 minutes an automatic power off circuit activates turning off the meter. To disable the auto-off function, when measuring for periods greater than 30 minutes, the PWR RST button must be depressed when turning the meter on.

It should also be noted that when testing on a vehicle, to avoid interference, the meter needs to be kept away from the secondary ignition system (sometimes this is nearly impossible). Otherwise its operating conditions should never exceed the limits shown in the table of Fig.3.

The meter can function as a normal multimeter, as it has volts, ohms, amps and diode check ranges. It also has capacitance testing capabilities, which are invoked by pressing the blue ALT button (which also toggles the meter between AC/DC and beep/ohms).

There's also an auto-ranging function, which can be overridden manually by pushing the range button. A summary of the meter button functions is provided in Fig.4.

One of the handy functions that allows the technician to connect the meter to the system and check the results later is the MIN/MAX function.

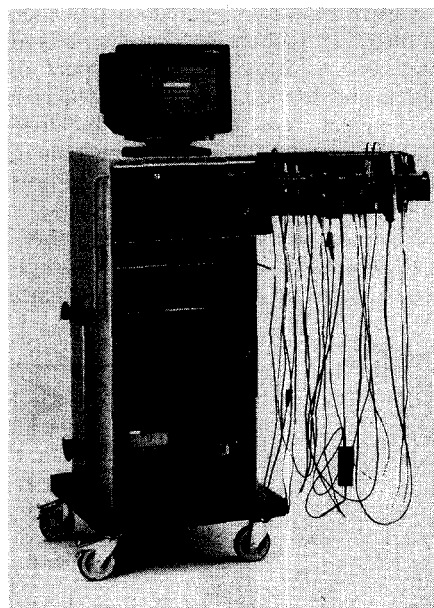

Fig.1: As you can see, the Bosch FSA 560 is a very impressive automotive diagnostic unit. (Photo courtesy of Bosch Australia)

The meter stores the highest and lowest measured values in memory, and these can be retrieved when required. To record values you select the required measurement, i.e., volts, temperature etc., then connect the meter probes to the test points and press the MIN/MAX button once to start. The min recording and the minimum reading will be displayed. If the button is pushed twice the maximum recorded value will be displayed.

If the hold button is selected the meter will stop recording, while pressing the hold button again restarts the recording. The hold button will also freeze the display in any of the modes.

The meter's MIN/MAX function is ideal for testing O₂ sensors, because the vehicle can be driven and the oscillations can be recorded. Then they can be displayed to ensure that the sensor is varying properly and therefore correct mixtures are being maintained.

Auto applications

Other functions of the CIE 8088 associated with automotive testing are TEMP (temperature), Hz (frequency), RPM, %DUTY (pulse duty cycle), ms PULSE (pulse width) and DWELL (dwell angle).

Temperature can be measured by plugging the temperature probe lead into the meter's two-pin socket and selecting the desired temperature scale (Celsius/Fahrenheit). Then you simply place the end of the probe into or onto the device to be measured, and as can be seen from the specifications the temperature range should cover all automotive applications (-50 to 1100°C).

Accurately measuring temperature is very important, because as indicated in previous articles covering modern engine management systems, specifications are always given about the coolant temperature sensor (temperature/resistance specs). If you have read these articles you will appreciate the importance of the CTS signal, because injection times will vary quite a lot between cold crank and during the warm-up cycle. So I think this is a fairly important function on any automotive meter.

One problem I did encounter was that when the meter was in Temp mode and the MIN/MAX function was invoked, if you changed the C/F function the c or f changed on the display but the actual value didn't. I might add this can be overcome by not changing modes during testing — so this is really only a very minor problem!

The Hz function measures frequency (yes, really!), and auto-ranges between

Fig.2: With the CIE 8088 Automotive meter, the rotary dial selects the particular function and the buttons select the required mode. The protective boot also provides a place to keep the leads when they are not being used.

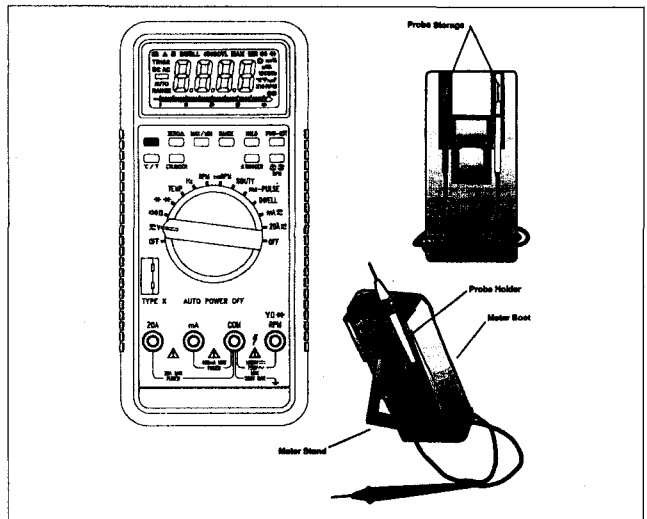

100Hz to 400kHz. Frequencies below 1Hz are displayed as 0Hz. This function is very handy for checking and validating signals such as idle speed motors, vehicle speed sensors, hall sensors and other repetitive signals under the bonnet.

When checking repetitive square wave signals, there is not much more to say about this function except that it is accurate and makes measurement of these signals a lot easier than converting them from milliseconds on an old oscilloscope.

The %DUTY cycle mode is another function that can be used to check a number of signals, but probably the best application is for testing idle speed motors.

On the VL Commodore the idle speed is controlled by a valve that is driven by a 160Hz varying duty cycle signal. To ensure the idle speed controller is working properly, the frequency can be mea-

sured and then by attaching the meter probes and invoking the duty cycle mode, the integrity of the signal can be checked. As the engine load, at idle, is changed — that is, the headlights switched on, power steering used, etc — the idle speed motor should compensate for these variations by varying the duty cycle. If there is an idle problem and the duty cycle is not changing, then further investigation may be necessary, such as TPS adjustment etc.

The 8088's '+/- trigger' button determines if you are measuring the proportion of time spent at 0 volts, or conversely the proportion of time spent at the higher extremity.

RPM and dwell

The RPM function is an absolutely fantastic inclusion on a handheld device. It's a pity a strobe light isn't provided as well, so that base timing

FUNCTION	RANGE	RESOLUTION	INPUT LIMIT
AC Volts	400mV - 750V	100 microvolts	1000V DC - 750V AC
DC Volts	400mV - 1000V	100 microvolts	1000V DC - 750V AC
Frequency	>1Hz - 400KHz	0.01 Hz	500V DC/AC RMS
Ohms	0 - Open	1.2- 2.0%	500V DC/AC RMS
Diode	0.6 mA Test I		500V DC/AC RMS
AC/DC mA	0 - 400 mA	0.1mA	0.5 mA - 600V
AC/DC Amps	400mA- 20A	0.1mA	20A - 600V
RPM (tach)	600- 12000	1.0 RPM	500V DC/AC RMS
Duty Cycle	0.0 - 90.0%	0.1%	500V DC/AC RMS
Dwell Angle	4,5,6&8 Cylinder	0.1 deg.	500V DC/AC RMS
Temperature	-50 - 1100 deg C	1.0 deg. C	60V DC 24V AC RMS
Capacitance	4nF- 40 microF	1pF	500V DC/AC RMS

Fig.3 : Specifications for the 8088 meter. The input protection circuit is adequate for dealing with most situations where the meter is accidentally connected to a higher voltage.

AUTO ELECTRONICS

adjustments could be done. But one must remember that this device is not really meant to replace a tunescope but complement it, even though it has many of its functions... (Well, maybe not a four gas analyser and kV display — but where was I? Oh, that's right.) Still, it's a great idea to include an RPM probe in the price of the meter, so that base idle checks and adjustment can be done.

Another great feature is that the meter will also measure RPM on DIS (distributorless ignition systems) and two-stroke systems, by pushing the RPM 1-2 button. However a word of warning: in the manual it states that pickup orientation is quite important, and also where you place it on the secondary lead. So before doing any RPM measurements, it's a good idea to read the manual.

DWELL can also be measured by the 8088, and on modern electronic ignition systems only a dwell check can be performed because the ECM controls the dwell function. So adjustment is not practical, unless you happen to know where in the ROM lookup table the dwell information is kept.

However on points-type ignition systems, dwell *can* be adjusted and in fact is part of the normal maintenance procedure. Adjusting the dwell requires selection of the correct number of cylinders and this done by pushing the #CYL button. The display will then cycle between the various cylinder numbers at the top of the screen.

But there's more

As mentioned before the meter has not only the standard measurement capabilities but extras as well. For example capacitance can also be measured and the meter will auto-range between 4nF (nanofarads) and 40uF (microfarads) ranges. It also has the standard diode test and audible beep for continuity.

Another nice feature is the ability to measure pulse width, which is very handy for measuring the on-times for injectors, in milliseconds. I compared the meter's readings against quite an expensive lab scope and I am happy to say that the meter was very accurate.

I only found two problems. One was the settling time when first connecting the meter to the injector circuit. Unfortunately it also doesn't measure the on-time for 'current control' injectors, such as the Commodore VL's

BUTTON	FUNCTION
C/F	Celsius Fahrenheit selection
Zero	Zeroes the display (zeroes any offset)
Min/Max	Invokes the Min/Max function and display
Range	Manually selects the range (overrides auto)
Hold	Freezes the display with the current value
Cylinder	Selects the required cylinder No. 4,5,6 & 8.
+/- Trigger	Selects the level for duty cycle measurement
RPM 1-2	Selects 4 stroke or DIS/2 stroke
Pwr-Rst	Turns the meter on, after auto shut off
Blue	Selects the Alternate blue functions

Fig.4 : A summary of the 8088 Meter's control button functions.

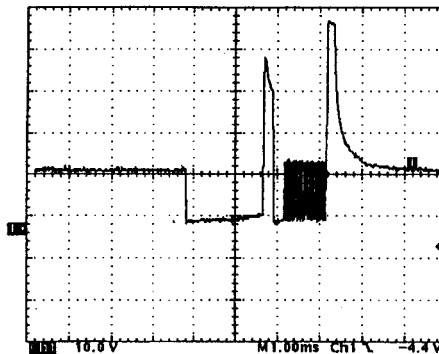
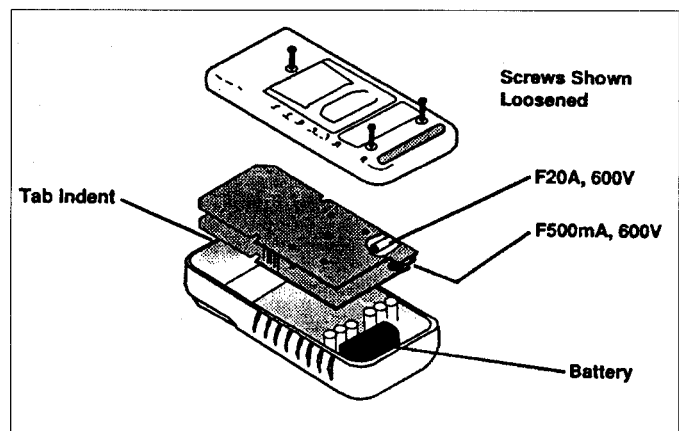

Fig.5: The injectors on a VL Commodore and some other vehicles are current controlled, and a pulsed wave form makes it difficult for the 8088 to measure injector open time.

injectors, with their pulsed waveform (Fig.5). But this doesn't matter too much, because there are still a huge amount of vehicles out there with 'normal' type injectors. All the same, it may be wise to ascertain what type of injectors are on the vehicle to be tested.

The battery can be easily changed (Fig.6), but when disassembling the meter there are a few precautions that should be noted. To avoid electric shock remove the test leads before opening the case and do not operate the meter or rotate the meter switch

Fig.6: Battery and fuse replacement is very easy on the 8088 meter. However when changing the fuses ensure that they have the correct rating, otherwise meter damage may result.



when the case is open. Replacing the battery or fuse is quite simple, but ensure that when touching the circuit boards you only handle them by the edges. The battery is a standard 9V alkaline battery and the fuses are an F20A/600V fast acting fuse for the 20amp range and a smaller F500mA/600V fast acting fuse for the milliamp ranges.

Summarising

The 8088 meter measures most of the signals necessary to do on-site diagnosis and basic engine setting and testing. But again I must remind you that it is not meant to replace the dedicated workshop automotive tunescope. Inevitably the more expensive equipment has the ability to do gas analysis, delta hydrocarbon testing, checking the kV system, base timing adjustments, performing power balance testing, testing for diagnostic codes and base timing adjustments.

Despite this the handheld CIE 8088 is definitely value for money, at the quoted price of \$375 including tax. If you are interested in purchasing one, you can talk to John Davidson at Injectronics on (03) 9792 4211.

Well, hopefully this article will make the choice of a handheld meter a little bit easier. You may not want to purchase this particular meter because there are quite a few on the market; but at least you may now know what is available in a handheld automotive test package, and basically what they can and can't do.

Another thing to remember is that there are also quite a few handheld ECM diagnostic decoding units available, and again some include voltage, current and waveform testing and some don't. It comes down to a matter of how much money you are willing to part with, and what functions you need...

Until next time, 'bye. ♦

Let's Get Fit!

Why are we talking about fitness in an Electronics Magazine?

Summer is on the way, and everyone tries to lose a few pounds. Including FORCE Electronics.
Pounds of Stock That Is!

We want to shed those Wintry Excesses and that means YOU SAVE! So, come on in to the fitter, more powerful FORCE Electronics during November where you can get what you need at a price you'll love by the people who know. If you're too far away to come in, pick up the phone or use the fax machine. It's all too easy.

IC SOCKETS - OUT THEY GO!

TINNED	SAVE OVER 50%	MACHINED
10 for \$2.00 IC8		10 for \$5.00 ICM8
14 pin \$2.50 IC14		\$7.00 ICM14
16 pin \$2.50 IC16		\$8.00 ICM16
18 pin \$3.00 IC18		\$9.50 ICM18
20 pin \$4.00 IC20		\$12.50 ICM20
24 pin \$5.00 IC24		\$14.50 ICM24
28 pin \$6.50 IC28		\$14.50 ICM28
40 pin \$7.00 IC40		\$17.50 ICM40



AND THE IC'S TO GO IN 'EM!

	normally	NOVEMBER
4013	\$1.75	\$1.00
4017	\$1.75	\$1.00
40106	\$1.95	\$1.00
4049	\$1.75	\$1.00
LM555	\$1.20	\$0.60



THE BOSS HAS TRIMMED THE FAT - SUPER SLIM PRICES!

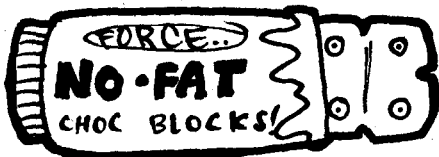

12 way terminal strips for every job.

TS1206 - 10 for	\$6.00 (6 AMP)
TS1210 - 10 for	\$9.00 (10 AMP)
TS1220 - 10 for	\$11.00 (20 AMP)
TS1230 - 10 for	\$15.00 (30 AMP)
TS1260 - 5 for	\$10.75 (60 AMP)
TS1280 - 5 for	\$14.50 (80 AMP)

Order Now By Phone Or Fax



YOU'LL HAVE TO RUN FOR THESE!

DIODES

1N914 ... 100 for	\$3.60
1N4007... 100 for	\$6.60
1N5408... 100 for	\$15.00

WE'RE RUNNING OFF MILES OF CABLE

75ohm COAX W0224	
normally	NOVEMBER
\$1.30 p/m	\$0.79 p/metre
or	\$79.00 p/roll

5mm REDLEDS 10 for	\$2.00
5mm GREENLEDS 10 for	\$2.00
5mm ORANGELEDS 10 for	\$2.00

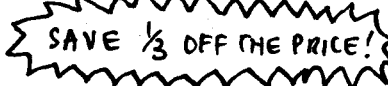

Heavy Duty Mic. Cable w1030
Twin Core with cotton Filler
normally \$2.20/metre
NOVEMBER \$1.40/metre

8 Locations Across Adelaide

Adelaide - 203 Wright St. Ph(08) 212 5505 Fx(08) 212 3979
Lonsdale - 9 Somerset Circ., Ph(08) 326 3331 Fx(08) 382 3366
Brighton - 2/417 Brighton Rd, Ph(08) 377 0512 Fx (08) 377 1440
Findon - 127 Findon Rd., Ph(08) 347 1188 Fx(08) 345 4746

Holden Hill - 4/650 North East Rd., Ph(08) 261 7088 Fx(08) 369 1366
Salisbury - 1700 Main North Rd., Ph(08) 283 0755 Fx(08) 283 0755
Colonel Light Gardens - 584a Goodwood Rd., Ph(08) 374 3346
Magill - 2/370 Magill Rd. Kensington Gdns, Ph(08) 332 2299



When I Think Back...

by Neville Williams

Maxwell Howden: the first two-way amateur radio link to USA & Britain (1)

Born around the turn of the century, Max Howden was one of the true pioneers of wireless/radio in Australia. Based in Melbourne, he could justifiably lay claim to having been the first experimenter to achieve direct two-way voice communication with the USA and Britain. In more recent times, he was better known throughout the industry as a manufacturer and supplier of quartz crystals for frequency control.

I must confess that, during my own career, Max Howden was best known to me in the latter role: as a supplier of precision quartz crystals, made to order for magazine projects. To be sure, I had seen his name in experimenters' magazines dating back into the 1920s. But, in terms of long-term publicity, he seems to have been overshadowed by high-profile Victorian contemporaries such as Ross Hull, Howard Kingsley Love, John Moyle and AWA's Lionel Hooke.

Now, thanks to his son John, we are able to give Max a more equitable place in the records — including recognition of his important role in supporting the Royal Flying Doctor Service.

Writing from his home in Hull Road, Lilydale (Victoria), John Howden says that his father Max was born on April 18, 1899. Sadly, Max was only two years of age when his own father, Thomas Montague Howden, an hydraulics engineer, died (in 1901).

Max's widowed mother — nee Alice Celeste Whitby of the locally prominent Whitby family — assumed the responsibility of bringing up Max and his elder brother Edward Montague (Jock) Howden (b. 1897), who later trained as an automotive engineer.

Max, as a youth, proved to be a scholar of some note and is on record as having been equal-Dux of the Brighton Private Grammar School in 1916. He continued his education at 'The Working Man's College' (now the Royal Melbourne Institute of Technology), and subsequently married Edith Lois Greenwood, who bore him four children.

John remembers his father as man of

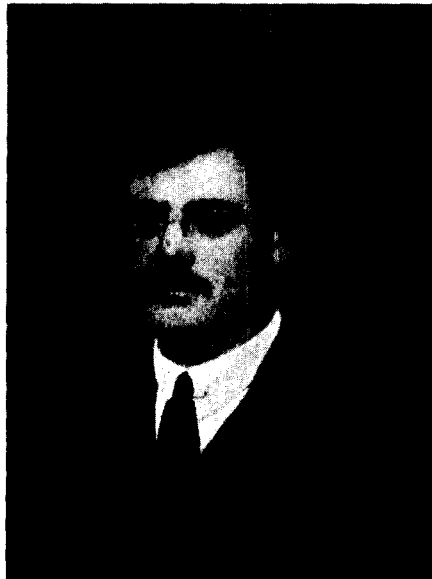

Max Howden at age 25, as pictured in Radio magazine for 25/7/1923, approaching the peak of his activity as a 'DXer' from amateur station 3BQ. In later years he supplemented his moustache with a full beard!

many and varied interests, at which he generally excelled: tennis, golf, trout fishing, chess, bridge and, in later life, lawn bowls. He loved music and played the flute.

More to the point, Max was profoundly interested in wireless, as was his brother by association. Max was a keen reader of wireless/radio magazines, and at one time or another contributed articles to most of them, bearing his byline. Included was *QST*, published in the USA by the ARRL.

Max worked as a design engineer

for Corbett, Derham and Co, and in association with his brother Jock, also built and sold 20s-style wireless sets, on the side.

Interview on tape

Thanks to John, I have to hand the transcript of a taped interview with Max, conducted by Mel Pratt for an oral history program on behalf of the National Library of Australia. This was climaxing some 50 years' involvement in wireless (described as 'the English term') or radio ('the American term').

John, incidentally, was subsequently issued with his late father's amateur radio call sign.

In the interview, Max confirms his educational record but explains that it was interrupted around 1909 by having to care for his brother who "couldn't get around like other boys", having to wear splints. Whether it was due to an injury and/or an untimely episode of poliomyelitis seems never to have been resolved...

Be that as it may, their mutual interest in wireless/radio was triggered by a visit to Brighton Grammar by a former 'Grammarians' — Mr (later Sir) Lionel Hooke, who had just returned from an expedition to the Antarctic where he had served as radio operator. Hooke graphically described the stringent conditions they had had to cope with, and went on the talk about radio generally.

That talk, plus a natural interest in physics as a subject, was all that was needed to capture the Howden brothers' attention!

At the time, radio transmission involved spark technology. But during

WW1, CW (continuous wave) technology emerged, along with the development of valves by the likes of Fleming and De Forest. To quote Max Howden's own analogy, "CW was like replacing a shotgun with a rifle".

Meanwhile, Max had been working his way through the Workingmen's College, where he had been instructed in pattern making, moulding, mechanical drawing, electrical wiring, fitting and turning and mechanical engineering. It had all been very worthwhile, he said, because, having come up with an idea, he could develop it personally instead of having to rely on others who may or may not interpose their own ideas...

Rebuilding the WIA

To supplement the Tech course, Max enrolled at Stotts College for instruction in Morse Code and signalling procedures. His original idea was to qualify as a wartime operator, but the war had ended by the time he had gained adequate proficiency. In the meantime, he was issued with Listeners Permit No.19 in 1916 and No.V104 in 1919.

With the war over, said Max in the interview, a group of the early prewar amateur operators got together with the idea of reconstituting the Wireless Institute, which had originally been formed in 1910. At the back of their minds was the possibility of securing a transmitting licence — heightened when the Federal Government returned supervision of the airwaves from the Navy to the Postmaster-General in 1920, administered by Jim Malone.

Max Howden went along, and (I quote): "met all the returned operators from the transports and so on... well known names like Tom Court, Bill Conroy, Charlie Hyam, — Page and many others. From that inaugural meeting, the Institute was reformed and we took a room in the Arcade Hall in Prahran".

"The objectives of The Institute were to further knowledge of wireless and do as much developmental work as we could".

Max went on to explain that the members of the re-formed WIA, as above, had experience mainly with spark transmitters, the occasional CW system using Poulsen's arc or an Alexanderson alternator, able to generate a waveform at a frequency sufficiently high to qualify as an RF carrier.

"Some of us used to hear them on our early valve receivers... stations in England, Germany and so on. But there were no transmitters in Australia of that nature to reply direct... that sort of traf-

MAX HOWDEN

—the man who is making Wireless History—
helped to make the model "RS"



TUNAFONE

A NEW Australian radio invention and Australian assembly were shown to the world at a recent exhibition. It has attracted attention and has attracted with interest and enthusiasm the world's leading radio engineers, radio men and radio amateurs. It has been the only radio receiver exhibited with interest in the exhibition. It has been the only radio receiver exhibited with interest in the exhibition. It has been the only radio receiver exhibited with interest in the exhibition.

WIRELESS BROADCAST RECEIVER

TUNAFONE "RS" is a 5-valve set, consisting of two stages of tuned radio frequency, detector, and two stages of audio frequency. Tuning is accomplished by two condensers, one of which tunes the aerial circuit and the other the radio frequency circuit. Apart from mechanical simplicity, the receiver has a wave length control, "TUNAFONE" and a wave length indicator. The circuit operating the valve used has been tested after they have been set. The receiver has been designed to cover the wave length range of 200 to 20,000 metres. It has been designed to cover the wave length range of 200 to 20,000 metres. It has been designed to cover the wave length range of 200 to 20,000 metres.

Manufactured by
CORBETT, DERHAM & CO. PTY. LTD.
MELBOURNE — SYDNEY — ADELAIDE



From the Melbourne Argus for 18/11/1924, this advertisement identifies Max Howden with Tunafone receivers from Corbett, Derham & Co Pty Ltd of Melbourne, Sydney and Adelaide.

fic went by telegraph or cable".

At the time, Max said, members of the WIA used to argue at meetings as to what happened to other, higher frequency CW signals. "Did they simply fade away to nothing, by absorption, as they radiated outwards, or did they travel indefinitely through space, growing gradually weaker but never actually diminishing to nothing? We had yet to learn about refraction and reflection from the Heaviside Layer and all that..."

"What we did in 1921 was to set about

organising tests, to discover whether amateur station signals from America would reach Australia at a strength sufficient to be detected, amplified and deciphered on existing receivers."

Trans-Pacific tests

"In those days it took five weeks for a letter to be delivered in the USA, therefore 10 weeks or more to receive a reply. As a result, the actual tests did not get under way until May 1923. It was essentially a WIA exercise and, while companies like AWA/Marconi, Neilsens and Noyes Bros offered incentives in the way of open orders, etc., they were not very optimistic about our chances of success."

However, on a cold, wet night — May 11, 1923 — Ross Hull VK3JU, of St Kilda, heard 6CGW calling Australia from California in the USA, through bad atmospheric, but clearly enough to identify the call.

Said Max: "The following night I also heard that same station, together with two or three others and was able, not only to identify the call, but the secret code word that each one sent as well. By the end of the month, when the tests finished, I had logged 22 stations along with their individual code words."

Interviewer: "Was this on your own gear, or did you have communal equipment?"

"No, it was my own home-brew receiver. Ross Hull and most of the others went to the extent of using five or six valves in their receivers, but I was of the opinion that, if it couldn't be done with three valves, it was hardly worth the effort."

Max went on to explain that, in those

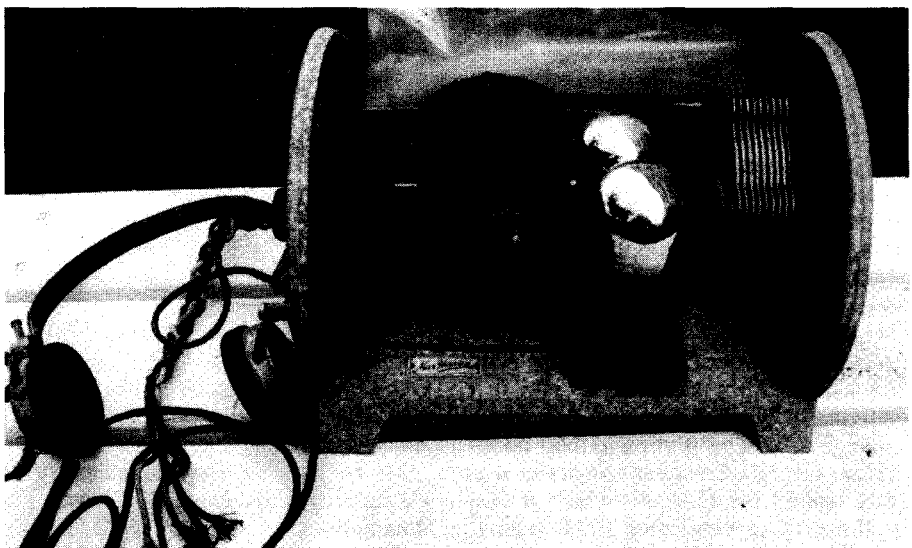

A home-made Max Howden receiver dating back to the mid twenties. The headphones are traditional Brown's Type F.

WHEN I THINK BACK...

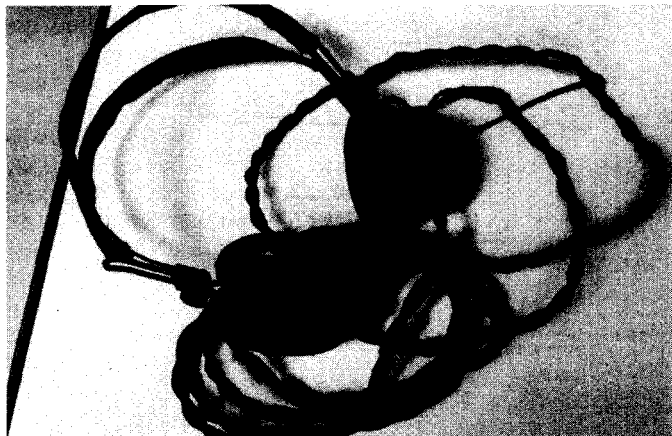

Max Howden not only won the Trans-Pacific competition to log US amateur stations, he also led the drive to achieve two-way contact with the USA and UK. His award: this pair of Nathaniel Baldwin headphones.

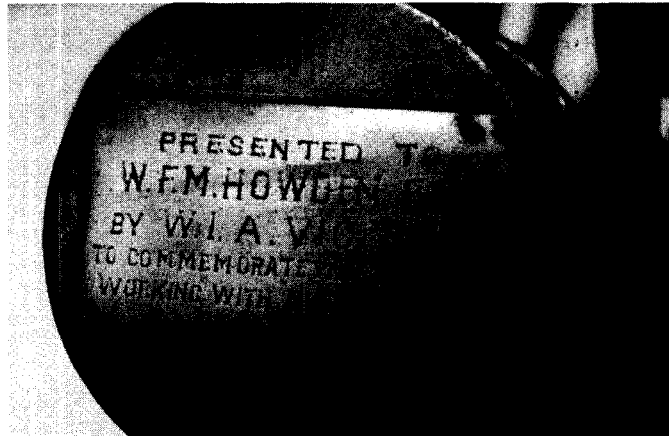

On the back of a Nathaniel Baldwin headphone (one of a pair), the plaque reads: Presented to W.F.M. Howden Esq. by the WIA Vic. Div., to commemorate two way working with USA and GB 25.11.24.

days, experimenters had to contrive their own tuning capacitors and make sure that they would be easy to adjust and keep in tune. Too many stages and too many controls made tuning a slow and tedious procedure.

"With only three valves, that I was using in a reflex arrangement, I was much more mobile over the spectrum and was able to pick up all these other stations".

Ham shack/workshop

Questioned by the interviewer, Max said that the Howden home was situated in what was then open country, with wild rabbits visible through the open door of the den/workshop used by Jock and himself. He and Jock had tried out wire cage aerials, but for the American tests they had a single wire supported by a 15-foot (5m) mast lashed to the top of a handy pine tree.

As a hobby, amateur wireless at the time wasn't unduly expensive, although the open orders they had won for the USA tests undoubtedly helped. Adapting and making parts was the greater challenge. Professionally, at the time, they were functioning as per their letterhead: 'Howden Bros, Automobile and Electrical Engineers. Magneto Experts'.

While Max was most familiar with amateur radio in Victoria, he said that activity in other Australian states was more or less in proportion to their population. Overall, however, Australia was way behind the USA — where it was said that there were some 200,000 amateur transmitting stations cluttering the airwaves on the most accessible frequencies. I quote (abbreviated):

"It didn't take me long to realise the need to lower the capacitance of my equipment, so that I could put a signal through on a higher frequency, clear of this concentrated interference. It wasn't until November 1924 that I got my signals through to 6AHP in America, who had been in contact with New Zealand shortly before."

"That contact with 6AHP on November 2, 1924, was the first direct two-way communication between Australia and America".

A couple of days later — Tuesday November 4, 1924 — the Melbourne Evening Sun announced that 'Last night Mr F.M.W. Howden made wireless history by exchanging messages with Mr W. Williams, an experimenter at Tomona, California. They continued:

Early morning Morse!

Sending at between 12 and 15 words a minute, Mr Williams sent greetings to all Australian amateurs, and briefly described the set he was using. Mr Howden reciprocated the message of greeting, described his own set and arranged with Mr Williams for another tryout tonight. Messages were exchanged for 40 minutes.

Afterwards Mr Howden kept an appointment with his contact at Gisborne, who, with several other New Zealanders heard both sides of the Australian-American contact.

Mr Howden used a wavelength of 86 metres and a power of 120 watts. The American used a wavelength of 75 metres.

Between 2.45 and 3.45AM today (Tues. Nov. 4, 1924) Mr Howden and Mr Cox, another Melbourne experi-

menter, also heard ACD, the Rome wireless station, and POZ, the station at Nauen, Germany.

Max Howden made the headlines in the Melbourne Herald the next day (Nov. 5, 1925) under: **WIRELESS FEAT: Melbourne to Boston, (Massachusetts).** Mr Max Howden of Box Hill (3BQ) added to his wireless records again last night by exchanging signals with an American amateur station at Boston. Owing to bad atmospheric conditions touch was held only for one quarter of an hour.

Mr Howden also exchanged signals with Mr Litten of Temona, California (AHP). Calls were noted from Texas, Maine, Vermont and Ohio.

A strange fact noted was the entire absence of New Zealand signals, which Mr Howden attributes to the peculiar atmospheric conditions obtaining.

The Herald quoted Max's transmission as a power of 120 watts, radiation current 1.2 amps and a wavelength of 8.5 metres. The Americans were using wavelengths between 70 and 80 metres. I would assume that 3BQ's wavelength was actually 85 metres, and that the figure had been corrupted by the inadvertent inclusion of a decimal point.

To Britain, direct

Reverting to the taped interview, Max revealed that, having bridged the Pacific Ocean with what were then regarded as shortwave signals, his objective was to bridge the Atlantic as well to reach Britain — if the waves chose that route. I quote:

"From there it was just a logical step to work out or find out the likely hours

in which amateurs in England would be listening. Having done so, I started getting up at four o'clock and calling CQ, on Morse. On the following Friday week, which would be November 13 (1924), I was delighted to hear acknowledgement from 2OD, about to become G-2OD, from Buckinghamshire in England. This, I believe, was the first two-way radio link between Australia and England."

On this occasion, the announcement was published by the *Melbourne Age* on Saturday, Nov 15, 1924: **MELBOURNE TALKS TO ENGLAND — An Amateur's Success — Mr Max Howden's Achievement.**

Referring to the occasion, Max Howden said: "After that, we used to work regularly every morning and I was quite surprised on one occasion when Mr Simmons had to close down earlier than usual because he had to go out. What should happen but that Mr Leon de Loy, from 8EX in France, broke in to tell me that he had been following my experiments with 2OD, but had missed out one night. Could I tell him about our results on that occasion?"

"I answered his question and since the signals were still good — to keep things going — I asked him 'what he did for a crust?' His reply amused me: 'Please signal slowly, old man, my American is not too good!'"

"After 2OD, I worked with the Partridge brothers on 2KF, Goyder 2LZ and Jerry Marcuse 2NM, who was later the President of the Radio Society of Great Britain — RSGB." (All of these call signs subsequently gained the prefix G-, denoting the station's location in the UK.)

Max went on to explain that commercial companies at the time were

Max Howden's amateur transmitting 'shack' in 1924, as pictured in his article in *Radio*. This was the equipment he used to make the first contacts with England and the USA.

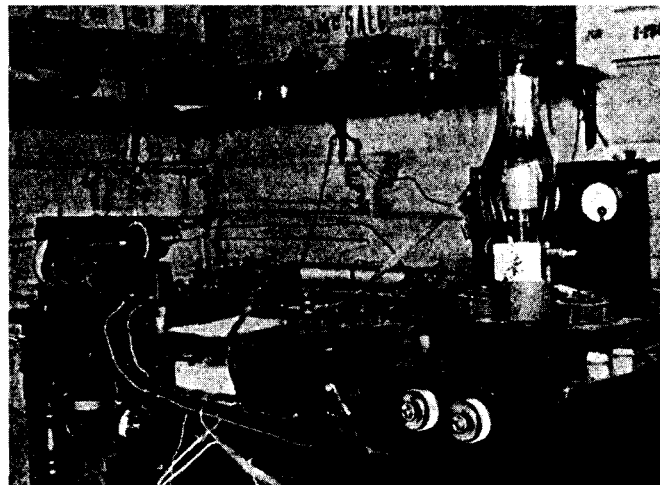

not interested in the shorter wavelengths, and his licence from the Australian PMG was for operation from 340 to 300 metres and from 250 metres downwards.

Round-the-world talk

To this point in time, his contacts had all been in Morse code, and the logical next step was to attempt voice contact. Accordingly, he fitted the transmitter with a grid modulation system and arranged with 2OD to stand by for a voice transmission. To his delight, 2OD's reply was "speech audible, mostly intelligible". As Max recalled, the date was February 9, 1925.

In this context, he said, Australian amateurs had an advantage in that the powers-that-be hadn't restricted telephony on the lowest frequency segment, because of Australia's isolation. So, thanks in considerable degree to Australian amateurs, commercial interests got involved and stations like KDKA Schenectady (USA) and PCJ (Holland) became a feature of night-

time listening.

Intense interest around the World saw the formation of the Radio Society of Great Britain (RSGB), the Amateur Radio Relay League (ARRL) in the USA and the International Amateur Radio Union (IARU).

Against this background came a surge of interest in the use of quartz crystals to control transmitter frequency. When relying on an ordinary tuned oscillator circuit, transmitters would drift randomly up and down the band, as often as not, suffering interference from adjacent transmissions. With receivers none too stable, either, it was a very frustrating situation.

Just when Max Howden was wrestling with this problem, he said, fate dealt him a cruel blow when the Howden brothers' workshop was burnt to the ground. He lost all his gear and most of his paperwork. Fifty years on, he could only apologise for his inability to resolve possible lapses of memory.

Crystal oscillators

It took him about two years to re-equip and re-tool, by which time he was due to marry and to move from Box Hill to Canterbury (Vic). In the meantime Harry Kauper 5BG in Adelaide had come up on air with a — literally — 'rock steady' crystal-locked signal, followed by Wally Coxon 6AC in Western Australia, with his own 3BQ further down the list. Max explained that, having once heard Harry Kauper's signal, "I did not consider myself ready to reappear on air until I could do likewise!"

In the late 1920s, when American Naval ships visited Australia, the *Seattle* carried two prominent amateurs, Lt. Snell and Ed Willis, equipped with an experimental crystal-locked transmitter under the call-sign NRRL. They were

Work of Years Gone Up in Smoke!

An indication of Max Howden's credibility, even in his early days, is given in a brief extract from a much longer article in *The Listener* in for July 5, 1927.

Fire has caused havoc with Mr Max Howden's House of a Thousand Voices at Box Hill. Only a white painted building in appearance, it was in reality a magic cabinet.

When he pressed the button, dwellers in Melbourne were able to hear the voices of people alien in language, nationality and mode of living from countries all over the globe. The building which is now the lifeless survival of the outbreak, was the wireless house of Mr Max Howden and his brother... inside a confused accumulation of metal plates, twisted wire...

"There goes the work of years," said Mr Max Howden as he looked upon the wreckage. "I started it in 1921... I had been improving this instrument... It had not been out of action all that time."

"This installation was the very latest thing in wireless science... There is hardly a country of any consequence that I have not managed to pick up in this little shack: Great Britain, Canada, United States, France, Germany, Belgium, Holland, Italy."

"In future, amateurs will be operating on a wavelength of approximately 90 metres. This activity should give radio a decided fillip, and will be hailed with enthusiasm by the thousands of listeners who will regularly tune in these amateur stations."

(Continued on page 97)

THE SERVICEMAN

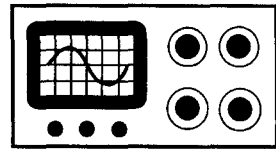

The biggest repair and reconditioning job of all time?

One of our stories this month concerns a repair and reconditioning job that must qualify as the biggest we've ever described — despite the fact that it had to be done as a 'freeby'. There's also a tale of an electronic church organ that became rather unstable, even to the point of 'blowing raspberries' during services, and another about an NEC colour TV that began making nasty hissing sounds...

This month we open with a story that is, to some extent, a continuation of one that appeared in the February 1995 edition of this magazine, under the title 'High Tech in a Modern Cinema'. It comes from Reg Leahy, of Shepparton in Victoria, and in his original story he described much of the technology employed in a typical modern cinema, with particular reference to his local drive-in cinema.

This new story relates to what must be the biggest repair and reconditioning job of all time. Not for Reg the simple restoration of a discarded television set. No — Reg goes the whole hog and restores the complete 500-car drive-in cinema, described in the 1995 story!

The story is more or less self-explanatory, so I'll let Reg get on with the job of explaining all that was

involved with his part of the exercise...

Being a member and presenter on the local Community Radio Station One FM, I was approached by the Station Committee to check over the old drive-in theatre, to see what the possibilities were of re-opening the cinema as a fund raiser for the station.

As I was the last projectionist to work at the drive-in, I agreed to check it over, to make sure that there was enough equipment left to get the show up and running without spending megadollars. After a quick check, I was satisfied that it could be made operational without major costs to the station.

The drive-in was originally opened on April 2nd 1957, with the capacity to hold 700 cars (currently 500), with a holding area for other cars waiting for the next session. The screen is 80 feet (24m) across, with the bottom of the screen 20 feet (6m) from the ground and the screen itself 37 feet (11m) in height.

The original projectors and lamp-houses had been replaced over the years with more modern equipment, and now consist of two Century projectors and Eprad lamp-houses with 3600W Xenon arcs and a carbon arc slide projector.

My first task was to clean out three years of accumulated dust and rubbish from the projection room, clean the projectors and hand crank the mechanisms to make sure that no parts had seized up through lack of use. All gears and bearings were lubricated and the 'smoke test' applied. The projectors started up without out any problems and were left to run for an hour or two. So far so good...

The next step was to test the Xenons

in the lamp-houses, and see if the passing of time had had any detrimental effect on their operation. I switched on the arc for the 'B' machine and it worked first attempt. Then feeling confident, I tried the other lamp-house; but nothing stirred.

I was already aware that the bulb in this machine was near the end of its life (the Xenon tubes are guaranteed a life of 1000 hours — this one had already achieved 1724 hours!), but there was no sign of life from the ignitor. When all else fails, it is time to bring out the instruction manuals and study the circuit.

After a careful inspection, I found the ignitor consisted of nothing more than a spark gap transmitter (see diagram). Where are you Mr Marconi, when I need your help?. The circuit consists of a 240 volt to 9000 volt transformer (T-1), with a spark gap and a Tesla coil primary in series across the secondary windings.

When power is applied to the circuit, a 45,000 VAC RF voltage is generated and superimposed upon the DC supply to the bulb. This causes the Xenon gas to ionise, thus creating a path for the DC across the gap between the electrodes in the bulb. Once this path has been established, the bulb remains on until the DC power is turned off.

Because of the possibility of the Xenon bulb igniting and/or exploding, there are a number of safety interlocks protecting the system and the operator. In this case, the bulb was removed from the lamp-house for my safety and the interlocks were then bypassed.

A visual inspection of the ignitor operation was made and after all the drama leading up to this point, the

Equalize..

..up to seven TV channels with 42dB UHF gain, inputs for Sat. and FM, and auto. level measure for around \$350 plus tax. New Alcad 905C.

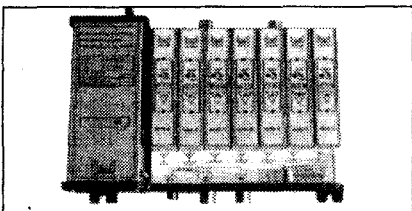

Peter C. Lacey Services Pty. Ltd.
80 Dandenong Rd. Frankston VIC. 3199
Tel:(03) 9783 2388 Fax:(03) 9783 5767

READER INFO NO.37

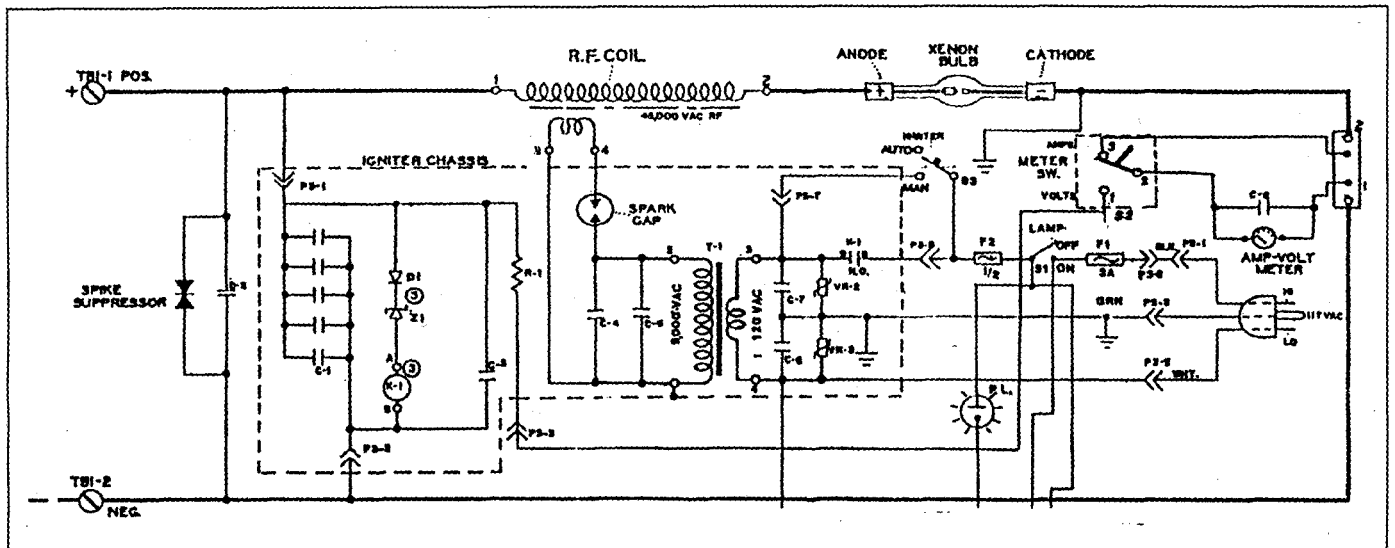

The circuitry for igniting and running the 3600W Xenon arc projector lamp, as discussed in Reg Leahy's drive-in story. The ignitor is essentially a spark gap driving a Tesla coil, to produce a burst of high voltage RF.

problem turned out to be quite simple. The transformer secondary lead (T-1 pin 1), which connects to the chassis was too close to the windings of the transformer, shorting the high voltage to earth.

After dressing the lead away from the transformer high voltage windings, and the installation of a new Xenon bulb, both lamphouses were operational. The final step was to adjust the focal position and alignment of the mirrors, to achieve the brightest and most uniform light on the screen, without creating a hot spot which could damage the lens.

The next step was to power up the sound system, which is duplicated from the photo-cell to the ramp

switches. This allows for the change over to the standby system in case of sound

failure during the screening. The power amplifiers consists of two rack mounted valve amps, using 807's in the output stage.

One amplifier was on line during the screening while the other was kept on standby. These amplifiers supplied the audio for the speakers attached to the back two rows. In the four years that I worked at the drive-in, there was never a failure in the sound system. The old valve amps proved to be very reliable.

The Cine-fi sound system consists of a solid state AM transmitter which takes the audio from the valve pre-

amp. The output AM signal is transmitted along cables to each ramp post, where a lead is then attached to the car antenna. The radios are then tuned to the frequency of the signal, which is 900kHz for this particular theatre.

(Is it possible that the valve amplifiers had originally fed 700 speakers, before the Cine-fi system was installed? This could account for their reliability when driving only a couple of rows — Ed.)

The smoke test proved OK, so a CD player was connected to the non-sync sound input and programmed to random repeat. I went for a walk along each of the back two rows to check out the remaining speakers, to see how many were still operational. Many of the speakers had been 'souvenired' during the period that the Drive-in was shut.

A quick check showed that half of the remaining speakers could be made operational with some maintenance. The rest were either full of insects, or had been left laying on the ground and now contained either dirt or mud. Others had their cones rain damaged or had icy pole sticks poked through them...

Fortunately, when the Cine-fi system was installed years ago, the speakers that were removed from the stands had all been stored in a shed. Enough workable speakers were made up from these spares to replace

The 3600W Xenon arc lamp fitted in one of the drive-in projectors. Some of the ignitor circuitry is visible behind the mirror.

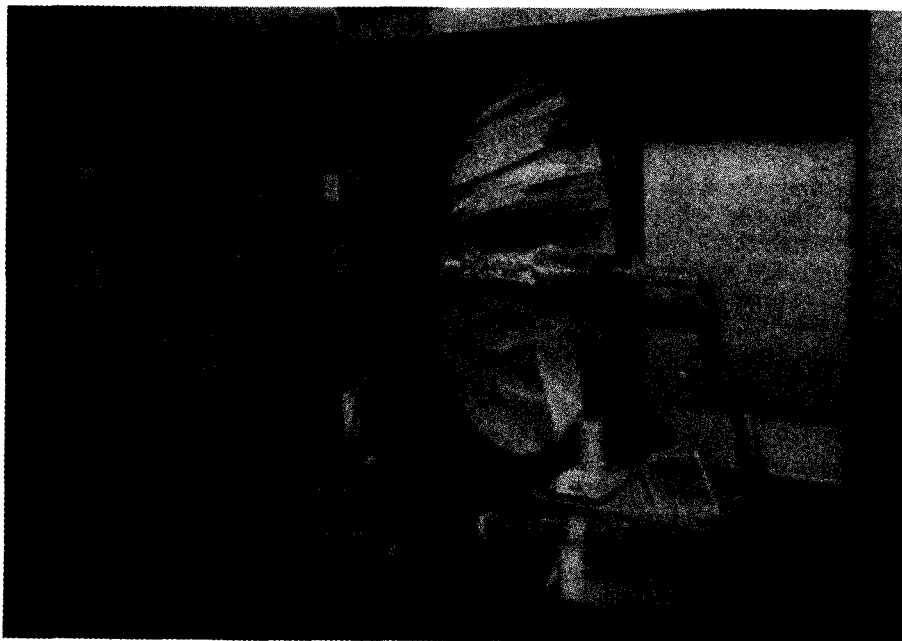

THE SERVICEMAN

the missing and damaged ones.

A quick drive around the theatre with the car radio tuned to the Cine-fi frequency indicated that it was working, but down in modulation. An adjustment of the modulation control soon rectified that problem.

Another problem noticed in the Cine-fi during this test was that when it was installed, it had been set up for the then 10kHz channel spacing. Manually tuned radios of that era could be tuned to the set frequency, even if it was slightly off. However nowadays most radios are digitally tuned and can only be tuned to frequencies on the 9kHz-spacing channels.

Correcting this required the two transmitters to have their frequencies adjusted to suit the 9kHz spacing. A check at night time found a quiet spot on the frequency band adjacent to the original frequency, and the two transmitters were adjusted to 909 and 918kHz.

The next stage, after consultation with the appropriate communications authorities, was the installation of a 'flea power' FM transmitter set to the frequency of 99.3MHz. The transmitter was connected to the audio signal from the projector preamp, an antenna was installed on the top of the projection room, and a good quality audio signal could be heard anywhere

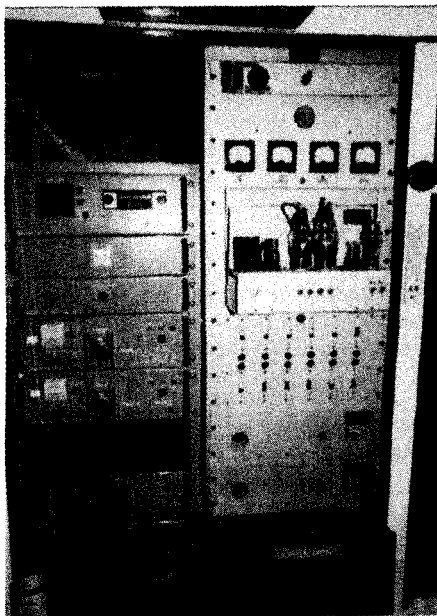

The sound system at the drive-in cinema discussed in Reg Leahy's story. Note the output valves at upper right.

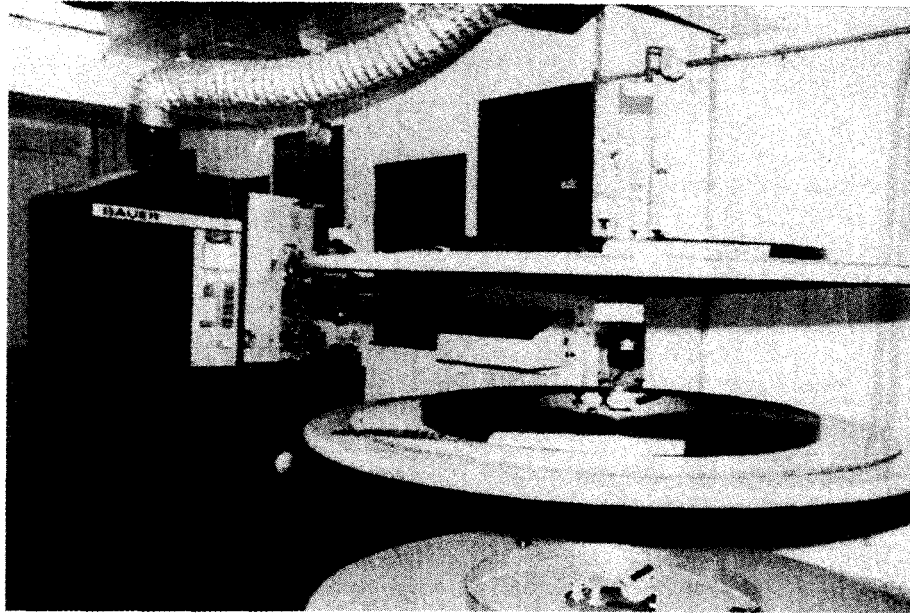

A horizontal platter system as used in many modern cinemas, to avoid changeovers and also the need for rewinding the film.

within the Drive-in.

(The next step will be to replace the mono sound cells in the projectors with stereo cells, and have the transmitter converted to stereo. Then the patrons will be able to hear the soundtrack in stereo. Unfortunately, this will have to wait until funds and time become available.)

To find anymore subtle faults that may have been still lurking in the system, a spool of film was run through the projectors.

There was a smell of burning flesh, and I quickly removed my finger from a very hot film gate. This suggested to me that the system was not going to let me win without a fight.

The original cooling system used a 'captive water' arrangement, because at the time the drive-in was built, in 1957 on the then outskirts of Shepparton, there was no town water available. On investigation, the problem was found to be that the impeller on the pump had rusted on the keyway of the shaft and had broken off when the pump was started.

There was a simple means of switching the cooling system to the town water supply, so over it went. But this created other problems. The increased water pressure soon found the weak spots in the hose couplings. These couplings were all re-tightened and a dry floor was eventually achieved!

While all of this was going on,

members of ONE FM Community Radio painted the outside of the projection room, the ticket box, cut the grass, re-painted the signs and generally rejuvenated the drive-in. A group of young lads were encouraged to apply their graffiti art to an area beneath the screen, and they did an excellent job.

A special 'shake-down' screening for the members of ONE FM was put on prior to our opening night, in appreciation of their wonderful effort in restoring the drive-in to its former glory. There were no hiccups, so all was in readiness for our grand opening. All this work was done on a voluntary basis; only the materials were paid for.

Opening night was a highly successful evening, with cars lining the roadway outside, waiting for the gates to open. It was all a fitting reward for a group of enthusiastic, dedicated volunteers after a couple of months hard work.

Well, Reg, I don't know about the other volunteers, but it seems that what you did was the biggest charitable 'freebie' of all time. It's also the biggest restoration job I've ever heard of.

The nearest I've ever come to that kind of exercise was when I stripped the equipment from a disused cinema and relocated parts of it in the theatrette belonging to an advertising agency. I had to rebuild the lamphouses, replacing the old carbon arcs with 100W

quartz iodine lamps. I have never fiddled with 3600W Xenons, and I don't think I would want to, either.

Anyway, thanks for your story, Reg. It's one of the most interesting contributions we've had for some time. I look forward to hearing from you again with more stories from the technical side of the movies.

Unstable Conn organ

Our next contributor is a true 'pioneer' serviceman. He began building crystal sets in the 1920s and retired from active servicing in the 70s. He has wide experience with radio and audio, and claims to have not become involved with TV only because of the mass of new test gear required. I guess if you were approaching retiring age, you would hesitate to spend good money on gear that would only serve you for a limited time. I know that's my excuse for not going deeply into digital technology!

But enough of that. Our contributor is Stan Allison, of Rosebud in Victoria, and he raises the general tone of the column by taking us into the realm of church music and PA systems. Here's what he has to say...

I serviced a 'Conn' church organ for some years. It was a very early solid state instrument and had no chips or master oscillators, just discrete transistors with a separate oscillator for each note. Most of the work involved tuning the oscillators, and this became more frequent as time passed. Eventually the organ needed retuning every couple of months, and I suspected that some of the oscillator transistors were unstable.

I found the particular transistor type listed in a catalog, but a note pointed out that the type included a range of six different characteristics, each identified by a coloured dot. I found a trade house that had about 100 of the old type left, so I bought the lot, for \$10! But oddly, none of them had coloured dots.

I removed the transistors from six of the oscillators that had never needed tuning, and averaged their characteristics. I was then able to select about 30 of the new stock that closely matched the good ones.

Then, while playing each of the notes in turn, I hit the corresponding transistor with freezer spray. They all drifted a little as the spray took effect, but some changed very dramatically. These I exchanged for new transistors, and that was the end of the tuning troubles.

Later, after the organ had been playing faultlessly for months, it began to occasionally emit a very ribald 'raspberry'. It greatly amused the congregation, but ruined the decorum of the service!

I struggled for some months to nail down the fault, until one day the organist showed me that she could produce the noise at will, by playing together two particular notes. Since these were part of a chord that didn't often appear in her music, it accounted for the very intermittent nature of the fault.

Careful examination finally revealed that the output wire from one of the oscillators was fractured inside its insulation. When played on its own, that note worked perfectly. But when the second note was played at the same time, it produced the 'raspberry'. It seems that the fracture vibrated in tune with the second note while at all other times the broken ends of the wire sat quietly in contact.

In the same church, a PA amplifier developed the habit of going quiet without warning. No plops or clicks etc., and never when anyone was speaking into the system. Simply, when the fault appeared, someone would start to speak but the system would be dead. All four inputs behaved in the same manner.

I connected the amplifier to my system at home and left it running with the cover off. However, on testing, I had only to touch any of the knobs or put the meter probes on any part of the circuit to restore the sound. I reasoned that as there were no clicks or plops, the fault must lie in part of the circuit not carrying DC. This eventually proved to be where the four inputs were commoned to the master volume control pot.

There was no fault to be seen, so I removed the master volume pot and gave it a thorough testing. I could find no fault with it, but on restoring the pot, I noticed one connecting pad looked as though it had never been tinned properly. I scratched at what looked like the pad, only to find that I was scratching at the board surface itself.

There was no sign of the pad, but I knew it had been there before. I eventually found it stuck on the end of the solder wick I had used to clean up after removing the pot. It seems that the track had been fractured where it met the pad and when the fault was present, any testing or electrical disturbance was enough to restore the low level circuit.

I have often commented that most

ROCOM

ELECTRONIC COMPONENTS SALE!! SALE!!

MONOLITHIC CAPACITORS (0.2" spac. T&R)

0.01uF	\$0.03	1000pF	\$0.03
0.047uF	\$0.03		

RB CAPACITORS

1uF 350V	8 x 12mm	\$0.20
22uF 350V	16 x 25mm	\$0.80
4.7uF 350V	10 x 17mm	\$0.30
47uF 350V	16 x 32mm	\$1.00

RT CAPACITORS

100uF 16V	\$0.05	4700uF 25V	\$0.30
4700uF 16V	\$0.25	1500uF 63V	\$0.15
680uF 25V	\$0.05	2.2uF 350V	\$0.15

CRYSTALS

6.475 MHz	\$0.20	10 MHz	\$0.20
8 MHz	\$0.50	11 MHz	\$0.20

EPROMS

27C512-12	CMOS 64K x 8	\$3.50
27C4002-10	CMOS 256K x 16	\$12.00

INTERGRATED CIRCUITS

NE566	Dual Timer	\$0.25
LM339N	L/Pwr L/Offset Volt. Quad Comp.	\$0.30

TRANSISTORS

BC548	NPN 30V 0.1A 500mW T0-92	\$0.04
BC547	NPN 45V 0.1A 500mW T0-92	\$0.04
PN2222A	NPN 40V 0.8A T0-92 G	\$0.04

MAINS TRANSFORMER

* Input voltage: 240VAC 50Hz
* Output voltage: 6.3V - 6.3V (12.6V - CT)

* Output current: 250mA
* Termination: Wire leads

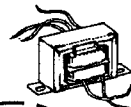

\$2.90

INDOOR

UHF/VHF/FM

COLOUR TV ANTENNA



\$6.50

REGULATOR

LM2925T

* Low Dropout Reg. with Delayed Reset
* 5V, 750mA output



\$1.00

DUAL 5 SECTION ANTENNA ROD

* Collapsed: 240mm * Rod Dia: 7mm
* Extended: 1030mm * Wire Length: 750mm



\$3.90

FREIGHT

\$5.50 (VIC ONLY) up to 3kg
\$7.00 (OTHER STATES) up to 3kg

STOCK IS SUBJECT TO PRIOR SALE.

ROCOM ELECTRONIC COMPONENTS

MAIL ORDER SEND TO:

P.O BOX 142 HUNTINGDALE VIC 3166

PH. 03 9548 9229 FAX. 03 9562 8772

WANTED EXCESS SURPLUS STOCK

READER INFO NO.9

faults in electronic equipment is caused by mechanical deficiencies, and Stan Allison's story here shows just how difficult they can be to find.

Wires broken inside the insulation can be the very devil to locate. First, they have to be suspected otherwise you could spend hours looking for something that isn't there. Then having suspected a break, there's the trouble of finding it.

Stan didn't say how he went about it, but I lift each suspect wire with a screwdriver then run the shaft along under the wire. If the conductor inside is broken, the insulation will tend to bend sharply as the break passes over the tool. By watching for this sudden kink, one can get a fair idea of the condition of the internal wire. (But I didn't say it was easy!)

Then Stan's problem with the broken PCB pad is just another of those trials that are sent to plague us. In this case, our contributor was lucky that the pad came adrift. If it had stayed in place, the break might never have been properly located and repaired.

Thanks for your contribution, Stan. I'm sure that we all feel better for that short visit to your local church.

NEC that hissed!

Finally, we come to another story that is essentially mechanical in its nature. It comes from Eric Rodda, of Marion in South Australia, and his contribution brings us back to more common ground, inside a television set:

The story concerns a NEC 22" TV, model N2266. This is the first time I've seen this model, as they are generally known to give years of trouble free service. The owner confirmed this — "It's never even flickered in all the time I've had it".

The symptoms, as explained to me, were that when the set was turned on (after working perfectly the night before) it had made a terrible hissing sound. The owner had turned the set off immediately — a good idea, as it turned out.

The set was subsequently delivered to me and I tested it for myself. I switched on and straight away saw LEDs flashing and heard the loud hissing noise. I hit the OFF button in half a second! The flashing lights suggested that the power supply couldn't handle the load presented to it, possibly by a faulty EHT transformer.

The line output transistor gave a funny sort of reading when I tested it on my meter, so I replaced it as a form of insurance. I had no way of testing the line output transformer and since a replacement was not as expensive as I would have expected, I fitted a new one.

A visual inspection of the rest of the circuit showed up nothing irregular, so power was applied to the set. Unfortunately the hissing sound continued, but this time the lights stayed on continuously — I was getting there!

After turning the set off, I could detect a slight burning smell so I used my nose to trace the odour. It was coming from the yoke!

I wanted to test further, so I unplugged the yoke and turned the power on once more. This time there was no hissing and the sound was OK; but there was an out of focus white blob where the picture should be. But particularly, there was no burning smell evident. This confirmed it to my way of thinking. The yoke must be faulty!

I rang the NEC spare parts dept and was told that the yoke is supplied as part of the tube, which I had already begun to suspect. As a last resort the chap at NEC asked if the yoke had a part number, which I found and read back. Negative results again — "that part number is no longer available" was the reply.

I told the customer what it had cost me so far, and what it was likely to cost with a new picture tube. But he still said "fix it".

I felt as though I should at least try to fix the yoke, if it was at all possible. So after removing the baseboard from the tube, then the convergence rings and cutting through some silicone compound, I carefully slid the assembly off the neck of the tube.

As soon as I looked at the windings inside the yoke, I could see where the trouble was. There were burnt wires either side of the charred remains of a plastic separator. The two windings were now coupled with carbon from the burnt plastic.

I wasn't too worried about why it had happened. My concern was: could I effect a repair? With a multi-meter connected to the horizontal winding, the resistance reading would vary from about 0.9 ohms to 1.8 ohms as pressure was applied to the dam-

aged area.

The first thing to do was to clean off as much of the burnt material as possible. This was done with iso-propyl alcohol on a small brush. I also scraped the black, burnt plastic away from between the two windings.

The next job was to try to separate as many of the wires in this area as I could — because, once they were clean, it was obvious that the insulation was missing from most of them. This was difficult because the windings were obviously soaked in some kind of varnish to stick it all together.

After managing to separate some of the wires, the meter reading steadied at 1.8 ohms; I could only hope that this was the correct value. I then dripped some high voltage varnish (originally in a spray can) into the cleaned area and left it overnight to dry.

The next task was to rebuild the plastic insulating barrier between the two windings. I figured silicone compound would do the trick. I ran a bead down between the windings on each side then smoothed it out with my finger and put it aside to set.

I left the silicone a whole day to gain its full insulating properties, before returning the set to normal. After reassembly and checking all plugs and attachments, I held my breath and turned it on.

The set came up with perfect picture and sound. I ran it on the bench for three days as I went about other work. It didn't miss a beat. The set was returned to the customer with a reasonable bill, and continues to operate 'without a flicker'.

Thanks for that story, Eric. In fact, it's about something that I have done myself several times in the past, yet never thought about writing up for this column. You've corrected a long standing deficiency.

These sort of breakdowns are not all that uncommon, and in the days when tubes and yokes were sold separately, one didn't try to repair a faulty yoke. One just replaced it. Nowadays, when tube and yoke are an integral component, the incentive to try a repair is very strong. And as Eric has shown, it can be done. Thanks again, Eric!

Well, that winds up the program for this month. We've got a few more contributions put aside for next time, but there will always be room for more. ♦

Experimenting with Electronics

by DARREN YATES, B.Sc.



Exploring CMOS - 2: gate circuits

This month, we start looking at some practical CMOS circuits from a wide range of circuit design areas. Some are simple, others more complicated — but all worth keeping in your circuit scrapbook.

The fact that you're reading this suggests you made it through last month's EWE — congratulations. CMOS theory can be as exciting as sitting at the SCG in the middle of winter, but if I may borrow some from an infamous phrase, it was the EWE we had to have...

To really understand digital logic, and thus, most of digital electronics, you must have an understanding of the basics. If you skip over this, you'll end up having problems with most of the circuits you read or design. Time spent studying this *now* is an investment in problem-solving for the future.

Digital electronics didn't start with the advent of TTL or CMOS. In fact, it started right back with Morse code and telegraphy. The simple action of opening and closing a switch is in itself a form of digital communication. It's the forebear of the digital mobile phone we have today — greatly more advanced I grant you. But from humble beginnings...

With the first computer cranking into life in the late 1940s, digital electronics began to find its feet before the advent of the transistor. But until integrated circuits (ICs) hit the streets, transistor logic formed the backbone of digital circuits. Circuit fragments like the transistor inverter we've looked at in previous articles are an example of this.

CMOS logic created a simple, smaller and more efficient solution, allowing designers to work with building blocks

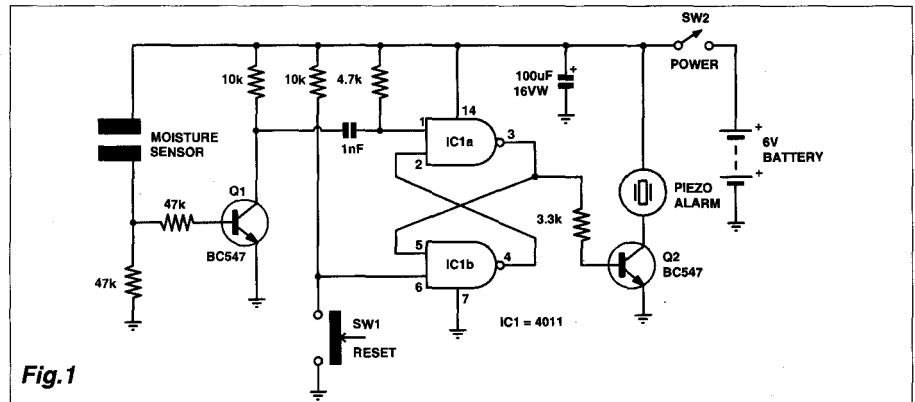

Fig. 1

in a way that isn't too dissimilar to Meccano or Lego.

Moisture sensor

Right then. Our first circuit for this month is a moisture sensor and is shown in Fig. 1. Now while it may not reach any great heights of excitement in terms of design, it contains a very simple building block which has formed the basis for everything we see in computers today. And remember — you have to crawl before you can walk.

Looking at the circuit, transistor Q1 acts as an inverter so that whenever moisture falls on the sensor and the resistance between the two pads falls below a preset value, Q1 turns on and the collector voltage goes low.

Now you'll notice two NAND gates

that are cross-coupled. The input to IC1a at pin 1 is connected to the collector of Q1 via an RC time constant. This produces a short negative-going pulse at pin 1 when the collector of Q1 drops. These two gates form what's technically known as a *bistable multivibrator*, more commonly referred to as a 'flip-flop'.

Normally the output of IC1a is low and the output of IC1b high. When the trigger pulse arrives, the input at pin 1 drops low for a short time. Since this is a NAND gate, whenever any input goes low, the output goes high. This high output is cross coupled back to the input at pin 5 of IC1b. Since the reset switch is not pressed, this means that IC1b now has two high inputs and so the output of IC1b falls low. With the output at IC1a high, transistor Q1 turns on and sounds

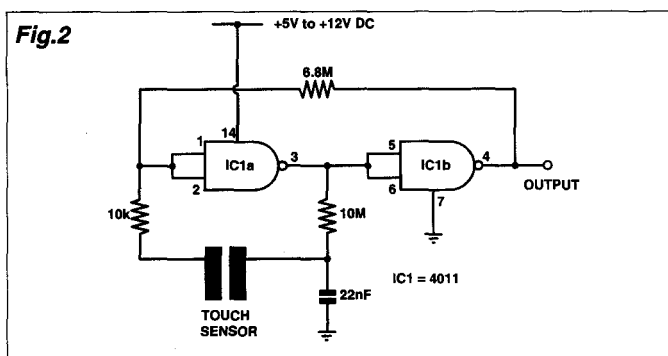

Fig. 2

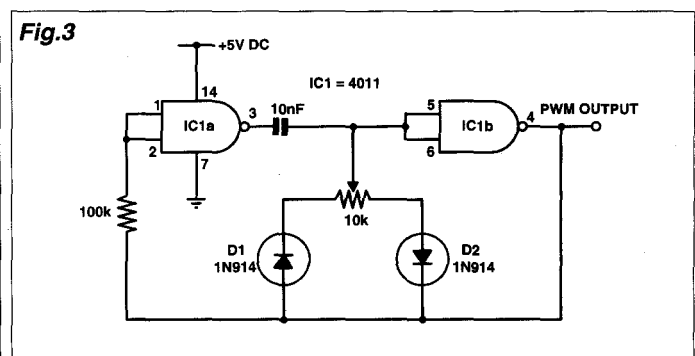

Fig. 3

the piezo alarm.

Note that even though the trigger pulse last only a short time, the low from the output of IC1b then holds the IC1a high, regardless of what happens now to pin 1.

When the reset button is pressed, this pulls the input at pin 6 of IC1b low, which sends the output high. IC1a now has two high inputs and its output now falls low, silencing the piezo alarm.

You could use this circuit as a classic rain detector or a liquid spill detector. One way of making the detector is to use a length of Veroboard or stripboard. Take the board and connect up every second strip as one arm and then the other remaining strips as the other arm. This matrix system works very well as a moisture sensor; it's easy to make and quite cheap as well.

If you like, you can replace the transistor inverter with one of the spare NAND gates. Simply connect both inputs together of one of these gates, and connect the sensor between the positive supply rail and the gate inputs and a 10kΩ resistor between the gate inputs and ground. The output of the gate then connects to the 1nF capacitor in place of the transistor collector.

If you're in a real hurry, you could also remove the transistor circuitry, leave the 4.7kΩ resistor in place and simply connect the sensor between pin 1 of IC1a and ground. This is the rough-and-ready way and risks damage to the IC. The transistor interface adds an extra line of defence between the outside world and the IC.

Alternatively if you're interested in just seeing how a flip-flop works, you could remove the front section altogether and connect another pushbutton switch between pin 1 of IC1a and ground, leaving the 4.7kΩ resistor to the supply rail from pin 1. You'll find that you can operate the flip-flop by pressing either switch.

Funnily enough, that's how the flip-flop gets its name. You can flip it in one direction with one switch and flop it back again with the other...

The point to make here is that the circuit remembers the last command you gave it via one of the switches. It won't change state until you tell it to, and that has made it one of the most useful circuit elements ever designed.

Obviously the flip-flop was around long before CMOS arrived on the scene, but the beauty of CMOS version

Fig.4

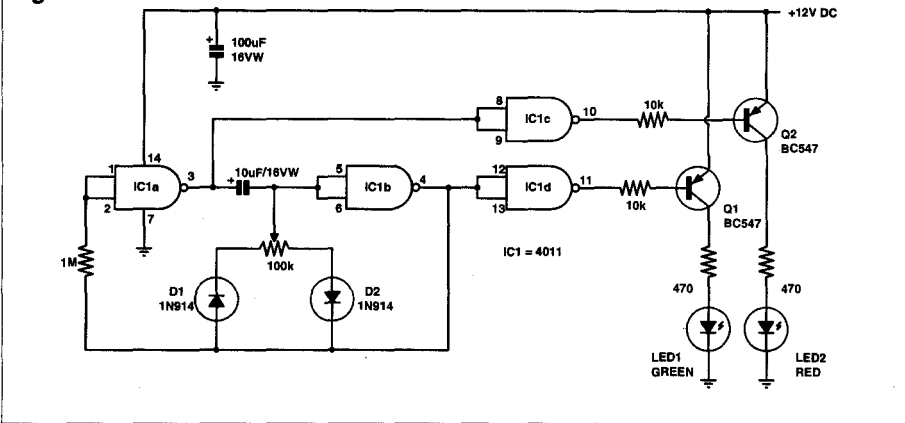

is that it draws only the smallest amount of current — around 30uA, making portable circuit designs so much simpler and smaller.

Touch switch

Every now and then you see ads on TV for those touch lamps. You know the ones — touch the base and the lamp switches either on or off depending on its current state. While the circuit in Fig.2 should never in its present form be used to control mains lights, it can form the basis of control for a wide range of battery-powered circuits.

Looking at Fig.2, it uses two NAND gates connected up as inverters. The good thing here is that you could use any inversion-type gate here — NOR, NAND or inverter — and the circuit will work exactly the same. You can also use a mixture of CMOS gates. This makes it easier to design into circuitry, because you can basically use whatever gates you have left over.

The two gates form yet another flip-flop. But notice that their connection is slightly different and the operation of the circuit relies on changes of resistance to change state. Let's take a look...

Since the output at IC1b can be either high or low at any one time, let's assume that it's low. This low is coupled back to IC1a via the 6.8MΩ resistor. Since there is no other DC path here, the inputs are considered low, and the output of IC1a is high.

Capacitor C1 is charged up via the 10MΩ resistor, but when the contacts are touched, the capacitor discharges into the low output of IC1b via the 6.8MΩ resistor, the 10kΩ resistor at the input of IC1a and the skin resistance of the finger.

By virtue of a voltage divider consisting of the 6.8MΩ, 10MΩ and 10kΩ

resistors and the skin resistance, IC1a now recognises the input signal to be high. Its output therefore falls low, which forces the output of IC1b high.

The low output of IC1a ensures that the capacitor is discharged now, through the 10MΩ resistor. If the contacts are touched again, the high output from IC1b is connected via the 6.8MΩ and 10kΩ resistor, and the skin resistance to the discharged capacitor. Initially, this looks to the input of IC1a as a low input, so it sends its output high, which pulls the output of IC1b low again.

The only problem with this circuit is that if you keep your finger on the circuit, it will act like a very slow oscillator with a time period of around half a second, sending the output of IC1b high, low, high, low, etc. The trick here is to just *tap* the contact — the circuitry will take care of the rest in a flash.

Variable duty cycle oscillator

Over recent months, we've looked at a wide range of oscillator circuits; in particular, those that allow you to vary the pulse width and frequency. One circuit we looked at recently was the 555 timer audio amplifier circuit, which used the 555 timer as a pulse position modulator.

While that circuit worked well in terms of producing a modulated waveform, it had the disadvantage of also varying the frequency.

Most often, these circuits use fancy filter networks to remove remnants of the carrier frequency so that you're just left with the audio once the signal has been demodulated. The problem is that if the carrier frequency is changing as well, it's virtually impossible with simple electron-

ics to remove this frequency.

This next circuit in Fig.3 is very basic, but it has the advantage of allowing us to change the pulse width without affecting the frequency. This type of circuit could be the basis of an excellent mini drill speed controller.

Looking at the circuit, it uses two NAND gates, although they could be any inverter-type gate, connected up in the standard oscillator configuration. The only difference is the diode/pot network between the inputs of IC1a and IC1b.

Normally here you would see just a single resistor, but this circuit uses a pot and two diodes connected in opposite directions. The diodes control the flow of current as the capacitor charges and discharges. When the capacitor charges up, current flows through one diode and when it discharges, it flows through the other.

The pot has two functions. First, the total resistance of the pot sets the overall frequency while the wiper allows us to vary the length of the pulse or duty cycle within that frequency.

Looking at the circuit, it may be hard to visualise what's going on here. So you might like to wire up the circuit in Fig.4, which should help you.

Fig.4 contains our basic PWM (pulse width modulation) oscillator plus the two spare gates from the same 4011 IC package. Each of these is connected up to the outputs of IC1a and IC1b. The outputs of IC1c and IC1d are themselves connected to two PNP transistors, which in turn operate a red and green LED.

So that you can see what's happening, we've made the oscillator run at a very low frequency. This will enable you to see each LED turn on and off. Looking at the circuit, when the output of IC1a is high, it sends the output of IC1c low which turns on transistor Q1 and the green LED. So the green LED indicates when the output of IC1a is high. Similarly, when the output of IC1b is high, the output of IC1d is low, which switches on transistor

Q2 and the red LED.

The way this oscillator works is that as you vary the pot control, you'll see the lengths of time each LED is on will vary, in converse fashion. But the total length of time for both together in any one cycle will remain the same. This is the essence of what a PWM oscillator does.

Another benefit with this circuit is that you get two outputs which are out of phase with each other. Normally, with circuits such as a drill speed controller you only need one output; but say you wanted to connect this up to two motors and wanted one to slow down as the other sped up, this circuit would be ideal.

You simply connect one output via a driver transistor to one motor and the other output to the second motor. As you varied the pot, the PWM signals of both outputs will vary accordingly. As the duty cycle of one signal increases, that is, the positive pulse gets wider and wider over each cycle, the other signal's duty cycle decreases.

While this circuit is not unique to CMOS or digital electronics, it is much easier to build with CMOS gates and to operate over a wide duty cycle range because of their very high input impedance, which is of the order of 10^{12} ohms — or a million megohms.

Audio Signal Injector

Most people tend to not to think of digital circuits being useful in the audio domain, unless you start talking about analog-to-digital converters (ADCs) or digital audio. But this simple circuit in Fig.5 will enable you to locate problems within your audio circuits and make diagnosing faults that much easier.

It uses a single 4011 CMOS quad dual-input NAND gate IC and a handful of other components, most of which you'll already have lying around in your junkbox by now.

Looking at the circuit, IC1a and IC1b form another type of oscillator. It's a little different to what we've looked at in

the past and relies on the AC signal being coupled back via cross-over capacitors from one gate's output to the other input.

Each gate is triggered when the output pulls low, say for example IC1a, allowing the capacitor connected to its output charge up via the $1M\Omega$ resistor. Once it reaches a certain voltage, it then triggers the other gate to lower its output and the other capacitor now charges. Meanwhile the output of IC1a has been pulled high again, because of the triggering of IC1b. This cyclic process continues on indefinitely.

This first oscillator, using IC1a and b, is set to a frequency of 2Hz. From the output of IC1a, the signal is split two ways. Firstly, it's connected up to transistor Q1 which fires up the indicator LED. Since it's a test circuit, you need to know that it is working; so that's why the LED is there.

The second path is to one of the inputs of IC1c. Notice that IC1c and IC1d are connected up in a similar fashion as IC1a and IC1b. The only difference is the signal coming from the first oscillator and a change of component value for this second oscillator.

The component values shown should give you a 1kHz signal at the output of IC1d. Since one of the gates is also driven by the previous oscillator, this produces a *gated* tone signal. In simple terms, the output of the first oscillator controls when the second oscillator operates. The resulting output signal is a 250ms burst of 1kHz tone, followed by a 250ms length of silence.

The output of IC1d is then fed to a buffer transistor and connected to the test circuit via a $1k\Omega$ pot and a $1\mu F$ bipolar capacitor. The $1k\Omega$ pot allows you to vary the amount of signal you feed into the input of circuit under test. If you're testing a preamplifier for example, then you're not going to need to blast it with tonnes of signal!

Now you could argue that all you need

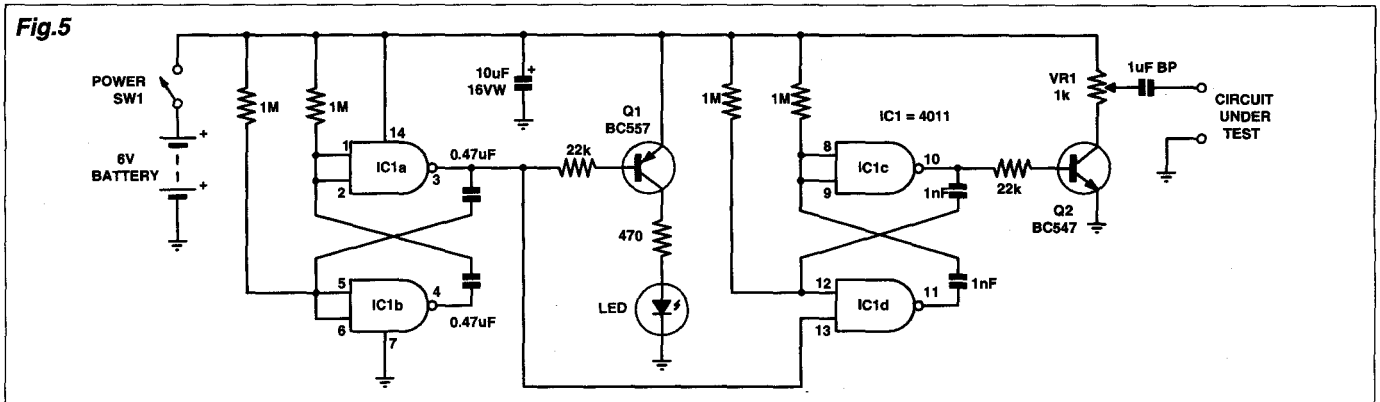

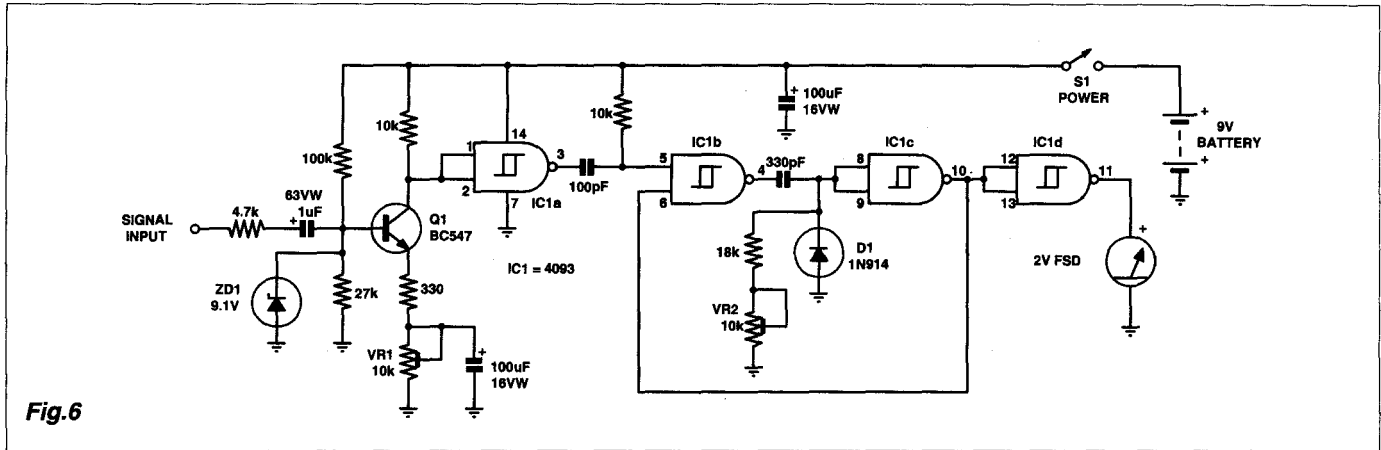

Fig.6

is a single tone oscillator to feed to your circuit under test. That may be so, but the signal from this circuit is much easier to hear, particularly if the circuit is noisy.

The way you use this circuit is just as important. If you have an audio circuit which you suspect has a problem somewhere, the best way to diagnose the problem is to start at the output, connect up the signal injector and listen to the output. That may sound a little like the bleedin' obvious, but you'll be surprised how many problems can be caused by dry solder joints even at the output.

Once you've found that the output is OK, you then start moving back through the circuit, one stage or even one component along the path at a time. Eventually you should get to a point where you find the test signal is being corrupted by the circuit under test. When this happens, you know that the area of fault is located between your current test point and the previous one. It's then a case of checking the various components along that section of the signal path, as well as checking various voltages to see where the problem may lie.

By necessity this is a very brief explanation and if by following this method you find the problem, then I would say that you've only had a fairly simple or obvious problem. Some problems require much more expensive equipment to find.

Audio frequency meter

While we're on the topic of digital circuits coming to the rescue of their analog cousins, this next circuit also falls nicely into that category. Looking at Fig.6, the circuit also introduces us to a new type of gate known as the Schmitt-trigger NAND gate. You'll only find these in a 4093 CMOS package.

Their basic NAND operation is the same as the more familiar 4011 IC, except that each input has a Schmitt trigger tacked on the front end.

Some time ago, we looked at a Schmitt trigger circuit using discrete transistors, and the operation of the Schmitt triggers in each of these gates is similar. Basically, when an input rises about 2/3rds of the supply rail, V_{cc} , the input is then considered a high but it has to fall below 1/3rd of V_{cc} to be considered as a low input.

The major problem with the 4093 gate is that the upper and lower thresholds are somewhat arbitrary and depend upon the manufacturing process; they can even vary within the same IC. If you intend to use these gates in time-critical applications where you're relying on the threshold levels of the Schmitt trigger, I suggest that you try again unless the circuit is just going to be a one-off and you can build in some adjustment tools in case you need to replace the IC at some time in the future. If the latter is the case, then it should be OK.

Back to the circuit, the input audio signal is coupled to a single transistor amplifier formed from Q1 and its surrounding components. It has a gain of about 33dB (45 times) and its job is to provide raw gain. Zener diode ZD1 protects the input stage by clipping any signal which wants to head above 9V. We're not really interested in the output quality to the point that we actually want as much signal as possible.

The output is taken from the collector of Q1 and fed directly into the input of IC1a. This gate is set up as an inverter, but it's the Schmitt trigger function that we really want.

The signal at the output of this first gate should be a clean pulse waveform which has had the noise removed. The

output from IC1a is then fed to a *monostable* ('one-shot') consisting of IC1b and IC1c, and their associated components. The 10kΩ trimpot, VR2, allows you to adjust the full scale output. For the 2V FSD meter, 20kHz equals 2V. You could also use your digital multimeter as well, if you like. Trimpot VR1 sets the sensitivity of the circuit.

The output from IC1c is then further inverted by IC1d and fed straight to a 2V voltmeter.

Now the way the circuit works is that the input signal is converted into a pulse waveform of the same frequency. On each falling edge, the monostable is triggered to produce a narrow negative-going pulse. If the frequency increases, the number of pulses also increases but the duty cycle also changes. Since the pulses are always the same length in time, if the number of them increases, then the duty cycle of the waveform changes accordingly.

The last inverter inverts the whole signal to produce a series of narrow *positive-going* pulses. The output signal going to the voltmeter is then a series of positive going pulses at the same frequency as the input. This change in duty cycle is picked up by the coil in the meter. Because the coil can't respond fast enough to instantaneous changes in voltage, it averages them to produce a constant voltage reading that is proportional to the duty cycle. The end result is that the needle rises in proportion to frequency — exactly what we want.

Obviously, by using a moving coil meter, we're limiting the accuracy. But as a guide to the input frequency, it should perform well.

OK, That should be enough to give you some ideas for projects of your own. We'll continue with our look at CMOS circuits next month. ♦

SHORTWAVE LISTENING

with Arthur Cushen, MBE

Satellites ahead of many listeners

Several international broadcasters using shortwave are also introducing a backup service by having their transmissions carried on satellite. However recent surveys show that the listening audience to satellite transmissions is as yet very small, and the signals are mainly being used for rebroadcasting by domestic radio stations.

A recent survey shows that some international broadcasters fail to comprehend that an audience for satellite home reception does not exist in the third world countries, and in fact it would only be Europe and North America within range of receiving these signals. It seems that technology at the moment is way ahead of the listening audience.

The VOA has indicated this low interest in satellite reception, and delegates at a conference in Hilversum, Holland, stressed the fact that the cost of equipment was well beyond the means of millions of people in Africa and Asia. At the moment satellite broadcasting in Africa and Asia is only a dream, as most listeners can not afford this equipment. It would initially cost US\$2000 to get started, and the average income is typically only around \$150 a month.

There is a growing technology gulf in the world today, and this was emphasized at the conference. It was explained that in India there is one television set for 28 peo-

ple, while in Nepal the ratio is one TV set to 500 of population.

In other fields of appliances and areas which we take for granted, even the telephone is severely limited in its availability. In Sri Lanka the telephone service is more often out of action than available to the household. In India there is one telephone for 88 people, and here again emphasis was on communication — where shortwave radio is often the only means of mass access to information.

Wind-up radio

The main problem for radio listeners in the third world is the high cost of batteries. To overcome this a wind-up radio receiver has been invented, which works on a clockwork system.

In 1990 a British engineer was listening to a BBC programme on AIDS in Africa, which mentioned the difficulty of sending the safe-sex message — because many villages could not afford batteries. After building a prototype of the wind-up radio and gaining sponsorship, he opened a workshop near Pretoria to build them.

The receiver covers all of the international shortwave bands and after the trial with several types of springs, he was able to get the receiver to run for half an hour before it

needs to be hand wound again. It uses a construction similar to the old fashioned gramophone, and weighs six pounds. The price is around \$40. The coverage, which also includes AM and FM, means that the BBC and VOA are in range of the receiver anywhere in Africa — so today even listeners living in mud huts can tune into the information age with a twist of the wrist.

Although this is getting back to the basics, it certainly overcomes a problem which has been the main deterrent to a wider listening audience.

Changes in NZ Radio

Australian listeners will have noticed when tuning to New Zealand mediumwave stations that the network of 42 stations formerly known as Radio New Zealand Commercial Stations has been sold. The stations were purchased by New Zealand Radio Network Limited for NZ\$89 million, and the company is jointly owned by New Zealand Herald Newspapers, Australian Provincial Newspapers Ltd, and Clear Channel Communications Inc. of the USA.

The new owners have made no major changes to the network, and have only replaced Radio New Zealand's identification by the announcement of 'Radio News Network'.

In purchasing the radio stations the official announcement indicated that the purchase covered the expertise and dedication of a team of radio professionals who have brought you New Zealand's finest news, sports, personalities and entertainment. The only immediate change that listeners will notice is that these are no longer Radio New Zealand stations but part of the Radio Network of New Zealand. ♦

AROUND THE WORLD

AUSTRALIA: The Radio Australia relay of the BBC World Service 2200-2300 is now from Brandon on 9660 and 12,080kHz.

INDIA: AIR is using a new frequency of 9705kHz at 2045-2230 along with 7410kHz, 9910, 9950, 11,620 and 11,715kHz, and again at 2245-0045 they are using 9705kHz with 7150kHz, 9950, 11,620 and 11,660kHz. Both transmissions on 9705kHz cause interference to VOA Udon for the period 2200-2400.

INDONESIA: RRI Ujung, Pandang is heard at 0900 on 9565kHz and past 1100UTC the station has news on the hour. English broadcasts from Indonesia continue to be heard 0800-0900 and 2000-2100UTC on 9525kHz. In recent weeks they have been running a contest with a free trip to Indonesia as the prize.

PAPUA NEW GUINEA: Port Moresby on 9675kHz has been mixed with Channel Africa until 0555UTC. At 0600 it gives a programme preview, including news in English at 0800.

PHILIPPINES: PBS is using VOA transmitters at Poro on 13,770kHz, 15,330 and 17,730kHz in Filipino and English, from 0330-0400UTC.

SAO TOME: VOA is planning to test in the tropical band with a 100kW transmitter which was used on 1530kHz, awaiting the 600kW installation. Test frequencies are 4750kHz and 4950kHz from 0700-1300UTC.

VOA transmitter number five is now in operation with a programme beamed to Africa at 0300-0400 on 7290kHz; 0400-0500 on 7180kHz; 1600-1700 on 11,880kHz; 1700-1800 on 11,890kHz; and 1800-2230UTC on 11,975kHz.

SOUTH AFRICA: Channel Africa has English 0500-0555 on 9675kHz, which is a move from 9590kHz. The reason for the move is there has been co-channel interference with Radio Nederland, Bonaire on 9590kHz which operates to North America from 0430. Channel Africa 9675kHz has interference from Port Moresby in this area.

THAILAND: According to the latest schedule English broadcasts from Radio Thailand are: 0000-0030 on 9690kHz; 0030-0100 and 0300-0330 on 15,370kHz; 0530-0600 on 15,115kHz; 1230-1300 on 9885kHz; 1400-1430 on 9810kHz; 1900-2000 on 7210kHz; and 2030-2045 on 9555kHz. The transmissions at 1230 and 1400UTC are to the Pacific.

VANUATU: Vila opens at 1900 on 3945kHz with an anthem and Yellow Bird; announces also on 1125kHz and 4960kHz. The frequency of 4960kHz is heard at 0500 and on Wednesday at 0530 has RNZI 'On the March' programme.

YUGOSLAVIA: Belgrade is excellent to Australia in English 2030-2100 on 7230kHz. ♦

This item was contributed by Arthur Cushen, 212 Earn Street, Invercargill, New Zealand who would be pleased to supply additional information on medium and short-wave listening. All times are quoted in UTC (GMT) which is 11 hours behind Australian Eastern Daylight Time and 13 hours behind New Zealand Daylight Time.

DICK SMITH ELECTRONICS

NEW PRODUCTS

Lug Crimping Tool

A handy tool when you're working with non-insulated terminals. Has strong metal jaws and cable cutter, plus handles 10-28AWG wire.

Cat T-3528

\$16.50

NEW

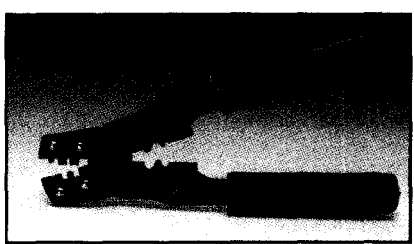

DSE Heavy Duty 200mm Pliers

Made from strong Chrome-Vanadium steel for long life.

Cat T-3305

\$16.95

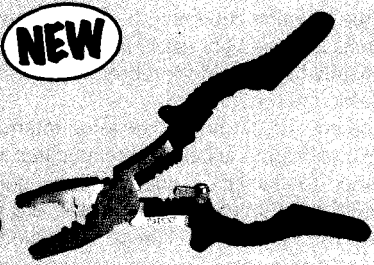

NEW

Cable Tie Gun

The convenient way to tighten plastic cable ties. Has rigid plastic body, pistol grip action, and adjustable tension control for the cutting of the unused tie end.

Cat T-3720

\$16.95

NEW



15-Piece Electronics Screwdriver Set

A handy collection of small screwdrivers for the electronics enthusiast. Includes 4 flat-blade drivers (1.4, 1.8, 2.4, 3.0mm), 3 Phillips heads (00, 0.1), 3 hex bar drivers (1.5, 2.0, 2.5mm). Complete with plastic storage case.

Cat T-4370

\$16.95

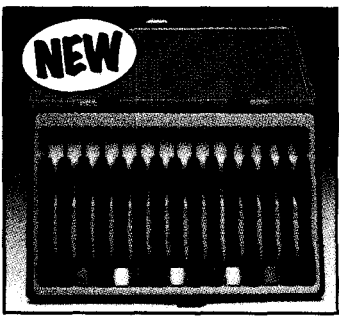

NEW

Security Torx Screwdriver Set

Medium sized security torx screwdrivers with strong 60mm shafts, easy-to-grip moulded handles and black oxidized tips. Set includes a wall-hanging holder for each screwdriver. Sizes T8, T10, and T15.

Cat T-6139

\$19.75

NEW

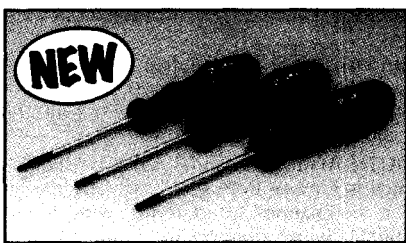

7 Piece Torx Screwdriver Set

A handy set of 7 small Torx screwdrivers with strong 50mm alloy shafts plus black oxidized tips for greater durability. Sizes T6, T7, T8, T9, T10, T15, T20.

Cat T-6140

\$24.95

NEW

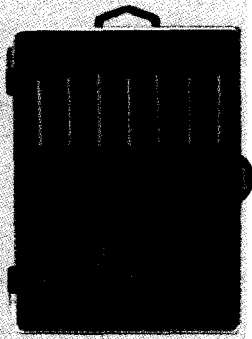

9-Piece Hobby Tool Kit

A great way to start building your tool collection. Includes 3 flat-blade screwdrivers (1.4, 1.8, and 2.4mm tips), 3 Phillips head screwdrivers (00, 0 and 1), stainless-steel side cutters and medium-nose pliers, and a 38mm magnifying glass, all in a handy storage case.

Cat T-4605

\$26.95

NEW

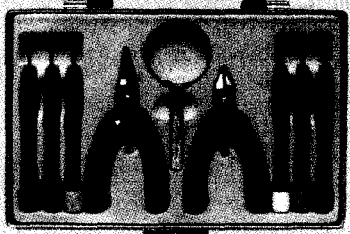

Multi-Angle Metal Vice

Beautifully crafted metal vice suitable for a variety of hobby uses. It mounts to a bench up to 50mm thick, has jaws with rubber covers 75mm wide that open to 55mm. Made from diecast aluminium alloy.

Cat T-4742

\$39.95

NEW

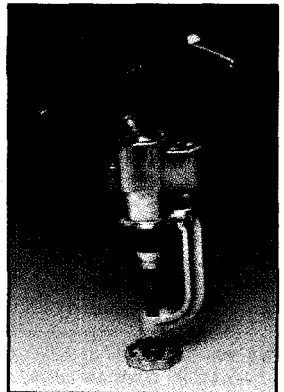

KITS TO BUILD & TEST

Comb Generator ⚡

Simple 10/20 Mhz 'Comb' generator. Generates a signal that is very handy for calibrating spectrum analysers and other instruments. Produces a train of narrow pulses, corresponding to a set of signals at 10Mhz, 20Mhz and their combined harmonics, extending up to 150Mhz and beyond. Suitable for K 7620 Spectrum Analyser. Kit is supplied in short form with PCB and components only. Cat K-7623

Case & hardware not supplied.

\$1870 Oct '96

NEW

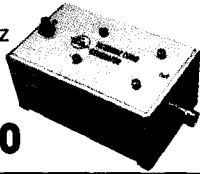

Insulation Tester ⚡

Measures resistance from 1 to 2200 gig ohms. Displays the readout on a 10-step LED display. Converter within the circuit produces either 100V, 250V, 500V, 600V or 1000V DC. Kit is supplied with all components, hardware (including test leads), PCB, case & pre-punched screened front panel.

Cat K-7002

SILICON CHIP May '96

\$6995

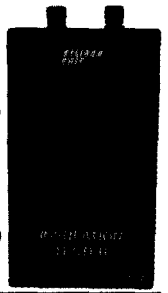

World's Simplest Motor ⚡

Simple and easy to assemble. Cat K-1046

\$850

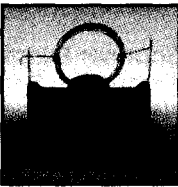

Steam Whistle Kit ⚡

Give your model railway life. K-3021

\$1295

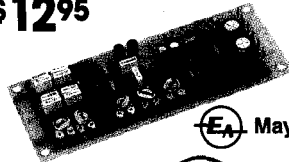

SILICON CHIP May '96

Zenor Diode Kit ⚡

Cat K-3054

\$1695

SILICON CHIP Mar '96

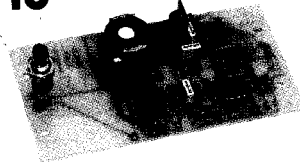

Multi 555 Timer ⚡

Comes with many circuits ideas. Cat K-2813

\$1695

SILICON CHIP Aug '96

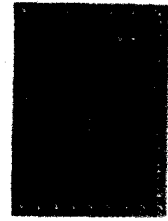

Knightrider Scanner ⚡

Comes with high intensity LEDs. Cat K-3168

\$2750

SILICON CHIP May '96

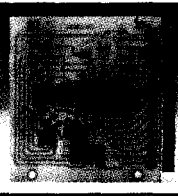

Low Ohms Tester ⚡

Cat K-7206

\$2850

SILICON CHIP Jul '96



Stereo Pre-Amp ⚡

Cat K-2811

\$3450

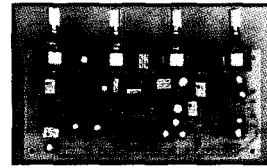

Stroboscopic Tuner ⚡

Cat K-5102

\$6495

SILICON CHIP May '96

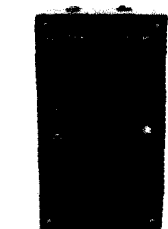

Sealed Lead Acid Battery Charger ⚡

Cat K-3211

\$3950

SILICON CHIP Jul '96



PC Driven EGO Analyser ⚡

Cat K-4214

\$4995



SILICON CHIP Jan '96

ESR/Low Ohm Meter ⚡

Cat K-7204

\$5995

SILICON CHIP Jan '96



Infrared Volume Controller ⚡

Suit K-5590 Amp. Cat K-5591

\$3950

SILICON CHIP Sep '96

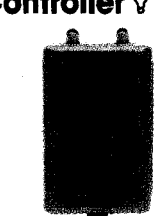

Laser Pointer ⚡

Complete with laser module. Cat K-1048

\$6995

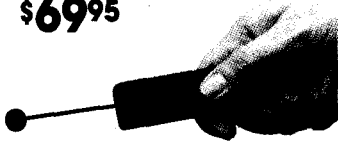

3 Band Amateur Receiver ⚡

Cat K-6007

\$99



SILICON CHIP Sep '96

300W Mosfet Amp Module ⚡

Cat K-5618

\$119



SILICON CHIP Apr '96

50W Stereo Amp ⚡

Cat K-5590

\$299

SILICON CHIP Jul '96



Fluke 7-600 Digital Multimeter

The ideal tool for electricians and maintenance technicians. Perfect for fast voltage and continuity checks. 4000 Count Display. Low impedance input eliminates reading "ghost voltages" on non-energized circuits. Includes test leads.

Cat Q-1633

FLUKE

NEW

\$145

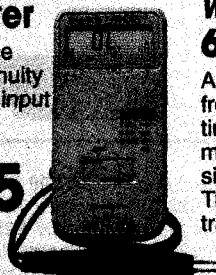

With Component Tester! 60 MHz Oscilloscope

An essential tool for anyone working on CB radios, high frequency transceivers and high speed computers. With dual timebase, make more accurate timing measurements and compare portions of a signal at two different sweep speeds. The Beam Finder allows you to find the trace on the screen.

Cat Q-1806

\$1290



SAVE OVER \$300

Availability: Our kits consist of many different parts from numerous suppliers. Whilst we have consulted closely with them and are satisfied as to their ability to supply, sometimes problems can arise in obtaining all of the parts. This means there is a slight chance that availability may be delayed. Rainchecks are available, however if you'd like to check beforehand, please don't hesitate to contact your local store.

BOOKS, BOOKS, BOOKS

Basic Principles Of Semiconductors

Concise & straightforward discussion of concepts from atomic theory to semiconductor theory and structures. 161 pages. Cat B-1415

\$21.95

NEW



Speakers For Your Home & Automobile

'How-to' construct a quality home speaker system & install automotive speakers. 164 pages. Cat B-1259

\$22.95

NEW

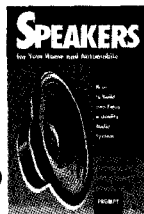

Simplifying Power Supply Technology

Simplifies concepts for the beginner and hobbyist so as to provide a stepping stone towards more advanced theories. 160 pages. Cat B-1743

\$23.95

NEW



Advanced Speaker Design

"How-to" create high quality speaker systems for the home, office or auditorium. Follows B-1259. 136 pages. Cat B-1262

\$24.95

NEW



Test Procedures For Basic Electronics

Covers electronic tests & measurement techniques with an emphasis on the use of commonly available instruments. 356 pages. Cat B-1626

\$24.95

NEW

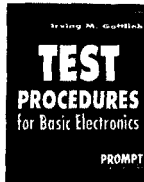

'Screwdriver Experts' Guide

The do-it-yourself CB repairs and modifications manual. 97 pages. Cat B-2324

\$24.85

NEW REPRINT



Understanding Electricity & Electronics

Guide to understanding & developing a working knowledge of electronics. 340 pages. Cat B-1748

\$29.95

NEW

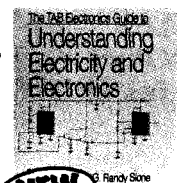

Scanner Fanatics Frequency Register

New Australian National Listing. Cat B-4210

\$38.80

NEW



GREAT ACCESSORIES

9V 1A Voltage Regulator

TO220 all plastic pack. No Mica insulation required for mounting to heatsink.

Cat Z-6550

\$1.95

NEW

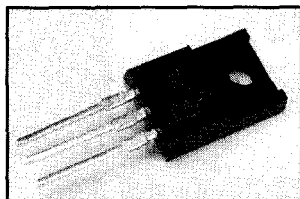

Green Tamper Lacquer

A one part, air drying seal for screws, nuts, tuneable items & other "factory fixed" components where tamper evidence is required. Tack-free after 10 mins, remains flexible for up to 24 hours - then becomes brittle.

15ml

Cat N-1210

\$6.95

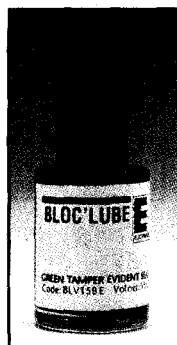

12V Illuminated Car Cigarette Lighter Socket

Green illumination. Comes with lighter.

Cat P-1679

\$5.95

NEW

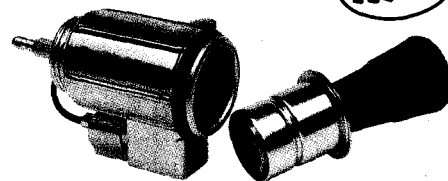

Circuit Works Conductive Pen

Silver-based pen ideal for electronic design, prototype and repair applications. Use Circuit Works to link components, repair defective traces and shield delicate electronics. Dries in minutes, solderable at low temperatures. Weight: 8.5g.

Cat N-5184

\$29.95



ELECTROLUBE

MAJOR DICK SMITH ELECTRONICS AUTHORISED STOCKISTS:

NSW: •Batemans Bay 725 030 •Bathurst 323 933 •Bowral 611 861 •Broken Hill 884 098 •Cootamundra 422 561 •Deniliquin 813 672 •Dubbo 828 711 •Goulburn 221 288 •Griffith 624 534 •Leeton 532 800 •Moree 522 091 •Mudgee 723 895 •Murwillumbah 723 684 •Richmond 784 101 •Tuncurry 545 006 •Windsor 776 722 •Young 821 279 VIC: •Ararat 522 345 •Bairnsdale 525 677 •Benalla 622 710 •Colac 312 847 •Echuca 822 956 •Hamilton 72 2865 •Horsham 824 680 •Morwell 339 458 •Rosebud 822 225 •Shepparton 219 497 •Swan Hill 329 303 •Warragul 234 255 •Warrnambool 615 111 •Wonthaggi 721 411 QLD: •Ayr 831 566 •Boonah (0754) 632 606 •Bundaberg 521 785 •Caloundra (0754) 916 533 •Gympie (0754) 836 677 •Innisfail 612 014 •Kingaroy 625 777 •Mackay 511 723 •Maryborough 214 559 •Mossman 982 200 •Mt. Isa 433 475 •Pialba 283 749 TAS: •Burnie 319 222 •Devonport 248 322 SA: •Whyalla 454 764 WA: •Albany 412 077 •Bunbury 216 222 •Busselton 542 991 •Geraldton 211 278 •Mandurah 581 4940 •Margaret River 573 888

Stores Across Australia & New Zealand

TOP SECURITY PRODUCTS

Security Floodlight

Automatically turns on or off.

- Manual override with existing wall switch
 - Range of around 12m
 - Adjustable ON time
 - 1 YEAR WARRANTY
- Globes not included

Cat L-5357

\$1995

RINGGRIP

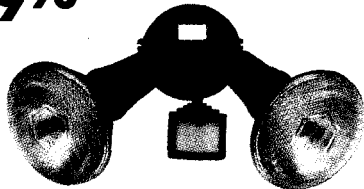

NEW

Security Pressure Mat

Great to use with an alarm system as a customer warning in shops. Almost impossible to detect under carpets or rugs - acts as a switch when an intruder steps on it, with normally open (N.O.) contacts. 790mm x 540mm.

Cat L-5270

\$2695

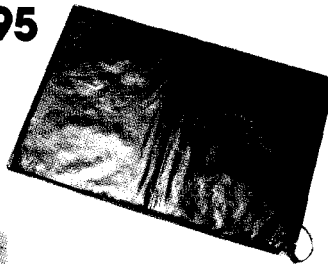

Security Door Chime

Ideal for use in shop doorways!

- Activates when someone walks past it
- Range of around 5m
- Operates under normal light conditions
- Requires 2 x 'C' batteries

Cat L-5043

\$2995

NEW

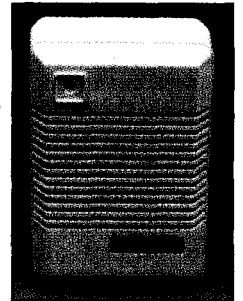

PIR Motion Alarm With Strobe

Great for the home, office or garage!

- Designed for indoor use
- 120° angle sensor
- Flashing strobe light
- 130dB siren
- Remote control
- Mounting bracket
- Requires 1 x '9V' & 4 x 'AA' batteries

Cat L-5056

\$6995

NEW

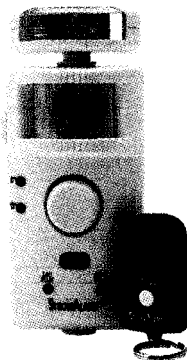

Rhino Remote Control Car Alarm & Immobiliser

This Australian made alarm allows for D.I.Y installation with easy to follow instructions. Features a passive arming system which switches the alarm on if the owner forgets. Door ajar warning signals one of the vehicle doors is not closed at the time of arming and safety circuit that prevents arming while the ignition is on. All entry points are protected including the doors, boot and bonnet. Current sensing circuit detects voltage drop in the vehicles electrical system such as the interior light coming on. Impact sensing system that warns away thieves. Also has optional central door locking. Includes engine immobilisation, battery back-up, 2 remote controls & a red flashing light. For professional installation ask our staff for more details.

Cat L-5419

\$399



5 YEAR WARRANTY



Central Car Door Locking System

Complete 4-door central locking system kit with hardware and electronic interface which converts standard door locks. Allows you to lock and unlock all doors from the driver's door.

Can be connected to certain Car Alarms and Engine Immobilisers to allow keyless entry to your vehicle.

Cat L-5421

For professional installation ask our staff for more details.

\$129

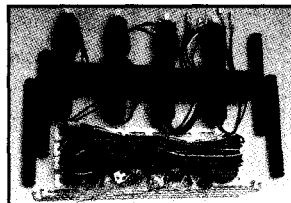

1 YEAR WARRANTY

DICK SMITH ELECTRONICS

This magazine is now on sale at all of our New Zealand stores!

PHONE, FAX & MAILORDER SERVICE

For further information, orders or the location of your nearest store call:

AUSTRALIA Phone: 1300 366 644 (Local Call Charge)

Or Fax: (02) 9805 1986 or write to:

Dick Smith Electronics, Mail Orders, Reply Paid 160
PO Box 321 NORTH RYDE NSW 2113

NEW ZEALAND Phone: (09) 488 2198 or (09) 488 2135

Or Fax: (0800) 800 290 or write to:

Dick Smith Electronics, Mail Orders Division, Private Bag 102-903
North Shore Mail Centre, Auckland

All major Credit Cards accepted. O/Nite Courier Available.

NSW • Albury 21 8399 • Bankstown Square 9707 4888 • Bankstown PowerHouse 9793 9677 • Blacktown 9671 7722 • Bondi 9387 1444 • Brookvale 9905 0441 • Burwood 9744 7299 • Campbelltown 27 2199 • Chatswood 9411 1955 • Chullora 9642 8922 • Gore Hill 9439 5311 • Gosford 25 0235 • Hornsby 9477 6633 • Hurstville 9580 8622 • Kotara 56 2092 • Liverpool 9600 9888 • Maitland 33 7866 • Miranda 9525 2722 • Newcastle 61 1896 • North Ryde 9937 3355 • North Sydney 66 Berry St. 9964 9468 • Orange 618 400 • Parramatta 9689 2188 • Railway Square 9211 3777 • Penrith (047) 32 3400 • Sydney City York St 9267 9111 & Mid City Centre 9221 0000 • Tamworth 66 1711 • Wollongong 28 3800 ACT • Belconnen (06) 253 1785 • Fyshwick 280 4944 VIC • Ballarat 31 5433 • Bendigo 43 0388 • Box Hill 9890 0699 • Coburg 9383 4455 • Dandenong 9794 9377 • Brighton 9592 2366 • Frankston 9783 9144 • Geelong 232 711 • Highpoint 9318 6300 • Knox Towerpoint 9800 3455 • Melbourne City Strand Central Arcade 9663 5320 & 246 Bourke St 9639 0396 • Niddrie 9379 7444 • Richmond 9428 1614 • Ringwood 9879 5338 • Springvale 9547 0522 • QLD • Alderley 3356 3733 • Booval 3282 6200 • Brisbane City 3229 9377 • Buranda 3391 6233 • Cairns 311 515 • Capalaba 3245 2870 • Chermerside 3359 6255 • Indooroopilly 3878 4944 • Maroochydore 791 800 • Mermaid Beach 5578 5600 • Rockhampton 27 9644 • Southport 5532 9033 • Toowoomba 38 4300 • Townsville 72 5722 • Underwood 3341 0844 SA • Adelaide City Pulteney St 8232 1200 & Myer Centre 8231 7777 • Elizabeth 8255 6099 • Enfield 8260 6088 • St Marys 8277 8977 • Westlakes 8235 1244 WA • Balcatta 240 1911 • Cannington 451 8666 • Fremantle 335 9733 • Perth City 481 3261 • Midland 250 1460 • Northbridge 328 6944 TAS • Glenorchy 6273 2176 • Hobart 6231 0800 • Launceston 6334 4555 NT • Darwin 8981 1977 • * STORES IN RED ARE OPEN SUNDAYS. STORES ACROSS AUSTRALIA AND NEW ZEALAND

Circuit & Design Ideas

Interesting circuit ideas from readers and technical literature. While this material has been checked as far as possible for feasibility, the circuits have not been built and tested by us. We therefore cannot accept responsibility, enter into correspondence or provide any further information.

Crystal filter has variable selectivity

The circuit at top right is one that is usually used in amateur radio equipment, and it gives a fixed selectivity that is dependent upon the value of the capacitors used.

This circuit, however, can be used to give a variable selectivity by varying the DC voltage applied across each of the three varicap diodes. These diodes exhibit a capacitance change that ranges from 10pF up to 450pF as the voltage applied is varied from 0 to 20 volts. A simple shunt regulator based around the 20V zener ZD1 provides a stable 20V reference from which the varicap control voltage can be derived, via the voltage divider RV1 and R1.

Stewart Farrant
Yangebup, WA.

\$25

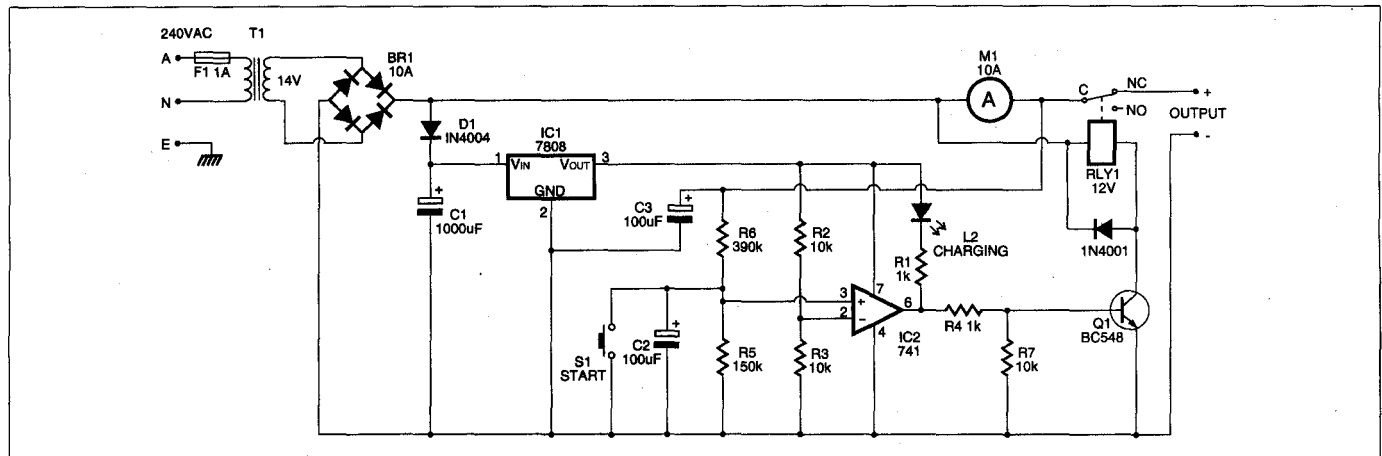
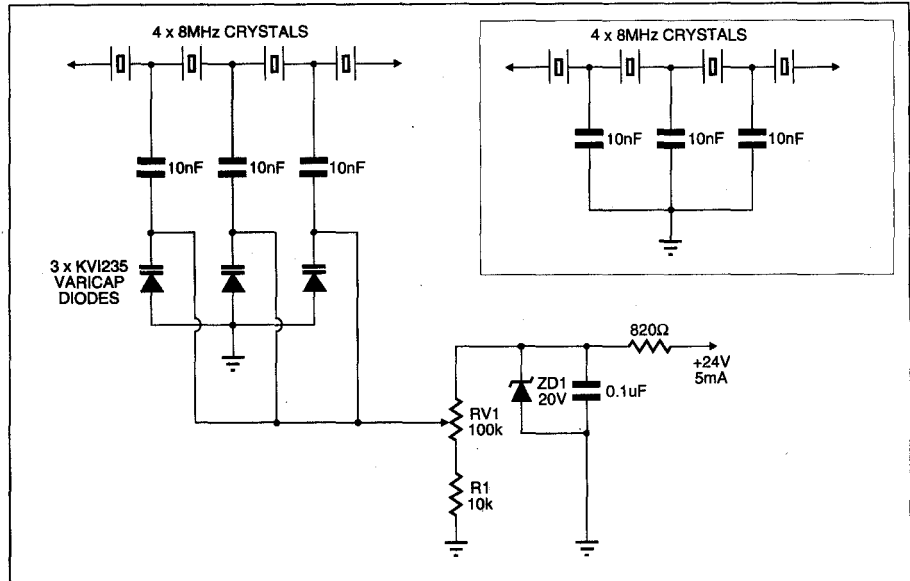

Battery charger auto cutout

Not wanting to overcharge my 12V lead-acid batteries, I designed this circuit that senses the terminal voltage of the battery, and shuts off the charge when the battery reaches 14.4V.

An op-amp is used to compare the battery voltage against a preset reference voltage, and when the battery voltage exceeds this reference the relay switches off the charging current. The battery voltage is detected 'up stream' from the relay, so that when the relay opens, the supply rises to its unloaded voltage, and charging halts.

The op-amp reference is generated by R2/R3, at about 4V, while the battery volt-

age is sensed by R5/R6. When the battery voltage rises above 14.4V (set by the ratio of R5/R6), the op-amp's output goes high and turns on the relay, disconnecting the battery. The transformer then becomes very lightly loaded, and its output voltage rises even further, ensuring that the output stays off. SW1 allows the circuit to be retriggered if needed.

C3 provides supply filtering to the battery sense circuit once the unit has

been triggered, and prevents the circuit from cycling on and off. D1 isolates the main filter capacitor C1 from the battery to ensure a clean supply for the circuit. An ammeter could be connected as shown, if an indication of the charging current is required.

This circuit is simple to build, and can easily be added to an off the shelf charger.

David Timmins
Randwick, NSW.

\$40

WIN OUR 'IDEA OF THE MONTH' PRIZE!

As an added incentive for readers to contribute interesting ideas to this column, the idea we judge most interesting and innovative each month now wins its contributor an exciting prize, in addition to the usual fee. The prize is a compact CCD video camera module from sponsor Althings Sales & Services, offering 460 TV lines of horizontal resolution and 0.08 lux sensitivity, and valued at \$199.00!

Quiet line/buzzer alert for coms handset

This circuit was designed to disable the received audio in a communications handset until a burst tone of 800Hz was received. The circuit would then enable the audio line and sound a pulsating buzzer for a set period.

The tone burst decoder module (an 800Hz module) responds to an 800Hz tone transmitted from a mobile two-way transmitter, and gives a three second active low output.

This low output sets the 4044 RS flip-flop, which gives a latched high on pin 1.

This high does three different things: first, it biases Q2 on, which removes the reset signal from pin 14 if IC3; secondly, it closes the 4066 analog switch in the audio line of the handset; and thirdly it enables the oscillator based around IC2a/IC2b, which clocks the decade counter IC3. As the decade counter starts counting, the OR gate of diodes D1 to D8 gives a high on one input of IC2d, causing the NAND gate's output to pass the clock signal through to the buzzer, via IC2c and

the driver transistor Q3. The buzzer will sound a total of eight times, after which the decade counter will disable itself as the ninth output is connected to the counter's clock enable pin.

Q1 continues to provide a pulsed low

to the intercom status LED, indicating that the 'Quiet line' had been opened.

Momentary toggle switch SW1 allows the audio line to be monitored manually.

Peter Howarth
Gunnedah, NSW. \$40

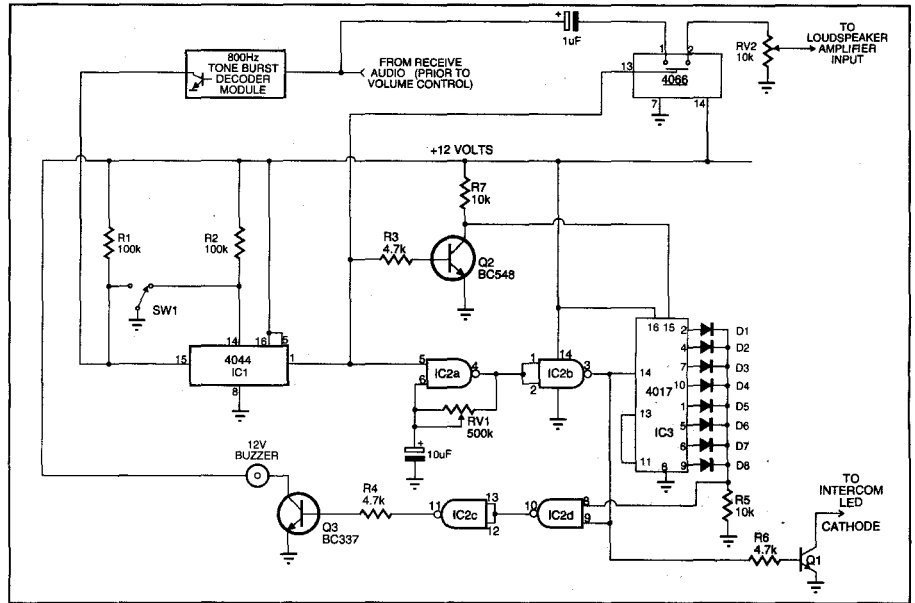

ADC supports up to 256 inputs

When a lot of analog measurements are required from a number of different sensors, finding an ADC computer interface card that supports the required number of inputs can be costly. For less than \$40 the following circuit can provide an 8-bit ADC with up to 256 analog inputs, with all interfacing through the parallel port of a PC.

Using a TLC548 8-bit serial ADC IC,

along with two 4067B analog multiplexers wired in a matrix configuration, any one of 256 inputs can be accessed, with U1 switching the positive side of the selected input to through to the ADC, and U2 switching the negative side to ground. A simple BASIC program sets the appropriate row and column addresses using the port's eight data lines, and the digitised data is sent back to the computer through the port's Error-bar line (pin 15), with the strobe line (pin 1) being used to clock the data through at the correct rate.

(It is important to note that each of the analog sensor inputs must be completely isolated from the others, that is they can't share a common ground, as this would defeat the switching performed by U2.)

The BASIC program to select an input channel and read in the data is available from the Electronics Australia BBS (02) 9353 0621, as the file 256ADC.ZIP, or can be obtained from our Reader Services Department by sending in a blank disk and \$5.00 P+P.

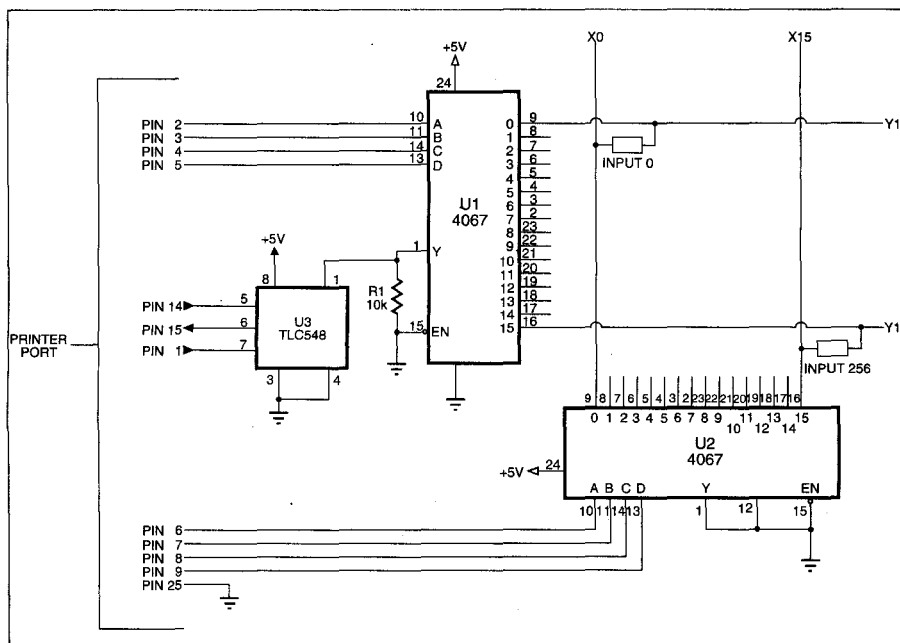

Toh Yue Khing
Singapore \$40 ♦

THIS MONTH'S PRIZEWINNER!

VIDEO SURVEILLANCE

- PCB VIDEO CAMERA MODULE \$ 93
- COLOUR ANALOGUE MODULE \$369
- COLOUR DIGITAL MODULE \$419
- MINI CUBE CAMERA w/LENS \$ 99
- 0.05 LUX 460TVL CAMERA \$129
- B/W DOME CEILING CAMERA \$139
- COLOUR ANALOGUE CAMERA \$369
- COLOUR DOME CAMERA \$399
- COLOUR DIGITAL CAMERA \$499
- AUTOMATIC SWITCHER \$109
- QUAD SCREEN PROCESSOR \$399
- Ditto with DATE TIME TITLE \$499
- DIGITAL QUAD COLOUR \$1299
- DIY SETS 4 Ch Audio/Alarm \$549
- 5.5 Inch 12 Volt DC Monitors \$119
- TV MODULATOR MIXER AMP \$ 20

Prices include tax & apply to bulk purchasers
Ask for our Illustrated Price List with Application Notes
ALLTHINGS SALES & SERVICES
Ph 09 349 9413 Fax 09 344 5905

READER INFO NO.11

Construction Project:

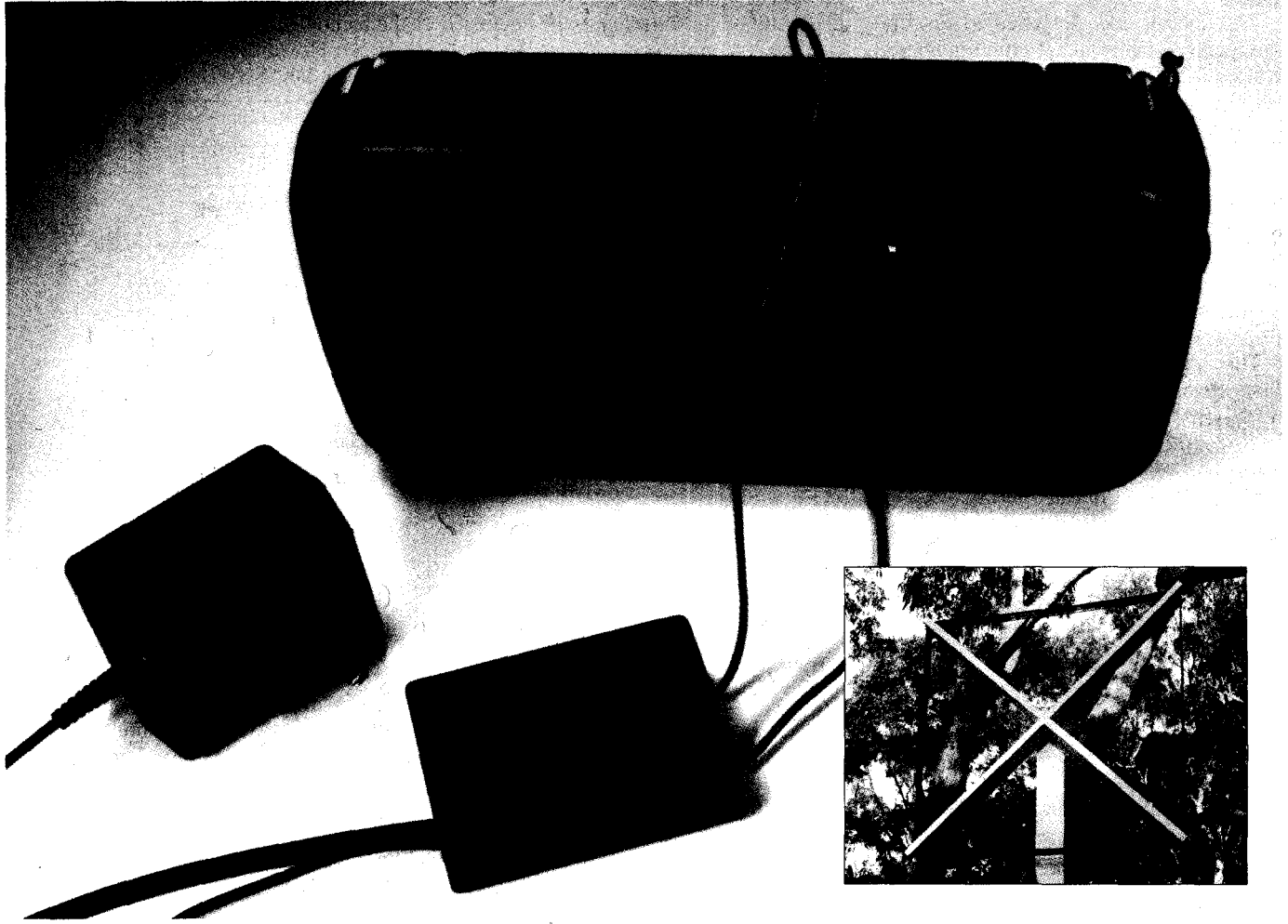

'MIRACLE' AM ANTENNA

This antenna system will pull in distant AM stations with amazing results. It has a simple loop antenna that can be 50 metres or more from the radio, connected with inexpensive coax to a loop of wire placed around the radio. Two PCBs, one at the antenna and the other at the radio, do all the work.

by PETER PHILLIPS

This project will appeal particularly to country readers, boat owners or anyone wanting to listen to distant AM radio stations. It was designed by Oatley Electronics and features two separate PCBs that link an external antenna to a loop placed around an AM radio. The PCBs are linked with coaxial cable which carries three electrical signals: the AM radio signal, a variable DC tuning voltage and the supply voltage to the PCB at the base of the antenna.

The coax linking the PCBs can be 50 metres or more long. As well, any cheap 50Ω to 75Ω coax cable will do.

Because the antenna can be some distance away from the receiver, it can be placed away from electrostatic signals, and out of sight. As well, the antenna need only be mounted a metre or so above ground level.

The antenna itself is several loops of wire on a one metre square wooden frame. The PCB mounted at the antenna is fitted in a waterproof enclosure, available from Oatley Electronics.

The whole thing is easy to build, as all parts mount on the PCBs. The frame for the antenna is simply an 'X' on a supporting pole, so it too is easy to build.

And as you can see in the price information at the end of the parts list, the whole system is inexpensive.

Operating principle

The antenna consists of eight turns of wire on a timber frame, tuned by two varicap diodes to the station you want to receive. The AM signal is amplified by circuitry on the PCB mounted at the antenna, then sent via the connecting coax to a second PCB near the radio. The inductance of the antenna is about 120uH, and tuning is done by adjusting a pot connected to

the PCB at the radio end.

The radio-end PCB has only a few components, mainly those to regulate the tuning voltage, and the coax connects via two components on this board to a loop of wire. The AM radio is placed inside the loop to give loose coupling between it and the internal antenna of the radio.

There is nothing really critical with the antenna design, or how the radio is placed in the loop. But when the antenna is tuned by the adjustable control voltage to receive the same station as the radio, distant AM stations can be heard almost as though they are close by.

But perhaps the most interesting aspect of this project is how the one coax cable carries the AM signal, the DC tuning voltage and a DC supply voltage. A description of the circuit will explain...

The circuit

Turning to the schematic, the loop antenna is tuned by VD1, a twin varicap diode. The DC tuning voltage for VD1 comes from the output of IC1, but we'll first trace the path of the AM signal on the assumption that the antenna is tuned correctly.

The antenna output connects to the base of transistor Q1, via DC blocking capacitor C1. This transistor presents a high impedance to the signal (50kΩ or more), achieved by the unbypassed emitter resistor R5 and by R2, which connects to biasing resistors R1 and R3. The common emitter amplifier around Q1 has a gain of about five, and its output goes to the emitter follower amplifier of Q2.

The output of this amplifier connects in turn, through R7 and C4, to the coax cable that couples the signal to the loop that fits around the radio. Resistors R7 and R18 give a nominal 56Ω termination for the coax, but as mentioned, the impedance of the coax is not critical. Inductors L1 and L2 isolate the AM signal from the DC side of both PCBs.

You might be surprised to see BC548 transistors as the amplifying devices. However the maximum frequency on the AM radio band is only 1.6MHz, which is well within the capabilities of these transistors.

Now to the DC control voltage, which is set by VR1. The input DC supply voltage for the system goes to the collector of series regulator Q4, and also to a two-stage zener diode regulator. The DC voltage at the base of Q4 determines its emitter voltage, which depending on the setting of VR1, can

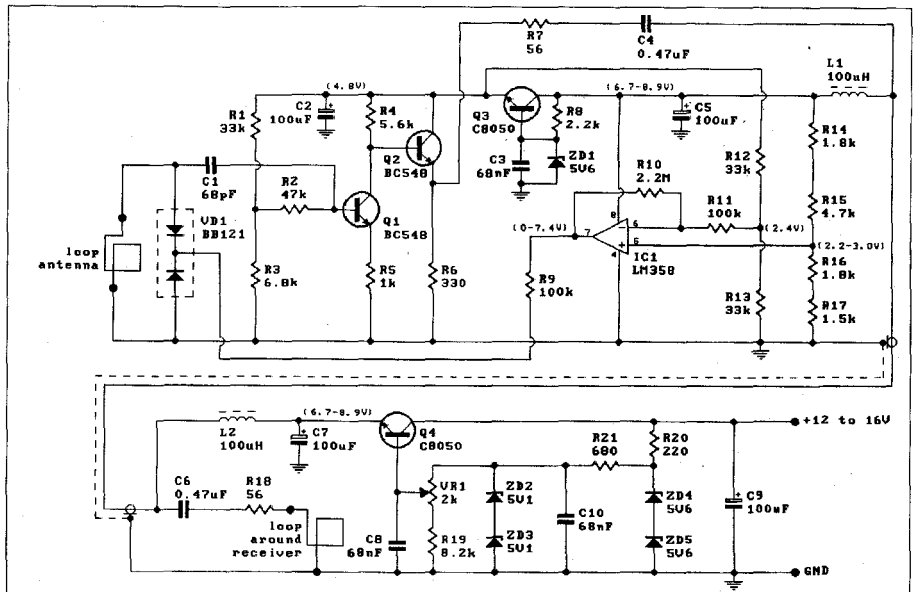

The top half of the circuit is on the PCB mount at the antenna end. The bottom half is at the radio. The antenna is tuned by the varicap diodes, whose capacitance varies with the voltage set by VR1.

range from 6.7V to 8.9V. This voltage supplies the PCB at the antenna, and goes via the coax cable (through L2) to the collector of Q3 and to R14. It also supplies op-amp IC1, of course.

The output voltage of series regulator Q4 is determined by ZD1, a 5.6V zener diode which sets the base voltage of Q3 to 5.6V. Therefore the output of Q3 is fixed at nominally 5V, and is the supply voltage to the RF amplifier sections just described. This voltage is also applied to the resistor network of R12 and R13. Because these resistors are equal in value, the voltage at the inverting (-) input of IC1 is therefore fixed at half the output voltage of Q3, or around 2.5V.

On the other hand the voltage at the non-inverting (+) input of IC1 depends on the output voltage from Q4, which supplies the resistor network R14-17. In fact the voltage at the junction of R15 and R16 varies from 2.2 to 3V, as set by VR1. Because the voltage at the inverting input of IC1 is constant, the output of IC1 will therefore vary with a change in voltage at the other input. For the values shown, the output voltage changes from zero to 7.4V.

This voltage connects via R9 to the cathodes of the varicap diodes, and reverse biases the diodes. When this voltage increases, the capacitance of the diodes drops.

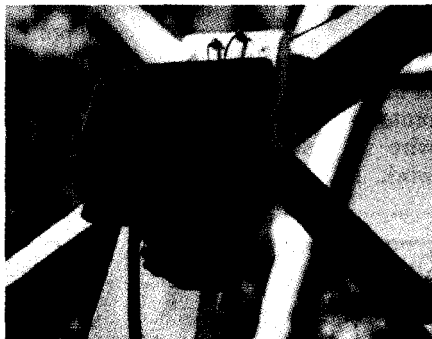

Above: A close-up of the completed antenna. The waterproof enclosure is available from Oatley Electronics and is used here to house the PCB that mounts at the antenna.

Right: As shown in this close-up, each turn of wire on the antenna is separated by about 5mm. Use silicone glue to hold the loops in place, with a cutout in the frame to help locate the loops.



AM 'Miracle' Antenna

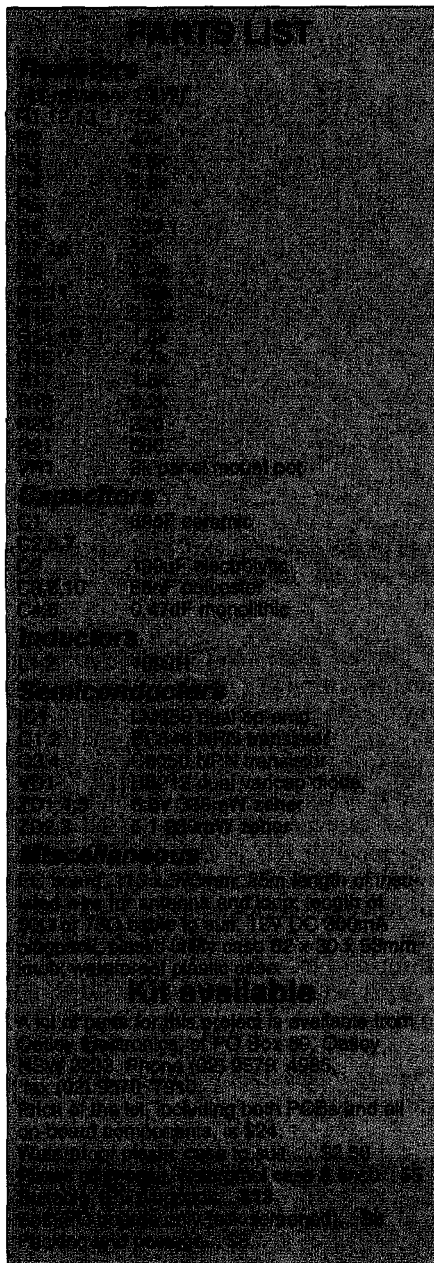

A close-up view of the PCB that mounts at the base of the antenna. The coax has been soldered on the track side of the PCB.



tuning voltage. The AM signal is isolated from the DC voltage by L1 and L2, and the DC voltage is isolated from the AM signal by C4 and C6. Nifty, isn't it?

Construction

Separate the two PCBs (if necessary) before starting construction, and confirm that the PCBs are free of any manufacturing faults. The photos and layout diagram show where the components go, and if you buy a kit of parts from Oatley Electronics, you'll get silk-screened PCBs also showing component placement.

Mount the resistors, inductors, capacitors and zener diodes first. Make sure you correctly identify the 5.6V zeners and 5.1V zeners. Also check the orientation of the zener diodes and the electrolytic capacitors. Note that there's one wire link required on the antenna PCB. Next fit the transistors and IC socket. Again, make sure you correctly identify each transistor before fitting it in place.

Although the PCB at the radio end will accept a PCB mount potentiometer for VR1, a panel mount type is much easier to use. As shown in the photos this is connected to the PCB with three wires. Drill a hole in the centre of the bottom of the plastic case for the pot.

Now for the antenna. As you can see in the photos, the antenna used with the prototype is eight loops of insulated wire wound around a wooden framework. The framework is made with 75 x

20mm Oregon pine, well painted to protect it from the weather. The two cross members are one metre long, with a 40mm deep cutout at each end as a guide for the wire. These members are attached to the support pole (also a length of 75 x 50mm Oregon pine), positioned at right angles to each other to give a distance of about 700mm between adjacent extremities. That is, you end up with a square antenna measuring 700 x 700mm.

The wire is wound around the assembly so each loop is spaced about 5mm from adjacent loops. This is necessary to minimise the capacitance of the antenna. Don't make each loop too tight, to allow for expansion and contraction with ambient temperature. When the loops are all in place secure them with dabs of silicone glue where they contact the framework, as shown in the photos.

Testing

Before final installation, test the system first, in case you need to alter the inductance of the antenna. To do this, connect the two PCBs with a length of coax cable. Connect the antenna to its PCB and, to the other PCB, connect the loop of wire that will wrap around the radio. Then with the plugpack also connected, apply power.

Tune your radio to the required station, then place it inside the loop, as in the lead photo. Adjust VR1 so the antenna is also tuned to this station. You will soon know

So, the DC voltage fed along the coax cable is both the supply voltage and the

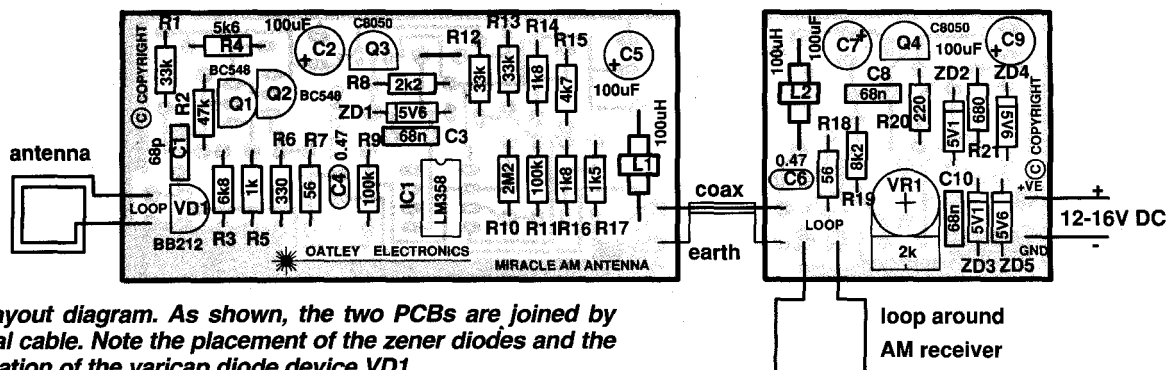

The layout diagram. As shown, the two PCBs are joined by coaxial cable. Note the placement of the zener diodes and the orientation of the varicap diode device VD1.

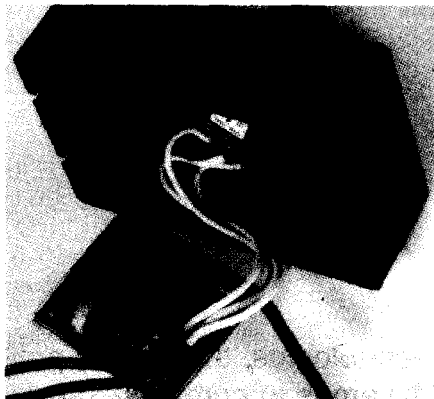

Left: This is the PCB that sits near the radio. The pot is fixed to the plastic box, rather than being mounted on the board. Note that changes have been made to the PCB design since this shot was taken. See the layout diagram for final component placement.

Right: The artwork for the PCB, for those who prefer to make their own.

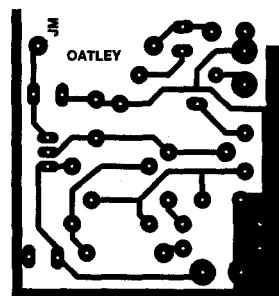
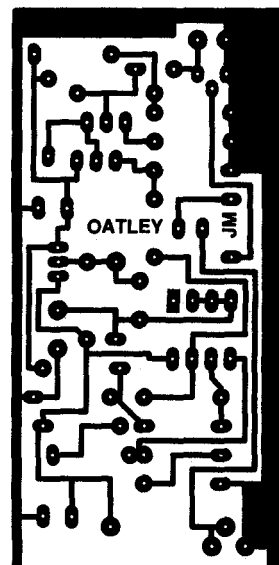

when the antenna is tuned, as the reception will improve markedly.

If you cannot get the antenna to tune correctly, you might need to add or delete turns, depending on which end of the AM RF spectrum you are trying to tune to. However before doing this, confirm that the voltage readings in your circuit agree (approximately) with those shown on the circuit diagram. These voltages are from the prototype with VR1 set first to one end of its travel, then the other.

If you want to receive a frequency at the low end of the spectrum, and can't tune the antenna to this frequency, try adding a turn to increase the inductance of the antenna. The opposite applies for frequencies at the high end of the spectrum — that is remove a turn, or make the antenna smaller. The aim here is to reduce the inductance.

The antenna orientation is not critical, but try different placements and directions for best reception. If you want to receive signals from a range of radio stations, compromise the position of the antenna to give the best overall effect. Note that the antenna should be 'side on' to the transmission.

Final details

The antenna dimensions given here are those for the prototype. However different designs are possible, providing the inductance of the antenna is similar to that of the prototype. You could try a smaller antenna with more turns, or a larger antenna with less turns. A possible design that should work is to wind 16 turns (spaced 5mm apart) wound on a square frame measuring 355 x 355mm.

Once you're satisfied with the tuning, it remains to position the antenna properly and to run the coax to the receiver. As already mentioned, there is no need to mount the antenna more than a few metres above the ground. However make sure you place it so it's away from any sources of interference.

The antenna PCB should be housed in

a waterproof enclosure, which can be attached to the antenna support pole. All wiring (leads from the antenna coil and the coax cable) should enter at the bottom of the enclosure. Form the leads from the antenna coil to give a 'drip loop', so water will drip off instead of running into the enclosure.

The coax cable can be run as required, even buried in the ground if you wish. Note that shielded cable is not suitable, as it is designed for audio applications only, not for RF.

You might find that you don't need to place the radio inside the coupling loop. Instead, depending on the signal strength, reception might be good enough by placing the loop near the radio, rather than around it. Like anything, it's worth experimenting to get the best results. ♦

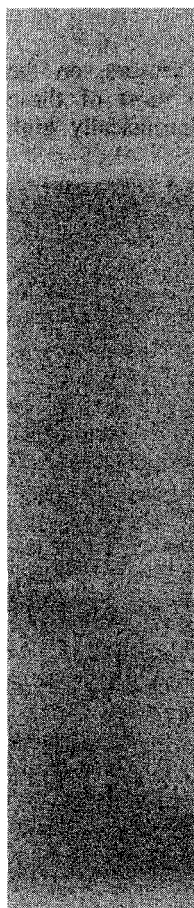

HY...-P DC/AC Current Transducer **LEM**

Six ranges from 0-5 to 0-20 A.

Fast response time
< 30 μsec.

Linearity error 1% max.

Full galvanic
isolation.



Low power
consumption.

Extended measuring
range (3x).

2.5kV rms 50Hz
isolation for 1 min.

High immunity against external noise.

Fastron
TECHNOLOGIES PTY. LTD.

QUALITY
SYSTEM
CERTIFIED
AS/NZ ISO9002



☎ (03) 9794 5566 📠 (03) 9794 6670 📧 fastron@ozemail.com.au

READER INFO NO.12

Construction project:

HIGH ISOLATION CURRENT ADAPTER

Making use of a new Hall effect sensor available from Fastron Technologies, this simple project enables you to take mains current measurements of up to 10 amps in complete safety, with readings accurate to 1%. Due to the high bandwidth of the sensor used in this project, you can also use your scope to examine and measure any waveform components from DC up to 25kHz — again in complete safety.

by **GRAHAM CATTLEY**

Examining mains current waveforms is usually quite a dangerous business. The usual way to do this is to insert a small value, high wattage resistor in series with the mains input, and then monitor the voltage drop across it with an oscilloscope. This requires the scope to be run off an isolating transformer, as the scope's ground will be effectively at mains potential. Needless to say, this situation is potentially lethal, as all exposed metalwork on the scope will be sitting at 240V...

You may be tempted to use a voltmeter instead of a scope, but if the current drawn by the device isn't sinusoidal (as in a switchmode power supply, for

example), the meter will often give you a false reading.

A common way around these problems is to use a current clamp ammeter. But although these are much safer to use, they tend to have a limited frequency range — which again results in false readings for non-sinusoidal currents. This, added to the fact that clamp meters usually only measure currents above 1A, makes measuring mains currents difficult, inaccurate and expensive.

A better way

Hall effect current sensors, on the other hand, eliminate most of these problems with their intrinsically high

galvanic isolation, high bandwidth, and low insertion loss. This project, based on the HY10-P Hall sensor offers a safe, accurate and cheap way out of all of the above problems, while incorporating the following features:

- Negligible insertion loss;
- No heat buildup in the sensing device;
- DC to 25kHz frequency response;
- A high slew rate (better than 30A/us);
- Negligible inductance, resulting in virtually no phase shift throughout the operating frequency range;
- An output of 400mV/A at an accuracy of +/-1%; and
- A minimum current measurement of around 10mA.

As you can see, these features add together to give a very useful piece of test equipment, and at quite a reasonable cost too.

About Hall effect

Before we get into describing the operation of this project, a brief explanation of the Hall effect might be in order.

Back in 1879, Edwin H. Hall, a little known American physicist at Johns Hopkins University discovered a phenomenon which later became known as the Hall Effect.

He began by considering a problem first posed by James Clerk-Maxwell, concerning the force on a conductor carrying a current in a magnetic field. Does the force act on the conductor, or the current carriers? Hall argued that if the current carriers were affected then there should be "a state of stress... the electricity passing towards one side of the wire".

In his original experiments, Hall found that if a strip of gold leaf, carrying an electric current longitudinally, was placed in a magnetic field, the points directly opposite each other on the edges

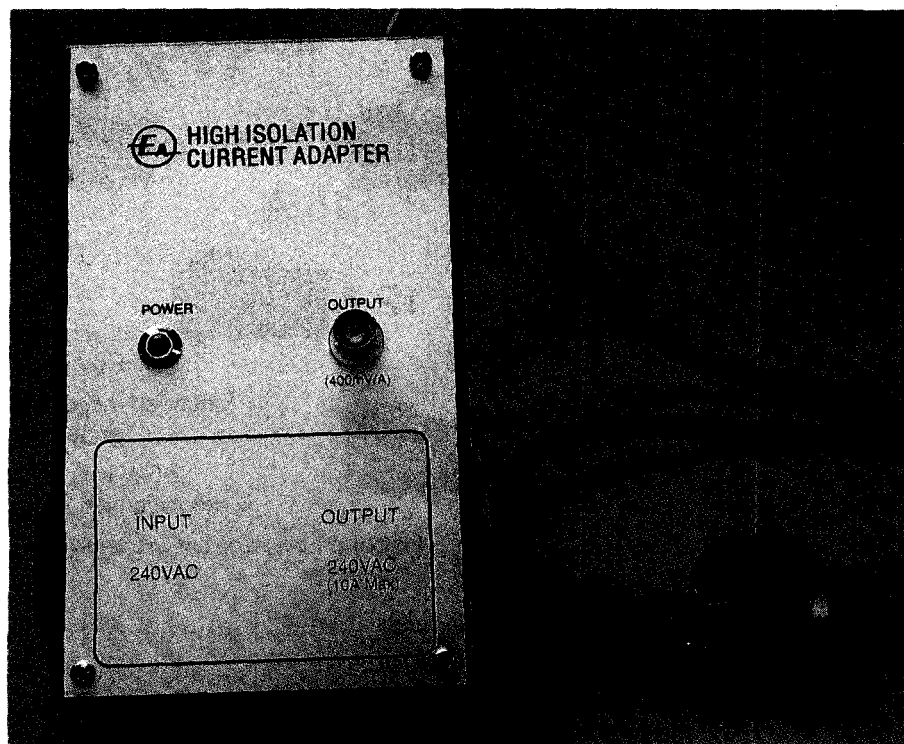

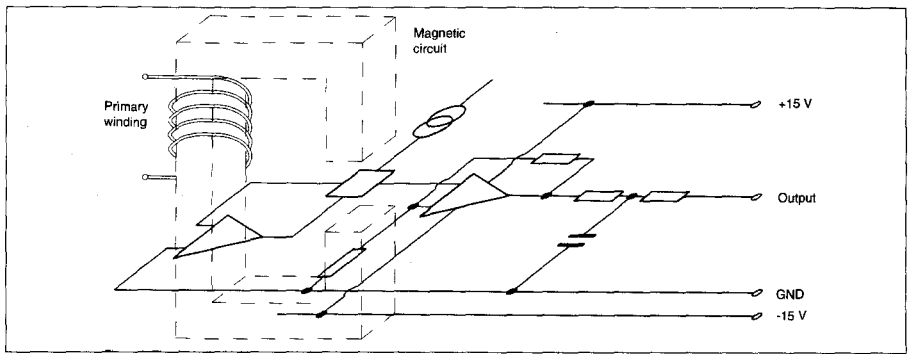
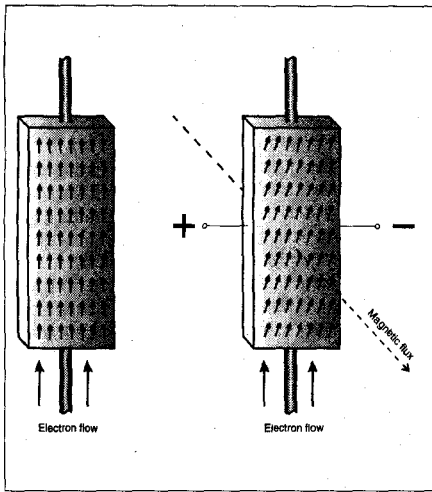

Fig.1 (left) shows how a magnetic field distorts the flow of electrons through a piece of silicon, causing a potential difference to be developed between each side of the wafer. Fig.2 (above) is a diagram showing the basic construction of the Hall current sensor, with the Hall element sitting in the magnetic field caused by current flowing through the primary winding.

of the strip acquired different electrical potentials which he was able to measure with a sensitive galvanometer. He later found that different metals caused different potentials and in some cases, even reversed polarities.

The ratio of this transverse electrical potential to the strength of the magnetic field became known as the 'Hall Coefficient' for the metal in question.

It was later found that *semiconductors* have higher Hall coefficients, and therefore produce higher voltages for given magnetic fields.

It is for this reason that most modern Hall effect devices consist of a small silicon wafer through which a reference current flows. If you look as Fig.1, you can see that on the left is a representation of a silicon wafer with a constant current flowing through it. On the right, however, is the same wafer when subjected to a magnetic field at right angles to the electron flow. Here, some of the electrons are pushed off-course by the field, and accumulate on the right hand

side of the wafer.

This results in a difference in potential between the two sides, which is the Hall voltage. This voltage is directly proportional to the strength of the magnetic field, and is defined as:

$$V = (Rh.I.B)/t$$

where V is the Hall voltage produced, Rh is the Hall coefficient for the material used, t is the thickness of the material, I is the reference current flowing, and B is the magnetic flux density.

In the Lem HY series of sensors (the type used in this project), the current to be measured is used to create a magnetic field within the device, causing the Hall element to generate a voltage of 1.25mV/mT. (A constant control current (I) is generated within the module, and is factory set to 5mA.) This Hall voltage is amplified within the module to give an output voltage of 400mV/A.

The sensor

The HY10-P Hall effect transducer (Fig.2) consists of a high current primary

winding (of only one or two turns), and a ceramic substrate on which the Hall sensor, amplifier IC, film resistors, and other SMD components are mounted. This is all encapsulated in a self extinguishing epoxy block, and gives an electrical isolation of 2.5kV.

While we have used the 10A version in this project, the HY series of sensors includes modules rated at up to 25A. Each module is laser trimmed to give 4V +/-40mV at its rated RMS current, and gives a measuring range of up to three times this value. (It is also rated to withstand surges of up to 50 times its rated current.) The HY range of sensors use an open-loop system, resulting in an accuracy of +/-1% whilst maintaining a low power consumption.

The main advantage of using Hall effect devices in current sensing is that they are able to measure current over a wide frequency range. The bandwidth of these devices is typically DC to 25kHz, enabling currents to be measured right through the audio spectrum with mini-

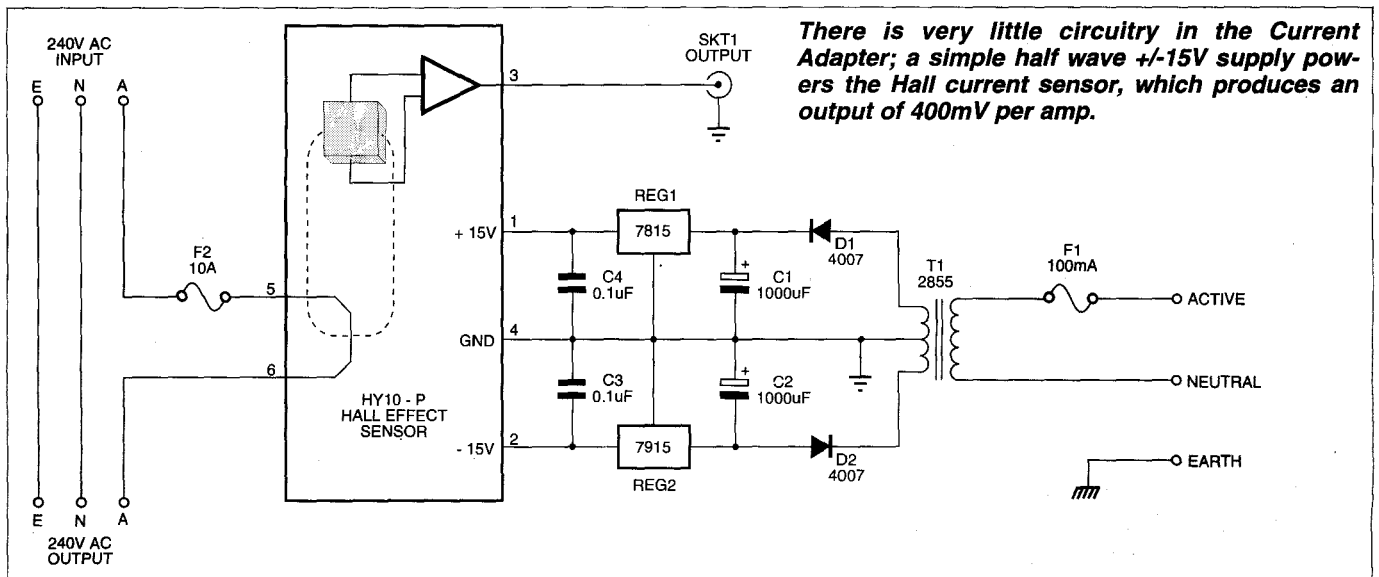

There is very little circuitry in the Current Adapter; a simple half wave +/-15V supply powers the Hall current sensor, which produces an output of 400mV per amp.

High Isolation Current Adapter

mal error. Due to the low inductance of the sensor's primary input, minimal phase shift is introduced into the circuit being measured.

Circuit description

Looking now at the circuit diagram, you can see that there is very little circuitry in this project, with most of the work done by the HY10-P Hall effect module. This module requires only a +/- 15 volts supply, and draws approximately 10mA. These supply requirements are provided here by a small centre-tapped 30V transformer, and simple half wave rectifiers using D1 and D2. The output from these diodes is filtered by the two 1000uF electrolytics, and each rail is then regulated by 15 volt regulator.

The output impedance of the sensor is quite low at 100 ohms, it's able to source up to 10mA. Thus it doesn't require buffering — the output is taken directly to the BNC socket mounted on the front panel.

Construction

Construction of the current adapter falls into two main areas: mounting the parts on the PCB, and mounting the power transformer along with the IEC power sockets and associated mains wiring.

Start by placing the unpopulated PC

board copper side down in the bottom of the box. Then with the box orientated as shown in the internal photo, position the PCB about 10mm from the left, and 15mm from the bottom end of the box, and mark off the four mounting holes using the board itself as a guide.

Cut two holes in each side of the box to accommodate the IEC mains connectors, remembering that the fused plug (input) goes on the left, while the socket (output) is mounted on the right.

Once you have finished this (surprisingly tedious) task, cut an 85 x 40mm piece of 1mm aluminium sheet, and mount the power transformer to it as shown in the photos. Use two short countersunk bolts to mount the transformer, and long countersunk bolts for both the earth connection and for securing the terminal block.

Position the transformer mounting plate 15mm from the top end of the box, and screw it into place with another two countersunk bolts and nuts. Drill two holes for the fuse holder and mains cable entry, and wire up the transformer primary with the fuse holder wired in the active line.

Use a piece of heatshrink sleeving over the fuse holder, and don't forget to use a P-clamp to secure the mains cable.

Moving onto the PC board, the nine

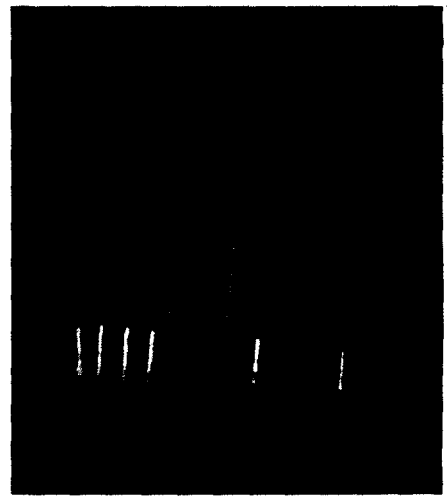

The HY10-P Hall effect current sensor. With a peak current rating of 500A, and a frequency response of DC to 25kHz, this sensor lends itself to many applications.

components on it can be installed in almost any order, but watch the orientation of the diodes, regulators and the electrolytics — check with the overlay diagram when installing these components.

Cut two 50mm lengths of brown or red mains-rated heavy duty cable, strip and tin the ends, and solder them to the two large pads that connect to the sensor primary. It is a good idea to use plenty of solder on these two pads, as they will need to carry up to 10 amps once the circuit is running.

Solder a short length of single core shielded cable to the output pads on the PCB, and connect the transformer's secondary to the board, ensuring that the centre tap is connected to the middle of the three pads.

The neutral and earth pins of the two IEC mains connectors can now be wired together with 100mm lengths of blue and green mains cable, using heatshrink sleeving to cover all exposed mains connections. One point to mention here is that some styles of fused IEC connectors don't have the fuse wired in and will need a short length of wire to join the active terminal to one end of the fuse, so that the fuse is connected in series with the active line.

Use four 10mm insulated spacers to support the board inside the box, and once secured, you can solder the ends of the two previously attached wires to the active terminals on the IEC connectors.

All that remains is to mount the neon indicator and the BNC socket in the box lid, and wire them into place. The neon is connected directly across the mains, and is best wired on the transformer side of the terminal block.

This photo shows how the PCB is mounted off-centre in the box, making room for the mains wiring from the IEC connectors. At right is the component overlay diagram.

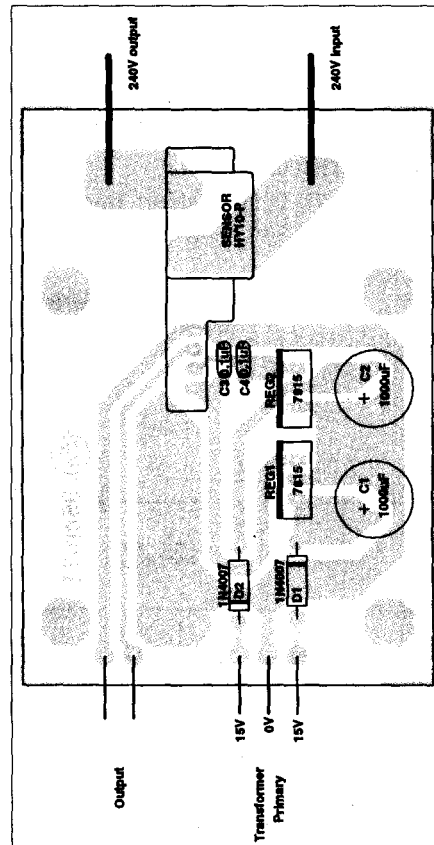

Using the adapter

Plug the current adapter into a mains socket, and the neon should glow, showing that the unit is operational. The unit will now produce an output voltage directly proportional to the current flowing through the two IEC connectors. Probably the best way to demonstrate the current adapter is to monitor the current flowing into a switch-mode power supply, as found in most computer systems.

Plug a computer into the output socket of the adapter, connect the input socket to the mains, and use an oscilloscope to monitor the output voltage. Fig.3 shows a plot taken from such an arrangement, and you can easily see the spikes of current drawn from the supply in these systems. This contrasts with the current waveform from a resistive load (a light bulb or heater for example), which results in a sinusoidal current waveform, reflecting the linear relationship between current and voltage.

One final note: if you want to measure higher currents, you can easily replace the HY10-P module with a higher current version, such as the HY25-P, which can handle up to 25A RMS. This will require high current wiring, and appropriately rated mains connectors to be used, however. You may also need to enlarge the holes in the PCB to accept the HY25-P sensor's larger primary pins.

If you wish to take advantage of the sensor's DC - 25kHz frequency response for audio applications (like measuring the current in a loudspeaker), you may want to replace the two IEC connectors with suitable connectors for your chosen application. ♦

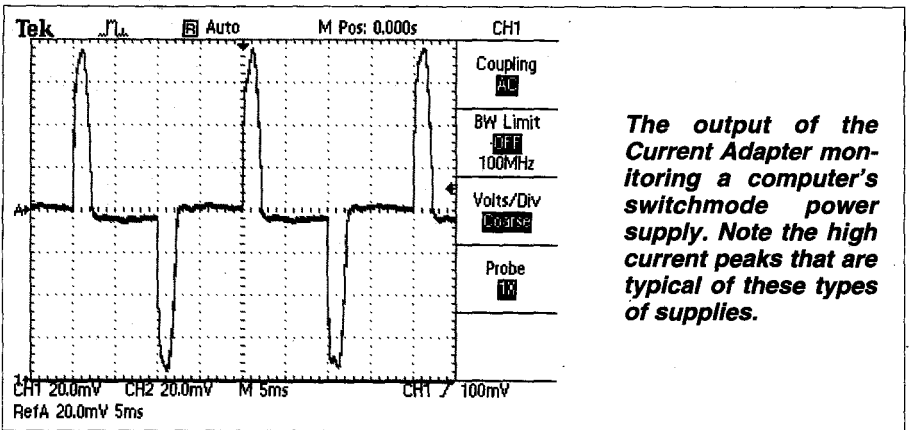

The output of the Current Adapter monitoring a computer's switchmode power supply. Note the high current peaks that are typical of these types of supplies.

PARTS LIST

Capacitors

C1,C2 1000µF 25VW electrolytic
C3,C4 0.1µF MKT

Semiconductors

D1,D2 1N4002 power diodes
REG1 7815 15V positive regulator
REG2 7915 15V negative regulator

Miscellaneous

HY10-P Hall effect sensor module; PCB, 55 x 78mm, coded 96cm11; Power transformer 15-0-15 volts, (type 2855); M205 safety fuse holder, 1 x 100mA and 1 x 10A M205 cartridge fuses; 240V neon indicator; Fused, 240VAC IEC panel mount mains plug; 240VAC panel mount mains socket; Panel mount BNC socket; Plastic box 150 x 90 x 50mm (type UB1); Two-way mains terminal block; Four 10mm insulated spacers; Mains cable with plug; P-type cable clamp; Heatshrink; Nuts, bolts, etc.

Note: the Lem HY10-P Hall effect sensor module used in this project is available from Fastron Technologies, of 14 Dingley Avenue (PO Box 1232), Dandenong 3175; phone (03) 9794 5566, or fax (03) 9794 6670. The quoted price for the device in unit quantities is \$36.00, plus \$3.00 packing and postage.

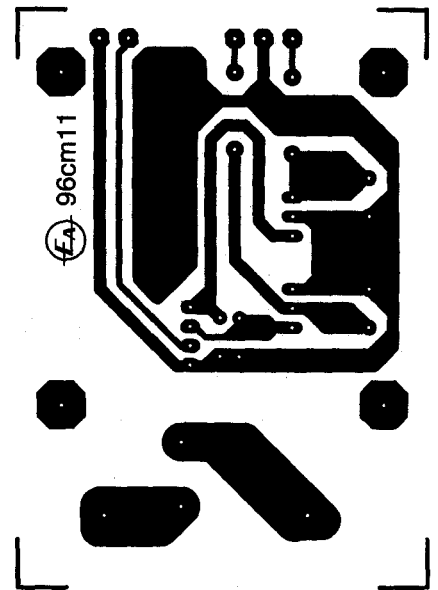

HIGH ISOLATION
CURRENT ADAPTER



POWER  (400mV/A)

INPUT 240VAC
OUTPUT 240VAC (10A Max)

Full size artwork for both the PCB (above), and the front panel, on the left.

NOVEMBER AT JAYCAR

AMERICAN LEGEND CAR ALARM



Start new remote control car alarm to replace our legendary HAGO unit. We have sold 600's of HAGO's, but with improvements in alarm technology, we have moved on to a more up to date alarm. The American modern design Legend Alarm is supplied with two very nice modern design small remote controls which are code loading. This means if you lose a remote, simply buy a new one at stock from Jaycar and reprogramme the alarm and you're done. The instructions are some of the best we have seen for a car alarm, very clear, precise and understandable. Features: Code learning, remote control, override function (if remote is lost and car is armed), remote control turn on, or automatic turn on 20 seconds after last door is closed when keys are taken out of ignition. Auto re-arming - if alarm is triggered, alarm re-arms itself after 45 seconds. Panic feature - alarm sounds if big button on remote is held in for 5 seconds. Tamper report - 4 chirps sound on when disarming if alarm has been activated. Installation by-pass system with automatically bypasses anti-theft alarm immobiliser system. Remote control trunk release (if fitted with solenoid). Door open warning. Three shock sensors if you don't have a hot lead sensor. With motion, proximity shock sensor detector. Drive in mode. System for security. The alarm system is a 12V DC system. It is a very simple system and is being driven by a 12V battery. The alarm system is controlled by a remote control which has a built in LED indicator. The alarm system is controlled by a remote control which has a built in LED indicator. The alarm system is controlled by a remote control which has a built in LED indicator.



5 REMOTE OPTIONS FOR ABOVE: You will require one of the following:
 5 REM, HORN: Cat. LA-8908 **\$29.95**
 BACKUP BATTERY 5 REM, HORN: Cat. LA-8910 **\$59.95**

FULLY COMPATIBLE WITH OUR 4 DOOR CAR CENTRAL LOCKING KIT
 Cat. LR-8830 **\$89.00**

SUPER DRILL SET

Fantastic new drill with precision quick-change chuck. Perfect for drilling, polishing, engraving, routing, shaping, sanding and milling. Supplied with the following accessories: 5 collets - Dia. 0.5, 1.0, 1.5, 2.4 and 3.0mm. 4 different shaped grindstones with about. 1 super thin grinding wheel. 5 sized drill bits. 240V mains plug pack.

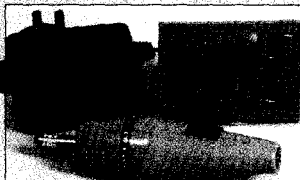

Cat. TD-2460 **\$59.95**

40 PC TOOL KIT

Ideal tool kit for the "weekend tradesmen" or to have in the car boot for those times you need a tool. Be careful when comparing prices for these type tool kits, they may look the same, but there is a different quality levels.

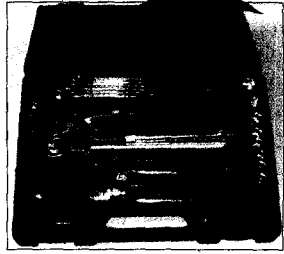

There is the standard level, then vanadium. Our sets are heat treated, so whilst they are not the top quality level, they are not the lowest level either. Tools that are not heat treated are pretty poor. But please note: these are not top brand tools, you get a lot of tools for the money!! Kit includes the following: 9x1/4" drive sockets imperial (5/32 to 7/16") 8x1/4" drive sockets metric (4 - 9mm) 1x3/8" flexible ratchet 1x8" cutting pliers 1x13/16" drive spark plug socket 1x3/8" (F) x 1/4" (M) adapter 6 combination spanners (5/16 to 5/8" and 8 to 17mm) 8 allen keys (1/16 to 1/4" and 1.5 to 6mm) 3 screwdrivers 1x6" extension bar 1 water pump pliers 1x1/4" drive spanner handle All supplied in its own plastic case.

Cat. TD-2100 **Only \$24.95**

100 PC TOOL KIT

If you want a more comprehensive tool kit than the 40 piece, then this 100 piece should do the trick. Tools are heat treated. (see 40pc. kit for explanation on tool quality) Again, please note that these are not top brand tools, but you do get a lot of tools for the money. Tool kit includes the following: 10x1/2" drive sockets (10-24mm) 1x1/2" drive sparkplug socket 21mm 1x1/2" drive ratchet handle 1x1/2" drive universal joint 1x1/2" drive 125mm extension bar 1x1/2" drive sliding Tbar 9x1/4" drive sockets (5-13mm) 8 combination spanners 4 hex allen keys (5-10mm) 1 water pump pliers 240mm maximum 1 vice wrench pliers 250mm max 1 crimping tool for lugs 39 el cheapo lugs 1 thickness gauge 1x6-24V auto test screwdriver 5 screwdrivers 11 screwdriver bits-slotted, Phillips, torx and posidrive 1 el cheapo hammer 1 T-handle screwdriver all supplied in a plastic case.



Cat. TD-2012 **Only \$49.95**

25 PC ALLEN KEY SET



25 different sizes. Metric in 1.5mm increments. There must be a hex key in every tool chest. They are made of high quality chrome vanadium steel. In both metric and imperial.

HEAVY DUTY CABLE CUTTERS

These are designed for cutting heavy cables. For example mains cable with earth, three phase, cable and automotive cables. Tools 8" (200mm) & has forged handles.

Cat. TH-1305 **\$14.95**

OFFSET RATCHET SPANNER SET



No more skinned knuckles trying to tighten awkward nuts and bolts. They are easily reversible by touching a tab on each end. They are offset, so the handle is raised, rather than flat, making them easier to use. Five double ended tools supplied, with the following sizes: 5.5, 6.0, 7.0, 8.0, 10.0, 11.0, 12.0, 13.0, 14.0 and 17.0mm.

Cat. TD-2112 **\$24.95**

CORDLESS HALOGEN SPOTLIGHT

This hand held mega bright spotlight has a built in 6V 4 AH rechargeable battery and is supplied with a 240V plug pack to recharge it. Also supplied is a lead to charge it from a car cigarette lighter. The battery is easily removeable by removing 4 thumbscrews when it goes flat. Extra batteries available cat. SB-2496 \$17.95. Unique trigger locking mechanism allows for hands free operation. Swivel handle allows for easy carrying. Provides up to 20 mins. continuous use. Brighter than a car headlight.



Cat. ST-3025 **\$57.95**

BULK USERS - CONTACT OUR WHOLESALE DEPARTMENT FOR SPECIAL PRICING (02) 743 5222

10 PC SCREWDRIVER SET IN CASE

Set of 10 Phillips and Torx screwdrivers. Includes a carrying case. Each screwdriver has a carrying case. Includes a carrying case. Includes a carrying case. Includes a carrying case. Includes a carrying case. Includes a carrying case. Includes a carrying case. Includes a carrying case. Includes a carrying case. Includes a carrying case.

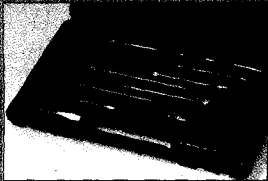

Only \$19.95

JAYTECH SOLDERING IRONS

SAVE IN NOVEMBER
 SEWATEL PROFESSIONAL
 Cat. TS-1260
 Was \$29.95 Now \$7
Nov \$22.95
 IRONCRAFT PROFESSIONAL
 Cat. TS-1280
 Was \$49.95 Now \$10
Nov \$39.95

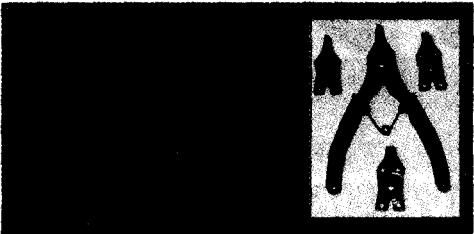

HOBBY "G" CLAMP SET

Set of three small "G" clamps that are ideal for hobbyists and model builders etc. The three clamps are different sizes, maximum jaw opening size is 25, 35, and 45mm. All clamp in to the magnetic base which is supplied. Ideal for holding small parts for glueing and soldering. Metal construction.
 Cat. TH-1962



\$5.95

10 PC SCREWDRIVER SET IN CASE

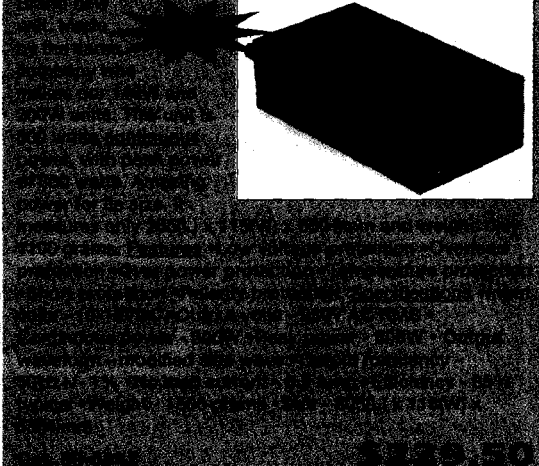

HI POWER ELECTRONIC SIREN

125db, 40W, 12V.
 Biggest meanest siren. Cat. LA-5262
Was \$52.95
Save \$13.00
Now \$39.95



5 PC TORX SCREWDRIVER SET

Easy to use colour coded torx screwdrivers in a plastic case. Each screwdriver has a swivel head for easy use. Blade length is 20mm and torx sizes are T6, T7, T8, T9 & T10.
 Cat. TD-2070 **\$7.95**



CAR BATTERY TERMINAL SET

Set of two, solderless two bolt plated car battery terminals which fit 6V and 12V positive and negative battery posts.
 Cat. HC-4010
Pkt. of 2 \$2.95



BUY 10 LESS 10%

PRECISION KNIFE SET



CAT5 RJ45 DOUBLE ADAPTOR

8 connector RJ45 plug to two sockets. Austel approved.
 Cat. YT-6082
Only \$9.95

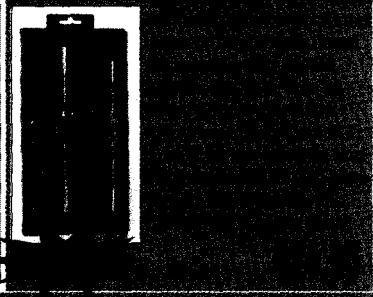

PRO-MECH 12 VOLT AUTO COMPUTER PROTECTOR



MAIL ORDER - FREECALL FOR PHONE ORDERS 1800 022 888

SAVE \$20 ON CENTRE SPEAKER



Speaker has 2 x 4" woofers plus tweeter. Shielded, so will sit on TV. Power handling 50WRMS. Size 335(W) x 110(H) x 145(D)mm See cat. page 48. Cat. CS-2510 **Was \$99.95**
Save \$20 Nov. \$79.95

LOWER PRICES ON CASES

See 96 cat. P84.
MEDIUM
Was \$16.95
Now \$13.95

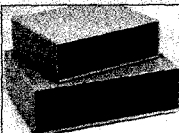

Save \$3.00
Cat. HB-5912

LARGE
Was \$21.95
Now \$17.95
Save \$4.00
Cat. HB-5910

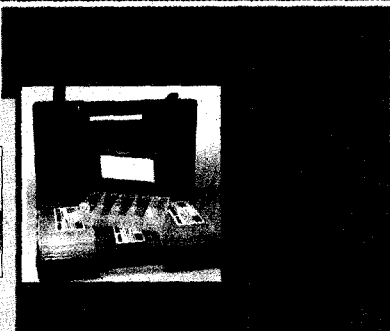

MANUFACTURERS CHECK OUT OUR BULK PRICES!!

BUY 10 LESS 10%

ADJUSTABLE CAR BATTERY OVER DISCHARGE PROTECTOR



15K DATABANK

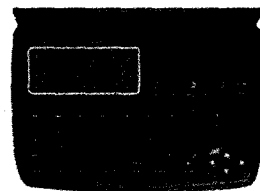

•Clock •Calendar •World time
•Calculator •Databank. Limited quantity. Cat. QM-7310
Was \$47.95 Save \$18.00
Now \$29.95



TALKING WATCH SELLOUT

Says the time when the "talk button is pressed" Limited quantity available.

Soundec



Cat. XC-0240
Was \$19.95
Save \$7.00
Now \$12.95

SAVE ON LED PACKS



5mm red LED Pack 100
Cat. ZD-1690
Was \$15.50 Save \$4.50
Now \$11.00

3mm red LED Pack 100
Cat. ZD-1692
Was \$16.50 Save \$4.50
Now \$12.00

TURN YOUR SURPLUS STOCK INTO CASH!

Jaycar buys surplus/distress stock of most electronic products from components to built products. If you have marketable quantities of stock you need to clear contact Bruce Routley or Mark Ostro on

Phone: 02 9743 5222
Fax: 02 9743 2066



PRECISION TOOLS
A complete set of precision tools including screwdrivers, pliers, and other essential instruments for electronics work.



BRAND NEW PACK full of 1000 top semiconductors, capacitors etc. Min. quantity in each 100 pcs.
Cat. ZP-0000
Only \$10



PRECISION SWITCH
A high-quality precision switch for electronic applications.

MEMOREX DIGITAL STEREO EARPHONES

Another distress stock purchase. Top quality MEMOREX brand "Expanded Digital Response" earphones provide powerful bass and crisp treble responses. Features non-slip Rims, extended length stems and side entry cord enhance comfort. Sturdy wind up storage case.
•Sensitivity: 103dB @ 1mW •Impedance: 6.4Ω •Max Input: 21mW
•Freq Resp: 16-22,000Hz •Speaker: 15mm •Magnet: Ferrite

Cat. AA-2032 **Retail Price \$39.95 Save \$20**
OUR PRICE \$19.95

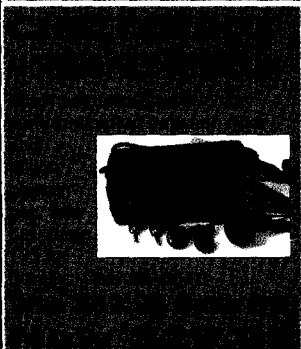
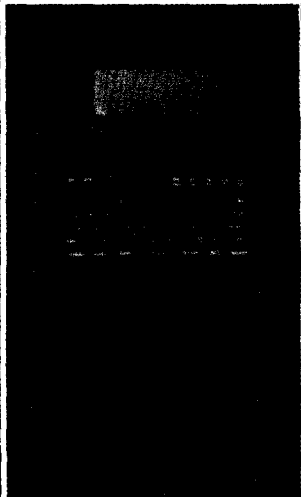

250 ASSORTED WASHERS

Assortment of both flat and locking washers with internal hole size ranging from 6.5 to 10mm and OD from 12 to 25mm.

All supplied in a handy case. **\$3.95**
Cat. HP-0632



LAST CHANCE FOR PLAYMASTER 300W

AMPLIFIER KIT Refer EA June 1980 & '96 cat P8
300 WATT AMPLIFIER
200W 8Ω. PCB, heatsink & all components. Cat. KA-1115
Was \$89.95 Now \$69.95 Save \$20
POWER SUPPLY

Transformer, rectifier and filtercaps. Cat. KA-1116
Was \$115 Save \$20 Now \$95.00
SPEAKER PROTECTOR
PCB, parts and relay. Cat. KA-1117
Was \$19.95 Now \$14.95 Save \$5

NEW KIT

EXTREMELY LARGE ANTISTATIC MAT

This mat will just about cover the whole top of a desk or work station!! It measures 1 meter x .5 meters - Yes 100cm x 50cm. Supplied with two snap type connectors at one end (for left or right handed use) for ground strap (which is supplied). Mat is over 3mm thick and has a hard wearing face over a dense sponge rubber base. Amazing low price.
Cat. TH-1785 Only \$59.95



3 WAY PCB TERMINAL BARGAIN

Standard 3 way terminals, but don't interlock with our usual ones. Your chance to grab a bargain.
Cat. HM-3170
Normal ones cost \$1.50 each
Only \$1ea or 10 for \$6

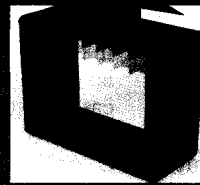

MONOPOD

Ideal for both 35mm and video cameras. Collapsible single leg floor stand, with 4 leg sections of which three are extendable. Supplied with zip up black carry case with shoulder strap. Has quick releases camera attachment, anti slip rubber foot and leg locks. Colour is black.
*Extended height 165cm
*Folded height 62cm
*Weight 650grams.

Cat. AA-2060
Normally pay up to \$110
These are only \$39.95
Surplus stock purchase
Limited qty available

HEAD OFFICE

8-10 LEEDS ST RHODES 2138
PHONE: (02) 9743 5222
FAX: (02) 9743 2066

Quality System
Distributed Under a Quality System
ISO 9002
Lic 6143
Standards Australia

WHOLESALE

PHONE: (02) 9743 5222
ORDERS: 1800 620 169
FAX: (02) 9743 3070

MAIL ORDERS FREE POST FOR ORDERS

Reply Paid 72. Jaycar Mail Orders. PO Box 185 Concord NSW 2137
FREE CALL FOR ORDERS: 1800 022 888
ENQUIRY HOTLINE: (02) 9743 6144 FAX: (02) 9743 2066

ROAD FREIGHT ANYWHERE IN AUST (up to 20kg) \$14.00

POST & PACKING \$10 to \$24.99=\$4.00 \$25 to \$49.99=\$5 \$50 to \$99.99=\$7 OVER \$100=\$8



ADELAIDE SA

•194 Wright St (Cnr. Selby St) •Ph:(08) 231 7355

BURANDA QLD

•Fax:(08) 231 7314 •Mon/Fri:9-5.30 •Fri:8.30 •Sat:9-4pm

CANBERRA ACT

•144 Logan Rd •Ph:(07) 3393 0777 •Fax:(07) 3393 0045

MELBOURNE CITY

•Mon/Fri:9-5.30 •Thurs:8.30 •Sat:9-4pm

COBURG VIC

•11 Kembla St. Fyshwick •Ph:(06) 239 1801

SPRINGVALE VIC

•Fax:(06) 239 1821 •Mon/Fri:9-5.30 •Sat:9-1pm

HOBART

•Shop 2,45 A'Beckett St •Ph:(03) 9663 2030 •Fax:9663 1198

•Mon/Fri:8.30-5.30 •Fri:8.30 •Sat:8.30-4 •Sun:10-4pm

•266 Sydney Rd •Ph:(03) 9384 1811 •Fax:(03) 9384 0061

•Mon/Fri:9-5.30 •Fri:8.30 •Sat:9-4pm

•887-889 Springvale Rd Mulgrave. Nr Cnr. Dandenong Rd

•Ph:(03) 9547 1022 •Fax:(03) 9547 1046

SYDNEY CITY

•129 York St •Ph:(02) 9267 1614 •Fax:(02) 9267 1951

BANKSTOWN

•Mon/Fri: 8.30-6pm •Thurs:8.30pm •Sat:9-4pm

GORE HILL

•363 Hume Hwy Cnr Meredith •Ph:(02) 9709 2822 •Fax:(02)9709

PARRAMATTA

•2007 •Mon/Fri:9-5.30 •Thurs:8.30pm •Sat:9-4 •Sun:10-4pm

PENRITH

•188 Pacific Hwy Cnr Bellevue Ave •Ph:(02) 9439 4799 •Fax:

RHODES

(02)9439 4895 •Mon/Fri:9-5.30 •Thurs:8.30 •Sat:9-4 •Sun:10-4

NEWCASTLE

•355 Church St (Cnr. Victoria Rd) •Ph:(02) 9683 3377 •Fax:(02)

PERTH

9683 3628 •Mon/Fri:9-5.30 •Thurs:8.30pm •Sat:9-4 •Sun:10-4

•199 High St •Ph:(047) 21 8337 •Fax:(047) 21 8935

•Mon/Fri:9-5.30 •Thurs:8.30 •Sat:9-4pm •Sun:10-4pm

•8-10 Leeds St •Ph:(02) 9743 5222 •Fax:(02) 9743 2066

•Mon/Fri:9-5.30

Mini Construction Project:

Improved 24-line I/O card for PCs

Here's an improved design for a flexible input/output card for ISA-bus personal computers. It provides a total of 24 digital lines, each of which can be programmed as either an input or output as required for interfacing to outboard input isolation circuitry or output relay or SCR/Triac drivers. It can be configured easily for any of the I/O base addresses allocated for 'prototyping cards', and the outboard connections are made easier by using three 10-way IDC headers positioned along the rear edge.

by JAMES BARKER

Back in its June 1989 edition, *EA's* former stablemate *ETI* published the design for a low cost, easy to build 24-line I/O card for PC's, presented by designer Graham Dicker. Christened the ETI 1623, it was a very handy card for anyone who needed to use a PC for monitoring and control of other equipment, and my friend Bob Barnes of Sydney-based PCB maker RCS Radio tells me that his firm alone has sold a large number of boards for it — so it was clearly a very popular project.

Very few designs meet everyone's needs, though, and recently I was made aware that the original design had a couple of small but sometimes frustrating limitations. One was that its off-board connections were all brought out to a

single 26-way DIL IDC pin header along the *top* edge, which meant that the ribbon cable to the 'outside world' had to be taken through one of those clumsy 90° turns to get out of the computer — and then split up into separate bits, if you wanted hook it up to separate input and output driver boards.

The other limitation was that the original card was configured for an I/O base address of 279H — that nominally allocated to the PC's games port. By cutting tracks on the PCB and fitting new links it could be moved to various other addresses between 201H and 280H, and no doubt this provided a satisfactory range of choices in 1989. However nowadays with many PCs having sound cards and/or games port cards fitted as

standard, it's often more convenient to have an I/O card located in a different part of the PC's 'I/O space' — and hopefully reconfigurable more easily, say with a jumper strip or DIP switch.

A couple of months ago, a friend of mine — Geoff Wrightson, of Cardiff Heights in NSW — decided that the time had come to try coming up with an improved version of the 1989 design, to remedy these limitations. Geoff himself worked out the modified I/O address decoding circuitry to allow the card to be repositioned in the area set aside for 'prototyping cards' (300 - 31FH), with either a jumper header or DIP switch for convenience, and then I was roped in to help produce a new PCB design.

The new card you see in the photo is

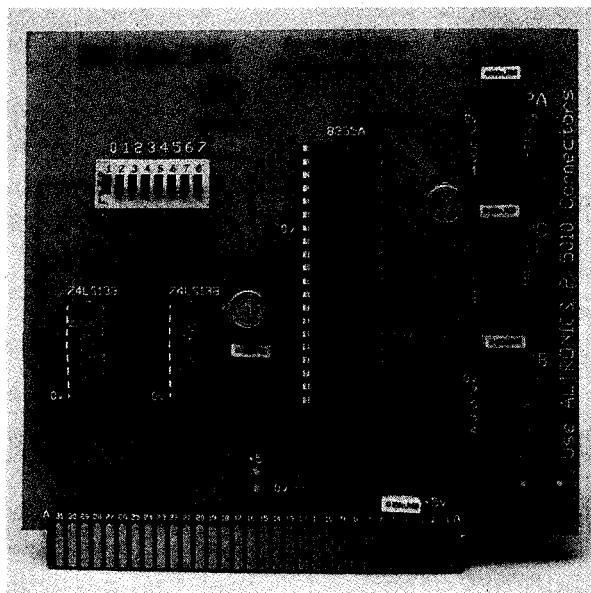

The new card is easily configured for any of eight I/O base addresses in the 'prototyping card' range, and provides its 24 I/O lines in three groups of eight along the rear edge.

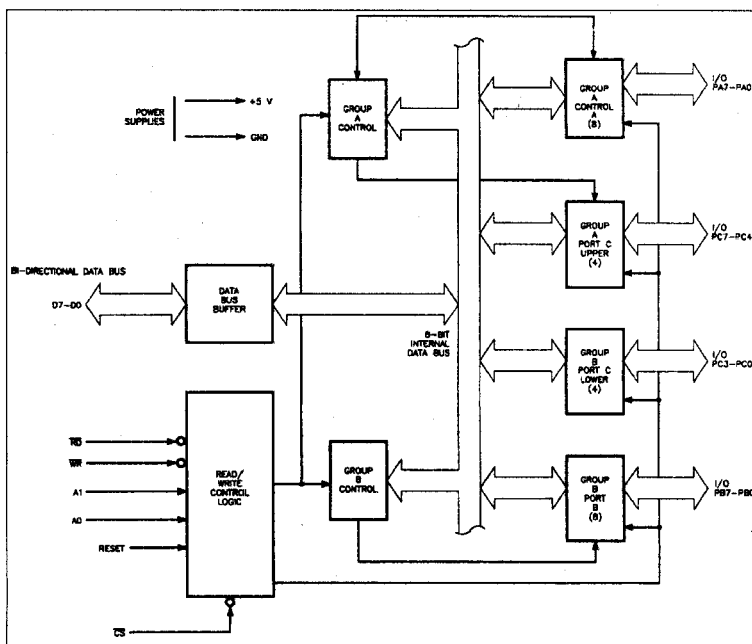
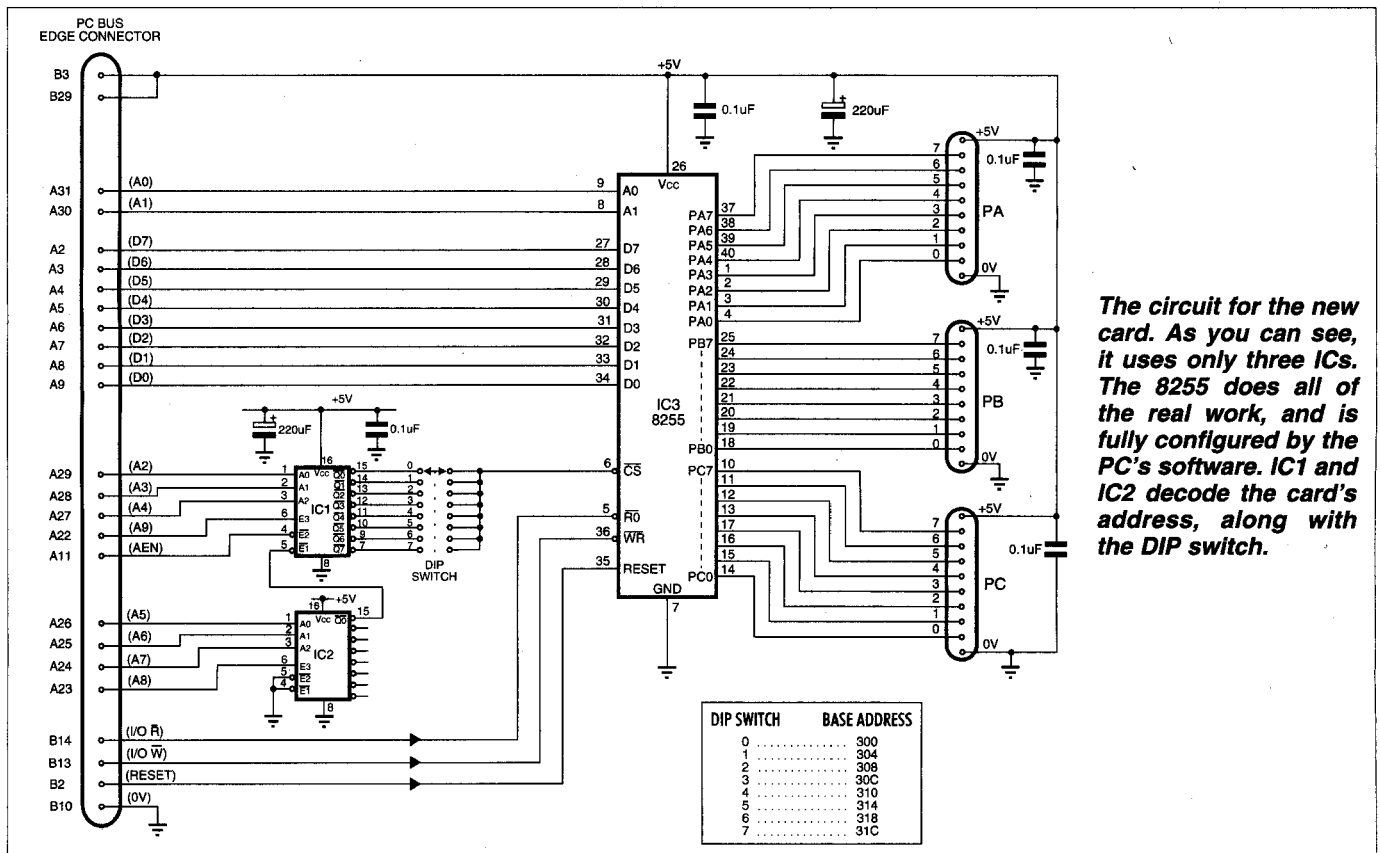

Fig.2: Taken from Intel's handbook, a block diagram showing the internal structure of the 8255 I/O controller.



The circuit for the new card. As you can see, it uses only three ICs. The 8255 does all of the real work, and is fully configured by the PC's software. IC1 and IC2 decode the card's address, along with the DIP switch.

what we've produced, and we believe it overcomes the original limitations fairly neatly. It's a little larger than the original, but still quite small enough to fit inside pretty well any standard PC. And since the off-board connections are brought out to three 10-way 'protected' header strips along the board's rear edge, the ribbon cables can be run straight out through the usual rear PC slot without any 90° bends, and connected easily to different driver modules.

Each of the 10-way headers makes available a set of eight I/O lines, together with connections to the PC's +5V and ground rails — which can be used to power low-drain input conditioning or output driving circuitry.

Circuit description

The circuitry on the card itself is very similar to the original design, with only three ICs: a pair of 74LS138 decoders and an 8255A programmable peripheral interface (PPI) IC, as made by Intel, NEC and other firms. However Geoff Wrightson's modified address decoding now allows the card to be located at any of the eight possible I/O base addresses in the range 300 - 31CH, simply by turning on one of eight DIP switches in SW1.

As you can see from the schematic, IC2 decodes PC bus address lines A5 - A7, and is also gated on when A8 is high. The

Q0-bar output of IC2 is then used to gate on IC1, along with A9 and the address enable (AEN) line. When IC1 is enabled, it then decodes address lines A2 - A4, and as a result each of its eight outputs goes low only for a particular group of four I/O addresses, each with its lowest or 'base'

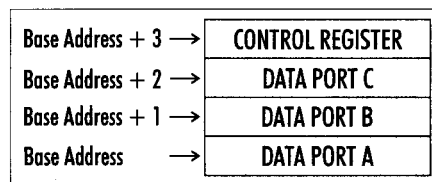

Fig.1: The registers inside the 8255 chip occupy the base address and the three addresses above it.

address as shown in the table. Closing the appropriate DIP switch in SW1 therefore allows the 8255 PPI chip IC3 to be enabled only when the CPU specifies that group of addresses.

This decoding scheme is very convenient as the 8255 has four internal eight-bit registers — three data registers, and a control/status register. And the chip's internal addressing allows any one of these registers to be 'connected' to its eight data I/O lines (D0 - D7), simply by manipulating the logic levels at its pins 9 and 8. So by connecting the PC bus address lines A0 and A1 to these pins,

the chip's internal registers are automatically located at the four I/O addresses starting at the base address selected by IC2, IC1 and SW1 (Fig.1).

As you can see, PC control lines I/O Read-bar, I/O Write-bar and Reset are also connected to the appropriate control pins of U1, allowing the CPU to exercise full control over data flow to and from the chip, when it is addressed. It's a very simple and straightforward arrangement as far as hardware is concerned, but still allows the software to manipulate IC3 as needed.

All the real work is done inside the 8255 chip, of course. This is a very flexible chip, which was specifically designed by Intel to implement flexible parallel interfaces for microprocessor systems. The internal structure of the chip is quite complex, as shown in Fig.2 — taken from the Intel publication *Microcomputer Components Handbook, Microprocessors and Peripherals*, Volume 2. I won't go into all the details of its operation here, and if you want more details I suggest you either refer to the Intel book or else the original article in the June 1989 issue of *ETI*.

Expressed simply, though, two of the three internal data registers are each allocated to handling one of two groups of eight I/O lines, labelled Port A and Port B. The remaining data register is effectively split into two groups of four I/O

I/O Card for PCs

lines, which together make up the third Port C. The fourth 'control' register is also effectively split into two four-bit sections, one of which controls the operation of the Port A and 'upper half' of Port C, while the other half controls Port B and the 'lower half' of Port C. The control codes written into the two halves of the control register can therefore be used — together with the main PC bus control signals Rd-bar, Wr-bar and Reset — to determine the I/O functions of all 24 I/O data pins, on the three ports.

It's fairly simple to program the chip so that the eight lines of Port A and Port B are configured together as inputs or latched outputs, as required, while the two halves of Port C can be configured either together or separately, in the same way.

The chip also allows a choice of three operating 'modes' for each of the two main groups (Port A and Port C upper half, Port B and Port C lower half), where mode 0 corresponds to basic I/O operation, mode 1 to strobed I/O operation and mode 2 to bidirectional bus operation. When one of the two groups is operating in modes 1 or 2, the various lines of that half of Port C effectively become control lines for the eight data lines of Port A or Port B.

It all sounds rather complicated, but the bottom line is that the operation of the card's 24 I/O lines can actually be controlled quite easily by the CPU and software, simply by writing data to and reading it from the four registers in the 8255. This can be done using OUT and INP commands in BASIC, for example, or the equivalent commands in lower level languages like C or assembly language. We'll look briefly at this shortly.

Construction

There's very little involved in building the new card, because it uses such a small number of components. The main thing is to use a good quality double-sided PC board, with gold plated edge connectors for good reliability. The prototype boards were made for us by Bob Barnes of RCS Radio, who can now supply them from stock as Cat. No. 4240S, for \$41.80 plus postage of \$4 within Australia.

Wiring up the PCB should be very straightforward, as there are only the three ICs, an eight-way DIP switch, the three guarded 10-way IDC sockets and a few bypass capacitors. It should all be quite clear from the photo and overlay diagram.

Note that while the two smaller and lower-cost ICs are best soldered directly to the board, I recommend that you use a socket for the more expensive 8255.

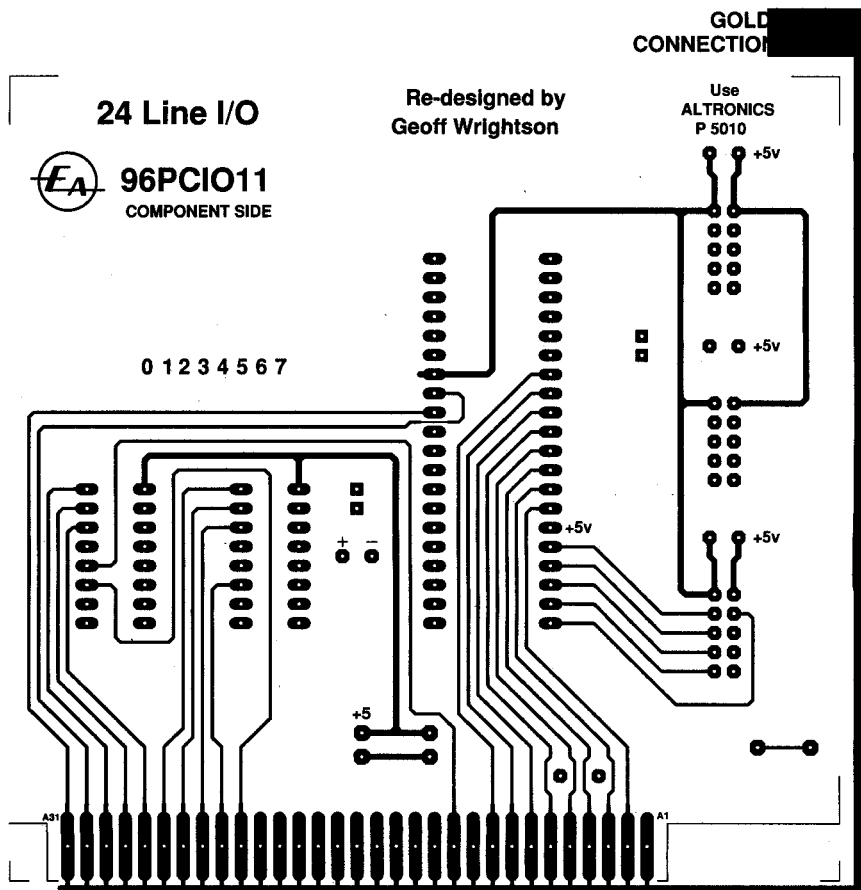
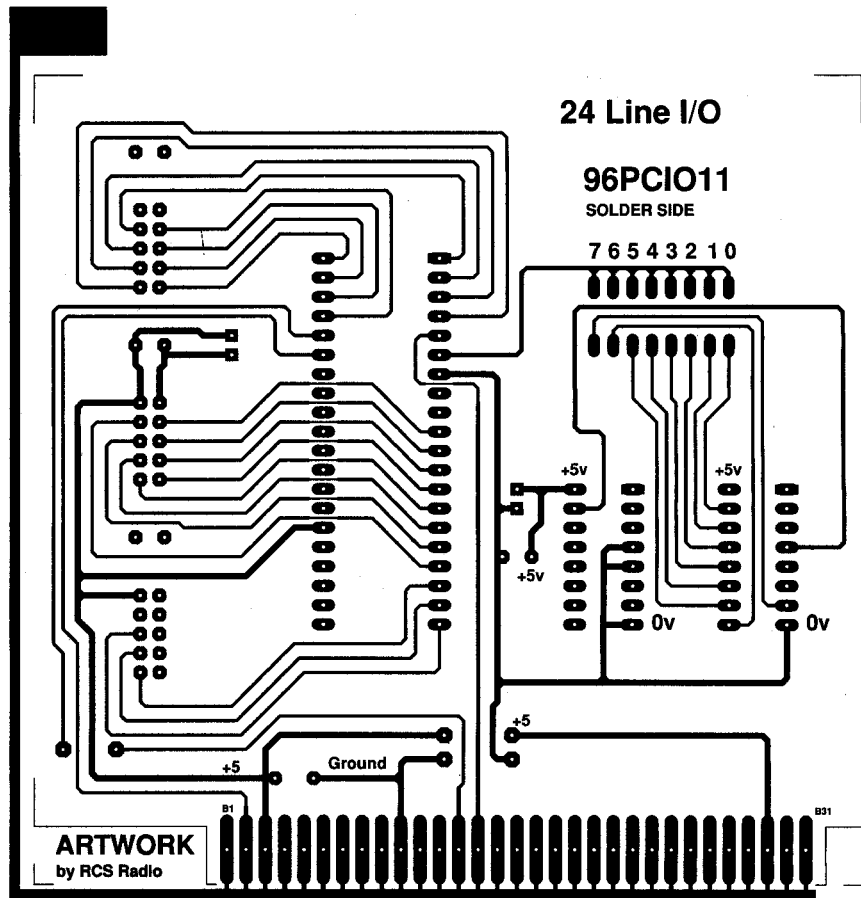

The copper patterns for both sides of the PCB, by courtesy of RCS Radio.

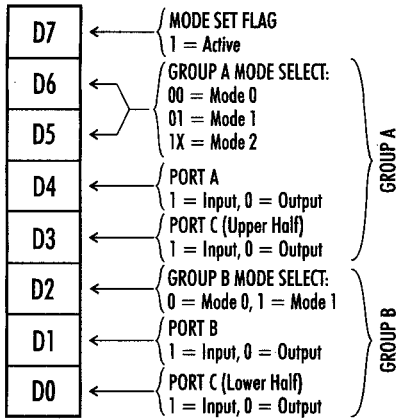

At right is the PCB overlay diagram, to help you in placing the components. Note the orientation of the ICs and I/O headers.

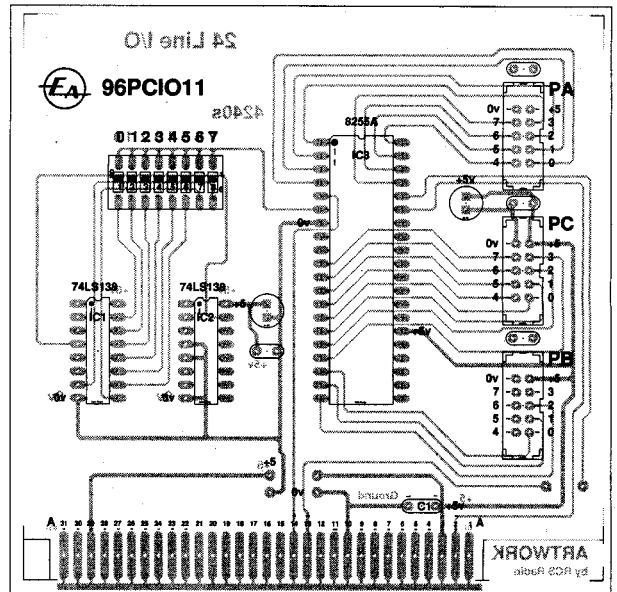

Fig.3 (left): The 8255 is configured by software, using the bits loaded into its control register.

Parts List	
1	Double sided PCB, 106 x 110mm (RCS Cat. No. 4240s)
2	74LS138 decoder ICs
1	8255 PPI chip
1	40pin DIL socket
3	10-way guarded IDC socket (Altronics P-5010 or similar)
1	8-way DIP switch
5	0.1uF MKT capacitor
2	220uF 10VW RB electrolytic

You'll need a 40-pin DIL socket, and it's a good idea to get a good quality socket to prevent problems down the track.

By the way if you make your own PCB, don't forget to remove the copper strip along the bottom shorting the edge connector pads, before you try plugging it into the PC. As you're probably aware, the strip is only used when the pads are being gold plated.

When your board is wired up, the only other thing to do as far as the hardware is concerned is to set the DIP switch for the I/O base address you want. Only one of the eight switches should be switched on, and in most cases it will probably be OK to set SW0 on — giving a base address of 300H. This shouldn't clash with any of the other cards in most PCs, and in most cases the only time you'd want to set it for another address is if you already have another similar card, already set to 300H.

Programming it

As mentioned, virtually every aspect of the card's operation is controlled by the CPU and its software. I'm not going to describe this in detail, just give you a sample or two to get you started.

The 8255 chip's operating mode 0 is the simplest, and is sufficient for many basic parallel I/O jobs. There are actually 16 different possible combinations of input and output functions for the three main ports, determined by the values of bits D0 and D1 (Group B) and D3 and D4 (Group A) in the byte written to the

8255's control register (Fig.3).

As an example, say you want to configure the 8255 to operate in mode 0, and so that it provides 12 input and 12 output lines — say with the eight lines of Port A all used as outputs, those of Port B all used as inputs, and those of Port C split with the lower four as inputs and the upper four as outputs. To do this you'd need to set the various bits of the control register as follows:

- D0 = 1 (Port C lower = inputs)
- D1 = 1 (Port B = inputs)
- D2 = 0 (Group B = mode 0)
- D3 = 0 (Port C upper = outputs)
- D4 = 0 (Port A = outputs)
- D5 = 0 (Group A = mode 0)
- D6 = 0 (Group A = mode 0)
- D7 = 1 (Mode set flag active)

And this combination of bits corresponds to a byte of 83H, so all you'd need to do at the start of your program is send this value to the 8255's control register — located at the card's base address plus three. You could do this in Quick BASIC or Visual BASIC by the statement:

OUT BaseAddress + 3, &H83

where 'BaseAddress' would be your variable representing the card's actual base address — say 300H, or whatever you've set the DIP switch for. You'd have already initialised the variable at the start of your program, with a statement like:

BaseAddress = &H300

Once you've set up the 8255 for the input/output configuration you want, and also set up the BaseAddress variable, it's then an equally simple matter to dump data to the various output lines, and read it back from the input lines. For example in Quick BASIC or Visual BASIC, you just use OUT and INP

statements. So to set all of the odd-numbered output lines of Port A, say, you'd simply send a byte of value &HAA (10101010) to the 8255 Port A register, at the card's base address:

OUT BaseAddress, &HAA

Similarly you can read in the values on the input lines of Port B, by grabbing the data from its data register:

InputVar = INP(BaseAddress + 1)

where the variable 'InputVar' will end up with a (decimal) value equal to the data byte read back from the Port B register.

Starting to get the idea? With the same configuration, you'd set all four upper bits of Port C to a 1 by sending F0H to the Port C data register, thus:

OUT BaseAddress + 2, &HF0

And if you wanted to read the four lower input lines on Port C, you'd use:

InputVar = INP(BaseAddress + 2) AND 15

where the 'AND 15' masks off the four high-order bits, to leave the lower four. Of course you can set up the 8255 for any other configuration of input and output lines, and any other operating mode, simply by sending a different control byte to the control register at (BaseAddress + 3). For all of the various possibilities you'll have to refer to the 8255 data sheets.

Needless to say, you can hook up the card's I/O lines to a wide range of input conditioning and output driver circuits. Some basic circuits were given in the original ETI article, while others were given in the EA article of August 1991.

I hope you find this improved I/O card as handy as I've done. My thanks to Geoff Wrightson for his help in developing it, and also to Bob Barnes of RCS Radio. ♦

ALTRONICS COMPONENTS

Fax Order Line: (09) 328 3487

ALTRONICS



ALTRONICS

Why buy from Altronics? Sounds like a fair question to me. Let me explain. All of our staff are just like you; electronic enthusiasts, so more than likely we have an understanding of what you are trying to do. We offer quality products at directly imported prices, saving you money and causing our competitors heartburn, and finally we have an overnight Jet delivery service to your door the next day in all major capitals. (Outlying country areas please allow an extra 24-48 hours). So, why don't you give us the opportunity to serve you and possibly save you some hard earned cash along the way?

Regards,
Jack O'Donnell, Managing Director

Jack O'Donnell

Multimedia Amplifier & Speaker Kit

See EA Nov '96. This multimedia audio amplifier kit is a great addition to your PC system. It features the excellent dynamic control when you listen to music, the clarity of the stereo sound, and the ability to connect to your TV, VCR, and other audio equipment. The kit includes a 20W amplifier, two 8Ω speakers, and a 12V DC power supply. It's a great way to enhance your PC's audio capabilities.



Add some punch & realism to your PC multimedia system!

K 2500 Multimedia Amplifier Kit **\$59**
K 2501 Multimedia Speaker Kit **\$59** FULL ENCLOSURE PLANS INCLUDED!

Video/Audio Transmitter & Receiver Kits

See EA Nov '96. These kits allow you to transmit video and audio signals over twisted pair cables. The kits are easy to use and provide a secure, reliable way to connect your PC to other systems. They include a transmitter and receiver module, a twisted pair cable, and a 12V AC plugpack. Perfect for home networks and security systems.



Transmit video and stereo audio over twisted pair cable! Ideal for security cameras, video networks, intercoms etc

K 2502 Video Transmitter & Receiver **\$49**
K 2503 Audio Transmitter & Receiver **\$29.95**
K 2504 Video/Audio Plugpack (not included)

3-Band Parametric Equaliser Kit

Add it to your Hi-Fi, A/V or PA system! See EA Nov '96. This kit allows you to adjust the frequency response of your audio system. It features three frequency sliders for bass, midrange, and treble. It's a great way to tailor your audio to your listening environment. Includes a 12V DC power supply and a 100k potentiometer.

K 2545 **\$45**

Pocket Audio Oscillator Kit

(See EA Nov '96) Here's a high performance audio oscillator that is small enough to actually fit in your pocket! Its size belies its amazing performance - as it produces sine or square waves from 41Hz to 18kHz with low distortion (0.16% @ 1kHz), and has a maximum output level of around 1V rms. Ideal for testing all sorts of audio gear, from speakers to amps or mixers, and is just the thing for on-site testing of audio systems! It can even be used to clock logic circuits on square wave. Powered by a 9V battery (not included). **NEW!**



K 2544 **\$22.95** Fantastic for on-site testing of audio / PA systems!

Hi-Efficiency Fluoro Inverter Kit

Designed to fit a standard fluoro fitting, enabling it to be powered by 12V DC eg. your car cigarette lighter socket. See EA Nov '96. This kit allows you to power your PC or other electronic equipment from a car's 12V DC power source. It features a high-efficiency inverter circuit and a standard fluoro fitting. Perfect for use in vehicles or as a backup power source. Includes a 12V DC power supply and a 100k potentiometer. **NEW!**

K 2575 Normally for The Month **\$55**

Hall Effect Current Probe Kit

(See EA Nov '96) Measuring high-potential currents can be fraught with danger, but this kit makes it safer, and has a better accuracy than most clamp-on meters or multimeters. Connected in series with the device under test eg. switched-mode power supply, television etc., it allows the current to be observed on a CRO, and uses a Hall effect sensor to effectively isolate the oscilloscope from the line. Features: • Bandwidth from DC to 25kHz • Current capacity up to 10A • Negligible insertion loss • No heat build up in sensing device • High slew rate (>30A/μs) • Negligible inductance • Output level of 40mV / Amp with ±1% accuracy. **NEW!**



K 2573 **\$99**

PC Data Logger Adaptor Kit

(See EA Aug '96) This "Probes Sampler" kit utilizes your PC to log voltage measurements over several minutes or even months, at a fraction of the cost of an RS-232 equipped DMM. It can also be used as a basic 5kHz audio digital storage CRO. It plugs directly into your PC's COM2 port, and no external power source is required. Sample rate ranges to 100us (10k/s). The software is available from Electronics Australia WBS for free, or by sending EA a formatted 3.5" diskette with a cheque or money order for \$3 to cover copying and return postage. **NEW!**

K 2524 **\$35**

PC Based EPROM Programmer Kit

Ideal for the experimenter or R&D work! See EA Sept '96. This kit allows you to program your PC to program EPROMs. It features a high-speed programmer and a 12V DC power supply. Perfect for use in laboratories or as a backup power source. Includes a 12V DC power supply and a 100k potentiometer. **NEW!**

K 2525 **\$98**

SPECIAL OFFER!
This month, K 9525 includes FREE SOFTWARE valued at \$19.95!

1 GHz Frequency Counter Kit

(See EA April '93) The ideal companion to the K 2546 signal generator, this amazing high performance 1GHz frequency meter features an incredibly accurate 7 digit LED display, 1 BNC input (0-50MHz and 50MHz-1GHz) and 4 input ranges (2MHz, 20MHz, 50MHz and 1GHz). An absolute must for the serious hobbyist and technician. **NEW!**



K 2517 **\$159**

SPECIAL OFFER!
Buy BOTH the K 2517 and the K 2546 for \$219 and SAVE 15%!

20MHz Function Generator Kit

(See EA Aug '96) Most frequency generators on the market have a maximum frequency of 20MHz and cost a fortune. This low cost unit comes complete with a silk screened and punched case, and it's the ideal companion to the K 2517 frequency counter, which can provide a precise reading of the output frequency of the function generator. Features: • Sine, square and triangle waveform • Low distortion (<1% on sine) • Variable and fixed TTL output sockets • 3 ranges: 10Hz - 200Hz, 500-100kHz, 100kHz to 20MHz • Requires 10VAC plugpack (not included). **NEW!**

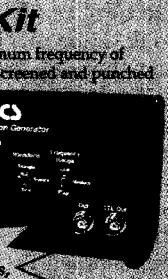

K 2516 **\$99**
M 9111 10V AC plugpack (not included) \$13.25

Great for testing amplifiers, clocking logic circuits, servicing and R&D work!

1-800 999 007 PERTH (09) 328 1599

OVERNIGHT DELIVERY

ALTRONICS Fax Order Line: (09) 328 3487

Radio Mic Bargain

These bargains are our opportunity to clear our inventory of professional grade equipment. They are priced to sell. They are priced to sell. They are priced to sell.

Professional Radio Mic Gear at INSANE Prices! Be Quick, Limited Stocks!

Normally \$705. **SAVE OVER 45%! THIS IS NOT A MISPRINT!!**

\$379

Mini Drill Set

A fantastic addition to any hobbyist tool kit, this powerful mini drill comes complete with a DC plugpack, a set of four grinding stone bits, a cutting disc, four chucks (0.5, 1, 1.5, 2.4mm), and 10 PCB drills (0.5, 0.5, 1, 1.2 and 1.5mm). It's lightweight yet sturdy enough to handle some really tough jobs. Features rubber wheel activation and easy release chuck mechanism. Great for drilling and tapping PCBs, your valuables, model making, polishing, engraving, etc.

NEW!

\$65

Ideal for making one-off PCBs or prototypes!

20MHz Dual Trace 4 Beam Oscilloscope

Highly recommended for the service bench, R&D laboratory, manufacturers, universities and the enthusiast.

Save a HUGE

Hurry, offer ends THIS MONTH!!

\$649

Rectifier Diode Dual Pack

Premium Quality! SAVE UP TO 60%

We've packaged our 1N100X series rectifier diodes in packs of 100 to offer you a HUGE saving! These general purpose rectifiers are used in hundreds of circuits. Here's a great opportunity to stock up your parts bin and make sure you're always got some of these handy!

Z 0105 1N1002 100V 1A Diode Pack of 100 **\$5**

Z 0109 1N1004 500V 1A Diode Pack of 100

Z 0112 1N1009 1000V 1A Diode Pack of 100

Piezo Buzzer

Most for driving alarm, warning, beeper, indicator, etc.

\$9.95

\$30

Pocket Digital Multimeter

This mini DMM has test leads which fit hand tight in the unit and plug into an integral display on the side of the unit. No more lost test leads! Features 1.5 digit LCD display, auto power off, battery check, and auto test function. Just the size for the student or enthusiast tool kit!

Range: DCV 2V, 20V, 200V, 500V; ACV 200V, 500V; Ohms 20k, 200k, 2000k, 200k; DCA 200mA (Peak); Battery Check 1.5V & 9V

Q 1680 WAS \$29.95, NOW **\$19.95**

The Powerhouse 300W, 600W & 1200W Inverters

Connects Direct to Your Vehicle Battery to Produce 240V AC!

600W and 1200W Models Incorporate New Micro-Processor Controlled Circuitry!

The Powerhouse Inverters will provide all your power requirements from a heavy duty 12 or 24V battery. Using the latest MOSFET output stage and toroidal transformer these inverters are efficient and will deliver high surge currents. The Powerhouse series has been designed not only for rugged bullet proof operation but for ease of construction. They include a fully drilled, pre-punched chassis complete with silk screened front panel. Suitable for use in camping, boating, fishing, mining, farming, remote settlements etc.

The 600W and 1200W models now feature ultra-stable Motorola CPU-based control circuitry!

K 6750 300W Kit Version 12V Input	\$315
K 6755 300W Built & Tested 12V Input	\$399
K 6776 600W Kit Version 12V Input	\$535
K 6778 600W Kit Version 24V Input	\$535
K 6777 600W Built & Tested 12V Input	\$699
K 6779 600W Built & Tested 24V Input	\$699
K 6796 1200W Kit Version 12V Input	\$799
K 6798 1200W Kit Version 24V Input	\$799
K 6797 1200W Built & Tested 12V Input	\$999
K 6799 1200W Built & Tested 24V Input	\$999

Half Price LED Bulk Packs!

Premium Quality!

LEDs are great for a clear status or level indication on test equipment, power supplies and metering equipment, and these bulk packs are a great opportunity to stock up. We've slashed prices on bulk packs of 100 5mm LEDs in red, green and yellow.

Z 0120 5mm Red Pack of 100 Normally \$20, This Month **\$10**

Z 0121 5mm Green Pack of 100 Normally \$23, This Month **\$12.95**

Z 0122 5mm Yellow Pack of 100 Normally \$25, This Month **\$12.95**

4" Mid/Bass Speakers

AMAZING! 2-for-1 deal on our 4" drivers! Ideal for car sound, ceiling speakers, mini-hi-fi cabinets etc.

SAVE 30% on this fantastic 4" (100mm) driver suitable for mini-bookshelf or car sound applications. As used in our Stoney Broke speaker kits, and it's the ideal companion to our C 3010 polyimide tweeter. Produces amazing response for it's size!

Max Input: 20W
Impedance: 8Ω
Resonant Freq: 80Hz
Freq. Response: 80Hz - 13kHz
SPL: 94dB @ 1W/0.5m
C 0629 Normally \$26.95 ea.
This Month Buy 2 for **\$26.95**

Micron Soldering Station

Electronic Temperature Controlled Soldering Station. The ultimate in controlled temperature hand soldering for hobbyist and professional applications. Features:

- Huge 60 watt heavy duty element
- Dial up temperature control with a 1°C stability at idle
- Temperature range 250°C to 450°C
- Ceramic heater element with speeded recovery for ultra-fast heat recovery. 2000W standby power for ultra-fast heat recovery.

Save a HUGE \$50! Features ceramic element with embedded thermocouple for ultra-fast heat recovery!

1-800 999 007 PERTH (09) 328 1599

ALTRONICS COMPONENTS

Multi-Function Remote Car Alarm



Save a **MASSIVE \$50** on a comprehensive car security system! **THIS MONTH ONLY!**

Easily the Best Car Alarm We Have Ever Evaluated!

Upgrade your vehicle with the...
 Save a massive \$50 on a comprehensive car security system! This month only!
 This multi-function remote car alarm system is designed to protect your vehicle from theft and vandalism. It features a built-in siren, shock sensor, and remote control. The system is easy to install and can be used on any vehicle. The receiver is connected to the car's battery and the siren is connected to the car's horn. The transmitter is used to lock and unlock the car doors and to start the engine. The system also has a built-in anti-theft alarm that will sound if the car is tampered with. The price is \$149 BARGAIN. Regularly \$199. NOW \$149.

Professional Rack Frames and Panel Sets

Featuring an industrial strength black powder coat finish and made right here in Australia, they conform to international rack frame specifications. Ideal for use in professional audio installations, banjo rigs, computer patch panels etc. Save Hundreds of Dollars on Similar Custom Made Rack Frames, and THIS MONTH SAVE 30%! Supplied in Kit Form. Assembles in Minutes!

SAVE 30%!
 Suitable for home or commercial use, these fantastic rack frames are durable, strong, good looking and light weight.
BE QUICK! We have LIMITED stocks of these rack frames!

Cat. No.	Overall Height	Normally	This Month
H 5312 Rack Frame 12 Unit Black	450mm	\$169	\$115
H 5313 Side & Top Panels for H 5312		\$109	\$75
H 5315 Rack Frame 18 Unit Black	450mm	\$189	\$130
H 5317 Side & Top Panels for H 5315		\$119	\$80
H 5324 Rack Frame 24 Unit Black	450mm	\$209	\$145
H 5325 Side & Top Panels for H 5324		\$149	\$105
H 5330 Rack Frame 30 Unit Black	450mm	\$229	\$160
H 5331 Side & Top Panels for H 5330		\$169	\$115
H 5335 Rack Frame 36 Unit Black	450mm	\$269	\$190
H 5336 Side & Top Panels for H 5335		\$199	\$140
H 5152 1u Vent Panel		\$24.95	\$15

1 Unit Vent Panel for rack frames is ideal for amp racks. It lets heat out and looks neat!

Digital Function & Sweep Generator

Sweep generators are used to obtain the frequency response of a device under test on a cyclic basis, so that the waveform can be observed on an oscilloscope. This function generator has variable sweep rate and width, and functions as a standard waveform generator with sinusoidal, triangle and square wave outputs, all with variable DC offset and symmetry. Output frequency is adjustable via a front panel dial over seven ranges. The unit also features a 2MHz bandwidth 4 digit frequency counter with external BNC probe counter input.
Q 1560 Was \$495. NOW \$445
Q 0175 CRO Probe to Suit \$39.95
 A Very Versatile Piece of Test Gear! Three Instruments in One!

Insulation Tester

Checks insulation electrical strength to 200MΩ, with a marked scale to 100MΩ. Also measures AC voltage to 430V, with a simple push-to-check button operation. Insulation testers, or meggers, are used for checking insulation breakdown in electrical wiring, appliances, alternator and motor windings and transformers.
 Specifications:
 Scale Range: 0 - 200MΩ
 Effective Range: 0 - 100MΩ
 Accuracy: Within 7% of indicated value on effective scale
 Terminal Voltage: 500V across 100MΩ
 Battery: 1.5V AA Cell
Q 1240 \$95



Check Insulation Breakdown in Electrical Appliances, Wiring, Alternator & Motor Windings and Transformers. A must for Electricians, Technicians and Electrical Engineers!

Why Pay \$300 or More?

Transistor, Diode, Thyristor & IC Comparison Tables

Volume 1 A-Z: This comparative data book contains more than 28,000 different semiconductors all of which are listed alphabetically from prefix A to Z with nearly 80,000 equivalents. Each page divided into 3 sections: description, data and equivalents. 150 pages.
H 1263 \$24.95
 Volume 2 1N-Z: This fully comprehensive data book contains over 28,000 different transistors, diodes, thyristors and ICs all of which are listed alphabetically from prefix 1N to Z. The volume is the normal 100 pages.
H 1271 \$24.95

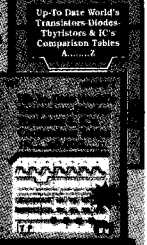

SPECIAL OFFER!
 Buy both Volumes 1 and 2 for only **\$39.95!**

ALTRONICS

174 Roe St. Perth W.A. 6000
 Phone (09) 328 1599, Fax (09) 328 3487
 MAIL ORDERS C/- P.O. Box 8350
 Perth Business Centre, W.A. 6849



Heavy Service: All orders of 10kgs or more must travel Express Road—Please allow up to 7 days for delivery. \$12.00 to 10kgs. \$15.00 over 10kgs. Insurance: As with virtually every other Australian supplier, we send goods at consignee's risk. Should you require insurance cover against loss or damage please add \$1.00 per \$100 of order value (minimum charge \$1). When phone ordering please request "Insurance". Altronics Resellers: Chances are there is an Altronics Reseller right near you—check this list or phone us for details of the nearest dealer. Blue Ribbon Dealers are highlighted with a ●. These dealers generally carry a comprehensive range of Altronics products and kits or will order any required item for you.

Standard Delivery & Packing Charge: \$4.00 to 500gms, \$5.50 500gms-1 kg, \$8.00 1kg-5kg. Where possible we process your order the day received and despatch via Australia Post. Allow approx 9 days from day you post order to when you receive goods.

Overnight Jetservice: Up to 3kg is \$9.50, 3kg to 5kg is \$16.00—We will process your order the day received (if placed before 2.00PM WST) and despatched for delivery the next day. Country areas please allow an additional 24-48 hours.

WA - COUNTRY	COUNTRY	NT
ALBANY BP Electronics ● (098) 412681 Micro Electronics (098) 412077	BALLARAT Ballarat Electronics (053) 311947	ALICE SPRINGS Farmer Electronics (089) 522388
BUNBURY Micro Electronics (097) 216222	BENDIGO Sumner Electronics (054) 431977	KATHERINE Logicware (089) 723030
BUSELTON Mark's Music (097) 523522	SHEPPARTON Andrew Guyatt Elect. (058) 219497	SA - CITY
ESPERANCE Esperance Comm. (090) 713344	QLD - CITY	BRIGHTON Force Electronics ● (08) 2126212
KALGOORLIE Golden Mile Electronics (090) 215212	Delsound PL ● (07) 38396155	COL LIGHT GDNS Force Electronics ● (08) 3770512
ROCKINGHAM TV Joe's (09) 5271806	E.C.Q. (07) 32541153	ENFIELD Force Electronics ● (08) 3496340
VIC - CITY	B.A.S. Audiotronics (07) 38447566	FINDON Force Electronics ● (08) 3471188
All Electronic Comp. (03) 96623506	WOODRIDGE David Hall Elect. ● (07) 38082777	HOLDEN HILL Force Electronics ● (08) 2617088
TECS ● (03) 96706474	COUNTRY	KENSINGTON PK Force Electronics ● (08) 3322999
Talking Electronics (03) 95842386	GLADSTONE Gladstone Elect. Services (079) 724459	LONSDALE Force Electronics ● (08) 3260901
TECS ● (03) 95629501	MAROOCHYDORE Mals Electronics ● (074) 436119	NSW - CITY
Truscott Electronics ● (03) 97233860	TOWNSVILLE Solex ● (077) 754522	SMITHFIELD David Reid Elect. ● (02) 2671385
G.B. Telespares (03) 93266035	TAS	COUNTRY Chantronics (02) 6097218
Preston Electronics ● (03) 94840191	HOBBART G.H.E. Electronics ● (002) 342233	COFFS HARBOUR Coffs Harbour Elect. (066) 525684
	LAUNCESTON G.H.E. Electronics ● (003) 316533	NEWCASTLE Novocastrian Elect. Supplies (049) 621358
		WARNERS BAY Vilec Distributors (049) 566792
		WOLLONGONG Newtek Electronics ● (042) 271620
		Vincom Electronics (042) 284400

1-800 999 007 PERTH (09) 328 1599

1-800-999-007

Hands-on review:

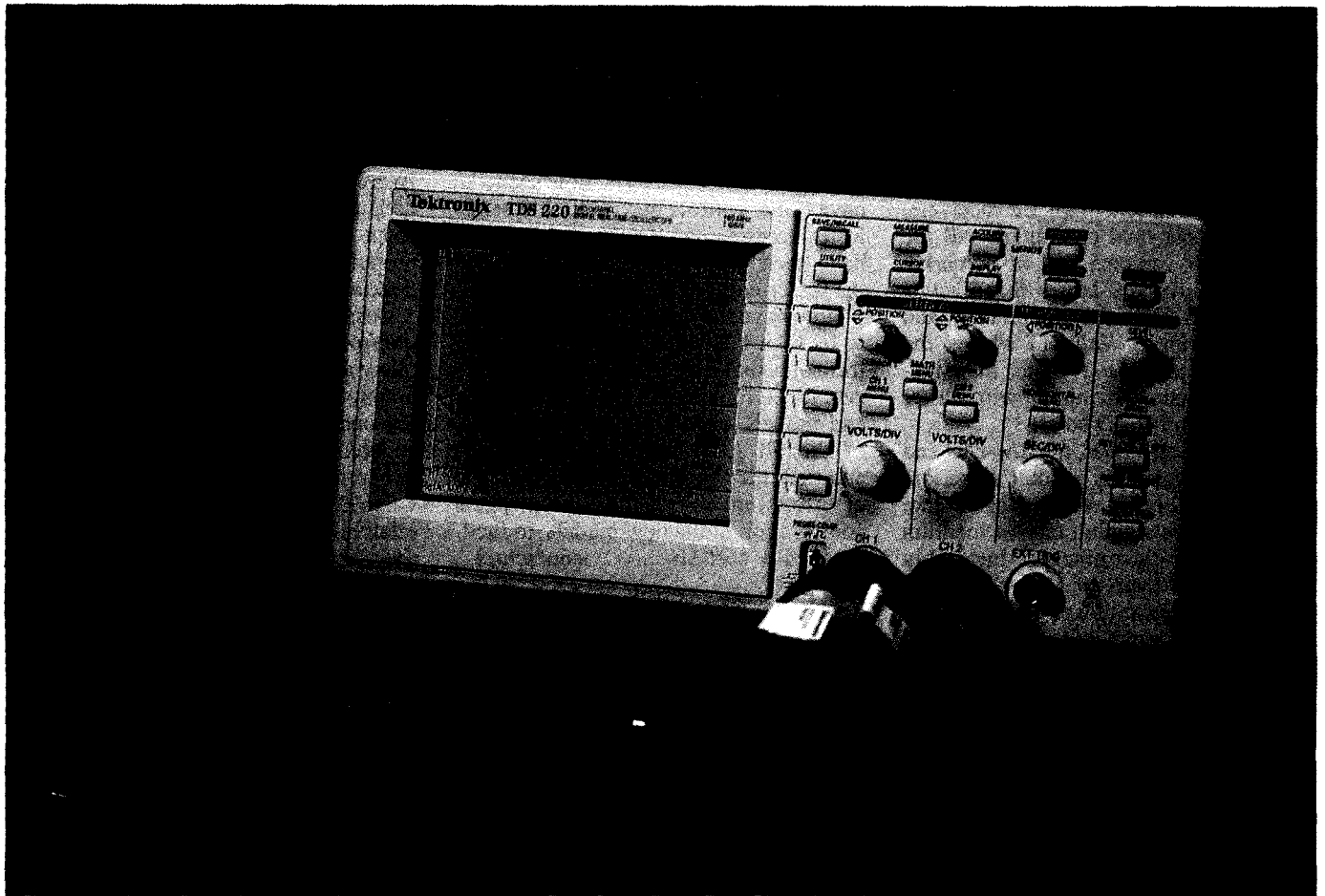

TEK'S NEW TDS 220 DUAL 100MHZ SCOPE

Tektronix has caused quite a commotion at the lower end of the traditional scope market, with its release of the new TDS 200 series of very compact and aggressively priced models. Here's a look at the new TDS 220, which offers two 100MHz channels and genuine 1GS/s real-time sampling — all in a case that's literally the size of a shoebox, and for under \$2000.

by JIM ROWE

For some time now, it's been clear that digital sampling oscilloscopes or 'DSOs' have many advantages over the traditional analog variety, and represent the future as far as scopes are concerned. They can trigger more reliably on complex signals; they can readily display signals *before* a trigger event as well as after it; they can easily capture and display transient events; they can make a wide range of automatic measurements on signals; they can provide

clean and stable display of virtually any signal, including those at very low and very high frequencies; and of course they can be conveniently linked to a printer or PC, to provide 'hard copy' records and data for further processing.

The only drawback has been that until now these advantages have come at a definite price premium, compared with traditional analog scopes based on CRT (cathode-ray tube) technology. Even portable digital scopes with modest

bandwidths have carried price tags starting at around \$2500, rising rapidly to \$4000 and well beyond for a wideband desktop instrument.

As a result, digital scopes have mainly replaced analog at the relatively low volume medium-to-high performance end of the market — plus specific applications where there's a clear need for portability and/or transient storage capability. At the lower-cost end, most users have stuck to the

Tektronix TDS 220 Dual-Channel 100MHz scope

familiar and rather bulky analog desktop scope with its CRT display. And in recent years most of these have come from manufacturers in Taiwan and Korea, much to the chagrin of the long established makers in the USA...

Of course scopes are never likely to be a big-volume product like TV receivers, VCRs and personal computers. All the same, the lower cost end of a market inevitably involves larger manufacturing volumes than the upper end, and with those larger volumes comes the opportunity to achieve higher manufacturing efficiency — along with faster amortisation of R&D costs.

In the case of scopes, the low-cost end of the market also has another attraction, particularly for big scope makers like Tektronix with a wide range of medium and high-end instruments. Inevitably many of the buyers of low-end scopes are cash-starved colleges and universities, training tomorrow's engineers, scientists and engineers. And if such people get their training on 'generic' low-end analog scopes, they're going to be less aware of the advantages of higher performance digital instruments...

So firms like Tek have clearly been faced with a challenge. There were clear advantages in wrenching back some of the lower-cost, high volume scope market; the problem was that this end of the market is very clearly cost sensitive. The

only way they'd ever be able to wrench low-end buyers away from 'analog clones' would be to come up with radically new models offering clearly improved performance, at *really* competitive prices.

That's exactly what Tek now seems to have done, with its new TDS 200 series instruments — and why the new models have been something of a bombshell in the lower-end scope market.

How have they done it? Well, basically by taking advantage of the high performance real-time sampling technology developed for some of their recent high-end models, and marrying it with state of the art LCD panel technology. In addition, they've clearly put a great deal of effort into redesigning the physical construction of the new models, to facilitate really cost-effective manufacture.

Radical change

There's no doubt that these two new instruments represent a radical change from both traditional benchtop scopes and the newer handheld DSOs in the 'enlarged DMM' or 'clay tablet' formats. In fact they may well represent the first of a 'new breed' of scope, replacing both of these existing paradigms and perhaps changing our concept of scopes forever.

Probably the most dramatic change is in their 'footprint' — the benchtop area

they occupy. Traditional analog scopes are very greedy in this respect, typically occupying an area at least 300mm wide by around 400mm deep. In contrast the new TDS 200 models have much the same width, but are only 115mm deep. As a result their footprint is only around 25% that occupied by a typical analog scope, and incidentally an even smaller proportion of the area taken by many desktop DSOs.

Despite this much smaller footprint, the front panel is not much smaller than many analog scopes, and has an overall layout that's both familiar and designed for operating convenience. There's no problem with instrument stability, either; although the TDS 200 models are taller (146mm) than they are deep and relatively light in weight (under 2.8kg), they have a low centre of gravity and 'stay put' on the bench when in use. When the fold-down tilting bail is used they also assume an operating attitude which is just as practical as the traditional analog scope or DSO, despite their much more compact and lightweight form factor.

So Tek really seems to have come up with a winner, with this innovative 'scope in a shoebox' concept. But what of the performance of these new models, and the resulting performance/cost factor?

In fact this seems to be the second area where the new models represent something of a breakthrough. In reality the TDS 220 and its little brother the TDS 210 seem to offer broadly comparable performance, and many of the features, of earlier DSOs like Tek's TDS 320 and 310, but for less than half the price. Late last year the latter models were selling for \$4560 and \$3450, for example, while the 220 and 210 carry price tags of \$1995 and \$1350 respectively — even though both offer sampling at up to 1GS/s, while the older models offered only 500MS/s and 200MS/s respectively. (All of the prices quoted are plus tax.)

Mind you, direct comparisons between the TDS 220/210 and earlier models show quite a lot of small differences, so you can't simply deduce from all this that Tektronix has performed a miracle and suddenly halved the price of DSO technology. They've certainly achieved quite an impressive breakthrough in this direction, but as usual in the real world, things aren't quite as simple as they might appear on the surface.

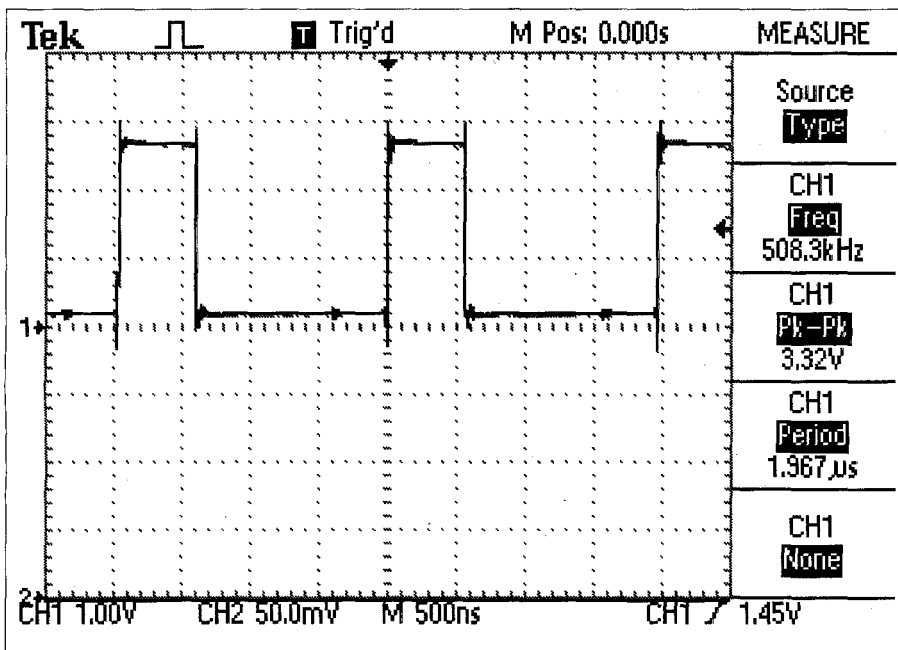

A typical hard copy printout from the TDS 220, with only one channel in use. Note the auto measurements down the right-hand side, and the vertical and timebase settings along the bottom.

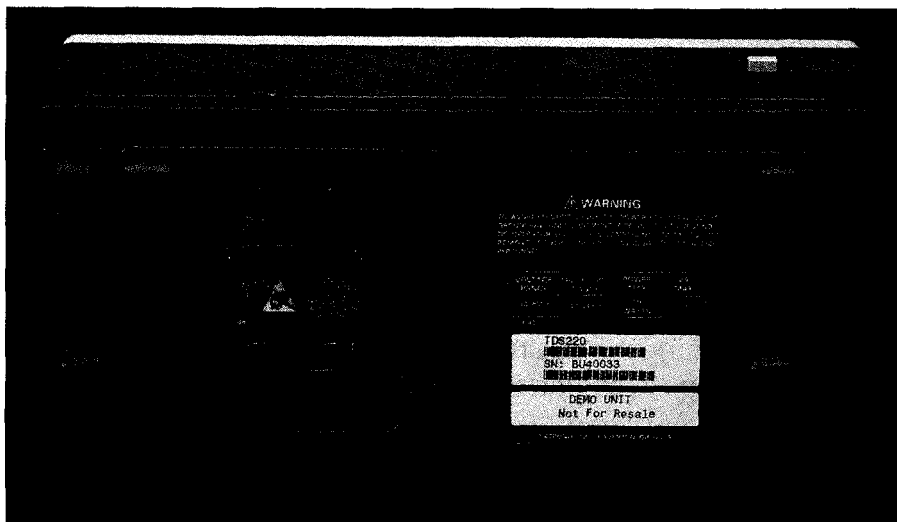

Visible in this rear view is the optional TDS2CM communications and hard copy module, plugged into the bay provided on the left of the rear panel. It provides both GPIB and RS-232C comms ports, plus a Centronics parallel port to drive a printer.

For example the TDS 220 does sample at up to 1GS/s, twice the top rate of the TDS 320, and also has a waveform record length of 2500 samples — compared with only 1000 samples for the TDS 320. But on the other hand the TDS 320's 170mm-diagonal CRT display has a 'VGA' resolution of 640 x 480 pixels, while the TDS 220's backlit LCD display has a diagonal size of only 120mm and a resolution of 320 x 240 pixels — a quarter that of the earlier model.

There are various other areas where Tek also seems to have cut minor corners in the new instruments, presumably in an effort to achieve their goal of really aggressive price points. These include a minimum vertical sensitivity of 5V/div, rather than 10V/div; a somewhat smaller range of automatic waveform measurements (only five: period, frequency, peak-peak, mean and cycle-RMS, compared with a total of 21 for earlier models like the TDS 320); no automatic sensing of probe attenuation coding; no 'CH1 * CH2' in the 'maths' functions; simplified video triggering (no field 1/2 select); and fewer setup memories (five, instead of 10).

On the other hand, the TDS 220/210 do offer some clear advantages over the earlier models. For example they're less intensively menu driven than previous models, which should make them more 'friendly' for users more familiar with analog instruments. Similarly there are individual gain and position controls for the two vertical channels, rather than 'shared' controls. There's also a neat 'self calibration' function, which automatically optimises scope operation for the current ambient temperature.

Another feature which should give the new scopes a much broader appeal in the global sense is the ability to change their display language between English, French, German, Italian, Spanish, Portuguese, Japanese, Korean and Chinese (either simplified or traditional). There are even clip-on front panel overlays to match the five non-English European languages, which come with optional translations of the User Manuals.

Of course the TDS 220/210 still offer that magic DSO button 'AUTOSET', which is already a big advantage over traditional analog scopes. They come with a pair of Tek P6112 100MHz passive 10:1 probes as standard.

As with previous Tek DSOs there are optional matching Hard Copy and Communications Extension modules, to hook up the TDS 220/210 to either a Centronics printer and/or a computer via either an RS-232C or full GPIB interface. Not surprisingly these are much smaller than those for previous models, and clip into a matching small bay at the rear of the scopes.

Trying one out

Tektronix Australia very kindly made an early sample of the TDS 220 available to us for a few days, so we could try it out for ourselves. It was fitted with the optional TDS2CM communications module, which provides both a Centronics parallel port for direct hard copy printout, and RS-232C/GPIB ports for connection to a PC.

In the limited time available we tried using the TDS 220 to examine a variety of signals, and in a number of different lighting conditions to gauge the 'user

friendliness' of its LCD panel. Basically we found its controls very convenient to use, and its waveform display as easy on the eyes as any LCD-based instrument we've ever used. The resolution is inevitably not as good as CRT-based instruments like the TDS 300 series, but on the whole we're inclined to think that most users will find it quite adequate considering the instrument's very compact format and attractive pricing.

By the way we liked the ability to adjust the LCD display contrast, which generally allowed 'good viewing' in almost any lighting conditions.

We checked the frequency response of the sample TDS 220's vertical channels with a single generator, and both were only just below -3dB at the rated 100MHz. This was directly into the scope inputs, without the 10:1 probes. The timebase, triggering and acquisition mode options allowed very fast and convenient arrival at a stable display of a wide range of typical signals, including video and assorted 'tricky' test signals...

To be honest, we did miss some of the automatic measurement options provided on the earlier TDS 300 models, like rise and fall time, and positive and negative pulse width. Still, the TDS 220 does carry a much smaller price tag than those earlier models, and you can't have everything!

Perhaps next year's models will have some of those missing auto measurement options, Mr Tektronix?

Summarising, we were most impressed with the TDS 220, both in itself and as a representative of Tek's new family of 'fightback' low-end scopes. The new 'shoebox' physical format is not only innovative but highly practical, and Tek has certainly managed to squeeze in a very attractive combination of performance and operating convenience — while at the same time achieving a significant reduction in price.

If *anything* can woo low-end scope buyers away from the Asian analog clones, these new Tek TDS 200 models surely have a good chance of doing so. In any case they surely represent a very significant milestone in scope technology, and I wouldn't be surprised if they change our expectations of scope packaging and price/performance factor forever.

For further information on the new TDS 200 series, contact your nearest Tektronix dealer or Tektronix Australia at 80 Waterloo Road, North Ryde 2113; phone (02) 9888 7066, or fax (02) 9888 0125. ♦

Construction Project:

A PC-BASED 32CH LOGIC ANALYSER - 2

Here's the second of two articles describing this new instrument, which offers sampling at up to 40MHz and fully maskable 32-channel triggering — all under software control. In this article the authors cover its construction, testing and use.

by **DAVID L. JONES** and **DAVID BULFONI**

The PCLA has been designed to be as easy to assemble as possible. All of the components, with the exception of the D25 connector, transformer, and two LEDs are mounted on a single sided PCB measuring 230mm x 115mm.

The project is neatly housed in an instrument case measuring 260 x 180 x 65mm. The PCB is butted up against the front panel, to allow the right-angle mounting test probe connectors to protrude from the front panel, eliminating any internal cabling. The only other components mounted on the front panel are two LEDs — one for power, and the other for data indication. A combined IEC mains input connector and fuseholder, along with a DB25 connector for the cable to the PC, are the only items mounted on the back panel.

After checking the PCB for the usual etching problems, work can commence on PCB assembly by installing the 50 or so wire links required. It pays to keep some of the longer links as straight as possible, to make the board look much neater. Take note of the angled link between the crystal and IC5.

Install the three resistors and five resistor packs next. Don't confuse RP1 (1k) with the other four 100k networks, and be sure to match the 'common' end of each network with that marked with a square on the overlay.

Now come all of the IC sockets. It is highly recommended that all of the ICs be mounted in sockets, especially the input latches and the RAMs. Using sockets, the repetitiveness of the circuit will make troubleshooting much easier at a later stage. About the only IC's which aren't either expensive or connected to an outside circuit which can cause damage are ICs 3, 4, and 5.

It may be difficult to obtain the 28-way 'skinny DIP' sockets required for the RAMs, but in this case two 14-pin sockets can be connected end to end. In

fact, two 14-pin sockets may also be cheaper than one 28-way one.

The three 44-way PLCC sockets rate a special mention. Due to Murphy's law, it is extremely easy to solder in a PLCC socket the wrong way around! A PLCC chip will only go into the socket in one of the four possible orientations, so it is vital to get the socket around the correct way.

The PLCC socket has a bevelled edge on one corner, and this must match the bevelled edge on the component overlay. Also make sure that all of the pins protrude through their holes. If you are using a homemade PCB and drill a few holes off centre, then it can be very frustrating trying to insert the socket!

Install all of the capacitors next, with the exception of C1. Watch the orientation of the two tantalum capacitors. Also install the five PCB stakes and bridge rectifier.

Next comes the three IDC connectors CN1, CN2, and CN3. The best way to install CN3 is to keep the header plug attached to the header pins. This will keep the header pins straight and aligned while they are being soldered. CN1 and CN2 should also be bolted to the PCB with M2.5 nuts and bolts. This will stop pressure from being exerted on the solder joints when the test probe leads are connected and disconnected from the front panel.

Lastly, install C1 and the regulator. Bolt the regulator and heatsink to the PCB before soldering the leads.

Attention can now be turned to the mechanical side of things. If you don't have pre-punched panels, then cutouts will need to be made for the mains connector, DB25 connector, the LEDs and probe connectors. The only cutouts which will need alignment are those for the probe connectors. The probe cutouts can extend down to the bottom of the panel if you wish, but some may prefer to take a bit more time to make the

cutouts only just big enough to accept the connector.

Holes will also need to be drilled for the PCB and transformer. The PCB should be as close to the front panel as possible, to allow the probe lead connectors to extend out. The PCB is just wide enough to fit between the two front support posts.

The transformer should be mounted in the middle of the back part of the case, with the mains input towards the rear panel. Securely connect the transformer frame to the main earth pin on the IEC socket. All mains wiring connections should be properly insulated with electrical tape and heatshrink.

Connect the 8.5V winding of the transformer to the AC input pins on the PCB, and connect the LEDs to their respective PCB pins.

The LEDs can now be wired to the PCB. Only three wires are required for this, one for the anode of each LED and their common ground connection. The cathode of both LEDs will have to be connected together on the front panel and connected to the ground lead.

Finally, assemble the IDC female DB25 connector and 26-way IDC header to a short length of ribbon cable, just long enough to connect from the PCB to the rear panel.

Before installing any of the ICs, apply power and ensure that 5V is available on the supply pins of each IC socket. The power LED should also be on. Disconnect the power, and install all of the ICs — paying close attention to the correct orientation. Be sure to use relevant anti-static procedures to avoid damaging any of the ICs. The LSI devices will be labeled 'LACC', 'LATC1' and 'LATC2'. Ensure that these devices are installed in their correct sockets as follows: LATC1 is IC14, LATC2 is IC15 and LACC is IC16.

Carefully check the orientation of

each LSI device before pushing it down into the socket. The bevelled corner on the chip must match the bevelled corner on the socket. Trying to force the chip in with the wrong orientation may damage the IC and socket pins.

Re-apply the power and check the 5V supply rail on all of the chips. If the heatsink gets overly hot, then something may be loading down the supply. If this is the case, then it is likely to be a PCB short somewhere. Start by removing the ICs one by one and repowering until you track down the fault.

Assuming that the hardware hasn't gone up in smoke, it's time to connect the PCLA to the PC. Use a 25-way ribbon cable with a DB25 IDC male on one end, and a DB25 IDC female on the other end. In fact, it is best to make up a 'universal' cable with both female and male DB25 connectors and a 26-way IDC DIL header on each end. This will also allow you to use the cable for all sorts of other projects as well. The cable should be kept as short as possible, with an absolute maximum length of about two metres.

Probe construction

One of the most difficult and expensive parts of building a logic analyser would have to involve the test probes. Unlike an oscilloscope or multimeter, the PCLA has 32 inputs, and if you want to fully use all 32 channels, then you will have to make 32 or more test probes!

Like most commercial logic analysers, the PCLA uses levered dual row IDC header connectors for the probe inputs, which provides a low cost and compact solution. Unfortunately, there is no standard pinout or connector size for logic analysers. Almost every manufacturer uses their own custom pinout, so don't rush out and buy a set of Joe Blow logic analyser probes...

The PCLA has two 34-way connectors which provide all of the 32 channel inputs, external clock, external trigger, ground and an external +5V supply signals. The front panel label shows the pinouts of the two connectors. The pinouts are the same for pins 1-32 on both connectors, but pins 33 and 34 differ. One connector provides the clock

and trigger inputs, while the other provides a +5V output on both pins.

So what kind of probes do you need? It all depends on what you want to measure. The photographs show two of the most common types of probes. One of them uses a commonly available 16-way DIL test connector, which simply clips over a DIL IC in-circuit. This sort of probe is useful for quick testing of all the pins on a single IC.

The prototype of this probe used 8-way SIL header connectors to allow easy disconnection of the test head. The SIL connector can then be used as a test head in its own right, but this makes it rather difficult to connect an external clock to one of the pins. If you need to easily connect the external clock, then it is much simpler to solder the wires directly onto the test head pins. This allows you to connect a clock line using an EZ-HOOK.

It might be wise to make up a 28-way, 20-way, 16-way and 14-way version of this test head, for general testing of ICs. With 32 channels available on the PCLA, two 16- or 14-way test heads can

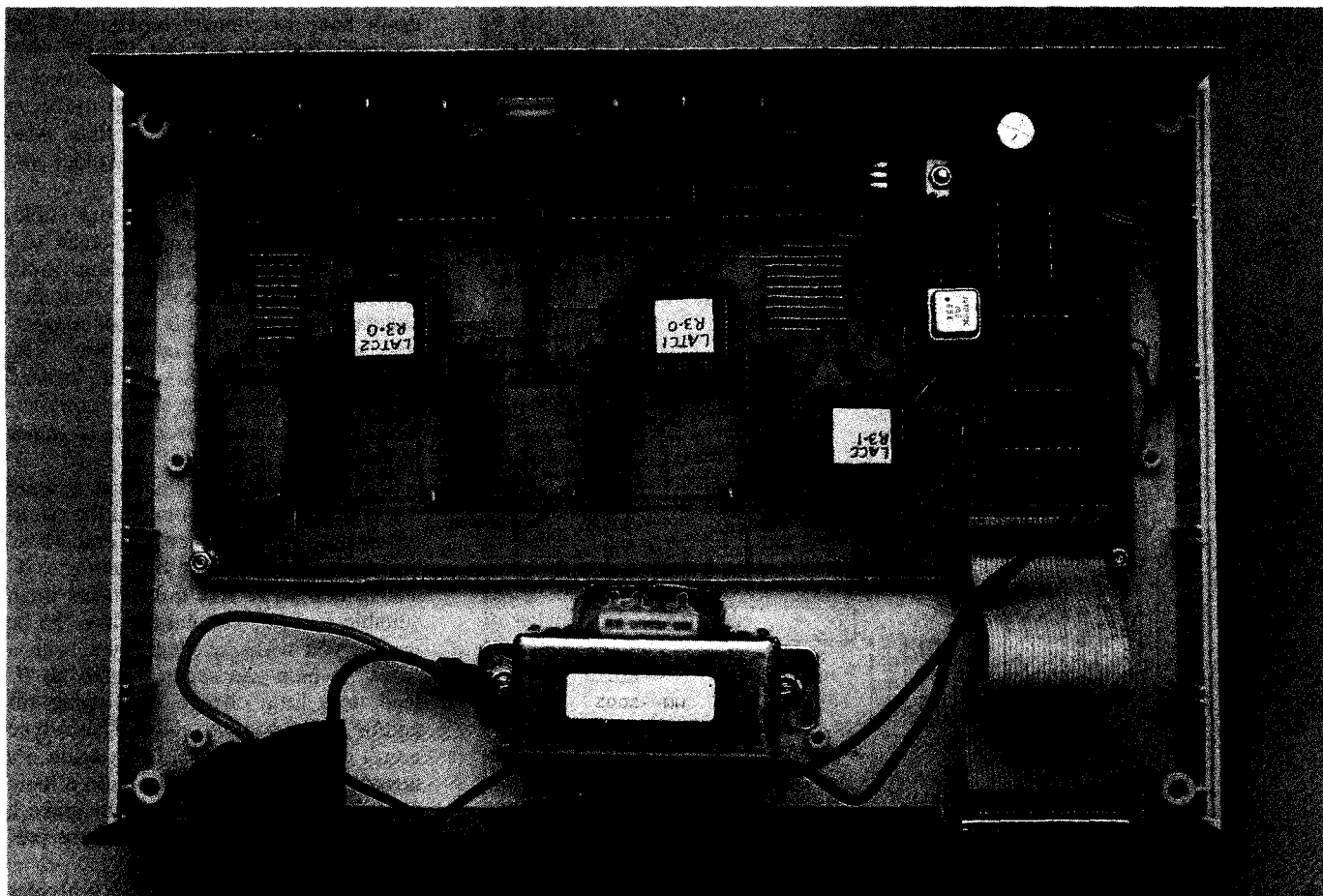

Inside the new Logic Analyser. Thanks to the use of three preprogrammed PLD chips, everything fits on a single-sided PC board. The input probe leads connect directly to the two 34-way IDC DIL connectors visible at the upper left, which protrude through the front panel.

A PC-Based 32Ch Logic Analyser — 2

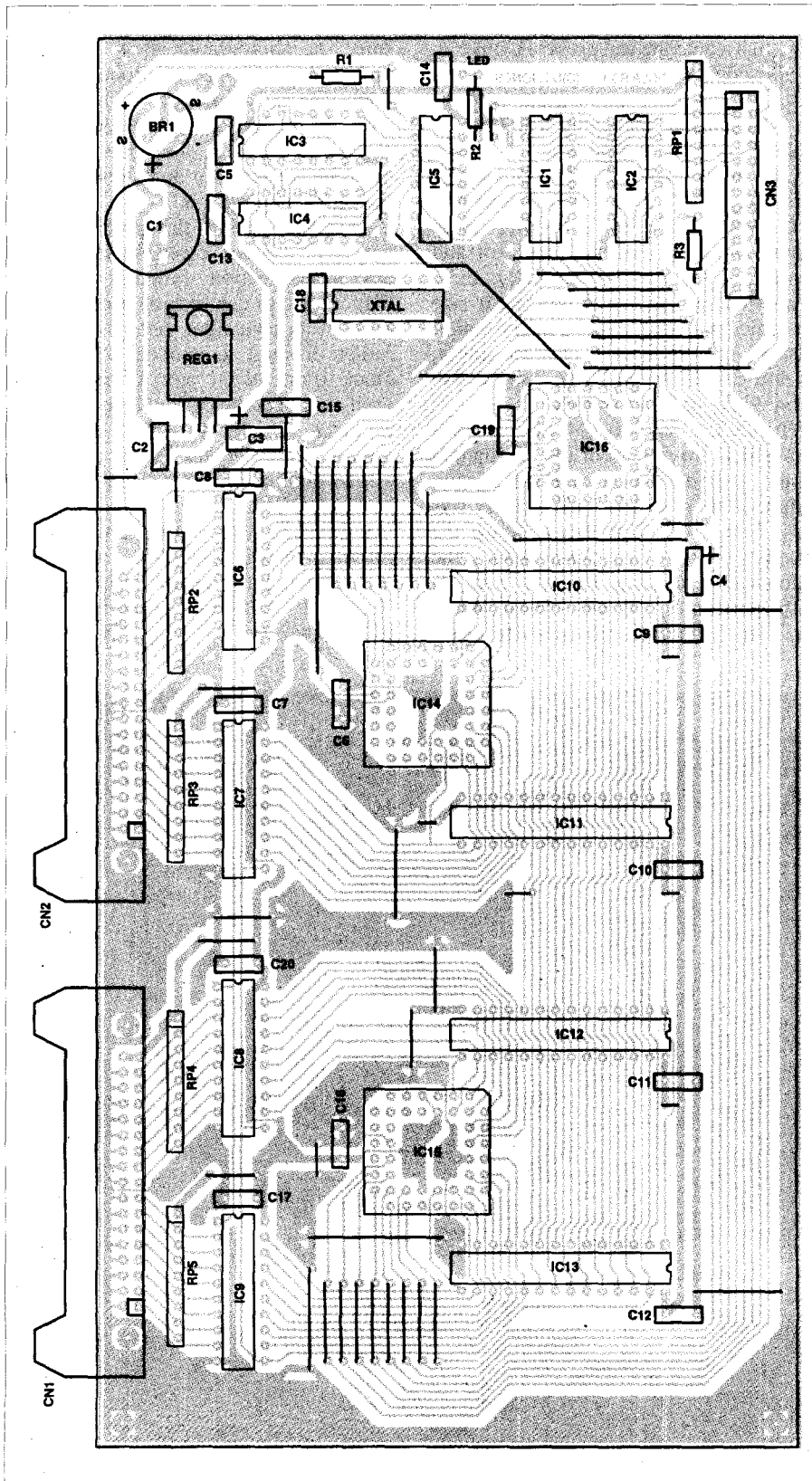

Use this overlay diagram as a guide, along with the interior photo, when you are wiring up the PCB for your own analyser. The author recommends that sockets are used for all ICs, and suggests that you take particular care with the orientation of the sockets for the PLD chips IC14, IC15 and IC16.

be used at the same time.

When making one of these connectors, it is recommended to match the actual IC pin number with the corresponding input channel on the PCLA connector. This just makes it a lot easier to remember which input goes to which pin, when using the software.

The other photograph shows a 16-channel EZ-HOOK test probe. I actually had a good quantity of these pre-made leads in my junk box from an old logic analyser, complete with 'claw' type EZ-HOOKs. They used 10-pin header connectors, so I just snipped off the connector and attached the individual leads to a short length of ribbon cable. The probes are arranged in the resistor colour code sequence to aid in identification.

You can make your own EZ-HOOK probes using a 34-way IDC DIL header plug, about 300mm of ribbon cable and a few dozen EZ-HOOKs. It's a simple matter of connecting the IDC connector to the ribbon cable, and then connecting an EZ-HOOK to each input wire.

When splitting the cable into individual wires, leave a ground wire attached to the side of each input wire — but you don't have to connect anything to the ground wire at the test end. Usually only one ground wire is enough to connect to the circuit, although you can make up extra ground leads if you like. Also make up leads for the external clock and trigger inputs.

If you don't use multi-colour cable, then you will have to label each test probe with the corresponding input channel number on the PCLA. Note that standard 'rainbow' cable is not compatible with IDC header connectors. You can also use the multi-colour 'twisted pair' ribbon cable like many commercial units do, but this cable is rather more difficult to obtain.

The type of EZ-HOOK used is quite important. I don't recommend the cheap type with just a 'hook' on one end. These are not really designed for attaching to IC leads; their large size only makes them suitable for resistors and the like. To be useful, you really need the type with a 'claw', which can securely grab an IC lead with little chance of slipping off and/or shorting two pins. These type aren't exactly cheap, but then again it's never going to be cheap to build a logic analyser probe! If you want to make a good range of test probes, then be prepared to spend over \$100.

These general purpose probes will cater for most of the common circuits, but if you want to test surface mount or large PLCC packages, then you'll have little

choice but to make up specialised probes.

It may be handy to make up some probes with a two-pin header on each of the channels. This is a common type of probe used in a lot of commercial equipment. In fact, many designs have built-in logic probe test points, usually of the two-pin header variety, where one wire is the signal, and the other a ground.

If you are designing a circuit of your own and think you may use the logic analyser for evaluation or troubleshooting, then it is a wise idea to add some two-pin header logic probe test points. As header connectors are very cheap, the main problem will either be lack of space for the connector, or lack of room to route the tracks to the connector.

If you've ever seen a commercial PCB with rows of unused two-pin connectors, or PCB pads without any connector, you'll now know what they are for!

Who knows, the way things are going, TV and VCR service manuals of the future may have logic diagrams instead of CRO shots...

Taking measurements

Using a logic analyser has many traps for the unwary. Unlike an oscilloscope, there is no easy way to tell what effect adding the logic probe to a circuit makes. The only output you have is either HIGH or LOW, and if you don't know exactly what the circuit is supposed to do, then you have little choice but to trust the logic analyser.

There are however two problems which are the most common and easy to look out for. One is the use of the PCLA at high speeds (greater than a few MHz), and the other involves data misinterpretation at the sampling point.

The first problem, of high speed operation, is fairly obvious. Usually when taking high speed measurements with an oscilloscope, a x10 probe is used. This provides a much lower probe capacitance and hence less disturbance of the circuit under test. The PCLA doesn't

have the same capability of using a x10 low capacitance probe, and all measurements are taken with a directly connected input. In our case, we're using a 74ACT series gate. Here the amount of probe capacitance will depend on the length and type of cable being used.

The probe capacitance has a dramatic loading effect on high speed circuits, so this is something to be wary of if you are not getting the result you expect.

The rule is to either keep the cable as short as possible — generally less than 300mm — or to use a buffered probe. A buffered probe is an external box with a buffer chip as close to the probe inputs as possible. You can then use a much longer cable to connect to the PCLA. The PCLA provides a +5V output which can be used to power external buffer probes.

Another use of a buffer probe box is to provide different types of input matching. The PCLA has 74ACT series logic on the input, and can therefore accept either TTL or 5V CMOS signal levels. If you want to measure 4000 series logic of a higher voltage, or the newer 3.3V logic, or even ECL, then you will have to make an appropriate buffer box. The box should convert the incoming signal to a TTL level acceptable for the PCLA.

The second problem concerns the fact that the PCLA has to 'latch' the data at some discrete point. If the input happens to be changing from one state to another at this same point, then the PCLA will not register the data correctly and may interpret the data as either logic level. This can readily be seen by measuring a constant square wave of lower frequency than the internal sample clock.

Say for example that the input is a constant 10MHz square wave, and the PCLA is using its internal clock of 40MHz. In this case you would expect to see the captured waveform change state every four clock samples, and this is what you get — most of time!

Every so often, the input may change

state right at the point the data is clocked into the latch. If the latch misinterprets the data, then the display will show the input pulse longer or shorter than it really is. There is no real way to avoid this when using the internal PCLA clock (TIMING mode), so be wary of it.

In effect, this is similar to the quantisation error in A to D converters. Just as they can only measure a finite number of levels, so too the PCLA in TIMING mode will always have a probable error of one sample clock period.

A similar problem exists in STATE analysis mode, but this time it is possible to prevent it. Because the external clock on the PCLA has to pass through IC5 and the control chip, it will inevitably have some delay or 'skew' associated with it compared to the input data.

If you are not getting the results you expect in STATE mode, then try inverting the external clock polarity in the software. This will usually fix the problem, but at high speeds the skew may be too much to capture data reliably. This is why the PCLA is arbitrarily limited to a speed of 20MHz in STATE analysis mode.

You can push the speed to the full 40MHz if you feel confident enough that the clock skew will not be a problem. Alternatively, you can use an external buffer probe to try and delay the data to match the delay of the clock. But you're on your own with this one!

Expensive commercial units get around the problem by switching the external clock straight through to the latch clock input. However, adding this feature to the PCLA would have overly complicated the design.

It is also important to select a proper ground when measuring high speed signals. In such circuits, moving the ground lead just a few inches can add significant 'ground bounce' to the signal being measured. Although this is more important (vital!) with an oscilloscope than a logic analyser, it's still something to watch out for. It's always good practice to connect to the ground pin of the chip you are testing.

The PCLA triggers off data fed from the input latches. This means that the PCLA does not have any 'glitch capture' capability like some of the more expensive commercial logic analysers. This may be a problem if you are looking for a particular fault which may only occur for a short period of time. If you

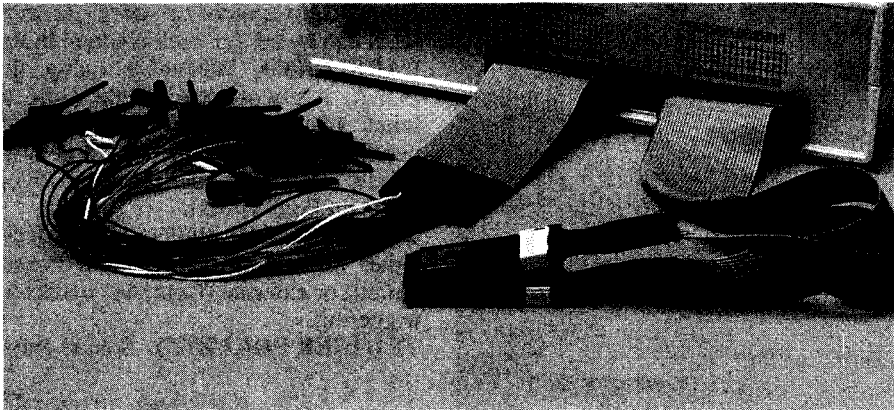

For general work, two different kinds of input probe are most useful: a set of individual EZ-HOOK leads like those at left, and a 16-pin DIL IC clip like that at right.

A PC Based 32-Ch Logic Analyser — 2

set the PCLA to trigger off the fault condition then depending on the sample rate, the input can match the fault condition, but if the data is not being latched and sampled at that time, the trigger circuit will never see it.

However, there is a partial solution to this. The 74ACT574 input latches can be replaced with 74ACT573 transparent latches. These will allow the data inputs to pass 'transparently' through the latch when the clock input is HIGH. This will at least give the PCLA glitch capture capability for at least half of the sample clock, which is better than nothing. The 573's will latch the data on the negative edge of the clock, but this is the same time as the data is written into the RAM. If the data changes just before the latching takes place, then the RAM may not have enough setup time required to successfully write the data into the RAM.

Using the 573's was the original intention for the PCLA, but the prototype proved a bit touchy at the higher sample rates. But if you're after a glitch capture capability, then this may be a worthwhile modification.

To design the PCLA to incorporate full glitch capture capability would have required the trigger inputs to be permanently connected to the inputs. This would require a set of buffer chips, and certainly a double-sided PCB.

Frankly I don't believe the lack of a glitch capture capability is a major disadvantage in a low cost design such as this. In fact, it's sometimes beneficial to have a design that will ONLY trigger off the data that is actually captured and displayed.

Using the software

The minimum requirements for the software are a DOS based 286 or higher IBM compatible, with a VGA screen and parallel port. Any standard printer which supports the IBM extended character set can be used for hardcopy printout, as the software prints using text mode. It is recommended to use a second parallel port if the printer is to be used at the same time as the PCLA.

After installing the software, start the program by running the PCLA batch file. A main menu will appear with the various options in the middle of the screen, and the channel information box on the left hand side.

The channel information box will always remain on screen, and provides the channel number, on/off control, trigger setting, channel type, and user

defined label for each of the 32 channels.

The main menu provides the following options:

TIMING DISPLAY: This displays a timing diagram waveform view of the most recently captured data. It allows you to zoom and expand the waveform

window, and scroll the entire 32KB buffer on all 32 channels. Two cursors are available to measure the time interval and number of clock periods between two points.

DISASSEMBLY DISPLAY: This routine decodes the most recent data into separate address and data fields specified by the channel type information. This is used for decoding microprocessor buses and the like. The information is display in two columns, one containing the address, and next to it the data.

CAPTURE DATA: Starts the PCLA sampling data using the current trigger information and options specified. It then retrieves the data from the PCLA after sampling has finished. The DATA LED on the front panel will change state according to what the PCLA is doing. During PRE-TRIGGER sampling, the LED will be fully ON. During data retrieval the LED will be blinking rapidly at half brightness, and the LED will be OFF when data retrieval is complete.

EDIT DATA: Allows editing of all the trigger and channel options. The USED check box turns each channel on and off. Turning off a channel will only stop it from being displayed, but it will still be retrieved and triggered from. Any unused channels should be turned off, as this will speed up the display refreshing.

The trigger check box can be set to HIGH, LOW, or DON'T CARE. This sets the desired trigger setting for that channel. Remember to set all unused channels to DON'T CARE (X). The default state is DON'T CARE for all of the channels.

The TYPE box allows the user to define that channel as a particular data bit or address bit, for use with the disassembly function. Both address and data can be up to 31 bits wide. You do not need to specify all of the bits for the disassembly function to work; you can skip unused bits and only specify the ones you are interested in. For example, you may only want to decode address bits 2, 5, 6, 7 and the first four data bits.

An eight-character user defined label can be set for each channel in the LABEL field. Whenever using the PCLA, it's worth taking the time to label all used channels, as it can become very difficult to remember which input you connected to which point on your circuit.

TRIGGER SOURCE: This selects either internal (from the word trigger circuit) or external (from the connector) triggering.

TRIGGER POLARITY: Selects either

PARTS LIST

Semiconductors

- IC-1 74ACT258 8 bit addressable latch
- IC-2 74ACT280 dual decade counter
- IC-3 74ACT151 8 bit multiplexer
- IC-4 74ACT574 octal 5-state latch (or 74ACT573 — see text)
- IC-5
- IC-6
- IC-7
- IC-8
- IC-9
- IC-10
- IC-11
- IC-12
- IC-13 20Kx32 20ns cache SRAM (any brand)
- IC-14 64Kbit DIP package as used on PC motherboards
- IC-15 82L51010-80 (LATCH_30_LED)
- IC-16 82L51010-80 (LATCH_30_LED)
- IC-17 82L51010-80 (LATCH_30_LED)
- IC-18 7805 (IC-220) 5V regulator
- IC-19 WDA 1A diode bridge
- IC-20 40MHz TTL XTAL oscillator (0714 pin DIL)
- IC-21 5mm green LED
- IC-22 5mm red LED

Resistors

- R1 100k 0.25W 5%
- R2 1k x 7 DIP network
- R3 100k x 8 DIP network

Capacitors

- C1 2200uF 10V RB electrolytic
- C2 100uF 10V tantalum
- C3 1uF 0.2 pin ceramic ceramic

Mechanicals

- T1 250VA 0.5V 1A mains transformer
- PCB single-sided (PCLA31)
- D30D female IDC connector (30mm pitch) of 25-way ribbon cable
- 40P case, 281 x 180 x 55mm (W x D x H)
- 40-pin type 925004 or similar
- Small sized TO-220 heatsink
- Three 40-way PLCC sockets eight 14-way DIL sockets five 16-way DIL sockets four 28-way DIL sockets two 34-way P/A-100 pin headers one 26-way dual row straight pin header one 28-way IDC header plug two 5mm LED bases six M3 nuts, bolts and washers four M2.5 nuts and bolts one IEC mains cord set of four PCB mounting spacers one fused panel mount IEC mains connector three copper wire, mains rated hookup wire solder

PCLA software availability:

The PCLA software box devices used in this paper (IC-1, 2, 3, 4, 5, 6, 7, 8, 9, 10, 11, 12, 13, 14, 15, 16, 17, 18, 19, 20, 21, 22) and also the PC software needed to control it, are available from Embedded Technology of 12 Copeland Road, Cammerays Park 2770. The quoted price includes postage within Australia.

Software only \$30
 PCLA programmed 1076 PLDs \$55
 Software and programmed PLDs \$80

Embedded Technology can accept pre-orders for the software but requires only after business hours, on (02) 8620 1223.

(Continued on page 97)

40MHz PC-BASED 32 CHANNEL LOGIC ANALYSER



DATA



POWER

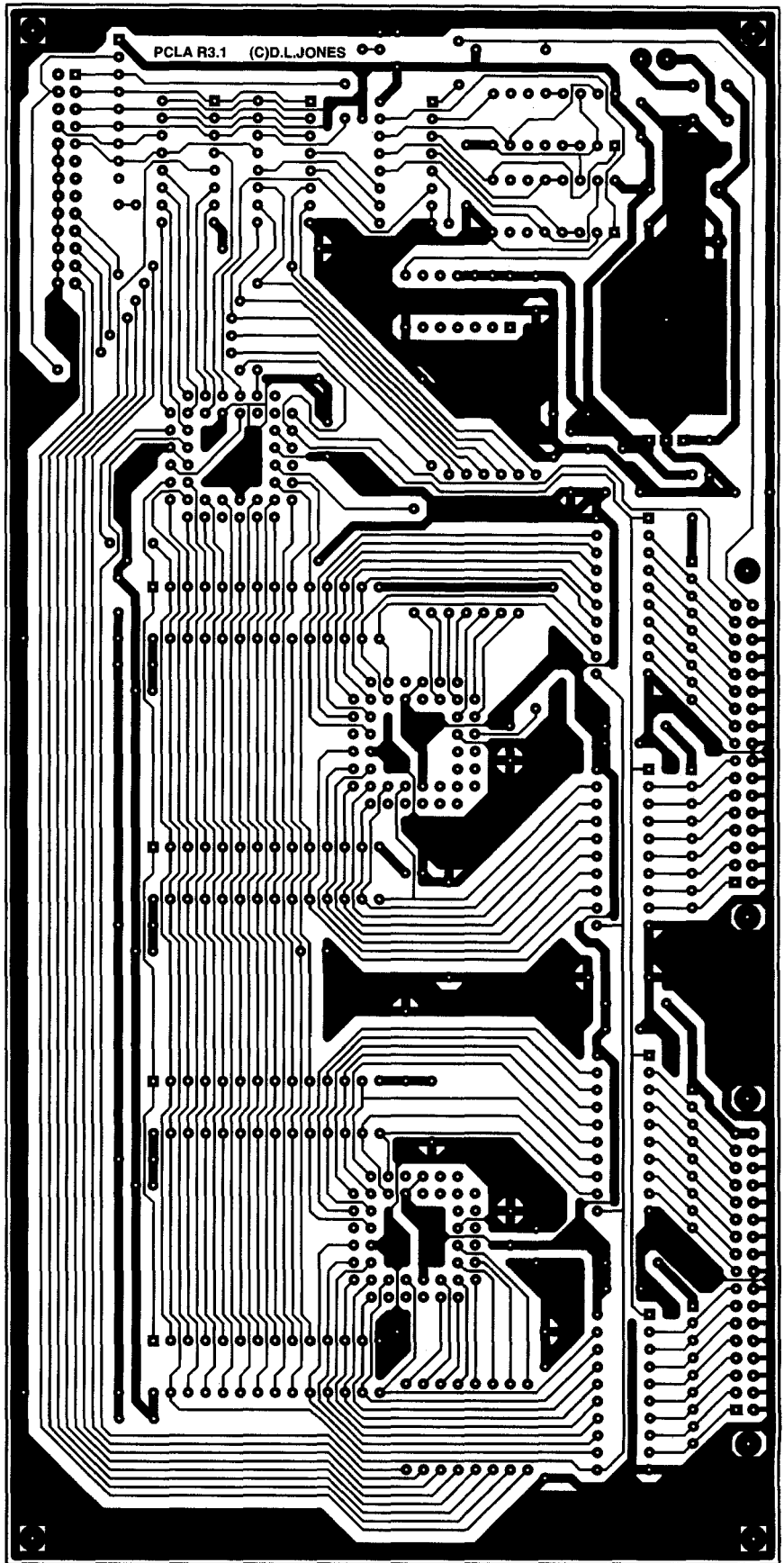
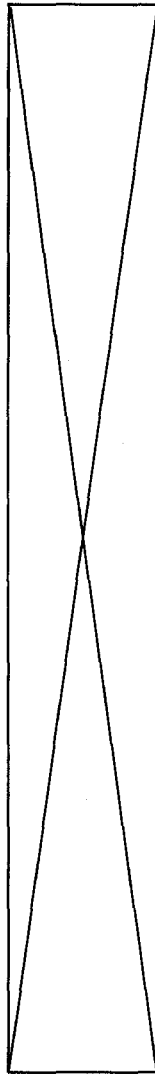
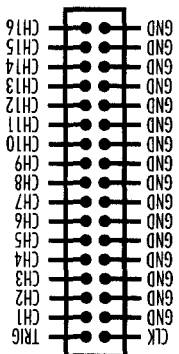
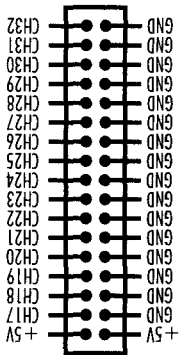

Here is the artwork for the Logic Analyser's front panel (left) and the PCB (above), reproduced actual size for those who like to make their own. The large rectangular area on the front panel with crossed diagonal lines is for the input connector cutout.

Vintage Radio

by ROGER JOHNSON

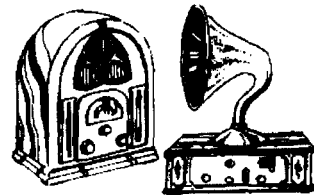

The Astor 'Mickey Mouse' and its descendants

With the exception of the AWA 'Radiolette', there is possibly no more recognisable Australian vintage radio than the Astor 'Mickey'. The postwar Mickeys, colloquially known as the 'loaf of bread', are very likely to be found in the most modest of collections, and also by those new to collecting vintage radios.

Receivers with the brand name 'Astor' were manufactured in South Melbourne by Radio Corporation, otherwise known as Radio Corporation of Australia. Some early advertisements even used the abbreviation 'RCA'. (I wonder why!)

In 1933 Astor adopted a design of the American Hazeltine Corporation, for a compact transformerless four-valve plus rectifier mantel radio originally intended for the American 60Hz 110V mains. It seems that the first pre-production model ran into problems, with heat dissipation from the large voltage dropping resistor required for Australian 210-240V AC mains.

The first production model, the 'OZ', incorporated a power transformer, and was released in December 1933. The distinctive cabinet, with its slightly raised and rounded corners, seemingly resembled Mickey Mouse's ears, and Astor quite deliberately marketed the set as the 'Mickey Mouse' as the

advertisement in *Wireless Weekly* for January 26th, 1934 clearly shows (Fig. 1). Note even the '(REGD.)' following the words 'Mickey Mouse' in the advertisement...

The association with Walt Disney's characters did not end there, however, for an 'Auditorium Console Attachment' was marketed as the 'Minnie Mouse'. A small switch on the back of the chassis, as shown in the circuit, enabled the connection of the large speaker enclosure. (Fig.2)

By the way, research suggests that the Mickey Mouses (mice?) were more extensively advertised in the Melbourne based radio magazine *Listener In*, rather than the Sydney-based *Wireless Weekly*.

Legal problems

Not surprisingly, this use of popular cartoon character names landed Radio Corporation in bother with the Walt Disney Corporation. The inevitable

legal battle ensued, with Walt Disney claiming that their trademarks had been improperly used, and that royalties should be payable. Radio Corporation lost, but not until 1940. Wartime restrictions put a halt to domestic radio production, and after the war, Astor continued the line but using the name 'Astor Mickey' (Fig.4).

Mr Ray Kelly, writing in *HRSA NEWS* number 39, stated *However, it seems that had Radio Corporation been willing to pay 50 pounds per year to Walt Disney, they would have been licensed to use the 'Mickey Mouse' tradename. They possibly spent more on legal fees, with appeals, than it would have cost to pay the royalty, a matter of principle.*

Pre-war models

The Model OZ had four valves and rectifier using the pre-octal 6.3 volt and 25 volt valves, 6A7, 6D6, 6B7, 43 and 25Z5, with about 130 volts HT. The

GUARANTEED SAME POWER AND RANGE AS FULL-SIZE SETS

YOU'RE TELLING ME!

ASTOR
Mickey Mouse
(REGD.)

FIVE VALVE SUPERHET for **12** grs

FULLY COVERED UNDER HAZELTINE PATENTS

The smallest, lightest electric receiver on the market (dimensions only: 7 in. high x 10½ in. long 5½ in. wide; weight 10½ lbs.). . . . Guarantees perfect Interstate reception.

... available also with
**AUDITORIUM
CONSOLE ATTACHMENT**
Minnie Mouse (illust.)

Gives auditorium volume. The Mickey set plugs into this acoustically perfect console and operates as remote control.

Extra price for Minnie attachment £5/5/-

Fig.1: (Above) The optional 'Minnie Mouse' external speaker attachment, as shown in another part of the 1934 advertisement.

Fig.2: (Left) This advertisement for the original 'Mickey Mouse' receiver appeared in *Wireless Weekly* for January 26th, 1934. The unauthorised use of a Walt Disney trademark landed Astor in a legal trouble.

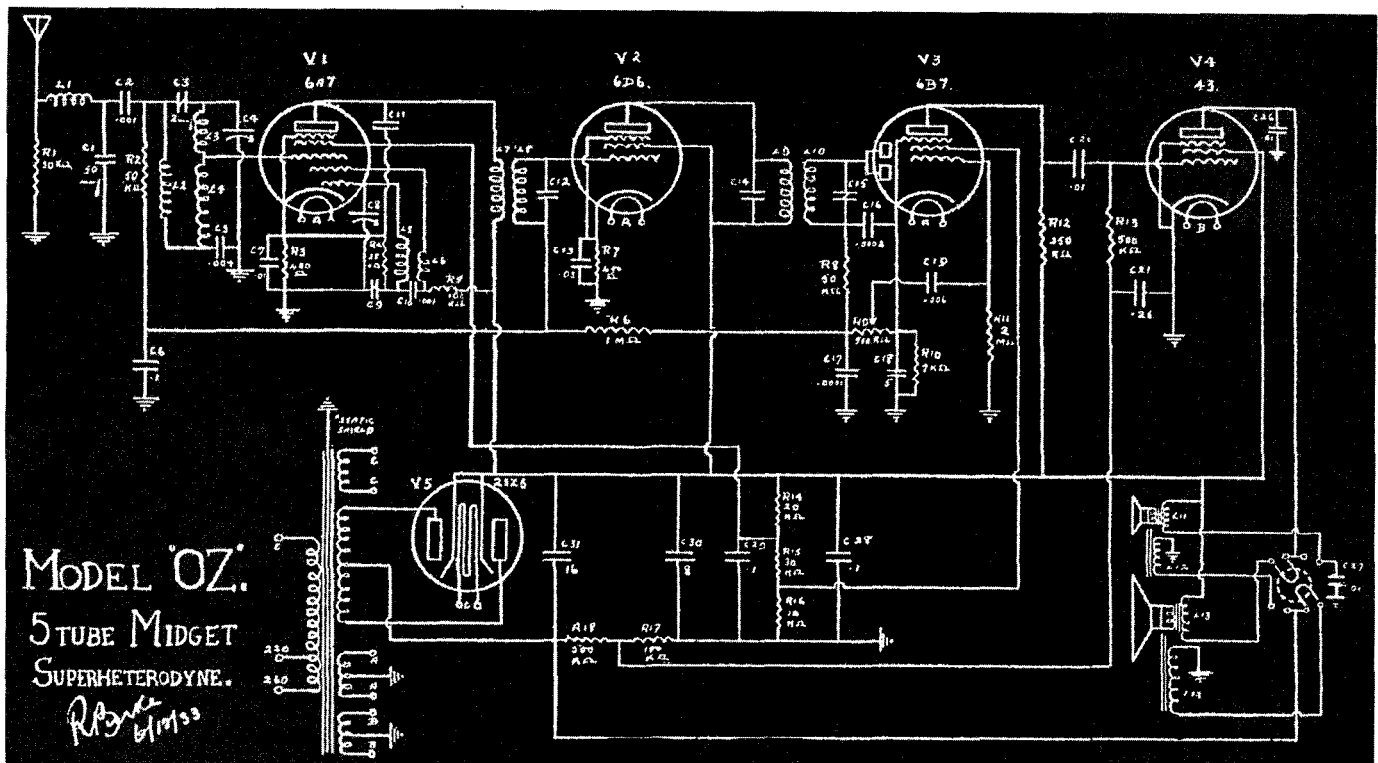

Fig.5: The circuit diagram for the original Australian Mickey Mouse, model OZ, released by Astor in December 1933. Note the use of a 25Z5 rectifier.

circuit is quite conventional apart for the aerial circuit.

Another early advertisement was for the car radio version of the 'Mickey Mouse'. The aerial input circuit of the OZ looks very much like an ignition filter, so perhaps the car radio version was adapted for domestic use rather than the other way around! The circuit is shown in Fig.5.

The model MZ is contained in a slightly larger cabinet, whilst in 1936 the model designation was model BE, which used a type 41 output valve and type 80 rectifier.

In 1936 a new cabinet was produced, in what was first thought to have been only brown bakelite. But while I was researching for this column, I discovered that it was also available in ivory (see Fig 3.). As this cabinet is probably the most prized amongst collectors, an ivory model would be very highly treasured indeed.

The new cabinets were used until 1939/40, and initially housed the model EC which used all-metal actal valves, but still a 25-volt output valve, type 25A6. The other valves were 6A8, 6K7, 6Q7 and a 5Z4 rectifier. The Model EC continued to 1939/40 without alteration.

In 1939 a model BP was released, using the 32L7-GT combination rectifier/output valve in a half-wave circuit, thereby reducing the valves to four —

the other three being glass octal types 6A8-G, 6U7-G and 6B6-G.

Not shown in the *Australian Official Radio Service Manual (AORSM)* Volume 3 for 1939 is the dual-wave version, model CN, using a 6J8-G for the converter. Also for 1939 was a battery version, the model EG which used the 1.4 volt octal valves type 1A7-GT, 1N5-GT, 1H5-GT and 1A5-GT.

After the war

The left hand cabinet pictured in Fig.4 is probably the most prolific of all the post-war Mickeys, and ran from 1946 to 1952/3. The right hand cabinet continued to about 1958/9, and is probably the

least desirable of all the Mickey Mouse or Astor Mickey models, even though there were technical innovations such as variable induction tuning rather than the familiar tuning capacitor.

The post-war Astor Mickeys were invariably a 3/4 valve reflex circuit incorporating bass boost at low volumes, AGC to the converter stage, and negative feedback via a 100pF capacitor from the plate to the grid of the output valve. The circuits were quite complex, and necessitate a degree of skill in following the actual circuit and the compact wiring.

Slight variations had different model numbers. For example, model JJ for 1946 used cathode bias on the output

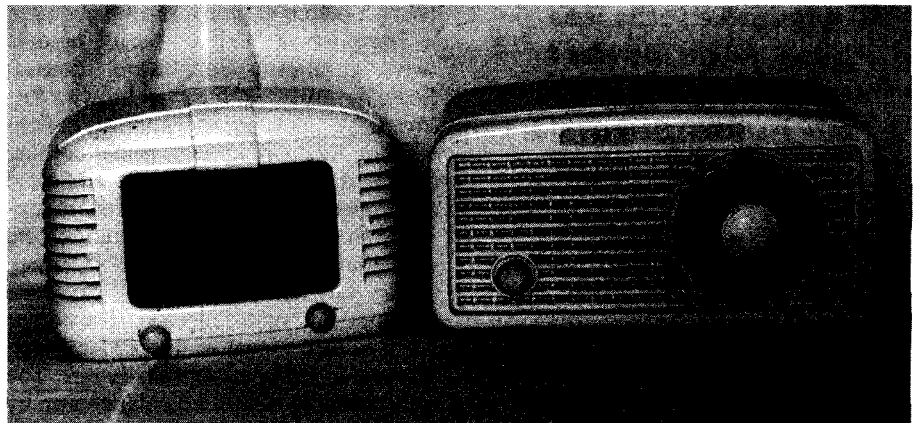

Fig.4: The postwar 'Astor Mickey' in two of the most familiar cabinet styles. That on the left is the one most popular with collectors.

READER INFI NO.15

EVATCO
ELECTRONIC VALVE & TUBE COMPANY

Music Retailers
Musicians
Audiophiles
Radio Collectors
Hobbyists
Industrial Users

We stock SVETLANA, SOVTEK & TESLA
Also a large range of Vintage & NOS tubes
Plus Valve SOCKETS & BOOKS

Send S\$AE for Catalogue
ELECTRONIC VALVE & TUBE CO.
PO Box 381 Chadstone Centre, Vic. 3148
Tel/Fax: (03) 9571 1160
Mob: 0411 856 171
Email: evatco@werple.net.au

READER INFI NO.16

WE MAKE IT FOR YOU
PAIR OF STANDS \$220

SP-252BR \$650*
SP-353DK \$900*

THE END OF
COLLECTOR?

Good Sound
by **TOMOTECH**
(03) 9580 9338
10 CARLA CRT, ASPENDALE 3195

READER INFI NO.17

Valve Audio

Valves sockets parts audio books. Repairs upgrades & custom construction of valve audio gear. Send \$1 stamp for illustrated audio catalogue.

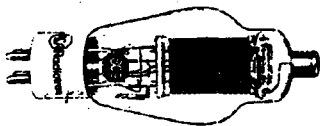

Vintage Wireless Radio Co.

239 Australia St Newtown 2042
P/O Box 467 Newtown 2042
Ph 02 557 2212 Fax 02 516 3981

VINTAGE RADIO

valve, whereas the model KL for the same year used 'back bias'.

The 3/4 valve reflex circuit was not strictly adhered to. The model HPM for 1952 used a 6BE6 converter, a 6U7-G IF amplifier, a triode connected 6U7-G audio amp and a type 6BV7 det/AGC/output valve, plus the rectifier. The dial even had '5 valve' as part of the markings.

Details of the model DK is not published in the AORSMs, despite the fact that both its cabinet and dial carry the wording 'Astor Mickey'. This particular model uses a straight 3/4 valve circuit and a 900 ohm electromagnetic speaker, mounted facing the side rather than being directly behind the slotted dial. Were these perhaps the very first of the post-war production models, made of 'anything that happens to be lying around', as the saying goes?

It is interesting to note that the Eclipse factory, also in South Melbourne, produced a 'Peter Pan' model BKL — the circuit of which, upon initial examination, appears to be identical to the Astor model DK. Perhaps these chassis were made in the Eclipse factory, while Astor were preparing for the reflex models...

Cabinet variants

The first Mickey Mouse models from 1934-1936 were as previously described and illustrated in Fig.1. The speaker is behind a very delicate fretwork speaker grille, and there are a series of ventilation slots cut into the cabinet sides. Unfortunately, the timber between the slots and also the speaker fret is easily damaged, much to the disappointment of a would-be purchaser.

The 1937-1940 models were housed in the mostly brown, and rarely found ivory bakelite cabinets shown in Fig.3.

The postwar 'loaf of bread' models were commonly cream in colour. Second most common is brown, followed by black. Prized amongst collectors are the seldom seen pastel colours of green, blue and mustard, and very rare indeed is red. The cabinets are louvered from the sides to the dial, with the dial slotted to allow the egress of sound.

The last cabinet style is the least favoured amongst collectors. The colour seem to be a repeat of the predecessors, with again red being extremely rare. The only example of this red cabinet seen by the author had cream knobs.

Mention must be made of the 'Mickey Grand' of 1936/7, which was

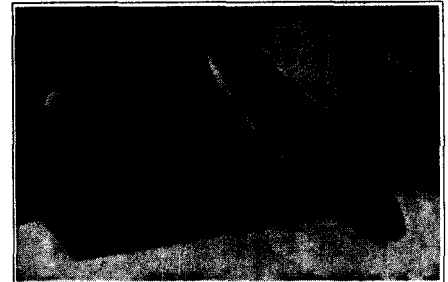

Astor 1937 Mickey Mouse

No other radio has all these features.

- Smaller than a man's felt hat yet
- 5 Valve Superhet. with Automatic Volume control.
- Metal Valves for greater efficiency.
- Interstate Reception Guaranteed without aerial or earth.
- Ferrocart Coils, station logged dial.

Price Only £12/19/6 or 3/9 per week
(In Ivory finish 12/6 extra.)

Fig.3: The bakelite 'Mickey Mouse' receiver, as shown in an advertisement appearing on the back page of *The Listener In* for April 10th 1937.

a very stylistic timber cabinet and which resembled a console in miniature. Space does not permit detailed descriptions or illustrations. There were several versions over that period.

Help required

The post war Mickeys are not designated as such in the AORSMs. They are merely described as four-valve AC mantels, or as appropriate. The exception referred to previously is but one example of possibly many variations.

In order to complete a comprehensive list of post war Mickeys, it would be appreciated if readers would send to the author, care of this magazine, their Mickey model type, cabinet type and colour, and most importantly, the valve line-up. That way a comprehensive list can be compiled and the results published.

In closing, I'd like to acknowledge the assistance I received from the library of the Historical Radio Society of Australia, in preparing this month's column.

For those who would like to read further about the Astor Mickey receivers, I can also recommend John Stokes' book *More Golden Age of Radio*, published by Craigs, 1990.

References

- (1) *The Listener In*, various issues 1937.
- (2) *Wireless Weekly*, various issues 1934 - 1937.
- (3) *Historical Radio Society of Australia Newsletter*, No 39, January 1992.
- (4) *Australian Official Radio Service Manual*, Vols 1 to 14, 1937 to 1955. ♦

RITRON EXPLORER

WARP SPEED SYSTEM
Taking you beyond where no other system has gone before...

12x SPEED CD-ROM DRIVE

\$2495
TAX EX

- IBM 6x86 - 133/166P CPU (faster than a Pentium 166 CPU)
- 2.1 Gig H.D.D.
- 32mb EDO RAM
- 12X Speed CD ROM Drive
- Latest 2 MEG DRAM Diamond Stealth 64Video Card PCI bus 64-bit
- 33.6K bps Internal Modem
- 15" Digital Monitor - 1280 x 1024 0.28mm D.P.
- * 20 hours free Internet kit
- Mini Tower Case & 200W P.S
- Genuine Microsoft Ergonomic Mouse • Magnetic Shielded Speakers
- Mouse Pad • Joystick
- Windows 95 104 keyboard
- Genuine SB Vibra 16-bit Sound Card

- Canon BJC-210 Colour Bubble Jet printer 360 x 360dpi
- Printer Cable • Win 95 on CD
- **BONUS 7 FREE CD SOFTWARE TITLES:** MS Money/ MS Encarta 96 /MS Golf/ MS CD Sampler & MS Works - which has integrated Spreadsheet, Wordprocessor Task Wizards and Font Viewer. Dangerous Creatures and Yellow & White Pages Phone Disk.
- 20 Megabytes FREE SHAREWARE GAMES.
- FREE MS Win 95 CD tutorial.
- VET Anti-Virus software installed

VIRUS CHECKED BY VET

VIRUS CHECKED BY VET

\$2895 TAX INC
CANON BJC-210 COLOUR BUBBLEJET PRINTER INCL. 1 YEAR WARRANTY ONLY

4 PARTS & LABOUR YEAR WARRANTY

FREE HOME DELIVERY & SET UP MELB. METRO ONLY. FREE 3 HOUR TRAINING COURSE IN OUR CITY STORE

16/32* WOW! MEG RAM

The ideal system for today's power-hungry users...
★ 12X Speed CD-ROM drive
★ 16/32 MEG FAST EDO RAM
*Pentium Pro's come with 32Mb of RAM
★ Latest 430 VX M.B. (256K pipeline cache/Upgradable to 200Mhz cpu) \$90 extra for 512K cache M.B. - does not apply to Pentium Pro - 430 HX M.B. \$60 extra

- ★ Diamond Stealth 64 Video Card 2MEG DRAM PCI bus 64-bit
- ★ 15" XGA Digital Mon-1280 x 1024 0.28mm D.P. Low radiation
- ★ 1.6 GIGABYTE HDD
- ★ 1.44 3.5" F.D.D.
- ★ Genuine Microsoft Ergonomic Mouse
- ★ Ritron Mouse Pad ★ Joystick
- ★ Windows 95 104 Keyboard
- ★ 16-bit Sound Card - Sound Blaster compatible ★ Magnetic Shielded Speakers ★ Windows 95 on CD (DOS & Windows 3.11 for Workgroup available on request)
- ★ 20 Hours Free Internet Access From On Australia
- ★ We install Vet OEM Antivirus software \$89 of bonus value

★ 20 Megabytes FREE SHAREWARE GAMES.

CPU CHOICES	TAX EX	TAX INC
5x86-100	\$1550	\$1720
6x86-100 120P	\$1790	\$1949
6x86-120 150P	\$1780	\$2070
6x86-133 166P	\$1870	\$2170
Pentium™ 100	\$1750	\$1999
Pentium™ 120	\$1800	\$2050
Pentium™ 133	\$1975	\$2250
Pentium™ 150	\$2020	\$2390
Pentium™ 166	\$2290	\$2595
Pentium™ Pro 150	\$2495	\$2895
Pentium™ Pro 180	\$3050	\$3530
Pentium™ Pro 200	\$3150	\$3650

Pentium Pro's come with 32Meg of Ram as standard with ATX style case and power supply. All Pentium™ Motherboards come fitted with 256K Pipeline Cache.

SPECIAL OFFER - 33.6K internal modem for only \$199 if bought with these systems. Hot Item! X18698

4 PARTS & LABOUR YEAR WARRANTY

NOW COME WITH FREE MS Windows 95 CD tutorial FREE HOME DELIVERY & SETUP. MELBOURNE METRO AREA ONLY 3 HOUR FREE TRAINING COURSE includes internet/modem training from 1st of July classes onwards. (FIRST 2 YEAR ON-SITE) MELBOURNE METRO AREA

800 dpi Scanmate Colour
Economical 800 colour handheld scanner. Incl. interface card • User's manual • PhotoFinish 3.0 • SmartPage OCR
\$189

EPSON PRINTERS SPECIALS LATEST NEW PRICES!!

	WAS	NOW
STYLUS 820	\$399	\$299
STYLUS COLOUR 200	NEW \$399	
STYLUS COLOUR Pro	\$1099	\$899
NEW Stylus 500 Colour Inkjet		\$629
NEW EP-5500W 600dpi Laser ..		\$699
NEW Stylus 1500 A2 Inkjet		\$1995

GUI Laser @ 6ppm • No ram or CPU - uses your computer

HOT SPECIALS MODEM SALE

14.4k bps Internal	\$99
14.4k bps External	\$159
28.8k bps External	\$199
28.8k bps Internal	\$169
33.6K bps Internal	\$199

PCMCIA Modem for Notebook ... \$459

HARD DRIVES Voice Coil IDE HD

Capacity	Access	Int. Ex.	Int. Inc.
540M	12ms	\$199	\$243
700M	12ms	\$205	\$249
850M	11ms	\$215	\$262
1.08GB	12ms	\$220	\$268
1.27GB	10ms	\$240	\$293
1.6GB	10ms	\$269	\$328
2.1GB IDE HD	10ms	\$340	\$415
2.5GB IDE HD	10ms	\$470	\$575
3.2GB IDE HD	10ms	\$489	\$589
1GB SCSI HD	10ms	\$470	\$575

FAST SCSI 3.5" HARD DISK DRIVES SPECIALS

2.1GB SCSI 2 HD	SPECIAL \$495	\$599
4.2GB SCSI 2 HD	SPECIAL \$1495	\$1800

SCOOP PURCHASE! BACK \$89
US Robotic IN SPORTS/STOCK!
14,400 DATA/FAX INTERNAL MODEM
Austel Approved. • 16550 UART high-speed connections • V.42/MNP 2-4 error control and V.42 bis/MNP 5 data compression

SOUND BLASTER RANGE:

X17348 SB 16 Value PnP/3D Sound	\$189
X17350 SB 32 Pnp/3D Sound	\$289
X17340 SB Value CD16/6x-15 Hex	\$429
X17354 SB Performance CD32/8x-17	\$549
X17352 SB AWE32/3D Sound	\$449
X17358 3D Blaster (VL-Bus version)	\$199
X17364 SB Discovery CD32/Hex-Speed	\$679
X17368 PCMCIA 4x CD-ROM Upgrade Kit	\$649

Quad speed CD-ROM Drive for your notebook!
X17372 Graphic Blaster Full motion/video playback 64-bit Graphics card

MS WINDOWS 95 UPGRADE
Free on this CD-ROM!
• Hover! action game, Win Resource Kit, network tools, & more • The MS Network - built in access to the online world, including the internet • PnP makes hardware installation easy

CD ROM ONLY \$89

MULTIMEDIA SPEAKERS
Amplified Stereo Speakers for your multimedia systems • Magnetically shielded with Plug "n" Play features:
120 WATT RM. RO.
• 4" woofer & 2" tweeter speakers • 220 H x 140 V x 180 D mm
• Suit PC/Macintosh
Cat No. C10181

\$89

UPGRADE NOW
10 & 16MB 100/120 CPU - FASTER THAN PENTIUM 120
LATEST TRITON M.B. UPGRADEABLE TO PENTIUM 200-256KB PIPELINE CACHE MOTHERBOARD
BOTH FOR \$349

1 MB Cirrus PCI VIDEO CARD...\$59
1 MB Trident PCI VIDEO CARD...\$69
2 MB PCI VIDEO CARD...\$84
2 SOJ CHIPS FOR IN UPGRADE...\$25

MEMORY

	1-8	28+
1M 30 pin	\$19	\$17
4M 30 pin	\$75	\$69
4M 72 pin	\$45	\$42
4M 72 pin EDO	\$46	\$44
8M 72 pin	\$79	\$76
8M 72 pin EDO	\$85	\$81
16M 72 pin	\$189	\$185
16M 72 pin EDO	\$195	\$189
32M 72 pin	\$389	\$379
32M 72 pin EDO	\$399	\$389

CD ROM DRIVES:

HEX-SPEED CD ROM DRIVE	\$140
NEW OCT-SPEED CD ROM DRIVE	\$160
NEW 12X-SPEED CD ROM DRIVE	\$270

IOMEGA ZIP DRIVE THE AFFORDABLE PERSONAL STORAGE SOLUTION

• Zip disks can hold all your stuff
• They are inexpensive, reliable & ready to help you get organized
• Use as many disks as you need

SCSI C11902 \$339

Parallel C11900 \$329

100MB ZIP DISK C11904 IBM & Macintosh in Stock!

THE ROD IRVING ELECTRONICS PTY LTD
ESTABLISHED SINCE 1977. 100% AUSTRALIAN OWNED A.C.N. 005 428 MELB CITY STORE: • 48 A BECKETT ST. CITY. • PH: (03) 9663 6151. • FAX: (03) 9639 1641
• OPEN 9AM-8PM ON FRIDAYS. SATURDAY-9AM - 5PM. SUNDAY: 10AM - 5PM

HEAD OFFICE: 56 Renver Rd Clayton, Victoria, 3168 Ph: (03) 9543 7877

Tax Exempt sales:
RITRONS WHOLESALE Ph: (03) 9543 2166 Fax: (03) 9543 2648
RIE BULLETIN BOARD Ph: (03) 9562 7877 For Specials, info & Shareware

NORTHCOTE: • 423 HIGH ST. • PH: (03) 9489 8866 • FAX: (03) 9489 8131
BOX HILL: • 1031 MAROONDAH HWY. • PH: (03) 9899 6033 • FAX: (03) 9899 0156
• OPEN 9AM-3PM ON SATURDAYS
VERMONT: • 190 ROOKS RD. • PH: (03) 9874 8888 • FAX: (03) 9874 2288
OAKLEIGH: • 240C HUNTINGDALE RD. • PH: (03) 9562 8939 • FAX: (03) 9562 8940
ADELAIDE • 241 - 243 WRIGHT ST. • PH: (08) 8211 7200 • FAX: (08) 8211 7273
SYDNEY • 74 PARAMATTA RD, STANMORE. • PH: (02) 9519 3888 • FAX: (02) 9516 5024

BLUESTAR COMPUTERS:
• 271 MAROONDAH HWY. RINGWOOD • PH: (03) 9870 1800 • FAX: (03) 9879 3027

NEW STORE
• 899 SPRINGVALE ROAD SPRINGVALE • PH: (03) 9574 6699 • FAX: (03) 9574 6633
• TRADING HOURS: MON/FRI 9AM - 5.30PM. SAT 9AM - 1PM

MAIL ORDER:
Ph: (03) 9543 7877
Fax: (03) 9543 8295

E-MAIL: rie @ ozemail.com.au
Web Site: www.ozemail.com.au/~rie

Pentium™, OverDrive™ & Intel486™ are registered trademarks of the Intel Corporation. Microsoft is a registered trademark of the Microsoft Corporation.

OUR ENTIRE KITS RANGE

PLEASE SEND ALL MAIL ORDERS TO: MAIL ORDER DEPT, ROD IRVING ELECTRONICS PTY. LTD., LOCKED BAG 620, ROSEBANK MDC, CLAYTON SOUTH, VIC 3149.

*SOON AVAILABLE

CAT	Description	R.R.P	K10340	CAMCORDER MIXER	\$29.95	K10680	BUDGET PRICED TEMPERATURE CONTROL	\$39.95
K10006	SOLAR VOLTAGE REGULATOR	\$13.95	K10345	KARAOKE BOX	\$29.95	K10685	NICAD ZAPPER	\$29.95
K10040	ETI 480 50W AMP	\$27.95	K10350	"IMPROVED" REMOTE CONTROLLER EXTENDER	\$66.45	K10690	GO/NO-GO CRYSTAL CHECKER	\$18.95
K10045	ETI 480 100W AMP	\$34.95	K10355	HIGH ENERGY IGNITION	\$48.95	K10695	CHAMP PRE-AMP	\$8.95
K10050	ETI 480 POWER SUPPLY	\$28.95	K10360	BREAKERLESS IGNITION	\$44.95	K10700	MINI/VOX VOICE OPERATED RELAY	\$13.95
K10060	BALANCED MICROPHONE AMPLIFIER	\$12.95	K10365	LOUDSPEAKER PROTECTOR	\$29.95	K10620	AUTO DISCHARGER FOR NICAD BATTERY PACKS	\$37.50
K10065	GENERAL PURPOSE AMPLIFIER	\$14.95	K10370	PORT. 12V LEAD ACID BATTERY CHARGER	\$27.95	K10630	TALKING HEADLIGHTS REMINDER	\$82.95
K10070	BALANCED INPUT DIFFERENTIAL PREAMP	\$19.95	K10375	15W 12-240V INVERTER	\$48.95	K10635	BEGINNER'S VARIABLE DUAL-RAIL POWER SUPPLY	\$39.95
K10075	FLOAT NICAD CHARGER	\$14.95	K10380	1GHz DIGITAL FREQUENCY COUNTER	\$147.95	K10640	CLIFFORD-A PESKY LITTLE ELECTRONIC CRICKET	\$15.45
K10080	TRANSISTOR TESTER	\$22.95	K10382	HI-RES MODULATOR FOR K10380	\$11.95	K10645	3-SPOT LOW DISTORTION SINEWAVE OSCILLATOR	\$48.95
K10085	300W PLAYMASTER AMP	\$119.00	K10390	LOW COST QUIZ GAME ADJUDICATOR	\$34.95	K10650	A BUDGET PRICED "SHOESTRING" STEREO AMP	\$99.95
K10095	2 TONE ALARM	\$9.95	K10395	16-SECOND MESSAGE RECORDER	\$85.95	K10655	A PHOTOGRAPHIC TIMER FOR DARKROOMS	\$64.95
K10100	1.5V TO 9V DC CONVERTER	\$11.95	K10400	WOOFER STOPPER	\$55.95	K10670	ECONOMY SURROUND SOUND DECODER	\$69.95
K10105	3 DIGIT COUNTER	\$22.95	K10405	COLOUR VIDEO FADER	\$32.95	K10675	LOW COST TRANSISTOR TESTER/MOSFET	\$29.95
K10110	ELECTRIC FENCE	\$23.95	K10415	PC-CONTROLLED EPROM PROGRAMMER	\$99.95	K10680	PC-DRIVEN ELECTROCARDIOGRAM	\$29.95
K10120	TV PATTERN GENERATOR	\$64.95	K10425	DELUXE CAR ALARM	\$55.95	K10685	IMPROVED FLEXTIMER MK2	\$22.95
K10125	UNIVERSAL POWER SUPPLY	\$12.95	K10430	REMOTE CONTROL ELECT. COCKROACH	\$99.95	K10690	LED BATTERY VOLTAGE INDICATOR	\$9.95
K10135	LED SCANNER	\$17.95	K10440	HIGH EFFICIENCY FLUORO INVERTER KIT	\$49.95	K10695	JACOB'S LADDER DISPLAY (Without Coil)	\$29.95
K10140	LOW FUEL INDICATOR FOR CAR	\$11.95	K10445	IMPROVED DECODER FOR ACS SIGNALS	\$19.95	K10695	JACOB'S LADDER DISPLAY (With Coil)	\$59.95
K10145	SCHUEFLER CAR ALARM	\$36.95	K10450	A SIMPLE LOW VOLTAGE SPEED CONTROLLER	\$13.95	K10700	FAST CHARGER FOR NICAD BATTERIES	\$18.95
K10150	12/24V LIGHT CHASER	\$21.95	K10455	PRINTER STATUS INDICATOR FOR PRINTERS	\$95.95	K10705	MODEL TRAIN CONTROL WITH SIMULATED INERTIA	\$34.45
K10160	THERMOSTATIC SWITCH FOR RADIATOR FANS	\$31.95	K10465	LOW COST 25W AMPLIFIER MODULE	\$18.95	K10710	A MORTUARY DISPLAY FOR FUEL INJECTED CARS	\$15.95
K10165	I/O ADAPTOR FOR PCs	\$59.95	K10470	VERSATILE 40V / 3A LAB POWER SUPPLY	\$106.95	K10715	GEIGER COUNTER	\$169.95
K10166	240VAC TRIAC TRIGGER (SHORT FORM)	\$59.95	K10475	CHAMP 0.5 WATT AMPLIFIER	\$9.95	K10720	ENGINE IMMOBILISER	\$33.95
K10167	240VAC TRIAC TRIGGER (FULL FORM)	\$109.95	K10475	90 SECOND MESSAGE HOLDER	\$97.95	K10725	LOW COST FIVE BAND EQUALISER	\$32.95
K10170	INPUT BUFFER & RELAY DRIVER	\$34.95	K10475	75 SECOND MESSAGE HOLDER	\$93.95	K10730	SHORTRUN Low Cost Micro-Based ESR & Low Ohms Meter	\$44.95
K10175	LOW COST SIG. TRACER/AMP	\$69.95	K10480	CONTROL STEPPER MOTORS WITH YOUR PC	\$85.95	K10735	PC DRIVEN EGO SENSOR ANALYSER	\$39.45
K10180	STEREO FM TRANSMITTER	\$33.95	K10485	EGG TESTER KIT	\$18.95	K10740	SMART DUAL 12V BATTERY CONTROLLER	\$49.95
K10185	LOW VOLTAGE CUTOFF FOR CAR/BOAT	\$22.95	K10490	LOW COST MIDI BREAK-OUT BOX	\$32.95	K10745	LOW COST RF TEST OSCILLATOR	\$139.95
K10200	IN-CIRCUIT TRANSISTOR TESTER	\$14.95	K10505	SIMPLE LED CHASER	\$19.95	K10750	STROBOSCOPIC TUNER	\$47.95
K10205	VHF POWERMATCH	\$99.95	K10510	LEVEL CROSSING DETECTOR FOR MODEL RAILWAYS	\$29.95	K10755	HIGH VOLTAGE INSULATION TESTER	\$89.95
K10215	TEMPERATURE PROBE FOR MULTIMETERS	\$19.95	K10515	SOUNDS & LIGHTS FOR LEVEL CROSSING	\$34.95	K10760	STEAM WHISTLE FOR MODEL BOATS & TRAINS	\$27.95
K10225	18V / 1AMP BENCH TOP POWER SUPPLY	\$79.95	K10520	AN IMPROVED DSO ADAPTOR FOR PCs	\$168.95	K10775	BUILD A LOW OHMS TESTER FOR YOUR DMM	\$39.95
K10295	LOW OHMS METER	\$29.95	K10530	LANOUSE UNI. STEREO PREAMP	\$19.95	K10780	LOW COST POCKET SAMPLER	\$32.95
K10300	TEMPERATURE ADAPTOR	\$24.95	K10535	LIGHT & SOUND TRIGGER	\$41.95	K10790	BUILD A VGA DIGITAL OSCILLOSCOPE	\$299.95
K10305	VOICE OPERATED RELAY	\$19.95	K10540	50W AUDIO AMPLIFIER	\$37.50	K10795	AUDIO/VIDEO TRANSMITTER	\$88.45
K10310	IGNITION KILLER	\$22.95	K10550	FAST CHARGER FOR NICAD	\$42.95	K10795	AUDIO/VIDEO RECEIVER	\$79.95
K10315	HEADPHONE AMPLIFIER	\$34.95	K10555	DUAL ELECTRONIC DICE	\$24.95	K10800	INFRARED STEREO AUDIO LINK	\$139.45
K10325	50W AUDIO AMPLIFIER	\$54.95	K10560	DIGITAL VOLTMETER FOR CARS	\$39.95	K10810	HIGH ISOLATION CURRENT ADAPTOR	\$59.95
E10325	PCB 50W AUDIO AMPLIFIER TDA1514A	\$19.95	K10565	DIGITAL TACHOMETER FOR CARS	\$49.95			
K10330	R232 FOR COMMODORE 64	\$24.95	K10570	COOLANT LEVEL ALARM	\$29.95			
K10335	RGB TO PAL ENCODER MODULE	\$49.95	K10575	STEAM TRAIN WHISTLE & DIESEL HORN SIMULATOR	\$22.45			

NEW KITS NEW KITS NEW KITS NEW KITS

HIGH ISOLATION CURRENT ADAPTOR

K10810
\$59.95



Making use of a new Hall effect sensor available from Fastron technologies, this simple project enables you to take mains current measurements of up to 10 amps in complete safety, with readings accurate to 1%. Due to the high bandwidth of the sensor used, you can also use your scope to examine and measure any waveform components from DC up to 25kHz - again in complete safety. **EA Nov '96**

INFRA-RED STEREO AUDIO LINK

K10800
\$130.45



Our new Infra-red stereo link allows you to relax in your favourite armchair and listen to stereo sound at a level that suits you. Individual volume controls allow you set the left to right balance. **SC Sept '96**

SMART DUAL 12V BATTERY CONTROLLER

K10740
\$49.95



This auxiliary battery manager takes full advantage of a dual battery setup's capabilities, by controlling when and how the "auxiliary" battery is connected to the electrical system. It's fully automatic, will cost you far less than an equivalent commercial unit, and is particularly suited to the new breed of deep-cycle auxiliary batteries. **EA JAN '96**

Video Transmitter and Receiver

K10795 Transmitter \$68.45
K10796 Receiver \$70.95

Now you can send video signals over a long distance using twisted pair cable. Use this Transmitter and Video Receiver to wire your home or business with a remote video outlet for entertainment or security. **SC Oct '96**

BUILD A VGA DIGITAL OSCILLOSCOPE

K10790
\$269.95



One of the real attractions of this digital scope, based on a VGA monitor, is that you don't have to peer at the display - it is large, bright and the different coloured traces and graticule make it easy to interpret what's happening. **SC AUG '96**

LOW COST POCKET SAMPLER

K10780
\$32.95



This compact PC-driven analog sampler requires no batteries or power supplies. It uses power from the PC, supplied to it via the parallel port. It allows you to monitor voltage changes over periods ranging from milliseconds to months. **EA AUG '96**

PC DRIVEN EGO SENSOR ANALYSER

K10735
\$39.45



With car engine management systems becoming more and more sophisticated (and complex), it is getting increasingly difficult to find out what's happening "under the hood". This low cost analyser, combined with any IBM PC and some special software can provide a large amount of information on your car's performance. **EA JAN '96**

LOW COST RF TEST OSCILLATOR

K10755
\$139.95



A low cost RF oscillator design that is suitable for checking and aligning HF radios and other equipment operating between 350kHz and 30MHz. Features digital frequency readout, the ability to provide either CW or modulated output and also audio and 1 MHz reference signals from auxiliary outputs at the rear. **EA MAY '96**

PC-DRIVEN ELECTROCARDIOGRAM

K10680
\$29.95



This simple project will let you take your own electrocardiogram, and display it on a PC. With the software supplied, you can read, display, save to disk and print the electrical waveform generated by your own heart (or anyone else's). Powered by a 9V battery and electrically isolated from the computer, the PC-ECG is a safe, low cost way to monitor the electrical activity of the heart. **EA JULY '95**

DIGITAL MULTIMETER

WITH CONTINUITY BUZZER & TEMPERATURE K TYPE PROBE.

Ideal for technicians with full 3 1/2 digit LCD readout & continuity buzzer. 9V alkaline battery supplied. Expected life of battery is 200 hours.

K13075
\$29.95

Specifications:
DC Voltage: 200mV/2/20/200/1000V
Basic accuracy: +/-0.5%
Input Impedance: 1M
Maximum output: 1000V DC
AC Voltage: 200/750V
DC current: 200A/2000A/20mA/200mA/10A
Resistance: 200Ω/2000Ω/20kΩ/200kΩ/2M
LCD Display: 15 x 46mm
Outer case size: 125 x 77 x 28mm

1-9 **\$29.95** 10+ **\$24.95**

DIGITAL MULTIMETER

The ideal meter for technicians with a full 3 1/2 digit LCD readout. Requires a 9V battery either alkaline or carbon. Expected life of carbon battery is 100 hours and 200 for the alkaline.

\$19.95

Specifications:
DC Voltage: 200mV/2/20/200/1000V
Basic accuracy: +/-0.5%
Input Imped: 1M
Maximum Input: 1000V DC
AC Voltage: 200/750V
DC current: 200A/2000A/20mA/200mA/10A
Resistance: 200Ω/2000Ω/20kΩ/200kΩ/2M
LCD Display: 15 x 46mm
Dimension: 70 x 126 x 24mm

ALL NEW ELECTRONICS COMPONENTS

*As used in kits published in the monthly magazines indicated

Cat No. T90794 **1-9** **10+**
BS-170 60V 300mA TO-92 MOSFET **\$1.95** **\$1.75**
*K10800-Infrared Red Stereo Audio Link/ Silicon Chip Sept'96

Cat No. U20747 **\$12.95** **\$10.95**
MAX-436CPD
*K10796- Video Receiver/ Silicon Chip Oct'96

Cat No. T90291 **\$9.95** **\$8.95**
BF-998 DUAL GATE TETRODE MOSFET
*K10755- Low Cost RF Test Oscillator/ Electronic Australia May'96

Cat No. R14110 **\$19.95** **\$17.95**
10K 10-TURN POTENTIOMETER
*K10755- Low Cost RF Test Oscillator/ Electronic Australia May'96

Cat No. Z10172 **\$1.95** **\$1.75**
100mA CQY89 Infrared Red Diode
*K10800-Infrared Red Stereo Audio Link/ Silicon Chip Sept'96

Cat No. U20746 **\$9.95** **\$8.95**
High Speed Video Transconductor Transmitter
*K10795- Video Transmitter/ Silicon Chip Oct'96

SyJET 1.3 GB - massive storage!

Removable Cartridge Hard Drive from SyQuest

SyJET is the ideal mass storage upgrade. It provides unlimited, affordable storage space. Just add additional cartridges as your storage needs grow.

Features & Benefits

- Vertical/horizontal operation
- Automatic SCSI termination with over-ride switch
- Full 7 position SCSI address switch
- Single button cartridge ejection
- New ergonomic drive and cartridge design

DRIVES OPTIONS AVAILABLE:

	TAX INC	TAX EX
External SCSI - C10844	\$899	\$720
Internal SCSI - C10842	\$825	\$676
Parallel Port - C10846	\$899	\$720
Internal IDE - C10848	\$825	\$676
Cartridges - C10852	\$195	\$160

Accessories

- Extra cartridges
- Carrying case
- International power supplies
- SCSI host adaptor
- Parallel port adapter kit
- SCSI cables

Great For:

- Multimedia development
- Desktop publishing
- Video editing
- Document imaging
- Audio management
- Network disaster recovery
- Storage for all your computing needs

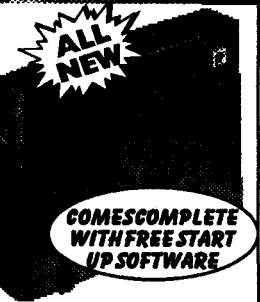

Specifications

- Av. Seek Time: <11msec
- Rotational Speed: 5400RPM
- Data Transfer Rate:
 - Sustained - 4 to 7MB/sec
 - SCSI Burst - 10MB/sec
- EIDE PIO mode 4 - 16.7MB/sec
- Buffer: 256KBytes

ezflyer 230MB Removable Cartridge Hard Drive

The EZFlyer 230 from SyQuest is one of the most solidly built, easy to use, small & lightweight drives available today. It combines the flexibility of a data cartridge three & a half inches square with blazing speed of hard drive technology. It is a hard drive that never fills up. When users need more space, they simply add more cartridges.

Can Be Used For:

- Desktop Publishing
- Pre-Press • Internet
- Photography • Multimedia
- Imaging • Video • Audio



Capacity: 230MB
Av. Seek Time: 13.5msec
Transfer Rate: SCSI - upto 1.25MB/Sec
Parallel Port - 1.4 to 2.4MB/Sec

External SCSI C-10830 \$595
External Parallel Port - C10834 ... \$595
Cartridges - C10836 \$69

INTERNAL POWER ADAPTOR



SAVE ON BATTERIES FOR YOUR SPEAKERS

An alternative device to replace a DC plug pack or batteries for powered PC speakers- the Internal Power Adaptor (IPA) fits into a free slot at the back of a computer & draws power from the floppy drive connector. Polarity & voltage are set using jumpers - the regulator can be set from 3.0V to 12V. A cable is then run from the IPA to the device, plugging in where a power pack would. (Before installing the IPA, you must know and set correctly the polarity & voltage required for the device you want to power.) The IPA can be used with any external device that draws DC- not AC- power, or to replace the batteries in PC speakers.

LATEST TECHNOLOGY 12X SPEED FROM LITEON - 12X CD-ROM DRIVE

Created by the very same company that supplied the components for major CD-ROM drives manufacturers, comes a Super Fast & Quiet 12X Speed CD-ROM drive! You can be assured of high quality and performance value.

- ATAPI/E-IDE CD-ROM Drive
- 1800 KB/Sec Data Transfer Rate
- Fully PnP & Windows 95 Ready
- Access All Format CD-ROM Titles
- Fast access time
- Low CPU Utilization
- Auto Switch Speed
- Emergency Manual Eject
- Power Saving Function
- DCS, Wn 3.X/95/NT, OS/2 Warp Compatible



LITEON
1800 KB/Sec Data Transfer Rate
INCREASE PRODUCTIVITY AS NEVER BEFORE POSSIBLE!
CI1943
\$279

5 YEAR RAM WARRANTY

Upgrade your system memory with us* and get a 5 Year Warranty, including a free copy of OEM Vet Anti Virus software **CHEAP BUT WORTHWHILE "INSURANCE"**

\$25 Installation fee

Installing SIMM modules incorrectly can destroy the RAM or damage the SIMM socket and cause many other problems. RAM is a static sensitive device, which should be installed by a skilled person.

OEM Vet Anti-Virus Software is normally worth \$89

*Valid only if our technician install the SIMM RAM module/s at \$25 per system

SOUND BLASTER 16 Starter



Be it surfing the Net or playing your favourite games, you'll hear the full excitement of Sound Blaster 16. Upgrade with Creative Wave Blaster wave-table functionality. Sound Blaster is the PC audio standard, hear the difference! • Surf & Communicate with Sound blaster INTERNETed™ Audio • 16-bit, CD-quality Stereo Recording and Playback • 20-Voice Stereo Music Synthesizer • Supported by Thousands of Multimedia Applications • Wave Blaster Upgrade Connector for Wave-Table Synthesis

X17348
\$199

CIGARETTE LIGHTER SOCKET FLASHING LED



Flashing 12VDC LED alarm indicator that plugs directly into your cigarette lighter socket.

- Ideal thief deterrent.

\$14043
\$4.95

ROD IRVING ELECTRONICS

MAIL ORDER COUPON

SEND TO: **FREE POST** **ROD IRVING ELECTRONICS P/L**
 REPLY PAID 8888, BAG 620, CLAYTON SOUTH, 3169.
 TOLL FREE: 1-800 33 5757

Please send me the following items:
 IF NOT ENOUGH SPACE PLEASE ATTACH SEPARATE LIST

Item 1.
 Item 2.
 Item 3.

Name:
 Address:
 P/Code:
 Phone: Date:

B/CARD VISA CARD AMEX DINERS **TOTALS**.....

Signature: Exp. Date:

NORMAL PACKAGE & POSTAGE:

\$1-\$9.95	\$3.00	\$50-\$99.95	\$6.00
\$10-\$24.95	\$3.50	\$100-\$199	\$7.00
\$25-\$49.95	\$4.00	\$200+	FREE

The rates shown here apply to Australia. Post Surface Mail within Australia only. Orders above 5kg or containing fragile parts will be sent by road freight at our discretion and charged to you. EANP1196

COMPUTER CARDS - HUGE RANGE!!

CAT NO.	DESCRIPTIONS	PRICE
X18075	1Meg 16bit VGA	\$159
X18004	IDE/SPG	\$39
X18005	High Speed I/O	\$59.95
X17072	ADAPTEC SCSI 16bit 1522A	\$189
X18165	16bit ETHERNET RJ45 + BNC	\$49
X18169	16bit NE2000+	\$119
X15810	Ethernet 5-port 10 base T hub	\$169.95
X18159	Ethernet 10 base T Connector	\$119
X18190	Printer 2-Port Sict Lpt 1-2 Card	\$39
X18191	Printer Port Sict Lpt 1-2-3 Card	\$49
X18141	High Speed Serial Card 1-Port 16550	\$49.95
X18041	High Speed Serial Card 2-Port 16550A/FN	\$89
X18143	High Speed Serial Card 4-Port 16550A/FN	\$189
X18019	Dual Speed 16650 UARTS modem chip	\$99
X18019	Games Card	\$19
C14260	SMART GAMES Cont	\$39.95
X18514	FULL -DUPLEX ISA ETHERNET	\$99
X18171	Ethernet Intel PnP BNC/RJ45 16-bit	\$199
	*Ethernet III Rev B Coax (BNC, AUJ)	\$250
X17396	OEM SBlaster PnP Vibra 16 with IDE interface	\$109
X17394	OEM SBlaster PnP Vibra 16 without IDE interface	\$89
X17398	OEM SBlaster PnP Vibra 32 Sound Card	\$209
X17250	ESS 16 Bit Sound Card	\$55
	SB OEM products do not have manual or connection cables	
*AVAILABLE TO ORDER		
X18003	ENHANCED VESA MULTI I/O	\$49
X18050	VESA IDE ENHANCED MULTI I/O - PROMISE TECH	\$129
X18195	VESA VGA CARD	\$149
PCI		
X17900	PCI 1M VGA TRIDENT 9440	\$79
X18206	PCI VGA DIAMOND STEALTH 1MEG DRAM	\$149
X18207	PCI VGA DIAMOND STEALTH 2MEG DRAM	\$179
X18208	PCI VGA DIAMOND STEALTH 2MEG VRAM	\$499
X18209	PCI VGA DIAMOND STEALTH 4MEG VRAM	\$899
X18218	NEW OEM PCI Diamond Stealth 3D Video 2MEG	\$229
X18483	PCI VGA CIRRUSS LOGIC 5430 1MEG	\$75
X18195	PCI VGA 64-BIT CIRRUSS LOGIC 5436	\$199
X18510	FULL -DUPLEX PCI ETHERNET	\$99
X18210	2MB WRAM GrafixStar 700 Video	\$499
X17073	PCI SCSI MASTER ADAPTEC 2940	\$595
X18212	PCI MGA MILLENNIUM 2MB WRAM	\$526
X18214	PCI MGA MILLENNIUM 4MB WRAM	\$795
X18216	PCI MGA MILLENNIUM 8MB WRAM	\$1399
X18510	PCI Ethernet BNC/RJ45	\$149
	*Ethernet III PCI Twisted Pair (RJ45)	\$185
	*Ethernet III Combo Pack (BNC, AUJ)	\$280
*AVAILABLE TO ORDER		



INFORMATION CENTRE

by PETER PHILLIPS

Keeping you informed...

We start this month with a David and Goliath story, in which I challenge Goliath (an unnamed manufacturer) to fix David's (my) computer problem. Next month I'll tell you who the manufacturer is, the product model and how everything turned out. The manufacturer in question has already been sent a copy of our opening story and we are all hoping for a happy ending. In addition we're giving advice on how to dispose of ammonium persulphate, having a discussion on appliance mains wiring and a reader confirms that there *is* anti-gravity.

I'm opening the column this month by describing an interesting — if rather frustrating — experience. It's to do with computers and computer software, and I suspect it's unlikely that you'll read about such a story very often. I'm writing about this experience as part of our role to keep you informed. The story goes like this...

Because a computer is a basic tool for my living, and because I tend to work in a variety of organisations, I recently decided to purchase a top-of-the-line laptop computer and docking station, to replace my desktop system. I won't at this stage mention the brand, as the problems I'm having have yet to be fixed. However, I chose a very well known brand, on the assumption that a 'brand' is better than a nameless clone.

The computer came with Windows 95 pre-installed, and I purchased some Win 95 software as part of the deal. All up I paid around \$14,000 — a lot of money, but worth it if my productivity could be increased. Unfortunately, my productivity has dropped to almost zero, and it's lucky I can even write this column.

First, the price. The first shock came when I learnt that the insurance deal advertised by the manufacturer was incorrect. Instead of the advertised 4% of cost price, it was 7%, quite a lot more. Being a leasing agreement, insurance was essential, and I've yet to resolve the issue. Next I discovered that almost within a week of having bought the machine, its list price was reduced by around \$1400. OK, this sort of thing happens, but to be a week late in a price cut is rather unsettling, particularly when I had lost nearly two weeks of work as a result of the problems I was now experiencing.

Now to the system itself. The dealer did most of the initial setting up, and demonstrated it all to me as a fully functioning unit. Back in my office, I transferred files from the old computer and finally changed over to the new system. A heart stopping moment, as there was now no turning back...

Unfortunately, I needed one more thing: a second serial port. The dealer supplied me with a serial/parallel card to replace the parallel card he had installed, and as I've done this sort of thing many times before, I decided to install it myself. However, it was to take some three days before I could even get the system to boot — caused, as it turned out, by some sort of hardware conflict. I began to suspect Windows 95 and its much vaunted plug 'n play (PnP) system.

Finally I got the system to boot, only to find all kinds of hardware problems. Of most importance was the fact that I could now no longer use my scanner, as the system did not recognise the inbuilt SCSI port in the docking station. I contacted the manufacturer's help service, and after about two hours, when the technician finally had to leave, I was left with a system that was worse than before. I persevered, and for reasons I can't explain, suddenly the system and the scanner worked. Great. I did the job that required the scanner, at last earning some income.

I then returned to the serial card, as I needed it for the modem. I never succeeded installing it, despite spending about six hours trying. Finally I gave up on it and asked the dealer to supply a card advertised as being PnP compatible.

At this stage, the system was sort of

functional, until I installed a basic piece of software sold in a pack marked as being Win 95 compatible. Another two days were to pass, before I got it all going again, only to find the scanner no longer worked, and that I had to remove the Zip drive to get the system to boot. As well, the device manager in Windows 95 was showing a number of devices to be 'unknown', including the inbuilt IRDA port.

So, back to the manufacturer. I pleaded for someone to come out to my office to help me, as the thought of lugging everything (including scanner, etc., etc) some 60kms to the help desk was almost too much to contemplate. To no avail however, and it appears that journey now has to be my next step.

So what is wrong? I first blamed Win 95, and decided to contact Microsoft. Being a Communicate member, I could at least get past the 'firewall' phone system, although with great difficulty. Finally a most helpful supervisor (and *EA* reader, as it turned out) took pity on me and actually listened to my story, rather than assuming I was a computer novice. He agreed that I was not causing the problem, and gave me lots of evidence that neither was Win 95. He could do nothing except sympathise. In any case, thanks Adam!

It now seems likely that the fault lies either in the BIOS supplied with the computer, some incompatibility with the computer hardware and Windows 95, or a combination of both. There have been two BIOS upgrades since May (I'm writing this in August), and a simple solution would be to upgrade the BIOS. I was advised to do this by the manufacturer's help desk, and was

told where I could find and download the two necessary files. Fortunately I had to contact the BBS sysop to ask why one of the essential files was not there. He advised me not to even think about doing this upgrade myself, as a failure would render my computer useless, and the last time this occurred the hapless owner had to spend \$8000 for a new motherboard. Perhaps someone should tell the help desk!

To date I have lost a lot of work, money and time. As well, I've only mentioned *some* of the problems I've had with this expensive, state-of-the-art machine. The manufacturer will only help me on its terms, not mine, even though I've spent so much money, and that it appears the fault lies with the product itself. So much for buying a brand name! I'll keep you informed.

Appliance mains wiring

Our first letter defends the way a particular European manufacturer wires the mains supply to its equipment. This issue was first raised by Peter Van der Wedden (Bull Creek, WA) in the July column, in which Peter suggested the wiring to be potentially unsafe. I agreed with Peter, and made a few suggestions on how to correct the problem. The manufacturer's wiring is shown in Fig.1, where you can see the fuse and mains switch are on either side of the primary of the mains transformer.

According to Peter, if the IEC lead supplied with the equipment was replaced with a standard IEC lead, the active and neutral would be reversed, putting the active to the switch and the neutral to the fuse. As Peter pointed out, if the fuse blew, and if the switch was turned on, this would leave the active connected to the transformer. Apart from potential danger to a technician working on the equipment, this wiring could cause further damage to the equipment should there be an earth fault in the transformer. With that background, here's the new letter:

Your correspondent seems to be concerned about the polarity of IEC power leads. Although the earth pin is specified, I'm not aware of any standard that specifies the active and neutral pins of an IEC lead. This is because continental European (and US) mains sockets are symmetrical, which means the plug can be inserted with either polarity, unlike the polarised British and Australian mains plugs. For this reason, the design of mains equipment must allow either lead to be the active.

The next question raised by your correspondent concerns using a single-pole

mains switch, and how it and the fuse should be wired. Since the equipment described by the correspondent was made in the '80s, it most likely has a short circuit proof transformer. This type of transformer has a PTC thermistor or thermal fuse located close to the core and connected in series with the primary. It will go open circuit when the transformer overheats. Such transformers are also usually encapsulated (so they fulfil the requirements of second class insulation), and therefore have no means of developing an earth fault.

The primary and secondary windings are wound on a plastic former that has a high melting temperature. This former gives full isolation between the primary, secondary and the core. So the only way the primary could contact the core would be under extremely high temperature conditions, when the protective device inside the winding would be open circuit. Even if this device failed (highly unlikely), the fuse would blow, due to the high fault current.

It's accepted practice to use a single pole mains switch in earthed equipment, as the earth connection will prevent accessible parts becoming live. A double insulated appliance should have a double pole switch. The logic behind fitting the switch and fuse on either side of the transformer is that when the fuse blows, it will isolate one side of the transformer. Should this happen, it's most likely the user will turn off the switch, thereby isolating the other side of the transformer.

So, what is the safest way to wire such equipment? This depends on many factors, such as the type of transformer in the equipment, the operating environment, and the user's knowledge of electricity. Some types of transformers and switches are unsafe, regardless of how they are wired. Equally dangerous are

those people with little or no knowledge of electricity, but who insist they know what they are doing.

In normal circumstances and with mains-carrying components carrying any of the European electrical certification signs (VDE, OVE, S, E, KemaKeur etc), the circuit for the equipment as given by your correspondent is safe. If uncertified components are used, it might be necessary to use a double pole mains switch and perhaps a second fuse so both mains leads are fused. As well, the core of the mains transformer should be earthed. (Marcin Frankowski, Warszawa, Poland, currently Wellington, NZ)

I didn't mention that Marcin holds a Polish electrical permit up to 1kV, a qualification recognised across Europe. Thanks Marcin, for your comments. I agree that if the equipment has the type of transformer you describe, the wiring is safe. My comments were based on the possibility of an earth fault, which is not possible (one trusts) in a transformer made to the specifications detailed in Marcin's letter. And now here's another short letter on this topic.

GPO polarisation

In my reply to the original letter from Peter, I made the point that, as far as I knew, there was no legal requirement concerning which pin was active in a power outlet. I'm wrong, as it turns out; there is a legal requirement.

In response to your reply in July concerning the polarity of socket outlets, I have enclosed the relevant section of the SAA Wiring Rules, which clearly outlines the requirements. Keep up the good work. (Terry Ives, Burnie, Tas)

The extract Terry sent reads:

AS 3000—1991. 4.14.8 Polarization. GPOs, 10A, 15A and 20A socket-outlets designed to accommodate flat-pin plugs

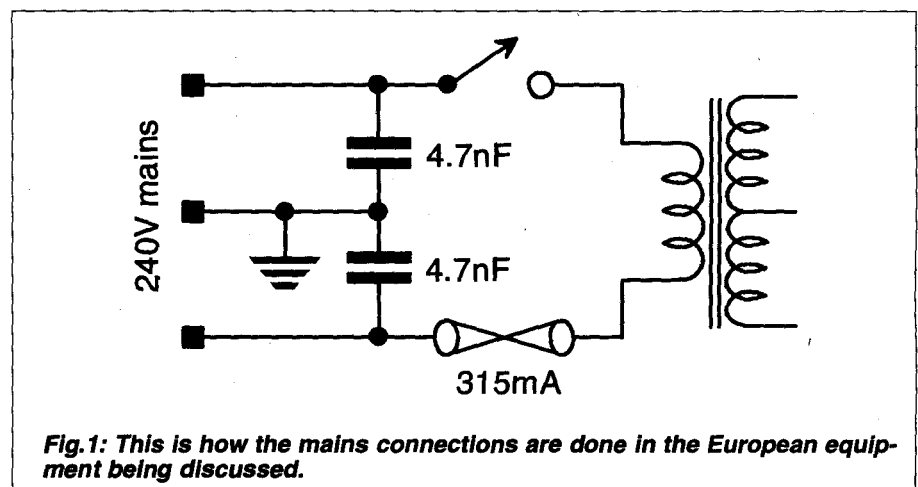

Fig.1: This is how the mains connections are done in the European equipment being discussed.

in accordance with the dimensions given in Figure 2.1(a) of AS 3112 shall be connected so that when viewed from the front of the outlet the order of connection shall be Earth, Active, Neutral in a clockwise direction. Note: it is recommended that the above sequence of connection be used for all other socket-outlets if applicable.

I happily stand corrected about this. However, I wonder about the note, which only makes a recommendation concerning all other socket-outlets. To me, 'other socket-outlets' means any outlet other than a 10, 15 or 20A GPO. A GPO, as I understand it, is a power outlet hardwired to the mains supply. So, excluded from this legal requirement are extension leads, power boards, power outlets on the back of electrical equipment etc. Quite an omission, I think you'll agree.

There is anti-gravity!

The next letter speaks for itself. It's prompted by the discussion in recent issues about anti-gravity and its possible relationship to superconductance.

Regarding recent correspondence on anti-gravity, you may be interested in the following. Anti-gravity phenomena is widespread in nature and manifests itself by certain plants growing vertically against the force of gravity. These plants are reacting to the gravitational force to which they are subjected. One example of this is a common palm tree, which often grows absolutely vertically to over 20 metres.

In 1959 I visited the Technological Museum in Paris where there was an exhibit illustrating the effect of gravity on plants. The display consisted of a grass garden plot two metres in diameter mounted horizontally on a wheel which was driven by a motor at 30rpm.

The speed was such that the grass at the outside edge of the plot tilted inwards towards the centre of rotation at an angle of 45°, while closer to the centre, it leaned progressively less. Calculations show that under these conditions the resultant force arising from the centrifugal force due to rotation and the natural gravitational force is 45° to the horizontal at the perimeter of the plot.

On a more esoteric note, current scientific literature on quantum theory and sub-atomic physics indicates that repulsive forces (anti-gravity) exist between objects in a negative vacuum,

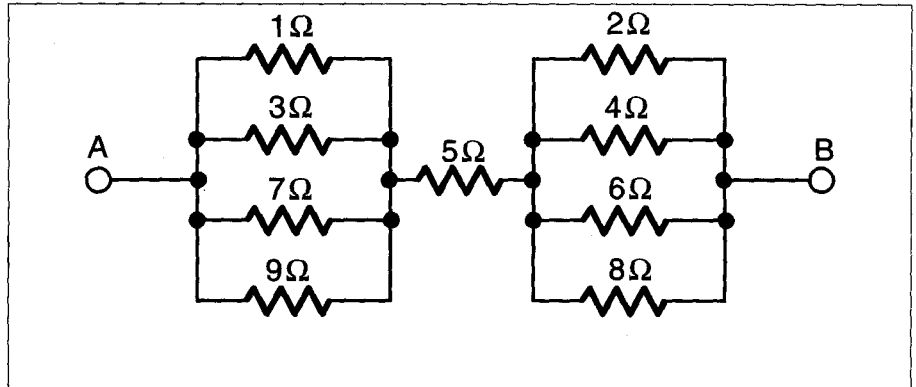

Fig.2: Without using a calculator, find the resistance between points A and B.

whatever that means. I don't profess to understand the mechanism, although I have a keen interest in the subject. (Stanley Ash, Forestville, NSW)

Thank you Stanley, for being a lone voice in support of the concept of anti-gravity. I'm sure that in years to come there'll be findings to prove that anti-gravity exists, but I guess we've a way to go yet. And like you, I'd love to know what a 'negative vacuum' is.

Ammonium persulphate

The following is part of rather long letter that asks a number of questions. I've separated this one as I think it deserves to stand out as an issue, rather than one of many.

Now that DSE stock it, I have switched from ferric chloride as a PCB etchant to ammonium persulphate. My first try with it was a disaster, as it etched everything, including the tracks. I use Artline pens to make the pattern, as they work just as well as Dalo pens, and are cheaper. This system always worked with ferric chloride, but this new stuff seems to be more fierce.

DSE suggest a temperature of 75°C, but I find this too high. Instead I mix it with warm water from a tap, then use an electric heater to get the mixture to around 70°C. This results in a board being etched in around one minute. A higher temperature causes the etchant to remove everything. Now that I have the knack of using it, I prefer this chemical to ferric chloride. As well, although DSE say a mixed solution should not be stored, I find I can use a mixture quite successfully the next day for another PCB.

My question however is about how to dispose of this chemical. I current-

ly pour it down my workshop sink, which sends it to a soak well, not the sewage or drains. Do you think it would be better to pour it down the toilet? I also find that if I leave the etchant for a few days, it will form into crystals, perhaps of a different chemical caused by the chemical reaction between it and the copper.

DSE don't make any mention of the fumes. Are they dangerous? What precautions should I take? (Stewart Farrant, Yangebup, WA)

We have used ammonium persulphate as an etchant for some time in our development laboratory, and agree it's better than ferric chloride. Being part of a large organisation, we can dispose of it through the company's chemical disposal system, so we have never really examined how hobbyists and home users should treat this chemical, and dispose of it.

When I received this letter, I read the information DSE supply with the chemical, noting that disposal methods are not mentioned. So I rang the NSW Environmental Protection Authority (EPA) to find out more. They were most helpful, and made the following recommendations:

First, the chemical is actually called ammonium peroxodisulphate. And yes, it is classified by the NSW EPA as a hazardous chemical. This may not apply in all States, but it's a good guess it does. The NSW EPA does not recommend the chemical be poured down the sink, or the toilet, but that it be collected by or sent to a chemical collection station, called a transfer station. Here you simply take the chemical to the station, who then arrange for its disposal.

In Sydney, and probably most capi-

tal cities, an annual service is provided for this sort of thing. For information about the Sydney service, phone (02) 9934 7000. In other parts of Australia, the EPA advise you to contact your local Council. The point is, although a home user might be dealing with small quantities of the chemical, collectively it amounts to a large quantity. The sewage system cannot deal with it, so it simply ends up in our rivers or the ocean. In rivers it will contribute to the development of the dreaded blue-green algae we read so much about.

So Stewart, don't pour it down the sink, or the toilet. Instead contact your local Council, for details of its chemical disposal system.

A hazardous chemical, such as this one, means it must not be ingested, injected, inhaled and so on. The damage it will cause depends on many factors, but clearly you should take care. I was not able to find out just how hazardous the chemical is, but we recommend all readers treat the chemical as you would any poison. Therefore, don't inhale its vapours, don't dip your hands in it or let it contact you. Treat it carefully. Thank you, Stewart, for asking this question, as it's given us an opportunity to address an important issue.

Now to a lighter vein...

July's What??

As I said last month, I received a lot of letters about the July What?? question, but none quite like this one:

At last you've put up a S'What?? question that suits my vintage — 50 this month.

I'd say the length of the line AB is 1.5 whatever, which just happens to equal the radius of the circle. This is based on one of the theorems (theora) of Euclid or someone else, that says that the length of one diagonal of a rectangle is pretty much the same as the other.

The above 'flash of insight' (or was it just arcing and sparking) came after about 15 minutes of hard mental arithmetic using another of Euclid's (or some other Greek's, doesn't madda) theorem that says that the height of the shown rectangle squared equals the length from the left extremity of the circle to point B multiplied by the distance from B to the right extremity.

In fact, it was more like dental arithmetic — that's a problem you can chew over in your mind and really get your teeth into. If you can handle only four bits at a time, then you're probably just a nibbler. Let's not quibble over a nibble, double or nothing would

make it quite a byte. (My word Mr Wolf, you seem to have a double byte there.) I wonder why humans have 32 teeth; is there a message there somewhere? Having your wisdom teeth in good working order also helps a lot!

I use this theorem from time to time to determine the radius of curvature of one thing or another.

Let h = height of the rectangle and r = radius of the circle, then: $h^2 = (r+1) \times (0.5) = (1.5+1) \times (0.5) = (2.5) \times (0.5) = (5/2) \times (1/2) = 5/4$ and $h = (5/4)^{1/2}$ then, by Pythagoras, $AB = (((5/4)^{1/2})^2 + (1)^2)^{1/2} = (5/4+1)^{1/2} = (9/4)^{1/2} = 3/2 = 1.5$

Boy, I'm so glad that mathematical short circuits reduce problems while electrical short circuits usually create problems. Maybe Mr P. Steel has a short-circuited brain? If his first name is Peter, he probably does! I just knew that all that geometrical swat back then (35 years ago) would contribute to my 15 seconds of fame.

Histoerical note: Did you know that the word radius is derived from the Roman expression for the radial beams of divine light emanating from behind the head of the Egyptian sun god, Ra? Ra Deus was eventually contracted and corrupted to Radius. If you believe that, you'll... (Peter (The Ponderous) Andjelkovic, Corio, Vic)

I could not have given a more understandable and straightforward solution to this problem, Peter. But then perhaps I also have a short-circuited brain. It sometimes feels like it!

Variable speed CDP

Regular readers are going to exclaim "not again", as only last year we dealt extensively with varying the speed of a CD player. But this letter has a new twist:

Can you tell me what types of CD players there are that have the capability to vary the tempo (bars per minute) of the music?

And, can you tell me what I would need to allow my 386SX computer do the same job, and also to allow parts of different tracks to be amalgamated. The only disadvantage is that it would need to be recorded on tape. (Eric Poole, Armadale, Vic)

Regarding variable speed CD players Eric, I can only refer you to previous issues of EA. That is: May '95 (p95), July '95 (p94) and September '95 (p88). We discussed this issue at length, so you should find the information you seek.

As for using a computer, about the only way I can see a 386SX doing this sort of thing is through MIDI. Here the music is played into the computer

from a MIDI keyboard, or entered manually as MIDI data. You then need a MIDI sound generator (plug in card or external) connected to the computer, to recreate the selected instruments. Most MIDI programs let you adjust the tempo, the pitch and so on. Doing it this way would not require a tape, unless you wanted to record the final result.

What??

We've had quite a few rather tricky What?? questions lately, so I thought it time to get back to basics. The question I have for you is one I devised. All you have to do is calculate the resistance between points A and B in Fig.2. Oh yes, you're not allowed to use a calculator, it should take around two minutes, and if you're really smart, you can do it mentally. Good luck!

Answer to October's What?

6.592

If you pick a component from a drawer marked RESISTORS, you'll either get a resistor or a capacitor, which won't help you, as the drawer might contain both components. The same thing applies to the drawer marked CAPACITORS. But selecting a component from the one marked RESISTORS AND CAPACITORS will help considerably. Let's say you get a capacitor from this drawer. Because you know it's labelled incorrectly it must only contain capacitors and should therefore be labelled CAPACITORS.

But what about the other two drawers? Because you know all drawers are wrongly labelled, the drawer that was incorrectly labelled as CAPACITORS must contain either resistors or both components. But the drawer marked RESISTORS is also wrongly labelled so it must contain resistors and capacitors, and the drawer marked CAPACITORS has both components. ♦

EA'S READER SERVICE BBS

As part of our service to readers, Electronic Australia operates a Bulletin Board System (BBS) which allows you to exchange information or seek information on a variety of topics and topics of discussion. You can also leave contributions to some of our columns.

The BBS is available on a 24 hour basis. For more information on the BBS, call 0353 027 1234 or write to: EA, PO Box 111, Sydney NSW 1585.

MARKET PLACE



FOR SALE

A real bargain: Riston type copper clad laminate. Develop cold, no toxic fumes, easy to use. Excellent results. Single sided 610 x 304 \$35; 305 x 304 \$17.50; 152 x 305 \$9.95; 152 x 152 \$6.50. 2 litre developer mix, worth \$2.50, free for this month. Add sales tax where applicable. Delivery \$6.00. Money back guarantee. Phone (02) 9743 9235. FAX: (02) 9644 2862.

Educational Electronic Kits: Best prices. Easy to build. Full details. Latest technology. LESSON PLANS FOR TEACHERS--See our web page. Send \$2 stamp for catalogue and price list to: DIY Electronics, 22 McGregor St, Numurkah, VIC, 3636. Ph/FAX 058 621915. Or Email laurie.c@cnl.com.au and let us send details. Go WWW: <http://www.cnl.com.au/~laurie.c> or BBS 058 623303. Download details free anytime.

Satellite Dishes: International reception of Intelsat, Panamsat, Gorizont, Rimsat. Warehouse sale - 4.6m Dish & pole \$1499, LNB \$50, feed \$75. All accessories available. Videosat, 2/28 Salisbury Rd. Hornsby. (02) 9482 3100 8.30-5.00 M-F.

Your products on the Internet: There are 25 million users on Internet waiting to read about your product. To have your own Web page call Andrew Mortlock on (02) 9411 4329 or email atm@zed.com.au

Homemade Generator-plans
URL: <http://www.onekw.co.nz/>

Rain Brain 8 Station Sprinkler Kit: Z8 smart temp sensor, LED display, RS232 to PC. Uses 1 to 8 Dallas DS1820. Call Mantis Micro Products, 38 Garnet St. Niddrie, 3042 P/F/A (03) 9337 1917
mantismp@c031.aone.net.au

68HC705 Development System: Oztechnics, PO Box 38, Illawong NSW 2234, Phone (02) 9541 0310, Fax (02)9541 0734,
<http://www.oztechnics.com.au/>
Video Camera Modules from \$99: Tiny 32x32x15mm. Low Light & Infra Red Sensitive. A.S. & S. phone 09 349 9413

460 TVL High Resolution Video: Camera Modules fr \$139. IR Low Light Sensitive. 0.08 lux. ph 09 349 9413

Mini Cube Cameras: Robust Alum Case with Lens. from \$109. 42x47x42. 12 VDC. A. S. & S. 09 349 9413 fax 09 344 5905

Video Cameras: C/CS Mount from \$99. A. S. & S. 09 349 9413

Micro C Mount Cameras: from \$169. A. S. & S. 09 349 9413

Dome Ceiling Cameras: from \$149. A. S. & S. fax 09 344 5905

Colour Dome Cameras: from \$439. A. S. & S. phone 09 349 9413

Colour C/CS Mount Cameras: from \$399. A. S. & S. phone 09 349 9413

Clearance Sale New & Used Elect. Equipment 09 349 9413

D.I.Y. \$549 CCTV Sets. 10 Inch 4 Ch Plug-In. Look. Listen. Speak. Record. Playback. 09 349 9413 fax 09 344 5905

Auto CCTV Switchers: fr \$169. 4/8 Ch. A. S. & S. 09 349 9413

Digital Quad Screen Processors: from \$399. Alarm In/Outputs. Freeze. 4 pix on 1 screen. phone 09 349 9413

1024 x 512 Hi-Resolution Quads from \$699. Zoom. Freeze. Time. date. Title. Alarm I/O. A. S. & S. fax 09 344 5905

Hi Output Infra-Red Leds 50mW 50/\$25. phone 09 349 9413

Colour Video Camera Modules from \$399. 420 TVL. 3.6mm Lens. 12 VDC. Auto Shutter. Small. Light. Phone 09 349 9413

TV RF Modulator - Mixer - Antenna Amplifier. \$30 Use with Video Cameras & Microphones. Video & Audio Inputs. VCR Like Installation. Tune on VCRs & TVs. Mixes with & Boosts TV Signals. A. S. & S. phone 09 349 9413

Video Monitors 5.5" 12 VDC from \$155. A. S. & S. 09 349 9413

Protel for Windows Advanced schematics V3, Advanced PCB V2.8, New in box \$1200. Melbourne (03) 9803 0376 or 019 424 294.

Video Frame Grabber monochrome card for your PC. Three separate video inputs. Display on PC screen or save to a file. Provides 12V for video cameras plus three switch inputs for remote control. Software drivers enable you to write your own software in assembler or C. Ideal for security systems or the internet. Australian design. \$250 Melbourne (03) 9803 0376 or 019 424 294

Unusual Books. Electronic Devices, Fireworks, Locksmith, Radar Invisibility, Surveillance, Self Protection, Unusual Chemistry and more. For a complete catalogue, send 95 cents in stamps to: Vector Press, Dept E, PO Box 434 Brighton SA 5048.

Experimenters put your old XT, 386 or 486 to use. 48 TTL I/O card 5V level \$80. Safe 64 individual opto isolated input 5V- 25V and four relays supports hardware interrupts \$160. Ideal for experiments control or monitoring, Easy single instruction programming b b 0in BASIC, C, Assembler or other. Australian design. Melbourne (03) 9803 0376 or 019 424 294.

ADVERTISING RATES FOR THIS PAGE

SMALL ADS:

The minimum acceptable size of two centimetres x one column costs only \$70. Other sizes up to a maximum of 10 centimetres are rated at \$40 per centimetre.

CLASSIFIEDS: \$6 for 40 letters. Just count the letters, divide by 40, and multiply by \$6.

ROUND UP TO THE NEAREST MULTIPLE OF \$6
MINIMUM CHARGE \$12

CLOSING DATE :

Ads may be accepted up to the 10th of the month, two months prior to issue date.

PAYMENT: Payment must be in advance by cheque, money order or credit card, include your name, address, and credit card details. Faxes accepted. Payment should be sent with your advertisement, to:

THE ADVERTISING
PRODUCTION MANAGER
ELECTRONICS AUSTRALIA,

P.O. BOX 199, ALEXANDRIA, NSW 2015
PHONE (02) 353 0740 • FAX (02) 353 0997

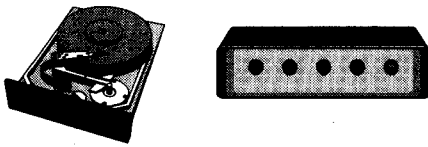

FOR SALE

Fully Approved 12V DC 1 Amp "plugpacks": Buy direct from importer. \$10 + sales tax. Many other models available. Call AV-COMM Pty Ltd (02) 9949 7417/ 99482667 or fax (02) 99497095.

PCB's made, one or many, low prices, hobbyists welcome. Also Touch Switch for lamps, 2A, 3 steps, \$7 ea. plus P+H \$3 for 3 units. Sesame Electronics (02) 554-9760, Fax (02) 9718-4762.

Easy Pic'n Beginners Book to using microchip PIC chips \$50, basic compiler to clone basic stamps into cheap PIC16C84's \$135, CCS C compiler \$145, heaps of other PIC stuff, programmers from \$20, real time clock, A-D. Ring or fax for free promo disk. WEB search on Dontronics P.O. Box 595 Tullamarine 3043 039338-6286 Fax 039338-2935

RCS RADIO PTY. LTD.
Established in 1933, RCS Radio is the only company which manufactures and sells every PCB and front panel published in Electronics Australia and I E S C. 651 Forest Road, Bexley, NSW 2207. Ring (02) 587 3491 for instant prices.

TORTECH PTY LTD
TOROIDAL TRANSFORMERS
Design and Manufacture
Approved to AS3108 - 1990 & U.L. Standards
Tel: (02) 642 6003 Fax: (02) 642 6127

KIT REPAIRS - R & D, prototyping, repairs to electronic equipment, all kits repaired
CAMPAD ELECTRONICS
26 KEITH STREET CAPALABA, Q. 4157
Phone (07) 3245 2008

Printed Circuit Board Manufacture
48-Hour service • High quality • Low prices
1 offs to any quantity
Artwork designed if required
Call for obligation free quote...
INSTANT PCB'S PO BOX 448 AVALON 2107
Ph: (02) 9974 1189 Fax: (02) 9974 5491

WANTED

Computer Programming Whiz! to create modules of code. DOS. W95. Pls fax details rates. 09 344 5905

A PC Based 32-Ch Logic Analyser — 2

(Continued from page 84)

somewhat surprised to find that 5BG, 6AC and 3BQ were already on the air in Australia using the same technique.

Max's remarks about his early efforts to produce an appropriate RF piezoelectric slab from a lump of crystalline quartz are quite fascinating:

"After much trial and tribulation hacking quartz crystal about with a carborundum strip on the reverse side of a hacksaw blade, I put a little diamond saw in our lathe — much to my brother's disgust. He had visions of the diamond dust getting into the bearings and ruining them."

"So, between us, we made up a separate grinding head to take the drive via a belt, to keep any dust well away from the lathe. With that I hacked my way through various pieces of quartz until I achieved a satisfactory one".

Royal Flying Doctor

As it happened, Max's venture into crystal control for the restored 3BQ had

a surprising outcome. Around 1930, he was visited at Canterbury by the Rev. John Flynn and Alfred Traeger, of the Royal Flying Doctor Service. Max was lavish in his praise of Traeger, (a) for his resourcefulness in devising the pedal generator to power the RFDS's emergency transceivers, and (b) for adapting a typewriter keyboard to produce Morse code from such a transceiver, intelligible to a central operator.

Anyone who could switch on a transmitter and spell out the necessary words could send a distress message in Morse. What the RDF needed now was a means of stabilising the transmitter frequency, so that scattered transceivers would all come up on the allotted spot on the band — notwithstanding temperature extremes and/or how erratically the generator was being pedalled.

At that point in time, Max Howden undertook to do his best to provide Alf Traeger with the crystals he needed. More about that in the next issue. (To be continued) ♦

WHEN I THINK BACK...

(Continued from page 41)

positive or negative triggering when external triggering is selected. This setting will automatically be set to positive when internal triggering is selected.

TRIGGER DELAY: A trigger delay of 0, 2, 4 or 8 cycles is selectable. This determines how long the trigger signal must be present in order for the PCLA to register the trigger event. It can be used to avoid false triggering, and also for a legitimate use when you want to distinguish between short and long trigger events.

CLOCK SELECT: Toggles through all of the internal TIMING mode clock sample rates, and also selects the STATE mode external clock.

CLOCK POLARITY: Determines if the data will be sampled on the positive or negative edge of the external clock. This has no effect when in TIMING mode.

That's about all there is to the software. As you can see it's quite straightforward. Further information is available in the software documentation provided on the disk.

The software and pre-programmed PLDs will be available from Tronnort Technology. Please refer to the note in the parts list for more details.

That brings to an end the description of the new PC based logic analyser. I hope you find it a valuable addition to your test gear collection. Happy triggering! ♦

NOTES & ERRATA

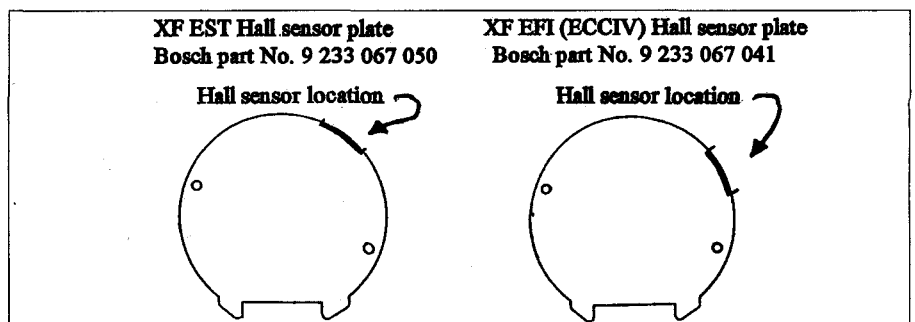

Auto Electronics (October 1996): In Fig.7, on page 45, the Hall Sensor plates for XF Falcon EST and EFI (ECCIV) systems were unfortunately swapped. The correct diagram is shown above.

50 and 25 years ago...

'Electronics Australia' is one of the longest running technical publications in the world. We started as 'Wireless Weekly' in August 1922 and became 'Radio and Hobbies in Australia' in April 1939. The title was changed to 'Radio, Television and Hobbies' in February 1955 and finally, to 'Electronics Australia' in April 1965. Here we feature some items from past issues.

November 1946

Crystals Stage a Comeback: Up until a short while ago, mention of crystal detectors was like a breath from a bygone age. However the humble crystal detector is making a comeback in no uncertain fashion, in ultra high frequency equipment. Duly modernised, it is taking its place in superhet, mixer circuits and — of all things — cavity resonators.

The diode detector has earned a very definite place in UHF equipment, but valve diodes like the 6H6 are at a disadvantage because of their inherently high inter-electrode capacitance. Now, under pressure of war research, the crystal diode has emerged with characteristics in almost every case superior to the valve.

In its new form, the crystal diode is being manufactured with a fine tungsten point contact touching a small piece of either germanium or silicon crystal. The germanium crystal detectors, of which the 1N34 is typical, is being applied in circuits which would normally require the 6H6, and at frequencies beyond which the 6H6 ceases to be a good choice. Silicon crystal detectors operate to advantage at still higher frequencies, extending up to about 25,000 megacycles.

November 1971

Mineral Analysis: A fully integrated computer controlled X-ray spectrometer has been installed at the central laboratory of the Colonial Sugar Refining Co., at Pymont in NSW, primarily for the analysis of mineral deposits. It has already

proven a boon to the company for both qualitative and quantitative analytical work. The basic system consists of an X-ray fluorescence spectrometer, an 8K 16-bit computer and software, an associated power generator and electronic interface units. All of the equipment was supplied by Philips Industries Ltd.

Weather Radar: Ansett Airlines will install RCA weather radars, type AVC-30X, in its fleet of 727-200 jetliners and in its future aircraft. First shipments of the equipment are scheduled for the end of this year. The AVC-30 is an all solid-state system that can view weather up to 300 miles away. It features a dual system configuration for increased operational reliability.

Police Facsimile: A new facsimile system, which sends from a fixed station to any number of radio-equipped mobile vehicles simultaneously, enables mobile police patrols in Bristol, England to receive visual information from their base stations while on the road — and in conditions where speech communications may be unsatisfactory. Identikit pictures or typewritten information is fed into the base unit, to be transmitted in the form of FM pulses. The printer in the mobile unit turns on automatically when a signal is received. ♦

EA CROSSWORD

ACROSS

- ~~1~~ Cooking appliance. (8,5)
- ~~2~~ Bring to a better standard. (7) *improve*
- ~~10~~ Adjusting device. (7) *tuner*
- ~~11~~ Melted (a fuse). (4) *fuse*
- ~~12~~ Name associated with EMI. (5)
- ~~13~~ Said of real-time transmission. (4)
- ~~16~~ Brand of fax machine. (6)
- ~~17~~ Name of French brothers of historic cinema fame. (7)

- ~~18~~ Activity in a dream. (3)
- ~~20~~ Held together. (7)
- ~~22~~ Conductive element. (6)
- ~~23~~ Gain illegal access to computer. (4)
- ~~24~~ European TV system. (5)
- ~~25~~ Source of diffraction. (4)
- ~~26~~ Reconstructed. (7) *edge*
- ~~32~~ Beams that oscillate with exciting potential. (7)
- ~~33~~ Disablement caused by current. (8,5)

DOWN

- ~~3~~ Recorders of data. (7)
- ~~3~~ Colour. (4) *ink Rose Comb Cold*
- ~~34~~ Reverberate. (2-4) *re*
- ~~35~~ Adjust to a suitable frequency. (4)
- ~~36~~ Accurate scale. (7) *calibrate*
- ~~7~~ Recording. (7)
- ~~8~~ Emit a high-pitched sound. (5) *SINEN.*
- ~~10~~ Metallic element named after an asteroid. (6)
- ~~14~~ Most brilliant mathematician, ever; (1707-1783). (5)
- ~~15~~ The digitron, or ... tube. (5)
- ~~17~~ Diode. (3) *LEJ*



SOLUTION TO OCTOBER 1996:

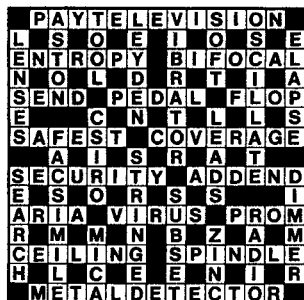

- ~~18~~ Replay a recording. (6)
- ~~19~~ Nationality of Chadwick, of neutron fame. (7) *English*
- ~~25~~ Unit used to measure circuit performance. (7)
- ~~30~~ Said of a certain type of grid of wire, etc. (4) ♦
- photoic light-sensitive cell*
- Electrical fault. (5)*
- Unit of measure used in astronomy. (6)*
- two-way trigger diode. (4)*
- Grid of wire, etc. (4) ♦*

Video

Electronics Australia's

Professional Electronics

S ♦ U ♦ P ♦ P ♦ L ♦ E ♦ M ♦ E ♦ N ♦ T

**NETCOMM'S CABLE MODEMS
NOW READY FOR PRODUCTION**

**TOSHIBA'S BLUE-PURPLE LASER
PUTS 15GB OF MOVIE OR DATA
ON ONE SIDE OF A DVD DISC!**

**QUEENSLAND FEATURE:
ANOTHER GOOD YEAR FOR
GRIFFITH UNI'S IAP PROGRAM**

**KEPCO'S SHORT HISTORY OF
PACKAGED POWER SUPPLIES**

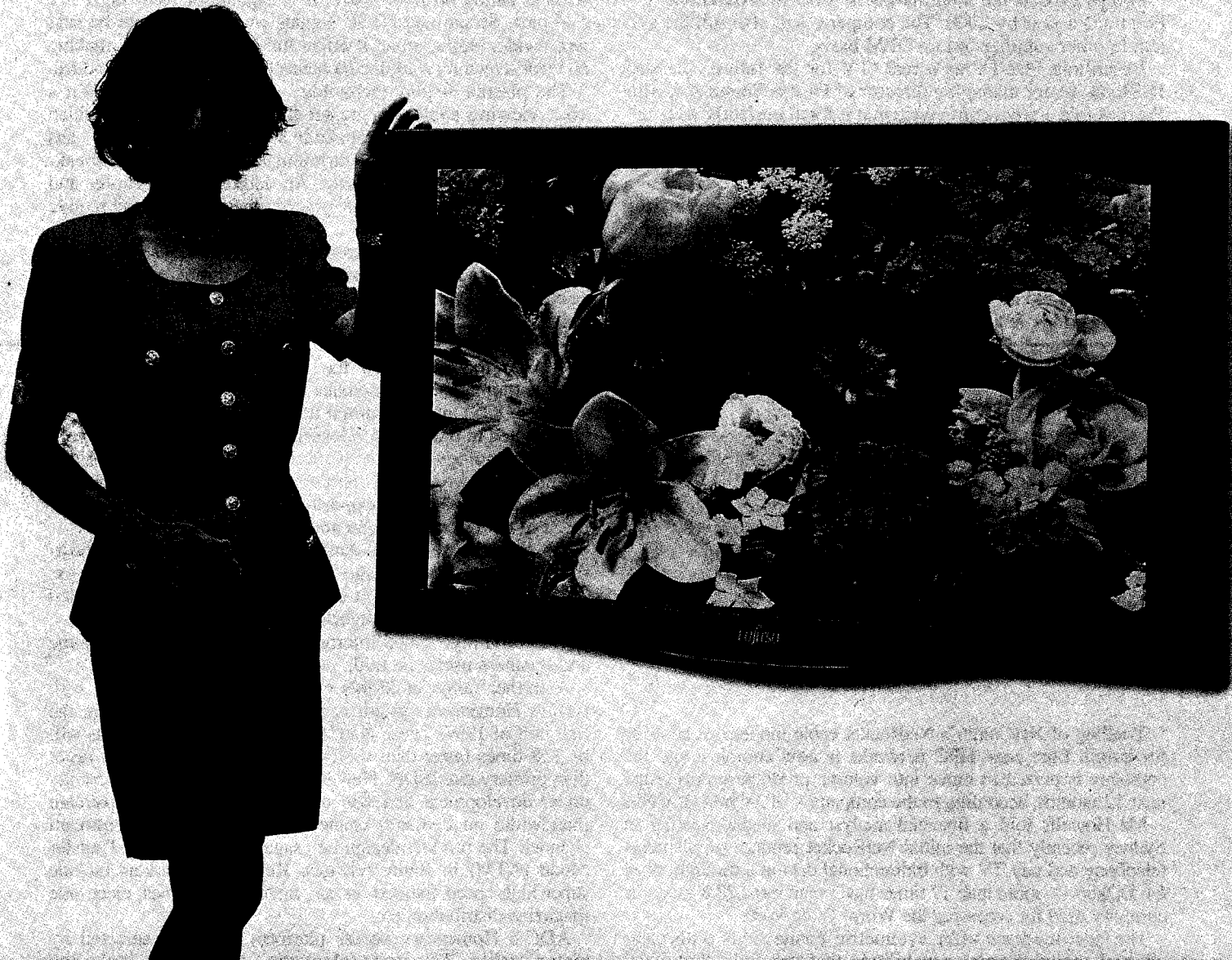

**FUJITSU RELEASES ITS NEW 42" (1067mm) WIDE-SCREEN COLOUR PLASMA
DISPLAY PANEL, WITH 852 x 480 PIXELS AND 16.7 MILLION COLOURS...**

NEWS HIGHLIGHTS

PHILIPS SHOWS FLAT SCREEN TV

Philips has given its first public demonstration of its yet-to-be-released large screen Flat-TV, at the CeBIT Home exhibition in Hanover.

The Flat-TV has a plasma display panel with a screen diameter of 1070mm (42") — yet with a depth of less than 100mm, can be hung on a wall like a painting, or suspended from a ceiling.

Although the model shown at CeBIT Home is a first generation prototype, Philips says it plans to introduce the Flat-TV onto the market in the first half of next year, at an expected price of around 22,000 guilders (US\$13,000). Initial demand is expected to come from businesses wanting to use the Flat-TV for multimedia displays, and from home cinema fans.

Philips expects the total market to grow to around one million units a year by 2000. The company will also sell the system to other suppliers on an OEM basis.

Describing Flat-TV as a real 'TV for the future', Jacques D'Elfant, senior managing director of Philips Sound & Vision Europe, told a press conference that it fitted perfectly with current and predicted market trends. These see increasing numbers of people moving towards large and widescreen TVs with home cinema capabilities.

However, at the same time that they want bigger screen sizes, people also want less bulkiness. With the largest cathode ray tube television sets already weighting over 100kg, bigger screen size TVs with conventional screens are totally impractical.

Flat-TV is the ideal solution to this conundrum, Mr D'Elfant said: "It brings real cinema-style viewing to the living room,

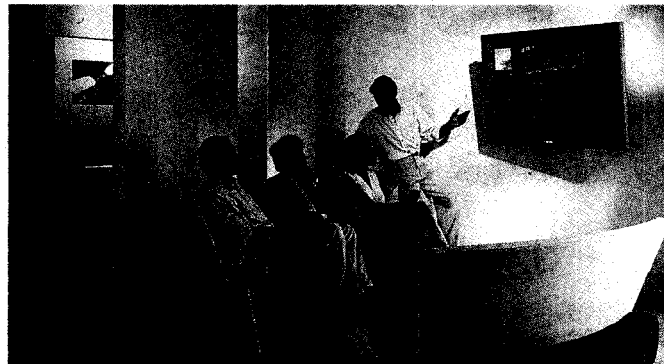

without taking up floor space. It is capable of receiving PAL, PALplus, Secam and NTSC signals and can therefore be sold worldwide. Furthermore, it offers full VGA resolution, making an ideal screen for multimedia presentations on a PC", he added.

The plasma display technology used in Flat-TV gives it a 160° viewing angle, far greater than LCD screens — which are extremely difficult to make in such large sizes. It also has an integrated hifi-standard surround sound system with speakers built into the TV's frame. An additional subwoofer and two separate speakers can be placed where desired and to give cinema-style sound.

The power supply, electronics and connections are housed separately in a TV receiver. All connections with external equipment go through this box, with only one pair of cables going directly to the flat display.

NETCOMM CABLE MODEMS READY FOR PRODUCTION

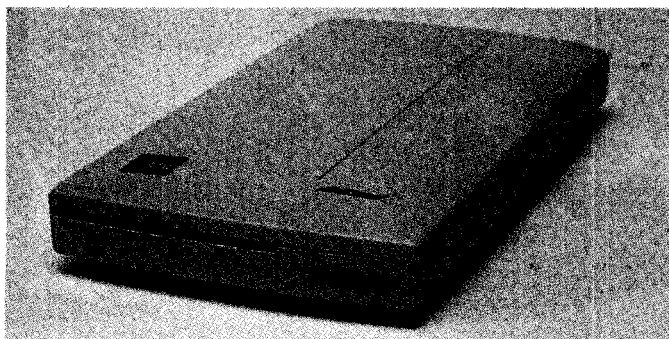

Trialling of NetComm's NetRocket cable modem technology for hybrid fibre coax HFC networks is now complete and the company is poised to move into volume production during the next 12 months, according to the company's MD Chris Howells.

Mr Howells told a financial analyst and media briefing in Sydney recently that the initial NetRocket product supplements telephony and pay TV with bidirectional data at a throughput of 64-512kb/s — more than 17 times faster than most 28.8 modems currently used for accessing the World Wide Web.

The new modems offer symmetric connections with clear channel, point-to-point capabilities that are fully integrated with ADC's Homeworx HFC telephony system for management and billing purposes. Unlike the 'first generation' over-

lay cable modems from the USA, these modems enable telecommunications companies to offer guaranteed quality of service (QOS) and committed information rates (CIR).

Designed to operate on networks based on ADC Homeworx HFC technology, the NetComm NetRocket products are intended for worldwide markets within the ADC customer base. Significant market opportunities have already been identified in the USA, Australia and South East Asia.

Mr Howells said that Australia remained uniquely positioned to take advantage of cable modem technology. "Australia will be the first country in the world to be cabled from coast to coast with hybrid fibre coax offering telephony, pay TV and high speed Internet communications to the home and business user", he said.

A further range of 8Mb/s cable modems that operate with ADC's Homeworx system is scheduled for completion in the first half of 1997. These NetComm cable modem products will be 128 times faster than ISDN basic rate and four times faster than primary rate ISDN. New 30Mb/s models are also currently under development and will offer a 64 to 512Kb/s upstream (bandwidth on demand) channel with a 30Mb/s downstream channel. The product design envisages Asynchronous Transfer Mode (ATM) in future releases. Key target markets include super high speed Internet access, multiplayer games, electronic magazine distribution etc.

ADC's Homeworx access platform has been selected by major cable TV and telephony companies including Ameritech, Southern New England Telephone, Cable Bahamas and Optus Vision.

NEW RAWARD FOR ENGINEERING EXCELLENCE

This year's RAWARDS presentation featured a new category for engineering excellence, sponsored by Comsys (Australia) and valued at \$10,000. The new RAWARD includes a scholarship to the USA that allows an Australian broadcast engineer to study new engineering developments.

The annual scholarship is awarded to one of the finalists from either Metro, Provincial or Country Divisions.

Managing director of Comsys (Australia), Mr Mario Fairlie, said the new category had been established in recognition of the achievements of Max Wilson, group general manager engineering of Wesgo, who died earlier this year.

"Max Wilson contributed significantly to the successful operation of Australian commercial radio throughout his life", he said. "Through his dedication and commitment to innovation and excellence in engineering, and his achievements in cost savings for stations and networks, the industry will continue to benefit."

Mr Fairlie said the category was judged by a specialist team of industry engineers and executives. "The judges looked for a single achievement or specific engineering project based on an innovative idea, which had a broad application to the industry and achieved cost efficiencies."

HUNTER CAL LAB ACHIEVES QA CERTIFICATION

The Wallsend (NSW) based testing facilities of Testing and Certification Australia have been certified for Quality Assurance. Their Quality Assurance system, which is designed to provide consistently high levels of customer satisfaction has been assessed and approved by NATA (National Association of Testing Authorities) for the granting of certification to the international standard AS/NZS ISO9002.

TCA's Manager-Hunter, Mr Richard Newell, explained how the certification will benefit customers in the Newcastle area. "Where companies already operate their own Quality Assurance System, TCA can now support their system through the provision of calibration services traceable back to national standards. In other cases customers benefit from the reassurance that their electrical and electronic instruments are being calibrated by experienced professionals operating under a certified quality system", he said.

TCA have invested in systems and equipment at Wallsend because its services are in great demand amongst industrial companies in the Hunter. The process has been assisted by the established expertise in Quality Systems developed in TCA's main Chatswood calibration laboratories, where services are provided to customers throughout Australia. At Chatswood full calibration services for most electrical, electronic, acoustic and temperature measuring instruments are provided.

Further accreditations are anticipated by Richard following approval of the QA System at Wallsend. "We are now engaged in achieving full NATA laboratory accreditation. This is planned by the end of 1996", he said.

OPTUS ENHANCING NETWORK WITH ATM

Optus Communications plans to invest \$50 million in what it claims as an Australian-first ATM enhancement to its existing network. This will provide it customers with advanced telecommunications services, not currently available through existing networks.

The new OptusNet ATM (asynchronous transfer mode)

technology will allow Optus to maximise its existing investment in a national integrated telecommunications network. ATM is widely considered to be the most advanced telecomm technology currently available.

Complementing the Optus existing SDH (synchronous digital hierarchy) network, already claimed to be the most efficient in the world, ATM will allow Optus to use the SDH network more efficiently by integrating voice, data and video traffic over the one network at high speeds. It will also allow the development of new applications such as high speed Internet access and Frame Relay, plus high speed data transfer for applications such as very fast transmission of medical records and X-rays between doctors and hospitals — where speed can be critical.

Optus is deploying the ATM technology in its Sydney and Melbourne networks from October this year, with Adelaide following in December and Canberra, Brisbane and Perth in the first half of 1997. Initial services offered by the OptusNet ATM network will be LAN connection (10baseT, FDDI), Internet and Intranet transport, WAN services (eg frame relay), video (conferencing quality), fixed data services (2MB/s - 45MB/s) and PBX trunks (via circuit emulation) for voice.

COM 10 DIGIGAIN-4'S FOR PHILIPPINES PLDT

The Philippine Long Distance Telephone Company (PLDT) has signed an agreement with Australia's COM 10 Pty Ltd for the supply of Digital Pair Gain Systems. The DigiGain-4 will allow four telephone services to be connected over an existing cable pair. This will allow PLDT to rapidly connect additional subscribers to the telephone network and to help meet the demand for telephone services under the PLDT's 'Zero Backlog' Program.

The agreement was signed by Mr Jose de Jesus, Executive Vice President of PLDT, Mr Malcolm Inglis, Managing Director of COM 10 and Mr Dilip K Khatri, Commercial Manager of COM 10, in the presence of Mr Rodolfo D. Cruz, Vice President of Eltech Resources Corporation, a COM 10 representative in the Philippines.

"This agreement being the first between COM 10 and PLDT marks the beginning of what I am sure will be a very successful partnership for the future. I believe that Australian companies should work closely with our neighbours in the Philippines to develop important strategic business alliances", said Mr Inglis.

PLDT is the largest telecommunications company in Philippines. COM 10 is a wholly owned subsidiary of

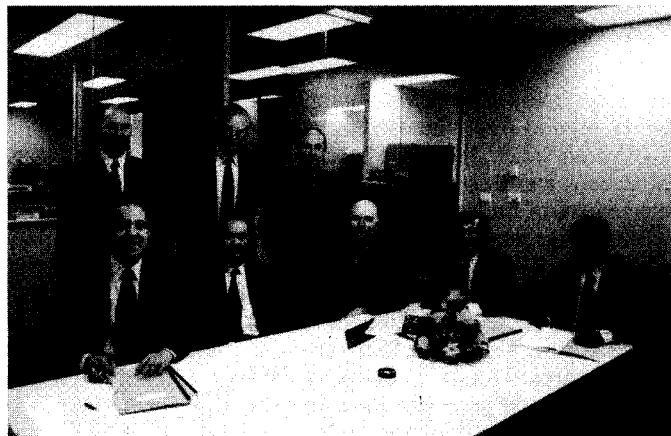

NEWS HIGHLIGHTS

Lemvest Ltd, an Australian publicly listed company. COM 10 was formed in April 1996 to acquire selected assets of Exicom Australia and is a leading supplier of telecommunications equipment such as DC power systems, telephone accessories, systems integration solutions, communications racks as well as data and transmission products.

NATIONAL'S DECT COMMS FOR INDIA

National Semiconductor Corporation and India's Centre for Development of Telematics (C-DOT) have signed a far reaching Memorandum of Understanding (MOU) for the development of DECT (Digital European/Enhanced Cordless Telecommunications) technology based systems for delivering telephony services to both urban and rural areas of India.

The MOU lays out the transfer of technology and the roles and responsibilities of the two organisations in developing a DECT based Wireless-Local-Loop (WLL) system. WLL reduces the costs of installation and ongoing maintenance of new telephone systems, by using digital cordless technology to eliminate the need for cables to link each individual household/office to the local exchange.

Currently a new urban line connection in India can cost as much as INR47,000 (US\$1330), while a typical rural line is estimated to cost around INR100,000 (US\$2820). The projected cost for the WLL system being developed is INR5000 - 10,000 (US\$140 - 280) per subscriber. Any subscriber within the range of the wireless exchange can send and receive calls on a small, light handset, with hundreds of hours of 'stand-by' time, due to low power requirements. Local roaming is also possible.

DECT is an advanced, completely open, digital standard for cordless and wireless telecommunication, and both voice and data applications. It employs the 1.88 to 1.9GHz spectrum and offers extensive user benefits such as excellent voice quality, high security due to in-built encryption, and low operating power.

C-DOT was set up in 1984 by the Indian Government with the objective of developing a new generation of switching systems relevant to the Indian environment. Today it is established as a premier R&D organisation financed by the Telecom department and is recognised as a pioneer in the field of rural telecommunications.

FUJITSU ANNOUNCES 42" COLOUR PLASMA PANEL

Developed by Fujitsu, what is claimed as the world's first 42" (1067mm) wide screen colour plasma display panel will be released in Australia early next year.

In recent years, there has been a distinct trend towards larger screens and this trend is expected to accelerate along with the growth of multimedia.

With large scale image display, colour plasma display panels (colour PDPs) are expected to replace traditional cathode ray tube (CRT) and rear projection type displays as the 'next generation' home entertainment system.

The Fujitsu 42" colour PDP screen measures 1040 x 640mm (display area 920mm x 518mm), is only 150mm deep and weighs 35kg. It promises to realise the long-awaited concept of a wall hanging TV. The 160° wide viewing angle ensures



clear visibility from the outer edges of the screen and with precision full-colour display of 16.7 million colours, picture quality is claimed to be superb.

Tentative specifications include a resolution of 852 x 480 pixels, a pixel pitch of 1.08 x 1.08mm, an aspect ratio of 16:9, a contrast ratio of 70:1 and a minimum display luminance of 150cd/m². Power consumption is 450W, and the unit accepts composite video, S-video, analog RGB and audio.

Last year, Fujitsu introduced the world's first commercial 21" colour PDP and with the launch of this 42" model, the company claims to lead the world in colour plasma display panel technology.

For further information contact Fujitsu General (Aust.) Pty Limited on (02) 9638 5199.

PIRELLI DELIVERS MULTI-GIGABITS VIA PHOTONICS

Pirelli Cables Australia claims to be the first company to deliver multi-gigabit photonic networks, thus enabling its customers to fully exploit the under-used available bandwidth.

"Pirelli's innovation helps to end capacity constraints for all of today's voice, data, image and video networks", said Colin Bale, MD of Pirelli Cables Australia Limited. "The industry's demand models show a doubling of capacity requirements every year. This includes today's corporate enterprise networks, the Internet, on-line service networks, medical applications and cellular network backbones. For all these and other capacity requirements, Pirelli has Dense(D)-WDM which is a cost-effective solution compared to the present 2.5Gb/s system."

Pirelli is able to deliver an open architecture D-WDM, which is said to offer great advantage over those vendors who are faced with problems in integrating WDM technology into SDH based products.

The Pirelli products fully exploit the 1550nm fibre-optic window that has been available for more than 10 years. By transmitting light waves with wavelengths on fractions of nanometres apart within the 1530 - 1560nm range, it is possible to load 32 channels onto a single fibre.

Pirelli has a long term, field proven D-WDM history around the world. The claimed leader in photonic transport systems, it has supplied thousands of units that incorporates WDM technology capable of increasing the capacity of existing fibres up to 20Gb/s. It claims to be the first com-



Taken inside Dick Smith Electronics' impressive new 'PowerHouse' store in Bankstown, western Sydney, this photo shows the large display and demo area for electronic construction kits.

pany in Australia to deliver commercial volumes of photonic systems for long distance and pay TV networks.

Formerly perceived as an abstract science, photonics has become a mature technology able to advance Australia by the provision of improved multimedia telecommunication services.

PAY TV CHANNEL FOR VIC EDUCATION

Victoria's schools, TAFE colleges and universities now have access to a dedicated pay TV education channel, allocated free of charge by Optus Vision as part of a \$60 million commitment to education. The School of Visual, Performing and Media Arts and Deakin University will be the host facility for the channel, on behalf of all other education providers in the state.

Victoria's Treasurer and Minister for Multimedia, The Honourable Alan Stockdale, launched The Education Channel at the Rusden campus of Deakin

University, with Vice-Chancellor Professor Geoff Wilson and the Victorian GM for Optus Vision, Paul Villanti.

Distributed on the Optus Vision broadband network, The Education Channel will coordinate programmes produced by students and teachers from primary and secondary schools, universities, TAFE colleges and community colleges. Students can watch the channel either at college or school, in their homes or wherever they have access to the Optus Vision network.

AAC TO DISTRIBUTE MOREL LOUDSPEAKERS

Morel Ltd, one of England's most prestigious manufacturers of loudspeaker drivers, has appointed South Australian firm Australian Audio Consultants as its sole Australian distributor. Morel offers drivers ranging from the highest audiophile quality through to drivers offering what is claimed as the best value for money on the world market.

The range includes subwoofers,

large diameter bass drivers, small midrange drivers, dome midranges and many varieties of tweeter. Most products are magnetically shielded and many are designed specifically for home theatre applications.

Hobbyists are more than welcome to make enquiries, and can benefit from Australian Audio Consultants' extensive experience in research and development of high quality loudspeaker systems.

AAC can be contacted by mail at PO Box 11, Stockport 5410, or by phone/fax on (085) 282 201.

HY-Q TO SUPPLY QUARZKERAMIK OCXO'S

Hy-Q International (Australia), one of the leading manufacturers and suppliers of frequency control products, has signed an exclusive agency agreement within Australia and New Zealand for the supply of high stability quartz crystal products from Quarzkeramik GmbH, a member of the Rhode & Schwarz group of companies.

Quarzkeramik has been committed to quartz crystal products for over 50 years, and specialise in the manufacture of high stability oven controlled crystal oscillators (OCXOs). The company maintains a quality assurance program conforming to ISO9001, guaranteeing the highest quality precision product.

Further information is available from Hy-Q International on (03) 9562 8222. ♦

NEWS BRIEFS

- MOD-TAP Australia is hosting a series of educational seminars *Trust your Connections* that will focus on the role played by telecom and data cabling in IT networks. Dates and venues are: Adelaide 11/11; Sydney 13/11; Canberra 15/11; Perth 18/11; Melbourne 20/11; Hobart 22/11; Darwin 25/11. For more details phone 1800 623 011.
- Sydney-based **Amtex Electronics** has moved to a new purpose-built office and warehouse facility at 2A Angas Street, Meadowbank 2114. The phone number is (02) 9809 5022, and the fax number (02) 9809 5077. Email can be directed to sales@amtex.com.au. ♦

Solid State Update

KEEPING YOU INFORMED ON THE LATEST DEVELOPMENTS IN SEMICONDUCTOR TECHNOLOGY

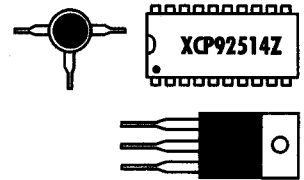

16Mb SDRAM for PC graphics

Texas Instruments has disclosed a new 32-bit wide 16Mbit synchronous DRAM (SDRAM) that it claims will improve performance while reducing costs, by cutting the chip count in mainstream PC graphics subsystems. The device is claimed to be a higher-performance, lower-cost replacement for either four 4Mb extended data output (EDO) memories, the most dominant type of memories used today in PC graphics subsystems, or two 8Mb synchronous graphics RAM (SGRAM) devices.

As synchronous memories, the new devices are synchronised to the system's clock and with a system clock speed of 125MHz, two 16Mb SDRAMs can provide graphics data at a rate of one gigabyte per second (GB/s) over a typical 64-bit graphics bus. The devices are organised as 256K words by 32 bits by two banks (256K x 32 x 2), to provide interleaved access. Interleaving operations between two banks of memory locations allows one bank to be accessed while a memory address in the second bank is being activated.

The 3.3V device will be packaged in JEDEC standard 100-pin Quad Flat Pack (QFP) packages, and fabricated using TI's EPIC (enhanced performance implanted CMOS) process. Samples of 512K word x 32-bit 16Mb SDRAM devices will be available during the first quarter of 1997. Volume production is scheduled for the fourth quarter of 1997.

For further information contact Texas Instruments Inc, Semiconductor Group, SC-96039 Literature Response Center, PO Box 172228, Denver CO 80217.

High speed microwave detector

Miteq Inc has released a new high speed microwave detector. With a DC to 1GHz video bandwidth, the new gallium arsenide microwave detector has been developed for demodulating ultra high speed data streams. It operates in the three to 6GHz RF band and requires a 9V bias for highest sensitiv-

ity, (approximately 100mV/1mW).

The input RF power at the transition between square law and linear operation is approximately -10dBm. The detector provides a negative output voltage of 1mV across 50 ohms at -20dBm RF input.

For further information circle 271 on the reader service coupon or contact Electronic Development Sales, Unit 2A, 11-13 Orion Road, Lane Cove 2066; phone (02) 9418 6999.

5V 1W DC/DC converter IC



Burr-Brown's new DCP010505 is claimed as the first in a series of high efficiency, 5V input isolated DC/DC converters available in a JEDEC plastic moulded low profile (3.8mm) package. It features a 1W nominal galvanic isolation output power capability, thermal shutdown, and output short circuit protection by means of watchdog circuitry.

The device is self-synchronised, so any number can be connected together as they will self-synchronise to prevent beat frequencies on the power rail, avoiding the need for external synchronisation. The IC will start into any load up to full power output. It is designed for applications such as point-of-use power conversion, digital interface power, ground loop elimination, data acquisition, and industrial control and instrumentation.

Specifications include 1W power output at 100°C, 70% efficiency at full load, 1kV RMS isolation, 400kHz switching, and operation over a -40°C to +100°C temperature range. It is pack-

aged in a standard 14-pin plastic DIP.

For further information circle 276 on the reader service coupon or contact Kenelec, 2 Apollo Court, Blackburn 3130; phone (03) 9878 2700.

30A Schottky rectifier

Taiwan Semiconductor recently announced that it has expanded its range of Schottky barrier rectifiers to include 16A, 20A and 30A devices, part numbers SR16X0PT, SR20X0PT and SR30X0PT respectively. They are all packaged in a TO3P/TO-247AD package.

These devices have a maximum recurrent peak reverse voltage rating ranging from 20V to 60V. They feature dual rectifier construction with positive centre-tap, low power loss (low forward voltage drop), and high surge capability. They are especially suitable for low voltage, high frequency inverter, free wheeling, and polarity protection applications.

For further information circle 272 on the reader service coupon or contact GEC Electronics Division, Unit 1, 38 South Street, Rydalmere 2116; phone (02) 9638 1888.

Surface mount power MOSFETs

SGS-Thomson Microelectronics has introduced a range of low power MOSFETs housed in one of the smallest surface mounting packages currently available, the SOT-223 package. The STNxNxx devices are N-channel enhancement mode MOSFETs designed to withstand high energy pulses under avalanche mode, making them suitable for applications in hard disk drives, DC/DC converters, power supplies and small motor current sensing circuits.

Initial members of the family include the STN2N06, which has a maximum drain to source voltage (V_{dss}) of 60V and a maximum continuous drain current of 2A. Other devices are the low threshold STN2N10L (100V and 2A) and the STN3N06 (60V and 3A). Maximum values of on-resistance are 0.15Ω (STNSN06), 0.25Ω (STN2N06), and 0.5Ω (STN2N10L). All devices in the

range have an internal fast recovery drain-source diode.

The SOT-223 package is a compact housing that is compatible with both wave and reflow soldering techniques. The devices are supplied in tape and reel format. The new devices are 100% avalanche tested and the avalanche current is specified and guaranteed at a junction temperature of 100°C as well as at the usual 25°C.

Avalanche breakdown, an important breakdown mode in power MOSFETs, occurs if the electric field near the body-drain junction exceeds a critical value. The sudden avalanche of mobile carriers results in a large increase in the current flowing through the junction. Unless the device can safely dissipate this current, transient overvoltages can destroy the device. The avalanche current that can be safely handled decreases as the junction temperature increases, hence the importance of characterising devices under all operating conditions.

For further information circle 273 on the reader service coupon or contact SGS-Thomson Microelectronics, Suite 3, Level 7, 43 Bridge Street, Hurstville 2220; phone (02) 9580 3811.

Op-amps with bandwidth and linearity options

The new IS0166 and IS0176 from Burr-Brown are precision, isolated amplifiers that offer a choice of 6kHz bandwidth at 0.062% non-linearity, or 60kHz bandwidth at 0.102% non-linearity. Both devices are rated at 1500V RMS continuous. The devices are suited for applications using thermocouples, RTDs, pressure bridges, medical instrumentation, analytical and biomedical measurements, data acquisition systems and test equipment.

The internal input protection of both devices can withstand up to +/-30V. Signals are transmitted digitally across a 2pF differential capacitive barrier, claimed to give excellent reliability and good high frequency transient immunity. Key specifications include 115dB at 50kHz IMR, +/-0.05% non-linearity, 5nA input bias current, +/-4.5V to +/-18V power supply range, +/-20uV input amplifier offset voltage, and an output voltage range of +/-10V. They are available in a 24-pin plastic 0.3 inch (7.6mm) 'skinny' DIP, and are specified over a -25°C to +85°C temperature range.

For further information circle 274 on the reader service coupon or contact Kenelec, 2 Apollo Court, Blackburn 3130; phone (03) 9878 2700.

16-bit ADC has 4-channel multiplexer

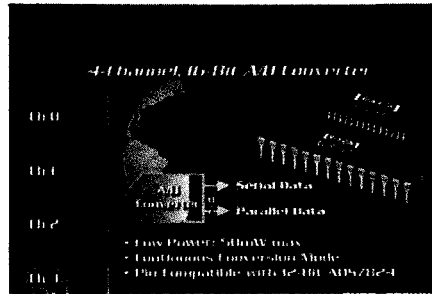

The new ADS7825 from Burr-Brown is a low power, monolithic 16-bit sampling A/D converter with a four channel input multiplexer, sample/hold, reference, clock, and a parallel/serial output microprocessor interface. The device can be configured in a continuous conversion mode to sequentially digitise all four channels, making it suitable for industrial process control, test and measurement, and analytical instrumentation applications.

The IC can acquire and convert 16 bits to within +/-2 LSB in 25us, while consuming 50mW. Laser trimmed scaling resistors provide a +/-10V input range and channel-to-channel matching of +/-0.024%. Specifications include +/-2 LSB max INL, DNL is 16 bits no missing codes, single +5V supply, and a 50uW power down mode. It is available in a 28-pin 0.3 inch (7.6mm) plastic DIP or 28-lead SOIC package, and is specified over a -40°C to +85°C temperature range.

For further information circle 278 on the reader service coupon or contact Kenelec, 2 Apollo Court, Blackburn 3130; phone (03) 9878 2700.

IC for closed loop PC control

The DS2407 addressable switch IC from Dallas Semiconductor is a sensor/actuator chip that can perform closed loop control from a central PC. It uses RS-232 communication, and can activate a switch and monitor the presence or absence of a voltage.

Said Michael Bolan, vice president of product development, "The chip was designed to exploit the computational, display and connectivity features of a PC. From the serial port of the PC, a twisted pair telephone wire can be routed up to 300 metres to multiple addressable switches. One signal plus ground provides the digital communication link as well as the power for the sensors/actuators."

Applications include home, laboratory or factory automation, comfort control,

burglar alarms, irrigation control, greenhouses, and vending machines. Driver software called TMEX (Touch Memory EXecutive) can feed sophisticated graphical user interfaces such as Lab View from National Instruments. Alternatively, the device can be connected to controllers on a FieldBus, DeviceNet or LonWorks, which are in turn connected to a PC.

Each device is individually addressable so dozens of chips can be put on the same twisted pair wire and have a central PC turn them on and off individually. This is made possible by a guaranteed unique serial number laser-etched in each chip that serves as a node address and an on-chip multidrop network controller. A 16 bit CRC generator guarantees that data packets are communicated with integrity.

The device provides a simple way to build a closed-loop system. The sensor responds to a stimulus and reports it to a PC which then turns a switch on or off to control a process. Both voltage sensors in the device can capture a one-shot pulse, such as that generated by a piezo sensor or momentary contact closure.

The IC has 1024 bits of user programmable and write protectable EPROM memory to hold data to describe the physical location, identify the controlled equipment, calibrate the sensor, or reference the actuator to a specific sensor. The dual-channel version is available in either a 6-pin TSOC surface mount package or as a single channel version in a TO92 package.

For further information circle 277 on the reader service coupon or contact Veltex Australia, 9 Bastow Place, Mulgrave 3170; phone (03) 9574 9300. ♦

SOLAR

warehouse

largest range of solar products in Australia

- CRYSTAL PANELS .5-120 watts
- AMORPHOUS PANELS to 11 watts
- CUSTOM PANELS TO INDUSTRY
- CONSUMER SOLAR PRODUCTS
- INVERTERS AND REGULATORS

TRADE and GOVT WELCOME

SolarCorp

IMPORT AND DISTRIBUTION OF ENERGY PRODUCTS
259 Broadway BROADWAY NSW 2007
Ph 02 9566 4340 Fax 02 9566 4360

READER INFO NO. 19

Silicon Valley NEWSLETTER



Toshiba's DVD laser puts 15GB per side

In another potential blow to the Sony-Philips digital video disk (DVD) alliance, Toshiba has announced the development of a blue-purple semiconductor laser that would allow for up to 15 gigabytes of data to be stored on a single-sided disk. By comparison, the red laser source used in the Sony/Philips DVD system stores 4.7GB on each side of a two-sided disk.

Toshiba's laser generates a 417nm wavelength at room temperature, compared to the 650nm wavelength of the red laser. The blue-purple laser is based on a gallium nitride compound.

With a capacity of 15GB, the Toshiba disks would offer enough storage capacity for full length movies with substantially less digital compression, and hence higher potential quality.

Matsushita first to market with DVD?

Less than a month after the fragile digital video disk (DVD) alliance fell apart, Japan's Matsushita Electric announced it will launch a DVD player system on November 1, and will sell it in retail outlets for around US\$700. The company will initially produce some 30,000 units per month.

"We'll create a vast, new market through the sale of players, production of discs, development of key parts and the OEM business", said Hiroshi Taniguchi, manager of Matsushita's DVD technical department.

DVDs have a storage capacity equivalent to up to 13 traditional compact audio discs, enough for a two-three hour full length movie.

When Philips and Sony pulled out of the DVD alliance, saying the members of the opposing consortium, headed by Toshiba, were dragging their feet in resolving technology licensing issues, it was speculated that the move would delay the availability of DVD systems during the coming Christmas season. However even if DVD players do become available in the next couple of months, it remains doubtful whether there will be any major movie titles to

sell along with them. The movie industry is still negotiating with DVD manufacturers to incorporate technology that would prevent consumers from copying the digital images to other discs, tapes or computer presentations.

While player manufacturers are said to be open to that idea, a major stumbling block is a second Hollywood demand for incorporating coding that would prevent movie discs from being played in parts of the world where the original movies have yet to be released. Manufacturers have ridiculed that demand, as it is practically impossible to prevent digital images from being transmitted from anywhere to anywhere in the world via the Internet.

35 firms support chip standards move

In an effort to develop uniform standards for functional building blocks that are incorporated into today's complex integrated circuits, a consortium of 35 high-tech companies have announced the formation of a joint venture to create such standards. If successful, the effort will speed up the development of new generations of consumer products built around so-called 'system-on-a-chip' components that will replacing current

system designs requiring a motherboard full of separate circuitry.

The joint venture, to be known as the Virtual Socket Interface Alliance (VSIA), hopes to have the first of the standardized IC building blocks such as graphics, sound and communications, logic, and memory, available by the end of this year.

Industry executives at the signing ceremony in Santa Clara agreed the program is a long overdue reaction to the growing complexity of chip design.

"This industry is heading towards disaster. This gathering will be viewed a few years from now as the birth announcement of a brand new industry: chip building-block designers", said Eric Schmidt, chief technology officer at Sun Microsystems.

Schmidt said today's chip design environment equates to a dozen automobile companies designing scores of new models every month without any standards for such things as how engines should work, the size of the steering wheel or where to put the steering wheel for that matter.

Among the companies supporting the VSIA chip design standards program are chipmakers National Semiconductor, Cadence Design Systems, Sun

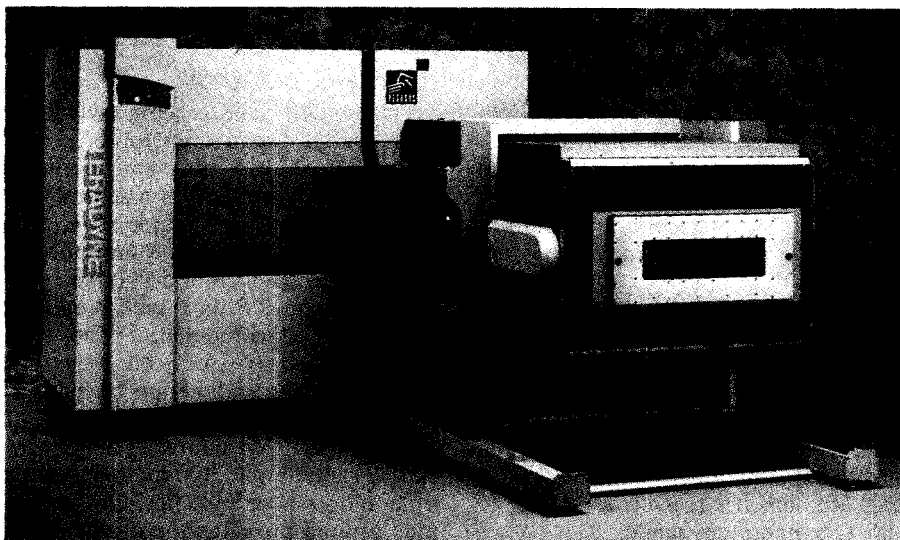

Many of the US firms traditionally involved in making production and/or testing equipment for the semiconductor industry are now investing heavily in developing equipment for the closely related flat-panel display technology. Teradyne Inc of San Jose recently displayed this 'Pegasus' test system for FP memories.

Microsystems, and Silicon Graphics. Others that joined the effort include Toshiba, Sony, NEC, and Fujitsu. Intel, Motorola and several of Korea's chip-makers are also expected to lend their support to the effort.

"The next generation of consumer electronics will not be possible if we don't go in this direction", said Joseph Costello, chief executive and president of Cadence Design. "Typically, industries are forced into crisis mode. They hit the wall before they will work together. With this new alliance, we've avoided that, but just barely."

Billion dollar set-top box order

An order for television set top boxes totalling a whopping US\$1 billion has been placed by the Americast cable TV programming consortium with Zenith.

As part of a mammoth deal, Zenith will deliver some three million set-top boxes to Americast, which will use them to deliver home entertainment services to its cable subscribers.

The set-top box will enable the Americast companies, which include Ameritech, BellSouth, GTE, SBC Communications and Walt Disney, to deliver multiple media services, ranging from basic television to electronics shopping and Internet access.

TI & Acer expand chip relationships

In a further expansion of their semiconductor pact, Texas Instruments and Taiwan's Acer have signed a broad patent cross-licensing agreement that will cover Acer's personal computers, peripherals and display devices.

"This cross-licence agreement serves the interests of both parties in further developing new technology in the PC area", said George Huang, Acer's general controller.

Acer and Texas Instruments already have extensive links through their TI-Acer DRAM semiconductor joint venture in Taiwan's Hsinchu Science-Based Industrial Park.

TV can be viewed through 360 degrees

Television technology that offers a 360° viewing angle was put on display at the 10th annual Invention Convention in Pasadena, California. The convention offers inventors a unique opportunity to showcase their products to potential manufacturers and venture capitalists who make up the majority of visitors.

The 360-degree TV technology was developed by ESP Electronics, which

Nolan Bushnell moves onto the Internet...

Few years go by without some announcement by Nolan Bushnell, Silicon Valley's all-time most prolific high-tech entrepreneur, about a new major venture he is getting involved in or starting up.

Now Bushnell, who started his legendary career with the invention of the Pong video game and the Atari company formed around it, said he wants to put high-tech jukeboxes and video games linked to the Internet in bars, hotels and other public places. Bushnell said he thinks the market for such systems could eventually turn into the billions of dollars.

"Do you think anyone can surf the Net? I do", Bushnell said at a news conference at his Silicon Valley mansion. The start-up company that will design, build and market the devices is called Aristo International. Bushnell showed off the first three such systems, which will eventually enable people to play video games with opponents in another location, order music as well as hear it, and access the Internet with the drop of a coin or the swipe of a credit card.

Bushnell is director of strategic planning for Aristo and he has a minority stake in the New York-based company. To date, he and Aristo have invested more than US\$10 million to develop the first three systems. Some 75-100 distributors are reportedly lined up across the United States to start selling the devices to sports bars, hotels, restaurants, airports and other public locations.

Pricing hasn't been set yet, Bushnell said, but he indicated they will cost around US\$2000, comparable to prices of popular video game machines.

The products are based on computers using high-speed Pentium processors and use Microsoft's Windows NT operating system.

claims its '360 degree Optical Technology' is patented worldwide. It is seeking about US\$6 million in first-round venture capital to ready the technology for commercial production.

ESP's technology is claimed to solve the problem of increasingly poor viewing angles when the viewer sits away from the centre axis of a TV or movie screen — by projecting a number of two-dimensional, real images into space, where they can be viewed simultaneously and continuously from any point in a 360° surrounding area. This is claimed to give viewers positioned anywhere in the 360° range an image perfectly centred on their line of sight.

ESP said applications, besides TVs and movie theatres, include stadium scoreboards, video arcades and teleconferencing systems.

Brooktree expands Austin chip centre

The Texas town of Austin has already become the largest centre of US semiconductor technology outside of Silicon Valley. Major chip fab operations from half a dozen of the world's largest chip-makers are located in Austin, along with the Sematech chip manufacturing consortium. During the last several years, the city is also becoming a hotbed of chip design teams. Now Brooktree Semiconductor is expanding its Austin chip design centre from 35 to 100 people over the next several months.

Brooktree, which was recently acquired by Rockwell International, specialises in chip that perform multimedia functions in PCs. "Our goal is to become a major market-share player in

the multimedia PC market. To do that we're getting ready for a lot of growth", said David Gelvin, vice president of the Brooktree multimedia business unit.

San Diego-based Brooktree was purchased by Rockwell for US\$275 million in July, but is keeping its name and operating as a subsidiary.

Besides scores of independent IC design service companies, other out-of-town chip companies with Austin design centres include Analog Devices of Massachusetts, Maxim Integrated Products of Sunnyvale, California, and Cadence Design, a major maker of computer systems used in chip design.

Sony releases Web TV terminal

Capitalising on booming consumer interest in the Internet and World Wide Web, consumer electronics giant Sony has announced the Sony Web TV Terminal which allows for netsurfing via a television set. The launch came several months ahead of schedule, but Sony said the overwhelming positive response to an early production version caused the decision to escalate production.

The Sony Web TV Terminal will sell for US\$349. It represents a small box that sits atop a TV, plugging into the TV set on one end and telephone wall jack on the other. Using a remote control devices that co-functions as a keyboard, users can surf the Web on their TV set from the comfort of their couch.

The Internet access is provided through Web TV Networks of Palo Alto, California, which recently agreed to license its technology to Sony and Philips Electronics. ♦

A SHORT HISTORY OF PACKAGED POWER SUPPLIES

Nowadays, we electronics people tend to take packaged power supplies for granted — whether they're benchtop units with variable outputs for powering experimental circuits in a lab, remotely programmable units under computer control for automatic equipment testing, or the compact modules built into a wide range of equipment. But it wasn't always this way, as the author of this article explains. Currently Sales Manager of leading power supply maker Kepco Inc., he's been in the power supply industry for 35 years and has seen it evolve from very humble beginnings.

by FRANK TOICH

The power supply industry dates back to the early 1920s, when crude devices were first developed to serve as 'B' battery eliminators, to power radios in both the commercial and consumer markets.

The market for separate receiver power supplies evaporated around 1929, when most radios manufactured included a built-in power supply. The need for stand-alone power supplies remained relatively small in the 1930s and into the 1940s. The dominant technology during this period consisted of vacuum tube linear regulators.

Power supplies used vacuum tubes for both the power and control elements. Typically, a voltage regulator (VR) tube, the forerunner of today's zener diodes, was used to produce a stable reference. Control was pretty much limited to the manual twisting of knobs.

In those days we did not care too much about dissipation. Under normal circumstances, vacuum tubes ran pretty hot — and unless the plate of the tubes glowed red, or glass started to melt, no one worried much about it.

In the mid 1940s, three companies set up shop in a relatively obscure community in Queens, New York. These companies, who eventually became leaders in the industry, were Lambda, Sorenson and Kepco. While all three companies exist today, only Kepco maintains its independence and original ownership and continues to operate out of Queens, New York.

A milestone in the industry occurred in the 1950s, when semiconductors were first introduced into the power supply design. As semiconductor designs proliferated in the market, with transistors replacing tubes, concerns about dissipation and heat dominated the thinking of power supply designers. Germanium transistors did

not have the ability to glow in the dark, as did tubes — they simply melted and quit. Designers of these products suddenly had to take their thermodynamics seriously.

Products using transistors were limited to low voltage models at modest power levels, or hybrid designs which used semiconductors in the control circuit and vacuum tubes in the power

stage to make possible higher voltage products. In the 1950s, and early 1960s, power supply products adopting Mag-Amp (magnetic amplifier) technology satisfied those applications requiring substantially higher power.

This same time period also brought us the concept of the first remotely programmable power supplies. A pioneer in this field was Dr Kenneth Kupferberg, one of the founders of Kepco, who in his career was credited with 14 patents.

In the 1960s, the world was still analog. Computers were still in their early phase of development. The big debate focused on analog computing (op-amp control for simulation and modeling), and that strange concept called digital computing.

In this time frame, linear series-pass power supplies were seen more as power amplifiers than a power source. This amplifier concept exploited the high gain and linearity of the transistors and created what were, in effect, high power operational amplifiers.

As op-amps, they were made to scale, sum, integrate, or manipulate signals. To accomplish this, power supplies were being produced which allowed access to all of the control nodes. Both input and feedback control elements could be removed and substituted by the user, to permit manipulation of the output to satisfy many diverse applications.

The 1960s also saw the introduction of true bipolar (four quadrant) source/sink units, and the concept of ferroresonance for correction of source voltage variation in a highly reliable, low parts count package.

In the 1970s, an energy crisis which affected the entire industrial world provided the switching power supply with an opportunity to re-surface and

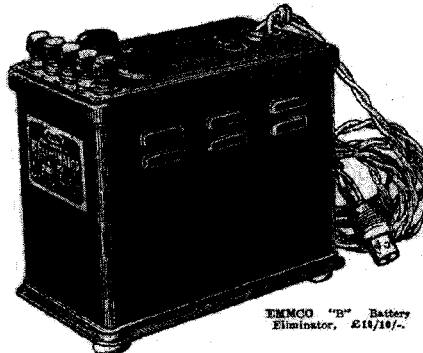

EMMCO "B" Battery Eliminator, E18/19/...

(Above) The first mains power supplies appeared back in the 1920's, advertised as 'B-Battery Eliminators'. This one was advertised in 1927, in Australia's Wireless Weekly.



(Below) Kepco's first power supply, the Model 103 Triple Output Vacuum Tube unit — made originally to power experimental valve circuits for universities and colleges.

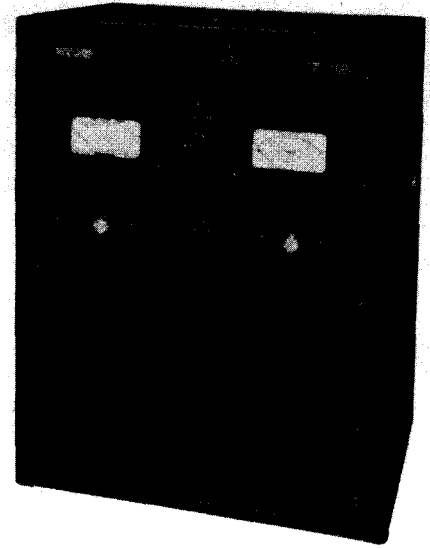
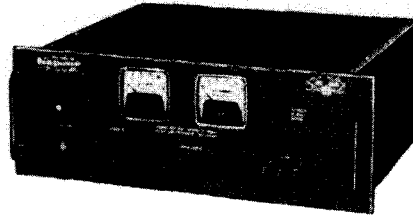

(Left) The Kepco Type SC, the company's first 'transistorised' power supply. (Centre) The Kepco Type KM, a high power supply using a magnetic-amplifier control system. (Right) The Kepco Model 700, a vacuum tube supply delivering 0-350V DC at up to 750mA.

establish a significant position in the electronic marketplace.

The design and manufacture of switching power supplies can be traced back at least to the 1950s. At that time, these products were produced in huge quantities, mostly to replace vibrators. In those days, vibrators converted an automobile's 12V DC into high voltage DC by mechanically switching the current into a transformer (the first switch-mode power supply)! Later, germanium transistors were used to switch electrically.

The fundamental problem which inhibited the advancement and greater use of this topology was its relatively low frequency range (within the mid-audio spectrum), which caused these products to whistle annoyingly.

The big breakthrough in the 1970s was the development of low-loss ferrite as a transformer core material — coupled with the readily available, higher speed silicon transistors. These made possible the practical reality of high frequency products which could operate above 20kHz, where they were inaudible.

During this same decade, the high gain series-pass linear power supply was enhanced with a new level of intelligence: the ability to follow commands from a host computer via a standard communications bus.

Digital control was being grafted onto the front end of linear power supply products. The very first interfaces consisted of resistor chains that were in parallel with reed relays, to create BCD digital control. Then came digital to analog conversion (DAC) for voltage control, and finally, in mid-decade, the power supply industry adopted the instrumentation bus standard introduced by the Hewlett

Kepco Model BOP supplies, which are of the bipolar four-quadrant type and able to sink power as well as source it.

Packard Company as HPIB. This was adopted as IEEE-488 by the Institute of Electrical and Electronic Engineers, and later renamed GPIB by instrumentation manufacturers. In Europe, this is known as the IEC bus.

Prior to this industry standard, the industry was limited to the RS-232 serial bus which was very slow and restricted to relatively limited distances between controller and instrument.

The 1980s saw many new startup companies enter the market producing switch-mode products. Many of these new companies were based in the Pacific Rim, first in Japan, and eventually shifting to Taiwan and Hong Kong.

During this decade, the quality and performance characteristics for switchers were substantially improved. Operating frequencies also increased from the 25-50kHz range on up to 100kHz and even 1MHz, as FETs replaced bipolar transistors.

So here we are now, more than half way into the 1990s, and we have already experienced numerous developments. For example, this industry,

driven by market demands, has produced switching products which operate at increasingly higher frequencies and are constructed using surface mount technology (SMT), substantially reducing their physical size.

We have seen these same products offering such features as wide range input to accommodate source voltages worldwide, active power factor correction to minimize harmonic distortion on power lines, and forced current sharing to provide these products with the capability of fault-tolerant operation.

Modern fault-tolerant power systems typically employ a technique known as parallel N+1 redundancy. The advantage of this method over the traditional paralleling scheme is the ability to distribute power (current sharing) and minimize the stress on individual units. The popularity of the

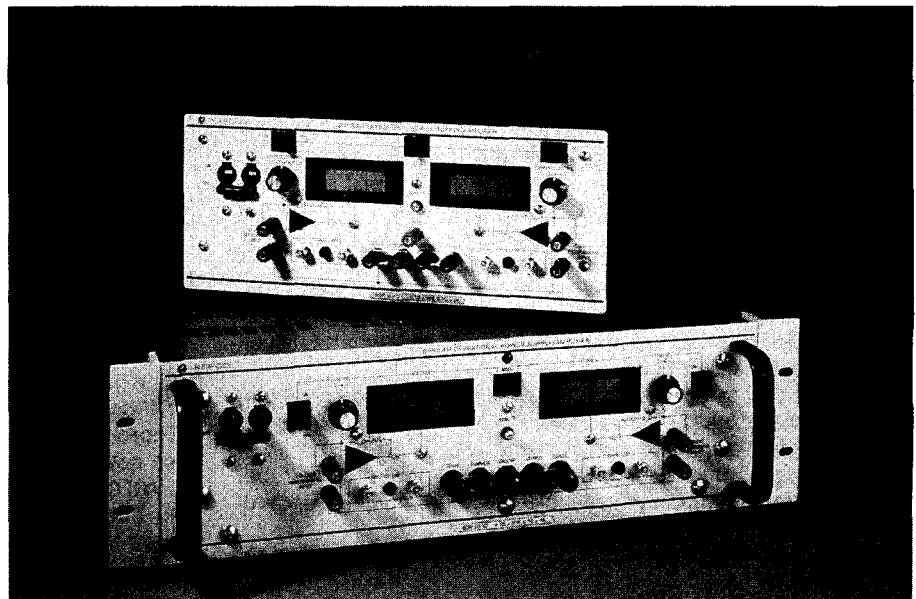

Short History of Packaged Power Supplies

N+1 redundant system approach with current sharing has increased so rapidly it has become a *de facto* standard in the industry.

Another trend which has enjoyed increased interest is that which is sometimes referred to as point-of-use stabilization; distributing the power at some intermediate voltage such as 48V, 150V or 400V. This technique is also known as 'distributed power'. It relies on the use of a bulk supply to perform the conversion of AC from the mains into DC, which then, in turn, powers any one of a number of lower power DC-DC converters placed directly at the point of load. This technique of power distribution has lowered the system wire count, resulting in more manageable harness sizes — making the products easier to build and reducing their overall size.

Instrumentation power supplies now interface with the IEEE 488.2 bus, support VXI and embrace various 'soft panel' architectures.

What's on the horizon for the next phase of the power supply evolution? Stay tuned!

Our thanks to Len Altman, principal of Kepco's Australian distributor Obiat Pty Ltd, for his help in preparing this article — which was adapted from the publication 'Kepco Currents', with permission. Further information on any of the Kepco range of power supplies is available from Obiat at



The latest Kepco ABC, a microprocessor controlled 'zero up' switchmode supply that is controllable all the way down to zero output.

129 Queen Street (PO Box 37), Beaconsfield 2014; phone (02) 9698 4111, or fax (02) 9699 9170. ♦

Kepco's own story...



I would like to share with you a little of the early history of Kepco, whose 50th anniversary we're celebrating this year.

Just after World War II, my brothers Jack, Jess and Ken and I came together to set up Kepco. Back then, we called it Kepco Laboratories. From our wartime experiences, we had some reasonable expertise in nuclear instrumentation and in all sorts of electronic gear. We were particularly interested in the possibilities for solar energy. We looked at all of these areas to decide what we might want to do and what sorts of equipment we might build.

We decided to address the possibilities for building teaching equipment, where we had some expertise too. This is how we came to design the circuit panel we called Model 103. Students could create some 30-odd circuits on this three-tube panel, using commonly available components. Cardboard overlays guided their construction.

The Model 103 triple-output power supply was designed to

power these 30 circuits. It featured a variable B+ (HT) supply for the plates and an adjustable grid-bias 'C' supply and, of course, an AC filament supply.

We had some brochures printed and I mailed copies to the chairman of every physics department, every electrical engineering department and every chemistry department at colleges around the country. We started to sell the panels, but it quickly became apparent that more people were interested in the power supply than in the circuit panel.

We recalled from our days at Los Alamos that there were lots of power supplies used in laboratories, and so we said to ourselves that this was an area where we might contribute. There seemed to be a need.

From then on, we solicited power supply requirements, designed some interesting vacuum tube and magnetic-amplifier products and began to deliver to the academic and industrial communities.

When transistors became practical, Kepco 'transistorized' its power supplies and pioneered such concepts as the programmable power supply and four-quadrant power supply.

In the mid 1970s, Kepco participated in the work of the IEC (International Electrotechnical Commission), writing safety and testing standards for the power supply industry. In that same period, Kepco began to produce IEEE 488 programmable power supplies and the analog instrument gradually became digital.

Today they work with microprocessors, keyboards and you need a password to adjust their calibration. They still work pretty good — which may be why we're celebrating our 50th anniversary.

We're a member of the VXI *plug&play* alliance and produce a wide variety of power supplies that can be linked directly to a VXI controller.

There are hundreds of companies in the power supply business now, a half century after we helped to invent an industry. We're not the largest, but a lot of customers have given us their business over the years and we're delighted to have earned their trust.

— Max Kupferberg, Kepco's General Manager

Power Supplies & Conditioners

300/100W Inverter

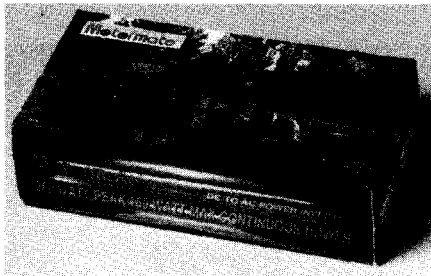

The Motormate DC to AC inverter plugs into a vehicle cigarette lighter and provides an output of 240V AC at 300 watts peak or 100 watts continuous power. It can be used to run appliances such as a computer, fax machine and cellular phone, or it can operate lights, power tools or a TV set. It can also be used to recharge batteries in portable equipment.

The inverter incorporates a low battery automatic shutdown to protect the vehicle's battery. It also has short circuit cut-off protection, over-temperature protection, and its input is fused.

For further information circle 202 on the reader service coupon or contact Powerbox Australia, 4 Beaumont Road, Mount Kuring-Gai, 2080; phone (02) 9457 2244.

5kVA to 15kVA programmable AC/DC power

California Instruments 'i' series of programmable AC/DC power supplies feature variable frequency, voltage and current functions. The 5001i is suited as a general purpose AC power source for both development and manufacturing applications. It is 178mm high, and is claimed as one of the highest power density AC power sources currently available. It has a rated output of 5kVA for a single unit configuration, and up to 15kVA for multi-unit configurations.

The series is microprocessor controlled, and is operated from a front panel keypad. Functions are logically grouped and are directly accessible from the keypad, eliminating the need to search through menus and/or softkeys. A large shuttle knob next to the display allows most parameters to be slewed up or down dynamically. The shuttle knob has a carefully tuned dynamic rate change algorithm that combines precise control over small parameter changes with quick sweeps through the entire range.

Typical applications for the series

include production testing, quality control and aircraft power simulation. They are especially useful where an appliance must be tested over a wide range of input line conditions to meet new international testing requirements. The optional low output impedance OMNI impedance matching network assures compatibility with the IEC 1000-3-2 and 1000-3-3 standards.

For further information circle 204 on the reader service coupon or contact Obiat, PO Box 37, Beaconsfield 2014; phone (02) 9698 4111.

Compact power converter modules

Amtex Electronics has available a range of DC-DC converter modules that feature small size and a power output ranging from 75W (LP series) to 100W (P series). The LP devices measure 61 x 58 x 12.7mm and the P series measure 61 x 117 x 12.7mm. Both series have an operating temperature range of 0 - 85°C in the industrial version, and -55 - +85°C



for the military version.

The series offers both single outputs ranging from 3.3 to 100V DC, and dual isolated outputs from 5 to 48V DC. Four input voltage ranges are available: 18-36V DC, 36-72V DC, 100-180V DC and 200-380V DC. The converters feature an input to output isolation of up to 2kV DC, short circuit protection, input voltage protection and parallel operation. All units have output voltage adjustment, remote shutdown and over-temperature shutdown.

For further information circle 205 on the reader service coupon or contact Amtex Electronics, PO Box 285, Chatswood 2057; phone (02) 9805 0844.

UPS has Plug 'n Play

The new PowerRite Max uninterruptible power supply (UPS) from Deltec comes with the latest version of Deltec's power management software, LanSafe III (for networks) or FailSafe III (for stand-alone systems), which includes Windows 95 plug-and-play (PnP) capabilities.

Both software packages are compatible with all major operating systems. The

PnP driver will also be included in the next release of the Windows 95 CD and on Microsoft's and Deltec's Web site. To get the PnP capabilities requires a PnP cable, available from Online Control. The UPS is available in 450, 700, 1000 and 1500VA sizes.

By incorporating its patented Advanced Battery Management (ABM) system, Deltec claims the life of the internal battery is doubled and that the user is alerted by a 60-day service warning before the battery expires. Once an alert occurs, the user can call the supplier (Online Control) and a new UPS will be sent immediately. For users who require on-site battery replacement, the UPS features a 'hot swap' capability, allowing the battery to be replaced without powering down the load.

Incorporating a network/modem surge suppression jack, the UPS also protects network cabling, modems, fax machines, and electronic equipment connected to the network.

The UPS has front panel status indicators, audible alarms, an RS-232 communications interface and is fully compatible with Deltec's LanSafe III software. In addition, it offers optional SNMP capabilities with Deltec's PowerLink II SNMP adaptor. The adaptor is MIB II compliant, is available with 10Base-2

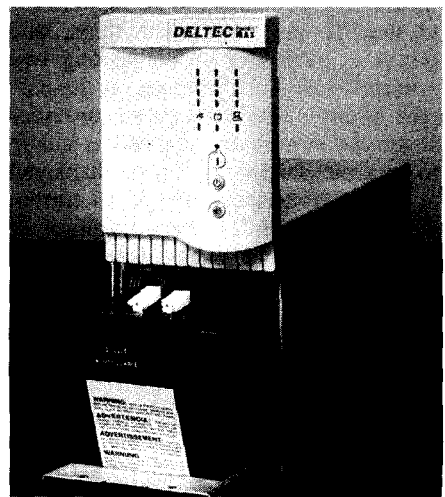

and 10Base-T support, and is compatible with both RS-232 and dry contact connections. List prices of the PowerRite Max start at \$593.

For further information circle 206 on the reader service coupon or contact Online Control, 29-31 Carlotta Street, Artarmon 2064; phone (02) 9436 1313. ♦

NEW PRODUCTS

Virtual DSO, spectrum analyser and DMM

The Pico ADC 200 is a virtual instrument designed for use with a PC. Together with PicoScope software, it performs the functions of a 50MS/s dual channel digital storage oscilloscope (DSO), a spectrum analyser or multimeter. The external trigger connector doubles as a simple signal generator.

The device plugs into the parallel port of the PC, and can be used with desktop or notebook computers, in the field if necessary. A signal can be viewed in several ways simultaneously. For example, a screen display can show an actual waveform, frequency components of the waveform like a spectrum analyser, AC voltage and frequency. The DSO function includes FFT spectrum analysis, oversampling for noise reduction and resolution enhancement, plus autoranging voltage selection.

The ADC 200 can also be used as a high speed data acquisition-data logging device. Windows (Visual Basic, Delphi and Excel), C and Pascal drivers are supplied, so the user can develop software to automate measurement, test and diagnosis activities.

Two versions are available: the ADC 200-50 with a sample rate to 50MS/s and spectrum analysis to 25MHz, and a lower cost unit with 20MS/s and spectrum analysis to 10MHz. Both units are supplied with cables, power supply

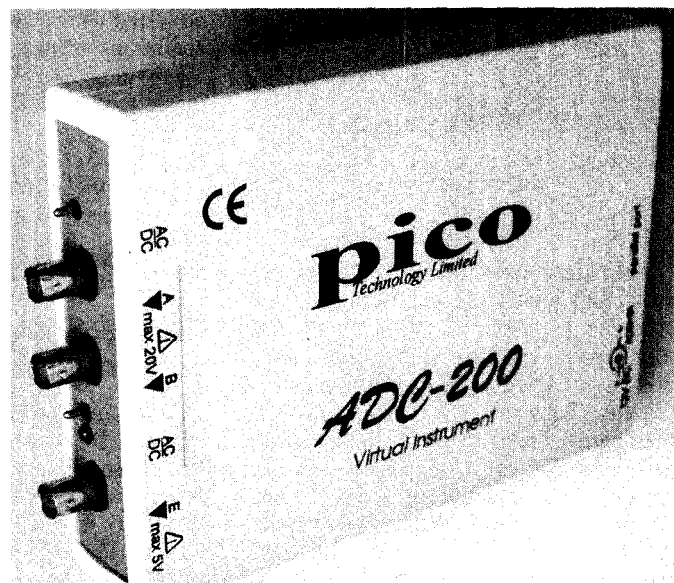

and all necessary manuals.

For further information circle 248 on the reader service coupon or contact Emona Instruments, PO Box 15, Camperdown 2050; phone (02) 9519 3933.

True RMS power meter

The AEMC true RMS power meter model 3910 is claimed to be very simple to use. It has four pushbuttons, and power is measured by connecting two voltage leads and clamping on the current probe. The instrument provides seven power measurement values and up to four measurements can be displayed at a time. It measures true RMS current and voltage, and shows readings of power factor (PF), active power (kW),

reactive power (kVar), apparent power (kVA) and frequency (Hz). The meter displays RMS voltage, current, active power and power factor on the first screen; and kVar, kVA and Hz on a second screen, accessed by a pushbutton. It can perform power measurements for single phase or balanced three phase, three-wire systems.

The Peak function lets the user select current, voltage or power for a peak measurement, and also displays the

associated values at that particular peak. For example, it displays the actual V, kW, PF, kVar, kVA and Hz values when peak current is selected. A memory function stores measurements, and lets the user compare subsequent readings by displaying the difference between the stored values and the new readings.

For further information circle 247 on the reader service coupon or contact Obiat, PO Box 37, Beaconsfield 2014; phone (02) 9698 4111.

CD jitter meter

Leader Instruments has released the new DVD/CD LE1853 jitter meter, designed to measure the jitter in EFM signals used for DVD players, CD players and CD-ROM drives, for up to x8 speed operation. Real time measurement is made by detecting the 3T component of the EFM signal and the instrument has a selectable high sensitivity up to 3ns. The GO/NO GO functions for the jitter and RF level measurement are ideal for production and inspection applications, service departments, and research and development.

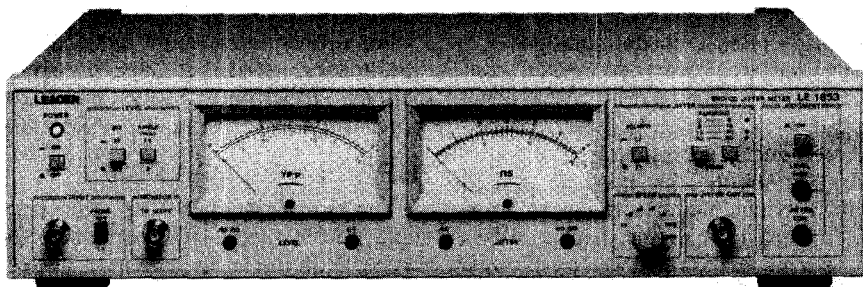

For further information circle 244 on the reader service coupon or contact

Stantron Australia, PO Box 4760, North Rocks 2151; phone (02) 9894 2377.

Test instruments with auto function select

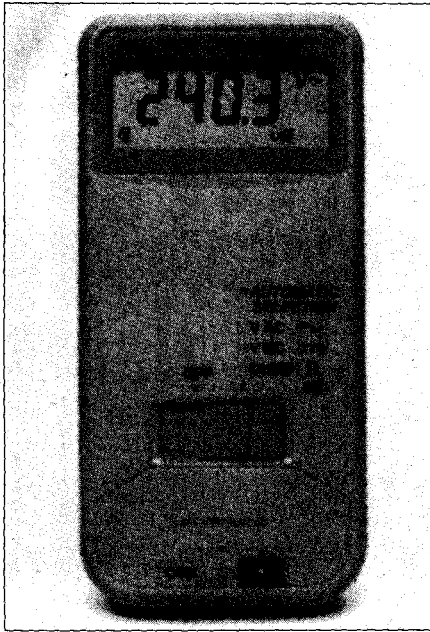

Fluke has announced four new test instruments: the 12B digital multimeter (DMM); the 7-300 and 7-600 electrical testers; and the VoltAlert voltage detector. The new electrical testers are claimed to be ideal for both entry-level users and for professionals as a first-line troubleshooting tool. The testers feature automatic selection of voltage (AC or DC), continuity and resistance, and a 4000-count digital display. The 7-300 measures AC and DC voltages to 300 volts, the 7-600 measures to 600 volts.

The VoltAlert AC line voltage detector pen has a touch-and-glow sensor that detects 90 to 600 volts AC. To test for energised circuits and defective earth connections, the user touches the insulated probe tip to an outlet, wire or metal enclosure. It operates on two AAA alkaline batteries and is UL, CSA and TUV listed.

Like its predecessor, the new meter has recording features to capture intermittent problems. Its 'V Chek' function will indicate open or short circuits, and automatically switches to measuring AC or DC volts. It also distinguishes real voltages from 'ghost' voltages and has overload protection if the resistance mode is used on a live circuit. Its min/max feature records the highest and lowest voltage readings during a 100-hour period and time stamps them to the nearest minute. The meter can also measure capacitance values up to 10,000uF.

For further information circle 245 on the reader service coupon or contact Obiat, PO Box 37, Beaconsfield 2014; phone (02) 9698 4111. ♦

Benefit by Bernie's better buying!

"Because I search worldwide for special stock offers, especially stockists quitting lines or terminating businesses, I am constantly aware of how to find the right equipment at the right price ... which is why I always have a big variety of stock, so when you want a particular piece of test and measurement equipment" **First!**

Ask Bernie First!



Bernie's Bargains

Austron 2010B Oscillator 1MHz.....	\$400
AWA A215-2 Trans. Measuring set.....	\$175
AWA E221 Level Meter.....	\$650
AWA F240 Distortion & Noise Meter.....	\$375
AWA G231 Audio 10Hz-30kHz.....	\$495
AWA G250 Test Oscillator 10Hz-10kHz.....	\$525
AWA G251 Level Oscillator 50Hz-2MHz.....	\$400
BALLANTINE 323AC Voltmeter.....	\$425
BECKMANN L10A Megohmmeter.....	\$1400
EATON 2075 Noise Gain Analyser.....	\$2500
ESI DR62 Decade Box.....	\$350
EUROCARD 4 Slot Frames.....	\$40
FLUKE 408B 84V 20mA Power Supply.....	\$800
GR 1381 Random Noise Generators.....	\$160
HP 204C Oscillator.....	\$225
HP 332A Distortion & Noise Meter.....	\$495
HP 334A Distortion Analyser 50Hz-600kHz.....	\$795
HP 353 Audio Attenuator.....	\$170
HP 400EL AC Voltmeter.....	\$195
HP 403B AC Voltmeter.....	\$150
HP 410C Multimeter.....	\$295
HP 427A Voltmeter.....	\$ 95
HP 432A Power Meter CWV Head & Cable.....	\$825

HP 435A Power Meter.....	\$495
HP 452A Test Oscillator.....	\$375
HP 454A Test Oscillator.....	\$495
HP 3336B Synthesizer/Lev. Generator.....	\$1650
HP 3400A RMS Voltmeter (1mV-300V).....	\$475
HP 3406A Broadband Sampling Voltmeter.....	\$575
HP 3555B Transistator & Noise Meas. Set.....	\$325
HP 3586B Selective Level Meter.....	\$1450
HP 4204A Oscillator 10Hz - 1MHz.....	\$350
HP 4260 LCR Bridge.....	\$295
HP 5248L/5253/5255 Electronic Counter.....	\$550
HP 5326B Universal Three Counter DPM.....	\$295
HP 5328A Universal Counter to 500MHz.....	\$495
HP 5335A 200MHz Universal Counter.....	\$4500
HP 6002 50V/10A Power Supply.....	\$1495
HP 8005A Pulse Gen. 20MHz 3-Channel.....	\$350
HP 41785/53555A Spectrum Analyser.....	\$7995
HP 8614A LHF Sig. Generator.....	\$525
HP 8640B Sig. Gen. 0.5 - 1024MHz.....	\$3995
HP 8690B/8698/8699 400Hz-4GHz Sweep Osc.....	\$2450
HP 8690B/8707A/8706A 4GHz-18GHz Sweep Osc.....	\$1500
MARCONI TF200S FM Sig. Gen. 100MHz.....	\$800
MARCONI TF2300A FM/AM Mod Meter 500kHz-1000MHz.....	\$450

MARCONI TF2500 AF Power/Volc Meter.....	\$180
MOTOROLA Sine Meter.....	\$325
NORTHEAST 400A Transducer Meas. Set.....	\$400
RACAL/DANA 9000 Universal Three Counter.....	\$350
SD 6054B Freq. Counter 20MHz - 1GHz.....	\$2500
SD 6054C Microwave Freq. Counter 1GHz - 18GHz.....	\$2000
SD 6152A 512MHz Counter/Timer.....	\$350
SYSTRON/DONNER 763 Spec. Analyser.....	\$3250
TEKTRONIX FG504/VT1503 4MHz Freq. Gen.....	\$1295
TEKTRONIX 047-0502-01 Scope Calibrator.....	\$550
TEKTRONIX 402 XY Display.....	\$350
TEKTRONIX Spectrum Analyser System (7619 Scanner, Handbook, 7L13 Spec. Analyser, plus 4 TR041 Tracking Generator, TH 503 3 Sec. Mainframe) (1024Hz - 180MHz).....	\$5600
WAGGERS Selective Level Meter CWV/WAG 753 Signal Generator 300Hz - 612kHz.....	\$450
WAVETEK 148 Function Generator 20MHz.....	\$495
WAVETEK 807 Signal Generator 7.1MHz.....	\$1600
WAVETEK 3000/200 Sig. Generator/Deviation Meter.....	\$1250

Great prices on new equipment!

LODESTAR

Affordable Laboratory Instruments

- Single Output Supplies.....From **\$265**
 - 0-30V & up to 0-10A • Two output meters • Constant 11V
- Digital Single Supplies.....From **\$320**
 - 0-30V up to 0-1A • Load & line regulation $\le 0.1\%$ • 3mV
 - Constant voltage digital display • Constant current analog display
- Dual Output Supplies.....From **\$420**
 - 0-30V & up to 0-3A • Four separate output meters
 - Independent or tracking modes • Low ripple output
- Digital Dual Supplies.....From **\$640**
 - 0-30V & 0-5A • Load & line regulation $\le 0.1\%$ • 3mV
 - Independent or tracking modes • Low ripple output
 - Constant current voltage • 1 x 1.5 dual purpose digital voltmeters
- Pattern Generators.....From **\$275**
 - Colour pattern to test PAL system circuit
 - Dot, cross hatch, vertical, horizontal, raster, colour
- Power Meters.....From **\$150**
 - SWR90 (Model 30) 1.5 - 200MHz • 4W / 20W / 200W
 - mTR90 (Model 30) 1.5 - 200MHz • 20mW / 200mW / 2W 4270 + Tr
- Grid Drip Meters.....From **\$125**
 - DM481 • 1.5MHz - 250MHz • 6 band freq. range
 - Modulation 20kHz approx. sine wave

C & C INSTRUMENTS CO., LTD.

FCI 13L Reciprocal Frequency Counter (1.3GHz)

Now only **\$295**

FCI 13U Universal Frequency Counter (1.3GHz)

Now only **\$395**

SAMPO

The name that means quality

SSI - 2360 60MHz Scope - Now only **\$1,110**

As Australian agent for Weinschel Associates, Macservice is able to offer you sensational prices on all your attenuator requirements.

Service & Repairs

Macservice employs a team of fully qualified electronic technicians. Which means you can be assured of a reliable, specialised, back-up network for repairs and service at a price well within your expectations. We've taken the shack out of after-sales service.

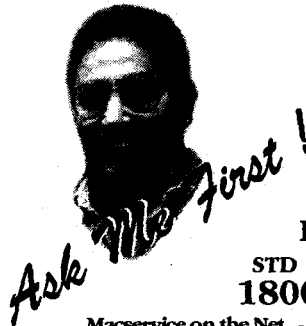

New Info Hotline
STD Freecall
1800 680 680

Macservice on the Net - visit our WEB Site
Web: <http://www.macservice.com.au/>
Email: enquiry@macservice.com.au

Macservice Pty Ltd 20 Fulton Street, Oakleigh Sth, Vic, 3167
Tel: (03) 9562 9500 Fax: (03) 9562 9590



Australia's Largest Remarketer of Test & Measurement Equipment

READER INFO NO.20

WIN ONE OF TWO Hewlett Packard 54645A Two Channel 100MHz Oscilloscopes

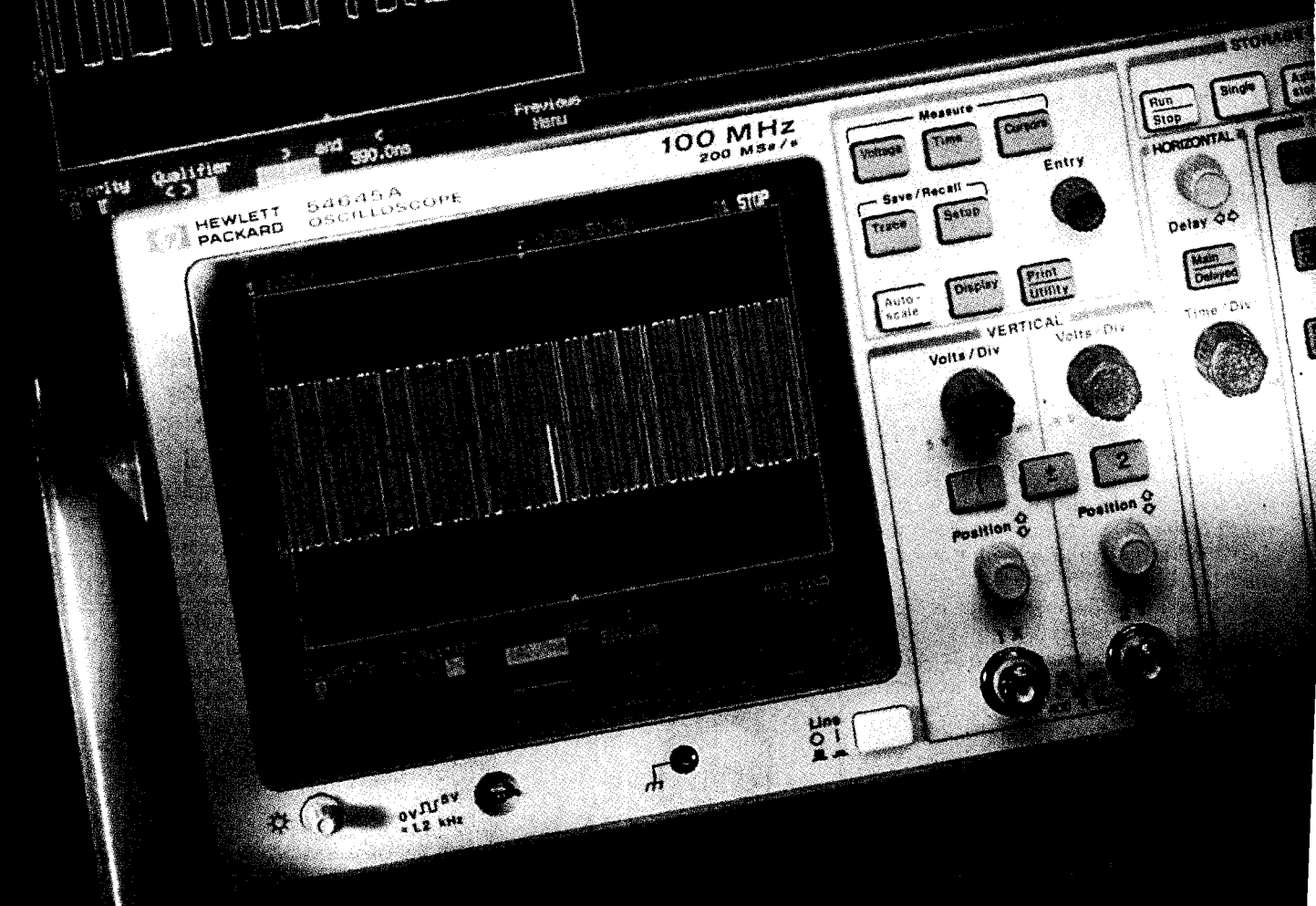

TOTAL PRIZE VALUE
\$10400

HURRY!

ELECTRONICS AUSTRALIA in conjunction with **Hewlett Packard** are giving away two **HP 54645A Two Channel Oscilloscopes** valued at \$5200 each.

To address unmet needs of high speed circuit designers, Hewlett Packard have introduced the **HP 54645A dual-channel oscilloscope** which is the highest performance product in the **HP 54600-series 100MHz** line.

The **HP 54645A** is ideal for the engineer or for anyone who is looking to simplify test procedures and speed up setup with an all-in-one solution.

Features of the **HP 54645A** include:

- Dual-channel 100MHz scope with 200 MSa/s
- 1 MB of memory per channel
- HP MegaZoom technology allows deep memory capture and a responsive display
- Simple easy-to-use controls
- Powerful triggering

HOW TO ENTER:

Simply subscribe to *Electronics Australia* for the discount price of only \$49, (saving you \$17 off the normal cover price) and you will receive automatic entry into the draw to win one of these two Hewlett Packard oscilloscopes.

Save over 25%

It's like getting 3 issues free

TO SUBSCRIBE:



FREECALL 1800 800 933
with your credit card details ready



Card attached to:
Federal Publishing Subscriptions
Reply Paid No.3 PO Box 199
Alexandria NSW 2015 (no stamp required)

fax (02) 9353 0967

WE'LL RUSH YOU THE FIRST AVAILABLE ISSUE.

Any new subscriber 1 year only required? Call our customer service line on 1800 800 933

Electronics Australia is a leading authority on the latest in electronics technology. We provide a comprehensive range of products and services to our subscribers. Our products are designed to meet the needs of both professional and amateur enthusiasts. We offer a wide range of products including oscilloscopes, signal generators, and test equipment. Our services include technical support, training, and consulting. We are committed to providing the highest quality products and services to our subscribers. We are currently offering a special promotion where subscribers who subscribe to Electronics Australia for one year will receive a Hewlett Packard oscilloscope. This offer is limited to the first 1000 subscribers. To take advantage of this offer, please contact our customer service line on 1800 800 933. We look forward to serving you and helping you achieve your electronics goals.

OFFER ENDS 21ST JANUARY, 1997.

Queensland Industry Feature:

ANOTHER GOOD YEAR FOR GRIFFITH UNI'S IAP

1996 was the fourth year of operation for Griffith University's innovative Industrial Affiliates Programme, in which final year undergraduate students in the School of Microelectronic Engineering worked with both private and public organisations on important R&D projects. This year some 28 projects were completed successfully, and the programme is expected to grow substantially in 1997.

The partnership between Queensland industry and fourth year Griffith University microelectronic engineering students has led to the successful completion this year of 28 projects, and the State's technological firms and organisations are being invited to seek involvement in the program in its fifth year in 1997.

The innovative, educational Industrial Affiliates Programme enables students to use the extensive electronic resources of the University to work on important research projects in a 'real life' situation, with an industrial partner. The programme is not only beneficial to the students' education, but also assists the development of high technology, intelligent electronics for Queensland's industries.

Chair of the Engineering Board of Studies and Director/Founder of IAP is Professor H. Barry Harrison, who is justly proud of the way it has taken off.

"Once again, the Industrial Affiliates Program, which aims to produce industry-ready graduates, will be of tremendous benefit to both students and Queensland industry," he said.

"Industrial partners gain an undergraduate — usually for three months, four days a week from late February to early June each year — who is committed to succeed."

"While students are exposed to the most recent technologies and techniques in particular industry areas, they gain valuable experience as well as an understanding of commercial operations. The end result of the Programme is a student with a broad understanding of the processes involved in making an industry work."

Professor Harrison said he anticipated a large influx of IAP industrial partners next year — up to three times the number involved during 1996.

During the past four years, 130 students have been placed in 65 companies

throughout south-east Queensland through the Industrial Affiliates Programme.

Details of some of the successful projects undertaken by IAP students in 1996 follow:

Fishing electronics

Brisbane electronics firm TMQ Electronics provided microelectronics undergraduate Binh Nguyen with the facilities to produce a serial interface unit that allows a computer to communicate with 12 input/output devices for standard fishing electronics equipment. The project is likely to benefit Queensland's commercial fishing industry.

TMQ Electronics Technical Manager Roger Webber said Binh's prototype was ready for preliminary testing. He said TMQ would be applying the research to the fishing industry, but the technology could be used whenever a large amount of data needed to be fed into a computer.

"We can use it on equipment such as

marine echo sounders, marine autopilots, radio communications/vessel location devices, global positioning satellites, plotting system keypads, Inmarsat terminals, seawater temperature devices and radar targeting systems," he said.

Mr Webber said the previous system could only communicate with four input/output devices, and the data units were not RS-232C compatible and operated at different communication rates.

"When the serial interface unit receives the data from input/output devices, firstly it checks to determine whether the data is correct or not. If the data is correct, it then packs it into a format and sends it to its destination," he said.

"The destination and data formats are initialised and controlled by the computer. The C-Coms unit will allow the PC to communicate with more devices and reduce the computer overhead times," he added.

Mr Webber said Binh had been an asset to the company.

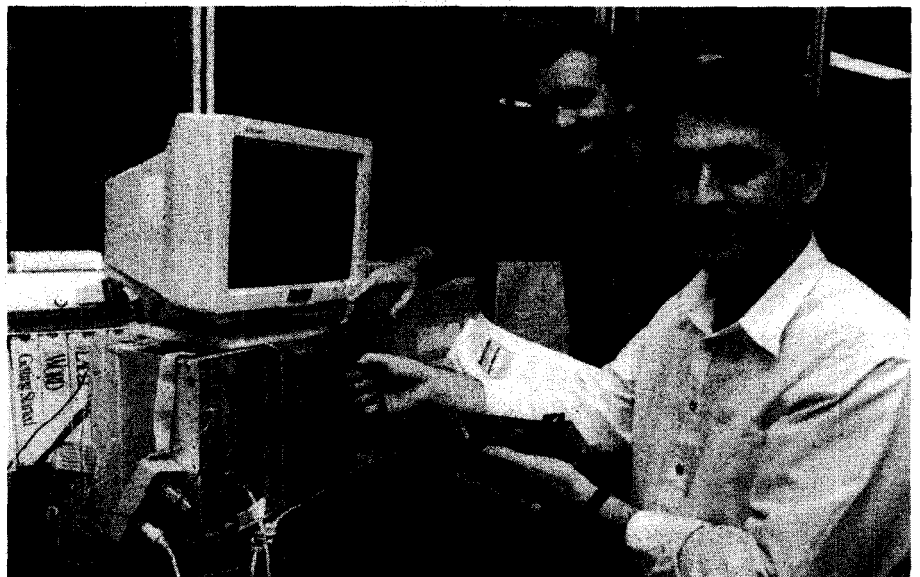

Foxboro L&N's Andrew Ward with IAP student Mark Hitchings (right), who worked on diagnostic software for SCADA remote control equipment.

"It was a very difficult project and every extra person helps", he said.

Parcel sorting simulator

Australia Post could soon have access to a more efficient and user-friendly Parcel Sorting Machine, thanks to the research efforts fourth year Griffith microelectronic students Zivan O'Sullivan and Andrew Hargreaves, who have been working at Australia Post's Engineering Branch at West End. This is the third year Australia Post has been an IAP partner.

Sectional Head of Electronic Development for Australia Post, Murray Dawson, said he was very pleased with the progress of both students and their software program.

"The final product will be a complete simulation software package to model Underwood's Parcel Sorting Machine," he said. "The project will increase the performance of the existing Parcel Sorting Machine as well as becoming a design tool in the development of new parcel sorting machines."

Mr Dawson said Andrew Hargreaves had been involved with the graphical side of the project, while Zivan O'Sullivan's involvement in the project was to develop a computer software package to control and monitor the operation of the Parcel Sorting Machine.

"In effect, we are using computers to design and provide a statistical analysis of the performance of parcel sorting machines with the end result being the optimum delivery of parcels", Mr Dawson said. He added that Australia Post will be able to use the technology the students had developed in a number of areas.

Diagnostic software

A more user-friendly and informative computer program with applications in mining industries and transportation systems has been developed as a result of fourth year microelectronics student Mark Hitchings working with Foxboro-L&N on diagnostic software for SCADA remote control equipment.

Mark's project, which he successfully completed, was to write software to run on a portable personal computer, allowing the user of the software to obtain data from Foxboro-L&N's equipment.

According to Firmware Design Engineer Andrew West from Foxboro-L&N, the computer program provides an auxiliary mechanism for obtaining and displaying data measured from the power grid by his company's equipment.



IAP student Glen Grice with Dr Bruce Goldberg of Creative Audio. Glen worked on the design of a new portable PA amplifier.

"This software also has applications in monitoring and controlling transportation systems such as railways, oil and gas pipelines and some mining applications", he said. "Ultimately, this software will provide Foxboro-L&N's customers with greater security and flexibility in the operation and maintenance of their control systems."

Mr West said this was the third year his company had been an IAP partner. Two previous IAP microelectronic students are working full-time at Foxboro-L&N.

Order Now!

Note: Tax exempt an order and exemption certificate must be supplied

Name: _____
 Address: _____
 State: _____ P/code: _____ Phone: _____

Qty	Item	Price	22 % Tax	Total
	Ungar 921ZXE	\$ 159.00		
Payment method: _____ Freight \$ 8.90				
<input type="checkbox"/> Cheque <input type="checkbox"/> Money order <input type="checkbox"/> Credit card				
Card Number: _____				
Name on card: _____				
Exp Date: / /19 Signed: _____				

ECONOMIC ELECTRONICS 22 Campbell Street Bowen Bowen Hills QLD 4006 Telephone: (07) 3252 3762 Facsimile: (07) 3252 5778	SOUTHPORT ELECTRONICS Unit 11, Brickworks Centre Warehouse rd Southport QLD 4215 Telephone: (07) 5531 2598 Facsimile: (07) 5571 0543
---	---

Ungar 921 ZXE

Buy Now

Here's How You Benefit.

- Reliability
- Temperature variable
- Quality
- Light weight, long life design
- ESD safe
- Full range of tips & parts

from
Weller

NEW

\$ 159.00 + 22 % Sales Tax

Save \$ 47.70
On RRP

READER INFO NO. 21

Another Good IAP Year

New audio amplifier

Organisations as diverse as churches, schools and amateur sporting bodies may benefit from the partnership between Brisbane firm Creative Audio and micro-electronic undergraduate Glen Grice. Creative Audio's project consisted of the design, manufacture and testing of an audio amplifier to be used in a portable public address system. The system is intended for use by organisations with a limited budget, but who need to be heard over a medium-sized area.

Creative Audio's Engineering Director Neil Packer said his company already sold a product using a similar amplifier, but wished to improve upon the design.

"The current design is 20 years old and needed to be brought up to date. The aim of Glen's project was to improve the product and redesign the amplifier to make it more cost effective", he said.

This is the third year for Creative Audio as IAP partners. The company has previously employed two AIP microelectronic graduates.

Mr Packer said the project would have been difficult for any student and Glen had acquitted himself well.

"He has a bench prototype ready and is in the process of completing a circuit board. If possible, we would like him to continue on the project with us", he said.

Hazard arrow display

Brisbane company Excel Infotech, in conjunction with undergraduate micro-electronic student Stephen Hill, have designed a control circuitry for a hazard arrow display. The display, to be mount-

IAP student Ian McKeachie (left) with Micromedical Industries' Andrew Loch. Ian worked on DSP algorithms for Micromedical's handheld 'Biolog' ECG monitor.

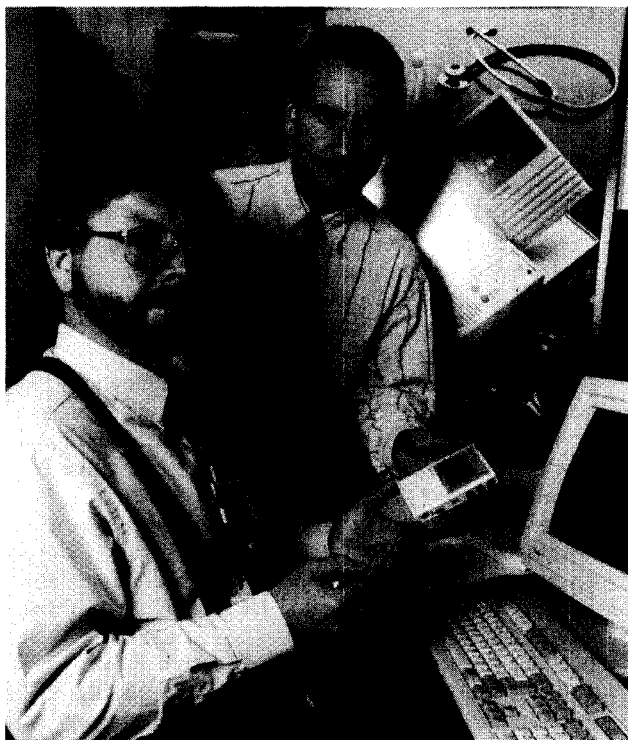

ed on a vehicle, will direct traffic at a roadwork site by using four arrow patterns, and is expected to improve operational safety for Main Roads Department and Council road crews. This is the second year Excel Infotech has been involved as an IAP partner.

Excel Infotech's Director of R&D Paul Higgins said his company — in conjunction with the manufacturer of the arrow display signs — will install the controller as part of an overall vehicle-based package.

"The aim of the project, which has been achieved, has been to design and produce an Australian-made control circuit proto-

type which conforms to Australian standard AS 4192", he said.

Mr Higgins said similar hazard arrows were already being used on the roads, but they were mostly American designed and imported.

"There is increasing demand for an Australian version of this product, especially with Workplace Health and Safety concerns and the fact that people are driving faster. There's no doubt that the hazard arrow may one day save a roadworker's life," he said.

Mr Higgins said Stephen had been diligent and meticulous with his work and documentation of the project.

ACN 009 892 031

TRADE WHOLESALES & RETAIL

HP HEWLETT PACKARD PALMTOP COMPUTER

HP200LX FEATURES

- IBM PC architecture
- 1meg or 2meg RAM available
- PCMCIA or PC Card Slot
- Serial Port for printer/modem
- Uses 2xAAA batteries & supports recharging of nicads
- Hewlett Packard quality & reliability
- Optional connectivity pack to transfer data to office computer, mobile phone, etc.



November special only
FREE 1.8meg RAM card
+ 57 software applications
\$1600 worth \$1275 inc tax

INBUILT SOFTWARE

- IBM DOS 5 • LOTUS 123
- POCKET QUICKEN • APPOINTMENT BOOK
- DATA COMMUNICATIONS • CC: MAIL
- FILLER • HP FINANCIAL CALCULATOR
- MEMO & TEXT EDITOR • NOTE TAKER
- DATA BASE • PHONE BOOK • WORLD TIME

QUEENSLAND DISTRIBUTORS OF

- * SWANN (McMURDO)
- * AUDITEC AUDIO MODULES
- * ALTRONICS
- * HEWLETT PACKARD
- * TRIMBLE
- * GME ELECTROPHONE
- * ARISTA PRODUCTS
- * ICON COMMUNICATIONS
- * TOA
- * ALPHONE
- * GARMIN
- * A.K.G.

1 Wickham Terrace,
Cnr Ann & Wharf Sts,
Brisbane. Q 4000.
Phone (07) 3839 6155
Fax (07) 3832 5278

DELSOUND

CUSTOMER PARKING AT REAR

OVERNIGHT PHONE ORDER AVAILABLE

READER INFO NO. 22

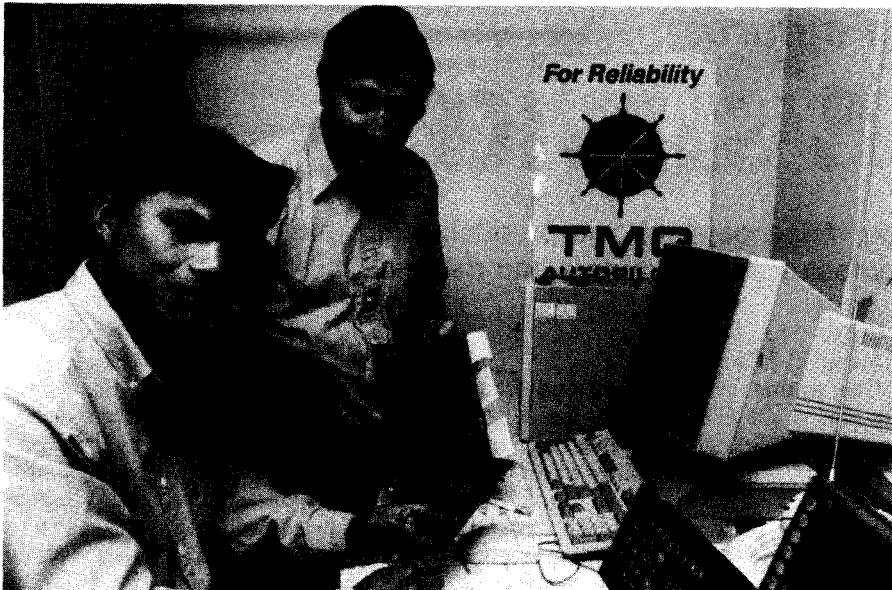

IAP student Binh Nguyen (left) with Roger Webber, technical manager at TMG Electronics, where Binh designed an I/O multiplexer for fishing electronics.

Flow rate display

Working with an IAP partner which does not wish to be named, fourth year Griffith University student Adam Ransley has produced a prototype for a fully electronic flow rate display. The display is capable of running off a lithium battery for approximately four years.

The host company's Project Engineer Grant Woolston said the electronic flow rate display was capable of operating over a large flow range. It also had a low power consumption and could be used in remote areas because of its battery power supply.

"The main use of this project, which is 90% completed, is to meet a possible future customer requirement for a flow rate display. The working prototype will accept pulse inputs from large and small diameter measurement equipment", he said.

Mr Woolston said Adam's work had been very worthwhile. "Adam's presence here gave us a chance to look to the future, discover the pitfalls that could occur with a fully electronic flow rate display and learn more about its technology," he said.

Portable ECG monitor

The work of Griffith undergraduate student Ian McKeachie at IAP partner firm Micromedical Industries is expected to attract further international interest in an Australian heart monitoring system.

The unique hand held 'Biolog' monitor developed by Queensland's Micromedical Industries, is a small portable ECG monitor used by physicians to monitor patient heart activity.

The Biolog monitor can transmit ECG data to a standard PC running Micromedical's ECG and patient database software product, called 'CardioView'. Together the Biolog and CardioView products form a sophisticated ECG monitoring system which can be used in telemedicine applications.

Micromedical Industries has already generated sales in Europe and the United States, where there is no similar product as compact and portable as the Biolog.

Final year Microelectronic Engineering student Ian McKeachie, working in close cooperation with Micromedical Industries' research division, developed Digital Signal Processing algorithms which further enhance the capabilities of Micromedical's products in the field of Telemedicine.

Mr McKeachie's software used Digital Signal Processing (DSP) algorithms executing on a commonly available PC DSP card, to improve Micromedical's transmission techniques of ECG data over standard telephone lines. This solution meets international telecommunication standards, allowing Micromedical to further enhance their overseas markets.

All patients have to do is dial their GP or surgeon who is equipped with the 'CardioView' software, hold the 'Biolog' to the phone, and the information is automatically transmitted for diagnosis.

Companies and organisations in Queensland industries interested in joining the Griffith University School of Microelectronic Engineering's Industrial Affiliates Programme in 1997 should contact the Manager, Carol-joy Patrick on (07) 3875 5007 or fax (07) 3875 6726. ♦

POWER PROBLEMS?

W.E.R. TAX AGENTS

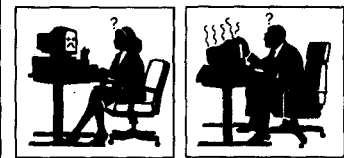

EXACTO FACTORY



ETTAMOGAH

WORKERS CLUB

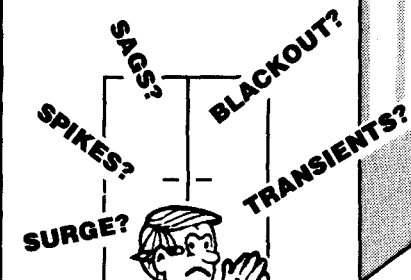
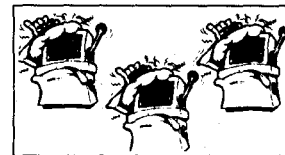

**CALL
PRECISION POWER**

008 777 446

READER INFO NO. 23

Queensland Industry Feature:

PRODUCTS & SERVICES

Here's just a sampling of the wide range of electronic products and services currently being offered by Queensland-based manufacturers, distributors and dealers...

Computerised transformer testing

Torema Australia is a leading Australian manufacturer of toroidal products including single and three phase power transformers, current transformers, audio output transformers, and inductors, with power ratings vary from 30VA to 18KVA. Recently the firm installed a new computerised transformer testing facility at their Brisbane factory. The installation of this new equipment is in line with the company's ongoing commitment to producing transformers of the highest quality, accompanied by the best pos-

sible level of service.

The testing system, purchased from Optimised Devices Inc. in the USA, comprises an accurate measurement electronics unit controlled by a personal computer. A wide variety of automated tests can be performed on each toroidal transformer, including winding resistance, output voltage, turns matching, excitation current, power loss, leakage inductance, inter-winding capacitance and insulation breakdown.

Additionally, all Torema transformers have a serialised part number which allows individual transformer test results to be automatically archived. This permits 100% traceability for all transformers.

All transformers manufactured are passed through this facility as a final production test, and are dispatched to customers with a printed report to verifying the test results. This report contains electrical test results and statistical information which allows Torema to guarantee 'six sigma' quality, as demanded by NASA and the US Military. All tests conform to industry standard test practices, and all measurements are directly traceable to international standards.

For further information, Torema Australia can be contacted directly at 12-14 Helium Street, Narangba (PO Box 244, Kallangur 4503); phone (07) 3888 2122 or fax (07) 3888 1432.

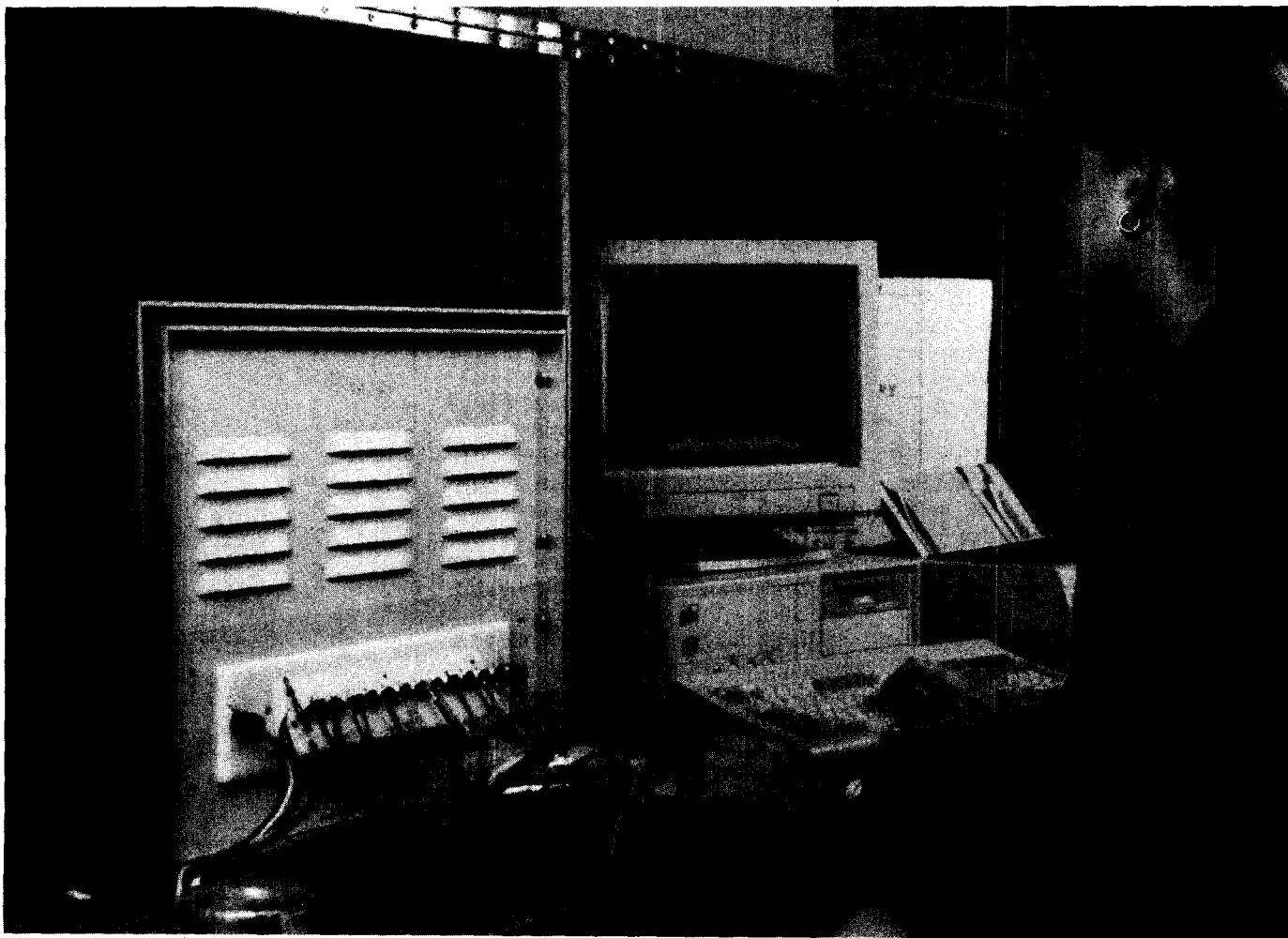

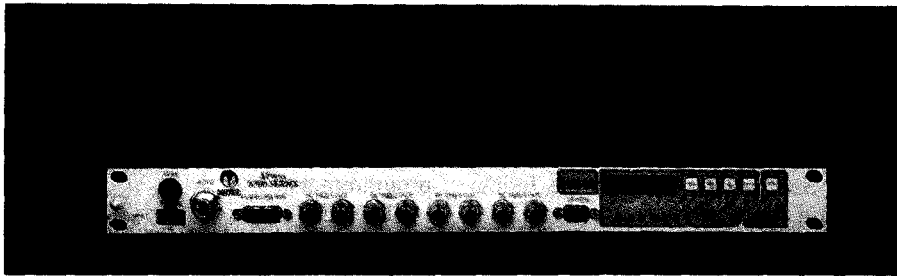

New Mitec factory, products

When questioned recently about what Australia's leading microwave technology company Mitec had been up to over the last year, Sales & Communications Manager Tony Reading commented "Mitec hasn't been sitting idly over the last 12 months — much has happened. Earlier this year, the company relocated from its eight separate buildings into a new purpose-built factory located in Brisbane's western suburbs.

Coinciding with the move, Mitec has also released a string of new products. The company has a contract with the Commonwealth to supply the most powerful solid state power amplifiers (SSPAs) available on the world market today. This highlights Defence's commitment to Australian industry and technology, and its confidence in Mitec.

But innovation has not been limited purely to SSPA technology. Mitec has also recently released its XPress 6500 series of Digital Millimetre Wave Radio Terminals, for high reliability short distance point to point communications. The XPress series are capable of flexible data transmission up to 16Mb/s, and employ advanced technology including a dielectric lens and hybrid assemblies using monolithic microwave integrated circuits (MMICs). A software based system allows operating parameters such as frequency, power levels and bandwidth to be reconfigured by remote dialup modem. They are easy to instal, offer a low system life cycle cost and are claimed to give Mitec a market lead of about 12 months.

Mitec's successful 10.5GHz 2Mb/s U-Link has also undergone a major upgrade, to make the equipment even more compact, as well as easier to instal

MICROWAVE COMMUNICATIONS INNOVATION

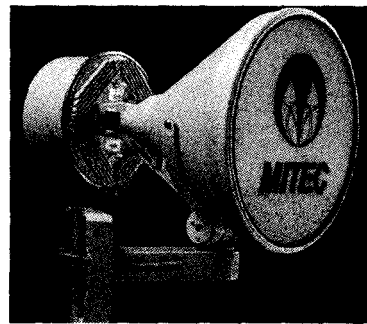

The MITEC XPress 6500 Series of Digital Millimeter Wave Radio Terminals are designed for high reliability short distance point-to-point communication. The XPress employs advanced technology such as:-

- Hybrid assemblies using Monolithic Microwave Integrated Circuits (MMIC)
- Software-based radio operating system
- Flexible data transmission rates up to 16Mbit/sec.
- Ease of installation
- Low system life cycle cost



MITEC

MITEC Limited,
532 Seventeen Mile Rocks Road,
Sinnamon Park. Qld 4073

Tel: (07) 3291 6333 Fax (07) 3291 6350

READER INFO NO.25

WIN

The Latest Exciting New Magnum & Virus Buster Software Packages

In The Magnum Challenge

Your Computer & Leprechaun Software, producers of the dynamic new high security package, Magnum and Australia's leading anti-virus software, Virus Buster throw down the challenge to you.

Complete this coupon and fax, mail or E.mail it to us & we will send you a FREE diskette with an encrypted message .

Do what a Pentium can't do in a million years & decode the message!

Then the prize is yours!

Leprechaun
SOFTWARE PTY LTD

+61 7 3823 1300 Fax.+ 61 7 3823 1233
BBS.+61 7 3823 1288

To Leprechaun Software, PO Box 826 Capalaba Q 4157.
Please send me my free Magnum encrypted message as part of the
Magnum challenge

Name: _____
Postal Address: _____
State: _____
Postcode: _____

READER INFO NO.24

READER INFO NO.24

Queensland Products & Services

and operate. Variants of the U-Link have been a runaway success in New Zealand, and have opened up new markets in South-East Asia and the Indian subcontinent.

Mitec's Systems Division has evolved as one of the region's leading systems houses. The division provides a wide range of consultancy and turnkey project services to the telecommunications, space and defence industries, one example being a recently completed consultancy project in Cambodia. This in-country consultancy was commissioned to provide recommendations for the expansion of Cambodia's communications infrastructure.

For further information on Mitec, its products and services contact Tony Reading at Mitec Ltd, 532 Seventeen Mile Rocks Road, Sinnamon Park 4073; phone (07) 3291 6333 or fax (07) 3291 6350.

Portable EPROM Flash Programmer Series

Sunshine Electronics has introduced the PEP series, a compact and versatile EPROM/Flash programmer. Interfacing

with a desktop PC or notebook via the parallel port, the PEP's mobility is a major advantage over existing EPROM programmers.

The PEP series is capable of programming up to 8Mb EPROM, EEPROM, and 4M Flash chips. The software for the series is a user friendly pop-down menu arrangement with devices selectable by brand or type, including utilities such as buffer editing, file conversion and selectable programming algorithms.

Available in both single and four-gang units, the PEP is suitable for both workshop production work as well as on-site servicing. Light in weight and small, the programmer uses a 12V DC plug pack or a power supply card which plugs into the ISA slot of a PC. Software upgrades which include newly released EPROM/Flash devices are available every 3-4 months.

Full specifications and demonstration disk for the PEPs and all other Sunshine products are available upon request from Baltec Systems, of 26 Mayneview Street (PO Box 107), Paddington 4067; phone (07) 3369 5900 or fax (07) 3369 5257.

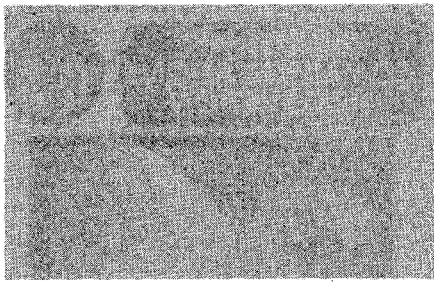

Get access to highly trained microelectronic engineering students and the extensive electronic resources of Griffith University.

The Industrial Affiliates Programme, an Australian first, makes final year students available to organisations for 3 months. Students get involved in industry projects at the conceptual stage through to the completion of prototypes.

The next programme starts again in March 1997.

To tap these resources, contact Carol-Joy Patrick now on phone (07) 3875 5007 or fax (07) 3875 6726.

**GRIFFITH
UNIVERSITY**

PREPARING YOU FOR A BETTER FUTURE

**UNIVERSITY
RESOURCES
AVAILABLE.**

READER INFO NO.26

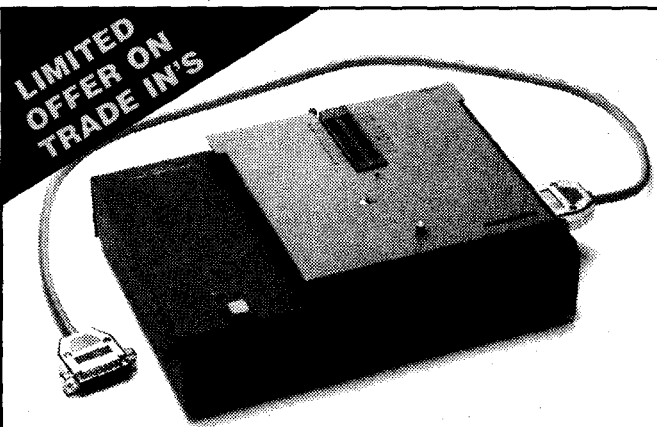

THE POWER-100

Universal Programmer & Tester

- Printer port connection for easy portability
- 48-PIN TEXTOL as standard
- Up to 8 gang programming
- Supports over 1500 devices
- Full range of Adaptors covering a wide range of packages
- Expandable to be standalone
- User definable devices
- ISO 9000

From the Design Professionals YOU get:
FREE Software Upgrade Offer
Extended Technical Support

**BALTEC
SYSTEMS**

**Special Adaptors
New Device Upgrades**

26 Mayneview St
Milton Qld 4064
Ph: (07) 3369 5900
Fax: (07) 3369 5257
Freecall: 1800 818 097

THE END OF ANALOG SCOPES IS NEAR

Here's all the oscilloscope you need at an analog price

Tektronix

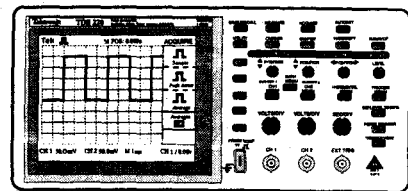

Width 305 mm X Height 150 mm X Depth 105 mm

Digital real time technology incredibly small & lightweight.

Only 30cm x 12cm x 15cm and 1.5kg.

TDS 210 60MHz TDS 220 100MHz

1395.00+tax

1995.00+tax

Call now for full information or demo.



EDSONFIELD PTY LTD
A.C.N. 010 378 588 trading as

ST LUCIA ELECTRONICS

24-26 Campbell St, Bowen Hills Q 4006

FAX (07) 3252 2862

TELEPHONE (07) 3252 7466

READER INFO NO.27

READER INFO NO.28

Tek's compact new TDS scopes

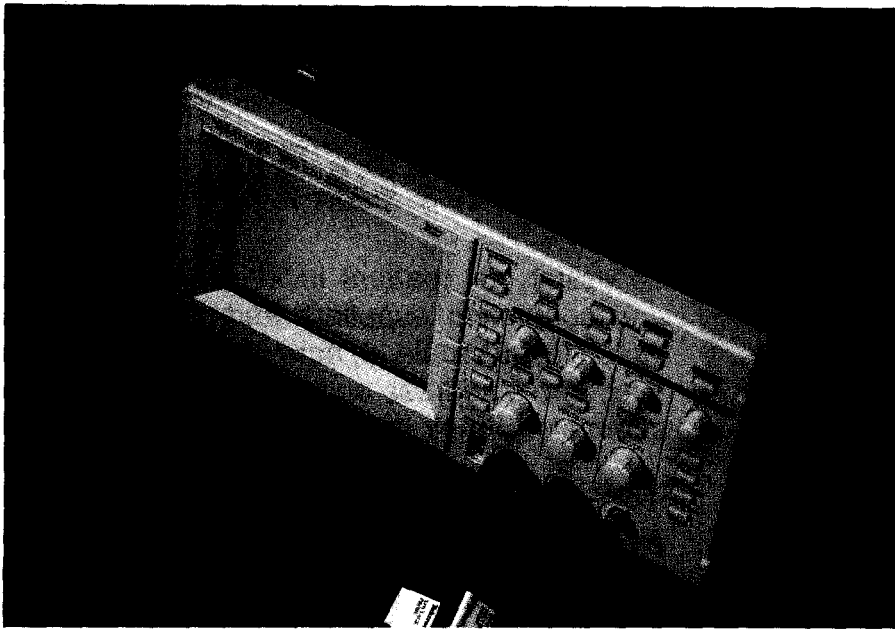





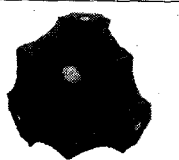
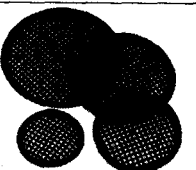

St Lucia Electronics, Queensland distributor for Tektronix, has available the newly released TDS 220 and TDS 210 models featuring a very small bench footprint combined with a maximum real-time sampling rate of 1GS/s, for prices very competitive with analog scopes. The TDS 210 offers a bandwidth of 60MHz and is priced at \$1395 plus tax, while the TDS 220 has a bandwidth of 100MHz and is priced at \$1995 plus tax.

Both models have the 'look and feel' of analog models, and use advanced and responsive liquidcrystal display technology. Their bench footprint has shrunk to a mere 305 x 120mm (12" x 4.75"). Ease of operation is enhanced with on-screen automatic measurements of period, frequency, cycle RMS, mean and peak to peak voltage, eliminating guesswork and calculations.

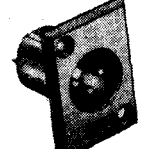
Options available include the TDS2CM GPIB/RS-232C Communications Module, with Wavestar Light software, and the TDS2HM Hard Copy Extension Module, both of which can be fitted by the user. A full range of current and voltage probes and accessory cables is also available. All models, options and accessories are available from stock.

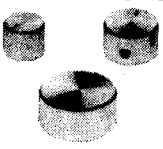
Further information is available from St Lucia Electronics, 24-26 Campbell Street, Bowen Hills 4006; phone (07) 3252 7466 or fax (07) 3252 2862. ♦

	
SPEAKER CORNERS	CASE CORNERS
	
SPEAKER GRILLES	SPEAKER CARPET
	
SPRING HANDLES	B/FLY CATCHES
	
STRAP HANDLES	XLR CONNECTORS
	
19" RACK STRIP	CABINET HANDLES
	
SOCKETS & PLUGS	CONTROL KNOBS
	
RCA PLUGS	SLIDER KNOBS

A wide range of Electronic and Flight case hardware including aluminium extrusions, hinges, castors and 19" rack accessories.

CLIFF ELECTRONICS
 34c CHESTER ST
 FORTITUDE VALLEY
 P.O. BOX 732, QLD, 4006
 TEL: (07) 3252 3178
 FAX: (07) 3252 3165

KIT REPAIRS

R & D, Prototyping,
 Repairs to Electronic
 Equipment,
 Pump Protection.

CAMPAD ELECTRONICS

P.O. Box 269
 Capalaba Qld 4157
 Phone (07) 3245 2008
 Fax (07) 3823 3428

READER INFO NO. 30

KYLE COMMUNICATIONS

Specialists in

**SATELLITE TELEPHONES
 SATELLITE TELEVISIONS
 TWO WAY RADIO
 SMALL RF DESIGN &
 MANUFACTURING PROJECTS
 VIDEO ENCODERS &
 DECODERS**

668 Lutwyche Road
 Lutwyche 4030 Brisbane
 Phone (07) 3857 4400
 Fax (07) 3857 7875

READER INFO NO. 31

POWER AND CONTROL IN A LOW COST PACKAGE
The SA-572 has set a new standard for cost-effective soldering stations. Its powerful 70W

SA-572 SETTING THE STANDARD FOR LOW COST SOLDERING

PERFORMANCE FEATURES
▶ Closed loop temperature control
▶ Zero voltage heater switching
▶ 600° to 800° F (316° to 427°C)

ceramic heater, in brass tip and precise RTD sensor combine to provide for efficient and controlled soldering

▶ Regulation (±1.5°C) temperature repeatability
▶ Less than 2mV rms leakage, 2Ω tip to ground resistance



DESIGN FEATURES
• Lighted power switch
• LED heater indication
• Variable temperature control knob
• External calibration ports
• Slim-profile iron handle with silicone rubber grip
• Flexible, non-burn silicone iron cord sleeve
• Externally fused

SPECIFICATIONS
SA-572
• Input: 240V AC, 50/60Hz • Iron: 70W, 230V
• Heater: Ceramic with Embedded RTD
Dimensions: 17.75x11.5x13.3 cm
Shipping Weight: 1.1 kg



\$129⁵⁰
PLUS TAX



ECQ ELECTRONICS PTY. LIMITED
Incorporated in Queensland
BRISBANE: Tel: (07) 3254 1153 Fax: (07) 3254 1391
MELBOURNE: Tel: (03) 9764 2040 Fax: (03) 9764 2070

READER INFO NO.32

Queensland Industry Feature: QLD SUPPLIERS & MANUFACTURERS

To assist our readers in identifying, locating and contacting suppliers and manufacturers based in Queensland, here is a listing showing each firm's address and contact details plus a summary of their main products and services:

Baltec Systems

PO Box 107, Paddington 4064. Phone (07) 3369 5900, fax (07) 3369 5257. Contact: Brett Riddell or Karen Guinea.

Baltec Systems is an ISO9001 certified company which specialises in control systems and electrical engineering in a diverse range of projects for clients in the heavy engineering and industrial process sectors.

Campad Electronics

PO Box 269, Capalaba, 4157. Phone (07) 3245 2008. Contact: Chris Alick.

Services include R&D for industrial electronics; protection of pool, spa and irrigation pumps; power supplies (both linear and switch mode); servicing and repair of electronic equipment and kits.

Cliff Electronics (Aust)

34c Chester Street (PO Box 732), Fortitude Valley 4006. Phone (07) 3252 3178, fax (07) 3252 3165. Contact: Paul Montague.

Cliff Electronics offers the Cliff brand of audio hardware, complemented by a wide range of electronic hardware and test equipment from Fluke, Black Star, DeltaOhm, Pantec and Penn Fabrication Flight Case Hardware.

Delsound

1 Wickham Terrace (cnr Ann and Wharf Sts), Brisbane 4000. Phone (07) 3839 6155, fax (07) 3832 5278. Contact: Trevor Dellit.

Specialists in public address equipment, radio communications, computer audio/video accessories and leading supplier of electronic components. Queensland agents for TOA Sound and Aiphone Intercoms plus distributor for Icom, Hewlett-Packard calculators, Swann switches, Altronics, Arista, Denon, AKG and JEIL.

Economic Electronics

Phone (07) 3252 3762, fax (07) 3252 5778. Contact: Keith Buettner.

Economic Electronics, Southport Electronic Shop and St. Lucia Electronics operating as retail, trade and wholesale suppliers, have grown into Queensland's largest supplier of tools, test equipment and components. The Company's most recent addition involves representing Tektronix in Qld.

ECQ Electronics

236 Arthur Street, Newstead 4006. Phone (07) 3254 1153, fax (07) 3254 1391. Contact: Mike Senescall.

MAKE YOUR OWN PCBs

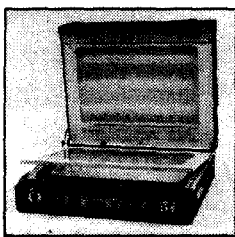

**KVB30D
UV EXPOSURE BOX**
Double sided simultaneous exposure
Exposure area 380 x 230mm
Digital timer & display

\$625.00
ex tax

CH-3 PCB DRILL STAND
High speed to 8500 RPM
Drill press ensures vertical drilling

\$250.00
ex tax

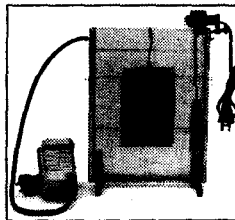
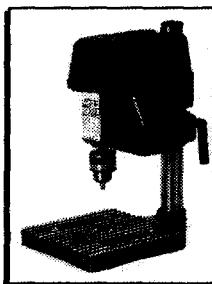

ET10 ETCH TANK
Suitable for ammonium persulphate
Includes heater & air agitator
Etch area 200 x 250mm
Larger size available

\$99.00
ex tax

Computronics

31 Kensington Street, EAST PERTH WA 6004
Phone (08) 221 2121 Fax (08) 325 6686

READER INFO NO.33

Supplier of electronic components, tools, soldering and desoldering equipment, surface mount rework equipment, data communications products, cables and connectors, power supplies, EPROM programmer and erasers.

Griffith University

School of Microelectronic Engineering, Faculty of Science & Technology, Griffith University 4111. Phone (07) 3875 5007, fax (07) 3875 6726. Contact: Carol-Joy Patrick.

Industry's avenue to research and design solutions, from concept to prototype. Expertise in intelligent sensors, automation and control, communication systems, digital signal processing and electromagnetics. Student project offers especially invited.

Kyle Communications

Contact: Mark Kyle. Phone (07) 3857 4400, fax (07) 3857 7825.

Satellite television, satellite telephones, HF RFDS equipment, radio communications, two-way and data systems. Design and manufacture of RF and video encryption/decryption systems.

Leprechaun Software

1/75 Redland Bay Road, Capalaba 4157. Phone (07) 3823 1300, fax (07) 3823 1233. Contact: Cheryl Underwood. Leprechaun Software specialises in anti-virus software and computer security. The company is based in Brisbane and is Australian owned. Its Virus Buster package has won acclaim both in Australia and overseas. A file encryption product, Magnum, ensures data security.

Mitec Ltd

532 Seventeen Mile Rocks Road, Sinnamon Park, 4073. Phone (07) 3291 6219, fax (07) 3291 6350. Contact: Linda Spence.

Mitec Limited designs and manufactures a wide range of terrestrial microwave links, satellite ground station equipment, and electronic subsystems for commercial and defence applications. The company is ISO9001 accredited and is listed on the Australian Stock Exchange with 140 staff in three locations.

Objectives

1 Bellambi Place, Westlake, 4074. Phone (07) 3279 5551, fax (07) 3279 4494. Contact: Lorraine Cobcroft.

Objectives distributes and supports the Forefront/Allmicro range of specialist diagnostic and data retrieval tools for computer technicians, including the unique Rescue which retrieves data from 'dead' drives, and the Troubleshooter Advanced Diagnostics kit.

Precision Power

Unit 6, 72 Riverside Place, Morningside 4170. Phone (07) 3395 7433, fax (07) 3395 6650, freecall 008 777 446. Contact: Paul Thomas.

Manufacturer and importer of products to overcome power-induced problems, incorporating the 'Islatrol' active tracking suppressor range of filters. Recently moved to the modern Morningside premises.

St Lucia Electronics

24 Campbell Street, Bowen Hills, 4006. Phone (07) 3252 7466, fax (07) 3252 2862. Branches also in Bowen Hills (22 Campbell Street) and Southport (Brickworks Complex). Contact: Peter Goleby.

Leading wholesale, trade and retail supplier of a wide range of electronic components, test instruments, equipment and tools. Recently appointed distributor of Tektronix test equipment. ♦

FLUKE Special Offer! Fluke 865 Graphical DMM for less than half price!



**ONLY WHILE STOCKS LAST
Very Limited Quantity!
Hurry for this
Bargain of the Year!**

Obiat has obtained a limited quantity of factory-new Fluke 865 Graphical Multimeters.

More versatile than a DMM, Graphical MultiMeters provide simultaneous Dual Display for both primary and secondary measurements (such as voltage with frequency). When analog read-out is desired the Analog NeedleGraph™ gives an easy-to-understand picture of dynamic signals. The Model 865 provides 0.04% dc voltage accuracy to 1000V and 0.5% ac voltage accuracy with ranges from 320 mV to 1000V.

Wide ranging measurement capabilities include resistance from 320Ω to 32 MΩ capacitance from 10,000 pF to 10,000 μF (suitable for electrolytic or SMT capacitors) and dB/dBm with selectable reference impedances. The 865 has a waveform display bandwidth of 1 MHz.

**Recommended list price was
\$1580 ex tax**

Our Price

\$749

**ex tax
(\$913.80 inc tax)**

FEATURES

32,000 Count Resolution	865
Measures AC/DC Voltage and mV DC	✓
(320 mV to 1000V with Input Protection to 8 kV spikes)	✓
High Impedance (Hi-Z) Input	✓
Basic DC Voltage Accuracy	0.04%
Measures AC/DC Current to 10A	✓
Current Ranges	6
True-rms AC Bandwidth to 300 kHz	✓
with Toggle for Average Responding AC Measurements to 50 kHz	✓
Graphical Features	✓
1 MHz Waveform Display Bandwidth	✓
Full Auto Waveform Display	✓
Analog NeedleGraph™ Display	✓
TrendGraph™ Display	✓
Logic Test Display	✓
In-Circuit Component Test Display	✓
Memory for Meter Readings/Configurations	✓
Waveform Memory	✓
Other Powerful Multimeter Features	✓
External Trigger	✓
Full Auto Mode	✓
Frequency Counter	✓
Resistance/Conductance/Continuity	✓
Capacitance	✓
Frequency, Duty Cycle, & Period	✓
dB with 16 Selectable Reference Impedances	✓
AutoDiode™ Function for Electronic Reversal of Test Leads	✓
Min/Max Recording	✓
Touch Hold® Function	✓
Internal Battery Charging	✓
Built-in Computer Interface	✓

SPECIFICATIONS 865 GMM

Function	Range	Best Accuracy	Resolution
Vdc	320mV-1000V	±(0.04%+2)	0.01 mV
Vac	320mV-1000V		
True-rms	50 Hz-300 kHz	±(0.5% + 10)	0.01mV
Average	50 Hz-50 kHz	±(0.5% + 4)	
Adc	320uA-10A	±(0.05%+15)	0.01uA
Aac	320uA-10A	±(0.75%+10)	0.1 uA
Ohms	320Ω-32 MΩ	±(0.07% + 2)	0.01 Ω
Capacitance	10000 pF-10000 uF	±(1.9% + 2)	100 pF
dB/dBm	2-1200 Ohm	±0.5 dB	0.01 dB
References			
Frequency	2 Hz to >10 MHz	±(0.05% + 1)	0.01 Hz

Ask for our 1996 Catalogue. Available FREE!

OBIAT PTY LTD

129 Queen Street, Beaconsfield.

ACN : 003 166 952

P.O. Box 37 Beaconsfield NSW 2014

Tel : (02) 9698 4111 Fax : (02) 9699 9170



READER INFO NO.34

Computer News and New Products

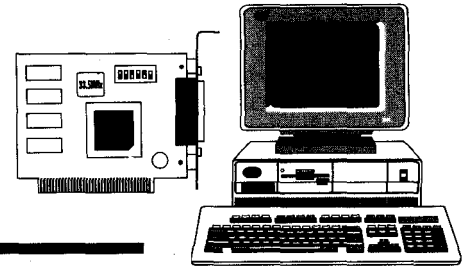

New colour Deskjet printer

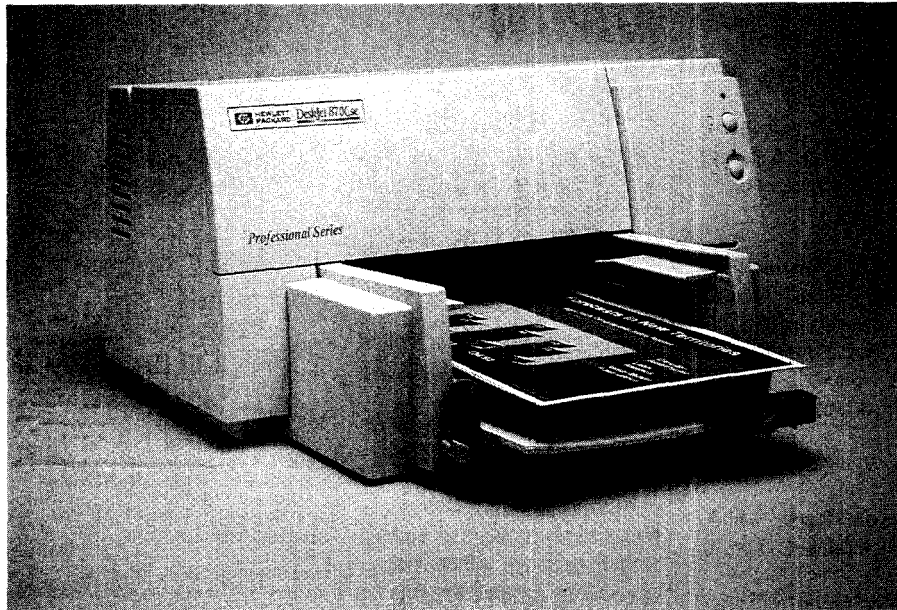

Hewlett-Packard has introduced the HP Deskjet 870Cxi, a colour inkjet printer claimed to combine premium performance and professional quality printing. According to HP, the printer

offers a number of significant improvements over previous colour inkjet printers in their class, including faster printing, excellent black and colour print quality, the largest profes-

sional font collection available in a personal colour printer and printer sharing over peer-to-peer networks.

The new printer, which is available for both PC and Macintosh platforms, is expected to sell for about \$1030 and replaces the HP Deskjet 850C printer, which debuted in 1995. It delivers black text at 600 x 600dpi and printing in colour at 600 x 300dpi. Black text is printed at up to eight pages per minute (ppm), and colour output at up to 4ppm. The printer comes with 110 TrueType Windows fonts available through FontSmart (and 16 more through the HP Deskjet font collection), 27 TrueType fonts for Macintosh users, and 26 built-in scalable typefaces for standalone DOS users.

The printer ships with everything necessary for peer-to-peer networking through a host PC in a Windows 95 or Windows for Workgroups environment. Installation is done through software tools already integrated into both Windows platforms.

For further information phone the HP Customer Information Centre on 131 347. Information about HP products is on the World Wide Web at <http://www.hp.com>.

Removeable hard disk kits

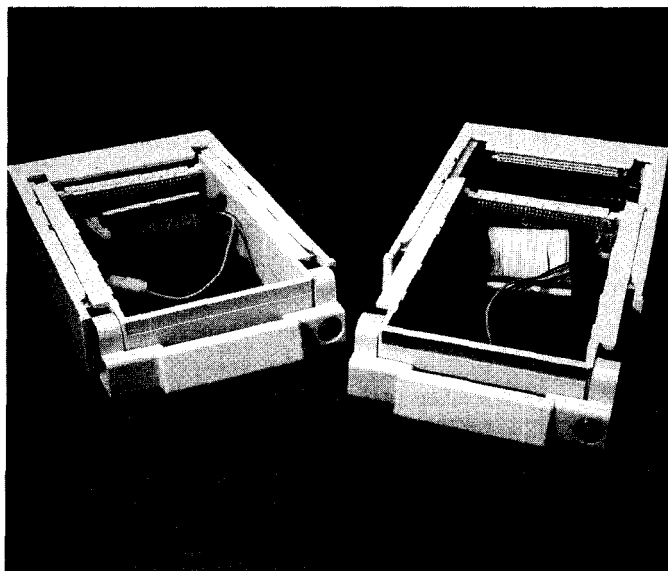

There are many new formats for removeable high density media, but many users have discovered that a very cost-effective solution is to use a standard 3.5" hard disk drive. These are available at relatively low cost and can be fitted into a removeable carrier, which docks with a matching bay fitted in the computer.

Rod Irving Electronics now stocks two different carrier/bay kits, one designed for IDE/ATA hard drives (C11919) and the other for SCSI drives (C11917). Both consist of a carrier into which the 3.5" drive mounts (complete with connection cables), and a matching bay unit which mounts into a standard 5.25" half-height drive slot. Both components are solidly made from high impact plastic and mate together via high quality 64-way DIL connectors. The carrier can be locked in the bay for security. All mounting hardware is supplied, along with a set of keys for the security lock.

The IDE version is priced at \$79.95 while the SCSI version is priced at \$99.95.

Further information is available from Rod Irving Electronics at 56 Renver Road, Clayton 3168; phone (03) 9543 7877, or on the World Wide Web at <http://www.oze-mail.com.au/~rie>.

Portable data acquisition system

National Instruments has released a high-resolution, multifunction, portable data acquisition (DAQ) box that communicates through the parallel port of PC/XT/AT and compatible computers. The DAQPad-MIO-16XE-50 is built on the company's enhanced E series architecture for PC-based data acquisition and features the company's custom system timing controller ASIC for counting and timing related functions.

The box has a built-in terminal block with screw terminals for signal connection. It can be powered from the supplied AC adaptor, an optional rechargeable battery pack or any 9V to 42V DC source. Features include a 16-bit ADC with a 20kS/s sampling rate, 16 single-ended or eight differential inputs and enhanced timing and triggering capabilities, programmable gain up to 100, two 12-bit DACs with voltage outputs, one constant current source for powering resistance temperature detectors (RTDs), eight lines of TTL compatible digital I/O, and two 24-bit up/down counter timers for timing I/O. It's com-

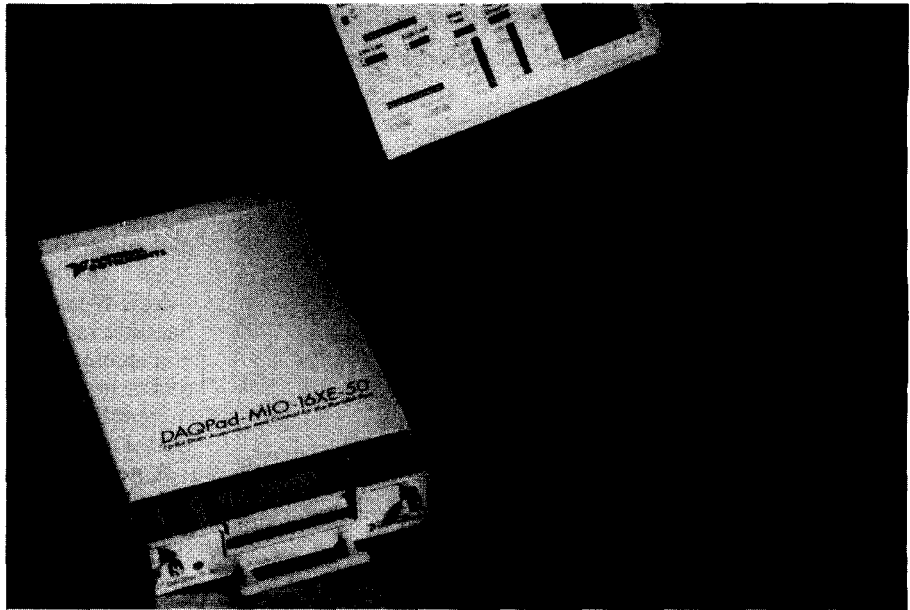

patible with the enhanced parallel port (EPP) standard defined by IEEE 1284, and has a second parallel port connector for a transparent, pass-through connection to an SPP device, such as a printer.

The package includes NI-DAQ version 4.8 driver software for DOS and Windows, and the device is compatible

with the company's LabVIEW and LabWindows/CVI application software.

For further information circle 164 on the reader service coupon or contact National Instruments Australia, PO Box 466, Ringwood 3134; phone (03) 9879 5166. (Internet site at <http://www.natinst.com>)

Computer is credit card size

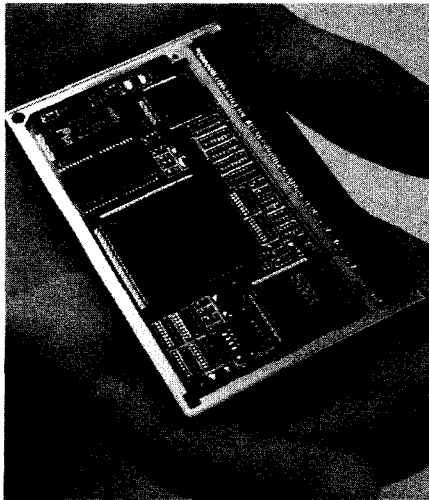

The comPCard 486-50 from Oki America is a complete Intel '486DX2 based computer in a package the size of a credit card. It runs at 50MHz, has a VL bus VGA display engine and up to 32MB of RAM support. It measures 54 x 85.6 x 11mm and weighs less than 55 grams, claimed as the smallest form factor PC/AT motherboard available.

The card has 128K Flash ROM Phoenix BIOS, and requires a 5V and 3.3V supply. Power consumption is 3W. It is intended for applications that include POS terminals, electronic musical instruments and handheld data capture terminals.

For further information circle 161 on the reader service coupon or contact Oki Products Australia, 63-85 Victoria Street, Alexandria 2015; phone (02) 9698 8211.

Half-size Pentium card

Intelligent Systems Australia has released the AP-5200IH, a half-size Intel Pentium all-in-one CPU card. The card includes the latest Intel Triton 8243VX PCI chipset, developed by Intel to support fully Intel Pentium PCI/ISA systems. It has a six-layer printed circuit board and CMOS technology, and is claimed to be able to withstand any industrial environment.

The card includes two enhanced FIFO 16550 RS-232 serial ports, one high per-

formance multimode parallel port, one PCI IDE interface for up to two IDE devices and one floppy disk drive controller. Two 72-pin SIMM sockets allow up to 64MB of standard or EDO RAM. A PCI bus piggyback connector is also provided for an optional VGA or SCSI daughter board.

For further information circle 160 on the reader service coupon or contact Intelligent Systems Australia, PO Box 118, Berwick 3806; phone (03) 9796 2290. (Internet site at <http://www.intelsys.com.au>)

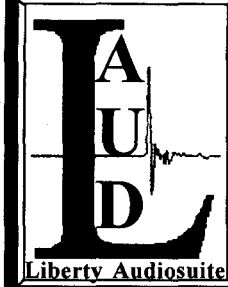

LAUD V.2 is an integrated collection of high performance audio test instruments implemented in software & making use of Personal SoundArchitecture DSP sound cards.

Demo Disk Now Available

ME Technologies

Surf with ME

<http://www.midcoast.com.au/bus/me>

Post Office Box 50, Dyers Crossing NSW 2429

Phone: (065) 50 2200 Fax: (065) 50 2341

Email: me@midcoast.com.au

LIBERTY AIDS

G R Koonce

\$30.75

These handy programs will add usefulness and value to your IMP or LAUD system. The files are equally usable with LAUD & IMP. IMPSPACE; IMPROOM; IMPZOBEL; IMPPCOEQ; IMPEQL. In addition the disk contains three datafiles to play with in IMPSPACE.

EXTENDS YOUR IMP

READER INFO NO.35

COMPUTER NEWS AND NEW PRODUCTS

A3+ colour inkjet

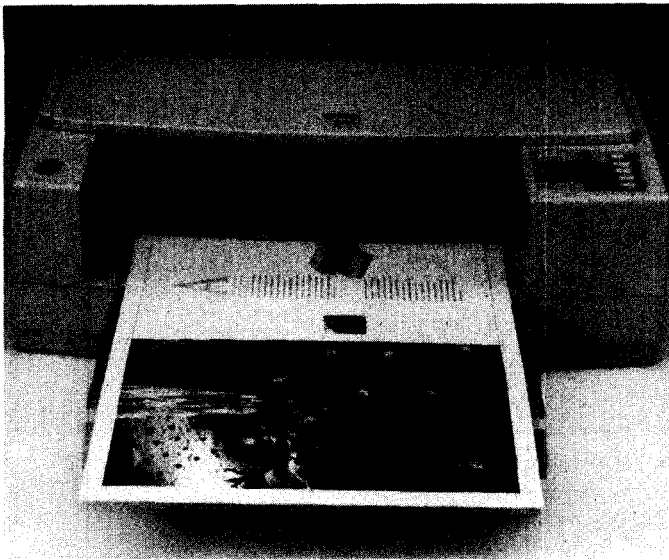

Epson has released a new A3 colour inkjet, the Epson Stylus PRO XL+, which supersedes the Stylus PRO XL and features improvements in performance, including a plain paper 720dpi printing resolution. It can produce full bleed A3 colour proofs with crop marks and footnotes, and handles paper sizes from A6 to A3+ (329 x 483mm).

As in previous models, the printer includes 'MicroWeave', a technology claimed to virtually eliminate banding in the printout. New printer drivers feature several enhancements over previous drivers, including a faster return to application time and an automatic mode claimed to simplify the printing process by setting defaults for various document types.

A new printer status monitor for Windows 95 users provides up to the minute information on the printer's status and the ink cartridge levels.

The printer is compatible with Macintosh and Windows platforms and has optional network capabilities for Ethernet/EtherTalk, LocalTalk, Coax, Twinax, and serial and parallel interfaces. The RRP is \$2999 (inc tax).

For further information circle 163 on the reader service coupon, see your local Epson dealer or contact Epson Australia, 70 Gibbes Street, Chatswood 2067; phone (02) 9903 9000.

Colour digital camera

Epson has released a colour digital camera, the Epson PhotoPC. The camera is targeted at the home and business user and provides 24-bit colour in 16.7 million colours, with a choice of high (640 x 480 pixels) and standard (320 x 240) resolution settings.

The base unit has one megabyte of flash memory, which stores up to 16 high resolution images and a minimum of 32 standard images. Optional expandable PhotoSpan memory modules increase total storage capacity up to 160 images in standard mode. The camera has the look and feel of a standard 35mm film camera. It weighs approximately 500 grams, measures 160 x 90mm and accepts any 37mm video camcorder lens or filter. Auto-focus and flash are included.

The digital camera is shipped with communications cable (8-pin DIN to RS-232) and EasyPhoto software. The software retrieves images from the camera and provides image management and enhancement capabilities. The camera also works with any TWAIN compliant application such as Micrografx Picture Publisher and Adobe Photoshop.

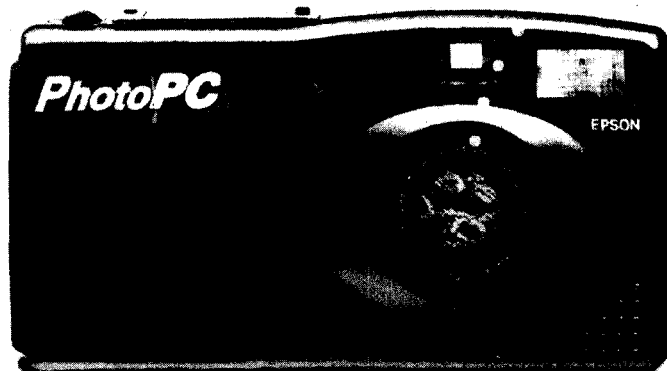

An LCD indicates the number of images taken, number remaining, image quality resolution, flash setting and battery level.

Australian Computers & Peripherals from JED... Call for data sheets.

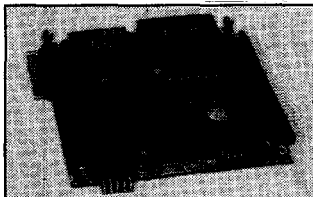

Australia's own PC/104 computers. The photo to the left shows the JED PC540 single board computer for embedded scientific and industrial applications. This 3.6" by 3.8" board uses Intel's 80C188EB processor. A second board, the PC541 has a V51 processor for full XT PC compatibility, with F/Disk, IDE & LPT. Each board has two serial ports (one RS485), a Xilinx gate array with lots of digital I/O, RTC, EEPROM. Program them with the \$179 Pacific C. Both support ROMDOS in FLASH. They cost \$350 to \$450 each.

JED Microprocessors Pty. Ltd

Office 7, 5/7 Chandler Road, Boronia, Vic., 3155. Phone: (03)9 762 3588 Fax: (03)9 762 5499

\$125 PROM Eraser, complete with timer

\$300 PC PROM Programmer.

Need to programme PROMs from your PC?

This little box simply plugs into your PC or Laptop's parallel printer port and reads, writes and edits PROMs from 64Kb to 8Mb. It does it quickly without needing any plug in cards.

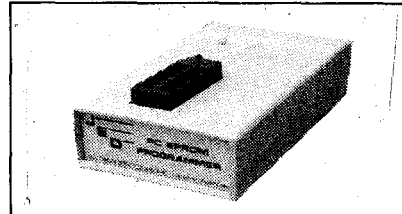

(Sales tax exempt prices)

To avoid wasted shots the control panel provides an 'erase last image' function and also has a self timer capability. The RRP is \$1149 (inc tax).

For further information circle 165 on the reader service coupon, see your local Epson dealer or contact Epson Australia, 70 Gibbes Street, Chatswood 2067; phone (02) 9903 9000.

Multi-system industrial PC

The IAC-C820A from Industrial Automated Computers is a 20-slot 19" rackmount multi-system PC chassis designed for use in engineering, scientific, telecommunications, data acquisition and process control applications where ordinary PCs do not operate reliably.

This rackmount chassis is designed to maintain high reliability in hostile work environments and is based on a 20-slot ISA passive backplane or 19-slot PCI/ISA passive backplane that supports up to four separate computer systems within the same chassis.

The chassis comes with four sets of system controls, like reset buttons, power LEDs and keyboard connectors, so the systems can work independently and simultaneously. It can be configured with various full and half size CPU cards and supports the low-cost PS/2 type power supply. It also provides space for six 3.5" drive bays and two 5.25" bays. It meets the EIA RS-310C rackmount standard and its rugged construction is ideal for harsh industrial environments.

For further information circle 166 on the reader service coupon or contact Intelligent Systems Australia, PO Box 118, Berwick 3806; phone (03) 9796 2290. (Internet site at <http://www.intelsys.com.au>). ♦

fischertechnik®

ROBOTIC KITS FOR COMPUTERS



- German quality – two year warranty.
- Five computer controlled kits available, Training robot (illustrated), experimental kit and others with instructions and software for up to 12 models in one kit.
- Program in QBASIC, C, Turbo Pascal and Visual BASIC for Windows.
- The interface unit plugs into your IBM-PC printer port and provides 8 digital inputs, 4 motor outputs and 2 analogue inputs for position, light and temperature sensing.
- Exciting and educational!

NOW AVAILABLE FROM:

PROCON TECHNOLOGY

BOX 655 MT. WAVERLEY
VICTORIA 3149

TELEPHONE: (03) 9807 5660
FACSIMILE: (03) 9807 8220

READER INFO NO.36

ADVANTECH. *Not Just A Programmer*

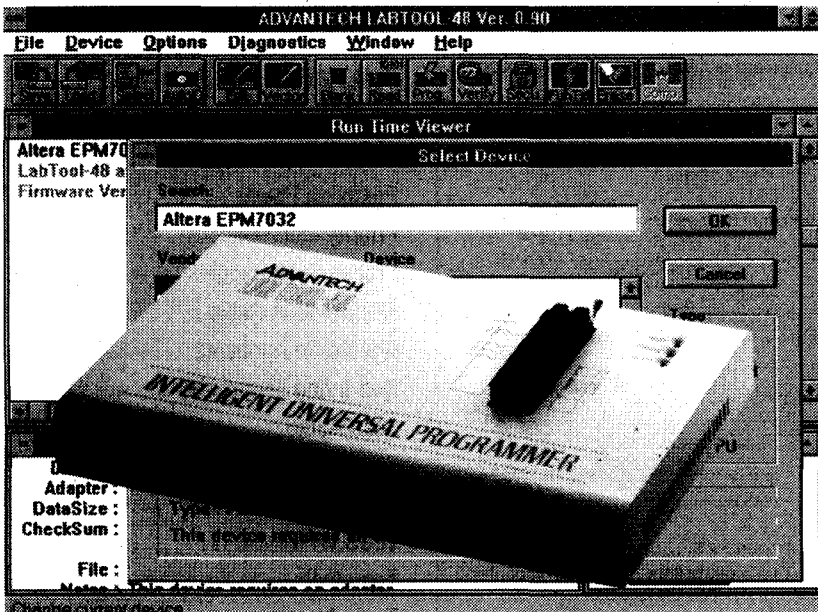

The LabTool-48 Universal Programmer features:

- 3 year limited warranty
- Printer port interface
- Guaranteed no adapters required for all DIL devices

IC Test Function

- TTL IC test library
- User creatable digital IC test feature
- Auto IC detect

Programmer Functions

- Featuring auto sense self-programme and EPROM detection
- Unbelievable programme speed and high yield rates
- MS-Windows support (optional)
- Optional 128K x 8 ROM emulator
- Supports memory, logic and microcontrollers, over 3000 devices



Priority Electronics Pty. Ltd.

Melbourne: TEL (03) 9521 0266 Sydney: TEL (02) 9482 2999

READER INFO NO.38

EA DIRECTORY OF SUPPLIERS

Which of our many advertisers are most likely to be able to sell you that special component, instrument, kit or tool? It's not always easy to decide, because they can't advertise all of their product lines each month. Also, some are wholesalers and don't sell to the public. The table below is published as a special service to EA readers, as a guide to the main products sold by our retail advertisers. For address information see the advertisements in this or other recent issues.

Supplier	State	A	B	C	D	E	F	G
Aitronics	WA
Dick Smith Electronics	ALL
Emona Instruments	NSW
Geoff Wood Electronics	NSW
Jaycar Electronics	Eastern
Kalex	VIC
RCS Radio	NSW
Rod Irving Electronics	Eastern
Scientific Devices	VIC
TECS	VIC

KEY TO CODING

A Kits and modules

B Tools

C PC boards and supplies

D

E

F

G

Components

IC chips and semiconductors

Test and measuring instruments

Reference books

Note that the above list is based on our understanding of the products sold by the firms concerned. If there are any errors or omissions, please let us know.

Electronics Australia Reader Services

SUBSCRIPTIONS: All subscription enquiries should be directed to: Subscriptions Department, Federal Publishing Company, P.O. Box 199, Alexandria 2015; phone (02) 9353 9992.

BACK ISSUES: Available only until stocks are exhausted. Price A\$7.50 which includes postage within Australia only. **OVERSEAS READERS SHOULD ADD A FURTHER A\$2.50 FOR EVERY BACK ISSUE REQUIRED.**

PHOTOCOPIES: When back issues are exhausted, photocopies of articles can be supplied. Price \$7.50 per project or \$15 where a project spreads over several issues.

PCB PATTERNS: High contrast, actual size transparencies for PCBs and front panels are available. Price is \$5 for boards up to 100sq.cm, \$10 for larger boards. Please specify negatives or positives.

PROJECT QUERIES: Advice on projects is limited to postal correspondence only and to projects less than five years old. Price \$7.50. Please note that we cannot undertake special research or advise on project modifications. **Members of our technical staff are not available to discuss technical problems by telephone.**

OTHER QUERIES: Technical queries outside the scope of 'Replies by Post', or submitted without fee, may be answered in the 'Information Centre' pages at the discretion of the Editor.

READER SERVICES BULLETIN BOARD: (02) 9353 0627; ANSI, 24 hour access; any rate to 28.8kb/s.

PAYMENT: Must be negotiable in Australia and payable to Electronics Australia. Send cheque, money order or credit card number (American Express, Bankcard, Mastercard or Visa card), name and address (see form).

ADDRESS: Send all correspondence to: The Secretary, Electronics Australia, P.O. Box 199, Alexandria NSW 2015; phone (02) 9353 0620.

PLEASE NOTE THAT WE ARE UNABLE TO SUPPLY BACK ISSUES, PHOTOCOPIES OR PCB ARTWORK OVER THE COUNTER.

Name:.....

Address:.....

State:.....Postcode:.....

Back issues:.....

Photocopies:.....

Amount: A\$.....

Signature:.....(Unsigned orders cannot be accepted.)

Method of Payment: (Please circle correct method.) Credit card / Cheque / Money order.

Credit cards accepted:

Mastercard, American Express, Visa Bankcard (please circle applicable card).

Expiry date:.....

ADVERTISING INDEX

Allthings Sales & Services	57
Altronics Distributors	74-76
Amber Technology	17
Baltec Systems	122
Campad Electronics	123
Cliff Electronics	123
Computronics	124
Delsound	118
Dick Smith Electronics	52-55
EA subscriptions offer	115
ECQ Electronics	124
Fastron Australia	61
Federal Marketing	0BC
Force Electronics	37
Freedman Electronics	22
Griffith University	122
Hewlett-Packard Australia	114
Hy-Q Electronics	11
Instant PCBs	96/97
Jaycar Electronics	66-69
JED Microprocessors	128
Kyle Communications	123
Leprechaun Software	121
Macservise	113
ME Technologies	127
Mitec	121
Oatley Electronics	23,1BC
Obiat	125
Peter Lacey Services	42
Precision Power	119
Priority Electronics	129
Procon Technologies	129
Resurrection Radio	88
Rocom Components	45
Rod Irving Electronics	89-91
Scan Audio	11
Solar Corporation	105
St Lucia Electronics	117,122
TECS Wholesale	1FC
Tomotech	88
Tortech	96/97
Vintage Wireless Radio Co	88

This index is provided as an additional service. The publisher does not assume any liability for errors or omissions.

AUTOMATIC LASER LIGHT SHOW

NEW

Our new and simplified light show kit gives a similar display to the kit published in SC (May 96), but is easier to assemble. It's also CHEAPER. We even supply a machined washer for mounting the mirror on the motor shaft. Kit includes 3 motors, 3 machined washers, PCB and all onboard components. A random variety of patterns is produced. Each pattern changes after a few seconds. **\$70**

Package deal that includes Laser Tube Supply (see below): **\$150**

LASER TUBE SUPPLY

A low power, used HeNe tube head. Typical output is 2mW. Includes a potted mains power supply that has an isolated TTL level (3-5V) enable input. (Use two AA batteries and a switch.) Needs a mains plug. **\$90**

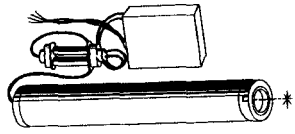

MOTOR WITH FEEDBACK

Quality seven pole, 2 to 12V DC motor with a separate feedback winding to give an AC voltage with a frequency proportional to the RPM. This allows the motor to be used in speed control circuits. Has small pulley suitable for small rubber band. As used in our Laser Light Show kit (see SC, May 96). 40mm dia, 40mm long. **\$4 ea, 5 for \$15.**

OVERSPEED MONITOR KIT

Gives a pulsed tone signal when preset speed is exceeded. Speed is set by a potentiometer: travel at the desired speed and adjust pot until tone is heard, then mark pot position for future reference. Requires two connections to vehicle: +12V and ground. A small PCB is provided for a Hall effect pick-up sensor. This assembly is mounted near the drive shaft and connected to the main PCB by three wires. Kit includes two PCBs and all on-board components, a small speaker, and even two small powerful 'rare earth' magnets: **\$22** Plastic case to suit: **\$4.**

DIGITAL VOICE RECORDING MODULES

NEW

Small recording modules as used in message recording greeting cards. Powered by watch batteries (included). Also includes a suitable mini electret microphone. 6 second module: **\$9**

MASTHEAD AMPLIFIER

High performance low-noise masthead amplifier covers VHF-FM-UHF and is based on a MAR-6 IC. Includes two PCBs, all on-board components and a balun former. REDUCED PRICE: **\$15** for basic kit. Suitable plugpack **\$10** Waterproof box for masthead amplifier: **\$2.50**, plastic box for combiner: **\$2.50**

COMPUTER CONTROLLED STEPPER MOTOR DRIVER KIT

Kit will drive two 4, 5, 6 or 8-wire stepper motors from an IBM computer parallel port. Motors require a separate power supply (not included). Includes detailed manual and software (on 3.5" disk). NEW SOFTWARE will drive up to 4 motors (needs two kits), with linear interpolation across four axes. PCB 153 x 45mm, all on-board components, manual, software and two M18 stepper motors: **\$44** This kit with the stepper motor pack: **\$65** Kit, no motors: **\$32**

POCKET SAMPLER KIT FOR PCs

See EA August 96. Data logger/sampler kit that connects to a computer's parallel port. Takes samples over a 0-2V or 0-20V range, at intervals from one per hour to one per 100uS. Ideal to monitor battery charging, can also be used as a basic low frequency (to about 5KHz) oscilloscope! Kit includes all on-board components, PCB, plastic box and software on 3.5" disk: **\$25**

WEB ADDRESS

See our web site for our latest catalog and list of items at

<http://www.ozemail.com.au/~oatley>

300W MOSFET POWER AMPLIFIER MODULE

A well constructed discrete audio amplifier module that uses eight 900V MOSFETS in the output. MOSFETS are mounted on a large heatsink that measures 280 x 125 x 40mm. You need +90V DC and -90V DC to get it operating. Use a 55 + 55V 300VA or larger transformer and 10000uF 100V electrolytic capacitors. **\$200**

WIRELESS IR EXTENDER



This kit converts the output of any IR remote control unit to a UHF transmission that is picked up by a UHF receiver and converted back to an IR signal. Can control appliances from anywhere in your house. No extra wiring! Self-contained (includes battery) UHF transmitter is attached with Velcro strap under IR transmitter. IR sensitive pin diode picks up the IR signal; transmitter takes no power when IR remote is not transmitting! Receiver has 2 IR LEDs, and is placed near appliance being controlled. Requires a 5-12V DC supply or, with two extra components, 24V DC. Kit includes two PCBs, all components, 2 plastic boxes, Velcro strap: **\$35.** (9V battery for transmitter not supplied.) Suitable plugpack: **\$10.** Components for 24V: **\$1.50.**

OSBORNE POWER SUPPLY BOARDS

SPECIAL

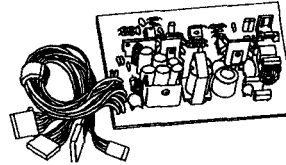

Australian made 200V to 240V AC computer power supplies rejected as faulty by Osborne Computers. These are therefore "as new" as they have never been used. Many faults are very minor, often poor soldering or a broken switch. Conventional switch mode circuit. Circuit diagram supplied. Output: +5V @ 6.5A, +12V @ 2.2A, -5V @ 0.1A, -12V @ 0.13A. A 12V/0.13A cooling fan included that's worth more than the asking price. PCB size: 145 x 105mm. WARNING, Suitable only for those familiar with mains voltage safety procedures: **\$9 ea or 5 for \$35**

STEREO SPEAKER SETS

Total of four speakers to make two 2-way speakers. Quality European cloth surround bass - midrange speakers, used in upmarket stereo televisions, rectangular, 80 x 200mm. Tweeters are good quality cone types, 85mm square. 2 woofers & 2 tweeters. **\$16** (Cat A02)

STEREO FM TRANSMITTER KIT

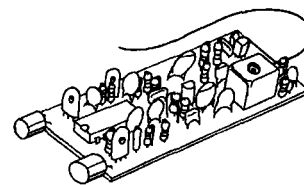

FM STEREO transmitter which can be used with electret microphones and line level audio signals. Specifications: Tuning range: 88 - 108MHz, supply voltage 6-12V, current 8mA (@ 9V), pre-emphasis 75ms, pilot signal is crystal locked, frequency response 40Hz-15kHz, S/N ratio better than 55dB, frequency stability with extreme antenna movements 0.03%, PCB dimensions 25 x 65mm. Kit includes PCB and all on-board components, 9V battery connector, wire for the antenna and two electret microphones: **\$25** Plastic case to suit: **\$4.**

FM TRANSMITTER KIT - MkII

Ref: SC Oct 93. Low cost FM transmitter features 100m range, excellent frequency stability, tuning range 88-108MHz, supply voltage 6-12V. Easy to build, has a prewound coil in a shielded metal can. Includes PCB, all on-board components, electret microphone, 9V battery clip: **\$12 ea. or 3 for \$33** (K11).

A suitable casing to allow this kit to be made into a wireless microphone is also available. Includes black aluminium tube, mic pop filter, unidirectional microphone & slide switch: **\$10**

NOV4SALE!

Our annual sale day is on again at our new premises:

**Saturday 9th November
9am to 3pm**

**68 Lorraine Street,
Peakhurst.**

A list of items will be available from November 4th. Poll our fax on (02) 9579 3955, or get onto our Web site. Mail orders will be accepted up to November 16. Phone/fax orders accepted from Nov 4 to Nov 8.

CHECK THESE ITEMS AND PRICES!

New fresh stock of 1.2V/800mAh AA nicad batteries: **10 for \$25**

New fresh stock of 12V/6.5AH SLR batteries (Hitachi): **\$30 ea**

Constant current, mechanical timer battery charger: **\$9**

550-100mCd @ 20mA red LEDs (about 100 times brighter than standard LEDs), as used in car brakelight arrays: **100 for \$25**

16mW/940nm @ 100mA IR LEDs. (High O/P, for remote controls etc): **10 for \$5**

30mW/880nm @ 100mA IR LEDs. (Ideal for CCD camera illumination — much better than 940nm): **10 for \$6**

STROBE KIT

Based on flash unit from a disposable camera, includes an extra PCB and components (plus instructions) to convert flash unit to a low power consumption, highly visible strobe light (works off 1.5V battery). Bicycle warning light, strobe light (several for best effect). **\$6 ea or 5 for \$25**

OATLEY ELECTRONICS

PO Box 89, Oatley NSW 2223

Phone (02) 9579 4985

Fax (02) 9570 7910 or 9579 3955

orders by e-mail: oatley@world.net

major cards with phone and fax orders, P&P typically \$6.

Want to get
more in-depth
with the 'HOW',
'why',
and **WHERE**
in the
music,
multimedia
READ

AUSTRALIA'S No.1 HI-TECH MUSIC MAGAZINE

on sale now

or phone 1800 800 933