

"Miniwatt"

DIGEST

VOL. 1 No. 12
SEPTEMBER 1962

— TECHNICAL AND COMMERCIAL TOPICS OF
CURRENT INTEREST TO THE ELECTRONICS INDUSTRY

CONTENTS

	Page
PLASMA, Part 2 —The Plasma Torch	182
THE AC128 —AF transistor	187
APPLICATIONS OF PHILIPS CIRCUIT BLOCKS	191

RF PLASMA TORCH

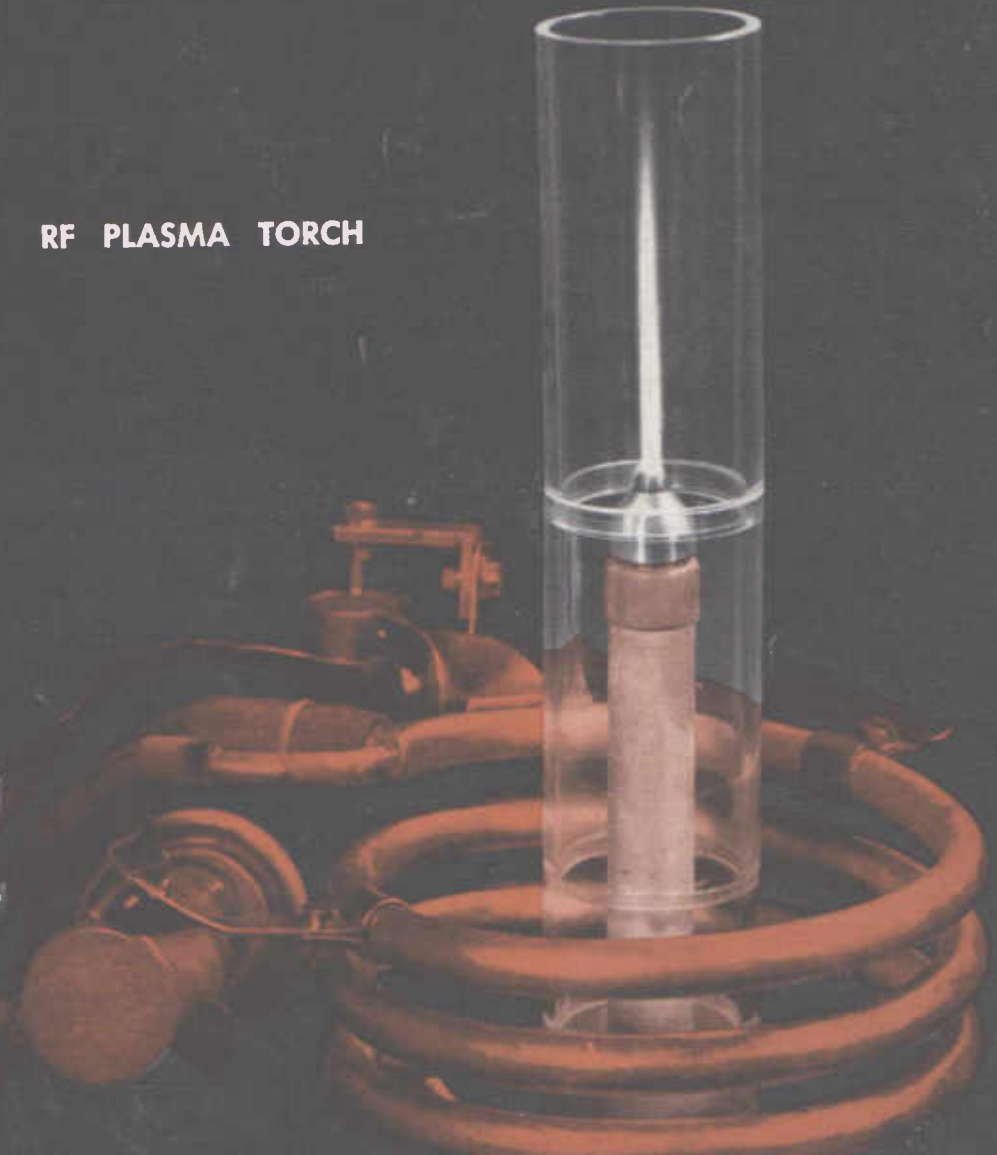

Published by the
Miniwatt
Electronics Division of
Philips Electrical Industries
Pty. Limited,
20 Herbert Street,
Artarmon, N.S.W.,
Australia.

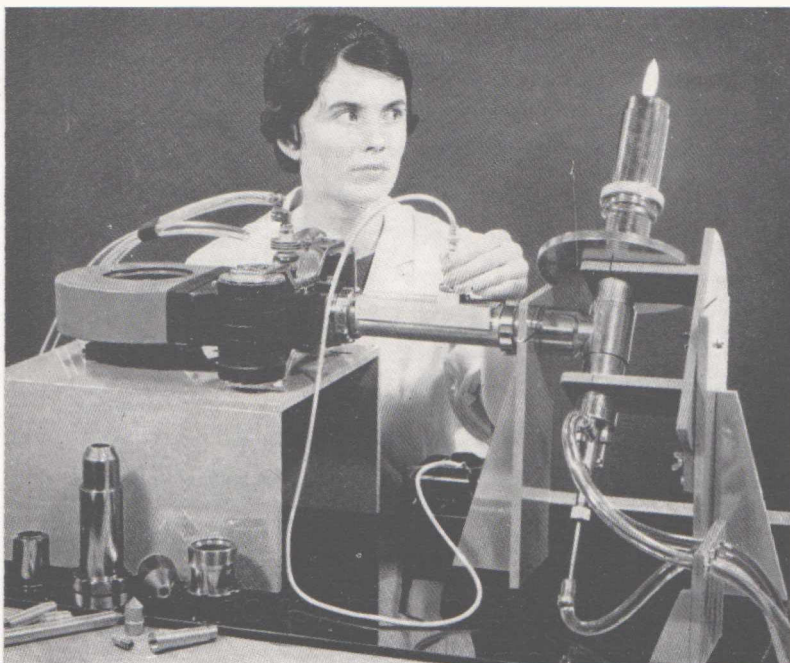

Fig. 1. Microwave Plasma Torch using a Philips CW Magnetron.

Besides the established uses of plasma, as previously described in Part 1 (September issue) the practical applications of the "new" plasma physics include use of plasma superconductivity for 10,000 amp. switches, and the production and use of plasma in "Plasma Torches." The following outlines the principles, construction and uses of representative Plasma Torches developed, in the main, within Concern laboratories.

A Plasma Torch is a device designed to produce, from a continuous plasma jet or stream, a temperature approaching, or exceeding, that at the sun's surface. In fact, it would not be wrong to consider certain aspects of solar phenomena as those of a gigantic plasma torch.

The experimental units to be presented cover wide ranges in both frequency and power, and form a selection which will be of considerable interest to universities and technical institutions—both for demonstrational purposes and in fundamental plasma studies. In regard to practical application, it should be pointed out that extremely high temperatures can be thus realised in a relatively simple fashion; however some further technological refinements will be required in order to suit specific circumstances. Practical potentialities include replacement of the oxy-acetylene torch in the higher temperature industrial

Plasma

Part 2—

The Plasma Torch

processes, suspension fusion techniques, heating processes in a controlled atmosphere and fabrication of improved refractory materials.

In considering Plasma Torches for practical application the usual frequency, frequency stability and spurious radiation constraints placed on users of general industrial equipment (microwave ovens, induction and dielectric heaters, etc.) are important. For this reason, the devices to be described have been engineered with this in mind, and operate in the 27, 461 and 2400 Mc/s bands allocated for industrial usage.

Formation of the Plasma Flame

The available techniques for generating and sustaining plasma may be divided into electro-magnetic (electrically excited shock tubes, electron beams, DC discharges, etc.) — and non-electromagnetic (diaphragm shock tubes, contact ionisation using cesium vapour, etc.) methods. In the devices to be described, the energy of a high frequency electro-magnetic field is used to dissociate gas molecules into electrons and positive ions. The kinetic energy of free electrons—and other particles—(necessary for the dissociation process, and of different magnitudes for the various gases) is provided by the RF field. The gas then transports this stored energy to a localised region where it is released as heat energy on the subsequent recombination of the charged particles of the dissociated gas. Standard industrial high frequency or microwave oscillators can be used as power sources.

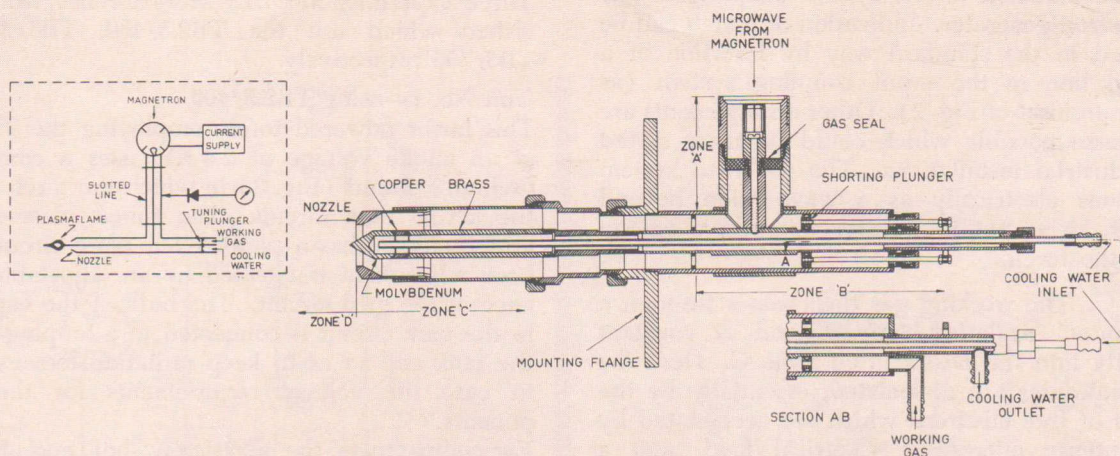

Fig. 2. Constructional details of the Microwave Plasma Torch.

Advantages and Uses of the Plasma "Flame"

A plasma "flame" is similar in appearance to a combustion type flame, but differs in that its temperature is not obtained as a result of an exothermal chemical reaction, and that its magnitude is much higher. This is important both in that the working gas may be reclaimed (instead of being consumed as a fuel) and recirculated, and that the following advantages attain:—

- (a) By choice of the working gas, material heating processes can be effected in either an inert atmosphere, or one selected so as to control the chemical composition of the material.
- (b) Flame temperatures, already extremely high, may be further controlled by the introduction of solid materials into the flame so as to promote recombination at the surface exposed to the flame. High melting point metals such as tungsten and ceramics may be melted using the Plasma Torch. Substances can also be vaporised for spraying operations, as has been done for ceramic spraying of rocket nose cones. (These high flame temperatures are obtained with relatively low gas pressures and low gas velocities.)
- (c) Heat energy can be concentrated onto a small (work) surface. Recombination of the charged particles of the dissociated gas (and thus the resulting high temperature) occurs mainly at the surface of substances introduced into the flame zone.
- (d) No electrode deterioration problems.

Microwave Plasma Torch

The first device (previously published⁽¹⁾ in Germany) operates at a frequency of 2400 Mc/s, using a CW magnetron (type 7091 or 7292) designed originally for microwave oven applications; type 7091 is forced air

cooled whilst 7292 employs water cooling. With this device, temperatures well in excess of 3000°C can be produced with microwave powers of less than 1 KW: it is illustrated in operation in Fig. 1.

A basic advantage in working with such magnetrons is that the problems of microwave technique can be clearly separated from the problems of the application. They form self-contained generating units working at high efficiency, with provision for coupling direct to an output coaxial line of 50 Ω impedance (1 5/8" outer diameter). Frequency stability is high and harmonic radiation low. The compactness of a plasma torch working in the microwave region is a further advantage. At the present time, the output powers of available magnetrons are limited to several KW. Thus although it is possible to operate several magnetrons in parallel, the total power available in the microwave range is limited compared with the range below 100 Mc/s.

Construction

The construction of the microwave plasma torch is given in Fig. 2. Here advantage is taken of the high electrical field existing at the end of a coaxial tube in order to dissociate diatomic gases, or monatomic gases mixed with a small quantity of diatomic gas. Monatomic gases, when used alone, produce very little heat owing to the low order of recombinational energy involved; however the addition of a small quantity of diatomic gas provides a means for controlling the flame temperature up to very high values.

The torch system can be subdivided into four zones:—

- Zone A is the region in which microwave energy is fed to the torch.
- Zone B contains the connections for the working gas and the coolant. This section is executed in coaxial construction, with the incorporation of a

tuning plunger so as to enable the torch structure be matched to the system coupling to the magnetron generator. Indication of match can be effected in the standard way by insertion of a slotted line in the input coupling system (as shown in inset of Fig. 2). Other arrangements are of course possible which could be more suited to industrial installations. The gas feed system functions electrically as a wave-guide beyond cut-off, so as not to transfer microwave energy from the torch.

- Zone C. The working gas then passes through a perforated insulating support, and at constant velocity into the Dissociation Zone C. Here the gas molecules are dissociated, essentially by the action of free electrons which are accelerated by the intense microwave electrical field, and a plasma stream is formed.
- Zone D. In the Working (or Flame) Zone D, the ions of the dissociated gas molecules recombine, the energy evolved producing the high temperatures of the flame zone. This zone may be enclosed so as to exclude foreign gases and substances.

As shown in Fig. 1, a range of nozzles having different shapes and orifices may be used to control the shape and size of the flame produced when using different gases, gas velocities and microwave powers.

The construction of the microwave generator itself (as well as measuring technique) has been previously described⁽²⁾ in relation to its microwave oven application.

Operation

In order to initiate the process of dissociation it is necessary to form free electrons in the region of the high voltage microwave electric field existing between the torch tip and the other cylinder. This can be achieved simply by producing a momentary arc discharge at this point.

It is obvious that during operation the loading of the generator by the torch assembly could vary appreciably. The base conductance of the flame zone (at the inner conductor tip in Zone D) depends, *inter alia*, on the work loading of the flame, the shape of the nozzle and the gas velocity. This load variation would be transferred to the flange plane of Zone A, and thence to the generator. However, in order to protect the magnetron from damage, as well as to maintain power transfer, the tuning plunger should be readjusted so as to obtain a matched condition. Furthermore, flame failure protection, and facilities for starting at reduced power are essential.

If the gas velocity is too low, the flame zone becomes wide and unstable and there is danger of arc formation between the inner and outer conductors within the dissociation zone. Conversely, too high a gas velocity cools the flame zone, and leads to turbulence and snuffing of the flame.

Three experimental 27.12 Mc/s torches will be described which use the TB2.5/400, TB5/2500 and TB3/750 respectively.

Unit No. 1—using TB2.5/400

This lower powered torch, employing the TB2.5/400 at an anode voltage of 2.5 KV, uses a conventional oscillator circuit (Fig. 3) in which the torch circuit is the actual tank circuit. The tuned plate—untuned grid oscillator has a parallel fed plate circuit. Feedback adjustment is effected by an adjustable inductance in the grid circuit. The bulk of the capacitance in the tank circuit is connected to a tapping point on the tank coil so as to keep radiation losses low, and to ease the voltage requirements for these components.

For compactness, the electrically “hot” end of the tank circuit inductor is doubled back up through the coil axis. The torch circuit is then closed by the effective capacitance of the flame. The tank coil tapping and feedback are determined in such a way that, with the flame ignited, the tube is correctly matched. Fig. 4 gives torch (tank) inductor details for both this unit and unit No. 2 below.

Even with such a low power level, as employed in this laboratory model, an extremely high temperature flame can be obtained. The construction and operation are simple, and the molybdenum tip remains cool, with no deterioration.

If air is used as the working gas a blue flame will be obtained, characterising oxygen. This is due to the lower dissociation energy of the oxygen constituent compared with nitrogen; nitrogen produces a red coloured flame. The optimum gas flow will be of the order of 2 cu. ft. per minute, and only a low pressure supply is required. The actual shape of the flame will be determined by the aerodynamic design of the region of the torch tip.

At “full load” (ignited flame) the following conditions apply. $V_a = 2.5$ KV, $I_a = 205$ mA, $I_g = 40$ mA; (RF power delivered to flame is about 200 W). At “no load” (unignited flame) $V_a = 2.5$ KV, $I_a = 90$ mA, $I_g = 80$ mA. The maximum voltage at the torch “tip” is approximately 5 KV. For satisfactory operation at this frequency, it is necessary to develop a voltage at least the order of 4 KV RMS. At lower voltages ignition difficulties will be encountered. Initial ignition can be achieved by use of an auxiliary electrode (10 MΩ resistor, connected to earth).

In this particular circuit a change from “full load” to “no load” is accompanied by a detuning of approximately 160 Kc/s (i.e. 0.6%).

Unit No. 2—using TB5/2500

This unit supplies approximately 2 KW of RF power for production of the plasma. It is similar in construction to the first unit described; however there are some basic circuit (Fig. 5) differences.

A variable tuning capacitance, C_4 (air spaced brass plates) has been incorporated in the plate circuit, with the plate itself at DC earth potential. An unfiltered DC supply, derived from three phase mains, has been utilised.

Plasma Torches for the 27.12 Mc/s Band

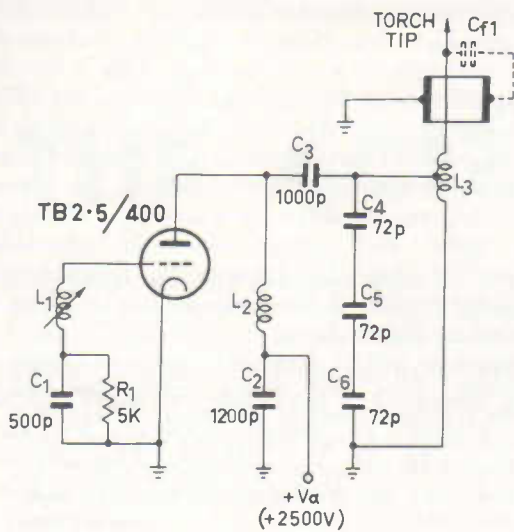

Fig. 3. Experimental 27 Mc/s Plasma Torch using TB2.5/400.

- C₁ 500 pF, Philips ceramic pot capacitor type T_u20/50
- C₂ 1200 pF, Philips ceramic feed-through capacitor type DWa30/80
- C₃ 1000 pF, Philips ceramic plate capacitor type FP_b100
- C_{4, 5, 6} 72 pF, Philips ceramic plate capacitor type FP_b100
- C_{F1} Equivalent capacitance to ground of the plasma flame
- L₁ 0.6 μH, 6 turns, 4 mm. copper 2" dia.
- L₂ 5 μH, in two sections mutually perp. (11T at anode + 14T), 2 mm. copper, 1 3/8" dia., silver plated.
- L₃ (tank coil) 1 μH, 5T (refer to Fig. 4)

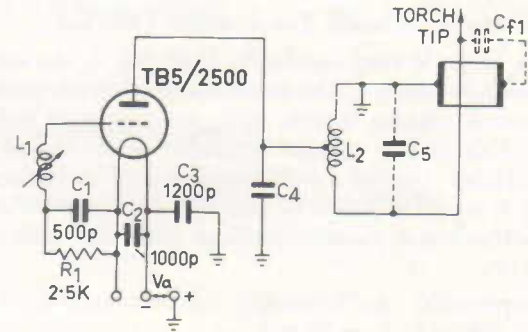

Fig. 5. Experimental 27 Mc/s Plasma Torch, using TB5/2500.

- C₁ 500 pF
- C₂ 1000 pF, mica
- C₃ 1200 pF, Philips ceramic plate capacitor type FP_b100
- C₄ Adjustable air spaced capacitor formed from brass plates (1/16" x 7/8" x 9 1/2")
- C₅ Coil capacitance to ground (including strays)
- C_{F1} Equivalent capacitance to ground of the plasma flame
- R₁ 2.5 KΩ, 200 W
- L₁ 6 turns, 4 mm. copper, 2" dia.
- L₂ Tank coil (refer to Fig. 4)

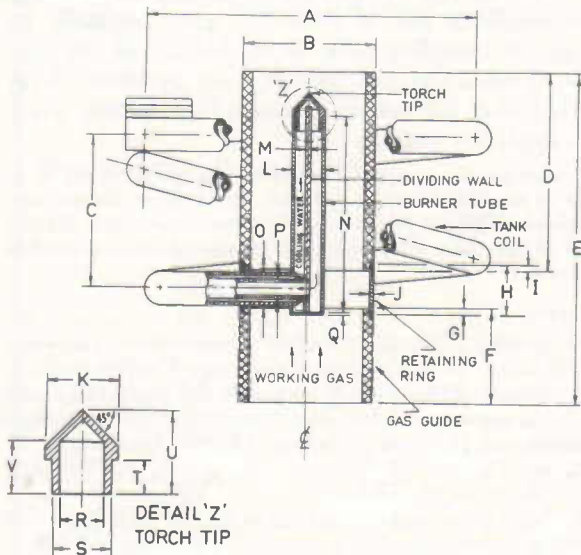

Fig. 4. Torch (tank) inductor details for 200 W and 2 KW, 27 Mc/s Plasma Torches. Dimensions are quoted to nearest 1/64" from original metric.

DIM.	TORCH TYPE	
	TB2 5/400 (200 W)	TB5/2500 (2 KW)
A	2 27/32"	4 5/16"
B	1 3/16"	1 37/64"
C	3 5/32"	
D	4 39/64"	3 15/16"
E	6 3/16"	7 1/4"
F	1 3/32"	2 23/32"
G	1/16"	1/8"
H	19/32"	1 19/64"
J	1/32"	1/32"
K	15/32"	5/8"
L	15/32"	5/8"
M	1/32"	1/16"
N	3 31/32"	3 15/16"
O	5/16"	25/64"
P	5/32"	15/64"
Q	1/32"	1/32"
R	9/32"	25/64"
S	23/64"	33/64"
T	5/32"	15/64"
U	15/32"	5/8"
V	9/32"	23/64"

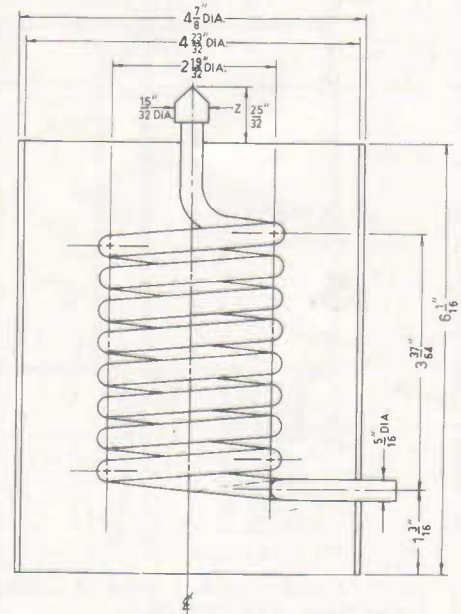

Fig. 6. Helical-coaxial tank circuit of experimental 27 Mc/s Plasma Torch, using TB3/750.

With the flame ignited the following values attain $V_a = 5$ KV, $I_a = 700$ mA, $I_g = 160$ mA, whilst the un-ignited flame condition is 5 KV, 230 mA and 230 mA respectively. The flame temperature is influenced by the velocity of the working gas and it is advantageous to incorporate a restricting nozzle at the burner tip. This will produce a high gas velocity using only a low quantity of working gas. Furthermore, a ring jet (external to the torch tip) has been found particularly advantageous where liquid clouds are to be sprayed into the flame.

Unit No. 3—Plasma Torch using TB3/750

This torch is very similar to Unit No. 2, the essential difference being in the substitution of a compact, well shielded, output circuit with an improved unloaded Q. This is the coaxial resonator with helical inner conductor treated by Macalpine and Schilknecht.⁽³⁾ Fig. 6 supplies details of this circuit, which once again has the torch circuit identical with the tank circuit proper.

In operation, the following values attain $V_a = 3$ KV, $I_a = 360$ mA, $I_g = 70$ mA.

For the HV supply a bridge rectifier configuration employing several series connected silicon diodes is used, supplied from a HT of 3 KV RMS. A 13 H choke and a $2\mu\text{F}$ capacitor provide the filtering.

UHF Plasma Torch

Grigorovici and Cristesku⁽⁴⁾ concluded that in a plasma flame equilibrium exists only for frequencies above 70 Mc/s. Thus in addition to devices constructed for the 27 Mc/s and 2400 Mc/s industrial bands, a torch was constructed for an intermediate (461 Mc/s) band.

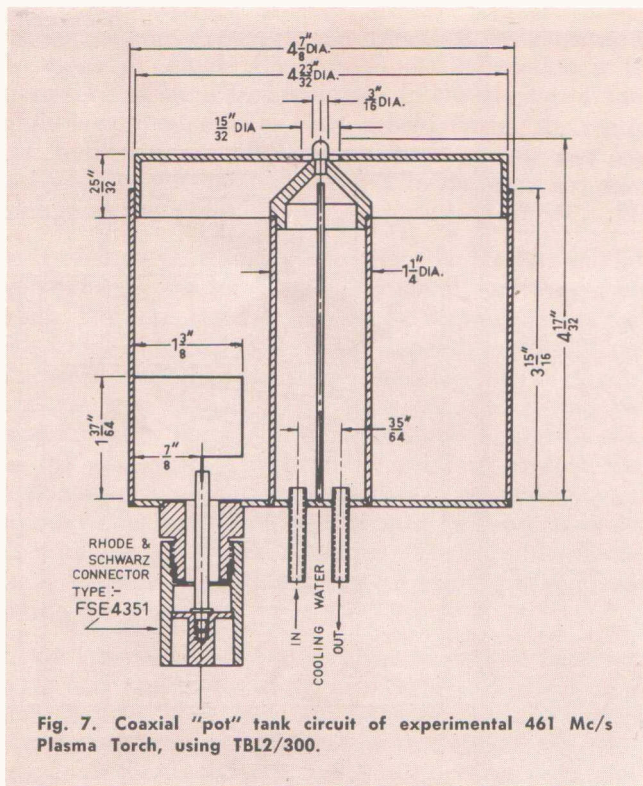

A generator incorporating the TBL2/300 was used in conjunction with a coaxial "pot" torch circuit (Fig. 7) similar in concept to 27 Mc/s Unit No. 3 above. This circuit consists of a short circuited coaxial "pot" having a characteristic impedance of 79Ω , which possesses only a small opening at the "open" end. It has a length somewhat less than a quarter wavelength owing to the capacitive end loading. This is formed by the capacitance of the torch opening and the effective capacitance of the flame, the latter depending on the type of gas used and its velocity. Thus some means of circuit adjustment is required which, in this experimental model, was provided by arranging a sliding fit for the "open" end section. Such an adjustable arrangement is also advantageous for spectroscopic studies in the region of the flame base (i.e. close to the "tip" of the inner line).

UHF energy from the oscillator is loop coupled into the torch circuit. The conditions for the TBL2/300 for the "loaded", or "flame", condition are $V_a = 1750$ V, $I_a = 340$ mA, $I_g = 100$ mA. The unignited flame condition ("no load") is 1750 V, 210 mA and 120 mA respectively.

Other Devices

Besides the devices described above, "induction-coupled" plasma torches have also been constructed,⁽⁵⁾ in which the high conductivity of a plasma has been utilized so as to provide, in effect, a transformer with a plasma "secondary". Also DC "electrode-coupled" torches have been described in which high plasma conductivity has again been utilized, this time in order to produce the high temperature by means of an arc discharge. All the devices described have their uses, but electrode deterioration is often severe with the DC "electrode-coupled" type.

In conclusion, it should be pointed out that in attempting to cover the field of Plasma in so short a space, some of the more detailed plasma torch information available has of necessity been omitted. In particular, a complete 10 KW, 27 Mc/s unit employing the TBW12/38 has received no mention. It is suggested that interested bodies (Universities, etc.) should apply for same.

(This completes the two-part Plasma survey, prepared by A. J. Erdman of the "Miniwatt" Electronic Applications Laboratory, with acknowledgment to overseas Concern laboratories for the detailed information concerning the range of plasma torches presented.)

References:

1. W. Schmidt, Der Mikrowellen Plasmabrenner, *Elektron Rundschau*, vol. 13 (1959), No. 11, pp. 404-406.
2. W. Schmidt, Mikrowellengeneratoren mit abgeschlossenem Arbeitsraum zur dielektrischen Erwärmung von Nahrungsmitteln und Industrie produkten, *Elektron Rundschau*, vol. 12, no. 11, pp. 390-393; vol. 12, no. 12, pp. 417-420; vol. 13, no. 1, pp. 13-16.
3. W. Macalpine and R. Schildknecht, Helical Resonator Design Chart, *Electronics*, Aug. 12, 1960, pp. 140-146.
4. Grigorovici u. Cristesku, *Optika i Spektroskopija*, Tom VI, Vyp. 2 (1959), s. 85.
5. T. B. Reed, Induction Coupled Plasma Torch, *Journal of Applied Physics*, vol. 32, no. 5, May 1961, pp. 821-824.

THE AC128

—New High-gain Germanium PNP Transistor for AF Output Stages

The latest addition to the Miniwatt Preferred Range of transistors, the type AC128 operates in Class A and Class B output stages with battery voltages up to 14 V. The AC128 is available in matched pairs under the type designation 2-AC128 for operation in Class B circuits with low distortion and for power outputs up to 2 W. The 2-AC128 is particularly suited for the class of combined receiver intended both for automobile and portable use.

A circuit is described for 14 V operation and illustrates the application of the AC128 to medium power output stages in automobile receivers and general portable equipment usage. In a subsequent issue of the Digest, a circuit arrangement suitable for operation with either 14 V or 9 V will be described.

MINIWATT AC128 (Abbreviated Data)

General Data

Outline TO1
Case Metal
Cooling fin Part number 56200
Thermal resistance: from junction to case $K_{j-e} = 0.05^\circ/\text{mW}$

Maximum Ratings (Absolute Maximum)

Collector to base voltage $-V_{CB} = 32 \text{ V}$
Collector current $-I_C = 500 \text{ mA}$
Total dissipation $P_{tot} = 550 \text{ mW}$
Junction temperature $T_J = 90^\circ \text{ C}$

Characteristics at $T_{amb} = 25^\circ \text{ C}$

	Typical	Range	
		min.	max.
Collector-cutoff current at $-V_{CB} = 10 \text{ V}$, $I_E = 0$	I_{CBO}	—	10 μA
DC current gain at $I_E = 50 \text{ mA}$, $-V_{CB} = 0 \text{ V}$	h_{FE}	90	55 175
	h_{FE}	90	60 175
Collector knee voltage at $-I_C = 500 \text{ mA}$, and at that value of $-I_B$ for which $-I_C = 550 \text{ mA}$ with $-V_{CB} = 1 \text{ V}$	$-V_{CEK}$	—	0.5 V
Common emitter cutoff frequency at $-V_{CB} = 2 \text{ V}$, $I_E = 10 \text{ mA}$	f_{ife}	15	10 —Kc/s
Extrinsic base resistance at $-V_{CB} = 5 \text{ V}$, $I_E = 1 \text{ mA}$	r_{ib}'	25	— Ω

Characteristics of Matched Pairs 2-AC128

Ratio of DC current gains of the two transistors at both $-V_{CB} = 0$, $I_E = 50 \text{ mA}$, and $-V_{CB} = 0$, $I_E = 300 \text{ mA}$

h_{FE1}/h_{FE2}	1.1	— 1.25
-------------------	-----	--------

Typical Operating Conditions

2-AC128 as Class B Output Amplifier at $T_{amb} = 25^\circ \text{ C}$, based on $K_{tot} = 0.09^\circ/\text{mW}$

The data below are valid for continuous operation up to an ambient temperature of 55° C , at which T_J may be up to 90° C .

Supply voltage V_S	6	9	9	V
Zero-signal emitter current $I_{E1} + I_{E2}$	6	6	6	mA
Bias resistor $R_1^{(1)}$	2.0	2.2	3.5 (var.)	$\text{K}\Omega$
Bias resistor $R_2^{(1)}$	47	39	68//130 (NTC) ⁽²⁾	Ω
Emitter resistor R_E	2.2	3.9	1.5	Ω
Source resistor R_p	1.5	1.5	1.0	$\text{K}\Omega$
Maximum transistor output power, two transistors P_{ec}	0.85	1.3	2.1	W
Maximum power delivered to the primary of the output transformer, two transistors P_o	0.75	1.1	1.9	W
Load impedance, collector to collector R_{cc}	65	98	62	Ω
Load impedance per transistor $R_{cE} = R_{cc}/4 + R_E$ R_{cE}	18.5	28.5	17	Ω

At $P_o = \text{max.}$:

Peak collector current $-I_{cM}$	300	300	500	mA
Collector current $-I_C$	95	95	150	mA
Required peak input voltage ⁽³⁾ V_{im}	5.5	6.0	6.5	V
Total harmonic distortion d_{tot}	3.5	4.0	5.5	%

At $P_o = 50 \text{ mW}$:

Required peak input voltage ⁽³⁾ V_{im}	1.6	1.4	1.1	V
Total harmonic distortion d_{tot}	2.0	2.0	2.5	%

⁽¹⁾ Tolerance of bias resistors is 5%.

⁽²⁾ Code No. E 201 BC/A 130 E

⁽³⁾ Losses in the driver transformer are not taken into account.

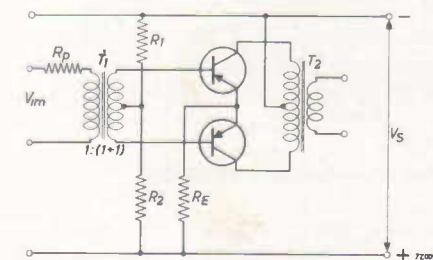

For providing stability, the total resistance in the base circuit of each transistor is $< 100 \Omega$.

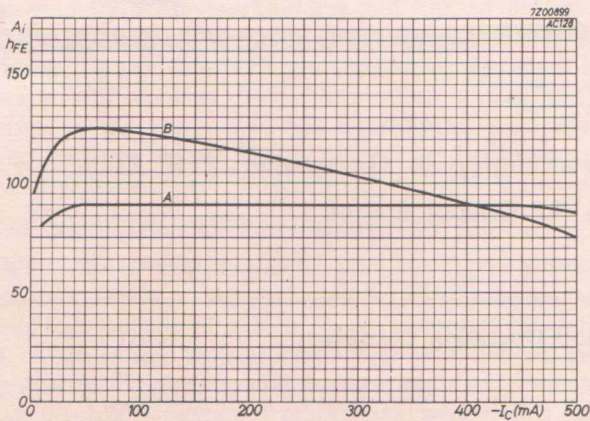

Fig. 1. Current gain linearity of AC128.

Curve A shows typical large-signal current gain (h_{FE}) as a function of collector current, at $-V_{CE} = 1$ V.

Curve B shows typical loaded small-signal current gain ($A_i = \Delta I_c / \Delta I_B$) as a function of collector current with sliding V_{CE} ; $V_{BATT} = 10$ V, $R_{load} = 16 \Omega$.

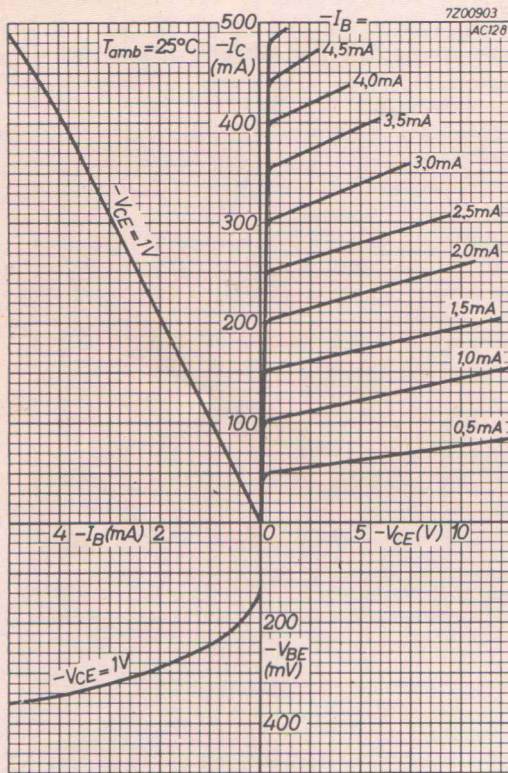

Fig. 2. Typical characteristics of AC128.

AC128 Features

The four features of the AC128 which make its use an attractive proposition for audio output stages are:

- Improved current gain linearity
- Low quiescent current in Class B stages for minimum crossover distortion
- High current gain
- High continuous junction temperature of 90°C .

The significance of each feature is now briefly examined.

Non-linearity of h_{FE} when measured at different points along a load line results in odd harmonic distortion in Class B stages. Even harmonic distortion is due to mismatch of the output transistors and will be low for the 2-AC128 which are carefully matched at two points on their characteristics. The ratio of DC amplification factors at 50 and 300 mA is typically 1.1/1 for a matched pair.

With an emitter resistance of about 3Ω , the crossover distortion may be kept below the detectable level when the quiescent emitter current of each transistor is 3 mA. Generally an emitter resistance smaller than this requires higher quiescent currents for the same level of crossover distortion and furthermore introduces problems with thermal stability.

High current gain minimises the current drive requirements, and in the case of the circuit described leads to a power sensitivity at the driver secondary of less than 1 mW for 2 W delivered to the primary of the output transformer.

The high continuous junction temperature of 90°C reduces the problem in designing equipment for ambient temperatures as high as 55°C .

Applications of 2-AC128 in Audio Output Stages

With the 2-AC128 it is possible (with the one transistor type) to design power stages ranging from the low levels used in the personal type of receiver up to medium power levels of 2 W suitable in most cases for automobile receivers. Provided that 2 W (approx. 3 dB lower than that obtainable with the OC26 in Class A) is acceptable, an advantage is obtained in the saving of space afforded by the smaller heat sink required for 2-AC128 in Class B. In a practical example using a heat sink of 35 cm^2 per transistor with a resulting thermal resistance (between junction and ambient) of $0.07^\circ\text{C}/\text{mW}$, an output power of 2 W can be obtained in the primary of the transformer at an ambient of 55°C .

MEDIUM POWER AF OUTPUT STAGE 2-AC128

The description follows of a Class B audio output stage providing 2 W into the primary of the output transformer from a 14 V supply and with a total distortion of 5%. The circuit (Fig. 4) is conventional and uses shunt feedback (R_{13}) between the output transformer and the driver base. Series feedback (R_4) is

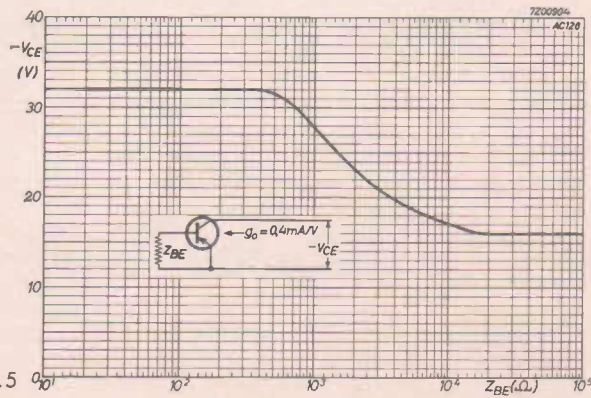
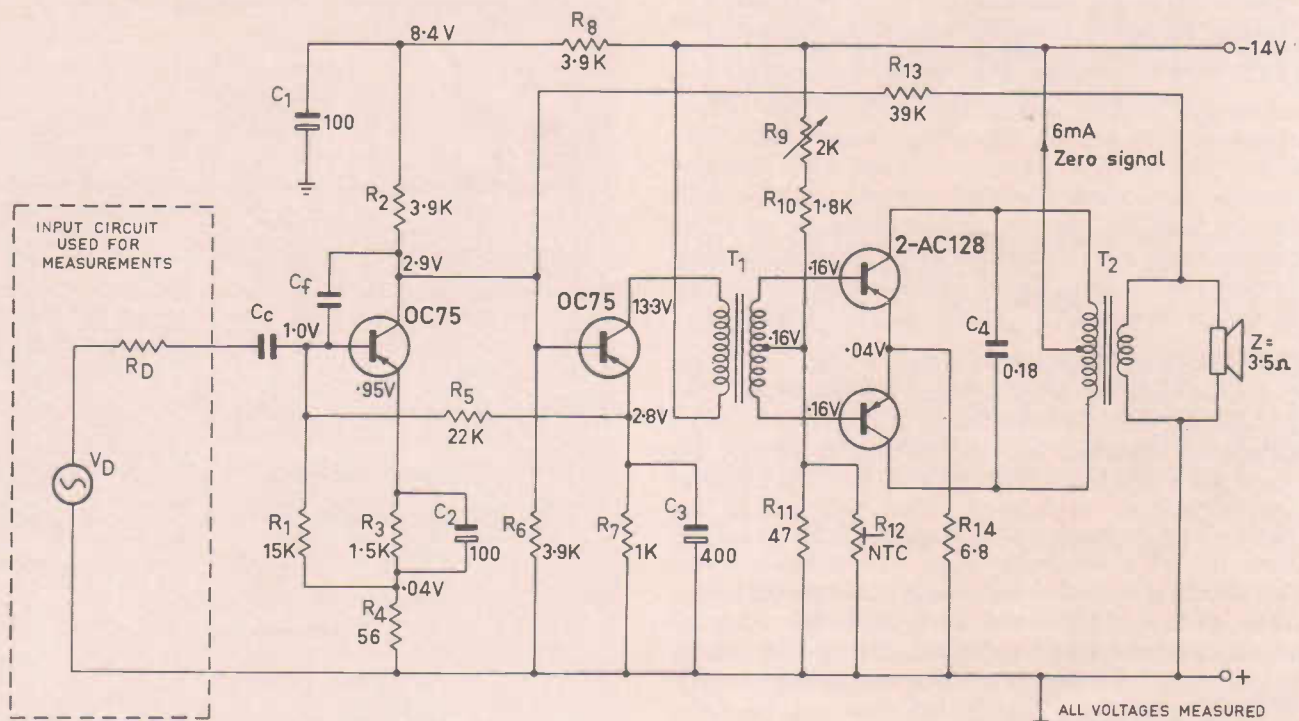

Fig. 3. Collector voltage derating curve. $-V_{CE}$ is the minimum collector voltage for which $g_o = 0.4 \text{ mA/V}$. Provisions must be made to ensure thermal stability.



ALL VOLTAGES MEASURED TO GROUND WITH ZERO SIGNAL USING 40,000 Ω/V METER.

R_D	C_c	C_f
2K Ω	0.12 μF	0.012 μF
5K Ω	0.082 μF	0.0068 μF

CIRCUIT N^o 412

R_1 15 K Ω , 5%
 $R_{2,6}$ 3.9K Ω , 5%
 R_3 1.5 K Ω
 R_4 56 Ω
 R_5 22 K Ω , 5%

R_7 1 K Ω
 R_8 3.9 K Ω
 R_9 2 K Ω , lin.
 R_{10} 1.8 K Ω
 R_{11} 47 Ω

R_{12} NTC, Philips type BB 320 01 A/130E, 130 Ω at 25°C
 R_{13} 39 K Ω
 R_{14} 6.8 Ω

All resistors used, Philips series BB 305 05—values required 10%, $\frac{1}{2}$ W, unless otherwise stated.

C_1 100 μF , 16 V W, electrolytic (Philips type C426 AM/E100)
 C_2 100 μF , 4 V W, electrolytic (Philips type C425 AL/B100)

C_3 400 μF , 4 V W, electrolytic (Philips type C435 AL/B400)
 C_4 0.18 μF (Philips type C296 AA/A 180K)

T_1 Driver transformer, e.g. Ferguson TRD 216
 T_2 Output transformer, e.g. Ferguson TRS 218

Fig. 4. Circuit details of Class B audio amplifier using 2-AC128.

used in the pre-amplifier, with additional feedback (via C_f) between collector and base to limit the frequency response to approximately 6 Kc/s. The low frequency response is restricted (to approx. 125 c/s) by the choice of the input coupling capacitor C_c .

Whilst a circuit can be designed about the 2-AC128 to have a much wider frequency response, the design aim here was to deliberately restrict the response for general automobile and portable use.

An investigation was made into the resonant frequencies of the speaker types generally used and it appeared that the most common frequency was 115 c/s. Since it is desirable to maintain feedback below the speaker resonant frequency in order to damp the resonant effect, the output and driver transformers were designed to have -3 dB frequencies of 70 c/s and 90 c/s respectively. Because the loading at the primary of the output transformer becomes essentially reactive and approaches a short circuit at low frequencies, excessive collector currents can be drawn. The -3 dB frequency of the driver transformer was accordingly chosen higher than that of the output transformer to reduce the drive before this could occur. The speaker resonance (even with damping provided by a shunt feedback network) can be sufficient to limit the effective output power of an audio system. Steps were therefore taken, using a coupling element (C_c) outside the feedback loop, to reduce the drive at a frequency above the speaker resonance.

The sensitivity, frequency response and distortion curves are shown in Figs. 5, 6 and 7 respectively. The amplifier is primarily intended to be driven from a low impedance detector, and the voltage sensitivity for maximum output is plotted as a function of detector output impedance. This will enable the reader to assess sensitivity in a more realistic manner.

The circuit is intended for continuous operation at a maximum ambient temperature of 55°C . The thermal stability of this circuit results in less than 10% change in quiescent collector current for temperatures up to 55°C .

Transformer Data

Output Transformer:

Full primary resistance: 1.8Ω
 Secondary resistance: 0.4Ω
 Self inductance of the full primary winding: at $f = 100$ c/s
 and $V_{\text{RMS}} = 1$ V, $L = 280$ mH
 Turns ratio—primary to secondary $(2.65 + 2.65)/1$

Driver Transformer:

Primary resistance: 250Ω
 Full secondary resistance: 50Ω
 Self inductance of primary: at $f = 100$ c/s $V_{\text{RMS}} = 1$ V and
 2.5 mA DC, $L = 8.5$ H
 Turns ratio—primary to secondary $2.5/(1 + 1)$

(This article is based on work carried out in the "Miniwatt" Electronic Applications Laboratory by T. Davis, with acknowledgment to earlier work carried out in overseas Concern laboratories.)

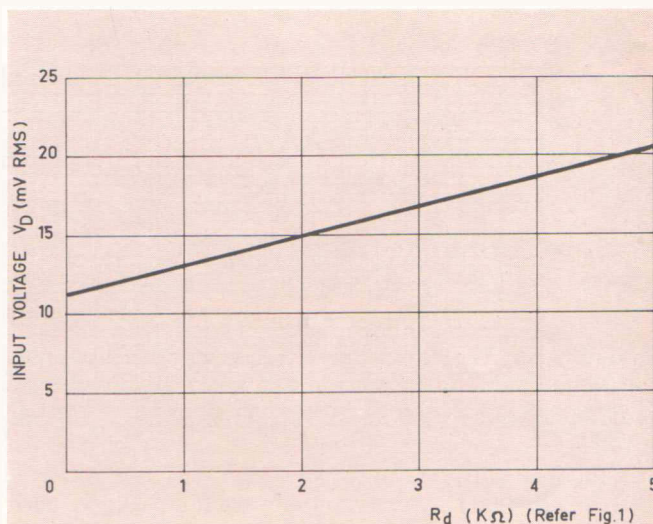

Fig. 5. Sensitivity for maximum output.

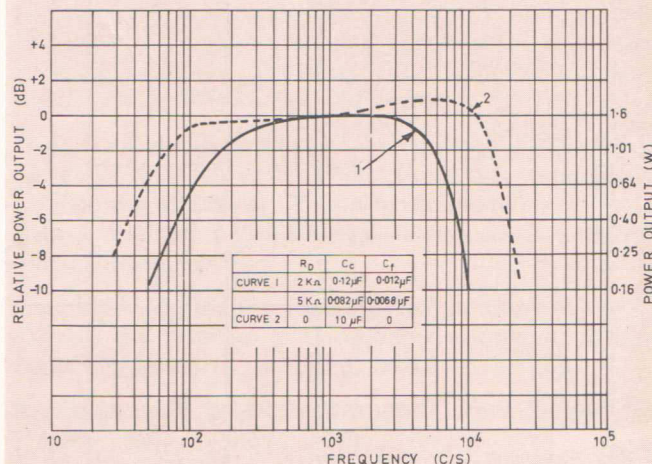

Fig. 6. Frequency response.

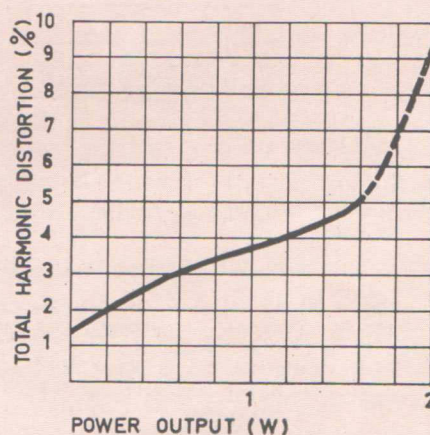

Fig. 7. Distortion characteristics at 1 Kc/s.

Applications of Philips Circuit Blocks

Decade Counter DC1 (Type B8 850 00)

An addition to the Philips range of Circuit Blocks is unit B8 850 00, which consists of four flip-flops type B8 920 00 mounted on a printed wiring board and connected as a decade counter. The counter operates up to frequencies of 100 Kc/s.

The counter is provided with pulse feedback to allow six of the sixteen possible states to be suppressed. The flip-flops can be reset by means of a common positive signal.

The reset diodes and the feedback network are mounted on the printed wiring board. This board is provided with plated-through holes, double-sided printed wiring and double-sided gold-plated contacts.

The mating connector type F 042 ZZ/03 (if required) is supplied separately.

Further information is available on request.

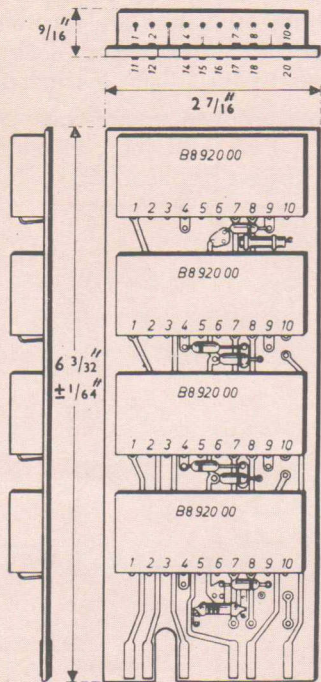

Philips Circuit Blocks are finding wide application in automation and the allied fields of electronic control and measurement, especially in any industrial application where a range of logical functions is required. The applications described are intended to illustrate such applications.

The PS1 Circuit Block, besides its normal function as a pulse shaper, can also be adapted to provide an inexpensive source of clock pulses. The variable frequency square-wave generator (Fig. 1) has a frequency range extending from extremely low frequencies up to 100 Kc/s, and can be gated by externally applied pulses. The crystal-controlled generator (Fig. 2) can be used where a fixed frequency of high stability is required within the range (10-100) Kc/s.

FF1 Circuit Blocks are basic bistable multivibrator circuits and can be used in frequency divider chains both in the production of accurately spaced pulses and in pulse counting. Such an example is their use in digital time clocks. Both fixed and variable ratio frequency divider circuits are described (Figs. 3 and 4 respectively) and Fig. 5 is representative of FF1's applied to counting.

Circuit Block gates performing for example the NOT, AND and OR functions can be used in the logical design of control circuitry (e.g. lift installations), in addition to their normal computer functions, and a typical gate sequence is illustrated in Fig. 6.

Circuits controlling powers up to 67 W are given in Figs. 7 and 8. In these, Circuit Blocks have been integrated with external components, including power transistors to form systems which are used to drive relays, electro-mechanical printers, etc.

Suitable set and reset circuits are included in Fig. 9 for resetting up to 50 units.

Visual Indication using DM160

Visual indication of the actual switching state of multivibrators, gates, etc., in Circuit Block assemblies can be accomplished by means of Philips subminiature DM160 indicator triodes.

Further Information

The "Miniwatt" Electronic Applications Laboratory will be pleased to advise on Circuit Block combinations to suit particular requirements. Information on the operating characteristics of the entire range of Philips Circuit Blocks is available on request.

CLOCK PULSE GENERATORS USING PS1

Variable Frequency Circuit

The RC oscillator circuit shown in Fig. 1 uses a PS1 Circuit Block. The high frequency limit is 100 Kc/s and the frequency can be altered simply by changing the value of the external capacitance C. Reference to Table 1 shows the approximate range of capacitance needed.

TABLE 1

Frequency	Capacitance
100 Kc/s	.0025 μ F
1 c/s	250 μ F

The circuit can be stopped at any time by application of a positive going voltage (whose peak amplitude exceeds -0.2 V) to any of the OA200 diode input circuits. The output frequency, with fixed load, changes $0.2\%/C^\circ$, and a $\pm 10\%$ change in supply voltage will result in a change of less than 5%. The oscillator produces a square-wave pulse (< 0.4 μ sec rise time) and is suitable for driving other blocks, e.g. PS1, FF1, etc. If a mark/space ratio other than that provided is required, an OS1 monostable multivibrator should be additionally incorporated.

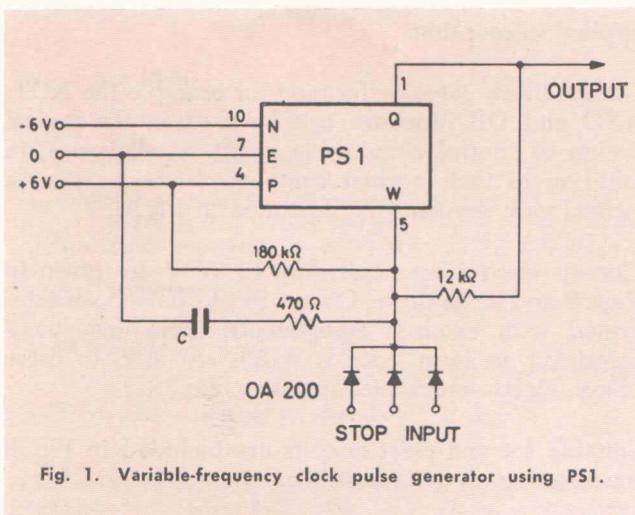

Crystal-Controlled Frequency Source

A source of clock pulses of high frequency stability in the range (10—100) Kc/s can be obtained by using a PS1 Circuit Block in conjunction with a quartz crystal (Fig. 2). If the series resonant impedance of the crystal is too high, the current fed back to the base of the input transistor may be too small to cause oscillations. At 10 Kc/s the maximum limit commonly set for typical NT cut crystal is approximately 21.5 K Ω , whereas this circuit will operate with a crystal whose series resonant resistance is as high as 39 K Ω . In some cases it will be found that on switching on, the crystal will tend to oscillate in a higher mode for a few seconds before settling down. This tendency can be substantially reduced by inserting some resistance, R (usually a few thousand ohms). However, the introduction of such a series impedance in this case has been shown to increase slightly the rise time of the output pulses. This effect is most apparent at 10 Kc/s (0.1 to 0.5 μ secs increase) and diminishes with increasing frequency.

Where small rise times are required in particular applications, both oscillators are recommended to be fed into another PS1 pulse shaper Block via an 18 K Ω resistor in parallel with a 330 pF capacitor.

These oscillators produce square-wave pulses suitable for driving PS1, FF1, OS1, etc., in addition to many other general purpose applications.

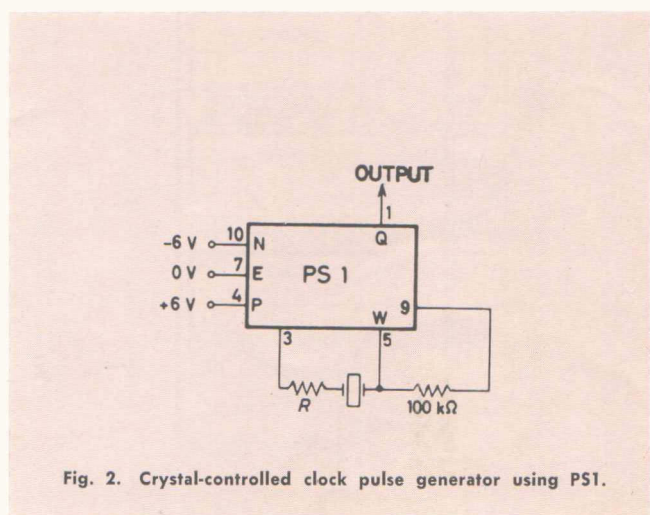

FREQUENCY DIVIDER CIRCUITS

Fixed Ratio Frequency Divider Circuits

Any number of FF1 bistable multivibrators can be connected in a chain to give large ratios of frequency division such as are required in digital clocks or timers, etc. If the number of feedback paths does not exceed two, the circuitry can be simplified as shown for example in Fig. 3 (a), (b) and (c).

The input waveform should have a sufficiently fast rise time to trigger the first FF1 in the chain (0.4 μ sec max.); if any doubt exists, a PS1 pulse shaper should be used.

Variable Ratio Frequency Divider

A variable ratio frequency divider is shown in Fig. 4. This circuit will divide the applied input frequency in any ratio of whole numbers between 1 and 16 for a frequency range up to 75 Kc/s. The input is usually supplied from a fixed frequency source of either sine or square-wave. Reference to the circuit diagram shows that the ratio is selected by a 4-pole 16-position switch. As a maximum number of four feedback paths is required, an OS1 is used for triggering the FF1 Blocks. If variable mark/space ratio is required the output should be fed into an additional OS1.

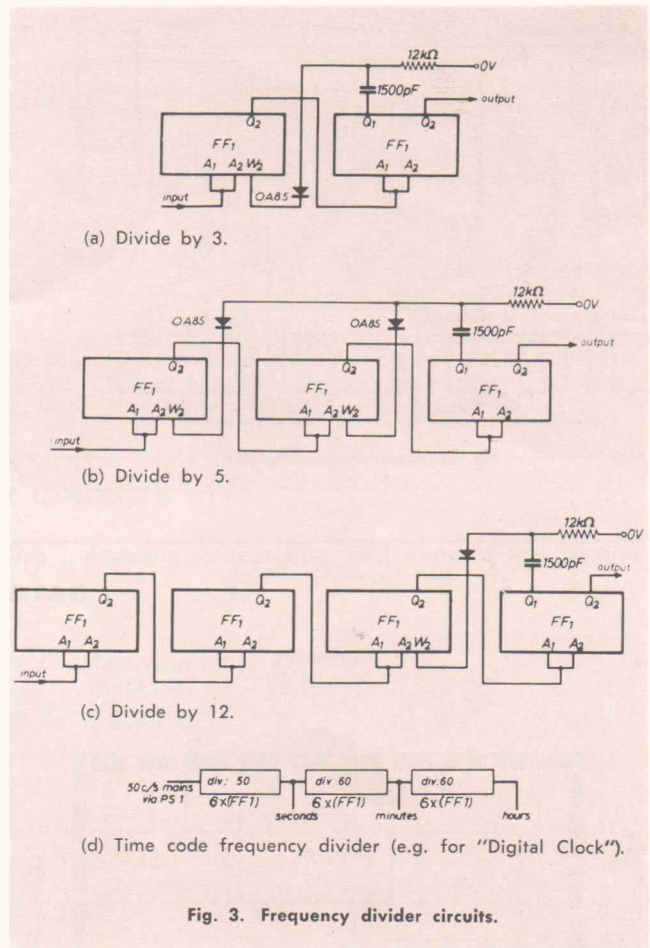

Fig. 3. Frequency divider circuits.

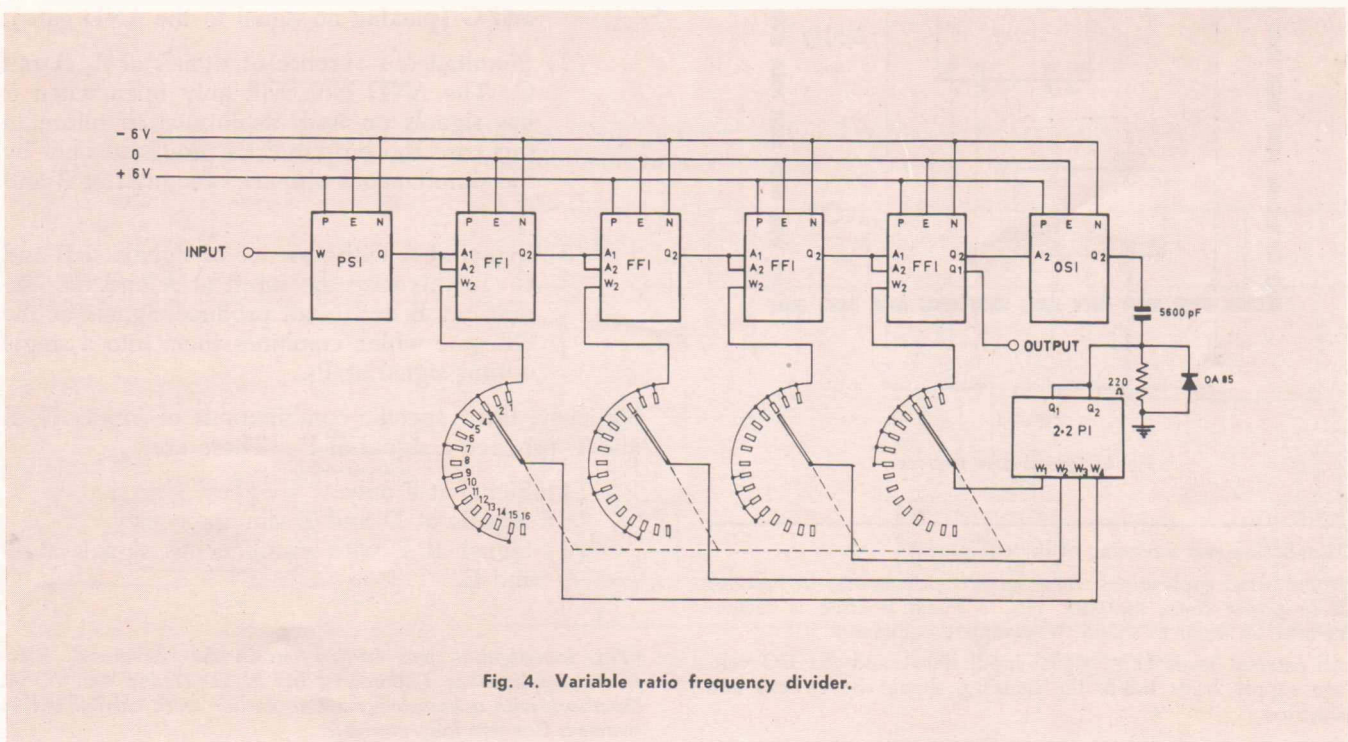

Fig. 4. Variable ratio frequency divider.

PRESET COUNTER

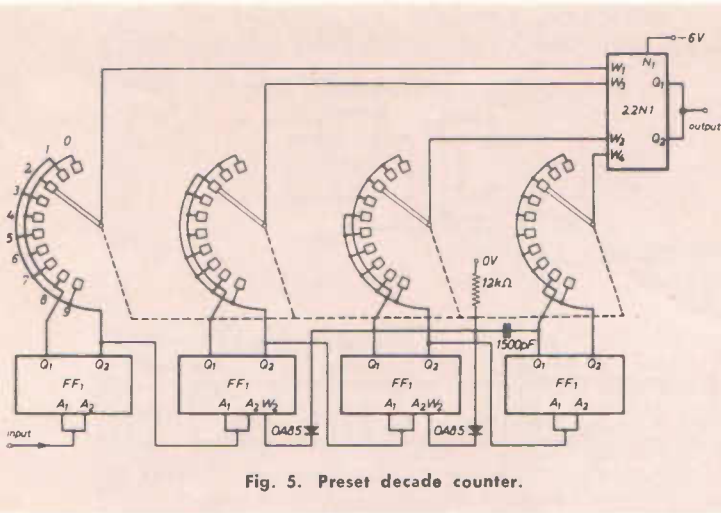

Fig. 5. Preset decade counter.

The preset counter shown in Fig. 5 (a fundamental industrial building block) is basically a decade counter in which an output voltage is produced when the counter stores the number chosen by means of the 4-pole 10-position switch. Similar configurations are also used for example in the determination of a time interval by counting cycles of an alternating voltage. The frequency range is between 0 and 100 Kc/s.

GATE CIRCUITS

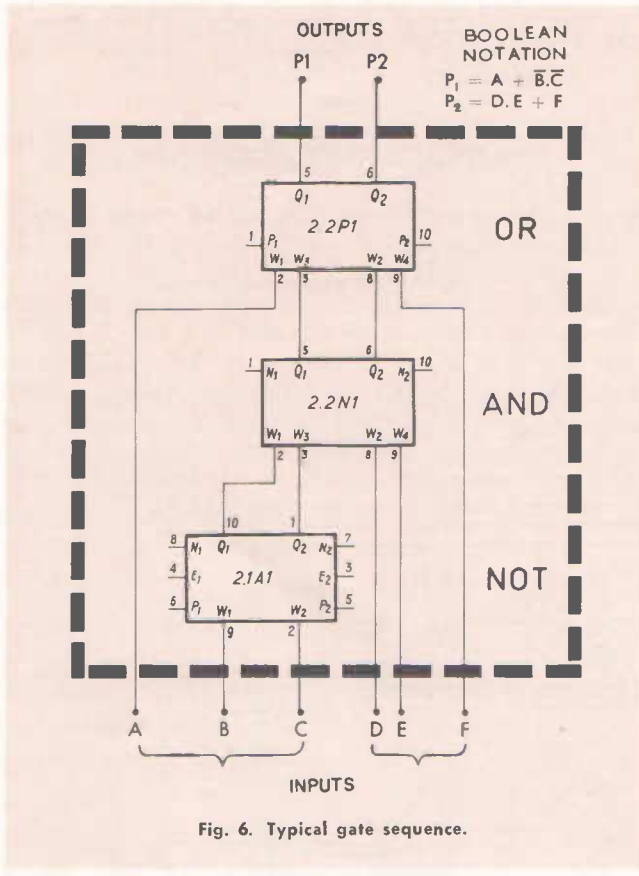

Fig. 6. Typical gate sequence.

Gates can be used in a variety of combinations in switching and control circuits to pass an actuating DC level, an initiation pulse or coded signal, after a given sequence of events has occurred. In this example a signal is defined as a negative voltage level or negative pulse (arising from the nature of Philips Circuit Blocks). Referring to the gate sequence in Fig. 6, three specific combinations of inputs A, B, C produce a signal at P₁. These are:

- (1) Simultaneous signals at A, B and C. In this case only signal A contributes to the output P₁ as the NOT gate inverts the signals at B and C (passing no signal to the AND gate).
- (2) Simultaneous absence of signals at A, B and C. The AND gate will only open when it has signals on both its inputs; therefore in this case the output P₁ is produced only by the simultaneous absence of signals at B and C.
- (3) Signal at A with absence of signals at B and C. In this case the input at A and the "inputs" at B and C all produce signals at the OR gate which combines them into a single output signal at P₁.

Similarly, three specific combinations of inputs D, E and F produce a signal at P₂. These are:

- (1) Signal at F only.
- (2) Signals at D and E simultaneously.
- (3) Signal at F with simultaneous signals at D and E.

Installation and screening of the equipment

In industrial applications where large transients may be induced from power lines, switches, etc., a metal housing is recommended in order to shield the complete equipment.

All external leads (e.g., signal input lines) and the DC voltage supply leads inside the housing, should be twisted and shielded.

(This investigation was carried out in the "Miniwatt" Electronic Applications Laboratory by A. C. Denne and N. A. Steadson, with acknowledgment to earlier work carried out in overseas Concern laboratories.)

POWER CONTROL CIRCUITS

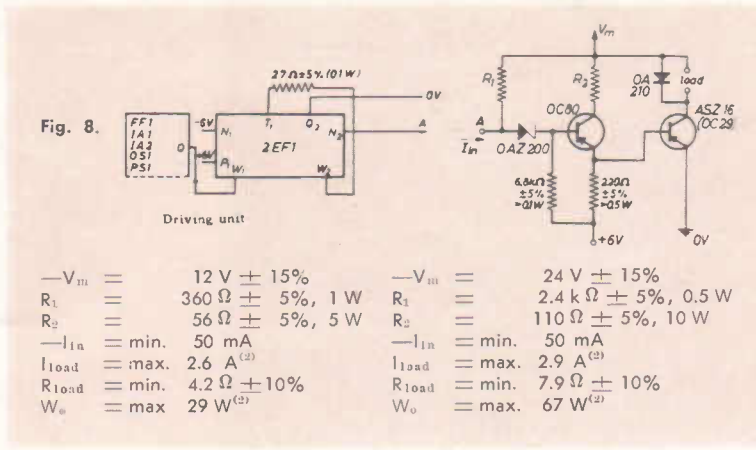
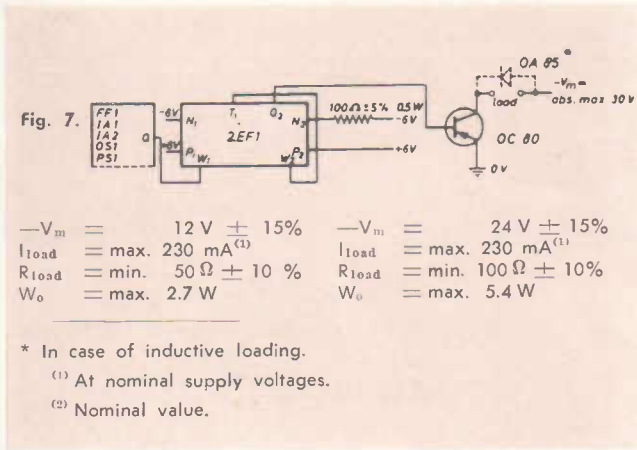

SET AND RESET CIRCUITS

A system in which flip-flops are used, often requires a means for setting or resetting, and some of the possible combinations are shown in Fig. 9 below.

Fig. 9.

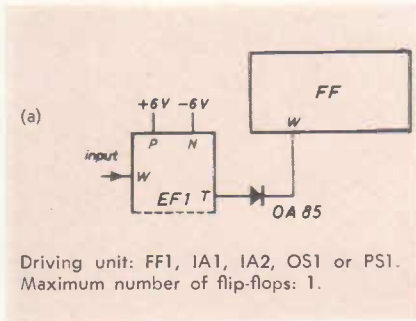

A simple circuit for resetting flip-flops using an FF1 is given in the figure below.

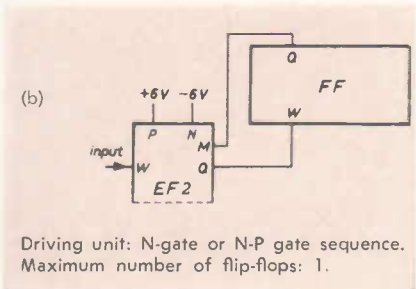
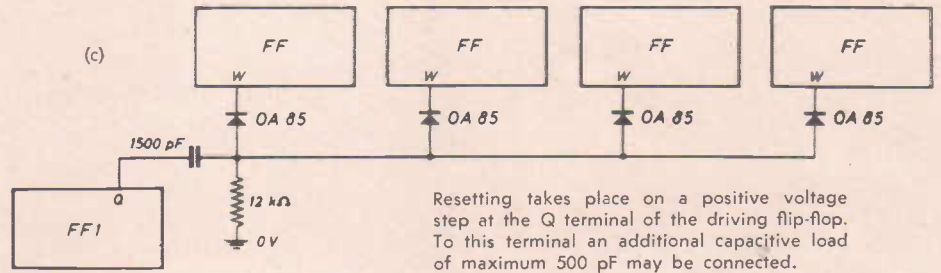

When a large number of flip-flops has to be controlled, the following arrangement can be used.

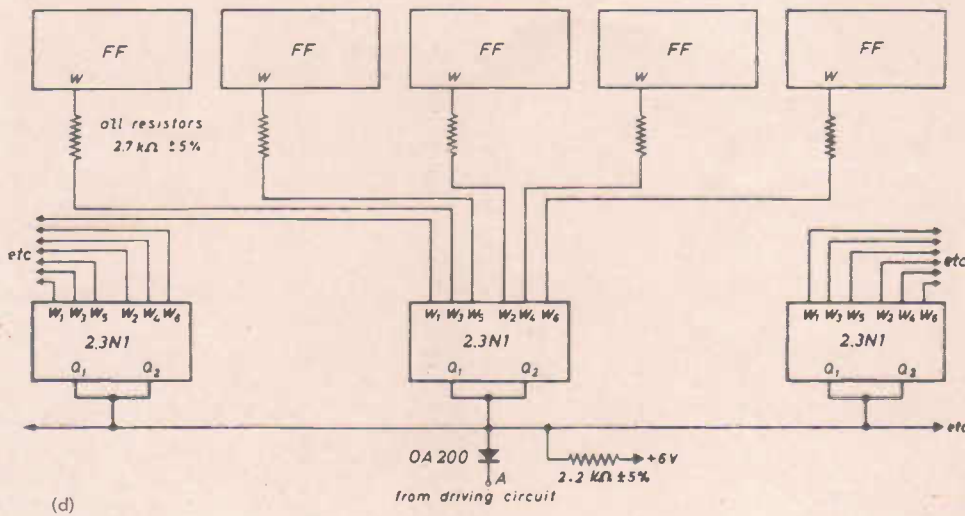

PHILIPS

- ELECTRONIC VALVES AND TUBES
 - SEMICONDUCTOR DEVICES
- CATHODE-RAY TUBES
 - LIGHT-SENSITIVE DEVICES
- TEMPERATURE-SENSITIVE DEVICES
 - FERRITES
- RADIATION-SENSITIVE DEVICES
 - FINE WIRES
- SPECIALIZED COMPONENTS AND DEVICES
 - SPECIALIZED MATERIALS
- TECHNICAL PUBLICATIONS

For Use in the Fields of—

ENTERTAINMENT — COMMUNICATIONS — INDUSTRY
COMMERCE — MEDICINE — SCIENTIFIC RESEARCH
AND DEFENCE



THE *Miniwatt* ELECTRONICS DIVISION

of

Philips Electrical Industries Pty. Limited
20 Herbert Street, Artarmon, N.S.W.
Phone 43 2171

Branches at:—

ADELAIDE	11-13 West Terrace, Adelaide, S.A., phone 51 6051
BRISBANE	56-58 Cordelia Street, South Brisbane, Qld., phone 42 4
CANBERRA	C.B.C. Chambers, Petrie Street, Civic Centre, Canberra City, A.C.T., phone J 4498
HOBART	73 Brisbane Street, Hobart, Tas., phone 3 3038
MELBOURNE	252 Sturt Street, South Melbourne, Vic., phone 69 0141
NEWCASTLE	194 Parry Street, Newcastle West, N.S.W., phone MA 5001
PERTH	672 Murray Street, Perth, W.A., phone 21 3131
SYDNEY	67 Mars Road, Lane Cove, N.S.W., phone 42 1261

Production Centre—

HENDON WORKS Tapley's Hill Road, Hendon, S.A., phone 4 5021

The information given in this publication does not imply a licence under any patent. Further information on the products described in this publication may be obtained on application to any of the addresses listed above.