

SOUND CHOICE

No. 4, Spring 1986: \$2.50



**An Audio Evolution Network Publication
for the Independent minded.**

**UNDER THE UNDERGROUND
NEW MUSIC FROM NEW YORK**



Dark Day—Beyond The Pale- A new audiocassette of material by the cofounder of DNA, Robin Lee Crutchfield, & his current associates Shawn McQuate, Steven Cheslik-DeMeyer, and Brian Bendlin. A collection of dark, mysterious instrumentals built around gothic organ work recalling darker days of the distant past or those yet to come. Lightened only by the medieval strains of soprano recorder, cello, and bowed psaltery, and punctuated by the primitive percussion sounds of rattles, bells, and bongos. Titles include: Meadowlands/Down To Elephantine/Letters To The Dead/Darker Days/Shod With Boots Of Ether/Heroiner/In Sickness & In Health/Rise To Fall/The Haunted Child/Lost In The Shuffle. **\$8.00**

Dark Day—Live At The Pyramid- A videocassette of a performance at New York City's infamous nightspot during the summer of 1985. VHS format only. **\$20.00**

Red Dress & Blue Dress- A short novel by Robin Crutchfield. Word play in the tradition of Gertrude Stein. In pocket-sized book form. **\$2.00**

Mail order: Make check or money order payable to R.L. Crutchfield at Nigh Eve Cassettes-231 Thompson St. Box 12, N.Y., N.Y. 10012. All domestic orders include postage & handling. Orders from abroad should be in U.S. currency and add \$1 extra to cover foreign postage.

Inquiries concerning booking and other matters regarding Dark Day may be sent to the above address.

The Sapphists—A Form Of Education- Nine or ten assorted pop songs (some fast, some slow, some in between) for those who think love. Titles include: *Last Year At This Time, The Woman In The Grey Raincoat, Working Relationship, I Can't Help Thinking, and The Voice Of Concern.* A PREFERENCE CASSETTE/Approx. 45 min. **\$5.00**

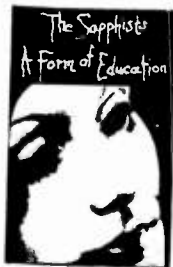

Make check or money order payable to Linda M. Smith, 67 Devoe St., 4L, Brooklyn, N.Y. 11211



**Steven Cheslik-DeMeyer/
Brian Bendlin — Songs
From Trouble Picnic-** New music from two members of The Woods, with Robert Huff, Carol Black Rutz, Scott Keys, Sybille Schempf, Elizabeth Periale, Paul Ermer, Antonio Tatum, Fred Cisterna; dulcimer, cello, piano, guitars, waterphone, percussion, voices, and other sounds. Instrumentals, love songs, and other songs for all walks of life. Cassette produced by Robert Huff **\$6.00**

Send check or money order, payable to Brian Bendlin c/o Trouble Picnic, P.O. Box 2386, N.Y., N.Y. 10009

10341 San Pablo Avenue El Cerrito, CA 94530 (415)525-0942

LES BLANK VIDEO TAPES

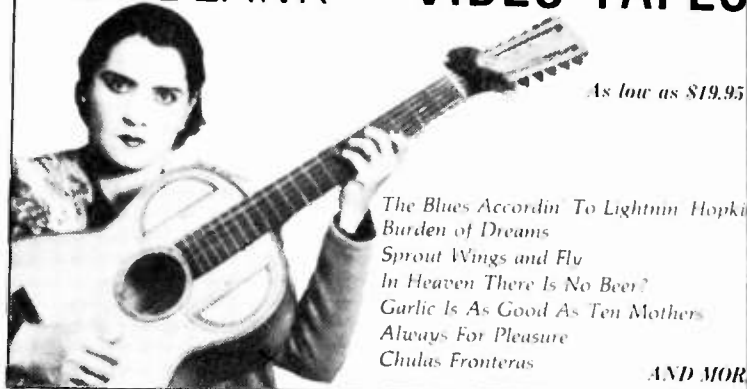

**CAT'S VOICE RECORDINGS
INDEPENDENT LABEL**

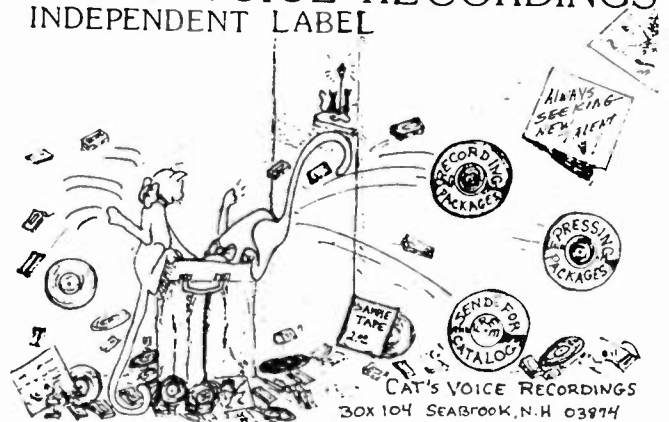

A VERY SPECIAL ALBUM

CARL WEINGARTEN WALTER WHITNEY

DREAMING IN COLORS



From The Producers of *DELAY TACTICS*
... Available Spring 86

Also, New on Cassette
**CARL WEINGARTEN/Living In The Distant Present
VARIOUS ARTISTS/Urban Cabaret Vol.2**

DISTRIBUTION: Backroads, Important, NMDS, Wayside
Systematic, Eye Records, Gut Level, Innersleeve,
Greenworld and Lotus, London
**MULTIPHASE RECORDS PO BOX 15176
ST. LOUIS, MO 63110 USA**

SOUND CHOICE

No. 4, Spring 1986: \$2.50

Table of Contents

- 3 State of the Network Address
- 4 Deadline Chart
- 5 Correspondence
- 8 Clone The Drone by George Ottinger
- 9 Publications
- 15 Contacts & Sources
- 17 From the Events Desk
- 19 Creative Mailers by James Hill
- 21 Heavy Mental by Wayne Kusy
- 23 Goodby Berlin by William Levy
- 25 Blackhouse by Pope Jamie Lee Rake
- 26 Ernest Free Man
- 27 Tom Furgas interviewed by Mark Kissinger
- 28 Backtracking by Sally Idasswey
- 29 Atom Club
- 30 Memories of the Jazz Age by E. Chadbourne
- 36 Record Reviews
- 67 Pirate Radio Manual by Zeke Teflon
- 78 About the Cover
- 79 Loose Ends
- 80 Unclassifieds



Sound Choice (ISSN 8756-6176) is published by the Audio Evolution Network, an organization dedicated to the positive evolution of independent music, audio art, experimentation and related ideas. We welcome contributions of articles, art, information and ideas. The Sound Choice staff includes David Ciaffardini, publisher/editor-in-chief; Eileen Sterling, events editor/international hostess; Bill Hubby, network trail correspondent. Audio Evolution Network/Sound Choice address is: P.O.B. 1251, Ojai, CA 93023, USA; phone: (805) 646-6814. Sound Choice ad rates are \$25 per eighth page; \$50 a quarter page, etc. All ads must be pre-paid and camera-ready. See deadline schedule on page 4.

Sound Choice Subscription Coupon

P.O. Box 1251, Ojai, CA 93023

I've included: \$12 for six issues \$24 for twelve issues

\$18 U.S. funds for non-U.S. \$30 for non-U.S. airmail subscription

Name: _____

Street or Box: _____

City: _____

State: _____ Zipcode: _____ Country: _____

Phone number (optional; for Sound Choice use only): (____) _____

HEY KIDS! IT'S THOSE FREAKY FUNGI!

CREEPIN CHARLIE

AND

WEED B. GONE

IN...

"SUBTERRANEAN'S NEW RELEASES!"

HEY, SLOPEHEAD! Quit watchin that cow and get over here!! We is bein innerduced!!!

I got us a job sellin these and other fine records! LOOK AT ME WHEN I'M TALKIN TO YA!!
Feh!



MUSKRATS descend upon us from Omaha! Washboard and acoustic git-box flailin, givin with a rousin. **BLISTERIN** kickoff to the new SF folk scene! LP for \$6.50!

PSYCLONES! Industrial pop music? Is it possible? They gots songs and melodies, yes, but they **RASP!** They **GRIND!** They **HAMMER!** Good as ol' TG! Hear for yourself, willya? An LP for \$6.50!!

PSYCLONES



WILMA is four Women! NO, not a schizo!! They are: Personal! Political! Imaginative and expressive! Lush! Lyrical!

WILMA



HELIOS CREED gives "X-Rated Fairy Tales!" Dis guy was in Chrome! Singer! Songwriter! Guitarist! This's the first from his **NEW BAND!!** A huge hunka noise, I'll say! LP for \$6.50!!

Emotionally intense! If ya dont believe me, get the sub catalog! OR the LP for \$6.50!!



ROD MYERS & THE RAMPS

ROD MYERS + THE RAMPS! What do ya do if yer a disabled Rock'n' Roller in Rockford, Ill?? Start a band and do songs about it! Is dis disability?? 7" single of "Wheelchair" and "Maybelline." Only \$2!!

Joe Pop • O • Pie

Third Record



Wheelchair

Z'EV gives "My Favorite Things," 9 live metal percussionations recorded in the US and Europe, 1979-83! PLUS! Six short tape compositions! Industrial trance HooDoo!! LP for \$6.50!

The cover Says it! Joe P.O.P. Does It again! The scrambled eggman, and more! you know! If ya don't, \$6.50 for LP!

JOIN us in our search for the Mythical GREAT SUBTERRANEANLAND! ADVENTURE! MYSTERY! (Hold still, Spores-for-brains, I can't read!)

Do fungi have 2 sexes? How do they write scripts? What's the premise? WHAT'S THE BIG IDEA??

I dunna! Watch for us in coming issues as we figure all this, and more out!



PRICES ARE POSTPAID, DIRECT FROM ...

SUBTERRANEAN!

577 VALENCIA

SAN FRANCISCO CA 94110 USA

WRITE FOR FREE CATALOG!



(Timothy Teague photo)

Sound Choice and the Audio Evolution Network fared better than this poor Ojai Valley home that fell victim to the recent mudslides and flooding hastened by the runoff from the fire-charred local hillsides mentioned last issue.

State of the Network Address

We made it. The first-year-of-publication marathon is over. Our canvas sneakers have holes in them, and our handkerchiefs wipe sweat from our brows. But we made it. Slow and steady. Testing the limbs. Feeling the muscles and exercising them from their childlike softness. And we go on. Slow and steady. Learning sure-footedness for the terrain ahead...

The staff's immediate goal is to get new editions of *Solund Choice* out more frequently. Four issues a year minimum. To this end we are forthwith printing our deadlines for *Sound Choice* #5. Records for review are to be received by *Sound Choice* no later than March 7. All articles, art and other editorial copy other than record reviews must be into SC headquarters by April first. All record reviews, solicited and otherwise, must be here by April 14. All hand decorated envelopes (9x12") must be here by May 1. All advertising must be delivered and paid for by May 7. *Sound Choice* #5 is shipped May 21.

The deadlines for *Sound Choice* #6 are exactly three months later. Same numbers, just change the months. For a graphic look at these deadlines see our chart on page 4.

Now let's talk about money. The financial scoop. Like who's payin' the bills and whos reaping the windfalls from this "Audio Evolution Network Publication for the Independent Minded"? Is this too crass a question? I mean, should we sully our creative minds and dirty the sheets of the higher levels of artistry we speak of in this mag?

Well, since most of you have invested at least a couple of bucks by buying a copy of *Sound Choice* or an ad therein, and we like to foster a cooperative atmosphere, we feel it is appropriately radical and anarchistic to open the financial books of *Sound Choice*,

the primary income source for the Audio Evolution Network -- of which remember, all *Sound Choice* SUBSCRIBERS are a member

Membership means, among other things, that when (or if) *Sound Choice* begins making profits (we have still not reached the point where *Sound Choice* is paying people adequately for their time -- except the printing press people that is), profits will go toward creating things for the benefit of the members of A.E.N. such as the A.E.N. Independent Recording Library and Archive. We welcome other ideas. A recurring request is to keep including sound recordings with the subscriber copies. This is something we all want, but at this point we must depend upon donations of flexi-discs, cassettes and 7" hard vinyl to achieve this. Donations of recordings must be in lots of at least 50 and trades for *Sound Choice* advertising space is a possibility.

Financially, *Sound Choice* is holding its own. The schedule layed-out above will be met. At that point, if things progress as we expect they will, we will consider publishing bi-monthly sometime after issue #6.

However, to keep things running smoothly and to continue to explore and upgrade the level of communication and A.E.N. projects, A.E.N. must bring in between \$2,000 and \$5,000 more income between issues of *Sound Choice*. This is not so much -- about the salary of an employee or two. (No one on the *Sound Choice* Staff -- two or three people -- makes close to a full-time salary.)

There are various ways to generate this amount of income for A.E.N. and we will reach our goal one way or another. And, as always, we welcome ideas and suggestions and ACTIONS to help A.E.N. reach its goal.

The least painful way to increase revenue for A.E.N. is to increase the number of

subscriptions to *Sound Choice*. Subscriptions are the most efficient way to distribute the magazine and service the desires of our readers. We know from observing *Square Dancing Magazine* (20,000 subscribers spanning 50 nations) that a similar subscription figure is possible for *Sound Choice*. *Square Dancing Magazine* has enough subscribers, to maintain a full time staff of five and yet has an operation small enough to be responsive to the needs of individual readers. The publisher/editor is in the office and has time and interest to hear the views of any reader.

Because this is the best way to generate income and strengthen the efficiency of *Sound Choice*, we greatly appreciate any help in increasing subscriptions. Tell people about the magazine, share your copy, give gift subscriptions, mention us in publications, etc., etc. It will be mutually beneficial.

Another way to increase income is to increase the subscription price. Would you like to pay an additional 50 cents or a dollar for each issue if it meant that you would always receive a record or tape with each issue? Would you like to pay an additional 50 cents or a dollar to help the *Sound Choice* staff have a office stereo, three square meals a day, etc. Let us know your ideas. Until then, rates remain the same, i.e. in the U.S.A., \$12 for six issues.

Another way to generate income is by increasing the number of ads we receive. This can be smooth or painful. When the ads just come in through the transom by deadline without cajoling or expensive telephone calls, it is a painless, uplifting joy. When we have to spend lots of energy convincing or stroking, it takes us away from more important tasks. Help us make people realize that our rates are very inexpensive for a publica-

Sound Choice Deadlines

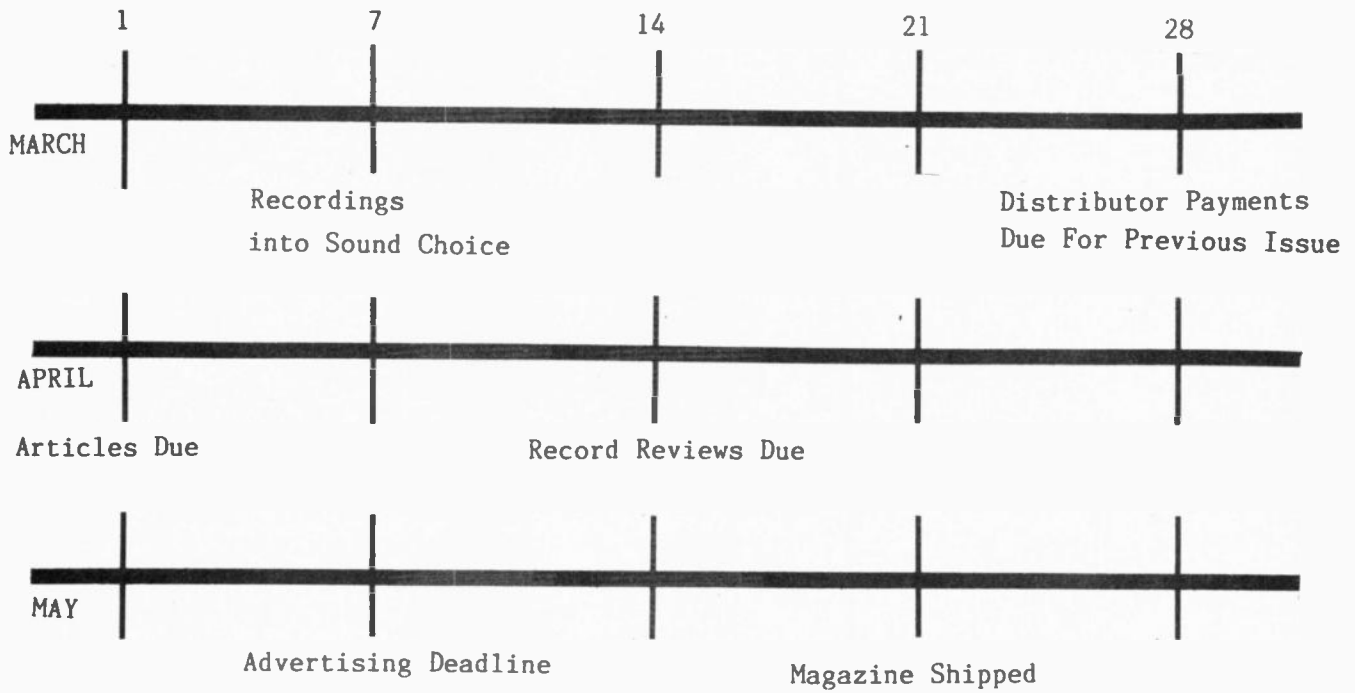

For deadlines for Sound Choice #6, just add three months to the above chart

10 INCH.....LIVE

VINYL



SEPTIC DEATH



DRUNK INJUNS

\$7.00 EA.

MAIL ORDER RECORDS, TAPES, VIDEOS, T-SHIRTS....
SEND S.A.S.F. FOR CATALOG

POSTAGE

\$1.00 for first 10" \$.50 for each additional Lp
California residents add 6.5% sales tax.
Please print your name and address with a check or money order to:



Correspondence

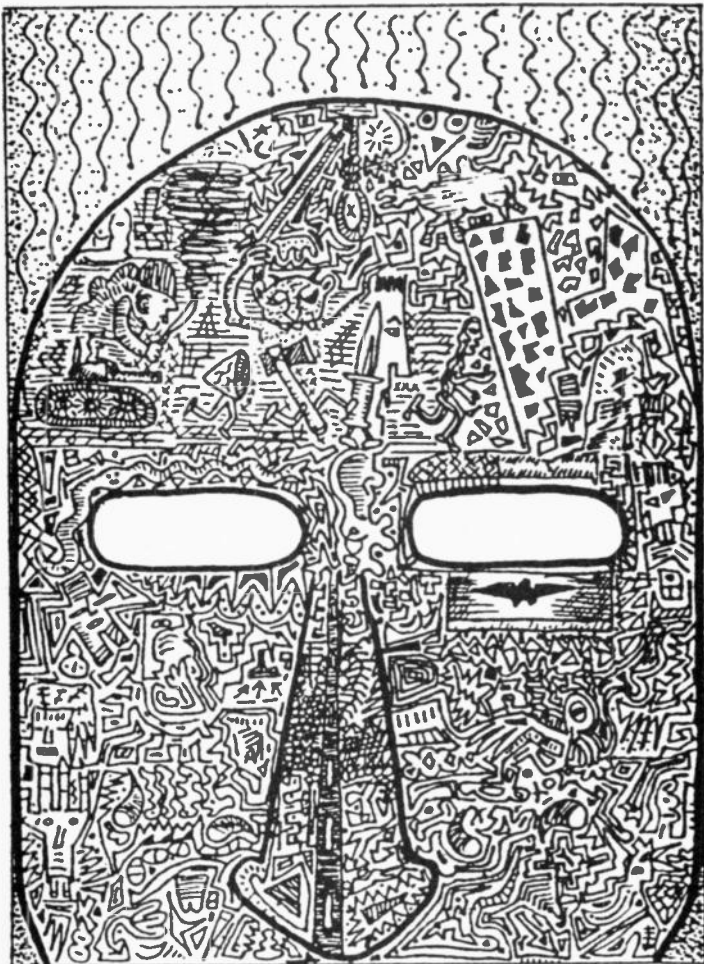

David:

While tuning my radio around the 100K station in Boulder on Nov. 21 I came across an illegal radio station! Right here in Boulder! It was at 97.7 FM and was sort of fadey but when it was on it sounded awfully good...playing what you call underground music. They were calling it Corsair radio and were using a pay phone for their request line. They were also doing live jams on real instruments! I listened til they went off a little after midnight. I was listening for about four hours. They also did a sign off that said that they were concluding their one and only broadcast day. How very exciting! Or was it Coarse Air?

If you decide to put this in your mag please don't use my name and you can burn this letter please and thank you.

Me? Paul
Longmont, CO

Don't B.S. me Paul. Reliable sources tell me that you were one of the people involved with that "illegal" radio broadcast. Why don't you tell us the REAL details? — DC

Dear Eileen:...I feel that I should also acquaint you with the situation with the music scene in my country. Firstly,

there's nothing similar to the independent music scene here, at least not in the form how it exists in your country and elsewhere. I mean fanzines and "indie" labels or records. We have a completely different system of government here in comparison to yours, and "indie" labels or fanzines would be considered here as a kind of free capitalistic enterprise. TV channels, radio station, record plants and almost anything else is under total control. The rock music scene here is small and only a few bands have record contracts with record companies. And of course, these bands generally play neat music.

This week I'm gonna send you a couple of albums sung in English. Please, do not expect anything blowing your mind out. Just ordinary music. It's possible that there are some bands playing experimental or more interesting music in Prague, but they have nothing out. And if they don't have the permission for gigs, they keep playing in flats, basements or garages, and they remain unknown. I live far away from Prague, so I know only bands that are played on Radio or have records out. In some ways I know more about the music scene in California than in Prague. I listen to foreign radio stations everyday and many U.S. bands get airplay in West Germany and Great Britain.

I'm not a musician, I'm just a common man, whose hobby is listening to rock music, no matter if it is from records or radio stations. I like a variety of music. Some of the bands I like are Sisters of Mercy, Green On Red, The Bangles, Big Black, The Dream Syndicate, Stevie Ray Vaughan, Los Lobos, The Cure, The Wipers, The Guadalcanal Diary, and others. And my fave DJ is John Peel.

By the way, if you know someone, who's into jazz and classical music and who'd like to trade U.S. rock records for East European jazz and classical records, forward him/her my address, please. Thanks a lot.

Needless to say, the U.S. records aren't available here and I can't order them through the mail, because sending the money abroad is restricted here. Because of this the only way to get records from the West is by trading for them. The surface mail is ok.

I suppose you're a little disappointed that there is no "independent" music scene here. So am I. In fact, the lack of more interesting bands here on records makes me interested in what's happening in foreign countries, mainly in Great Britain and yours.

I'm quite curious to see "Matter", "Jet Lag", "99-th Floor", "Bang!" and "Punk Globe" and other fanzines.

Thanks for wishing me a peaceful New Year. Being quite honest, I have to admit I'm quite pessimistic about the future of our planet. The so-called peace is more fragile than ever. We are all just standing on the edge of the abyss and any wrong step forward will cause the nuclear suicide. Certain people seem to have completely lost common sense. Money changes everything. I wonder if we will all survive until the year 2000. I don't wanna dissuade you from believing that we all will maintain peace. Sooner or later something's gonna happen. I wish I was wrong. This is just my personal opinion. I do know the majority is quite optimistic.

Yours sincerely,
Milan Hlubucek
463 42 Podlesi 547okres Liberec
Czechoslovakia

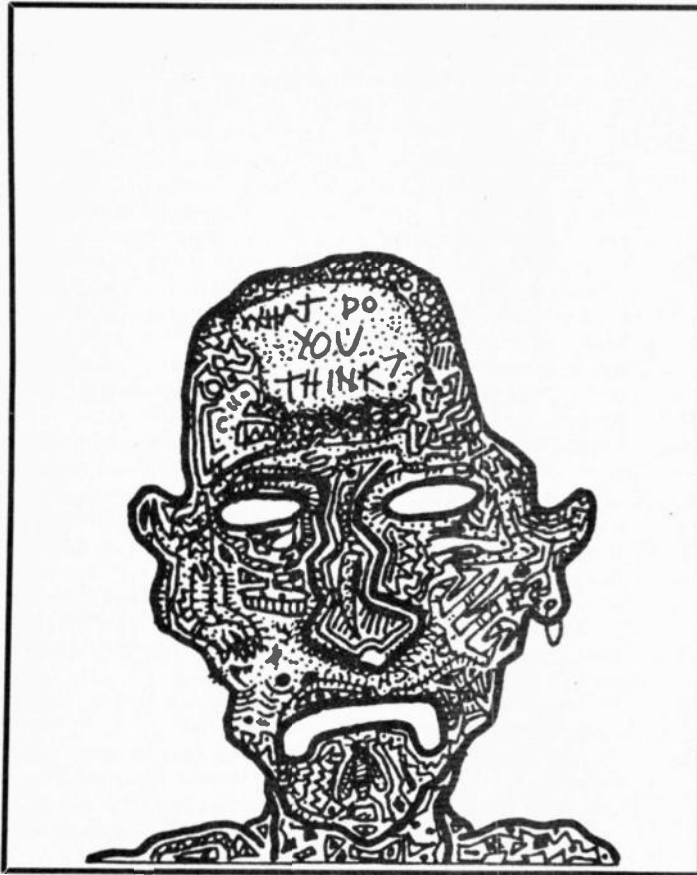

Dear David,

Enclosed find a sum of money in payment for your favorable review of *Stars Vomit Coffee Shop*. AHA! SEE — EVEN YOU CAN BE CORRUPTED. HEH-HEH....What I wanted but didn't get from you *Cassette Revolution* issue was a feeling that any of it matters. I does matter! I think. Sometimes I think it matters. Sometimes it doesn't matter. It's YOUR FUCKING JOB TO CONVINC ME THAT IT DOES. Well, you personally communicate enthusiasm in your writing but overall — so far — *Sound Choice* reads like the magazine of well-meaning hobbyists. My two cents:

It's funny, living in New York, where everyone spouts off all the time, the insane walk the streets, ranting, all cars are blowing horns. It sounds like an excess of self-expression, but the sound is misleading, it's just an ugly amount of accumulated blats that substitute for expression. It's the frustration of people that were never invited to speak, people that are afraid to speak if not first invited. Do it yourself recordings are the vanity press of music. I vastly prefer vanity press to humility press. Vain people start talking before the teacher calls on them. Deep down, musicians have been crushed as much or more than every body else has been crushed. Maybe that's why we're willing to make noise before arbiters of whatever tell us that our noise is legitimate because we need so desperately to prove that we haven't been crushed lifeless. So cassette cheapo records aren't merely "new orality" or "medium of future" (Big fucking deal) but Life and Death. Though maybe self-done cassettes are just the newest form of mere harmless social outlet blat, little "creative" projects that distract us from the knowledge of our own lifelessness.... (Hey, I hate happy endings.)

Frank Kogan

P.S. I'm moving to San Francisco

Dear Sound Choice:

In the Wanda Coleman interview (Issue #3), Ms. Coleman states "Racism is the ultimate obscenity." She also says "...they can bar-b-que eleven people — only one of those people was a man — that's an obscenity. That a whole black community can be destroyed. That's an obscenity. That's pornography to me." What I would like to know is...What if twelve WHITE MEN were killed (in the MOVE bombing in Philadelphia)? Would that be just fine with Ms. Coleman? Would that be less of an obscenity?

Ms. Coleman goes on to say "When the bomb was dropped, honey, it was dropped on them YELLOW people, it wasn't dropped on no white people, honey." Again, one has to assume that if it had been "whites", it would have been just fine with her.

I got the impression from reading the interview that Wanda Coleman thinks it's only blacks and women in particular that have ever experienced real suffering, real persecution. If you want to talk numbers, what about the SIX MILLION "whites" that were systematically butchered by the Nazis during World War II?

I ask you if you would have allowed some white male to pour out a litany of complaints and self-pity and accusations (i.e. "That a whole white community can be destroyed...that's an obscenity!") and pass it off as an "important" interview with an "artist"?

This is a "person of great depth and knowledge?" Come on! Just because a person is a non-white non-male? I thought the whole article was an obscenity.

Sincerely,

Todd Kinney
Solana Beach,
CA

Todd, The LOGIC is all fucked up in YOUR litany of complaints, self-pity, and accusations, but we decided to run your letter anyway, not because of your race, but because your comments and deductions are an excellent example of irrational, reactionary thinking.

Editor:

It was with great dismay and astonishment that I read your review of Ancient Future's now classic *Natural Rhythms* album (Sound Choice #3). First of all, it is a disservice to liken Ancient Future to Windham Hill. To my mind, the Windham Hill genre is consistently bland, simplistic, inobtrusive, and doggedly American in its orientation. It does indeed serve as good background for meditation. But Ancient Future by no means plays "new age muzak." If you recall, it is Windham Hill that inspired the epithets "hot tub music," "new age yuppie muzak," and "Keith Jarrett with a lobotomy." Ancient Future possesses a depth and intensity revealed by few. I have had the pleasure of seeing the ensemble in concert many times, and I would have to say that I have never seen another ensemble that could even play the music that Ancient Future performs. Their master of Indian rhythms and melodies, African polyrhythms, and Balinese kotekans is simply stunning. The nicest thing about their performances is that you get both superb musicianship and an accessible show. At their concerts you see a very diverse group of people — everyone from classical music aficionados to rasta devotees.

I would keep an eye on this group. With time, I have confidence that Ancient Future will equal, if not surpass, what I consider to have been the ultimate fusion band, John McLaughlin's Shakti.

Sincerely,
Adriana Delma
San Rafael, CA

Dear David:

The Sound Choice has hit new lows in journalistic writing. It appears that the radio station reviews lack any sense of journalistic objectivity. Does anybody at this magazine possess any real research skills? What do you boys and girls do when you rate a radio station? It is obvious that you do not care what the stations are playing, in a qualitative sense. You place more emphasis on the quantity of indies a station programs.

I would like to know where you get off deciding the proper percentage of indies to majors for individual radio stations. Furthermore, it seems that you think that stations like ours have an obligation to put food on the table of independent musicians regardless of their musical merit. Musical merit, by the way, is determined by individuals. Our individual, Chris Werner, was hired to decide what records he thinks are deserving of our airtime. His decisions are based on his determination of quality. His decisions are not based on the label of a record. As far as KRUI's programming lows, why are our playlists consistent with other college radio playlists? Why are we receiving some of our best response yet? For answers to questions like these, I urge you, Mr. Ciaffardini, to put your ear to reality. Music and musical tastes are constantly changing. We feel that we should keep on top of new sounds. The fact is, good, new music is coming from a variety of sources. We will continue to examine all possibilities and not limit ourselves. After all, concentrating on only independent artists is just as bad as strictly being a Top 40 radio station.

Sincerely,
Robert Cable,
General Manager, KRUI

It doesn't take elaborate research skills to decide that your station's music programming is poor. Why are your playlists consistent with other college radio playlists? Because your music director is a slave to the same promotional propaganda and advertising campaigns as many other music directors. He reads (and follows) the same college radio programming journals — CMJ and/or Rockpool — that urge college radio programmers to play a certain narrow range of music (they go as far as picking out particular songs that college DJs should play). Why are you receiving some of your best response yet? You're not. You're getting slagged in Sound Choice, and you deserve it. Or perhaps you mean that more people are listening to your station than before? That is no more of an indication of quality programming than the fact that McDonalds has sold more hamburgers than anyone else is an indication that they make the best hamburger in the world. Have you ever heard the term "lowest common denominator?"

It's obvious that you are very possessive and egotistical in your approach toward college radio. You write of playing only music "deserving of OUR airtime." Well, it's not YOUR airtime buddy. The radio airwaves are a limited resource that cannot be legally "owned" in the United States, just as no one can "own" the air we breathe. Radio Stations are awarded licences to "utilize" the airwaves — licenses that can theoretically be taken away if they are being used by boneheads or greedheads who are not responsive to the needs of the communities they broadcast in. College Stations like yours are given "non-commercial" licences in order that there are radio airwaves accessible to and responsive to people who don't wish to use the resource for business purposes.

And you are a fool if you can't understand why a radio station that only plays independent releases would be of much greater significance (artistically, culturally and historically) than a Top 40 station.

Wise up quick, or get another job, or else you are liable to cause your station to lose its broadcasting license. — DC

Dear David:

Regarding your comment about our station in the radio section of Sound Choice #3: Putting aside whatever I've said and for whatever reason I said those things, our station currently has the strongest listenership ever and has more potential listeners than 90 percent of the non-commercial stations that exist across the country. An average of 50 percent of each playlist still consists of indie labels. Our programming fits well into the community and is very different than any other station in Los Angeles.

Further, in response to your claim that I'm using the station to get a job, if anyone in the industry wants to offer me a job, I wouldn't mind doing what I love and being able to eat, too. Actually, I have a job — wasn't looking for one. My intention in writing some of the things I did was to help unite the majority of non-commercial rock stations nationally from more of an operations point-of-view than a musical one. This will help to more widely expose independent and more "avant-garde" music. In fact, my personal musical taste differs from much of what our station plays. I must play to an audience of hundreds (or even thousands — who knows?) not just to myself. You must've missed my personal summer favorites in "Music Connection" and my comments AGAINST major record company promotional methods in the widely (industry) read "CMJ" dialog.

Finally, if you want to tell people the facts about stations and music...great. However, I think it's wrong for you to push your personal opinions on your readers, pretending they are facts. If everyone were a little bit more objective and open-minded in this industry, we'd all be a little better off...musicians, radio stations AND magazines.

Sincerely,
Howard Schlossberg
Rock Program Director, KCSN

Mr. David Ciaffardini:

I am writing in reply to your fall 1985 issue of Sound Choice where you sighted the programming of KRUI to have "hit new programming lows." I think that a more objective look at KRUI would have proved you wrong.

All music that comes through our door is listened to and evaluated in order to see if it fits into our format. The records are looked at from a MUSICAL point of view. I won't give a record a break if it is on an independent label, and won't play a record just because it has major label backing. The best of what we get is what goes on the air.

I have been hired to find the best "alternative MUSIC," and that is exactly what I do. KRUI would be doing its listeners a great injustice by ignoring quality and alternative major label products. At the same time, we don't ignore any independent products either. When it comes down to it, people hear the music, they don't see the label going around in circles. Perhaps the staff of Sound Choice should spend more time helping ARTISTS get attention rather than labels. I hope that any independent label that has seen your article will not be afraid to send its product to KRUI. We program the best MUSIC, from the largest to smallest labels, we don't offer favoritism to anyone.

Sincerely,
Chris Werner, Music Director, KRUI

Why should I be objective? Are you objective when you pick out "the best alternative music" for your DJs to play? Objective or not, I certainly don't want you deciding what kind of music I'm going to be able to hear. Why don't you just forget about playing only "good music" and let hour DJs play a representative variety of what is being recorded these days? Your programming as re-

ported in your playlists sucks, in my opinion. Objectively speaking though, your programming also sucks because the parameters that you have set for determining what is "good" excludes some of the most heartfelt and unusual music being created these days. You say you "don't offer favoritism to anyone". What a bunch of bullshit. You favor any musician who makes music that coincides with your narrow-minded concept of "good music". — DC

Dear Dave:

After getting my first issue of S.C. which I really enjoyed a lot, I answered one of your ads. On page 14 Lee Scott is advertising a directory of radio stations that will play music made by independently produced artists such as myself. Sounds great since my first tape is going to be ready for distribution real soon. However, I sent this guy a check more than two months ago and he's cashed it and I've yet to get anything for my money. Is this guy for real?? Has anyone else complained? What gives? Please warn the rest of your readers if this is a hoax! We indies can't survive on this kind of deal and your mag surely is going to suffer as well if word gets around. I hope this gets straightened out soon. Thanks, Zenon Washington DC

Thanks for letting us know! Situations like this don't come up often, but when they involve advertisers in Sound Choice, we want to know and we want our readers to know. Sometimes, of course, things take longer than expected in this indie scene, ya know what I mean? We're not sure what happened to Lee Scott. We tried calling him but the number was changed. His ad wasn't a hoax though. We got a copy of his radio list several months ago. The addresses appeared to have been gathered from back issues of Op. Hey, Lee, if you're out there, what's going on?

To Whom It May Concern:

I was looking at the Fall '85 edition of Sound Choice and noticed a review by Christopher Pettus of Elaine Silver's Wandering Woman LP.

Why did he take up valuable space complaining about

the fact that she sent her promotional package when he could have said at least one specific positive thing about this talented woman? Her voice is exceptional and she is not only adept on banjo, she plays guitar and Appalachian dulcimer as well.

For his information, the correct pronunciation of "plough" in Scotland does rhyme with "flu". She sings it flawlessly. Her attempt at revitalizing Woody Guthrie's heritage is a hell of a lot better than Christopher Pettus' expertise as a record reviewer. His insight on Folk Music is about as clear as a kelp bed in New York Bay.

Please get a reviewer that can at least communicate an understanding of this type of music. This type of negative "know-it — allness" is enough to make me cancel my subscription to Sound Choice — if I had one.

Sincerely,

Thomas Mooney Madison, NJ, USA

Thomas, If you are interested in doing some folk reviews, let me know. — DC

Editor:

Sound Choice music reviews seem well written, but they go over my head — the words don't translate into sounds. Seems to me they are musicians/musicologists talking to each other. Seems to me underexposed groups need ways to circulate their sounds. How about a cheap lending (with option to buy) library shipping bunches of sampling cassettes book rate? Or?

Hank Schultz

Message Post Portable Dwelling Infoletter

P.O.B. 190

Philomath, OR 97370, USA.

Good idea. Now we just have to figure out a way to work out all the details, such as funding, storage, royalty payments, etc. We welcome input about such a project — a project we are calling the (non-profit) Audio Evolution Network Independent Recording Library.

Clone The Drone

Clone The Drone

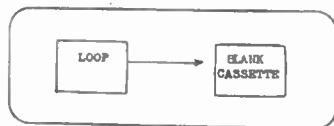

by George Ottinger

Here's a cheap and clever way for a band to make backing tapes.

It's designed for the avant-garde industrialists in the world who are poor in equipment but rich in spirit. If you can borrow a double cassette deck you are halfway there. Now all you need is a walkman and a couple of bucks for your visit to the store. (Actually, three single-cassette players will work too. — DC)

Step 1: Buy a 10 second endless loop cassette — the type you use in answering machines. Now record a snippet or two of sound in your 10 seconds. Steal less than three bars from the radio and you're safe. It's even legal. Or perhaps put a mike to your neighborhood. You now have a repetitious loop of 10 seconds of activity — hopefully musical or percussive.

Step 2: Place it in the playback unit of your friend's cassette deck. Remember, I mean the type of deck that can copy from one cassette to another. Stick an everyday blank cassette in the

STEP 1: Record loop, using deck or walkman in the environment of your choice.

STEP 2: Copy the loop varying the speed, or the volumes of the 2 channels.

STEP 3: Mix tapes so that their timing is synchronized, phlanged or syncoated.

recording unit of the deck. Copy the repeating loop for as long as you want. Vary the volume or pan the effect from side to side if possible. Perhaps quick-copy part of it. It might slip or slide. You have finished step 2.

Now for the final step. Put this creation into your walkman. Connect the output of the walkman to the input of the deck. As you play the walkman, also play the original loop that should still be sitting in the deck. Record a mix of these on another blank cassette. The slippage of the loop should create some true phlanging effects. You're done.

This is reminiscent of early works by Steve Reich circa 1965. If you are willing to disassemble the loop's cartridge, you can rediscover the techniques of the classical electronists of the '50s. Cut and splice together pieces of tape. Remember to construct a tape of length that is exactly equal to the original loop. It must also have as many twists as the original loop. Reloading the cartridge takes true patience.

There are some other simpler techniques. For more diverse patterns of sound, use two loops of

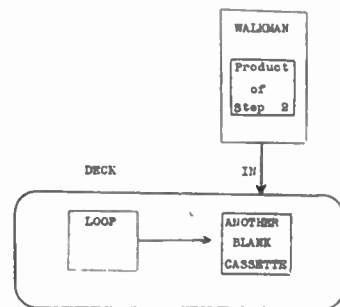

differing time duration. Place one in the deck and one in the walkman. You can use the same source for each or use differing sources. You can make the tape as dense as you desire by repeating any of the above steps. The variations are countless. To imitate Faust or Throbbing Gristle do everything from scratch live. Use your band and audience, shortwave and TV, powerdrill and compressor. Continue to clone the drone.



Publications

Because of the enormous number of publications we receive, we have not yet been able to repeat listings of publications we have mentioned in the previous three issues. We have included (U.S.) price information when available. Where there isn't a price, those interested should send a self-addressed, stamped envelope (SASE) when inquiring. (Publishers: please try to include a price for post-paid delivery of your creations when sending them for review.) Most of the following are periodicals, though many are published sporadically. Reviews are often based on the perusal of a single issue and may not reflect subsequent issues. The word "tabloid" usually refers to publications larger than 8 1/2 X 11"; "zine" usually refers to smaller, often homemade/photocopy publications that are put together for the joy of it rather than as a commercial venture. We welcome unsolicited reviews of publications we may not have seen, but especially in the case of readers who have not written anything for Sound Choice before, it would be a good idea to send a copy of the publication with the review. In addition to reading Sound Choice, those who want a different viewpoint about underground press publications, and like reading lots of reviews of such, may wish to obtain Michael Gunderloy's "Factsheet Five" quarterly, available for \$2 postpaid, from 41 Lawrence St., Medford, MA 02155, USA. The following reviews, except where noted otherwise, were written by David Ciuffardini.

Alcoholic Tendencies (P.O.B. 13011, Philadelphia, PA 19101-3011, USA; ph. 215-386-3033; SASE) Underground rock zine about stuff from around Philly, plus record and zine reviews from around the country.

Alternative Press (P.O.B. 1141, Aurora, OH 44202, USA; ph. 216-562-8688; monthly, \$10/12 issues) Free local music tabloid. Reviews of major and indie records, concerts. John d'Beers regularly contributes zine reviews and other underground culture stuff including a cassette column.

American Forum (Box 261, Dept. E, Staten Island, NY 10302, USA) A periodical (monthly with weekly "updates") where people share opinions and stories about losing personal liberties. Twelve pages.

Another Room Magazine (2216 Fifth St., Berkeley, CA 94710, USA; ph. 415-548-2426; quarterly, \$12/yr) An impressive tabloid, given away free on the streets of Berkeley and beyond, but fair priced at \$3 each by mail. Many other free "alternative" newspapers stacked in the coffee houses and records stores of U.S.'s major cities end up being fashion-conscious yuppie shopping guides by mealymouthed writers and editors who gloat over their snide self-congratulatory prose, as they mill about the underground china shop waiting to hook their literary leashes around the next bull to stampe through enroute to throw itself (with the hope of glorification) on the bloody altars of the nationwide broadcasting and publishing monopolies. The editors at Another Room don't get dragged into that, preferring to work with writers and artists who understand that precise writing and thought leading toward viable, positive alternatives is more important to the well-being of the world than the cliched thought, mindless put-downs and out-of-breath exclamations. Each issue of Another Room contains audio and video reviews, interviews, poetry/verse and idea-invoking features. Subjects of past issues include Emily Dickinson, Malcolm McClaren, Jello Biafra, Leonard Cohen, Van Morrison, Wallace Berman, Phillip Glass, the outrageous nuclear weapon military build-up of San Francisco Bay, film-maker Jim Jarmusch, George Coates, and S.F. Chronicle music critic Joel Selvin.

Apaeos (Sylvia, c/o Correspan, P.O.B. 759, Veneta, OR 97487, USA; SASE for sample, must be over 18 yrs old) A reader-written forum about sex and erotics published photocopy style. (Sorry, no photos, glossy or otherwise) Down to earth approach to a subject of interest to everyone. Along with stuff like sexual fantasies and erotic scenarios, are practical stuff such as info on sexually transmitted parasites and illustrated instructions about how to make a dildo that can be used comfortably while reclining flat out on one's back.

Apocraphasis (Cykxincorp, P.O.B. 299, Lenox Hill Station, New York, NY 10021, USA; \$5.50) Poetry and illustrations by composer Ray Buttigieg.

Atom Club (Prins Hendrikkade 142, Amsterdam, Holland, \$2) William Levy and Willem de Ridder (see S.C. #3) edit this journal which "Chronicles Europe's first cassette nightclub." Stimulating ideas and contacts for people looking for new ways to utilize cassettes. 88 quarter-size pages.

Bad Alchemy (c/o R. Dittmann, Semmelstrabe 51, 8700 Würzburg, West Germany) Oh gosh, this looks like a hot magazine, the only problem (for me) is that it's written in German. Fifty handsome pages (great clear photos) with articles and interviews with Lindsay Cooper, Joelle Leandre, Daniell Dax, Ambiances Magnetiques and Shockabilly. Other stuff too, including a C-45 cassette featuring the music of the above artists!

B.A.N.G. Notes (P.O.B. 2666, Brooklyn, NY 11202, USA) The Brooklyn Anti-Nuclear Group's latest (18 pgs) includes action-oriented info about the horrors the U.S. government continues to inflict upon Native Americans (Indians). Plus anti-nuke, anti-war and anti-apartheid stuff and more. They say this might be the final issue (grant funding has run-out) and are asking for donations (but they don't give a suggested cover price for the newsletter).

Banned Productions (Box 691184, Los Angeles, CA 90069, USA) Little photocopy zine with info about cassette releases, contacts, interviews. An interest in societal cruelty and perversions.

Beef (659 Haight St., San Francisco, CA 94117, USA; tel. 415-626-3817; quarterly, free in S.F., \$12 year by mail) An interesting, eclectic tabloid difficult to pigeon hole. "Contemporary art, music, performance, video, transformationists." Down to earth "new age" interests. Hip but not chic. Purposeful, entertaining and inspiring. But the editors deceive when they continue to claim, in bold print, a "50,000 circulation" when I KNOW they print no more than 15,000 copies of each issue.

Black Sheep Bulletin (One Camp St., Cambridge, MA 02140, USA; ph. 617-491-4435; SASE) Folk publication "The Black Sheep Review" has temporarily ceased publication and this six-page newsletter comes in its place until the business situation with the magazine is "reorganized." The people are looking for input and in the meantime still offer some useful info through the bulletin.

Blatch (741 Jenkins, Norman, OK 73069, USA; ph. 405-366-1485, \$2) Indie record and publication reviews, interviews and — what makes this handsome zine so special — lots of full-page, comix-type art from awesome pen and inkers like X.N.O.D. Worden, Jimm B./Kegel, Peter Danko, Crawford, Peter Bagge, and R.K. Sloane. High quality paper and printing.

Bluegrass Breakdown (University of Illinois Press; \$19.95) Author Robert Cantwell combines a deep insight into the bluegrass form with an ability to pull surprising insights out of his writer's hat. Complex and multifaceted ideas are presented in a clear understandable way and the reader is introduced to heretofore unexplored theories on topics such as the relationship between jazz and bluegrass, the heavy debt which bluegrass owes to African sources, the social and cultural backdrop to the music as well as numerous other areas. Using Bill Monroe, the acknowledged father of Bluegrass, as the centerpiece, Cantwell weaves a fascinating pattern of an American music which borrowed heavily from other sources but paradoxically is a highly original form. Bibliography, no discography. — Keith Wilson

The Blues Connection (P.O.B. 161272, Memphis, TN 38186-1272, USA) Publication of the Blues Foundation (\$15 membership). Six pages of mostly requests for money and other support for "The Sixth Annual Blues Awards Show."

Brave Ear (P.O.B. 3877, Berkeley, CA 94703, USA) This on-again, off-again mag is back. Latest issue features lots of rock. R.E.M., Sonic Youth, D.O.A., Deviation Social, others.

Breakfast Without Meat (1827 Haight, Room 188, San Francisco, CA 94117, USA; \$1.25) Sixteen pages of humor, music and recipes. No 8 features an unusual, irreverent interview with Husker Du and Meat Puppets.

Broadside (P.O.B. 1464, New York, NY 10023, USA, monthly, \$2) "The National Topical Song Magazine." Issue #166 has 20 pages of left-leaning political songs and lyrics, reports on the Newport Folk Festival and reprints of decades old Phil Ochs and Arlo Guthrie articles.

The Burning Spear (P.O.B. 27205, Oakland, CA 94605, USA bi-monthly, \$10 year) Published by the African People's Socialist Party, this 28-page newspaper calls itself "the voice of the international black revolution." If what these people print is true, then this country is a lot closer to fascism than most of us middle class white boys realize. Enlightening.

OUT NOW

ANGRY RED PLANET

GAWKERS PARADISE 4 SONG 7" EP

BUTTHOLE SURFERS

CREAM CORN FROM THE SOCKET OF DAVIS 12" EP

KILLDOZER SNAKEBOY LP

STILL AVAILABLE: DIE KREUZEN lp

BUTTHOLE SURFERS Another Man's Sac lp

MEATMEN - We're The Meatmen...lp



LP'S \$5.00 P.P. \$6.50 P.P. SURFACE OVERSEAS
12" EP'S \$4.00 P.P. \$5.50 P.P. SURFACE OVERSEAS
7" EP'S \$3.00 P.P. \$4.00 P.P. SURFACE OVERSEAS



Catch a BUZZ

BUZZ available by subscription --
4 issues for \$6 (First Class Mail),
PO Box 3111, Albany, NY 12203

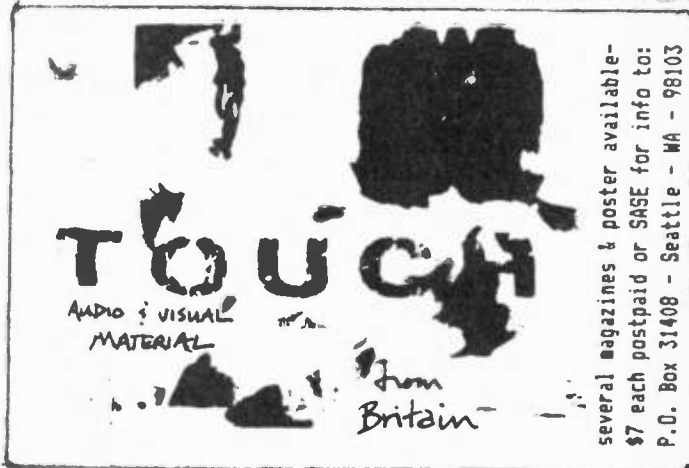

several magazines & posters available -
\$7 each shipped or postage paid for info to:
P.O. Box 88413 - Seattle - WA - 98103



PUBLISHER'S EXCLUSIVE

"Hooray! The first participatory coffee table book! Strap on the provided 3D glasses and suddenly you're catapulted into a jungle of arms and legs. Watch out for that stage diver! ... The action shots are the most successful, capturing some of the kinetic energy of the dancing/performing at hardcore shows. The book also includes commentary from the scene's makers and shakers on the genre's fashion, dance style, international network, and reason for being ... From the printed lyrics to the use of 3D itself, the 'message' seems to be one of encouragement: participate!"

BAM - THE CALIFORNIA MUSIC MAGAZINE

"... slickly packaged and professionally done, an obvious artistic devotion is exhibited throughout ..."

- FORCED EXPOSURE

LOUD 3D

by Gary Robert, Rob Kulakofsky, Mike Arredondo

over 100 OUTRAGEOUS 3D ACTION photos featuring

- Dead Kennedys - Circle Jerks - Crucifix - Verbal Abuse - FU's
- Raw Power - Cause for Alarm - Youth Brigade - Rllystytel - Fear
- 7 Seconds - M'D'C - Toxic Reasons - Minor Threat - MIA
- Reagan Youth - Stranglehold - DOA - Sado Nation - Die Kreuzen
- Black Flag - Battalion of Saints - Lewd - TSOL - Target Video

SPECIAL COLLECTOR'S EDITION

Signed and Numbered with extra glasses **\$1295**

Send check or money order to:

IN3D, 5841 Geary Blvd. San Francisco, CA 94121

Add \$1.50 for shipping & handling. CA residents add 6 1/2% tax.



WIRING DEPT.

EMPTY MILK BAR

The silence when doors open and where people could pay to see inside for entertainment they watch his body twist behind his eyes he says I still exist This is the way, stop inside.
Ian Curtis
\$2

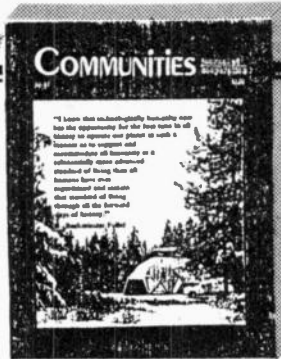

The Church Of The Subgenius (P.O.B. 140306, Dallas, TX 75214, USA) This is the church of J.R. "Bob" Dobbs, a humorous, "pseudo-religion" with much more good sense than most other organized churches. These people publish all sorts of humorous magazines, brochures, pamphlets, buttons, stickers, etc. Reading this stuff will give you new understandings about modern culture and a few belly laughs, a couple giggles, and an assortment of tee-hees. Send an SASE for more info about this incredible organization.

Common Cause (1501 Billings St., Oxnard, CA 93033, USA; 80 cents) From the land of Hardcore (a Mystic Records' concept to promote Oxnard punk bands) comes Todd Castor's (with assistance from Brian Walsby) punk/hardcore zine. Usual stuff — record and zine reviews. Twelve pages.

Communities (126 Sun St., Stale, IL 60919, USA; \$3) Journal about creating and/or maintaining "intentional cooperative communities" [where people obtain land, live on it and work toward certain shared goals.] Lots of pages, networking, etc.

Chemical Imbalance (c/o Mike McConigal, 801 Ave. Conde, Miami, FL. 33158, USA; bi-monthly, \$1.50) New fanzine with a great cross section of interests. Premiere issue shares words with and about Dim Things, Don Cherry, Meat Puppets, Love Tractor, Broken Talent, Yard Trauma, The Outnumbered, more. Great beginning.

Duckberg Times (P.O.B. 382, Alexandria, VA 22313, USA; ph. 703-684-7224; monthly, \$10/12 issues) Reprinted articles, art and comix culled from the nation's underground press. Some original stuff. Tabloid, 20 pages, distributed free in the region.

Emotional Vomit (c/o M. Schaefer, 75 Fariview Ave. #3B, New York, NY 10040, USA; 50 cents) Schaefer clips oddball news items, ads and illustrations, throws in his own comments and humor, cuts and pastes and voila — a fun, pocket size 32-page zine. "Any music stuff sent free gets reviewed!"

Famous Hardcore Of Punkland (c/o Craig Hill, P.O.B. 26684, San Jose, CA 95159, USA; \$1) The cover of the "Second Shocking Issue!" has the following epigram (with a photo of Raw Power Iggy Stooze) that sums things up: "Hardcore: Definitely. Politics: Yeah, OK... Preaching: Never! Fast & Loud: Always!" I met editor Craig (a big friendly fella whose Plasmatics T-shirt was two-sizes too small) at the KPFA studio as he single-handedly downed a Bud six-pack (at least) as he listened to the Maximum Rock N' Roll show and repeatedly struck a Statue of Liberty pose with his beer cans and proclaimed in a drunken slur: "Fukin' A, man — Hardcore will never die!" When he told me he published a zine (but didn't have a copy on him) I didn't hold much hope. (Even if he did publish, I doubted he'd remember to send me a copy.) But jeez, loueeez, I owe Craig an apology. True to his word, I received a copy a few days later and was impressed. Like its creator, the zine is large (52 pages), enthusiastic, sincere, with a "what the hell, let's go for it" inebriation.

Fatalistic Funnies (2910 W. Ashland Ave, Muncie, IN 47304, USA; 75 cents each, ppd.) Various mini-comix (8 small pages) from E.E. Emmer.

Feed: Optional Information (P.O.B. 7601, Louisville, KY 40207, USA; \$1) A 12-page, soon to be a 18-page zine of mostly major-label rock record and video reviews. These people are pretty good writers (perceptive enough to realize that most of what they review is lowest-common-denominator, mediocre crap) but they haven't quite tapped into what's REALLY happening, i.e. the independent underground, which, ironically, their zine is a part of.

Foundations Of Computer Music (MIT Press; 1985; \$50) Edited by Curtis Roads and John Strawn, this massive (712 pages) volume is an assemblage of works by some serious practitioners of computer music. Being, for the most part, a collection of articles that appeared in "Computer Music Journal" in the late 1970s, it contains a number of seminal articles, many in revised versions. John Chowning's original article on FM synthesis is presented. This is the technique Chowning tried peddling unsuccessfully in the U.S. before eventually selling to the Japanese who were able to develop the technology commercially. Unless you are quite analytic of mind, and mathematically inclined, however, this volume will not help you enhance your DX-7 patch library. This book is not for the MIDI enthusiast. Although some of the work described is done on personal computers, most of the articles document systems implemented on larger machines or installations. This is to a minor degree, a function of the times from which these writings date, and it would be interesting to read about what these researchers (or their kids) do in their home studios in 1986. Some chapter titles suggest the level of work going on here: "A Tutorial On Nonlinear Distortion Or Waveshaping Synthesis", "Table Lookup Noise For Sinusoidal Digital Oscillators", "The Use Of Hierarchy And Instance In A Data Structure For Computer Music", "Timbre Space As A Musical Control Structure". Not material for the casual reader. The book is divided into four categories: Digital Sound-Synthesis Techniques, Synthesizer Hardware and Engineering, Software Systems for Music, and Perception and Digital Signal Pro-

cessing. Each section begins with a preface by the editors which provides a useful overview. If your interests extend to computer music hardware or software, psycho-acoustics, theoretic music systems, or computer music making in general, this book ought to be in your library; but the non-specialist should be warned that this is no gentle introduction to the subject. — Leland Saintry

Full Disclosure

(P.O.B. 8275-FD6, Ann Arbor, MI 48107; monthly, \$1.50 each) This is a type of publication that is especially needed. Full Disclosure publishes research on government agencies' illegal and immoral (and often highly secret) actions against its citizens and environment. They also like to report on commercial organizations and multi-national corporations that are also fucking people over. Reader input is encouraged and efforts are being made to coordinate a nationwide network (Citizen's CIA) to report on and take action against such problems. These people seem to have a well-organized game plan and I hope others are inspired by it. According to the L.A. Times, the U.S. government funds many highly secret organizations including the N.S.A. which has 65,000 (!) employees — manpower enough to pay for at least one "secret agent" to live and gather info and perpetrate actions and/or propaganda in every small town in America. Don't think such things aren't happening — they are. Don't get scared — get aware.

Fuzzbrains (P.O.B. 2436, Worcester, MA 01613, USA; \$1) Clean zine about rockin' garage sounds, ala Barrance Whitfield and the Savages, The Cannibals, Fuzztones, Plan 9, etc.

Generic Drive! (c/o Rob Rebsel, 7522 Crawford Dr., Delta, B.C. Canada, V4C 6X6; 60 cents) This issue has interviews with R.E.M.'s Michael Stipe and Vicious Circle. Recording reviews, humor and comix too.

Glitch News (P.O.B. 4429, Austin, TX 78765, USA; ph. 512-453-8575; SASE) Promo for Glitch Records plus some guitar tune-up info.

Gene (c/o Denver Tuscon, 2481 Ellsworth St. #21, Berkeley, CA 94704, USA; SASE) A couple photocopy pages of poems, stories, drawings and humor edited by Denver Tuscon, a groovy woman who likes to travel, but can't seem to find the time or money. D.T. also creates the endearing Bone Family comic strip found in The Monthly Independent Tribune... (see below).

Gorilla Ice Cream (c/o Gunni, Alfholvsvegur 30A, 200 Kop, Iceland) Short hardcore zine from Iceland. Written in English.

Guest Check Comix (Dolphin-Moon Press, P.O.B. 22262, Baltimore, MD 21203, USA; \$2.50) Standard size neo-underground comix compilation with nice glossy color, wrap-around covers. The most sophisticated effort this side of the similarly ambitious "Scratchez" comix line. Thirty-two pages of differing styles from a variety of active artists. What definitely stands out in Guest Check #1 is the art of editor Margot Insley, who invokes a spare, often surreal, haunting style full of personal symbolism that is intriguing to say the least. She also illustrated the beautiful X-rated cover. Looking forward to #2! — John E. Guillotine (c/o Wendy Eager, 37-21 80th St. Apt. 8-H, Jackson Heights, NY 11372, USA; \$1) Issue #9 has 50 neat pages focussing on hardcore music, including Dr. Know, D.O.A., Government Issue, Murphy's Law and The Freeze.

Handicap News (c/o Phyllis Burns, 272 North 11th Ct., Brighton, CO 80801, USA; ph. 303-659-4463; sample \$1 ? SASE) Blurbs of info relevant to handicapped people. Six pages.

Hemlock Quarterly (P.O.B. 86218, Los Angeles, CA 90066, USA; tel. 213-391-1871) A compilation of four years of newsletters from the Hemlock Society, a group advocating the legalization of suicide (they call it "self-deiverance") and helping others commit suicide. Heretic's Journal Bulletin (P.O. Box 12347, Seattle, WA 98111, USA; SASE) Eight page periodical advocating "radical political/spiritual synthesis." Challenges the Judeo/Christian mindset, technocrats, more.

Incoherent House (c/o Mitzi Waltz, 539 Scott, San Francisco, CA 94117, USA) Music zine, 14 pages. Interviews with Helios Creed, T.S.O.L., tattoo artist Grek Kulz, more.

Jazz Styles: History and Analysis (second edition) (Prentice-Hall, Englewood Cliffs, NJ 07632, USA) Written by Mark C. Gridley, this is a basic textbook used in college and high school jazz history courses intended for non-music majors. Gridley's explications of certain key ideas, e.g. chord voicings and song forms, are models of clarity — perfect for the non-musician. Further aid to understanding jazz structures is offered through listening guides to specific performances. The author writes that his book "is intended to make jazz more comprehensible by improving your listening skills. The most important section of the book is the guide to records and record collecting." As a long-time record collector, I can vouch for the good advice in that section. However, I do find some problems with Gridley's view of jazz history. He writes as if jazz-rock in general, and Weather Report in particular, were the only viable form of the '70s and '80s. The author all but ignores the work of players and bands such as James Newton, Anthony Davis, Rova Sex Quartet, Evan Parker, and many more. — Stuart Kremsky

**LANTERN
IN THE WINDOW**

A soothing assortment of piano solos for meditation and daydreams . . .

By Susan Kennedy



P.O. Box 1641
EUGENE, OR
97440

Audiophile LP and Real-Time Cassette
\$10 by mail.
Distributed by FORTUNA & LADYSLIPPER



**"LEMME LOVE YOU"
SCOTT WILLIAMS' DEBUT L.P.**

"A VINYL GEM" *Bill Chemerka, Aquarian Arts Weekly*
DISTRIBUTED BY

IMPORTANT RECORDS • WIN RECORDS • MIDNIGHT RECORDS
Available by mail at \$8. (post-paid) Double Bill Records P.O. Box 20485
Midtown Station, New York, N.Y. 10129

FREE "Love 'em One" single w/ every order

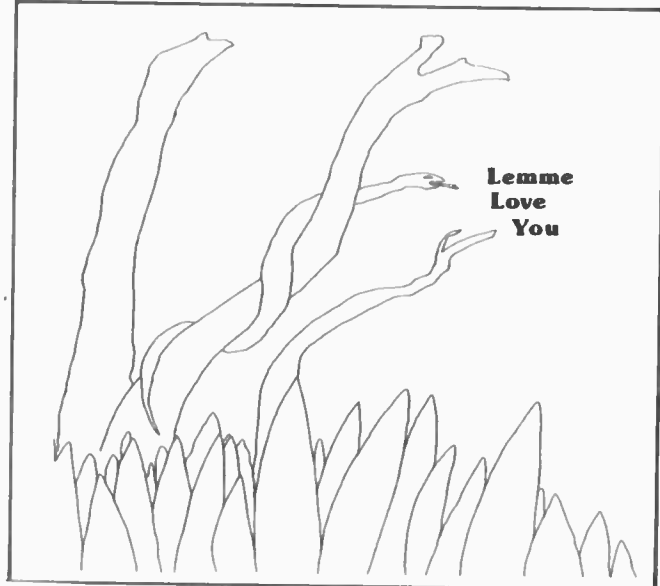

JUST SOME TUNES THAT ARE KIND OF INTERESTING
AND SOUND LIKE SOMETHING INSTEAD OF NOTHING
NOTHING REALLY CONTROVERSIAL --
-- REALLY CONTOVERSIAL PEOPLE GET SHOT
THIS STUFF IS CALLED **GEOMETRY** BECAUSE, WELL IT JUST IS
WHY SHOULD YOU BUY IT? WE'VE NEVER MET.
IF YOU DO, TELL ME WHY -- THEN WE'LL BOTH KNOW
GEOMETRY CASSETTE E.P. \$3.00 4 SONGS
P.O. BOX 655, URBANA, IL 61801

AccountMate

Come to the source for a sound choice in accounting software. Our complete integrated dBASE II and III accounting software can make your business or non-profit organization sing! Put the easy-to-use AccountMate modules to work as they are, or modify them with your knowledge of dBASE to suit your organization's specialized needs.

General Ledger, Sales Order, Accounts Receivable, Purchase Order, Accounts Payable, Payroll, Time and Billing, Fund Accounting and Manufacturing Inventory Control. Reasonably priced from \$195 to \$795.

For more information, contact us at:

(415) 381-1011



20 SUNNYSIDE AVE. MILL VALLEY, CA 94941-1928
TELEX: 510 (40) 5270. ANSWERBACK: ACCOUNTMATE



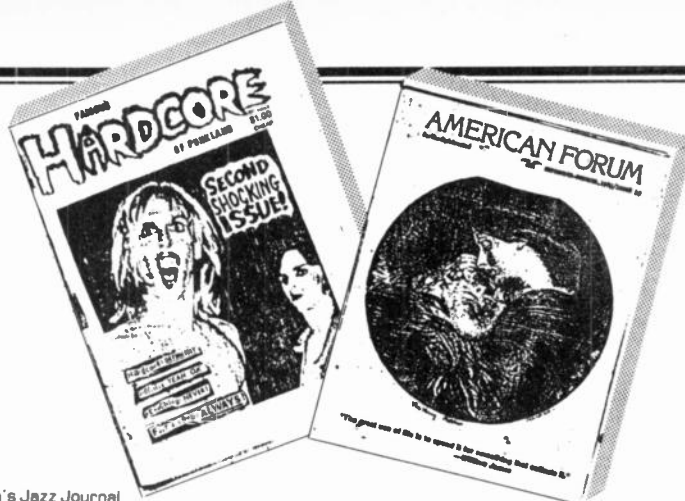

Joslin's Jazz Journal (P.O.B. 213, Parsons, KS 67357, USA; quarterly, \$7.50/yr) "Dedicated to the glory of record collecting." Features, discographies, lists. Similar to Goldmine magazine except the focus is jazz. 50? tabloid pages.

Keldron (P.O.B. 7036, Halcyon, CA 93420-7036; \$5) Tabloid with a visual art piece filling every page. Submissions considered. At 24 pages, \$5 seems steep.

Lightworks (P.O.B. 1202, Birmingham, MI 48012, USA; \$4) Subtitled "illuminating new and experimental art", this has 56 glossy pages with all sorts of info on interesting projects including mail art. Very well done and lacking the pretentiousness of similar journals.

Limit Of Maps (Reissue Inc., P.O.B. 39, World Trade Centre, Melbourne VIC 3005, Australia; tel. 03-419-5562; \$3) I'm still trying to figure this one out. Is it the cultural differences between the U.S. and Australia that have me confused? A surreal travel magazine? Glossy pages. Definitely avant-garde or underground or something. When I see the next issue I think I'll understand better.

Lookout (c/o Lawrence D. Livermore, P.O.B. 1000, Laytonville, CA 95454, USA; monthly, \$10/yr) Ten pages of strong writing about politics and social issues (some San Francisco issues, some national) and indie rock. Lawrence Livermore is a perceptive, articulate writer who complains a lot (S.F.'s two-faced, back-stabbing mayor Diane Feinstein's atrocities against life and liberty are frequent topics); and sometimes, when he's really cookin', offers solutions/alternatives to the messes. Some humor too.

Make Up That Clogs Pores (Grux, c/o Subterranean Records, 577 Valencia St., San Francisco, CA 94110, USA; SASE) Lots of tiny print; interviews with Meat Puppets, Red Kross, Fang. Grux is cool and fronts his own demented band, Caroliner Rainbow.

Making Tyme! (131 W. Passaic St., Maywood, NJ 07607, USA; 50 cents) Mick London, leader of Mod Fun, lets us know about the groovy mod bands of the sixties and contemporary bands that get their guitar sounds and clothes from the same era.

Meta-Scoop (1004 Live Oak Ln., Arlington, TX 76012, USA; tel. 817-277-7310; monthly, \$10 year) Meta-physical stuff like astrology, astral projection (editor Barbara Sowell lectures on the subject — for a fee) and "new age chapels". Eight pages.

The Monthly Independent Tribune Times Journal Post Gazette News Chronicle Bulletin (2510 Bancroft Way #207, Berkeley, CA 94704, USA; 50 cents or stamps) Some very funny and charming stuff by T.S. Child and Denver Tuscon. Comix and humorous writing. A small photocopy treat. Has been published every month without fail for three years.

Mescow Graffiti Magazine (c/o Richard A. Box 20722, New York, NY 10009, USA; SASE) "Free single page public service magazine." Protestations, anecdotes, humor, plus hype for Richard A's books.

Musicians Monthly Newsletter (P.O.B. 4006, Ventura, CA 93004, USA; ph. 805-525-4720) A free tabloid highlighting live entertainment in Ventura County, Calif. Mostly mainstream bar-band rock stuff, but hey, that's what the Ventura music scene is dominated by — so far. Even the Oxnard skate punks don't play here. Now if the editors could dig a little deeper, or explore the fringes, they could help pull together a real, HAPPENING scene.

Mystery Hearsay (c/o Mike Honeycutt, P.O.B. 240131, Memphis, TN, 38124, USA) Small contact zine focusing on "exchange of sound and image." Those involved have a radio program and compile cassette compilations.

Nervel (380 Victoria St., Toronto, Ontario, Canada M5B 1W7; tel. (416)595-1490) Music tabloid periodical. Lots of interviews, reviews etc. of well known "alternative rock" stuff.

Not Available Comics (P.O.B. 5803, Raleigh, NC 27650, USA) Matt Feazell and friends put together lots of entertaining mini-comics that sell for 25 cents each. Send for catalog.

Now! (P.O.B. 436, New Philadelphia, OH 44663, USA; ph. 216-339-4644) Diverse zine of rock music and "modern cultural development" is off to a great start. One huge newsprint sheet.

Nu Rite (P.O.B. 25719, Raleigh, NC, 27611, USA) A radical broadsheet: one side is a radical political poster, the other side has a lot of lively writing including a few record reviews.

Outside In: A Self Portrait Gallery (M. Dowler, 3615 Phinney N., Seattle, WA 98103, USA, 75 cents p/d) A mini-zine booklet of artists' self-portraits and addresses. An ingenious networking tool for cartoonists, this also works as an on-going chronicle of the art of self-perception, an often telling guide to ego-land some are more comfortable with than others. Fascinating. Seeking submissions, but the publisher may have changed so write before sending portraits. — John E

Overthrow (P.O.B. 392, Canal St. Sta., New York, NY 10013, USA, ph. 212-533-5028; \$1) Newspaper of the Youth International Party (Yippies). Lots of info about all the incredibly fucked things governments are to people around the world. Plenty of other radical left-wing stuff as well. Humor too.

The Pig Paper (Pig Productions, 70 Cotton Dr., Mississauga, Ontario, Canada L5G 1Z9) A single sheet of humor and music stuff.

Poetry Flash (P.O.B. 4172, Berkeley, CA 94704, USA; monthly, \$8 year) Tabloid featuring poetry reviews and events from the San Francisco Bay area.

Pointless (P.O.B. 4093, Greensboro, NC 27404, USA) Impressive, semi-annual photocopy journal of art, comix and fiction and non-fiction literature. Some really good stuff, including the Eugene Chadbourne piece which was the first thing I read and immediately inquired about republishing (should be in this issue). Haven't had a chance to read Tony Pizzini's pieces yet, so can't pass judgement — yet. Fifty pages.

The Quarternion Journal (c/o Fraser Hall, 101-1345 West 13th, Vancouver, Canada, V6H 1N7) Twelve pages devoted to "various examinations of highly abstract probabilities in science and art." Sample paragraph: "Thus it becomes an intellectual imperative to adopt a discipline that allows for maximal information velocity without exposing oneself to the risks inherent in adopting the definitional framework of a solitary consensus, or even a series of them. This discipline is multidimensional thinking." I think they're on to something.

Random Thought (P.O.B. 5341, Station B, Victoria, B.C. V8R 6S4, Canada; tel. 604-386-5037; \$12/12 issues) Tabloid of music, fiction and art.

A Real Gein Zine (R.K. Sloane, 500 Montclair S.E., Albuquerque, NM 87108, USA; \$1.50) Everything you never wanted to know about Ed Gein, the infamous Wisconsin lonely guy, grave robber, cannibal. Grotesque details rendered in text and illustration by Sloane who is able to instill a sense of humor in the bizarre, grisly subject. — John E

Rock & Roll Confidential (Dept. 30, Box 1073, Maywood, NJ 07607, USA, \$1.25) Longtime rock writer ("Rolling Stone", etc.) Dave Marsh and associates use this monthly 8-pager to criticize aspects of corporate-rock business; while also including reviews of mostly major label recordings. This is an encouraging direction for a big name mainstream rock critic to take (pointing out the fucked aspects of rock business that people are buying into) but he's wrong, thinking (or pretending) that he or anyone else can reform the major labels' slimey business practices to any significant extent. (He'd have a better chance, though, if he spent more time investigating and writing about the major label's manipulation of radio and video airplay.) The solution (which Marsh doesn't write about) is for artists to take more control of all aspects of their music making (including business practices) and quit trying to be part of a system where 99 percent of an artist's record profits are siphoned for "corporate overhead"; and artistic compromises and/or mainstream attitudes and actions are expected in exchange for some or all of the following: drugs, travel, cars, TV appearances and lots of hours in expensive high-tech recording studios (where the inflated costs are billed against future royalties.) For every Bruce Springsteen and Michael Jackson (two names Marsh can't seem to get his mind off of), there are hundreds of other musicians who hoist the corporate-rock flag, get their chance to run through the spot light, and end up a year or two later broke, burnt out; their careers on the garbage heap and their artistic vision (if they had one) drained by platoons of money-grubbing and status-seeking leeches. The alternative to all this B S is the independent recording movement, something that Marsh hasn't quite caught onto yet, or else sidesteps in the vain hope that rock culture can rally and recreate the excitement of Marsh's salad days in the sixties when the major labels lost control for a couple years (how could Pat Boone and TV compete against novelties like LSD, pot, love-ins and protest rallies) and had to go begging on hands and knees to sign up bands like the Jefferson Airplane and Grateful Dead who had throngs of fans (TRUE grass root support) way before they ever released records. Marsh tries to tidy up a deceptive, uncaring, manipulative system that should be abandoned. But we realize of course, it is that insidious system that nurtured Marsh into a "respected" rock journalist, and complaints or no complaints, Marsh will likely keep sucking on that corporate rock tit until it dries up or he finally chokes to death on its poisons. Nevertheless, Marsh is a thousand paces closer to enlightenment and/or integrity than his "respected" colleagues ass licking, corporate-rock promotion people like Robert Hilburn (L.A. Times critic) and the writers for those big slick (don't let the indie label tokenism/co-option fool you)

Rock Jocks: A Pillow Book For Women (c/o The Noise, 74 Jamaica St., Boston, MA 02130, USA, ph. 617-524-4735) Twenty-one full-page B/W snapshots of Boston area rock musicians and DJs clad in nothing but jock straps. That's it. Edited by the Flange sisters, this is a limp accomplishment (not very funny or erotic, or artistic even) especially compared to work of the The Plaster Casters, a dynamic female duo who, in the sixties, hit the backstages and dressing rooms of America and returned with plaster cast sculptures of rock stars' dicks (To top it off, all the models got blowjobs.) Try to beat that, Flange sisters!

The Rolling Stone Jazz Record Guide (Random House) A useful reference guide to in-print, major label jazz records. Concise bios of artists.

Scavenger's Newsletter (c/o Janet Fox, 519 Ellinwood, Osage City, KS 66523, USA) "A marketletter for writers and artists with an interest in the sf/fantasy/horror small press."

Shaman's Drum: A Journal Of Experiential Shamanism (Cross-Cultural Shamanism Network, P.O.B. 2636, Berkeley, CA 94702, USA, \$3) Anyone intrigued by the spiritual wizardry in Carlos Castaneda's books can pursue similar ways of thought and action through this quality magazine that provides inspiration, technical info and contacts for all potential shamanic healers of the world.

Southern Libertarian Messenger (Rt. 10 52A, Florence, SC 29501, USA) Newspaper and magazine clippings documenting the erosion of Constitutional freedoms of U.S. citizens. 8 pages.

Starhead Comix (3615 Phinney N., Seattle, WA 98103, USA) This is the home for all sorts of mini-comix from various artists. Plus, they have begun the "Seattle Star", a free monthly with comix and ads.

Suburban Muckraker (8814 Appleseed Dr., Cincinnati, OH 45242, USA; tel. (513) 489-5424; 50 cents) Music fanzine with interviews with Pink Holes, BPA; plus reviews.

Task Fanzine (JAF Box 7814, New York, NY 10116, USA; \$1) Latest issue has 60 pages featuring Corrosion of Conformity, Suicidal Tendencies, Mighty Sphincter, Agnostic Front, more.

Thoughtcrime (P.O.B. 57104, Atlanta, GA 30343, USA) Latest issue received was published months ago but contains 50 pages of interesting anarchist related material.

Tonight I Am A Mac Magazine (P.O.B. 4726, Berkeley, CA 94704, USA) Aaron (Cometbus) Cometosa changes the name of his punk zine every issue "to confuse people." No. 21, the four year anniversary issue, is hefty (48 pages) and includes a lengthy and enjoyable account of Aaron's search for punk culture during a recent trip to Europe. Includes a healthy list of European contact addresses.

Transnational Perspective (Case Postale 161, 1211 Geneve 16, Switzerland; \$10/year) "Independent international journal of world concerns." Great, serious, slick journal dedicated to forging world peace. Related cassette reviews too!

Triester Keane's Magazine (Steve Puchalski, 1114 E. Genesee St. #2, Syracuse, NY 13210, USA; \$1.50) Bizarre, tongue-in-cheek, neo-dada surrealist mag brought to you by the same zanies that produce the "Emotional Vomit" mini-series. This one's digest-size and full of humorous stories and fragments of larger pieces with such titles as "Lost Bladder" and "Nancy Reagan's Suicide Note." No. 2 features more comix, some "poems" and a history of Godzilla movies. My favorite essay is "Death At The Dome", an eye-witness account of a Bob Hope performance from 1983. — John E

Troubled Times (P.O.B. 1539, Santa Cruz, CA 95061-1539, USA; \$1) Really good, clean, alternative zine: music and publication reviews, interviews and an intelligent, anarchist-type slant that leads to interesting non-music articles.

Uncle Fester (c/o Jake Wisely, 2235 France Ave. So., Minneapolis, MN 55416, USA; \$2) No. 9 includes interviews with Husker Du, The Replacements, Soul Asylum, The Form, Tommy Ramone, Mike Stipe, Theatre Of Ice. 24 pages.

Urban Saint and Shrit (c/o Pizz Publications, 626 Temple Ave., Long Beach, CA 90814, USA) Savage pseudo-science fiction ala modern day "Junkiestein" monster tales done in a lively, quick cartooning style, jam-packed with interesting, tiny

panels; some contain 48 on one 8 1/2 X 11" page! Emphasis on punk/nihilist philosophy. Fast paced and entertaining. These books run about \$2 each. — John E

Urgi-urg (c/o Nicole, Garbenzo House, 46 Louisa St., Ottawa, Ont., kir 6y8, Canada; \$1) A "Peaceful Coexistence Collective Publication" that [in the creators' words] "covers music as well as feminism, animal rights, personal anarchy..." Not much music in No. 11 but plenty of other good stuff including a lengthy first-person article on the ups and downs of setting up a communal living situation of; alternatives to unhealthy processed foods, more. 24 pages.

West Virginia Surf Report (P.O.B. 663, Dunbar, WV 25064, USA; SASE) Innocent humor and music notes on this one sheet periodical that could help Jeff pull down a pretty good grade in a high school creative writing class. No surfing stuff though, darnit.

Willpower (c/o Bill Callahan, 6009 Camelback Lane, Columbia, MD 21045, USA; \$1) "The Replacements Magazine." No. 4 had 20 pages from/for rabid fans of the band.

Wiring Dept.: San Francisco Underground '85 (P.O.B. 5599, San Francisco, CA 94101, USA; \$2) Sharp, simple, attractive 64 pages. Lots and lots of S.F. "underground" musicians/bands get about a page each to be interviewed or fill in the blank themselves. Provides a representative, non-hype picture of a significant part of S.F. music culture and the ideas behind it. Photos, contact addresses and phone numbers too. This is an excellent primer for any "underground music" aficionado planning to visit or relocate to the City By The Bay.

The Worker Poet (c/o Michael R. Hill, 327 Pacific St., Franklin, PA 18323, USA; \$2) A digest-size journal of art, poetry, cartoons, and occasionally book and film reviews. Always nicely packaged and tastefully layed-out. Works from the premise that serious art or poetry books should be accessible to PEOPLE instead of some art-crowd "Artforum" elite. What strikes one immediately about editor Mike Hill is his integrity and sincerity of purpose. W.P. #8 is a special look back at the Kent State tragedy. — John E

World War III Illustrated (176 E. 3rd St., New York, NY 10009, USA; ph. 212-505-6457; \$2.50) High quality comix, art and miscellaneous. No. 5 is filled with strong anti-church, anti-fundamentalist stuff. Glossy cover, 64 pages of newsprint.

Zyzyva (55 Sutter St., Ste. 400, San Francisco, CA 94104, USA; ph. 415-387-8389; \$6 ppd) Literary and art quarterly that publishes works only by "living West Coast writers and artists." A high-brow package [excellent printing and paper] with fresh writing pulled together by an editor who wasn't afraid to include a story that spoke of ingesting psychedelic drugs. 144 pages.

both these LP's satisfaction guarenteed ... or your money back!

EUGENE CHADBOURNE - RRR - 001

COUNTRY MUSIC OF SOUTHEAST AUSTRALIA

(\$6.00 Postpaid)

free improvisational country and western madness.
recorded live in actual c & w labor camps in SE Australia.
featuring the supposed talents of
David Moss, Rik Rue, and Jon Rose.

SPASTIC - DEMENTED - INSANE.

the most fucked-up LP ever recorded.

BLACKHOUSE - RRR - 777

"HOPE...."

(\$6.00 Postpaid)

the first LP from Salt Lake City's infamous Blackhouse -
a perfect blend of electronic feedback and The New Testament
a strictly LIMITED EDITION of 500 numbered copies.

SAY YOUR PRAYERS

Write For Our FREE Catalog Of These Fine Artists

RRRecords 151 PAIGE ST
LOWELL, MA 01852

RRR- MAIL ORDER
DISTRIBUTION
SOVIET FRANCE
PSYCLONES
NURSE WITH WOUND
ESPLENDOR
GEOMETRICO
SLEEP CHAMBER
CURRENT 93
KONSTRUKTIVITS
PGR
LEGENDARY PINK DOTS
ORGANUM
SMERSH
VISCERA
VAGINA DENTATA ORGAN
HUMAN FLESH
D.D.A.A.
MERZBOW
CONTROLLED BLEEDING
COIL
P16.D4
PTOSE
PSYCHIC TV
BORBETOMAGUS
BENE GESSERIT
DIMTHINGS
ZOS KIA
WHITEHOUSE



Radio listeners bemoan tape

It was like something from Orson Welle's infamous "War of the Worlds" radio broadcast, said program director John Stark.

But for the KNPR radio listeners Halloween night, the screams, moans and groans coming from their radios were too realistic to be ignored.

Stark reported that his station, as well as Metropolitan Police, received a number of calls enquiring whether there were any problems in the broadcast booth.

The trouble began when volunteer disc jockey Lon Spight, a professor of physics at UNLV, played the "Dance of the Furies" portion of Christoph Gluck's "Or-

pheus and Eurydice" opera.

To accentuate the Halloween mood of the 10-minute piece, Spight dubbed in a BBC special effects recording of blood-curdling screams and screeching chains, Stark said.

The effects were so realistic, Stark said, that listeners actually thought someone was being attacked at the station.

The special effects were in keeping with the intent of the opera, Stark said, but the station had not intended to frighten anyone.

As workers told callers Thursday night, there was not a murder in the sound booth, even though it sounded like one, Stark said.

GIGGING

Folks at CFUV, University of Victoria suggest Club Hacienda, 560 Johnson St., Victoria, BC, Canada; ph. 604-384-1514. Interested in all kinds of music.

CONSIDER SENDING YOUR RECORDINGS TO:

Rabbit Suit Productions, P.O.B. 33127, Baltimore, MD 21218, USA; ph. 301-243-8224 or 301-243-6808. Deadline is March 28 for musical and graphic submissions for a mail art show titled: A World Without Imperialism, Not An Imperialist World War!. The music will be used as background for the show. All genres are welcome as long as the music reflects the theme.

International Music Network Compilation - "Sheet Music." Soliciting original works of music derived from any form of notation or scoring. Submissions should be five minutes or less and be recorded on high-bias chromium tape with home dolby. The complete score of the music submitted should be included also and should be in black and white. (Photocopies of score are acceptable. All contributors will receive one copy of tape and accompanying portfolio of scores. Subsequent copies are available to the artists at cost. Deadline: Dec. 31, 1986. Write Audio Muzixa Qet, 1341 Williamson, WI 53703, USA.

Pat Thomas is looking for tapes of bands doing cover versions of songs by the following bands for three different compilations to be released in Europe and the USA: 1) Velvet Underground/ Lou Reed / John Cale 2) Bob Dylan/ Neil Young 3) Big Star/ Modern Lovers / Soft Boys. Write Thomas c/o Heiselbaek, Norregade 49, 6690 Gording, Denmark.

Sherman Loper is making a compilation tape to "promote usical open-mindedness." It will be accompanied by a fanzine. Any kind of music will be considered. He seeks one song per artist (nothing over 10 minutes) and a page of literature. Write Sherman via 4260 Niblick Way, Fair Oaks, CA 95628, USA.

MISCELLANEOUS:

Country music performers with an interest in competition may be interested in the annual Western States Country Music Association contest. Winners receive money, equipment and studio time. Contact: WSCMA, 3333 So. Carson St., Carson City, NV, USA; ph. 702-882-3286.

An archive for the "Creative Performer" is being established at the University of California, San Diego. The archive will contain tapes, records, scores, writings and video cassettes of performer/composers, improvisors and groups whose work extends the language, technique and form of a medium. "Creative Performer" is defined as an artist whose work is directly linked to the mastery of a medium and whose work is manifested in "real-time" performance. Contact John Fonville, Creative Performer Archive, Music Dept. B-026, UCSD, La Jolla, CA 92093, USA.

John d'Beers reviews cassettes and 'zines for Alternative Press in Ohio as well as creating his own zine Avant Garage (formerly AHA!; see S.C. #2 Publication section). Write to Suite 651, 1840 Rhodes Rd., Kent, OH 44240, USA.

Andrew G. Stergiou is "very much interested in 'the revolutionary socialist communist trade union labor oriented bands'" and seeks recordings and writings regardless of language. Write P.O.B. 63, Queens, NY, 11694, USA.

Brian Lunger has begun Equally Different, a non-profit distribution system to help Canadian independent recording artists. Write: 2581 Vista Bay Rd., Victoria, B.C., Canada V8P 3G1.

Blues artists and fans heading to the Pacific Northwest might wish to contact Dale Knuth who plays the blues on his radio show at KAOS and is eager to help out blues artists any way he can. Write Dale c/o KAOS, Olympia, WA 98505, USA.

Lang Thompson publishes Funhouse, a contact list of subcultural activities. Send \$1 to 2111 University Blvd. E., Apt. 33, Tuscaloosa, AL 35404, USA.

Richard Frannecki (Uddersounds and F/I) also "publishes contact listings and in general, passes on information". (His list inspired Lang Thompson to create Funhouse.) Write Uddersounds, P.O.B. 27421, Milwaukee, WI 53227, USA.

Images from South Africa is the theme of mail art show. Deadline is April 1, 1986. Write Images From South Africa, 135 Cole St., San Francisco, CA 94117, USA.

Composer/percussionist David Moss and Frank Hoffman have produced US EAR, a series of 10 radio programs for National Public Radio featuring a "magazine" format of interviews, features, original audio art along the lines of "new music". If your local NPR station is not broadcasting US Ear, David suggests you bug them about it. Moss will be working on a similar project revolving around artists involved with the New Music America festivals. Contact Moss via Box 33, Marlboro, VT, 05344; ph. 802-254-2918.

Manifestos/Movements 1986 is a mailart project. All submissions should include the following 1) Name of your movement. 2) Date founded. 3) Description of activities, medias, influences, publications, 4) Founder. 5) Manifesto. 6) Any supporting information, graphics, articles, publications and recordings. Deadline is Dec. 31, 1986. No rejections, copy of book to each contributor. Write: The Avant Garde Museum of Temporary Art, 1341 Williamson, Madison, WI 53703, USA.

The **Radio Art Foundation** is creating a series of English language "new form radio dramas" and is looking for Radio Stations that will broadcast them, then send them on to another radio station for broadcast (thus saving mailing and duplicating costs.) Any radio programmer interested should contact the Foundation c/o Alexander Boersstraat, No. 30, Amsterdam 1071 KZ, The Netherlands; ph. (0)20-792620.

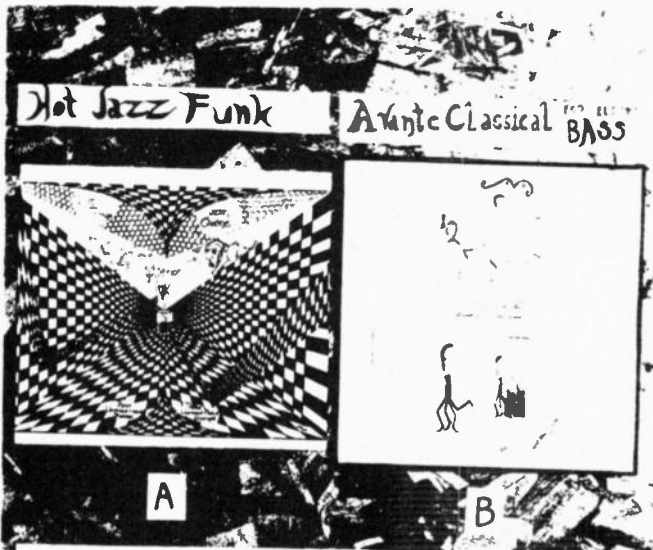

"Jean Chino burns with the intensity + proficiency of a Jaco P. or Stanley C. (when they're smokin')!" - Sound Choice #3
 "... somewhat like Sun Ra... Material... The Residents...
 ...wildest record I've heard in a long time." - Option Bissus
 A. Those Unforgettable Shaman 6.⁵⁰
 B. Distant Suns 6.⁵⁰
 Two or More 5.⁹⁹ SALE

FEATURING
 DIM THINGS

KETA Music P.O. Box 42 Newfane VT 05345-0042
 802-345-9958



FLOATING WORLD

804 NORTH CHEROKEE
 HOLLYWOOD, CA 90038
 (213) 464-5628



The Latest from Private Studio

The Blurbs



Keep listening or well!

cut your ears off!!

Tape #2 & Industry available by mail
 for \$5 each plus 63¢ postage.
 P.O. Box 531

Wyandotte, MI 48192
 See reviews in this issue.

BE-BOP AND BEYOND

THE jazz magazine of Los Angeles
 and the West Coast
 Celebrating America's indigenous artform—
 Black Classical Music.
 From Louis Armstrong to Miles Davis,
 from Fats Waller to Cecil Taylor,
 from Billie Holiday to Betty Carter,
 Our music lives and grows.
 Interviews, live sets, features and more.

Send \$3.00 for sample copy.
 One year subscription:
 \$10.00 (U.S.), \$12.00 (Canada), \$14.00 (Elsewhere).
 P.O. Box 54337, Los Angeles, CA 90054

812-824-2400 **SIRIUS MUSIC**
 New Tapes Out Now!!!
 20 min. Cassette EPs from Bloomington's Wildest Bands

SALLY'S DREAM
 "Midnight Matinee" — Tough, Melodic Rock & Roll

THE DEADBEATS
 "Strange Tales—Amazing Facts"
 — Post Punk Psychedelic Hardcore
 \$4.00 each, mail order

Still Available:
Son of Segments \$8.00 mail order
 (The Kentuckiana Compilation)
 (40 song compilation cassette with local &
 area bands, complete with 36 page booklet)
 "...If the beginning and ending sound crazy,
 you should hear the stuff in between."
 —Mike Leonard, H-T
 "...Has me jumping up and down..."
 —Chris Stigliano, Option Magazine

Playette \$4.00 mail order
 (Rich Stim & MX-80 & Friends)
 "If you call yourself an aficionado of post-
 Velvets R&R you should get this..."
 —Chris Stigliano, Option Magazine
 Tapes available by mail from
SIRIUS MUSIC
 611 Empire Mill Road
 Bloomington, IN 47401



Eileen demonstrates how simply taking clothes off the line is an event when you've got a colorful Sound Choice T-Shirt among your wardrobe. Sizes small, medium, large and extra-large are available for \$12 each. Red and black on a white, 100% cotton, heavy duty shirt.

From the Events Desk:

FROM THE EVENTS DESK:

These are "event"ful times, literally. Events are reaching new heights of inventiveness and self-expression. After organizing, inviting, decorating, the word "event" was tagged to secular as well as religious occasions. In 1985 fundraiser events rocked the fabric of world politics and "the summit" rose on the mainstream of media foreplay onto the international stage of political entertainment. In 1986 people are marching to experience events of socially redeeming value.

It was an event when I got my job at Sound Choice. And it has been one event after another...I lost an ad (thanks for the second copy Smiley Turtle, see page 20)...lost a tape (Raymond please send another copy of "Person to Person".) I even spent a week coming in and going out the back door and missing a United Parcel notice at the front door. Well, in the event of such a catastrophe (break glass) go public, get rad, dress up and shake your bad self. Only boring people get boed and that's by taking themselves too seriously. If things are not happening that's the most likely time to create your own event.

Showcasing local talent is one of the best reasons for a party. My parties are successful by giving friends an opportunity to perform and provide innovative entertainment. DARKHORSE, a four piece original rock and roll electric blues band created a wild mood at my last party. Good luck in the studio this year, pals.

Sound Choice invited Eugene Chadbourne to perform at the Ojai Art Center during the week of his appearance at the New Music America Festival in Los Angeles. Eugene, you can't draw a big crowd (or a big paycheck) in an off the path town like Ojai,

but you're getting more famous all the time. Charlie and Jessie came all the way down from KCBX, San Luis Obispo and are great new friends and SC supporters. Sartuse and Ayanna, thanks for your opening set. Your music is a perfect blend of primitive and genteel.

Band contests are great events for promoting bands and building team spirit...rah, rah. Thanks to Michael Levine of Ventura, Calif. I was invited to judge the Ventura Band of the Year Contest. I wore my Sound Choice T-shirt, of course. Although I thoroughly enjoyed all the music, the competition made me tense and the judges simultaneously looked for a back door when the winners were announced. SPY MOVIE, "Ventura County #1 band of the year" won \$250 of recording time from Goldmine Studios. The contest succeeded in promoting local bands, publicizing The Musicians Monthly Newsletter, an informative music newspaper servicing Ventura, Calif., and giving everyone attending a great time. THE STRANGERS took 2nd place, CHECKMATE took 3rd, and CONVERTIBLE, with a dynamite female lead vocalist, took 4th.

Ideas for events that arrive at Sound Choice headquarters would take up more room than one may imagine. Here are a few that are particularly innovative and bizaare that you might want to rerun in your own neighborhood:

The bi-annual Mid America Festival of the Arts - Sound Fair: A MUSICAL WALKING TOUR presented by the Bloomington Indiana Arts Council and private businesses. The event happens simultaneously at three city parks with a separate musical environment for each one. In one park, environmental sounds are recorded and played back to the crowds.

From PRIAPISMUS SOFTWARE (c/o Franz Liebl, Deisenhofener Str. 37, D-8000 Muenchen 90, Fed. Rep. Germany) came the invitation for the ultimate event...COMMIT YOUR OWN SUICIDE, send tape and photos. Each contributor receives two copies of the results.

Back here on the western edge of the U.S.A. Bonnie Barnett, during New Music America in Los Angeles had the airwaves of KPFX filled with humming E-flat and encouraging all listeners at home to do the same. "Auto Hum is a synergistic live group event that truly feels great," she says.

For those who find time on their hands, and want to create an event, first set a date. This is best done by seaside, stream or fountain. Then begin the list of everything you'll need.

Send me something funny (thanks James Hill for that idea) or money (that always makes me laugh) with the theme of your next event and I'll send you a list and ideas for a bag of tricks.

Others who find free time as rare and beautiful as an opening through a dense forest, should probably keep their minds open to spontaneous events. Ideas and resources are in abundance, improvising is not difficult, and things often appear magically just when you need them.

If you called Sound Choice headquarters during December you found out that David and Bill were off on the network trail creating a traveling event that spanned half the state of California. One of the events within the event was recording an interview about the corruption of college radio by major label music companies for Maximum Rock 'N' Roll radio program. See David's article in the March issue of MAX R 'N' R.

—Eileen Sterling

RESTORATION OF MONARCHY



MUSIC FOR THE ESOTERIC FEW

Send \$7 to

TCAB Studio
POB 884763
SF CA 94188

Like Thousands Of Tiny
Voices Urging You To
Buy This Album!



New from

PRESENT

Le Poison Qui Rend fou

Available at record stores or write:
Cuneiform Records P.O. Box 6517
Wheaton, Maryland 20906 USA

◀ CUNEIFORM
◀ RECORDS

minimal COMPACT

RAGING SOULS



New Album

Produced by Colin Newman

cram 042 lp

PROMOTED AND MARKETED BY **OF FACTORY** 325 SPRING STREET, 233, NYC, NY 10013 212 741.0329 contact Cheryl

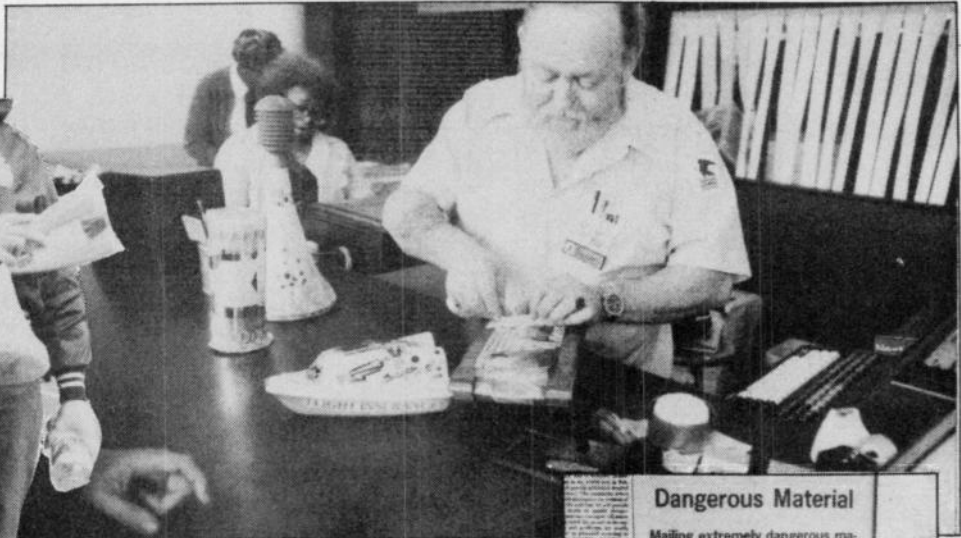

Creative Mailers

Dangerous Material
 Mailing extremely dangerous materials, and potentially dangerous materials which are improperly prepared, is prohibited by law. You must insure that your mailings comply with the law. Ask about postal requirements before you deposit any questionable materials into the mails.

by James Hill

Greetings to your independent minded selves. I invite you to ask yourself this question, "Do I enjoy the unusual?" If your answer is yes then you may find this article to be right up your alley.

A few weeks ago I was strolling down the street when my eye caught this two-foot disengaged doll leg lying in a pile of trash on the street corner. The thought occurred that this doll leg would make a great mailer. I picked it up and rushed back to the studio to see if I could cram a tape into it.

Much to my joy, a tape fit perfectly into the upper portion of the leg allowing the rest of the leg to be filled with all sorts of other stuff such as puffed yellow corn, buttons, and an assortment of other mail art.

I thought I discovered the ultimate mailer. Not only is a doll leg light, it's sturdy and hollow and you can slap an address on it and mail it to the Pope if you like with no postal problems.

The next day I hit all the thrift stores on Mission Street looking for doll legs. Unfortunately there aren't too many two-foot doll legs to be found in the city.

What I did find though was a pair of red plastic high heel shoes for only 90 cents. Once again I brought my find back to the studio and wouldn't you know it, a tape fit snug as a rug in those shoes. I wrapped a little clear plastic tape around those puppies, slapped an address on them and off they went. On to Nort B.C. in London and the other to Henning Mittendorf in Frankfurt. When I saw the postal worker hand-cancel that doll leg and those two red shoes I knew was on to something.

My greatest passion at this time is focussed on creative mailers. You can experience the thrill of mailing your tape or underwear for that matter, anywhere in the western world in a creative mailer for a very small price. Once you get over the emarrassment of standing in line at the post office with an armful of creative mailers and hiping your postal worker up to the marvel of mail art,

there will be no stopping you. I find that a lot of tension is relived at the post office when I wear my button that says, "I Love Postal Workers."

The best places to find creative mailers are in the seedy parts of town and along railroad tracks. I seldom pass a dumpster without a little peek inside, and of course thrift stores shouldn't be overlooked either. Personally, I never spend more than a dollar for a mailer and I look for something that not only will be a good mailer but can be used by the person it is being sent to. If you know that the person you are contacting has kids, find some old broken toy that can contain the stuff you are sending. That way not only the postal worker will have a laugh but your friend's kid will experience hours of fun playing with the creative mailer.

I bought this plastic army tank (with a little secret compartment) for 25 cents that's going to make some kid really happy.

Realize that the post office will mail any object

as long as it is addressed properly. Of course you wouldn't want to mail a piece of broken glass or anything else that could harm our beloved postal workers.

And don't forget, when you walk down the street keep your gaze in the gutter. You'll be amazed at the number of creative mailers that will be passed up if you keep your sights on the horizon.

Also keep in mind that whatever you are mailing doesn't need to be wrapped up. Zan The Man and Ed Special have enjoyed mailing pieces of styrofoam to each other and during the course of it being mailed chunks of styrofoam would break off, but it still got delivered.

Creative mailing is fun and it doesn't have to cost any more than a traditional mailer. In fact, I found mailing tapes in zip lock baggies costs less to mail than in those brown envelopes.

You won't regret creative mailing if you are inclined to give it a try.

Creative mailings to James should be addressed c/o TCAB Studio, P.O.B. 884763, San Francisco, CA 94188, USA.

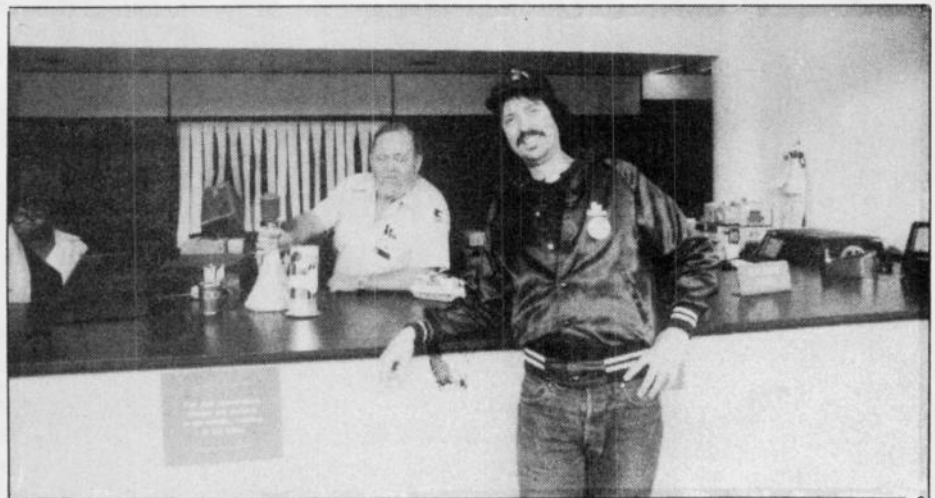

The Long Awaited
NEW
 Release!

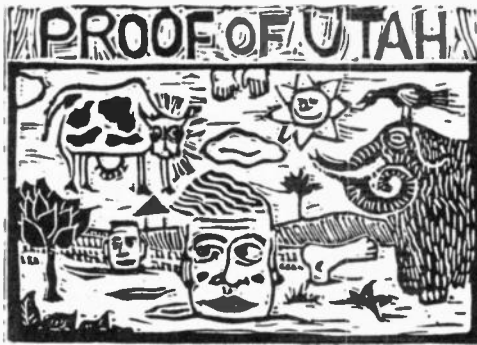

IT DOESN'T MATTER MUCH

distributed by: GREENWORLD, NEW MUSIC DIST. SERV.,
 DUTCH EAST INDIA, IMPORTANT, METRO AMERICA

OR MAIL ORDER JUST \$7.00 TO

SMILEY TURTLE RECORDS
 228 CLOUGH ST.
 BOWLING GREEN, OHIO 43402

← ALSO AVAILABLE ←

Proof of Utah's debut album
 "A DOG, A DODO & A FOOL"
 "...best mullerlings under-towed
 with fringes of psychosis"
 —DUCKBERG TIMES
 only \$7

→ THE BELLY'S VIRGINAL POLYUPS
 —non-lp, non-pop
 P.O.U. 60 min. Chrome cass. \$6

Algy Krebs Quartet
 eccentric blues from Athens, OH
 IQ8 "JUST GOODS" Cleveland's
 best hardcore, electrified, recorded
 30 min. cass. \$4.00 each

**JANDEK
 on
 Corwood**

Corwood Industries
 Box 15375
 Houston, TX 77020

PLACEBO RECORDS

NEW



ARTLESS 12" EP

You've read his columns in Maximum Rock n' Roll now you can hear Mykel Beard and his band Artless on this new Vinyl Masterpiece! Comes complete with etching of Mykel on flip
 \$5.00



DRY LUNGS

Industrial music compilation from all over the world (Controlled Bleeding, Mertzbow, John Duncan, Maybe Mental, Sleep Chamber + 13 others)
 16 songs (\$6.00)



MORE COFFEE FOR THE POLITICIANS

Phoenix Underground Music Compilation #3
 JFA, Zany Guys, Sun City Girls, Mighty Sphinxter,
 O.N.S. Harvest, Maybe Mental + 7 others
 14 songs (\$6.00)

PLACEBO RECORDS
 P.O. Box 23316
 Phoenix, Az. 85063

Send \$1.00 for Catalog & Sticker

distributed by: rough trade, jam, important,
 dutch east india, sounds good, Caroll/ite,
 systematic, greenworld, toxic shock



IF YA CAN'T SELL IT, GIVE IT AWAY!

spotlight they had found. And the reason for that is very simple: many musicians are under some hypnotic trance believing that one day they will be discovered and made instant stars. As reality sets in, band members lose their cockiness and eventually their resolve to play on.

Our band, Heavy Mental, is a good example. After unsuccessful attempts at playing in suburban bars around Chicago and producing an ill-fated EP that was never promoted right, the drummer, rhythm player and bassist told band leader Darrel Lichtt that they resigned, leaving him with only the name Heavy Mental and a few hundred records. Without haste Darrel formed a new band from friends who were more committed that he had jammed with in other bands. Eventually myself and three other players caught wind of what Darrel's new Heavy Mental was up to and decided that their psychedelic sound was worth investing in. And so Persistant Productions was formed, financed by Heavy Mental themselves and a third party who have high hopes to create a formidable promotional outlet.

At first we produced a single named "Atomic Shockability". Since Heavy Mental wasn't well known, no distributor would carry the record. Thus Persistant spent money that no other company would dare do and distributed the single themselves. After painstakingly pulling at least 700 addresses out of state telephone directories at the library, we managed to establish correspondence with 156 record stores around the country. We spent a lot of money mailing out 700 inquiries and only got a fraction in response, but we knew of no better alternative. If you think that's expensive, you'll be wiped out keeping track of the record sales every two weeks with stores who never reply or who move from the face of the earth without a change of address.

Believe it or not, we did this for a whole year, spending more money in correspondence than we made from the records. Finally, it got to the point where this project was not only wasting

cash, but wasting time as well. In fact, way too much time for any of the band members or the rest of Persistant Productions were willing to commit. After selling 3,100 *Atomic Shockability* singles, we gave it up.

For all the money we had spent in promotion and radio play, we could have given the records out for free. It probably would have saved us a sum as well, compared to distributing through stores. Giving material away for free? And still save money? That thought gave us an idea for our current promotion.

Since there was still a large portion of the public who had never heard the name Heavy Mental and would thereby be unwilling to risk investment in a Heavy Mental record, why not entice tightwad listeners with a free sample? If they like it, great, if they don't, tough.

In May of 1985 the band recorded 25 minutes of music. As soon as our finances were replenished, we purchased a bulk of 1,000 tapes and began researching fanzines and magazines deciding where to place ads. We took chances placing ads not knowing whether the fanzine editors were honest or not. Ads were placed in zines of all sizes from the *New Number 2* (Minneapolis) to *Sound Choice* and *Maximum Rock 'N' Roll*.

Two weeks after the first ads were published, we were bombarded with replies. There are some days when we were get more than 50 letters a day. People have been very receptive, some putting strange items in their letters in appreciation for their free cassette. We have received cartoons, rubber gloves, snot, skin, nude pictures one woman took of herself, stuff that looks like pubic hair, and a condom (unused thank god).

Probably the most dramatic little gift we've seen was a plastic sealed pack containing a substance that immediately evaporated when it was exposed to air. It was a stink potion in the guise of a free men's cologne sample. The smell was so tremendous, Persistant Productions had to be abandoned for a day.

More importantly, we have received inquiries from radio stations, fanzines and possible distributors, where as before we had no such luck. When *Atomic Shockability* was released, we had trouble finding zines who would review the single. Now the press seems more willing to try the group. Radio stations have been writing for more tapes for airplay, and indeed Heavy Mental is getting its fair share of it. We just got a few letters from L.A. from those who had heard of the freebie tape on a college radio program. A few distributors have expressed interest in carrying Heavy Mental's upcoming four song EP entitled *Economic Growth*.

In case you are wondering if we are rich or not — We're not! We all have low paying jobs on the side. But we are shrewd enough to do without some of the extravagancies of life in order to finance our operation. We are the conclusive evidence that if you are really serious about your rock 'n' roll band, it is time to put your money where your mouth is. Instead of investing in new amps and fancy guitars, those funds could be better used getting your name out of the garage where you practice. Unless you know someone who has the bucks, you can't depend on fantasies like instant stardom. There's an old saying, "it pays to advertise" and it does!

by Wayne Kusy

In this country there is estimated to be at least 25,000 or more bands ranging from Jazz to Hardcore all competing for the same goal: mass recognition as a success in whatever type of music they are associated with. Out of that number, only a handful will ever reach that goal.

There are several stages of bandhood. First, there are the basement band jam sessions. Second, there is the "professional" band that plays the clubs with their choppers slurping for that forever evasive record contract. Then there are the bands with "connections" enabling them to play large arenas and back national acts. You've probably seen them before, they usually have no talent and their show leaves you wondering how the hell they ever landed such a gig. But even "connection" bands never know enough VIPs to connect them with the number of good gigs they'd like to have.

Though you might think that some promising bands have too much talent to quit, most end up breaking up or fade away from what little public

HEAVY MENTAL FOR FREE

THE PSYCHEDELIC MUSIC GROUP HEAVY MENTAL HAS JUST RELEASED A 25 min DEMO TAPE FOR RADIO PLAY. A LARGE QUANTITY OF THESE HAVE ALSO BEEN PRODUCED FOR FREE PUBLIC CONSUMPTION. THATS RIGHT, ITS FREE! NO OBLIGATIONS, NO BITTERSWEET SURPRISES. WANT SOME FREE MUSIC????? WRITE TO:

PERSISTANT PRODUCTIONS LTD
PO BOX 777 Evanston IL
60204

NEW RELEASES

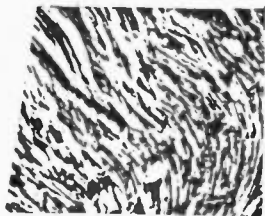

Nathan Griffith:
Walking Thru Walls
Phyllip Vernacular:
Cognitive Dissonance



Sand For Our
Free Catalog

C-90 Sampler
Still Only \$5

EUGENE ELECTRONIC MUSIC
p o box 3219
COLLECTIVE Eugene OR 97403

NEW MUSIC: HOUSTON

A SHOWCASE OF ALTERNATIVES
VISUAL, ACOUSTIC, & PERFORMANCE ART
IN CONJUNCTION WITH NEW MUSIC AMERICA '86
FOR BOOKING/SCHEDULE
INFORMATION CONTACT:

3rd Coast
MEDIAGRAPHIX
PO BOX 85
CENTERVILLE TX 75833

DIRT HEROES

"Out Of The Basement
Into Your Ear!"

HOW TO
ACT

THINKING
OF YOU

WHITE
LIES

REINCARNATION

4 - SONG 7" EP

\$3.00 PP

"...grungy guitar rock in the finest
Velvets tradition..."
-CMJ New Music Report

"Thick layers of guitar churn over an
equally dense rhythm section..."
-Aquarian

Propulsion Records *Music from the Heart
of the Earth*

P.O. BOX 1563
FLUSHING, NY 11354

(718) 445-8191

DIRT heroes



PEACH OF IMMORTALITY

PUSSY GALORE

TOUR JAN FEB

ACR 004 PUSSY GALORE "FEEL GOOD
ABOUT YOUR BODY" EP. ACR 003 PEACH
OF IMMORTALITY "TALKING HEADS '77" LP.
SOON: ACR 005 WHITEHOUSE NEW LP. ACR
006 PEACH OF IMMORTALITY "REMIS AIR SUP-
PLY" NEW LP. ADULT CONTEMPORARY RECO-
RDINGS 2151 CA. ST # 402 WASH DC 20008.



SCENE REPORT

B ERLIN

By
WILLIAM
LEVY

"The Land belongs to France and Russia/ The sea belongs to Britain/ But we reserve an unchallenged dominion/ In the Empire of Dreams." — Heine, Germany: A Winter Fairytale

"Der Wagen der rollt, bup bup bup bup, der Wagen der rollt, der jagen nach Gold, bup bup bup bup..." from Conrad Schnitzler blasts through the Walkman into my ears as the car rolls along the gun metal gray streets of West Berlin.

Europe committed suicide and Berlin is the most dramatic relic of this verdict. Both Hitler and Lenin saw this city as their capital of a single central political institution destined to bring about the pacification of the world — through terror. Destroyed and divided by having welcomed the embraces of low consorts, Berlin is a fourth dimension in the center of a continent, like a geopolitical E.T., a looking glass world.

One of the most important cultural phenomena from Europe in the weighty Eighties has been German New Wave Music. It's center of gravity is this haunted, divided city.

Moving away from the Wall, I pass over the Landswehr Canal where the saintly, crippled Rosa Luxemburg was murdered by army officers for her part in the Spartacus uprising of 1919. Some say her spirit can still be seen hovering above the still, dark water. Then down Grossbeeren Strasse to number 50 — Scheissladen.

This is the rendezvous point of the new music scene. Scheissladen (Shit Shop), is an independent record store: it stocks music produced only by the musicians themselves. An active scene judging from the large amount and variety of home-made cassettes and records to be seen. On the walls are posters for Agressive Rock Productions offering the public LPs from Slime, Yankee Raus and Daily Terror. Another group of united artists from suburban Spandau offer a sampler of Soylenr Grun, Dreidimensional, Mob and Leer. I speak with Norbert, the founder and owner; a genial lad wearing a second-hand brown suit with a button on the narrow lapel demanding "Legaliser Himbeereis" (Legalize Raspberry Ice Cream).

"Berlin is the cultural capital of Germany in everything," he says, eyes gleaming through his silver wire-rimmed spectacles. "It's a magnet for young people, especially because of its political situation; it's the only place in all Germany without military conscription."

"Tell me about the new German music," I ask. "In the past few years Neue Deutscher Welle has taken international pop music by storm!"

Norbert hands me a chipped mug of instant coffee.

"Well, yes..." he begins. "At first the music was



CONRAD SCHNITZLER

Photo courtesy of Onslaught Magazine.

a copy of English and American. In the English language. In 1977 Punk came, everywhere, and in Germany too. The German groups got more confidence. The Neue Deutscher Welle begins, however, with DAF, or Deutsch-Amerikanische Freundschaft (German-American Friendship). Their death and suicide song called 'Mussolini' had everyone dancing last year. Also Fehl Farben (Missing Colors). And the Ideals — they made their first record themselves, in one thousand copies, and it was sold out in two weeks.

"In fact, all the groups started as independents. Der Plan has refused to go with record companies; they are very popular. And the split came with DAF when they signed a contract. Two of them left the group. The bass player to Fehl Farben, the guitar player to Mau Mau. Tempo had a contract with Polydor, then went back to home productions. Einsturzende Neubauten (Collapsing New Buildings) began as self-tapers making their own cassettes. Now they are number one in Berlin, in Germany, in Europe, and tomorrow the North Pole! Malaria is number two; that's a group of five women. Over the music they scream: 'Achtung! Achtung! Achtung! Geld! Geld! Geld!' (Attention! Attention! Attention! Money! Money! Money!). Interzone is literary. They took their name from that mythical country in Burroughs' *Naked Lunch* and they sing the poems of Wolf Wondratschek, Germany's most popular poet since the Second World War. Slime is more concretely political; songs about police and demonstrations. The texts of other groups are about sex and drugs...all the situations of life.

"Then there are the performances. The lead singer of Didaktische Einheit (Didactic Unity) comes on stage wearing a large baby's diaper covered with mud made to look like shit. He throws the mud at the audience and by the end of the evening many people are rolling in it on the floor. You know, when it gets heavy we are all very glad!"

Trying to ferret out the new trends, I ask: "Are there any exciting groups coming up?"

Norbert gets up and walks to the front of the shop and returns with a record. "This!" he says. "It's by Die Todliche Doris (The Deadly Doris). They just flew off to Paris this morning to be the supporting act for Einsturzende Neubauten at the Festival Autonome."

"This is Die Todliche Doris's first LP, and it was

banned," he tells me still holding up the record. "There are three in the group — men play bass and accordion and a woman plays violin and drums."

Norbert takes the record out of the sleeve and puts it on the turntable.

The first side is like a noisy, radio drama. They describe seven accidents that could happen in the home, in horrifically explicit detail, complete with screaming. On the other side, they sing: "Better no heart/ than a heart of paprika." Industrial music sounds melodic in contrast with this.

"But," Norbert confides in me sadly, "the Neue Deutscher Welle is in a transition period. People are confused about what to play, or listen to — especially after its unexpected enormous success."

The group Trio is the case in point. Three musicians living quietly in a small town near Hannover. They made a single called: "Da da da I don't love you/ You don't love me aha aha aha." Feeling themselves to be isolated artists, they printed their address and phone number on the record sleeve — hoping someone would respond. The song became a smash hit. It sold more than six hundred thousand copies. Their phone didn't stop ringing 24 hours a day. When they woke up in the morning they found fans camping out in their garden. So they had to first disconnect their phone, then move to another house and they haven't made another record.

The Neue Deutscher Well might be characterized as the language of prophecy and absurdity as a worldview. For the past few years young German musicians have been playing what could easily pass as soundtracks for *Metropolis* and *Der Golem* — those great expressionist silent films made in Berlin during the Twenties. If Weimar is upon us, can the Third Reich 'n' Roll be far behind?

Driving back to West Germany along the 110 mile no exit autobahn through the Deutscher Demokratische Republic, I turn on the radio. They are playing a song from Grauzone (Gray Zone), one of the currently popular groups:

Ich mochte ein Eisbar sein/ am kalten Polar/ dann musste ich nicht mehr wein'/ alles war so klar! (I want to be a polar bear/ in the cold arctic/ then I wouldn't have to cry anymore/ everything would be so clear!)

Foreign correspondent William Levy lives in Amsterdam.

AVAILABLE NOW

"The Doc of Comedy Rock"

The hilarious debut solo Lp from
DR. GONZO

DA 104

Also available on chrome cassette*



Also available from Dublab

**2-Ton
Machine
Chinatown***

DA103

\$8.98



**Bobby Ellis
& The Crew
Shaka***

DA102

\$8.98

**The Impostors
Mask**



DA101

\$8.98

**Robin & The Rocks
Unknown Lover**



DM100

\$5.98

**Tazmanian Devils
Live**



EP001

\$4.98

How to Order by Mail

Just send us a list of the items you want, along with a check or money order. Be sure to indicate (where applicable) whether you want cassettes or records. List each item, the price, the quantity and the total amount you're sending us. Allow 4-6 weeks for delivery. Prices include postage and handling. Calif. residents add appropriate tax.

DUBLAB

RECORDS & TAPES

1537A Fourth St., San Rafael, CA 94901

(415) 492-9733

Stores Contact CITY HALL and RAS record distributors

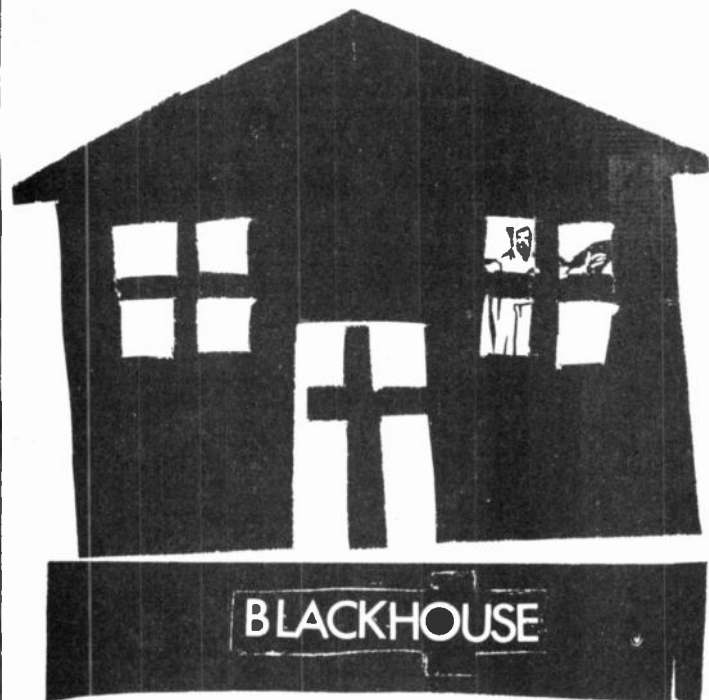

by Pope Jamie Lee Rake

In the burgeoning world of contemporary Christian music, some acts have made the attempt to be so "harsh" as to attract new wave and punk crowds to the Gospel. However, none so far have been as abrasive as Blackhouse, the first Christian industrial (or as they prefer "power electronics") group. The trio, consisting of Ivo Cutler, Sterling Cross, and Roger Farrell, have thus far released two cassettes, *Pro-Life* and *Hope Like A Candle* and a new album.

The following mail interview was conducted with Ivo Cutler.

Ivo Cutler: Our goal is to destroy tired myths and political/religious dogma in an effort to get the individual to think more freely. Society tends to view the contemporary Christian in a certain, stereotypical way. Industrial music is thought of as being a sort of negative reaction to the world as we know it. Both are lies which need to be disposed with.

Jamie Lee Rake: How would you describe yourselves musically?

IC: Musically, we are OPEN.

JLR: Do you see any irony in the lack of "beauty" in your music and the notions many Christians have about how their "pop" music should sound? If so, why not?

IC: First, we are not a "pop" group. We don't make pop music. Second, we feel there is a great wealth of "beauty" in our music (*Writer's note: Yeah, I was probably thinking in the mind of the typical Godpop fan when asking this question*). Just because it's not pop doesn't mean that it's ugly. Again, we are confronted with a power-

ful myth which needs to be abolished. True beauty lies in the interior — the heart — not in the polished exterior which is manufactured for mass consumption and popularization.

JLR: Who do you think your audience consists of? Do you have any expectations for reaching the crowd Amy Grant or even the 77s or Undercover, reaches?

IC: Open-minded individuals, Christian and non-Christian alike. They are those who seek a higher understanding for themselves. We have NO expectations of becoming a pop music group. It is not important to be popular.

JLR: What instruments do each of you use?

IC: Sterling and I both sing, talk, and play "instruments" like: electric and acoustic percussion, media devices, and (very infrequently) synthesizers. A lot of people think we use the synthesizer all the time, but it's only been used on side two of *Hope Like A Candle*. We don't need a synthesizer.

JLR: What part do you think Christians should have in developing the secular culture? What contribution, if any, do you want/expect to make to secular culture?

IC: This question does not interest us.

JLR: I found your tapes to be some of the most disturbing music I've heard, especially coming from a Christian band. Do you believe art should be a confrontational experience?

IC: Thank you very much. That which disturbs is that which makes us think. Industrial music as a whole is pretty disturbing stuff, and we're right up there with the best of 'em. Art can be passive and art can be demanding. Neither one is better than the other, but we prefer "demanding". Yes, our art is particularly confrontational because we are involved in topics of great controversy and conflict.

JLR: What other Christian musicians do you listen to? What secular musicians do you listen too? Should distinctions be made if the music of either makes a positive statement about faith?

IC: We don't listen to other Christians actively. If we HAD to pick out a favorite Christian group (besides ourselves), we'd choose Stryper because they are coming from (and at) a much different audience than would be considered "appropriate." It's too easy to make a "certain type" of music for a "certain type" of audience. The challenge is to gain an audience that's considered "inappropriate". The goal is to reach NEW minds. No distinction should be made whatsoever (regarding religion) if the music is positive.

JLR: What's the rationale behind the symbology of the skull in your logo? Skulls can be taken so many different ways.

IC: There is no skull in our logo. There are *some* buttons appearing with a smiling skull and our name, but it is not an official logo. Anyway, death is not the ultimate END to everything ya know.

JLR: Do you play live often and, if you do, do you then offer altar calls?

IC: No. We don't play live often anymore. In the early days, we had some bad experiences with the audiences (at the Dirt House), and so recording is our desire right now. BUT...we are talking about a tour right now. Nothing positive yet, though. No altar calls, but we do like to offer select words of encouragement upon occasion. STATEMENT: We are NOT out to save the world — we don't have the power — we are not out to change people's minds — we are out to OPEN people's minds. We are not out to create lies, we are out to destroy them. We are not a "pop" group. We are ourselves...we are BLACKHOUSE.

For information about Blackhouse and their cassettes, write them in care of Object Magazine, P.O.B. 967, Eureka, CA 95502, USA.

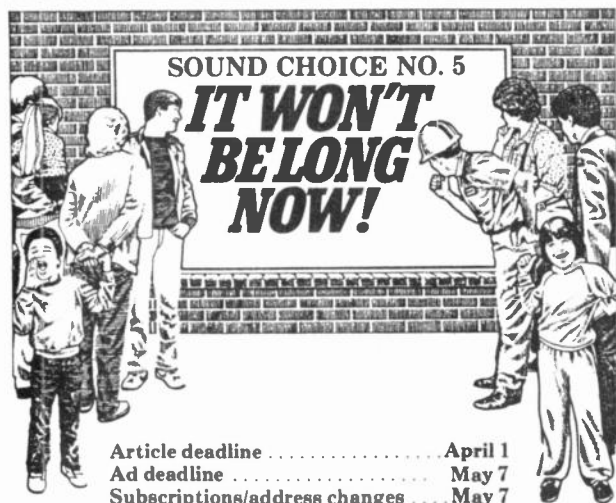

Article deadline April 1
 Ad deadline May 7
 Subscriptions/address changes May 7
 S.C. No. 5 mailed May 21



SOUND CHOICE T-SHIRT: Design No. 1, "Cassette Revolution" (S.C. issue No. 3 cover design). Red and black silk-screen design on a white, top quality, 100 percent cotton T-shirt. Small, medium, large or extra-large. \$12 each. Sound Choice, P.O.B. 1251, Ojai, CA 93023, U.S.A.

Warbucks Leaving Earth!

A Telepathic Message
From the Warbucks Family

[It is around midnight, I think. I have just awakened from a vision which told me to wake up and start writing. I can hear the music of the spheres clearly in my head at this moment. I'm being told a story and I'll write it here as fast and as accurately as I can.]

I'm being told that the Warbucks' Family is sending this message to the people of the world. They are tired and bored with making all of our major decisions for us. They are in the process of withdrawing their leadership from our planet. They have now finished development of spacecraft with which to return to their home planet. They are taking all of their family with them. They thank us for all of our labor which they used to develop the necessary technology. They say they are withdrawing their key management personnel slowly so that we will have time to assume management of our planet by ourselves.

The Warbucks wish us luck. They warn us not to continue with the money and ownership system they established, because after they leave there will be no reason for power to remain centralized and thereby controlled by just a few people. They're saying that if we stop taking pay for our work and start giving the products away for free, we will then get leaders from amongst our own kind who will lead us in unselfish pathways. This free system will encourage leaders who have the vision to see how beautiful this planet will be when it is not being raped for profit. These leaders will have nothing to gain but the chance to exercise their abilities as visionaries and seers into the future. They will know that if they can steer you into a wonderful "Garden of Eden" relationship with your planet, that they too will have a more wonderful life and so will their children and grandchildren. Listen to the visionaries who have nothing more to gain from their ideas than you do.

Beware of those who speak of some great power which will save you. We, the Warbucks Family, were that Savior. We invented that fable, and at that time wrote all of the "Holy" books to substantiate it. Because you believed what we told you, you were much easier to manage and control. We were stranded here on Earth thousands of years ago when our spaceship ran out of fuel. We promptly began the management of your planet and proceeded to upgrade your species and teach you how to obey orders. In this area we have been extremely successful. We tried to keep you always too busy to do your own thinking.

As I said before, we are giving your planet back to you. However, it will not be necessary for you to start thinking for yourselves if you do not wish to. Some of your brothers and sisters (our lieutenants) who have been and still are controlling your media will continue to tell you how and what to think. They will wish to continue with the pay system because this will give them the power that we had. We took this power from you and we are giving you back this closely-guarded secret so that you can regain

your freedom — your Garden of Eden way of abundance and plenty if you wish it. Never vote away your power by allowing anyone to represent you. Share this planet. There is plenty of room for all of you. Use it to live, not for profit. Harmonize with nature. Never kill unless in self-defense or for food. Never even cut a blade of grass unless you are going to eat it. Do not interfere with nature's natural cycle of life.

If you wish to destroy your bodies and minds as we taught you, with drugs, alcohol, nicotine, caffeine, sugar, white starch and auto and factory exhaust, go ahead and do it. You have that right. You have a choice, however. You can learn to treat your body better and be healthier and happier or continue down your well-greased slide into misery and an early death.

We have allowed the first three Warbucks' Letters to "leak out" and be published by Ernest Mann of the Little Free Press, who we are dictating this message to telepathically.

We speeded up the evolution of man, on your planet Earth, by millions of years by breeding with your lower ancestors when we first arrived and now you all look just like us. You are made in our image, you are Gods along with us. You can follow us into outer space in a few years if you accomplish your freedom. If you choose to continue in your slavery, we will see to it that you do not gain "outer" space travel. We give you your freedom. But you will now have to take it from our lieutenants, the Rockefeller, Rothchild, etc., families. They can retain our power only if you continue to acknowledge a right of ownership and if you continue to take pay. They may try to retain you in the Pay System of Slavery. Some of them, I'm sorry to say, are very short-sighted. They are not the visionaries who can see how everyone would be so much better off in a Free System. In this system, everyone will have everything to gain by just "carrying a little bit of the load". Even the greedy money/power-hungry lieutenants will eventually see how power is a burden — not a thing to be

sought after. Freedom and happiness bring health and abundance. Friendships and true love can flourish when you discontinue competition and begin independence and cooperation.

When you discontinue ownership as we taught you and begin to practice your old system of "usership", you will have many of your people leave the ratbox cities and start communities out in the fresh-air country. Those who remain may dismantle most of the buildings and allow trees and plants to grow where the cement was. When the cement companies, chiropractors, doctors, and shoemakers stop taking pay, they will not want cement sidewalks either. You will discover dirt paths to be much more healthy and natural to walk upon. It will put your bodies in direct contact with the higher vibrations of health, peace, and pleasure.

Please remember we are giving you a choice. You can continue to follow orders or you can "take the time" to think for yourselves. If you elect the former — keep your eyes and ears glued to the media, especially to the TV, radio, newspapers, movies and music, they tell you what to think and how to feel. In this way you live your lives vicariously — it's much easier. If you prefer the latter — then wean yourself from all of the media. Cut drastically back on your buying. This will give you lots of spare time because you won't have to work so much. Take this spare time and observe what's going on. Dream about how you think things should be. Be careful with this spare time — there is a trap-door called "diversions". If you fall in, you will be too busy to find your freedom. You don't find freedom with booze or drugs — you find enslavement and diversion. You have a limited amount of time left to live. Decide what you want from life. Then go for it!

Nature, if encouraged with the right seeds in the right places at the right time, will provide all the food you need. People for thousands of years have been able to build shelters from the materials at hand that nature provides. 35-year mortgages of indentured slavery for a shelter was one of our clever inventions. Here again you can choose — either continue with this enslavement or create your own independence.

We cannot emphasize strongly enough that if your leader, teacher, guru or guide is taking any kind of pay from you, you have reason to be skeptical of him/her. We should know. They may be using you as a means to their own ends. There are many leaders (people with vision) rising up today among you. You may be one yourself. You can at least be your own leader. You can immediately start making your own decisions. You can decide to continue all the bad habits we taught you to harm your body and mind, or you can decide to discontinue them, one at a time. This little change in your life will give you a grand new feeling of power over your own destiny. You will soon learn that you can gain full control of your life once you vow not to let the media continue to condition and program your mind-computer.

When you get your head above water you may even wish to help a brother or sister along the way to get their heads above water too. When you see that you don't need or really want all of those "things" that the media condition you to want, then you will begin to have some breathing space — some time to think about what it is that really makes you happy.

We're telling you these things so you can take over now that we are leaving. We couldn't tell you our secrets before, but there is no point in holding them from you any longer.

This message was written down as it came into my head.

5/31/79

— Ernest Mann

Ernest Free Mann

Reprinting Encouraged

Please make at least 2 copies of this paper and pass them out. Thanks.
Reprinting Permissible FREE
Little Free Press, Rt. 2, Box 136A, Cushing, MN 56443

EMANCIPATION PROCLAMATION

We, the people who take pay for our work, in order to form a more perfect union of humanity, with liberty and justice for all, do hereby enter into this agreement.

We hereby acknowledge that people who take pay, must obey orders. This is slavery. We are controlled by money. Basic prices and wages are set by the cartels.

We hereby join in with our fellow "pay takers" to form a natural society in which there will cease being a reason to steal or starve. There will not be a reason to cheat. There will no longer be a reason to pollute our planet. There will not remain a reason to produce inferior products — junk production. (This alone will reduce working hours by at least 50%.) There will no longer be a reason to have unemployment, recessions, depressions, and inflation. There will no longer be a reason for war. There shall be no more taxes. There will be every reason to learn to harmonize with nature. We will allow nature to restore her natural balance. We shall no longer give anyone a right to "own" the natural resources which the earth has produced. We will "use" the resources which our labor takes from nature.

We do hereby solemnly swear and agree that on January 1st, 1980, we shall take full control of our own labor by beginning on that date to refuse to take pay for our work, and shall from that day forth give all products away for free. We will then have everything we need for free; therefore we can be very choosy about who or what we give our labor to — we will then have control over what we produce and how we produce it. From thenceforth, everyone will have equal access to all products. We will thereafter have much time to enjoy ourselves and each other.

Time is of the essence. The cartels have a 20-year deprivation and misery plan they are already beginning to implement. They are steadily reducing the gap between wages and prices. They are reducing our "savings" (independence) potential. If we act fast, we will have the advantage. We have the capability to make this great change before they get into phase two of their plan. They expect us to continue to be passive and obey all their orders like good sheep. They do not anticipate seeing their herd set up its own alternative system. The "Big Shots" will lose their power and their henchmen when we stop using money. As volunteers working for our freedom and happiness, we are far more efficient, creative, and effective than when we were the paid slave labor of the cartels.

In order for everyone to know about this proclamation, we hereby vow and promise to inform every "pay taker" that we can of this great change. Those of us who have a little money saved up can quit the Rat Race right now, and create the Natural Society within our own lives by working without pay in any manner we choose, to help give birth to a wonderful and glorious natural era. Working together for the greatest change in human condition since the beginning of time, pay takers will triumph, because we comprise more than 99% of the earth's population. We will all be much better off than we are now if we choose to act like men and women instead of passive sheep.

MAKING CONTACT WITH TOM FURGAS



By Mark Kissinger

Mark Kissinger: So, you don't strive to develop a specifically defined style in your work?

Tom Furgas: That's true. I've done tapes that are ambient, tapes that are industrial, such as *Quantum Geometry Networks*, tapes that have a lot of variety and are very tuneful, like *Sitting Without Flinching* which has a lot of very distinctive melodies, I think. But I wouldn't want any one of them to be the whole of my work. I worry about being a jack-of-all-trades, master of none. I'm using so many different styles, I can't really master any of them.

MK: Have you recorded any improvisational music?

TF: A lot of what I do is sort of semi-improvised. I have the basic concept down, sometimes I jot down notes or maybe even write out a full score if the idea demands it. Other times I'll just be winging it, once the tape starts rolling, and then I can edit and improve upon these spontaneous ideas as I go along. So it's kind of composed on tape.

MK: In addition to your solo work you also do some through-the-mail collaborating. Who have you been working with?

TF: I've done two with Richard Franhecki, the electronic composer from Wisconsin and one with Ken Clinger, who recently moved from the west coast to Pittsburgh. Those are cases where they've sent me material on tape and I've added to it, edited it, or whatever, and then released it myself. It's a lot of fun working with them although it can be frustrating trying to fit my ideas onto theirs and have them mesh well. The easiest ones to do are the ones with Richard Franhecki because the material is very plastic and allows me to manipulate it quite a bit. It's not quite as rigorous and melodic in the sense that I can't really toy with it much, but his material, being abstract and electronic as it is, lends itself to a lot of sculpting, changing, mixing around.

MK: How would you describe the tape with Ken Clinger?

TF: I would say it's mostly on the ambient side or minimalist. The melodies are very simple and they repeat quite often. There's very little textural variation with-

in any of the three pieces on that tape (*Sanguine Impants*). The idea was generally a very beautiful and lush kind of sound, very atmospheric and impressionistic.

MK: What about your current collaboration with guitarist Mark Hanley?

TF: Although we live right down the street from one another, we haven't gotten together and played together at once. We both feel more comfortable working by trading tapes back and forth and adding overdubs to each other's material. That gives us time to experiment, work out things and see what works and what doesn't.

MK: Is this mainly in a rock vein?

TF: Very much, yeah. Everything on it so far. Side two we plan to be a long, droney, spacey kind of piece that will have a lot of textural variation in it but within a very small framework. It's hard to say 'cause it's still in the planning stages. It's hard to say how it will turn out in the end, but side one is intended to be a series of rock pieces and I've decided to incorporate found vocals on all the pieces that will be on this since one piece that Mark gave me had his girlfriend reading part of an interview in "Cosmopolitan Magazine" with Madonna and it's done very humorously.

MK: Have you ever considered having your tapes handled by a distributor rather than selling them yourself?

TF: I really prefer to have control over them. There are several fine distributors around and I've considered it but I prefer to have a one-to-one relationship with the people who hear my music and since I do a lot of trading, it's the only way to work it. I'm willing to send a tape to anyone who's willing to trade with me. I will even send out music if someone will send me a blank tape to put it on and return postage.

MK: Do you have any idea how many other home tapers around the world you've contacted and/or traded with over the years?

TF: Oh, it must be over three hundred by now. And growing every week.

MK: Have you noticed any difference between American home tapers and those from other countries in terms of attitude or ideology?

TF: There's more of a striving for professionalism with the Europeans and Australians. The Canadians also

seem very professional in what they do. Americans take it a lot more casually on the whole. I would say, although that's not true in every case. I've gotten some tapes which were very casually made, very casually packaged...if you want to call that packaging. I wish people would pay more attention to the packaging of their tapes. It's like, if you serve a seven course meal on paper plates...

MK: In the third issue of Sound Choice, the article "Here's a Great Idea" mentioned an idea of yours called "A Day Of Music" which would employ 24 hour-long cassettes.

TF: I got that idea from an article on Throbbing Gristle in the "T" issue of Op and they mentioned having a set of 24 live tapes in a boxed set. And I thought, well, 24, that corresponds to the hours in a day. Why not make a piece of conceptual music correspond to that. And they could be like something that would build very gradually from midnight, say, very soft and moody, and would continue to be in the small hours of the morning and then just gradually build up. It would start sort of ambient and gradually become more active until it would reach a peak at noon and start to descend from there. By the time it got back to midnight it would be back to the ambient thing, but it wouldn't be a complete retrograde of the first half.

MK: What do you like and dislike about being involved in the indie scene?

TF: I like the vitality of it. All of these people working in a craftsman-like way, not being overly concerned about money, but wanting to communicate with other people musically. On the other hand, I don't like all of the self-indulgence that I've come across, a lot of really awful recordings by people who are more or less dilettantes, rather than trained musicians. And by training I mean just the rudimentary fundamentals. Anyone can turn on a rhythm box, but to do something interesting and vital, that takes a little more work and a lot of people are doing that but there are those few who still do, uh, a lot of really crappy work that I can't stand. But I'd never tell them so. (laughs.)

Tom Furgas can be reached at his home address: 1840 Paisley Rd. #3, Youngstown, OH 44511, USA.

Backtracking

Easley Blackwood (1933-) *Symphony No. 1*, Boston Symphony Orchestra, Charles Munch, cond. RCA Victor LM-2352 (mono) LSC-2352 (stereo). Released 1959. Unavailable since 1961.

Little did the train engineers who roared through Indianapolis, Indiana in 1937 realize that four-year-old Easley Blackwood was intently listening, and picking out the notes of their whistles on the piano. This same little boy would someday in the not too distant future study composition with Olivier Messiaen at the Berkshire Music Center, and later with Paul Hindemith at Yale and Bernard Heiden. His *Symphony No. 1*, composed in Paris during 1954-55, indeed shows influences of these great 20th century masters. However, it retains a special quality all its own, described by the composer as being "on the brink of atonality." The *Symphony* was introduced in 1958 by Charles Munch and the Boston Symphony Orchestra, along with Alexei Haieff's *Symphony No. 2* (also included on this disc). 1958 was also a significant year for Blackwood in that this was the year he joined the faculty of the University of Chicago, where he still teaches composition.

Easley Blackwood, as of this writing, has written four symphonies (the fourth being commissioned by the Chicago Symphony Orchestra in 1976), a piano concerto, numerous chamber works, a violin concerto, and most recently (1980) released an LP independently of his "Twelve Microtonal Etudes for Electronic Music Media." Very few of his works have been recorded commercially and those that have, have leaped from the record presses to out of print bins to obscurity. Which is why this disc is such an interesting and unusual item. Here is one of the world's most famous conductors leading one of the world's most famous orchestras in a performance of an obscure work by a virtually unknown composer...on one of the world's major record labels.

The composer describes the symphony as "conceived along completely abstract lines. The first movement is in modified sonata form with a slow introduction from which grows the first theme. The second theme is entirely new material and of a much different nature. The unusual feature of this movement is that the development and recapitulation are combined. It ends with a brief coda, the material of which is used to conclude each of the four movements. This motif also serves as the starting point for the first theme of the second movement and the second theme of the third movement. The second movement consists of two themes. There is no real development of either; they are juxtaposed and changed in register rather than being worked out. The third movement is a scherzo, in classical sonata form. The striking feature of this movement is that it is built on ostinato figures which range in length from one to eighteen measures. The second theme is based on the material which concludes each movement. This is heard near the beginning played by a single horn unaccompanied. The last movement is in large part a variation on the first, although it contains some new material which has not been heard before. Of special interest is a progression of two chords which recurs throughout, taking on greater importance as the end is reached. The work concludes on the progression of two chords reiterated by muted violins pianissimo."

There was an artistic phenomenon in the 1950's known as "atomic art." This art form extended beyond galleries and museums and right into everyday life in the form of cars that looked like rocket ships, boomerang shaped tables and ashtrays, and slanted, unsymmetrical furniture and buildings. In short, the key word was: excess. Many volumes have been written about the atomic age in artistic design, but little has been said about its application in music.

EASLEY BLACKWOOD
TWELVE MICROTONAL ETUDES
FOR ELECTRONIC MUSIC MEDIA

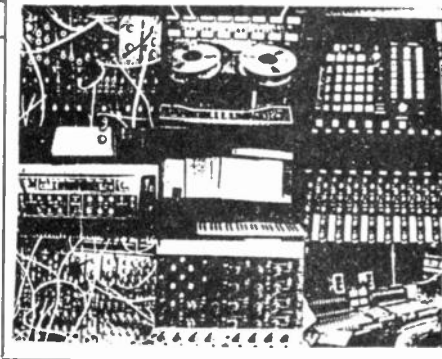

Blackwood's *Symphony No. 1*, though not intended specifically as program music (i.e. intended to suggest specific images or scenery) indeed is almost arrogantly suggestive of the artistic trends present at the time it was composed. The long tonal but awkward melodies, the different sections of the orchestra playing in different time signatures simultaneously, and the rather traditional form of the work despite its non-traditional structure strongly suggest the unsymmetrical, almost minimalist though excessive art of the 1950s (If that makes any sense to the reader!)

It is highly unlikely that RCA will reissue Blackwood's *Symphony No. 1* in their half-speed mastered "Point-5" series, or even at all. It was originally recorded under the 1958 Recording Guarantee Project of the American International Music Fund, and thus did not have to compete with RCA's bestsellers. However, LSC-2352 sold poorly and was withdrawn from circulation shortly after its release. In 1959, the stark yellow painting by Olga Albizu on the cover probably put off record buyers who had never heard the music contained therein. Blackwood's *Symphony No. 1* is not an easy disc to find. But those who are patient enough to eventually locate a copy will not be disappointed.
- Sally Idasswey

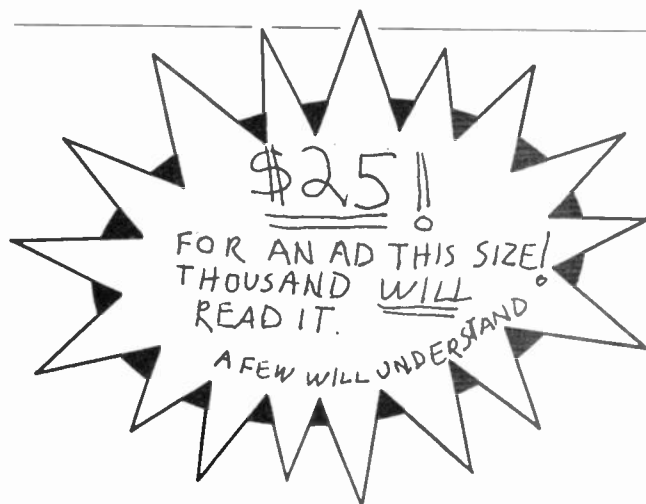

PETER GRIGGS - guitar, lute, synthesizers
IRIS BROOKS - flutes GLEN VELEZ - percussion

also
HANDDANCE/FRAME DRUMS
SOUNDS OF THE ANDES
CROSS-CULTURAL JAZZ
PERU : HARP & MANDOLIN
and others
send for a free catalog
MUSIC OF THE WORLD
P.O. BOX 258
BROOKLYN NY 11209

WHAT THE HELL IS THE ATOM CLUB??

I told you already! But if you don't know what ULTRA CLUB means, let me try to out some other flashy labels on you: It could be a Sonar Theatrum or a Diskette Vaudeville or a Culture Club, Performance Gallery, Photo Play Sensorium, Fashionist New Music Hall, gothic art crematorium, Scratch Video Factory, Dome Dance Dungeon or perhaps even a Post Art Art Looney Bin, or what you what you want to make out of the Atom Club yourself.

IS IT JUST A NIGHTCLUB WITH WEIRD ENTERTAINMENT??

It's even worse. It's a nightclub with totally unpredictable weird entertainment. Nobody will know what's going to happen there. Not even the organizers. But let me show you around a bit, so you will get at least an idea what this atom business is all about. Are you ready?

OK! WHERE IS THE ATOM CLUB LOCATED??

It's easy to find. At the Central Station in Amsterdam ask for the SEA PALACE, the biggest floating Chinese Pagoda in all of Europe. It is not very far! Opposite that pagoda is THE ATOM CLUB, right on the waterfront. Most guests are invited, just like you! If you have no reservation for one of the seats around the parquet dance floor, you better phone to make sure you can get in. In all the seats are taken, the doors will close!

DO I HAVE TO DRESS UP??

Of course! Although, if you decide to come nude, it's OK! One of the attractions of this nightclub is the DRESSING FOR PLEASURE Code. It is one of the reasons why only a limited amount of guests are invited, because this place is ONE BIG STAGE! The light is adjusted so you will look better. Photographs are taken of you, to be published in this mac-magazine. We guarantee you the utmost visibility. No big crowds to cloud the picture. Even if you're a NORMALITE, who likes the invisible look, you will be seen!

BUT WHAT IS HAPPENING THERE??

After you sign your name in the guest book and leave your coat in the lobby you will enter THE LOUNGE where you can sit down for drinks and snacks. A small musical ensemble plays there. On the huge walls of this elegant room hangs the artist of the week. It could be your latest wet work. Paintings or photos, made that week, to keep in touch with your (invited) fans. Fashionable big sizes no problem.

JUST ANOTHER WEI ART GALLERY??

Good name! Let's move on and you will enter a white marble hallway. Perhaps you'll find a tattoo artist there or a master piercer if you are interested in some body modification or other permanent forms of body adornment. You can also buy this magazine there. Cassettes from all over the world, a catalogue of the exhibition you just saw, perhaps cassettes or printed matter from the ensemble in the lounge and from the people waiting for you upstairs.

CAN I GET A HAIRCUT??

If you qualify a new form hair artist who wants to perform there, we will give you some invitation cards. How about a scarification expert? But let's

go upstairs! A majestic stair case brings us to the first floor. We enter the ATOM GALLERY. A clean white space with parquet floor, perfect for video installations, continuous performances, sculpture, etc. etc. A place where you can show off your latest tricks and try them out on innocent bystanders.

MY GOD! NOT ANOTHER GALLERY!!

Don't worry. We leave this place to enter the elegant Japanese Palace. Around the dance floor are tables with fresh flowers, candle light and a menu. Sit down on your reserved chair. Drinks and a special delicacy are served. On a small stage in front of a huge projection screen, stands the Master of Ceremonies. All the guests who wrote their names (and eventual comments) in the guest book are introduced to each other. Then the show starts. All the different acts are announced and there are several intermissions for some of the guests who like to dance.

WHAT KIND OF SHOW DO WE GET TO SEE??

Sorry, I don't really know at all. Nobody knows. You are in a cassette club for the first time! If you bring your diskette, audio or video cassette. It will be played on a high quality system. As soon as you hear or see your tape, YOU have to show off. Something visual has to happen. It doesn't matter if you bring friends to perform with your tape, as long as we can see something. If nothing happens at all, your tape will be stopped. That's the way this Japanese Palace operates.

YOU MEAN WE HAVE TO PERFORM OURSELVES??

Indeed. It's up to you and it's very simple. If you want to show off, hand your cassette to the receptionist in the lobby. Write on the box what you want the master of ceremonies to say. You can even get in FOR FREE if you want. But it doesn't mean that you have a seat. All seats have to be paid for. If you get in for free, you are allowed in the dressing room and in the rest of the building, but NOT in the Japanese Hall, except when it is your turn in the show!

WHAT HAPPENS IF NOBODY WANTS TO PERFORM??

Then we don't have a show and THE ATOM CLUB will fade away in the mists of time. But we know there are many people who are just waiting for a place like this. Aren't you an artist? Everybody is an artist nowadays! We even did some marketing research and organized some secret "mini-atom-clubs". They were just great! No, this club is sorely needed here. It's all about the de-massification of culture, about 'cassette networks' and computer creations, the end of copyright, the new use of old media and the electronic note paper of the future now!

WHAT TO DO IF I WANT TO PERFORM??

Just come to the Atom Club with your cassette if your act is not longer than 6 to 8 min. and you need no technical help. If you have bigger plans, come visit us on Monday evening from 19.30 to 22.00 hrs. Bring some photographs and text with you, so you can be announced in this mac-magazine. We will give you the date & time of your appearance in the show plus a pile of invitation cards for your fans. You can talk with the technical staff and we will tell you about the Golden Rules.

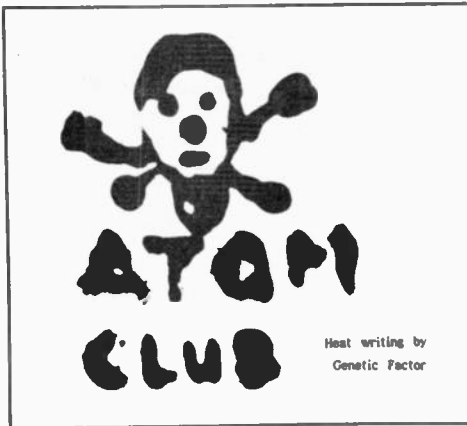

WHAT ARE THE GOLDEN RULES??

Some of them you know already, and the rest of them you will find somewhere in this mac-mag. They are very simple and have nothing to do with the content of your ideas. It is the return of the old intimate European Art Salon. If you have friends or guests from other countries, who would love to show their vision and meet some kindred spirits, bring them to the Atom Club. It has been difficult in Amsterdam to create instant public appearances for some of our unexpected artist visitors (passing through). As long as they follow the rules, the Atom Club is theirs!

SO ANYTHING CAN HAPPEN??

That's right. It's up to you! Just try us out! Genuine torture. Horrible sounds, blasphemy, sad porno drills, dangerous rituals, deep mesochism, devil worship, painful truths, genetic games, force-meal fanatics, holy women, fakirs, poets, computer widows, as long as the Golden Rules are obeyed. Unexpected guests could even do a short talk show with the Master of Ceremonies while the screen is used to show their movies, slides, architecture, paintings etc. etc. If you don't like what's happening in the show you can always leave the Japanese Palace and roam through the building. You can even take a refreshing bath in our all night sauna, while you listen to nude poets who recite their word construction poems.

DO I GET PAYED??

The Atom Club is NOT sponsored or subsidized by anybody. We're FREE but poor. Nobody gets paid, except the people who run the building. The only money that comes in, is from the seats. The amount of seats is limited. (we hate big crowds). Now you can understand why absolutely NO! free seats can be offered. Not even to your sick mother. We need your money desperately for the rent, power, equipment, printed matter, phone, fresh flowers and free SONARIA tapes!

ANYTHING I CAN DO IN THAT CLUB???

It's all up to you, my dear. If you have a suggestion how to make the toilets more exciting, please let us know. There will be a permanent group that's called THE ATOM DANCERS. They fill up all the holes in the show with unpredictable simultaneous acts. If you want to be part of them, get in touch. If you want to prepare exclusive snacks at home and sell them in the Japanese Palace, come visit us with your proposal. If you have new ideas for serving food and drinks at the tables in the Palace Room, please announce yourself. There are many arts that we don't know. Cooking is definitely the highest art. If

Everybody can perform in the Atom Club. If you don't dare, first check out what kind of stuff others are doing there. As long as you don't need half an hour to do your act, you are very welcome. Keep it compact, so other guests are able to show off too!!

If your act is not longer than 6 to 8 minutes, hand your audio cassette to the receptionist in the lobby. Write enough information on the box for the Master of Ceremonies to announce you properly (name, title, etc.)

As soon as the Master of Ceremonies announces you, your act has to start! If nothing happens, your tape will be stopped immediately. No sound checks, building of stage sets or other time consuming preparations!!!

You can do what you want, except fun suicide or snuffing. It is not allowed to create a mess that you can't clean up yourselves completely within 2 minutes.

Some acts can be shown in combination with others (so called 3 ring circus system). Let us know on that Monday if you want that to happen with your act.



In China and ancient Egypt, music was a science whose practitioners had an awesome responsibility. The mental and physical balance of populations, the possibilities of peace or war were governed by the strictly controlled use of musical instruments and human voices to produce objective and unequivocal effects. "So the people shouted when the priests blew with the trumpets: and it came to pass...the wall fell down flat" (the destruction of Jericho, Joshua 6,20)." Jazz and rock music has evolved from voodoo origins. "Feel good" music of this sort can be seen to be objectively harmful. It is not a question of taste, but of objective physiological effects. And it is no coincidence that many of the founding fathers, the "greats" of modern jazz led degenerate lifestyles, wrote and played sounds that emphasised despair, animalistic sexuality, bitterness and defeat, and died violently or disease-ridden. The echoes of this music are loose upon the planet. And worse, music, far from being recognised as a powerful force to be handled with care by priest-like practitioners, is being used irresponsibly. We are now polluted by music as much as we are by noise. The performers of violent contempo-

rary music do believe that their music has an effect on listeners. That is, they do not perform such music out of the belief that it is harmless, but out of deliberate desire which in former days would only have been called evil. People are now conducting their whole lives to the accompaniment of sometimes destructive noise emitted from radios, public address and stereo systems. The music we respond to in supermarkets may have its roots in magical rhythms specifically designed to induce helplessness, compliance and suggestibility.

There was a craze at American concerts for placing eggs on stage - halfway through the concert the protein would have been congealed by the sound and be ready to eat. It demonstrates how the listeners consciousness is altered by music. Its 'fans' are addicted, though they know it not, to the 'feel good', egocentricity-enhancing, para-hypnotic effects of its insistent beat. It is a critical problem which our civilisation must get to grips with in some genuinely effective way, and without delay, if it wishes to survive.

From The Secret Power of Music by David Tame

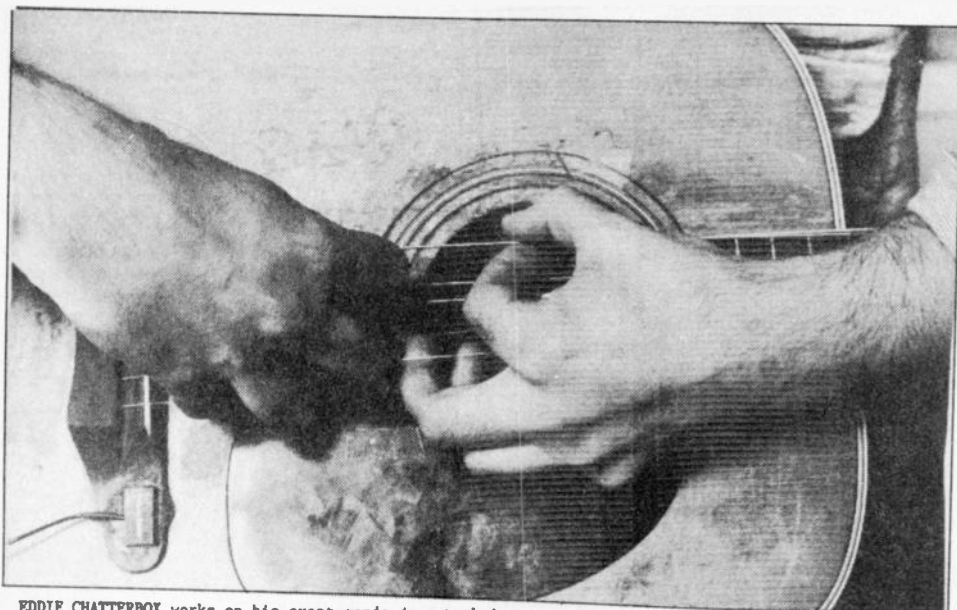

EDDIE CHATTERBOX works on his avant-garde jazz technique.

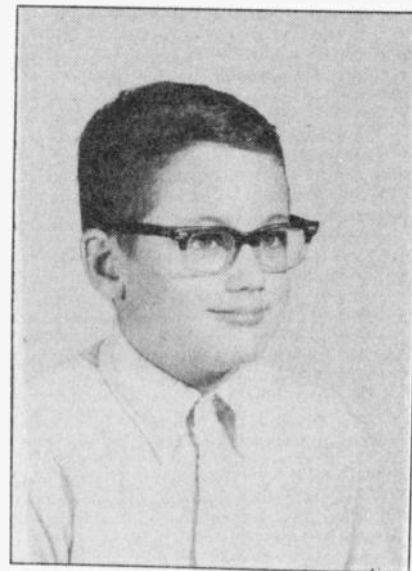

LITTLE EDDIE CHATTERBOX looks forward too...

by Eugene Chadbourne

Since my retirement from the jazz scene, there has been a lot of speculation concerning just what prompted me to play jazz in the first place and what happened to force me out of that exciting music scene and back into my old job as a homicide detective.

The answer to the first question is easy: it was encouragement from other jazz greats that made me quit the police department and start playing jazz fulltime.

Why I dropped out is another story. Perhaps the retelling will provide a few clues as to why I quit just as I was making a reputation for myself as a jazz guitarist.

It all began when composer and multi-instrumentalist Tony Axeton came through the little town I was living in. I took the chance to drop by his dressing room and play him some stuff. He listened carefully for a few minutes and then began rapping intensely.

"Fantastic, man! Original! Totally original! You have to first look at the entire planet from the perspective of someone who has created a multi-faceted extension of himself as a creative individual, and then say, fuck it!"

He asked me if I was familiar with the John Coltrane recording, *Ascension*, which of course I was.

"That album established those cats that were on it as the purveyors of planetary dimensional inter-disciplinary creativity. In that period, of course. Now it is a different period. I would call this the 57th ictonian icogon period. If you want to establish yourself as the guitarist for this period, you have to put a record out — fast!"

Taking all this into consideration, I decided he was right, and I put an album out — fast! He told me to call

him at his home when the LP came out, and I did.

"The record is beautiful, man," he told me. "What you have done is to take all the different time zones that are present in this period on the planet and meld them into a relationship that has absolutely no direct resemblance to this groove or that groove but instead comes down on the side of the guitar as a quasi-utopian premise."

Then he told me to quit my job and come to New York. There I would not only be able to take the bus up to his place for orchestra rehearsals and a place in the new combo he was forming, I would also be able to mingle with all the jazz greats and build my name and reputation even further.

I decided he was right, so I quit my job and went to New York, where I sized up the situation quickly. I called up the company that was distributing my new album and told them here I am.

The promotion man, Lip Panmahand, said that was great and asked what job I had lined up.

I told Lip I was going to make it on the jazz scene. There was a pause and then what sounded like peals of laughter coming from his office.

It was a smoggy day in New York so I decided to drop in on old Tony Axeton. So I took the bus up there, hitchhiked to his house and knocked on the door.

He came down after awhile with a pencil over each ear. He didn't look to happy to see me.

"Oh, Eddie, man," he said. "Come in and take a look at my new project, which has to do with the alignment of the universe into sixteen different distinct phases, one of which is controlled by a slide projector and the other fifteen controlled by systems based on the

rate different types of coffee beans absorb water when the water is coming through old-fashioned corrugated piping. But you gotta be quick, man, I have to catch the Concorde to go to Paris to rehearse my Ensemble there in a program of pieces I wrote five years ago on the back of napkins taken at random from sixteen different restaurants located in fourteen different cities, none of which begin with the letter A."

Upstairs in his study there was the number 16 written on a blackboard the size of a billboard. Next to it was a crate about as large as five Sumo wrestlers.

"That is my contra contra contra contra contra Contra. It has to be shipped by the U.S. Army because it is too big for commercial airlines. I just got it back from Berlin where I needed it to play one note in the first movement of my suite for chamber orchestra, jazz septet, 15 tubas, jeep, aircraft carrier and small girl named Wendy."

The subject of tubas reminded me of an anecdote I had just read in my extensive research on jazz. A violinist who loved pranks called every tuba player in New York, telling each of them about a high paying gig and giving them an address to meet him. The next morning there were 750 tuba players standing around, so the violinist drove by and took a picture. I told Axeton this story and he listened seriously.

"What a waste," he said. "I wish someone had contacted me. I have a piece for 750 tubas which I can't get realized."

He looked at the clock then. "It is 3:16," he said. "That is a good time for you to go. I have to get back to my work." On the way out I asked him about the combo, the orchestra and

“Memories of the JAZZ AGE”



everything else he had mentioned, but he was in a real hurry and just told me to call him.

I went to the bus station and encountered a lot of guys sitting around with instrument cases. There were two tenor saxophone players, three guitarists, a guy with a whole drum set and another guy lugging a big case that must have had a contra contra contra Contra in it or something. Another guy carrying only a book of music was there, too.

We all got into a conversation and it transpired that all of us had come up to

drop in on Axeton today.

“He told me I was the most original tenor saxophone player since Coltrane,” one guy said.

The other tenor player looked miffed. “He said the same thing to me!”

The guy with the music book sighed. “He told me to come here and I could be the new pianist in his quartet. He said to come by his place and bring a music book, we’d work on tunes immediately. So I show up and he said he’d give me a call when he gets his piano tuned.”

Everybody had a sob story but the worst was the guy with the big case. He had come all the way from Marseilles to play one note on Axeton’s new album. However, at the last minute Axeton decided to replace the note with a recording of a dog howling. So now the guy was going back to France empty-handed, although considering the size of his case, that isn’t the best choice of words.

I decided to drop by the record distributor, which was still open when I



THOSE WERE THE DAYS. Tony Paxton and Eddie Chatterbox in 1976.

got back to New York. Maybe Lip would give me some encouragement.

"Have you found a job yet?" he asked the moment I walked in the door. I didn't bother to answer because I was absorbed in a poster on the bulletin board. It said tonight at the Da Papa Theatre on East 7th St. there would be the beginning of a new jazz series, the featured artists being the new Hank High Trio.

Hank High had always been a favorite tenor saxophonist of mine, especially on an album he cut for FTQ records back in the sixties.

I headed down there on the subway. The neighborhood was on the colorful side. I had to walk in the street for one block because there were so many card games going on the sidewalk. Another corner I avoided completely because a Hell's Angel in full colors was firing a flame thrower out one window into another across the street.

I finally found the Da Papa Theatre. It was the only building standing on the block. A rat that was large enough to open his own newspaper stand had done just that, so I bought a copy of the Village Voice in case there was an intermission.

I went into the theatre. There was a short hall and then kind of a large open room. Everything smelled really musty. There wasn't anyone in there. A chair was lying around so I sat down on it. I waited about twenty minutes and nothing happened. Just when I was considering leaving, Hank High walked in. He was a tall black man with a beard and mustache.

I asked him if he was playing tonight and he said sure, sure. "Give me a chance to go round up the cats," he said.

Right away I whipped out my new album and gave it to him. He seemed interested. I told him I really liked his playing, and mentioned the album on FTQ records.

"Ah shit, man, we were tripping on acid when we cut that," he said. "Let me go get the cats and we'll lay down some of my new sound. I'm into a Sonny Rollins groove now."

Thirty minutes later he was back with two other guys. The drummer was also black, with a rasta hairdo. I recognized him immediately as Yoyo, the brilliant drummer from the California Collective Consciousness of Creative Consciousness, called the CCCCC, although it was hip to drop the last two Cs and call it the CCC.

The bass player was a pale white man with blonde hair. I didn't recognize him. He looked sick. Neither he nor Yoyo looked too happy about playing, but as soon as they were set up they played about four songs.

Then High came over to me and said that was it for the night. He mumbled

something about the \$4 admission charge. I gave him the \$4 and he wadded it up and put it in his pocket.

Then he introduced me to Yoyo who looked me over and said "Cool man." The bass players' name was Donny Eisenhower and he had moved here from the midwest. It even turned out we had a mutual friend on the police force.

The three of them disappeared abruptly and I went home.

I was woken up early the next morning by a phone call. It was Hank High.

"Hey man, I was listening to your record," he told me. "You got a unique

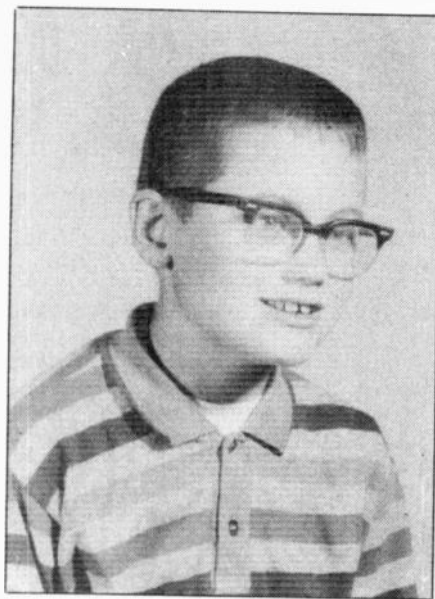

A YOUNG Chatterbox

concept, man. Listen, I've got a record date coming up for a new company, Bummer Records. We're gonna do it in two days. It will pay about \$300."

I was ecstatic. Here I was in New York two days and I already had a record date lined up with Hank High. And I was sure that the other sidemen would be famous, too. I was so excited I could barely get the address down of his place, also in the east village. Of course he wanted me to come down and rehearse.

There I was, on the subway on my way to a rehearsal with Hank High. I was so excited I missed my stop and went to Brooklyn. Now I was going to be late but I knew Hank wouldn't mind. I got back on the right side of the bridge in pouring rain. I was drenched as I attempted to heave my amplifier over the stacks of bodies lying around on Houston Street, but I was still so charged up I didn't care.

We had a good rehearsal and wrote down a lot of ideas for music. He walked me to the subway station,

philosophising about music.

"I want to be one of the hip cats," he kept telling me. We rounded a corner and all of a sudden there was gunfire. Someone in a window high up was shooting down onto the street while several police cars barricaded the road and police snipers answered the fire.

"Holy shit!" Hank screamed. "Come on man, let's get the fuck out of here." He ran frantically back two blocks, then turned around and said, "Ah come on, let's go back and look."

As a seasoned policeman, this type of stuff was dull for me. My mind was on the music we worked out and the recording session coming up.

The next day Hank again woke me up. "Uh...listen, man...uh...I've been talking to Dick Farro, the guy who runs Bummer Records and his partner Fatso, and these cats really want this company to be a success and they really want the records to sell, so...uh...what they told me is that since you really aren't famous yet your name won't help sell the album, so I'm gonna have to use Dizzy Jones on trumpet instead."

Of course I was crushed. I suggested that I play in the session for free, just to help me get more famous so I wouldn't keep having this problem.

"I can't let you do that," he said. "Be cool."

About an hour later he called back and said I could still do a gig with him at the Studio Creeky next week. Run by the jazz great Dam Creek, this was the alternative to the Newport Jazz Festival, so of course I was excited. I was still disappointed, but I could tell Hank felt bad about it and that made me feel better. He invited me to come watch the recording session, so I did.

I had to go all the way down to Wall Street, to an address that turned out to be a private apartment.

One large room was full of Fuller Brush products. Both Dick Farro, a little pimply guy with glasses who smoked cigars constantly, and Fatso, whose name summed it up, were Fuller Brush men.

The recording situation they had set up consisted of one microphone hanging from the ceiling. Fatso had the tape recorder sitting at the kitchen table, surrounded by Enteman's pineapple cheese coffee cake.

One by one the musicians showed up, first Hank, then the drummer and bass player. The latter was Ed Miriam, a new guy in town who was considered quite hip to use on a session. He didn't say much. The drummer turned out to be famous Noslow Phillip. He was a really big black guy with big muscles in his arms.

"What the fuck is this?" he said, pointing to the microphone. "That ain't no fucking way to get a good

drum sound. Who is running this session, Santa Claus?"

Dick Farro almost burst into tears. He turned red, then walked out of the room. He came back in and got me, then took me off to the side where there were thousands of jazz albums and cassettes, each of them marked as to the identity of the radio shot they contained.

"All my life it has been jazz," he said. "This day for me is like a dream come true. I'm recording my own session."

Things were held up by the fact that Dizzy Jones hadn't shown up. We waited one hour, two, three. Then Fatso started pressing Hank, asking him what he wanted to do. Hank was jittery. He kept calling the Jones house but there was no answer.

"Shit! I know Jones is cool. He wouldn't hang me up," Hank said.

"We should call another trumpet player," Noslow said. "How about Lulu Aard?"

I didn't care much for Lulu Aard, but he was famous, no doubt about that. They gave him a call. Hank was polite as hell on the phone. "I know you and Dizzy are the only cats who can play the music, but I don't know where Dizzy is so can you come down?" was his way of explaining the situation.

Aard was apparently in the middle of something but said he was on his way.

We waited for him to show. Then the buzzer rang. It was Dizzy. He had been waiting for a cab five blocks away the whole time.

"This is a fucking racist country," were his first words upon coming in. "They wouldn't pick me up 'cus I'm black."

Fatso and Farro took Hank aside. "What the hell are we going to do? they asked him. "We can't pay two trumpet players." They called Aard's house but he had already left.

Fatso took out a check book and leafed through it. He took Hank by the hand and said. "Okay, Hank. Do you really want it? Do you want the two trumpet players?" Hank nodded yes. Fatso asked "Do you really, really want it?" When Hank said yes, that was it. Now it was just a matter of waiting for Aard to show up.

In the meantime Hank took me aside. He was really excited. "I'm gonna have two trumpet players on my fucking session, man! Like Mingus!"

He then told me Noslow would be the drummer on the upcoming Studio Creeky session because although Yoyo was cool, Noslow shared Hank's concepts of "space." I glanced over at Noslow and saw what Hank meant. He had fallen asleep over his drum set.

I was really looking forward to the concert at Studio Creeky but unfortunately some problems developed on the

New York jazz scene.

Dam Creek had apparently worked long and hard to get civic grants to pay the performers at least something for their work. So he was furious when he picked up the week's Village Voice and found that Stan Grouch, a writer and percussionist, was running his own series down the block, and competing with Studio Creeky.

The Studio Grouchy series featured a lot of the same musicians, except in his case they had agreed to work for nothing!

Creek blew his top. He called everyone in his festival and said if they



EDDIE CHATTERBOX WAILS, 1974

played for Grouch, they couldn't play for him. Everyone involved reacted differently to this, but in the long run it didn't matter. Creek and Grouch got into a fist fight in the middle of the street on a spot equidistant to both studios, and as a result of the ensuing legal difficulties both festivals were cancelled.

I was again out of a gig I had looked forward to, but just as I was getting depressed I got a phone call, this time from Noslow Pillip.

"I'm cutting an album, man, this one is a trio, just drums, bass and guitar, and I want you to be the guitarist." He told me the bass player would be Beanz McBuzz, who was really famous. This could be the disc to really establish me on the jazz scene!

Noslow wanted me to come over right away to rehearse, so I went out to his loft in Brooklyn. We ate a little spaghetti and didn't quite hit it off in the conversation department. He told me there was a new lady piano player in town and I inquired if she was a good musician.

He looked at me like I was out of my mind. "Is she a good musician? I don't

give a damn, man. I just want to fuck her!"

Then he put on a tape of some of his compositions and asked me to play along on my guitar, which I did. Within two minutes he was fast asleep next to me on the couch and snoring so loud I could barely understand what key the tunes were in. When he woke up he said, "You got it, man!" He said he would call me.

While I waited around for this session to happen I called my old friend Tony Axeton. He was excited to hear from me and told me he was going to take an orchestra to Europe and I would be the guitarist. Naturally I was thrilled and I went right down to the music store to buy some strings. I mentioned the tour to a clerk there and a skinny guy with long hair came over and shoved me.

"That's my gig, man!" he said. "Tony said I was going."

I said maybe we were both going.

"I doubt it," he said.

This made me nervous but I tried to forget about it. Hank High had been calling again, wanting to get together to work on music.

He decided he wanted to try out another drummer. This was a guy he had played with in the past named Abdul Ali Alphonse Alcaca. In fact, it was the drummer on the FTQ album I liked so much. He lived out in Brooklyn and so one day I went out to his place to meet Hank and Donny Eisenhower, who was to play bass.

I got there early and Alcaca showed me in. He was really tough looking and said nothing to me until Hank showed up.

"Donny's sick, man," Hank said.

The three of us set up and began working when there was a knock on the door. It was two Italian guys, wearing suits. They came in and started talking to Alcaca about the rent. I got the feeling he hadn't paid in awhile. In fact, I got the feeling the last time he paid the rent I was playing in a field with my third grade buddies.

These guys were slick. One guy said, "I don't like to hassle people. I don't like the way things work out when people get hassled. As a matter of fact, I had to kill someone last week over a hassle." He gave Alcaca a telling glance.

Alcaca's response was to push to guy out of his way, storm into another room and come back brandishing a .45.

"Alright, fuck face!" he yelled. "Cut the shit. Cut the talk and the shit and the talk and lets get down to some business. Kill me, kill me now! But I'll blow your fucking ass away you Wop shithead."

The other Italian guy nudged his partner. "Let's come back sometime when Alcaca ain't so busy." They left in a big hurry. So did we.

"Alcaca ain't gonna be relaxed now.

OH MY GOD!

BOOKS & PERIODICALS FOR EROTIC INTELLECTUALS

- **SUCK**, the First European Sexpaper. Find out what the coke-sniffing jet-set does when the doors are closed. Instantly arousing. Very special collector's items. Available from the publisher. Nos. 1, 5, 6, 7, 8 - Circle your choice(s). \$10 each
- **NATURAL JEWBOY** by William Levy (Amsterdam 1981). This book, if properly understood, could even cure cancer! "An annal straight out of Discordia... an underground cult classic". - *Home Grown* (London) - One hundred and twenty pages of stories and persuasions, with drawings by Peter Pontiac. \$10 paperback; \$25 hardboard in burlap and goat's skin
- **RADIO ART: A Print Culture Transmission** (Amsterdam 1981). Includes "Careers in Radio Art" by William Levy; *The End of the Graven Image: A Rart Manifesto*; and an annotated checklist of first radio works by Willem de Ridder. "Une nouvelle forme d'art!" - *Charlie Hebdo* (Paris) \$5.
- **RAG: Radio Art Guide** (Utrecht 1981). Documents the history and development of Radio Art of Willem de Ridder, transmissions together with items of effect research. Written and made up by the artist in cooperation with William Levy. Sixty four pages, fully illustrated. \$10
- **JEREMIAD CHANTS** by William Levy (Amsterdam-Genoa 1979). A small, funny book of ranting poetic froth. "I show it to everybody" - Ken Kesey. \$5
- **THE FANATIC: A Paper of Passion** (Amsterdam 1976). Suicide Notes, The Best of Anti-Semitism (previously unpublished work of L.F. Céline and Ezra Pound), Sexual Jealousy, Keys to Ring and Why phanatic? "Strange" - *Star* (Barcelona); "Revolutionary" - *Screw* (New York). \$5
- **OFFICIAL LYNCHING OF MICHAEL ABDUL MALIK: Souvenir programme** (London - Cambridge 1973). "A writer of considerable distinction". - William Burroughs. Edited & with biographical notes by William Levy and John Michell. Rare, \$10.

1. Check the above choices. 2. Fill out coupon. 3. Send your money (check, cash, or IPMO) to JOY PUBLICATIONS: Postbus 2080, 1000 CB Amsterdam, The Netherlands

Name
Address

All prices include postage by seaimail. For airmail add 30% of your total.

His time will be too uptight, let's split," Hank said.

On the way out, Alcaca gave me a dirty look and said to Hank, "It's been a long time since we've played, now tell me something, is this going to be straight or weird? Just tell me so I know."

Hank explained that he wanted a little of each and we agreed to all meet in a few days, when Donny got better. The next rehearsal would be at Da Papa.

When I got down there no one was around. After about an hour Hank showed up, then Donny. But Alcaca couldn't make it, so Hank invited Yoyo to sit in.

"Alcaca has seen the music, so now we can show it to Donny and then we can put the music on the stand when we hit!" Hank explained.

Before we started playing Hank suggested we score some grass. He was swigging out of a bottle of booze.

"I drink the liquor, it makes me mellow. I smoke the reefer, it makes me high, THEN I play," Hank said. Everyone chipped in and Yoyo snapped his fingers at Donny.

"Go out and get the reefer," he said. Donny said "I don't feel so good."

"Come on, get your ass out there," Yoyo said. Donny was back in a few minutes with several nickel bags.

Yoyo rolled up the first one all into one joint and smoked it all by himself. Hank did the same thing to the second bag. After about an hour of this kind of thing we decided to rehearse.

I had just plugged my guitar in when Donny, who had gone back out for a few minutes, came back and sidled up to Hank.

"Hey Hank, man," he said in kind of a forced whisper. "Heroin, man!"

Hank, Donny and Yoyo left the room so fast it made my head spin. The never even looked back at me. I waited an hour and then left.

The gig took place as scheduled with no rehearsals. I made a terrible impression immediately upon showing up. A fancy Porche was parked outside Da Papa and because it was so out of place among all the poverty I assumed it must belong to the landlord.

"Must be rent time," I cracked to Hank, Alcaca and Donny. They looked horrified.

"Shut up," Hank shushed me. "That's Murras David's car." Murras was a black tenor player who was really hip these days.

The gig went allright I guess although the audience was small and the music, unrehearsed as it was, didn't fulfill the promise of the tunes Hank had been working on.

I told him as much between sets and

Subscribe!

THE DIFFERENCE IS CLEAR.

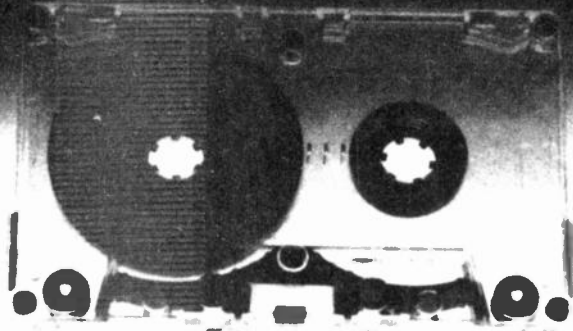

WE SPECIALIZE IN CASSETTES

REAL-TIME STEREO DUPLICATION • 24-HOUR SERVICE ON REQUEST
GUARANTEED FOR LIFE

CLEAR-CUT CASSETTES

ACME AUDIO, 3821 N. SOUTHPORT, CHICAGO, IL 60613
312 477-7333

he shrugged. "Hey man, I know where you're coming from but its Friday night at Da Papa and the cats want some fire!"

To speed up ignition he invited Dexter Stogie, Lulu Aard and three other trumpet players I had never seen in my life to sit in.

One of the trumpeters turned out to be Blooey Jimson, who as you know was featured on Coltrane's *Ascension*. I was thrilled. Now I had played with someone who had played with Coltrane, thus connecting me to the entire jazz tradition.

We all went out for some fried chicken and brought it back to Da Papa. Sitting upstairs, Donny and I were eating when Yoyo walked in. Donny had just served up a full plate of chicken for himself.

Yoyo snapped his fingers. "Gimme," he said. Without a word Donny handed over his food. Yoyo sat down and started eating.

"Must be nice to have power over people," I said to Yoyo.

He didn't think that was a humorous remark. He looked me over and snarled. "Some people are dumbshits like you, Chatterbox. Other people realize that cats like me are hip and deserve respect."

"You gotta give them older cats respect," Hank chimed in.

I felt confused about everything that night and the confusion continued the next morning as Hank called me up to announce he was beginning work on a big band project that would not only be performed at Studio Judy, a new loft downtown, but would be recorded, again for Bummer Records.

About 18 musicians were involved, some of them famous like trombonist Jimmy Stogie and violinist Bobby Boom. Hank was also calling a few more unknowns like myself to participate. He told me he wanted me to help him get the music together, so a week of rehearsals began.

Every day we would get started, work for a few hours and then take a break to buy a joint. This was accomplished by walking into a grocery store, going up to the counter and saying "Gimme a joint, man." The first time Hank did this I admit I was shocked but after watching the clerk reach under the counter and pull out a bag of joints I got used to it.

We came up with a lot of good ideas for orchestration. Hank was charged up about the project and was really nervous at the first rehearsal.

All the white players were on one side of the room and the blacks on the other. Donny was on bass again, and he looked terrible.

I was just setting up when Noslow came over and handed me a five dollar bill.

"Go out and get me a bottle of booze, boy," he said.

"Go out and buy your own booze," I said. "I'm not an errand boy."

Noslow was speechless, then recovered his composure and went over to Donny. He gave him the bill and I heard Donny whine something about feeling awful, but within a few minutes he had his coat on and was out the door.

The trombonist Stogie showed up late and was on something. He put his music upside down on the stand. When someone pointed this out to him, he said "Its cool, man, I'll get it right side up when we hit."

After a couple of hours without accomplishing much of anything Hank decided that was enough rehearsing. "I don't want to put the cats out," was his explanation.

"Thanks man, I gotta go uptown and fuck a white chick," Noslow said.

The concert itself was discouraging. The owner of the loft could be heard yacking on the phone through the whole show. And there was a replacement bass player, Ed Miriam, because something had happened to Donny. It turned out he had died of a heroin overdose.

The next day I admitted to Hank I was upset about Donny's death.

Hank was casual. "Hey, man, check out your history, man, Bird did heroin, Miles did heroin, Trane did heroin, Ornette did heroin. You got to do heroin to play jazz, man!"

On one hand I was repulsed. On the other, I didn't want to break off the relationship with Hank because he had started talking about taking me on an upcoming European tour which would also include Noslow.

But my decision was made for me a few days later by Hank himself. He called to say I was out of the European tour because Noslow refused to play with me.

"He says you came by his pad and couldn't figure out his tunes."

"Hank, he went to sleep soon as I came over. He never even heard me," I said.

"He's more famous than you," Hank argued. "That's what the European promoters care about. They don't want you either."

I lost my temper. I told Hank I couldn't figure him out. On the one hand he seemed serious about his music, and he worked hard on it, and he used me to help him work. Then on the other hand, when it came time to perform he could give a shit about me or the music."

"Don't push me," he said. "Look, I know what's going down. I been under a lot of pressure since you came to town. Everyone been sayin' to me, what you doin' playin' with that crazy white

boy!" He told me how even the famous pianist Cecil Taylor had stopped him on the street and bugged him about it.

"I'm hip to white music," he said. "I am hip to Benny Goodman, I'm hip to Warne Marsh, I'm hip to Lenny Tristano, I'm hip to Frank Zappa, and I'm hip to you. But now we gotta cool it."

And so we did. Occasionally we'd see each other or he'd phone. One phone call was strange. He called at three A.M. to tell me the Bummer record he'd made with two trumpeters had gotten a good review in *Deadbeat* magazine, considered the Bible of jazz.

"I got four stars in *Deadbeat*," he said. Then there was a weird sound, and we were disconnected.

I didn't hear much about Hank for awhile after that, and he was never home when I phoned. Then I heard on the grapevine he had almost died of a heroin overdose. He had collapsed talking to someone on the phone. If good old Noslow Wilson hadn't happened to drop by to shoot up with him and found him, Hank would have been dead.

I didn't quit playing jazz that day. The whole process took a little while. Maybe this isn't much of an explanation.

At any rate, a few years later I went back to New York on a little vacation. I was tooling around the Times Square area when I ran into Hank. He was standing on a street corner, trying to trade a subway token for the money to buy a joint.

I asked him how it was going. He seemed excited. "I just did a Monday night down a Sour Basil's, he said. "They told me it was the best Monday night they'd had in years.

"You know something, Chatterbox?" he said. "I ain't never gonna be no household word like Prince or something but on the jazz scene, you know the hip jazz scene, like I'm talking about, with the hip cats, one of these days I'm going to make it."

"Memories of the Jazz Age" is a first draft of Chadbourne's upcoming book "Your USA and My Face."



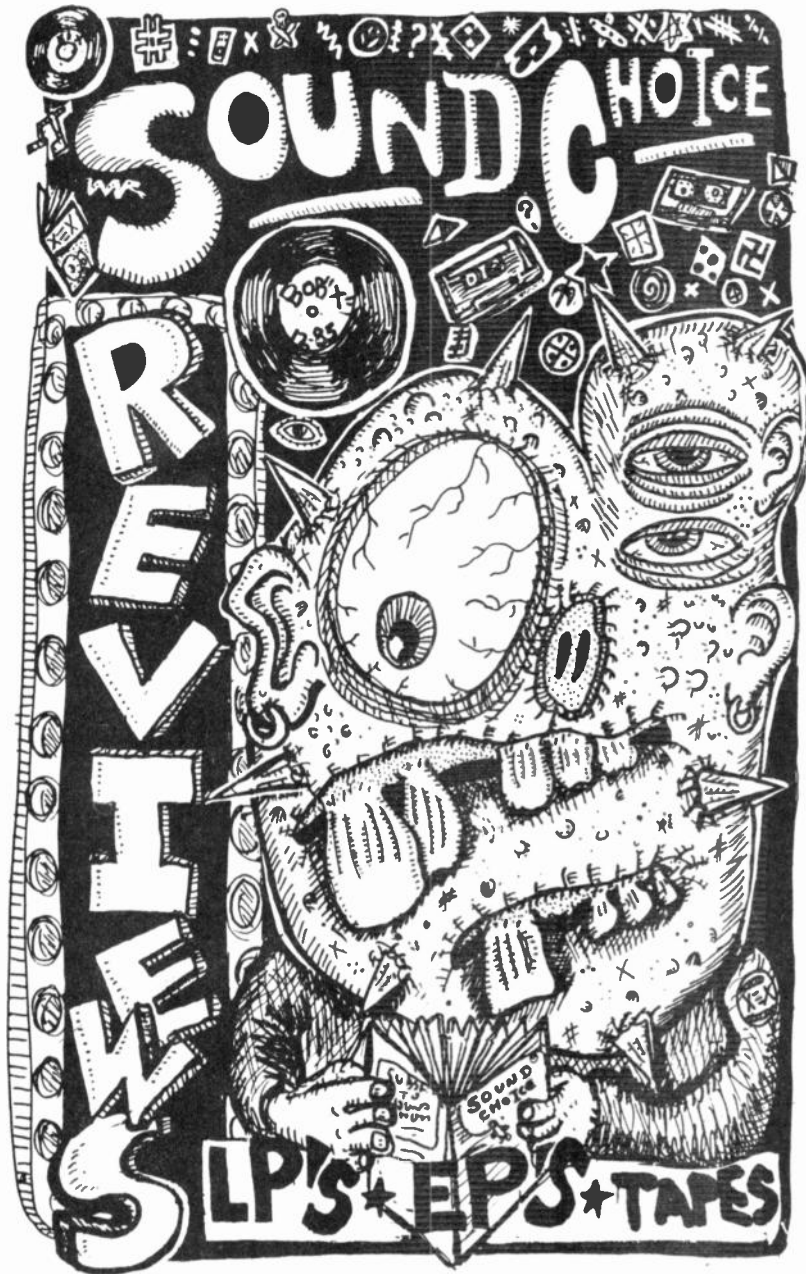

How the review section works: We only review independent label recordings that are available to the public (no demos). We don't review recordings manufactured or distributed by the six major record labels — CBS, WEA, MCA, RCA/A&M, EMI and Polygram. (Labels like Sire, Grammevision, Reprise, Island and others are subsidiaries for the majors, and we don't review those either.) People send us their independent label recordings and then the S.C. staff sorts them out and sends them to reviewers who we think will have an understanding and/or appreciation for recording's particular genre. We try to review everything sent (Occasionally things mess up — mail is lost, reviewers flake-out, etc.) When possible, we suggest people send two copies of recordings, one for the reviewer, one for PERMANENT storage in the Audio Evolution Network independent recording library (which we hope to make an "official" non-profit archive someday). Also, as soon as we get S.C. coming out on a more regular basis, we WILL have an independent label radio show which will draw from this archive. And if any of you philanthropists wish to send a third copy of your recordings, they will be shared and/or traded for indepen-

dent recordings that we might not otherwise receive. Sound Choice reviews independent music of ALL GENRES. If there are types of independent recordings that are not being reviewed in Sound Choice it is only because they are not being sent to us and that the people involved are not aware of Sound Choice and its liberal, open reviewing policy. Help us get the word out, if you can. We can accept unsolicited reviews, especially of recordings from areas we are weak in. Reviews must be neatly written or typed, double-spaced, and contain a contact address for obtaining the recording. (Follow the format of reviews below) Those who wish to be sent recordings for review must be extremely reliable and should subscribe to S.C. and send us a note about their audio interests. Records and tapes sent for review must contain a contact address either on the tape or record or on the cover or case. A price for post-paid delivery is a good thing to include also — but put it on the recording or cover! Also, cassette artists, be sure that the cassette itself has a label on it. We have a number of cassettes without labels that have gotten separated from their cases or envelopes and we can't figure out what is what.

ABSOLUTE CONTROLLED CLINICAL MANIACS (C: 3riotapes, Magisch Theater, Julindillenstraat 22 B., 2018 Antwerpen, Belgium) Live recordings of the Maniacs in Belgium and Norway. Flying pieces of metal and rhythm fill the air delivered with synth, tape manipulation, electronic rhythm instrument, and vocals. The first song has a masturbation tape narrated by a horny bank-teller. Hubba, hubba. Titles to give you an idea of the mood: "Braindamage," "Sick In Your Mind," "Ronald Reagan," "Torture," "Power of Passion," "Let The Bomb Go," "Vietnam," "Rosenberg's Dead," etc. Fear of this century, military and imagined. — Robin James

ACADEMY OF ST. MARTIN-IN-THE-FIELDS, CONDUCTED BY SIR NEVILLE MARRINER: More Music From the Original Soundtrack of the Film AMADEUS (LP; Fantasy, Tenth and Parker, Berkeley, CA 94710, USA) As a classical music snob of considerable pretentiousness, I absolutely abhor albums made up of "bloody hunks" of music torn from a composer's corpus. Yet I truly enjoyed this album, despite the fragmentary contents. Of course, anything by Mozart is well worth hearing, especially when performed as delectably as that provided by Marriner and company. The selections stand fairly well, with care evidently taken to avoid snipping and cutting the pieces making musical nonsense of them. Several segments are by Salieri and Giordani. Some selections were re-recorded by Marriner to meet his "exacting demands." Several selections were not heard in the movie, having been lost on the cutting room floor in the editing of the film. The album is beautifully recorded and the selections are logically arranged for smooth, comfortable listening. — Norman Lederer

ALGEBRA SUICIDE: An Explanation For That Flock Of Crows (4-song 7"; \$3; P.O.B. 14257, Chicago, IL 60614-0257, USA) The simplicity of their approach continues, freeing Tomkiw's sharp little images to provoke imaginations, followed by Hedeker's haunting, often cascading guitar which cements these images in my head. In the title cut, Tomkiw coos and whispers in my ear. Pleasurable chills roll through me when an Algebra Suicide tune pops into my head. — Oleh Hodowanec

DAVIE ALLAN AND THE ARROWS: Arrow Dynamic (LP; Arrow Dynamic Records, P.O.B. 3625, Northridge, CA 91323, U.S.A.) Allan teams his fuzztone surf guitar with wretched techno-disco arrangements on some old and new (I think) numbers. All the good groovin' is on the second side where Davie licks through "Peter Gunn" and "Blues Theme From The Wild Angels." — Jamie Rake
Second opinion: During the past few years, Allan has issued several records that showed the sixties legend still had something to offer and was willing to take some chances. This is, by far, his best yet. Most of this consists of fuzz guitar instrumentals, not unlike his early hits, but now, instead of a simple, stark backing, Allan colors his playing with keyboards and synthesizers. Allen succeeds in blending the best of the high energy biker/surf instrumentals with today's technology. The highpoint is "Surf Trek," which is a duet between Allen and "The King Of The Surf Guitar" Dick Dale. — Charles P. Lamey

G.G. ALLIN AND THE SCUMFUCS: "I'm Gonna Rape You" / "Devil's Prayer" / "I Wanna Fuck Your Brains Out" / "Teachers Pet" (7"; P.O.B. 54, Hooksett, NH 03106, USA) Metallic garage punk for sick people. Cliche ridden, unexciting thrash. Allin obviously spends too much time, as his promotional material suggests, playing with himself instead of working on creating a truly exciting metallic sound. — Gina Graziano

AMEBIX: Arise (Alternative Tentacles, P.O.B. 11458, San Francisco, CA 94010, USA) This record starts with an eerie instrumental. From here on the record gets better with each song. The band is basically a three-piece with some synthesizer accompaniment by George The Dragon. Bass player Baron Rockin' Von Aphid leads this dark ensemble with his rasping vocals similar to those of black metal master Kronos of Venom. One could almost mistake this band for Venom but the slow to mid-paced music adds a new twist to this defiled punk rock sound. Lyrics range from doomsday to religion to existentialism and other darkened fairytales. This record embodies the true spirit of hardcore because it is original and intelligent. Included is a mile-long list of equipment damaged while recording the album. — Scabies and Rabies

AMOR FATI: Body w/o Organs (LP; \$7.50 pp; Flesh, P.O.B. 5040 N. Bergen, NJ 07047, USA) This doesn't sound much like anything you'll hear elsewhere. Creator Amaury Perez hates the masses and admires Dalí, Nietzsche, Artaud and Camus. This is a raw, painful recording done at home on a four-track cassette with a variety of sounds and ideas. Perez is in pain just being a human, and he lets you know. The music is harsh (except for "Untimely Meditations") and unnerving at times — a perfect backdrop for Perez' strained, painful vocals and found sounds. Raw, searing music that doesn't fall into a predictable category. — Lawrence Crane

DAROL ANGER / DAVE BALAKRISHNAN / MATT GLASER: Jazz Violin Celebration (LP, Kaleidoscope, P.O.B. 0, El Cerrito, CA 94530, USA) This 1984 live set features the above named on violins with Mike Wollenberg on electric guitar, Rob Wasserman on string bass, and Mike Marshall on mandolin, guitar, mandocell, and on two numbers, fourth fiddle. Lots of great violin playing from the leaders with little of the hyper-technical grandstanding so common to same-instrument "battles." In fact, the other three musicians get plenty of solo space and make the most of it. There are jazz standards by Horace Silver, Lennie Tristano, Louis Armstrong, and Thelonious Monk. Each violinist has a featured spot with the

trio for one tune. One of the fiddle quartets is a highly-charged, and, in places, tonally restructured version of Bill Monroe's "Big Man". A lot of fun, and one of the most continually interesting LPs to come out of the new acoustic/Dawg/jazz bluegrass fusion scene. — Bart Grooms

ANGST: Lite Life (LP; SST Records, P.O.B. 1, Lawndale, CA 90260, USA) The group has come a long way from their one-dimensional EP of 1983. At their best, they make speed work for them, never sounding rushed. "The Poor (Shell Refuse)" and "Lite Life" are shallow critiques of poverty and materialism, respectively, but there is some good stuff here. My favorite is "Friends," a convincing bitter gripe packed into less than two minutes. It works without sounding contrived, despite the vocals copped from John Doe. A diverse and entertaining record. — Bill Neill

ANTIVETAM (LP; Homestead Records, c/o Dutch East India, P.O.B. 570, Rockville Centre, NY 11571-0570, USA) Folk-rock, art-damage, garage-grunge, jazz, you-name-it, all finds its way into these grooves. At times, like on "Orange Song," everything works powerfully. At other times, like "B.M.W.," the disconnected fragments tug at one another, deadlocked and immobile. Lot's of good ideas surface on this disc. Look at the song titles: "Good Kirk/Bed Kirk," "Don't Go Back To Greenville" and "Ready Swing." The band's double bass attack is not always used to its best advantage, but it gives "New Crime" an authentic feel and the instrumental "The Latest" a swinging punch. The production is dense and murky. It forces you, as does the band's performance and song structures, to dig in and listen closely. Most often, the effort is rewarded. **ECENTRIC SOUNDS** for introverts. — Scott Jackson

ANTI-SCRUNTI FOUND: A Bare Fock (5 song 7"; \$2.50 ppd; Unclean Records, P.O.B. 725, Sand Springs, OK 74083, USA) ASF is to hardcore as Delta V or the Kleenex were to punk. The music is simple compared to today's slick, metal shrouded, complicated thrash. The guitar plays staccato crunch chords and the drumming is inept but not annoying. The words are about (against) beatings by cops, Fawcett-headed armpieces (Scruntis), and Lebanon. Good unpretentious punk from a predominantly female band. — Jeff Wechter

ANIMAL SLAVES: Dog Eat Dog (LP; Mo-Da-Mu; Box 374, 810 W. Broadway, Vancouver, BC, Canada V5Z 1J8) Slightly askew synth-pop with psych overtones and jumpy, inventive percussion. Elizabeth Fischer's vocals are frequently slurred, but it's part of the package and the lyrics are printed on the cover. "Learning to Live" is the melodic standout. Unfortunately, it's energetic promise is not realized through the rest of the LP, which is generally slower in tempo. Not a bad record for a rainy afternoon. — Jack Jordan

ANZALONE ALONE: The Unsliced Cucumber (C-30; Anzic Creative Outlets, P.O.B. 891, S. Lynnfield, MA 01940, USA) A homemade slice of one man's mind. Rich Anzalone plays Casio and sings: a dumb anti-Reagan tune that sounds a bit like Eugene Chedbourne's folksy messages and uses a Reagan acceptance speech tape as a background; a twilight zone theme rap; a cute Casio ditty with really bad lyrics about lost love; a happy Casio arpeggio "too bad you're dead"; and spooky wailing with titles like: "Insanity Exhibition," "Prisoners of Life" and a cover of Roger Water's "Goodbye Cruel World." Ugh. Dump your Casio, get a cheapo organ, and get outta your head, man! — CDinA2

HOWARD ARMSTRONG: Louis Blues (LP; Arhoolie Records, 10341 San Pablo Ave., El Cerrito, CA 94530, USA) Material culled from a movie about Howard Armstrong, formerly of Martin, Bogan and Armstrong. Since the death of Carl Martin in 1978 Bogan and Armstrong have continued the tradition and what a wide-based tradition it is: from Tin Pan Alley, gospel to blues and country. There's even a Polish number or two thrown in for good measure. All done in an infectious, toe-tapping manner highlighting Bogan and Armstrong plus the banjo and vocals of Ikey Robinson and the mandolin and voice of Sleepy John Este's old running buddy Yank Rachel. The musicianship is great for men of any age but most of these guys are in their early seventies which makes it truly amazing. — Keith Wilson

ARTICLES OF FAITH: Give Thanks (LP; Reflex Records, P.O.B. 8646, Minneapolis, MN 55408, USA) Basic punk rock with flailing guitars, fast leads that aren't complicated or impressive, and speedy drumrolls. The guitar didn't come out as powerful or distorted as it should have. Most of the songs are fast with lyrics sung too fast to be understood, with the exception of "Everyman For Himself." — Josh Hatch

ART ZOYD: Symphonie Pour Le Jour Ou Bruleront Les Cites (LP; Cryonic, Inc., dist. by Wayside Music, Box 6517, Wheaton, Maryland, 20906, USA) Modern chamber music. Stravinsky comes to mind, both in the rhythms and the dissonant (but not grating) harmonies. The electric guitar on two of the five pieces highlight rock influences; the Don Cherry-like trumpet solos enlighten the free jazz interests. Zappa's instrumentals are another reference. This is an impressive ensemble playing tight in complex and free sections and generating powerful rhythms without percussion instruments. But the music is too discontinuous for me — sections last no more than two minutes, then abruptly shift to new ideas. I'd like more development. — Mark Sullivan

JOSEPH ABITON: A Hundred Camels (C-6; \$8.50; RIF, 461 Anderson St., San Francisco, CA 94110, USA) Inspired by travels and the hope of reaching a unity of spirit between people of all cultures. One song has his infant kid screeching and hollering dub style. Kinda cool. Each camel represents a link in the chain of world



peace. Some of the sounds were recorded in Morocco. Ashton plays synthesizers, flutes, mijwiz, raïta, electric and ghost guitar. Afghani rebab, tabla, bendir, darbuka, handclaps, kelimba, a homemade marimba, and assorted percussion and effects. Some titles: "Fractured Angel," "Ya Fatah," and "Hungry Ghosts." — Robin James

ATTRITION: Shrinkwrap b/w Pendulum Turns (12" single; Third Mind Records, 20 Spire Ave. Tamerton, Whitstable, Kent, England) High-tech dance rock with slurred, angst-ridden vocals. The overall feeling of both cuts is dark and disposable yet the beat is irresistible. Glossy synth textures punctuated with two-four electro-drum patterns form the backdrop for Attrition to sing about disposable people and disposable society, with two or three voices at a time each carrying the melody in totally separate directions. The effect is disturbing, which is appropriate for the messages delivered...but if you're not concerned with messages, there's plenty of solid music for your feet. — Allen Green

AZYMUTH: Spectrum (LP; Milestone Records, 10th and Parker, Berkeley, CA 94710, USA) The tenth album by this Brazilian trio is a slick, unpretentious product of complete mastery. These guys make upbeat dance music without skipping on the music. You like to dance? You like the latin beat? You'll love it. — Sam Mental

BAD CHECKS: Graveyard Bump (12"EP; Loretta Records, 2903 Colclough Ave., Durham, NC 27704, USA) Cramps fans won't be let down by these Southern boys, who are off and running with this promising start. The music is raw and angry, giving the right support for Hunter Landon's snarling vocals. — Charles P. Lamey Second opinion Voodoo rock pinched from The Cramps, pulls a dirty r&b feel copped from the sixties' garage band genre; nothing here is felt, it's all received. Lurid, soulless lyrics are these guys ideas of invention. Only on "17" does any of this click, and it manages to bury itself in the band's misogyny. — Scott Jackson

BAG OF TRICKS (7"; B.O.T., P.O.B. 8745, Wichita, KS 67208, USA) Spunky power-pop from this three piece — drums, bass, guitar — replete with solos from each instrument. The music is technically proficient pop with lackluster vocals on "Crotch And The Family Jewels," on the "A" side. On the flip side is "Power To The People" which gets into a real bar-crowd pleaser. Nice hand-colored sleeve with artwork by Eric Cale. — John E.

BALCONY OF IGNORANCE: "...These Meddling Kids (C: \$2 ppd; c/o Carson, 14 Pearl St., Rouses Point, NY 12979, USA) Sooner or later there had to be a dark side to the record-it-at-home, do-it-yourself ethic this magazine promulgates. Sooner or later people with absolutely no talent at all were going to start making tapes of zero quality. And here it is. This came to me on the cheapest "K-Mart special" tape available and proceeded to jam my deck twice before it got through the first "song." Probably recorded on a cheap walkman style recorder. It's awful — wonderfully awful, and these folks know it. I can't stop laughing when I listen to it. You say you've always wanted a ZZ Top/Bryan Adams medley that flows from one song to the other via a dead stop? It's here. In fact, if it's stupid, or over-played, or pretentious, this is the band to do the definitive cover. The contempt is so offhand (i.e. a

guest appearance by someone named Ted Pepper Mellancamp). I'm sure no one involved in this gives a fuck what I write here. — W. Mueller

PATRICK BALL: The Music Of Turlough O'Carolan and Patrick Ball and From A Distant Time (LP; Fortuna Records, P.O.B. 1116, Novato, CA 94947, USA) Ball is a Northern California traditional musician and storyteller. He uses a Celtic harp, which is a folk harp smaller than the large concert or pedal harp. It is strung in bronze or brass wire, rather than nylon or gut, and played with the fingernails using a technique very different from that used on other harps, all of which gives it a unique, bell-like tone. On the first record, Ball plays tunes written by Turlough O'Carolan, an 18th century Irish harper and certainly the most famous traditional composer for the Celtic harp; an enormous quantity of his work (or works attributed to him) survives to this day, and has been arranged for every imaginable instrument. The second consists mainly of other traditional tunes and his own compositions. His playing is good but his arrangements are uninventive. These albums do not really show off the tremendous range of expression possible in the traditional harp. However, they are definitely pleasant as background or light instrumental music. Fortuna Records' specialty, and anyone contributing to the Celtic Harp revival (an instrument which has nearly died out in its home, Ireland) deserves respect. — Christopher Pettus

BAM BAM: Disarm! (C; Camaradene Music Cassettes, P.O.B. 403, Kenmore Station, Boston, MA 02215, USA) Recorded at a benefit concert for Performing Artists For Nuclear Disarmament held Sept. 22, 1984 in Cambridge, Mass. It is an invigorating, electric documentation of a very inspired and inspiring event. Bam Bam plays "Politically conscious music" mating Afro-Cuban rhythms with socially aware lyrics; and the results are often...disarming. The eight delightful selections are charged with layer upon layer of rhythmic texture. Two guitars, bass, drums, and various percussion instruments create a kind of American clave — impeccably played and irresistibly danceable. Their clattering and chattering form the basis of the band's charm. However, the vocals on some cuts are shouted and threaten to turn the songs into abrasive harangues. Look, guys, I'm on your side. I don't mind thinking while I dance but I hate being yelled at. Ease up on the melodrama. — Gerry Speca

GEORGE BARKER: Tape 1 (C-90; c/o CA Productions, 1801 S. Monroe St., Tallahassee, FL 32301, USA) Barker with his performance art group CA utilizes film, slides, lasers, and costumes in conjunction with his live musical offerings. The music here is almost exclusively electronic, alternating between Fripp/Eno loopish ambience and seemingly improvisational synthetic soundscapes. The synth work is of the textural noise school. — Ed Blomquist

THE BARRACADES: I Wish It Could Be 1965 Again (LP; GMG, L'Evasion, 145, rue de Vaugrand 75015, Paris, France) Solid collection of early "A" and "B" sides by Britain's sadly defunct Barracades. Unlike their more sombre releases, which came later, these early sides are up and very cheerful with a heavy surf music influence. — Charles P. Lamey



JOE POP-O-PIE—This shot was taken when Joe was looking for investors to raise three thousand dollars to complete **JOE'S THIRD RECORD**. Three months later the album is about to be shipped, Joe says he doesn't like the other guitar player on the album, but wants to take him on tour anyway, just to watch the guy whine when faced with the horrors of touring an independent band. We eagerly look forward to the tour.

CAREY AND LURIE BELL: Son Of A Gun (LP; Rooster Blues Records, Dist. by Flying Fish, 1304 W. Schubert, Chicago, IL 60614, USA) Combine the talents of the reigning king of Blues harmonica with one of the rising guitar players of the Chicago Blues scene and the result is **SON OF A GUN**, one of the hottest Blues albums of the year. Carey and Lurie are father and son, and in this case nepotism is a reason to rejoice. From the opening song "Bellbuster" to the closing notes of "Gate Bait", the Bells take you on a blues merry-go-round filled with brass rings. Carey's harp playing is in top form, often sounding like an entire harmonica orchestra, his cascading runs sending shivers up my spine. — Dale Knuth

SAM BENNETT: Solo Percussion Music (C-60; 74 S. Portland Ave., Brooklyn, NY 11217, USA) Sam has an impressive list of teachers from around the world, fellow improvisors, and extensive European solo concerts. This tape shows that schooling, jamming, and traveling pays off. Recorded between 1981 and 1984 in Brussels, Boston, and Birmingham, it features Sam playing various percussion styles, some compositions, some improvis, on a drum set he designed. "Gaining Ground" features metal percussion. "Option 2" features a bass drum groove with beat electronics. Two outstanding ethnic grooves "From Which Side?" and "Home Away From Home" feature complex polyrhythms. Bennett, with only two hands, can sound like an entire drum ensemble. — CDinA2

BIOHAZARD: Biohazardous Materials (C; \$7; Groushov Prod. Distribution, 8074 Berri, Montreal, Canada H2R-2H9) Un-even, but the best of these 12 songs are minimally melodic and cool. Synthesized, slowly developing pieces highlight, on various numbers, distorted guitars, saxophone, and wordless choral sounds. In a league, at times, with Tangerine Dream. I can put this on and cook dinner and enjoy the whole thing; but if I find myself listening too closely to all of it it gets a bit boring. A more considered selection could be very impressive. —W. Mueller

BIRELLI LAGRENE ENSEMBLE: Live (LP; Jazz Point, Reinsburgstr 104 d-7000 Stuttgart 1, West Germany) Having the fortune to see guitarist Lagrene in person, I know he will be a major force in the future of jazz. This album marks what I believe to be his fourth and most challenging release to date. Lagrene originally played in the stunning fashion of his disciple Django Reinhardt, but has since branched out to show other influences ranging from Jimi Hendrix to Ornette Coleman. The disc features four originals, two Reinhardt classics, and an impressive interpretation of Parker's "Ornithology" — [no name on review]

THE BLACKJACKS: Dress In Black (LP; Throbbing Lobster P O B 205, Brookline, MA 02146, USA) Years ago Boston notable Johnny Angel drove his uptown-smooth sensibility out to the suburbs in search of the perfect piss-off; shortly thereafter, he blasted out with the Blackjacks to claim a place among the universe's reigning rude-rock frontmen. The Blackjacks are as nasty and hard-driving a rock band as you will hear, although they have toned down considerably since their last recording, the

BASIC BLACKJACKS EP. Angel's thrashing guitar and hard-guy vocals define this group's personality as it plays songs made of spare arrangements, melodic hooks and acerbic lyrics with lines like "You got anorexia in your imagination", "I don't hurt anyone if they leave me alone," and "She's got a nose just like Pinocchio's/ When it comes to finding the wealth of a man." — Gerry Speca

BLACKOUTS: Last Seats Club (three song 12"; Wax Trax!, 2445 N. Lincoln, Chicago, IL 60614, USA) The songs here might be labeled Dance Oriented Confusion. I can't figure it all out, but it's got a good beat and you can dance to it. The first thing one might notice is Eric's unique vocals. My fave song is the dubbed out "Everglades." But don't get the idea the Blackouts are just a studio band. If you get a chance to see them live, do. They rock out on those CCR covers and more. — Calvin Johnson

TERRY BLANKENSHIP: Daemon Deluxe (7" EP; \$3; Daemon Deluxe, P O B. 901892, Dallas, TX 75390-1892, USA) Nice homemade techno-pop with guitars, bass, drum machine and synth by Blankenship, who also engineered and produced. Some catchy stuff here, particularly "Rumors" on the trancier, robotic side two. Mannered Gary Numan-esque vocals. — Gage Kenady

PAUL BLEY: Questions (Steeplechase Records, 3943 West Lawrence Ave., Chicago, IL 60625, USA) Bley, a premier contemporary jazz pianist, releases his first trio LP since 1976's **JAPAN SUITE**. And it's the best of his recent releases so far. This is surprising considering that the trio on this LP is not a regular working unit. [Bassist Jesper Lundgaard and drummer Aage Tanggaard appear to be the current Steeplechase house rhythm section.] Bley's concept of a trio is a highly personal extension and refinement of the ideas of The Jimmy Giuffre Three [of which he was a member] and the Bill Evans trios of the early '60s. All three voices function independently, working to create an organic, free-flowing whole. That Lundgaard and Tanggaard contribute so much and so well to his LP is a testimony to their flexibility. Tanggaard is more of a straight ahead drummer than Bley usually uses but this does not detract from the music. The recording is beautiful, picking up every nuance in Bley's playing. If you're unfamiliar with Bley's playing, this LP is an excellent place to start since it gives a good example of both his trio playing and an ample amount of his highly personal solo style. — R. Iannopollo

THE BLURBS: Industry (C-60; Private Studios, P.O.B. 531, Wyandotte, MI 48192, USA) Love those catchy stop-and-start rhythms, spitting and growling vocals, and messages that should be printed. Composed with punch and conviction. — Tom Furgas

BODY SINK: Lung Ties (LP; 54 Locust St., Mesepeque, NY 11758, USA) A new release of blistering progressive sounds recorded at CBGB's in 1980. Body Sink, a trio of guitar, drums and organ, combines the violence of hardcore with the odd tempo changes and complex time signatures of progressive music. This curious blend of musical styles is best illustrated in the vigorous "Control The Blood Flow," a ten-minute tour de force that shifts from industrial improvisation to the haunting beauty of Fripp and

Eno's ambience, before ending with a high energy, locomotive powered percussive workout. The musicianship is first-rate, forcefully driven by Paul Lemos on guitar and Meola on drums indicating a rare command of dynamics, melody and experimental sound. — Andrew Levitt

BOB AND JEFF SHOW: Welcome To My House (C-60; \$5; Home Recordings, P.O.B. 4071, Bloomington, IL 61702, USA) A well-recorded manic sampler of a variety of music styles that these boys seem to effortlessly glide in and out of. They get able musical help from a few friends. Something for everyone, as Bob and Jeff explore rock, reggae, blues, free-form progressive rock, and country. It can be pretty frustrating to experience as a listener though, especially whenever they just throw on a new style for the sake of framing yet another of the many jokes they're always cracking. But hey, they don't do it all the time, the jokes can be pretty funny, and there are songs like "unrequietus sniffunke", a twisted and tender belted in a John Cale vein. You come to realize that these guys really do have a lot of talent, and, uh — jokes. "Uncle Pity" is one of the funniest things I heard all month. — Oleh Hodowanec

ERIC BOGLE WITH JOHN MUNRO AND BRENT MILLER: When The Wild Wind Blows (LP; Flying Fish, 1034 West Schubert, Chicago, IL 60614, USA) Australian/Scottish folkie Bogle conjures up lots of mysterious, cute, angry and calming imagery with a modern folk context. Instrumentation includes acoustic and electric guitars, bass (electric), mandolin, banjo, cello, drums and synth; some a capella work also. Unfortunately Bogle's visions rarely have depth or refreshing insight. There is talent here; I am hoping for more next time around. — Jamie Rake

THE BOMBADIERS: Fight Back (C; \$6; Green Monkey Records, P.O.B. 31983, Seattle, WA 98103, USA) If high-energy rock and R&B is your bowl of bouillon then this tape is for you. Steeped in the exciting and sensual rhythms of '60s garage bands and soul reviews, The Bombadiers surge from the speakers from the first drumbeat of the opening song, "Fight Back". Pounding drums, rumbling bass, stinging guitar, and wailing sax provide a backdrop for the vocals of Leaf Cole. While some would consider Cole's vocals mannered (and it's obvious he's listened to his '60s garage bands) they are perfectly suited to The Bombadiers's brand of pub-rock. While the primary topics of the songs are the usual love and partying themes, The Bombadiers branch out to include songs of encouragement, such as "Fight Back" and "Shoot," and other socially-conscious themes, such as "peace" in "The Only Prize." — K. Crothers

BOX O' LAFFS: Doghook (C-90; \$3; Warp West, P.O. Box 8045, Santa Cruz, CA 95061-8045, USA) The band seems to exist mainly as a vehicle for vocalist Eric the Eric to spout his rampant, insane visions. This guy is a genius, telling bizarre stories and singing of incredible subjects. The music is a metal-punk-funk-disco hybrid played with perfect sloppiness (several of the people here are in Camper Van Beethoven, a band from the same town.) At times, I was reminded of The Fall, Love Circus and Flipper. Comes with a weird lyric book. — Lawrence Crane

BOYS WITH TOYS: Big House (LP; Hot Fudge Records, P.O.B. 14, Cedar Falls, IA 50613, USA) A tight little combo like a cross between Nick Lowe and The Hoodoo Gurus with some Bobby Fuller overtones. The guitars bounce and jangle and the vocals harmonize like a punkified Everly Brothers. — Jordan Oakes

RUBY BRAFF/DICK HYMAN: Fireworks (LP; Inner City Records, 50 S. Buckout St., Irvington, NY 10533, USA) A fine unpretentious set of duets from a pair of "mouldy fig" players. Cornetist Braff is one of the keepers of the Armstrong flame and plays with the infectious joy of Louis' best playing. Hyman is one of those stylistic player's who, in other circumstances tends to sound a bit show-offish. He plays here in the pre-WWII style of Teddy Wilson, Art Tatum, etc. (the piano style he obviously loves) and he's obviously having fun as he laughingly darts in and out of Braff's lines. The rapport between these two comes out of a musical friendship that's developed over the years, and it sounds like they'd rather be doing nothing else than playing together. The repertoire of this live 1983 recording is drawn mostly from the pre-WWII songbook (heavy on the Gershwin.) — R. Iannopollo

BRANLE PARTY: Welcome To Maryland (LP; Fountain Of Youth Records) The hardcore formula modified with odd time signatures and rhythms, harmonies, lots of changes, big hooks, verses, choruses and bridges. They have a pop/hardcore sensibility with writing ability echoing the pop/punk prowess of early Elvis Costello and The Damned. — Jeff Wechter

BREAKING CIRCUS: The Very Long Fuse (LP; Homestead Records) Dance-oriented heavy grooves like Gang of Four, or a less frenzied Killing Joke. Bass and drums lock into a deep funk/trance groove, and the rhythm section has an almost dub texture. Over this bottom, the guitars grind and jab. The vocals are, for the most part, uninvolved — in tune, on the beat, and nearly monotonal. There's not too much to get excited about lyrically either. All the textures of the record fit together well, giving it a polished, slightly industrial feel, but the songs remain static and unsurprising. An exception is "Knife In The Marathon," an affecting mood piece with floating acoustic guitar and mysterious vocals. — Scott Siegal

THE BROADCASTERS: Killing Time (C; Reel Records, 22 4th Ave., Nyack, NY 10960, USA) A smoking blend of roaring rock 'n' roll and nostalgia-free blues/rockabilly revivalism. This tape should make George Thorogood and Jeffrey Lee Pierce envious.

Rarely do I get this excited about a recording, but when I find myself breathless after a superbly paced rockably lament like "Last Letter" or when I wind up trashing my dishes as a result of the relentless rhythms in "Me and the Devil," "World Of Hate" or "Fed Up," how can I not cry out, what with all the dull fluff cluttering the airwaves? — Richard Singer

BRONX STYLE BOB: N.Y. Ninja b/w Bob-Didi-Bob (12" single; Nightbeat Records, 2818 Jeffries Ave., Los Angeles, CA 90085, USA) My guess is that Bob is an ex-New Yorker who digs the smoother version of hip-hop coming out of California. The story line of "Ninja" is straight out of a Chuck Norris movie. The flip is more traditional rapping with no plot, a just a lot of brags; some are justified and some aren't. With a little better production, Bob could be the logical successor to the Egyptian Lover or Bobby Jimmy. — Jamie Raké

MICHAEL BROOK WITH BRIAN ENO AND DANIEL LANOIS: Myrial (LP; JEM Records Inc., South Plainfield, NJ 07080, USA) Well-recorded ambient music. Composition is credited to Brook who plays a variety of guitars, keyboards and percussion. Lanois and Eno both play and "treat" the music. Eno's influence is especially evident. The guitar playing is strong, creating a wide spectrum of sounds. The music is generally very static and often hauntingly beautiful. — Robert Dot

CHRIS BROWN: Alternating Currents (C-60; 1951 Oak St., #4, San Francisco, CA 94117, USA) Three compositions and one free improvisation for acoustic and electronic instruments from composer/pianist/instrument designer Brown, who is joined by Rova sax man Larry Ochs, trombonist Toyoi Tomita, and percussionist William Winant. Two instruments of Brown's own design are featured throughout: the "electric percussion piano," a variation on the prepared piano, and amplified metal rods which, when bowed, create shimmering, elongated tones rich in harmonics. The rods are used excellently in "Conjunction For JKP," a delicate musical koan where evanescent smears of sound entwine a fragile, music box-like melody. The structured sections of Brown's work, with their percolating polyrhythms and frequent use of vibraphone, often recall Anthony Davis' work with Episteme; some passages have a vaguely tropical feel. Like Davis, Brown is making genuine progress in exploring the interface between new jazz and "new music." — Dennis Rea

BOB BROZMAN: "Hello Central...Give Me Dr. Jazz" (LP; Rounder Records, One Camp St., Cambridge, MA 02140) When Brozman joined the great Cheap Suit Serenaders a while back, he brought along his superb slide guitar abilities. The end result was a group with a fantastic sense of humor and an always interesting instrumental arrangement. On this solo release (it's his second) are the same ingredients: humor and some really nice music. Playing a number of tunes, ranging from blues and jazz to Hawaiian, Brozman utilizes the brilliant tones supplied by his impressive array of National steel guitars and ukes. Also appearing on the disc is the piano of George "Wind-HAM-Hill" Winston, who is ultimately hipper than his solo muzak records would indicate (also check out the Professor Longhair album Mr. Winston produced — it's a must!). The sound is great and the music is just as fascinating as the original 78s that Brozman covers. — [no reviewer name listed]

ROY BUCHANAN: When A Guitar Plays The Blues (LP; Alligator Records, P.O. B. 60234, Chicago, IL 60660, USA) Buchanan is the perfect example of an artist with all the talent in the world, who, when he gets in the grasp of a major label record company, gets packaged by a corporate mogul, and the music suffers, let alone the artist. Lucky for Roy and his fans he has finally gotten the chance to make a record the way he wanted it made, and the results are stunning. This LP is a masterpiece. Nobody can make a Telecaster scream and cry like Buchanan can. Guest vocalists Otis "Soul Man" Cleary and Gloria Hardiman shine on "A Nickel and A Nail" (the great O.V. Wright tune) and "Why Don't You Want Me?" respectively. Judging from her performance here, Hardiman is a talent deserving her own record. As usual Roy adds his own unique vocals to the title cut and "Country Boy." I always get a kick out of Roy's singing, because it always reminds me of Lorne Green doing "Ringo", but then we buy the albums for the guitar don't we? — Dale Knuth

BUSHIDO: Deliverance (LP; avail. from Third Mind Records, 20 Spire Ave., Tankerton, Whitstable, Kent, England) A sick, hook-laden record whose only hint of the industrial sound of their early recordings is in the anguished vocalizing of singer Chris Elliott who has double-tracked the daylight out of his harsh British twang. The album is divided into half dance-oriented tracks and more grandiose layered electronic instrumentals. A nice bit of balance. — Greg Taylor

DONALD CAMPAU: New Monetary Road Sounds (C-90; 5020 Page Mill Dr., San Jose, CA 95111, USA) Don plays guitars, keyboards, bass, and sings. His voice sounds a bit like Leo Kottke and his songs are very wordy with lots of rhymes. He talks, sings about D.J.s, cruisin', and "Zen Buddhist ceremonies at the burger joint," over frantic Snakefinger guitar, acoustic country slide, funky fusion, Heads-type new wave, casio, and harmonica. The instrumental side has a few gems: "Fantasy Dub Time," with Frappish guitar, "Potato Bowling," a noise tape collage with tooth-

brush scrub and Bill Cosby on drugs, delicate percussion, sax and bells. "Crunchy Zen Cereel" is Don's answer to "Alan's Psychedelic Breakfast," and "Pearl Harbor Dub Day" is a real blow out. Creative homemade music. — CDinA2

CAMPER VAN BEETHOVEN: Telephone Free Landslide Victory (LP; Independent Project, Box 60357, Los Angeles, CA 90060, USA) If you live in a town with a college radio station, you've probably heard "Take a Skinhead Bowling" to death. Let it be known that Camper Van Beethoven's unique blend of ska, punk and garage pop has gleaned several such gems on this, their first LP. "Oh No!" and "Border Ska" are two of my favorites. The use of instruments such as mandolin and violin add an unusual edge; the inclusion of several instrumental numbers is also cool. Overall, a great record. — Calvin Johnson

THE CANNIBALS: The Rest Of... (LP; CMG, L'Evasion, 145, rue de Vaugirard 75015, Paris, France) The 12 cuts on this cover the best of the shockingly neglected British-based Cannibals between the years of 1977 and '79. These boozy, R&B tinged garage rockers are raw, intense performances, capturing true primal rock and roll. Although The Cannibals are loose and carefree, they're not sloppy. This is a cool album and GMG promises a '79-'85 "best of" soon, as well as solo efforts from The Cannibals' American lead vocalist Mike Spencer. — Charles P. Lamey

CHRIS CARTER: Mondo Beat (LP; CTI Records, BM CTI, London WC1 3XX, England) Best known for his work with Throbbing Gristle and later with Chris and Cossy, Carter continues his pursuit of electronic music that is both commercially viable yet creatively adventurous, on this, his first solo release on vinyl. Aptly titled, "Mondo Beat" stresses electronically generated rhythms throughout the six mostly instrumental tracks, and indeed four of these are fairly dance-oriented. The sound is similar to earlier Chris and Cossy LPs, combining solid synthesized strains of melody, incessant rhythm and shrieking, and distorted electronic tones. Pieces like "Moonlight" and "Mondo B" are light and pleasantly ambient, whereas others like "No Evil" or "Real Life" harken back to the abrasive sounds of T.G. and early SPK. This is a simple, well recorded LP of modest artistic expression and is generally very enjoyable listening. — Paul Lemos

NICK CAVE AND THE BAD SEEDS: The First Born Is Dead (LP; Mute/Homestead, dist. by Dutch East India, P.O.B. 570, Rockville Centre, NY 11571-0570, USA) The album opens with a crash of thunder; a storm/rain and an insistent beat that pulses and slithers... the song is "Tupelo", the story of Elvis Presley, Nick Cave and Christ (or the Anti-Christ's) birth. Nick and the Bad Seeds (Barry Adamson, Mick Harvey and Einsturzende Neubauten's Blixa Bargeld) explore the backwoods of the old south, a world of obsession, murder, love, insanity, the Old Testament, long black trains howling in the distance, outsiders, death-row prisoners, despair and a cast of characters caught on the wrong side of many laws. There's a version of Dylan's "Wanted Man" (a song he wrote for Johnny Cash) that is one of the best things Nick has ever sung, a song about a man on the run from everywhere to nowhere, a song where paranoia and justifiable terror meet and merge. Like Jeffrey Lee Pierce, Cave is obsessed with Jim Morrison, Elvis Presley and the darkest dirtiest blues, but Nick seems to have ventured a little farther into the dark, enough to appear to be more than a little crazy. Nick is a scary wimp who bristles with a fringe of genius and real madness. — Geo Parsons

JOEL CHADABE: Settings For Spirituals (LP; Lovely Music, 325 Spring St., New York, NY 10013, USA) Side A features the beautiful, strong, and controlled voice of Irene Oliver recorded in 1965 singing spirituals and being "followed" by Chadabe's computer. The liner notes don't tell us much about the techniques that were employed, but the computer is quite delicate when generating responses to the vocal nuances. The effect is engaging and does not compromise the strong character of the spirituals. The final spiritual is unprocessed and presented with a simple piano accompaniment, providing a pleasing reminder of the source of what Chadabe so effectively transforms. Side B is a unique and beautiful collection of pieces. Side B presents Solo, a computer controlled by Chadabe's hand movements in relation to two proximity-sensitive antennas. The sonorities are not unpleasant, but the piece has a meandering feel that to me, inspires lethargy. — Leland Saintry

EUGENE CHADBOURNE: People Want Everything (Canadian Version) (C-60; \$7; Parachute Tapes, 2308 Sherwood, Greensboro, NC 27403, USA) This is what is written on the cover: "You are holding an illegal recording in direct violation of legal relations between the United States of America and Canada. I am not responsible for anything that happens to you. But you know that already." Featuring Chadbourne and friends from the famous German band "The Flying Undercupps" in Vancouver B.C.. Very different from the other version of "People Want Everything" which has connections in Australia. The same bizarre mix of real-life country western performance artistry, commercial television turned weapon, and avant-garde politics, turned up real loud with distortion. — Robin James



DENISE DEE—Joe Pop-O-Pie's boss at the telephone survey company. Dee also edits the Closest Penguins and is a former Dyke. (The band.) She doesn't go to many punk or hardcore shows anymore because she says if you wear a dress you get beat up. And she likes wearing dresses. Her new address is: 625A Matome, San Francisco, CA 94103.

EUGENE CHADBOURNE: The Dine Chicken (C-60; \$7; see address above.) Chadbourne is a guitar warden who plays a lot of different items (including rakes and birdcages), specially wired for sound. He creates unbelievable collages of his twisted blend of live and studio country-western, shockability, and avant-garde humor, with a generous supply of old rock standards. This features the "Wild Angels Theme": "I just want to ride my machine and not get hassled by the man." Alphonse Mouzonski plays trash cans. — James Robins

EUGENE CHADBOURNE: Country Music Of Southeastern Australia (LP; RRRecords, 151 Paige St., Lowell, MA 01852, USA; Chadbourne cranks out another chapter in what is one of the most interesting catalogs of recordings issued by any active singer-songwriter of this decade. Side one features five Chadbourne originals; side two has nine cover versions of mostly country and western material (including a Willie Nelson medley). Accompanying Chadbourne are three other avant-gardes: David Moss on percussion, Jon Rose on violin and piano, and Rik Rue who spices things up with a slew of tape recordings and dementia. Don't expect a straight approach on any of this (if you did, you don't know Chadbourne.) Everything's twisted: avant-folkrock, country/punk. It's music as novelty; novelty as art; art as a joke; a joke that is as serious as life itself. It's not my favorite Chadbourne record or tape (who in the world has heard them all?), but it is idiosyncratic, original, and maintains the Chadbourne standard that will assure that, although the record is not a masterpiece in itself (who has the time or money to create masterpieces these days?), it is a valuable, relevant, and essential part of Chadbourne's body of work which taken as a whole IS a masterpiece of musical independence. Collect them all and you will have a set that will surely be the envy of some future musicologist. Oh, yeah. All copies bought directly from RRRecords are guaranteed. You love it, or else you can get your money back. — David Ciaffardini



GARY FLOYD—They said that this was The Dicks last San Francisco performance. One more gig in L.A. and the band splits. Boy, were we glad to have caught this. This was the most exhilarating performance of the trip. Gary Floyd can sing. He can belting. He can wail. The records only hint at the power and charisma. At one minute he's the Jackie Gleason of hardcore, soft and rolly polly. The next moment he belts out one of his songs with a conviction to incite a riot. Someone referred to him as a 250 pound Connie fag but she didn't mean it as an insult—simply as a description of his uniqueness in the hardcore scene. They say Floyd wants to get more into the blues, but there are already hard rocking bands seeking his talents. But what about The Dicks? They certainly had one hell of a pounding drummer—the amazing Lynn Perko. You say chicks can't hit hard? She'll pound you to the floor.

EUGENE CHADBOURNE: Wombat On-The-Way (C-60; \$7; see address above) Guest artist Spiro Agnew. The greatness of the Republican party is summed up by this talented man, who left a successful career in politics behind in order to play avant-garde music. "I want to expose sound and all its implications" he told a meeting of the Joint Chiefs of Staff. He is currently booked solid on the avant-garde circuit and we appreciate his time. Appearances of Chadbourne's legendary guitar with Jimi Hendrix, John Costrane, Afghanistan National Radio, Elvis Presley, Prince Far-I and the Arabs, Fernando Lamas. Unbelievable, doing acoustic "Purple Haze," "Happy New Year," "They Froze Jim Jones' Brain," "Burl Ives Medley," "Costrane The Wombat," and "Chitlin Con Carne." The hits just keep on comin'! — Robin James

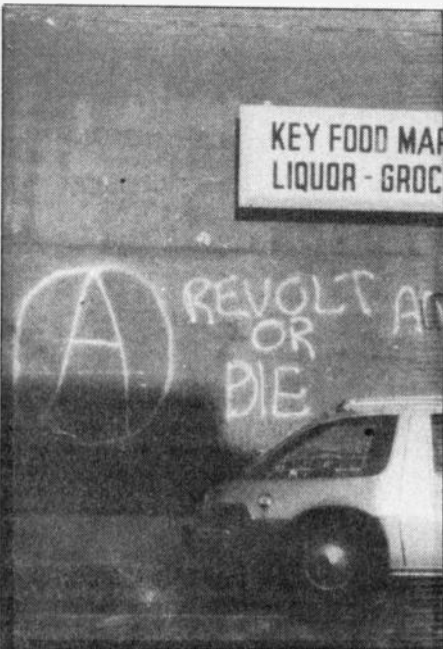

GRAFITTI CLICHES on the streets of San Francisco.

CHAIN LINK FENCE: Fireworks (6-song EP; Throbbing Lobster, P.O.B. 205, Brookline, MA 02148, USA) Punchy, well-recorded performances, promising songs, and enthusiasm for bright, tasteful rock music. Billy Barret's lead vocals echo and threaten to go out of tune (like Elvis Costello or the Adventure Set's Ken Scales), occasionally sounding forced or insincere. The musicianship (mostly guitar, bass, and drums) however, is confident and believable. **FIREWORKS** subtle touches are its most endearing: a tinkling piano, a cowbell, folksy, full-group background vocals. There is a high-spirited intelligence that has crafted a pleasant if not completely arresting set of tunes. — Gerry Speca

SHEILA CHANDRA: The Struggle (LP; Indipop, 98 Gordon Hill, Enfield, Middlesex EN2 005, England) Chandra pursues something interesting here, a combination of modern pop and Indian music, but the record falls flat. Steve Coe and Martin Smith who produce and play on this record write the two worst songs and help make the rest mediocre. Some cuts, like "The Struggle" and "Om Shanti Om" are interesting non-lyrical pieces with Indian-styled music and "expression vocals," but other songs are too long with overlaid electronic drums, sometimes funk-styled. The Indian melodies are frequently predictable (clichéd) and trite. If Chandra performed more of her own songs maybe she could create a very satisfying record. — Lawrence Crane

EMMETT CHAPMAN: Parallel Galaxy (LP; Back Yard Records, 8320 Yucca Trail, Los Angeles, CA 90048, USA) Emmett Chapman invented The Stick, a ten-stringed electric fretboard capable of bass, rhythm and lead lines; the resulting sound being a curious blend of guitar and clavinet. Chapman also invented a technique for playing his invention — a technique demonstrated on this, his first album. Chapman's chosen direction is definitely jazz fusion, and he emulates the likes of McLaughlin and DiMeola. Having seen him live, the album provided some jolting surprises I never would have expected from this man who comes across so serious and self-absorbed. On the first cut, "Back Yard," brother Dan Chapman joins in on harmonica to open the album with an unmistakable country feel. A tasty Latin jazz piece follows, leading into an arrangement of "Eleanor Rigby" featuring Josh Henne, a virtuoso in vocal effects. Henne provides an element I found both excitingly original and abrasively unsettling...it definitely can't be kept in the background! "Waltzing Matilda" is particularly bizarre, with neo-eastern wailings leading into a militaristic march. Drummer Bruce Gary contributes solidly to the more conventional cuts, "My Favorite Things" and "Pumpnickel Pump." Chapman pays tribute to McLaughlin in a solo version of "A Lotus On Irish Streams", which sharply contrasts with the totally improvised "Voices", featuring Henne and kalimba. Chapman's ambition is highly evident in "Parallel Galaxy", an embodiment of his concepts of astrological music theory, again featuring the highly vocal Henne. "Gypsy", a litig solo, closes the album on a Spanish jazz note. Even for those acquainted with Chapman and his invention, there are surprises in store. — Michael P. Goodspeed

GUGOU CHENVIER AND SOPHIE JAUSSEERAND: A L'Abri Des Micro-Climats (LP; RecRec Music, Magnustrasse 5, 8004 Zurich, Switzerland) Chenvier is the drummer for Etron Fou Leloublan, but this doesn't sound like a drummer's solo record. It's an ensemble sound with vocals emphasized, accompanied by Chenvier's overdubbed saxophones and light percussion (playing a full drum kit on only three songs) and Christian Cohade's bass. Jausseerand wrote lyrics for five of the 10 songs and is vocalist on four of them. The style is typical of Recommended releases — more art than rock or jazz. It reminded me of the Art Bears. The songs are light and charming with lyrics in French. — Mark Sullivan

CHILD SUPPORT: One To Year Kids (4 song C; Neophyte, P.O.B. 5502, Berkeley, CA 94705, USA) This tape came out in 1983, but seems older than that. This is mid-tempo '77 punk with catchy songs about family and personal relationships. The vocals are a bit unemotional and the guitar solos are long and flashy at times. Not a bad tape, just nothing new. I also wonder why I've never heard of them since I go to shows in the areas they claim to have played. — Lawrence Crane

CHILD SUPPORT: Come To Amerika (LP; see address above) This LP is more recent than their cassette EP. Instead of dealing with personal relationships, they now deal with "issues" (political.) The spirit of 1977 mid-tempo punk still rules and any claims to hardcore roots or ideas seem ungrounded. One song, "Don't Hurt The Children," is very good but the rest is lifeless. — Lawrence Crane

MICHAEL CHOCHOLAK: Skomorokhi (C; M&M Music, Route 1, Box 55, Cove, Oregon, 97824, USA) In this music for the novel "Skomorokhi", Chocholak creates a number of easily digestible and wonderfully beautiful electronic vignettes. Loosely structured and approaching improvisation, Chocholak combines traditional electronic timbres, digital sampling, and flutes from wife Michelle. The result is sometimes jazzy, ala "ECM" and the more adventurous works on Windham Hill (i.e. Mark Isham.) — Nathan Griffith

MARK CLEAR: Nazi Spies b/w Thought You Were Mine (12" single; Lite Records, 1609 NE 75th St., Seattle, WA 98115, USA) Real catchy, fun stuff. I played this at a party and everybody danced. "Nazi Spies" is not a political song, just a fun one bopping along with an unpretentious beat. Nice horns. The B-side is surf-style music. — Jim Butterfield

THE CLINTONS: Girl Next Door/Drive Me Home (7" single; Coyote, Box 112, Uptown, Hoboken, NJ 07030, USA) More garage rock. The music sorta rocks unpretentiously. I like the B-side for its speedy mouth harp. I hate the jacket sleeve. — Richard Singer

WILLIAM CLIPMAN: Nerve Chorus (C; Silverlake Sound 3371 East Silverlake, Tucson, AZ 85713, USA) A street-punk suicide, emotional impotence, violence, war, and the threat of nuclear annihilation are the somber themes poet/musician Clipman treats in a mild funk-rap style. No doubt he's aiming this direct street-credable approach to underscore his socially conscious verse. Unfortunately, at times, the funk is a tad too festive for this journey through bleak and dangerous landscape, and the vocals sound affected. The solid drumming is memorable; the synth lines are weak and constipated. On "Billy Pain", however, Clipman makes good use of these sparse elements. In this tale of a wester life ending in a jail cell suicide, a stunning series of images are carried by forceful rhyming, a throbbing beat, and an on-target delivery. — Oiah Hodowanec



SNAKEFINGER—Snakes the guy on the right. His picker. Something like Les Paul. And he plays FullMoon Saloon on Haight Street was awesome. So cool and controlled, like some British. Sophisticated yeah, but a sense of humor too. A

CLUBFOOT ORCHESTRA: (demo cassette) (Clubfoot Orchestra, 18 Sycamore St., San Francisco, CA 94110, USA) Are these people legendary yet? What a band! An eclectic assortment of eclectic musicians with credentials all the way from Benny Goodman to Captain Beefheart, with the likes of Ali Akbar Kahn in between. And the music? It's hot, but how to describe it? Yiddish rock? Afro-Strevinsky? Kabuki jazz? They'll start with unlikely musical juxtapositions followed by several more off-the-wall combinations to elegantly traverse before they finish. This band is long on musical ideas and they've got "chops"! Richard Marriott is credited as the compositional genius. Some high-profile players like guitarist Philip "Snakefinger" Lithman, and producer, bass, and keyboardist Eric Drew Feldman join together with sax players, trumpet players, accordion players, clarinets, drums, trombones, flutes, dancers and singers and it comes together as great fun. — Leland Saintry

PETE COE: It's A Mean Old Scene (LP; Backshift Music, 21 Halfax Road, Ripponden, Sowerby Bridge, West Yorks, England HX6 4AH; avail. from Down Home Music, 10341 San Pablo Ave., El Cerrito, CA 94530, USA) With British rock and roll's idea of incisive social comment reduced to "wer sucks, and everyone likes to dance," it's left to folk music to say something useful about the desperate situation in England. (Hey, Christopher! What about British rock band CRASS? — DC) Groups like the Pogues and Men They Couldn't Hang turn out electrified folk with the element of threat that rock and roll is supposed to have, and singers like Pete Coe still tell things as they are. Intelligent, powerful songs are delivered by a great singer with fast moving, tight arrangements with guitar, synth, small pipes, banjo, sax. Included are traditional songs which haven't lost a bit of their truth; and original compositions. All this, and wry comments by someone who knows what he's talking about. — Christopher Pettus

COIL: Aqua Regis/Panic b/w Tainted Love (12" single; Wax Trax!, 2449 N. Lincoln Ave., Chicago, IL 60614, USA; ph. 312-929-0221) The worst nightmare you've ever had. You sit frozen, aqua eyes wide open, staring as your tormentor bends and breaks you. The ganging of electronics shatter your mind as your thoughts are replaced by smashes and bangs. "Panic" grips you in a beat that gets you to your feet. It has the beat but the devil controls our soul as you feel the meaning swirl in the pit of your gut. Your tormentor slaps you down, nails your head to the floor and gives you his "Tainted Love" recreated by willing sinners in Hell. — Sam Rosenthal

LUI COLLINS: There's A Light (LP; Green Linnet Records, 70 Turner Hill Road, New Canaan, CT 06840, USA) This album, Collins third on Green Linnet, breaks through into a difficult to classify mixture of New Age, folk, and pop — very personal and introspective. The arrangements are exceptional (due, perhaps to John Cunningham's production talents), and her voice (especially on the a capella pieces) is crystal pure and expressive. Her material, es-



pecially that written by others, could be better, although one guitar-driven hymn on the record is worth the price of admission in itself. — Christopher Pettus

...st name's really Phil. He's a fuckin' cool guitar
...with The Residents too. His performance at the
...records I've heard don't do the job justice. Ever
...car driver going through the S turns at 150.
...the rest of the band wailed. A definite highpoint.

pecially that written by others, could be better, although one guitar-driven hymn on the record is worth the price of admission in itself. — Christopher Pettus

CONTROLLED BLEEDING: Body Samples (LP; Dossier Records, Prinzenallee 47b, D-1000 Berlin 65, West Germany) From the routine "shocking" rear-cover photography to the lack-lustre muzak-like pieces that sandwich the periodic forays into unconvincing mayhem, this is a disappointing album performed by practitioners of an over-worked genre. There are, however, portents of a more original musical stance. Tracks on both sides of the album (there are titles this time) feature interesting treatments of metal percussion, and on side one is a humorous excerpt from what appears to be a disrupted game of cards. Unfortunately many of the more ambient selections are straight out of Eno/Fripp-land, down to the apparent use of the distressing E-bow. A few frissons are raised, but the more powerful tracks are painfully imitative, and evidence to the widespread inculcation of a style pioneered years ago by the far-superior Whitehouse. Moments of arrest are constantly undercut by tired industrial elements. Even at higher volume there is no sense of catharsis, certainly none imparted to the listener. Controlled Bleeding are a band in obvious, painful transition. — Chris Willing

CONTROLLED BLEEDING: Death In the Cameroon (C; Ladd-Frith, P.O.B. 967, Eureka, CA 95502, USA) OK, here's how it goes: first ambient sounds, electronics and found vocals, then a barrage of noise, mostly angry guitars, then ambient sounds, then barrage, and on and on. Pure torture. This tape's redeeming quality is that it scares the hell out of the neighbors. — Nathan Griffith

COPERNICUS: Nothing Exists (Ski Records, P.O.B. 150, Brooklyn, NY 11217, USA) A musical sundae. The ice cream is improvisation with reggae sauce, punk rock sauce, electronics, and sound effects, with liberal sprinklings of free-form poetry for lyrics. And what poetry! Everything from Captain Beefheart's style of word salad to deep drama, like Leonard Nimoy doing Samuel Beckett. One listen to Copernicus is worth 10 000 music videos. If this stuff doesn't give you pictures in your mind, if it doesn't make you sweat, nothing will! — Paul Goldschmidt Second opinion: Copernicus is a singer/poet who declaims his lyrics over a variety of musical backgrounds. The music is supervised by the keyboard/guitar team of Pierce Turner and Larry Kirwan, and played by a group that at times includes up to 11 additional musicians. They cover a lot of ground, from mellow funk to Eno/ECM noodling, from OMD synthesizer textures to wild rock and roll freak out. Copernicus lays out his feelings on love, hate, nuclear war and other more personal items on top of the music. Unfortunately, due to his gruff, bellowing approach, and a mix that buries him in echo, it's hard to understand what he's saying. On a project like this, that's a major problem. — Scott Siegal

COPULATION: Copulation (LP; \$5; N. Leresole, 21 West 86th St., #705, New York, NY 10024, USA) This Swiss band was formed in Geneva in 1979. They have been on two Swiss compilations, and also on ROIR's WORLD CLASS PUNK tape. This, their first album, is reminiscent of Bauhaus and Sonic Youth, but has its own original probing and wild rambling. A great album for self-induced gloomy moods. The vocals are haunting; unfortunately the lyrics are almost impossible to understand, even the English songs. Solid musicianship, not too weird, definitely worth five bucks. — Miki Pohl

CORROSION OF CONFORMITY: Animosity (LP; Death Records/Metal Blade, 2458 Ventura Blvd., Suite F, Woodland Hills, CA 91346, USA) Pay no attention to Metal Blade's FEEL classification of this record as "The ultimate thrash METAL PUNK." I didn't even know you could use those two words in the same sentence. What ever you want to call it, this is far from thrashy. The overriding sound is tight and clean with a good studio mix. The drum tracks pound. The singing, though intense, doesn't hold up to these precision tunes. Is heavy metal and punk rock fusing into one super-force? The answer is yours but this record is hardcore without question. The front cover is a striking, color one by Pushed. — Scabies and Rabies

STEPHEN COUGHLIN: The Song Of The Reed (LP; Fortuna Records, Box 1116, Novato, Ca 94948, USA) Coughlin's record — "an East/West tapestry of gentle mystical sounds, woven from bamboo flutes, elegant soprano sax, zither, and now and then a quiet drum" — is a genuine (though subdued) pleasure. His fluent playing is articulate, subtle and emotionally contained reflecting his affinity for classical Eastern music. Devotional music without being overbearing. Even though I kept hoping Coughlin would cut loose a little bit, I recommend this offering wholeheartedly. Coughlin's gentle virtuosity is in its own class and deserves attention. — David Meltzer

CRASS: Acts Of Love (Fifty Songs To My Other Self) (LP; Crass Records, P.O.B. 279, London N22, England; dist. in U.S. by Rough Trade) Different than most Crass records, this is a project carried out by just three members of the band, and has more in common with classical music and opera than it does punk. Penny Rimpaud writes the words and music. Eve Libertine sings, and G creates the fifty terrific collages that illuminate the handsome 32 page libretto. Musical accompaniment is primarily electronic keyboards piloted by Paul Ellis who is not a part of the Crass core. Fifty brief songs are sung. The lyrics are Taoist in their simplicity and regard for man's place in nature: "Yesterday I laughed with you/Yesterday the song of the earth rang in my ears/Sweet fool, listen. You can hear the song of the earth." Be it punk or opera, the far-reaching importance of Crass won't be proved or necessarily appreciated from single recording, but is based on a much broader view, one that takes in the band's entire catalog of recordings (including compilations of other band's music), their ideals, business practices, lifestyles, literature and various provocative accomplishments — one of the most important being their refusal to tour the U.S.A., preventing the mainstream American mass media from labeling the band, distorting their messages and turning them into a cheap punk circus act. Crass succeed despite breaking established rules/dogmas for success, and that alone pushes down barriers for the rest of us. — David Claffardini

CRAWLING WALLS: Inner Limits (LP; Vox, needs address) One more band cashing in on the re-hashing of '60s garage rock. All the elements are here: the jangling guitars, the organ, the druggy lyrics, etc. All the elements but one: creativity. Crawling Walls show very few ideas, nor even an appreciation of '60s music's relentless drive. Crawling Walls music is tensionless and the lyrics trivial. — John Grooms

CRAWLING WITH TARTS: Loneliness (C-55; \$4; ASP, 312 Covered Bridge Road, Felton, CA 95018, USA) My Crawling With Tarts tapes always come with beautiful, hand-crafted cassette covers. They're not always easy to put back together, but... Maybe you're wonder how this one sounds? Keyboards, bass, guitar, voice, bells, percussion — it sounds recorded with a multi-track gizmo using mics more than direct line-in, adding more texture to the sound of the instruments. Very delicate beat, more poetic or jazz-space than rock. — Robin and David



THE DAVE: Lois (C; \$4 ppd.; 2269 Market #241, San Francisco, CA 92114, USA) Four-tracker in the kitchen. Lots of instruments — violin, cello, guitars, drums, xylophone, synths and female voice. The music suggested: The Shaggs, Marine Girls, Y Pants, Raincoats, Residents, and The Roaches. The Shaggs, Marine Girls, Y Pants allusion relates to the incompetent musicianship and female voice; Raincoats for unusual lyrics. Residents for uncommon melodies relying on repeated figures, and the Roaches for a pithy sense of humor. Add nursery rhymes, and happiness. I like this cassette a lot. It's full of hooks and simple cantabile melodies. If you like any of the earlier mentioned girl groups, you probably won't be disappointed. Highly recommended. — Jeff Wechter

BLIND JOHN DAVIS: You Better Cut That Out (LP; Red Beans, address needed) Intimate and homespun piano musings and vocals by 71-year-old Mississippi-born/Chicago-bred veteran blues pianist. All the tunes were first takes — the classical Chicago blues of Sonny Boy Williamson (the title tune and "Sail On"), to the subtle blues shadings in a sensitive rendering of Duke's jazz standard, "Mood Indigo," to a soulful version of "Born to Lose," to the blues/pop medley of "Frankie and Johnny/Canadian Sunset" (yes, it really works) to the rolling boogie of Davis' own composition ("Texas Tony"). Originality was never Davis' forte, but if you like to mellow down easy with your blues, this is for you. — Ron Sakolsky





FRA LIPPO LIPPI

IN SLANK' LP. THE DARK AND POWERFUL DEBUT OF THIS PREMIER NORWEGIAN BAND. MELODIC YET DENSELY TEXTURED GUITAR, SYNTH, AND VOCALS.

SMALL MERCIES LP. FILL'S RAVISHING SECOND LP FEATURES A LEANER, SPARSER SOUND THAN THEIR DEBUT. VERY NICELY COMPOSED AND PRODUCED, THE ALBUM WAS NOMINATED AS ONE OF 1984'S 10 BEST IN THE UK'S RESPECTED *MUSIC WEEK*.

THE TREASURE 12" EP. B-SIDE CONTAINS 2 PREV. UNRELEASED LIVE CUTS.

SAY SOMETHING 12" EP. NEW TRACKS, UNAVAILABLE ON LP.

HOLY TOY

PERFECT DAY 12" EP. THE BRILLIANT 4-SONG DEBUT BY THIS EXCELLENT BAND LED BY POLISH EMIGRANT ANDREJ NEBB. A READY MIX OF PUNCKY EXPERIMENTALISM, WRENCHING LYRICS, AND INSPIRED INSTRUMENTATION. JOHN LECKIE PRODUCED.

MARSEANA LP AND CASSETTE. HOLY TOY'S FIRST FULL-LENGTH LP IS 'A CLASSIC. OVER A STARTLING BACKING OF FREE FORM JAZZ AND ECHOING SYNTHS, A STORY OF RESISTANCE, DEFEAT, AND RESILIENCE... HEART-RENDING.' (*MME*, ENGLAND)

MEETING II 12" EP. MORE INSPIRED VINYL, UNAVAILABLE ON LP.

TIM STORY

IN ANOTHER COUNTRY LP AND CASSETTE. ACCLAIMED FIRST LP OF SPARSE, EVOCATIVE COMPOSITIONS FOR PIANO AND ELECTRONICS. 'CLEAR, CRISP, BEAUTIFUL INSTRUMENTALS.' (*OP MAGAZINE*) 'SUBTLE, UNCLUTCHED, TRULY ORIGINAL... ONE OF THE YEAR'S FINEST.' (*W. FENCHEL. NEUMUSIK*)

UNTITLED LP AND CASSETTE. 'AN ELEGANT, GRACEFUL WORK, *UNTITLED* PRESENTS A TEXTURAL SIMPLICITY THAT IS HAUNTING, MELANCHOLY, AND DEEPLY MOVING. ONE OF THE BEST AND MOST OVERLOOKED DISCS OF LAST YEAR.' (*PAUL LEMOS, SOUND CHOICE*) 'MOMENTS OF SILENT SUSPENSE THAT BALANCE THE LISTENER ON A KNIFE-EDGE.' (*SOUNDS, ENGLAND*)

THREE FEET FROM THE MOON LP AND CASSETTE. NEW RELEASE.

POPOL VUJI

AGNE AGNE LP AND CASSETTE. IMPASSIONAL, LONG-LIVED GERMAN GROUP LED BY FELICIA FRICKE. THE BRITISH PRESS SAID 'HAUNTING AND ADDICTIVE...' 'A REMARKABLE ALBUM', 'INTANGIBLE AS DREAMS AND SPIRITS, BLINDING IN ITS PURITY.'

BIRD OF PEACE LP AND CASSETTE. ALL NEW MATERIAL. NEW RELEASE.

EYELESS IN CAZA

PALE HANDS I WAVED SO WELL LP. THEIR HARD TO FIND THIRD LP FEATURES THIS BRILLIANT DIO'S IMPROMPTU INVENTIVENESS, WITH LESS EMPHASIS ON VOCALS THAN THE CHERRY RED RELEASES.

DOME

ALL YOU SPEAK THIS WORD LP. BRUCE GILBERT AND CRABAN LEWIS OF THE LEGENDARY GROUP BIRD, COLLABORATE ON THIS, THEIR FOURTH PROJECT. FASCINATING, UNCOMPROMISING NEW MUSIC.

VARIOUS ARTISTS...

BURNING THE MIDNIGHT SUN LP AND CASSETTE. SPECIALLY PRICED SAMPLER OF UNITON ARTISTS. INCLUDES TRACKS BY MOST OF THE ABOVE AND MORE. A GREAT INTRO. 'A FANTASTIC 10-SONG SAMPLER... MY FAVORITE COMPILATION OF THE YEAR.' (*ALTERNATIVE RHYTHMS*)

SENSE OF BEAUTY LP AND CASSETTE. A FINE COLLECTION OF CONTEMPORARY INSTRUMENTAL MUSIC FROM RIDD & ENO, PHILIP GLASS, PENGUIN CAFE ORCH., TIM STORY, AND MANY OTHERS. NEW RELEASE.

some or all UNITON releases available from; SYSTEMATIC, HOUSE, TWIN CITIES, SILD, EYE, BACKROADS, RRR, DEADLY, FORTUNA, WAYSIDE, PMT, HTS OF SPACE ETC.

OR BY MAILORDER:

- \$8.98 lp and cassette
- \$5.98 burning the midnight sun
- \$4.98 12" ep

UNITON RECORDS
P.O. BOX 415
MAUMEE, OH 43537

special offer-----

- for a limited time, we'll pay all postage, AND:
 - buy ANY 7 items and we'll send a free copy of FRA LIPPO LIPPI's 7" 45 SAY SOMETHING (w/pic sleeve, now out of print!)
 - buy ANY 3 items and we'll send a free lp or cass. copy of our compilation album BURNING THE MIDNIGHT SUN.



DEPRESS

ON THE OTHER SIDE LP AND CASSETTE. LAST LP BY THE SEMINAL NORWEGIAN ROCK BAND FRONTED BY FUTURE HOLY TOY PIONEER ANDREJ NEBB. ENERGETIC LIVE PERFORMANCES AND STUDIO CUTS.

ROLF TROSTEL

DER PROPHEZ LP. TROSTEL IS AMONG THE NEW GENERATION OF GERMAN SYNTHESTISTS WORKING IN THE HERILIN 'TRADITION'. DRIVING ELECTRONIC MUSIC.

KETIL BJORNSTAD

PRELUDES, VOL. 1 LP AND CASSETTE. A WITTY AND SINCERE COLLECTION OF PRELUDES FOR SOLO PIANO BY NORWEGIAN COMPOSER BJORNSTAD.
PRELUDES, VOL. 2 LP AND CASSETTE. NEW RELEASE.



UNITON RECORDS

THE WORLD'S BEST NORWEGIAN RECORD COMPANY? FINE EUROPEAN-MADE RECORDS AND TAPES, NOW AVAILABLE IN THE U.S., FOR LESS THAN YOU'D EXPECT TO PAY FOR A NEW AUTOMOBILE.



ANTHONY BRAXTON—We call up Larry Polansky at Mills College's Contemporary Music department. He sets us up to speak at a class taught by Anthony Braxton. We're thrilled. Braxton, a woodwind master, is an inrush of humility, warmth and enthusiasm. He immediately makes sure the music library subscribes to Sound Choice. He introduces us to his class, telling the graduate students to listen carefully, because we have something important to talk about—about what they can do with their music outside of academia. We give our rap and stay for the rest of the class and watch avant-garde music videos by some of his students. He compliments the students and tells the class that he too is excited about the possibilities of video. (Perhaps for the Opera he is writing?). At break I overhear Braxton discussing a student's recent performance. You didn't take it seriously enough, he counsels with a smile. "When you step into that magic circle it is very serious." As it ends up, the next album I buy is *LIVE AT WIGHOR* featuring Braxton and guitar improviser Derek Bailey. Way out there Jazz from June 30, 1974. (Although it doesn't seem to have been released until at least 1977.) I love it. Shortly thereafter I read Eugene Chadbourne's "Memories of the Jazz Age" for the first time. Blustery revelations engulf me, as I inhale my humble capacity.

GINO D'AURI: Passion Play (LP; Sonic Atmospheres, 14755 Ventura Blvd., Suite 1776, Sherman Oaks, CA 91403, USA) D'Auri is a fine guitarist; he plays with energy, and his execution seems flawless. There are four long pieces on this album—two uptempo, with castanets, and two that are more mellow. The music is electronically-enhanced (with "electrocystals") and flamenco-inspired, although I couldn't begin to guarantee its authenticity. A purist might recoil, but the improvisations sound first-rate to me. As in the East Indian raga form, there is substantial repetition, and the skill lies in the control of minor variation, nuances and techniques. — Bill Tilland

D.C. 3: This Is The Dream (LP; SST, P.O.B. 1, Lawndale, CA 90260, USA) A refreshing glimpse back at post-psychedelic heavy metal with songs that reflect a new feel for chemically influenced rock. Lyrics this side of Pink Floyd (Syd Barrett period) and just short of Meat Puppets abstraction; long, meandering jams with guitar/bass/organ interplay recalling Cream or Third Stone From The Sun or anything from *ELECTRIC LADYLAND* by Hendrix, that get over by way of synthesis instead of imitation without copying to the excessiveness of the period (long, boring, self-conscious solos, etc., see SWA) Rootsrock for the first-wave metal generation — John E

DEAD KENNEDYS: Frankenchrist (LP; Alternative Tentacles, P.O.B. 11458, San Francisco, CA 94010, USA) Except for two or three cuts, the songs are not as fast and thrashing as before although the band has lost none of its punch and are as tight as ever. East Bay Ray has expanded the sound with the addition of 12-string Bellzouki and synthesizer on a few cuts while retaining his distinctive, jangling electric guitar. Bassist Klaus and drummer Darren play as strong and forcefully as ever. Even more singular are the vocals of good ol' Jello Biafra. Unique? Well, how many hardcore vocalists can YOU think of who can utilize such trained vocal techniques as vibrato in the same breath with the customary banshee-like scream? The subject matter ranges from MTV and industry in general to air-headed jocks and rednecks. These and other issues are dealt with in a hilariously biting manner. Instead of mellowing with age, these guys are getting more pissed off. Some people have mistaken past songs like "Too Drunk To Fuck" or "Kill The Poor" as glorifying those ideas rather than sarcastically speaking out against them. Most of the new tunes, like "MTV Get Off The Air" leave little doubt of where the D.K.s stand. — Bryan Sale

DEADLINE: Down By Law (LP; Celluloid, 155 West 29th St., New York, NY 10001, USA) If you're interested in "diaspora music" that really works, this is it. If you've always wanted to know what an Aboriginal didjeridu would sound like in an electro-funk context, you got it. The wooden didjeridu, one of the most primitive instruments, turns out to be the perfect accompaniment to high-tech Laswellian funk. The didjeridu produces a deep note, which is heard as a drone broken up into a wide variety of rhythmic patterns, accents and tones by the skilful use of tongue, cheeks and mouth cavity. Once you've heard this sound, you're never likely to forget it (See AUSTRALIA; SONGS OF THE ABORIGINES, Lyrichord 7331), and Steve Turre does an excellent job of blending its unique voice into the avant-funk proceedings (using it to much better advantage than jazz trombonist Craig Harris does on the nevertheless interesting *ABORIGINAL AFFAIRS*, from India Navigation.) But wait, what's that harmonica doing in this mix, and Paul Butterfield at that? Well, ya know, Butter once played with co-producer Philip Wilson (of early Art Ensemble of Chicago fame) in the Butterfield Blues Band, so it's reunion time for these two in a "makossa" tune aided and abetted by funkateer Bernie Worrell on synthesizer. Oh yeah, you can dance to it. — Ron Sakolsky

THE DEAD MILKMEN: Big Lizard In My Backyard (LP; Fever Records, 621 South Fourth St., Philadelphia, PA 19147, USA) A tame, remotely punk album that many parents could tolerate. Musically it's a cleanly recorded four piece garage band ranging somewhere between Violent Femmes and Angry Samoans, adding occasional funk and psychedelia. The words poke fun at: human quirks ("Nutrition"); organized religion and cults ("Serrated Edge"); politics ("Right Wing Pigeons"); love and crushes ("Laundromat Song"); etc. Words to 11 of the 19 songs are included on a lyric sheet. — Jeff Wechter

DEATH OF SAMANTHA: Amphetamine/Simple As That (7"; St. Valentine Records, P.O.B. 79118, Cleveland, OH 44107, USA) Although suffering from poor production, this reveals the ghost of Iggy, Doors, and Dead Boys. Solid garage sound with shouted/yelled lyrics. I bet these guys put on a good live show. — Robert Mendoza

Debie Menthal: Battre Campagne (LP; Rec Rec Music, Magnusstrasse 5, 8004 Zurich, Switzerland. Also available through Wayside Music) Whoa shit, who the hell are THESE guys??? Hailing from Switzerland, they are one of the most talented and adventurous new music bands around. They use jazz, rock, ethnic, and good old-fashioned weirdness to come up with a sound in the early Mothers Of Invention/Henry Cow tradition. The arrangements, sometimes fiendishly complex, require superb technical prowess. The incredible instrumental velocity causes either the hair on the back of my neck to tingle or a fit of laughter. — Bryan Sale

DEJA VOODOO: Too Cool To Live, Too Smart To Die (LP; Midnight International, Box 390, Old Chelsea Station, New York, NY 10011, USA) The promo says they "steal from blues, punk, country, R&B, garage rock... whatever we can pick up." Unfortunately, they seem to have lost whatever they've gleaned, because all that's left are vague rockabilly guitar licks and vocals that resemble a drunken Boris Karloff being strangled. — John Grooms Second opinion: If you dig the primitive sound, this one's for you. A la' The Cramps. Deja Voodoo subscribe to the jungle-rama school of rock combining pounding drums, bluesy, fuzzi-wah geetar and a vocalist who must be an only child. Sure it's evil, vile and redundant — but I love it! — Bob-O Walesa

JACK DEJONNETTE: The Jack DeJonnetta Piano Album (Landmark Records, 2800 Tenth St., Berkeley, CA 94710, USA) Although he is an acclaimed jazz drummer, throughout his career DeJonnetta has recorded albums that included himself playing piano. In his short-lived, rock-oriented group Compost, he functioned mainly as the group's keyboardist. So, although this is his first all-piano album issued in America (there were two Japan only LP's issued in the seventies), it should not come as a surprise. Side one cooks on lesser known jazz tunes such as Gigi Gryce's "Minority." DeJonnetta's fascination with Coltrane's catalogue (especially the Atlantic period) continues with covers of "Countdown" and "Spiral." He fares well over the lightning fast changes of the former. He also revises his own pretty, impressionistic ballad, "Lydia," first found on his NEW RAGS LP. Eddie Gomez on bass and Freddie Wailes on drums swing things along. The weakest track is the umpteenth version of "Time After Time" (yeah, the Cindy Lauper one) which is married by some un-funky synthesizer work and a rhythm that boxes everyone in, ending abruptly and sounding incomplete. This very good LP shows DeJonnetta to be a double threat. — R. Iannepollo

DENCON (3-song 7"; 12" single; ESYNC Records, P.O.B. 380621, Miami, FL 33238, USA) The records have a British feel but the label says Miami. The sound is smooth and slick, like a leisurely version of the Cars. "She Was Rocked" is a rockin', guitar-powered tune; the others are more sedate and purposeful. "Ferris Wheel" is a memorable, moody ride. Dencon's stuff is pop music with a dark side. — Bill Neil

THE DESCENDENTS: I Don't Want To Grow Up (LP; New Alliance Records, P.O.B. 21, San Pedro, CA 90733) They may not want to grow up, but their sound sure has. They still have a pumped-up punk approach full of humor and hubris, but now the guitar is fatter, the drums punchier, and the vocals more varied. The production and songwriting shows maturity that other Descendents recordings lacked (but didn't necessarily need.) Some of the songs are pure pop reminiscent of Big Star's *RADIO CITY* LP replete with smooth, melodious vocals and harmonies but with harder rock instrumentation. — John E

THE DESCENDENTS: Bonus Fat (12" EP; New Alliance, see address above) Hilarious adrenalin-fueled, teen-angst, classic west coast punk rock from these hardcore progenitors. Contains their "Ride The Wild"/"It's A Hectic World" single from 1979 on one side, and the incomparable "Fat" EP circa 1981 on the other. Great band; great EP. — John E

MANU DIBANGO: Electric Africa (LP; Celluloid, 155 West 29th St., New York, NY 10001, USA) Dibango's 1973 multi-million seller "Soul Makossa" seemed to open the floodgates for the current wave of African pop crossovers. Dibango mixes Cameroonian Makossa rhythms (themselves built on soukous, rumba and highlife) with New York/USA electro-funk à la producer Bill Laswell. The album features Dibango's band, the "Soul

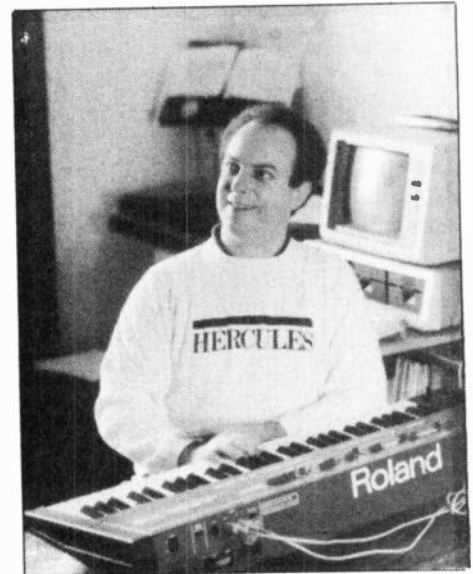

FLAND SAINTY—At home in his playground. Says he wants more writing about music, rather than personalities. I say write me some more stuff. He says he will.

Makossa Gang." Joining the band are such familiar "Sound System" stalwarts as Herbie Hancock and Aiyb Kieng, but Foday Suso is substituted on kora by Mora Kante on the only non-funky cut on the album so that his kora shines through in a way that Suso's never could on Hancock's record where it was easily lost in the mix. While Dibango has always consciously sought to break down African record marketing barriers by stirring heaping portions of Afro-American jazz and funk (and more recently, reggae) in with the indigenous rhythms, he is not naive about the inherent dangers. Dibango uses electro-funk to add to the African core of his music rather than vice-versa unlike the approach Laswell took with Hancock, an approach which seemed to use African instrumentation for exoticism alone. This album creates a diasporic blending without losing groove appeal. — Ron Sakolsky

DIE KREUZEN: Die Kreuzen (LP; Touch and Go, P.O.B. 433, Dearborn, MI 48121 USA) This is an old one, but... Twenty-three tracks from Milwaukee's most outstanding hardcore ensemble including six cuts from their great "Cows And Beer" 7". The sound quality is enough to have you on your feet applauding, but the wicked intensity of the music will slam you to your knees so fast you won't have any choice but to pray for mercy. Booming overtones of bassist Keith Brammer grind you through a demonic fest in the true spirit of mayhem. Wailin' guitar tracks accompany the searing shrills of vocalist Dan Kubinsky. The drum work is deep, clean and commendably loud, summing up this all-star lineup. This alone can be accounted an excellent example of realisticality and professionally produced underground American hardcore. — Scabies and Rabies

DIMTHINGS: Dis-Ci-Plined To A Spontaneous Way Of Life (LP; Thingsflux, 7829 Miramar Pkwy, Miramar, FL 33023, USA) A collection of loosely structured, highly eclectic recordings from a guy who calls himself Dimthings. The pieces run the gamut from environmental to studio experimentation to garage thrash, so it is

best approached with an open mind; not only do diverse styles but also do instrumental approach. As evidenced best on a version of Stevie Wonder's "Superstitions", looseness and gut-level lunacy take precedence over tightness and polish in the works of Dimthings. For me, the high point is "Transformed", a seven or eight part suite monopolizing side two. Many artists come to mind in this piece: early Zappa, Residents, Angkorcan, Skeleton Crew, Philip Glass, Gustav Holst, and you might hear many others. Aside from guitarist/bassist/cellist Jean Chaine, Dimthings applies his diverse and very weird talent exclusively through the miracle of four-track home recording. His enthusiasm is dominant throughout. Highly inspirational creative disturbance. — Michael P. Goodspeed

DIMTHINGS: In Spite Of What They Say (5-song 12"; see address above) Volume 3 of Dimthings' notorious "Garage Recording Series", provides a relatively fearless initial taste of this four-track free spirit. If spontaneous lunacy is to your liking, so it is to Dimthings. With just enough structure to distinguish the tracks, Dimthings bursts forth into these uninhibited flights of fancy with aggressive cheer. "There's a conspiracy going on that one can be aware of," he proclaims in the first cut, "and it wants one to be a way of it. Kill it! Kill it!" So said, he proceeds against the conspiracy of conditioning, conformity and complacency with flailed percussion, abrasive synth-noise, environmental chanting, creepy wailing and howling, and elaborate mutated orchestration. All done at home, all played by Dimthings, with the exception of guitarist Ron Brown on one song. While the level of musicianship and proficiency is uncertain, that is entirely irrelevant to this album's message. I mean, proficiency is conditioned thought, right? And conditioning is a social suppression and part of the conspiracy, right? Fuckin' A!! Kill it! KILL IT!! — Michael P. Goodspeed



THE DICKS

DOT 3: In The Desert (8-song C; \$4; Dot 3, 661 University Ave., Los Altos, CA 94002, USA) Exciting, dense layers of funky ethno-rhythms. Lots of killer drums. Occasional punchy horn lines. Quirky, strained vocals mesh with the overall effect of the music, which, considering the complex nature of the music, is an accomplishment in itself. This tape is guaranteed many repeated plays on my Walkperson. Neat tribal-looking insert and lyric sheet included. — Allen Green

THE DROOGS: Stone Cold World (8-song LP; address needed) These guys play psychotic-blues and power-pop reminiscent of The Plimsouls, Yardbirds and Seeds. Every song has strong muscle tone and lasting durability. I'd suppose these guys could best up The Fleshtones in an imaginary sixties' biker movie. — Jordan Dokes

DROWNING POOL (4-song C; \$3; IPR, P.O.B. 60357, Los Angeles, CA 90060, USA) Drowning Pool has progressed far beyond the definable categories of their last tape into a moody, atmospheric world of their own. Film soundtracks, '80s gloom and a little of '70s progressive rock all appear on this work, and though it is pretentious at times, the music is still uncomplicated and the instruments are played and treated effectively. The best track is "Toy Soldiers" with its haunting, obscure lyrics. — Lawrence Crane

TOM DYER: I Lived Three Lives (C-60; \$4; Green Monkey, P.O.B. 31983, Seattle, WA 98103, USA) Fifteen songs from the Green Monkey's main man. Good rockin' you bet. This tape's got 14 musicians playing drums, bass, guitars, and singing. Some song titles: "The Laboratory," "High School," "Girls Smoking Cigarettes," "Here Come The Communists," "Gutter Of Love," "Dedicated," and my favorite, "Complicated." "Life gets so complicated, complicated...." Good production and orchestration of talents. — Robin James

developed, and the transitions are natural. The quality of the music is matched by the first-rate recording, pressing, and packaging. — Mark Sullivan

JOHN ETNIER: The Dome (LP; Disques Dual, see address above) It's refreshing when people who really sound like they love to make music get onto vinyl. Etnier and friends aren't desperately trying to get commercial airplay — though much of the music has a distinct "pop" flavor. They use processed vocals, found sounds and lots of electronics, but it's all part of the music, not an artsy add-on. And although the group seems to draw a lot of inspiration from R. Stevie Moore's music and off-the-wall sense of humor, this is anything but a sound-alike album. The music goes from Eno-esque spaciousness to King Crimson guitar acrobatics to a smooth, almost AOR sound, with a little cocktail piano jazz thrown in for good measure. These guys sound like they had a good time making the album. — Paul Goldschmidt

EUROCK — A HISTORY OF PROGRESSIVE WORLD MUSIC CASSETTE SERIES: 1) German Roots; 2) German Electronics; 3) French Pioneers; 4) French Underground; 5) Italian Rock Renaissance; 6) Eastern European Progressives; 7) South American Fusions; 8) Zen Electronics (C-60s; \$6 each; Eurock Distribution, P.O.B. 13718, Portland, OR 97213, USA) For more than ten years Archie Patterson has been tirelessly promoting "progressive world music" through his EUROCK magazine and music distribution service. Recently he offered an eight-part continuing education course on the history of progressive world music. These are the tapes of that course. "Progressive world" is a somewhat fuzzy but nonetheless useful concept, which Archie traces back the late '60s and the Grateful Dead in particular — because it was the Dead who first invoked the expanded consciousness and eclectic spirit typical of this music. Progressive world music is diverse; the foundation is almost always rock music, but everything from folk/ethnic and jazz to Gregorian chant, opera and avant-garde electronics can become part of the mix. Progressive world music offers a creative reworking of musical traditions, with unpredictable and sometimes dazzling results. The eight tapes offer a mixed bag in several regards. Tapes #1 and #3 serve as historical documents. Some of the music sounds self-indulgent and dated — especially the Amon Duul and Faust selections — but are important representations of the early days of French and German progressive music. Tapes #2, #4 and #5 feature artists still active, and offer recordings culled from one or two points in their careers. Tapes #6 and #7 showcase relatively unknown musicians from geographically isolated areas. Tape #8 is a combination of historical document and esoteric sampler; the verbal commentary covers mainstream Japanese progressive quite effectively, but instead of Kitaro, Ito, Fumio and the like, the musical examples are from excellent but obscure artists such as Magical Power Mako. The music on all eight tapes, while it's not ultra high-fidelity, is adequately recorded. All the music sustained my interest; the selections were obviously chosen with care and intelligence. As for Archie's commentary, don't expect anything pedantic or rehearsed, but do expect a thoughtful, informed perspective. The audio fidelity of the commentary is not great and the pace is sometimes a little sluggish, but Archie's longstanding involvement as a distributor and collector gives him an authoritative point of view. — Bill Tiland

THE EX/ SVATOX: Pay No More Than 6 Fr. (C; Calypso Now, P.O.B. 12, Obergestri, 4 CH 2500 Biel 3 Switzerland) Two thrash rock bands back to back, recorded live. Evidently they are pissed off about all those missiles sitting around over there. The Ex has some Joy Division influences, maybe a bit more frenetic. The vocalist sings sometimes in German, mostly in English. Some song titles: "Long Live," "Pleased to Meet," "U.S. Hole," "W.K. Soldier." Svatox is good music for slamming to. Eleven songs including "Killtime," "Greyish Skyscape," "The Nineteenfortyfour House Of Fear," "This Could Be A Discobest." — Robin James

FAIRPORT CONVENTION: Gladys' Leap (LP; Woodworm Records, P.O.B. 37, Banbury, Oxon, England OX154BH) A brand new Fairport studio LP as fresh and original as when they began. Dave Pegg, Dave Matlock, and Simon Nicol are joined by Richard Thompson and Cathy Leung of The Albion Dance Band and violinist Sanders. Three songs were written in collaboration with Ralph



TIM YORLADOW—The driving force behind Maximum Rock 'N' Roll, he let us gab about college radio on the syndicated Maximum Rock 'N' Roll radio show. (See the March '86 MAX RGR for my article on the same subject). His straight gig is working in shipping and receiving at the university. When he gets home, he's at the Max 'N' computer working for a dollar an hour getting editions out like clockwork. He shows us a hate letter from Henry Rollins and tells us about a psychopath underground cartoonist from the east who publishes lies about him. But he's as much of a punk as anyone and he's not afraid to stir things up. He even has the courage to wear sparkly polished wingtips instead of Doc Martins.

from other parts of the world, specifically Ireland. They have a flair for both serious playing and fun and games; the latter exemplified by their tucking the theme from Woody Woodpecker in the middle of an instrumental break. Vocals on several songs are by Molly Mason (bass & guitar) who hails from the midwest as an alumnus of the Powder Milk Bleucuit Band (Prairie Home Companion). The other four all fiddle and double on another instrument as well. Included are original songs, adapted and rearranged tunes and several standards including the title tune which the band borrowed from Roy Acuff and Hank Williams and then added lyrics. The group works as both a concert and dance band, lending their summers to The Ashokan Camp in the Catskill Mountains where they teach workshops and provide entertainment for local festivals. To reach the band directly contact Jay Unger: Fiddle and Dance Workshop, R.D. 1, Box 489, West Hurley, NY 12491, USA; ph. 914-338-2806. — William Paul

DINO DIMURO: Dinosaur (C-46; Phantom Soil, 578 N. Gower, Los Angeles, CA 90004, USA) This gives home taping a good name. DiMuro is an accomplished guitarist/keyboardist/composer/producer and this outing proves to be a highly personal, genuinely charming, and yes, homey collection of diverse musics. Snatches of Steve Hackett are hurled against cubist Beefheart clusters flowing into Philip Glass synth-mantras. DiMuro sings and recites verse involving home jam sessions, a dead doggy, sibling pillow fights, and when it's over (much too soon) you kind of know this guy and his strange friends and you really like him. He's real; he has kind of odd tastes but he's a nice guy. It's good structured material with a generous smattering of dissonance, a variety of textures and energies, a fun sense of humor, and beneath it all, a person. — Michael P. Goodspeed

DINOSAUR: Dinosaur (LP; Dinosaur, 27 Jeffery Lane, Amherst, MA 01002, USA) Metalattings of hardcore, new wave, neo-psychadelic, and heavy metal, all clearly produced. The vocalist sounds halfway between Michael Stipe and Leo Kottke and one can hear influences varying from Neil Young to the Replacements and R.E.M. A lyric sheet would have been helpful. — Hudson Luce

RICHARD DIRLAM: Pure Saxophone (Minnesota Composers Forum, Market House, 289 East 5th St., St. Paul, MN 55101, USA) There's a fairly broad representation on record of orchestral and chamber music utilizing the saxophone as primary soloist, e.g., pieces by Glazunov, Richard Strauss, Revel, Paul Creston, Bizet, Debussy, Delibes. But recitals of compositions for solo saxophone are less readily available, despite that more music has been composed (in this century) for the saxophone than for the cello," according to Dirlam. His recent album is a stunning and diverse performance of solo saxophone music written by contemporary composers. Side one is devoted entirely to "Hänlecheyapi: Crying For A Vision" by Minneapolis-born Michael Aubert. Inspired by the death of John Lennon, Aubert's three movement work is a deep lament utilizing tape sounds as both texture and commentary to Dirlam's virtuosic saxophone part, exploring the instrument's unexpected tonal range. Side two presents three works: "Stockhausen's 'Tierkreis [Zodiac]'", originally composed for music boxes, a suite of 12 melodies corresponding to the planetary and astrological configurations; Kozu Masuda's "Piece breve," fusing Japanese tonality with European atonalism, turning Dirlam's saxophone into a shakuhachi one moment and then a chanter in gagaku modalities and then, without pause, edgy Schoenberg sound splinters; and, finally, "Tag" by Eric Stokes, a theater piece for Dirlam and a self-prepared tape, creating a fascinating dialogue, sonically articulate and propulsive. Dirlam's brilliant technique and exacting musicianship are as exciting as they are impressive. — David Meltzer

DIRT HEROES: Out Of The Basement Into Your Ear (4-song 7"; Propulsion Records, P.O.B. 1563, Flushing, NY 11354, USA) This is straightforward 60's rock with the guitar a little on the metal side. The best songs are "How To Act" and "Reincarnation," the latter being thoughtful and quieter than the others. They need more power in the vocals. — Miki Pohl

DOG AS MASTER: Black Body (C-46; Cause and Effect, 5015 1/2 N. Winthrop, Indianapolis, IN 46205, USA) One long, lo-fi, tape noise loop; the start of each side fits with the end of the other. Stuff keeps merging with more good stuff: drone saw electronic gets thicker/rises, insects sliding, loopy tones, Xmas birds, organ heavily treated, cough loop white noise, sinister atmosphere guitar thins out, beep beep male voice, steel drum gregorian chants, radio voice machines pulse high interference vocal loop, she laughs, alarm tone click click drone — wish I didn't have to keep getting up to turn this one over. — CDinA2

STEVE DOLLINGER: What The Fuck, Who Cares Anyway? (C-20; 1629 S. Michigan #305, Villa Park, IL 60181, USA) Seven enjoyable songs with synthesizer, guitars, percussion and occasional vocals ranging between synth-dance and all electronic numbers. Also heard are Julie Dollinger, David Crigger and a recording of Quentin Crisp. Created in a small home studio, the material is as sharp and slick as any vinyl disc recording. It has melodic sensibilities that are accessible to more people than either art-noise or the brutal low-tech garage styles that I like so much. — Robin James

EDEN'S REBELS (4-song 12"; ESYNC Records, P.O.B. 380621, Miami, FL 33238, USA) These good ol' boys mean to sound like Trouble, but this amalgam of southern rebel rock (i.e. Allman Bros., Marshal Tucker Band and The Outlaws) is pretty tame. The guitarist, Dave Cabera, is all cliché. Vocalist Smin' like bears resemblance to the dark, gruff tone of Jeff Waryan and successfully evokes the rebel image. "Bang Bang" carries a good hook. — Scott Jackson

E'TH'0: Land Of Opportunity (LP; Demon Records Ltd., Brentford, Middlesex, England) Band from Madison, Wisconsin finds fame and record deal in England on Elvis Costello's label. The music could be grouped into the new "American music" revival but why are they on an English label? Could be because they also sound like a ballier early solo Nick Lowe with more spiritual overtones. I'm guessing when I say some members might be Christian by hearing "Me & Jesus Christ" and other numbers with ethereal references, not to mention that they are helped out by T-Bone Burnett on a bluegrass spiritual stomper called "Blue Mountaintop." Other numbers have a dense, country/powerpop/Merseybeat sound with good lyrical insights. — Jamie Rake

88: Closely Guarded Secret (12" EP; OHP, P.O.B. 30042, Knoxville, TN 37930, USA) Sounds like the kind of band you see at a club in a college town who plays originals and everyone dances and has fun. The only problem is that you forget the songs the next day. Rough production (guitar mixed very low), and no new ideas. A mix of King Crimson pop and Gang of Four repetition. — Lawrence Crane

ROBERTA EKLAND: Go Tell It On The Mountain (C-20; Cause and Effect, 5015 1/2 N. Winthrop, Indianapolis, IN 46205, USA) Side two is my favorite. "Manifesto" uses voice, piano and theramin to create a swirling, hypnotic enumeration of various facets of sexual passion. The latter portion of "Ha-Ha" is a fascinating noise experiment using tape manipulations to, at once, tickle and torment the ear. Side one is an experiment for multi-tracked voice. John Giorno is the clear influence for "Some Days" (in fact — Ekland even mimics his delivery toward the end of her poem.) So then why does this effort end up sounding anonymous and incomplete to me? Because Ekland starts out side one sharing personal experience with the listener in an open and direct way. She then abandons self-disclosure for more general material on side two. It's unfortunately at a point when her persona is about to further evolve or come, perhaps, to some resolution of conflicts. Still an enjoyable tape, but...Roberta, I hardly know ya! — Oleh Hodowanec

EMILY: Neat And Tidy In Your Mind (C-30; Mo-Da-Mu, 374-810 W. Broadway, Vancouver B.C., Canada V5Z 1J8) Low-key and impressionistic gloom-rock with pointedly depressing lyrics. Lacks punch, meandering around minor keys and sounds a bit muddled, probably intentionally. Velvet Underground a possible influence. — Tom Furgus

ROGER ENO: Voices (LP; Jim Records, South Plainfield, NJ 07080, USA) Produced by Daniel Lanois and treated by his older brother Brian, this beautiful solo album features Roger on piano and various electronic keyboards. The music is largely centered on Satie-esque piano figures over which are laid layers of euphonious electronic sounds. That the record has such a peaceful, soothing effect is not surprising. Prior to being recruited by Brian to collaborate on the Apollo soundtrack album, he had supported himself by working as a music therapist at a hospital. Stylistically influenced by Satie, other musical points of reference would include Harold Budd and ZNR. My appreciation for this work continues to grow. — Robert Ott

JOHN ETNIER: Arterial (LP; Disques Dual, P.O.B. 4395, Sta. A, Portland, ME 04101, USA) This is the score for a multimedia dance performance. Etnier plays synthesizer and piano, plus occasional marimba, guitar, percussion, and birdcalls. Others contribute drums, bass guitar, electric guitar, and trumpet. There's also a little girl reciting Darwin and a boy's choir. This eclectic music calls to mind Eno (in the ambient synthesizer sections), David Bedford (in the recitation and choral sections), and ECM-style jazz (in the ensemble sections) — and that's only a partial list. It is remarkable how well Etnier makes it work. The two parts of the piece flow smoothly, despite the stylistic diversity; ideas are fully

explored. — Steve Hill
STREET STREET: Street Street (LP; Phono, 127 Irvington, NY 10533) This quintet from Philadelphia is co-lead by vocalist Wendy Simon and vocalist/pianist Eric Shaw and includes Tony Williams (alto sax), Craig Thomas (bass), and Tony Green (drums). The music is vocal jazz in the tradition of Lambert, Hendricks, and Ross, and similar to numbers by Manhattan Transfer and Rare Silk. In fact, if you can put up with the Transfer's campier material because it's so well done and because it's mixed in with some great bebop singing, you'll enjoy this LP. Included are versions of "Everybody's Boopin'" (even faster than the LHR original), "Take The A Train" (wherein S & S have nice scat exchanges with Williams), "Jumpin' With Symphony Sid" (King Pleasure's lyrics to Lester Young's music), and an exhilarating version of "My Favorite Things", with several choruses of new lyrics by the leaders. Strong performances from all involved. — Bert Grooms

THE FALL: The Wonderful And Frightening World Of.... (LP; PVC/JEM) A U.S. release of one of 1984's best albums, with the inclusion of the EP-only tracks "C.R.E.E.P." and "No Bulbs." If you're looking for pop songs like "C.R.E.E.P." then "Slang King" and the rockin' "Lay Of The Land" are recommended. The rest is pure Fall, sometimes irritating, sometimes amusing, completely incomprehensible; in other words, brilliant. My only complaint is that there's not enough Brix on vocals. — Calvin Johnson

THE FAT BOY INTERNATIONAL BAND: Do The Postman (4 song 12"; \$5.75 ppd.; Jumbo Beach Records, P.O.B. 933, Cambridge, MA 02238, USA; ph. 617-354-5859) Well produced, dance-oriented material. There are two standout songs, "Change The Driver" and "The Promise Of Our Silences", the latter featuring fine pop/funk lead vocals by Sheila D. Winn. — Jim Butterfield

FELA ANIKULAPO KUTI: Army Arrangement (LP; Celluloid, 155 West 29th St., New York, NY 10001, USA) Fela has been lionized for his political resistance to neo-colonialism and military rule in Nigeria (which has imprisoned him) and his promotion of Pan-Africanism. However, despite his struggle for African liberation, he has been criticized for the formulaic sameness of his recordings in the last decade. Perhaps reacting to this, changes emerged when his band's name was switched from Africa 70 to Egypt 80. While musically-speaking, this was merely a superficial change, the mix for the band's recent LIVE IN AMSTERDAM album was done with reggae producer Dennis Bovell, creating the first Fela album in years with a somewhat different sound. On this record, Fela's working band and the brilliant trademark horn arrangements are augmented by the likes of P-Funk veteran Bernie Worrell on Hammond B3, Aiyb Kieng on Yamaha RX 111, talking drum, chatan and cowbells, and, on the title track, reggae superstar, Sly Dunbar, on Simmons drums. The result retains the rhythmic punch of Afrobeat and the lyrical bite of one of the world's foremost oppositional songwriters, while adding new layers of sound. The change is subtle enough not to bury the essence of Fela's propulsive thrust but rather to envelop his saxophone in a post-James Brown techno-tribal framework. So if you be "government chicken boy," "army Zombie," or "African colonial soldier," watch out — these songs are musical barbs aimed at you. It would have been nice if Celluloid included informative liner notes. When was it recorded and where? It is listed as a Fela/Bill Laswell production. Does this mean it was recorded before he went to the joint or, more likely, that Fela produced this record for Yaba Music and then turned the tapes over to Laswell, who subsequently added the Worrell, Dieng and Dunbar tracks for a 1985 release? If this is the case, did Fela collaborate on these additions before it was released, or did Laswell just go ahead without his having heard them first? Fela has said that music is his weapon, and it would be nice to know to what extent he was consulted by those who have taken up the sword now that he can't wield it directly. — Ron Sakolsky

FERIAL CONFININE: Meiosis (C; Broken Flag, c/o Andrew Chalk, 18 Fellbrook Ave., York, England, YO2 5PS) At points one of the most intense aural assaults I've experienced. The project is master-minded by Andrew Chalk. Side A is an extended piece of harrowing, relentless multi-layered feedback, grinding metal, tape manipulation and electronics that will pulverize you after five minutes. The level of intensity and volume separates this from similar noise oriented material. Chalk pulls out all the stops and impresses with the purity of violent sound. Side two presents a very different aspect of Ferial Confinine's work. While retaining its intensity, the material is far more subtle and expressed texturally, atmospherically and dynamically. The electronics swell in and out of the mix, and are combined with processed voices, percussive accents, and interesting use of tapes. A very strong debut, at times recalling the sounds of New Blockaders, Organon and Mb, and indicates great future possibilities. Very serious material! — Paul Lemos

FIDDLE FEVER: Waltz Of The Wind (LP; Flying Fish Records, 1304 W. Shubert, Chicago, IL 60614, USA) Here is a five-piece bluegrass band from upstate New York who do Bill Monroe proud. They combine the traditional American fiddle sounds with those

Buckout St., Irvington, NY 10533) This quintet from Philadelphia is co-lead by vocalist Wendy Simon and vocalist/pianist Eric Shaw and includes Tony Williams (alto sax), Craig Thomas (bass), and Tony Green (drums). The music is vocal jazz in the tradition of Lambert, Hendricks, and Ross, and similar to numbers by Manhattan Transfer and Rare Silk. In fact, if you can put up with the Transfer's campier material because it's so well done and because it's mixed in with some great bebop singing, you'll enjoy this LP. Included are versions of "Everybody's Boopin'" (even faster than the LHR original), "Take The A Train" (wherein S & S have nice scat exchanges with Williams), "Jumpin' With Symphony Sid" (King Pleasure's lyrics to Lester Young's music), and an exhilarating version of "My Favorite Things", with several choruses of new lyrics by the leaders. Strong performances from all involved. — Bert Grooms

FILL IN THE BLANKS/ SWING SET: Two Bands, One Cassette (C-80; Quikity Tape Labs, address needed) One drummer and two different approaches and a bunch of other guys coming and going. Fill In The Blanks is kind of traditional, lounge jazz and Swing Set proffers the more avant-garde policy. I like 'em both. I think yer jazz lovers would sneer at the naive but that is what puts it kind of in the rock vein. It has a warm feel. Swing Set gets too academic at times. Recorded at Ethos Studios it says. In the bathroom? — Evan Schoenfeld

FIRST LIGHT (12" EP; 4308 E. 173rd St., Cleveland, OH 44128, USA) Well done pop-reggae. Of the three songs, "Musical Uprising" is the most traditional. "Holdback Syndrome" is a pop-adult song in reggae trappings. The final selection, "Movin' On" is powerful and has a surprising electric guitar solo (somewhat heavy metalish) right in the middle. — John L. Basalla

THE FLIES: Got Wise (LP; Homestead) A three man unit with obvious ties to the garage band sound. However, unlike other '60s inspired bands, they do more than just slavishly copy song structures, instrumental textures, and punky attitudes. The Flies take the '60s sound and filter it through an '80s sensibility. There's a tempo that's faster, more modern, as well as space in the arrangements allowing fluid rhythms and raw, grungy guitar. Fans of The Replacements would feel at home here along with more '60s oriented listeners. Guitarist/lead singer Nate Freedberg wrote eight of the ten songs here, and they all share strong hooks, catchy lyrics, and lean, tight grooves. The mix buries the guitar behind the drums and vocals, losing some of the nastier sounds. Nevertheless, The Flies turn out some quality rock and roll here. — Scott Siegal

FLYING BURRITO BROTHERS: Cabin Fever (LP; Relix, P.O.B. 92, Brooklyn, NY 11229, USA) My expectations weren't very high for this, feeling it was just a poor excuse for some older country-rock statesmen to be a dead horse. But I was pleasantly surprised when my needle hit the opening track's groove. These performances of old Burritos, Byrds, Dylan, and Doug Kershaw chestnuts are uniformly sincere and quite often exciting, making superb use of Sneaky Pete's pedal steel and the vocals of Skip Battin and Greg Harris. — Charles P. Lamey

FLYING PIGS: Mexican Diverse (C; Flying Pig Productions, Box 4251 Duke Station, Durham, NC 27706, USA; ph. 919-493-7786) This foursome from Durham produce light garage rock arrangements on 13 original songs by guitarist/keyboardist P.J. O'Connell and two covers including the classic "Modern Don Juan." These are mostly crisp, mid-tempo guitar-based rockers with versatile guitar work and finely crafted melodies. On a couple of songs the Flying Pigs sound tentative but for the rest of the tape these Carolinians deliver solid, good-humored tunes with insightful lyrics about, among other things, relationships, social pretensions, and the end of the world. — John Grooms

FOR AGAINST: Autocrat/It's A Lie (7"; Republic Issue, P.O.B. 5794, Lincoln, NE 68505, USA) This kind of music (pop rock mood music, a la England's The Sound) is deceiving; the first time I listened to this I found it boring but after repeated listening it crept up on me, drifting in and out of my mind, mysteriously and eternally. Memorable moments included fluttering wind chimes with a somber bass on "It's..." Their lyrics are about alienation,

60 min. case \$35-yearly (6)
 \$6 - per issue

Tellus: the
 Audio Cassette mag.
 143 Ludlow (#14)
 Ny Ny 10002

MASKING TAPES

RUSS SPIEGEL - PASTURE FOR REBELS.
 Spiegel's first tape, a mixture of Jazz, Reggae and electronic. Includes insert and a hand painted cover. c-50 \$4.-ppd

DOC WOR MIRRAN. Their first tape, re-released. Combines poetry and electronic music. Includes poetry sheet. c-60 \$3.- ppd

Order both tapes and receive Doc Wor Mirran's first poetry booklet free.
 Joe Raimond
 Am Elfengrund 71
 6100 Da-Eberstadt
 West Germany

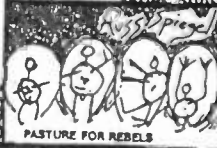
Manifest Ecstasy

9 selections on a one hour cassette
 by Peter Stenshoel
 Numazu 001
 Sound collage and intuitive overdub with a respect for ambience, synchronicity, and quirks of the recording process. The theories of Dane Rudhyar meet Messiaen, New Order, Terry Riley and Cecil Taylor. \$6 pp from P. Stenshoel/4249 Pleasant Av. S./Minneapolis, MN 55409
 As heard on The Little City in Space show.

Redux Records
 1310 College Avenue
 Suite 1030
 Boulder, Co. 80302



c-60
 \$6.-ppd

ROOM 4291

ROCK HUDSON

BY

K.G.B.

SEND \$ 3.00
 TO

VELVET ELVIS RECORDS
 P.O. Box 23336
 Minneapolis, MN. 55423

ROCK

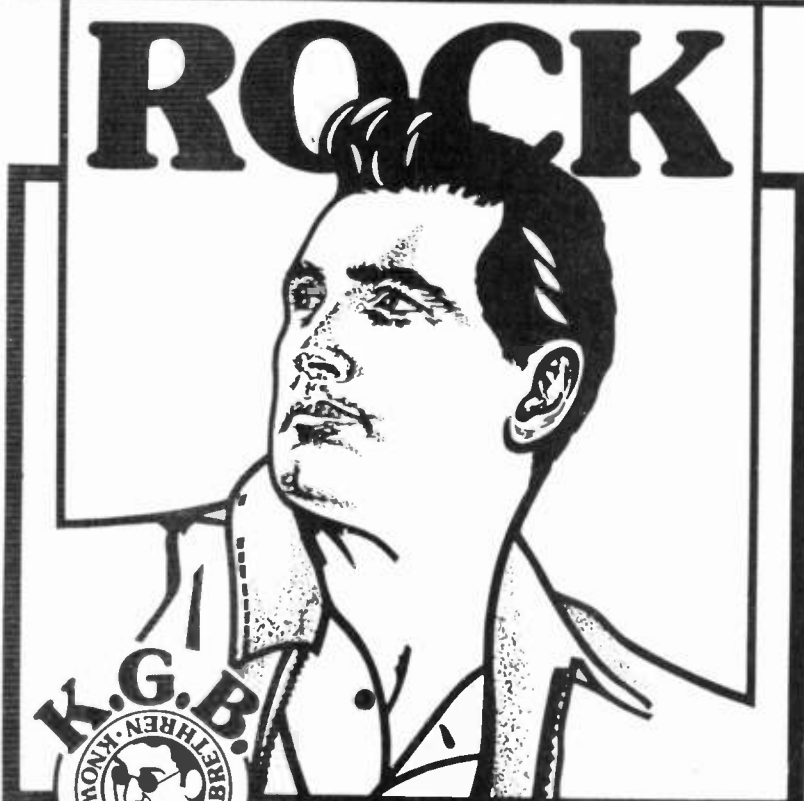

K.G.B.
 KNOWLEDGE · GOD · BELIEF

THE FORM: It Happens That Way/All The Young Dudes (7" Twin/Tone Records, 2541 Nicollet Ave. So., Mpls, MN 55404, USA) On the A side you're treated to a thunders riff that's tuned into the years 1977/78. Early Ramones with a punchy, wailing moan riding over top. Lead Form Nic Santiago is a welcome voice with a playful wit and a passion for The Runaways. — Scott Jackson

PRESTON FRANK AND AMBROSE SAM (LP: *Archie Records*, 10341 San Pablo Ave., El Cerrito, CA 94530, USA) Half of this record is devoted to Preston Frank and his Swallow Band and the other to Ambrose Sam. The Frank side is more modern with a streamlined sound retaining that accordion and fiddle heavy Cajun style which pumps out and never lets up. Cajun releases in the last few years have increased and more and more of them are from West Coast emigrated Cajuns. This record though is straight from the Bayou country of Louisiana and the feel and approach retains those beautiful quirks which make the music distinctive. Frank has these quirks in good supply but it is Sam who really makes the old time Zydeco come to life with his accordion. — Keith Wilson

DAVID FRISHBERG: Live At Vine Street (LP: *Fantasy*) On this solo live recording, jazz songwriter Frishberg strolls through several gems with his piano. Performing his own tunes, some co-written with others (notably Blossom Dearie), and a medley of Johnny Hodges tunes, Frishberg proves himself a gifted songwriter-performer. Armed with wit and style, he injects humor and melodic invention and delivers a winner. — Mark Dickson

FRONT 242: Politics of Pressure (12" EP: *Wax Trax!*, 2445 N. Lincoln Ave., Chicago, IL 60614, USA) After many EPs and two LPs recorded on their home 8-track, this Belgian group went into a 24-track studio to record this EP of aggressive electronic dance music. "Don't Crash" is more straight forward than usual, complete with lyrics, a melody and a powerful electro-bass. The band hits strong with their rhythm-oriented attack on "Funkadafi" which features manipulation of found voices speaking about the hippest of Libyan fashion-setters. On the flip side, the band presents "Commando (remix)" a new version of "Commandomix" off their early '85 NO COMMENT LP. This version is dragged out and extended to please the kid in all of us. If you are into the Cabaret Voltaire theory of big beat/rhythm over lyrical fluency, then check into FRONT 242. — Sam Rosenthal

FROZEN CONCENTRATE: A.Fre.Zen.Con.Cent.Rate (LP: \$10. Melted Productions, 312 Redmond St. #2, New Brunswick, NJ 08901, USA) A very Talking Heads big band sound with female singer Tina Maschi. Funky, slightly jazzy music, with lyrical ambiguity which suggests but doesn't force meanings. "Afro-zen" has jittery guitars and rollicking percussion and lyrics about meeting Buddha while getting a perm. "He/she/it" is about looking for oneself outside rather than inside and finding nothing there. "The Real Thing" rails at pompous "art appreciation" in museums by people trying to get laid. A well produced album — the rhythm section is hot. — Ed Blomquist

FUZZTONES: Lysergic Emanations (LP: ABC, 1-2 Munro Terrace, London, England, SW10 0DL) Ten tracks. Six '60s covers (from The Bold, Haunted, Godz, Kenny & The Kasuals, Sonics, and Calico Wall) and four competent and compatible originals. A bit tighter than their debut EP, the "Tones sound in top form and serve up a tasty revivalist, psych-punker here. I think the rarely-covered Godz would approve of this trippy "Radar Eyes" — now someone needs to do "Permanent Green Light." — Jack Jordan

GLENN GANT: Enlightenment On The Black Market (C-30: Club Abyss Records, 1141 N.E. 140 St., N Miami, FL 33161, USA) Intense, crass electric jazz pop. Lots of scat-influenced, stream-of-dungheap lyrics. High-speed copying quality but it's technically precise, if anyone could care. For those who are gullible and want some electronic decadence on their car stereos. Too many words — Evan Schoefeld

GARGOYLE SOX: As The Master Sleeps... (12" EP: *Metro-America*, P.O.B. 37044, Detroit, MI 48237, USA) The music is in line with English "gloom" music such as Bauhaus and Dead Can Dance. The failures of Gargoyle Sox unfortunately outweigh the successes. The lyrics are horror movie style like early Bauhaus, but are either dumb or predictable, and the vocalist seems to put little energy into making them work. The electronic drums become a detriment when they are not dynamic enough, as in "Sickness." This record could have been good, but not enough mood has been created to achieve the scariness they may have intended, and no new ideas are presented — Lawrence Crane Second opinion: Looking like the half black/half white aliens on Star Trek, the Gargoyle Sox duo invite you to bleed in a bucket. Soft electronics lead you into a haunted house of drum machine programs and heavy fuzz guitar. Metal percussion and harmonics ring out. A muffled underwater harmonica. A deep scary voice sings of pirates on a ghost ship — yo ho ho! Some gothic synth, marching drums, a bit of spaghetti western guitar. WATCH OUT! Someone's trying to break your neck — crack! Or worse. The rack, molestation, castration, lots more — CDinA2

GEOMETRY (4 song C, c/o *Empress Music*, P.O.B. 655, Urbana, IL 61801, USA) Geometry is Andre Kuzniarek on vocals, guitar, and keyboards, and Bill Webber on drums and percussion. They are both members of Crayon Rubbings. This tape consists of out-takes from a planned LP. The sound is very clean and full, and the lyrics lean to the socio-political. "I'm Not Afraid To Live Today" is anthemic with '60s metal overtones. "Playing With Fire" is about nuclear destruction. "Silence" recalls early Genesis and Van

Der Graaf Generator — lots of anguish and artistry. A fine effort. — Ed Blomquist

GLEAMING SPIRES: Welcoming A New Ice Age (LP, P.O.B. 1421, Hollywood, CA 90078, USA) Combining synthesizers with acoustic guitar and keyboards, The Gleaming Spires at times sound like Fairport Convention staring Roxo Music in face. The guitars ring like church bells, the vocals meander, and the whole project seems to have emerged from another dimension. As much as they seem to know about arrangements and production, they could use a tutor like The Cars for instance, to teach them a thing or two about hooks. At least they know where to go fishing. — Jordan Oakes

VINNY GOLIA QUINTET: Goin' Ahead (LP: 9 Winds Records, 6325 DeSota Ave., Suite J, Woodland Hills, CA 91367, USA) Multi-reedist Vinny Golia has a reputation for independence both in his complex music and his business dealings. His label, Nine Winds, has at least 17 releases of which GOIN' AHEAD is a bit of a surprise. A set of chordally-based freebop, this date has the impressive rhythm trio (usually featuring a walking bass) playing straight-ahead changes while Golia (on soprano and baritone) and trumpeter John Fumo are free to shift back and forth between the inside and the outside; alternating between playing conventionally and sounding more abstract. Of the six Golia originals, "Lib-Nan-Ave" is a moving ballad for Bill Evans; "Sez You" has some of the freest moments of the date; and "Squints" is a drunken struttin' blues dedicated to Robert Mitchum. "Foro Colombo", a perfect example of freebop, has a melody that is difficult to sing but also hard to forget, along with solos that explore many moods. A very impressive outing that, because it's more accessible than most of Golia's albums, serves as a perfect introduction to his dynamic music. — Scott Yanow

DEXTER GORDON QUARTET: The Shadow Of Your Smile (LP: SteepleChase Productions, 3943 West Lawrence Ave., Chicago, IL 60625, USA) Recorded in a noisy club in Stockholm by Swedish Radio in 1971, this release captures Dexter in good form, but with less than inspired support. Pianist Lars Sjosten is a little too smooth, but he manages a good solo on "Summertime." Drummer Fredrik Noren is steady but unexciting, and I'm not sure bassist Sture Nordin even knew the tunes. The situation leaves the leader with all the attention, but even Gordon can't remain inventive forever without some lively support. My favorite moment is Dexter introducing "Summertime" with a snippet of lyrics. — Stuart Kremsky

GRADE ULTRA: Hey Girl/What Do Women Want (7": Cats Voice Records, Box 564, Newburyport, MA 01950, USA) Sounds like some throw away Motels track. This is basic uninspired rock and roll of the wimp variety. — Robert Mendoza

THE GRAPES OF WRATH: September Bowl Of Green (LP: Network Productions, P.O.B. 330, 1755 Robson St., Vancouver B.C., Canada V6G J09) This pop trio features that good old ringing 12-string guitar backed by attentive bass and drums. Lyrics mirror love in an age of high anxiety. Instrumental chops are wasted on xeroxing the Athens' sound. The one Beatles cover ("Someone") is a welcome exception. — Norman Weinstein

GORDON GREEN/STEVE WOLLENBERGER: Improvised Piano Duets, May 10, 1984 (LP: Impossible Music, P.O.B. 659, Cambridge, MA 02238, USA) Two side-long duets bordering on the ambient/new age genre. Side One opens with a free-form exploration of cloudy tonalities, clusters, and jugged, splintery lines. The tumult soon subsides, however, into more pastoral meditations; indeed, most of the vitality and invention on this recording is contained in its first ten minutes. The remaining music is tonal in the tradition of Harold Budd circa THE PLATEAUX OF MIRROR: sighing, undulating swells and spare, lazy melodic figures. There is little movement, harmonic or otherwise and the overall effect is one of torpor. The empathy between the performers is exceptional — so much so that it is difficult to distinguish individual contributions. New Age aficionados will find this LP rewarding, although the brief atonal passage may daunt some. — Dennis Rea

GOVERNMENT ISSUE: The Fun Just Never Ends (LP, Fountain Of Youth, 5710 Durbin Rd., Bethesda, MD 20817, USA) One of Washington D.C.'s most prolific, seminal thrash bands, G.I. continues their departure from hardcore to hard rock on this 18-minute disk which sounds like a collection of leftovers from their excellent JOYRIDE album. On JOYRIDE they abandoned typical thrash speed (playing at about 70% max velocity), added big hooks, and preserved the HC spirit with frenetic drumming and intense guitar. On FUN however, they nearly eliminate thrash idioms and hooks. What remains is pre-'77 metal/rock. Unremarkable at best, boring at worst. — Jeff Wechter

GOVERNMENT ISSUE: Give Us Stabb Or Give Us Death (5 song 12": Mystic, 6277 Selma Ave., Hollywood, CA 90028, USA) Just when you thought hardcore was falling into a bottomless rut along comes this great EP by D.C.'s Government Issue (my copy's pressed on clear red vinyl) that's red hot and anything but generic. Every track is unique while sharing a strong rock approach with full guitar sound reminiscent of Minor Threat. "Written Word" almost comes too close vocally; the phrasing is straight out of the Ian MacKaye songbook; but overall this influence is fully integrated. The EP is in fact co-produced by Brian Baker who also shares background vocals on one cut: "The Next Time," a song that speaks directly to all the HC bands (and fans) out there in Rutland. "The scene is just an empty dream. And who wants to face reality?" The EP is proof the genre can evolve. — John E

GRAB GRAB THE HADDOCK: Four More Songs By... (12" EP: Cherry Red Records, 53 Kensington Gardens Square, London W2 4BA, England) Light folk-pop about love and relationships. Guitar, bass, light percussion and clarinet back up the subtle, unsteady vocals. An open, naive sound. — D. Maryon

THE GRIP: The Grip (C-30: Quality Tape Laboratories, 809 N. Russell, Portland, OR 97227, USA) I dunno, Quality Tape Labs churn out enjoyable music but I would give the actual tape quality an "uh" in fidelity. But one overcomes such a problem with simple production, as with THE GRIP. Good restrained arrangements of eighties technopop; you got yer Chrissie Hynde vocals, which I think are better than Chrissie's 'cause she gushes so much. Not very intense, but with energy and enjoyable pop junk. — Evan Schoefeld

NATHAN GRIFFITH: Waiting For Teast (C-60: Eugene Electronic Collective, P.O.B. 3219, Eugene, OR 97403, USA) Although many might compare this tape of solo electronics to a Tangerine Dream soundtrack, it is actually closer to the sound of Mother Mallard, a trio that was from upper state New York. They were the thinking man's answer to T-Dream. Likewise Griffith successfully blends counterpoint with synthesis and melodies that



JOE REES—Head Honcho at Target Video, a company that busted its ass documenting the San Francisco punk scene in the seventies. A long time San Francisco resident, Joe tells us "I've seen three of these waves come through (the beatniks, the hippies and the punks). Who can guess what the next one will be? Who could have foreseen punk? That was short and intense. The bands used to come to town and sleep on my floor. Some wild times." Joe's old studio burnt down the night he was at the Cow Palace seeing the Sex Pistols.

go somewhere. Most pieces are up tempo and average five minutes. While the timbre of the lead voices are relatively constant, the accompanying sequences and effects vary. They include gentle sirens, birdlike bursts, quasi-jaw's harps, plus ringing, gurgling, and stuttering sequencers. Overall, the weaknesses are some abrupt endings and too liberal use of vibrato — it's omnipresent. Also, the pieces tend to develop sluggishly. Flourishes and arpeggios remind one of Terry Riley's works at times. A respectable achievement. — George Ottinger

GEORGE GRITZBACK: All American Song (LP, Flying Fish Records, 1304 W. Shubert, Chicago, IL 60614, USA) A relatively pleasant record in the folk-blues mold cum Dylan/Bromberg ala Jerry Jeff Walker. There are no surprises as Gritzback puts forth the umpteenth patent on "cafe americana" with a little unrequited love thrown in. The moody clarinet is a nice touch, but Hoagy Carmichael did it better. His live audience no doubt enjoys the wry sense of humor, the heart wrenching personal touch and safe politics over their beers, but on record Gritzback is just another John Doe. — William Ponsot

GROUND ZERO: Pink (LP: Reflex Records, P.O.B. 8646, Mpls., MN 55408, USA) These guys are hip enough to know that if you wanna make real fun, you gotta play it straight. This teases the punk lifestyle while playing their music better than 95% of that crowd. Put these guys in a bag with Joe Pop-O-Pie, Camper Van Beethoven and Husker Du, as the sharpest of the young razzors "The 11th Hour Of The Skippy Peanut Butter Cluster" sounds so much like Zoogz Rift, I had to check the songwriting credits. A lot of this sounds like the album Neil Young and Crazy Horse might have made if they'd decided to go hardcore. Produced and engineered by Bob Mould (Husker Du) and Steve Fjeldstad. Only on "One Half Hour/The Legendary Rose" do they falter, blending a Beefheart style rant/poem with a jagged semi-hardcore

RadiosTations

Blue Tropic
 Fifth Column
 Billy Bragg
 Vance Frankson
 Giuseppe Saccide
 Ghoni
 Rising Tide
 Sakonny Popsi
 DeLanda Jullian
 Oregon Justice
 Michael Stevens
 Zelig
 Greek Copulation
 The U-1
 Home & Garden
 Rightleg
 Larry Douglas Rillet
 Scene Is Now
 Arms of Sorrow
 Phillip Perkins
 Luteacion
 Beath of Somaiba
 Ritual Slava
 African Heritage
 Dan Berquegn
 BPH
 Scratch Field
 Herb Moore

POLLUTION CONTROL is an indie only record and cassette promo service. The artists above are just some of the music we've distributed in 1985. Want more info? Write us for a complimentary copy of the PC Newsletter and our Radio Fact Sheet.

POLLUTION CONTROL
 1725 E 115 St Cleveland, OH 44106
 216-791-7286

BAMBOO SUN

Jack Spence

exotic, primal,

EQUATOR MUSIC
 12750 Pacific Ave.
 L.A., Calif. 90066

\$7.50 (pp U.S.)
 +\$1.50 (Foreign)

Real Time
 Chrome Cassette



WRITE
 THE ARMS
 OF SOMEONE NEW
 BOX 2081, STA. A
 CHAMPAIGN, IL 61820

I WOULD
 BE LYING IF
 I SAID THERE
 WASN'T SUCH A
 THING AS TRUTH?

SHARE YOUR MUSIC

Audiocassettes are the wave of the future for music distribution. Resolution is leading the wave with audiophile quality real-time cassettes for musicians all over the country. Let us help you put your music to work.

- *Fast turn around
- *No minimum runs
- *Custom Printing
- *Best prices
- *All real-time
- *From any master

PHONE NOW TOLL-FREE 1-800-862-8900 for your free brochure which explains how you can join the cassette revolution! or write:

Resolution, 1 Mill St., Suite A, Burlington, Vt. 05401-1514.

RESOLUTION
 VIDEO AUDIO AND FILM PRODUCTION

rave-up that sticks too many elbows in each others sides. One art-attack and eight great tunes, isn't too bad. The cover art is also kinda lame, but the record is good. — Geo Parsons

GROUP OF INDIVIDUALS: Destroyer Of Fun b/w The Sallow (7"; \$2, Geduzks Music/Single Wreckchords, P.O.B. 528200, Chicago, IL 60652, USA) Side A: Fast and basic hardcore with a hook chorus. Husker Du come to mind. Side B: Very weird song; fast with words spoken. Lyrics easy to hear and comprehend, even a bit precious. Instrumentation is rough and honest. Song is in the British-Damned school in a way, although they also remind me of the Replacements. Talented. — Paul Luchter

GUARDABARRANCO: Si Escalaba (If You Were Looking) (LP; Redwood Records 476 W. MacArthur Blvd., Oakland, CA 94609, USA) It's been a little over six years since the 40-year Samoza dictatorship in Nicaragua was overthrown by the Sandinistas. And although the attitudes of these artists may not speak for all Nicaraguans, they speak with beauty and eloquence. The mostly acoustic duets of Salvador Cardenal and his sister Katia are clear, timeless tributes to the hope and promise of a better future brought on by the Sandinistas. Hope, love, commitment and camaraderie are the subjects. The sentiments could easily have reflected our own citizens' attitudes after the American Revolution. An important document politically as well as a musical treat. All lyrics are sung in the native tongue, but English translations are included. — Mark Dickson

THE HAUNTS: Mademoiselle (C-60; \$6; Minoy, 923 W. 232 St., Torrance, CA 90502, USA) Rich, dense listening; lots of layers of happening at once. Sounds like zillions of loops at times; lots of activity in the high-frequency spectrum. Pulsing and terrifying, whistles and crashing, voices, little bells. The cover is fantastic, hand-drawn letterings and an interesting silhouette of a person on a stairway. The Haunts are Minoy, Richard Meade, Creature Thing, and Earle Lee Crumb. One side is titled "Mademoiselle" and the other, "Going Home." — Robin James

STEN HANSSON: Secret Connection (LP; Radium Records, Husargatan 5, 413 02 Goteborg, Sweden) Hanson, born in 1936, has been working within a wide range of artistic activities in experimental music and literature since the early sixties. His work is reminiscent of avant-garde purveyors like Cage and Tudor. On "Secret Connection" Hanson works with processed computer and acoustically generated sound. Side A is comparable to the more subtle, atmospheric works of Italian composer M.B.; a unified opus consisting of altered, non-rhythmic, non-melodic electronics, that gradually shift in tone and texture, producing a foreboding, trance inducing effect. Side B presents a wider variety of experiments ranging from vocal manipulation to the quasi-classical "Nightwoods" which features the sparse interplay of three processed clarinets. For Hanson "music (in the traditional sense) serves no purpose other than to separate man from pig." Through the use of sophisticated computer systems, sounds of his own body, sounds from his friends and other found sources, he has produced an album that evokes mental imagery and thought. A very worthwhile and obscure release. — Paul Lemos

SCREAMIN' JAY HAWKINS AND THE FUZZTONES: Live (4-song 12"; Midnight Records, P.O.B. 390, Old Chelsea Station, New York, NY 10011, USA) Recorded at Irving Plaza in New York but unfortunately, not much was going on. Hawkins' singing is in fine form, with some talking in tongues and voodoo mumbling. The backing by The Fuzztones is competent but not much more, consisting mainly of sparse guitar chords and keyboards. Save your cash for the Screamin' Jay LP recorded years ago, in which Hawkins put a spell on us all. — Bill Neill

HEAVY MENTAL (C; free while supplies last; Persistent Productions Ltd., P.O.B. 777, Evanston, IL 60204, USA) A four-piece garage band with a lead vocalist singing lyrics of suburban angst, with a heavy sneer. At times Heavy Mental sounds like any other grunge/garage and, while at times comparisons to such late-'60s bands such as The Brotherhood and Tomorrow (Keith West and Steve Howe) are appropriate, particularly on "Republican" and "Mr. Cold." The lyrics borrow from the Beach Boys, nursery rhymes, commercials, and the Beatles (they also cover "Revolution 1"), and seem more important than the music. The fidelity is only fair, as the bass is noticeably thin. The extreme stereo separation of the guitars is nice, however. Maybe with time and a better recording environment this band will fulfill the creative potential of its inspired name. — K. Crothers

MILTON HENRY: Who Do You Think I Am? (LP; Wackie's, 4731 White Plains Rd., Bronx, NY 10470, USA) Reggae vocalist/composer Henry is a superlative performer who has surrounded himself on this album with backing musicians including Sly Dunbar on drums, Jackie Mittoo on keyboards, and Max Romeo and Sugar Minott on background vocals. Songs like the title cut and "No Dreams" offer political realism grounded in personal pride that most commercial reggae these days can't even begin to pretend to achieve. Henry is more conventional sounding when he does romantic lover's rock in the vein of "Send Me That Pillow." But there is not a weak cut on this album due to Henry's throaty and piercing delivery. These are hypnotic songs filled with the emotional richness of a singer who turns his vulnerability into musical and spiritual strengths. — Norman Weinstein

MERBELF (C-30; 5912 Rossmore Dr., Bethesda, MD 20814, USA) Six songs: "Pig, Flora," "For All We Know," "Daddy," "Random House," "Autogenic Relaxation." Harsh screaming, industrial accompaniment. Uncompromising. This is one of the most daring and

upsetting tapes ever made. Singing and moaning at the same time with abrupt loud noises or grating and pounding. Some extended songs are so bewildering that the intent might be to provide entertainment that every artist or psychic would feel at home with. — Robin James

THE HONEYMOON KILLERS: Love American Style (LP; Fur Records, P.O.B. 20898, New York, NY 10009, USA) An industrial landscape of noisy hammering bombast; like, remember that movie "Kronos" where the mile high metal milk carton stomped around the beach in Mexico? Well if Kronos and all his pals had a big dance party, it might sound like this. Two Meta Hari/Tokyo Roses on drums and bass and Lydie Lunch (voice) boxes; one guy attempting a flamenco/junkie Johnny Rotten on the backcover, all dressed in black, though he sounds more like a strangled Iggy Beefheart. Think: Swans or Sonic Youth, but sorta poppier, yeah...noise-pop for a bad accident. — Geo Parsons

SHIRLEY HORN TRIO: The Garden Of The Blues (LP; Steeple-Chase, 3943 W. Lawrence Ave., Chicago, IL 60625, USA) A live recording of a 1984 concert at Florida Memorial College in Miami in tribute to an unused artist, Curtis Lewis. Lewis was one of the first black composers and lyricists to set up a Broadway publishing line in the early forties. Among the vocalists who have recorded his songs are Billie Holiday ("Now Or Never"), Ray Charles ("All Night Long"), Aretha Franklin and Helen Humes ("Today I Sing The Blues"), Net Adderley ("Old Country"), Count Basie and Arthur Prysock ("Gone Again"), and Shirley Horn herself ("All Night Long") on her debut album of the same name (SteepleChase 1157). If you like your jazz sophisticatedly urban, yet introspective and intense (this is definitely not cocktail piano), then Shirley is sure to please. For fans of Curtis Lewis, the high point of the album is the side long recording of his four-part suite, "The Garden Of The Blues," complete with Horn's spoken introductions from prose written for this piece by Lewis himself. Here Horn deftly weaves both music and prose into a wistful tale of city life from a personal point of view. Her piano shadings are the perfect foil for the vocal phrasing that has made her Miles Davis' favorite singer. The rest of the very capable trio is Charles Ables on bass and Steve Williams [replacing former accompanist, Billy Hart] on drums. — Ron Sakolsky

HOT TUNA: Historic (LP; Relix, P.O.B. 92, Brooklyn, NY 11229, USA) The acoustic side stems from a KSNB broadcast in 1971 and it's prime Tuna, with Jack Cassidy's jazzy bass runs neatly enhancing Jorma Kaukonen's brilliant, complex country-blues picking and stirring vocals. The electric side also comes from '71, but it was cut at the closing of the Fillmore and brings in drummer Sammy Piazza and violinist Papa John Creach. It too consists of inspired performances from all concerned. — Charles P. Lamey

RICHARD HUNTER: No Regrets b/w Pure Beat (7", Arf Art Records, P.O.B. 954, East Dennis, MA 02641, USA) No frills rock with vocalist Hunter (I presume) with a grating voice. Influences seem to be the Stax/Volt review but these songs lack the soul. The harmonica playing is a redeeming value. — Robert Mendoza

ROBERT HUNTER: Flight Of The Marie Helene (LP; Relix, P.O.B. 92, Brooklyn, NY 11229, USA) One of the most unusual albums to grace my turntable in months. Author/poet/singer/songwriter/Grateful Dead lyricist Hunter's latest is one long narrative set to an acoustic backing. The storyline concerns itself with a seven day voyage on the sailboat Marie Helene. On the surface this might appear too offbeat to appeal to anyone other than Hunter's cult following or rabid Deadheads, but Hunter's folksy delivery makes him a fine storyteller. It's a fascinating tale, and there's plenty of dazzling guitar picking, all of which should be appreciated by those who respect an artist who takes bold chances with his craft. — Charles P. Lamey

HUNTING LODGE: The Harvest (C-60; P.O.B. 1282, Port Huron, MI 48060, USA) The new primitivism of Lon Diehl and the various incarnations of Hunting Lodge, recorded in late '84 live in Detroit, Chicago, Boston, and Kansas City. Drones, guitar feedback, electronics, and chanted vocals, but mainly pounding tribal rhythms and metal percussion. "Is That Right?" features voices overlaid with electronics and percussion. "E.G.T.P.M." has feedback, and a click-click beat that builds into a sinister almost heavy metal anthem. "Learn To Will" is a spooky atmosphere of tone cycles, wavering feedback, and clanging. — CDinA2

CRAIG HUXLEY: Genesis Project (Double LP; Sonic Atmospheres, 14755 Ventura Blvd., Suite 1776, Sherman Oaks, CA 91403, USA) Huxley might be the ultimate trekky. When he was a kid he made guest appearances on the "Star Trek" TV show...remember the one where the kids took over the Enterprise with the help of "The Friendly Angel"? The oldest kid was Huxley. Nowadays, Huxley is a leading LA studio synthesist. His performances and programming have been heard on numerous TV programs and films including the three "Star Trek" movies. This album opens with a revamped version of the "Star Trek" TV theme, then proceeds with a broad sampling of Huxley's compositional and arranging abilities. The first of the two LPs contain a lot of typical sounding TV background music...kind of a laid-back southern California jazz sound you might hear in a "Love Boat" episode. The second LP contains adventurous experiments in microtonal tunings (including Huxley's own invention, the "Blaster Beam" — a massive bar of aluminum about 15 or 20 feet long with steel strings played with a "highly polished artillery shell casing." You may recognize the sound of this gizmo as being the enormous

"twang" whenever V-ger showed up on the first "Star Trek" movie.) The title cut is a newly recorded version of the piece Huxley wrote to accompany the "Project Genesis" sequences in the second and third "Star Trek" movies. Also included is music from the film "The Disappearance." Despite the blander moments on the first disc, this is a fine collection of sounds. — Allen Green

IDEALS: What It Is! (LP; Inner Sacrum Records, c/o Ideals, 1616 W. 8th #232, Austin, TX 78703, USA) All signs indicate these cards are having a good time. The 15 tracks range from Tex-Mex to jump blues to good old you-know-what (what? — DC), with a strong foundation in R&B to support it all. These Ideals have a sense of humor, too, covering topics from "Gun Control" to "Professional Attitude(s)" to "Breakfast Tacos" (an instrumental). Though fine musicianship and intelligence abounds, this sounds like a test drive. The Ideals are probably damn good live, though. — Scott Jackson

IF SWANA: Sex, Insanity, Death (C-60; \$4; c/o Al Margolis, 28 Bellagham Lane, Great Neck, NY 11023) Fifteen songs including "Tiny Bladders," "Insanity," "Los Pollos De Sabidorias," "Chicken Stamped," "Nuclear Winter," "Autoerotic Asphyxiation," "Captive Plastic," "Massacre," and "Sex." All weird sounding with strange electronic sounds, rhythm, beeps, ambient hums, growling and receding rumbles. Some are more melodic compared to her works in the "strange sounds" field. However, we're still talkin' huge clouds of pulsating light and metallic fluids. — Robin James

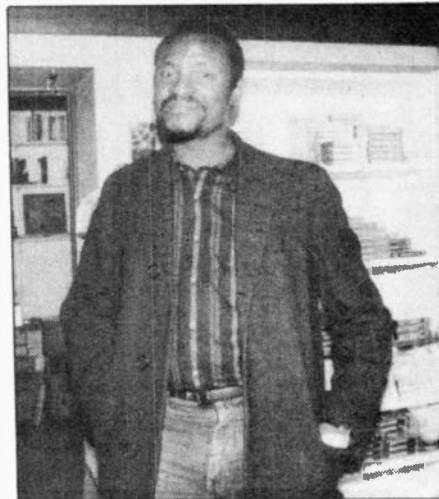

ETHAN—The boss at Fortuna Records, a label that developed when he helped a musician friend sell copies of his independent record. "Don't call it a 'new age' label," he says. "I like all kinds of music. I don't like the word new age. It's inaccurate for a lot of this stuff," he says while boxing records for customers and ad pointing to the racks of product behind him. We like Ethan, he likes us, and he writes a check for a full page ad. Way cool.

I LOST IT AGAIN: I Lost It Again (C-15; Quality Tape Laboratories, 809 N. Russell, Portland, OR 97227, USA) Is this poetry? A bored female says a bunch of random sentences: "The music — it was like underwater," "my painting's bleeding," and "I almost cut my hair," with bursts of electronics. Then, two treated voices describe a Grateful Dead concert — He: "Beautiful, nude, psychedelic, yeah." She: "So high, no possessions, cardboard shoes, like dogshit." Guitars riffing in the background. Then, a story of "being had by big tits," a real life incident. This is strange and funny stuff, not as wild as Negativland, but headed in that direction. It's Pat Baum's project — she writes, speaks, plinks, riffs, scratches, and gets her friends to help out with other voices and sounds. — CDinA2

INDUCHINE: L'Adventurier (LP; Clemence Melodie, 26 rue de Bessano, 75019 Paris, France) Le Peril Jaune (LP; Clemence Melodie; dist. in U.S. by Aphrodisiac, c/o Ben Kosman, 11 S. Clinton Ave., Hastings-on-Hudson, NY 10706, USA) First two albums by a top-selling French synth-pop band. L'ADVENTURIER (1982) has six songs with a wall of electronic sound and a rockabilly beat. Like the first synthesizer-oriented bands, the electronics carry the sound, and there are occasional bursts of twangy guitar and sax solos to relieve the monotony. Mostly an upbeat sound, the band doesn't seem to use the electronics with much depth. LE PERIL JAUNE (1983) shows the band's talents better, with digital recording and a wide range of electronic sounds. The music is much more varied, still very danceable, with a couple of standout cuts. As a concept album it's a little pretentious but I'd give the music a strong recommendation. — D. Maryon



SCARY
WORLD
COMPILATION
C-60 \$3.00

FEATURING: Room 291 No
Unauthorized Monochrome
Bleu Le Syndicat Psyclones Minoy
Skoptzies Blackhouse Vcidkampf
Josef K. Noyce
From: Sound of Pig Music
c/o Al Margolis
28 Bellingham Lane
Great Neck, NY 11023
USA

THE WOOFLES
Nick Booke + Dod Buckley

ART IS FUN + FUN IS GREAT
and vice-versa!

TO ORDER SEND CHECK
OR MONEY ORDER
TO: GRAPEFRUIT RECORDS
P.O. BOX 961
BRONXVILLE, N.Y. 10708
Add 1 dollar postage

- 1: 7" E.P. \$2.00
- 2: 60 minute cassette... \$4.00
- 3: 12" E.P. \$6.00

ORDER 2+3 and get the 7" E.P. FREE!

NOW AVAILABLE:

- 1: The Woofles 7" E.P.
3 songs! "Nice Funky
Touches and
Rhythmic Devices"
-OP mag
- 2: "A RECENT DANCE"
60-minute cassette
24 songs + experiments
"They get the most out of
purely sound-making
device in the neighborhood"
-OP mag
- 3: "STATE OF THE HEART"
12" E.P. 8-Songs
"Sensitive Pop and the
Spirit of experimentation"
-OP

NERVE CHORUS



▶ william clipman ◀

8 songs including the single "BILLY PAIN"

available on cassette from: **SILVERLAKE SOUND**
3371 East Silverlake
Tucson, AZ 85713
602-795-9047

\$5.00 each includes postage & handling ▶

OUT NOW! A MESMERIZING NEW CASSETTE RELEASE FROM CAMARADERIE MUSIC

LAUGHING ACADEMY



...a certain way of seeing!

Available at your local record/tape store (distributed by Resound)

Send \$3.00 (postage included) to CAMARADERIE MUSIC CASSETTES, P.O. BOX 488, 42 HINDEN STATION, BOSTON, MA 02215 (U.S.A.)

812-824-2400 **SIRIUS MUSIC**

New Tapes Out Now!!!

20 min. Cassette EPs from Bloomington's Wildest Bands

SALLY'S DREAM

"Midnight Matinee" — Tough, Melodic Rock & Roll

THE DEADBEATS

"Strange Tales—Amazing Facts"

— Post Punk Psychedelic Hardcore

\$4.00 each, mail order

Still Available:

Son of Segments \$8.00 mail order

(The Kentuckiana Compilation)

(40 song compilation cassette with local & area bands, complete with 36 page booklet)

"...if the beginning and ending sound crazy, you should hear the stuff in between..."

—Mike Leonard, H-T

"...Has me jumping up and down..."

—Chris Stigliano, Option Magazine

Playette \$4.00 mail order

(Rich Stim & MX-80 & Friends)

"If you call yourself an aficionado of post-

Velvets R&R you should get this..."

—Chris Stigliano, Option Magazine

Tapes available by mail from

SIRIUS MUSIC

611 Empire Mill Road

Bloomington, IN 47401

Boston's Underground Music Personalities
Posing in Jock Straps...

**ROCK
JOCKS**

**A PILLOW BOOK
FOR WOMEN**

includes members of:
DEL FUEGOS, VOLCANO SUNS, CHRISTMAS, FLIES, BLACKJACKS, SCRUFFY THE CAT, CLASSIC RUINS, OUTLETS, MOOSE & THE MUDBUGS, CHAIN LINK FENCE, CHILDREN OF PARADISE, SKIN, BAND 19, SWINGING ERUDITES, VALDEZ THE SINNER and more

ORDER YOURS NOW!

\$6.95 ppd

74 JAMAICA ST.
BOSTON, MA 02130

INTIMATE OBSESSIONS: Erebus To Hades (LP; avail. from Third Mind Records, 20 Spire Ave., Tankerton, Whitsable, Kent, England) Releases on Third Mind exist in the interstices between the more classically toned stuff of Tangerine Dream's soundtrack music and the itchy, fragmented angst of Cabaret Voltaire. This record lives on both sides of the fence and you may be inclined to come down solidly in favor of half of the album, as I do (the dance tracks are great, and the arty stuff a bit on the theatrical and pretentious side.) Stay away from the lyric sheet — it will make you wince — and simply enjoy a decent splintered rhythm 'n' bruise track and some effective whispered vocalizing. This is on the livelier side of the "slebs of electrodoom" school and deserves a nod for mixing High Art and High Pulse Rates. — Gregory Taylor

THE ITALY: Give Me Power (LP; Nighthawk Records, P.O.B. 15856, St. Louis, MO, 83114, USA) Sincere, catchy, traditional reggae from a vocal trio that has been getting a well-deserved good reputation. The Italys use Rastafarianism metaphorically to relate struggles of their people on a musical/poetic way with real mystic flair. The sentiments of "Physical Pollution" and "Material Gain" are universally philosophical. As for the music, it is deep-grooved though mostly mellow, with country-style horn tinges. You won't likely find this in a program of lover's rock — praise Jah. — Jamie Rake

JANDEK: Foreign Keys (LP; Corwood Industries, Box 15375, Houston, TX 77020, USA; \$6 ppd) Jandek continues to blow minds, outrage detractors, and charm and perplex fans. FOREIGN KEYS is a departure for this iconoclast who, as this release proves, is not immune to musical trends: this time invoking the Jandek version of the sixties garage-band psychedelia trip in its most raw, sincere form: a jefferson airplane years before the record deal, in some warehouse crash-pad, three hours after the sacrament, five hours before they knew they were a "band"; doin' their own thing, ya know, forgetting all that uptight structuring that the MAN teaches us; somewhere in the middle of it a female voice, the chick from across the street who was fooling around with that funky tape recorder, a Signe Anderson?, a Grace Slick?, conjures the microphone away from one of the glassy-eyed boys and starts singing her old man's poetry written on the back of a shopping bag when he was peaking. A guy kicks in on a drum kit he inherited last week when his brother got drafted to the war or a job at Bank America or somethin', what's the difference?; someone else with a guitar, the first time he's ever played an electric. Nobody has a reason, but it feels good; it flows somehow even though no one's listening, its beyond that, its a feeling. To anyone outside that warehouse of the mind and soul, it might sound like a mess, like a lost cause, but its real, so real...the imperfections, the clumsiness — and for a few moments, if you can forget about the establishment's glossy cover-ups of shamed musical souls, and you love, really let go and love, the music is beautiful, flesh and blood real; frail, imperfect, pathetic even, but human; music that you rarely hear but is always all around. An acquired taste for sure, but after 11 albums, it's definitely no put-on. — David Ciffardini

GREGOR JAMROSKI: Phylums In Flux (C; Jamroski, 4007 Whitman Ave., N. Seattle, WA 98103, USA) One man's music is another man's misery, but at this point I'm not too sure which side of the fence I'm on. PHYLUMS IN FLUX once again displays Jamroski taking his minimalist approach, using only a clarinet, guitar, and mussels (with no other treating or processing techniques) to create a multi-layered sound barrage. So, what does it sound like? A cross between the Plebs and a post-modern Philip Glass, along with an ample dose of entropy. You're probably asking yourself if this writer could be more exacting in his description — thank you, no. My closing words, "Welcome to the world of art-damaged basement tapes." — Mike Troughan

MAURICE JARRE: Dreamscape (LP; Sonic Atmospheres, 14775 Ventura Blvd., Suite 1776, Sherman Oaks, CA 91403, USA) Composer Maurice Jarre, father of Jean Michel Jarre (remember OXYGENE?), is trying not to let the '80s pass him by. Composed by Jarre and realized by Craig Huxley who uses synthesizers and drum machine here. If it was created by an orchestra it would have been more effective. In the same way Tomita has bastardized the classics, so too do Jarre and Huxley. Not that this is bad music, it isn't. The point is that electronic music has certain inherent qualities and the least desirable of which is the one which this album is based — the imitation of an orchestral composition. — Nathan Griffith

JFA: Live 1984 Tour (LP; Piascabo Records, P.O.B. 23316, Phoenix, AZ, 85063 USA) After five years and four pieces of vinyl to their credit (not to mention numerous compilation contributions) this highly touted group of sun-warped crazies has come out with a definitive collection of their most sought after hits. Recorded live in New York and Pittsburgh during their 1984 tour, these 20 songs showcase JFA like never before. Their unique fusion of thraash and surf music comes through loud and clear with the added bonus of wonderful renditions of War's "Lowrider" and the "Charlie Brown" theme (the Vince Giraldi Trio never heard it so good!). A thoroughly enjoyable LP that will appeal to the ardent JFA aficionado and greenhorn alike. Skateboarding and the desert playing roles in making JFA what they are today: a great band. — Mike Troughan

CHUCK JONKEY: Latindia (C; Jonkey Enterprises, 863 W. California Ave., Glendale, CA 91203, USA) When Jonkey is not trying to compose sugary pop love songs he almost succeeds in making listenable, gentle music. Side one opens with nice guitar/s

riter interplay over a catchy percussion track. The mood is immediately shattered, however, by rapid singing and insipid lyrics: "Baby, I want you, need you, got-to-have-you..." A universal sentiment, of course, in the East or West, but the way it is presented here is pure American pop. An occasional table in the background is about as far as the Indian influence goes on the cuts that have vocals (about half of the tape.) The dominant instrument is a standard multi-national major brand synthesizer. Sounds...OK, but there's not much of a heart there. The Latindia concept may be important to Jonkey, but the fusion never takes root in the songs themselves; that, I suggest, would demand a more rigorous commitment to the instruments unique to those country's indigenous musics. Production values throughout are good, even slick. — W.R. Borneman

THE KILLER BEES: Scratch The Surface (LP; Bee Hive Records, P.O.B. 50063, Austin, TX 78783, USA) Supposing there are more unlikely things than reggae in Texas, it is surprising that such a rough-and-tumble state would not produce harder riddims. The Killer Bees perform pretty, mainstream, poppy reggae with occasional thematic surprises, as in "Stereo" where a peaceful Rasta gets busted for cranking his tunes too loud. Strangest of all, though, is a tune called "Rastaman No Go Viet Nam." Just how many years ago did Tricky Dick haul home the soldiers? The music is modern-sounding with synths and such, not unlike Black Uhuru or Peter Tosh, but the vocals lack depth. — Jamie Rake

KING KURT: Read To Rock And Rain (LP; Ralph Records, 109 Minne St. #391, San Francisco, CA 94105, USA) The band proclaims that they are back on the road to rock and roll on this disc, and that seems to be an accurate assessment. Apparently from the U.K., the members maintain a sardonic style with titles like "Destination ZuluLand" and "Alcoholic Rat." Their forte is relentless boogie in the Dr. Feelgood mold, but they stomp on other musical forms in the samba-style "Banana Banana" and the pseudo-uptown version of "Mack the Knife." Rattling, machine-gun snare drum and blaring sax are coupled with gruff, bar room vocals as they advise the listener to "Gather Your Limbs." — Bill Neill

BIG DADDY KINSEY AND THE KINSEY REPORT: Bad Situation (LP; Rooster Blues Records, 2615 Wilton Ave., Chicago, IL 60614, USA) Lester "Big Daddy" Kinsey is a bluesman from Gary, Indiana who leads this band, which includes his sons Donald, Ralph and Kenneth. This is straight ahead Chicago-style blues, with a slightly contemporary touch (it's those background vocals.) Big Daddy plays a slide guitar with a heavy Muddy Waters influence — in fact, "Tribute To Muddy" sounds so close to the early '70s Muddy Waters band it's eerie. Son Donald is a fine lead guitarist of the Albert King school. Lots of good solid playing here. — John Baxter

RAMON KIREILIS: New Music For Clarinet (LP; Owl Recording, P.O.B. 4536, Boulder, CO 80306, USA) An album of new, conservatory-style pieces for solo clarinet and clarinet with tape or electronics. Featured on side one are "Rhapsody" by Wilson Osborne, "Composition For Clarinet And Tape" by David Olan, "Piece For Clarinet And Tape" by Edward Miller, and Laetantur Archangeli by Richard Toensing. Side two is devoted to a premiere recording of "Passages Of The Beast" by Morton Subotnick for clarinet and electronic ghost score, in which the sounds of the clarinet are altered with respect to pitch, timbre, loudness, and spatial location automatically and in real time. This is one in a series of 14 such pieces created by Subotnick for instruments and interactive electronics. The sound is excellent, and the clarinet playing superb. Kireilis teaches clarinet at the University Of Denver. — Chris Brown

MASAYUKI KOGA: The Distant Cry Of Deer (C-45; Fortuna Records, P.O.B. 1118, Novato, CA 94947, USA) Masayuki Koga is a Japanese master of the shakuhachi, a five hole bamboo flute used by zen monks for hundreds of years. Koga came to the U.S. in 1972 and has been teaching and performing here since then, as well as founding the Japanese Music Institute. This tape features three traditional Japanese pieces, three improvisations, and a piece by Koga. The sound of shakuhachi is unspeakably beautiful, and Koga evokes the full range of its expressive capacity. This is enlightened music indeed. Favorite cuts — bass shakuhachi improvisation, and "Shika No Toume" (the distant cry of deer), a 17th century piece "reflecting the sound of deer calling each other in the mountains." Highly recommended. — Ed Blomquist

KRONOS QUARTET WITH RON CARTER: Monk Suite: Kronos Quartet Plays Music Of Thelonious Monk, with Special Guest Artist, Ron Carter (LP; Landmark Records, 2600 Tenth St., Berkeley, CA 94710, USA) This amalgamation of high and low brow is neither fish nor fowl. It is audibly edible, not as jazz nor as classical music, but rather as very pleasant, nonobtrusive background music which from time to time intrudes on one's musical consciousness and then returns to a secondary auditory role. Whenever Carter's bass is present, those selections possess more jazz verisimilitude than the others, namely on the "Monk Suite" side of the album. The flip side is not quite up to the standards of the other, perhaps because much of it is devoted to the efforts of the quartet to interpret Monk's interpretations of musical selections penned by Duke Ellington. Excellently recorded. — Norman Lederer

RON KUVILA: Fidelity (LP; Lovely Communications, 325 Spring St., New York, NY 10013, USA) Kuvila is a composer and musical inventor who removes familiar sounds from context and exploits their acoustical properties through the use of homemade processing devices. His work tends toward the more academic

side of electronic music, but he possesses a greater sense of humor than many of his contemporaries, making for some refreshing experimentation. "Household Object," with its bursts of white noise and skidding Doppler effects, recalls Cage's "Fontana Mix" though the technology employed is vastly different — in Kuvila's piece the sound source is a cheap hand-held Casio. "Time" is a love song for alarm featuring talking alarm clocks blasting through multiple delay lines. "Keyboard Study" is a composition for electric piano played through a clock-like mechanism which accelerates the music; superficially the music sounds like a swarm of cicadas, yet reveals a fascinating subtext of overtones. One of the more noteworthy electronic/experimental releases in some time. — Dennis Rea

KU KLUX FRANKENSTEIN (4-song 12"; Crash Records, 203 Balacleva Rd., Caulfield 3161, Victoria, Australia; Ph. 03-527-5191) Bluesy acidic demon-rock. On "Well Hung Boy" we hear an attempt to marry Hendrix to Jim Morrison that ends up sounding more like Johnny Winter. Sorta post-punk '60s revivalists? — Geo Parsons



KATHERINE SPIELMAN—Editor of Puncture—The Magazine of Punk Culture. She told us she enjoys reading NME (New Music Express). I told her that all NME writers work for the major record labels and promote bands as being great and popular before anyone has ever heard their music. Yeah, but have you read about Jesus and Mary Chain? she asks.

DAVID LAHM: The Highest Standards (LP; Plug Records, 20 Martha St., Woodcliff Lake, NJ 07675, USA) After a serious trumpet drought in the 1970s (try to name one significant brassman to emerge in jazz between Woody Shaw in the late '60s and Wynton Marsalis in 1980), the trumpet has enjoyed a renaissance in the 1980s. In addition to Marsalis, Terence Blanchard, Wallace Roney and Vaughn Nark (among others), John D'Earth can be added to the growing list of potentially great players. D'Earth, who made a very favorable impression with his contributions to two Emily Remler albums in 1983-84, is heard here in a slightly earlier context as the main soloist on four of the six selections (all standards). Whether playing with emotion on "You Go To My Head" or sounding sarcastic on "You'll Never Walk Alone," D'Earth is in fine form, displaying his own personal sound. The other two cuts, moody piano/vibes duets for David Lahm and David Friedman, are worthy if anti-climatic. Recommended. — Scott Yanow

LAIBACH: Rekapitulacija 1980-1984 (Double LP; Walter Ulbricht Records, Durchschmitt 15, D-2000 Hamburg, W. Germany) Little had been heard from Laibach since their "Sila" 12" of a couple of years ago. During that time, however, they have carved out a prestigious position in Europe. Hailing from a small mining town in Yugoslavia, Laibach's music and live presentation are entirely political. Their attempt is to espouse the doctrines of totalitarianism, the bonding of the masses under one unified ideology, the voluntary abandonment of personal taste, faith, and reasoning, the acceptance of total depersonalization. This LP documents their most vital musical output of the past four years and



CHARLIE GOODMAN in his studio in Grover City, Calif. Goodman owns *A Hole In The Sky*, a small novelty shop that sells paraphernalia. He is an enthusiastic music supporter and networker. He has a radio show and helps book shows. His address is c/o *A Hole In The Sky*, 1111 Grand Ave, Grover City, CA 93433.

is rigidly structured and delivered with militaristic regimentation and coldness. The sounds of industry and war are recreated in Laibach's music, providing an appropriate backdrop for their manifesto, which is clearly narrated in "Mars" ("our work is industrial, our language, political.") In their own words, "Laibach is the pure politicalization of sound as a means of manipulating the masses." This potent political stance is reinforced by hammered steel and syncopated drumming, under which all manner of grinding, howling sound reverberates. Surface comparisons to Test Dept. and Neubauten are unavoidable, but in truth, Laibach's music is far more controlled, far more subtle and directed than that of the aforementioned groups. **REKAPITULACIJA** is a two record box set that is magnificently packaged with various rustic, cardboard prints depicting industry, work, and strength. Perhaps the manifesto is not for everyone, but it is articulately stated and reinforced by some stunningly powerful music. This is one of my favorites in a long time. — Paul Lemos

THE LAST POETS: Oh My People (LP; Celluloid, 155 W. 29th St., New York, NY 10001, USA) Great lyrics about this society we live in. "This Is Your Life" is a rap about the "madmen that man the controls" and nuclear war. Replacing the drumbox is talking drum and other percussion. "What Will You Do" has that line chanted continuously under the lyrics creating a hypnotic effect. "Get Movin'" sounds more like Funkadelic and, in fact, as with two other songs here, has P-Funk's Bernie Worrell on synth. This was produced by Bill Laswell who also played DMX drumbox on "Get Movin'" To my knowledge, this is the first album by The Last Poets that features music as opposed to strictly poetry. The words are intensely thought-provoking. — Tony Pizzini

BENJAMIN LEW/STEVEN BROWN: A Propos D'un Paysage (LP; Crammed Discs, 52 Rue Paul Louters, 1050 Brussels, Belgium) The second collaboration LP between former Tuxedomoon member Steven Brown and Belgian avant-gardist Ben Lew moves far beyond the obscure minimalism of their debut. This time, with support from Vini Reilly, Mark Hollander, Rami Fortis and Alain Lefebvre, Brown and Lew present exotically alluring, ethnically influenced compositions. The occasional integration of what sounds to me like Iranian vocal chants, Indian zither, and hand drums reinforce the exotic, multi-cultural sound. Through the eleven tracks, an evocative unified ambience exists as in Eno's *MUSIC FOR FILMS*. Lew's subtle use of electronics, tape and digitally looped, muffled percussives, provide a rich backdrop which Brown's sax, clarinet and piano glide over with Reilly's ethereal guitar chords. The warm, hauntingly beautiful tones and the creative, technical musicianship ensures an adventurous, highly emotional listening experience. — Paul Lemos

LES CALAMITIES: Pas la Peine (4-song EP; New Rose Records, 7 rue Pierre Sarrasin, 75006 Paris, France) This French group has recreated the essence of the American girl-group sound with charm and wit. Not as recklessly fast as their LP, this EP has mid-tempo teenage tunes with wry lyrics about boy problems. The two versions (English/French) of "Boy From New York City" seem slow, but are pure pop. If someone would get this group together with Plastic Bertrand, pop history would be changed. — D. Maryon

LIFE: Optimism b/w Better (7", Of Factory, 325 Spring St., Rm. 233, New York, NY 10013, USA) "Optimism" is a strange mixture of hooky pop intercut with gloomy melancholy. Male and

female voices intertwine. Very sensual. "Better" features dual acoustic guitars on a catoysish mid-tempo ballad. Very catchy, soothing, ethereal. — Paul Luchter

THE LIMITS (12" EP; Flying Governor, 1724 Elm St., Bethlehem, PA 18017, USA) This mid-sixties British invasion styled band have decked their music out with a high-tech gloss that makes them better than the run-of-the-mill pop combo. The originals are tight and powerful, the guitars ring crystal clear, and the harmonies are fresh and exhilarating. — Charles P. Lamey

LIQUID GENERATION: I Love You b/w 1/4 to Zen (7", \$2; Green Monkey Records, P.O.B. 31983, Seattle, WA 98103, USA) A riotously classic achievement, right alongside "Wild Thing" and "Incense And Peppermint", "I Love You" could be early Ramones but with lighter touch love harmonies. No fat, just a wall of sound that makes the vocal hard to understand. "1/4 To Zen" has a great Trogglike quality that makes you ask, seriously, "just what kind of drugs are these guys on?" — Evan Schoenfeld

LIVE SKULL: Stringing Home The Bait (LP; Homestead, P.O.B. 570, Rockville Centre, NY 11571-0570, USA) I don't get it so it must be ART. This is modern noise-rock. It feels painful and static, but big like a building, a big tall building shooting up into the sky all the way from Hell. I wish there was a lyric sheet. Guitars, bass, drums, four people and beautiful graphics with a cover photo of a cow's brain in a loving cup. I've felt this bad a couple of times, but do I wanna wallow in it again? Why do I love Sonic Youth and find this hard to take? Maybe because Sonic Youth live in that big building mentioned earlier, but they live on the 27th floor, they party, get drunk and have fun sometimes, while Live Skull are stone cold sober, riding the elevator all the way down. — Geo Parsons

LIVING LINKS (C-30; Skratz Records, P.O.B. 80691, Baton Rouge, LA 70898, USA) Living Links are a Baton Rouge couple who have put out a very well done nine-song cassette. The instrumentation is guitar, bass, synth and drum machine played in a semi wave-modern-funk style. His vocals remind me of modern day Iggy without being as heavy; her vocals are a bit folk style, a bit Siouxsie Banshee. — Tom Dyer

JEAN PIERRE LLABADOR: Coincidences (LP; Breakthru Records, 2 Lincoln Square, New York, NY 10023, USA) The young French jazz guitarist Labador has an individual voice influenced by Wes Montgomery and John Abercrombie. He is backed by a tight piano/bass/drums band following a vague fusion concept. Labador's original, incohesive compositions are another disappointment. Pop influences from unexpected sources (listen to the riff stolen from Donovan's "There Is A Mountain" in "St. Dreary Blues") sound undigested. On the plus side: He gets a lovely and deftly executed tone from his guitar and plays with a fast and thoughtful technique. — Norman Weinstein

LMNOP: Forever Through The Sun b/w *Three Colon Oh Oh* (7", LMNOP, P.O.B. 90803, Atlanta, GA 30364-0803, USA) Happy sounding melodic pop with imaginative lyrics. "Forever Through The Sun" is the kind of song one hums in the shower. The single comes with a magazine full of stones and poetry. A well-produced single with a nice balance of guitar and keyboard. Lots of fun! — Gina Graziano

LOGOS DUO: Improvisation/Composition (LP; Igloo a.s.b.l., 88 Rue Kessels, 1030 Bruxelles, Belgium) Three music theater works fill side A. "The Wall" explores themes of confrontation and liberation. Godfried-Willem Raes plays various percussion instru-

ments alongside the fragmented vocal ejaculations of Monique Derge. The theatrical emotions of this first piece contrast sharply with the soft spoken second. The subtle nuance and variety of vocal inflection in "Sotto Voce" is striking. There are moments when Derge's expressive cries and mutterings seem to emanate from deep in the recesses of the electronic circuits. "Time Frames" depicts the combat of the actor against the uncertainty of troubled times. After an introduction of electronic sounds, the two performers settle into a long dialogue featuring vocal sounds and their distortion on tape using a "Manipulaphone," a device to control the playback speed (what a rapping D.J. does by hand on the turntable but without the beat). Once they get beyond the pointilistic cliches and transitional noodling, the Logos Duo's extended instrumental techniques yield some engaging passages on the side B improvisation. — Ralph Blauvelt

LOST GENERATION: Victim (LP; Inces, 272 Benham Ave., Bridgeport, CT 06604, USA) Very clearly produced slow hardcore punk songs about personal freedoms, people, etc. Songs are sometimes too long, as are the guitar solos. The singer seems real laid back. I started thinking of Lynyrd Skynyrd for some reason. This album is a sort of hardcore, heavy metal, rock-n-roll hybrid. — Lawrence Crane

THE LOUNGE LIZARDS: Live 78-81 (C; ROIR, 811 Broadway, Suite 725, New York, NY 10012, USA) Here is a more accurate portrait of the Lounge Lizards as they were originally conceived than anything yet released on vinyl. Culled from gigs in Berlin, London, Cleveland, and New York — including their first live appearance in 1979 — these tracks reveal the group at its most reckless and abrasive. LP versions of the same songs sound tame and polite in comparison. The original lineup, featuring Arto Lindsay and Arto Fier, appears on several numbers, and it is easy to see what the early excitement was about. The patented film noir stylizations are there, alongside controlled cacophony which suggests the influence of Ornette Coleman. The Lizards have frequently been denigrated by their critics for affecting a jazz stance without the musical wherewithal to back it up. There is plenty of evidence to the contrary on this cassette which chronicles a great group in its heyday. — Dennis Rea

LUCKY PIERRE: Muchacha Latina Today b/w *Birdman* (Bena Records, P.O.B. 18621, Cleveland, OH 44116, USA) Lucky Pierre is an appropriate pseudonym for Kevin McMahon, a guileless fellow with a sunny disposition who's created some ingratiating, sprightly paced pop. He borrows from the litigous sounds of south of the border on "Latina", playing the giddy admirer of a young Latina he corresponds with since seeing her picture in one of those catalogs filled with eager foreign women who want to marry Americans. The flip side is a gentle lesson to a boy to put aside his slingshot and be kind to birds. Despite the songs' lofty sentiments ("Latina" mentions a uniting of cultures), this is still goofy, enjoyable music cleverly arranged and performed creating a pleasant diversion. — Gary Chun

LUCKY 7: Lucky 7 (7" song 12; Midnight Records, Box 390, Old Chelsea Station, New York, NY 10011, USA) This four-piece band delivers a loose rockabilly sound. Fluid bass lines and nimble guitar work drive raw, enthusiastic performances that usually make up for their lack of great material. However, when accordionist Kenny Margolis injects New Orleans zydeco music, as in "Rosalie," "Cajun Man," and an inspired remake of Chuck Berry's "You Never Can Tell," Lucky 7's music enters another dimension: the rockabilly stylization is infused with genuine feeling, and the richer cultural mix shows a band with imagination and depth. — John Grooms

LYDIA LUNCH: The Uncensored Lydia Lunch (C; Widowspeak Prods., c/o Rough Trade, 61 Collier St. London, England N1) Powerful, and (although Ms Lunch might call me an asshole for this), beautiful. She recites her lurid, sexual and psychotic poetry. "Daddy Dearest" is a true story I guess, told with more conviction than I've heard anyone tell anything in a good while. More than a few people I've played this for were left speechless by the end. The stories lead you in and then make you feel like hell for having heard so tragic and personal a story in the guise of entertainment. Good luck, Lydia, in marrying heaven and hell. — Tony Pizzini

KAREN MACKAY: Annie Oakley Rides Again! (LP; West Virginia Woman Records, P.O.B. 3174, Madison, WI 53740, USA) Here is a female Appalachian banjo-playing coffee house balladeer. Her singing and playing are pleasant; her songwriting is self-indulgent. She takes swipes at men who rape, men who work for corporations, and men who start wars. She offers poems to an unspecified Goddess. Mackay studied with many formidable talents of the West Virginia folk tradition but she side-steps the humor, unselfish insight and elliptical poetry that the tradition draws its strength from. — Christopher Pettus

MADHOUSE: Madhouse (LP; Fountain Of Youth Records, 5710 Durbin Rd., Bethesda, MD 20817, USA) A band with a singer who can yelp and wail like Siouxsie Sioux and then sing pop like Robin Lane. Pretty good. The songs are good, fuzz-chorded and power-driven Banshee type numbers with short, sharp guitar solos. This band looks like they're in high school and maybe they think the whole world is a madhouse, so they're angry. But they're smiling on the back cover photo, probably happy to know they've made a record. — W. Mueller

JACK N. MADNESS: I Like Percussion (12" single, Z28 Records) For years, decades really, young white kids have been buying cheap instruments and forming garage bands to ease their anx-

ities and hopefully make some bucks. Rap gave young blacks the same opportunity on inner-city streets using boom boxes, turntables and percussion machines. Now here, we have a garage mix/scratch record. We first hear a Chipmunk voice say "I like—I like—I like percussion" after which we hear a constant drum pattern—echoy as all get out—over which about a dozen different records, many of them obscure, are mixed together with occasional scratching. — Jamie Rake

MAGICAL STRINGS: Above The Tower (LP; Magical Strings, P.O.B. 4086, Seattle, WA 98104, USA) Magical Strings are Philip and Pam Boulding, a husband and wife team of musicians and instrument builders. They play original and traditional material in the Celtic vein. This, their third record, was produced by Michael O'Donnell, famous for his work with Skara Brae and the Bothy Band. Their music is quiet and graceful, very representative of the New Age Celtic folk which the West Coast seems to specialize in. No high-energy jigs and reels, no lyrics in an unintelligible language, and no bagpipes. Likely to appeal to fans of the Fortuna and Windham Hill labels. — Christopher Pettus

ARNOLD MATHES: Monitoring (C, \$5; Arnold Mathes, 2750 Homecrest Ave., Brooklyn, NY 11235, USA) My only complaint is that the best pieces were just too short. This guy is hot. Mathes runs the gamut of electronic music from '50s sci-fi to Klaus Schulze, and then into the quirky world of Chris and Cossy. But he is an innovator, molding the essence of these types into a very personal vision. The music is not usually pleasant and cannot be put on and forgotten. It demands attention. On the technical side, the vast array of equipment that he uses and his addition of some interesting found vocals keep things very fresh and interesting. The production is tight, well-produced and recorded. And aside from this work, Mathes has a whole catalog of other works to choose from. — Nathan Griffith

LES McCANN: Les McCann's Music Box (LP; JAM, Dist. by Jem) Electric keyboardist McCann leads a quartet (saxophone/electric bass/drums) through four extended cuts and two brief segments of his old hit "Compared To What", recorded live. There is a pronounced rock beat throughout, even on Dizzy Gillespie's pop classic "Blue 'n' Boogie", and the ensemble is tight and energetic. McCann's soul/gospel phrasing dominates his solos, but his articulation seems limited by the tone of his keyboard. Saxophonist Bobby Bryant, Jr., however, sounds confident and aggressive on his tenor and soprano spots. The ambience is similar to the numerous live albums Cannonball Adderley made for Capitol and Fantasy—lots of audience response, nothing overly cerebral. Those who like their jazz in that vein will have fun with this LP. — Bert Grooms

HOWARD MCGHEE QUINTET: Just Be There (LP; Steeplechase, 3943 West Lawrence Ave., Chicago, IL 60625, USA) McGhee is a veteran of the jazz life. He worked with Bird and fellow trumpeter Fats Navarro in the '40s, then succumbed to drug problems in the '50s. Active again since the early 1960s, he has developed a warmer sound than he displays on his early recordings. This 1976 session, recorded in Copenhagen, finds him in the company of two more elder statesmen of pop, the late drummer Kenny Clarke and pianist Horace Parlan. Rounding out the quintet are bassist Mads Vinding and saxophonist Per Goldschmidt, playing a new baritone and just getting used to it. With the master Kenny Clarke kicking everyone along, this program of four McGhee originals plus J.J. Johnson's bouncy "Wee Dot" is a winner. There may be a few flubbed notes, but the spirit is definitely here. — Stuart Kremsky

JIMMY MCGRIFF: State Of The Art (LP; Milestone/Fantasy) McGriff is a jazz organist who gets a pilingriving sound out of his Hammond B-3. His indebtedness to Jimmy Smith is obvious in this collection of seven funky and fat-toned numbers. "Heebender" does exactly that, opening the album with a partying spirit. "Stormy Weather" is a drawn out drag. McGriff needs uptempo numbers to keep his sound fresh. His four backing musicians know how to strut soul stuff, but it is McGriff's energy that makes this album a success. — Norman Weinstein

THE MEATMEN: War Of The Superbikes (LP; Homestead, P.O.B. 570, Rockville Centre, NY 11571-0570, USA) Take a walk through hardcore raunch and roll Meatmen style. Dr. Demento eat your heart out. Let's face it, the world's a vile place and men's sick creature who created it. So let's take a few minutes out of the hectic structure we call life and enjoy ourselves. Let the notorious Tesco Vee be your guide as his merry men drive you past Hell's gate on a non-stop through Sodom, leaving you back at your turntable with a smile on your face and a tune on your tongue. Great sound production. Nice cover art. A good follow-up to a first release that left something to be desired. — Scabies and Rabies

THE MEKONS: Fear And Whiskey (LP, Sin Record Co., 6 Clifton Mansions, Coldharbour Lane, London SW98LL, England) The Mekons return with original members Tom Green, John Langford, and Kevin Lite with new partners and a new sound. Sure, those snarling guitars, driving rhythms and plain, earnest vocals are still there. They've just been pushed along the road to the country, Cajun country that is. And while the Mekons won't make anyone forget Ernest Tubbs or Zachary Richard, they do play some damn fine music. English country reels mix it up with stomping Cajun two-steps. Ghosts of departed hillbilly rockers look on and smile. A manic fiddle embroiders the vocals as the drums just keep on pounding. — Scott Siegal

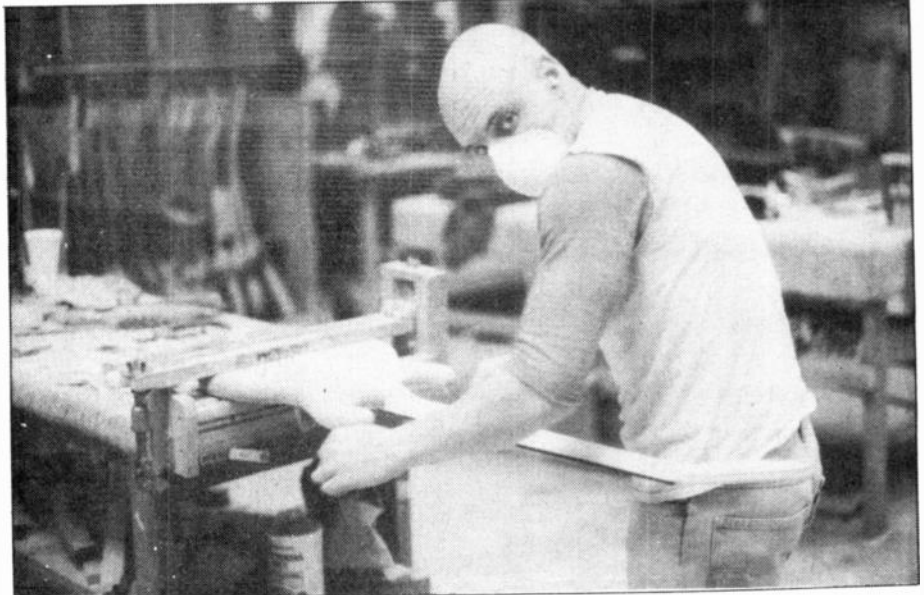

UNIDENTIFIED LUTHIER whittling down the neck to create an Alembic bass at the Alembic factory in Santa Rosa.

DICK MELDONIAN TRIO: It's A Wonderful World (LP, Statras Record Co., 1304 Fletcher Rd., Tifton, GA 31794, USA) The Trio, according to the liner notes, are the pride of the Hoboken House restaurant in Hoboken, New Jersey. The Trio plays solid, mainstream, jazz-tinged, pop standards and fairly swinging jazz opuses. It's a nice sounding group that has obviously played together for a while and is comfortable with the style and format of their renditions. Dick Meldonian plays a mean soprano sax which can be piercing; it is fortunate that he also uses the clarinet to vary his approach. The guitarist, Marty Grosz, contributes vocals on various selections deriving voicings from Fats Waller, among others. Pete Compo plays the bass and evidently must have offended someone connected with producing this recording, since while his colleague's biographies receive considerable liner note space, poor Pete gets nary a word. — Norman Lederer

THE MICRONOTZ: The Beast That Devoured Itself (LP; Fresh Sounds, P.O.B. 36, Lawrence, KS 66044, USA) This has it all: heart-pounding rock 'n' roll, mutant R&B, and flat-out garage punk. "Proud To Be A Farmer" rocks out like a champ. The Micronotz have always exhibited a raw, intuitive feel for playing belsy punk, but here they stretch out and define their own brand of "American" music, a hybrid of Mid-West rock not unlike The Replacements. Great rhythm section, versatile guitar playing and now, since signing up Jay Hauptli as lead singer, classic rock 'n' roll vocals. From drunken-punk abandon to mature SONGS. — John E

MIGHTY SPHINXER: Ghost Walking (double ep; \$5; Phoenix Records, P.O.B. 23316, Phoenix, AZ 85063, USA) This Phoebe band innovates by playing slowed down hardcore, and the result is one squeaky, squealy, and plodding guitar number after another. The vocalist sounds like he's just had an axe driven through his skull, screaming about everything "scary" he can think of. The lyrical highlight is a song about the punk who gets impetigo (a pustulus skin disease) because he cuts his arms to look mean. Otherwise, the lyrics are tasteless and vague. This hardcore is more overblown than Jethro Tull. — W. Mueller

MINISTRY: The Nature Of Love (12" EP; Wax Trax, 2449 N. Lincoln Ave., Chicago, IL 60614, USA; ph. 312-929-0221) Ditched by their major label, Ministry took to the indie-field, and strikes it big with this killer dance track. It hits with a tough-beat, angry-synths, and smooth vocals. They throw in all the bitchin' effects, touching on most of the tricks known to man. Great found voice usage (in the vein of Paul Hardcastle's '19'), with clippings of some authoritative-types discussing the beating of one's animal (the nature of love?). The voices are drawn to their logical conclusion, completely dominating the final half of the "Cruelty Mix" (on the flip side). Forget that wimpy-shit you hear on the urban-contemporary stations, especially the recent ca-ca from bands like Depeche Mode. Check out Ministry to hear where intelligent dance music is today. A great 12", far ahead of the "Halloween/All Day" 12". — Sam Rosenthal

MINOY: Tomorrow And Tomorrow/The Source (C-60; \$6; 923 W. 232 St., Torrance, CA 90502, USA) More textural madness from Mino. He seems to draw upon influences like Ligeti, Penderacki, Xenakis, and generic industrial. Thick roaring, hissing, synth tones mixed in. Sounds like a dozen overdubs or so, processed with maximum echo, creating an atmosphere all it's own. Very good. — Tom Furgas

THE MIRACLE LEGION: The Backyard (6 song EP; Incas Records, 817 Chapel St., New Haven, CT 06510, USA) Very serious folk-rock that constantly skirts a pop core. They sound more "message" oriented than R.E.M. without a bit of that band's British Invasion kick, focusing on more a Television channel but with added melodicism. There is definitely that Tom Verlaine-inspired knack for bent story telling. The vocals are mixed way back with a tapestry of guitars on the forefront. I fall for this kind of record everytime. — Jordan Oakes

THE MIRACLE WORKERS: 1,000 Micrograms of... (LP; Sounds Interesting Records, Box 54, Stone Harbor, NJ 08247, USA) Six straight rockers from this Portland fivesome. The music is crashing, jagged and driving. — Calvin Johnson

THE MIRACLE WORKERS: Inside Out (LP; Vaux Records, 2702 San Fernando Rd., Los Angeles, CA 90065, USA) Captures the sound and spirit of classic mid-to-late '60s garage rock. The band smokes through energetic and tight arrangements that are busy without sounding cluttered. The singer, Gerry, is wonderful, sounding like a cross between a very young Jagger and a whiny brat, while Matt Rogers blazes through startling, searing guitar work. The Miracle Worker's music is rebellious and intelligent; nasty but charming and filled with enough vitality to make garage rock sound like it's being played for the first time. — John Grooms

MISFITS: Legacy Of Brutality (LP; Plan 9, address needed) "Thirteen unreleased tracks" the jacket says. Seven are dated twice '78 and '81 and a couple titles are familiar to me, so I presume these are alternate versions of earlier releases. The other six may be tunes that didn't meet Glenn's standards for release when they were recorded. This stuff all seems to be pre-WALK...while not as strong as that LP — Jeff Wechter

VIN MITCHELL & GUITAR MADNESS (LP; buye Crescent, 4 Donegal Rd., Peabody, MA 01960, USA) The instrumentation is intriguing: six electric guitars, bass and drums. Leader Mitchell plays one of the six, and wrote all but one of the tunes. Most of the music is instrumental rock with few "fusion" cliches. Contrapuntal themes occur frequently. There is quite a bit of tonal and timbral variety and the rotation of soloists keeps things interesting as well. The musicians are all accomplished players individually, but it is the group identity that makes this LP distinctive. The solos are relatively short with a lot of care given to highlight and contrast the compositions. The band seems adept at other styles. Included are an uptempo blues shuffle and a brief jazz number. And while the rest of the material is rock, it's melodic and tasteful without being slick or pretentious. Solid, honest guitar music. — Bert Grooms

MOD FUN: 90 Wardour Street (8 song EP; Midnight Records, Box 390, Old Chelsea Station, NY 10011, USA) These '60s revivalists deliver solid, rocking songs exhibiting a mastery of many styles. This three piece band from Maywood, New Jersey is led by guitarist Mick London whose frantic garage-power attack is impressively mixed with the British Invasion harmonies of bassist Bob Stretre and drummer Chris Collins. "A Minute Twenty" features jangly guitar and tambourine-shaking evoking nothing less than the Monkees-with-a-purpose. — John Grooms

MOFUNGO: Frederick Douglass (LP, Coyote Records dist. by Twin/Tone, 2541 Nicollet Ave. South, Minneapolis, MN 55404

UNCLE FESTER NO. 9 \$2.00

REM'S MICHAEL STIPE
HUSKER DU
 Tommy RAMONE
 REPLACEMENTS
 SOUL ASYLUM
THE FORM
 THEATRE OF ICE

UNCLE FESTER
 2235 France Ave. So.
 Mpls. MN 55416

3 stickers for \$1.00
 7-shirts for \$8.50 od.

+ a limited edition(500) HUSKER DU, REPLACEMENTS poster!

DISTRIBUTED BY: DUCH EAST, IMPORT



OUT NOW! ANOTHER HOT NEW CASSETTE - EP FROM CAMARADERIE MUSIC



the ironies
 Prepared By Mr. Curt

Rated: 1

A splendid, serio-comic treat for the "funny bone!"

Available at a choice record/tape store (distributed by Camaraderie Music)
 Camaraderie Music Cassettes - P.O. Box 402 - Kenmore Station - Boston, MA 02715 (U.S.A.)

Victimless
Crime PaperBag: Live
 IMPROVISATIONAL MUSIC CO.

AND... DRAPES OF RAIN
PaperBag: LIVE NOV. '85
 IMPROVISATIONAL MUSIC CO.

"ONE OF THE BEST IMPROVISATION TAPES I'VE RECEIVED"
 — MAGISCH THEATRE, ANTWERP, BELGIUM —
 "A BAND THAT DARES TO IMPROVISE"
 — L.A. WEEKLY —

EACH TAPE IS 45 MIN. LONG • VICTIMLESS CRIME \$4.00 EACH
 • DRAPES OF RAIN

AVAILABLE FROM: M. SEGAL 5828 TOPEKA DR. TARZANA, CA. 91356
 OR SYSTEMATIC 1331 FOLSOM ST. S.F., CA. 94103 ...

MUSIC FROM THE PRIMAL MEMORY



DOT-3.
IN THE DESERT

"IF WE ARE NO DIFFERENT FROM SAVAGES
 IF WE ARE NO DIFFERENT FROM CANNIBALS
 IF WE ARE NO DIFFERENT FROM ANIMALS
 WE'LL LIVE BY THE LAW OF THE JUNGLE
 UNTIL WE DIE."

NEW SIX SONG TAPE AVAILABLE NOW

FROM **-DOT-3-** CASSETTES

661 UNIVERSITY AVENUE, LOS ALTOS, CA 94022



DISTRIBUTED BY **SOUNDS GOOD**

USA) Noise-rock stalwarts Mofungo have come up with an album of politically polarized songs which might be their most lucid statement to date. Mofungo succeeds where many like-minded outfits fail by virtue of their unwavering rhythm section which keeps up the momentum even when the brittle, strident guitars are clawing at each other obvious to the best. The interplay between the sourly tuned, skewed guitars, now meshing, now fighting, generates tension and interest. Augmenting the sound on this LP is the saxophone and keyboard work of producer and longtime associate Elliott Sharp. Song titles such as "Ronnie Thinks He Can Rock 'N Roll" is indicative of the band's politics, but unfortunately the lyrics, delivered in a dry, tuneless vocal style resembling New Order, are often unintelligible. The studio robs the music of some of its impact, but the musicians should not be faulted, since theirs is a very tactile music best experienced live. — Dennis Rea

MOJO NIXON AND SKID ROVER: Mojo Nixon And Skid Rover (LP: Enigma Records, P.O.B. 2428, El Segundo, CA 90245, USA) These two guys mix rockabilly, country, and talking blues tunes with such instruments as blues harp, stick drum, and as the main percussion instrument, a washboard. The general setup goes something like this: Mojo stompin' away to the beat while picking rockabilly guitar licks and shouting out wild storytelling blues while, partner Skid is keeping things in time by sleppin', rappin', and tappin' away on washboard. Half of the time Mojo is talking, telling a story, then the beat picks up and he starts screaming and shouting to such songs as "Jesus At McDonald's", "Mushroom Mania", "I'm In Love With Your Girlfriend" and "Black Yo' Eye." A humorous two piece blues band with up-to-date political awareness. A perfect musical couple to add life to just about any party. — Josh Hatch

MORALLY BANKRUPT (LP: Slime Records, P.O.B. 88031, San Francisco, CA 94188-0312, USA) Fairly original punk and thrash. This four member ensemble from San Francisco fuse funky bass lines, thundering guitars, and a healthy dose of humor to create an amalgam of very listenable tunage. Lyrically, this 16-song album covers a wide range of topics, including young lust, skateboarding, Yassar Arefat, telecommunication stimulation, and a C.I.A.-backed AIDS epidemic. And who can pass up their version of the Three Stooges theme song? Not me. — Mike Troughon

GEOFF MORGAN: At The Edge (LP: Nexus, P.O.B. 5881, Bullinham, WA, 98227, USA; dist. by Flying Fish) A native of Connecticut, Morgan has been playing music for years, accumulating some notable credits writing for major country singers including Ronnie Milsap, Barbara Mandrell, Charlie Pride and Ernest Tubb. On this album he breezes through various styles and pays tribute to John Wayne, marvels at pending fatherhood, decries injustices in South America, and adjusts to that first pair of glasses. His playing skips around from folk to country to a Celtic influenced instrumental. His lyrics bounce from serious political issues to solemn public issues to amusing personal issues. — William Ponsot

THE MORLOCKS: Emerge (LP: Midnight International, P.O.B. 390, Old Chelsea Station, New York, NY 10011, USA) This offshoot of the now defunct Gravedigger Five have come up with a sizzling debut, recorded in two days. Rocking in the grand tradition of The Seeds and Chocolate Watchband, the Morlock's stockpile of guitar riffs is impressive and Leighton's lead vocals are brutally nasty. — Charles P. Lamey

VARIOUS ARTISTS: Musicworks #29: Times And Tides 1985 (C-60 plus a tabloid size magazine; \$6; Musicworks, 1087 Queen St. West, 4th floor, Toronto, Ont., Canada M6J 1H3) New concepts and methods of organizing time are dealt with in this issue of Musicworks periodical. Albert Mayr's "Hora Harmonica" uses the pitches of an overtone series organized symmetrically to delineate the passing of an hour's time. Udo Kasemets uses much broader time spans (a sidereal day, a solar year) but highly compressed, and organized around the chromatic 12-tone scale in his works "Earthspin" and "Celestial Timescapes". These works and others are excerpted on the cassette. Side one provides a slow, graceful montage of excerpts and commentary. Side Two provides a 30-minute segment of Kasemets' "Celestial Timescapes", which is utterly astounding. The movements of the 12 signs of the Zodiac are represented by the 12 chromatic pitches, the sun by white noise, the moon by various harmonics of a 60-cycle tone (the different harmonics representing the different phases of the moon.) As an amateur-astronomer, I was struck by the direct and very appropriate translation of these celestial movements into music. There is an awesome and majestic force to this music, and I'd love to hear the full six-hour version. Editor John Oswald has done a wonderful job of assembling this tape, and for Oswald a wonderful job is no less than we've come to expect from his work with Musicworks. — Tom Furgas

NICO AND THE FACTION: Camera Obscura (LP: Beggars Banquet/Jem Records) For those who feel Nico is no more than an artsy poser and for those who feel she is an artist, this record will strengthen both side's convictions. Some songs here like "Win A Few" make me want to throw the record across the room, sounding like a leftover from the soundtrack to "Liquid Sky" with its insistent drumbox, under-mixed singing, and pointless length. "My Funny Valentine" is very well done, with trumpet and piano accompaniment, as is "König" in which she accompanies her voice with harmonium. Keyboards by James Young; percussion by Graham Dids; production by John Cale. This is the first Nico record I've heard that has no guitar or bass on it. — Tony Pizzini

1989: Drink The Exhaust (4-song C; Testfall Productions, Box 28, New Kent, VA 23124, USA) Moody minor-key synth pieces. Depressing. Needs more variety and oomph to make it more interesting. Anyone can noodle around in minor keys while a rhythm box churns away. — Tom Furgas

NISUS ANAL FURGLER: Die Russen Kommen (C-60; Calypso Now, P.O.B. 12, Obergeassli 4, CH-2500 Biel 3, Switzerland) Kurt Rivella and Anal Furgler are Swiss media artists involved in business, radio, concerts, and fashion, and put together this tape collection of previously released music recorded for international samplers and other Calypso Now tapes. These are tape collages of radio voices, laughs, moans, chants, loops, bits of music (Bonanza), squeaks, scratch, plinks, and percussion. The outstanding cuts: "Write Miss Lonely Hearts," voiced from a cell-in radio dete show, feedback and a wild scratching and guitar spazz that brings to mind Eugene Chadbourne bluegrass; "At The Massage Parlour," crash, bang, an old man yells, a cool electronic jazz beat with melow guitar and saxes is wiped out by guitar feedback. "Des Gedankenschrapnell" has George Benson on acid, crickets, gamsel, sax and trumpet, burst of electronics, tribal drum and yells. — CDinA2

NORTHERN LIGHT: Children's Tape (LP) This follow-up to their debut from '83 emphasizes songs for kids but can just as easily be enjoyed by adults. Among the fine playing, campy vocals and wide range of traditional instruments, you get songs about whales, the colors of the rainbow, woodchucks (yup, it's the tongue-twister turned into a tune) and a trilogy about lepruchans, among others. There are numbers done as a capella story telling, honky tonk country-western and mellow, lounge jazz. Wonderful it is to find music for children that does not try to subliminally sell them something other than good feelings. Wouldn't you rather have them listening to this than the Smurfs? — Jamie Rake

THE NORTHERN PIKES: The Northern Pikes (six-song EP; Black 'n Round Records, Box 3065, Saskatoon, Saskatchewan, Canada) Perky pop/rock. Rhythm guitarist Jay Semko writes catchy songs around deceptively simple but driving riffs. Aspects of his material, especially the chiming guitar sound and soaring vocal harmonies, will remind the listener of several mid-sixties bands: the Byrds and the Searchers in particular. The lyrics are not profound, but not embarrassing either; and the melodies are hummable. Not very challenging or ground-breaking. — G. Specs

N.O.T.A.: N.O.T.A. (LP: Rabid Cat Records, P.O.B. 49263, Austin, TX 78765, USA) What the hell is it about Texas that causes that state to produce so many fine hardcore bands? Whatever the reason, N.O.T.A. (None Of The Above) are yet another example. These guys have a very full, tight sound and the two guitarists, Jeff and Russell, play extremely well together. Drummer Bob and bassist Bruce are equally energetic and all four play with amazing enthusiasm. The songs range in tempo from medium fast up to blindingly fast. The subject matter includes peer pressure, violence, rednecks, relations with the boss, the police and various other authority figures, loss of rights, asshole who try to act cool and so on. Some of N.O.T.A.'s ideas on how to deal with these problems are kinda screwed-up (e.g. "Fuck you up with a baseball bat!"). — Bryan Sale

NO TREND: A Dozen Dead Reses (LP: No Trend Records, 1014 Ashton Rd, Ashton, MD 20861, USA) Depressing, low-life lyrics your thing? How about bellowing vocals, repeating, simplistic bass lines, gothic synths and fuzz lead guitar? If so, these are your dead roses. The LP features special guest chanteuse Lydia Lunch, purveying neo-psychedelic gloom rock and roll. The bass throbs, the drums pound, the guitar whines, the songs go on and on, not doing much. Vocalist Jefferson Scott has a Henry Rollins-like delivery (we're talking urgent here). Lunch injects a measure of drama and humor to the relatively monotonous, gloom, doom surroundings. — Scott Siegel

NURSE WITH WOUND: Sylvie And Babs (12" EP; Laylah, rue J. Bassein, 68, 1160 Brussels, Belgium) Apparently, Steven Stapleton, mastermind of N.W.W., has spent more than two years completing this record which includes unidentifiable contributions from nearly 50 individuals (Graem, Revell, William Bennett, Dave Jackman and Robert Haigh, to name a few.) The campy, neo-dadaist packaging and kitschy big band music that appears throughout, suggest an overall theme which drags the "modern age of high fidelity sound" straight through the muck. Through careful sequencing of pre-recorded, looped and manipulated big band muzak, secret agent themes (etc.) combined with all manner of vocal excerpts and altered electronic sound, Stapleton and company have molded a disc that is both funny and musically coherent. One may draw comparisons to Negativland, Faust and occasionally, The Residents, but on the whole SYLVIE AND BABS is remarkably original and beautifully organized. N.W.W. does not rely on clutter or "information overload" but instead integrates silence into the material, doubling the effect of the continuously jarring shifts in volume and sound. Wonderfully creative! — Paul Lemos

MICHAEL NYMAN: The Kiss And Other Movements (LP; Editions EG/Jem Records) Nyman's press kit warns against labeling him as a composer of minimal or "systems" music. However, it is hard to dismiss the fact that his music bears a marked resemblance to that of Glass, Reich, et al. Which is not necessarily a criticism — Nyman, one of the most celebrated modern British composers, is a veteran of the post-60s avant-garde and can hold his own with the best of them. What's more, his music is seldom

as self-consciously academic as that of many of his peers. This LP is pretty rugged stuff — lively, varied, and injected with humor. Nyman's band, augmented by strings and voices, performs five compositions, two of which feature text set to music. The title track, with vocals by Degmar Krause, among others, is reminiscent of the work of Michael Mantler. The punchy "Nose List Song" despite the awkward juxtaposition of dramatic, driving rhythmic figures with silly-ass lyrics, is a high point of the LP. Throughout, the music is vigorous and tuneful, with strings sawing busily away. This LP is a successful example of the much-vaunted synthesis of popular and "serious" music attributed to composers of [oops!] systems music. — Dennis Rea

THE OCTOBERFACTION: The Nazi Sex Doctor (LP: SST, P.O.B. 1, Lawndale, CA 90260, USA) It sounds as if seven people who have never previously practiced together were put in front of a live audience and told to play "rock" for an hour or so until the band showed up. Each instrument is on a different road, none of them leading anywhere. The vocals are unintelligible grunts and screams with long intervals between lyrics. Musicians include Chuck Dukowski, Greg Ginn and Henry Rollins, but don't expect it to sound like Black Flag. — Josh Hatch

OFFICER: Desaffection (LP: A.Y.A.A. Records, 121 rue de Courancy, 51100 Reims, France. Also available through Wayside) An unusual disc. Officer is Nick Hobbs' (former member of The Work) band. The album includes appearances by the other three Work members, Tom Hodgkinson, Bill Gilonis and Rick Wilson as well as Georgie Born, Tom Core, Zeena Parkins, Catherine Jauniaux and many more. Many of these folks are part of the Recommended Records/Henry Cow stable of exploratory players and the sound reflects this. Lots of ye olde English light chamber music influences abound with an occasional hint of a sea shanty. This record is lighthearted and the lyrics tend to bare this out (i.e. "god is a creep but you can't know him" or "You scare the living daylight's out of me when you dust the furniture like that.") The use of recorders, string quartet, harmonium-like keyboards and bassoon give the LP a very warm, polite parlor concert feel. As painful, energetic and forceful as some of The Work's material used to be, the humor and good nature of this record will come as a delightful surprise to many. Aye, a merry, merry album to be sure! — Bryan Sale

PAULINE OLIVEROS: The Wanderer (LP: Lovely Communications, 325 Spring St., New York, NY 10013, USA) Composer/national treasure Oliveros continues to explore the potential of the accordion, correctly described as "the only surviving portable, acoustic instrument capable of playing melody, harmony, and rhythm without accompaniment." If you have ever considered the accordion a cornball instrument, think again — this LP will destroy your preconceptions. With THE WANDERER Oliveros realized a long-standing ambition to write specifically for a large ensemble of accordions; in this case the youthful Springfield Accordion Orchestra, who execute her demanding scores admirably. The piece's two movements highlight two very different aspects of the instrument: Part 1 focuses on the accordion's rich timbres, employing sustained tones which swell and are punctuated dramatically by silences; the darting rhythms of Part 2 evoke folk dances from many cultures, including Ireland and Bulgaria. Also included is a new version of "Horse Sings From Cloud," scored for accordion, concertina, bandoneon, and harmonium. Microtonal differences in tuning and phrasing determined by breathing cycles result in a dense weave of shifting tonalities recalling some of composer Gyorgy Ligeti's work. This is music of depth and beauty; a truly modern work for an often-neglected instrument. — Dennis Rea

ONE PLUS TWO: The Ivy Room (6-song EP; Dutch East India, P.O.B. 570, Rockville Centre, NY 11507-0570, USA) There are obvious similarities to R.E.M. here, what with that ringing guitar and all, not to mention the Michael Stipe-ish lead vocals. Nevertheless the band is original, the tunes rock and the lyrics are clearer than Georgian spring water. — Jordan Oakes

ORGANIZATION 31: Organization 31 (C-46, P.O.B. 21, Fullerton, CA 92632, USA) Applause. Electronics. Breathhhhh. Vocal bursts: growls, raving, screaming — oo, my throat hurts for him. Clang — kick a cookie pan around. Press machines bang, police dispatchers converse. Bells toll amidst drones and metal percussion. Pulse. Monsters in soft atmospheres and thick wind. The tolling bells get a bit overlong, but in general, this soundscape keeps moving through the dark spaces. — CDinA2

ORGANUM: Tower Of Silence (12" EP; Laylah, Rue J. Bassein 68, 1160 Brussels, Belgium) Organum is a recent sound project pursued by David Jackman, formerly of New Blockaders. To anyone familiar with the crushing density and abrasiveness of his past recordings (such as the brilliant "Pulp" single) "Tower Of Silence" will seem a bit subdued. Actually this EP reflects Jackman's strongest work to date, combining the key metallic screeching that marked New Blockaders' sound, with a variety of subtly interwoven mechanical shadings. The result is a record of great originality and power. Imagine the sound of a great, rusty hinge moved to and fro, recorded and manipulated repeatedly. Jackman offsets this shrillness with strong undulating bass tones creating very brittle, hard music that is at once unsettling yet ambient. — Paul Lemos

THE OUTNUMBERED: Why Are All The Good People Going Crazy (LP: P.O.B. 2082, Station A, Champaign, IL 61820, USA) With a subtle country ambience, this garage-based quartet play

the sort of raw pop that's currently being recorded to death. These guys have at times an intoxicating way of meshing their guitars and harmonies into a folksy haze pioneered by The Byrds, but most often don't come through with great songs, unlike, say R.E.M. or Robyn Hitchcock. The production is raw, and the music anonymous. — Jordan Eagles

OVERKILL: Triumph Of The Will (LP; SST, P.O.B. 1, Lawndale, CA 90260, USA) This should please punks and metalheads alike with a hard driving rock attack that never lets up. Great vocals by Merrill Ward that prove what a difference a band makes (he also sings with SWA). Backed by a muscular rhythm section and locomotive guitar, these guys steamroll through 14 songs that gradually gain in momentum and intensity right up to the last cut: "Head On", a song about a guy so caught up with drag-racing his car through the night with a girl at his side he doesn't notice the brick wall until it's in his face. Overkill successfully bridge the gap between Black Sabbath and Black Flag (DAMAGED period). — John E

PACIFIC 231: The Last Morality (C; Ladd-Frith, P.O.B. 967, Eureka, CA 95502, USA) Although Pacific 231 has prolifically released material in his native France, few American documents of his work have appeared. THE LAST MORALITY is the best of these domestic releases because it displays intensity which overshadows the minimal instrumental accompaniment and textural variation. The cassette consists of two versions of a mega-performance entitled "The Last Morality", the first of which is more exciting, made up of solo voice, feedback and effects, with sparse taped accompaniment in the form of "industrial" grinding and electronic drones. I enjoy the piece because Pierre (231) is able to manipulate the feedback into continually shifting patterns and regularly changes his vocal intonation. At points the performance is crushingly aggressive and at others, roughly ambient. Obvious comparisons will be made to the vocal hysterics of Whitehouse's William Bennett, since both artists effect the voice with various devices (flanger, distortion, delay, etc.) THE LAST MORALITY presents one very limited view of Pierre's work, since his newer studio material is lushly ambient and brilliantly varied in texture and atmosphere; and with this in mind, the cassette is recommended. — Paul Lemos

PAPER BAG: Victimless Crimes (C; 5828 Topoka Dr., Tarzana, CA 91356, USA) At their best, this mostly instrumental improvisation band reminds me of Soft Machine's third LP. At it's worst, mainly the songs with words, it makes me want to fast-forward. This music has a jazzy, progressive feel, sometimes very soft and melodic and sometimes harsh. The guitar sounds like Robert Fripp at times and all the musicians are very competent, even if the drums are over-played. In all, there's more musicianship than ideas and the bad poetry-style vocals are a definite bad point. — Lawrence Crane

TOM PAXTON: Bulletin...We Interrupt This Record (LP; Hogeye Records, 1920 Central St., Evanston, IL 60201, USA) Like all Paxton albums, this is a political folk album. Although I've been listening to Paxton for a long time, I never realized how effectively he mixes pathos and humor. This album is full of both. Of course, most of his funny songs tend to date easily when the news events they refer to have disappeared from the public consciousness. However, the hope expressed in the humor of "The Perfect Bomb" is something we all need to hang onto in these dangerous times. The serious songs, like "Johnson" will also stick with you. Musically, this is typical Paxton, folk guitar with assorted backup instruments. — Billie Aul

PEACH OF IMMORTALITY: Talking Heads '77 (LP; Adult Contemporary Recording, 506 10th St. NW, Washington, DC, 20004, USA) Peach of Immortality have dipped their malformed, leathery feet into the wading pond of industrial convention and proceeded to kick like hell. In the grey on grey cover disguise that could pass for a government-authored agricultural treatise, the former Athens, Georgia-based trio have thrown a quill-lined coat across the shoulders of the restless ghost of Throbbing Gristle, and staked out new territory beyond the increasingly familiar white bread agonies of an army "ov" "23"-festooned would-be mystics. The band (now residing in DC) employ homicidal cello lashings and an intriguing prepared guitar as a play against the extraordinary tape manipulations that wrack TALKING HEADS '77 with spasms after gut-pulling spasms. This is the closest corollary to the body rushes of good acid we may ever come across. The five tracks (untitled, lasting over 55 minutes) unfold defiantly, resisting interpretation and confounding expectations. The litany of a multitude of sound-a-like power electronic Psychic Youth is thankfully not evoked. On side A, Captain Beefheart's early "Giddy Wah Diddy" is run through a grinder to a mournful accompaniment that shifts, disappears and appears again, albeit in horribly mutated form, and Little Richard's seminal recording of "Robby Teddy" exploded "Alien"-like through the body of a piece where Jared Hendrickson's brutal evocation of Rogelio Maxwell's cello incisions frame the numbing words of a hospitalized schizophrenic who claims that the portrait on the wall of his room has a headache. Throughout the LP Tom Smith's tape freak-outs are astoundingly novel. More impressive is that all five selections on this consummate anti-album were recorded live, with no overdubbing. This reporter witnessed the 9:30 Club performance from which the fifth piece was drawn, and especially in the context of THAT club, it was mind-boggling, with completely fucked-up music that stunned the audience. They made the headliner, Birdsongs of the Mesozoic,

seem rather less essential. There is a great deal of surface noise, a lot of hiss, and two of the selections better a bit too long. None of these minor grievances interfere with the enjoyment of one of THE albums of 1985. (P.S. The inside of the poster sleeve is hilarious — liner notes lifted straight from CHICAGO III) — Chris Williging

PERVERTED SCIENCE: Perverted Science #1 (C; P.O.B. 7601, Auburn, CA 95604, USA) This first tape by Perverted Science is full of a variety of sounds performed by a loose aggregation of three people using cheap synthesizers, tape loops, and vocals. The music ranges from sound-track style electronics to easy-listening industrial and even electronic reggae dub. Their influences are varied, sometimes mimicking Eno or Tangerine Dream and other times sounding like artists they've probably never heard, like Hunting Lodge or Data-Bank-A. Recording quality is not perfect, tape hiss is noticeable, but if these people keep progressing there is sure to be some incredible work. The tape comes spray painted with a neat pattern. Send them a few dollars and I'm sure you'll get a tape. — Lawrence Crane

BARRY EDGAR PILCHER: Wave Sax (C-90; available for blank C-90 tape and postage; Pilcher, Valley Of The Ice Cold Rain, Lletty'r Nest Llanelwddog, NR Carmarthen Dyfed, Wales, SA32 7JE) Very fine solo sax in one long continuous work incorporating a wide range of electronic treatments which enhance a series of related melodic cells and motifs. Incredible continuity and flow. Lies stylistically somewhere between John Klemmer and Philip Glass with a warm, rich sound, little eddies of melody, and soothing washes of echo. Never becomes dull. A thoughtful, melodic, well-crafted work. — Tom Furgas

PISCINE ET CHARLES: Quart de Tour, Mon Amour (LP; Another Side, division of Les Disques du Crapuscule, 4 rue de la Fourche, Brussels 1000, Belgium) Background music for a fashion show? This LP has quiet synths, piano, nice guitar sounds and a nagging drum machine, and sounds smooth and a little shallow. The music is gentle, artsy pop muzak; pleasant, but not demanding, with some spoken vocals and wordless singing that create an odd balance. Nice, motionless music. — D. Maryon

PLAN 9: I've Just Killed A Man — I Don't Want To See Any Meat (LP; Midnight International, Box 390, Old Chelsea Sta., New York, NY 10011, USA) An excellent psych-punk package. Deb DeMarco's acid organ remains instrumental in flavoring the whole sound. Lots of energy and sincerity. This is a "Live" album. Studio versions of seven out of nine of the songs here have been previously released on vinyl. — Jack Jordan

PENDRAGON (C; P.O.B. 26244, San Jose, CA 95159, USA) Four head-banging metal demo numbers. Some tips of the hair to Led Zep, oh yeahhhh, done in classic form. Needs a heavy-metal rock and roll oriented graphic — some armored warriors at a truck stop late at night, all glittery and imposing. Shreds. It's got everything ya need scream right there in your own room. — Robin James

BLAIR PETRIE: The Meaning Of Love (C; avail. from CLAS, P.O.B. 86010, N. Vancouver, BC, Canada V7L 4J5) Petrie has a list of previous releases a mile long. This cassette is yet another indication of his propensity for doing it right — so right that you've got no choice but to take or leave what he does on his own terms. He appears to be a songwriter who took to electronics for the control it offered and the option of covering all the bases alone after a life among the wastelands of "progressive" music in the early '70s. He's got a voice that hovers somewhere between Mac from Echo and the Bunynpersons and the full-throated post-Bowie school. The similarities to the above and there though — the music runs the gamut from cabaret-inflected acoustic guitar laments in the confessional style of Peter Hamill to a more straightforward "new Romantic" style of wail over digital drums and the polyphonic synthesizer. What ties it all together is Petrie's general sensibility and the wise decision to base all the stuff on this particular release on that old chestnut "love"...its presence, absence, and obsessive nature. Petrie studiously avoids cliches as he shares confessions and demons with the listener. THE MEANING OF LOVE succeeds admirably in a field I don't normally find very interesting. — Gregory Taylor

PEKKA POHJOLA: Space Waltz (LP; Breakthru Records, 2 Lincoln Square, New York, NY 10023, USA) Pohjola is classically trained in both piano and violin, but began his recording career in 1969 as a bass player with the Finnish supergroup Wigwam. He has recorded seven solo albums. His strength is his compositional skill, creating lengthy pieces of jazz-rock fusion using traditional melodies, often hiding Finnish folk tunes beneath the music. SPACE WALTZ is five instrumentals featuring Pohjola on bass and keyboards. Two more keyboards, drums and guitar complete the lineup. Seppo Tyini, having recently rejoined the band, brings an improvised guitar sound that is more daring and aggressive. Moody themes are stated and then varied melodically. A few bars on synth that resemble jazz-polka will be echoed by searing guitar. Throughout it all, the bouncy bass connects the discourse, or abruptly changes the tempo and mood. Unusual time changes seem effortless. The arrangements are creative enough that a single theme is varied for over 13 minutes and never sounds repetitious. — George Ottinger

POISON GIRLS: Songs Of Praise (LP; CD Presents, 1230 Grant Ave., #53, San Francisco, CA 94133, USA) I perceive a gap between ambition/intent and actual results. The press info indicates that Poison Girls spent years as a hardcore/punk band, but most of the music herein is nondescript, quasi-funky art rock.

The songs contain strains of poetry that fit neatly into two overlapping album themes, a brewing inner chaos masked by outward peace and/or the calm at the dawn of destruction: "There's a riot in my mind but the streets are quiet." "People just standing on corners, waiting for the end to come." "Like a ghost town valley, like dust on the street...but the crowds gather round when the ambulance screams..." Unfortunately there is also a plethora of irritating political or linguistic cliches: "I'm not a real woman, I won't cook your food." "Don't come too close for comfort." There is one song, "Desperate Days," in which the music and lyrics really work. Here a beautiful, melancholy theme is accompanied by allegorical images of society on the verge of apocalypse. At one point lead vocalist Vi Subversa sings, "We aimed too high, we aimed for the sky, now we've gone to ground." I know this is a reference to Western civilization, but I can't help wondering if it also applies to Poison Girls themselves. — Richard Singer

POPEDEFECT: One By One/Hard Times (7"; \$1.50; Heert Murrur, P.O.B. 42602, Los Angeles, CA 90042, USA) A very danceable single. Good, energetic rock 'n' roll, a little influenced by rockability. The lyrics are critical yet optimistic. The word for this music is FUN. — Mikki Pohl

POPULAR HISTORY OF SIGNS: Ladder Jack/House b/w If She Was A Car/Stigma (12" ep; Wax Trax, 2445 N. Lincoln Ave., Chicago, IL 60614, USA) Good English dance music that makes me realize how much I miss early Orchestral Manoevers In The Dark. The tracks are great; dance beats, cool electronics, and relatively simple (but effective) lyrics. Romanticism and emotion mix together creating music to dance to and enjoy. — Sam Rosenthal

KENNY PORE: You Don't Know Me (LP; Passport/Jem) Finely crafted, mostly instrumental pop. Pore produced, arranged, and did most of the writing, but does not play or sing on the LP. The dominant instruments are Pat Coil's keyboards and Brandon Fields' soprano and alto sax, laid over a lush but not overpowering electric rhythm section. Vocalist Rick Aiso appears on three of the seven cuts, and the results are reminiscent of Michael McDonald and (somewhat more distantly) the Police. In places the sax gets some improvisatory space, but not much. Overall the LP is like the soundtrack of a film romance. — Bart Grooms

POSSESSED: Seven Churches (LP; Combat Records, 14505 Hindry, Lawndale, CA 90280, USA) Totally raging Death Metal from this Slayer-ish four-piece from Frisco. Their songs are incredibly powerful and fast while still retaining some well-constructed riffs and melodies. Another young band, (two of their members are only 17), they prove they can thrash with the best of them, ranking right up there with such major thrash bands as Slayer, Exodus and Metallica. The band members are excellent musicians and bassist/vocalist Jeff Beccara has the most wicked sounding voice I ever heard. Though the whole LP is lethal, my fave tunes are the lightning-speed "Burning In Hell", the slower grinding "Holy Hell", driven by drummer Mike Sus' pounding double-bass rhythm, and the thrashing anthem, "Death Metal." Lead and rhythm axe-wielders Mike Torrao and Larry Lokone unleash a flesh ripping axe-assault through the LP, especially on "Evil Warriors" and "Seven Churches." — Dmitry Owens

KEVIN POSTUPACK: Voice Of Silence (LP; PRM Records, P.O.B. 210, New Brunswick, NJ 08903, USA) This is moody acoustic jazz of the pastoral variety, somewhat akin to the music of the group Oregon. There are no horns here, unless your idea of a horn includes a recorder. Postupack plays acoustic guitar with admirable agility and sensitivity, ably accompanied by the four other musicians on this record, though he doesn't let them do very much. Composition is weak, however. Too much interest in soloing and not enough compositional development. It all sounds so flashy and uninspired. — Sam Mental

PRESENT: Le Poison Qui Rend Fou (LP; Cuneiform Records, P.O.B. 6517, Wheaton, MD 20906, USA) This is a significant one. Present is led by Univers Zero founder Roger Triguera who is credited with most composition and plays superb guitar. His is joined by current U.Z. leader Daniel Denis on drums, Alain Rochette on piano, Ferdinand Philippot on bass and Marie-Anne Pollaris on vocals. This music is composed rock. Essentially chamber music (a guitar quartet), the classical influence is heavy. Stravinsky, Bartok and the second Viennese school come to mind. It is comparable to the music of U.Z. but generally rocks more. The music rewards serious listening, revealing outstanding composition and precise execution. It is a fairly intense but often beautiful album — a classic within its genre. This is strong, wonderful stuff, representing a complex interface between rock and classical influences. Flawlessly produced and recorded. — Robert Oot

PRIMITONS: Primitons (LP; Throbbing Lobster, P.O.B. 205, Brookline, MA 02148, USA) First of all, they ain't no primitives, as the name and the stark black-and-white woodcut on the cover might suggest. Instead, this trio plays well-rehearsed, brightly produced pop. The songs are well-meaning but empty. The lyrics suggest cosmic non-answers to questions nobody was asking anyway. The music is lively but forgettable. — Bill Neill

PROBLEMIST: After Sanity (C-90; Ladd-Frith, P.O.B. 967, Eureka, CA 95502, USA) Some of the social commentary of '9 TIMES SANITY' continues here on Problemist's follow-up cassette. However, most of it, such as the line "Can you explain without discussion the belief of your own opinions?" pops in and out of the mix rather than dominating the whole. AFTER SANITY resembles the experimental pieces found on 1983's WHAT IS TO

BEGÜN while utilizing more complex and sophisticated studio methods; processing percussion, found spoken pieces, bass, guitars, electronics, and what not, often beyond the point of recognition. A forward progression with a glance or two over the shoulder from an important and interesting artist. Note: one side of this C-90 is blank. — John E

PROJECT ELECTRONIC AMERIKA: Secret Flight (C, Projekt, 8951 SW 53rd St., Cooper City, FL 33328, USA) This is the soundtrack to the movie inside your head, says Sam Rosenthal (aka Projekt Electronic Amerika). This is a very slow moving film, one that gives the viewer a lot of time for some deep psychological contemplation. Some is sad and some not so pleasant in the feeling you are left with. The music is thoughtful and well presented, never terribly complex or fleshy (less it would detract from the contemplative nature.) In most instances, the foundation for each piece is a sequence that drifts effortlessly from key to key. Over the top he meanders from place to place with melodic washes of sorrowful tones. Throughout, his inclination is to lean on a sound, derivative of Baroque harpsichord music, perhaps in an attempt to provide a feeling of aspiration in the midst of the gloomy world within. — Nathan Griffith

PSYCHIC TV: These Who Do Not (LP; Gramm Records, Laugavegur 17, 101 Reykjavik, Iceland) A live double recorded in Iceland, this shows Psychic TV exploring powerful, trance-like music. Bells, droning vocals and guitars flow through the stately rhythms in unpredictable, engaging ways. Clear recording helps as does the fact that this is neither a descent into the maelstrom nor an invocation of facile magic but a haunting vision of... what? You tell me but it's definitely worth a look. — Lang Thompson

PSYCLONES: Cult Leader Gang-Raped By Disciples (C-60; Ladd-Fritch, P.O.B. 967, Eureka, CA 95502, USA) The clever title of this wonderful tape by Psyclones is complimented by the cover photo pulled no doubt from a hardcore leather s/m sex mag showing a guy being forced to drink "it" hot from the tap. The music is an ingenious blend, combining sarcastic lyrics based on themes of control and rebellion: "C'mon down and get saved, this is your chance to get emotional, come on down, you can cry if you want to..." and electronics, fuzzy bass, grinding psychedelic wiggled out guitar, radio, TV, and machine noise, echo effects, and incredibly overdriven 500 mph drum fills. Out of this cosmic soup the Psyclones mold 14 songs rich in invention and variety. Though no category can really be applied, if such a genre existed, I'd be tempted to call this "Industrial Pop". — John E

PSYCHODRAMA (C-60; c/o Brett Kerby, 4833 Walney Rd., Chantilly, VA 22021, USA) This is meant to accompany a live, puppet-show style performance. Creative use of the Casio and voice, with unusually recorded sounds added in. The theme and conception is powerfully revolting. Anyone who listens to this tape now that the warning is up should be killed. Seriously, the pedophile homosexual garbage, the cat murder and climax child murder sequence at the end of the tape, the blasphemy and vomiting and shit leaves me cold, even doubtful (one time I listened to this and I was suddenly seized with irrational revulsion, furiously trying to drown it out in any way I could, TV on and radio alarms up, blender on the highest setting with gravel and nails in it, all the dogs barking, the parrot screeching, neighbors pounding on the doors. Everybody was not happy to hear this tape.) Goll dang. Hey, I'm hip. I just turn it off. Check out the other tapes from Psychodrama for some very clever melodramatic music with vomiting and vivid self-crucifying numbers and an ear for self-molesting sonic accompaniment a la Casio and microphone effects. — Robin James

PSYCHOTICS: Mass Insanity Destroying Civilizations (12" EP; Olive Tree Records, P.O.B. 13026, Washington, DC 20009, USA) Psychotics fuse reggae, ska, dub, funk and pop with humor and strangeness. Headly, pumping grooves are laid down in "Up-town Psychosis" and "CUBU" over high-pitched rantings by Carl Cephus. They get topically heavy on the dub toast "Ethiopian News" with DJ Mikey White. A couple of relatively captivating dub versions round out the second side for a party-worthy debut. Check out the riotous liner notes. — Jamie Rake

QUITE RIDICULOUS NONSENSE: Laxative (C, \$3; Daniel Foley, 3440 Aylmer #22, Montreal, Quebec, Canada H2X 2B7) This review carries a heavy responsibility: the tape came with a heartfelt letter from creator Daniel Foley who felt "on trial." It asks "What will be the judgement? What will be the sentence? You realize you literally decide my own future, my own life?" Well, Daniel, I guess you can live. For you have produced a tape that comes from as weird an area of consciousness as your letter. What we have here is ten items of pounding, reverbed bass wash in a lot of swelling, echoey electronics and a bunch of noises. Machine noises, radio squeals, people brushing their teeth, and distorted voices from police, preachers, Sesame Street and what sounds like an abortion rights rally. There's really no ambience, except, through both sides, maybe that of a swirling headache that won't go away. Muzak for an armaments factory, or a party tape for the avant-garde. — W. Mueller

QUITE RIDICULOUS NONSENSE (4-song 7"; see address above) Heinous noise with a backbeat and a sense of humor from Quebec. Repetitive pop bass and primal drum machine carry early Residential noises and washes. Vocals and lyrics are punny/industrial parody ('tis a fine line), reminding me of Daemon Edge. Some of Chrome's early experiments with processed vocals and tapes are heard grafted to a random rhythm escapade for guitars and machines ala one of Half Japanese's instrumentals from their

first LP. Most of this is danceable and wouldn't get thrown off at your new wave party. — Gege Kenady

RAGING FIRE: A Family Thing (4-song 12"; Pristine Records, 10-C Hickory Village, Hendersonville, TN 37075, USA) This band from Nashville sounds like a combination of Au Pairs and Hank Williams, especially relying on the former. Furthermore, Melora Zener's lyrics evoke southern culture and literature, bringing to mind the pursuits of Nick Cave. This could be called Cowpunk, but it is considerably more dynamic than most of the bands in that genre that boozie their way through sets in L.A. The band is tight and inventive, Michael Godsey's guitar is a screamer. But the focus is on Zener's powerful vocals; honest, sexy and wildly emotional. The performances are strident but mannered. An adventurous and creative beginning. — Scott Jackson

RAJAH: Nataraja (LP; Juniper Recording, c/o Herman Brooks, P.O.B. 4479, Culver City, CA 90230-8079, USA) Rajah's eight members mix traditional Afro-American and Indian melodies with reggae rhythms in songs that flow smoothly through masterful arrangements by Herman Brooks who wrote all of the music, arranged all but one of the songs, and produced the album. The bass and percussion create a slow rhythmic reggae background while following the Indian style acoustic/electric leads, setting this band apart from other Afro-American or Indian bands I've heard. Lots of percussion such as tablas, bongos, cabasas, Linn drum, bells, and a tambourine blend with two acoustic guitars, a piano, and a synthesizer. A relaxing and well mixed album; the songs are based on "kirtan" or chanting which is done in spiritual communities throughout the world following morning and evening meditations. — Josh Hatch

SCOTT RANDOLPH: Miracle Season (C-30; \$6; 28 Peach Court, Flemington, NJ 08822, USA) This solo electronic tape is derivative of Eno, Teutonic electronics and Tonto's Expanding Head Band from the West Coast circa 1971. Many moments of creative brilliance. — George Ottinger

RASZEBRAE: Cheap Happiness Or Lefty Suffering (LP, RZ Ent., P.O.B. 93802, Chicago, IL 60693, USA) How about unendurable suffering? This is the most awful trash I have ever heard in my life. The title is from Dostoevski, but the liner photo of the drummer enraptured with a comic book is more telling. It appears, nevertheless, that the vocalist of this four-woman metal band has great literary aspirations. Each song is paced with trenchant observations of the human condition. We learn, for example, that "There's no angels/ There's no Hell/ There's no beer/ There's only blood." No beer?! If that isn't enough to make you look deep inside yourself, or if it simply makes no sense, we are later advised "Fuck you if you can't dream my mind." It's the band that gets fucked, though, so busy trying to jump around these pretentious lyric contortions that it never has a chance of kicking in. — W. Mueller

THE RAVE-UPS: Town And Country (LP; Fun Stuff Records, 1014 Laurel Lane, Beverly Hills, CA 90210, USA) Not far from the mainstream, but well above most commercial rock albums. The record is very "with-it" thanks to the country influence, but the group handles it so well you can't blame them. They avoid most of the pitfalls of country-rock. Guitarist Terry Wilson was in the Ozark Mountain Daredevils, and his professional playing shows. Town & Country sounds like a cross between the Del Fuegos and the Flying Burrito Brothers. I think the title is meant to suggest some synthesis of country twang and urban rock n' roll. Well, okay. They pull it off. — Bill Neill

THE REAL ROXANNE: Romeo Pts. I & II / Roxanne's Groove (Select Records, 175 5th Ave., New York, NY) A veteran of the "Roxanne" wars tries to break out of that trap, though not very hard, as "Romeo" has a very similar structure to the rap mega-hit from whence she was spawned. With the help of Hitman Howie Tee, Roxanne tells the story of her clash with the arrogant Romeo. Witty and charming. Part One ends with a cliff hanger, urging the listener to turn over the record to hear the conclusion of the saga. This definitely has merit beyond being just another in the endless stream of "Roxanne" answer records (which it is not), and I hope there are more fun records to come from the Real Roxanne. — Calvin Johnson

THE RESIDENTS: The Big Bubble (LP; Ralph Records, 109 Minna St. #391, San Francisco, CA 94105, USA) An album within an album from those merry masters of musical mutation. As the Big Bubble, The Residents portray a pop group that is the product of generations of cross breeding between Moles and Chubs, the warring cultures introduced on "Mark Of The Mole". Some of the lyrics are sung/chanted in Mohelot, the long-forbidden ancient tongue of the Moles. In the interest of initiating those unfamiliar with The Residents, this album offers the unlikely blend of state-of-the-art technology with primitive human elements, which has become the group's trademark. The lush orchestral quality of the Emulator system has never sounded better, and in the playful hands of The Residents we are presented with an avant-garde excursion which manages to entertain as well as baffle and disturb. The material conveys a dark, oppressive melancholy for the most part, with strange bits of Residential mischief lightening the mood by means of playful scat verse. While this disc may not offer much of consequence in context of the group's more than a dozen LPs, this is probably the slickest sound production by these boys to date. I can't help but wish they had done just a bit more with it, been even more creative and bizarre as they have proven to be in the past. — Michael P. Goodspeed

MICHAEL RICHARDS: Can't Love A Good Woman Enough (7" single; Skipper Records/Allegiance Records, 7525 Fountain Ave., Hollywood, CA 90046, USA) Richards employs to good effect a plaintive, "ole timey" country sound reminiscent of Merle Haggard. Backed-up by a traditional country music aggregation and using a modest, uncomplicated musical arrangement, Richards displays heightened consciousness as he sings of the need to treat well members of the opposite sex instead of beating them around the head or doing whatever it is that "good ole boys" do to contrary country. This is a good, solid, satisfactorily recorded mainstream country ballad. — Norman Lederer

MARC RILEY AND THE CREEPERS: Fancy Meeting God (LP; In Tape, Unit 3, 104 Northenden Rd., Sale, Cheshire, England) Alright! "Breakneck 2" makes me think of a longer meander version of the original Modern Lovers that "Pablo Picasso" crossed with a weirdo bagpipe-music ghost orchestra, though I have no idea what he's singing about; the vocals sound like they were recorded down the hall. This is FUN music; loose, loud, sorta jovial and loopy at the same time. "Fly The Nest" is Syd Barretty in a giddy music-hall way. Overall this is like a low-tech version of the Damned at their most playful (re. sensible), which is not to say this isn't a serious work. "Judas Sheep" is as beautiful as "Telstar" or "Here Come The Warm Jets" and it's one of the best songs of it's kind written since John Lennon's "Gimme Some Truth" (and this one rocks better). This takes on all those Judas Sheep that lead the rest of the herd into the slaughterhouse of drugs, dogma, pose and clothes that passes for hipness. — Geo Parsons

JEAN RITCHIE: The Most Dulcimer (LP; Flying Fish Records, 1304 W. Schubert, Chicago, IL 60614, USA) Ritchie is a traditional instrumentalist and singer in the English-Appalachian school; her singing is often considered the standard by which others in the genre are judged. This album, made in response to the question "which album has the most dulcimer?" is an excellent introduction to her bewildering array of over forty records. The songs and tunes are wonderful, some traditional and some composed by her (including "Edward," a version of one of the creepiest ballads ever written), and each track features her mountain dulcimer playing, along with various talented supporting players. Ritchie is one of the most exceptional talents working in folk today. — Christopher Patus

DAVID ROACH: The Talking City (LP; Passport Records/Jem, P.O.B. 362, South Plainfield, NJ 07080, USA) Roach is a decent saxophonist (alto, tenor, soprano) whose melodic soulful playing is influenced by David Sanborn, but lacks Sanborn's creativity and adventure. His pleasant sound is featured as the lead voice on a set of crossover (jazzy pop/rock) originals. The unimaginative rhythm section (complete with drum machine) keeps things dull although the vocalists (on some cuts) are generally harmless. Nothing too memorable occurs since no chances are taken, creating innocuous background music. — Scott Yanow

STEVE ROACH: Structures From Silence (LP; Fortuna Records, P.O.B. 1116, Novato, CA 94948, USA) This is a consciously meditative, ambient album; somewhat of a departure for Roach. His earlier work was more vigorous and much closer to "space music." Side one consists of two pieces, both excellent. The longer "Reflections In Suspension" has an opening pattern like drops of light — delicate pairs of notes making up a long, melodic line which sounds cyclical and irregular at the same time. The effect is similar to Eno's landmark "Discreet Music"; you think you know what's coming, but you're never quite sure. On the long title piece, which occupies all of side two, Roach tries to stretch his musical material as far as it will go; again, Eno's "Discreet Music" is a definite influence, but Roach's piece is even slower and more static. I don't hear enough of the subliminally seductive quality I value in ambient music. I respect what Roach is trying to do on side two, but I find the two pieces on side one more satisfying. — Bill Tiland

SCOTT ROBINSON: Multiple Instruments (LP; Multijazz Records, P.O.B. 722, Boston, MA 02199, USA) Robinson goes out of his way to show off his versatility on this straight-ahead jazz date. Strongest on the tenor (particularly during his passionate original "New" and the ballad "Ben") Robinson plays 34 (!), other instruments throughout this album. On "If I Were A Bell" the tale turns on three obscure brass horns (the ophicleide, nomaphon and double-belled euphonium) that all sound like bass valve trombones. On a brief "Muskrat Ramble" (through overdubbing) Scott performs on eight Dixieland instruments, even inserting scratches to make it sound like a 78 rpm record. "Survival On Venus (A Science Fiction Adventure)" is conventional despite Robinson's 23 instruments, including the bombardon, solaristic sound sculptures (say what?), the overpopular rotary valved posthorn, a helicon and the bagpipes. Oddly enough this session needs MORE variety. The talented rhythm trio that joins Robinson keeps things in the groove of the Oscar Peterson Trio. I hope Robinson will try a less inhibited "history of jazz" format next time. Imagine the potential! — Scott Yanow

ROOM 201: The Green River (C-60; Redux Records, 1310 College Ave., Suite 1030, Boulder, CO 80302, USA) Imaginative environmental sounds — some peaceful, others dark and angular. Lots of subtle synth textures combined with treated voices, occasional industrial percussion, and found sounds. Highly recommended for those who like ambient electronic music that dares to leap out from the background and grab your attention once in a while. — Allen Green

DAZIBAO audio magazine

Chaque Mercredi à partir de 22h.
Every Wednesday from 10.00 P.M.

L.V.A.G.H.
99,20 mhz
33000 Bordeaux
FRANCE

PLAYLIST OCTOBRE 1985

SKI RECORDS	-U.S.A.	-COPERNICUS	:NOTHING EXISTS LP.
KELVIN 422 RCDS.	-U.S.A.	-WISEBLOOD	: MOTORS LUG 12"EP.
AUTOPRODUCTION	-U.S.A.	-S.GANNON/D.LIFE	: FESTIVAL OF LIGHTS Cassette
THINGSFLUX RCDS.	U.S.A.	-DIMTHINGS	: IN SPIRE OF WHAT THEY SAY 12"EP.
TWINTONE RCDS.	-U.S.A.	-NOFUNGO	: FREDERICK DOUGLASS LP.
AUTOPRODUCTION	-U.S.A.	-AUDIO LETER	: IN THE GREEN NIGHT Cassette Live
THINGSFLUX MUSIC	-U.S.A.	-DIMTHINGS	: DIS-CI-PLINED TO A SPONTANEOUS...L
FLESH RECORDS	-U.S.A.	-AMOR FATI II	: 10 1/2 SONGS Cassette
MATAKO MAZURI RC	-U.S.A.	-BANDS ON THE BLOCK	: WHAT IT IS LP.
MATAKO MAZURI RC	-U.S.A.	-IDEALS	: PSI COM LP.
MOHINI RECORDS	-U.S.A.	-PSI COM	: MONDO BEAT LP.
C.T.I. RECORDS	-U.K.	-CHRIS CARTER	: I TELL YOU EVERYTHING Cassette
AUTOPRODUCTION"	-U.S.A.	-S.A.HARKEY	: WHEN IN ROME DO AS THE VANDALS LP
NATIONAL TRUST	-U.S.A.	-THE VANDALS	: A DOZEN OF DEAD ROSES LP.
NO TREND RECOR.	-U.S.A.	-NO TREND	: THROB THROB LP.
HOMESTEAD RCDS.	-U.S.A.	-NAKED RAYGUN	: BRINGING HOME THE BAIT LP.
HOMESTEAD RCDS.	-U.S.A.	-LIVE SKULL	: DEATH OF SAMANTHA EP. 45rpm.
ST VALENTINE P.	-U.S.A.	-DEATH OF SAMANTHA	: DRASTIC EP.
DEATH TRAIN MU.	-U.S.A.	-ANTISEEN	: BODY W/O ORGANS LP.
FLESH RECORDS	-U.S.A.	-AMOR FATI	: A LITTLE FISH IN THE BIG OCEAN LP
COUCH RECORDS	-U.S.A.	-MUSICAL SUICIDE	: BRINGING DOWN THE BIG BOYS EP.
ACTIVE INGREDI.	-U.S.A.	-ACTIVE INGREDIENTS	: NONE OF THE ABOVE LP.
RABID CAT RCDS.	-U.S.A.	-NONE OF THE ABOVE	: PEACE INTERNATIONAL COMPILATION DOUBLE LP.
ROCK RADICAL RC.	-U.S.A.	-PEACE INTERNATIONAL	: SOMETHING TO BELIEVE IN COMPILATION LP.
FRINGE PRODUCT	-Canada	-SOMETHING TO BELIEVE IN	: U.F.O. LP.
GASATANKA RCDS.	-U.S.A.	-WHITE FLAG	: W.F.O. LP.
ANOTHER ROOM MAG	-U.S.A.	-AUDIO A.R.M. No1	: Cassette Magazine compilation
ANOTHER ROOM MAG	-U.S.A.	-AUDIO A.R.M. No2	: Cassette Magazine compilation
WIDOWSPEAK RCDS.	-U.K.	-LYDIA LUNCH	: THE DROWNING OF LUCY HAMILTON EP
BUZZERAMA RECORD	-U.S.A.	-ALGEBRA SUICIDE	: AN EXPLANATION FOR THAT FLOCK EP
I.P.RECORDS	-U.S.A.	-CAMPER VAN BEETHOVEN	: TELEPHONE FREE LANDSLIDE LP
SOME BIZZARE RC.	-U.K.	-EINSTURZENDE NEUBAUTEN	: 1/2 MENSCH LP.
ATMOSPHEAR RCDS.	-U.S.A.	-THE FOUND OBJECTS	: COMPILATION LP.

*Dear Joseph,
Sincerely yours,
H.*

**c/o Philippe Soussens - 72, rue des Menuts
33000 Bordeaux France**

Copernicus - "Nothing Exists" — "What kind of record is this? ... very difficult to describe but very original and creative. Is Copernicus the beatnik / punk / poet of the 80's? Just listen! Objekt Magazine.

Autographed copy of "Nothing Exists" available from Copernicus, Box 150, Brooklyn, N.Y. 11217 \$8.00 postpaid.

Look for the 2nd Copernicus album
"Victim of the Sky", to be released Feb. 1, 1986.

MUKEL ROUSE BROKEN CONSORT: A Walk in The Woods (LP; Club Soda Music, 405 W. 45th St., New York, NY 10036, USA) A suite of seven contemporary chamber/orchestral works by New York composer Rouse. His second release with Broken Consort, this LP is a contribution to the growing body of artistic mandates for nuclear disarmament. Working in the mode of other minimalist composers such as Philip Glass and Steve Reich, Rouse creates linear lines, superimposing and then omitting voices. The pieces are controlled, methodical, symmetrical and dynamically homogenous. The ensemble includes violin, viola, double bass, oboe, bassoon, clarinet, soprano sax, trumpet, and, of course, synthesizer. — Mark Dickson

RUDI DADD: Rudi's Dead (4-song 12"; Monkey's Paw Records, 4409 Guadalupe #7, Austin, TX 78751, USA) There are a couple outbursts of shrieking guitar, but overall the music is tightly controlled. "When You're Young" owes a lot to the Psychedelic Furs, especially the singing. The four songs proceed at a medium-slow tempo and could have used more variety. The vocals have a very solemn tone. They got stuff on their minds, you know? — Bill Neill

SACRILEGE: Behind The Rooms Of Madness (LP; Children Of The Revolution Records, Box 333, 110 Cheltenham Rd., Bristol, U.K.; licensed in U.S. by Psmort, P.O.B. 701, San Francisco, CA 94101, USA) No need to continue to complain for lack of new and interesting material coming from the U.K. We can all finally put away our barely audible (due to years of over-play) Discharge, Anti-Sect, and Icons Of Filth records and open the way for Sacrilege. These blokes are pure power in the true tradition of good ole English punk rock. With all these new speed metal thrash bands coming out its good to hear a hardcore band with no compromise to wimpy vocals or setanic cliches. Vocals are rhythmic but fast and undecipherable — just the way I like them. (Lyric sheet is included.) The full sound will be appreciated by head-bangers of all types. — Scabies and Rabies

MICHAEL SAHL: Music From The Exiles' Cafe (LP; \$8.50 Musical Heritage Society, 1710 Highway 35, Ocean, NJ 07712, USA) An excellent recording of music in the Penguin Cafe/Michael Nyman style of modern chamber music. Sahl, who some may remember for THE TANGO PROJECT on Nonesuch Records, has concocted a work that reminds me, aside from the above performers, of Carter Bley, cocktail lounge music, even Chicago. His style is marked by constant change; rarely does one mood stay in place for more than 30 seconds. Three works make up the records. "Doins" — for violin, piano (played by Sahl), bass and drums — sports very complex rhythms expertly played by all, especially violinist Mary Rowell. "Cocktail Wanderings" played by Sahl on piano, is described in the liner notes as "the apparent aimlessness of the piano in some midtown hotel bar at 5:30 p.m." "Symphony 1983" is my favorite piece. Scored for a nine piece group and conducted by Sahl, it is like a little symphony — a fast, Art Zoydish beginning followed by a slow, quiet middle, and a pretty, medium-tempo ending. A very rewarding album of neo-romantic music. And if you're a member of M.H.S. (write to the above address for details) you can get it for only \$5.45! — Douglas Bregger

THE SCENE IS NOW: Burn All Your Records (LP; Lost Records, 361 Canal St., New York, NY 10013, USA) Short, quirky songs with an air of whimsy and political engagement, including a song with lyrics by Chairman Mao. Although the instruments include such oddities as pens, velcro and bicycle wheel, this isn't self-indulgent experimentation. It is a thoughtful, irreverent delight. — Lang Thompson Second opinion: This is great stuff, like post-hardcore psychedelic Charles Ives meets Jonathan Richman. The instrumentation ranges from Fairlight and DX7 to pots and pens, velcro, sandpaper, and bicycle wheel. This is a "rock" band influenced by classical, jazz, avant-garde, musique concrete, and dekadent approaches resulting in a sound that is anarchistic yet structured, scary but fun. — Ed Blomquist

SCHLAFENGARTEN: Strange New City b/w Mousonite (C single; Cause And Effect, 5015 1/2 N. Whiprop, Indianapolis, IN 48205, USA) Side A: Synth and drum machine layers march across the shifting sands...but when does it kick in? Side B: A bit more up — electronics and city rap. Treated and layered. — CDnA2

STEVEN SCHOENBERG: Three Days in May (LP; Quabbin Records, P.O.B. 102, New Salem, MA 01355, USA) When I was in my teens, trying my hand at spontaneous composition, my technique was never a match for the ideas of expression. Brimming over with a bust-e-gut passion to hear my inner turmoil and emotions expressed through the piano, I tried, but always fell short of the scope of my musical feelings. If I'd had the chops in those days, I might have sounded something like Steven Schoenberg on this LP. So full of youthful passion and a bias for sustain and arpeggio in this music, that the unfulfilled aspirations of my youth come flooding back with every track. No particular standout tracks, but every one seems like an uninhibited celebration of the joy of playing the piano. — Mark Dickson Second opinion: Pianist Schoenberg presents nine carefully-crafted solo compositions on this beautifully recorded LP. Reference points include George Winston and the more lyrical ECM pianists such as Richard Beirach and Steve Kuhn, although the link to jazz is tenuous — the music is rather formal than spontaneous. The compositions are not especially adventurous, but neither are they fluff, falling somewhere comfortably in the middle. Most of the pieces have a wistful, pensive quality — not that they are sluggish; there are enough surprises

along the way to save this from being another exercise in bland bookstore music. The music is executed concisely and with attention to detail. There is enough personality in Schoenberg's work to set him apart from most of the Windham Hillbillies in the home-grown acoustic music community. — Dennis Rea

KLAUS SCHULZE: Inter-Yase (C-80; Klaus O. Mueller, Kurfurstenstr. 24, D-100 Berlin 48, West Germany) The Boss is back! After his disappointing collaborations on his InTeam label, Schulze has returned to his old label, Metronome, and this advance tape indicates his loss of creativity was temporary. Side one consists of three pieces, all moody and orchestral, with prominent synthetic string sections and electronic percussion. The frequent key changes and restrained dissonance give the orchestral elements a restless, romantic quality, reminiscent of Wagner and Mahler, while the electronic percussion, sequencers, and other "hard edges," provide a modern context. One piece, "Le Beat Planet", suffers from electronic percussion, but side one bears up under repeated listening. The long title piece, on the other side, also bears up well, but it is much more in the Schulze space music tradition, and incorporates many riffs and instrumental voicings from earlier albums, while adding new wrinkles — such as tympany — to avoid redundancy. Side one probably points more to the future; side two is certainly a strong summary of Schulze's musical perspective. — Bill Tiland

ROBERT SEIDLER: Dotted Line (5-song 12"; Hill Avenue Records, San Francisco, CA; ph. 415-834-5914) Very slick, very commercial rock. Groups like The Motels, Simple Minds and modern-era Bowie come to mind. Everything is well produced, well played, and quickly forgotten. They've got songs that sound like hits. Maybe next time they'll write songs that are hits. Competent, unexciting, and docked a notch for crediting their hand-dresser on the backcover. — Scott Siegel

THE SERVICE: Zulu (4-song EP; Pvrde Records, P.O.B. 288043, Chicago, IL 60628, USA) A Chicago quintet that plays basic, non-nonsense, meat-and-potatoes music — quirky, gritty, and marvelously entertaining. Guitar, bass, drums, and piano [yes! the real thing!], augmented in spots by trumpet, sax and tube. You will find a hint of blues (ala Captain Beefheart), a taste of country, some basic rock and in the case of "Arctic Express", a blaring, music hall/strip joint tour de force that features a pumping tube and braying brass — even a guitar solo. Now, I can't tell you what songwriter/guitarist Rick Mosher's editorial position is. When he talks about being "inside looking in", when he says that "death walks" inside his door, or when he mentions a "pocket full of ashes" he doesn't offer enough information for us to get a clear picture. Nevertheless, the potent musicianship, the innovative and whimsical arrangements, the complement of instrumental voices, and the seductive rawness of the lead singing are not to be missed. It's not commercial, it's not trendy, but it sure sounds good. — G. Specs

SEVENTH AVENUE: Heads Up (LP; ITI Records, P.O.B. 2188, Van Nuys, CA 91404, USA) A conventional jazz quintet of L.A. musicians. This, their debut album, features seven group originals. The music is sincere, acoustic, and well-played but none of the players have strikingly original styles. One hears the usual 1959 John Coltrane influence in Bob Sheppard's tenor (with a touch of Wayne Shorter) while cornetist Bob Ojeda often brings to mind Blue Mitchell. Pianist Tom Garvin is the biggest "name" but even he would be difficult to identify in a blindfold test. Overall, the music could have been recorded in 1974 instead of 1984 but it mostly looks back to the '60s anyway. — Scott Yanow

SHADOW OF FEAR: Shadow Of Fear (12" EP; St. Valentine Records, P.O.B. 79118, Cleveland, OH 44107, USA) Angry postpunk played and recorded very well. Generally the message is to not blindly follow governments or false prophets. As stated in "Song And Dance": "We are only taught what they want us to know/They forget one thing, we can think on our own..." Like many punk and post-punk artists, they don't see things getting better. In the depressing "Puppet Life", Shadow Of Fear state "In the end, we'll all lose, trapped inside, living behind all their lies..." The music is droning and cryptic. — John L. Basalle

BUD SHANK AND SHORTY ROGERS: California Concert (LP; Contemporary Records; dist. by Fantasy) Also saxist Shank and flugelhornist/arranger Rogers spent many years in the L.A. studios, but their recent return to performing straight-ahead jazz proves 1) they lost none of their chops while in exile; 2) if they were ever classifiable as part of the enigmatic "West Coast" jazz sound, that's ancient history now. Backed by a first-rate rhythm section of George Cables (piano), Monty Budwig (bass), and Sherman Ferguson (drums), Shank and Rogers blow focused, masty and relatively concise solos on four standard tunes and three Rogers originals. Rogers turns in some creative arrangements — the old warhorse "Makin' Whoopee" is embellished by a bebop style theme at twice the tempo, and Duke Ellington's "Echoes of Harlem" is done in 12/8. And when the horns enter for the theme on the latter, they sound remarkably like Ornette Coleman and Don Cherry. Rogers' "Aurex" recalls mid-80s Miles Davis. It's a hard to make an album of mainstream jazz that really sounds fresh to these ears, but Shank and Rogers have done just that. — Bart Groome

SHANE: Unexpected Dream (C-80; Flying Sun Tapes, P.O.B. 738, LaPorte, CO 80535, USA) Highly reminiscent of several late sixties bands coupled with an eighties approach, Shane provides a peaceful, melodic backdrop. Their vocal style is straight out

of the Pentangle/Renaissance school from the sixties; and the music could easily be from contemporary band C'est What? from New York. Sand uses table, bells and chimes for percussion. Jeff and Crystal Goldberg are the heart of Shane and have been playing together for more than 10 years. They write all their own material and play all 14 instruments on the tape. Despite my overall enthusiasm for this recording, I feel that it is somewhat too meditative, some songs sounding more like mantras than entertainment. — William Pansot

ROXANNE SHANTE VS. SPARKY DEE: Round 1 (12" EP; Spin Records) A couple of the original fly girls to record "Roxanne", Roxanne answer records fight it out in authentic rap battling. You get ones that helped to start it all, "Roxanne's Revenge" and "Sparky's Turn," along with a profile of each and two versions of the title cut, one uncensored and the other censored. In the latter, both Rox and Sparky trade insults with the flair of pro wrestlers. Sparky is great and she knows it. Her insults would not have to be so rude but to combat Roxanne's potty-mouth, they have to be. Roxanne has to prove her desirability by squawking on about all the shit she owns, how she goes to the manicurist, etc. The biggest lowlight is when Sparky accuses Rox of being "too damned black." Musically, Sparky's sides are better grooved but Roxanne's best shots have more immediate kitsch appeal. Could it be that only in America insults can become art and teenage girls can make money from verbally mowing each other down? Say "Yo!" — Jamie Reke

SHOCKABILLY: Heaven (LP, Fundamental Music, P.O.B. 2309, Covington, GA 30209, USA) Issued on the heels of the bands' break-up, HEAVEN is a vicious tease — I mean fuck, shit, hell, — it's all here: grit, skill, roots, dementia, love, hate, drugs, rebellion, intelligence, madness, childishness; pulled together by a now defunct avant-garde rock 'n' roll trio. Shockabilly can't rightly be pigeonholed (rock-jazz-punk psychosis? Country-Western/heavy metal/glitter/schlock rock?) but their reputation will grow as people buy their first Shockabilly record and realize, fuck, shit, hell, they must have really missed something special last time Shockabilly clamored into their town while they sat watching TV. A band of the '80s, Shockabilly reflects the era, rising like a bubble from a healthy fart to the top of a cultural sludge-pot of undiagnosed pain, stress, fear, anger, cynicism, paranoia; fragile egg-shell minds, shook, rattled and rolled; mindlessness and disregard. Shockabilly is rock and roll on its knees, swinging wildly at invisible demons, laughing in the face of love, crying on the sidewalks of purgatory; self-conscious, schizophrenic guitar, embarrassed by the simple, extremely manipulative power of amplified music. Rock and roll is an inscrutable joke and Shockabilly didn't know whether to laugh or cry — but they turned on the tape recorders and went for it anyway. — David Ciffardini

MICHAEL SHRIEVE: Transfer Station Blue (LP; Fortuna Records, Box 1116, Novato, CA 94947, USA) As members of the long defunct band Go, Shrieve and Klaus Schulze helped bring fusion and electronics together into a very tasteful hybrid. Now, the two are back together adding Kevin Shrieve on guitar and creating more powerful sounds, remarkably close in many respects to some of Schulze's recent releases (DRIVE IN and ANGST). The accent is on hard driving percussion with the staccato rhythm of Schulze's synthesizers, and the addition of some very tasteful guitar licks. The album is slickly produced, even commercially accessible (to the despair of a few), and truly powerful. — Nathan Griffith

THE SHY: Statistical Emotions b/w Fall Rain (7"; Hot fudge Records, P.O.B. 14, Cedar Falls, IA 50613, USA) Opening with a guitar riff straight out of '80s surf music and quickly launching into '80s retro, jangly guitar (hee-hi, Mr. Buck), hook laden, power pop. The Shy have concocted some danceable, intriguing music. One minor flaw is the vocalist, whose voice lacks passion on the A side, a few made up for on the B side through more adventurous delivery creating some exciting crescendos. Give the singer a kick in the pants and you have a first rate band. — Kim Knowles

DICK SIEGEL: Level (C-80; \$7.50 ppd; P.O.B. 8078, Ann Arbor, MI 48107, USA) Music that combines swing, rockability, old jazz, a little folk, and country and western. The Ministers of Melody (aka Rebbis of Rhythm) in their incarnation here are HOT. Siegel's words range from the inane ("Yum, Yum, Yum") to the politically charged ("Beware.") — Jeff Wechter

SILVER CHALICE: Evil Birds (12" EP; XES Records, P.O.B. 2521, Hollywood, CA 90028, USA) Entrepreneur Geze X. Gadsden wants this new band of his to be wicked and dark, the kind of band for those death rock kids you need about in "Rolling Stone". He has the influences in order: some psychedelic '60s punkisms, some carry trash-guitar riffs and gothic metal touches. The lyrics emulate Edgar Allan Poe and Iggy Pop. But Kim Comet's vocals don't fill me with anything doomy-gloomy. Can you imagine Dirty Harry with Gomer Pyle's voice and mannerisms? Sad, ain't it? If you could turn down the vocals this would be good for your next serene, kids. — Jamie Reke

SKATE DEATH: You Break It, You Buy It (LP; Warning Mgt., P.O.B. 102993, Anchorage, AK 99510, USA) This wild bunch of young'uns has come up with quite a debut release: faster-than-average punk of the '82-'83 vein, reminding me a bit of the Delinquents. This album boasts its fair share of hook-laden classics, including "Food Is Good," "My Parents Are Disappointed", and

the sweet and transitory smell of plum blossoms before a spring shower. Like many koto pieces, it creates a subtle mood of melancholy. The two contemporary compositions — "Kaminu" by Hazan Yamamoto and "Shinsenchō Bukyoku [Shinsenchō Dance]" by Shinchi Yaiza — add more modern colorings and rhythms to the koto's vocabulary, yet still retain traditional modes as their base. The album concludes with "Shin Musume Dojo Ji [Maid of Dojo Temple], a three-part composition for shamisen (three-stringed lute) and voice, composed in the 19th century by Ishikawa Koto. This spare work is an appropriate finale. The interaction between Sunazaki's voice and single-string notes of the shamisen create a sense of elegiac majesty. This record was co-sponsored by the Japanese Music Institute of America. Those interested in the Institute's other activities and their quarterly newsletter, can write: P.O.B. 22003, San Francisco, CA 94122, USA. — David Meltzer

TOMOKO SUNAZAKI: Sound Of Silk Strings (C-80; Japanese Music Institute Of America, P.O.B. 22003, San Francisco, CA 94122, USA) Sunazaki plays pieces written between 1700 and 1970 in a variety of styles, the standout being "Mi'ttsu No Dansho", written in 1942. It employs alternate tunings in the bass and treble strings and rhythmic striking of the strings at opposite ends, even the body of the koto itself. A fine tape from a master musician. — CDinA2

SUNNYLAND SLIM BLUES BAND: Chicago Jump (LP; Red Beans, address needed) Chicago blues patriarch Sunnyland, approaching his eightieth birthday, is joined by his current working band which can be caught on Sunday nights in Chicago at the North Halsted St. venue, B.L.U.E.S.. North Halsted is a long way from the Southside origins of the Chicago blues, and what's missing on this set is the down-home eccentricities of a band that is regularly playing to a black audience in their own community. This record seems designed for someone who would never venture into the still existing ghetto blues scene and certainly not designed for someone living on the SOUTH side of Halsted (that amazing street that runs through so many ethnically diverse neighborhoods as it carves its way through the Windy City). Almost half of the tunes are penned by Luandrew (Sunnyland Slim), and the musicians provide competent, predictable support for his musical excursions and his unmistakable vocal phrasings. Of Sunnyland's recent recordings, I prefer Red Beans SUNNYLAND TRAIN for its introspection and because it captures the authentic Delta Piano sound shaped by the jook joints and roadside taverns of the sawmill shanty towns where Sunnyland got his musical teeth before he hit Chicago in the forties. — Ron Sakolsky

SWA: Your Future If You Have One (LP; SST, P.O.B. 1, Lawndale, CA 90260, USA) Heavy bass, echoey guitar solos running over and under everything, songs so slow they're best described as sludge, anguished vocals; in short, straight out of the late '80s, post-summer of love, acid-rock school of wretched excess. — John E

RIC SWANSON: Urban Surrender (LP; American Gramophone Records, 9130 Mormon Bridge Rd., Omaha, NE 68152, USA) Light, slick, upbeat background music can be done badly as well as with skill. This record largely succeeds as background music, never demanding an ounce of your attention until a choral group inconspicuously pops up on one cut and sings repeatedly and without inspiration the title of the song and makes you wonder if you were supposed to be listening to this stuff all along. Except for that one outburst of "creativity" this record is utterly without invention or idiosyncrasy. — Sam Mental

SYNAPTIC SOUND: Life Among Frequency (C-30; \$5; Synaptic Sound Design, 1838 48th Ave., San Francisco, CA 94122, USA) Synaptic Sound is G. Richard Weisberg and friends. This tape includes a couple of synth improvs, some spacey art rock with guitar riffs, drum machine beat, and electronic keyboard layers. "Cutting Stone With Paper" is melodic electropop with dancebeat box, and loopy treated vocal "rap" bits. It ends with a well-tempered baroque synth overlay. "Leave It To Me" sounds like the music to a Miami Vice spin-off: much more active and produced. Fuzz guitar wails over a clap pattern. Like much of this tape, it's too long. One piece is too short — the electric jungle sounds of "Machu Picchu" just get going, then fade. — CDinA2

KOKO TAYLOR: Queen Of The Blues (LP; Alligator Records Box 60234, Chicago, IL 60660, USA) Taylor, one of the Chess label's first lady stars who rose to prominence in the early '60s, ignites a riot of on-the-move urban blues on this release. The four-piece Blues Machine, her solid four-piece back-up, is joined on assorted tracks by guests including guitarists Lonnie Brooks, Albert Collins, and Son Seals; harpist James Cotton and tenor sax player, Abb Locke. The band fuels the fire, setting this bowlful of blues to boil without let-up. Taylor is a full-steem blues belter whose forceful confrontational style is somewhat comperable to Howlin' Wolf. Taylor's healthy bluesblood is an important part of the vigor and vitality of the contemporary blues tradition. — David Meltzer

THE TELL TALE HEARTS (LP; Vox, 2702 San Fernando Rd., Los Angeles, CA 90065, USA) Rave-up R&B garage-rock complete with fuzzy guitar, vox organ, gusto and hip attitude. Grows like a fungus. — Bob-O Walesa

THE TERRIBLE PARADE: The Terrible Parade (4-song 12"; After Hours Records, 300 Prospect Ave., Cleveland, OH 44115, USA) This Cleveland avant-pop band's strong point is song writing. The execution is good, but these songs cry for more than just two

DAVID WHITTAKER,
San Francisco poet,
has seen trends
come and go
in the Bay Area.

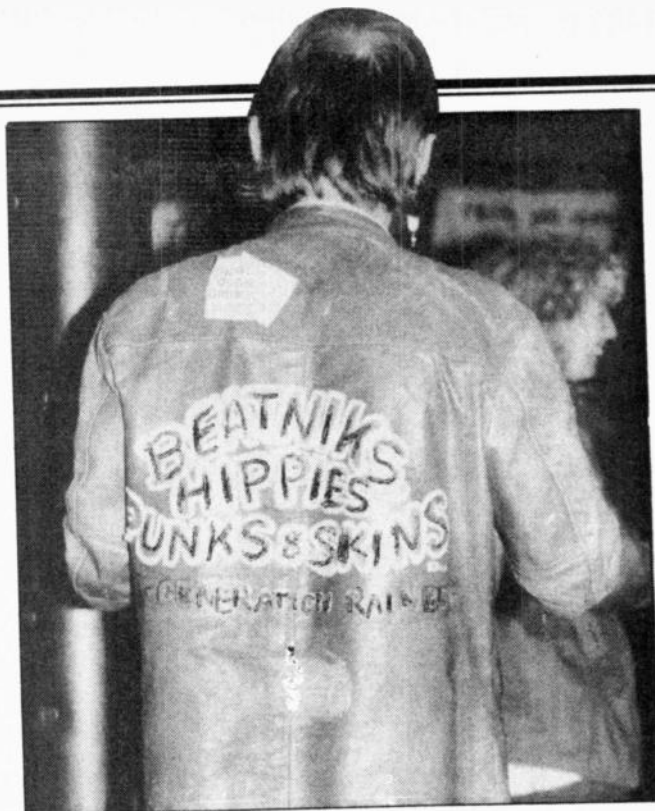

guitars, a bass and drums. Alan Grandy's haunting vocals on "China Turns To Dust" make it a standout. The cover art from "The Dwell Series" by Drew also impressed me. — Jim Butterfield

TEX AND THE HORSEHEADS: Life's So Cool (LP; Engine Records, P.O.B. 2428, El Segundo, CA 90245-1528, USA) First of all, if life's so cool, how come you're drunk all the time? I've had high hopes for these guys, especially since hearing "Oh Mother" But nothing on this LP lives up to that song's promise, instead going for a hokey "Hee Haw" version of country-punk that doesn't do much for either genre. Like all those report cards of the past: "They've got lots of potential, but they never apply themselves." At their best they mix equal parts of Patti Smith group and EXILE ON MAIN STREET Rolling Stones with a dash of Lorretta Lynn. But I'm really tired of the "I live on the edge, I'm so bitchin,' cause I'm fucked-up all the time" pose. That's not a lifestyle, that's a recurring problem. — Geo Parsons

ERIC THERER AND SCHLAFENGARTEN: Les Enfants Terribles (C single; Cause And Effect, 5015 1/2 N. Winthrop, Indianapolis, IN 46205, USA) Two simple slow, gloomy synth rock songs. Sung-spoken vocals, annoying plosive "p"s in the mic. Mercifully short. Schlafengarten is capable of better. I know. — Tom Furgus

ERIC THERER, DEBBIE JAFFE, AND HALL MCGEE: The Concrete Entendues (4-song C; Cause And Effect; see address above) Neurotic-industrial gloomy synth toons for voice, synths, noise and rhythm box. Crude sound. Nothing shocking or amazing. Kind of run-of-the-mill for this kind of music. Too bad. I really enjoy the other work done by Jaffe and McGee as Viscera. Get a hold of the Cause And Effect catalogue, it's full of fine tapes, though this isn't one of them. — Tom Furgus

PETER THOMAS: The Hours Away (C-60; Thomas, 2045 Pierce, Eugene, OR 97405, USA) A soothing collection of electronic vignettes, this tape represents "the best of Peter Thomas' works for synthesizers." Thomas is a classically-influenced synthesist with an ear for rich, mellow timbres and uncomplicated arrangements. A sprinkling of gentle classical guitar highlights some pieces pleasantly contrasting with the electronics. Thomas shows sophistication and steers clear of today's electronic music clichés. — Allen Green

THOR: Only The Strong (LP; Enigma, P.O.B. 2428, El Segundo, CA 90245, USA) Without the vocals this would be pretty standard heavy metal — medium pace overkill sludge. But Thor happens to be a body builder with a voice, so... we have the funniest, most riotously fascist and posedly powerful music galloping down the pike in a long while. Thor and his merry crew of cacophonists (including token female singer) want you to know they are tough mutha fuggin' warrior types. Get a load of these titles: "Start Raising Hell," "Knock 'Em Down," "Let The Blood Run Red" and "When Gods Collide" all sung in the most forced sounding meanness this side of an anarchist punk band made up of Yuppies. One drawback is the violent sexism that gets out of hand on side two. If you want to overrun the world, that's one thing, but your dick is no weapon, Thor, buddy. — Jamie Reke (Speak for yourself, Reke. — Thor)

TIME ZONE: World Destruction (7"; Cellulid Records, 155 W. 29th St., New York, NY 10001, USA) Featuring John Lydon/Johnny Rotten and Afrika Bambaata singing over a combination of synth/pop and breaking music with the drums being the most dominant instrument. The duo rap about world problems leading to the self-destruction of the world. Example: "Nothing in your power that you can do/ yes the world is aimed for destruction/ you and I know it/ If you don't stop to look for a better life/ The world will destruct in a time zone." Catchy. — Josh Hatch

TINY GIANTS: Cartoon Violence (C; 3138 Overhulse Rd. NW, #43, Olympia, WA 98502, USA) Unique funk collage/dance wave and a twangy rasta-country fusion. I hear some Little Feat, Grateful Dead, Chicago, and N.R.P.S. influences. Five guys singing about their minds. A very uplifting and healing theme if you're into meditation and that stuff. Everybody's dancing. Eight rockin' songs including "Sound Wave," "Rediation Baby," "Ego Go," and "Modern Prophet." Sounds good, excellent production. — Robin James

TOILING MIDGETS: Dead Beats (LP; Thermidor, 5618 Central Ave., Richmond, CA 94804, USA) Eight post-punk instrumentals and two vocal tracks recorded 1981-1983 by this defunct band. It's a super clean recording with excellent melodic guitar work, interesting song structures, and catchy riffs, and various textures and dynamics. Most rock guitar instrumentals sound derivative; so the uniqueness of this album is a real treat. — Lawrence Crane

TONES ON TAIL: The Album Pop (LP, PVC/Jem, 3619 Kennedy Rd., S. Plainfield, NJ 07080, USA) After the break-up of England's premier horror/gloom band, Bauhaus, Daniel Ash and Kevin Haskins (guitar and drums) formed Tones On Tail with Glenn Campeling on bass. Their England only LP, POP, was a brilliant record released several years ago. Now, PVC releases POP with three cuts changed. "The Never, Never (Is Forever)," "Slender Fungus" and the hit, "Performance," are deleted and replaced with some of the leftover songs. The three missing tracks are crucial but this release can't go wrong with songs as evocative as "Rain" or as scary as "Movement of Fear." — Lawrence Crane

TOM TROCOLI'S DOG: Tom Troccoli's Dog (LP; SST, P.O.B. 1, Lawndale, CA 90260, USA) Three piece electric folk rock that pays dues to punk, hardcore and heavy metal. Everything is loose, raw and live sounding. Things work best when the band gets in a languid, from-the-gut playfulness like the Meat Puppets UP ON THE SUN and when the grungy, meandering lead guitar solos are minimized (they'd probably work better if there was a second guitarist to work off of.) Troccoli's "Suicide" and the cover of Dylan's "Girl From North Country" are among the endearing moments, but most of the album sounds like it was conceived and recorded during a promising, but unfocused, first-day-the-band-got-together garage rehearsal. — David Ciarfardini

DAVID TUDOR: Pulsers/Uncited (LP; Lovely Communications, 325 Spring St., New York, NY 10013, USA) Electronic sound revelations. Electronic primitivism. Electronic ritual. With a workbench of "home-brew" electronic noise-makers (in the sense that the squeaking and rat-tat-tatting musical instruments used



Little Joe Blue

I got nothing I wouldn't lose to keep on singin' the blues . . .

Read about all the "Dirty Work Goin' On" in Living Blues magazine!

Please send \$18.00 for a one-year subscription (six issues—U.S.A. rate) to:

Living Blues

Center for the Study of Southern Culture
The University of Mississippi
University, MS 38677
(Telephone: 601/232-5993)

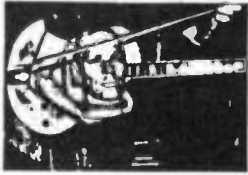

If you think this looks like a strange way to play guitar, just wait until you hear the lp!

CRIMINAL PURSUITS
DAVEY WILLIAMS
electric guitar solos

\$7 ppd, \$9 overseas
Trans Museq
1311 18th Ave South
Birmingham AL 35205

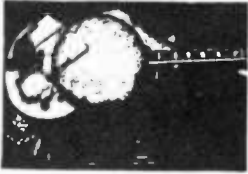

LUXURY RECORDS
is proud to present the Fourth release from...

THE Limits

Is It True What They Say About The Limits?



limits

"The Songs are inventive & well done"
... Billboard

"They create infectious melodies, strong harmonies, forceful guitars & strong vocals"
... Sound Choice

"Without warning came this honey of a record. The Limits are a vibrant, exciting band"
... Option

"They combine the innocent enthusiasm of the past with the knowing flash of 80's pop rock"
... Philadelphia Daily News

limits

... vingt

Find Out For Yourself!

Distributed by IMPORTANT & other fine distributors or available by mail order: \$7.00

Luxury Records
1724 Elm Street • Bethlehem, Pennsylvania 18017
(215) 866-5191



P.O. Box 390, Old Chelsea Station, New York, NY 10011
Phone (212) 675-2768 or 741-7230. Telex 469796.
Hours: Mon.-Sat. Noon-8 pm

MIDNIGHT

MIDNIGHT RECORDS

Check out these new MIDNIGHT releases:

MIR LP 111 MORLOCKS: Emerge (ex-Grave-digger V-California's Best)

MIR LP 114 SCREAMIN' JAY HAWKINS & THE FUZZTONES: Live (Two Legends Together - Live n Wild!!)

MIR LP 115 UNDERTAKERS: Greatest Stories Ever Told: (Raucous Swedish Garage At Its Best!)

MIR LP 116 DEMENTIA 13: (A Young New Band From Mid U.S.A With a Syd Barrett Touch)

MID 4513 TRYFLES: Your Lies 7" (NY's Rawest From the Midnight Xmas LP: Wall-Of-Guitars!)

MID 4510 PLASTICLAND: Flower Scene 7" (Great Psych From the Most Upcoming Band Around!)

SCREAMIN' JAY HAWKINS and THE FUZZTONES



Request our new In-Print catalogue featuring all the newest and 50's & 60's reissues, indies, 45's and much, much more! Send \$1.00 Today!!

Also request back issues for an even wider selection.

The Midnight Label is distributed by: Midnight Int'l., Dutch East India, Important, Greenworld, Jem

We distribute hundreds of titles, from indies to reissues, not to mention our own "Home-Grown" label.

Retail Stores: call or send for our wholesale catalogue today!

WHEN IN NEW YORK: VISIT OUR STORE!!

We have New York's finest rock selection. 255 West 23 St. phone (212) 675-2768 or 741-7230 Open 12 noon to 8:00 pm Mon thru Sat

to celebrate New Year's Eve are also called "noise makers" ex-generian David Tudor taps into a universal aural soul, blurring distinctions between natural and man-made sounds. The two, approximately 20-minute pieces are ironically primitive: Pulsers uses analog, rather than digital circuitry to create lumbering, unstable staccato rhythms; "Untitled," uses electronics to create lyrical squeaks and scratches, approaching the sounds of jungle wildlife alluded to in Tarzan soundtracks. The electronics are not cajoled into impersonating orchestral or traditional jazz or rock instruments. Sounds often relegated to subservient roles in the laboratories of movies' med scientists, are here the basis of lengthy, dramatic compositions. These two pieces, composed in the 1970s, are precursors to today's "power-electronics" and "industrial music." But whereas the power electronics try to shock or "blow-away" listeners' mind-sets with electronic sounds and high volumes reflecting a destructive, industrialized environment, Tudor, on this record explores primitivism with spacious, delicately structured invocations, where the intricacies of sound are highlighted. Contemporary power electronic enthusiasts turn the faucet on full to saturate their aural canvas with bucket after bucket of electronics; Tudor uses strokes and splashes of sound and the blank canvas of "silence" is ever present. (Tudor's friend John Cage reminds us that there is no such thing as complete silence.) This album would be of much greater value, especially to those who might want to emulate Tudor's compositions, if it included a thorough, detailed, clearly written set of liner notes about the specific equipment, recording and mixing techniques, performance notes and expectations and intentions of the artist. Such notes could also help the uninitiated understand the value and historical significance of the record which they might otherwise incorrectly dismiss as "a bunch of incoherent noise" and not give it the attentive, open-minded listening that this unusual recording requires of those who wish the greatest appreciation. — David Ciuffardini

TURNING CURIOUS: Soul Light Beams (B-song EP; P.O.B. 2632 Sca. A, Champaign, IL 61820-8832, USA) A midwestern pop band filling the promising gap between R.E.M. and Game Theory. They draw inspiration from good ole' Alex Chilton, but utilize a folk-rock approach thickened by hard-edged, catchy beats. For anybody that wished Lou Reed tried powerpop. — Jordan Oakes

TURBINES: Last Dance Before Highway (LP; Big Time, 6410 Santa Monica Blvd., Los Angeles, CA 90038, USA) Solid Boston rock and roll band with enough sixties influences to endear themselves to garage fanatics, yet "hip" enough to break into the international new wave clique. — Charles P. Lamey

21: House Of Nerves (LP; Goat In A Birdsuit Records, c/o Jay McHale, 58 Clarence Ave. SE, Minneapolis, MN 55414, USA) Very funny and very danceable without dance-pop repetition. Although drum machines are used, this is definitely music played by human beings. And it's hot enough to get you out of your seat. Some of the vocals remind me of Broadway musicals. One cut sounds like Public Image with Jim Morrison. Weird. — Paul Goldschmidt

UNITED MUTATION: The Rainbow Person (5-song 7"; DS1, P.O.B. 348, Dunn Loring, VA 22027, USA) Wow, just when you've thought hardcore punk was all the same, some band crawls outta hell to prove you wrong. Strangely recorded, these crossed/imbred cousins of Capt. Beefheart and Swans play short, varied hardcore. Unintelligible snarls and guitar warps all over space. This is really nice experimental punk recommended if you need shaking up after too many generic HC bands. — Lawrence Crane

UNIVERSE: New Day (LP; Satsyagraha, 3696 W. 135 St., Cleveland, OH 44111, USA) Acoustic protest music. The leader of Universe are Tom and Chuck Smith. In "Haiti" they sing about Haitians being treated poorly upon arrival in America. In "The Disappearing Ones", corrupt foreign governments suppress freedom and don't care about their people. My favorite is "One For The Gipper" lecturing President Reagan to help him understand that Hollywood movie tactics won't solve the problems of the world. The first cut on each side features instruments such as flute, saxophone, and piano which give them a touch of jazz and blues. — John L. Basella

UNIVIDUAL: Drinking Silences (C-80; H. Walleys, Postbus 11, 9980 Aelter, Belgie, Belgium) Unividual (aka Henk Walleys) calls this tape mood music in between Jerré and Eno. But this tape of electronic music succeeds best when it becomes more adventurous than those two. Side one is delightfully diverse but side two could use some editing. The song in Flemish is superior to those in English. "Polar Tango" staggers through an rhythmic and atonal series of notes offset by splashy synth drums and melodic keyboards. Then a futuristic callopo bursts at you as the drummer walks out the back door, through the echo chamber. Quite moving. Better editing would make this tape one of the best I've heard in months. — George Ottinger

PHIL UPCHURCH: Companions (LP; Jam, dist. by Jern) Veteran studio guitarist Upchurch plays fluid, romantic solos over a competent dance-funk rhythm section. Saxophonist Gerald Albright is the other main soloist, helping to define a sound reminiscent of Crusaders, Grover Washington, et al. There are cover versions of pop hits "Rosanna" and "Tell Me I'm Not Dreaming." Surprises are two guest spots by the late jazz guitarist Lenny Breau (unfortunately, the liner notes are contradictory as to which guitarist plays which solo) and one straight blues track, "See See Rider", with a vocal by Jimmy Witherspoon. The other two vocals

are by Mike Baker, who pales by comparison — he's a sweet soul crooner who sounds a little like Stevie Wonder on one of the cuts. — Bart Grooms

URGE OVERKILL: Partion-Controlled (3-song C; P.O.B. 1544, Evanston, IL 60204, USA) Bright, trebly bass, chaotic guitar slashing and dissonance, and over-acted singing in a sort of Gang of Four frantic-punk style. A cover of the Zombies' "She's Not There" is interesting. And guess what "Lympdicous" is about? Above average stuff, musically; but the vocals can be annoying and silly. — Lawrence Crane

VALLEY OF KINGS: Victory Garden (LP; Inca Records, 817 Chapel St., New Haven, CT 06510, USA) The resemblance to R.E.M. is acceptable, since this east coast trio avoids being a clone. Their sound is darker and more Gothic than R.E.M. and bring to mind The Church. A sense of melancholy pervades the atmospheric writing of Gabriel Cohen, with haunting effect on the songs "Children's Crusade" and "Sight". Too often, however, the band burrows into a dark, lifeless, murky dirge. — Scott Jackson

VARIOUS ARTISTS: Bands On The Block (LP; Matak Mazuri, P.O.B. 4084, Austin, TX 78785, USA) Side one is the jangly guitar side — if you like R.E.M. you'll dig it. The best tracks are by the two best known bands: The True Believers and Zeitgeist. Doctor's Mob, The Wild Seeds and Go Dog Go are also excellent. All in all, it's a consistently appealing collection of (mostly) modern folk-rock. Side two is the uneasy-listening side with punk, punky hardcore, CSW punk, a little psychedelic gloom and some garage grunge. Especially excellent are The Hickoids "Committed" and The Criminal Few's "Maniac". Eighteen bands, 18 songs. Low-fi, honesty-of-sound recording, cheesy cheap pressing, cool simple graphics and o.k. liner notes. A labor of love. Texas sure puts out some cool sounds. — Geo Parsons

VARIOUS ARTISTS: The Cold-Drill Cassette — Oral Poetry, Sound-Text Poetry, Songs & Strange Noises (C; Boise State University) Much of this tape is very poorly recorded which seems inexcusable with all the adequate, inexpensive recording equipment in this day and age. We have here: straight readings of poems; dramatic recitations (post assuming a person, e.g. a derelict); "sung" poems, with say, a guitar accompaniment; poems with lots of invented words which explore the sound-values of syllables; and one pure vocal noise improvisation. A rather irritating grab-bag of possibilities considered in the abstract. But these particular realizations I don't care for at all — too many under-grade and none of Idaho's more established, substantive voices. However, experimenting with audio recording is a vital direction for poets to be taking, and this cassette shows a spark of adventure from the people in Boise who put this together. — W.R. Borneman

VARIOUS ARTISTS: Dry Lungs: A Compilation of Industrial Music From Around The World (LP; Placebo Records, P.O.B. 23316, Phoenix, AZ, 85083, USA) "Industrial music" as presented here might be roughly categorized as the punk and hardcore of electronic music. Seventeen bands/artists create 17 primarily lyric-less tracks of angst, frustration, madness, and destruction. Forthright composition is minimal; noises pile up, delicacy is pounded into oblivion, and the listener is assaulted with the pent-up problems of a destructive society. This comp offers a taste of what industrial music and power electronics sounds like. (The choice of bands/artists is swell) but the power of the genre and the purposes of the artists are only hinted at. Pieces seem abbreviated for the sake of fitting in a large number of artists, and there are no liner notes or other information (not even contact addresses) about the bands involved. — David Ciuffardini

VARIOUS ARTISTS: de Best-e-e (LP; Mystic Record Group, 8277 Selma Ave., Hollywood, CA 90028, USA) These are the musical highlights (I'm assuming) from an avant-garde film featuring Joan Jett, Derf Scratch (Fear), Tex (of the Horseheads) and El Duce of the "gulp" infamous Mentors. This soundtrack includes speeded diatribes, random dialogue, nonsensical musical burps, and a few decent songs from Tex and the Horseheads, Social Distortion, Dr. Know, Johanna Went and the Mentors. Unfortunately, the leekluster compositions on the majority of this album fuck things up. — Mike Troughon

VARIOUS ARTISTS: Flipside Vinyl Fanzine Vol. 2 (LP; Flipside Records, P.O.B. 363, Whittier, CA 90608, USA) Like it's precursor, Vol. 2 includes bands from all over the good ol' U.S. of A., plus a few groups from beyond the borders. Of the offerings by the 21 bands, the standouts include cuts by M.I.A., Decry, Necro, and the Catstronics. Those who remember what life was like prior to the popularization of the mohawk, will likely appreciate the live tracks from the Germs and the Misfits. In case you're wondering, each band is again responsible for introducing their own song and yes, the intros are as funny as they were the last time around. — Mike Troughon

VARIOUS ARTISTS: Home Sexpiens Project (C; Magic Theater Productions, Juliaandillenstraat 22 B, 2018 Antwerpen, Belgium) ADULTS ONLY. This tape delves into the electronic world of the Homo Sapien and his sex life. Thirty-five international contributors. Comes with 18 page booklet of xeroxed photos, predominantly images of women in bondage and homosexual women poses. Comes in a box. Loaded with suggestive tape manipulations and treatments of theatrically recorded sexual sound experiences (dialog and other sounds) combined with various electronic instrumental effects and styles. Various languages. Some sadistic violence, too. — Robin James

VARIOUS ARTISTS: In Another Context (C-80; AMK/sb, c/o Banned Productions, P.O.B. 891184, Los Angeles, CA 90069-9184, USA) Twenty-five audio art recordings featuring some of the most engaging sound experiments I've heard. Just the stuff for underfed imaginations grown weary and wary of this sort of thing. Remember "Surfin' Bird" and that weird little mouth solo midway through the song? Well, Pierre Andre Arcand's piece, "He," takes a similar idea, multitracks the voice into a starting, industrial sounding configuration. Blackhumour's "Snakes In An Atheist's Grave Part 2" is a dark, simple manipulation of tape and electronics, and leaves me feeling like I'm being rolled around inside a metal sphere, chin deep in a fetid liquid. Yow! Big City Orchestra's "Beetle's Hell" is a sound collage of Beatles' interviews and song snippets, and ends with an outrageous and hilarious "the time I met the Beatles" story. Grief and Svobada's "The Marvelous Free Standing Works" is much like a dream, actively devouring the random phrase that's found its way into a sleeping consciousness. This tape makes you hate things like MTV all the more. — Oleh Hodowanec

VARIOUS ARTISTS: International Sound Compilation No. 6 (C-80; \$3 ppd. airmail; Andi, 154 Alexandra Rd., Peterborough, Cambridgeshire, PE1 3DL, England) Tunesful compilation of 15 artists or bands from England, France, Belgium, Wales, Czechoslovakia, and U.S.A. A few industrial media soundscapes, but mostly a lot of upbeat indie-rock. My favorites include Antibiotic, Unividual, Mama Bubo, X-Ray Pop, and Barry Weinberg And The Blues Chargers. A very fresh and engaging collection, and a steal at only \$3 for U.S. residents. I'm impressed. — Tom Furdge

VARIOUS ARTISTS: Landa End (C-80; \$4 U.K. ppd.; Touch Ritual Series, P.O.B. 139, London, England SW18 2ES) Previously unreleased music by: Nocturnal Emissions, Det. Wiehl, Pink Elin, and Sudden Sway, among others. An outstanding tape with great graphics, different styles of music, and smooth transitions. We hear: a Japanese potato vendor's chant, a Sanskrit hymn, a snake charmer, sliding piano distortions, electrobeat, new chamber orchestral, bombastic rock, poetry, tape cut-ups, and a Lol Coxhill sax solo. The prime cuts: Graeme Miller's "Ash-wei-ai-wah, ash-wei-ai-wah" with drip, drip piano and voices on tape recalling foghorns years ago; an "I was Jim Jones attorney" religious broadcast moving into Soviet France's thick airspace; and Elliott Sharp's mallet bass quartet "Black Rain." An intelligent program of wonderfully varied sounds. — CDnA2

VARIOUS ARTISTS: Let's Breed (LP; Throbbing Lobster, P.O.B. 205, Brookline, MA 02148, USA) "Fourteen swell Boston bands" (several now defunct) on this second installment of Chuck Warner's Throbbing Lobster saga (originally released in 1984). This is a good rockin' party of the rude-boy, buzz-saw guitar, howling vocal variety. Plenty of energy, not much pretense, and lots of not-so-clean fun. The uninitiated or unenamored might use this record to cite the genre's limitations: the relentless pounding becomes monotonous and sometimes the lyrics and musicianship are rudimentary (read: boring) despite the energy behind them. Be that as it may, BREED contains cuts nobody ought to miss: Scuffy The Cat's slam-bang hoodlum "Oldest Fire In The World"; Chain Link Fence's "All Except You," a relentless, exuberant piece of guitar rock; Noonday Underground's "Simple Man" where Leslie Greene's singing leaps out at you; The Outlets' "Not Too Late," if for no other reason than to hear David Barton's distinctive vocal delivery; The Blackjacks' "Dress In Black," a dramatic, rough and tumble performance; and The Unattached's "Close Your Eyes." — G. Specs

VARIOUS ARTISTS: Musicworks 30: Sound Constructions (C-80; Musicworks, 1087 Queen St. West, 4th Floor, Toronto, Ontario, Canada M8J 1H3) This companion cassette to issue 30 of the Canadian contemporary music journal, Musicworks, features the work of several vanguard designers of new musical instruments. Together, the 20-page magazine and cassette comprise a well-researched project essential to those interested in the construction of original instruments. Side one presents the large-scale string installations of Paul Panhuysen and Johan Goedhart, as well as the pneumofoon, cracklebox, and other inventions of Belgium's Logos Foundation. The instruments are each demonstrated briefly and discussed by their makers. I would prefer to hear the music unadulterated by speech, especially since the same information is in the magazine. The instruments and their sounds are striking, but I wish someone would do something with them other than admire them for their own sake. Side two, a collage combining Aeolian harps of various design with Laif Brush's Terrain Instruments, is a more cohesive statement. The Aeolian harp, a stringed instrument set into motion by the wind, effortlessly produces the sort of overtone-rich "music of the spheres" which many "new age" synthesists try unconvincingly to manufacture. Brush Terrain Instruments monitor and amplify the hitherto inaudible inner processes of trees, ice floes, and other natural phenomena. As in nature, the sounds complement each other beautifully. Forget about Paul Winter — this is REAL Earth music. — Dennis Ree

VARIOUS ARTISTS: New Jersey's Got It (LP; \$6.50 ppd.; Buy Our Records, P.O.B. 363, Vauxhall, NJ 07088, USA) Nine New Jersey acts offer two selections each creating a slightly better than average (because of the variety) 1985 HC comp. The bands are as follows: Bedlam, kind of generic; Bodies In Panic, a little different, but annoying; Cynimid, metal/HC maybe; Pleased Youth, too bad about the swastika in their logo; Children In Adult Jails; picked by two critics (at least) as something special; Stetz,

pro-M.A.D.D.; My Three Sons, garage-industrial; Sacred Denial, young with a lot of potential; Adrenalin O.D., very fast with metal tendencies. — Jeff Wechter

VARIOUS ARTISTS: Private Studio Tape #2 (C-60; Private Studios, P.O.B. 531, Wyandotte, MI 48192, USA) Frank Pahl brings us: The Goode Guys' bizarre country ballads, a couple from Rascal Reporters, backward female singers, bass pipe in the rain, and sinister fusion, this time with great wood percussion. It fades too soon. Other stuff includes: some quirky pop, an acoustic jam that builds and explodes, funky electrobeat with lots of treated radio voices, out of tune piano romanticism, a couple wordy raps on TV as sickness and vacuum diagrams, cabaret and cellope. "Big John" slowed way down, sexes honking, laughing, dreams, and a bit of great hardcore. — CDinA2

VARIOUS ARTISTS: Rockers All-Star Explosion (LP; Alligator Records, Box 60234, Chicago, IL 60660, USA) A reggae anthology united by the guiding hand of composer/producer and talent promoter Augustus Pablo. Young artists sing or chant on top of classic Pablo rhythm tracks plus two instrumentals by Pablo. Quality is erratic. A few week cuts, like those by Jah Bull and Junior Delgado, are salvaged by quirky production touches like the unexpected xylophone in one case and yawning trombone in another. The jewel of the album is when the nasal, child-like lit of Sister Frica's singing is sternly met by first-rate nyahbingi drumming. Ricky Grant and Norris Reid of the enormously underestimated (in the U.S.) Viceroys shine. Pablo's "Straight to Ethiopia" has a great kalimba interlude. There is enough of the hypnotic and rooty that I can ignore the amazing lack of judgment responsible for including a barely tuneful track by Tetrack. This gains through repeated listenings — but lacks the cohesion of the reggae anthologies from the Nighthawk label. — Norman Weinstein

VARIOUS ARTISTS: Sexsicle Cartes (7" EP; Orange Productions, 243 Lincoln Way, San Francisco, CA 94122, USA; ph. 415-588-3848) Features three San Francisco Bands (Artichokes, Iobly Bibbly, Steve Mackey's Carnal Kitchen) and four songs unified by sex player extraordinaire, Steve Mackey. The tunes vary from insightful (Artichokes' "Nothing") to humorous (Bibbly Bibbly's "Squompy"), but all are original and unpretentious. Three tunes rely heavily on Mackey's rock and roll sax riffs. My favorite is Mackey's own "Ground Zero", an intelligent look at nuclear war. Worthily effort by each of these bands. — Madeline Finch

VARIOUS ARTISTS: Son Of Segments (The Kentuckians Compilation) (C, Sirius Music, 611 Empire Mill Rd., Bloomington, IN 47401, USA) If you miss the nation-wide fun of the old Sub-Pop cassette series, here's something even better. Although limited to bands from around the greater reaches of Bloomington, Indiana, this covers a world of variety; a reggaeified "Rocky Top"; a for-real country and western love song; local hardcore (band: "Are you afraid?" crowd: "No!"); sweet melodies on the topic of blueberries and watermelon; a tribute to actor William Holden and a boppin' jazz workout about a fat man in love with his science teacher. You may not know it, but Bloomington is a crazy, happening place (and I'm not just talking about their nationally renowned Soil Conservation Service office under the leadership of rockin' local soil god Jeff Schmidt). This tape is fun, fun, and more fun — and it comes with a nifty little book and a magnifying glass. — W. Mueller

VARIOUS ARTISTS: Telus #9: U.S.A./Germany (C-60; Telus, 143 Ludlow St., #14, New York, NY 10002, USA) This issue of cassette periodical Telus features 16 artists/bands currently active in New York and West Germany, with an emphasis on the East Village scene. A lot of ground is covered, from hardcore to synth-pop to steel drum music. Side one is dominated by straight-forward (for the East Village) '80s rock by His Master's Voice, Cargo Cult, and Yellow Grave. No new ground is broken instrumentally, but the lyrics are always disturbingly off-center. Details At 11 contribute engaging quirky art-rock along the Henry Cow/Etron Fou axis. Hardcore is represented by Live Skull and Rat At Rat. The "outside" pieces are on Side two: Elliott Sharp's soprano saxophone improvisation utilizing circular breathing and multiphonics; Christian Mercley conjures subterranean drums and didjeridu-like drones from his turntables; and Fast Forward's stuttering jackhammer rhythms on steel drums. Included are selections from four West German artists, most notably Asmus Tetchers, whose Residents-inspired electronic music is a welcome alternative to the German sequencer school, and Nicolas Nowack, who warbles loonily atop a quasi-hip-hop rhythm track of delay-manipulated voices. This cassette provides a very good overview of two diverse musical communities circa 1983-84. — Dennis Rea

VARIOUS ARTISTS: Telus #9 — Music With Memory (C-60; \$7; Telus, 143 Ludlow St., #14, New York, NY 10002, USA) Telus, the Audio Cassette Magazine is a bi-monthly subscription cassette of audio art, new music, poetry and drama. Offering #9 is a collection by artists who plug into microcomputers to assist their music. Techniques and results vary widely. Nicholas Collins' "Devil's Music" is a live performance using two digital memory devices that record, loop and retrigger fragments of radio broadcasts in real time. The success depends on what happens to be broadcasting at the time: this rendition I found quite satisfying. Wear headphones to listen to John Driscoll's excerpts from "Stall", a composition for a rotating loudspeaker instrument broadcasting live and taped electronic sounds. Brande Hutchinson's "Voices Of Reason" knocks over the apple cart of unhappiness with an unsettling, plaintive electronic wash featuring

women complaining and arguing in a variety of languages. Ron Kuivie's two pieces for an Apple computer controlling a Memory Moog offer welcome rhythmic relief. The first, "Periodicals," is a buoyant example of high-tech hocket, a 13th century technique of rapid alternation of voices with short groups of notes. The tape concludes with a couple of Paul Desmarinis numbers which probably amuse his friends. — Leland Saintry

VARIOUS ARTISTS: The Texas-Mexican Conjuento (LP; Folklyric Records, 10341 San Pablo Ave., El Cerrito, CA 94530, USA) Chris Strachwitz should be given a medal for his continual unearthing of little known gems of American music and then proceeding to never let them go out of print. The material on this LP represents the best artists recording Conjuento (a popular style of accordian music) in the form's peak years. Men such as Narciso Martinez, Pedro Ayala, Conjuento Bernal, and Los Relampagos produce a lovely, easy introduction to a music that deserves greater exposure. Although the recordings date back as far as 1935, the sound is uniformly good. Don't overlook this one. — Keith Wilson

VARIOUS ARTISTS: A Tearing Compilation (LP; Fipside Records, P.O.B. 363, Whittier, CA 90608, USA) Two Australian hardcore bands — Perdicion on one side; Vicious Circle on the other. Both have a healthy powerful sound unlike most American hardcore bands. Instead of flailing guitars and drums rippling into all the changes, these bands sport a powerful, but not extremely fast guitar with bass and drums adding variety instead of only holding the guitar together. Both bands are vociferously anti-war and all members are vegetarians. They also frequently perform at the same gigs. Alby, bassist in Vicious Circle, puts out a hardcore fanzine "Regression" and corresponds with people worldwide. [Vicious Circle, 19 McKinley Ave., Malvern 3144, Victoria, Australia; Perdicion, c/o Reactor Records, P.O.B. 623 Camberwell, Victoria 3124, Australia]. Sues it out meta. Create, educate, survive, be free — this is the new anarchy. The vicious circle still turns on. — Josh Hatch

VARIOUS ARTISTS: The Urban Cabaret, Vol. 2 (C-60; c/o Multiphase Records, 6955 Cornell Ave., St. Louis, MO 63130, USA) Arranged and produced by Carl Weingarten, this sampler contains the work of 12 groups from St. Louis and one from Baltimore. The first side is primarily "new-wave" music by Times Beach ("Shopping"); Fairchild ("Mechanical Heart"); and Langrehr ("Just A Machine.") These are solid cuts, but are overshadowed by a wonderfully goofy song by the Fizzies ("What Is Your Name?"), and by Aviation Club's "It's Alright" — a neo-psychedelic delerium. Also noteworthy are Welter Whitney's "Help Us", and Delay Tactics "Nuke The Best". Side two has more good stuff, from Bob Fishbone's "Love Will Ya Merry Me?", a lovely Irish sounding instrumental, to Jon Bouise's "Tango Palace", an ode to theater of the night penned by Dr. John. Favorites: Gary Sykes' "Urbend Griot" (a madman let loose in a drum shop); and Exiles' "Burning Bridges" (flute and piano chasing each other like amphetamine speed). Also noteworthy: Maintenance's "Corridor", and Wax Theatrics' "Black Olive." I had no idea that so much was going on in St. Louis! — Ed Blomquist

VARIOUS ARTISTS: Walls Of Genius: Madness Lives (C-90; P.O.B. 1093, Boulder, CO 80306, USA) A compilation with 27 entities. Solid madness, just what the doctor ordered. Snotty kids bangin' and rockin', weird tape collage madness and perversions, casual mix vocals. Comes with an excellent little booklet with a graphic from each entity represented. Tons of cocaine brutal congo blaster non-sequitur dry heaves and the last electric guitar, drugs and girlfriends on the Jerry Galvin Show. On tape that is. Some entities and song titles: "Everybody's On The Bus" from Tara Cross; "Go Die" from Jay-Co; "Castrated For Jesus/Homosexual Orgy In Heaven" from Psychodrama; "Plastic Irene" from Peter Catham; "Who Is This One? (Party Mix)" from Viscera; and more and more. — Robin James

VARIOUS ARTISTS: War Is The Health Of The State (C-60; Sound Of Pig Music, c/o Al Margolis, 33-28 148 St., Flushing, NY 11354, USA) Twelve artist compilation with expectable peaks and valleys of interest. Standouts include Ken Clinger (unsettling recitation), Zanstones (intriguing loop manipulations), Problemist (brave media collages), and Bocal 5 (funky Hrrrangements and good use of flanger). On the whole an interesting and well-arranged compilation, one of many available from Al Margolis. — Tom Furgus

VOLCANOSUNS: The Bright Orange Years (LP; Homestead, P.O.B. 570, Rockville Centre, NY 11571-0570, USA) Loud, energetic, distortion-guitar chords dominate this one-dimension power-trio. Strident tones of voice is more important than the lyrics. Like a thrash band that decided to smooth things in hope of finding a niche in the mainstream. — David Ciuffardini

C.W. VRTACEK AND DANCING LESSONS: Monkey On A Mandi Roll (LP; Leisure Time Records, Box 337, New Milford, CT 06776, USA) On this, Vrtacek's third LP, he departs from his previous releases. This LP is a group effort hosting Brian Ogan (sax), Steven Lewis (bass), and John Roullet (drums). With nods to two obvious influences (Robert Fripp and Frank Zappa) VSDL offer danceable rhythms along with commitment to craft and form. The sax takes most of the melodic lines with frequent guitar support and embellishment. Conceptually, this LP falls in line with works by Unrest, Work, and Play's IN FORMS and the Residents' THIRD REICH AND ROLL. It is an idiosyncratic synthesis of sixties and seventies influences with contemporary attitudes. Clever. — Mark Dickson

WAILERS: The Fabulous Wailers At The Castle (LP; Etiquette, 2442 N.W. Market St., Ste. 273, Seattle, WA 98107, USA) Another respectable release (1962) from Etiquette. This is early '60s dance-club rock 'n' roll with a mix of instrumentals and vocals. Everyone's having a good time. No heavy messages or trips. "Tall Cool One" was the group's claim to fame, and Kent Morris, Gail Harris, and (Rockin') Robin Roberts contribute the vocals. The Wailers are a definite step above "OK" because, even though it's not on this album, they (with Rockin' Robin) made the best "Louie Louie" ever! — Jack Jordan

WALLS OF GENIUS: The Mysterians Case Of Pussy Lust (C; P.O.B. 1093, Boulder, CO 80306, USA) Male sexuality is a complex phenomenon. This rock and roll/country cassette is useful as a diagram of unfounded suspicions (for example "Everybody's Fuckin'", but they're glad that I'm not...) and false expectations. It has vocals, well arranged guitars and gizmos (shower curtain, cork and screw, slide whistle, percussion and, of course, organs) by Red, Joe and Fyodor. Funnier 'n shit. Infectious. — Robin James

THE WANIKTONES: How A Bell Y'all (LP; Midnight International Records, P.O.B. 390, Old Chelsea Sta., New York, NY 10011, USA) This isn't exactly emotionally charged or roots-searching, and Dave Edmunds would probably chuckle and John Doe would make one of his unpleasantly bemused faces. But I, in spite of my instincts, like this. It's gimmicky, but it's outrageously gimmicky. It's not just stylish, it's overstylish. And it's goddamn fast and funny. It's not like the Rezillos...so that's why they cover "Someone's Gonna Get Their Head Kicked In Tonight." Anyone should be able to see fun and humor in "Hiccapped To Hell," "Vuelve Prime Vers" (ever hear fast rockability in Spanish?) or "Shortnin' Bread" even if he hates this kind of music. — Richard Singer

WATERMELON MEN: Past, Present, and Future (LP; What Goes On Records, Third Floor, The Metrostars, 5-10 Eastman Rd., The Vale, Acton, London, W3, England) Romantic Swedish new wave, homogenized and commercialized. Well produced but all the songs, save for a cliched Hungarian love ballad (which sounds like music for a grade B spy movie), are alike. Try playing 15 seconds of each song and running them together — you can't hear any difference. — Hudson Luce

DOC AND MERLE WATSON: Pickin' The Blues (LP; Flying Fish Records, 1304 W. Schubert, Chicago, IL 60614, USA) An intimate and relaxed album, surprisingly sedate, highlighted as always by Doc's warm voice and gorgeously stated guitar solos — condensed statements played with deeply-felt restraint. His unique rich tone emanates from each well-placed note. A dozen blues in all, from Barbecue Bob's "Mississippi Heavy Water Blues" to "St. Louis Blues," including many white country blues like Roy Acuff's "Freight Train Blues," Jimmie Rodgers' "Hobo Bill's Last Ride," and the Delmore Brothers' "Jailhouse Blues." Doc, his son Merle, and bassist T. Michael Coleman are joined by newgrass mandolinist Sam Bush who primarily plays fiddle here. The liner notes are transcripts of Doc's memories connected with each piece. (Code: Shortly after the release of this album Merle, 36, was killed in a tractor accident.) — David Meltzer

KATIE WEBSTER WITH HOT LINKS: You Know That's Right (LP; Arhoolie Records, 10341 San Pablo Ave., El Cerrito, CA 94530, USA) I had the pleasure of seeing Katie Webster live and solo at the Bowful of Blues in Sound Choice's home-town, Ojai. She was introduced as the reigning queen of swamp blues piano and she drew a greater audience response than blues greets on the bill that afternoon — Johnny Copeland, John Hammond, Margie Evans, and Tom Bell and Kenny Sulten. She was hot and had the whole crowd screaming for more, then drew a standing ovation after her encore. This, her fifth album, was cut on the eve of her forty-sixth birthday. Her 30-plus years as a Louisiana style blues pianist is complemented by a smokin' backup band, the Hot Links. Webster's intense enthusiasm, liveliness and piano mastery sets her apart. — Josh Hatch

CARL WEINGARTEN: Living In The Distant Present (C-50; Multiphase Records, 6955 Cornell Ave., St. Louis, MO 63160, USA) Weingarten makes heavy use of loops and delays on his guitar and synthesizer, and has an ambient orientation. It's true that Fripp and Eno were there first, but their body of similar work is not large, and they certainly didn't exhaust all the possibilities. Weingarten reworks and extends the territory — and does a very nice job of it. Virtually nothing on this cassette is staccato or busy, and each is usually confined to a restricted range analogous to violin and flute. Textures are more dense and complex than in Fripp's solo work — probably the result of the synthesizer. And there is surprising diversity within the chosen framework. Like Fripp/Eno, Weingarten uses a constant, slowly shifting series of patterns. There is little melody — certainly nothing to hum along with — but then, ambient music is not supposed to be catchy. As in the best ambient music, there are rewards for the sensitive listener — nuances and shades of feeling, otherworldly scenarios, and various dream states — all conjured up by a dedicated and intelligent artist. — Bill Tiland

ERIC WESTFALL: The Doctor Is In h/w Nuclear Guitar (7"; Ordinary Records, P.O.B. 481036, Los Angeles, CA 90048, USA) Lots of tape splicing, drum loops, pots-n-pans percussion,

and voice editing. I was blown away by the beat on 'The Doctor Is In'. I had never heard anything like it and can't begin to convey it in writing. In the promo material it says: 'As it's author confirmed, it's really the doctor himself, ranting and raving to the most perverse beat I've ever heard on record.' The pots-and-pans percussion is great and the split-second bass riff pull-offs add a lot. This is bouncy and fast cartoon music — paranoid robots that have gone out of whack and are now dancing uncontrollably. On the reverse side bassist Dusty Wakeman plays 'Nuclear Guitar' which sounds like he's hitting a chord, holding it with the fretboard hand and a sustain box and playing with feedback with the other hand. — Josh Hetch

A WESTERN FRONT: Off To The Angels (7 song EP; 11273 Palms Blvd. #D, Los Angeles, CA 90066, USA) A fantastic psychedelic record. Mushrooms to the umpteenth. The styles shift from a Velvet-drone to a Mitch Easter-trang to XTC-ish rhythm perversion. All songs are bingy catchy and appropriately threatening; more so than many paisley bands' diversions. Imagine Tommy James And The Shondells involved with the Dream Syndicate. — Jordan Oakes

WHIPPING BOY: Mura Mura (LP; CFY Records, Box 8271, Stanford, CA 94305, USA) Unlike most of the punky despair based in suburban anxiety, this record exudes a more fundamental, existential angst. Not some campy, Cramps-like voodoo death thing either. I think these guys are sincerely concerned about what everything means, and the result is a very intelligent record. Two of the band members are black, and the intensity is surely rooted in a deep feeling for the band's name. When Eugene Robinson sings he moans and groans and anguishes through brooding lyrics, and even though you can't understand what he's singing most of the time, you know he means it. (Fortunately, there's a lyric sheet.) Behind this is some great grinding, dirty psychedelic guitar and a pounding, deliberate rhythm section. This is painful truth. — W. Mueller

WHIRLING DERVISHES: History Kicks You (8-song LP; WM Records, P.O.B. 88, Garwood, NJ 07027, USA) Gloomy pop with some unexpected, quirky effects. Bassist Jerry Herd describes the band's sound as 'danceable tunes with a lyrical purpose.' The lyrics are cynical in a rather indiscriminate, random fashion. — Miki Pohl

WHITEHOUSE: Live Action #1 (LP; Dom Productions, Am Haarberg 26, 5100 Aschen, W. Germany) This LP, recorded at London's Whisky A-go-go in 1982, is regarded by Whitehouse as one of their most inspired and powerful performances to date. This LP features all of the usual Whitehouse elements: screamed, sexually graphic narratives, intermittent barrages of electronic violence and constant squealing feedback. Distinguishing LIVE ACTION #1 from other Whitehouse material is the appearance of G.M. Walls (of Konstruktivists), who adds textural dimension to certain tracks. William Bennett (vocalist and chief writer) was in fine form, with a vocal assault that is as manically intense as you're likely to hear. He obviously thrives on inciting confrontation, referring to the audience as 'Fucking Wankers!! Fucking Whores!!' I wish the instrumentation matched the violence of the vocals. As with any Whitehouse LP, you either enjoy it or despise it. — Paul Lemos

WHITE LIBERALS: Cat Behavior (EP; \$6; Solid Citizen's Records, P.O.B. 100, Eugene, OR 97440, USA) The best of psychofunk for the '80s. Every song's a gem. Composer/arranger Michael Billings searched for years for a viable outlet for the musical muck inside his head and has now put together the finest collection of noisemakers in this sleepy little burg. They spew their deviant combination of '80s soul, salsa, and New York loft sound of the Golden Palominos and the Talking Heads circa '77. Poking and jabbing you with an endless perverted staccato dance rhythms, Billings puts the icing on the cake with his diabolical lyrics of love/hate, societal disgust, and people acting like cats. Guaranteed to keep you on your feet and scratching your head. — Nathan Griffith

J.D. WILBORN: Electric Vacuum (C; Subspecies Recordings, 682 McDonough Blvd., Atlanta, GA 30315, USA) Four astonishing recordings — a manic holding us hostage for some kind of message or attack or something. The packaging contains images of a nude boy in bondage. Looks like it would hurt. The song titles are 'Prolixin', 'Biological Stimuli', 'Electric Chair', and 'John Wayne Memorial Day Barbecue (recorded live at Blue Rat Atlanta).' Noise and weird craziness. — Robin James

DAVEY WILLIAMS: Criminal Parasites (LP; Trans Museq B, 1311 18th Ave. South, Birmingham, AL, 35205, USA) An excellent album of new guitar solos by this Alabama-based improviser. With a full bag of techniques on arco, slide, and 'object' guitar, Williams takes the guitar sound beyond itself again and again without extensive use of electronics; yet in each of these pieces there are gestures toward more traditional styles. Among those I heard reflected (but never sped) were Hawaiian guitar, North Indian sarod, Nashville pedal steel, and (throughout the record) Delta blues. Authentic and evocative new music. This record achieves a masterly combination of fantastic and 'real' worlds. — Chris Brown

SCOTT WILLIAMS: Lemme Love You (LP; Double Bill Records, P.O.B. 20485, Middtown Sta., New York, N 10129, USA) Williams has a very uncommercial voice, but it lends itself to these avant-pop tunes. Some people would call this artistic. I call it interesting. Good, imaginative production by Naux. — Jim Butterfield

ROBIN WILLIAMSON: Legacy Of The Scottish Harp (LP; Pigs Whisker Music, P.O.B. 27522, Los Angeles, CA 90027, USA) An excellent collection of beautiful solo harp pieces played with exquisite and sensitive skill. Williamson's liner notes are thorough and very informative, providing an insightful and detailed history of the Celtic harp tradition. He does not sing on this recording, but the bard bestows great musical blessings upon the listener in traditional masterpieces glimmering from the strings of the Scottish harp. This album will appeal to all who appreciate the lovely simplicity of folk melodies and tunes for the unaccompanied harp. — Seabury Gould

BOB WILLS AND HIS TEXAS PLAYBOYS: The Tiffany Transcriptions, Vol. 4: You're From Texas (LP; Kaleidoscope Records, P.O.B. 0, El Cerrito, CA 94530, USA) More Western Swing treasures from recently-discovered transcriptions cut during 1948 and 1947 in San Francisco for the Tiffany Music Company, who supplied 16" acetates of the music to subscribing radio stations for airplay. Undisputed maestro of Western Swing, Wills heads what would be his last 'hot' band. Various groupings of players appear in these sessions, including trumpeter ace Alex Brashear; Eldon Shamblin on electric guitar; Herb Remington, steel guitar; and Tiny Moore playing electric mandolin and fiddle. The sessions took place after-hours, usually after a gig, and project all the energy of musicians at their peak, warmed-up and ready to cook. Though the Wills band played its share of cowboy ballads, pop filler, and traditional stringband tunes, they did it in the spirit of jazz. Wills and The Playboys were musical innovators. Even on clunker cuts, a few bars improvised by pianist Millard Kaleso, or an amazingly advanced Tiny Moore solo, make it all worthwhile. Almost every cut crackles with vitality and a propulsive spirit. Classic material: immediate, fresh, timeless. — David Metzger

WINDBREAKERS (LP; Homestead) Jingly guitar power-pop from Tim Lee and Bobby Sutliff who trade off on singing and song-writing chores. A safe, clean, studio formula that keeps things light, melodic and even-keeled. The restrained urgency of Lee's vocals (which makes me favor his songs over Sutliff's) almost makes you forget that all the lyrics on this album are unremarkable laments about break-ups between boyfriends and girlfriends. Their sound owes debts to Television (they do a version of TV's 'Glory') but they lack the idiosyncratic guitar and twisted (if not always meaningful) lyrics that gave Television their endearing edge. — David Cifaretti

JOHNNY WINTER: Serious Business (LP; Alligator Records, P.O.B. 60234, Chicago, IL 60680, USA) Coming on the heels of the artistic and commercial success of Winter's 1984 GUITAR SLINGER LP, this album is a disappointment. Many of the elements that made the earlier album a success are here again: the crack production team of Dick Shurman and Bruce Iglauer, the best rhythm section in the business (Johnny B. Gayden, bass; and Casey Jones, drums) and steady work from Ken Saydak and Jan Paris on keyboard and harmonics respectively. But those are the only strong points. I swore there was something wrong with my turntable the first time I laid the needle on SERIOUS BUSINESS, but it's the record. The slow songs are too fast and the up-tempo tunes come at you at a frantic pace. The absence of a horn section is also felt. Instead all we get is one redundant speed guitar solo after another. Only the most die-hard fan will appreciate this record. — Dale Knuth

WISEBLOOD: Motorslug b/w Deathrape 2000 (12" single; Wax Trax! Records, 2445 North Lincoln Ave., Chicago, IL 60614, USA) Obsessive, hellish, intelligently stooped disco which takes hip-hop's fascination with swift, orchestral violin crashes to a logical extreme. Clint Ruin/Jim Foetus' vocals add loads of oozing evil to this. I can imagine working up heavy sweat to this if I ever heard it in a dance club. The B-side is the three note violin crash that ends 'Motorslug' repeated nearly ad infinitum, like Flipper's 'Brainwash', only more annoying in its lack of words. — Jamie Rake

WISE-MAGRAW (LP; Red House Records, P.O.B. 4044, St. Paul, MN 55104, USA) Some might call this new age music but I feel it's more along the lines of Penguin Cafe or Anthony Phillips. Mercuse Wise plays tables and studied them in India with Ustad Dham Ali Qadri. Dean Magraw plays a hand-made classical guitar and studied with John Damian of Cambridge, Mass. The guitar plays rage-like figures and at times might switch to something jazzy; the same is true for the tables. Unlike most new age music, this becomes quite involving. Most pieces are about two to four minutes long. There is accompaniment on some by tambura (a drone string instrument) and harmonium (an organ-like instrument). This is more folksy (as in Middle Eastern) than, say, McLaughlin's group, Shakti. Might make a great film soundtrack. — Tony Pizzini

THE WOOLFES: State Of The Heart (8-song 12"; Grapefruit Records, P.O.B. 961, Bronxville, NY 10708, USA) These fellows live up the folk-rock myth. They sing nervously but without a hint of anger. Imagine The Only Ones on parole. These guys play it cool but also play it right. Decent harmonies and trebly, minimalist guitar. I only suggest they write some songs worth putting their nerves into. — Jordan Oakes

WURM: Feast (LP; SST, P.O.B. 1, Lawndale, CA 90260, USA) Recorded in 1983 by a band that has formed and reformed since

1972. In their last incarnation they were joined by Chuck Dukowski on bass who also co-wrote over half the songs and takes producer credit on FEAST. The songs could pass for basic heavy metal from 1975 except for the truly crazed vocals by Simon Smallwood. The rhythm section is great and the guitar often soars, but it's the intensity and sheer dementia of the singing on cuts like 'Feast', 'Nailed To The Wall' (This cut is particularly frightening), 'Song For Jimmy' (some hybrid boogie psychosis), and the slobbering, growling scapella 'Robin Dogg' that takes this band over the top. At times the vocals seem to inspire the band into an all-out frenzy. Their rewrite of 'Padded Cell' from Black Flag's DAMAGED LP makes the original version seem tame. To call this band a throw-back would be beside the point; a 'missing link' is more like it. — John E

X-DREAMS: Space Shuttle Stowaway/ Nocturnal Rambling/ Murder At The Met (7"; c/o Wayne Potash, 33 Calumet St., #3, Boston, MA 02120, USA; ph. 617-738-9535) 'Space Shuttle Stowaway' is the best of them, a pop tune aided in large part by Tex-Mex keyboards and cheerful harmonizing. 'Nocturnal Rambling' could fit in easily on a local Easy Listening station's play list. — Madeleine Finch

X RAY POP: Alcohol b/w Amazone (7"; Pilot, 10 Rue de l'Élysée, 37000, Tours, France) Doc and Zouka return with another quirky bit of synthesized pop. Tape manipulations, various keyboards, synth-noise, and Zouka's pouting, tongue-in-cheek vocals (all in French) come together for a catchy, hooky 'Alcohol.' The sound is similar to the Dave Steward/Barbara Gaskin duets. 'Amazone' is a bit more adventurous and more similar to their 'After Bathing At Berlin...' cassette. Sort of Zappa's UNCLE MEAT meets T. Rundgren's WIZZARD/TRUE STAR. Clever and delightful and comes on green vinyl. — Mark Dickson

YARD TRAUMA: Must've Been Something I Took Last Night (LP; Dionysus Records, P.O.B. 1975, Burbank, CA 91507, USA) Yard Trauma is one of the better '80s-influenced psychedelic outfits around. This, their second LP, showcases a band with more adept musicianship and a more polished sound. Their upbeat song structures, ringing guitar sounds, and perfect proportion of Farfisa organ gives Yard Trauma's music that head-shakin' quality that's near to irresistible. MUST'VE BEEN SOMETHING I TOOK LAST NIGHT mixes slower, powerful, melodic numbers with rippin' psyche outbursts to produce a very groovy album indeed. — Mike Trachten

THE ZASU PITTS MEMORIAL ORCHESTRA: The Pitts Bear Down (LP; Kaleidoscope, P.O.B. 0, El Cerrito, CA 94530, USA) In San Francisco this band is who you go to see when Greg Kihn and Huey Lewis are out of town. Yep, 18 yuppies on stage doing, you guessed it, Motown covers! Despite the multi-piece aspect of the band, there is little to save them from being another She-Na-Ne. Surprisingly enough, the always interesting Henry Kaiser plays guitar on this 'Big Chill' inspired album. Buy the old Stax and Motown hits from the original artists and labels and leave the Zasu Pitts Memorial Orchestra alone in their hot tubs. — Rex Doane

ZEITGEIST: Translate Slowly (LP; Landslide Records, Inc., 450 14th St., Suite 201, Atlanta, GA 30318, USA) A promising garage-styled combo with powerful pop-folk leanings. If the early Jefferson Airplane put song-structure ahead of drugs, they might have emerged this crisp-sounding. With gutsy male and female vocals sung in unison, this guitar-based combo delivers a melodic quality that most like-minded groups only think they have. This is organic pop-rock at its rootsy best. — Jordan Oakes

ZIRBEL: Me[n]tal Insect — Anatomy Of A Pig (c-30; Pteron Ltd., 3552 N. Southport #240, Chicago, IL 60613, USA) Zirbel used to play bass with Bohemia; now he's put out a beautifully packaged tape of his own on which he sings, plays bass, synth, violin, and percussion. Recorded on a Teac four-track, the sound quality is very good. Though permeated with synths, the music is varied: from industrial [Vincent Price Is Not The Only Fly] to pretty Euro-soundtrack music to warped psycho-rock [The Idiot]. Zirbel has control of his instruments and his sound. — Ed Blomquist

ZUT UN FEU ROUGE: Who's Afraid (LP; Bauta Records, dist. by Wayside Music, P.O.B. 6517, Wheaton, MD 2906, USA) Zut Un Feu Rouge are from Sweden and this is their first LP. The group utilizes guitar, alto and tenor saxes, keyboards, bass, vocals and percussion and sound a lot like the Rock In Opposition bands in Europe. You could drop these guys somewhere between Zaria Mammaz Manna and Etron Fou Leloublan, but a bit closer to the Etrons in the way they use the saxes and their more rock-like rhythmic approach. Drummer Lars Druid plays fairly sparse, steady patterns, accenting the first beat with his snare. The compositions, however, go on through all kinds of odd time signatures. It's their occasional nod to their native folk/ethnic roots that remind me most of the Zarias. This band's music is not as aggressive or as improvisational as the above mentioned bands. It has more of an even flow to it, although there are some really nice twists in melody and time. This LP is very pleasant with enough good ideas and chance taking to make it engaging. — Bryan Sale

ZIMBO CHIMPS: In A Cave b/w Inca Vacation (7"; Budget Ranch, Box 242, Pomona, CA 91769, USA) If this is a joke, I don't get it. The A side is a fast dirge (if you can imagine that) with pretentious lyrics delivered tunelessly. The B side is a spoken narrative about a trip to Peru backed with a rock vamp and flute fills. I found it much more interesting at 45 rpm than at its intended 33. — Stuart Kremsky

New Vistas in Music

from

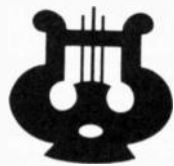

Fortuna Records

From traditional Zen Koto and Celtic harp music to contemporary electronic rhythms with searing synthesizer and guitar . . . Fortuna Records has music to inspire and stimulate. Expand your listening pleasure with more than 400 musical experiences to choose from.

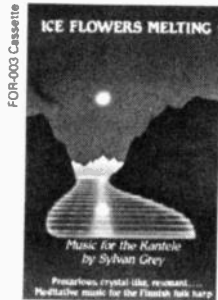

ICE FLOWERS MELTING
by Sylvan Grey
The meditative simplicity of Finnish folk harp

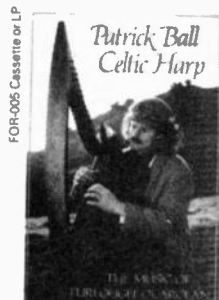

CELTIC HARP
by Patrick Ball
The resonant sound of traditional Celtic folk harp



AURASOUND II
by William Aura
Synthesizer, flute and piano pleasures that soothe the soul



THE SONG OF THE REED
by Stephen Coughlin
An East/West tapestry of gentle mystical sounds



CELTIC HARP VOL. II
by Patrick Ball
The haunting and lyrical folk music of the British Isles

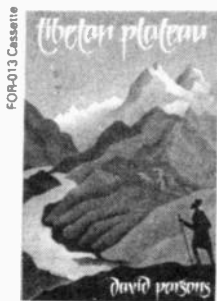

TIBETAN PLATEAU
by David Parsons
A journey through plateaus both earthly and celestial



WIND FOLLOWS THE TIGER
by Kit Walker
A collection of mystic tone poems for solo piano



SEA OF BLISS
by Don Slepian
A glimmering electronic dance and buoyant meditation



YEARNING & HARMONY
by Tri Atma with Klaus Natzle
A fusion of Eastern rhythms and electronic popular music

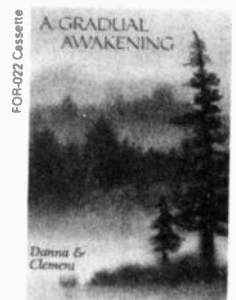

GRADUAL AWAKENING
by Danna and Clement
A blending of electronic and acoustical instruments

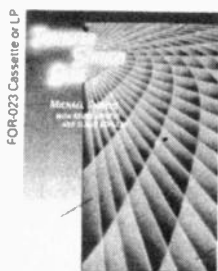

TRANSFER STATION BLUE
by Michael Shrieve
Progressively upbeat synthesizers and drums with guitar

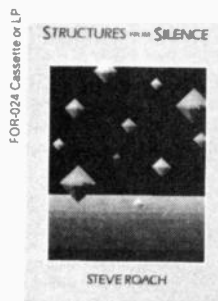

STRUCTURES FROM SILENCE
by Steve Roach
Flowing and melodic impressions create a serene mood



MOSAIC
by Richard Burmer
Electronic vignettes of rich emotional color

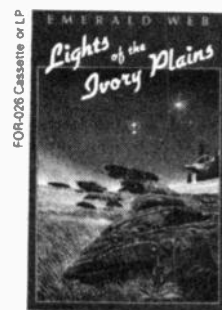

LIGHTS OF THE IVORY PLAINS
by Emerald Web
Ethereal to arousingly energetic music on synthesizer and flute

All LPs and cassettes list for \$9.98 including shipping. Full payment in check or money order must accompany each order. No C.O.D.s. Please allow 3 weeks for delivery. CA residents add 6% sales tax. To order your selection and for more information on new releases and our music catalog, write to:

Fortuna Records
P.O. Box 1116
Novato, CA 94948
(415) 883-9054

Additional selections:

THE DISTANT CRY OF DEER
by Masayuki Koga
Shakuhachi music with a distinct Zen feeling
FOR-001 Cassette

SOUNDS OF MOTHERSHIP
by David Parsons
Synthesizers and Indian instruments relax your mind
FOR-006 Cassette

AURASOUND I
by William Aura
A musical guide through the galaxies of your mind
FOR-007 Cassette

RHYTHM OF LIFE
by Don Slepian
Effervescent electronic music showers you with light
FOR-008 Cassette

NOCTURNE
by Emerald Web
A riveting blend of flutes and synthesized orchestra
FOR-012 Cassette

MUSIC MANTRAS
A Johannes Walter Production
Music for relaxation with flute, synthesizer and guitar
FOR-017 Cassette

SPRING NIGHT—KOTO SOLO
by Tomoko Sunazaki
Classical and modern pieces performed on the Koto
FOR-020 Cassette

SOUND OF SILK STRINGS
by Tomoko Sunazaki
Impressive pieces of classical Koto performances
FOR-021 Cassette

The Complete Manual of PIRATE RADIO

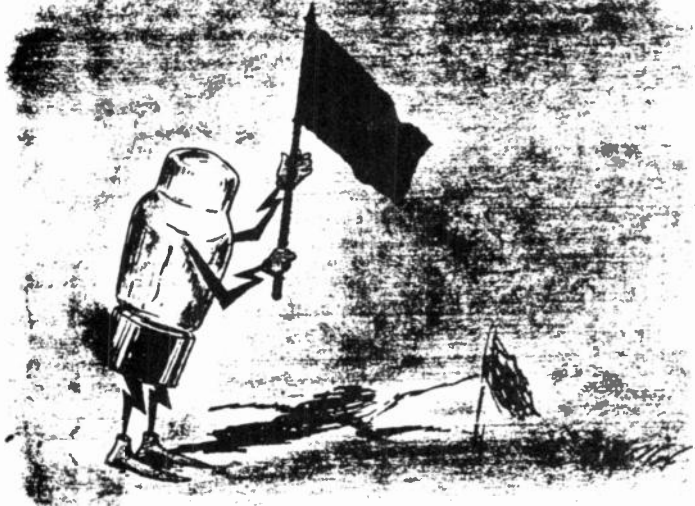

By

ZEKE TEFLON

This pamphlet is intended for everyone who has a message to communicate but no means with which to do it. This piece will provide the information necessary to obtain that means. So, if you're interested in providing an alternative to corporate-controlled newspapers and magazines, the insane howling on religious radio and television stations, the reactionary pap on commercial stations (designed to offend neither advertisers nor corporate owners) and the innocuous animals-and-British-accent programming on "public" (government-owned stations, read on. Anyone with a year or two of high school electronics or ham experience should be able to take full advantage of the information presented here, although most of it should be accessible to anyone. Those with no previous experience would be well advised to build a couple of kits (Heathkits, etc.) and to read the first few chapters of the American Radio Relay League's *Radio Amateur's Handbook*, hereafter referred to as RAH. In theory, freedom of the press exists in this country. But in practice, only those individuals and groups with very large amounts of money can take advantage of that freedom. For example to start a daily newspaper in just one major city would require assets of at least five, and probably ten, million dollars.

The use of television is almost equally out of reach. Television is considerably more technically sophisticated than radio, and so TV equipment is considerably more expensive and requires considerably more maintenance than radio equipment. Putting a bare-bones commercial TV station on the air would require an investment of a million dollars or more; and be-

cause of licensing requirements, it would be virtually impossible for an anarchist group to receive a license. While a pirate TV station could be put on the air for a few thousand dollars, such an undertaking would require a fairly high degree of technical sophistication on the part of its staff, further, because of the attention-drawing nature of television, such a project would in all likelihood be quickly busted by the FCC.

Commercial—or "nonprofit" for that matter—radio is almost as out of reach as television. The costs of starting a commercial station run into the tens or hundreds of thousands of dollars, and even the costs of putting a low-power noncommercial station using mostly donated and used equipment runs into thousands of dollars. And even if you can raise a reasonable amount of money—say \$10,000 or \$20,000—you're still a hell of a long way from being on the air. First of all, the government's licensing procedure is lengthy—it takes years. Secondly, the FCC will give licenses only to "respectable" hierarchically organized groups with boards of directors, officers, etc. The problems this poses for anarchists are too obvious to go into. Finally, what the government gives, the government can take away. If by some miracle you would make it on the air with a noncommercial license, the government could easily pull your license should you do anything to displease it.

FREEDOM OF COMMUNICATION

Freedom of communication is a basic human right. Like all rights, freedom of communication consists of being able to exercise your own abilities without interference. Government cannot give you your own abilities, but it sure as hell can (and will) interfere with you when you exercise them. Government CANNOT give you rights. It can only take them from you. If all governments (goons with guns forcing others to follow their dictates through violence and coercion) were to cease to exist, human rights would certainly not cease along with them.

The naive objection could be raised that while governments cannot give you rights, they can protect them by preventing your fellow citizens from interfering with you. In theory, that is possible. But in practice, governments have rarely "protected" citizens' rights, and then only when it has suited their political purposes. Invariably, when governments feel the least bit threatened, they place their own "security" needs above the human rights which they supposedly safeguard. Throughout history the vilest and most consistent violators of human rights have been governments. Governments have been responsible for the overwhelming bulk of human rights violations in every human civilization.

We cannot look to government to protect our rights. We have to do it ourselves, and an effective means of doing that is by exercising our rights.

PRELIMINARY CONSIDERATIONS

(Which Band Are You On)

There are several things to consider when setting up a pirate station before you spend a dime or solder a single connection. The first thing you need to determine is whether you want to reach a local audience or an audience several hundred or thousand miles away—that will dictate your choice of bands. If you're aiming for local coverage you'll want to operate on either the AM (540 - 1600 KHz) or FM (88 - 108 MHz) broadcast bands. If you're aiming for an area a long distance away you'll want to use the shortwave bands. The shortwave bands are (all frequencies in MHz): 2.3 - 2.495; 3.2 - 3.4; 3.9 - 4.0; 4.75 - 5.06; 5.95 - 6.2; 7.1 - 7.3; 9.2 - 9.7; 11.5 - 11.95; 15.1 - 15.45; 17.7 - 17.9; 21.45 - 21.7; 25.6 - 26.1.

There are advantages to all of the bands. The advantage of working on the AM broadcast band is that AM radios are slightly more common than FM radios, and that high quality used ham transmitters which can be easily modified to work on the top end of the AM band are available dirt cheap—in the \$50 to \$150 range.

The disadvantages of the AM band are that it takes more power to cover a given area than it does on the FM band (the reasons for this are that static can be a problem on AM but not on FM and that pirate AM antennas are generally less efficient than FM antennas) and that AM antennas are bulkier than FM antennas and thus harder to hide and less suitable for mobile work.

The advantages of the FM band are that FM antennas are much smaller and generally more efficient than AM antennas, less power is needed to cover a given area on FM than on AM, FM antennas can easily be disguised for mobile work, and the simplest FM transmitters are easy and

WAX TRAX!

R E C O R D S

WAX TRAX! RECORDS INC. 2445 N. LINCOLN AVE. CHICAGO IL 60614 U.S.A. 312-528-8793

UK OFFICE: WAX TRAX! RECORDS P.O. BOX 59 LONDON N22 ENGLAND 01-888-8949



REVOLTING COCKS
No Devotion 12" 45 WAX 011



FRONT 242
Politics of Pressure 12" EP WAX 014



LUC VAN ACKER
LP WAX 015



MINISTRY
Cold Life 12" EP WAX 003

SOON TO BE RELEASED:
REVOLTING COCKS | LUC VAN ACKER
Big Sexy Land LP | Heart and Soul 15" EP

Jonathan Richman
and **The Modern Lovers**

David Thomas
and **the Pedestrians**

The Slickee Boys

Figures

The Replacements

Soul Asylum

The Form

available at cool record stores everywhere
write for free mail order catalog



2541 Nicollet Avenue South • Minneapolis, Minnesota 55404

New from FUN MUSIC
Philip Perkins'

DRIVE TIME

a new series of pieces
about commuting, work
and modern life.

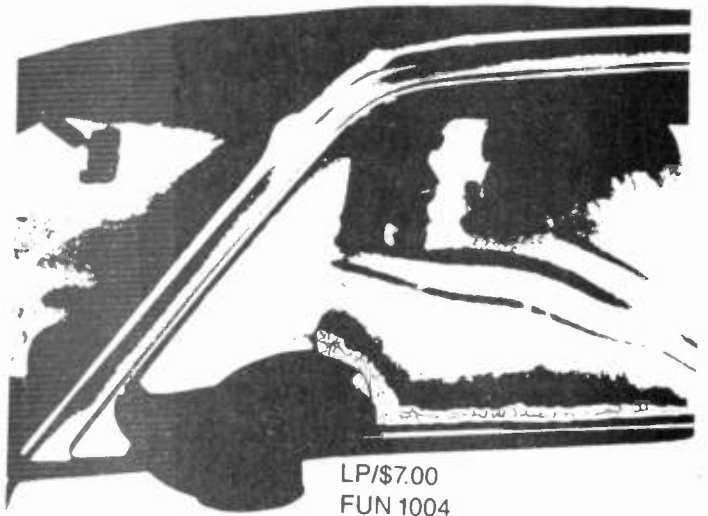

LP/\$7.00
FUN 1004

Systematic, Rough Trade, Wayside, Eye, RRR, Marginal, CLAS

FUN MUSIC
171 South Park
San Francisco, CA 94107

cheap to build (as low as \$15 or \$20).

The disadvantages of FM are that it's virtually impossible to find ready-made transmitters and that it's essentially a line-of-sight means of communication. That is, a low-power FM transmitter can only be heard when there's an unobstructed line between its antenna and the antenna of the receiver. But that's generally not a serious problem, especially if you operate from a hill.

The advantages of short wave bands are that it's possible to cover huge distances for a very small investment and that used ham transmitters are readily available which can be used with only very minor (or no) modifications on several shortwave broadcast bands. (A further advantage of using old ham transmitters for shortwave broadcasting is that those transmitters can generally be easily modified to work on the AM broadcast band also.)

The only disadvantages of shortwave broadcasting are that shortwave antennas are fairly large (this is less of a problem at the higher frequencies) and that listenership will generally be small in comparison with local audiences listening to AM and FM transmissions.

Your choice of shortwave bands will be determined by two things: 1) the equipment you're using; and 2) the distance to your listeners. Most old ham transmitters with amplitude modulation (AM) can be easily modified to work on the 3.2 to 3.4 and 15.1 to 15.6 MHz bands, and can be operated on the 3.9 to 4.0, 7.1 to 7.3 and 21.45 to 21.75 MHz bands without modification to their radio frequency (RF) circuitry. A word of warning: Do not operate on the 3.9 to 4.0 and 7.1 to 7.3 MHz bands. They overlap the 40 and 80 meter ham bands. For some reason hams tend to be rather fascistic, and if they hear you operating on "their" band they'll probably either jam your signal or turn you in to the FCC.

If you're planning on broadcasting a relatively short distance—say from Florida to Cuba or Texas to northern Mexico—the 3.2 to 3.4 MHz band would be a logical choice. With moderate power (say 50 to 200 watts or so) this band is good for distances of up to about 400 miles during the day and up to about 1000 at night. For longer distances the 15.1 to 15.6 and 21.45 to 21.75 MHz bands are good choices. On those bands it's quite easy to reach as far as Africa or South America from the U.S. with transmitters running as little as 50 watts input. In general, the 15.1 MHz band is useable both day and night while the 21.45 MHz band is best during the day. Where signals broadcast on these bands will land, however, is highly dependent on the time of day when they're broadcast. There are two ways to determine this. One is to listen on these bands with a shortwave receiver. The other is to look at propagation charts. QST, the publication of the American Radio Relay League (ARRL), the national ham organization, publishes detailed propagation charts every month. For the 15.1 MHz band you would look at the 20 meters chart, and for the 21.45 MHz band you would look at the 15 meters chart.

Long distance broadcasting can also be done on the frequencies between 29.7 and 30 MHz using old ham transmitters (the government reserves these frequencies for diathermy), but this band is generally only useful at or near the height of the sunspot cycle and listeners would be few and far between even then. For propagation information for these frequencies see the 10 meter ham band chart in QST (all propagation charts are in the "How's DX" section) or listen to the 10 meter ham band with a shortwave receiver. At the time of this writing, July 1985, we're near the bottom of the 11-year sunspot cycle and the 10 meter band is all but useless except for local communication. It should begin to improve in a year or two.

TO BUY OR BUILD?

No matter what your level of technical competence it makes no sense at all to build certain of the components you'll need. Similarly, it makes no sense at all to buy certain others. The decision with still other components will depend on your technical competence and financial state.

Those which you should buy include tape decks, turntables, and shortwave (used ham) transmitters. It would be a waste of time and money to build such equipment which can be purchased for less than the cost of the parts needed to build it from scratch.

Probably the only pieces of equipment which should be built by everyone engaging in piracy are antennas. They're easy to build; even most directive arrays are pretty simple.

If you're going to be broadcasting on the FM band you'll probably want to build your own transmitter. While kits are available for those with little or no construction experience, the designs for FM

transmitters contained in this article are easy to build and much cheaper than the kits I've read about. If you have previous electronics construction experience I'd suggest that you build your own transmitter. If you have no previous experience but are on a tight budget, I'd suggest that you try building one of the schematics contained here. And if you have no previous experience but can afford to shell out \$100 or \$150 for a transmitter, I'd suggest that you buy a kit. If you do buy a kit, get one with at least one or two watts output. A source for kits (for AM transmitters too) is Panaxis Productions, P.O. Box 130, Paradise, CA 95969.

The only two pieces of necessary equipment on which you really have the option of building or buying are your studio control board and AM transmitter. If you have previous building experience, you might want to build your own control board if you're on a tight budget. If you don't have building experience and/or can afford to spend \$150 or more for a board, I'd suggest buying a used commercial mixer. (Check music stores; many mixers made for music applications will work OK.) And if you're on a tight budget, but have no construction experience, you could buy a cheap passive (no tubes or transistors) mixer somewhere and then run the output through a preamp before feeding it into your transmitter or tape deck. (Electro-Harmonix makes a good guitar preamp, the LPB-2, which would serve the purpose and costs about \$20 new.)

With AM transmitters you have the choice of building your own low-power rig, buying a kit (not recommended—too expensive for the low power output delivered), or buying a used ham transmitter and modifying it. The approach I favor is buying an old plate-modulated (some cheaper transmitters have screen modulation—you don't want one of these) ham transmitter with 160 meter capability for \$50 or \$100 and then modifying it.

A large number of suitable transmitters are available. My favorites are the E.F. Johnson Company's Viking Ranger and Viking Valiant. These two transmitters are very similar, with the Ranger being basically a lower-powered version (75 watts) of the Valiant (200 watts). The advantages of these rigs are that they're readily available, built like tanks, have excellent audio, have built-in variable frequency oscillators (VFOs) and are very easy to modify to work on the top end of the AM broadcast band. The modifications should take no more than an hour or two to accomplish. All you need to do to the RF circuitry is to add capacitance to the 160 meter tuned circuits. (It's even possible to get the VFO to work on the top end of the broadcast band by adding capacitance.) And all you need to do to the audio circuitry is to bypass the first preamplifier (assuming you're using a line-level and not a microphone-level input) and—this is important—to bypass the speech-frequency filter, which as I recall is located between the second preamp and the driver. If you can read a schematic you'll spot it instantly.

When shopping around for an old ham transmitter keep the following things in mind: 1) Don't pay much more than about \$100 for one; 2) Make sure that it has 160 meter capability; 3) Make sure that it has amplitude modulation (AM); 4) Make sure that it has plate modulation: look inside and make sure that there are two transformers of approximately equal size and that they're well separated—if they're sitting next to each other, one of the "transformers" is almost certainly a power supply choke; 5) Look at the wiring—a lot of old transmitters were built by the manufacturer, but a lot of others were sold as kits—and don't buy such a transmitter at any price if the wiring is a mess unless you can pick one up for \$10 or \$15 and intend to use it solely as a source of parts; 6) If you can, check the tubes while you're at it—replacing tubes can be an expensive proposition.

Suitable used transmitters are available at virtually every ham/CB store, ham swap meet and through the classified ads in QST, CQ, and 73. It's generally preferable to buy at a store or swap meet because there you're not buying a pig in a poke. Needless to say, do not tell the person you're buying the transmitter from why you're buying it. If pressed, a decent dodge is to say that your younger brother living somewhere out in the sticks just became a ham and asked you to pick up a cheap transmitter for him. But it's better to say nothing if at all possible.

GETTING AWAY WITH IT

Piracy is illegal. If you're busted the government can seize your equipment, drag you through the courts, fine you hundreds or even thousands of dollars, and, theoretically, throw you in jail, although I've never heard of that happening to anyone. So, it makes sense to take

every possible precaution to avoid The Knock (on your door from the FCC).

The ideal situation—in terms of maximizing listenership—for a radio station is to broadcast 24 hours a day, on a set frequency, with high power, from a fixed location. Attempting such operation as a pirate, however, would be suicidal.

On the other extreme, you could go on the air with an extremely low power (under 100mw) transmitter which would be legal under FCC rules and regulations. If you would be satisfied with a broadcasting radius of a couple of blocks, that would be the route to go. In fact, in cities with high population densities such as San Francisco and New York, such an approach makes a lot of sense.

For those who wish to reach large numbers of people with their broadcasts, the trick is to find as safe a compromise as possible between the two approaches. If you fall into that category, there are several steps you can take to protect your self:

1) First the obvious—don't talk unnecessarily. It's tempting, but if people don't need to know about your operation, don't tell them about it.

2) Another obvious one—don't broadcast your location or phone number. Broadcasting a false location is not a very effective subterfuge, but there's no reason to make the FCC's job any easier.

3) If you're soliciting comments or contributions from your listeners, use a maildrop. Do not use your own address even if it's only a post office box. Setting up a maildrop is easy. Simply have a trusted friend (one who knows how to keep his/her mouth shut and who doesn't mind the possibility of getting hassled) rent a post office box and have all of your mail sent there and have your friend forward it to you. You'll have to pay for the box rent and also for the forwarding postage, but the small expenses involved with this system are well worth the price in terms of security.

4) Separate your studio and transmitter sites. It's a hell of a lot easier to hide a transmitter and a cassette player than a complete studio. Separation of studio and transmitter is especially important if people are in the habit of smoking dope even occasionally in the studio. If you do separate your studio and transmitter, it's generally better to prerecord programs rather than transmit them via phone lines. It's easy for the feds to trace and (tap) phone lines.

5) If you're operating from a fixed location, hide your transmitter and antenna. I've heard of pirates making hidden compartments in walls and floors to hide transmitters, which is a good idea, but even if you don't go to such extremes, at least have your transmitter set up so that it can be disconnected and moved to a good hiding place very quickly.

In the case of antennas, there are a number of steps which can be taken to hide them. One is to make your antenna (and guy wires) out of very thin wire (#20 or #22), and make your antenna insulators from clear plexiglass or plastic and as small as possible. This will make the antenna and guy wires almost invisible from distances of more than a few feet away, but unfortunately, the feed line will still be visible. Another step is to hide your antenna in trees. Most of the antennas I'll describe will work fairly well when hidden in this manner, although their efficiency will suffer to some degree. If you do hide your antenna in a tree, construct it from insulated wire. Another good step is to bury your transmission line if you're operating from a fixed location and your antenna is some distance from your house.

6) If you're using expropriated equipment, eradicate all serial numbers on it. If the numbers are stamped on a metal chassis, get an electric drill and a large steel bit, drill out the numbers and then file down the edges. Do not attempt to file off serial numbers; it's virtually impossible to eradicate them that way.

7) Go mobile. It's a hell of a lot harder for the FCC to track down a moving automobile or bicycle than a stationary target. Portable operation (driving up the side of a mountain and setting up there for a short period, for example) will also make it harder for the feds to track you down. The disadvantages of this method are that mobile antennas tend to be less efficient than fixed antennas and the FCC will not need a search warrant to bust you if you're engaged in mobile or portable operation.

8) Have someone watching (preferably with binoculars) for suspicious vehicles if you're operating from a fixed or portable location.

9) Switch frequencies often. This will make it much harder for the FCC to track you down. On the other hand it will also make it much harder for listeners to find you. A reasonable compromise would be to pick a slot, say between 90 and 91 MHz if that was clear in your area, and to operate on frequencies between those boundaries.

10) Operate sporadically. Maintaining a regular schedule (especially if you're always on the same frequency) makes it easy for the FCC to lay you for you.

11) Operate for short periods of time, especially in cities with FCC regional offices and "cars in town." If the FCC is on to you, they can track you down in as little as 10 or 15 minutes using direction-finding equipment. So, keep your operating periods short, especially if you're operating from a fixed location. If you're using mobile operation, you can get away with longer transmissions, say up to an hour or so, without too much danger.

12) If you feel like getting exotic you could use the square wave generator and decoder outlined here to operate from a remote location via a phone line. You would turn your transmitter on (at the remote location) by feeding a square wave into the phone line at your end; at the transmitter site the decoder would trigger the latching relay which would connect the transmitter to its power source. For increased security, rather than feeding your audio signal via the phone line, you

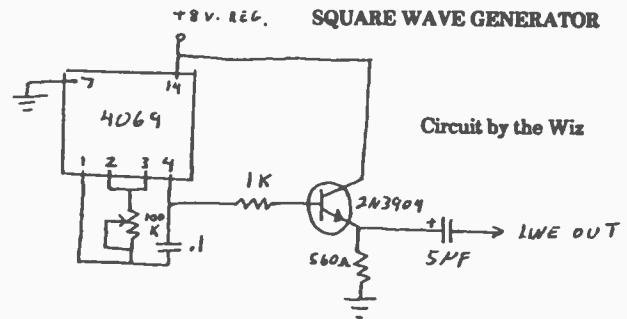

could have a tape deck (which would also be turned on/off by the decoder) as your audio source. To turn off the transmitter you would merely send the decoder another square wave via the phone line. Square waves are made up of overtones, and phone lines are designed to carry speech frequencies (about 300 to 3500 Hz), so if you use this system the fundamental of your square wave should be somewhere around 400Hz.

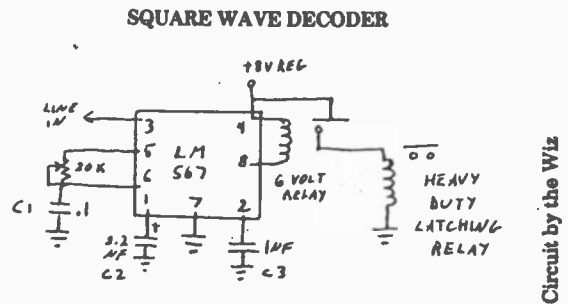

$$C3 = 10 \times C1$$

$$C2 = 2 \times C3$$

$$FREQ. = \frac{1}{R1 \times C1}$$

13) If you don't want to get exotic, but still want to use remote operation from a fixed site, I'd suggest that you buy a timer to turn your equipment on and off. As a safety precaution you might want to buy a fairly elaborate timer which would allow you to set it for varying times days in advance. (For the extra \$15 or \$20 you'd pay over the cost of a simple timer, I think it's worth it.) A further safety precaution would be to observe your transmitter site while it's on the air in order to be sure that the FCC was not on to you. A still further precaution would be to have your transmitter site located in a storage space you had rented under a phony name. (The telephone can be an invaluable tool in obtaining references from "ex-landlords" and "employers"—in reality your friends—for prospective landlords.)

If you follow the preceding advice, you'll greatly reduce your chances of being busted by the FCC.

THE STUDIO

It's relatively easy to build a studio. Chances are that you may already have some of the equipment you need to put one together. A typical studio would contain the following:

- 1) A control board (mixer).
- 2) Two or three turntables.
- 3) Two or three cassette decks.
- 4) Two microphones (one for the jock, one for those being interviewed).
- 5) A telephone and telephone patch (for conducting over-the-phone interviews).

For those who choose to build their own boards, the following design should serve well. It's cheap and easy to build, uses readily available components, will handle up to about a dozen inputs (add FET preamps as needed), and even has a cue channel. Its only drawback is that the chip has a tendency to oscillate—so keep leads short.

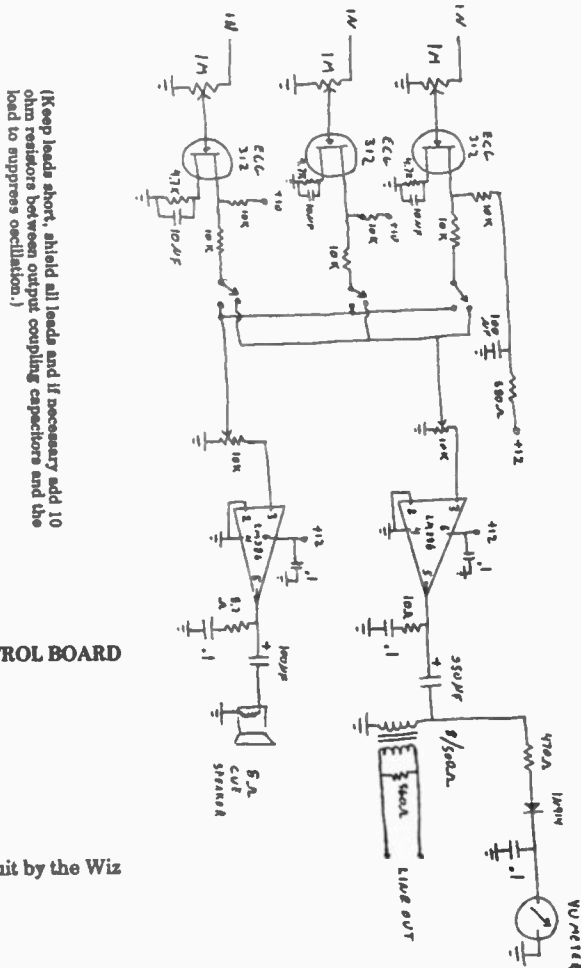

At least two tape decks are necessary, and three are preferable, in a studio: one or two for playing spots, taped interviews, etc., and one for recording programs. For playing spots, commercial broadcast cart machines are preferable to cassette decks, but cart machines are hard to come by, and cassette decks are a reasonable substitute.

Don't spend a lot of money on microphones. Twenty dollar wholesale house specials will do fine for your purposes. You can get by with one, but if you want to do interviews or have guests you'll need two. Before buying mikes make sure that their impedance and output level matches your preamp/board combo.

The easiest way to record telephone conversations is to use a microphone built for that purpose; these come with built-in suction cups which allow them to be attached directly to the headpiece of a phone. Contact mikes for musical instruments should also be able to be used for this purpose, although audio fidelity might suffer. If you do much over-the-phone work, though, keep one thing in mind: phones can be, and frequently are, tapped. So, if you're concerned about security you might want to avoid this use of the telephone.

You don't need to spend much money on a desk or table for your studio. Hollow wooden doors set on cinder blocks will do just fine.

If you're feeding the output from your board directly into your transmitter (not recommended—see section on "Getting Away With It") you'll want to protect your board by feeding its output through a RF choke and/or coupling transformer.

The importance of proper grounding must be emphasized. Very little care is often taken in this area and it leads to hum, ground loop, inter-modulation, noise, etc. Large copper strapping going to a physical earth ground (water pipes are generally suitable) is recommended. All equipment should be chassis-connected to the ground buss.

If money is no object, audio patch bays and distribution amps are preferred as is 600 ohm balanced audio. On audio lines, ground the shield at one end of its run only. Care should be taken with RF shielding if the transmitter is located close to the studio. Attention to AC polarity when plugging gear in will sometimes reduce ground loop and hum. (An AC polarity tester is handy to have.) Keep cables with line-level differences apart, for example, keep AC lines isolated from mike lines. And finally, make sure that your solder connections are good.

When designing a studio you need to keep one thing in mind: operator convenience. Everything should be within easy reach of the operator. A typical design would look something like this:

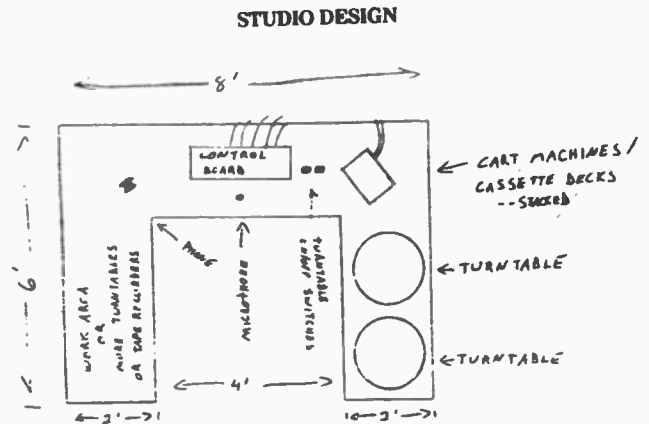

You'll need at least two turntables; don't try to get by with one—it'd be too awkward. If you can get some, get old broadcast turntables. If you can't, use the cheapest manual turntables you can find. Don't use automatic turntables if you can avoid it. Simplicity is a virtue, especially in turntables.

Use cheap cartridges. The life of a stylus tends to be short in studios (due more to operator carelessness than anything else—broadcast engineers, with good reason, often refer to disc jockeys as "monkeys with microphones"), so there's no point in spending more than is absolutely necessary for cartridges.

You'll want to mount toggle switches (wall-type light switches work nicely) in your desk to turn the turntables off and on. This is much more convenient than using the controls on the turntables themselves and will allow you to cue records—just leave the turntable controls in the "on, arm down" position and turn them on and off with the toggle switches.

TRANSMITTERS

The three transmitter schematics presented here are all simple. Anyone with electronics construction experience (even building kits) should be able to build any of them.

A schematic for a transistorized transmitter which can be easily modified to work on the AM broadcast band can be found on page 500 of the ARRL's 1972 RAH.

I haven't included any schematics for shortwave transmitters for the simple reason that it would be pointless to do so. There are vast numbers of high quality old ham transmitters available at low cost which can easily be modified to work on several shortwave bands, and can work on others without modification. The cost of parts to build equivalent transmitters from scratch would probably run to two or

**DID YOU KNOW THAT THE POPE
AND RONALD REAGAN ARE A
COUPLE OF ANTICHRIST DEVILS!**

EUGENE CHADBOURNE

Send S.A.S.E. for catalogue.
EUGENE CHADBOURNE PRODUCTIONS
1985 album releases
RRR1 COUNTRY AND WESTERN MUSIC FROM SOUTHEAST AUSTRALIA
Fundamental Save 7 COUNTRY PROTEST
I-22 THE PRESIDENT: HE IS INSANE (Iridescence)
198666 productions Coming in March on Fundamental!
CORPSES OF FOREIGN WARS featuring Eugene backed up by Brian Richey and Victor de Lorenzo of THE VIOLENT FEMMES!

****CASSETTES**CASSETTES**
Prices are coming down and the quality up this year! We have

The guitarist has created a thriving cottage industry in tapes of his music, marketing multiple recordings of his live performances as well as other novelties. The tapes, with names like *Chicken on the Way* — and its sequels, *Dinosaur on the Way* and *Wombat on the Way* — *My First LSDC&W Trip* and *You Are in Bear Country* (featuring political discussions with truckers), have become classics of independently distributed music.

By Michael Point
Austin American-Statesman

Chadbourne
2306 Sherwood St.
Greensboro, NC 27403

a new source for TDK or Maxell 90 minute cassettes and are offering THREE new cassette releases at our standard price: only \$6 each postpaid!

1. TUCSON ARIZONA RK Sloane cover, recorded at hard core shows '85
2. EUGENE STINKS Comedy epic with unbelievable guest stars!
3. THE LOST EDDIE CHATTERBOX SESSION All jazz standards, get it now before it turns into a Prestige "two-fer"

1986
More News
Now 250 pages?
Publishers:
Still finishing
The novel
and my first
story

YOU BREAK IT - YOU BUY IT
DEBUT LP FROM
SKATE DEATH
20 SONGS ON
BULLHEAD



ONLY \$7.00 PP
(\$ 8.00 OVERSEAS)
FROM:
WARNING FANZINE
P.O. BOX 102993
ANCHORAGE, ALASKA
99510
MAKE ALL M.O. PAYABLE TO
BULLHEAD
(CASH OR M.O. ONLY)
DISTRIBUTOR INQUIRIES WELCOME

SPRINGSTEEN



SPRINGSTEEN FANS:
Discover BACKSTREETS,
the Springsteen magazine.
Subscriptions \$10 year,
current issue \$3 ppd. Box
51225-E, Seattle, WA 98115.

WANTED-PENPALS-WORLDWIDE!

Imprisoned artist (see my work in Sound Choice 3), wants to hear from caring people out there, especially single women 18 and older. I'm 35, 5'7", 140lbs., green eyes, single and out of here next year in July. Will answer all your letters. Write: James Waltman 283751, Lynne, Rt. 1, Box 1, Huntsville, Tx. 77349-USA

GROUND PLANE

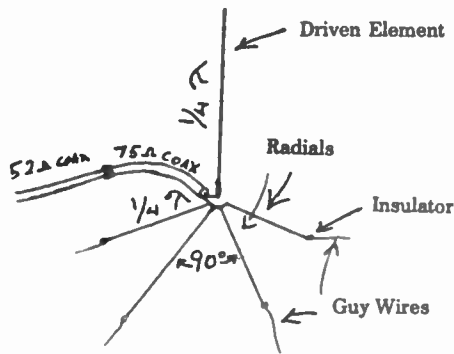

Freq.	Driven Element	Radials	75-ohm Matching Section
15.3	15'5"	15'9"	10'3"
21.5	11'6"	11'9"	7'8"
90.0	2'9"	3'10"	1'10"
100.0	2'6"	2'7"	1'8"

HELICALLY WOUND VERTICAL

The helically wound vertical is a "compromise" antenna—in other words it should be used only where a full-size antenna is not practical. On the negative side, the helically wound vertical is a much less efficient radiator and tends to be more frequency conscious than a full-size antenna. On the positive side, it's easy to construct and takes up comparatively little room. As this antenna is used only because of space reasons, it makes no sense to use it at frequencies above approximately 10 MHz. If you build a helically wound vertical, keep the

HELICALLY WOUND VERTICAL

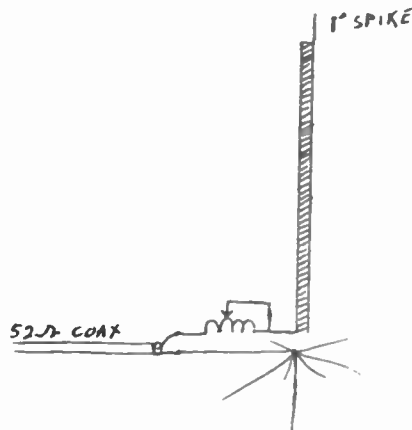

COIL -- 30 turns #14, 3" diameter, 5 turns per inch
 POLE -- 10' to 25' of PVC pipe 2" in diameter
 LENGTH OF WIRE -- 307' for 1.6 MHz; 147' for 3.4 MHz

following things in mind: 1) As this antenna is fairly frequency conscious, build it for the highest frequency you'll be using, e.g., 1.6 MHz for the AM band, and put a tapped loading coil at the base if you plan on going much below that frequency; 2) The size of the loading coil isn't terribly important—just make it fairly large; 3) Wind the antenna with insulated wire; 4) Use a good ground system (this is important—a half-inch steel pipe driven three or four feet into the ground with several radials connected to it will do nicely (chicken wire mesh will do in place of the radials), and in general it's better to have a lot of short radials than a few long ones.

MONOPOLE

The monopole was originally invented as a limited-space 160 meter ham antenna. It's a good choice for AM and 3.2 to 3.4 MHz operation as it's cheap and easy to build, and is well-adapted to being hidden in trees because of its construction from 300 ohm ribbon. This antenna

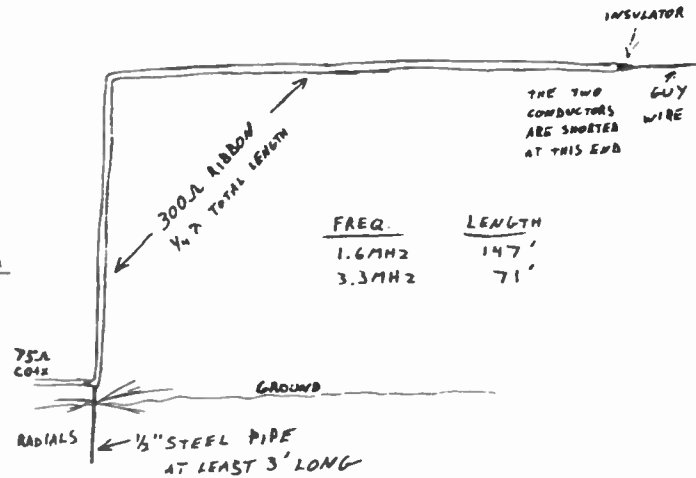

requires a good ground system. (See the comments regarding the ground system for the helically wound vertical.) The greater the length of the vertical section, the better this antenna will work—but it'll still work reasonably well with a short vertical section and a long horizontal section.

YAGI

The yagi, named after its inventor, is the most common type of directional antenna, and with good reason—its construction is relatively simple and it delivers a relatively high amount of gain. For stationary operation, yagis can be constructed from wire; and for rotatable use can be constructed from aluminum conduit ("plumber's delight" construction—see the section "Rotary Beam Construction" in the ARRL Antenna Book for examples of this type of construction). If you're operating on the 15.1 or 21.45 MHz shortwave bands and aiming for a particular country or region, a wire yagi would be an excellent choice.

2 ELEMENT YAGI

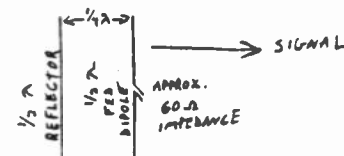

Freq.	Element Lengths	Spacing
15.3	30'7"	16'1"
21.5	21'9"	11'6"
90.0	5'2"	2'9"
100.0	4'8"	2'6"

GAIN -- 4.5db
 FEEDLINE -- 52 or 75 ohm coax

Using a yagi on FM you can set up literal miles farther away from your intended audience than you could if you were using a dipole or some type of omnidirectional antenna. (The four element yagi outlined here will deliver approximately 9 db of gain; this is equivalent to multiplying the power output of your transmitter by eight.)

3 ELEMENT YAGI

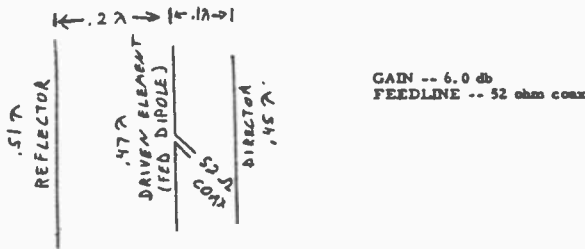

4 ELEMENT YAGI

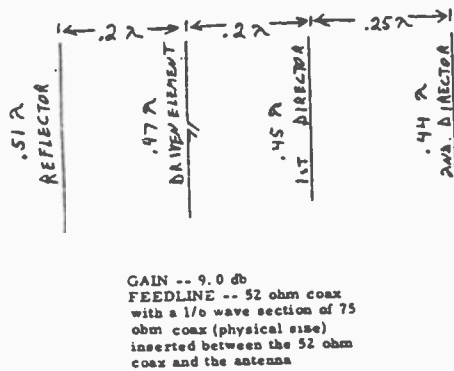

CUBICAL QUAD

The cubical quad is another type of directional antenna. It's cheap and easy to construct, but bulky and not really practical for pirate use except for the FM band. For the FM band the sides of the quad will only be about two-and-a-half feet long. A two element cubical quad will deliver about as much gain as a three element yagi (about 7 db). There are a few things to bear in mind if you build a quad: 1) The wires making up the loops must be insulated from the supports (TV standoff insulators and bamboo poles will work fine); 2) The two loops should be as nearly parallel as possible; 3) You'll need to tune the rear loop—using the shorting bar on the tuning stub—to maximize gain; an easy way to

CUBICAL QUAD

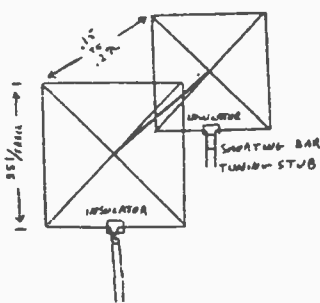

(Loops parallel to each other)

GAIN -- 7 db
FEEDLINE -- 75 ohm coax
SPACING -- .15 to .2 wavelengths between the loops

Freq.	Side	Stub
90	2'9"	6"
100	2'6"	6"

do this for quads for the FM band is to set up a FM receiver without an antenna 50 or 100 feet directly in front of the quad, feed a low-level signal to it, adjust its tuning stub (turn off the transmitter while you're making the adjustments) and have a friend watch the signal strength meters or LEDs on the receiver for maximum signal strength.

MOBILE OPERATION

Mobile operation is basically pretty simple—it consists of broadcasting from a moving vehicle. That vehicle can be a car, van, truck, or even a bicycle or motorcycle. Because of antenna size considerations, mobile operation is most practical at frequencies above 15 MHz. While mobile operation is possible at lower frequencies, such operation does have drawbacks: 1) Mobile antennas for frequencies below 15 MHz require bulky loading coils which are highly visible; 2) Such antennas are relatively inefficient. Because of these reasons I won't bother to include designs for such antennas. (Those interested in mobile operation on the lower frequencies should consult *The ARRL Antenna Book*.)

Mobile operation on the shortwave bands doesn't make much sense either, for the following reasons: 1) Pirate shortwave operation is relatively low risk; 2) If you're operating on the 15.1 or 21.45 MHz bands you'll in all probability be aiming for a specific region thousands of miles away and will want to use a directional antenna, an impossibility with mobile operation. For those reason, I'd recommend portable or fixed rather than mobile operation on the shortwave bands and the use of two or three element yagis.

That leaves the FM band. Fortunately, mobile operation on FM is easy. If you're using a transistorized transmitter you can, in most cases, run it directly off your car battery (this is the case with all the transistorized schematics in this pamphlet). If you're using a tube-type transmitter, you'll need a DC/AC inverter. Your best bet is to buy one at an auto parts store.

Your antenna for mobile FM operation is simplicity itself—a quarter-wave vertical radiator with the car (or bike) body acting as ground. This antenna should be fed with 52 ohm coax with a one-sixth wave (physical length) matching section of 75 ohm coax inserted between the 52 ohm line and the antenna. For concealment purposes you can simply adjust your car radio antenna to the proper height for the frequency you're on and feed it. The pattern you'll get from this will not be strictly omnidirectional (your signal will be reflected away to an extent from your car's roof), but this isn't terribly important.

A small portable cassette player will provide a suitable audio source for mobile/portable operation.

Finally, if you do engage in mobile operation, in addition to following the recommendations in the "Getting Away With It" section, you'll probably want to take the additional safety precaution of operating on busy streets during times when there's a fair amount of traffic.

FINDING PARTS

Electronics parts are easy to come by—just open up the yellow pages if you live in an urban area. Radio Shacks generally have a fair supply of the most common parts, but their prices tend to be high. If you live out in the sticks, you can order parts by mail from many sources which advertise in *QST*, *CQ*, *73* and other electronics magazines. And the 1985 version of the *RAH* contains a list of parts suppliers on page 35-28.

A good source for parts such as variable capacitors which cost an arm and a leg if purchased new is the ham swap fest. You can frequently pick up parts at these gatherings for a small fraction of the cost new.

If you're really broke you can get parts free quite often by cannibalizing junked radios, TVs, stereos, and any other type of electronics garbage you can lay your hands on. If you follow this course, you need to be aware that some parts are more affected by use than others. Paper capacitors from junked equipment should not be used unless you have no alternative, and carbon resistors from such equipment should be carefully checked for heat damage. If resistors are heat damaged they'll often take on a shiny appearance, become brittle, show hairline fractures, or simply look burnt. Use of such resistors should be avoided as should use of fixed value capacitors which show signs of leakage (such leakage is pretty obvious). Most other parts from junked equipment will work as well as new parts. All parts should, however, be tested before you attempt to use them.



FRANKENCHRIST

The
3rd LP
by

DEAD KENNEDYS

\$6.75 POSTPAID

KLAUS FLOURIDE
CHA CHA CHA WITH
MR. FLOURIDE
VIRUS 36

\$5.75 POSTPAID



Please write for our free catalog or call
the A.T. HOTLINE: News of upcoming gigs,
tours and releases, mail order catalog by
phone, and requests for anything and every-
thing. Call (415) 863-4281 24 hours a day.

Alternative Tentacles Records
P.O. Box 11458
San Francisco, CA 94101



Popdefect



ONE BY ONE / HARD TIMES

SEVEN INCH SINGLE \$1.50 POSTPAID

ALSO AVAILABLE THIS END UP / ROCOCO CRISPIES SINGLE

PLAYING FOR TIME FIVE SONG E.P.

E.P. Four fifty. Other single, Buck fifty.

Whole fuckin deal, Six Bucks.

From Heart Murmur Records

P.O. Box 42602 Los Angeles, CA 90042

ZIMBO CHIMPS

BUDGET RANCH

ZIMBO CHIMPS - "In A Cave/Inca Vacation"

Raucous wierdness from quartet that includes Mark Erskine of Savage Republic. Recorded live, one take.

ink DJ SEASE If high
adventure is what you desire, the Zimbo
Chimps make for the most affirmative
listening since the sound track of "Jungle
Book." --Steve

\$3 postpaid

(Budget Ranch, c/o Toxic Shock, P. O. Box 242, Pomona, CA 91769)

TEST EQUIPMENT

There are several pieces of test equipment you will find useful. First, you will need a good quality volt-ohm-milliamper meter (VOM). Radio Shack sells a good one for around 30 bucks. Secondly, you'll probably want a standing wave ratio (SWR) bridge for use between your antenna and transmitter, although a SWR bridge isn't really essential for a "cheap and dirty" approach. See page 531 of the 1972 RAH and page 16-32 of the 1982 RAH for schematics as well as any edition of the ARRL Antenna Handbook.

Another useful piece of gear is a field strength meter, which is helpful in adjusting directional antennas. The following field strength meter should work for frequencies from the broadcast band up to around 30 MHz.

FIELD STRENGTH METER

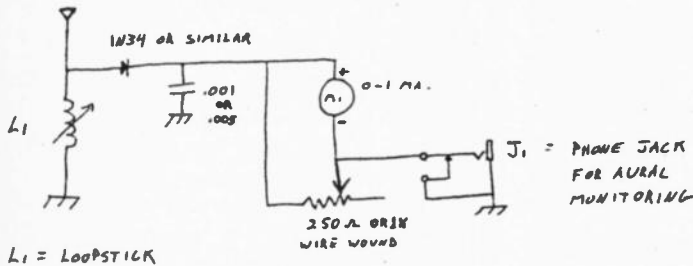

(This circuit should be enclosed in a metal box. Its antenna is a short piece of wire mounted on a feed-through insulator.)

Another very useful piece of equipment is the dip meter, which will let you know the resonant frequency of any tuned circuit or antenna. See page 16-20 of the 1982 RAH for a schematic.

A transistor checker can also be useful, especially if you're using salvaged parts. See page 16-27 of the 1982 RAH for a schematic.

The simple 12 volt supply on page 27-1 of the 1985 RAH will provide all the power any of the transistor circuits in this pamphlet require. Simple designs for high-voltage power supplies can be found in any edition of the RAH.

SAFETY MEASURES

It's extremely important to ground all of your equipment, both at the studio and at your transmitter site.

Avoid the use of solvents for cleaning. Virtually all common solvents (benzene, acetone, xylene, carbon tetrachloride, etc.) are highly toxic and carcinogenic. Alcohol and burnishing tools are all you'll normally need for cleaning purposes. If you do use solvents for cleaning or do much soldering (solder contains a lot of lead) do so in a well ventilated area.

TECHNICAL REFERENCES

The Radio Amateur's Handbook, published yearly by the American Radio Relay League. **YOU NEED THIS BOOK.** This is the single best source of information for pirate operators. It contains straightforward explanations of almost any technical questions you might have, vast amounts of useful technical information (color codes for resistors and capacitors, specs for all common tubes and transistors, etc.) and many schematics which can be used or easily modified for pirate use. This book is updated yearly, so it's actually not a bad idea to own copies from different years—any copy from around the mid '50s on should be of use to you. Be aware that there are other books bearing the title Radio Amateur's Handbook; all are vastly inferior to the ARRL's Handbook. Fair Radio Sales, P.O. Box 1105, Lima, Ohio 45802 sometimes has used handbooks available for a few dollars; the price of a new book is now around \$20.

The ARRL Antenna Book. Another fine ARRL publication. It contains all the information you'll probably ever need about antennas.

Seven Steps to Designing Your Own Ham Equipment, by L.B. Cebik, a SAMS publication. This contains a lot of useful information on designing and constructing equipment and is well worth owning.

VHF Projects for Amateur Experimenters, by Wayne Green, TAB Books #608. This contains many circuits which can be modified for use on the FM band.

Engineer's Notebook, by Forrest Mimms. Contains good info on integrated circuits. Available at Radio Shack.

Cienfuegos Anarchist Review #5. Contains step-by-step instructions for the complete novice on putting together a simple FM transmitter.

The Complete Handbook of Radio Transmitters, by Joseph Carr. TAB publication #1224. Contains much useful information including schematics for amplifiers for the HF and VHF bands.

Simple, Low-Cost Wire Antennas, by Wm. Orr and Stuart Cowan. An excellent introduction to antenna construction for those with no previous experience in this field. Highly recommended.

Here are some more addresses that might be helpful. However, much of the info is up to two or three years old, so some of the addresses may have changed. Explore.

A directory of pirate radio activity and other services are available by writing to Box 5074, Hilo, HI 96720, USA.

Data Radio, P.O. Box 46199, Baton Rouge, LA 70895-6199 is a source for The Monthly ACE (publication of the Association of Clandestine radio Enthusiasts).

A second address for ACE is P.O. Box 452, Moorhead, MN 56560, USA.

For people with computers and modems, a 24-hour a day message system has been set up. The phone number is 913-677-1288.

Popular Communications, 76 North Broadway, Hicksville, NY 11801, USA, is a glossy mag that includes a regular feature called "Pirate's Den."

***** SOURCES *****

*PUBLICATIONS

The Monthly ACE
P O Box 452
Moorhead MN 56560
news of pirate stations;
sample for \$1

Clandestine Confidential
RR 4 Box 110
Lake Geneva WI 53147
covers political clandestine
stations; sample \$2

Ham Trader Yellow Pages
Box 356
Wheaton IL 60189

The Ham Boneyard
364 Kilpatrick Ave
Port St Lucie FL 33452

*ANTENNAS

Barker & Williamson
10 Canal St
Bristol PA 19007

Butternut Electronics
405 E Market St
Lockhart TX 78644

Western Electronics
Box 400
Kearney NE 68847

*CRYSTALS

International Crystal Mfg Co
Box 26330
Oklahoma City OK 73126

*TUBES

Ceco Communications
2115 Avenue X
Brooklyn NY 11235

Elmira Electronics
Box 4230 SS Station
Elmira NY 14904

Unity Electronics
Box 713
Elizabeth NJ 07206

Rubin Electronic Sales
16A Cooper St
New York NY 10012
sent LASE for list

ACOE Column Editors:

Eric Baxter DIALOGS
c/o Box 2571, Shames-Russion, PA
56201-2571 (913) 262-3247

Loni Pettit SPY CENTRE
3412 Old Lakeport Road, Sioux City,
IA 51106

*MANUALS:

(for Collins gear)
Rockwell International
Collins Division
Cedar Rapids, IA 52498

(general and hard to find)
HI Manuals
Box 864
Council Bluffs IA 51502
catalog; \$1

(for military surplus gear)
S Consalvo
7218 Roanoke Dr
Washington DC 20021
list \$1

(for Hallicrafters gear)
Arco Electronics
P O Box 95
Berwyn IL 60402
send SASE and model number needed

National Radio Corporation
89 Washington St
Melrose MA 02176

*PARTS, CABLES, MIXERS
your local Radio Shack store

*CIRCUIT COMPONENTS

All Electronics Corp
Box 20406
Los Angeles CA 90006

Semiconductor Surplus
2822 N 32nd St Unit 1
Phoenix AZ 85008

Ramsey Electronics
2575 Baird Rd
Penfield NY 14526

Westcom
1320 Grand Ave
San Marcos, CA 92069

Sintec Co
28 8th St., Box 410
Frenchtown NJ 08825

Amidon Associates
12033 Otsego St
N Hollywood CA 91607

For shortwave pirates, a lot of
helpful technical articles are
published in these magazines:
CQ...QST...QRP

John Arthur VERIFIED RESPONSE

15-2700 Kala Br., Pahoa, HI 96770

Ralph Martinez AOCe Art Editor
17 Glenwood-Over Rd., Lynnwood, IL
60411 (312) 895-2137

This Issue's Cover

The young kid on your upper left of the photo is my father, Aldo Nicholas Ciaffardini, the only non-musician in the picture. His father is Nicholas Ciaffardini, the round-faced man with the mandolin on your left of the big drum in the middle. The photo was taken sometime in the 1920s near Fabrica de Roma, a small town just north of Rome, Italy. It was a time and place where if you wanted music, it had to be live. If you listened to music, you had to be right there with the musicians.

These days we carry music around in our back pocket. The musicians that make our music may never come closer than 5,000 miles from our ears. The great significance of this turn in the evolution of music--such a big change in such a short period of time--has changed the world to a degree few of us realize. Will we live to see and hear another equally significant development in audio history?

How or why my father got into this band photo is not clear. My father never played a musical instrument. His father wanted him to learn the mandolin. It was reportedly a source of heated discussion, Aldo rebelling against his father's wishes. Nobody should be forced to play an instrument, that's true. And I can imagine the elder's frustration, telling his son something like, "How are you going to be sure you'll have good music to listen to if you don't know how to make it yourself?" And then the son, responds, "It's a whole new world, Pop. Haven't you heard about the new phonograph recordings? I don't need a mandolin, I need a record player!" Impetuous youth.

But wisdom grew with age, and although Aldo never did take up

an instrument, the value of such a musical skill was eventually appreciated. My father never asked or hinted for me to learn to play an instrument--I too, may have rebelled against such force feeding--but one time in my youth, when I brought up the subject, he told me that should I ever wish to learn an instrument, he would help me purchase one and get lessons. No pressure, just an offer of support for which I am eternally grateful.

My father died Friday, Dec. 13, 1985. He had worked very hard all his life and took little time out for hobbies or other recreation. I know from seeing a couple of his paintings and other things dredged from his youth that he was, deep inside, a creative and artistic person, but the realities of life--growing up very poor in America during the depression and working hard all his life to put that kind of trauma behind him--weighed heavily upon him, allowing him little time or energy for his artistic side. When he could have retired, he didn't. What would he do with his spare time? So, toward the grind-stone he was always pointed.

I used to wish he had learned the mandolin or continued with his painting, if just to have something to turn toward when his work was through. During his last weeks I almost bought him a mandolin, but decided against it, for fear that it would embarrass him or frustrate him, or that it might not mean anything to him. And when the end was near, words between us were not easy. But I brought my guitar into his hospital room, ignoring the stares from the hospital attendants who acted like it was such a strange thing to do. I played a little music for my father for the first time. There were no miracles, not even a smile from my father. He was very sick, and I'm not even sure if he heard me. But during those moments of helplessness and impending loss, playing my guitar was the best medicine I could offer and I am very glad I had at least that.

Thank you, Father. --David

State of the Network

tion of our size. You can buy an entire page to do with whatever you want for less than the price of a bribe for a mention in the editorial section of many other music magazines. We keep the overhead low. The publisher sleeps next to his desk.

One of the most painful ways to increase income is to raise the advertising rates. Advertising rate increases are bad news because they threaten to alienate the small operation entrepreneurs and artists to which Sound Choice is dedicated. One of the reasons Sound Choice is a success is that it is one of the few if any places one can buy an entire page for about the price of one week's minimum wage salary.

Nevertheless, we have raised our rates slightly, but in a unique way that is the least painful and in the spirit for which Sound Choice was born. And, what is even more important, we plan to never raise our rates again. Actually, we have simply eliminated the discount that we gave advertisers who bought a half-page or more. As of April 15, all non-cover ads will be based on the \$25 an eighth page rate. A quarter page is \$50 as always, but the half page is now \$100, and the full page \$200. We feel this is the most equitable and constructive type of increase. Now, unlike most magazines, the people with the least money to spend do not have to pay more per inch than the people with the most money to spend.

There is a type of advertising that has not entered into Sound Choice as much as some people would like. And that is musical and recording equipment ads. Sound Choice seems like the ideal place to advertise magnetic tape, tape recorders, amplifiers, etc. Our 1985 survey indicated that 80% of Sound Choice subscribers own two or more tape recorders (25% own four or more); 60% own musical instruments (35% own five or more); and 55% described themselves as "involved in a working

capacity with professional or semi-professional musicians."

But the large equipment manufacturers have been slow to catch on to what is happening in the subculture, as always. And we haven't been busting through the doors of their ivory towers to give them the news. The people that make the advertising decisions at these companies are usually overworked and out of touch. You'd think the ad man at Fostex, a company that pioneered four track cassette equipment, would be very interested about all the unusual creative things people are doing with four and eight-track mini-studios as reported in the review section and elsewhere in Sound Choice? He wasn't in the least. He was too busy busting his ass to make the budget and deadline for some multi-thousand dollar ad in one of the slicks. You think he would want to check out a copy of a Sound Choice with a cover headline declaring "a cassette revolution." Barely.

Sound Choice is a little too unusual looking. As Mike Maia at ADA Signal Processors told us about his company: "We're a conservative company. If we see our competition advertise in Sound Choice then we'll consider advertising." He didn't know or care anything about what is going on in the audio subculture. He is an insecure follower who can't think or see things for himself. After talking with Maia personally at his office, his company, ADA, is not one that we would recommend. To him, selling his company's audio products is little different than selling toasters or vacuum cleaners. That his product might be used to aid in someone's audio artistry did not concern him at all, except what it means to his wallet.

Even an equipment company that I can recommend, Mesa-Boogie Amplifiers, is hesitant to advertise in a magazine where no other amplifier companies have tested the water. Again, Sound Choice looks a little

continued from page 3

too unusual, a little too non-mainstream, a little too, err, irregular. Nevertheless, it is companies like Mesa Boogie that we would like to attract to Sound Choice. We dropped by Mesa-Boogie unannounced and found the owner/inventor Randall Smith himself, there like the rooster in the henhouse, designing and testing his company's equipment and willing to greet a couple of strangers who wanted to plug their guitars into one of his new creations.

Smith built his company from a small shack and as he succeeded he refused to give up control and sell out to one of the larger conglomerates. Today his company makes some of the best amps and all the employees seem to have a sincere desire that every customer is completely satisfied. As we walked through the factory, the employees were enthusiastic and really seemed to care about and have pride in their product. And some seemed truly interested in Sound Choice and what is going on in the world of independent recording.

Sound Choice readers can help the magazine by mentioning it in correspondence with equipment manufacturers that they like. The really ambitious may send any company their copy of Sound Choice with a note saying why the company should support the magazine. Send us a copy of the note and we will replace the magazine you sent or give you another issue credit on your subscription -- and maybe we'll even throw in some token gift or something. A nice full color, full page ad on one of our covers by a company that can afford it, would make things less stressful. Our rates are chicken feed for these companies.

And what other ways can we improve the Audio Evolution Network and Sound Choice? Let us know your ideas. But don't forget, we all need your ACTIONS too. We need your articles, art and goodwill. Thanks for taking us this far. --The Staff

The sounds of music can come from 'junkyard'



Ann Landers

Dear Ann Landers: I was interested in that column about rock music and how parents were upset by the dirty lyrics. According to the Wall Street Journal, noise levels might produce the most damage.

It is my belief that the younger generation has gone bananas.

Diane Petzke reports that junk rock (also known as industrial music) is produced by scrap metal, car parts and air-conditioning ducts rather than by guitars and drums. Any object that can be made to emit a sound when coaxed with an aluminum pipe, a lead mallet or a power drill qualifies. And if the sound is reminiscent of a garbage truck at 5 a.m., this is intentional.

One group uses a pneumatic drill that screeches like several thousand long fingernails dragged across a chalkboard. Then one hears the slamming of a drum pedal against a 500-gallon storage tank. A skinny young man screams in German amid a collection of dented car doors, a cement mixer and a refrigerator scavenged for the occasion, ready to be banged, drilled and scraped.

A Milwaukee group called Boy Dirt Car uses junkyard items or

special sound effects in a record album called "Catalyst." It was recorded beneath an underpass in an old Schlitz brewery.

"Machine Age Voodoo" uses airplane wings, crushed glass in mosquito netting and a shotgun. If all this doesn't add up to a mass nervous breakdown and the desecration of everything sacred in the world of music, I miss my guess. No signature -- Just Disgusted (A Father In Rhode Island)

Dear Rhode Island: Cool it, Dad. This, too, shall pass. Let us hope it doesn't produce a few million deaf kids in the process. Aside from the hearing loss I see no danger of mistaking this trash for music long enough to make an impact on anyone.

LOOSE ENDS SECTION

PLEASE NOTE: We will publish anything you send poetry, letters, opinions, drawings, your records & tapes. We will also charge your records & tapes. Please send a label for our independent cassette label. For a sample copy, send \$1.00. P.O. Box 10700, Rochester, NY 14600.



In reference to his Red Rat Recordings listing in the catalog section of S.C. #3, Otto Grimbauer offers an address change: Red Rat Recordings, van Alphenstraat 29, 3581 JA Utrecht, The Netherlands.

We would like some article input regarding recording techniques.

Of course we welcome all sorts of writing about all sorts of stuff. Let us know. Phone 805-646-6814 if you have any story ideas to discuss.

HEY, LOOK AT THIS. YOU WON'T SEE IT ANYWHERE ELSE IN THIS MAGAZINE!!!!!!!!!!!! All those who subscribe to Sound Choice before May 14, 1986 will get two free back issues of Op magazine or one back issue of Sound Choice. However, you must indicate which issues you would like AT THE SAME TIME YOU SEND IN YOUR SUBSCRIPTION. The list of Op back issues is listed in the Unclassified section of this issue.

Buy a Sound Choice T-Shirt. \$12. Check out page 17 to see how they hang.

Remember Deadlines!!!! We want your input.

I got this whole cloth bag of art and stuff. It was the Level Mail Art project. Its a periodical open to the public. Really quite charming, but hard to classify or file neatly, thus it got overlooked when we did our publication section. Very groovy. Send an SASE. I know you won't regret it. Write Level, P.O.B 50164, USA.

Hey! We need some flexi-discs, or cassettes, or 7" records donated so we can distribute them to SC subscribers. We are looking for lots of at least 50 or more. Could be good advertising, if you have something good. Actually it might be good advertising even if you have something bad. Free records and tapes are like that.

In case you didn't see the fine print: Eugene Chadbourne's "Memories Of The Jazz Age" is an excerpt from the first draft of his upcoming book: YOUR USA AND MY FACE. It might be a good time for some independent entrepreneur out there to see if they can strike a financial deal for the publishing. His address is in the record review section under Chadbourne.

Okay, here the Sound Choice staff asks for help in getting us out of a sticky situation. We kind of screwed up the ad that was sent to us by Archie Patterson, someone whose accomplishments and ideas regarding music we highly respect. We didn't get his ad in the regular section and because of production problems we aren't able to solve at this very last moment, his ad probably won't come out looking very good. But if you are into progressive music, especially electronic, or should I say electric?, then write to him, send him \$1 and get some of his stuff. There's a review of some of his work under "Eurock" in the review section. Write him, tell him you care.

Same with SYNE magazine advertised in this issue's unclassifieds. It seems publisher James Finch wasn't entirely satisfied with the response he got from his ad in SC #3 (I think it was because his ad wasn't designed well). But his magazine, if you are interested in electronic music, is very well done and I recommend it to people who wish to explore that area further. Write him, buy his mag, help us all out. Thanks.

Writer Craig O'Donnell will be writing articles about music-composing software and he would like to hear ideas and experiences of others who have used such software. "No 'MIDI'-based software please!" he says. He also wants to "cajole Sound choice into setting a page aside for computer-composers and softmusic swaps." What do readers think? Will O'Donnell be the only person writing about this stuff or will others chip in their two bytes? You may write him directly at 528 Oakdale #432, Chicago, IL 60657.

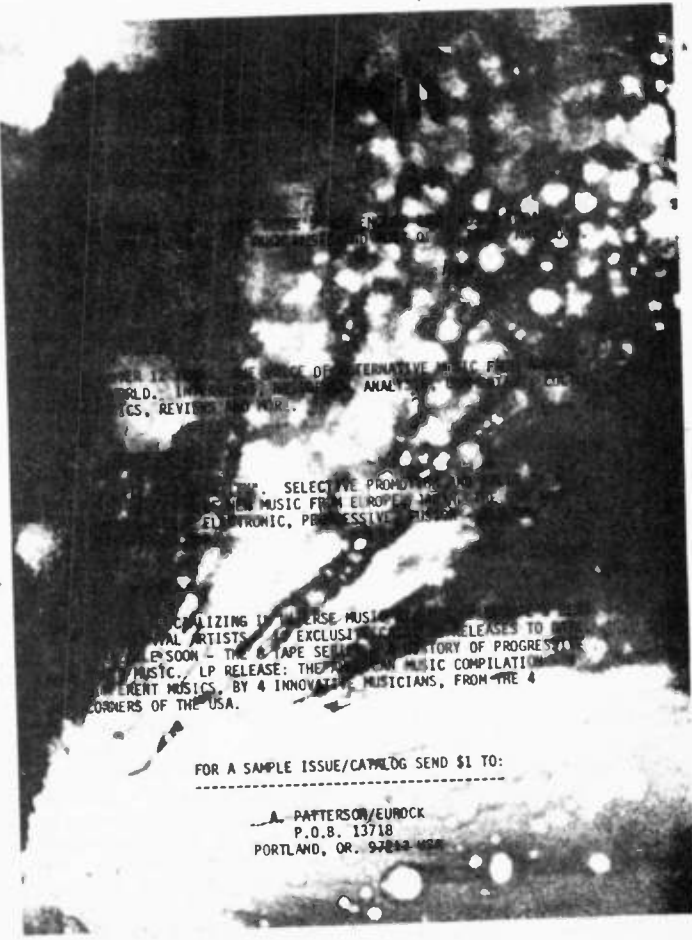

WORLD... ANAL...
SELECTIVE PROMOTION...
MUSIC FROM EUROPE...
ELECTRONIC, PROGRESSIVE...
EXCLUS... RELEASES TO...
THE 8 TAPE SE... HISTORY OF PROGRES...
MUSIC. LP RELEASE: THE... MUSIC COMPILATION...
CURRENT MUSICS. BY 4 INNOVATIVE MUSICIANS, FROM THE 4...
CORNERS OF THE USA.

FOR A SAMPLE ISSUE/CATALOG SEND \$1 TO:

A. PATTERSON/EUROCK
P.O.B. 13718
PORTLAND, OR. 97222

UNCLASSIFIED ADS

Unclassified ads: forty words or less are \$15 for non-subscribers, \$10 for subscribers. Additional words are 25 cents each. The first two words will be printed in bold and/or all capitals at no extra cost if desired. Add 25 cents for each additional word in boldface and/or all capitals. All Sound Choice charter subscribers who still have credit for free 15-word-plus-name-and-address classifieds (offer good through issue no. 6) can extend their credit to the forty word limit.

SUBURBAN UPRISING: The Jersey Beat Compilation, a 19-song cassette featuring an hour's worth of music by a wide-ranging selection of indie bands from the NY/NJ area. Punk, pop, hardcore, mod, and more! \$4 postpaid to: Jim Testa, 418 Gregory Ave., Weehawken, NJ 07087, USA.

ALBUMS: Celtic, Balkan, Bluegrass, old time, jug band, blues, Klezmer, jazz, swing, Hawaiian, Fiddle, Dulcimer, topical, women's, cajun, dobro, dance, and much more. Over 800 titles. Discount prices. Free catalog. Elderly Instruments, 1100 N. Washington, P.O.B. 14210-H12, Lansing, MI 48901, USA; ph. 517-372-7890.

ALCOHOLIC TENDENCIES cassette compilations is just starting out. We accept contributions from musicians and poets of all genres. Please write: Alcoholic Tendencies Compilations, P.O.B. 13011, Philadelphia, PA 19101-3011, USA.

COMIX WAVE is the place to improve or learn cartooning. Join us. Send a stamped and self-addressed envelope for a free sample copy of the Comix Wave Letter. Clay Geerdes, Box 7081, Berkeley, CA 94707, USA.

CAMERA OBSCURA — A publication devoted to the undeservedly obscure in music (and art and literature, occasionally). Literate and humorous, with a sometime concern for music's social issues. Six issues, \$1.50 each, to: Marc Tucker, 1508 Faymont, Manhattan Beach, CA 90266, USA.

PRODUCTION: I am interested in producing an independent music project in the NYC metropolitan area. Please contact: Ross Mohn, ACME Plastics, 607 East Park Ave., Long Beach, NY 11561, USA.

LOOKING FOR lurid sexual desires. Submit in writing or cassette. For compilation with booklet. No money. Just fun. Participants will receive a copy. Will be for sale, no profit. Fuck yourselves silly. R.D. c/o Floating World, 804 N. Cherokee, Hollywood, CA 90038, USA; ph. 213-464-5628.

BUZZ MAGAZINE Ready to review your records and tapes. Send two copies of vinyl along with material to: Buzz, P.O.B. 3111, Albany, NY 12203, USA. Receive free Buzz.

EUROCK: An underground journal and specialist distributor devoted to promoting artists and music ignored by other mainstream and alternative outlets. Interested in electronic music, experimental fusion, progressive rock? Send \$1 for sample issue to: Eurock, P.O.B. 13718, Portland, OR 97213, USA.

FRITH. ENO. Electronics. Improv. Muffins. Cartoon. Classical Training. UZero. Crimson. Mixed Metre. Egg. Samlas. Frace Ditch. Home-made Instruments. Knebnagauje. Sound interesting? Lets form a band/ensemble. For more info write: Brian Magill c/o E.E.M.C., P.O.B. 3219, Eugene, OR 97403.

PETER CATHAM'S latest tour through his "New Possibilities Musics" can be heard on cassette-album #3, "Pinched Awake". "The key word is 'Possibilities'. New possibilities in instrumentation, arrangements, and topics, and a disregard for the ordinary in all three of these areas." \$3.50 postpaid for top quality cassette and packaging to P. Catham, P.O.B. 73, Pasadena, CA 91102, USA.

MONA'S RAG will publish anything you send; poetry, letters, opinions on any subject. Mona Blake will also review your records and tapes. Chordtapes is our independent cassette label. For a sample copy, send \$1 to: P.O.B. 40708, Rochester, NY 14604, USA.

IS YOUR SET INCOMPLETE? Sound Choice back-issues — \$2.50 each; \$3.50 beyond North America. Write Sound Choice, P.O.B. 1251, Ojai, CA 93023, USA.

META-SCOOP. Greet your destiny. Your magnetic network shares psychic's best kept secrets of the Universe. Challenge your beliefs, open Pandora's box, and dare to be a part of the whole story. Subscriptions \$10/12 issues. Send SASE to Meta-Scoop, 1004 Live Oak, Ste. 102, Arlington, TX 76012, USA.

OUTER SHELL — The music 'zine that lets you speak out, and — it's free! Send a SASE to P.O.B. 7053, St. Petersburg, FL 33734, USA

ALTERNATIVE PRESS — Ohio's major alternative music and art monthly. Looking for stringer throughout the country to report on local happenings and interviews bands/records/shows or whatever. Ohio does exist!! Contact us at P.O.B. 1141, Aurora, Ohio 44202, USA.

AT PRODUCTIONS cassette releases by Bliss, The Fundamentalists, Jim Clinefelter, more info: AT Productions, 812 Stadelman Ave., Akron, OH 44320, USA.

WORLD WAR III 1. When? 2. Why? 3. Who starts wars? 4. Time for prevention? 5. Who is trying? 6. How can we help? Write Little Free Press, RT. 2, Box 136A, Cushing, MN 56443, for a free paper which attempts to provide answers.

FREE DISCOUNT RECORD CATALOG: banjo, Cajun, dulcimer, English, fiddle, gospel, harmonica, Irish, Japanese, Klezmer, labor songs, mandolin, newgrass, old time, pipes, Quebec, ragtime, slide guitar, Tex-Mex, ukulele, Western swing, Zydeco, and tons more. Elderly Instruments, 1100 N. Washington, P.O.B. 14210-G12, Lansing, MI 48901, USA; Ph. 517-372-7890.

NEW YORK MUSIC TELEVISION SHOW looking for videos to include in future episodes. Send 3/4 or 1/2 VHS to: P.O.B. 724, C.P., NY 12065 — Receive free Buzz magazine.

GEOMETRY GEOMETRY Geometry Geometry: Cassette. Geometry, Geometry, Geometry, Geometry: 4 songs. Geometry, Geometry, Geometry, Geometry: \$3.00. Geometry, Geometry, Geometry: Box 655. Geometry, Geometry, Geometry, Geometry: Urbana. Geometry, Geometry, Geometry, Geometry: Illinois. Geometry, Geometry, Geometry, Geometry: 61807.

MUST SELL about 100 collector's records, used, mostly mint condition, 45s and LPs. The lot for \$100 plus shipping, or write Records, Box 2081, Station A, Champaign, IL 61820, USA. No reasonable offers refused.

THE REAL OP MAGAZINE! Gone but not forgotten. Back issues of the real thing are still available. See other ad in this classification for details.

COMMON CAUSE — Ventura County's alternative music monthly covers all the bases! December issue features A Black Afaire, Blast!, underground press, news, reviews and more. Sixty cents postpaid to Todd Castor, 1501 Billings St., Oxnard, CA 93033, USA.

OWN THE WHOLE WORLD an Akron music publication. Issue #11/12 out now. Info: OTWW, 812 Stadelman Ave., Akron, OH 44320, USA.

PIANO REFLECTIONS: Lantern In The Window by Susan Kennedy. "Pretty...Full of humor," says New Age Journal. "Exqustely passionate...Deserves wide recognition;" Fortnightly Report. "Exceptionally fine;" Sound Choice. Record, cassette \$10: Teddy Bear Records, Box 1641, Eugene, OR 97440, USA. (Ladyslipper, Fortuna.)

LIKE ELECTRONIC MUSIC? Check out Syne magazine and the International Electronic Music Association. Send SASE to I.E.M.A., P.O.B. 176-SC, Salamanca, NY 14779, USA.

JAZZ DISCOGRAPHIES FROM EUROPE: Bud, Mobley, Ra, Evans, Tristano, more. Send SASE to Mr. Stu, Suite 9L, 1716 Ocean, San Francisco, CA 94112, USA.

SOUND CHOICE BACK-ISSUES: \$2.50 each; \$3.50 each beyond North America. Sound Choice, P.O.B. 1251, Ojai, CA 93023.

DEAR AIR and The Mad Draconians! — A soundtrack by Michael Willis and the first solo release from Zenon featuring Kurzweil, DX7, and acoustic instruments. Both digitally mastered in real time on agfa chrome audiophile cassettes. Send \$8 for each, to Newrioux Productions, 2616 Garfield St., N.W. Washington, D.C. 20008, U.S.A.

GUIDE TO UNUSUAL HOW-TO SOURCES: Describes over 40 periodicals and guides on alternative tech, backpacking, gardening, low-cost shelters, portable dwelling, travel, woodlore, etc. All addresses included. Free for SASE. Light Living, P.O.B. 190-SC, Philomath, OR 97370, USA.

DUBLAB RECORDS: See advertisement this issue. Newest release, Dr. Gonzo "the Doc Of Comedy Rock", hilarious romp through rock and roll. Gonzo has toured as opening act for Huey Lewis (Sports Tour) and has just finished Starship Tour. He's hot!

FULL LISTING of sources for electronic and independent music send IRC for more info. CLEM, P.O.B. 86010, N. Vancouver, B.C., V7L 4J5 CANADA

Op Magazine back-issues available: Learn more about this legendary independent music publication that printed its last issue in Nov. 1984. This is a valuable reference for all those interested in the history of independent recording and music networking. Hundreds of reviews in every issue, plus features, etc. You won't find all these back issues available anywhere else. Available issues include: A, B, I, O, P, Q, R, T, U, V, W, Y, and Z. Issues O through Z have glossy covers and at least 82 pages each. \$2.50 each postpaid. \$20 for the whole set. Prices are for North America only. For other countries add \$1 per issue. U.S. funds or I.M.O. only. Write to Sound Choice, P.O.B. 1251, Ojai, CA 93023, USA.



INTERDISC, INC.

P.O. Box 42214

PORTLAND, OREGON 97242

UNITED STATES OF AMERICA

TELEPHONE:
(503) 236-5568

TELEX:
4993702
(VIA ITT)

AN OPEN LETTER TO AMERICAN INDEPENDENT LABELS concerning **EXPORT**

It is no mystery that the interest in American independently produced records is rapidly growing worldwide. However, the overseas consumers sometimes have considerable difficulty to obtain them. On the other hand, the U.S. labels do not always exploit all available avenues to penetrate the overseas markets. The aim of this letter is to draw your attention to the export possibilities you might have not considered before and to answer the most frequently asked questions.

Why pay attention to export at all?

There are at least two reasons. First, you would certainly like to make your music available to overseas consumers. And apart from that, each record sold in export is an additional revenue for your label — and who doesn't want more money all the time?

How to enter the export market?

You may try to do it on your own, and sometimes quite successfully. However, international business is a very complex affair. Apart from the fact that you need the overseas contacts, importers are always looking for a supplier able to supply the majority of labels simultaneously. Also, the entire venture might be quite risky if it is not properly handled. Unless you have enough experience, you might end up with a considerable loss rather than profit.

In this highly specialized age, it is best to have an experienced export agent, who knows how to penetrate the overseas markets, how to enhance the sales and, last but not least, how to ensure the payments are received on time and without risk.

What can Interdisc, Inc. do for me?

All the above. The most important export areas for U.S. records are undoubtedly Japan and Europe. Due to our location, we can move the product to Japan at economical freight prices, and our contacts there are very good. In Europe, we have our own branch directly at the Schiphol International Airport in Amsterdam, The Netherlands. This excellent location gives us the unique opportunity to penetrate the entire European continent and to exploit the local markets to the limits. Our aim is to build a pan-European distribution network fully specialized on U.S. recordings. The branch executives have years of experience in distribution of imports and contacts throughout Europe. Naturally, the U.S. home office executives have similarly high credentials.

There are thousands of labels available — what can make my product competitive?

Apart from the quality of the music itself (and you know best how good YOUR product is), just two things: immediate availability and price. To ensure the availability, we have set up a warehousing facility in Amsterdam, able to ensure same day shipping to any European customer. In respect to the prices, that is a chapter for itself.

So what about the prices?

You have to realize that the effective cost price of your record overseas is much higher than just the amount you get for it. Air freight, customs duties, import taxes, copyright payments — the list seems endless. Also, the high exchange rate of U.S. dollar towards foreign currencies can make costs prohibitive. It is a fact that an American record costs in an overseas record store twice as much as a domestic title, or even more. We can cut this quite considerably by using more economic transport routes and reducing other expenses. A big advantage of our venture is that we entirely eliminate the usual obstacle exporter-importer by being both at the same time — that reduces the cost very much. But the major contribution is still at your hands — so-called 'export price'. That means a special, reduced price for export purposes only. Of course we understand that your production costs have to be covered and your profit made, but it is our experience that there is always something that could be done.

Also, in many cases we can be of assistance to reduce YOUR manufacturing costs — more about this later.

OK, lower export price, how does it work with terms, and where are my guarantees to get my money?

To the first part: Our standard terms are 90 days consignment period (negotiable). That means in plain English that after an export contract is signed, our overseas buyers submit their initial order of your produced based on their sales expectations, the product is transferred to our warehouses and offered to our customers. The important point is that you do not send your bill overseas — all financial matters and responsibilities are handled by our U.S. headquarters. That answers the second part of the question — by dealing with a domestic corporation, all the risks of international banking jungle are eliminated entirely. And if you ever tried to collect an overseas payment directly before, you know what it means.

So far so good, but I don't want to make any major commitment without first trying how it all works!

We don't ask for exclusive deals or anything like that. Our goal is to sell as much as we can, and if you have other channels, feel free to use them any time!

Is there any minimum or maximum quantity limits?

No. It all depends on how your product will appeal to our customers.

How about promotion, samples, etc.?

Good question. First of all, the success depends very much on the quality of the information we get from you, especially on new releases. A detailed promo kit or sample (even on a cassette, if the record is not out yet), received a few weeks before the release date, gives us the chance to promote the item and solicit advance sales before it is actually pressed, so you can calculate the figures in your initial pressing.

Providing promo samples is generally a good idea — we have enough contacts with major importers and overseas magazines to ensure you that such material will reach the right destination.

Apart from the export sales of my records, what else can you do for me?

Quite a few things. For one, we can take one of the major burdens off your shoulders — the manufacturing. Having numerous contacts with the major European pressing plants, we can arrange for you the pressing overseas, one-time deals or regularly. This way you can obtain the famous European pressing quality, and not only that — it could be CHEAPER than over here!

Another thing is a licensing possibility. In the event any particular title seems to sell good, this is the only way to go to talk thousands of copies sold. We can either act as an intermediate partner, or to do it on our own, even using your label name.

Also, we can represent your label at all major world conventions at a fraction of the cost you would have going there yourself.

OK, I guess I can give it a try. What am I supposed to do?

Just send us a complete list of your product including your export prices (please note the prices should include domestic shipping charges) to our address above. If you have reviews, promo kits, etc., send them along. Samples are quite important. We need at least three of each in order to retain one for our records and forward the rest to our overseas branch. And if you have more questions, just pick up the phone and ask them — that's what we are here for!

Sincerely,

Douglas K. Ashland
- President -

Rory J. H. Faber
- Branch Manager -
Amsterdam

Ladislav Hanousek
- Chairman -



Algebra Suicide

**NEW
E.P.**

AN EXPLANATION FOR THAT FLOCK OF CROWS

**4-song 7" E.P. P.O. Box 14257
\$3 postpaid Chicago, IL. 60614**

Reggae for the Eighties
THE KILLER BEES
Scratch the Surface



BH 1001

Debut Album by One of America's
Hottest Reggae Bands

On Beehive Records, PO Box 50063, Austin, TX 78763

Distributed by House Distributors, 800 821 3324

For more info call EZ Money Productions, 512 451 9949

"A SOUND SO BIG, IT TAKES TWO EARS TO HEAR IT."

FAITH NO MORE

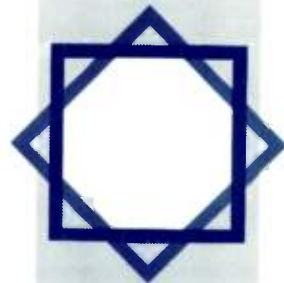

WE CARE A LOT

ON MORDAM RECORDS
AVAILABLE THROUGH ALL FINE DISTRIBUTORS, SHOPS, AND
MAIL ORDER OUTLETS.
PO BOX 988 SAN FRANCISCO, CA 94101

**LIVE WIRE
RECORDS**
P.O. BOX 1222 · SANTA FE, N. MEX.
87504

- LW1 DELINQUENTS E.P. \$2.50
- LW2 DELINQUENTS L.P. \$5.00
- LW3 LESTER BANGS AND
THE DELINQUENTS L.P. \$7.00
- LW4 FINAL NOTICE CASSETTE \$5.00
- LW5 ROCKY ERICKSON
EVIL HOOK WILDLIFE E.T.
12" SINGLE \$5.00
- LW6 27 DEVILS JOKING
CASSETTE \$3.50
- LW7 PELVIC THRUST E.P. \$3.50
- LW8 BRIAN S. CURLEY
"ALONE IN THE BACK
BEDROOM" CASSETTE \$5.00

**LIVE WIRE
RECORDS**