



# RECORDING engineer/producer

*relating recording science • to recording art • to recording equipment*

## DIFFERENTIAL MICROPHONES

PAGE 13

## A SURVEY OF RECORDING STUDIO MONITORING

PROBLEMS...

PAGE 19

## AUTOMATING TRANSPORT CONTROL

PAGE 33

01701PTAMLXLD  
LARRY PATAKI  
9 WELD ST APT 44  
FRAMINGHAM

MA 01701

# ULTIMATE



**PERFORMANCE:** SPECTRA SONICS design and quality control assures undistorted reproduction. Empirical data conclusively confirms that noise, frequency response, distortion, square wave response, peak overload and phase distortion specifications for SPECTRA SONICS control consoles are goals as yet unattained by other manufacturers of audio products.

**DEPENDABILITY:** SPECTRA SONICS consoles operate reliably, consistently and assure the maximum production time for the highest investment return.

A SPECTRA SONICS audio control console can be built to your special requirements, at competitive production prices.

Measure the performance of your console, compare it with SPECTRA SONICS specifications. For data on SPECTRA SONICS consoles or other quality audio products, write or call:

770 Wall Avenue  
Ogden, Utah 84404  
(801) 392-7531

6430 Sunset Blvd., Suite 1117  
Hollywood, Calif. 90028  
(213) 461-4321

**SPECTRA SONICS**

LEADER IN ADVANCED TECHNOLOGY





# RECORDING

engineer/producer

the magazine to exclusively serve the recording studio market . . . all those whose work involves the recording of commercially marketable sound.

— the magazine produced to relate RECORDING ART to RECORDING SCIENCE to RECORDING EQUIPMENT.

Editor/Publisher MARTIN GALLAY

Associate Editor WAYNE YENTIS

Engineering Editors . . . RON MALO  
WILLIAM ROBINSON  
CHUCK DAVIS

Business/Circulation  
Manager . . . . . V. L. GAFFNEY

Art Director . . . GERRY SADOWSKI

RECORDING engineer/producer is published bi-monthly and is sent free to qualified recipients in the United States. Subscriptions for other than qualified individuals or companies may be purchased at \$5.00 per year. (All foreign subscriptions, \$6.00 per year.) Material appearing in Re/p may not be reproduced without written permission of the Publisher.

*RECORDING engineer/producer is not responsible for any claim made by any person based upon the publication by RECORDING engineer/producer of material submitted for publication*

Controlled circulation postage paid at Los Angeles, California.  
RECORDING engineer/producer  
6430 Sunset Boulevard  
P.O. Box 2287  
Hollywood, CA 90028  
(213) 461-7907

Microphone Techniques . . .		
DIFFERENTIAL MICROPHONES	13	Jim Coe
A Survey of	19	John Eargle &
RECORDING STUDIO		Mark Engebretson
MONITORING		
PROBLEMS		
AUTOMATING	33	Jim Furman
TAPE TRANSPORT		
CONTROL		

Letters & Late News	8
New Products	39
Classified	47
Cartoon	47

## ADVERTISERS INDEX

AKG	42	MAZE	43
ALTEC	6-7	MULTI TRACK	17
AUDITRONICS	21	PARASOUND	11
BURWEN	9	QUAD-EIGHT	32
COUNTRYMAN	41	SCULLY/METROTECH	38
DBX	41	SHURE BROTHERS	CUR 4
ELECTRO-VOICE	12-20	SPECTRA SONICS	CUR 2
GARNER	10	TABER	17
INOVONICS	44	TASCAM	16-34
JBL	28-29	3-M, MINCOM	18-19
McGREW	40	UREI	8-40
MCI	14	WESTLAKE	23-24-25-26

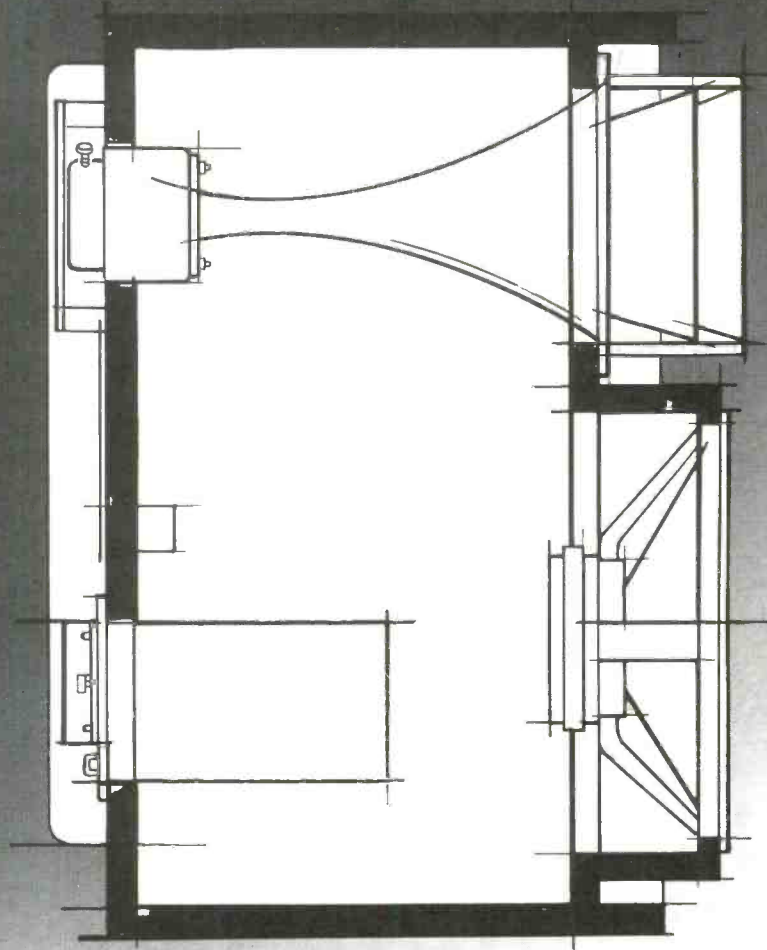

- Maximum acoustical output:** 112 db SPL @ 4 ft., equalized for flat response (pink noise), 40 to 15,000 Hz, in a free field.
- Dispersion:** 40° vertical x 90° horizontal.
- Bi-amplifier:** Altec Model 771 B. Input sensitivity: .5 VRMS-60 Kohm unbalanced input for full output. .1 VRMS-600 ohm balanced input for full output.
- Crossover:** 500 Hz, 12 db/octave.
- Noise (both sections):** 80 db below rated output.
- LF section:** 60 watts, continuous sine wave power, 0.3% THD.
- HF section:** 30 watts, continuous sine wave power, 0.3% THD.
- Dimensions:** 26.5" wide, 31" high, 23.5" deep.
- Weight:** 112 lbs.
- Finish:** Grey epoxy with black grille fabric.

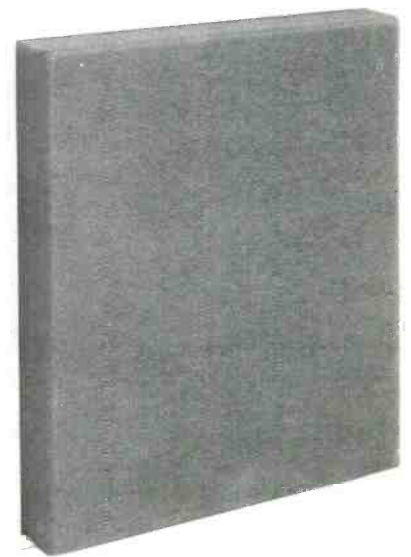

## The New Altec 9846 Bi-amplified Studio Monitor Speaker System

# If stereo disk cutters go down to 30 Hz, shouldn't the monitors?

## Yes. Because the music goes down that far.

You should hear everything when you're laying down tracks or you might not really know what you've got. Why wait till you play a test cut to find out what's at the low end? You don't have to with our new monitors.

What have we done differently to get that low end? First of all we're using sealed boxes. No more ports or bass reflex cabinets. We've gone to a very high-compliance speaker with a big magnet structure. It's well damped so that it responds accurately to signals down to 30 Hz. There's very little distortion. You can't get this with ported boxes.

Above 500 Hz things are different too. There's far more smoothness than in previous designs. Notice the proximity of the woofer and the HF horn. They're within inches of each other. This creates a smooth transition from one source to the other as you go up the spectrum.

Have you ever wondered why good monitor systems are two-way systems? It's because they guarantee transient accuracy. They don't have the inevitable problem of source displacement that occurs in systems with separate tweeters. And they don't burn out, as tweeters in most 3-way systems are prone to do, with the super highs present in much of today's music. Few drivers are capable of such a wide frequency range. Because so few speaker builders use the kind of phasing plug which makes this possible.

To make the system work, power has to be delivered. Biamping is the only solution. So we built a biamp right into the enclosure. It provides more than enough power to make the components produce more than enough sound. Depending on the music, the 90 watts of available power may be equivalent to three or four times that amount when compared to single amplifier systems.

This is truly a new recording tool.

Write for further information on the 9846 Monitor Speaker system. Altec, Professional Studio Products, 1515 South Manchester Avenue, Anaheim, California 92803.

# LA-3A would like to level with you

...you'll like it! The LA-3A is fast and smooth operating...no fuss or bother. It's one of the industry's two best peak leveling products. (Our 1176 LN is the other!) Our patented electro optical attenuator eliminates all traces of distortion and thumping, by adjusting automatically to varying program materials. Two LA-3A's can be coupled for stereo. HF Pre-emphasis is included for FM broadcasting.

Available from better professional audio dealers everywhere.

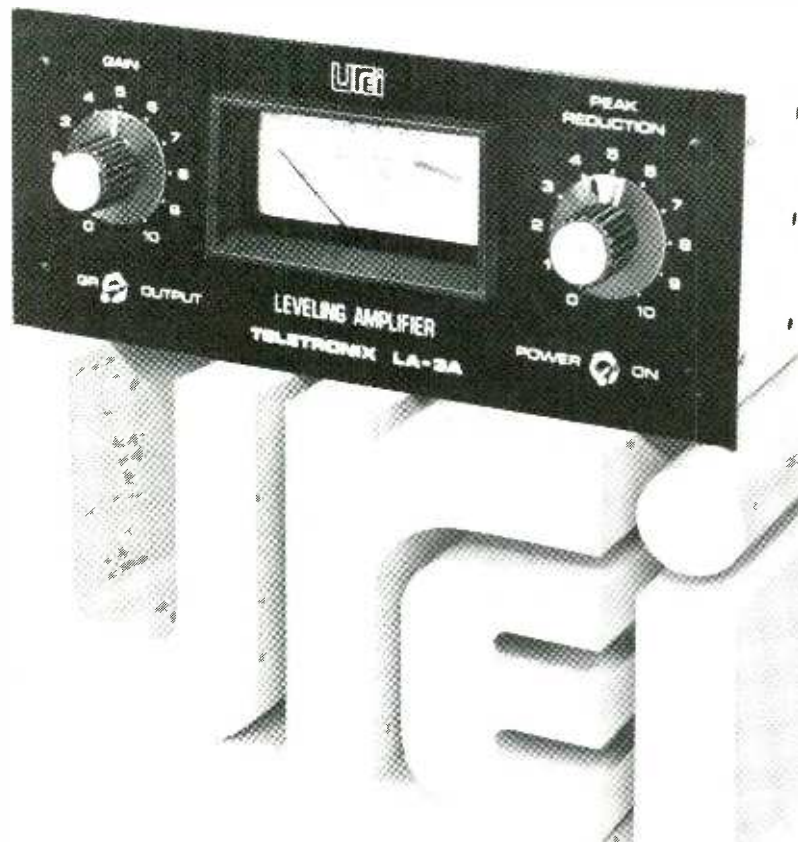

**URC** company

11922 Valerio Street, No. Hollywood, California 91605 (213) 764-1500  
Exclusive export agent: Gotham Export Corporation, New York

## LETTERS and LATE NEWS

FROM:

*Claude Hill, Jr.*

*V.P. Marketing & Product Development  
M.C.I.*

*Ft. Lauderdale, Florida*

In light of a second major audio industry supplier bankruptcy (ed: FLICKINGER ASSOC.) during the past few months the letter to the editor from Mr. Bill Evans, owner of the Studio In The Country, which appeared in the March/April issue of RECORDING engineer/producer, seems to us to subtly contain a much more significant message than just the praise which is certainly due WESTLAKE.

The fact is that supplying the audio market there are examples of another kind of exemplary company. Specifically, these are the companies whose sound engineering, operational and financial bases precludes the need for any third party to have to protect the deposit, or down payment, or progress payment of any customer.

We at M.C.I. are indeed proud to be among those manufacturers, small or large, supplying the audio industry whose records of accomplishment, customer commitment, and delivery are unblemished.

---

### From the READERS \_\_\_\_\_

*An editorial material rating of the most useful feature article, as gathered from the Reader Service Cards received prior to press time.*

#### MARCH / APRIL ISSUE:

SELLING A MASTER . . . . 31.18%

*by Errol Carmel*

MICROPHONE

TECHNIQUES . . . . . 30.65%

*by Bill Lazarus*

GROUNDING . . . . . 38.17%

*By Don Foster*

---

**WESTLAKE CITED BY 3M  
FOR SALES ACHIEVEMENT**

Westlake Audio of Los Angeles, recording studio acoustical designer, has been initiated as the charter member of the "3M Pro Audio Million Dollar Sales Club."



HIDLEY

BURNETT

A plaque was presented to Westlake Audio President T.L. Hidley in recognition of its sales achievement as a dealer of 3M professional audio recorders and accessories. In making the

presentation, Robert F. Burnett, marketing manager, 3M professional audio products, noted that Westlake "has proven time and again its ability to represent 3M products with vigor, determination, cooperation and integrity, resulting in a sales milestone of which both companies can be proud."

He also noted that "quality studio design and equipment installations throughout the U.S. and Mexico have earned Westlake an unequalled reputation as the industry's leading turnkey dealer."

**SECOND ANNUAL NASHVILLE  
RECORDING ARTS SEMINAR -  
AUGUST 22-26.**

Co-sponsored by Nashville's Fanta Sound, and Nashville Record Productions the second annual Seminar, expecting record registrations, will move to larger quarters at the Nashville Sheraton Motor Inn.

The four day meeting will present expert panelists and speakers on a wide range of recording subject matter, including recorder maintenance, acoustics, music publishing, recording techniques, as well as financial aspects of studio operation and equipment acquisition.

Cost of registration is \$35 for the seminar.

Additional information and requests for registration forms should be addressed to: NASHVILLE RECORDING ARTS SEMINAR, 1811 DIVISION STREET, NASHVILLE, TN. 37203.

**'ASD' NEW AUDITRONICS  
DISTRIBUTOR DIVISION**

Auditronics, Inc., Memphis based manufacturer of electronics for recording studios, announces formation of a new distributor division and addition of executive offices at 207 Summit Street, Memphis.

The six year old firm formed the new division to handle sales of Auditronics consoles and systems and support equipment from various manufacturers beginning May 1, 1973.

"The additional 2,400 sq. ft. of office and display space is necessary to accommodate the company's growth resulting from nationwide acceptance of their recording studio products and systems," according to a statement by Auditronics President Welton Jetton.

Manufacturing operations will continue in the 180-B So. Cooper Street building, while sales, distributor operations and executive offices will be in the new facility. The new division phone number is 901/272-9641.

# What they don't hear... can do wonders for your profits!

**Burwen's standard-setting  
capacitor microphone  
adds new dimension to its  
noise eliminator system.**

The increasing consumer demand for better sound and less noise has created a great profit potential for quality recordings. Burwen Laboratories' new Low Noise Capacitor Microphone with (integrated) Sound Equalizer can help you capitalize on this opportunity. The maximum input signal has been extended upward to 140 dB. The Microphone delivers +20 dBm into 600 ohms at maximum sound pressure levels from 110-140 dB. It is a natural companion to Burwen's Model 2000 Noise Eliminator which when coupled with most studio tape units, provides the only recording system with 110 dynamic range and 50 dB reduction in tape noise.

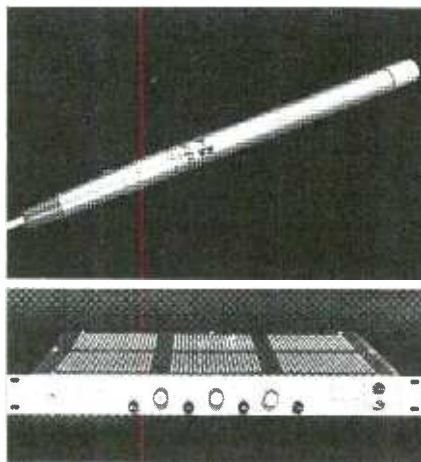

You won't believe what Burwen Laboratories' equipment can do... until you don't hear it! For complete details on the best system available anywhere, call or write:

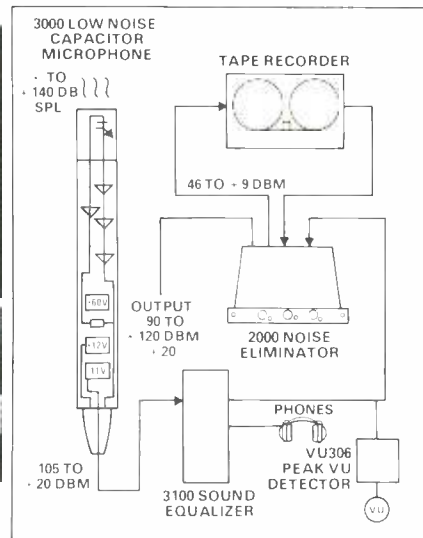

209 MIDDLESEX TURNPIKE, BURLINGTON, MA. 01803/TEL (617) 273 1488

**BOZAK APPOINTS MORRIS SALES MANAGER**

The appointment of Nick Morris as National Sales Manager has been announced by Rudy Bozak, President of Bozak, Inc., South Norwalk, Connecticut 06854.

With over twenty years varied electronics experience, Mr. Morris is probably best known to the audio industry as co-founder of C/M Laboratories, Norwalk, Connecticut.

As National Sales Manager for Bozak, Inc., Mr. Morris will be responsible for the marketing of Bozak consumer and professional audio equipment (loudspeakers and

electronics), designed and manufactured at the Bozak facility in South Norwalk.

**L.J. SCULLY FORMS NEW COMPANY**

Lawrence J. Scully, formerly president of Scully Recording Instruments Company, has announced the formation of L.J. Scully Manufacturing Company in Bridgeport, Conn.

Mr. Scully, a fellow of the Audio Engineering Society and holder of that society's Berliner Award for outstanding contribution to the audio industry, is well known as the designer and manufacturer of the famed Scully Lathe for disc recording.

The new company will concentrate on the development and production of professional audio devices for the recording and broadcast industries. The first of the new products is the extended play tape reproducer, primarily designed for utilization in the growing broadcast automation field.

Introduction of a preview head tape reproducer for tape to disc transfer applications is planned for early summer. This new unit will accommodate all current automatic feed systems in the recording industry, including the JVC Quad discrete system. A new recording lathe is anticipated by late fall '73.

"I have personally worked with all of the employees in our new company for many years," states Mr. Scully, "and can therefore be certain that the traditional Scully reputation for quality will be maintained." Joining the new company in management and engineering capacities are Jerry Scully, John Curtis, Dan Politi and Richard Havanec.

**SOVIETS BUY U.S. MADE RECORD-MAKING SYSTEMS**

Lened, Inc. of Elizabeth, New Jersey has announced the receipt of a \$360,000 contract to supply 12 complete, automated record-pressing systems to Melodia, the Soviet Record Company.

This is the second contract the company has received from the Soviets and additional follow-on orders for up to 200 complete systems are expected within the next five years.

# SPEED AND QUALITY

The new GARNER table-top Model 1056, a heavy-duty, precision reel-to-reel copier, makes five quality copies from the master reel. Ideal for mass production of professional quality tapes by commercial or institutional organizations.

A single capstan drives master and all copies. New two-speed drive allows slower speed for higher fidelity. Solid state electronics, special heads and mechanical excellence, provide good frequency response. Extra-fast rewinds of master tape speeds production.



## Model 1056 High Speed Professional Tape Copier



Rep. territories available.  
Call 402/466-1816

## GARNER ELECTRONICS

A SUBSIDIARY OF GARNER TOOL & DIE

4200 N. 48th Street

Lincoln, Nebraska 68504

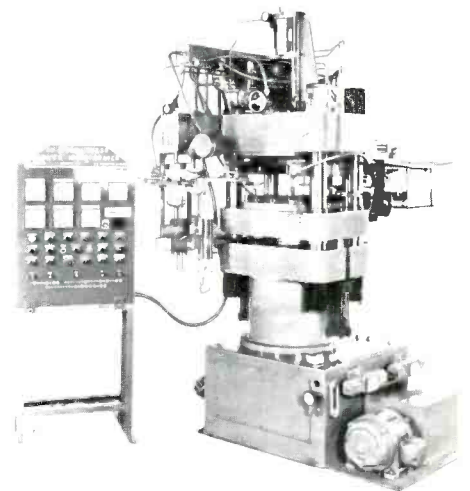

The company's first shipment of six automated record systems have been installed at the Melodia pilot plant near Moscow which started producing records in October, 1972.

Since its inception in 1957, Lened, Inc. has become the leading producer of automated record-pressing systems with more than 250 complete systems in operation throughout the U.S., Canada, Europe, and Japan.



The company now produces complete, pre-packaged systems for high speed production and packaging of 7-inch and 12-inch records.

The Lened systems are said to be the first of their type to completely automate the entire record-making production process — from extrusion of the plastics — to pressing, trimming, and insertion into protective sleeves. All operations are controlled from a single control console.

Lened is currently negotiating with British and French for sales of automated systems in those countries.

---

#### ARP INTRODUCES NEW COLOR CATALOG AND DEMO RECORD AND REPORTS FACILITY EXPANSION

ARP Instruments has recently introduced a new 8-page full color catalog showing the complete line of ARP Synthesizers. The new catalog shows detailed 8-1/2 x 11 color photographs of each of the ARP synthesizers along with full specifications. The new catalog was prepared for ARP by Learning Unlimited.

A new Demo record prepared by two great synthesizer artists, Dave Fredericks and Roger Powell, entitled "The ARP Family of synthesizers," is also being distributed to ARP dealers. The new ARP demo record appeals to all audiences and includes both popular and

jazz/rock selections performed on ARP synthesizers.

ARP has recently occupied their new 16,000 sq. foot corporate headquarters and manufacturing facilities.

Free copies of both pieces are available from the ARP Instruments Literature Dept. 320 Needham St., Newton, Mass. 02164.

---

#### MAZE CORPORATION OF BIRMINGHAM, ALABAMA ANNOUNCES NEW OFFICES AND WAREHOUSE FACILITIES.

This dynamic young company began its operation only six years ago with just two employees and has grown to what is now said to be, the nation's largest independent supplier of new and used broadcast and recording equipment, as well as being the South's largest supplier of custom built professional sound systems for the performing artist.

Under one roof are executive and sales offices, a 6,000 square foot warehouse with loading ramp and drive-in facilities, another 12,000 square feet of space for future expansion, a studio type tuned showroom filled with professional products and components, shop and lab facilities for repair, maintenance, and fabrication of custom installations plus a design and engineering department in which broadcast and recording consoles are designed.



In addition to being one of the industry's prime sources for used equipment and technical assistance, Maze stocks and sells over thirty major new equipment product lines such as Ampex, AKG, Altec, JBL, Mincom, Scully, and UREI, just to mention a few. As an example of the company's ability to produce sales, Maze sold over seventy-five thousand dollars for a major recorder line their first year as a distributor.

---

#### MAXELL ANNOUNCES REALIGNMENT OF EXECUTIVE RESPONSIBILITIES

Mr. T. Okada, Executive Vice President of MAXELL Corporation of America, 130 W. Commercial Avenue, Moonachie, New Jersey today announced a realignment of corporate executive responsibilities.

Under the new organization plan, Mr. Gene La Brie, National Sales Manager, will now have the responsibility for professional studio sales and O.E.M. — audio products added to the Consumer Products Division he headed.

---

## a small american success story orban/parasound reverberation

What with our roads full of Japanese cars, and our studios full of German microphones, it is refreshing to come upon an American product that offers such good value for the money that it has achieved wide success both in the U.S. and abroad. Orban/Parasound is reverberating not only back home, but also in Canada, Mexico, South America, England, and the Continent. And we are reverberating people like the Jefferson Airplane, the Grateful Dead, Emerson, Lake, and Palmer, the Youngbloods, Stevie Winwood, Tony Bennett, and almost two hundred others—live in concert and recorded. We have echoed our way into radio stations, electronic music studios, and recording studios small and large.

Orban/Parasound Reverb uses ingenious electronics to attack the classic faults of spring reverbs, including excess noise, flutter, peaky frequency response, and popping on transients. To handle the last problem, we invented the "Floating Threshold Limiter", which also protects against input overload. We build to the highest commercial standards, put the works in your choice of three ultra-compact packages, and charge \$595/channel—the same as we did two years ago. Today, after all the inflation and revaluations, Orban/Parasound Reverb is a bigger bargain than ever.

For an exciting free brochure, contact:

PARASOUND, INC., 680 Beach St. Suite 495, San Francisco, Calif. 94109 or your Orban/Parasound distributor.

# Please don't dance on your tape recorder!

We've seriously gone about the business of designing the best possible loudspeaker for monitor use. With computers, and anechoic chambers, and all the rest. And, having gained a monster new insight into bass speaker performance, we've come up with what looks like a winner. The Sentry III.

We've run all the curves that prove, in a most scientific, sober fashion, that the system is really quite good. We've got polar graphs, and frequency response curves, distortion measurements, total power output curves, power handling test results, and SPL data galore.

But what happens when we demonstrate the Sentry III? Leading engineers (whose names we hesitate to divulge—but you know them) leap about in their control rooms DANCING for heaven's sake! Snapping their fingers and feeling the sound, and reveling in the sensory pleasure of a clean first octave. And last octave too, for that matter.

And they run from one side of the studio to the other trying to find holes in the distribution of the highs... and they can't... and they LAUGH! It's very unseemly (but secretly quite gratifying). So we try to thrust our good numbers and graphs at these

serious engineers, but they'd rather listen and compare and switch speakers. And make rude remarks about their old monitors.

Who will stand still long enough to heed our technical story? Perhaps you're the serious-minded, sober-sided engineer we're looking for. If so, by all means write us. We've got quite a stack of strait-laced, objective literature describing the new Sentry III monitor loudspeaker just waiting to be seen and appreciated.

And after you've read our story, perhaps we can arrange a demonstration of this new speaker for you. The Sentry III. Bring your tap shoes.



## New SENTRY™ III Monitor Loudspeaker

a **Gulton**  
COMPANY

*Electro-Voice*®

SENTRY III Frequency Response 40-18,000 Hz  $\pm$  3 dB; Sound Pressure on Axis at 4' with 50 watt input 113 dB; Dispersion 120° horizontal, 60° vertical; Size 28½"W x 20½"D x 34½"H; Weight 156 lbs. \$600.00 suggested professional net. SEQ active equalizer extends response to 28 Hz, \$60.00.

ELECTRO-VOICE, INC., Dept. 631RP, 674 Cecil St., Buchanan, Michigan 49107

## Microphone Techniques :

# DIFFERENTIAL MICROPHONES

by JIM COE  
"SOUND"  
JEFFERSON AIRPLANE  
HOT TUNA

Have you ever been able to hear intelligible vocals at a loud "rock 'n roll" concert? The difficulties you have probably experienced are traceable to some interesting technical phenomena, and they are likely shared by the audience, the musicians (especially the

singers), and perhaps an engineer trying to record the show in a remote van behind the building.

We know these problems well. The bands I work with commonly create a sound field of 115-120 dBc ('slow scan') on stage, and we project a field measuring 100 to 115 dBc in the center of a 10,000 seat hall. At these levels most single vocalists will be drowned out by the ambient level of drums and amplified instruments. To thicken the plot, the instrument amplifier system is relatively insensitive to acoustic feedback problems and so, can deliver much greater sound levels to the singers' ears... which is also the microphone position.

So, we have a situation in which the vocal is buried in the ambient level, and amplifying the vocal also amplifies the band leakage into the vocal as well. The vocal amplification is then severely limited by acoustic feedback. Aesthetic and acoustic trauma arguments aside, how can a 'vocal image' be projected above these ambient levels realistic enough for the singer to stay in key, the audience to *get-off* and the record company to sell?

Until recently, the approach was to attempt an electronic 'tuning' of the stage area and the monitor system with a 1/3 octave filter set. This is expensive and time consuming, often resulting in an unstable system which can 'come

FIGURE 1

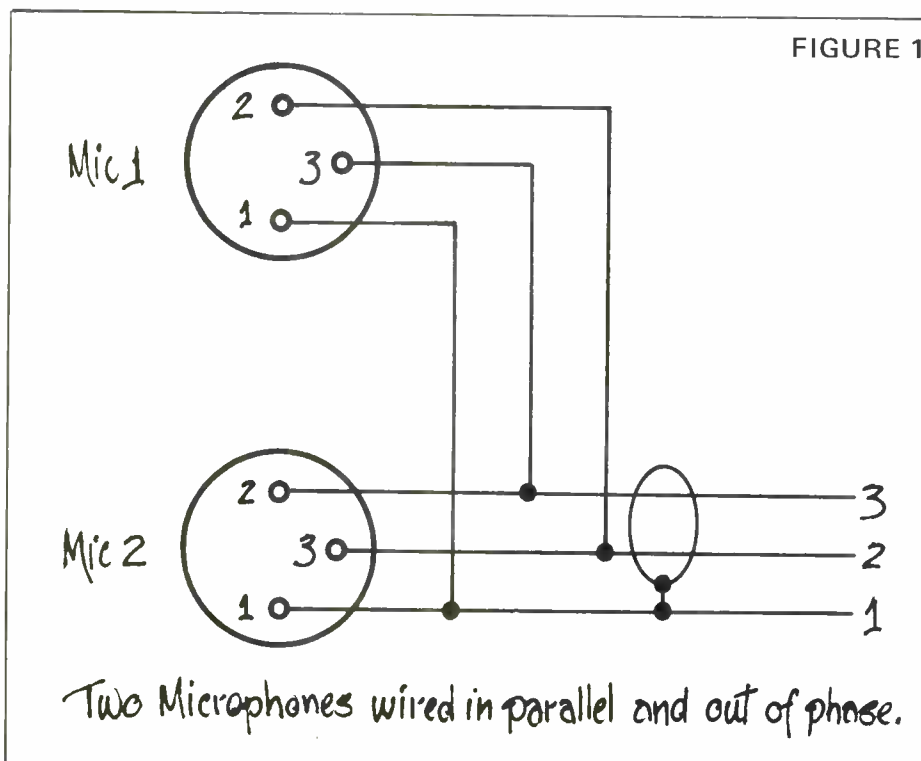

**MCI has made  
two goodies  
even better.**



Models Courtesy of  
**MAI-KAI**  
Restaurant, Ft. Lauderdale, Fla.

MCI listens to its customers—because our customers know their business. That's why we've responded to them by incorporating the following features in MCI's stock JH-416 board and JH-100 transport:

#### **JH-416 RECORDING CONSOLE NOW HAS . . .**

Improved conductive plastic faders by Penny and Giles, Ltd. ● Illuminated channel mute switch with channel number ● Monitor mute switch ● Full reciprocal midrange equalization-boost or cut of 14db ● EQ in/out switch ● Mike input pad and new higher gain preamp to accommodate the full range of professional microphones (I.M. distortion @ ODBM input less than .15%) ● Full quad panning, both L-R and F-B for 360 degrees of quad positioning on all input modules and echo returns ● 48 additional tie-lines and jacks on patch bay.

The MCI JH-100 transport replaces the JH-10 transport in MCI's JH-16, JH-8 and JH-24 8-, 16-, and 24-track recorders. The JH-100 combines state of the art electronically controlled tape handling and other unique features, so that:

#### **JH-100 TAPE TRANSPORT NOW HAS . . .**

D.C. capstan servo drive; super-accurate, crystal-controlled fixed tape speeds 15-30 ips (7.5 ips available) ● Stable variable speed operation from front panel for special effects and speed corrections ● Wide range external speed programming for inter-machine sync, audio/video or audio/audio remote speed control, special effects ● "Piano proof" flutter; typically .04% 15 ips DIN weighted, .06% 15 ips DIN unweighted ● All mode reel tension control system; constant tape tension; high speed accuracy anywhere in reel; consistent tape packing ● Full manual velocity programming for cueing, editing, special effects ● Totally "relay-less" design with full TTL deck logic ● New "Mark II" auto locator; full bidirectional operation; keyboard entry; readout and operation in real time; no overshoot—controlled approach speed ● New decor and trim.

**ALL THESE IMPROVEMENTS AT  
ONLY A VERY SLIGHT INCREASE  
IN PRICE (the 16-in, 16-out console  
is still under \$20,000!)**

**WANT TO KNOW MORE? Call  
Claude Hill today: (305) 566-2853.**



4007 NE 6th Ave. / Fort Lauderdale, Fla. 33308 • TELEX: 514362

Circle No. 108

FIGURE 2A



FIGURE 2B

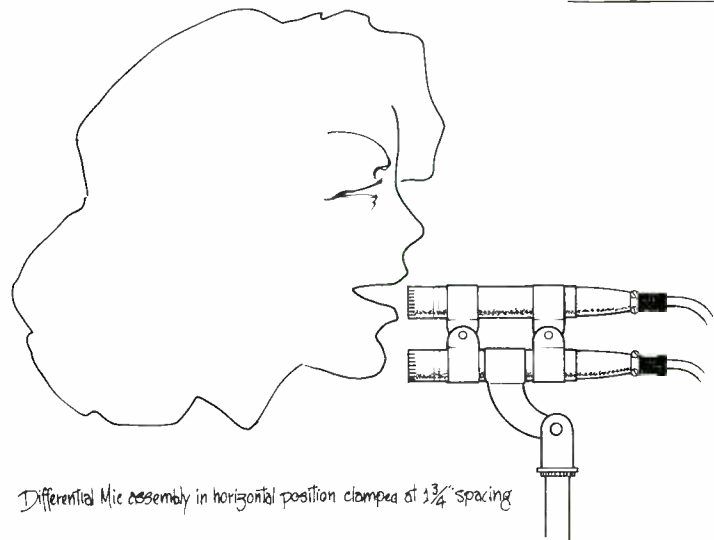

untuned' in the middle of a show because of such effects as a major change in air temperature. Heavy notch filtering puts the system at the mercy of all the variables of an environment. Additionally, notch filtering does nothing about the problem of microphone leakage.

An electronics engineer faced with similar 'signal to noise' problems would likely turn to the notorious DIFFERENTIAL AMPLIFIER. For those who are unfamiliar with this popular gain block, an ideal differential amplifier could care less about signals which are common to both its two inputs, since they are delivered to its single output 180° out of phase with each other. They are effectively cancelled and only the *difference* in voltage between the inputs is amplified. Differential amplifiers with common mode rejection greater than 90 dB are numerous.

In the same manner, two microphones connected in parallel, but out of phase, will mutually cancel signals common to both mikes. An output is obtained only from an input applied to one or the other, but not both mikes.

To return to the problem of vocals: the band level comes from a broad source more than 15 feet from the vocal mikes. The vocalists are a "point source" less than an inch away from the microphone. So by having the vocalists sing into one microphone (quite close) while both microphones receive the ambient level, and summing the two inputs, out of phase, we have a differential microphone. (Figure 1)

The author was initially exposed to the differential microphone concept while attending a Lou Burroughs "Medicine Show,"<sup>(1)</sup> and have since put the concept to the test in several simulations of actual stage use and two

concert tours of twelve concerts each.

#### ADVANTAGES

The inherent advantages of an ideal differential amplifier are:

1. Cancellation of ambient (common mode) signals including, mechanical vibrations, acoustic feedback, leakage, etc. With a practical differential microphone this is equivalent to increased 'head room' between ambient level and the upper limitations imposed by amplifier and speaker distortion on acoustic feedback (not to mention the pain threshold).

2. Freedom from restriction to cardioid microphones for stage use... with their inherent proximity effect and generally poorer frequency response.

3. Freedom from constraints in speaker placement caused by acoustic feedback.

#### DISADVANTAGES

Disadvantages inherent in a differential microphone are:

1. The microphone must be driven by an approximate point source (vocalists must work close to the mike, and must sing only into one mike of the pair).

2. Microphone cost is doubled.

3. "Sight Lines" are disturbed, to a degree, by the use of two microphones in front of the performers head.

4. Differential microphones are difficult to hand hold.

5. Frequency response and sensitivity matching of microphone pairs is desirable.

#### THE PRACTICAL DIFFERENTIAL MICROPHONE

To date, we have used three types of circuits in our tests (two of these circuits have been tested during actual

performances, each with two different microphone spacings). FIGURE 2. In all cases the Sennheiser MD 211 omni-dynamic microphones were used.<sup>(2)</sup>

The most elementary circuit simply uses a "Y" cord to sum the two microphone outputs, with one leg of the "Y" wired out of phase with the other. This circuit results in some electrical interaction of the two microphone elements, causing somewhat "peaky" frequency response, but it is certainly usable.

Electrical isolation between the microphone elements was attempted in two ways: a transformer with a split and balanced primary was used to sum the mike outputs, one mike of course out of phase. FIGURE 3A To date, this technique has not resulted in quite as good a common mode rejection as the first method, but provides good electrical isolation while maintaining balanced lines and using simple reliable components. The other isolation method, which is the third circuit and which has yet to be used on stage is currently being studied. A differential amplifier is used to isolate the two microphone elements and provide a method of *nulling* the individual microphone output levels for best common mode rejection.<sup>(3)</sup> A popular differential instrumentation amplifier circuit is used. FIGURE 3B This circuit requires gain stages and a power supply onstage and is inherently less reliable.

#### MICROPHONE PLACEMENT

The highest frequency the differential microphone is able to cancel depends of course on the distance between mikes. (FIGURE 4) In the first use of this technique, the mikes were simply taped together, pointed straight up, and the vocalist was asked to sing

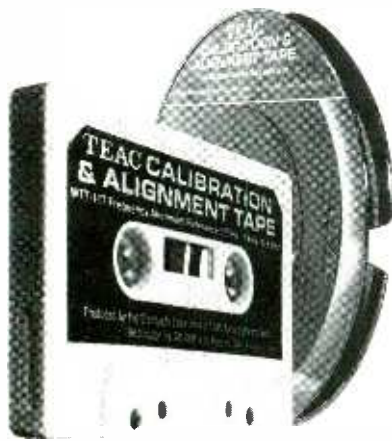

# TEST TAPES

Available in cassette or open reel, each precision calibration and alignment tape is individually mastered from the finest instrumentation by the Standards Laboratory of TEAC Audio Systems Corporation of Japan.

To avoid undue aging, the tapes are normally produced to order and are shipped in a shielded metal canister.

Each tape is individually serialized and includes specific tolerances where applicable.

Test tapes are available for speed deviation checks, standard operating levels, azimuth standards, frequency alignment standards and references, standard reference level, and cross-talk checks.

Tapes made to custom requirements will be quoted on request.

TEAC Calibration & Alignment Tapes are exclusively distributed in the U.S. and Canada by

**TASCAM CORPORATION**  
 5440 McConnell Avenue  
 Los Angeles, Calif. 90066  
 (213) 390-3566

across the top of the pair with one microphone at his lips and the other behind the first. (FIGURE 2A) Later, when pink noise simulation of the live performance demonstrated the best trade-off between mike spacing distance and higher frequency cancellation a distance of 1-3/4" was used. Now, the

mikes are horizontal, with one pointed at the singers lips and the other below the chin. (FIGURE 2B) Used in this way the differential microphone yields an isolation or gain in dynamic range between vocals and ambient level of from 12 to 16 dB depending on the room acoustics.

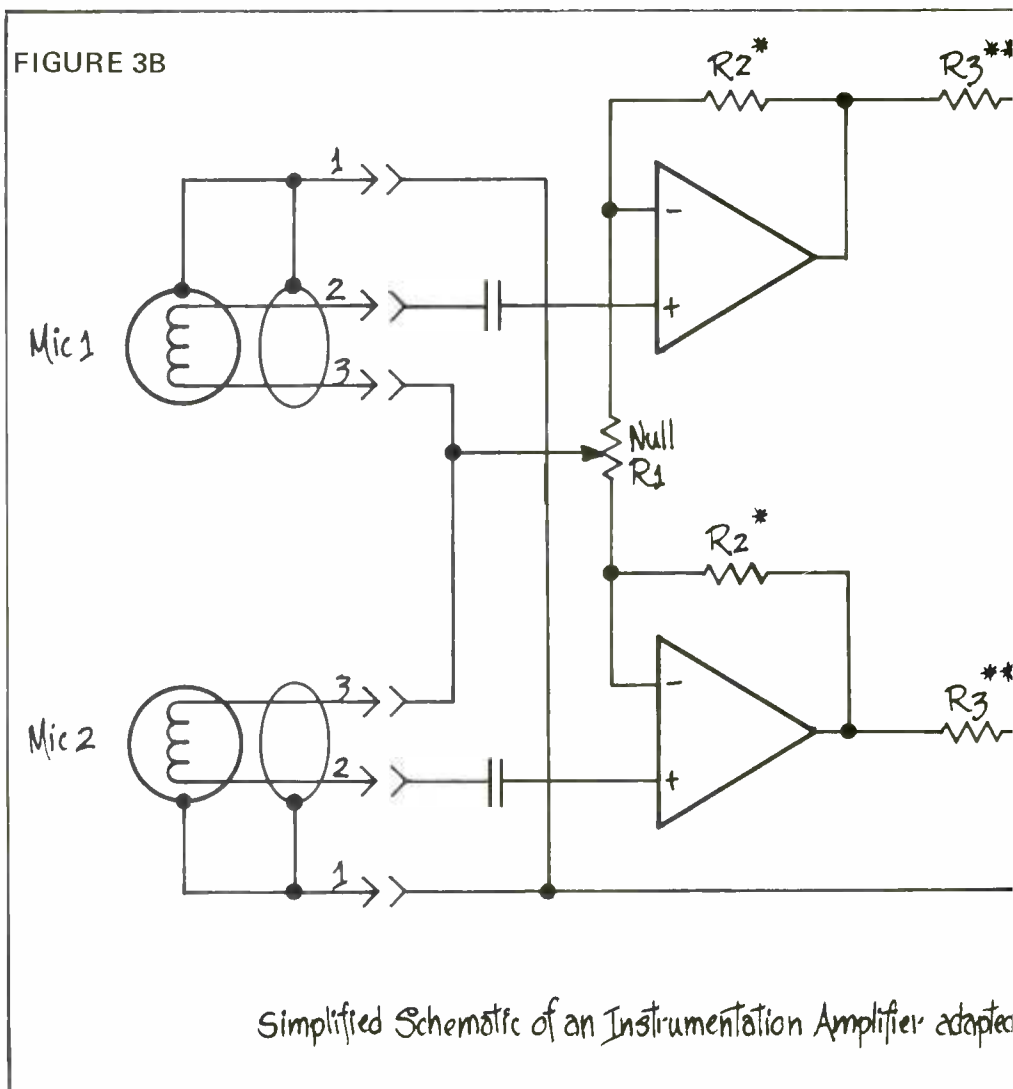
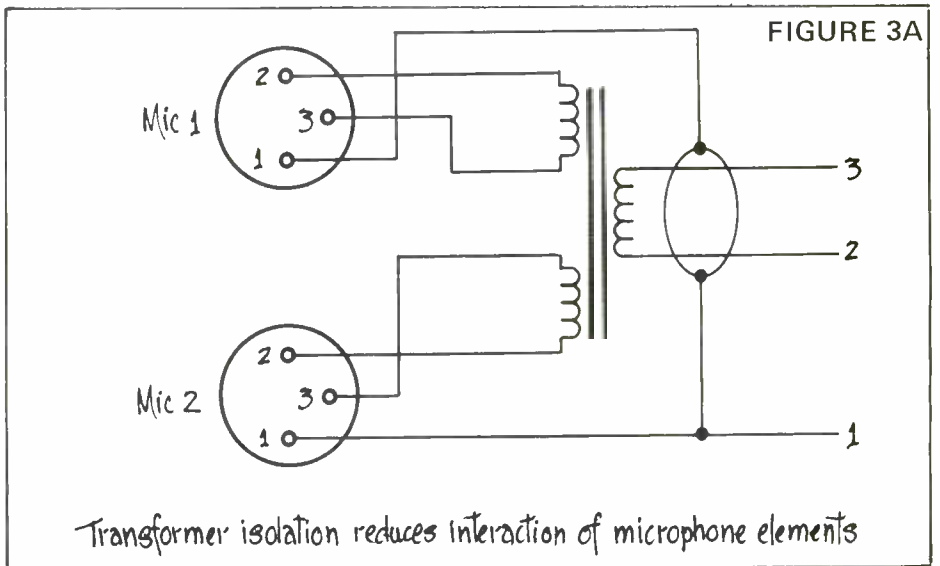

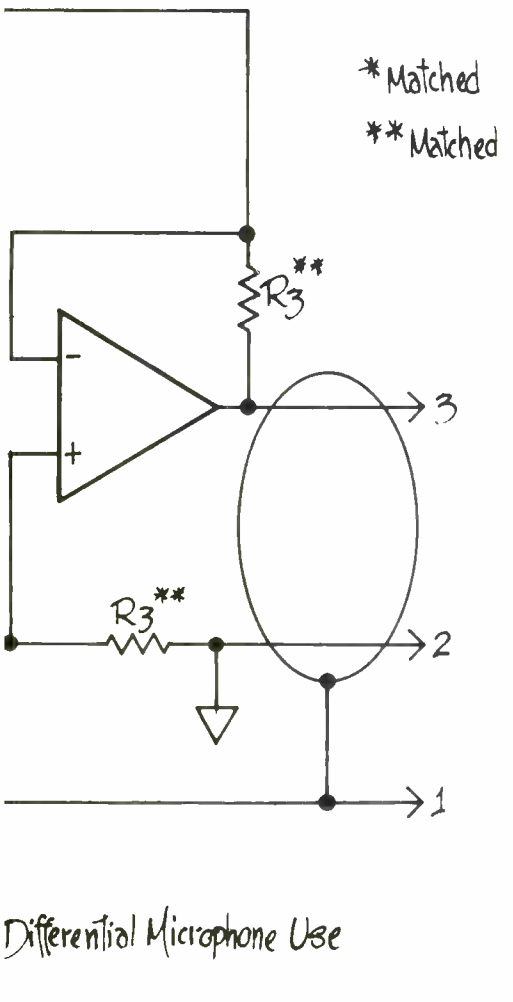
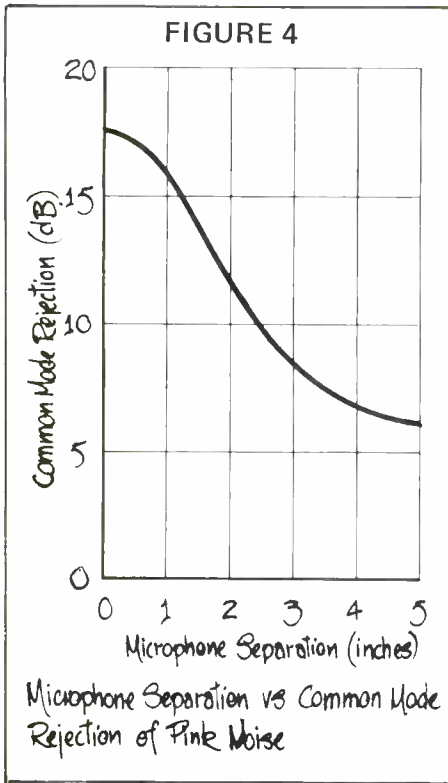

On-going experiments show that 25 to 30 dB of common mode rejection is now practical. This will effectively isolate the vocal section of a sound system from the room acoustics almost entirely. Future work will determine what difficulty vocalists may have adjusting to this type of microphone and whether the need for frequency response matched pairs remains a necessity and what maintenance problems this incurs.

**ACKNOWLEDGEMENT**

I'd like to thank all those who helped me with ideas and advice, including: Paul Stark, Carl Countryman, Sennheiser of New York, Alembic and the Grateful Dead.

**FOOTNOTES**

1. "Make a Quality Differential Microphone" by Lou Burroughs db Magazine, Jul '72.
2. Special thanks to the men at SENNHEISER'S New York office, who were most helpful in locating well matched pairs of their fine MD211 microphones.
3. The circuit of Fig. 3c is an adaptation of one appearing on page 207 of "Operational Amplifiers - Design And Applications" from Burr Brown by McGraw Hill 1971.

Presenting The

**VARI-BAND SWEEP EQUALIZER!**  
Equalization any way the ear can hear it.

Continuously variable bandcenter, bandwidth (slope) and amplitude at a price comparable to non-sweeping equalizers.

**SCULLY-TABER**

P. O. Box 3187, Hollywood, CA 90028  
1965 Chermoya Ave., Hollywood, CA 90068  
(213) 467-2800

Circle No. 110

# For Tape Heads Head for TABER

At Taber you get precision work, quality results and low price . . . unmatched by any other audio head manufacturer.

We will install three new heads in your full track Ampex assembly for only \$97.50...Scully at \$186.00. Or, wear permitting, an Ampex or Scully three head reconditioned assembly for only \$45.00.

VTR audio is priced at only \$310.00 for four new heads installed, or \$100.00 for four reconditioned heads. (Add \$25.00 if monitor post needs lapping).

Loaner assemblies are available.

For heads, head for Taber . . . the best source available.

Send for free brochure.

**TABER** Manufacturing & Engineering Company  
2081 Edison Ave. • San Leandro, Ca. 94577 • (415) 635-3831

Circle No. 111

Re/p 17

# With our mono recorder you get the low end of our line. Not the short end of the stick.

If you've heard our 24-track recorder, you've heard our mono, two and four track units — they're like peas in a pod.

Because while our new low end Series 79 mono, two and four track Professional Audio Recorders are priced like the competition, they're built like our high end eight, sixteen and twenty-four track machines.

You get the same IsoLoop® differential drive transport, with its extremely low flutter and wow, automatic tape tensioning and easier editing.

The same electronics, with built-in overdub, three selectable speeds and state-of-the-art signal-to-noise ratios and frequency response.

The same dc servo capstan with external input to enable the use of synchronization and resolving equipment.

Even the same convenient, high-performance options: A synchronizer/reader for instant sound sync. Selectake® for automatic tape positioning. Remote transport



controls. A 5 to 45 ips variable speed control. And an update kit for adding more tracks to the mono or two track units.

At their new prices, the 3M Series 79 mono, two and four track recorders are more than competitive for mastering, mixdown, editing or station automation. We don't give you less machine when what you want is fewer tracks.

For the full price and performance story, contact one of the listed dealers or Professional Audio Products, 3M Company,



300 S. Lewis Rd., Camarillo, CA 93010. Ph: (805) 482-1911. TWX: 910-336-1676.

**We've been there.  
And brought the answers back.**

**3M**  
COMPANY



**Give a listen at any  
of these 3M dealers:**

**Dealers:**

Accurate Sound Corporation  
2702 National Circle Road  
Garland, Texas 75041

Aengus Engineering, Inc.  
50 Oak Hill Road  
Fayville, Mass. 01745

Audio Designs & Mfg. Inc.  
16005 Sturgeon  
Roseville, Mich. 48066

Audio Recorders of Arizona  
3830 No. 7th St.  
Phoenix, Arizona 85014

Automated Processes, Inc.  
80 Marcus Drive  
Melville, N.Y. 11746

Fidelity Sound Company, Inc.  
GSA Dealer  
1200 18th St., N.W., Suite 105  
Washington, D.C. 20036

Gill Custom House, Inc.  
8813 W. 95th St.  
Palos Hills, Illinois 60465

High Fidelity Showroom  
6383 Clayton Road  
Clayton, Missouri 63105

Houston Electronics  
5709 Savoy Lane  
Houston, Texas 77036

Jackson Sound Productions, Ltd.  
1403 So. Lipan  
Denver, Colorado 80223

Martin Audio  
320 W. 46th St.  
New York, N.Y. 10036

The Maze Corporation  
1900 First Ave. No.  
Irontdale, Birmingham, Ala. 35210

Milam Audio Corp.  
700 West Main St.  
South Pekin, Ill. 61564

Pams, Inc.  
4141 Office Parkway  
Dallas, Texas 75204

Sound Specialties  
2009 Naudain St.  
Philadelphia, Pa. 19146

Westlake Audio, Inc.  
6311 Wilshire Blvd.  
Los Angeles, Calif. 90048

**Sales Offices:**

3M Company  
P.O. Box 76  
West Caldwell, New Jersey

3M Company  
P.O. Box 28158  
Dallas, Texas

3M Company  
220 E. 21st Street  
Chicago, Illinois

**International Sales Offices:**

Sunitomo 3M Ltd.  
3M Building 1-21 Akasaka 7  
Chome Minatoku  
Tokyo, Japan

3M Canada Ltd.  
Mincom Products  
P.O. Box 5757 Terminal "A"  
London, Ontario, Canada

3M U.K. Ltd.  
3M House  
Wigmore Street  
London W1A 1ET England

Mincom Products, Sales and Service  
410 Taunton Road  
Greenford, Middlesex, England

3M France  
135 Boulevard Serurier  
75019 Paris, France

# A SURVEY OF RECORDING STUDIO MONITORING PROBLEMS...

by JOHN EARGLE  
MARK ENGBRETSON  
ALTEC CORP

In today's new world of pop recording, monitoring remains a chronic problem. While tape recorders, amplifiers, and disk cutters have achieved high degrees of consistency, monitoring is still subject to a wide variety of tastes, prejudices, and habits. In this paper, we will examine the many factors which bear upon this problem; we will consider the esthetic demands of the control room and its environment, the optimization of its physical characteristics, the optimization of the loudspeaker's characteristics as well as electrical equalization of the monitor system and practical power handling calculations.

## INTER-RELATION BETWEEN THE LOUDSPEAKER AND THE CONTROL ROOM

It is ironic that so many of the esthetic demands of the monitoring environment are antithetical to the acoustic demands of good listening. Control rooms are often too small for good low-frequency propagation, and the usual location of the engineer and producer toward the middle of the room surrounded by equipment only intensifies this problem. The hanging of loudspeaker enclosures from the ceiling, often done in an effort to arrive at a more intimate loudspeaker-listener relationship, usually results in very erratic low-frequency response due to cavity resonances between and behind the enclosures. The trend toward built-in loudspeakers has certainly done a good deal in alleviating this problem as

well as affording a more pleasing appearance.

The creative environment should be intimate; this calls for lots of carpet and absorptive wall and ceiling treatment. More and more, producers want to be located well within the "direct field" of the loudspeakers; they want to minimize the local effects of control room reverberation in an effort to hear only the ambience they are attempting to record.

Given the limitations of the size of the control room, every attempt should be made to insure that absorption is uniform with respect to frequency. This calls for considerable amounts of high-frequency absorbers as well as fairly resilient boundary structures at mid and low-frequencies. This often poses a problem as regards unwanted transmission into neighboring rooms, but it is essential.

Adequate baffling should be provided for the loudspeakers in order to minimize peaks and dips in the mid-range response. And this is important whether they are housed in the manufacturer's enclosures or actually built into the environment. Care should be taken to insure that there are no highly reflective surfaces in proximity to the loudspeakers which could provide interferences at mid and high frequencies. Acoustical absorption coefficients should be held to the 0.5 - 0.7 range across the bandwidth, and there should be no perceptible reverberation in the environment.

Control rooms vary in size from the confines of a mobile recording van

*\*Originally presented at the 44th AES Convention*



In past columns in this series we reported on a novel concept for improved distant sound stage pickup that involves locating the microphone quite close to the floor. Further experiments by a number of engineers have fully proven the validity of the idea.

Briefly, the technique is designed to eliminate pickup of out-of-phase sound reflected from the floor which degrades level, frequency response, and gain before feedback. However, to work properly, the microphone head must be within 1/4 inch of the floor surfaces, yet isolated from it to reduce mechanical noise.

The success of the "floor wave" concept gave rise to the need for suitable microphone stands. And while the purpose can be served with traditional hardware approaches, a simpler method has been devised to solve the problem.

The new "stand" (Model 411) is simply a block of Acoustifoam™ with a hollow core, about 8" long and formed as a half-cylinder with a 2" radius. The microphone is inserted from the bottom into the hollow core so that only the connector projects from one end (the other end is closed to surround the microphone head).

The final result is a 2"-high mound of charcoal grey foam with a cable extending from the back. Its inconspicuous appearance has earned it the informal nickname of "stage mouse." Despite its simple nature, the foam has several advantages over more complex hardware approaches. It provides an integral windscreen, plus protection against dust from the floor, while shielding the microphone from accidental impacts from performers.

Foam characteristics are carefully chosen and controlled to offer no acoustic barrier, while supporting the microphone at a uniform distance from the mounting surface and offering excellent isolation. The "mouse" is washable, and has no moving parts to adjust, wear or break. Its large contact area makes it unlikely to creep or bounce, and it can be stuck to the floor (or even a vertical surface) with double-sided tape. It can be used on desk tops for talk shows or news programs. And there is no gleaming metal or complex shape to distract the audience.

Finally, because it is simple to manufacture, the cost is low. The Model 411, designed exclusively for the Electro-Voice RE10 and RE15 Super Cardioid Microphones, is less than \$10.00 to professional users.

For reprints of other discussions in this series,  
or technical data on any E-V product, write:  
ELECTRO-VOICE, INC., Dept. 533RP  
674 Cecil St., Buchanan, Michigan 49107



up to rooms, say, 20' x 25' x 11'. Rooms larger than this lose their feeling of intimacy, but they certainly have advantages for low frequency propagation. In the smaller enclosures, significant musical information may lie below the lowest normal modes of the enclosure, and of course the nature of sound propagation will be quite different from that encountered in the larger rooms. Electrical equalization will invariably be called for here. Also, one should not stint on loudspeaker power handling capabilities at low frequencies in such enclosures; the response can be surprisingly good if the power capability is there.

### DIRECTIVITY OF MONITOR SPEAKERS

Q is defined as the ratio of the sound energy at some distance along a specified axis for a given radiator compared with an isotropic, omnidirectional radiator of the same efficiency along an axis of the same length. Thus, a hemispherical radiator has a Q of 2, while a loudspeaker radiating into a dihedral 90° corner has a Q of 4. An omnidirectional speaker located in a 90° trihedral corner would have a Q of 8.

Detailed discussions of Q (1, 2, 3, 4) describe the radiation characteristics of practical devices, and this has been found particularly useful in sound reinforcement work. Q is related to directivity index (DI) as follows:

$$DI = 10 \log Q$$

DI is a convenient measure of the "apparent gain" of a radiator in a specified direction over an equivalent

isotropic radiator.

Another concept closely related to Q and DI is Critical Distance ( $D_c$ ). This is the distance at which the direct field and reverberant field in a normal environment are equal. Again, the concept is most useful in sound reinforcement work, but it may have its consequence in some monitoring situations.  $D_c$  is arrived at by equating the two terms in the following equation, which gives the relative attenuation of sound with respect to distance (r) away from a radiator:

$$\text{Relative Attenuation (r)} = \left[ 10 \log \frac{Q}{4\pi r^2} + \frac{4}{R} \right]$$

R is the "Room Constant" and is given by:

$$R = \frac{Sa}{1-a}$$

S is the boundary area, and a is the average absorption coefficient in the room (4).

The first term on the right side of the equation expresses the familiar "inverse square" relationship of the direct field. The second term relates to the constant reverberant field level. Equating the two terms gives the value of critical distance:

$$D_c = .14 \sqrt{QR}$$

While a precise determination of  $D_c$  may be unnecessary in most monitoring situations, it can become important in certain "live" environments at middle and low frequencies. Any attempt to monitor or play back a recording in any room other than a well-designed control room must certainly pay attention to the relation

FIGURE 1. "Q" Characteristics of Altec 9846B Monitor System

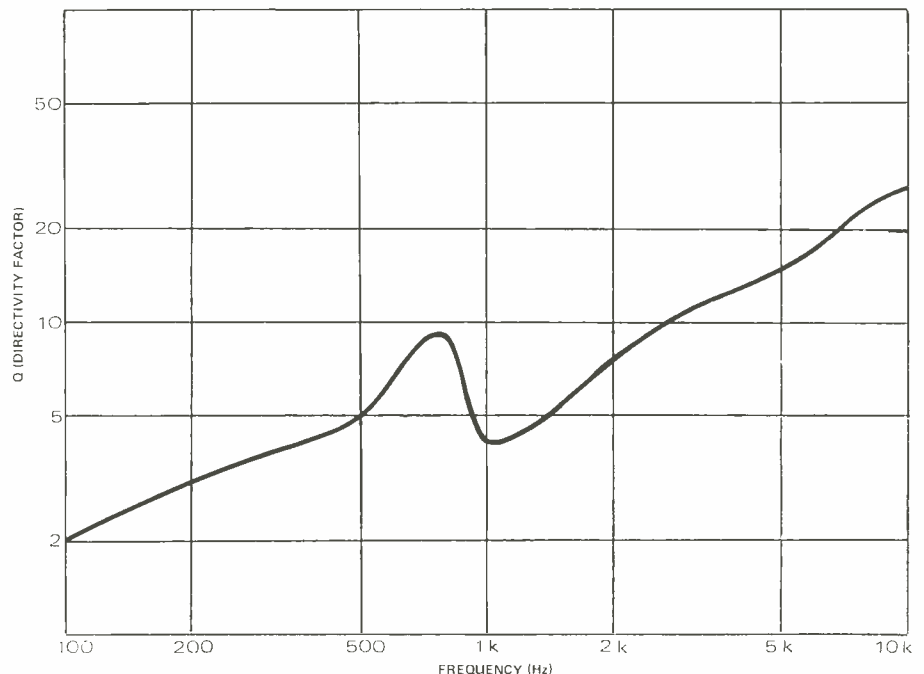

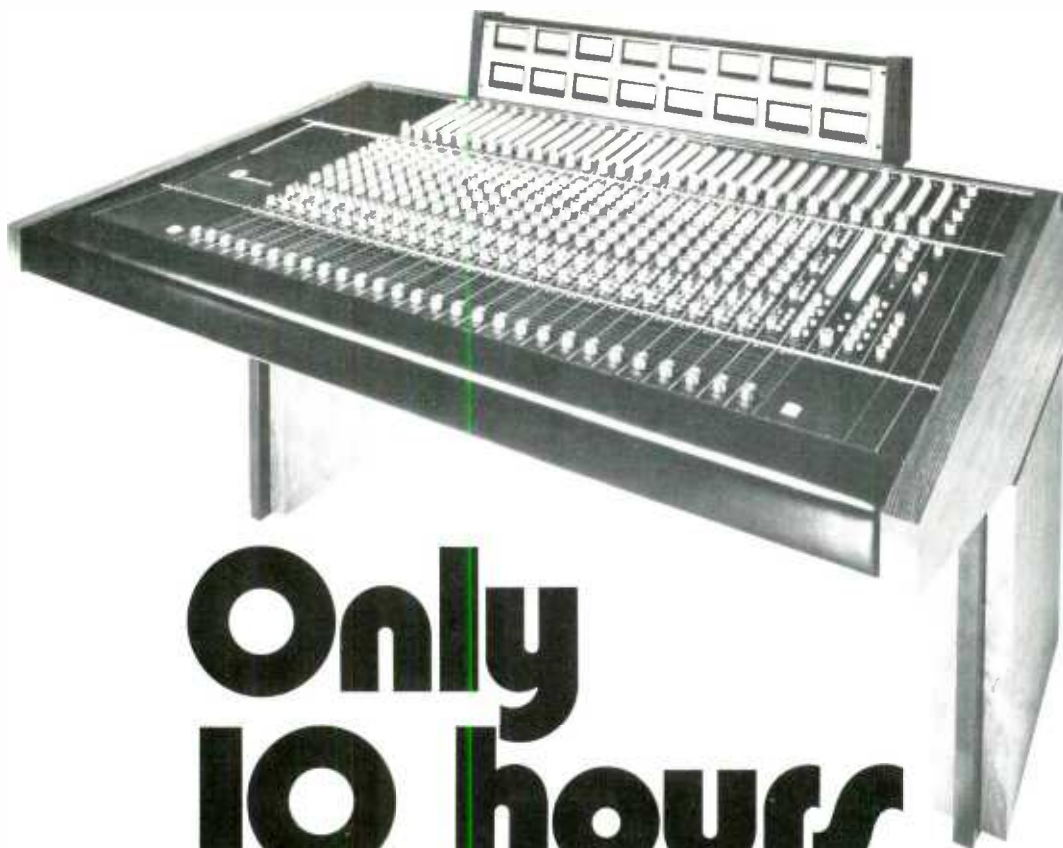

# Only 10 hours from opening crate to opening date

SON OF 36 GRAND is swift, because we spend 50 or more hours in factory checkout and proving performance.

Your SON OF 36 GRAND starts work as soon as it's installed. And the SON's track record for reliability, flexibility, and performance are your assurance that it will keep on working, keep on paying the rent.

But if problems arise, servicing is simply a matter of substituting modules. And that, too, is swift.



**auditronics. inc.**

P. O. Box 12637  
Memphis, Tenn. 38112  
(901) 276-6338

Distributed by:

Auditronics Systems Division, Memphis (901) 272-9641  
Milam Audio, South Pekin, Ill. (309) 348-3112  
Westlake Audio, Inc., Los Angeles (213) 655-0303

Circle No. 114

Re/p 21

between Q and R inasmuch as monitoring should always be done in the direct field of the loudspeaker.

Let us look at some practical examples: Figure 1 shows the mean Q for the Altec Model 9846B Monitor System. At low frequencies, the Q is, as we would expect for flat baffle mounting, equal to two. Beyond 500 Hz, the sectoral horn takes over, and the Q rises substantially. The bump in the curve is caused by the considerable Q difference between the

woofer and HF horn in the crossover region. Note that a Q of 4 at 1 kHz and a Q of 30 at 10 kHz represent a difference in directivity index of 6 dB. This means that for flat energy output between 1 kHz and 10 kHz there would be a rise of 6 dB in the on-axis response at 10 kHz relative to 1 kHz. Figure 2 shows the Q of an Altec 604E loudspeaker mounted in a Model 612C enclosure. Here, the differences in Q between 1 kHz and 10 kHz result in a directivity index of less than 1 dB

between those frequencies. Between 2 kHz and 5 kHz however there is a change in directivity index of 3 dB.

Q is important in determining the ratio of direct-to-reverberant sound at the listener. If this can be maintained fairly high from, say, 500 Hz to 10 kHz, then variations in Q are relatively unimportant; what then becomes important in a more practical context is *horizontal angular coverage*. Figure 3 shows the effective horizontal coverage angles for the two loudspeaker systems examined in Figures 1 and 2. Note that, while the directivity index variation between 1 and 10 kHz for the 604E is more ideal than for the 9846B, the maintenance of a more even horizontal angular coverage is evident in the 9846B.

FIGURE 2. "Q" Characteristics of Altec 604E Loudspeaker in 612C Enclosure

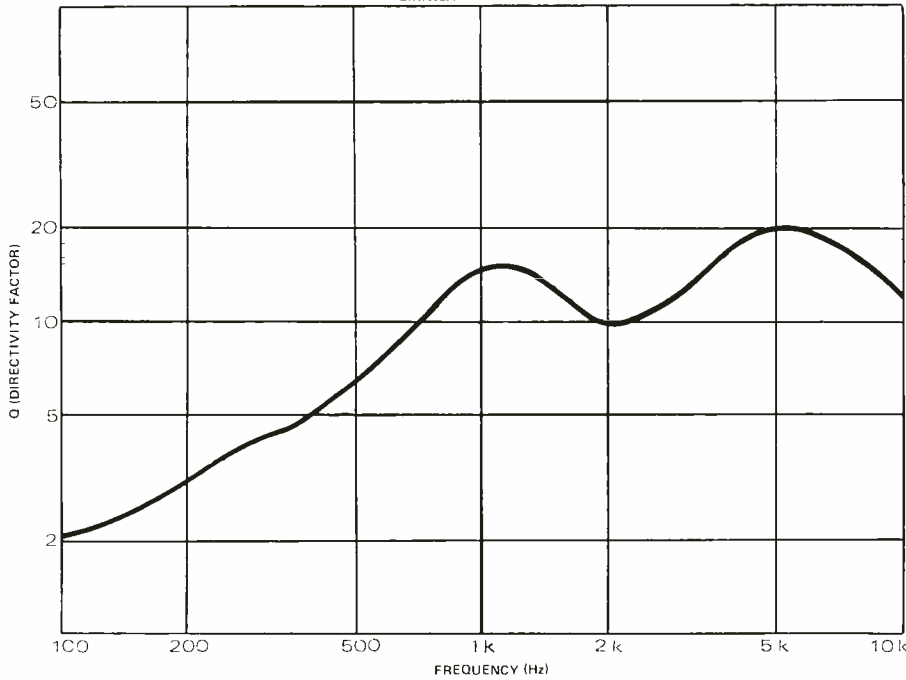
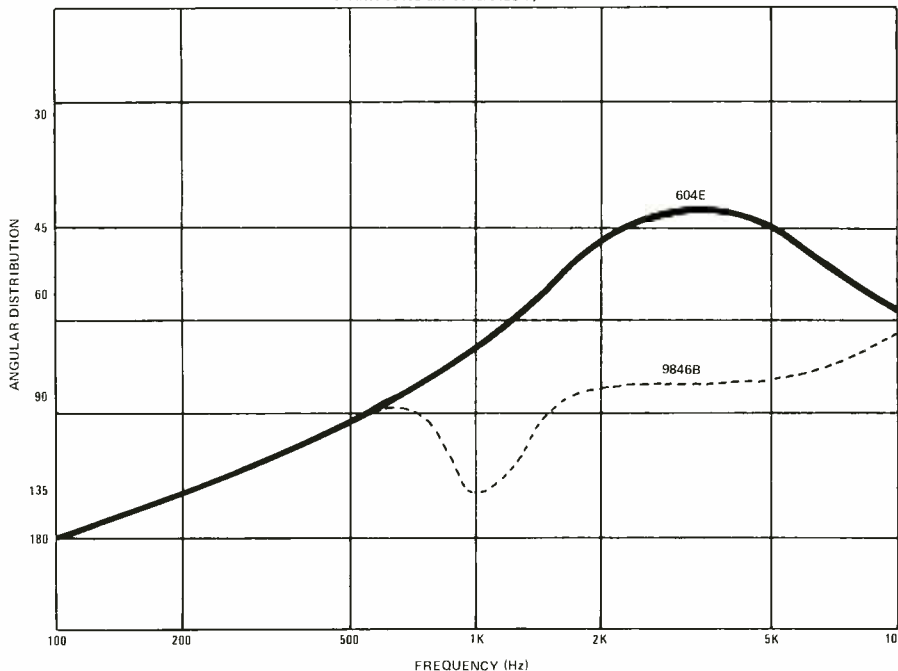

FIGURE 3. Horizontal Angular Distribution between 6 dB-down points of Altec 9846B and 604E/612C Systems



### RELIABILITY AND POWER HANDLING CAPABILITY

With today's modern music—and recording practice—a single monitor speaker can be called upon to deliver sound pressure levels (re .0002 dynes/cm<sup>2</sup>) of perhaps 105 dB at distances of, say, 8 feet under substantially free field conditions. The demand is a severe one, and it has historically been met through the use of ported enclosures operating up to, say 500 Hz with horn-loaded units above that frequency. Recently there has been a trend toward sealed enclosures for the low-frequency units since this permits better control of the system's response in the 30 to 50 Hz region.

Today's music often requires that a monitor system be able to handle a flat energy spectrum out to 10 kHz at full level. A two-way system of the type just described will have invariably been designed with those demands in mind. Most three-way systems with tweeters crossing over in the 3 to 5 kHz range have been designed under the assumption that the normal musical spectrum rolls off above 3–4 kHz and consequently that the tweeter need not be able to handle such large amounts of power. This need not always be the case, but the user should always make sure before using such systems for high-level flat-spectrum monitoring.

There is no reason why cone type systems, whether of medium or low-efficiency, cannot be used for monitoring purposes provided the components are available in sufficient quantity to produce the required levels and there is enough power available to drive them. Historically, this type of system has played a far more important role in home listening than in studio monitoring. The user, whatever his taste in loudspeakers, should then carefully determine his needs for the applications he may have in mind. In a later section, we shall see how power handling

*continued on Page 27*

# Planning to Build a Professional Recording Studio?

From 4 to 24 Track • For Live Recording, Mix Down, Remote or Mastering.

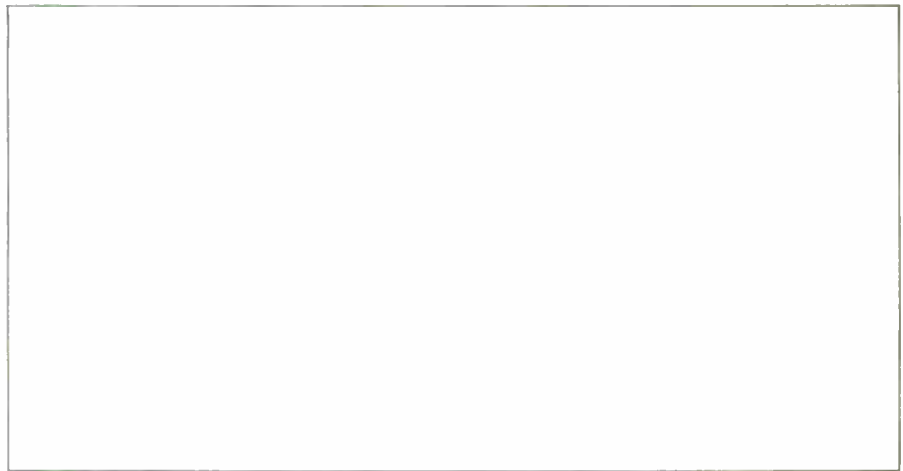





**JOIN THE GROWING LIST OF MAJOR  
PACKAGE AND TURN-KEY  
INSTALLATIONS BY  
**Westlake Audio****

RECORD PLANT	Los Angeles	2 Studios
RECORD PLANT	New York	3 Studios 1 Mastering
MGM RECORDS	Los Angeles	3 Studios
WARNER BROS. RECORDS	North Hollywood	2 Studios 1 Mastering
WESTLAKE AUDIO	Los Angeles	1 Control Room
PREMORE, INC.	Chicago	1 Studio
PREMORE, INC.	Los Angeles	1 Studio
LOCATION RECORDERS	Burbank	1 Mastering
CARIBOU RANCH	Nederland	1 Studio
DEVONSHIRE SOUND	North Hollywood	1 Studio
WEST MINST'R SOUND	Iowa	1 Studio
BEARSVILLE SOUND	Bearsville	1 Studio
WALLY HEIDER	Los Angeles	1 Remote Truck
NEIL YOUNG	Redwood City	1 Studio
PACIFIC VIDEO	Los Angeles	1 Remote Truck
KAYE-SMITH RECORDING STUDIOS	Seattle	2 Studios
SOUND LABS	Hollywood	1 Studio
SAUSALITO MUSIC FACTORY	Sausalito	2 Studios
ELEKTRA RECORDS	Los Angeles	1 Studio
STUDIO IN THE COUNTRY	Bogalusa	1 Studio
STUDIO TEMPO	Montreal	1 Studio
LAGAB	Mexico City	1 Studio 1 Mastering
OSMOND BROTHERS	Provo	1 Studio
MIKE NESMITH	Los Angeles	1 Studio
MIKE LLOYD	Los Angeles	1 Studio
MIKE ALLSUP	Los Angeles	1 Studio
KENDUN RECORDERS	Burbank	1 Mastering
MUSIC RECORDERS, INC.	Hollywood	1 Studio

**MORE SCHEDULED - Hawaii to New York,  
Canada to South America**

from acoustic design  
to down beat...

**Westlake  
Audio**

177 West 17th Street  
New York, NY 10011-3602  
(212) 255-1100

STUDIO IN THE COUNTRY  
Bogalusa, Louisiana

# SERVICES AVAILABLE TO OUR PACKAGE AND TURN-KEY CLIENTS

**PRE-PLANNING:** Which markets are you going after? One studio or two? What is the sound character desired? How much multi-track separation? Your budget? Future expansion? These are just a few of the questions discussed at this stage. From the answers, we'll provide you with a comprehensive proposal covering our recommendations and the cost for the entire project.

**SITE EVALUATION:** If you're planning to build from the ground up or within an existing shell, we'll help you to select the best building or location in terms of size, demolition and construction costs, zoning, noise transmission problems and those "hidden" costs. Remodeling an existing studio? We can show you how to get the best results from your space.

**DESIGN:** Acoustical design is the key to the success of a studio. Westlake Audio's geometric and acoustic designs will provide you with a winning "sound." **Prior to construction,** we will guarantee the performance of your studio and control room with respect to isolation, response, decay time in various frequency bands and dispersion.

**EQUIPMENT SELECTION:** We have carefully evaluated the many products on the professional audio market to provide our clients with a broad selection of the finest recording equipment available. From consoles, automation and tape machines to monitors, microphones and support equipment, we have the lines to satisfy your requirements and budget.

**FINANCING:** We work closely with several companies whose specialty is providing clients with a lease or conditional sales plan tailored to your needs.

**CONSTRUCTION:** As the proper implementation and execution of the geometric and acoustic designs requires unique construction techniques, Westlake Audio will provide a construction foreman to oversee and work with your local construction crew and electrical and air-conditioning subcontractors.

**WIRING:** Our technical crew will install all the audio wiring throughout the studio complex and tie down the wiring to the microphone, headphone and tape machine panels, echo chambers, console, amplifier room and monitors.



RECORD PLANT Sausalito, California

**SYSTEM INTERFACE:** Our engineers will install all the recording equipment and interface the entire system to the console. A total system checkout is performed from microphone phasing to monitor equalization and balancing.

**TRAINING:** Technical and mixing engineers will train your personnel in the operation and maintenance of the studio and equipment.

**STUDIO MANAGEMENT:** Upon request, Westlake Audio will offer guidelines and suggestions for all facets of studio management including rates, booking procedures and controls, personnel requirements, wages, work orders, tape legends, library systems and credit.

**NO OTHER PROFESSIONAL AUDIO DEALER CAN OFFER THESE UNIQUE SERVICES AND THE EXPERIENCE GAINED FROM BUILDING THIRTY-NINE MAJOR FACILITIES.**

From a splicing block to an automated console, a home studio to an extravaganza

WRITE OR CALL AND WE'LL SHOW YOU HOW TO EARN A 50% RETURN ON YOUR INVESTMENT.



**Westlake  
Audio**

6311 Wilshire Blvd  
Los Angeles, California 90048  
(213) 655-0303



FIGURE 4 On-Axis (4-foot) Anechoic Frequency Response of Altec 9846B Monitor System

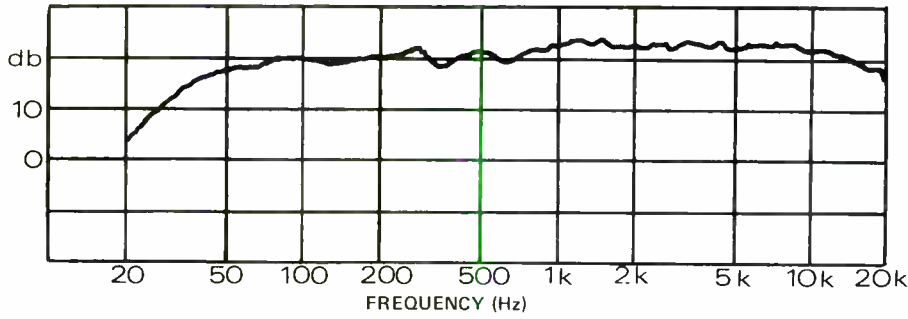

FREQUENCY IN HERTZ

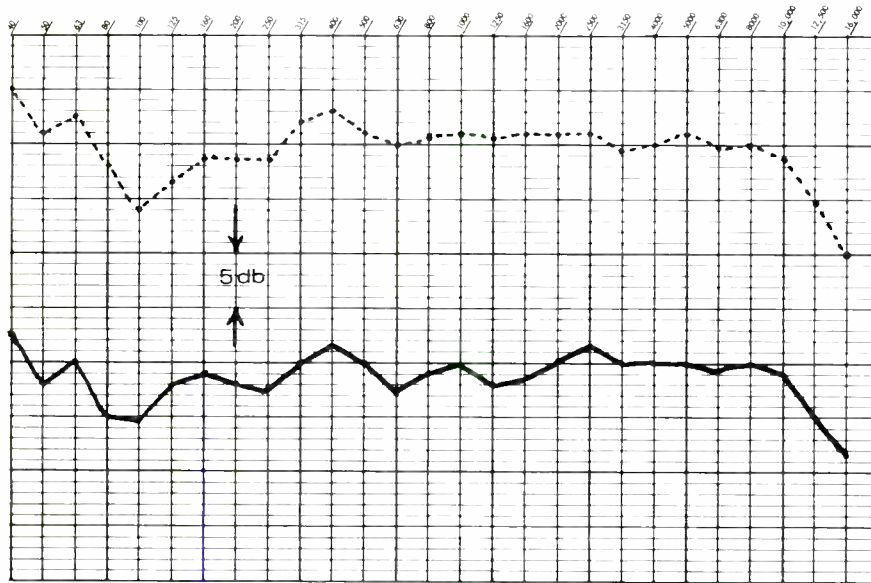

FIGURE 5 Pair of 9846B Systems in Location A (Left Channel, Dotted Line; Right Channel, Solid Line)

FREQUENCY IN HERTZ

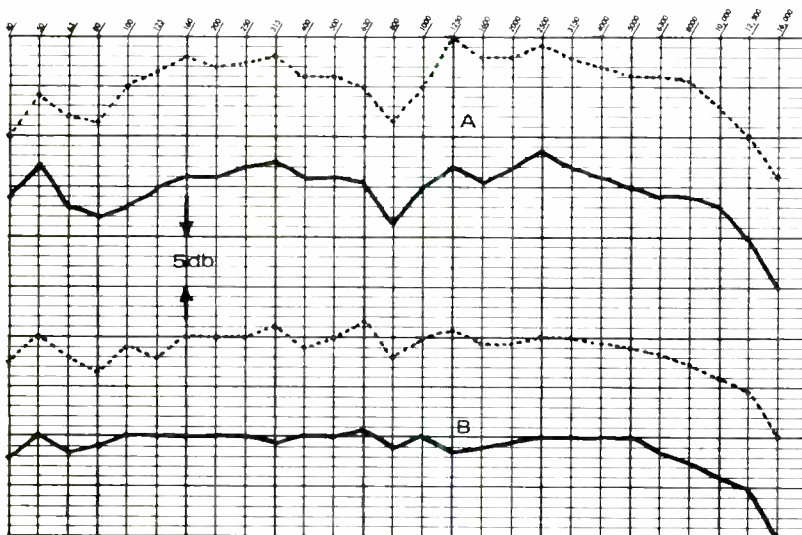

FIGURE 6 Pair of 9846B Systems in Location B (Left Channel, Dotted Line; Right Channel, Solid Line). A - Unequaled; B - Equalized

requirements can be quite accurately determined.

**ELECTRICAL EQUALIZATION OF MONITOR SYSTEMS**

The requirements, practice, and devices used in monitor system equalization have been discussed in detail (5). Here we will examine a typical monitor system in a variety of acoustical environments, observing the effectiveness of electrical equalization in tailoring the total system response.

Figure 4 gives the on-axis response of an Altec Model 9846B loudspeaker system as measured in a flat baffle in an anechoic environment. We have seen the directional characteristics of this system in Figure 1. Figure 5 shows the response of this system as measured with a 1/3 octave Spectrum Analyzer (Altec Model 8050A), using an omnidirectional instrumentation microphone located at the listener's position in a typically good control room. Both right and left channels exhibit remarkably flat response except for a gentle roll-off at the high end and a few minor variations at the low end. The loudspeakers were properly baffled and located in corners in a well-designed control room. Equalization was not even felt to be necessary, and any further improvement in response could probably be more economically attained through minor acoustical changes and adjustments of the high-frequency shelving controls on the loudspeakers.

Figure 6-a shows the same pair of loudspeakers in another control room. Here, the room was asymmetrical, and the loudspeakers were hung without proper baffling and with consequent cavity resonances between and behind the loudspeakers. In Figure 6-b we see the correction introduced through the use of Altec 9860A Active Equalizer 5.

Figure 7-a shows the response of the same pair of loudspeakers in a remix facility of unusual characteristics; heavy carpeting and draperies accounted for high absorption at high frequencies while wall-board construction and large windows resulted in considerable low-frequency absorption. At Figure 7-b, we see the two systems electrically equalized. We note in passing that particular attention must be paid to both low-frequency capability as well as power availability in playing these systems at the sound pressure levels we would like to attain. The response at 40 Hz in both cases is some 10-12 dB below that of the mid band, and it is evident that the two systems as equalized require some caution, where high levels at low frequencies are called for.

Another important consideration in equalizing monitor systems is the

continued

precise tailoring of the high-frequency response. The question of "flat vs. rolled-off" response has been discussed in some detail (5,6), and there is a general consensus among recording engineers that some sort of high frequency roll-off is desirable. The reasons, of course, are obvious; most home playback equipment exhibits substantial high-frequency roll-off at normal listener's positions, and a recording monitored and equalized over a system exhibiting the same kind of roll-off will convey most of the musical values the recording producer had in mind. On the other hand, a recording monitored and equalized on a flat system would surely sound dull and lifeless played over the rolled-off system. The answer to the problem is

not to make all systems flat; that would call for a reassessment of present disk equalization standards, not to mention the problems of playback equipment design and obsolescence. Rather, the answer is to be found in standardizing on a degree of roll-off, with reasonable tolerances, which can be met by the manufacturers of home playback machinery and studio monitors alike. Once this has been done, an orderly change toward flatter monitoring and home playback can get underway with the cooperation of hardware and software manufacturers alike.

Some typical center-line equalization curves are shown in Figure 8. At Figure 8-a we see a curve commonly used in sound reinforcement work and at 8-b a curve recently suggested for equalization of cinema

systems. In both these cases we are observing measurements which would be made at some considerable distance from the loudspeakers, upwards of, say, 80 or 100 feet. At a distance of 100 feet at 40% RH, there is a loss at 10 kHz of 9 dB due to air absorption, and it is doubtful if systems used in rooms large as these could be equalized for flat response at such great distances without inviting high-frequency driver burn-out. But the reasons for these roll-off curves are not for driver protection; rather they are largely the result of a certain amount of empirical practice over the years, the general agreement amongst practitioners being that such systems simply "sound better" rolled off. Schlein (6) offers an interesting explanation of why reinforcement systems are traditionally rolled off based upon an analysis of the direct and random incidence response of the microphones used in the operation as well as calibration of sound systems.

At Figure 8-c and d are typical curves which have been used in a number of control rooms. Usually, in a normal control room, there is no difficulty in equalizing a system as shown in these curves—are even flat, for that matter. In fact, the most flexible monitor systems would be equalized flat and then modified, according to taste or use, with a set of switchable roll-off contours. In this way, a wide variety of playback conditions could be effectively duplicated in the control room.

A note on tolerances is in order. The curves shown in Figure 8-a and b would normally have  $\pm 3$  dB tolerances in practice while those of Figure 8-c and d would normally be held to  $\pm 2$  dB from, say 150-200 Hz up to 15 kHz. Below the 150-200 Hz region, in most control rooms, the distribution of normal room modes makes precise equalization difficult with most of the 1/3 octave equalizers used in room equalization.

A very interesting approach to monitor equalization has been employed by the Mastering Lab in Hollywood. They have integrated the functions of room/loudspeaker equalization with those of the normal passive crossover network for the Altec 604E loudspeaker. The device has two high-frequency shelving controls so that it can be adjusted to the acoustics of a variety of rooms. One control varies frequencies above 2 kHz and the other above 8 kHz. The network also provides a low-frequency boost which is non-adjustable. Figure 9 shows how it works in a typical living room environment. The solid curves represent the third-octave pink noise response through the Mastering Lab network. The upper dotted curve is the response

FREQUENCY IN HERTZ

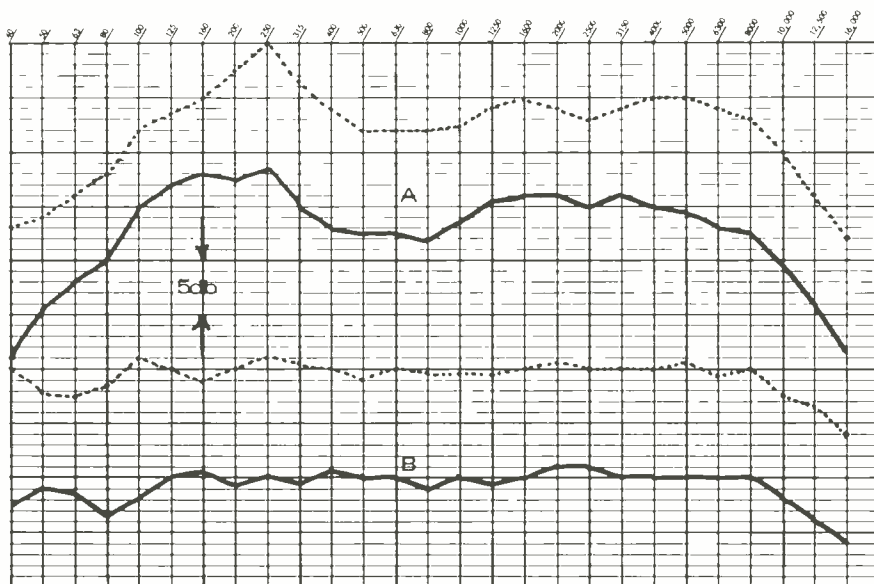

FIGURE 7 Pair of 9846B Systems in Location C (Left Channel, Dotted Line; Right Channel, Solid Line). A - Unequalized; B - Equalized

FREQUENCY IN HERTZ

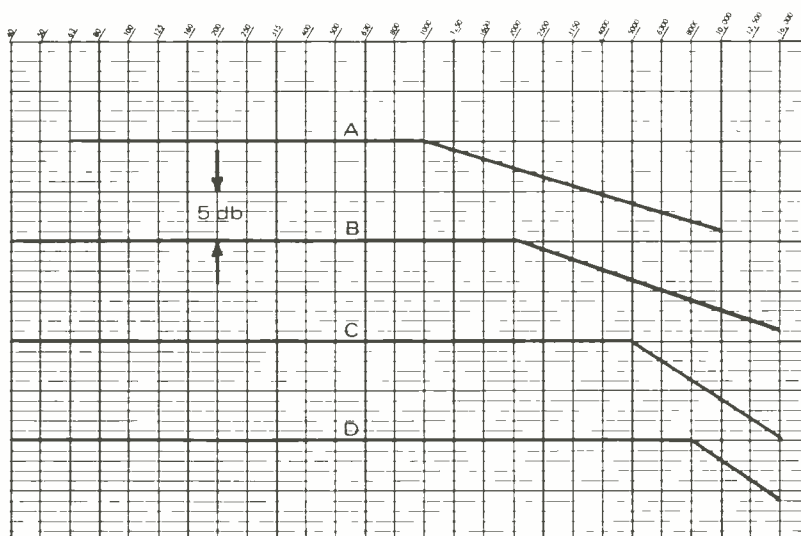

FIGURE 8 Typical Center-Line Equalization Curves for Monitor and Reinforcement Systems

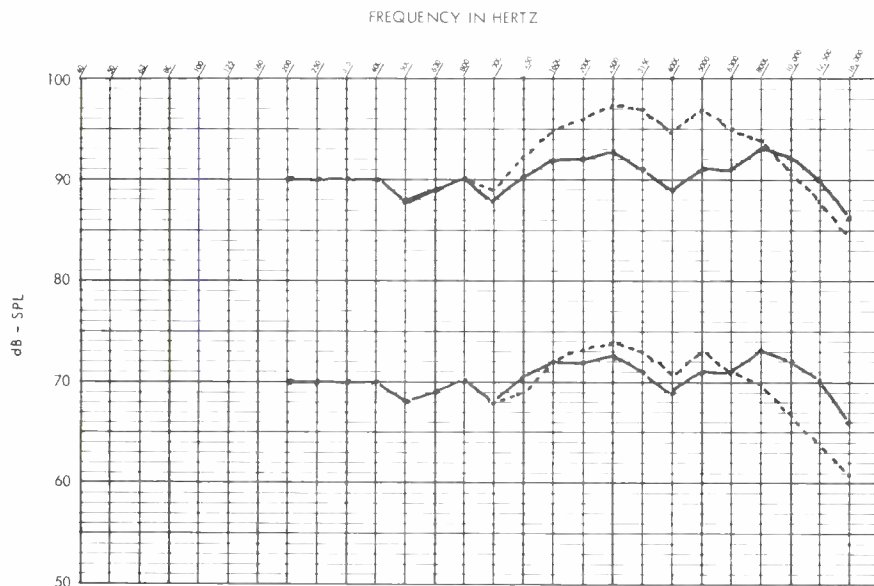

FIGURE 9

through the normal network with the HF attenuator set for flat response at 10 kHz, while the lower curve is with the control set for flat mid-range response. In one case there is too much mid-range, and in the other too little response above 8 kHz. These conditions would vary considerably from room to room, but the Mastering Lab design seems to have struck a center line, so to speak, through the requirements of most control room environments. It does not, however, permit the fine detailed equalization we have seen in earlier examples.

#### POWER REQUIREMENTS

A number of manufacturers publish sensitivity data on their components by means of a "four-foot-on-axis-one-watt-input" SPL (re  $.0002 \text{ dynes/cm}^2$ ) rating. This data is given for many combinations of drivers and horns, woofers and enclosures. The one-watt input signal is customarily a band of pink noise over the operating bandwidth of the device applied at an RMS voltage across the rated impedance which yields one watt. Such data is essential in sound reinforcement engineering; with it, the designer can determine quite accurately his needs in components and watts to drive them to the acoustical power levels required. If the device is flat over the band the rating is made in, then a sine wave input of one watt will yield a SPL approximately equal to the pink noise rating of the same device.

Another rating given by manufacturers is the maximum steady state sine wave wattage a given driver can be expected to withstand without burn-out.

This allows us to determine the normal maximum levels we can expect from a driver-horn combination for a given peak-to-RMS, or "crest factor", for the signal. A useful figure here is 10 dB; that is, a driver with a sine wave rating of 100 watts can be expected to operate with a complex program level of 10 watts. This is a conservative rating; it provides a degree of "headroom" in loudspeakers which we normally take for granted in recording devices and amplifiers.

Let us examine the components of the Altec 9846B Monitor System. This is a biamplified system with 60 watts (continuous sine wave power) available for the LF portion and 30 watts (continuous sine wave power) available for the HF section. From 500 Hz upward, the 802-8A driver is coupled with the 511 horn. The one-watt sensitivity for a pink noise bandwidth of 500 Hz-3 kHz at four feet is 104 dB SPL. The driver is rated at 30 watts, so this means that it can handle sine waves at that power—119 dB SPL at four feet. At a distance of eight feet, typical in a control room, the level would be 113 dB. Assuming a crest factor of 10 dB, we could then expect this combination to produce a level of 103 dB SPL at eight feet with wide band pink noise with an input power of three watts with sufficient headroom to allow for program peaks 10 dB higher.

When mounted in a flat baffle, the 411-8A LF loudspeaker in the 9846B system is rated 94 dB SPL 4 feet on axis with a pink noise input of one watt over a band from 50 to 500 Hz. This speaker is also capable of sustaining a 60-watt sine wave input over the range in question. If we were to allow for 10 dB

of acoustical headroom, then the output at 6 watts would be about 102 dB SPL. Going from our reference distance of 4 feet to 8 feet would reduce the level to 96 dB SPL. Experience has shown, however, that LF systems do not need as much acoustical headroom as HF systems do. The reason for this is that they operate over a relatively restricted bandwidth; also, the nature of music is such that high crest factors are far less likely in the 50-500 Hz region than they are in the 500-15,000 Hz region. Accordingly, we can reduce the headroom requirement of the LF section to, say, 6 dB. Under these conditions the LF section would "coast along" at 15 watts producing a level of 100 dB SPL at 8 feet. Finally, when the HF and LF units are matched in level, the combined output would be about 104 dB SPL at 8 feet with ample acoustical headroom.

Where systems such as we have described are to be operated at very high levels, it is wise to insert high-pass filters (12 dB/octave at around 40 Hz) in order to prevent excessive cone motion which could result from subsonic noises, wind noises at the microphone, and the like. The reason here is that at extremely low frequencies the low-frequency loudspeaker's performance is limited mechanically rather than electrically.

#### CONCLUSIONS

We have examined in detail the general requirements of monitor loudspeaker systems with particular attention to their directional properties, power handling capability, and their relation to the environment. Electrical equalization of monitor systems was examined as a means of minimizing the differences between locations so that equivalent musical judgements might be made at those locations. Finally, we examined in detail the calculations involved in proper specification of power handling capabilities and amplifier power availability.

#### REFERENCES

1. Altec Technical Letter No. 221 "Directivity of Altec Loudspeakers"
2. Altec Technical Letter No. 211 "Notes on Loudspeaker Directivity"
3. Altec Technical Letter No. 183 "Comments on Directivity of Loudspeakers and Microphones."
4. Beranek, Acoustics (McGraw-Hill Book Co., New York, 1964)
5. Eargle, J., "Equalizing the Monitoring Environment," J. Audio Eng. Soc., Vol. 21, pp. 103-107 (March 1973)
6. Schulein, R., "In situ Measurement and Equalization of Sound Reproduction Systems" (presented at the AES Convention, Los Angeles, May 1972)

1.

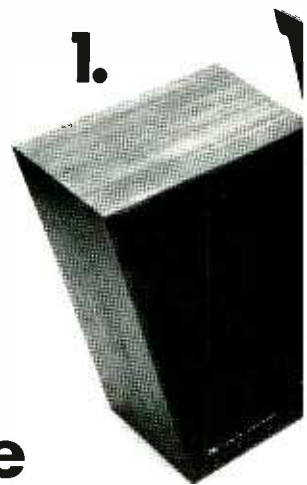

## Four reasons why more music is recorded, played back, mixed down and mastered on JBL monitors than on any other brand.

1.

### **JBL 4310 Control Monitor**

Especially designed for small studios and portable playback systems.

Wide range response. Full 90° dispersion for vertical or horizontal placement. Power handling capability: 50 Watts program power. 98.5 dB SPL at 10' at rated power.

12-inch long-excursion low frequency loudspeaker, massive mid-frequency transducer, separate ultra-high frequency transducer.

2.

### **JBL 4320 Studio Monitor**

For control room, studio and laboratory playback.

Extremely smooth frequency response. Full 120° horizontal, 40° vertical dispersion. Power handling capability, 120 Watts program power. 108.5 dB SPL at 10' at rated power.

15-inch long excursion low frequency loudspeaker and horn-loaded compression driver with acoustic lens.

3.

### **With every JBL Professional Product, you get one of these:**

A live, responsive, checked-out applications engineer. He can tell you how it works, how to fix it and how to use it. Let him help. Call him at (213) 665-4101. Or, if you can wait a day or two, write us.

**Professional Division,  
James B. Lansing Sound, Inc.  
3249 Casitas Avenue,  
Los Angeles 90039**

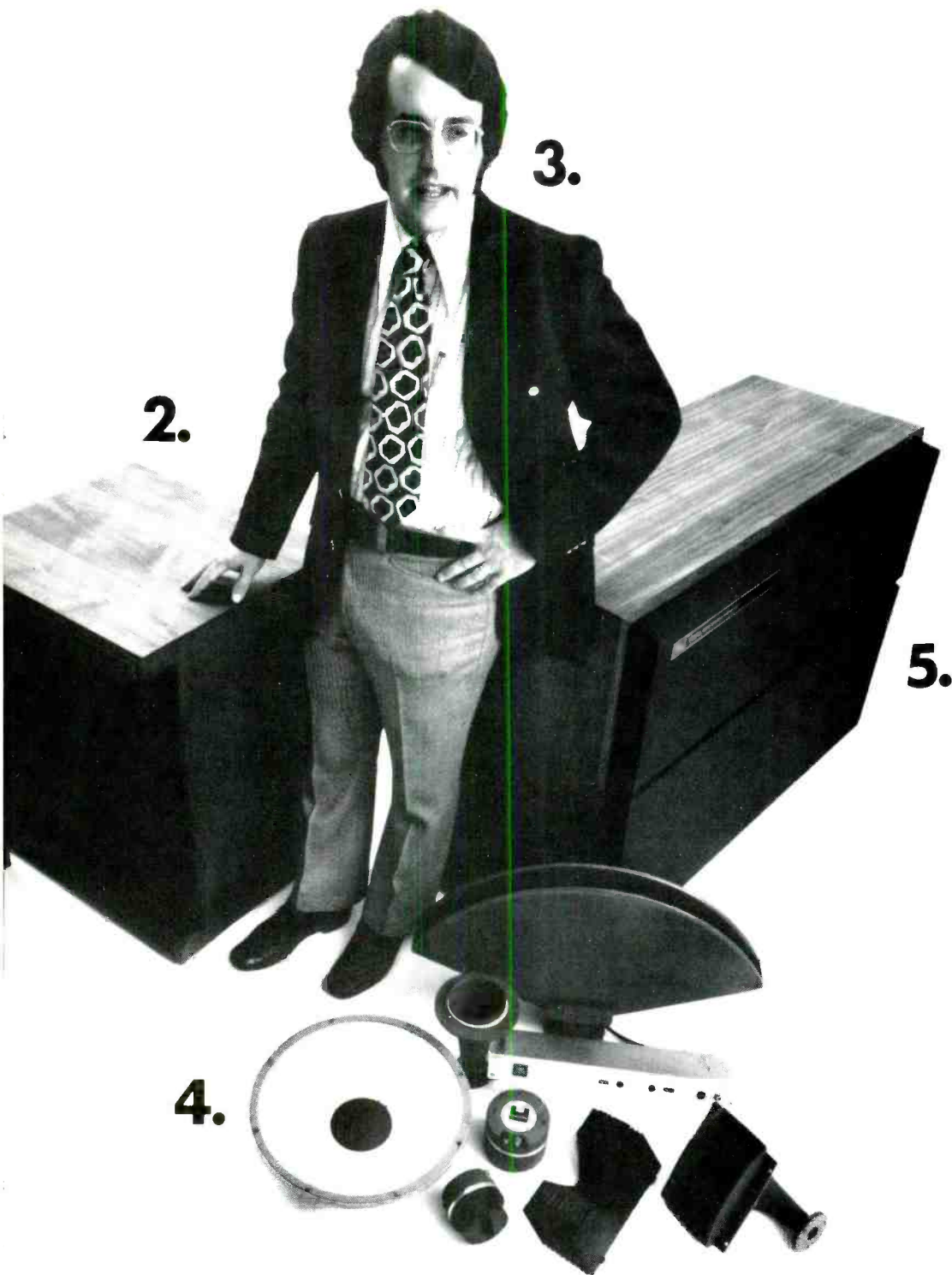

#### 4. JBL Components

How many combinations are there of low frequency transducers, medium and high-power midrange compression drivers, high frequency and ultra-high frequency compression transducers, full range cone transducers, radial horns for short and long-throw applications, mid-frequency and high frequency dispersion lenses, enclosures, high and low-level cross-over networks?

Thousands, of course. That's what makes sound installation a profession.

Circle No. 116

#### 5. The next reason.

JBL's new 4350 Studio Monitor. Ready to go to work in control rooms, studios, small auditoriums or theaters.

Extremely wide-band, linear response, controlled dispersion, 60° horizontal, 30° vertical.

Bi-amplified steady state power capability, 200 Watts at 4 ohms below 250 Hz. 100 Watts at 8 ohms above; 114 dB SPL at 10' at rated power.

The enclosure features separate acoustic loading of the low frequency

and midrange loudspeakers and provides for mirror image mounting of the high frequency and ultra-high frequency drivers.



# Big Board at The Burbank Studios

When the Burbank Studios decided to create the finest sound scoring facility in the world they came to Quad/Eight Electronics for their recording console.

Experienced in the manufacture of both film scoring and dubbing consoles, Quad/Eight can design and engineer any system — large or small. Write or call for full information.

We know film sound.

## quad/eight electronics

11929 Vose Street, North Hollywood, California 91605  
Telephone: 213/764-1516

Dan Wallin  
Scoring Mixer at  
The Burbank Studios



# AUTOMATING TRANSPORT CONTROL

by **JIM FURMAN**  
ALEMBIC, INC.  
SAN FRANCISCO, CA.



*the author at the controls*

Have you ever had your nerves frazzled or your mind boggled by the sheer number of non-creative, repetitive, and routine button-pushing that must be done in the course of a lengthy mixdown session? Here is a plan which can greatly reduce the machine-hopping that the set-up man or second engineer must do to

prepare for each take or run-through, enabling him to free his mind for more lofty endeavors.

Outlined here is a system which has been in use at Alembic, Inc.'s main control room in San Francisco, for about a year. It has been declared a useful timesaver by all who have had a chance to try it, and it's kind of fun, too.

Basically the system is an extension of the familiar remote box concept: bringing the transport motion controls (stop, fast forward, rewind, play, and record) away from the transport to a more convenient location, usually within arm's reach of the mixer as he or she sits at the console. The system departs from this simple device in that one set of pushbuttons can control all of the various and sundry transports to be found in a control room, and not just the multi-track transport. The transport to be controlled is selected by punching a button. In Alembic's installation, one of five machines can be chosen by means of a six position, illuminated interlock type switch (meaning that only one button can be punched at a time — punching a second button pops up the first, etc.) The sixth position of the switch selects "mixdown mode."

In mixdown mode, the transports of more than one machine are controlled simultaneously. The various machines in the system are each assigned one of four designations, depending on the role they are to play in the session. These designations are as follows:

1. Multi-track Master: The machine playing the pre-mix-down raw material.
2. Master: The machine or machines recording the mix.
3. Delay: The machine or machines supplying tape delay, for echo or phasing effects used in the mix.
4. Off: All machines not in another category. However, they are not necessarily unused; they might, for

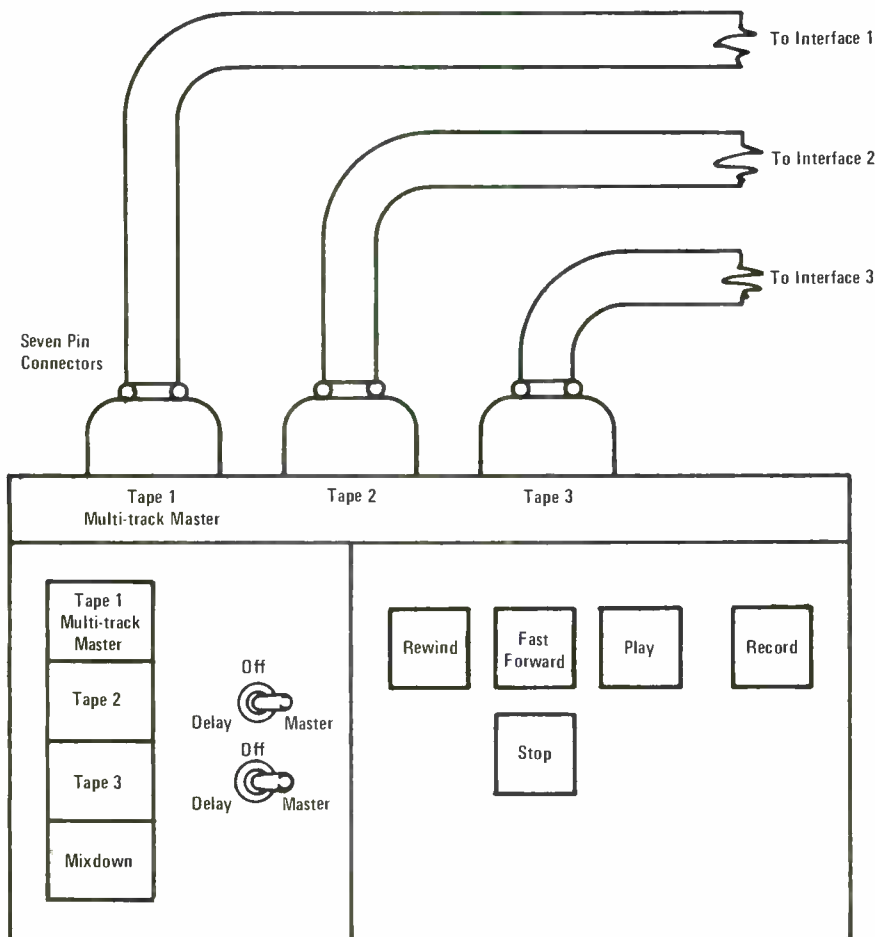

Figure 1. Control Center Box



If you're seriously into music or sound reinforcement you want more than hi-fi products can give you. But full professional studio gear costs an arm and a leg, and you pay for a lot of things you may not really need.

## You pay for what you need

up to four additional input modules and other optional accessories including talkback, remote transport control, quad pan-ner, and headphone monitor.

That's why there's a TASCAM Model 10. It's an 8-in, 4-out mixing console, and it's just \$1890.

With the Model 10 you get what you have to have. Without sacrificing a single necessary function.

Each input module gives you mic and line attenuation, three bands of peak and dip equalization (two with frequency selection), pre- and post-echo send and receive circuitry, pan function, and a unique straight-line fader.

Each of the four submasters has a meter control switch (line/echo), independent monitor level control, echo receive level control, and a straight-line fader. You also get a master gain module and 4" VU meters with LED peak indicators. Plus pre-wired facilities for

That's what you need and that's what you pay for. Some things, however, you may or may not need, and we leave that choice up to you. For instance, the basic Model 10 is high impedance in and out, but studio line impedances are available optionally. You'll probably want low impedance mic inputs, but you may not need all low impedance line inputs. So we don't make you pay for them. You can order any combination of high and low input/output impedances according to your application.

Details and specs on the Model 10 are available for the asking. At the same time we'll tell you about our new Series 70 Recorder/reproducers.

We've got what you need.

 **TASCAM CORPORATION**  
5440 McConnell Avenue  
Los Angeles, California 90066



instance, be engaged in making transfers independently of the mixing going on in the same room.

The various machines are given their mixdown mode designations by means of switches immediately adjacent to their corresponding pushbuttons. The switches, pushbuttons, and transport motion controls are all located in the same general area, either built into the console, or in a separate box near it, or as a modification of the existing remote box which usually also remotes machine functions other than transport motion. Such a box might look like Fig. 1. For simplicity it shows a system for only three transports.

Note the umbilical cables connecting each transport to the control center box. These cables terminate in 7-conductor connectors which mate with receptacles on the control center box which are numbered Tape 1, Tape 2, Tape 3, etc. They need not be shielded as they carry only d.c. Additionally, the receptacle for Tape 1 is reserved for the cable connecting to the machine designated to be the multi-track master. Thus the multi-track master machine is selected by plugging the appropriate cable into a socket, rather than by a switch. This was considered reasonable since it saves an awful lot of switch wiring, and this designation is infrequently changed within an installation (almost never during a session).

To proceed with the routine operations of the mixdown session, the transport motion controls operate in the following fashion while in mixdown mode:

“Stop” stops all transports other than those in Off.

“Fast Forward” and “Rewind” apply only to the multi-track master. Master and Delay transports are stopped when either is pushed. Off transports are not affected.

“Play” is the button that is pushed for a trial run-through. The multi-track master plays, the Delay transports record, the Master transports stop, and the Off transports are not affected.

“Record” (to enter this mode, both “Play” and “Record” must be pushed simultaneously) is the mode for a take. The multi-track master plays, the Delay and Master transports record, and the Off transports are not affected.

Note that in mixdown mode, the multi-track master can never record, thus adding another level of protection against accidental erasure.

Having defined the rules, now let us turn to the electronics which enable us to realize them. To begin with, consider the internal system which a professional transport uses to enter a mode (play, fast-forward, etc.) Pushing, say, the “Play” button merely supplies a d.c.

voltage to a relay coil, energizing it. This does not happen directly, however. The button is a momentary contact type, yet the transport must continue in “play” mode even after the finger is removed. To accomplish this an IC Flip-Flop may be used, but more commonly a pole of the relay is used to perform a latching function. The “play” button momentarily closes a set of relay contacts which is in parallel with the play button, so that when the coil current path through the play button is broken there will be an alternate route for it and the relay latches. See Fig. 2. The coil is also in series with one or more normally closed switches which are poles of the stop relay, and perhaps the fast forward and rewind relays. When these latter buttons are pushed, their normally closed switches open, cutting off current to the play coil and unlatching the play relay. The “Play” relay has other poles, too,

which may control larger currents necessary for such functions as energizing solenoids to pull the idler puck against the capstan and to release the brake, and supplying appropriate voltages to the takeup and supply motors to produce correct tape tension. Different starting and running torques may be required, in which case the first relay may activate a preset time delay relay which times the start up period. (In many tape decks designed primarily for use in the home, the transport motion controls are mechanical linkages and not switches at all.)

Now, most professional transports have a special connector available for hooking up a “remote control box” or more simply, a “remote box.” On the remote box are found a set of momentary contact switches, some normally closed and some normally open. A d.c. voltage is also brought out to the box, and pushing

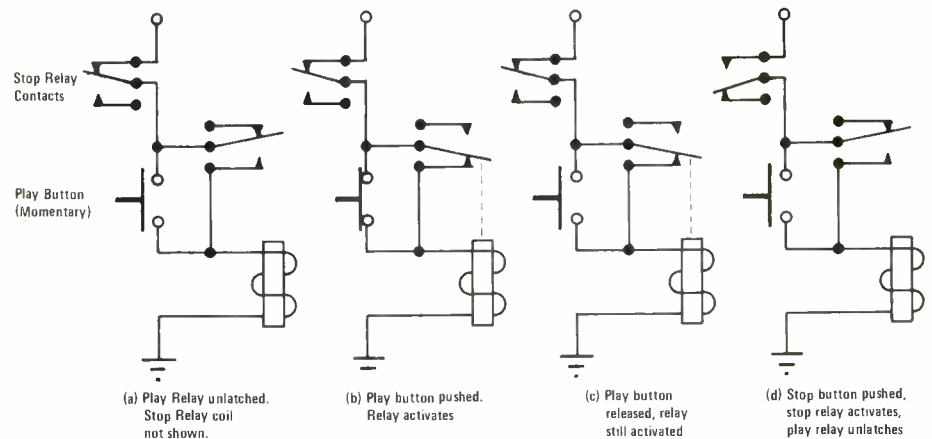

Figure 2. Latching Relay Operation

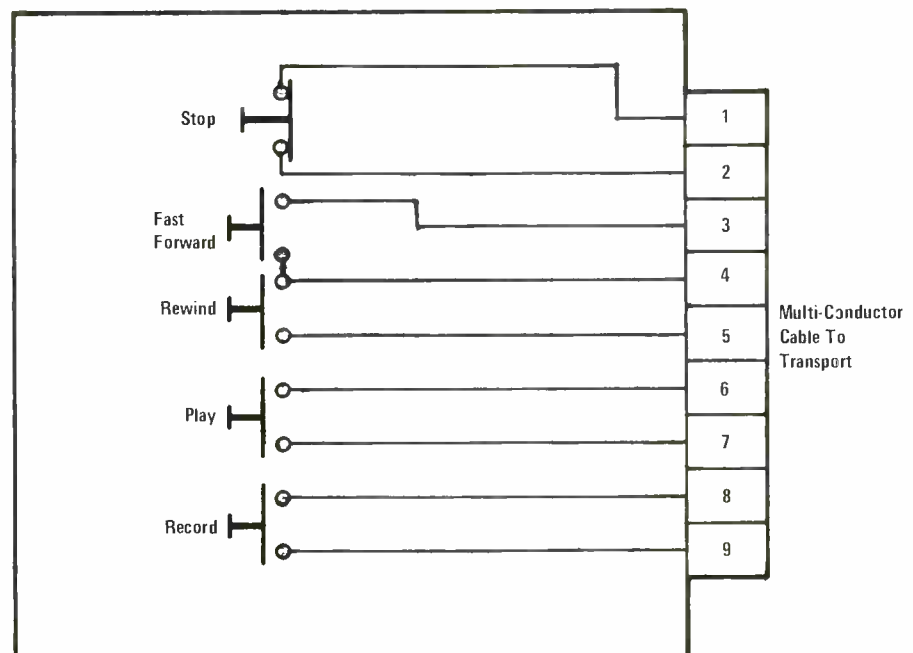

Figure 3. Typical Remote Box Schematic

the various transport motion controls sends control pulses down the cable to the appropriate relays at the transport.

The length of these pulses is the length of time that your finger holds the button down, perhaps 100 ms. to one second.

See Fig. 3.

Unfortunately, this description has been a bit vague because there are no standards. The exact voltages and switch configurations vary from manufacturer to manufacturer and even from model to model. So, in order to control more than one transport with one set of controls, a standard had to be established. The standard we chose was the 5-volt logic of TTL (transistor-transistor logic) gates. Furthermore, for simplicity the logic was so designed that the presence of a "high" pulse on a line universally meant "enter the transport motion mode" of that line. TTL was chosen because it is cheap (30-40c per IC, surplus), readily available, and practically foolproof at the slow speeds involved. Perhaps someday manufacturers will adopt a similar standard.

Thus, the next problem was translating, or interfacing, between the standard logic system and the specific systems of the various transports. Particular attention was given to keeping all the grounds separated from each other; this avoids creating ground loops, as all the transports were already grounded together via a different route.

Figure 4 shows a typical interface circuit. Basically, the presence of a logical "high" biases a transistor on, which allows current to flow in a relay coil,

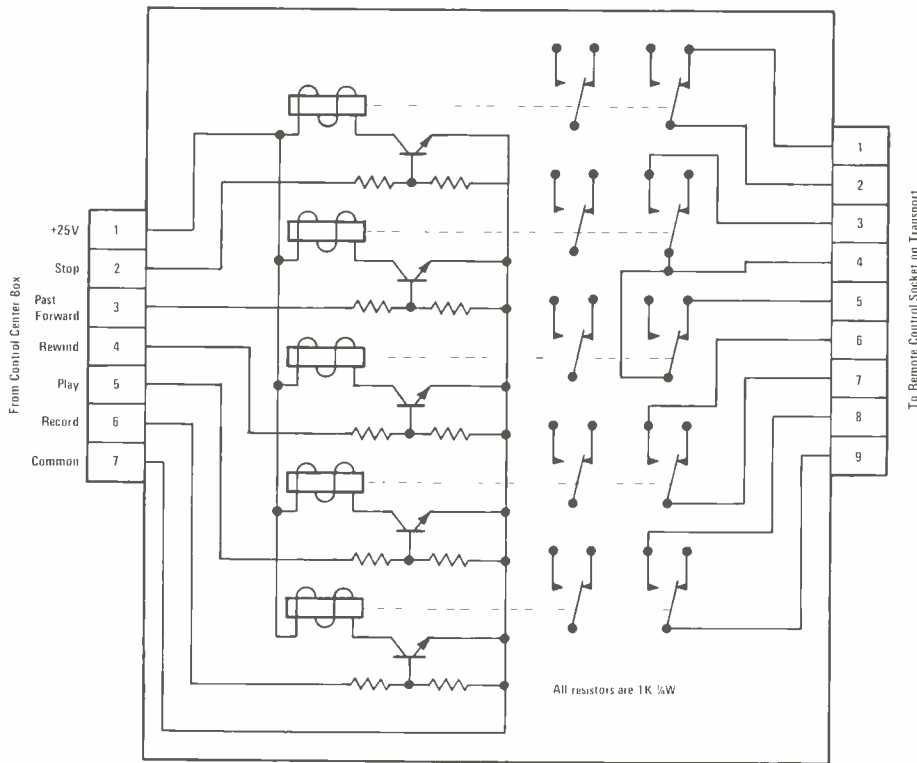

Figure 4. Typical Interface Circuit

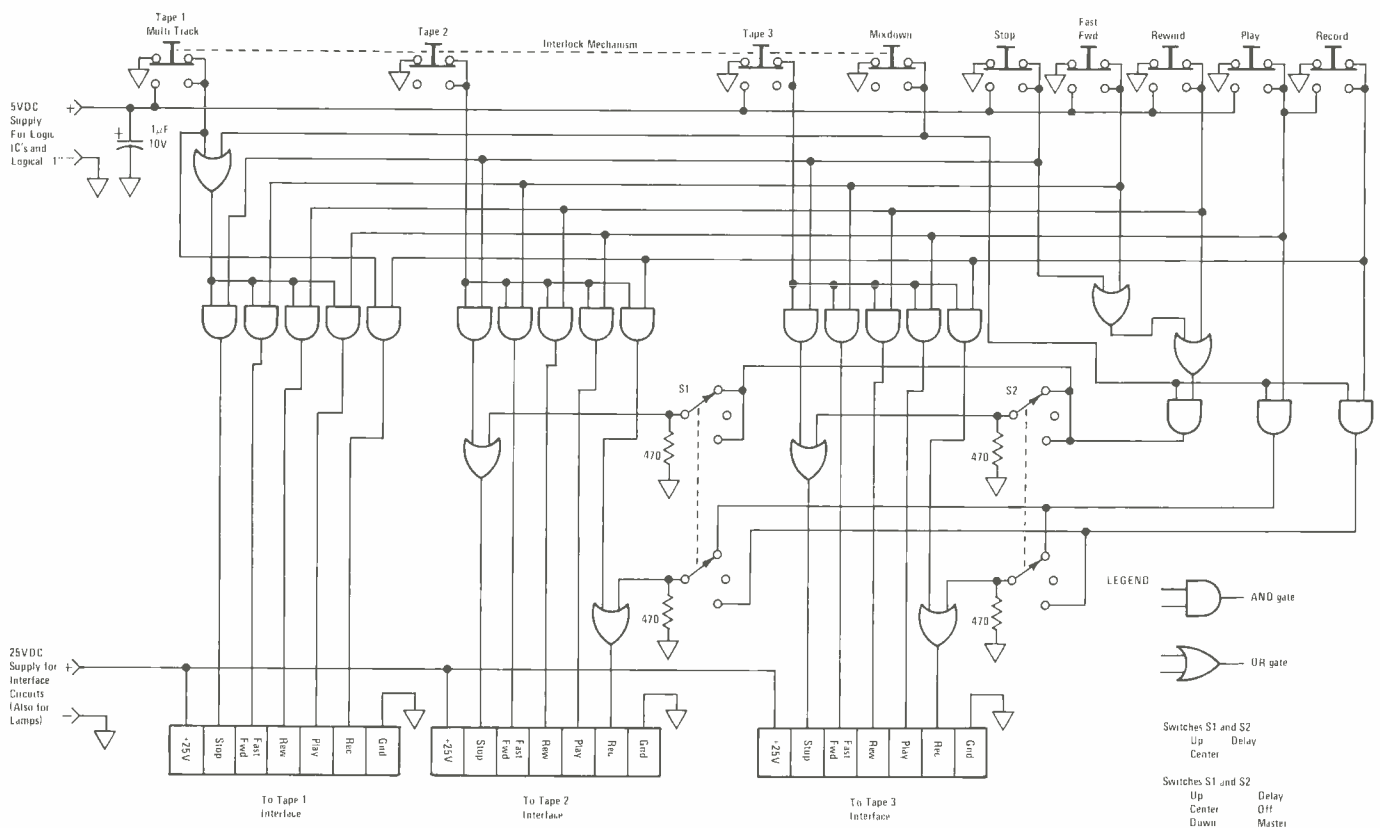

Figure 5. Control Box Logic Schematic

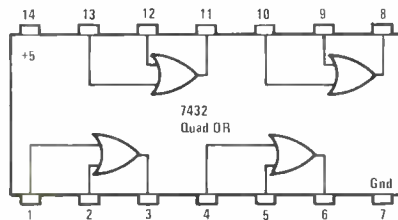
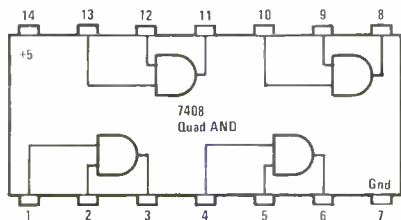

Figure 6. Pin-Outs (Top Views)

energizing it. Each interface assembly was built in a small box which plugged directly into its corresponding remote control connector, and in turn the appropriate umbilical cable from the control center box is plugged into it. None of the parts values are critical. With the resistor values shown, the transistors must be silicon. The relays used were miniature DPDT types with a 25 VDC coil, available at 75¢ each from the local surplus store. The advantages of the relays are that they maintain complete ground isolation, and can supply either normally-on or normally-off switching, as required. A quick check of the remote box schematic in the tape machine manual will reveal what switching is needed for which function. The transistors used must also have a sufficiently high collector-to-emitter breakdown rating to withstand the relay coil supply voltage.

The only unusual problem we encountered with the interfacing was with an Ampex MR-70 which does not have either a rewind or fast-forward button but rather a slider which allows winding at any intermediate positive or negative speed. Since this is not a momentary action type mechanism, there is no latching relay built in for these two

functions. So to get around this two extra relays were put into the interface box, to be latches. In this case, when a pulse is received by, say, the "rewind" input, it activates the first, or isolation relay, which in turn activates the second, latching relay which then keeps the MR-70 in "rewind" until either "stop" or "fast-forward" is pressed (unlatching the relay). This is the same approach that Ampex takes in the accessory remote box, which does not have the slider feature either.

This leaves only the wiring of the control center box itself. Two power supplies were built into Alembic's installation: a 5 VDC one for the logic IC's and a 25 VDC one for the interface relays. The five-volt supply was regulated with a regulator IC, an LM 109, from the same surplus store (which also supplied the transformers and filter capacitors). The 25 volt supply was initially unfiltered but as our relays were DC types, they tended to buzz when energized until we improved the filtering. The latter supply was also used for the lamps in the illuminated pushbuttons.

The actual logic is shown in Fig. 5. All gates are either two-input OR's or two-input AND's. These are available with four gates per IC, as the 7432 and

the 7408 respectively. The pin-outs are given in Fig. 6. The four gates within each IC are completely identical and interchangeable. If a system is built to accommodate three transports, as shown in Fig. 5, then 18 AND gates and 7 OR gates are required (hence 5 quad-AND IC's and 2 quad-OR IC's). Of course, the system can easily be extended to any number of transports. All resistors shown are 470Ω ¼ watt; their purpose is to keep gate inputs when not connected to anything else in the "low" state. The capacitor is for power supply decoupling and should be mounted physically close to the IC's.

All the IC's were mounted on a special printed-circuit card designed specifically for breadboarding dual-in-line type IC's. The one we used had room for fifteen IC's and cost about \$5. They are generally available from the same surplus dealers who handle the IC's.

The "delay-off-master" switches were miniature DPDT toggle switches with a center off position. The transport selector switch, which also selects mixdown mode, was as mentioned above an interlock-type pushbutton switch bank with lockout mechanism, and with one more switch position than the number of transports to be controlled. These usually come with DPDT circuitry, with one pole being used to turn the lamp on.

Of course, the system that has been described here does not totally free the engineer from button-pushing. Nor is it completely automatic in itself. But when used with a transport with brains enough to rewind to a specified point (such as by scanning for a particular time-code) it can come quite close. Even without that luxury, though, it offers the elimination of a bit of the clutter interfering with the mixdown engineer's concentration.

- Universal because it works with any system — anywhere — anytime. And the price is good enough for anybody.

## the TOY CHEST UNIVERSAL LIMITER

- Adjustable gain bridging input works from virtually any system; even Hi Z low level simi-pro gear.
- Low source output drives any load.
- Phono pin plug in and out for easy hookup.
- Large VU meter monitors gain reduction.
- Performance exceeds units costing twice as much.
- Quiet, clean, advanced op-amp/FET design with internal AC supply.

arriving on your tracks

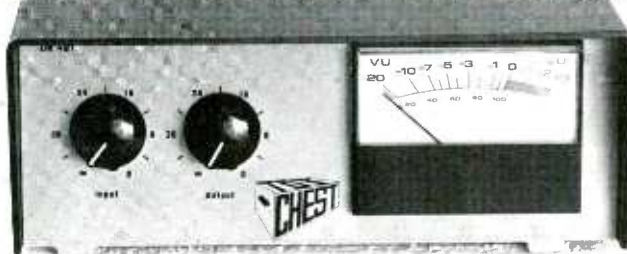

AVAILABLE NOW  
CALL TODAY

Audiotechniques Stamford, Conn.	(203)-359-2312
Martin Audio New York, N. Y.	(212)-265-5470
Studio Supply Co. Nashville, Tenn.	(615)-327-3075
Westlake Audio Los Angeles, Calif.	(213)-655-0303

ORDER TODAY

**\$197**

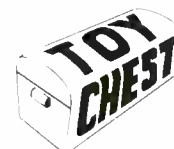

BOX 280 —  
NASHVILLE,  
TENN. 37202

# Ain't nobody else can give you an S/N ratio up to 72 dB. Nobody.

We call it the Scully 280-B Professional Recorder/Reproducer. Not a very fancy name. But it's so new, we haven't had time for anything else but a number.

Briefly, here are the high points, new electronics for up to 72 dB S/N ratio on full track .25" tapes. And a greater dynamic range than you've ever been used to.

Two-track quarter-inch and four track half-inch 280-B lays on a crisp, clean 69 dB on an NAB weighted basis.

We've built in some other choice features, too. Like an OPTAC™ optical motion sensing system that gets rid of deck plate sensor mechanisms. Plus a new mother-daughter board architecture for super easy maintenance.

The spec sheet has all the details.

*For more  
information  
contact your  
Scully Distributor  
or write direct to  
Scully/Metrotech.*



# NEW PRODUCT NEWS

## QUAD-EIGHT TIME CODE SYNCHRONIZING SYSTEM

QUAD/EIGHT ELECTRONICS introduces -TCS- Time Code Synchronizing system. This series of components is designed for synchronization of multitrack audio tape machines with similar slave units, VTR, or sprocketed film inter-lock systems.

The basic system features SMPTE Generator, Reader, and Synchronizer. A family of optional accessories is also offered, including a Motor Drive Amplifier and "Search and Find" match-up system.

The TCS 180 (Synchronizer) is the heart of the system. Operating with the TCS Reader, it provides the requisite speed up or down error signals to capstans that can be either AC Synchronous or DC Servo controlled. Offset (slewing with frame indicator and pre-select lever-wheel switches), time/phase lock selection, and on/off line

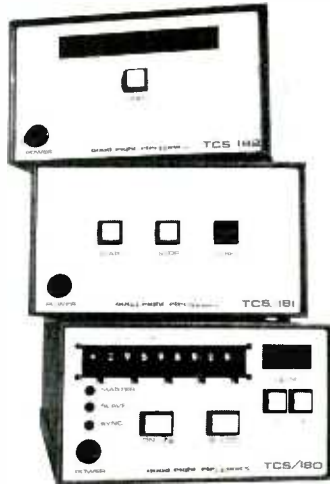

switch are some of the unique extras of this device.

The TCS 181 (Generator) is NTSC

Circle No. 121

## NEW MAGLINK SYNCHRONIZER FROM AUTOMATED PROCESSES CONTROLS ANY NUMBER OF MAG TAPE MACHINES

A new synchronizer called MagLink, introduced by Automated Processes, Inc., 80 Marcus Drive, Melville, N.Y. 11746, is said to offer a faster and more efficient capability for synchronizing, position logging, editing and indexing of video and audio magnetic tapes.

Through the use of a unique time code system developed by the company, videotape, multi-track audio, and magnetic film machines may be controlled simultaneously. They can be locked in sync, offset in their relative positions, or stopped and started according to a pre-set program. With the MagLink Synchronizer, master and slaves will remain synchronized in all operating

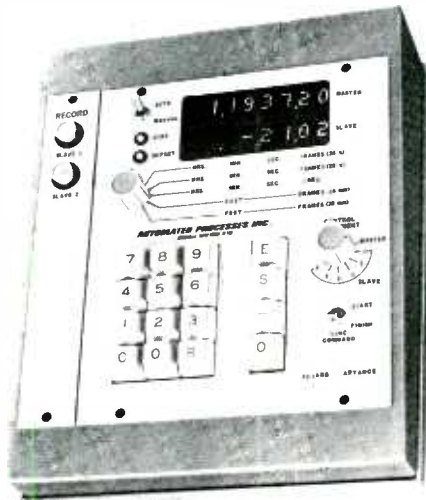

Circle No. 122

## SPECTRA SONICS LINE/DISTRIBUTION AMPLIFIER

SPECTRA SONICS has designed a versatile, solid state, line/distribution amplifier, the Model 109, in the intermediate power range (3 watts) for a wide range of applications. The Model 109 amplifier may be used as: a distribution amplifier to power numerous outputs, for example, 15 or more with 37dB to 43dB gain; high output line or program amplifier for use when unusually high average line levels exist and additional isolated outputs are needed; low output power amplifier, for use with

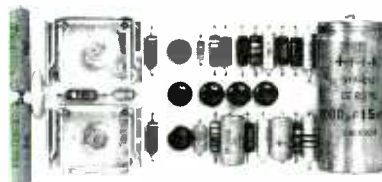

dynamic program material of a wide range, with output resistance from zero to infinity and power output up to 3 watts.

Some performance specifications of the Model 109 are: Gain, 40dB  $\pm$  0.1dB; output, 3 watts into impedances from 8

Circle No. 123

or 60Hz data rate selectable. A provision for optional data display and lever-wheel code preset allows SMPTE hours, minutes, seconds and frames to be read and/or pre-selected. Power, start, stop and reset controls, as well as connector provision for parallel data output, are provided.

The TCS 182 (Reader) receives time codes from master or slave machines and provides a large character display of SMPTE encoded tapes at NTSC or PAL frame rates. A hold button is provided to allow annotation of exact tape position. It incorporates a high speed forward or rewind reading capability which allows complete synchronization in the reeling modes of each slaved machine.

Basic system price for -TCS- is \$9,100.00 Complete. Including 1 Synchronizer, 2 Readers, 1 Generator.

QUAD/EIGHT ELECTRONICS, 11929 VOSE STREET, NORTH HOLLYWOOD, CALIFORNIA 91605.

modes, including rewind and fast forward. A converter module is available to interface with the SMPTE time code.

When used for multi-track audio production, video mixing, editing and "sweetening," production of film sound tracks, or foreign language over-dubbing, MagLink provides a degree of accuracy and production flexibility not heretofore available. The unit has a sync resolution (accuracy) of 1/300 of a second and a typical search accuracy of 0.2 seconds at 15 ips.

A special feature of MagLink is selectable conversion display. This enables the operator to convert a position code on the tapes to the format (hours, minutes, seconds, frames or feet) selected by the switch.

AUTOMATED PROCESSES, INC., 80 MARCUS DRIVE, MELVILLE, N.Y. 11746.

to 50 ohms, +24dBm into 600 ohms, frequency response, within  $\pm$  0.1dB from 50Hz to 50kHz (50 ohms load); output noise, not over an input equivalent of -122dBm, unweighted 20Hz to 20kHz, input terminated 600 ohms. The Model 109 will recover from 1000% overload practically instantaneously (less than 5 microseconds).

The Model 109 is contained on a printed circuit card (2-1/2" x 5" x 1") and is available now.

Price \$75.00.

SPECTRA SONICS, 770 WALL AVE., OGDEN, UT 84404.

for that heavy studio sound!

# LA-3A leveling amplifier

The great one with the  
Electro-Optical attenuator

- Half rack size
- High output (+25 dBm)
- Low price (under \$400.00)

See your dealer or write for complete specifications.



11922 Valerio Street, No. Hollywood, California 91607  
(213) 764-1500  
Exclusive export agent:  
GOTHAM AUDIO DEVELOPMENT CORP., NEW YORK, N.Y.  
Telex #233353 GADC UR

Circle No. 124



## Cut it in half

Half the cost, time,  
and worry, at  
Dick McGrew  
Recording Service  
in Dallas.

Dick beats the competition with record master costs like \$30 per side for stereo 12 inch 33 1/3 rpm, and \$10 per side for 45's. The day he receives your tape, he'll groove your master with the Neumann SX 68 cutter, the ultimate in cutting machines. Dick'll give it the individual and expert attention of a man who does a lot of producing himself.

For no extra charge, Dick will provide equalization, reverberation, or other special services at your request. And he's used to giving attention to problem tapes.

Interested in album pressing or singles? Dick's got a competitive price list for these services, too. Let us hear you!

### Dick McGrew recording services

7027 TWIN HILLS AVE • DALLAS 75231 • 214 691-5107

Circle No. 125

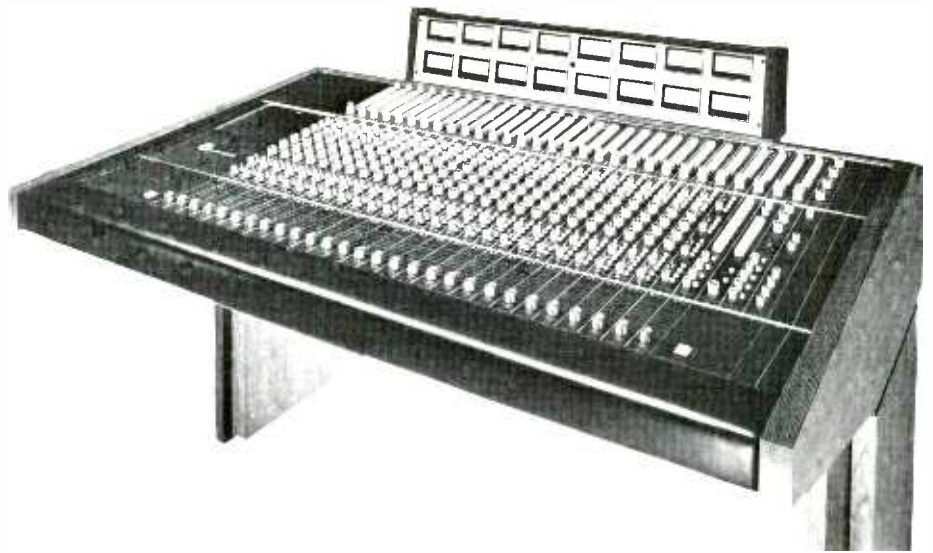

AUDITRONICS MODEL 501 CONSOLE SON OF 36 GRAND, Model 501, is an expandable, modular professional recording/remixing console from Auditronics, Inc. of Memphis, designed to accommodate 24 track recording and quad mixdown. Expandable to 26 inputs with complete metering, expandable patching, and a full line of matching accessories.

Up to 26 input channels, each for mic and line with the following: Linear motion fader; microphone gain trim; input on/off switch; solo tape track or input fader; two independent studio cue mixes; echo selectable from monitor channel or input position; echo level control; echo send to four echo chambers in any combination; four knob equalizer; low & high cut filter; equalizer in-out switch; monitor level control; monitor channel assignment L-C-R; monitor sync overdub switch; quad pan pot; quad source selector from monitor matrix or program; independent selection to main 16 output channels.

There are twenty-three program output channels, 16 main, 4 quad, stereo and mono; four echo send & return channels; independent monitor echo return control; two cue channels; four control room monitor channels with automatic change over for multi-track;

quad; stereo; mono; and two studio monitor channels.

All console outputs are at +24 dBm capability, balanced, transformer isolated. Also included are talkback and communications facility with independent select & level control to program busses, studio, cue 1, and 2, plus built in test and calibration oscillator, and silent electronic switching for all monitor muting, selection, and input group muting.

Sixteen VU meters are switched to indicate level conditions of 31 output channels, a built-in supply for phantom powering of FET condenser mics is included, and all active circuitry is contained within plug-in modules.

Extensive patching facilities are standard - all line level inputs and outputs are normalled through jacks as well as numerous internal insertion patch points. Total of 288 jacks with space for 624 total.

Master input muting kills all inputs simultaneously. A full complement of accessories including matching equipment cabinet, phase meter, digital stop clock, and Producers desk is available.

Free replacement of faulty parts for one year from date of installation.

AUDITRONICS, INC. 180-B SO. COOPER, MEMPHIS, TN 38104.

Circle No. 126

## TAPE-ATHON PROFESSIONAL TAPE RECORDER / REPRODUCER FEATURES ELECTRONIC EDITING

The availability of a new high-performance tape recorder for studio and broadcast application has been announced by Tape-Athon Corp. of Inglewood, California. The new recorder/reproducer has several innovative features, of which the most impressive has been designated "electronic editing" by the manufacturer.

Electronic editing allows the operator to move the tape across the recording heads so precisely that he may

actually "split" musical notes and phrases and avoid the tedious practice of physically splicing tape. This precision control is accomplished by putting the recorder in a balanced torque mode which activates the drive motors of both tape reels simultaneously and in opposite directions. In this mode, either reel may be moved manually, in minute increments, without the creeping effect usually experienced in conventional machines.

The new system has been designated Tape-Athon's Model 1001 (ten-oh-one) and incorporates a number

of other user-oriented features. Among these are tach-controlled motion sensing, which detects motion of the tape when switching from fast speeds to recording or play back, and prohibits tape stretching, breaking, or spillage. Other benefits of



the new 1001 are excellent recording quality due to closed loop dual capstan drive, fast tape threading, and a pause control feature that will hold the tape movement as long as the PLAY control is depressed, very advantageous when recording.

Priced at \$1,695.00, the new 1001 tape recorder/reproducer is available 30 days ARO.

TAPE-ATHON CORP., 502 S. ISIS, INGLEWOOD, CA 90301..

Circle No. 127

#### THE OMNIPRESSOR FROM EVENTIDE

THE EVENTIDE OMNIPRESSOR is a professional quality dynamic modifier. It combines the characteristics of a compressor, an expander, a noise gate, and a limiter in one convenient package. Its unusually wide range of controls allows it to be used in almost any application where program controlled gain change is useful. Additionally, it can generate new effects, such as infinite compression and dynamic reversal. Dynamic reversal makes high level input signals lower than corresponding low level inputs. Musically, this reverses the attack-decay envelope of plucked string and similar instruments, and gives the effect of "talking backwards" when applied to a voice signal.

The OMNIPRESSOR has a continuously variable Expansion/Compression control which goes from an expansion range of 5 to 1 (gate) to a compression range of -5 to 1 (abrupt reversal), and all possibilities in between. Attenuation and gain limit controls adjust the gain control range from a full 60 db to as little as plus and minus 1 db. Thus, with the gain limit set

# dbx 216 provides

16 channels of noise reduction in seven inches of rack space. The system improves headroom by 10dB and delivers 30dB of noise reduction. Simultaneous code, decode and bypass functions can be selected at the panel or by remote control. Price, including a spare 310D module, is \$8,200.

Available from professional audio dealers or direct from dbx, Incorporated, 296 Newton Street, Waltham, Massachusetts 02154.

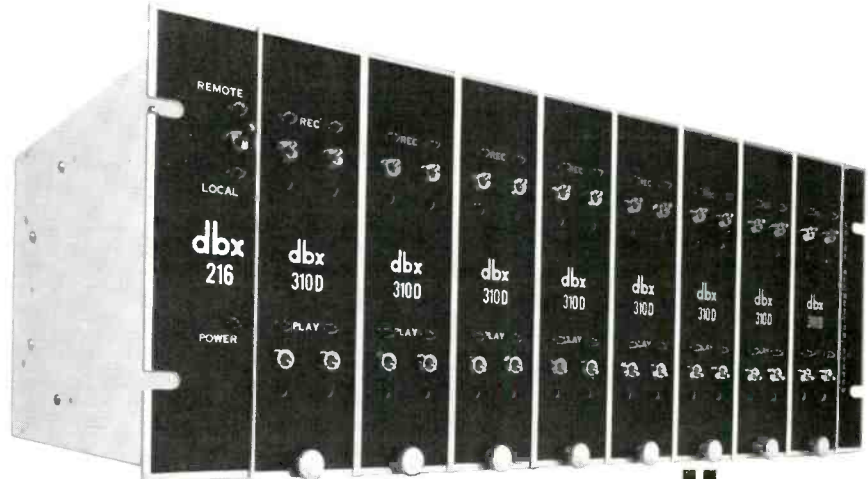

dbx inc.

Circle No. 128

## THE PHASER

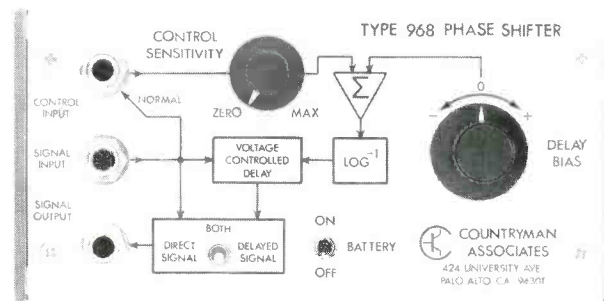

Would you use phasing and flanging effects more often if they were less difficult to obtain? Now you can produce these effects without tape machines, reproducibly and with complete control.

The Type 968 Phase Shifter electronically delays an input signal and then mixes the delayed and undelayed versions together. It allows you to add the striking "turning inside out" effect of Phase cancellation to any audio signal live or recorded, in the studio or in performance, in minutes instead of hours.



COUNTRYMAN ASSOCIATES

424 University Avenue  
Palo Alto, Calif. 94302  
Phone 415-326-6980

Circle No. 129

at 0, the unit can attenuate up to 30 db, but cannot boost the input signal. Depending upon the setting of the compression control, all signals below 0dbm will not be modified (gain increase limited), while all signals above 0dbm will be attenuated at the appropriate ratio. A step-variable time constant control adjusts attack/decay times over an approximate 100 to 1 ratio. A bass cut switch is provided to limit low frequency response in the level detector.



The unique metering system employs a logarithmic amplifier to generate the following useful information:

**INPUT:** Reads signal level over a 60db range. Input level control may be used to calibrate the meter in absolute dbm.

**GAIN:** Reads relative gain of OMNIPRESSOR. Shows how signal level is modified over 60db range. Used in setting up limit controls.

**OUTPUT:** Reads output level in dbm. Red line warns of possible limiting in output amplifier.

An IN/OUT switch is provided to bypass the OMNIPRESSOR when a

return to normalcy is desired. The graph illustrates some of the unusual capabilities of the unit.

EVENTIDE CLOCK WORKS, 265 W. 54TH ST., N.Y.C. 16019.

Circle No. 130

#### NEW SHURE COMPONENT SOLVES FEEDBACK PROBLEMS

Feedback, one of the most worrisome problems common to sound amplification, now may be drastically reduced through the use of a new dramatically effective component announced by Shure Brothers Inc., Evanston, Illinois.

Called the M610 Feedback Controller, the new unit can be easily added to any sound system for relatively little cost.

In a typical application, the M610 is inserted in the sound system between the preamplifier-mixer and the power amplifier, or between the microphone and the preamplifier-mixer in a single microphone system. Once the M610 is part of the system, its special set of variable depth filters and roll-off switches can be used to smooth out the peaks in the total system's frequency response, so that the system gain may be increased to significantly higher levels before the feedback threshold is reached. The user is able to "tune" the total sound system to correct for the acoustic irregularities of

the room, to gain maximum output — without danger of generating feedback. The M610 provides the basic advantages of room-system equalization, but without the very high cost involved in elaborate, complex equalization equipment.

Other capabilities built into the versatile M610 include variable-control preamplification, which allows the user to raise the overall gain of a sound system after "tuning" the room so a direct before and after equalization, comparison can be made. The M610 may also be used to improve sound quality and increase intelligibility by filtering "problem frequencies" that cause oscillating, boominess and other disruptive resonance in acoustically different rooms.

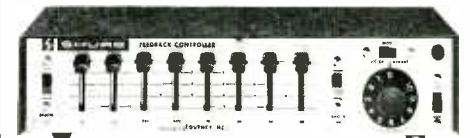

The M610 is self-contained but can be rack mounted in a standard 19" audio rack, with an accessory rack mount kit. A specially fitted lock-on cover is also available as an accessory to guard against tampering with control settings once they have been optimized. Actual size of the M610 is 2-1/2" high, 12" wide, and 7" deep. Weight is only four pounds.

User Net Cost is \$117.00.

SHURE BROTHERS INC., 222 HARTREY AVENUE, EVANSTON, ILLINOIS 60204.

Circle No. 132

#### PENTAGON HIGH SPEED OPEN REEL EIGHT TRACK DUPLICATING SYSTEM

The new PRO-series 2800 Line is directed towards individuals that are starting up new duplicating facilities or expanding their present operations. The new Pentagon Line offers one of the lowest priced professional 8-track

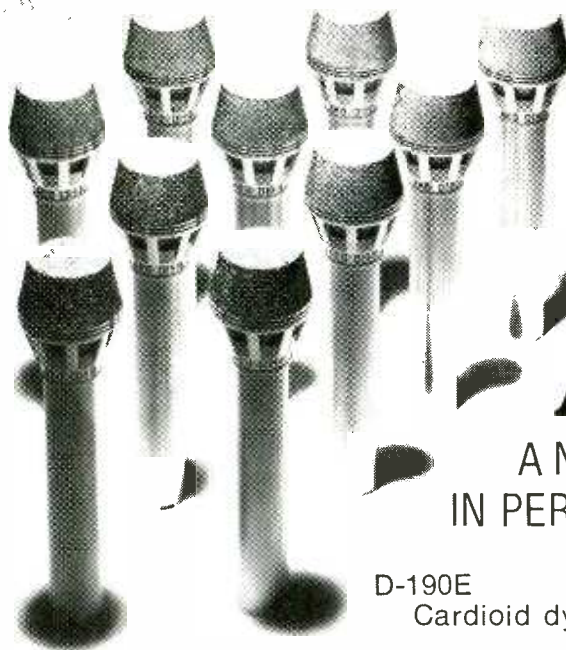

**AKG**  
A NEW STANDARD  
IN PERFORMANCE

D-190E  
Cardioid dynamic microphone.

For information on the entire  
AKG product line call or write



**MICROPHONES • HEADPHONES**

DISTRIBUTED BY  
NORTH AMERICAN PHILIPS CORPORATION  
100 EAST 42ND STREET, NEW YORK, NEW YORK 10017

AKG CANADA • DIVISION OF DOUBLE DIAMOND ELECTRONICS • SCARBOROUGH, ONTARIO

AKG 35



duplicating systems on the market place today.

Features built into all of Pentagon's 8-track duplicators, to name a few, are modular plug-in solid state electronics, full control facilities, fully automated operation for reel to reel duplication, reel master transports available in either 1/4 inch or 1 inch tape configurations, the ability to duplicate 8-track programs directly onto pancakes for later loading into cartridges, or, if you prefer, duplication directly onto cartridge hubs (to eliminate the loading procedure).

PENTAGON INDUSTRIES, INC.,  
4751 N. OLCOTT, CHICAGO, IL.  
60656.

Circle No. 133

#### ELECTRO SOUND 100 WATT SOLID-STATE POWER AMPLIFIER

A 100 watt solid-state power amplifier, designated the Model 810, is now being made available for professional sound applications. This amplifier joins with other sound components in Electro Sound's complete line for professional sound systems.

Of all solid-state design, the Model 810 is intended for continuous non-attended service in installations where trouble free operation over long periods of time is required. According to Mort Fujii, general manager of Electro Sound, "The Model 810 has several

design features that make it especially useful for applications requiring long term reliability. For example, the unit has an internal current sensing circuit which protects the unit from overloads and holds its output within safe operating ranges even if an accidental short should occur. This design feature, along with massive oversized heat sinks for the output transistors, assures maximum protection and reliability."



According to Fujii, the unit occupies only 7 inches of vertical rack space, yet provides a full 100 watt rms output with less than 0.5% total harmonic distortion. Frequency response is  $\pm 1$  dB from 40 to 20,000 Hz at 100 watts or  $\pm 0.5$  dB from 20 to 20,000 Hz at one watt. For input versatility, the unit has a pre-wired socket for plug-in bridging or matching input transformers. Standard output impedances of 4, 8, and 16 ohms are provided, plus 50 ohms (70 volt line).

The unit is powered by a standard

117 volt ac input voltage, of either 50 or 60 Hz, and will operate at ambient temperatures up to 55°C. It is also available in a version that contains a +24 and -24 volt supply to power preamplifiers, switching circuits, and similar external devices.

Available for immediate delivery, the Model 810 is priced at \$340, end user list price. Literature with description and complete specifications is available on request.

Electro Sound is one of the world's leading manufacturers of high speed tape duplication equipment, theatre, and professional sound system components.

ELECTRO SOUND, INC., 725  
KIFER ROAD, SUNNYVALE, CA  
94086.

Circle No. 135

#### NEW INTERCOMMUNICATION SYSTEM FOR SOUND, LIGHTING AND CAMERA CREWS

Lumiere Productions, Inc. announces the formation of its new division Clear-Com. Clear-Com will manufacture its newly developed System CCX100, a closed-circuit intercommunication system designed specifically for the high noise level encountered in the entertainment business.

Clear-Com System CCX100 is designed to provide clear headphone intercommunication for sound, lighting

**MAZE**  
Introduces  
the First  
Professional  
Recording  
Console  
under  
**\$10,000**

30 DAY DELIVERY

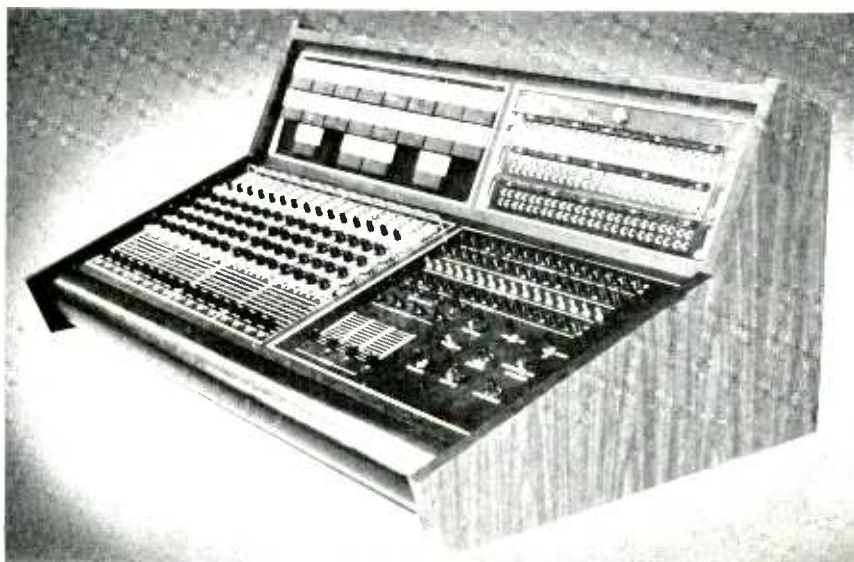

OUR NEW MODEL  
A-MAZE-INGLY PRICED  
at  
**\$9500**

Features 16 inputs and 16 outputs; four submixed busses; pan pots on each input; echo send pre-post; variable gain mic preamps; solo; 9 frequency equalization in three ranges (low-mid-high); conductive plastic mixers; complete 16 track monitoring with wet monitor-dry record; patch access for limiting and to all inputs and outputs; op-amp circuitry throughout; -29 dbm headroom; two cue systems; talkback; 20 VU meters; noise 68 dB below +4 output, mic input to stereo out; distortion less than 0.1%; frequency response -1 dB 20 - 20,000 CPS. Cabinet dimensions are 28" x 48" x 15".

**M MAZE**  
CORPORATION

P.O. BOX 6636 BIRMINGHAM, ALABAMA 35210 PHONE (205) 591-4000

Circle No. 134

Re/p 43

and camera crews. It is intended for application in production use for concerts, theaters, TV studios, and arenas.



The System consists of two basic units: the Main Station, which houses the power unit, overall system controls, and station controls for the Main Station operator; and the Remote Stations, which are lightweight belt-packs with headphones. Up to 30 Remote Stations can be looped into the system. Shielded two-conductor microphone cables connect stations to the Main Station or to other Remote Stations.

Additional features of the Clear-Com System CCX100 include call light communication and auxiliary input and gain. Call lights back up the audio system to cue operators who have removed headphones. The auxiliary input and gain

allow the operator at the Main Station to input additional audio signals to all stations.

CLEAR-COM, 759 HARRISON STREET, SAN FRANCISCO, CA 94107.

Circle No. 136

### NEW MODERATE PRICED STUDIO AMPLIFIERS FROM SUNN

Both of these new Sunn amps are rated at 50 watts RMS. The bass amp has an enclosed cabinet with a 15" Sunn Transducer. The lead amp is open-back with two Sunn 10" transducers. The Studio Lead retails for \$399.00. The Studio Bass for \$379.00.

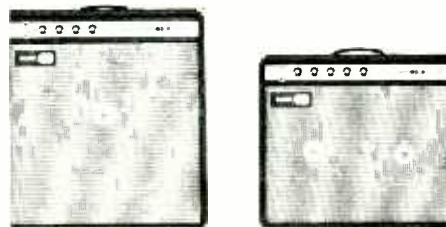

The Studio Bass has bright and normal inputs plus volume, bass, treble, and presence controls. The Studio Lead has the same control array plus a reverb level control. Both amps weigh about 60 lbs. — light enough for hand carrying.

SUNN MUSICAL EQUIPMENT COMPANY, AMBURN INDUSTRIAL PARK, TUALATIN, OREGON 97062.

Circle No. 137

### CLARK/4CH-A FOUR CHANNEL HEADSET

The David Clark Company announces its entry into the 4 Channel Headset market, the Clark/4 CH-A.



In addition to the Clark/4 CH-A Headset, the David Clark Company offers an accompanying DC-2A "Derived Ambience" Decoder designed expressly for 4 Channel Headset use with existing 2 Channel equipment and is physically separate from the headset.

The combination headset and decoder provides a complete system for 4 Channel Headset Listening. The owner uses his present 2 Channel equipment and plays 4 Channel program media, encoded records or FM.

Marketing and Development personnel at the David Clark Company felt the Clark/4 CH-A Headset and DC-2A Decoder System would fill a gap for the headset enthusiast who does not presently own discrete or matrixed 4 Channel equipment but, does desire 4 Channel listening. For those owning discrete or matrixed equipment with appropriate phone jacks the Clark/4 CH-A Headset may be purchased separately without the decoder at \$80.00 suggested list price. Headset and DC-2A decoder at \$95.00.

The exciting 4 Channel Sound produced by the Clark/4 CH-A Headset is due to the coupling volume which is greater than 100 cubic centimeters and provides a desirable acoustic source impedance. In addition, the decoded 4 Channel signal creates a greater spatial depth totally immersing the listener in the sound field. In spite of the large coupling volume, the moving-coil drivers are capable of low-distortion, high-level output at 30 Hz and uniform frequency response up to 16 kHz.

The decoder mixing ratio provides superb imaging — a strong central image simultaneously with strong left and strong right images. Soloists are unquestionably in the center (if the recording mix-down engineer wanted it that way).

DAVID CLARK CO., 360 FRANKLIN ST., WORCESTER, MASS. 01604.

Circle No. 139

## good grief, not another limiter!



How can we  
morally justify this contribution  
to the limiter population explosion? This way:

Independently adjustable average- and peak-responding limiting functions  
• Calibrated, detented controls to end setup guesswork • A "Slow A.G.C." mode to control long term level variations • An exclusive "Peak Hold" feature that "remembers" levels and automatically sets proper gain for mastering  
• Unique ripple-cancelling circuits for low distortion (even at low frequencies!) • Instantaneous gain state indicators and an optional meter that can be console-mounted.

The MODEL 200 Average and Peak Responding Limiter from:

**i** INOVONICS  
INCORPORATED

1630 DELL AVE. — CAMPBELL, CA 95008  
(408) 374-8300

# CLASSIFIED

## CLASSIFIED ADVERTISING RATES

Prepaid\* with submitted copy:  
One column inch (1" x 2 1/4") ... \$20.00  
1/2 column inch (1/2" x 2 1/4") ..... 14.00  
\*(If billing is required add 20%).

Send for **FREE** Catalog  
and Audio Applications



**OPAMP LABS**  
172 S. Alta Vista Blvd  
Los Angeles, Calif. 90036  
(213) 934 3566



Circle No. 152

## MULTI-TRACK

8 and 16  
TRACK RECORDING CONSOLES  
THE SOUNDEST DOLLAR SPENT  
IN PRO AUDIO TODAY  
1965 CHEREMOYA AVE.,  
HOLLYWOOD, CALIF. 90028  
P.O. Box 3187, Hollywood, CA. 90028  
(213) 467-7890

Circle No. 153

## EQUIPMENT AVAILABLE

ONE STOP FOR ALL YOUR PROFESSIONAL  
AUDIO REQUIREMENTS.  
BOTTOM LINE ORIENTED  
**F. T. C. BREWER COMPANY**  
P. O. Box 8057, Pensacola, Florida. 32505

USED MYLAR TAPES. L 1800 foot. Ten  
for \$8.50 postpaid. Fremerman, 4041  
Central, Kansas City, Missouri, 64111

AUDIO EQUIPMENT NEW AND USED  
whatever your needs. Whether you're  
building a new studio or re-modeling  
your present one, check us first for a  
package price. We will not be undersold.  
AMBOY AUDIO ASSOCIATES, 236  
Walnut St., South Amboy, N.J. 08879.  
(201) 721-5121

FOR SALE: 16 brand new MCI I.O.  
modules (the old model for the JH-416  
console)-\$500 each. Call or write  
Alan Kubicka, Sound House, P. O.  
Box 135, Roselle, Illinois, 60172.  
Phone: (312) 529-1001.

Langevin Custom Console: 11 In 2 Out  
(Wired For 3 Out) AM-16 Preamps  
AM-17 Program Amps W/Power Supply.  
Best offer.

Continental Recordings, Inc.  
12 Irving Square  
Framingham, Massachusetts 01701  
(617) 879-2430

2" x 10 1/2" Precision reels reconditioned  
as new - \$5.00 each.

ACCURATE SOUND  
P.O. Box 2159  
Garland, Texas 75041  
Telephone (214) 278-0553.

RECORDING / REHEARSAL STUDIOS  
For sale. In N.Y.C. 2 floors fully  
equipped & air cond. Incl. lux. 5 rm apt  
w/frplc & terrc. Estab, lucrative, low  
rent. Great potent. for expand. 212.  
OX 1-6661.

TELEX 230, four channel recorder with  
sel-sync and compressor for each  
channel. Write for particulars.  
HEAD SOUND, INC.  
7215 Jackson Road  
Ann Arbor, Michigan 48103

## EMPLOYMENT

ENGINEER WANTED: New country  
atmosphere 8 track studio in the Holly-  
wood Hills. Experienced. Possible  
partnership; live-in, share English three  
story house. Incredible potential.  
ROB DeMARS  
"THE MINE"  
5843 TUXEDO DR.  
HOLLYWOOD, CA 90068  
(213) 463-9584

Recording engineer with excellent 16-  
track experience to work in Washing-  
ton, D.C. Send resume to Track Re-  
corders, 8226 Georgia Ave., Silver  
Spring, MD. 20910

## POSITION SOUGHT

Experienced in professional  
lighting/sound control package design  
and construction. Solid technical  
background, BSEE with credits towards  
MSEE. Seeking design position in  
Southern California. For resume, reply  
to Box PM, 1125A Loma Street, Long  
Beach, California 90803.

"Engineer with electronics and 8-track  
experience needs a position as a record-  
ist or set-up man in a 16-track studio  
anywhere except L.A. Contact Scott  
Morrison, 2113 So. Garden, Visalia, CA  
93277 (209) 732-2747 after 5 pm."

Employment wanted: Engineer, exper-  
ienced in all phases of recording, mix-  
ing, maintenance, construction, and  
design as well as in music, seeking posi-  
tion with larger studio. Interest and  
expertise in music recording as well as  
commercial. For resume and further  
information write: Box WN R:e/p.





## Wally Heider and friend.



When Wally Heider, the internationally known master of the art of location recording, talks about recording techniques, we're very frank to admit that we listen! Imagine how pleased we were to hear him talking about our own SM53 unidirectional dynamic microphone in terms such as these: "The loudest guys in the world, screaming into them, won't break them up"; or "They sound good on any assignment"; or "The front-to-back characteristics are excellent"; or "Whenever I'm not locked into a performer's own microphone, I prefer to use the SM53." We can tell you about eight advantages that can make the SM53 your most effective and reliable recording microphone.

Shure Brothers Inc.  
222 Hartrey Ave., Evanston, Ill. 60204.

**SHURE**

Circle No. 140