

September 1985

£1.50

# STUDIO SOUND

AND BROADCAST ENGINEERING



ALINKHOUSE PUBLICATION

## MICROPHONES

# WE'VE GONE TO GREAT LENGTHS TO MAKE SERIES 600 THE ULTIMATE 16 TRACK CONSOLE.

The new Series 600 has been designed as the universal 16 track console. From 1/2" personal recording facilities to the professional 2" studio standard.

In analogue recording, the tape is the weakest link. Therefore, it's vital that whatever you put onto the tape is of the highest quality – whichever tape format you use.

At Soundcraft we've used all our latest technology in circuit design to ensure that the performance of Series 600 outshines any other 16 track console.

We've included internal line matching links and switches which enable the user to re-set the console from the professional +4dBu standard to -10dBV for 1/2" and 1" multitrack.

In addition to 16 equalised monitor channels which are separate from the input modules, Series 600 includes 16 LED bargraph meters, switchable peak/VU, plus two conventional VU meters on the mix buses.

Four auxiliary sends on each channel can be routed to six auxiliary buses. And the master module contains extensive monitoring facilities, including access to three two track sources for playback.

All line inputs and outputs (except input channel direct out) are balanced, utilising Neutrik XLR connectors. An external 19" rack mounting power supply allows for clean and stable DC voltages to the console.

Series 600 also incorporates many more features than you'd expect from a console so reasonably priced.

So, whichever tape format you use, you should go to great lengths to ensure your console is a Soundcraft Series 600.

1/2"

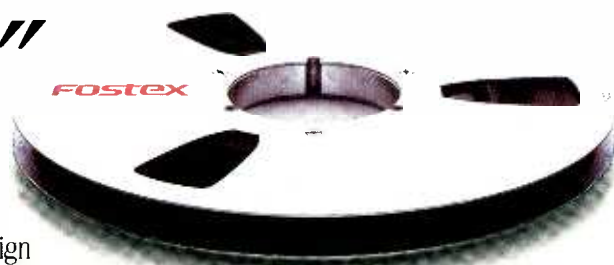

1"



2"



**Soundcraft Series 600**

Soundcraft Electronics Ltd., 5-8 Great Sutton St. London EC1V 0BX. Tel: (01) 253 6988. Facsimile: (01) 253 7118. Soundcraft Electronics USA, 1517 20th. St. Santa Monica, California 90404. Tel: (213) 453 4591. Facsimile: (213) 453 5634. Soundcraft Japan, 4F Yoyogi Living, 12-21 Sendagaya 5, Shibuyaku, Tokyo 151. Tel: (03) 341 6201. Facsimile: (03) 341 5260. Soundcraft Canada Inc., 1444 Hymus Blvd., Dorval, Quebec, Canada H9P 1J6. Tel: (514) 685 1610. Facsimile: (514) 685 2094.

# STUDIO SOUND

AND BROADCAST ENGINEERING

## SPECIAL FEATURES

**46** **The ribbon microphone:** The beginning of a two part article by Michael Gayford reflecting new interest in established technology

**50** **Vocalising on vocals:** The opinions of a discussion group on techniques and mic preferences when recording voice—reported by Janet Angus



## FEATURES

**64** **In perspective:** US correspondent Martin Polon writes on film sound in relation to stereo TV

**78** **Ambisonics—round and round:** Mike Skeet reports on overdubbing vocals using the *Soundfield* mic

**82** **Dark Rides:** Robert Simpson and Peter Smith describe a sound system at the British National Motor Museum which is the first to use solid state audio



**90** **A classical approach:** Janet Angus talks to Brian and Ralph Couzens of Chandos about classical recording and production techniques

## REGULARS

**5** **Editorial:** Keith Spencer-Allen takes a new look at old technologies

**26** **Diary:** APRS orders for Harrison—Azimuth Productions—Northern ASCE show—Address changes—Literature received—Forthcoming events—Corrections—Agencies—US stereo television—Apologies—State Group acquisitions—Contracts—Stolen—Real-time cassettes—Sterling service—saved by HHB

**32** **New products:** Sony AES launch—Loft 410 processor—Regentport Platinum console—Acoustic Physics Laboratories control room monitors—Barcus-Berry microphone—Digital tape from 3M—Coustone acoustic panels—Neotek Elite console—Timeline LYNX timecode module—Qu Play on cue—3M wire marking system—ACO Pacific ACM48UP microphone—Digital tape from Ampex—Munro Electronics amplifiers—Bodysonic transducer—In brief—Amek equipment—Beyer Dynamic HM 560 microphone—Powertran MCS-1 digital sampling unit—New Bel units—Audio Precision System One—Totalsystems bargraph meter

**40** **Music page:** Introducing a new column on electronic equipment for the studio, and software updates. U-Music MIDI system—SIEL software—E-mu SP-12 percussion system—Roland SBX 80 synchroniser—Steinberger/Roland guitar synth

**42** **Business:** CD sub-codes—Four into two. By Barry Fox

**66** **Studiofile:** The Burbank Studios, Hollywood—Studio 21, Yorkshire



### EDITORIAL

**Editor:**  
Keith Spencer-Allen  
**Assistant Editor:**  
Carl Anthony Snape  
**Production Editor:**  
Ann Horan  
**Production Assistant:**  
Beverley Hudec  
**Consultant:**  
Hugh Ford  
**US Commentator:**  
Martin Polon  
**Contributing Editor:**  
Richard Elen  
**Secretary:**  
Carrie Love

### ADVERTISEMENTS

**Advertisement Manager:**  
Kerr Duffy  
**Secretary:**  
Mandy Paul  
**Production Manager:**  
Jacky Thompson  
**Japan and Far East Agent:**  
Media Sales Japan Inc. Tamuracho  
Bldg 3 3 14, Shimbashi Minato-Ku  
Tokyo, Japan  
**US West Coast Agent:**  
Herb Schiff, 1408 Santa Monica Mall  
Suite 200, Santa Monica  
CA 90401 USA

**COMMERCIAL MANAGER**  
Phil Guy

**Cover:** Old familiar shapes.  
Photography by Tony Petch.



Editorial and advertising offices:  
LINK HOUSE, DINGWALL  
AVENUE, CROYDON CR9 2TA,  
GREAT BRITAIN  
Phone: 01-686 2599  
International: +44 1 686 2599  
Telex: 947709

© Link House Publications  
PLC 1985. All rights reserved.

 A LINK HOUSE  
PUBLICATION

Publisher and consultant to  
APRS for Studio Sound's  
Producer's Guide to APRS  
Members 1984/85

September 1985 Number 9  
Volume 27 ISSN 0133-5944



# This much power in this much amp.



The Amcron tradition of peerless performance was established with the introduction of the legendary DC300 series in 1967. Now, in 1985, on the back of modern technology and two decades of experience, Amcron bring you the Micro-Tech 1000 amplifier.

The Micro-Tech 1000 is the amp we've all been waiting for - lightweight, compact, and with more than enough punch to suit the increased power requirements of the digital age. These are the facts:

- 400 watts RMS per channel into 4 ohms.
- 500 watts RMS per channel into 2 ohms.
- 1000 watts RMS into 4 ohms - bridged mono.
- Safe operation at high power to 1 ohm.

- Reversible forced-air cooling.
- Amcron performance in 3½" rack space.

We believe that these facts, coupled with Amcron's reputation speak for themselves. But if you wish to know more about the Micro-Tech 1000 and how it can solve your headroom problems, call HHB Hire & Sales at: Unit F, New Crescent Works, Nicoll Rd, London NW10 9AX. Tel: 01-961 3295. Telex: 923393.



# EDITORIAL

# EDITORIAL

This month's comment from Keith Spencer-Allen

## Something old, something new?

We should never make the mistake of thinking that we necessarily know any more in total than past generations—just more about certain specific areas and less about others. This is reinforced by the way we can learn a lot by looking at the past and maybe see something of use for the future or even the present. Some discoveries and developments remain dormant for many years apparently just waiting for the 'future' to pull them out, dust them off and try to make them meet a new requirement. A very good example of this latter point is of course PCM technology, the basic elements of which were developed during the thirties and forties although applications within the area of professional audio processing are of course far more recent.

It is therefore quite fascinating that such a 'hi-tech' development should be responsible for revitalising interest in another technology—'hi-tech' in its developing years—that appears to be all but forgotten except for a small minority of users although it was high technology in its developing years. I am referring to the ribbon microphone.

Those of you who started engineering more than 15 years ago will be familiar with the problems—the mics are delicate, often too delicate for use with many of the sources that you felt that they would be best at; they were often large and most important they seemed to spend half their life at the repairer's being re-ribboned. In the same way that it was convenient to get shot of the valve (tube) mics not having to rely on ribbons was good. With more choice of microphones available these days, it is now of course possible to use mics for the purposes that they fulfil best. Without a doubt ribbon mics have numerous uses particularly in the area of distant or ambient miking. They form a good partnership with digital recording as the sound is quite often uncoloured (relatively) and of course being dynamic, they are quiet. Many users are now rediscovering the ribbon—witness the marketing angle seen from one distributor: finally perfected after 30 years development!

There are to our knowledge, few manufacturers of ribbon mics left perhaps just Coles, Beyer and Speiden. Fostex have developed the printed ribbon, which is a cross between the moving coil dynamic and a ribbon, but there is little more to choose from. Which all brings us to the contents of this issue. We start a two part article on the ribbon mic which may either refresh memories or be a complete introduction to a increasingly popular type of mic—once again.

While on the subject on increasing and declining—we have another discussion feature which is this time between four respected British engineers on the topic of vocal microphone technique and vocal recording in general—

possibly the only remaining recording technique that engineers *have* to learn to varying degrees, there not being a satisfactory DI short cut! The idea was to cover some current practices and ideas rather than teach which is probably not possible anyway. We also have the first of an occasional series on classical techniques as practiced by engineers (and due to the nature of the classical recording world these will most likely be based around companies rather than individuals).

Lastly, and by no means least, we have our survey of microphones in current use for recording vocals. We sent out nearly 250 questionnaires worldwide to recording engineers in a wide cross section of studios asking 'difficult hypothetical' questions that proved too much for some. As the response has been good and the questionnaires are still coming in, I have decided not to publish full details this month but give those who haven't replied yet, more time; this will also allow us the opportunity to analyse the results more deeply. Although the questionnaire may have seemed too black and white to some, the results are forming a pattern and throwing up some interesting aspects. Thanks to all who have participated so far and those of you who are still agonising over your choices.

## And something to stop!

Not all ideas from the past are commendable. The CD 'jewel case' housing is not perfect but protects the disc, is aesthetically pleasing and provides hours of fun when novices try to open the case (now try it with one hand/your eyes closed, etc). There are current moves to replace this case with an inferior cardboard type sleeve for reasons that have no logic at all. There is one very good reason, however, for not making this retrograde step. The more familiar you become with CD you realise it is not quite the robust medium that the original launch publicity had us believe. If one practises the same degree of care as with vinyl discs then for all intents and purposes there is a permanent life to the disc. Cleaning instructions, however, state that all movement with the cloth should be radial—from the centre outwards. With a sleeve—an idea just passable for 78's—scratches from the card/paper and enclosed atmospheric dust will be inflicted on the surface of the disc. As you slide the disc in and out these scratches will certainly only be radial for a very small section of the disc and we may find a vastly shortened version of 'forever' more appropriate. □

**STUDIO  
SOUND**  
AND BROADCAST ENGINEERING

STUDIO SOUND is published on the second Friday of the preceding month. The magazine is available

on a rigidly controlled requested basis only to qualified personnel (see back page for terms) or for an annual cost of £18.00 UK, \$40 US surface mail, \$75 US airmail, £24.50 overseas surface mail or £46.50 overseas airmail to non-qualifying readers or where more than two copies are required in a studio or small organisation. New subscription enquiries should be sent to the Croydon address on page 3. All other enquiries should

be made to Studio Sound Subscriptions, Link House Magazines Ltd, Central House, 27 Park Street, Croydon CR0 1YD. Tel: 01-760 0054.

US mailing agents: Postmaster please send address corrections to Studio Sound, c/o Expeditors of the Printed Word Ltd, 515 Madison Avenue, New York, NY 10022.

Total average net circulation of 13,981 per issue during 1984. UK: 5,735. Overseas: 8,246. (ABC audited).

Studio Sound and Broadcast Engineering incorporates Sound International and Beat Instrumental. Printed in England.

ABC

MEMBER OF THE ASSOCIATION OF PUBLISHERS

# Serious Effects, Sale or Rental.

Now you can buy or rent the best range of studio processors available from Music Lab



■ **AMS RMX16** 9 program plus "soft shoe" locations for previously issued programs, optional 99 memory remote control/bar code reader, optional delay memory extension (1600m/s).



■ **LEXICON 200** 6 program digital reverb, stereo in/out, 9 memory.



■ **LEXICON PCM60** 2 program (room/plate) digital reverb with suitable size and decay settings, and bass/treble cut off.



■ **BEL BD80** up to 8 seconds digital sampling, full bandwidth, external trigger, loop edit facility, VCA.



■ **DRAWMER DS201** 2 channel stereo linkable noise gate, frequency conscious keying with adjustable attack, hold and decay controls.



■ **KLARK TEKNIK DN780** Now available, new digital reverb offering choice of simulated plate, hall, chamber, or room settings. 39 presets and 50 available stores.



■ **APHEX AURAL EXCITER TYPE B** Psychoacoustic processor, fast becoming standard studio tool.



■ **ADA STD-1** Stereo tapped delay image processor, multivoice chorusing, true stereo flanging, holographic positioning, true stereo outputs, stereo outputs from mono source.



■ **AMS DMX15-80S** 2 channel digital delay available with up to 32 secs at full bandwidth, full loop editing, VCA, external trigger, 9 memory locations, optional pitch change cards/de-glitch cards, plus optional DMX-K Interface allowing sampled sounds to be played under keyboard control.



■ **LEXICON 224XL** The ultimate digital processor featuring all hyperthetical reverb programs plus many effects and split programs. LARC Remote/control, 60 stores.



■ **DRAWMER VACUUM TUBE 1960** Dual compressor limiter using vacuum tubes in conjunction with semi conductors. Soft-knee compression characteristics. Classic valve guitar sound, stereo linkable.



■ **DRAWMER DL221** 2 channel, stereo linkable compressor/limiter, variable threshold, ratio, attack release, separate peak limiter, VU and gain reduction display.



■ **BSS DPR 402** 2 channel compressor limiter, de-esser and peak limiter. All facilities available at once, stereo linkable.



■ **DBX166** 2 channel dynamics processor featuring gating, over-easy compression, gain reduction LED display.



■ **RANE HC6** six stereo headphone amplifiers in a single rack space, individual volume controls. Up to six separate mixes available.

**MUSIC LAB SALES 01-388 5392**

**MUSIC LAB HIRE 01-387 9356**

72-76 EVERS HOLT STREET, LONDON NW1 1BY, TELEX: 28159 MUSLAB G

# We're extending our Otari backup - to everyone.

When we took on Otari, the best thing we did was to invest in the finest service engineers.

As a result, our reputation for backup is as powerful a sales tool as any advertisement which we have ever run.

Our investment in support of Otari goes far beyond the tens of thousands of pounds in backup spare parts.

Our engineers are 'factory trained' and we maintain very close contact with Otari engineering staff. We run monthly tech meetings during which finer points of operation and backup are clarified.

Every machine we deliver undergoes a major checkout of transport and electronics. Commissioning involves a final line up that brings the machine tight in on spec. It is our experience that these machines perform well inside their quoted tolerances.

And of course, for a full year of warranty or more thereafter, we make sure that the machine runs true.

We're flexible too. To give the studio industry the backup it needs our service often extends beyond normal hours.

The result of our commitment to the Otari range of products is our enviable reputation for service and backup.

Good news in this industry travels fast and far. Over the past year, Otari customers that our sales department did not find first, have found our service department!

So, we're now offering out our expertise publicly.

Wherever you bought your Otari, new or old, we extend our services to you.

We insist on an overall line up at the first visit. From then on, you will receive the same attention as any Otari owner we deal with now. (Of course original Otari from Turnkey customers get this service free or at a special preferential rate!).

Call Mike Paige for full information on Otari backup, or speak to Jon Ridell for Otari sales. No one offers a more comprehensive service of supply, installation and backup.

**turnkey studio systems**

Brent View Road, London NW9 7EL Tel: 01-202 4366



# ASONA for Complete Cassette Production

ASONA offers a complete program of tape duplication and winding systems.

The ASONA loop-bin, a high-speed master tape reproducer, feeds and controls up to 40 slave recorders. Long-life ferrite heads provide flat frequency response and high dynamic range.

Available for 16 : 1 and 32 : 1 duplication ratios for a variety of tape formats.

Robust construction, with a minimum of moving parts.

Low maintenance requirements, low personnel costs.

Economically priced.

## ASONA High-Speed Loop-Bin

The loop-bin/slave system employs neither compressed air nor vacuum. Completely self-contained; requires only one mains connection.

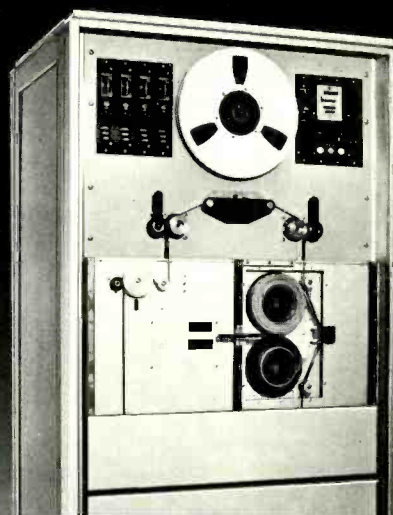

**We can tailor a cassette production system to your needs.  
Write or call for a proposal.**

ASONA is manufactured in West Germany by AUVIS.ASONA GmbH & Co. KG, Bahnhofstraße 60, D-7634 Kippenheim  
Tel.: (0)7825-1068, Telex: 754325 auvis d

# IS YOUR EDUCATION COMPLETE?

**C~duce** (c-diū·s). *v.* To lead sound engineers astray from habitual use of microphones, stands and isolation booths. To include commitment to studio quality sound with maximum separation at a cost effective price. To persuade abandonment of setting-up problems and clutter in the studio or on stage, by attractive thing or quality.

**C~duceable** (c-diū·sāb'l). *a.* Drums, Congas, Bongos, Timbales etc., Acoustic Guitar, Mandolin, Lute, Balalaika, Violin, Cello, Double Bass, Harp, Banjo, Piano, Harpsichord, Celeste, Dulcimer, Zither, Speaker Enclosures, Solid Electric Guitars et cetera.

**C~duces** (c-diūsī·s). *n.* Dire Straits, Stevie Wonder, Chick Corea, Toto, Willie Nelson, Kris Kristofferson, Spandau Ballet, Grand Ole Opry, Abbey Road Studios, PRT Studios, Lansdowne Studios, Olympic Studios, Limehouse Studios, Sydney Opera House, National Theatre, Royal Opera House, BBC Radio & TV, Danish Radio, Swiss Radio, German Radio, Dutch Radio, London Weekend Television, Anglia Television, Scottish Television, Mobile Studio, *et al.*

**C~ducer** (c-diū·sər). *n.* Studio quality contact microphones.

**C~ducer**

**C-TAPE DEVELOPMENTS LIMITED**

Unit 19, Holder Road, Aldershot, Hampshire GU12 4RH  
Tel: (0252) 319171 Telex: 858623



# Are you ready for a new mixing console?

A major decision like the choice of a new console is not to be taken lightly.

If you pass the test below, we can help you to select your next major investment.

From eight track upgrades to major studio refurbishment, we have wide experience of every aspect of console supply.

We can arrange demonstration or a full hands-on evaluation. We can answer every question about interface and installation. We can customise in many cases to your exact requirements.

And when it comes to the deal, we naturally offer the best price and terms.

Sooner or later, the time for a new console arrives. We offer a wide range of choice from major manufacturers with complete support in finance, installation and backup.

Call David Whittaker or Jon Ridell and find out more about our products and services.

**turnkey studio systems**

Brent View Road, London NW9 7EL Tel; 01-202 4366

Yes No If you keep your present mixer much longer, will it become too old to realise a good price?

Yes No Do you find the need for more line inputs to cope with the many outputs from sequencer controlled instruments?

Yes No Is upkeep costing more or is the mixer built in a way that's difficult to service?

Yes No From what you know, would you say that there are more up to date, quieter and faster amplifiers than the ones in your present desk?

Yes No Are you using more effects and building reverb fields so more returns or inputs are necessary?

Yes No Do you think a more prestigious manufacturer would attract more clients?

Yes No Do you plan to move on to more tracks and more comprehensive monitoring in your setup?

Yes No Is your patchbay external, so awkward to work with, or simply not versatile enough for all the latest production techniques?

Yes  No Would a new mixing console improve your own performance?

# THE ULTIMATE

As a main stereo microphone you get an image that is clean, clear, and rock steady at all frequencies.

As a Vocal microphone you get close mic presence from 3 feet away.

And you can always zoom, steer, rotate and vary width either live or in mixdown.

The CALREC Mark IV Soundfield Microphone is now recognised as the most accurate and versatile studio production microphone ever produced.

Arrange a demonstration with your distributor -  
AND JOIN THE NEW FASHION, NOW!



## THE SOUNDFIELD MkIV STEREO MICROPHONE

**Audio Design  
CALREC  
LIMITED**

**AUDIO DESIGN CALREC LTD**  
PO BOX 182  
READING RG2 9BA - ENGLAND  
Tel: 0734 861088 Telex: 848722

**AUDIO DESIGN CALREC, Inc.**  
PO BOX 786  
BREMERTON, WA 98310 - USA  
Tel: (206) 275 5009

and Distributors Worldwide

# A SIGHT FOR SORE EARS.

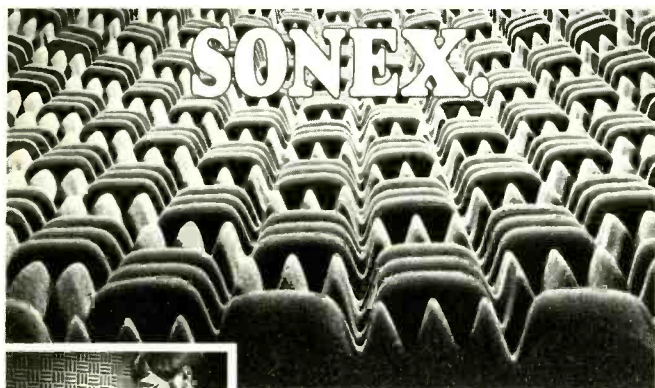

If ears could talk, they'd scream for SONEX. The only patented acoustic foam with a specially sculptured anechoic design can replace traditional studio materials for a fraction of the cost. SONEX absorbs sound,

controls reverb, eliminates stray reflections, and kills standing waves. What's left is true sound. Your ears know. Listen to them. Simple to apply and economical to buy, SONEX blends with almost any decor and looks clean, sharp, professional. Call or write us for all the facts and prices.

SONEX is manufactured by Illbruck and distributed exclusively to the pro sound industry by Alpha Audio.

**Alpha Audio**  
2049 West Broad Street  
Richmond, Virginia 23220 (804) 358-3852  
Acoustic Products for the Audio Industry

## Success is Good Timing

*A Synchroniser That Speaks Your Own Language!*

Our brand new **CM250** synchroniser is a two part rack-mount and control unit that should make synchronising audio to video and audio to audio a great deal simpler.

The control unit has an 80 character LCD display to give full information on the status of the system.

It even has a 'help menu' in a choice of languages to guide you through the various functions of the system. The CM250 is totally SMPTE compatible and incorporates a code generator with later software options for event controlling. It's available now for all current U-Matic and professional VHS machines with interfaces for a wide range of audio multitrack machines. There is so much new and exciting to say about this system, you'll simply have to contact us for more information.

### Applied Microsystems

Bagshot Road, Chobham, Woking, Surrey GU24 8BZ.  
Telephone: (09905) 6267. Telex: 8952022 CTYTEL G.

AUSTRALIA: Klarion Enterprises, (03) 613541. CANADA: Gerr Electro Acoustics, (416) 968-0528. DENMARK: AB Music, (06) 198733. FRANCE: Studio Du Hitbou, (76) 880158. GERMANY: S.C.S., (71 59) 7222. HOLLAND: P.A.C., (040) 424455. ITALY: Startek, (051) 321063. NORWAY: Audiotron, (02) 3520 96. NEW ZEALAND: Maser Communications, (444) 3583. SOUTH AFRICA: Eltron, (011) 293066. SWEDEN: Stage & Studio, (031) 2240 90. SWITZERLAND: EMM Studio, (061) 728972. U.K: Don Larking Audio Sales, (0582) 450066. In the USA, call: (213) 854-5098.

# Now you can audition the latest processing, by simply using your telephone.

There are now more than fifty studio rack mounting processors imported exclusively by Turnkey.

We've assembled our wide range from specialist manufacturers in the US.

**ART** Originally the MXR company. Still producing ultra-clean graphics and now digital reverb systems.

**APHEX** As well as the type A and B Aural Exciters, innovative signal levelling products such as the Compellor and Dominator are available.

**Ashly** Particularly six electronic crossovers, well established in the sound reinforcement field. Also power amps and level control.

**DOD** More cost effective graphic equalisers and now 'Digitech' branded delays and effects too.

**Studio Technologies** Their leading product is a highly acclaimed stereo simulator that must be heard.

**Symetrix** Experts in dynamic level control. As well as comp/lim/gate products they produce a remarkable single ended noise reduction unit.

**Valley People** Kepex and the latest Gain Brain continue their success as specialist level control devices. A new sibilance control is now available.

## Our unique auditioning offer

In the first place you'll need a copy of our new 48 page signal processing catalogue.

This contains facts and figures as well as reviews and opinions on the products we sell.

If you did not get a copy during the APRS, call and we'll send you one immediately.

When you've read the descriptions and reviews, and identified the products that interest you, give Tony Williams a call.

On completion of some simple formalities Tony will arrange a demoloan for you. This will allow you to audition these exclusive products at your own studio, and in your own time.

Our demoloan is a unique, no obligation way to evaluate many new and innovative signal processors. Call for full details now.

**turnkey studio systems**

Brent View Road. London NW9 7EL Tel; 01-202 4366



# ACOUSTICAL INTERFACE™ SYSTEM

precision acoustical measurements  
with your FFT, scope or meter

## PS9200 POWER SUPPLY

- Dual Channel
- 9V "Radio" Battery
- Portable
- 50 Hours Operation
- Low Noise
- LED Status Indicator

## 7000 SERIES MICROPHONES

- Type 1 Performance
- ¼, ½ and 1 Inch Models

## 4000 SERIES PREAMPLIFIERS

- 2Hz to 200kHz ± 0.5db
- Removable Cable
- PS9200 and 7000 Series Compatible



## NEW LOW COST PRECISION MEASUREMENTS

- SINGLE CHANNEL SYSTEM UNDER \$1,200
- DUAL CHANNEL SYSTEM UNDER \$2,000  
(½ or 1 inch microphones)

© 1984

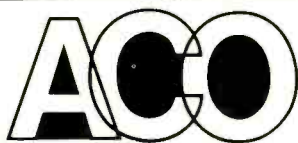

**ACO Pacific, Inc.**  
2604 Read Avenue  
Belmont, CA 94002  
(415) 595-8588

ACOUSTICS BEGINS WITH ACO

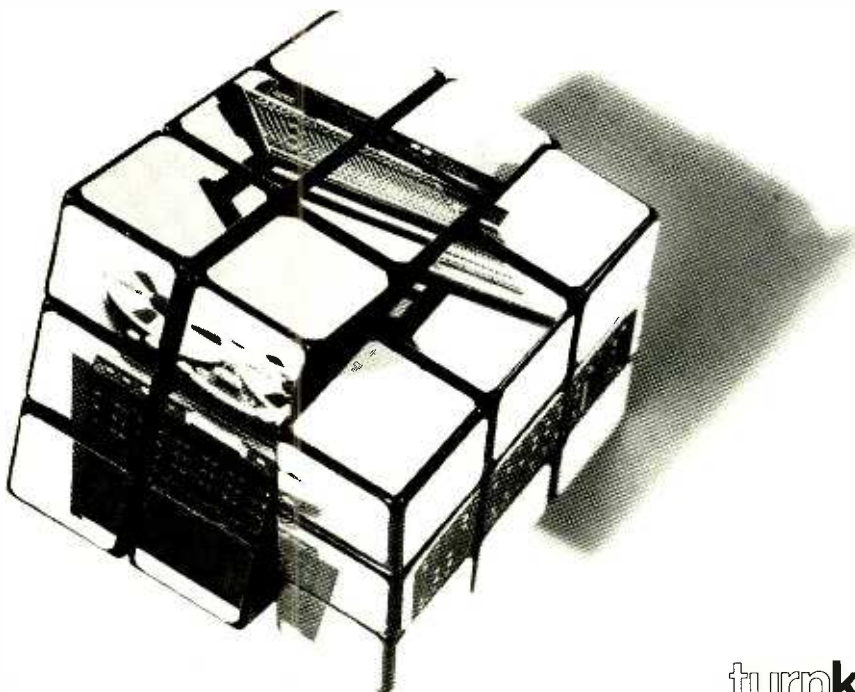

**turnkey studio systems**

# Still spending too much?



contact your dealer or us and you'll find out that you can pay less for more.

● **SERIES 8000**  
in-line mixing desk in 24/32 in/output channels, 24 subgroups, 8 aux-sends, 4 band parametric equalizer, 'solo in place', patch-panel, automation optional.

● **SERIES 4000**  
in-line mixing desk available from 8 to 32 in/output channels, 4 band sweep eq., 6 aux sends, separate monitor fader, +4/-10 levels, automation optional.

● **SERIES 2000**  
in-line desk in 10, 20 or 30 channels, 4 band sweep eq, Floating Subgroup System, 4 aux sends, effect returns per channel.

● **SERIES 1500**  
in-line desk in 8, 16 or 24 channels sweep equalisation, Floating Subgroup System, separate monitoring.

● **SERIES 300**  
19" rack mounting desk 8 channels, stereo channels optional, for location-recording, video-post production etc.

● **SERIES 200**  
6 channel desk with 4 outputs, 3 band eq., patch bay, etc.

● **BISCOM I**  
Production mixer for broadcast and discotheques, stereo channels, 19".

● **SERIES 900**  
The D&R PA and recording desk. 8, 16 or 24 inputs, 4 or 8 subgroups, 8 or 16 returns, sweep eq., 3 aux sends, -20dB pad, phase rev., channel mute.

● **SERIES 700**  
PA desk in 6, 12, 18 or 24 channels, sweep eq., 3 aux sends, stereo-channels with RIAA optional.

ANCILLARY EQUIPMENT; our program consists of module and 19" equipment with the following items: compressor-limiter, stereo limiter, noise gate, param. eq., compander- and high-com system, disc-amp, led-bar, phase meter, high- low pass filter, stereo reverb, patch-panels, DI box, cable tester.

U.K. Studio Spares London, FINLAND Lahti Sound Lahti, FRANCE Mettler Audio Paris, ITALY CEM Elettronica Varallo Pombia, NORWAY Jon Vedum Oslo, SWEDEN Music Workshop Stockholm, SWITZERLAND Isler ag Zuerich, GERMANY Sound Service Berlin, BELGIUM ASE Mechelen, CANADA J Mar Toronto, USA J Ray Associates Atlanta.

**D&R** THE ULTIMATE MIX  
electronica b.v.

SEE US AT THE SALON DE LA MUSIQUE, PARIS  
AND AT AES - NEW YORK

rijnkade 15 b 1382 gs weesp holland -2940-18014\* tlx 18503 dr nl  
production and design of mixing consoles and ancillary equipment

# AUDIO SERVICES

BRITAIN'S LARGEST MULTITRACK STORE  
OVER SEVEN THOUSAND SQUARE FEET OF MIXERS,  
TAPE MACHINES, HI-TECHNOLOGY KEYBOARDS,  
EFFECTS & PA.

## WE ARE HERE



7 miles from MANCHESTER AIRPORT  
2 miles from INTER CITY BRITISH RAIL  
Easy access to Motorway, yet nestles in quaint village.

06632 4244 (6 LINES)

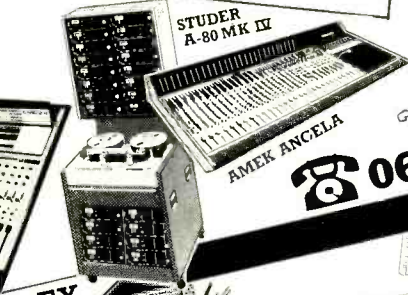
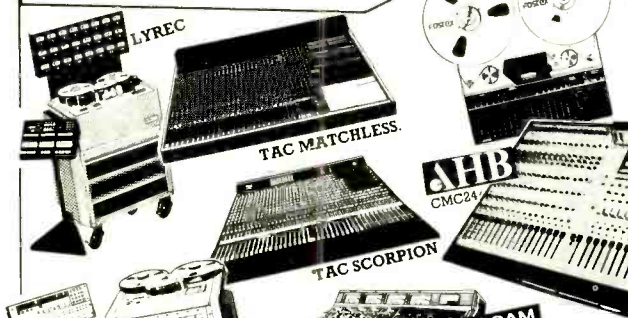

**EXPERIENCE...** This is the ultimate in showrooms... 3000 watts of JPL/RSD MOSFET power. Our sales staff are highly trained in the programming and technology of Midi keyboards and computers. They will be able to help you choose which system is right for you and because our range is so vast there is no bias towards one particular brand. So whether you are new to the world of Midi and want to gain informative tuition or you simply require to upgrade your system, then there is no substitute for experience.  
Call Tim Eastwood on 06632 4244

**ON DEMO NOW!**

**POWERED BY**  
STUDIOMASTER  
MOSFETS  
YAMAHA  
& QUAD



**A LOT OF OUR OWN KEYBOARDS HAVE NOW EXPIRED THEIR "SELL-BY" DATE!**  
**SELECTION OF OVER-RIPE PERISHABLES...**



06632 4244 (6 LINES)  
STUDIO HOUSE, HIGH LANE VILLAGE, NR STOCKPORT  
SK6 8AA. TELEX 665721 SOTA.



Stellavox SP 8  
Recorder

**The lightweight portable with heavyweight features.\***

- \* 4.9 kg Total operational weight.
- \* EBU SMPTE Time-code generator version available.
- \* Universal option includes mono neo-pilot compatible, mono synchrotone and stereo synchrotone.
- \* Optional plug-in 50 60 Hz synchronizer.
- \* Very low power consumption (90-110 mA).
- \* 6 Simultaneous inputs: 2 x mike, 2 x variable line, 2 x fixed line.
- \* Passive big reel adaptor allows up to 12" spools to be used, including NAB.

**STELLAVOX** SWITZERLAND © 2068 Hauterive-Ne,  
Switzerland. Tel: 038 33 42 33.  
Telex: 35 380.

UK Distributors: FUTURE FILM DEVELOPMENTS, 114 Wardour Street, London W1V 3LP, England.  
Tel: 01 434 3344 & 01-437 1892 Telex: 21624 ALOFFD G. Cables: Allotrope-London W1.

**For every connection...**

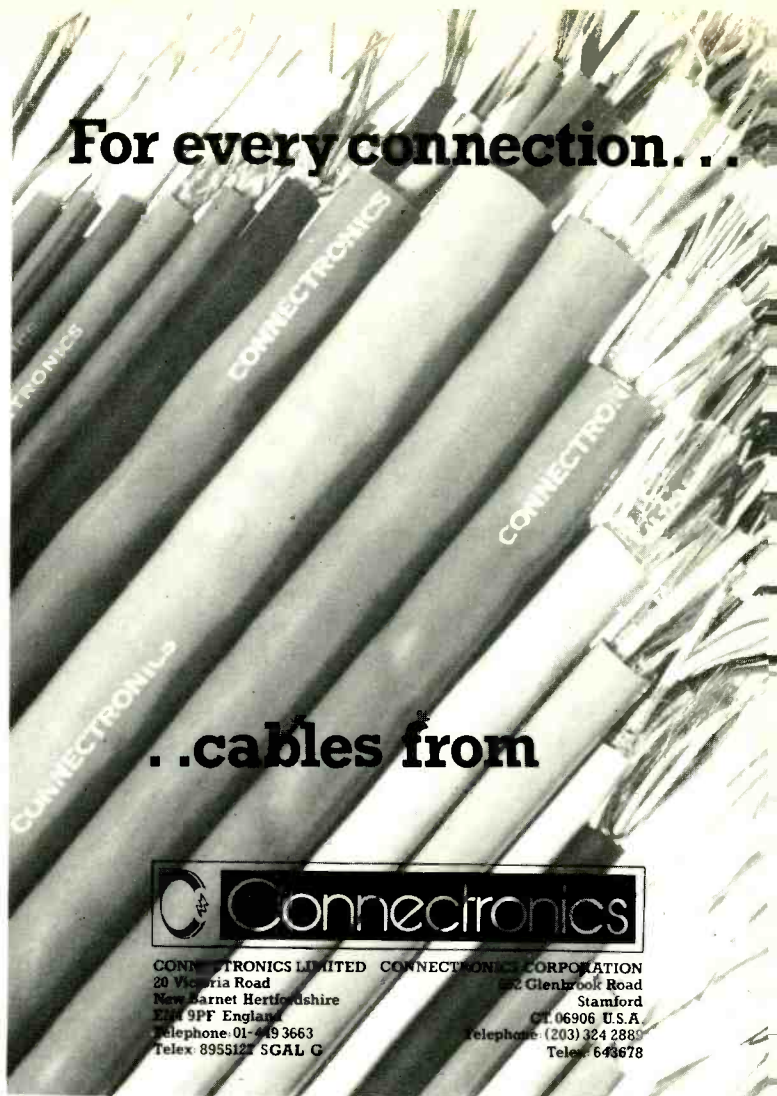

**...cables from**



**Connectronics**

CONNECTRONICS LIMITED    CONNECTRONICS CORPORATION  
 20 Victoria Road    22 Glenbrook Road  
 New Barnet Hertfordshire    Stamford  
 EN4 9PF England    CT 06906 U.S.A.  
 Telephone: 01-449 3663    Telephone: (203) 324 2885  
 Telex: 895512 SGAL G    Telex: 643678

# HARDWARE HOUSE



As UK distributors for Nady radio systems and Countryman microphones, we have brought together two products which between them can produce the high dynamic range and audio quality essential for live performance.

To find out more about these and our full range of technical and engineering services and equipment rental, phone us on:

## 01-986 6111

**Hardware House (Sound) Limited**  
 West Works, Chalgrove Road, Morning Lane, London E9 6PB  
 UK distributors for Nady radio systems and Countryman microphones.  
 Dealers for AMEK/TAC (live performance), Amcron, Court, JBL.





# STUDIO SPARES

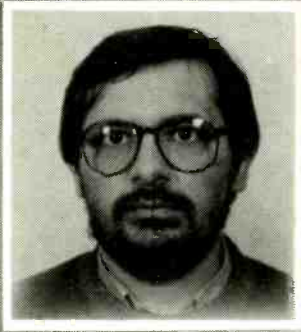

I buy my gear almost exclusively from Studio Spares in England on my Visa Card because of their efficiency and very friendly service which by far exceeds the ordinary.

*Aleksandar Stojanovic* Aurora Studio, Norway  
The worlds most northern studio

A call to the Studio Spares trade counter is our guarantee of delivery through our door within 90 minutes everytime

*Simon*

F.2. Studios London

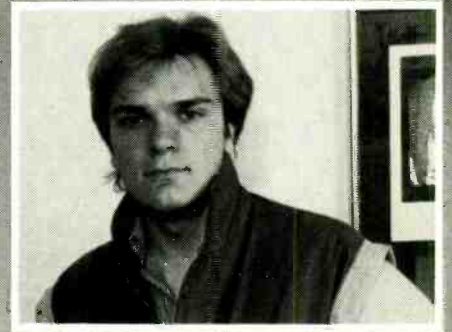

Located within 5 miles of Lands End did present us with supply problems - until Studio Spares showed everyone the real meaning of a 24 hour service.

*John Morris*

Sentinel Records Cornwall

Sentinel  
Records

We simply need a supply service to match our ever changing requirements. Fast and friendly everytime - Studio Spares is the answer

*Charles Barrett*

Terminal Studio London

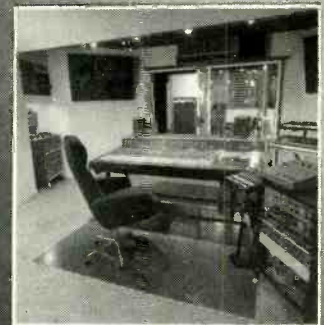

# STUDIO SPARES

**YOU GET A FREE  
WITH EVERY**



# PAIR OF HANDS MASTER MIX



Remember the old days? That homely atmosphere you got in the control room as the musicians and their roadies gathered round the console to help you with faders on the final mix? That wonderful sense of achievement that greeted you as, finally, the drummer's roadie managed to bring the brass section in on cue after the hundredth attempt? What you needed was an extra pair of hands – and that was on sixteen-track.

Now, thank goodness, those days are passed. Now you have Master Mix, by Audio Kinetics. The independent console automation system. It's easily fitted to your automation-ready console, and to many others with the addition of the Master Mix VCA fader system. You'll hardly know it's there – until you need it. Master Mix doesn't interfere with your normal mixing process – it enhances it. It remembers your fader movements, your channel muting, your chores. No longer do you have to go over the same complex sequences time and again, because Master Mix remembers it the first time. Instead, you can concentrate on the music. Isn't that what you were trying to do in the first place?

And the free pair of hands? They're yours.

Audio Kinetics Ltd.  
Kinetic Centre, Theobald Street,  
Boreham Wood, Hertfordshire,  
WD6 4PJ England  
Tel: 01-953 8118 Telex 299951

Audio Kinetics Inc.,  
4721 Laurel Canyon Blvd.,  
Suite 209, N. Hollywood,  
California 91607, USA  
Tel: (818)980 5717



**AUDIO KINETICS**

# Our standards are even higher than yours

DIBOX II	Active direct box
DIP	Passive direct box
PC80	Phase checker system
SRL2	Dual compressor-limiter, de esser
RBS2	Stereo spring reverb
NGS2	Frequency selective noise gate
EQ 213	Dual 13 band, 2/3 octave EQ
EQ 128	28 band 1/3 octave graphic EQ
EQ 228	Dual 28 band 1/3 octave graphic EQ
RE 209	Stereo, parametric room EQ
M 222	Stereo, 2 way crossover
FA4-2	Stereo, 3-4 way crossover
UB 280 series	Universal buffer
824 series	Active mic splitter

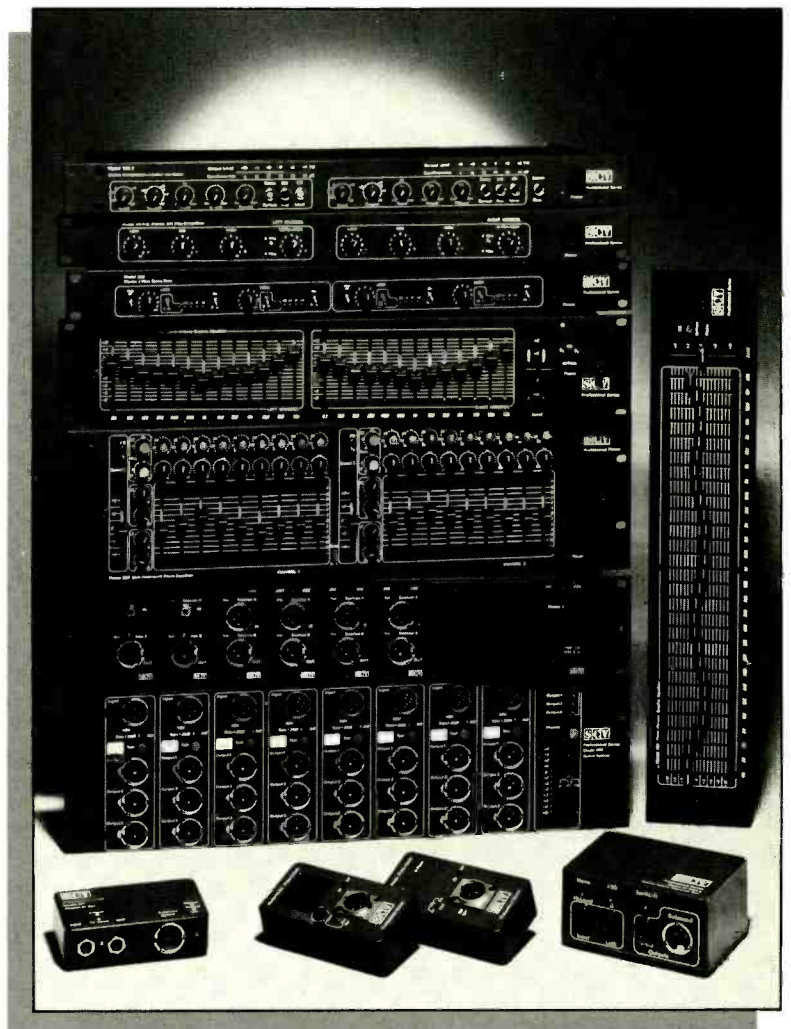

## DISTRIBUTORS

### AUSTRALIA

AR audio engineering  
59 Bristol rd, Hurstville 2220,  
Sydney — Australia  
Tél.: (02) 57.12.36  
Contact: Anthony Russo

### BELGIUM

Inelco  
Avenue des Croix de Guerre, 94  
1120 Brussel  
Tél.: 32.02.216.0160  
Tlx.: 22 090  
Contact: Luc Vandeneynde

### CANADA

SF Marketing  
312 Benjamin Hudon, St-Laurent  
Québec H4N1J4  
Tél.: 514.337.6113  
Tlx.: 826 765  
Contact: Sol Fleising

### GERMANY

BFE  
An der Ochsenwiese 6  
6500 Mainz/Gosenheim  
Tél.: 06131/463  
Tlx.: 187 300  
Contact: Bodo Feldmann

### ISRAEL

Sontronics electronic equipment Ltd  
103 Nordau BLVD P.O.B.  
21511 Tel Aviv  
61214 Israël  
Tél.: 03.44.22.33  
Tlx.: 361 579  
Contact: Sonny Shmueli

### ITALY

Audio equipment S.R.L.  
20052 Monza Mi  
Via C.Rota, 37  
Tél.: 039.836767  
Tlx.: 323668  
Contact: Giuseppe Porro

### NORWAY

Nortek  
Nydalsveien 15,  
0483 Oslo 4.  
Tél.: (02) 23.15.90  
Contact: Truls Berger

### SOUTH AFRICA

Tru-Fi electronics  
4 a Chadwick avenue,  
Wynberg, Sandton  
P.O. Box 84444  
Tél.: (011) 786.71778  
Tlx.: 4 28708SA  
Contact: Flemming Ravn

### SWEDEN

Tal & Ton Ab  
Kampegatan 16 S; 41104  
Goteborg  
Tél.: 031803620  
Tlx.: 27492  
Contact: Jan Setterberg

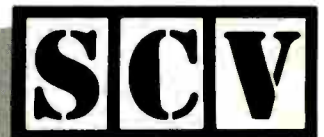

## PROFESSIONAL SERIES

USA SCV Inc.

414 North Spark St.  
91506 Burbank USA  
Tél.: 818.8437567  
Contact: Ron Fuller

FRANCE S.C.V. Audio

186 Allée des Érables  
ZI Paris Nord II BP 50056  
95947 Roissy C.D.G. Cedex  
Tél.: (1) 863.22.11 Tlx.: 212802  
Contact: Richard Garrido

# MS-MULTIMIX

## TOTALLY MODULAR

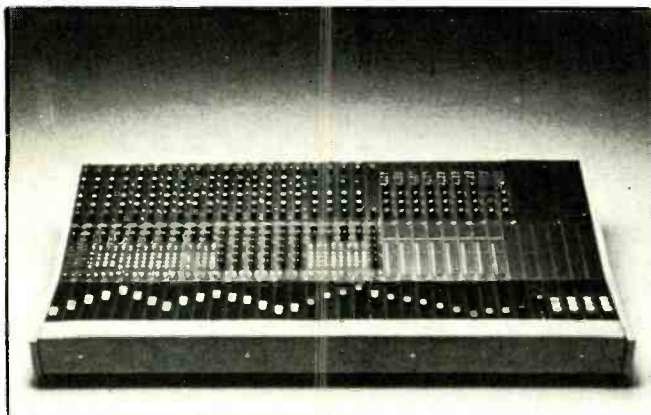

- True modularity to really meet your requirements, in theater and multipurpose hall installations.
- A family of some 20 different input, grouping, fader, metering and output modules.
- Special modules for control room and headphone monitoring, test signals, talkback, remote control etc.
- Heavy duty steel chassis.
- Transformer balanced inputs and outputs.
- Wide range meters, 60dB display.

### MCA; MICROCOMPUTER CONTROLLED AUDIO SYSTEM

- Stores up to 600 cues (scenes) on floppy disk
- Controls up to four tape recorders.
- Assignable digital fader and meter to set and control output levels.
- Eight output groups.
- System operation by single cue entry push button.
- Pocket terminal for remote control and cueing
- Optional speaker switching matrix.

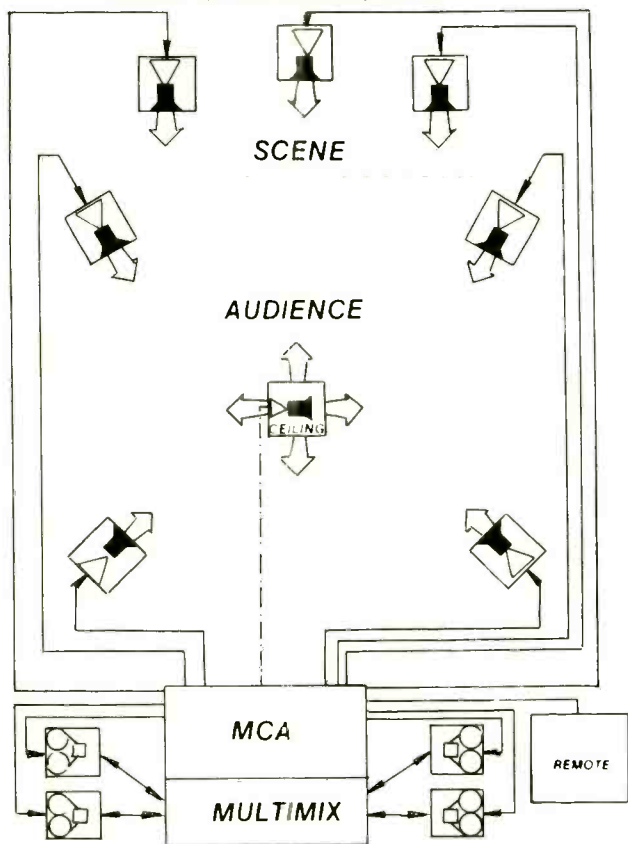

### MS-AUDIOTRON

Laitilantie 10 00420 HELSINKI 42  
 FINLAND ☎ 90-5664644  
 Telex: 125778 msa sf

# ams

## AUDIOFILE

# MUCH MORE THAN DIGITAL AUDIO RECORD/PLAYBACK



### •ADVANCED MUSIC SYSTEMS•

Wallstreams Lane, Worsthorne Village, Burnley, Lancs,  
 BB10 3PP. England.

Tel: (0282) 57011 Telex 63108 AMS-G.



## SANKEN EXPANDS DEALER NETWORK

**S**anken Microphone Co., of Japan, proudly announces that it has expanded its worldwide dealer network for marketing the CU-41 uni-directional double condenser microphone and its related accessories. The CU-41 is one of the first microphones in the world to unlock the full potential of digital audio recording. Dealers for the CU-41 (outside the U.S.) are:

### Belgium

Radelco  
Lialelei 179  
B-2000 Antwerpen, Belgium  
TEL (03) 233-7800  
TELEX 31640 RADCO B

### England

Turnkey  
Brent View Road  
London NW9 7EL England  
TEL (01) 202 4366  
TELEX 25769 TKBAND G

### France

3M France  
Boulevard de l'Oise  
95006 Cergy Pontoise  
TEL (03) 031 6423  
TELEX 695185 TRIMI F

### Denmark

Studie- & lydteknik ApS (SLT)  
Helgesvej 9-13, DK-2000  
København F, Denmark  
TEL (01) 34-1284  
TELEX 22924 SLT DK

### The Netherlands

Stage Theater En Studietechniek  
Ankermonde 5, 3434 GA  
Nieuwegein, The Netherlands  
TEL 03402-65780  
TELEX 76428 STAGE NL

### Norway

Sivring Benum A/B  
Box 2493, Solli, 0203 Oslo 2  
Norway  
TEL (02) 44 22 55  
TELEX 17681 BENUM N

### South Africa

Eltron (Pty) Ltd  
PO Box 23656, Joubert Park  
Johannesburg 2044, South Africa  
TEL (011) 29 3066  
TELEX 48 9416 SA

### Sweden

Tal & Ton Elektronik AB  
Kampegalan 16, S-41104 Goteborg  
Sweden  
TEL (031) 80-3620  
TELEX 27492 TALOTON S

### Switzerland

Sonosax SA  
Route Cantonale 116, CH-1025  
St. Sulpice/Lausanne, Switzerland  
TEL 021 35 35 01 02  
TELEX 26 325 SX CH

### Australia

Syntec International Pty. Limited  
53 Victoria Ave., Chatswood  
N S W, Australia 2067  
TEL 406 4700  
TELEX 02 70570 SYNTEC AA



Japan's most original microphone maker

Sole agent: Pan Communications Inc. 5-72-6 Asakusa, Taito-ku, Tokyo 111, Japan  
Telex J27803 Hi Tech Telephone 03-871-1370

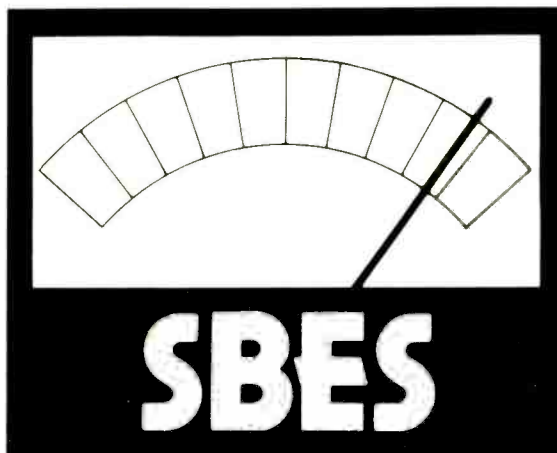

# TENTH SOUND BROADCASTING EQUIPMENT SHOW

**Tuesday 22nd October, 1985  
Albany Hotel, Birmingham.**

An informal show of sound  
broadcasting equipment and  
services.

ADMISSION BY INVITATION ONLY

available from any exhibitor or  
the sponsors

Audio & Design (Recording) Ltd.  
FREEPOST, Pangbourne  
READING RG8 1BR

SPONSORED BY

Audio & Design  
**CALREC**  
LIMITED

**BROADCAST  
- SYSTEMS -  
ENGINEERING**

Full exhibitors details from  
POINT PROMOTIONS  
18 Ferndale Avenue  
Reading RG3 3NQ  
Tel: 0734 861078

# VITAVOX



ANNOUNCE THE **NEW** INDUSTRY STANDARD

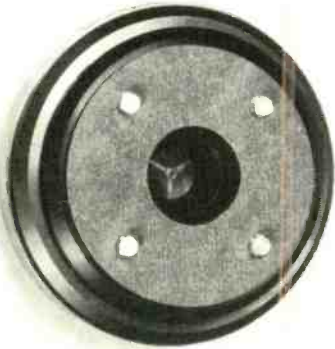

**S6 PRESSURE DRIVER**  
HIGH/MID FOR PROFESSIONAL  
HIGH QUALITY MUSIC P.A.  
AND  
HIGH POWER MONITORS  
STANDARD 2" DIA PLATE MOUNT



AVAILABLE **NOW**

FOR DETAILED SPECIFICATION AND APPLICATIONS INFORMATION, PLEASE TELEPHONE.

OUR NORTHERN DISTRIBUTOR:

## VITAVOX LIMITED

WESTMORLAND ROAD,  
LONDON NW9 9RJ

TELEPHONE 01-204 4234  
TELEX 8954243 VITVOX G

## SSE HIRE LIMITED

UNIT 5, KENT HOUSE,  
GOOCH STREET NORTH,  
BIRMINGHAM B5 6QT

TELEPHONE 021-622 4572/4029  
TELEX 37329 AMEKN T G



# PRECISELY.

Precise answers from  
Toa's reference monitors.

How closely do Toa's reference monitors fulfil standards set by today's professional engineers? Precisely.

How well does the range match the demands of commercial broadcast and studio control? Precisely.

How suited are Toa's monitors for serious amateur use? Precisely.

How well do Toa's monitors combine excellent frequency response, low distortion, smooth crossover and wide directivity? Precisely.

Toa's range of reference monitors includes the 3-Way 312-ME, the 3-Way 280-ME and the 2-Way 265-ME.

Toa reference monitors. Precision units for precise audio reference.



TOA

**Toa Electronics Limited,**  
Tallon Road  
Hutton Industrial Estate  
Hutton, Brentwood, Essex  
Tel: 0277 233882

**IT'S MIDNIGHT,  
THE BAND'S IN A  
SESSION AND THE STUDIO'S  
DELAY LINE HAS DROPPED  
OUT.....**

**MUST REACH HILTON SOUND...**

**WITHIN 10 SECONDS HILTON  
SOUND'S NEW CCF EQUIPMENT  
IS AUTOMATICALLY TRIGGERED.**

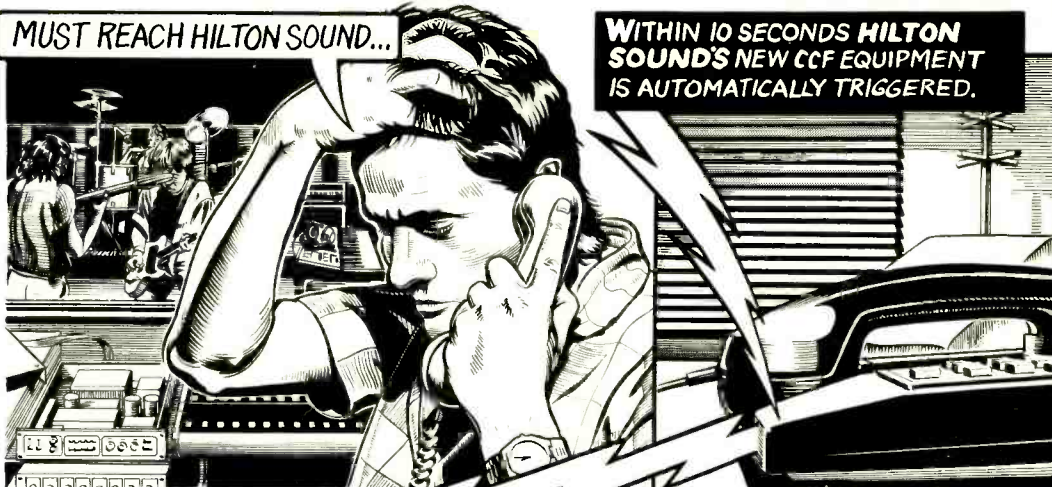

**AT HOME, HILTON'S DUTY  
ENGINEER TURNS OFF  
THE VIDEO AND PICKS  
UP THE PHONE..**

**THE URGENT CALL IS  
INSTANTLY REROUTED...**



**'HILTON  
SOUND CAN  
I HELP YOU..'**

**30 MINUTES LATER A NEW UNIT  
IS POWERED UP IN POSITION AND  
WORKING. AND THE BAND PLAYS ON**

When you have a gear breakdown you can lose your temper, your clients and your reputation. Hilton Sound can save all these with just a 'phone call.

Anytime, anywhere - we'll be with you immediately, giving you expert service, advice, or the right replacement. There's nobody else who gives you the best in pro-audio gear.

The last thing you need is down time, so the first people you call should be us.

**AT HILTON SOUND WE'RE ONE CALL AWAY  
NIGHT OR DAY!**

**01-708 0483**



# GRAFF Today's sound buy

**For the transfer of music,  
speech, computer  
software and  
audio visual  
formats.**

The all British Graff series 11 has no peers among High Speed Cassette Duplicators.

- Fast precise cassette copying - both sides simultaneously - at 16 times normal speed
- Highest quality recordings in stereo or mono
- Advanced technology built into proven design
- Modular system to meet specific requirements
- Excellent sales and after sales service



**GRAFF the sophisticated aristocrat of sound copying**

Graff Electronic Machines Limited, Collingham, Newark, Notts. NG23 7NR Telephone 0636 893036 Telex 377119







# The Essentials.

## **111B Dual Spring Reverb**

The most cost-effective spring reverb on the market

## **245F Stereo Synthesizer**

Convincing pseudo-stereo from any mono source

## **412A/414A Compressor/Limiters**

Smooth, undetectable level control. Ideal for production, PA, and fixed installations. Highly cost-effective.

412A (mono); 414A (stereo)

## **422A/424A Gated Compressor/Limiter/De-Esser**

A complete level control system with de-esser which provides natural, transparent processing at a highly-competitive price (mono or dual-channel)

## **536A Dynamic Sibilance Controller**

Clean, inaudible de-essing of vocals with consistent action regardless of levels

## **622B Parametric Equalizer**

An exceptionally versatile EQ which has become the standard in studios, broadcast, and road shows

## **672A/674A Equalizers**

A Parametric EQ with graphic controls, including variable high and low-pass filters usable as an electronic crossover (mono or stereo)

## **New Security Covers**

Attractive acrylic security covers are available for all products in clear, transparent blue and translucent grey.

Orban Pro Audio Products are sold through a worldwide dealer network. Call or write for the name of the dealer nearest you.

# orban



SCENIC SOUNDS EQUIPMENT LIMITED  
Unit 2, 12 William Road, London NW1 3EN.  
Tel: 01-387 1262, 01-734 2812  
Telex: 27939 SCENIC G

Belgium Trans European Music (Bruxelles) Finland Studiotec (Espoo) France 3M France SA, Mincom Div (Paris) Germany Estemac (Hamburg)  
Germany Hausman Electronic (Berlin) Greece Audiolab (Hellas (Athens) Holland Cadac Holland (Hilversum) Italy Audio Products International (Milano)  
Norway LydRommet (Oslo) Portugal Amperel (Lisbon) Spain Mike Llewellyn-Jones (Madrid) Sweden Tal & Ton (Gothenburg) Switzerland Audio Bauer (Zurich)

# DIARY DIARY

## APRS orders for Harrison

Both Marquee and Red Bus studios placed orders for the new Harrison series 10 console at the APRS 85 exhibition, London.

The Marquee order is part of the planned extensive rebuilding and expansion programme at their Wardour Street premises. The new console will be 80-input with automation on all functions

including EQ in main and monitor paths, dynamics, patch and routing, etc.

At the time of writing size details of the Red Bus order are not known but both studios follow Westlake Audio, Los Angeles, in ordering this as yet unseen console whose first public showing we understand will be in the New York AES in October.

## Northern ASCE show

The Association of Sound & Communications Engineers has announced a northern trade show allowing visitors the opportunity of viewing products and services without travelling to London. It will be held over two days, November 5th and 6th, 1985, at the Barton Grange Hotel and Conference Centre which is on the A6 just two miles North of the M6/M55

interchange.

This location was chosen as it is well positioned in relation to Liverpool, Chester, Manchester and Wales as well as being convenient for those travelling from Scotland. At the time of writing there are 23 committed exhibitors.

For more information contact ASCE, 4B High Street, Burnham, Slough SL1 7JH, UK. Tel: 06286 67633.

## Saved by HHB

Due to HHB's efforts to exploit new markets for digital recording equipment Sony has now reversed their decision to cease manufacture of the *PCM-F1* and *701ES* digital processors. In addition to supplying recording studios, HHB have also identified a number of new applications for both the digital recording equipment and their computer-controlled logging and editing system—*CLUE* which works

with either a *PCM F-1* or a *701ES*.

Among the new users for Sony's digital equipment are the British Gas Corporation, British Telecom, the Home Office, Ministry of Defence and various universities and education establishments. Speech recognition, detecting metal fatigue and checking the subjective audio quality of telephone lines are just some of the new applications.

## Address changes

● Alpha Products Inc have informed us that their address is: Alpha Products Inc, Electronic Products Div, 5740 Corsa Ave, Westlake Village, CA 91362, USA. Tel: (818) 889-9304/5/6.

● The Real World Technologies Group Inc has moved to larger premises. Their new address is: 130 McCormick Avenue, Suite 109, Costa Mesa, CA 92626, USA.

Tel (714) 957-1061 remains unchanged.

● Standard Telephones and Cables plc have informed us that they are now officially called *STC PLC*.

● D&R Electronica have acquired larger premises due to their expanding export business. The new address is: D&R Electronica BV, Rijnkade 15B, 1382 GS Weesp, Holland. Tel: 02940-18014.

## Literature received

HHB has produced a full colour brochure explaining the theory and operating features of the Sony *PCM-F1* and the *701ES* digital audio processors.

The brochure also includes some useful information on PCM mastering and choice of VCRs for digital recording.

## Azimuth Productions

Aiming to complete a link between the recording studio, record company and the tape duplicator, Azimuth Productions is providing an independent facility for the production of 1 in loop bin masters, equalised copy tapes, editing and album make-up.

Formed in November 1984 by ex-CBS and Decca engineer Mike Randall, and business manager John Duffin, Azimuth are based in North London. The facilities are spacious with plenty of room for growth.

John tends to look after the business side of things while director, Mike Randall is responsible for all the technical developments, quality control and equipment.

Lyrec *TR55s* were specifically selected for their 14 in capability and 3-speed options. Azimuth have two of these and are able to offer 1/2 in to 1/2 in copying (15 or 30 in/s) as a regular part of their service. Other equipment includes a Leavers-Rich multitrack; a Philips 1/4 in for spooling tapes; two *360*, four *361* and one *301* Dolby A units; Sony *701E* digital processor, a modified 8-channel DDA *S* series desk; Klark-Teknik *DN360* graphic equaliser and *DN60* spectrum analyser plus 10 Alpage cassette machines for real-time copying. Monitors are Tannoy and Lockwoods.

Visiting engineers and producers are especially welcome and John and Mike express some surprise that more producers don't follow through on the cassette

duplication 1 in mastering session as they would the disc cutting. As Mike Randall explained, "Inevitably there are decisions to be made during the transfer to 1 in. Setting the overall levels for example can be a compromise and the same applies to equalisation."

According to Mike if producers understood the limitations facing duplicators then some problems could be avoided or at least resolved in a more understanding way.

Although production decisions such as level, dynamic range adjustment and early fades, etc. can be made in the absence of the producer and/or engineer some of the problems Mike encounters are simply due to poor quality master tapes. Tapes will vary from the clearly excellent to masters without line-up tones or even Dolby level. The problems are compounded on compilation albums with tapes sourced from several different locations.

Since opening, Azimuth Productions have completed work for World Chief Records, Foundry Records and Starblend Records and edited down the Darts 7 and 12 in single *Blow Away* with producer Roy Carter.

In addition to their copying and mastering service, which also includes *701/F1* and *1610* digital equalised copy tapes, Azimuth can also arrange artwork, printing, disc cutting and record pressing for clients.

Azimuth Productions Ltd, 23A Benwell Road, London N7 7BW, UK. Tel: 01-609 8081.

## Forthcoming events

● October 8 to 10 Internepon, Brighton, UK

● October 12, 13 to 16 AES Convention, New York

## Corrections

In Tony Batchelor's Disc Cutting System Improvements article (July issue) it was suggested that half speed cutting reduces the high frequency power requirement by one quarter. This should have read, '...to one quarter'.

In the Effects, Reverb and Equalisers update piece in the June issue, the AN-2 Stereo Simulator was listed as being a product from Audio

Engineering Associates. This was in fact incorrect. The AN-2 is manufactured by Studio Technologies Inc, 7250 North Cicero Avenue, Lincolnwood, IL 60646, USA. Tel: (312) 676-9177. Audio Engineering Associates are a West coast dealer for Studio Technologies. Apologies for any inconvenience that this may have caused.

PROCESSOR KEYBOARD FD



# 16 bit Processor Keyboard Floppy Disk — but very piano.

The Processor Keyboard FD is the creative component of the PPG Music Computer System. Its engineering creates your music: 72 high quality weighted wooden keys for dynamic touch playing, just like on an acoustic piano. 16 bit processor for perfect reproduction. Every nuance in touch is enhanced through individual selection of 8 combinable parameters for volume, filter, pitch, attack etc., each adjustable on 8 levels. Simultaneous triggering of PPG WAVE 2.3 and Expansion Voice Unit, even with differential dynamic values. Floppy disk for loading more than 500 PPG Sample Sounds, sequences and MIDI programs — 25 sound disks provided with the PRK FD. Fast loading of complete keyboard arrangements for multifaceted use on stage. Realtime sequencer for quick and exact composition. Songmode for putting together sequences to complete songs. As MIDI master keyboard dividable in up to 16 Midi split ranges. Actuation of up to 16 synthesizers, each self contained in dynamic, pitch, modulation and program selection. New, state of the art "realtime arpeggiator" for control of connected units. For more information about the PRK FD, the complete PPG System, the PPG Sound Library and the PPG Demo Cassette contact your local music dealer.

## turnkey

Brent View Road, London NW9 7EL.  
Telephone: 01-202 4366. Telex 25769.

# PPG

## system

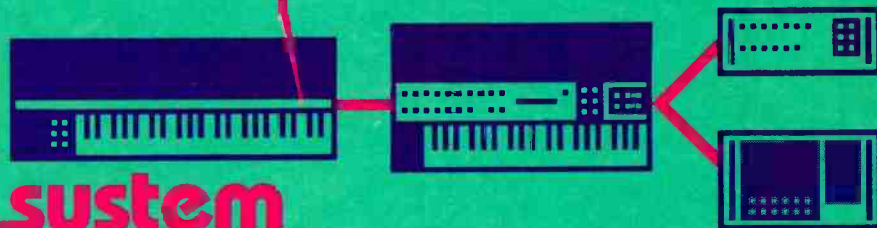

# DIARY DIARY

## Agencies

- Shuttlesound have recently been appointed UK agents for SAJE and BES. SAJE are French manufacturers of recording and live mixing consoles with the top of the range being the *ULN* automated console. BES are US manufacturers of slim-line speaker systems for installation use.
- Cardiff-based ECO Ltd, who specialise in audio post production, are now an official UK distributor for the BASF range of professional magnetic tape products.
- Atronics Ltd are now distributing the Alpha Products range of components, cable assemblies, plugs and

sockets in the UK. Tel: 0628 781008

- Audio+Design Calrec Ltd are to distribute worldwide the products of S W Davies. These will include the *Tonemaster* automatic oscillator a device for automatically providing line up tones before recording, and the Davies *841* monitor speaker.
- KEF Electronics Ltd have restructured their American operations with the creation of KEF Electronics of America Inc and Tovil Distributors of America Inc. A distribution agreement with Quad has already been finalised and Tovil are currently negotiating and actively seeking further brands.

## Apologies

Apologies to Bob Todrank of Valley Audio and Neil Grant of Discrete Research when in the July issue we mistakenly referred to Valley People and not Valley Audio as the importers of their jointly-developed monitor system... and apologies to Electrospace Developments

who we did not mention as the manufacturer of *The Gate* and *The Strate Gate* in the July issue. Electrospace have since adjusted the specifications and the units now have attack time variable between 2  $\mu$ s to 0.5 s and a new threshold range adjustable from -53 dBm.

## State Group acquisitions

The State Group operates Odyssey Studios in London, State Music publishing and State Records amongst others, and has recently acquired Reliable Source—an independent production company. Ex-Reliable Source

chief executive Tim Blackmore has joined State as director of operations and development. The company also announces the formation of Odyssey Broadcast and Cable specialising in technical and production facilities.

In looking at the changing components of progress in audio from studios to manufacturers to the consumer market; no technology offers more potential for growth worldwide than stereo television and stereo video services. The size of the total equipment market for television stations, production centres and re-recording/sweetening studios alone promises to sustain TV stereo as an 'international professional audio economic recovery act'. Some analysts think that in the home, stereo TV will equal the impact of the compact disc and perhaps even encompass it as CD technology expands to include video and computer storage. A vice-president of sales at one of the Japanese electronic giants summed it up thus: "Stereo TV/stereo video means new equipment offering new experiences for 150 million 'television homes' in the USA, Canada, Great Britain, Australia, New Zealand and the entire range of the European Common Market membership. Stereo visuals will complete the cycle of bringing the movie theatre experience into the home, all over the world."

It would seem at first glance that this equation operating on both sides of the Atlantic, puts the software 'horse' in front of the hardware 'cart'. In many ways entertainment software for the English speaking world and all of Europe, are inexorably bound

## US stereo television

in the common elements of 'Hollywood style' film, television and music video programming. To assess stereo television/stereo video it is necessary to discard the traditional linkage of software becoming available only after the development of the technology/hardware. With stereo television, the principal software of the theatrical motion picture and/or television videotape are fully evolved formats endorsed by viewing populations as the software of choice the world over. This requires the technology to develop around the available programming. More important, the future of stereo television is an element of an international homogenisation of electronic entertainment in general. *Dallas*, *Dynasty* and *Hill Street Blues* grace Edinburgh television screens in the same way that *The Jewel In The Crown*, *Monty Python* and *Agatha Christie* are seen regularly in Boston. French producers are preparing a Gallic version of life, love, hate and lust a la *Dynasty* that will very likely reach American television as soon as it leaps onto European screens.

Hollywood producers regularly reach out to German interests as often as they travel to Texas to co-finance American motion pictures. Syndication contracts for successful television series such as *MASH* have

distribution procedures for London and Munich spelt out in as much detail as for Denver and Chicago. British television programmes that originate from the BBC or Independent Television (ITV) companies frequently have American co-production funding since the shows will run in the US commercially or on public television. American films such as *Raiders Of The Lost Ark* are produced by Americans using British studios and technology and have an enormous following in British and European theatres, on television and via video tape sales. The awaited inception of pay satellite service in the UK and Europe will be dominated by theatrical films; just as comparable pay services are already dominated in the US.

The challenge for the world's programme producers, users of electronic distribution systems and broadcasters is to make the interchangeability of stereo audio for film, television and video as convenient as the exchange of entertainment culture has become. The on-air television visual and aural transmission systems for Germany, Great Britain (when completed) Japan and the US lack any kind of compatibility in terms of stereo broadcasting. Timecodes are not all that interchangeable from SMPTE to EBU. But, there is no reason why all the recording and distribution of

stereo audio for programming cannot be of a uniform standard in terms of channel hierarchy, audio levels and response curves, etc. One European broadcaster jokingly absolved himself from a discussion of stereo TV standards by referring to the problems with technical regulation. "In Germany, everything is prohibited unless it is expressly permitted. In France, everything is permitted unless it is expressly prohibited. In East Germany, everything is prohibited particularly that which is expressly permitted. And in Italy, everything is permitted particularly that which is expressly prohibited." To avoid that dilemma in developing stereo television, it is time for the members of the European Broadcasting Union (EBU) to sit at the same table with the representatives of the rest of the world. Those from the BBC and the ITV companies should join staff from the three major US television networks, Canadian broadcasters, the movie studios, major project developers such as Lucas Films, prominent Japanese, European and American manufacturers, and technical groups such as AES, NAB and SMPTE to forge a co-operative standard. Only in this way will the development of stereo TV programming avoid being the 'Chinese Fire Drill' that has been a part of every major technical development in the past.

Martin Polon ▶

# Low-cost digital audio comes of age.

The Sony PCM series has now been available for several years. In this time recording and broadcast organisations, government, educational and industrial establishments, as well as individual users have all acknowledged the unique value of these units, and made them a new standard. It is the superlative quality of Sony PCM digital, coupled with extremely low cost that has brought about this professional acceptance of the range. This is borne out by the number of new ancillary products from other manufacturers, that have further increased the flexibility and versatility of the range. Examples of these products are the 'CLUE' logging and editing system from HHB, as well as various interfaces which allow digital communication with the PCM 1610.

Sony has acknowledged that this acceptance by professional users necessitates a change of

policy towards these products. Accordingly they have upgraded them from the domestic catalogue, and, realising the need for professional support and all that that entails, have appointed HHB as specialist dealers to represent them in the pro-audio market.

We are proud to announce this appointment, and happy to assure our customers of continued availability of the PCM range. The re-instatement of the PCM production line has been very largely due to pressure from end-users, who are after all the motivating force in the audio world. So if you are involved with audio recording and are still unfamiliar with Sony digital, then you owe it to yourself to call HHB - the No. 1 name in Digital Audio.

**SONY** FROM 

HHB HIRE & SALES, UNIT F, NEW CRESCENT WORKS, NICOLL ROAD, LONDON NW10 9AX. TELEPHONE: 01-961 3295. TELEX: 923393.



THE SONY PCM1610 AND PCM701ES DIGITAL AUDIO PROCESSORS.

# DIARY DIARY

● Merien Utama, Soundcraft Indonesian, dealer has so far installed Soundcraft consoles and tape machines in 18 Indonesian recording studios with the consoles ranging from the series 200 to the TS24.

This further backs Mr Utama's claim that this area is one of the most prolific recording centres in south-east Asia.

● Jacob's Studio, Farnham, Surrey, have taken delivery of a complete Mitsubishi digital mastering system which includes the new X850 32-track recorder, X80 2-track and XE-1 digital editor.

● Architects Hutshinson & Partners have recently supervised the renovation and refurbishment of Britannia Row's Studio One. Acoustics have been designed by Westlake Audio and the studio has been fitted with an SSL 48-channel SL 4000E console with Total Recall and a Studer A-800 multitrack.

● New Islington, London, facility Swanyard Recording Studios have taken delivery of a 48-channel SL 4000E console with Total Recall interfaced with MTR 90 multitrack machines. The large control room was designed by Neil Grant of Discrete Research.

● Harmonia Mundi have announced orders for the BW 102 digital interface from EMI Germany, Cologne; Warner Brothers, LA; Digital Magnetics, LA; PolyGram, Hannover, and French record company Pierre Verany.

● Recent clients for Adams-Smith system 2600 timecode and synchronisation equipment include Eel Pie Recording, Twickenham, and Jacob's Studios, Farnham.

● Monitor Systems Technology

## Contracts

has recently won the £100,000+ contract to design and supply Turbosound and Rauch-based monitor systems to the Nomis Studio complex, Hammersmith, as part of their expansion and refurbishment programme.

● Solid State Logic have supplied a 40-channel SL 4000E Master Studio System for Platinum Studios, Australia. Also in Australia an SL 4000E console has been installed in the re-opened Studio B at Thorn-EMI Australia's Studio 301 complex in Sydney. The console includes Total Recall and SSL's 200-segment plasma metering and is the fourth EMI studio worldwide to be equipped with SSL.

● Genesis have selected an SL 4000E console for Fisher Lane Farm, their private studio in Surrey. The console has 56 channels of Total Recall. Also installed is an SSL Integral Synchroniser controlling Studer A-800 multitracks and a Sony U-matic machine thus enabling the group to perform post-production work on their videos. Sam Toyoshima of Tokyo executed the acoustic design.

● Also designed by Sam Toyoshima is the new Studio 4 at the Townhouse. The control room will feature a custom 56-channel SL 4000E with Total Recall interfaced with either the Sony 3324 digital multitrack or Studer A-800. Mastering can either be analogue (ATR 100) or digital (PCM-1610).

● Eden Studios is adding a second studio to its Chiswick facilities. The new room, with acoustic design by Ken

Shearer and interior design by Robert Byron, will feature a 48-channel SL-6000 console and Studer A-800s. Opening is scheduled for September.

● Westside Studios has purchased a 40-channel SL 4000E console with Total Recall for its new Studio Two.

● Power Plant Studios which has had Studio Two completely refurbished by Turnkey is using an SL 4000E 36-channel console along with an Otari MTR 90 multitrack.

● Island Studios, London, now has a 40-channel SL 4000E with Total Recall. The console is basically identical to the SSL at Caribbean-based Compass Point Studios which will allow clients to interchange desk settings when working between the two studios.

● Marcus Studios has ordered a second SL 4000E console equipped with Total Recall. The new 48-channel desk will be installed in Studio Two.

● Yellow Two Recording Studios in Stockport has just taken delivery of a new Neve console. The custom built 48-channel console is the first of its kind in the world according to Neve and incorporates many new designs and technical features.

● Philips has just completed the installation of the new sound and video facilities at the restored Zurich Opera House. In addition to sound reinforcement there is provision for recording or broadcasting of live performances when required.

● Toronto-based Comfort Sound has been awarded the contract to record the Concerts In The Park series for CBC-TV.

● Counterpoint Recording Studios, New York has completed a major renovation programme which has included enlarging Studio B's control room and making various cosmetic and acoustical improvements to both studios. Both control rooms have SL6000E consoles with Total Recall and Otari MTR 90 MkII 24-track recorders and MTR 12 2-track and 4-track machines. With the exception of the consoles all the new equipment was supplied by Martin Audio, New York.

● FWO Bauch has received orders for two Studer A800 2 in 24-track recorders, two A810 stereo machines and a D820X DASH digital tape recorder from Paul McCartney for his new studio. Other A800 orders include West Side Studios, Andy Hill, RAK Records, Jeff Wayne Music, Battery Studios and Fisher Lane Studios. Orders for A820 mastering machines have come from Tape One, Eden Studios, RAK Records and The Master Room.

● Recent Neve contracts have included 14 5432 consoles to the Federal Broadcasting Corporation of Nigeria, a film dubbing console based around the 51 series for ABC in Sydney, Australia and six 5322 self-op consoles for SSVC (broadcasting entertainment for British forces overseas) two of which are in operation in Europe and the remainder are being built into mobile studios for other parts of the world.

● NBC Television, now operating network satellite distribution of true stereo programming to its affiliates, has ordered three additional Solid State Logic 6000E series stereo video systems.

## Stolen

A LinnDrum digital drum machine (REV 3) from Digital Percussion serial no 0092. Any

information please ring Peter Boita 01-771 2037 (London, UK).

## Real-time cassettes

Eastern Standard Productions is now offering a real-time cassette facility. Either digital or analogue masters can be used and each cassette is individually calibrated to ensure accurate and faithful reproduction. Dolby B and C is available and a wide variety of

different tape oxides can be specified.

Mastering is also available along with a complete printing and packaging service.

Eastern Standard Productions Inc, 26 Baxter Street, Buffalo, NY 14207, USA. Tel: (716) 876-1454.

## Stirling service

Andrew Stirling, a founder director of British pro audio dealer Turnkey has recently left that company to pursue a commitment to address the recording industry as he sees it now. His first step is the establishment of Stirling Audio Services Ltd, which he describes as a "second generation pro audio dealer". According to Andrew a second generation dealer is someone who recognises that home studios are often equipped to a standard that equals full

commercial facilities and so need a dealer that will approach them on a similar level.

Initial agencies include Otari and Soundcraft. There will be an emphasis on complete systems and they will be aiming to supply at the broadcasting and post-production areas as well as recording studios. Stirling Audio Systems Ltd, 1 Canfield Place, Swiss Cottage, London NW6, UK. Tel: 01-625 4515. □

Following the recent upheavals in the audio supply industry, we felt it was a good moment to remind you of one company which has been growing quietly but steadily, for the last 13 years.

That company is ITA and now, more than ever, it makes sense to talk to us about your studios' future needs.

After all, if you're intending to make a major investment in your business, you should take the stability of your supplier into account.

#### THE ITA TEAM

The ITA team is here to help you make the right decisions. Each of the team has direct, practical experience of the problems modern studios face, and our in-depth knowledge of all currently-available equipment is there for you to call on.



Martin Parmiter, Managing Director, has overall responsibility for all sales.



Mick Boggis is in charge of ITA's major projects and systems installations, and has an extensive knowledge of all Otari and Amek products.



Dave Cottam and Simon Phillips are our on-the-road sales team, who will be glad to give advice or arrange demonstrations of any of the products in ITA's huge range.



Paul Wells, Field Service Manager. Paul is in charge of after-sales service of our larger installations and has many years' experience in all areas of the audio/video/broadcast industry.

**NOT ONLY PRODUCTS,  
BUT...**

In addition to just about the widest range of products available from any UK supplier

**AFTER 13 YEARS,  
WE THOUGHT WE  
WOULD INTRODUCE  
OURSELVES.**



Simon Browne is always available to answer your telephone sales enquiries and to deal with mail orders. Also, Simon is very knowledgeable about synths, computers and other aspects of modern electronic music.

(including Otari and Amek, of course), we can offer a complete systems service that can include studio design, building work, complete installations, etc. In fact, we've already been involved in several of the country's largest installations so far this year.

**For more information on  
ITA products and services,  
call us on 01-748 9009.**

INDUSTRIAL TAPE APPLICATIONS  
PROFESSIONAL PRODUCTS DIVISION



1 Felgate Mews, Studland Street, London W6 9JT. Telephone: 01-748 9009. Telex: 21897.

# NEW PRODUCTS

# NEW PRODUCTS

Equipment, modifications, options, software

## Powertran MCS-1 digital sampling unit

A low cost digital sampling unit has recently been announced by Powertran Cybernetics. The *MCS-1* has up to 64 kbytes of memory and can provide delay times from 0.3 ms to 32 s. Storage is 8 s for a 8 kHz sampling rate and 2 s for 32 kHz. The unit's MIDI control range covers five octaves, the CV range two octaves with optional transpose of five octave pitch shift.

The *MCS-1* uses an 8-bit companding ADC/DAC giving a 72 dB dynamic range. Internal 4-pole tracking filters are provided for anti-aliasing and recovery. The unit has a

software generated programmable wide range sweep with fully variable memory length.

MIDI recorder, sequencer, editor, MIDI code generator and sampled sound data dump are available to BBC computer users via the Powertran BBC-MIDI Interface. With the interface sampled sounds (up to 64 k max) can be stored on disk enabling digital sound libraries to be created.

The *MCS-1* is available ready-built or in kit form. **Powertran Cybernetics Ltd, Portway Industrial Estate, Andover, Hants SP10 3NN, UK. Tel: (0264) 64455.**



## New Bel units

Bel introduced two new digital delay processors at the APRS exhibition in the form of the *BD-240* and the *BD-320*. These are similar to the original *BD-80*—digital delays with expandable memories, loop editing, synchronised record and playback, 1 V/octave external control (which has also been added to the *BD-80*), and echo/flanging capability.

The *BD-240* is, however, expandable from 6 s basic to 24 s with optional cards and maintaining a 18 kHz bandwidth. The *BD-320* is expandable from 8 s basic to 32 s with 15 kHz bandwidth. In both cases, the machines

are also capable of operating with half bandwidth at x2 delay capability.

New versions of established units were also shown—a cosmetically different *BC3* noise reduction rack (grey rather than blue) and the *BF20* stereo flanger Mk IV is now in a single U rack size with the addition of an external bypass socket.

**UK:** Studio Equipment Distribution, 27 Guildford Street, Luton, Beds LU1 2NQ. Tel: 0582 452495.

**USA:** Agents to be appointed by SED.

**Export:** Musimex, 46a Marlborough Road, London N22 4NN, UK. Tel: 01-881 6060. Telex: 262284.



## Beyer Dynamic HM 560 microphone

Beyer Dynamic has introduced a new ribbon head microphone specifically designed for the studio musicians, for example drummers, who would find it difficult to be tied to a single mic position whilst singing and performing. The *HM 560* microphone can be attached either to the left or the right-side of the headband and is adjustable for both distance and angle to the mouth. A conversion plate, *BN54-164/A* enables the microphone to be used with a pair of Beyer *DT100* headphones.

Frequency response is given

as 20 Hz to 20 kHz with a figure-of-eight polar pattern. Nominal impedance is 200  $\Omega$  and the microphone weighs 66 g.

**Eugen Beyer Elektrotechnische Fabrik GmbH & Co, Theresienstrasse 8, PO Box 1320, D-7100 Heilbronn. Tel: (07131) 617-0.**

**UK:** Beyer Dynamic, Unit 14 Cliffe Industrial Estate, Lewes, Sussex BN8 6JL. Tel: (0273) 479411.

**USA:** Beyer Dynamic Inc, 5-05 Burns Avenue, Hicksville, NY 11801. Tel: (516) 935-8000.

## Audio Precision System One

*System One* is a new computer-based audio test set from Audio Precision. Used in conjunction with an IBM-PC or fully compatible computer such as the Compaq Portable nearly all common audio tests can be run automatically by selecting the test from the computer menu. Results are graphed while the test is being made.

Figures quoted by Audio Precision show residual noise less than 1.5  $\mu$ V, distortion less than 0.001% and level measurements accurate to

0.1 dB. Testing is claimed to be three to 10 times faster than obtained previously.

Being a modular system, *System One* can be ordered in a large number of different configurations.

**Audio Precision Inc, PO Box 2209, Beaverton, OR 97075, USA. Tel: (503) 297-4837.**

**UK:** Scenic Sounds Equipment Marketing Ltd, Unit 2, 8-14 William Road, London NW1 3EN. Tel: 01-387 1262.

## Totalsystems bargraph meter

Totalsystems has developed a high resolution 100 segment bargraph display for digital recording. The *PCM-1610* remote digital meter has 0.5 dB resolution between 0 and -40 dB with 1 dB steps from -40 to -60 dB. Scaling is in dB and bits (6 to 16). Additional features include peak hold, variable decay times, *PCM-1610* status and

overload indicators.

Also new is the *DC-1* delay corrector. This is designed to fit between the Audio+Design *PCM-701* and the Sony *1610* and avoids signal break-up when long cables are used.

**Tendrshaw Ltd, 41 Windermere Avenue, Basingstoke, Hants RG22 5JH, UK. Tel: 0256 468555.**



# Here's to the next 100 units sold around the world

Sony Pro-Audio has good reason to propose a toast. After all the PCM-3324 DASH recorder has outsold all its rivals by a considerable margin and is in use throughout Europe, North America, Australia and Japan.

Despite all the words about formats we believe that the PCM-3324 is the best Digital Audio Multi Track Recorder in the world.

We're biased, of course, but countless top artists and producers keep telling us the same story.

So, we raise our glasses to them "Good recording, great chart success and here's to the next one hundred."



**SONY**  
Broadcast



**Sony Broadcast Ltd.**

Belgrave House  
Basing View, Basingstoke  
Hampshire RG21 2LA  
United Kingdom

Telephone (0256) 55 0 11  
International +44 256 55 0 11  
Telex 85 84 24  
Fax G2/G3 (0256) 474585

# NEW PRODUCTS

# NEW PRODUCTS

Equipment, modifications, options, software

## ACO Pacific ACM48UP microphone

ACO Pacific have developed a precision studio microphone designed to meet the demands of digital recording.

The *ACM48UP* is an unterminated cardioid microphone, 2.5 in in length and finished in black chrome. A companion black chrome gooseneck (*AGN 13B*) is also

available. Frequency response of the *ACM48UP* is given as 30 Hz to 16 kHz 3 dB with a sensitivity of -35 dBV/Pa. The microphone requires a 48 VDC and 9 VDC power supply.

**ACO Pacific Inc, 2604 Read Avenue, Belmont, CA 94002, USA. Tel: (415) 595-8588.**

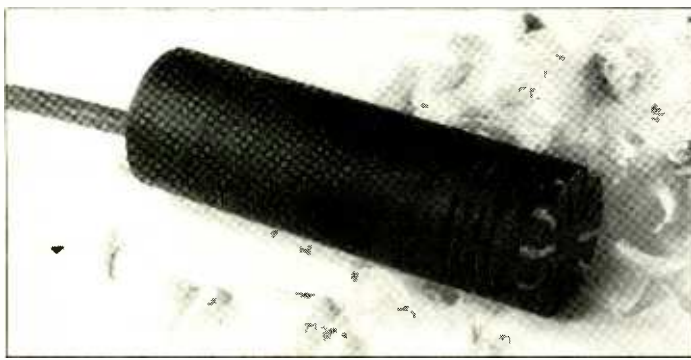

## Digital tape from 3M

3M has just released Scotch 275 a high density digital audio mastering tape designed for use on various digital systems including the 3M *Digital Mastering System*. The new tape will be available in ¼, ½ and 1 in widths and in various lengths ranging between 4,610 and 7,200 ft.

The new tape is laser inspected which according to Scotch virtually eliminates coated-in errors and the highly

durable binder system is designed to provide dependable operation for multi-pass applications.

Scotch 275 is a direct replacement for Scotch 265. **3M 223-5S-01 3M Center, St Paul, MN 55144-1000, USA. Tel: (612) 736-9567. Telex: 297434.**

**UK: 3M UK Ltd, PO Box 1, Bracknell, Berks RG12 1JU. Tel: 0344 26726. Telex: 849371**

## Munro Electronics amplifiers

Munro Electronics (Sound Systems) has released two new amplifiers. The *MPA 1504* is rated at 75 W/channel into 8 Ω and is also available in a 150 W (4 Ω) mono version. The *MPA 5002* is rated at 250 W/channel into 4 Ω switchable to 500 W/8 Ω or 800 W/4 Ω in the bridged mono mode. The 1½ U amplifiers can be free-standing or supplied with ventilated 2U

mounting brackets.

Other output configurations can be supplied, ie tri-amp or 4-channel versions and all amplifiers can be supplied with or without meters/level controls and/or the loudspeaker fail-safe protection circuits.

**Munro Electronics (Sound Systems), 36A Broughton Street, Edinburgh EH1 3SB, UK. Tel: 031-556 1707.**

## In brief

**Harman (Audio) UK** has introduced the Tascam *34B*, an up-dated version of the Tascam *34* ¼ in 4-track recorder with mic inputs, input/output level controls and headphone monitoring for each channel. . . From **Jensen**

**Transformer Inc:** a new 1:1 high-performance output transformer using a special 80% nickel alloy core. The *JE-11-BM* has a wide bandwidth, low phase shift, lack of ringing or overshoot and a flat frequency response.

## Bodysonic transducer

Built into the control room seating, the *SC6024* Bodysonic transducer is claimed to extend bass response into the infra-sonic range. Free from room effects and the space requirements of conventional sub woofer systems, according to the new American agents, Menlo Scientific, extended bass response through bone conduction can be an especially useful tool in digital recording where wind or air conditioning noise or traffic rumble will be felt even though they might not be noticed on the studio monitors.

Bodysonic Company Ltd (Japan) designs and manufactures a full line of

professional low frequency transducers (for seating), floor panels and associated signal processor/amplifiers that use bone conduction to radiate the tactile perception of sound and music.

According to Bodysonic one application of their system is in studios where drums for example are acoustically isolated from the rest of the group. By wearing headphones and standing on a Bodysonic floor panel, musicians can hear and feel the drums and other tracks with no leakage to the mics.

**Menlo Scientific, 39 Menlo Place, Berkeley, CA 94707, USA. Tel: (415) 528-1277.**

## Amek equipment

Amek has announced several new products: the *M1000* series 2/ABC (Assignable Broadcast Console) due to be released later this year; the *BC01* series 2 portable broadcast mixing console and the *RM01* auxiliary rack.

The Amek *BC01* series 2 is an updated and enhanced version of the original *BC01* portable broadcasting console allowing increased flexibility of operation with up to 24 mono and/or stereo channels. The new console has Audio Follows Video ports as standard and at the present time is available in either the following single chassis configurations: 10/4, 8/4/2, 12/2 or as a dual chassis version: 24/4/2. Although a complete mixing system in itself, the *BC01/S2* also forms a subset of the forthcoming *M1000* series 2 console.

Due to be available late in the autumn of this year the new *M1000* series 2/ABC is a radical re-design of the original *M1000*. An extremely flexible system, its most significant feature is the extended automation. All switching functions on the input channels (ie routing, pre/post on auxiliaries, Mute groups, input selection etc) are assigned from a central keyboard and thus configurations of the console may be stored in long term memory or recalled to reconfigure the desk either

between or during sessions.

Automation options include Amek/GML VCA control; Amek/GML moving fader system or the Audio Kinetics *Mastermix*. The new console has VCA faders as standard.

In the broadest sense, the general configuration of the *M1000* series 2 is (n) inputs with routing to eight subgroups and two independent stereo buses, one for each input. The maximum amount of modules which may be used in any one console is 88. Within this framework almost any variant is possible.

A large number of further developments and options are envisaged for these new console systems and further information will be available later.

The Amek auxiliary rack (*RM01*) is based on a 19 in rack with separate power supply and is intended to house up to 10 sound-processing devices. So far three devices are available: The *PM01* 4-band parametric equaliser, the *CL01* compressor/limiter and the *BP01* bandpass filter for broadcast use.

**Amek Systems and Controls Ltd, Islington Mill, James Street, Salford M3 5HW, UK. Tel: 061-834 6747**

**USA: Amek Consoles Inc, 10815 Burbank Blvd, North Hollywood, CA 91601. Tel: (818) 508 9788.**

# TWENTIETH CENTURY BOX



**T**wentieth century standards of quality and performance require the 'human engineering' of the Electro-Voice Sentry 100A monitor.

Designed specifically to meet the needs of the professional studio engineer, the Sentry 100A combines a full range of performance characteristics in an efficient no-nonsense package that's deceptively compact.

It measures just 44cm x 31cm x 29cm.

With its high efficiency, uniform frequency response, and superior stereo imaging across the critical bandwidth, you would expect a much larger enclosure.

Like all Electro-Voice products, we're confident that the Sentry 100A will still be giving startling performances well into the next century.

No wonder we call it the Twentieth Century Box.



**SOUND THINKING ABOUT SOUND PRODUCTS · SHUTTLESOUND**

Unit 15, Osiers Estate, Osiers Road, London SW18 1EJ Tel: 01-871 0966 Telex: 27670 SHUTSO G.

# NEW PRODUCTS

# NEW PRODUCTS

Equipment, modifications, options, software

## Sony AES launch

Sony announced several new products at the AES show in Anaheim.

The 'ready for digital' *MX-P3000* console will be available in three input frame sizes: 20, 36, and 52. Along with unipoint grounding methods and oxygen-free copper wiring the console also features low noise hybrid technology in all appropriate signal processing sections.

The *MX-P3000* includes a frame-accurate hard disk automation system with addressable faders. Fader assignments and fader commands are via a wireless infra-red keyboard situated at the front of the console. Five choices of plug-in equaliser, four mic preamps and three VCA options are planned.

Primarily designed for film and video units the *APR-2003* is a portable three-head 2-track open reel recorder with a 0.38 mm centre-track for timecode. The recorder will accept mic and line levels via balanced transformerless *XLR* connections and can use its 7-pin Tüchel connector for external noise reduction (eg Dolby model 372, A module) and external powering with the Sony *AC-500 AC* adaptor. Current draw is 700 mA and with the rechargeable *NPI* battery pack the *APR-2003* can operate for more than two hours. Other features include 48 V/12 V A-B phantom powering, switchable limiter, 20 dB mic pad, monitor gain for internal loudspeaker and headphones. Recording speeds

are 3¼ and 7½ in/s.

Among the five new microphones to be announced two, *C-535P* and *C-536P*, are condenser mics. Both are unidirectional, the *C-535P* being designed for on-axis pickup and the *C-536P* for right angle pickup where minimum clearance is desirable. Both microphones have a frequency response of 30 Hz to 16 kHz and offer a dynamic range of 116 dB. Maximum SPL is 138 dB. The microphones are 48 V phantom powered and have a 10 dB switchable pad.

The new lavalier series comprises three models *ECM-55*, *ECM-66* and *ECM-77*. Sony claim the *ECM-77* is the world's smallest microphone. It has an omnidirectional polar response and a capsule diameter of just 5.6 mm.

The *ECM-66* has a unidirectional back electret capsule and is designed for musical instrument miking. The *ECM-55* is an omnidirectional electret intended for both musical instrument and voice pickup.

**Sony Corp, PO Box 10,  
Tokyo Airport 149, Japan.  
Tel: 03 448-2111.**

**UK: Sony UK Ltd, Pyrene  
House, Sunbury-on-Thames,  
Middlesex TW16 7AP.  
Tel: 09327 89581/876441.**

**USA: Sony Corporation of  
America, Professional Audio  
Products Division, 9 W 57th  
Street, New York, NY 10019.  
Tel: (212) 371-5800.**

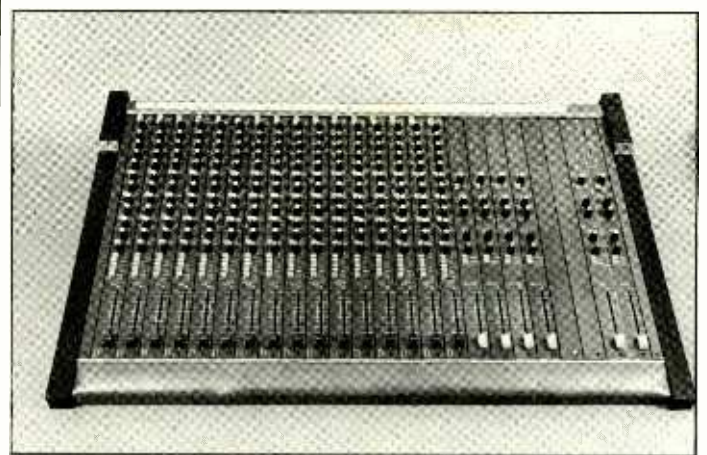

## Regentport Platinum console

New from Regentport Ltd is the *Platinum* series of totally modular in-line consoles currently available in the following options 16/8/16, 26/8/26 and 34/8/34. Each channel includes 4-band EQ with twin swept mids, EQ bypass switch, six aux sends (pre and post switchable), sub-group routing matrix, channel

on/off switch, solo with LED indicator, peak LED and 100 mm ALPs fader. Additional features include comprehensive solo network, four aux returns and full mix and tape returns.  
**Regentport Ltd, 159 Park  
Road, Kingston upon  
Thames, Surrey, UK.  
Tel: 01-546 9540.**

## Acoustic Physics Laboratories control room monitors

The *Control Room Monitor* by Acoustic Physics Laboratories is claimed to be a high output/high accuracy loudspeaker system designed for critical digital and analogue monitoring.

Each monitor is tri-amped and incorporates four 12 in polypropylene bass units and 8 in polypropylene midrange, a 2 in upper-mid soft dome and a 1 in soft dome tweeter.

Frequency response is claimed to be 20 Hz to 20 kHz ±2 dB with a peak SPL of 135 dB.

Acoustic Physics

Laboratories performs a complete on-site factory set-up and alignment with phase response, group delay, first arrival spectral accuracy, room integrated response and a 3-dimensional FFT reverberation plot of the room. Upon completion of the installation a certification report is provided. Overall size of the loudspeaker is 48×32×24 in.

**Acoustic Physics  
Laboratories, 3877 Foxford  
Drive, Doraville, GA 30340,  
USA.**

## Barcus-Berry microphone

The new Barcus-Berry model *1525* electret microphone is intended specifically for use with stringed instruments such as violin, viola, cello and bass. The manufacturer particularly recommends using the new microphone in combination with a Barcus-Berry contact-type transducer. The *1525* is suitable for use as a viola/violin pickup but is not intended as a solo pickup for cello and bass.

The power unit, which

operates from two AAA batteries, has a very low current drain. The microphone can be supplied without power supply (model *1525-1*) and used directly with the electret inputs on the Barcus-Berry model *101* mixer or with the optional Barcus-Berry model *1585* electret power supply.

**Barcus-Berry Inc, 5381  
Production Drive,  
Huntington Beach, CA  
92649, USA. Tel: (800)  
854-6481 and (714) 898-9211.**

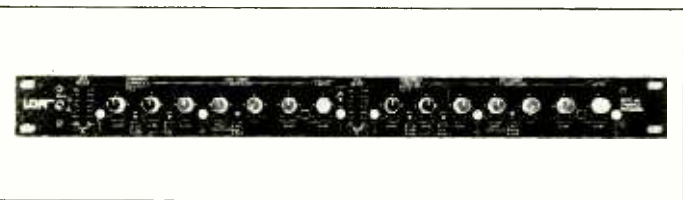

## Loft 410 processor

The Loft model *410* is a 2-channel dynamic processor with three independently usable sections: expander/gate, compressor and peak limiter. Also included is a mild de-esser circuit (75 ms) which can be switched into the compressor path. Only one VCA (Valley People *TA-101*) is used per channel which,

according to Loft, gives a performance similar to separate processors and avoids any signal degradation by running through three VCAs. The *410* can be used in stereo or a dual mono mode.

**Phoenix Audio Laboratory  
Inc, 91 Elm Street,  
Manchester, CT 06040, USA.  
Tel: (203) 649-1199.**

# First we proved it. Then we improved it.

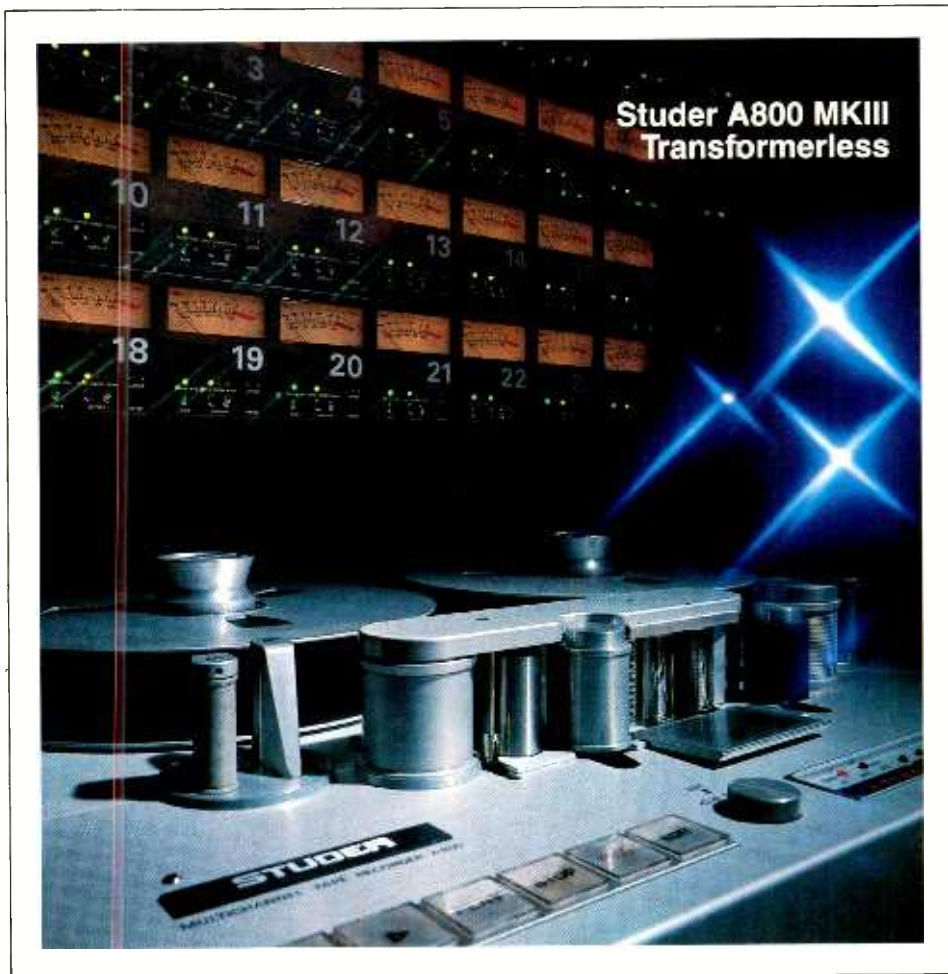

Over the past four years we've installed over 500 Studer A800 multi-track recorders in studios all around the world. We've proven this machine on all counts—reliability, sonic performance, production versatility, and total client satisfaction. No other recorder has earned such widespread admiration among recording professionals.

And now, with the introduction of the A800 MKIII, we've improved on the proven standard. We've removed all transformers from the record and reproduce paths. We've added interfaces for Solid State Logic and

Neve/Necam automation, and for all SMPTE/EBU synchronizing and editing systems. We've also updated the software for the microprocessor controls to meet the most demanding industry requirements.

Improving the A800 was not an easy assignment, but at Studer the pursuit of perfection has become an ingrained habit. Discover the difference yourself.

**STUDER**  
INTERNATIONAL AG  
CH-8105 Regensdorf Telephone (01) 840 29 60

## **F.W.O. Bauch Limited**

49 Theobald Street, Boreham Wood, Hertfordshire WD6 4RZ  
Telephone 01-953 0091, Telex 27502

# NEW PRODUCTS NEW PRODUCTS

Equipment, modifications, options, software

## Digital tape from Ampex

Ampex Corporation has announced the introduction of a new high-energy digital mastering tape—Ampex 467. Designed to perform optimally on all digital multitrack recorders, the tape will be available in ½ and 1 in sizes and from 4,600 to 9,200 ft lengths.

According to Ampex their new tape is 100% tested for dropout performance and due to the smooth, blemish-free

surface will require less error correction activity by the recorder even after hundreds of passes.

**Ampex Corporation,  
Magnetic Tape Division,  
401 Broadway MS22-02,  
Redwood City, CA  
94063-3199, USA. Tel: (415)  
367-3888. Telex: 348464.**

**UK: Ampex Great Britain Ltd,  
Acre Road, Reading, Berks  
RG2 0QR. Tel: 0734 875200.  
Telex: 848346.**

## Coustone acoustic panels

Coustone is a new sound absorption material discovered by ICI and manufactured by Sound Absorption Ltd. Each panel measures 500×500×28 mm and weighs approx 9 kg. According to the manufacturers, Coustone is tough, fire resistant (a 2 hour fire rating) and acoustically

effective. It is available in a wide range of sealed-in colours and individual panels can incorporate company logos or special motifs. A hidden fixing system is also available.

**Tractor Music, 79 Drake  
Street, Rochdale, Greater  
Manchester OL16 1SD, UK.  
Tel: 0706 56287.**



## Neotek Elite console

The Neotek Corporation has announced the *Elite*, a new console with 'Dual Channel' input configuration. The main signal path (fader channel) and the secondary path (monitor channel) have separate inputs, input selection and output channels. Main functions such as highpass filtering, patch point, aux sends and parametric equalisers can be assigned to either path. The main signal path can be split or 'Y-ed' at five different points so the main fader and

monitor fader can simultaneously control different mixes on stereo or multitrack buses.

As with all Neotek consoles the *Elite* is built to order and can be supplied with up to 56 inputs and with any popular automation interface. Automation can easily be retrofitted on site if required.

**Neotek Corporation, 1154  
West Belmont Avenue,  
Chicago, Illinois 60657, USA.  
Tel: (312) 929-6699.**

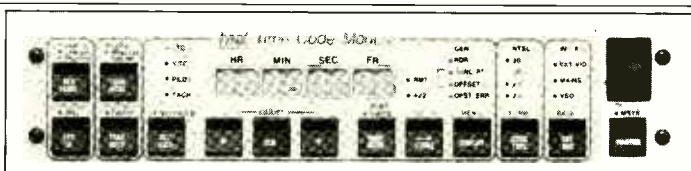

## Timeline LYNX timecode module

Timeline has introduced an SMPTE timecode module incorporating the three elements of a complete timecode system in a single half-rack enclosure.

Each *LYNX* module contains an independent timecode generator, a wideband timecode reader and a transport synchroniser with built-in parallel interface.

When in use as a chase synchronising system one module is connected to each controlled transport. The *LYNX* will run up to 32 machines and has the ability to freely select any machine as

the current timecode master and to take machines on and off line without regard to hierarchy. Also featured is an *RS422* port for external computer control and for interconnecting the forthcoming timecode controller.

The system is compatible with all worldwide timecode standards and comes complete with a self-contained 100 to 250 VAC 50/60 Hz power supply.

**Timeline Inc, 458 Minneford  
Avenue, City Island, NY  
10464, USA. Tel: (212)  
929-1311.**

## Qu Play on cue

The *QPI* from Qu Play is a tape recorder programming aid which comes in the form of a hand-held package to be used in conjunction with multitrack tape recorders.

The unit allows the programming and memorising of drop-in/out sequences and

co-ordinates the triggering of external devices. Options are available for the Otari *MTR 90*, Otari *MX 70*, Tascam *50* series and Fostex *B16*.

**Qu Play Ltd, 121 Southgate  
Road, Potters Bar,  
Hertfordshire EN6 5ES, UK.  
Tel: 0707 44616.**

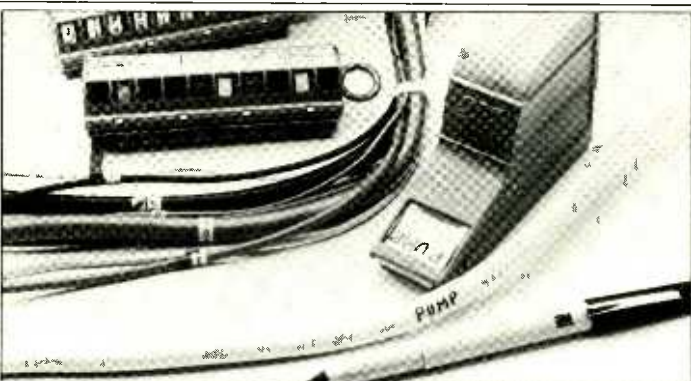

## 3M wire marking system

3M has developed an alternative way to identify cables. The ScotchCode Wire Marking System is based on two different dispensers, one holding 250 white adhesive labels with clear plastic tails to provide protection once wrapped on a cable and the other dispenser holding 10 separate rolls of 5 mm wide self-adhesive tape. These are

available in a variety of colours or pre-printed with numbers, letters or symbols. Unlike standard PVC tape an epoxy film tape is used which will not flag after application. □

**UK: 3M UK Ltd, PO Box 1,  
Bracknell, Berks RG12 1JU  
Tel: 0344 26726  
Telex: 849371.**

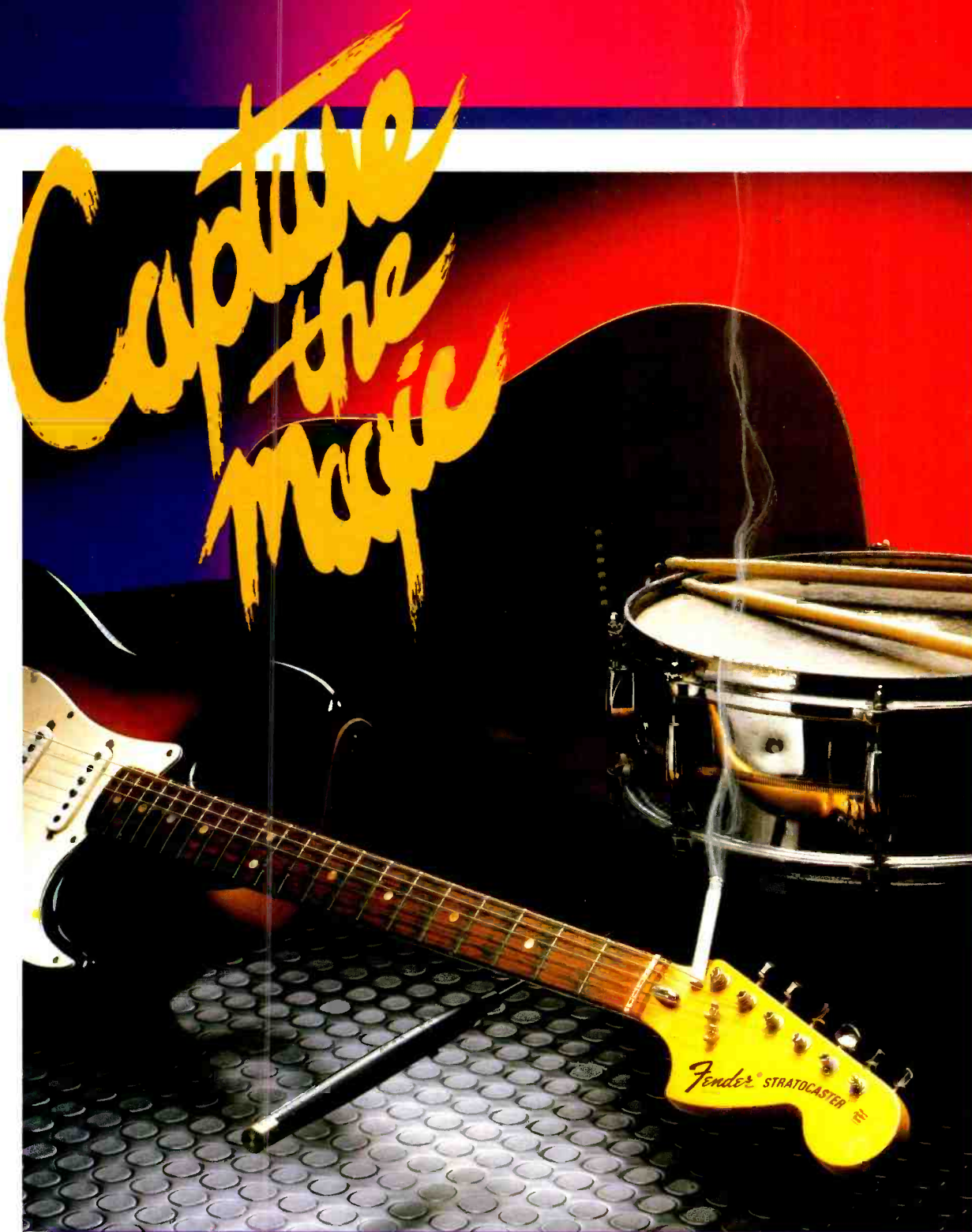

WITH BRÜEL & KJÆR SERIES 4000 PROFESSIONAL MICROPHONES

THESE WORLD-CLASS RECORDING STUDIOS AND RECORD COMPANIES ALREADY HAVE · CBS RECORDS, NEW YORK · TREASURE ISLE RECORDING  
STUDIOS, NASHVILLE · SURREY SOUND, ENGLAND · MAD HATTER RECORDING STUDIOS, LOS ANGELES · DIGITAL MUSIC PRODUCTS, NEW YORK · DENON  
RECORDS, JAPAN · UNIVERSAL RECORDING STUDIOS, CHICAGO · SIGMA SOUND STUDIOS, NEW YORK · STREETERVILLE STUDIOS, CHICAGO  
CASTLE RECORDING, ENGLAND · B & K SERIES 4000 PROFESSIONAL MICROPHONES, THE CHOICE OF PROFESSIONALS THE WORLD OVER,  
CONTACT THE B & K MICROPHONE DEALER NEAREST YOU FOR FURTHER EVALUATION

## SERIES 4000 PROFESSIONAL MICROPHONES



**Brüel & Kjær**

World headquarters: DK-2850 Nærum, Denmark · Telephone: +45 280 05 00

# Prefer



20 years experience...

.....and turnover.

**MPR-1425**

*Line of products includes:*

*full range of back electret & dynamic microphones; mike mixers, disco-mixers, mike cable + multi cable, headphones*

Please write for information of distributorship to:

### Production & Distribution

**headoffice: ummels bv**

Hofdwarweg 57, 6161 DE Geleen  
p.o. box 1002, 6160 BA Geleen  
Tel. (04494)-47373  
telex: 36008  
The Netherlands

# MUSIC PAGE MUSIC PAGE

## U-Music MIDI system

Developed by U-Music and marketed in the UK exclusively by London Rock Shops is the UMI MIDI system. The UMI-2B system consists of a MIDI interface unit and a software program for the BBC 'B' micro, and provides a real-time and step-time multi-MIDI sequencer with song chain formation, versatile interfacing and dumping to disk or cassette. Among the features of the UMI-2B are four MIDI outputs, Trigger Out, Sync 24 Out, variable clock in, Sync to Tape, On Screen Note Editing and Yamaha DX7 Patch/Bank Dump.

**UK:** London Rock Shop, 26 Chalk Farm Road, London NW1, UK.

Tel: 01-267 5381.

**UK:** London Rock Shop, 7 Union Street Bristol. Tel: 0272 276944.

## SIEL software

SIEL (UK) Ltd have a number of new software items available including a MIDI Digital Delay and Multitracking program for the Commodore 64, and a Steinberger/Roland guitar synth

Database Synthesiser/Graphic Editor for the DK/EX-80, CBM-64 and Spectrum.

Also new is the SIEL DX-7 Editor package and Island Logic's Music System for the CBM-64.

**UK:** SIEL (UK) Ltd, Ahed Depot, Reigate Road, Hookwood, Horley, Surrey RH6 0AY, UK. Tel: 0293 776153/4.

## E-mu SP-12 percussion system

E-mu Systems has released the Emulator SP-12 sampling percussion system. The SP-12 comes pre-programmed with a full complement of acoustic and electronic drum and percussion sounds. Additional sounds can be loaded from cassette, optional disk drive or recorded straight into the built-in sampling facility. All user created sounds are instantly available at switch-on due to the battery back-up memory. Tuning, decay, mix level and tempo, including gradual accelerandos and decelerandos, are totally programmable.

In addition to 24 pulses per quarter note the SP-12 has a built-in SMPTE timecode reader and generator. The

E-mu SP-12 percussion system

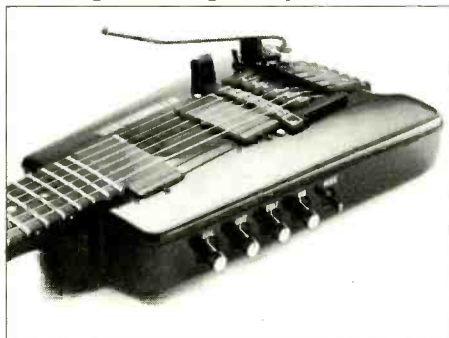

U-Music MIDI system in situ





# SCHOEPS

Colette series with interchangeable capsules for a variety of applications.



## Get the Iron Out!

Since more than 10 years,  
Schoeps has got the transformer out of the microphone.

— Contact —

- AUS Klaron Enterprises Pty. Ltd., P.O. Box 379, South Melbourne, Victoria, 3205. Tel.: (03) 613801
- A Studer Revox Wien Ges. m.b.H., Ludwiggasse 4, 1180 Wien, Tel.: (0222) 473309
- B Heynen B.V., Bedrijfsstraat 2, 3500 Hasselt 2, Tel.: 011-210006
- BR Centelec Equipamentos e Sistemas Eletrônicos Ltda., 22440 Rio de Janeiro/R.J., Tel.: (021) 287-6198
- CDN Studer Revox Canada Ltd., 14 Banigan Drive, Toronto, Ontario, M4H 1E9, Tel.: 416-423-2831
- SF Lounamaa Electronics Oy, Uimariopolku 27 A, 00330 Helsinki 33, Tel.: 90-488566
- F Société d'Exploitation du Groupe ELNO, 18-20, rue du Val Notre-Dame, 95100 Argenteuil, Tel.: 982.29.73
- HK Audio Consultants Co., Ltd., 58 Pak Tai Street, Tokawan, Kowloon, Hong Kong B.C.C., Tel.: 3-7125251
- IL Koliner Ltd., 18 Ha'arba'a Street, Tel-Aviv, Tel.: 03 - 263298
- J Inai & Company Ltd., 1-6 Tomihisacho, Shinjuku Tokyo, Tel.: (03) 357-0401
- NL Heynen B.V., P.O. Box 10, 6590 AA Genneep, Tel.: 08851-1956
- N Siv. Ing. Benum A/S, Boks 2493, Solli, Oslo 2, Tel.: (02)442255
- I Roje Telecomunicazioni S.p.A., Via Sant' Anatalone 15, 20147 Milano, Tel.: 415.41.41/2/3
- P C.E.R. Av. E.U.A., 51 5<sup>o</sup> Dto, 1700 Lisboa, Tel.: 884021
- E Singleton Productions, Via Augusta, 59, Desp. 804 - Edif. Mercurio, Barcelona-6, Tel.: 2377080
- S Natab. Nordisk Audio Teknik AB, P.O. BOX 6016, 55006 Jonkoping, Tel.: 036-140680
- CH FAJAC - Jaques Zeller, Morges 12, 1111 Echichens, Tel.: 021 - 72 24 21
- GB Scenic Sounds Equipment Ltd., Unit 2, Comtech, William road, London NW 1, Tel.: 01-3871262
- USA Posthorn Recordings, 142 West - 26th Street, 10th Floor, New York City, N.Y. 10001, Tel.: (212) 242-3737

Schalltechnik Dr.-Ing. Schoeps GmbH,

Postbox 410970 D-7500 Karlsruhe, Telex 7826902, Tel. (0721) 42016/42011

percussion system can also be connected to external MIDI drum pads and an SP-12 Turbo kit is available to expand the sequencer and sampling memory.

**E-mu Systems Inc, 2815 Chanticleer, Santa Cruz, CA 95065-1891, USA.**  
Tel: (408) 476-4424. Telex: 172951.

## Steinberger/Roland guitar synth

The Steinberger guitar is to be available with onboard electronics designed and built by Roland. The new guitars, model numbers *GL-2/GR* and *GL-2T/GR* (with Transposing Tremolo), will interface directly with Roland's *GR-700* synthesiser via a 24-pin connector. With the additional Roland pickup (the original Steinberger EMG pickups are retained) each string on the guitar is individually picked up and processed by the *GR-700* module. In spite of the modifications Steinberger say the overall design of the guitars has remained virtually unchanged.

**Steinberger Sound Corp, 475 Oakland Avenue, Staten Island, NY 10310, USA.** Tel: (718) 447-7500.

## Roland SBX 80 synchroniser

Roland have developed the *SBX 80* Sync Box. Essentially it is an SMPTE timecode reader and generator capable of syncing rhythm machines and sequencers through real-time MIDI signals, the Roland *Sync 24* system or via a variable clock rate of 1 to 120 pulses per quarter note.

Complete songs can be memorised by the *SBX 80* including all tempo changes which can be set by calculator-type key pad, the Tempo Adjust control, click track or tapping a button.

Comprehensive editing is possible and the unit comes with a useful total and segmented time display.

**UK: Roland (UK) Ltd, Great West Trading Estate, 983 Great West Road, Brentford TW8 9DN.** Tel: 01-568 4578.

**USA: Roland Corp US, 2401 Saybrook Avenue, Los Angeles, CA 90040.**  
Tel: (213) 685-5141. □

Roland SBX 80 synchroniser



# BUSINESS BUSINESS



Barry Fox investigates the facts behind the industry news

## CD sub-codes

Thanks be to Philips of Eindhoven for hoisting me over to their labs for some hard fact talk about CD technology. When I arrived at the local airport there was a police guard, a choir and dozens of mobile stalls selling beer. I have to admit it wasn't for *Studio Sound*. The Pope was on his way from Rome.

In Britain Philips has a problem. The company literature boasts: 'We are in business to explore the frontiers of electronic technology'. But with a few exceptions, the knowledge power base on new and future technology is in Eindhoven. I have already posed a question raised by BBC engineers. Would there be room in the compact disc sub-codes for some data to control the gain of a replay amplifier, as encoded by a real live recording engineer, rather than an electronic AGC or limiter circuit?

I never did get an answer from Philips UK or their PR people, but was able to get this and other points on CD technology clear by talking to those in the know in Philip's research labs. Thanks also, incidentally, to the *Studio Sound* reader who worked out some of the coding pattern. Here are the bare facts: Data comes off compact disc at a rate of 4.3 Mbit/s. On an audio disc (as opposed to a CD ROM data disc) the bit stream is a mix of synchronisation, error correction, sub-coding and audio data. To avoid confusion, note that the sub-coding information is also called control and display, as it carries the flags needed to control the player and the text and graphics which can be displayed on screen.

The control and display data is in 8 bit bytes. The 16 bit audio words are split into 8 bit bytes for storage. For recording each 8 bit byte is increased in length to 14 bits (8 to 14 modulation or EFM) and there are extra bits for housekeeping. This data is split into separate blocks or frames (not to be confused with CD ROM data frames or SMPTE data frames). Each frame contains six stereo samples (ie 12 mono samples) and one 8 bit control and display word.

The frames run at a rate of 7.35 kHz, making a total sub-code data rate of around 60 kbit/s. From this sub-code stream each channel runs at a data rate of 7.35 kbit/s, because one bit of each control and display word is allocated to each one of the eight sub-coding channels P-W.

Sub-code channel P is intended for future use, to control very simple players without any microprocessor on board. The bits change between one and zero depending on whether there is music present or not. If compatibility with simple players is to be maintained, there is little chance of introducing any extra information into the P channel.

The Q channel carries timecode, track numbering, copyright data, total playing time, time left, pre-emphasis, copy

inhibit and access. There is room in the Q stream for bits to define possible future options, like 4-channel interleaving. There might (and here I quote Philips' engineers), be a little room left in the Q stream for features like pre-programmed dynamic range control. The emphasis is on *might*.

The remaining sub-code channels R-W are all allocated to graphics. They are not available for other uses. Only text and pictures can be stored. Doubtless this is wonderful for Japanese karaoke. As a nation they love singing in bars along with pre-recorded backing tracks and words on the screen. But the graphics function may prove less appealing in the West.

It costs money to prepare text and graphics. Will the public want to pay extra on a music CD for the inconvenience of reading off a screen, rather than a record sleeve?

## Four into two

Nippon-Columbia Denon, has always had an interest in 4-channel recording. Remember the old *UD 4* system? It was arguably the best of the four ill-fated quadrasonic systems. British Ambisonics has a licence agreement under the patents for *UD 4*, many are held by American Duane Cooper.

Denon has recently been making 4-channel digital recordings on the Continent, with Bruel and Kjaer and Schoeps mics. Two of the channels are mainly ambience. According to Denon, all four are recorded on a single U-matic cassette. Wait a minute, I said, surely all U-matic PCM recordings have two channels serially interleaved? How do you get four into the space for two? Denon explained:

The bit rate for Denon's 4-channel audio is quite simply double the bit rate for 2-channel PCM. But contrary to what you might think, it is possible to get the higher data rate on to U-matic tape. With a (maximum) sampling frequency of 50 kHz and 16 bit coding, the basic data rate for two channels is 1.6 Mbit/s and for four channel 3.2 Mbit/s. With

additional error correction and auxiliary data codes which are synchronised with the audio data, the total data rate for 4-channel PCM recording is 6.048 Mbit/s.

By comparison, for compact disc the data rate coming off disc is 4.3218 Mbit/s. This is for two channels of 16 bit audio sampled at 44.1 kHz, with error correction and sub-code data.

Denon engineers have found that the big problem with PCM on video tape is dirt building on the recorder head gaps. This causes catastrophic signal loss, rather than the partial, intermittent dropouts caused by production faults or dirt blemishes on a compact disc. So the tape system manages on relatively less error correction. This still poses the question: how does Denon get a data rate of 6.048 Mbit/s off a U-matic cassette system with video bandwidth of only around 4 MHz?

The answer corrects a common misconception. For convenience we tend to equate video bandwidth with data rate, ie a 4 MHz bandwidth will record a 4 Mbit/s data stream. In fact the two are not directly equivalent. Of course data rate depends on bandwidth. The medium has to resolve the short pulses of a rapid data stream, just as it has to resolve the short wavelengths of a high frequency analogue signal. If the pulses merge, ones and zeros become indistinguishable, just as high frequency detail is lost in an audio or video signal if the short wavelengths merge into mush. But bandwidth is not the only factor. Noise plays an important part in the equation.

The guiding principle was put together by Claude Shannon, of Bell Labs in 1948. Shannon's equation ties bandwidth (B) to signal-to-noise ratio (S/N), and gives a maximum information carrying capacity in bits per second (C). The equation,  $C = B \log_2 (S/N + 1)$ , applies to any kind of information, whatever coding system is used. Usually bit/s capacity is higher than bandwidth in Hz. This is how Denon gets away with recording four channels of PCM on a U-matic cassette; providing the heads are kept clean and only random dropout noise enters Shannon's equation. □

## STEREO STABILIZER



- Rack mounting frequency shifter for howl reduction in public address and sound reinforcement
- Mono version and box types also available

SURREY ELECTRONICS, The Forge, Lucks Green, Cranleigh, Surrey GU6 7BG.  
Tel. 0483 275997

# The Mitsubishi X-850 We thought we'd better look after it.



After all, it is the best. Nothing else gives you 32 channels of state-of-the-art PCM digital audio plus extra time-code and analog tracks. Nothing else gives you the best error-correction circuitry in the world and the revolutionary innovation of razorblade editing – a digital first!

There's only one company to call for the Mitsubishi X-850.  
Hilton Sound.

Nobody else is as far ahead of the field in professional audio.  
Nobody else has the combination of expert knowledge and superb service.  
And nobody else was judged suitable to have the first Mitsubishi X-850 available for hire in the UK.

**HILTON SOUND – THE FIRST FOR MITSUBISHI.**



10 Steedman Street,  
London, S.E.17  
Tel: 01-708 0483  
(24 hr Service)  
EMAIL REF: HILTON-SOUND UK  
DGS 1311

# DON SELLS SOUND!

DON LARKING

Luton: 29 Guildford Street, Luton, Beds  
Telephone: Luton (0582) 450066  
Telex: 825488 DONLAR G

Stoke-on-Trent: Stafford House,  
Clough Street, Hanley, Stoke-on-Trent  
Telephone: Stoke-on-Trent (0782) 24257

Don Larking  
audio sales



# WHO'S USING SOUNDTRACS CM4400?

**Steve Glen** chose the CM4400 for his studio 'The Chateau'. Some of the artists which benefitted from his songs and productions are: Hot Chocolate, Sad Cafe, Suzi Quatro, Phil Fearon & Galaxy, Bucks Fizz and Roger Daltry. Steve's experience in recording led him to the obvious choice, the CM4400.

**SAV Studios** using the CM4400 in a commercial situation, Tony Frossard and Marc Lacomme use the 'Q' Lock Events Controller to trigger the 30 routing patches of the CM4400 speeding up complicated mixes often used in their type of work.

**Richard Harvey** owner of the Snake Ranch Studios. Richard chose the CM4400 for his own private studio. He found the internal computer which can be used to route and mute the equalized section of the monitors, as well as the channels, into the mix made the CM4400 the most advanced console available even at 3 times the price.

**Blue Weaver** As a member of the Bee Gees, Blue has recorded in studios all around the world and definitely knows what he wants from a mixing console. Blue uses a Fairlight Computer Synthesizer and finds the CM4400 not only complements his electronic instruments but also has a great sounding E.Q. for the vocal overdubs.

The CM4400 features:  
**Internal computer allowing 30 different mixes to be pre-programmed.**  
**Pre-programmed triggerable routing patches.**  
**RS 232 Interface for personal computer to display routing.**  
**Up-dateable software.**  
 The CM4400 is always up-to-date.

**THE CM4400 BY**  
  
**affordable quality**

**Soundout Laboratories Limited**  
 91 Ewell Road, Surbiton, Surrey KT6 6AH  
 Tel: 01-399 3392 Telex: 8951073/SNDOUT/G



U.K. Distributor

**Don Larking**  
 audio sales

Luton: 29 Guildford Street, Luton, Beds  
 Telephone: Luton (0582) 450066  
 Telex B25488 DONLAR

Stoke-on-Trent: Stafford House,  
 Clough Street, Hanley, Stoke-on-Trent  
 Telephone Stoke-on-Trent (0782) 24257

**America** Soundtracs Inc., 745 One Hundred and Ninth Street, Arlington, Texas 76011. Tel: (817) 460 5519 **MCI Intertek Inc.**, 745 One Hundred and Ninth Street, Arlington, Texas, 76011. Tel: (817) 469 1600  
**Australia** Rank Klaron Pty Limited, 16 Suakin Street, Pymble, N.S.W. 2073. Tel: 2 449 5666. Tlx: AA71289 **Austria** Audiosales, Postfach 168, A-2340 Modling. Tel: 2236 88 81 45. Tlx: 79456 AUDIO  
**Canada** Omnimedia Corporation Ltd., 9653 Côte de Liesse, Dorval, Quebec H9P 1A3. Tel: 514 636 9971 **Denmark** Kinovox AS, Industrivej 9, 3540 Lyngby. Tel: 02 187617 **Finland** MS Audiotron, Laitantie 10, 00420 Helsinki 42. Tel: 90 5664644 **France** Phase Acoustic, 163-165 Bd Boisson, 13004 Marseilles. Tel: 91-4987 28 **Germany** Amptown, Hamburg. Tel: 040 6460040 **Session Musik**, Walldorf. Tel: 06 2272876 **Sound & Drumland**, Berlin. Tel: 030 88279 1 **Musik Shop**, Munich. Tel: 089 341111 **Der Musikladen**, Nürnberg. Tel: 0911 445454 **R & H Studio Sound**, Waldkirch-Kollnau. Tel: 07681 5043 **Greece** Sound Centre, 22 Tossitsa Street, P.O. Box 148, Athens. **Greece** **Hong Kong** Ace (International) Co. Block A, 10/F., AB Hong Kong Industrial Centre, 489/491 Castle Peak Road, Kowloon, Hong Kong. **Indonesia** P. T. Kirana Yudha Teknik, P.O. Box 71, JNG. **Jakarta** Tel: 487235. Tlx: 48120 HASKO IA **Israel** Barkai Ltd., P.O. Box 2263, Ramat Gan, Israel 52122. Tel: 03-735178/732044 **Italy** Linear Italiana S.p.A., 20125 Milano, Via Arce, 50. Tel: 02-6884741 **Japan** Trichord Corporation, Bunsei Building No. 3 1F1 B-8, 5 Chome Toranomon, Minato-Ku, Tokyo, Japan. Tel: 3 433 2941. Tlx: 2524324 CMOSL J **Korea** Computech, Kwanghwamun, K P O Box 1706, Seoul **Netherlands** Pieter Bollen geluidstechniek bv/PAC, Hondsruglaan 83 A 5628 DB Eindhoven. Tel: 040-424455 **Norway** BE siving Benum as, Boks 2493, Solli, 0203 Oslo. Tel: 02-442255 **Portugal** Amperei Electronica Industrial LDA, Av. Fontes Pereira, De Melo, 47, 4º D 1000 Lisboa. Tel: 532227/532698 **Singapore** Lingtec Pte. Ltd., 246 MacPherson Road 07-04, Betime Building, Singapore 1334. Tel: 07-471951/07-471952 **South Africa** Eltron (Pty) Ltd., 2nd Floor Film Trust Building, 112 Polly Street, Johannesburg 2001. Tel: 11-29-3066 **Sweden** Septon Electronic A.B., Box 4048, S-42104 Västra Frölunda. Tel: 31299400 **Switzerland** Studio M & M, Villa Tannheim, CH5012 Schoenewerd. Tel: 64 4149 69 **Thailand** Kitcareon Machine Tool and Musical Ltd., 73 Asadang Road, Bangkok 2. Tel: 2224712 **United Kingdom** Don Larking Audio Sales Ltd., 29 Guildford Street, Luton, Beds. Tel: 0582 450066

# THE RIBBON MICROPHONE

**A** microphone represents the interface between the live sound field and our electronic systems. The requirements of the sound field as regards environmental acoustics and microphone placement are much more demanding than ever in many cases, and electronic systems show ever-increasing complexity. Although, in many ways, electronics has changed radically in the last few decades, the operating principles of microphones have not altered in any commensurate way.

Thus, failing the invention of some marvellous new system of transduction, microphones remain dependent upon mechanical elements of finite size, set in motion by the movement of the air particles in the sound field. Mechanical-electrical transduction systems have to be coupled in to give a suitable electrical output. The fundamental limitations of such systems are only too obvious. Mechanical systems have many resonant modes of vibration, and in order to be efficient and to provide an adequate signal, the elements have to be of a certain size. This can exceed the wavelength of sound at the higher frequencies, causing alterations in the response. Not all the air particle movements encountered represent wanted sounds. Wind, draughts, breath noise, building vibrations, thermal convection currents, to say nothing of the random atmospheric movement of the air molecules, all have to be guarded against in various ways. Also we note that overall feedback cannot be applied across a normal microphone system, as one can on active loudspeaker systems equipped with motion sensors, in order to correct response errors, distortion, etc.

The modern reproduction chain is subject to continual advances in fidelity, as regards upward and downward extensions of the audible frequency band, extended dynamic range, further noise reduction, improved transients, etc. This is particularly true of the new digital systems and CD.

It is apparent that the microphone designer, without any radically new principles at his disposal, over recent years had to strive to improve his designs and to exploit new materials and processes, in order to achieve products which can measure up to the potential offered by the new electronic systems.

## Ribbon microphones

Although ribbon mics have been subject to certain limitations, particularly as regards size, which have tended to militate against them, they continue to offer certain advantages, which have ensured their continued use.

As compared to the more basic designs of earlier years, ribbon microphones have now been refined to an extent that would seem to ensure their continued use in the foreseeable future, especially in applications where they offer particular advantages.

The ribbon is a very thin strip of

## In part one of this two part feature Michael Gayford examines the theory and operating principles of the ribbon microphone.

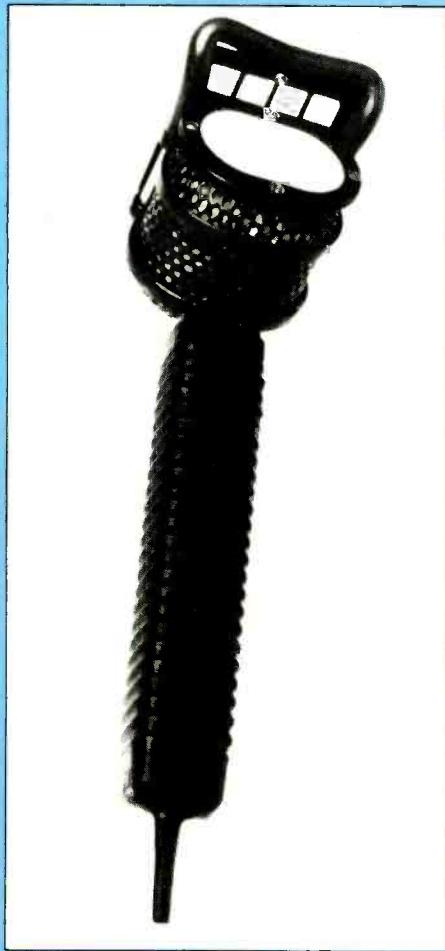

Broadcast quality commentator's microphone

aluminium foil, clamped to terminals at the ends and lightly suspended between magnetic poles. It is a combination of a diaphragm and a half-turn coil. The classical bi-directional ribbon unit is symmetrical about the plane in which the ribbon lies, and is open to the air at the front and back. The driving force is due to the sound pressure difference due to the wave diffraction around the ribbon and pole pieces, giving a null output in

M L Gayford is the author of several books on acoustic techniques and transducers. After research work in acoustics he spent 40 years with STC and was primarily responsible for their microphone developments. He retired five years ago and is currently a freelance consultant for, amongst others, Coles Electroacoustics Ltd.

the plane of the ribbon. The polar response is then the familiar cosine figure-of-eight curve in both the horizontal and vertical directions, except in so far as the effective distance around the poles and ribbon becomes a significant fraction of the wavelength. Two typical forms of ribbon have been used. One has some corrugations at each end, giving flexibility to allow perpendicular movement of the bar-like centre section, thus cutting the magnetic flux across the poles due to the permanent magnet.

The second type of ribbon, now more generally used, has lateral corrugations along its entire length, the corrugations being stretched out until they almost disappear. The function of the corrugations is to give controlled flexibility, whilst preventing curling of the edges.

The bi-directional cosine response is fairly accurately defined at most important frequencies and can be useful in various ways. The dead axis can be oriented to eliminate unwanted sounds from particular directions. The directionality can be made to reduce the effect of excessive random reverberation or noise, whilst the use of two ribbon microphones, with their front axes at  $\pm 45^\circ$  to the perpendicular line to the centre of the 'sound stage', can give a simple means of producing automatic 2-channel stereo encoding, as described in a later section.

Another well-known effect with gradient microphones is the enhanced response or proximity effect which gives enhanced response in the near sound field to small, approximately spherical sources, such as voices, especially at low frequencies. This is easily compensated by a bass roll-off, in some cases selected on the microphone by a 'voice or music' switch. This effect can also be exploited to give a considerable degree of noise reduction for close-talking microphones. A pronounced middle and low frequency suppression of far-field sounds by over-damping the ribbon and/or electrical means is achieved, whilst close talking at a controlled distance gives a normal response to speech, with good quality.

A particular point to note is that a ribbon behaves like a stretched string with a fundamental and a large number of harmonics. The deflections of a ribbon which is symmetrically stretched and properly mounted are all substantially perpendicular to its plane, without the excitation of any torsional or longitudinal modes, which, whilst not cutting magnetic flux to produce an output, could absorb energy and cause 'suck-outs' in the response at these modal frequencies. For good fidelity all the ribbon resonances must be critically damped. In other words, if a sharp uni-directional transient is applied, the ribbon deflection must return to rest without any over-shoot or hang-over oscillation. The way in which this damping is applied is of crucial importance and is described in detail in part two of this article. See Fig 1.

## Historical aspects

The idea of using a conductive ribbon moving between magnetic poles dates back many years. It was certainly used in the Gerlach ribbon loudspeaker in Germany in 1923. This led Olson and others to experiment with ribbon microphones in 1930. A pressing need then developed for various types of improved microphones in talking films, recording studios and for broadcasting. Virtually all the previous types of microphone in use had been omnidirectional, which caused difficulties with camera and set noises as well as excessive reverberation, sets and studios often having to be heavily lagged or draped.

The basic ribbon microphone with open pole pieces was bi-directional with a dead axis, thus offering a fair degree of noise suppression if suitably oriented, together with a reduction of random reverberation. By 1934 the BBC had adopted the famous type A studio ribbon microphone, which was manufactured for them by Marconi Ltd. The later *AXBT* used more modern permanent magnets and remained in service until the mid '50s, when it was gradually replaced by newer types of microphone.

Other types of ribbon microphones have been developed and produced throughout this period by RCA, Western Electric, Shure, STC, Reslo, Beyer, Lustraphone, Coles and others. The *AXBT* microphone became so familiar that it was thought of as a symbol of broadcasting and featured on postage stamps, etc.

However, the *AXBT* had its limitations, the long flexible ribbon being easily disturbed by motion and it was bulky, causing problems for boom use. In the early '50s WE and STC both produced robust unidirectional or cardioid types of microphone which combined a ribbon and a moving coil unit in one case. By varying the proportions of the output contributed by each unit, the polar response could be varied from bi-directional to cardioid, to omnidirectional, by switching. The photograph of the STC 4033 microphone clearly shows the ribbon, with a rigid central portion and corrugated ends, and the small moving coil unit. This became the standard BBC TV boom microphone until the '60s, when single unit unidirectional microphones, line microphones and other smaller and lighter types of microphone came into use.

Going back to earlier days, another property of the ribbon microphone was the effect of controlled damping of the ribbon by means of gauzes closely coupled to the ribbon at the front and rear. This caused the ribbon to be resistance controlled rather than mass controlled, giving a rising response to far-field sounds. The proximity effect to close near-field (spherical) sound sources could bring the response up to nearly level. This can result in the suppression of far-field noises at middle and low frequencies by up to 20 to 25 dB. In fact, the BBC developed this idea into the close talking 'lip' microphone in 1937. This was held at a controlled close distance from a commentator's mouth,



The 4038 microphone

Fig 1: Motional impedance curves of a thicker undamped and a damped thinner ribbon

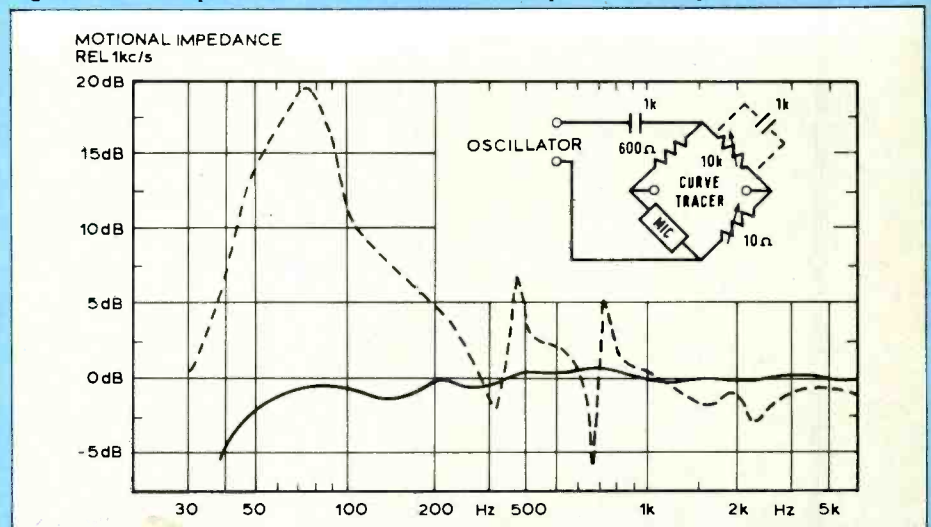

and gave an unprecedented degree of noise suppression at that time, the improvement being such that commentators could be released from the stuffy soundproof boxes hitherto found necessary to obtain reasonable suppression of background noise. This was known as the BBC type *L 1* lip microphone. The idea was further developed in the USA during the war for speech communication microphones for use in aircraft, tanks, etc. More robust

microphones were designed as carbon, moving iron and moving coil types. As a result of further research, the BBC produced a new design in 1951 which incorporated various refinements, such as better screening and response, up-grading the speech quality virtually to studio standards and exploiting new types of magnet materials. Commercial designs were made by STC under agreement with the BBC and these have been continued by Coles with various

# THE RIBBON MICROPHONE

improvements, and are used throughout the world by broadcasters and others; one example being commentaries on Olympic games events. In the USA small lapel mounting ribbon microphones have been developed on the same principle, to give a somewhat smaller degree of noise suppression, the maximum lobe of response being oriented towards the speaker's mouth. Small electret microphones are now widely used as lapel microphones, mainly gradient types, giving some proximity advantage.

In the '60s, Beyer in Germany introduced small double ribbon microphones. Two ribbons are mounted closely one behind the other between the poles, the object being to reduce the slight loss due to air leakage through the inevitable small slit between the edge of the ribbon and the poles. This is more serious with a small narrow ribbon. These were made as small tubular unidirectional microphones.

As regards the main type of bi-directional studio ribbon microphone, the BBC in 1951 produced an optimised and more compact design as a result of extensive research by D E L Shorter and H D Harwood of their Research Department. A commercial version suitable for quantity production was developed by myself through STC by agreement with the BBC as the type 4038. This used commercially available magnets and a small toroidal matching line transformer in the base. The BBC ordered several thousand of these microphones, which have become their standard studio ribbon mic for radio and TV broadcasting, and they are in extensive use today; as certain of their properties and performance aspects

have never been superseded. The 4038 microphones are now made and serviced under an agreement by Coles Electroacoustics.

Many amateurs and professionals world wide have also used the 4038 ribbon microphone because of its sound quality and the accuracy of the bi-directional response. This is of particular value for 2-channel stereo encoding by the crossed

STC 4038 microphone



AXBT mics set up for a 1938 Studio 3 session at the BBC Maida Vale



microphone technique. Another interesting aspect of this ribbon is that users who have access to suitable fine beaten aluminium foil have found, with some skill and practice, that they have been able to recondition microphones by replacing the ribbons when these become damaged or deteriorated in use. This is almost a unique advantage, as nearly all studio types of microphone have to be returned to the makers for reconditioning, at some considerable expense.

## Stereo microphones

A large number of recordings and studio set-ups are now arranged for stereo. The norm is still 2-channel stereo, as broadcast and recorded for home reproduction. Recordings may be mixed down from many channels and more advanced stereo systems such as Ambiophony are available, requiring specialised microphone arrangements. However, one advantage of standard bi-directional microphones with a cosine pick-up pattern is that two microphones may be closely spaced either laterally or one above the other, with their main axes at  $\pm 45^\circ$  to the front. This automatically gives 2-channel stereo encoding on the Blumlein principle. Crossed 4038 microphones in particular are favoured by many amateurs and professionals because of their simplicity, the accuracy of response over the whole frequency range and the constancy of the cosine response in both the horizontal and the vertical planes, as compared to earlier microphones. Random reverberation picked up in the rear lobes does not usually obtrude but strong rear reflections which appear in antiphase, may be objected to. Acoustic absorbing screens may help in many cases. Ideally, microphones with front lobes only are desired and microphones with a hypercardioid front curve and a minimum rear response are used as an alternative.

Like many of the greatest inventions, those of the legendary A D Blumlein are characterised by their elegance and great simplicity. The basis of the crossed cosine curves is that sounds at differing angular positions relative to the microphones are made to appear as amplitude differences in the two channels. When reproduced on the two spaced loudspeaker systems, the sound vectors produce an amplitude to phase conversion at a listener's ears, giving a good directional illusion at the important low and middle frequencies. Higher frequencies are located with the aid of the obstacle effect of the head and ear pinnae.

A variant of the above 2-channel system was invented by Lauridsen in Denmark in 1957, known as the mid-side system. This used a forward-facing omni or cardioid microphone with a figure-of-eight microphone facing sideways arranged coincidentally. The outputs when processed by sum-and-difference circuits produce a similar result to the Blumlein system.

The second part of this article deals with the design and operation of the ribbon microphone type 4038 in more detail, as well as various mounting systems, wind shields and other accessories. □



ANNOUNCING THE  
NEW EXPANDED  
LEXICON 200  
STEREO DIGITAL  
REVERBERATOR

AGAIN!

You see it's the second time we have expanded our popular model 200, adding new programs for stereo reverberation and room simulation. Now there are six basic programs – and infinite variations – They include an imaginative inverse room and an exclusive program that lets you split the 200 into a pair of independent reverbs.

You can quickly and simply select any of 54 pre-set program variations by push-button control. Or if you wish you can operate and store your own variations for instant recall.

In fact, the expanded but moderately priced Lexicon 200 offers more flexibility and capability than most other digital reverbs at any price. It also offers something other manufacturers cannot: renowned Lexicon quality and the excitement of that unique Lexicon sound.



Scenic Sounds Equipment Marketing Ltd,  
Unit 2, 12 William Road, London NW1 3EN.  
Tel: 01-387 1262  
Telex 27939

Audio Export, Badstr 14, 7100 Heilbronn, Germany.  
Tel: 07131 82275

**lexicon**

Lexicon Inc, 60 Turner Street, Waltham, MA 02154, USA. Lexicon International, PO Box 122, CH-8105, Regensdorf, Switzerland.

# VOCALISING ON VOCALS

Recording the voice is perhaps the last area of compulsory mic technique for the engineer. We arranged a discussion between four established engineers at Marcus Studios London. Janet Angus reports

Ben Fenner: freelance with lot of European experience  
Tim Hunt: chief engineer Marcus studios (two studios SSL/Harrison/Sony 3324)  
Mark Dearnley: engineer Roundhouse studios (two studios SSL/3M digital)  
John Mackswith: freelance with very long track record.

## Choice of microphone

**BF:** I don't really have a first choice of microphone; there are ones I would choose if I was under pressure in a session because I know they would work. A *U47* is a good general purpose microphone because it has a nice presence boost and so you don't need that much EQ with an average voice. I use a *U87* as first choice for female vocals because that just tends to be a bit smoother. And again for the backing vocals it is an *87* because sometimes if you've got more than one singer you appreciate the choice of polar patterns; that is a fairly important reason.

Normally if I have got a bit of time and am recording a singer that I haven't recorded before, I will put at least three microphones up (depending on what the studio that I am working in has got) and just line them all up, each with their own channels and decide which one sounds best flat, with no compression, and work from there. Everybody's voice is different.

Somehow microphones always seem to react differently. And it also depends on the music you are trying to set the voice into. Sometimes you don't want a completely open sound—particularly in heavy rock it is good to have a very tight compressed sound and also quite thin to pull through the huge mish mash of backing track that you've got round it.

**TH:** My first choice is the Calrec *Soundfield* mainly because I find it is the most transparent, open sounding mic and it is steerable electronically from the control room.

**BF:** Can you basically zoom in on the mouth?

**TH:** Yes you can. You can get rid of all sorts of sibilance problems, reflections from glass, by steering the mic.

Obviously it has to be roughly in the right position for the vocals. You can work with the mic further away than conventional mics and then compensate with the dominance controls and the azimuth to adjust the balance of the acoustic, *before* you start EQ'ing or pressing buttons.

My second choice of microphone is the

Neumann *TLM 170*, a mic you can put up quickly and it works well on most vocals. Placement of the *Soundfield* would be anything up to 8 or 10 ft away. I would record it on two tracks.

**BF:** It is still steerable after you've got it on the two tracks isn't it?

**TH:** No. The only way you can do it after tape is to record all four tracks separately. I've always wanted to do that but with the producer in control of the session, to get to the stage where you are about to put the vocals on and you are talking about four tracks for one take—it just doesn't happen like that.

**BF:** If you don't want a stereo image on the lead vocal, you just sum them and it doesn't come out sounding too ambient or anything?

**TH:** No. On the subject of choosing a different microphone. . . I remember the first time I ever used a *414* on a bass drum and the drummer gave me a hell of a lot of stick. He said 'what are you using that for?' You know, he was

expecting to see an *RE20* or a *D12*. Anything else: 'This guy's a bit of an anarchist.' It is very difficult convincing them, especially session singers who tend to be much better trained in the use of microphones and they will, 99 times out of a 100 expect to see an *87* or *47*; anything else will really surprise them.

**MD:** It comes down to them trusting you. It's all down to the first playback as to whether it actually sounds good to them when they come back to listen to it.

**JM:** My first choice of vocal microphone is always a valve *47*. This is the mic that I would set up and if it is not applicable to the particular vocalist then one has to assess the quality of the vocal and choose a microphone that you feel is a valid contribution to the project that is underway.

**TH:** The weaknesses of the *47* would point you in the direction to go?

**JM:** I'd answer that question with two points: obviously one favours a microphone that suits your mode of work. If the voice does not suit your mode of work then you have to point to another direction, ie the format of the track, the concept of the song, production. We are assuming, obviously, that the singer can sing and he or she is of a good standard. Then obviously the next microphone that springs to mind would be an *87* because one accepts the lack of modification to sound that an *87* might make, one then assesses that quality against it, and if you then have further problems, I would personally recommend that it is not the fault of the microphone, it is not the fault of the situation. It is the singer.

This does work because I have been frustrated on many occasions by vocalists who cannot control their voice, do not have the projection that is necessary, and obviously invite inadequate producers to offer: 'Shall we limit it? Shall we compress it?' If you are using a microphone that is of a very high standard on let's say 'low standard input', then you are recreating further problems because you are getting

I have been frustrated on many occasions by singers who cannot control their voice.

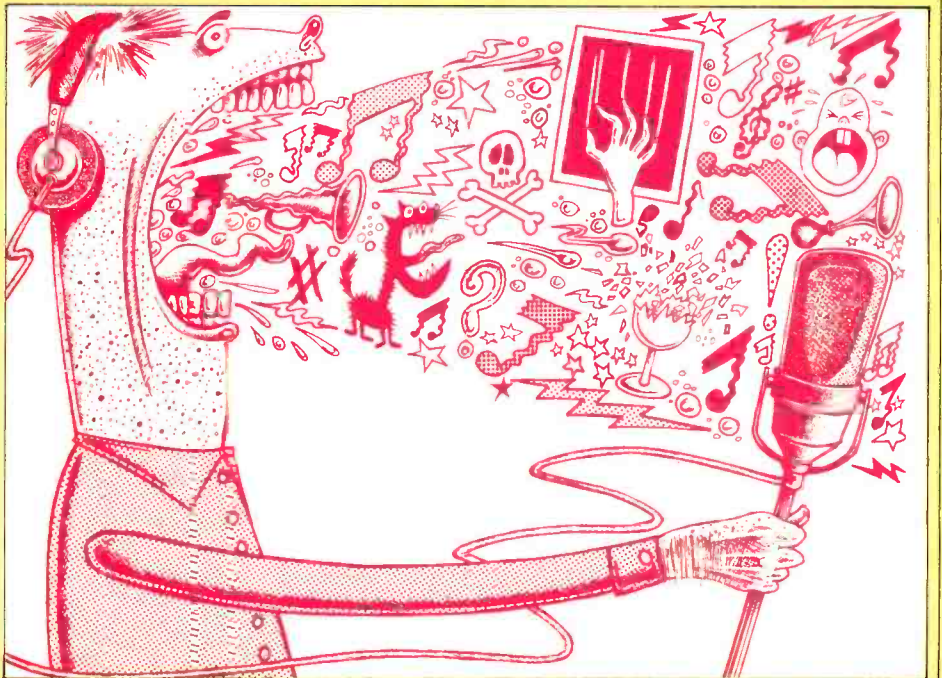

# When it comes down to it...

A recording studio's reputation rests on two qualities. The first is its ability to help each artist deliver the performance of a lifetime. The second is the ability to help each producer capture those performances in exact detail, and to shape them at will.

The truly great studios are distinguished by their uncanny knack for making this kind of magic happen time and again. They are staffed by people who have mastered their art and know how to bring out the best. Because of their creativity, each of these top studios is successful in its own unique way.

Which makes it all the more remarkable that out of all the possible choices, the world's leading studios have independently selected a common standard of excellence for their mixing consoles and computers—the Solid State Logic SL 4000 E Series.

If you're searching for a first class studio anywhere in the world, we'd like you to have the latest SSL Network Directory. It lists over 200 data-compatible SSL rooms in 72 cities and 24 countries, complete with booking information. And if you're a studio owner wondering why your phone doesn't ring as often as it used to, we'd like to send you complete details on the SL 4000 E. Just give us a call. We're here to help.

## Solid State Logic

Oxford • New York • Los Angeles • Hong Kong

Stonesfield • Oxford, England OX7 2PQ • (099 389) 8282

200 West 57th Street • New York, New York 10019 • (212) 315-1111

6255 Sunset Boulevard • Los Angeles, California 90028 • (213) 463-4444

22 Austin Avenue, Suite 301 • Tsimshatsui, Kowloon, Hong Kong • (3) 721-2162



yourself into bending the sound that is not originally true. This of course leads you to further problems with compression/limiting and equalisation—all of these factors contribute to the fact that the sound source is not pure in the first place.

**MD:** Is it valid to talk about a pure sound though?

**JM:** We are not talking about a pure sound, we are talking about the competence of a person and is he/she able to interpret what they should do? In other words it boils down to the same factor that we have all been presented with in any situation in the recording media, that if the sound source is not pure, or let's say the sound source is not good you are not going to be able to enhance it in the control room.

**TH:** But that is what we all do for a living!

**JM:** Then we go into the realms of bullshit. But you are talking on a purist level. I'm sure it is relevant to discuss the problems before we discuss the areas of how to cure them. I would have thought this was the prime importance of this discussion. But not necessarily why we were employed.

**MD:** Surely there is a lot to be said for someone who can be singing in the band and you might not ever regard them as being a great singer, but nevertheless there is something in a performance that they can give and it is down to you to get that onto tape with a minimum of fuss.

**JM:** Indeed. But then we are talking about more of a live situation.

**BF:** Well that is the way a lot of the bands who come into studios arrive. They do a first album when they have been doing a gigging circuit.

**JM:** Then surely on that basis, if I may be profound and correct once again, how many sessions have you conducted recently where it has all been totally live, capture the performance, put it down on tape?

**BF:** I'm not saying that everyone has got to play together. I am talking about the attitude that the band has coming in and the way the singer is used to singing. He is used to singing on stage.

**JM:** But then when you put him into a clinical situation we come to the point I made earlier: the sound source should be, for the point of this discussion, on a purist basis. We are not talking about particular application because we could go on for quite a considerable length of time discussing application of purist or non-purist recording, couldn't we? So, primarily, if you make a point of microphone choice, microphone discussion, you have to talk about the situation, the sound source and the application.

I would normally use a valve 47. The output is fairly coloured, but it is a colour I like to hear. Now if I can apply that particular coloration of sound to the project that I am working on I will indeed do so. But if not, then I have to think about another mode of technique.

**MD:** That is the reason, you hope, you are employed, because of your particular input in a certain situation. It is not the fact that you can record on tape plainly.

**TH:** Oh yes. You can get away with murder as long as it sounds good. But by

## VOCALISING ON VOCALS

and large what people remember about records is drum sounds, not vocal sounds.

**MD:** There are one or two people who say: 'What a great voice sound', but generally you find that you are dealing with a great singer, and the actual sound is coming from the person. They are great, not the recording.

**TH:** It would probably be more difficult to lose it than to try and capture it, yes. People come in and want to sound like someone else; they'll bring in a record and say 'can you make me sound like this?'

**MD:** The famous ones are: 'I want the Stevie Wonder voice sound' or 'the John Lennon voice sound.'

**JM:** Generally it depends, obviously if it is my own project then I can dictate the terms of how I record and what approach I take. But I would rather—an interesting case was the young Welsh choirboy Aled Jones; I recorded him last week.

He has a very pure voice, and if you take somebody that has a pure voice and has the ability to take direction, then you can ask the chappie to do something for you with the interpretation, with the expression of the voice to the microphone. In other words the execution of his performance, so that it eliminates using correction from the control room's point of view.

Now this particular chappie, he had a score six or seven pages long to sightread and perform. So imagine the score open around the microphone, there is no way you can use cardioid pattern, you have got to switch the microphone to all round or omni; take the chap a little bit back so that he is in a position whereby he can read his part and he has the flexibility to move, to express what he feels during the performance. If indeed he moves in directions that are not conducive to sound you can simply point out areas in the score: 'please could you help us a little bit here to project this particular line, to ease off of this little line.' You are asking him to be your limiter. You are asking him to be the control. This, I think, is a far more valid point of execution in interpreting the project and the sound. In other words, we ask the performer to manipulate his own voice, his own performance to suit what is going down as opposed to using a certain type of microphone and a certain type of limiter and a certain type of equaliser, because each time they are in circuit the sound is degraded. The idea is obviously to capture what the chappie is doing with the least inhibitions in the recording chain.

If you apply these techniques to a rock performance, you are not talking about a purist approach. You have got to screw and bend the sound in the way that the track is going. If a track is laid down very hard and it is a hard sounding track, then we have got to have a hard sounding vocal. Obviously the vocalist

has got to be pretty hard because, if he is a soft sounding vocalist then he shouldn't be there in the first place.

If the guy is hard sounding, a U47 valve does have a hump in the middle frequency so it is going to give that little bit more apparent hardness, but obviously it is going to break up a little easier when the guy starts to pump singing, so therefore will the mic be suitable? Can it comprehend the signal that's coming into it? Will it be able to cope? You make these assessments at the time.

I would say that with a rock singer singing loud the U47 has to take the elbow because the mic is not going to perform in the way that one would expect to hear the sound. I would go to something like a Shure 56 to take that sort of sound. You are talking about a rock performance. You are talking about a rock singer. You are talking about a guy that is really used to singing on a close miked performance with very little characteristic via the microphone. You should give him something of that nature to listen to so that he feels more comfortable with what he is hearing. Then I would have thought primarily this is obviously supposition, this particular instant would fit.

This would be the microphone that I would start off with. If it is not correct for the particular project then I will change it. I would go between a valve 67 and an 87. So in other words my prime choice is a valve 47. I will then look between a valve 67 and an 87, then as a fourth choice I would probably go to a 414 and I think it would end there.

Female vocals I would probably start with an 87, and if an 87 doesn't suffice a 414 is probably not going to improve the situation. With female voices you are in the soprano area; if an 87 doesn't really suit, you have got to look then to a 47 FET and then I don't know. The FET 47, in my opinion, is a relatively gutless microphone. It has very little to offer in terms of establishing character from the sound but thereby a female vocalist does have a certain difference from a male vocal, and you are going into the soprano ranges. I would have thought that the coloration of a fairly gutless microphone would enhance the area of soprano singing.

The polar pattern depends on the sibilance factor because, as you know, with the proximity effect of microphones and the pattern of HF around an omni pattern increases from a cardioid, so if a guy is relatively sibilant or a girl is relatively sibilant then the omni pattern is going to increase this, which is undesirable. It is really a matter of assessment between the microphone that you are using, the pattern you choose to use according to the sound source.

**MD:** Horses for courses.

**JM:** If you are using it in conjunction with a compressor the frequency response in the omni pattern, let's take one particular microphone, the HF response with the vocalist at the proximity of 18 in to 2 ft is going to be greater than that at 1 ft with a cardioid pattern and a compressor, so the presence area is going to be increased. As Mark said, horses for courses. All these parameters that have been discussed so far are a matter of

AMEK M2500 46/24



***“Without a doubt the eq  
on the AMEK is the best  
on any console in the  
world...”***

Jerry Boys, Livingston Studios

Now available – the world’s most advanced mixing computer from AMEK/GML with ultra-fast motorized faders, twin 68000 processors and Winchester disk storage. The AMEK PM01 Parametric Equalizers may be purchased in Rack-mounting form.

**AMEK**

AMEK SYSTEMS AND CONTROLS LTD  
Islington Mill, James Street  
Salford M3 5HW, England  
tel: 061 834 6747  
telex: 668127

AMEK CONSOLES INC.  
10815 Burbank Blvd.  
North Hollywood, CA 91601  
tel: 818 508 9788  
telex: 662526



assessment to see which pattern, which microphone, sound source, compression, limiting, all meet at a centrifugal point, ie the sound that you think is desirable for the particular project.

**MD:** There are in fact no rules. You start off with your prejudices and go on from there.

**TH:** Exactly. There is the classic situation when I was tape opping where an engineer went through nine or 10 microphones and it took him about three hours with the singer singing right the way through the song. He narrowed it down to eight and then seven. Finally he got one mic that I would never have chosen in a million years an old Milab. I wouldn't have even thought of using it on a vocal and it sounded tremendous, never heard a vocal sound like it. Obviously it is a marriage between the sound, the singer and the microphone in the studio, but it sounded tremendous. But when he went to put it down he got the most listless, tired, rather bored performance.

I think singing is so much more difficult than playing an instrument. It's so personal so changeable. You can find if you are doing an album, you can put one mic up and get a great lead vocal sound and the next day it doesn't sound remotely the same.

**BF:** That's often the case with guide vocals. When the guy is singing with the backing tracks you get fantastic vocal sounds when you just put any old dynamic up.

**MD:** Surely the major part of the engineers' job is mainly to get the music on tape, and retain the musicianship, retain the performance? The technical side of it is actually secondary to the performance. As I see it, my job is to make sure the guy is happy singing and for me to get my act together as quickly as possible, which may mean not experimenting in some cases. Maybe sometimes I'll say, 'Well, I'll just try a guide vocal', then that's the time you can experiment.

## VOCALISING ON VOCALS

**TH:** Exactly. I'd sooner capture a performance, however duff it sounds and sort it out later, rather than spend hours tweaking something and getting it perfect.

**MD:** Which is why we tend to go for our favourite microphones and probably not try different things unless somebody said 'Oh, you really ought to try that one.'

**BF:** Ideally you should put say three microphones up so they all pick up the sound at the same point in front of the singer and that usually isn't physically possible. A lot of singers like to perform to a microphone, visually, and if they have got a lot it makes them feel like they are at a press conference. So if you actually select between them then it has to interrupt a bit. You have to say to the guy: 'Look, I'm just going to try these microphones out. Don't give your full performance because you are saving that for the real take, but first sing in this microphone, then this one, then this one.' You have just got to do it as quickly as possible.

**MD:** So many times we have sat there and the singer has said: 'Well, how did that sound?' and the producer says 'Well, I don't know, he was messing about with the microphones,' when you try different things. Having just settled on something you probably stick with it for the duration of an album for the vocals anyway.

**TH:** I'm a great believer in changing mics if you are on a project from song to song, even for backing tracks, I know it's a lot of work...

**MD:** It's the same as Ben will choose a backing vocal mic with a switchable characteristic.

**BF:** Or use two mics. You could use a stereo pair of Schoeps.

**TH:** But you get an artist who is not well established who comes in and says 'I always use this microphone,' and you know that that particular microphone doesn't suit their voice and you can think of two or three that would be better, but you can't convince them to change.

**MD:** The only way to do that is to set up your one and their one, put them on two separate tracks and say 'listen'.

**BF:** John, would you, given the time, actually put several microphones up that you think might be good, all side by side and go through them one by one, given that your 47 has not proved to be ideal?

**JM:** No. I think on that basis, having used these microphones frequently in the past, and varying types of the same microphone, and indeed, as you know, the characteristic of each microphone can indeed be different. I think one's original conception of the way a microphone performs is enough for the brain to evaluate whether the sound of the next microphone, be it an 87, is going to suffice.

**BF:** I just find myself surprised when using a microphone that I have used over the past few albums a lot, I will use it in a similar situation, similar sounding voice, similar sounding track and it just won't sound good at all, and in that situation I will listen to a lot of other microphones as well.

**JM:** Have you considered factors of temperature, humidity?

**BF:** Whatever the factors may be, the fact is that it sounds different.

**JM:** If you are using a condenser microphone these factors do make a hell of a difference. We are talking about a condenser microphone, we are talking about the capacitor plate, the humidity factor of the room, be it morning, evening or afternoon, if you really want to get into the realms of discussion of how to utilise and captivate sound, these factors must make a difference.

**MD:** There may be a valid point in the singer who says I can only sing at night!

**JM:** In Lansdowne Studios in days of old, what we used to do before we started, was to actually spray the studio. We would cause a humidity factor before everybody started. This improves the separation because the actual air pressure and the transmission of sound is diminished through the humidity.

**MD:** That's a wonderful idea. Rain in the studio!

**TH:** Do you ever experiment with microphones?

**JM:** Oh indeed. From time to time, whereby I will use my own voice characteristics which obviously I know all about. One always hates the sound of one's own voice, but at least you know what it is. I have lined up several microphones, tried to create a unity gain situation and then gone through and recite, as near as damn it at the same proximity, any form of reading matter and then try to assess the difference off tape. I think when you line up an array of microphones for a particular vocal session, I think really it does one of two things: I would have thought (a) it can portray a lack of confidence in yourself and (b) if you don't, it could lead to a more definite area of recording and then

There may be a valid point in the singer who says 'I can only sing at night'.



change the microphone.

**MD:** I wouldn't agree with that. In an unfamiliar room I would be inclined to set up a microphone that I knew plus one that somebody from the studio said 'Why don't you try this' and another, maybe an 87 or a 414 that I knew the characteristics of.

**BF:** I would, given the time and given that the singer doesn't mind indulging me.

**TH:** You haven't come up with anything that you prefer to a 47?

**JM:** It goes in descending order: 67/87, then 414. These are the microphones I would use generally, then listen to the qualities of what's happening and choose accordingly.

**MD:** I chose the Schoeps CMC5 with the omni capsule for the same reasons as Tim was saying about his Calrec. It is the microphone that I found to be very natural sounding and I tend to use it out 2 to 3 ft away, even for heavy rock. I try to get a clean sound on tape although it may be fairly compressed at times.

Afterwards you tend to equalise and put all your fancy tricks on to bring it out; you can go either way if you have got a natural sound on tape. I complicate the issue generally by putting up an SM58 dummy mic or something that is just fed to the performer's cans and then he actually gets some feel off the two. By using a dummy mic the singer can then do what he likes with it—hold it, throw it about, and you have still got your... Because it is an omni you have to have a lot of space behind the mic. It depends on the room of course. I generally use that microphone in that pattern in the middle of the room. There are occasions when you can use it elsewhere with suitable baffles around. It depends so much on the studio, and on occasions you do have to put the cardioid capsule on to get rid of various noises that are happening off set.

**BF:** If I'm using 87 for vocals I put it on omni, just because it will sound cleaner. There is less proximity effect.

**TH:** Where would you place your 87?

**BF:** Usually about a foot to 18 inches away. I prefer a big room with some screens round the back of the singer. I like a bit of the room in there, but not too much. It is also better for the singer psychologically. He likes to see a lot of space in front of him which is good from an acoustic point of view because then you don't get any reflections.

**MD:** A really annoying thing I find is those music stands with flat tops. You get a horrible reflection off those. I find them the worst problem using distant and omni techniques.

**BF:** Someone should invent non-reflective paper!

**TH:** Do you tell your singer what you are doing with your 58?

**MD:** Well, I was just thinking about that actually. I'm going to get into trouble here, because there are a lot of people who don't actually know that I'm not using the one they think I am!

**TH:** But what about when you are dropping in? The sound coming off tape from the Schoeps is obviously different.

**MD:** You have to feed a little bit of the natural one in. Not enough to get phasing problems. I find generally if they have sussed that I am using a different one then they think 'Oh well, I

like the sound', and it goes out of their head. If they don't like the sound then you are in trouble! If people are happy with their balance and they are happy with the sound when they come back into the control room it is generally never questioned. You've got to watch the phasing between the two microphones when both are on. If you are not careful you do get weird voice effects.

**JM:** The perception of live singing with headphones, as soon as you come to a live situation your perception of voice is totally different to the guide line that happens. When you are not singing you hear a performance better by microphone A or microphone B. The singer himself is really not that aware.

**MD:** I find it actually helps as well, because when somebody is going to drop in they get much more of a sound change between what's on tape to suddenly switch to what's live they prefer to sing

along and hear their own voice with the track and they get less of a change effect when you drop in.

## Type of sound

**BF:** In some cases it may be possible to gauge what type of mic to use from someone's speaking voice, but in my experience a lot of singers sound completely different when they are singing to when they are talking.

**MD:** The only problems I have had with that is when somebody's really excessively sibilant, then you can run into problems; you have to adjust your microphone technique accordingly.

**JM:** The type of sound you go for is their decision. As an engineer I would always give them what they wanted.

**MD:** I'd be inclined to put the natural sound of the voice on tape, then I could go any way from there. You generally add so many harmonisers and things it

# multimax

16:2:1 12:4:2:1 16:4:2:1

All from one 19" rack mount console

- 3 band Equalisation
- 2 auxiliary sends
- 90mm smooth action faders
- Mic and Line inputs
- Subgroup direct outputs
- RIAA equalised inputs
- Peak LED on inputs
- 12 way LED displays on masters
- Phantom power on every input
- 5532 Op-amps throughout



Hill Audio, Inc.  
231 Marquis Court  
Lilburn, GA 30247 USA  
(404) 923-3193  
TLX 293827 HILAD

Headwater Industries  
635 Caron Avenue  
Windsor, Ontario N9E 5B8, Canada  
(519) 256-2454

Hill Audio, Ltd.  
Hollingbourne House  
Hollingbourne, Kent ME17 1QJ, England  
(062 780) 555  
TLX 966641 HILL



# VOCALISING ON VOCALS

doesn't really matter at the end of the day!

**TH:** I wouldn't necessarily choose a different mic for male/female vocal. My choice is stick with the sort of music.

**MD:** On backing voices I would normally go for a stereo mic: Schoeps 501U for the natural sound of the microphone and because you can have it in a variety of patterns. Especially in bands you get a variety of levels, sounds and voices. But again, I prefer to balance the voices in the studio relative to the microphone than have a microphone for each and balance it upstairs.

**BF:** You get a better balance if the singers are balancing between themselves. What they hear in the headphones, all grouped round one stereo microphone, an acoustic balance of the voice levels is generally better than an electronic one, with experienced singers. **MD:** But even with experienced singers sometimes you have to chalk on the floor where people are standing.

**BF:** I would say generally with backing vocals that the choice of microphone isn't quite so important as lead vocals because they are backing vocals. They are further back. When I am mixing I will generally tend to try and make the backing vocals quite a lot thinner than the lead vocals. Unless the lead vocalist is either double tracking himself or giving himself a harmony line in which case it should sound like two people with the same kind of sound. But if you have got people going 'ooh' and 'aah' or something like that in the chorus, then it really should sound like part of the backing track, not something that's going to spring out. I end up winding a lot of backing out anyway.

**TH:** For most backing vocals I would certainly try and have far less dynamic range on the track than on the lead vocals so effectively it just becomes another instrument. You don't want to have to be fiddling with backing vocals in the middle of a mix. You want to record it so that you can establish it at a rough level and it can stay there. I think rather than choice of mic it would be choice of compression; that would probably be more important. I would certainly squash backing vocals a hell of a lot, more than a lead vocal.

My second choice is a valve 47. I find I like the contrasty sounds. I don't necessarily try and thin backing vocals out like you two who obviously have a lot in common. I like having warmer, more middly backing vocals sound.

**MD:** It depends of course on the sort of music you are doing. If you are doing a heavy thing then it needs to be more middly.

**BF:** If you are doing a heavy rock thing they need to be pretty thin because if you leave them middly then they are competing with guitars a lot of the time.

**MD:** It depends very much on the track and the song.

**BF:** I would leave them all natural if I

was doing say a country and western song.

**MD:** It is always difficult to generalise. Every song demands different things and every different set of backing vocalists.

## Singers' mic technique

**TH:** I think it is dying out. Most singers you encounter are completely untrained...

**TH:** Which is refreshing in some cases because a lot of really famous singers are people who, in conventional musical terms, don't have a voice, but who manage to communicate (given that music is a form of communication) without having a classically trained voice or without doing breathing exercises and practising scales.

**MD:** You do find you have to prompt people towards what we may regard as microphone technique; things like moving when you've got Ps and Bs and all the rest of it. Again the important thing is not to constrict them so much that they can't perform. Your job is to get the thing on tape and get the performance.

**TH:** You can actually limit your creative horizons because you think in terms of set patterns. I find a problem with inexperienced vocalists is trying to restrict dynamic range, you have only got a certain amount of headroom.

**BF:** You've got so much a compressor can do. If they are singing live they don't really need any microphone technique because they are struggling to get the vocal through the mix anyway.

**MD:** Even live, as well, they are right on top of the microphone.

**BF:** Plus you've got compressors on PAs which obviates the need for even more mic technique.

**JM:** In this day and age there are very few people who do really have a good microphone technique. I've worked with Mike Smith, who used to be in the Dave Clark Five, for a long time now, and I don't use compressor/limiters or de-essers anymore because we simply have eye contact.

Then I move my eyes to another part of the room and listen to what he is doing. So therefore I don't want to hear his microphone technique. All I want to hear is the projection of his voice, and he now, through his experience of recording with me and other people like me, he is able to conduct and contain his voice to whatever standard or whatever medium is appropriate at that time.

So there is an experienced singer with a microphone technique where you need no correction or very little correction. If you present a situation whereby you take a young band with a few months' routine experience, all they have are PA microphones—in other words up to the mic, gob in it, and go as hard as you can and get it across—in a studio obviously that just does not work. So you then have to take the situation from square one. You have to groom to the best of your ability in the time available to get this chappie to be able to use a microphone—to use it, to give you far less problems. In other words, one should never, ever put a microphone up, give it to a singer, and then rely on outboard equipment to correct any imperfections. One must take the attitude that if I am

**Akai (UK) Limited-Electronic Music Division**, Haslemere Heathrow Estate, Silver Jubilee Way, Parkway, Hounslow, Middlesex TW4 6NF.  
Telephone: 01-897 6388  
Telex: 892555 AKAIUK G.

### Stockists:

#### Aberdeen

Bruce Miller, 363 Union Street, Aberdeen, Scotland.

#### Cambridge

Cambridge Rock, 8 Burleigh St, Cambridge, Cambs.

#### Cardiff

Music Land, 148-152 North Road, Cardiff, S. Wales.

#### Chelmsford

Future Music, 10 Baddow Road, Chelmsford, Essex.

#### Eastbourne

Peter Bonner Musical, 12a Grove Road, Eastbourne, E. Sussex.

#### Edinburgh

Gordon Simpson Ltd, 6 Stafford Street, Edinburgh, Scotland.

#### Fleet

Kingfisher Music Co, 20 Kings Road, Fleet, Hampshire.

#### Glasgow

McCormacks Music, 29-33 Bath Street, Glasgow, Scotland.

#### Liverpool

Hesseys Music Centre, 62 Stanley Street, Liverpool.

#### London

Freedmans, 627-631 High Street, Leytonstone, London E11.

London Rock Shops, 26 Chalk Farm Road, London NW1.

Turnkey, 14 Percy Street, London W1.

Sycos Systems, 20 Conduit Place, London, W2.

Chromatix, 12 Oak Road, Ealing Broadway Centre, London W5.

Rod Argent Keyboards, 20 Denmark Street, London WC2.

Gig Sounds, 86-88 Mitchum Lane, London SW16.

#### Maidstone

E & S Electronics, 2 Upper Fant Road, Maidstone, Kent.

#### Manchester

A1 Music Centre, 88 Oxford Street, Manchester.

#### Newcastle-upon-Tyne

Rock City Music Ltd, 10 Moseley Street, Newcastle-upon-Tyne.

#### North Mansfield

Carlsbro Sound Centres, 182-184 Chesterfield Road, North Mansfield, Notts.

#### Romford

Monkey Business, 66 Victoria Road, Romford, Essex.

#### Swindon

John Holmes Music, 21-23 Faringdon Road, Swindon, Wilts.

# AKAI

A new world of sound creation





# NOW AN INCREDIBLE EXPERIENCE IN SOUND CREATION...

## THE MG1212 RECORDER/MIXER

If you're looking for a complete recording system – combining multitrack recorder and mixer into one – then look no further. You've found it in the AKAI MG1212.

Imagine a unique  $\frac{1}{2}$ " cassette tape – the first of its kind – offering no less than 12 audio tracks (with dbx noise reduction) plus special sync and internal control tracks, with the ease and simplicity of a home video recorder. A sophisticated on-board autolocator with pinpoint accuracy. And much more. It's already exciting.

Now imagine a full-function 12-channel multitrack mixing console with professional-standard controls and flexibility. 3-band sweep EQ. LED bargraph metering. XLR mix inputs. Insert points. And a unique centralised push-button routing matrix. It's all there: just what you'd expect from a company like AKAI.

But now imagine both these units –  $\frac{1}{2}$ " 12-track recorder and mixer – together in the same machine. The result is a unique, compact, integrated package that no-one else can match. Its all-in-one concept eliminates tiresome multitrack wiring looms and brings you flexibility, versatility, ease of use and sensational sounds.

It's that special combination of versatility and ease of use that gives the MG1212, and the whole AKAI Micro Studio System, the edge. If you're looking for a new creative experience, AKAI's got your sound.

For stockists see facing page.

# AKAI

A new world of sound creation

going to record your voice, if I am going to put you to tape and you are going to perform to your track then you have to give me something extra, because I cannot create anything from you that you do not give me.

**BF:** Don't you think that you then might take something away from the character of his performance if you give him instruction on how to actually sing into the microphone, then he is going to be thinking about that all the time?

**JM:** It is not an instruction, it is a guideline.

**MD:** It depends how well you know them as well. If you are lucky enough to work with the same person album after album, you just give little pointers along the way.

I was recently with a band who could actually play—we recorded the whole damn lot all at once. It was suddenly great. There wasn't a click track in sight, the foot was tapping through first take, second take, and third take; you realised it had gone cold—tea break and then play again—it was great.

**TH:** Should they sing when they're drunk, that's another question.

**MD:** Tea changes the sound, but the best thing is alcohol, although they do tend to fall over after a while.

## Windshields

**BF:** Hate them! Try and avoid them wherever possible.

**TH:** To my mind none of the windshields that any microphone manufacturer supplies work. I find they still let pops and sibilance through, and they just make the vocal sound duller.

**MD:** Nylon stocking and coat hanger.

**BF:** That's it. That is *the* windshield.

**TH:** The pencil technique is quite good as well. Say you have your 87 hanging down, you just gaffer tape a pencil so that it is right across the middle of the axis and it just diverts the pop.

**MD:** You can always tell a great story about whose the nylon stocking was!

**BF:** It is also good for keeping the

# VOCALISING ON VOCALS

singer's position constant. With heavy rock anyway where you need a fairly close thing, you put the stocking roughly about 6 inches away from the microphone and you have him singing right next to the nylon stocking (which they quite enjoy sometimes) and they stay there. You do get a little bit of loss if people move around.

**MD:** Much less than you would get from any of the proprietary makes.

**BF:** The foam's useless really. It takes away so much of the presence.

**TH:** Will you automatically put up something like that before you start?

**MD:** I have it handy but I only use it when it is necessary. It usually is necessary.

**BF:** If I'm not using a pop shield I will tend to make the singer sing a bit further away. I only use a pop shield when it is necessary to get that close to the microphone. The only time the proprietary ones are any use is when you are actually recording outside and using them as wind shields which is what I think they were designed for in the first place.

## Tailoring dynamic range

**TH:** The delight of working the digital multitrack for the first time, you think 'Right, I'll throw all the compressors away, you can capture the dynamic range'.

**MD:** Then you realise you are wrong!

**TH:** And you end up with an unmixable tape, or one that if cut by someone who doesn't squash it to death just sounds nothing on the radio in comparison with the record either side of it.

**MD:** You have these wonderful clear

peaks going off up into the gods and no volume to support it.

**BF:** The thing is that you can use the dynamic range, where it is possible, where you couldn't have done before.

**TH:** Digital forces you to be much more careful.

**MD:** You are very hypercritical about it aren't you?

**TH:** Everything. Anything. Headphone spill.

**MD:** Yes, drives you up the wall doesn't it?

**TH:** Specially on Beyers because what comes out the back of Beyers when you've got a mic at a fairly high level in the mix is quite apparent. Almost like sitting next to someone in the tube with a Walkman on.

## Headphones

**TH:** People who sing for a living, professional session singers, get to know what their voice sounds like and they are going from one studio to another perhaps doing three or four sessions in the day, five days a week. I would think that most studios use Beyer headphones. They know what they sound like and, by putting up a different mic that might surprise them. They might say 'Oh, what's this?' but providing they have got roughly what they expect in their headphones they are not going to bother about it. I think there is a very big difference between recording session singers, who do it for a living, and singers in bands.

**BF:** Rather more paranoid.

**TH:** Yes. It is much more personal. It is generally their song, their group, it is their money they are spending in the studio.

**MD:** Very few people like the sound of their own voice, that applies as much to bands as it applies to us.

**JM:** This is the experience of the performer. Generally you will find that a jolly good singer with experience will obviously require the tempo and tuning factor and he will take that to one ear and sing with the other ear off and he will concentrate on the dynamics of his own voice against what he is hearing in the cans, and that is just the basic quantities that he is listening to.

It depends at what stage you are recording the vocal. If you have sweetened the track to virtually the ultimate then you feed that to the vocalist and the approximate headphone balance in the monitor, the chord construction will give him an indication of the dynamics within the track, and he then will accord his voice. On the other hand if you are just feeding a singer the raw rhythm track and he is laying down the performance nobody knows what is going to go on top of it. So you adopt the attitude of let's just get it down as safely as possible as we discussed earlier. Really it's one of the hypothetical areas of the recording industry that we have discussed over and over again, what is (a) and what is (b). Unless you are given a specific application you really cannot give a concrete answer.

**MD:** It's the weakest point of recording vocals as far as I'm concerned. It must be the most unnatural thing in the world to sing with a loudspeaker clamped to your head. It would be easier if we could

Should they sing when they're drunk? . . . although they do tend to fall over after a while



# BASF Studio Master Series. The new Tape Generation.

## BASF Studio Master 910

*This sophisticated recording tape of high dynamic was designed especially for the high professional demands of modern multi-track technology.*

*The wear resistance of the magnetic layer ensures reliable operation even after hundreds of passes.*

*In spite of its considerable high MOL (+ 11.6 dB over reference level 320 n Wb/m), BASF Studio Master 910 has an unusually good print ratio of 57 dB and is therefore also suitable for long-term archiving. The BASF typical constancy of the electroacoustic properties and the excellent winding characteristics also ensure easy hub operation.*

## BASF Loop Master 920

*The chromium dioxide master tape for high-speed duplication systems. At 64-times duplicating rate, the master is usually recorded at 9.53 cm/s. It is only the typical chromium dioxide properties featured by Loop Master 920 which offer that extra quality needed to allow exploitation of all the advantages of a high-class cassette tape (eg. BASF chromdioxid II). In spite of the mechanical stress to which it is subjected in the "loop bin", the durable magnetic layer means that the recording level remains extremely constant, particularly in the high frequencies, even after running thousands of times.*

## BASF Digital Master 930

*This professional chromium dioxide tape is especially tailored to the requirements of digital sound recording (PCM), where the high storage density makes exceptionally high demands on the evenness of the coating. The typical chromium properties are brought out excellently in this latest form of sound storage. The antistatic magnetic layer and the black, conductive matt back protect the recording against dust-induced dropouts and ensure smooth, steady winding without damage to the tape edges.*

**Coupon:** Please send me further information on the BASF Studio Master Series.

Name/Company \_\_\_\_\_

Address \_\_\_\_\_



BASF United Kingdom Ltd.  
4 Fitzroy Square  
London W1P 6ER  
Tel: 01-388 4200  
Telex: 28649

BASF Aktiengesellschaft  
Gottlieb-Daimler-Str. 10  
D-6800 Mannheim 1  
Tel: 06 21/40 08-1  
Telex: 4 62 621 basf d

 **BASF**

use speakers for the vocalist, because it's a horrible thing if you try singing along. **BF:** There is a tendency now for quite a few people to record in the control room with the monitors on—if you put the monitors out of phase, put the microphone bang in the middle they are much more comfortable. It works. In fact, sometimes you don't even have to put the monitors out of phase.

**MD:** I've tried recording vocals with speakers, but you have got to go another generation to then add any compression that you might be using on the voice.

**JD:** The only way you can satisfactorily do that is to take a vocal performance with no compression, no equalisation, and take it to one track and then simply take the foldback situation to another track, then combine them out of phase, then apply your compression. But then you are two generations away from the original and sound has deteriorated.

In my experience, when you record, whatever the situation is, your presentation must be of the best possible standard and that means both whatever you are going to put to tape and whatever you are going to apply to a headphone mix. Let's say we record with a certain amount of presentation towards the end product, so each stage of the recording process we are re-presenting the product, the recording. If we are fortunate to be able to record in stereo pairs and have a certain amount of effect within the recorded item, our presentation is improving as the recording is progressing so therefore you can apply that to the headphone mix so that the artist then hears the progression that's been made and therefore it's easier for him to conceive, perceive and give a performance, whereas if you had taken the simple plug-in technique: 'Well here is the plugged in recordings of what we have done so far', with very little dynamic control, give them to the singer, of course it is bland, and you cannot expect him to give his full performance against your bland foldback. It's a matter of presentation. But there again the presentation does really reflect and depend upon the production and production team how the session is progressing and at what stage you deem the vocal is necessary whether it be a guide vocal which could turn out to be the master vocal or whether it is intended to be a good performance. You cannot give somebody a Ford Escort and expect them to drive it as they would a Porsche Turbo. So if you give a bland foldback mix, that's what you are giving: a Ford Escort. If you have recorded and produced your product properly at each stage, then you have the presentation factor of the product you are working with.

**TH:** Do you generally run a different mix in the headphone to that in the control room?

**JM:** No.

**MD:** I would attempt to get it the same as the mix in the control room—I would attempt to send most of the effects that I've got in the control room to the headphones except perhaps vocal reverb.

**BF:** Yes, except a lot of singers have got their own pet effect that they like to hear in the headphones—a certain repeat or something.

## VOCALISING ON VOCALS

**MD:** Which doesn't usually help.

**TH:** One of the things I always try and do is to make sure that everyone is hearing the same mix. But you start to find that what the producer wants out of a particular song and what the guys want out of a song are different and it's a situation at the overdub stage that hasn't been resolved and you end up in the control room with the producer's interpretation—how he sees the mix finishing up—and the guy in the studio has got something less—those tracks on the multitrack that aren't in his headphones.

At that stage you are looking at a picture and the producer is seeing it through a green filter and the singer is seeing it through a red filter. When we do things like vocals and backing vocals, if they are hearing different things they are going to perform differently and I do find as an engineer it really disturbs me, even doing backing tracks; when a four piece rhythm section are on four completely different foldbacks, they are not all hearing the same thing. They are hearing their own interpretations of how they think it should be, therefore they don't really play together.

**MD:** In common with many people, at the Roundhouse we have got an individual foldback balancing system—four discrete channels that the people can balance themselves. There certainly is an argument for everybody hearing the same thing except that very often the drummer doesn't want to hear himself in the cans and everybody else wants to hear the drummer.

### Post recording techniques

**JM:** Once again, if you are given the performance you, in other words, are given X amount. There is no way that you can make X sound like X+X. You are given one particular situation and you can only enhance it to the best of your ability, or to the best of what's offered to you. Given a tape that is oversibilant, then obviously the correct area is de-essing. If you are given a tape that is over-compressed you then have your ultimate sibilance problem. You must then de-ess. Then you have to manipulate via automation, to try and re-create the dynamics that were possibly there in the first place and obviously that's going to decrease the bass area proximity effect assuming that the vocalist was two feet away from the microphone. There is very little that you can do to create the bass presence because there is a distinct lack of technique. So on those two counts, if you have an over-compressed voice given to you that is rather bland, all that you can do is obviously de-ess because that's the result of compression, then you will have to

manipulate between perhaps one, two or three faders that are via automation, with the characteristics of the sound, to try and recreate the dynamic that has been taken away.

**BF:** There aren't any hard and fast rules about it. It depends what is happening in the music and the backing track. You can always make a vocal sound bigger, you just delay left and right, close repeat or something or chorus, Quantec 'Room' or something, the list goes on and on and on.

**MD:** It also depends how long you are going to spend on the voice. If you can spend all of an evening doing one vocal on one track it's very difficult to get your act together to do it manually the whole time.

**JM:** The safest approach to that, instead of having the compressor with the pre inset situation is to have the compressor between your hand and the tape machine because any mistake you make is then going to be supported by the compressor/limiter.

**BF:** Then you will get the same degree of compression on everything; if the vocal input level goes up you bring the fader down.

**MD:** That goes back to having two channels—for verse and chorus for example. Same sort of thing. It will be fairly soft compression: two or three to one.

**BF:** For most things I use a fairly soft compressor on it just to get it on to tape and then process it in the mix accordingly depending on what's added to the track afterwards. With heavy rock I do tend to compress them an awful lot, sometimes I will use two compressors on record just to get that characteristic.

**MD:** Yes, I find two compressors work much better than one. Two compressors just slightly touching, let me qualify that! Rather than one flapping over.

### Summing up

**TH:** To my mind the vocal should be the icing on the cake, and the sessions I enjoy most are when the producer actually appreciates how important the vocals are. You spend hours changing drum mics, and doing synthesisers and guitars and you spend a week doing one track and the vocalist gets a few hours before you mix.

**MD:** Everybody else has spent hours doing their bit and then the vocalist has got 10 tracks to do in a week which is crazy. That puts so much pressure on them. If you're a player you can play on remote on occasion; if you're a singer you have to put all your effort in.

**TH:** How long do you think you will be recording vocals, given that 15 to 20 years ago it was revolutionary to have strings coming out of a box, given that now we have computers that can talk? Now you can sample vocals, correct pitch and correct timing.

**MD:** Well, we're all probably spinning in choruses and things and have done for some while.

**TH:** Yes but being able to put it in a box...?

**JM:** It will come down to everybody having that box and everybody will be able to manipulate in a certain degree.

**BF:** Maybe it will be a novelty to have a real voice! □

VIENNA, AUSTRIA. KORTRECHT, BELGIUM. BRAZZAVILLE, CONGO. COPENHAGEN, DENMARK. HOERVE, DENMARK. OXFORD, ENGLAND. LONDON, ENGLAND. DORKING, ENGLAND. LIVERPOOL, ENGLAND. MANCHESTER, ENGLAND. QUAYAQUIL, ECUADOR. HELSINKI, FINLAND. PARIS, FRANCE. BERRE-LES-ALPES, FRANCE. BERLIN, GERMANY. HAMBURG, GERMANY. NUREMBERG, GERMANY. MUNICH, GERMANY. ATHENS, GREECE. DUBLIN, IRELAND. ROME, ITALY. MILAN, ITALY. EINDHOVEN, NETHERLANDS. HILVERSUM, NETHERLANDS. LAGOS, NIGERIA. ONITSHA, NIGERIA. TRONDHEIM, NORWAY. OSLO, NORWAY. SINGAPORE, REPUBLIC OF SINGAPORE. MADRID, SPAIN. IBIZA, SPAIN. STOCKHOLM, SWEDEN. KUNGALV, SWEDEN. ZURICH, SWITZERLAND. MONTREUX, SWITZERLAND. LOME, TOGO. CARACAS, VENEZUELA. MARACAIBO, VENEZUELA. CAIRO, U.A.R. VIENNA, AUSTRIA. KORTRECHT, BELGIUM. BRAZZAVILLE, CONGO. COPENHAGEN, DENMARK. HOERVE, DENMARK. OXFORD, ENGLAND. LONDON, ENGLAND. DORKING, ENGLAND. LIVERPOOL, ENGLAND. MANCHESTER, ENGLAND. QUAYAQUIL, ECUADOR. HELSINKI, FINLAND. PARIS, FRANCE. BERRE-LES-ALPES, FRANCE. BERLIN, GERMANY. HAMBURG, GERMANY. NUREMBERG, GERMANY. MUNICH, GERMANY. ATHENS, GREECE. DUBLIN, IRELAND. ROME, ITALY. MILAN, ITALY. EINDHOVEN, NETHERLANDS. HILVERSUM, NETHERLANDS. LAGOS, NIGERIA. ONITSHA, NIGERIA. TRONDHEIM, NORWAY. OSLO, NORWAY. SINGAPORE, REPUBLIC OF SINGAPORE. MADRID, SPAIN. IBIZA, SPAIN. STOCKHOLM, SWEDEN. KUNGALV, SWEDEN. ZURICH, SWITZERLAND. MONTREUX, SWITZERLAND. LOME, TOGO. CARACAS, VENEZUELA. MARACAIBO, VENEZUELA. CAIRO, U.A.R. VIENNA, AUSTRIA. KORTRECHT, BELGIUM. BRAZZAVILLE, CONGO. COPENHAGEN, DENMARK. HOERVE, DENMARK. OXFORD, ENGLAND. LONDON, ENGLAND. DORKING, ENGLAND. LIVERPOOL, ENGLAND. MANCHESTER, ENGLAND. QUAYAQUIL, ECUADOR. HELSINKI, FINLAND. PARIS, FRANCE. BERRE-LES-ALPES, FRANCE. BERLIN, GERMANY. HAMBURG, GERMANY. NUREMBERG, GERMANY. MUNICH, GERMANY. ATHENS, GREECE.

---

# *Eastlake Audio*

---

*studio design,*

*control room monitoring systems*

*and construction services –*

**WORLDWIDE**

---

DUBLIN, IRELAND. ROME, ITALY. MILAN, ITALY. EINDHOVEN, NETHERLANDS. HILVERSUM, NETHERLANDS. LAGOS, NIGERIA. ONITSHA, NIGERIA. TRONDHEIM, NORWAY. OSLO, NORWAY. SINGAPORE, REPUBLIC OF SINGAPORE. MADRID, SPAIN. IBIZA, SPAIN. STOCKHOLM, SWEDEN. KUNGALV, SWEDEN. ZURICH, SWITZERLAND. MONTREUX, SWITZERLAND. LOME, TOGO. CARACAS, VENEZUELA. MARACAIBO, VENEZUELA. CAIRO, U.A.R. VIENNA, AUSTRIA. KORTRECHT, BELGIUM. BRAZZAVILLE, CONGO. COPENHAGEN, DENMARK. HOERVE, DENMARK. OXFORD, ENGLAND. LONDON, ENGLAND. DORKING, ENGLAND. LIVERPOOL, ENGLAND. MANCHESTER, ENGLAND. QUAYAQUIL, ECUADOR. HELSINKI, FINLAND. PARIS, FRANCE. BERRE-LES-ALPES, FRANCE. BERLIN, GERMANY. HAMBURG, GERMANY. NUREMBERG, GERMANY. MUNICH, GERMANY. ATHENS, GREECE. DUBLIN, IRELAND. ROME, ITALY. MILAN, ITALY. EINDHOVEN, NETHERLANDS. HILVERSUM, NETHERLANDS. LAGOS, NIGERIA. ONITSHA, NIGERIA. TRONDHEIM, NORWAY. OSLO, NORWAY. SINGAPORE, REPUBLIC OF SINGAPORE. MADRID, SPAIN. IBIZA, SPAIN. STOCKHOLM, SWEDEN. KUNGALV, SWEDEN. ZURICH, SWITZERLAND. MONTREUX, SWITZERLAND. LOME, TOGO. CARACAS, VENEZUELA. MARACAIBO, VENEZUELA. CAIRO, U.A.R. VIENNA, AUSTRIA. KORTRECHT, BELGIUM. BRAZZAVILLE, CONGO. COPENHAGEN, DENMARK. HOERVE, DENMARK. OXFORD, ENGLAND. LONDON, ENGLAND. DORKING, ENGLAND. LIVERPOOL, ENGLAND. MANCHESTER, ENGLAND. QUAYAQUIL, ECUADOR. HELSINKI, FINLAND. PARIS, FRANCE. BERRE-LES-ALPES, FRANCE. BERLIN, GERMANY. HAMBURG, GERMANY. NUREMBERG, GERMANY. MUNICH, GERMANY. ATHENS, GREECE.

---

1985 CLIENTS INCLUDE 'THE TRUCK' FOR TRILION VIDEO, LONDON – THE MANOR OXFORDSHIRE (RE-CONSTRUCTION) – COMFORTS PLACE STUDIO, SURREY (DESIGN & CONSTRUCTION) – CA VA STUDIOS, GLASGOW (DESIGN & CONSTRUCTION) – TOWNHOUSE STUDIOS, LONDON (CONSTRUCTION) – MPL STUDIO, SUSSEX (CONTROL ROOM MONITORING) – LOMBARD SOUND, DUBLIN (DESIGN, CONSTRUCTION & CONTROL ROOM MONITORING).

---



EASTLAKE AUDIO (UK) LTD  
UNIT 2, 12 WILLIAM ROAD, LONDON NW1 3EN  
TEL: 01-262 3198 TELEX: 27939 SCENIC G

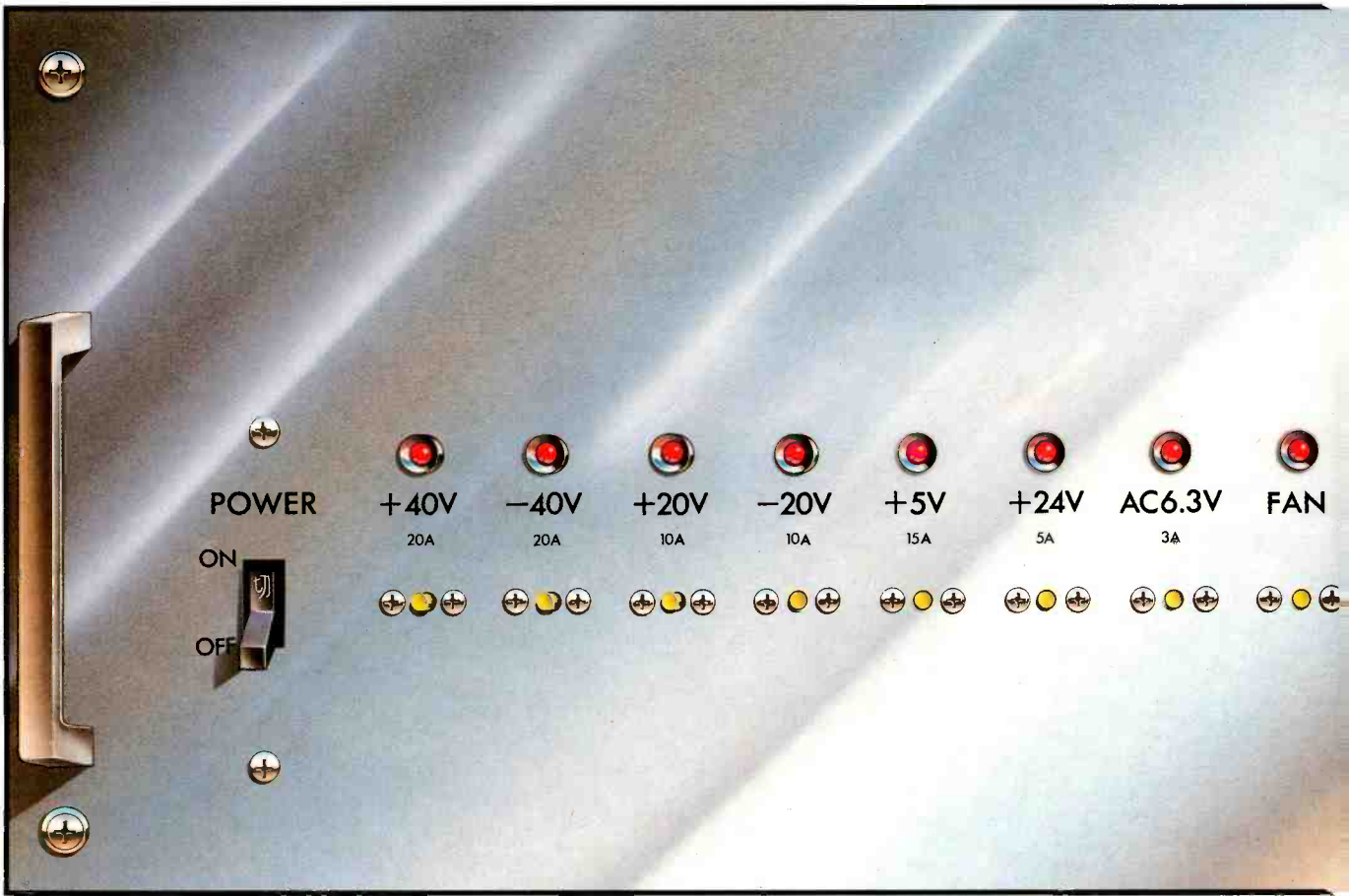

# THE **///** FUTURE **///** OF **///** MULTITRACK IS **///** IN **///** YOUR **///** HANDS

Otari Corporation  
2 Davis Drive,  
Belmont, California 94002  
Telephone: (415) 592-8311  
Telefax: (415) 591-3377  
Telex: 910-376-4890 OTARICORPBLMT

Otari Electric Co. Ltd.  
4-29-18 Minami-Ogikubo,  
Suginami-ku.  
Tokyo 167  
Telephone: (03) 333-9631  
Telefax: (03) 331-5802  
Telex: J26604 OTRDENKI

Otari Singapore Pte Ltd.,  
625 Aljunied Road,  
07-05 Aljunied Ind.,  
Complex Singapore 1438  
Telephone: 743-7711  
Telefax: (743) 6430  
Telex: RS36935 OTARI

Otari Electric Deutschland GmbH  
Gielen Strasse 9,  
4040 Neuss 1  
Telephone: 02101-274011  
Telefax: (02101) 222478  
Telex: 8517691 OTELD

Otari Electric (UK) Limited  
22 Church Street,  
Slough,  
SL1 1PT  
Berkshire  
Telephone: (0753) 822381  
Telefax: (0753) 823707  
Telex: 849453 OTARIG

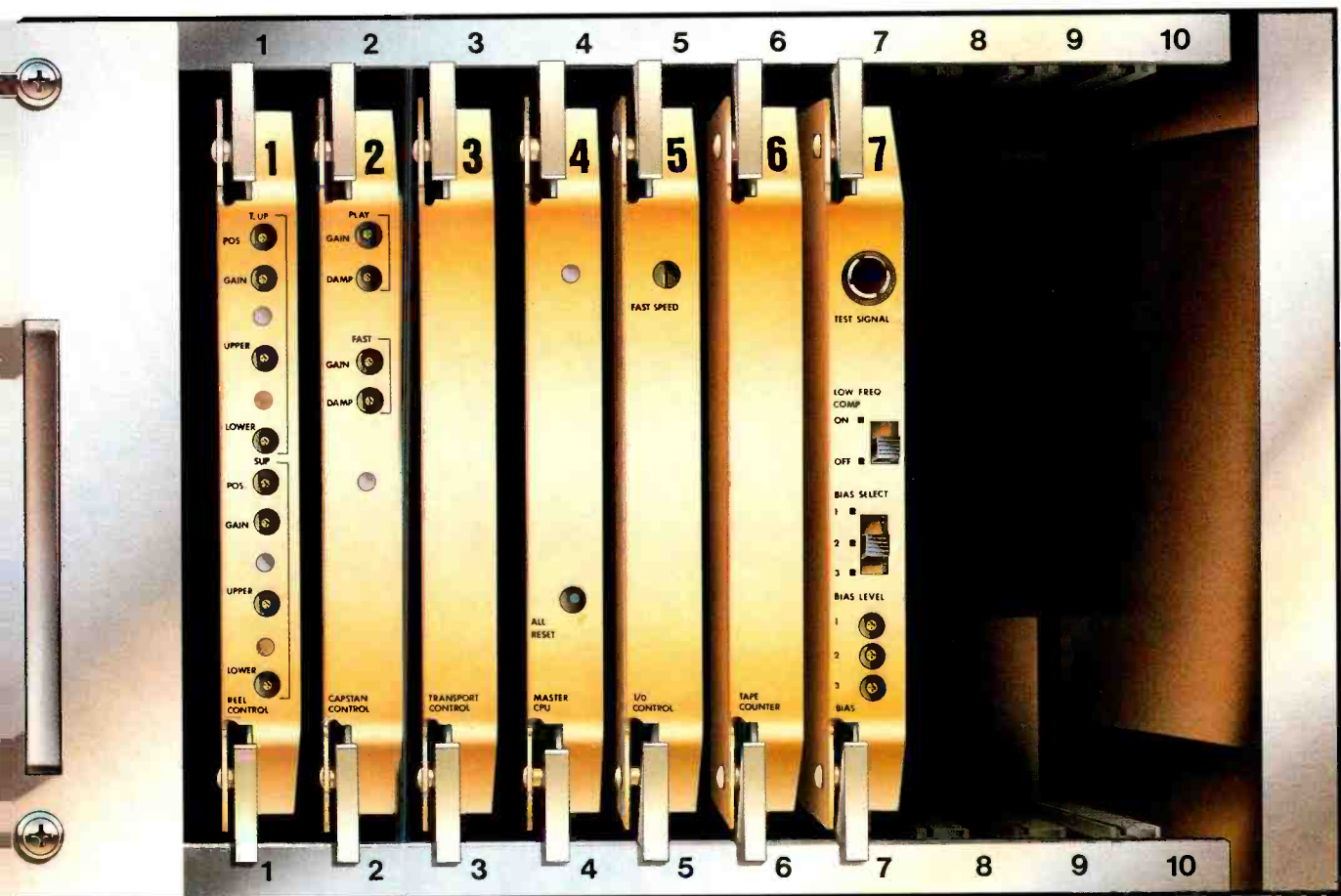

You're holding a picture of the MTR90's most remarkable feature.

A hole.

To be precise, the hole is located in circuit board slots 8, 9 and 10 on the Otari MTR90 Mk.2's transport and CPU cardframe.

That's the part of the MTR90 that does all the thinking.

On a mere seven cards is contained all the information the MTR90 Mk.2 user needs

to create perfect master recordings, with microprocessor control to achieve ultra-fast, split second accuracy and total ease of operation.

But it says a great deal for Otari's vision that despite everything that seven cards can do, they've left space for ten.

What could the other three slots contain? An integral synchroniser? Something even more advanced?

The answer is that those slots will control the features that Otari users will be demanding from their MTR90s in 1986. Or 1987. Or 1990.

Those spare three cardframe slots may be empty now. But to Otari users, they're the future of multitrack.

Because the most important thing about that hole is the fact that Otari are looking into it.



**OTARI**®

For more information on the MTR90 Mk. 2 Series or other Otari products, contact Turnkey Studio Systems, Brent View Road, London NW9 7EL. Telephone: 01-202 4366  
Industrial Tape Applications, 1 Felgate Mews, Studland Street, London W6 9JT.  
Telephone: 01-748 9009

# IN PERSPECTIVE

# IN PERSPECTIVE

Comment from Martin Polon, our US columnist

## Stereo TV—let's go to the movies

Having established via any number of studies in recent years that theatrical motion pictures are the primary software choice for purchase and viewing in the home and clearly of the Hollywood variety, the development of stereo television/video differs greatly from the usual pattern of new technology. Instead of the software developing after and being shaped by the technology; the obverse has taken place. The visual software for home audiences in stereo is the existing pattern of theatrical films, plus some television programming and video music. The technology will develop from this, rather than in a vacuum without existing software. For stereo video/television to achieve substantial audience penetration it must still wait, to ride the double-edged sword of new programme development achieving sufficient mass. There must be enough stereo visuals available in the retail and distribution channels to make the public want to buy the hardware. The hardware technology is in place, both for the production of programming and the consumer units to reproduce it. The funding and convictions to produce all current and future films and TV in stereo is missing.

The history of movie making and television has left a large library of monaural theatrical software and television programming. But, few problems are solved by this available product and its familiarity to the viewing public locks in the size and shape of future programs in stereo. On-the-air television or cable requires a minimum of 6,570 hours of programming to supply just one video channel operating from 7am to 1am each day for 365 days for one year; if there are to be no repeats. Since the average theatrical movie runs anywhere from one and a half to two hours, that would require at least 3,285 films if movies were used to fill that channel. Hollywood at its peak, from the very beginning of talking pictures, only made about 400 films per year and started to slack off in the '50s.

The total, then is about 400 (films) times 20 (years) from 1930 to 1950 or 8,000 films. The period from 1950 to 1970 produced 300 (films) times 20 (years) or 6,000 films. From 1970 to 1980, the film industry averaged about 100 films a year or 10 times that for a thousand films. Currently, only about 80 major films are made with another 50 or so of secondary value. But of the 14,000 major films made between 1930 and 1970, only about 40% (5,600) have survived less-than-adequate storage on volatile nitrate negatives. Some films have been saved only because they were thrown in cold basements in Alaskan theatres (and discovered 40 years later)

since it was cheaper than shipping them back to the studios. Only about 20% (2,800) of these films have any relevant video entertainment value; some of that very marginal—*The Thing From Planet Nine*, *Godzilla Meets the Smog Monster*, etc. The majority of the post-1970 films, of the so-called modern era, are usable as video software in terms of entertainment value, but that only totals about 1,400 films for the last 14 years.

The story of sound quality for existing films is even bleaker. Due to the practice of using the so-called Academy curve established in 1938 to correct for the weaknesses of theatre acoustics and the frequency limitations of optical recording; the majority of films made from the 1930s well into the 1970s exhibit such limited audio characteristics that affordable re-recording options for stereo are virtually nil. That coupled with the industry-wide practice of discarding production materials hampers most efforts at stereo audio archeology. Even in the post-war wide screen spectaculars, where stereo was used the practice of creating a stereo effect by panning monaural tracks to match visual orientation leaves little room for improvement. The combination of limitations on much of the film sound recorded optically, early magnetic film recorders, noisy tracks, nitrate shrinkage, problems associated with the now obsolete variable density (Western Electric) release track process, all combine to eliminate many monaural film sound tracks from use in stereo television/video except as historical curiosities. A university researcher tells a story about the film handling and sound for the gala re-release of *Gone With The Wind* in the early '70s.

"The film had been left in storage vaults on its original nitrocellulose-based negative. When it came time to pull the negative for a commemorative re-issue; the horror of a shrunken and faded negative greeted the editors. It could have been worse. Some nitrate negatives turned to either dust or explosive powder. Anyway, the picture had to be optically printed, carefully using any existing release materials to supplement the negative. The soundtrack had much noise. The question of how to fix it came up at an SMPTE convention. The sound department heads described their task. They had opted for transfer 'as is' and treatment with noise reduction amplifiers and the potential for 'pumping' and 'breathing' on the resuscitated track. I suggested that a computer could read the track with a silicon photo cell and use a vector transform program to mathematically recreate a new soundtrack by driving a lamp in an optical recorder. It was as though I had suggested using plague-invested rats to walk on the sound track."

In 1985, the *GWTW* videocassette was

released with computer-enhanced stereo!

The net result of all of this is a potential stereo software base of about 2,500 films or about 5,000 hours of viable theatrical product. This considers both the visual quality and audio suitability. Of these, there are about 450 films in Dolby optical or multitrack stereo; either as original process or remastered from multitrack mixing materials still available.

Alternative theatrical product has not fared well in satisfying the mainstream of home viewers. Producers have argued that the added cost of stereo sound is not recoverable for features that do not have strong theatrical value. European film productions frequently take a secondary position for domestic theatrical release in the US and often end up on cable. The lack of viewer endorsement has been clear via several studies for non-'Hollywood' product. International co-production items such as the *Marlowe* series and *Far Pavilions* have had some on American cable and more success on British TV, but it is necessary to note that programming management's perception of the 'made for Cable' genre is not good. Co-production deals between HBO and independent large-scale units like Metromedia in the US have not been as successful in creating either 'fourth networks' or satisfying cables' prodigious need for product. In addition, the phenomenal growth of cable at the beginning of the '80s and the current slowdown since last year both seem to emphasise middle-class family hookups for upwardly mobile young marrieds and professional people whose transition into the child bearing state and whose entertainment options become limited. The 'wall' that cable has hit is as much a function of the prodigious cost of wiring new areas and cities at 1980's system prices, as it is the inability to meet the demand for new product.

The network made-for-television movie has become a polished and much appreciated art form, with over a thousand productions in the can. Almost all of these were done on film with monaural sound tracks and the traditional studio attitudes towards storage for interim materials. Relatively few are functional for remix to stereo. Some were shot on videotape and had Dolby noise reduction available.

Production costs differ widely for theatrical film versus television programmes versus made-for-TV movies. Theatrical films today have an average cost in the range of \$12-18 million per film for a 2 hr feature. *Indiana Jones* and *Ghost Busters* cost much more due to the elaborate special effects. That breaks down to \$125,000 per minute. Some experts still use \$100,000 per minute as an average figure for theatrical movies. A weekly TV series costs as much as \$500,000 per episode hour (\$250,000 per half hour) with a show like *Miami Vice*



# IN PERSPECTIVE

# IN PERSPECTIVE

costing in excess of that much just for production without sweetening. *Miami Vice* incidentally did shoot its pilot in stereo to emphasise the show's lush use of sound and Music Video style tracks. That breaks down to a per minute cost of \$8,333 with \$10,000 per minute being used as an example by many. Two hour made-for-television movies can run from a low of \$1,500,000, a more realistic average of \$3,000,000, to a high of \$6,000,000; breaking down to \$25,000 to \$50,000 per minute. Mini-series are loss leaders and ABC's *War and Remembrance* could cost in excess of \$60 m.

Although most theatrical films today are made with Dolby stereo, several problems surface in trying to tack stereo soundtracks on to any production that begins its life as a television series. Most studios producing television 'product' claim they do not see a profit until the show goes into syndication and they control all of the revenues, while paying out smaller residuals to actors. The costs of sweetening for stereo TV can be a real problem unless we are talking about a *Hill Street Blues* or the aforementioned *Miami Vice* that already expends a sizeable effort on audio post-production for dialogue replacement; for which stereo sweetening would be less difficult to integrate into the existing post production process. For other shows, especially where talk predominates rather than action, a 10% surcharge on a half hour show of \$25,000 for TV stereo can further delay profitability.

It seems on reflection that compact disc has a leg up on stereo television; in being able to go back and recreate great performances from the near and in some cases distant past. The record industry has always been on the leading edge of technology rather than at least 10 years behind it. The coming of digital has also been clear from work at the AES level since 1975. The warning signals have been very hard to miss. So careful storage of master tapes and even the recording of special uncut multitrack masters for future use has been the fortunate legacy of many great classical performances. Many more recordings of all types of music over the last five years have been similarly protected; so that the advent of digital recordings has carried with it a backlog of materials suitable for re-issue.

Sadly, the motion picture industry has little in the way of such a legacy to offer stereo TV/video. The frequency demands of digital audio laser discs and VHS/Beta hi-fi VCR recorders are really no less stringent than that of the compact disc. Yet only the Dolby-recorded pictures beginning in the late 1970s possess anything approaching acceptable soundtracks and some of the earlier examples of these have seen the post-production materials discarded in Hollywood's relentless disregard for its

magnetic and optical history. The future does appear brighter as studio moguls (or mini-moguls as the case may be) have realised the value of 'new technology' distribution. In a further example of the 'sensitisation of the new Hollywood' to technology, the Writers Guild, and technical workers' unions (grips, gogers, carpenters, sound, etc) plan to strike in 1985 if necessary so that they too can share in the 'obviously unlimited' pieces of the 'great electronic pie in the sky'.

The economics as perceived by programming and film producers still do not favour stereo production and post-production for all projects or even for

many, especially in digital formats. But it has become clear that the provision of high quality stereo audio may be a dollars and cents bargaining chip in the future and that is the language the programme producers and the studios understand. The quality of equipment and skill of personnel have made quantum jumps in the sound departments of the various studios over the last few years. It seems clear that technology and skill is available if the movie and television producers want to spend the money to make stereo TV/video available. That must happen, for the format to attract the public. □

## IN PURSUIT OF EXCELLENCE

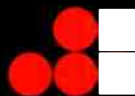

You have a vision for your studio. For more than 10 years Scenic Sounds have been committed to helping people realise their technical ideals. We are dedicated to excellence, we import, distribute and support the widest range of specialist high technology audio and post-production tools available in the UK. These include Amek, dbx, Lexicon, Cipher/BTX, Orban, H H. and Schoeps products.

As the approachable specialists we can provide superb back-up and down to earth advice. Why not call or visit us (easy parking in central London) to discuss how we can help you with affordable excellence.

Scenic Sounds Equipment Marketing Ltd.

Unit 2, 12 William Road, London NW1 3BN. Tel: 01-387 1262. Telex: 27939

# STUDIO FILE

# STUDIO FILE

The film industry is sometimes rightly or wrongly accused of being traditionalist in terms of technical innovation, even though certain productions become famous for the new techniques that were required for their realisation (such as the sound for *Fantasia* or the multitude of special effects for *2001: A Space Odyssey*).

One of the largest film sound studios in the United States, The Burbank Studios near Hollywood has been at the forefront of the latest technology in sound recording and indeed, can be considered on a par with the top music recording studios.

"The Burbank Studios was one of the first film studios to get involved with the use of multitrack tape recording of motion picture and television scores while simultaneously recording on conventional 3-track 35 mm magnetic. This first began in the '70s with the use of specially designed Ampex MM1000s with *Filmlock*, a system designed to frame lock a 16-track tape recorder with a 35 mm magnetic recorder and projector," said maintenance engineer and tour guide Jim Walker.

"This later gave way to the use of 24-track tape recorders

## The Burbank Studios, Hollywood

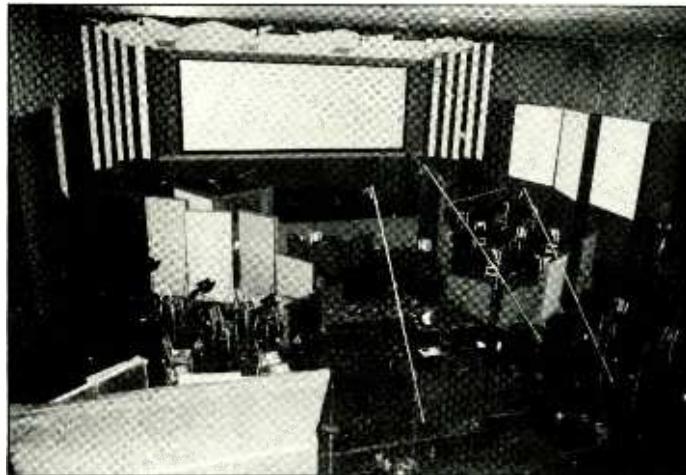

Music Recording Stage One

for added flexibility in overdubbing and remixing. By 1977, when the first 32-track digital soundtrack recording was made for Disney's *The Black Hole*, it became obvious that a new custom console would be needed to take in the variety of recording formats already in use or looming on the horizon."

The first place to visit was the large scoring stage Music Recording Stage One. Holding

up to 125 musicians in comfort, the studio can accommodate all styles, from sweeping Hollywood strings to the more hit-parade oriented sounds of today. The building goes back to the 'Golden Days' and the overall sound of the room—though it would be more appropriate to say hall—is equally golden.

Basically rectangular in shape with a high ceiling, the response of the studio can be

modified by the use of very large panel absorbers and polycylindrical diffusers. Numerous screens of differing sizes are also available for greater separation. The floor is of very handsome hardwood, which no doubt contributes largely to the overall presence of the room. Though always difficult to describe acoustic environments in words, Music Recording Stage One can be said to have a warm, bright sound, free of the muddiness that can be present in a large room.

One end of the studio is dominated by the Cinemascope size screen, with five Altec A2 cinema speakers for playback monitoring placed behind it. Further 'spot' monitoring is provided by smaller JBL studio monitors.

In keeping with the size of the studio, the microphone complement is very comprehensive with a selection of over 200 microphones.

At the opposite end to the screen are the control and machine rooms. These are quite large and built on to the main studio floor in the manner of large booths, leaving a large air space between the control/machine room ceiling and the studio ceiling. The 'booth' ceiling is

**M**usic recording in the film industry has generally kept pace with audio technology. Yet the laborious steps of getting the finished mixes to film-based optical tracks have remained since they were developed in the 1940s. Even with sophisticated studio recording equipment and playback gear in the theatres (like Lucas' *THX* systems) these 'conventional' transfer methods still cause degeneration of sound quality, which can mask some of the subtle nuances important to the story plot.

Luckily, major film studios like Warner Brothers and Columbia Pictures, through their shared post production sound facility at The Burbank Studios, are realising the power of the new digital technology. Their commitment to pioneering innovative applications are improving the overall level of the recording, mixing and dubbing process to produce premium soundtracks that are several generations cleaner and clearer than their analogue counterparts.

One example is the music track for the film *Body Double*, directed by Brian DePalma. In October 1984, DePalma took his project, which had an extremely tight schedule, to Burbank for post,

production and scoring work. (The music tracks had to move from initial recording to release prints in 10 consecutive days.) Under the direction of Tom McCormack, head of the post production sound department, the studio recommended using their Mitsubishi *X-800* 32-track recorder and *X-80* 2-track mastering machine. This was cost effective and also cut production time.

### Yesterday's methods

"The mixing process usually takes quite a while," says maintenance engineer Jim Walker. "Every time something goes wrong in the mix, the recordists have to rewind three machines and start again from the top."

Besides racking up a lot of hours in the studio, keep in mind that other negative factors are also involved. Material stored on any magnetic media degenerates over time. And repeated replays, such as those that occur during the overdubbing or mixing process, take a toll on the overall sonic quality, too.

On the dubbing stage, the 4-track music print master on 35 mm mag (a second generation copy that contains all the music cues timed and sequenced in the appropriate order, and probably took

several days to put together) is mixed with the sound effects and dialogue masters to produce the 4-track stereo composite master, the final version of the whole motion picture soundtrack (third generation). From there, the 4-channel mag copy is Dolby encoded and reduced to two channels on a 2-track recorder (fourth generation), which then serves as the print master for the production of the film's optical tracks (fifth generation) for distribution. In local theatres, a Dolby decoder translates the two encoded optical tracks back to 4-channel stereo (left, centre, right and surround).

### Today's digital innovation

Generally speaking, the use of digital technology in any medium—film, records, TV etc—can easily improve sound quality. But to fully understand the role the *X-800* plays in the studio's productions, we should first take a look at the method TBS has developed for recording music tracks. Ever since the studio purchased the *X-800*, studio scoring mixers have produced soundtracks for movies (*Ghostbusters*, *Gremlins*, *Tightrope*, etc) and television

THE

# Mic Shop

AT **MUSIC LAB**

RECORDING VIDEO P.A.

SHURE SM58

SHURE SM57



NEUMANN U87

AKG  
451E/CK1

SENNHEISER MD421

STUDIO TECH  
BOOM STAND

SENNHEISER MKH816

The Music Lab Mic Shop is London's leading supplier of Microphones to the Recording, A/V, Film, Video and P.A. industries. Our expert sales team are available to give advice on all microphone applications and techniques.

SAME DAY DESPATCH · BARCLAYCARD · AMERICAN EXPRESS · ACCESS  
72-74 EVERS HOLT STREET, LONDON NW1 1BY  
TELEPHONE: 01-388 5392 TÉLEX 28159 MUSLAB G

# NEXT...

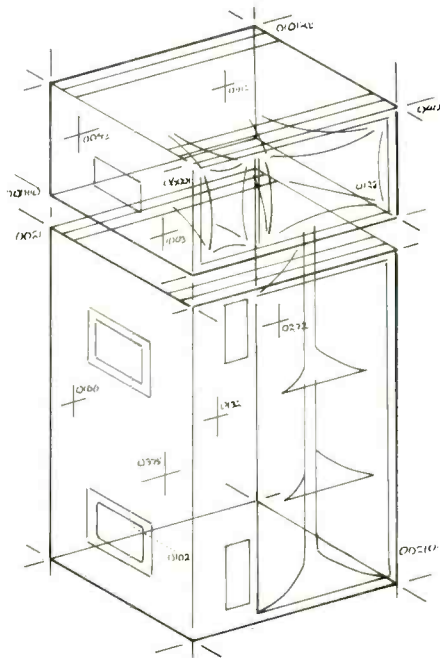

PROJECT: A SPECIFICALLY COMPUTER-DESIGNED  
INTEGRATED SYSTEM: COMBINING MAXIMUM ACOUSTIC  
OUTPUT WITH OPTIMUM FREQUENCY & DYNAMIC RANGE:  
COMPUTER-OPTIMISED BASS FREQUENCY EXTENSION:

LONDON BOROUGH OF ISLINGTON

# BRITANNIA ROW

N.I

COMPLETE SERVICE AUDIO HIRE

- 2-24 TRACK TAPE RECORDERS
- BTX SYNCHRONISERS
- DIGITAL TAPE RECORDERS
- NOISE REDUCTION SYSTEMS
- PROFESSIONAL VIDEO EQUIPMENT



01-226 3377 TELEX: 268279 BRITRO.G

BRITANNIA ROW LTD 35 BRITANNIA ROW LONDON N1 8QH

# STUDIO FILE

# STUDIO FILE

heavily braced and damped down with concrete beams in order to eliminate any unwanted resonances. Both rooms have large windows looking into the studio providing good communication. The machine room is brightly lit whereas the control room, in contrast, has that low-down nightclub atmosphere where dim lights and soft furnishings are the rule.

The machine room houses the recorders and a lot of the patching and serves as a general maintenance area. Due to the spartan appearance of the room and the bright lighting, the window has heavy drapes in order to curtain it off from the studio when preferred. Equipment consists basically of two Ampex *MM1200* 24-track recorders, Studer *A80* 4-track machine and numerous Ampex *AG440* 2-track and mono machines, the number depending on the job in hand at any one time. Film recorders consist of two RCA 35 mm machines with 3, 4 and 6-track capability. Also in evidence are racks filled with Dolby noise reduction for the multitrack and film recorders, together with additional units that can be patched in at will to the various master

## Burbank continued

recorders.

Leading off from here is the studio control room, with an abrupt change of atmosphere. The console is mounted on a dais to provide better visual contact with the studio, and is placed quite far back to allow for seating on the lower level in front of it. This way the engineers can concentrate without having people breathing down their necks! Suspended just above the control room window in an arc are five bi-amplified JBL *4333A* monitors, plus a rear

mounted monitor for the 'surround' channel in 6-track.

The recording facilities for Stage One are designed to handle all present and foreseeable formats and the console has been specially designed to this end. The console was designed from the ground up by Quad-Eight and Burbank. The basic design brief was that the console should be able to handle 32-track digital recording, as well as 24-track analogue and all other tape and film recording formats. Though

similar to a standard multitrack console, the TBS desk has a number of important differences.

The console features 55 inputs, with 15 of these being straight microphone channels. Equalisation modules can be patched in at will putting EQ only where it is needed. The other 40 channels feature 3-band equalisation over 44 fixed frequencies plus variable Q and variable low and highpass filters for overall frequency shaping. Six of the main inputs can also be designated as echo returns and include 'Grand Master' defeat switches should the situation arise. The desk has full DC subgrouping and is scheduled to be fitted with the new Quad-Eight *Compumix 4* computer mixdown system.

The monitor section of the console is very comprehensive and consists of what TBS call 40 positions. This provides monitoring facilities for two 32- or 24-track machines, six cue lines, a dialogue track and a click/effects track. In addition, a direct 6-track (or 3-4 mix on) to the magnetic 35 mm recorders can be made from the monitor section, which is also the reason for the independence of the six echo return channels.

32-channel custom built console



shows (*Mike Hammer, T J Hooker, Scarecrow and Mrs King*, etc) by first recording music on 20 or more tracks, for example, and then mixing back to open tracks (three, four, six or more depending on the project requirements) on the same *X-800*. This yields three advantages right away: all reprints remain first generation (digital-to-digital transfers incur no generation losses); only one operator is needed to run the single machine, instead of two people for two machines; and the amount of tape consumed is virtually halved (no extra reels of tape to mix to), which also cuts down the amount of physical space necessary for long-term storage.

When this capability was used in tandem with the btx *Softouch* system other advantages were realised. According to scoring mixer Frank Jones, "It was just like having automation. If I missed a cue during the mix, or the producer wanted to change something afterwards, I could run the tape back to the right place, make the level adjustment, and punch in the new part to the previous version of the mix."

Because the music was mixed to open tracks on the same reel, the mix and initial tracks never go out of sync with each other. To do an update, the

engineer simply enters the location of the change via the *Softouch* keyboard, initiating the punch-in/punch-out automatically and without risk of operator error. Once the appropriate music track(s) is re-adjusted to the desired level, the 'Rehearse' feature of the *X-800* lets the mixer and producer listen to their change before committing it. If it's not quite right, new location values can be re-entered as often as necessary until the exact punch-in and punch out spots are perfect. When everyone is satisfied, the update is recorded without having to re-do the entire piece of music from the top. "We punched-in two or three bars in the middle of a string sustain with no problem," says Jones. "Mitsubishi's error-correction system made the music totally seamless. And we probably cut our time just about in half."

While Jones did much of his recording/mixing for *Body Double* this way (with one machine), some of the cues filled as many as 30 channels at one time with a 60-piece orchestra and 12 to 15 overdubbed tracks of synthesizers. To mix these sections, the studio brought in a second *X-800* and tied it to the first digital machine via a btx *Softouch* synchroniser without sacrificing any

recording channels. In addition to the 32 digital audio recording tracks the Mitsubishi has five auxiliary tracks for storage of other signals. Two of those five can hold various sync data and a third channel is dedicated to SMPTE timecode. The other two are analogue audio tracks that can record material for purposes like tape rocking.

For example: after a bass drum track has been transferred to one of the analogue channels, the engineer can find the downbeat just as he would on a totally analogue recorder—by rocking the digital reels back and forth. That SMPTE, or other code number can be entered into the btx and punch-ins/punch-outs occur automatically, as mentioned previously. "If the *X-800* didn't have that tape-rocking feature," says supervising music editor Richard Stone, "this digital music soundtrack would have been totally impossible. In a sense, the two *X-800* digital machines locked together to become a sort of *Moviola*, which is how we edit on mag."

All Stone's editing was done on digital tape instead of using more conventional cut-and-splice techniques to produce the music print master. He did, however, rehearse his edits on mag copies prior to doing his final digital edits.

# AUDIO JACKFIELDS & JACK SOCKETS

Mosses & Mitchell are the largest manufacturer of Audio Jacks and Jackfields in the UK. We are approved suppliers to the BBC, British Telecom, Pye Telecommunications and many other major telecommunication companies throughout the world. We manufacture a complete range of Audio Jacks & Jackfields and offer a design and manufacturing service geared to meet your specific requirements. For further information and technical data on our products contact:

## MOSESSES & MITCHELL

Mosses & Mitchell Limited  
Weydon Lane, Farnham Surrey GU9 8QL  
Telephone: Farnham 721236 (STD 0252)  
Telex: 858820

# NEXO PARIS



PAUL FARRAH SOUND

NOW PHONE FOR TECH SPEC OF FINISHED PRODUCT:  
PAUL FARRAH SOUND 01-549 1787 TELEX: 945114 FARRAH G

JACOBS'S

STUDIOS

Up the JACOBS'S DIGITAL ladder another rung

1st UK studio with MITSUBISHI 32 track digital

Bookings (0252) 723518 Telex 85862/858393

## NEW

A4 size STUDIO SOUND binders are now available (each holds 12 copies). Keep your copies of STUDIO SOUND in smart black binders with the title in gold block letters on the spine.

At only £3.50 each including inland and overseas postage and packing. Send your order with cheque or postal order to: Modern Bookbinders Ltd., Chadwick Street, Blackburn, Lancs BB2 4AG (state clearly your name and address and the relevant magazine title).

OVERSEAS READERS MUST SEND INTERNATIONAL MONEY ORDER

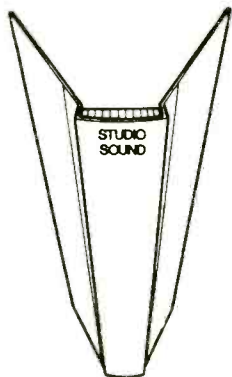

(Limited number of old size binders available).

## AMBISONIC SURROUND SOUND DECODERS

Ambisonic surround sound gives a realism in the reproduction of music that is hard to describe without using hackneyed expressions like 'natural' and 'being there'. Positioning of the performer becomes obvious and the acoustic of the original environment comes through to the listening room. The Minim decoders also provide enhanced results from conventional stereo material. We can now supply UHJ encoded records, tapes and compact discs.

And don't forget our other products:

PROGRAMMABLE WEEKLY TIME SWITCHES  
TELEVISION SOUND TUNERS

Please send me information on: Time switches/Television Tuners/Ambisonics

Name .....

Address .....

Minim Electronics Limited, Lent Rise Road, Burnham, Slough  
SL1 7NY. Tel: Burnham 63724

SS9

# STUDIO FILE

# STUDIO FILE

The console is designed and set up to simultaneously record 32-track digital, 24-track analogue, 3-track on ½ in tape, stereo and mono, together with the 3, 4 and 6-track 35 mm film mentioned earlier. As can be seen, this offers an enormous amount of flexibility accompanied by the minimum of head scratching! Metering on the console covers all formats from mono to 32-track.

One noticeable feature for someone used to recording studios was the apparent lack of signal processing equipment. Jim explained that the studio has many effects units on call and that each session is set up as required, rather than having racks of equipment which may remain largely unused and thus take up space for no useful purpose. The console patchbay is extremely comprehensive and versatile. Another factor which has to be borne in mind is speed: "It's not like a record company where they have several months to do a project. Here it has to go down fast and accurately," says Jim.

In some ways the multitrack is used as insurance, where sections can be re-done if

## Burbank continued

necessary or overdubs added, rather than have a whole orchestra hanging around. Very often the 2, 3, 4-track mixes are used, with remix versions being done for the soundtrack record release.

monitor section. Other features include six DC subgroups with 'Grand Master', 12 mic submixers, simultaneous mixdown for quad/stereo/mono and film formats, 6-channel monitoring

TBS's large Music Recording 1 can hold 125 musicians

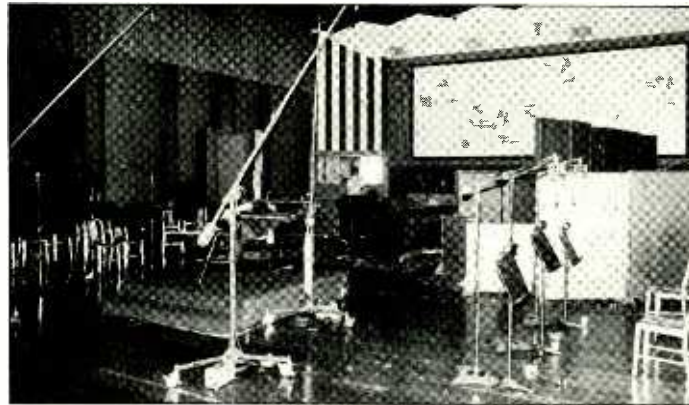

The smaller scoring stage, Music Recording Two, accommodates 35 musicians and has virtually identical recording facilities as One. The console is a custom built 44/24 from Quad-Eight in a 'wrap-around' construction and features a separate 24-track

for film mixes, six cue sends and four joystick quad panners.

The studio was designed to be used as a music recording studio in addition to film scoring, and various chart successes have been recorded there over the years. The

acoustics are quite bright with a low reverberation time, making it quite suited to rock and pop. Stage Two is not used as often as it once was (perhaps the red and silver console colour scheme with the mauve armrest has something to do with it) and it may be renovated and turned over completely to music recording.

TBS is not short of transfer facilities and these number no less than seven rooms, all of which are equipped for Dolby encoding and decoding. For reasons best known to Burbank, the rooms are labelled A, C, D, E, O, P and T; an idea of the flexibility afforded by these rooms is shown by glancing through the equipment list for each room.

### Room A

1×single-track reproducer (35 mm)  
1×3-track reproducer (35 mm)  
2×single-track recorders (35 mm)  
1×¼ in tape recorder

### Room C

1×single-track reproducer  
1×single-track recorder  
1×¼ in 3M tape recorder  
2×¼ in Ampex tape recorders  
2×cassette recorders  
1×record turntable

### Rooms D & O

1×Magna-Tech 35 mm recorder—  
1, 3, 4-track or 16 mm EBU  
1×Magna-Tech 35 mm reproducer—

## Music edits on 32 tracks

On *Body Double*, director Brian DePalma requested some tight music edits, because he wanted to fit specific musical notes with particular visual shots. And in some cases, there were editorial changes in the film introduced after the score was completed.

Richard Stone pre-cut the mag versions of the cues, so he knew exactly where the changes were to take place. Using an HP-85 computer to convert film footage in feet and frames to SMPTE timecode, Stone knew how to translate his mag version to the SMPTE coded digital tape. For example: if he had to remove a section of music that was equal to 2 ft, seven frames of mag film, the conversion of feet and film frames to SMPTE would yield the equivalent amount in seconds and video frames.

After entering that information into the btx system, he created what amounted to a mag edit by taking out the correct number of (musical) bars on the digital music master. No one on the dubbing stage knew the difference between those electronic edits and the usual mag edits. "In fact, I feel the digital edits are better," says Stone, "because we got even closer to the edit points than we could have using mag. The tape sounded as though the

musicians had just recut their edited parts live."

Following editing, the X-800 was rolled on to Dubbing Stage Five, and interfaced with the RCA film chains via another btx *Softouch* system. The btx converts tach pulses from the RCA film chain to SMPTE timecode so the digital recorder is locked frame for frame to the film, utilising the SMPTE timecode as electronic sprocket holes. This ensures that during 'Fast Forward', 'Rewind' and 'Play', the digital runs along in sync with the film machines and other audio playback units. The btx lets the operator 'slip' the tape with only a couple of keystroke commands. ('Slipping' denotes moving the music tracks forward or backward anywhere from a few frames to many feet to compensate for last minute film edits or sync changes.)

After the digital music masters and the analogue dialogue and sound effects print masters were combined to a mag master (the only time the music was ever in the analogue domain), the 4-channel stereo mix was encoded using a Dolby DS-4, which collapsed the four signals to two piggy-back signals that would eventually go on the finished optical release print. (A complementary unit in theatres decodes the signal back to the original four channels.) Usually, these two encoded tracks are transferred

to a mag film 'print master'. But laying them on two open channels of the X-800 succeeded in eliminating another generation loss, and proved that encoded information could be saved digitally. Another digital-to-digital transfer moved that mix on to a ¼ in reel of tape on the Mitsubishi X-80 2-track digital mastering recorder, which could then serve as the source for running off optical release prints.

## Additional benefits

In retrospect, a couple of unforeseen benefits became readily apparent. "The digital recording process actually puts more apparent level on the film," says music dubbing mixer Vern Poore, "so the actual level of the music can be lower."

"The sound effects and the dialogue came through much better on the final master," adds Richard Stone. "Because the digital added no hiss, and the high strings were much cleaner than an analogue recording, the digital music actually left more space for the other elements to come through. I'm sure that if people invest the time to experiment with this new technology, we'll see all the components being recorded digitally very soon." □

Tony Ryder

# STUDIO FILE

# STUDIO FILE

1, 3, 4-track or 16 mm EBU  
 1× Studer full track ¼ in recorder  
 1× Studer 2-track ¼ in recorder  
 1× cassette recorder

## Room E

1× 35 mm reproducer—1 or 3-track  
 1× 35 mm single-track recorder  
 1× 35 mm 3-track recorder  
 1× 16 mm edge recorder  
 1× ¼ in tape reproducer  
 1× ¼ in 4-track recorder

## Room P

1× 35 mm reproducer—1 or 3-track  
 1× 35 mm single-track recorder  
 1× 16 mm edge/35 mm single-track recorder  
 1× 35 mm 3-track recorder  
 1× 16 mm magnetic recorder/optical reproducer  
 1× ¼ in 4-track tape recorder.

## Room T

3× 35 mm reproducers—1, 3 or 4-track  
 3× 35 mm recorders—1, 3, or 4-track  
 2× Ampex ¼ in 2-track recorders  
 2× Ampex ½ in 4-track recorders  
 1× Ampex ¼ in mono recorder  
 1× Ampex ¼ in mono/2-track reproducer  
 4× cassette recorders  
 1× record turntable  
 1× high speed cassette duplicator

In addition to the transfer rooms are two for ADR and Foley: the ADR room and Room 14. These are fairly small (as would be expected

## Burbank continued

for dialogue use) with dead acoustics. Foley effects can either be done with imported materials or from the adjoining Foley room itself. Capabilities of the ADR room consist of automated dialogue replacement, narration with or without picture, Foley (natural sound effects), 1, 3 or 6× speed operation, playback of one, three or four cue tracks and simultaneous recording on one, 3-track 35 mm and ¼ in tape. Equipment includes a Magna-Tech 1, 3-track 35 mm reproducer, Magna-Tech 1 and 3-track 35 mm recorders, Ampex ¼ in recorder and a Magna-Tech high speed 35 mm projector. Mixing is via a custom built Quad-Eight automated console with six inputs and three outputs.

Microphones are an assortment of Sennheiser, Neumann and Electro-Voice.

Room 14 is similarly equipped the differences being

1 or 1½ speed operation, playback of only one cue track and recording on 1 or 3-track 35 mm and ¼ in tape. Equipment differences are RCA single-track reproducer, RCA 1 or 3-track 35 mm recorder, Simplex XL projector—otherwise the same as the ADR room.

Dubbing Five is the largest dubbing (or re-recording) stage at Burbank. The size of an average cinema, the theatre has recently been completely refurbished and the previous Quad-Eight console replaced by yet another Quad-Eight/Burbank designed desk.

On entering Dubbing Five at the rear of the room, one is confronted by rows of dubbers and 35 mm magnetic recorders in the machine room running behind the back of the theatre. These consist of 17 double RCA 85SL reproducers (which translates to 34 individual sprockets) with

interchangeable 1, 3, 4 or 6-track heads and switchable equalisation from RCA to SMPTE; three RCA 86SL recorders with 1, 3, 4 and 6-track heads (this should now be up to four as a fourth was on order at the time of writing) and an RCA projector with high speed shuttle.

The reproducers (or dubbers), recorders and projector are all driven from an RCA PX-21 servolock signal generator which provides 10 pps (which I take to be pulses per second). The PX-21 works hand-in-hand with a PA 302 which provides the start cue-stop cue counter functions. The start cue-stop cue footages (in feet and frames) are entered at the console by the mixer, each mix position having its own remote control panel. The appropriate button—start/stop/cue—is pushed and the whole system takes off at six times normal running speed and searches for the cue point or preset footage. When the machine reaches within 30 ft of the footage

The FX Series  
 by

 NEUTRIK

Sole Agent UK

**Eardley Electronics Ltd.**

Telephone: 01-221 0606

Telex: 23894



Photography Francis Loney  
 Smiles Studios at Eardley House

# STUDIO FILE

# STUDIO FILE

number, the speed slows to normal running speed of 24 frames/s until the cue is reached.

Another feature is the remote advance/return system—a rather sophisticated form of rock and roll. This allows the mixer to advance or return each or all of the machines assigned to him individually by up to 100 frames. A digital readout indicates the offset position of any machine assigned to that remote control, advance/return controls being fitted to each mix or console position.

The new dubbing console is one of the largest in the US and is certainly impressive! However, it is more than just cosmetic and provides the nerve centre for post production from the simple to the highly complex. The 24 ft long console is 3-position which means that it is, in essence, three separate consoles combined into one, each section dealing with either music, effects or dialogue. It has less than 10% of blank panel space, the rest being filled by the equally large patch and equipment bay behind the seats. Each console section features its own output buses, record bias control, playback/direct keys and power supply. There is also a transfer function on each section that allows a mix (or portions of it) to be transferred to another station during complex mix situations. The versatility of the console is completed by a 2000 point patch bay, enough to keep most people 'knitting' happily!

The total input/output configuration of the console is 108 inputs with 40 outputs plus a solo bus. The inputs are broken down to 60 fader channels with 3-band equalisation and four 12×6 mixers—one for dialogue, one for music and two for effects—making up the additional 48. The output buses are split into five groups of eight, these being effects, dialogue, music, main buses (a composite of music, effects and dialogue) and music and effects (or mix minus), which is a composite of the two. The channel routing is such that any programme assigned to the music or effects section also appears on the main bus and mix minus bus, thus allowing

## Burbank continued

a stereo music and effects recording to be made at the same time as the complete product. The console is also equipped with special panners enabling the signal to be spread across three channels. Nine 7-band graphics are incorporated, with five often inserted into the main bus section for fast changes or overall shaping, eg: environment changes, indoor to outdoor, etc. Metering on the desk appears at first sight to be VUs, but in fact are LED

rear racks or in the console itself, with Orban paragraphic equalisers and de-essers. UREI parametric and *Little Dipper* filter sets, Eventide DDL and *H910 Harmonizer*, UREI compressor/limiters, a dbx modular rack with compressors, gates, de-essers, etc and two Quad-Eight *CPR-16* digital reverberation and echo units.

Post production sound director Tom McCormack: "The big difference today is that the kids want—and expect

that so I went behind the screen and found this old Altec *Voice of the Theatre* lying on its side on the floor with the horn firing into the bottom wall under the screen! It just took us three minutes to raise it up and place it properly behind the screen and the sound was back in business. I mean, what do you do with people like that?

"We have a philosophy here to make the best product we can and if the theatre systems can't reproduce it, well it's their problem. There is a growing awareness among theatre owners and managers of the importance of good sound but the main problem is that they are often using systems that are over 30 years old and replacing them is expensive. They have to justify the expense to themselves; will it bring in more customers? If they stop selling ice-cream for a week they can see the effect, but if they install new sound equipment, is it that or the picture that is bringing the people in?"

"In the end I think it is the public that will force the issue, especially the younger generations. They are used to hi-fi sound as an everyday thing—it's no longer an elitist situation, and theatres will just have to go along with it, the same way that television is finally waking up to the fact that sound exists!"

"On the one hand we have these incredible advances in technology on the production side, both in film and sound, and on the other the presentation often gets worse and worse. Projectionists, for instance, are often not up to their jobs. It will all take some sorting out but I'm confident we'll get there in the end."

The Burbank Studios are confident of the future for a new dubbing studio is under construction with acoustic design by Jeff Cooper and another 'super console' from Quad-Eight in the pipeline. The future of film sound, and film in general, holds a lot of promise. Let's hope the cinema/theatre owners realise it and give the public the full benefit of it. □ Terry Nelson

**The Burbank Studios,  
4000 Warner Boulevard,  
Burbank, CA 91522, USA.  
Tel: (213) 954-6000.**



Control room of TBS Stage 1

PPMs with the LEDs arranged in an arc along the lines of a VU scale. There are also the traditional oversized VU meters installed under the large wide screen.

Ergonomics play an important part in film consoles and controls should not hide amongst a forest of twiddly switches and buttons. As one of the mixing engineers explained: "99% of the time you are looking at the screen so the controls have to be right there under your fingers—you can't waste time looking around for them. The EQ on the console may not be as complex as some would like to see but it is very effective. Besides, what we are doing here is remixing what has already been recorded and we assume that that has been done properly. Most situations can be handled by the console, otherwise we can always patch in external gear."

Having said that, Dubbing Five boasts a respectable amount of fixed outboard equipment installed in the

—high fidelity sound. They've all got record players, they go to concerts and discos, in short, they are filled with sound. They usually have it on loud all the time at home—except at my house; when I come in, they turn it off!—and it's become part of their way of life.

"The older generation always put up with bad sound even though we, the industry, knew that reasonable quality was there. However, if no one complains, theatre (cinema) owners don't care about the sound (apart from maybe a few) and continue using outdated amplifiers and speakers.

"I remember one case where a theatre owner kept calling up and saying there was no treble in the sound and that his equipment was OK. I finally went down there so as to have some peace and had a listen. Sure enough, the sound was very muffled. The first thing I asked the owner was, 'have you checked the speaker?' He hadn't thought of



# Leap into the future with the SA PPE-2400 the equaliser with Brains...

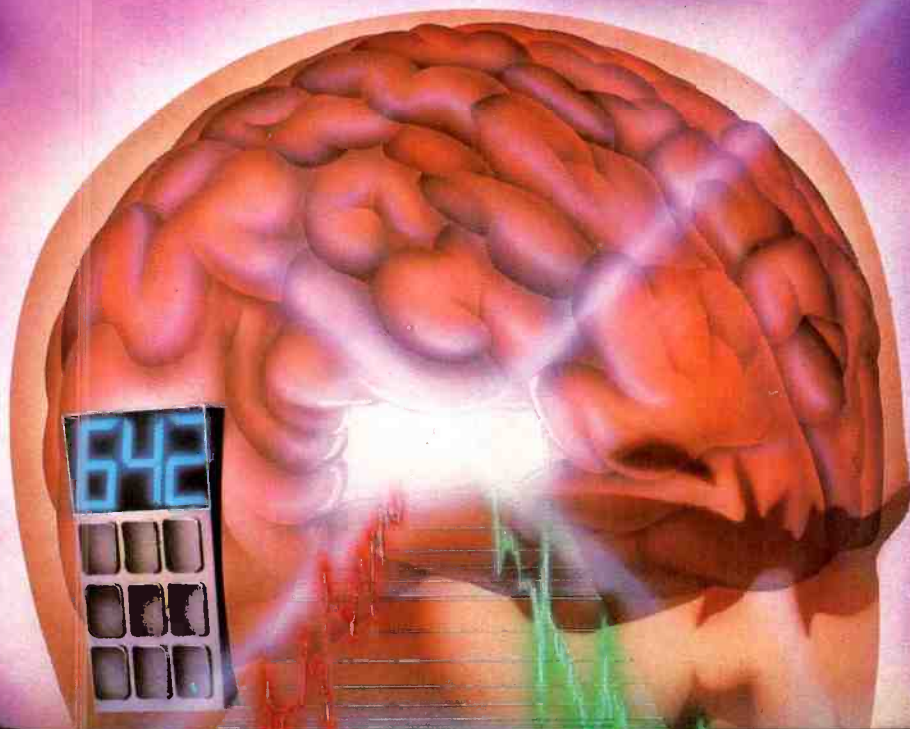

- FULL PARAMETRIC EQUALISER  
stereo 4-band; dual tracking possible
- ALL FUNCTIONS PROGRAMMABLE  
ultimate versatility through full programmable functions
- 64-REGISTER MEMORY BANK  
preserve and recall your favourite settings
- AUTOMATION READY  
with serial buss for computer link-up
- STUDIO QUALITY  
extreme low distortion
- ROAD-PROOF  
very solid construction



## STAGE ACCOMPANY

Anodeweg 4, 1627 LJ Hoozn, Holland, phone (0)2290-12542 telex 37989 Stage nl  
 Marienburger Straße 29, 4460 Nordhorn, Germany, phone (0)59211-6196  
 Spiseeggstraße 30, 9030 St. Josefen, Switzerland, phone (0)71-281696  
 Kennell s.n.c., 324 Corso Unione Sovietica, 10135 Torino, Italy, phone (0)11-612148  
 Caw Sonoss, 3 Rue Vieille, 59160 Lomme, France, phone (0)20-925091  
 Kühnl & Wurzer, Waldeggstraße 68, 4020 Linz, Austria, phone (0)732-668125  
 S.E.D., 27 Guildfordstreet, Luton LU1 2NQ, Beds, England, phone (0)582-452495



stage accompany

# STUDIO FILE

# STUDIO FILE

The Yorkshire moors and dales form a very pleasant, if rather unlikely, background for a studio. However, husband and wife team Barry and Jenny Pyatt felt the call of the wild and have installed an audio-visual studio in the heart of Bronte country, about mid-distance from Haworth and Bradford.

Studio 21 is installed on the first floor of a large farmhouse which provides living space for the owners and ample room for the studio. At present there is the main studio and combined audio/video control room and by the time this article appears in print two or three other rooms will have been renovated and be ready for incorporation into the studio.

Access is currently via outside stairs or from the interior but the renovation will take in the ground floor rooms underneath and the final decision has yet to be made as to their use. One room with ground floor access will be the main reception area and leads on to the wide interior staircase, thus making unloading and transport of instruments to the upstairs studio reasonably painless. The reception area will also be wired through to the control room so that it can serve as an isolation room in addition to the main studio.

One of the first noticeable things is the lack of parallel walls in the studio, there is also an impression of space accentuated by the two windows that let in that rare studio commodity—daylight. As might be expected from an old farmhouse, the walls follow various devious routes around a basically rectangular room and this serves to play the sound and cut down on standing waves. The ceiling is crossed by two large beams and the subsequent sections have been angled in various directions to avoid floor to ceiling resonances. The roof side of the ceiling features “substantial piles of Rockwool, glassfibre and anything else that happened to be lying around” with the studio side being fairly reflective. The acoustic treatment as such consists of moquette on the floor and multicoloured carpets (brought in at ‘bargain prices’—the studio is in the

## Studio 21, Yorkshire



Control room

wool district) at various places on the walls. Other surfaces include bare brick and plaster with some wood panelling. In the interests of continuous improvement, Studio 21 will be experimenting with different surfaces in the studio as time goes on but already the basic sound of the room is quite live with a reverberation time of around 0.9 s, thus making it suitable for recording in a ‘live’ situation.

“A lot of the bands that come in here want to make demo cassettes or tapes, or perhaps a limited run of cassettes or singles to sell at their gigs,” explained Barry. “They aren’t really into multitrack recording techniques such as putting down rhythm tracks, solo overdubs and vocals, and we often end up with them playing in the studio as they would on stage; with maybe the vocals and a few solos being re-done afterwards.”

The large isolation room has sliding glass double doors and is very absorbent with carpets on the floor and walls. The sound tends to be distinct and forward without being too dry and the room is used a lot for vocals and acoustic instruments where an artificial acoustic is to be added.

At the time of my visit the control room was in a fairly basic state with plaster walls and acoustic tiles on the ceiling. However the plans for the projected modifications were available. The audio section is at the far end of the room with the control room window in front of the console, the other half of the room is the video section. Studio 21 is unusual in that it has a package of ACES equipment,

with this being a 24-channel in-line console with 24-track routing and 24-track machine running at 15 in/s plus varispeed.

“Like a lot of people in the industry,” says Barry, “I started out as a musician while at school and played with various bands—mainly around London—and abroad throughout my career. I went to university to study electronics and ended up at the BBC where I was involved in colour television before moving on to the audio department. After a fairly brief foray into the world as a professional musician, I joined Rediffusion before setting up my own company, Pyatt Design, in Bradford. However, I had always wanted to get involved with a studio of my own—I had done recording work in the past, like everybody else—and when I ran into the guys from ACES I felt I could do something with their gear.

“The price was right—I couldn’t afford anything else, anyway—and I could always do modifications. Having bought the equipment, I then needed the studio. Pyatt Design was doing well but things were getting a little frenzied so in the end Jenny and I decided to run the business as a two person operation and stop employing staff and all that that entailed.

“The offer of Black Edge Farm came along and though the house needed quite a bit of work on it, there was a lot of space, thus possibilities. My bank manager reckoned that buying the house would be a good investment and as he’s Scottish, I went along with him!”

The ‘modifications’ to the

ACES have amounted to what is virtually a re-build, with BBC spec star earthing, improvements to the mic preamps and 5-band EQ section (this has fixed high and low frequencies with three switchable mid bands) with the latter possibly being a little violent for some tastes.

“With the work we do here, you need to hear the EQ working straightaway otherwise it’s a waste of time! It’s rare we need subtle touches and they can be done if required.” Another touch has been the addition of Pyatt Design DIN spec 45406 LED peak meters in an overall meter bridge together with tickling up the LED ladders alongside the channel faders indicating pre-fade level. Needless to say, the performance of the console has been improved considerably and comparable performance from another desk would spell money.

“To build a console like this is expensive—the time alone for the console earthing and busing would double the price. However, as I’m charging myself, I can always live on baked beans for a while.”

The multitrack has enjoyed similar treatment and “though it may not be a Studer, it gives a good account of itself now”. An intriguing accessory is a proverbial black box perched over the edge of the machine: “That’s a Pyatt Design electronic flutter eliminator—what others bust a gut to do mechanically, I do electronically and it works extremely well,” and it does.

Other equipment in the control room consists of a Teac 32-2B with dbx for mastering, Teac A108 cassette recorder, NSF stereo plate (a nice crisp sound, by the way), A+D Gemini stereo compressor, two Drawmer dual gates, Roland SDE 2000 DDL, Pyatt Design gates and companders, and four channels of dbx. Monitoring is JBL 4311 speakers powered by Pyatt Design 100 W amplifiers — as also are the Ross headphones for studio foldback.

The microphone complement for the studio combines cost effectiveness with a twinge of nostalgia with Film Industries ribbon microphones and AKG D160 dynamics (“both great for vocals”), modified Ross

# STUDIO FILE

# STUDIO FILE

electrets and Audio Technica AT818s. Studio 21 also uses PZMs a lot. "We bought a whole bunch of those 'cheap' PZMs from Turnkey and they're great! We always use at least two for the drums and we quite often use them on vocals."

Instruments are not forgotten either with Roland SH-101 synthesiser and HP-70 piano, Casio 601 synth, Pearl drumkit plus a *The Kit* drum synth, Laney and Carlsbro amps and wah-wah pedals, fuzzes, choruses, etc.

The left side of the control room houses the video equipment with pride of place going to a Panasonic 9600 series U-matic editing setup. Beta and VHS formats are represented by NEC and Panasonic NV-8200 machines respectively. Other equipment includes a Panasonic WJ 5500 8-channel effects mixer, CEL digital frame store and synchroniser ("highly modified by CEL"), Sony colour

## Studio 21 continued

generator, TR99 computer with dedicated colour test card, captions, and chroma key. Monitoring is with JVC multistandard sets. For the occasions when 16 mm telecine is required, there is a Philips studio projector, together with a Murray 16 mm editor and 35 mm slide projectors. Audio is backed up by a JVC CD1635 cassette recorder.

Studio 21 do a fair amount of location work and already have two videobooks out on the Yorkshire dales with a third one in preparation. Equipment for 'mobile' work consists of two Sony 4800 portable U-matics with JVC KY 1900 3-tube colour cameras and a Zenith 16 mm film camera.

Studio 21 provides a small production and demo studio. "People passing through here do get good support from us and there are often times when I end up by recording,

arranging, producing—and even playing—the songs.

"The range of work we do keeps things interesting, from singles to demos, limited release records, A/V productions as well as our own videobooks. One chap comes in from Liverpool every year to do an album of his songs that he writes for a hobby. I don't know whether they sell or not but we have a lot of fun doing them! Another songwriter had a local 'hit' with a Christmas song that was recorded in the afternoon, mixed in the early evening and a cassette copy rushed down to Pennine Radio for airplay that same night. It's not the 'big time' but it's still very much the music and recording business.

"One thing that I have to moan about is the number of 'studios' that buy up secondhand gear—or it used to be the band's, or whatever—and offer studio services at

ridiculous prices that do nobody any good. The results are poor and they soon go broke but there's always someone ready to carry on and keep the merry-go-round turning. We charge what I call very realistic rates with a good all-round service and I prefer to turn down work than lower prices. When they tell me the guy down the road is cheaper I reply that they might as well go there in that case. Of course, they expect all the latest gadgets but don't want to pay for them. We are going to keep chugging along whatever happens and if things get a bit thin it just means that Pyatt Design will work a bit harder for a while. Jenny and I want to build the studio up as we go along but there is no deadline."

Terry Nelson

Studio 21, Black Edge Farm, Denholme Gate, Yorks BD13 4ET, UK. Tel: Bradford (0274) 834036

**AKG**  
ACOUSTICS

## International Musician comes to some interesting conclusions about the AKG C535 EB . . .

Here's an extract from the conclusion of a glowing report on our C535 EB condenser microphone, in a recent International Musician lab test:-

*"I am most impressed by this microphone, my favourite to date. It offers the high performance specification demanded for studio applications, with the robust and durable construction features necessary for stage use. The C535 could very well break the long held monopoly of dynamic microphones in fronting rock bands and top solo artists on stage."*

Apart from a few abbreviations to fit this ad, that's what the man said and if you want to see the full report which also praises the 'crisp, clean natural sound quality' and 'the immunity from handling noise', clip the coupon and we'll send it to you, together with details of other superb condenser and dynamic microphones used by the world's top artists, studios and broadcast authorities.



Yes I'd like to see the C535 EB report, and details of other AKG microphones.

Name .....

Address .....

.....Tel: .....

AKG Acoustics Ltd., Vienna Court, Catteshall Wharf, Catteshall Lane, Goldalming, Surrey GU7 1JG. Tel. (04868) 25702



The TS24 is the first in-line console from Soundcraft.

And it represents a major breakthrough in in-line technology, because it now makes the console far easier to understand and operate.

Believe us, this is no hollow promise. Our argument is built around two rock solid foundations. Firstly, a new concept in console layout so logical, engineers used to split or in-line consoles can start work from day one. And secondly, a set of master conditions so advanced they'll amaze you.

### STATUS.

One touch of the status button will configure the whole console for each particular stage of recording, mixing, broadcasting and video post production without sacrificing any flexibility whatsoever. In other words, one touch and you're off and running.

### NEW DESIGN.

Conventional in-line consoles suffer from the limitations of one long travel fader and one equaliser being shared by two signal paths. With the engineer fader reversing and moving the equaliser back and forth throughout the recording, overdubbing and mixing process to optimise the situation.

The TS24 eliminates these shortcomings, thanks to its logical design. The long travel fader is in the section called MIX, which is the signal path for both monitoring and mixing. The equaliser moves between the MIX and CHANNEL

signal paths automatically by use of the master status switches. 'Soft' switches may locally move EQ and AUX sends between the two signal paths but are also automatically reset.

When mixing, the Channel sections become available as additional inputs or effects sends without the limitations imposed by more conventional designs.

### DROP-IN. BOUNCE.

Drop-ins are made easy by the use of the TAPE and GROUP button (T & G). Tape and Group enables you and the musician to monitor the original track and the overdub simultaneously.

The Bounce button facility enables you to take any combination of channels with their fader and pan settings directly to the routing matrix giving you instant bounce down.

### SOUND AND VISION.

To create perfect sound, you also need perfect vision. With the TS24, that's exactly what you get. Separate scribble strips are provided instead of the usual confusing double one, and the Mix and Channel controls are in clearly defined areas for easier use.

### AUTOMATION.

Soundcraft have developed a unique interface to the disc based MASTER MIX automation system, which enhances its operational flexibility by totally integrating the full extent of the console muting.

One feature of this system enables you to by-pass the Channel VCAs, thereby

optimising the original recording quality.

Surprisingly enough, all this practical technology, combined with sleek good looks doesn't carry a huge price tag. So our doors are open to practically everybody.

Which only leaves us with one thing to say: if you want to keep your finger on

the button in the most up-to-date mixing console design available, contact us.

## Soundcraft TS24

*Soundcraft Electronics Ltd., 5-8 Great Sutton St. London EC1V 0BX.  
Tel: 01-253 6988. Telex 21198 SCRAFT G.*

*Soundcraft Electronics USA, 1517 20th. St, Santa Monica,  
California 90404. Tel: (213) 453 4591. Telex: 664923.*

*Soundcraft Canada Inc. 1444 Hymus Blvd., Dorval, Quebec,  
Canada H9P 1J6. Tel: (514) 685 1610. Telex: 05 822582.*

# JUST ONE TOUCH.



# AMBISONICS ROUND AND ROUND

Natural acoustics in the Church of St Silas The Martyr in London provided an ideal environment for Ambisonic recording of contemporary classical music ensemble Electric Phoenix. The four singers 'expanded' to 12 in surround sound with the aid of 'analogue' overdubbing on a Sony PCM-701ES recording system. Terry Edwards, bass singer and manager of the co-operative group, produced the sessions with John Whiting of October Sound engineering. John handles all live sound projection in

**Mike Skeet relates the practicalities of recording a classical music ensemble Ambisonically in church and making four voices sound like 12**

their international tours and as such is a full member of the ensemble.

Electric Phoenix could be described as an up-market version of the Swingle Singers specialising in contemporary works, often unaccompanied and usually with close miked sound projection via 'treatment' boxes operated by the performers. These incorporate ring modulators, delay lines, variable bandpass filtering and similar effects. But for these sessions it was back to nature: the four singers were arranged in a semi circle around the UHJ encoded Calrec *Soundfield* microphone and two overdubs were made with the singers in different positions within in the semi circle.

## Equipment

In the church the *Soundfield* was set up some 3.5 m back from the semi circle. Careful measurement made sure that tape markers on the floor were equidistant from the mic and were at equal distances around the circumference. Four sets of Sony *Walkman* headphones were fed the prepared 'click' track from a splitter box. The only other piece of gear out in the church was the talkback loudspeaker mounted in an RS cable drum.

The St Silas control room is large enough to allow full Ambisonic surround sound monitoring and four Spendor *SP1* loudspeakers were set up, well away from walls and corners. These were driven by two Quad 405 amplifiers.

Central to the interconnection were seven channels of a Soundcraft 200 desk. Channels 1 and 2 were fed the *Soundfield* control unit output at line level via a Calrec UHJ encoder; channels 3 and 4 were the Sony PCM-701ES playback; channel 5 was the original source (for the first pass) of the 'click' track and this came from a Sony TC-D5M cassette deck; channels 6 and 7 had the audio track playback of the two Sony Beta *SLF1* VTRs from whence the click track came when the overdubs were being done. The click track was transferred as needed via mix four output.

Two *SLF1* Beta VTRs and just one PCM processor complete the essential items as far as overdubbing is concerned. The PCM 9-facility switch box was the essential interconnection of the VTRs and the processor. Another two-way switch was employed to direct the 'click' track to the appropriate VTR audio track input.

Monitoring in Ambisonic horizontal surround sound with an alternative stereo check. This is a simple matter through the Minim *AD10* Ambisonic decoder fed from live signals via the mic after UHJ encoding, or from the PCM

## '000' series power amplifiers

\*3000 watts in 5 1/4 inches

- HIGH EFFICIENCY dual power supplies from TOROIDAL transformer and computer grade capacitors.
- FULLY PROTECTED against damage to either load or amplifier.
- SPACE SAVING occupies only 3 units (5 1/4") of 19" rack space.
- RELIABLE output devices can handle 6 times rated power.
- UNIQUE ultra linear transformer coupled driver stage.

dx1000	1000W	into 8, mono
	600W	into 4, per channel
	300W	into 8, per channel
dx1000A	1500W	into 8, mono
	800W	into 4, per channel
	450W	into 8, per channel
dx2000	2000W	into 4, mono
	1200W	into 8, mono
	1000W	into 2, per channel
	600W	into 4, per channel
	300W	into 8, per channel
dx3000	3000W	into 4, mono
	1600W	into 8, mono
	1500W	into 2, per channel
	800W	into 4, per channel
	450W	into 8, per channel



\*dx3000 bridged mono



Hill Audio, Inc., 231 Marquis Court, Lilburn, GA 30247 USA (404) 923-3193 TLX 293827 HLAID  
Headwater Industries, 635 Caron Ave., Windsor, Ontario N9E 5B8, Canada (519) 256-2454  
Hill Audio, Ltd., Hollingbourne House, Hollingbourne, Kent ME17 1QJ, England (062 780) 555 TLX 966641 HILL

playback of the UHJ recording. Incidentally the phase coherence of digital recording systems allows better decoding of UHJ thus producing better results than are possible with analogue recording and playback.

The overdubs, of course, consisted of overlaid UHJ encoded material and the system can easily cope with this. You do not get, as some might think, 'additional' ambience at each pass but each recording has its own, once and for all ambience with no subsequent build up. The acoustic at St Silas is sought after—it is smooth, not over-emphasising any part of the frequency spectrum and, more importantly, has a smooth exponential die-away without bounce or slapback. The other requirement of location recording is well met there too—external traffic ambience is at a very low average as far as London venues go, and with a low peak to mean ratio.

After the first recording the required take was held on the PCM with the click track on its audio track. It comprised an identifying slate of the title of the piece, 5 s gap for linking ambience, regular tuning tone bursts from a Yamaha synth, along with a bar count and other spoken notation idents. Terry Edwards had recorded this some days earlier using a visual electronic metronome for strict tempo. Essentially this track became the conductor and led to some speculation that perhaps orchestral recordings could be controlled this way.

When the first overdub was required, the PCM playback was mixed with the new *Soundfield* output, the performers having been moved to different positions. This was recorded via the other half of the PCM 701ES on to the second SLF1 VTR. Also the playback was fed to the performer's headphones along with the replay of the VTR's audio track copy of the click track. This latter is also fed to the second VTR's audio track. It was interesting how this deteriorated at each pass but of course none of this applied to the PCM's analogue link overdubbing despite numerous A/D and D/A processes and brick wall filtering.

Operationally John Whiting made use of the return to zero feature on the SLF1 VTRs. None of the unsatisfactory or aborted takes were kept. It could get very difficult to locate a particular take when one has abandoned the conventional logging in favour of the very useful return to zero. There are of course numerous aborts and improvement takes plus the inevitable intrusion of aircraft noise but not really for technical reasons. After all there was no multitrack routing and mixing, just a fixed crossed pair and once levels were set for the feed and for the zero level transfer of earlier passes, all was straightforward. The PCM-701ES was an Audio+Design version with the zero level in and out facility.

As the PCM unit's metering is playback connected this couldn't show the overdubbed summed levels. Also the Soundcraft had VUs which were superfluous in this context except for tone line ups. So a Surrey Electronics twin PPM augmented by *The Box* stereo

soundstage analyser was employed in the monitoring chain prior to the UHJ decoding. The latter is particularly useful at showing channel balance, soundstage positioning and stereo width, apart from true peak signal levels.

## Ambisonics/stereo

John Whiting was particularly enthusiastic about the stereo imaging compatibility of the multi-UHJ playback. On the basic sound quality aspects, John has demonstrated many times at his sessions the ease with which the *Soundfield* mic, normally in stereo usage, with the Spondors consistently provides the same sound qualities in the control room as one hears at the mic position. The SPIs seem to be much less room dependent than many monitors and this is another vital aspect of location

recording.

The Ambisonic monitoring proved to be first class also with a 'fuller' sound where the images were seemingly clear of the loudspeakers as their sources. Certainly 2-dimensional and with very good image stability with varying listening position. Where the loudspeakers can be set up for Ambisonic playback well away from walls and corners, it is always fascinating to move outside the sound field square. One still hears the main soundstage correctly positioned and one appears to be eavesdropping on the events within the reproduction area.

The sessions described are due for early LP release after the takes are stitched together at Bob Auger's PCM-1610/DAE1100 editing facility at Henley□.

Mike Skeet



A studio quality microphone designed to be rugged enough to withstand the rigours of hard use on the road.

sole U.K. importers of Milab



Audio Video Marketing Limited  
Unit 20/21, Royal Industrial Estate, Jarrow, Tyne & Wear, NE32 3HR.  
Tel: 091 4893092/4896233 Telex: 537227

# THE BLACK & WHITE S

The **PSP** represents the last word in electronic percussion interfacing. In addition to conventional pad to MIDI and MIDI to trigger conversion facilities, signal processing tasks are performed. Special techniques are employed to extract every ounce of information from standard piezo-electric drum pads, so that the smallest subtlety of performance is conveyed along the information path. Thus the **PSP** enhances a standard electronic drum kit's playability whilst providing a window into the world of MIDI.

## "PSP M.I.D.I. MEDICINE FOR DUMB DRUMS"

Despite the underlying sophistication, a great deal of effort has been invested in ensuring the controls are simple and quick to use. The front panel is ergonomically designed to minimise mistakes, making the **PSP** ideal for live use.

Information from the drum pads is analysed and regenerated by the **PSP's** microprocessor before it reaches the sound producing electronics. In this way the signals may be processed to yield a variety of playing characteristics, or allowed to pass unchanged. By introducing this digital stage we can now incorporate MIDI into the information path. MIDI is transmitted from pad hits and triggers regenerated from MIDI received. It is therefore possible, using a MIDI sequencer, to record and playback complex polyphonic drumming with the dynamic inflections retained.

In addition to pad signals, the **PSP** is capable of analysing audio signals and deriving MIDI or trigger signals dynamically. For example, a snare drum sound on tape could be used to trigger the **PSP** in order to replace it with a new sampled snare.

Up to 8 drum pads and a hi-hat pedal may be connected. Each input having its own set of performance parameters. These parameters may be adjusted independently or recalled from a bank of 50 user-definable Patches. Once a particular configuration, or Patch, has been set up, it may be stored in memory and called up when required. Patch changing may be accomplished remotely using a footswitch and two of the drum pads to increment and decrement.

All memory is retained when the unit is powered down and may be downloaded, via MIDI, into a MIDI sequencer for archiving purposes.

In short, the **PSP** must be the key component in any electronic drum setup, receiving and regenerating both analog and digital signals concurrently.

**Sycologic PSP** – state of the art MIDI signal processing for electronic percussion. **Sycologic** equipment sprang from a need to constantly interact and innovate. Taking the view that today's musician must be allowed maximum creative freedom and flexibility within the confines of today's available technologies.

Sycologic, 20 Conduit Place, London W2.  
Telephone 01-724 2451  
Telex 22278 SYCO G, Fax 01-262 6081





# ELECTION FROM SYCO

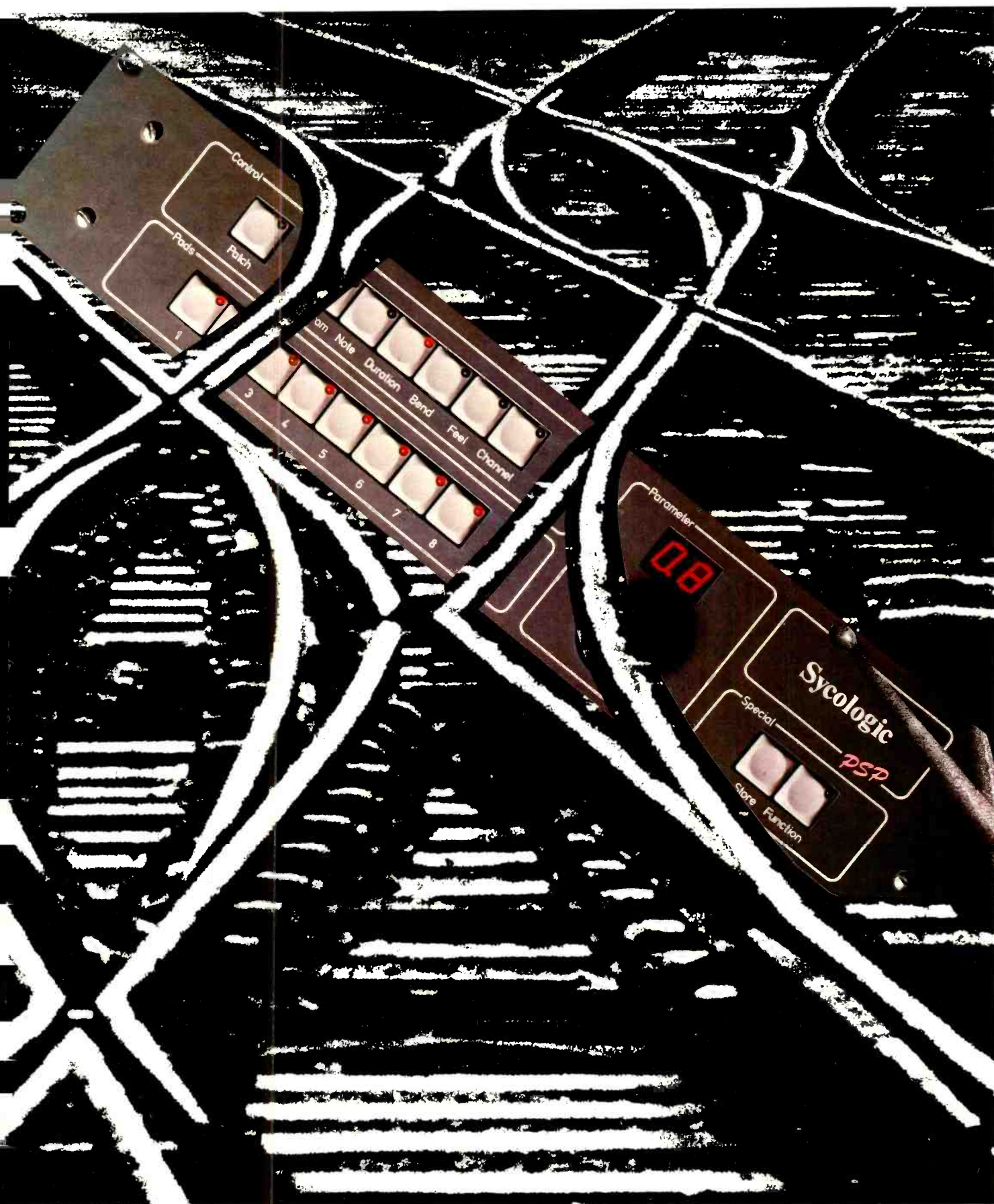

Syco. We are

# DARK RIDES

In days gone by there were ghost trains. Now there are dark rides. The best known exponent of the dark ride is the Walt Disney Organisation, who use them for many different themes ranging from the high class ghost train in the Haunted Mansion at Disney World to the imaginative and future oriented Horizons ride in the General Electric Pavilion at EPCOT.

These rides all involve the audience being transported on a continuous transport system of linked 'pods', each one seating two or three people. A feature of many of the rides is that each pod has its own individual sound commentary, which must synchronise exactly with the movement of the pod. There are two fundamental problems; one is how to transmit the sound to the moving car, and the other is how to arrange that each car receives its own signal. An indication of the traditional approach can be gained from reading Terry Nelson's article Theme Park

**The recently opened 'Wheels' display at the National Motor Museum makes much use of sound. It also represents the first use of solid state audio in a dark ride. Robert Simpson and Peter Smith of Electrosonic describe the system, and explain why tapeless systems are ideal for this application**

Sound at Disney in the June issue of *Studio Sound* in which he refers to 'the largest collection of NAB cartridge machines ever seen in one place'.

## Wheels

For a number of years the British National Motor Museum at Beaulieu had been planning a major exhibition to celebrate the centenary of the motor car. They wanted a display that would show the impact of the automobile on how we live, and it ideally had to fit in an existing storage area underneath the museum. They decided that a dark ride would be the ideal medium; and after a lot of work the excellent Wheels ride was opened to the public by Prince Charles on June 5.

Right from the start, sound was seen as a major component of the ride experience. The Museum appointed Prater Audio Visual to advise on sound and projected imagery, and they advocated the use of strong synchronised effects sound tracks within the exhibits, and a separate interpretive sound commentary to be given in each pod. The museum makes considerable use of AV systems, and on the whole has good experience of them; they know, however, that it is one thing to run a system for a one week show, and quite another to run one eight to 10 hours each day, 364 days a year.

The Museum approached Electrosonic Ltd for a proposal for the ride sound system; specifying that it must require minimal, or preferably zero, maintenance. As a result of their discussions with Prater they also asked if the system could be solid state. By chance Electrosonic was already considering developing digital message repeaters and was quickly able to demonstrate that such a system was feasible, and put forward a fixed price proposal for carrying out the work.

It is interesting to analyse the problems of dark ride sound, and to show how the Wheels system evolved the way it did. It quickly demonstrated some unexpected advantages of using microprocessor controlled sound stores.

## Sound zones

Regardless of the system used the 'ride problem' can be described by Fig 1, in which the concept of the 'sound zone' is illustrated. A zone is a length of the transport track that is an exact multiple of pod spacing in length. There is no theoretical requirement that this should be a particular number—it could be 1, 2, 3, 4 or even 6 pod spacings. In practice too close or too wide a spacing makes production of the sound track rather

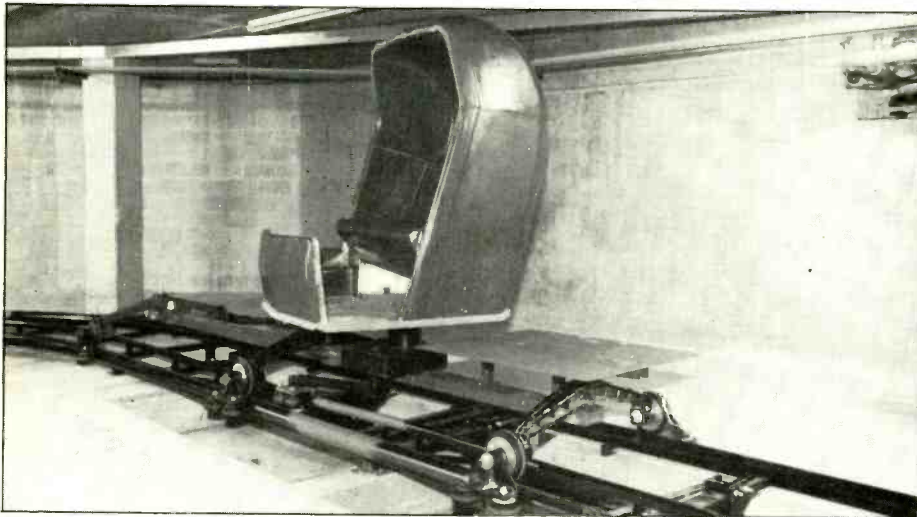

The car or 'pod', an experimental version of which is shown above, passes through exhibits such as the one below. The track is shown prior to installation of the power and audio pick up rails



# John Bowers active 1

"A few seconds' listening is enough to convince most people that Active 1 is something exceptional.

... Alert, commanding, perky, delicate, direct, realistic, raring to go, discerning, utterly natural, enthusiastic, awesome ...

... Certainly I know no neater, tidier and less obtrusive path to the full range of musical enjoyment ..."

GEOFFREY HORN  
OF GRAMOPHONE

## MUSIC LOVERS' SOUND SYSTEM

We have appointed a few exclusive dealers where you can hear a full demonstration. Please write or phone for details.

UK B&W Loudspeakers (UK Sales) Ltd Marlborough Road Lancing West Sussex BN15 8TR Te. (0903) 750750

WORLDWIDE John Bowers Ltd Elm Grove Lane Steyning West Sussex BN4 3SA England Tel. (0903) 815666

**AKG**  
ACOUSTICS

AS  
MONITORS  
THEY'RE  
TOP OF  
THEIR  
CLASS



### The AKG LSM 50's

These mini-monitors, designed and built to AKG's exacting engineering standards, can be used for monitoring, reference and comparison, mix down or as extension speakers or part of an intercom system, to provide up to 50 watts of superb studio quality sound.

A range of mounting brackets provide for their fixing on walls, desk tops, microphone stands or you can use them free standing.

Scholars of good sound will tell you that AKG professional products walk away with all the prizes – with the LSM 50, we'll chalk up another success!



Clip the coupon for full details of AKG products  
AKG Acoustics Ltd., Vienna Court, Catterhall Wharf, Catterhall Lane,  
Goldalming, Surrey GU7 1JG. Tel. (04868) 25702  
Please send me details of the  LSM 50 loudspeakers  AKG professional microphones

NAME

ADDRESS

# DARK RIDES

difficult. In the case of Wheels the zone was chosen as three pod lengths which was actually 6 m.

As the first car enters a zone the relevant commentary must start up. When the second car enters the same zone, it must start to hear the same commentary, but delayed by an interval dependent on ride speed. Similarly as the third car enters the zone it hears a still further delayed commentary. The arrival of the fourth car coincides with the first car entering the next zone, so whatever was used to feed sound to the first car through can now be used to start the commentary again for the fourth car.

It is easy to see that in a complete system there has to be one replay device for each car. The reason for using sound in small zones (as opposed, for example, to allowing each car to have its own full length tape) is to simplify the synchronisation with the ride—in particular to cope with some variations in ride speed and with enforced ride stops. It also simplifies the transmission problem. For maintenance reasons it is not a good idea to have the main sound replay devices travelling around on the ride. It would be very complex to have a system that needed a separate transmission channel for each car; whereas a zone system might only need a 3-channel transmission system.

## Transmission system

A typical ride sound system has in the past, consisted of as many cartridge players as there are cars and some means of transmitting the audio to the moving cars. For Wheels three different transmission systems were considered.

The first was the system widely used in the USA of induction loop. Here each zone has an induction loop laid under

the track, and a pick up coil on the car picks up the signal. In a three-car zone system three different carrier frequencies are used, so each car requires a small receiver with every third car tuned to the same frequency. Such a system needs some care in laying the loops to ensure no crosstalk between zones.

The second was the use of infra red. Such a method is now similar in cost to the induction loop system, however considerable care has to be taken to prevent unwanted crosstalk. Both the infra red and induction loop systems require some electronics on board the cars.

The third and simplest method was chosen, using pick up rails and requiring no electronics in the cars. The possible disadvantage is that of pick up noise and induced interference. In practice the use of high quality enclosed pick up rails, designed for continuous industrial use and using double sprung contacts able to follow bends in the track while maintaining firm contact, is proving both reliable and noise free. A 100 V line

drive is used to eliminate contact resistance problems and the loudspeakers in the cars are tapped to 0.5 W.

In fact the ride system has two sets of pick up rails. One is a three phase supply to feed a compressor carried round on the ride. It is also used to provide compressed air for operating the passenger safety barriers. The other, which is sited on the opposite side of the track to the power rails, is a six way pick up rail, carrying the three audio signals in isolated pairs. The sound rails have insulating sections within them at each zone boundary Fig 2.

## Digital sound store

Electrosonic developed the *ES1320* Digital Sound Store as a universal product, however it has features that make it especially suitable for ride work. In the case of Wheels the ride runs at between 0.3 and 0.4 m/s; implying a zone length of between 15 and 20 s. The *ES1320* has a capacity of 96 s when fully equipped (externally extendable to 8 min)

Fig 1 The audio zone concept applied to dark rides

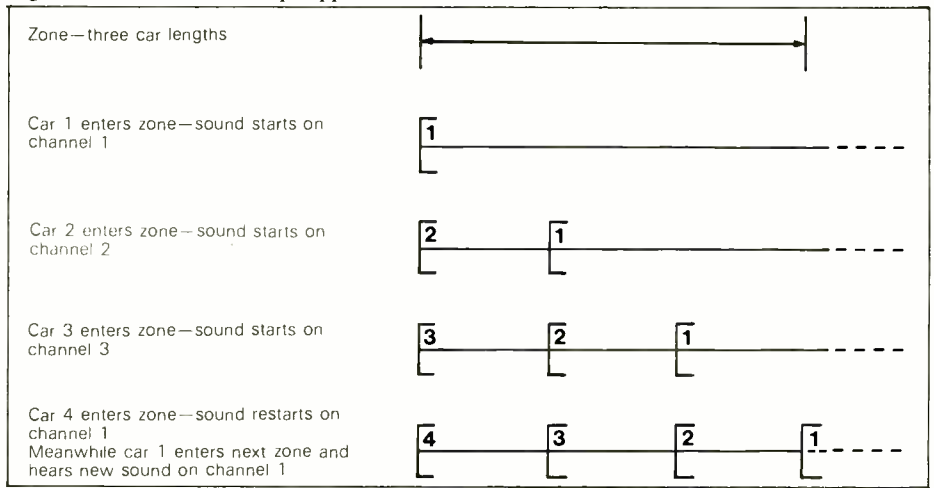
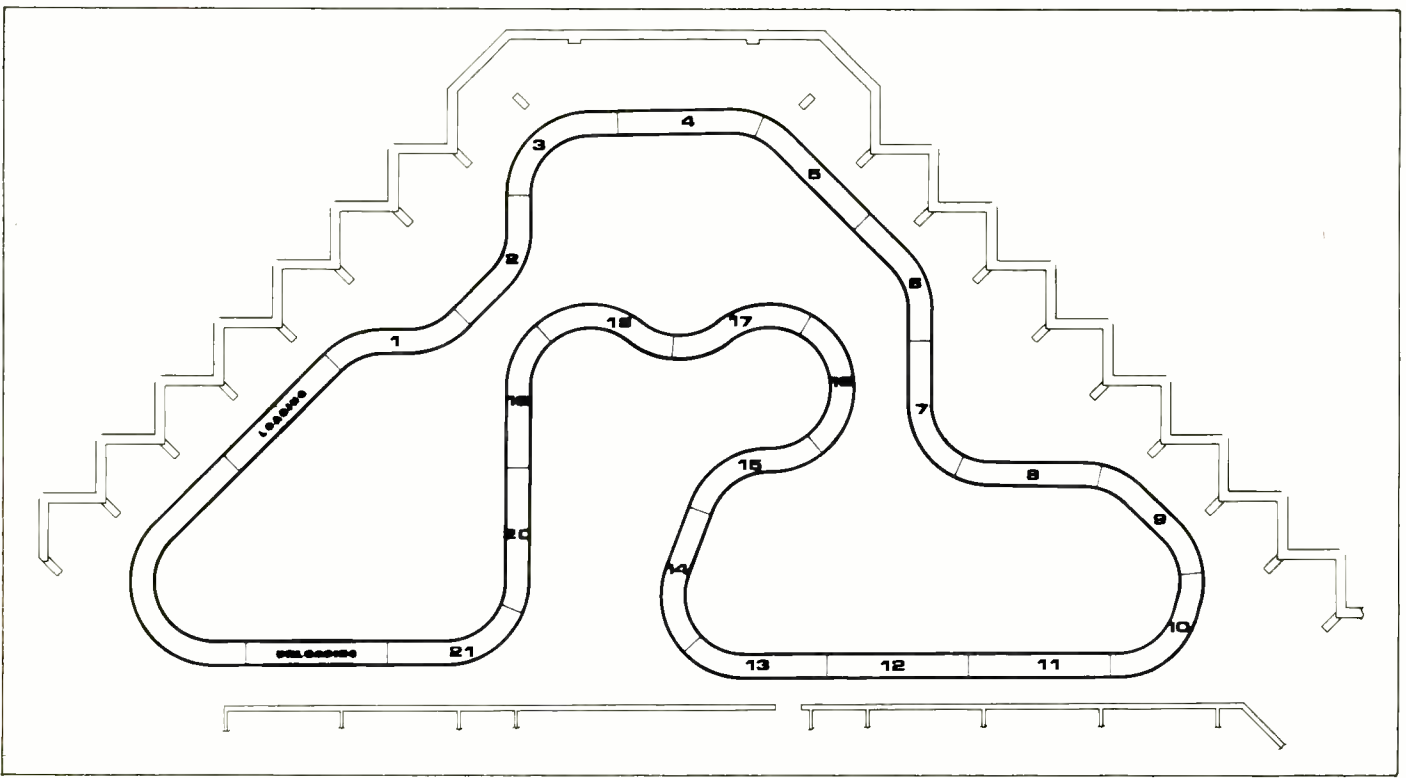

Fig 2 Track layout of Wheels showing zone sequence—all zones are of equal length



# Digital Power

## Reflections Of The Future

Digital Energy Conversion Amplification™... A new standard of power. Brought to you by Peavey via the DECA™-700 and DECA™-1200 power amps. The world's first (and only) 90 percent efficient and truly digital power amplifiers.

Because linear amplification allows at best between 40 and 60 percent efficiency, we knew that in order to manufacture a 90 percent efficient power amp, we would have to depart from conventional technology. DECA™ is not magnetic field nor is it analog. It's a totally new discovery on which we have applied for six patents.

The DECA-700 and DECA-1200 power amps deliver time after time with virtually no heat, very little mass (24 and 26 pound units) and 90 percent efficiency. The DECA-700 specs out at a rated minimum power output of 350 watts RMS per channel into 4 ohms and 700 watts RMS into 8 ohms (in bridge mode). Our DECA-1200 is rated at minimum power of 600 watts RMS into 4 ohms and 1200 watts RMS into 8 ohms (in bridge mode). Other features include DDT™ compression circuitry to prevent amplifier overload, absolutely no measurable TIM or slew rate induced distortion, multiple overload output and load protection features. They are both available in a 19" rack mount (two space) configuration.

DECA Technology. Yesterday our competitors said it couldn't be done. Today they're wanting to know how we did it.

Discover for yourself our exclusive DECA power amps by visiting your nearest authorized Peavey dealer or writing us at Dept. DECA, Peavey Electronics, 711 A Street, Meridian, MS 39301.



PEAVEY ELECTRONICS (U.K.) LTD., UNIT 8, NEW ROAD, RIDGEWOOD, UCKFIELD, SUSSEX TN22 5SX, ENGLAND (Registered Office) TELEPHONE (0825) 5566 TELEX 957098

# DARK RIDES

so only partial equipping with EPROM is needed for this application. The traditional cartridge system would need three machines per zone, but the *ES1320* needs only the one sound store; the built in microprocessor control providing the necessary delays for the other two outputs. The *ES1320* is complete with its own small (5 W) power amplifiers.

The *ES1320* Digital Sound Store uses 128 k or 256 k EPROMs for sound storage. In the interest of reasonable economy the audio bandwidth is limited to about 4 kHz. However the system has a full bass response and a dynamic range of 54 dB, so is suitable for speech commentaries and a wide range of sound effects. In principle it is possible to offer the system with a wider frequency response (eg 8 kHz or 12 kHz) which requires a corresponding increase in the memory. The standard system needs 64 k bit/s.

At present recording of the chips is provided by Electrosonic as a studio service but the equipment needed will in due course be made available as a product. The choice of EPROM as the storage medium (as opposed to battery backed RAM) is deliberate. The system is intended to ensure that recordings cannot be accidentally lost. It is important to understand that the system is a recording system (ie does not use speech synthesis) so a client only has to produce a standard audio tape for transfer to the store.

## Storage efficiency

The design of the *ES1320* store and its associated recording equipment is based on the idea of getting a perceived 10 bit audio data sample quality from an 8 bit wide data memory. The recording and playback processes are shown in block form in Fig 3, and it can be seen that a system of digital compression and expansion plays an important part.

During the recording process a decision is made whereby audio levels between 0 and -18 dB are deemed to be high level and are stored with a coarse seven bit resolution; and those below -18 dB are deemed to be low level and are stored with a fine 10 bit resolution. In each case there are seven data bits and one control bit stored ie one byte of memory per audio sample.

The control bit is used to position the seven data bits to either the seven most significant bits for coarse resolution, or

the seven least significant bits for fine resolution at the digital to analogue converter input. This system results in a benefit of 12 dB (2 bits) of resolution for low level signals, at the expense of loss of 6 dB (1 bit) resolution for high level signals.

The standard system takes 8000 samples per second, hence the requirement for  $8 \times 8000 = 64,000$  bit/s. This gives a maximum audio bandwidth of 4 kHz, but as mentioned earlier a faster sample rate would give a wider response.

## Unexpected problem

The kind of problem that may seem trivial, but can have unexpected side effects, is the ride layout. When the original plan for *Wheels* was drawn up, the track length was an exact multiple of zone lengths. In principle when a lead car of a group of three enters a zone it starts the appropriate sound store. A

The digital sound stores *ES1320*



simple analysis shows that if the overall track length is an exact multiple of zone length, only one sensor is required for the whole system. This is because all the cars are mechanically coupled together and all zone lengths are equal.

Thus there was some consternation when John Willrich, the *Wheels* project manager at Beaulieu, let slip that mechanical and layout considerations meant that one car length had to be omitted. This apparently trivial change to the system meant that 21 trackside sensors had to be fitted instead of only one!

## Ride speed change

A particularly elegant feature of the *Wheels* system is its ability to adapt to different ride speeds. The sound commentaries automatically speed up or slow down, without change in pitch, in accordance with the detected ride speed. This is done by storing the silences between words and phrases as separate quantities in the memory. The microprocessor controller then scales these quantities as required. The system works over a remarkably wide range without it being obvious that the speech is being processed in this way; for example a change of plus or minus 20% from nominal speed is achievable.

The fact that the *ES1320* Digital Sound Store is microprocessor controlled allows it to be custom programmed for other applications—it can carry three independently controllable messages (as opposed to the one message with three staggered outputs used in the ride) or it can be used as a random access sound store with 32 messages disposed in any required manner to the the three outputs. It can also carry simple switching data to control other devices—such as relays and dimmers—during the message playback.

While a few further *ES1320* units are used for spot effects in *Wheels*, it must be admitted that the main ambient sound, which is based on a strong musical theme track, is carried on conventional magnetic tape. This is because at the time the system was designed it would not have been economically feasible to use a solid state system with a bandwidth of at least 12 kHz. (Although for short programmes this argument will not hold for much longer). Again the decision of what to use at Beaulieu was made on common sense grounds, rather than following any fashion.

Thus while a bin loop machine might seem the correct solution to the problem of providing absolutely continuous sound, it is in fact far more expensive than installing two standard reel-to-reel machines. So in addition to the Digital Sound System, *Wheels* also boasts two Soundcraft 16-track tape recorders, under the control of an Electrosonic tandem deck control which ensures no break in the programme sound.

Solid state sound is having increasing application in communications, simulators, process control and consumer electronics. The application at the National Motor Museum shows one of the ways it can be best configured for use in exhibitions, museums, displays—and dark rides. □

Fig 3 The record/playback block diagram

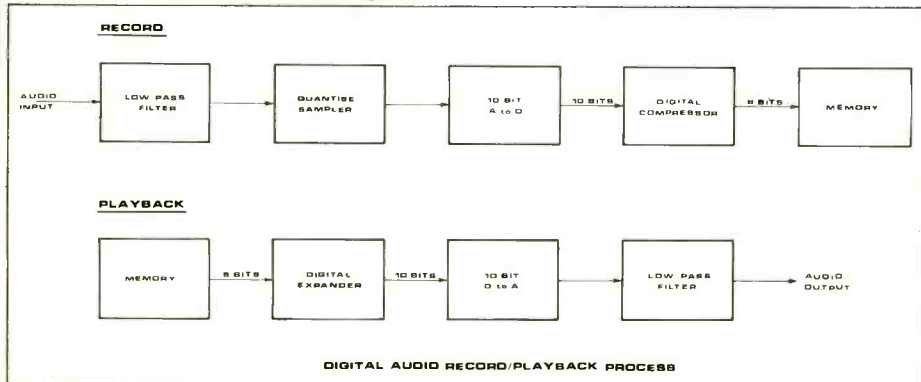

Worldwide List of Audio Developments Ltd., Agents

COUNTRY	AGENT
Australia	Rank Electronics Tel: 2 449 5666 Telex: 71289 Contact: Andrew Harrison
Austria	Peertronic Tel: 43 222 832224 Telex: 134072 Contact: Gunther Friedrich
Balkan States	Constantin Stavriniadis Tel: 4121 39 5015 Telex: 26297 Contact: C. Stavriniadis
Canada	Gerr Electro Acoustics Ltd. Tel: 416 868 0528 Telex: 065 24385 Contact: G. Eschweiler
China	Ace (Int'l) Co. Tel: 852 3 7452343 Telex: 4C442 Contact: Michael Pang /Whyman Chan
Denmark	Kinovox Tel: 452 187617 Telex: 40394 Contact: Steen Peitersen
Finland	Studiotec KY Tel: 358 0 514133 Telex: 125284 Contact: Peter Stralman
France	Simplex Electronique Tel: 331 271 5330 Telex: 230045 Contact: J.C. Thobois
Germany	Nagra Kudelski GMBH Tel: 4989 656633 Telex: 5295893 Contact: J. Weber
Greece	K. Stavriniadou Tel: 607 7782938 Telex: 21C934 Contact: K. Stavriniadou
Hungary	Cinac Tel: 4124 711600 Telex: 451070 Contact: Henri Suter
India	Cinerama PVT Ltd. Tel: 293873 Telex: 1171198 Contact: S. Agarwal
Israel	Sontronics Electronic Equip. Ltd. Tel: 9723 442233 Telex: 361579-Ref SSK Contact: S. Shmueli
Italy	Audio International SRL Tel: 392 7384751 Telex: 322251 Contact: R. Beppato
Japan	General Traders Ltd. Tel: 813 2912761 Telex: 24754 Contact: H. Saitoh
Korea	Saetong Corp. Tel: 783 6551 5 Telex: 23596 Contact: J.B. Kim
Kuwait	Light & Sound Elec. Co. Tel: 965 434307 Telex: 4528 Contact: A. Al-Baghli
New Zealand	General Video Int. Ltd. Tel: 644 881 169 Telex: 30129 Contact: Gerry Smith
Norway	Siving Benum & Co. Tel: 472 44 2255 Telex: 17681 Contact: Bjorn Benum
Singapore	Rank O'Connors Sing. PVT Ltd. Tel: 65 637944 Telex: 21023 Contact: Patrick Ching
South Africa	Prosound (PTY) Ltd. Tel: 27 11 337 6556 Telex: 485712 Contact: D. Feldman
Spain	Telco Electronic S.L. Tel: 341 231 5601 Telex: 27348 Contact: J. Escrig
Sweden	Intersonic N.B. Tel: 468 744 5850 Telex: 11136 Contact: R. Isacson
Taiwan	Linfair Eng. & Trading Ltd. Tel: 886 23214454 Telex: 22563 Contact: Duncan Chang
Thailand	Ace (Thailand) Co. Ltd. Tel: 2812512 Telex: 72300 Contact: Bundhit Thongpen
Tunisia	Soger Electronique Tel: 2161254 230 Telex: 13447 Contact: C. Barouch
Turkey	Nefan Ltd. Tel: 465952 Telex: 26304 Contact: A. Fresco
Zimbabwe	Audex (PVT) Ltd. Tel: 26370 Contact: W. Mueller
U.S. Office	Audio Developments Inc. Tel: 818 843 7567 Contact: Ron Fuller

# TOTAL CONTROL AT YOUR FINGERTIPS

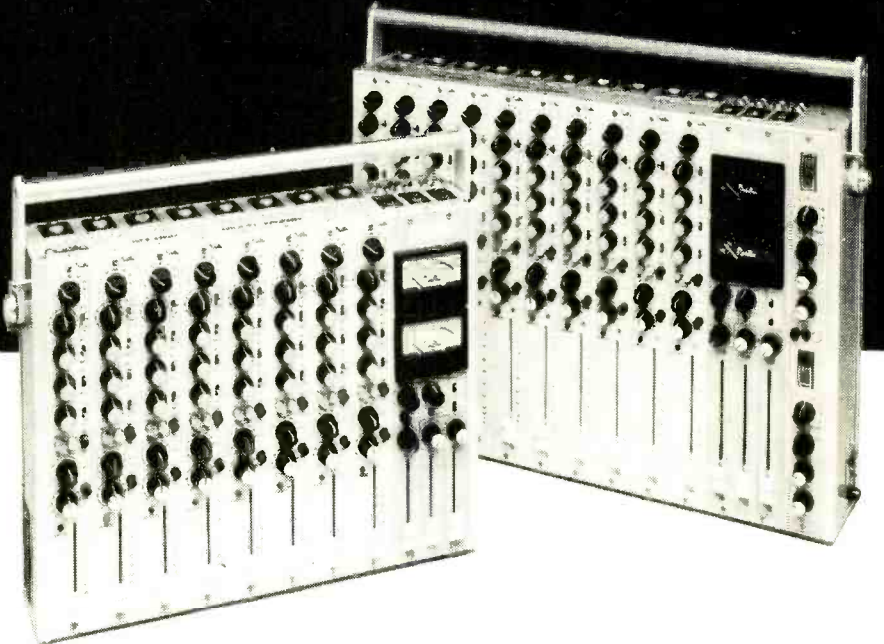

JUST TWO OF OUR WIDE RANGE OF PROFESSIONAL MIXERS FOR BROADCASTING, FILM SOUND AND POST PRODUCTION. CONSOLE MOUNTED, RACK MOUNTING AND PORTABLE VERSIONS AVAILABLE TO ORDER.

**Audio**  
DEVELOPMENTS LTD

Audio Developments Ltd, Hall Lane, Walsall Wood,  
Walsall, West Midlands, WS9 9AU  
Telephone: Brownhills (0543) 375351 Telex No: Audev G 338224

---

**TELL THEM YOU HEARD IT**



**ON THE**  **GRAPEVINE.**

01-625 4515

SOUNDCRAFT

OTARI

# A CLASSICAL APPROACH

In the first of an occasional series on classical recording and production techniques, Janet Angus talks to Brian and Ralph Couzens whose Chandos label is acquiring an international reputation.

**B**rian and Ralph Couzens work very closely as a team. They may fight about exactly which microphone goes where or the finer details of the balance, but this only serves to pull together the workings of a Chandos recording. Over the five and a half years they have been in the business of making records, these have received much critical acclaim and awards such as the Gramophone Award in 1984 for the engineering and production of Bax *Symphony No. 4*.

Brian summed up the major headache causers as follows: "There are three categories. Bad acoustics, bad orchestration or composition and poor playing standard on the part of an orchestra. An orchestra playing slightly out of tune will suddenly make the sound go dull and you think something has gone wrong with the equipment, but it is just the orchestra."

Acoustic-wise Chandos have spent a lot of time and energy finding suitable halls all over Britain and in the various countries where they record. "It is most important to look for the right location—if you get the sound right in the first place then that's half the battle."

Brian and Ralph don't feel that London itself, where they are based, has many good halls. For large orchestral work they use All Saints church in Tooting,

and for smaller orchestral works St Barnabas church in North Finchley. Chalk Farm's St Silas church is a favourite for chamber orchestra and the like and that's about it for London. Moving out a bit Watford Town Hall appears to be good for large works as is Walthamstow Town Hall.

Because these venues are not specifically for the purpose of recording

music occasionally the frustration of changing acoustics can be added to the list of problems. For example Walthamstow was a favourite among many record companies until somebody took it into their head to double glaze and paint it without considering the effect on the sound. It was ruinous and so that is one which has been struck off the list. "Maybe the paint is peeling off

Brian and Ralph Couzens



Chandos Records Ltd is a small, though expanding, classical music record company catering for all aspects of the production of a record, cassette or CD. Ninety per cent of their current catalogue is digitally recorded and mastered and includes a large number of works which are not available on the major record company labels. They aim to differ rather than directly compete with the type of record company which produces all the classical and romantic standard repertoire, seeking out new artists and lesser known or recorded composers. For example they have committed to disc (both vinyl and compact) the complete works of Hamilton Harty and Arnold Bax; other British composers which have otherwise tended to fall by the wayside include Elgar, Delius and, surprisingly, some of Holst's work. Brass bands are another speciality.

Departing from their normal formula, however, Chandos have recently recorded the Tchaikovsky Symphonies with the Oslo Philharmonic, but their tendency to stick with lesser recorded music and musicians has proved to be successful for them.

Brian (producer) and Ralph (engineer) Couzens are quick to emphasise the fact that all aspects of the recording,

## Background

from the venue to the record sleeve are taken care of in-house, and it is this all round experience they feel has been their mainstay through a time when record companies have, as a whole, experienced enormous difficulties.

When Chandos first launched their label in December 1979 it was more or less a direct result of the industry recession. Having previously worked with RCA, PolyGram, EMI and others as an outside producer Brian found that as the companies tightened their belts, so they closed their doors to the likes of him. There was only one way to go: "It was that or become a road sweeper." Some of the artists the Couzens's had been working with, including the Scottish National Orchestra and the Bournemouth Symphony and Sinfonietta orchestras went with them and the company started out on fairly solid foundations. Subsequent additions include the Ulster Orchestra and the Oslo Philharmonic Orchestra, coupled with several solo artists leading to diversification and expansion of the label's repertoire.

Total digital converts, Chandos leapt into digital recording at the first possible opportunity feet first. They

started in 1978 with a Sony *PCM-1* which was the very earliest prototype and had the serial number '1', as did their next machine in 1980, the *PCM 1600*. It wasn't until 1980 that they could edit, when they acquired the first available editor and released their first all digital recording: *The Planets* suite by Holst. Finally in 1981 they bought two *PCM-1610s*.

"We were the first company in Europe to start recording in digital. We were also the first company, along with PolyGram, to produce CDs on to the marketplace." Brian went on to explain that the majority of their compact discs are in fact manufactured for them by PolyGram, although recently the increased demand has meant that they also use CTA in Japan.

Chandos recordings have been critically acclaimed all over the world, and 80% of their business today is exported, their biggest market being America. "We didn't set out to compete in America, it just happened." Their success in America is illustrated in the American magazine *Digital Audio's* readers' poll of the top ten record labels: it is headed by Chandos.

**Chandos Records Ltd, 93 Shepperton Road, London N1 3DF. Tel: 01-359 8186.**

# RTW Studio-Processor-Set

EIAJ-standard digital sound recording on PAL, SECAM or NTSC video recorders.

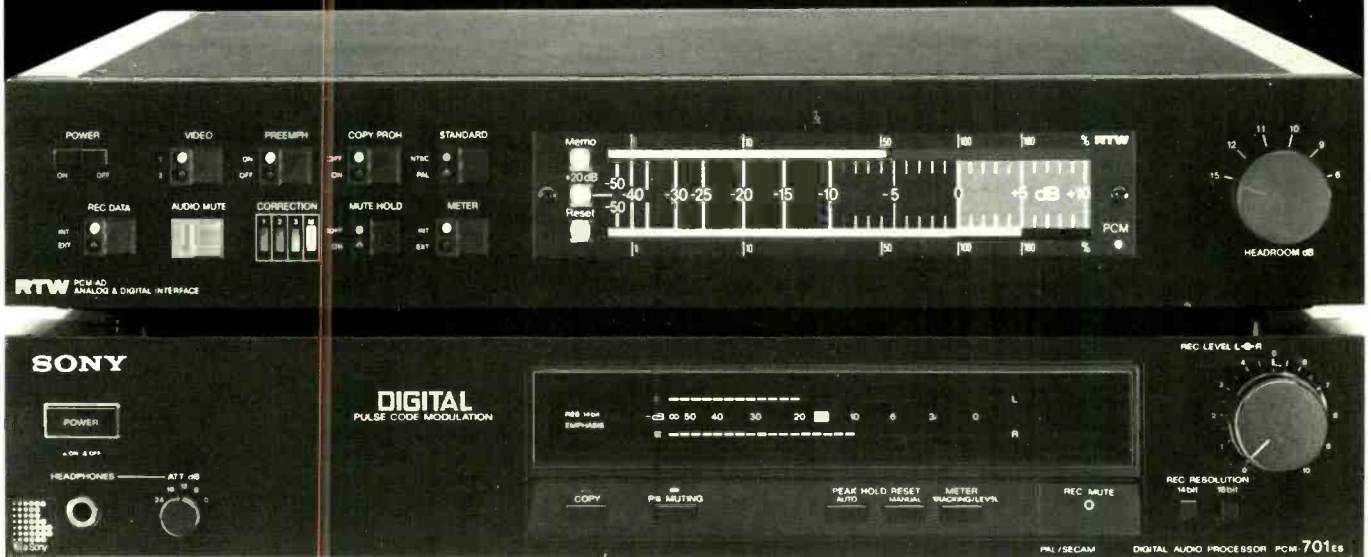

For recording studios which want to introduce digital sound recording. Master or backup recorders with digital copying option from and to the PCM 1610 processor (bidirectional). For low-cost, full quality enhancement of digital recording capacity (in studios already equipped with processor and editor systems).

For the record industry, to enable direct digital copying of masters in EIAJ-standard on to compact disc masters. Write in for detailed information and list of distributors:

**RTW**

RADIO-TECHNISCHE WERKSTÄTTEN GMBH  
Telefon (0221) 701055 - Tx 8885 217 - Postfach 710654  
Elballe 19 - D-5000 Köln 71 - W.-Germany

# It took 20 years of commitment to build a speaker this accurate, this loud, this versatile, this good.

KEF is not necessarily the first name that springs to mind when thinking of heavy duty rock or pop speakers.

This is not due to any lack of interest in this particular field.

On the contrary, the problems associated with rock and pop music monitors have occupied our designers and engineers for twenty years.

It is simply that we couldn't bring ourselves to build a speaker that achieved volume at the expense of fidelity, which is the universal problem with high level studio monitors.

Many speakers widely used for rock monitoring even have frequency response distortion deliberately introduced to make them sound more



KM1 high level monitoring loudspeaker system

efficient than they actually are.

In 1981 the BBC commissioned us to develop a speaker for them that would be loud enough for heavy rock but which should also be accurate enough to mix a symphony orchestra from.

The KM1 is the result. It has been in use at the BBC's Maida Vale studios since 1982 and has proved itself to be probably the world's most versatile music monitor and the first real hi-fidelity rock speaker.

The KEF KM1 is now in production.



**The speaker engineers.**

For full information on the KM1 or any other KEF loudspeaker, write or telephone:  
KEF Electronics Ltd, Tovil, Maidstone, Kent ME15 6QP. Tel: Maidstone 672261

# A CLASSICAL APPROACH

again by now and it's OK again, who knows?"

The Scottish National and Ulster orchestras are blessed with the Henry Wood and City halls, in Glasgow, and Belfast's Ulster Hall which Brian considers to have the best concert hall acoustic.

"The London concert halls are useless for recording, except for the Albert Hall where we recorded the brass band national championships. It's controllable there, you can create any ambience you want. There are several layers, starting under the canopy and then going out into the hall."

For solo work the Snape Maltings and Layer Marney Church are favourite haunts. "We simply look for places with beautiful acoustics. If you get the room right and it is a good orchestra, that's half the battle."

London's Henry Wood Hall which is popular with other companies Chandos do not use at all, finding it too boomy.

They do not have a mobile as such, preferring to set up a 'control room' in whatever space is available at the venue, be it the vestry or the ladies' loo. "We normally have to dampen it down with lots of blankets and cushions and whatever we can lay our hands on." Some places have rooms set aside for recording such as All Saints in Tooting where PolyGram have built a control room which Chandos are able to use.

**T**hey decided to build their own mixing console because they felt there wasn't really a desk on the market designed specifically for recording classical music. Their first was a "big old quad desk" which they used to use for 1 inch 4-track recording and which is still brought in to supplement their more usual 16-channel console on large projects.

The main console is 16 in, stereo out and is very simple. "It gives very good figures because it is so simple—the less circuitry there is, the better the sound is going to be.

"We also use a Quantec *Room Simulator* for very dry rooms. We try not to, but if the room really is too dry, that's what we use.

"As for monitoring, if you are in a difficult room for listening like the ladies' loo, it doesn't matter how much you try to dampen it down and things, you are going to end up with a coloured sound. So we rely on headphones a lot, using the Sony *MR80s* or Stax electrostatics. You need to listen on headphones really when you are recording because the room you are in is probably not soundproofed from the outside world and you need to know whether the plane flying overhead or the train going past outside is being picked up on the mics. The only disadvantage is that it tends to sound more reverberant."

Brian and Ralph always record straight to stereo, feeling that if you can't get it

right in the control room you never will. Going straight to stereo with no noise reduction has advantages of quality which they do not feel can be forgone. A brief encounter with 8-track in the Albert Hall for the National Brass Band Championships did little to sway them—"We're still not convinced."

Choice of microphone as well as placement are therefore critical. Setting up time is often painfully short since there is a limit to how long you can keep an orchestra hanging around while you adjust your balance. In such a situation the Couzens's have their tried and trusted methods which they will fine-tune to suit the acoustics of the hall.

A typical symphony orchestra set up will have three microphones over the strings (Neuman *84s* or Schoeps cardioid "... which are very similar in characteristic. The Schoeps is slightly brighter, so it just depends on the sound in the hall. We have just started using AKG *414s* on the basses"). For woodwind there will be two Neumann *87s*; harp, a Neumann *86*, and timps a *47*. "For percussion we use whatever is left by way of cardioids."

The main pick up mic is normally a Schoeps stereo with AKG *414s* on either end or a pair of *86s* (set to omni pattern) on either end of the Schoeps to widen the stereo picture. A pair of *83s* are placed at the back of the hall for reverb. If the hall is on the dry side then the main pick up mic would be the Bruel & Kjaer.

Symphony orchestra percussion, especially timpani, can cause terrible problems in a reverberant hall, setting up ringing. So against their better principles Chandos will request that the players use hard sticks whilst playing with less volume than they would during a concert performance, and spot mic them. "It is the one sound we do have to slightly doctor. Most companies do the same. You have to get the articulation and avoid the ringing round the hall."

By 'spot miking' they do not mean close miking, but rather providing overall sound sources of sections of the orchestra, for example stereo woodwind and stereo strings. The first step will be to achieve a balance of the spots, then

## Equipment

Two Sony *PCM 1610*  
One Sony *5850 U-matic*  
One Sony *DMR2000 U-matic*  
Monitoring: Rogers *LS5/8* with active Quad drivers  
Custom 16-input, stereo out mixing console  
Quantec *Room Simulator*  
Microphones: Neumann *SM69* with remote, two *U87*, four *U77*, six *KM84*, four *KM83*, one *U47*, four *KM86*;  
Schoeps *CMTS501U* stereo, two *CMC5U* cardioid, two hypercardioid and one switchable; AKG three *414EB*; Bruel & Kjaer *4006*

Editing Suite  
Sony *DAE-1100* digital editor  
Studer *A80* 2-track, *A80R* 4-/8-track  
Nakamichi cassette machine  
Philips and Sony CD players  
Sony *PCM-701* with Audio+Design interface rack.

open up the stereo pair main mics and blend these in with the spots. If the hall is fairly dry then the ambient *83* mics at the back will compensate. If it is very dry the ambient mics are not used, being replaced with the Quantec.

"It is very important to recreate a concert hall sound. You cannot do this if you are looking at the orchestra, because no matter where you sit, your eyes are feeding information to your ears—you hear what you see. But when you are sitting at home listening to a record you don't have that visual aid, so we have to create something to compensate for that. So I stand in front of the orchestra and get the sound into my head and then I rush round to the control room and try to recreate the same sound in there.

"The analogy I draw is taking a photograph with a camera. People can take a picture of a beautiful view and not notice the telegraph wires going right across the middle until they get home and have the film processed. It's the same thing. And that is why all these *Soundfield* and single stereo microphones simply can't work. This phenomena is something which these people just seem to miss. They don't give a natural sound because they don't take these things into consideration.

"We are also very against fader pushing in order to highlight certain soloists. You would be surprised how many people do it. CD has been showing up so many bad balances, and at first CD got the blame for it—that hard upfront sound."

**F**or smaller ensemble work the Bruel & Kjaer comes into its own. Having carried out comparison tests between the B&Ks, Schoeps and Neumann *84s*, they found the B&Ks to give the most uncoloured, natural sound.

"The B&K is a super-flat mic. The only drawback is that they do tend to pick up a lot of bass and sometimes rumble. Because it is an omni, it is very critical to find the placement for correct phase response. It takes longer to set up but you do get a better sound. You can't afford to take risks with a symphony orchestra because you can't just ask them to come back and do it again. You just have 20 minutes at the beginning to set up so you tend to stick to what you know. With a soloist you have more time to experiment."

Or, indeed, with a string quartet. The Couzens's will set up three things: a crossed pair over the quartet, two or three B&Ks further back, and the Schoeps stereo and then listen to decide which is most appropriate for that particular acoustic by process of elimination. "The B&Ks might be best, but then again, they might pick up too much ambient, traffic or jet noise."

A piano trio is another opportunity for experimentation. A recent recording of the Borodin Trio took place in a fairly dry hall so Ralph chose a B&K placed close to the violin, one looking at the cello and away from the piano; another B&K or a crossed pair on the piano. In a reverberant hall they would also use an overhead stereo very lightly; for the soloists, cardioid mics back to back for stereo in a figure-of-eight.

"We experiment in each acoustic. We

# The Aphex Aural Exciter.<sup>TM</sup>

## The Best Way to Improve Your Sound System.

By now you've probably invested in flangers, reverbs, delays, and other accessories for special effects. But, there's still something missing in your sound. The excitement of an Aphex Type B Aural Exciter.

The Type B generates the same psycho-acoustic excitement pros have used for years for that *extra punch*. The Type B restores natural brightness, presence and detail. Your live sounds fill the room with-

out all the problems of high frequency EQ. Even multitrack tapes made on narrow format machines sound like they were made on expensive studio recorders! All for less than \$500.

Hear the difference an Aural Exciter can make at your dealer today. Or, write us for the name of your nearest dealer and a demonstration record that's fun and informative, "Trouble at Madame Long's."



# The Aphex Compellor.<sup>TM</sup>

## Invisible Compression in Stereo or Mono.

The Aphex Compellor is the most acclaimed compressor/leveler/peak limiter ever made. With good reason... you simply can't hear it work. It doesn't add *any* color or other sonic effects. Best of all, the Compellor is easy to use. Set it once and it goes to work automatically... inaudibly controlling your dynamics.

Ask your professional sound dealer for a demonstration of the remarkable Aphex Compellor. Available in monaural and

stereo versions. Or write us for the name of your nearest dealer and more information on the full line of innovative Aphex products.



Aural Exciter and Compellor are registered trademarks of Aphex Systems Ltd., North Hollywood, CA  
© 1985 Aphex Systems Ltd.



**Aphex Systems Limited**  
At antex Music Ltd.  
3 Cadwell Lane, Hitchin  
Hertfordshire SG4 0AG  
Telephone: (0462) 31511  
Telex: 826967

**AUSTRALIA**  
East Coast Audio Sales,  
Melbourne

**AUSTRIA**  
AKG, Vienna

**BENELUX**  
Trans European Music,  
Dilbeek

**CANADA**  
AKG Acoustics,  
Scarborough

**DENMARK**  
SC Sound, Taastrup

**FINLAND**  
Nores Oy, Helsinki

**FRANCE**  
3M France  
Cergy Pontoise Cedex

**GERMANY**  
AKG, Munich

**GREECE**  
Omikron, Athens

**HONG KONG**  
Audio Consultants,  
Kowloon

**ITALY**  
M. Casale Bauer, Bologna

**JAPAN**  
Matsuda Trading, Tokyo

**KOREA**  
Young Naksoris, Seoul

**NEW ZEALAND**  
Maser Comm., Auckland

**SINGAPORE**  
Audi Private Ltd.

**SPAIN**  
Neotecnica, Madrid

**SWEDEN**  
AB Betoma, Solna

**SOUTH AFRICA**  
Tru-Fi Electronics,  
Wynberg, Sandton

**SWITZERLAND**  
Audio Systems  
PAS AG, Basli

**TAIWAN**  
L'nfair Engineering, Taipei

# A CLASSICAL APPROACH

are very fond of the B&Ks and if we can we will use them: a pair or three on the piano. When it is three, the middle one is slightly in front of the two outside and has to be used with discretion to avoid pulling the others into a mono picture. The centre mic holds the phase together. We may use a crossed pair or stereo on the sound source. B&Ks have to be very carefully placed, the distance from the sound source is critical in order to get the right signal:ambience ratio."

Guitar music calls for fairly close miking but not too much or else all you get is the finger noise; B&Ks are quite nice for that, and further back to give the stereo. Miking a brass band calls for much the same method as an orchestra. Each section is miked up at a reasonable distance, then the stereo pair, and then the two reverb mics at the back, and all three sources are blended together.

"The worst thing you can do with brass is mic directly into the bell—you get all sorts of horrible noises." This is what they use: Cornets: 87; trombones: 87; horns, baritones, euphoniums and basses: 86; percussion: 84; timps: 47. "You have to mic percussion fairly close because they are inclined to swim a bit otherwise." For the stereo, Schoeps; for ambience, two 83s.

**O**n the whole, then, Brian and Ralph have a pretty good idea what they will use where and it doesn't require much pre-planning. There are odd occasions, however, when the scale of the work is so huge that it cannot be ignored. For example, a recent recording of *Lux Aeterna* by William Mathias involved the London Bach Choir, an expanded London Symphony Orchestra with lots of extra percussion, piano and two harps, three soloists, a boys' choir and organ. That needed a bit of planning.

"We decided to record it in Tooting and we hired in a scaffold firm to build the rostra for the choirs. We had to decide obviously where we wanted the choirs. We have two big Danner stands with T-bars on the ends which we placed looking across the choir each with a pair of 77s. The soloists were placed in front of the Bach Choir with an SM69 stereo mic. The orchestra was the usual set up with extra mics for the piano and percussion. For the boys' choir at the other end of the church we used two B&Ks, and the organ was recorded with an 86 omni stuck on a 30 ft pole in front of it!"

The recording method after all the preparation is fairly straightforward. They will probably start off with a straight take, followed by playback to listen for technical and artistic flaws. Then they will do a second take. There will now still be a few places almost certainly where they are still not



Cantilena at the Henry Wood Hall, Glasgow

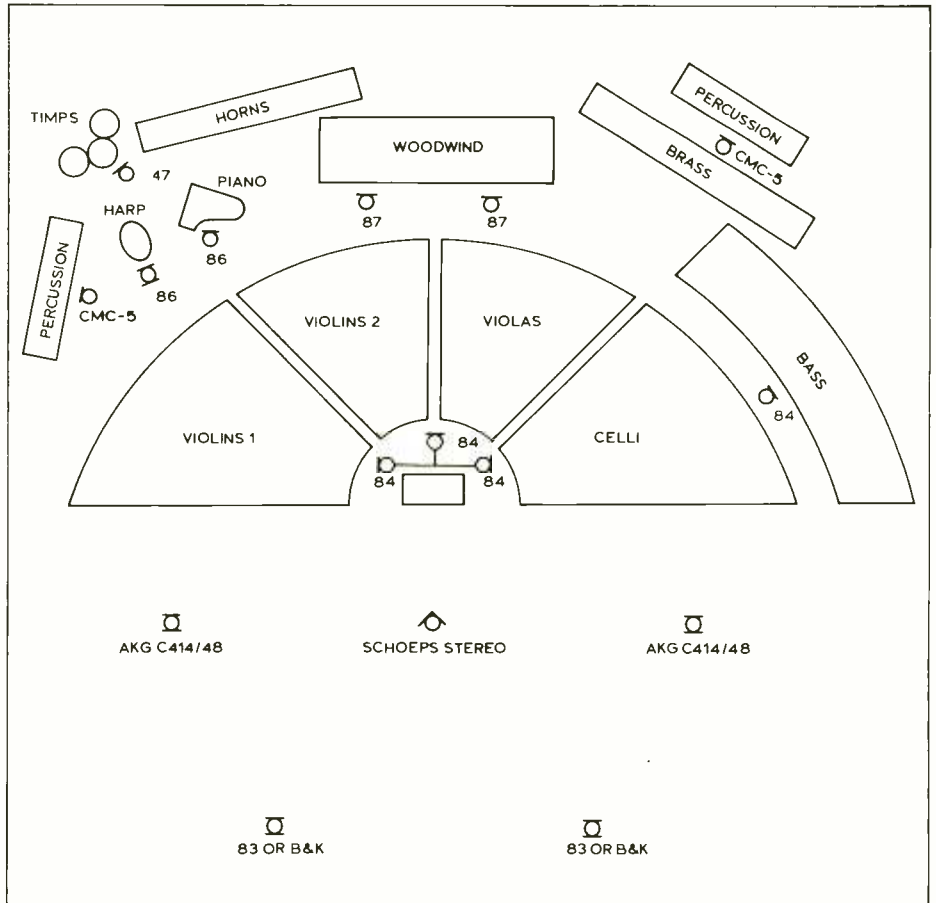

Set up for Scottish National Orchestra at the Henry Wood Hall, Glasgow

covered, so either a third take or sections will follow.

"We do quite a lot of takes for editing. The thing is to get the natural sound and the performance—that is what's lacking in records today—they sound manufactured, they've got no life."

The conductor's involvement in the recording process is really down to the individual, although most do tend to get quite involved. Apart from the principles of each section of the orchestra, who for artistic reasons the Couzens's encourage

to listen and voice opinions, the other musicians are best not encouraged.

"Everywhere you sit in the orchestra the music sounds quite different, so each musician wants the recording to sound different. One particular orchestra we work with the brass players used to make a fuss about not being loud enough, so now we give them their own microphone. The only thing is we don't plug it in. But they don't realise that! As long as it is there they are happy," explained Ralph. □

# STUDIOMASTER

## 16-16-2

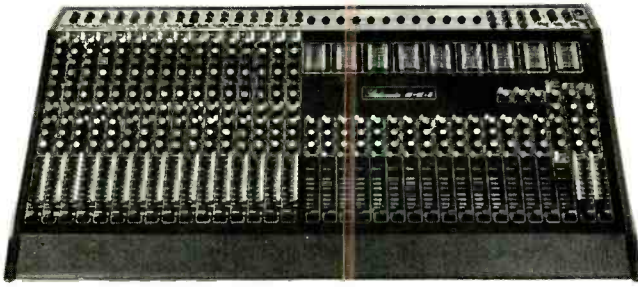

The 16/16/2 is designed to complement budget 16-track recorders. It features its own external P.S.U. which can supply even a fully expanded 16/16/2 (a 32/16/2!). All mic. channels have 48V Phantom Power, parametric E.Q. network, and 3 auxiliary sends. Full 16 channel monitoring is included in the 16/16/2 package. 12 segment 2 colour bargraphs are fitted to the 16 sub-mix stages and the master output which is also fitted with 3 band E.Q. As well as optional expander modules for the mic. channels, a double patch bay is available.

## 16-8-2

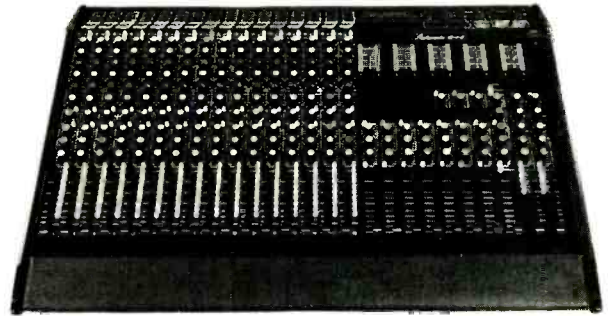

The 16/8/2 is compatible with 8-track recorders and has all the versatility of the 16/16/2, like optional expander modules for the mic. channels (an extra 16 mic. channels may be fitted without altering the unit's P.S.U.) and a double patch bay. Mic. channels feature 48V Phantom Power, parametric E.Q. network, 3 auxiliary sends and 90mm faders. Full monitor and foldback systems are included. Master outputs have 3-band E.Q. and 2 colour 12 segment bargraphs. These bargraphs are also fitted to the 8 sub-mix stages. Applications for the 16/8/2 include small 8-track studio mixing and live sound reinforcement.

## 16-4-2

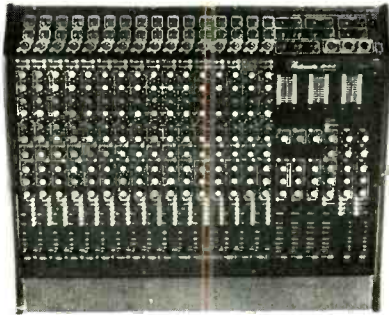

The 16/4/2 is the mixer that the 16/8/2 and 16/16/2 developed from and consequently contains all their superb features. It is expandable to 32/4/2 on its existing P.S.U. and a patch bay is also available. Mic. channels have parametric E.Q. network, 48V Phantom Power, 3 auxiliary sends and 90mm faders. Full monitor and foldback systems, 3-band E.Q. on the master outputs and 2 colour 12 segment bargraphs are all supplied on the 16/4/2. Use of this mixer include live sound reinforcement and for use with 4 track recorders in small studios.

## 6-2-1



The STUDIOMASTER 6-2-1 mixing console offers features and performance normally obtainable from mixers costing twice the price. Mic. channels feature three band e.q., effects and monitor sends as well as the usual gain and pan controls. 2 colour, 12 segment bargraphs allow monitoring of channels, auxiliaries and both stereo and mono sum outputs. This outstanding specification makes the 6-2-1 ideal for sub-mixing, P.A. and recording.

## Mosfet 500



With distortion not exceeding 0.005% (1kHz sinewave at 200 watts/4ohms) this amplifier provides reliable amplification of outstanding fidelity in all applications. The extensive protection circuitry ensures failsafe protection against D.C., thermal overload and short circuit conditions. The front panel carries LED indication allowing instant monitoring of the amplifier's operational status. The Mosfet 500 is ideally suited to all professional applications requiring medium power, accurate reproduction.

## Mosfet 1000



This high power amplifier delivers twice the power of the MOSFET 500 with the same 0.005% distortion (1kHz sinewave at 400 watts/4 ohms). This amplifier has already proved itself under the most stressful of applications and is fast becoming the standard against which all other amplifiers are measured. The Mosfet 1000 delivers high power with total fidelity in all applications.

Studiomaster, Faircharm Industrial Estate, Chaul End Lane, Luton, Bedfordshire.  
Tel: (0525) 221331 Telex: 825612 STUDIO G





COMPUTER AIDED DESIGN



# M M M M M M M **M SERIES** **NO MORE SLEEPLESS NIGHTS!**

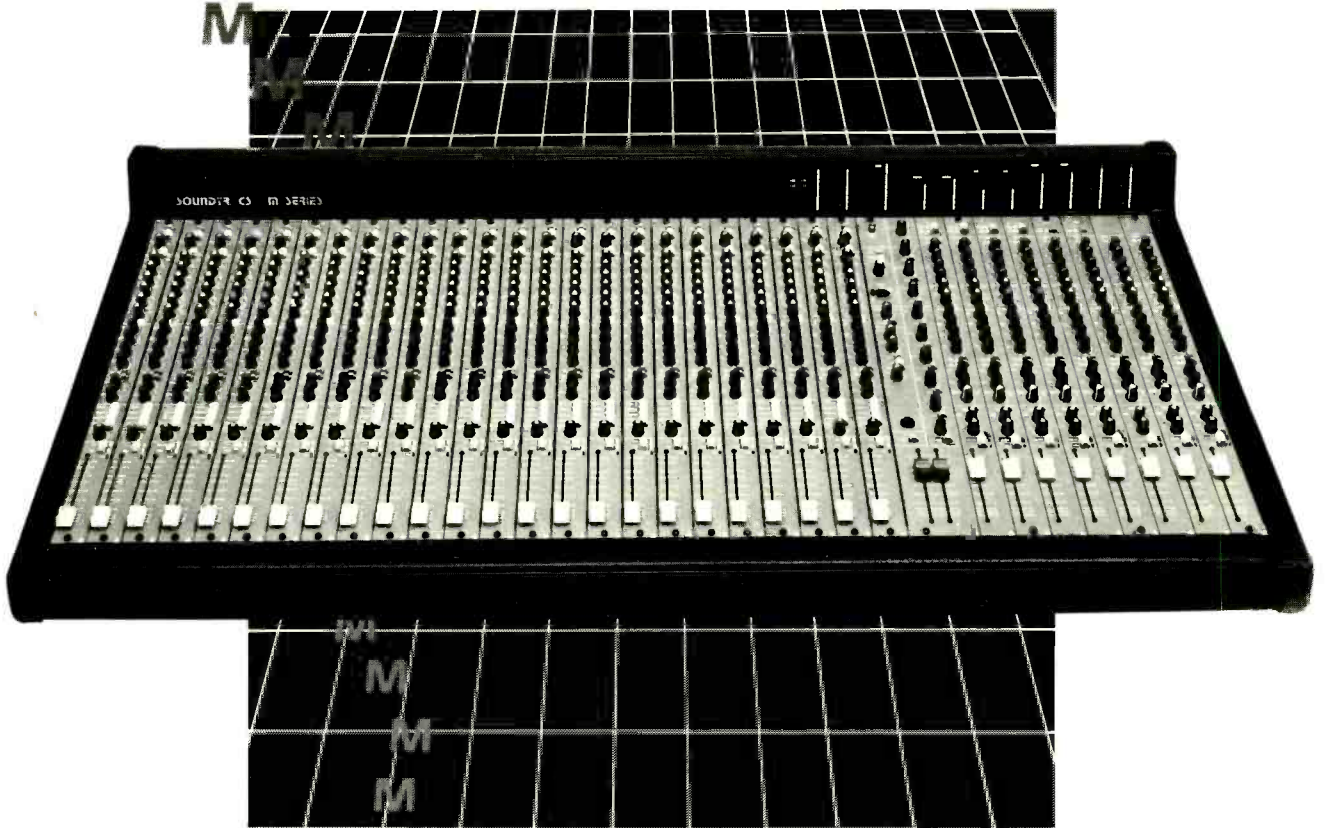

M  
M  
M  
M  
M  
M  
M  
M  
M  
**No nonsense eight buss mixing console designed for live sound reinforcement, theatre or eight track recording. Unique facilities such as +30db input headroom, 4 band equalisation, six auxilliary sends, switchable pre or post fade and settable using hand set jumpers to pre or post**

**equ. By four matrix on each sub group pre or post fade. Stereo return to masters. Fader reverse. Eq on group output, permanent access to all eight busses for effects returns with eq option. Full monitoring of groups. A total solution to an eight buss mixer that will not fail on you; So **NO MORE SLEEPLESS NIGHTS!****

**THE M SERIES BY**



**affordable quality**

Soundout Laboratories Limited  
91 Ewell Road, Surbiton,  
Surrey KT6 6AH Tel: 01-399 3392  
Telex: 8951073/SNDOUT/G

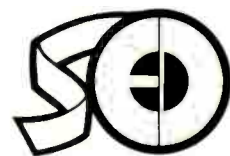

Distributed by:

**Studio Equipment Distribution Ltd**

27 Guildford St., Luton, Beds., LU1 2NQ  
Tel. Luton (0582) 452495



# AVIM StudioSound Film Recorder

The Avim StudioSound is a lightweight portable reproducer or recorder/reproducer which is ideal as a transfer machine or for interlocking to projectors etc. With prices from £3,000 the system features:



- 16mm
- Electronic interlock drive system
- Single/two track EBU standard
- Automatic Pilottone transfer
- 24/25 f.p.s.
- Variable speed
- Forward and reverse
- Film advance/retard system
- Stacked or rack mounted
- Lightweight, transportable
- 2,000 ft film capacity
- Synchronisation of 5 machines via 1 control unit

For further information, please contact:

**VIDEO CINE SOUND**  
238 Sandycombe Road, Kew,  
Richmond, Surrey TW9 2EQ  
Tel: 01-948 3615  
Telex: 24224 (Ref. 292)



## Le catalogue FFD nouveau - est arrivé!

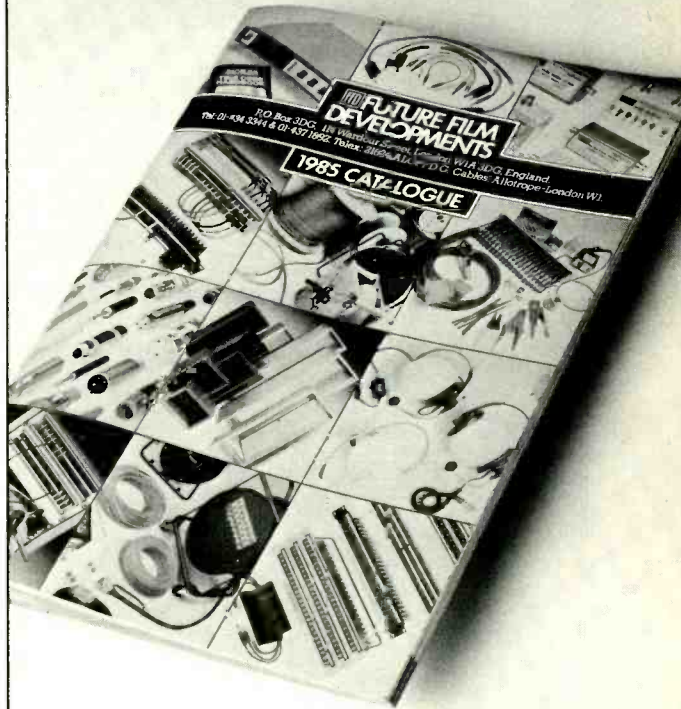

### FFD FUTURE FILM DEVELOPMENTS

P.O. Box 3DG, 114 Wardour Street, London W1A 3DG, England.  
Telephone: 01-434 3344 & 01-437 1892. Telex: 21624 ALOFFD G.  
Cables: Allotrope-London W1.

# "More Talkback, less argument.."

A good, easy to use Talkback System – smooth production, saving time and improving programme quality.

Contact TecPro for Talkback systems that are:

- Simple to install – using standard mic extension leads.
- Reliable – proven by over 5 years of use in the field.
- Inexpensive.
- Non-tiring – due to wide band width and low distortion.
- Easily added to almost any existing system. Radio links are also available.
- Available off the shelf.

TecPro – Active in Talkback since 1975.

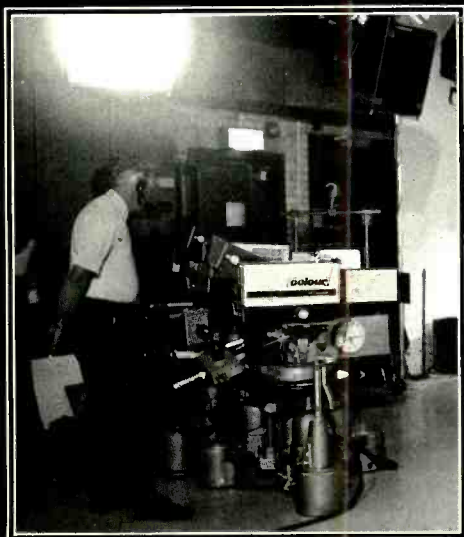

**Technical Projects Ltd.**  
Unit 2, Samuel White's Industrial Estate,  
Medina Road, Cowes, Isle of Wight, PO31 7LP, England.  
Telephone: (0983) 291553 Telex: 869335 TECPRO G

**TecPro Inc.**  
PO Box 1069, Palatine, Illinois 60078, USA.  
Telephone: (800) 562-5872 From IL AK HI (312) 359-9240  
Telex: 280 5C2 (PROTON PALTN)



ANNOUNCING



RCF LOUDSPEAKER COMPONENTS  
AVAILABLE FROM THEATRE PROJECTS SALES  
EXCLUSIVE UK DISTRIBUTORS.  
BROCHURE AVAILABLE.

**THEATRE  
PROJECTS**

Theatre Projects Sales  
10-16 Mercer Street, London WC2H 9QE Tel: 01-240 5411 Telex: 27522

# TRAD

FOR SALE	£	FOR SALE	£
Studer A800, 24-track	2,500.00	Quad eight 32-16-24	8,000.00
Studer A80, Mkl, 16-track	8,500.00	Neve "Kelso", 10-2, mint	4,000.00
Studer B67 Stereo	2,500.00	M.C.I. 500, 42 in	34,500.00
Studer B62 Stereo	1,200.00	Soundcraft 1624, 24-16-24	8,500.00
3M M79, 24-track with XT24 autolocate, new heads	11,500.00	Trident VFM 20-8-16	1,200.00
3M M79, 16-track	6,250.00	Dolby M24H	7,500.00
3M M56, 16-track	4,750.00	Dolby M16H	5,500.00
3M M56, 16-track	3,750.00	Dolby A361	400.00
3M M23 Stereo	1,000.00	Dolby A360	375.00
M.C.I. JH24, 114 autolocate III	13,000.00	Dolby A301	450.00
M.C.I. JH110 Stereo	2,500.00	Master Room XL305 reverb	900.00
Lyrec 532, 24-track ATC	12,500.00	EMT 140TS Echo plate, remote	2,200.00
Lyrec 532, 24-track TPC	9,500.00	A.K.G. BX20 reverb	1,400.00
Lyrec Stereo TR55	2,600.00	EMT 240 Gold foil	2,600.00
Ferroglyph studio 8 stereo	500.00	Klark Teknik DN22	320.00
Ampex ATR700	700.00	Klark Teknik DN34 graphic equaliser	250.00
Proline 2000 stereo	1,200.00	DBX Comp/lim 160	280.00
ITAM 1610, 16-track 1"	4,750.00	8 Kepex I cards and p.s.u. in frame	1,500.00
Trident series 80, 32-24-24	14,000.00	Amber test set	950.00
		Audio & design F760XRS	850.00

Pultec-type all valve equalisers and Fairchild pattern comp/limiters now in stock P.O.A.

The above prices do not include V.A.T.

**TRAD**

**ELECTRONICS SALES LTD**

149b. St. Albans Road, Watford, Herts, WD2 5BB, England  
Tel: Watford (0923) 47988/9 Telex: 262741

# More effects from HHB.

Introducing the amazing Yamaha REV 7 digital reverb + effects processor.



At last, a professional quality, programmable digital reverb with the sounds and features you want, at a price so low you won't believe it.

Here are a few of the REV 7's features:

- True or simulated stereo.
- 30 factory presets and up to 60 user stores.
- Hall, Plate & Room reverb programs.
- Reverb available with gating, reverse, flanging...
- Early reflection programs.
- L/R delay and stereo echo.
- Stereo phasing and flanging.
- MIDI interface.
- Remote control.
- 16 bit @ 31.25 kHz sampling giving 20-12kHz response
- 3 band parametric EQ.

**£1040**



For the more demanding user, don't forget Yamaha's original REV 1 digital reverb with its full function remote control at £6595.

At £1040 the REV 7 must be the year's best buy; send now for colour brochure.

In addition to the REV 7, here are some more gadgets from HHB's effects collection:

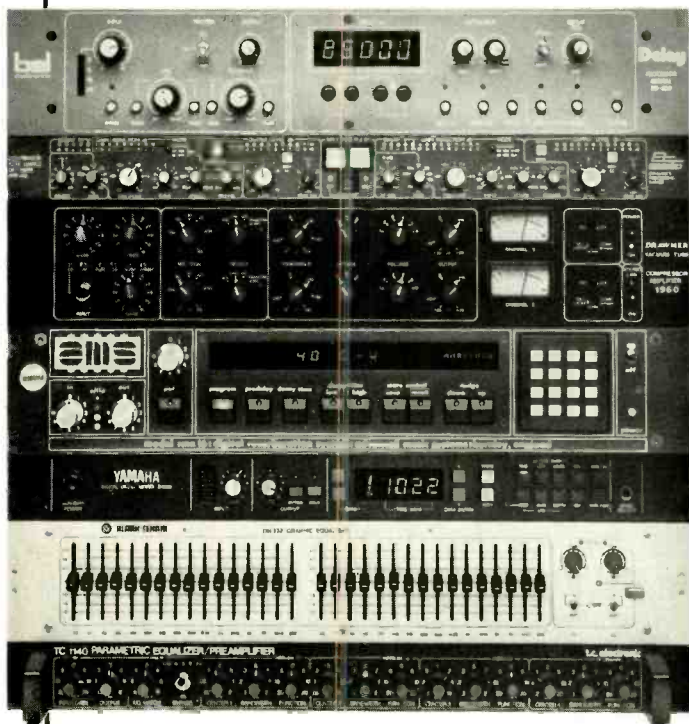

The newest from the BEL stable, the BD320 gives all the functions of the popular BD80, but with up to 32 (yes 32) seconds of delay. BD80 £695 (2 secs) + £200 per extra 2 secs. BD320 £1200 (8 secs) + £500 per extra 8 secs.

The BSS DPR402 is an all in one dynamics processor, providing compression, peak limiting, de-essing and expansion, all with frequency keying all in a lu package £615.

For that authentic 60's sound, DRAWMER's 1960 valve compressor/pre-amp is a must. "Soft knee" compression, microphone inputs, side chain operation etc £750. (Don't forget the DL221 @ £325, and DS201 @ £275.)

The AMS RMX16 shown here is the state-of-the-art in programmable reverb. We also try to keep the DMX 15-80 DDL/pitch transposer, but demand is high so order now. RMX16 £4680. DMX15-80 £POA.

The YAMAHA D1500 is a low-cost, high-value programmable DDL with MIDI interface; it gives up to 1 sec delay, with 16 user memories. Our price is so low that we don't dare print it! £POA.

KLARK-TEKNIK's range of equalisers should need no introduction: they are simply the industry standard for graphics. We also stock other Klark-Teknik products, such as their excellent digital reverb and the DN60 analyser. DN332 (shown here) £525. DN360 £980. DN60 (analyser) £1650. DN780 reverb £3580.

TC ELECTRONICS TC2240/1140 are stereo/mono 4 band fully parametric equalisers offering 20dB of cut and boost. We think they are the best value and best sounding outboard EQ's around. TC2240 £330. TC1140 £195.

We also keep toys from Lexicon, Urei, ElectroSpace, dbx, Eventide and many more. Our demo room is ready for you to try before you buy; or take advantage of our mail order service for best prices and free delivery.

Access, Barclaycard/Visa, American Express, Finance arranged (All prices exclude VAT and are correct at time of going to press.)



HHB HIRE & SALES, UNIT F NEW CRESCENT WORKS, NICOLL ROAD, LONDON NW10 9AX.  
TELEPHONE 01-961 3295 TELEX 923393

## Cable Technology. The one stop cable shop.

- Klotz audio cable
- Klotz modular stageboxes & multicores
- "Broadcast Series" studio interface cables
- Neutrik XLR connectors

Full colour catalogue  
and price guide  
available on  
request.



**Cable Technology**

72-74 EVERS HOLT STREET LONDON NW1 1BY  
TELEPHONE 01-387 5783 TELEX 28159

## Your Guarantee

*NO GUESSES*

*NO GIMMICKRY*

The circulation of this publication  
is independently audited to the  
professional standards  
administered by the Audit  
Bureau of Circulations

**ABC**

*The Hallmark of Audited Circulation*

## AUDIO · VIDEO · DATA

A superb range of innovative loading  
and duplicating technology  
· Worldwide ·

  
**the leaders**

Tape Automation Ltd, Unit 2, River Way, Harlow, Essex CM20 2DN.  
Telephone (0279) 442946, Telex 265871 MONREF G quoting Ref: 84: AUL001.

EUROPE · USA · JAPAN · UK · INDIA



**WHEN ALL IS SAID AND DONE.... IT'S THE MICROPHONE THAT COUNTS. AT THE LAST COUNT WE HAD OVER 100 TYPES TO CHOOSE FROM. HERE'S A FEW.**

AKG D190E General Purpose	d	49.00	SENNHEISER K3U Powering Module	p/b	46.00
AKG D202E1 Vocal General Purpose	d	119.00	SENNHEISER ME20 Omni Capsule		26.00
AKG D22EB Vocal General Purpose	d	101.00	SENNHEISER ME40 Uni-Capsule		36.00
AKG D17E Bass Mic	d	121.00	SENNHEISER ME80 Short Gun		50.00
AKG D330EBT Vocal	d	113.50	SENNHEISER MD421U Vocal General Purpose	d	91.00
AKG C414EB General Purpose	p	349.00	SENNHEISER MD441U Super Cardioid	d	126.00
AKG C451E + CK1	p	135.00	SENNHEISER MKH416 Short Gun	p	276.00
AKG C451EB - CK1	f	159.00	SENNHEISER MKH816 Long Gun	p	352.00
AKG C535EB Vocal	p	115.00			
AKG C568EB Short Gun	p	118.00	SHURE SM58 Stage Vocal	d	121.00
BEYER M201 General Purpose	d	78.00	SHURE SM57 General Purpose	d	94.00
BEYER M550 Omni Interview	d	28.00	ELECTRO VOICE RE20 Studio Mic	d	425.00
BEYER M98 General Purpose	d	123.00	ELECTRO VOICE RE50 Omni Directional	d	139.00
BEYER MM560 Head Mic	d	109.00	ELECTRO VOICE PLS5 Omni Directional	d	74.00
SONY ECM30 Miniature Tie Clip	b	58.00			
SONY ECM50 PSFB Miniature Tie Clip	b	110.50	NEUMANN U47 FET	p	573.00
SONY ECM969 Single Point Stereo	p/b	114.00	NEUMANN U87i	p/b	591.00
SONY F115 Omni Interview	b	75.00	NEUMANN U89i	p	591.00
AUDIO TECHNICA ATM41 Rugged Vocal	d	65.00			
AUDIO TECHNICA PRO4L Stage Vocal	d	39.00			
AUDIO TECHNICA ATM83G Talk-Back Mic	d	48.00			

**MICROPHONE TYPE CODES**  
 b = Battery d = dynamic p = phantom

ALL PRICES SUBJECT TO VAT. CARRIAGE EXTRA

**NOW WE'VE ADDED EVEN MORE!**



**A RANGE OF TOP QUALITY UK MADE CONDENSER MICS OFFERING EXCELLENT QUALITY AT MODEST PRICES.**

<b>1000 Series with integral capsule &amp; 48v phantom powering:</b>	£
CM1050C cardioid	101.00
CM1051C cardioid, bass roll-off	101.00
<b>2000 Series with detachable capsule &amp; 48v phantom powering:</b>	
CM2001C hand held omni	149.00
CM2003C omni	139.00
CM2050C cardioid	135.00
CM2051C cardioid, bass roll-off	135.00
CM2056C cardioid, bass roll-off, windshield	160.00
<b>2100 Series with detachable capsule &amp; 7.5-54v phantom powering:</b>	
CM2101C hand held omni	172.00
CM2103C omni	162.00
CM2150C cardioid	158.00
CM2151C cardioid, bass roll-off	158.00
CM2156C cardioid, bass roll-off, windshield	183.00

Capsules & powering modules available separately plus a full range of accessories.

*Michael Stevens & Partners*

**The Sight and Sound Specialists**

Invicta Works Elliott Road Bromley Kent BR2 9NT  
 The Homesdale Centre 216-218 Homesdale Road Bromley Kent BR1 2QZ  
 01-460 7299

# Subscribe Now.



AND BROADCAST ENGINEERING

**JOIN THE AUDIO PROFESSIONALS**

You're obviously interested in professional audio.

You want to know what's going on in the world of professional sound, be it in music recording, new equipment, techniques or live sound reinforcement.

There's only one answer, subscribe to **STUDIO SOUND.**

STUDIO SOUND gives you the hard facts, techniques and opinions which cannot be matched by any other publication in the field.

**Keep in touch**  
**Subscribe to Studio Sound Now**  
**The International Publication of the Professionals in Sound**

Please send me \_\_\_\_\_ magazine for 12 issues. I enclose a cheque/postal order/International Money Order payable to LINK HOUSE MAGAZINES for £18.00 UK or £24.50 Overseas. US rates: \$40 surface, \$75 airmail.

Or debit my credit card account

(please tick box)

CREDIT CARD NO. \_\_\_\_\_

SIGNATURE \_\_\_\_\_ Credit card holders can order simply by ringing 01-760 0054, quoting your credit card number

NAME \_\_\_\_\_

ADDRESS \_\_\_\_\_

(please print in block capitals)

Commencing with the \_\_\_\_\_ issue I understand that I am committed to one year's subscription to the above magazine, and should I wish to cancel my subscription, no refund will be made.

To:  
 The Subscriptions Department, Link House Magazines Ltd.,  
 Central House, 27 Park Street, Croydon CR10 1YD.  
 Tel: 01-760 0054

# PERFECTONE

Continuous Motion Projector

for 16 and 35mm Film

# UNITOR 16/35

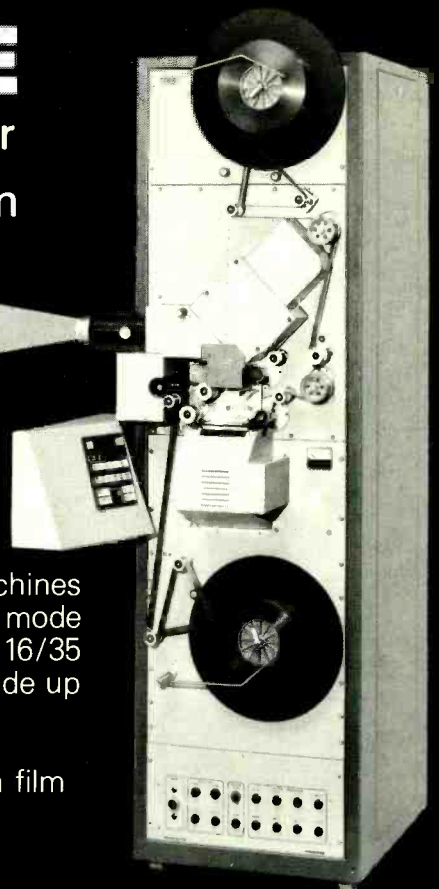

- optical compensation by rotating and segmented mirror unit
- capstan drive system similar to the Perfectone Capermag machines
- basic speed 24/25 f.p.s. for 16/35mm film in forward and reverse mode
- variable speed forward/reverse up to 100 f.p.s. with projection 16/35
- high variable speed without projection in forward/reverse mode up to 750 f.p.s. for 16mm and up to 300 f.p.s. for 35mm film
- still projection
- optical and magnetic replay for 16 and optical only for 35mm film
- projector is capable of running as «Master» or «Slave»
- light source: Xenon lamp 1000 W or 1600 W

PERFECTONE PRODUCTS SA

2560 NIDAU SWISS

TEL.: 032 51 12 12

TX 34383 Perbi CH

# NEW POWER IN BATTERSEA

All power needs a PLUG.

And this is it!

PMD, Britain's No. 1 Magnetic Media distributors are pleased to announce the opening of their new London Sales Office.

Write or 'phone today for our CURRENT price list. You could be in for a SHOCK when you see how competitive we are.

The jokes get worse—the service gets better.

Ampex Professional Tape, Editing Sundries, Accessories, Spools, Boxes, Video Products, Floppy Disks

London Sales Office  
Battersea Wharf  
Queenstown Road  
London SW8  
Tel: 01-627 3760

Head Office  
Tel: (0789) 68579  
Telex: 317148 Datas G (prefix messages PMD)



NUMBER ONE IN MAGNETIC MEDIA

PANGBOURNE MUSICAL DISTRIBUTORS LTD

the know-how, the back-up and the goods

# AVCOM

SPECIALISTS IN CASSETTE DUPLICATORS  
SUPPLIERS OF

## TELEX

HIGH SPEED DUPLICATORS

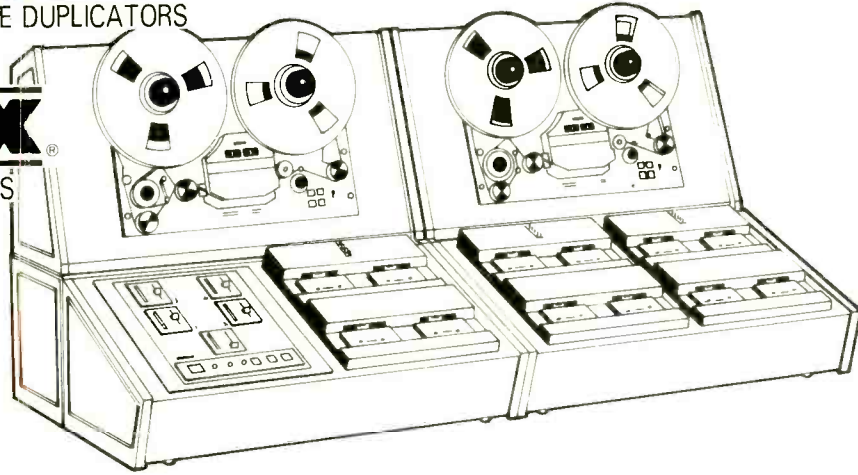

The TELEX 6120—just one of a wide range of cassette duplicators for the production of audio and data cassettes. Efficient and durable. TELEX equipment is backed up by 15 years of AVCOM experience and reliability.

Tony Martin, AVCOM SYSTEMS LTD, Stanlake Mews, London W12 7HS Tel no 01-740 0051 Telex 892513

# WHAT THE BEST CANNOT BETTER



STANFORD 751   
SILVER SHADOW

- seven input channels
- four of them with three source connections

## YOU MAKE YOUR OWN MIX

Manufactured by TELEVIC  
Panoramastraat 36  
B-1810 WEMMEL (Brussels)  
Tel.: 32-2/479 99 70  
Telex: 24120 Televic b

# Why do Jensen Transformers have Clearer Midrange and Top End?

The high frequency rolloff of a *Jensen Transformer* is optimized, by computer analysis, to fit the *Bessel Low Pass Filter* response. This means *minimum overshoot and ringing* and *flat group delay* for best *time alignment* of all spectral components of the musical waveform.

In other words, the harmonics arrive at the same time as the fundamental frequency.

The result is a clear midrange and top end without the harsh, edgy sound which has been one of the most objectionable sonic complaints about transformers.

There's no "midrange smear."

Only *Jensen* has this benefit of hi-tech computer optimization.

Visitors by appointment only. Closed Fridays.

10735 BURBANK BOULEVARD • NORTH HOLLYWOOD, CA 91601 • (213) 876-0059

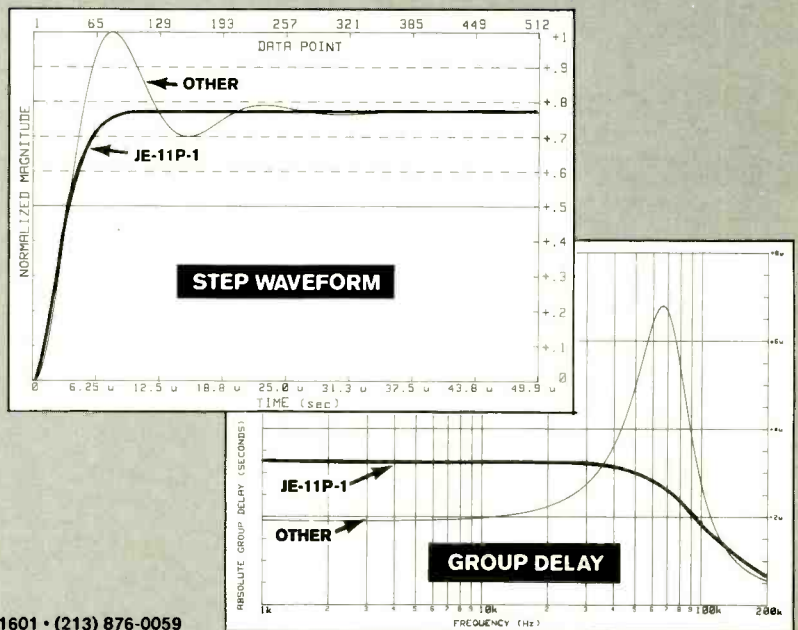

**jensen transformers**  
INCORPORATED

BOSE  
MAIN  
DEALER

N O R T H E R N  
**A U D I O**

STARSOUND  
DYNAMIX  
DEALER

## PROFESSIONAL STUDIO EQUIPMENT

### SECONDHAND PRODUCTS FOR SALE

Otari MTR 10 Stereo machine (mint)	£3,950
Otari MTR 90 autolocate	£995
Otari 50/50 MK3 8-track	£1,650
MCI JH 116 24-track	£13,250
MCI JH 114 24-track	£14,500
Trident TSR 24-track (12 months old mint)	£12,250
Lyrec 24 track with autolocate	£12,250
Tascam 38 S/hand nice condition	£1,375
Tascam 44 Ex-demo (SMPTE)	£790
Tascam 35 2B Stereo	£770
Soundcraft 16 track @ 30 imps only	£5,350
3m M79 16-track recorder	£5,750
Tascam 85/16b New in the box	£6,500
Tascam X1000 Stereo (slow speed), mint	£425
Tascam 80-8	£1,350
Tascam 48 (SMPTE)	£1,995

ACES. 16- and 24-track machines to order

P.O.A.

MCI JH400 28/24 with JH50 Automation (superb)	£16,500
MCI JH542 42 in-line console with automation	£34,000
Trident TSM 40/25/40 Frame 36/24/24 fitted with automation, 3 years old	£38,500
AHB Syncon A 28/24 with fully wired patch bay	£7,500
Soundcraft 1600 series console 32/16/24 mon (new in stock)	£9,500

Soundcraft 800 console 24/8/2 with 18-channel extender	£3,900
Soundcraft series 2 16/8/2	£1,100
Amek M1000 Road desk 2-years old in superb order	£7,500 o.n.o.
Trident 70 series console 28/16/24	£9,900
Helios console 1978 revamped 80 28/16/24 nice one	£7,000
Seck 16/8/2 console in very good order	£900

WE ALSO STOCK NEW PRODUCTS SUCH AS DYNAMIX 3000, AMS BOSE TAC TRIDENT, TANNOY QUAD, DRAWMER, BELL

EMT 240 plate with remote	£2,250
Stocktronic plate with remote	£1,250
Roger Quedest monitors with ATC crossover	£2,250
Tannoy Little Reds new in the box	£710
Bose 301 monitors	£200
Bose 802 monitors	POA
Bell stereo noise reduction	£175
Lexicon PCM 60 reverb	£1,500
Ibanez GE1502 Graphic	£265
Vestafire SL200 Com/lim new	£240
AMS 1580 mono with two 408 cards	POA
JBL 4401 monitors s/hand	£175
Lexicon 224x with 3.2 seconds	£4,750
Trident two-channel lim/compressor	£300
Trident parametric TC	£295
Aces 12/2 P/A mixer new	£395

WE ARE CONSTANTLY ON THE LOOKOUT FOR USED EQUIPMENT. PLEASE GIVE US A RING.

RING TONY BAYLEY ON 061-483 9563/4299 *anytime* or WRITE TO US AT:  
4 CHEVIOT ROAD, HAZEL GROVE, STOCKPORT, CHESHIRE SK7 5BH

Tel: 061-483 9563/4299

Telex 666576 HTNRGSG



# CLASSIFIEDS

Advertisements for this section must be pre-paid. The rate is 50p per word, minimum £12.50. Box Nos. £3.00 extra. Semi-display rates on application. Copy and remittance for advertisements in **NOVEMBER** issue must reach these offices by **11th SEPTEMBER** addressed to: The Advertisement Manager, **Studio Sound**, Link House, Dingwall Avenue, Croydon CR9 2TA. Cheques made payable to Link House Publications (Croydon) Ltd. **Note:** Advertisement copy must be clearly printed in block capitals or typewritten.

Replies to Box Nos. should be addressed to the Advertisement Manager, Studio Sound, Link House, Dingwall Avenue, Croydon CR9 2TA, and the Box No. quoted on the outside of the envelope. The district after Box No. indicates its locality. **SEX DISCRIMINATION ACT 1975:** No job advertisement which indicates or can reasonably be understood as indicating an intention to discriminate on grounds of sex (e.g. by inviting applications only from males or only from females) may be accepted, unless (1) the job is for the purpose of a private householder or (2) it is in a business employing less than six persons or (3) it is otherwise excepted from the requirements of the Sex Discrimination Act. A statement must be made at the time the advertisement is placed saying which of the exceptions in the Act is considered to apply.

The attention of advertisers is drawn to "The Business Advertisements (Disclosure) Order 1977", which requires that, from 1st January 1978, all advertisements by persons who seek to sell goods in the course of business must make that fact clear. From the above date consumers therefore should know whether an advertisement relates to a sale by a trader or a private seller.

## SERVICES

**QUALITY HIGH-SPEED** and real-time audio and video cassette copying and processing. Any quantity. While you wait. 24-hour, 7-days-a-week service. Central London W2. GWBB Audiovision. Tel: 01-723 1583/5190. (X)

**STREET COPYS—A CASSETTE COPYING SERVICE SECOND TO NONE!** We can arrange collection and delivery of master tapes, so for high-quality, real-time chrome cassettes call Street Cops on 01-251 3924. (N)

**THE COMPLETE SERVICE.** Disc cutting (masters and demos), pressings, sleeves, cassettes, labels. Fixed and mobile recording studios. Free brochure. **TAM STUDIO**, 13a Hamilton Way, London N3. Tel. 01-346 0033 (X)

**FREELANCE RECORDING ENGINEER** vast experience, truly professional seeks quality work abroad or England. More information ring 0252 710206.

**CASSETTE DUPLICATING.** Label and Inlay cards printed or supplied blank. Shrink wrapping. Rate card from **AUDICORD Records**, 59 Mayfield Way, Barwell, Leicester LE9 8BL. 0455 47298. (M)

**WHO SAYS YOU DON'T NOTICE THESE SMALL ADS!** For as little as £12.50 + VAT you too could be getting your service message across. For more details contact Kerr Duffy at **STUDIO SOUND**. Tel: 01-686 2599.

**USED STUDIO EQUIPMENT FOR SALE?** Advertise it now in **STUDIO SOUND CLASSIFIEDS** for as little as £12.50 + VAT. For more details call Kerr Duffy at **STUDIO SOUND**. Tel: 01-686 2599.

### WHY PAY LONDON RATES?

Professional Disc Mastering operation offering top quality with over 20 years experience. Contact Brian East, "Suncliffe", 43 Sandgate Hill, Fokestone, Kent.

**SPECTRUM SOUND**

0303 38752

### MUSIC-SPEECH-COMPUTER

REAL-TIME or (Slow) HIGH-SPEED Quality Cassette Duplication and Blanks from 1 to 1000+. Computer printed Cassette Labels, Speech and 3/4" reel-to-reel recording/editing. Fast Security Delivery service.

jsb records - a division of **FILTERBOND LTD.**  
19 Sadlers Way, Hertford SG14 2DZ. 0992-551188.



## Angel Talk Limited

FOR HIGH QUALITY, REAL TIME, AUDIO CASSETTE DUPLICATION. Small runs 30+ a speciality. Rapid service. stereo format cassette or open reel masters

Ring 0344 425200 ANYTIME for details or write to:  
6 ABBEY CLOSE, HARMANS WATER, BRACKNELL RG12 3NX

*Check It Out...*

**DIRECT FROM OUR MODERN U.K. PRESSING PLANT**

- CUTTING · PRESSING
- TEST PRESSING
- LABELS · SLEEVES
- CASSETTES
- ARTWORK
- COMPETITIVE PRICES

**MARKET LEADERS**

**SRT**

**01-446 3218**

### REAL TIME CASSETTE COPYING

All work carried out on Nakamichi machines to the highest standard. Normal or chrome tape available.

We also supply blank cassettes wound to length. AGFA, BASF Chrome and Maxell XLII tape available.

**GATEWAY CASSETTE SERVICES**  
1 GAUDEN ROAD, LONDON SW4 6LR  
TEL: 01-627 4758

## CASSETTE DUPLICATORS

**SALES SERVICE MAINTENANCE**  
High speed cassette duplicators throughout the United Kingdom and export.

**GRAFF TANDBERG WOLLENSAK**

**Sound Cassette Services Ltd.**  
P.O. Box 2, South Chard, Somerset  
0460 20988

## 3M WOLLENSAK SERVICING

## MAGNETIC TAPE/FILM HEADS

\*We manufacture to order, 1/4", 1/2", 1" and 2" tape heads and a wide variety of film heads at very competitive prices. Please specify machine type for an early quotation.

\*We also offer a prompt RELAPPING service at standard prices.

**BRANCH & APPLEBY LTD.**

Stonefield Way, Ruislip, Middx. HA4 0YL  
Tel. 01-864 1577

**PAVS**  
**01-540 2164**

7 DAYS A WEEK 24 HOUR  
EXPRESS STUDIO EQUIPMENT  
HIRE SERVICE.

DIGITAL DELAY · HARMONISERS

DIGITAL REVERB UNITS

DIGITAL RECORDERS

DIGITAL RHYTHM COMPUTERS

VIDEO EQUIPMENT

COMPRESSORS/NOISE GATES

## SALES TECHNICAL SERVICES

PAVS offers a full studio equipment maintenance service and a comprehensive studio and studio equipment design service.

**CASSETTE DUPLICATING:**  
**GAUSS Loop-Bin / TELEX In-Cassette**  
**High Quality Blanks / Label Printing**  
**OPEN REEL DUPLICATING**  
(ANY SPEED - ALSO TO BROADCAST SPEC.)  
**SPEECH RECORDING**  
(VOICE-OVERS; LANGUAGES; AUDIO-VISUALS)

**SPEECH-PLUS RECORDINGS LTD.**

UNIT 32, NO. 19, PAGES WALK, LONDON SE1 4SB. TEL: 01-231 0961

## SERVICES

### HIGH QUALITY CASSETTE DUPLICATION AND SPECIALISED LENGTH BLANK CASSETTES

*Leeholme Audio*

Leeholme Audio Services Ltd., 350-4 Leabridge Road, Leyton, London, E10 Telephone 01-556 4748

Let Saki expertise relap your tape heads in London

Factory-approved laboratory and training guarantees finish to original performance specification

**ALL MAKES RELAPPED**

Tapetek, 44A Brighton Road, London N16 8EG  
Tel: 01-254 5203 or 0860 317260 (mobile)

Replacement Saki heads from:  
Tape Marketing, 13 Elm Road  
Faringdon, Oxon SN7 7EJ



DOES YOUR STUDIO NEED A FACELIFT?

STUDIO REFURBISHMENTS —  
CALL THE SPECIALISTS

RECORD CONSTRUCTION LTD  
01-985 7573

### WEST 5 Tapes Ltd.

Rapid supply of high quality blank bulk cassettes C1-C120

5-screw C Zero — no minimum or maximum order.

Phone Dave West 01-502 2447  
West 5 Tapes Ltd. Unit 34, Oakwood Hill  
Industrial Estate, Loughton, Essex.

### THE COMPLETE SERVICE

includes:

BLANK CASSETTES (C1 - C100 incl. Chrome)  
HIGH-SPEED LOOP-BIN CASSETTE COPYING  
OPEN-REEL COPYING  
CASSETTE LABELS & INLAY CARDS  
EMPTY TAPE SPOOLS & TAPE BOXES  
LEADER TAPE & SPLICING TAPE  
AMPEX MAGNETIC TAPE

and is available from -  
MEDIATAPE LIMITED

The Courtyard, 152-154 Ewell Road, 01-399  
Surbiton, Surrey KT6 6HE England 2476 7

### SOUND BUSINESS

The home of home studio recording  
onwards and upwards to the fully  
professional



Suppliers of all Studio Equipment and  
Musical Instruments — New and  
Secondhand

PLUS: STUDIO TECHNICAL INFORMATION SERVICE  
SUPPLY AND INSTALLATION · RECORD PRODUCTION  
SOUND BUSINESS LABEL 'MAGIC TUNNEL RECORDS'.

SUPPLIERS OF: TASCAM · YAMAHA · FOSTEX · DRAWMER  
ALLEN & HEATH · STUDIOMASTER · SOUNDCRAFT  
ELECTROVOICE · TANNØY · JBL · AKG · LEXICON · DBX  
AMEK · BELL · SOUNDTRACS · ORBAN · REBIS · MTR  
LYREC · TRIDENT · AMPEX TAPE · ETC, ETC

BEST PRICES · MANY SPECIAL DISCOUNTS  
FULL BACK-UP

Open 7 days a week, 9am to 9pm. LONDON CENTRAL LINE

SOUNDCRAFT HOUSE  
SOUTH WOODFORD, LONDON E18 1DG  
TEL: 01-989 6359

### Revox & Uher Sales & Service

16mm sound 35mm slide projectors, open reel and cassette  
recorders, amplifiers, etc., serviced and repaired.  
Bell & Howell, Elf, Ferrograph, Revox, Tandberg, Uher  
approved service agents. Maintenance contracts available.  
Visit our Amateur Radio Showroom at:-  
58 High Street, Newport Pagnell. Tel: 0908 610625.

### Photo Acoustics Ltd

## WANTED

TANNOY MONITOR GOLDS, REDS,  
SILVERS, X/Os CONES, CABINETS ETC.  
EMT 927, 928, 930 ST. Neumann U47, STC 4038.  
Valves PX4, PX25 KT66. Midland Radio Supplies,  
021-430 7817. (J)

WANTED TRIDENT TSM, Neve or similarly  
large impressive desk. Private Buyer. Telephone  
0757 638812 or 0482 25850.

## WANTED DEAD OR ALIVE

Neumann valve mics  
Types U47, U48, U67

Tel: 01-387 9356

## FOR SALE—PRIVATE

FERROGRAPH TEST SET £350; Alice 6-2  
Mixer £200; AKG C452 Mics £120 each; Scully  
4T 1 inch £1000; Radford Distortion set, £200;  
BASF SPR50LH 1 inch tape, once used, uncut,  
£10 per reel; Neumann KM53 valve mics and  
power supplies, Grampian and Sansui reverb,  
quantity TR90 spares, offers. Phone 05086 4274.

ONE PAIR TANNØY 15" monitor golds in york  
cabinets £450 o.n.o. Tel: Hull (0482) 212780.

COMPLETE STUDIO SELLING UP. Including  
Neve 28/8/24 £33,000 o.n.o. Neumann Senn-  
heiser AKG EV RCA mic — (some valve).  
Neumann VG66 cutting rack with all  
amps/limiters/power supplies complete £1,000  
o.n.o. Sony U-Matics, loads of effects, plus lots  
more. Phone for list 01-521 2040.

SOUNDCRAFT 1624 console 3 yrs old — £7,500  
+ VAT. DBX noise reduction 150 type 1 24  
channels £2,160 + VAT. Ursa Major space  
station — £800 + VAT. EXR Exiter — £230 +  
VAT. Ferrari 308 GTB white 34,000 miles  
warranty full history '81 — £17,000. All prices  
o.n.o. Contact Jon Turner 031 440 1084.

## CLASSIFIEDS

## FOR SALE—TRADE

**DISC CUTTING EQUIPMENT** and systems bought, sold, installed and manufactured (under licence from ORTOFON). TAM/ENGLAND, 13a Hamilton Way, London, N3 1AN. Telephone 01-346 0033. (X)

“PHASE” THE MUSIC and see it as others hear it with “THE BOX” by TAPETALK. Ring Milton Keynes (0908) 77710 for full details of these unique SOUNDSTAGE analysers.

**MAGNETIC REFERENCE LABORATORY** 2 inch TEST TAPE, 30 ips, full N.A.B. reel, 2 years old, one lady owner for church line up on Sundays. Cost £600 — offers. Also **COMPUTER MEMORY CHIPS**, Bulk discount prices. S.A. Electronics (09327) 83168.

**TEAC** 244/34/38 discounts and HP and leasing. Erricks Bradford 309266 (Julian). (X)

**NAKAMICHI TRI-TRACER 1000 CASSETTE DECK**, mint. £250 + carriage. Tapes on 10½” NAB reels. Good condition, not splice free. Some have extra footage. 20 TDK LX 35 180M — £8. 11 TDK LB 3600 & 1 L 3600M — £6. 1 Maxel 35 180B — £6. 3 Scotch Cassic — £5. Prices each, plus 50p P&P, subject unsold. SME Limited, Steyning, Sussex BN4 3GY (0903) 814321.

# NEXO

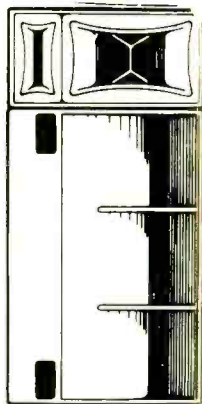

PAUL FARRAH SOUND  
01-549 1787 TELEX: 945114 FARRAH G

### IT'S FREE

Don Larking audio sales produce a free bi-monthly newsletter which is mailed direct and contains lists of new and used recording equipment for both the professional and home studio. Telephone now and get your name on our computer. (0582) 450066 or telex 825488.

Otari MX7800 1”  
8-track + remote 15/30 ips.  
Very good condition. £3,000.  
Tel: Mick Ilka 0582 412331

**PAUL FARRAH SALES**

AKG  
Beyer Dynamic  
DDA  
Klark-Teknik  
Martin Audio  
Micron

Psionics  
Quad  
Rauh  
Revox  
Roland

Sennheiser  
Shure  
Soundcraft  
Technical Projects  
Yamaha

Telephone: 01-549 1787  
Telex: 945114 FARRAH G

### K.G. MUSIC

Northern Stockists and Distributors for  
**RSD/STUDIOMASTER** Audio Consoles and Amplifiers.  
ALL DRAWMER PRODUCTS IN STOCK  
AND ON DEMONSTRATION

Large stocks of new and used Recording and Audio equipment—extensive range of connectors and accessories—Send large S.A.E. for lists.

18/42 Charlotte Street, Wakefield, W. Yorks WF1 1UH  
Tel: (0924) 371766

Due to reorganisation  
**CAVE STUDIO** has for sale:  
3M M79 24 track £10,500 ono  
Studer A62 ½ track £500 ono  
Rebis rack including five noise gates,  
two comp/limiters, two de-essers, five  
parametrics £700 complete  
24 + 2 dbx noise reduction £2,000 ono  
One Dolby A301 £350  
MR3 reverb £290

All prices are subject to V.A.T.  
TELEPHONE BRISTOL 426409

## FOR SALE

Converted stable block, comprising attractive 3-bed accommodation and 24-track studio set in grounds of historic Hertfordshire house.

If you would like more details write to  
Box No. 925

## FOR HIRE

DIGITAL HIRE

PCM 1610  
with u-matic

£175 plus vat/day

Marquee Electronics  
01-439 8421

## MUSIC LAB HIRE

### 24 HOUR RENTAL

A comprehensive range of Digital and Analogue effects including AMS, Lexicon, Eventide and Roland. Plus Sony PCM systems, Tape machines, Noise reduction, units, Signal processors, Microphones, Drum computers and Keyboards.

Immediate delivery and collection service.

**01-387 9356**

24 HOUR STUDIO EQUIPMENT RENTAL  
76 EVERSOLT STREET, LONDON NW1 1BY

**HIRE MULTITRACK**

Q-Link  
Tape Recorders  
Digital  
U-matic  
Monitors

01-267 9395

## AUDIO HIRE

Specialist audio equipment hire  
and audio engineering for  
stage, conferences and tours.

PAUL FARRAH  
SOUND

Telephone: 01-549 1787  
Telex: 945114 FARRAH G

## SAM THERAPY

FOR AURAL EXCITEMENT

FAIRLIGHT + . . .

Tel: 01-221 5967

WORKING IN THE USA?  
NEW YORK NASHVILLE



“THE AUDIO RENTAL PEOPLE”  
Complete selection of pro audio equipment for hire.  
Recording ★ PA ★ Digital Audio ★ Audio for Video  
A/T Scharff Rentals. 1619 Broadway, New York.  
Phone (212) 582-7360/(MC)3671/(MCI) Mail 260-0455

# CLASSIFIEDS

## FOR HIRE

The First Name in  
Sound Equipment Hire

**FELDON AUDIO**

# 580 4314

126 Great Portland Street, London W1N 5PH. Telex 28668 AUDIO G

- \* Sony PCM-3324 24-track digital recorders.
  - \* Sony PCM-1610 2-track digital recorders.
  - \* Sony F1 and 701 2-track digital recorders.
  - \* Plus the most comprehensive range of audio effects and ancillary equipment available.
- Electronic editing facilities for 24-track digital  
New fully equipped 2-track digital editing and transfer suite

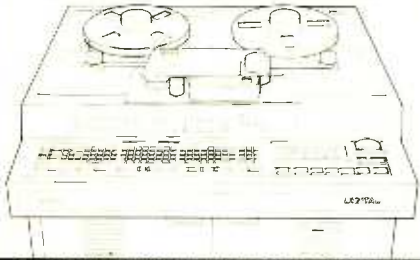

24 HOUR SERVICE RING: 0860-313-990

## FOR HIRE

Lexicon 224X Larc  
AMS 15-80s 6.4s/1-6s 2pc De-Glitch  
AMS RMX-16 Digital Reverb  
Drum Computers, Keyboards, etc

# 01-228 0984

**THE  
P.A.  
COMPANY**

HIRE • SALES  
INSTALLATIONS  
01-607 0087

PROFESSIONAL SOUND SYSTEMS AND  
CONTROL EQUIPMENT (TOYS)

## FOR HIRE

LEXICON 224X Larc.  
£85 per day including delivery.

Tel: 0582 30072

24-hour service

## Studio Hire



Full range of  
effects, keyboards  
and drum  
computers etc.  
Phone for a  
competitive  
quote.

Emulator II £100, Oberheim X-Pander £35,  
AMS from £75, Yamaha QX1 £35.

Phone Paul Tattersall on 01-640 8487  
01-646 3137

## MIDI SYSTEMS

01-995 4730  
24 HOUR SERVICE

### WE HIRE

Personal Multitrack systems from a Portastudio to a full 16 track home recording package

A range of the latest and most cost effective digital mix for use at home or in the studio

Comprehensive range of signal processors, mics and studio monitors to complete your package

The latest MIDI compatible keyboards expander modules sequencers and interfacing equipment

Digital Drum Machines some with alternative sounds and Simmons electronic drum kits

Our large range of equipment is being constantly revised so send for the latest edition of our professional hire list

# DIGITAL AUDIO RENTALS

## SONY DIGITAL

PCM 1610 DIGITAL AUDIO PROCESSORS

5850D/A U-MATIC RECORDERS

DAE 1100 DIGITAL AUDIO EDITOR

PCM F1 DIGITAL AUDIO PROCESSORS

SLF1 BETAMAX RECORDERS

FULLY EQUIPPED AIR CONDITIONED  
DIGITAL EDITING & TRANSFER FACILITY



HHB Hire & Sales, Unit F, New Crescent Works, Nicoll Road,  
London NW10 9AX Telephone 01 961 3295 Telex 923393

## SITUATIONS VACANT

**FREELANCE ENGINEER REQUIRED** for busy Hertfordshire 24-track studio to work perhaps one or two days per week. Must be experienced and have transport. 0920 871090.

## UNIVERSITY OF SURREY DEPARTMENT OF MUSIC

### LECTURER IN ACOUSTICS AND RECORDING

Applications are invited for the above post, which will be operative from 1st January, 1986

The successful candidate will be primarily responsible for the teaching of acoustics—both introductory and more technical—and will also be required to assist in the supervision of the Department's activities in Sound recording. Strong research interests will be expected and encouraged. A scientific qualification is essential. Experience in electronics and/or electro-acoustic music would be an added advantage.

Salary will be in the range £7520-£14,925 per annum (under review), according to age, qualifications and experience. Superannuation under USS conditions.

Further particulars are available from the Academic Registrar (AA), University of Surrey, Guildford, Surrey GU2 5XH or telephone Guildford (0483) 571281, Ext 633. Applications from men and women in the form of a *curriculum vitae* giving details of qualifications and experience in teaching, research and studio work, and including the names and addresses of three referees, should be sent to the above address by 30 August, 1985, quoting Reference 408/SS

## STUDIO DESIGNERS AND CONSULTANTS

### KENNETH SHEARER AND ASSOCIATES

Consultants in acoustics

30 years' experience in the custom design of all kinds of recording and TV studios, remix, dubbing and viewing suites — new and conversions. Down to 25 Hz

Tel: 0442 54821

## STUDIO CONSTRUCTION

Studio environments built to the highest standards.

Our services include:

Fully engineered floating floors, suspended ceilings, high density doors, sound lock lobbies, concrete and brickwork, double glazing, low frequency absorbers, attenuated ventilation systems, insulating sealants, acoustic screens, electrical and electronic installation, equipment sales and commissioning

U.K. and international projects undertaken.

Planning, design and materials expert.

Ring RECORD CONSTRUCTION LTD  
01-985 7573 — London, England

## SITUATIONS VACANT

## SALES PERSON

SSE has been selling and supporting sophisticated audio and digital products for more than ten years. We have a team of people committed to providing excellent service in a friendly and informal way.

We are now looking for a sales person with enthusiasm, technical knowledge and, ideally, an interest in music, to join our team.

We offer the challenge of selling some of the industry's leading products to some of its most sophisticated customers. If you feel that you could respond to this challenge and grow with our company, then please contact Nick Martin or David Rivett.



SCENIC SOUNDS EQUIPMENT LIMITED

Unit 2, 12 William Road, London NW1 3EN.

Tel: 01-387 1262, 01-734 2812

## CLASSIFIEDS

## SITUATIONS VACANT

# Audio Service Engineer

London based

Company car

**SONY BROADCAST LIMITED is one of the world's leaders in professional broadcast equipment with offices throughout Europe, the Middle East and Africa.**

A further excellent opportunity has now arisen for an experienced audio engineer to join our dynamic Field Service team in a newly created position covering our London operations. Working out of our recently acquired London premises the successful applicant will report to the Head of Audio Service, who is based in Basingstoke. Responsibilities will include the Service, Repair and Commissioning of our wide range of sophisticated products, including RF equipment, mixing consoles, portable and studio analogue tape machines and the exciting new Digital products.

Candidates should live in the London area, possess a relevant qualification in electronics and have several years' experience gained in studio recording or its allied manufacturing industry. A high level of self motivation and initiative is required together with the ability to effectively maintain a good rapport with customers. Full product training will be provided.

This position carries an attractive salary with a London weighting and excellent conditions of employment including a Company car and considerable prospects for personal development.

*If you are interested, please write to or telephone David Parry, Personnel Officer on 0256 55011*

**SONY**  
Broadcast



**Sony Broadcast Ltd.**

Belgrave House  
Basing View, Basingstoke  
Hampshire RG21 2LA  
United Kingdom  
Telephone (0256) 55 0 11

## FIELD MAINTENANCE ENGINEER

A VACANCY HAS ARISEN FOR A COMPETENT AND RESOURCEFUL ENGINEER TO TAKE FULL RESPONSIBILITY FOR THE MAINTENANCE OF OUR DISCOTHEQUE SOUND, LIGHTING, LASER AND VIDEO SYSTEMS.

Although based in London, this post would ideally suit a young (21-30) single person as extensive travel to our contracts located throughout the UK, Europe, Scandinavia and the Middle-East will be part of this exciting position.

The successful candidate will possess the following:

A RECOGNISED ELECTRONICS APPRENTICESHIP TRAINING QUALIFICATION TO MINIMUM OF HNC LEVEL AT LEAST 3 YEARS INDUSTRY EXPERIENCE, PREFERABLY IN A TEST REPAIR ENVIRONMENT.

This position offers an initial salary of £10,000 p.a. together with participation in our profit-based incentive scheme.

APPLICATIONS TOGETHER WITH C.V. TO:

**COLIN L MITCHELL**  
CHIEF ENGINEER

**JULIANA'S SOUND SERVICES**  
4 ADDISON BRIDGE PLACE, LONDON W14 8XP



**JULIANA'S**

A MEMBER OF JULIANA'S HOLDINGS PLC



**TELEPHONE SALES**  
**STUDIO SOUND**

and

**BROADCAST SYSTEMS ENGINEERING**

Require a dynamic, experienced telephone sales person to join the young hardworking team selling advertisement space on these successful controlled circulation titles covering the international professional recording and broadcast industries. A good telephone personality and the ability to work well under pressure are essential requirements.

If you are motivated by success, can sell enthusiastically to all levels and are looking for a position where you can demonstrate your skill and initiative this could be the right career for you.

Based in Croydon, we offer a good salary, plus incentive scheme and the usual benefits associated with a major publishing company.

Apply to:

**Janice Bradley,**  
**Link House Magazines Limited,**  
**Link House,**  
**Dingwall Avenue,**  
**Croydon CR9 2TA.**  
**Tel. 01-686 2599**

## ELECTRONICS ENGINEER

THE POLYGRAM RECORDING STUDIO AND COPYING SUITE REQUIRE AN ELECTRONICS ENGINEER.

APPLICANTS SHOULD HAVE AN INTEREST AND EXPERIENCE IN THE FIELD OF MODERN RECORDING AND DIGITAL ELECTRONICS. ABILITY TO OPERATE AND IMPLEMENT A FAULT DIAGNOSIS AND REPAIR PROCEDURE IS ESSENTIAL.

EXPERIENCE WITHIN A RECORDING STUDIO OR SIMILAR ENVIRONMENT INVOLVING MAINTENANCE OF ELECTRONIC, ELECTRO-MECHANICAL AND DIGITAL SYSTEMS WOULD BE AN ADVANTAGE.

THE SUCCESSFUL APPLICANT MUST HAVE A FLEXIBLE APPROACH AND BE ABLE TO FIT INTO A BUSY WORKING STUDIO. THERE IS A REQUIREMENT FOR SOME OVERTIME AND WEEKEND WORKING TO MEET RECORDING STUDIO DEADLINES.

APPLICANTS SHOULD HAVE A DEGREE OR HNC IN A RELEVANT DISCIPLINE.

PLEASE SEND A DETAILED C.V. WITH COVERING LETTER TO:

**VERONICA SPICER, PERSONNEL OFFICER,**  
**POLYGRAM RECORD OPERATIONS LTD., 54 MADDOX STREET, LONDON W1**  
**01-491 4600**

## STUDIO PACKAGES

**FOR SALE**

**24 TRACK STUDIO**  
**JACKSON MUSIC GROUP**  
The Studios, Rickmansworth,  
Herts, England WD3 2XD  
Telephone: 0923 772351 or Vodafone 0836 203557

## CLASSIFIEDS

# AUDIO SERVICES

# BUY IT!

"WE SHIP TO ANYWHERE"

STUDER A90 MK IV 24 track	£23,181
LYREC TR532 24T inc. loc.	£22,500
TASCAM MS 16 (in stock)	£5,995
TASCAM 480B (special price)	£2,495
TASCAM 38 (few left at pre-increase price)	£1,529
TEAC 80-8 with Dx8 (mint)	£11,495
FOSTEX B16 from stock	£P.O.A.
FOSTEX A80 stock	£P.O.A.
FOSTEX A8 (re-con. new heads)	£895
TASCAM ATR 60 2T with CNTR. time code	£2,750
TASCAM 52 NAB/IEC record/play front panel switching	£1,595
TASCAM 52 new (1 only left)	£1,295
REVOX PR99 HS NAB & ICE new	£895
REVOX PR99 II HS	£P.O.A.
REVOX B77 II HS (few left at pre-increase price)	£695
TEAC A3440 (new in box)	£795
TEAC A3440 S/H mint	£595
TEAC x 1000M (new in box)	£675
TEAC x 2000M (new in box)	£750
TASCAM 22-2 15IPS 7" spool	£425
M.C.I. JH 110BC 8T 1" (outstanding)	£3,500
TASCAM 234 4T cassette (few at)	£460
TASCAM 244 portastudio	£600
FOSTEX 250 portastudio	£550
TASCAM PORTA 1 with P.S.U.	£345
FOSTEX x 15 portastudio	£240
FOSTEX MN 15 mixer/comp for x 15	£443
TASCAM 225 syncassette 2T	£195
TEAC CI MKII with Rx8	£495
TEAC V700 3H B&C	£295
TEAC V707 auto-rev B&DBX	£245
TEAC V360C B&C	£95
TEAC V330 B	£75
UHER 4200 P.S.U. C.H.GH. NI-CAD. ST. MIC.	£675
I.T.C. DELTA stereo rec/play cart deck and amp 8 months old, as new, offers around	£2K
TASCAM T2640 MS duplicator	£1,500

### STUDIO MONITOR SPECIALS

Sale of ex-demo loudspeakers from JBL, Tannoy, TOA and Visonik.

### COMPLIMEX/P.GATE

AUDIO & DESIGN F760 xRS 'complex' mint	£795
AUDIO & DESIGN transdynamic + 3 express	£ OFFERS
DBX 165A (new)	£695
B.S.S. DPR 402	£595
DBX 166 (new)	£560
DRAWMER 201, 221, 231 and new 1960 from stock	£P.O.A.
FOSTEX 3170	£216
YAMAHA G.C.	£199

### SPECIALS

MOBILE PRO-EIGHT TRACK PACKAGE BRENELL 8T 1" with full remote/locate Allen & Heath Mod III 16:8 with multicore all in flight cases by C.P. condition literally "as new"	£1,795
KLARK TEKNIK DN22 (perfect)	£295
KLARK TEKNIK DN34 (pair with link)	£595
AUDIO & DESIGN SCAMP RACK & PSU (maj) with S.24 and S.08 + extender 400 the lot!	£400
M.B. ELECTRONICS STEREO PZM mics, new	£195
HILL DX700 power amps, new	£395
TURNER B502 power amp, new	£395
FOSTEX 600 power amp, new	£375
AMCRON D150 All, new	£395

Please add VAT (UK customers)

AMEK 2800 series and ANGELA 'To order' T.A.C. MATCHLESS & SCORPION 'From stock or demonstration'	
ALLEN & HEATH CMC 24 with COMMODORE COMPUTER, on demonstration and from stock	
ALLEN & HEATH SYSTEM 8II 24:8:16 with fully wired 128 hole patch bay & console stand (P.O.A.)	
ALLEN & HEATH SYSTEM 8II 16:8:2 as new	£1,195
TRIDENT TRIMIX 10:8:2 in 16 way frame (mint)	£2,900
STUDIOMASTER 16:16:2 new (old price)	£1,295
STUDIOMASTER 16:8:2 new (old price)	£950
RAM MEGA	£1,495
RAM RM 16 & RM10	£ Best
SECK 18:8:2 in-line from stock	£1,225
A.H.B. SR SERIES 16:2 (on demo)	£P.O.A.
SECK 12-2	£495
SECK 6-2	£345
TASCAM M30 ex-demo bargain	£595
New model TASCAM M2116 (16/4/2) £725	
TEAC M2A with MB20 (S/H good) £250 cash	
TASCAM MM 20 new (1 only)	£125 cash
PROMARK Mx3 8:4:2 new bargain	£365
MILLBANK STEREO DISCO MIXERS NEW	£75
TASCAM new model 106 (on demo)	£335

### NOISE REDUCTION

TASCAM Dx4D	£236
TASCAM Dx2D	£193
DBX 150	£250
DOLBY 360 (1 only)	£295
8/9 CHANS BEL	£295 (16 CHANS £500)

### REVERB & D.D.L.

AMS RM x 16 & DMX 1580s plus keyboard interface in stock!	£P.O.A.
LEXICON 200	£3,995
LEXICON PCM 60	£1,575
AKG Bx20E	£1,195
ROLAND SRV 2000 digital reverb	£P.O.A.
ALESIS XT digital reverb (new prod)	£865
BEL BD 80 (2 secs)	£695
Keyboard interface	£90
YAMAHA R1000	£395
ROLAND SDD 3000	£695
BEL BD 240 & 320	(coming soon)
ROLAND SDD 1000	£335
ROLAND SBF 325	£95
YAMAHA REV 7 (coming soon)	
KORG SDD 1000	£295
DELTA LAB EFFECTRON	£195
KORG SDD 2000	£595
YAMAHA D1500	£495
BOSS DE 200	£245
IBANEZ DM 500	£150
IBANEZ DM 2000	£250

### COMPACT PA SPECIALS

BOSE 802 pair	£650
JBL 4612 pair	£650
BOSE 402 pair	£350

### KEYBOARD SPECIALS

ROLAND MKB 1000 motherboard	£795
ROLAND MKS 10, 30 & 80	from £595
KORG DW 6000, new	£P.O.A.
S.C.I. six trax (surplus)	£433
S.C.I. max (surplus)	£378
ROLAND JX8P	£795
360 SYSTEMS digital keyboard OFFERS!	
KORG EX-800 + DW100, ex-demo	£634
ROLAND MSQ 100, no box	£295
ENSONIQ MIRAGE	on demo
YAMAHA KX5	£173
YAMAHA RX11 & RX15	from £395
S.C.I. MULTITRAX, ex-demo	£895

## INDEX TO ADVERTISERS

ACO Pacific Inc	12
Advanced Music Systems	21
AGI Electronics Ltd	91
Akai	56, 57
AKG	75, 83
Alpha Audio	10
Amek Ltd	53
Ampex (UK)	IBC
Andrew Stirling	88, 89
Aphex Systems Ltd	93
Applied Microsystems Ltd	10
Asona	8
Audio Design Calrec Ltd	10, 22
Audio Developments	87
Audio Kinetics	18, 19
Audio Service Co	15, 110
Audio Video Marketing Ltd	79
Avcom Systems Ltd	103
BASF AG	59
Britannia Row	67
Bruel & Kjaer A/S	39
C Tape Developments	8
Cable Technology	100
Connectronics Ltd	16
D & R Electronica BV	14
Don Larking Audio	44
Eardley Electronics	71
Eastlake Audio	61
Future Film Developments Ltd	16, 97
FWO Bauch Ltd	37, OBC
Graff Electronic Machines Ltd	24
Hardware House	16
HHB Hire & Sales	4, 29, 99
Hill Audio Ltd	55, 78
Hilton Sound	24, 43
ITA	31
Jacobs Studios	69
Jensen Transformers	104
John Bowers Ltd	83
Lexicon	49
Michael Stevens & Partners	101
Minim Electronics	69
Mosses & Mitchell Ltd	69
MS Audiotron	21
Music Labs Group Ltd	6, 67, 101
Northern Audio	104
Orban	25
Otari	62, 63
Pangbourne Musical Distributor	102
Paul Farrah Sound	67, 69
Peavy Electronics	85
Perfectone Products SA	102
Prefer	40
RTW	91
SCV	20
S.E.D.	96
Sanken Microphone Co Ltd	22
Scenic Sounds	25, 49, 65
Schoeps	41
Shuttlesound	35
Solid State Logic	51
Sony Broadcast Ltd	33
Soundcraft Electronics Ltd	IFC, 76, 77
Soundout Labs	45
Stage Accompani	73
Studer	37
Studio Master	95
Studio Spares	17
Surrey Electronics	42
Syco Systems Ltd	80, 81
Tannoy	OBC
Tape Automation	100
Technical Projects	97
Televic	103
Theatre Projects Services Ltd	98
The Mic Shop	67
TOA Electric Co Ltd	23
Trad Sales & Services	98
Turnkey	7, 9, 11, 13, 27
Video Cinesound	97
Vitavox	23

PART EXCHANGE WELCOME

CAN I BUY ANY OF YOUR SURPLUS EQUIPMENT  
CAN I SELL ANY EQUIPMENT FOR YOU ON COMMISSION

SINCERELY  
ALAN CHEETHAM

# STUDIO HOUSE

High Lane Village, Nr Stockport SK6 8AA. Telex 665721 SOTA.

# 06632 4244



Studio Sound is available without charge to qualified readers: these are directors, managers, executives and key personnel actively engaged in sound recording in any part of the world. The Publisher reserves the right to refuse applications considered inappropriate and restrict the number of free copies sent to any one company or organisation. Non-qualifying readers can buy Studio Sound at an annual subscription of £18.00. All enquiries to: Subscription Department, Link House Magazines, Central House, 27 Park Street, Croydon CR0 1YD. Tel: 01-760 0054. Published by the proprietors Link House Magazines Limited, Link House, Dingwall Avenue, Croydon CR9 2TA and printed by Lawrence-Allen Ltd., Gloucester Street, Weston-super-Mare, Avon BS23 1TB.



# REFINING THE FINEST

*Advanced recording equipment demands advanced recording tape. Which is why for ten years Ampex has continued challenging machine capabilities. Through a decade of technological improvements, Grand Master® 456 remains an audio tape of unequalled sophistication and consistency. Which is why more top albums are recorded on Ampex tape than any other tape in the world. For Grand Master 456, the beat goes on.*

**AMPEX**

Ampex International, Magnetic Tape Division, Acre Road, Reading RG2 0GR, England, (44) 734-875200

Ampex Corporation - One of The Signal Companies

**AND THE BEAT GOES ON**



# If only your ears could see.

If you could see what your ears can hear, the precision which makes Tannoy monitors different would stare you in the face.

You would see the time difference in high and low frequencies on other, ordinary monitors. You would probably even spot the nasty phase incoherence and other unsightly phenomena.

Now put a Tannoy with SyncSource under the magnifying glass, and see what you can hear. Look at the phase perfection and the way in which the correct time relationships of fundamentals and harmonics are maintained.

Then look at the practical advantages. More complete audio information, and greater freedom of movement behind the recording console without being restricted to an on or off axis listening position.

For more information on Tannoy monitors with SyncSource single point sound sources, just 'phone or write.

**TANNOY**  
The Name for Loudspeakers®



**F.W.O. Bauch Limited**

49 Theobald Street, Boreham Wood, Hertfordshire WD6 4RZ  
Telephone 01-953 0091, Telex 27502