

VACUUM TUBE VALLEY™

Published Quarterly
Price \$8.00

Celebrating the History and Quality of Vacuum Tube Technology

Issue 4 Volume 1
Spring/Summer 1996



Harman-Kardon Citation II

In This Issue...

Editor's Page	2
6L6 Forever: History and Tests	3
VTV Listens to 6L6 Types	11
Why 88 to 108 FM?	12
HK Citation I and II	15
Citation II Modification	22
Designing for Sound	23
Tube Industry News	25
Review of Tube Manuals	26
Vintage Bookshelf Speakers	28
Audio Test Bench AC Meters	33



Harman-Kardon Citation I

Classic Vacuum Tube Manuals

VTV reviews GE, RCA, Sylvania, Tung-Sol and other tube manuals by era and tube manufacturer **Page 26**

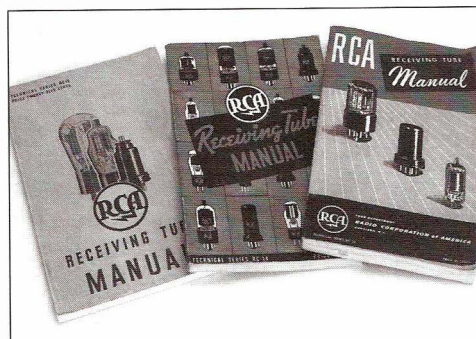

Happy 60th Birthday to the 6L6
The history and test results of this legendary audio power tube **Page 3**

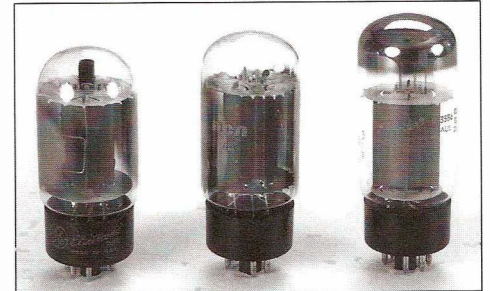

GE, RCA and Sylvania 6L6GCs

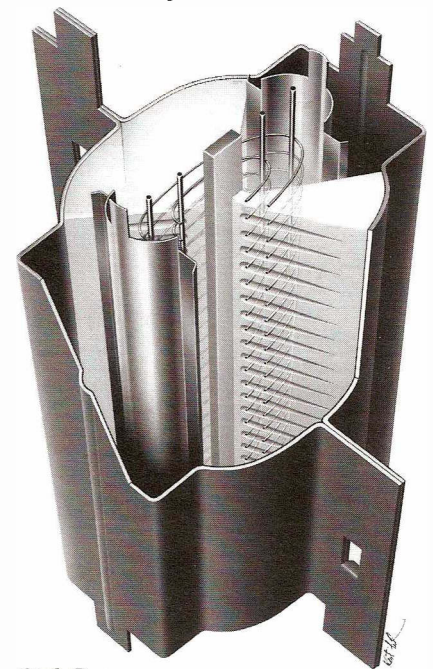

6L6 Cutaway

Vintage Bookshelf Speakers

An examination and listening evaluation of the most popular home hi-fi bookshelf loudspeakers from 1955-1972 **Page 28**

Early FM Broadcasting

A Battle of the FM Bands between the bureaucrats, broadcasters, and manufacturers in the 1940s **Page 12**

Vacuum Tube Valley is published quarterly for electronic enthusiasts interested in the colorful past, present and future of vacuum tube electronics.

Written and Produced in the United States of America

VTV Control Grid

by Charlie Kittleson, Editor

Turn a Friend on to Tubes

Have any of you ever lent a tube amplifier to a friend who is new to tubes and find that you couldn't get it back? Most music lovers who hear tubes for the first time in their own home become hooked and transistor audio never satisfies them again. I have given Stereo 70s and Scott integrated tube amps to friends and relatives as gifts and they continue to rave about how much they love them. It doesn't take a megabuck high-end system to make good music. If you have a friend who you think might enjoy his/her music through tubes, lend them your spare tube amplifier or preamp for a week or two. You may not get it back right away, but you may have converted another to our ranks.

VTV in the News

We have had a number of requests to reprint recent articles from VTV. One of them includes Mark IV Audio Corp. in Buchanan, Michigan who obtained permission to reprint my article on the Altec 604 coaxial loudspeaker story from VTV #3. Mark IV owns Altec-Lansing Corporation and used the article for a recent sound contractors trade show and for marketing purposes. AC/DC Magazine of Taiwan, ROC asked permission to reprint Eric's 300B article translated to Chinese.

John Atwood, our Technical Editor, has been busy these days. Besides being President of the Northern California Tube Enthusiast Group, John has been teaching classes on tube amplifiers!! Cogswell College in Sunnyvale has added a college level class on tube amplifier theory in their Musical Engineering

Technology department. John will teach this class starting this fall. John is also on his second session of a class entitled "Audio from Tubes" at the Randall Museum in San Francisco. In this class, attendees listen and learn why tubes get the music right. They also learn about tube electronics by building an excellent tube stereo amp step-by-step in the class!!

MJ Magazine of Japan recently published a detailed article by John Atwood on a single-ended amplifier he designed that can use a variety of octal based pentodes or triodes.

Safety First!

When working on any type of vacuum tube equipment, remember that tubes run on high voltages that can and will kill you! Please exercise caution when working with tube circuits by de-energizing before work, wear shoes to insulate you from ground, and never poke around a live circuit with a screwdriver or other conductive tool. VTV assumes no liability for injury from readers working on tube equipment mentioned in this magazine.

VTV Subscription Increase

It is official; VTV, due to a 150% increase in size (from 16 to 40 pages) plus the added postal expense has raised

the annual subscription rate only 28%. For subscribers in the US, the rate is **\$32.00/yr**-four issues, for Canada **\$40.00/yr** and for Asia, Europe and the rest of the World **\$45.00/yr**. Please send payment in cash, US Money order, personal check (US only), or bank check drawn on a US bank with magnetic encoding.

Don't miss out! Be sure to renew your subscription to VTV. We have some great articles coming up next year including: KT88/6550 history and tests, 6DJ8 history and tests, Theremin construction project, Fisher 500 receiver history, Vintage Tuner Shoot-Out number 2, SV-811 tube amp construction projects, Audio Test Bench Series, VTV interviews with audio pioneers and more!

Credit Cards in VTV Future

Due to a significant demand from our subscribers, VTV will begin accepting credit cards for subscriptions, renewals, books and other products beginning **July 15, 1996**. This will allow foreign subscribers to save money and hassle and hopefully increase our overseas subscriber base. We will be able to accept VISA, Master Card and American Express. Just send us your name, card number, bank and expiration date for fast service.

We Need a Few Good Articles

Here is your chance to get published. VTV is always seeking quality articles from our readers; in particular, audio and vacuum tube historical perspectives, broadcasting history, early recording studio equipment, early theater sound systems, microphones, speaker and equipment manufacturer profiles and more. We will also consider do-it-yourself or technical articles on your audio, radio or electronics construction projects relating to vacuum tubes. Authors whose articles get published will receive payment, the amount depending on the length, research involved and graphics.



EDITORIAL STAFF

- Charles Kittleson** - Editor and Publisher
- John Atwood** - Technical Editor
- Eric Barbour** - Associate Editor
- Dave Wolze** - Audio Consultant
- Steve Parr** - Art Director
- Julie P. Werner** - Copy Editor

Vacuum Tube Valley is published quarterly for electronic enthusiasts interested in the colorful past, present and future of vacuum tube electronics.

Subscription is US\$32.00/year (4 issues) \$40/Canada and \$45/Asia and Europe
CASH, US BANK CHECK, CREDIT CARDS

To subscribe, renew or change address call or FAX us at **(408)733-6146**.

Copyright 1996 **Vacuum Tube Valley™** and **Big Tone™** All rights reserved.

No part of this publication may be reprinted or otherwise reproduced without written permission of the publisher.

Send circulation and editorial correspondence to:

Vacuum Tube Valley
1095 E. Duane Ave., Suite 106
Sunnyvale, CA 94086 USA
vtvchk@aol.com

Printed by Olympic Screen Crafts, Fremont, California

6L6 Forever 1936-96

60 Years of Amplifier Service

By Eric Barbour

If you ever find yourself being harassed by techies who insist upon criticizing you for your interest in vacuum tubes, there is an easy answer. They can be silenced with a simple question. Ask them if any early type integrated circuits will still be manufactured and used in new products in, say, the year 2030. If they're honest, the answer will be "no". Then tell them that the first-ever beam power tube is still selling in the millions today, and shows no sign of becoming obsolete.....after 60 years. That should get rid of them.

As of March 1996, the mighty 6L6 is celebrating its 60th birthday. It's still being manufactured in Russia and China. And its popularity in guitar amps is assured for the conceivable future. Various "experts" in the mainstream electronics industry, who relentlessly kill old technologies and curse people who use them, can do nothing about the 6L6 - it continues to be a dominant voicemaker of rock'n'roll guitar.

Many "experts" have tried to simulate the 6L6 guitar amp with various semiconductor-laden gizmos, from complex analog computers to DSP chips, with varying technical success, and with little or no financial success. There are numerous companies making 6L6 powered amps today. Fender, Mesa-Boogie, Ampeg, Peavey, Kendrick, Victoria, Soldano, THD, Louis Electric and many others have staked some of their product lines on the 6L6. So don't accept the muttering about "dead technology."

1. History

In 1931, the audio outputs of radio sets were dominated by triodes such as the UX-171 and UX-245. But even though push-pull 245s could produce 5 watts easily, there was ongoing pressure from manufacturers for ever-more-efficient output tubes. The pentode was the answer at first. It originated in Europe, with the first American power types being the Champion P-704 and Arcturus PZ. These were very early types and had some reliability problems. They were quickly superseded by RCA's UX-

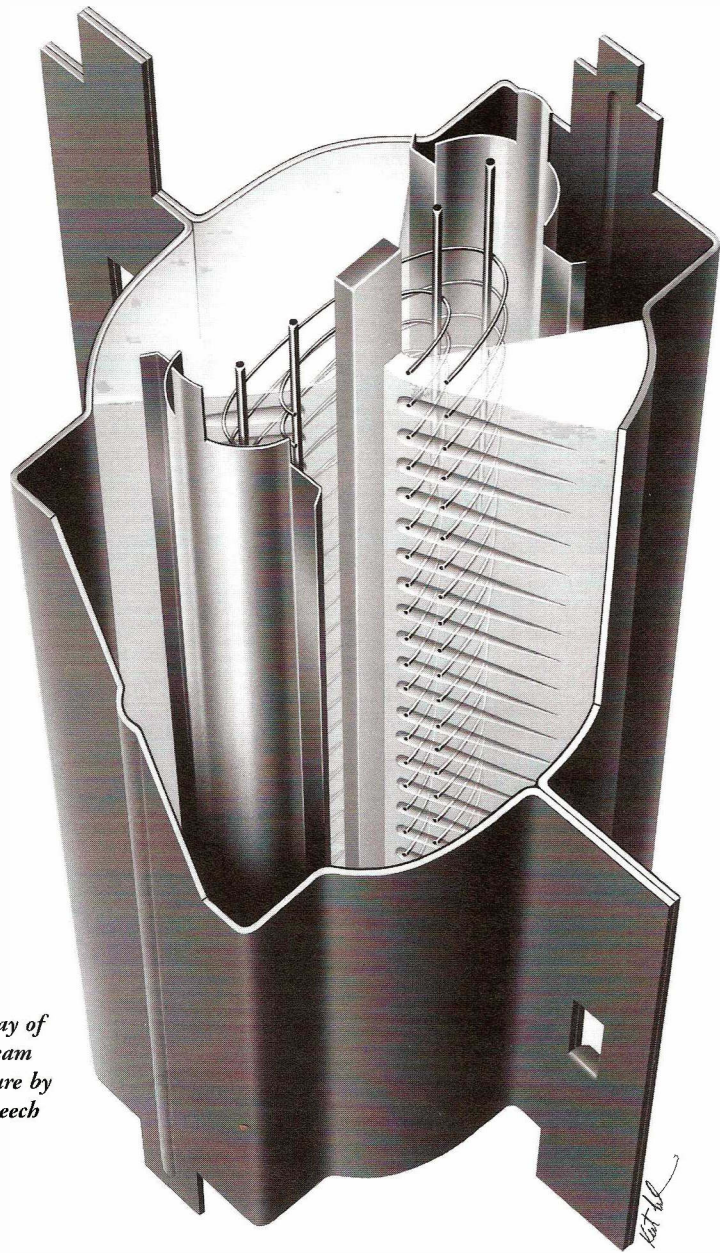

*Cutaway of
6L6 Beam
Structure by
Kent Leech*

**NOW . . . you can get full
60 Watts from a pair of 6L6's**

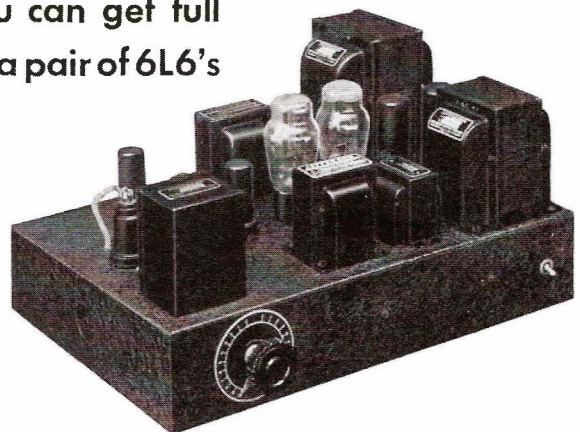

Early 6L6 Amp



Type 48

247, released June 1931. Suddenly you could get 2.5 watts out of a single tube, with easy drive requirements and at only 250 volts! Millions of radios used the '47, and its descendant, the 42 with its 6.3 volt heater, was even more popular. The 38, 48, 59, 2A5, and 6F6 followed, as did European types such as the Mazda AC/Pen, Cossor MP/Pen, Osram MPT4, Mullard PenA4 and numerous others.

But RCA engineers were pursuing more lofty goals: low distortion with high efficiency. They were developing special power tetrodes, such as the 46 (intended for Class B push-pull and giving 20 watts from a pair) and the smaller battery-set types 49 and 52. Late 1932 saw the 48, which was intended to have its screen grid connected only as a screen grid, not in parallel with the control grid as in the

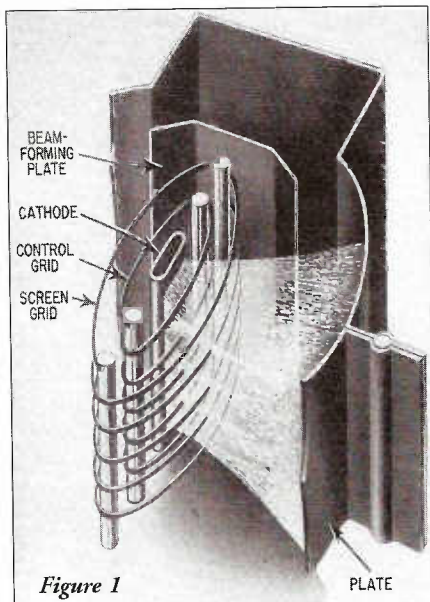

Figure 1

PLATE

RCA 1614 and 6L6 metal tubes



6L6GX (Isolantite base) and 6L6G

46. A similar development in Britain was the Hivac "Harries". But the 48 was the ultimate father of the 6L6, and all that came after.

This is a good place to describe the technical basics. In a triode electrons are boiled off the cathode or filament by heat. The electrons are attracted strongly to the positively-charged plate. But to get to it, they must pass through the control grid in their path. By varying the voltage on the grid, the electron stream is varied. Simple enough.

Unfortunately, there are three problems here. First, the maximum current that can flow at low plate voltages is limited, and this limits the maximum power output. Second, in order to get a high maximum plate current, the "mu" (voltage gain) needs to be low, requiring a high

grid drive voltage. The third problem is that the capacitance between the plate and grid is magnified by the gain from the grid to the plate. This is the "Miller Effect,"



Early Fifties Heathkit A-8 6L6 Amp

6L6GAY, 6L6GA and 6L6G



response. It also increased gain, as the fixed voltage on the screen made the plate current less dependent on the variations of plate voltage. The resulting "tetrode" became a standard for RF amplifiers in radios, and the RCA 48 was about as good as a tetrode could be made for audio.

Figure 4

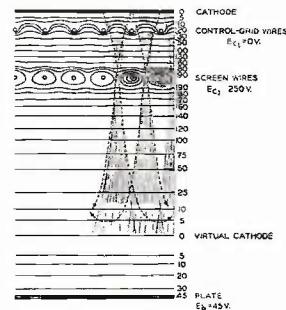

But when used for amplifying audio, tetrodes have a problem. The secondary emission can be attracted to the screen grid, which lowers the plate current for low plate voltages. This is the famous tetrode "kink" (Fig. 2). It is a source of distortion in audio, and represents some wasted energy as well. Because of this, a third grid was added between the screen and plate. The "suppressor" grid is widely spaced and is at the same voltage as the cathode. Thus, secondary electrons which bounce off the plate will be repelled away from the screen and back to the plate. The kink disappears, and we have a "pentode". Gain and efficiency are very high, frequency response is excellent, and distortion is lowered.

Even so, the RCA engineers knew that the pentode has problems. One obvious one is that the screen and control grids are wound with different wire spacing. Some electrons will pass through the spaces in the control grid, only to strike (or be deflected in a useless direction by)

and it makes triodes harder to use at high frequencies. So triodes have limits on their frequency response and efficiency, when used as power amplifiers.

Figure 2 - Tetrode "kink"

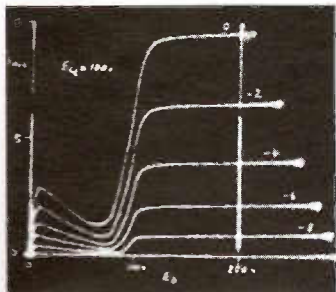

In the 1930s the problems were difficult to get around; triodes with low capacitance were eventually designed. But at the time, efficiency was best improved by adding another grid (Fig. 1 previous page). This was called a "screen"

grid, because it acted as an electrostatic screen between the grid and plate, reducing the plate-grid capacitance. This opened up the short-wave bands, because the screen allowed greater frequency

Raytheon 6L6GB and GE 6L6GB

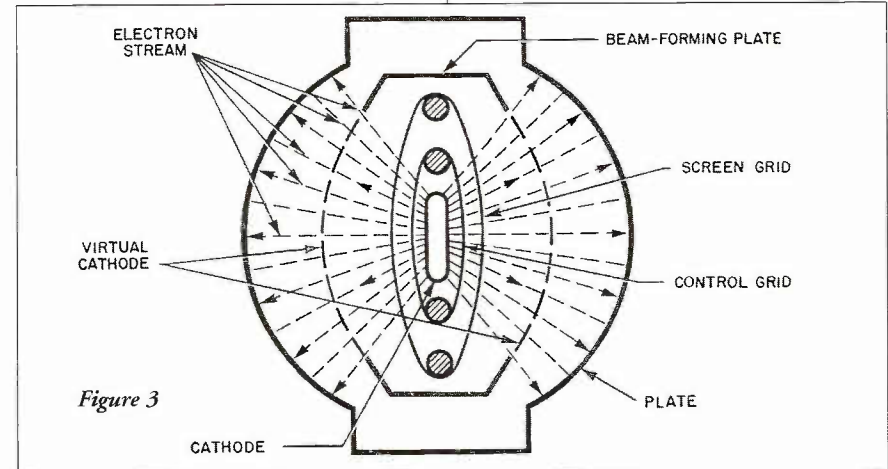

Figure 3



GEC KT66 and Gold Lion KT66

GE 6L6G, RCA (Black Plate) 6L6GC and Sylvania 6L6GC STR



a screen-grid wire directly in that space. Those electrons are wasted energy, and do not reach the load. The electrons that strike the screen just heat it up. A similar interaction can happen with the screen and suppressor, but it mostly involves the secondary electrons. And some electrons can pass through gaps at the top and bottom of the grid assembly, or strike the side rods of the grids. So the main electron beam can have a circuitous route. Most of the wasted energy heats the screen grid, which in an extreme case can make it emit electrons, causing the tube's plate current to run away.

In England, studies on secondary emissions showed that by spacing the plate a critical distance from the screen grid in a tetrode, a "virtual cathode" is formed. [1] (Figures 3 and 4 on previous page) Schade and his fellow RCA engineers took this concept and perfected its implementation in several ways. First,

they wound the control grid and the screen grid with the same pitch. The wires were aligned, so very few electrons would strike the screen. Second, the suppressor grid was replaced with a pair of "beam plates" on either side of the grid structure. This assured that the only electrons reaching the plate were in the area where the critical plate distance was right, insuring the "virtual cathode" was effective. The result was extremely high efficiency, high linearity and lowered grid heating. The first production version of this was encased in a metal envelope with a then-new octal base. Thus was born the 6L6.

It was an immediate hit. All the major radio manufacturers started using it in their audio output stages, essentially eliminating the triodes, such as the 45 and 2A3, and elbowing out old tetrodes like the 46 and 48, and pentodes like the 47 and 6F6. And new applications

appeared; ham-radio operators found that it could give usable power in a transmitter, even at shortwave frequencies, and at far lower cost than previous tubes or the official transmitting version of the 6L6, the 807. The cost of public address amplifiers was affected by the new tube, as it was now practical to get 25 watts without using four 2A3s or expensive larger triodes like the 50 or 211. Only two 6L6s were now needed, at a fraction of the cost.

2. Types

The 6L6 gave birth to a vast array of beam tubes. The 6V6, 25L6, and others were immediate developments, which gave lower power for small radios at lower cost. The 807 was the beginning of a series of beam tubes intended for radio transmitters, some of which are usable beyond 500 MHz. The 807 was the direct ancestor of the famous 6146 transmitting tube. The major VHF push-pull tetrodes of World War II, the 815 and 829, were based on the 6L6. The 6550 was a high-power audio tube based on classic beam tetrode principles.

The first American television horizontal amplifier or "sweep" tube, the 6BG6G, came out in 1946, and was a repackaged 6L6. It was followed by dozens of derivatives ending up in the monster color TV sweep tubes of the 1970s, such as the 6LQ6 and 6KG6/EL509. To this day, new tubes are being developed that are descended from the 6L6. The KT90, KT99 and KT100 are examples. These recent audio tubes are derived from TV sweep tubes.

The original metal 6L6 was a typical design for RCA at the time. Metal-shell tubes were popular in the 1930s. They were heavily marketed to the public who feared injuring their hands on broken glass and to radio manufacturers who, among other things, appreciated the fact that metal tubes were less likely to break during shipping of their radio sets. An added feature was the shielding effect of the metal envelope, which improved radio performance.

The steel envelope was more expensive to manufacture and had real problems dissipating heat, so the fad was virtually over by 1950. The metal 6L6 and its premium version, 1614, were often used in early jukebox amps and in many Zenith radio chassis, not to mention PA amps.

A few maniacal radio hams found that a metal 6L6 could be operated in a bath

WE 350B (built by National Union) and Mullard EL37

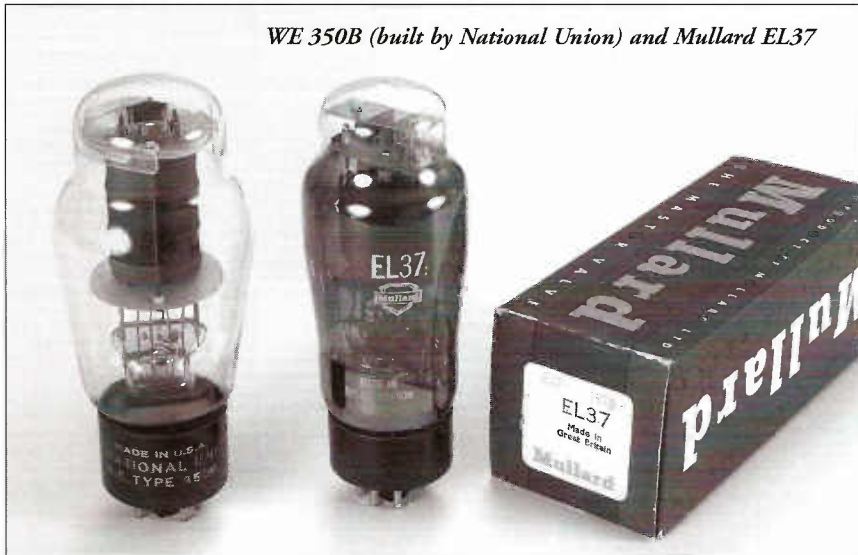

of transformer oil, allowing a pair to dissipate 150 watts for short periods. The glass 6L6G and 6L6GX, appearing in 1937, were more popular with the conservative audio industry. The 6L6G was common in nearly all WWII jukeboxes, and became nearly universal in thousands of PA amps right through the early Fifties. Although the G version had the same ratings as the metal style, it took over the market.

During World War II, improvements were made in the glass envelopes, and in 1944, the 6L6GA and 6L6GAY were introduced. They had the smaller ST-14 "coke-bottle" envelope. In the early 1950s, the 6L6GB came out, having a straight-sided T-12 envelope. These all had the same maximum ratings as the original 6L6G.

Tung-Sol 5881s and 6L6WGB



After 1945, an escalation in power ratings began. This had been prefigured in the 1938 introduction in Britain of MOV's KT66, a more powerful version of the 6L6. OEMs wanted more and more power, without resorting to transmitting tubes. In 1947, Mullard introduced the EL37. It and the KT66 were more expensive in America than the 6L6s, so the RCA/GE/Sylvania business continued as more and more dissipation was demanded from the tubes. The result was a group of "super tubes," which became standard for high-power American guitar amps and some hi-fi amps.

In 1955, the 6550 was introduced by Tung-Sol. During 1958, RCA came out with the 7027. In 1959, a five-ply combination metal sandwich type plate design and a different maximum rating system allowed the 6L6GC to raise the plate dissipation from 19 to 30 watts. In the early 1960s, the 8417 was developed.

GE 7581 and Tung-Sol 7581



The 5881, introduced by Tung-Sol in 1952, was intended as a smaller 6L6 version for use in military and industrial equipment. Millions of 5881s were plugged into servo amplifiers in aircraft such as the B-52 bomber, so this had to be a rugged and reliable tube. It was standard equipment in some home hi-fi amplifiers, such as the classic Bell, Bogen, Heathkit WM-3 and WM-4 series, Fisher 70A, Pilot AA-410 and many others. Fender's early Bassman was equipped with 5881s, and this guitar amp (like many later models) is very demanding of its power tubes. 6L6Gs simply cannot be used in such amps!

The 5932 was Sylvania's rugged 6L6 type. It was never used in audio equipment and is extremely scarce. See below for more information on the 3 variations

Sylvania 5932s (single plate, single plate w/holes, dual plate)



on this tube. General Electric tried to make a super-6L6 in the late Fifties, and the result was the 7581. You can easily recognize a real GE 7581 by its pinkish flesh-colored base, which is virtually unique. It was the standard tube in the classic Harman-Kardon Citation 5 amplifier, but was rarely used otherwise due to its high cost. Tube manuals sometimes give the 7581 as an exact replacement for the KT66, although it is mechanically quite different. Still, it has become a valuable tube due to its ability to tolerate the high voltages in post-1958 6L6 guitar amps.

Table 1:

Escalation OF 6L6 Ratings Over The Years

	Plate Watts	Plate Voltage	Screen Voltage
6L6/G/GA/GB	19 W	360 V	270 V
KT66 (1940s-on)	25 W	500 V	400 V
EL37 (1947)	25 W	800 V	800 V
5932 (1950)	21 W	400 V	300 V
5881 (1951)	23 W	360 V	270 V
6L6GC (1959)	30 W	500 V	450 V
7027 (1958)	35 W	600 V	500 V
7581 (1959)	30 W	500 V	450 V
7581A (1960)	35 W	500 V	450 V

[It should be noted that tubes introduced after 1957 use the "Design-Center" ratings. This adds about 10% to the maximum ratings without any other changes to the tube. - Tech Ed.]

All of the above 6L6 derivatives were compatible into any 6L6 socket, and biased very similarly. They all used 0.9 amps at 6.3 volts on the filament, except the KT66 which used 1.25 amps and the EL37 which used 1.4 amps.

There were so many variations of this form that don't have space to list them in this magazine. I could go into the 6AR6, or the Bendix Red Bank 6384 (to be covered in a separate article), or variations with different filament voltages like the lower-power 25L6. There are numerous variations of the 6V6, there are Western Electric types like the 350B, there are numerous transmitting types, there are hundreds of sweep tubes. There are miniatures like the 6AQ5 and 7189. There are the late-50s audio types like 7591, 7868, 7355. Those will have to wait for future articles.

As I said, the major applications of these tubes were in PA amplifiers and radio outputs, jukeboxes, and some early hi-fi amps. But the future and longevity of the 6L6 were assured when Leo Fender put them in his large guitar amps, starting with the Dual Professional in 1947. Fender's large amps of the late 1950s, including the Showman, Bandmaster, Bassman, Pro, and Twin models, became the essence of American rock. Indeed, the 1959 Bassman and 1960 Twin are among the most copied electronic gadgets in history, with a variety of new "boutique" manufacturers producing their own versions. If you include the 6V6-powered Deluxe models in that short list, then the old Fender designs are the undisputed standards.

During 1972, the late Tom Ruberto of Sylvania developed a special version of their standard 6L6GC, for Fender. The STR-387 type had extra mica spacers and was designed to hang upside-down, as well as being designed to tolerate 500 volts on the plate and screen. This was the first STR (special test requirement) 6L6. It became a standard, so much so

that "STR," long after the 1988 shutdown of the Sylvania tube factory, is a standard term used to describe 6L6GCs with this large cylindrical envelope. GE even introduced its own version, and both had numerous guitar amps designed around them. I once repaired a guitar amp made by Acoustic, circa 1979. It had four 6L6GC-STRs, and put 750 volts on them. The owners of this model don't realize that they have a dangerous beast there. Unfortunately, many such amps continue to be used, although the STR tubes are no longer being made and are getting expensive.

Because of the chaos of 6L6 types and the often-brutal conditions they endure in music amps, testing becomes even more important. The problem with some types is usually their design limitations, not design flaws. Older tubes often had surface treatments on their mica insulators which reduced manufacturing costs, while allowing some leakage current to reach their control grids. Such tubes are limited in plate-voltage capability. Super tubes like the KT66 usually have gold-plated grids to prevent grid emission, which can also destroy the tube. Since I have tried out many tubes for this magazine (primarily with an eye toward high-fidelity use), it's worth looking at the 6L6 types closely to also determine what vintage-guitar-amp users need.

3. Tests

As with previous tube tests in past issues of VTV, I used a special single-ended test amp to examine the distortion characteristics of a large cross-section of old 6L6 types, as well as a few current-production items. The driver was a 6EM7 and the output load was a One Electron UBT-1 SE transformer with the 8-ohm test load connected to the 4-ohm tap, thus presenting 3200 ohms to the tube's plate. This test has been most revealing in the past, and the 6L6s were even more unexpected in their behavior. As in the past, distortion is almost all second-harmonic and was measured at 1 watt into an 8-ohm load. Each tube was biased to 50 milliamps, a typical value for 6L6s, then tested. All the types were run at 300 volts triode connection, then types that were rated to accept 500 volts on plate were run again at 500 volts, with 300 volts on the screen.

These lists only show types for which I was able to obtain multiple samples. The 5932s came in 3 styles. I tested one of each and combined them; they weren't much different electrically. Only one WE 350B was tested; it warmed up very slowly but gave excellent results.

Russian 6P3S, Sovtek 5881 and RCA 7027



6L6 Types with Multiple Samples:

1. Triode 300V average distortion

1614 metal RCA	.61%	4 samples
6L6 metal RCA	.62	4
KT66 MOV	.63	4
6P3S Russian	.64	12
6L6GC Sylvania short	.72	4
EL37 Mullard	.78	4
5881 Sovtek Russia	.85	4
6L6G RCA	.85	3
5932 Syl JAN	.91	2
6L6GC China	.93	2
6L6WGB Philips short	.93	8
6L6WGB GE Canada	.96	9
7027A RCA	.97	4
5881/6L6WGB TungSol	.98	18
7581A Philips 1985	1.06	2
7581A GE pink base	1.06	2
6L6GC GE short	1.18	3

2. Pentode 500V (screen 300V) average distortion

KT66 MOV	.88%	4 samples
EL37 Mullard	.91	4
6L6GC Sylvania short	.95	3
5881 Sovtek 1989	.97	4
6L6WGB GE Canada	1.07	6
5881/6L6WGB TungSol	1.08	17
6L6GC China	1.08	2
6L6WGB Phil/Syl short	1.12	10
7027A RCA	1.14	4
6L6GC Sylvania STR	1.16	2
5932 Syl JAN	1.16	2
7581A GE pink base	1.19	2
7581A Philips 1985	1.22	2
6L6GC GE short	1.25	2

Many tubes that appear on the 300V list are not on the 500V list. This is because those particular tubes are NOT rated by their manufacturers for operation at 500 volts on the plate. This includes the metal 6L6s and 1614s, the 6L6G, GA, GB, and the Russian 6P3S, which is often sold as a 6L6GC even though it is not intended for more than 400V on the plate. (A true GC should be rated for 500V.) We respect the intentions of the original manufacturers. So, too, should users stick to the published ratings. I have tried to put 500V on the older types and on 6P3Ss, and they usually start to creak (and, sometimes, try to self-destruct due to grid emission or leakage currents). I definitely do not recommend these types for guitar amps, which often have plate voltages of 450V or more.

The peak-power tests are not listed here, but we will summarize: it was revealed that the MOV KT66, Mullard EL37, Sylvania GC and the rare 350B (a Western Electric type) are superior to other 6L6 types in peak output. If the application demands maximum peak output (and money is no object), these tubes are best. Be prepared to pay more than \$150 for each KT66, EL37 or 350B. NOS usually brings such prices, but good used tubes are acceptable. Make sure your NOS dealer warranties that the used tube is healthy!

In using this list, keep in mind that the needs of hi-fi and guitar amplification do not necessarily match. It is typical for hi-fi users to prefer tubes from the top of the list; the KT66 and EL37 are especially sought-after, and the list reflects this. On

the other hand, for guitar the tubes preferred are usually the short GE 6L6GC, the "STR" 6L6GCs made by Sylvania and GE, and the various 5881s, 6L6WGBs, 7581As and 7027As. In this case, distortion is OK (and sometimes deliberately sought by the user) but physical ruggedness is more critical. This is why the metal types and the old 6L6G, GA, and GB are less sought-after. The latter are in demand, but mostly by radio collectors and juke-box owners who want to use original tubes. For applications like these, where the plate voltage is below 350 volts, the current Russian 6P3S works just fine and is very inexpensive.

Metal 6L6s (including the 1614) are low in distortion, but tend to be microphonic and can have dissipation problems. A power tube with a metal envelope really should be cooled by forced air or attached to a heat-sink, neither of which is practical in typical audio amps. The more extreme collectors of McIntosh hi-fi equipment usually insist that their MC-30s be equipped with 1614s, the original equipment in these amps.

For true obscurity, the Sylvania 5932 is worth looking at. It is a special super-rugged 6L6 replacement for military equipment. The 5932 came in three versions; two had a conventional single structure. The other version is unique—it has a pair of smaller oval structures connected in parallel. There is an underground following in the guitar world for the 2-plate 5932, and the prices charged for it reflect the demand (high). Its distortion and power output were only average, similar to Tung-Sol 5881s.

All of the tubes listed here are pin-compatible replacements for any 6L6 type, except the 7027 and 7027A. Sockets must be rewired to use them in place of 6L6s. A good tube-amp technician can do this at a reasonable price. Because of the manic market for NOS types that can substitute for 6L6GC, 7027s have become very scarce. There were few audio amps that used them as original equipment. They are very tough and are popular in Fender amps that have been rewired appropriately. Purists tend to scoff, as 7027s are quite different from 6L6GCs and the like; but they do work fine with just a socket rewiring and rebiasing.

The 6L6 is not often seen in high-end hi-fi amplifiers. There are some old amps out there, however, and they can be kept going with the Russian 5881. It is unpopular in guitar amps, even though it's rugged and inexpensive. Guitarists

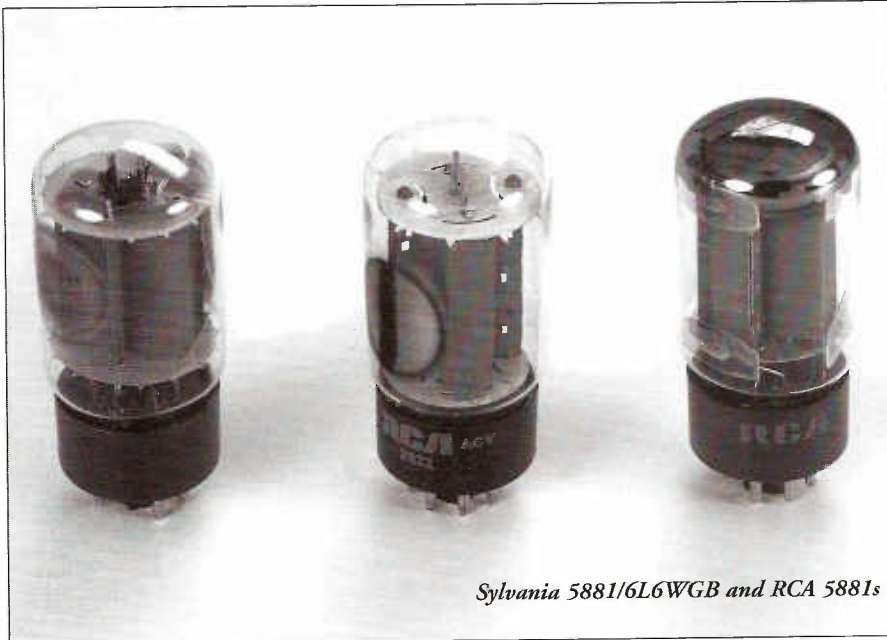

Sylvania 5881/6L6WGB and RCA 5881s

tend to dislike Russian 5881s because they sound "bland." A shame, as they're good hi-fi tubes but rarely used for that. Most contemporary high-end designers have tended to stay away from using 6L6/5881s in their amp designs. The Golden Tube Audio SE-40 single-ended amp, Mesa Baron and various VTL push-pull amplifiers are among the few contemporary high-end amps that use the button-base Russian 5881.

I conducted casual listening tests at the VTV office; they tended to back up the distortion tests above. The old 6L6GCs tended toward a warm, "romantic" sound with greater "darkness" and much more distorted, fat bass. The metal types and Russian 5881s were more "dry" and clean, as were 6L6Gs and Sylvania GCs. The 6P3S has a slightly wetter sound than the Russian 5881, but the same kind of clarity. Old 5881s were mostly made by Tung-Sol, and sounded warm, slightly nasal, with good bass. The KT66s and EL37s were outstanding hi-fi tubes, more like triodes in character and very detailed.

Two examples of the "skinny" Shuguang 6L6GC are listed here. These look remarkably like the Russian 6P3S, but are slightly different. The Chinese version has four square holes in its top mica spacer, rather than the two in the Russian tube's spacer. Chinese 6L6s also look less well-made and use the same ugly brown refractory cement to hold bases on that is seen in other Chinese octal tubes. These, like the 6P3S, are not really 6L6GCs and should not be used at more

than 400V. During test at 500V pentode, they creaked and groaned alarmingly. Note that their distortion was much higher than in the Russian ones. Obviously these tubes were made with Russian tooling, but are much poorer quality. There is a new "Coke-bottle" shaped 6L6 from Shuguang, with a brown base and optional blue glass; it is too new to appear here and will be reviewed later.

All of the NOS tubes are out of production, leaving only the Russian 6P3S, 5881, and the Chinese types. The Russian tubes are old Soviet commercial and military types, not originally intended for export. Svetlana is going to introduce a new 5881 of its own soon, and we will report on it in a future issue of VTV.

4. Outro

It is estimated that more than 2 million tube guitar amps exist in the world today. Of that number, probably more than 40% use push-pull 6L6s. To claim that this market will soon dry up and be replaced by transistors is simply prevaricative. Although no 6L6 type is being produced in America or Europe at the present time, there are a few popular ones from Russia and China which own the market. The Shuguang types, including a new 6L6GC with a blue glass envelope, are consistent sellers; and although they are very clean-sounding tubes, the Russian-made 5881s are Soldano's favorites and are used widely. They will likely be available for years, if not decades, to come. Add in the soon-to-come Svetlana 5881 and a rumored

The British Connection

In England in 1931, J.H. Owens Harries discovered that if the electron flow in a tetrode was confined to beams, and that the distance from screen grid to plate was kept at a critical distance, secondary emission from the plate would be suppressed, just as in a pentode [1,3]. This discovery enabled the British General Electric Co. (GEC, unrelated to the American General Electric) to bring out a sensitive, high-power output tube without infringing on the pentode patents held by Philips and Mullard. M.O. Valve, a division of GEC, then came out with a series of beam tetrodes, with their most famous being the KT66. KT stood for "Kinkless Tetrode" – since it eliminated the kink in the transfer curve that happened with regular tetrodes. The KT66 was meant to be a plug-in replacement for the 6L6, but had superior characteristics. It was introduced in 1937. These and other M.O. Valve tubes were marketed in America under the "Genelex" name.

Due to the head start the British had in developing component-type high fidelity systems, the transfer of British RADAR technology to American during WW II, and the common language, Americans in the late 1940s looked to England for ideas in hi-fi design. Williamson's seminal *Wireless World* articles gave British hi-fi a tremendous boost in America. The marketing efforts of the British Industries Corp (B.I.C.) brought the best of British hi-fi components to America during the 1950s. The net result of this was the inclusion of "foreign" tubes, such as the KT66, KT88, EL34, GZ34, etc. into American hi-fi and even guitar amp designs.

- Tech. Ed.

6L6GC-"STR" which may be produced in California soon, and the 6L6 looks good for another 60 years.

References:

- 1 - Harries, *Secondary Electron Radiation*, Electronics, Sept. 1944.
- 2 - Schade, O.H. *Beam Power Tubes*, Proc. of the IRE, Feb. 1938.
- 3 - Harries, British patents 380,429 and 385,968, 1931. and *Wireless Eng.*, vol. 13, pp. 190-199, April 1936.

Thanks to Kent Leech from Orinda, California for his cut-away illustration of a 6L6 on page 3.

6L6 Listening Impressions

Hi Fi - by **Charlie Kittleson**

Guitar - by **Terry Buddingh**

This comparison will be in two parts. I will give listening impressions of the 6L6 in hi fi applications using John Atwood's SE amp with all tube regulation, variable plate current and a Tango SE transformer. John wrote an article on this amplifier that was published in the March 1996 *MJ* magazine. Terry Buddingh, tube amp guru for *Guitar Player Magazine* uses both an original 1959 Fender Bassman and a 1963 Fender Twin Reverb for his listening impressions.

6L6 for Hi Fi

All of the tubes were set at 50 ma plate current except for the KT66, EL37 and WE350B which were set at 60 ma.

Tung-Sol 5881-This tube has a punchy midrange, however the highs were harsh and there was no major depth in the bass. **Sovtek 5881**-Good detail, but somewhat dry sounding. Fine tonal balance and tight bass with good damping. Not as musical as some of the vintage tubes, but may please the detail oriented audiophile. The best 6L6 type for hi fi currently being manufactured.

Sylvania 5932-The twin plate version of this tube was well balanced with nice highs. It was relaxed sounding and not harsh. The single large plate version with holes seemed to have notable distortion in the mids and highs. The large plate version without holes again had a balanced sound with lots of midrange and high frequency information. It was very pleasing, with full sound.

RCA 6L6G-A very laid-back, round sound with a smooth low end sweet highs and not too forward sounding. **Sylvania 6L6GA**-Good-deep bass, rich low-mids, nice balance, smooth and easy to listen to. **GE 6L6GC**-Refined and balanced, not hyper-detailed, a semi-punchy vintage-type sound. **RCA 6L6GC**

Blackplate-Heavier bass, but not as balanced as the GE version. Slightly thinner sounding in the mids and highs.

Sylvania STR387(6L6GC)-Strong bass, thinner upper-mids and highs than the GE 6L6GC. **GE 6L6 GB** -A fatter, vintage sound with more depth in the bass and mids.

Tung Sol 7581-Lots of meat in the upper-mids, but somewhat harsher highs. **USSR 6P3S (6L6GC)**-This tube lacks bass depth and the highs are slightly



Atwood 6L6 SE Amp

rolled off at the top. Mids not very detailed and a noticeable bump in the higher mids. Overall, a softer, vintage-type sound.

RCA 6L6 (metal)-Very detailed, rich mids with a noticeable mid-bass resonant peak, a good audiophile tube if plate voltage is kept to a max of 360 volts.

WE350B-Sweet upper-end detail with lots of headroom. Very balanced with tight bass. Three dimensional and live sounding. Easily the most musical tube of the test. **Mullard EL37**-Warm and round sounding with lots of detail and depth. Not a hint of harshness, very much like a triode. Not quite as lush in the midrange as the WE350B. **GEC KT66 (early smoke glass)**-Lush upper-mids, but somewhat bright highs. Extremely smooth, but clean and detailed. Bass was not as deep as the WE350B. Excellent vintage sounding tube. **Gold Lion KT66 (clear glass)**-Detailed high-end, a sensitive tube, but the midrange sounded a bit congested and the bass was not super-deep.



6L6 Types for Guitar Amps

Terry Buddingh, from *Guitar Player Magazine* and a contributor to VTV from the guitar amp side, gave us his

impressions of 6L6 types in vintage Fender guitar amps:

Sovtek 5881-This tube has a lean, colorless midrange and a slicey top. **Philips/Sylvania 7581**-A tube with good head-room and tight bass. The loudest and cleanest of the 6L6 types. **Chinese 6L6**-Not super musical, harsh treble and can't handle high B+ plate voltages. **Tung-Sol 5881**-Definitely a tube with that grindy twang that sounds great in early Fenders amps.

Sylvania 5881/6L6WGB A good vintage sounding 6L6 with smooth, creamy mids. **RCA 6L6GC (black plate)**-This tube from the late Fifties and early Sixties is especially rich and full sounding. The **Sylvania STR 6L6GC**-This tube has a tight, firm bottom and a hard, stiff midrange and top. **Mullard EL37**-EL37s are incredible - sonically, they're between a Mullard EL34 and a GE 6L6GC - strong and punchy with good richness and complexity in the midrange. **Genalex KT66**-The KT66 has the most incredibly refined sense of midrange presentation and detail. The bass can be somewhat loose. **GE 6L6GB**-Nice and smooth, a good vintage-sounding tube for guitar. Cannot safely handle much over 360 volts on the plate, however.

Terry's Recommendations: "For blues and rock one of my favorite tubes is the **RCA 6L6GC**, "Black plate" for its rich and smooth sonic presentation. For a loud and clear sound, try the **Philips 7581**, easily the cleanest tube of the lot."

Why 88 to 108?

The History of Early FM Radio

by **John Atwood**

Our day-to-day environment was once defined by objects: mountains, buildings, roads, houses, food, and books. Nowadays, technological standards define more of our environment: 50 or 60 Hz power, Public Broadcasting Channels, speed limits, e-mail addresses. One of the technological landmarks of our environment is the existence of radio frequency bands – and the focus of this article, the 88 to 108 MHz FM broadcasting band – used in North America and in many other parts of the world. Why 88 to 108? The answer became clear after going through a stack of post-war *FM-TV* magazines, edited by one of the pioneers of high-fidelity, Milton B. Sleeper. Sleeper was an ardent supporter of FM in all forms, and while his magazine clearly is slanted towards FM, he presents enough source material (FCC announcements, letters from the anti-FM side, etc.) that a fairly clear picture of the politics of post-war FM emerges. This article will focus in on the events from 1945 to 1948; however, the history, personalities, and conflicts surrounding early FM broadcasting are fascinating, and deserve an in-depth treatment elsewhere.

A Little FM History

The concept of frequency-modulation for radio communications goes back to the 1920s. Some misguided studies by Bell Labs had convinced most communications engineers that FM was no better than AM. However, Major Edwin H. Armstrong was a firm believer in the superiority of FM over AM, and on Nov. 5, 1935 conducted a dramatic demonstration before the Institute of Radio Engineers in New York. Broadcasting from Yonkers to the Empire State Building, the New York Section of the IRE was the first to experience clear, static-free radio transmission. Armstrong received permission to regularly broadcast at 43.1 mc [1] (We will use Megacycles instead of MegaHertz in this article, just to keep the flavor of the time.) Soon FM stations were being set up in both major cities and in rural areas in the 42 to 50 mc. band. High power stations demonstrated that clear, noise-free signals could propagate over a bigger area than daytime AM broadcasting. The Yankee Network in the north-east U.S. showed that by

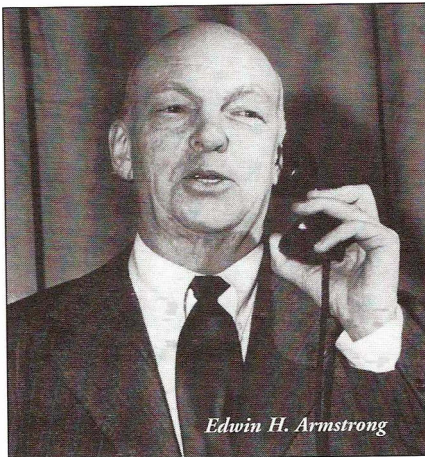

Edwin H. Armstrong

simply receiving a noise-free signal from another station and rebroadcasting it, a radio network could avoid the high costs and (at that time) limited fidelity of AT&T's leased lines. By the beginning of America's involvement in World War II, there were 115 FM stations on the air, all between 42 and 50 mc.

FM's rise was not viewed positively by the dominant economic force in the radio world at the time: AM commercial broadcasters. FM broadcasters tended to be forward-thinking innovators, and even though AM broadcasting was only 20 years old at the time, it had become an entrenched big business. The telephone monopoly, AT&T, saw a loss of leased-line revenue. And at the biggest radio company, RCA, Sarnoff, formerly Armstrong's supporter, had turned against Armstrong, and was trying to neutralize his patents. While the AM broadcasters were simply greedy and short-sighted, RCA actually saw the benefit of FM, but worked hard to develop circuits outside of Armstrong's patents. RCA actually pushed to make the sound channel of the NTSC television specification FM, just before it was adopted in late 1941. But Sarnoff wanted FM on his own terms, not Armstrong's.

The Power of the FCC

During the war, AM and FM broadcasting continued, but few new station permits were granted. By 1944, it was clear that all the frequency allocations would be reevaluated – both because of all sorts of new military radio uses, and because of the expected boom in television and radio broadcasting. The Federal Communications Commission, formed by the 1934 Communications Act, established all radio frequency allocations and regulations. Given America's technological and political dominance at the time, there was little input from any interna-

tional bodies. The seven FCC commissioners as well as the chairman of the FCC were political appointees.

In late 1944, Franklin Roosevelt (FDR) had won an unprecedented 4th term. Among the political appointments made after the election, the publicity director of the Democratic National Committee, Paul Porter, was rewarded by being made chairman of the FCC. Paul Porter was a lawyer, and had never been involved with radio or broadcasting until his appointment.

The Secret Hearings

With the end of the war in sight, the FCC began preparing the new frequency allocations. Interested parties were given chances to explain their needs and desires to the FCC in public hearings before the commissioners. However, on March 12 and 13, 1945, secret (non-public) hearings were held to discuss the allocation of FM broadcasting frequencies. Apparently, Kenneth Norton, the FCC's chief engineer, gave testimony that propagation at high frequencies was better for FM broadcasting than the current 42 - 50 mc. band. [2]

We don't know all the details of the hearings, but the net result was that when frequency allocations for all services above 30 mc. were announced on May 25, 1945, no decision was reached for FM broadcasting. Instead, three alternatives were announced. At this point Milton Sleeper explains it best:

"Manufacturers protested vigorously against the delay in assigning FM Broadcast frequencies. Television Broadcasters Association, FM Broadcasters, Inc., and the Pioneer FM Manufacturers Conference promptly passed resolutions calling upon the FCC to make the No. 1 Alternative effective at once, giving FM 48 to 68 mc., with 68 to 74 and 78 to 108 mc. for television.

"The announcement of the three alternative plans [by the FCC] was accompanied by an explanation which stated, in part, that "equipment considerations should not be complicated by moving to higher frequencies unless it is clear that there will be definite advantages from a propagation standpoint."

"However, under pressure from the AM broadcasting industry, the final choice of the No. 3 Alternative, moving FM to 88 to 108 mc., was announced on June 27, 1945. This was done in the face of statements from manufacturers explaining that neither designs nor tubes were available for receivers and transmitters on 88 to 108 mc. Moreover, as was disclosed subsequently, the Norton testimony supporting



...featuring the

Genuine Armstrong

Circuit in Both the

50 and 100

Megacycle Bands

\$59⁹⁵

And Up!

**The Public Is Demanding FM
... And Zenith Has The Answer**

It will shortly be very difficult to sell any radio (except in the lower price brackets or portables) which does not incorporate FM. Zenith has long recognized the universal appeal of this new kind of static-free, true fidelity broadcasting as developed by Major Edwin H. Armstrong. To meet it, Zenith engineers have perfected two-band Armstrong FM in table model sets designed to appeal to the mass, volume market, as well as in the finest console combinations . . . all with Zenith's patented built-in light-line antenna. That is why Zenith is recognized by broadcasters, dealers and the public as the outstanding manufacturer of FM receivers.

Zenith Is Building A Mass FM Audience:

70.10% of all the FM equipped table model sets produced during the period from January 14, 1946 to January 4, 1947 were Zeniths. These latest available figures (February 5, 1947) are from Haskins & Sells, the official reporting agency of the Radio Manufacturers Association.

ONLY ZENITH HAS THIS!

- ★ Genuine Armstrong FM On Both Tuning Bands
- ★ Super 6-Purpose Tube
- ★ Built-in FM Antenna, Even for Table Models
- ★ Big, Easy-Tuning Dial
- ★ Permeability Tuning
- ★ Compact Chassis
- ★ Built-in Wavemagnet
- ★ Sensitive, Selective Circuit



ZENITH RADIO CORPORATION

CHICAGO 39, ILLINOIS

the use of higher frequencies had been proved, at the Secret Hearing on March 12 and 13, 1945, to be grossly in error."

"Confronted with a complete shift of FM frequencies, the Pioneer FM Manufacturers Conference, meeting on July 6th, announced that as a service to radio listeners, they would provide 2-band FM tuning. Thereupon, Chairman Porter stepped into a situation over which he had no jurisdiction whatever with the pro-

nouncement that "The Commission is informed that 10-kilowatt transmitters will be available for the new band," and that "the Commission might very well take the position that it was necessary to put an end immediately to all FM transmissions in the old band in order to protect the public from an unnecessary expense and to insure that the change-over to FM's new and permanent home should not be delayed."

"Now the truth was that Chairman Porter had not been informed by any authoritative source that "10-kilowatt transmitters will be immediately available for the new band." That statement was nothing more than a lawyer's answer to justify his position. There was not a word of truth in it, and the RMA [Radio Manufacturer's Association] would not have 10-kw. equipment for FM for 10 to 12 months." [3]

As it turned out, the very first new-band 10 kw FM transmitter came on the air in late August, 1946, over a year after Porter's claim that they would be "immediately" available. This station, by the way, was Armstrong's Alpine, New Jersey station, W2XEA. Another postscript: In May, 1945, the FCC requested Zenith Radio to conduct tests comparing broadcasting on the 50 and 100 mc. bands in Deerfield, Illinois. On December 28, 1945, Zenith reported to the FCC that "while rendering good service to a limited area, [the new band] will satisfactorily cover only 40% of the area which could be covered by a similar transmitter of identical power in the 50 mc. band. This means that the majority of rural population of the United States would be deprived of static-free FM service if FM were confined exclusively to 100 mc." [4] These findings came seven months too late.

The Single-Market Plan

While not directly related to the shift of FM broadcasting to the "new band", another thorn in the side of FM broadcasters was the "single-market" plan. Tests by "super-power" FM stations in the early 1940s showed that FM could deliver 24-hour-a-day quality service over a surprisingly large area. The AM broadcasters had limited ground-wave coverage by day, but interference from far-away stations on the same frequency at night.

To ostensibly equalize the coverage of AM and FM station, Paul W. Kesten, the vice-chairman of the board at CBS (one of the two big AM radio networks of the time) proposed to the FCC the "Single-Market Plan." In this plan, FM stations would be limited to an effective radiated power of 20 kw in metropolitan areas, with the goal to limit effective coverage to a 35-mile radius, or thus a "single market" from the advertising point of view, allowing AM and FM stations to compete on a similar coverage area. Despite protest from FM broadcasters, the single market plan was effectively implemented when the detailed FM frequency allocations were made, which remain basically in effect today.

At the same time the AM broadcast interests were pushing for the single-market plan, they were trying to get AM channel assignments shifted to allow 50 kw "clear-channel" stations with no interference. As an example, WOR in New York was advertising that "If a sponsor uses WOR, it's a sign that his program will be heard in 16 of America's greatest cities of more than 100,000 each." [5] So much for a single-market!

Zenith's Request For Two Band Coverage

On January 2, 1946, Zenith Radio Corp. filed a petition with the FCC to allow broadcasting on a limited section of the old 42 to 50 mc. band, primarily to allow better FM coverage of rural areas. By this time the results of Zenith's dual band tests had come in, showing a 40% loss in area covered (for the same power level) for the 100 mc. band. The FCC scheduled hearings on Jan 18. [6] Afterwards, on Jan. 23, the FCC reaffirmed its decision to keep a single FM band at 88 to 108 mc., without issuing the customary explanation of its decision until March 5. Commenting on the fact that the FCC did not admit the technical errors (Norton's flawed estimates of 100 mc. propagation), Major Armstrong commented:

Controversies regarding the laws of nature are never closed until the facts come out. The only way the facts in this situation can be suppressed is by shutting down the present 40-megacycle stations before comparative performance of the two bands can be observed in actual practice by engineers and the public alike. [7]

In anticipation of acceptance of the dual-band proposal, Zenith's new post-war radios were dual-band models - covering both the 50 and 100 mc bands. These ranged from table radios to consoles. However, other manufacturers were not as optimistic as Zenith, and didn't offer the low-band option on their first post-war FM sets.

Postmortem

In February, 1946, FCC chairman Paul Porter was appointed to the Democratic party's board of strategy. He was replaced by Charles R. Denny, Jr. as an acting chairman. Like Porter, he was a lawyer, but unlike Porter, had risen through the ranks at the FCC since joining it in Oct. 1942. Denny's track record as chairman of the FCC was more even-handed than Porter's but the FM allocation change could not be undone.

The change in bands cost the FM industry an estimated one year delay in ramping up production of both transmitters and receivers after the war. There still was a lot of interest in FM though, even by AM station owners. By April, 1946, there were 834 applications for FM stations filed, almost equal to the number of AM stations on the air. 67.2% of these were by AM station owners. [8]

Average monthly FM set production

peaked in 1948 at 132,500 per month. Production dropped to an average of 32,000 per month in 1952. [9] FM's replacement of AM clearly didn't happen. However, the numbers above do not include separate FM tuners, and the growth of the hi-fi industry kept the FM market alive. It wasn't until the late 1960s that FM would become a broadcasting market comparable with AM.

One of the good things that came out of the move to the new FM band was an enlargement of the band, and the allocation of 20% of the band to public and community broadcasting. Enlarging the old 40 mc. band would require conversion of TV channel 2, to FM. CBS, whose New York TV station was on channel 2, would have surely objected. The college and community radio stations that exist today from 88.1 to 92.9 MHz provide some of the few alternatives to the commercial "wasteland."

Other countries took the lead from the United States in moving their FM broadcasting band (if they had one) to the 100 mc. region. Most countries had government-run broadcasting, with very few channels, so their frequency needs were less. Europe generally uses 88 to 100 MHz, while Japan uses 79 to 88 MHz (which makes you wonder why the Japanese import Marantz 10Bs!).

It is interesting to see how the political backroom dealings during a time when VHF frequency allocations were in flux shaped today's broadcasting landscape. Similar things are taking place today regarding HDTV and digital radio standards. It would be interesting to think how things would be if Armstrong had his way.

References:

- [1] - "Empire of the Air", Tom Lewis, pp. 266-267.
- [2] - FM & Television, March, 1946, "The Radio Industry Needs the FCC's Help," Milton Sleeper, p. 23.
- [3] - Ibid.
- [4] - FM & Television, Jan. 1946, p. 70.
- [5] - FM & Television, Feb. 1946, p. 4.
- [6] - FM & Television, Jan. 1946, p. 4.
- [7] - FM & Television, April, 1946, "Notes on FM Frequencies," p. 52.
- [8] - FM & Television, May, 1946, "Progress of FM Broadcasting," Milton Sleeper, p. 21.
- [9] - FM-TV, Dec. 1952, p. 4.

Golden Age of Stereo Harman-Kardon Citation I, II

By Charlie Kittleson

In 1960, the missile age was in full glory and the Golden Age of hi-fi Stereo was nearing its peak. Production of vacuum tubes and related equipment was at its all-time high. Also, this was the era of Popular Electronics and Popular Mechanics. American males enjoyed hands-on craftsmanship and building their own electronic equipment and tools. The electronic kit business was at near record levels and the transistor was still an oddity used by the telephone company and the government.

Just as the competition for more horsepower was on in Detroit in the early Sixties, the race for more watts was running at the local hi-fi shop. With the advent of inefficient speakers like the AR-3 acoustic suspension speaker in 1959 and the larger, concert hall speakers like the B-310 Bozak Concert Grand (which actually came out in 1951), more watts were needed for more realism. In the post-war mono era, 10 to 30 watts was more than adequate for the popular, large horn-type speakers (read: Altec, JBL, Klipsch, Tannoy, etc) with 12 or 15 inch woofers and compression-type horn high frequency drivers. On many of these systems, a two watt triode amp is more than enough to drive you out of the room with volume. However, inefficient speakers like the AR-3 needed at least 35 to 40 watts to get any volume. Even the famous KLH Model Nine Electrostats needed at least 40 watts continuous for any volume. This inefficiency trend still continues today with most speakers being no more efficient than 87-91 dba one meter at one watt. But that is another issue to be covered at a later date.

The Competition

About the same time, a number of hi-fi manufacturers took on the challenge to develop and market tube stereo "super power" amplifiers in kit and/or assembled form. Acrosound developed the UL-120, a 120 watt stereo power amplifier kit using Ultra-Linear T0-600 output transformers driven by push-pull KT77s. A similar amplifier kit was sold under the Radio Shack label as the HK-210. In late 1960, EICO brought out the HF-89, a beefy 100 watt stereo amplifier kit with push-pull EL-34s. Lafayette introduced the KT-550 in late 1960. The KT-550 was actually designed by Stewart

Hegeman and featured push-pull 7027As generating 50 watts per channel continuous. H.H. Scott came into the fray with their powerful LK-150 - 65 watt per channel amplifier kit using pentode-connected Tung-Sol 6550s and huge, in-house wound output transformers. Finally, McIntosh unveiled their legendary MC275, a 150 watt chrome stereo powerhouse that is still a demand item and status symbol in today's crowded audio amplifier market. Clearly, the race for high power amplification was on!



The Citation Line is Born

Harman-Kardon had been in the audio business since the post-war era, but now was encountering much more competition from Fisher, McIntosh, Marantz, H.H. Scott and many others. Most of the equipment sold by HK previous to the Citation line was integrated mid-fi amps and receivers, nothing really special compared to the Fisher and McIntosh equipment starting to appear. A decision was made by HK management in 1959 to start a separate, high quality line of audio components for the discerning audiophile. The line would be available either as a kit or fully assembled and tested. Stewart Hegeman, a well-known recording and audio engineer and designer of the time was brought in as Director of Engineering for the Citation Division in 1959. During the same general timeframe, Hegeman also designed the Lafayette KT-550A amplifier and KT-600A preamp.

Throughout that year, lots of late-night engineering was going on behind closed doors getting the design down and developing the kit packaging, etc. In late 1959, the first of the Citation line was introduced to the press. The Citation II (\$159.95 kit/\$229.95 assembled) tube stereo power amplifier was introduced first and shortly after, the Citation I (\$159/249) tube preamp began selling to the public in early 1960. The first equip-

ment reviews of the I and the II were in the January and February 1960 *Audio* and the January 1960 *Electronics World* magazines.

Design Considerations

Hegeman's approach to designing the Citation line was from a professional recording engineer's perspective. When you listen to recorded music for a living, listener fatigue becomes a major concern. Hegeman felt that distortion and frequency response were main factors in amplifier design and superior performance. He believed lower distortion, wide bandwidth and multiple feedback loops were essential for realism and to reduce listener fatigue. The amplifier must have minimal distortion to reduce the overall distortion generated from the cutting head, cartridge and speakers. "Distortion," he said, "is a deviation from the original. It includes harmonic, transient and intermodulation distortion components as well as phase response, restricted dynamic range and restricted distribution patterns from microphones and musical instruments."¹

Frequency response of the amplification system was another major design consideration. The musical response bandwidth must extend considerably beyond the hearing characteristics of the human ear in order to provide satisfactory reproduction. Thus, the concept of "wide band" amplification was further developed. Hegeman felt that amplifier performance below the 20 cycle range is very important to a tight and clearly defined low end. Conversely, an amplifier which has a frequency response beyond 100,000 cycles without evidence of ringing or instability when hooked to a reactive load can offer clean, transparent tone in the higher frequencies with outstanding instrument separation.

A New Approach to Feedback

In the Fifties, the use of feedback in amplifiers was controversial in some designs. Typical amps used a "single loop" feedback circuit from the voice coil terminals to the cathode of the input tube to smooth the frequency response and lower distortion. This approach limits usable feedback to 20 - 26 db. This method can reduce distortion components by a factor of up to 20 to 1.

Hegeman felt that a "multiple loop" method to increase the overall feedback was the answer to providing lower distortion without sacrificing stability. Multiple loops become additive if their ratio is adjusted to the relative degree of

HARMAN - KARDON CITATION I AND II

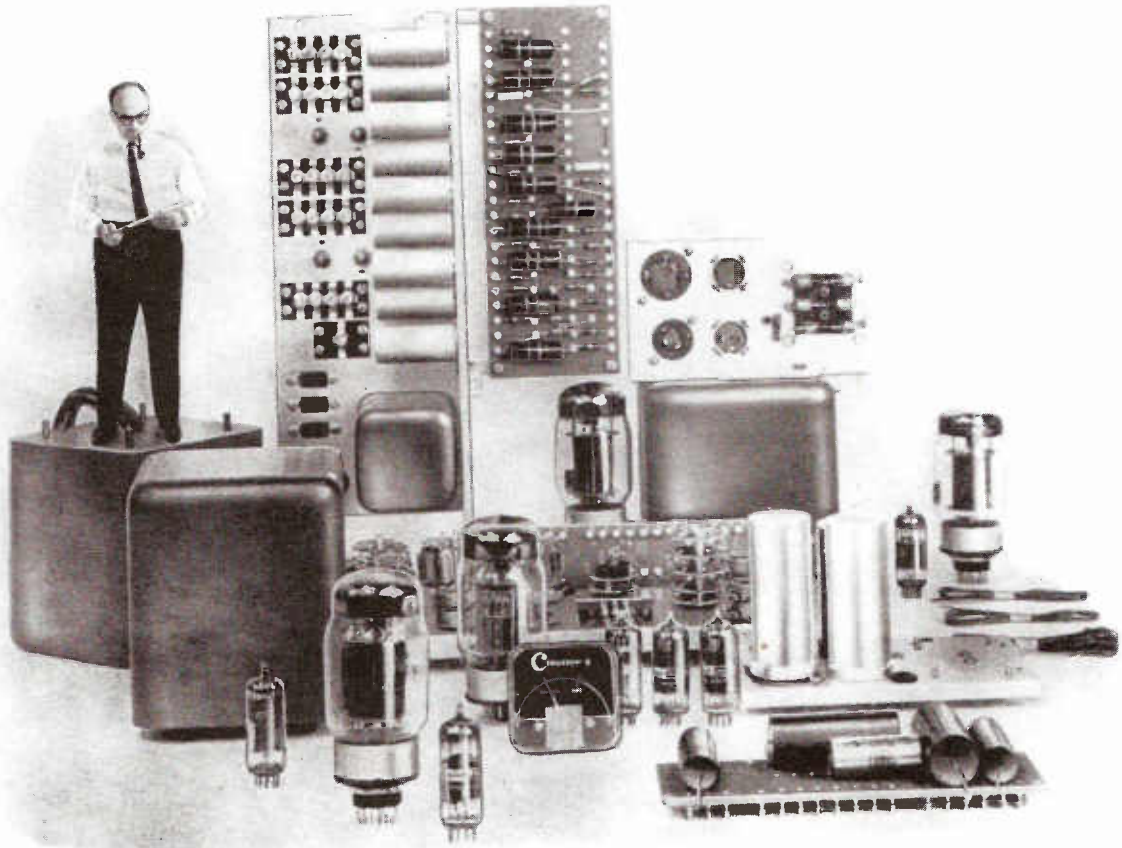

We don't pack an engineer into each new Citation Kit but...

... the engineering built into each kit is so precise that the unit constructed in the home will be the equal of the factory-produced instrument.

It is far more difficult to design a kit than to produce a completely manufactured product. In the plant the engineer can control his design from the moment of inception until the final packaging. The kit builder has only his tools, his ingenuity and little, if any, test equipment.

Therefore, the complex process of in-plant production and control which guarantees the fine finished product must somehow be embedded in the kit design. The Citation engineering group at Harman-Kardon, headed by Stewart Hegeman, has succeeded in doing just this in the design of the new Citation I, Stereophonic Preamplifier Control Center and Citation II, 120 Watt Stereophonic Power Amplifier.

Only heavy duty components, operating at tight tolerances, have been selected for the Citation Kits. As a result, even if every component is operated at its limit — remote as this possibility is — the instruments will perform well within their specifications.

Rigid terminal boards are provided for mounting resistors and condensers. Once mounted, these components are suspended tightly between turret lugs. Lead length is sharply defined. The uniform spacing of components and uniform lead length insure the overall stability of the unit.

Improper routing of leads, particularly long leads, can result in unstable performance. To prevent this, the Citation II is equipped with a template to construct a Cable Harness. The result: each wire is just the right length and in just the right place to achieve perfect performance.

These truly remarkable achievements in Control Engineering are only a few of the many exciting new developments in kit design from the Citation Division of Harman-Kardon.

THE CITATION I, Stereophonic Preamplifier Control Center, is a brilliantly designed instrument, reflecting engineering advances found only in the best professional equipment. The control over program material offered by the new Citation I enables the user to perfectly re-create every characteristic of the original performance. (The Citation I — \$139.95; Factory-Wired — \$239.95; Walnut Enclosure, WW-1 — \$29.95.)

THE CITATION II, 120 Watt Stereophonic Power Amplifier, has a peak power output of 260 Watts! This remarkable instrument will reproduce frequencies as low as 5 cycles virtually without phase shift, and frequencies as high as 100,000 cycles without any evidence of instability or ringing. At normal listening levels, the only measurable distortion in this unit comes from the laboratory testing equipment. (The Citation II — \$159.95; Factory-Wired — \$219.95; Charcoal Brown Enclosure, AC-2 — \$7.95.) All prices slightly higher in the West.

Harman-Kardon has prepared a free detailed report on both of these remarkable new instruments which we will be pleased to send to you. Simply write to Dept EW-1, Citation Kit Division, Harman-Kardon, Inc., Westbury, L. I.



Build the Very Best **CITATION KITS** by **harman kardon**

VACUUM TUBE VALLEY



Citation II

distortion produced. Thus, if one stage has twice the distortion of another, it should have twice as much feedback around it. The three feedback loops employed in the Citation II include: one from each 12BY7 driver tube plate to its own grid, one from each KT88 output tube plate to the opposite driver grid and one from the secondary of the output transformer to the cathode of the 12BY7 input stage. With this design, 32 db of overall feedback was achieved in the Citation II with unconditional stability.

Circuitry of the Citation II

The power amplifier consists of two identical 60 watt continuous rated power amps on one chassis with a shared power supply. The power supply is a low-resistance voltage doubler type with silicon rectifiers, more than adequate capacitance mounted under the chassis and a filter choke for B+ filtering. Basically, the amplifier design employs a distributed-load (Ultra-Linear) output circuit using KT88 beam tetrodes operating in push-pull with fixed bias. Still thought by many as controversial, 12BY7A video-output pentodes were used in all low-level stages for extremely wide frequency response and minimal distortion. To test the wide frequency range, pulse amplifier techniques were applied to the 12BY7A video pentodes feeding into a low impedance load which provide a flat frequency and phase response beyond the capability of the output transformer.

The front-end of the amplifier starts with a 12BY7A as the input amplifier driving a pair of 12BY7As as a long-tailed phase splitter which in turn, drives a pair of KT88 beam power pentodes. Later versions of the Citation II were shipped with Tung-Sol 6550s which were mentioned as the recommended replacement in a 1963 Citation newsletter.

Bias for the output tubes was individually adjustable with four separate pots on the back of the chassis. Bias readings were read using the handy built-in meter and a six position switch. The AC balance was also metered and was adjustable

with two additional pots on the top of the chassis. The early Citation IIs had a larger black-faced square bias current meter and later units had the smaller, built-in bias current meter. Negative control grid bias voltage on pin 5 of the KT88 is set at -45 volts with the plate and screen at 450 volts dc.

Nice Things Come in Big Packages

The amplifier was beefy in size and weight. Dimensions were 16 3/8 inches wide, 11 1/2 inches deep and 9 inches high (41.6cm by 29.2cm by 22.7cm). Finish was gloss charcoal brown with gold highlights and lettering. The bottom plate was light champagne gold and made of either iron or aluminum sheet metal. An optional perforated metal tube cage was also available. When sold as a kit, the three transformers were shipped in a separate box that weighed in at 50 pounds (22.7 Kg). The completed amp weighed 60 pounds and shipping weight was 70 pounds!

Speaking of output transformers, the Citation II's were outstanding! They were huge, well-potted units that had extremely wide response characteristics. Leakage inductance in these transformers was kept to an absolute minimum and the distributed capacitance of the primary halves were carefully balanced against each other to maintain natural resonances of the unit well above 200,000 cycles. The massive design utilized the highest grade core materials available which lowered the effect of core distortion to a region well below the limit of human hearing. With feedback, the Citation II transformers were capable of high frequency response up to 270,000 cycles!

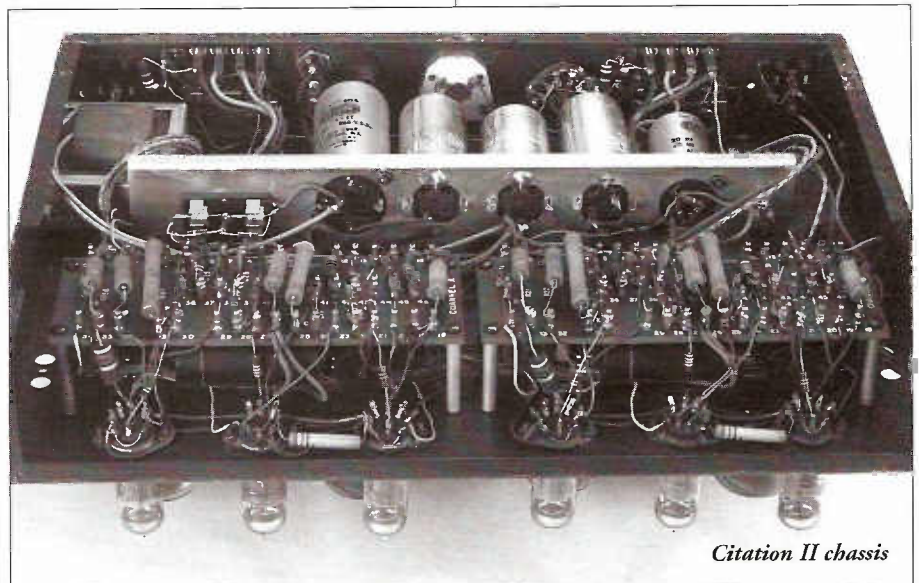

Citation II chassis

Harman-Kardon Citation II schematic - early version

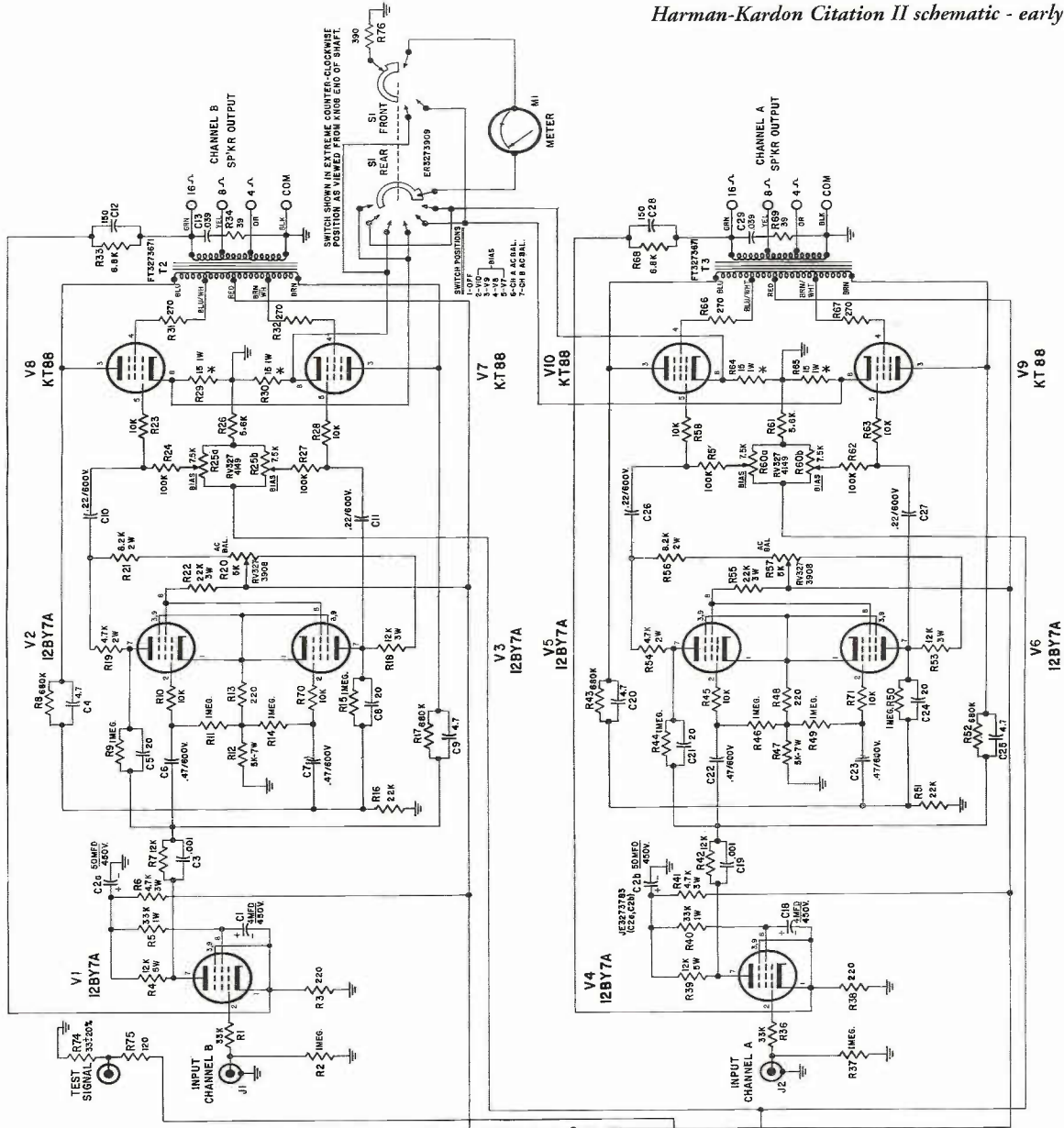

- NOTES:**
- 1- ALL RESISTANCE VALUES IN OHMS ±10%
 - 2- ALL RESISTORS 1/2 WATT
 - 3- ALL CAPACITORS WITH DECIMAL VALUES IN MFD
 - 4- ALL CAPACITORS WITHOUT DECIMAL VALUES IN MMF
 - 5- ALL COMPONENTS MARKED WITH * MUST BE MATCHED

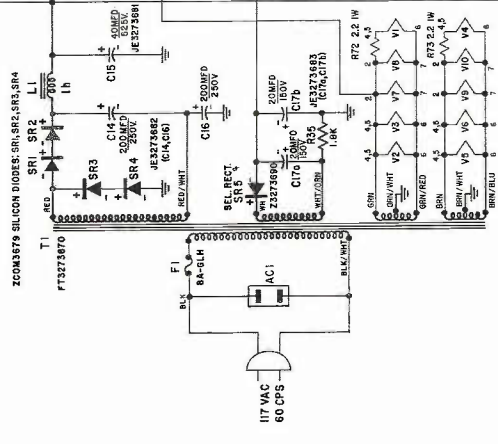



Late Citation II Bias Meter

There appear to be three distinct variants of these transformers: the early version had cloth tubing to guide the wire out of the bottom of the transformer, the next version had rubberized cloth wiring for the same purpose and the last version had the wire going through rubber grommets on the bottom of the can. Apparently, the first versions of this transformer did not have the performance of later versions according to local amp builders and transformer experts. Freed Transformer Corporation of New York was the sole manufacturer of the output transformer and their part number is FT-3273671A. Freed also made the power transformer for this unit.

Building the Kit

The Citation II was a kit builder's dream: no circuit boards and components that were bigger than life. The instruction manuals were well-written and easy to understand. Large diagrams illustrating various stages of construction were included to avoid confusion and errors. Much of the wiring was in the form of a harness that is assembled on a cardboard jig by the builder before it is installed in the unit. The cardboard jig showed the correct length of the wire to be cut and even had holes punched to hold the wire in place. Military type turret boards were used with an outline of the part and its value stenciled on the board. All small parts were poly-bagged and detailed instructions with templates were included and a diagram to make up the wiring harness made construction easier. It was apparent that considerable thought and preparation went into the development of the Citation II as a kit. Approximately 12 to 20 hours were required to assemble the Citation II and when it was complete,

you can be sure the new owner was very pleased.

Factory Specification of the Citation II

- Sustained power output: 60 watts per channel
- Peak power output: 130 watts per channel
- Harmonic distortion:
 - <.5%, 20 - 20,000 cycles @ 60 watts
 - <.1%, 20 - 20,000 cycles @ 20 watts
- Intermodulation Distortion =Same readings as Harmonic Distortion;
- Frequency Response:
 - 60 watts, 18-40,000 cycles +0, - 1.0 db
 - 20 watts, 12-60,000 cycles +0, -1.0 db
 - 1 watt, 2-80,000 cycles +0, -1.0 db
- Output impedance:- 4, 8, and 16 ohms
- Damping factor: Greater than 18

- Feedback: 30+ db
- Hum and noise: Better than 90 db below 60 watts
- Sensitivity: 1.5 volt RMS input for 60 watts
- Power consumption: 350 watts

Restoration of the Citation II

Over the years, I have personally owned several IIs and have found them in all types of conditions. Typically, the tops of the transformers had scratched or scraped off paint. Some were missing meters or bias adjustment switches, many had broken or missing tubes and all had leaky capacitors. If you are planning to listen to and use a II, careful planning is in order for proper restoration. Items to consider include: replacement of all electrolytic capacitors, replacement of all coupling and bypass capacitors, replacement of all power supply diodes, checking and replacing drifting value resistors, checking all wiring for shorts and bad solder joints, possible replacement of tube sockets with modern ones, testing and replacement of all tubes.

Many Citation IIs have blown up because some idiot plugged the amp in without trying to form the electrolytic capacitors with a regulated power supply or a variac. NEVER plug any old amp directly into AC power until you check all electrolytic power supply capacitors for leakage and form them up slowly. Sometimes old electrolytics have a constant leakage and must be replaced for correct operation of the amplifier. Can-type twistlock electrolytics are difficult to find anymore but the blue plastic covered British electrolytics available from the mail-order suppliers will work fine when

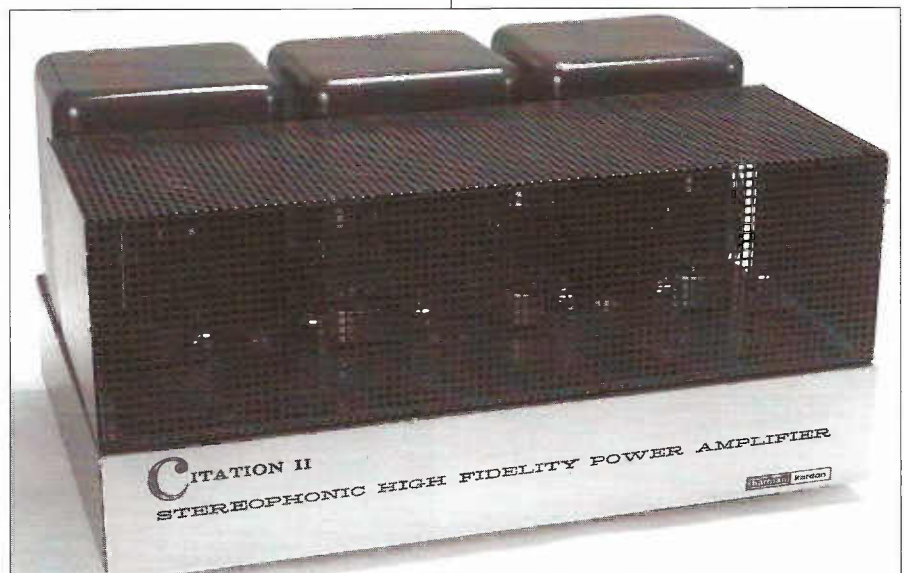



Citation I

you change the mounting hardware. You can also try single-value axial electrolytics wired in series or individually, if rated at a higher (350 +v) voltage.

On the Citation II, the original black plastic paper coupling capacitors are located on the bottom of the two terminal boards. To access them for removal, it may be necessary to remove the screws holding the boards to remove them. Some nimble fingered types can also try to remove the caps by de-soldering them first. For replacement coupling capacitors, try Hovland Musicaps, Kimber or Rel-Caps. They are expensive, but worth it in gear you plan to listen to. They will open up the soundstage much better than NOS Sprague Black Beauties or Vitamin Q oil types. Some of the other "designer" capacitors can sound harsher to sensitive ears.

The ultimate output tube for the II is the original GEC KT88. However, this vintage glass is extremely rare and costly. GEC KT88s have a rich upper-bass and a glorious mid-range. The highs are sweet and extended but the low bass is not as tight as a good 6550. I have used all types of 6550s in the Citations. The Tung-Sol 6550s are typically your best bet, but are now quite expensive. They warm up faster, have sweeter mids and highs, but do not have the "slam" type bass some people like. On the other hand, the GE-6550As are less expensive, have stronger bass, but are harsher on the top end and take at least an hour to warm up before they sound bearable. The new 6550C Svetlanas (flash getter) are improved with better tube burn-in and aging at the factory and feature a gold plated grid wire. They have the bass of the GE-6550As, but are warmer in the mids and highs. The new Svetlanas are more bias stable than the early clear top version of this tube, which is noticeably

inferior. The six 12BY7 video pentode front-end tubes are still available from mail-order tube dealers and Hamfests, etc. Good 12BY7 brands to use are RCA, Sylvania and GE. Avoid Japanese types that are often rebranded as Amperex, CBS or Raytheon as they are less reliable and typically more micro-phonous.

Diodes do go bad with age and heat, contrary to some "experts." It is best to replace both the voltage doubler diode bridge and the bias supply with newer silicon diodes or the new, high speed types for the best reliability.

Modifications - Worth it ?

Most modifications of Citation IIs revolve around replacement of the 12BY7 pentode front-end circuitry. For whatever reason, some tubeheads insist that a

pentode front-end cannot possibly sound good and that all tubes in the first audio and phase inverter stages must be triodes. This theory has resulted in thousands of Citation II amplifiers being hacked up by audio experimenters. If the amp is a basket case cosmetically and not worth restoring or collecting, it might be ok to experiment with front-end tubes like the 12BH7, 6CG7, 6FQ7, etc. Remember, however, that the circuit parameters, voltages and tube pinouts will all be different and taking on a project like this is a lot of work if you want to do it right. Some folks have even use 6SN7s in the front end by cutting octal sized holes in the chassis. Many Citation II amplifiers have been killed for the transformers to build custom amplifiers, which in some cases sound worse than the original and wind up having little resale value, except for the transformer set.

The Sound of Citation

For two and a half years, I used a stock Citation II in one of my home systems and was impressed with the more than ample headroom, ease of high frequency passages, big soundstage and solid, tight bass. Speakers used in my system were Klipsch Chorus ones for progressive rock and jazz and Acoustat Model II-MHs electrostats for classical and acoustic music. The Citation II drove the more inefficient Acoustats with ease in my large listening room. In fact, the Citation II was the amplifier of choice at the FM tuner shoot-out #1 in 1992. Several members of the Northern California Tube Enthusiasts present commented on how

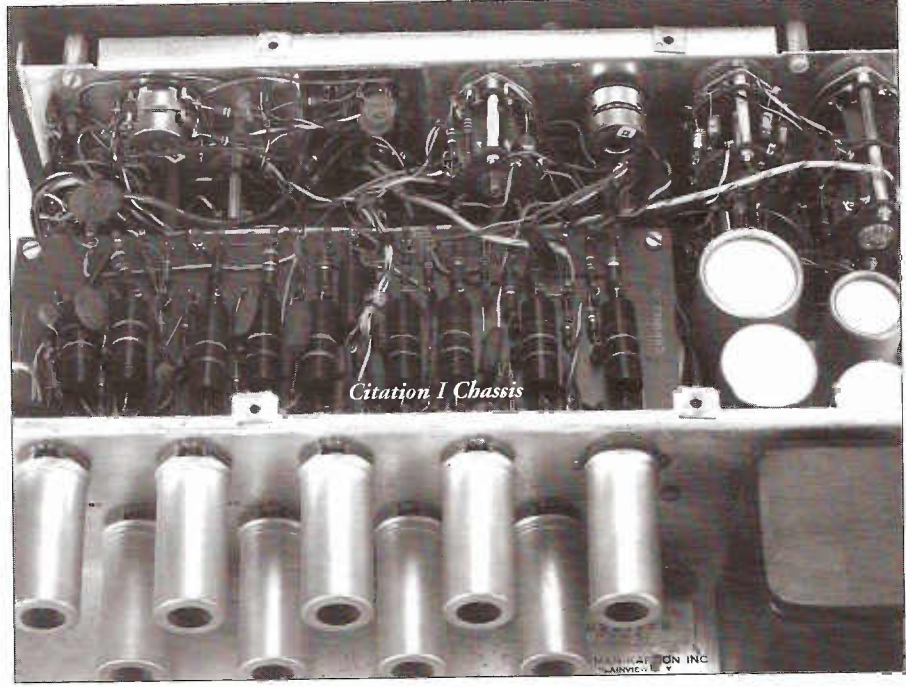

Citation I Chassis

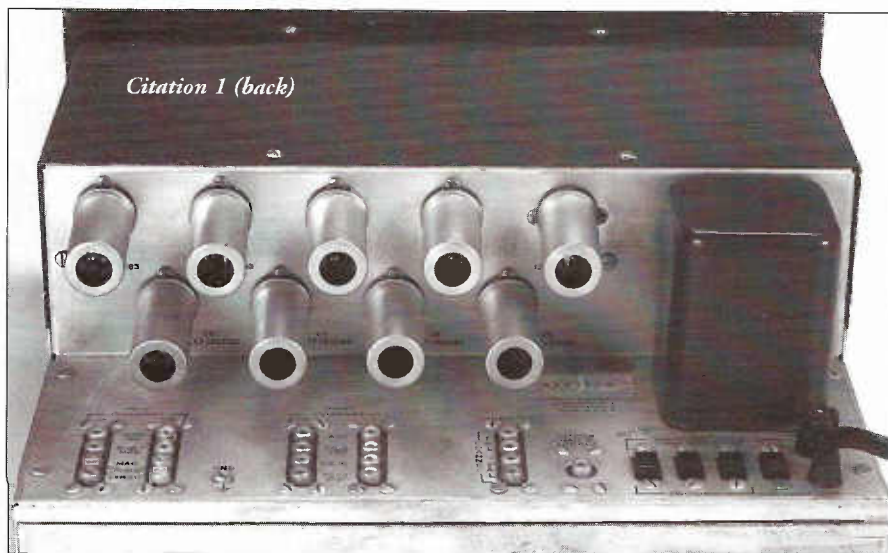

natural the amplifier sounded. I prefer the Citation II for popular music because it is very live sounding, with big punchy bass. Others listeners insist that the Citation is too hard sounding for classical or acoustic music. Some feel that the pentode front-end limits the sound quality and try to modify the unit by putting triodes in place of the 12BY7s. I think this is kind of a waste because the original designer knew what he was doing. If properly restored and used with the right music and speakers, the Citation II is a brilliant performing amplifier however, It is definitely not for the typical single-ended fanatic.

The Citation I is Born

Within a month after the Citation II kit was introduced to the electronics press to assemble and review, the Citation I (\$159/249.), a matching tube stereo pre-amp kit, was unveiled. It was an impressive, full-featured unit with 18 stages featuring nine dual triodes (four ECC83/12AX7 and five ECC81/12AT7.)

Some of its unique features were:

1. Separate bass and treble step-type tone controls for each channel. Tone controls completely out of circuit when in the flat position. The stepped bass and treble controls had four boost positions, one flat and five cut positions. Each bass and treble switching position was carefully contoured for optimum response and a minimum of treble ringing.
2. Each amplification stage was flat over a wide frequency range and was surrounded by a feedback loop.
3. Anode follower outputs extended low frequency response by including the

output coupling condenser in the feedback loop.

4. D.C. via silicon rectifiers on all heaters and low noise resistors in critical areas.
5. Separate turnover and roll-off equalization controls for continuously variable phono equalization.
6. Continuously variable blend control control acting as a third channel control or a crossfeed control if center channel is not used.
7. All inputs and outputs on the same plane in the back of the chassis. Heavy-duty 14 gauge metal faceplate. Heavy-duty potted power transformer and smoothing choke for B+ voltages.

Citation I Specifications

Frequency response: +0, -5db, 5 - 80,000 cycles
Distortion: Less than .05% at 2 volts output
Total noise: Less than 85 db below rated output (high level)

Assembling the Citation I Kit

The assembled version of this unit cost \$100 more than the kit version. It typically took over 30 hours for a beginner to assemble a Citation I kit. The pre-amp consisted of five basic sections: two military-type phenolic terminal boards, one for each channel, the main chassis, the front panel and the power supply. The assembly job required patience and some degree of skill with hand tools and soldering. You can bet that when it was done, the new owner was thrilled.

Restoration of the Citation I

When first introduced, the Citation I was a revolutionary preamp with features

ahead of its time. When used with a Citation II and the right speakers, the results were outstanding. As a vintage piece of gear, it has its limitations due to the high number of capacitors in the circuit that give the sound a veil or haze and seem to limit the high-frequency response. If you plan to actually listen to the Citation I in your system, you should consider a complete re-cap job using modern polypropylene capacitors in all signal path applications. Also, resistors should be checked for drifting values and replaced with newer carbon film or high-quality types, especially in the signal path. The electrolytic capacitors should be replaced as should the older silicon diodes with low noise - fast switching diodes, such as the International Rectifier HexFRED™ type. When restoring classic hi-fi equipment such as the Citation I, remember to take your time, be neat and do a good job.

Sound of the Citation I

If a good restoration is done, the Citation I can sound excellent, with full frequency response, and clear, musical highs. According to some tube enthusiasts who have restored a I, the sound is similar to a Marantz Model 7, but with more features, such as the stepped attenuators and full featured phono stage. Other tube audio hobbyists have taken tube stages out of the preamp and simplified the circuit because they were unhappy with the stock sound after restoration. Remember any significant modifications will affect the value and resale potential to a collector of vintage hi fi.

In Conclusion

In their day, the Citation I and II were the hot set-up for high performance audio. They provided more watts and sound for dollar than almost any of the competition. If these units are obtained by the reader, they should be kept stock if you are collecting them, but if you will be using them in your system, do a careful job in restoring them and you will be rewarded with a very versatile and powerful audio amplification system that rivals contemporary tube amplifiers costing up to \$3500.

Citation 3, 4, 5 and 10 will be covered in a future VTV article.

References:

1. *Electronics World*, June 1960, 2. *Audio*, January 1960, 3. *Audio*, December 1960.

Original Harman-Kardon Citation factory manuals and Harman-Kardon catalogs.

Purple Speaker Eater

Citation II Mod

California Style

by Charlie Kittleson

In his typical Southern California style, Dan Steele of San Luis Obispo has come up with another creation. This time it is a modification of the Harman-Kardon Citation II called: *The Purple Speaker Eater*.

The amp was completely stripped and rewired with teflon coated silver wire on ceramic terminal strips from an old Tektronix scope. Power supply was beefed up with four 1800 mfd @ 200 volt filter caps for the voltage-doubler supply. All diodes were upgraded to 1000 volt at one amp premium units. Power resistors and signal resistors were upgraded with premium units. Dan even included a solid-state time delay that lights the filaments first, then 45 seconds later applies B+ to the plates of the KT88s.

The front end was completely re-done with new ceramic and gold tube sockets, the usual removal of the 12BY7 pentodes which were replaced with an EF86 first audio, one-half of a 12BH7 dual-triode as the phase inverter and a 6GX7 eye tube tied to the output of the amplifier!! The power tubes were a set of original Genalex KT88s in like-new condition.

Dan knows an excellent powder coating operation in San Luis Obispo who finished his amp in candy apple purple with lots of clear coat for a super deep gloss effect. The front panel is done in platinum powder coat with the same clear coat. Transformers are done in gloss black enamel as they couldn't be powder coated.

We auditioned the amp at VTV offices after a recent flea electronics market and did some tube rolling and listening. First, we tried the amp with the 12BH7 and noted the sound to be solid, with tons of headroom. The modified Citation easily drove the inefficient BW DM110s and filled the room when hooked to the Klipsch Chorus ones. The highs were sweet and extended, bass was solid and powerful and the mids were good, but not outstanding. Then Dan

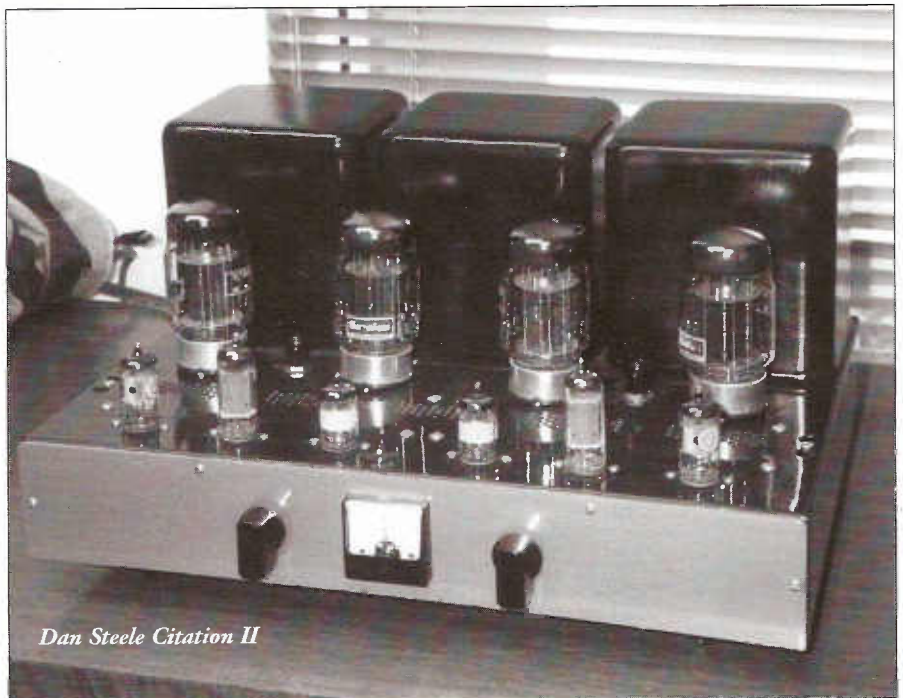

Dan Steele Citation II

pulled out an adapter socket that permitted a 12B4 triode to be used as the phase inverter. With the 12B4, the bass was too forward and the mids and highs were more recessed.

Needless to say, we went back to the 12BH7. Overall, the modified unit was tighter sounding than a stock, restored Citation II but was more refined. In a later issue of VTV, we will feature more detail on this modification and other Citation II mods.

john d. eckland
 Expert HI FI Service
 Custom Built Amplifiers
 969A ADDISON AVENUE PALO ALTO, CALIFORNIA 94301
 Davenport 3-0101

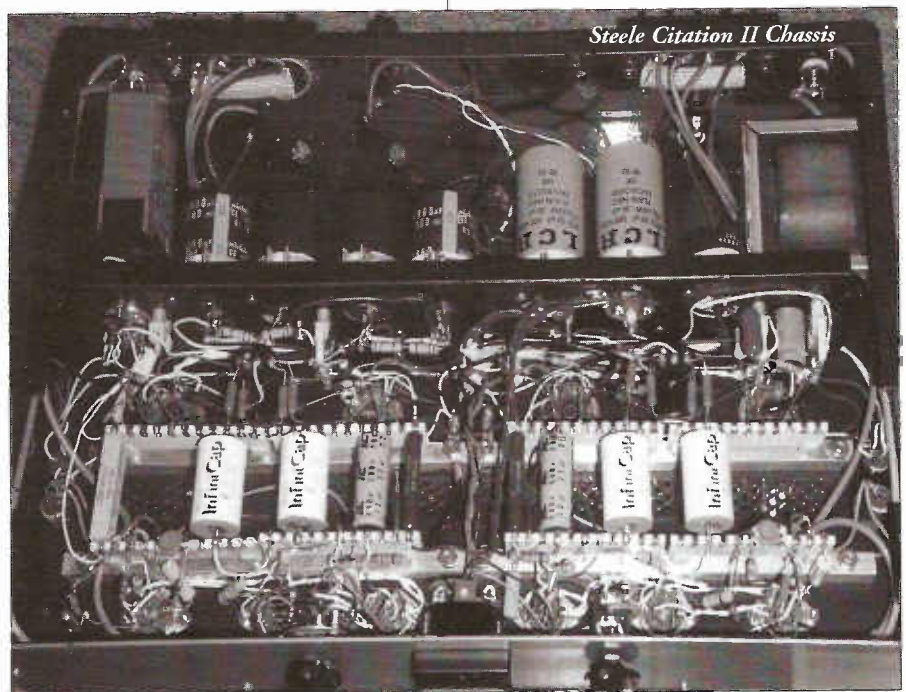

Steele Citation II Chassis



Cathode Bias

by

John Atwood

Designing for Sound

One of the most misunderstood aspects of audio design is the impact of sound equipment on the nature of the reproduced sound. Whether we like it or not, all equipment (both electronic and acoustic) leaves its imprint on the sound passing through it. In purist audiophile systems, this imprint may be nearly insignificant, while in a guitar amplifier, the imprint often *is* the desired sound. The misunderstanding comes about from both the designers and the users of audio equipment. The designers can have various ideas about the sonic imprint of their equipment – ranging from denial of the imprint to strange theories on the cause of the imprint. The users may not understand the relationship between what they hear and what they want – resulting in them specifying one thing while actually wanting another. I am in the process of trying to sort out these misconceptions. Some of the different needs and misconceptions for various categories of audio design will be discussed below.

High-End Audio

High-end audio is the direct descendant of the “high-fidelity” movement of the 1940s through the 1960s. The engineers of hi-fi audio equipment constantly strived for less distortion and more accurate reproduction. The culmination of this was Harry Pearson’s concept of the “Absolute Sound” – the illusion of live musicians playing in your living room. To even remotely approximate this requires minimal coloration of the sound and extremely careful miking and recording techniques. Individual enthusiasts can lavish time and money on systems that often are far less colored than even excellent recording studios. This leads to an ironic situation: that the more accurate you make your system, the worse it can sound. This is because deficiencies in the recording studio end of the reproduction chain become more and more apparent.

Efforts by audiophiles to make their systems sound better are often just unrecognized attempts at coloring the sound to counteract or mask deficiencies in the recording studio or recording medium. However, overlaying one type of coloration over another can be unpredictable, especially when the user doesn’t recognize the coloration for what it is. It

isn’t helped, either, by unscrupulous manufacturers, dealers, and magazine reviewers who feed the audiophile’s compulsion for better sound with various “snake-oil” solutions. The result is a constant turnover of equipment and uneasy frustration with the sound quality.

High-end equipment designers have generally polarized into the “meter-reader” and “golden-ear” camps. What each side won’t admit is that they need each other. The meter-readers need to actually use their ears and admit that their measurements don’t tell the whole story about the sound. The golden ears need the engineers to keep their equipment reliable and need measurements to keep their systems from degenerating into a miasma of conflicting colorations. Above all, the audiophile consumer needs to use his ears and cultivate an understanding of what high-quality sound is like.

Casual Listening

Casual listening is defined here as a listening situation where the prime goal is to enjoy the music as reproduced, not recreate a live performance. Strict accuracy is not necessary, and actually is not desired, since some colorations are needed to mask deficiencies in the recording process and playback environment. Casual listening can take place on anything from a good hi-fi system to a decent portable radio to a car audio system. The key here is to make the music enjoyable, and that means: balanced, but not excessive frequency response, moderately low distortion with even order distortion products dominating, and an absence of non-euphonic artifacts (such as “digititis,” crossover distortion, and intermodulation distortion).

The most common problem with casual listening is that the reproduction systems most commonly used (cheap stereos, car stereos, boom-boxes) are pallid imitations of true hi-fi systems. They have too broad a frequency response, cheap solid-state amplifiers with too much crossover distortion and high-order harmonics, marginal digital circuits, and speakers with excessive cabinet resonances (if they have cabinets at all). The result is listening fatigue. Listening to a good 1930s or ‘40s AM radio would be an ear-opener to the designers and users of this equipment. The specs are awful, but the mellow, balanced sound is really enjoyable.

Home Theatre

The movie industry has developed the art of sound to support on-screen action to a high degree. Any motion-picture

sound engineer will tell you that the goal of movie sound is not accurate sound reproduction, but to create an emotion in the viewer. Thus, in the same way movie shots are staged and edited, the work on a motion-picture sound-stage is to create, modify and enhance the sound to complement the action on the screen. Over time, certain sound stereotypes have developed (a movie gun-shot sounds nothing like the real thing), and these stereotypes must be preserved. Other techniques have been developed in efforts to impress the audience, such as loud effects, surround sound, and “Sensurround”. The important point, though, is that the sound reproduction exists to support a visual image, not to be enjoyed on its own.

The trend towards “Home Theatre” installations in the home is an effort to bring the impressive audio effects of a movie theatre into the listening room. It also is an acknowledgement of the poor sound of regular TVs. However, the exaggerated dynamics, synthesized hall acoustics, and disregard for phase coherence makes home theatre poor for either high-end or casual listening. People who replace their hi-fi system with a home theatre system or those who rely on home theatre for casual listening will be disappointed.

Elevator Music

Elevator music, easy listening, background music, and Muzak® all have the purpose of providing a musical wallpaper: a nondescript background noise that triggers positive responses in the brains of the listeners, without distracting them from their work. Pioneered by Muzak in the 1930s and ubiquitous today, background music distills the essence of music to a bare minimum, yet recognizable form. Recent relatives of elevator music include new-age music and “ambient” music.

Although most elevator music offends the sensibilities of nearly anyone with musical interests, it has been the most scientifically studied class of music and reproduction of any of the categories listed here. It is also one that is treated as a complete system, often under the control of the same company from recording studio to supermarket loudspeaker. As a result, its implementation, at least by commercial providers, is quite effective. This is a sad commentary on the state of audio reproduction in other fields.

Radio and Public Address Systems

Practically speaking, commercial radio broadcasting and public address systems share the same goal: to bring a message to people in the most effective form. Often, this means overcoming background noise, resulting in the need for compression and limited frequency response. This is the case of AM radio. FM radio was founded on the premise of true high-fidelity. However, market forces being what they are, virtually all commercial FM broadcasts are compressed to play better in a car and to sound "louder." Non-commercial FM stations often treat their sound the same way because their technicians try to copy the techniques of the commercial stations. The result is a disappointment for those who listen to FM radio in their living rooms for musical enjoyment.

Public address systems will intentionally limit the bandwidth to improve "intelligibility." Since intelligibility is little affected by amplitude distortion, little care is taken in the signal path to keep distortion very low. For simple systems for broadcasting voice, this is not much of a liability, but the big problem is that P.A. equipment is often used by the next category.

Sound Reinforcement

Most "live" performances today use some form of sound reinforcement. Unlike a public address system, a sound reinforcement system needs to faithfully reproduce the instrument or voice it is amplifying. It actually has the same goal as high-end audio, and thus needs as good electronics and speakers as high-end audio. It actually has a more difficult task, since uniformly good reproduction is necessary over a large area.

Unfortunately, most sound reinforcement is done using P.A. equipment. This is so common that many people come to expect an "electronic" sound coming from the stage, with all sorts of artifacts. Sound engineers involved in sound reinforcement would do well to study the ideas behind high-end audio, and use their ears to judge their results.

Electronic Musical Instruments

Electronic amplification of musical instruments started as an attempt to simply magnify the sound level of instruments. With the advent of rock and roll, guitar amps got pushed well beyond their linear regions, and soon the sound of the amp and speaker became the major part of the desired "tone." A few designers, such as Leo Fender, designed their equip-

ment by ear, but as guitar companies were bought by big corporations, and technology marched into the solid-state era, many amp designs lost the classic tone. Because the players still wanted it, though, the result was the current surge in amplifier mods and classic amp reissues.

Of all the categories, guitar amp designers and users are the most acutely aware of the contribution of their equipment to the desired sound. The problem here is that the technical sophistication of most players and even designers is poor. Attempts to get the right tone are often hit or miss, with the result that many fall back to the "safe" designs, such as the 1959 Fender Bassman or 1965 Marshall. There are lots of voodoo and snake-oil solutions. Reliability often goes out the window. What is needed is a bit of scientific method and scholarly interchange in analyzing and recreating the right tone.

Summary

In nearly every area of audio reproduction is an element of dysfunctionality – a persistent gap between the optimum solution to the particular reproduction problem and what the manufacturers make or what the users "want." This usually is the result of manufacturers' failure to improve their designs or the brain-washing of consumers with marketing hype. Solutions to this problem cannot be legislated. The only answer is encouraging both designers and consumers to use their ears and to be aware of what sounds they are creating or listening to. In the future, some of these issues will be explored further in this column. My goal here is to raise everyone's consciousness about the sound they are creating or hearing.

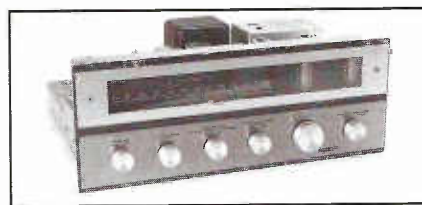

Next Time in VTV: FM Tuner Shoot-Out Featuring The Best Vintage Tube And Solid State Tuners. Don't Miss it in VTV #5 out Late Summer 1996

Subscribe Today!!!



S.E. OUTPUT TRANSFORMERS

MODEL	PRIZ	Ip	PRICE
CT3KB	3K Ω	100mA	\$195.00
MT5KB	5K Ω	60mA	\$195.00
VT2KB	2.7K Ω	160mA	\$249.00
*E18B	6K Ω	100mA	\$195.00
**E48B	1.8K Ω	350mA	\$425.00

- -.5DB 20 KHz to 30 KHz
- End Bell Construction
- Secondary Wire Output (No Splice)
- * For SV 811-3
- ** For 4 x SV 811-3 60+ Watts

Call Our Design Department For Any Custom Requirement

Electra-Print Audio

1311 N. Winwood St.
Las Vegas, NV 89108
702-646-7990
FAX 702-646-7752

Dr Bottlehead says:

Hey bottleheads! Have you built an amp with TV tubes? Ever put QUADS, Lowthers, and A7's in the same room? Did you make a tube output for your CD yet? NO? Well quit readin' and dreamin' and get that iron hot. It's time to put your solder where your theory is. Join **VALVE**, a gonzo, dumpster-divin' tube audio club, stuff your head with a monthly newsletter full of radical tube ideas, and build somethin'! Send me 25 bucks (\$35 overseas) and I'll send you 12 monthly issues. Heck yeah, we got back issues. Two years worth!

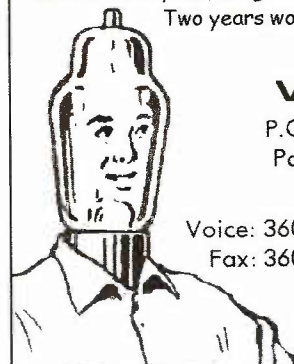

VALVE

P.O.Box 2786
Poulsbo, WA
98370

Voice: 360-697-1936
Fax: 360-697-3348

Tube Industry News



by
Eric Barbour

300B Forever Indeed

The 300B is becoming so popular that Shuguang is trying to market four (count 'em, four) versions. We obtained a distributors price list at the recent Winter CES in Las Vegas, and it listed all of Shuguang's audio tubes. There were a few things listed that had not been seen before. In addition to something called an "EL34 copy of Mullard," there were four versions of the 300B. One was "standard," one was "copy of WE," one had a graphite plate, and the fourth was not given any special designator.

Thanks to J.C. Kuo of Quadric Audio, we obtained one each of the "copy of WE" and graphite-plate versions. Both were in cartons marked with the Royal brand name, which was also on the tubes themselves. The graphite-plate unit had the Royal brand in gold flash on the inside of the envelope.

I tested them on our bench amplifier, in the same manner as the 300Bs in our report in VTV #3. Running at 300V 75mA, and at 500V 50mA, distortion at 1 watt into 8 ohms was measured.

Distortion and Bias at 300V 75mA:

WE Westrex 300B(1995)	095%	-51V
Shuguang 300B standard	.125	-50
Royal 300B "copy of WE"	.170	-54
Royal 300B graphite plate	.130	-51

Distortion and Bias at 500V 50mA:

Shuguang 300B standard	.270	-112
Royal 300B "copy of WE"	.590	-122
Royal 300B graphite plate	.330	-115

The graphite-plate unit looks very interesting. I suspect that it can be run much harder than any other 300B, and distortion will decline (and sound quality will increase) as plate current is increased. The "copy of WE" was indeed very close to an old Western Electric in appearance, with wire-hook filament tensioners and a center-tapped filament. But you can tell that it is not original, as the getter flash doesn't look the same and the glass envelope is not top-quality. Still, if you are in the market, these tubes are worth trying.

Rumors

There are persistent stories about a small tube production line being started

in the L.A. area, trying to make 6CA7s, 6L6GCs and 6V6GTs the way Sylvania used to. Still no product in sight. I know you guys are reading this: how about sending us some samples?

Ei-RC, the valve manufacturing arm of Elektronska Industrija Nis, Yugoslavia, has signed an agreement with Edicron Electronic Components of Oxfordshire, UK under which Edicron will be responsible for the international marketing and have the exclusive world-wide sales rights. The first valves off the production line will be the **KT90** in May 1996. For more information contact: Adrian Bailey, Edicron, Park Road, Faringdon, Oxfordshire, SN7 7BP England +44 (0) 1367 243030 (FAX)

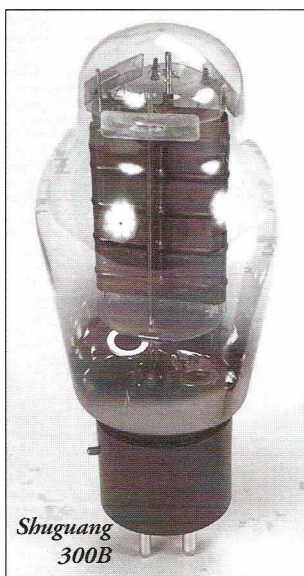

Hammond is trying to get into the SE output-transformer market. We saw one of their 1629SE units, and it wasn't exactly the world's best. But they seem to be serious about it, and are working on new designs, primarily for 300Bs.

The VAIC Valve VV30B and VV52B tubes will be available exclusively in their amplifiers. They are allowing no sales to DIY builders or OEMs. According to a letter VTV received from VAIC owner, Dr. Riccardo Kron - "Our retailer experience in America has shown that 80% of the hobby do-it-yourselfers and small cottage home builders lack minimum know-how in approaching a completely new tube and tube technology, in that copying from old diagrams is not sufficient to design."

VAIC is coming out with a VV300B, intended as a compatible replacement for the WE 300B.

We got two samples of the new Tesla KT88. It is being sold by Groove Tubes now, and my tests show that it is excellent. I put 500V at 100 mA into one, and it did not protest at all. The new KT88s also had an excellent sound, with rich midrange and solid bass. Should be good for all those DYNA Mark IIIs, Citation IIs, Mac 275s, etc. out there. More about it in my 6550/KT88 article in a future VTV article.

Hello Out There !!

When we ran issue #1, we asked for press releases for manufacturers and distributors. But not much has come our way. Most of what we do see is either from readers (usually telling us how much they like VTV.....thanks to all), or from transformer manufacturers reacting to our SE transformer articles in the last issue.

C'mon! Why are companies like Richardson and Eimac being so secretive?? It can only help sales if you are mentioned in VTV. We are read by numerous OEMs and dealers, in high-end, pro audio and guitar amps. So do yourself good and tell us (and our readers) what you're up to!

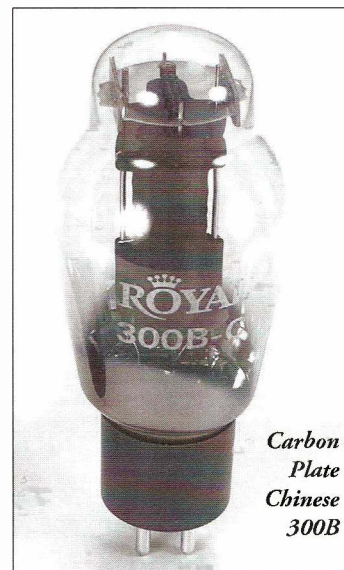

one electron™
tube audio designs and consulting

One Electron
65 Washington Street, Suite 137
Santa Clara, California 95050 USA
FAX: 408 985-2006
email: atwood@one-electron.com
<http://www.one-electron.com>

John Atwood
Engineer

A Tube Manual Fragment Or a Comparison of Various Tube Manuals

By Paul Joseph Bourbin

Tube manuals are a necessary part of the tube audio enthusiast's library. They can provide a wealth of information that helps the tube enthusiast to appreciate their equipment, and are a necessity if they want to design or build their own equipment. They also can be useful when troubleshooting; especially when you don't have a schematic.

Typical information included in tube manuals includes: base pinout, physical dimensions, bulb type, heater voltage and current, plate and grid voltages, plate and grid dissipation, transconductance, amplification factor, plate current, grid bias resistor value and plate resistance. As you can see, a lot of application and technical information.

The dilemma is that there are a lot of tube manuals around. While some obsessive types want as many manuals as they can find, many of us are limited by space, or other considerations, and just want a practical number that will satisfy our needs.

In this article, the author will review a number of different manuals in the hope that this exercise will enable the reader to be able to intelligently choose the manuals that will be the most useful for their needs and, perhaps, save some space and money as well.

RCA

The first company that we will explore is RCA. Their manuals seem to be the most commonly available and, therefore, merit the closest consideration. They are the type that one is most likely to find at bookstores, swap-meets and mail order book sellers. RCA tube manuals come in many different types.

According to Barry Nadel, who has made a study of the RCA-Cunningham series, the series went from RC-11 to RC-30 (1975). There were separate RCA Radiotron and Cunningham manuals published prior to 1932. A single example, R-10, is known to the author. It is postulated that the "RC" designation delineates a combination of the Radiotron and the Cunningham manuals. The "RC" series of softbound RCA tube manuals started about the same time as did the beginning of High Fidelity, 1932,

and continued to the end of the tube era (1975).

Each of these manuals contains a wealth of material, much of which is repeated from manual to manual. One need not own the entire series to obtain the information required. As older tubes became obsolete (in the eyes of the manufacturer, not necessarily the tube enthusiast), they would be relegated to the back of the manual and less information would be given about them. Therefore, it behooves the enthusiast to acquire at least some of the older numbers to be sure to have all the necessary information. For this article, we will examine RC-11,12,13, RC-14,15, RC-20, RC-22,23,24 and RC-29 and 30 receiving tube manuals.

RC-11-13 manuals were printed in the mid-Thirties. Herein, one will find the 2A3, the 2A5, the 10, 250, 6L6 and



RC-13, 14 and 15

even the '01A discussed in detail. The manual starts with a discussion of vacuum tubes. The end of the book has circuit diagrams showing "typical" examples of various circuits, as well as tabular tube information, base diagrams and obsolete tube information. This format was followed throughout the series.

Manual RC-14 (1940) and the RC-15, from 1947, are almost twice as thick as their predecessors. While there is great detail for the 2A3 and the 6L6, the 10 and 50 tubes are discussed only briefly. There is a nice discussion of resistance coupled amplifiers, along with the usual circuit diagrams and tabular information. These manuals were printed at the start of the "Golden Age" of High Fidelity.

RC-20 - 22 were printed from 1960 - 1962 towards the end of the "Golden Age," when tube hi fi stereo became fully established. They have much interesting information for the High Fidelity amplifier designer and appreciator. Various circuits used in Hi-Fi applications are discussed in detail. The 2A3 and 6L6 are

still mentioned in detail, but most of the early triodes are barely mentioned. Few industrial numbers are mentioned (5881, 6973, 7025, 7189, 7199, 7591 are), and only one foreign-numbered type is mentioned.

RC-23 (1964) is essentially the same as RC-20, except the 2A3 is obsoleted and there are more of the industrial types.



RC-22 and RC-24

RC-24 (1965) is heavily weighted toward the (then) latest Compactron television and sweep tubes and only has older tubes very briefly mentioned in the back.

RC-29 (1973) is similar to RC-24, except that there is more emphasis on the



RC-29 and RC-30

industrial and foreign tubes with even more Compactron television tubes with non-standard filament voltages. RC-30 was the last full range tube manual produced by RCA and is also the one most sought after by tube enthusiasts because it has the most tube types listed. As you can see, possession of a smattering of the RC-series manuals can give the enthusiast much of the tube information that he needs.

RCA also produced a loose-leaf, six volume manual called the RCA Tube Handbook HB-3. This was a subscription service for designers, engineers and technicians where the subscriber would be sent new tube update sheets regularly to be inserted into their proper places in the binders. The HB-3 set goes back to the early tubes and continues into the sixties

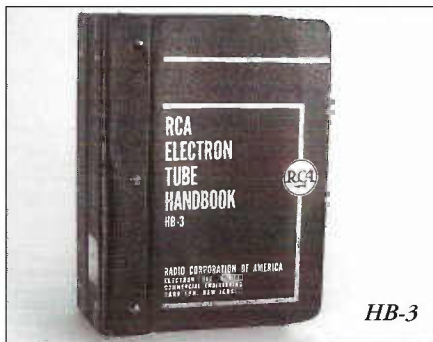

HB-3

including Nuvistors. The data on each tube is about the same as the best information available on the tube in the "RC" series. The information covers all types of tubes including receiving, transmitting, Thyratrons, phototubes etc.

Unfortunately, since the Handbook was a subscription service, the completeness of any given set is dependent upon: when the original owner subscribed, how diligent and accurate he was in updating the set, and whether or not he deleted material that he felt was not useful to him. Beware when purchasing an HB-3 set. Many collectors will buy a set to remove pages to be used in upgrading their sets, and then selling what was left. A set that has gone through this process a few times could be worthless. A complete set is a valuable resource.



Resource Books

RCA also produced a pocket sized series called the RCA Resource Book. These were given away by tube distributors and contained base diagrams, RCA test equipment ads and tabulated tube data for all tubes made by RCA up to the date of that particular edition. These handy pocket guides also contained other useful information. While lacking the depth of the larger manuals, they are handy for quick reference at flea-markets and are small enough (and hardbound) to keep on your bench.

Since many audio designers and builders are using transmitter tubes for power output purposes such as the 211, 811, 812, 845, etc., the RCA TT-3 through TT-5 series transmitting tube manuals can be quite useful. Although

written primarily for professionals and the radio amateur, the information is quite relevant to the audiophile. In the transmitting tube field, however, there were many proprietary types, and the RCA manuals only covered tubes manufactured by RCA.

Sylvania



1959 and 1970s Sylvania

Sylvania produced a loose-leaf Technical Manual during the Golden Age. Editions vary considerably in their content. The author's 1951 edition contains little information not available in any other "standard" manual, but the 1959 edition is much more interesting. The special purpose audio power output types section shows many of the interesting High Fidelity tubes from the Golden Age, not found in the RCA manuals. For instance, one can find the 5930, an industrial equivalent to the 2A3. Sylvania also published a tube manual in booklet form. Since Sylvania produced, or sold, a few tubes that RCA did not, it is worthwhile to get at least one comprehensive Sylvania Tube Manual.

CBS-Hytron

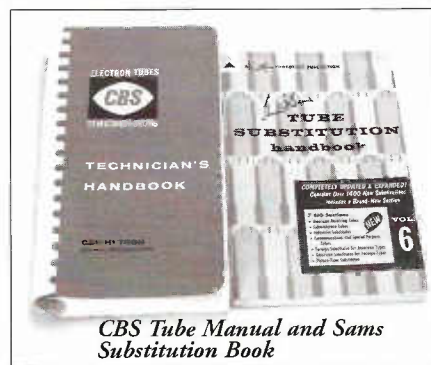

CBS Tube Manual and Sams Substitution Book

CBS-Hytron produced a loose-leaf tube manual very similar to the Sylvania manual. It is notable in having its extensive set of characteristic curves located in the back of the book.

General Electric

General Electric published two types

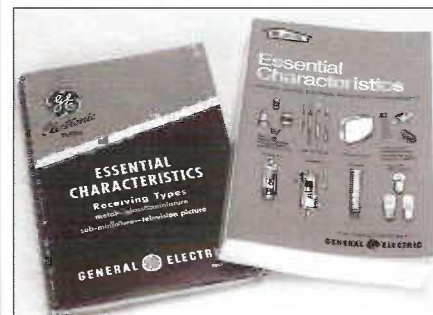

of tube information: a loose-leaf subscription-based manual on 8 1/2" x 11" pages, intended for professional design engineers, and the more common "Essential Characteristics," intended for servicemen and amateurs. Originally in a pamphlet form in the late 1940's, it became a spiral-bound book with the unique feature that the bottom part of the page containing the basing diagrams was separate from the top part containing the data, allowing the basing to be matched up with the data. This format was continued until the 1970s when a regular paper-back format was adopted. The spiral-bound editions also had circuit diagrams.

The GE Essential Characteristics manual is different from most other tube manuals in that it contains only a tabular listing of data, although a few characteristic curves of common tubes were given in the back. The outstanding feature of the GE manual is that it lists data for nearly all RMA-registered tubes, not just the ones manufactured by GE. It is a little spotty in the industrial series, but still has far greater coverage than any other manual.

Tung-Sol

Tung-Sol also published a loose-leaf set of Technical Data Books on a subscription basis. These are similar to the RCA Handbooks. Tung-Sol also published tube characteristic books in tabular form. Be sure to find a late edition if one is interested in information on the 5881 and 6550.

Western Electric

Western Electric manuals cover only their own tubes. Since Western Electric Tube data is rarely given in other manufacturer's data books, one has to get a Western Electric manual to have that information. The manuals are in tabular form and only give specifications for tubes that were current at the time of publication. Obsolete numbers are mentioned and cross-referenced to other WE

tubes in the back. There is no attempt at substitution with tubes of other manufacturers. Since Western Electric made almost exclusively commercial and military equipment (they did make a consumer radio in the twenties), and since there is great interest in WE tubes in the audio community, these manuals are coveted and are difficult to find. An original one can be relatively expensive.

Vade Mecum

A truly international, but difficult to find, tube manual is Vade Mecum. Published in Europe, it references tube from all major European countries, the United States, Russia and Japan. It is very useful in that it cross-references tubes from different countries as well as giving tube characteristics.

Another type of manual that is quite useful is that of the tube substitution manual. They were issued by many companies including Sams and Radio Shack. Most are fairly good and also reference industrial and foreign tubes. A military-commercial cross reference chart is also a useful item. One must be careful following the information contained in substitution manuals. The information given is approximate; not all tubes will substitute properly in all applications.

Reprints of desirable tube manuals have recently come out. For example, Antique Electronic Supply has reprinted the 1973 edition of the GE Essential Characteristics (the last one), the RCA RC-19 (1959) Receiving Tube Manual and the RCA TT-5 Transmitting Tube Manual. A reprint of the Western Electric tube data manual is also available. Original manuals can often be found by mail from the usual suppliers of vintage electronic books.

Conclusion

As one can see, acquisition of the correct tube manuals can increase the enjoyment of one's hobby. Remember that different manufacturers sold different tubes and other manufacturer's tubes often did not get into their manuals. A small collection of one company's manuals over a long period of time, augmented with a few selected ones from other major companies, will provide the owner most of the tube applications and specifications needed.

If you have any questions concerning tube manuals or other books of interest to the vintage electronic enthusiast, please feel free to contact me through VTV.

Copyright 1996 Paul Joseph Bourbin.

Great Sounds From Vintage Home Hi-Fi Speaker Systems 1958 - 1969

by **Charlie Kittleston**

Good sounding speakers are one of the most important parts of any sound reproduction system. Throughout audio history, there have been "classic" speaker designs that set the standard for quality listening in their era. In this period of audio history, speaker research and development was in high gear to satisfy the new generation of discriminating listener.

New England vs West Coast

During the Fifties and Sixties, there were two major camps of music listeners. The "East Coast" or "New England" sound really started in the mid-Fifties with inefficient speakers like the AR-1 and AR-3 acoustic suspension speakers. East Coasters, many of whom listened to classical and acoustic music, preferred a drier sound with less boomy bass and a balanced presentation. Their amps of choice were typically Marantz or Fisher which were hooked up to AR, Bozak and other non-horn loudspeakers. The "West Coast" or "Tish-Boom" camp was the other main listening camp of hi-fi listeners. The Tish-Boomers liked jazz, rock and pop music. They wanted to feel like the band was in their living room and in their faces. Big, boomy bass, extended and bright highs with little or no midrange was their choice for the "live band" effect. The Tish-Boomers preferred Altec Lansing or JBL horn-type loudspeakers hooked to McIntosh amplifiers and preamps. Some listeners of this group with upper frequency hearing loss even used solid-state amps with their horn speaker systems to get that extra treble "bite."

Why Old Speakers?

Today, strange as it may seem, most loudspeaker manufacturers are still making inefficient systems that require high powered amps of 60+ to 200+ watts. While some of these speakers sound outstanding, many lack the smooth, easy listening sound that may be important in non-critical applications. This article will cover the basics of speaker components and explore some of the better hi fi packaged loudspeakers that were popular in the late Fifties through the Seventies that can still provide the listener with pleasing sound. Not all speaker manufacturers

will be covered, nor will coaxial or triaxial speakers be covered.

Most of these speakers are not meant to be for your reference system or for high-end systems. They will work great for second systems, bedrooms, office and resort cabin systems. Many of these speakers were highly rated in their day for their balanced, smooth sound and economical price. Most are of the bookshelf size, but a few are floor standing units which provide a "bigger" sound if you have the room.

Things to Consider When Acquiring a Vintage Bookshelf Speaker System

1. **Price:** A primary source source for prices on vintage bookshelf loudspeakers is the Orion Blue Book. The Blue Book is fairly accurate in contemporary audio prices, but can be way off with most vintage audio equipment. Most of the speakers listed in this article are mass-market types that were very popular in their day and still hold some appeal today to music listeners who want to experiment. Try to avoid paying high prices (over \$200 each) for any of the speakers listed in this article. There are other larger, higher quality vintage speakers that command very high prices because of their unique sonic characteristics which are appreciated by select user groups.

2. **Condition of Drivers:** Avoid speakers with obvious and not so obvious defects. Inspect the cones or diaphragms of all drivers for holes, tears, etc. If possible, try out the speaker and listen for cone rubbing or other mechanical speaker distortion. If that is not possible, bring an ohmmeter to measure the continuity and impedance of the speaker and drivers. If they test open, the speaker is worthless and will be very expensive to restore or repair.

3. **Condition of Cabinet:** It can be very expensive to restore speaker cabinets. Do not pay premium prices for speakers with finish or structural problems. Try to purchase speakers with cabinets in good condition. They may be slightly more expensive, but less hassle. Grill cloth can sometime be cleaned by removing it from the baffle board and using mild detergent, then drying it on a flat surface. However, replacement grille cloth is available from some vendors that is close to the original type and should be considered.

4. **Crossover:** Wax-paper and electrolytic capacitors typically deteriorate significantly after 20-35 years. This manifests itself as decreased high frequency

response and/or "dead" sounding upper frequencies. These capacitors must be replaced with more modern units if you expect to get optimum performance from your loudspeakers. In addition, crossover potentiometers usually go bad, become noisy and/or become intermittent. These also should be replaced with newer units of the same value.

The following sections go into more detail about speaker construction and restoration.

Speaker Cone Construction and Materials

In the so-called Golden Age of Audio from the post-war through the early 1960s, quality materials were typically the standard and not the exception for many audio equipment manufacturers. The same is true for speakers. Many of the speakers today are made from cut and folded paper or molded plastic. In days of yore, most speaker cones were made from a combination of paper pulp, felt, asphalt, cotton and other materials that were manufactured by a floatation process in a slurry that was poured into a brass or stainless-steel strainer mold machined to the exact shape of the speaker cone. The slurry was molded through a variable vacuum process, dried and weighed to exact specifications. The quality manufacturers used this method to get the most accurate and lifelike sound from their drivers.

The cone edge suspension system on earlier quality speakers was either rolled paper (i.e.: Altec and JBL) or molded fabric material, either rounded or pleated, which allowed for high compliance and long-throws. The surround was typically treated either with rubber or a viscous material to protect and prolong the life of the unit. Early Wharfedale and other British speaker manufacturers used a felt material for the cone edge, which seems to last much longer if cared for.

In the late Fifties and mostly in the Sixties, several speaker manufacturers resorted to the wonder material for cone edge suspension - foam rubber. Although this material is still used by the "bargain" speaker manufacturers now, it is problematic. The foam tends to deteriorate with time, temperature extremes, cigarette smoke, etc. Many of the low-frequency drivers from the Sixties and Seventies built by Electro-Voice, Jensen, Acoustic Research, Wharfedale and others are unusable because the foam surround has deteriorated or melted into a tar-like goo. There are kits available to re-foam these speakers and some businesses specialize in re-foams, but these can be tricky and the

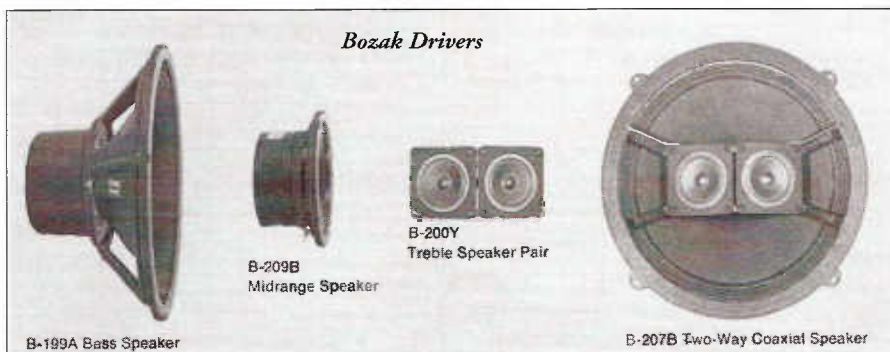

sound may not be the same as the original.

Butyl rubber and other rubber compounds were also used by AR, Jensen and JBL on some of their LE series speakers. With age, this material can deteriorate or become stiff, making the speaker dead sounding. Some speaker "gurus" suggest putting a drop or two of automobile brake fluid on the JBL LE surrounds to loosen it up. This is not recommended and we assume no liability if you try it and ruin your speaker.

Typically, for the best durability and quality in older speakers, look for composition paper cones with a felt, pleated or rolled and treated cone edge. Avoid older speakers with foam rubber edges or butyl rubber compounds, because more often than not, the foam or rubber has deteriorated, making the speaker useless, unless you can find someone who can re-foam the surround.

Magnet Construction

Pro-audio speakers made by Altec and JBL typically used high-quality machined ALNICO-V magnet material because of its superior sonic qualities. Many home speaker builders also used ALNICO equipped drivers during the Fifties and Sixties for the same reasons. In the Seventies, ALNICO V became more expensive because it contained so-called "strategic" metals that were being used in defense electronics and weapons systems. By then ALNICO was replaced by so-called "mud" or ceramic magnets made from a ceramic and ferrite slurry. While some speaker enthusiasts insist that there is no difference in sound, others claim that the ALNICO magnets have a more "live" or extended sound and ceramic have a "duller" sound. Whatever the case, they do sound different and the choice is up to the end listener. In addition, earlier drivers with ALNICO V have higher value to collectors than their ceramic counterparts.

High Frequency Drivers

In older speakers, the high frequency cone and dome-type drivers were in developmental stages and may not have the high frequency extension of the newer kevlar or titanium dome super tweeters of today. Many tweeters were simply small cone-type drivers two to three inches in diameter. Others used small horn-type tweeters of varying quality. Later designs, including the Dynaco A-25, used dome-type tweeters that can be quite respectable performers.

A problem you may run into when acquiring older loudspeaker systems is blown tweeters. In most cases, they cannot be repaired easily. For the true collector, only the original replacement part will do, but that may involve running a want ad in AudioMart or related publications. Newer, generic replacement tweeters including cone, dome and ribbon types may be used if they are the right impedance, efficiency, size, etc. There are several manufacturers and mail-order suppliers of replacement high-frequency drivers, so start experimenting!!

Crossovers

Crossover technology and materials have come a long way from the Fifties and Sixties. Most manufacturers used wax paper and foil or oil-filled paper capacitors in their crossovers. Many of the later designs used bi-polar electrolytic capacitors which were usually of mediocre quality. Some collectors and a few listeners leave the original crossovers unmodified because they prefer the vintage "veiled" sound which limits high frequencies. Older capacitors can also soften the sound, which may be desirable in horn-type loudspeakers.

Probably the single most important factor in the performance of high-frequency response in old speakers is to replace the crossover capacitors with high quality, modern components. Some new capacitors take some time to break in as they may sound a little harsh when the first several hours of signal are put

through the speaker. Some brands require more time to break in than others. Generally, new capacitors tend to mellow out and sound smoother with more music being played through them.

Cabinets and Enclosures

In most cases, early speaker enclosures used real mahogany or oak veneer with other quality features such as internal bracing. Older speaker cabinets can be repaired, sanded, re-oiled and re-finished for a beautiful piece of audio furniture. Generic replacement grill cloth is available from various suppliers if yours is ripped, missing or soiled.

If you find speakers with blown or damaged drivers, they can be rebuilt with modern woofers, tweeters and crossovers for an exceptional sounding system. It can be a lot less hassle to rebuild an old speaker enclosure than to make a new one.

The Good Stuff

Used speakers can be found at flea markets, in classified ads, garage and moving sales, electronic swap meets, etc. The key is to not buy a turkey. This can include early sixties speakers with foam woofer surrounds and/or cheap horn or co-axial units, which tend to be coarse sounding or may be unusable because of foam rot.

With the speakers listed, you will not achieve audio nirvana, but you may be pleasantly surprised with a musical, smooth and balanced presentation. The highs may be rolled off, but that can be fixed. The sound will get even better when the crossover capacitors are upgraded to higher quality polypropylene units and the speaker cone has had a chance to break back in again after sitting dormant for ten or more years. The more you play them, typically the better they will begin to sound.

The following is a list of manufacturers and some of their better sounding earlier units. This list is by no means complete, but it does include some of the more common units that can still be found used at reasonable prices (read: \$25 to \$200 each).

Acoustic Research (AR)

Edgar Villchur introduced the AR-1 in 1955 as the first AR product. The cabinet was a large bookshelf acoustic suspension unit with a 12 inch woofer and eight inch mid-range. The mid-range was typically a Western Electric 755 "pancake" speaker that is highly

regarded now. To get high-frequencies, AR recommended using the Janszen Electrostatic tweeter with the AR-1 starting in 1957. Other electrostatic units became available including the popular priced Electrostat 3 sold by Radio Shack starting in 1958. With this combination, the bass was full, the mids were 3-D and the highs were smooth, giving a balanced presentation. Unfortunately, not many AR-1s have survived as many "scavengers" have sacrificed them to retrieve the WE 755 driver to sell to the export markets or for home experimentation.

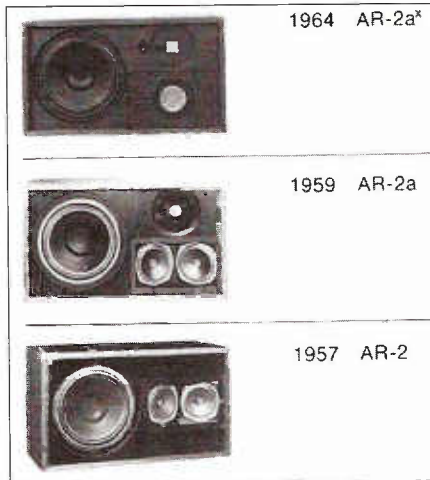

For lower budget audiophiles, AR introduced the AR-2 (\$100.) a two-way acoustic suspension bookshelf in the early 1958. It was a bookshelf unit featuring a ten inch woofer and two-5 inch cone tweeters in a sealed enclosure. Speaker impedance was eight ohms, response was 42 to 14,000 cycles and minimum power was 20-25 watts continuous. The AR-2 was also popular with the Radio Shack Electrostat 3. In 1958, the AR-2 was rated as a "best buy" by Consumer Reports magazine. The AR-2 was thought of as a very musical speaker back then. Many AR enthusiasts preferred the first version of this speaker for its richer midrange presentation. We had a pair of AR-2s in the VTV offices for evaluation and were not very impressed. The highs were very rolled off, the mids were very recessed and the speaker was unmusical. We even checked the drivers and the crossover and they were functional.

About 1960, AR introduced the AR-2A which was basically the same as the AR-2 except it included the same 1 3/8' dome tweeter as the AR-3. In the early sixties came the AR-2X (\$122) with a ten inch woofer and a single 3 1/2 inch tweeter. The last version of the AR-2 was the AR-2AX (\$128), a three-way speaker

introduced in the mid-sixties. The 2AX was the same as the 2X except that it featured the 1 3/8 inch soft dome tweeter from the AR-3A and the 10 inch woofer had a foam surround.



For 1959 AR introduced the three-way acoustic suspension AR-3 (\$225) loudspeaker. It featured a 12 inch cloth surround woofer, a two inch dome mid-range and a revolutionary 3/8 inch hemispherical dome tweeter. The driver technology was revolutionary for the time and created quite a stir in the audiophile circles and hi-fi show demonstrations. Speaker impedance was four ohms, rated frequency response was 38 to 20,000 cycles. The classic AR-3 was an instant success as it was the first of the "East Coast" sounding speakers with a balanced, clean and musical presentation, perfect for acoustic jazz and classical music. Piano and orchestral music was especially good sounding on these units.

The AR-3 was one of the first inefficient loudspeakers available and needed at least 35 watts continuous to get any volume. The down side of this inefficiency is that you cannot use most AR speakers with SE or low powered triode amps. There are several versions of the AR-3, and some of the later units (AR-3X) featured a foam surround on the 12 inch woofer which typically must be re-foamed before the speaker can be played. Fortunately, there are a few companies that can provide re-foam kits for the AR-3 and other later AR speakers. The AR-3A had a soft-dome mid range which was not as hard sounding as the AR-3. Older AR speakers can sound kind of "thick" if they have been sitting for a while. If they are played and re-broken in they will start to sound better. Another problem with AR units are the crossovers which must be rebuilt with new polypropylene caps. The adjustment pots are also likely to be noisy and either must be cleaned or replaced.

One of the last "classic" AR bookshelf speakers from the 1960s was the AR-4 (\$57) which was introduced in 1965. The eight ohm AR-4 was a smaller bookshelf with a ten inch treated cloth surround woofer and a single 3 1/2 inch tweeter which crossed over at 1500 cycles.

Suggested amplifier power was 15 watts, but this unit will run fine with seven to ten watts or more. The AR-4 was a very smooth little speaker which was almost like an AR-3, except less bass. It also sounded clean and musical with a soundstage that belied its physical size. This speaker received many positive reviews from the audio press in its day. A later version of the AR-4 was the AR-4X. It used an aluminum voice coil which can be a problem and cause the tweeter to go out prematurely.

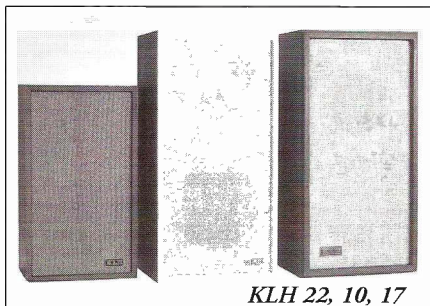

KLH 22, 10, 17

KLH

Henry Kloss was designing quality loudspeaker systems for AR in the mid-fifties. In 1957, he left AR to start his own company, KLH. He had a number of different offerings including bookshelf units, large floor standing cabinets and the famous KLH-9 electrostatic panel speakers. KLH speakers were made in great quantities and many are still around because they were favorites of the time. Kloss used cloth and fabric molded speaker cones with a special formula of cotton, wood pulp, asphalt and wool. Each cone was made under tight tolerances for dimensions, rigidity and weight. The result was a balanced sounding speaker.

One of their first widely available bookshelf speakers was the KLH-4 (\$209) featuring a twelve inch woofer and two-small cone-type tweeters with a three-way crossover variable at 1500 cycles and 6000 cycles. The KLH-4 is less common because of its higher price and lower production.

For 1958, the KLH-6 (\$129) was introduced as a full-range bookshelf unit. Dimensions were 23 1/2 inches tall, 12 5/8 inches wide and 11 7/8 inches deep. The KLH-6 featured a 12 inch cloth surround woofer and two small cone type high frequency units crossing over at 1500 cycles. The eight ohm speaker was typically rated for between 20 and 60 watts continuous. However, the speaker is relatively efficient and will run just

fine on seven to eight watts of SE tube power. *Consumer Reports* in 1958 rated the KLH-6 as a "best buy" full-range loudspeaker, saying it had "excellent bass, smooth mids with good, smooth highs."

Later versions of the KLH-6 featured two high frequency drivers, then a single 1 3/4" tweeter. This speaker was made well into the early 1970s and is still relatively easy to find due to wide distribution and high production figures. Also, some later KLH units had foam surrounds, so look out for that.

A little brother of the KLH-6 was the KLH-10 (\$99) with cabinet dimensions of 23 1/2 inches tall, 11 25/32 inches wide and 8 3/4 inches deep. It featured a ten inch acoustic suspension woofer with a single 3 1/2 inch cone-type tweeter. Power range was 12 to 60 watts. The KLH-10 was available from the late Fifties through the mid-Sixties.

KLH introduced the KLH-17 (\$69.95) in 1965. It was a smaller bookshelf with dimensions of 23 1/4 inches tall, 11 3/4 inches wide and 8 1/4 inches deep. The 17 featured a ten inch cloth surround acoustic suspension woofer and a 1 3/4 inch direct radiator tweeter. The 17 featured a three-position switch in the back of the speaker to add or subtract 2.5 db of high frequency. This is actually not a bad sounding speaker for smaller listening rooms or second systems. For better performance, you can upgrade the crossover capacitors and the tweeter with a newer dome-type unit.

From the mid-Sixties through the mid-Seventies, KLH sold several versions of an even smaller bookshelf speaker. These were typically sold in pairs for under \$100. Some of the models included: KLH-22, KLH-24, KLH-32 and others. The cabinets were all smaller (19 3/8 inches tall, 10 7/8 inches wide and 7 3/16 inches wide) than the KLH-17, but featured the same eight inch cloth surround woofer and the 1 3/4 or two inch direct radiator tweeter. Look for the models with hand screw type speaker terminals, and avoid the ones with the RCA jack inputs or two flat-head screws, as these typically have foam surrounds and may use lower quality materials.

Though they are small, these speakers can sound great with tube amps, including integrated units with 5 to 15 watts of continuous power. They have a fairly large soundstage and are very smooth sounding in the typical musical spectrum. They do not have strong bass, nor do they have super extended highs, but you

can upgrade the crossover capacitors and tweeter driver for better upper frequency results.

For 1969, KLH introduced the Model 23 (\$99.95), a two-way system that was slightly larger than the Model 6. It featured a 10 inch acoustic suspension woofer with a heat-molded cloth surround impregnated with synthetic rubber. The tweeter was a molded paper dome type similar to earlier designs with a few subtle improvements. The crossover had a three-position switch and a crossover point of 1500 cycles.

Advent

Henry Kloss started the Advent Corporation in 1970 after he sold his holdings in KLH. Kloss felt that there was a future in home theater and with Advent, he produced and sold television projection systems and related audio equipment. Kloss introduced the Advent acoustic suspension loudspeaker in 1970 as well. It was one of the largest selling acoustic suspension speakers of all time. The Advent speaker featured a foam surround woofer with a 9 inch piston on a 12 inch frame similar to the woofer used on the Dahlquist DQ-10. Any Advent speakers you find today will have deteriorated foam woofer surrounds and should be refoamed. The high-frequency driver was a screen-covered mid-tweeter shaped like a hard donut with a high-frequency dome in the middle.

Advents were very popular with college students and other audio enthusiasts on a budget. They were available in a "utility cabinet" with vinyl covering made to look like real wood and a deluxe version with real wood veneer sides. The Advent had a tight sounding bass with pretty good upper ranges. It was popular to "stack" two pairs of Advents to get that "wall of sound" effect.

Several versions of Advent speakers were sold including the four ohm "Baby" Advent which used a six inch woofer and a dome tweeter. Babies image very well and put out a lot of sound for their size. They are a bargain if found at garage sales or flea markets.

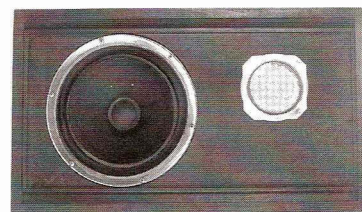

KLH 23



Dynaco A-25

Dynaco

One of the most popular producers of amps and preamps, Dynaco introduced a line of speakers starting in 1969 with the A-25. Dynaco used Bang and Olafsen of Denmark to manufacture their speakers.

At \$79.95, the A-25 was one of the largest selling acoustic suspension speakers ever produced. It featured a ten inch butyl rubber surround woofer made by SEAS of Scandinavia, with an aperiodic design slotted and friction damped port. The tweeter was a one and one-half inch dome tweeter made by SEAS which crossed over at 1500 cycles. It also featured a five-position stepped attenuator tweeter control. Frequency response was 47-20,000 cycles and power handling capacity was 35 watts, but you could run them just fine with ten watt amplifiers.

The A-25 was the first bookshelf speaker that imaged well. The sound came "out of the box" and was very linear and natural sounding. In an October 1969 product review of the A-25, *Audio* magazine noted that the speaker gave the best square wave response of any speaker they had tested to date, regardless of price. *Audio* also felt the A-25 had a relatively uncolored and neutral sound. In our listening tests of vintage speakers, most VTV associates agreed that the A-25 sounded as good as or better than many \$750+/pr modern speaker systems. The new re-issue A-25 from Dynaco/Panor Corporation seemed to have less midrange response and should be broken in for maximum performance.

Other Dynaco speakers of note include the A-50 (dual woofers), the A-35 (larger cabinet), the A-15 and the A-10 (five inch piston woofer with a small dome tweeter and a small resistance damped slot). Of these, the A-10 should be one to look for because of its superior imaging qualities for satellite speaker applications or smaller listening rooms.

Bozak

Rudy Bozak began selling his speakers to the hi-fi market in 1949, beginning with the famous "kettle drum" unit. Throughout the Fifties and Sixties, a wide line of high quality speakers were sold, although most of them were larger, floor standing units. A few bookshelf units were sold in the Sixties and early Seventies which were fairly low in production. Heathkit even offered a few speaker kits using Bozak components in the Sixties.

Bozak tried to standardize components in their speaker systems so they could concentrate on higher-quality materials. Large, high quality ALNICO V magnets were used with cast aluminum speaker frames or baskets. Speaker cones were high-quality composition-type with cloth surround edges. Legend has it that Rudy used horse hair in the speaker cone material. The tweeters were typically aluminum cone-types with rubber damping to reduce harshness.

The low frequency Bozak driver was the B-199A 12 inch woofer rated at 20 watts with a response of 40-4500 cycles. The tweeter was the B-200Y, a twin-cone three and one inch diameter aluminum cone unit rated at 20 watts and a response of 2000-20,000 cycles. These were typically combined as the B-207A, a two-way coaxial speaker. Mid-range drivers were the B-209B six and one half inch sandwich fiber cone or aluminum cone (later), rated at 20-40 watts and response of 200-3500 cycles and the B-800 a full range aluminum cone eight inch rated at 15 watts+ with a response of 35-20,000 cycles.

Some of the mid-sized floor-type enclosures (if you have the room) include: B-302A (\$261), a three-way with one-B-207A coax and one B-209A midrange; dimensions on this unit were 24 inches wide, 30 inches tall and 20 inches deep. The bigger brother to the B-302A was the B-305 (\$397) which featured an additional B-207A coax and had dimensions of 40 inches wide, 20 inches deep and 31 inches tall with a rated frequency response of 35 to 20,000 cycles. These speakers sound great with a 10-75 watt tube amp.

Bozak also sold a few bookshelf sized units including the B-313 Concerto III (\$197.50), a three-way unit with a single B-207A coax and a single B-209A midrange rated at 20 watts with a response of 45 to 16,000 cycles. The dimensions of the cabinet were 23 1/8 inches high, 14 1/4 inches wide and 11

1/2 inches deep. Another good sounding, but rare Bozak large bookshelf is the 401B Rhapsody which has a single B-199 woofer, a single B-209C midrange and a 200Y dual tweeter array. The 401B is very balanced with good efficiency and nice soundstage.

The sound of Bozak speakers is big, warm and inviting. They are very pleasing to listen to with low to mid-power range vintage tube equipment. Many type of Bozak loudspeakers were sold and usually they can be purchased for reasonable prices.

Other Notables:

UTC Minimax

Made by Goodmans of England, this mini-monitor had a four inch, long-throw woofer with a dome tweeter. The Minimax had a big sound for its size and imaged very well. These may be hard to find as they are not very common.



Rectilinear

In the late 1960s, Rectilinear introduced the popular Rectilinear III (\$234) a floor standing unit with dimensions of 35 inches tall, 18 inches wide and 12 inches deep. The eight ohm unit was very sensitive, so it could be used with low-powered tube amps and had a very natural presentation with a nice soundstage. It was considered one of the very first "transparent" sounding speakers by some listeners. The unit was a four-way system with six drivers per speaker enclosure. Drivers included four Peerless tweeters (two different sizes), a hex-shaped Phillips mid-range and an Electro-Voice high compliance woofer. There are a few variations of the Rectilinear III, but those who have lived with this speaker agree that the model with the single crossover control sounds better than the two-control version.

Wharfedale

Many later versions of Wharfedale speakers in the Sixties used foam surrounds on their woofers which deteriorated very quickly. A good sounding smaller speaker is the W-25, which is a great performing mini-monitor which does have a foam surround, but the foam material is longer lasting.

Fulton/EMI

During the Sixties and early Seventies, Fulton, a Minneapolis, Minnesota based company, sold a few good loudspeaker systems including the FMI-80 (\$80). This unit was a two-way bookshelf system with an eight inch woofer and two Peerless paper cone tweeters. The FMI-80 had excellent imaging and was considered to be open and natural sounding.

Recommendations

Don't look for Altec, JBL or Tannoy here. Those speakers are in a different class and will be covered in future articles. This survey is of mass-market, home hi-fi units only.

If I wanted an older speaker that sounded modern and imaged well, my choice would be the original Dynaco A-25.

For a smaller bookshelf unit that was smooth and easy listening, I would choose the KLH-22, 24 or 32 models because they are relatively easy to find and do throw a nice soundstage for their size. For more bass, check out the KLH-6, 10 or 23s. In this same category, the AR-4X is an excellent performer, with a more detailed, refined sound.

For bigger sound with more soundstage and bass, look for Rectilinear IIIs or you may even try some Bozaks, but with those, plan on rebuilding the crossovers for optimum performance.

A special thanks to Roger E. Coon of Redwood City, California; Earl Yarrow of Fremont, California and John Eckland of Palo Alto, California for their assistance with this article.

References:

Audio Magazine, Oct. 1969,
Consumer Reports, June 1958

Specifications and other information were obtained from original manufacturer's advertisements (AR, Dynaco, KLH, Bozak, etc.)



AC Meters

In the last issue of VTV, we talked about DC Meters. We will now turn to AC meters, or more specifically, AC voltmeters. Why a whole article on AC meters? Don't most DVMs or VTVMs have an AC range? Yes, but when working on audio equipment, you need more than just a simple AC meter, often with unknown characteristics. You need a meter with significantly more sensitivity than your utility meter. You also need to understand the different ways AC signals can be measured, and choose a meter that matches your needs.

Uses of AC Meters in Audio Testing

Here are some of the tests in audio work that require a good audio voltmeter:

- Gain measurements – Voltage gain is the ratio of output to input voltage. While sometimes given in absolute numbers (e.g., a gain of 25), it is more commonly given in decibels (db), where the gain in db = 20 * log(absolute gain).
- Distortion Measurements – Distortion analyzers measure the residual distortion through a system, whether harmonic distortion or intermodulation distortion. If you are working with low distortion systems, these distortion products can be quite low, often -60 dbm (1 microvolt). Most distortion analyzers have built-in sensitive AC voltmeters, although some older ones require an external meter.
- Hum and Noise Measurements – Measuring the residual noise in a good audio system requires an AC meter with a least a sensitivity of -80 db below maximum output. Sometimes an "A-weighting" filter is used ahead of the meter to emphasize the noise that the human ear is most sensitive to.

Dependence on AC Waveforms

Since AC signals can come in many different waveforms, methods of defining how these waveforms are measured have been developed to suit different needs. For this discussion, all waveforms described here are recurrent waveforms, i.e., repeat the same wave shape over and over. There are three main ways of mea-

suring the amplitude of an AC signal.

1. Peak-to-Peak – This is difference between the most positive point on a waveform and the most negative point.
2. Average – This is the average value of the waveform, referenced to ground. Mathematically, this is defined as the integral of the voltage over the period, divided by the period.
3. RMS (Root-Mean Square) – If the AC signal delivered power to a resistive load, a DC signal that delivers the same power would have a value that is the RMS value. Mathematically, this is defined as the square-root of the integral of the voltage squared over the period, divided by the period.

The peak-to-peak method is sometimes used in RF measurements, and is convenient to use when reading the voltage off of an oscilloscope screen. However, this method tells us nothing about the amount of energy in the waveform, and so is rarely used in audio measurements.

The RMS method indicates the true amount of power delivered to a load, so is important in output power measurements. Since wire and transformer heating is dependent on RMS voltage and current, RMS measurements are important for power supply and distribution design. However, as explained later, implementing a "true-RMS" meter is more difficult than the other methods.

The implementation of an average-reading voltmeter is simple, and since its reading is fairly close to RMS reading for sine waves, most AC voltmeters are average reading, but recalibrated to indicate an RMS value for sine waves only. Since most audio testing uses sine waves, this is a reasonable compromise. However, if there is significant distortion in the measured sine wave or the waveform is not sinusoidal (as in square waves, IM distortion measurements, or white noise), the average-reading voltmeter will not give correct RMS readings.

If the shape of the waveform is known, then correction factors can be applied to give correct readings on average-reading meters.

Implementations

Since a sensitivity of at least .001 volt (1 mV) is needed in an audio-grade AC voltmeter, these meters incorporate a highly-sensitive AC amplifier, typically

Ballantine 300, Hewlett-Packard 400, and Fluke 910A AC Meters



using feedback to stabilize the gain. An accurate input attenuator selects the sensitivity. The bandwidth of this attenuator/amplifier needs to go from below 10 Hz to well above the highest frequency to be measured, typically 300 KHz or more. The hum and noise level of this amplifier

and performing the RMS calculation in a microcontroller. This is the technique used in nearly all modern true-RMS voltmeters.

A problem with either the thermocouple or synthesized techniques is that there

mic converter circuits, or, in the case of newer digital meters, do the conversion in software.

Many hand-held DVMs can be used for AC measurements, but have some potential pitfalls. They often have limited sensitivity, and their accuracy can be a lot worse than the number of digits would indicate (check the specification carefully!). Even worse, though, is that many DVMs, especially older or cheaper ones, are only accurately calibrated in the 50 to 60 Hz range, and can give grossly erroneous readings at other frequencies, especially above 5 KHz. Again check the manufacturer's specs carefully.

Most AC meters have "Output" terminals that allow the calibrated high-gain amplifier within the meter to be used as a utility amplifier. An oscilloscope can also be attached to the output to allow waveform monitoring. However,

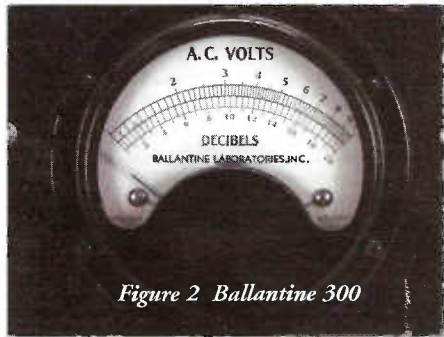

Figure 2 Ballantine 300

needs to be low enough to not obscure the lowest intended measurements.

In average-reading meters, the amplifier is followed by a rectifier and filter circuit to convert the AC waveform into a DC value. This value is then displayed on either an analog meter or digital display.

There are two main schemes to measure RMS voltages. The traditional method has been to use a bolometer or heated thermocouple (see figure 5 next page) to convert the AC signal into a DC value. Since the temperature of a resistor is proportional to the power dissipated in it, and thus the RMS voltage, this is an effective method of measuring a true-RMS voltage, regardless of waveform. However, the thermocouple is delicate and the DC output voltage is very small, requiring special DC amplification techniques.

The other scheme for measuring RMS voltage is to synthesize the root-mean-square, either by analog multipliers and dividers or by digitizing the waveform

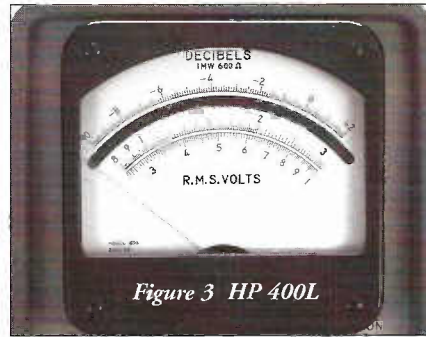

Figure 3 HP 400L

is a limit to the peak-to-average value that these RMS circuits can validly measure. In both techniques, the dynamic range of the AC input amplifiers limits the peak signal that can be accommodated. The synthesized RMS scheme also has errors and dynamic range limitations in the multipliers and/or converters. The key spec to look for in True-RMS meters is the maximum "crest-factor" they can handle.

There are two types of display: linear and logarithmic (see figures 3 and 4). The most common is the linear scale, which is most convenient for routine AC voltage measurements. Analog meters of this type will have decibel (db) scales, but these will be compressed at low readings. Since so much of the measurements in audio revolve around logarithmic db readings, having a scale where db are displayed linearly can be quite convenient. Older meters of this type used special meter movements to do this logarithmic conversion. Newer meters either used logarithmic



Figure 4 Fluke 910A

some meters, most notably the Hewlett-Packard meters, run feedback around the meter rectifiers, as a way of linearizing the analog scale. (Most other AC meters have scales that get cramped at low readings). The effect of this feedback, though, is to put a non-linear kink in the output signal at low voltage levels. This kink is below the minimum meter reading, but is clearly apparent on an oscilloscope. This limits the usefulness of H-P meters as general-purpose amplifiers.

Measurement Techniques

As mentioned in the previous article on DC Meters (VTV Issue #3) any voltmeter, including an AC voltmeter, will load down the circuit being tested. However, in addition to the DC resistance, AC measurements are affected by the shunt capacitance of the meter. The shunting effect of DC resistance is to give a lower than expected reading at all frequencies, while the shunting effect of meter capacitance is to cause the reading

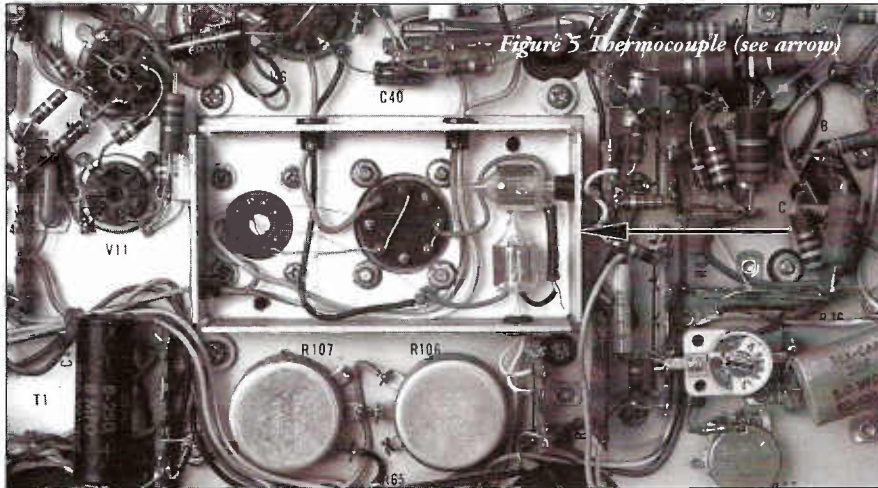

Figure 5 Thermocouple (see arrow)

to decrease with increasing frequency.

To give an idea of how much capacitance is a problem, let's look at three different situations: measuring the signal on the plate of a low-level driver stage, the signal on a 600-ohm line output stage, and the signal on an 8-ohm speaker output. In each case, the shunt capacitance is treated as a capacitive reactance (X_c), and the voltage divider equation is used to calculate the voltage drop. If the error is low, say 1%, then $X_c = -100 R_s$. Working backwards, the capacitance is derived from X_c by the equation $X_c = 1/2\pi fC$, where f is the signal frequency.

For the low-level stage, if the plate resistance of the driver stage is 50K and the plate resistor itself is 100K, then the source impedance is $50K \parallel 100K$ or 33K. For the line-level measurement, a source impedance of 600 is assumed. For the speaker test, if the damping factor is .1, then the effective source impedance is 8×0.1 or 0.8 ohms. The following table summarizes the shunt X_c and C required to create a 1% error in the AC measurement at 20 KHz:

Source Impedance	X_c for 1% drop	C at 20 KHz
33K	3.3Meg	2.4pF
600Ω	60K	132pF
0.8Ω	80Ω	0.1μF

As can be seen, an extremely low capacitance is needed for decent measurements at 20KHz for the plate measurement. Even for a 600 ohm line, a pretty low capacitance is needed. Only on the speaker load would average load capacitance not be a problem.

Typical AC voltmeters have an input capacitance of 15 pF. However, the capacitance of the test lead needs to be

accounted for. RG-58/U (or any 52 ohm coax cable) has a capacitance of 29 pF per foot (95 pF per meter), which can be a significant load. Open wire can have lower capacitance, but is susceptible to hum pick-up. A low-capacitance attenuator probe (to be described in detail in an upcoming article on oscilloscopes) can reduce the capacitive loading to about 5 to 10 pF, at the cost of a loss of signal level. These probes are only accurate if matched to the resistive and capacitive load of the meter, and need to be carefully adjusted. For the ultimate in low-capacitive measurements, an active probe, typically using an FET right in the probe, with a "guard" signal surrounding the input lead can be used, resulting in a capacitance of as low as 1 pF. However, active probes are expensive, and are seldom needed for routine audio measurements.

Classic AC Meters

Sensitive meters designed specifically for audio applications became available just before World War II. One of the most popular was the Ballantine series of AC meters. A hallmark of the Ballantine

meters was a linear logarithmic scale. The most common model, the 300 (figure 2, page 34), looks a lot older than it really is, and makes a good routine meter, although is not as sensitive as other models. In 1954 Hewlett-Packard brought out the model 400 (figure 3, page 34) probably one of the best-known audio voltmeters ever. This model was continued through various versions until 1965, when it was superseded by the solid-state model 400E. Tube-type true RMS voltmeters were made by various manufacturers, including Ballantine and John Fluke Mfg.

Older tube-type AC meters can be quite competitive with newer models, often at a much lower cost. The analog meters can be more convenient to use than digital ones when tweaking for a peak or a null signal. The standard precautions for bringing up old tube equipment apply for these meters: test the tubes, reform the filter capacitors, and check for coupling capacitor leakage. Since these meters have very sensitive amplifiers, noise and microphonics in the first or second amplifying stages can be a problem. It will often be necessary to try out lots of tubes or swap tubes around within a unit to find quiet ones.

Wrap-up

A good, sensitive AC meter is an essential part of anyone's test bench if they plan to do serious audio work. A stand-alone AC meter, as described in this article, can suit this need, or a meter that is part of a distortion analyzer (to be described in a future issue) could also be used. However, to make the meter truly useful, a knowledge of the limitations and applications of AC meters – RMS vs average reading and the effects of meter loading – is also needed.

In the next Audio Test Bench: *Signal Generators*

VTV Renewal or Subscription Form (Photocopy form)

Yes, I want to subscribe _____ renew _____ to VTV Number of Years _____
 \$32/yr four issues US, \$40/yr Canada and \$45/yr Asia, Europe and World.

Cash, US Bank Check, Money Order or Credit Cards (after 7/96)

Vacuum Tube Valley, 1095 E. Duane Ste. 106, Sunnyvale, CA 94086 (408) 733-6146

NAME _____
 ADDRESS _____
 CITY _____
 STATE _____
 COUNTRY _____ MAIL CODE/ZIP _____
 CREDIT CARD TYPE _____
 CREDIT CARD NUMBER _____ EXP. DATE _____
 AMOUNT ENCLOSED _____

It's Magical.

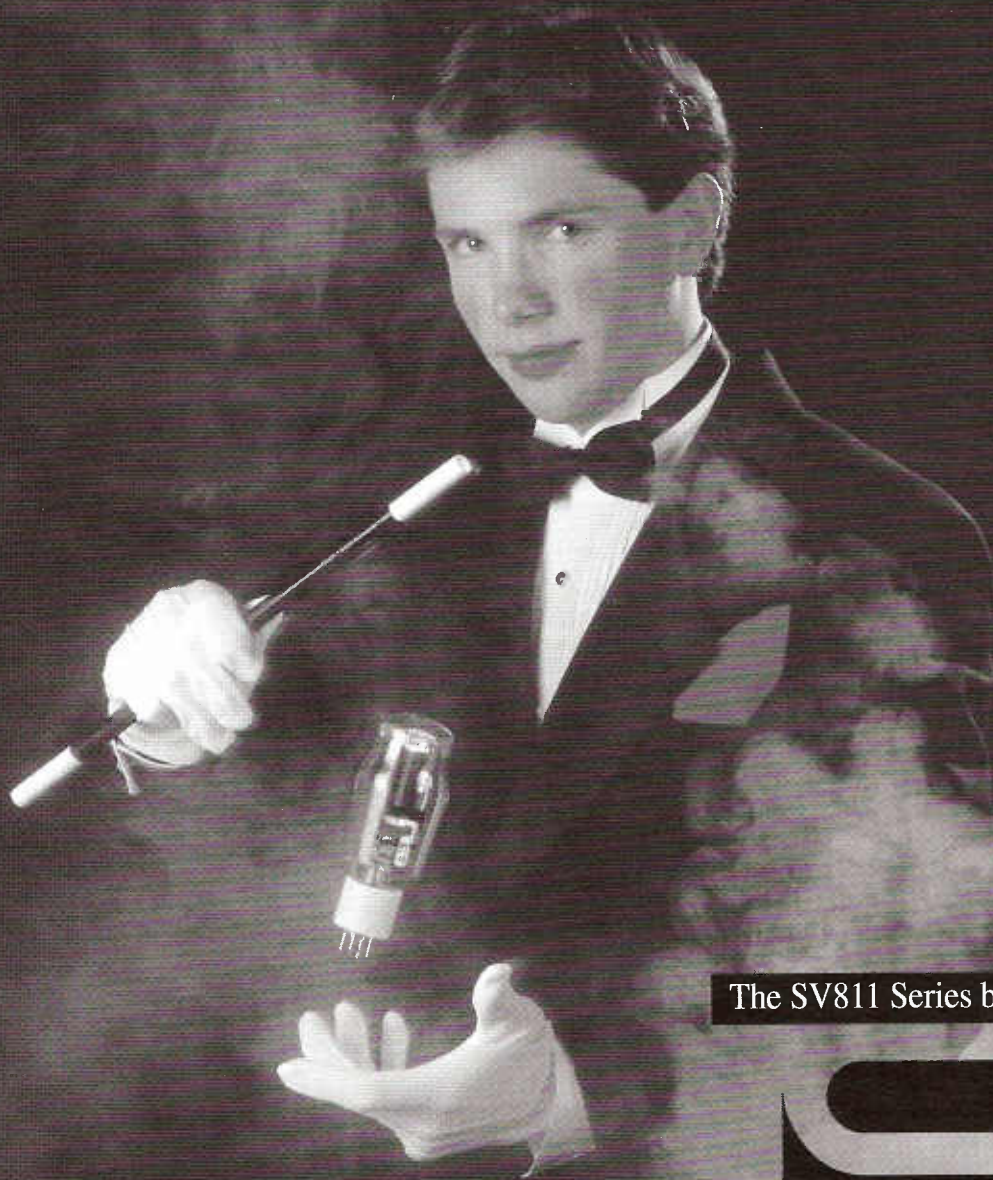

The SV811 Series by Svetlana



Svetlana
ELECTRON DEVICES

8200 South Memorial Parkway • Huntsville, AL 35802 • Toll Free (800) 239-6900 • Phone (205) 882-1344 • Fax (205) 880-8077

<http://www.svetlana.com>

Have You Been Wondering Which Tubes Sound The Best? Then You Need This Report!

Eric Barbour of Glass Audio and Vacuum Tube Valley, recently tested more than 1000 audio tubes-both vintage NOS and current production. These tests resulted in a list of distortion readings that correspond to the sound clarity. Now YOU can know what tube dealers know.

Tubes Covered

EL-34	300B	6DJ8	7591	6550
2A3	6L6	12AX7	8417	6V6

The test reports in VTV were derived from this raw data!

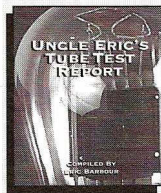

\$49 Send Check or Money Order To:

METASONIX
1095 E. Duane #106
Sunnyvale, CA 94086

GO AHEAD

Ask top engineers and music lovers worldwide what capacitor they choose for their ultimate designs.

H O V L A N D

MUSICAP®

The most naturally revealing capacitor. Film and foil polypropylene construction - optimized for fine speakers and vacuum tube electronics. Precision made in the U.S.A.

Values from .01 µF to 10 µF.

Listen and compare for yourself.

UPGRADE NOW

"If you want see-thru, high definition, detail and listenability, try the Musicaps." **Joe Roberts**

SOUND PRACTICES, Issue 6

For more information and to purchase, contact these quality distributors:

- Welborne Labs 303-470-6585
- The Parts Connection 800-769-0747
- A & S Speakers 510-685-5252
- Allpass Technologies, Inc. 407-786-0623
- Anchor Cross Co., Japan 81-3-3203-5606
- SJS Electroacoustics, England 44-1706-823025
- Tang Hill International Ltd., 886-2-5813605

OEMs and international distributors may contact HOVLAND COMPANY at 209-966-4377 Fax 209-966-4632

one electron™

Single-Ended Output Transformers
High Quality for a Reasonable Price
Designed and Built in the USA

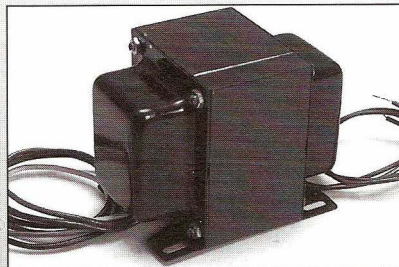

UBT-1 Designed for parallel operation of:
1.6k primary 15 watts 160 mA **\$90.25** 2A3s, EL34s, 300Bs 6AS7s, etc. or Sweep-tube in "enhanced triode" mode

UBT-2 4.8k primary 15 watts 110 mA **\$112.10** Can be used with: 300B, 50, SV811-3, etc.

BFT-1 **\$160.55** Also Available Power transformer for use with UBT-1

Call for more information and quantity discounts available

ANTIQUE ELECTRONIC SUPPLY™
LIMITED PARTNERSHIP
6221 S. Maple Ave. • Tempe, AZ • 85283
Phone (602) 820-5411 • FAX (602) 820-4643 or 800 706-6789

VTV Back Issues Get yours now before they are out of print!

VTV #1 \$8. ppd US **\$10.** Foreign

Early Tube Amps 1920-1938
History of Dynaco Tube Gear
Tube Testing Methods
Audio Test Bench Set-up
12AX7/ECC83 History and Tests

VTV #2 \$10. ppd US and **\$13.** Foreign

EL34/6CA7 History and Tests
Healthkit WM Series Williamson Tube Amp History
Western Electric Large Theater Sound 1930
Great Tube Guitar Amps and Tubes
Tube Matching
Magnum SE Amplifier Construction Project

VTV #3 \$12. ppd US and **\$15.** Foreign

Western Electric 300B History and Tests
Single Ended Transformer Tests
SE Transformer Listening Tests
1935 E H Scott 48 Tube Classic Radio
EICO Tube Mono HiFi History and Photos
McIntosh MI 200 Adventure and Mods
Dynaco Stereo 70 Super Modification
VTV at the Winter CES
Power Line Conditioning - An Explanation
Vintage Audio Book Review

Vacuum Tube Valley

1095 East Duane Avenue, Suite 106
Sunnyvale, CA 94086 USA
408-733-6146 phone/FAX

Cash or US Bank Check. Credit Cards (after 7/15/96)



VACUUM TUBE VALLEY
SUNNYVALE, CALIF. U.S.A.

Be the first in your neighborhood to have the official VTV "BIG TONE" T-shirt.

2 color heart print available in either **Blue Spruce** or **Desert Sand** colors. (Please Specify when ordering)
100% cotton shirt. Only extra large available.

Only \$14.50. plus \$3.00 postage US, CA residents add \$1.12 Sales Tax
Canada and Mexico add \$7.00 postage
Europe and Asia add \$12.00 postage
Cash, Check or Money Order
Credit Cards OK after 7/15/96

Vacuum Tube Valley
1095 E. Duane Ave., Suite 106
Sunnyvale, CA 94086 USA

LOOKING FOR SOME REALLY GOOD PARTS FOR D.I.Y. TUBE AUDIO?

Audio Note UK Kit Amplifiers

Kit One! 8 glorious watts of pure Class A single-ended triode power! Tubes: 2-300B, 2-5687, 6SN7, 5U4/GZ37. Designed for experienced D.I.Y. tube audio enthusiasts but several absolute beginners have also crashed the party. If you can mod a Dyna you can build the Kit One! Price \$1300. **TUBES INCLUDED!** We ship anywhere! Curious? 40 page Kit One Assembly Manual available for \$15 postpaid. If you'd like to hear the Kit One, call us for an appointment when you're in the Baltimore-Washington area. Hundreds of these fine amps are now in service worldwide!
Kit Two! 6550 single-ended, 15 watts Class A on a stereo chassis. Can be adapted by crafty homebrew gangstas to use other output tubes! Uses the same chassis as the Kit One. \$875! CHASSIS ONLY \$150!

Kit Three! Essentially a monoblock version of the Kit One with double the power, the same components and on two chassis instead of one. Features 2-300B per channel running in parallel single-ended yielding 17 watts, vastly expanding your speaker choices. Price \$2400 per pair, complete with tubes. Kit Three Assembly Manual only \$17 postpaid.

Kit Four! Stereo 10 watt per channel push-pull Class A amp design from the brilliant Steve Wroe of Audio Note UK. Tube complement: 4-6V6GT, 2-6SN7GT, 2-12AX7. Designed for beginners, the Kit Four is fairly easy to build, even if you've never soldered before! Any careful person willing to follow the instructions and learn E-Z basic electronic assembly and test procedure can successfully build this great sounding amp in a couple of evenings. **UNBELIEVABLE PRICE! A REAL AUDIO NOTE UK AMP FOR \$400, COMPLETE WITH TUBES!**

Audio Note Preamp Kit! Due out late Spring or early Summer, we hope (right, Peter?)! All tube, phono and line, available in a basic, 'bare bones' hardcore D.I.Y. version for only \$199! Other, more Deluxe packaging will also be available. If you've been thinking about buying a new tube preamp, better hold on until these babies hit the street. Believe me, it'll be worth the wait!

Angela Model 91 Single-Ended 300B Triode Mono Amp Plans! Back by popular demand, The Angela Instruments '96 Catalog (\$5) once again features simplified pictorial plans for building the classic Model 91 style monoblock 300B theatre amplifiers as featured in Issue One of *Sound Practices* mag. These plans include a parts list, schematic, beautiful easy to follow pictorial by the great Adam Apostolos plus other hints you need to know. Dozens of our customers worldwide have successfully built these fine *music* amplifiers. *Our '91'* compares very favorably to similar 300B designs costing thousands more. Why not build 'em yourself? It's easier than you think! Our '96 Catalog also offers ALL of the individual parts you'll need, including transformers and metalwork.

Audio Note "Experimenter" Output Transformers For Single-Ended/PSE

1.25K, 20W, 300B/2A3 PSE, 150mA, \$135
 2.5K, 15W, 300B/2A3 SE, 90mA, \$68! **6K, 20W, 845/VT62 SE, 100mA, \$120**

Audio Note "Audiophile Standard" Transformers For Single-Ended/PSE

1.25K, 30W, 2A3/6B4G PSE 130mA, \$160
 1.25K, 50W, 300B etc. PSE, 180mA, \$240
 1.5K, 30W, EL34/6CA7 PSE, 180mA, \$175
 2.1K, 30W, 6L6/5881 PSE, 140mA, \$175
 2.3K, 60W, KT88/6550 PSE, 110mA, \$200
 2.5K, 25W, 300B/2A3 SE, 90mA, \$145
 2.5K, 50W, 845 etc. PSE, 180mA, \$275
 2.6K, 20W, EL84/6V6GT PSE, 100mA, \$155
 3K, 30W, Model 91 300B SE, 140mA, \$160
 5K, 75W, 211/VT4C PSE, 240mA, \$350
 10K, 50W, 211 'Ongaku' SE, 150mA, \$225

All A.N. SE trans are air-gapped. Most are 4-8 ohm secondaries. As found on the excellent A.N. UK SE amps! 1000's of these fine music transformers are now in service worldwide! Most models are now available with end bells installed for \$15.

Audio Note "Deluxe C-Core" Output Transformers For Single-Ended/PSE

1.25K, 50W, 300B PSE, 4/8/16, 180mA, \$450
 2.5K, 30W, 300B etc. SE, 4/8/16, 90mA, \$400
 10K, 50W, 211/845 SE, 4/8/16, 150mA, \$475

Audio Note Pure Silver Wired Output Transformers For Single-Ended/PSE

2.5K, 25W, 2A3/300B SE, 90mA, \$2500
 10K, 50W, 211/VT4C SE, 150mA, \$3000

Audio Note "Audiophile Standard" Output Transformers For Push-Pull and P-P Parallel

2.2K, 100W, KT88/EL34 PPP UL, \$100
 3K, 50W, 6L6/5881/KT66 PPP, \$100
 4.3K, 60W, KT88/6550/EL34 PP UL, \$110
 5K, 30W, 300B/2A3/6B4G PP, \$65
 6K, 25W, 6L6/5881/300B, EL34 PP, \$80
 6.6K, 50W, 6L6/5881/807 PP, \$115
 6.8K, 50W, 845 etc. PP, \$180
 8K, 15W, EL84/6V6/ECL86 etc. PP, \$65

All impedances are calculated for Class A. Most have 4/8 ohm secondaries. * Dyna-Acro etc. "Ultralinear" with screen taps and 4/8/16 secondaries. Made in England.

Audio Note Chokes And Inductors

.5H/400mA, \$35
 3H/100mA, \$30
 3H/200mA for 'Ongaku' etc., \$42
 5H/150mA, \$40
 5H/400mA, \$60
 10H/125mA, \$50
 10H/200mA, \$65
 20H/50mA, \$45

Audio Note Power Transformers

1. For Stereo 300B amp/Kit One, \$160
 2. For Stereo 211SE 'Ongaku', \$175
 Send SASE for diagrams of above iron.

Angela "Universal" Power Transformer For Monoblock Tube Amp Projects!

120V/240V primary! 380-320-55 (Bias Tap!) 0-320-380 at 200-mA! 6.3V at 2.5A! 5V at 3 amps for rectifier tubes! 5VCT at 1.5A so ya can run a 300B or 2A3! Simple hook with color coded leads; send SASE for diagram. Build a classic Model 91 300B SE triode amp! Or if you need more power build a 50W Acro/Dyna EL34 amp with fixed bias, using the 55V bias tap! **YOU be the BIG BOSS MAN!** Made in USA! Conventional upright end bell mounting. FIVE YEAR GUARANTEE! EACH \$90!

'MIL. SPEC.' Potted Power Transformers For Tube Amps

120V primary, 6.3V at 5.5A, 560VCT at 110mA. Built like a little tank! Potted, sealed, welded steel cans like some old UTC military units. MINT condition USA GONZO government surplus! **KILLER** for building compact single-ended EL34, 6L6 or other tube monoblock amps. Mounting studs and solder lugs on bottom of transformer. Approx. 3.5"X3"X4" tall. TONS IN STOCK! WOW! \$38!

Need 'HEAVY DUTY' Power Iron?

Here's a 'REAL MUTHA' FOR YA!
 Chicago Standard MASSIVE potted USA N.O.S. military power transformers!
 115V-230V dual primary, 980VCT at 250mA, 5VCT at 2A for rectifiers, 6.3V at 5A. Build a 'high power' triode amp! Build an 80W 6146 amp! Sealed steel can with nice locking rounded edges. Schematic printed on side of cant BIG ASS mounting studs and solder terminals on bottom. This is one SERIOUS chunk of iron! Individually boxed, MINT! Each \$55!

Bartolucci Double C-Core Output Transformers For Single-Ended/PSE

1.25K, 52W, 6C33/300B PSE, 220mA, \$225
 2.5K, "10W", 2A3/300B SE, 90mA, \$185
 3K, 30W, Model 91 300B etc. SE, 90mA, \$225
 7.8K, "18W", 811 etc. SE, 60mA, \$225
 10K, 30W, 211/845 SE, 150mA, \$250

Individually wound by G. Bartolucci and Co. in Italy, these fine transformers feature double-C core construction found on Tango and some of the best vintage iron. All have 4/8.16 sec., solid brass hook up terminals on the bottom and are potted in beautiful handmade black finished steel enclosures. Each transformer comes with a signed test certificate. See the most recent issue of Vacuum Tube Valley for a report.

Bartolucci "UNIVERSAL" Double-C Core Output For SE/UL-PP/UL!!!

A unique 'breakthrough' product! Configurable for 3K SE 300B OR for 3K EL34 SE with 50% Ultralinear screen tap! Also for push-pull 3.2K 48W UL! Just think of all the different KOOL circuits you can try out with this transformer! Potted in steel cans, brass hook up terminals, 4/8/16 secondaries. PAIR FOR \$300!

Bartolucci Double C-Core Output Transformers For Push-Pull Amps

4.3K, 60W, EL34/KT88/6550 UL PP, \$160
 6.6K, 30W, KT66/5881 Williamson UL PP, \$160

For "Ultralinear" designs, 4/8/16 sec., potted.

Hammond Transformers In Stock!

10H/125mA choke for tube amps, \$21!!
 1.5H/200mA choke for Dyna-junk, \$10!
 2H/200mA choke for tube amps, \$19!!
 Hammond offers a vast range of good power, output, filament, choke, etc. iron! We deal the entire line; see our '96 Catalog for detailed specs and unbeatable discount prices. Also, unlike our competitors, we handle special orders quickly and efficiently. **STOP PRESS!** Hammond has just announced a new range of tube audio output transformers, including **NEW single-ended types!**

Audio Note 99.99% Silver Wire and Silver Solder
 A.N. 99.99% Silver Wire Priced per meter:
 .05mm (\$30), .2mm (\$40), .35mm (\$45), 6mm (\$55), 8mm (\$60), 1mm (\$70).
 A.N. Silver Solder is 1mm diam., acid and chlorine free, available in 9 meter length (\$30) or in a one Kilo roll (\$245). As used on Ongaku, etc.

Audio Note Paper In Oil Signal Capacitors

2.250V, \$19
 .1200V, \$7
 .56200V, \$8
 .001/400V Silver Leads, \$9
 .0028/400V Silver Leads, \$9
 .0082/400V Silver Leads, \$10
 .01/400V Silver Leads, \$10
 .015/400V, \$6
 .022/400V Silver Leads, \$10
 .047/400V Silver Leads, \$11
 .082/400V, \$8
 .12/400V, \$9
 .15/400V Silver Leads, \$12
 .18/400V Silver Leads, \$13
 .22/400V Silver Leads, \$13
 .33/400V, \$13
 1mF/400V Silver Leads, \$25
 1.4mF/400V, \$30
 .0018/630V, \$6
 .0004/630V, \$6
 .00082/630V, \$6
 .0015/630V, \$6
 .0047/630V, \$6
 .012/630V, \$8
 .015/630V, \$8
 .022/630V Silver Leads, \$12
 .033/630V, \$7
 .039/630V, \$7
 .047/630V Silver Leads, \$14
 .056/630V, \$8
 .065/630V, \$8
 .072/630V, \$8
 .082/630V, \$9
 .1/630V, \$12
 .15/630V Silver Leads, \$15
 .18/630V, \$10
 .22/630V, \$14
 .22/630V Silver Leads, \$18
 .27/630V, \$11
 .33/630V, \$13
 .36/630V, \$15
 .39/630V, \$16
 .47/630V Silver Leads \$20
 .018/100V, \$11
 .021/100V, \$15
 .39/100V, \$23
 .68/100V, \$30
 1.2mF/100V, \$35
 .022/100V, \$20
 .22/200V, \$25
 1/400V, \$5

These axial lead caps are thought by many D.I.Y. hipsters to be superior to ANY other oil or plastic caps available today! Try 'em! Great UPGRADE for old or new tube amps!

Audio Note Paper In Oil Copper Foil Axial Lead Signal Capacitors

.001/630V Silver Leads, \$21
 .0028/630V Silver Leads, \$21
 .0082/630V Silver Leads, \$22
 .01/630V Silver Leads, \$23
 .022/630V Silver Leads, \$26
 .047/630V Silver Leads, \$30
 .1/630V Silver Leads, \$32
 .15/630V Silver Leads, \$33
 .22/630V Silver Leads, \$40
 .33/630V Silver Leads, \$46
 .47/630V Silver Leads, \$55
 1mF/630V Silver Leads, \$85
 Feature silver leads, oxygen free copper foil. Highly recommended for premium applications!

Audio Note Paper In Oil Silver Foil Axial Lead Signal Capacitors

.047/630V Silver Leads, \$70
 .1/630V Silver Leads, \$130
 .15/630V Silver Leads, \$170
 .22/630V Silver Leads, \$225
 .47/630V Silver Leads, \$325
 1mF/630V Silver Leads \$850

icar (Italy) Axial Paper In Oil Signal Capacitors

Special! .047/1500V (\$5), .1/1500V (\$6), .22/1500V (\$7) and .33/1500V (\$8). Similar in build quality and sound to A.N. oil caps.

Angela Oil/Polypropylene Caps For Tube Amps

15MFD/600VDC, 1.75" diam., \$12
 50MFD/515VDC, 2.50" diam., \$18
 30MFD/515VDC, 1.75" diam., \$15
 Clamps for tube amp (specify size) \$2 each. **GREAT for tube amp power supplies!**
More Good Capacitors For Tube Amp Projects!
 Sprague axial lead 'ATOM' electrolytics for tube power supplies! Solen 'FAST CAP' 630V metallized polyprop. film caps for replacing cheap electrolytics in tube power supplies, bypass, signal, and speaker X-overs. SBE (Sprague) film and foil 715P/716P polyprop. signal caps. MORE! See big Angela '96 Catalog for KILLER prices!

Audio Note Ceramic Tube Sockets

1. Octal, ceramic/silver, chassis mount 1.125" hole, for EL34 etc. fits Dyna etc. exactly, \$5.50
 2. Octal, ceramic/gold, chassis mount 1.125" hole, \$7
 3. 9 pin for 12AX7 etc., top chassis mount to 1" hole, finest white ceramic and silver, \$5.75
 4. 9 pin top chassis mount, ceramic/gold, \$6
 5. 9 pin for 12AX7 etc., chassis mount from below to 1" hole, ceramic/silver, \$5.75
 6. 9 pin chassis mount below, ceramic/gold, \$6
 7. 9 pin PC mount, ceramic/silver, \$4.95
 8. 9 pin PC mount ceramic/gold, \$4.95
 9. 7 pin chassis mount above, silver, \$5
 10. 7 pin chassis mount above, gold, \$6.50
 11. 7 pin chassis mount from below, silver, \$5
 12. 7 pin PC mount, ceramic/silver, \$5
 13. 7 pin PC mount ceramic/gold, \$6.50
 14. UX4 for 300B etc., ceramic/silver, mounts from below to 1.1875" chassis hole, \$ 8.50
 15. UX4 for 300B, ceramic/gold, \$8.50
 16. Johnson "224" W.E. style wafer socket for 300B and other triodes, ceramic silver, \$22
 17. UX5 five pin socket for 807, etc., mounts below to 1.1875" chassis hole, ceramic/gold, \$8

A.N. sockets are the very best you can buy! As used on Ongaku, etc! Finest white ceramic and special alloy GOLD or SILVER plated metal contacts. Essential for serious D.I.Y. projects or for UPGRADES to vintage and modern gear.

Shinkoh Tantalum Film .5 Watt Resistors

Available in the following values: 10, 12, 15, 22, 27, 39, 47, 56, 68, 82, 100, 120, 150, 220, 270, 330, 390, 470, 560, 600, 620, 680, 820, 1K, 1.1K, 1.2K, 1.5K, 1.8K, 2K, 2.2K, 2.7K, 3.9K, 4.7K, 5.6K, 6.8K, 8.2K, 10K, 12K, 15K, 22K, 27K, 33K, 39K, 47K, 56K, 62K, 68K, 75K, 82K, 91K, 100K, 120K, 150K, 220K, 250K, 270K, 330K, 390K, 430K, 470K, 510K, 560K, 620K, 680K, 820K, 1Meg. **ONGAKU STYLE!** Each \$5

Audio Note Tantalum Film 1 Watt Resistors

15, 47, 91, 100, 150, 220, 330, 470, 600, 680, 890, 910, 1K, 1.24K, 1.33K, 1.5K, 2.2K, 2.7K, 3.3K, 4.7K, 6.8K, 9.1K, 10K, 15K, 17K, 22K, 33K, 39K, 47K, 56K, 68K, 82K, 100K, 150K, 178K, 182K, 220K, 270K, 470K, 620K, 1 Meg. all 1%. Each \$7

Could these be the BEST resistors for audio?

Black Gate WKZ 'Heart Of Muse' Electrolytics!

1. 100x100/500V, standard 1.3125" diam., clamp mount, solder lugs on bottom, NEW WKZ! \$125!
 2. 100/500V, 1.3125" diam., WKZ! \$90!
 3. 47x47/500V, 1.3125" diam., WKZ! \$95.
 4. 100/100V radial, popular bias cap., \$12.

If you must use electrolytics, these are the best.

Elna Ceramfil Electrolytic Capacitors

47/500V (\$16), 47x47/500V (\$18), 100/500V (\$22), 100x100/500V (\$30), 220/500V (\$33), 220x220/500V (\$53), 330/500V (\$45). Power supply UPGRADES!

TONS OF Great N.O.S. Tubes In Stock!

Handpicked, Tested & Guaranteed!

1. EL34, Mullard N.O.S. 72, THE REAL THING! Welded plates, perfect for Marantz! Matched quads \$300, pairs \$150
 2. EL34 Siemens German, quads \$98
 3. 7027 Philips USA '80s, quads \$150
 4. EL84 Philips USA '80s, quads \$40
 5. 7581A/6L6GC Philips USA, quads \$80
 6. 5881/6L6WGB Philips USA, quads, \$32
 7. 6V6GT Philips USA, quads \$70, pairs \$35
 8. 5691 JAN Philips USA, KILLER 6SL7 \$15
 9. 6SN7WGTA JAN Philips USA, \$8
 10. 6SJ7WGTA JAN Philips USA, \$7
 11. 6072/12AY6 GE black plates, \$10
 12. 5842/417A Amperex, still a steal at \$6
 13. 5687 JAN Philips '80s, \$5
 14. GZ37 '60s Mullard, KILLER 5U4! \$15

GZ34 Mullard UK '70s, THE BEST! \$85

ORDERING INFO: VISA/MC/AMEX OK

for phone/fax/mail/E-mail orders or prepay with cert. funds. Most goods shipped on 7 day approval! We ship **WORLDWIDE!** Angela '96 Catalog \$5 USA, \$8 elsewhere



ANGELA INSTRUMENTS, 10830 GUILFORD ROAD, SUITE 309, ANNAPOLIS JUNCTION, MARYLAND USA 20701 PHONE (301) 725-0451 FAX (301) 725-8823 E-MAIL steve@angela.com

HI-FI SPOTTER'S GUIDE SERIES

Brought To You By

VINTAGE HI-FI PRODUCTIONS

order now!

1. VINTAGE HI FI SPOTTER'S GUIDE - VOLUME 1

A unique collection of photos, specifications and advertising from the Golden Age of Hi Fi. Over 450 amps, tuners, and other equipment is depicted. **\$18.95**

2. VINTAGE HI FI SPOTTER'S GUIDE - VOLUME 2

This Volume covers equipment not listed in Volume 1. Almost 500 amps, preamps, tuners, etc are depicted. This edition covers early audio, Golden Era (1947-63) and includes a "Speaker Spotter" section with Altec, EV, JBL, Jensen, University and more. **\$18.95**

3. VINTAGE HI FI PRICE GUIDE

The first grading and price guide for vintage hi fi amps, preamps, tuners, etc. Includes NOS audio tubes and quality transformers as well. Over 1200 items included. Covers grading guidelines and collector information. Corresponds with Volumes 1 and 2 of the Spotter's Guides. **\$25.00**

4. "VINTAGE HI FI THE GOLDEN ERA 1947-65"

A one-of-a kind video covering the nostalgic post-war and 1950s home hi fi era. Over 80 classic audio amps, tuners, etc are shown. This video is professionally produced and is 34 minutes in length. **VHS NTSC \$25.00**

5. THE ULTIMATE TUBE SUBSTITUTION GUIDE

No tube electronics enthusiast should be without this book. Over 10,000 tubes are listed on 240 pages including: audio, radio, transmitting, and special. Also features an audio tube section with tube evaluation and testing information. **\$29.95**

6. VINTAGE HI-FI SCHEMATIC AND LITURATURE LIST

A large list of tube hifi schematics and owners manuals available for: Altec, Bell, Dynaco, Eico, Fisher, Grommes, Harman-Kardon, Heath, Leak, Marantz, McIntosh, Newcomb, Pedersen, Pilot, RadioCraftsmen, Scott, and more. **\$5.00**

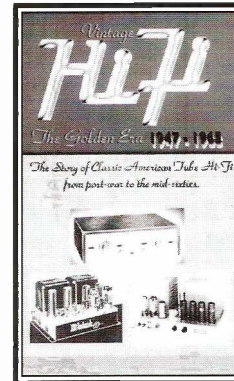
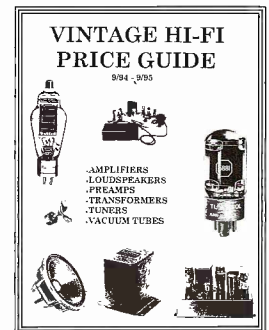
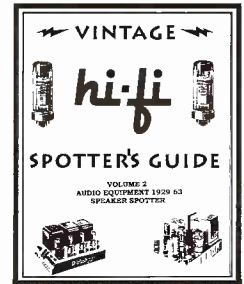
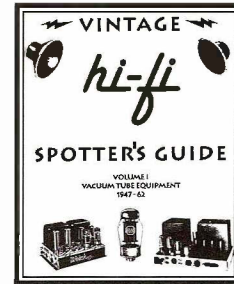

VIDEO

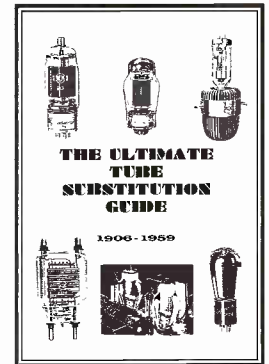

VINTAGE HI FI PRODUCTIONS
1095 E. DUANE AVE. STE. 106
SUNNYVALE, CA 94086
408-733-6146

ORDER FORM

NAME _____
 ADDRESS _____
 CITY _____ STATE _____ ZIP _____

PLEASE SEND THE FOLLOWING PRODUCTS!

FREE SHIPPING IN USA ADD \$7.00 PER ITEM FOREIGN (foreign shipping)
 CA RESIDENTS ADD 7.75% STATE SALES TAX (CA TAX)

NO CREDIT CARDS - CHECKS OR MONEY ORDERS ONLY TOTAL ORDER \$

PRICE

\$ _____
 \$ _____
 \$ _____
 \$ _____
 \$ _____

DON'T FORGET TO ORDER
VACUUM TUBE VALLEY
 A MUST READ TUBE AUDIO
 ELECTRONICS MAGAZINE! IT
 HAS VINTAGE AND MODERN
 TUBE AUDIO ARTICLES
US\$32/YR (4 ISSUES)
US\$45 FOREIGN

VINTAGE HIFI PRODUCTIONS
1095 E. DUANE AVE STE 106
SUNNYVALE, CA 94086
408-733-6146

TUBES • LITERATURE • PARTS • SUPPLIES

YOUR COMPLETE SOURCE FOR...

TUBES:

Over 3500 audio, receiving, transmitting and industrial types in stock, including many foreign and early types. We offer the complete line of Svetlana audio, amateur radio and industrial power tubes.

TRANSFORMERS:

Hard to find power, filament and output transformers as well as filter chokes for tube equipment. We feature HAMMOND performance transformers, MagneTek and Thordarson as well as many new old stock transformers.

CAPACITORS:

High voltage electrolytic and mylar capacitors, multi-section capacitors and more for tube circuits.

PARTS:

Resistors, tube sockets, potentiometers, chassis boxes and aluminum enclosures, knobs, dial belt, lamps, diodes, speakers, wire, phonograph needles and cartridges and much more.

LITERATURE:

Extensive selection of literature and books on tubes, hi-fi equipment, circuits diagrams, communication gear and antique radios. Some items not available elsewhere!

SUPPLIES:

Grill cloth, cabinet restoration supplies, batteries, chemicals, tools, test meters, gifts and kits.

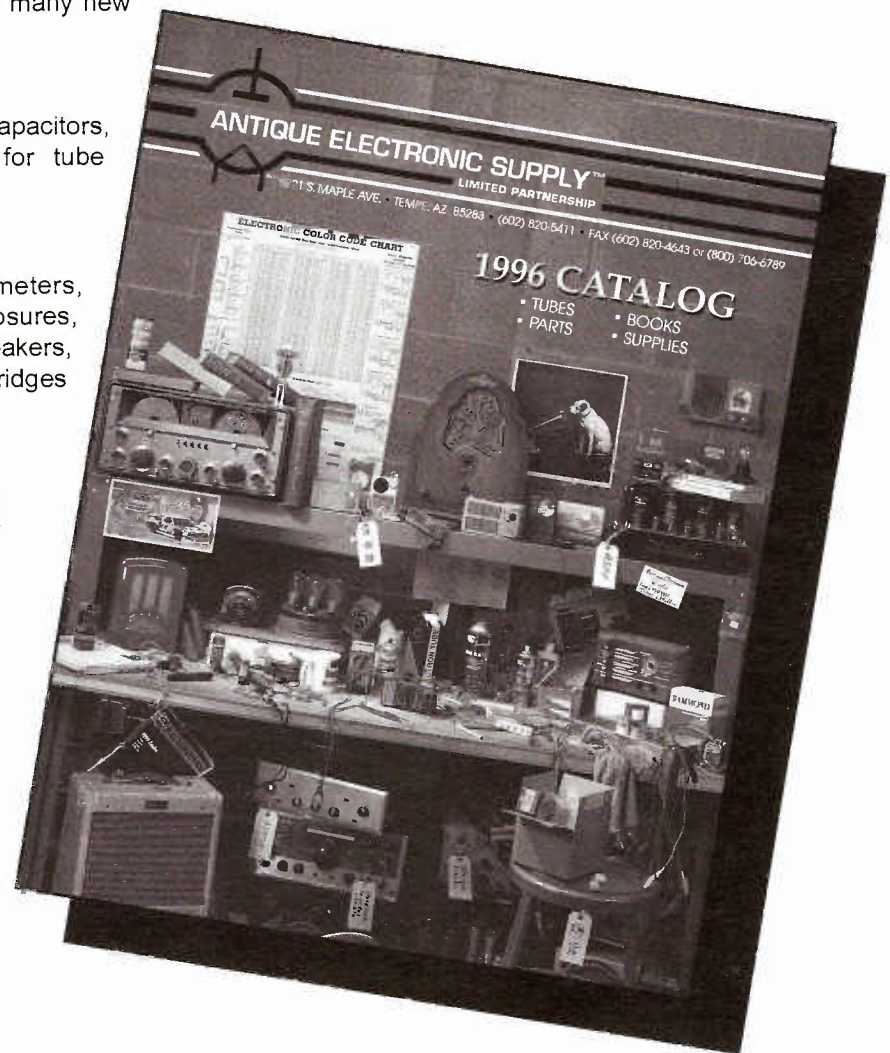

AUTHORIZED DISTRIBUTORS FOR



**HAMMOND
MANUFACTURING™**
TRANSFORMERS
SMALL CASES



Svetlana
ELECTRON DEVICES

 **one electron™**

CALL OR FAX FOR OUR FREE 40 PAGE CATALOG

ANTIQUE ELECTRONIC SUPPLY™

LIMITED PARTNERSHIP

6221 S. MAPLE AVE. • TEMPE, AZ 85283 USA • (602) 820-5411 • FAX (602) 820-4643