

HOW TO IMPROVE YOUR LISTENING ROOM

audio **X**PRESS

IT JUST SOUNDS BETTER

AUGUST 2002

US \$7.00 Canada \$10.00

Continuing Audio Electronics, Glass Audio & Speaker Builder

**FURNITURE GRADE
FINISHES FOR YOUR
SPEAKERS**

**TAKING THE
MYSTERY OUT
OF DUAL
VOICE-COIL USE**

**RELAYS TO PROTECT
YOUR SPEAKERS**

**BUILD THIS
BIG 45W/CHANNEL
POWER AMP**

**REGULATORS FOR
THE PASS
ZEN AMPS**



www.audioXpress.com

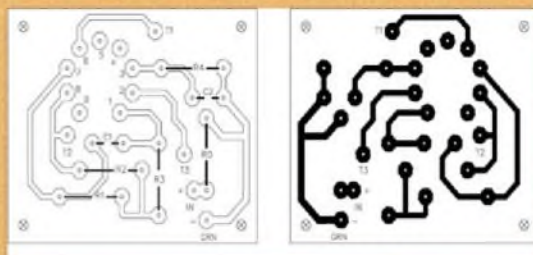
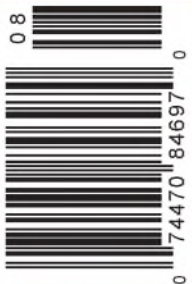

**BUILD A SIMPLE
SINGLE ENDED AMP**

**QUICK GUIDE TO
OLD, OLD TUBES**

Over the Top

Music performance and craftsmanship that exceed your expectation in every way

Compass DANCER SERIES

Compass DANCER SERIES DESIGN HIGHLIGHTS:

- Carbon-paper woofer cone
- Silk-fabric soft dome tweeter; Ceramic type on some models
- Innovative magnet flux design with corrective cooper elements on all drivers, resulting in significantly reduced third and second harmonic distortions
- Cast aluminum driver frame
- Hand picked, matched-pair drivers on all models
- Phase coherent crossover designed by world renown master of speaker design, built with components of the highest quality and thoroughly tested with digital-based measuring equipment
- Massive, sonically dead front baffle which places drivers in a time-coherent physical arrangement
- Multilambr reinforced cabinet with solid wood side panels, handcrafted to the highest furniture grade



Behind the Scene

Dr. Joseph D'Appolito has been working as consultant for Usher Audio since early 2000. A world renown authority in audio and acoustics, Dr. D'Appolito holds BEE, SMEE, EE and Ph.D. degrees from RPI, MIT and the University of Massachusetts, and has published over 30 journal and conference papers. His most popular and influential brain child, however, has to be the MIT loudspeaker geometry, commonly known as the "D'Appolito Configuration," which is now used by dozens of manufacturers throughout Europe and North America.

Dr. D'Appolito designs crossover, specifies cabinet design, and tests prototype drivers for Usher Audio, all from his private lab in Boulder, Colorado. Although consulting to a couple of other companies, Dr. D'Appolito especially enjoys working with Usher Audio and always finds the tremendous value Usher Audio products represent a delightful surprise in today's High End audio world.

With an abundance of original concepts in loudspeaker design, backed by thirty years experience in manufacturing and matched with an eye for fashion and unparalleled attention to detail, is USHER the ideal original design manufacturer you've always been looking for? Find out the answer today by talking to an USHER representative.

USHER

USHER AUDIO TECHNOLOGY

67, Kai-Fong Street, Sec. I, Taipei 100, Taiwan

Tel: 886 2 23816299 Fax: 886 2 23711053

Web site: www.usheraudio.com E-mail: usher@ms11.hinet.net

PARTS
EXPRESS
 ELECTRONICS & MORE
www.partsexpress.com

**1 HOUR
KIT!**

**TITANIC
SERIES**

Designed By

Vance Dickason

NEW

GOT BASS?



Textured Black Polymer Coating



Black Chrome Spikes



10" Titanic Subwoofer System

ASK FOR #300-739

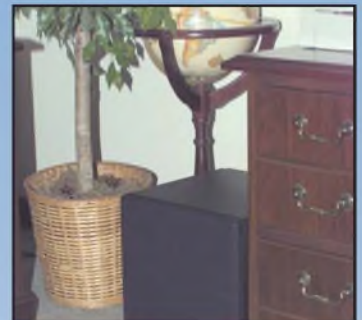

Perfect For Any Room



Complete Kit

BUILD THIS KIT AND YOU WILL!

This system was designed by Vance Dickason and is featured in the 6th. Edition Loudspeaker Design Cookbook. It produces quick, accurate and powerful bass. Perfect for small to medium size home theater or listening rooms. It comes in kit form and can easily be assembled in less than 1 hour. The 3/4" MDF cabinet is finished in a durable textured black polymer coating and is rigidly coupled to the floor using our "black chrome" spikes set. The 10" Titanic driver is precision crafted using only the finest components and features a build quality that rivals the best European drivers. Coupled with our (#300-794) 250W amplifier, this system produces a maximum output of 112dB and yields an F3 of around 24Hz when room loaded. The amplifier contains variable phase, 30Hz bass boost and other high-end features. ♦Frequency response: 24-160 Hz ♦Exterior dimensions: 14-1/4" W x 14-1/4" H x 14-1/4" D ♦Net weight: 46 lbs.



**FREE CATALOG
CALL FOR YOURS
TODAY!**

1-800-338-0531

www.partsexpress.com

**Check us out online or give us a call
for all of your audio electronic needs.**

725 Pleasant Valley Dr., Springboro, OH 45066-1158

Phone: 937/743-3000 ♦ FAX: 937/743-1677

E-Mail: sales@partsexpress.com

SOURCE CODE: AXM

SUPRA[®]

Cables



AER



TONIAN LABORATORIES
specialty Audio Imports & Distribution

Phone: 818.848.9881

Fax: 818.848.9090

www.TONIANLABS.COM

PHY-HP



PHY-HP (Haut parleurs)[®]

NOISE WIZARD

Virtos GmbH introduces "Noise Wizard," a software package of five DirectX-based plug-ins for high-quality audio restoration, specializing in analog sources such as LPs or cassette recordings. The plug-ins are: Denoiser (with three different tools for reduction of stationary noise), Declicker/Decrackler (for removal of clicks, pops, and crackle without corrupting source material), Filter Toolbox (containing a set of versatile digital filtering tools), Stereo Processor (for phase corrections, stereo field adjustment, or enhanced stereo perception), and Band Extrapolation (synthesizing high or low frequency harmonics to give life to dull recordings). Noise Wizard is available as a complete package or as separate plug-ins. For more, visit <http://www.virtos-audio.com> (to download a demo), or call +49 (0) 721-384 21 24, FAX +49 (0) 721-384 21 15, or e-mail lundqvist@virtos.de.

BUILDING PRO AUDIO LOUDSPEAKER ENCLOSURES

Grubsrof, Inc., publishing division, releases *Building Pro Audio Loudspeaker Enclosures*. This 196-page book covers materials, machinery, hardware, rigging, design tools, application, design concepts, assembly, and painting, and also includes two projects to help integrate this information. Also provided is a CD containing resource listings for material, hardware, CAD drawings, software, websites, and more to help you find what you need to build professional loudspeaker enclosures. For more, visit <http://www.grubsrof.com> or call 919-786-2700.

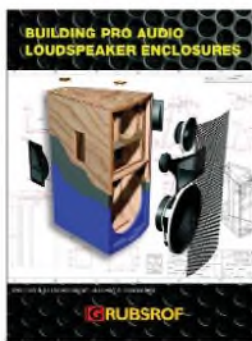

VACUUM TUBE MOTHERBOARD

AOpen announces the world's first vacuum tube motherboard, the AX4B 533, designed for those searching for "perfect" tube sound reproduced from a desktop PC. The tube output stage of the AX4B 533 couples the two front digital stereo output channels with tube output to enhance the sound. This motherboard employs a single dual-triode as the main amplification device (Sovtek 6922), a switching mode power supply to properly operate the tube, and the Frequency Isolation Wall (FIW) method of noise reduction (separating each operating frequency region). The AX4B 533 Tube Motherboard comes with the Intel 845E chipset design and features DDR SDRAM memory channels delivering 2.1 GB/s of memory bandwidth to the processor, 4X AGP slots and new ICH4, and also supports 4USB 2.0 ports and Ultra ATA/100 interface. For more, call 408-232-1297 or visit the website at www.AOpen.com.



CMC
Charming Music Conductor®



Specialist of
Audio
Connection

We have been over 15 years experience for produced hi end audio connector, we are also available OEM, If you want to look for best partner of your products, Please contact us today.

www.nelsonaudio.com.cn

Nelson Audio

Sales Dept.:

Tel: (+86) 20 8385 5292

Fax: (+86) 20 8134 9084

E-mail: nelson@nelsonaudio.com.cn

Factory:

No.19, Alley 27, Lane 55, Sec 4,
Hai Tien Rd, Tainan, Taiwan.

Tel: (+886) 6 246 9393

Fax: (+886) 6 247 2901

HI-FI SHOW & AV EXPO 2002

London's *Hi-Fi News*-sponsored Hi-Fi Show & AV Expo 2002 will take place September 13-15 at Le Meridien and The Renaissance hotels, Heathrow. The show typically attracts over 1000 registered trade and press visitors every year, representing over 60 countries, and also features live music and special events. Exhibitors including Marantz, Chord Electronics, Nagra, Musical Fidelity, MartinLogan, Tannoy, Unison Research, and Halcro are expected, representing 80 brands of audio and video equipment, accessories, and software. For more, call 011-44 8774 0847, or e-mail janet_belton@ipcmedia.com.

MONSTER CABLE

Monster Cable Products, Inc., introduces a lineup of premium M Series® subwoofer interconnects. These three interconnect cables—M Series Bass™ 1000, Bass™ 850, and Monster Bass 550—are designed especially for powered subwoofers. For more, contact Monster Cable, 455 Valley Dr., Brisbane, CA 94005, 415-840-2000, FAX 415-468-0204.

Enjoy the thrill and excitement of building your own audio gear. We are pleased to offer quality electronic parts and kits for the DIY audio enthusiast. You may find complete amplifier and preamplifier kits your bag. Or, maybe a few mods with true audio grade components to your existing components. We have what your need at your one stop supply source: Audio Electronic Supply.

We also have an incredible line of Super Amps and Preamps in either kit form or factory assembled. The vacuum tube based Super Amp was nominated as one of the best buys by Stereophile magazine in 2001. Sound Stage voted the Super Amp as an Editors Choice component. This is certainly an amplifier to love.

Please visit our on line shopping mall at www.audio-electronicssupply.com for the parts and kits, and www.super-amp.com to learn about Super Audio products.

E-mail or call for the latest Audio Electronic Supply catalog today.

The Audio Electronic Supply Source



111A Woodwinds Industrial Court
Cary, NC 27511
919 460 6461
919 460 3828 fax

FEATURES

6B4G STEREO 90 POWER AMP

This power amp design offers a solution to the problem of distortion in a push-pull parallel configuration.

By Michael Burrows 6

THE ZEN AMP VARIATIONS, PART 3

Adding a simple power-supply regulator to the Zen amp.

By Nelson Pass 16

IT'S NOT JUST A SPEAKER—IT'S FURNITURE

Here's a step-by-step guide to help you make your speakers look as good as they sound.

By Bill Fitzmaurice 22

RELAYS FOR LOUDSPEAKER PROTECTION

Discover how relays can offer speaker protection in the event of amp failure.

By Charles Hansen 30

DUAL-DRIVER CONFUSION REVISITED

Getting a handle on system response when using a dual-voice-coil driver.

By G. R. Koonce 40

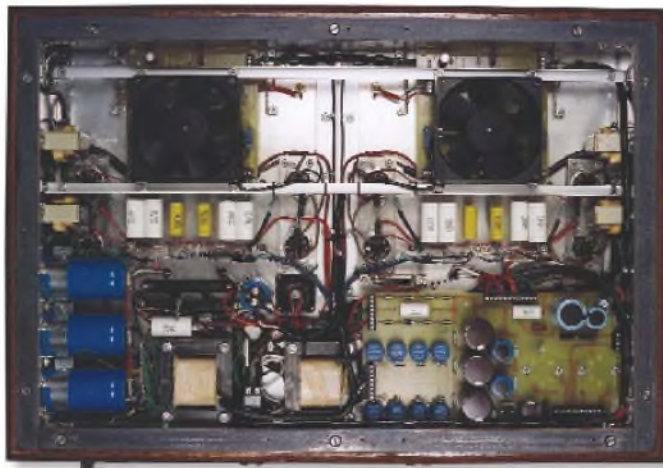

page 6

REVIEWS

B2 SPICE A/D V4

This computer simulation program lets you test your circuit designs.

Reviewed by Tom Harman 44

CARA 2.0 COMPUTER-AIDED ROOM ACOUSTICS SOFTWARE

Design a room for the best placement of your sound system.

Reviewed by Richard Honeycutt 48

CARA TEST DISK

Test the acoustics of your listening room.

Reviewed by Richard Honeycutt 52



page 22

audioXpress (US ISSN 0004-7546) is published monthly, at \$34.95 per year, \$58.95 for two years. Canada add \$12 per year; overseas rates \$59.95 per year, \$110 for two years; by Audio Amateur Inc., Edward T. Dell, Jr., President, at 305 Union St., PO Box 876, Peterborough, NH 03458-0876. Periodicals postage paid at Peterborough, NH, and additional mailing offices.

POSTMASTER: Send address changes to: audioXpress, PO Box 876, Peterborough, NH 03458-0876.



page 48

THE STAFF

Editor and Publisher
Edward T. Dell, Jr.

Regular Contributors

Eric Barbour	Erno Borbely
Robert Bullock	Richard Campbell
Joseph D'Appolito	Vance Dickason
Bill Fitzmaurice	Gary Galo
Charles Hansen	G.R. Koonce
Nelson Pass	Richard Pierce
Reg Williamson	

Vice President
Karen Hebert

Dennis Brisson	Assistant Publisher
Marianne Norris	Editorial Assistant
Amity Palmer	Editorial Assistant
Tina Hoppock	Graphics Director
Amy Wyman	Production Assistant
Laurel Humphrey	Marketing Director
Kelly Bennett	Customer Service

Advertising Department

Strategic Media Marketing
1187 Washington St.
Gloucester, MA 01930

Peter Wostrel
Phone: 978-281-7708
Fax: 978-283-4372
E-mail: peterw1@igs.net

Nancy Vernazzaro
Advertising/Account Coordinator

*The peculiar evil of
silencing the expression
of an opinion is, that it is
robbing the human race;
posterity as well as the
existing generation; those
who dissent from the
opinion, still more than
those who hold it.*

JOHN STUART MILL

Department, *audioXpress*, PO Box 876,
Peterborough, NH 03458, 603-924-7292,
FAX 603-924-6230,
E-mail nancy@audioXpress.com.
Printed in the USA. Copyright © 2002 by Audio
Amateur Corporation. All rights reserved.

DEPARTMENTS

AUDIO NEWS

What's new on the audio market.....2

XPRESS MAIL

Readers speak out55

BOOK REVIEW

The Collector's Vacuum Tube Handbook
Reviewed by Larry Lisle64

NEW CHIPS ON THE BLOCK

AK4360
TDK AVPro 501
Charles Hansen65

CLASSIC CIRCUITRY

Pilot AA-908
Courtesy of Lance Cochrane67

AUDIO AID

Shishido 300B SE Amp Mod
Ignatius Chen68

TEST TRACKS

Readers' favorites to test audio systems
Dan Stanley72

IN EVERY ISSUE

CLASSIFIEDS

Audio-related items for
sale or wanted 70

AD INDEX 70

YARD SALE

Free classifieds
for subscribers 71

WEBSITE RESOURCES

Find your favorite advertisers
on-line 71

Articles and letters identified with the following symbols:



solid state



tubes



speakers

LEGAL NOTICE

Each design published in *audioXpress* is the intellectual property of its author and is offered to readers for their personal use only. Any commercial use of such ideas or designs without prior written permission is an infringement of the copyright protection of the work of each contributing author.

SUBSCRIPTION/CUSTOMER SERVICE INQUIRIES

A one-year subscription costs \$34.95; a two year subscription costs \$58.95. Canada please add \$12 per year. Overseas rate is \$59.95 for one year; \$110 for two years. To subscribe, renew or change address write to the Customer Service Department (PO Box 876, Peterborough, NH 03458-0876) or telephone toll-free (US/Canada only) 888-924-9465 or (603) 924-9464 or FAX (603) 924-9467. E-mail: custserv@audioXpress.com. Or online at www.audioXpress.com
For gift subscriptions please include gift recipient's name and your own, with remittance. A gift card will be sent.

ent's name and your own, with remittance. A gift card will be sent.

EDITORIAL INQUIRIES

Send editorial correspondence and manuscripts to *audioXpress*, Editorial Dept., PO Box 876, Peterborough, NH 03458-0876. E-mail: editorial@audioXpress.com. No responsibility is assumed for unsolicited manuscripts. Include a self-addressed envelope with return postage. The staff *will not* answer technical queries by telephone.

CLASSIFIEDS & WEB LISTINGS

Contact Nancy Vernazzaro, Advertising



6B4G Stereo 90 Power Amp

You might call this tube power amp a dream come true for this veteran designer.

By Michael Burrows

In the 38 years I have been working with and designing audio equipment, I've dreamed of someday building my own cathode-follower power amplifier. And there are numerous advantages, such as greatly reduced distortion and excellent electrical damping of the speaker system.

Unfortunately, the major obstacle is the enormous driving voltage required, almost always requiring driver transformers. And the downside of driver transformers is increased distortion, often poor bandwidth, and serious phase-shift at the extremes of the frequency range.

This article describes my many trials and tribulations using directly heated triodes in a push-pull parallel design (Photo 1) that can produce over 45W per channel, as well as an ultralinear driver stage that can produce over 500V RMS at low distortion. It is capable of driving a pair of 4CX50,000 tetrodes for an output of 44kW!

THE SOVTEK 6B4G

You probably noticed that amps with 2A3s, 6A3s, and 6B4Gs typically use self bias, and produce 10W of power. Amps that employ fixed bias can produce

ABOUT THE AUTHOR

Michael Burrows has been working in the field of electronics for over 35 years. He enjoys building audio equipment and listening to good music. He also has a website, www.vacuumtubeamps.com.

WARNING!

The 6B4G Stereo 90 power amplifier is intended for people who have considerable experience and confidence working with high voltages. This amplifier produces voltages of nearly 1.8kV, and *must not be attempted* by anyone who hasn't had the proper training in the use of, and knowledge of, high-voltage components, test equipment, and wiring technique.



PHOTO 1: Completed amp.

15W. And if you used four tubes in a push-pull parallel configuration, you would obtain 20W and 30W, respectively. These tubes had a maximum plate dissipation of 15W and a maximum plate voltage of 300V–325V, and those two factors limited the maximum power output.

About three years ago, Sovtek introduced an updated 2A3 and 6B4G with higher ratings. Maximum plate voltage was boosted to 450V, and the maximum plate dissipation is, well, a bit nebulous.

The Sovtek 6B4G data sheet indicates that the maximum plate current is 100mA, and the plate dissipation is 15W, although I distinctly recall reading that it was rated at 30W. There are no curves with the data sheet. The other difference is the amplification factor. The US-made 6B4G was 4.2, the Sovtek 2.2.

FULL SPEED AHEAD

In spite of the meager data, the plate structure is quite massive, looking like

a down-sized 300B, so I designed the output stage assuming a 30W plate dissipation rating.

The only available plate curves are for the US-made 2A3, and it was not very helpful. Nor was a computer program based on the US 2A3, because the program assumes that you will be using the tubes at 300V or less; over 300V, it's next to useless. So I had no choice but to design the output stage empirically, as well as formulas from tube manuals^{1,2}. Table 1 shows the output stage parameters, and as you can see, plate dissipation is 25.75W per tube.

The ideal load impedance for a quad of 6B4Gs was 1910Ω, but I chose to use

TABLE 1
6B4G OPERATING CONDITIONS—
PUSH-PULL PARALLEL

CLASS AB ₁	
Power Supply Voltage	400V zero signal 375V @ 45W
Minimum signal plate current	185mA
Maximum signal plate current	304mA
Plate voltage swing	300V
Maximum output power	50W
Plate input power	150W
Plate efficiency	39%
Plate dissipation	103W
Load impedance	2300Ω
Grid bias voltage	–75V
Peak AF grid-to-grid voltage	706V

Look!!

Click <http://www.netspace.or.jp/~eifl/eifl/export/export2.htm>
for more products information

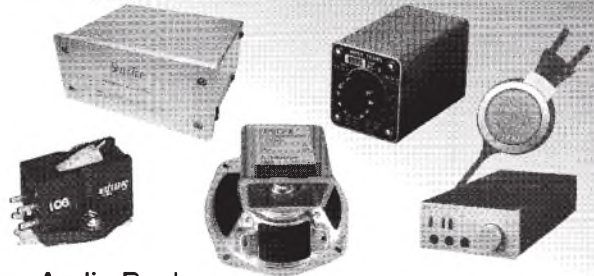

Cartridge

Model	Price (US\$)	Postage (Air Economy)	
Denon DL-102 (MONO)	150	Area I \$ 18	China, Korea Hong Kong Taiwan
Denon DL-103 (STEREO)	200	Area II \$ 22	Singapore Malaysia Indonesia
Denon DL-103R (STEREO)	250		
Denon DL-103 PRO (STEREO)	350	Area III \$ 27	North America Oceania Europe
Shelter Model 501 II (CROWN JEWEL REFERENCE)	650	Area IV \$ 34	Africa South America
Shelter Model 901 (CROWN JEWEL SE)	1,300		
These Area I ~ IV are for all products except book.			

Japanese Audio Book

Postage \$ 15

Title	Author	Price (US \$)
Attractive Tube Amps Vol. 1&2	(Isamu Asano)	30 each
Top-Sounding Vintage Power Tubes (Stereo Sound)		30
Output Trans of The World (Stereo Sound)		30
The Joy of Vintage Tube Amps (Tadaatsu Atarashi)		30
MJ Selected 300B Amps (MJ)		30
Audio Tubes (Hisashi Ohtsuka)		35
SE Amps by Transmitting Tubes (Kouichi Shishido)		50
Classic Valve (Hisashi Ohtsuka)		40
20TH CENTURY OF AUDIO (Stereo Sound)		30
The Remembrance of Sound Post (Susumu Sakuma)		30
Tube Amp Craft Guide (MJ)		30
FOSTEX CRAFT HAND BOOK (FOSTEX)		20

MC STEP UP TRANS

Model	Specifications			Price (US\$)	Postage**
	Pri.Imp(Ω)	Sec.Imp(kΩ)	Response		
Shelter Model 411	3~15	47	20Hz~50kHz	980	Area I \$ 25 Area II \$ 30 Area III \$ 40 Area IV \$ 50
Jensen JE-34K-DX	3	47	20Hz~20kHz	550	
Peerless 4722	38	50	20Hz~20kHz	300	

STAX

Model	Price(US\$)
OMEGA II System(SR-007+SRM-007t)	Ask
SRS-5050 System W MK II	
SRS-4040 Signature System II	
SRS-3030 Classic System II	
SRS-2020 Basic System II	
SR-001 MK2(S-001 MK II +SRM-001)	

Speaker

** Air Economy

Model	Specifications					Price* (US \$)	Postage** (US \$)			
	D (cm)	Ω	Response	db	w		I	II	III	IV
Fostex FE208 Σ	20	8	45Hz~20kHz	96.5	100	296	62	74	120	156
Fostex FE168 Σ	16	8	60Hz~20kHz	94	80	236	42	50	73	98

* Price is for a pair ** Air Economy

TANGO TRANS (ISO) (40models are available now)

Model	Specifications				Price (US \$)	Postage* (US \$)			
	W	Pri.Imp(kΩ)	Freq Response	Application		I	II	III	IV
XE-20S (SE OPT)	20	2.5, 3.5, 5	20Hz~90kHz	300B,50,2A3	396	47	56	84	113
U-808 (SE OPT)	25	2, 2.5, 3.5, 5	20Hz~65kHz	6L6,50,2A3	242	42	50	73	98
XE-60-5 (PP OPT)	60	5	4Hz~80kHz	300B,KT-88,EL34	620	62	74	115	156
FX-40-5 (PP OPT)	40	5	4Hz~80kHz	2A3,EL34,6L6	320	47	56	84	113
FC-30-3.5S (SE OPT) [XE-60-3.5S]	30	3.5	20Hz~100kHz	300B,50,PX-25	620	62	74	115	156
FC-30-10S (SE OPT) [XE-60-10SNF]	30	10	30Hz~50kHz	211,845	620	62	74	115	156
X-10SF [X-10S]	40	10W/SG Tap	20Hz~55kHz	211,845	1160	90	110	180	251
NC-14 (Interstage)	—	[1+1 : 1+1] 5	25Hz~40kHz	[30mA] 6V6 (T)	264	30	40	50	70
NC-16 (Interstage)	—	[1+1 : 2+2] 7	25Hz~20kHz	[15mA] 6SN7	264	30	40	50	70
NC-20F (NC-20) (Interstage)	—	[1 : 1] 5	18Hz~80kHz	[30mA] 6V6 (T)	640	42	50	73	98

Price is for a Pair

TAMURA TRANS (All models are available)

** Air Economy

Model	W	Pri.Imp	Freq Response	Application	Price	I	II	III	IV
F-7002 (Permalloy)	10	3.5	15Hz~50kHz	300B,50	740	60	70	110	145
F-7003 (Permalloy)	10	5	15Hz~50kHz	300B,50	760	60	70	110	145
F-2013	40	10	20Hz~50kHz	211,242	730	70	84	133	181
F-5002 (Amorphous)	8	3	10Hz~100kHz	300B,2A3	1276	65	80	120	160

Price is for a Pair

** Air Economy

EIFL Corporation

1-8, Fujimi 2-chome, Sayama City, Saitama Pref. 350-1306 JAPAN.
Phone: +81-(0)42-956-1178 FAX: +81-(0)42-950-1667
E-mail: eiflcorp@netspace.or.jp
Wire Transfer: MIZUHO BANK, SWIFT No. DKBLJPJT a/c # 294-9100866



Card Charge 6%

a 2300Ω output transformer. There are definite advantages to having a slightly higher load resistance, such as reduced peak plate current and distortion. The disadvantage is a reduction in output power and damping.

I used the Lundahl LL1627 output transformers for my design. It is an exceptionally versatile unit, with all primary and secondary windings attached to two terminal boards, providing a choice of 650Ω, 1200Ω, and 2300Ω. It is rated for up to 250W, depending on how it's wired. The LL1627 has exposed connections, so I used the Hammond 1590V aluminum enclosures. For a

close-up look at how I wired and constructed this unit, see *Photos 2-7*.

QUIRKY TUBES

Push-pull Class AB₁ using fixed bias produces about 40%–60% more power, and approximately 45% less distortion. I knew that using fixed bias with multiple high-transconductance tubes would require separate bias controls for each tube. Even with matched quads, there is still considerable variation between tubes, and if you don't have separate bias adjustments, you will end up with a severely unbalanced output stage.

Due to the sensitivity of high-transconductance triodes to small changes in supply voltage, I have chosen to balance the output stage at 10W, instead of at idle. If you balance the output stage at idle, it will become increasingly unbalanced as the power level goes up.

Figure 1 shows the output stage using separate

coupling capacitors (C2–C5), driver load resistors (R1–R4), and grid stoppers (R5–R8). Resistors R9–R12 are 10Ω, 5W, 1% wirewound that are hand-selected for the exact resistance. These are used to measure DC balance, but more on that in the adjustments section. R1–R4 should also be hand-matched. Capacitors C1, C6, C7, and C8 serve as additional filters, and to ensure that each section of the driver stage “sees” an equal AC load regardless of the bias control settings.

Transformers T1 and T2 are 6.3V, 2A filament components with separate primary and secondary bobbins, whose center tap supplies the audio signal to the output transformer. T3 is the Lundahl 1627 output transformer wired for a 2300Ω primary and an 8Ω secondary. If you desire different combinations of impedance, visit their website. (*Table 2* is the output stage parts list.)

INPUT/DRIVER CIRCUIT

The input stage (*Fig. 2*) consists of a 12AT7A, SRPP (shunt-regulated push-pull) configured, directly connected to a 12AU7A common-cathode phase splitter.



PHOTO 2: Right side view of amp.

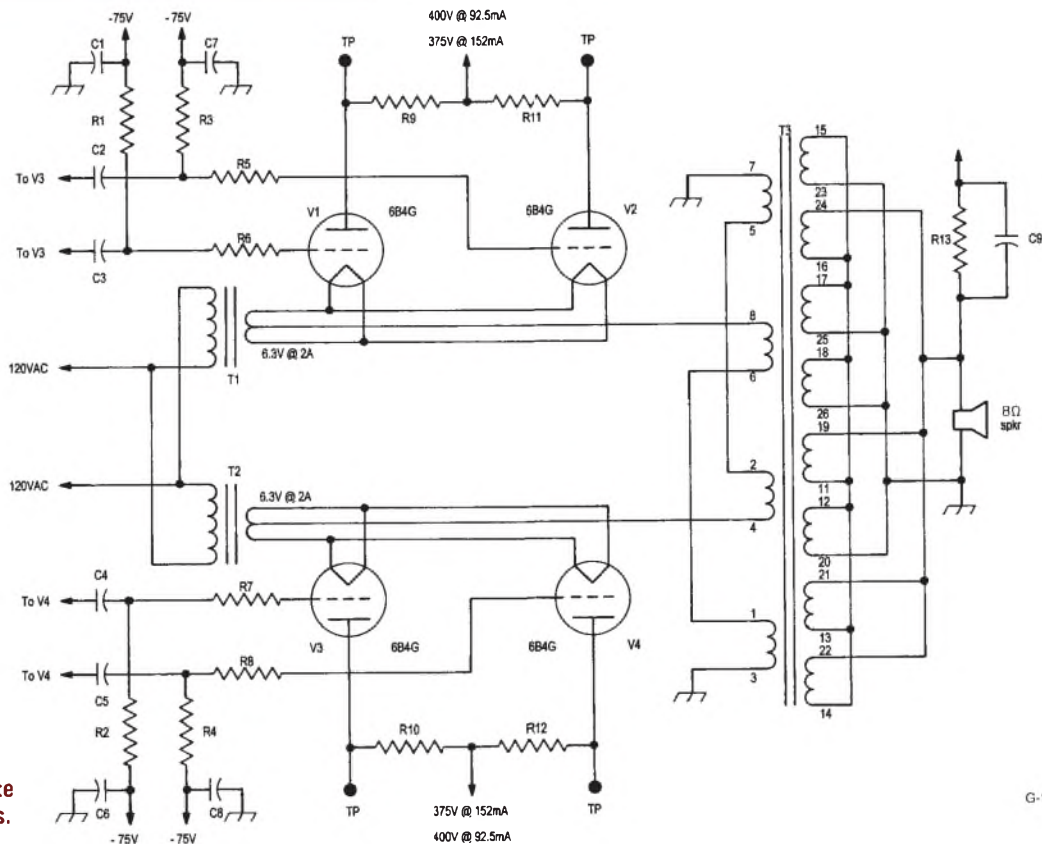

FIGURE 1: Output stage using separate coupling capacitors.

G-1910-1



ALPS

PARTS CONNEXION



Alps "Black Beauty" 100K 21-Step Dual/Stereo Series Attenuator

When Alps used their "Black Beauty" case style to build a special order "series attenuator" primarily for the pro-audio market, the result was a substantially sonically superior, 21-step, 60dB range pot with superior channel-to-channel tracking. Compared to other discrete series attenuators at well over \$100 US, this is an absolute best buy! Anyone looking for a stereo volume control between 50K and 250K, should consider this part. Completely sold out of our first lot, pcX has tracked down more - now available at **\$49.95** US each. Don't delay, limited quantity.



Audio Note

Audio Note Tantalum Resistors

Highly regarded, sought after - and difficult to get! pcX has acquired 1/2 watt, 1 watt and 2 watt Tantalum film resistors with tinned copper axial leads. Many audiophiles and manufacturers consider these resistors the best resistor for audio, delivering unparalleled resolving power and transparency with warmth and musicality. Visit our website for a complete listing of values and pricing.

Pearl Tube Coolers with Carbon-Fiber Sleeve

An all new design of one of the most useful accessories in tube audio! Incorporating a new carbon-fiber sleeve - reduced tube microphony results in noticeably improved sonics - and improved transfer of heat from the tube's glass envelope to the copper-finned cooler prolongs tube life. Available for all types of octal power tubes (3 diameters: KT88/2", 6500/1.5", EL34 /1.25") - octal input tubes (6SN7) - 9-pin miniature input tubes (12AX7, 6DJ8, etc.) - and 9 pin power tubes (EL84s). Priced from **\$6.95 to \$11.95** US each.



PEARL

pcX Catalog

Order the pcX Catalog for \$5 US or visit our website for our **FREE** downloadable PDF version.



Subscribe to **eConnexion**, a monthly email newsletter featuring the latest happenings at Parts Connexion - including great specials, clearance items & new product introductions.

toll free order line

1-866-681-9602 US & Canada only

www.partsconneXion.com

Tel: 905-681-9602 Fax: 905-631-5777 info@partsconneXion.com

Visa, MasterCard, American Express, Paypal, Money Order/Bank Draft/Cashier's Check, Personal Check (after clearance)

PARTS CONNEXION, 2885 Sherwood Heights Drive, Unit #72, Oakville, Ontario, CANADA L6J 7H1

IMPORTANT NOTE: No "on-site/walk-in" business at this time



The enormous driving voltage required to operate the 6B4G output stage proved to be the most daunting challenge. In order to get 45W of power, each side of the output stage requires 250V RMS (353V peak, 707V peak-to-peak), and no voltage amplifier tube can do that.

I had no choice but to use a power tube, but which one? I ruled out the EL34, KT88, and the 6550, because the high emission cathode would be overkill in this design. So I chose the venerable 6L6GC.

As a power tube, the 6L6GC has a maximum plate voltage of 500V when used in a choke or transformer loaded circuit. When you use output tubes in a resistance coupled circuit, you can safely double the maximum plate voltage. However, in the case of tetrodes and pentodes, it is wise to keep the screen grid voltage at 40%–60% of the plate voltage in order to prevent overdissipation of the screen grid. The screen grid has a very limited ability to dissipate heat, and thermal runaway will result due to the white-hot screen acting as a secondary emitter. In this design, the 6L6GCs dissipate only 23W, well below the 35W (30W plate, 5W screen grid) rating.

Having decided on the 6L6GCs, I next had to decide whether it should be operated in tetrode, triode, or ultralin-

ear (partial triode) mode.

My first attempt used the 6L6GCs in triode mode, with a plate voltage of 750V and a screen voltage of 400V. I varied the tube current from 10mA to 35mA. The results were very disappointing. The distortion at 1kHz was 5.6% (THD + noise) at 250V RMS.

Next, I tried it in tetrode mode, under the same conditions, with better results. Distortion decreased to 1.9%, but this

was still completely unacceptable to me.

Finally, I tried ultralinear mode, and the results were astonishing! Distortion dropped to only 0.7%, and without

**TABLE 2
OUTPUT STAGE PARTS LIST**

RESISTORS	
R1–R4	200k Ω , 2W*
R5–R8	1k Ω , 2W
R9–R12	10 Ω , 5W, 1%, wirewound* (see text)
R13	2.0k Ω , 1W
TRANSFORMERS	
T1, T2	Hammond 166L6 6.3V @ 1.0A
T3	Lundahl LL1627 (see text)
CAPACITORS	
C1, C6, C7, C8	1.0 μ F, 100VV
C2, C3, C4, C5	0.47 μ F, 1200VV
C9	220pF, mica, 5%
VACUUM TUBES	
V1–V4	6B4G Sovtek
MISCELLANEOUS	
TP	Pin jacks
	Octal sockets
	Hammond 1590V aluminum enclosures

*Hand matched.
All resistors are metal oxide, 5%, except where noted.

**TABLE 3
INPUT/DRIVER STAGE PARTS LIST**

RESISTORS	
R1	100k Ω , trimmer
R2, R5, R6, R14, R15	100 Ω
R3	1k Ω
R4	910 Ω
R7	1M Ω
R8	270k Ω , 1W*
R9	24k Ω , 1W*
R10	82k Ω , 1W*
R11	100k Ω , 1W*
R12, R13	470k Ω
R16	5k Ω , 3W ten-turn wirewound
R17, R18	2k Ω , 1W*
R19, R20	270k Ω , 3W*
R21, R22	300k Ω , 3W*
R23, R26, R27, R30	30k Ω , 5W*
R24, R25, R28, R29	20k Ω , 5W*
CAPACITORS	
C1	470 μ F, 6WV electrolytic
C2	1.0 μ F, 250WV electrolytic
C3	0.01 μ F, 600WV film
C4	10 μ F, 450WV electrolytic
C5	0.22 μ F, 600WV film
VACUUM TUBES	
V1	12AT7A
V2	12AU7A
V3, V4	6L6GC
MISCELLANEOUS	
	3kV rated wire
	9 pin sockets
	octal sockets
	All resistors 1/2W, 5% metal film, except*, which are metal oxide.

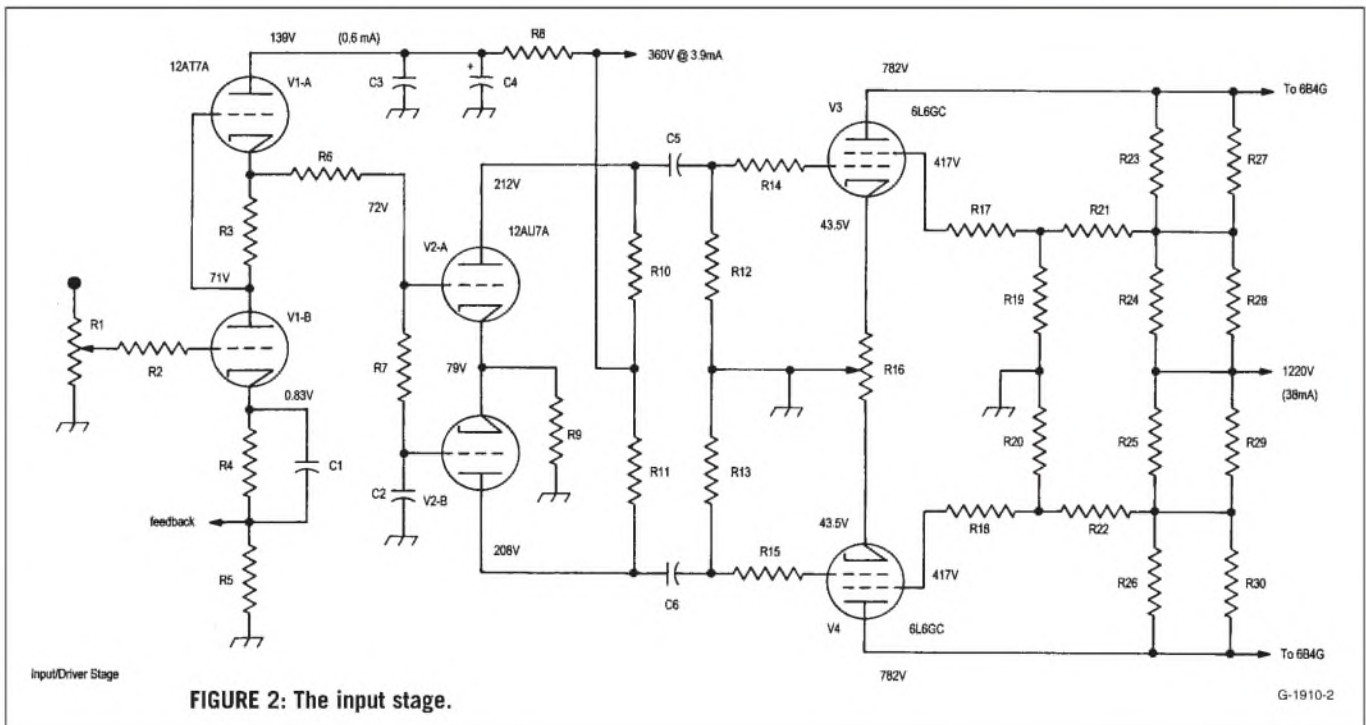

negative feedback! You will notice that the balance potentiometer is not bypassed with a capacitor. I found that distortion increased about 10% with a bypass capacitor.

The moral of this story is this: If you have no choice but to use a power tetrode or pentode as a voltage amplifier, the ultralinear mode will give you the best results.

Resistors R14, R15, R17, R18 are grid/screen stoppers designed to prevent parasitic oscillations, because when used in this configuration the 6L6GC has a frequency response that extends beyond 1MHz.

Resistors R19–R22 are part of a voltage divider that reduces the 1220V supply to 417V. R23–R30 are the plate-load resistors that are connected in a series/parallel arrangement, as each one has a power rating of 5W. Figure 3 illustrates the output voltage versus distortion versus frequency. Figure 4 shows the input/driver frequency response. (Table 3 is the input/driver parts list.)

THE POWER SUPPLY

One of my design goals was to have a vacuum tube rectifier for the output stage, because I believe that solid-state rectifiers are not always the best sonic choice for some power tubes, such as the

aforementioned triodes. I realize this is the least scientific statement I've made so far, but I can hear the difference.

The power supply (Fig. 5) for the output stage originally used three paralleled 5AR4 rectifiers with equalizing resistors, but the voltage drop was too great. I didn't want to bother with mercury vapor rectifiers,

so I used two 3B25 xenon gas half-wave rectifiers (Photo 8). Like their mercury vapor cousins, they have a constant

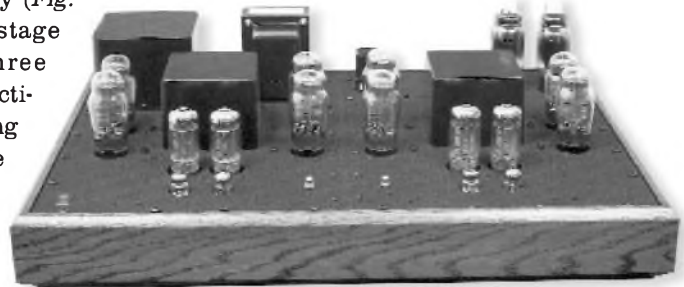

PHOTO 3: Front view of amp.

Chelmer Valve Company Ltd

The Stables, Baddow Park, Great Baddow, Chelmsford
Essex, CM2 7SY, England.

email: sales@chelmervalue.com ** tel. 44 1245 241 300 fax. 44 1245 241 309 ** www.chelmervalue.com

for High Quality Audio Tubes

Everybody in the audio tube business knows that the justly famous brand names of yesteryear like Brimar, GEC, Mullard, RCA, Telefunken etc. etc. are scarce and often quite expensive. Although we supply all major brands as available (and we have many in stock) our policy is to offer a range of tubes, all new and mostly of current manufacture, the best we can find from factories around the world, which we process to suit audio applications. The result **CVC PREMIUM** Brand. Our special processing includes selection for **low noise, hum & microphony** on pre-amp tubes and controlled **burn-in** on power tubes to improve stability avoid tubes with weaknesses etc.

A selection of CVC PREMIUM Audio Tubes

PRE-AMP TUBE	POWER TUBES	POWER TUBES cont.	RECTIFIERS cont.
ECC81 5.90	EL34G 8.30	6L6/ 5881 WXT 9.00	5Y3GT 4.80
ECC82 5.90	EL34 (JJ) 8.50	6V6GT 5.50	5Z4GT 5.80
ECC83 5.90	EL34(Large Dia) 11.00	6080 11.50	SOCKETS ETC.
ECC85 6.60	EL84 5.50	6146B 11.00	B9A (Ch or PCB) 1.60
FCC88 5.70	EL509/519 13.00	6336A 48.00	Ditto, Gold Pl. 3.00
ECF82 5.50	E84L/7189 7.50	6550WA/WB 15.00	Octal (Ch or PCB) 1.80
ECL82 6.00	KT66 11.00	7581A 12.00	Ditto, Gold Pl. 4.20
ECL86 6.30	KT66R 22.50	807 10.70	LX4 (4-Pin) 3.60
EF86 6.00	KT77 13.20	811A 11.80	Ditto, Gold Pl. 5.50
E80F Gold Pin 11.00	KT88 13.50	812A 31.00	4 Pin Jumbo 10.00
E81CC Gold 8.00	KT88 (Special) 17.00	845 (New des) 33.50	Ditto, Gold Pl. 13.00
E82CC Gold 9.00	KT88 (GL Type) 30.00	RECTIFIERS	5 Pin (For 807) 3.30
E83CC Gold 8.50	PL509/519 9.90	EZ80 5.10	7 Pin (For 6C33C) 4.70
E88CC Gold 8.80	2A3 (4 pin) 15.50	EZ81 6.00	9 Pin (For EL509) 5.00
6EU7 7.00	2A3 (8 Pin) 17.50	GZ32 15.50	Screen can B9A 2.20
6SL7GT 8.90	211 23.00	GZ33 15.50	Ditto, Gold Pl. 4.30
6SN7GT 5.30	300B 45.00	GZ34 7.20	Top Con. (For 807) 1.70
6922 6.40	6C33C-B 25.00	GZ37 15.50	Ditto, (For EL509) 2.00
7025 7.00	6L6GC 7.60	5U4G 6.30	Retainer (For 5881) 2.20
	6L6WGC/5881 8.90	5V4GT 5.00	

And a few 'Other Brands', inc. rare types

5R4GY <i>Fivre/GE</i> 8.50	6SL7GT <i>STC</i> 13.00	13E1 <i>STC</i> 100.00	6550C <i>Svetlana</i> 18.00
5R4WGY <i>Chatham</i> 10.50	6SN7GT <i>Brimar</i> 13.00	211/VT4C <i>GE</i> 120.00	6146B <i>GE</i> 18.50
5Y3WGT <i>Sylv</i> 6.50	12AT7WA <i>Mullard</i> 6.00	300B <i>JJ</i> 56.00	A2900 <i>GEC</i> 15.00
6AS7GT <i>Sylv</i> 12.00	12AU7 <i>Mullard</i> 12.50	300B <i>Svetlana</i> 80.00	E88CC <i>Mullard</i> 14.60
6AU6WC <i>Sylv</i> 5.10	12AY7 <i>GE / RCA</i> 8.40	300B <i>WE</i> 195.00	F2a <i>Siemens</i> 145.00
6B4G <i>Sylv</i> 27.00	12AZ7 <i>West'h.</i> 8.00	805 <i>USA</i> 52.00	KT66 <i>GEC</i> 69.00
6BW6 <i>Brimar</i> 5.40	12BH7A <i>RCA</i> 14.00	5842A <i>GEC</i> 15.00	KT88 <i>JJ</i> 17.40
6BX7GT <i>GE / RCA</i> 9.00	12BY7A <i>GE</i> 9.50	6080 <i>Telef.</i> 13.30	KT88 <i>Svetlana</i> 35.00
6CG7/6FQ7 8.50	12F1 <i>STC</i> 12.50	6550A <i>GE</i> 31.50	PX25 <i>KR</i> 128.00

ALL PRICES IN U. K. POUNDS £

Please note extras: carriage charge (£3.00 in U.K.) & in EEC VAT (17.50%). When ordering please state if matching required (add £1.00 per tube). Payment by credit card (VISA, AMEX etc.) or TRANSFER or CHEQUE (UK only). FAX email or POST your ORDER for immediate attention - We will send PROFORMA INVOICE if required. MILLIONS OF OTHER TUBES & SEMICONDUCTORS IN STOCK!

**** Valve Amplifiers sound better still with CVC PREMIUM Valves! ****

**

PRICE VALIDITY TO END APRIL 2002 - ASK ABOUT ANY TYPES NOT ON THIS LIST

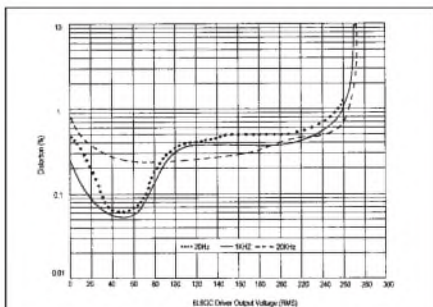

FIGURE 3: 6L6GC driver output voltage (RMS).

G-1910-3

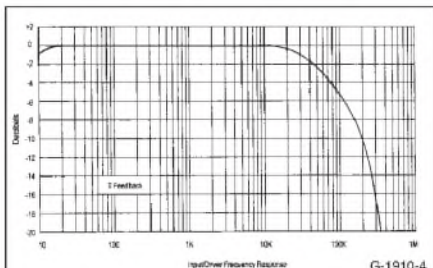

FIGURE 4: Input/driver frequency response.

G-1910-4

5V–15V drop over the usable current range, must be used with choke-input filters, and require a delay in application of plate voltage. Unlike mercury

types, xenon gas rectifiers can be used in any position, and they have a large operating temperature range, relatively immune to magnetic fields, less noise, and no poisonous debris to clean up if they break.

Transformer T1 supplies 2.5V @ 10A for the 3B25s (Photo 3), while T2 supplies bias, filament, and plate voltage. The plate winding is rated at 500mA

with a capacitor-input filter, but since it is used with a choke-input filter the rating increases 40%–50%.

Transformer T3 supplies high voltage to the driver stage and is rated at 250mA with a choke-input filter. Since a capacitor-input filter is used, the current rating drops to about 130mA.

When power is applied, time delay relay TDR begins a 30-second delay and

controls RY, a DPDT rated at 15A. RY's contacts bypass R1, which soft-starts T3, allowing the capacitors to charge slowly; otherwise, the high voltage would race through the input/driver stage before the cathodes heat up, and *nearly everything would be reduced to ashes!* RY's other contacts ground T2's center tap.

Finally, I used two low-

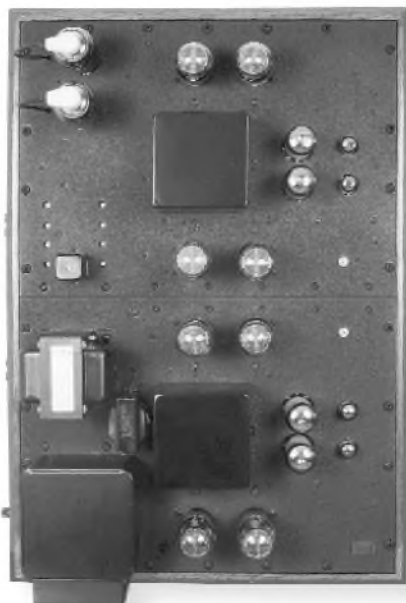

PHOTO 4: Top view of amp.

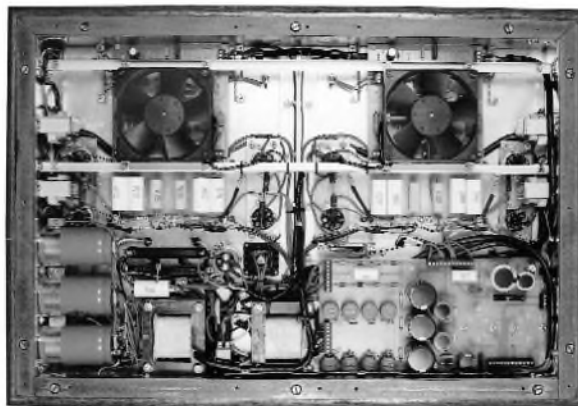

PHOTO 5: Underside view of amp.

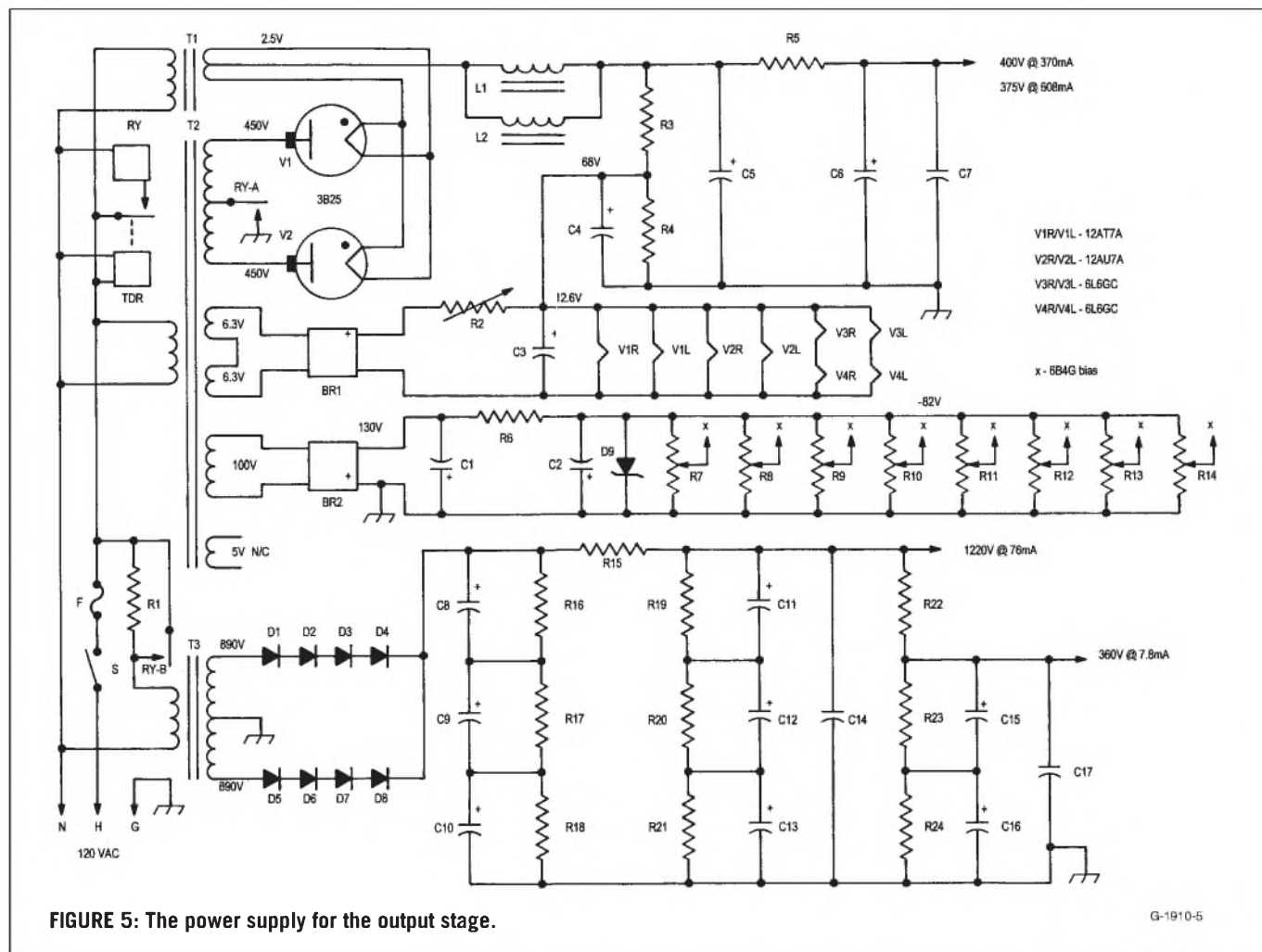

FIGURE 5: The power supply for the output stage.

G-1910-5

noise fans mounted under the amp to keep everything cool to extend component life. (Table 4 is the power-supply parts list.)

CONSTRUCTION TIPS

It has been my experience that filamentary (directly heated) tubes almost al-

ways die an early death if you mount them horizontally, or even test them briefly at high power. This is due to the long filament bowing due to gravity and heat. So my advice is to design your amplifier with this fact in mind. My design has test jacks, as well as bias controls that can be accessed from the top. Make sure your design doesn't require tipping the amp on its side to make adjustments.

Because of the large amount of parts and wiring required, I suggest that you build the amp in stages to re-

duce the chance of errors. First build the output stage and associated power

TABLE 4
6B4G STEREO 90 POWER-SUPPLY PARTS LIST

CAPACITORS

C1	330µF, 200WV electrolytic
C2, C4	47µF, 100WV electrolytic
C3	33,000µF, 16WV electrolytic
C5	100µF, 450WV electrolytic
C6	470µF, 450WV electrolytic
C7, C17	0.1µF, 600WV film
C8, C9, C10	470µF, 450WV electrolytic
C11, C12, C13	1000µF, 450WV electrolytic
C14	0.1µF, 2kV film
C15, C16	220µF, 350WV electrolytic

SEMICONDUCTORS

D1-D8	3A, 1000 PIV
D9	Zener diode, 82V, 5W, 5%
BR1	Bridge rectifier 25A, 100 PIV
BR2	Bridge rectifier 4A, 600 PIV

TRANSFORMERS

L1, L2	Hammond #193L 5H, 300mA
T1	2.5VCT, 10A
T2	Audio Electronic Supply #PT-9077 900V @ 500mA 100V @ 60mA 6.3V @ 4A 6.3V @ 4A 5.0V @ 6.5A
T3	Hammond #726 1780 @ 175mA

RESISTORS

R1	750Ω, 50W wirewound
R2	1Ω, 50W wirewound (adjust for 12.6V)
R3	620kΩ, 1W
R4	130kΩ, 1W
R5	20Ω, 12W
R6	3.9kΩ, 2W
R7-R14	50kΩ, ten-turn wirewound
R16-R21, R23, R24	200kΩ, 3W
R22	8kΩ (4-20kΩ, 5W wirewound in series)

RELAYS

RY	DPDT, 15A
TDR	Time delay, N.O. 30-second delay

VACUUM TUBES

V1, V2	3B25
--------	------

MISCELLANEOUS

F1	6.0A, time-delay
S1	15A
Wire	3kV rated
Sockets	4-pin (2)
Plate connector	9/16" (2)
All resistors are 5%, metal oxide, except where noted.	

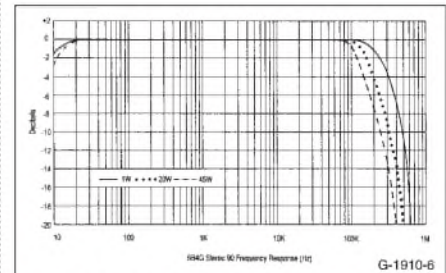

FIGURE 6: 6B4G Stereo 90 frequency response.

Over 2,000 Tube Types for All Applications

RECEIVING • SPECIAL PURPOSE • POWER • INDUSTRIAL • ANTIQUE

★ Highest Quality from the World's Most Popular Manufacturers ★

TYPE	TYPE	TYPE	TYPE
3A3C	6EJ7	12A27A	811A
5AR4	6GH8A	12BA6	812A
5R4GY	6GJ7	12BE6	813
5U4G	6HA5	12BH7A	2050/2050A
5Y3GT	6J5	15CW5	5749/6BA6W
6AJ8	6J7	17J28	5814A
6AL5	6JZ9	30AE3	58B1
6AQ5	6K7	33GY7A	5965
6AU6	6SA7	35W4	6146A/B
6AX5GT	6SG7	38HE7	6350
6BA6	6SJ7	50C5	6463
6BE6	6SK7	62E7	
6BH6	6SN7GT6	6973	
6BL8	6SQ7	7025A	
6CA4	6U8A	7189A	
6CA7	6X4	7581A	
6CG3	6X5GT	KT88	
6CX8	6XB	2D21/EN91	
6CW5	12AT7	65A2/0G3	
6DL5	12AU6	109C1/0B2	
6DQ6B	12AU7	150C4/0A2	
6DR7	12AV6	572B	
6DX6	12AV7	805	
6EA8	12AX7A	807	
6EH7	12AY7	810	

VOLUME DISCOUNTS

Solid State Replacements as low as \$4.00

Write or call for complete tube range, price list and accessories catalog.

International[®]

International Components Corporation

178 Marcus Blvd., Hauppauge, NY 11788 • N.Y. State 631-952-9505 • FAX 631-952-9587

Call TOLL FREE 800-645-9154 www.icc107.com

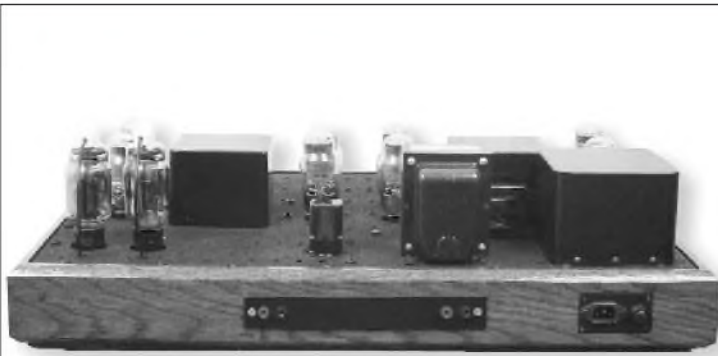

PHOTO 6: Rear view of amp.



PHOTO 7: Right side view of amp.

supply, then adjust and test for problems. If the output stage works OK, next start working on the input/driver stage and its associated high-voltage power supply. The tube pinouts are shown in Fig. 8.

ADJUSTMENTS

You will need at least two *battery-powered* digital multimeters (three DMMs

would be best) and a dual trace oscilloscope. Don't use any DMM that requires power from the AC line!

Remove the 3B25s and disable the high-voltage power supply. Turn on the power and adjust bias pots R7–R14 for –75V on the 6B4G sockets (pin 5). Turn the power off.

Reinstall the 3B25s, and with the 6B4Gs in their sockets, connect one DMM lead to the junction of R5 and C6 in the power supply, and the other lead to the chassis. Connect the second DMM to the same R5 and C6 as above, and the second lead to the test point (TP) in the output stage. *Danger!* This procedure will place the entire meter at a potential of 400V to ground, and you must keep your wits about you, and be aware of any object that is grounded!

Remember, the first DMM is used in the normal mode with its case grounded. The second DMM is used in differential mode. You must keep the two far apart so that you can't touch both at the same time, or use rubber gloves. See warning note.

Connect an 8Ω non-inductive resistor with an appropriate power rating to the speaker terminals and turn the power on. The 3B25s and 6B4G filaments will light up, and after 30 seconds, the relay contacts will close, and the first DMM will read between 380V and 420V.

The second DMM (the one that's electrically hot) will measure the voltage drop across the 10Ω, 5W resistors that are in the 6B4Gs plate circuit. Adjust each bias control for 0.42V. This will be the most cumbersome and frustrating process when using these quirky tubes. As you set the bias on one tube, it affects the supply voltage,

which will either increase or decrease, thus unbalancing the other 6B4Gs!

You must repeat the bias settings at least 30–50 times in order to get all eight output tubes balanced. I have a suggestion that works for me. Turn off any high current household appliances (clothes dryers, heat pumps, and so on) as their on/off cycling will affect the line voltage. And don't adjust the bias during high peak power demands.

The DC balance adjustment mentioned previously is a preliminary adjustment. The final adjustment is done at a power output of 10W. It would be wise to let the output tubes age for at least 24 hours, making periodic bias adjustments.

Assuming everything has gone well with the output stage, shut the power off and allow the power-supply capacitors to discharge. Remove the 3B25s and the 6B4Gs, and be sure to number them so they go back in the same sockets. Set volume control trimmer R1 to its maximum.

Install the 12AT7s, 12AU7s, and 6L6GCs. Set AC balance control R16 to the center of its range. Enable the high-voltage power supply, and turn the power on. With a signal generator con-

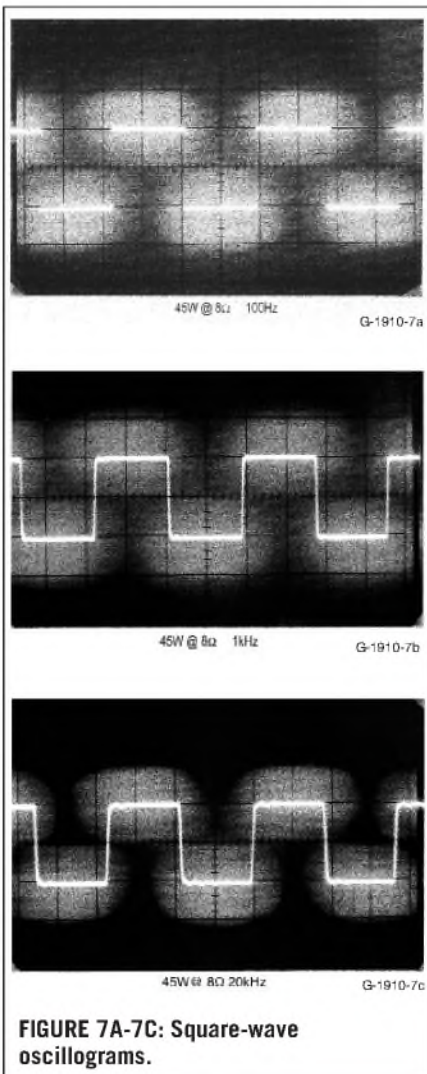

FIGURE 7A-7C: Square-wave oscillograms.

TABLE 5
6B4G STEREO 90 SPECIFICATIONS

Power output	45W @ 20Hz–80kHz @ 8Ω
Clipping point	50W @ 8Ω
Frequency response	22Hz–80kHz, +0 –0.25dB @ 45W 18Hz–110kHz, +0 –0.25dB @ 1W
THD + noise	0.2% @ 10W @ 1kHz 0.6% @ 45W @ 1kHz
Hum + noise	2.5mV RMS, input shorted
Input sensitivity	1.2V RMS
Negative feedback	14dB
Damping factor	26 @ 8Ω
Tube complement	12AT7 × 2, 12AU7A × 2, 6L6GC × 2 6B4G × 8, 3B25 × 2
Power consumption	480W @ zero signal 630W @ maximum signal



PHOTO 8: 3B25 rectifiers.

Reinstall the 3B25s and 6B4Gs and turn the power back on. Allow the amp to idle for at least six hours so that the temperature of all components stabilize. With 8Ω resistors and DMMs connected to the speaker terminals, adjust the signal generator for 9V RMS (10W). Readjust *all* of the 6B4G bias pots *again*(!) so that each 10Ω, 5W plate resistor reads 0.46V, all the while readjusting the signal generator output to maintain a constant 9V RMS across the 8Ω load resistors. Finally, adjust one or the other volume control trimmers so that both channels

As you can see from the specifications, hum and noise is only 2.5mV. This very low figure proves the advantage of having a balanced output stage, even with AC on the 6B4G filaments.

After nearly three years of work on this project, I say unabashedly that this is the best power amp I have ever built. The damping has a profound effect when listening to the pedal notes of the pipe organ, where each note is clearly articulated, as is the bass viola da gamba. Vocals are rich and transparent, while the cymbalstern stop and orchestral bells project with crystalline clarity. ❖

connected to the input (any frequency between 100Hz and 1kHz) and set to sine wave, connect a dual-trace oscilloscope to the 6B4G's grid terminal.

After a proper burn-in period, adjust AC balance control for equal traces at an output of 700V P-P each side. Turn off the power and allow the capacitors to discharge.

produce equal power.

RESULTS

As you can see from Fig. 6, distortion remains well under 1% at an output of 45W or less. Table 5 shows the complete specifications for the 6B4G Stereo 90, while Figure 7 contains the square-wave oscillograms.

SOURCES

ANGELA INSTRUMENTS

10830 Guilford Rd., Suite 309
Annapolis Junction, MD 20701
301-725-0451
www.angela.com

ANTIQUE ELECTRONIC SUPPLY

6221 S. Maple Ave.
Tempe, AZ 85283
602-820-5411
www.tubesandmore.com

AUDIO ELECTRONIC SUPPLY

111-A Woodwinds Industrial Ct.
Cary, NC 27511
919-481-4494
www.audioelectronicsupply.com

LUNDAHL TRANSFORMERS AB

Tibeliusgatan 7
SE-761 50 Norrtälje
Sweden
+46-176 13930
www.lundahl.se

NEWARK ELECTRONICS

800-463-9275
www.mouser.com

PARTS EXPRESS

725 Pleasant Valley Dr.
Springboro, OH 45066
513-743-3000
www.partsexpress.com

RADIO ELECTRONIC SUPPLY

3500-R NW 97th Blvd.
Gainesville, FL 32606
352-332-8881
www.vacuumtubes.net

RICHARDSON ELECTRONICS LTD.

40W267 Keslinger Rd.
La Fox, IL 60147
630-208-2200
www.rell.com

TRIODE ELECTRONICS

2225 W. Roscoe St.
Chicago, IL 60618
773-871-7459
www.triodeel.com

REFERENCES

1. RCA Receiving Tube Manual RC-19.
2. RCA Transmitting Tubes TT-5.

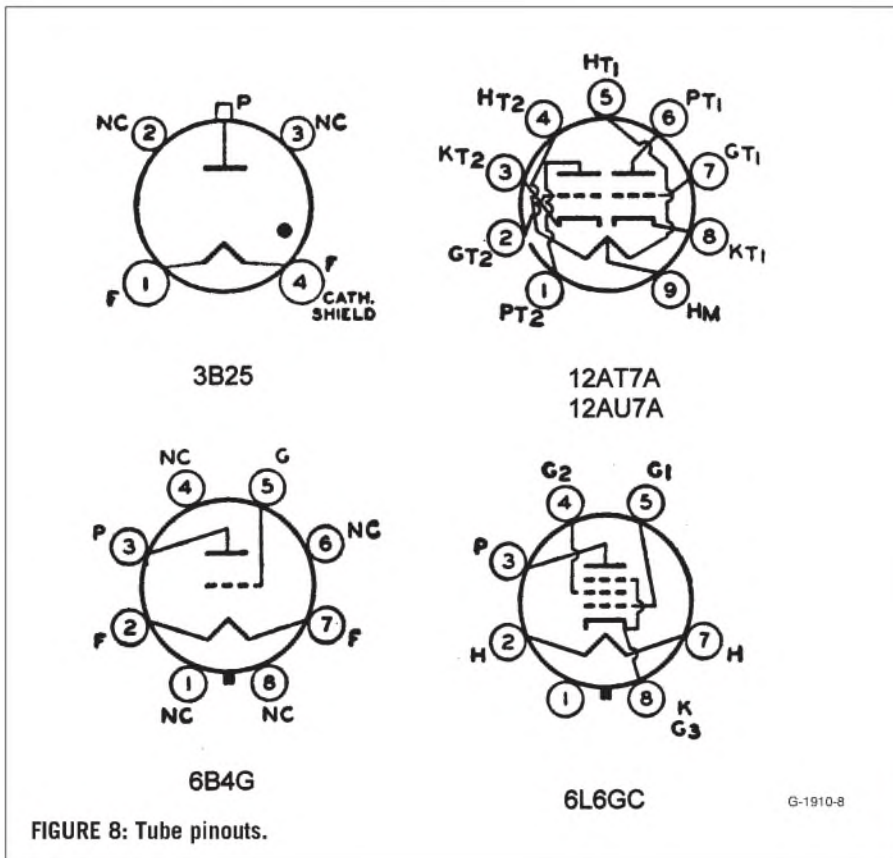

FIGURE 8: Tube pinouts.

G-1910-B



The Zen Amp Variations, Part 3

In Part 2 (July '02) we developed a new active current source for the Zen amplifier. In this part, we create a power-supply regulator suitable for the Zen amplifier projects. **By Nelson Pass**

Previous versions of the Zen amplifiers had no power-supply regulation at all, or used capacitor/inductor/capacitor “pi” filters to smooth the ripple on the DC supply lines. In keeping with our philosophy of simple-as-possible, we want to develop a supply regulation system which gives us good regulation, with low AC noise and a stable DC value.

ACTIVE SUPPLY REGULATION

The need for a good regulator is obvious enough. As simple as they are, the Zen amplifiers do not have particularly great power-supply rejection ratios (PSRR), the measure of how much of the power-supply variations bleeds into the signal path. In the original Zen amplifier, ripple voltages of 1V or so typically caused 2mV or more of the same noise on the output of the amplifier. In this case the PSRR is about 500 to one, or about -54dB. 2mV might seem sufficiently low, that is until you hook up the amp to a 110dB sensitive horn midrange, and then you will start looking for less noise.

You can make the PSRR of the amplifier higher, or you can clean up the supply. A “pi” filter will take out most of the ripple, but will not stabilize the value of the DC against fluctuations in AC line voltage. For this you need an active regulator.

A BASIC REGULATOR

Figure 1 shows an N-channel MOSFET set up as a voltage follower regulator. The Drain gets power from the positive unregulated supply, the Gate is presented with a positive reference voltage, and the Source delivers the value of the

reference voltage minus the Gate-Source voltage of the MOSFET (Vgs), which is about 4V. To get the correct regulated output voltage, the reference will be adjusted by this amount greater than the desired output.

The output impedance of this circuit is fairly low, being the inverse of the transconductance figure of the MOSFET, which for the IRFP240 is about 5S (siemens), which means that the output impedance will be about .2Ω.

This figure is not particularly great as a regulator, and ordinarily we would look to improve on it, usually by enclosing the regulator transistor in a feedback loop to correct for this variation. If this were a higher power Class-B or AB type amplifier, such an output impedance could easily result in 1 or 2V of nonlinear distortion signal in the power supply, and this would bleed into the output circuit as distortion.

With a Class-A amplifier, we have the advantage that the current draw from the supply is a linear function of the output current, and so no distorted “half waveform” is seen impressed on the supply voltage. This being the case, the importance of the output impedance becomes less, and we can consid-

er using this follower without feedback.

Figure 2 embellishes on the concept of the one transistor follower. In this circuit R1 is used to bias up the zener (not related to Zen) diodes which provide the reference voltage. A capacitor C1 is placed in parallel with Z1 and Z2 to remove the intrinsic noise of the zeners and further smooth the ripple out of the reference voltage. C1 is not essential, and can be a large or small value.

We will want to send about 2mA or so through the zener diodes to get it into the proper voltage region. Z1 plus Z2 have been chosen to be 4V above the desired regulated voltage, and some more voltage will be needed across R1 to deliver the current through Z1 and Z2. If the regulated voltage is to be 40V DC, and the zener diodes sum to 44V, and the unregulated supply is 47V, then R1 will have 3V across it, and will want to be about 1500Ω in value.

As a practical matter, this is a lossy circuit, in that it takes 7V or more of unregulated supply voltage than the output voltage. Four of those volts are used up by the Vgs of the MOSFET, and about 3V are required to send 2mA of current through R1 at 1500Ω.

If the capacitance of C1 is substantial, we will want to include D1, which provides a path for the charge on C1 in the event that the main or regulated supply is discharged much more rapid-

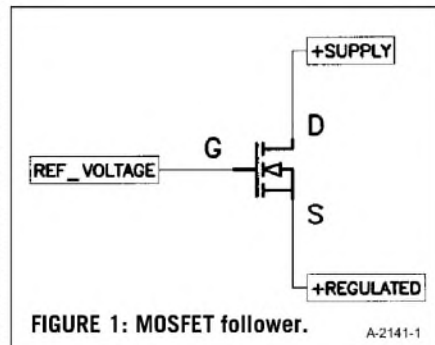

FIGURE 1: MOSFET follower. A-2141-1

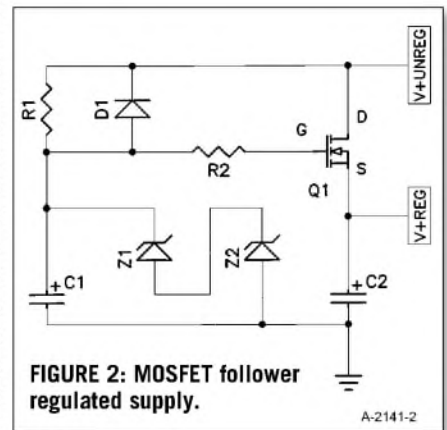

FIGURE 2: MOSFET follower regulated supply. A-2141-2

Transformers & Enclosures

In Stock...



"Classic" Tube Output:
Single Ended (up to 75 watts),
Push-Pull and Potted (up to 280 watts)

Torodial Power:
13 sizes (15 - 1500 VA)
6 VAC - 240 VAC



Enclosures:
Aluminum & Steel Chassis,
Diecast Aluminum, Plastic
and Rack Mount



**Filament & Low Voltage
Power Transformers:**
Open & Enclosed

**"Classic"
High Voltage Transformers:**
Plate, Plate/Filament Combo
& Filter Chokes (Open & Enclosed)

Contact us for free catalogs & a list of stocking distributors



HAMMOND MANUFACTURING™

256 Sonwil Dr. - Cheektowaga, NY 14225 USA
Phone: (716) 651-0086 Fax: (716) 651-0726

394 Edinburgh Rd., N. - Guelph, Ontario N1H 1E5 Canada
Phone: (519) 822-2960 Fax: (519) 822-0715

www.hammondmfg.com



ly than C1. If this happens, the voltage on C1 might be enough to damage the Gate of the MOSFET Q1, which is rated at a maximum of 20V Gate-Source. A high value of C1 not only improves the value of the noise on the regulated supply, but also gives a very slow turn-on time, which can aid in avoiding transient turn-on noises in the amplifier, depending on the design of the amplifier. In the case of the Zen circuits, it is a definite help.

R2 is included to suppress any parasitic oscillation on the part of the MOSFET. The intrinsic bandwidth of a MOSFET is very high, and this much speed in a part can make an oscillator out of even the modest stray capacitance and inductance found in ordinary hookup wire, so we slow it down just a bit with a Gate resistor.

C2 is just some more capacitance to ground. It helps to stabilize the high-frequency response, and like C1, can be large or small, according to taste and need. Large values of C2 will lower the output impedance of the regulator circuit, as the output impedance becomes .2Ω in parallel with the impedance of C2 at any given frequency. To substantially lower the impedance at low frequencies takes some serious capacitance; for example, 40,000μF represents .2Ω at 20Hz.

The circuit does not actually require the use of zener diodes to work well for many purposes. If you take the zener diodes out, then the circuit simply filters out the AC voltage from the supply value, leaving the DC value and giving a DC output voltage about 4V less than the unregulated voltage. I prefer the value stability with the zeners in, as they represent only a small investment in parts.

In this project I use several zener diodes in series, building up higher voltages from smaller voltage zeners. I do this mostly for reliability. Five ½W zener diodes at 9.1V each can take five times the bias current of a single 45.5V zener, and if the AC line voltage goes very high, it might have to. Using multiple zeners in a stack also gives some flexibility in getting exactly the value you want, as seen in Fig. 3, where one of the 9.1V zeners is replaced by 7.5V to get the 44V desired.

You might ask me, “Why do you always use 9.1V 1N4739s in your projects?” The answer is that I have a lot of them on the shelf, and I am very comfortable with them. You might also ask, “Why an IRFP240 instead of some other MOSFET or even a bipolar transistor?” Same answer.

A REGULATOR FOR PENULTIMATE ZEN

Figure 3 shows the circuit of Fig. 2 applied to our Zen amp. Q5 is the new name of our pass transistor, and Z1 through Z5 form the zener reference. In this circuit, the unregulated voltage is about 47V, and the regulated voltage is about 40V. R24 passes about 2mA through the zener stack, and C9 and C10 provide additional filtering.

The values of C9 and C10 are arbitrary, and can be made quite large or small as you like. As you increase the value of C10, keep in mind that very

large caps have some leakage current which might exceed the bias current value, so figure on having less than 10,000μF or so for C10. Very high values for C9 might have the effect of overheating the MOSFET on turn-on, but by high I mean maybe 100,000μF. You can eliminate C10 altogether, but I suggest a minimum of .1μF for C9.

You will note that R1 has been increased to 1500Ω for the purposes of the next section's modification.

Q5 in this circuit must dissipate the amplifier's bias current of 2A with 10V across the Drain to Source. This equals 20W of dissipation, and Q5 should have the appropriate heatsinking for this, which would be approximately 1°C per watt.

(In Part 2 of the Zen Variations, resistor values were given as “three digit and multiplier,” which meant that 1000 in the schematic was a 100Ω resistor, and that is how my RN55D resistors are

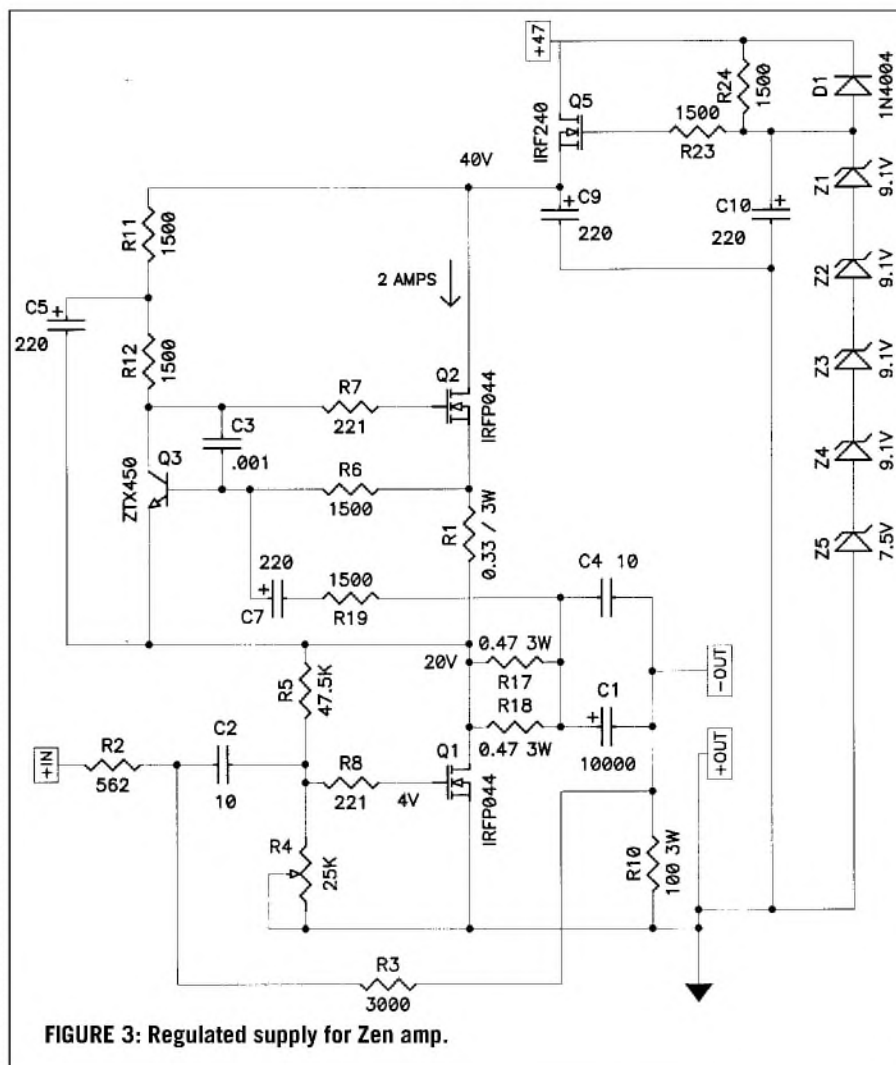

FIGURE 3: Regulated supply for Zen amp.

marked, as well as the banding convention used in other 1% tolerance resistors. However, this has produced so much confusion and complaint in the readership that I will hereafter use the older convention in an effort to end the ongoing flood of e-mail.)

The performance of the circuit of Fig. 3 is quite good, taking the Zen amp to 20W at .7% distortion. The unregulated supply for this circuit had an AC ripple of 3V peak-to-peak, and regulated supply's noise was 10mV peak-to-peak, which is a reduction of 50dB. It resulted in a few microvolts of supply ripple on the output of the amplifier.

The output voltage of the regulator varies with the output current of the amplifier, and with 1.8A output peak, we saw a .35V peak on the output of the regulator, giving a .2Ω output impedance, close to what we expected. If this is not good enough, there are still ways to improve it without recourse to feedback.

MODULATING THE REGULATED SUPPLY

The 14W loss on the MOSFET pass transistor is a bit much to put up with. Figure 4 shows a technique by which we can modulate the regulated supply voltage with the output signal of the amplifier, allowing the regulated supply to swing up to within a volt of the unregulated supply, increasing the peak-to-peak output swing by about 6V, and our power from 20W to 25W.

R25 and C11 have been added, communicating a portion of the output voltage of the amp to the Gate of the pass transistor, causing the regulated output to reflect a small version of the output wave and giving the circuit a small boost at high output levels. Note that the output capacitor C9 in this case is now 1μF so that the regulator does not have to drive a large capacitor. Note also that the standing DC value for the output voltage of the amplifier is not 20V, or half the regulated supply, but

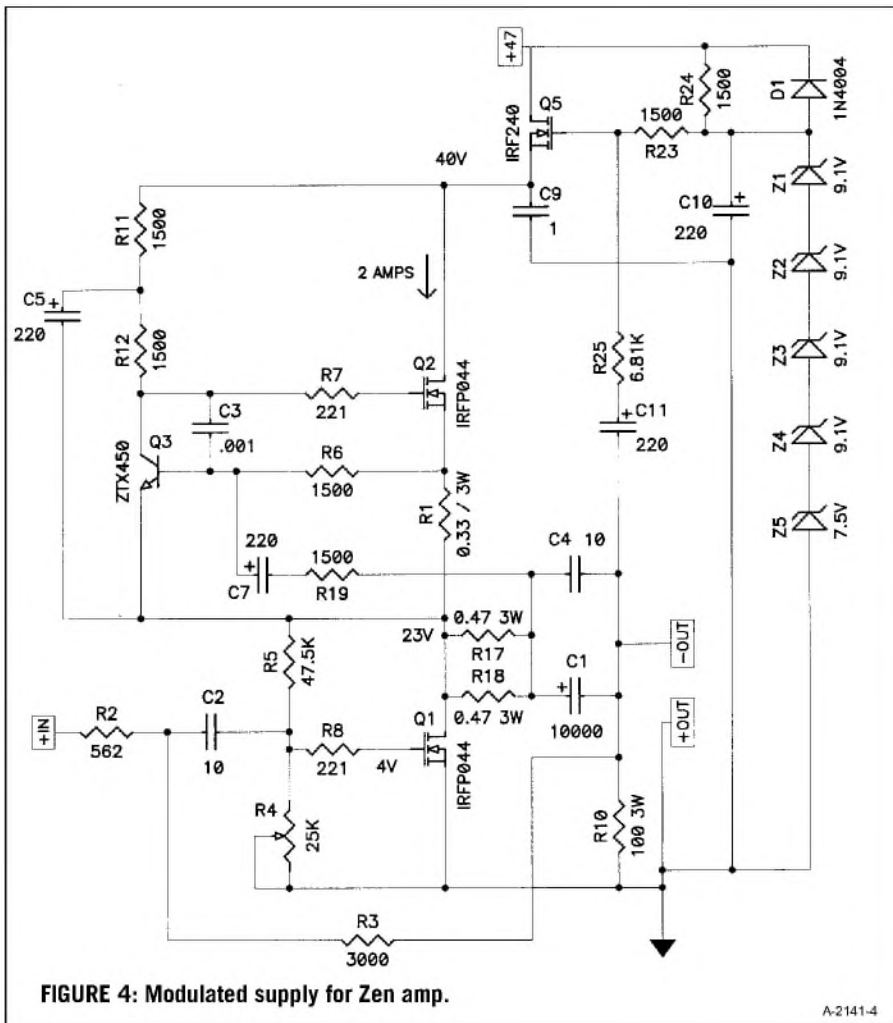

FIGURE 4: Modulated supply for Zen amp.

A-2141-4

Sound Product. Pure Sound.

Improve your audio experience with non-inductive **metal foil resistors** by Alpha Electronics.

- Metal foil technology
- Available in any value
- Quality sound **for less**

Pure and simple...

Contact Sara at (763) 258-8550
Email: audiofoil@alpha-amer.com

AE Alpha Electronics Corp. of America
Minneapolis, Minnesota
www.alpha-amer.com

Electronic Crossovers

Tube
Solid State
Powered
Passive Preamps
46 Step Attenuator
Power Amps
100% MOSFET

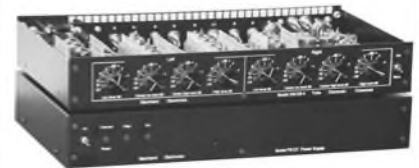

XM126 tube crossover, available 2,3 and 4 way

All available as kit also
Free Catalog:
Marchand Electronics Inc.
PO Box 473
Webster, NY 14580
Phone (716) 872 0980
FAX (716) 872 1960
info@marchandelec.com
www.marchandelec.com

23V, to take better advantage of the higher peak supply voltage.

The performance of the Zen amp with this modification is shown in Fig. 5, where the clipping point is modestly improved to 25W RMS.

A BIPOLAR VERSION FOR SON OF ZEN

We can also build this supply as bipolar. No, not with bipolar transistors, but a supply with both plus and minus voltages for those amplifiers preferring two rails. Figure 6 shows such a version of this MOSFET follower supply applied

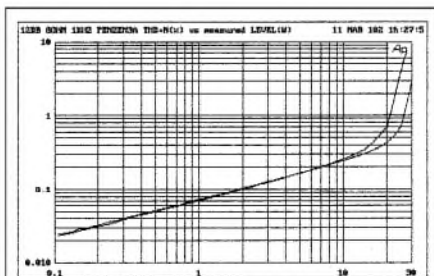

FIGURE 5: Performance with supply modulation.

A-2141-5

to a 10W version of the Son of Zen (*Audio Amateur* 2/97). The Son of Zen has a poor PSRR by itself, and relies on the matching of its balanced halves for low noise. It much appreciates a quiet and stable supply, and previously we have only seen it with "pi" filtering.

We do not modulate this particular supply as it sources two halves of a balanced channel which operated out of phase. The supply draw of this circuit is truly constant at all times, a "zero sum game" for the circuit. By contrast, the Zen has a constant draw averaged over time, and the instantaneous draw from the supply reflects the output current of the amplifier.

PARALLELING DEVICES FOR MORE CURRENT

There are instances where we want the supply to deliver more voltage and current. Since the MOSFETs and other parts can easily be set up to handle 100V or more, the issue comes down to current and dissipation. The circuits presented here are capable of 4A con-

tinuously with moderate dissipation on the series pass transistors, but more current will require parallel devices.

Figure 7 shows additional parallel transistors added to the circuit of Fig. 6. These devices are best matched for V_{gs} within .1V to ensure that they do a good job of sharing the output current. They also use Source resistors at .1 Ω each to further encourage the transistors to share the current equally.

You can parallel as many matched MOSFETs in this manner as you like, each with its own Gate resistor, and stability will not be an issue. The output impedance of each transistor will be the Source resistance plus the inverse of the transconductance of the MOSFET, which in this case is .1 Ω plus .2 Ω = .3 Ω . If you parallel two such devices, you will get .15 Ω , and with six such devices you will get about .05 Ω , and so on.

MATCHING MOSFET REDUX

First presented in the A75 project in issue 2/92 of *The Audio Amateur*, the

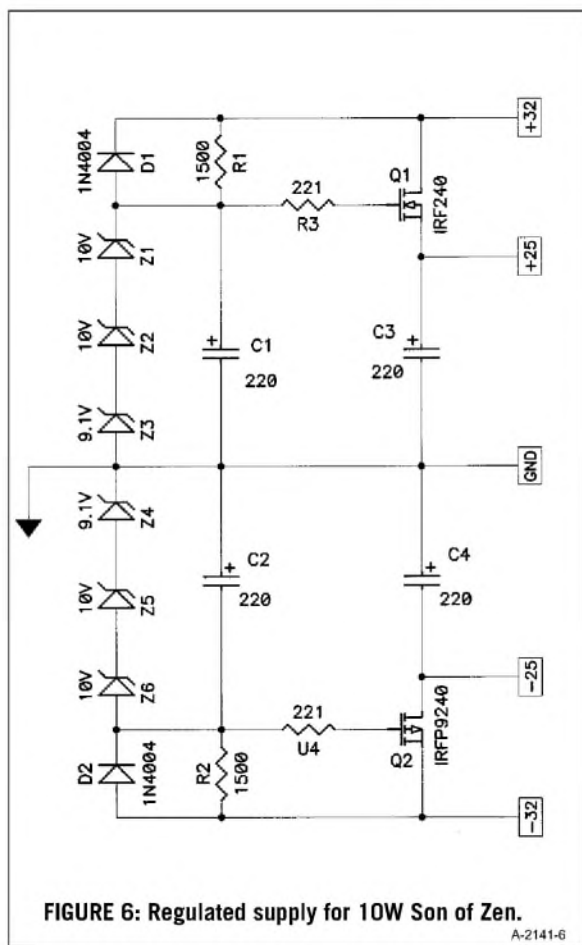

FIGURE 6: Regulated supply for 10W Son of Zen.

A-2141-6

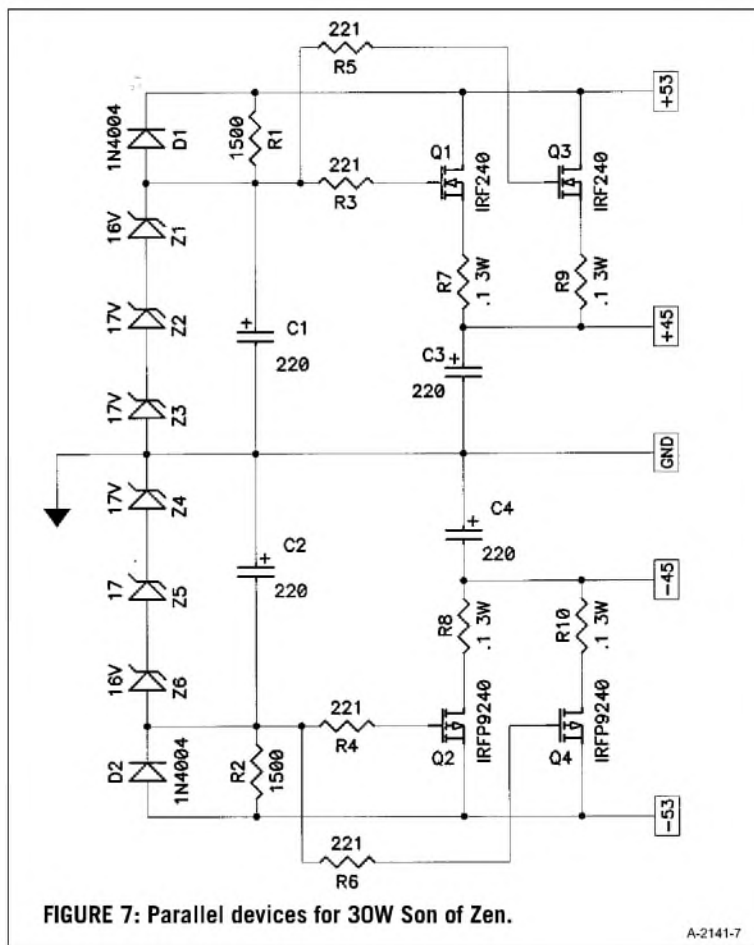

FIGURE 7: Parallel devices for 30W Son of Zen.

A-2141-7

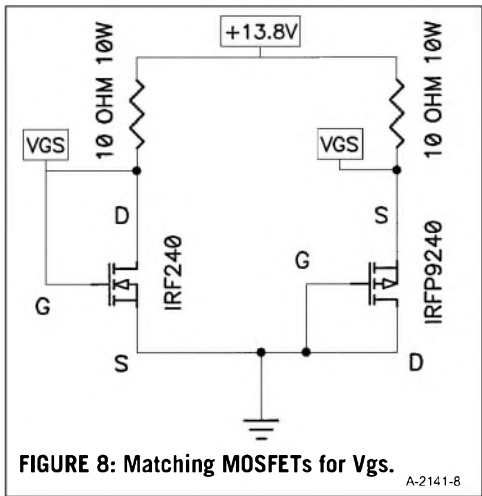

FIGURE 8: Matching MOSFETs for Vgs.

A-2141-8

setup and procedure for matching the Vgs of power MOSFETs is simplicity itself. We repeat it here with slight modification in Fig. 8. Using a car battery voltage or a 15V regulated supply, we bias the MOSFET up as shown through a 10Ω 10W resistor, with the Gate attached to the Drain. With the Vgs measuring about 4V, we will see about 10V across the resistor, and about 1A of current through the device.

With the devices at about the same temperature, measure the Vgs for only a few seconds (the device will heat up within 20 seconds or so) with a DC voltmeter and make note of the value. Those devices which are within .1V or better can be considered a match for these purposes. The circuit for the N-channel devices is shown on the left, and for the P-channel devices on the right.

As a practical matter, in deciding how many to parallel, consider that the output devices will be very reliable at up to about 25W if provided with enough heatsinking to keep the case at 60°C or so. To give you a rough sense of where the parts become unreliable, experience shows that when you run them at 50W at 70°, you will occasionally lose one, as I did last week. No matter, DIYers are a fearless breed; we keep lots of spares, and it took me about ten minutes to pop another one in.

You can pretty easily substitute NPN and PNP bipolar Darlington devices as the series-pass transistors in these schematics without loss of quality, and in the case of paralleling devices as in Fig. 7, you can do so without matching the devices. Darlington types are neces-

sary, however, for while the current gain of a MOSFET is practically infinite, the bipolar device requires a finite DC input current. This is typically about 300 or 400µA per output amp. In high current regulators, you will want to provide slightly extra current going through the zener stack to accommodate this.

IN CONCLUSION

So now we have a nice simple regulator for this and future Zen amp projects. It is not the highest performing regulator, but we don't

need high precision for these amplifiers. And as long as the amplifier is biased Class-A, any voltage appearing on the supply will be a linear function of the output waveform, and is benign in its character. Of course, if you want a lower source impedance, you can start paralleling devices and/or piling on the output capacitance.

In Part 4 we will wrap up the Penultimate Zen with an input buffer and PC artwork.

SALE! PLUS FREE ADHESIVE!

MARKERFOAM™ ACOUSTIC FOAM

GIANT 54" x 54" 2" Just \$19.99
IMMEDIATE SHIPPING 3" Just \$29.99
Kill Noise Quick! Maximum density, full-size sheets of Markerfoam offer super-effective sound absorption for studios worldwide. Easy to mount in your choice of Blue or Charcoal Gray. Markerfoam offers the best value and looks professional. Request your Catalog, specs & free samples today!

Bass Traps

Unique, low frequency diffuser blades cut in a triangular profile mounts with ease to walls & room corners for perfect low end control. 23.5" H x 11" D. Charcoal gray. \$19.99 each



16" Blade Tiles

High performance, low, low cost! America's best acoustic tile value only from Markertek!



2' Charcoal or Blue...\$3.49 ea.
 3' Charcoal or Blue...\$4.49 ea.
 4' Charcoal.....\$5.49 ea.



Jumbo Sound Blankets

Heavy-duty 76" x 58" padded blankets absorb sound wherever they're hung or draped. Fabulous for stage, studio and field use. Top professional quality at a super saver price! Weight: 6 lbs. Black \$19.99

FREE Markertek Foam Adhesive with any 5 sheet Markerfoam purchase when you mention this ad! Limited offer. A \$8.95 per tube value.

FREE America's most unique catalog featuring 364 pages of over 16,000 exclusive and hard-to-find supplies for Pro Audio, Broadcast Video, Audio Visual & Multimedia production.

MARKERTEK®
 VIDEO SUPPLY

800-522-2025
 www.markertek.com

812 Kings Highway, Saugerties, NY 12477 • Fax: 845-246-1757

AUDIO TRANSFORMERS

AMERICA'S PREMIER COIL WINDER

Engineering • Rewinding • Prototypes

McINTOSH - MARANTZ - HARMAN-KARDON
 WESTERN ELECTRIC - TRIAD - ACROSOUND
 FISHER - CHICAGO - STANCOR - DYNACO
 LANGEVIN - PEERLESS - FENDER - MARSHALL
 ELECTROSTATIC SPEAKER TRANSFORMERS

Williamson Amplifier Transformer Specialist

WE DESIGN AND BUILD TRANSFORMERS
 FOR ANY POWER AMPLIFIER TUBE

PHONE: [414] 774-6625 FAX: [414] 774-4425

AUDIO TRANSFORMERS

185 NORTH 85th STREET

WAUWATOSA, WI 53226-4601

E-mail: AUTRAN@AOL.com

NO CATALOG

CUSTOM WORK



It's Not Just a Speaker—It's Furniture

This veteran speaker builder details the process to ensure your units are pleasing to look at, as well as listen to. **By Bill Fitzmaurice**

One disadvantage of being a speaker builder is that sooner or later your relatives start hitting you up for some of your creations. The good news is that when they do, for once you know what to give your sister/brother/daughter/mother/father/and so on for Christmas. When my sister and younger daughter both said to me this summer, “I need new speakers!,” I was able to cross two names off the “what the heck do I give them this year?” list.

At this point you'd expect me to start describing technically the systems I built for Erin and Sherry, but I won't. There is nothing sonically special about them. But how they look is special. You see, not only am I a speaker builder, I'm also a furniture maker. When I build speakers for the home I won't accept anything less than great sound, and I also demand a cabinet that looks as good as the finest furniture.

If you were buying a \$20,000 piano, for instance, you wouldn't want an instrument that sounded less than perfect, and you wouldn't want it to look less than perfect, either. To that end, this article won't talk about drivers, crossovers, f_s , f_B , or V_{AS} . Instead, I'm going to show you how to build speaker cabinets that are not only the sonic equivalents of a Steinway™, but the visual equivalents as well (*Photo 1*).

WOOD SELECTION AND PREPARATION

Like Steinway, I build furniture-grade cabinets from solid wood. There may be advantages in cost to building with veneered sheet goods, but when you're building your own I figure that you're

already saving money anyway, so why go cheap on the materials? A good set of speakers, like a fine table or dresser, should last decades. With luck, and the occasional new surround, maybe even centuries.

The best way to ensure that your speakers look as good after 20 years as they did when you built them is to use only the best materials, and that means solid hardwood. Now, working with hardwood requires a fair stable of tools, many of which you won't have in your garage. But you can either rent or borrow most of what you'll need, and any tools that you do buy are an investment in future projects—be it speakers for your Aunt Nellie or a fine oak computer table for your own living room.

The first tool you'll need for the job is a chainsaw. Go into the woods, cut down a tree, trim the branches off, and let the trunk dry in your garage for two years. Then slice the trunk into inch-thick slabs and let them season for another year or two.

OK, assuming that you'll want these speakers for next Christmas, you can skip those steps. But if you want fine wood at a good price, the best place to get it is from a lumber mill, not a lumberyard. Check your Yellow Pages for lumber mills in your area. Chances are, unless you live in the Great Plains or the desert Southwest, there is a mill nearby, where they'll sell you rough-cut lumber or planed stock.

With planed wood, $\frac{3}{4}$ " thickness is fine, but rough-cut must measure a full inch thick, because you'll lose at least an eighth of an inch in the planing



PHOTO 1:
A fine finish—urethane over red oak.

process. Buy your stock at least $\frac{1}{4}$ " wider than your intended finished width—more if it is particularly crooked. As to the species, a good choice is the same as your furniture at home (if the speakers are for you).

Because my sister and daughter both live out of state and I don't know what they have for furniture, I used red oak, which I consider to be the most beautiful of native woods. Be sure that the lumber you choose has been well seasoned—at least a year. With rough-cut oak don't worry if there are a fair number of shallow cracks in it, as they are a normal product of the seasoning process. No cracks at all could mean that the wood is still “wet.”

To paraphrase Forrest Gump, rough-cut wood (*Photo 2*) is like a box of chocolates: you never know what you'll get. Most hardwoods in a lumberyard are premium grade, which means no

HI-VI RESEARCH®
 you can hear the difference

The new *compact* drivers
 full range and midrange woofers

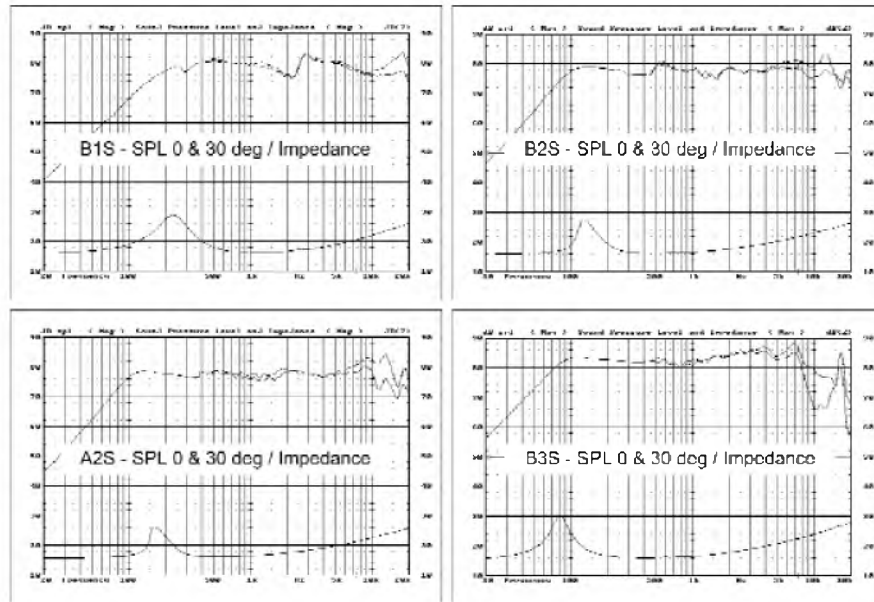

- Aluminum-magnesium cone — an improvement over pure aluminum cone technology
- 100% shielded magnet system - home theater/computer ready
- Optimized T/S parameters for more flexible cabinet design



www.swanspeaker.com
www.dulcet.com

Distributed by
Parts Express
 Tel: 1-800-338-0531
www.partsexpress.com

Hi-Vi RESEARCH(USA)
 Swans Speaker Systems, Inc. 2550 Corporate Place, Suite C 103, Monterey Park, CA 91754 USA Tel: (323) 881 0606 Fax: (323) 881 0957 e-mail: jannie@swanspeaker.com
 Hi-Vi RESEARCH(HongKong)
 Hongo (Holdings) Ltd. Flat 1709, China Merchants Tower, Shun Tak Centre, 168-200 Connaught Road, Sheung Wan, Hong Kong Tel: (852)2587-8728 Fax: (852)2587-8768 e-mail: hongo@netvigator.com
 Hi-Vi RESEARCH(China)
 Hi-Vi RESEARCH ELECTRONIC CO., LTD. FuXing Building 21st / FL, East Tower, 163 HuangPu Ave. GuangZhou, Guangdong, (China) Tel: 86 20 34919808 Fax: 86 20 85201261 e-mail: yan@dulcet.com

©2002 Swans Speaker Systems, Inc. Hi-Vi RESEARCH and the Swan logo are registered trademark of Swans Speaker Systems, Inc. or its subsidiaries in the United States and other countries. All right reserved

knots or burls, for a premium price. I prefer wood that has a few knots, provided they are solid. But with rough-cut lumber you're never entirely sure what is there until you run it through the planer.

To plane your own wood, place a straight edge across the board from edge to edge, to determine which side of the board is crowned. Feed the board through the planer crowned side up (*Photo 3*), taking off the smallest possible amount of wood. With soft woods you can plane off $\frac{1}{16}$ " per pass, but with hardwoods you'll be lucky to get more

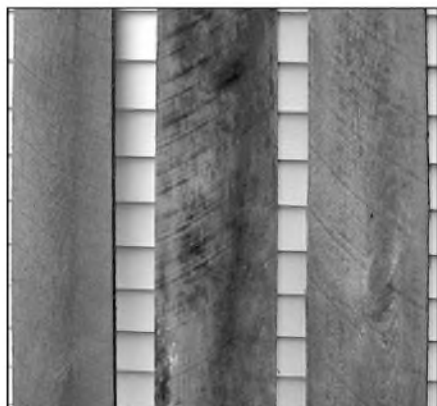

PHOTO 2: Rough-cut red oak boards.



PHOTO 3: Feeding a board into the planer.



PHOTO 4: The board emerging from the planer after one pass.

than $\frac{1}{64}$ " per pass without burning the wood.

With your first planing pass take off only the highest portion of the crown (*Photo 4*). Continue making shallow planing passes until the board is completely flat, and then flip the board over to plane the other side. Since only one side of the board will be exposed when assembled into a box, it isn't necessary for the second side to be planed to perfection, just flat enough for tight joints.

Whether you plane your own wood or buy finished stock, chances are it won't be perfectly straight. To make it so, you'll need a straight board (a piece of $\frac{3}{4}$ " plywood with a factory edge will



PHOTO 5: A router bit with guide bearing above the cutting edge.



PHOTO 6: Cutting a board to finished width.



PHOTO 7: Cutting to length with a panel-cutting jig.

do) to use as a guide for a router. Fit the router with a straight cutting guide bit, one that has a guide bearing either above or below the cutting edge.

Using a minimum of three clamps, clamp the guideboard above or below the stock to be edged, depending on the bearing location, and run the router down the edge (*Photo 5*). With three or more clamps you'll always have at least two holding the boards together when you need to move one out of the router's path. With a particularly warped board, cut it into shorter pieces before edge trimming to minimize the amount of selvage loss.

Now that you have one straight edge, run the board through a table saw with the rip fence set to the finished board width. Working with long, heavy hardwood boards requires a hold-down attachment on the rip fence and a roller support on the out feed (*Photo 6*). Cross-cutting boards to finished length is best accomplished either on a miter saw or on a table saw equipped with a panel cutting jig (*Photo 7*). The highest precision in cutting two pieces to identical length is achieved by cutting both a bit oversize, putting them back to back, and final-cutting them simultaneously.

One place where using solid wood serves no purpose is the cabinet back, assuming that it won't be seen. Here you should feel free to use either plywood or other sheet goods at least $\frac{3}{4}$ " thick. If your cabinet design calls for internal cross bracing, that may be done with sheet goods as well, though you may have enough leftover hardwood scraps to do the job.

JOINERY AND ASSEMBLY

There are many ways to joint parts together to form a cabinet, but to my mind the best is butt joints and biscuits. Biscuits give the strength and accuracy of a splined joint with the simplicity of a butt joint, without fasteners that complicate the finishing process. You can use a biscuit in a joint as short as 3"; in a long joint you should space them no more than 8" apart on center.

If you set the slot height adjustment of the cutter shoe the same for both parts, their edges will meet perfectly. Should you want the cabinet back recessed—for an external crossover, for

DRIVERS:

- ▶ ATC
- ▶ AUDAX
- ▶ ETON
- ▶ FOSTEX
- ▶ ILLUSION AUDIO
- ▶ LPG
- ▶ MAX FIDELITY
- ▶ MOREL
- ▶ PEERLESS
- ▶ SCAN-SPEAK
- ▶ SEAS
- ▶ VIFA
- ▶ VOLT

COMPONENTS:

SOLEN HEPTA-LITZ AND STANDARD INDUCTORS AND CAPACITORS - THE CHOICE OF MANY HIGH-END SPEAKER MANUFACTURERS.

HARDWARE:

POWER RESISTORS, L-PADS, CABLE, ABSORBING AND DAMPING MATERIALS, GOLD SPEAKER TERMINALS, GOLD BANANA PLUGS AND BINDING POSTS, GRILL FASTENERS, PORT TUBES AND TRIM RINGS, PAN HEAD SCREWS, SPIKES AND TEE NUTS WITH ALLEN HEAD BOLTS AND PLENTY MORE...

CUSTOM COMPUTER AIDED CROSSOVER AND CABINET DESIGN

HOW TO BOOKS

The Process of Design.



When designing a loudspeaker, the initial driver considerations and final driver choice can make or break a project. To ensure your success - you want the most complete information and specifications at your finger tips - the Solen catalog.

Order the **FREE** Solen catalog and CD - containing a wide selection of quality drivers - with complete manufacturer's spec sheets, as well as applications in detail on woofers, with predicted response in different sealed and vented enclosures. It is a valuable resource that will bring out the possibilities in your designs.

Order the **FREE** Solen Catalog and CD.

Forward your request by phone, fax, mail or email - or fill in the online request form at solen.ca.



Name: _____

Address: _____

State/Prov: _____

Zip/Postal Code: _____

Country: _____

Tel: _____

Email: _____



SOLEN INC.

4470 Avenue Thibault
St-Hubert, QC J3Y 7T9
Canada

Tel: **450.656.2759**

Fax: 450.443.4949

Email: solen@solen.ca

WEB: <http://www.solen.ca>

instance—you can set the shoe height accordingly (Fig. 1).

There are a number of assembly schemes for even a simple box. The most attractive is to use all 45° mitered joints, which renders joint lines virtually invisible. This is also the most difficult method of assembly to master, requiring extreme precision of parts cutting. 90° joints are easy to do, and proper parts layout will minimize visible joint lines.

My method is to have the top, bottom, and sides wrap the back to keep it invisible, while the baffle is cut to the full width and height of the box so that joints are not on the cabinet face. After cutting the top, bottom, sides, and back to size, place them together, drawing lines on both parts on the edge adjacent to where the center of the biscuit will run (Photo 8). Number both pieces at each biscuit point. Place the center mark of the cutter's plate at the mark made at each biscuit location (Photo 9).

After cutting the slots, place a biscuit in it to check for proper fit (Photo 10). Then put biscuits in all the slots and assemble the pieces dry to be sure of proper parts alignment (Photo 11), trimming as required. When the fit is right, disassemble everything and do it again, this time with glue.

ADHESION

I've recently changed to urethane glue for working with hardwoods. Urethane works especially well for speakers, because it expands when it cures, filling voids in joint lines and eliminating the need for additional caulk. It expands so much that you need apply only a thin layer of glue to the joint line, and then only to one of the pieces being joined. Put glue into the biscuit slots as well, but don't overdo it. A curious aspect of urethanes is that they stick tenaciously to joints that are well clamped, but hardly at all otherwise, so use plenty of clamps, along with wood scrap cauls so that the clamps won't gouge the cabinet (Photo 12).

With open-grained wood such as oak, you'll see the urethane expand through the pores in the wood, while on surfaces it foams up. Don't bother trying to wipe away the excess; you can easily scrape off where the glue does foam

when cured.

After the glue has cured, drill holes in the cabinet back for ducts and hardware (Photo 13). I always put my ducts through the cabinet back; nothing is more ugly on the front of a fine cabinet

than a duct. Use the assembly to gauge the distance on the table saw to the rip fence for cutting the baffle to size (Photo 14). If anything, cut the baffle a bit too big—no more than 1/16"—because it will be trimmed flush later.

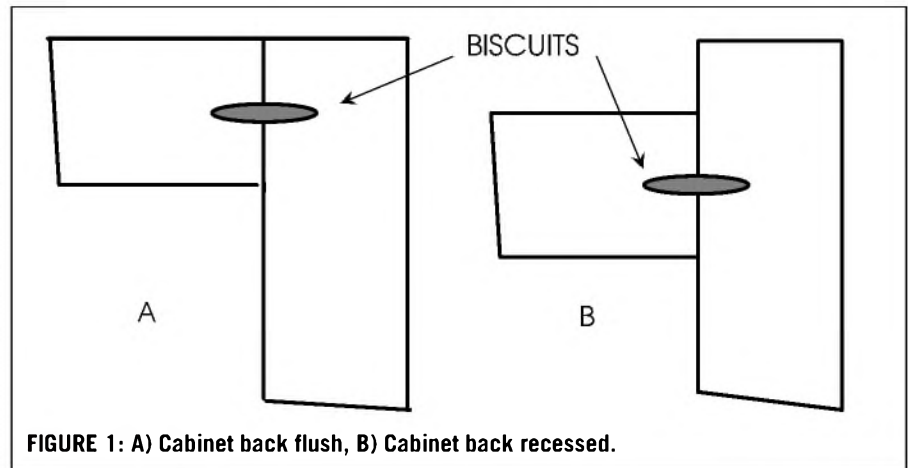

PHOTO 8: Marking the center of a biscuit joint.



PHOTO 9: Setting the biscuit cutter shoe at the joint center mark.



PHOTO 10: A biscuit in its slot.



PHOTO 11: Dry-assembling the box parts.



PHOTO 12: Clamps and cauls hold the parts while glue sets.



PHOTO 13: Holes in the rear of the box for port and wiring cup.

Place the baffle over the assembly and draw lines where the biscuit centers will go. Cut the biscuit slots and dry-assemble. Chances are the biscuits won't quite line up; if that's the case, you can move the shoe of the slot cutter a bit and re-cut the slots in the baffle to no more than $\frac{1}{16}$ " of extra width.

The resulting slop of the biscuit fit in the baffle will allow easy assembly, and the expanding urethane glue will eliminate the slop when it cures. As for the holes in the baffle for the drivers, don't cut them yet, because it's difficult to rough-sand around holes without cham-

fering the edges, ending up with a baffle that's no longer flat.

If your speaker plans call for using foam or other lining of the box, do it before you install the baffle (Photo 15). Glue up the parts and assemble, again using lots of clamps and cauls. When the glue has set, it's time to use the router again, this time with a trimming bit with the guide bearing below the cutting edge (Photo 16), to trim all edges flush. You can also accomplish this task with a belt sander (Photo 17), though I prefer to rout the edges flush first and then use the belt sander to

rough-sand the whole cabinet, using a 60-grit belt.

Switch the router to a round-over bit (Photo 18), preferably a $\frac{1}{8}$ " radius, and round off all the edges. Do this in two steps, first making a rough pass with the bit about $\frac{1}{16}$ " higher than flush, and then a finish pass with the bit flush. Now sand the entire cabinet with a random-orbit sander (Photo 19), using 80-grit discs. Make sure the sander is equipped with a soft "contour" pad, which allows the discs to conform to the radii of the edges. Sand the box smooth all over, but don't bother being



PHOTO 14: Setting the fence with the box to cut the baffle to size.



PHOTO 15: Lining the box with foam before attaching the baffle.



PHOTO 16: Router bit with guide bearing below the cutting edge.

SONIC CRAFT

Bringing Loudspeakers and the Hobbyist into the 21st Century

A Proud North American Distributor of

ACCUTON

P.O. Box 9085, Wichita Falls, TX 76308, USA
Phone: (940) 689-9800; Fax: (940) 689-9618; E-mail: mail@soniccraft.com
See us at: www.soniccraft.com

too perfect, because minor flaws will be taken care of in the next steps.

Using a flexible steel-bladed scraper, apply paste wood filler to the entire box (*Photo 20*). (If you're using a fine-grained wood such as maple, you may omit this step.) Use filler that is darker than the wood's natural color to highlight the grain. Scrape the wood as clean as possible; it's easy to remove filler before it cures, but hard to sand away after.

After the filler has thoroughly dried, it's time to cut the driver holes and rout recesses into the baffle, if your cabinet plans call for it. The sole of your jigsaw or router will make some marks on the baffle, especially on the soft grain filler (*Photo 21*), but not to worry, because finish-sanding will remove them.

Sand the box with the random-orbit sander, this time using 120-grit discs. The filler will clog disks quickly, so change them often. My method is to give the box a pass to remove the excess filler, and then a second pass with a fresh disc until it sends up pure sawdust, just hitting the wood surface. When done sanding, thoroughly vacuum the box inside and out and wipe the sawdust from the outside with a tack cloth.

FINISHING TOUCHES

It's time to put down a finish. First, I never apply a stain. Most furniture makers agree that you put stain on cheap wood to make it look better, but fine wood doesn't need it. Stain is recommended only if you are trying to match existing furniture.

Second, as to the finish method, that depends on what you're trying to achieve. If you want an easy-to-apply finish, use tung oil. Wipe on two or three coats with a clean rag and you're done. It will look great, as good as most furniture, but the pores of the grain of the wood will show. If that's how your furniture looks anyway, then oil is a good choice.

On the other hand, if you want a smooth-as-glass, see-your-face-in-it finish, urethane is the most durable finish available. You have a choice as to water base or oil base, both of which have advantages and drawbacks. Oil base dries overnight, which is a pain if you want a



PHOTO 17: Rough-sanding with a belt sander.



PHOTO 18: Routing the edges with a round-over bit.

mirror finish ten coats deep, but it adds a beautiful golden color to the wood. Water base dries in minutes, and you can apply ten coats in a day if you wish, but it adds no color to the wood.

My preference? I use both. It takes a bit of special care to do so, because oil- and water-based finishes truly don't mix, but when done right, it works very well.

Getting a mirror finish has little to do with the thickness of the finish; completely filling all grain pores is what does the trick. With a fine-grained wood such as maple, two coats are often sufficient, but with an open-grained wood such as oak, even after using filler, at least six coats are usually required. The final finish is not any thicker, because most of what is applied is sanded off. You apply finish, sanding between coats to remove what doesn't go into the pores, until the level of the finish in the pores of the wood rises to the surface.

Some further tips on applying a finish:

- apply urethane with either a brush or a pad, but don't try to eliminate brush marks, because they'll be sanded away



PHOTO 19: A random-orbit sander for finish sanding.



PHOTO 20: Applying grain filler.

- always work in a well-ventilated area, preferably one with an exhaust fan, or outdoors in the shade
- when covering oil-base coatings with water-base coatings, or vice versa, allow a minimum of 24 hours for the last application to cure fully, or the next may not cure properly

Keeping those tips in mind, start applying your finish.

Apply a coat of oil-base urethane, which will cause the beauty of the wood grain to jump right out (*Photo 22*). Let the finish set for at least 24 hours, and then lightly buff it with a Scotch-Brite™ pad to dull it down, so the next coat will stick. Apply water-base urethane, allowing about an hour between coats. After every other coat, sand the finish smooth with a 180- or 220-grit paper, but don't overdo it, or you may sand through the finish. You may sand with a random-orbit sander if it is a variable speed model set at slow speed, or by hand with a flexible sanding block, being especially careful at the cabinet edges and around the driver holes.

The key to a perfect gloss finish is to first get a perfectly dull one. After sand-



PHOTO 21: Driver holes are cut before sanding filler.

ing, wipe the dust away and look at the wood. If there are pores that are not filled they will show up as shiny areas where the sandpaper has not hit them. Continue the coating/sanding process until there are no shiny streaks or spots after sanding. At that point apply two more coats for good measure, and let the box sit for a day or two so that the finish can hard cure. Then fine-sand one more time to prepare the surface for the final steps.

There are two options here. The simpler is to apply a coat or two of aerosol spray oil-base urethane, which leaves a finish with no brush marks, just a bit of "orange peel" effect that isn't noticeable much more than from a couple of feet away. The oil-base urethane will also help even out any color variations if you have sanded through the finish. Spraying is easier if you put the cabinet on top of a turntable (*Photo 23*), which you may already have on hand if you're into reconing.

The second option is to rub out the finish, exactly as you would do when painting a car. A machine buffer makes the job easier, but you can do it by hand. Go to your local auto supply store and get heavy grained rubbing compound, fine grained compound, glaze, and polish. The guy behind the counter can tell you what to use.

Following the label instructions, apply each in succession to end up with a finish even Steinway would be proud of. When using the abrasive compounds be careful not to overdo, as you could rub through the finish and need to start from scratch.

There are options in this procedure. You may opt to use only water-base urethane, at the expense of some richness of color. This may be preferable if



PHOTO 22: Before and after applying oil-base urethane.

you're not experienced at sanding and are afraid of sand-through problems. You may use only oil-base urethane, which would limit you to applying only two coats a day at best, but if you're in no hurry it does simplify things. Using only an aerosol spray urethane will minimize sanding, as there are no brush marks, but the four or five cans per cabinet required would be a pricey option.

Aerosol lacquer is another possibility if you want a perfectly clear finish. It dries very fast and rubs out well, but is as expensive as aerosol urethane and



PHOTO 23: A final coat of spray urethane is easier to apply with the box atop a lazy Susan.

is not as durable. My method combines techniques to achieve a fine finish at the lowest cost in the least amount of time.

There is one problem with building cabinets so nice that everyone will want them: everyone will want them! I've already given cabs to my dad and oldest daughter, and once my mother and brother see the ones I've built for my sister I'm sure that they'll want some, too. The good news is that I can scratch two more names from my "what the heck do I get them this year?" list. Next year, that is. ❖



SILVER SONIC™

HIGH PERFORMANCE AUDIO CABLES

INTRODUCING The Air Matrix Interconnect and Q-10 Speaker Cable

www.silversonic.com



www.silversonic.com

DH Labs, Inc.

612 N. Orange Ave #A-2
(561) 745-6406

Jupiter, FL 33458



Relays for Loudspeaker Protection

Here's everything you need to know about relays, to help you design better circuits. **By Charles Hansen**

It has been over 100 years since the electromechanical relay (EMR) was first invented to "relay" telegraph signals from one location to other, more distant, outlying stations. While solid-state relays (SSR) are now widely available, their MOSFET or thyristor output devices are not conducive to speaker protection. This article will focus on EMRs¹.

EMRs allow complete isolation between input and output circuits. Closed contacts have a very low on-resistance. Open contacts have nearly infinite off-resistance with no leakage and very low capacitance. EMRs can withstand the high-energy spikes and surges that can damage SSRs. Complex multiple-contact arrangements are easily implemented.

EMR disadvantages are many:

- their moving parts have a finite life compared to SSRs
- they exhibit pickup and dropout delays and contact bounce
- they are larger, heavier, and consume more power than SSRs

- they generate magnetic fields, EMI, and voltage spikes
- they are more sensitive to mechanical shock and vibration and, sometimes, operating position.

Finally, high-quality EMRs are more expensive than SSRs. Automated assembly has pretty much been optimized at this point, so further cost reductions will not be very dramatic.

EMRs find widespread application in:

- High-voltage and/or high-current circuits
- Low-voltage transducer signals
- High-impedance low-current (dry circuit) signals
- RF signals

THE RELAY ASSEMBLY

A relay allows operation of one or more electrical output circuits by means of an electrically isolated input signal. Relays that switch higher currents (>25A) are also called contactors. They have heavy contacts with a large surface area, large

contact gaps to extinguish arcing, and large actuator springs to assist in separating any localized contact welding.

EMRs consist of a coil and a movable actuator and contact assembly, as shown in the single-pole double-throw (SPDT) relay in *Fig. 1*. An enclosure keeps out dirt and other contaminants. Connections to a relay are made by plug-in contacts or soldered connections.

ACTUATOR COIL

The actuator coil is the input circuit for the relay. It consists of a solenoid-type coil wound on a bobbin that surrounds a soft iron core. One end of the core is connected to a fixed iron frame, called the back iron. It completes the magnetic circuit for the armature, which is held in position by the armature return spring.

The majority of relay coils are designed to be powered by a DC voltage. Relays with AC coil voltage ratings have either an internal diode bridge or a shaded-pole core. When the coil is energized, the iron armature, which carries the movable contacts, is attracted to the pole face of the core. The core magnetic flux generates a mechanical force proportional to the ampere-turns in the coil.

Because the coil is highly inductive, the coil current is initially too low to generate sufficient force to overcome the armature return spring. As the coil current (and the flux) increases, the mechanical force generated by the magnetic field increases. Finally, after an initial period in which coil flux must build against coil inductance, armature inertia, hinge pivot friction, return spring force, and magnetic circuit losses, the armature begins to move. This delay between applying coil power and armature response is the initial actuation time.

As the distance between the armature and pole face decreases, the relay magnetic circuit air-gap reluctance drops, and more flux (and more force) is generated for a given coil current. The arma-

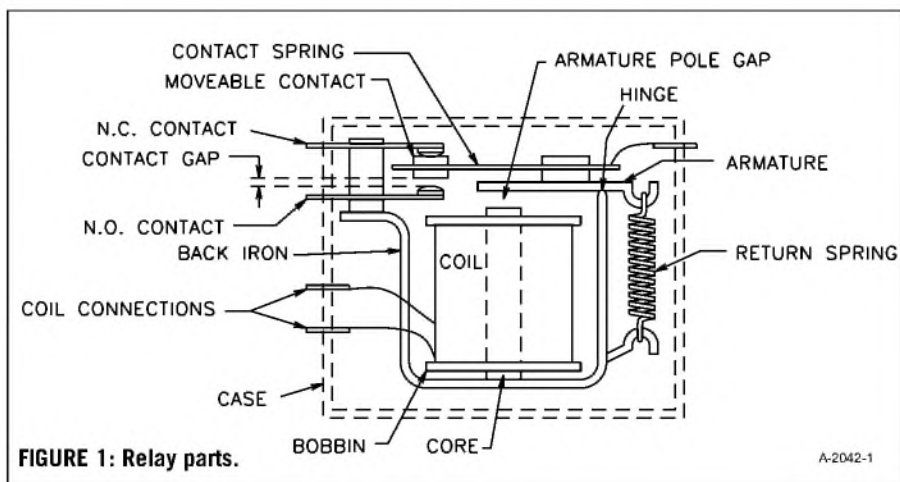

ture then closes and actuates all its attached contacts. The delay from initial motion to closing the normally open (NO) contact is called the transfer time. The total pickup delay from energizing to closing is called the operating time.

The operating time varies with the force generated by the coil, the mass of the armature assembly, the return spring force, and the distance the movable contacts must travel. More than 85% of the total operating time is due to the electrical lag caused by coil inductance. Once the relay closes, the hold-in voltage requirement is reduced.

Due to changes in the magnetic circuit from pickup to dropout, the operate and release voltages are not identical. Dropout voltage can be as low as 10% of the pull-in voltage. Also, the copper wire in the coil increases its resistance (0.39%/°C) with temperature, so the coil current decreases as the energized coil heats up.

Additional allowance must be made for a ±10% production variation in the coil resistance. Relay manufacturers generally rate relay coil voltage for twice the minimum pickup voltage at 25°C so they will operate without performance degradation in all the rated environmental conditions. *Figure 2* shows a typical relay “performance triangle” of time and coil voltage/current.

The operation of any relay can be optimized by initially applying greater-than-rated coil voltage (overdriving), then reducing the voltage to the minimum hold-in level after transfer occurs.

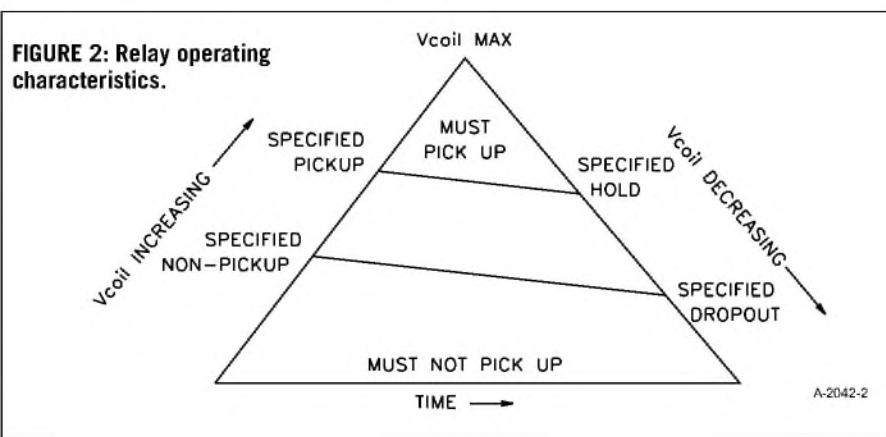

**TABLE 1
RELAY ABBREVIATIONS**

- SP—single pole
- DP—double pole
- ST—single throw
- DT—double throw
- CO—center-off
- NO—normally-open
- NC—normally-closed
- B—break
- M—make
- DB—double-break
- DM—double-make

**TABLE 2
CONTACT LOAD DERATING FACTOR**

Resistive loads	1.00
Inductive loads	0.35
Motor loads	0.20
Capacitive loads	0.10
Lamp loads	0.10

THE SCIENCE OF SOUND

Morel's R&D department continually researches the science of sound.

engineered to provide uncompromising sound, Morel is offering you top-of-the-line hybrid units with a diameter of either 4", 5 1/4", 6 1/2", 8" & 10".

Morel's Hybrid Range features:

- 2 1/4" or 3" Hexatech Aluminum Voice Coil
- Powerful Compact Hybrid Magnet Motor
- High Degree of Magnetic Shielding
- One-Piece Integrated Dome and Surround Cone

Morel's drive units are the choice of many of the world's high-end loudspeaker manufacturers.



Making a LoudSpeaker Music to Your Ears

USA Distributor:
Madisound Speaker Components
Tel: 608-831-3433
e-mail: info@madisound.Com
Web Site: www.madisound.com

MOREL:
Tel: ++972-8-9301161
Fax: ++972-8-9301312
Email: info@morel.co.il

www.morelhifi.com

There is no longer any connection between Morel and morel acoustics u.s.a.

Morel name and logo is a worldwide registered trademark of Morel Israel. Reg USA No. 1549884

Because it requires a more complex power supply, few circuit designers seem to take advantage of this opportunity to reduce the steady-state coil power dissipation. The only limitations are that the overdrive voltage must not exceed the coil insulation breakdown limit nor cause the coil to exceed its

maximum rated temperature. Generally, there is little additional speed to be gained in applying more than 8-12 times the maximum pickup voltage. Also, a lower hold-in voltage does not appreciably decrease the release time.

In some military relays, there is no return spring. A high coercive force

permanent magnet is used to hold the armature in the normally open position. Coil power is used to both cancel the permanent magnet's field and to provide additional magnetic field flux to pull in the armature. The advantage, though costly, is that there is no spring to fatigue and vary its restoring force over the life of the relay. It is also less affected by temperature changes.

When a relay coil is de-energized, its magnetic flux does not decay immediately, due to the coil inductance. The relay remains closed for some time, depending on its release characteristics and especially by the type of suppression circuit connected across the coil. This dropout delay is called the release time. The delay from initial motion to closing the normally closed (NC) contact is called the transfer time.

Coil suppression circuits are necessary to protect the solid-state relay drive transistor from the high voltage spike generated by the back EMF of the

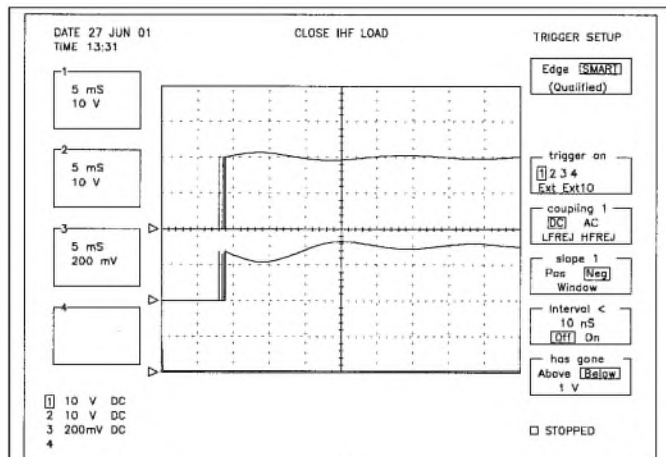
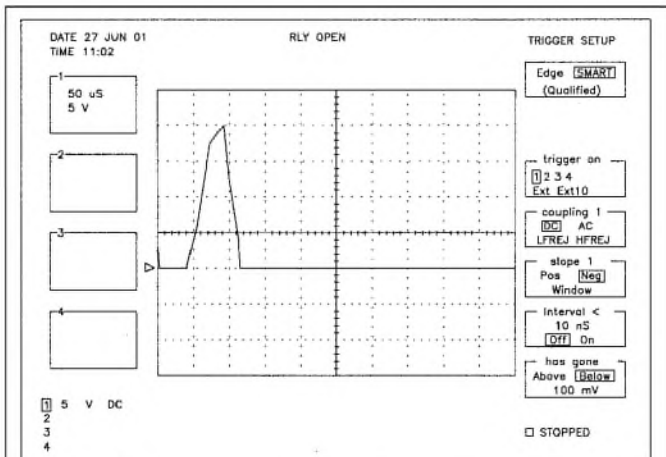
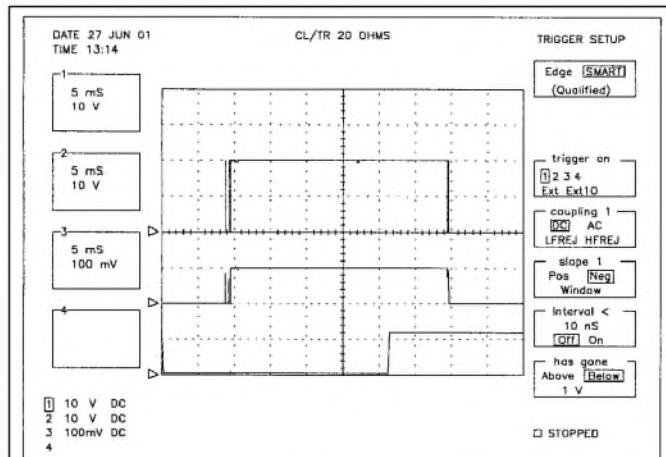
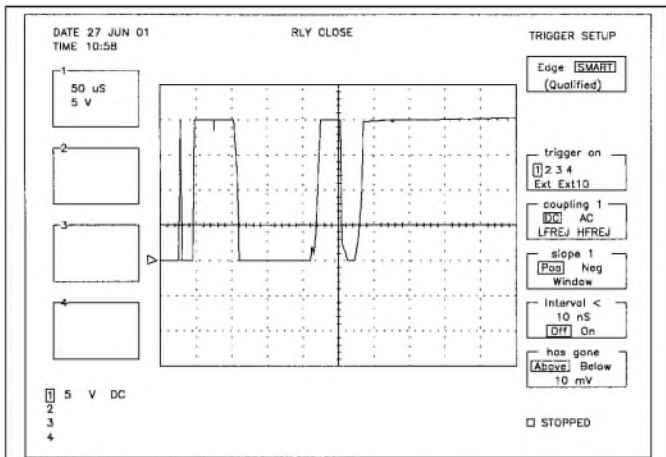
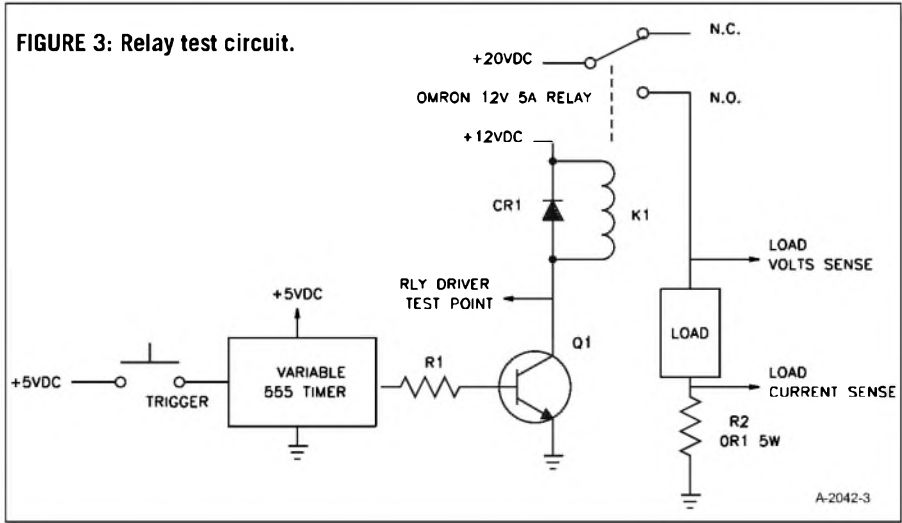

coil when it is suddenly de-energized. They do this by providing a controlled path for the coil current to flow while the magnetic field collapses. The collapsing field current also holds the armature closed, lengthening the release time and reducing contact speed. Ideally, the suppression circuit should limit the voltage across the driver to less than its maximum rating, yet allow rapid decay of the coil flux. *Figure 3* shows a single reverse diode, the most common of coil suppression circuits.

The actuators described previously are electrically-held or side-stable types, whose contacts are held in position only as long as coil power is applied. Latching relays are bistable types. Contact transfer is initiated by momentarily energizing one of two coils. Contact position is maintained after coil power is removed by a mechanical latching mechanism or a permanent magnet.

The "set coil" closes NO contacts, and the "reset coil" re-opens them. Latching relays were the original logic flip-flops. Latchers use considerably less power and retain their position during power-off conditions.

CONTACTS

The output circuit of a relay is its contacts. The first event after initial armature movement is that the normally closed (NC) contacts are opened. Then after a small transfer time, the NO contacts are closed.

A single NO contact set is called Form-A. A single NC contact set is called Form-B. A Form-C contact set consists of one NO and one NC contact with a single common transfer arm (*Fig. 1*). EMRs with one to nine contact sets are readily available. The abbreviations used to define the status of relay (and switch) contacts are listed in *Table 1*.

The order of abbreviations used in describing a contact assembly is (1) poles, (2) throws, (3) normal position, and (4) double-make or -break (if used). Thus, a DPDT contact set consists of two Form-C contacts operating together. Double-make and double-break contacts consist of two series contacts, one on each end of a single center-driven armature.

In order to ensure low resistance in the circuits operated by the relay contact, the movable contacts are mounted

Accuracy, Stability, Repeatability

Will your microphones be accurate tomorrow?



Next Week? Next Year? After baking them in the car???

ACO Pacific Microphones will!

**Manufactured to meet IEC, ANSI and ASA standards.
Stainless and Titanium Diaphragms, Quartz insulators**

Aged at 150°C.

Try that with a "calibrated" consumer electret mic!

ACO Pacific, Inc.

2604 Read Ave., Belmont, CA 94002

Tel: (650) 595-8588 FAX: (650) 591-2891 e-mail acopac@acopacific.com

ACOustics Begins With ACO™

SEARCH & BUY ONLINE
www.mouser.com

145,000+
**ELECTRONIC
COMPONENTS**

Semiconductors, Optoelectronics, Lamps & Holders, LED's, Displays, Wire & Cable, Connectors, Assemblies, Sockets, Terminals, Terminal Blocks, Capacitors, Resistors, Potentiometers, Crystals, Oscillators, Inductors, Transformers, Circuit Protection, Fuses & Holders, Resettable Fuses, Breakers, Thermistors, Varistors, Industrial Automation, Switches, Relays, Speakers, Piezo Devices, Microphones, Fans, Heatsinks, Knobs, Hardware, Cabinets, Racks, Enclosures, Batteries, Battery Chargers, Battery Holders & Snaps, Power Supplies, DC-DC Converters, UPS Systems, AC Adapters, Panel Meters, Test Equipment, Tools & Equipment, Supplies & Chemicals, Prototyping Supplies . . .

MOUSER 
ELECTRONICS

on a flexible contact spring arm. The spring deflects and allows armature overtravel to ensure that positive contact is made despite wear and erosion, and to provide some wiping action to keep the contacts clean.

As the NO contacts come together to make up the intended circuit, the impact causes the contacts to bounce. Contact bounce is accounted for in the total operating time from initial energizing to final stable NO contact closure. If the contacts close into a high surge current, the resulting magnetic field sets up a repulsive force that tries to force the contacts back open.

Similarly, when the NC contacts separate, the flexible armature contact arms may allow some reclosing of the contacts, which results in additional contact bounce. *Figures 4 and 5* show oscilloscope traces of relay pickup and dropout, respectively, including contact bounce.

Contact bounce is a highly variable event. It is not consistent over an individual relay's life. Closing bounce is usually longer, with multiple reclosures. Opening bounce does not always occur,

and is usually of shorter duration.

The contact resistance of a new relay decreases slightly as contact operation burnishes the contact surfaces and increases the contact area. As the relay continues to be used and the contacts wear and erode, the contact surfaces degrade and the resistance increases. Contact resistance is specified in milliohms for contacts rated 2A or less. Typical values are from 25mΩ to 200mΩ. Contacts rated more than 2A may have a defined maximum millivolt drop at rated load.

CONTACT RATINGS AND LIFE

The contact current ratings for relay (and switch) contacts are determined by the voltage being switched, whether it is DC or AC, the power factor if AC, the current level, and the type of load.

Relay loads fall into six categories: resistive, dry, lamp, inductive, motor, and capacitive. Contact current ratings are specified for resistive loads at rated AC and DC voltage. Whenever a load is switched, arcing occurs. The speed of the contacts and the voltage and current being switched determine the relay life.

AC loads are easier to switch than DC loads because the voltage passes through zero twice each AC cycle. Any arc that occurs is quenched at each zero crossing, making contact welding much less likely.

Contact life is given as the minimum number of electrical operations before the maximum contact resistance or millivolt drop is exceeded at rated current and maximum rated temperature. All relay specs assume resistive loads, unless otherwise stated. When loads other than resistive are switched, you should apply the derating factors in *Table 2* to the contact current to achieve the rated resistive load contact life. A relay contact rated for 5A resistive loads should not switch more than 1.75A of inductive load, for example.

Dry circuits are low-level loads whose voltage and current are so low they do not cause any electrical erosion of the contacts. If the contacts oxidize, however, there may be enough resistance to prevent proper operation of the switched circuit. Precious metals are used in relay contacts intended to switch dry circuits. This ensures that low contact resistance is maintained over the mechanical life of the relay, which can be twice as long as the rated electrical life.

Dry loads are defined as those with a maximum current and voltage of 1mA and 50mV, respectively. However, once relay contacts have been used to switch high currents, the precious metal coating can be damaged so they are no longer suitable for dry service.

Tungsten lamp loads, when cold, pre-

**TABLE 3
RELAY CONTACT MATERIALS**

MATERIAL	ADVANTAGES	DISADVANTAGES
Silver	Low resistance	Reacts with sulfides, easily deforms
Silver-Cadmium Oxide	Low resistance, resists welding	Reacts with sulfides
Silver-Nickel	Low resistance, good arc resistance	Reacts with sulfides
Tungsten	Good arc resistance	High resistance, high contact force required
Mercury	Continuously renewed contact surfaces	Requires capsule, position sensitive
Gold	Corrosion resistance	Cost, dry circuit use only
Platinum/Palladium	Corrosion resistance	Cost, dry circuit use only
Rhodium	Corrosion resistance	Cost, dry circuit use only

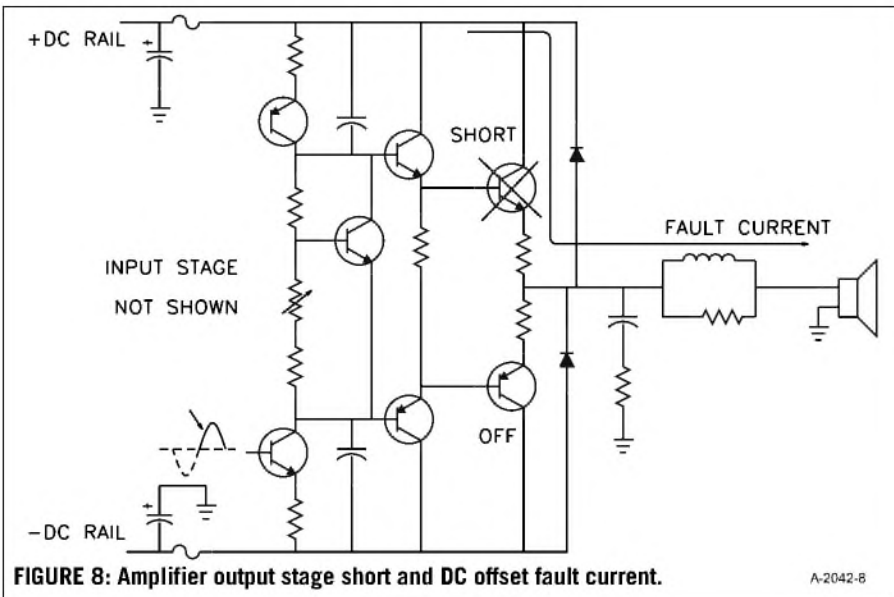

FIGURE 8: Amplifier output stage short and DC offset fault current.

A-2042-8

**TABLE 4
OMRON G6B-2214P-US-DC12
SPECIFICATIONS**

Coil	12V DC nominal, 480Ω
Vpickup max (25°C)	9.6V DC
Vdropout min (25°C)	1.2V DC
Tdropout typ	10ms
Contact rating	5A resistive

**TABLE 5
LEACH TYPE-X RELAY
SPECIFICATIONS, PART 1**

PARAMETER	RATING
Coil, 25°C	12V DC, 125Ω ±10%
Pickup voltage max, 120°C	9.9V DC
Dropout voltage min, -55°C	4.5V DC
Operate/release time, max	4ms
Make bounce, max	0.5ms
Break bounce, max	0.1ms (42V suppression)

sent a resistance that is $\frac{1}{10}$ of the rated steady-state value. This results in a high inrush current when the lamp is first energized. Any contact bounce can produce arcing that may cause the contacts to weld when the lamp load is energized. The 0.10 lamp load derating factor allows for this high inrush.

The collapse of the magnetic field in inductive loads produces a voltage across the relay contacts as the current continues to flow. This voltage, which depends on load inductance and circuit "Q," produces a high-temperature arc that rapidly erodes the contacts (and causes RFI). A small inductance can generate a large voltage. Providing a suitable suppression circuit across the inductive load (also recommended for the relay coil itself) easily controls these effects. The inductive load derating factor assumes the load is not suppressed, however.

Motor loads are highly inductive and also present a high inrush current. Capacitive loads impose a high inrush current, especially for large value low-ESR types.

From the developers of IMP and Liberty Audiosuite...

-praxis-

Full Featured, customizable measurement system for loudspeakers, transducers, electronics, room acoustics, and vibrational systems.

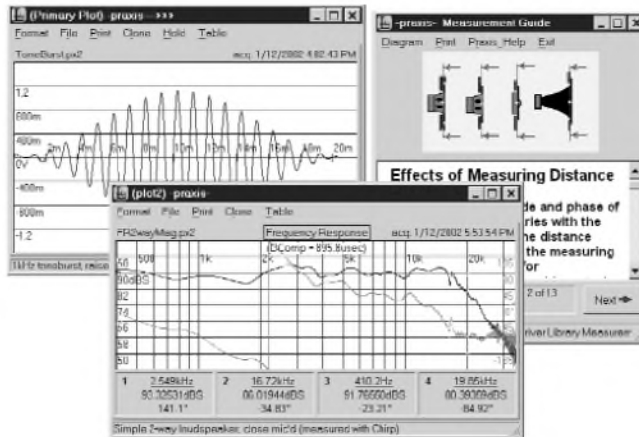

Compatible with laptops and PCs and a wide variety of soundcards running under 32 bit Windows operating systems. Features built-in measurement guides for easy operation. Samples to 24-bit and 192kHz.

For more information please visit us at www.libinst.com

Liberty Instruments, Inc.

P.O. Box 1454, West Chester, OH 45071 USA

Phone/Fax 513-755-0252 carolst@one.net

Design speaker boxes with BassBox Pro

Design speaker boxes for any space: car, truck, van, home hi-fi, home theater, pro sound, studio, stage, PA and musical instruments. Import acoustic measurements. For example, the response of a car can be imported to simulate the in-car response.

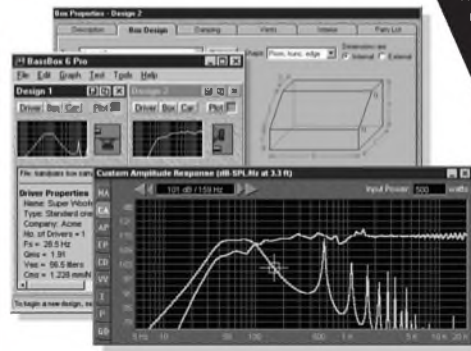

\$129 plus S&H

Need help with your speaker designs? BassBox Pro & X-over Pro can help!



Harris Tech Pro software for Microsoft® Windows can help you quickly create professional speaker designs. Our software is easy to use with features like "Welcome" windows, context-sensitive "balloon" help, extensive online manuals with tutorials and beautifully illustrated printed manuals. We include the world's largest driver database with the parameters for many thousands of drivers.

For more information please visit our internet website at: www.ht-audio.com

Tel: 616-641-5924
Fax: 616-641-5738
sales@ht-audio.com

Harris Technologies, Inc.
P.O. Box 622
Edwardsburg, MI
49112-0622
U.S.A.

Design crossovers with X-over Pro

Design 2-way and 3-way passive crossover networks, high-pass, band-pass or low-pass filters, impedance equalization, L-pads and series or parallel notch filters. Its Thiele-Small model provides professional results without complex testing.

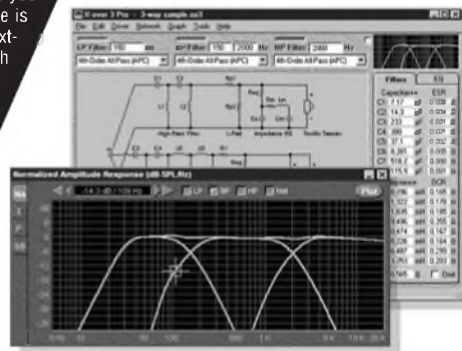

\$99 plus S&H

Sophisticated Driver Modeling and Advanced Box Design

- Multiple drivers with isobaric, push-pull and bessel options. • 3 dual voice coil wiring options. • "Expert Mode" dynamically analyzes driver parameters. • Design closed, vented, bandpass and passive radiator boxes. • "Suggest" feature provides fast box design. • All box types account for leakage losses and internal absorption.
- Advanced vent calculation. • Bandpass boxes can be single or double-tuned with 2 or 3 chambers. • 22 box shapes (shown below). • Open up to 10 designs at one time.
- Analyze small-signal performance with: Normalized Amplitude Response, Impedance, Phase and Group Delay graphs. • Analyze large-signal performance with: Custom Amplitude Response, Max Acoustic Power, Max Electric Input Power, Cone Displacement and Vent Air Velocity graphs. • Includes a helpful "Design Wizard" for beginners.

Passive Crossover Filters and Scalable Driver Modeling

- 1st, 2nd, 3rd and 4th-order "ladder" filter topologies. • Parallel crossover topology. • 2-way crossovers offer Bessel, Butterworth, Chebyshev, Gaussian, Legendre, Linear-Phase and Linkwitz-Riley filters. • 3-way crossovers offer All-Pass Crossover (APC) and Constant-Power Crossover (CPC) filters. X-over Pro's capabilities scale to fit the amount of driver data. • A crossover, filter or L-pad can be designed with just the nominal impedance of each driver. • With full Thiele-Small parameters, impedance equalization can be designed and the performance graphed.
- Graphs include: Normalized Amplitude Response, Impedance, Phase & Group Delay.
- Graphs can include the full speaker response including the box. • Estimate component resistance (ESR & DCR). • Calculate the resistance of parallel or series components.

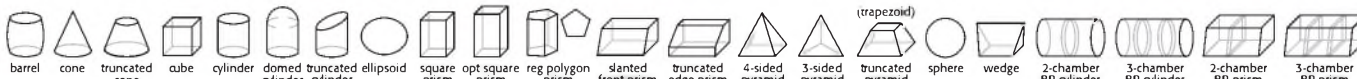

Copyright © 2002 by Harris Technologies, Inc. All rights reserved worldwide. BassBox is a trademark of Harris Tech. Other trademarks belong to their respective companies. Harris Tech reserves the right to make changes without notice. All prices are in U.S. dollars.

CONTACT MATERIALS

Table 3 lists the available contact materials and their characteristics. Precious metals for dry low-level circuits may be flashed (<2 microns), plated, or clad (>5 microns) over a base metal such as nickel.

Relay contacts must be large enough to prevent destructive melting, yet not so large that the current density falls below the level required to ensure a low-resistance circuit closure. The best contact occurs when there is sufficient voltage and current, along with mechanical pressure on the contacts, to cause a slight melting of the contact surfaces on each operation.

When contacts close into a high current, damage occurs because the low initial contact forces permit contact sliding and bounce. An asymmetrical weld or "bridge" can form at the point of contact closure in DC circuits, which ruptures when the contacts open, resulting in metal transfer. There is usually a loss of contact material in AC circuits. Black metal vapor condenses in the vicinity of the contact area and is often mistaken for carbon.

Current surges are practically guaranteed whenever contacts open a DC circuit. The energy in an inductive load will be dissipated by contact arcing unless some other means of energy absorption is provided. Some of the load energy will be dissipated as heat in the winding resistance, eddy-current losses in the magnetic circuit, and in the distributed capacitance of the coil winding. The arc from an AC load is terminated when the current passes through zero and

reverses at the end of the first half-cycle following contact separation. Contact life can be greatly increased by shunting the load with a resistor-capacitor-diode combination whose time constant is equal to that of the load.

MISAPPLICATIONS

Relay coils should never be operated from slowly rising voltages. The resulting relay chatter can quickly damage the contacts, especially if an inductive or high inrush current load is being switched.

Never connect contacts in parallel in an attempt to handle higher load current. Relay contacts never operate at precisely the same time, so one contact will always make or break the entire current first.

Similarly, never connect contacts in series in an attempt to handle higher voltages. Double-break series contacts have some value in switching inductive loads, because the armature opens twice the gap length at twice the actuator rate. The case-to-ground rating of most relays is much lower than the contact-to-ground ratings.

Switching a load between two unsynchronized AC sources requires a relay with contacts rated for double the peak voltage. If a fault occurs at the load, the relay may be required to interrupt a current much higher than its rating. Some relays are rated to interrupt ten times rated current one time, but may weld if subject to the same current again.

The coil of a relay can generate a magnetic field that may have an adverse effect on nearby components such as inductors, wirewound resistors, and other electromagnetic devices.

In some latching relays the two coils share a common iron frame, where a single bar magnet is used to hold the relay armature in each latch position. Sufficient transformer action exists between the two coils to allow spikes to pass to the drive transistors in the opposite circuit. These spikes can have enough energy to damage semiconductors. Suitable clamp or blocking diodes should be used to prevent problems.

SPEAKER PROTECTION

The relay must be sized to break the worst-case energy resulting from an

TABLE 6
LEACH TYPE-X RELAY SPECIFICATIONS, PART 2

LOAD RATINGS	28V DC	115V DC	LIFE
Resistive	5A	5A	100,000 cycles min
Inductive	3A	5A	DC 20,000 cycles, AC 50,000 cycles
Motor	2A	3A	
Lamp	1A	1A	
Overload	20A	30A	
Rupture current (one time)	25A	40A	
Low-level rating	10-50mV, 10-50µA	10-50mV, 10-50µA	1 million cycles

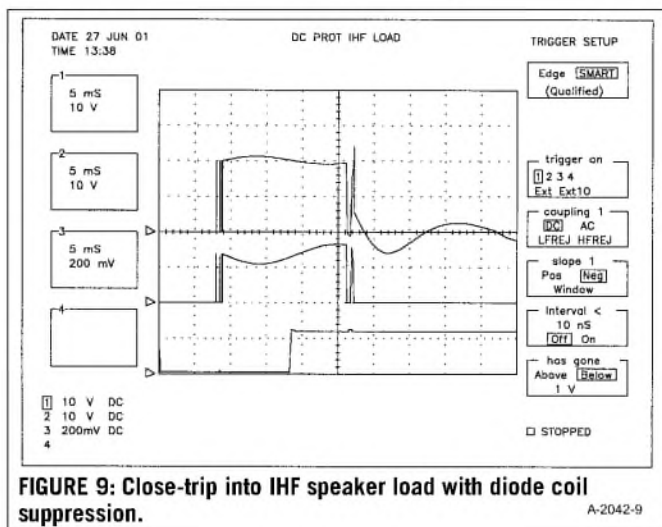

FIGURE 9: Close-trip into IHF speaker load with diode coil suppression.

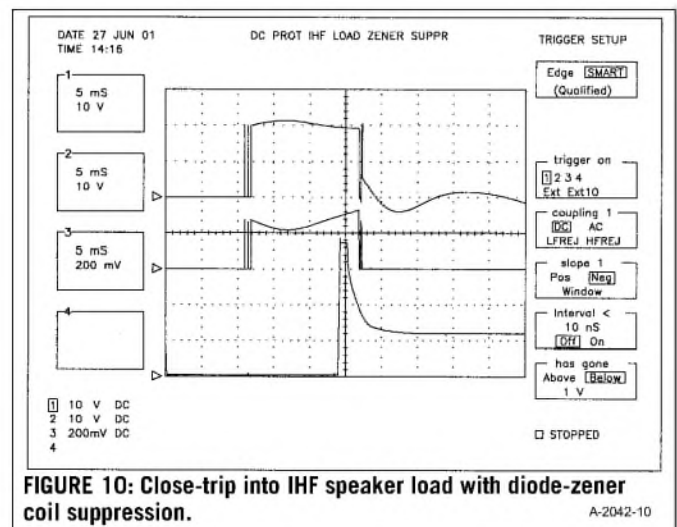

FIGURE 10: Close-trip into IHF speaker load with diode-zener coil suppression.

amplifier fault². There are many audio power amplifier failure modes that can cause a very large DC voltage to appear at the output terminals. This DC voltage can force the speaker voice coil beyond its maximum excursion and cause it to overheat and perhaps burn out.

Many amplifier manufacturers provide some sort of output DC offset protection, implemented with an EMR. The

typical protection level is 1 to 4V DC. This relay may also provide a turn-on delay and high temperature and overload protection.

A speaker driven to its mechanical extremes, whether by a high power audio signal or a DC voltage due to amplifier failure, can generate a high inductive back emf when the voice coil returns to position. Many amplifiers use catch diodes in parallel with the output transistors to protect these devices from the high reverse voltage that the speaker can generate, even during normal operation at high volume.

TESTS

I breadboarded the small relay driver circuit shown in Fig. 3. A 555 timer IC generates a variable duty-cycle pulse from 5ms to 100ms. The relay is an Omron G6B-2214P-US-DC12, with the specifications listed in Table 4. I used a 20V DC supply for the load and a 12V DC supply for the relay coil.

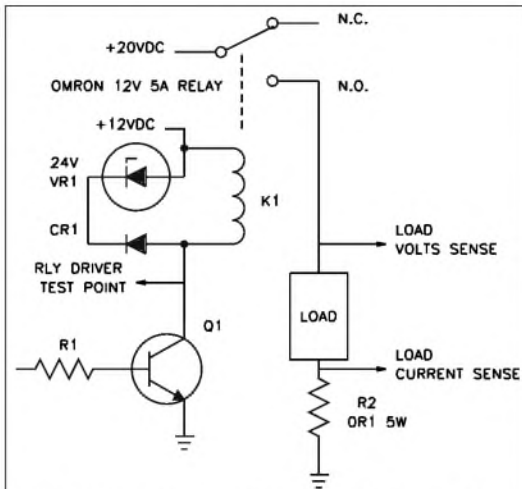

FIGURE 11: Relay test circuit with diode-zener coil suppression.

A-2042-11

SCH
Sound Clearing House
 Kit Ko8T23
 8" 2-way tower
 \$180 pair
 In Stock, really!
 Other High-Quality Kits Available
 www.speakerpage.com
 1-888-3-SPEAKER

General attenuator specifications

Number of steps:	24	
Bandwidth (10kOhm):	50	MHz
THD:	0.0001	%
Attenuation accuracy:	±0.05	dB
Channel matching:	±0.05	dB
Mechanical life, min.	25,000	cycles

CT2 6-gang
volume control for AV Audio

CT100 key specifications

Gain (selectable):	40 to 80	dB
RIAA eq. deviation:	± 0.05	dB
S/N ratio (40/80dB gain):	98/71	dB
THD:	0.0003	%
Output resistance:	0.1	ohm
Channel separation:	120	dB
Bandwidth:	2	MHz
PCB dimensions:	105 x 63	mm
	4.17 x 2.5	"

CT100
Phono Stage Module

CT101 key specifications

Gain (selectable)	0, 6 or 12	dB
Bandwidth (at 0dB gain)	25	MHz
Slew rate (at 0dB gain)	500	V/μS
S/N ratio (IHF A)	112	dB
THD	0.0002	%
Output resistance	0.1	ohm
Channel matching	± 0.05	dB
PCB dimensions:	100 x 34	mm
	3.97 x 1.35	"

CT101
Line Stage Module with a stereo CT1 attenuator added.

DACT
 DANISH AUDIO CONNECT
DACT

Sales Dep.: Tel.: (+66) 2 260 6070
 Fax: (+66) 2 260 6071
 E-mail: info@DACT.com

http://www.DACT.com

High quality audio parts for upgrading existing equipment, DIY constructions and for audio equipment manufacturers. DACT audio components offer unusually large bandwidth, low distortion, high accuracy, low noise and long lifetime. DACT products:

- Stepped Audio Attenuators
- Stepped Balance Controls
- Audio Input Selector Switches
- Phono Stage Module
- Line Stage Module
- Different Accessories

Made in Denmark

I contacted Omron to find more specifications: contact ratings for inductive loads, overload and rupture current, maximum bounce time, and so on, but they never responded. The specifications for a Leach Type-X Mil Spec relay of the same basic rating are listed in *Tables 5 and 6*, but they may not apply to the Omron. They will at least give you a feel for the variables in a well-specified relay.

You've already seen the oscilloscope traces for closing and opening contact bounce (*Fig. 4 and 5*). I used a 20 Ω load resistor for these tests. Note the places where the slope of the trace is not vertical. This represents the areas where the contact shows some significant resistance, probably due to arcing, even though the load current of 1A is only 20% of the contact rating. This arcing is especially noticeable when the relay contact recloses once during the release cycle of *Fig. 5*.

Figure 6 represents one close/trip cycle. I triggered the scope when the relay drive transistor turned on in the bottom trace (relay driver test point in

Fig. 3). Here you can see the 9ms operating delay between the time the voltage is applied to the coil and the contacts complete their travel. You can also see the NO contact bounce. The top trace is load voltage and the middle trace is load current—100mV across 0R1 resistor R2, for 1A load. When the coil voltage is removed, the release operating delay is about 8ms.

Figure 7 shows the relay closing into an IHF simulated speaker load. This consists of a parallel RLC circuit (12.5mH, 800 μ F, 18R3 Ω) in series with a 5R4 Ω resistor³. This network has a resonant frequency of about 50Hz. You can clearly see ringing at this frequency in the voltage (top) and current (middle) traces. Its DC resistance is about 7 Ω .

Next, I added a circuit that would cut off the relay drive transistor when the load voltage exceeded about 4V DC. This is designed to reflect the action of a speaker protection DC offset voltage detector. Assume the upper transistor in a solid-state output stage suddenly fails shorted, while the lower transistor is biased off by a positive input signal

(*Fig. 8*). The entire positive rail DC voltage is impressed on the speaker.

At low audio frequencies, or idle, the speaker could see the full voltage for a significant time—even more for a low or no feedback design. Of course, if the bottom transistor conducts due to a negative-going input or feedback correction signal, it will absorb some of the current into the negative rail supply. Now the race is on between the protection circuit, the lower output device surge capability, and the rail fuses.

Figure 9 shows the close/trip cycle using my 20V DC power supply. Here it is shown just after relay closing. In a real amplifier a fault is more likely to occur after some period of steady-state operation. You can see from the middle trace that the current was interrupted almost at its 3A peak (I didn't design for this—it was the unfortunate result of the relay and detection circuit delays).

The contact bounce on opening produces some interesting voltage spikes in the top trace. Note that the voltage across the load continues to ring at 50Hz even though the driving voltage



DLSA Pro Test & Measurement System

from RCM Akustik, Germany

New to the North American market, this affordable computerized loudspeaker test system consists of a hardware box, test microphone, a 10:1 attenuator probe and software for your PC. Available measurements include:

- Impulse or MLS based Time, Frequency, and Phase Response
- Impedance plots, Waterfall plots
- 1/3-octave Real-time analyzer
- T/S measurements
- DB_{SPL} measurements

Hardware attaches to computer via printer port with standard printer cable. System Requirements: IBM-compatible 486+, Windows 95-98, minimum 16MB RAM. Shipping Wt: 3 lbs.
KR-DLSA\$450.00

Call
1-888-924-9465
 to order today
 or order on-line at
www.audioXpress.com



Old Colony Sound Laboratory,
 PO Box 876 Dept. LIS2,
 Peterborough, NH 03458-0876 USA
 Toll-free: 888-924-9465 Phone: 603-924-9464
 Fax: 603-924-9467 E-mail: custserv@audioXpress.com

has been interrupted by the relay. The contact opening time with the coil suppression diode is about 9ms.

The 50 to 60V DC rails in high power audio amplifiers would produce a much higher current into the speaker system. 5A mute/protection relays are fairly typical, so when they interrupt a worst-case type of failure, the contacts could be well above their inductive load rating, even approaching the rupture current limit.

Figure 10 shows the contact opening time when I connected a 24V zener in series with the suppression diode (circuit in Fig. 11). The contacts open in only 2.5ms, a significant improvement. The 4V DC detector circuit was a bit slower for some reason, so the total close time is the same.

You can see the 37V peak voltage across the drive transistor (25V across the diode-zener added to the 12V DC coil circuit supply), so you must be sure to use a transistor with a high enough Vce rating to use this suppression circuit. The release contact bounce is of shorter duration as well, since the ener-

gy in the coil inductance is dissipated much faster. In fact, I needed to run this test a number of times to show any release contact bounce at all.

SUMMARY

As with all electronic and electrical components, adequate derating is necessary to ensure a long relay life. Diode/zener coil suppression provides a much faster trip time than the more common single diode suppression.

Plan for worst-case fault current, which will vary with the amplifier's rail voltages and the speaker impedance. Remember, rail fuses take some time to open, and reservoir capacitors can deliver a lot of energy. You must choose the relay contact ratings to handle the maximum inductive current without welding. ❖

REFERENCES

1. *Engineers' Relay Handbook*, 3rd Edition, 1980. National Association of Relay Manufacturers.
2. *High-Power Audio Amplifier Construction Manual*, G. Randy Stone, McGraw Hill, 1996.
3. "Passive Loads for Audio Testing," Hansen, C., *Audio Electronics* 1/00, p. 34.

Toroids for Audio



Tube Output

Toroidal transformers for tube output applications. Plus related products.

Standard Series (push-pull)

Single-ended

Specialist Range

Special Designs

Power Transformers

Chokes

Chassis for Tube Amplifiers

PCB for 70W & 100W Amps

Book by Vanderveen

Electrostatic

Step-up toroidal transformers for Electrostatic loudspeaker applications.

Solid State Power

Low noise, low inrush
500 to 2000VA fully encapsulated power transformers.

Standard Power

A broad range of high quality, approved, toroidal transformers. Designed for general purpose applications. From 15 to 1500VA.



PLITRON
MANUFACTURING INC

8-601 Magnetic Drive
Toronto, ON M3J 3J2
Canada

416-667-9914

FAX 667-8928

1-800-PLITRON
(1-800-754-8766)

www.plitron.com

It is not enough to put oil into a Capacitor to make it musical....

KRISTALL CAP



Forget about resistive devices for the volume setting. We offer a silver wired transformer approach

Silver Rock Transformer-Potentiometer



It is not enough to use silver wire for a good SE-OPT...

Silver Rock Output transformer



There is only one optimum solution for a given problem.

Audio Consulting / 14B chemin des Vignes / 1291 Commugny / Switzerland

Fax: 00-41-22-960-12-59 / e-mail: serge.schmidlin@span.ch

<http://www.audio-consulting.ch>

Dual-Driver Confusion Revisited

Further investigation of system response when driving dual-voice-coil drivers. **By G. R. Koonce**

In the article “Dual-Driver Confusion” (*SB 5/00*), I tried to clarify the situation when dual drivers are used in parallel in direct-radiator systems. Mr. Fitzmaurice (*SB 7/00*, p. 38) provided additional information showing that dual side-by-side horn systems behave in the same manner as direct radiators.

There seems to be a consensus that driving two speakers side-by-side in parallel will double the input power while the output level at low frequency rises 6dB, and that 3dB of the output rise is due to the doubling of the input power and that the other 3dB rise must be due to an efficiency increase of the composite speaker system. What seems to be in question is the reason for this efficiency increase.

Three of the reasons proposed for this efficiency increase are:

1) I believe it is simply a property of

passive linear systems that the efficiency changes with multiple and independent inputs as predicted by the superposition theory. No other explanation is required. I had tried to demonstrate this with a simple three-resistor network that showed this same efficiency increase—an example that was not well received.

2) Many attribute the efficiency increase of dual side-by-side drivers to a mutual acoustic interaction between the two drivers.

3) Many others attribute the efficiency increase of the dual drivers to the increased radiating area of the system. Mr. Fitzmaurice supported this reason.

DUAL-VOICE-COIL DRIVERS

This article is the result of testing inspired by a short e-mail from David Weems. David asked, “Would your solution for dual-driver confusion apply to

a double-voice-coil driver when both coils are used?” A simple enough question, but one for which I clearly did not have the answer.

I must admit I was “uneducated” on the topic of dual-voice-coil (VC) drivers. In the past I had always used them as a single-VC driver, using them with the two VCs wired either in series or in parallel. Now David raised the question of the intended application of these drivers where they are used with one VC driven by each of two signal channels. This in turn raised the following questions:

- 1) How do you establish the T/S parameters for a dual-VC driver for two-channel use? Do you measure the parameters for the two VCs in series, in parallel, or driving just one of the VCs? Certainly the possibility of some confusion exists here.
- 2) If the two channels have identical input signals, does the output rise 3dB or 6dB above the level of one channel driven? A very interesting question.

Many years ago I had a friend who used to build with dual-VC drivers. He would drive one VC and “tune” the system by putting various resistors across the other VC. Did this approach really vary the response of the system?

I had on hand a pair of ELDN 6.5” dual-VC drivers purchased several years ago as subwoofers. Testing had

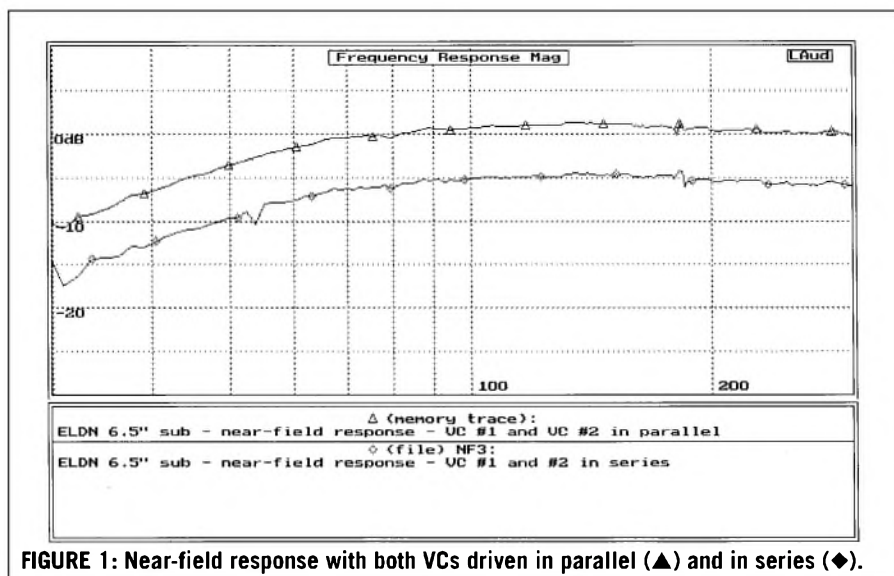

FIGURE 1: Near-field response with both VCs driven in parallel (▲) and in series (◆).

**TABLE 1
RESULTS FOR ELDN 6.5” DRIVER**

	F_s	Q_{TS}	R_{DC}
VCs in parallel	54.4	0.634	3.05
VCs in series	54.1	0.642	12.3
Looking at VC #1, VC #2 is shorted	53.2	0.649	5.92
Looking at VC #1, VC #2 loaded by 10Ω	53.9	0.818	5.74
Looking at VC #1, VC #2 is open circuit	54.3	1.129	5.96

shown that f_s was up near 60Hz, so these drivers did not fit my definition of subwoofers. They would, however, be ideal for testing to answer the foregoing questions.

T/S PARAMETERS

I measured Q_{TS} and f_s for one ELDN driver for the cases of the two VCs in series, two in parallel, and driving one VC with the undriven VC shorted, open

circuit and loaded via 10Ω. Testing was done via Liberty Instruments' AudioSuite, and the resistance reported is that predicted by the software as frequency tends to zero. Table 1 shows the results.

I find these results interesting. First, Q_{TS} does not change much for the two VCs in series or in parallel; you just see a four-to-one change in input impedance as you would expect for series ver-

sus parallel VCs. When you drive one VC with the other shorted—the condition for two-channel use when one channel is not driven— Q_{TS} is about the same as for driving both VCs. Thus it is clear that if you design the enclosure for the Q_{TS} measured for both VCs in parallel, it will be the proper size when only one VC is driven while the other is connected to an amplifier output.

The other interesting thing about driving one VC is the importance of how the other VC is terminated. For all cases, R_{DC} is about 6Ω; this is reasonable for VCs that show 12Ω in series and 3Ω in parallel. Note, however, that there is an effect on Q_{TS} . Driving one VC and putting a variable resistor on the other will allow “tuning” the system by changing Q_{TS} . Note that Q_{TS} always stays above what you would get when testing with both VCs driven.

David had on hand some old Radio Shack #40-1348 dual-VC woofers. He measured one with the Woofer Tester for the same test conditions I had used. Table 2 shows that his results agree with mine.

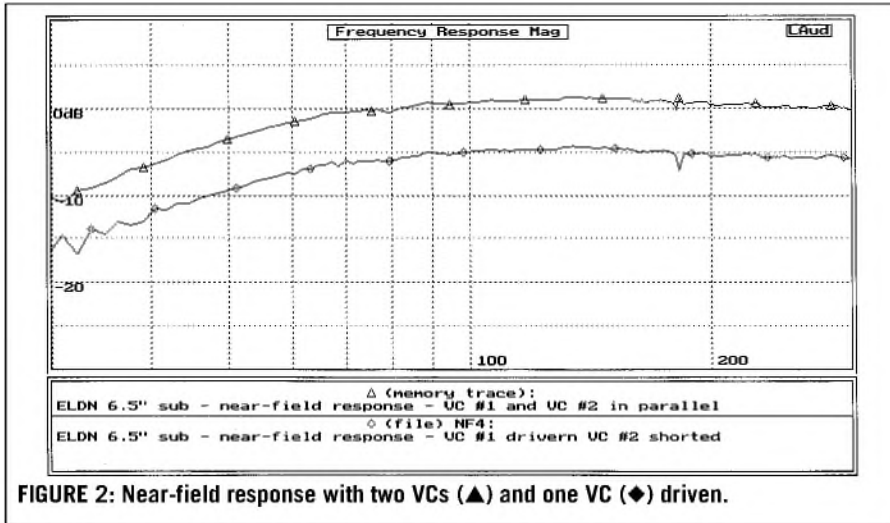

FIGURE 2: Near-field response with two VCs (▲) and one VC (◆) driven.



THE REAL DEAL!



EVO-R 15 \$349

“Over 4.4 liters of linear displacement...”

“1,500 watts RMS”

“Over 1-inch (25mm) x-max”

“One of the first things you will notice when listening to this subwoofer is the lack of overhang. That is a really well-controlled subwoofer... for the serious listener that wants to hear what the artist intended their music to sound like... a great looking subwoofer and a real value.”

Eric Holdaway —
Car Audio and Electronics

“The Audiomobile EVO 2210 delivered the best performance of any 10-inch subwoofer I’ve tested... the most stroke of any 10-incher I’ve tested to date, in fact.”

Tom Nousaine —
Mobile Entertainment

“The Audiomobile MASS 2012 is the best 12-inch subwoofer at any price that I’ve reviewed. In fact, it could even be the best 12-incher currently on the market.”

“...Of course the limits of this sub are beyond the limits of other subs... in a 1 cubic-foot enclosure... **\$299. Wow!**”

Tom Nousaine —
Car Stereo Review



ADVANCED TECHNOLOGY

“Audiomobile’s latest offering reaches its goal, providing a considerable bang for the buck!...”

“...the motor structure on the EVO-R is also impressive...”

Vance Dickason —
Car Audio and Electronics

Call or log on for more information
(800) 564-2558 AudiomobileDirect.com

NEAR-FIELD RESPONSE

I mounted the ELDN 6.5" driver in my 6' diameter test baffle and tested for low-frequency response via near-field techniques over the frequency range of 30-300Hz. *Figure 1* shows the response plots for the two VCs driven in series and in parallel. Ignore the wiggles at low frequency; they are noise interfering with the testing. The difference in level is 6dB, which agrees with the four-to-one input impedance change and is the same result you obtain for two individual drivers driven in series versus in parallel.

Figure 2 shows response plots for the two-channel case of an amplifier connected to each VC. When both VCs are driven with identical signals, the output is 6dB higher than when only one channel is driven. Thus, a dual-VC driver behaves just like a pair of side-by-side drivers and shows the 6dB output rise for a 3dB input power increase.

Figure 3 shows the plots for one VC driven and the other either shorted or open circuit. It is clear that driving one VC and playing with a load resistor on the other not only changes Q_{TS} but also has a major effect on the low-frequency response for this driver type.

FAR-FIELD RESPONSE

I measured the far-field response for the ELDN driver at a distance of one meter with quasi-anechoic testing over the range of 250Hz-8kHz. *Figure 4* shows that the results for the two VCs in series versus in parallel are the same as the near-field result, a 6dB difference. Results are also the same for the two-channel case (*Fig. 5*), with both channels driven by identical signals, raising the output level 6dB over a single channel driven. Once again, for this

driver type, driving one VC and dummy-loading the second can have a major effect on the frequency response (*Fig. 6*)—this time at high frequency.

CONCLUSIONS

Testing shows that if both VCs are connected to a stiff source, then driving both channels with the same signal

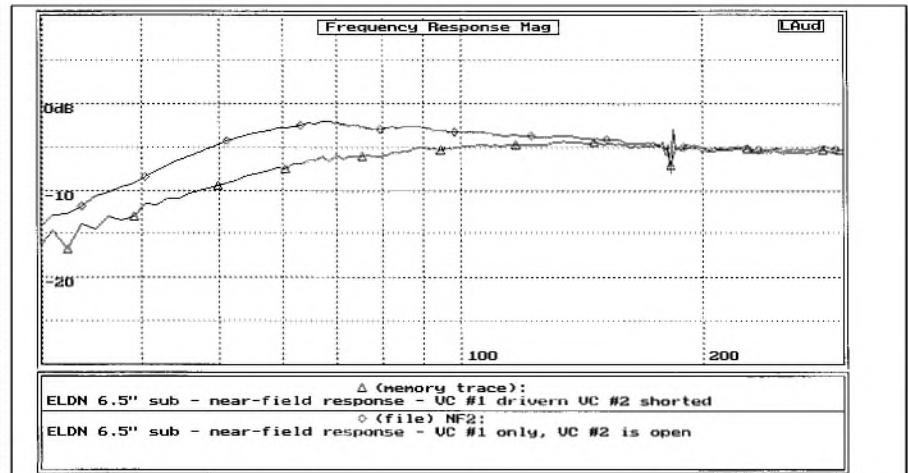

FIGURE 3: Near-field response when driving one VC with the other shorted (▲) and open (◆).

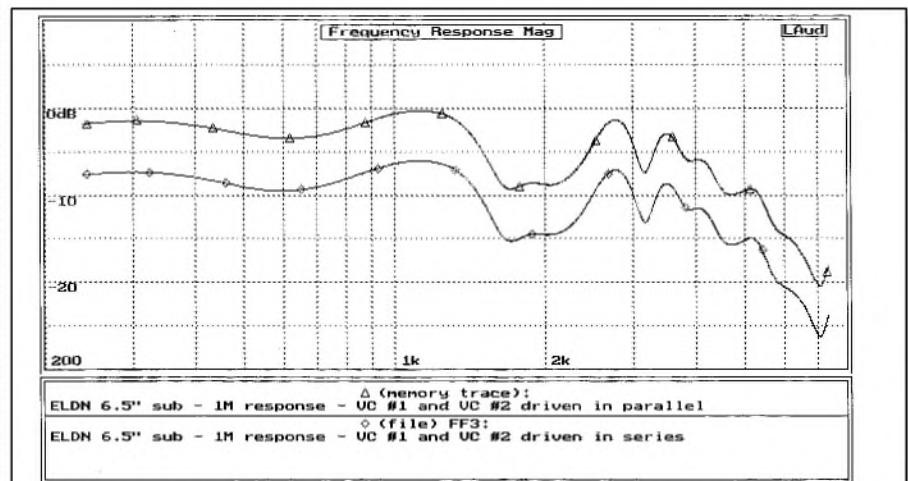

FIGURE 4: Far-field response with both VCs driven in parallel (▲) and in series (◆).

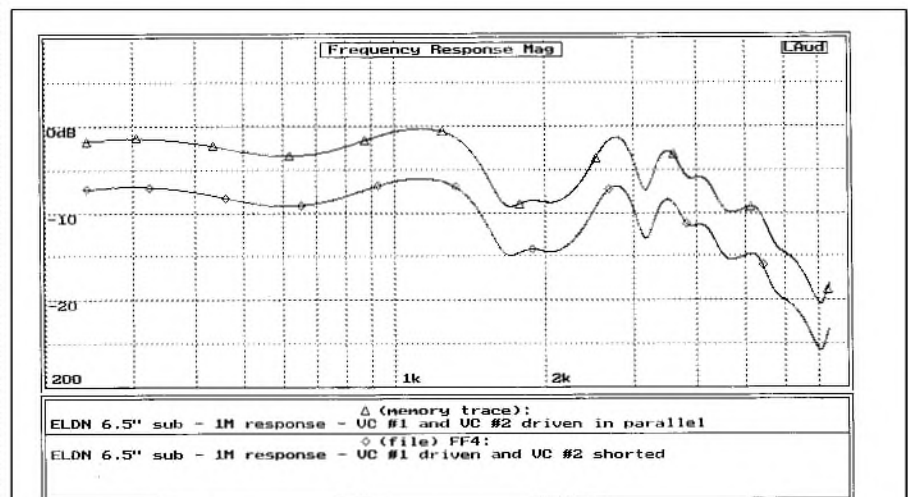

FIGURE 5: Far-field response with two VCs (▲) and one VC (◆) driven.

TABLE 2
RESULTS FOR RADIO SHACK
#40-1348 DRIVER

	F_s	Q_{TS}	R_{DC}
VCs in parallel	51.4	0.608	2.72
VCs in series	51.0	0.609	10.65
Looking at VC #1, VC #2 is shorted	51.0	0.693	4.99
Looking at VC #1, VC #2 loaded by 10Ω	51.1	0.829	4.94
Looking at VC #1, VC #2 is open circuit	51.1	0.973	5.01

raises the output level by 6dB over a single channel driven. This is the same result as for dual side-by-side drivers or systems. How do you explain this by "radiating area increase" when the cone area has not changed? How do you explain this as "mutual driver interaction" when you have only one driver? It is, however, easily explained

as a normal characteristic of passive linear systems.

When you design a two-channel system using a dual-VC woofer, establishing the T/S parameters is straightforward. Measure the driver with the two VCs in series or in parallel or driving one VC with the other shorted. The resulting parameters will all produce

about the same box design. The only case that would not be valid is to measure the driver via one VC with the second one anything but shorted.

My friend's technique of "tuning" his boxes by driving one VC of a dual-VC driver and varying a dummy load on the second surely will cause major changes in the box response. Not only does this change the driver Q_{TS} , but it can also have a major effect on the driver's low- and high-frequency response. Play with this approach carefully.

With a dual-VC woofer, you could drive one VC with the normal bass signal and use the second to produce increased bass response, possibly for diffraction-spreading loss compensation. Near-field testing shows that 6dB of compensation is available with this approach. Far-field testing shows that the high-frequency response of the driver may also rise if the compensation VC is not driven by a source with a low impedance at high frequency. This would indicate that a first-order crossover is not ideal for driving the compensation VC. ❖

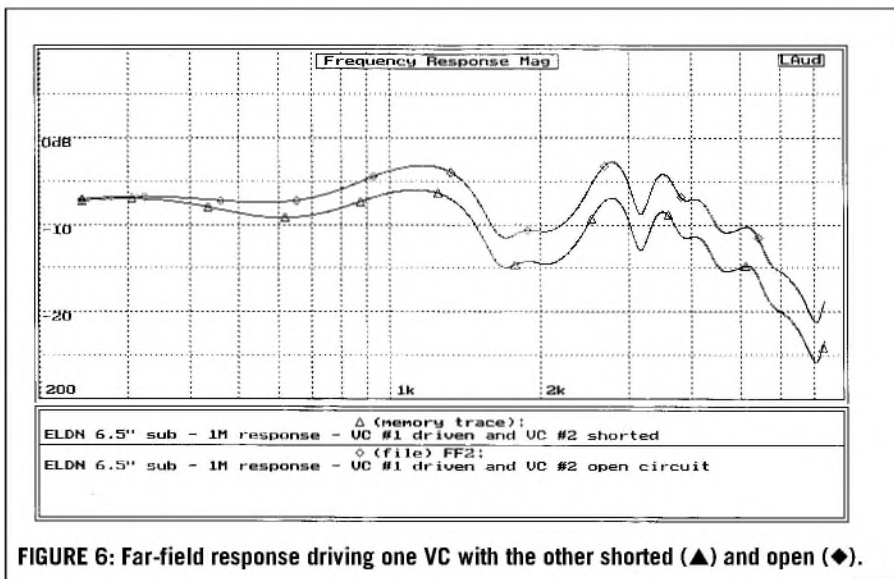

FIGURE 6: Far-field response driving one VC with the other shorted (▲) and open (◆).

TURBOCHARGING YOUR REGA ARM



"Nothing less than total dynamite" **HI-FI WORLD MAGAZINE**

If you are the proud owner of any Rega arm why not utterly transform it into the league of super arms with the Origin live structural modification:- \$91. This modification will enable your Rega to perform at a level exceeding that of arms costing over \$1700. Rewiring with high grade litz cable is also offered at an additional \$85 and external rewiring is \$99. All these modifications are available in kit form if you wish to do the job yourself or you can send us your arm for us to do the work.

"I have to say the Rega modifications turn this humble arm into a real Giant killer. Gone is the rather grey, sterile sound of the cooking Rega. Instead, tonal colour is fresh, dynamics have great speed and impact, and the sound stage is huge." **HI FI WORLD SUPPLEMENT** (structural modification to an RB250)

WHAT HI-FI MAGAZINE gave this modification a 5 star rating.

For arm modifications we normally turn around your arm in 1 - 2 days

OTHER KITS & PRODUCTS FROM ORIGIN LIVE INCLUDE:-

- **TURNTABLES (Kits & Retail)**
"the best sounding deck here...sounds fantastic" **WHAT HI-FI MAGAZINE** group comparison test of 8 leading turntables
- **SILVER 250 TONEARM \$729**
Probably the best tonearm available at any price (except for the Silver Taper).
- **SILVER TAPER TONEARM \$1491**
- **DC MOTOR UPGRADE**
suitable to upgrade all turntables including Linn Lingo, Armageddon, Roksan, Thorens, Ariston, Rega, Systemdek etc \$319
Well reviewed as a massive upgrade for all turntables

FULL INFORMATION ON WEB SITE OR CONTACT:-

Origin live, 87 Chessel Crescent, Bitterne, Southampton SO19 4BT

Tel: 023 80442183 / 80578877 Fax: 023 80398905

E MAIL: originlive@originlive.com **WEB SITE:** <http://www.originlive.com>

Software Review

B2 Spice A/D v4

Reviewed by Tom Harman

B2 Spice A/D v4 circuit simulation program. Beige Bag Software, 279 E. Liberty, Ann Arbor, MI 48104. (734) 332-0487, Fax (734) 332-0392, www.beigebag.com, e-mail info@beigebag.com. \$349 Professional Version, \$199 Standard Version, free download Lite Version. Previous B2 version upgrades and competitive product upgrades available.

B2 Spice v4 is a full-featured analog and digital SPICE electronic circuit simulation program by Beige Bag Software. Beige Bag regularly advertises B2 Spice in *audioXpress*. It seems that Beige Bag believes Spice A/D v4 is a product *audioXpress* readers should use. It made sense for me to review this program as my first submission to *audioXpress*.

PAPA'S GOT A BRAND NEW BEIGE BAG

There are three different levels of Beige Bag's Spice v4 program. The Lite Version is a junior version of the other two programs. Your schematic may contain a maximum of 25 components, and only six simulations are available. The parts library has 300 devices. At the cost of a free download, this is an excellent introduction to anybody who is curious about how SPICE programs work.

The primary difference between the \$349 Professional Version and the \$199 Standard Version is a larger library of parts (15,000 versus 5,000) and more

ABOUT THE AUTHOR

Tom Harman is a video systems engineer for Sony Electronics. He has been an audio hobbyist since age 14. He enjoys designing and building all audio equipment. He can be contacted at audio@bestbatchyet.com.

simulations (19 versus 12). Either version is very attractive and competitive in the SPICE market. Beige Bag has the Professional Edition, fully functional, as a free download. The catch: This version stops working 30 days after you install it on your computer. Thirty days should be long enough for you to decide whether you wish to pay the additional \$150 for the Professional version.

SPICE, SPICE, BABY

SPICE programs allow you to design and test (the SPICE term for test is "simulate") an electronic circuit, using a computer. No components to buy, no soldering irons to heat up, no smoking components.

Why would you choose to use a SPICE program? For me, there are several answers:

1. Time—I can build a circuit quicker on my computer than I can on my test bench. I can change components quickly using a PC.
2. Education—I find technical material easier to follow if I build the circuit and "see" the ideas presented.
3. Math—SPICE does the boring math for me. More time to experiment.

I do not want to mislead you. A SPICE program will not eliminate the prototype stage. It can shorten the design stage considerably. There are some real-world factors that might not be practical to simulate, such as: lead inductance, PCB capacitance, RF interference, real-world power supplies. Of course, SPICE does not have capacitors that are low distortion, nor can it tell you which cable sounds better.

INTRODUCING THE SPICE GOALS

SPICE software has been around since the early 1970s. SPICE stands for "Simulation Program with Integrated Circuit Emphasis." Students and faculty at UC Berkeley first developed SPICE and have maintained it since. This is why some people call it "Berkeley SPICE." It has gone through three major revisions during the last 30 years. It has received a digital circuit simulation add-on, XSPICE (for Extended SPICE), which students at Georgia Tech University wrote.

Berkeley SPICE has become the world standard simulation engine. Almost all circuit simulation programs use the Berkeley SPICE engine as their core. This has the advantage of competition between products, but still continuity and familiarity among vendors. SPICE models need to be produced in a specific format; this makes them (more or less) interchangeable from one vendor's version of SPICE to another vendor's version. In fact, many component manufacturers supply free SPICE models of their products to encourage you to use their products in your designs.

SPICE was developed using public funding. The program is an open license. You can legally get versions free. FREE! The audio amateur's favorite word. Why should you spend \$10,000 or even \$99 for something you can get free?

Using the core SPICE program is cumbersome and anti-intuitive. There is no graphic input. You define your circuit using a text editor, such as Windows Notepad. Consider the following example. *Figure 1* is a simple schematic and *Table 1* is the SPICE file version of *Fig. 1*.

One line of text describes one component and how it is connected to the rest of the circuit. "R1 1 2 100.0Ω" tells you that R1 is a resistor, the first lead connected to node 1, the second lead is connected to node 2 and has a value of 100Ω. "Node" is SPICE speak for conductor.

A file of a typical power amplifier would be large, difficult to edit or troubleshoot. Most (if not all) SPICE programs will come with a schematic drawing tool, called "schematic capture." Select your components, place them on your sheet of paper, and then play connect-the-dots to wire your circuit. The software translates your graphic work into a file like the previous example to be used by the simulator.

The core SPICE program comes with only a few basic components: resistors, capacitors, voltage sources, generic NPN transistor, and so on. Commercial SPICE programs come with a library of SPICE models for specific components, such as Analog Devices AD-711, TIP 32C transistor, IRF610 power FET, 12AX7 vacuum

tubes. The SPICE program uses these models to predict how your circuit will behave.

When you specify a Texas Instruments TL071 op amp, you simulate the circuit using a TL071's electrical characteristics, such as bandwidth, gain, current draw, and so forth. The more accurate the model, the more accurate your simulation results will be. When evaluating a SPICE package, examine the library of components carefully.

WHAT IS A SIMULATION?

A simulation is the computer equivalent of testing your circuit on the test bench. Different vendors will make different simulations available. The core SPICE program is capable of generat-

ing a great amount of data, which can be presented in many different ways, usually in the form of tables and graphs. Manipulating and displaying this data requires programming, and programming costs money. How much programming do you want to buy?

That is about it. Draw your circuit and then run the simulations.

This review is addressed to a "typical" *audioXpress* reader. I do not intend this to be for professionals. Should your international mega-corporation

**TABLE 1
SPICE FILE OF FIG. 1**

```
*Voltage divider circuit
VIN 1 0 10.0V
R1 1 2 100.0Ω
R2 2 0 200.0Ω
.End
```

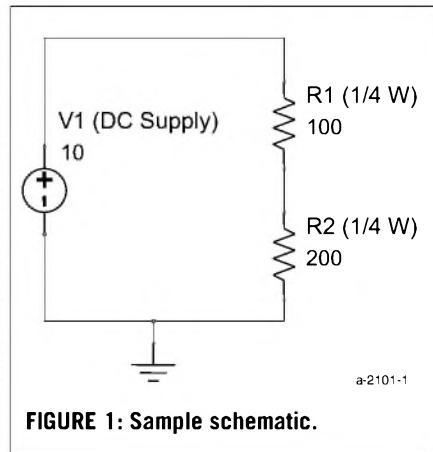

LANGREX SUPPLIES LTD

DISTRIBUTORS OF ELECTRONIC VALVES, TUBES & SEMICONDUCTORS AND I.C.S.

1 MAYO ROAD, CROYDON, SURREY, ENGLAND CR0 2QP

24 HOUR EXPRESS MAIL ORDER SERVICE ON STOCK ITEMS

E-MAIL: LANGREX@AOL.COM

PHONE

44-208-684-1166

FAX

44-208-684-3056

A SELECTION OF OUR STOCKS OF NEW ORIGINAL VALVES/TUBES MANY OTHER BRANDS AVAILABLE

STANDARD TYPES			AMERICAN TYPES			SPECIAL QUALITY TYPES		
ECC81	RFT	3.00	5R4GY	RCA	7.50	A2900/CV6091	G.E.C.	17.50
ECC82	RFT	6.00	5U4GB	SYLVANIA	15.00 pounds each	E82CC	SIEMENS	7.50
ECC83	RFT	8.00	5Y3WGT	SYLVANIA	5.00	E83CC	TESLA	7.50
ECC83	EI	5.00	6BX7GT	GE	7.50	E88CC G. PIN	TESLA	8.50
ECC85	RFT	5.00	6FQ7	SYLVANIA	7.50	E188CC	MULLARD	20.00
ECC88	BRIMAR	6.00	6L6GC	SYLVANIA	20.00	ECC81/6201	G.E.	5.00
ECC88	MULLARD	10.00	6L6WGB	SYLVANIA	15.00	ECC81/CV4024	MULLARD	6.00
ECL82	MULLARD	5.00	6SL7GT	USA	7.50 pounds each	ECC81/M8162	MULLARD	7.50
ECL86	TUNGSRAM	10.00	6SN7GT	USA	7.50	ECC81/6201 G. PIN	MULLARD	10.00
EF86	USSR	5.00	6V6GT	BRIMAR	7.50	ECC82/CV4003	MULLARD	10.00
EF86	MULLARD	15.00	12AX7WA	SYLVANIA	6.00	ECC82/M8136	MULLARD	12.50
EL34	EI	6.00	12BH7	BRIMAR	12.00	ECC83/CV4004	MULLARD	40.00
EL37	MULLARD	30.00	12BY7A	G.E.	7.00			
EL34G	SOVTEK	5.00	211/VT4C	G.E.	85.00			
EL84	USSR	3.00	807	HYTRON	7.50			
EL519	EI	7.50	5687WB	ECG	6.00			
EZ80	MULLARD	5.00	6072A	G.E.	10.00			
EZ81	MULLARD	10.00	6080	RCA	10.00			
GZ32	MULLARD	25.00	6146B	G.E.	15.00			
GZ33/37	MULLARD	20.00	6922	E.C.G.	6.00			
PL509	MULLARD	10.00	6973	RCA	15.00			
UCH81	MULLARD	3.00	7308	SYLVANIA	5.00			
UCL82	MULLARD	2.00						

MANY OTHER BRANDS AVAILABLE

These are a selection from our stock of over 6,000 types. Please call or FAX for an immediate quotation on any types not listed. We are one of the largest distributors of valves in the UK. Same day dispatch. Visa/Mastercard acceptable. Air Post/ Packing (Please Enquire). Obsolete types are our speciality.

ration buy a license for every engineer's desk? I do not answer that question. This is a review written for *audioXpress* readers, by an *audioXpress* reader.

B2 Spice has the ability to export your schematic to certain PCB layout programs. I do not have access to any of the supported PCB formats. I could not verify the functionality or quality of this feature.

B2 Spice v4 also has digital circuit capabilities. You can design circuits with TTL logic and all that nonlinear stuff. I am an analog/linear person. I do not feel comfortable criticizing or endorsing the digital section of the program. If you are interested in the digital section of B2 Spice v4, please be careful how you apply my comments. Or go ahead and try the download.

PUT ME IN, COACH, I'M READY TO PLAY!

It was not until after I started writing this review that I revealed my literary intentions to Beige Bag. I purchased the product and tested their customer service as a civilian. I received no special attention. I believe you will receive the same level of service I describe here.

Let me start off on a big positive note. I was impressed with Beige Bag's customer service. I placed my order late Tuesday afternoon, and the CD-ROM was in my mailbox two days later. The product was delivered just as I had ordered. Installing the program on my IBM-style PC was as easy as it gets.

As a test for this review, I e-mailed some technical questions to see how quickly and completely Beige Bag tech support would respond. On my first attempt, they experienced a glitch in their e-mail system. After a couple of days I did not receive a response. I made a phone call to the Beige Bag office and obtained a prompt reply.

The next week I sent several more questions. I made these questions slightly annoying and of a pestering nature. I always received a quick, complete, and courteous response—sometimes within two hours. Beige Bag passed the tech support/customer service test with flying colors.

RATING THE PROGRAM

I really like this program. It does an excellent job delivering all the reasons to buy a SPICE program. You get features galore and tons of simulation options. The simulations run smoothly. The program was stable and never locked up on me.

When I was experimenting with the program, I trusted the data generated by B2 Spice. Any time I derived a result that didn't make sense, I assumed (quite rightly) that the error was mine. For example: The RIAA preamplifier I simulated did not have enough LF boost. After an hour of adjusting simulation variables, I realized that I had used the incorrect multiplier on a capacitor value (.1 μ F, not .1F. Duh!).

The 233-page printed manual that comes with the program is adequate. It starts off with some step-by-step tutorials. It took me a couple attempts to go through each tutorial to figure out exactly what was intended. Still, the tutorials are a good introduction to get you up and running. A feature-by-feature description of each part of the program occasionally makes reference to terms that I did not find in the printed manual index or in the program's help file.

At first, I was disappointed and expected more from the supplied documentation. A trip to the bookstore and a search of the Internet, however, caused me to soften my criticism. I reminded myself that this isn't a video game; this is a complicated beast requiring much learning. The volumes that cover the subject in more detail cost \$40 to \$75. I realized that to expect a text like that with a \$199 program is unrealistic.

If you are serious about learning SPICE, expect to purchase additional material on the subject. So far, I have invested \$120 in additional textbooks. Maybe someday, there will be a "SPICE for Dummies."

As I looked over the notes I made while preparing this review, I realized that most of my criticisms of B2 Spice was not the SPICE program itself. Where B2 Spice is lacking is the Windows-related part of the program.

The schematic capture section of B2 Spice is usable and functional, but graphically awkward. I come from a graphics background and have paid my

rent drawing schematics. Maybe that is why I am so critical. The schematics generated by B2 Spice are not presentation quality.

For example: You have the option to "show device names." You wish to show 1N4148, with the mnemonic D1. (Or add 50V to C25, $\frac{1}{4}$ W to R1, and so on.) The 1N4148 appears in parentheses after the D1. What you get is a single string of text, "D1 (1N4148)." When you reposition the D1 text, "(1N4148)" moves along with the D1.

This is an option you turn on globally to all components. There is no way to turn off the parentheses. If there is no appropriate device name, the

UPDATE

Since submitting the review, Beige Bag has updated A/D Spice to Version 4.1.2. I updated my version by downloading the free upgrade available on beigebag.com.

I tested the items I specially criticized in my review. Beige Bag nailed it. Printing the schematic is predictable, the graphs display exactly as I specified, zoom works as I want. My criticism of the device mnemonics and ancillary information has been addressed. They are now two independent lines of text that you can place where you like, without parenthesis.

I guess I did a poor job of making my point about the supplied documentation. Jon called it "my big complaint." While there is room for improvement, I was trying to explain why I shouldn't complain. Beige Bag A/D v4 is a tool. I would not expect a 300-page home remodeling book to come with every saw and drill I buy.

The second point I was trying to make is that you will have to do some additional study and obtain additional materials. The same as buying a \$3,000 CAD program doesn't make you an architect, and a 1962 Fender Statocaster won't make you Jimi Hendrix.

Publishing deadlines being what they are, I did not have much time to test beyond my original gripes. I did get some glimpses of new features that are very intriguing. I gave it a strong review in the first place. Beige Bag addressed my complaints in the second place, which amplified my original enthusiasm. Throw in a free trial and the 30% discount Jon mentions, and you have the best deal this side of winning the lottery.—TH

mnemonic has a “()” tagging along behind it. See Fig. 1 for an example.

To improve their schematic capture Beige Bag should: A) Allow the ancillary text to be visible on a component-by-component basis. B) Kill the automatic parentheses. C) Make the ancillary text position independent of the mnemonic.

The zoom is not accurate. A command to “fit circuit into view” does not work exactly correct. Instead of making every part of my schematic visible, some elements appear outside the schematic window. I got into the habit of executing a “zoom to fit circuit” command, then a zoom out a bit to see the missing part of the schematic. Two steps instead of one.

Printing a schematic is not smooth. I had to adjust printer settings using trial and error. The print preview did not always accurately show what will be printed. To produce a more professional drawing, I used a different graphics program to draw and print border/title block. I made a second pass through the printer to print the schematic.

The save file command does not always work correctly. Sometimes to save the file, I needed to put a resistor into the drawing and then immediately delete it. Then I could save the file.

The program can generate many different types of graphs. Supposedly you can control the color scheme of the graphs as they are displayed on your monitor. The default is white background and various colors for different plots. My preference is a black background.

Every time I changed the default, I got into trouble. At one point, the program started plotting black plots on a black background. Eventually, I resigned myself to living with a white background on my graphs.

I do not want to complain too much. These things fall under the category of annoyances. The excellent value of B2 Spice A/D v4 makes up for the little bits that could be better. It reminds me of an amplifier that has poor cosmetics, but sounds fantastic and costs less than everything else in town.

Beige Bag has only three employees. They put their effort into making a

product that is a great value. I am willing to overlook some of these problems to get my hands on this very useful product. If you are looking for a design tool/aid such as a SPICE program, do yourself a favor and take advantage of Beige Bag Spice A/D v4.

Manufacturer's Response:

Regarding the specific problems in the schematics and graph appearance, we fixed up some of these problems in our 2001 year-end revision. We fixed the Zoom to Fit feature, and the black graph background feature, for example. Regarding the appearance of the parts in the schematic, the user can modify the parts in the schematic to show the mnemonic and device name in separate fields. All symbols can be fully customized and even stored back to the database. This was not well documented in the user manual when Tom reviewed the product, but we are taking steps to remedy this in our documentation. Also, we will change the symbols in the database to separate those two fields.

Tom's big complaint is that B2 Spice

A/D v4 is difficult for novices to get a grasp of. In the past, we spent a lot of energy working on the flexibility and power of this product. For example, we added monte-carlo complete with histograms for displaying results, and high-frequency models and two-port simulation capabilities. I agree with Tom that circuit simulators are challenging for new users and it's time to focus on solving this problem. I am already working with an audio electronics expert to add help, possibly in the form of wizards, for users to design and test their circuits. I'm planning to release a new, more novice-friendly version in early 2003.

This is a live product, and we regularly release free patches to our customers with small improvements and fixes to known bugs.

In the meantime, please try out our free 30 day, full-featured trial and let us know what you think of the program. And mention this review to get 30% off the retail price when you decide to purchase the program.

*Jon Engelbert
President
Beige Bag Software*

FREE SAMPLE

*IF YOU BUY,
SELL, OR COLLECT
OLD RADIOS, YOU NEED...*



ANTIQUE RADIO CLASSIFIED

Antique Radio's Largest Monthly Magazine
100 Page Issues!
Classifieds - Ads for Parts & Services - Articles
Auction Prices - Meet & Flea Market Info. Also: Early TV, Art Deco,
Audio, Ham Equip., Books, Telegraph, 40's & 50's Radios & More...
Free 20-word ad each month for subscribers.

Subscriptions: \$19.95 for 6-month trial.
\$39.49 for 1 year (\$57.95 for 1st Class Mail).
Call or write for foreign rates.

Collector's Price Guide books by Bunis:

Antique Radios, 4th Ed. 8500 prices, 400 color photos	\$18.95
Transistor Radios, 2nd Ed. 2900 prices, 375 color photos	\$16.95

Payment required with order. Add \$3.00 per book order for shipping. In Mass. add 5% tax.



A.R.C., P.O. Box 802-A16, Carlisle, MA 01741
Phone: (978) 371-0512 — Fax: (978) 371-7129



Web: www.antiqueradio.com — E-mail: ARC@antiqueradio.com

Software Review

Cara[®] 2.0 Computer-Aided Room Acoustics Software

Reviewed by Richard Honeycutt

ELAC Technische Software GmbH, Rendsburger Landstr. 215, D-24113 Kiel, Germany, +49 431 680779, FAX +49 431 682101, e-mail: tho@cara.de, www.cara.de. Also available from Old Colony Sound Lab (PO Box 876, Peterborough, NH 03458, 888-924-9465, Fax 603-924-9467, custserv@audioXpress.com, www.audioXpress.com

Cara is produced by ELAC Technische Software GMBH of Kiel, Germany. The program provides a number of calculations to assist the home user in optimizing speaker locations and room acoustical treatment. The results are displayed in three ways: as numerical values where appropriate, as 2-D graphs (frequency response, reverberation decay), and as 3-D plots. The program retails for \$49.95.

Cara is made up of five major modules (Table 1).

CARACAD

Inputting the room design using CaraCAD is intuitive in most respects. You begin by selecting the loudspeaker configuration (stereo, quad, surround, or PA), then enter the room dimensions; select the materials for the walls, ceiling, and floor; identify the listener position; choose your loudspeakers from the database; and define the loudspeaker positions. Optionally, you can model large pieces of furniture and non-rectilinear room features such as sloped walls, and you can describe locations where boundary material changes (windows, and so on).

If your room uses materials not listed in the materials database, and you know the acoustical absorption of those materials at various frequencies, you can add these to the database. Also, if your loudspeaker system is not included in the speaker database, you can add it.

CaraCAD provides five views of your room: floor, walls (you can select which

one), ceiling, speaker and listener, and room. The speaker and listener view is just the floor-plan view with the speakers and listeners added. The room view is a 3-D view from the listener position that allows you to select the viewing angle. Figures 1 and 2 show the floor view and a wall view. Figure 3 shows the 3-D room view.

CARACALC

After entering your room design, you select Caracalc either from the Windows start menu or from within CaraCAD using the file-calculate menu. You can choose sound field calculation or positional optimization. Before beginning the actual calculation, you can choose various calculating parameters; the help tutorials tell you how to do this, and what the effect will be. For example, the number of reflections you calculate strongly affects calculation time.

When the calculations are complete, you can choose displays of whatever results you desire. Figures 4-10 show calculation results.

The frequency response shown in Fig. 4 illustrates the direct sound (quasi-anechoic response of the speaker), the first wavefront (including the effect of early reflections from objects so near the speaker that they are acoustically part of the speaker), and total sound energy including the effect of all reflections cal-

culated. Figure 5 shows the frequency dependence of the overall acoustical absorption in the room; the reverberation time calculated by the Sabine, Norris-Eyring, and Kuttruff equations; as well as the results of a proprietary calculation called Cara T-10.

The sound map in Fig. 6 is one of many calculated at closely-spaced frequencies. You can watch as the room response is swept through the frequency range by means of a built-in animation routine. You can also display the total SPL map (Fig. 7) with animation so you can watch the buildup of sound with time. The Dirac function input signal possesses a flat frequency spectrum.

The display in Fig. 8 is called "location." Actually, it attempts to depict errors in localization as a function of listener position. It is expressed as a percentage that is roughly proportional to the square root of the angle of localization error, with a 2° error being represented as 20%.

"Coloration" (Fig. 9) is the RMS deviation of the actual frequency response from the target function (usually the direct wave from the speaker), with the individual deviations that make up the average sampled at 1/8-octave spacing from 30 to 16,000Hz (or as selected by the user). It is expressed as a percentage, apparently calculated as follows:

Figure 10 displays what is called

**TABLE 1
CARA MODULES**

MODULE NAME	FUNCTION
CaraCAD	<ul style="list-style-type: none">• Create room drawings including internal objects• Select or create loudspeaker model• Select material properties of boundaries and internal objects• Customize material properties if necessary• Identify listener location
CaraCAD Help	<ul style="list-style-type: none">• Provides both a generalized on-line Help Document and context-sensitive Help for CaraCAD.
Caracalc	<ul style="list-style-type: none">• Performs sound-field calculations, including the effect of a user-selectable number of reflections• Performs reverberation calculations• Performs a number of room-acoustics calculations• Coordinates the display of calculation results
Caracalc Help	<ul style="list-style-type: none">• Provides both a generalized on-line Help Document and context-sensitive Help for Caracalc.
3-D Setup	<ul style="list-style-type: none">• Permits activation of a number of bug fixes specific to certain video cards and video acceleration strategies.

speech intelligibility. For those of us outside Europe, it requires some elucidation. In Europe, intelligibility is stated by relation to figures called clearness and clarity. These figures quantify the ratio of sound occurring in the first 50 or 80ms, respectively, to that occurring later. The result is a sort of signal-to-noise ratio expressed in dB. Caracal displays this data as a percentage, in which 0dB is displayed as 20%, -5dB as 30%, and -10dB as 50%. The data is then called "intelligibility."

The final 3-D display that is available is the weighted average of coloration, location, and intelligibility, to yield a

sort of figure of merit for sound quality at each position in the room.

COMMENTS

There are many positive attributes of Cara. Room data is easy to input, and even custom loudspeaker units are not difficult. The CD liner gives a good summary of the program's capabilities, and gets you started on the right foot in installing the program. Although there is no printed manual, the online help files are very well-done. With the exception of an occasional head-scratcher, the English help files are quite clear—remember that this is a German company.

The program can handle rooms up to 100 × 100m, which could give it some application for sound professionals who do not choose to spend the many hundreds required to obtain EASE or CATT. The range of calculations performed is really quite extensive. All this in a \$50 package is well-nigh incredible.

With any calculations of this type, processor time is likely to be quite long. The room shown in *Fig. 1* required a calculation time of 1 hour, 20 minutes for a 300MHz computer running Windows 95. On the same computer, the positional optimization required 5 hours, 33 minutes. This is not a fault of the program, simply a result of the enormity of the calculation job. Thirty years ago, calculations like these were seldom even attempted on supercomputers because of the long times required.

However, no product is perfect. Here are the quibbles I found with the design and operation of the program.

1. Off the top of my head, I'd say that the most popular brands of speakers in the US include Technics, Klipsch, JBL, Boston Acoustics, Advent, Acoustic Re-

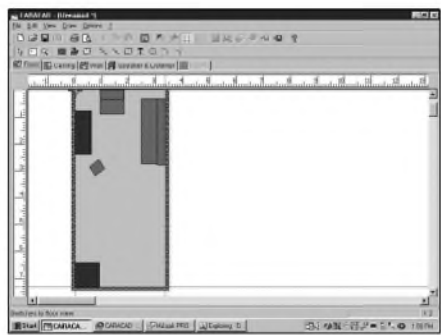

FIGURE 1: Floor view.

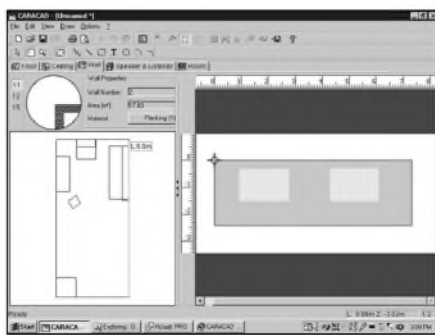

FIGURE 2: Wall view.

COMPONENTS:

SOLEN HEPTA-LITZ AND STANDARD INDUCTORS AND CAPACITORS - THE CHOICE OF MANY HIGH-END SPEAKER MANUFACTURERS.

HARDWARE:

POWER RESISTORS, L-PADS, CABLE, ABSORBING AND DAMPING MATERIALS, GOLD SPEAKER TERMINALS, GOLD BANANA PLUGS AND BINDING POSTS, GRILL FASTENERS, PORT TUBES AND TRIM RINGS, PAN HEAD SCREWS, SPIKES AND TEE NUTS WITH ALLEN HEAD BOLTS AND PLENTY MORE...



Solen crossover components - used by the most discriminating loudspeaker manufacturers.



SOLEN HEPTA-LITZ INDUCTORS

Air Cored Inductors, Litz-Wire Perfect Lay Hexagonal Winding
Values from .10 mH to 30 mH
Wire Size from 1.3 mm (16AWG) to 2.6 mm (10 AWG) 7 Strands



SOLEN FAST CAPACITORS

Fast Capacitors, Metalized Polypropylene
Values from 0.10 µF to 330 µF
Voltage Rating: 630, 400, 250 VDC



SOLEN STANDARD INDUCTORS

Air Cored Inductors, Solid Wire Perfect Lay Hexagonal Winding
Values from .10 mH to 30mH
Wire Size from 0.8 mm (20AWG) to 2.6 mm (10 AWG)

CROSSOVER AND SPEAKER PARTS

Metalized Polyester Capacitors, 1.0 µF to 47 µF, 160 VDC, Non Polar Electrolytic Capacitor, 22 µF to 330 µF, 100 VDC, Power Resistors 10 W, 1.0 Ω to 82 Ω, 8 Ω L-Pads plus all the hardware and supplies to complete any speaker project.

ORDER THE FREE SOLEN CATALOG AND CD.

FORWARD YOUR REQUEST BY PHONE, FAX, MAIL OR EMAIL - OR FILL IN THE ONLINE REQUEST FORM AT SOLEN.CA.



SOLEN INC.

4470 Avenue Thibault
St-Hubert, QC J3Y 7T9
Canada

Tel: 450.656.2759

Fax: 450.443.4949

Email: solen@solen.ca

WEB: <http://www.solen.ca>

search, Yamaha, Cerwin-Vega, Bose, and a few others. Of these, the Cara database includes JBL, although there are many European brands. This is certainly understandable, and will no doubt be rectified as more manufacturers submit data. But for now, it's inconvenient for us Yanks.

2. Even though the program includes PA speakers as a configuration option, there are no professional speaker systems in the database.

3. When you enter data for custom speakers, horns are not an option. This is important, since the directional characteristics of a 3" round horn will be very different from those of a 3" round cone speaker; the latter will beam much worse at very high frequencies.

4. The materials menu does not include any of the popular materials used for suspended ceilings. Again, you can input these, but how many users have access to the necessary data? In many rooms this is the single largest sound absorber, and errors in the material specification can therefore seriously impair the accuracy of the results.

5. You must enter the dimensions in centimeters. A simple routine to convert from feet and inches would simplify life greatly for us Yanks.

6. One of the room dimensions to be entered is "wall thickness." I assumed that this is the thickness of the wall as-

sembly, not of the wallboard, but the program was not clear on this point.

7. The first time you position a loudspeaker, you get a dot connected to what turns out to be an arrow. I finally figured out that this represented the center of the speaker and the direction of radiation, but nowhere was I told that this was the case. I really expected to see a block the size of the footprint of the speaker, since I had entered the dimensions of the box.

8. The vented-box option on the loudspeaker editor refused to work without data in the "Dist. from Ref. Edge" box, but that box was grayed out and would not accept data.

9. On this side of the world, intelligibility is stated in %ALCONS, which means percentage articulation loss of consonants. The idea is that if a good talker pronounces a list of carefully-selected words at the front of the room, and a good listener writes down what (s)he hears, some of the consonants will inevitably be misunderstood. The percentage of such misunderstood consonants is inversely correlated with the intelligibility. Thanks to the work of M. A. Peutz, this measure can be predicted from the room information.

When you see intelligibility expressed as a percentage, you think %ALCONS. Ideally, I would like to see Cara present %ALCONS. But as a mini-

mum, since Cara uses a signal-to-noise ratio to quantify intelligibility, it would be clearer to express the results in dB. (The results of localization error and coloration also do not seem ideally suited to expression in percentage.)

Now, how about the accuracy? *Figure 11* shows the predicted frequency re-

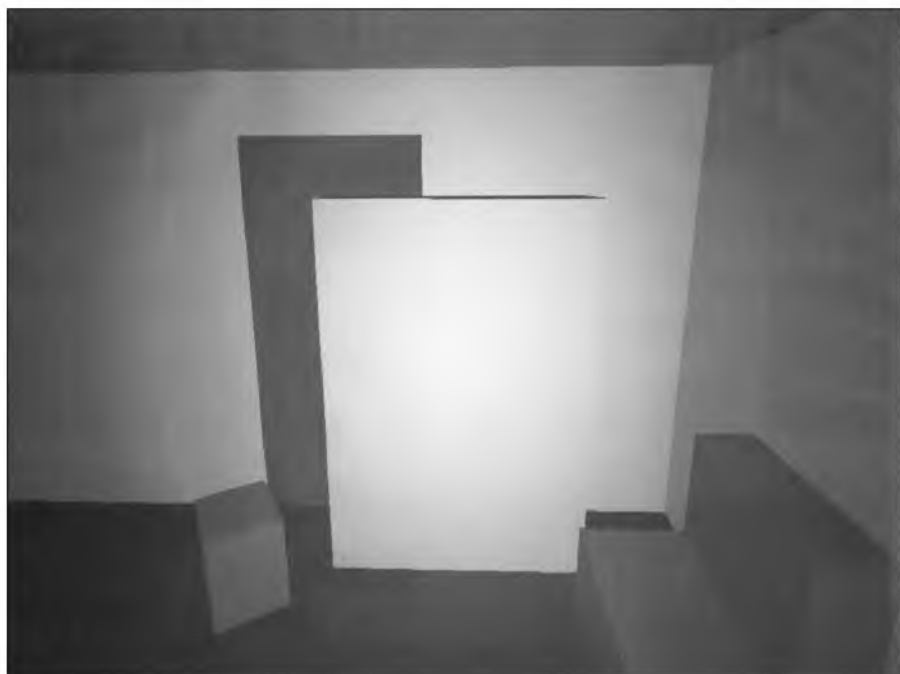

FIGURE 3: Room view.

B-2082-3

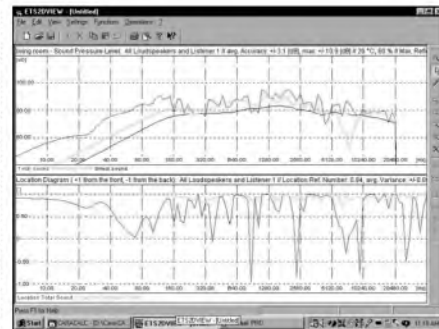

FIGURE 4: Frequency response.

B-2082-4

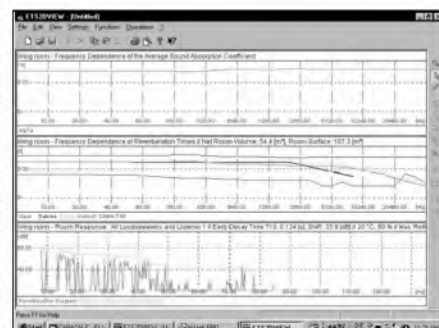

FIGURE 5: Reverberation.

B-2082-5

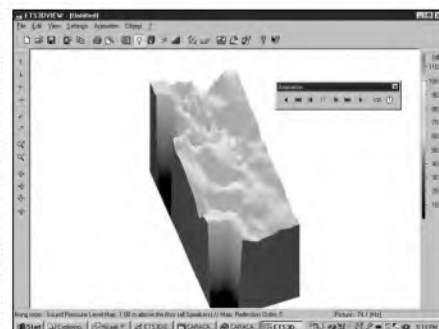

FIGURE 6: Sound map at 74.1 Hz.

B-2082-6

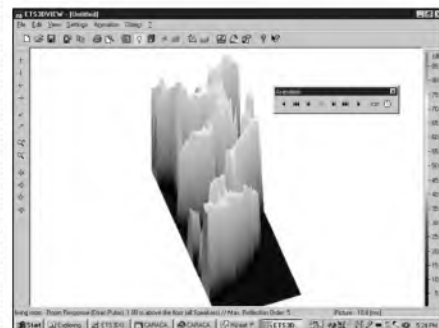

FIGURE 7: Sound map in response to a step function after 10.8ms.

B-2082-7

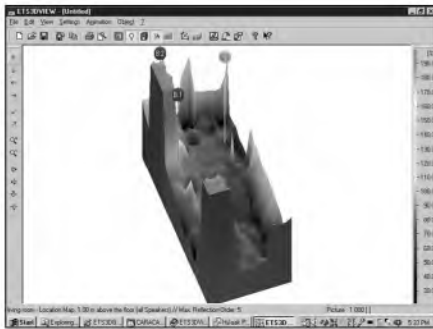

FIGURE 8: "Location."

B-2082-8

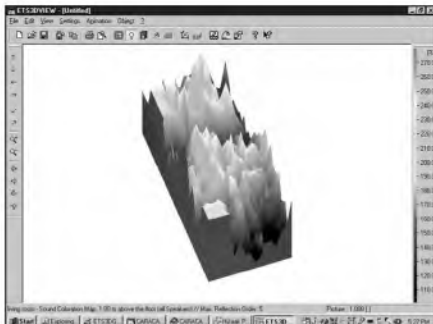

FIGURE 9: "Coloration."

B-2082-9

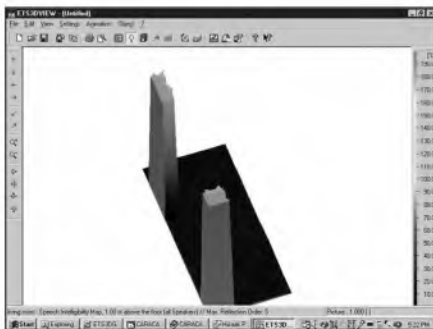

FIGURE 10: "Intelligibility."

B-2082-10

sponse at the specified listening location compared with the $\frac{1}{3}$ -octave measured response using pink noise and a 5-second integration time. (Of course, the Cara predictions are much more detailed than the $\frac{1}{3}$ -octave measurements.)

The difference in low-frequency response is a result of not having carefully modeled my subwoofer. Note, though, that the general shape of the hump centered about 100Hz was correctly predicted, as was the general shape of the hump around 2.5kHz. Since the system is equalized for flat quasi-anechoic response, the curves in the response are the result of room interactions, which on the whole Cara seems to have modeled correctly.

As you may have noticed from Fig. 5, there was significant uncertainty in the predicted reverberation time of the room, but Cara seemed to think it was around 0.2 to 0.3 seconds. Actual measurements using Liberty Audiosuite indicated a reverb time of almost 0.6 seconds. I suspect that the errors came

from two sources.

First, the equations for predicting reverb time assume uniform energy distribution in the reverberant field. In a small or highly-absorbent room, this condition may well not be met.

Second, my inability to find a material in the Cara database corresponding to my actual ceiling material probably resulted in the use of incorrect absorption figures for the ceiling.

Neither of these is properly a fault in Cara, since it is always the responsibility of the user to know the limits of accuracy of any model, computerized or not; and since I could have obtained the actual absorption figures from the Celotex Corp.'s website in order to model more accurately. But these results do emphasize once again the principle of GIGO!

SUMMARY

In summary, Cara is an outstanding software bargain. It has a few small bugs and a few more places where in my not-so-humble opinion there is

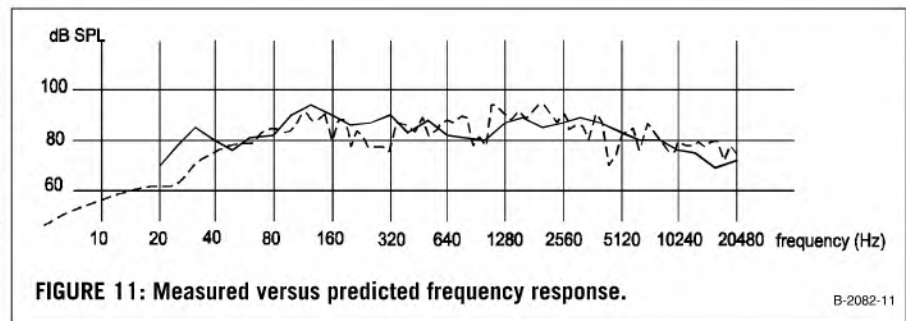

FIGURE 11: Measured versus predicted frequency response.

B-2082-11



ZALYTRON

**YOUR ONE STOP SPEAKER
AND SPEAKER COMPONENTS CENTER**

**Check our web site www.zalytron.com
for cutting edge technology in the
Speaker Industry. Need we say more?**

Call, Write, Fax or email for our latest catalog
Mailed FREE in the USA. Canada \$5 P&H, Worldwide \$10 P&H

ZALYTRON INDUSTRIES CORP.
469 JERICHO TURNPIKE, MINEOLA, N.Y. 11501
TEL. (516) 747-3515 • FAX (516) 294-1943
www.zalytron.com • email zalytron@juno.com

Our warehouse is open for pick-up 10 AM to 6 PM daily, Saturday 10 AM to 5 PM • UPS orders shipped same day • Minimum order \$50.00

room for improvement, but on the whole it performs outstandingly well for home applications, and could be used for limited professional work. If you're interested in this sort of program, I'd say look no further.

Product Review

Cara® Test Disk

Reviewed by Richard Honeycutt

I still have my first test disk. It was produced by CBS Labs and contains calibrated tones covering the audio range. There was also a silent track. The disk is about 12" in diameter. Yep, it's vinyl. Cost about \$60 in the late 1960s! My Sony reel-to-reel test tape was less expensive, but it also had far fewer tones on it.

I also have several test cassettes in the lab. Unlike the CBS test disk, whose tones were recorded with better than a ± 0.1 dB level tolerance, the cassettes disagreed with each other by several dB. Setting playback and record EQ was something of a challenge. Of course, these test tapes cost about \$10 apiece in the early '80s. In the immortal words of Mike Klasco, "A bent ruler is always cheaper."

I am now a proud owner of three test CDs. With the extreme accuracy available in the CD production process, you would expect a test CD to be extremely accurate. Not so, my friend. In spite of the fact that the costs would support the production of a precision product, tests made with my first two test CDs disagree with each other. So when I was asked to review this test CD, I only had two questions: what test signals are available, and how accurately are they recorded?

A TEST CD FOR ROOM ACOUSTICS

Now bear in mind that the Cara test CD is designed specifically for room acoustics. Room modes or resonances are very sparse at low frequencies, but as the frequency rises, two things happen.

First, the modes become closer together. Second, the acoustical absorption of the room usually increases, so

that the modes have lower Q, meaning that each mode affects a broader range of frequencies, and that the peak effect of the mode is less pronounced. Thus, in a typical room above a couple hundred Hz, the modal response has become so dense that the room response is essentially flat. So a test CD for room response does not need to have test signals at frequencies above about 200Hz.

The Cara test CD has 28 sine-wave tones ranging from 16 to 201Hz, 28 $\frac{1}{3}$ -octave noise signals with center frequencies ranging from 15 to 201Hz, a track of 150-1,000Hz bandlimited pink noise, a track of 20-1000Hz bandlimited pink noise that is recorded with the channels alternately in- and out-of-phase, and a track of 20-20,000Hz bandlimited pink noise.

The purpose of the sine waves and narrowband noise signals is to help you identify modes in a listening room. The CD liner thoughtfully advises the user to remove small pets from the vicinity before making these tests in order to avoid their interpreting the low-frequency sounds as a major thunderstorm and thus taking up permanent residence in an inaccessible corner, and/or "losing it" (pet owners will understand the euphemism).

You begin with sine-wave tests using either your ears or an accurate sound-level meter. Please note that ears are really not flat below 200Hz, and many sound level meters may not be either. In fact, many sound level meters are not even specified below 50Hz. But since what you're looking for are frequencies that "stick out," you can find these even with limited instruments. In my case, at 125Hz I found a really high-Q buzz in the wall near my subwoofer.

Next, repeat the tests using the noise signals. These more nearly simulate musical signals, since even with precise instruments such as synthesizers, pure tones are rare; usually there is some natural or artificial vibrato or other pitch wandering. *Figure 1* shows a graph of the sine and narrowband noise tests in my living room.

Having located problem frequencies, you can experiment with moving the speakers, the prime listener location, or both. In extreme cases, you can consider installing bass traps or other acousti-

cal solutions.

The 150-1000Hz noise test is to help you locate coloration in your sound. This will be apparent if the noise seems to have a pitch. Pure pink noise sounds like a muffled air-rush noise, and has no associated pitch. If in doubt, ask a good musician to match the pitch of the noise. If (s)he can't do it, coloration is not a problem.

The 20-1,000Hz noise test is to help you locate out-of-phase speakers. Low-frequency left and right signals in phase add, and they sound as though they are coming from the center, between the speakers. If the signals are out of phase, they will cancel and sound weaker, and will give the impression of the source being inside your head. (OK, I know, your friends have been saying for years that there must be *something* inside your head . . .)

The final noise band can be used with a real-time analyzer to check the frequency response of your system, including room effects. The results of such a test must be interpreted with care, because the ear/brain system is extremely complex. If you think about it, you'll realize that you can recognize the voice of a friend outside, in a living room, in a gym, or even in a bathroom. The ear/brain system is quite good at separating the sound of the real signal from the sound of the room.

When you use a pink-noise test, the analyzer must use some form of averaging in order for the level to hold still long enough to be read. The averaging time used by the ear for "direct" sound is on the order of 10-15ms. In order to read a pink noise level, you must average over something like two seconds or more. And even if you could read the instant-

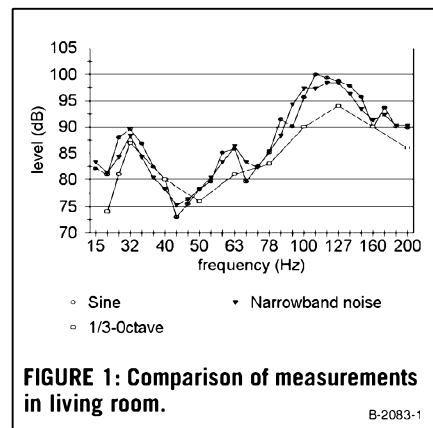

FIGURE 1: Comparison of measurements in living room.

B-2083-1

neous pink-noise level, it would be meaningless, since pink noise is a random signal, and therefore its instantaneous level can be literally anything between the noise floor and the peak recorded level. So you must average in order to get a flat spectrum with pink noise.

Thus there are two problems in listening rooms. (OK, there are a lot more than two, but I will discuss only two.) First, there is the accuracy of the signal your speakers are feeding into the room. You can adjust this with tone controls and/or a graphic equalizer, and also you can affect it by speaker position, since reflections that occur within a few milliseconds of the original sound are acoustically indistinguishable from the direct sound itself.

Second, there are the room effects, which you can adjust by moving things: speakers, listeners, chairs, your mother-in-law; or by acoustically treating the room. If you try to fix room effects with EQ, your ears and brain will tell you that both the direct and the reverberant sound are now screwed up.

A pink-noise test lumps all these effects together. This means that you need to listen carefully as you adjust positions and controls: A speaker with a dip in the response centered around 800Hz (as many have) will sound unnatural no matter where you put it, but can be helped by equalization. A room hump at 150Hz will stay there no matter what you do with the EQ, but you can cut the bass

control and have it sound both thin and 150Hz-humpy. The unnatural sound that you have likely noticed in many churches and auditoria may result from improper use of pink noise and a real-time analyzer to adjust equalizers.

COMMENTS

But now back to the Cara test CD. How accurate is it? I used Cool Edit® to check the actual tracks without results being skewed by a digital/analog converter and analog electronics. The sine waves are recorded as nearly equal in level as I can read. The levels of the narrowband noise tracks are equal within ± 0.07 dB, an outstanding result. (I used Average RMS and Total RMS analysis to check these levels.)

The pink-noise bands are flat within the limits of measurement of my equipment (± 1 dB), except that the 20Hz and 20kHz bands read about 4dB low, and a dB or two of this may be my equipment error at those frequency extremes. So the quality and accuracy of the test signals is excellent.

Since the Cara test CD is designed for room acoustics measurements, and not for subjective assessment, it does not include music tracks; you'll need to buy other test CDs for those. However, it does what it is designed to do, and does it extremely well. For \$19.95, you can't go wrong with it.

The Cara Test CD for Room Acoustics is produced by ELAC Technische Soft-

ware GMBH of Kiel, Germany. Also available from Old Colony Sound Lab.

Manufacturer's Response:

The reader should know that CaraCAD's 3-D view enables the user to (virtually) view his room in any direction and to walk around in his room, much like you see in many computer games.

Referring to the reviewer's numbered comments (p. 49):

4. There are many materials used for suspended ceilings contained in the material database (wooden panels or plaster boards). What is missing are suspended ceilings with relatively large distances (larger than 2-3") to the real ceiling. I would be happy to find some in the respective data tables.

5. The new release CARA 2.1 PLUS (published in January 2002) provides for many new functions (e.g., auralization). One of these enables the user to enter dimensions in inches, feet, or yards.

7. I am not sure if I understand the described problem of the visualization of the loudspeaker "footprint." Of course, the "footprint" should be displayed; however, we know of some problems arising in certain graphic cards when textures are displayed. These problems seldom occur, but it appears that the reviewer had those problems.

8. The reviewer wrote that he could not enter the value for the "Dist. from Ref. Edge" in the case of a vented box. This box (edit control) is only grayed out if, for example, the size of the selected driver is too

thetubestore.com

Your online source for name brand audio tubes

- Over 1000 types available online
- Perfect Pair matched power tubes
- Capacitors and sockets

Order online at **thetubestore.com**

or call toll free **1-877-570-0979**



large with respect to the size of the cabinet wall being selected. We are very interested in getting some feedback about this issue because none of our users ever had this problem and we cannot reproduce this "bug."

9. Cara uses many different so-called "Reference Numbers" to describe the attributes of a sound field (e.g., Location Ref Number, Signal to Noise Ref Number (SNR), Lateral Sound Level, Rev Time). All of these Reference Numbers are given in well-known units; e.g., the SNR is given in dB. If the user brings up the resulting property sheet dialog boxes, those Reference Numbers are displayed on the tab "Ref Number."

In addition to these Reference Numbers, Cara defines so-called Quality Reference Numbers (QRFN) as a percentage. These QRFNs describe the "quality" of the sound field (at the listening position) on a somewhat unified scale (% scale from 0–100%, and more). These percentage values describe the deviation of a certain Reference Number with respect to a "perfect" value; e.g., SNR = 0dB (excellent) corresponds to a 20% deviation.

We did this kind of projection of physical units (e.g., dBs) on the % values in order to compare on a unified scaling the "quality"

of SNR with the quality of Stereophonic Localization and with the quality of Sound Coloration (peaks and dips in the SPL frequency response), and finally to come up with one single (averaged and weighted) Quality Reference Number combining several room acoustic aspects of the total sound field. This is one of the basics for the automatic positional optimization procedure. These % values are displayed in the resulting property sheets on the tab "Quality," together with the weighted averaged values. They are also used in the 3-D results presentations to provide for a common scaling, as well as their averaged values.

I know that this procedure is somewhat unique or strange. But implementing a sophisticated optimization procedure—taking into account SNR, Location, and Sound Coloration for each single loudspeaker, for loudspeaker groups, and finally for the total loudspeaker configuration—requires the use of a unified or harmonized scaling system.

Finally, with regard to the comparison of simulated and measured reverberation times: Increasing the parameter "Maximum Reflection Order" in Cara increases (unfortunately) calculating times considerably, but also in-

creases the accuracy of Rev. Time results. The most interesting point in this field, however, is—I first learned this from Cara—that the Rev. Times (the real as well as the simulated ones) are noticeably dependent on the 3-D dispersion characteristics of sound radiation of different loudspeakers. Front-firing speakers produce less reverberation than omnidirectional loudspeakers. This is more noticeable as the frequency increases.

The strangest effect is produced by large flat-panel speakers in which the distance dependence of the SPL at mid and high frequencies no longer follows the $1/r$ law. For large distances to the loudspeaker (e.g., sound waves being reflected several times at the room walls), the elementary sound waves being produced at the border of the panel and those in the center of the panel are more and more in phase, producing an increasing SPL with increasing distance (correcting the $1/r$ decrease). The result is longer Rev. Times at midrange, and especially at high frequencies, when using large-panel dipole radiating loudspeakers. ❖

Dr. U.F. Thomanek
ELAC Technische Software GmbH

audioXpress

The monthly magazine for the audio DIY enthusiast



Advertise your products to over 15,000 active audio constructors! It's a cost-effective, one-stop way to reach consumers.

To discuss advertising opportunities in *audioXpress* contact Peter Wostrel

Phone: 978-281-7708 • Fax: 978-283-4372 • E-mail: peterw1@gis.net

Xpress Mail

VOTE OF CONFIDENCE

After reading through my first few issues of your magazine, I have a couple of comments to make. I find the content very informative, but I'm thinking that there's something missing for the "newbies."

For example, in your Jan. issue, there's an article on the push-pull and SET tube amp ("A Beginner's Push-Pull or Single-Ended Amp," p. 24). I'm quite sure that this amp is a monoblock and is not stereo, but this isn't mentioned at all. Nor is the fact that it would require a volume control. There's no perspective picture of the amp, only a couple of overhead photos. It would be nice to have a photo beside the title of the article!

These are minor shortcomings, but I think that these should be foreseen, depending on what type of audience you're trying to cater to. Perhaps you're looking for a more advanced beginner than I think you are looking for.

My next point could alleviate this issue a bit. I think a way to get more traffic through your website (which would be positive for business) is to add on-line forums. There is good forum software out there, and a very popular one is the Ultimate Bulletin Board. Regardless of the software used (it should be of a certain level of quality), I think that this would be a good opportunity for sharing among people with questions or who have tried some ideas, furthering the knowledge base out there, which I think is what you are all about in the first place.

For instance, one thing that I've thought about regarding the infinite box project (p. 8) is that the bass exiting from the rear of the box, for the most part, is not in phase with the sound coming from the front of the speaker. As the frequency increases, it becomes more in phase. Unfortunately, this bass-boosting is not in the frequency zone that I would like to see it (>100Hz), and further, as it becomes more in phase, the high-frequency attenuation becomes a factor. My understanding of a transmission line, for example, is that

the sound from the terminus is in phase where the bass matters most—at the low end. I can see some of the potential in the design, but it'd be interesting to talk to others in the industry who may be more knowledgeable than I am about some of these things.

The next item is your back issues. I was very pleased to see you offer your 2001 back issues on CD. I'm assuming that files are in PDF, which is an amazing format that we often take for granted in everyday use. Why not put your back issues that are out of stock onto CD? What about *all* the back issues? I'm sure that the paper that you have in your inventory would still be purchased by those not interested in electronic media. But for those who are researching a particular concept, if you had a number of years worth of articles on a single CD, the searching capabilities could be quite incredible.

I'll step off my soapbox for now, but thanks for the great periodicals!

Brendon Cook
Calgary, AB Canada

audioXpress will offer more of its back issues—in PDF format—in the future.—Eds.

PANEL PROPOSALS

I read the article entitled "Panel Damping Studies" (Feb. 2002, p. 12) and would like to thank you for doing such a great job and sharing it. Would you consider doing a few more panels of a slightly different construction?

I would like to suggest an idea that has been in the back of my mind for too many years to recall. This is a design of a panel that has a $\frac{3}{4}$ " layer of MDF with a second $\frac{1}{2}$ " (or $\frac{5}{8}$ ") layer of MDF spaced off the first layer by a $\frac{1}{4}$ " thick by $\frac{1}{2}$ " wide MDF spacer extending around the periphery of the panel. After laminating these two layers together, you drill a small hole through the center of the $\frac{1}{2}$ " thick side, inject some white glue into the hole, and then use a wood screw or a bolt and nut to draw

the two panels together. Once the glue has set, you should have a $\frac{3}{4}$ " panel with a concave $\frac{1}{2}$ " constraining layer.

Next drill a small hole in the $\frac{1}{4}$ " spacer and fill the gap between the two panels with sand to damp out any remaining panel resonance. The $\frac{1}{2}$ " layer, once forced into a concave shape, should become very stiff due to one side of it being under tension and the opposite side being under compression. It would also be interesting to measure the panel first without the sand and then with the sand. This kind of panel would best be used with the concave side toward the outside of the box so that you could incorporate an interior brace inside the box cavity on the flat (you hope) $\frac{3}{4}$ " panel.

Thanks again for such a useful study. I do hope that constructors take note of all your efforts and rethink many of the time- and performance-wasting but popular construction techniques. This arti-

JFETS

ULTRA LOW NOISE
LS843 - 3nV/Hz typ

TIGHT MATCHING
LS843 - 1 mV max

- ◆ N & P Channel
- ◆ Duals & Singles
- ◆ Custom Screening
- ◆ Die, SMT, Thru-Hole
- ◆ No Order Minimum
- ◆ COD's Accepted

Second Source for Domestic
& Foreign JFETs & Bipolars

Full Service U.S. Manufacturer
of Specialty Linear Products

LINEAR SYSTEMS

4042 Clipper Court
Fremont, CA 94538
510-490-9160/510-353-0261 (Fax)
E-mail: 3623671@MCI.MAIL.COM
WWW.LINEARSYSTEMS.COM

cle of yours should be renamed "The Poogeing of The Box."

Moray James Campbell
Calgary, AB Canada

James Moriyasu responds:

Glad you found the article to be to your liking. Sharing the information is just another way of contributing to the body of knowledge. I also do fine woodworking, as a hobby, and find it interesting that most of the tried-and-true methods (of fine woodworking) have evolved over the last hundred years and have been proven to be effective.

By comparison, it seems that loudspeaker cabinet construction techniques are still evolving and are not yet as refined. For example, I now use brass-threaded inserts and black oxide stainless-steel machine screws to attach drivers, whereas, until a few months ago, I used wood screws. And I prefer to fabricate driver gaskets with 1/2" cork-neoprene instead of using foam tape.

Recently I purchased a vacuum press, which is used by fine woodworkers for veneering, and have been laminating 1/2" nine-ply Baltic birch panels with soft glue. I prefer to use the constrained layer damped sandwich instead of MDF. So, it is my hope that the information in the article is used by hobbyists to develop better cabinet-making practices.

Your idea sounds attractive, if not labor intensive. Since it resembles a braced panel and has a layer of sand, I'm sure it will be better than 3/4" MDF. However, it might work better if it were thicker, because a 1/4" layer of sand might not help much. Since it reminds me of a sand-filled panel with bracing and is time consuming to build and bulkier than other approaches, I'm not interested enough to give it a test.

However, I am interested in testing a constrained layer damping panel made of 3/4" MDF, North Creek soft glue, and plastic laminate (like Formica) as the constraining layer. This approach would "kill two birds with one stone" if the soft glue and Formica can effectively serve as the damping layer and the finish material.

Great article regarding panel damping. You certainly did your research and put a lot of work into the project. Thank you for your efforts on our collective behalf.

Since you ended it on a note of being open to suggestions, here goes: Most at-

tempts at damping (with the exception of the SONY speaker you referred to in the article) apply damping materials and schemes to the interior of enclosures. How about plain old rubbery foam attached to the outside of the box? I would love to see the results of such an approach on the panel resonances and CSD (cumulative spectral decay). Granted, aesthetically it would probably leave a lot to be desired; however, a sculpted foam approach could yield some new and innovative forms of box design.

Roy Cizek designed some classic sealed box speakers back in the 1970s-80s. In one of his designs, the front panel was covered by—are you ready?—thin black foam, and it was actually quite attractive.

Since you are already set up for making accelerometer measurements, how about giving this a whirl? I'm sure other readers would be as interested as I in your findings.

Thanks again for a great article.

Angel Rivera
Bradenton, Fla.

Jim Moriyasu responds:

Thanks for taking the time to read the article. I hope it helps you to build better cabinets. I'm sure your idea will help reduce the resonances radiated by cabinet panels; I think it's similar to surrounding the loudspeaker with sound-absorbing panels. However, I don't think attaching an accelerometer to the outside damping panel would work as well as a comparison sound-pressure-level measurement.

LEAKY BOXES

 "The Infinite Box Concept, Part 1" in the Jan. 2002 issue is most welcome. I'm always pleased to see a Koonce effort. And I'm likely premature in writing before Part 2 shows up next month, but I think a little language-policing is called for, and the sooner, the better.

Let's not call these things "infinite boxes." IB is too close to Infinite Baffle, which is an established if seldom seen subgenre of the closed box (or sealed box, or air suspension, or acoustic suspension) type. Mr. Dickason, in the *Loudspeaker Design Cookbook*, makes the useful if maybe arbitrary distinction that Infinite Baffles are CB designs in

which the box lifts the woofer's resonance by an octave or less (i.e., V_{box} is one third or greater V_{AS}). Let this be designated IB.

What to call these designs featuring a resistive aperture? Again, I rely on Dickason, who heads his treatment of such like as "Aperiodic Closed-Box Loudspeakers," describing the salient feature as "provid(ing) a flow resistant path out of the enclosure, converting the sealed box into a resistively leaky closed box."

There it is: Let us all please agree to call these things Leaky Boxes, or LB designs.

The term is descriptive. Unlike "aperiodic," it is not obscure, and arguably more accurate. (So far as I know, "aperiodic" was used by Dynaco to describe its range, the A-25 et al. Maybe it was current in Denmark, but the term was otherwise unknown here. I would also note that the generally forgotten up-market models, the A-35 and A-50, did not leak to the outside world, but into another volume in a divided box.)

Unfortunately, these resistively loaded treatments of the troublesome back wave have a history of befuddling their proponents. E.J. "Ted" Jordan may have been the first to tackle this turbulent beast (See *Audio Anthology, Vol. 4, p. 111*, for a survey of enclosure types from Jordan's pen, including what he calls the "friction loaded enclosure," in 1956). Jordan says an LB built according to his lights will extend a woofer's response well below its natural resonance (!) and that "The optimum port area is considerably less than that of cone piston so radiation from the port may be neglected,"—which seems, ah, unlikely. Jordan later (1963) authored a book, *Loudspeakers*, which I have not read, so maybe he thought better of his analysis of LBs.

And there it languished until David Hafler brought his SEAS-designed and Danish-made units to market in the '60s. After the Dynas died out, the leaky box was again spurned, save for a few spurious designers who offered owners the option of stuffing the ports in their vented box designs. [SEAS, Norway, still manufactures a damped port panel for Aperiodic designs.—Ed.]

The only exceptions are some M B Quart efforts which, if memory serves, had apertures so densely stuffed as to be

indistinguishable from a CB, and some models from I.M. "Bud" Fried. The Fried designs are influenced philosophically by respect for Danish engineering and love for transmission lines (TLs).

Which is altogether proper. The leaky box has more in common with T-lines than anything else; indeed, LBs are probably best regarded as a murky hybrid of the CB and TL. I would go so far as to lump John Cockroft's various diminutive lines (short-, un-, micro-, simp-, et al.) which populated the pages of *Speaker Builder* up through the '90s, into the LB category. Perhaps Mr. Cockroft will offer some thoughts on the Koonce-Wright articles?

At any rate, whatever the history, can we please prevent a lot of confusion and do justice to accuracy by naming these designs, indeed, dubbing them leaky boxes, or LBs?

(While I'm at it, how about adopting a new abbreviation for "crossover"? XO would be a great improvement over "CO," yes? "X" is visually descriptive of what a crossover is all about. And "CO" is an all-too-common prefix, which always brings my eye to a halt when it stands alone in a sentence. "XO" for crossover, please.)

T.D. Yeago
Staunton, VA

G.R. Koonce responds:

I want to thank Mr. Yeago for his interest in our article and his information on others who have meandered down this same road. I was not aware of many of these efforts and will try looking them up.

I agree that our concept seems to fit somewhere between the closed box (CB) and the transmission line (TL). I tend to think of it as a very short, highly-packed TL. Unlike the conventional TL, the IB is aperiodic; i.e., the enclosure itself has no intended resonance in the bass frequency range. What we were trying to document was how this technical functions and how to use it.

Mr. Yeago does not like the name "infinite box" for our concept. I must admit I am responsible for that name. When Bob Wright suggested that we explore this concept, I labeled my folder "Infinite Box" based on my initial erroneous assumption that the concept was the equivalent of placing the driver

in an infinite baffle. As our article explains, this assumption was not true. As work progressed, I could think of no better name and thus stayed with infinite box (IB).

The true definition of infinite baffle is when the driver is mounted in a flat plane that is infinite in both directions! The closest approximation would be when the bare driver is mounted in the wall, and the room behind the wall is big enough it does not change the driver resonance any noticeable amount.

I was aware that a CB raising the driver resonance by very little was sometimes referred to as "infinite baffle." This type enclosure was generally from the "old days" before the development of the current CB concept using a high-compliance woofer. I have always found this confusing, because the true definition of "infinite baffle" has nothing to do with "boxes."

While the IB concept we developed is actually a leaky box as Mr. Yeago points out, I sure don't like the name "leaky box." It makes me think of poor construction practices rather than a design concept. A statement such as "System performance was greatly improved because of the use of a leaky box" might cause reader confusion. Since the concept has been published with the IB name, I will stay with that.

R.O. Wright responds:

I was most gratified that Mr. Yeago found our article of interest. It has always been our main objective to present new and interesting ideas in the world of audio.

Mr. Yeago's questions about functionality and terminology are very well taken. It has long been my wish that the audio nomenclature be standardized. In most scientific communities this function is performed by the various scientific societies and standards organizations (i.e., AES, IEEE, and ANSI) that deal with this discipline. To my knowledge this has not been adequately done in the audio world.

When G.R. Koonce produced the article I thought that the term "infinite box" adequately described the audio concept being presented. I believe it is not within the scope of the article to define audio terms other than those used in the article. I do hope this explains to Mr. Yeago what happened and why. May I wish him happy experimenting.

SAFETY CONCERNS

 In looking at the stuffing guide in Figure 33 on page 56 of Jan. 2002 aX



New! SUPREME Tweeters

Madisound is pleased to introduce new More! High Performance tweeters, the Supreme 110 & Supreme 130. The Supreme tweeters use a combination of innovative features to achieve a new level of excellence.

SUPREME 110
\$253.00 / pair



Features:

- Underhung Voice Coil
- Acuflex™ Coated Soft Dome
- High Sensitivity
- Fast Transient Response
- Flat Neodymium Motor with High Magnetic Power
- Matched Pairs

SUPREME 130
\$335.00 / pair

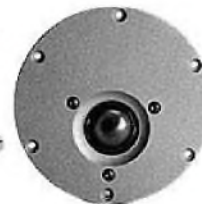

The underhung voice coil configuration and high energy neodymium motor work together to allow the Supreme's voice coil to operate in a significantly stronger magnetic field and to remain in that field at all times during operation.

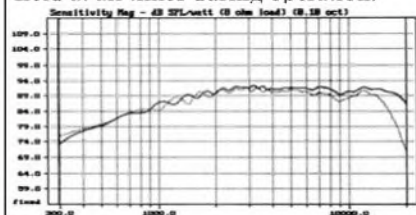

Specifications for 110 & 130:

- Resonant Frequency 650 Hz
- Sensitivity 91.5 dB @ 1W / 1m
- Power 220W 12db@2200Hz
120W 6db@2200Hz
- Flange Ø: 110mm - Supreme 110
130mm - Supreme 130

MADISOUND SPEAKER COMPONENTS, INC.
8608 UNIVERSITY GREEN
P.O. BOX 44283
MADISON, WI 53744-4283 U.S.A.
TEL: 608-831-3433 FAX: 608-831-3771
e-mail: info@madisound.com
Web Page: http://www.madisound.com

(“The Ultra Fidelity Computer System”), it is obvious that there are serious safety issues with the layout of the PC board for this project. The separation between the hot power-line traces and other parts of the board are obviously inadequate. This board, as laid out, is a serious hazard to life and property, and should be built only if you do not populate the AC power-switching corner. I didn’t find the PC board image files on your website; please do not post them in their present form.

The most serious problem is the 0.05” separation between the + end of resistor R1 and the junction of R2 and IC1. It will not take much of a power-line surge at all to jump across this very small gap and connect the surge directly to the attached computer’s +5V supply.

The reason that the two “circuits” of the optoisolator come out on pins on opposite sides is to allow you to get the maximum separation of the two circuits. You want to use the maximum 0.3” separation available. This has been completely violated in the layout of IC1, with many etches from opposite sides running closely together underneath the IC.

Similarly, I expect that the separation of the hot (unfused) AC line terminal and the ground network next to it (about 0.1”) is inadequate as well. A power surge that jumps that gap would have a lot of energy available to start a fire before the circuit breaker for the branch circuit could fire.

I also expect that there are special requirements on the type of PC board materials that UL allows to be used when those PC boards have AC line traces on them. The flammability ratings (such as 94V-0) would have to be appropriate for a board with AC line traces on it.

I also suspect that there should be a surge suppressor (after the fuse) to protect the triac (S1) from AC line surges. This isn’t so much a safety issue as a practicality issue.

After talking to the safety/compliance engineer at my work office, here are more details on the issues with this PC board.

The basic rule for AC wiring is 5000V of isolation from all other circuits, especially DC power buses. On a printed circuit board, this requires 5mm of separation. This circuit board vastly fails that requirement.

Circuit boards bearing any line-powered etch must meet the 94V-0 flameproof specifications, which should be clearly marked in the etch of the circuit board, so that no ethical PC board manufacturer would make it from any other material.

The MOC3021 optocoupler from Motorola is sufficient for this application, is rated for 7500V of isolation, and has all the necessary safety certifications. But, the etch around it must be correctly designed, so as not to degrade the necessary 5mm separation.

Resistors R2 and R3, because they are in a line circuit, must be flameproof; flameproof metal oxide resistors would be suitable. Metal film (as specified) is unsafe and unacceptable.

I see no specification for the rating of the fuse. The correct value should be specified for each line voltage.

The use of a 6A-rated triac at S1 is a strange choice. The triac is really going to serve as an additional fuse when a serious line surge comes in. Since 6A is clearly vastly in excess of the current which will actually be drawn through it, using a 6A triac means that a lot of energy will be inside the triac when it finally explodes during the line surge. It’s much safer to use one that has only a little excess rated current capacity. Less energy will be dissipated in the part, with less risk of starting a fire.

C1 must not merely be mains rated. It should probably have Class X2 safety approvals for “across the line” service. (These are not as stringent as for “line to ground” service.) This has to do with self-healing, and non-combustible construction.

John Shriver
Arlington, Mass.

R. K. Stonjek responds:

The optocoupler switch circuit is basically the same as published in Electronics Australia and is rated at 240V AC. That’s more than twice the line voltage in, say, the USA, and all the prototypes run at this voltage without any problems. The resistors and other components around the switch are the same as for the 240V version.

The snubber network (C1) takes care of switch-on surges. As mentioned, the circuit

works fine at more than double the USA voltage (local voltage in my area is 230 to 250v). Surges under 500V should not be a problem.

A modified PCB layout with greater spacing is now available to address concerns. Those who already have a PCB may consider trimming the + on the input end of R1 for greater clearance.

The two resistors R2 and R3 are metal film, which are capable of handling in excess of 1,000V. There is negligible current in this circuit, so ¼W is more than adequate for the job. You can use flameproof resistors as an added safety feature. Anyone considering supplying this project as a kit should seriously consider such improvements over the original specification.

Fuse should be 1A.

I thank Mr. Shriver for drawing my attention to these points, which have now been addressed.

Charles Hansen responds:

The PC board layout rules I use are based on MIL specs MIL-STD-275, MIL-S-13949, and Industry Spec IPC-CM-770B, Guidelines for Printed Board Component Mounting. Personally, I do not put AC line power on any PC board with other circuitry, preferring to hard-wire the primary power.

In the case of Mr. Stonjek’s amplifier project, which uses an optoisolator and triac, there is no reason not to put AC line side components on the same PC board if proper precautions are taken in the layout.

I fully agree with Mr. Shriver’s comment about the track layout with respect to the optoisolator and the AC line track proximity to the computer input signal. The minimum conductor spacing should be 0.00012 inch/volt. The reader letter recommends 0.3” for 5kV isolation, but 5kV per my referenced standards would require 0.6” separation. (I assume the 5kV recommended in the reader letter is due to the 240V mains used in Mr. Stonjek’s project, so 0.3” would be sufficient for 120V mains.)

In addition, there should be a minimum of 0.06” spacing from PC tracks to any adjacent metal-mounting hardware, or to the edge of the PC board.

I am also concerned with the method used to connect the AC active and transformer primary to the PC board. There is no through-hole that would provide a good mechanical connection. It appears that relatively large wires are soldered flat against the copper pads. The PC board material and the

copper have vastly different coefficients of expansion, and the stiff wire will exert mechanical force on the solder joint, causing it to crack over time. If a mains-level wire breaks loose, it could cause serious damage to other circuitry, the computer, or present a shock hazard to the computer user.

Another problem with high voltage on a PC board involves moisture retention. The guidelines specify that no component case shall be placed in contact with more than one PC trace unless the PC board is suitably protected against moisture traps by a compatible conformal coating. I am also somewhat concerned with the triac heatsink, which is in direct contact with a large area of the component side of the PC board.

Fire-resistant PC board material, such as glass epoxy FR4 meeting UL Flammability Rating 94V-0, is required for mains level circuitry. I can't tell from Photo 18 whether a solder mask is used on the solder side, but this is another area where moisture or contaminants could bridge mains level voltages.

The reader letter is absolutely correct in stating that flameproof resistors must be used in AC line circuitry. They don't need to be metal oxide types. Flameproof metal film resistors are available (the IRC "FA" series is one example), as are wire-wounds. The flameproof characteristic is derived from the cement coating used over the resistor element. I believe that Canadian and EU requirements are even more stringent, requiring flameproof resistors in power amplifier output stages.

I don't agree with the last two points made in the reader letter. A triac is either "on" or "off." It has no active region where it dissipates a large amount of power, like a transistor. In addition, the triac is in series with the transformer primary, which limits the available fault current. A 6A triac will not "explode" in a properly fused mains circuit. Unfortunately, there is no fuse indicated in the power supply schematic (Fig. 30, Dec. 2001 aX, p. 64). The 80VA transformer, T1, could be slow-blow fused at $\frac{1}{2}$ A (240V mains) or $\frac{3}{4}$ A (120V mains).

The PC board tracks in series with the triac could also be sized to open before the triac does anything dramatic, although this does not obviate the need for proper fusing. A standard 2-ounce copper (2 oz/ft²) track with a width of 0.025" is rated for a continuous current of 3.5A.

Finally, since C1 is in series with R3 and not directly "across the line," I don't believe

it needs to have class X2 safety approvals. I would use a metallized film cap for its self-healing properties, rated for 1200V (240V mains) or 600V (120V mains).

NEW CLUB MEMBER

 I recently completed the 25W per channel "tube amp for beginners" from your December '01 issue (p. 18). I have never built anything like this before, and the amp worked upon first power-up! I have been using a pair of Kenwood LO9Ms for the past 25 years, and for me to go to 25W per channel was a big culture shock.

I love the new amp. The sound is incredible. I am hearing much more definition in the mids and highs. I can hear decay on stringed instruments that I have never heard before.

I think my lower frequencies are actually deeper as well. 25 watts is surprisingly solid. However, I would like a little more power in the future. I am looking forward to you publishing plans for a 100W tube amp!

Don Corby
Ontario, Canada

Rick Spencer responds:

I want to congratulate you on the successful completion of your amplifier project. It really is a good feeling, isn't it?! Your reward should be very great indeed, especially since you noted that you have never built a project like this before. I can truly imagine the excitement and joy you felt when the amp worked the first time you powered it up!

Thank you for your kind comments regarding the sound quality of the unit. Tubes do seem to have the ability to give a certain warmth and bloom to most music. This "little amp" possesses the sound qualities of a lot of larger tube amps, yet contains only a simple circuit. Remember, it doesn't always require a complex circuit to achieve a good sound. Such is really evident in the case of my single-ended 6550 amp (Sept. '01 aX), which is built around one of the most simple, straightforward circuits ever used and yet, on certain recordings, will almost bring a tear to your eyes with its pure sonic beauty.

By the way, Mr. Corby, you had stated how surprised you were to find that 25W per channel could sound so powerful—well, you'll be even more astonished to learn that 25W is the

total of both channels combined! The actual power output per channel is around 12 to 13W. I myself have always been amazed to find that most low power tube amps can sound louder than some solid-state components that have more than twice the power rating of the tube amplifiers!

You also mentioned that you desire a tube amp project with more power—around 100W or so. Well, I can certainly help you there. Let me whole-heartedly recommend that you build the 6550 triode amp that Joseph Still contributed to Glass Audio March 2000! When it comes to a high-powered tube amp project, I personally have seen none that are better than this one! It is a unique, one-of-a-kind, super strong amplifier and, if you build it, you won't believe just how loud those 100W per channel can drive your speakers, and do so with great clarity and effortless ease.

Again, congratulations on your new amplifier, which sounds as though it has found a permanent home as part of your system. You should be very proud of your accomplishment, and, oh yeah, now that you are hooked on building your own equipment—welcome to the club!

ADIRE AUDIO

High quality 3 way center channel kit: **KIT LCC**

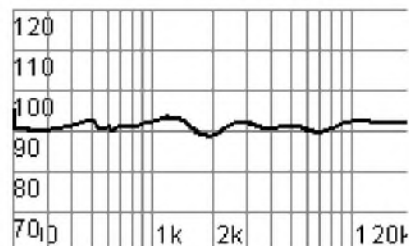

The KIT LCC is the perfect match to the KIT 281, KIT 81, and other home theater speaker kits. A full 3 way design with twin 8" woofers, single 5.25" midrange, and 1" tweeter yield high accuracy and SPL output for today's demanding HT uses. 92 dB efficiency, 6 Ohm load, 150W power handling, 45 Hz to 20 kHz response.

All for \$259 complete.

Adire Audio carries a broad range of complete systems, custom drivers, fully engineered speaker kits, and other specialty items. For more information on our products and services, please contact us at:

www.adireaudio.com

PHONE: 206-789-2919

FAX: 800-437-2613 or 630-839-6192

DOPPLER DISTORTION

 I was minding my own business the other day, reading the February 2002 issue, when (Oh no!) mention was made in the "Infinite Box Concept" article (p. 38) of the injurious Doppler effect. I thought that this misguided idea had died a deserved and final death. Maybe not. So please allow me to finish it off, a long-overdue responsibility that I guess I'll just have to take on.

If you think about what a loudspeaker diaphragm is doing, it makes sense that if a 500Hz tone and a 30Hz tone are being reproduced, the 30Hz cone movement will frequency-modulate the 500Hz tone, stretching it to a lower radiated frequency as the cone moves back and compressing it to a higher frequency as the cone moves forward.

And in fact, if you pull a groove off a record like a strand of cooked spaghetti and lay it flat on the table and look at it, that's exactly what you'll see. As the 30Hz wave pulls positive, the 500Hz wave actually has a longer period than it should, and as the 30Hz wave pulls negative the 500Hz tone goes sharp.

No, wait—that's backwards . . .

Well, yeah. It's supposed to be. *The loudspeaker diaphragm is moving exactly the same way that the microphone diaphragm did. All of these modulation-induced frequency shifts are encoded onto the recording by the microphone diaphragm. When the loudspeaker diaphragm decodes them in your listening room, they come out into the air correctly.*

Now, of course, if you have different speakers for different frequency ranges, you've got a problem, because the decoding never really gets a chance to happen; the two frequencies go to different drivers. This is exactly the opposite of what the Dopplerphobes say; they say that if you have a single speaker the problem is solved if you use a single full-range speaker.

Now, if the recording was made with individual microphones for each of numerous instruments that will end up getting piped into your room through the same driver, well, that Doppler thing will indeed happen to you. The playback will be a bloody mess, and there's nothing you can do about it. Hey . . . they have 31-band equalizers . . .

how about a 31-way speaker system? Or 31-channel playback?

You're not going to cure any of this with anything that you do with your home-brewed speaker design. Well, maybe some of it. If you ever get the chance to listen to minimally-miked recordings with speakers that put the majority of the tonal range through a single good-quality driver, you're about as close to real accurate playback as you'll probably get.

And let me say this: For all the abuse that Bose gets from Holier-than-Thou hi-fi snobs*, some of their little single-driver loudspeakers have the potential to sound far more realistic in certain ways than the usual small inexpensive woofer-tweeter combo. I know this from actual A-B-C-D-E tests.

Anyway, I hope that nobody takes this Doppler thing too seriously. You're either totally okay or totally up the creek, depending on the microphone count and the loudspeaker driver count. Less is better, and choosing to live with the problems of simple transduction is like learning to live with the problems of any high-end approach. You'll have to listen through certain inaccuracies, but you'll get to hear things that the rabble and the snobs will never hear.

Hilary Paprocki
Rochester, N.Y.

*They say that special-interest groups are formed for the purpose of sharing common interests. Well, maybe sometimes that's true. But the historical function of common-interest clusters is a human instinct that goes back to caveman days: defense against some perceived danger.

What kind of dangers? Dangers like this: the creation of a happy subgroup of ordinary Mom-and-Pop non-audiophiles who are getting better sound than they've ever heard from their Bose Wave Radios, without ever having to pay homage to any Hi-Fi Gods. Imagine the heresy!

G.R. Koonce responds:

Hilary Paprocki offers the concept that Doppler distortion occurs at the microphone

and this distortion can only be corrected by using a single cone speaker to reconstruct the sound. Let us examine this concept based on the available published information.

Doppler, or frequency-modulation, distortion is a fact of life when any vibrating diaphragm is receiving or radiating multiple frequencies. As developed by Klipsch¹, if the same diaphragm handles a high frequency (f_2) at the same time it handles a low frequency (f_1), then the high frequency will see a modulation. The shift in the higher frequency is proportional to the ratio of the diaphragm velocity at the lower frequency to the speed of sound. The diaphragm velocity at low frequency is directly related to the diaphragm displacement at this frequency. Thus the higher the diaphragm displacement amplitude at the low frequency (A_1), the worse the modulation of the f_2 frequency and thus the higher the Doppler distortion.

Beers and Belar² go on to define a distortion factor (d) as the total RMS value of generated sidebands as a percent of amplitude at f_2 :

$$d = 0.033 A_1 f_2$$

d = Doppler distortion factor in percent

A_1 = peak amplitude in inches of diaphragm motion at lower frequency f_1

f_2 = the higher frequency in Hertz

This shows the percent distortion becomes worse when f_2 and A_1 go higher. Where a speaker system may get into trouble is when the woofer is asked to produce large bass amplitudes and upper midrange, or higher, frequencies. Since the displacement needed to produce a bass frequency increases the smaller the woofer cone, and such small drivers may be used quite high in frequency, they are more prone to Doppler distortion problems. As with most other types of speaker distortion, Doppler distortion increases with increased playing level due to the increased driver displacement. The questions are: is this a real problem in microphones or loudspeakers, and will microphone Doppler distortion be canceled via the loudspeaker Doppler distortion of a single-cone driver?

As just developed, the amount of Doppler distortion is proportional to the peak displacement of the diaphragm. The diaphragm of a microphone moves very tiny distances, and thus Doppler distortion is extremely low. Coloms³ points out microphone Doppler distortion

tion is negligible and can never be counted on to cancel the Doppler distortion in a speaker. The concept presented by Paprocki has thus been shown to be invalid.

The question remains, "Is Doppler distortion in speakers a problem?" There is still discussion of what level of Doppler distortion is detectable by ear, with the threshold value proposed in the 0.1% to 1% range. Early work had indicated that other distortion problems in drivers would generally exceed the Doppler distortion generated in most applications. Thus Doppler distortion was not considered a problem with well-designed drivers.

I have the feeling, however, that the situation may be the same as with the gyroscopic forces of a spinning propeller. These were studied early and found to be insignificant. When the four-engine Electra appeared with its turbo-prop engines spinning huge propellers, the gyroscopic force was no longer insignificant. The unfortunate consequences of ignoring it were several crashes as the gyroscopic force aided in tearing off the wings in rough weather.

Doppler distortion will never have such fatal effects, but could cause problems with the modern breed of high displacement drivers. You can easily now get woofers that have a linear peak (one-way) displacement of 1" or more. Using such a driver in a subwoofer producing frequencies up to 100Hz might show a Doppler distortion factor of:

$$d = 0.033 \times 1" \times 100\text{Hz} = 3.3\%$$

This is probably no problem with a subwoofer application. However, consider a small

woofer with 0.5" peak displacement capability used in a two-way system up to 2,000Hz. This could produce a Doppler distortion factor of:

$$d = 0.033 \times 0.5" \times 2,000\text{Hz} = 33\%$$

There is little doubt that this amount of frequency modulation would be audible. So

Doppler distortion is real and something that readers should watch out for. It is most likely to cause trouble in systems with large low-frequency displacement by the same driver producing relatively high frequencies. Thus one- and two-way systems are the most vulnerable. This may be why so many single cone loudspeaker systems employ horn load-

Looking for the Old Colony Sound Laboratory Catalog?

Find it on-line 24 hours a day, seven days a week at www.audioXpress.com

Books • Kits • Test Equipment
Test CDs • Software

On-line specials
Clearance items
Secure shopping basket

www.audioXpress.com
Find all of your audio information needs on-line!

Old Colony Sound Laboratory, PO Box 876, Peterborough, NH 03458-0876 USA
Toll-free: 888-924-9465
Phone: 603-924-9464 Fax: 603-924-9467
E-mail: custserv@audioXpress.com



Creative Sound Solutions

loudspeaker kits and components

North American distributor for
Jordan and Lambda



Jordan JX92S

- ▶ Shielded full-range driver (no crossover)
- ▶ Light-weight metal cone for excellent transient response
- ▶ Suitable for sealed, ported, and TL enclosures
- ▶ Exceptional performance for in-wall HT applications

Lambda Acoustics

- ▶ State-of-the-art hand-built 10, 12 and 15-inch woofers
- ▶ Seven series of drivers cover every application
- ▶ Sealed, ported, high-efficiency, dipole, pro and mobile
- ▶ Apollo high-performance ultimate upgrades



Lambda TD15M

For more products and services, see our Web site:

www.creativesound.ca

email: sales@creativesound.ca

ing on the bass to greatly limit the cone displacement at low frequencies.

My personal experience is that most two-way systems do not sound as "clean" to me in the midrange as do three-way systems. When I found the two-way system using the IB concept showed an unusually clean midrange, I proposed part of the reason might be due to reduced Doppler distortion. No testing has been attempted to verify this is indeed the reason, but Doppler distortion is a real effect to consider, especially for one- and two-way systems.

References:

1. Paul W. Klipsch, "Modulation Distortion in Loudspeakers," Loudspeakers, An Anthology, Vol. 1-Vol. 25, Journal of the Audio Engineering Society.

2. G. L. Beers and H. Belar, "Frequency-Modulation Distortion in Loudspeakers," Proc. IRE, Vol. 31, pp. 132-138, (April 1943).

3. Martin Colloms, High Performance Loudspeakers, Halsted Press, New York, 1978.

HARTLEY "BOFFLE"

Having just read the Infinite Box article (Jan. and Feb. '02), it seems that the Hartley Baffle of the late 50s and early 60s has been rediscovered. Hartley made his own speakers, and if memory serves, the original Baffle used a 10" or 12" full-range unit. The sound exiting the rear of these was more or less a low frequency, low volume gargling when playing music. The term "Boffle" signified "open baffle."

Cornelius Morton
Phoenix, Ariz.

G. R. Koonce responds:

Mr. Morton raises the question of how the Hartley "Boffle" compares to the infinite box (IB) concept. While working on the IB concept I was unaware of the "Boffle." After submitting the original manuscript, I was sent information on the "Boffle" by our esteemed editor-publisher. Reading this material, I believe there are some fundamental differences in concept.

Mr. Hartley expressed the belief that any structure adding a resonance to the speaker system greatly harmed the sound quality. He

believed that even the open-back baffle, formed by a frame around the front panel, was a resonant pipe. This is generally not true, because a pipe normally must be about three times as long as its diameter before it will support an air-column resonance.

To eliminate any air column, Mr. Hartley's "Boffle" had multiple damping layers that started well ahead of the driver magnet structure and extended to the back of the enclosure placed at regular intervals. Mr. Hartley also used a much lower density of damping material in his layers than we employed in the IB.

Never having tested a "Boffle" system, I don't know how they work, but in developing the IB concept, it was clear that you did not want our very dense damping layers right against the back of the driver. When a given amount of air is trapped between the driver and the damping layers—the dead-air volume—the overall system performance is enhanced. I have no reason to believe the "Boffle" concept does not work just fine; it is just that it is somewhat different from the IB concept.

As stated in our article, the IB concept is not new. Damped, open-back systems have been used in many forms over many years. We were simply trying to add some understanding of how one particular configuration functions and how readers could apply it in designs. I have now personally built four systems using the IB approach, and I am delighted with all of them. I surely will continue to use the IB concept.

Excerpt from *Hi-Fi Annual*, 1958:

The inert non-resonant device I finally produced I called a "Boffle," an abbreviation of box baffle. A cross-section is given in Fig. 1. It is quite unlike any other form of enclosure, for it is an acoustic filter. In electrical filters we have inductance, capacity, and resistance; in mechanical filters (and acoustics is a form of mechanics) the elements are masses, springs, and friction. In the "Boffle" the sound waves from the back of the speaker hit the second screen (the first is merely an anti-reflection device); if it were not perforated the screen would be unduly stressed, so part of the pressure passes through to the third screen, and so on.

The diagram shows two graded filter stages, but except in deep cabinets, one filter with up to eight screens is all

that is necessary. The semi-porous screens of carpet felt act as masses, their slight elasticity and the air pockets between the screens as springs, and their acoustical semi-transparency as friction. The back must not be rigidly closed, and all that emerges from the rear is a very low-pitched "grumble," which has no harmful effect on the speaker output.

Wrapping the felt around the wooden frames of the screens is an essential feature of the device. The screens are rather a tight fit in the box and the felt is slightly compressed as the screens are slid into place. Every part of each side is therefore properly damped against nodes and resonances, and thinner wood can be used for the box than is necessary for any other form of enclosure.

The "Boffle" has been described for home constructors (*"Radio Electronics,"* February, 1956) with interesting consequences. Designed for my own speakers, I did not suppose it would be much favored for housing speakers that normally require a reflex enclosure for neutralizing the bass resonance of the speaker.

It turns out, however, that owners of more conventional speakers than mine have made it up and like it very much indeed. They say that the "Boffle" gives very clean and clearcut reproduction having noticeable "presence." This is due to the almost complete suppression of cabinet and air-column resonances. With these removed, the bass resonant frequency of the speaker is not unduly noticeable. These experiences suggest that the "non-resonant school" has some justification for thinking that way.

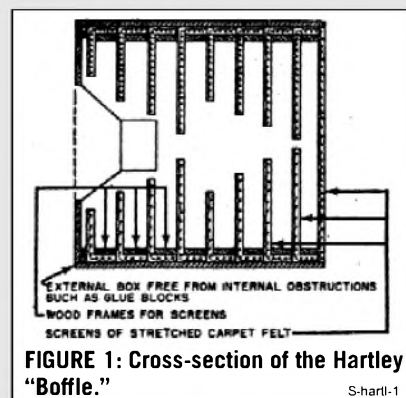

Really looking forward to the next issue of aX—the article in the current issue (Jan. '02) about IB loudspeakers is very interesting, as is the letter about the good sound of the old Westinghouse console radios (p. 76). Both of these make me wonder: have the designers of the IB speakers considered exploring other types of backs for their boxes? Would a back with several small holes drilled in it perform differently from one with one large hole. What about a slot? Or moving the hole, holes, or slot to the rear bottom of the box so that the leakage is “floor loaded”?

Keep up the fine work.

Ray Putnam
putnamrj@juno.com

G. R. Koonce responds:

Our Infinite Box (IB) concept work established that setting the open area behind the damping material slightly greater than the cone area of the driver was beneficial. We have successfully built IBs using one, two, and four holes to meet this area requirement. Thus how the open area is implemented is not critical.

The use of a large number of small holes or multiple narrow slots would be a different design from what we have studied. This is because a small hole or narrow slot introduces a resistive element behind the damping material. This approach may work, but we have not investigated it. Anyone building an IB with removable back could easily make

multiple back boards and try various open area configurations.

There is no reason an IB would not work with the damping layers and open area on any side of the enclosure. We intentionally kept these on the back of the enclosure to take advantage of the reverse diffraction spreading loss (RDSL) attenuating the high-frequency portion of the rear leakage. This helps to smooth the response.

Generally the open-area holes nearly cover the complete back board just as the driver about fills the woofer portion of the front panel. This would limit the ability to get the entire open area located close to the floor for “floor loading.” Also, remember the back board compresses the damping material and you must thus keep it rather stiff. This sets constraints on the hole size and location.

You could place the damping layers and open area on either side or the bottom of the enclosure, but this would increase high-frequency leakage and thus response ripple due to loss of RDSL attenuation. With a bottom open area, the enclosure could have the front and both sides extended to the floor. Then the bottom radiation would be restricted to the rear maintaining the RDSL attenuation.

There is one practical construction problem with the side or bottom opening. Generally, the dead-air volume for an IB is reasonably small resulting in a fairly shallow enclosure. It would be difficult to get sufficient area on the side or bottom to allow a reasonable size for the damping layers and for meeting the open area requirement. I have examined using the bottom for the damping

layers and open area on a few systems and never produced a design I thought was usable. At this time it is thus something that we have not tried.

HELP WANTED

I am in the process of building a subwoofer for my home theater. I want to know the best material to use to construct a round sub enclosure (similar to the HSU Research sub). How do you calculate the dimensions for such an enclosure?

Jimmy Lowe
jlowe@directus.net

I'm looking for a replacement woofer for my 1974 IMF Monitor MKIIIs transmission-line loudspeaker. It's odd-shaped—about 8" × 11". I'm using them as subwoofers with an electronic crossover. Can you suggest a woofer for transmission lines?¹ Has audioXpress done past articles on mods of the vintage IMFs?² ❖

John Loudenback
j_loud@mindspring.com
Salt Lake City, Utah

1. Any reader suggestions?
2. Nope.

Readers with information on these topics are encouraged to respond directly to the letter writers at the addresses provided. —Eds

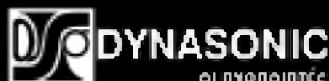

INTRODUCING THE NEXT GENERATION OF PLANAR TRANSDUCERS

PL-180 the first planar driver with esoteric Binary Interlaced Coil™ (BIC) diaphragm held exchangeable. A distinct performance driver with electroacoustic virtues, satisfying critical listeners and functionality motivating ambitious designers. All in a single, state of the art device.

FEATURES - PERFORMANCE - SPECIFICATIONS

- Ultrafast transient response, for stunning transparency
- Linear Phase response, for time coherent reproduction results in accurate imaging and sonic clarity
- True line source image behavior
- Controlled dispersion in horizontal and vertical plane
- Frequency response 1.6-40KHz
- Sensitivity 2.83Vrms/1M 97db SPL
- Extremely light, ultrathin, high temperature, interchangeable diaphragms in Ohmic Values: 2x9 - 2x5.3 - 2x3.4"
- Constant resistive impedance throughout operating range for ideal amplifier load and easy crossover design
- Massive, Neodymium, High energy magnet system
- Magnetically shielded system
- Rattle mounting without screws
- Rear support for free standing upgrading applications
- Dimensions: WxHxDmm: H4 x 164 x 100 Weight 1.5kg

THE NEW BIC™ DESIGN IDEAS THAT HELP YOU BUILD BETTER SPEAKERS

Double coil proprietary diaphragm configuration allows series connection for max transducer sensitivity or parallel connection for max power handling.

The two symmetrical interlaced coils, break the rules of acoustic reproduction in many forms such as:

- Crossover at two different frequencies
- Feedback optimizer circuitry
- Magnetic damping circuitry
- DDLC (Direct Digital Loudspeaker) circuitry
- Possible other inventive applications

Unit price: \$ 320 (includes delivery to your address)

*PL-180 is sold with 2 x 9 Ohms diaphragm.

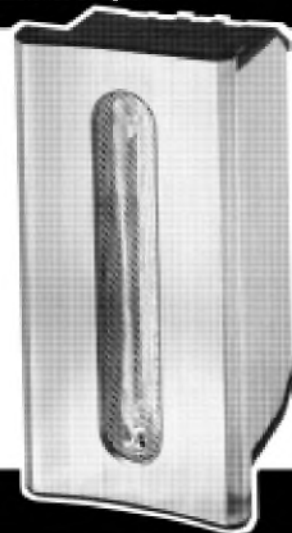

For orders visit our web page www.dynasonic.gr E-mail: info@dynasonic.gr Or contact us directly at:
DYNASONIC LTD 59, Iliiss Septemvriou str., Athens 104 33, Greece, tel.: +30-1-38 30 311, fax: +30-1-82 29 483

Book Review

The Collector's Vacuum Tube Handbook

By Larry Lisle

What's a UV876 tube good for? How about an L10 or SO27? If you had looked at *The Collector's Vacuum Tube Handbook* before the flea market, you might be the only one there to know that a UV876 is a rectifier, while the others are power triodes, equivalent to types '10 and '50!

Tube audio lovers, you're not alone! There are others who love tubes, too! Among them are the collectors and restorers of antique radios, the tube collectors, and ham radio operators who like old equipment. All love and use tubes, and we can all learn from each other and from *The Collector's Vacuum Tube Handbook, Volume I, The Non-RMA Numbered Receiving Tubes* by Robert T. Millard (available from Old

Colony Sound Laboratory, PO Box 876, Peterborough, NH 03458-0876, (603) 924-9464, FAX (603) 924-9467, www.audioXpress.com, \$25.95).

The 196 pages of this volume are crammed with information about the earliest American vacuum tubes that were widely available. Some of these are already of great interest to tube audio people, while others should be!

Unlike a manufacturer, a do-it-yourselfer can build something using uncommon tubes, as long as you have a couple of spares, and there were some very interesting tubes made in the early days of radio that are covered in this volume.

But first you must understand the numbering system. Before the Radio Manufacturing Association method became standard, there was much confusion about tube types. Manufacturers could name their products anything they wanted. Very different tubes were sometimes given the same number, while interchangeable tubes were given different designations.

In addition, by the early 1930s manufacturers often dropped the letter prefix and first number. For example, the UX232 became the 32, although it was the same tube. The author does a nice job of explaining this in his preface.

The rest of the book is about the tubes. Most of the tubes, beginning with the UV200 (00), are presented on a single page. Each has a base diagram with pin-out connections, a brief description of what the tube was intended for (similar to that in the RCA manuals), a chart showing maximum ratings, another chart showing typical operation in the service it was designed for, a photograph of the tube, and a representative carton!

This information is not available anywhere else in one book, and some of it just isn't available at all. In some cases where the author couldn't find printed



information, he actually measured samples of the tubes!

For the tube audio lover, this book can be of considerable value. For instance, most do-it-yourselfers are familiar with the type UX245 (or 45), but how many have thought about the 46? This is a "dual grid" tube intended to be used with the screen tied to the plate as a Class-A driver for a pair operated with the screens tied to the grids as Class-B output tubes. Class-B, of course, went nowhere except for public-address systems and portable work, but the 46-operated Class-A is very close to a type 45 and a lot cheaper!

To be honest, it doesn't sound quite as good (very few tubes do), but it rivals a 2A3. If you come across some at a swap meet, it might be worth your time to give them a try.

It's also fun to look through the book at the small signal triodes. Some use an odd filament voltage or require DC, but that isn't much of an impediment anymore. I know from experience that some of these old triodes such as the '27, '30, and the '56 sound very good indeed.

The only way to find out is to try them. Look through the book and find likely candidates. Then shop the catalogs of the used tube dealers for the ones that are low priced and buy one with your next order. If it works out, buy a couple of spares while they're still cheap and before they are "discovered" and enjoy!

The Collector's Vacuum Tube Handbook is a valuable addition to a tube library, and I'm looking forward to subsequent volumes. ❖

DIY AUDIO

Audiokits.com is the Internet's best source for hi-tech, hi-end audio kits, DIY speakers, and components.

We offer a variety of options for audiophiles and hobbyists who demand higher performance from their systems!

www.audiokits.com

Audiokits.com

New Chips on the Block

AK4360

By Charles Hansen

AKM has introduced the AK4360 low power 20-bit 2-channel DAC, digital filter, analog filter, and headphone amplifier. The device offers high perfor-



PHOTO 1: Low power DAC with HP-AMP

mance and low power consumption, which makes it ideal for portable audio devices such as MP3 players. A mute circuit eliminates the popping noise generated when power is switched on or off. A low-frequency compensation circuit and de-emphasis circuits are also built in.

20-bit DAC

Sampling rate ranging: 8kHz-50kHz
On-chip perfect filtering eight times
FIR interpolator

Passband: 20kHz

Passband ripple: 0.02dB

Stopband attenuation: 57dB

Digital de-emphasis for 44.1kHz sampling

Master clock: 256fs or 384fs

Digital audio I/F format: twos complement, MSB first MSB justified, 1¹/₂-bit LSB justified, I²S

THD+N: -60dB (-11dB = -20dBm input)

S/N: 93dB

On-chip headphone amplifier

Low voltage operation:

DAC: 2V (1.8V 3.3V)

HP-AMP: 1.2V (0.9V 3.6V)

Power dissipation: 13mW

Small package: 24-pin VSOP

AK4360 pricing \$1.59 US (10k pieces)

AKM Semiconductor, contact Richard Kulavik toll-free at 888-256-7364, or icinfo@akm.com for info and engineering samples. ❖

TDK AVPro 5001 Quad AV Driver IC

By Charles Hansen

TDK Semiconductor has introduced the AVPro® 5001 quad universal audio/video driver IC that supports four video and two audio inputs. Design applications include DVD players, VCRs, and digital receivers for satellite, cable, and terrestrial television, with numerous features.

The AVPro 5001 is designed so that each of the four video inputs includes a path that has a gain of two with output buffers to drive a 150Ω load. Two versions of the device are available

depending on the application used. One version supports RGB video with an additional composite (CVBS) channel, while the other supports S-video (Y&C) with independent composite channels.

The AVPro 5001 accepts stereo audio inputs, typically from an external stereo DAC. Each audio path has two output drivers that are buffered to provide 2.0V RMS outputs into 600Ω. The drivers have a nominal gain of two, but gain can be individually set

using a pair of external resistors. In addition, the audio drivers use ±5V power supplies so that the outputs are centered around ground. This allows direct coupling of the audio outputs to the associated load.

The device is available in a 24-lead SOL package. Samples and evaluation boards are available. Additional product information or a free 2000 Data CD-ROM can be obtained by visiting the "Products" section on www.tsc.tdk.com, or by calling 714-508-8800. ❖



Subscribe to *audioXpress* for:

Projects—including schematics, parts lists, photos, construction details, sources—everything you need to get right to building.

Technology—theory & knowledge to improve your capabilities to build great sounding equipment

Reviews—previews of kits—do you want to build it? Previews of products—does it perform as the manufacturer states? Previews of books and software—Is this information you want?

Letters, Tips, & Techniques—Read questions, clarifications, debates, tips, and reader comments to learn even more from each article. As a subscriber, you're instantly part of a community of thousands of audio craftsmen like yourself.

Easy-access to information—*audioXpress* is written for you with an easy-to-read table of contents and regular departments focused on specific areas of audio technology.

Information you can depend on—the knowledge presented and the quality of articles presented in *audioXpress* is unparalleled. You'll be treated to articles by experts in their fields including Douglas Self, Nelson Pass, G R Koonce, and many others from our cadre of over 700 authors.

12 monthly issues for only
\$34.95!

That's less than **\$3.00** per
issue for all this!

Call **1-888-924-9465**

to request your first issue

FREE TO TRY

or e-mail custserv@audioXpress.com!

audioXpress

PO Box 876 Dept. X2,

Peterborough, NH 03458-0876 USA

Phone: 603-924-9464 Fax: 603-924-9467

www.audioXpress.com



Classic Circuitry

Pilot AA-908

This 1959 top-of-the-line model was direct competition for the Acrosound UL-II. This unit had DC balance, AC balance, variable damping factor, and used half of a 12AX7 as a reference to set the AC balance.

Lance Cochrane
San Francisco, Calif.

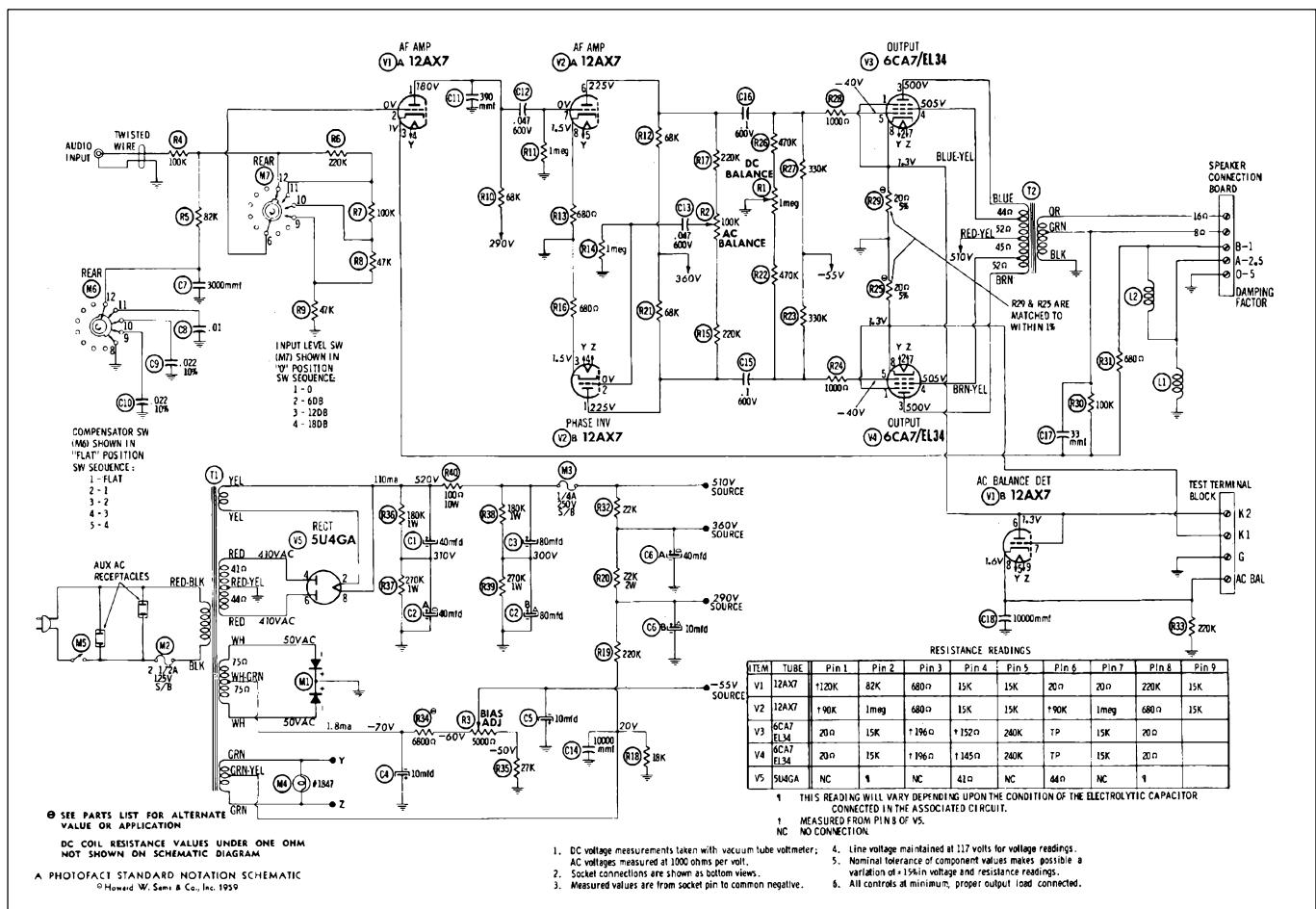

Pilot AA-908.

Audio Aid

Shishido 300B SE Amp Mod

I built this amp with reference to Nobu Shishido's 300B SE amp (*GA 3/97*), Fabio Comorani's Kismet ("A Simple 2A3 SE Amp," *GA 6/96*), and Bruce Rozenblit's line-level preamp (*GA 2/91*) and *Beginner's Guide to Tube Audio Design*.

The gain stage uses the Hitachi 12AU7. I did not run the V1b plate to +265V, because this will cause the driver cathode to reach +190V, which will increase the driver plate-supply voltage. I set the V1b plate to cathode voltage at +85V. With bias at -2V, the plate current according to the plate curve should be 3mA; I got 2mA. At V1a, under 75V plate voltage, I got 2mA plate current, which is in accordance with the curve. The plate load for V1a is 67.5k. You can see that the load line falls into a little nonlinear zone.

For further experiments, you could try two alternatives. One is to find another tube with more linear amplification at lower plate voltage compared to 12AU7, such as the 6SN7. Or, you could apply higher plate voltage for V1b (try 300V). But as mentioned before, this will cause a higher driver tube plate-supply problem (Note: the 12AU7 curve attached is not derived from the Hitachi 12AU7).

Driver 6L6 is a used tube, probably Japanese made. I use the Svetlana 6L6 (triode connection) curve as a reference. I found that the actual working point (voltage and current) differs a little bit with this curve.

You can also experiment with RC coupling from gain stage to driver stage, with fixed bias or self bias to the driver tube.

Instead of a 300B, I used a second hand RCA 2A3. Again, I found a discrepancy between the curve and what I measured. I got lesser plate current with a higher plate voltage and a little

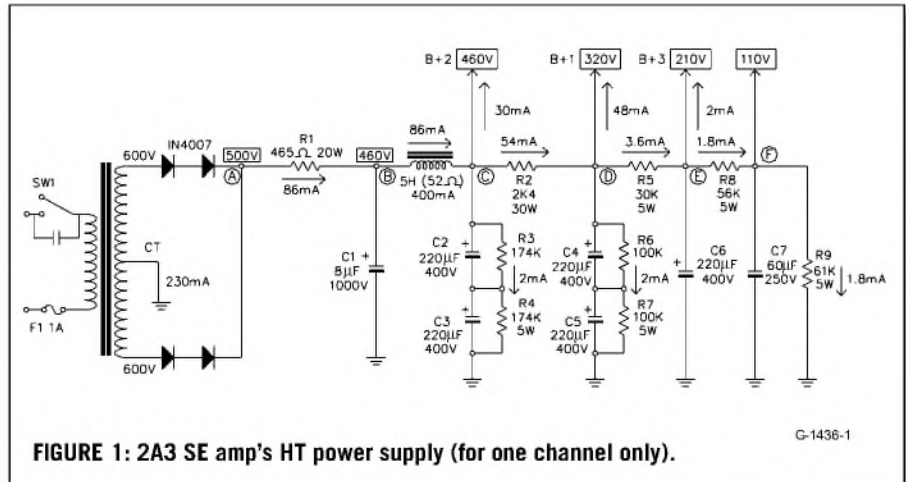

FIGURE 1: 2A3 SE amp's HT power supply (for one channel only).

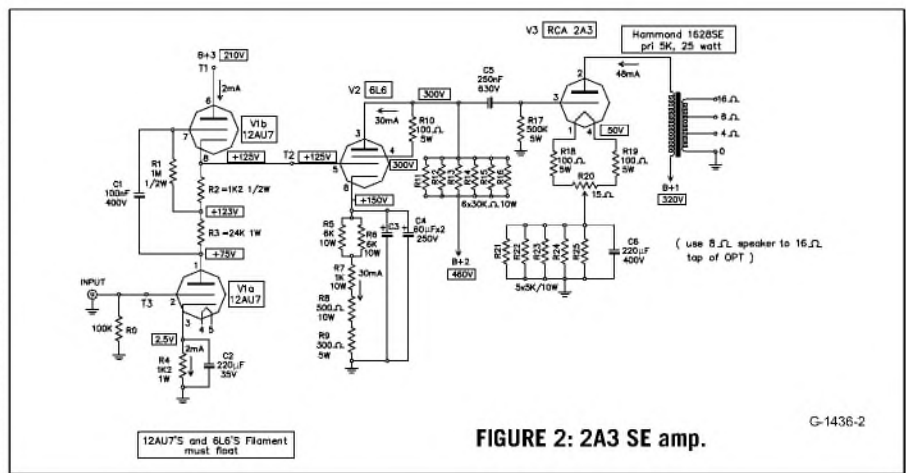

FIGURE 2: 2A3 SE amp.

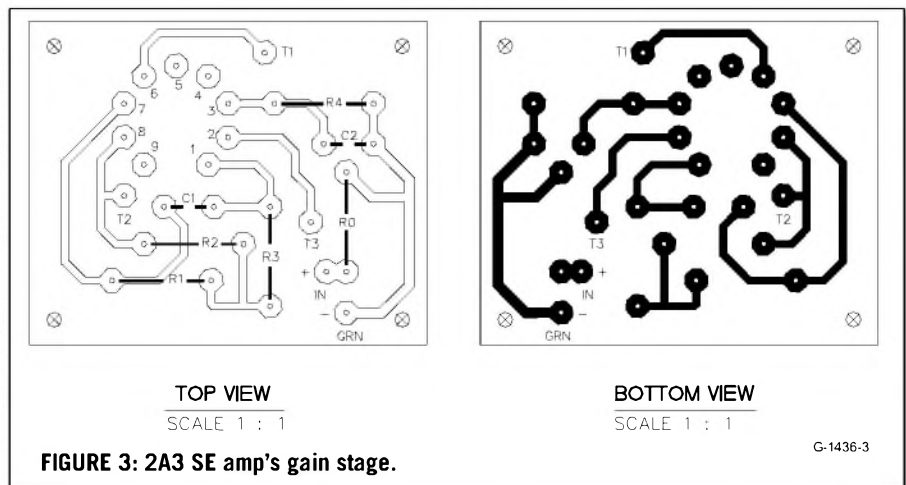

FIGURE 3: 2A3 SE amp's gain stage.

bit higher bias. I believe this is due to the fact that the tube is used.

The only new part in this amp is the Hammond 1628 SE (primary 5k) OPT, which can handle two 300Bs in parallel. It is too big for a single 2A3, so you could use One Electron UBT I for this amp.

After using this amp for several weeks, I found the mid and low were excellent. The only problem is heat dissipation from 6L6 and 2A3 plate and cathode resistor. Using the highest possible wattage for those resistors is a must. ❖

Ignatius Chen
Bandung Indonesia

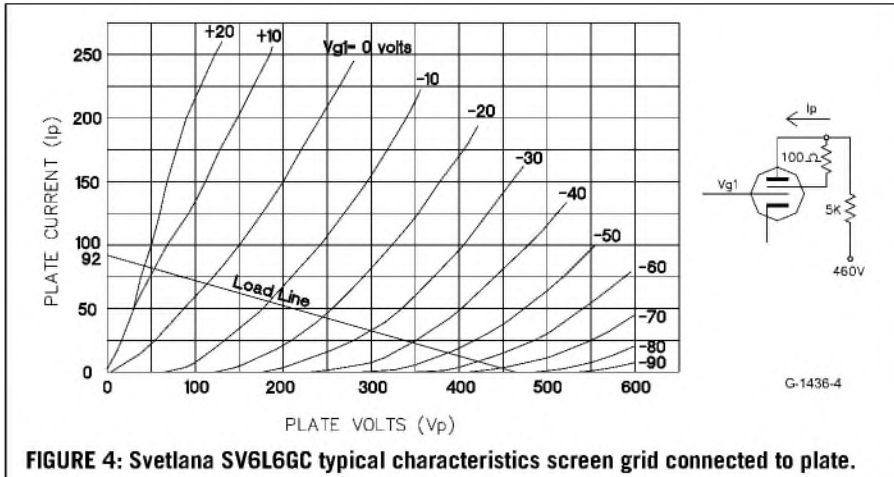

FIGURE 4: Svetlana SV6L6GC typical characteristics screen grid connected to plate.

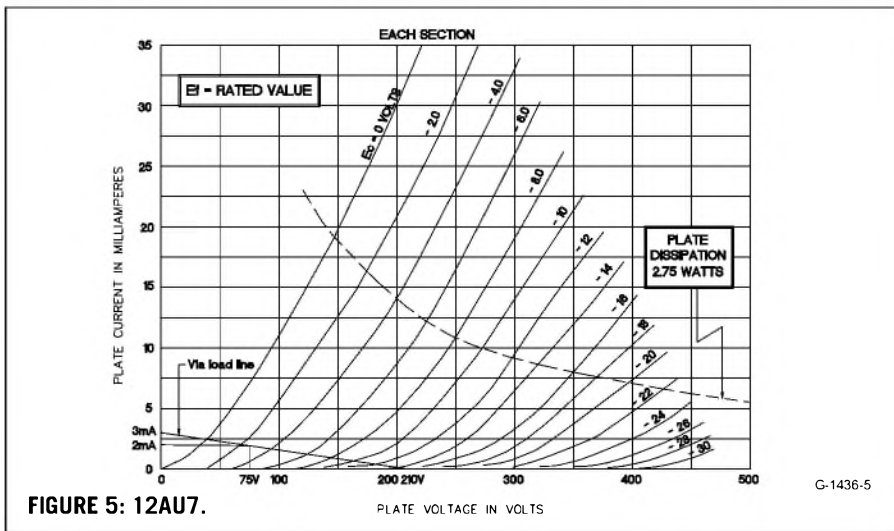

FIGURE 5: 12AU7.

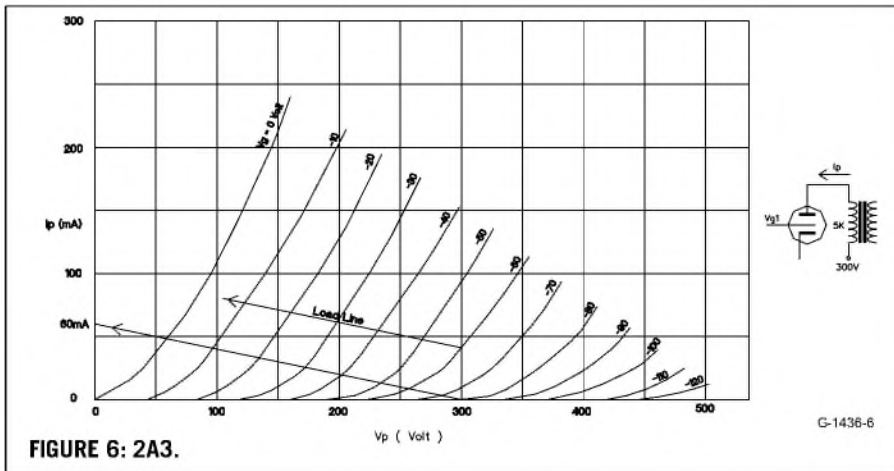

FIGURE 6: 2A3.

The British specialists in tube amplifiers and pre-amplifier kits, loudspeaker kits and related publications

Visit our informative website:
www.worldaudiodesign.co.uk
Enter our HD83 competition on-line



KIT88 integrated amplifier kit

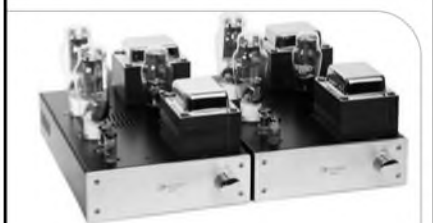

300b PSE monobloc kit



Kel84 integrated amplifier kit



Series II modular pre-amplifier kit

World Audio design
World Audio Publishing Ltd.
12a Spring Gardens.
Newport Pagnell.
Milton Keynes.
MK16 0EE. England

tel/fax: 00 44 1908 218836
e-mail: inquiries@worldaudiodesign.co.uk

Classifieds

VENDORS

ALL-FET kits, tantalum resistors, JFETs, MOSFETs
www.borbelyaudio.com

Low density **concrete cabinet** loudspeakers
www.faradaysound.co.uk
 Self-build instructions available

Cabinets for North Creek Okara 2 or other design using Vifa P13WH. EBS alignment, -3dB @ 56Hz. Cabinets for ACI SVC10. Both customizable, starting at \$175. 505-280-8829. E-mail: kennethmartinez@earthlink.net.

tubes?
www.tubes.it

The LP track carries both stereo channels vs. alternating pits on the CD. The LP remains superior with "tight coupling for audio," \$15; using an "OTL amplifier circuit," \$35; driving efficient "Bass Horn" plans, \$50. Visa, MC. **STEEN AUDIO LAB**, PO Box 2185, Vancouver, BC V6B 3V7, CANADA.

Principles of Power, tube audio books, kits, FAQ www.londonpower.com.

DIY HI-FI SUPPLY

www.diyhifisupply.com

Tubes: Valve Art, TJ Meshplate, Sovtek, Svetlana, China milspec NOS

Kits: Billie 300B, Ella KT88, Joplin 2A3, Basie pre, Origin Live turntable kit, DAC

Accessories: XO Clock, S&B transformers, SSC isolation

Parts: Audionote copper and silver caps, Goldpoint, DACT, Seiden, Bullet plugs, Ultra-refined silver wire, SCR, Kiwame, etc

www.diyhifisupply.com
sales@diyhifisupply.com

Tubes & Transformers
www.southwesttubes.com

BILLINGTON
 EXPORT LIMITED

All types of audio tubes. 300B 6DJ8 ECC81 ECC83 KT88 Mullard GEC Sylvania. Discount for large quantity. Billington UK. Tel (0)1403 784961. Fax (0)1403 783519. Email/website www.bel-tubes.co.uk

www.audioXpress.com

AD INDEX

ADVERTISER	PAGE	ADVERTISER	PAGE	ADVERTISER	PAGE
ACO Pacific Inc	33	Harris Technologies	35	WBT-USA/ Kimber Kable	CV2
Adire Audio	59	Int'l Component	13	World Audio Design	69
Alpha Electronics Corp of America	19	Kimber Kable/WBT-USA	CV2	Zalytron Industries	51
Antique Radio Classified	47	Langrex Supplies	45	CLASSIFIEDS	
Audio Amateur Corp.		Liberty Instruments	35	Billington Exports	70
Advertising contact information	54	Linear Integrated Systems	55	Borbely Audio	70
<i>audioXpress</i> subscription	66	Madisound Speakers	57	DIY HiFi Supply	70
Catalog Online	61	Marchand Electronics	19	Faraday Sound	70
Classifieds	70	Markertek Video Supply	21	London Power	70
DSL Pro	38	Morel (IL)	31	Ken Martinez	70
Virtual Crossover Box	71	Mouser Electronics	33	SouthWest Electronics	70
Audio Consulting	39	Nelson Audio	2	Steen Audio Lab	70
Audio Electronic Supply	3	Origin Live	43	Vintage HiFi	70
Audio Transformers	21	Parts Connexion	9	AUDIO NEWS/NEW PRODUCTS	
Chelmer Valve	11	Parts Express Int'l., Inc.	CV4	Grubsrof, Inc.	2
Classified Audio-Video	64	Pliitron Manufacturing	39	Hi Fi Show & AV Expo	2
Creative Sound Solutions	61	Solen, Inc.	25, 49	JASONI Electronics	2
Danish Audio Connect	37	Sonic Craft	27	Monster Cable	2
DH Labs Audio Cables	29	Sound Clearing House	37	Noise Wizard	2
Dynasonic Ltd	63	Swans Speakers	23		
EIFL	7	Thetubestore.com	53		
Evo Technology	41	Tonian Labs	1		
Hammond Manufacturing	17	Usher Audio	CV3		

Yard Sale

FOR SALE

Tektronix RM503 oscilloscope—4.5MHz, 3 vert, 2 horiz plug-ins, \$100; HP 302A wave analyzer 1–50kHz tunable voltmeter, \$125; HP 5248L freq counter with HP 5253B freq converter counts 0–50MHz direct and to 500MHz with converter, \$150; Dynaco ST400 one channel intermittent, you fix, \$50. All work and have operation, maint manuals. Ron, 650-948-8441.

Featured in Aug. '01 aX was "A Start-Up Delay for Vintage Amplifiers." Due to the great demand, this circuit has been redesigned, making it smaller. Check out: <http://www.rubli.net>.

Parts collection—approximately 40 electrolytic capacitors, 80 disc capacitors, 30 high power (10–12W) fixed and variable power resistors, 18 full-size potentiometers, 15 small/medium transformers about half wall warts, \$25. Rotary autotransformer, 8 amps, 0-130 VRMS, \$22. Two matching HiComp Auto stereo amps, 18 WRMS, \$15. Contact Buzz, nad512@erols.com, or 301-872-5982.

Dynaco Pas phono only preamp, \$70; Dynaco Pat-4, \$40; Altec 342B PA Amp, \$100; Eico 2510 FM stereo VT receiver, \$60; Eico St-70, \$135; Sherwood 36 VT amp with matching VT tuner, \$75; Rauland PA amp 6L6 SE, \$40; APT Holman Pre-amp, \$100; Dynaco FM-3 Tuner, \$40. Reed Hurley, 770-474-6594, or srhurley@southernco.com.

Abundant selection of upgraded classic FM tuners, \$100 to \$1,200. All have audio and rf improvements. Don Scott, bdscott@nac.net.

Assemblage L-1 preamp—Platinum version—Vishay, MIT RTX caps, \$600; and DAC 3.0 Signature version (has both Burr-Brown 1704 24/96 and HDCD PMD 100 digital filters) balanced, Caddock, Burr-Brown OP 627, Linear Technology regulators, Oscons, HFQs, \$900. dave.pitt@rogers.com, or 905-819-8462.

WANTED

Old *Audio Engineering Magazine* (original name of *Audio Magazine*) 1952 and before. Also, *Stereo Review* and *High Fidelity* 1963 on up. Mike Stosich, 4813 Wallbank Ave., Downers Grove, IL 60515, EsotericTT@aol.com.

Good quality tonearm (SME, and so on) for Thorens TD-125 turntable. Reed Hurley 770-474-6594, or srhurley@southernco.com.

Schematic and PC layout (or service manual) for SONY TAE-5450 FET preamp. Copy fine, reasonable cost. Harry Conover, 303-934-4210, Denver, CO.

WEBSITE RESOURCES

Solen Electronique
<http://www.solen.ca>

www.partsexpress.com

Your internet source of audio, video and speaker building components for home, office, mobile and pro sound.



<http://www.partsexpress.com>

Virtual Crossover Box

from Vidsonix Design Works

A self-contained variable crossover circuit (passive and analog) that lets you change components instantly by using labeled rotary switches and pre-determined network paths on a printed circuit board. It lets you create new crossover versions and modify them instantaneously, in real-time, resulting in less time testing and building multiple prototypes. This box is a must-have companion to any speaker system design or analysis software.

With the Virtual Crossover Box you can—

Design, test, and modify crossovers in real-time, while listening or comparing software curves. Great for A/B testing!

Eliminate countless hours of design and mock-up building time.

"Tune" your home or car audio speaker system installations.

Use external components with the quick-connect push terminals or select from over 85 components by using robust, long-life rotary switches.

The Virtual Crossover Box—

Uses an internal PCB for tight tolerances and reliable performance.

Has a tough, injected molded plastic top panel with silk-screened component values to guarantee years of productive use.

Is streamlined—14¼" × 10¼" × 2½"—and fits into a standard size briefcase.

Weights less than 7 lbs.

Has a full one-year function warranty.



Shipping Wt:
7 lbs.
K-VCB100
\$249.95

Call 1-888-924-9465
today or order on-line at
www.audioXpress.com!

Old Colony Sound Laboratory, PO Box 876
Dept. LIS2, Peterborough, NH 03458-0876 USA
Toll-free: 888-924-9465 Phone: 603-924-9464
Fax: 603-924-9467
E-mail: custserv@audioXpress.com

Test Tracks

These CD tracks are some of my favorites for testing the performance of my system and individual components that I sometimes audition. These selections cover a wide range of specific characteristics that can be used for system/component evaluations, and are also great for general listening pleasure. I am sure that any home hi-fi setup that does well with the challenges included here will provide a satisfying listening experience.

1. Joni Mitchell, *Court and Spark*, Asylum 1001-2 EUR 253002.

This album was a popular benchmark for Mitchell during the early '70s. The album's title track, "Court and Spark," is blessed with a very fine vocal recording. Joni's voice comes through with amazing naturalness and presence, without any recorded ambience or other artifacts to rob you of the feeling that she is really present in the room, hovering between your speakers. An excellent test for natural vocal reproduction.

2. Andreas Vollenweider, *White Winds*, CBS MK39963.

The third track on this album, "The Glass Hall," has a wide range of detailed and delicate sounds to test the resolution and lifelike presentation of a hi-fi system. There are bells, glass shards, wind instrument sounds, and Vollenweider's harp plucking laid out in a large ambient space. Listen for the minute details of the tinkling shards that seem to be hanging in space.

3. Shirley Horn, *You Won't Forget Me*, Verve 847 482-2.

This lady really belts out the lyrics with a smoothness and savvy that reveals

her talent and long heritage as a jazz vocalist. Aside from being another great Verve recording, the subtle inflections of her voice are very well captured here. There is a clear sense of even very fleeting sounds off her lips during short refrains and in the beginnings of vocal lines that she is delivering.

4. Antonin Dvorak, *Symphony 9*, Jascha Horenstein, Royal Philharmonic Orchestra, Chesky CD 31.

This recording, by the famous team of Charles Gerhart and Kenneth Wilkinson, must surely rank as one of the best symphonic recordings available, with a great sense of dynamics, soundstaging, clarity, and naturalness, not to mention the exciting performance. Here is a symphonic recording capable of giving a system and the listener a good workout. With the lights out, this recording can feel like the excitement of a live performance if a system is up to the task.

5. Aaron Copeland, "Fanfare for the Common Man," Louis Lane, Atlanta Symphony Orchestra, Telarc CD-80078.

This short, simple, and moving musical piece is a fantastic test of any system's dynamic capabilities, and the ability to project powerful low bass energy. The music starts out with a very loud and dynamic cymbal crash, and has a series of powerful bass drum notes during the piece. A great test for tweeters and subwoofers!

6. Michael Hedges, *Aerial Boundaries*, Windham Hill, WH-1032.

The track "Aerial Boundaries" is great fun as a solo acoustic guitar perfor-

mance and conveys the name of the piece quite well. There is an abundance of rich guitar string resonances in a large space, with many quick transient plucks that produce faint echoes that seem to "ping" off the walls of the acoustic space used for the recording. See whether your system can sort out and clearly portray the faint echoes reverberating in the recording space.

7. J.S. Bach, *The Complete Flute Sonatas*, Aurele Nicolet, Denon 33C37-7331.

The Partita in A minor is a great piece of solo flute music that clearly projects many performance details. On a good system, it is possible to easily hear the many nuances of the mechanical levers and valves of the flute, as well as the character of the breaths that are taken by the soloist during the performance. Having heard this piece of music live and close up, this recording comes surprisingly close to reality.

Dan Stanley
Indianapolis, Ind.

Let's hear from you. Simply describe your favorite pieces (not to exceed 1,000 words); include the names of the music, composer, manufacturer, and manufacturer's number; and send to "Test Tracks," Audio Amateur, Inc., Box 876, Peterborough, NH 03458. We will pay a modest stipend to readers whose submissions are chosen for publication.

www.audioXpress.com