

POLYPHONY

2/76

THUNDER & EXPLOSIONS

CONSTRUCTION PROJECTS

REVIEWS

PATCHES



Editorial

Once again - welcome! We received good material from you during the past months, and as a result, I feel that this issue will be a good representation of Polyphony style in the future. This issue contains an abundance of good patches, experimenter projects and technical information.

One item that I would like to explain briefly is the questionnaire in the center of this issue. As most of you know, PAIA's product philosophy is to produce kits geared for the electronic hobbyist. We are honored that some of you are using our products in professional applications, even though they were initially conceived to provide a starting point for experimentation. Recently we have concentrated most of our research and development in the area of electronic music synthesizers as they have been overwhelmingly popular products. We intend to continue releasing new synthesizer modules, but also expand into new lines of kits. There are many areas that we could delve into that are related to synthesizers, and there are many that are completely different technologies. What we are concerned with is - what areas are our readers interested in experimenting with? The questionnaire is your chance to "sound off" as far as what products you have been wishing someone would make, and what kind of information you'd like to see published in Polyphony. There are also a few questions about you, so that we can learn more about you, thus allowing us to more efficiently produce publications, products, instructions and advertising.

It shouldn't take more than 10 minutes and 13¢ to let us know how we can best serve your interests. If there are things you'd like to mention that aren't on the form, use an extra sheet and enclose it in the questionnaire. In the next issue (late August or early September), we will do a short summation of what we have learned from the questionnaire. It should be interesting, and I look forward to hearing from each and every one of you!

Marvin E. Jones, Editor

Subscriptions

Subscription rates are \$2.00 per year mailed in the U. S. A.
\$3.00 per year mailed to Canada and Mexico. International Subscriptions are \$5.00 per year. Address corrections requested.

Published quarterly by PAIA Electronics, Inc., 1020 W. Wilshire Blvd.
Oklahoma City, OK 73116

©1976, PAIA Electronics, Inc. All rights reserved.

contents

Volume: 2 No. 2 1976

FEATURES

Thunder and Explosions	6
Pedal Your Way to Success in the Music Business by: Marvin Jones	9
More Fun and Games Emanating From the 4780 Sequencer	14

NEW FROM PAIA

OZ	16
Binders (At Last!)	17
Experimenter's Kit	17

CONSTRUCTION

Switch Selectable Range for the 2720-3B Filter by: Robert Matarazzo	8
Build a Wa/Anti-Wa by: Craig Anderton	18

COLUMNS

Polyphony Reviews:

Book	4
Record.....	5
Random Noise	15
Dear PAIA	20
Editorial	2
Patches	21
Local Happenings	24
Lab Notes by: John S. Simonton, Jr.	25
Next Issue	31

DON'T MISS THE POLYPHONY QUESTIONNAIRE - CENTER SPREAD

Marvin Jones: EDITOR - Linda Kay Brumfield: Assistant Editor
John S. Simonton, Jr. : Contributing Editor
Ramona French: Production
COVER: Reflections in a Crystalline Sphere
By: Linda Kay Brumfield
With credit given, and apologies to: M. C. Escher - Inventor

POLYPHONY REVIEWS!

A NEW "HOW TO" BOOK WITH PLANS FOR 19 PROJECTS

ELECTRONIC PROJECTS FOR MUSICIANS

By: Craig Anderton
with

Illustrations by:
Vesta Copestakes

Guitar Player Productions
- \$6.95 -

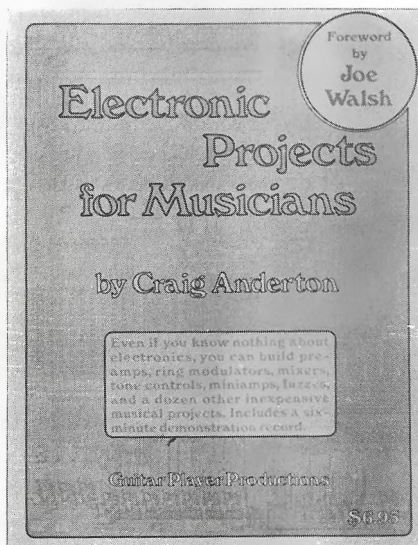

In Craig's biography it says that he's been doing this sort of thing since he was 15 - which works out to about a dozen years. In that amount of time you would expect that he would get pretty good at it. He has.

Probably the best part of the book is that he assumes you know nothing and proceeds to teach you everything about construction techniques, parts and how to substitute them, that you need to know to build the book's 19 projects from scratch. If we could get everyone to read these first sections before assembling a kit, we could cut our repair department in half.

If it happens that you already know everything, you can skip the first part of the book and get right to the projects; but if you do, you will miss most of Vesta's terrific illustrations.

From compressors through ring modulators and electronic switches, these designs form an excellent introduction to the basics of electronic music modifiers. And, a bound in demo record features Craig showing you how all the goodies will sound when you're done.

"Electronic Projects for Musicians" is a permanent addition to my library and chances are good that yours could benefit from it too.

-John S. Simonton, Jr. -

A TOTALLY SYNTHESIZED RECORDING

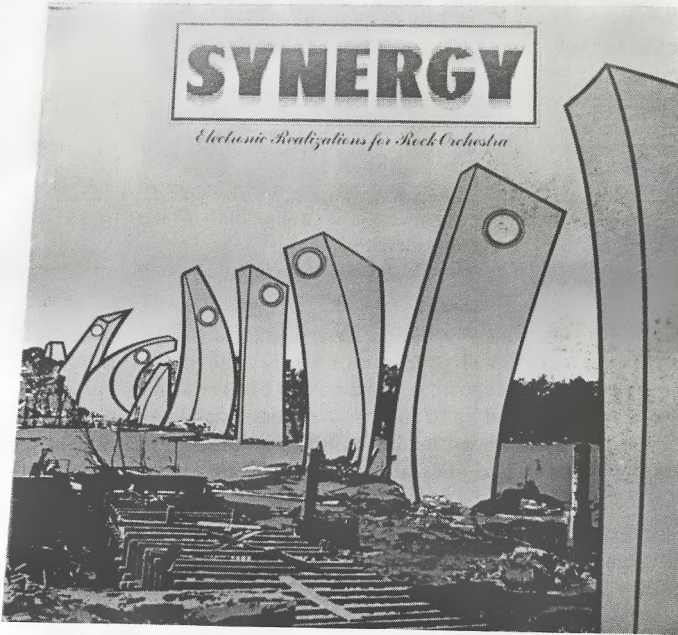

SYNERGY by: Larry Fast, Passport Records # PPSD-98009

When we first decided to start doing reviews in Polyphony, the first thing that came to mind was the Synergy album. This album is not new, it's been out since last fall. Since it's release I haven't found anything to take it's place at the front of my stack of records.

In my opinion, Synergy is easily the best example of a one man, fully synthesized recording since the turn of the decade when Gershon Kingsley, Beaver and Krause, and Mort Garson were actively synthesizing. In addition to his outstanding mastery of the equipment, Larry Fast composed all but one of the pieces on the album. The patches used throughout the album, although taken singly many are basic and straightforward, complement each other so that the overall effect of the album is very powerful. The subtitle sums it up very well -- "Electronic Realizations for Rock Orchestra".

Although it isn't mentioned in the album notes, I suspect that fifty or more voices were used in some of the sections. All Synergy albums were pressed in QS quad which also adds some heightened stereo effects.

Polyphony readers will also be interested in the fact that Larry Fast is a fellow electronic experimenter and constructed several circuits, such as auto quad panners and galvanic skin response controllers, which were used in recording the album. He has built some PAIA kits that he uses along with his Mini-Moog, ARP 2600, Oberheim, Mellotron, Eventide and other varied equipment. I strongly recommend Synergy as an example of what synthesis is all about -- creating music from the ground up.

THUNDER AND EXPLOSIONS

In the last issue of POLYPHONY, there was a letter from Dale Naylor requesting thunder-type patches. In response to his request, several readers sent patches they had used to create thunder and explosions (a close relative of thunder). Since there seems to be considerable interest in these types of sounds, we decided to present several thunder patches for your evaluation.

The first response we received was from Hank Jones of Mesquite, Texas. He suggested using a reverb module whose output was connected to an amp., but with no input applied. Make sure that the external amp is at a low setting (due to the high output level which will be produced) and gently shake the cabinet which houses the reverb spring unit. The induced vibration of the springs will cause a decaying rumble similar to thunder. If you have the spring can mounted such that you have access to the actual springs, a different sound can be achieved by rubbing the springs with a finger or other object.

A short time later, we received a contribution from Allen Fairfield of Wakefield, Mass. His patch was entitled "Galactic Explosion", but as he pointed out, it could be converted to thunder by extending the envelope attack time. Allen's complete patch can be found in the Dear PAIA section.

When I realized that there were a number of people interested in these types of sounds, I decided to do some work in our studio concerning subharmonics and subaudio signal generation. In the process, I developed a very interesting patch. But, before talking about the patch, there are some important points that must be covered concerning amplification. The frequencies produced by this patch are very low -- mostly below audibility. The resulting effect is similar to the "Sensurround" effect in the Earthquake movies, in that we are dealing with considerable air motion to create a physical feeling rather than an audible sound. Consequently, considerable amplifier power and speaker response are required to get the "earth shaking" effect. This doesn't mean that you have to go out and buy a stack of Phase Linears and Cerwin-Vega speakers. It simply means to make sure your system can handle the signal. Low frequencies always use more amplifier power than an equal amplitude high frequency, and low frequencies at high power cause tremendous woofer excursions.

The subsonic patch is shown on the facing page with comments for setting the various modules.

As mentioned in the comments, make sure that all VCO's are tuned to minimum, and that no two VCO's are tuned together. A properly set 4730 Filter will pass only frequencies below 30 to 40 Hz., and what you hear will be a combination of the beat frequencies created by the mistuned oscillators and mistuned fundamental frequencies of the more complex VCO outputs. No VCA is required due to the cut-off frequency of the 4730 going far below the lowest frequency we will be using. This patch is a lot of fun and is great for freaking people out.

P. S. - After you've done the thunder, try this: Turn the keyboard pitch control to maximum, Leave the VCO's mistuned. Set the ADSR Attack and Release controls to 25%, and set the 4730 range control to maximum (leave the High/Low switch at low). Press the second C from the top of the keyboard and you've got a diesel truck horn!

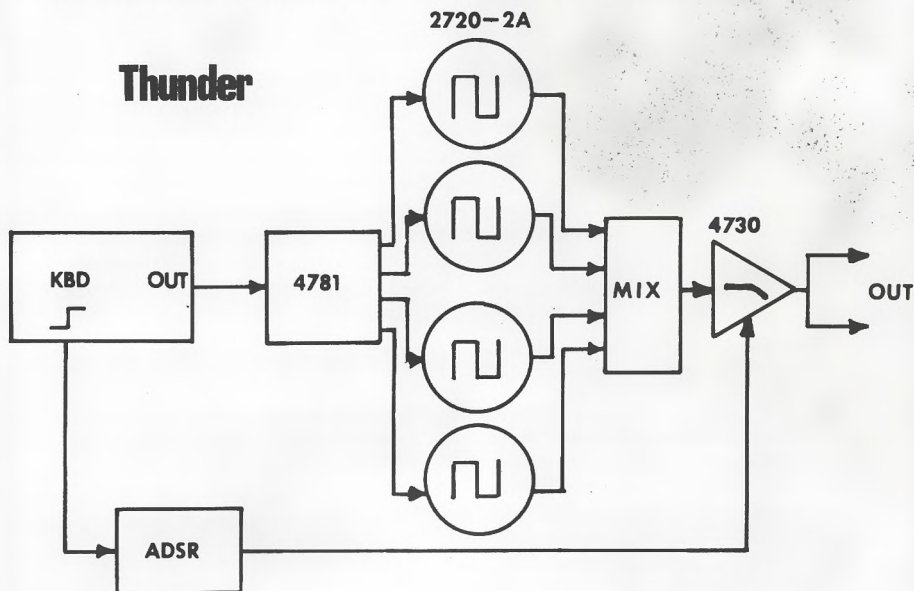

- COMMENTS:**
- Keyboard - Set pitch at minimum and press lowest C for thunder.
 - Transposer - Set all controls to minimum, but check to make sure that no two VCO's are at the same frequency.
 - VCO - Use square wave outputs.
 - ADSR - Attack - 50%
Decay - Minimum
Sustain - Maximum
Release - Maximum
 - Mixer - All inputs mixed equally with maximum amplitude.
 - 4730 - Low-pass output, Range switch - Low
Initial frequency - 50%
Sweep switch position
Q - 50% or less.

Switch Selectable Range for the 2720-3B

IMPROVE THE VERSATILITY AND VARIETY OF SOUNDS AVAILABLE

By: Robert Matarazzo

In the 2720-3B manual, it is indicated that changing the values of C3, C4 and C5 will change the range of the filter. Halving the values will double the upper and lower limits of the range, while doubling the values will cut the limits in half.

Original 2720-3B Circuit

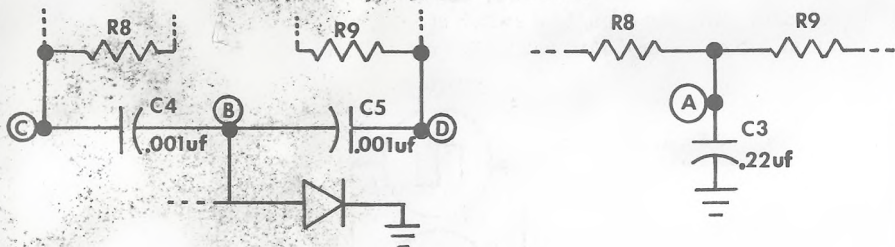

If the three capacitors are replaced by the following switching network, the filter will have three switch selectable ranges. When the switch is in position #1, the two capacitors in that branch are in parallel, which gives an equivalent capacitance of twice the original value. This corresponds to halving the frequency limits.

When the switch is in position #2, only one capacitor is switched in, thus duplicating the original circuit.

When the switch is in position #3, there are two capacitors in series to give an equivalent capacitance of half the original value. This position will double the filter's frequency limits.

Switches S1a, S1b, and S1c are a three pole, three position rotary switch (similar to the range switch on the 2720-5 Control Oscillator). Note that all capacitor values are equal to the original values.

Modified 2720-3B Circuit

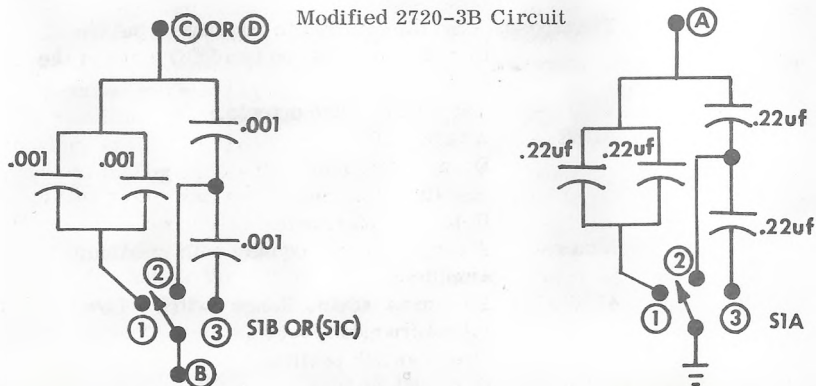

Using Terminal Sections of Vertebrate Anatomy for Increased Control Capabilities of an Electronic Music Synthesis System or... How to Pedal Your Way to Success in the Music Business

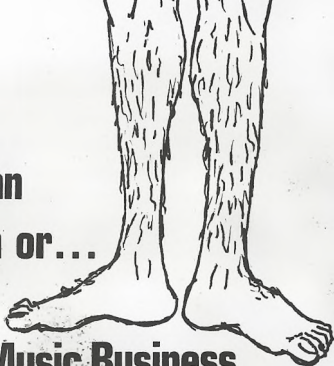

by: Marvin Jones

With the release of the PAIA DeArmond foot pedal in the last issue of POLYPHONY a new area of synthesizer control has been opened for experimentation. Foot pedals allow the synthesist to move one step closer to one of the prime goals of electronic music, increased human control over the electronics. Rather than being limited to two hands as control elements, two more human variables can now be used. Undoubtedly, future developments will bring into being brain wave and programmed (computer) control -- all of these being merely extensions of the person operating the machine. But, not to loose our footing here, let's get back to foot pedals and their use as control elements.

The pedal volume control can serve a multitude of uses without any modification at all. The inside of the pedal consists of a 1 meg potentiometer wired as shown on the right. As you can see, there is no capacitive coupling in the unit so it can be used with control voltages as well as audio signals. All

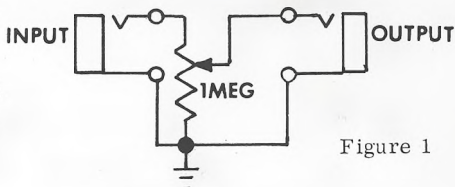

Figure 1

you need are some special, easily constructed, patch cords and you're in business. You will need to construct four patch cords, two with shielded audio cable and a 1/4 inch phone plug on one end (to fit the pedal) and a mini-phone plug on the other (to fit the synthesizer). The other two cords use two conductor shielded cable with a 1/4 inch phone plug on one end and pin plugs installed on each of the two conductors on the other end. For easy reference, use two colors of pin plugs on each cord: red plugs for signal lead and black for ground. Connect the shield to the 1/4 inch plug. Remove about 6 inches of the cable cover and shielding on the pin plug end of these cables allowing about 12 inches between plugs just in case a grounded jack is not available near the control voltage jack that you wish to use.

Now that we're past the mechanics of cord construction we can put the pedal to use. The first and most obvious use is that which the pedal was originally intended for -- a volume control. Since using a VCA which generates the same dynamics for each note and an Envelope Generator producing a programmed output level can be rather monotonous this simple patch can be extremely important from a musical standpoint. Patch the synthesizer audio output to the pedal input (labeled "INSTR"), and the pedal output (labeled "AMP") to your external amplifier. You can now add expression through phrasing, dynamic changes over a period of time to accent certain melodies, or accent a particular note within a phrase.

Other audio applications include adding pre-programmed chords or intervals to a basic one note patch via foot control by running the mixed chord or interval through the foot pedal prior to mixing with the single note patch at another mixer or VCA; as shown in figure 2; and adding reverb to selected notes or passages by patching the final signal to an output mixer and to the reverb input as shown in figure 3. The reverb should be set for full reverb effect, and no normal signal. The reverb output can then be passed through the pedal prior to being added to the original at the mixer.

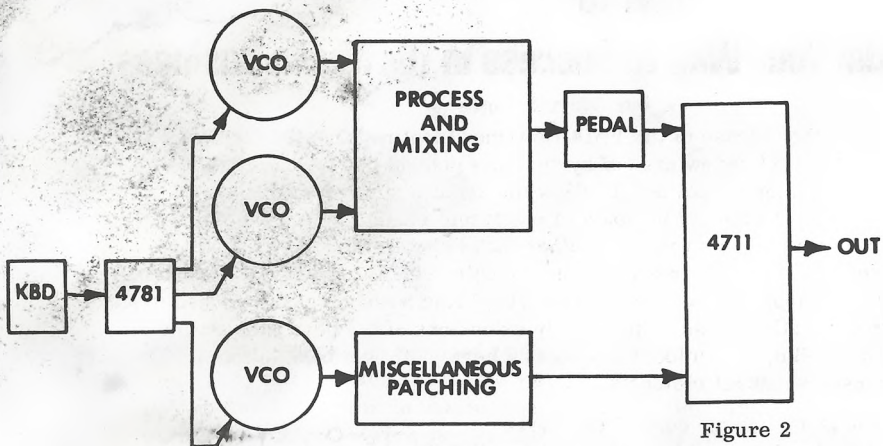

Figure 2

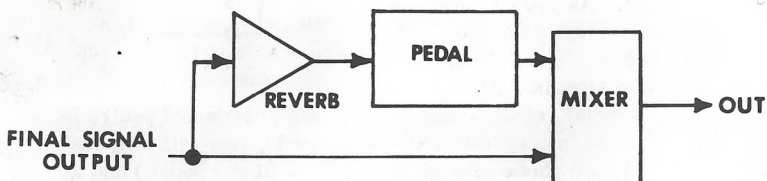

Figure 3

As the pedal has no capacitive coupling, control voltages can be processed without fear of loosing DC levels or low frequency waveforms. For use with control voltages, your other set of patch cords (with pin plug connectors) will be used. Patch configuration is similar to audio use, with the control voltage source being fed to the pedal input, and the pedal output being fed to the module to be controlled.

A basic example would be using the pedal to sweep a filter, similar to a guitar player's Wa-Wa. Adjust a bias supply for the maximum voltage you wish to be fed to the filter. Connect the "hot" plug of the pedal input cord to the preset bias output. The ground plug of this cord can be connected to a 4761 ground jack, or to a "variable" output of some module (control oscillator, envelope generator, etc.) where the variable output control has been set to minimum to ground the output jack. The "hot" plug of the pedal output cord is fed to the filter's control input. The ground plug on the second

cord need not be connected due to the common ground between all modules via front panels and power supplies. Now the pedal can be used just as a guitarist uses his wa-wa pedal, only you can preset the range of your foot action due to the preset bias supply.

An envelope generator output can be used rather than the bias supply, giving the popular "sweeping filter on each note" effect, but using the pedal, you can vary just how far the filter deflects on each note or phrase.

Another popular use is pedal control of vibrato (or modulation of VCO's). This will give the effect popularized by the Mini-Moog modulation wheel, but you won't have to waste a hand doing it. Using the variable output of a low frequency oscillator, select the frequency and Maximum output level (vibrato depth) you will desire. Run the output through a coupling capacitor on the 2720-7 power supply to remove DC level (to eliminate any pitch shifts, or detuning as vibrato is applied), and connect the capacitor output to the pedal input. The pedal output is then connected to a VCO input. (Make sure one of the cords has a ground connection made). Now you can apply vibrato at will by depressing the pedal. Similarly, a bias voltage can be processed by the pedal prior to feeding a VCO to produce foot controlled pitch bending.

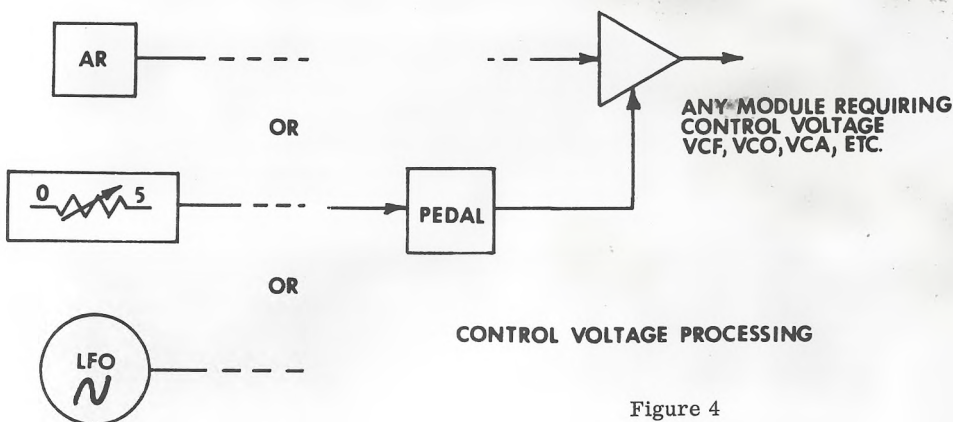

Figure 4

For use as a stereo panning pedal begin by feeding a 5 volt bias to the pedal input. The pedal output is then fed to a jack multiple, where one connection is made to a VCA control input and another connection to the input of an inverter (2720-12). The inverter output is fed to a second VCA, and the inverter offset is switched to 5 volts. A single audio source is fed to both VCA's but each VCA output is fed to a separate amplifier system. When the foot pedal is at minimum the signal is fed to one amplifier, and when the pedal is depressed, the signal will move to the other amp causing a stereo sweep or panning action. A slight variation of this patch would be to feed two separately patched sounds to the two VCAs, and feed the VCA outputs to a mixer. Now you can switch instantly between two completely different sounds at the touch of a toe, or you can select a blend of the two patches by leaving the pedal at an intermediate setting.

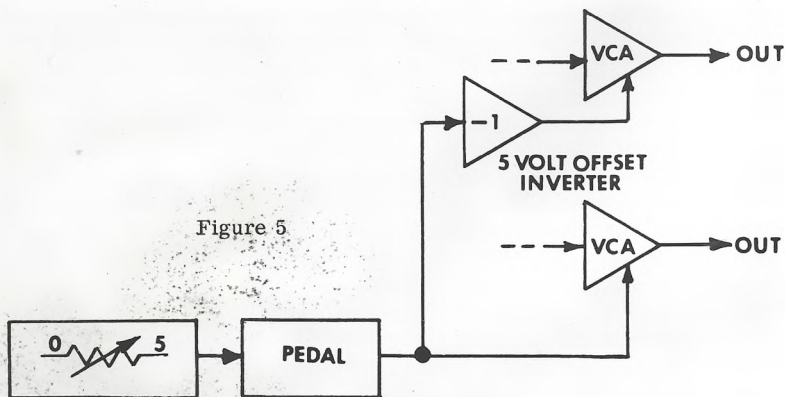

Figure 5

Another interesting type of pedal control can be obtained by using an audio cord to apply a higher frequency signal to the input of the pedal, and using a control voltage cord to apply the pedal output to the control input of a module. Try this with a VCO feeding another VCO or a VCF.

As you can see the possibilities are as unlimited as the synthesizer itself. Everything so far uses only a stock, unmodified pedal! Imagine the capabilities when you start experimenting with installing custom circuitry inside the pedal. The PAIA/DeArmond pedal is well suited to experimentation, as it has areas molded into the case to mount extra jacks, pots, etc. and it even has circuit board standoffs molded on the inside.

There are a lot of easy modifications which can be made to customize your pedal but one of the most beneficial is adding self contained bias supplied to the pedal. This modification need not eliminate the standard "volume control" function, as a switching jack can be used to select either mode of operation. A schematic and required parts list are given below.

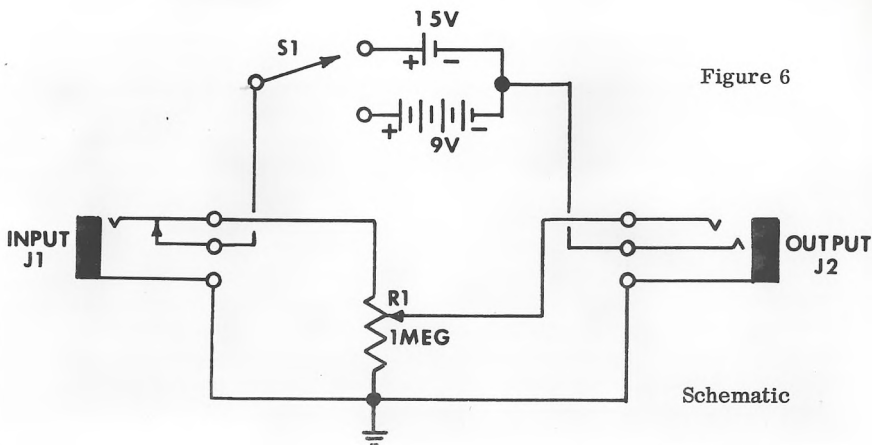

Figure 6

Schematic

PARTS LIST:

- 1 - PAIA/DeArmond Foot Pedal
- R1 - 1 meg ohm potentiometer (supplied with foot pedal)
- S1 - SPDT toggle switch (miniature type)
- J1 - 1/4 inch closed circuit phone jack (Switchcraft type 12A or similar)
- J2 - 1/4 inch 2 conductor phone jack (switchcraft type 12B or similar)
- Misc. - 9 volt type battery snap, 9 volt battery holder, size AA penlight battery holder, wire and 9 volt & penlight (AA) batteries.

The battery holders are fastened to the bottom plate of the pedal using hot glue or epoxy. The voltage selector switch is mounted in a hole drilled in the side of the pedal. Also, make sure that the proper type jack is mounted at the input/output jack holes. Since the pedal will still be used for audio signals, keep the wiring between the jacks and R1 shielded (as originally supplied).

Inserting a standard two conductor phone plug into the output jack completes the connection between batteries and ground. The selected battery voltage is applied to the pot via the switch contacts of J1. This allows use of the pedal as a self contained bias supply. Plugging the input jack disconnects the bias supply and routes an external signal through the pedal normally. Batteries are always disconnected when input is applied or output is removed, so the batteries should last for quite a while. Always be sure to remove all plugs when the pedal is not being used to prolong battery life.

As you can see, by now, a foot pedal (or two) is a very beneficial, as well as fun, addition to a synthesis system. You'll be seeing more about neat gadgets that can be built right into the pedal. The 9 volt bias modification can be used as a foot control for the "Speed" and "Center" jacks on the rear of the PAIA Synthespin and, if you play in a band and your guitar player likes Wa-Wa's, tell him that he hasn't heard a Wa-Wa until he has run his guitar through a 4730 filter set up for foot pedal control. Not only will it have a wider frequency range than any on the market, but it will have high-pass and low-pass response as well as the standard band-pass sound. The capabilities are tremendous, let your imagination take over and be sure to let us know what you come up with.

**** LAST MINUTE NEWS FLASH ****

The night before we sent this issue to press I heard the NEW SYNERGY album. (See record review, page 5.) It's entitled SEQUENCER, Passport Records - Disc Number PPSD-98014.

It's every bit as good as the first! Musically somewhat more sophisticated, some new equipment, very smooth ----- WOW!

-Marvin Jones-

More Fun and Games Emanating from the 4780 Sequencer

The "Beat the Clock" sequencer game in the last issue stirred up some interest, so here's another one. This time we will use the sequencer in a game of chance. Depending on the patch used, you can create a roulette wheel, dice roller, or coin flipper, all automatic at the push of a button. The patch includes diagrams for pretty good roulette wheel sound as a bonus.

As the drawing shows, the sequencer is set up to reload itself and continue cycling. Feeding the twelfth stage back can be used for roulette wheels, or rolling two dice. Feeding the sixth stage back can be used for rolling one die, and feeding the second stage back can be used for flipping a coin, answering true/false questions on your next exam, or whatever. An envelope generator output is fed to the RUN input on the sequencer and the clock is switched to STOP. Clock speed should be set at maximum. The envelope generator is set for minimum attack and maximum decay. If a 4740 is being used, sustain should be at maximum as well as initial decay.

Pressing the manual trigger on the envelope generator starts the sequencer. When the output of the envelope generator falls below the required bias voltage of the RUN jack, the sequencer will stop.

To add sound effects, run a noise source through a bandpass filter and VCA. The extra envelope generator output can be used to control the filter. Set the sequencer trigger width between minimum and 50%, and apply the step trigger output to the VCA control input.

Thanks to Greg Leslie, Ponca City, Oklahoma, for the initial inspiration to figure out this little piece of demented patchwork.

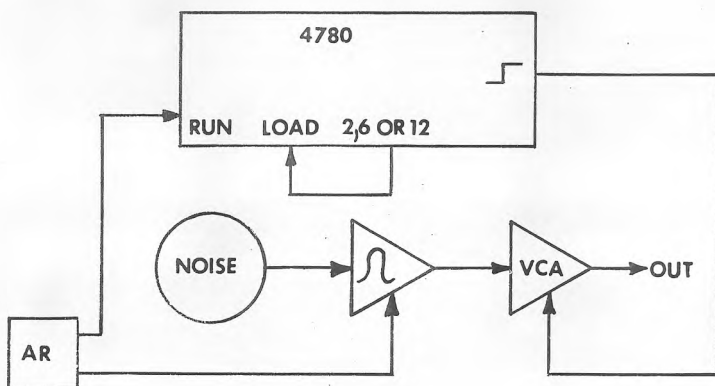

Random Noise

A sharing of miscellaneous hints which might prove helpful in an electronic music studio but are not directly concerned with the Synthesis equipment.

KEEPING A SPARE FUSE HANDY

Robert Bailey, from Norfolk, Va., included the following tip in a recent letter. "While making some minor adjustments, I dropped a screwdriver into my synthesizer. It landed - you guessed it - right across the power supply, resulting in a blown fuse. Not having a spare fuse, I was left "synthesizerless" for several days, while trying to locate a replacement. Horror of horrors! Anyway, my tip is to buy a clip-in fuse holder (and a spare fuse) similar to the type used in the 2720-7 power supply. Mount this somewhere inside the case, and you have a convenient place to keep a spare fuse. These can be obtained from any Radio Shack for 2/79¢. If desired, the second one can be mounted on the front of the case. It makes a dandy pencil holder for anyone who likes to keep a record of all their patches."

This idea could be helpful in other equipment also: guitar amps, test equipment, anyplace you always seem to need a fuse.

LOW COST SWITCH LOCK FOR THE GNOME

Paul Nelson, music instructor at Bozeman, Montana, sends this tip for Gnome users.

"Since it rapidly becomes obvious that the Gnome eats batteries for breakfast unless you keep the switch off, and that sometimes the switch is 'on' when you thought it was 'off', the need for a switch lock seems obvious. Cut a piece of wood 1" X 1" X 7-3/4", cover it with a soft cloth and tie it to the front of the Gnome with a rubber band. This will hold the power switch in the 'off' position. The Gnome can then be placed in the shipping box for transporting, with the assurance that the power has not been left on.

We went a step further and redesigned an old portable phonograph to use as a portable amplifier. I removed the turntable and wired a jack to the amplifier section. The Gnome, safely padded in it's shipping box with the power switch locked 'off', will just fit inside the lid. The students in my Junior High Electronic Music class can check out a synthesizer, amplifier and all."

BULLETIN

STEREO CHORD EGG* - The ultimate meditation/environment machine?

What happens when you combine a top octave chip, random chord select circuitry, random voltage generators, 4 voltage controlled attenuators and 2 voltage controlled filters? In a word, MAGIC!

The EGG plugs into any stereo amplifier and provides soothing, flowing environmental effects - but, with headphones it's unbelievable. The chords and notes EXIST in your head. They pan and flow and sweep through your mind in patterns that never repeat and can't be predicted. We try to avoid superlatives, but this is the most completely incredible device we've ever produced. ANOTHER PAIA ORIGINAL EXCLUSIVELY TO POLYPHONY READERS. Target delivery date: 7/15/76.

STEREO CHORD EGG #3790 \$24.95 postpaid
(no case available - 8 "AA" penlight batteries required)

*EGG - Encephalo-Gratification Generator.



is here!



OZ is the latest addition to PAIA's line of low-cost, high-value electronic music kits. It's a fully polytonic instrument that can be used as a portable practice keyboard, mini-organ system or trigger and pitch source for any synthesizer.

OZ has a built in speaker and 1 watt (RMS) amplifier allowing performances outdoors, in your van or anywhere that amplifiers aren't normally available. A mixing input allows other instruments to share OZ's amp.

Oz's unique, pressure sensitive pitch bender provides vibrato, glissando or trilling of single notes or whole chords and always returns to proper pitch when your hand is removed.

Front panel features include a fine tuning control with a full octave range for tuning OZ to other instruments. A five position range switch transposes the keyboard by exact octave steps allowing instant changes from rich bass to piercing highs. Two trigger modes are switch selectable: STEP which goes high as long as any keys are down or PULSE which delivers a 10 ms. pulse each time any key is pressed (even if other keys are already down). LED indicators provide visual feedback of range setting and trigger status. Volume and tone controls are provided.

Interface OZ with the Gnome Micro-Synthesizer for a completely portable, polytonic synthesizer system with amplifier and speaker for less than \$140.00 (slight modification required to the Gnome).

Kit includes circuit board, all parts, sturdy vinyl-covered road case with removable keyboard cover and our step-by-step, loaded with pictures instruction manual (8 "AA" size pence cell batteries required)

OZ Kit #3760 \$84.95 shipping wt. 12 lbs.

The PAIA Demo-Line currently features OZ - (405) 843-7396. Leave your name and we'll send a far-out OZ brochure and demo patch book. Or, order on your Bank-Americard or Master Charge Card.

AT LAST our very own BINDERS

At long last, we've selected the perfect multi-copy publication binders. No more punching holes in your Polyphony copies to keep them in a dime store ring binder!

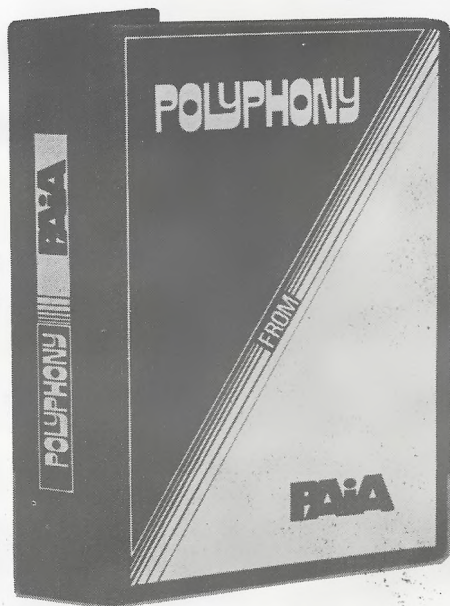

Bold, white on black POLYPHONY/PAIA graphic designed by Linda Kay Brumfield (our assistant editor) accents the 9 X 6 inch binder. Twelve wire rods hold magazines (or instruction/using manuals) in binder. Easy to add and remove copies from the special spring rod holders that also allow for binding of publications of varied thickness.

POLYPHONY/PAIA Binder #QS-7 \$4.95 Postpaid

Top-Octave Experimenter's Kit

If you have been inspired by John's copy in LAB NOTES and are anxious to get your hands on a Top Octave chip, this is for you! Kit includes one #50240 top-octave chip, a CD 4001 NOR gate IC and a circuit board to mount them on.

Remember, this is an "Experimenter's Kit" without any elaborate instructions. We do provide a circuit board parts placement diagram and a list of recommended parts values for the resistors, capacitors, etc. that you'll have to scrounge from your junk box.

It's an inexpensive introduction to "experimenting", and who knows where that can lead to!

Top-Octave Experimenter's Kit #EK-1 \$12.50 postpaid

BUILD A WA/ANTI-WA PEDAL

Using the PAIA/DeARMOND Foot Pedal

by: Craig Anderton

The first question is what do I mean by Wa/Anti-Wa. Well, a normal footpedal wa-wa usually has a simple bandpass filter, and you can sweep the bandpass of that filter up and down by a rocking motion with the pedal. In normal practice, the resonant frequency of the filter increases (higher apparent pitch) when you push down on the pedal, and decreases when you pull up on the pedal. By this definition of wa-wa, the anti-wa behaves in exactly the same manner but with one difference: pushing down on the pedal lowers the resonant frequency and pulling up on the pedal raises the resonant frequency.

By itself, this isn't too useful an effect, since you have to reverse your thinking compared to a regular wa-wa pedal. BUT -- if you could combine two filters into one pedal, so that as you pushed down one filter went up and a separate one went down -- and as you pulled up the reverse occurred -- then you'd have something. The effect is quite interesting, especially if you tune the filters differently; more about this later. Frankly, there's no way to describe the sound in print. Let's just say that if you like wa type pedals but have gotten a little tired of the sound, or want something that's a little different, then read on.

Luckily, the Wa/Anti-Wa can be easily configured using a PAIA /DeArmond foot control. Let's look at the schematic:

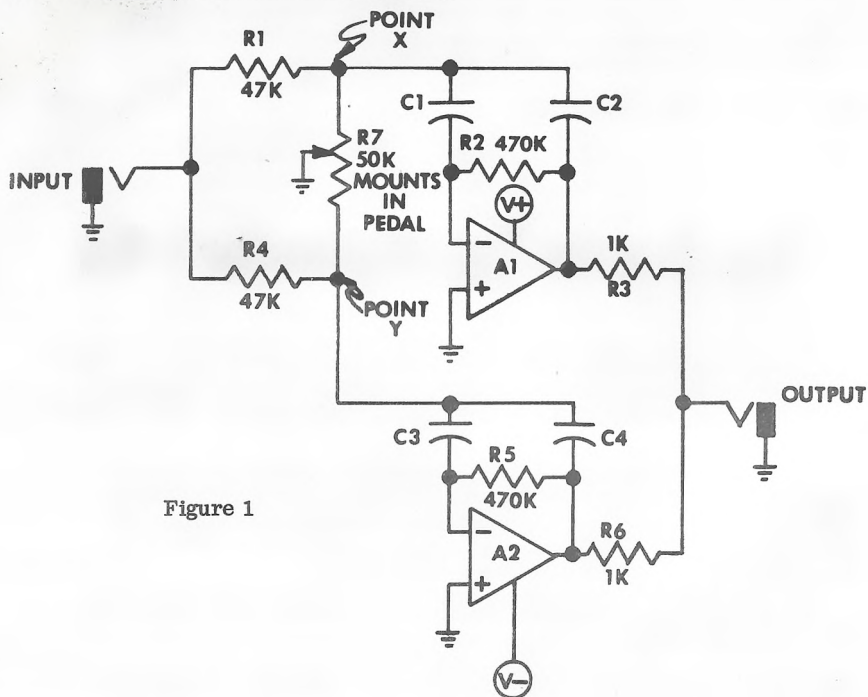

Figure 1

A1 and A2 are operational amplifiers, such as two 741's, a single 5558, a 4739 or whatever. Keep in mind, though, that this is a filter and for best results choose the lowest noise IC you have. You could also use something like an LM3900 if you bias the (+) inputs and add output coupling capacitors. Anyway, each op amp is configured in a filter. The resonant frequency of filter A1 depends upon the resistance from point X to ground; the resonant frequency (r. f.) of filter A2 depends upon the resistance from point Y to ground. Therefore, by connecting each point to the extreme ends of a 50K pot and grounding the wiper, we end up changing the resonant frequencies of the filters --- equally, but in opposite directions.

So, take a PAIA DeArmond pedal and remove the nice 1M pot that's already in there, and replace it with a 50K pot that has a reasonably long shaft (so the little gear thingie can screw onto the shaft). I don't really want to go into details here; the modification is pretty obvious with a pedal sitting in front of you.

For best results, connect up the V+ and V- lines to a regulated source of ± 5 v. to ± 15 v. Batteries will also work, but a supply is generally a much better idea.

THE FUN AND GAMES PART OF THE WHOLE THING

There are several variables in this circuit that make it fun to experiment with. The tuning of the filter depends upon the value of C1 and C2 for filter A1, and C3 and C4 for filter A2. (Note that these capacitor pairs should be matched). Different instruments will require different tunings. For example, with guitar, .001 for C1 and C2 and .0039 for C3 and C4 gave wonderful results. With bass, .002 for C1 & 2 and .005 for C3 & 4 works pretty well. For electric pianos and such, try .001 for C1 & 2 and .005 for C3 & 4. Make sure, though, that you don't tune the two filters the same, as the sound produced is remarkably dull compared to the interesting stuff that occurs when you tune them differently.

Another variable in the circuit is R2. If you'd like a peakier sound and a little more gain, change it to 1M (ditto R5).

The final variable we'll talk about is in the pedal itself. Like most volume pedals, the PAIA DeArmond pedal doesn't give a full pot rotation; unlike most volume pedals, it comes pretty close. I'd recommend playing with the gear / pot combination until you get a sound that pleases you the best. For example, mine is set so that even with the pedal all the way to one extreme there is still a little resistance between point X and ground; at the other extreme, point Y goes almost completely to ground -- just a few hundred ohms stand in the way. I've played with a lot of different choices ... some of them really didn't make it, but after a little experimentation you're sure to hit someplace where you say "Eureka!" and just leave it at that.

PLAYING WITH THE PEDAL

The Wa/Anti-Wa I built has the higher-tuned filter going up in r. f. when I push down on the pedal, with the lower tuned filter going down in resonant frequency. This seemed to work best. You'll find the extra wide throw of the pedal makes the Wa/Anti-Wa even more useful, as you can selectively "Wa" just one filter, just the other, or sweep back and forth over the whole range of the pedal and get a variety of bizarre effects. In any event it's a lot of fun and sounds different from your average Wa pedal ... and it's not at all expensive to build.

Dear PAIA,

A column devoted to answering your questions about PAIA, electronic music or any other area which might be of interest to our readers.

DEAR PAIA,

On the first page of your catalog #974, you said you can synthesize the sound of a Galactic Explosion. I'd love to know how to do this.

Roger Lippincott, Connersville, Indiana

Dear Roger,

Recently, Allen Fairfield of Wakefield, Mass. sent us a patch he devised. His letter and patch should answer your question.

"Your catalog mentioned being able to synthesize a galactic explosion. Well, after getting a nifty idea from the "Jetliner Take-Off" in the 1/76 issue of Polyphony, I figured out a pretty good explosion.

The bias controls for both filters should be adjusted for the best explosion. I used a function generator in the patch, but the ADSR would most likely give a better result. A reverb unit might be nice, too, but I don't have one (yet). Also, how about changing attack time to about 50% and adding reverb to get a thunder sound." (Also, see the Patch section of this issue for more thunder patches.)

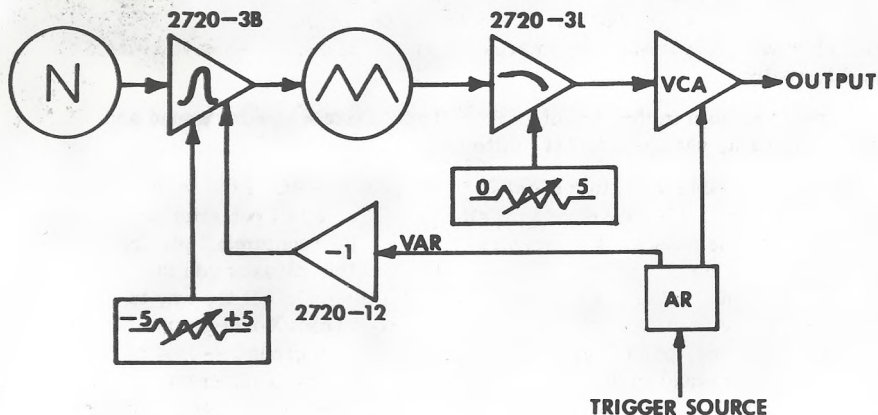

Comments: Bandpass Filter Q: 75% to 100%
-5 to +5 bias: -1 volt
0 to +5 bias: 4 volts
Inverter: 5 volt offset
AR: Expand off
Attack - minimum
Release - maximum
Variable output - 60%

Try setting envelope attack to maximum and release to minimum for humorous "backwards" explosion effect.

PATCHES

SHARE
YOUR FAVORITE SOUNDS
WITH US!

GNOME STRING BASS:

Use slow VCF and VCA attack for "bowing" effect.

Set Skew control for metallic "twang".

Set VCF range and Q controls to a low range or the patch loses it's string bass sound.

Submitted by: Bob Yannes, Media, Pennsylvania

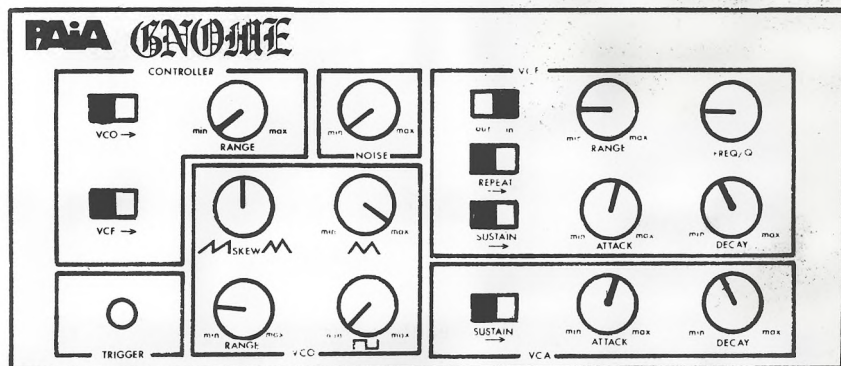

TWO NOTE TWIDDLES

0 - 5 volt bias: approx. 2 volts

-5 to +5 bias: approx. 1 volt

LFO: 9-12 Hz. Variable Output:
approx. 1 volt (as required
to trigger AR generator)

AR: Attack: Min.

Decay: 50%

Expand: Off

Variable output: 50%

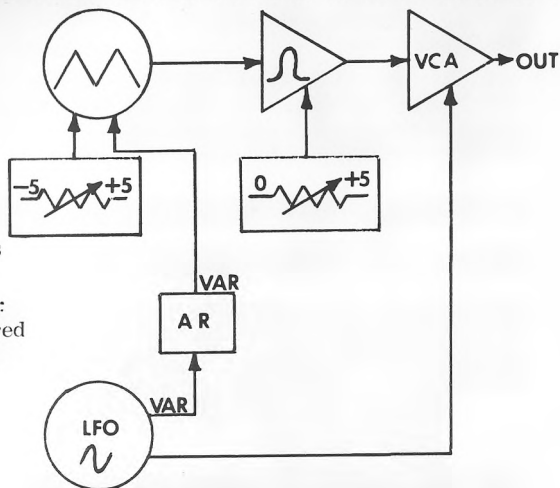

COMMENTS: The ± 5 volt bias raises or lowers both notes. The AR output level changes the interval between notes. This can be made to sound like a "Hollywood Flying Saucer". The patch lends itself to hours of experimenting.

Submitted by: Win Bent, Yellow Springs, Ohio

more... 21

patches

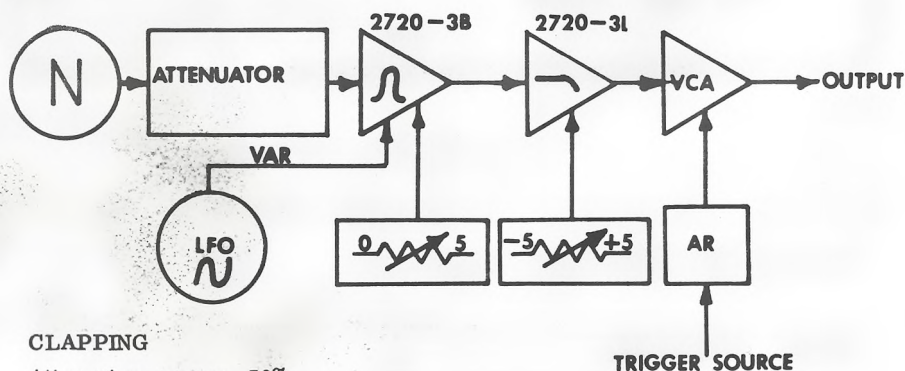

CLAPPING

Attenuator: approx. 50%

LFO: Approx. 25% output

Frequency: 1 - 3 Hz.

0 to 5 bias: 2 volts

-5 to +5 bias: 2 volts

AR: Expandoff

Attack: Minimum

Release: 10%

Bandpass Filter: Q at minimum

Submitted by: Allen Fairfield, Wakefield, MA

SPECIAL NOTES: This patch produces the sound of one clap each time the circuit is triggered. For the most realistic effects, a repeating trigger source (such as a sequencer trigger output or the Multi-Trigger from the last issue of POLYPHONY) should be used to trigger the patch at approximately 5 cps (claps per second). Also, to make the effect of several people clapping, try setting up at least three of these patches, all with slightly different settings. The realism of this patch depends on how much time you spend on getting everything set up just right. But, after spending about an hour setting this up in our studio, the effect was amazingly real -- and hilarious. What a great ending for a recorded piece on a synthesizer!

STRING EFFECTS FROM TRILOGY by ELP

AR #1: Expand off, Attack: 40%, Decay: 40%, Level: Max.

AR #2: Expand off, Attack: 40%, Decay 60%, Level: Max.

Mixer: Input 1 - Level Max., Pan 75%

Input 2 - Level 70%, Pan full left

Master Right 80%

Master Left 70%

LFO: 6-7 Hz. Level- very slight

Glide: 15%

Use Reverb if possible.

Submitted by: Robert Matarazzo, Brooklyn, NY

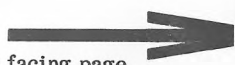
shown on facing page 

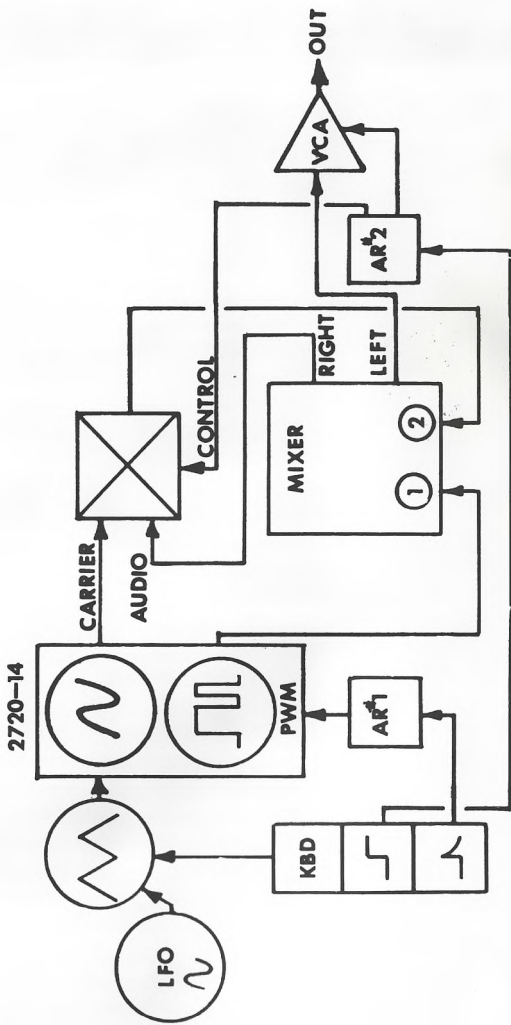

STRING EFFECTS FROM TRILOGY by: Emerson, Lake & Palmer

more next issue ...

Local Happenings

If you live near any of these people, contact them. They are anxious to talk with other synthesists, organize ensembles and exchange information.

Robert Council
4304 Via Olivero
Las Vegas, NV 89102

Kenneth Caron
1271 Water St.
Fitchburg, MA 01420

Robert Graves
4746 Nugent Dr.
Columbus, OH 43220

David M. Green
73 Goodyear Ave.
Grand Falls, Nfld.
Canada A2A 1J4

Sol Stillman
1598 Unionport Rd.
Bronx, NY 10462

Don Strauss
1416 E. Nevada
Oshkosh, WI 54901

Tom Fenwick
2601 Muskogee St.
Adelphi, MD 20783
301-434-2360

Robert Bailey
942 Bolling Ave. #107
Norfolk, VA 23508

Win Bent
425 WS College
Yellow Springs, OH 45387
(also plays bass guitar)

Paul Fontana
14441 Nordhoff St.
Van Nuys, CA 91402
213-892-1367
(Paul has a quad tape
deck and a piano)

Brain Bordash
9020 Kester Ave.
Panorama City, CA 91402
213-892-9474
(Brain has a stereo tape deck
and plays acoustic guitar)

Carlos Deza
Constituyentes 3840
Buenos Aires 1431
Argentina

Greg Leslie
1905 Meadowbrook
Ponca City, OK 74601
(Greg also plays sax)

Gary Bannister
7208 New Augusta Rd.
Indianapolis, IN 46268
317-293-0606
(Gary also has a wide assort-
ment of test equipment)

If YOU would like other PAIA user's to contact you, drop us a line giving permission to publish your name and address. Should anything come of these meetings such as Jam sessions, Lecture/demonstrations, rap sessions, etc., be sure to fill us in on the details. A little publicity couldn't hurt, could it?

LAB NOTES

By: John S. Simonton, Jr.

I just discovered Top Octave Dividers!

I know, they've been around for years.

I've had them in my "junk box" for years but thanks to a shove from Craig Anderton I finally got around to powering one up to see what it would do. Hey, surprise; you don't have to build organs out of them - they'll do some neat stuff too. You see, it's not that I don't like organs; though in all honesty they too often sound like they should be accompanied by thousands of whirling ball bearings. It's just that it always seemed like there wasn't a whole lot of imagination and creativity involved in taking a top octave chip, combining it with a crystal and liberal doses of dividers to come up with a musical instrument.

For those of you who have not yet been exposed to them, here is a top octave chip:

This particular one is called a 50240 and it's made by Mostek and AMI. They're a lot more expensive than they need to be but other than that they're OK.

They're called "top-octave" dividers (or chips to pro's like you and me) because when you put a 2 mHz. clock frequency into the pin marked "CLOCK", a full octave (plus one note) of equally tempered semi-tones come flowing out of the rest of the pins. Oh yes, V_{SS} and V_{DD} are where the power goes in (V_{DD} is ground, V_{SS} is the positive supply point).

The "top" part comes from the fact that with the recommended 2 mHz. clock frequency the highest note from the chip is C₈ (about 8,369 Hz.) and the rest go down from there. If you're building an

FUNCTIONAL DIAGRAM

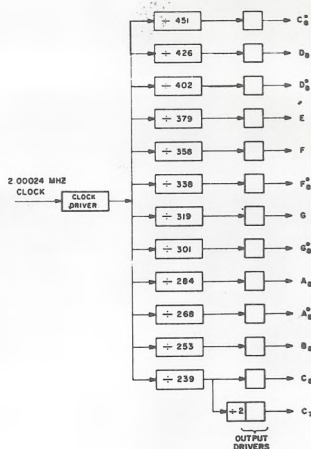

V _{SS}	1	16	÷ 478
CLOCK	2	15	÷ 239
V _{DD}	3	14	÷ 253
÷ 451	4	13	÷ 268
÷ 426	5	12	÷ 284
÷ 402	6	11	÷ 301
÷ 379	7	10	÷ 319
÷ 358	8	9	÷ 338

PIN CONNECTIONS

organ the normal procedure is to apply each semi-tone output to a string of bi-stables to get the corresponding note in the lower octaves. Then you use all the standard organ tricks of summing the square waves to get ramps or triangles or whatever before going through filters for harmonic control. And so on.

If you're interested in this sort of thing, and it is interesting the first time, American Micro-Systems, Inc. (AMI) used to put out a little pamphlet called "MOS MUSIC" which may or may not still be in print and which they may or may not send to you - depending, I think, on the phase of the moon and whether or not the month has an "r" in it. Be that as it may, it certainly wouldn't hurt to try.

American Micro-Systems, Inc.
3800 Homestead Rd.
Santa Clara, CA 95051

If you are building organs, these things are obviously something you would trade your sister for because all of the notes are derived (some ad men simply can't resist the temptation to say "computed") from a single reference frequency - there's no way that you can get just one note out of tune. If any one is right then the rest have to be right.

There are a couple of tricks to using these things that you would discover for yourself after working with them for a while, but why re-invent the wheel.

First, like most digital stuff, you are going to need to by-pass the power supply to the circuit itself as close to the chip as possible. That means a .01 mfd. disk right at the Vdd and Vss pins. Unlike most other digital goodies, I recommend putting about a 5 mfd. electrolytic cap. in parallel with the disk. This larger capacitor de-couples tones that will otherwise be wandering around on the ground line waiting to spring out and cause difficulties.

Second, you can make simple organ type things just by closing switches to mixing resistors BUT, make sure that the switches close to a point that is about half of the top octave's supply voltage. If you don't, you will not only get square waves out but also the average value of the square wave which will be heard as an objectionable "thump" that will eventually drive you berserk. By closing to a point that is already at the average value of the waveform you eliminate this transition.

Last (and best of all) these chips are static, which means that you don't have to clock them at that 2 MHz. frequency if you don't want to. It should go without saying that the lower the clock frequency, the lower the pitch of the semi-tones will be that come out of the chip. But, thanks to our old friend the equally tempered scale, the notes will all be chromatic no matter what the clock frequency.

These points are incorporated in this drawing of a simple 1 octave organ:

Shown on following page 

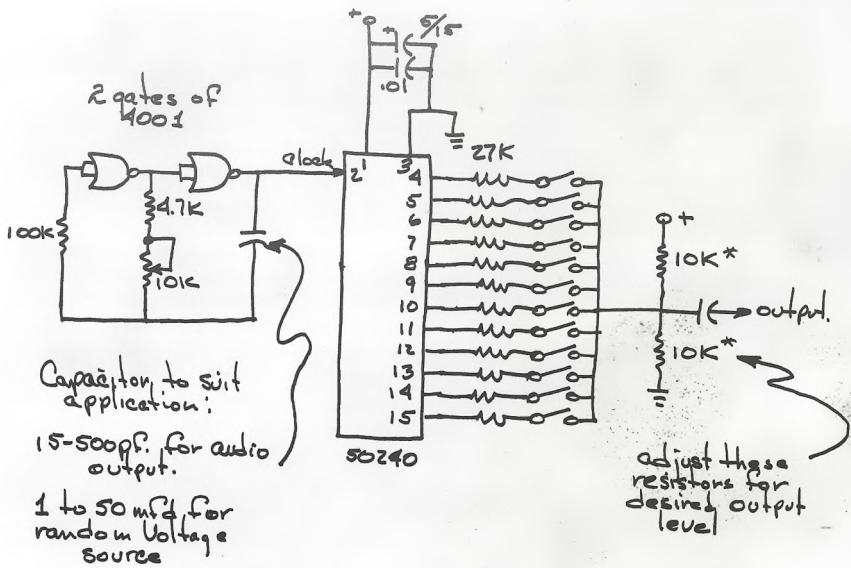

Figure 2

With this simple arrangement you may still notice some slight keying pops but they're not caused by DC level shifts, they come from bouncy switch contacts not switching the output waveforms cleanly on and off.

When you're through playing with that, you can re-arrange the parts like this:

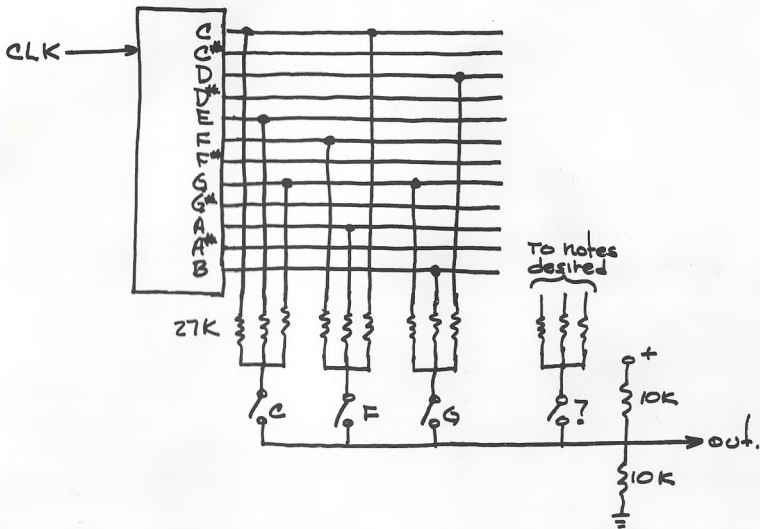

Figure 3

and now you've got (for lack of a better name) a "chord box" with individual switches that select chords instead of single notes. You can make the chords as simple or complex as you wish but since you're working with a single octave of notes some of the chords you want will undoubtedly have to be done as inversions (as are F and G in the example). This kind of thing would be slick in some sort of box that goes on the floor (like a pedal bass only for chords). This would make a nice kit if we had a source of foot switches. Maybe I'll start looking for some.

So, those kinds of things are alright, but they're not really breaking any new ground; they're pretty much what the manufacturers had in mind in the first place.

Here's something they didn't have in mind. Remember that I said that these chips are static and can be pumped by any sort of low frequency clock you want? Because of that you can turn a top octave chip into a pretty credible random voltage source just by lowering the clock frequency to a few hundred Hz. (or lower). Changing the clock frequency is simply a matter of substituting a capacitor in the mfd. range for the pf. job shown in the second set of drawings. By the way, this capacitor must be non-polarized or if you don't happen to have a 10 mfd, or so non-polarized capacitor around a couple of back to back electrolytics will work. The top-octave pseudo-random voltage source looks like this:

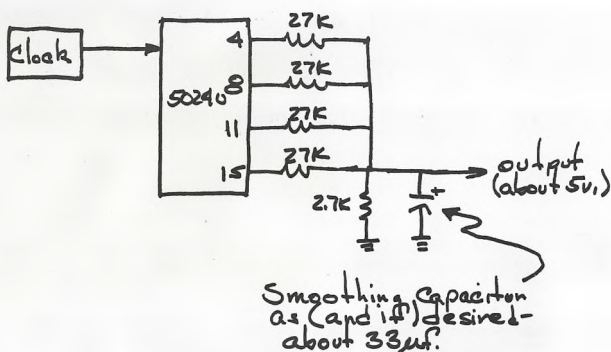

figure 4

To see why this works, assume that at some time t_0 we turn on the chip and that at that time pins 14 and 15 of the chip are both high. After 239 clock cycles the voltage at pin 15 goes low and 14 cycles after that (at the 253rd cycle) pin 14 goes low. These two outputs will continue going high and low, apparently asynchronously until 239×253 (or a little over 65 thousand) clock cycles later when they will both simultaneously go high again. At a clock frequency of 200 Hz. it's going to be a little over 327 seconds before we get back to the starting point of both outputs transitioning high at the same instant. Throwing a third and fourth output into this mess gives another two terms to form the product so you can see that it's going to be a while before the cycle repeats. This is approximate, of course, because under most conditions the pattern will repeat in a period that is an integral division of what would appear to be the actual period; but, even then, it's a long time. The configuration that I've shown is one that I like but there are a lot of combinations of 13 things taken

from 2 to 13 at a time, even when you throw out the combinations that are trivial. Any of you that are math buffs (as I am, a little) will really have fun with this.

I can see that I'm getting carried away - Marvin and Linda Kay will scream about the length of my copy - again.

Quickly, quickly -- one more.

Environment machines, like our Surf Synthesizer, Wind and Wind Chimes are really my favorite kinds of products. Even I can work them since all you do is plug them in and let them do their thing. We're getting ready to do one (it's done, actually, but instructions take forever) that uses a top octave chip and is based on an idea originated by Craig Anderton called a "Chord Egg". It's a lot like the "chord box" thing that we looked at earlier except that it's got a random voltage source that provides 4 independent control voltages to a like number of voltage controlled attenuators. The voltage controlled attenuators are in the lines going to the notes that make up a major 7th chord. It looks a lot like this:

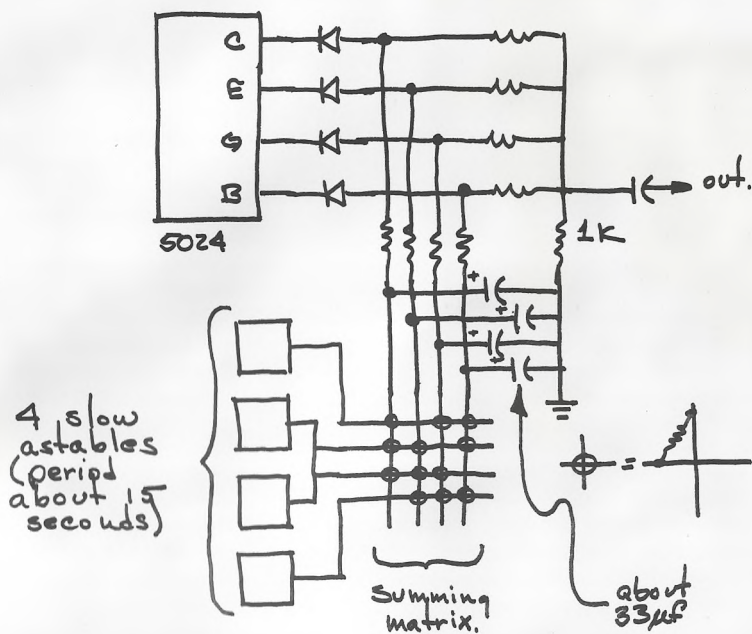

All resistors about 10K except as marked.

Figure 5

and the idea is that as the random voltage sources change, the notes that we hear change - but slowly. And they are always notes that make up that major 7th spelling. This is a simplified drawing; the final unit also includes a circuit that randomly selects one of four chords: C^7 , A_m^7 , G^7 and/or F^7 . This has got to be the ultimate meditation machine; and I think that we'll be able to sell it for about \$25.

Just one more, I promise.

We can't take the output of a VCO and use it directly as the clock signal for a top-octave chip (at least not with any useful result) but we can come up with a frequency multiplier built out of a phase locked loop and use that as the top octave clock like in this block diagram:

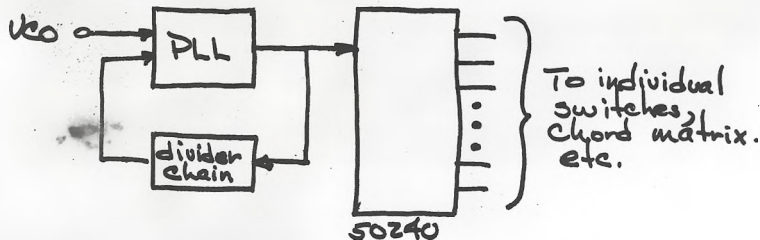

Figure 6

The result is that we have a complete octave of semi-tones tracking along with the VCO and we can pick those semi-tones up as intervals or complete chords. This sort of thing would have been prohibitively expensive 10 years ago when the only PLL's you found were in ground stations for satellite communications; but now that you can get them from just about any surplus house it's a different story. If you try to build one of these to play with you might get by with a 565 type PLL but you'll find the tracking range prohibitively small. A much better choice is an RCA 4046.

This is going to be a new product for us before too much longer* - as soon as we decide how best to take advantage of the notes present. Do you have individual switches that allow you to select the notes (versatile, but a little expensive)? Are there 12 pots so that you can mix the notes that you want (more versatile, but really expensive)? Maybe about 8 buttons labeled something like "tonic, 3rd, 5th, 7th, major, minor," etc. I don't know. If you come up with any ideas I wish you'd share them with us.

If you want to play with top-octave chips we have an inexpensive experimenter's package that consists of a 50240 top-octave chip, CD4001 quad NOR gate and a circuit board that will mount both. You have to supply your own resistors and capacitors and stuff and the only instructions are recommended parts values for different things and circuit board parts placement. But it's a pretty good buy at \$12.50 postpaid. That's about what you'd pay for the top-octave chip (if you can find someone who will sell you just one.)

*Since I wrote this column it has occurred to me - and been verified on the work bench - that there is a simpler way to go than the scheme shown in the block diagram. So - We're having a contest.

*CONTEST-CONTEST-CONTEST

The first person who can correctly tell us why this drawing is more complicated than necessary will receive - absolutely free - the first of these tracking top octave gadgets that we produce.

We have on file a notarized statement of what we have in mind and it is in less than 25 words (so please don't send in any book length manuscripts on what's wrong with it). Send your entry to " JOHN'S CONTEST, c/o PAIA/POLYPHONY, 1020 W. Wilshire Blvd., Oklahoma City, OK 73116.

The winner will be selected July 30th, 1976 and will be notified by mail. If you send a SASE (self-addressed, stamped envelope), we'll send you a copy of the notarized statement and the name of the winner. If your idea is better than what we had in mind we may kit it and if we do you'll be paid our standard royalty for undeveloped ideas.

Next Issue:

- * Plans are in the offing for a photo essay featuring photographs of our reader's systems. To have a photo of your system published in the next issue, send us a good, clear, BLACK AND WHITE GLOSSY photograph. We will publish as many as we can.
- * SOUND SYSTEMS FOR USE WITH SYNTHESIZERS, outlining such subjects as speaker design, amplifier power and frequency response and a discussion of the difference between a live performance system and a studio monitor system.
- * MUSIC NOTATION SYSTEMS - first of a series dealing with standard music notation and writing scores.
- * ADDING MUTING FUNCTION TO THE PAIA 4740 ENVELOPE GENERATOR.
- * MORE PATCHES, MODIFICATIONS and TRIVIA.
- * A SUMMARY OF THE RESULTS FROM THE QUESTIONNAIRE.

PMA POLYPHONY

P. O. Box 14859
Oklahoma City, OK 73114

OKLAHOMA CITY
JUN 19 1976
AM

OKLA. 731
OKLA. CITY
OKLA. 731
P.METER
P.D.865045

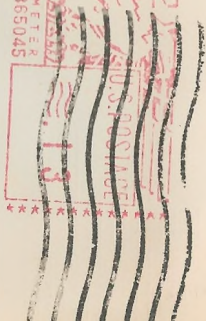

This magazine PDF has been downloaded for free from www.muzines.co.uk

The mu:zines project is a non-commercial, labour of love archive of music production magazines from the 1970s-2000s.

mu:zines

musicmagazinearchive

Making Music II
Electronic Soundmaker & C
Technology Electronics
Recording Musician M
& Recording World Electronic S
On Sound Music Tech
Music Maker Home & Studio Recording
Music International Musician & P
Soundmaker & Computer
Technology Elect
Recording