

# POLYPHONY

\$1.50

Sept./Oct.

1978

*ELECTRONIC MUSIC & HOME RECORDING*

**RECORDING NOTES ON SYNERGY'S "CORDS"**

**SEQUENCERS - DIGITAL & ANALOG**

**BUILD A VOCODER**

**NOTATION - TOUCH SWITCHES - PATCHES**



# SWT **ANALOG DELAY**



## INTRODUCING... TWO-CHANNEL ANALOG DELAY UNIT FOR AMBIENCE SYNTHESIS AND DELAY EFFECTS

### FEATURES

- \* TWO INDEPENDENT CHANNELS
- \* 3072 STAGES OF DELAY PER CHANNEL
- \* ADJUSTABLE INPUT AND OUTPUT LEVELS WITH INPUT OVERLOAD INDICATION
- \* INTERNAL OR EXTERNAL VOLTAGE CONTROLLED DELAY TIME
- \* COMPANDOR IN EACH CHANNEL
- \* 3 MODES/CHANNEL WITH ADJUSTABLE MIX
- \* CONVENTIONAL REVERB OUTPUT FOR MUSIC EFFECTS

If you haven't heard what analog delay can do for home music reproduction, you're missing something. Let's face it, stereo in your living room is flat and

2 dimensional. Without the mixture of direct and delayed sounds that a large hall provides, almost all music reproduced in the home is lifeless. Quadraphonics has not proved to be the solution to this problem. The recent development of bucket-brigade semiconductor technology has made it possible to offer a reasonably priced delay unit that can transform your listening room into a concert hall. Using your present stereo system, the 2AS-A, and whatever you have in the way of 2 additional speakers and 2 channels of power amplification—you have all the parts to put together an ambience system that is capable of creating the kind of 'space' you enjoy music in. You don't need state-of-the-art components to enjoy an ambience system. The secondary power amplifiers and speakers can be of very modest perfor-

mance and yet still serve to create strikingly realistic spaciousness in your listening room. If you don't have 2 extra power amp channels on hand, we offer several low cost, low power amps in kit form that would be ideal for this purpose.

Although the 2AS-A has been designed for use in music reproduction systems as an ambience synthesizer, its voltage controlled clock and mixing capabilities allow it to be configured in a number of ways for delay effects such as phasing, flanging, chorus, and vibrato. External voltage control for special effects must be user supplied.

The 2AS-A is sold in kit form only and includes the circuit boards, components, chassis (11½" x 10" x 4"), cover, 120VAC power supply, assembly instructions and application notes.

2AS-A Analog Delay Unit  
\$250.00 ppd. Cont. U.S.



Southwest Technical  
Products Corp.

219 W. Rhapsody, San Antonio, Texas 78216

London: Southwest Technical Products Co., Ltd.  
Tokyo: Southwest Technical Products Corp./Japan

### MAIL THIS COUPON TODAY

Enclosed is \$ \_\_\_\_\_ or BAC # \_\_\_\_\_

or Master Charge # \_\_\_\_\_ Bank # \_\_\_\_\_ Expire Date \_\_\_\_\_

NAME \_\_\_\_\_

ADDRESS \_\_\_\_\_

CITY \_\_\_\_\_ STATE \_\_\_\_\_ ZIP \_\_\_\_\_

SOUTHWEST TECHNICAL PRODUCTS CORPORATION  
Box 32040, San Antonio, Texas 78284



# STAFF

**EDITOR:**

Marvin Jones

**ASSISTANT EDITOR:**

Linda Kay Brumfield

**CONTRIBUTING EDITOR:**

John S. Simonton, Jr.

**PRODUCTION:**

Anita Jenkins  
Donald Cooper  
Marcina Howard

POLYPHONY is published bi-monthly at 1020 W. Wilshire Blvd., Oklahoma City, OK 73116, by Polyphony Publishing Co. Entire contents copyright ©1978, Polyphony Publishing Co., All rights reserved. No portion of this publication may be reproduced in any manner without written permission from the publisher. Application to mail at second class postage rates is pending at Oklahoma City, OK.

ADVERTISING rates and deadline schedules furnished upon request, contact: Marvin Jones or Linda Kay Brumfield (405) 842-5480.

DEALERS & DISTRIBUTORS bulk purchase discount schedules available upon request, contact: Marvin Jones.

SUBSCRIPTIONS: Accepted on a one year (6 issues) basis. Rates: Mailed in the USA - \$8.00/yr.; Canada & Mexico - \$9.00/yr.; International - \$10.00/yr.

BACK ISSUES: All back issues are still available at \$2.00 per copy.

FOR CHANGE OF ADDRESS: Be sure to send in your former address (enclose mailing label if possible) along with your new address. Also include the numbers at the top of your mailing label to enable us to make your address change as efficiently as possible.

POLYPHONY  
P. O. Box 20305  
Oklahoma City, OK 73156

ADDRESS CORRECTIONS  
REQUESTED

NATIONAL  
ASSOCIATION OF  
MUSIC MERCHANTS

MEMBER  
  
NAMM

# CONTENTS

ISSN: 0163-4534

VOLUME 4, NO. 2, 1978

FEATURES:	Page No.
Notes on the Recording of Synergy's "Cords" by: Larry Fast .....	6
Electronic Music Notation by: Brian Folkes .....	9
Rhythmic Control of Analog Sequencers by: John Duesenberry .....	26
Magic Buttons - Touch Switch Theory by: Steve Wood .....	30

**CONSTRUCTION:**

Build a Modular Vocoder by: Jeff Wurstner .....	34
PET/ Muse; Interfacing Paia Synthesizers to PET Computers by: Russell Grockett, Jr. ....	40

**DEPARTMENTS & COLUMNS:**

Editorial (Guest Editorial by: Douglas Townsend) .....	4
Lab Notes: Seque and Ye Shall Find (Digital Sequencing Software) by: John S. Simonton, Jr. ....	15
Polyphony Reviews by: Marvin Jones .....	19
Bookshelf .....	20
Patches .....	36
Industry Notes .....	38

**ON THE COVER:**

Monkeying Around with Electronic Music Equipment  
graphically represented in art by Greg Schneck, Terre  
Haute, Indiana.

## Some Thoughts About Contemporary Music

BY: Douglas Townsend

One phase of music that seems to get the greatest (negative) response from our readers, is the music (or comments relating to it) of today -- or yesterday. Lack of sympathy for the present state of music is not new, as the following comments, written almost two hundred years apart indicate:

1791: "... modern composers resort to arbitrary complexities in order to conceal their inability to write a good tune. Sometimes the key is perfectly lost, by wandering so far from it that there is no road to return -- but extremes meet at last of themselves. . . And when discords get so entangled, that it is so past the art of man to untie the knot, something in place of Alexander's sword does the business at once."

1952: "Almost all contemporary composers are producing music which is uninteresting, distressing, or positively repellent to the vast majority of the American public."

Obviously it is impossible to like all the music one hears, just as it is impossible to like everybody one meets. There is, however, a middle road, which is frequently overlooked. We refer to a sense of perspective, of history, if you will. It also helps to have some understanding, however minimal, of the creative process, since the artist, although he is like everyone else in most respects, is always developing as a creative personality.

In this respect the artist is different from the average person; he is never satisfied with things as they are, but is always trying to broaden his intellectual horizon by study, and to enrich his artistic and his emotional life by evolving newer and more satisfactory idioms to work in. It is possible that this is basically what is at the root of most of the criticism of contemporary music. Too frequently it is listened to with ears and mind attuned to the artistic past (or, in another sense, the traditional), and not as it should be, as a living, dynamic force, which may easily be appreciated

and understood (with its good and bad respects) if viewed in the correct perspective.

It is generally accepted that the young artists of today are better equipped than their counterparts were forty or so years ago. However, the function of the teacher is to see that his students learn as much as he has to offer, or as much as they can accept. He is not responsible for their inspiration. In other words, although the teacher may equip a student to write equally well for the string quartet as for the modern symphony orchestra, the aspiring composer simply may not have the talent equal to his technique. This is not unique with our age; the ability to express oneself on paper or canvas has always been more prevalent than the ability to create a masterpiece. The important thing is not the quantity of great works which are produced, but the ability of the artist and layman to express himself creatively. Sean O'Casey summed this up nicely when he wrote that "Only a few great should come of time to live beyond it."

It is easy to criticize the composers of our own time as writing non-music, as agonizing in sounds, etc., but Monteverdi, too, was just as severely criticized for his "modern" music as Davidovsky, Powell, Shapely and Wuorinen are today.

Virtually every "serious" composer, that is, those that we of the twentieth century consider "masters", was attacked by the conservative intellectuals, less knowing, and ignorant factionalists, as musical radicals who were "so full of oddities and personal caprice that they completely corrupted the quality of instrumental and vocal music." (So wrote Rossini in 1817 concerning the music of Haydn and Beethoven! The entire quotation will be given later in this essay.)

In the past, musical evolution, like social and political evolution, literally walked; now these influences on our life travel faster than sound. A hundred years ago it was difficult for people to get used to the chromaticism of Wagner and Mahler. Now not only must the ear become used to the

sensuous harmonies of Tristan, but in the space of, say, 40 years, we are confronted with several radically different means of musical expression, each purporting to be an expression of our time!

Most of us, I think, listen to one type of music or another. Unfortunately, too many people hear either "only with their feet," as Sousa said, or only what they want to hear. Very few people are willing to put forth the same amount of effort in listening to music (whether Beethoven or Berg) that they do when they read Defoe or Faulkner. The reason for this is, I suspect, partly because music involves listening, feeling and thinking, while reading rarely involves more than thinking.

In general we are not used to regarding the arts as anything but a pleasant adjunct to the basic necessities of life. For example, we are taught to read almost as soon as we enter grade school, but the arts are generally relegated to classes (usually once a week), of "appreciation". In a society where we must take classes in order to "appreciate" even the most conservative and traditional art, it is hardly surprising that today's composers of serious music are frequently regarded as avant garde and experimental. We may not like, "understand" (dare I say "appreciate"?) the music of Rochberg, Kupferman or Cage, because it is "new" (in the sense that it was written within the past few years instead of a hundred and fifty years ago) --yet how many of us like to learn anything new, even if it complements what we already know? It is not always easy, or for that matter, pleasant, to bear in mind that the experiments and innovations of one era have frequently become the fashion if not the commonplace of another. This is as true of music as it is of the other arts, science and industry. Let's not forget that Schoenberg, Webern and Berg were condemned as musical barbarians; it was said that they destroyed all the beauty of harmony and melody in music and made of it an atonal hodge-podge. Today these masters are looked up to by increasing numbers of aspiring



young composers because though their music may not be an end itself, it furnishes to many that point at which basically different musical temperaments meet and go their own ways.

There is, of course, much more which can be said regarding contemporary music of their own time, just as we discuss ours today:

- 1600 (G. M. Artusi) "Instead of enriching, augmenting, and ennobling harmony by various means, as so many noble spirits have done, they (Monteverdi, Rore, Gesualdo, etc., the composers of the new, 'modern' music) bring it to such a state that the beautiful style is indistinguishable from the barbaric. . . ."
- 1651 (Samuel Scheidt) "I am astonished at the foolish music written in these times. It is false and wrong and no longer does any one pay attention to what our beloved old masters wrote about composition. . . I hope this worthless modern coinage will fall into disuse and that new coins will be forged according to the fine old stamp and standard."
- 1737 (J. A. Scheibe) "This great man (Bach) would be admired of the whole nation, had he more agreeableness and did not keep naturalness away from his compositions by employing bombastic and intricate devices and darkening beauty with over-elaborate art."
- 1787 (anonymous) "... it is a pity that in his (Mozart's) ingenious and really beautiful compositions he goes too far in his attempt to be new, so that feeling and sentiment are little cared for. His new quartets, dedicated to Haydn, are too strongly spiced and what palate can stand that for long?"
- 1793 (anonymous) "Mozart was a great genius, but he had no real taste, and little or perhaps no cultivated taste. He missed, of course, any effect in his original operas."
- 1810 (C. M. von Weber) "The fiery, nay, almost incredible, inventive faculty that inspires him (Beethoven) is attended by so many complications in the arrangement of his ideas that it is only his earlier compositions that interest me; the later ones, on the contrary, appear to me only a confused chaos, an unintelligible struggle after novelty, from which occasional heavenly flashes of genius dart

forth, showing how great he might be if he chose to control his luxuriant fancy."

- 1817 (Gioacchino Rossini) "Formerly Haydn began to corrupt purity of taste by introducing into his works (for cembalo) strange chords, artificial passages, and daring innovations. He still preserved so much sublimity and ancient beauty, however, that his errors could be forgiven. Then came Cramer and Beethoven with their compositions so lacking in unity and naturalness and so full of oddities and personal caprice that they completely corrupted the quality of instrumental music."
- 1853 (Louis Spohr) "Yesterday they gave Tannhauser for the third time and we had a full house again . . . Last night there was a lady in the loge next to my wife who kept telling her neighbors what she had read in the paper, (the new Leipzig Musikzeitung) and she remarked that in this work Richard Wagner had created a completely new catastrophe in music. Others said: 'This is no music at all,' and left after the second act." (A little farther in the same letter Spohr wrote that he "felt somewhat reconciled to the far-fetched and unnatural modulations. It is astonishing what the human ear can gradually get used to.")
- 1883 (Eduard Hanslick) "Thus the overall impression of the work (Tristan), despite its outstanding individual beauties, remains one of oppressive fatigue resulting from too much unhealthy overstimulation -- a condition unchanged by the fact that it has been occasioned by a great genius."
- Although some of us may never enjoy listening to the serious music of our contemporaries, we do owe it to ourselves to try to understand it, if only because it is as important to our way of life as the automobile, television, and the Concorde. Music is a part of our culture, but we must remember that it is difficult to understand something we experience once a week -- usually on a Sunday or Saturday afternoon. Art, along with economic and governmental functions is one of the patterns found in almost all cultures, and until we regard it with the latter two, as an essential part of our everyday life, we can scarcely hope to appreciate, understand and evaluate accurately that which is developing around us.
- D. T.

# SPEAKER INFORMATION KIT.



Get 70 pages of speaker facts in three fact-packed publications.

Speakerlab's Speaker Operating Manual covers everything you need to know to get the best performance out of any loudspeaker, including placement, wire gauges and allowable lengths, amp overloads, room acoustics, L-pad adjustments and impedances.

Our 54-page color catalog covers enclosures, designing your own speakers and driver principles as well as our line of nine easy-to-build speaker kits ranging from a miniature two-way system only ten inches high to a massive all-horn corner system.

"How To Hook Up Your System" spends twelve pages of text and diagrams really explaining system hookup. From where to place your electronics for maximum cooling to the intricacies of installing a cartridge; from eliminating hum to proper record care.

Get all three for just a dollar from the folks who take speaker information seriously...



Dept. PY-A 735 N. Northlake Way  
Seattle, WA 98103

Here's a buck! I can really use 70 pages of speaker information from the world's largest manufacturer of speaker kits.

name \_\_\_\_\_ PY-A  
address \_\_\_\_\_  
city \_\_\_\_\_ state \_\_\_\_\_ zip \_\_\_\_\_

## ADVANCING the state of the art



in automatic percussion units...

### PROGRAMMABLE DRUM SET

features: score editing, bridges, intros, external sync. to sequencers or foot controls, memory save switch & much more.

Enter scores in seconds - NO PROGRAMMING KNOWLEDGE IS REQUIRED! High Fidelity describes the kit as "an easy project... fun to do and yields delightful results... an excellent educational tool and versatile aid to the musician who can't afford a live rhythm section."

Programmable Drum Set Kit... \$84.95  
-Also available fully assembled... \$149.95 - from: (plus \$3 shipping)

PELA ELECTRONICS, 1020 W. WILSHIRE, OKLAHOMA CITY, OK 73116

( ) Send Programmable Drum Set Kit... \$84.95 plus \$3 shipping enclosed.

( ) Send Fully Assembled Programmable Drum Set... \$149.95 plus \$3 shipping enclosed.

( ) Send FREE catalog

name: \_\_\_\_\_

address: \_\_\_\_\_

city: \_\_\_\_\_ state: \_\_\_\_\_ zip: \_\_\_\_\_

PELA ELECTRONICS, DEPT. 2Y, 1020 W. WILSHIRE, OKLAHOMA CITY, OK 73116



# NOTES ON THE RECORDING OF SYNERGY'S "CORDS"

by: Larry Fast

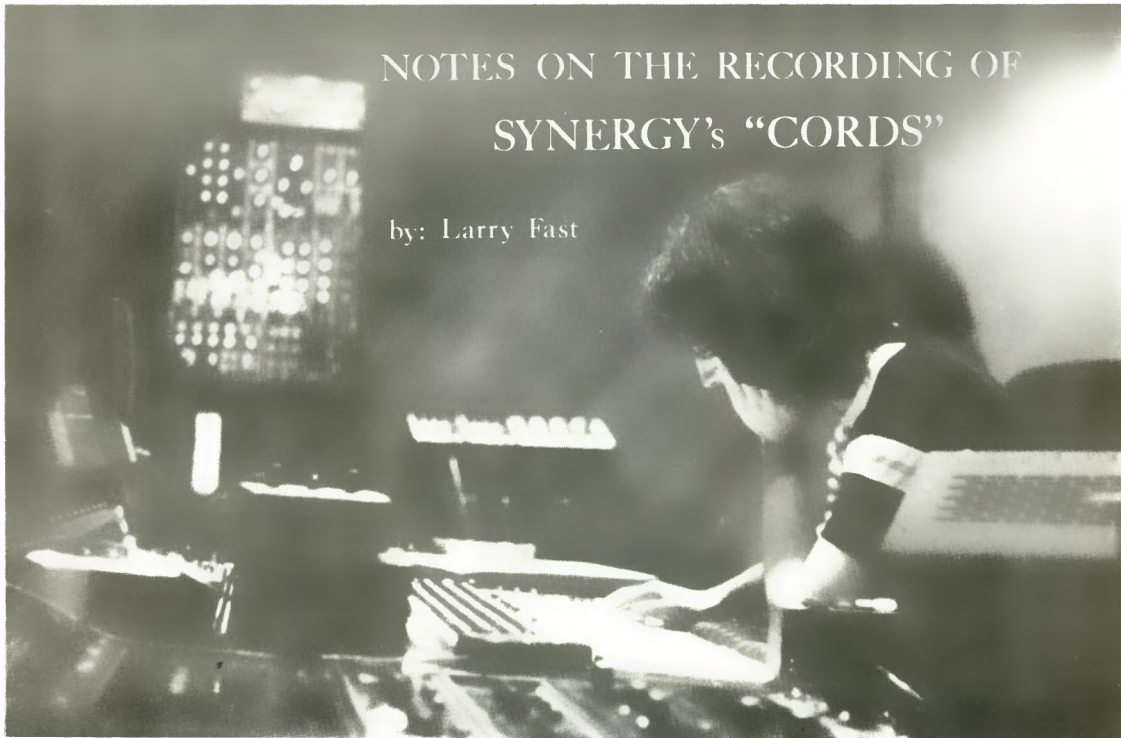

Larry Fast

Photo by: Anne Albright

"Doing" an electronic album is the best way to describe the process of committing a Synergy work to the recorded medium. There is an involved interplay of every aspect of composition, electronic music technique and the recording process. All three interact and all occur simultaneously although in different proportions during the time the album is being created. For anyone used to recording conventional multi-track records, the way an electronic album is done breaks a lot of the "rules". My way of doing Synergy records is not the only way to record electronic music, but it is the way that I have found makes the best use of my electronic music techniques and multi-track recording.

The composition of the pieces on the album may come from many sources. The more melodic ones usually are initially organized on a polyphonic instrument (on "Cords", a Polymoog). I may set up various support sounds on other synthesizers or groups of modules, but the idea is to simply construct a sketch of what the piece or segment of a piece should sound like. Sometimes a rhythmic patch or a particularly unusual sound will come to life and I will generate a

piece around that sound ("Phobos and Demos Go To Mars" is an example of this). Initial composition of pieces, bits and segments will go on for months. Anything that sounds interesting will go on a cassette for later reference. Every once in a while, though, a piece will either be made up of a "happy accident" patch that will be extremely difficult to duplicate at a later date or will simply be as developed as I feel it needs to be. At that point things move right into recording. The synthesizer system is set up to record onto an 8 track that I have at home. The machine is an MCI JH-110/8 One inch recorder with remote controls and automatic return. This remote feature I have found to be absolutely essential if you are to be your own engineer and tape machine operator.

Composition will continue until there is enough material from which to pick and choose an LP's worth of music. During this period I will be making notes on how I am going to deal with the pieces in the more advanced stages of production. Another decision to be made is that of tempo for those pieces that will not start with a sequencer. This is a simple matter of playing the segments to an old

metronome and listening for the most natural timing. The timing may be different for various sections of the piece and this will be taken into account in order to keep the developing track from sounding too rigid. For melody based pieces I will work with a click track made up of a recorded metronome and a simple pilot track that serves as a "scaffold" for the rest of the tracks to be built around. As soon as possible the scaffold-pilot track is removed so that an accurate indication of how the track is developing is apparent. If a piece or section uses a sequencer as its core, however, I will usually try to get a sound that will be used in the piece right on this "basic track" (rather than an expendable pilot track). Most of the time when using a sequencer I will also take a track of clicks mirroring the sequence timing. This becomes a great aid in resequencing to the partially completed track at a later date in order to alter the sound of the original sequence, add perfectly synched secondary sequences, or percussion.

It is difficult to write about all that goes down during the recording of an album. The creative end of things is



something that seems more to happen on a subliminal mental level than something that occurs according to formula. The mechanics of the recording are easier to describe, so here goes -- All 8 - track work is in the compositional period. Recording is on the MCI as described. The rest of the Synergy Studio is very basic, not unlike what most home synthesists seem to have. All signals are patched from the synthesizer's output mixer directly to the MCI's inputs and record levels are controlled from the machine panel. Playback is monitored through a Yamaha PM-400 Mixer, an old stereo amplifier and a pair of homebuilt Electro Voice 3 way speakers. This equipment is sufficient for what is mostly a thought gathering process. At this stage I use very little in the way of outboard equipment and ignore minor equalization (EQ) problems that can be corrected later at House of Music Studios. Since "Cords" was completed I have added DBX noise reduction to the MCI.

During all early recording, a good part of the Synergy synthesizer arsenal is present. For "Cords", the equipment was substantially the same as for "Sequencer" with the addition of the Polymoog (mine is the last surviving design prototype - a mixed blessing of extra features and non-standard parts), some PAIA Phlangers and sound processing modules that can work in conjunction with the rest of my 1 volt per octave equipment, and of course the guitar synthesizer. On my equipment I have adapted all triggers to be Moog type S-triggers. These are particularly easy to interface with most external devices including computers.

This is a good place to bring up the use of computers on "Cords". During recording I made use of some elementary sequencer programs using first a KIM-1 and later an Apple-II. These programs were the early modules of a more extensive computer based compositional system ( hybrid analog/digital control) not unlike the growing PAIA system or Roland and E-Mu hardwired systems. Unfortunately, during the time "Cords" was recorded, my system was still limited to nothing more than remembering, editing, and playing back single musical lines (though of greater length than commercially available sequencers). This was helpful during the recording but nowhere near the aid it will be someday.

The guitar synthesizer on "Cords" is the prototype of a developing system designed by Russ Hamm, an Engineer

involved in many areas of sound and recording who works in New York. Russ delivered a paper at the Fall 1977 A. E. S. (Audio Engineering Society) convention describing the theoretical basis for a fast pitch detection system based on a digital analysis method worked out as a computer model ( AES preprint 1265, E-4). Pete Sobel (Associate Producer and resident guitarist) and I approached Russ after his talk and found that he had constructed a working prototype of a guitar synthesizer. Russ loaned us his prototype and became as much a part of the Synergy team as we became a part of his guitar synthesizer development process. Because of his new system of pitch detection, Russ's system is far cheaper, more easily built and maintained and much more accurate for the guitarist than any presently marketed guitar synthesizer. The unit really shines on "Terra Incognita" which is live guitar synthesizer, recorded directly to a 2 -track.

Eventually the day comes when the 8 - track is brought to House of Music for 24 - track transfer. H. O. M. has two 24 - track control rooms that have tie lines to each other. One 24 - track is set up with 8 track heads and 1 inch tape mechanics. The original tape is transferred to the 2 inch 24 - track using DBX noise reduction. Recording is done on Ampex 406 tape on a MCI 24 - track JH-16 machine at 15 IPS aligned for elevated level recording (+3 vu ). Once this is done the main overdubbing can begin.

This is the fun part, where the LP really begins to take shape. There is extensive use of effects (delays, flanging, etc.) in order to add some life to the purely electronic sounds. I tend to use the devices to add a sense of "natural" ambience (i. e. the real world as we hear it as opposed to the totally flat electronic sound the synthesizer studio inherently produces). This isn't to say that dry electronic sound is bad - only that I prefer to have a range of ambience fields at my disposal: from flat and dry through over-accentuated. The newest ambience toys are digital echo systems and the Aphex Aural Exciter - more about that when we get to the mix.

Once voicing groups or related overdubs have fallen into place, they get "bounced" from the half-dozen or more tracks they may be occupying down to a two-track sub-mix on the 24 track. These sub-mixes are very useful for saving track space without giving up sonic complexity, for not tying up limited outboard equipment later during the mix, and simplifying the mix process by enabling time consuming and repetitive work to be simplified before the final mix. By the end of the recording process there may be as many as six or eight sub-mixes already placed in their stereo perspective with all effects already taken care of, ready for the final mix where they will need only echos, Aphex, and maybe a little touch-up EQ. The rest of the tracks, obviously, contain the rest of



Pete Sobel

Photo by: Larry Fast

# create Your own sound

We have:

- Parts kits for Craig Anderton's GP column projects
- Individual circuit boards for the above
- Individual components (4739, CLM6000, etc.)
- Parts kits for the projects in "Home Recording for Musicians" and "Electronic Projects for Musicians"

Our parts kits contain electronic components, IC socket(s), circuit board, pots, and data (case, hardware, connectors not included). Look over any kit for 10 days; if not satisfied return for refund. Here are some of our best-sellers...

**NOISE GATE** (project 27) \$20.00 Eliminates low level hiss from effects or tape; voltage controlled attenuator cuts off signal below a variable threshold level. Data also describes special effects usage. Includes SP6T rotary switch.

**SPLUFFER** (project 26) \$10.00 Dual splitter/buffer, with footswitch controlled outputs. Splits instrument into two channels, select either (or both) with footswitches. Also buffers instrument for clearer, brighter sound. (Dual footswitch for above in sturdy rubber-like case — \$6.95)

**SUPER TONE CONTROL** (project 17) \$14.00 High pass, low pass, bandpass, notch outputs. Ultra wide range.

**BUDGET NOISE REDUCTION** (project 34) \$20 each, 4/87. Simple pre-emphasis/de-emphasis unit helps clean up echo units, tape recorders, delay lines. See Craig's Oct/Nov '78 columns.

**TERMS:** Add \$1 to orders under \$15. Allow 9% shipping, express refunded. VISA, MasterCard, call 24 hrs. (415) 562-0638, CDD OK with street address for UPS.

**GODBOUT**  
BILL GODBOUT ELECTRONICS  
BOX 2355, OAKLAND AIRPORT, CA 94614

**COMPRESSOR** (project 8) \$17.00 Increase sustain without distortion; adds gain if required.

**BASS BUZZ** (project 7) \$10.00 A fuzz designed specifically for bass (retains full bass sound).

**NEW! Hefty Power Supply Parts Kit** (as featured in Craig's column Dec. Guitar Player)  
**\$15.00 Order Project 13A.**

OUR FREE FLYER GIVES DETAILS ON OUR OTHER MUSIKITS™ AND COMPONENTS. SEND US YOUR NAME AND ADDRESS, WE'LL TAKE CARE OF THE REST.

NAME \_\_\_\_\_  
STREET \_\_\_\_\_  
CITY \_\_\_\_\_  
STATE \_\_\_\_\_ ZIP \_\_\_\_\_

the musical information that comprise the piece except for those tracks reserved for computer mix data.

The mix on "Cords", because of the sub-mixes and the computer mix capabilities went very quickly - much less time than for most conventional albums. The computer mix at House of Music is built into an MCI JH-528 console and is a firmware controlled 6502 based system. The computer scans the position of those controls able to be digitized (levels and echo returns primarily), converts the levels to serial data streams and stores the data on an unused audio track. It's possible to up-date data by reading the old data, changing that information which was incorrect and storing the new data on a second track. This process can be repeated between the two data tracks until the mix is perfect.

Certain tracks of the mix were processed through an Aphex Aural Exiter. Aphex is very secretive about their process, but it seems to be an induced phase shift that corresponds to frequency. It introduces a psychoacoustic sense of natural brightness into the recording (a crystalline sparkle) without the associated shrillness of top-end EQ. The Aphex won't make a bad recording good but it can enhance one that's already in good shape.

The mix was monitored on John Gardner Associates/House of Music designed speakers similar to modified Westlake Audio Monitors and a pair of Auratone 5 inch small speakers to maintain a real-world perspective. Amplifiers were a pair of Crown DC-300's strapped for mono, and Sony V FETs as biamp top end drivers. The 24 track master was mixed down to a 1/4" 1/2 track Studer A 80 machine running at 15 IPS with DBX noise reduction.

With the Mix finished (the first mix completed at House of Music's Studio B which was under construction during most of the recording) the album was mastered (disk-cut) at Sterling Sound in New York, pressing plant parts cut, test pressings approved and the countdown for album release begun.

## SELECTED DISCOGRAPHY

1975 Electronic Realizations for Rock Orchestra  
Synergy  
Passport Records PPSD-98009

... continued on page 33

## FOR AUDIO ADVENTURE



A new, exciting discovery in great sound awaits you in **THE AUDIO AMATEUR MAGAZINE**.

It's delightfully easy to improve, maintain, and even build your own audio components. Thorough articles—everything from amps to speakers, simple add-ons or improvements to intricate modifications—help even our non-technical readers develop superior sound equipment.

Subscribe now on a guaranteed satisfaction basis or send for our **FREE prospectus**.

### HANDY COUPON

Fill in the coupon, include a check or money order payable to **The Audio Amateur** and send to TAA Dept M38, Box 176, Peterborough NH 03458 USA.

Enter my sub for TAA for one year/four issues for \$12.

I want to know more. I enclose \$3.50 plus 50 cents postage for the current issue of *The Audio Amateur*.

Send free prospectus.

Name \_\_\_\_\_  
Street \_\_\_\_\_  
City \_\_\_\_\_ State \_\_\_\_\_  
ZIP \_\_\_\_\_

Foreign subscriptions are \$13 per year and all remittances must be in US funds.



# ELECTRONIC MUSIC NOTATION

by Brian Folkes

Why? Why is a system of notation for Electronic Music needed? After all, what is the purpose of notation? Notation was devised to provide a means of communication from composer to conductor to player. In Electronic Music, conductors and players are normally eliminated, (except in multi-media and live electronic works.) Electronic Music Notation is therefore superfluous. Excepting, of course, analysis or re-creation of a piece. For the most part, a composer of electronic music commits to tape the sounds in his head. Whereas, in writing for conventional instruments, the composer commits his thoughts to paper. The advantage is that no longer is the composer at the mercy of conductors and performers in interpreting his work. The writer now is the interpreter and performer, only limited to his imagination (and perhaps keyboard ability). However, if a work is for multi-media,

to be performed live, or just copyrighted, some form of notation must be devised. An unpublished electronic work is protected against unauthorized use by the "Common Law" of the United States. To secure a statutory copyright protection, a claim must be made to the Copyright Office by filing form "E" and one copy of the work. Recent changes in Copyright laws now allow recordings to be submitted. Previously, scores or notation were required.

Consider, for a moment, the possibilities. Seismograms, charts, graphs, alpha numerical indicia, even a film of the oscilloscope tracings or digital data. Perhaps you might even consider an actual score. Now please understand, I'm not talking about linear music. Music composed mostly of pitches, rhythm and timbre - in other words pop/rock/jazz, etc. . . . I'm talking about what musicologists call

20th century "Art Music." This is music consisting of and built upon logical progressions of sounds. Not necessarily notes. The best way to notate sound is by drawings, diagrams and explanatory text. You see, to be copyrighted a work must convey exactly or approximately most of the actual sounds which constitute the work.

To get an idea of what I'm talking about, try this experiment. Take any purely electronic work. Listen to it a channel at a time. As you listen try, as best you can, to diagram the sounds you hear. Yes, draw. It will take several listenings to catch all of the subtleties, but it is great practice for when you notate your own scores.

Before I go into ways and examples of notating live and tape works, I want to delve into an easier style of Electronic Music notation: Multi-media works. Multi-media is a combination of tape and

EX. 1

TROMBONE

TIME :20"

RIGHT CHANNEL

LEFT CHANNEL

M2 E C225C

:15"

\_\_\_\_\_. You fill in the blank. Cello, trumpet, percussion, clarinet, actor, chorus, dancer, film, etc. . . . or any of these in combination. That's multimedia. Now in your score you still want to visualize your sounds, but now the main thrust is to provide cues for your performers. As an example of this I'll use a piece of mine, Intravision-1975 for the trombone and tape. My score consists of trombone, a time line, right and left tape channels. In example 1, the right channel begins with this particular sound of repeated rhythm, then sustains with vibrato. As the sound sustains another rhythm is heard beneath it. This repeats for 20 seconds. At 0 seconds (system 2) a ring modulated chord is struck, and at 1 second the trombone enters. At 12 seconds the left channel sound glides downward, at 15 seconds the right channel repeats seven notes and also glides down. This is followed by a 2 second rest. Example 2 shows a bunch of squiggly lines. (actually, a trombone was previously recorded glissing all over the place and balance modulated). Example 3 shows synchronizing tape to trombone. Tape doesn't start until trombone plays G. The drawings are just representative of the sounds.

(In this case electric piano processed with an envelope follower and filters.) Example 4 shows synchronizing trombone to tape, which is followed by just a cue for what is happening tape-wise (assorted balance modulated pops and pings over a static drone).

These examples are just one solution to the problem of providing visual cues to the performer(s), (and to the composition faculty). For more examples of tape and \_\_\_\_\_, take a look at Electronic Music - A Listener's Guide by Elliott Schwartz. This is a good all around book on Electronic Music. It is by no means a technical book, but it does go into a history of the art, a look at the future and observations by composers. The book has examples of scores by Davidovsky, Schwartz, Subotnick, Burge, Bassett and Hiller, ( who is quite detailed as to the tape part which is quite linear anyway).

Notating a strict tape piece is nearly impossible or at best a pain. Since most scores don't lend themselves to a note by note transcription, a more visual route is taken. The solutions to notation are as varied as the composers. An excellent book which shows several scores is

The Technique of Electronic Music by Thomas Wells and Eric Vogel. This book is a must for the serious electronic musician with a library - very technical. The book delves into physics, electronics and trigonometry. I have no examples to show of the various methods of notation - due in part to copyright laws, a disservice to the many types of notation, and lack of time and space. However, a few written descriptions may suffice. The most detailed system of notation is by Karlheinz Stockhausen. His score for Kontakte took seven years to prepare. The score consists of a notated score and a realization of the score. The actual score is footnoted and refers to the realization. This then contains patches and information about how the sounds are constructed.

A score by Thomas Wells, 12.27.2, Electronic Music, plots time versus amplitude, with numbers which refer you to patches. In a piece by Bruce Faulconer called Electronic Music: 1973, he plots frequency and amplitude, amplitude being a V.U. meter reading. (Good idea, that one!) On every score page are his patches. Another score by Thomas Wells (Why not, it's his book) is called Systems of Electronic and Instrumental Music. The



24.4

REST FOR AS LONG AS IT TAKES TO COORDINATE WITH TAP

work is for piano, cello and tam-tam which are modified by a balanced modulator and multi-modal VCF. The score is notated more or less conventionally. Underneath the instrumental parts is a graph showing the various timbre modifiers, (cutoff frequency, amount of modulation, frequency of modulations, etc.).

A method of scoring Electronic Music which I'm starting to use is a graph. As I see it, the most important modules are the VCO's, VCF's and VCA's. These are modulated by a variety of sources. (Keyboards, S/H, sequencer, LFO, etc.). So, if I take a graph of each major module (VCO, VCF, VCA) and use the Y axis for voltage and the X axis for time, and superimpose each of the modulators on the same graph, I come up with example 5. Now the score is going to be gigantic as you can see. You will also have to stack above and/or below the VCF graph, those of the VCA and VCO. Also this is only one patch and one channel. As you add channels and patches of sound, the score becomes more and more bulky and complex. (Albeit a good and accurate realization notation-wise of a work). Now this idea is only one solution. Your solutions are

just as valid as mine or Stockhausen's. Check out other composers' notational systems besides the ones that I've mentioned. Experiment and find out which works for you. Another idea is - instead of plotting a VCA graph, how about plotting VU meter readings as an indication of overall loudness contour. The key is to experiment with your own

ideas and those of others in order to come up with a system of notation that is tailored to your style of composition.

This brings us to the last section-- notation for live Electronic Music. This, again, is just one solution. The piece is called Prelude and Conclude for two or more synthesizers.

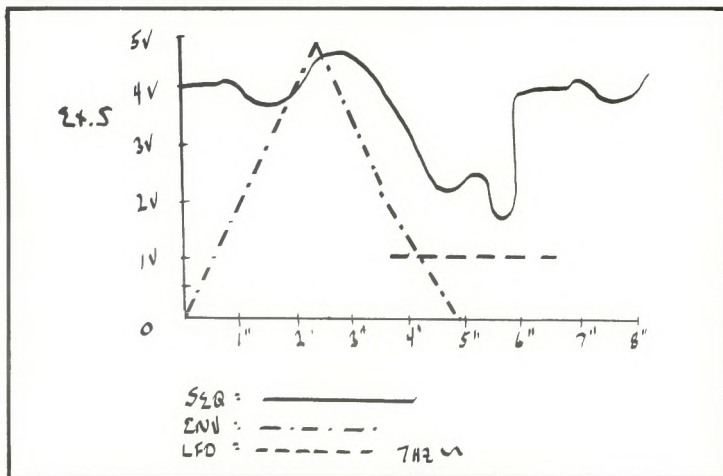

# PRELUDE & CONCLUDE

:60

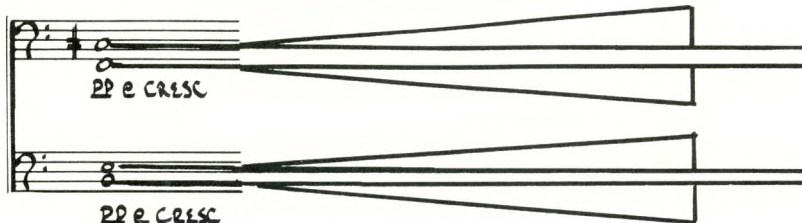

## EVENT #1

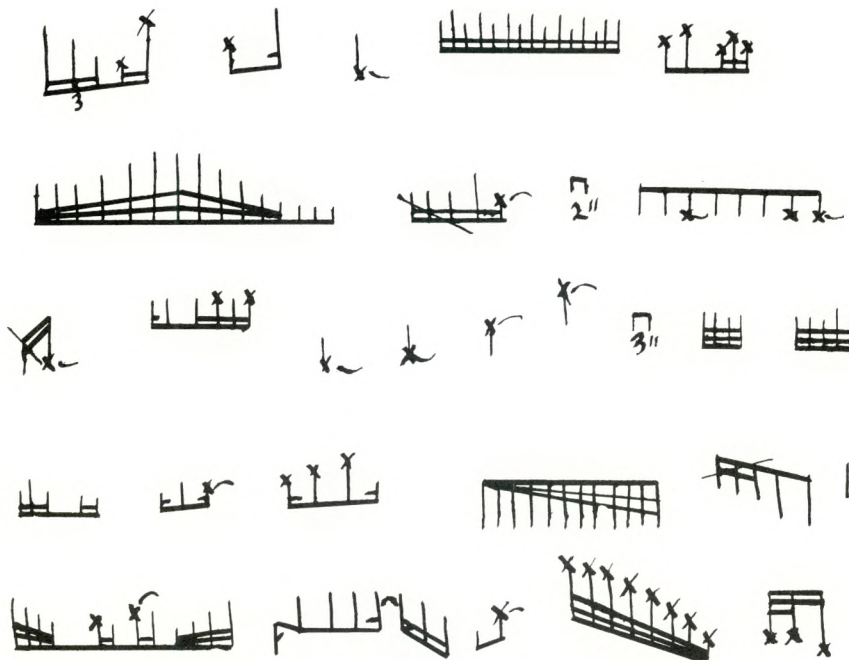

© 1978 BY BRIAN FOLKES - USED BY PERMISSION

Performance notes: The same basic patch is used on both synthesizers. (Ex. 6) Except on synthesizer 2, substitute Hi pass for Low pass VCF. Instead of a Sequencer controlling the VCF use the variable output of the ADSR. Also VCO1 will use a sine wave instead of a sawtooth. (Triangle remains same). Mixer initially for both synthesizers

should be all inputs pan right, right channel up full, left channel minimum.

### Prelude:

Use pots 1 and 2 only. Volume and activity crescendos for 60 seconds. By activity I mean speed of LFO, sequencer, VCF settings, are to increase in speed and intensity along with an overall volume change over this steady drone. After 60 seconds

reduce activity immediately and prepare for the next events.

### Event 1:

Use only pot 3. Height of events indicates relative pitch. Tempo is at the discretion of the performer. All attacks are set to minimum. See example 7 for notation guide.



## EVENT #2

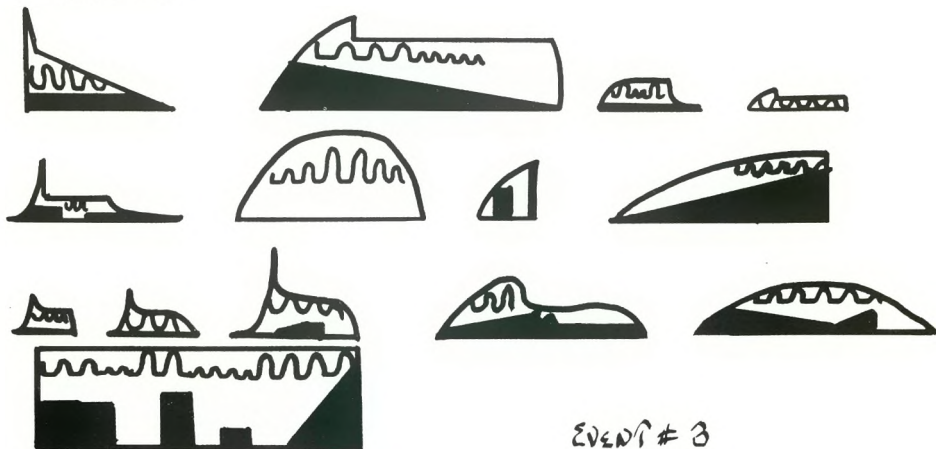

## EVENT #3

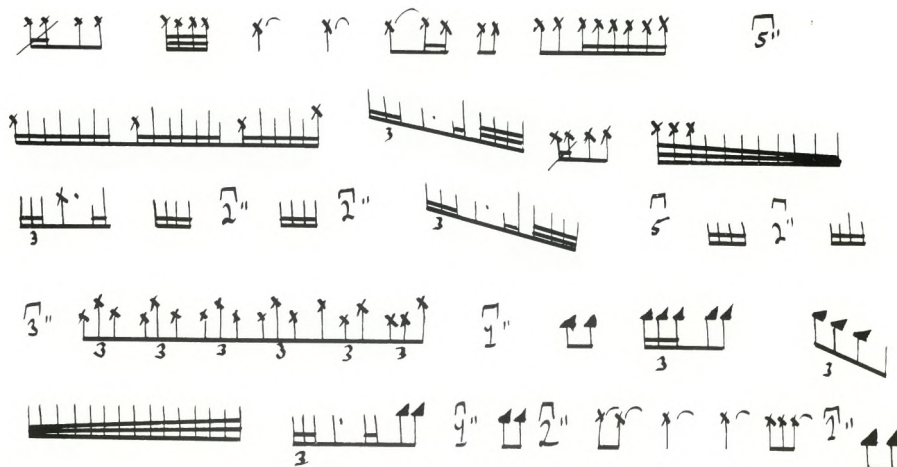

### Event 2:

Use pot 2. Synthesizer 1. Remove sequencer control of VCF use ADSR instead - change back after event. Shapes represent settings of ADSR controls. Sine wave lines indicate amount of LFO applied to the VCF. Speed of LFO is up to the performer. The filled in shapes within the envelope indicate the initial filter setting, which like the LFO is adjusted during each separate event. It is advised to apply a bias of about .5v. to the VCF input since at times

there are no control voltages controlling the filter. Again, height of shape is to be interpreted as relative pitch. Also, tempo and lengths of events are up to the performer.

### Event 3:

Use pot 3, pan fully right. Pot 1 and 2 up also with pan in middle. Left output up full. Event 3 is similar to 1 except for patch and most of the rhythms are static pitch-wise.

After all three events are played return to prelude and wait for other player to return also. The conclude which is played next is the exact opposite of the prelude. Once players are together and begin their static drone, proceed to bring up volume and activity levels to maximum then gradually decrease activity, intensity and volume until you end with the same drone that started the piece. Finis.

One final note: Except for the actual prelude and conclude, all of the three events are to be played in what-

EXAMPLE 6

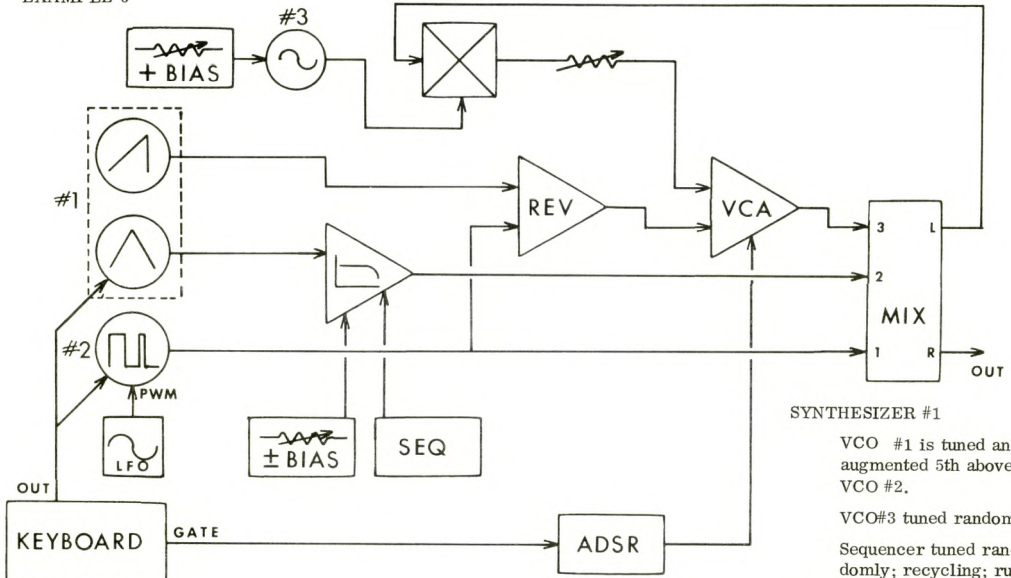

SYNTHESIZER #1

VCO #1 is tuned an augmented 5th above VCO #2.

VCO#3 tuned randomly. Sequencer tuned randomly; recycling; run.

SYNTHESIZER #2

VCO#1 is tuned a perfect 4th above VCO#3. VCO#3 is tuned randomly.

Except for section #2 of the composition, VCF frequency and Q controls, ADSR parameters, and LFO outputs are set per the performer's taste.

ever order the players choose and not necessarily should the players play the events that the others are playing. (although that is also one of the possible permutations.)

The hows and whys of the composition is not the subject here. The piece is provided as an example for notating a live electronic work. It also is provided for any group of synthesists looking for material to play. If after reading this and seeing my examples you decide I'm out of my gourd, and that you have a better solution, well great! That proves my point. There is no definitive way of scoring electronic music. There is no way, for that matter, of scoring avant-garde music. And for that matter, no real way for a composer writing a tonal string quartet in sonata allegro form to have it played exactly as he/she envisions it. It's all relative to the amount of control (or lack) that one wishes to convey to conductors and performers. So check out the reference books I have mentioned plus some of the books that Marvin has reviewed in past issues, and work on your own solutions. The possibilities are endless. ●

EX. 7

|: SHORT ATTACK SHORT DECAY

∩: SHORT ATTACK MODERATE DECAY

∪: SHORT ATTACK LONG DECAY

⌞: LONG ATTACK SHORT DECAY

▬: GRADUAL SPEEDING UP & SLOWING DOWN

⌘: SLASHED NOTE(S) IS TREATED LIKE A GRACE NOTE(S)

□: A PAUSE - IN THIS CASE 2 SECONDS

EXAMPLE 7



by John S. Simonton, Jr.

Now we're going to start a long discussion of sequencers.

It's going to be long because there is no single kind of sequencer that's best in every situation. Some will do better on stage and others will be more at home in a studio setting. Polyphonic sequencers should at times be structured for storing and reproducing chord sequences while at other times each channel should be treated as a separate voice. The only really workable solution is to come up with an entire "family" of sequencers.

The common limitation of all programming devices currently available is that none of them can offer this kind of versatility. But, this is an area where the system that we've developed, with its ability to accept a wide variety of personality endowing programs, will really come into its own. If we need a studio sequencer (with click track synchronization and full score editing features, etc.) we can load that program; when a chord sequencer is required, that software can be loaded.

These programs will all be "complete" in that once they are running, the system loses any "computer personality" that it may have had. All of the features that the program offers will be available with one or two touches of the "command" (computer) keyboard. Whereas the composer program that we did last time could only be changed by resetting the computer, using the Monitor to deposit data into memory, and running the program again (very arcane stuff, I sympathize), these programs accept all recognized commands and data "on the fly". You can forget that the computer's there because its control keys are dedicated exclusively to functions assigned them by the program. "This key makes it play - this key makes it play faster." Easy.

To illustrate these points, we'll begin with a program called SEQUE 1.0, a monotonic sequencer written to run on a PAIA P-4700/C or its equivalent. It can also be easily patched to run on a P-4700/J as outlined in the box.

SEQUE 1.0 is an acceptable "general purpose" sequencer (acceptable from the standpoint of our new perspective - in terms of the alternatives that are available it is the most sophisticated sequencer

ever produced). It has some features tailored for live performance and others that are primarily for studio use. Altogether, it's a larger program than we can fully examine in a single story, so we'll look at the live features this time and studio features next issue. The program listing and some additional notes appear on page 18.

## COMMAND KEYS

When SEQUE 1.0 is running, the command keys should be thought of as being labeled like this:

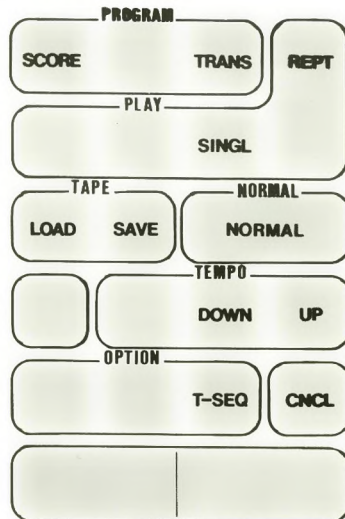

Figure 1

Keys that are not labeled are being held in reserve for the studio operating modes. The old Monitor-assigned meanings of the keys (as shown in light type) should be ignored. To help you ignore them, a self-adhesive overlay is available.

Undoubtedly, some of the designations on the keys still seem a little on the cryptic side. Let's look at function and begin by pointing out some of the ways that SEQUE 1.0 is different from what you're accustomed to.

## PROGRAMMING A SEQUENCE

The first way that it's different is that you don't program it with knobs,

you simply enter the note sequence from the AGO keyboard. More specifically, the operating mode that we're looking at now is a completely "real time" performance mode. You simply touch the "PROGRAM SCORE" key and start playing. Except for the fact that we will be able to do much magic, the result is the same as if there were a tape recorder somewhere recording what you're playing. Whatever tempo you play in, including subtle timing nuances, are faithfully captured by SEQUE 1.0 and stored in the computer memory. When you reach the point at which you want the sequence to repeat, touch REPEAT PLAY and it all comes back.

## PLAYING THE SEQUENCE

Since this is a real time mode, the timing of punching up REPEAT PLAY is important. If you were storing a repeating bass line, for example, you would play the single figure that characterizes the bass line and then, at the exact point (and on the beat) where the first note of the figure was to be repeated, touch REPEAT. Perhaps this is difficult to visualize (perhaps not, I've been living with it for so long that I can't tell anymore) but the first time you ever use it, you'll see how simple and convenient it is.

There are other sequencers beginning to appear that operate this way, and if real music was played with droning bass lines that repeat unchanged, endlessly, they would all be perfectly adequate. And the music would be perfectly boring.

Not that real music doesn't frequently have the characteristic of a repeating bass figure, it does, but it's also made to sound different by transposing the figure into different keys to follow key changes in the composition. While this fact seems to have been largely ignored by sequencer manufacturers, we don't have to settle for that.

## TRANSPOSING

SEQUE 1.0 has a variety of provisions for transposing the programmed sequence. The simplest of these is that while in a playback mode it can accept information on key changes directly from the AGO keyboard. A little explanation.



Since we will obviously want to be able to transpose both up and down in pitch, we need to decide that some arbitrary key represents no transposition (play the sequence as programmed). SEQUE 1.0 assumes that the 2nd C on the keyboard is the "0 transpose" key. Keys up-scale and down-scale from this one, then, represent transpositions up and down scale respectively. Press the C# above the 2nd C, and the entire sequence plays with each note a semitone higher than was originally programmed. Press the F below the 2nd C and then each note plays a fifth lower.

As an example of this, suppose that we were going to want to play a walking bass line as shown in figure 2.

Because of the things we've talked about already, it should be relatively obvious that we only need to really "play" this much of the entire bass line:



(NOTE: Do not hit this note!  
Hit repeat at exactly the time  
you would have played it.)

Figure 3

because from then on it simply repeats, transposed into different keys. As the riff from figure 3 plays, we can extend it out to the entire bass line simply by pressing keys on the AGO keyboard to perform the appropriate transpositions at the proper time. Like that shown in figure 4. Pretty exciting. And we really haven't even started yet.

### THE TRANPOSE SEQUENCE

While being able to transpose the programmed sequence with real time keyboard entries will be plenty useful again and again, there are also going to be times when it will be at best a pain in the neck. You'll be busy doing other things. For these times, SEQUE 1.0 offers another feature, the ability to save a programmed sequence of transpositions.

Programming the T-sequence (as we'll call it) is just as simple as programming the melody sequence (M-sequence), you simply touch the PROGRAM TRANS pad and enter the sequence from the AGO keyboard. The major difference from a programming standpoint is that the T-sequence is a sequence of events, which



Figure 2

Figure 4

is to say that it is not sensitive to the tempo in which you enter the information. We'll talk more about EVENT sequences next time.

When the PROGRAM TRANS pad is first touched, it wipes out any previously programmed T-sequence and starts a new one. Each subsequent AGO keyboard entry then represents a key change that the M-sequence will go through at the point at which it repeats.

During the programming of a T-sequence, the displays count to show where we are in the sequence, and the note corresponding to the transposition will play while the key is held down. When the key is released, the note stops completely, so that there is no possibility of confusing this programming mode with others.

On playback, the M-sequence will be played completely through, transposed to the key signature corresponding to the first T-sequence entry; then completely through transposed by the second T-sequence entry, then the third, etc. When the end of the T-sequence is reached, the whole thing starts over again with the first note and the first T-sequence entry. To go back to our walking bass line for a moment, the T-sequence would program like this:



Figure 5

In the terms which we will find most useful, enabling the automatic transpose is an OPTION which may be selected along with one or more of the major operating MODES. If we want to assert the T-sequence option during playback, we do so by touching the T-Seq. OPTION key. To stop the T-sequence and revert to the manual entry

of transpositions, simply touch the OPTION CANCEL pad.

It is important to note that canceling the T-Seq. option simply keeps the system from invoking the T-sequence, and does not in any way alter the sequence as stored. You can turn the option on and off as many times during a set as desired.

And still there's more.

### SINGLE PLAY

There will be times when we don't want the sequence to repeat endlessly, but simply to play one time through and stop. A SINGLE PLAY mode.

An important difference between the two modes is that whereas REPEAT begins playing the sequence as soon as it is touched, SINGLE PLAY waits for an AGO key to be pressed and then plays.

The T-sequence option may also be asserted in the SINGLE PLAY mode, but it has been my experience that it's not tremendously useful. Much more useful is to have the T-Seq option cancelled (which selects the AGO keyboard as the transposition source), so that pressing an AGO key not only starts the sequence playing, but causes it to play in the key selected.

Releasing the key which initiated the sequence will not cause it to stop (once started it always plays to the end), but pressing a different key in the middle of the sequence will immediately transpose it to the new key signature.

### TEMPO KEYS

The function of the TEMPO UP and TEMPO DOWN keys is just what you would expect. Touch TEMPO UP and the tempo of the sequence being played doubles. Touch it again and the tempo doubles again. Touch TEMPO DOWN and the tempo rate is divided in half.

If not over-used, these two keys will



increase and decrease tempo while still keeping relative timing of notes unchanged; however, raising the tempo too high will cause some timing information to be lost and will cause the notes to be "jammed" together so that synchopation will change. Beware and be aware that this fact has special effects implications - there may be times when you want to do just this.

#### TAPE SAVES AND LOADS

The TAPE pads control a couple of operating modes which should also be useful. TAPE SAVE causes the M-sequence and T-sequence information currently in the computer's memory to be dumped to magnetic tape. When you come up with a "keeper", start your recorder going (recording) and touch TAPE SAVE. After a short leader and synchronizing tone is generated, the displays will start to count and within a few seconds your complete composition will be stored as data on the tape (a hint - always save things twice).

Loading a composition that was previously saved on tape consists of playing the tape and touching the TAPE LOAD command pad. As with the saving operation, the displays count as the data transfers from tape to memory. If, after loading a tape, you punch up a PLAY mode and nothing happens, it means that the load was unsuccessful. Try again with the second copy (and review the "tape selection" section of PAIA's CS-87 POT-SHOT manual).

#### NORMAL MODE

Of the MODE commands up for discussion this month, only NORMAL is left, and this is simultaneously the most straight-forward, and ubiquitous of all. NORMAL is nothing more than a normal monotonic synthesizer function, the important point is that asserting this mode of operation does not alter previously programmed M or T sequences. It simply ignores them as long as this mode is selected. At any time you can punch-up SINGLE or REPEAT PLAY and do that magic and with a touch of the NORMAL pad be back to plain synthesizer.

#### SUBTLITIES AND TRICKS

It seems to me that a sequencer for use on stage should have two major design goals: it should be easy to program and operate (which SEQUE 1.0 certainly is) and it should enable the user to do a better job of the thing he's there to do - put on a show. As theatrical a show as

possible. SEQUE 1.0 has several of these "show" features.

The ability to shift back and forth between the various modes of operation (and specifically the availability of the NORMAL mode which doesn't mess up programmed sequences) is definitely one of these.

Others are less obvious, for example:

When you have the T-sequence option selected (so that transpositions come from their programmed sequence) and you go directly from the PROGRAM SCORE mode to REPEAT Play without first asserting another operating mode, the first entry of the T-sequence will be skipped and the melody sequence will begin playing immediately transposed by the second entry in the Transpose Sequence.

Why?

Because, when you entered the characteristic sequence it was equivalent to its being played the first time through (which would have been done using the first T-sequence entry). When you hit REPEAT PLAY and the computer takes over, it is in effect playing the sequence the second time - which should be done in the key of the second T-sequence entry.

The major application here is to allow you to enter (during set-up and tuning) a T-Sequence for the number that you're going to be doing and then enter the actual sequenced figure extemporaneously. We all know how great it is when the magic is working and everybody's really cooking. This feature allows your automation equipment to tap into that energy and the innovation that frequently results from it.

If for some reason you don't want to skip the first T-seq. entry, you simply terminate the PROGRAM SCORE mode with a command other than REPEAT PLAY (NORMAL, for instance; or SINGLE PLAY), then punch into REPEAT PLAY. Remember always, though, that the termination of PROGRAM SCORE mode must be done "in tempo" if the timing of the playback is to be correct.

Here's another special application:

In most cases, the M-sequence is reserved for the melody, but the UP TEMPO command allows you to enter some short riff (live, yet) then speed the sequence up to the point that it has the effect of being a "voice" of its own. By then punching into SINGLE PLAY mode, the sequence can then be used as you would a single note, which you "play" by transposing it. Naturally, the T-seq option should be cancelled for this.

Just one more, then the program

listing.

REPEAT PLAY mode always starts the M and T sequence from the beginning, making it an easy matter to use the first few bars of the sequence again and again, for introductions, bridges, and special effects.

Next time, we'll add studio features to this basic sequencer program and we'll probably take a look at a D/A that will allow all of our programs to be used with exponential response equipment, which should open a whole new world to owners of MOOG's, ARP's, etc.

### **SEQUE 1.0 COMMAND SUMMARY**

#### **PROGRAM**

**SCORE** - Saves melody sequence in real time.

**TRANSPOSE** - Saves transpose sequence as events.

#### **PLAY**

**REPEAT** - Plays sequence from beginning, cycles until stopped.

**SINGLE** - Waits for key on AGO then plays sequence from the beginning. Stops at end of melody.

#### **TAPE**

**SAVE** - Dumps current Melody and Transpose sequences to mag. tape.

**LOAD** - Loads M & T sequences from tape.

#### **OPTIONS**

**TABLE** - Selects transpose sequence table as source of transpositions (otherwise AGO is source).

**CANCEL** - Turns all selected options off.

#### **TEMPO**

**UP** - Doubles tempo of melody sequence.

**DOWN** - Halves tempo of melody sequence.

#### **MISC**

**NORMAL** - The "normal synthesizer" mode. Does not alter stored sequences.

# SEQUE 1.0

Below is a hexadecimal dump of SEQUE 1.0. Notice that the dump is divided into three sections with portions on pages 0, 1, and 2 of an 8700 memory. Before loading the program, the monitor stack pointer, User's stack pointer and status register must be pre-set as below:

```
0-0-E-D-Disp-F-F-Ent      sets Monitor stack
0-0-F-E-Disp-F-F-Ent-0-0-Ent  sets user stack and
                                status
```

Setting of the stack pointer is necessary since some of the SEQUE 1.0 program is on the stack page (page 1).

With these initial parameters set, the program may be loaded as outlined in the various 8700 manuals:

```
0-0-0-Disp-A-9-Ent-0-0-Ent-8-5-Ent-(etc.)
```

for the programming on page 0,

```
1-0-0-Disp-8-5-Ent-1-0-Ent-8-5-Ent-(etc.)
```

for the programming on page 1, and

```
2-0-0-Disp-8-D-Ent-0-6-Ent-1-2-Ent-(etc.)
```

for the final block on page 2.

When the programming has been loaded and verified, it may be dumped to tape as one continuous block, if precautions are taken to once again set the stack pointers and status register as above. The tape should be dumped from \$0000-\$0280 as outlined in the Pot-Shot manual. These same locations should also always be pre-set when loading the tape.

Location 0 on page 0 is the starting location for the program.

```
0-0-0-0-Run
```

TO ALTER THE PROGRAM TO RUN ON A P-4700/J, change locations \$14B & \$14C as follows:

```
1-4-B-Disp-F-F-Ent-0-9-Ent.
```

A fully documented assembler listing of SEQUE 1.0 will appear in the next issue of POLYPHONY.

Note: The following is available from PAIA Electronics, Inc., Box 14359, Oklahoma City, OK 73114 - complete documentation, cassette tape and plastic keyboard overlay for SEQUE 1.0 for \$6.95 postpaid.

PAGE 0

```
000- A9 00 85 E2 A9 0C 8D 7B
008- 11 4C 18 11 B0 05 85 E6
010- 8D 20 08 A5 EC D0 04 A5
018- EB 29 3F 85 EB 60 B0 0A
020- 85 E6 85 EB 85 E7 A9 80
028- 05 E2 A6 E7 8E 20 08 A5
030- EC F0 06 C5 EB F0 05 E6
038- E7 9D C0 02 85 EB 60 20
040- 84 11 E6 E5 60 38 20 AC
048- 11 AD 14 11 C5 E3 D0 02
050- E6 E9 24 E2 30 0A A5 EC
058- F0 02 85 E4 A5 E4 85 E6
060- E6 E5 60 90 04 A5 EC D0
068- D0 20 46 10 A5 EA D0 0B
070- A9 00 85 E5 A6 E8 B0 01
078- 03 85 EB 60 A9 7E D0 02
080- A9 3E 4C 00 12 18 A5 E5
088- 65 E1 85 E5 A5 E3 8D 7B
090- 11 60 B0 0E A9 FF 85 E5
098- 20 B6 11 8E 20 08 A9 00
0A0- 85 E6 60 B0 02 85 E5 20
0A8- 84 11 A5 E5 D0 05 18 65
0B0- E1 85 E5 60 85 E9 A5 E2
0B8- 09 80 D0 0E A5 E2 09 40
0C0- D0 08 A5 E2 09 01 D0 02
0C8- A9 00 85 E2 4C 0F 12 18
0D0- 20 25 1E 60 4C 54 12 4C
0D8- 20 12 4C 33 12 FF FF 00
0E0- 00 04 00 00 00 00 00 00
0E8- 00 00 00 00 00 FF FF FF
```

PAGE 1

```
100- 85 10 85 85 C2 BC B4 C8
108- CF D4 80 7C DA D7 0C 0C
118- 45 92 63 46 3F A3 1E 46
118- A5 E2 48 0A 10 22 C6 DF
120- 10 1E A6 E1 CA 86 DF A9
128- 80 AA 18 65 E0 85 E0 10
130- 0C A5 EB 09 80 85 EB 18
138- 20 25 1E A2 08 8E 20 08
140- A5 E6 F0 03 18 69 A4 18
148- 65 EB 8D 40 08 68 6A 90
150- 06 20 49 1E 4C 6D 11 2C
158- 10 08 10 FB AD 10 08 30
160- FB 2C 10 08 30 85 50 F9
168- AD 10 08 85 EC 20 00 1F
170- B0 06 B9 00 11 8D 7B 11
178- A9 00 20 83 00 AD 7B 11
180- 85 E3 D0 94 B0 09 8D 81
188- 03 85 E8 85 E6 85 EB A5
190- E5 A6 E8 9D 00 03 20 13
198- 10 29 7F D0 01 03 F0 0B
1A0- E8 E8 96 E8 9D 01 03 A9
1A8- 00 85 E5 60 B0 08 85 E4
1B0- 85 E9 85 EA 85 E5 A5 E5
1B8- A4 E9 A6 EA D0 02 03 90
1C0- 15 A9 00 85 E5 E8 E8 86
1C8- EA E4 E8 D0 09 C8 C4 E7
1D0- B0 DE 84 E9 D0 DC B0 83
1D8- 03 85 EB B9 C0 02 85 E6
1E0- 60 FF 00 FF 03 C0 02 C0
1E8- 02 FF FF FF FF FF FF
```

PAGE 2

```
200- 8D 06 12 A2 00 18 7E 02
208- 03 E8 E8 E4 E8 D0 F6 A5
210- E3 8D 7B 11 60 A2 07 BD
218- E1 11 95 F8 CA D0 F8 60
220- 20 15 12 A5 E8 8D 00 03
228- A5 E7 8D 01 03 A9 D0 20
230- 46 12 60 20 15 12 A9 11
238- 20 46 12 AD 00 03 85 E8
240- AD 01 03 85 E7 60 20 AA
248- 1E AD 0F 11 8D 7B 11 18
250- 20 22 1F 60 85 DF 66 E1
258- 90 02 66 E1 D0 B1 FF FF
```



# POLYPHONY REVIEWS:

By: Marvin Jones

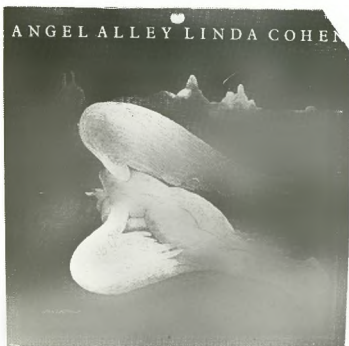

ANGEL ALLEY  
By Linda Cohen  
Tomato TOM-7010

Synthesis techniques are becoming quite accepted and are being used in an increasing number of situations. Coupled with that trend is another which sees synthesis being used in much more subtle contexts, sometimes to the point of not knowing what it was that made the sound or even that any type of processing or synthesis is occurring. Such is the case with "Angel Alley". Linda Cohen plays a very refreshing style of acoustical guitar which draws noticeable influences from classical, jazz and folk styles. Linda wrote all but one of the songs on this album. Craig Anderton was responsible for production and occasional background, and this is where the subtle processing comes in. Throughout "Angel Alley", Craig processes Linda's guitar with envelope controlled filtering, phasing, flanging, chorusing and Leslie simulation, location modulation through delay line processing, vibrato, and much more. Additionally, Craig played synthesizer and organ background for a few songs. This should serve as a very educational album for many synthesists, for it spotlights several unique and clever applications for the technologies originally inspired by a more aggressive electronic music.



CORDS  
By Synergy  
Passport PB6000

Larry Fast's music has undergone a great deal of change since his first two Synergy albums. Larry has always been much more intimate with music technology than most of the popular synthesists. As a result, he is able to really make the technology work for him in creating very subtle, yet intricate, developments in his music. During the (seemingly) extensive time period between "Sequencer" and "CORDS", Synergy was preparing a great deal of current technology for the next album. Polyphonics had arrived; micro-processors provide alterable storage of extended event strings; and finally a development in guitar synthesizer technology that worked well enough to warrant it's inclusion on such an album. While a great deal of technological development undoubtedly precipitated this album, it is not initially so obvious. The technology is primarily working to make the music more refined, layered, structured, ... more coherent. The most apparent developments are in the composition. Chord structures and progressions, counterpoint techniques, and theme manipulations definitely take a superior position to sound structures, special effects, and diversity of patches which were so predominant in the previous albums. But never fear; many of the Synergy trademark patches are here. Small bells are on "Phobos and Deimos..",

as is a good bass guitar part with string bending. Harpsichord on "Disruption in World Communications" and "A Small Collection of Chords" is reminiscent of "Chateau". "Trellis" is full of 'Sequencer' trademarks such as harpsichord, flutes, sequencing, bells, and so on. What seems to be the latest Synergy patch perfected is drums. Throughout "CORDS" are a number of excellent tom and bass drum sounds. Snare drum rolls are performed a number of times, also. But the tympani ... wowie zowie ... this has to be a new standard for low frequency transient response tests on your stereo!! The Hamm guitar synthesizer on "Terra Incognita" is a good demonstration of the solid tracking of the Hamm system, but I feel the composition could have benefited from the use of some lighter voicings on the guitar controlled parts, especially where use of tape loops was a major processing element. The compounded heaviness of the repeating voices seems to obscure a lot of the subtleties of the guitar system. It would have been quite nice to have parts of the guitar signal mixed in as well. "CORDS" will probably be of more interest to musicians in general than Larry's previous albums. This could be good. But many of the early Synergy fans may fail to see the developments here. That would be a shame. Be sure to listen to it several times before making your decision!



OPEN FIRE  
By Ronnie Montrose  
Warner Brothers BSK 3134

Ronnie Montrose could easily be thought of as the American answer to Jeff Beck. His versatility ranges from hard searing rock to mellow jazz and classical guitar pieces. This alone is good reason for buying this album. And that's what I did. It wasn't until I had the album home

... continued on page 42

# POLYPHONY Bookshelf

"The Craig  
Anderton  
Music Tape"

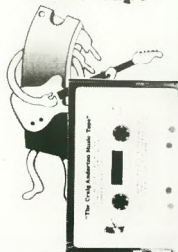

AUDIO  
CYCLOPEDIA

TREMAINE

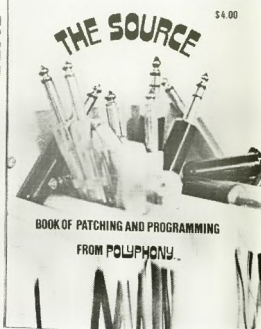
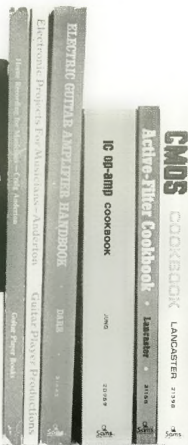

A collection of books, recordings, and supplies that are a must for every active music experimenter's lab or studio bookshelf.

Craig has prepared two fine books to serve as continuous reference manuals in building, and using musical electronics. *Electronic Projects for Musicians* is a perfect introductory manual for the musician with no previous experience in electronics. *Home Recording for Musicians* outlines the selection and operation of recording equipment for the musician with BIG ideas and small budgets. *The Craig Anderton Music Tape* is a collection of original compositions recorded by Craig while he was writing HRFM.

**ORDER**

- #EPFM \$7.95
- #HRFM \$9.95
- #CAMT \$5.95

Order CAMT with either book and deduct \$1.00!

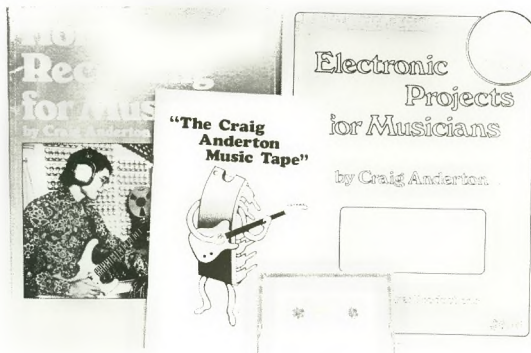

Howard Sams' cook books are an excellent way to stock your library with materials that are not only heavy on theory, definitions, and educational material, but chock full of practical applications as well! These books can easily replace stacks of manufacturers' data sheets and applications notes all in an easy to use reference. "Audio IC Op Amp Applications" is a smaller version of the Op Amp Cookbook. This edition contains only the sections which are pertinent to audio circuitry.

**ORDER**

- #OACB Op-Amp Cookbook \$12.95
- #AFCB Active Filter Cookbook \$14.95
- #CMCB CMOS Cookbook \$10.50
- #AUOA Audio Op-Amp \$7.95



Jack Darr's Electric Guitar Amplifier Handbook is stuffed with schematics for popular amplifiers and effects units from major manufacturers. This book is an aid to service shops as well as the advanced experimenter. Contains thorough discussions of typical amplifier problems, locating them, and repairing them.

ORDER #EGAH \$10.50

Audio Cyclopeda is subtitled "the most comprehensive and authoritative reference volume on audio ever published". With 1760 pages, 3650 entries, and hundreds of illustrations and schematics, that description can't be too far off.

ORDER #CYCLO Audio Cyclopeda \$39.95

ALSO: We have a few of our old style magazine binders left. These were designed for our 5.5" X 8.5" issues, but will serve well to hold other small publications, such as manuals from Paia, Strider, or old copies of Musicians Guide, etc. 1/2 price while they last!

ORDER #Bind-S \$2.50

We have new binders to hold the large format Polyphony -- or any other 8.5" X 11" publication. Black vinyl over hardboard is silkscreened with the Polyphony logo and a spot to index the contents. Wire-type magazine holder eliminates punching your magazines for ring binders, and keeps issues like new for reference use.

ORDER #Bind-L \$4.95

The Source is finally here! Over 125 pages of patches, synthesizer notation, and computer software for music applications. Regardless of the synthesizer you own, these patches serve as an intense study of the capabilities of synthesizers. As an inspirational guide or departure point for deriving your own patches, The Source can't be beat! Convenient thumb index leads you to the patch you're after! Tonal patches, sound effects, patch techniques -- it's all here!

ORDER #Source \$4.00

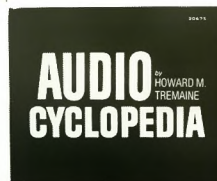
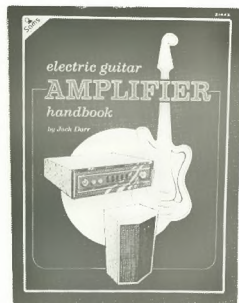
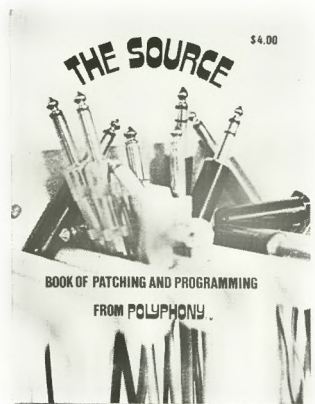

the most comprehensive and authoritative reference volume on audio ever published covers every phase of the subject, including the latest solid-state and integrated circuits.

#### ORDERING INFORMATION

Use the handy order form in the center of this issue or, if someone beat you to it, use the coupon below. All prices postpaid in U.S. Others add \$1.00 per item for additional postage. We are looking for other books that may be of interest and would appreciate any recommendations. Drop us a line, tell us the book (and publisher if you know it). With sufficient interest we will begin stocking the book. What other types of materials would you be interested in seeing presented here? Other home-produced albums? Circuit boards for Polyphony projects? Blank patch chart pads? Let us know your ideas!!

Send to: Polyphony Bookpage  
P. O. Box 20305  
Oklahoma City, OK 73156

Name: \_\_\_\_\_  
Address: \_\_\_\_\_  
City, State, Zip: \_\_\_\_\_

___ EPFM	\$ 7.95	___ AUOA	\$ 7.95
___ HRFM	\$ 9.95	___ CYCLO	\$39.95
___ CAMT	\$ 5.95	___ EGAH	\$10.50
___ OACB	\$12.95	___ Source	\$ 4.00
___ AFGB	\$14.95	___ Bind-S	\$ 2.50
___ CMCB	\$10.50	___ Bind-L	\$ 4.95

TOTAL \_\_\_\_\_

Foreign Postage \_\_\_\_\_

(\$1.00 per item) \_\_\_\_\_

# Rhythmic Control of Analog Sequencers

By: John Duesenberry

This article will not be a general discussion of sequencers and how they work. It will be confined to analog, as opposed to digital sequencers. ( Examples of analog sequencers are the Arp 1027 and 1613; the Oberheim Mini-Sequencer, the Moog 960, and the Aries AR-334. ) We assume that the reader has a basic working knowledge of the general operating principles of the analog sequencer, and of voltage-controlled synthesizers in general.

Specifically, we will be dealing with a question that, sooner or later, occurs to most sequencer users, who quickly become bored with producing sequences of events of uniform duration. The question is: How do you control the duration of each step of the sequence? Exactly? (With the exception of a few of the masters of the art, such as Roger Powell and Morton Subotnick, this question seems never to have occurred to most synthesists on record. )

The answer to the question of rhythmic control boils down to finding a method for controlling the frequency of the sequencer's clock. The theoretical basis of the solution can best be approached by clarifying what frequency ratios mean to us.

To most musicians, frequency ratios are equivalent to musical intervals. Ask the average synthesist what it means when two oscillators are tuned to a 3/2 frequency ratio, for example, and you will probably get the answer: "It means they're tuned a perfect fifth apart."

This could be true, if the oscillators in question were operating in the audio frequency range. But what if they were in the subaudio range? (i. e., below 20 Hz. ) If you listened to the outputs of these two oscillators, would you hear a "fifth"? Would you hear anything? If you were listening to the sine or triangle outputs, you would hear exactly nothing.

If you were listening to the sawtooth outputs from the oscillators, you would hear each one emitting a series of evenly spaced clicks; one oscillator would be clicking slightly faster than the other. If you listened to both signals at the same

time, you would hear these two "click tempos" superimposed, in other words a cross-rhythm like the one in figure 1. (Assuming the oscillators were synced exactly into a 3/2 ratio).

Looking at it from another standpoint: if you're playing 3 in your right hand against 2 in your left, your hands are tuned to a perfect fifth. Tell that to your drummer.

What we are getting at is simply this: pitch and tempo, two musical parameters which have been traditionally considered unrelated, are actually two perceptually different manifestations of the same physical signal parameter: frequency. As a corollary, pitch intervals, whether successive or superimposed, are a function of frequency ratios of audio-range signals; the corresponding ratios in the subaudio range are perceived as sequences of events of varying durations (successions of different frequency ratios) or as cross-rhythms (superimposition of different frequencies).

This idea of the mathematical equivalence of pitch (and, if you think about it, melody, harmony, and timbre) and rhythm, which may seem novel at first, is, in fact, not so new. At least one composer - Henry Cowell - was speculating about these relationships and incorporating them into his work as far back as the Twenties. More recently, in the Fifties, Stockhausen has utilized some of the same ideas in his electronic music, most notably Kontakte. For those interested, I suggest looking into Cowell's book New Musical Resources, and Stockhausen's article in Perspectives of Contemporary Music Theory.

Now, before dealing with the implications of the above for the sequencer user, there is another mathematical relationship we must consider: the relationship of frequency, period, and duration. This relationship is quite simple: period is the inverse of frequency. ( $P=1/F$ )

For example, if a waveform of any kind has a frequency of 100 Hz., its period (duration of a single cycle) is .01

sec. If the frequency is 1Hz., its period is 1 sec., and so on. From now on, the term duration will be substituted for period, since this is a more common term in describing the relative lengths of musical events.

From the above information, we can now infer that durational ratios are the inverse of frequency ratios. As an illustration, let us refer back to the previous example of a 3-against-2 cross-rhythm. (see figure 2)

We can say that the lower-frequency oscillator has a frequency F, and the higher-frequency oscillator has a frequency 3/2 F. Therefore, if the quarter note has a duration D, the triplet quarter note has a duration 2/3 D.

To take another example: if the hypothetical subaudio oscillators are tuned to a 2/1 frequency ratio (octave), the resultant clicks could be notated as shown in figure 3.

The translation from frequency to duration should be obvious. The 1st, 4th, and 5th columns of the chart shown in figure 10 should clarify these, and other, basic examples of the translation of frequency ratios into ratios of durations.

This completes our theoretical exposition; now we can start talking about sequencers.

Until further notice, we will be assuming that we are dealing with a sequencer which - like the Moog 960, for example - has a voltage controlled clock with 1 volt per octave sensitivity. This is not something you can take for granted about your sequencer, so make note of the exceptions discussed later in this article.

The simplest and most commonplace application of a sequencer is to use it to create a repeating sequence of varying voltages, which are used to control audio-range VCO's. The result is, of course, a sequence of varying pitches, since the frequency of the VCO varies proportionally to the voltage output of the sequencer. This typical patch is shown in figure 4.

What is it, in this patch, that

---

John Duesenberry is a faculty member of the Boston School of Electronic Music.



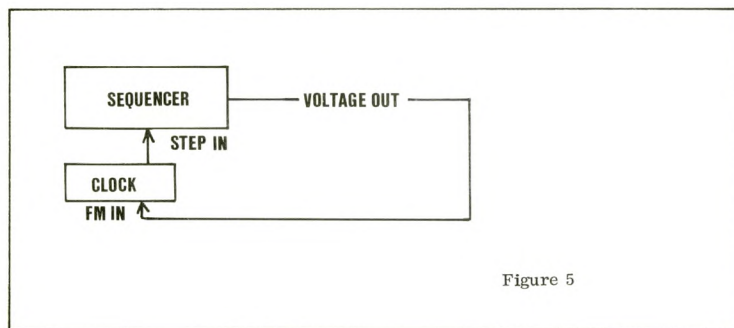
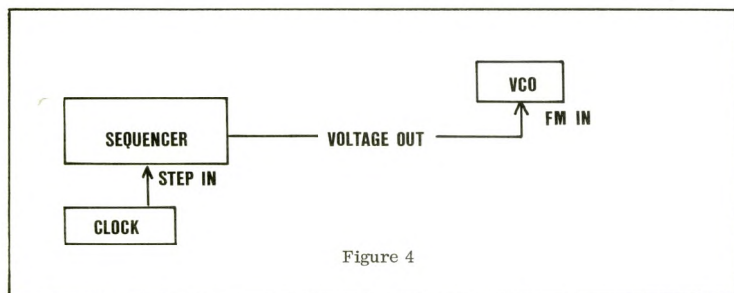
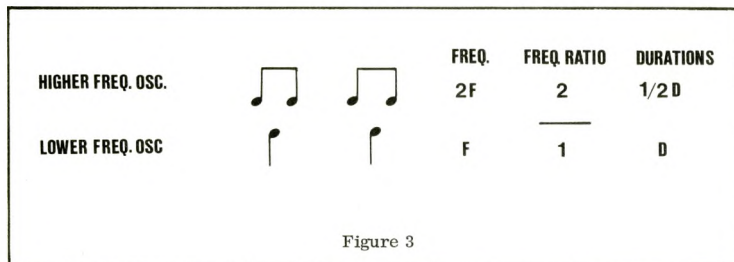
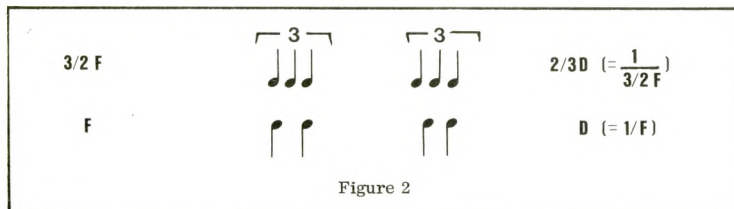
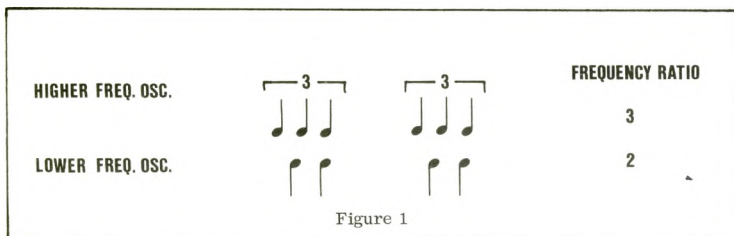

determines the tempo of the sequence? Obviously, the frequency of the clock. The clock is a subaudio pulse or square wave oscillator which may be internal or external to the sequencer, but which in either case is patched into the step input of the sequencer. If the clock can be voltage controlled, then we can vary the duration of each sequencer step by feeding a voltage output from the sequencer into the frequency control input of its own clock. (see figure 5)

A voltage controlled internal clock is standard on most analog sequencers. There are certain problems, which we will note shortly, which will make it necessary to use an external clock; in such cases a pulse or square wave output from a voltage controlled subaudio oscillator should be used.

Getting a sequence of varying durations is thus quite simple; no great discovery at all, in fact. In light of the consideration of the pitch-rhythm relationships above, adjusting the sequencer voltage steps to produce a desired sequence of durations should be no problem.

Before outlining a "rhythm tuning" procedure for analog sequencers, let us remember, again, that we are assuming a 1 v./octave control sensitivity (known as exponential sensitivity) for our clock.

The tuning procedure is as follows:

- 1) Write out the sequence of durations desired.
- 2) Translate this into ratios of durations. (i. e., the ratio of each duration in the sequence to the longest duration in the sequence, to which we will refer as D from now on.)
- 3) Translate the durational ratios into frequency ratios. (i. e., invert the durational ratios.)
- 4) Translate the frequency ratios into pitch intervals.
- 5) Patch a sequencer output voltage into an exponentially-controlled, audio range VCO, and tune the sequencer voltages to produce the pitch sequence you arrived at in step 4.
- 6) The sequencer voltages are now adjusted properly on the output channel you have just tuned up. Patch the same channel of voltage output into the clock's FM input, unattenuated.

This procedure may seem like a pain. It is, at first; so are most synthesizer patches which produce worthwhile results. However, once you get the hang of it, you will be able to program any rhythmic sequence (within the inherent limitation of the number of available sequencer steps) with super-

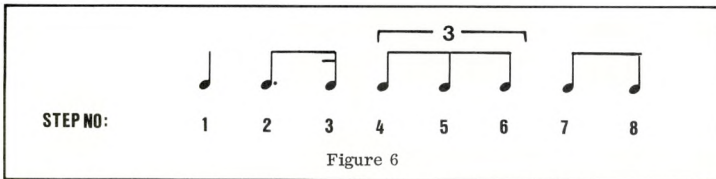

Figure 6

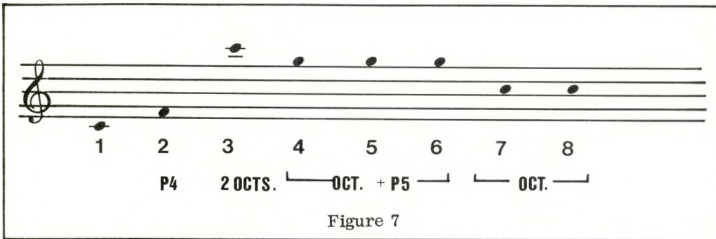

Figure 7

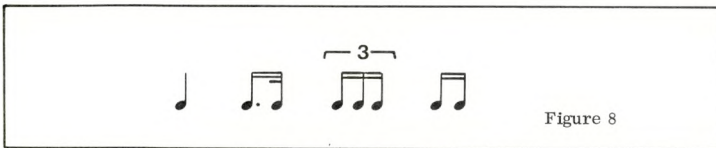

Figure 8

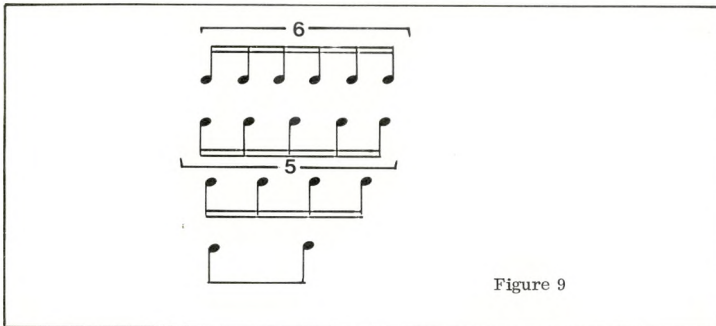

Figure 9

human accuracy.

To make things simpler, let's consider a simple example. Suppose we have an 8-step sequencer, and we want the 8-note rhythm pattern shown in figure 6.

In step 2 of the tuning procedure, we would get the following durational ratios:

D 3/4D 1/4D 1/3D 1/3D 1/3D 1/2D 1/2D

In step 3, these translate into frequency ratios:

F 4/3F 4F 3F 3F 3F 2F 2F

In step 4, these translate in turn into pitch intervals, from which we can get the pitch sequence shown in figure 7. (We start arbitrarily on C; we could start on any note, since only the intervals matter.)

We now have only to complete steps 5 and 6.

The Rhythm Tuning Chart in figure 10 is intended as an aid to beginners in making the necessary translations between pitch and rhythm. Obviously it does not include all possible rhythmic values, but, with practice and an understanding of the theoretical basis of our method, it should be possible to tune up any rhythmic sequences desired.

In using the chart, keep in mind that the choice of a whole note as D is completely arbitrary; the same set of rhythmic ratios may be notated in terms of any basic unit.

Having arrived at a general method for rhythmic control, we must now deal with exceptions and various quirks of particular types of sequencers. As we mentioned, the Moog 960 has an exponentially controlled clock. This is not

always the case. Going down the list of manufacturers:

**ARP.** Arp's 1027 sequencer module (one of the 2500 series of modules) has a voltage-controllable internal clock, but it is not exponentially controlled. Arp's model 1613, a self-contained sequencer, also has a voltage-controlled clock. Whether it is exponentially controlled or not is somewhat irrelevant, because of the presence of an attenuator on the FM input which has a gain of less than unity. In either case, an external clock should be used. Any Arp VCO, in its subaudio operating range, will do, since all Arp VCOs are 1v. per octave.

**ARIES.** The new Aries sequencer, soon to be released, does not have an internal clock at all. Use any of the Aries VCOs, or the internal clock of the Sample/Hold module if you have one. Do not use the dual LFO, since it's not voltage controllable.

**SEQUENCERS WITH QUANTIZED OUTPUTS.** Some sequencers, such as the Arp 1613 and Electrocomp, have "quantizers" which digitally round off the voltage settings to the nearest 1/12 volt, to make equal-tempered tuning easier. In voltage-controlling the clocks, internal or external, of such units, don't use the quantized outputs. The un-quantized outputs are available, and should be used for rhythm tuning; otherwise inaccuracies will result.

**OBERHEIM.** In dealing with the above mentioned sequencers, no adjustment to our tuning method had to be made. The Oberheim Mini-Sequencer is an exception, however.

If we wanted to get the same 8-step rhythm sequence as that in the example previously mentioned, and tuned the Mini-sequencer as we would ordinarily, we would instead get the sequence shown in figure 8.





















Why? Because the control sensitivity of the internal clock is 2 octaves per volt. There is no input for an external clock on the Mini-sequencer; otherwise that would be the best way around this problem. (You could have your sequencer custom modified for this, of course.) We therefore have to resort to a kludge. The method is: when you get to step 4, cut all the pitch intervals in the sequence in half (Octaves become tritones, semitones become quarter tones, etc.).

The reason for this should be obvious. All the voltages must be halved, since a voltage that would ordinarily cause a VCO's frequency to be multiplied by some value n will now cause it to be multiplied by 2n.

Another option would be to put an



## RHYTHM TUNING CHART FOR ANALOG SEQUENCERS

Clock Freq.	Pitch Interval*	Halved Interval**	Duration	Note Value
F			D	
4/3F	P4	2-1/2 semi. (bM3)	3/4D	
3/2F	P5	3-1/2 semi. (bM3)	2/3D	
2F	Oct.	tritone	1/2D	
8/3F	Oct. +P4	bM6	3/8D	
3F	Oct. +P5	#M6	1/3D	
4F	2 Octs.	Oct.	1/4D	
5F	2 Octs. +M3	Oct. +M2	1/5D	
16/3F	" +P4	" +bM3	3/16D	
6F	" +P5	" +bM3	1/6D	
7F	" +m7	" +P4	1/7D	
8F	3 octs.	Oct. +tritone	1/8D	
9F	" +M2	" +P5	1/9D	
10F	" +M3	" +m6	1/10D	
32/3F	" +P4	" +bM6	3/32D	
11F	" +tri- tone	" +M6	1/11D	
12F	" +P5	" +bM7	1/12D	
13F	" +M6	" +bM7	1/13D	
14F	" +m7	" +M7	1/14D	
15F	" +M7	" +#M7	1/15D	
16F	4 Octs.	2 Octs.	1/16D	

\* For exponentially controlled clocks (1v./octave), internal or external

\*\* For 2 oct./v. clock (Oberheim Mini-Sequencer)

FIGURE 10

attenuator with a gain of 0.5 between the sequencer's 2nd voltage output and the clock's control input; this, however, would again involve some custom work.

As an aid to users of the Mini-Sequencer, an extra interval column has been included in the tuning chart. (3rd

column: Halved Interval) All intervals which have been indicated as flat or sharp should be tuned a quarter-tone flat or sharp. Even if you aren't so hot at tuning quarter-tones, the resultant rhythms will be perceived as accurate, as long as you're in the ball-park. The

human ability to detect small pitch deviations is much more accurate than the ability to discriminate the equivalent deviations in duration.

Now have some fun with this: What chord is the equivalent of the complex cross-rhythm shown in figure 9? ●

# MAGIC BUTTONS

## Touch Switch Theory

By Steve Wood

I suppose that before long I'll be sitting in front of a typewriter like this not pushing down keys, but touching pads that represent the keys and watching the print go down on paper. Not a particularly exciting thought to me as I have yet to master this ancient electro-mechanical wonder I'm working with. But the idea of touch pads instead of mechanical switches is a downright nice thought when considering the many applications to which one might put these "Magic Buttons". For instance, suppose you've got your guitar plugged into a box full of modules for some "special effects", and in order to get a certain effect you have to trigger one of the modules. Well, you could step on a mechanical (yuck) foot-switch on the floor, or you could set up an envelope follower that has a variable threshold trigger output and try to control the triggering with the pulse output of the envelope follower. This is not too bad under the right conditions, but you could put a "Magic Button" on your guitar (or any other electrical instrument you may be using), and accomplish the effect much more easily.

A single capacitive type touch switch can be constructed around one IC chip, (like a 4001 MOS quad NOR gate). It can be made to take up very little room, and be placed strategically on your ax so as to be convenient for your picking hand pinky to reach down and stroke when-

ever it gets the urge to send a trigger pulse to that box of modules, or whatever you want to trigger, (lights maybe?).

The particular touch switch circuit I have in mind is like that found in figure 1. We may need to add a simple differentiating circuit that will provide us with a pulse output. Let's take a look at these circuits, shall we? Using the values shown here the clock should run at a frequency of about 45k to 50k Hz. If we pump this clock signal into the remaining circuit as shown in fig. 1, here is what will happen. On the positive or high half cycle of the clock, diode D1 will be forward biased and a positive voltage will appear at the junction of D1's cathode, R2, input pin 6 of gate "C", and the touch pad. The second input to gate "C" is connected directly to the clock output. This being a two input NOR gate, both inputs must be at ground before the output can switch to a high state. If the inputs are in any other condition the output will be low. The touch pad represents a very small capacitance that has to be charged before the voltage at the input (Pin 6), of gate C can rise to a value that will cause this gate to switch. With the very low "on resistance" of D1 during the positive half cycle of the clock as a current path to the touch pad, the time required to charge this "capacitor" is very short. So short, in fact, that the voltage at the input of the gate (Pin 6) can easily

reach a value sufficient to switch the gate within one clock cycle. When the clock is in the low half cycle, the only discharge path available to the pad is R2. D1 is now reverse biased and the gate input represents a very high impedance. If the pad can discharge completely on low half cycles of the clock it is of no consequence at this point because all we need is the inverted replica of the clock signal at the output of gate "C". Actually, the arbitrary capacitance of the touch pad assumed in this writing is exaggerated to aid in circuit analysis and, in reality, is significantly small in relation to the other values in the circuit. The high portion of this 50k Hz. square wave forward biases D2 and causes a voltage drop across R3 charging C2 to a value near supply. When the output of gate "C" goes low, D2 is reverse biased and the only discharge path available to C2 is R3. The time required to discharge C2 is longer than the duration of the low half cycle, so both inputs of gate "D" (pins 1 & 2), are held high, and it's output is low. This is the off condition of the switch. Now, if a finger is placed on the touch pad, the capacitance offered by the body belonging to that finger is added to that of the pad. The total (several hundred pico-farad) is quickly (within a few clock cycles) charged to a value near supply via D1 during positive clock half cycles, but is more than can be fully discharged through R2 in the 20 microseconds or so allotted during the negative half cycle of the clock. This phenomenon is somewhat dependent on the assumption that some part of the body is at ground potential. So, with a finger on the pad the voltage at the first input (Pin 6) of gate "C" never gets to a low value and the gates output cannot

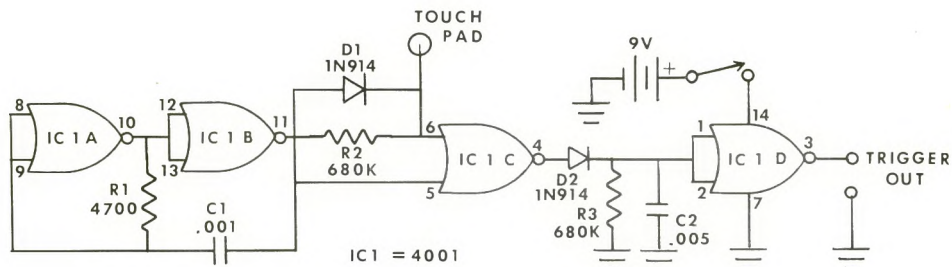

Figure 1



switch in accordance with the signal from the clock, but instead remains low. This leaves us with no means of charging capacitor C2. So it discharges through R3 allowing the inputs of gate "D" to be pulled down to ground, which in turn causes the output to switch to a high level. This is the "on" state of the switch.

In case your clock must drive many touch switch circuits, there should be a buffer between the clock and the inputs to the switch circuits. This will reduce any interaction caused by the increased touch switch load on the clock circuit.

Something else worth mentioning is that changes in clock frequency will cause corresponding changes in the sensitivity of the touch switch. That is, the higher the clock frequency the more sensitive the switch becomes, and vice versa.

Fig. 2 shows a circuit which can be added to produce a differentiating circuit that will provide pulse outputs. This is the circuit that would serve best as a "Magic Button" on a guitar, except that perhaps the RC pulse output section should be placed in whatever cabinetry houses the unit to be triggered, or somehow built into the end of the cord that will carry the trigger voltage from the output of the touch switch to the receiving unit. If you're thinking about incorporating this line into the audio patch cord from your guitar, don't. The resulting snap, crackle, pop would be more than you would be able to handle at any time of day! It is too bad there has to be an extra cord running from your ax, which will no doubt hold some folks in favor of the good old foot-switch but I feel it's worth having an extra cord to tend in exchange for the extra control afforded by the touch switch.

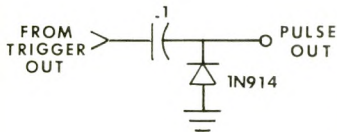

Figure 2

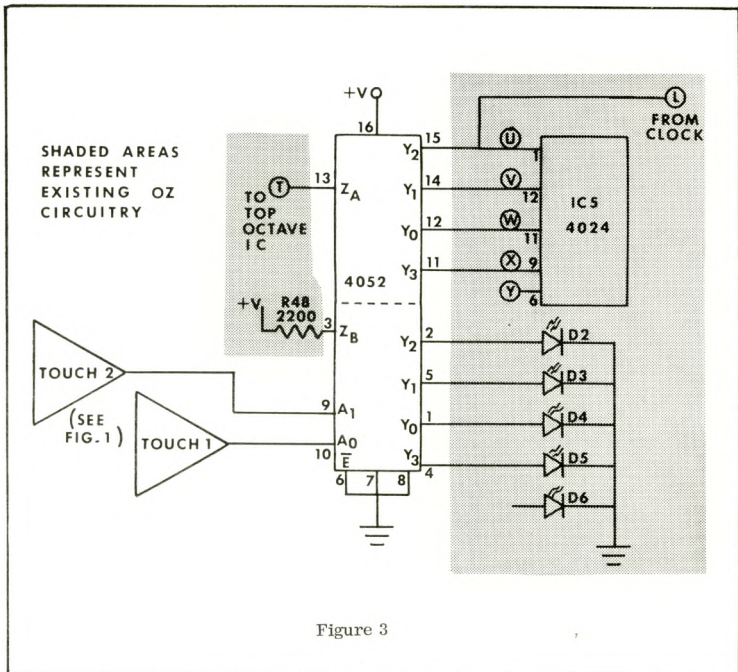

Figure 3

Are you thinking radio? Yeah that would be neat, but if we're going to do that let's just put the audio signal on the air too. And maybe a few effects, and .....No. Let's just keep our clunky old patch cord so we can talk about touch switches. Besides, not everyone plays guitar! (Or do they? Sometimes I wonder.) In fact one would expect that there are more keyboard freaks reading this than guitar thrashers anyway. It would probably even be fair to say that a good number of those people are Oz owners. So, for those of you who presently fall in this category, as well as those of you who intend to join the club, here's a fun way to exploit the use of "Magic Buttons" on your Oz.

#### TOUCH SWITCH OCTAVE SELECTION FOR OZ

With three IC chips (two 4001 quad NOR gates and a 4052 dual four channel multiplexer), we can add a couple of "Magic Buttons" to Oz and have touch octave selection. Fig. 3 shows how the 4052 is incorporated into the Oz octave selection circuitry so as to replace the 5 position rotary switch, S2. If you're not familiar with the 4052

check out fig. 4. This chip serving as a multiplexer will pass one of the three output signals from the 4024 clock frequency divider or the clock output from IC6b, to the clock input of the MK50240 top octave generator. The lowest octave can be omitted without too great a loss. Selecting which channel is activated is a function of the two digit binary number applied to the address inputs A 0 and A1. This number is a representation of the status of the touch pads since it is in fact composed of the voltages appearing at the

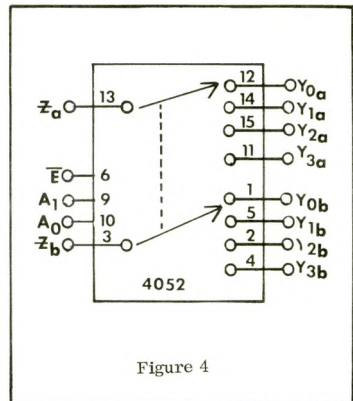
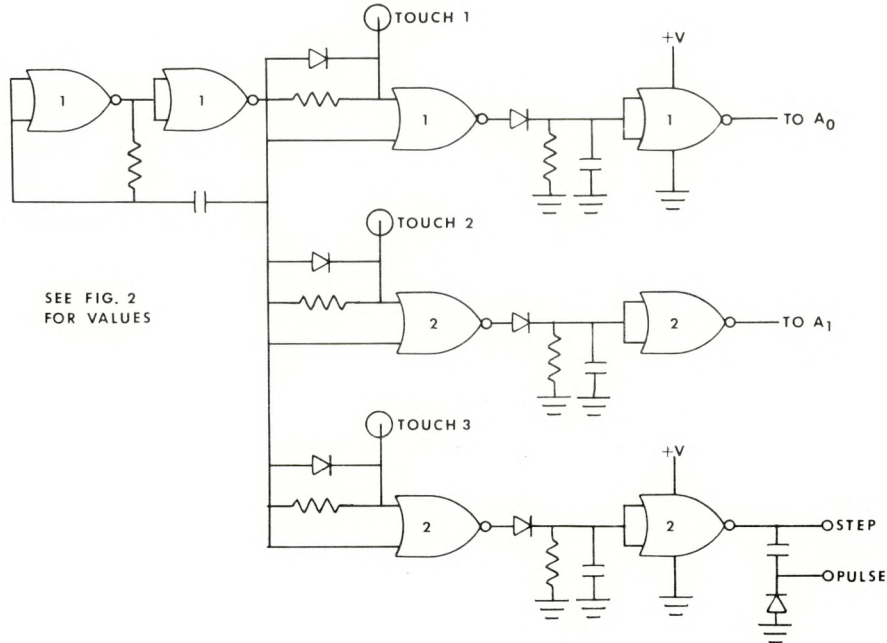

Figure 4



SEE FIG. 2  
FOR VALUES

Figure 5

outputs of the two touch switch circuits. Thus far we have described the action in 1/2 of the multiplexer. The other half works in the same manner. The two address inputs are common to both four channel multiplexer networks in the chip. That is, if the binary number 00 is presented to the address inputs, channel Y0 in the A section is connected to the Za pin while channel Y0 in the B section is connected to the Zb pin. This B part of the multiplexer we can use to switch in the appropriate LED octave indicator for whatever octave has been selected. So if you arrange the connections as shown in fig. 3, Oz will be in it's center or third octave position when no "Magic Buttons" are being touched. Under these conditions, both touch switches will have low outputs presenting a binary 00 to the two address inputs of the 4052, enabling channel Y0.

There are two gates left over in IC1. Waste is a drag. We ought to give them something to do. We can use

them in a third touch switch circuit, but we don't need another address bit for the 4052. Maybe this third switch could serve as a trigger, second to and independent from the existing "key-board activated" trigger. Might be a handy thing to have if your Oz spends much of it's time as a pitch source for a larger synthesizer system. Fig. 5 shows how the circuitry looks with the third switch utilized as a trigger.

Another little goody that you may find interesting is shown in fig. 6. The binary counter circuit can address the multiplexer so that neighboring octaves can be sequentially selected automatically. This is a neat little cheater gadget because you can just hold a chord and do some fancy arpeggiation by letting the counter run. This also gives us something else to do with the third touch switch. Fig. 6 shows how the 4052 can be addressed either by touch switches or the counter. Diodes are used to AND the outputs of the touch switches and the counter cir-

cuit into the address inputs of the multiplexer. The third switch is used to enable the counter. When this switch is activated the output of Touch 3 is switched high. IC3A inverts this high state to a low. This holds the one input of the clock buffer, IC3D, at ground which enables the buffer to switch at the clock frequency. IC3B and IC3C form a low frequency clock which drives the counter circuitry. This, in turn, causes the automatic arpeggiation through 4 octaves of transposition. The output of IC3D is binary bit 0 of the counter circuit and also drives the Cp input of the flip flop. The flip flop divides the clock frequency by two and output Q1 is the second bit (bit 1) of the two bit binary counter circuit. (By the way, there is an unused flip flop of this type on the Oz P.C. board. Half of IC1 is not committed and if you don't mind cutting some foil and doing a little point to point wiring, you can save yourself the cost of a 4013). Notice that the first two touch switches are still func-

Steve Wood is Director of Technical Services at PAIA Electronics, Inc., Oklahoma City.



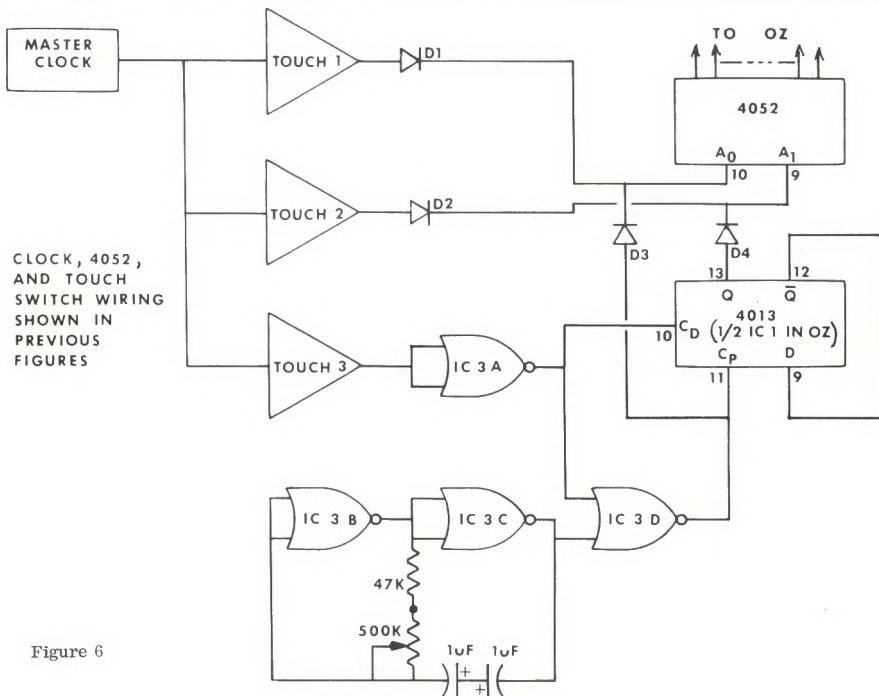

Figure 6

tional even when the counter is enabled so that they may be used in conjunction with the counter.

When the third switch is released, it's inverted output at IC3A goes high pulling the input of IC3D high to disable the switching action of this buffer and hold it's output at ground. The counter is stopped. This would be all that needed to be done except that we don't know whether the Q1 output of the 4013 will be high or low when we stop the clock. In order to control address input A1 of the 4052 from the second touch pad the Q1 output of the flip flop must be low when the counter is not running. To insure that this is the case the output of IC3A is also connected to the "Cd" (clear direct) pin of the 4013. When this line is high the Q1 output is switched to ground regardless of other input status. With both outputs of the disabled counter at ground, diodes D3 and D4 serve to isolate the counter outputs so that the touch switches 1 and 2 can have complete control of the multi-plexer addressing.

### Notes on the Recording of Synergy's "CORDS"

..... continued from page 8

- 1975 Watercourse Way (Producer) Shadowfax Passport Records
- 1975 Recycled Nektar Passport PPS-9811
- 1976 Sequencer Synergy Passport Records PPSD-98014
- 1976 Peter Gabriel Atlantic SD36147
- 1976 Dr. Buzzards Savannah Band RCA Victor APL-1504
- 1977 A Short Trip to Space John Tropea T.K. MAR 2204
- 1977/78 Cords Synergy Passport/Arista PD-6000
- 1978 Peter Gabriel Atlantic SD19181

## INTRODUCING

# PAIA

## Factory Representatives

**Doug Slocum**  
**Synthetic Sound Labs**  
 1 Gale Road  
 Bricktown, NJ 08723  
 (201) 477-3319

**Gary Bannister**  
 7208 New Augusta Rd  
 Indianapolis, IN 46268  
 (317) 293-0606

PAIA Factory Rep's are people who have used PAIA equipment for years. Give them a call, they'll be happy to tell you all about PAIA gear and arrange for a demonstration.

# BUILD A MODULAR VOCODER

BY: Jeff Wurstner

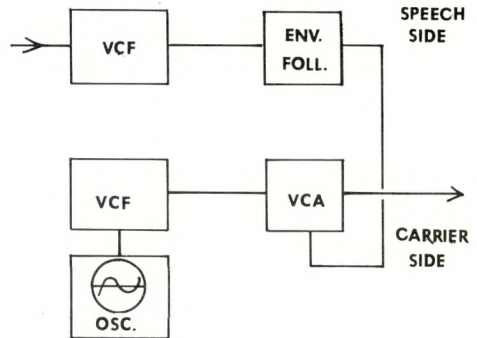

Figure 1

Have you ever heard of a "Vocoder"? It is a device that enables you to impart vocal inflections on a synthesizer (or other) signal. It accomplishes this by breaking down an incoming microphone signal into a series of frequency bands, and applying the strength of the signal at each band to another signal, at the same frequencies. In this way, much of the timbral characterization your mouth and voice are capable of producing can be used to "shape" the other signal, which we will call the "carrier".

Figure 1 is a block diagram typical of any commercially available vocoder. Of course, different manufacturers offer different features, but the basic operation is always the same.

The top half of the diagram comprises the "speech side" ("analyzer") of the device. This section separates the input signal into different frequency bands by passing it first through a series of bandpass filters. The outputs of these filters are applied to envelope followers which use the signal content in each frequency band to generate a control voltage proportional to the amount of audio activity in that band. Thus, at this point, the voice input has been

analyzed and converted to a set of varying control voltages which represent the frequencies that the voice input is using to express itself.

The bottom half of the diagram is the "carrier" side ("synthesizer") of the device, in which a signal from an internal VCO or from an external source is passed through another series of bandpass filters tuned identically to the analyzing filters. Ideally, several filters tuned one-half octave apart or less would break the audio and voice signals into their components. This would allow individual access to a wide range of harmonic structures and would allow reconstruction of the voice harmonics which are generally quite complex.

The arrangement shown introduces vocal "intonations" to the carrier by placing the outputs from the envelope followers at the control voltage inputs of the VCAs, whose audio inputs have the carrier side VCF outputs feeding them. Other patching arrangements can be used for special effects, however, we will stick with the basic application to begin with.

Sounds great, doesn't it? And it's even better in action! You've probably heard vocoder effects on records recently. Perhaps without knowing it! Alan Parsons used one on "The Raven", Pink Floyd used one on their "Animals" album to superimpose a barking/howling dog over a string synthesizer, ELO used one to superimpose voice on thunder for their "Out of the Blue" album, and the

Intergalactic Touring Band used one throughout their recent album. Walter Carlos "made" his own, which brings us to the point here. Using synthesizer modules, you can build a modular vocoder for (at best) less than one tenth the price of a commercial unit, depending on how sophisticated you want to make yours. Store-bought vocoders are presently manufactured by: Bode Sound Company (whose two models sell for \$2995 and \$4995), EMS, and Sennheiser. All are very sophisticated units with access to no less than ten frequency fands of both speech and carrier signals, and they offer a variety of other features. Bob Moog's column in the May 1978 issue of Contemporary Keyboard fully explains these units and gives manufacturers' addresses. For the synthesizer hobbyist, semi-professional or rising star these prices are out of reach.

Thus, the modular vocoder, designed with economy and versatility in mind. We'll outline a basic, no-frills approach, and offer suggestions as to how you can build an ultra-sophisticated system.

For a convenient point of reference PAIA module numbers were used, although similar modules from any manufacturer would work equally as well. For a basic vocoder you will need: two - 4730 Multi-Modal VCFs, three - 2720-11 Envelope Followers, one 4720 VCO, three 2720-1 VCAs and one 4711 Mixer. If you total the cost and tack on a wing cabinet to house the



modules, the cost comes to \$270 which is much less than you'd pay in any store. If you don't have a power supply to drive these modules, a 2720-7, at \$24 should do the trick. That will still keep the price under \$300 - a pretty good bargain.

Ready to start building? Good. You can mount the modules any way you like, it's your system, but the configuration shown is designed to be somewhat logical and to cut down on nerve-wracking patch cord traffic. This system will produce a "custom tailored" carrier signal; however, if the carrier is to be a "ready-to-go" signal source provided by an external source (synthesizer patch, tape recorder, etc.), the VCO can be eliminated with no pain, knocking \$35 off the price. You can use any signal, pre-processed or not, to drive the VCF in the "synthesizer" section of the vocoder.

How will your vocoder work? The miked speech signal enters the VCF, whose initial frequency should be tuned to taste. If you have the resources, use several VCFs, tuned to cover as many frequency bands throughout the audio spectrum. The three outputs from the VCF are applied to the "Lo", "Wide", and "Hi" envelope followers as shown in figure 2. This causes each of

the three envelope followers to cover its own frequency band. The control voltages that interface the envelope followers to the VCAs should be taken from the "envelope" outputs of the envelope followers, however, envelope generators could also be triggered from a trigger output of the envelope follower for special effects and advanced voice synthesis experiments.

The outputs of the carrier side VCF are applied to the audio inputs of the VCAs; the envelope followers' outputs are control voltages for the corresponding (Lo, Wide, Hi) VCAs. The envelope followers and envelope generators have attenuators on them, so you can mix and balance the synthesized speech bands right at the envelope followers.

That covers the basic operation. Try starting with a harmonically rich sawtooth wave as a carrier, and go from there. Since this is a modular, patchable system, the possibilities are endless for expansion and advanced experimentation.

... Add two Low pass filters to both signal paths to further break down the speech and carrier signals. Of course, to do that you'll need another envelope follower, VCA, and more mixing channels. This would probably

run about \$100 extra, but the intelligibility of the synthesized voice is increased with each additional frequency band used in the process. ... Interchange the VCF outputs, so some of the original frequency bands in the speech input are now controlling different frequency bands in the synthesized signal. .... Store control lines in a sequencer. .... Use a random voltage to control one band of the synthesized voice. .... When you are using a fixed internal VCO for the basic voice signal, use an envelope follower or generator output at a very low level summed in with the bias voltage you are using to set the pitch of the "voice". This will cause the voice to deflect in pitch when triggered, giving the overall sound a more "human" feeling with inflections, accents, and so on. Also, try using a bit of low frequency oscillation to add some vibrato to the voice.

Good luck -- the vocoder is an interesting and versatile device, ready-made for the synthesist who isn't the hottest keyboard magician in town but can get the sounds he/she wants from his/her voice. And imagine what the keyboard ace can do!

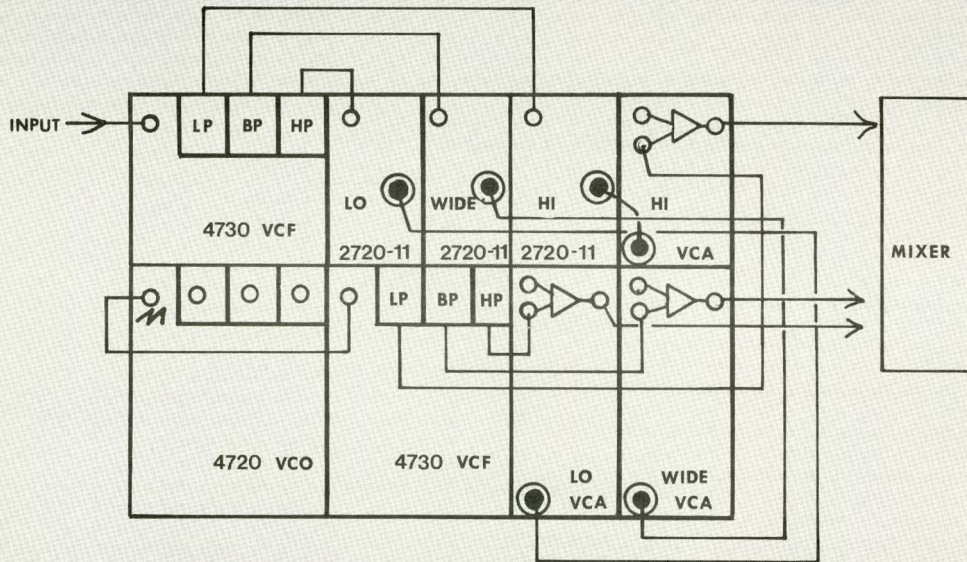
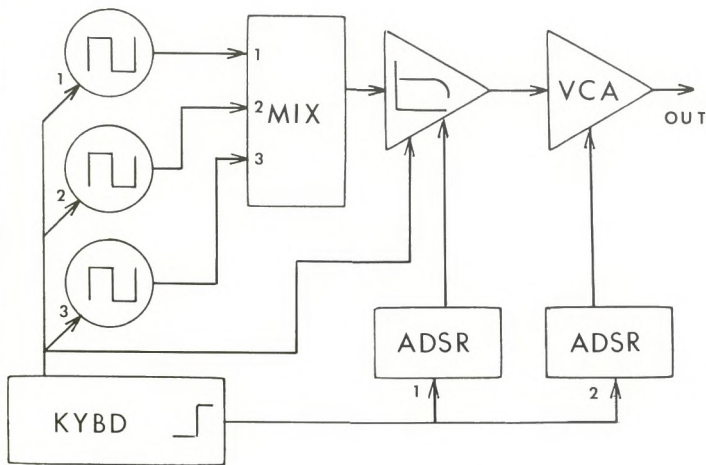

Figure 2



Keyboard: Anywhere sounds good.

VCOs: Tune these to the chord C F G with narrow pulse. Later, try square wave for a "full" sound.

Mixer: All 3 inputs equal amplitude.

Filter: Low Pass output

Mode: Track, "Q" at 50% ; Init. Freq. High at 75%

ADSR 1: A - 5 to 10%  
D - 15%  
S - 10%  
R - 5 to 10%  
Var. Out: 75%

ADSR 2: A - 0%  
D - 0%  
S - 100%  
R - 0%

Submitted by:  
Robert Fly  
Jackson, TN

## BLUE GRASS BANJO

(VERY REALISTIC 5 STRING SOUND)

Uses PAIA P4700/J

Adjust D/A to low range, detune VCOs just a pinch to get realistic string sound. Use alternate tapping on keys to get good blue grass sound or hit "C" chord (2nd C) and at same time hit low "C" note (using both hands) Also strum keys like you would if play-

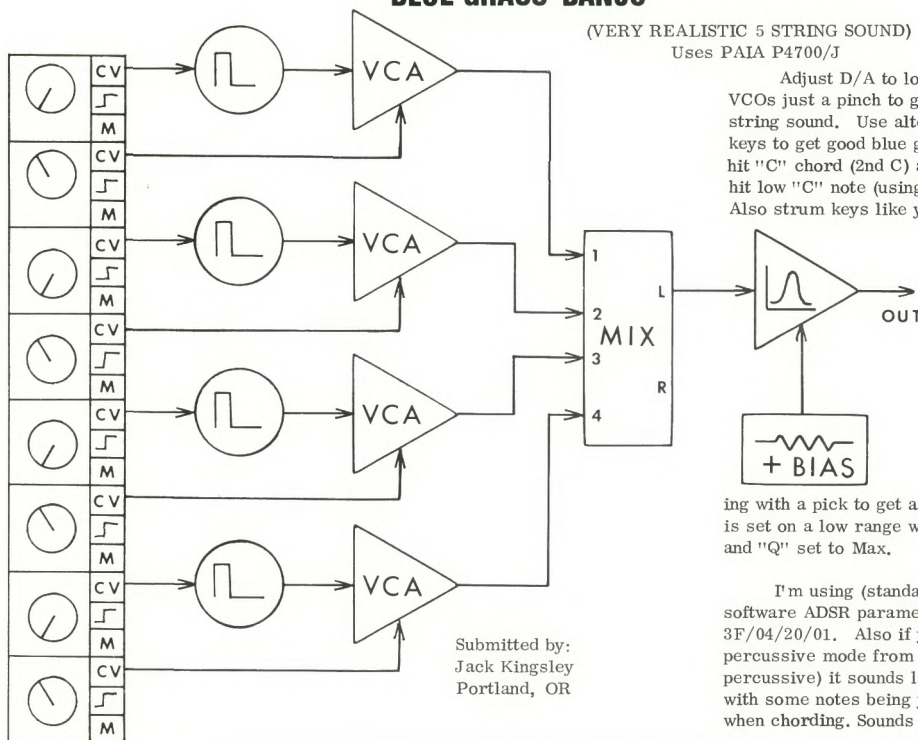

Submitted by:  
Jack Kingsley  
Portland, OR

ing with a pick to get a ukulele. VCF is set on a low range with Init. Freq. and "Q" set to Max.

I'm using (standard) settings for software ADSR parameters in MUS-1 at 3F/04/20/01. Also if you change percussive mode from 3F to BF (non-percussive) it sounds like old pump organ with some notes being just a little flat when chording. Sounds corny, but fun.



## 3750 MAIN ROCK PATTERNS (bridges not included - use as melody patterns)

### MAIN PATTERN 1

Prep.: Reset, program

Main #1 data: AB, R, R, R, S, R, R, R, AB, R, B, R, S, R, R, R,  
 AB, R, R, R, S, R, R, R, R, R, AB, R, S, R, S, S,  
 AB, R, R, R, S, R, R, R, AB, R, B, R, S, R, R, R,  
 AB, R, R, R, S, R, R, R, R, R, AB, R, S, S, CO, CO.

Main #2 data: AB, R, R, R, S, R, R, R, AB, R, AB, R, S, R, R, R,  
 R, R, AB, R, S, R, S, R, R, R, AB, R, S, R, S, S,  
 AB, R, AB, R, S, R, CO, CO, AB, R, AB, R, S, R, T, T,  
 T, T, T, R, CO, CO, CO, R, T, CO, AB, R, CL, T, CO, T.

Main #3 data: AB, R, R, R, S, R, R, R, AB, R, R, R, S, R, R, R,  
 AB, R, AB, R, S, R, R, R, R, R, AB, R, R, R, S, R,  
 AB, R, R, R, S, R, R, R, AB, R, R, R, S, R, CO, CO,  
 AB, R, AB, R, S, R, R, R, R, R, AB, R, R, R, S, S,

Main #4 data: AB, R, R, R, S, R, R, R, AB, R, R, R, S, R, R, R,  
 AB, R, AB, R, S, R, CO, T, AB, R, R, R, S, R, S, S,  
 AB, R, CO, CO, S, R, T, T, AB, R, T, T, S, CO, T, R,  
 T, T, T, T, CO, CO, CO, CO, S, S, S, S, CO, S, WB, S.

Each pattern requires 64 events.

Hit "Reset, Play" to play each program. No repeat required, due to use of the entire 64 event memory.

"Bridge" and "Score" switches may be changed during playback to move from one pattern to another.

### COMMENTS

DRUM PATCH BY: CRAIG ANDERTON

The drum abbreviations are as follows:

AB - Accent Bass	CO - Conga
B - Bass	CL - Clave
S - Snare	WB - Wood Block
T - Tom Tom	R - Rest

Other programming steps are self-explanatory.

more next issue...



### ANALOG/DIGITAL ASSOCIATES INTRODUCE NEW PHASE SHIFTER

A/DA has incorporated patented phase shift stages and a sweep modulation scheme to achieve the ultimate in phase shifting, the FINAL PHASE.

Fully adjustable sweep modulation allows asymmetrical sweep patterns, modulated sweep and many other effects. Continuously variable Range and Intensity controls produce effects as subtle as rotating speakers or intense phasing that sounds like flanging. Overdrive footswitch introduces distortion to enhance phasing or be used by itself.

Final Phase is synthesizer compatible and may be triggered, swept or modulated externally with a 0 to +5v. control voltage. Optional A/DA Control Pedal A may be used to sweep the Final Phase to obtain Wah-phase effects.

A low noise FET input stage will not load sensitive guitar pickups and assures clear, undamped high frequency response. Low 3 milliamps current consumption guarantees long battery life or an optional AC/DC converter is available. Housed in a sand cast aluminum case with recessed knobs, the A/DA Final Phase carries a one year warranty. Suggested retail prices: A/DA Final Phase \$139.95; Control Pedal A \$49.95; AC/DC Converter \$9.95. For more information contact: Sales Dept. A/DA, 2316 Fourth St., Berkeley, CA 94710.

### UPDATED KEYBOARD COMPUTER

RMI announces the availability of the new KC-II Keyboard Computer, an improved and easier to operate version of their first Keyboard Computer released in 1974. To aid the customer in understanding the operation and features of this new instrument, RMI has prepared two booklets entitled "KC-II Keyboard Computer: A Technical Explanation", and "KC-II Keyboard Computer: A Musical Explanation". The technical book describes principles involved in digital circuitry, digital-to-analog conversion, waveform storage and reconstruction from memory, computer controlled frequency multiplication and similar topics. The musical booklet describes how the digital features relate to the musical terms and features most musicians are familiar with from shopping for traditional analog instruments. Additionally, RMI has prepared a demonstration album which is available for \$2.

Features of the new KC-II include twelve presets featuring the most popular of their card-programmable voices from the last several years, three independent signal generator/processor systems for complex-multi-voice or stereo output configurations, an improved variable envelope control system, additional foot controls, and the popular card reader for instant reprogramming of the voice capabilities of the instrument.

For more information, contact: Rocky Mountain Instruments, Inc., Macungie, PA 18062.

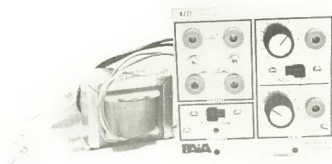

### NEW REGULATED POWER SUPPLY

PAIA Electronics announces the availability of their new 4771 Regulated

Power module kit. Designed to be used with their 2720 and 4700 series modular synthesizers, the double width module will provide unregulated +18 volts, regulated positive and negative voltage which are adjustable from 5 to 15 volts, and two front panel accessible bias supplies which can be trimmed to provide exactly 5 volts, positive and/or negative. The 1 amp transformer provides enough power to provide 200 mA per supply line and still maintain stable operation. The 4771 will easily power a dual wing full of modules, or a fully populated keyboard/case system. The 4771 Regulated Power Supply Kit is priced at \$29.95 plus shipping for 3 lbs. A fully assembled and tested version is also available and is priced at \$39.95. For more information contact: PAIA Electronics, Inc., 1020 W. Wilshire Blvd., Oklahoma City, OK 73116.

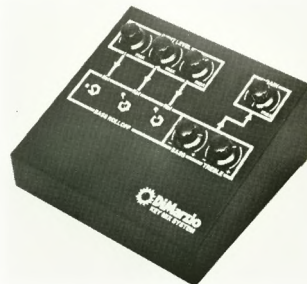

### DIMARZIO KEY MIX SYSTEM

The Key Mix System offers three distinctive functions: An accurate, low cost piano pick up, using three Acoustic Model Contact pickups, which are included; A mixing system for up to three acoustic instruments; A deluxe pickup mixing system for the acoustic guitarist wishing to utilize amplification to its fullest.

The Key Mix unit features individual volume controls for each input, as well as master volume, bass, and treble controls.

For complete information, contact: DiMarzio Pickups, Inc., 1388 Richmond Terrace, Staten Island, NY 10310.



January 8 through February 2, 1979.

Courses offered by BSEM range from introductory synthesis, electronics, and music theory, to intensive lab courses dealing with tape techniques, computer programming, psychoacoustics, composition, and performing ensemble groups. BSEM's teaching philosophy has always been based on extensive "hands-on" experience, and practical application of classroom material. The wide range of in-house equipment to back this philosophy includes: ARP 2600's, MiniMoogs, MicroMoogs, Oberheim, RMI, Aries, Polymoog, and Polyfusion synthesizers, two four channel and one eight channel recording studio (TEAC 3340s and an 80-8) each with capabilities for 1/2 track mixes onto Revoxes, and a recently completed digital music lab utilizing a TDL/ Digital Group Z-80 system with video and DECwriter communications.

For more information, and a current catalog, contact: Boston School of Electronic Music, 28 Highgate Street, Allston, MA 02134.

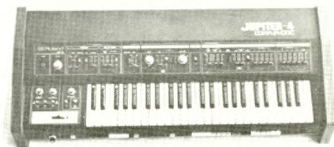

## ROLAND POLYPHONIC SYNTHESIZER

Roland Corp US is marketing a computer controlled polyphonic synthesizer with 10 pre-sets and (8) eight additional memory presets that can be programmed by the musician.

The Jupiter 4 (JP-4) is a four-voice variable synthesizer with a four-octave keyboard, bend/mod wheel, polyphonic portamento, four different keyboard assign modes and pre-set/memory. The 10 pre-sets include such commonly used keyboard synthesizer sounds as strings, bass, voice, piano, trombone, sax and trumpet, and less conventional sounds as funky clavi, synth and The Force. All 18 voices are instantly available while playing. A memory protect switch prevents erasure of programmed sounds.

The Jupiter 4 carries a suggested list of \$2795.00.

Unusual features include a special wide-range, multi-waveform LFO and an arpeggiator that arpeggiates intervals in the order played: up, down, up and down, and randomly controlled. The VCFs are the 24 dB, 4-pole type; they double as VCOs, and they are controlled by the ADSR (regular or inverted) Keyboard, arpeggiator, LFO and bend/mod wheel.

Roland points out that the single-panel control approach gives the Jupiter 4 an accessibility and versatility not common in polyphonic synthesizers and also makes it a marvel in ease of performance and response.

For more information contact Roland Corp US, 2401 Saybrook Ave., Los Angeles, CA 90040, 213/685-5141.

## IMPROVED MX-5050-B TWO-CHANNEL RECORDER

Recently released by Otari is a completely new version of its popular MX-5050 series two channel professional recorder. The new model is called the MX-5050-B and sells at the

..... continued on page 42



## PORTABLE DRAWBAR ORGANS

Music Technology Inc., distributors of Crumar Keyboards, have announced the addition of two portable organs, the T-1, T-2 to their keyboard family.

Both organs authentically recapture the classic tone wheel sound and feel of the Hammond B-3, but have been "modernized" with a variety of innovative features. Examples are a completely variable synthesizer bass section, nine draw bars, independent percussion voicings, LED's and pitch bend.

The T-1 features a 61 note keyboard, while the T-2 offers a double manual version. Both organs are completely portable (each weighs under 100 lbs.) and come with individual carrying cases.

Suggested list prices are: T-1 \$1495; T-2 \$2295. For more information contact Music Technology Inc., 105 Fifth Ave., Garden City Park, NY 11040, (516) 747-7890.

## NEW COURSE LISTINGS

The Boston School of Electronic Music has announced an expanded curriculum for their 78-79 academic year. A new catalog is in the works, and interested readers should contact them directly for more information. The Fall '78 semester started on September 11, but the Spring semester starts February 5th, immediately following their intensive four week Winter Session which runs from

## AUDIO PITCH SHIFT MODULE

A compact LSI microprocessor-based module for OEM's that shifts pitch in the voice audio spectrum is available from Lexicon, Inc. of Waltham, Massachusetts.

The Lexicon Model 20, is an LSI-based pitch shift module that uses a patented, digital "intelligent splicing" technique to provide speech time compression/expansion with noise free splicing. For all frequency components of the input, the module produces, in real time, a true multiplicative pitch shift over the range of 0.4 to 2.0 times the input. It also has provisions for slaving the control of an external D.C. motor to the selected pitch factor. Simple to use, the module requires only D.C. voltage and audio input to function.

Over its continuously adjustable X2, 0 to X0.4 pitch shift range, the 3.5" X 5" Lexicon Model 20 provides a frequency response from 100 to 5000 Hz, +0/-3dB; a dynamic range greater than 56 dB; and a total distortion and noise of 0.6%. Operating on +12V @ 150 mA and -12V @ 50 mA, it is ideal for use in tape, disc and film sound reproducers to provide off speed intelligibility, in audio equipment for the entertainment industry to produce special effects, and in helium speech decoding.

For more information contact: Lexicon, Inc., Jack Letscher, Marketing Manager, 60 Turner St., Waltham, MA 02154.



# PET-MUSE

## Interfacing the Commodore PET to PAIA Synthesizers

By: Russell Grokett, Jr.



Commodore has recently introduced a new line of low-cost computer systems for home users. Using over a quarter of a million transistors inside 70 ICs, the PET is probably one of the most complicated simple devices ever built by man. Yet, even a child can operate it. Like PAIA, Commodore is making new technology available at a minimum cost.

PET includes a keyboard, cassette recorder, and TV monitor all built into one 44 lb. case. Like its forefathers, the Jolt and KIM, PET uses a 6502 microprocessor. It has a 14K firmware system (including 8K BASIC, 4K operating system, 1K machine language monitor, and 1K diagnostic routine) and is available with either 4K or 8K of user memory. For outside expansion, there are 4 plug-in connectors on the back and side of PET, which include an IEEE-48 intelligent interface, a memory expansion connector, a second cassette interface, and an 8 bit parallel user port. It is the user port in which we will be most interested for interfacing PET to PAIA.

### HARDWARE INTERFACING

Simple! The PAIA 8780 Digital to Analog Converter module connects easily to PET using a 12 and a 24 pin edge connector and a couple of feet of 10 conductor cable. The connectors are available from most mail order houses or can be fabricated by cutting a Radio Shack 44 pin connector into the proper lengths.

### CONTROL SOFTWARE

PET can talk in two "languages", BASIC (the easier of the two to use) and machine (or Assembly) language.

BASIC is a high level language designed to be learned quickly by begin-

ning programmers and is simple enough that even children can learn to write short programs. There are quite a few books and magazine articles available on learning BASIC so I'm not going into the language itself here; only where it applies to PET's musical abilities.

The output port on PET is software accessible by the following BASIC commands:

POKE 59459,255 (sets the in/out port to OUTPUT)

POKE 59457,N (sets the port DATA lines to "1", N = a number (note) between 0 and 255)

If N=0 nothing comes out of the 8780 D/A (rest).

If N=1 to 63, a note is set on the output of the 8780.

If N= 64, triggers flag #1.

If N= 128, triggers flag #2.

To play a note using the 8780 to trigger a function generator and control a VCO you first set the I/O to output using POKE 59459,255 (this need only

be done once at the beginning of the program). Then set the note with POKE 59457,N (so the VCO can settle) then trigger the flag with POKE 59457,N=64 (sets flag #1 and keeps VCO at same note. Hopefully, you have connected flag #1 to the ADSR trigger!). Then reset the trigger by POKE 59457,N (VCO still holding). Then reset the note by POKE 59457,0 and start all over again. NOTE: The above does not take into account TIME. PET BASIC is a very fast keyboardist, you have to slow things down in order to hear them properly! Use the program in example #1 to play a song (?) with PET.

### MACHINE LANGUAGE

BASIC can play the 8780 fast but is not nearly fast enough for a QuASH (Quad Addressable Sample & Hold), so we switch to a lower level, but much faster language called Assembly language. PET has the capability of running both in BASIC and machine language in the same program by using the USR and SYS commands.

PAIA's Poly 1.0 and MUS1 should

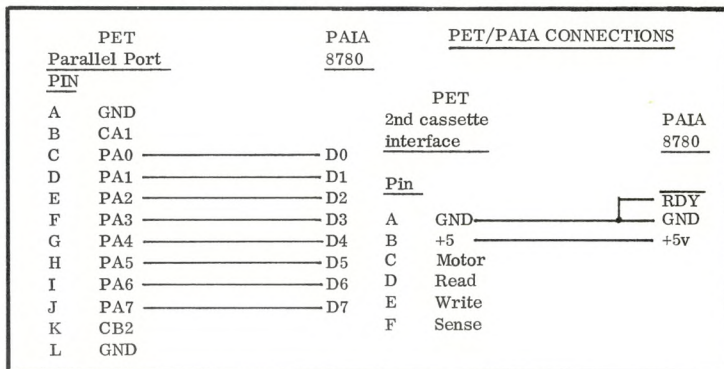



be usable with some modification in PET since they were written in 6500 series Assembly Language.

I am now in the process of converting them for PET and will cover the conversion in a future article. For now, BASIC is doing an exceptional job in the performing arts. Definitely, the PALA/PET combination is the way to go.

Listed below are descriptions of three music programs available for the PET.

PET MUSE 1.0 - designed for multi-tracked sound effects.  
PET COMPOSER - PET composes and

plays infinite variety of "songs" (true computer music).  
PET-MUSE - turns PET into a quality sequencer with over 500 note capability. Includes one classical song.

These and over 40 other PET programs are available on cassette for \$2.50 for the first program and \$1.50 for each additional program (\$4.00 minimum order) postpaid from:

PET LIBRARY  
c/o Russell Grokett  
401 Monument Rd. #177  
Jacksonville, FL 32211

Send a SASE for a list of all programs available.

#### EXAMPLE #1

```
3 REM ** SIMPLE MUSE PROGRAM FOR PET **
5 REM ** BY R. GROKETT 7/78 **
10 POKE 59459,255
100 POKE 59457,N
110 POKE 59457,N+64
120 FOR I=1 TO 50: NEXT I
130 POKE 59457,N
140 N=N+1
150 FOR I=1 TO 150: NEXT I
160 IF N = 63 THEN N=0
170 GOTO 100
200 END
```

Remove lines 120 and 150 to find out how fast PET-BASIC can play!

#### MANUFACTURERS & INFO SOURCES

Commodore  
901 California Ave.  
Palo Alto, CA 94303

Manufactures and sells  
PET 4K - \$595 8K \$795

PET Users Notes  
P. O. Box 371  
Montgomeryville, PA 18936

Publishes excellent PET  
info. \$5/year- bi-monthly

Rico Enterprises  
8J Lakeside Dr.  
Ledyard, CT 06339

sells connectors needed  
for PET-PAIA connection.  
\$6.00 postpaid for both  
connectors.

## Jay Ellington Lee

### "Quality Music Systems"

- \* Bode Vocoder
- \* Polyfusion -  
Frequency Follower
- \* E-Mu Systems
- \* Ampersand  
Products

CUSTOM DESIGN  
of  
Digital Music Systems  
over 40 lines  
available

## "Quality Music Systems"

Jay Ellington Lee  
4517 Longridge Ave.  
Sherman Oaks CA 91423  
(213) 995-6869

## HARDWARE REALIZATIONS FOR SYNTHESIS:

**The Voltage Controlled Analog Delay**— One of the new generation of devices that have extra long delays and cleaner sound.

**The Voltage Controlled Phase-Filter** — A phase shifter and low pass filter in one module; accurate exponential control and programmable architecture.

**The Digital Pattern Generator** — For sequencer control voltage subtleties, with some unique properties.

**The Frequency Divider** — For those fat sounds - plus frequency dependent event triggering.

**The Voltage Controlled Clock With Programmable Event Arrangers** — To maintain structure in complex sonic events.

If you're building your own synthesis equipment or adding to commercial devices, one of our high-quality CMOS kits is just what you need. All of them are designed to be compatible with existing modular or prepatched equipment. The Analog Delay and Phase-Filter make great effects boxes. For more information drop us a line along with a fifteen cent stamp. We'd be glad to hear from you.

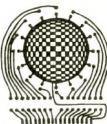

**BLACK MUSIC RESEARCH**  
18405 OLD MONTE RIO RD.  
GUERNEVILLE, CA.  
95446



**Get A GNOME**  
**the original micro-synthesizer**

John Simonton's time-proven design provides two envelope generators VCA, VCO & VCF in a low cost, easy to use package. Use alone with its built-in ribbon controller or modify to use with guitar, electronic piano, polytonic keyboards, etc. The perfect introduction to electronic music and best of all, the Gnome is only \$59.95 in easy to assemble kit form. Is it any wonder why we've sold thousands?

( ) Send GNOME MICRO-SYNTHESIZER Kit (\$59.95 plus \$2.00 postage)  
( ) GNOME MICRO-SYNTHESIZER (Fully Assembled) \$100.00 plus \$2 postage  
( ) Send FREE CATALOG

name: \_\_\_\_\_  
address: \_\_\_\_\_  
city: \_\_\_\_\_ state: \_\_\_\_\_ zip: \_\_\_\_\_

BAC/ VISA MC card no. \_\_\_\_\_  
DEPT. Y  
PMA 1020 W. WILSHIRE, OKLAHOMA CITY, OK 73116

## Industry Notes

... continued from page 39

same price as the older machine,

Among these new features are: Newly designed control circuitry with TTL/IC logic for noise-free punch-in and punch-out.

28 dBm maximum output to provide 24 db of headroom over the switchable fixed output level of +4 dBm. (An alternate level of -10 dBm continues to be available as in the MX-5050, rear panel selectable.)

Capstan is driven by a dc servo system that also provides  $\pm 7\%$  speed control during record and reproduce.

Peak reading LED indicators (set to +10 VU, but also adjustable) are incorporated inside the standard VU meter housing.

The record ready position is indicated by a pulsing LED. In addition, all indicators are now LED's instead of lamps.

Return to zero memory rewind feature, useful for locating selections during mix down sessions.

Plug-in heads for ease of maintenance and adjustment.

All XLR connectors, line and microphone in and out. Also, a 20 dB microphone attenuator is included to accommodate high output condenser mikes.

These new features are in addition to the standard MX-5050 series features such as front panel edit and cue controls,

selective reproduce on all channels, front panel continuously adjustable bias and record EQ, built-in 1 kHz test oscillator, quarter-track playback capability, built-in splicing block, and balanced 600 ohm outputs as standard.

Price of the MX-5050-B is \$1795 complete with dc servo.

For full information contact Otari Corporation, 981 Industrial Road, San Carlos, CA 94020.



## Polyphony Reviews

... continued from page 19

that I realized that the recently transparent Edgar Winter had done the production and performed on many of the songs. He has definitely had an influence on Montrose, and adds some good touches to some already powerful material. "Openers", the intro orchestral piece, is a fairly boring Hollywood-type fanfare for the album, but offers some flanged orchestra and Theremin towards the end. Later on side one, "Mandolinia" starts off with some heavy flanged sequencer bass work which pans from side to side throughout the song. "Town Without Pity" is probably the album's best example of Montroses emotional mastery of the electric guitar -- no flash here. "Leo Rising" offers some tasty classical guitar work, which is later backed up

with Martenot accompaniment. Interesting sounds from an obscure instrument. Side two is heavy on processing of Montroses guitar work. Scattered throughout four songs is quite a bit of compression, clipping, echo, flanging and doubling, pre-echo and pre-reverb. The closing cut, "No Beginning/No End", starts with an extensive sound collage which fades into a processed acoustical guitar part. The transition is very smooth, considering the extensive change in styles. Overall, it is interesting to hear Winters influences on Montrose but Winter's work is still the basic flashy bursts of technology which was characteristic of his synthesis with his own band. Better showmanship through technology, or something like that. I just thought some of you may be interested in what Winters has been doing during his absence from the pop charts.



## Equipment Exchange

A place for our readers to offer for sale or trade equipment related to music and electronics. Keep listings as brief as possible and enclose \$1.00 for each listing. Persons responding to ads should write directly to the other party. DO NOT write to POLYPHONY. Polyphony is not responsible for any claims made in ads or results of transactions. We reserve the right to refuse or edit any ads submitted.

For Sale: Synthesystems 8 in-4 out mixer with EQ, 2 and 4 channel panning, 2 channel echo send and return. \$250. Dwight Gatwood, 161 Meadowbrook Dr., Martin, TN 38237.

For Sale: EML 200, contains 2VCOs, LP and HP filters, reverb, electronic switch, 6 in stereo mixer with pan pots, mic amp, 2) balanced modulators, envelope generator, master (multi-waveform) oscillator, noise source, and sample/hold. Lists at \$950, now asking \$300. Synthetic Sound Labs, PO Box 668, Bricktown, NJ 08723, Phone (201) 477-3319.

LOOKING FOR: Bionic Sax (Polyphony Nov. '77) or someone who'll build me one. I've built kits before, but don't understand enough electronics to build from author's schematics. How much? Sid Berger, 3853 Deerrun Lane, Harvey, LA 70053.

For Sale: 2720A, used little, some modules need work. \$180. Bill Frank, Bonar Hall, Room 313, WLSC, West Liberty, West Virginia 26074.

For Sale: All 2720 series modules in custom case, most 4700's in road case, 8700 keyboard with encoder. All in good condition. Also, Synthaspin. Please send SASE for more info and prices. Prefer to sell as package, but will deal. Brian Parks, 342 Highland Ave., Johnstown, PA 15902.

For Sale: 2720-1, (3) -2A, -4, -3B, -3L, -5, -7, -11, -12, -14, 4710, 4711, 4740, (2) 4770, 4781, all in excellent shape. Fully calibrated and tested. In custom travel cabinet. Going to college, must sacrifice for \$195. Call 609-625-7141. Norm Nealy, 11 Rundle Ave., Mays Landing, NJ 08330.

For Sale: Paia 2720R plus 4710, 4760, -9, 4720, 4711 circuit board, plus lots of miscellaneous extra jacks, low cost AR generators, etc. All control voltage jacks converted to banana jacks. Only \$300. Professionally built and calibrated. Frank Waters, 129 Canal St., Apt. 210, San Rafael, CA 94901, Phone 415-457-1736.

WANTED: Assembled Paia kits in good condition. Please write and list the items you have, and your offer. Best offers taken. Pte. Unger R. W., 2 Field Ambulance, CFB Petawawa, Ontario, Canada K8H-2X3.

For Sale: Tektronix T-922 portable oscilloscope. 15 MHz, dual trace. \$700, including probes and manual. Bill Boydston, 2207 NW 20th, Okla. City, OK 73107.

E-Z Way to keep Gnome and 2720 patches. Blank programming sheets. 100 for \$7.50. Send SASE and \$1.00 (refundable) for free sample. (Please specify Gnome or 2720) Peter Dlugokencky, 9 Russet Lane, Wantagh, NY 11793.

For Sale or Trade: Gnome with external input switching jack plus 2-4018 and 2-4011 for "Super Gnome" circuits in Polyphony July '77. \$40. Eico Alpha Brainwave Monitor \$35. Both fully assembled, working fine, include instructions, postage, etc. Ron Minemier, 414-748-2793.

For Sale: Paia 4700S with 2720-12, works to specs. TEAC 3340S 4 track recorder with sync, still under transferrably warranty. All equipment with original manuals, wish to sell together. \$1500. K. McDonald, PO Box 1006, Sedona, AZ 86336, 602-282-7479 evenings.

# Subscribe to Synapse

For the people, the music, the instruments, and the ideas that make up the electronic music world. Featured in each issue are interviews with the most famous and the most obscure musicians, designers, and composers. You'll also find performance and disc reviews, construction projects, technical articles and more. People involved in all aspects of synthesis have been reading Synapse for nearly two years. Find out what you've been missing.



## SUBSCRIBE!

Send your subscription order to: Synapse, Subscription Dept. PM... 2829 Hyans Street, Los Angeles, California 90026 USA. All orders must be prepaid in US funds.

Name \_\_\_\_\_

Address \_\_\_\_\_ City \_\_\_\_\_

State/Country \_\_\_\_\_ Zip \_\_\_\_\_

### If you live in the US:

- One year/six issues is \$8.00.
- Two years/twelve issues is \$14.00.
- One year/six issues by First Class Mail is \$14.00.

### If you live outside the US:

- One year/six issues by surface mail is \$10.00.
- Two years/twelve issues by surface mail is \$18.00.
- One year/six issues by Air Mail is \$20.00.



# PAIA P-4700/J POLYPHONIC... Of Course!

## SYNTHESIZER/COMPUTER

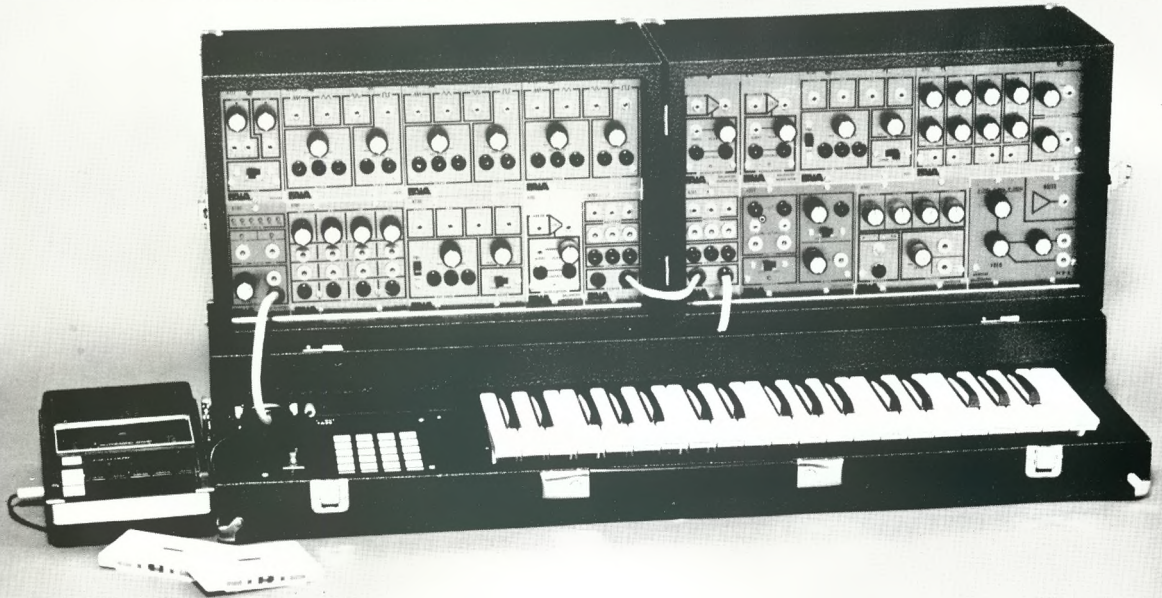

But that's just the beginning, because only PAIA Synthesizer/Computers Allow you to use any of a growing number of personality programs.

Including:

### POLYPHONIC

MUS 1.0 - a 16 voice polyphonic synthesizer with software transient generators.

### SEQUENCERS

SEQUE 1.0 - a general purpose monotonetic sequencer.

POLY SEQUE - a 4 voice sequencer.

### COMPOSERS

PINK TUNES- Composes 4 part harmonies  
PINK FREUD - Composes 4 part canons.

### SPECIAL EFFECTS

SHAZAM - Multiple keyboard split and chorusing.

AND MANY MORE COMING SOON!

The P-4700/J Synthesizer/Computer package includes the following module complement: two 4710 Balanced Modulator VCAs, 4711 Stereo Mixer, 4712 Reverb, three 4720 Wide Range VCOs, two 4730 Multi-Modal VCFs, 4740 ADSR Envelope Generator, 2720-5 Control Oscillator/Noise Source, 8780 Digital to Analog Converter, 8781 QuASH (Quad Addressable Sample & Hold), and the 8782

Intelligent Keyboard with 8700 Computer Controller housed in sturdy vinyl covered road cases.

System firmware includes: PIEBUG - system monitor; POT-SHOT - cassette interface and MUS 1.0 synthesizer operating system.

P-4700/J Synthesizer/Computer Kit .... \$749.00  
Includes all listed software (shipped freight collect)

- ( ) Sounds intriguing, but I need a lot more information. Please send the most recent edition of your "Friendly Stories About Computers/Synthesizers" .....\$3.00 postpaid
- ( ) Please also send complete instruction manual set for the P-4700/J .....\$10.00 (refundable upon purchase of P-4700/J Kit)
- ( ) I've been with you all along. Please send complete P-4700/J Synthesizer/Computer Kit. ....\$749.00 ..... shipped freight collect .....

Name: \_\_\_\_\_  
Address: \_\_\_\_\_  
City: \_\_\_\_\_ State: \_\_\_\_\_ Zip: \_\_\_\_\_  
Visa/BAC \_\_\_\_\_ Master Charge \_\_\_\_\_ Card No. \_\_\_\_\_  
Expiration date: \_\_\_\_\_

PAIA ELECTRONICS DEPT. Y 1020 W. WILSHIRE BLVD., OKLAHOMA CITY, OK 73116 (signature)

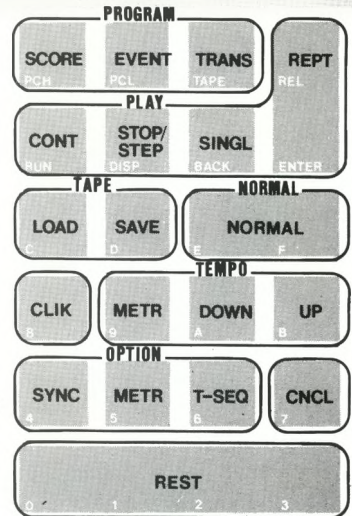

Typical control panel configuration

ONLY FROM: **PAIA ELECTRONICS, INC.**  
1020 WEST WILSHIRE BLVD.  
OKLAHOMA CITY, OKLAHOMA 73116  
(405) 843-9626



*This magazine PDF has been downloaded for free from [www.muzines.co.uk](http://www.muzines.co.uk)*

*The mu:zines project is a non-commercial, labour of love archive of music production magazines from the 1970s-2000s.*

# mu:zines

musicmagazinearchive

Making Music II  
Electronic Soundmaker & C  
Technology Electronics  
Recording Musician M  
& Recording World Electronic S  
On Sound Music Tech  
Music Maker Home & Studio Recording  
Music International Musician & P  
Soundmaker & Computer  
Technology Elect  
Recording