

# Polyphony™

\$2.50

*ELECTRONICS - MUSIC - HOME RECORDING*

*October 1984*

**64 SOUNDS, PART III**

**DR. BOHM DRUM REVIEW**

**BUILD A SYNTHESIZER PHASE SHIFTER**

*ISSN: 0163-4534*



Creative choice is what TASCAM's broad line of professional mixing consoles is all about. Whether you're polishing your musical skills or polishing your fourth gold album, opening up your audio to video, or opening up your own studio, TASCAM's comprehensive mixer selection lets you focus on your specific music needs.

Starting with our M-30, we've packed more artistic choice into a modestly-priced package than any console in the industry. This versatile 8x4 is ideal for everything from basic recording to video production and comprehensive small studio applications.

Increased flexibility highlights the M-30's big brother, our M-35. This durable 8x4 combines wide-ranging function capabilities with operating ease. The M-35 features 4 separate sub groups, solo, independent monitoring, built-in effects loop, and much more.

For more elaborate production demands, our rugged new M-520 console gives exceptional precision and complete control of your 8 and 16 track recording, overdubbing and mix down. The M-520's creative options include multiple inputs per channel, 8 independent subgroups, stereo solo-in-place, PFL, balanced and unbalanced inputs and outputs, multiple auxiliary mixes, and long-throw faders.

And if you're recording needs are met by 8 tracks, our M-512 console gives you the sophisticated functions, easy operation, and technical quality of the M-520, with fewer input channels.

See your TASCAM dealer today. He'll tell you about these and a wide range of other professional TASCAM mixers, and get you hands-on with the console that was built for you. Or write for more information to TASCAM, TEAC Professional Division, 7733 Telegraph Road, Montebello, CA 90640, (213) 726-0303.

Copyright 1984-TEAC Corporation of America

# Tascam Recording Consoles. Mix With The Professionals.

*Wherever you want to go with your music, TASCAM's extensive console line has the mixer to take you there.*



# STAFF

PUBLISHER  
John S. Simonton, Jr.

EDITOR  
Craig Anderton

EDITORIAL ASSISTANT  
Vanessa Else

MANAGING EDITOR  
Linda Kay Brumfield

PRODUCTION MANAGER  
TECHNICAL ILLUSTRATOR

Caroline Wood

CIRCULATION  
Ramona French  
Peggy Walker

BOOKKEEPING  
Cathi Boggs

PRINT PRODUCTION

Phuong Nguyen  
SEMCO Color Press

POLYPHONY (ISSN 0163-4534) is published bimonthly at 1020 W. Wilshire Blvd., Oklahoma City, OK 73116, by Polyphony Publishing Co. Entire contents copyright (c) 1984 by Polyphony Publishing Co. All rights reserved. No portion of this publication may be reproduced in any manner without written permission from the publisher. Second Class postage is paid at Oklahoma City, OK 73125.

ADVERTISING rate card and deadline schedule is available upon request. Contact Linda Brumfield at (405) 842-5480.

DEALERS & DISTRIBUTORS bulk prices are available upon request. Contact Linda Brumfield at (405) 842-5480.

SUBSCRIPTION rates:  
American 1 year \$12.00  
2 years \$22.00  
Foreign 1 year \$14.00  
2 years \$26.00

We now accept MasterCard and Visa payment for subscriptions, back issues, and PolyMart items. Foreign payments must be by charge card, money order, or certified check in US funds drawn on a US bank.

BACK ISSUES are available at \$2.50 each ppd. Send SASE and request our 'Back issue List' for a complete index of issues and their features, or see the back issue ad in this issue.

CHANGE OF ADDRESS notifications must include your former address and zip code, and any numbers from the mailing label, as well as your new address. When you move, be sure to notify your post office that you DO want second class and controlled circulation publications forwarded. This will save lost or returned issues. Polyphony is not responsible for replacement of lost or returned issues when we have not been supplied with change of address information.

TO POSTMASTER, send address changes to:

POLYPHONY  
PO Box 20305  
Oklahoma City, OK 73156  
Ph. (405) 842-5480

# CONTENTS

ISSN: 0163-4534

## Polyphony

VOLUME 9, NUMBER 6

OCTOBER, 1984

### FEATURES

'64 SOUNDS, Part III By: James A. Lisowski .....	8
Dr. Bohm Drum Review By: Craig Anderton .....	18
Joystick Revisited By: Stefan Hawk .....	24
Analog Delay Clock Modulation Revisited By: James F. McConkey .....	25
More Pickup Switching Tricks By: Chris Meyer .....	28
The K.I.S.S. Module By: Charles J. Lauria .....	30
On Location: Pat Metheny Synclavier II Clinic, Georgia By: Allen Campbell .....	32
Using Experimenter's Board System By: Ronald L. Oberholtzer .....	40
Quad LED Readout By: Jack Orman .....	41

### COLUMNS

Practical Circuitry: Synthesizer Phase Shifter By: Thomas Henry .....	14
Re-View By: Robert Carlberg .....	6

### REGULARS

Ad Index .....	42
Current Events .....	34
DataBank .....	26
Equipment Exchange .....	42
Letters .....	4

COVER PHOTOGRAPH BY: CYNTHIA RUEB

## WIND PLAYERS VOCALISTS

You can use your own  
instrument or voice to  
control any standard synthesizer,  
with more expressiveness than  
a keyboard.

### THE GENTLE ELECTRIC PITCH AND ENVELOPE FOLLOWER

Write for our free detailed  
brochure, patch diagrams,  
and application notes.

Also available as modules for Aries and  
Serge synthesizers, or as circuit boards  
for custom systems. Dealers inquiries  
welcome.

*gentle electric*

Dept P  
P.O. Box 132, Delta, CO 81416  
303-874-8054 / 303-874-7171

# FEEL THE POWER

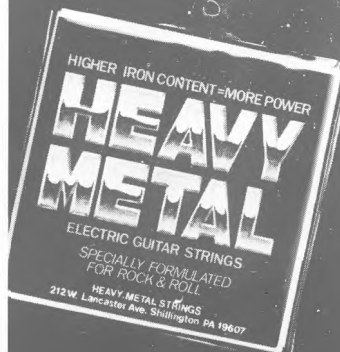

### ELECTRIC GUITAR & BASS STRINGS

#### INTRODUCTORY OFFER

Guitar Strings—2 sets for \$8.00

Bass Strings—one set for \$12.00

Send check or money order to: Dept.PH

HEAVY METAL STRINGS 212 W. Lancaster Ave.,

Reading PA 19607



For Visa or Mastercard  
call (215) 775-9472



(Be sure to specify gauge—008, 009, 010)

**DEALER INQUIRIES INVITED**

# Letters

## SPRING REVERB REVISITED

(Ed. Note: The following was submitted as "A Brief Philosophical Digression for 'Why Spring Reverb Will Never Die'"; the latter article, by Craig O'Donnell, was published in the August 1983 issue of *Polyphony*.)

South Seas culture believed in "mana", a power, or demon, inherent to an object which influenced the personality and actions of its user. In the Philippines, a knife called a "crease" was thought to be alive, possess a soul, and require regular feedings with a special oil applied to its blade. The crease could choose to reject you, and find another partner.

The object of digital sound reproduction can be thought of as "perfect mapping". The digital device must be capable of reproducing a perfect copy of the input. This "mana" can thus influence how the music will eventually sound -- something that can easily be proven by inversion. How did Sun Records get that sound in the Fifties? How did Phil Spector get that sound? By experimenting with their limited analog resources until they jelled. And no one in their right mind today will claim that these recordings have 20 Hz - 20 kHz frequency response, 60 dB S/N, or anything else we take for granted today. Why, a market developed for a secret DISTORTER (the Aural-Exciter-type boxes) because modern equipment got too clinically clean. And yet records made then, on lousy equipment, in basements and garages, possess a sound and power that a modern engineer might kill to also possess. The very faults of the equipment influenced the actions of the user and helped create that sound!!! How can digital gear fail to exert a similar influence? It cannot.

Because digital gear must be perfect or one gets a dozen varieties of crazy space-age (ugly) distortion, its philosophies will

come to get us too. Look how long it took the industry to realize the importance of time-aligned speakers in preventing ear fatigue -- we'll discover even stranger distortions in digital as we go along. There is no "perfect mapping" for emotion, or for the incredibly perfect hum and crash of Jimi's guitar and amps, or the secrets of another science that some believe lurk encoded in an octave...the Space Shuttle goes fast, but it would be a lousy dragster. **Ponder your tools as you work.**

Craig O'Donnell  
Chicago, IL

## HELP!

How much current does your Chorus/Delay (January 1982 *Guitar Player*) draw? I need to know so that I can design a power supply.

Also, I'm having trouble with PGS Electronics. They sent me my circuit boards in record time, but that was it. I have not heard from them since March 29. Can you help?

Finally, I built your cord tester (December '83 *Guitar Player*) and it works great. I think I'll modify it to accommodate plugs other than 1/4" phone types.

Robert Dever  
South Boston, MA

Robert -- The Chorus/Delay draws approximately +75 mA. Virtually all three terminal regulators can handle this amount of power.

Concerning PGS, they are a small operation and although we get an occasional complaint (often caused by circumstances beyond PGS' control), by far the majority of customers have been satisfied with the level of service and quality of parts. While I understand how frustrating it is to wait for letters to get answered, their resources are limited. As



# Letters

with any company, if you don't hear anything write and inquire about your order; there could have been a foul-up somewhere along the line. For every horror story a customer has about parts that were never received, companies have similar horror stories about UPS shipments being returned because the customer never claimed it, illegible handwriting, customers who build kits with blowtorches then demand refunds when it doesn't work, and so on. If a couple of letters don't do the job, then call. Yes, it costs a bit more, but if you really want to work out a problem human contact usually does the job.

Since I do a lot of business by mail, I have had a number of negative experiences. All were due to human error or understaffing, not malice, and all were eventually worked out to my satisfaction without having to call on the Better Business Bureau or other consumer organizations. I'm sure any problems you have with PGS will have been resolved to your satisfaction by the time this issue goes to press.

## BARGAINS

Here's a tip for those who like to find equipment at great prices: go to local hamfests and ham conventions. You can pick up scopes, parts, and so on at a fraction of the original cost. To find out where these are being held, look on the "Coming Events" page of ham magazines such as QST, 73, etc. Also check with local amateur radio clubs for info.

Reginald Leister  
DARE Diversified Electronics  
Pottstown, PA

## MORE INFO NEEDED

I am an electronic tech working for a large aerospace company in L. A. However, I don't have the technical "expertise" that I would like to have concerning musical effects. Maybe you could suggest some sources for technical data.

cont. .... pg. 23

Polyphony

SUBSCRIBE! SEE PAGE 40

for info.

## BY PROFESSIONAL DEMAND

DDC OFFERS FREE ADVICE, PERSONAL SERVICE AND ONE-DAY SHIPPING OF THE FINEST MUSIC AND SOUND EQUIPMENT AVAILABLE ANYWHERE:

**CROWN** Traynor  
**EV** KORG polyfusion  
**KELSEY** **COLGATE**  
**TEAC** Strobotuner **MXR** **RM**  
**LP** Zildjian **DiMarzio**  
**TAPCO** **U** **REMO**  
**CRUMAR** Oberheim **YAMAHA**  
**SHURE** **DM** **whirlwind**  
**prophet** **ROSS**  
**KRAMER** **QSC** **ASHLY**  
**ARP** intersound

PLEASE CALL OR WRITE FOR PRICES & ORDERING INFORMATION - YOU'LL BE GLAD YOU DID!

**DDC** DICKSTEIN DISTRIBUTING COMPANY  
1120 QUINCY PPK - SCRANTON, PA 18510  
PHONE ORDERS WELCOME 1717 344 7469

## MAKE YOUR MARK!



PASSPORT DESIGNS, INC. HAS OPENINGS FOR EXPERIENCED MUSIC PROGRAMMERS AND ENGINEERS. OPENINGS FOR STRONG 6502, Z-80, AND 68000 PROGRAMMERS WITH ASSEMBLY AND HIGH LEVEL LANGUAGE EXPERTISE. JOIN THE #1 MUSIC SOFTWARE DEVELOPMENT TEAM AND "MAKE YOUR MARK" IN MUSICAL HISTORY. PLEASE SEND RESUME AND SALARY REQUIREMENTS TO: PERSONNEL DEPT., PASSPORT DESIGNS, 625 MIRAMONTES ST., HALF MOON BAY, CA 94019.



October 1984

# re-view

The Art of Noise **Who's Afraid Of?** (Island 90179-1). I've been waiting for someone to take an Emulator and produce dance music from sampled sound effects. Finally someone has -- and it may not be High Art but I predict it is the beginning of a trend.



Prince **Purple Rain** (Warner Bros. 25110-1). Much ballyhooed follow-up to **1999** (reviewed April '83). Although the song structures are a little more advanced here, lyrically it's rather banal (for a change). The frequently slower pace also leaves Prince's prodigious excesses exposed.

Breather **Loves and Disloves** (Sonic Incision Records). Breather is basically Bliss Blast on bass, noise and spoken vocals; with occasional clarinet, guitar and synthesizer. It's rather inhospitable -- when he intones "I love you" you don't know whether to fight or run. P.O. Box 881974, San Francisco, CA 94188.



Tangerine Dream **Firestarter** (MCA 6131). Conventional wisdom says that soundtrack music should sup-

port the drama without drawing attention to itself, so maybe it's not fair to fault the music as characterless and lacking in inspiration.

Eno, Moebius, Roedelius, Plank **Begegnungen** (Sky 090). Warning! Not new material -- only a "best of" compilation from 6 albums of solos and collaboration. It's a good cross-section but it's not obvious that everything's been released before.

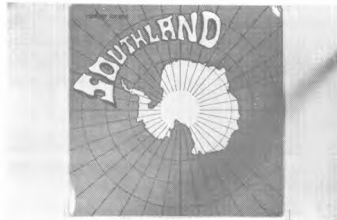

Rudiger Lorenz **Southland** (Syncord 003) Using his self-built synthesizer and recording at home, Lorenz demonstrates that it all begins and ends with composing. This disc stands up against any by the magabuck big names. Binger Str. 6, 6507 Ingelheim, W. Germany.

Iverson and Walters **First Collection** (Eagle 4188). Using such non-EM instruments as mandolin and 12-string guitar, Jon Iverson and Thomas Walters produce a distinctly folk-oriented electronic music, full of exquisite acoustic sonorities along with their lovely digital synthesis. Wonderful job of recording, too. Among the "thanks to" listed on the back cover is William Ackerman, which seems appropriate. Eagle Records, P.O. Box 23344, Nashville, TN 37202.

Data Bank A **Intervention** (EP). DBA is Andy Szaba-Kovats on rhythm box, keyboard synths and vocals,

and Chris Elston on guitar. Together they sound an awful lot like "Repeat Repeat"--period Peter Baumann, which could be either praise or criticism depending. 262 Mammoth Road, Lowell, MA 01854.

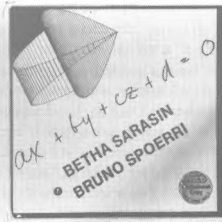

Betha Sarasin/Bruno Spoerri **ax + by + cz + d = 0** (Meteor 32027). Musique Concrete in which various sounds are looped (in a digital delay?) and the speed changed. Some keyboard synthesizers and Lyrico also appear, although the record is not strongly musical.

Nightcrawlers **Nightcrawlers** (Synkronos 101). The first vinyl venture, although their tapes and performances have built them a substantial following among cognoscenti. A quartet of long (11+ minutes) hypnotic pieces for synthesizer trio, using sequencers and e-percussion as bases for extended journeys into territory opened, but not mapped, by Tangerine Dream. \$8 postpaid from 1493 Greenwood Avenue, Camden, NJ 08103.



Laurie Anderson **United States** (Harper & Row CN-1110). An over-size coffee table book of the musical epic of the same name. Includes lyrics and photos of performances and slides shown and stories told -- no backstage comments unfortunately. The work itself is entertaining, provoking fleeting insights without really challenging our assumptions.



# re-view

Peter Kaminski **Synthesis** (cassette). Keyboard synthesizers and rhythm box are used for 3 neo-classical rock tunes and a Bach fugue. Standards are so high today that these don't really stand out, although in isolation they would be amazing. \$6 post-paid from P.O. Box 5026, 4709 Bergkamen, West Germany.

Steve Meehleder **R.O.M. (Rough Order of Magnitude)** (cassette). The predominating feature of this tape is the wealth of great sounds Meehleder gets from his machines. Organizationally it's more neo-classical rock, done with taste and skill. A brief snippet of Scott Joplin makes me wish for a whole tape of it, but his own composing is a good time too. 6049 Butternut Drive, West Olive, MI 49460.

Peter Schafer **Wavescapes** (Ohrwurm 1026). Neo-classical rock from this cassette pioneer (April '83) marks his disc debut. As always, it's performed with skill, taste, and a lot of variety in sounds and tempos. Standards are high. Distributed in this country by Eurock, P.O. Box 13718, Portland, OR 07213.

Craig Burk **Codes of Abstract Conduct** (Alia 001, EP). Pretentious songs, spoken in exaggerated voices, with minimalist guitar and synthesizer backing. At least, at under a minute a piece, they're concise. New Music Distribution, 500 Broadway, New York, NY 10012. (Beware of people who send reviews.)



Ernst Fuchs/Klaus Schulze/Rainer Bloss **Aphrica** (Inteam 20.001); Rainer Bloss/Klaus Schulze **Drive Inn** (Inteam 20.002); Klaus



Schulze **Angst Soundtrack** (Inteam 20.003); Manuel Gottsching **E2-E4**

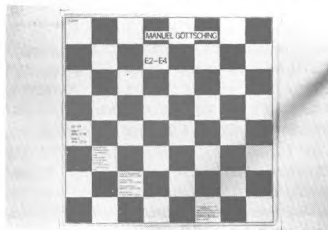

(Inteam 20.004); Michael Shrieve with Kevin Shrieve and Klaus Schulze **Transfer Station Blue** (Fortuna 023). Klaus Schulze has released (or appeared on) well over 30 LPs, and his style remains remarkably consistent. Composing not so much with notes as with sounds (lately on the Fairlight and PPG digital systems), simple repetitive sequencer and drumbox rhythms are overlaid with arpeggiated chords. His distinctive trance music, which develops momentum but not direction, dominates each of these discs. On **Aphrica** painter Ernst Fuchs intones religious lyrics in German -- very reminiscent of the old Cosmic Couriers albums with Tim Leary. **Drive Inn** is meant to, and does, reflect the tedium of driving long distances. **Angst** is pure Schulze. The Gottsching is one continuous pattern, very similar to Schulze but less inventive for its continuity. Shrieve adds a little real drums and guitar but it remains Schulze's show.

David van Tieghem **These Things Happen** (Warner Bros. 25105-1). Van Tieghem is a session drummer, appearing on "Mister Heartbreak", "My Life in the Bush of Ghosts", and others. Predictably his solo is percussion-based, layered with light synthesizer and found tapes. It's not composed so much as assembled on tape.

The Electric Guitar Quartet (cas-

sette). In the tradition of the New York Rock & Roll Ensemble, classical music for 4 guitars (self-built). Long hair music needn't be uncivil. \$7 from TEGO, Suite 202, 904 Irving Street, San Francisco, CA 94122.

Negativland **A Big 10-8 Place** (Seeland 003). The Residents meet Pierre Henry. Totally strange tape collaging with recurring themes to tie it together. Instead of a cover it's packaged in a poster, folder, bumper sticker, postcard, newspaper excerpt, etc. Mine even had a baggie of grass. Not marijuana, grass.

David Parsons **Sounds of the Mothership** (Fortuna 006, cassette); **Tibetan Plateau** (Fortuna 013, cassette). Parsons is a New Age synthesist from New Zealand who also plays classical Indian instruments in a dreamy manner. Music for deep relaxation.

William Aura **Aurasound I** (Fortuna 007, cassette); **Aurasound II** (Fortuna 008, cassette). Aura is a New Age synthesist from San Diego who also plays zither in a dreamy manner. Music for very deep, possibly permanent, relaxation.

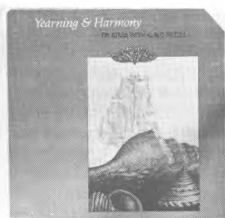

Tri Atma with Klaus Netzle **Yearning & Harmony** (Fortuna 016). Tri Atma is a duo of a German guitarist and an Indian drummer. Klaus Netzle plays Fairlight and Synclavier synthesizers. Today's Global Village makes possible such intercultural cross-pollination, resulting in a viable hybrid of tabla, jazz guitar and beautiful synthesis.

Steve Roach **Structures from Silence** (cassette). Unlike his previous tape (10/83) and record

cont. pg. 20

October 1984

# 64 SOUNDS, Part 3

by: James A. Lisowski

(Editor's note: In Part 1, James described the basics of sound generation using the Commodore-64. In Part 2, he described a way to explore these sounds. Part 3, the concluding installment, presents a number of practical sound programs for the C-64. As mentioned previously, this article doesn't just present some neat sounds -- it's a pretty comprehensive tutorial on how to write programs in BASIC.)



When you are done with this article your Commodore 64 program library will include:

- a SOUND TEST breadboard
- a GUITAR TUNER
- a METRONOME
- a HAND CLAP / PERCUSSION UNIT
- an EXTERNAL AUDIO FILTER UNIT

as well as several other UTILITY and SOUND EFFECT programs written in BASIC.

Directory of Programs on the "64 SOUNDS" Disk

- INIT SOUND S200
- SOUND TEST V3
- PADDLE SWEEP V3
- EXPLOSION ECHO 3
- PAC SOUND V3
- GUITAR TUNER V3
- JIFFY SOUND V3
- FROG POND SOUND
- METRONOME V3
- RANDOM BELLS V3
- HELICOPTER PADV3
- SCRATCH SOUND V3
- PERCUSSION SEQ3
- CLAPPER V3
- XAFILTSWEEP3

**Paddle Sweep Sound.** While SOUND TEST (see page 23 which is explained in Part II) is good for developing quick effects, PADDLE SWEEP is better for getting an idea of the total range of the oscillators, the degree to which the fine and coarse frequency controls alter the output frequency, and also, makes waveform and

pulse width value selection easier and less error-prone. Ready? Plug your paddles into Port 1, LOAD INIT, type in the PADDLE SWEEP SOUND LISTING (including DATA line 230), check and SAVE the finished program, then RUN. Lines 0 through 450 run INIT and set up the screen with some instructions. The user is asked for a waveform value from the list that appears on the screen, and Line 500 accepts your input and places it into variable WV. Line 510 checks IF WV is one of the valid waveform numbers and passes execution to Line 530 IF this condition is TRUE. If not, program flow goes back to Line 310, which clears the screen, repeats the message, and requests INPUT. Continuing, Line 530 checks IF the wave value was 65, the PULSE waveform value. IF it is not, the program continues at Line 600. If it was Pulse, instructions prompting the user to enter a PULSE WIDTH value are PRINTed by Lines 540 and 550. Line 550 also contains the INPUT statement that accepts the value from the keyboard and saves it in variable PW. Lines 560 and 570 are a "value range check" that makes sure the value was between 0 and 15 (inclusive), then the program either moves on to Line 600 or goes back to Line 540 to give the user another try. Line 600 clears the screen and PRINTs some instructions. Line 610 is another of those FOR-NEXT time delay loops ("do nothing 999 times") that keeps the previously PRINTed messages on the screen for a few seconds. When time's up, Line 700 takes the values PW and WV (which have just been entered) and POKEs them into the SID VOICE 1 HI PULSE WIDTH and WAVEFORM registers. Note that the WAVEFORM value was POKed last and that the other SID registers, including a SUSTAIN value, have already been setup by

INIT, therefore you hear the sound at this point and it remains ON because of the SUSTAIN (without RELEASE). Lines 800 through 830 form the main program loop, starting with Line 800 PEEKing the values of Game Paddles 3 and 1 and placing the values in variables LF and HF respectively. Line 810 clears the video screen and PRINTs out the values of LF and HF with descriptive labels to give the paddle turning user some numerical feedback, then POKEs these two values into the SID VOICE 1 LO and HI FREQUENCY registers. Line 820 PEEKs a look at the paddle button memory location. IF the button is not pressed, the paddle button value will read 255, the IF condition in Line 820 will fail and the program flow will continue on to Line 830, which says GOTO Line 800, get and PRINT another set of paddle values and keep looping. IF the paddle button is pressed the rest of Line 810 is executed (therefore POKeing off VOICE 1) and sends execution back to Line 310, where the user is prompted for a new waveform. You'll find that the fine frequency control is very fine indeed. Sweeping the NOISE waveform from low to high sounds like a rocket taking off; you can make motor or automobile sounds with the other waveforms. Selecting a PULSE wave and zero HI FREQUENCY will allow you to use the program as a metronome with the LO FREQUENCY paddle as a rate control. You might consider some modifications such as adding the other two voices (perhaps offsetting each at a chromatic interval) or adding control over the LO portion of the PULSE WIDTH. Also, because of the slow speed of BASIC, the action of the COARSE FREQUENCY control paddle has a definite quantized (stepped) effect on the output frequency. To minimize this, skip the PRINTing



of values (which takes time) and to try to fit the PEEK paddles / POKE FREQUENCY loop on one line to make it as fast as possible.

```

0 REM PADDLE SWEEP SOUND V3 (C)1983 JAL SOFTWARE
200 AU=54272:F1=AU+1:F2=AU+8:F3=AU+15
210 T1=54276:T2=54283:T3=54290:AA=AU
212 P1=54297:P3=P1+1:B1=56321:BD=53280
215 FORI1=AUTO54300:POKEI1,0:NEXTI1:POKEAU+24,15
220 READAV:IFAV>1THENPOKEAA,AV:AA=AA+1:GOTO220
229 REM FL FH PL PH W AD SR
230 DATA 000,000,000,000,000,005,240
235 DATA 000,000,000,000,000,000,000
240 DATA 000,000,000,000,000,000,000,-1
300 POKEBD,15:POKEBD+1,15
310 PRINT"(SC)(G1)(CD)(CD) PADDLE SWEEP SOUND
V3 JAL SOFTWARE":PRINT
320 PRINT"PLUS PADDLES INTO PORT 1."
330 PRINT"THE PADDLES ACT AS FREQUENCY CONTROLS."
340 PRINT"ONE PADDLE IS A COARSE CONTROL."
350 PRINT"THE OTHER PADDLE IS A FINE CONTROL."
400 PRINT"PRINT WAVEFORMS:"
410 PRINT"17 = TRIANGLE":PRINT"33 = SAWTOOTH"
420 PRINT"65 = PULSE":PRINT"129 = NOISE"
430 PRINT"PRINT TYPE ONE OF THE ABOVE NUMBERS AND"
440 PRINT"THEN PRESS THE RETURN KEY.":PRINT
450 PRINT"WHICH WAVEFORM DO YOU WANT?"
500 INPUT WV
510 IF WV=17 OR WV=33 OR WV=65 OR WV=129 THEN530
520 GOTO 310
530 IF WV<>65 THEN600
540 PRINT:PRINT"ENTER A PULSE WIDTH FROM 1 TO 15"
550 PRINT:INPUT"WHICH PULSE WIDTH":PW
560 IF PW>0 AND PW<16 THEN600
570 GOTO 540
600 PRINT"(SC)(CD)(CD)PRESS THE FIRE BUTTON TO
CHANGE WAVEFORM"
610 PRINT:PRINT" TURN PADDLES TO CHANGE
FREQUENCY"
620 FORI1=1TO999:NEXTI1
700 POKEAU+3,PW:POKEI1,WV
800 LF=PEEK(P3):HF=PEEK(P1)
810 PRINT"(SC)(CD)(CD)LF:LF, HF:HF:POKEAU,LF:
POKEI1,HF
820 JFPEEK(B1)<>255 THENPOKET1,0:GOTO310
830 GOTO800

```

READY.

• • • • •

**Echo Explosion.** SOUND TEST presented fixed frequency and envelope sounds, PADDLE SWEEP illustrated steady tone with manual frequency modulation and EXPLOSION ECHO continues with a fixed envelope and a PROGRAMMED sweep. After you load INIT, (do that now), there are only a few lines to type for this program. When RUN, INIT sets a long DECAY value for VOICE 1 and Lines 300 and 310 make the usual title screen. Line 320 brings something new: the RND() pseudo-random number generating function. This function returns a number value in the range of zero to one (non-inclusive), and the

function is initialized with the negative value of the special time variable TI (as recommended by Commodore). Thereafter, Line 330 generates the same kind of random number, multiplies it by 9 (\* means multiply in BASIC) and then adds 1 to yield a random number in the range of 1 to 9 (R). Line 330 continues by PRINTing a title and the INTEger value of the random number for user reference, and then POKEs the random number into the SID VOICE 1 HI FREQUENCY register and follows this with a POKE to the WAVEFORM register with the NOISE waveform value, 129, to trigger the sound. (The integer value was PRINTed because the POKE statement actually POKEs the integer value of the given number.) Line 340 generates a random number in the range of 0 to 255 and places it in variable VV. This line also starts a FOR-NEXT loop that increments variable VV from 0 to VV and POKEs the current V value into the SID VOICE 1 LO FREQUENCY register (F1-1). Line 350 starts another FOR-NEXT loop with variable D; this creates a slight time delay that holds the current frequency value for a bit before the NEXT V statement sends control back to the FOR in Line 340, where the frequency is again incremented and the process continues until the random length loop is done. Then Line 360 POKEs the VOICE off and sends execution back to Line 330, which generates new random numbers. This frequency sweep sound is hard to describe; it sounds somewhat like an explosion in a large cave or a ball in a tennis court, depending on the random number. Because of the long decaying envelope and the sweep, there is a subjective "receding sound" characteristic. Changing the delay, decay and waveform values creates other types of sounds. For example, making the waveform a PULSE and the ATTACK / DECAY value 204 creates a long ATTACK / long DECAY sound which resembles an automobile going past the listener.

```

0 REM EXPLOSION ECHO V3 (C)1983 JAL SOFTWARE
200 AU=54272:F1=AU+1:F2=AU+8:F3=AU+15
210 T1=54276:T2=54283:T3=54290:AA=AU
212 P1=54297:P3=P1+1:B1=56321:BD=53280
215 FORI1=AUTO54300:POKEI1,0:NEXTI1:POKEAU+24,15
220 READAV:IFAV>1THENPOKEAA,AV:AA=AA+1:GOTO220
229 REM FL FH PL PH W AD SR
230 DATA 000,000,000,000,000,012,000
235 DATA 000,000,000,000,000,000,000
240 DATA 000,000,000,000,000,000,000,-1
300 PRINT"(SC)PAC SOUND V3 JAL SOFTWARE"
310 VL=AU+24:X=11.2:POKET1,17
320 FORI1=1TO15:POKEI1,1*X:POKEVL,1:NEXT
330 FORI1=1TO15STEP-1:POKEI1,1*X:POKEVL,I:NEXT
340 GOTO320

```

```

310 PRINT"(SC)(G1)EXPLOSION ECHO V3 JAL SOFTWARE"
320 R=RND(-TI)
330 R=1+RND(1)*9:PRINT"HF":INT(R):POKEF1,R:POKET1,
129
340 WV=RND(1)*256:FOR V=0TOVV:POKE F1-1,V
350 FORD=0TO2:NEXTD:NEXTV
360 POKEI1,0:GOTO330

```

READY.

• • • • •

**PAC Sound.** The PAC Sound program, another programmed sweep example but with a few new wrinkles, creates the classic video arcade game sound effect. First, load INIT; change the DATA values to provide SUSTAIN, and add on the few remaining program lines. Save and RUN. Line 300 PRINTs the title, Line 310 creates two variables: VL, which contains the address of the SID Master Volume control register, and X (a constant). It also POKEs VOICE 1 ON with a TRIANGLE (17) WAVEFORM. Line 320 features a FOR-NEXT loop that increments variable I from 1 to 15. This Line also multiplies I times X and POKEs into the HI FREQUENCY register, then POKEs the value of I into the Volume register. The net effect of Line 320 is to create a sweep in frequency and volume from low to high values. Line 330 also does a frequency / volume sweep with its FOR-NEXT loop, except that this loop starts with a value of 14 and STEPs down (STEP -1) to 1, creating a high to low sweep direction. Line 340 directs the program back to Line 329 for another up sweep, which results in a digital simulation of LFO TRIANGLE WAVE type modulation controlling a VCO and VCA. Also try different X and delay values.

```

0 REM PAC SOUND V3 (C)1983 JAL SOFTWARE
200 AU=54272:F1=AU+1:F2=AU+8:F3=AU+15
210 T1=54276:T2=54283:T3=54290:AA=AU
212 P1=54297:P3=P1+1:B1=56321:BD=53280
215 FORI1=AUTO54300:POKEI1,0:NEXTI1:POKEAU+24,15
220 READAV:IFAV>1THENPOKEAA,AV:AA=AA+1:GOTO220
229 REM FL FH PL PH W AD SR
230 DATA 000,000,000,000,000,005,128
235 DATA 000,000,000,000,000,000,000
240 DATA 000,000,000,000,000,000,000,-1
300 PRINT"(SC)PAC SOUND V3 JAL SOFTWARE"
310 VL=AU+24:X=11.2:POKET1,17
320 FORI1=1TO15:POKEI1,1*X:POKEVL,1:NEXT
330 FORI1=14TO1STEP-1:POKEI1,1*X:POKEVL,I:NEXT
340 GOTO320

```

READY.

• • • • •

**Guitar Tuner.** While the PAC SOUND is not one that is likely to be used often, here is a program that I use all the time: a GUITAR TUNER / PITCH REFERENCE. Because it is so simple and frequently loaded, this program does not use INIT (to keep it short for quick loading). Line 10 POKES the screen GRAY. Line 20 sets variable AU to the address location of the first SID register and then uses a FOR-NEXT to clear SID to VOICE 1 with a SAWTOOTH waveform (33); this comes closest to the soft twang of a guitar string. Line 100 clears the screen and PRINTs a title and instructions. Line 300 is the beginning of the main program loop; it does the basic "wait for a key to be pressed" routine. If no key is pressed the program keeps looping here; if, say, the spacebar (an easy to hit target) is pressed, execution goes on to Line 400. Line 400 READs 3 values from the DATA statement in Line 999. The first value is a note title string that goes into variable NT\$, the other two values are HI and LO FREQUENCY number values that go into variables FH and FL. IF the NT\$ value happens to be the special "end of data indicator", "EE" THEN a RESTORE statement resets the next READ of DATA back to the first DATA value, and the program flow goes back to Line 300 to wait for the next keypress. If the value is other than "EE", Line 500 clears the screen and PRINTs a title. Line 600 TABs (moves the PRINTING position left) FH number of spaces, PRINTs the note title, POKES the SID volume register with full volume (15) minus a scaled amount (FH divided by 10), and then POKES the LO and HI FREQUENCY registers of VOICE 1 with the LF and HF values. Line 700 then says go back to Line 300 and wait for the next keypress. The logic behind all these statements is to provide frequency pitches that correspond to the normal frequencies of the open strings of a 6 string guitar. The names and positions of the titles follow those of the strings and the sound volume is decreased as the notes get higher to match the energy of the strings. The program is meant to be used as a pitch reference where the user plays the proper guitar string and tunes it to match the computer's pitch, while trying to minimize any "beating" (sum and difference error frequency resulting from the

acoustical or electronic mixing of the reference and guitar tones). When that string is in tune, press the spacebar to get the reference tone for the next string and tune that one, etc. If you don't have a free hand, plug a joystick into Game Port 1 and place it on the floor nearby. The FIRE button on the joystick will work just like a keypress, thus giving you a makeshift footswitch. Because the SID is so stable and the frequency increments are so fine (remember PADDLE SWEEP LO), this program compares very favorably with a commercial guitar tuner. In fact, I've tuned with this program and then checked the results with a "store bought" +/- meter type tuner. The strings were not even off by 1 cent, even on my "worst" string! If you already have the computer, the additional cost of this tuner is cheap indeed. If you want, you can "de-tune" (or "re-tune") the pitches to any scale or microtone desired just by changing the DATA values. The proper numbers for the HI and LO FREQUENCY registers for the 12 tone even-tempered scale notes are listed in the back of your computer manual. With these values at hand it shouldn't be difficult for even a novice programmer to modify this program to tune bass guitars or adjust intonation at any desired string frequency. And, yes, the general technique lends itself to synthesizer-type note sequencers for music production.

```

1 REM GUITAR TUNER V3 (C)1983 JAL SOFTWARE
10 BD=53280:POKEBD,15:POKEBD+1,15
20 AU=54272:FORI=AUTO54300:POKEI,0:NEXT
30 POKEAU+24,15:POKEAU+6,240:POKEAU+4,33
100 PRINT"(SC)(G1)(CD)(CD) GUITAR TUNER V3
    JAL SOFTWARE":PRINT
110 PRINT" PRESS THE SPACEBAR"
120 PRINT" OR THE PORT 1 JOYSTICK FIRE BUTTON"
130 PRINT" TO SELECT THE NEXT NOTE.":PRINT
300 GETA#:IFA#="THEN300
400 READ NT$,FH,FL:IFNT#="EE"THENRESTORE:GOTO300
500 PRINT"(SC)(G1)(CD)(CD) GUITAR TUNER V3
    JAL SOFTWARE":PRINT
600 PRINTTAB(FH);NT$:POKEAU+24,15-FH/10:
    POKEAU+1,FH:POKEAU,FL
700 GOTO300
999 DATA2,5,71,42,7,12,43,9,104,63,12,143,83,
    15,210,E4,21,31,EE,0,0

```

READY.

• • • • •

**Jiffy Sounds.** The next few programs ("Jiffy Sounds") build on the previous techniques and add a

new one. I've already mentioned the special variable TI that holds and maintains a free running time-clock value. PRINT TI a few times to see how it works. This timer is updated 60 times a second as part of the C-64's interrupt/key-board scan routine. Because of its high speed, Commodore literature refers to this 1/60th second resolution timer as a "jiffy clock." The number of elapsed "jiffies" since the computer was first turned on is kept in decimal memory locations 160, 161, 162, with the value in location 162 counting from 0 to 255 jiffies before resetting to 0 and incrementing the binary count in the previous two locations. Because of this linear build up and reset action, the value in location 162 makes a good "digital" sawtooth waveform that runs independently of other BASIC programming. But, since this timer is moving along pretty fast and BASIC statements and calculations take a lot of time (relatively speaking), only the tightest BASIC loops can keep up with the jiffy clock. Anything longer than a line or so of BASIC will catch times a few jiffies apart and appear to be something like a synthesizer's "sample-and-hold" representation of a sawtooth. This can be used for its advantage in making an otherwise rock steady computer sound more random or modulated, but if you want complexity and speed, you'll need to program in 6502 machine or assembly language, not BASIC. Nonetheless, the following examples are in BASIC and manage to make effective use of the jackrabbit jiffy.

Load INIT and type in the rest of JIFFY Sound. When RUN, Lines 300 and 310 set up the instruction screen and Line 320 asks you to INPUT a delay value, DD, that Line 330 tries to keep in a reasonable range. The delay controls the amount of time in-between samples of the jiffy clock. Line 400 PEEKs a look at the current jiffy value and saves it in variable JV. Line 410 clears the screen, PRINTs the value of JV, POKES it into the SID VOICE 1 HI FREQUENCY register, then triggers the voice ON with a TRIANGLE waveform. Line 420 does a FOR-NEXT delay DD times then POKES the voice OFF and makes the program GOTO Line 400 to get another jiffy value. Let the program run awhile and then press the STOP key to end it. Try several delay values to



get an idea of the sample-and-hold frequency sweep effect. Two other variations are cited in REMarks on Lines 500 and 510. If you use the sample on Line 500 to add Line 340 to the program, the voice will now be SUSTAINED to give a more continuous sweep sound. Replacing Line 420 with what's in Line 510 will add a new set of possibilities to the program: Instead of just waiting for a while, the FOR-NEXT in the new Line 420 repeatedly (DD times) PEEKs the jiffy timer and adds this value to the value of a calculation. The calculation in question takes the current DD value and LOGICALLY ANDs that value to the sum of several numbers that have binary significance. The final result is POKED into the HI FREQUENCY register. The FOR-NEXT loop continues and when it is done the program will GOTO the start of Line 420 for another round. Although the subject of LOGICAL operations, such as AND, OR, NOT, XOR and the like is not within the scope of this text, I will say that its use in this example creates a kind of pattern matching that produces a note or fixed frequency sequence. The use of the ever-incrementing jiffy gives this frequency sequence an upward direction but because of calculation and loop time delays, no two sequences are quite the same. If you want, take a look at your computer manual to find out how LOGICAL operations work. If you are not so inclined, just try different numbers inside the parentheses (the total sum should not exceed 255) and different delay values for some new sound sequences. Also, try the jiffy/logic technique for uses other than frequency control.

```

0 REM JIFFY SOUND V3 (C)1983 JAL SOFTWARE
200 AU=54272:F1=AU+1:F2=AU+8:F3=AU+15
210 T1=54276:T2=54283:T3=54290:AA=AU
212 P1=54297:P3=P1+1:B1=56321:BD=53280
215 F1F1=AUTOS4300:POKEI1,0:NEXTI1:POKEAU+24,15
220 READAV:IFAV)-1)THENPOKEAA,AV:AA=AA+1:GOTO220
229 REM FL FH PL PH W AD SR
230 DATA 000,000,000,000,000,006,000
235 DATA 000,000,000,000,000,000,000
240 DATA 000,000,000,000,000,000,000.-1
300 POKEBD,15:POKEBD+1,15:PRINT"(SC) (61)JIFFY
    SOUND V3 JAL SOFTWARE":PRINT
310 PRINT"TYPE A DELAY VALUE FROM 0 TO 500":
    PRINT"THEN PRESS THE RETURN KEY."
320 PRINT:INPUT"DELAY VALUE":DD
330 IFDD<0 OR DD>500THEN300
400 JV=PEEK(162)
410 PRINT"(SC)":JV:POKEF1,JV:POKET1,17
420 FORD=OTODD:NEXTD:POKET1,0:GOTO400
500 REM 340 POKET1+2,240

```

```

510 REM420 FORD=OTODD:POKEF1,(PEEK(162) AND
(2+B*16+64+128)):NEXTD:GOTO420

```

READY.

• • • • •

**Frog Pond Sound.** Type FROG POND SOUND in as is, even though it looks a bit strange and could be shortened. Do not use INIT. The layout of this jiffy sound example is critical to its timing in that using INIT or different line lengths will totally destroy the desired sound effect. (But, you might rearrange it or add characters to the REM line -- yes, even the REM affects the timing -- to get some other sound.) Briefly, Lines 1 and 5 set variable D to a number to be used in a logic pattern, while Line 10 sets variable A to the start of SID. Line 20 turns ON the volume, Line 55 makes sure there is no SUSTAIN, Line 60 POKEs a HI FREQUENCY value, Line 61 makes the envelope DECAY short. Line 63 is the main event and it POKEs ON a SAWTOOTH wave only IF the jiffy clock matches the value of D. Whether the condition was TRUE or not, Line 64 immediately turns the voice back OFF, then Line 99 does a GOTO 63 for another test. Line 111 is never reached in the program but is still required for timing. When RUN, FROG does what you would expect by creating a semi-random, ever-changing amphibian sound. It was the happy, unexpected result of an early experiment that is so unique that it disappears when you try to modify it...back into the pond, perhaps? It also shows how obscure these programs look without something like INIT to maintain order. Try some long digital delay or tape loops to enlarge the pond.

```

0 REM FROG POND SOUND (C)1983 JAL SOFTWARE
1 D=16
5 D=16
10 A=54272
20 POKEA+24,15
55 POKEA+6,0
60 POKEA+1,100
61 POKEA+5,2
63 IF(PEEK(162)ANDD)=DTHENPOKEA+4,33
64 POKEA+4,0
99 GOTO63
111 A=54272:POKEA+4,0

```

READY.

• • • • •

**Metronome.** If you don't like "critters" or random samples, here's a more practical program that can be done in a "jiffy": a METRONOME. This program uses some speed tricks to track the jiffies accurately and avoid the random sample-and-hold effect. One of the tricks of faster BASIC is to define the speed sensitive variables as the first variables encountered in the program. This helps because BASIC creates a table of variables in the order in which they are encountered. The closer a variable is to the top of the list; the less time it takes for BASIC to find its value. So, if a variable is used often or will delay a part of a program that has to be fast, give it a value (even a temporary zero value), as early in the program as possible and order the variables in descending frequency of use. Eliminating unneeded REM statements will make the program shorter and faster, but keep an additional copy of the program that contains the line-by-line REM explanations for documentation. Packing as many statements as you can on every line speeds up their execution. Keep line numbers short and use variables instead of constant numbers. Avoid PRINTING or repeated calculations in program sections that have to run fast. If possible, jump from BASIC into a special purpose machine language program for the best in programming ease and high speed.

Load INIT and type the rest of the lines in the METRONOME listing. METRONOME takes the first opportunity to define its critical variables in Line 10. (INIT always does this same thing for the same reason: speed.) Lines 300 through 330 create the screen that tells you where to put your paddles. Then, the IF on Line 400 PEEKs at the paddle button location and keeps the program there until someone presses the button. When that happens, Line 500 clears the screen and PRINTs the result of 3600 divided by variable V (initially equal to 60), and the label "BEATS/MINUTE." Now for something new: The first thing that happens in Line 510 is that memory location 162 (T) is POKED with a zero value (Z). (This line is speed sensitive so preset variables were used instead of constant numbers.) We know that location 162 is the jiffy

clock count, but previously, the programs only PEEKed the count value from it. This time the program POKEs the jiffy count with a zero, effectively resetting the jiffy clock to zero. (If Commodore can do it, so can we!) Line 510 continues with a PEEK to see IF the paddle button (B1) is still being pressed (value less than FF or 255). IF this condition is TRUE, THEN the value of paddle 3 is PEEKed and that value is added to an offset of 18 (M), and execution will GOTO Line 500 to print out the new metronome setting, which reflects the value of the paddle setting. This loop continues until the user selects the desired number of BEATS/MINUTE and releases the paddle button to keep it. When this happens, Line 510 resets the jiffy clock again and the IF decides that the button is not pressed, so execution passes on to line 520. Line 520 is part of another tight loop that checks to see IF the jiffy clock has incremented up to a point of equalling the value of V. (Remember the Jiffy clock advances independently of BASIC.) IF the condition is FALSE, the program flow drops to Line 530 which says, GO back TO Line 520 and keep checking, and this continues until V 60ths of a second tick by. Then the IF in Line 520 is TRUE and SID VOICE 1 is first triggered OFF, then ON with a SAWTOOTH (W=19) waveform that produces a very quick audible TICK (the envelope DECAY value is only 1) from the TV speaker. The program flow will then GOTO Line 510, reset the clock, and drop to Line 520 to continue the time check and tick procedure (IF the paddle button is not pressed). The division of 3600 by V 60ths is a unit conversion from jiffies to minutes. The offset value of 18 (M) is added to the paddle value in Line 510 to establish a minimum time range value, since, even with the special care and tight loops, accurate time checking will not take place for values of less than 18 jiffies. Even so this gives an adequate range of from 15 to 200 BEATS/MINUTE. If your needs are greater, eliminate the excess, don't use INIT and otherwise slim down the program and offset. As mentioned before, the PADDLE SWEEP program can also be used as a metronome that can be adjusted to go faster (since it uses a SID oscillator, not jiffies), if you can do without the BEAT rate printout. If you are more adven-

turous, you can modify this program to use INPUTs instead of paddles, flip bits on the USER ports to provide external sync pulses to some other device, allow an accented beat (longer decay or different frequency) at intervals of the user's choice, or go to a full-blown machine language version that has no trouble keeping time on an animated, hi-res or sprite metronome that looks like a old-time, pendulum-swinging version -- for people who don't understand computers and hate digital readouts! Seriously, one modification I do use is to make the background BLACK and the text GRAY, then FLASH the background WHITE when the tick sounds to give a visible as well as audible tempo indicator. (POKE BD and BD+1, the border and background color control locations, zero (0) for BLACK and one (1) for WHITE.)

```

0 REM METRONOME V3 (C)1983 JAL SOFTWARE
10 T=162:T1=54272:T2=0:W=17:M=18:FF=255:B1=56321:
   BD=53280:P3=54298:V=60
200 AU=54272:F1=AU+1:F2=AU+8:F3=AU+15
210 T1=54276:T2=54283:T3=54290:AA=AU
212 P1=54297:P3=P1+1:B1=56321:BD=53280
215 FORII=AUTOS4300:POKEI1,0:NEXTI1:POKEAU+24,15
220 READAV:IFAV>1-THENPOKERA,AV:AA=AA+1:GOTO220
229 REM FL FH PL PH W AD SR
230 DATA 000,050,000,000,000,000,001,000
235 DATA 000,000,000,000,000,000,000
240 DATA 000,000,000,000,000,000,000,-1
300 POKEBD+1,15:POKEBD,15:PRINT"(SC):(B1)"
310 PRINT" METRONOME V3 JAL SOFTWARE":PRINT
320 PRINT" FLUG PADDLES INTO PORT 1."
330 PRINT" PRESS FIRE AND TURN KNOB TO SET SPEED."
400 IPEEK(B1)=FFTHEN400
500 PRINT"(SC):(CD):(CD)"*3600/V:"BEATS/MINUTE"
510 POKET,2:IPEEK(B1)^(FFTHENV=M+PEEK(P3):GOTO500
520 IPEEK(T1)=VTHENPOKET1,2:POKET1,M:GOTO510
530 GOTO520

```

READY.

• • • • •

**Multi-Voice Sounds: Random Bells.** So far the program examples have made use of only one of SID's 3 voices. This section deals with more complex multi-voice effects. It sounds off with an effect every synthesist can use and is just the thing for programmers that like to add plenty of "bells and whistles" to their programs: RANDOM BELLS. Peel out INIT and BRING in the rest of the BELLS claptrap, including those "chiming" DATA statements. (If you're at the end of your rope from Bell puns, you can GONG me when this is over!) When RUN,

INIT does its work and the DATA statements make use of a long DECAY on VOICE 1 and a SUSTAINED VOICE 3. Line 300 makes the screen GRAY and line 400 creates variable FL which points to the LO FREQUENCY SID register of VOICE 1, then POKEs the volume control with the usual 15 (full volume) plus 128, which keeps VOICE 3 from being heard directly in the output sound. VOICE 3 also is triggered ON with a SAWTOOTH waveform in this Line. This special treatment for VOICE 3 is due to the fact that its output will be used to RING MODULATE the frequency of VOICE 1 to create a bell-like sound. Line 500 generates HI and LO random FREQUENCY values in the range of 0 to 255 and calls them RH and RL. Variable DD becomes a time delay value that comes from PEEKing the value of paddle 1 and multiplying it by 2, while the value of paddle 3 goes into RI for later use as a ring modulation oscillator HI FREQUENCY value in Line 510. Lines 520 through 560 clear the screen and PRINT some instructions, including the INTEGER values of RL, RH and RI. Line 570 then POKEs VOICE 1 OFF and POKEs the random HI and LO FREQUENCY values in their proper registers. Line 580 does the same for the random HI ring FREQUENCY and then POKEs VOICE 1 ON with a SAWTOOTH wave plus the RING MODULATION bit (GATE+RING+SAW or binary 1+4+16=21) that says "Ring modulate OSCILLATOR 1 with the FREQUENCY of VOICE 3." Line 590 is a FOR-NEXT time delay loop of random (DD) length that allows the long VOICE 1 DECAY envelope to die out before the program Goes back TO Line 500 to make up new random numbers, read the paddles, etc.

Even though this program uses two voices, only one is directly present. If you want to keep VOICE 3 in the output, remove the 128 from Line 400. Note that only TRIANGLE waves can be used for ring modulation and that any voice can be selected to modulate any other voice. If you add assigned keyboard (GET) frequency selection or note sequencing (as in GUITAR TUNER), a "bell tree", vibes or chime set is easily constructed. One modification I use is to constantly PEEK paddle 3 and POKe its value into the VOICE 3 FREQUENCY register during the Line 590 delay loop; as a result, instead of a fixed ring modulation frequency, I can twist the paddle to "Bend" or sweep the bell in realtime. Paddle note: The reason I've used a

"set number via paddle and fix it" procedure versus realtime settings in BELLS and METRONOME is that occasionally, the paddle A/D converters output a "glitch" or bad value. You probably noticed this glitch as a random high frequency beep during PADDLE SWEEP. Commodore states that the paddles are "not reliable" when read from BASIC and supplies a suitable machine language paddle read routine in the reference manual. My experience indicates that the machine language routine is also glitchy and the procedure is slow and complicates the BASIC program. If you only need one set of paddle values, plug them into Game Port 1 and use the P1/P3 single PEEK technique presented in these example programs -- it works just as well and is much simpler. For glitchless paddle readings, I do several quick, sequential paddle PEEKs, compare them to see if they are all the same number, then return that value if the condition is true or try again if a glitch crept in. This kind of routine is easy to write in BASIC or machine language.

```
0 REM RANDOM BELLS V3 (C)1983 JAL SOFTWARE
200 AU=54272:F1=AU+1:F2=AU+8:F3=AU+15
210 T1=54276:T2=54283:T3=54290:AA=AU
212 P1=54297:P3=P1+1:B1=56321:BD=53280
215 FORI1=AUTOS4300:POKEI1,0:NEXTI1:POKEAU+24,15
220 READAV:IFAV)-1THENPOKEAA,AV:AA=AA+1:GOTO220
229 REM FL FH PL PH W AD SR
230 DATA 000,000,000,000,000,011,000
235 DATA 000,000,000,000,000,000,000
240 DATA 000,000,000,000,000,005,128,-1
300 POKEBD,15:POKEBD+1,15
400 FL=F1-1:POKEAU+24,15+128:POKET3,17
500 RH=RND(1)*256:RL=RND(1)*256
510 DD=PEEK(P1)*2:RI=PEEK(P3)
520 PRINT"(SC):RANDOM BELLS V3 JAL SOFTWARE"
530 PRINT"PADDLES CONTROLS RING"
540 PRINT"PADDLE1 CONTROLS SPEED:PRINT
550 PRINT"LO/HI FREQ":INT(RL):INT(RH)
560 PRINT"RING":INT(RI)
570 POKET1,0:POKEFL,RL:POKEF1,RH
580 POKEF3,RI:POKET1,21
590 FORD=OTDOD:NEXTD:GOTO500
```

READY.

.....

**Helicopter Paddle Sound.** This simple program simulates a helicopter takeoff where realtime paddle control changes the frequency of two audible voices, a continuous SAWTOOTH motor whine and a swept NOISE "blade through the air" sound. Load INIT and change the DATA values to provide the SUSTAINED voices. Lines 300

through 320 create the instruction screen. Line 400 sets variable FL as a pointer to the SID VOICE 2 LO FREQUENCY register and then POKES VOICES 1 and 2 with NOISE (129) and a SAWTOOTH (17), respectively. Line 500 is the start of the main program loop that fills variable X with the current paddle 1 value, scaled by multiplying it by 0.3 and adding 1, then POKES that value into the HI FREQUENCY OSCILLATOR register of VOICE 1, producing a high-to-low (the bottom end is limited to a value of 10) noise frequency sweep to create the rotating blade sound. Upon finishing a sweep, Line 700 directs the execution back to 500 to check on the paddle. Towards the top of paddle rotation there will be some abrupt motor frequency changes as the frequency value exceeds 255 and is chopped off by the AND; use this for "engine trouble." Altering the SUSTAIN values also makes a big difference in the overall blade/motor presence of this effect. Try other frequency (multiplier) ratios to fine tune your 'copter and add digital delay to get an entire squadron.

```
0 REM HELICOPTER PADDLE SOUND V3 (C)1983 JAL SOFTWARE
200 AU=54272:F1=AU+1:F2=AU+8:F3=AU+15
210 T1=54276:T2=54283:T3=54290:AA=AU
212 P1=54297:P3=P1+1:B1=56321:BD=53280
215 FORI1=AUTOS4300:POKEI1,0:NEXTI1:POKEAU+24,15
220 READAV:IFAV)-1THENPOKEAA,AV:AA=AA+1:GOTO220
229 REM FL FH PL PH W AD SR
230 DATA 000,050,000,000,000,015,240
235 DATA 000,009,000,000,000,005,204
240 DATA 000,000,000,000,000,000,-1
300 POKEBD+1,15:POKEBD,15
310 PRINT"(SC):(G1)HELICOPTER PADDLE SOUND V3 JAL
SOFTWARE"
320 PRINT:PRINT"TURN THE PADDLE TO CHANGE SPEED"
400 FL=F2-1:POKET1,129:POKET2,17
500 X=PEEK(P1)*.3+1:POKEFL,(X*6)AND255
600 FORI=255TO10STEP-X:POKEF1,I:NEXTI
700 GOTO500
```

READY.

.....

**Scratch Sound.** Here's an example of a multi-voice, no input, programmed sweep sound that is very popular in today's modern electronic funk/rap music: The phonograph-stylus-sliding-across-the-album SCRATCH SOUND. Load INIT, DATA and program, then RUN. Lines 300 and 310 make the title screen and initialize the random (RND) function; Line 400 makes VL point to the SID master volume

register and POKES SUSTAINED VOICES 1 and 2 ON with NOISE and SAWTOOTH waves. Lines 410 and 420 set up constants in variables Q, QQ and M and also sport REMarks with suggested alternative values for later experimentation. Line 500 starts the main loop by creating a random R value in the range of 0 to almost M, then begins a FOR-NEXT that takes I from 1 to 15 times R and POKES the current I value times Q into the SID VOICE 1 OSCILLATOR HI FREQUENCY register. Line 510 completes the I loop by POKING VOICE 2 HI FREQUENCY with I times QQ and POKING the VOLUME register with the straight I value. By now, you likely recognize that this produces an upsweep in both volume and frequency with each parameter having a slightly different progression because of the different constant multipliers. The sweep loop in Lines 520 and 530 act similarly to that of Lines 500 and 510, except that this loop sweeps down (STEP-1) from 14 to 1, then goes back to Line 500 for a new random number. The random R value produces different sweep lengths and thus a spontaneous "scratch rhythm" to which you can jam. Try some of the other multipliers; some of them have funkier results than others. If you want, this program can be modified to produce a scratch of desired modulation, length and direction on cue. Your new album? zzzeeewWWeepppp!!! "Oops, sorry 'bout that, must have bumped the turntable," or "Your computer is skipping..."

```
0 REM SCRATCH SOUND V3 (C)1983 JAL SOFTWARE
200 AU=54272:F1=AU+1:F2=AU+8:F3=AU+15
210 T1=54276:T2=54283:T3=54290:AA=AU
212 P1=54297:P3=P1+1:B1=56321:BD=53280
215 FORI1=AUTOS4300:POKEI1,0:NEXTI1:POKEAU+24,15
220 READAV:IFAV)-1THENPOKEAA,AV:AA=AA+1:GOTO220
229 REM FL FH PL PH W AD SR
230 DATA 000,000,000,000,000,005,208
235 DATA 000,000,000,000,000,005,208
240 DATA 000,000,000,000,000,000,-1
300 POKEBD+1,15:POKEBD,15:R=RND(1)
310 PRINT"(SC):(G1)SCRATCH SOUND V3 JAL SOFTWARE"
400 VL=AU+24:POKET1,129:POKET2,33
410 Q=4:QQ=4:REM TRY 10,13,15
420 M=.6:REM TRY .9
500 R=RND(1)*M:FORI=1TO15:R:POKEF1,I*Q
510 POKEF2,I*QQ:POKEVL,I:NEXTI
520 FORI=14RTO1STEP-1:POKEF1,I*Q
530 POKEF2,I*QQ:POKEVL,I:NEXTI:GOTO500
```

READY.

.....

**CONT. Pg.21**

**October 1984**



## SYNTHESIZER PHASE SHIFTER

by: Thomas Henry

It's easy -- often too easy -- to stereotype musical devices. For example, some people (and this used to include me) tend to think that flangers and phase shifters are primarily guitar effects. Well, even though guitarists may have been the first musicians to popularize these exotic devices, flangers and phase shifters also make perfect additions to any synthesizer system. Of course you already know this if you built the Synthesizer Delay Line presented here in the June '84 issue; that circuit made possible a whole new family of weird timbre modulation effects. This time, we'll open up more possibilities by examining a high-quality, low-noise phase shifter you can build for your synthesizer.

In terms of sound, flangers and phase shifters have a lot in common. For example, with high resonance, both create the so-called "jet sound." This being the case, why would a system need both circuits? Well, we are entering a highly subjective area, but I feel that the flanger imparts a mood of tension to music. There's something almost brittle, metallic or mechanical about the timbre changes it renders. The phase shifter, on the other hand, always makes me feel like I'm sitting in front of a warm fireplace on a winter night. It has a smooth, even sound about it. My metaphors may not jibe exactly with the sensations you'll experience when you hear both units, but that's not the point. The important thing is that the flanger and the phase shifter, while creating similar effects in a vague sort of way, each have something new to add to a sound. In short, having both units available in a system makes a lot of sense!

This circuit has been optimized for use with a synthesizer

system. As such, it assumes most of our usual standards. For example, input impedances are 100K, output impedances 1K, signal levels 10V p-p, and the control signal response is 1V/octave. If you're looking for a phase shifter more suitable for use with a guitar or other low level signal sources, get out your back issues of DEVICE and check Craig Anderton's AMS-100 design ("AMS-100, Part 4: Voltage Controlled Phase Shifter Module", DEVICE, Volume 1, Number 4-79, pp. 7-10.) You will notice a lot of similarities between that design and the circuit we're going to look at right now, since both circuits are based upon Solid State Micro Technology for Music's application note for the SSM2040 chip.

We won't get into the theory of phase shifters here beyond noting passing a signal through an allpass filter, then mixing it with the dry signal, creates the "swoosh" sound. An allpass filter, as the name implies, passes signals of all frequencies. However, even though the amplitudes of these signals are left unaltered, the phase responses are greatly modified. In general, then, an allpass filter changes phase but not amplitude.

**How it works.** Refer to Fig. 1, the Synthesizer Phase Shifter schematic. Now before you go and assume that I fibbed about the simplicity of the circuit, notice that the entire design utilizes only two chips. The four op amps labeled A1 through A4 are each one-fourth of the 4136 quad op amp package, and all of the other amps (toward the middle of the schematic) are contained in the SSM2040 chip. The four transconductance amplifiers in this IC form the allpass filter network mentioned above. As an extra benefit, the SSM2040 also contains all of the

necessary exponential converter circuitry. So, while the schematic is somewhat drawn-out, the actual circuit is a snap to build.

In general, circuits employing the SSM2040 need to see a 1V p-p maximum input signal. Thus, after the audio input enters jack J1, R24 and gain control R17 attenuate the signal by a factor of 10. This reduces a 10V p-p audio signal to 1V p-p, which is then buffered by amplifier A1 and sent to the rest of the circuitry. You may wonder why the input is attenuated in this fashion as opposed to, say, using a standard inverting amplifier with a gain of less than unity. As it turns out, the output amplifier (A3) of this circuit must be a non-inverting stage to make the blend control work properly, so to maintain phase integrity of the dry signal, the input must be non-inverting as well.

Let's return to the input signal. The buffered signal first goes to the input of the SSM2040 via voltage divider R8/R1. This pair of resistors reduces the signal level to the transconductance op amp in the SSM2040, which keeps the amp working in its most linear range. C3 is the timing capacitor of the allpass network and R9 forms the feedback loop. The audio signal then passes down three more stages identical to the first stage; modulating the effective resistance of all four transconductance amplifiers phase-shifts a particular harmonic of the input signal from 0 to 720 degrees. The sum of the shifted signal and the dry signal then create the cancellations which characterize the "swoosh" sound of a phase shifter.

Next, the output of the allpass network goes to a polarity changer formed around amplifier A2

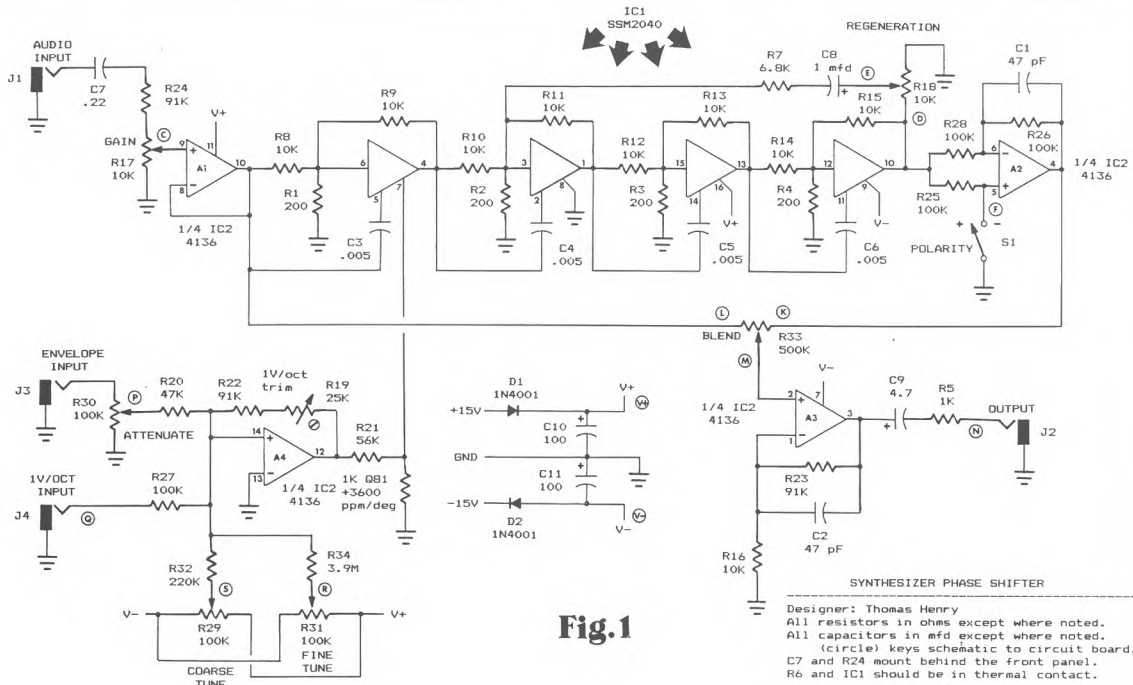

Designer: Thomas Henry  
 All resistors in ohms except where noted.  
 All capacitors in mfd except where noted.  
 (circle) keys schematic to circuit board.  
 C7 and R24 mount behind the front panel.  
 R6 and IC1 should be in thermal contact.

and associated components. We have seen this idea before in previous columns, ("Quadrature Function Generator" and the "Synthesizer Delay Line"), so not much need be said about it. With switch S1 open, the allpass signal is left uninverted. However, when S1 is closed, the signal is inverted before being sent to the final blend. The sound created by the two positions of this switch are quite different, with positive phasing giving a more biting edge and negative phasing yielding a more mellow, bassy response. Note that by using the sign changer idea, we get around the need for a DPDT switch (usually required for this type of function) and as a bonus we keep the audio signal close to the circuit board.

In the design of lowpass and band pass filters, undesired supersonic oscillations are seldom a problem since the amplitudes of the frequencies involved are naturally attenuated by the filtering nature of the circuit. Highpass and allpass filters are altogether a different matter, though. In particular, allpass filters can start oscillating very easily at

supersonic frequencies due to the unpredictable nature of the phase response. To get around this problem, C1 rolls off the response of amplifier A2 at about 35 kHz, which is low enough to stop unwanted supersonic activity without affecting the general tone color of the audio input signal.

After the polarity processing, the signal finally goes to the output blend control, R33. Note that one side of this pot receives the allpass signal while the other gets the dry signal from the output of the input buffer, A1. R33's wiper thus picks off a blend of the two. This can be continuously varied from full dry signal to full allpass, with any ratio of the two available at in-between settings of the pot. By the way, many phase shifter circuits include a switch which can be flipped to generate a pleasant vibrato effect. The Synthesizer Phase Shifter eliminates the need for this switch, since the vibrato effect can be attained simply by dialing R33 to its full allpass position.

The output mix, as created by

R33, is buffered and amplified by A3. Since the audio signal was attenuated way back at the input of this circuit, A3 brings the level back up to spec by introducing a gain of 10. Again, the frequency response is rolled off a bit by C2 to reduce the possibility of supersonic nastiness.

To keep annoying "thumps" to a minimum and also to avoid hassling around with output trim pots, I decided to AC couple the Synthesizer Phase Shifter. C7 accomplishes the input coupling, while C9 handles the output. Of course, this conflicts with our standard specifying DC coupling throughout, but since it's unlikely you will want to shift the phase of a DC signal, the tradeoff seems justified. By allowing this deviation in our standard, we are able to maintain simplicity of execution without losing versatility.

To increase the effect of phase shifting by accentuating the hills and valleys of the response, C8 and R7 provide a feedback path back to the second stage of the allpass filter. R18 is the regeneration control, and can add a

real bite to the sound. Select R7 so that the filter will start oscillating if this control is increased to its maximum setting. This bonus allows you to employ the unit as an auxiliary sine wave oscillator as well! When using the circuit in this way, turn the blend control to the full allpass position and then raise the regeneration control until oscillation just begins reliably. This will yield the lowest distortion sine wave.

**Controlling the Synthesizer Phase Shifter.** A4 forms the control voltage summer. R29 and R31 are the coarse and fine tuning controls, respectively. Since these controls are strung across the bipolar supply, they have enough "oomph" to compensate for any offsets in the other control signals. The coarse control will sweep the phase shifter over a range of a dozen octaves or so, while the fine control sweeps less than an octave.

Envelopes, which usually swing from 0V to +5V, may be applied to J3, the envelope input. Resistor R20, with respect to R22 and R19, sets this input's gain to about two, thus letting an envelope signal modulate the device over its entire range. Attenuator R30 tames the sweep as needed.

J4 is the 1V/octave input. You may wonder why an input of this nature is needed in a circuit like a phase shifter; consider a situation where your keyboard is controlling a VCO whose output is fed to the phase shifter. Now imagine that you hit upon a pleasant timbre while adjusting the coarse and fine tuning controls. By connecting the keyboard's control voltage output to the phase shifter's 1V/octave input, the circuit will track the VCO wherever it goes. Therefore, the timbre remains constant regardless of frequency. Of course, there is some evidence which shows that acoustic instruments themselves don't obey this relationship, but all the same it's probably better to have this feature and not use it (you might use it someday) than not have the feature at all.

After A4 mixes all of the control signals, the result is attenuated by divider R21/R6 and sent to pin 7 of the SSM2040. Note that R6 is actually a ther-

mistor and performs temperature compensation for the exponential converter within the SSM2040. In order for this to work correctly, R6 must be in close thermal contact with the chip. If this is done, the Synthesizer Phase Shifter will perform reliably under any temperature conditions. Of course, if precise tuning doesn't matter all that much to you, R6 could be replaced with a regular 1K resistor. This would make the sine wave oscillator application unpredictable, among other things, so stunting on the thermistor really doesn't seem like such a good idea. After all, we've come this far, so why not cinch the circuit with the addition of a fairly inexpensive part!

**Building the Synthesizer Phase Shifter.** Fig. 2 shows the complete parts list. Most of the components are easy to find; the SSM2040 and the thermistor are the only unusual parts, but fortunately PGS Electronics (Route 25, Box 304, Terre Haute, IN 47802), a regular advertiser in *Polyphony*, has these parts available thus putting them within reach of readers of this column.

FIG. 2

SYNTHESIZER PHASE SHIFTER: PARTS LIST

RESISTORS	
R1 - R4	200 ohms
R5	1K
R6	1K 081 thermistor
R7	6.8K
R8 - R16	10K
R17, R18	10K potentiometer
R19	25K trimmer
R20	47K
R21	56K
R22 - R24	91K
R25 - R28	100K
R29 - R31	100K potentiometer
R32	220K
R33	500K linear
R34	3.9M potentiometer
CAPACITORS	
C1, C2	47 pF disk
C3 - C6	.005 mfd mylar
C7	.22 mfd mylar
C8	1 mfd electrolytic
C9	4.7 mfd electrolytic
C10, C11	100 mfd electrolytic
SEMICONDUCTORS	
D1, D2	1N4001
IC1	SSM2040 filter IC
IC2	4136 quad op-amp
MISCELLANEOUS	
J1 - J4	1/4" phone jacks
S1	SPST switch
sockets, wire, solder, knobs, front panel, heatsink grease, hardware, etc.	

NOTE: C7 and R24 mount behind the front panel.

To simplify building this device, Fig. 3 shows the artwork for a printed circuit board. Other modes of construction are possible, but a circuit board tends to give the best and cleanest results, while making things that much easier for the final front panel hookup. Fig. 4 gives the circuit board parts placement guide.

Using Figures 1, 3 and 4, load the board, saving the thermistor, R6, for the last step. Fig. 5 shows how this part mounts right on top of the SSM2040 chip. Notice that special solder holes on the board at either end of the chip have been provided to facilitate this operation. Before soldering the thermistor in place, spread some heat sink grease over the top of the chip and then press the thermistor down onto it. This increases the thermal tracking of the two parts.

After preparing a suitable front panel, you may complete the final wiring. Since this circuit is sensitive to hum, notice that shielded wire is used for many of the connections. To ease the task of running shielded wire from the circuit board to the front panel, note that a number of extra ground pads (denoted by the letter "G") are provided on the board. In all cases, the shield is soldered to the circuit board, but not the front panel! Let's run through a sample hookup to point "C" to see how this works. Note that a ground pad, labelled "G", is available next to it. Strip the insulation from a shielded wire, exposing both the hot wire and the shield. Connect the hot wire to point "C" and the shield to point "G". Now, at the panel end of things, strip the wire and cut off the shield entirely. Connect the hot wire to the wiper of R17. Continue this process for all of the other connections which require shields (these are "C", "D", "E", "F", "K", "L", "M" and "N"). In the case of point "F", the shield hooks up to one side of switch S1, but in all other cases the shield is ignored at the panel end of things.

Of course, the front panel eventually will need a ground path, so take one of the uncommitted "G" pads and form an electrical connection between this and



FIG.3

© 1984 THOMAS HENRY

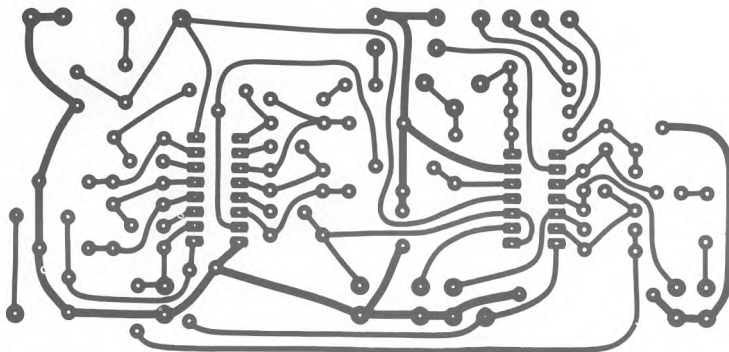

**PHASE SHIFTER**

FIG.5

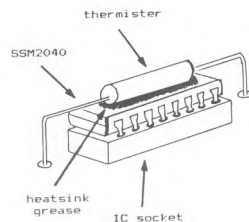

Detail showing how the thermistor is mounted in thermal contact with the SSM2040. Note that solder holes are provided on the circuit board, at either end of the socket, for installing the thermistor in this fashion. The two holes are marked on the parts placement guide with asterisks.

Tweaking the scale trimmer, R19, is fast and easy. Simply start the device oscillating (as described above) and tune it just like you would any VCO. You'll find this easiest to do if you work in the 200 Hz to 1 kHz range.

And there you have it, a high quality Synthesizer Phase Shifter. I think you'll find this to be an exciting addition to your system, since it really opens up the door to more animated sounds. So what are you waiting for? Start phasing today!

**PHASE SHIFTER**

© 1984 THOMAS HENRY

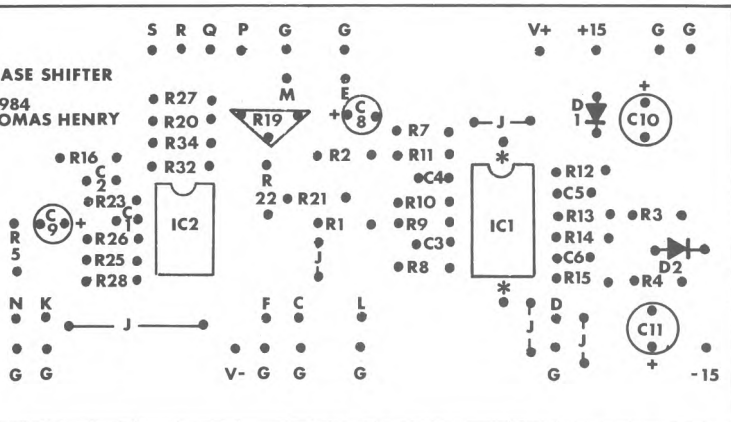
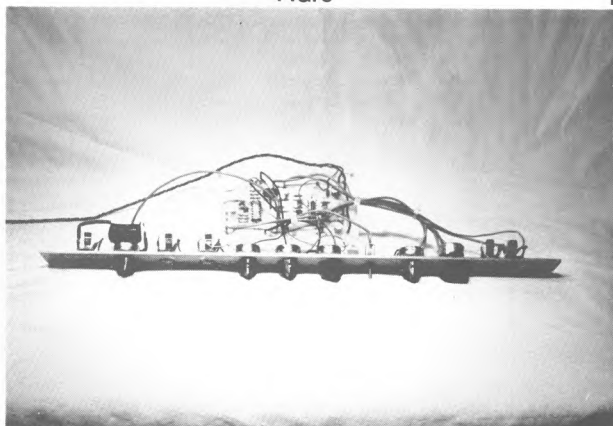

FIG.6

the panel. What we have done here with all of this monkey business is shielded all of the sensitive wires while maintaining a single ground path to the front panel. This reduces the possibility of hum caused by ground loops.

Fig. 6 shows the prototype of this circuit. C7 and R24 mount behind the front panel and if you look carefully at the picture you will notice C7 directly behind potentiometer R24. I used some five minute epoxy cement to secure the capacitor to the pot and then completed the hookup accordingly.



# DR. BOHM DRUM REVIEW

By: Craig Anderton



One of the Platters playing the Dr. Bohm drum unit.

For many years, the United States, Great Britain, and Japan have gained the most attention for their work in musical electronics, but now Germany is rapidly gaining her share of the spotlight as well. The PPG Wave synthesizer has already stirred up much interest among musicians on this side of the Atlantic; and at the Summer '84 NAMM show, the Dr. Bohm company, known primarily for producing home organs in both kit and assembled form, introduced their Digital Drums (DD) to this country. The DD combines impressive features and digitally-recorded drum sounds at a reasonable price -- \$890 in kit form, \$1,320 assembled and tested -- and is well worth investigating if you have an interest in digital drum machines (especially if you're a kit builder).

**Preset rhythm options.** Unlike most current digital drum units, the DD emphasizes preset rhythms; however, you may also program your own rhythms from scratch. This emphasis on presets recalls the early home organ drum machines (in fact, the DD was designed to complement the Dr. Bohm line of organ products), but the DD brings these functions up to date in several innovative ways that give far more real-time control than you might expect from a preset drum box.

Referring to Fig. 1, the 18 buttons towards the right of the top row of buttons select the various presets -- the usual pop, rock, foxtrot, swing, etc. The button to the immediate left of these selects either the presets indicated below or above the 18

right-most buttons, therefore giving a total of 36 basic presets. We all know how boring playing the same rhythm over and over can be, though, so fortunately there are four Variation buttons. Selecting the 1st variation (the default setting when you call up a pattern, incidentally) produces the simplest variation on the preset; selecting higher-numbered variations produces more complex variations on the basic sound. Each variation can be pre-selected while a song is playing; the pre-selected button's LED will blink until the previous pattern has finished playing, at which point the new variation will kick in and the LED will shine continuously. If you de-select any variation without selecting a new variation, you will hear the fifth

Fig. 1  
Control Panel

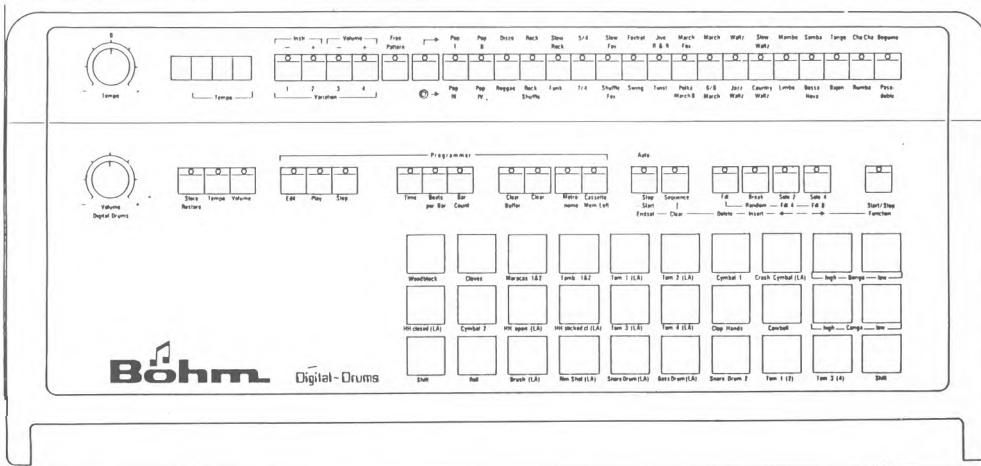

variation which is the most complex of the set. Therefore, with 36 basic patterns and five variations, you have a grand total of 180 different patterns.

In addition, there are four more ways to vary the sound via the Fill, Break, Solo 2, and Solo 4 buttons. As a rhythm is playing, you may press one of these buttons to insert the particular function at the end of the rhythm pattern. Fill adds additional sounds to the basic pattern, Break gives a one-measure break, Solo 2 a two-measure solo and Solo 4 a four-measure solo. After the function is complete, the DD goes back to playing the previously selected rhythm. The fact that you can switch over to different patterns and/or variations in real-time means that you can "play" the patterns, which is especially useful for situations involving improvisation or song-writing. Those who find programming tedious, or want an instant "groove" to practice against, will find this capability most useful.

You can also play drum sounds in real-time against the programmed patterns, and these are mixed in at a somewhat louder level (nice touch). And what drum sounds are available? Keep reading...

**The sounds.** The thirty buttons in the lower right hand corner of the machine play the various drum sounds, and there are a lot of sounds! Unfortunately, though, to my ears some of them are rather weak so don't expect the DD to sound like a LinnDrum, DMX/DX, or Drumulator; the toms in particular sound quite flat, the handclaps are dull, and the percussion sounds often lack presence. Still, the snare and kick are strong, the cymbals are quite acceptable, and the sheer number of available sounds helps offset any lack of fidelity.

The Bass, Snare, Toms 1 through 4, Hi-Hat Closed, Hi-Hat Open, Hi-Hat Stick, Rim Shot, Brush-on-Snare, and Crash Cymbal offer two amplitude levels; pressing one of two available "shift" buttons selects the "low amplitude" (LA) version. Normally, these drums are accented unless you press shift at the same time as the play button. Other sounds include Woodblock, Claves, Maracas, Tambourine, two different Ride Cymbals, two Bongos, two

Congas, Claps, Cowbell, and Drum Roll. (The latter provides a drum roll sound which plays continuously until stopped by playing one of the other snare sounds.) All sounds are mixed in stereo; with the upper and middle row of play buttons, the right hand drum sounds tend to appear on the right of the stereo field, and the left hand drum sounds towards the left. The lower row of buttons tend to appear more towards the center. Note that the four tom sounds appearing on the upper two rows may also be played from the two lower row tom buttons ("shifting" these provides the remaining two tom sounds) to allow for different stereo placement from the toms played on the upper rows. Also, the maracas and tambourine, when shifted, change their spatial location (but not their sound).

Several of these drums are combined on the same software channels and cannot be played at the same time. For example, the high and low bongos cannot be played simultaneously; if you play a beat on the low bongo and then attempt to play a high bongo sound on top of it, the new sound will replace the old one. Other drum units have the same limitation, but the problem is more noticeable with the Dr. Bohm since it has such a large number of drum sounds. Well, no one ever said you get something for nothing -- however, at least the DD color-codes the different drum groups so that you are aware which drums can, and cannot, be played simultaneously (as a matter of fact, color-coding is used for several drum functions to simplify matters).

There are also eight output jacks on the back, one for each software "channel". When used in conjunction with a stereo mixer, this feature allows you to create your own stereo spread if you don't like the one present at the existing stereo outputs.

**Programming your own patterns.** The DD allows for both real-time and step-time programming; probably most readers are familiar with these approaches (if not, refer to the August 1983 issue of *Polyphony*, which features an in-depth comparative review of the MXR Drum Computer, E-Mu Drumulator, and Oberheim DX drum machines). It is possible to program in one mode and edit in the other, which is quite helpful.

Before programming a rhythm pattern you can choose from various time signatures (2/4, 3/4, 4/4, 5/4, 6/4, and 7/4), number of steps per quarter note (1, 2, 3, 4, 6, 8, 12, or 16), and number of measures in the rhythm. Note that the more steps per quarter note, the fewer the number of measures; if for example you select 16 steps, the rhythm will only be one measure long. The DD will auto-correct to the nearest step when doing real-time programming, but unfortunately, unlike most drum machines you cannot change auto-correct for different overdubs. This means that if you choose lots of steps per quarter note, you will have to play with considerable precision. It is easy to erase drum beats, though, so if you screw things up it's not at all hard to try again; and of course, you can slow the tempo way down to make life easier. Still, for those of us who were raised on Drumulators the lack of auto-correct sophistication can be somewhat frustrating.

The DD also includes a button that lets you practice along with your pattern without recording the drum beats. You can then switch over to regular mode after you get the part right and record (this is like the Drumulator's "Assign" mode).

You may store up to 36 patterns in addition to the preset patterns, and also program your own fills, breaks, and solos. You may edit the factory presets as well and store the edited versions.

**Tempo options.** Each rhythm pattern can have its own tempo (in fact, all factory presets are programmed with an "optimum" tempo although this can be easily changed); the tempo may then be fine-tuned over +30 BPM with the front panel tempo control. You can alternately program a master tempo for all the patterns, or return to any default settings if desired (whether programmed by you or the factory). A seven-segment readout displays the tempo and the section of the pattern being played; it can also indicate time signature, steps per quarter note, and the number of measures for either self-programmed or factory preset rhythms. Interestingly, the DD claims to use a "humanizing" device which subtly alters the timing for the various sounds, with handclaps exhibiting the



greatest variation and the bass drum the least variation. I could not notice this effect, but then again, you wouldn't want something like this to really be noticeable.

#### Creating sequences (songs).

You can string together any combination of factory preset or self-programmed rhythms into a song. In this respect the DD operates like other drum units, and includes options such as insert, delete, step forward, step backward, and the like. One useful addition is the ability to insert stop points in a song, where the pattern stops until re-started; you can also start in the middle of a sequence if desired. The DD stores up to 36 sequences, with the tempo for the sequence being determined by the tempo of the first pattern. However, you can also insert tempo changes while programming a sequence.

**Total storage.** The total sequence storage of the DD is about 500 steps. With typical drum patterns, you can store about 2000 bars, which can be distributed among the 36 sequences. A memory FULL indication warns when you've just about used up your storage, indicating that it's time to think about saving what you have via the cassette interface.

**Other features.** Each sound can have any one of nine volume levels, and the volume level for each sound can be changed as you play a pattern. Thus, you can bring in a pattern with, say, just snare and bass, and slowly (or rapidly) mix in the other sounds. This is a very powerful feature. The volume level can be temporarily changed (in which case stopping and then re-starting the pattern restores the original volume setting), or permanently programmed as part of the rhythm pattern. Each rhythm pattern (with its accompanying variations, breaks, fills, and solos) can have its own volume settings for the various drum sounds. The DD comes with the drums programmed for an "optimum" balance but like most of the default settings, these are not only easily changed but can be easily restored to their original values.

The DD also includes a cassette interface and sync-to-tape feature. The sync-to-tape seems to be some kind of non-standard FSK system (a la Oberheim DMX and

DSX). While this admittedly tends to promote more reliable results than a simple click track type sync, don't expect to use the DD with MIDI, SMPTE, or 24-pulses-per-quarter note devices.

**Overall evaluation.** One of my favorite features of the DD is something that doesn't show up on a spec sheet: attitude. The unit is well made, fairly compact, the manual is quite comprehensive (although there are some minor translation problems), and numerous options -- some dipswitch selectable -- are well-documented. (For example, there are two selectable Baud rates for the cassette interface so that you can choose the rate most appropriate to the quality of your tape recorder.) The use of color-coding is considerate, and the readout can display 12 different error messages, indicating not only catastrophic problems but also operator errors.

I realize that this has been a relatively favorable-sounding review, primarily because I think Dr. Bohm deserves credit for producing an innovative, user-friendly drum box with lots of sounds and features at an extremely competitive price. And, offering it in kit form -- thereby allowing musicians to save almost \$400 -- is something which I feel deserves particular commendation. But the DD does have some limitations. The main one is sonic; while some of the drum sounds are excellent, some of them are rather muffled-sounding. Also, the DD does not have the sophisticated programming versatility of a device like the Drumulator, nor does it include many of the professionally-oriented features of top-of-the-line devices such as the LinnDrum or Oberheim DMX. Yet it also offers features unique in the world of digital drums, such as the ability to really "play" the 180 presets. Certainly the DD isn't all things to all people. But just as certainly, it's a worthwhile addition to the growing number of digital drum units, and Dr. Bohm deserves respect for producing a professional-quality, and well-designed, drum box at an affordable price.

## re-view

(4/84), Roach here is non-rhythmic, non-sequenced and totally blissed out. Ranks with Slepian (10/81) and Schoener (4/83) at the tippy top of the 100% electronic New Age. This tape, as well as all Fortuna releases listed and lots more meditative music, available from Fortuna for \$8.98 plus postage, P.O. Box 1116, Novato, CA 94947. Write for their catalog; it lists almost every release in the field.

Arnold Mathes **Technical Ancestors** (AM #10, cassette); **Cateclipse** (AM #11, cassette). Mathes performs slow solos over long-running rhythm box and sequencer patterns. It's rather like uptempo New Age. These and ten other tapes are \$5.00 each postpaid from 2750 Homecrest Avenue, Brooklyn, NY 11235.

Mark Lane **Who's Really Listening?** (Idiosyncratics 1-84-101, EP). Keyboard synthesizers, rhythm box and marginal vocals in underwritten overwrought rock tunes. \$5 postpaid from Idiosyncratics, 832 Empire Avenue, Ventura, CA 93003.

**On-Slaughter No.5** (cassette + pamphlet). The other Mark Lane project, an on-going sampler of independents in words and music. The nine here range from strict amateurs to Rudiger Lorenz, with a couple familiar faces in between. \$5 from Lane, above.

Bluetoy **Reinventing the Wheel Without a Third Eye** (cassette). Instrumental tunes, showing imagination and attention to detail, and a restraint notably missing from some of the above. The sounds are all synthesizer, but it's so non-cliche I just now realized it. \$7 postpaid from Christopher Laird Simmons, P.O. Box 7000-822, Redondo Beach, CA 90277.

Michele Musser **A Cast of Shadows** (cassette). Musser sets up rhythms on keyboards and rhythm box, then tears them down and sets up another. The constant shifting, interesting voicing, and tasteful restraint make for a well-above average effort -- even among current high standards. \$7 from 1125 Rolleston St., Harrisburg, PA 17104.

## 64 Sounds, Part 3 continued

**Percussion Sequence** uses all three voices to give the user an initial example of the wide range of simulated and electronic drum effects that the C-64 can make. Load INIT, change the DATA lines, add the other lines, SAVE and RUN. Lines 300, 310 make the title screen. Line 320 creates the VOICE 3 LO FREQUENCY pointer, FL. Lines 400 through 420 do a series of snare drum rolls with the help of a small subroutine that does most of the work. Taking Line 400 apart, a FOR-NEXT loop using variable X will create six individual drum beats as it steps through values 1 through 6. X in turn is multiplied by a constant, in this case 22, to create a gradually lengthening time delay value that will be used later. With every loop, program flow jumps to the drum beat subroutine in Line 800 then back to Line 400 due to the GOSUB 800 statement. Line 800 POKES VOICES 1 and 2 OFF, then triggers them ON with TRIANGLE and NOISE waveforms respectively. The program continues on to Line 810, which presents a FOR-NEXT delay loop that uses the value of DD as a delay length, allowing the VOICE 1 and 2 envelopes to run their courses. Finally, the RETURN statement at the end of LINE 810 sends program execution back to where it was when the subroutine was called (Line 400). If you look at the length of the envelopes as well as their frequencies and waveforms, you will discover that this snare drum is synthesized from a short, nearly unpitched strike sound as well as a longer noise rattle like that of a drum head. The same rules you would use to create a realistic sound on an analog synthesizer can be used in computer synthesis. Going back to Line 400, when program flow RETURNS from subroutine 800, the next statement encountered is NEXT X, which completes, then directs, program execution to the FOR X part. This increments X, calculates a longer DD, jumps to 800 and back, repeating the process a total of six times before going on to Line 410. Line 410 acts just like Line 400 to roll out another six beats. Line 420 acts the same way except that the delay multiplier is smaller, so shorter beats are produced in a faster tempo. Line 420 finishes

by POKING VOICES 1 and 2 OFF. Lines 430 through 460 work together to sound three quick beats of a downward droning oscillator "synth drum." Line 430 does a little setup work, making sure VOICE 3 is POKED OFF and that the LO and HI FREQUENCY register variables FL and F3 start out at 255 and 19. Line 440 starts the main FOR X repeat loop and POKES VOICE 3 OFF then ON with a TRIANGLE wave. Lines 450 and 460 contain two FOR-NEXT loops: an outside N loop that sequences HI FREQUENCY register values, and an inside NN loop that changes the LO FREQUENCY value of VOICE 3. You will find, if you follow the logic (or substitute PRINT statements for the POKe statements so that you can watch how the values change), that the LO starts at 255, then the HI gets a 19 (31-12=19), then the LO goes down from 255 to 0 in STEPS of -35, the NEXT NN ends and FOR N starts again, setting N to 13, etc., gradually sweeping the oscillator downward in fine increments and periodically adjusting the coarse frequency register for continuity. When the above is finished, Line 460 says go back to Line 440 (NEXT X) until all three synth drum beats have sounded, ending by POKING VOICE 3 OFF, waiting a while quietly (FOR D) and preparing for the finale, a cymbal crash, by turning VOICE 3 back on -- this time with a NOISE waveform. The rest of the program, up to Line 480, animates the cymbal. While NOISE and a long envelope DECAY come close to the crash of an open cymbal, I add a little more frequency processing to give the sound a more complex but subtle effect. Line 470 starts by presetting the jiffy clock to 74 (a value achieved by trial-and-error). Line 480 has a main FOR-NEXT loop that provides a low to high HI FREQUENCY register sweep (1 TO 33) of values that are POKED in after being added to a constant offset (31) and the current jiffy clock value, with the total sum ANDed with 255 to keep it in range. There is a short delay or holding period, provided by the FOR D loop, that gradually lengthens as N gets larger; when the N loop ends, VOICE 3 is turned OFF. Line 490 says GOTO to start the performance over again.

I'm sure that after hearing this program you will have all sorts of ideas for different drum sounds, and their pitch, envelope, filter (the next subject), real-time and external control (like

paddle or drum head sensor) programming. The variety of percussion sounds SID makes available, even with just BASIC programming is astounding. I have created many percussion programs, some like this one with a fixed sequence, some with paddle control and triggering, some that record, playback and edit realtime playing sequences by use of interfaced drum pad switches, as well as "programmed", enter/edit voice and rest stepped drum sequencers that have hundreds of steps (and hundreds of program lines), multi-voice selections and disk sequence storage and recall (like the commercial "drum boxes"). Although making the program "user-friendly" is always the toughest job in any type of general-use application program, I've found that trying to offer a wide range of different drum sounds that are adaptable and "user programmable" has been one of the most difficult SID music applications. Even a system of "presets only" has hundreds of voice choices and many implementation schemes. The next program illustrates my point by exploring the complications and benefits of the SID feature that we haven't touched yet: filtering.

```
0 REM PERCUSSION SEQUENCE V3 (C)1983 JAL SOFTWARE
200 AU=54272:F1=AU+1:F2=AU+8:F3=AU+15
210 T1=54276:T2=54283:T3=54290:AA=AU
212 P1=54297:P3=P1+1:B1=56321:BD=53280
215 FORI1=AU054300:POKEI1,0:NEXTI1:POKEAU+24,15
220 READAV:IFAV>1-THENPOKEAA,AV:AA=AA+1:GOTO220
229 REM FL FH PH PL W AD SR
230 DATA 000,011,000,000,000,005,000
235 DATA 000,071,000,000,000,009,000
240 DATA 000,000,000,000,000,011,000,-1
300 POKEDD+1,15:POKEBD,15
310 PRINT*(SC)(G1)PERCUSSION SEQUENCE V3 JAL
SOFTWARE*
320 FL=F3-1
400 FORX=1TO6:DD=22*X:GOSUB800:NEXTX
410 FORX=1TO6:DD=22*X:GOSUB900:NEXTX
420 FORX=1TO9:DD=20*X:GOSUB800:NEXTX:POKET1,
0:POKET2,0
430 POKET3,0:POKEFL,255:POKEF3,19
440 FORX=1TO3:POKET3,0:POKET3,17
450 FORN=12TO20:POKEFL,255:POKEF3,31-N:
FORNN=255TO0STEP-35:POKEFL,NN:NEXTNN
460 NEXTN,X:POKET3,0:FORD=1TO20:POKET3,129
470 POKEL62,74
480 FORN=1TO33:POKEF3,(31+N*PEEK(162))AND255:
FORD=OTON:NEXTD:NEXTN:POKET3,0
490 GOTO400
800 POKET1,0:POKET2,0:POKET1,17:POKET2,129
810 FORD=1TODD:NEXTD:RETURN
```

READY.

• • • • •

**Filtered Sounds: Clapper.** Of all the programs presented here, CLAPPER is definitely my favorite. Conceptually, it's a very simple effect: A short clap of NOISE run through a moving BANDPASS FILTER. What results, is a diversified galaxy of percussive energies that remind one of soft thumps, cycles or steady beats of handclaps, slaps, wood blocks or splashing water. Load INIT, the new DATA and program lines. Lines 300 and 310 bring forth a title; Line 320 a request for INPUT of a DECAY value DK that is checked to see IF it is in range. Lines 330 and 340 instruct the user to operate the paddles as speed and resonance controls. Lines 350 and 360 set up variable pointers to the FILTER FREQUENCY HI (FH), LO (FL) and RESONANCE (FR) SID registers as well as the instantaneous waveform amplitude value of OSCILLATOR 3 (be sure to type O3, not zero three). Lines 370 and 380 POKE the FILTER/VOLUME register with full volume, BANDPASS filter mode and VOICE 3 OFF (15+32+128); VOICE 3 ON with a TRIANGLE wave and DECAY to the selected value (DK). Line 400 is the start of the main loop. It POKES the filter RESONANCE register with the current value of paddle 3 (ANDED with 15 to keep it in range), multiplied by 16 to position the value in the upper part of the register with 15 filling the lower part (15 selects filtering for all voices). Line 410 POKES the LO FREQUENCY register of OSCILLATOR 3 with the value of paddle 3 and the FILTER LO FREQUENCY register with the current value of the waveform PEEKed from OSCILLATOR 3 (O3). Line 420 POKES the HI FREQUENCY register of VOICE 1 with the current output of the OSCILLATOR 3 waveform (now a little different than the sample taken in Line 410). Line 430 turns the NOISE VOICE 1 OFF, then ON for a quick CLAP. Line 440 now does a FOR-NEXT delay based on the realtime value of paddle 1 and sends execution back to Line 400 to start the process over again. With all of the realtime changes, this program has elements of frequency change, filter sweeps (this time based on OSCILLATOR 3's waveform) and user controlled delayed strike rates. As I said, simple program, but one with very interesting and complex results. Modifications for this one are wide open, but more sound voices and different filter modulations and modes are good for

starters.

```

0 REM CLAPPER V3 (C)1983 JAL SOFTWARE
200 AU=54272:F1=AU+1:F2=AU+8:F3=AU+15
210 T1=54276:T2=54283:T3=54290:AA=AU
212 P1=54297:P3=P1+1:B1=56321:BD=53280
215 FORI1=AU054300:POKEI1,0:NEXTI1:POKEAU+24,15
220 READAV:IFAV>1THENPOKEAA,AV:AA=AA+1:GOTO220
229 REM FL FH PL PH W AD SR
230 DATA 000,010,000,000,000,000,000
235 DATA 000,000,000,000,000,000,000
240 DATA 000,000,000,000,000,006,240,-1
300 POKEBD+1,15:POKEBD,15
310 PRINT*(SC)(G1)CLAPPER V3 JAL SOFTWARE*
320 INPUT*CLAP DECAY (0-15)*:DK:IFDK<0ORDK>
    15THEN310
330 PRINT*PRINT*PADDLES CONTROLS FILTER RESONANCE*
340 PRINT*PADDLE1 CONTROLS SPEED*
350 FM=AU+21:FL=FM+1:FR=FL+1:REM FILT H/L/RES
360 O3=AU+27:REM O3CS OUT
370 POKEAU+24,15+32+128:REM FULL VOL, BP FILT
380 POKET3,17:POKET1+1,DK
400 POKEFR,(PEEK(P3)AND15)*16+15
410 POKEFS-1,PEEK(P3):POKEFL,PEEK(O3)
420 POKEF1,PEEK(O3)
430 POKET1,0:POKET1,129
440 FORD=OTOPEEK(P1):NEXTD:GOTO400

```

READY.

• • • • •

**External Filter Sweep.** While CLAPPER was a fixed use of one filter mode, EXTERNAL FILTER SWEEP is a general use program for using all of the filter modes to sweep internal voices as well as external sounds such as guitar, voice, or synthesizer via the C-64's AUDIO INPUT. It is both easy to use and simple to modify for different kinds of sweeps, voices, etc. To create it, load INIT and the rest of the program, SAVE and RUN. Lines 300, 310, 320, 330 PRINT the title screen and a request for the filter resonance value (higher numbers = greater effect). Line 330 accepts the value (RS) IF it is in the proper range. Line 340 POKES the resonance value in its SID register. Lines 350 and 360 PRINT a filter mode menu and request the selection of one mode by its first letter. Lines 370 through 470 GET a character from the keyboard and IF one is present (370), check to see IF it is one of the valid filter mode selectors; otherwise it keeps checking Line 470. IF one of the mode selections is found, THEN variable FM is set to a value that sets that filter mode, and program flow Goes TO Line 425 where FM is POKEd in the proper register. In a similar manner, Lines 425 through 470 prompt, GET, check and POKE the

NOISE voice ON. This allows the user to observe the filter action without requiring an external sound source to be present (the POKE in Line 340 also set all internal voices to be filtered). When this has been done, Lines 500 through 550 PRINT some instructions about the use of the paddle controls and they stay on screen until the FOR-NEXT delay in Line 560 times out. Line 600 starts the main loop by PEEKing the current paddle values and storing them into variables PL and PS. Line 610 clears the video screen and PRINTs the current resonance value, filter mode, low range of the filter sweep value and the sweep STEPPing (increment) value, to keep the user informed. Line 700 goes through an ascending filter frequency sweep via the FOR-NEXT that takes I from PL (paddle set low range value) to 255 in STEPs of PS (the other paddle setting) and POKES it into SID FILTER LO FREQUENCY register (FQ). Line 710 clears the screen and PRINTs the current value of I, continues the loop and when it ends, GOs TO Line 600 to sample the paddles and run through the rest of the sweep again. Line 800 contains one modification I've found useful, adding an offset to the low range limit so that it never goes lower than 90, as it seems filter values below this are nearly subsonic and only produce a silent period as they are swept. There are many other possible modifications: realtime paddle control, different kinds of sweeps, graphic input for the resonance value, simpler menu selection code, presets, fixed point filtering, resonance sweeping etc., but EXTERNAL FILTER sweep should send you off to a good start and give you a useful SID filter tool.

```

0 REM EXTERNAL FILTER SWEEP V3 (C)1983 JAL SOFTWARE
200 AU=54272:F1=AU+1:F2=AU+8:F3=AU+15
210 T1=54276:T2=54283:T3=54290:AA=AU
212 P1=54297:P3=P1+1:B1=56321:BD=53280
215 FORI1=AU054300:POKEI1,0:NEXTI1:POKEAU+24,15
220 READAV:IFAV>1THENPOKEAA,AV:AA=AA+1:GOTO220
229 REM FL FH PL PH W AD SR
230 DATA 000,010,000,000,000,005,240
235 DATA 000,000,000,000,000,000,000
240 DATA 000,000,000,000,000,000,000,-1
300 POKEBD+1,15:POKEBD,15:FQ=AU+22
310 PRINT*(SC)(G1)EXTERNAL AUDIO FILTER SWEEP*:
    PRINT
320 PRINT*ENTER RESONANCE (0-15) AND PRESS RETURN*
330 INPUTRS:IFRS<0ORDRS>15THEN320

```



```

340 POKEAU+23,15+8*16:REM FILT123X/RES ONANCE
350 PRINT:PRINT"WHICH TYPE OF FILTER
      (TYPE 1ST LETTER)"
360 PRINT"LOPASS / HIPASS / BANDPASS / NOTCH"
370 GET#F6:IFFT#=""THEN370
380 IFFT#="L"THENFM=16:GOTO425
390 IFFT#="H"THENFM=64:GOTO425
400 IFFT#="B"THENFM=32:GOTO425
410 IFFT#="M"THENFM=80:GOTO425
420 GOTO370
425 PRINTF#6:POKEAU+24,15+128*FM
430 PRINT:PRINT"WANT NOISE? (YES OR NO)"
440 GET#Z9:IFNZ#=""THEN440
450 IFNZ#="Y"THENPOKET1,0:POKET1,129:GOTO500
460 IFNZ#="M"THEN500
470 GOTO440
500 PRINT"(SC)PLUG YOUR GUITAR INTO THE EXTERNAL"
530 PRINT"AUDIO INPUT (5 PIN DIN) CONNECTOR:"PRINT
540 PRINT"PADDLE1 SETS THE LOWEST SWEEP FREQUENCY"
550 PRINT"PADDLE3 CONTROLS THE SWEEP STEP VALUE"
560 FORI=0TO999:NEXT
600 PL=PEEK(P1):PS=PEEK(P3)+1
610 PRINT"(SC)(CD)RES";RS;"MODE ";FT#;" LOFREQ";
      PL;"STEP";PS
700 FORI=PLTO255STEP5:POKEFI,I
710 PRINT"(HM) ";PRINT"(HM)";I:NEXTI:GOTO600
800 REM FORI=PL+90TO255STEP5

```

READY.

• • • • •

```

0 REM SOUND TEST V3 (C)1983 JAL SOFTWARE
200 AU=54272:F1=AU+1:F2=AU+8:F3=AU+15
210 T1=54276:T2=54283:T3=54290:AA=AU
212 P1=54297:P3=P1+1:B1=56321:BD=53280
215 FORI=AUTO54300:POKEI1,0:NEXTI1:POKEAU+24,15
220 READAV:IFAV>1THENPOKEAA,AV:AA=AA+1:GOTO220
229 REM FL FH PL PH W AD SR
230 DATA 000,000,000,000,000,000,000
235 DATA 000,000,000,000,000,000,000
240 DATA 000,000,000,000,000,000,000,-1
300 POKEBD+1,15:POKEBD,15
310 DIM MV(3),MS(3)
320 PRINT"(SC)(G1)SOUND TEST V3 JAL SOFTWARE"
330 PRINT:PRINT"SET UP SOUND DATA THEN"
340 PRINT"PRESS SPACEBAR TO TRIGGER THE SOUND"
350 PRINT"OR:"PRINT"PRESS RETURN TO END"
360 PRINT"THEN USE SCREEN EDITING TO MAKE NEW"
370 PRINT"CHANGES AND RE-RUN"
380 RESTORE:FORI=1TO3
390 FORI=1TO7:READV:IFI1=STHENMV(I)=V
395 IFI1=7THENMS(I)=MV(I)+V*0
400 NEXT I,I
410 SF=(MS(1)+MS(2)+MS(3)<0)
500 GET#IN:IFIN#=""THEN500
510 IFIN#CHR$(13)THENPRINT"(SC)(CD)(CD)(CD)(CD)
      (CD)(CD)RUM":PRINT"(HM)";LIST229-240
515 POKET1,0:POKET2,0:POKET3,0
520 POKET1,MV(1):POKET2,MV(2):POKET3,MV(3)
525 IFNOT(SF)THENFORI=1TO500:NEXTI
530 POKET1,MS(1):POKET2,MS(2):POKET3,MS(3)
540 GOTO500

```

READY.

• • • • •

**Conclusion.** Well, that's the end of the "guided tour" but certainly not the end of what YOU can do with SID on the Commodore 64. None of the programs here are to be found in textbooks, although the fundamentals of the programming methods and sound synthesis application concepts are "text-book" cases. Most of the results are achieved through an understanding of the tools available -- mind, machine and logic. A logical design plan, coupled with consistent (modular) construction, can make any project go more smoothly. But then, take those nice, neat designs and EXPERIMENT with them. Usually, experimental sound computer programs have the same unsightly, haphazard structure as their "haywire" patchcord synthesizer counterparts. And in the same manner, few of those "really different" sounds come from fully pre-conceived designs -- many come from the cut-and-try, "I wonder what will happen if I run this signal through that black box and use it to modulate that other thing?" kind of development. Experiments involve unknowns. Sometimes they yield pleasant surprises; sometimes they blow up. There will be plenty of preset, shiny commercial software and hardware products available for plug-in solutions to the "popular sound." However, I feel that the resources of the SID/C-64 and YOUR UNIQUE MIND AND TALENTS present a challenge to go beyond the concepts and techniques of past artists. There is much to be explored here and some of the territory doesn't even have a name yet. With a tweak here and a subroutine there, it's entirely possible that the next "popular sound" might have your name on it. So don't just type in these programs and say that you are finished, because really, it's just the beginning. Try some of the options, try your own ideas, and don't be afraid to show them to your friends in order to incorporate their opinions and ideas. Use your EQ, delay and mixer to enhance the sound; fiber in that new optical controller; enhance your band's videotape with synchronized sound and computer graphics; conduct a computer concert; research a new psycho-acoustic effect or just replace your old doorbell with "modern digital technology", but whatever you do, let your inspiration run free.

If your computer hasn't had a magnetic meal lately or your typing finger seems to be the

least inspired part of your body, you can send \$20.00 in Money Order or Cashier's Check (Wisconsin Residents, please add \$1.00 for State Tax), for the postpaid magnetic disk of 15 programs and/or \$5.00 (WI + \$0.25) for an Audio Demo Tape (in case you want to hear the sounds and don't have the computer) to: JAL SOFTWARE, Box 128, S. Milwaukee, WI 53172. Otherwise, fire up the 64, start typing, and when your friends ask where you can get a sound effects box, guitar tuner, metronome, drum/handclap machine and guitar filter sweep effect for \$2.50, tell 'em you saw it in **Polyphony**!!



Also, I understand Reticon is no longer manufactures the SAD 4096 analog delay, but that they are introducing a new line of delay parts. Could you suggest a modification for the Chorus/Delay, a secret stash of 4096s, or at least more data on the SAD 4096 functions and pin diagrams.

Jeff Farris  
Long Beach, CA

Jeff -- Polymart offers two such books (see pages 42, 43), my "Electronic Projects for Musicians" and Barry Kein's "Electronic Music Circuits," as well as DEVICE (which ran a series on Electronic Music Circuit design). Also, many libraries have "The Musical Engineer's Handbook" by Bernie Hutchins; for more information on obtaining a copy you can try writing to: **Electronotes**, 1 Pheasant Lane, Ithaca, NY 14850.

Concerning the 4096, I hope to check out Reticon's new chips soon and, if possible, will redesign the Chorus/Delay and Hyper-flange+Chorus to use the new parts. A few distributors still have 4096s left, but you might as well go with the newer part. Regarding functions, write to Reticon (345 Potrero, Sunnyvale, CA 94086) for data on the 4096.

# THE JOYSTICK REVISITED

by: Stefan Hawk

I've always considered the joystick as being particularly useful for electronic music, but sometimes it's hard to find the right circuit for a particular application. This article gives some suggested circuits using a quad joystick that take good advantage of the joystick's potential. Note that all these circuits are DC coupled so that you can process audio signals, control voltage, modulation signals, or bias voltages with equal ease.

Figure 1 shows one quarter of a Quad Panner/Fader. The input jack is a closed-circuit, switching type (such as the Switchcraft 42a "mini" jack or 112a "1/4" jack) which, with nothing plugged into the input, connects to either a + or - bias voltage source. Combining four of these stages together and distributing an audio signal to the four inputs will provide 4-channel panning; if nothing is plugged into the inputs, then this circuit provides four variable bias sources. You could also use a combination of audio and bias sources for unusual applications. Depending on your application the 100k trimpots set

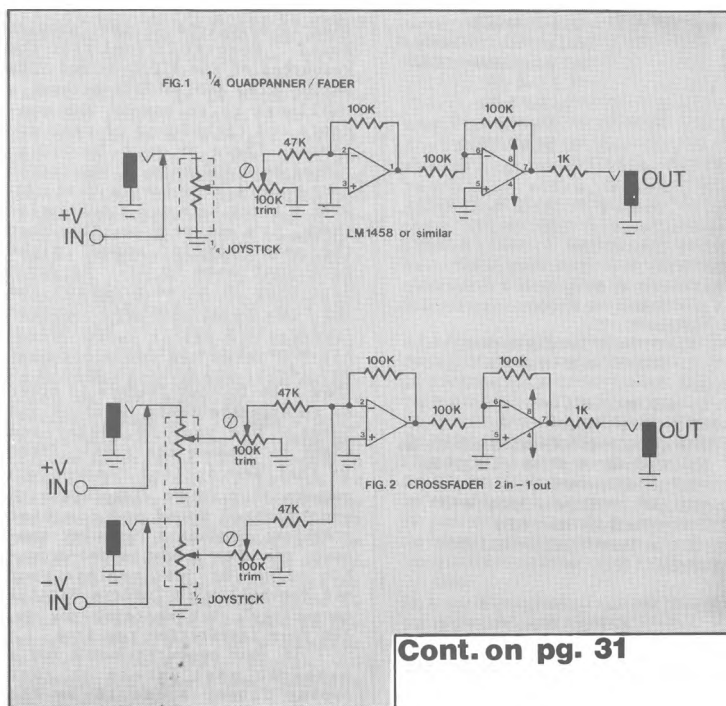

Cont. on pg. 31

# ANALOG DELAY CLOCK MODULATION REVISITED

by: James F. McConkey

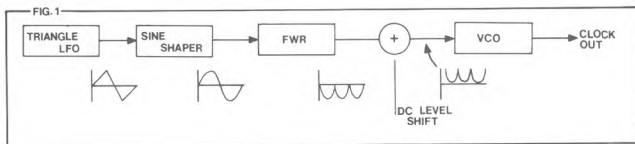

In the March/April 1982 issue of *Polyphony*, Jacques Boileau presented an interesting alternative to the standard triangle type sweep circuitry for flangers and choruses. Figure 1 shows the block diagram for his basic idea; a standard LFO generates a triangle wave, which is converted to a sine wave and then full wave rectified. The rectified sine wave is level-shifted and used to modulate a voltage-controlled clock.

The idea behind all this is to make a more natural sounding sweep. Since the ear is logarithmic, a flanger controlled by a normal triangle wave seems to spend most of its time at the high end of the flanging range. For a uniform sweep, we require a log sweep (preferably a log-sine sweep). Jacques found that a full wave rectified sine wave is almost the same as the log of a sine wave, hence the system described above.

However, there is a much easier way to create this sweep waveform. Figure 2 shows Jacques' sine converter; note that by re-

moving one of the diodes, only one side of the triangle is rounded off (see Figure 3). The resulting waveform is very close to the desired log-sine sweep. Using this trick allows us to eliminate

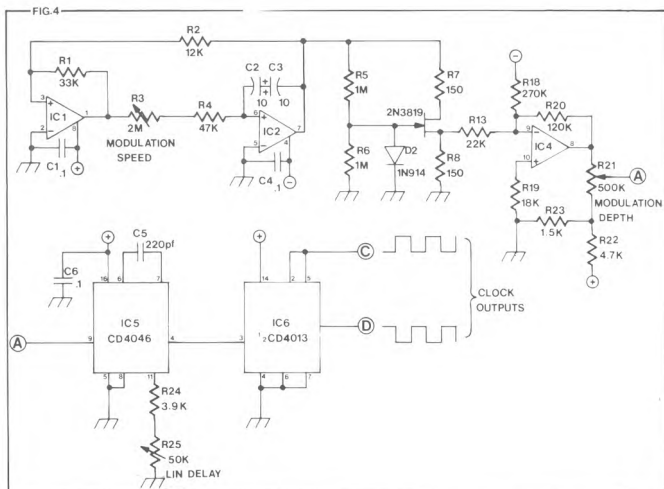
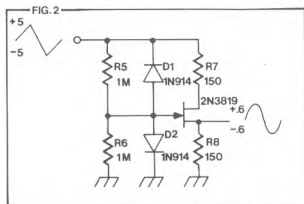
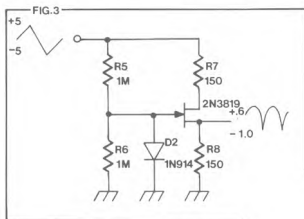

the full wave rectifier and also eliminates the need for any trimming.

Figure 4 shows the adaptation of Jacques' circuit. I have purposely kept the circuit as close to that of the original as possible. The full wave rectifier has been eliminated along with D1. R13, R8 and R19 have also been changed.

Since the new circuit requires no calibration, just build it and use it. There is one word of caution, though; if your modified sine converted puts out a hotter signal than mine, you may have to increase R13 slightly to prevent IC4's output from running into the positive supply.

Also note that this circuit has more potential than just being a flanger sweeper. By eliminating IC5 and IC6, and making the appropriate changes in IC4's gain and offset, this circuit can be used to provide a more natural sounding sweep for phase shifters. I would also imagine that the modified sine converter might also make an interesting amplitude-sensitive timbre modulator, although this has not yet been tried. I hope readers will find this trick useful, and I would be very interested in hearing from anyone who has tried this as a timbre modulator or has found any other novel uses for it.

# DATA BANK

b/w - Backed With

DAC - Digital-to-Analog-Converter

DPDT -- Double-Pole-Double-Throw switch

**International parts specification standard:** This standard avoids the unnecessary repetition of zeroes, decimal points, and stating ohms or Farads where it is implicitly understood. It is widely accepted in the international community and Polyphony would like to bring it home. Following are some examples.

USA Int'l

1k	1k
1.5k	1k5
2.2M	2M2
1uF	1u
0.01uF	10n
3300pF	3n3
0.0022uF	2n2

where

- k =  $10^3$  Ohms
- M =  $10^6$  Ohms
- n =  $10^{-6}$  Farads
- u =  $10^{-9}$  Farads
- p =  $10^{-12}$  Farads

**Hexidecimal numbers** - are numbers specified in base 16 where A is the character representing 10, B=11, C=12, D=13, E=14 and F=15 and 16 in decimal equals 10 in hex. To convert from hexidecimal to decimal apply this formula:  $H_n$ . For example, A92B in hex equals  $(10 \times 16^3 + 9 \times 16^2 + 2 \times 16^1 + 11 \times 16^0) = 43307$  in decimal. To convert from hex to binary simply turn each hex digit into a four digit binary word. For example, F(16)=1111(2), C(16)=1100(2) and 3(16)=0101(2). Therefore, FC3(16)=1111 1110 0101(2).

Molex Connector

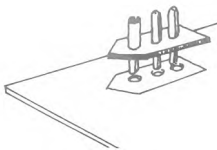

**negative phasing** - the phasing sound obtained by subtracting the phase shifted signal from the straight signal (any feedback is out-of-phase).

**non-polarized capacitor** -- electrolytic capacitors, like batteries, are polarized with one end positive and the other negative. Polarity must be observed for a circuit to work properly, however, you can create a non-polarized electrolytic by connecting two electrolytics in series, with the negative ends connected together. Connecting two capacitors in series halves the capacitance, so use capacitor values twice as large as what's called for (i.e. for a 1 uF NP capacitor, connect the negative terminals of two 2 uF capacitors together). The positive leads become the two leads for the non-polarized capacitor).

p-p - peak to peak.

**positive phasing** - the phasing sound obtained by adding the phase shifted signal with the straight signal (any feedback is in-phase).

**S-trigger gates** - signals resulting from switch closures rather than logic level changes.

SPDT - Single-Pole-Single-Throw switch

VCO - Voltage Controlled Oscillator

VDU - Video Display Unit.

WVDC - Working Volts DC

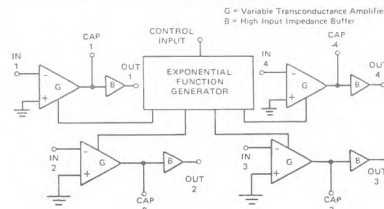

SSM2040 Block Diagram

PIN NAME	DESCRIPTION	TYPE
R/W	Read/Write control	output
IRQ	Interrupt request	input
NMINT	Non-maskable interrupt	input
RESET	Reset	input
DD	CPU clock	input
D1, D2	System clocks	output
DB0-DB7	Data Bus	Tristate, Bidirection
AB0-AB5	Address Bus	output
RDY	Single Cycle control	input
SO	Set Overflow flag	input
SYNC	Identify op code fetch cycle	output
V <sub>CC</sub>	Power	
V <sub>SS</sub>	Ground	

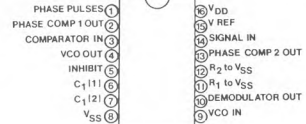

CD4046

COS/MOS Micropower Phase-Locked Loop

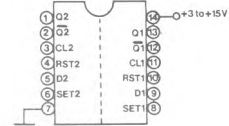

CD4013

Dual 'D'-Type Flip-Flop

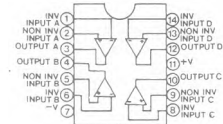

RC4136

Quad 741 High-Gain Op-Amps

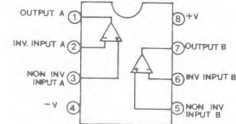

LM1458 Dual Op-Amp

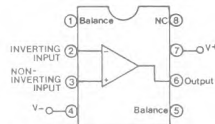

LM356 (commercial grade) Series Monolithic JFET-Input Op-Amps

LM741 Op-Amp

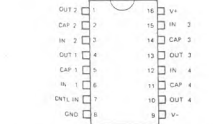

SSM2040

Voltage Controlled Filter

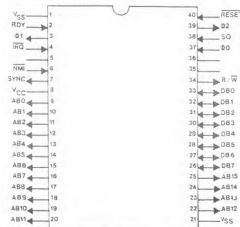

6502 8-bit Microprocessor

CONT. PG.31



## LINEARS

TL061.....BiFet .....	.72
TL062.....Dual BiFet .....	.99
TL064.....Quad BiFet.....	1.95
TL071.....BiFet .....	.65
TL072.....Dual BiFet.....	1.15
TL074.....Quad BiFet.....	1.95
NE555.....Timer .....	.39
NE570.....Compander .....	3.80
NE571.....Compander .....	2.95
NE572.....Compander .....	4.95
UA741.....Comp. OpAmp .....	.29
MC1456.....Low Noise OpAmp .....	.90
RC1556.....Low Noise OpAmp .....	1.48
CA3080.....OTA .....	.94
CA3280.....Dual OTA .....	1.98
RC4136.....Quad OpAmp.....	1.10
RC4739.....Dual Low Noise .....	1.19
NE5532.....Dual High Perf .....	3.70
NE5534.....High Performance .....	2.65

## SPECIAL PURPOSE

SAD-1024.....Analog Delay .....	17.50
SAD-4096.....Analog Delay .....	37.50
MK50240.....Top Octave Div .....	5.95
SN76477.....Sound Generator .....	3.45

## SANYO HYBRID POWER AMPS

STK050.....50 Watt Power Amp .....	19.40
STK070.....70 Watt Power Amp .....	24.20

## SSM- SOLID STATE MICRO-TECHNOLOGY

SSM 2010.....VCA .....	7.50
SSM 2011.....PreAmp .....	5.75
SSM 2012.....VCA .....	9.50
SSM 2020.....VCA .....	7.50
SSM 2022.....VCA .....	7.50
SSM 2030.....VCO .....	7.50
SSM 2033.....VCO .....	10.00
SSM 2040.....VCF .....	7.50
SSM 2044.....VCF .....	7.50
SSM 2050.....VCTG .....	7.50
SSM 2056.....VCTG .....	5.75

## THERMISTER (Temp. Sensing Resistor)

TSR-Q81.....Tel Labs Q81 1k .....	\$3.50
-----------------------------------	--------

## OPTO-SOLATOR

CLM6000.....Clairess CLM6000 .....	\$2.85
------------------------------------	--------

## CAPACITORS (25 volt)

701-100.....100 pf polystyrene .....	.25
701-180.....180 pf polystyrene .....	.25
701-1000.....1000 pf polystyrene .....	.25
701-2200.....2200 pf polystyrene .....	.25
701-2200.....3300 pf polystyrene .....	.25
701-3900.....3900 pf polystyrene .....	.25
702-005......005 uf mylar .....	.12
702-01......01 uf mylar .....	.12
702-05......05 uf mylar .....	.16
702-1......1 uf mylar .....	.21
702-22......22 uf mylar .....	.33
703-1.0.....1.0 uf tantalum .....	.39
703-3.3.....3.3 uf tantalum .....	.49
703-4.7.....4.7 uf tantalum .....	.59
704-2.2.....2.2 uf electrolytic .....	.21
704-4.7.....4.7 uf electrolytic .....	.21
704-10.....10 uf electrolytic .....	.21
704-100.....100 uf electrolytic .....	.31
705-10.....10 pf ceramic disk .....	.15
705-01......01 uf ceramic disk .....	.12
705-1......1 uf ceramic disk .....	.17

## IC SOCKETS (soldertail)

IC-S-08.....8 pin high quality socket .....	.27
IC-S-14.....14 pin high quality socket .....	.30
IC-S-16.....16 pin high quality socket .....	.34
IC-S-18.....18 pin high quality socket .....	.40
IC-S-28.....28 pin high quality socket .....	.60
IC-C-08.....8 pin economy socket .....	.13
IC-C-14.....14 pin economy socket .....	.15
IC-C-16.....16 pin economy socket .....	.17
IC-C-18.....18 pin economy socket .....	.20
IC-C-28.....28 pin economy socket .....	.40

## RESISTORS 5%, 1/4 watt

All EIA values available from 2.0 ohm to 5.1 Meg.  
Also available is 10 Meg.

100 each of same value .....	\$1.50
50 each of same value .....	.98
25 each of same value .....	.75
10 each of same value .....	.40
5 each of same value .....	.25

## ASSORTMENTS

10 each of 10 values (100) .....	3.00
25 each of 10 values (250) .....	6.50
50 each of 20 values (1000) .....	16.00

## CHORUS/DELAY KIT

This chorus/delay unit, designed by Craig Arderton and featured in *Guitar Player* magazine, provides flanging, slapback echo, and automatic double tracking effects. The delay range is from 2 ms to 80 ms. Due to the use of compression and expansion techniques, the unit has dead-quiet operation up to about 50 ms and only minimal noise out the full 80 ms. This project kit consists of all electronics, pots, jacks, etc. Also included are the two circuit boards (etched, drilled, and legended) needed for the project. Not included is wire, solder, case, knobs, etc. The Chorus/Delay unit also needs a well regulated bi-polar 15 volt power supply (not included). (A punched and legended rack mount panel will soon be available for this project.)

Order KT-CD777..... \$78.00

## "SNARE +" DRUM VOICE KIT

This percussion synthesizer was designed by Thomas Henry and appeared in *POLYPHONY* magazine. Here's what Craig Arderton had to say about the "SNARE +". "At last - an inexpensive drum voice that has a punchy, full sound. ....All in all, the Snare + delivers a lot of drum sounds, and I would unhesitatingly recommend it to anybody who's tired of the thin sound found in most electronic drum units."

We offer the kit with or without a panel. Kit 3770 contains all electronic parts, switches, jacks, pots, etc, as well as etched, drilled, and legended circuit board. Kit 3772 includes all this plus a punched and legended rack mount panel (standard 1/4 by 19 inches) available in black or blue (both with white legends).

Not included with either kit is wire, solder, mounting hardware, etc. The SNARE + also needs a bi-polar 15 volt power supply (not supplied).

Kit 3770 Basic SNARE + kit..... \$33.95  
Kit 3772 SNARE + with rack panel... \$44.94

## THE "CLARIFIER" GUITAR EQ/PREAMP

The "CLARIFIER" is an onboard preamp/EQ module for guitar. This design, by Craig Arderton, was first seen in the pages of *GUITAR PLAYER* magazine. Here's what the CLARIFIER will do: Replace the guitar's standard passive tone control with a two control, active circuit which provides over 12 db of bass and treble boost and up to 6 db cut. Buffer your pickups from external loading, giving additional output and improve high freq response. Add a nominal 6 db of gain to give your signal a bit more punch, as well as improve the signal/noise ratio in multiple effects systems... make your guitar immune to the high freq loss caused by long cable runs.

The CLARIFIER kit is available in two options, both of which include a high quality drilled, legended, and masked circuit board, as well as complete step by step instructions. Kit 2450 contains everything needed for a complete unit. Kit 2455 contains everything except the pots (for those who prefer a particular brand of potentiometer). Batteries are not included with either kit.

Kit 2450.....Complete CLARIFIER kit, \$18.95  
Kit 2455.....CLARIFIER less controls, \$14.95

**TERMS: (Check Money Order, Cashiers Check - Add .75 if under \$10.00) - (\$10.00 minimum on C.O.D. (UPS only) add \$1.50) - (Mastercard and Visa: \$10.00 minimum. You must supply exp. date.) - (Indiana residents add sales tax.)**

**SHIPPING AND HANDLING: \$1.00 plus 5% of purchase. We will credit any amount over our standard rate.**

**SAISFACTION GUARANTEED!**

## SIGNAL DIODE

601-60.....1N914 (1N4148) signal diode. 5/35

## TRANSISTORS

2N3904.....2N3904 NPN Transistor .....	.25
2N3906.....2N2906 PNP Transistor .....	.25

## POTENTIOMETERS

(3/8 long shaft, 5/16 mounting hole)

854-401.....10K Linear taper .....	1.09
854-501.....100K Linear taper .....	1.09
854-505.....500K Linear taper .....	1.09
855-401.....10K Audio taper .....	1.09
855-501.....100K Audio taper .....	1.09
855-505.....500K Audio taper .....	1.09
856-401.....10K Audio taper with on/off switch.....	1.25

## TRIM POTS (vertical mount)

802-251......250 ohm trimmer .....	.40
802-103.....10K trimmer .....	.40

## MINI TOGGLE SWITCHES

403-20.....SPDT (on/on) sub-mini (3A).....	1.20
403-40.....DPDT (on/on) sub-mini (3A).....	1.50
405-10.....SPST (on/off) bat handle (6A).....	1.85

## LED's

Please note that the typical DC forward current (I<sub>fw</sub>) of these LED's is less than those offered elsewhere making these LED's ideal for battery circuits or others where current consumption is a factor.

305-201.....Red T-1 1/4 jumbo diffused (20 ma) .....	.30
305-202.....Green T-1 1/4 jumbo diffused (30 ma) .....	.40
305-203.....Dual T-1 1/4 jumbo diffused (50 ma) .....	.90
305-204.....Tri T-1 1/4 jumbo diffused (20 ma).....	1.50

Note: 305-204 is a three lead, tri-color (green, red, yellow) device. It is essentially two separate LED's in one package. (The yellow is obtained by turning on both green and yellow.)

## JACKS and PLUGS

1/4 in. PHONE JACKS

901-101.....Mono standard phone jack .....	.45
901-103.....Mono with n/closed contact .....	.52
901-105.....Mono encl. jack (open back).....	.55
902-211.....Stereo standard phone jack .....	.70
902-213.....Stereo encl. jack (open back) .....	.77

1/8 in. MINI JACKS

903-351.....Mono with n/closed contact .....	.32
903-353.....Mono encl. (open back) .....	.36
903-355.....Mono enclosed with contact .....	.35

RCA JACKS

921-100.....RCA jack, chassis mount .....	.34
921-200.....RCA jack on phenolic mount .....	.25
921-300.....Dual RCA on phenolic mount .....	.43

1/4 in. PHONE PLUGS

911-201.....Mono, black phone plug .....	.48
911-203.....Mono, red phone plug .....	.48
911-205.....Mono, chrome (metal) plug .....	1.20
911-211.....Stereo, black phone plug .....	.65

1/8 in. MINI PLUGS

913-251.....Mono, black mini plug .....	.38
913-253.....Mono, red mini plug .....	.38
913-255.....Mono, chrome (metal) plug .....	.56

**SWITCHING JACKS**  
These are stereo phone jacks that contain an independent switching system that is controlled by the insertion of the plug. Jack 905-301 contains the equivalent of a DPST normally on switch. Jack 905-302 contains the equivalent of a DPDT on/on switch making it ideal for switching bi-polar power supplies on and off in effects boxes, etc.  
905-301.....Stereo jack with SPST switch ..... .90 || 905-302.....Stereo jack with DPDT sw. .... | 1.00 |

## PGS ELECTRONICS

Route 25 - Box 304  
Terre Haute, IN 47802

# MORE PICKUP SWITCHING TRICKS

by: CHRIS MEYER

In addition to being a synthesist, I also like to modify (and naturally, play) older bass guitars. As a result I spend a good deal of time dreaming up new ways to rewire the insides of guitars. One of my main trademarks is a disdain for tone controls; I would rather mix the volume and phases of multiple pickups. And as you may have guessed by now, that's what this article is all about.

One recent rebuilding project involved a 1966 Gibson EB-3 electric bass, which has 2 pickups and one of the worst tone selector switches I have heard. It was obvious that the old electronics would have to go. One pickup switching scheme I wanted to try had been described by Steve Morrison in the Jan/Feb 1981 issue of *Polyphony* (see Figure 1). To summarize his article, with switch #1 in the "A" position, switch #2 decides if the pickups are in-phase or out-of-phase with each other. With switch #1 in the "B" position, switch #2 sends one or the other pickup's signal (but not both) to the output.

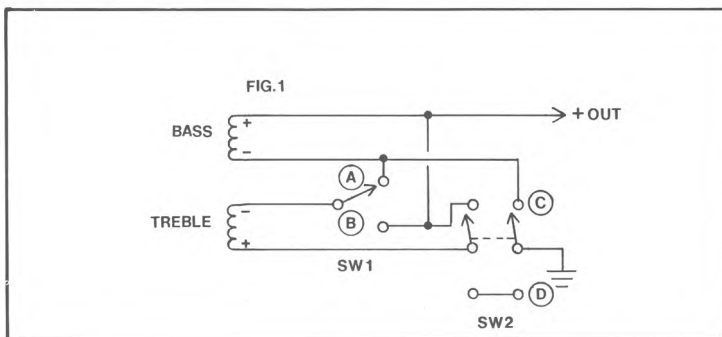

This nifty little circuit works fine, but there are some limitations. With switch #1 in the "B" position, the treble pickup is always out of phase. This may not cause a problem with modern pickups where the negative lead and shield are separated, but with old pickups where the shield is negative, it's Hum City. It quickly became apparent that this scheme would not work with the EB-3.

After shopping around for awhile, I decided to replace the neck (bass) pickup with a DiMarzio

Model-One. This is a dual (four-wire) pickup, which therefore gives full phase switching capabilities without any hum or shielding problems. After consulting DiMarzio's sheet of recommended wirings, I decided on the circuit shown in Figure 2. With this circuit, setting switch #1 to "A" wires the dual coils in series (for more output), with switch #2 deciding their phase relative to the treble pickup. With switch #1 in position "B", switch #2 decides which coil gets sent to the output.

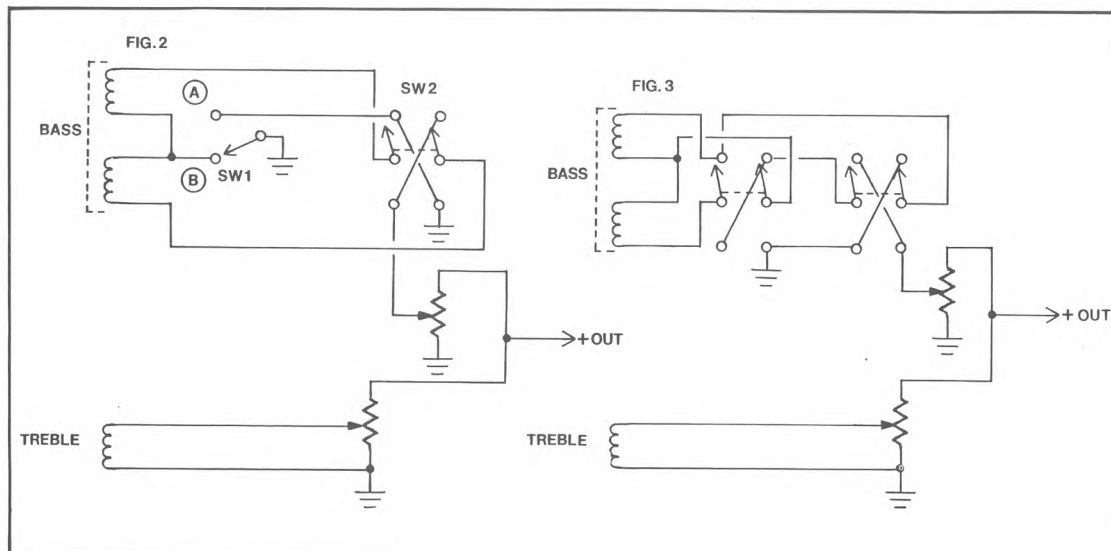

This may seem similar to a three-pickup version of Steve's circuit, but look at Figure 2 again. Note that in the single coil mode, the top pickup is in-phase with respect to the treble pickup, but the lower pickup is out-of-phase. Actual playing confirms this quite quickly. The circuit basically works okay, but gave me two in-phase sounds and two out-of-phase sounds for the four switch positions. Since I tend to prefer in-phase sounds, it was back to the drawing boards.

I then realized that I couldn't keep the coils in series in the dual mode, and in-phase in the single mode, with only the two DPDT switches already mounted on my bass. However, if I was willing to put the two coils in parallel in the dual mode, I could get away with it. Figure 3 shows the results.

I now had a set of satisfying, useful sounds underneath my fingers. But, after experimenting with different volume mixes, I ran across another problem: Due to the different impedances of the different pickups, my volume controls now possessed anything but smooth response (the treble volume was practically an on-off switch). At ten bucks a throw for precision sealed pots, I was not about to go out and experiment with different values so I developed the alternate wiring scheme shown in Figure 4. The added resistor reduces the effective resistance between the pickup and output, while maintain-

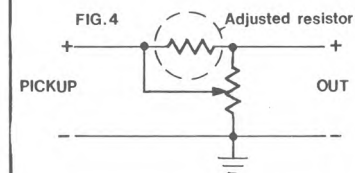

ing the same resistance to ground. After some experimenting with different value resistors, I settled on a 220K resistor for the treble control and a 330K resistor for the bass control (both controls are 500K). I now have a much smoother fadeout, custom tailored to the sound I wanted.

There was joy in Mudville for some time, until Al Peterson's letter appeared in the April 1983 issue of *Polyphony*. Figure 5 shows the essence of what Al suggests. With the control at full "minimum", the pickup is mixed in at full volume, out of phase. If the pot is set half-way, the pickup is essentially "off". At full "maximum", the pickup is mixed in at full volume, in phase. What this means is that you need only one volume control per pickup for full volume and phase mixing -- a

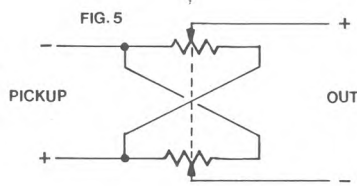

literally fantastic idea. This idea applies to synthesizers as well as guitars; imagine what a neat little VCO output mixer this would make. Only two caveats: One, use linear pots (the center "off" position will be in a strange place with exponential pots), and two, you may still run into pickup shielding problems. If you run into problems, and don't mind including a little active electronics, add Dennis Bohn's unbalanced-to-balanced circuit that appears in the July/August 1981 issue of *Polyphony*.

Well, after all this, I should be satisfied with the sound of my bass for at least a little while. And remember -- guitar wiring is half magic, but with a little common sense and electrical know-how, you can become a magician, too.

# THE K.I.S.S. MODULE, A SUPER USEFUL and VERSATILE ADDITION to YOUR SYSTEM

BY: CHARLES J. LAURIA

When I was about 9 or 10 years old, I used to go for accordion lessons every week. Then, as now, I could never leave well enough alone. If my teacher would give me a song to learn, I would quickly learn it and become bored. As a result, I would sometimes add fuller chords or fancier finger-work here and there to keep my interest up until the next lesson. And each week, upon hearing my "improvements", my teacher would shake his head in amazement and say "Why do you have to make such a simple song so complicated?" and he would then write K-I-S-S in bold letters at the top of the page. It was an anagram for a few words of advice: "Keep It Simple, Stupid!" Now I am almost 15 years older (and wiser?) and I am beginning to believe that sometimes simple really is better.

It is in that spirit that I created this module. It doesn't do anything fancy or amazing, but what it **does** do is so useful in many ways. It is so obvious an idea that many of you will wonder why you never thought of it yourselves; and undoubtedly, there are many others who have thought of it already.

The KISS module is simply a level controller (see Figure 1 and

Figure 2) which allows the output of any module to be attenuated via front panel controls or other external controllers. There certainly is nothing new about attenuators, but you can never have too many of these little gadgets, especially in building a complex sound. For example, PAIA's 2720-5 synthesizer module has two output jacks but only one of them is variable. For some applications, this is okay because the fixed output might be put to use in some less critical job like triggering an ADSR, while the variable output is still available for VCO modulation or other precise applications. But there were many times

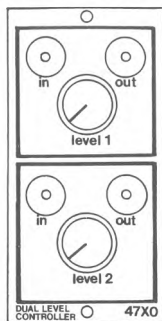

Fig.1 Suggested for front panel layout/graphics.

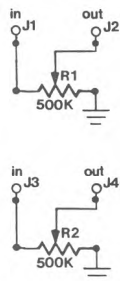

Fig.2 Schematic for "level module" in it's simplest configuration.

when I needed a second variable output to use for subtle filter sweeps or secondary VCOs. The same situation has occurred with the 2720-4 and the 4740 modules. The Dual Level Controller is also an invaluable add-on for modules that have no provision for output attenuation (such as the 2720-11 Envelope Follower or 2720-12 Inverter).

In addition to the basic "Level Controller" module, I've come up with the really nifty modification shown in Figure 3.

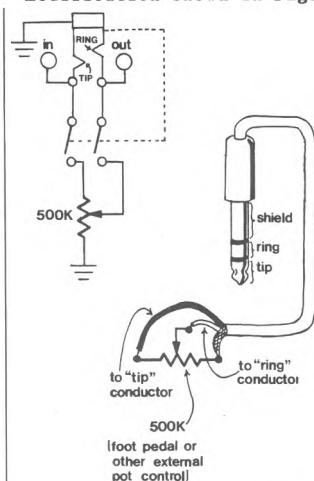

Fig.3 Schematic for adding an "External Level Control" jack to this module or any other C.V. source such as the 2720-5.

(I still can't leave well enough alone!). This modification allows an external controller to be plugged in to any existing level control circuit, which substitutes for the front panel pot as the new controller is inserted into a jack. For this project, I used a 3-conductor headphone jack which

(cont. pg.31)



(continued) K.I.S.S.

has two electrically independent SPST, normally closed switches attached to it (available from PGS Electronics, among other sources). The switches open when a 3-conductor 1/4" phone plug is fully inserted into the jack.

The front panel pot is connected in series with the switches so that when no plug is inserted, the switches are closed and the original front panel pot is operational. But when a 3-conductor phone plug is inserted, the switches open, isolating the front panel pot from the in/out jacks of the module. The tip and ring conductors of the jack are permanently connected to the in/out jacks so that with the plug inserted, its three conductors become the three connections to an external pot (which can be anything from a foot pedal to a joystick).

The "External Controller" jack may be mounted on the front panel or anywhere else on the synthesizer case. If you mount it on something other than the front panel, use shielded cable to prevent hum and static from getting into any CV (control voltage) inputs. Mounting the jack on the rear or side of the cabinet has the added advantage of keeping things neat (the last thing anyone needs is another cord stretching across the front panel controls!). Be sure to use shielded cable for the connection between the 3-conductor plug and the new external controller.

One more suggestion before I finish up: The pin jacks used in my module design could have just as easily been miniature phone jacks for the attenuation of an audio signal. This could provide such goodies as pedal control of volume or joystick control of waveform mixing when the "External Controller" jack is installed. A little imagination goes a long way with this module; it lends itself to myriad applications and is also easy to expand and modify. So you see sometimes simple is better ...my accordion teacher would be so proud of me!

### JOYSTICK cont.

the audio gain, or the amount of bias voltage, available at each output.

Figure 2 shows a crossfader for panning two bias voltages or audio inputs to a single output. By connecting one switching jack to a + bias voltage and the other to a - bias voltage, you can pan between positive and negative voltages at the output. This circuit does not use all four joystick sections; the remaining sections could perhaps be put to some other use.

Figure 3 shows a 4-in-1-out panner which allows you to select any blend of four input signals. Try connecting up four different modulation waveforms at the inputs, sending the output to a VCO, and panning between the various modulation sources for some very interesting effects.

The power supply voltage is not particularly critical, however, for best results use a regulated power supply in the +9 to +15V range. Be sure to bypass the supply with a couple of capacitors as shown in Figure 4. Virtually any op amps will work for this application; I've used LM1458s because they're small and cheap, but if you expect to do a lot of audio processing, you might want to choose a lower noise op amp (LF351, RC4136, etc.).

## DATA BANK

(continued from page 26)

- LM - National Semiconductor
- SSM - Solid State Micro Technology
- TL - Texas Instruments (Linear)

Note on chip numbers: many chips of the same number are available from different manufacturers. The lettered prefix identifies the manufacturer.

Note on IC substitution: some chips of similar operation but slightly different characteristics and specifications may be substituted for each other. Refer to the manufacturers' data-books for more info.

Joysticks can be very useful for more than just video games -- try out one of these circuits and you'll see what I mean.

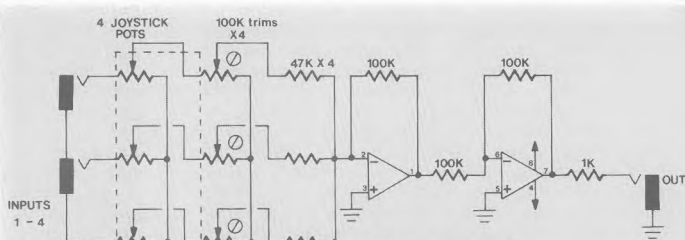

FIG.3 4 in - 1 out PANNER

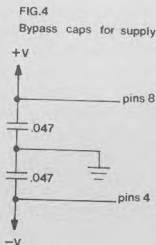

FIG.4 Bypass caps for supply

# ON LOCATION:

## PAT METHENY SYNCLAVIER II CLINIC, GEORGIA

**By: Alan Campbell**

New England Digital recently sponsored a series of Synclavier II "clinics", presented by jazz guitarist Pat Metheny, as announced by full page ads in Keyboard and other magazines. Given the choice of artist, N.E.D. clearly wanted to show off the Synclavier Digital Guitar Option as well as promote sales, but was there something else in the works? I arranged to cover the June 8th clinic in Atlanta for Polyphony, and received a press kit containing an announcement of a "new instrument". Needless to say, my interest was piqued.

The clinic was held in the recital hall on the campus of Georgia State University, in downtown Atlanta. At the site we were met by Lisa Holding of Songbird Studios (regional sales reps for New England Digital and organizers of the clinic). We were early, yet there were already people waiting to get in.

Prior to the presentation I had a chance to view the equipment on stage: the Synclavier's mini-computer was in left-center stage, with two Winchester hard disks and a minifloppy drive on top, all in blue Anvil ATA cases. At right-center stage was a rack of standard audio processing gear -- mixers, EQ, and the like, also in an Anvil case. The Synclavier II itself was on the left of the computer and the Terminal Support Option was on a stand to the right of the audio rack. Behind and to the left of the Synclavier II was a large projection screen displaying the information currently on the terminal. A Roland GR series guitar was up front, cabled to its interface. On each end of the stage was some modest P.A. gear.

Metheny opened the clinic with a four-and-a-half minute Synclavier/guitar solo, using brass-like multiple timbres, microtonal scales, and altered tunings. It was progressive. From the facial expressions of the audience, I wasn't the only one wondering if what we were hearing was avant-garde jazz or performance limitations of the system. Boy, were we in for a surprise.

Pat went directly from his solo to an overview of the Synclavier's main functions. But, as Metheny is not a technologist or professional lecturer, the clinic did not become really exciting until he in-

terrupted his talk to demonstrate how he uses the instrument. He called up a modified, sampled brass sound from disk and just played; the results were very impressive.

The GR series guitar works extremely well with the Synclavier II. The pitch-tracking and trigger derivation are excellent. The pitch-tracking can work in a quantized mode or not, and in non-quantized mode audibly resolves pitch to within a few cents of its nominal value, with reasonably fast settling time. The non-quantized mode is used to compositional advantage by Metheny, as in his radical Synclavier/guitar solo. Alternately, the quantized mode avoids unintended inflections of pitch, and might be preferred for controlling imitative timbres via the guitar. To cop a good brass, woodwind, vibes, etc. line on the guitar, the technique and fingerings are difficult enough without the added considerations of mis-fretting, slight detuning, or unintentional bending.

There is also a velocity-sensing mode that controls peak envelope amplitudes by how hard you pluck the strings. However, when the velocity-sensing mode is in use, there is an audible "thump" at the beginning of each envelope. This could be a "pluck artifact" due to the envelope detection scheme employed, or a transient generated by the attendant amplitude modulation. In any case the effect is not as pronounced as, say, an analog VCA with a DC balance problem, and the musicality of the velocity-sensing mode more than outweighs this apparent drawback of the design.

The Synclavier can assign different timbres and different scales to each string of the guitar. Metheny used both of these effects in his solo; one string was responding with a scale that increased about a minor third per fret -- wild.

The Synclavier can latch and hold pitches played on the guitar, so that the guitarist can readily play timbres that have long decay times or sustained amplitude envelopes. It was incredible to hear a skilled guitarist play accurately and musically with brass, vibes, organ, even piano timbres. Applying guitar technique to an alternate imitative timbre, such as a sampled piano sound, could inspire

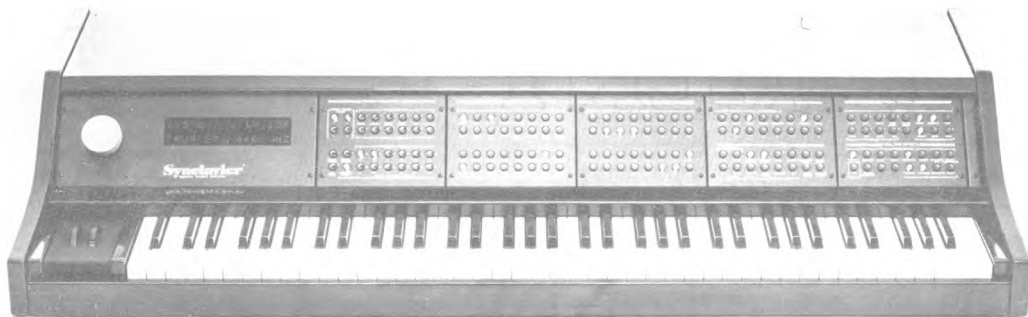

entirely new types of technique and composition for the original instrument. The musical implications are considerable.

Metheny demonstrated a number of sampled sounds, and some sampled sounds that had been modified in software, using the polyphonic Sample to Disk Option. As a sampling system, the sound quality of the Synclavier really rivals that of its nearest competitor, the Fairlight CMI; and you can control all this from the guitar. It should be emphasized that imitative timbres, either ensemble or solo voices, don't necessarily suffer any significant loss of authenticity or musicality when controlled by the Guitar Interface.

Of course, the Synclavier is also a powerful digital synthesizer. Partial timbre manipulation and FM synthesis techniques were demonstrated, in addition to additive synthesis with real-time parameter control, although the Synclavier's control of phase and inharmonicity of overtones is still exceeded by the now out-of-production General Development System, from MTL. However, the Synclavier II is being continually upgraded and expanded by New England Digital. Pat's machine included the recent Stereo Option, which he demonstrated by its application in a motion picture soundtrack he had recently recorded entirely on the Synclavier II, using the guitar as the sole control source. The Stereo Option is more than a mixing and panning function for instrument voices. It allows both timbres and partials to be spatially located and modulated in the stereo field. To me, this subtle and powerful effect was one of the most impressive aspects of the machine. The effect was discernible even in the sub-optimal acoustic space of the recital hall. Techniques such as this are capable of encoding aural cues on conventional recordings, thus establishing upon playback the "sound" of most any listening environment, as well creating sonic images that "move" without relying on panning. Similar synthesis methods can even elicit a wide range of predictable emotional responses from the average listener. Readers who are not familiar with these techniques might refer to Robert Carr's article "Recording Synthesizers and Drum Machines", in the December 1982 issue of *Recording Engineer/Producer*.

Metheny demonstrated the enhanced Music Printing Option, driven directly from the Guitar Interface. He created a polyphonic score of bass, organ, and harmonica lines from an impromptu multi-track sequence. Thanks to the projection screen, a significant portion of the Terminal graphic output was visible to the audience. The Synclavier delivered a

perfect 3-stave score in seconds. Incredible. The difference in this music transcription software and others seems to be that this one works. In general, I was impressed by the quality and user-friendliness of the Synclavier's software. For example, a sample of vocalise was recorded, and one could view a real-time display of the amplitude envelope as the sample developed. Editing and looping from the display would be a piece of cake, and the sampling system seemed very easy to use.

Pat closed the clinic with a question-and-answer session, the emphasis of which seemed to be the new Synclavier Digital Music System. This is an upgrade of the current Synclavier Keyboard. The new unit incorporates the Prophet T-8 76-note weighted keyboard, with velocity and pressure sensitivity. Included are an onboard 32 Track Digital Memory Recorder, a 32-Character Alphanumeric Display, an expanded real-time effects section, pitch and mod wheels, an optional breath-controller input, and provisions for SMPTE and MIDI interfacing. Right now, N.E.D. is retrofitting/upgrading customers' Synclavier Keyboards to the new configuration, with commercial release of the new product scheduled for late summer or early fall '84.

After the clinic, Pat remained by the stage to meet members of the audience, shake hands, encourage others, and even sign a few autographs. A more accessible and congenial artist would be hard to find.

I went to the clinic wondering what to expect from an instrument whose Superstar-owners endorse it by saying, "... (it's) really all you need...paid for itself on the first project," or even "Thank you, thank you, thank you." But I must say, if one considers the \$40K+ investment in a Synclavier II not as the purchase of an instrument, but as a capital investment in production equipment, the prospect is more tenable. Clearly, most successful musicians "are" a small business, and no small business could make a capital investment in equipment, except during profitable periods. Considering that the Synclavier has the required functions and features, is supported to the hilt by the manufacturer, and really works, it probably is all the synth you'll need...and if you're taking care of high-level professional business it should pay for itself on the first project, for which you probably would say "Thank you, thank you, thank you."

Acknowledgement: Thanks to Richard Head, of Songbird Studios, for providing arrangements for our attendance and coverage of this event.

# CURRENT EVENTS

*'Tell Them You Saw It In Polyphony'*

**Silicon switching.** SGS Semiconductor (1000 East Bell Road, Phoenix, AZ 85022; tel. 602/867-6264) has introduced the M093, a high-density 12x8 crosspoint switch in a 40 pin DIP package. Quoted specs include -95 dB crosstalk at 1 kHz and less than 1% distortion at 0 dB (ref. 1mW). The chip also includes 7 to 96 line decoder and latch circuits; any of the 96 switches can be addressed by selecting the appropriate 7 bits. A reset signal can turn off all switches.

**Just intonation news.** Other Music Inc. announces the formation of the Just Intonation Network, an organization intended to encourage communication among composers, musicians, and instrument designers working with just intonation. While the exact scope of the network will be determined by members' needs as the organization evolves, current plans include a quarterly newsletter, production of records/tapes of members' work, organization of seminars and workshops, creation of educational materials, and compilation of an archive. Contact: Henry S. Rosenthal, Other Music Inc., 535 Stevenson St., San Francisco, CA 94103 (tel. 415/864-8123).

**Polywriter goes MIDI.** The popular Polywriter program from Passport Designs (625 Miramontes St., Suite 103, Half Moon Bay, CA 94019; tel. 415/726-0280) is now available for MIDI instruments. Features of the program include eight different score formats (from solo instrument to full orchestra), automatic transposition for brass and reed instruments, and full editing capabilities. Lyrics and chord symbols may also be typed in.

Polywriter retails for \$299 and requires an Apple II-type computer with disk drive, MIDI instrument, Passport MIDI interface, and dot-matrix printer.



**TOA introduces synth speaker system.** The 380SE from TOA (480 Carlton Court, So. San Francisco, CA 94080) is designed for professional applications that involve electronically-created music and sound (TOA feels that "traditional" speakers cannot live up to the powerful levels and complex timbres of synthesized music). This three-way system with exponential horn tweeter and Thiele-Small aligned bass reflex design. It handles 360 Watts continuous power and includes bi-amp and tri-amp connectors, four bridging connectors, and adjustable mid- and high-frequency level.

**New MIDI synth.** MTI (105 Fifth Ave., Garden City Park, NY 11040) has announced the DK-600 (\$1295 list), a six-voice poly synth with two DCOs per voice and dynamic keyboard response. The DK-600 also includes a MIDI port and three LFOs for complex modulation effects.

**FM technology to go.** Yamaha (PO Box 6600, Buena Park, CA 90622) has introduced the PS-6100 (\$1499 list), a portable keyboard that uses Yamaha's FM digital technology. It includes 42 solo and orchestra voices, a rhythm





Yamaha PortaTone PS-6100

unit with 64 preset rhythms and custom programming capabilities, MIDI, touch-responsive keyboard, built-in four-track sequencer, auto bass chord, etc.

**Roland re-discovers the modular synthesizer.** Roland (7200 Dominion Circle, Los Angeles, CA 90040-3647) has introduced two "Mother Keyboards" designed to send velocity and pitch information through MIDI to other synthe-

sizers and expander modules. The MKB-1000 has 88 wooden, piano action keys while the MKB-300 has a lighter, faster action with 76 plastic keys. Master control panels on the mother keyboards allow the user to change a wide variety of settings on any of the "slaved" sound sources in the MIDI chain including patch change, keyboard split, MIDI channel assignment for both splits, key transposition, and more.

Recommended expander modules include Roland's MKS-30 PLANET S (six-voice programmable poly synth with dynamics), MKS-10 PLANET P

(16-voice electronic piano module with dynamics), and the MKS-80 SUPER JUPITER (8 voice, 16 VCO synth with dynamics and several other features).

**CDs getting cheaper.** Sharp Electronics (10 Sharp Plaza, Paramus, NJ 07652) has announced the DX-100, a compact disc player that lists for \$399. It includes 3-way search system and programmable operation.

**Reverb update.** URSA Major (Box 18, Belmont, MA 02178) has updated their rack-mount 8X32 digital reverberator into the 8X32 Mk II, which includes more features at a lower cost (\$4000 list). There are four new reverb programs (including backwards reverb) for a total of eight reverb programs; a remote is also available at extra cost.

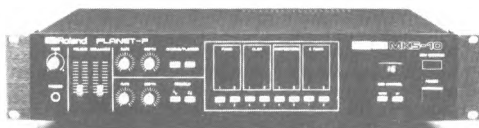
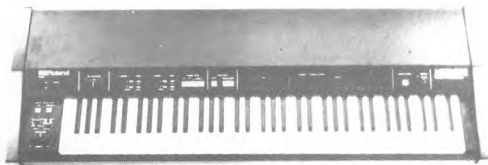

# POLYMART BOOKS

## NEW BOOKS!

**GUITAR ELECTRONICS FOR MUSICIANS** by Donald Brosnac is a comprehensive guide for anyone interested in electric guitars. It clearly explains guitar electronics step-by-step with over 350 photos, drawings and schematics. Chapters include: types of pickups, design and function of hardware components, servicing electric guitar circuits, hot rodding electric guitars and more. Anyone who wants to increase his knowledge of guitar construction and function will benefit from reading this book. # GEM..... **Guitar Electronics for Musicians..... \$12.95**

**GUITAR GADGETS** by Craig Anderton — A consumer's guide written by *the* expert on the subject. For the guitarist who wants to know all about electronic gadgets. How to buy them, fix them, and get the most out of them. Includes a demonstration record. #GG **Guitar Gadgets..... \$14.95**

**CUSTOMIZING YOUR ELECTRIC GUITAR** by Adrian Legg — An Easy to follow guide for customizing your guitar to turn it into a unique and personal instrument. Easy to follow diagrams and step-by-step instructions shows you how to get new and better sound from your guitar. #CEG **Customizing your Electric Guitar..... \$7.95**

**STUDIO RECORDING FOR MUSICIANS** by Fred Miller — Tells you everything you need to know about modern studio recording. Easy to follow text, backed throughout with illustrations. A must for professional and aspiring musicians — and for producers, engineers, arrangers and contractors. #SRM **Studio recording for Musicians..... \$14.95**

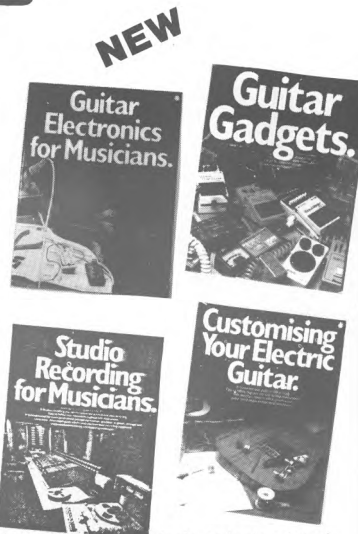

**HOME RECORDING FOR MUSICIANS** is Craig Anderton's original guide to outfitting and operating a budget studio for maximum results, includes mixer and other audio processing circuits and a sound sheet demo recording.

#HRFM **HOME RECORDING FOR MUSICIANS \$14.95**

Synthesists must be well versed in a number of techniques and principles. "How To" and project oriented books are a great way to pick up these skills. **MULTITRACK PRIMER** by TEAC is a step-by-step guide to building, outfitting and operating your home studio.

#TEAC **TEAC MULTITRACK PRIMER \$4.95**

**MAKING MONEY MAKING MUSIC** by James Dearing — Everyone dreams of being at the top, but there's an enormous amount of "middle money" out there for the taking. This is not a book about how to become a Millionaire Rock Star, but the strategies revealed will give you the knowledge you need to keep afloat if you decide to pursue a recording contract. A fresh and practical approach to staying alive in the music business. From the publishers of *Writer's Digest*.

#MMM **MAKING MONEY MAKING MUSIC \$12.95**



## REFERENCE

Often used reference materials to answer the many questions encountered in everyday synthesis. **THE SOURCE** Book of Patching and Programming from Polyphony has over 125 pages of patches in universal flow chart notation; the largest publication of its type.

**ELECTRONIC MUSIC SYNTHESIZERS** by Delton Horn devotes the first half to descriptions and functions of commercial electronic music synthesizers (Moog, Arp, PAIA, Oberheim, EML, and RMI); the second section provides schematics and projects for the experimenter.

#SOURCE **THE SOURCE \$4.00**

#EMS **ELECTRONIC MUSIC SYNTHESIZERS \$6.95**



## SCIENCE OF SOUND

The physical and psycho-acoustical background to music is an important part of musical synthesis. Helmholtz's **SENSATION OF TONE** is, a century after its publication, still the standard text for the physiological acoustics. **PSYCHOLOGY OF MUSIC** by Carl Seashore, developer of the Seashore Music Test, provides an in-depth analysis of musical style and performance characteristics of many instruments. **MUSIC, PHYSICS AND ENGINEERING** by Harry Olson, who worked on the first RCA synthesizer, is a thorough discussion of the physical properties and design of traditional musical instruments (plus a chapter on electronic music). **MUSIC, SOUND AND SENSATION** by Winckel is much like the Helmutz work, with a bit less detail and more concentration on psycho-acoustics.

#SENS **ON THE SENSATIONS OF TONE \$8.95**

#MPE **MUSIC PHYSICS AND ENGINEERING \$6.95**

#PSYCH **PSYCHOLOGY OF MUSIC \$6.50**

#MSS **MUSIC, SOUND AND SENSATION \$4.50**

**ORDER FROM: POLYMART, P O BOX 20305, OKLAHOMA**

# USE THE ORDER FORM ON THE NEXT PAGE

**THE BEGINNERS BOOK OF ELECTRONIC MUSIC** by Delton T. Horn — A fascinating introduction to synthesized sound using build-your-own circuits or commercial equipment.  
#BEM **Beginners Book of Electronic Music** ..... \$12.95

**MUSICAL APPLICATIONS OF MICRO-PROCESSORS** by Hal Chamberlain — If you only have space in your library for one book on music synthesis, this is the book. The easily read text is entertaining and enlightening and teaches both basics and advanced theory without plowing through pages of equations. Liberal examples illustrate theory and practice of both digital and analog signal generation and processing.  
#MAM **MUSICAL APPLICATIONS OF MICRO-PROCESSORS** ..... \$21.95

**THE COMPLETE GUIDE TO SYNTHESIZERS** by Devarahi — An extraordinarily thorough treatment of the subject of analog synthesizers. Covers everything clearly, and the suggested experiments are excellent. Well organized and leaves nothing out.  
#CGS **THE COMPLETE GUIDE TO SYNTHESIZERS** ..... \$18.95

**PRACTICAL GUIDE FOR CONCERT SOUND** by Bob Heil — Finally, a manual that explains in very simple language those many "magic terms" you've heard for years and never really understood. It's the first book written especially for musicians, roadies, and sound technicians who want to KNOW and UNDERSTAND what their sound system is all about.  
#PGC **PRACTICAL GUIDE FOR CONCERT SOUND** ..... \$10.00

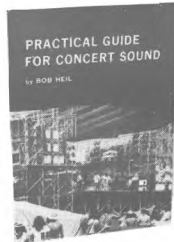
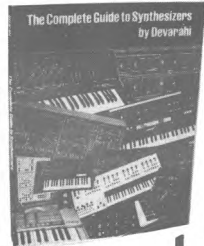
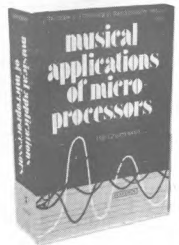

## ELECTRONICS

Electronic Cookbooks are a great way to stock your library with materials that are not only heavy on theory, definitions and educational material but chock full of practical applications as well. These books can easily replace stacks of manufacturers data sheets and applications notes all in an easy to use reference. Walt Jung's **OP-AMP** and Don Lancaster's **ACTIVE FILTER** Cookbooks are self-explanatory — required reading for synthesists! **ELECTRONIC PROJECTS FOR MUSICIANS** by Craig Anderton is almost in a class by itself. It discusses electronic construction technique for the novice and provides 27 projects with printed circuit board patterns and a demo recording of the effects. Even if you're an old hand at musical electronics, you'll appreciate that all of these processors, from Tube sound Fuzz to Phase shifter are compatible and work together without creating noise, signal loss, bandwidth compression or any of the problems common to interconnecting effects from different manufacturers. There's even a complete chapter on how to modify and combine effects to produce your own custom pedalboard. **ELECTRONIC MUSIC CIRCUITS** by Barry Klein covers synthesizer system design, power supplies, control voltage generators, VCOs, Filters, analog multipliers and more. Lots of schematics and data sheets on the most popular music oriented ICs. An excellent technical reference.

#EPFM	<b>ELECTRONIC PROJECTS FOR MUSICIANS</b>	\$14.95	#OACB	<b>OP-AMP COOKBOOK</b>	\$15.95
#EMCR	<b>ELECTRONIC MUSIC CIRCUITS</b>	\$16.95	#AFCB	<b>ACTIVE FILTER COOKBOOK</b>	\$14.95
#CMCB	<b>CMOS COOKBOOK</b>	\$13.95			

## & MORE FROM POLYPHONY

**4/8 TRACK STUDIO LOG BOOK** designed by Craig Anderton provides a place to keep all the important information on your tape library. Log in timing, type of tape used, record patches, make notes and use the expanded track sheet to list sequential changes in tape tracks relating to the settings of the index counter. Craig Anderton's **CONTEMPORARY KEYBOARD ARTICLES** is a collected reprint of all the articles from June 1977 through February 1981, covers tips, technique, theory, maintenance, and numerous construction projects. **DEVICE BACK ISSUES** — during the year that this newsletter was published, it featured almost 200 pages of technical information for the guitarist/musician. A wealth of articles on design, product reviews, and modification and construction projects. Sold in complete set, individual issues not available. Limited number available. **CRAIG ANDERTON MUSIC TAPE** — Delightful listening plus a booklet explaining how the effects were achieved.

#SLB	<b>STUDIO LOG BOOK</b>	\$4.95
#AA	<b>CRAIG ANDERTON'S CONTEMPORARY KEYBOARD ARTICLES</b>	\$5.95
#DEVICE	<b>COMPLETE SET (12) DEVICE BACK ISSUES</b>	\$18.00
#CAMT	<b>CRAIG ANDERTON MUSIC TAPE</b>	\$5.95



**CITY, OK 73156 (405) 842-5480**

# BACK ISSUES \$2.50 each ppd

## Find out what you've missed!

- #0301: 7/77: frequency divider project, random tone generator project, normalizing synthesizer controls, eliminating patch cords, computer control of analog modules, Chord Eggs
- #0302: 11/77: The Sensuous Envelope Follower, digital gates, LED wall art, build a bionic sax, data to music peripheral project, Apple II as a music controller, using the NE566 as a VCO, patches.
- #0303: 2/78: computer controlled Gnome, using joysticks, build a bionic trumpet, ultra-VCO modifications, voltage control the Mu-Tron Bi-Phase, oral joystick, patches.
- #0304: April/May '78: MiniMoog Mods, non-keyboard module use, phasing and flanging (theory and circuits) memory expansion for programmable drums, digitally addressed transposer, polyphonic software.
- #0402: Sept/Oct '78: electronic music notation, notes on the recording of "Cords" by Larry Fast, sequencer software - part one, rhythmic control of analog sequencers, touch switch projects, modular vocoder techniques. PET as a music controller, patches.
- #0404: January/March '79: add-ons for vocal F and V converter, shorthand patch notation, more on notes to frequency conversion, graphic monitor project, George Russell, super VCA circuit, echo software, Vol. 4 index.
- #0502: July/August '79: hex VCA/mixer project, electronic music schools and studios, modify the Oberheim Expander Module, profile of Ernest Cartwright, budget microphones, digitizer projects and software, bar graph ICS
- #0505: January/February '80: Joseph Byrd, Mort Garson, Larry Fast on "Games", composing for "live plus tape", using the CR280, recording vocals, ADSR circuits.
- #0506: March/April '80: Computers in Music: real time audio processing hardware, Powell sequencer system, Max Mathews, advanced STG software, PortaStudio, phase modulation, Volume 5 index.
- #0601: May/June '80: Gary Numan, Microcomputers in Real Time Audio, Build a Digital Audio Delay Line, writing Documentation, Richard Hayman Composer/Performer Home Recording: Applying Harmonizing and Pitch Transposing Techniques by: Craig Anderton.
- #0602: July/August '80: Peter Gabriel, digital VCO project, Dream modules, optimum level settings, dynamic phrasing, patches.
- #0603: Sept/Oct combined with Nov/Dec '80: alternate controllers, add voices to Casio M-10, voltage controlled quadrature oscillator project, cordless patch bay, recording rules, patches.
- #0604: January/February '81: Special Construction Edition! Build: Audio Circuit Breaker, Pulse Width Multiplier, Magnetic Harp, 50 Watt/Channel Stereo Power Amp, Quad Sequential Switch, DOD Mods, patches.
- #0605: March/April '81: Portable Music Issue, reviews of Remco's FX, E-H Mini-synthesizer, Casio's VL-Tone, plus mods for the M-10, GR-500, mini-amp, and the Korg X-911. Introducing: Practical Circuitry and On Location, new columns.
- #0606: May/June '81: Synthesizer: Hardware Mods and Software. Modular Synthesizer Effects, Environmental music, Keyboard assignment for the 8700, new columns; Details, Practical Circuitry, and On Location. Volume 6 index.
- #0701: July/August: Guitar Electronics: Modify: Fender Amp, MKR Phase 100, GR-500. Input/Output Structures, \$5 Analog Programmer, Sample and Hold Technique, Modular Synthesizer Effects, new column: Applied Synthesis, Marketing Your Records.
- #0702: Sept./Oct. '81: Harald Bode Interview, Live Plus Tape - New Technique, Xenharmonics, Kraftwerk Live - Review, Psycho-Acoustic Experiments, Practical Circuitry - Super Controller, Applied synthesis - Brass, Construction Tips For Beginners.
- #0703: Nov./Dec. '81: Dave Rossum interview, Applied Synthesis: Strings, Details: Series-parallel/Sum-Difference. The Sound Gizmo and Pro-One Reviews, Practical Circuitry: VCO Deluxe.
- #0704 Jan./Feb. '82: Bob Moog interview, Chip Power - STK-050/070, Simple Square Wave Shaper; Tape Timer Ruler, Practical Circuitry: VCAs made simple, Details: Gozinda & Gozouta Revisited, Korg Trident & Casiotone 202 Reviews.

- #0705 Mar./Apr. '82: Electronic Music Math, Analog Delay Clock / Modulation; Frequency Domain Modifiers; Screen-Wave for the TRS-80; Touch Switches Revisited; Practical Circuitry: ADSR the Easy Way; Getting the most out of a Cheapo (Guitar).
- #0706 May/August '82: Anatomy of a Private record, Don Slepian Interview, Understanding Digital Synthesizers: A Digital Filter, Syn-Bow Review, Optical Audio, Profiles of SSM 2033 & 2044, The PAL Filter, Bill Rhodes Applied synthesis: Bells, Pipe Organ, Harpsichord, Electronic piano; The Realistic MG-1 Reviewed.
- #0801 Sept./Oct. '82: Ambience in Electronic Music, Tone Bypass for Fender Amps, 8 Track Reviews, Parametric EQ Tips, Solo/Cut Circuit for TASCAM Model 3, The SSM 2011, Tube Preamp, Snare + Drum Voice Circuit, Triple Pick-up Switcher, Simulated Stereo, When Quality Record Mfg. Counts, Independent Record Mfg. Convention report.
- #0802 February '83: AMS-100 Gate Output, Bus Distribution Modules for Modular Synthesizers, Dynamic Touch Controller, Expanding Envelopes, MKR Limiter Review, New Age Music, An Overview, Synsonics Drum Review, Interface, Practical Circuitry: A Patch Over Scheme for Small Synthesizers, Lab Notes: Shepard Functions.
- #0803 April '83: Sound Interface Device, Build a Bass Pedal System, Dr. Rhythm Mod., Switched Capacitance/Transversal Filters, Voltage Controlled LFO, Rockman & Voyetra Eight Reviews.
- #0804 June '83: MIDI Hardware Fundamentals, What MIDI Means for Musicians, The Vangelis Interview, Creative Recording on a Shoestring Budget, A One Chip ADSR, An Electronic Switch.
- #0805 August '83: Donald Buchla Interview, An Overview of Digital Drums, Exploring Just Intonation, Build a simple Drum Synthesizer, Micro-Drums part I, The Penultimate Compressor, Why Spring Reverb Will Never Die, Gate/Sample & Hold Circuit.
- #0806 October '83 Larry Fast Interview, Basic Film Scoring Math, Fostex X-15 Review, Build the Hip Bass Drum, Applied Synthesis: Orchestral Voicings Using the Tenth Interval.
- #0901: December '83 John Foxx Interview, Build: a Dual Trigger Delay; Center Channel Reverb. Drum Machine Modifications - FAIA, E-Mu, Roland; Polyphonic Keyboard Reviews, White noise.
- #0902 February '84 Commodore Music Software Review, Build a Just Intonation Generator, NES72 Noise Reduction Unit, 3D Video, Vocal Basics, Build a Quadrature Function Generator
- #0903: Remote MIDI Keyboard Project part I, Casio 202 Mods, Easy Firing ADSR, Low Budget Sequencers, Alternative Keyboard Designs, Winter '84 NAMM Report.
- #0904: Wendy Carlos Interview, '64 Sounds Part I, Fostex 2050 Review, Synthesizer Delay Line, DSX to Drumulator Adaptor.

## APPLIED SYNTHESIS

NEW from POLYMART - Bill Rhodes "APPLIED SYNTHESIS" .... a no nonsense guide to the mechanics of electronic music for orchestral synthesis. Order No. APSN APPLIED SYNTHESIS \$3.75



## HOT MUSIC HARDWARE: NAMM ON VIDEO

MIDI, computers, digital sampling, synchronization, synthesizers, new stringed instruments ... although closed to the public, you can go behind the scenes at the largest music industry trade show in the U.S. with the Summer '84 NAMM-ON-VIDEO. Hosted by Polyphony editor Craig Anderton, this 1 hour VHS video includes demos of the latest gear, interviews, commentary, and background on what changes in the industry mean for musicians. Send \$49.95 ( plus \$2.50 shipping/handling) to POLYMART.

ALSO available: The Winter '84 (January) NAMM-ON VIDEO (featuring the Emulator II, Kurzweil 250, Chapman 'Stick', Yamaha DX7, and Tom Coster with the Moog Liberation) for \$49.95; or order both tapes for a special package price of \$79.95 ( plus \$2.50 shipping/handling).

## ORDER FORM

We cannot invoice; payment must be enclosed with your order. There is a flat \$5.00 handling fee per order plus postage costs. MasterCard and Visa are welcome. (\$10.00 minimum charge). Foreign orders must be paid by certified check or money order in U.S. \$ drawn on a U.S. bank for by charge card). Phone orders welcomed for charge card orders.

### SHIP TO:

Name: \_\_\_\_\_

Address: \_\_\_\_\_

City \_\_\_\_\_ State \_\_\_\_\_ Zip \_\_\_\_\_



Card # \_\_\_\_\_

MasterCharge Bank # \_\_\_\_\_ Expiration Date \_\_\_\_\_

Signature \_\_\_\_\_

Quantity	Item	price ea.	amount
<input checked="" type="checkbox"/> SUBSCRIPTION <input type="checkbox"/> U.S. \$12/YR. FOREIGN \$14/YR.		sub total	
Shipping Charges		handling	.50
U.S.: add 10% of Sub/Total or \$5.00 maximum Foreign: 20% of Sub/Total or \$10.00 maximum		shipping	
		total enclosed	

**MAIL TO: POLYMART, P O BOX 20305, OKLAHOMA CITY, OK 73156**



# CURRENT EVENTS

## New from Europa Technology.

The PPG Music Computer System, distributed by Europa Technology (1638 W. Washington Blvd., Venice, CA 90921), consists of four PPG components: the WAVE 2.3 eight-voice digital synth with MIDI and 8-track sequencer (\$895 list); WAVETERM computer for sampling, processing, and 24-track sequencing using two 5.25" floppy disk drives (\$11,995); the PRK Processor Keyboard (\$2995), a 6-voice weighted piano-action keyboard; and Expansion Voice Unit (\$6995), an eight-voice, rack-mount digital synth without hardware controllers.



Also from Europa: The SRC SMPTE Reading Clock synchronizes synthesizers, sequencers, and drum machines to SMPTE time code. Adjustable tempo from 30 to 255 BPM.

**Shhhh.** Furman Sound (30 Rich St., Greenbrae, CA 94904) has announced the QN-4 Quad Noise Gate (\$395 list) using PWM (pulse width modulation) technology. Each gate includes a threshold and fade time (decay) control.

## MOVING?

When writing to change the address on your POLYPHONY subscription it is important that you enclose the mailing label. Our computer cannot locate your name on the subscription list without it.

ATTACH OLD LABEL HERE

### NEW ADDRESS

Name \_\_\_\_\_  
 Address \_\_\_\_\_  
 City \_\_\_\_\_ State \_\_\_\_\_ Zip \_\_\_\_\_

mail to: **Polyphony**  
 PO BOX 20305  
 Oklahoma City, OK 73156

## SAVE BY BUILDING OUR RACK MOUNT STUDIO EQUIPMENT

**QUADRAFUZZ** — four separate frequency bands of distortion are mixed for the smoothest fuzz you've ever heard. no. 6720 . . . . . \$39.88

**HYPERFLANGE/CHORUS** — the cleanest, widest range, most versatile flanger anywhere at any price. no. 6750 . . . . . \$149.95

**VOCODER** — unmatched performance in a versatile, low cost rack package. no. 6710 . . . . . \$99.95

**HOT SPRINGS** — user's agree, short of studio plate systems, you won't find a better reverb at any price: no. 6740 . . . . . \$59.95

ADD \$3 SHIPPING  
 FOR EACH KIT ORDERED

Innovative, cost effective designs by Craig Anderton in easy to assemble kits from:

## PAIA Electronics, Inc.

Direct mail orders and inquiries to: Dept. 11Y  
 1020 W. Wilshire, Oklahoma City, OK 73116 - (405) 843-9626

Ask for your free catalog.

CHARGE TO VISA OR MC TOLL-FREE  
 1-800-654-8657 9AM to 5PM CST MON-FRI

# USING EXPERIMENTER'S BOARD SYSTEMS

by: Ronald L. Oberholtzer

The experimenter's board system (such as Radio Shack #276-170 and Jameco EXP-300 PC) provides many advantages for the home constructor. It is simple to use, if not mistreated it can be reused, and it enables one to make a professional-looking project. Four items make up the system: 1) The printed circuit board, 2) a matching paper scratchboard pad for preliminary layouts, 3) a duplicate board with 'push-in' terminals, and 4) a mounting panel for pots and switches that locks on the board with the push-in terminals.

**Scratch boards.** The scratch boards come in an inexpensive paper pad. Layouts can be worked out on the scratch board before any parts are used, which is a realistic way to transfer a schematic diagram into a practical parts layout at a reasonable cost. If a design has possible improvements, a second layout can be prepared and the two layouts compared without committing any parts. If pencil is used in making the layout, it can be erased for corrections. The cost of preparing a second or third layout is minimal.

**Push-in board.** From the scratch board, the proposed layout can be tried out on the push-in terminal board. In most cases it will not be necessary to cut leads on the components, so the components can then be used in the final version or returned to the stock bin. At this time different values of resistors or capacitors can be tried to achieve different design characteristics. Once the design is operating as desired,

transfer the components to the experimenter's printed circuit board for the permanent project.

**Printed circuit board.** First, clean the foil side of the board with steel wool but be careful to remove all the steel wool residue. Secondly, install the IC sockets using a low wattage iron. While holding them in place I solder the four corner pins and, after checking that the sockets are flat on the top of the board, solder the remaining pins. Next add the components and leads. Make sure to add a jumper between both ground strips at the end of the board with the power supply ground lead. I use Radio Shack 278-752 miniature single shielded cable with a plastic cover to provide shielded leads from the board to controls and jacks; this cable has a spiral wrap shield for convenient end dressing and also fits the board holes nicely.

Install resistors vertically if possible to save space. Use radial lead electrolytics unless a long stretch is needed. If this is the case, then use the axial lead electrolytics or a radial lead electrolytic and a wire lead. Leads clipped from resistors and capacitors make good jumpers. For wire connections on (or to and from) the board I use plastic insulated #26 stranded wire in six different colors. This wire comes in 100-foot spools at my local electronics parts supplier, but other types of wire are of course also suitable.

**Mounting the finished board.** Use #4 hardware and spacers that are at least 1/8" long. Radio Shack has push-in plastic spacers for mounting printed circuit boards on thin metal, spacing the board 3/8" from the metal. These

spacers require larger holes in the experimenter's board and provide a snap fit in both board and metal mount. The part number is 270-1391.

Using this system of construction will give your individual projects a compact, professional appearance and at the same time provide short lead lengths so necessary to modern electronic construction.

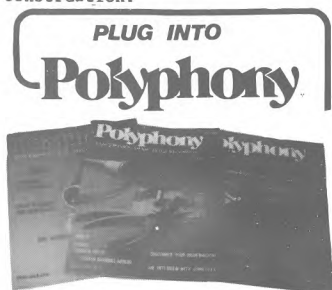

**FOR  
ELECTRIFYING IDEAS!  
DON'T MISS AN ISSUE  
SUBSCRIBE TODAY!**

- ( ) One year \$12 US/\$14 foreign  
(6 issues)  
( ) Two years \$22 US/\$26 foreign

Name: \_\_\_\_\_

Address: \_\_\_\_\_

City: \_\_\_\_\_ state: \_\_\_\_\_ zip: \_\_\_\_\_

VISA/ Mastercharge accepted.

Card No. \_\_\_\_\_

Expiration date: \_\_\_\_\_

(signature) \_\_\_\_\_

Mail to:  
POLYPHONY, P. O. Box 20305  
Oklahoma city, OK 73116

# QUAD LED READOUT

by: Jack Orman

There have been many times when I wanted to monitor the input levels to a device, but a single clipping indicator didn't give enough resolution and I couldn't justify the cost or complexity of an LM3915 or LM3916 LED meter. This simple circuit, which can be wired up on a piece of perfboard with the LED legs holding the whole thing in place, is a good compromise between the two approaches.

Referring to Figure 1, IC1 forms a precision half-wave rectifier with a 100k input impedance. C2 smooths out the rectified signal and holds the peaks long enough for them to be visible; you may vary the circuit's reaction time by altering C2's value. Each section of the RC4136 quad op amp forms a non-inverting comparator, with the voltage level for each section derived from a point on resistor string R8 - R12. Trimpot R12 calibrates the unit to the desired signal level, but regardless of how you vary this trimpot, the decibel relationship between steps will remain the same. To calibrate, send a 0 VU signal into the input and adjust R12 until the required number of LEDs light up. Depending on how you calibrate the Quad Readout, any one of the LEDs can be considered the 0 dB point. Since R8 - R11 are standard 1% resistor values, they set the difference between steps quite accurately. Don't forget about power supply bypassing; adding a 0.1 uF disc capacitor from each power supply lead to ground, paralleled with a 10 uF electrolytic, will prevent spikes generated within the 4136 from getting back into the power supply lines.

ted to devices already in operation or incorporated into new units. One way to use this circuit is to monitor the action of an NE570 (or NE572) when the 570 is used as a compressor. IC1, C1, D1, D2, C2, and R1 - R3 can be deleted, and point A would connect to the attack capacitor pin on the compander chip. For example, with the Penultimate Compressor shown in the August 1983 issue of *Polyphony*, point A could connect to A11 and/or A12's output to monitor the compressor levels. You can tap power for the Quad Readout

from the bipolar supply that is powering the device being monitored.

Another application I tried was with my "Hot Springs" reverb; combining the Quad Readout with the existing on-board clipping indicator created a five stage readout. Overall, I have found this readout useful for a number of circuits -- from compressors, to delays, to reverb units. I hope that you find as many uses for this circuit as I have.

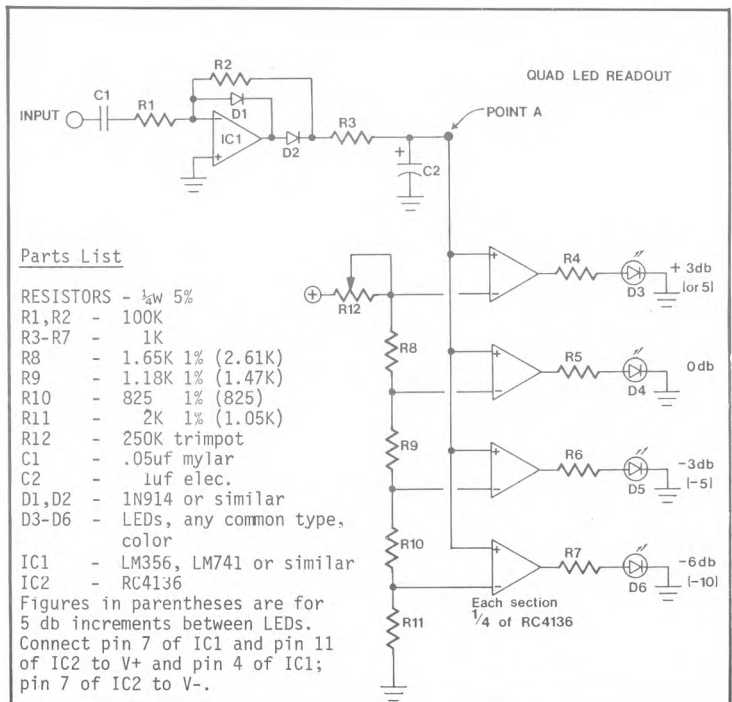

This circuit can be retrofit-

**Polyphony**

October 1984

# EQUIPMENT EXCHANGE

PUT POLYPHONY TO WORK FOR YOU. List equipment for sale or trade, job openings, positions wanted, etc. Equipment exchange classified rates for individuals offering goods or services for sale or trade: 25c per word, 20 word (\$5.00) minimum charge; Commercial establishments: 50c per word. Prices, zip, phone numbers count as one word each. DISPLAY CLASSIFIED: \$15 per column inch, one inch minimum, camera ready art to be supplied by advertiser. All classified advertising must be prepaid. Advertisers using a Post Office Box number for responses must furnish Polyphony Publishing Co. with a complete street address and phone number. Readers should respond directly to advertiser. Polyphony is not responsible for claims made in ads, or for the results of any transactions. Polyphony reserves the right to edit or refuse any ads submitted.

## Music equipment

LARGE MODULAR SYNTHESIZER Custom system, CEM/SSM based. 35 modules: 9 VCOs, 4 VCFs, 8 VCAs, 9EGs, Much more. Unique Touch-plate keyboard, velocity sensitive, etc.. one of a kind, dear to my heart, but need cash. An outright theft at \$950. 19" RACK EFFECTS & CASE Anderton designs: 2 parametric EQs (4 bands each), 2 chorus/delay lines, 1 octave divider w/harmony mode, 1 phase shifter, 2 noise gates, 1 dual limiter, 1 15v. 1 amp power supply Handsome, durable, all work great. More theivery, \$350. CASIO MT-31, great shape \$50. MXR DUAL 15-BAND GRAPHIC EQ, New, \$250.

TASCAM 22-4 4 track reel to reel with matching dbx unit. Cost \$1650, sell \$950 very low hours. Will consider all offers on these items. Call Dave at (212) 989-5260

PAIA 4700 ROAD KEYBOARD, 8782 encoder, EKx-40 VCO, 8785 DAC, road case, 2720-12, all for \$75 plus shipping. Call (602) 225-0870.

## Misc.

UNIQUE COMMODORE 64 Audio/music disk software including "64 SOUNDS" (featured in POLYPHONY), Guitar Pak and others. JAL Software, Box 128, S. Milwaukee, WI 53172.

PIANO TECHNICIANS GUIDE for the Piano owner. Protect your investment. This book explains how your piano works, and how to keep it working. \$3.00 ppd. Bookman House, PO Box 271804, Houston, TX 77277.

## Recordings

KEY ESSENTIALS LP on cassette (\$6.00) and NEW EARTH SYMPHONY EP on chrome cassette (4.00), by Bill Rhodes: Jazzical Records, 1 Wyndemere Road, Piscataway, NJ 08854.

# AD INDEX

Dickstein Distributing Co. ....	5
Gentle Electric .....	4
Heavy Metal Strings .....	4
Passport Designs .....	5
PGS Electronics .....	27
Polymart .....	36
POLYPHONY .....	40
Synchronous Technologies .....	43
TEAC Corp. of America .....	2
TOA .....	44

U.S. POST SERVICE  
STATEMENT OF OWNERSHIP, MANAGEMENT AND CIRCULATION  
Required by 39 U.S.C. 3685

1A. TITLE OF PUBLICATION <b>POLYPHONY</b>	1B. PUBLICATION NO. 0 1 6 1 1 5 1 4	1C. DATE OF FILING 10/1/84
2. FREQUENCY OF ISSUE MONTHLY	3A. NO. OF COPIES THIS ISSUE 1000	3B. ANNUAL SUBSCRIPTION PRICE \$12.00
4. COMPLETE MAILING ADDRESS OF KNOWN OFFICE OF PUBLICATION (Street, City, County, State and ZIP or City) (Do not print)		
1020 W. Wilshire Blvd., Oklahoma City, OK 73116		
5. COMPLETE MAILING ADDRESS OF THE HEADQUARTERS OF GENERAL BUSINESS OFFICES OF THE PUBLISHER (If none)		
1020 West Wilshire Blvd., Oklahoma City, OK 73116		
6. FULL NAMES AND COMPLETE MAILING ADDRESSES OF PUBLISHER, EDITOR, AND MANAGING EDITOR (Do not print if none)		
PUBLISHER (Do not print Complete Mailing Address) John S. Whitton, Jr., 1020 W. Wilshire Blvd., Oklahoma City, OK 73116		
EDITOR (Do not print Complete Mailing Address) Celia Anderson, 1020 West Wilshire Blvd., Oklahoma City, OK 73116		
MANAGING EDITOR (Do not print Complete Mailing Address) Linda Kay Brumfield, 1020 W. Wilshire Blvd., Oklahoma City, OK 73116		
7. THREE (3) copies of a copy of this statement to be printed and mailed to the publisher. If the name and address of the publisher are not printed in the publication, the name and address of the publisher must be printed. If the name and address of the publisher are not printed in the publication, the name and address of the publisher must be printed. If the name and address of the publisher are not printed in the publication, the name and address of the publisher must be printed. (Do not print if none)		
8. KNOWN BONDHOLDERS, MORTGAGEES AND OTHER SECURITY HOLDERS OWNING OR HOLDING 1 PERCENT OR MORE OF TOTAL AMOUNT OF BONDS, MORTGAGES OR OTHER SECURITIES OF ANY KIND OR KINDS		
NONE		
9. FOR COMPLETION BY NONPROFIT ORGANIZATIONS AUTHORIZED TO MAIL AT SPECIAL RATE (Section 412 (2) (D) of Internal Revenue Code, and Sections 501 (c)(3) and 501 (c)(29) of Internal Revenue Code)		
10. EXTENT AND NATURE OF CIRCULATION (Do not print if none)		
A. TOTAL NO. COPIES (See Form 3500)		
B. PAID AND/OR REQUESTED CIRCULATION		
C. TOTAL PAID AND/OR REQUESTED CIRCULATION		
D. FREE DISTRIBUTION BY MAIL, CARRIER OR OTHER MEANS		
E. TOTAL DISTRIBUTION (Sum of C and D)		
F. COPIES NOT DISTRIBUTED		
G. TOTAL (Sum of E and F) should equal total paid plus non-paid		
11. I certify that the statements made by me above are correct and complete		

Signature: *John S. Whitton, Jr.*  
Date: *10/1/84*  
Title: *Editor*  
Address: *1020 W. Wilshire Blvd., Oklahoma City, OK 73116*

PS Form 3526, July 1984



# AT LAST!

# COMPUTER AUTOMATION FOR THE SMALL STUDIO

## THE SMPL SYSTEM BREAKS THE PRICE BARRIER FOR SMPTE TIME CODE

Synchronous Technologies' SMPL System is the only time code device specifically designed to solve the problems of the smaller recording studio. In one integrated package it provides functions and features which can't be duplicated with existing time code equipment even at many times the system's low price. Functions include:

- SMPTE Time Code generator
- SMPTE Time Code reader
- Automatic Punch In/Out
- Drum and Synth Synchronizer
- Programmable 8 event sequencer
- Autolocator
- Time Code Metronome
- Recorder Remote Control

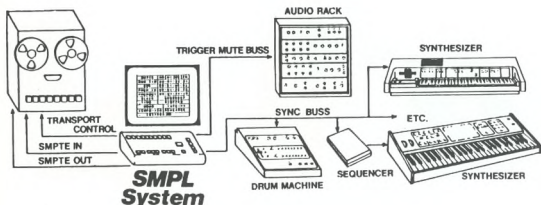

## IT'S THE ENGINEER YOU ALWAYS WANTED

With the SMPL System, insert editing no longer requires the combined skills of engineer, musician and juggler. During review, Punch In and Punch Out points are set on the fly and saved in the computer's memory. Separate Rehearse and Take modes allow you to rehearse and preview the edit points as many times as necessary before committing to tape.

Eight programmable event outputs are useful for triggering effects, changing instrument presets, fractional measure channel muting and much more.

The eight autolocator points let you get from section to section with a minimum of hassle and wasted time. And a separately programmable CUE point controls the recorder for a looping function at the end of rehearsals and takes. You concentrate on the art, the system attends to details.

## SYNC-LOCK THE NEW GENERATION OF INSTRUMENT/RECORDERS

Through the SMPL System's MIDI standard 24 tick/beat synchronizing buss, an ever increasing number of Polyphonic Synthesizer Sequencers and Electronic Drum Sets can be precisely synchronized to material on tape. Many pre-MIDI instruments also conform to this standard and other non-standard sync formats can be handled with modest additional equipment.

Unlike tone or click-track type synchronizers, the SMPL System can be started at any arbitrary point in the work and the computer intantly calculates the correct phase of both metronome beat and synchronizing signal. You save time and aggravation by not having to play through the entire work to do an edit at the end.

## MORE, HIGHER QUALITY "TRACKS"

Since much of today's commercial music involves digital drums and sequencer controlled polyphonic synthesizers, the SMPTE track can replace numerous tracks which might otherwise be re-

corded as audio. Not only does this effectively increase the number of tracks available, it allows these tracks to be mixed first generation to the master tape. No more loss of quality from ping-ponging and dubbing.

## AN OFF LINE TERMINAL FOR THE ENTERTAINMENT INDUSTRY'S SYNCHRONIZING NETWORK

The benefits of using industry standard non-drop format SMPTE Time Code can't be overstated. With the SMPL System, tapes produced in the small studio will transport to larger studios and be compatible with automatic mix-down and chase-locking equipment.

Even if you never need to sync audio to video, this compatibility has compelling economic advantages. Tapes produced on machines with limited tracks can be "pyramided" to 24 and 40 track studio machines, allowing you to create in your own environment at your own pace and still have easy access to expensive studio facilities on an as-needed basis. In many cases, your savings in billed studio time will quickly pay for the SMPL System.

## A VERY HUMAN INTERFACE

Either a Color or B/W Monitor, or TV set can be used as the display device for the SMPL System. The easily readable display provides all current information on the operation of the system including operating mode, metronome tempo, current time, In/Out points, CUE point, recorder status and more. And the SMPL System doesn't require an advanced engineering degree to operate, all functions are straight forward and obvious.

## IT'S A COMPLETE, LOW COST SYSTEM

Not only is the SMPL System itself low in price, it's designed to be used with lower cost multi-channel cassette or open reel recorders by simply plugging into their normal remote control jacks. Neither tachometer output nor speed control input are required. Even recorders without remote control jacks can usually be modified for use with the system.

The complete SMPL System consists of: Personal Computer with keyboard modified for SMPL functions, SMPL System Software/Interface cartridge, VHF channel 3/4 modulator, power supply and Using and Installation manual.

**SMPL System** .....\$995.00 (12 lbs)

CALL OR WRITE FOR THE NAME OF YOUR NEAREST DEALER.



No representation that SMPL is a product of Commodore Business Machines, Inc. or an affiliated or related company is intended; nor is there any representation that there is any source of origin of Commodore Computers other than Commodore Business Machines, Inc. or its affiliated or related companies.



# SYNCHRONOUS TECHNOLOGIES



P.O. Box 14467 • 1020 West Wilshire Boulevard • Oklahoma City, Oklahoma 73113 • (405) 842-0680



# be SYNTHABLE

**T**he software wizards stuck a 9-foot concert grand onto a tiny silicon chip . . . a world-class speaker is the way to hear it.

Because a system designed only for "traditional" sounds can't live up to the powerful levels and complex timbres of electronically-created music.

That's why we created the 380SE.

### **Total Transparency—and Psychoacoustic Satisfaction, too.**

The 380SE is a clean and powerful three-way speaker system. Electronic reeds and strings, flutey and brassy tones, percussive accents, special effects . . . all sounds at all levels come through with exacting sonic accuracy. The 380SE illuminates subtle variations in pitch and level, whether handling one note at a time or a full synthesized chorus.

### **Attention to Detail**

The digital wizards must master every detail of their technology. A speaker designed for electronic music gives them the freedom to concentrate on sound creation rather than sound reproduction.

So we paid attention to every detail of the sound system. That's why the 380SE is constructed entirely from our own high-quality components. With continuous power handling of 360 watts. Full range inputs. Bi-amp and tri-amp connectors. Four bridging connectors. Mid- and high-frequency level controls, flush-mounted where you can get right to them.

And as you can see, we didn't overlook the visual details. The 380SE's appearance is visual confirmation of its class. The 380SE's performance proves its ability to handle electronic music.

**That's what being synthable is all about.**

For complete technical data, call or write:



**TOA Electronics, Inc.**  
480 Carlton Court  
So. San Francisco, CA 94080  
(415) 588-2538  
In Canada: TOA Electronics, Inc.  
10712-181 Street  
Edmonton, Alberta T5S 1K8  
(403) 489-5511

© 1984 TOA Electronics, Inc.



*This magazine PDF has been downloaded for free from [www.muzines.co.uk](http://www.muzines.co.uk)*

*The mu:zines project is a non-commercial, labour of love archive of music production magazines from the 1970s-2000s.*

# mu:zines

musicmagazinearchive

Making Music II  
Electronic Soundmaker & C  
Technology Electronics  
Recording Musician M  
& Recording World Electronic S  
On Sound Music Tech  
Music Maker Home & Studio Recording  
Music International Musician & P  
Soundmaker & Computer  
Technology Electronic  
Recording Musician

[www.muzines.co.uk](http://www.muzines.co.uk)  
[info@muzines.co.uk](mailto:info@muzines.co.uk)