

ADDING EASY SATELLITES TO YOUR SYSTEM

THREE: 1995

US \$7.00

CANADA \$8.00

Speaker Builder

THE LOUDSPEAKER JOURNAL

GALO

**AC'S SAPPHIRE III
IS A KIT AGAIN**

PIERCE

**ORDER PUZZLES
REVISITED**

FITZMAURICE

**HAVE TWO-WAY,
CAN TRAVEL**

FLORIAN

**HARDWARE
A SAAB**

KOONCE

**BENSON
VERSUS SMALL**

WAYLAND

**WHEN BRACING
GETS TRICKY**

00785740ENRPI 0th 0195
DAVID B WEEMS
BOX 99
NEWTONIA MD 64853



HARLEY'S HIGH END OMNIBUS APPRAISED

World Radio History

Cabasse

True geodesic honeycomb diaphragm. Only from Cabasse.



Exclusively from:

ORCA, Design & Manufacturing Corp.
1531 Lookout Drive
AGOURA, CA 91301
United States of America

Tel: (818) 707-1629
Fax: (818) 991-3072

For informations, call or write.
Free brochure upon request.

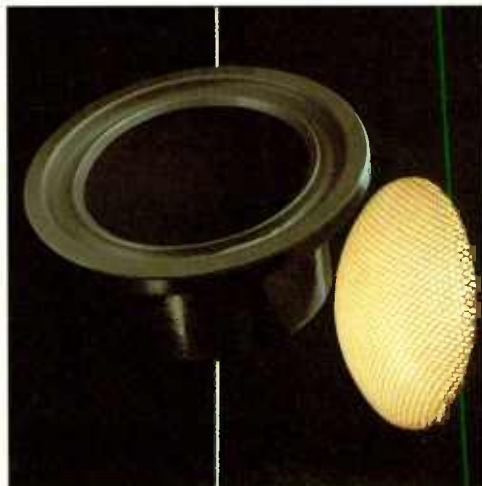

Stocking distributors:

W.A.R. Audio
396 Scarborough Beach Rd. #203
Osborne Park 6017, W. Australia
Tel: (61)-9-242-5538 Fax: (61)-9-445-2579

Technologie MDB
4000 Terrasse Jean XXIII, St. Hubert
Québec J4T 3L6, Canada
Tel: (514) 891-6265 Fax: (514) 443-5485

Zalytron Industries
469 Jericho Turnpike
Mineola, NY 11501
Tel: (516) 747-3515 Fax: (516) 294-1943

Good News

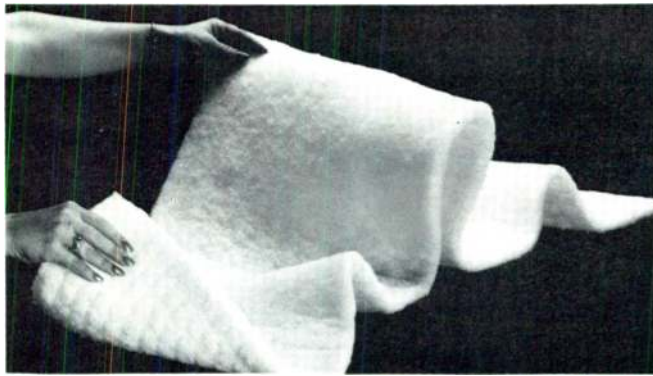

SECURITY BLANKET

Insultone™ is a fine glass and synthetic microfiber blanket which offers a wide range of OEM thermal and acoustical applications from 0 to 250°F. The insulation combines thermal efficiency and acoustical performance with a soft feel. Performance is comparable to blanket insulations currently in use. The sound absorptive and thermal control material can be used for speakers and wall units, as well as for industrial applications. Schuller International, PO Box 625005, Littleton, CO 80162-5005, (800) 654-3103.

Reader Service #101

DYNAMIC DUO

The Spica TC-60 is a time-coherent loudspeaker, with Gravity™ speaker stand comprised of cylindrical support tubes for less resonance and greater damping. The TC-60 incorporates a 6½" polypropylene bass/midrange woofer and 1" impregnated cloth-dome tweeter in a ported, sloping baffle cabinet. It handles 120W peak power and offers smooth frequency response from 48Hz–20kHz–3dB, plus enhanced dynamic linearity. Gravity stands feature steel construction, black finish, and flexible tilt adjustment. Spica is a subsidiary of Parasound Products, Inc., 950 Battery St., San Francisco, CA 94111, (800) 822-8802, (415) 397-7100, FAX (415) 397-0144.

Reader Service #103

PROS TELL ALL

A workshop on the Theory and Design of High Performance Professional Loudspeakers will be held June 22–24, 1995, at Soundcheck, Music City, Nashville, TN. Staff members Bruce Howze, Don Keele, and Eugene Patronis will share their knowledge and experience in the areas of compression drivers, coaxial systems, constant directivity, and crossover networks. An important part of the workshop will be specifically developed measurement

computer programs. Sponsors include Community Loudspeakers, Systems Contractor News, and Syn-Aud-Con. Contact Synergetic Audio Concepts, 12370 W. CR 100 N, Norman, IN 47264, (812) 995-8212, FAX (812) 995-2110.

amplifiers for low-power applications. The units draw less than 6.6mA of supply current, can drive a 50pF capacitive load with a distortion of –66dBc at 5MHz, and are suitable for use with low-power, high-speed analog-to-digital converters in power-sensitive video applications. Serving a wide range of active filters, the units can also be used as IF/RF amplifiers or cable drivers. Analog Devices, Inc., 181 Ballardvale St., Wilmington, MA 01887, (617) 937-1428, FAX (617) 821-4273.

Reader Service #102

AND THE WINNER IS...

A first-time-ever speaker design competition, devised to showcase the sonic merits of low-powered, single-ended amplifiers, has recently been announced. Although the contest is open to all designs, emphasis is on speakers with average sensitivities in the 94dB+ range. Grand prize will be the Welbome Labs Laurel II 300B monoblock amplifier kit featuring Magnequest's hand-wound output transformers. Additional prizes will be supplied by Parts Connection, Audio Electronic Supply, Hovland, Positive Feedback, and Sound Practices. Entries are due by Sept. 31, 1995. For rules and entry forms, send a SASE to Colorado Audio Society, 1941 S. Grant St., Denver, CO 80210.

VOLTAGE FEEDBACK OP AMPS

The new AD8047 and AD8048 from Analog Devices are 250MHz, wide-bandwidth, high-speed voltage feedback

Speaker Builder (US ISSN 0199-7929) is published every six weeks (eight times a year), at \$32 per year, \$58 for two years; Canada add \$8 per year; overseas rates \$50 one year, \$90 two years; by Audio Amateur Publications, Inc., Edward T. Dell, Jr., President, at 305 Union Street, PO Box 494, Peterborough, NH 03458-0494. Second-class postage paid at Peterborough, NH and an additional mailing office.

POSTMASTER:
Send address change to:
Speaker Builder, PO Box 494
Peterborough, NH 03458-0494

The Industry's Finest Connectors.

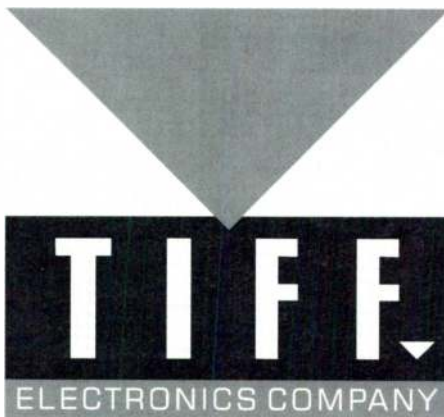

TIFF Electronics Company • 44 Pearl Pentecost Road / Winder, GA 30680 • (404) 867-6300 / 2713 (Fax)

Precision Development Tools for Precision Loudspeaker Designs

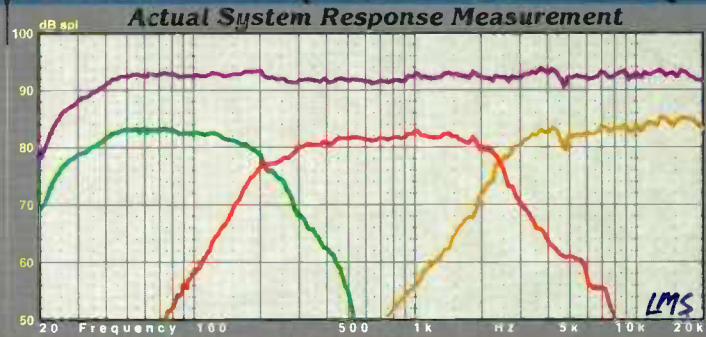
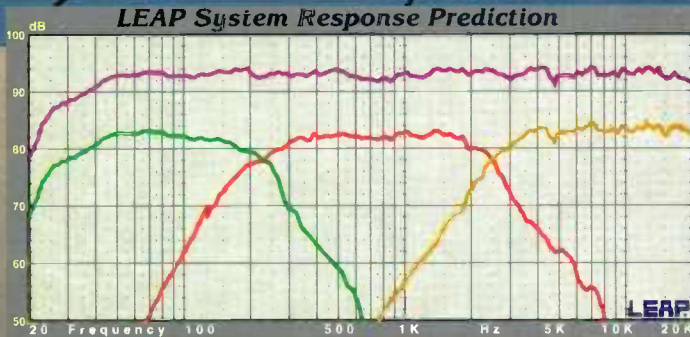

The Art and Science... of loudspeaker system development today has become more complex than ever before. Competition is tough, and to compete each design must perform to the best of its ability, and make the most out of every dollar's worth of transducer cost. The simple approach of choosing a combination of seemingly appropriate transducers coupled with ordinary networks and filters, has given way to a painstaking process of meticulously blending selected transducers in combination with carefully devised and matched crossover designs.

■ Seminars/Workshops available, call for details

LEAP (Loudspeaker Enclosure Analysis Program) is a complete full range analysis package which provides virtually all of the tools necessary to develop precision loudspeaker systems, for today's demanding audio markets. Whether your applications are consumer audio, car stereo, professional audio, or custom esoteric marvels, LEAP provides the power, flexibility, and accuracy to investigate every possible design permutation. The open architecture and broad spectrum of features provided will dramatically reduce your development time, while improving the quality of the final result... and demonstrates why LEAP has become the #1 choice of professional loudspeaker designers world-wide!

Advanced Transducer/Enclosure Simulations

- ✓ Sealed, Vented, Bandpass, PR Simulations with multiple speaker/ port capability.
- ✓ Large signal analysis of TempVC, and Non-Linear BL/ Ports/ Compliance.
- ✓ Acoustic Parallel or Acoustic Series (Isobaric) Driver Mounting.
- ✓ Port Standing Wave resonance modeling.
- ✓ Frequency Dependent Rvc and Levz modeling.
- ✓ Library storage of 36 transducer parameters, and over 24 enclosure parameters.
- ✓ Generic transducer modeling of electro-dynamic, ribbon, and piezo devices.

Advanced System Analysis Features

- ✓ Use simulation or imported actual measured SPL/Z data.
- ✓ 5-Way crossover system modeling, and more.
- ✓ Time offset between transducers.
- ✓ Active or Passive based crossovers.
- ✓ Hilbert-Bode transform for deriving phase.
- ✓ 22 Passive components per crossover section.
- ✓ 16 Active filter blocks per crossover section.
- ✓ Passive Network Optimizer for single/system response.
- ✓ Active Filter Optimizer for single/system response.
- ✓ Frequency ranges from 11Hz to 100kHz.

Printer/Output Formats

When you wish to produce a hardcopy output of your finished designs and graphical data, LEAP supports a large number of printer standards, and even supports numerous desktop publishing graphic formats in both black & white and color! Portrait/Landscape orientations in any custom size and aspect ratio are user controllable.

- ✓ IBM/Epson 8 Pin Dot Matrix
- ✓ Epson 24 Pin Dot Matrix
- ✓ HP LaserJet Series Printers
- ✓ HPGL Compatible Plotters
- ✓ PostScript EPS/TIF/ B&W/Color
- ✓ AI Adobe Illustrator B&W/Color
- ✓ NEC 24 Dot Matrix
- ✓ TOSHIBA 24 Dot Mat
- ✓ HP DeskJet 500C
- ✓ PostScript Printers
- ✓ DXF AutoCAD
- ✓ TIF/ BMP, PCX Plots

Development Utilities

- ✓ Quick Cabinet Box Designer
- ✓ Conjugate Network Designer
- ✓ Wire Table Calculator
- ✓ Multi Curve Averages
- ✓ Import Data from ASCII Files
- ✓ Crossover Network Designer
- ✓ Spki Parameter Measurement
- ✓ Voltage/Current/Imp Calculator
- ✓ Motor Constants Calculator
- ✓ Export Data to ASCII Files

Extensive Documentation

The two volume manual set comprises almost 1,000 pages of documentation which thoroughly covers the operation of the program- and provides numerous examples of how to maximize your use and understanding of the program's many features. The Reference Manual describes all graphs, menus, commands, and their operation. This manual explains the unique and special non-linear speaker and port models, as well as proper use of the optimizers, importing data, and the many other utilities. The Application Manual provides many exciting examples showing how to use the powerful features of the system in a combined manner to perform both simple and complex design tasks. Both novice and experienced users alike will find this information invaluable for exploiting the full power of the system. Additional information is also provided on loudspeaker measurements, design tips, filter calculations, and complete crossover system development for both passive and active based systems.

- ✓ 502 Page Reference Manual
- ✓ 436 Page Application Manual

Call for a free Demo Disk!
TEL: (503) 620-3044



LinearX Systems Inc 7556 SW Bridgeport Road Portland, OR 97224 USA Tel: (503) 620-3044 Fax: (503) 598-9258

International Dealers: Argentina: Interface SRL (54-1)741-1389/Australia: ME Technologies 61(0)65-50-2200/Austria: Audiomax 49(0)71-31-162225/Belgium: Belram 32(0)2-736-50-00/Canada: Gerraudio 416-696-2779/Denmark: AET Ljudproduktion 46(0)8-623-08-70/France: Belram 32(0)2-736-50-00/Germany: Audiomax 49(0)71-31-162225/Indonesia: Ken's Audio 62(0)21-639-5806/Italy: Outline snc 39-30-3581341/Korea: Sammi Sound: 82(02)463-0394/Luxembourg: Belram 32(0)2-736-50-00/Malaysia: AUVI 65-283-2544/New Zealand: ME Technologies 61-65-50-2254/Norway: AET Ljudproduktion 46(0)8-623-08-70/Philippines: Dai-ichi Denshi (63)-2631-69-80/Poland: Inter-Americom 48(22)43-23-34/Singapore: AUVI 65-283-2544/Sweden: AET Ljudproduktion 46(0)8-623-08-70/Switzerland: Audiomax 49-71-31-162225/Taiwan: Gestlon Taycan Int 886-2-786-3468/Thailand: AUVI 65-283-2544/The Netherlands: Duran Audio 31-41-80-15583/UK (England): Munro Assoc 44(0)171-403-3808.

Editorial

KIT KICK

Climbing up the ladder leading to the swimming pool's diving boards for the very first time imprints memories in the mind which remain vivid and unforgettable. "Am I really going to do this? How come I want to do this?" and other terrifying questions race through the mind as your feet move up one rung after the other. As you step onto the board, which from the firm cement perimeter of the pool looked so substantial, it seems to shrink and grow narrower with each step. The water looks very far away, even though there are two, much higher, boards above your head. You resist the temptation to fall to your knees and grip the sides of the board with both hands to make a safe journey out to the matted end. Your legs feel terribly foreign and unstable, not to mention rubbery.

Things go from bad to worse when your friends notice your hesitation and fear. Their shouts of encouragement turn eventually to exasperation and finally to jeers. In the end you just stop thinking at all, push with all your might, and dive. If you're lucky you hit the water in a reasonably perpendicular angle. If not, you learn one of the prime lessons about diving: water is much friendlier entered with a small portion of the body as possible.

However much you have hesitated, and however frightened you may have been during the agony of becoming airborne, the realization that you have actually done it, alone, and successfully (you are still alive) is one of life's best moments.

The conquest of your own fear in the face of doing something for the first time is also one of life's most important experiences. I receive letters often from readers who write to ask "What happens if I..." Each time I am reminded of a vignette from Richard Feynman's early life. His biographer reports that Feynman's mother, usually in the middle of a Bridge game with neighbors, knew that young Richard was performing yet another experiment when she could smell something burning. This usually meant he was leaning out his upstairs bedroom windows gingerly holding a metal trash can from which smoke billowed. When I get a "What happens" letter, I usually think, why not try it and see?

Feynman's rise to a place of great distinction in the exploration of physics owed a great deal to his willingness to take any risk to learn what happens next. My most important electronics diving board was a 7W integrated amplifier kit from the Heath Co. Ordering and receiving goods via mail order is still magical to me, even

to this day. But the feelings on opening the box from Heath were a combination of anticipation, excited discovery, and a massive attack of butterflies somewhere in the upper colon.

Fortunately, the Heath support system provided a sure-footed way to find the end of the board as well as the courage to plunge. It also furnished the kind of instruction and support which were important to my success in finishing the amplifier. The pleasure and sense of accomplishment when the device you have assembled actually works and then produces sound when you hook up the phono and the speaker is unique. The sensation is something more than a triumph of courage, it breaks a wall of mystery which too often surrounds complex devices. Our increasingly complex technology, or, more accurately, our perception of a more complex technological environment, has the majority of the population cowering in the bathhouse, unwilling even to put on a bathing suit.

The steady decline of electronics periodicals dedicated to building equipment, combined with the slow evolution of Heathkit into merely Heath with a yuppie catalog of wading pool gadgets, is symptomatic of the declining interest and personal involvement in how things are assembled. The language has changed too: techies are all automatically nerds. If a book on CD-ROM technology sets out to describe how a disk is recorded, the authors are obliged to issue dire warnings about the upcoming techie territory ahead.

This attitude is pretty much limited to electronics, though. I suspect the terminology is defensive paranoia for the most part. I don't hear such comments about guys who modify stock cars for racing. Are these techies too? The differences escape me, somehow.

Fortunately, humankind can walk around frightened for just so long. After a while our curiosity overcomes our fears and we begin to dabble again. Public television has been one of the primary influences in encouraging ordinary mortals to try handcraft skills again. Cooking and gardening were the first camel noses under the edge of the tent. We've gone on to upgrading houses, building furniture, and trying craft ideas of nearly every description. These crafts are less frightening and thus more acceptable, so more people can adopt them without becoming too daunted. When the talk turns to rockets, telescopes, lasers, computers or power amps, the fear sign rises very quickly. These are not crafts, they're arcane, scary science for techies only.

We are just beginning to see some encouraging

signs of change, however. Science fairs are a good omen. Technological contests for inventiveness, lightweight aircraft, solar-powered cars, as well as fancy kites and balloons are all excellent evidence of a less fearful, adventurous generation.

Closer to home it is heartening to see more loudspeaker kits offered from a number of sources. Last issue we accompanied Nancy MacArthur on a trip through one of Vance Dickason's Audax-based designs, with contributions by Madisound and Solen. In this issue Gary Galo updates his review of the Audio Concepts Sapphire III system—which I am delighted to say is again a kit offering from that company. The policy change is a direct result of your letters and phone calls to Mike and Mary Dzurko asking for a reprieve on their decision to discontinue kits. Any number of *Speaker Builder* advertisers offer speaker kits, with or without boxes, but usually with cabinet plans for the asking. Obviously your positive feedback does wonders in persuading company managers to offer kits. Supply and demand still works quite well.

Other good signs for the valiant builder dot the horizon. New electronics kit offerings are available from Parts Connection in Toronto, Audio Electronic Supply, Welborne Labs, Angela Instruments, World Audio Supply in the UK, Copeland Electronics, Curcio Electronics, Bear Labs, and PAiA Electronics, just to name a few. Kits of speaker parts are equally numerous.

A distinct difference in both electronics and speaker kits is clearly evident, however. In the past kits were often "economy versions" of the commercial counterpart, but today, kits are quite often indistinguishable from the equivalent high-end product. The price may differ significantly, but the parts are very often identical.

This trend fits exactly into the underlying purposes of the three magazines published by this company: upgrading stock equipment for better performance (in *Audio Amateur* it is Progressive Optimization Of Generic Equipment, or P.O.O.G.E.). Then why should kits enter the world at the bottom rung of the ladder? No reason, I suppose, just shortsighted thinking.

As an encouraging starting point, kits make great diving boards for this avocation. They are more than a mere economy move, however. They educate. They build confidence. They build bridges to new territory. But they are the beginning of a journey through more experience, more learning, and better and better sound.—E.T.D.

Design a PWM switching power amplifier into your next powered audio product... and do it without R&D.

LGT Technologies provides OEM power solutions for audio designers requiring small size, ultralight weight, and clean high-efficiency output.

We offer a range of power modules, with ratings of 150 to 500 watts*... optimized for full-range or low-frequency reproduction... with conventional linear power supplies or switching mode supplies. We can incorporate custom circuitry for your specific design onto the same circuit board... such as an active filter network or special processing.... all with little or no R&D expense.

LGT Class-D amps are stable and reliable, providing low distortion, and excellent frequency response. Contact Terry Taylor for full details and a development kit with demo board.

*4Ω

895 Cherokee Boulevard Chattanooga, TN 37405

Tel: 615-756-0706

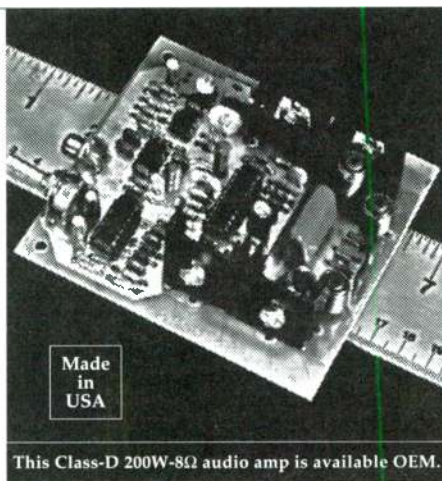

This Class-D 200W-8Ω audio amp is available OEM.

Sales Agent: **ACOUSTICAL SUPPLY INTERNATIONAL** ©1995 ASI

Fax: 615-756-0860

Reader Service #79

In Memoriam

Raymond E. Cooke
1925-1995

We were saddened to hear of the passing of KEF founder, Raymond Edgar Cooke, 70, on March 19. He received an OBE (Order of the British Empire) for his service to the British audio industry and served as president of the Audio Engineering Society in 1983.

His interest, at an early age, in music and gramophones soon evolved to loudspeaker and amplifier design. His first job was as an analytical chemist for the London North Eastern Railroad, but it was in the Navy that his audio interest flourished. He served in World War II as a radar technician and began to design and build amplifiers.

At the age of about 22, he took up formal study of electronics, radio, and loudspeaker research at Battersea Polytechnic (later part of Surrey University), from which he obtained a BSc in electrical engineering. His work impressed Gilbert Briggs, and he became a consultant to Wharfedale and collaborated with Briggs on several of his books. He worked with the BBC in the design and manufacture of disk and tape recording equipment. In 1955, Cooke joined the Wharfedale company in a full-time position as technical manager, and, while there, is credited with inventing the acoustic filter, as well as with his work on enclosure design and high-frequency units.

After six years, he left Wharfedale and started KEF (Kent Engineering Foundry) Electronics in 1961. His pioneer work in diaphragm design (from paper to plastic) as well as his attention to system integration in producing "matched" speaker pairs led to the success and high regard of the company, which is headquartered in Tovil, England, about 40 miles south of London.

The company introduced new materials, chiefly plastics, and, with input from Bradford University and Hewlett-Packard in California, developed revolutionary new measurement techniques using early computers. The research led to a number of seminal loudspeaker designs in the 70s and early 80s, all as successful commercially as they were acoustically, and are still to be heard today in the KEF Reference Series of loudspeakers.

He is survived by his second wife, Jennie Goossens, a son and daughter by his previous marriage, and two grandchildren.

Speaker Builder

The Staff

Editor and Publisher

Edward T. Dell, Jr.

Contributing Editors

Joseph D'Appolito Robert Bullock
Richard Campbell John Cockroft
David Davenport Vance Dickason
Bruce Edgar Gary Galo
G.R. Koonce Richard Pierce

Assistant Publisher

Karen Hebert

Dennis Brisson Managing Editor

Mary Wagner Associate Editor

Glenn Galloway Graphics Director

Production Assistants

Brian Jenkins Diane Luopa

Laurel Humphrey Marketing Director

Robyn Lasanen Circulation Manager

Kathleen Kennedy Circulation Assistant

Allison Pelkey Administrative Assistant

Advertising Rates & Schedules

Martha L. Povey National Advertising Director

Laura Brown Advertising Assistant

(603) 924-9464 FAX (603) 924-9467

The peculiar evil of silencing the expression of an opinion is, that it is robbing the human race; posterity as well as the existing generation; those who dissent from the opinion, still more than those who hold it.

— JOHN STUART MILL

Speaker Builder is published eight times a year in the interest of high-quality audio reproduction.

No material in *Speaker Builder* may be used in any form without the written permission of the publisher.

Subscription Inquiries

A one year subscription to *Speaker Builder* is \$32. Canada please add \$8. Overseas rate is \$50 per year.

To subscribe, renew or change address write to Circulation Department or call (603) 924-9464 or FAX (603) 924-9467 for MC/Visa/Discover charge card orders.

For gift subscriptions please include gift recipient's name and your own, with remittance. A gift card will be sent.

Send circulation and editorial correspondence to *Speaker Builder*, PO Box 494, Peterborough, NH 03458-0494. No responsibility is assumed for unsolicited manuscripts. All manuscripts must include a self-addressed envelope with return postage. The staff *will not* answer technical queries by telephone.

Printed in the USA. Copyright © 1995 by Audio Amateur Publications, Inc. All rights reserved.

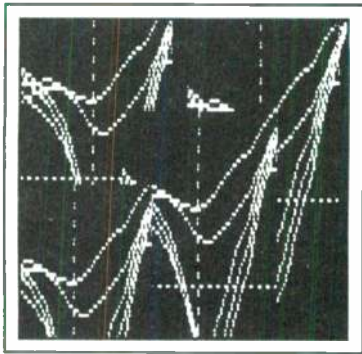

14

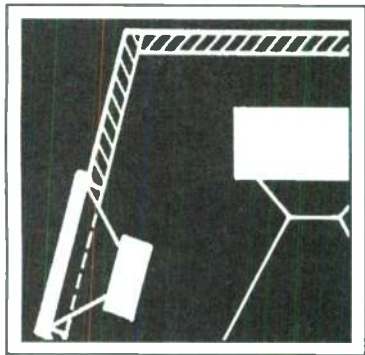

28

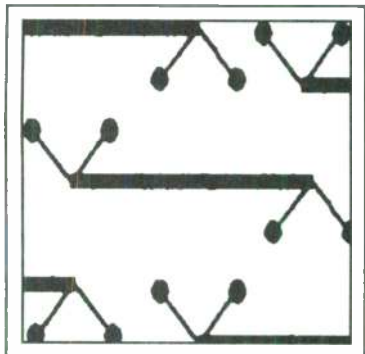

40

Speaker Builder

THE LOUDSPEAKER JOURNAL

VOLUME 16 NUMBER 3

APRIL 1995

8 Satellites For a New System

BY MATTHEW EVERIST

14 Box Models: Benson Versus Small

BY G.R. KOONCE

22 From Sad to Sparkle: A SAAB Story, Part 2

BY MARK FLORIAN

28 A Compact Two-Way PA, Part 2

BY BILL FITZMAURICE

40 PRODUCT REVIEW Sapphire III Reference Monitor

BY GARY A. GALO

49 BOOK REPORT The Complete Guide to High-End Audio

BY GARY A. GALO

DEPARTMENTS

3 GOOD NEWS

5 EDITORIAL Kit Kick

32 WAYLAND'S WOOD WORLD
BY BOB WAYLAND

48 VINTAGE DESIGNS

53 READING ROOM

54 ASK SB

BY DICK PIERCE

57 TOOLS, TIPS & TECHNIQUES

BY PHIL BAMBERG AND ALAN ERSEN

58 SB MAILBOX

67 CLASSIFIED

70 AD INDEX

SATELLITES FOR A NEW SYSTEM

By Matthew Everist

My speaker building started in the '60s, when I became interested in rock-'n'-roll music. Like many young people, I had visions of becoming a star performer. With a little help from my friends, I learned to play bass guitar and attempted backup singing. Little did I realize then that this youthful experience would spark a lifelong interest in electronics and building my own speakers. By the way, my career as a rock-'n'-roll star earned me about \$100 for three sock hops.

My first stereo system consisted of a Dynaco (I think) amp and preamp that I built from kits, along with drivers from an old Fender bass guitar amplifier. I didn't even put the drivers in separate cabinets; I simply wired each driver to its appropriate amplifier channel. I believe Leo Fender used modified JBLs in those days. Needless to say, it had very little high-frequency content.

My first full-range system included JBL drivers and assembled crossovers that were offered to speaker builders in the late 1970s. These drivers lasted in various boxes until late 1991, when I burned out both tweeters. In my search for replacements (the tweeters were repairable, but for \$50 apiece), I discovered *Speaker Builder* magazine. With two years of back issues and a current subscription, I set out to design and build my first full-fledged speaker system.

SYSTEM REQUIREMENTS

I chose a speaker system best-suited for music, but I also needed a system consisting of a center channel with four satellites and two subwoofers for my Dolby Pro Logic video setup. The satellites and center channel speakers need the same sonic signature, which is one of the most important criteria in a stereo/surround setup. What better way to accomplish this goal than to build the speakers with the same drivers.

Finding room for two subwoofers can be difficult in a normal-sized living room, but they provide a more balanced sound—no hot spots or nulls. I

planned to position my subs in corners or built into end tables, so their size would not cause any problems. I intended to place the center channel on the top or the bottom of the TV, and the satellites in some small area, such as a bookcase, a wall, a corner, or on stands in a corner. After I determined their locations, I would optimize each speaker's crossover.

With these parameters in mind, I started looking through catalogs and talking to suppliers. I also purchased the latest edition of *The Loudspeaker Design Cookbook* and Ralph Gonzalez's *Loudspeaker Modeling Program*—both outstanding tools for amateur speaker builders (both are available

from Old Colony Sound Lab, PO Box 243, Peterborough, NH 03458 (603) 924-6371, FAX (603) 924-9467).

COMPONENT SELECTION

After reading Mark Rumreich's "Box Design and Woofer Selection: A New Approach" (*SB* 1/92, p. 9), I chose a pair of JBL 128Hs (12" woofers) from my old speakers to use as the subwoofers. I decided to put one of the subs in the lower corner of a ceiling-high wall-unit bookcase with a usable volume of 4.68 ft³. I used the entire area, and as you can see from the calculations (*Table 1*), f_3 will be about 27–29Hz.

The only discrepancy I encountered between the calculations and computer-generated charts was the vent lengths. I have no test gear with which to tune the cabinet, so I compromised by using a 3" long port with a 3" diameter. I decided to use only one sub and leave the other one until I finished the satellites. Maybe I will have test gear by then and be able to tune them correctly, although the one sub sounds very good as it is.

The drivers for the satellites and the center channel will not handle any low-frequency information (the subs will handle below 80 or 100Hz), which allows me to keep them compact. I chose the Focal 5K013L and the Morel MDT30 drivers, both of which have good power response curves and reasonable power-handling capabilities. I read positive things about both in *SB* articles. With these drivers in mind, I proceeded to design my cabinets.

CABINET DESIGN

As a novice speaker builder, I did not find anything intuitive about the whole project, but I did borrow a few ideas from my reading to incorporate into my design:

1. Concerned with phase shifting and lobing problems, because of non-coincidental radiation from the two drivers, I considered a stepped baffle, but did not like its looks nor its con-

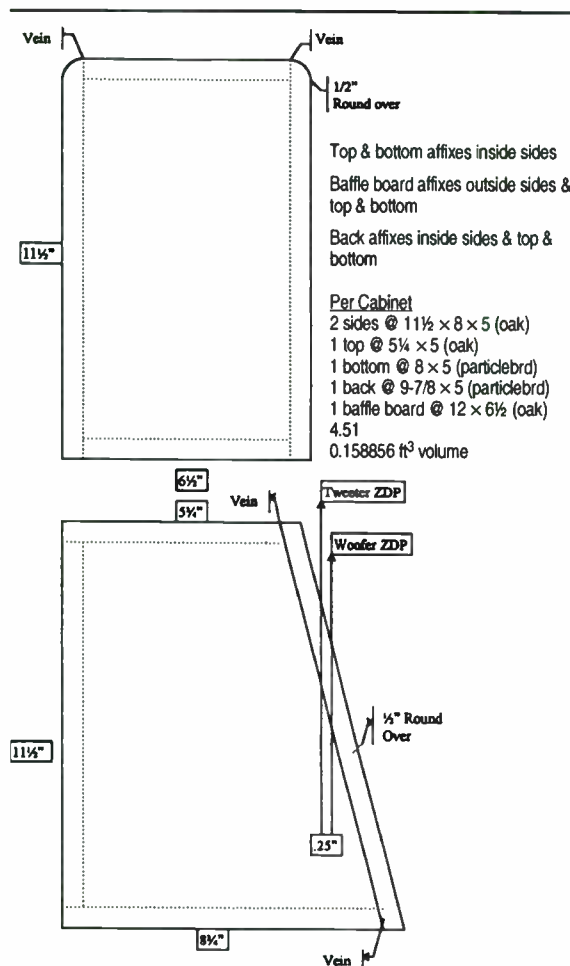

FIGURE 1: Cabinet design and specs.

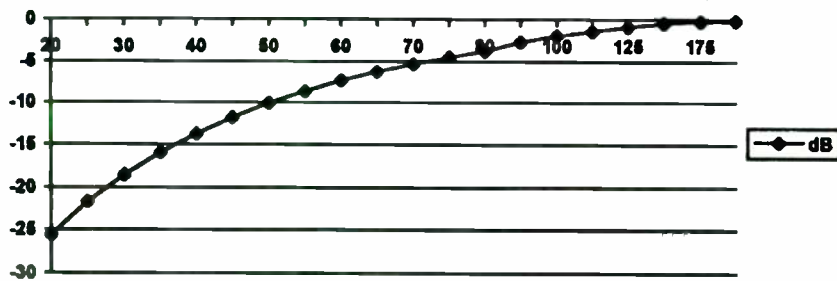

FIGURE 2: Program printout showing stuffed/unstuffed responses.

struction difficulty. I also considered using the crossover to handle the time delay problems, but felt this would be too involved for my first design. Instead, I decided on a sloped baffle board.

2. Much of my reading mentioned standing wave problems (I understand the principle, but am not sure what a speaker with a bad standing wave sounds like), and I fig-

ured enclosure stuffing and a sloped baffle would help with this problem.

3. Flush-mounting both drivers helps with diffraction effects caused by protrusions on the baffle board. I even designed the cabinets without grille covers, eliminating associated protrusions. The tweeter was easy to flush-mount, but the irregularly shaped mid-woofer proved too difficult to handle.

4. I needed to maintain as small a distance as possible between both drivers, and also keep the baffle board small with respect to the drivers. This helps with the speaker imaging, and also with interference between the drivers' outputs at and around the crossover frequencies.

5. I liked the look of rounded-off edges, which might also provide a smoother response.

6. My goal was to achieve a sealed cabinet with a Q_{TC} of around 0.71 to produce close to the lowest f_3 point attainable. Also, of the systems I have heard, I prefer ones with the cleaner and more detailed midbass that a Q_{TC} of 0.71 produces.

7. The design should allow a -3dB point of between 80 and 100Hz; the subs would handle the rest.

CONSTRUCTION

Most people have access to the tools I used to construct the cabinets, except maybe a portable table saw (although they are not very expensive). I extensively used a T square, clamps, a router with a circle-cutting adapter, and an oscillating hand sander, among other usual tools. In most construction projects, it is very important to use sharp saw blades that are adjusted correctly and squared up with the table. It's best to make all similar cuts at one time, so all the pieces end up the same and you avoid any surprises when you assemble the cabinets. It is also a very good idea to measure at least three times. Of course, I discovered this after wasting some wood.

After many calculations, drawings, and wadded-up paper, I arrived at a cabinet design that met my parameters (Fig. 1). My design presents a usable volume of 4.51, which easily lets me meet my -3dB point. I

Response Chart

Frequency 1A CB (dB, $Q_{TC} = .71$)

(Hz)	1A CB	$Q_{TC} = 0.71$
20	-25.57	$f_s = 51.50\text{Hz}$
25	-21.71	$Q_{TS} = 0.420$
30	-18.57	$V_{AS} = 0.407\text{ft}^3$
35	-15.94	$V_B = 0.219\text{ft}^3$
40	-13.70	$\alpha = 1.862$
45	-11.76	$f_3 = 86.77\text{Hz}$
50	-10.07	$f_c = 87.12\text{Hz}$
55	-8.61	
60	-7.33	
65	-6.23	
70	-5.28	Driver Data
75	-4.47	Priss2591
80	-3.78	$f_s = 51.50\text{Hz}$
90	-2.70	$Q_{TS} = 0.420$
100	-1.94	$V_{AS} = 0.41\text{ft}^3$
110	-1.41	$V_{AS} = 11.50\text{lit}$
125	-0.89	
150	-0.45	
175	-0.24	
200	-0.14	System Data
		1A CB
		$Q_{TC} = 0.71$
		$V_B = 0.219\text{ft}^3$
		$V_B = 6.177\text{lit}$
		$f_3 = 86.77\text{Hz}$
		$\alpha = 1.862$
		$f_c = 87.12\text{Hz}$

TABLE 1

DESIGN CHART

Parameters	JBL128
f_s Driver free air resonance (Hz)	20.00
Q_{ES} Driver electrical Q at f_s	0.250
Q_{MS} Driver mechanical Q at f_s	7.000
R_E Driver voice coil resistance (Ω)	5.70
R_G Added resistance in driver circuit (Ω)	0.200
Q_{ESC} Corrected Q_{ES} for addition of R_G	0.259
Q_{TS} Driver total Q at f_s	0.250
V_{AS} Driver compliance volume (in ft^3)	9.900
(in liters)	279.48
V_B Enclosure net volume (in ft^3)	4.679
(in liters)	132.09
α System V_{AS} to V_B ratio	2.116
f_3 System -3dB frequency (Hz)	27.81
f_B Box tuned frequency (Hz)	25.23
Rh System has a response anomaly of:	-2.00dB

Note: +Rh indicates a peak in response, -Rh indicates a dip.

JBL128 VENT DESIGN

Vent Diameter (inches)	Vent Length (inches)
2.00	1.39
2.25	1.96
2.50	2.63
2.75	3.38
3.00	4.22
3.25	5.15
3.50	6.17
3.75	7.28
4.00	8.48
4.25	9.77
4.50	11.15

$$\text{box freq } (f_B) = f_s \times 0.39 = 31.2\text{Hz}$$

$$\text{opt box freq } (f_{ob}) = f_s / Q_{TS} = 80\text{Hz}$$

$$\text{opt freq vol } (vol) = V_{AS} / Q_{TS}^2 = 0.619$$

$$\text{fixed box freq } (f_{fb}) = f_s \times V_{AS}^{1/2} = 62.93$$

$$\text{fixed freq } (vff) = V_{AS} \times f_s^2 = 3,960$$

$$V_B = vff / f_3^2 = 4.68\text{ft}^3$$

$$f_3 = f_{fb} / V_B^{1/2} = 29.04\text{Hz}$$

$$\text{Port length } 3" \text{ Dia.} = \frac{2.117 \times D^2}{F_B^2 \times V_B} - 0.732D = 2"$$

used biscuits to join the sides with the back and the bottom (Photo 1). I also attached the baffle board with biscuits, and the top with glue. Glue blocks on the entire length of all the joints (Photo 2) ensure strength and an airtight cabinet.

I used $3/4"$ red oak board from the local hardware store. This wood, after sanding, sealing, and staining (if desired), does not require any other treatment for a very professional look. I learned from this project that it is not a good idea to use two different types of wood on one cabinet. The bottoms and backs are particleboard, and no matter how many times you sand the joints smooth, the two wood types will contract and expand with humidity at different rates, regardless of how well you seal them.

Displeased with the way the oak looked at the joints (the grain abruptly changed directions), I used a router and a small vein bit to cut a groove where the tops, sides, and the baffle boards are joined. I painted this groove black, which helped break up the changing direction of the grain and produced a better look (Photo 3).

All I needed to flush-mount the tweeter, with its round shape, was a router with a circle guide attachment. But the midwoofer with its irregular shape proved too difficult to flush-mount. I tried making a template, as well as freehand, but nothing worked to my satisfaction. Any suggestions from readers?

After building all four satellite enclosures

ABOUT THE AUTHOR

Matthew Everist lives in Orlando, FL, with his wife of nine years and their very active 5-year-old son. Matthew has an AS degree in electronics, and has been a sales rep for a bus parts company for 14 years. Other than working with his hands, he enjoys going to the beach and trying to keep up with his son.

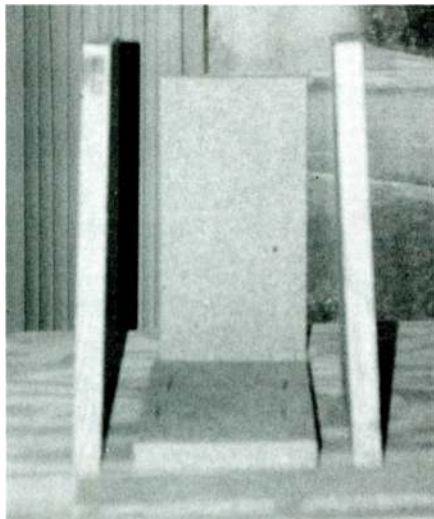

PHOTO 1: Biscuits join the sides with the back and the bottom.

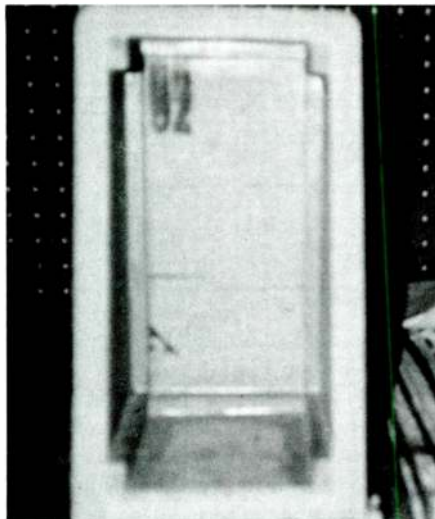

PHOTO 2: Glue blocks on the length of all joints.



PHOTO 3: A groove improves the appearance of the joints.

minus their baffle boards, I reexamined the intended drivers. Because of some cash-flow problems, I was unable to purchase these drivers. But in my supplier catalogs, I found very good substitutes that would fit in the enclosures I built.

I bought the Peerless 130WR (4Ω) and the Vifa D19TD-05 (8Ω) drivers from Madisound Speaker Components. I chose

TABLE 2

SYSTEM RESPONSE

Without stuffing	With stuffing
$Q_{TC} = 0.7907$	$Q_{TC} = 0.707$
$\alpha = 2.5486$	$\alpha = 1.8336$
$f_C/f_S = 1.8826$	$f_C/f_S = 1.6833$
$f_3/f_C = 0.9075$	$f_3/f_C = 1.0$
$V_B = V_{AS}/\alpha = 4.51$	$V_B = V_{AS}/\alpha = 6.27$
$f_C = (f_C/f_S) \times f_S = 97\text{Hz}$	$f_C = (f_C/f_S) \times f_S = 87\text{Hz}$
$f_3 = (f_3/f_C) \times f_C = 88\text{Hz}$	$f_3 = (f_3/f_C) \times f_C = 87\text{Hz}$

the 4Ω midwoofer because the sensitivity of the two drivers matches better, and I would not need any attenuation circuits in the crossover for the tweeter. The Vifa tweeter provided good performance and required the same size cutout as the Morel tweeters, in case I wanted to update them later.

STUFFING RESPONSES

Other than the obvious suppression of internal standing waves, enclosure stuffing with certain types of material has a definite effect on system performance. The most important is the increase in compliance, which is the equivalent of increasing the enclosure volume, which, in turn, lowers the Q_{TC} . Without any way to test the response, I assumed that the Q_{TC} dropped by 10% when

I stuffed my enclosures (a valid assumption?) and calculated both with and without stuffing (Table 2). I filled my enclosures about 75% with standard R19 fiberglass (the amount is difficult to judge because fiberglass is very easily compressed).

As you can see from the Table 2 results, stuffing my enclosures did not make much difference. The resonant frequency of the enclosure drops almost 10% (does this make for more detailed bass?), but the f_3 point of the enclosure hardly changes. When I test my speakers, I will know if my assumptions are correct, but in the meantime, I will assume that I have attained a closed box with a Q_{TC} of 0.71 and an f_3 of 87Hz (Fig. 2).

CROSSOVERS

Throughout this construction project, I used the Loudspeaker Modeling Program. As with any computer program, it is only as good as your input data. After carefully modeling the drivers' parameters (Table 3) and entering that information, I started working toward a crossover that would enable an acceptable frequency response.

I needed at least a second-order crossover; a first-order wouldn't provide enough protection for the tweeter, and a third- or fourth-order would be too complicated for my first design. After many iterations, I discovered a suitable crossover (Table 3), which, along with the input data of the drivers, results in a theoretical frequency response shown in Fig. 3. On the midwoofers, I used an impedance equalization circuit, which I mounted across their terminals. This placement makes more sense to me, because if I ever move the driver somewhere else, the equalization circuit will go with it.

Since I planned to mount the front satel-

lites in the wall/bookcase, the books surrounding the speakers act as an extension of the baffle board, so I made no adjustments in the crossovers for the response step that Ralph Gonzalez has discussed in various articles. Also, putting the front satellites in the bookcase helps with any wall-reflection problems. The unevenness of the books scatters reflections randomly throughout my listening room. I placed the rear satellites in the rear upper corners, which act like the bookcase, and require no adjustments for the response step.

I mounted the crossover components on two separate boards with tie wraps. The separate boards keep any interaction between the inductors at a minimum, and the tie wraps make it easy to change components.

IDEAL CROSSOVER

I anticipated I would need to change crossover component values to spread the knees of the crossovers' frequencies to produce a smooth theoretical frequency response. But I was wrong. After adjusting the crossovers to produce the frequency response shown in the graph (Fig. 3), I calculated their Q values. The Q value for the tweeter crossover was 0.54, and 0.49 for the midwoofer crossover.

PREVIEW
Glass Audio

Issue 2, 1995

- Peak Reading Level Meter
- 15W Triode Power Amp
- Guitar Amp Refinements

Forgings TWEETER / SYNCHRONOUS SPEAKER

HUNDREDS OF OUTSTANDING TWEETERS
ARE AVAILABLE FOR EVERY OF YOUR PROJECT



Eyeball Tweeter

Newest Tweeter with
one-piece diaphragm in Super
Duralumin, Titanium ...
material.

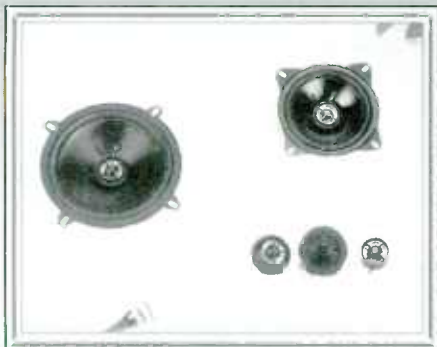

DOME TWEETER :
@USD 0.79



**Ø 13mm Neirbon
Super-Tweeter**

- ❑ Supreme know-how and continuous research
- ❑ Hi-quality products at the most competitive pricing
- ❑ Available for OEM design and free catalogues

You'll be surprised to find we're the one you've
been looking for !



FORGINGS IND. CO., LTD. / P.O. BOX 1823, TAIPEI, TAIWAN, R.O.C.
TEL: 886-2-585-3316/7 FAX : 886-2-594-2708 ATTN: MS. LU CHI YING

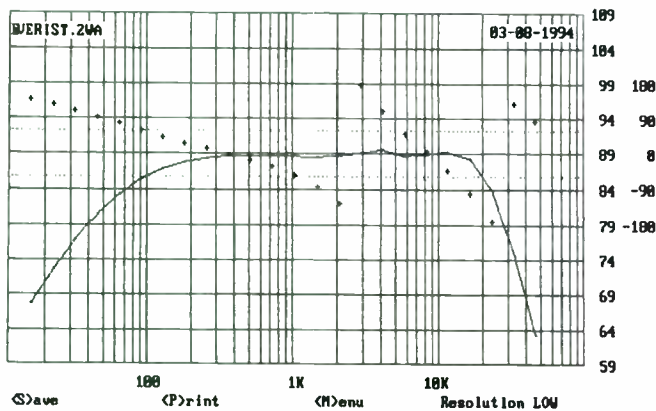

FIGURE 3: System's crossover and frequency response.

From my reading, I learned that a Q value of 0.50 is ideal for a two-way Linkwitz-Riley second-order crossover with the drivers -6dB down at the crossover frequency, assuming no driver offset occurs. This ideal crossover sums the two drivers' outputs for a flat frequency response.

I cannot attribute this almost perfect crossover to blind luck and/or knowledge. Without test equipment, getting this close to the ideal would have been impossible if not for the Loudspeaker Modeling Program (LMP). I recommend it to anybody just getting started, and even to more experienced builders.

After loading the drivers in the cabinets, I measured again and found that the driver ZDPs were not aligned. The tweeter was 0.25" behind the midwoofer. After entering this information into LMP, I ran another graph (Fig. 4). I was afraid my mistake would ruin my hard work, but the graph tells a different story.

My surround decoder has a second-order 12dB/octave crossover for a subwoofer built into it. It has a two-position switch for crossover frequencies of 80Hz or 150Hz. I am using the 80Hz setting, and it sounds wonderful with the satellites, but someday I will design my own active crossover for the entire system.

LISTENING TESTS

Placing speakers on their sides is not ordinarily done, but I don't understand why. I achieved my goals using the sloped baffle board, and the distance between each driver and my ears is the same from a vertical or horizontal speaker placement position. With such a small speaker, it does not sound as though I have traded a tall sound for a wide sound; the drivers are so close they almost sound like a coaxial driver. The shape of my cabinets gives me a natural toe-in position, so the tweeters are pointed just in front of my listening area. This shape also keeps the midwoofers' output pointed away from walls,

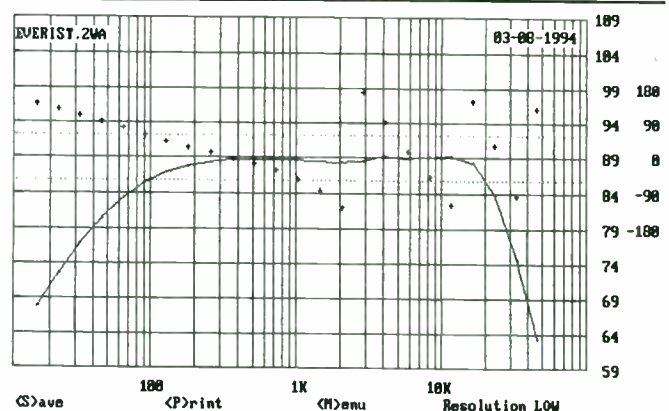

FIGURE 4: Measurement after loading the drivers in the cabinets.

TABLE 3

MODELING PROGRAM INPUT

Driver # 1 parameter entry	Number of drivers in model: 2
Driver description: 5" Mid-woofer (PEERLESS 832591)	
You may <TAB> to next driver	
Low frequency corner (Hz) 52	Low frequency DR/Q 1.190
High frequency corner (Hz) 5000	High Frequency DR/Q 0.500
High freq. rolloff order (2 or 4) 4	Sensitivity (dB) 89
Polarity inversion (Y/N) N	Response step freq (Hz) 0
Depth displacement (inches) 0	Response step height (dB) 0

2nd-order Lowpass

L(k2)
C(k1)
k0 (LOAD)
C1
R1



Load description: 5" mid-woofer (Peerless 832591)

Drive #1 Crossover components

k0 4.000Ω
k1 7.000μF
k2 0.400mH
C1 35.000μF
R1 5.000Ω

Driver # 2 parameter entry	Number of drivers in model: 2
Driver description: 3/4" Dome Tweeter (D19TD-05-08)	
You may <TAB> to next driver	
Low frequency corner (Hz) 1700	Low frequency DR/Q 0.704
High frequency corner (Hz) 22000	High frequency DR/Q 0.625
High freq. rolloff order (2 or 4) 4	Sensitivity (dB) 89
Polarity inversion (Y/N) N	Response step freq. (Hz) 0
Depth displacement (inches) -.25	Response step height (dB) 0

2nd-order Highpass

c(k2)
L(k1)
k0 (load)

Load description: 3/4" dome tweeter (D19TD-05-08)

Driver #2 Crossover Components

k0 8.000Ω
k1 0.400mH
k2 3.000μF

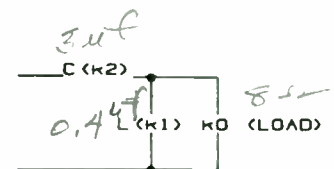

which, in turn, reduces boundary-induced interference.

I entered into this project with many reservations, but because of help from Madisound Speaker Components and the information from *The Loudspeaker Design Cookbook* and *Speaker Builder*, I feel more

confident about this project and have a better understanding of speaker building in general. I have enjoyed many hours of listening to my speakers, which is our speaker building goal. I look forward next to building the subwoofers and center channel speaker for my system.

The Sixth Annual A&S Speakers
Audiophile Sound-off will be held
in July, 1995. Judges include
Vance Dickason, author of the
"Loudspeaker Design Cookbook".
Contact A&S Speakers for details!

A&S
speakers

3170 23rd Street; San Francisco, CA 94110
Telephone: (415) 641-4573 Fax: (415) 648-5306

BOX MODELS: BENSON VERSUS SMALL

By G.R. Koonce

For many years I used R.H. Small's enclosure models in my software and design work. When I received the book *The Theory and Design of Loudspeaker Enclosures* by Dr. J.E. Benson, I decided to try his model. I had hoped R.M. Bullock's excellent review of the Benson book (*SB 6/94*, p. 48) would describe the differences between the Benson and Small models. But, Bullock always worked with an independently developed model that was, in effect, the same as Benson used, so he did not discuss differences between models (although he includes a section on model differences in the AES preprint covering his model).¹ I will discuss the differences and software for both models.

VENTED BOX Q FACTOR

Part 1 of Small's work on the vented box (VB) outlines assumptions in developing his model, which seems to be the standard for home speaker design.² The Small VB has a single Q factor, identified as Q_L , associated with leakage losses from the box. For convenience, most people simply refer to it as Q_B . Small discusses two other Q factors for a VB enclosure and explains why you may omit them from your design with little error.

The concept of Q, or quality factor, which may seem mysterious to some speaker builders, is simply a number applied to how well the system conserves energy referenced to a specified frequency. The higher the losses, the lower the Q. Small's model has its single Q_B defined at the box tuned frequency f_B , and much of the software and many alignment tables assume a Q_B value of 7 for design purposes.

When I first started using a more scientific approach for speaker design, there were an intimidating number of Q factors to consider: three (Q_{ES} , Q_{MS} , and Q_{TS}) applied to the driver, with one (Q_B) for the Small model enclosure. Now the Benson model and Bullock's work add two more to the system:

1. Q_A is associated with the absorption of energy in the box. Benson called this Q_B , but I will label it Q_A to avoid confusion with the general Q_B of the Small model.

2. Q_p applies to losses due to vent or passive-radiator effects.

The three Q factors in the Benson model are defined at the frequency f_B , whereas for design purposes Bullock defines them at f_S , since f_B is not known at the time of data entry and the differences are not great ("Boxmodel: An Aid to Woofer System Design," *SB 6/90*, p. 26).

LEAKY OUTPUT

Which is correct: a VB system model with three Q factors or one with one Q factor? No

one would argue that the Benson model with three Q factors is more accurate. The Small VB model is a simplified version based on Small's work, showing that:

1. If you assume all the losses are associated with leakage, the model will produce the basically correct response shape.

2. Even though the losses are attributed to leakage, the amount of leakage from a reasonably designed enclosure is slight and contributes little to the system output.

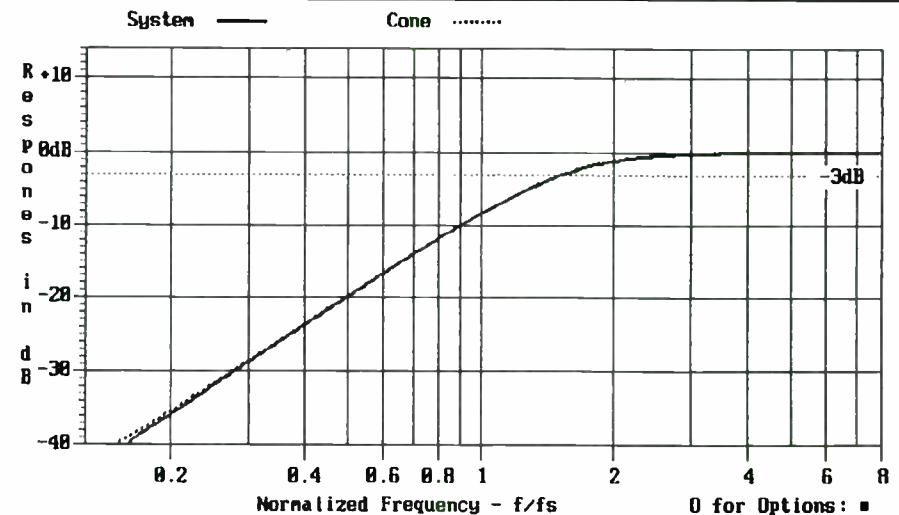

FIGURE 1: Closed box system responses via Benson.Exe, default Q values.

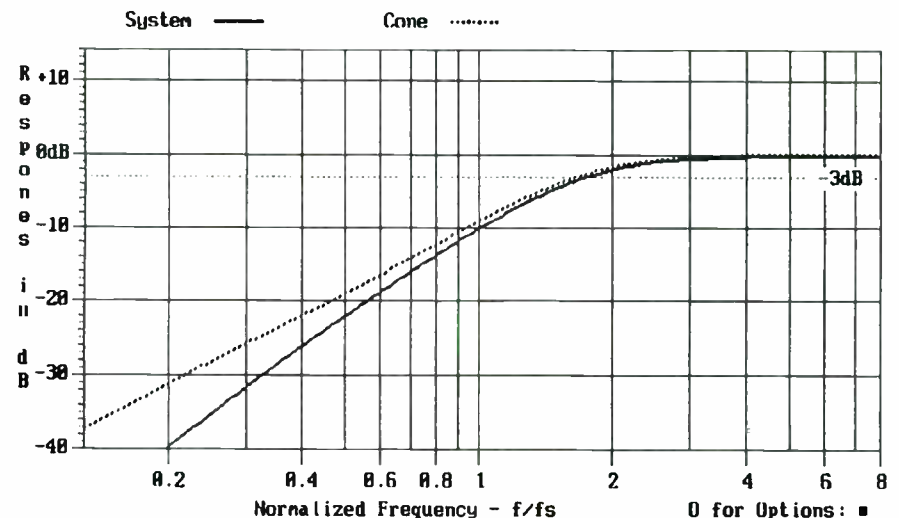

FIGURE 2: Closed box system responses via Benson.Exe, high leakage loss.

This second item seems to present a difference between VB models and may cause some confusion, since Benson's equations clearly include leakage contribution to the system response (i.e., leakage represents a loss of energy, but is also an enclosure output just like that of the driver or port). The driver, the port, and leakage all contribute to total system output. Working with the VB system response equation of Benson, I let the values for Q_A and Q_P go to infinity, removing absorption and port losses. The resultant equation was the same as the one used with the Small model. Thus there is no basic difference in the leakage contribution to system output with the two VB models.

OTHER SYSTEM TYPES

Benson's model and equations for the passive-radiator (PR) system also contain Q_L , Q_A , and Q_P factors. Small's PR system work is basically equivalent to his approach with the VB; he assumes all losses are associated

with leakage, giving a single Q_L (or Q_B) factor. He developed alignment charts with $Q_L = 7$ from lossless alignment charts by manipulation based on his earlier VB analysis. The synthesis model and system response equation in Small's PR work do not match, since the equation is for the lossless case (no Q_A , Q_L , or Q_P).³

The PR system response equation that fits the Small synthesis model (Q_L included, but not Q_A or Q_P) is in "Computing Box Responses" (SB 3/91, p. 88). Again, I let Q_A and Q_P in the Benson equation go to infinity; the results agreed with the Small synthesis model equation containing Q_L (or simply Q_B). This also shows no basic difference in how the two models handle leakage contribution to output. Keep in mind that the system response equation in reference 3 is for a lossless enclosure.

The models and equations for the closed box (CB) system are the simplest, but also the most confusing. Small's CB analysis

work includes absorption loss, but not leakage.⁴ However, most published design formulas and software (including mine) based on the Small model assume that the total system Q (Q_{TC} at f_C) is related to the total driver Q (Q_{TS} at f_S) by the same factor that relates system resonant frequency (f_C) to driver resonant frequency (f_S). This assumption, which Small uses in his CB synthesis examples⁵, effectively sets absorption losses to zero ($Q_A = \text{infinity}$).

Generally, a CB system is designed for a total system Q_{TC} value in the range 0.5 to just over 1. Omitting Q_A is thus quite reasonable unless you intentionally introduce major absorption loss. If you use such equations to design CB systems and then fill these systems with damping material, you should review Small's work, which details how to account for such stuffing. In summary, the Small CB model includes absorption losses but not leakage effects, while most CB designs based on the Small model assume a lossless enclosure.

Benson's model and equations contain Q_L and Q_A factors, whose definitions change somewhat. For the CB system they are defined at driver resonance f_S , rather than at the box tuned frequency f_B , which has no meaning for a CB system.

The Benson and Small models differ for the CB systems, since leakage contributes to system output with the Benson model. CB systems plotted with Benson's equations can show a difference between system output

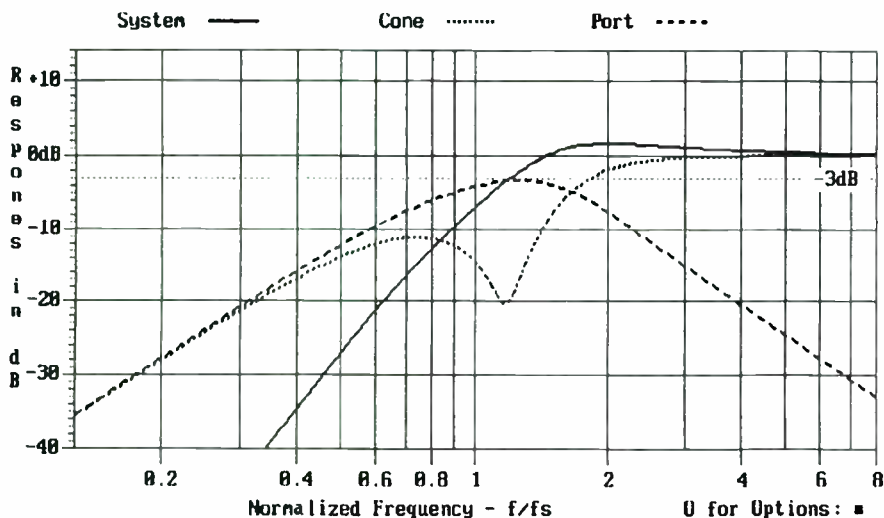

FIGURE 3: Vented box system responses via Benson.Exe, default Q values.

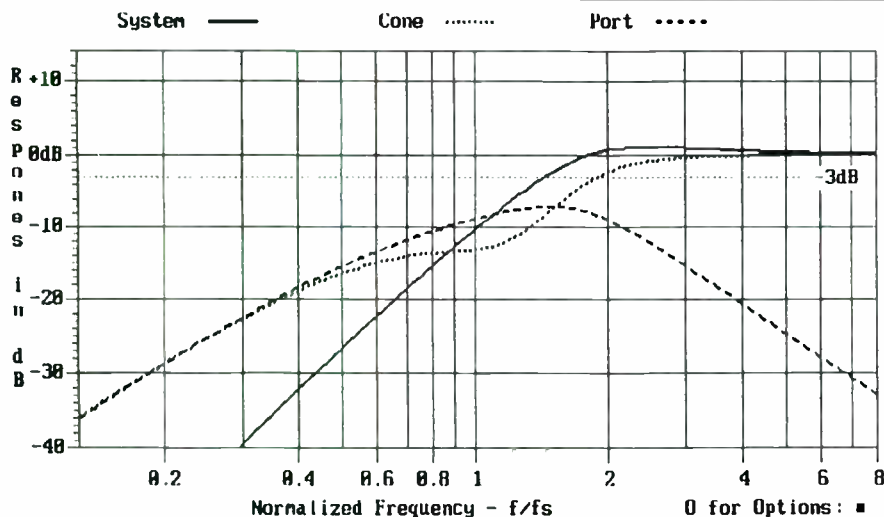

FIGURE 4: Vented box system responses via Benson.Exe, high port losses.

The following products in this article are available from Old Colony Sound Lab (PO Box 243, Peterborough, NH 03458, (603) 924-6371, FAX (603) 924-9467).

SOF-BEN1BXG — Benson.Exe and SmallPlt. Exe programs on 1 × DS/DD disk. Specify disk size. Requires IBM-compatible with 640 × 480 16-color VGA. \$9.95

BKSA1 — *The Theory and Design of Loudspeaker Enclosures* by J.E. Benson. \$24.95

BKSA1/S — BKSA1 book and SOF-BEN1BXG software. Specify disk size. \$29.95

SOF-MOD4BXG — Version 3.0 of BoxModel program on 1 × DS/DD disk. Specify disk size. For IBM-compatible computer with CGA, EGA, or VGA graphics. \$59.95

SOF-MOD4BXGD — Demo of BoxModel program for IBM on 1 × DS/DD disk. Specify disk size. (Usable as credit toward purchase of full package.) \$5.00

SOF-MOD4BUP — BoxModel 3.0 upgrade from previous version (provide Old Colony invoice number or photocopy of original disk label). Specify disk size. \$29.95

SHIPPING: \$3 US, \$5 Canada, \$10 other surface, \$20 other air

DESIGN SOFTWARE

Old Colony offers Benson.Exe and SmallPlt.Exe on a single disk. These plotting programs do not design the enclosure, but require you to enter the box size and tuning information. Unlike some software, SmallPlt.Exe does not work at a fixed Q_B value for VB and PR systems, but allows you to enter any real (it can have a decimal portion) Q_B value.

Both programs are developmental and may still contain bugs, so be warned to question results. Each program contains information screens indicating where the equations come from and what assumptions were made in program development. Be sure to read and become familiar with them.

These programs feature an unusual text-based interface, with the computer in VGA graphics mode at all times. As a result, and due to the complexity of the equations, they run very slowly on a slow computer, so I recommend a fast computer with a coprocessor. Both programs are IBM-compatible, require 640 × 480 16-color VGA, run under DOS, and lack mouse support.

Benson.Exe: Based on the Benson model and equations, this program allows you to enter the T/S parameters for a single driver, including added resistance R_G if Q_{ES} , Q_{MS} , and R_E are entered. You may then define up to three systems (CB, VB, or PR) for this driver. You can define Q values for leakage, port (not used in CB designs), and absorption; reasonable default values that produce response shapes nearly identical to those of a Small model, with $Q_B = 7$, are provided. The program then plots small-signal response magnitude, or phase or system group delay.

Low-amplitude-signal response plots show the driver (cone), system, and port/PR responses individually. With a single keystroke, you can call other plots for any valid system or call up the screens to edit driver or system data. This program plots in frequency normalized to f_s , but provides tabular printout of data in actual frequency. It contains no provision to print the plots, so you must load a VGA screen-dump program prior to running. Outputs display a Q_B value useful for

comparison with the Small model and computed as follows:

$$\text{For a CB: } Q_B = 1/(1/Q_A + 1/Q_L)$$

$$\text{For a VB or PR: } Q_B = 1/(1/Q_A + 1/Q_L + 1/Q_P)$$

SmallPlt.Exe: This program is based on the Small models and equations, and accepts the T/S parameters for a single driver with the same Benson.Exe options. It will optionally take large-signal driver parameters. Again, you can define up to three systems (CB, VB, or PR). CB plots are for a lossless enclosure.

Each VB or PR system has a single Q_B value. You can thus define the same system with up to three different Q_B values and quickly compare the results. The program plots the small-signal frequency response magnitude and the input impedance magnitude and phase (Q_{ES} , Q_{MS} , and R_E must be properly entered), and will plot driver and PR displacement functions and maximum input or output power capability. Again, a single keystroke allows you to move between curves or call up screens to edit driver or system parameters. This program plots in actual frequency and provides tabular printout if you can't screen-dump the plots.

BoxModel version 3.0 for IBM-compatible computers (by R.M. Bullock and R. White): This DOS-based program designs CB, VB, and PR systems with a model matching that of Benson and supports CGA, EGA, or VGA display capability. It provides port length calculations; absorption, port/PR, and leakage losses; filter-assisted alignments; equalized alignments through eighth-order; and file save/recall capability. Plotting capability includes maximum and relative SPL, voice coil impedance magnitude and phase, acoustic phase response, vent air speed, driver and PR excursion, transient response, and group delay. The program allows series and parallel compound and isobaric designs, and has graphics printing capability for over 300 printer types.

Other publishers of loudspeaker design software include:

Access Acoustics & Signal Processing

Jacob Canisstraat 60
NL-6521 HW Nijmegen
The Netherlands
011 31 80 233360
Boxdraw

Acoustical Supply

895 Cherokee Blvd.
Chattanooga, TN 37405
(615) 756-0706
Cleo & Speakerphile

Blaupunkt Division of Bosch Corp.

2800 S. 25th Ave.
Broadview, IL 60153
Blaubox

C & S Audio Labs

8036 Camerado Ct.
Jessup, MD 20794
(310) 498-8737
The Woofer Tester

Installer Institute

460 Walker St.
Holly Hill, FL 32117
(800) 354-6782
Porta-Calc

Maximum Effort Software

2701 Cedarwood Ave.
Bellingham, WA 98225
Loudspeaker 6.0

MicroAcoustics

2553 Carpenter St.
Thousand Oaks, CA 91362
(805) 495-8945
PC Audiolab

Pyle Industries

PO Box 620
Huntington, IN 46750
(219) 356-1200
Pyle's Pro Designer

SpeakEasy

46 Cook St.
Newton, MA 02158
(617) 969-1460
Low Frequency Designer

True Image Audio

349 West Felicita Ave., Suite 122
Escondido, CA 92025
(800) 621-4411
The Speaker Design Toolbox

and driver output response shapes if there is high enclosure leakage (i.e., Q_L is low). If you let Q_A and Q_L go to infinity in the Benson system response equation (lossless enclosure), then it reduces to the same equation normally used for the Small model.

You will usually not experience trouble with any of the Small models if you keep enclosure leakage to a small value and introduce no extreme intentional losses into the acoustic system. I would prefer the Benson (or equivalent Bullock) model for a better understanding of what was happening if I were filling the enclosure with material-

causing losses, developing intentional port losses for a VB ("Acoustic Resistance-Tuned Enclosure," *SB* 5/92, p. 10), or permitting intentional leakage through the enclosure/driver.

BENSON.EXE

Table 2 (denominator) and Table 3 (numerator) in part 1 of Benson's book provide the coefficients for response equations fitting his model and usable for CB, VB, or PR systems. For VB or CB systems simplify the coefficients by eliminating terms associated with the PR unit or VB vent, respectively.

Benson's equations provide the responses of the driver (which Benson calls cone), the vent or PR (if used), and the total system independently. My program, Benson.Exe, plots the responses based on Benson's equations (available from Old Colony Sound Lab).

In a typical CB response, using Benson.Exe default values for leakage and absorption losses, the driver (cone) and system responses are nearly identical, and are about the same results predicted by the standard CB response equation (*Fig. 1*). However, when the box has high leakage (Q_L is set to the low value of 2), the respons-



VERSA-TRONICS INC.

P.O. Box 87, Amherst, N.H. 03031

(603) 883-1960

FAX (603) 886-1592

NEODYMIUM RARE EARTH MAGNET TWEETERS



66-25Neo/8F

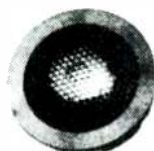

49-25Neo/8F



WITH

REPLACEABLE DOME/VOICE COIL

Specifications

Impedance: 8 Ohm
 Resonance Freq: Fs..... 1500 Hz
 Frequency Response: 20,000 Hz
 Dome Material: Drawn Titanium
 Suspension: Supronyl
 Voice Coil: 25,4 mm
 Layers: 2
 Winding Length: 2.0 mm
 Former: Titanium
 Magnet: Rare Earth Neodymium
 SPL: 90dB 1/W/1M
 Rated Power: *100 W
 *Music Power

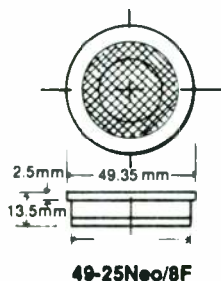
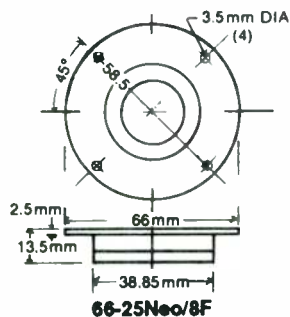

The introduction and utilization of the new rare earth Neodymium magnet allows for the production of much smaller drivers without any compromise in quality. The Neodymium material produces a magnet at least ten times the strength of the conventional ferrites and also does not require the top and rear plates.

Now and only now can the tweeter be brought in close proximity to the woofer and if necessary be placed in the cabinet corner for those desiring this type of design.

The Versa-Tronics Neodymium is constructed of a one piece drawn Titanium voice coil-former combination. This allows us to bypass the normal glue joint between the voice coil and the dome. There are 3 versions so as to provide the necessary configuration as required by the various system designs. All are Ferrofluid cooled.

DISTRIBUTED BY

Speaker City

115 S. Victory • Burbank, CA 91502
 Tel. (818) 846-9921 • Fax (818) 846-1009

The Speaker Works

1021 E. Camelback • Phoenix, AZ 85014
 Tel. (602) 230-0344 • Fax (602) 230-8533

Toutant Electronics

246 E. 131st Street • Cleveland, OH 44108
 Tel. (216) 451-6325 • Fax (216) 451-0226

es are not identical and clearly do not match typical equation predictions (Fig. 2). As you would expect, leakage has affected the system response. You can combine independent plotting of system and driver responses with near-field testing to produce a useful troubleshooting tool if your CB system is not behaving according to chart or software data based on no enclosure losses.

When plotting a VB system, Benson.Exe produces three curves: driver response, vent response, and system response (Fig. 3). It's interesting to see what produces the system response in various portions of the frequency band. Figure 4 shows the results for the same system with vent loss (Q_p is low) due to obstruction in the port duct.

If you obtain a near-field driver response for a VB system that does not show a very pronounced dip at f_B , you should suspect losses are being introduced. If these losses

Grille Cloth over Port	Near-field Dip at f_B	Approx. Q_p to Match
None	-25.1dB	100
Hanging 0.6" from end	-24.4dB	55
Hanging 0.3" from end	-22.7dB	25
Hanging right at end	-18.0dB	7.3
Tight on end	-16.2dB	3.8

are unwanted, playing with Benson.Exe until you get driver and vent responses that match your measurements can help determine the problem. Remember when you compare Benson.Exe plots with real near-field data you must correct the near-field data for relative sizes of the driver and port. Certainly, you can determine this with other methods; Benson.Exe is simply one more computer-aided design tool.

Finally, Fig. 5 illustrates the unusual PR system response shape in certain alignments. Benson.Exe lets you play with the effects of losses on the PR system to determine just when the PR unit versus the driver dominates the system output. Use this, or another troubleshooting program, if your PR system does not behave as expected. Bullock reports on a possible minor error in the Benson equations relating to the PR compliance ratio, which would affect Benson.Exe.

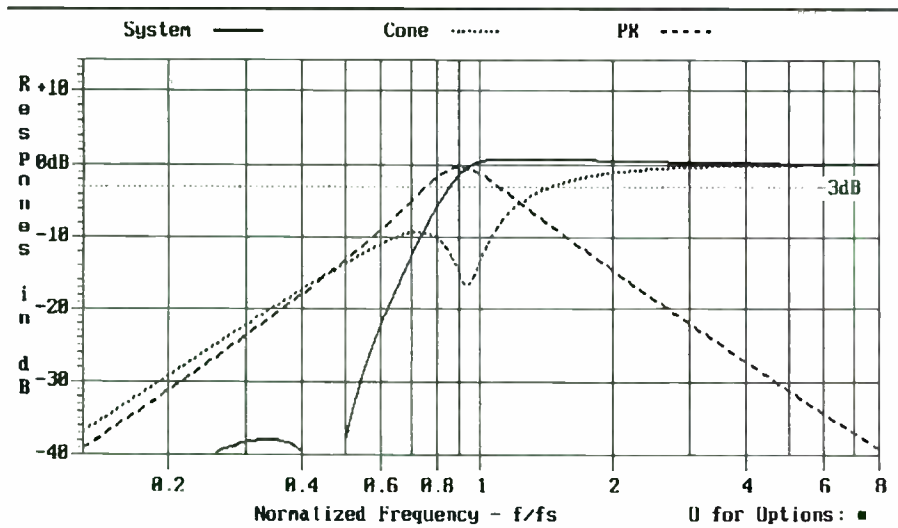

FIGURE 5: Passive radiator system responses via Benson.Exe, default Q values.

EXTENDED VB BASS POWER

Federoff produced a clever double-vented bandpass system ("The Birdhouse," *SB 2/94*, p. 36) that extends power capability near cut-off with a port rather than the driver producing the system output at lower frequencies, where driver cone excursion becomes a problem. This same effect occurs in VB systems, and I have been using alignments which optimize the effect with small drivers to get fairly high playing levels.

In the area about f_3 the system output contribution is from the port, not the driver (Fig. 3). The driver displacement is greatly reduced in this region, allowing the system to play louder than you would think possible. Stenton considered this in his design ("The System III Loudspeaker," *SB 5/94*, p. 8). You must be careful that the driver doesn't overload for frequencies well below f_3 (always a problem in VB systems). I have used this approach to produce systems with f_3 down near 40Hz with 6.5" woofers that play quite loudly, without a problem with reasonable program material input.

Benson.Exe shows just where the port output dominates. Any software—such as SmallPlt.Exe and BoxModel 3.0 (both described later)—that plots maximum system output and identifies whether driver displacement or electrical power limit is setting the output limit can provide this same information.

DO MODELS WORK?

Models are fine for developing equations for computational purposes, and I believe they represent quite well what really happens. When I started designing VB systems using equations and alignment tables based on the Small model, I tested the finished systems.

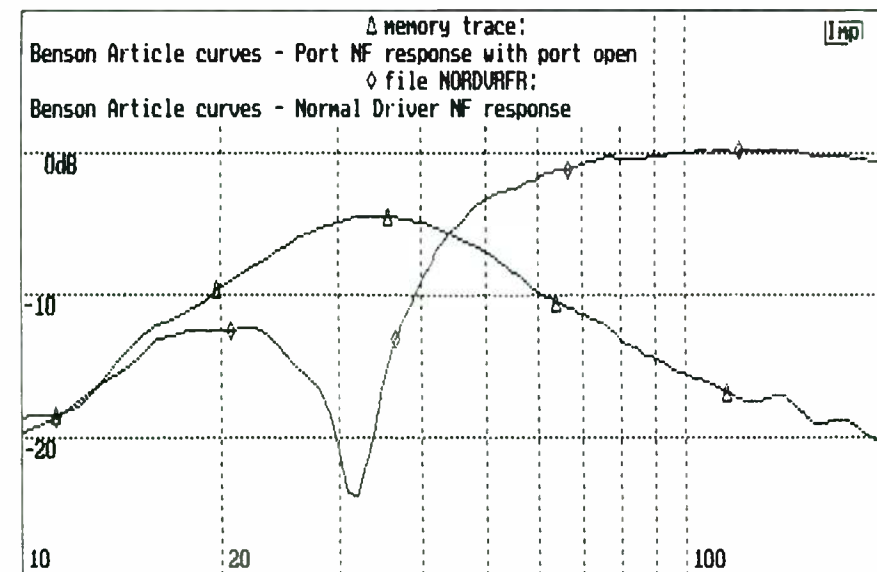
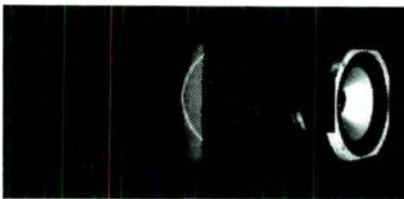

FIGURE 6: Near-field test results on vented box system, no added losses.



DEFLEX

ACOUSTIC PANEL TECHNOLOGY

TECHNICAL SPECIFICATION

	<i>Standard Panel</i>	<i>Sub-woofer Panel</i>
Material.....	Advanced polymer	Advanced polymer
Colour.....	Charcoal grey	Charcoal grey
Surface emulation.....	Spherical concave	Spherical concave
Defined radius - nominal.	200 mm	300 mm
Focal point - nominal.....	100 mm	150 mm
Thickness at centre.....	5 mm (maximum)	12 mm (maximum)
Max. edge thickness.....	12 mm	12 mm
Overall dimensions.....	280mm x 210mm	340 mm Diameter
Density / hardness.....	1.36 / < 15° A	1.36 / < 15° A
Rebound resilience.....	< 15%	< 15%

GENERAL DESCRIPTION

Deflex acoustic panels have excellent performance characteristics.

The polymer is specially formulated to absorb shock and vibration, thus minimizing cabinet resonances.

The surface emulation has been carefully designed to help eliminate standing waves.

The energy inside the enclosure is controlled - NOT ABSORBED.

Independent tests on MLSSA show an energy gain of over 50%.

DEFLEX panels are purposely designed, Hi-Tech speaker linings, and are not by-products from any other industry.

"...A marked improvement was obvious from the first few bars of REM's *Automatic for the People* album..."

"...Vocals took on a air of presence that was stunning compared to what had gone before..."

"...Rhythm was more definite and seemed to 'glue' the musical experience together..."
HI FI News & Record Review - March 1994

"...The special surface pattern reduces standing waves to cure boxiness and resonance without killing the vitality of the sound..."

"...expect tighter cleaner bass, crisper articulation, and an increase in liveliness without loss of control..."

"...The result was sharper imaging, wider dynamics and a more natural sound..."
HI-FI Choice - January 1994

"...Deflex panels seemed to give greater tightness and control, improved internal clarity, and better pitch definition - all without deadening the sound in any way..."
Audiophile - January 1994

" THE ONLY CURE FOR BOX NOISE AND STANDING WAVES "

CURRENT PRICE LIST

Standard Panel	@ \$ 13.00	each
Sub-woofer Panel	@ \$ 22.00	each
Panel adhesive	@ \$ 8.00	200 ml
Trade inquires welcome!		



Madisound Speaker Components
(8608 University Green)
P.O. Box 44283
Madison, WI 53744-4283 U.S.A
Voice: 608-831-3433
Fax: 608-831-3771

Reader Service #1

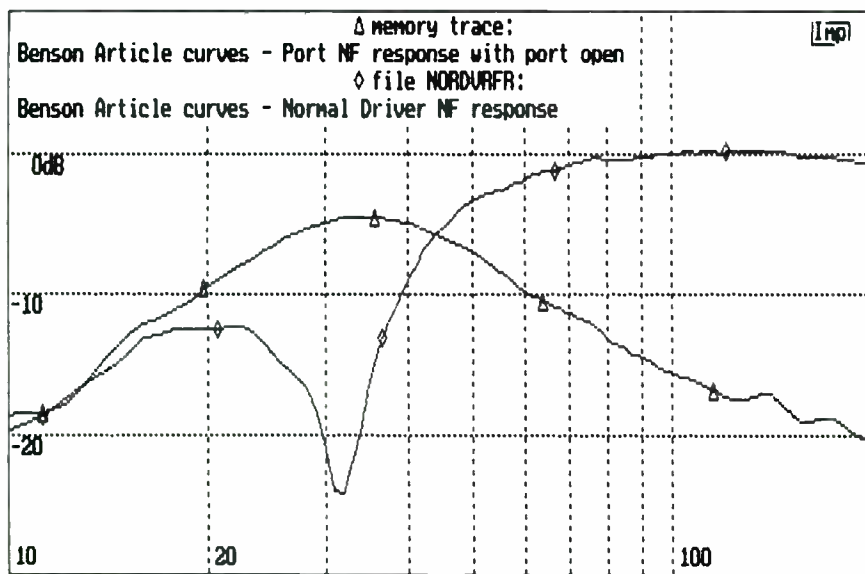
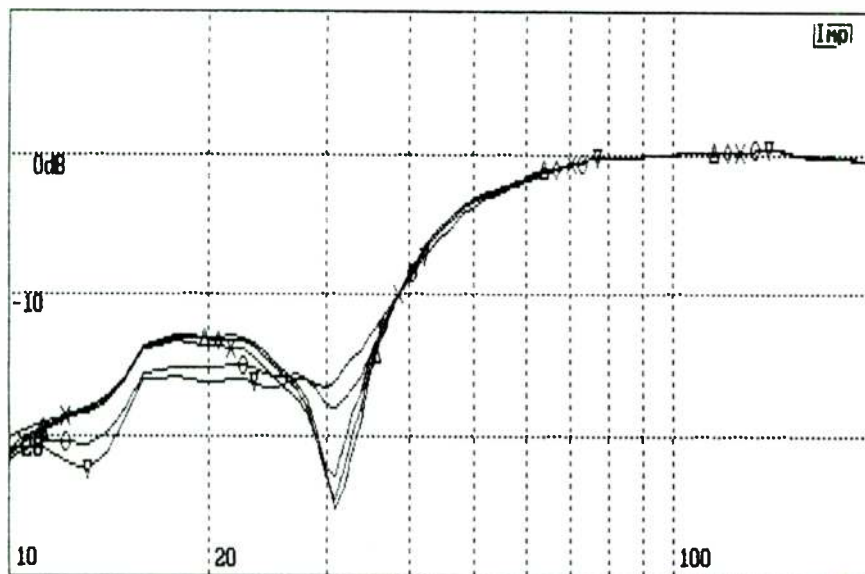

FIGURE 7: Near-field test results on vented box system, loss added to port.



- Δ memory trace:
Nearfield response for Driver - normal port
- ◇ file GCDUR5:
Nearfield response for Driver - Grille cloth hung 0.6" from end of port
- × file GCDUR7:
Nearfield response for Driver - Grille cloth hung 0.3" from end of port
- file GCDUR9:
Nearfield response for Driver - grille cloth hanging right at end of port
- ▽ file GCDUR3:
Nearfield response for Driver - Grille cloth tight against port

FIGURE 8: Near-field test results on vented box system, effects of grille cloth over port.

In the old days this difficult test involved calibrating two mikes against each other, measuring the driver and port near-field outputs and the phase shift between them, and then manually calculating the system response at each desired frequency.

The results agreed with the performance calculated with the Small model, and today I avoid testing unless the system does not perform as expected. Remember that the mod-

els and matching near-field testing predict the anechoic response into 2π steradian (sr) half-space. You must independently account for where the system radiation changes from 4π sr to 2π sr and other live room effects.

I have had much less experience with the Benson model, but to date it has predicted accurately. Figure 6 shows the measured near-field driver and port outputs for the 10" driver in Fig. 3, with the port response

plot lowered to match the driver response at low frequencies. I generated these curves with the IMP Audio Analyzer using the MLS test signal.

The agreement between test and model is good, with the driver response dip at $f_B = 31\text{Hz}$ even lower in the test, indicating the total box losses are lower than represented by the default Q values of Benson.Exe. This is probably due to the driver being in a stiff test box with no acoustic wall lining and tuned via a 3" ID duct only 4" long.

I plugged 3" thick fiberglass into the port to introduce port losses. This converted the system to a poor CB. I thinned the fiberglass plug until I obtained the results in Fig. 7, a fairly good match to Fig. 4. The fiberglass plug was now only about 1/8" thick, and I could see through it.

If this thin piece of fiberglass has so much effect, how does grille cloth over the vent affect port Q value? Figure 8 shows some results for the same system with the thin black grille cloth sold by Radio Shack over the port. The worst case occurs when you tie the cloth tightly over the end of the port duct. In the other cases the grille cloth hangs from a rod and is weighted to stretch taut, and set at the indicated distance from the end of the port duct.

Table 1 shows the results from these tests, indicating the driver response dip at f_B from the IMP near-field tests and the approximate Q_p from Benson.Exe, which gives the same dip. For the modeling work, Q_p was taken as 100 for the normal open port, and the other losses reduced until the correct dip resulted. The Q values were $Q_L = 25$ and $Q_A = 50$. For comparison, fine mesh window screen directly against the end of the port duct produced results about the same as with the grille cloth hanging 0.6" from the duct end. Keep in mind that the system response does not vary nearly as radically as the driver near-field response with the port losses (compare Fig. 3 to Fig. 4).

I will continue to build VB systems in which the port is outside the grille-cloth-covered enclosure area. I'll also use the diffuser port approach ("The Diffuser Port For Small Boxes," SB 2/81, p. 16, and "The Diffuser Port," SB 2/91, p. 45), which greatly reduces the vent air velocity at the front of the cabinet. On VB systems be sure to attach the grille cloth loosely over the port end and use as large a port area as possible. Also, keep the grille cloth back from the port end as far as practical and, if possible, locate the port end outside the enclosure's grille area.

Very little obstruction in the port is required to greatly reduce the port Q value and produce a VB system that does not work quite as you intended. A program working with the Benson model can be very

useful in helping to diagnose the problem and apply numbers to the effects of port or other losses. With its individual driver and port responses along with the system response, the Benson.Exe plots are ideal for comparison with near-field test data without performing the vector summation to obtain the system response.

SUMMARY

The Benson VB and PR models and equations account for enclosure losses associated with leakage, absorption, and the port/PR unit. The Small VB and PR models are "simplified" versions of the Benson model. Small has verified that the response shape is basically correct if all enclosure loss is attributed to leakage, and that for most systems leakage does not significantly contribute to the system output.

The Small CB model takes enclosure absorption loss into account, but not leakage loss and its contribution to the system output, while Benson's model and equations include both losses and the leakage contribution to the CB output. However, most CB design software and equations based on Small's model assume a lossless enclosure. The Benson (or equivalent Bullock) model is beneficial if you intentionally introduce leakage, absorption, or port/PR losses to the enclosure, or as a troubleshooting aid.

Benson.Exe is a plotting program based on the Benson model and equations showing system, driver, and port/PR output independently. Its companion program, SmallPlt.Exe, uses the Small models and equations, and lets you enter real values of Q_b for VB and PR systems. BoxModel is a design program that uses the Benson model and provides most of the information available from Benson.Exe and SmallPlt.Exe, but displayed differently.

REFERENCES

1. R.M. Bullock, "A Unified Model for Closed-Boxes, Vented-Boxes and Passive-Radiators with Losses," AES preprint 2841, 1989.
2. R.H. Small, "Vented-Box Loudspeaker Systems, Part I: Small-Signal Analysis," *JAES*, Vol. 21, No. 5 (June 1973): 363-372. (This work is also in the original *AES Loudspeakers, An Anthology*, p. 302.)
3. R.H. Small, "Passive-Radiator Loudspeaker Systems, Part I: Analysis," *JAES*, Vol. 22, No. 8 (Oct. 1974): 592-601.
4. R.H. Small, "Closed-Box Loudspeaker Systems, Part I: Analysis," *JAES*, Vol. 20, No. 10 (Dec. 1972): 798-808. (Also in the original *AES Loudspeakers, An Anthology*, p. 271.)
5. R.H. Small, "Closed-Box Loudspeaker Systems, Part II: Synthesis," *JAES*, Vol. 21, No. 1 (Jan./Feb. 1973): 11-18. (In original *AES Loudspeakers, An Anthology*, p. 282.)



JBL Professional, a division of Harman International Industries, Inc. has immediate opportunities in the areas of professional loudspeakers and electro-acoustic system design in our Research & Development department:

MANAGER - Amplifiers

Supervise the design, development, industrialization and production of advanced high-performance audio power amplifiers. Work with and supervise existing off-site development team.

Successful candidate will possess a degree in Electrical Engineering with minimum of 5 years industrial experience. Good presentation skills required to support interactions with sales & marketing. Background in manufacturing of commercial audio/electronic systems desirable. Previous management experience extremely helpful.

MANAGER - Wireless Technology

Initiate effort to develop in-house design capability in wireless control and audio signal communication for advanced audio systems. Staff up effort to support implementation in JBL Pro products. Manage and lead in-house effort in amplifier design, manage in-house staff as well as off-site consultants.

Successful candidate will possess a BS or ME in electrical engineering with minimum of 5 years experience in industrial electronic design. Familiarity with RF techniques such as spread spectrum and frequency hopping and experience in infrared desirable.

STAFF ENGINEER - High/Low End Audio Systems

Responsibilities of the Staff Engineer of High/Low End Audio Systems include undertaking electro-acoustic measurements of transducers using both Bruel & Kjaer and computer based, MLSSA, measurement systems. Participate in the design and engineering development of acoustical systems, using both active and passive crossover networks. Design and develop horn loading techniques for pattern control of high-frequency components and documenting all aspects of the process.

Successful candidate will possess a BS in Electrical or Mechanical Engineering with 3-5 years experience in high-performance loudspeaker design. 5 years experience in design, project management and excellent track record of producing viable and practical engineering solutions for High-End Engineer are highly desired.

STAFF ENGINEER - Transducers

Develop and commercialize advanced audio loudspeaker transducers. Work with manufacturing to assure quality production and customer satisfaction.

Successful candidate will possess a degree in Electrical or Mechanical Engineering with a background in numerical analytical or design techniques. Prior experience with audio technology. Familiarity with adhesives, metals and magnetic materials highly desirable.

QUALITY ENGINEER

Develop and implement QC processes, procedures and statistical techniques pertaining to the manufacture of audio and electronic systems. Additional job duties include solving problems and improving product quality.

Successful candidate will possess 5 years experience in manufacturing, experience with inspection techniques, quality standards and strong statistical measurement theory. Degree or formal training in quality and statistical methods highly desirable.

JBL Professional is an equal opportunity employer, offers a competitive salary and a comprehensive benefits package. If you would like to join our team, send resume with salary history to:

Lynda Kim
JBL Professional
8500 Balboa Blvd.
Northridge, CA 91329
FAX (818) 830-1220

FROM SAD TO SPARKLE: A SAAB STORY

By Mark Florian

In Part 1, I described how I made the car "enclosure" quiet and well-damped. With this done, I was ready to proceed to the next step: designing and installing a system.

My vehicle came equipped with a 4" driver installed in each front-dash speaker plate, as shown last time in Photo 6. These plates are easily removed by undoing two screws and prying loose a couple of clips. I wasn't very impressed with the small tweeters I had added several years ago (more about this later). The factory locations accommodated 4 × 10s on each side of the rear package shelf, but I abandoned these in favor of Infinity 6 × 9s which I installed under the shelf.

The woofers had stopped producing bass in favor of rattles, because the foam surrounds had disintegrated. Infinity had said that reconing wasn't an option, so I thought I was out of luck.

Typical auto sound drivers don't impress me: lightweight magnets and frames, foam surrounds, poor sound, and outrageous prices. For example, the ½" Coustic tweeter I had previously installed had a DC imped-

ance of 4Ω and a 2.2μF factory-installed cap. The crossover point of 18kHz ($1/[2 \times 3.14 \times 4 \times 0.000022]$) means the response was down 6dB at 9kHz. No wonder I couldn't hear anything out of them!

I picked up copies of Madisound's catalog and Dan Ferguson's *Killer Car Stereo on a Budget*.¹ Having been sold on the satellite/subwoofer concept by the Swans, I decided to use the same approach for the SAAB. The many accolades for Vifa drivers convinced me to build an all-Vifa system. I would use their 4" M10MD394 midrange in the front on both sides with either a 14mm Audax TWO14B5 tweeter or 1" Vifa D26NC05 in a hinged wedge mount to free it from the dash and place it on-axis with the passengers. For the rears, I opted for Vifa's 5" P13WH04 woofer and ¾" D20TD05 tweeter in a small ported box where the factory 4 × 10s had been.

To top it all off, I added one of Vifa's 8" M22WR29DVC woofers. These units, recommended by Bryan at Madisound, feature dual 2", vented, 4Ω voice coils, a very stiff paper cone, and rubber surround. They handle 200W, Q_{TS} is 0.66, V_{AS} is 19 liters, X_{MAX} is 11mm (P/P), and the price a mere \$63. I had initially considered a Madisound woofer, but the Q_{TS} was too

low for a free-air installation. (The 10" version was a bit too tight to squeeze in.) Madisound provided the necessary crossovers.

FRONT SPEAKERS

Within two weeks, UPS had delivered a rather large, heavy box to my doorstep. After unpacking it, I inspected the contents. Each well-built speaker featured a magnesium cast frame, heavy magnet assembly, rubber surround, and polypropylene cone (except the sub). Photo 7 shows the drivers laid out in their respective places. My challenge was to fit them in, plus wiring, and create a neat, good-sounding installation.

To begin, I unscrewed the front-dash access plates and removed the small tweeter and 4" midrange. I intended to install the tweeters on-axis, using small hinged mounts so they could be aimed for a better, more focused sound. Vifa sells a fixed wedge mount, which I wasn't sure would work in my application. Audax and LPG, however, offer hinged mounts that also swivel; I ordered both to see which would work best.

First, though, I had to decide which tweeter to use: Audax or Vifa. With the appropriate cap in place, I wired up the units for a listen. The Vifa sounded much smoother and more open than the smaller Audax, and I thought it would blend better with the 4" midrange. Even though it was also twice the price, I believed it would be worth it.

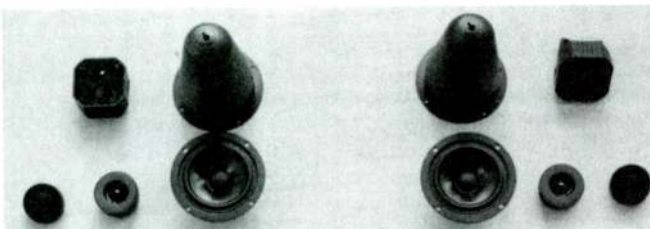

PHOTO 7: The Vifa ensemble arranged according to placement. Top left: Audax hinged wedge mount; back chamber for Vifa 4" midrange. Second row: Vifa 1" neodymium tweeter; Audax TWO14B5 tweeter; Vifa 4" midrange. Third row: Vifa ¾" D20TD05 dome tweeter. Fourth row: Vifa P13WH04 5" woofer; Vifa M22WR29DVC 8" woofer.

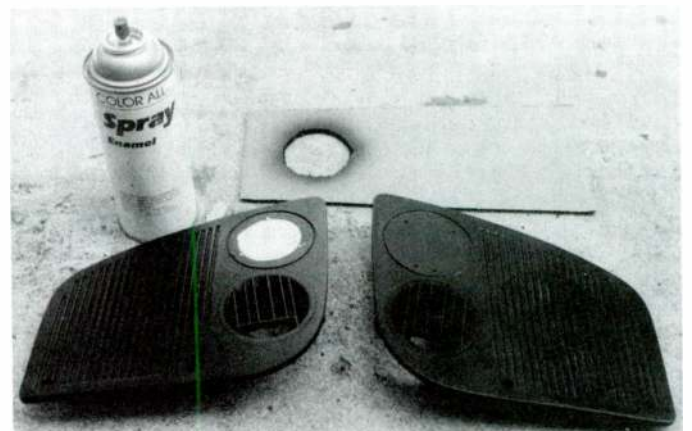

PHOTO 8: Apply several light coats of spray enamel for the best finish.

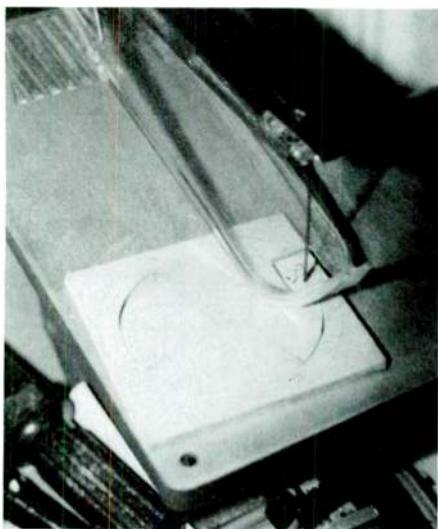

PHOTO 9: A scroll saw comes in handy for cutting out circles on small parts.

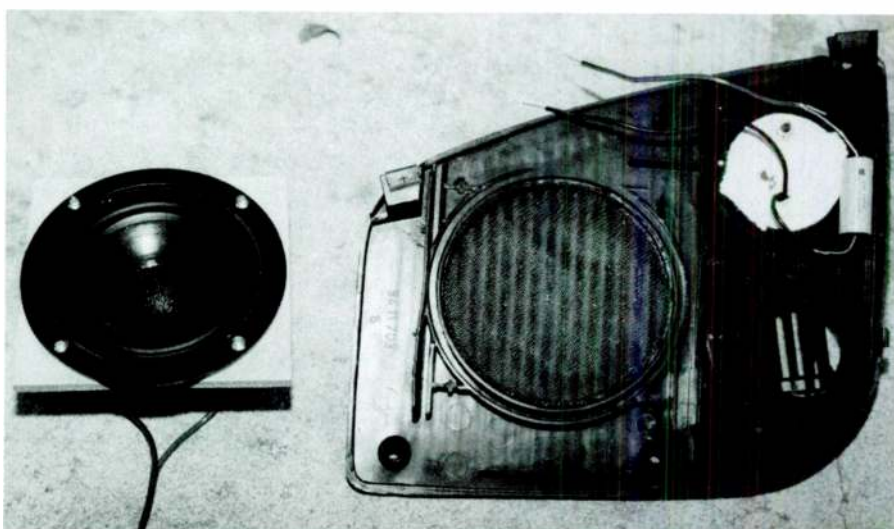

PHOTO 10: The midrange driver was mounted to the plywood using small #6 × 1/2" screws. This is then held to the plate with the original metal clips.

The LPG mounts with Vifa tweeters were the best combination. By wrapping a few layers of black electrical tape around the body of the tweeters, they would fit snugly in the LPG mount. I decided to attach the mounts to the plates rather than the dash. The best location was where the former tweeters had been flush-mounted, but first I needed to close the hole.

FILLING THE GAP

After considering various options, I elected to cover the hole from the rear with a piece of plastic laminate held in place with hot glue. I would then fill the "crater" with water putty and sand it smooth.

To prepare the plastic laminate, I sanded it with 100-grit paper and scratched lines into it with an X-acto knife so the hot glue and water putty could better grip the slick surface. When the glue was hot, I applied a thick layer to the back of the speaker panel, quickly pressed the laminate into position, and clamped it with a couple of spring clamps.

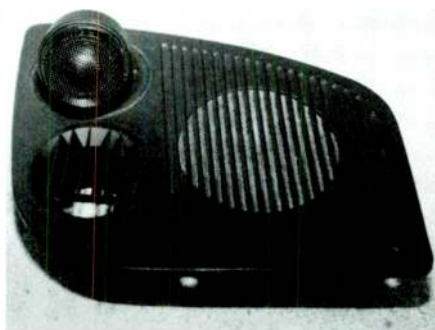

PHOTO 11: A completed front plate, showing the Vifa tweeter mounted in the LPG hinged mount. Black tape wrapped around the tweeter housing helps ensure a snug fit.

Depending on the temperature, hot glue sets rather fast—usually within five minutes.

Now it was time to mix up some water putty. I used Durham's Rock Hard Water Putty, a light-colored powder that mixes easily with water to form a moldable substance which is, in fact, rock hard when fully set. This is my kind of product: it's easy to work with and cleans up with water. Using a small plastic cup and a popsicle stick, I mixed a small amount for the two "craters."

Smooth the surface as much as possible *before* the filler sets, when it is much easier to work with. Go over it with a wet putty knife, or place clear plastic wrap on top of it, gently pushing out the air bubbles and drawing it smoothly across the top. Allow it to sit overnight before doing any further work.

Next I sanded with 100-grit disks chucked into a Dremel Moto-tool. You can tell here how good a job you did when the stuff was wet. After the surface was smooth, I made a mask from a piece of cardboard and sprayed the patch with flat black paint (*Photo 8*). I applied three light coats and then set the panels in the sun to dry thoroughly.

As you can see in *Photo 6*, the square frame of the original 4" OEM driver was held to the access plate with four metal clips. Because the Vifa driver has a round flange, to use the clips I needed to make a plate. I accomplished this easily enough by cutting a small piece of 1/4" plywood the same outer dimensions as the square OEM frame, then cut a circle into which the Vifa driver would fit using a scroll saw (*Photo 9*). The driver mounts to the plywood plate via screw holes in the flange, and the metal clips hold the assembly in place.

I drilled two small holes in the "crater" area for the tweeter: one for the mounting

bolt and another for the wires. Lockwashers ensure that vibration won't loosen anything. *Photo 10* shows the bottom of a completed plate prior to mounting the 4" midrange. A dab of hot glue holds the tweeter cap in place. The completed plate, ready to be reinstalled in the dash, is shown in *Photo 11*.

Incidentally, throughout this project I used crimp terminals to allow removal of the various parts, and polarized the plugs so they could be reinstalled only one way. These plates also provide access to the dashboard instruments and blower motor; quick-disconnects allow the service mechanic to remove them so they are out of the way. Some of the connectors were very tight, especially on the drivers, so I used some Cramolin Blue to lubricate and prevent oxidation.

ROAD TEST

With new speakers in the front dash and all the rattles suppressed, I took a short trip to check out my handiwork. For the first time I actually had an auto audio soundstage. What an improvement! I could imagine that a little band was playing on my dashboard. I listened to a few cuts from Streisand's *Broadway* CD: her voice sounded clean and natural—very Swanlike. Even her breaths were distinct. Then I switched to James Newton Howard's *She*, a real tweeter tester. The wind chimes were crisp without being overbearing.

The Vifa tweeters sound great: very open and musical, and not harsh, brittle, or screechy. Of course, since they are only 2" or so away on-axis, they can also be very loud. In order to balance them with the midranges, I would need to add a clean resistor. Furthermore, I was hearing this great music in a quiet, rattle-free environment—even in traffic. My earlier work had definitely paid

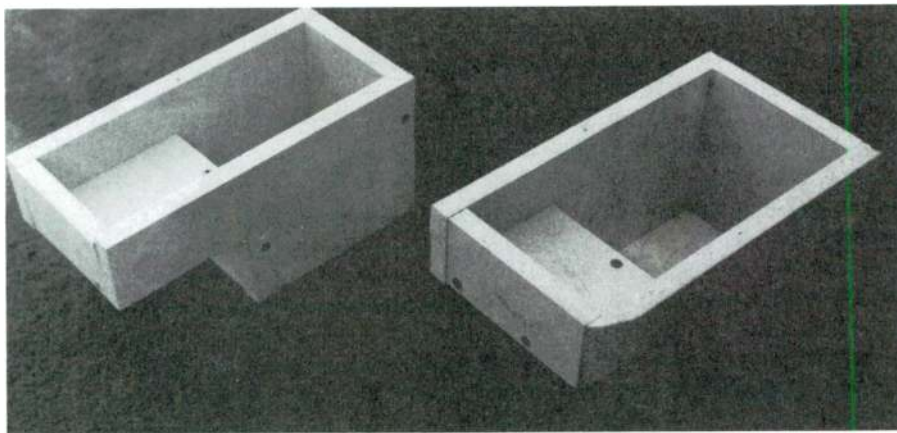

PHOTO 12: The first prototype is shown on the left, the final design on the right. The cabinets are the same length overall; however, the right cabinet has a larger volume due to the reduction in overhang.

off. Enthused by my positive results, I started planning for the rear speakers.

ASSAULT ON THE REARS

My plan was to install two-way speakers where the original factory 4 × 10s had been. I also intended to use an enclosure so the sound would not change when the rear seat was lowered. Vifa suggested a 5 ltr ported box, but I wasn't sure there would be enough room. Lying on my back inside the car with the rear seat folded down, I measured out a cardboard template. So far so good. But when I lowered the trunk lid, I

realized the spring arms were about to crush my plans: I couldn't close the trunk. Back to the graph paper.

I thought enough clearance might be provided by cutting out a lower section of the box to allow for the spring arm, although I would lose some volume. To test my idea, I made a text box from 5/8" particleboard shelving material. Carrying the prototype, I crawled into the trunk and pulled in my legs. While both hands supported the box over my head, I held the trunk nearly closed with my foot on the latch. The box cleared the trunk arm—but by too wide a margin. I could regain some needed volume by decreasing the length of the shelf.

The upper spring arm was also digging into the side of the box. I raised and lowered the lid several times until a groove was worn; the rest I would remove with my

router. I also shaved off part of a corner (*Photo 12*). Initially, I used a wood rasp, but found it tough going. Then I remembered a Stanley saw I had recently purchased which is perfect for cutting thick MDF or industrial particleboard. It has a firm, steel-topped blade like a miter saw, so it will not bow, and very aggressive offset teeth. Do not use the side of your thumb to start a cut with this saw or it will look like a shark bite. I highly recommend this saw when you need to notch particleboard. I made two angled cuts to allow clearance for the trunk spring arm.

Once I had made the necessary modifications to the box, I laid out the baffles and cut the holes with a router (*Photo 13*). I then used one of these prepared baffles to trim the car's rear deck, so none of the cone would be obstructed. After scribing a line with a pencil, I turned to the trusty Moto-tool with a small saw blade for the cutting. I also marked and drilled the mounting holes for the t-nuts that attach the boxes to the deck. These holes penetrate the boxes, but the backs of the t-nuts are also sealed so the cabinets do not leak air. It was for this reason that I didn't mount the t-nuts inside, because they would leak even with screws in them.

I glued the t-nuts to the cabinets and used short screws so the seals were not punctured. Washers under the screw heads dissipate some of the load. As one edge of the cabinet would sit on the wheel well in the trunk, this helped support it from below. The screw heads would then be covered by the speaker grille. Rope caulk ensures an air-tight seal of the drivers and the fronts to the boxes.

The completed rear speakers are shown in



PHOTO 13: For construction plans on making your own clear circle cutting jig, see Spielman's book.



PHOTO 14: Completed rear speakers. Note the three t-nuts used to anchor each box to the underside of the rear deck.

ZALYTRON

YOUR ONE STOP SHOPPING CENTER

FOCAL

VIETA

Coltase
A DIVISION OF THE FOCAL GROUP

more!

SR

PHILIPS

Polydax
speaker corporation

(seas)

ZALYTRON
CUSTOM WOOFERS

l'atelier audio

ACCUTON

ZALYTRON PRESENTS THE NEW LINE OF HOME THEATER KITS FROM FOCAL

SURROUND SPEAKER A 100

Bass reflex with slot-vent
H x W x D: 31 cm x 20 cm x 12 cm
(12.1/4" x 7.7/8" x 4.3/4")
Don't be fooled, this is a small but very potent home theater two way unit. You can use it as a front and/or rear speaker in any of the popular surround sound systems. The speaker mounted on a wall can generate a wide range of frequencies with surprising power thanks to a few special Focal Features:

- The 5N 412-DBL mid bass drive unit is one of the best Focal makes, combining dynamics (dual voice coil wiring) and natural sound.
- The TC 90 tweeter unit is of the latest generation of concave dome units with field replaceable moving assembly.
- The slot-vent open on the top of the enclosure couples with the wall and ceiling to naturally increase the bass output.



CENTER SPEAKER A 200

Bass reflex with front slot-vent
H x W x D: 18 cm x 50 cm x 22 cm (7.7/8" x 19.3/4" x 8.5/8")
The A200 center channel offers very low distortion, natural sound and high power handling. It features two 13 cm (5.1/4") midbass units of the same size and of the same cone technology as on the A 100, so that the same timbre will be produced harmoniously and consistently throughout your whole Home Theater system. The tweeter is also the same as on the A100 speaker, again to blend seamlessly with the other speakers. All units here are carefully shielded to protect your TV or your monitor from any magnetic interference coming from the very powerful magnets of the Focal units.

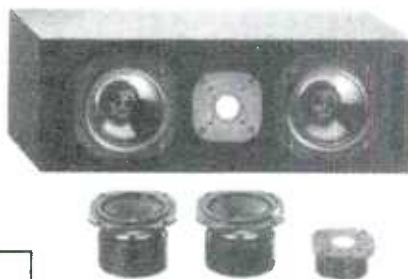

FOCAL

COMPACT B 300

Bass reflex with front slot-vent
H x W x D: 34 cm x 18 cm x 27 cm (13.3/8" x 7.1/8" x 10.5/8")
Certainly a small bookshelf speaker by its size, the B 300 is a real size performer, thanks to its unique dual voice coil mid bass unit and to the special crossover designed by Focal which uses the second voice coil in parallel with the first for a natural bass extension. In a 8.5l net internal volume (0.3 cu. ft.), this unique arrangement provides a -3dB response at 60 Hz! The tweeter is from the latest generation of Titanium dioxide concave dome tweeters with field replaceable moving assembly. A unique impedance adaptation device, positioned in front of the dome, controls its high frequency dome break up for an extended and sweeter, almost "silky", treble. This system will play loud enough for most mid size listening rooms, without ever become fatiguing. All crossover components have been carefully selected (we use high quality metalised polupropylene caps).



Send stamped self addressed envelope for a Focal Kit Brochure showing all their new kits.

ZALYTRON INDUSTRIES CORP.
469 JERICHO TURNPIKE, MINEOLA, N.Y. 11501
TEL. (516) 747-3515 FAX (516) 294-1943

Our warehouse is open for pick-up 10AM to 6 PM daily, Monday thru Saturday — UPS orders shipped same day • Minimum order \$50.00

CALL OR WRITE FOR OUR LATEST CATALOG

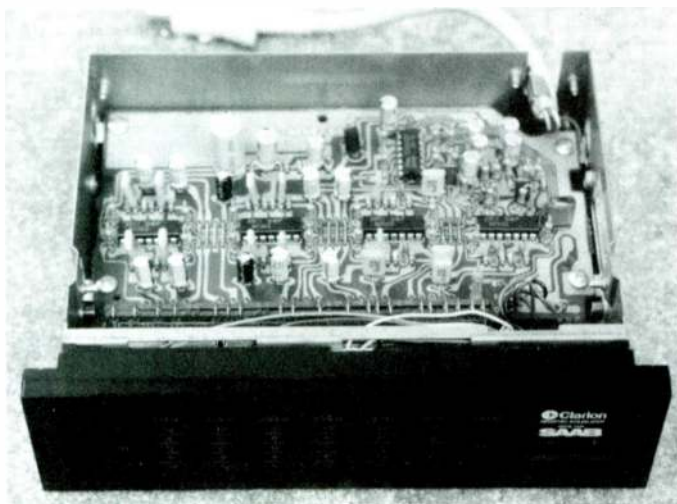

PHOTO 15: Original SAAB/Clarion equalizer.

Photo 14. Each is held securely in place by three #10 × 24 screws. I used Belden #8719 100% shielded, 16-gauge cable to wire them. The shield, which prevents the signal in the wires from interfering with the automotive electronics, is grounded at the tape deck. At \$.026/ft, it's also easy on the wallet.

With the rear speakers in place and all four corners emitting sound, it was time for another road test. The rears added depth, and I obtained a good balance by adjusting the front/rear fader. In fact, I was overwhelmed by the clarity of the sound. The old system could play loudly, but over time it grated on the nerves. This system, on the other hand, is very open, relaxed, and pleasing, even at high volume levels.

The lower octaves, however, were definitely lacking. The cabinet box volume had to be reduced to provide clearance, and I was listening at 90° off-axis. In the future, I plan to take some measurements and try different component values to see whether the sound can be improved. For now, though, it's so much better than what I'm used to that I'll leave it as is.



PHOTO 17: Completed Vifa subwoofer ready to be installed. Both holes were enlarged to ensure the rubber surround would not contact the plywood during large excursions.

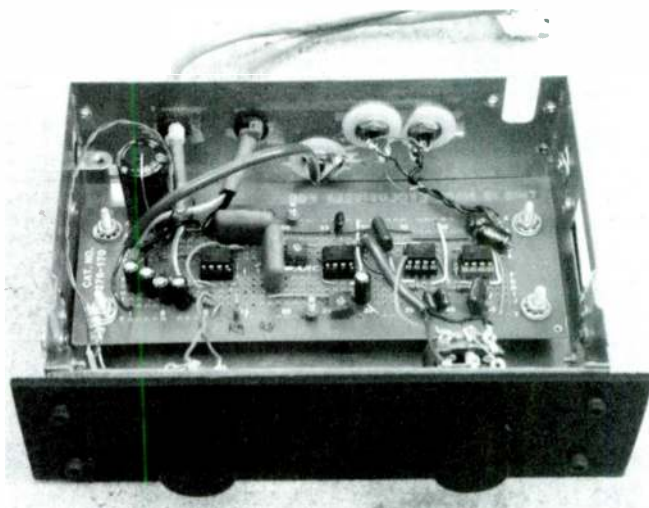

PHOTO 16: Completed subwoofer crossover. The knob on the left controls volume, the one on the right frequency.

TROLLING FOR DEEP BASS

The SAAB OEM radio package came equipped with a graphic equalizer (*Photo 15*). Since I couldn't get it working again, I thought it would make a perfect chassis for one of Ferguson's crossover units. The finished product is shown in *Photo 16*.

Basically, I removed the equalizer board, front panel, and DIN connector, and drilled the lower metal panel to accept a Radio Shack board with standoffs. I tried to locate a piece of black ABS or PVC plastic to retain the dark front panel, but to no avail. Instead, I took some clear scrap polycarbonate I had used to make router bases. With a sanding block and 100-grit paper, I scratched up one side so paint would stick to it, and sprayed on several light coats of flat black.

I installed this piece with the painted side facing away from the front of the panel, so you look at the back of the painted side through the clear polycarbonate. Mounted in this way, the black surface cannot be scratched and the panel has the appearance of depth. The front panel can be any color you wish. I backed up the panel with a piece of ¼" plywood, also sprayed black, and used black Allen head screws to attach both pieces to the metal frame.

The active crossover circuit received a few additions: 0.01µF stacked film caps across each of the op amp's supply and ground pins; a reverse-biased 14V zener from the positive rail to ground to shunt any inductive spikes to ground; a phono input jack to the rear panel for easier hook-up of an audio oscillator; and a small LED and current limiting resistor so I can tell when the crossover power is on, as there is no switch. In addition, I used multi-pin connectors to attach the signal and power lines to facilitate disconnecting the filter.

I took advantage of the black panel when installing the LED by drilling a same-size

hole in the plywood and a few millimeters into the polycarbonate. The LED is wedged into the plywood, but it shines through the polycarbonate when power is applied. When power is off, it cannot be seen. Other "black-out" indicators could be made in this way, and the front panel would protect them. Since I used the original chassis, installation was a snap.

SUBWOOFER MOUNTING

The M22WR29DVC woofer is quite heavy, weighing in at over 2½ lbs. The SAAB's rear deck is made from a heavy fiberboard material about 5/16" thick. It is braced along the front width by a metal pole and along the rear with rivets. I considered completely removing the deck and constructing a new one out of oak plywood laminated to MDF. This would involve far more work than I was ready to invest though, so I looked for a way to strengthen the existing deck.

First, using #8 × ¾" metal screws, I bottom-mounted the woofer onto a piece of ¾" plywood with an appropriate-size hole cut out for the cone. I then cut a 6 × 9 oval into a ¼" oak plywood sheet, and widened the cutout so the rubber surround would not touch the top piece, as shown in *Photo 17*. These boards are as deep as the shelf and approximately 14" wide. Four screws through the top into the bottom secure the two pieces without hitting the woofer frame; four more screws (#8 × 1") with washers attach the woofer board to the rear deck.

Additional support is provided by metal pipe strap, which shifts most of the weight onto the rear metal railing and front support tube. To tighten it, I used a small bottle jack inside the cargo space to raise the rear deck until it was level and then attached the pipe strap with sheet metal screws. The strap carries most of the weight and prevents the deck from sagging.

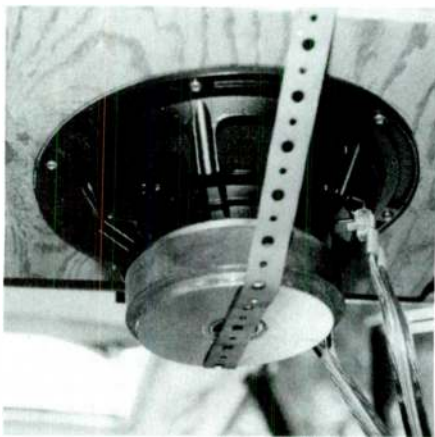

PHOTO 18: The pipe strapping supports the bottom and provides some protection from items loaded into the trunk. Note the large vent on the magnet.

Photo 18 shows the woofer mounted under the rear deck. Just to the right, you can see one of the black rear enclosures. The other 6 x 9 hole is blocked off by a similar-sized piece of 1/4" plywood held in place with four #8 x 1" wood screws. With black oak visible from the top, and covered with a similar grille finish as the sub, no one will know it is a blank.

CUSTOMIZED GRILLES

What with a rather large amount of material removed from the outboard boxes, and holes in the rear deck, of course the factory grilles wouldn't fit. Once again, I thought of several options, but settled on fashioning frames from 1/4" plywood and covering them with cloth from a fabric store.

For the rear outboard boxes, I started with a large piece of cardboard. I drew a rough shape with a pencil, making sure all screw heads were covered and the grille would conform to the rear windshield and side headliner contours. The results are shown in Photo 19.

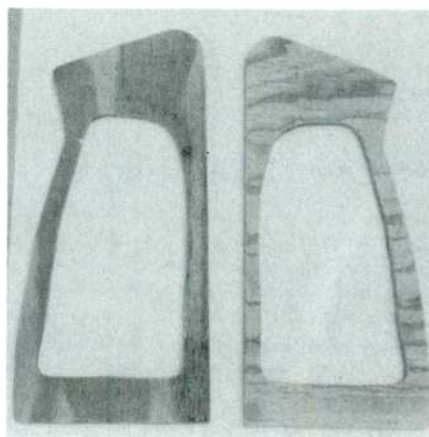

PHOTO 19: Left and right speaker grille frames. Fine-mesh window screen is shown to the left. The grille frames were held to the rear deck by Velcro tabs.

After cutting the pattern, I traced the outline onto scrap 1/4" plywood and cut the lines with my band saw. The next step was a thorough sanding to prevent snagging the fabric. The unexpected snag proved to be finding a suitable fabric. Calls to several varieties of fabric end-users didn't turn up any sources of light tan, open-weave polyester.

Then one day, in the painting section of a large do-it-yourself supply store, I noticed the wide assortment of spray paint colors. I picked up one I thought would match and also purchased some plastic window screen. I could stretch the screen over the frame and spray it the appropriate color (similar to the metal grilles used on in-wall speakers). The fine-mesh screen is shown on the far left in Photo 19.

This technique works very well, and the wide variety of spray paint offers many options to match interior color. To attach the frames to the rear deck, I used small Velcro® hook-and-loop fasteners. Depending on the type of material in your auto's interior, you may only need to use the hook piece mounted on the underside of the grille frame, using the deck fabric as the corresponding loop.

SOURCE

Madisound Speaker Components

PO Box 44283

Madisound, WI 53744-4283

(608) 831-3433

Vifa drivers, LPG hinged mounts, crossover design and components

REFERENCE

1. D.L. Ferguson, *Killer Car Stereo On a Budget: An Easy Cure for Ho-Hum Auto Sound* (Audio Amateur Press, 1989). [Available from Old Colony Sound Lab as BKAA4 for \$9.95 plus \$3 S/H in the US.]

RECOMMENDED READING

Patrick Spielman, *Router Jigs and Techniques* (Sterling, 1988), p. 193.

The other day I was driving home in traffic and listening to Handel's *Water Music*, enveloped in the sound. Although outside it was very hot, with heavy traffic and lots of noise, inside it was so quiet and the music was so relaxing that I was already unwinding. I knew then that all the work and time invested had been well worth it.

Of course, this is all Joe D'Appolito and Jim Bock's fault. If they hadn't designed the wonderful Swan IV system, I wouldn't have realized such transparent, spacious, and three-dimensional sound could exist—and I could afford it!

I was able to meet my design objective: a system which would fit in the SAAB and still allow me to carry plenty of cargo and fold down the rear seats. Thanks to the enclosed boxes, the sound is the same when the rear seat is folded down.

The sub doesn't work well with the rear seat down, however, so I turn it down. I've also found that the rear headrests greatly affect the sound from the rear, so I keep them stored in the trunk for easy access. For those of you with SAABs, I highly recommend this system. It will greatly improve your listening enjoyment while on the road.

Digital Storage Oscilloscope For \$189.95 ???

And much, much more!
O-Scope I turns PC-ATs into DSO, Spectrum Analyzer, Frequency Counter, DVM. DC-50KHz

Sinewave Sweep

Spectrum

Actual O-Scope I Captured Signals

For Orders and Inquiries Call: 1-800-980-9806
For Technical Assistance: 1-713-777-0401

Allison Technology Corporation
8343 Carvel, Houston, TX 77036
FAX and BBS 1-713-777-4746

A COMPACT TWO-WAY PA

By Bill Fitzmaurice

Traditionally, PA speakers have resembled oversized home units, as we saw in Part 1 (*SB 2/95*, p. 14). But mounting high- and low-frequency drivers in the same box severely restricts a PA system's flexibility. The usual result of using multi-driver cabinets to cover a large area is an assortment of hot and dead spots, especially in the treble.

The audience will routinely be either blasted by 120dB barrages or unable to hear any top end. Often, only a few feet make all the difference. Another approach to PA construction is needed for even high-frequency distribution over a large area.

OVER THEIR HEADS

The top box resolves the problem with a multiple-driver, high-frequency unit (*Photo 7*). A high-efficiency horn provides power projection at long distances, while two cone drivers offer wide-angle coverage close to the stage. Mounting the top box on a pole anchored to the bass bins allows you to aim the horn driver and achieve unimpeded projection over the audience members' heads.

The main unit is a JBL 2426 driver coupled to a JBL 2370A horn (*Fig. 5*). A nomi-

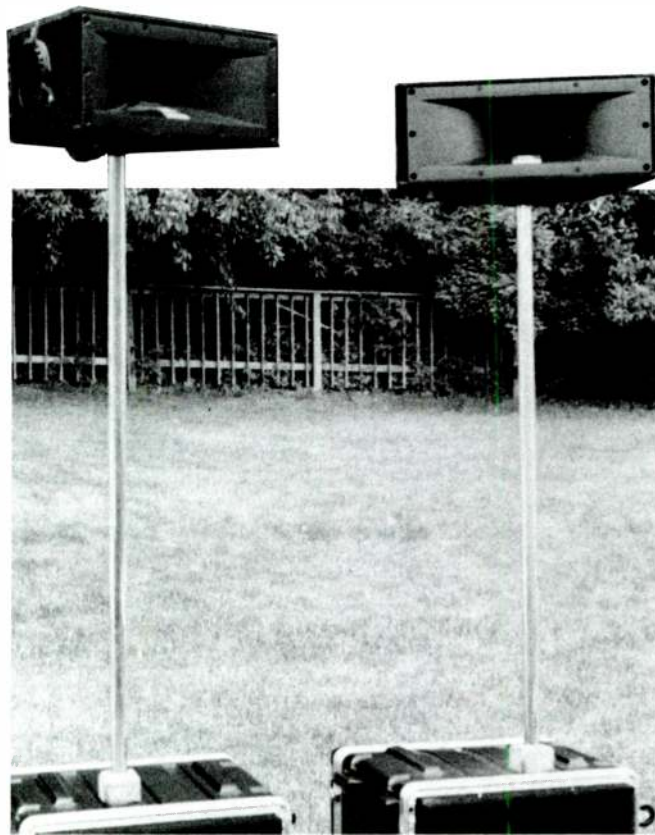

PHOTO 7: Assembled top box.

nal efficiency of 110dB allows operation with at least 6dB less input power than the bins for equal output. Its 50W rating is thus a good match for the bins' 200W. The 2426 is available in either 8 or 16Ω impedance; the latter is preferable for the top box.

The sidefill drivers are Pyle MH-516s,

which have a frequency response reasonably close to the JBLs. Their combination of low impedance and efficiency works well for our purposes (*Photo 8*).

The keys to this system's operation are the polar patterns and the drivers' relative outputs. The horn's narrow beam (90° × 40°) focuses its high output to the rear of the audience, while the cone driver's 100° spread enables wide coverage at low levels close to the sides, where standard arrays cannot reach.

CUTTING TIME

Construction is the utmost in simplicity (*Table 2*). Heavy, tight cabinetry is unnecessary, because only high-end is fed to the drivers. First, cut the top and bottom pieces. To determine the exact lengths of the back and sides, draw their layout on the top and bottom pieces, then cut them from 7" wide stock. Note that the sides stop 1/2" shy of the cabinet front (*Fig. 6*).

Cut 1 × 1 stock (3/4" × 3/4" actual) for the horn flange and attach the parts with either nails or screws and glue. For the jack and switch plates, cut holes of appropriate size in the bottom, and in the sides for the Pyles. A

piece of scrap wood, glued and screwed to the inside bottom as thick as clearance allows and drilled with a 1 1/4" bit, forms a receiver socket for the mounting pole. An additional piece of 3/4" plywood on the outside bottom maximizes the socket's depth. To determine the location of the socket, trial-mount the drivers and find the box's center of gravity (balance point).

For protection, cover the cabinet with carpet and add rubber feet. A simple hole in the top serves as an adequate handle (*Photo 9*).

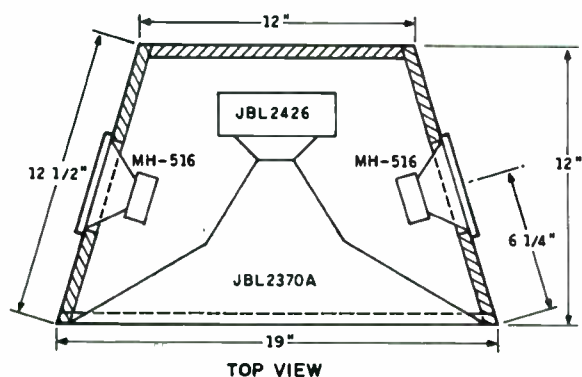

FIGURE 5: Top box parts layout. Overall height: 7 1/2"; side, back pieces cut 7" high; Pyle MH-516s front-mounted in center of side panels; cabinet is not sealed; all edges rounded 1/4" radius.

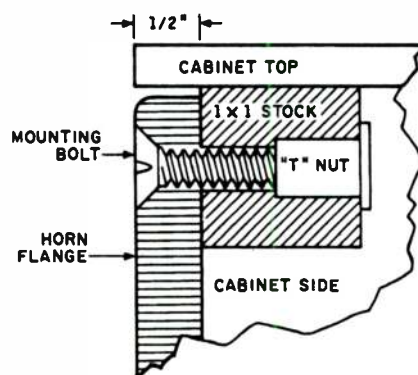

FIGURE 6: Mounting details (side view).

Announcing

The First Ever

Efficient Speaker Design Competition

GRAND PRIZE

Welborne Labs

Laurel II 300B Amplifier Kit

featuring

MagneQuest

"First Series"

Hand wound

Output Transformers

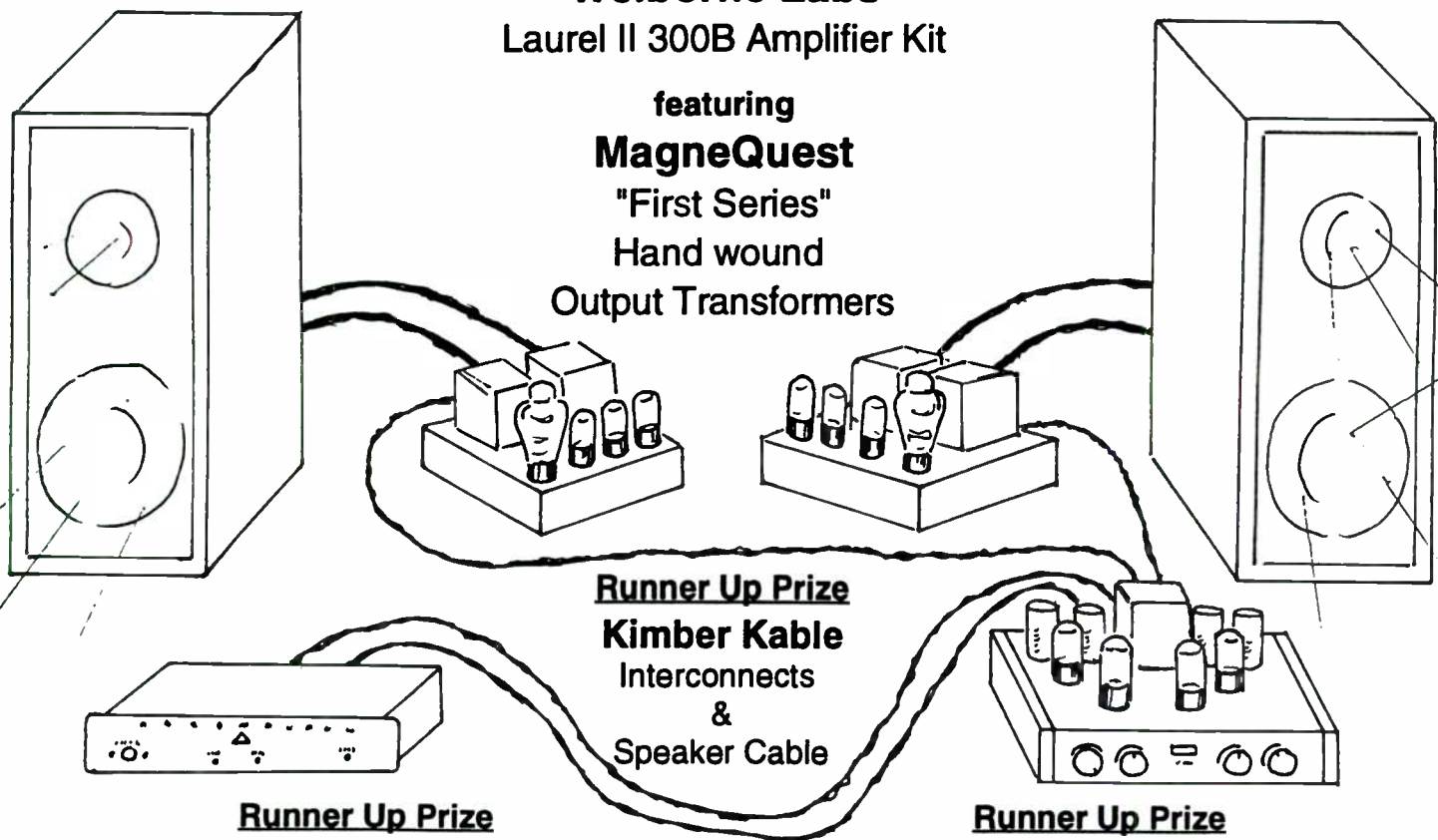

Runner Up Prize

Kimber Kable

Interconnects

&

Speaker Cable

Runner Up Prize

The Parts Connection

Assemblage DAC-1 D/A Converter Kit

Runner Up Prize

Audio Electronic Supply

AE-1 Dual Mono Preamplifier Kit

Plus many other exciting prizes including **Hovland MusiCaps**, and subscriptions to **Sound Practices**, **Positive Feedback**, and **Speaker Builder**. Everyone is a Winner!

Since our decade is shaping up to be the era of the low-powered single-ended amplifier, what could be more timely than a contest devised to spotlight efficient speakers that can showcase the dynamics, power, and sonic glory these wondrous little amps can provide? Mainstream speaker manufacturers are saying that it can't be done, but you know it can!!! So break out those driver catalogs and sharpen your table saws, the competition is about to begin!

All judging will be performed by the prestigious Colorado, Oregon, and Philadelphia audio societies
Construction articles for the winning designs to be published in **Speaker Builder**, **Positive Feedback** & **Sound Practices**

Entries must be received by September 31, 1995

For ground rules and entry form, send a stamped, self-addressed, business size envelope to one of these audio clubs:

Oregon Triode Society
4106 N.E. Glisan
Portland, OR 97232

Philadelphia Audio Society
P.O. Box 91
Devon, PA 19333

Colorado Audio Society
1941 S. Grant Street
Denver, CO 80210



PHOTO 8: Pyle MH-516 side-firing driver with protective grille.

TAKE AIM

The Pyles' on/off switches make it possible for only those drivers needed for listening area coverage to be actually switched into the circuit. The 4Ω total draw when both Pyles are engaged pulls power away from the JBL. While this is perfect in a small club, it's undesirable when you need maximum long-throw SPLs, such as an outdoor gig. With the switches, you can tailor the system to the venue.

While there is no crossover per se with

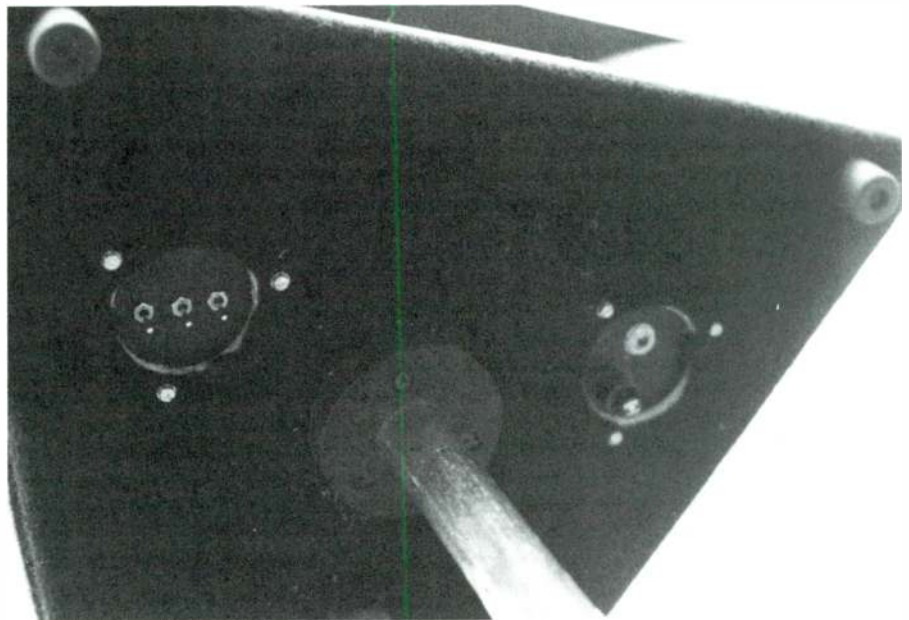

PHOTO 9: The box atop its mounting pole viewed from below. Note the 1/4" input jack and fuse, and switches for the MH-516s. (The third switch went to the JBLs on the prototype; I found it unnecessary.) Also note the rubber feet to protect the cabinet and switches when traveling.

biamping, the JBL drivers should be protected against amp failure and errant low-frequency pulses with a 20μF 250V Mylar® cap. A 4A fuse is also a good idea. The Pyles, rated for 50W full-range, don't need protection (Fig. 7).

You have some flexibility in setting the active crossover point: 650Hz–1kHz is the acceptable range, with a 24dB/octave slope. The determining factor will be the relative size of your power amp. My rack has 175W/channel for the bass bins and 100W/channel for the top boxes; a crossover at 800Hz provides equal headroom in both amps. Adjust your crossover point to the

same end—there's no sense in one amp clipping while the other is barely breathing.

Once you've tried this system, you'll love how easily it sets up. Just place the stacks on each side of the stage and aim the JBLs at the farthest point in the room. Where audience seating exists to the side of the stacks, switch on the appropriate Pyle to cover.

The most notorious dead spot is directly in front of the stage, too close for the main PA. The inboard Pyles cover this area, but with a low enough level to avoid overpowering the audience or causing microphone feedback. When you need maximum power, leave the Pyles off and the JBLs will give you 125dB+ with only 50W.

At the end of the gig, when the real work begins—tearing down and packing up—you'll be glad you don't have to haul a 150 lb monster out to a semi. At 3 a.m. everybody agrees that smaller is better.

TABLE 2

TOP BOX PARTS LIST

- (Per unit; double for a pair.)
 JBL 2426 driver, 16Ω
 JBL 2370A horn
 Pyle MH-516 drivers (2)
 1/4" plywood for box top and bottom
 1/2" plywood for sides and back
 1 x 1 stock for horn flange
 Scrap stock for pole socket
 1/4" phone jacks
 20μF, 250V Mylar cap
 4A fuse
 14-gauge hook-up wire
 5" metal grilles for Pyles
 SPST switches, jack plates, fuse post, carpet covering, nails, glue, spray glue for carpet. Rubber feet, if desired; switch and jack mounting plates, driver mounting bolts, and T-nuts.

(Note: JBL has recently introduced some new components of which I do not yet have specs. The 2426 may be superseded by a newer model.)

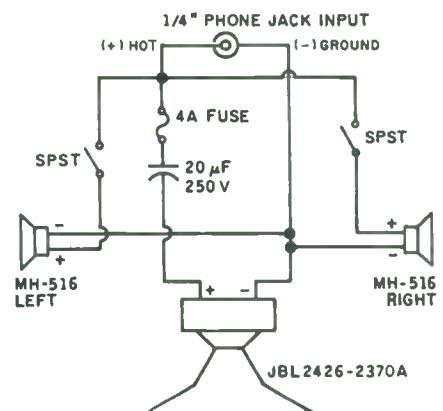

FIGURE 7: Top box wiring diagram.

SALE! PLUS FREE ADHESIVE!

MARKERFOAM™ ACOUSTIC FOAM GIANT 54" x 54"

Immediate Shipping

2" Reg. \$29.95 Now \$19.99 • 3" Reg. \$39.95 Now \$29.99! **KILL NOISE QUICK!**

High performance, full-size sheets of super high density Markerfoam. EZ mount. Blue or gray. Super-effective sound absorption for studios. Markerfoam offers best value, looks professional & is proven in studios worldwide. Request Foam-Buyers Guide/Catalog, specs & free samples today. VISA, MC, AMEX, COD, PO's, QUANTITY DISCOUNTS.

MARKERTEK JUMBO SOUND ABSORB BLANKETS
 Heavy-duty 72"x80" padded blankets absorb sound wherever they're hung or draped. Fabulous for stage, studio & field use. Top professional quality at a super saver price! Weight: 6 lbs. Black, \$19.99.

MARKERTEK BLADE TILES™
 HIGH PERFORMANCE
LOW, LOW COST!
 \$3.49 per tile, 16x16x2". America's best acoustic tile value, only from Markertek! Charcoal. Also available 16x16x3" as shown, \$4.49 each.

MARKERSTIK™ foam adhesive. FREE with any Foam purchase in this ad! Limited offer. A \$5.95 per tube value.

SONEX
 All the colors and sizes plus great prices!

* **Get our FREE 149-page catalog of over 6,000 exclusive and hard-to-find supplies for audio & video.**

800-522-2025 America's most unique catalog for audio & video!
 FAX: 914-246-1757

MARKERTEK™
 4 High St., Saugerties, New York 12477 U.S.A. **VIDEO SUPPLY**

Reader Service #10

April Showers Bring

Madisound Savings

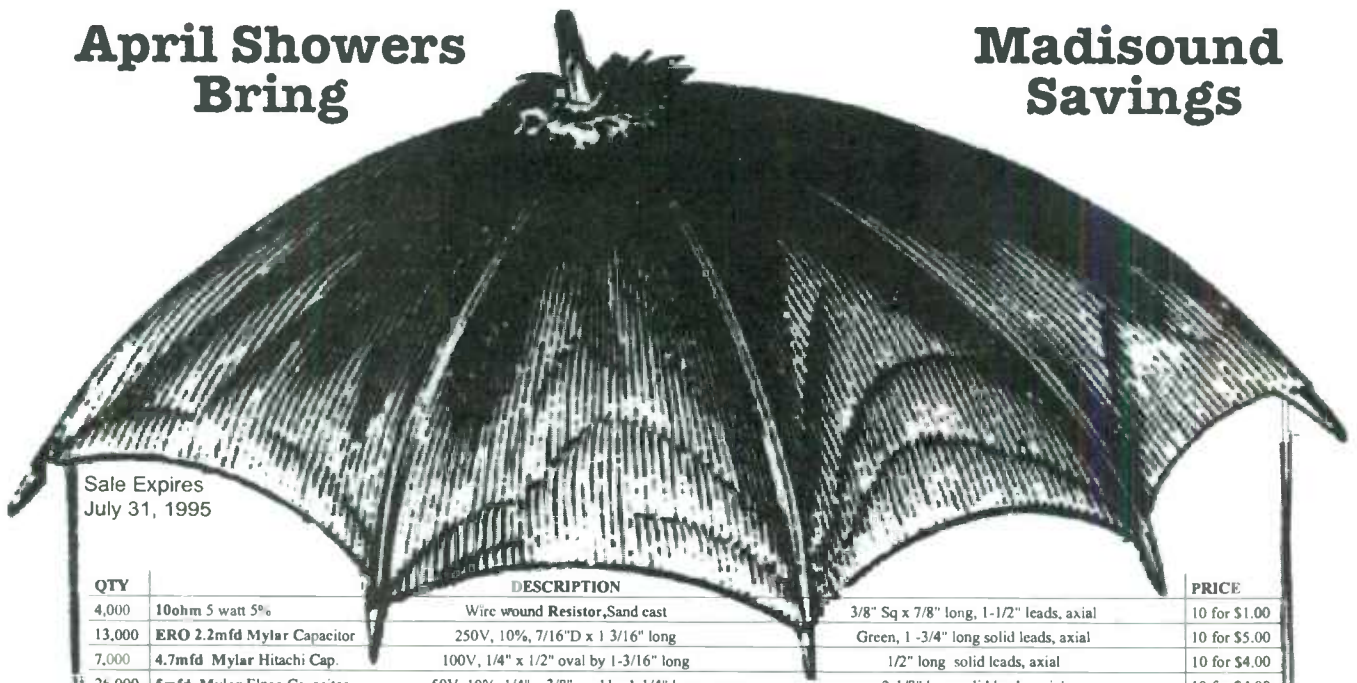

Sale Expires
July 31, 1995

QTY	DESCRIPTION	PRICE		
4,000	10ohm 5 watt 5% Wire wound Resistor, Sand cast	3/8" Sq x 7/8" long, 1-1/2" leads, axial	10 for \$1.00	
13,000	ERO 2.2mfd Mylar Capacitor	250V, 10%, 7/16"D x 1 3/16" long	Green, 1-3/4" long solid leads, axial	10 for \$5.00
7,000	4.7mfd Mylar Hitachi Cap.	100V, 1/4" x 1/2" oval by 1-3/16" long	1/2" long solid leads, axial	10 for \$4.00
26,000	5mfd Mylar Elpac Capacitor	50V, 10%, 1/4" x 3/8" oval by 1-1/4" long	2-1/8" long solid leads, axial	10 for \$4.00
1,000	NPC 10mfd Mylar Capacitor	100V, 10%, 1 3/16" T x 9/16" W, 1 1/4" L	Black, PC mount	10 for \$6.00
500	T.I. 25mfd Electrolytic Capacitor	100V, 2%, 1/5" Ø x 1" long	PC mount	10 for \$4.00
750	KSC 500mfd Electrolytic Capacitor	100V, 10%, 7/8" Ø x 1 5/8" long	Radial, 7/8" lead and 1 1/4" lead	\$2.00 each
200	.15mH Iron core Inductor, 24awg wire on an iron bar		1/2" D x 2" long	10 for \$5.00
1500	.2mH Air core Inductor, 19awg wire on a plastic bobbin		1-1/2" D x 1-1/8" tall	10 for \$6.00
800	2.0mH Air core Inductor, 19awg wire, bobbinless		2" D x 1" tall	\$1.50 each
100	Seas 25TF 11456 1" Damped Textile dome tweeter; 104mm glassfibre/plastic flange, 72mm cut out, Fs 1000Hz, 6ohm, 91.5dB, 50W, 26mm VC			\$12.00 each
168	Europa 23 Surface Mount Autosound tweeter module, 6dB mylar filter, 1" soft dome, 4 ohm, 70mm T x 60mm D x 68mm W, sloped front. 25 watt			\$15.00 pair
200	Klipsch K82K Horn Tweeters, 4" x 10" Exponential; Fs 1500; 100dB; 16Ø; use a 12dB x-over at 3K; 3 to 17.5K; Exceptional value.			\$20.00 each
200	MB Quart MCD-25S Titanium dome tweeter, Single magnet version of MCD-25M, Fs 1000, 90dB, 8 ohm, 100W @ 12db/3K, 3 3/4" square flange			\$20.00 each
14	Focal T120KT 1" inverted kevlar dome tweeter, 8ohm, Vented pole piece(must be chambered!), Fs 680, 93.5dB, 120mm square, 96mm magnet, 20mm VC			\$59.00 each
12	Eton 4-203/25HEX 4" Kevlar midrange, cast frame, foam surround, yellow kevlar hexacone. Fs 59, 92dB, Qts .26, Vas 6 ltrs, 70 watts, F3 150 in 1ltr sealed			\$70.00 each
10	Eton 5-80/25HEX 5" Kevlar woofer, cast frame, rubber surround, yellow kevlar hexacone. Fs 57, Qts .36, Vas 8.3 ltrs, 88dB, 70W, 8ohm, X-max 3mm pk.. Very smooth response with gradual rolloff to 7K. F3 of 110Hz in 3 ltrs sealed, F3 of 70Hz in 5 liters vented, 1.5"Ø vent by 5.5" long. An excellent driver!			\$80.00 each
350	Audax IN130W0 5.25" Carbon fiber cone autosound woofer, 4 ohm, 90dB, Fs 69Hz, Qts 0.82, Vas 9.1ltrs, F3 60Hz in small sealed enclosure or 70Hz free air			\$15.00 each
110	Dynaudio 19W38 4Ω Poly cone woofer, 89dB, Fs 46Hz, Vas 17.6 ltrs, Qts .37, X-max 3mm, Maximum excursion 13mm, 70W, 1.5" VC, F3 of 88 Hz in 7 ltrs sealed, F3 of 54Hz in 11 ltrs vented, smooth to 3KHz, special purchase. The normal price of this driver is \$84, take advantage of this special price.			\$55.00 each
100	Eminence 121321-4 Car Woofer, 12" Cast Frame, 3" voice coil, Paper cone, Rubber surround, 80oz magnet, 95 dB, Fs 321Hz, DCR 3.44 ohm, Vas 130 liters, Qms 10.75, Qes .34, Qts .34, 150W, F3 of 40Hz in 2 cf vented cabinet, 4" Ø x 6.7" long. 12 3/8" Diameter, 11 1/8" cutout This woofer is an exceptional deal!!!			\$90.00 each

*** Vifa speakers are regarded as an exceptional combination of high quality and moderate price. Madisound has been able to make a special purchase of surplus inventory from Vifa, and we would like to offer the following items to you at a price far below replacement cost. Please note that quantities are limited.

124	D26TG-00-06 One inch Textile dome tweeter, identical to the D26TG05 but without ferrofluid. Fs 1200 Hz, 92dB, 6 ohm, 60W @ 12dB 3K, 3-30K Response.	\$9.00 each
194	D25AG-65-06 One inch Aluminum dome tweeter, same as D25TG05 but with ferrofluid and braided tinsel leads., Fs 1500 Hz, 90dB, 100W @ 12dB 3K	\$13.00 each
277	M10MD39-04 3.5" Midrange that Madisound regularly stocks, but at a bargain price. 4 ohms, Fs 110Hz, Cast frame, Damped paper cone with rubber surround, 110mm flange size with 81mm cutout. Must be chambered. recommended crossover frequency of 700Hz in 1 liter sealed and stuffed.	\$10.00 each
200	Isolation chamber for M10MD39; 45 liter	\$1.00 each
139	P13WG-00-04 5" Woofer 4 ohms, Cast frame, rubber surround, Poly cone, 8.5oz magnet, 140mm flange Ø, 112mm cutout, Fs 60Hz, vas 10 ltrs, Qts .48, suitable for either sealed or vented boxes. Smooth response both on and off axis. Frequency range 60 - 5,000Hz. 70W music power. F3 of 85Hz in 5-9 ltrs.	\$16.00 each
110	M21WJ-09-08 8" Woofer 8ohm, damped paper cone, rubber surround, cast frame. Fs 29, Vas 136 ltrs, Qts .36, 91dB, 80Watt, 32mm voice coil, 4mm X-max. For bass reflex enclosures of 28 to 60 liters. Alignment of 1.3 cf gives an F3 of 49Hz, 2"Ø vent by 3.2" long. F3 of 60Hz in 1 cf sealed enclosure.	\$20.00 each
70	M25WO-49-08 10" Woofer 8ohm, Paper cone, rubber surround, cast frame. Fs 25, Vas 164 ltrs, Qts .29, 90dB, 80 Watt, 40mm voice coil, X-max 4mm, 24.6oz magnet, 260mm flange with 230mm cutout. For bass reflex designs of 40 to 70 liters. QB3 alignment of 47 ltrs, F3 42Hz, 3"Ø vent x 7" long.	\$30.00 each
147	M26WO-45-08 10" Woofer, 8ohm, damped paper cone, Cast magnesium frame, rubber surround, 37oz magnet, 6.5mm X-max long throw, 40mm voice coil. Fs 24, Vas 136 ltrs, Qts .29. 260mm flange with 230mm cutout. For bass reflex designs of 35 to 65 liters, B4 alignment of 47 liters, F3 39Hz, 3"Ø vent x 7.8" L.	\$40.00 each



Madisound Speaker Components; P.O. Box 44283, Madison WI 53744 Tel:608-831-3433, Fax:608-831-3771

Wayland's Wood World

BRACING FOR SHAKING

By Bob Wayland

How many times have you built an enclosure, only to determine the structure acted like a second speaker? The muddled sound from such a monster can be difficult to correct. The best way, of course, is never to let it happen in the first place by using braces on any piece of the structure that can be forced to vibrate. You can correct this problem after you have built the enclosure, or, better yet, make the enclosure structurally solid during construction.

CORNER BRACES

The first step in designing and building the enclosure is ensuring structural integrity. One of the weakest areas is the joints, especially in the corners.

If you use butt joints, you'll need a corner brace, which is also good insurance for any type of joint.

Your choice of material is not critical. The very high dimensional stability of medium-density fiberboard (MDF) and plywood lets you employ most woods with equal effectiveness if the grain of the brace is along the joint. If you use solid wood, you should also use it for the braces. Larger enclosures require braces the most, and I suggest 8/4 (2") lumber.

First, cut square pieces of stock the length of the joints. Simply set the cutoff width using the material itself (Photo 1). You'll need half as many squares as corners, plus one extra. We will use one of the pieces to

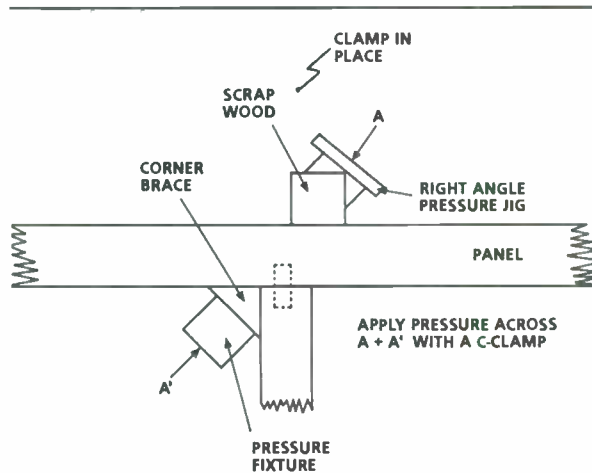

FIGURE 1: Bracing a joint not at a corner.

make a clamping brace, a *pressure fixture*. With a hand plane or a taper cutting jig for your table saw, make a set of back-to-back tapers so one side of the pressure fixture forms a very flattened V-shape (Photo 2). Cutting one of the square pieces lengthwise along a diagonal (Photo 3) produces the actual corner brace (you'll need four).

You must clamp the corner brace firmly in place during gluing. The problem is how to apply pressure to the center of the brace without buying some incredibly expensive long-throated clamps. Before I show you how to use the pressure fixture, you need one additional fixture.

On a small (2" x 3", for example) piece of plywood, glue some scrap 45° right angle

braces face-to-face to form a *right angle pressure jig* (Photo 4). (Construct different sizes of these handy clamping aids for other projects.) Apply glue to the two sides of the brace that will adjoin the corner joint. Now, using a right angle pressure jig on the exterior edge of the joint, position the glued brace. Place the pressure fixture along the back of the brace and clamp one end with a C-clamp (Photo 4). Do the same on the other end of the joint.

PANEL BRACES

If you are fastening a brace for a joint that is not at a corner (where a shelf meets a side, for example), you need to construct an artificial corner to clamp across. Usually you can do this by clamping a scrap of wood in place and using a right angle pressure jig (Fig. 1).

Problems occur when you can't use C-clamps, as for interior joints. The solution is to clamp a bit of scrap so that you can insert another scrap stick between it and the corner brace. Cut the scrap stick a little long and tap it into place, sliding it along the brace. Clearly, the more complex the shape of your enclosure, the more ingenious you must become in devising fastening arrangements. We'll also use this type of clamping with the flattened V pressure fixture in the other wooden braces described below.

You can use square corner braces if you don't have access to a table saw. There are some problems with this, however. First, it

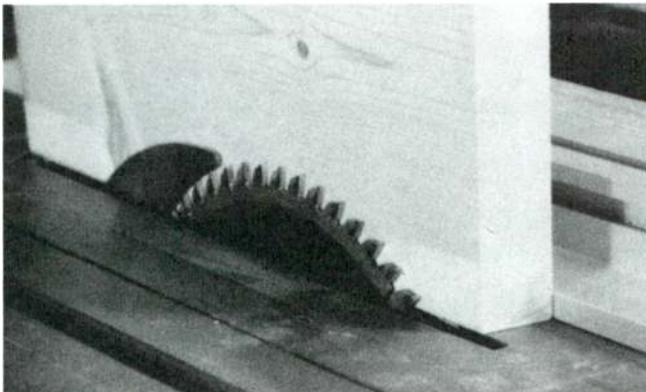

PHOTO 1: Setting cutoff for making the braces.

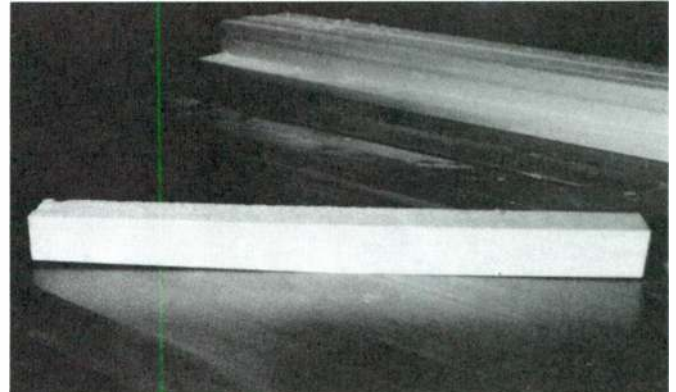

PHOTO 2: The V-tapered clamping brace.



AEON 250 VDC 5% FINE CAP

Metallized polypropylene capacitors for loudspeaker passive network.

Another brand of metallized polypropylene capacitors ? Well, not exactly ... At Orca we have been thinking for a while about how to make polypro caps more affordable for a larger number of speaker builders, people who use caps only for speaker passive X-over network. We thought that it would be tremendous if we could offer a line of polypro caps that would be so affordable that people would have no reason to use cheap mylar, as they would be able to get for not much more money a much much better cap. As you know, even extremely powerful solid state amps (we are talking KW here) can barely produce rail voltage higher than 60 V. So it is safe to assume that a 100 VDC cap would be a pretty robust cap to use in a passive loudspeaker network. So to be really safe, we decided to make all the AXON cap of our FINE CAP basic line 250 VDC. Now that's about where the compromises start and stop. On the other hand for example, you may or may not know that when a cap value is said to be 10.0 μF with 5% precision, it means that the manufacturer of caps sets its winding machine to 9.7 μF and then produces this series with 2% tolerance (not very difficult with numeric controlled winding machines). The result: the manufacturer saves more than 3% in material, the precision is respected, but chances are all your caps will measure on the low side ! Orca made the special arrangement that all the AXON caps were to be wound with 5% precision with the target value set at exactly the nominal value. That means now, as most of you do, and rightly so, expect, that you should find a much greater proportion of caps very close to exactly 10.0 μF , if not 10.0 μF exactly! As for the rest, we could display here all sorts of figures and graphs that would only makes sense to 1% of our customers, but what for ? We can simply tell you this is the first polypro cap at a price closing on mylar caps. It is made by the same company that makes all our high voltage and very high voltage SCR caps, as well as our film and foil caps. Some of the best loudspeaker manufacturers have already made that easy choice. Now see for yourself and ... let your ears make the call.

Value μF	Diameter mm	Length mm	SRP US\$	Value μF	Diameter mm	Length mm	SRP US\$
1.0	11	21	1.23	12.0	25	33	3.56
1.5	12	22	1.44	15.0	25	38	4.18
1.8	13	22	1.49	20.0	29	38	5.16
2.2	15	22	1.58	24.0	29	43	5.98
2.7	14	25	1.67	30.0	32	43	7.30
3.0	15	25	1.73	33.0	32	48	7.74
3.3	16	25	1.78	41.0	35	48	9.32
3.9	16	25	1.83	50.0	37	53	10.96
4.7	18	27	1.96	51.0	37	53	11.16
5.6	18	30	2.10	56.0	39	53	12.00
6.0	19	30	2.20	62.0	39	53	12.98
6.8	20	30	2.33	75.0	43	58	15.12
8.0	20	33	2.91	82.0	45	58	16.28
8.2	21	33	2.97	91.0	47	58	17.50
9.1	22	33	3.08	100.0	49	58	18.76
10.0	23	33	3.23	120.0	51	63	21.98
11.0	24	33	3.38	130.0	54	63	23.38

STOCKING DISTRIBUTORS:
W.A.R. AUDIO AUSTRALIA
 tel:(61)-9-242-5538 fax:(61)-9-445-2579
SPEAKERS ETC...
 tel: (602) 944 1878 fax: (602) 371 0605
TECHNOLOGIE MDB
 tel: (514) 526 8851 fax: (514) 443 5485
ZALYTRON INDUSTRIES
 tel: (516) 747 3515 fax: (516) 294 1943

OEMs & EXPORT
 Contact **Kimon Bejjas**
 or **John Sangalli**
 tel: (818) 707 1629
 fax: (818) 991 3072
ORCA
 1531 Lookout Drive
 Agoura, CA 91301
 USA

NOW AVAILABLE:
FILM / FOIL 630 VDC CAPS for
 electronics and bypass from
 0.1 μF to 1.0 μF .
POLYPRO ULTRA HIGH
VOLTAGE
 1200 VDC 20 μF
 for power supply & tube
 electronics



PHOTO 3: Cutting a corner brace on a table saw. I removed the blade guard for this illustration. Be very careful and use push sticks to make the cut.

looks horrible and decidedly unprofessional, although it is on the inside and you can't see it. You can construct a quick and easy right angle pressure jig from short pieces of corner molding, but it is not very strong. Also, the sound from an enclosure with square braces

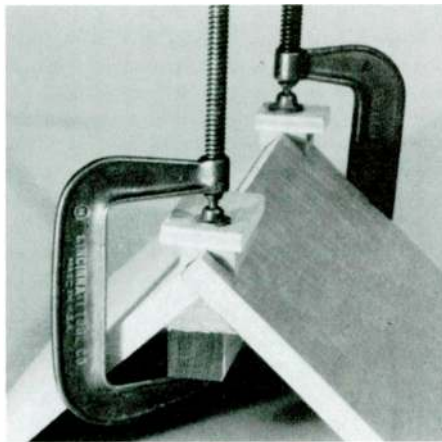

PHOTO 4: Clamping the corner brace in place using a right angle pressure jig and a tapered pressure fixture. If you clamp a corner that doesn't form a right angle, make the pressure jig fit the angle.

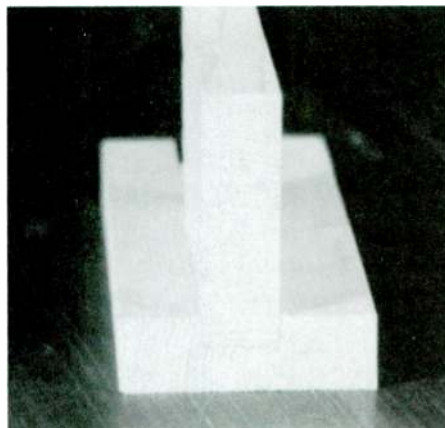

PHOTO 5: The fully housed dado joint.

sometimes has annoying overtones, although I can't prove this.

It is good protection to "buck up" (strengthen) large panels. Of course, the best time to do this is during construction. The brace doesn't need to be massive, but it should add stiffness to the panel. This is most easily accomplished with a rib attached perpendicularly to the panel's surface. The rib can be of uniform height or have a triangular peak; it really is not critical. However, I avoid the triangle-shaped braces, which are harder to clamp.

There are three basic designs: fully housed dado, tongue and groove, and spline joints. Each has advantages and disadvantages.

FULLY HOUSED DADO

This is a very simple joint made with dado cutters set to the width of the rib. The depth of the dado should be one-third the thickness of the panel. The dado cut should be clean and flat.

After applying glue to the surfaces of the dado, clamp the rib into place. You can use the tapered clamping brace method described above. A completed joint is shown in *Photo 5*. I avoid this joint because the shoulders of the dado are not reinforced and can fail, especially in particleboard and MDF. If you use corner braces, this is not a problem, but it complicates construction.

TONGUE AND GROOVE

This joint is very similar to the dado joint, but the edges of the groove are reinforced. Instead of making the groove the thickness of the rib, it should be about one-half its thickness. (The following construction techniques are for a much narrower groove.)

First, set the depth of the saw blade to one-third the thickness of the panel (*Photo 6*). Cut the groove along one edge of the marked channel. A good practice is to mark the material to be cut out with Xs to remind you on which side of the line to cut.

Reset the saw fence to cut the other side of the groove (*Photo 7*). Then move the fence, making filling cuts until the groove is clean-

cut (*Photo 8*). Clean and smooth the bottom of the groove with a chisel, or with dado cutters. To form the tongue, first center the rib over the groove (*Photo 9*), carefully mark the width, and clearly place Xs on the material to be removed. With the saw blade depth still at one-third the panel thickness, use the marked rib to set the saw fence to cut out the waste material (*Photo 10*).

If you have perfectly centered the tongue on the rib, rotate the rib and cut the other side. Of course, you should check the position of

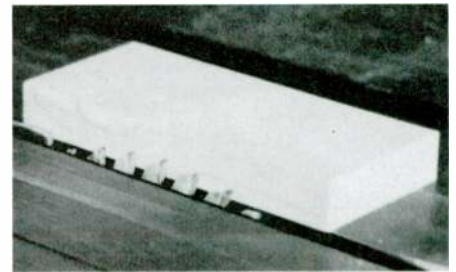

PHOTO 6: Setting the depth of cut for the groove in a tongue-and-groove joint.

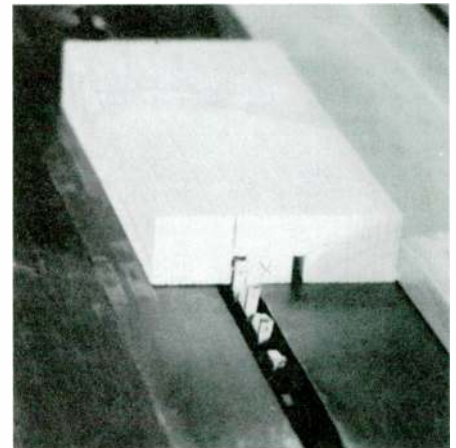
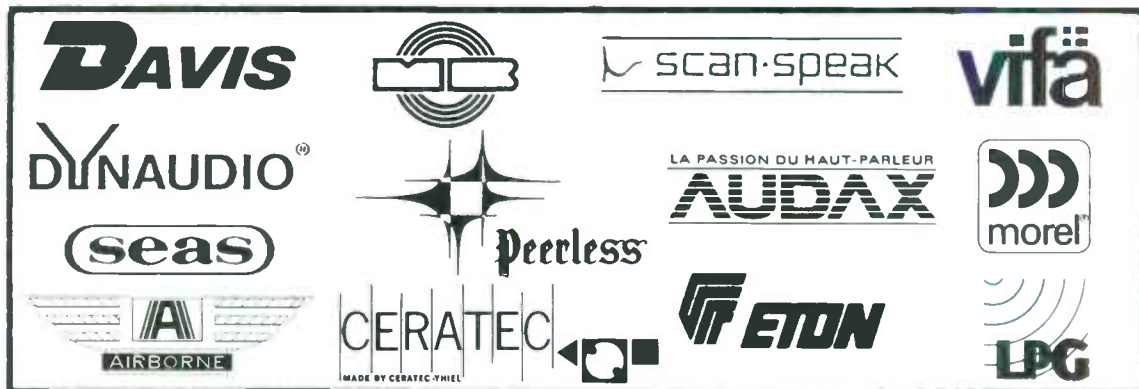

PHOTO 7: Making the second cut.

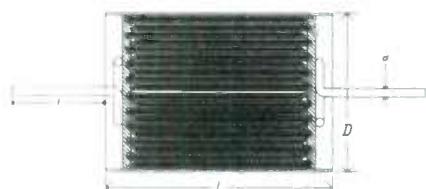

PHOTO 8: Cleaning out the center of a groove.

SOLEN SPEAKER COMPONENTS



CROSSOVER, SPEAKER COMPONENTS



FAST CAPACITORS

Metallized Polypropylene (Non-Polarized)
 Values from 1.0 mfd to 200 mfd.
 Voltage Rating: 250 VDC / 150 VAC

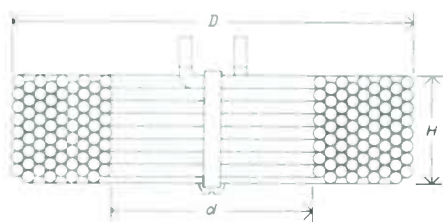

SOLEN INDUCTORS

Perfect Lay Hexagonal Winding Air Cored
 Values from .10 mH to 30 mH
 Wire sizes from #20 AWG to #10 AWG



HEPTA-LITZ INDUCTORS

Seven Strands Litz-Wire Constructions
 Values from .10 mH to 30 mH
 Wire sizes from #16 AWG to #12 AWG

SOLEN CROSSOVERS

Custom Computer Design
 Passive Crossover for Professional, Hi-Fi and
 Car Hi-Fi, Power up to 1000 Watt

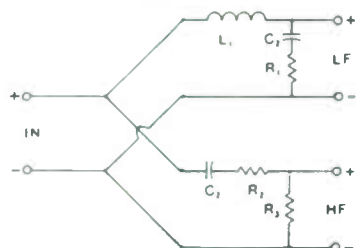

CROSSOVER, SPEAKER PARTS

Gold Speaker Terminals, Gold Banana Plugs
 Gold Binding Posts, Crossover Terminals
 Power Resistors, Mylar Capacitors,
 Bi-Polar Capacitors, Plastic Grille Fasteners,
 Nylon Ties, Car Speaker Grilles, Speaker Books,
 Speaker Kit Brochure, Miscellaneous Parts



SOLEN INC.
 4470 Thibault Ave.
 St-Hubert, QC J3Y 7T9
 Canada
 Tel.: (514) 656-2759
 Fax: (514) 443-4949

**COMPUTER AIDED DESIGN FOR
 ENCLOSURE AND CROSSOVER
 AVAILABLE TO CUSTOMER**

Catalog \$6.00 refundable.

the second cut against the marked position. If it is imperfect, adjust the fence and then make the second cut. Test your settings on a scrap piece until you are sure they are correct.

With the rib on its side, set the depth of the saw blade, using the top of the cut as a gauge. Next, set the fence so the cut will remove the marked waste (again, one-third the thickness of the panel). Turn the rib over and, if the tongue was not exactly centered, readjust the depth of the saw blade.

By forming the tongue this way, you will have a clean shoulder that ensures a strong joint. Don't be tempted to make a series of

cuts with the rib in the vertical position. Shoulders formed by this method will not be smooth and tight-fitting even if you clean up the ridges left by the top of the saw cuts. If you cut the tongue a fraction fat, a quick sanding will provide a perfect fit. After coating the joint surfaces with glue, clamp the rib into place, using the tapered clamping brace, if needed. A completed tongue-and-groove joint is shown in *Photo 11*.

COMPOSITION BOARD

You will most likely be making solid wood braces when using particleboard or MDF.

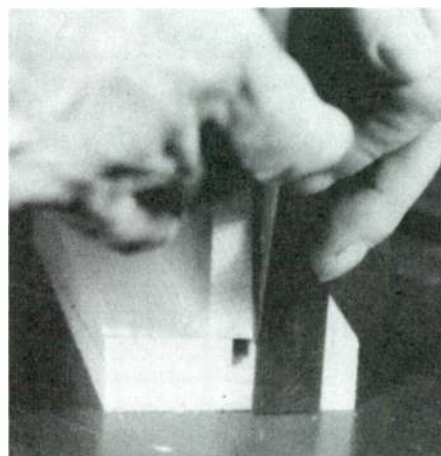

PHOTO 9: Marking the tongue on the rib.

Increase your electronics know-how and skills

The speed and intensity with which electronics penetrates our daily lives at home, at work, or in our car, tends to make us forget that we **can use electronics creatively** by building designs with a practical application and having the satisfaction of a successfully finished project. *Elektor Electronics*, which is distributed all over the world, can help you achieve these goals. Throughout the year, the magazine features original construction projects, informative articles and news on the gamut of electronics, science & technology, book reviews and information on new products. The past 11 issues contained 80 major and 97 minor construction articles, 21 articles of an educative or instructional nature, and 10 articles dealing with Science & Technology.

If you wish to increase your electronics know-how and skills, take out an annual subscription to *Elektor Electronics* by writing or faxing to

**World Wide Subscription Service Ltd
Unit 4, Gibbs Reed Farm
Pashley Road, Ticehurst
East Sussex TN5 7HE, England**

Telephone +44 580 200 657; Fax +44 580 616

You will then have the convenience of having the magazine delivered to your home, and the peace of mind that you will not miss any issue. The current rate for an annual subscription (11 issues) is \$US 57.00 (post paid - airspeeded).

There are also a number of *Elektor Electronics* books geared to the electronics enthusiast - professional or amateur. These include data books and circuit books, which have proved highly popular. Two new books (published November 1993) are *305 Circuits* and *SMT Projects*. Books, printed-circuit boards, programmed EPROMs and diskettes are available from

**Old Colony Sound Lab
PO Box 243, Peterborough NH 03458
Telephone (603) 924-6371, 924-6526
Fax (603) 924-9467**

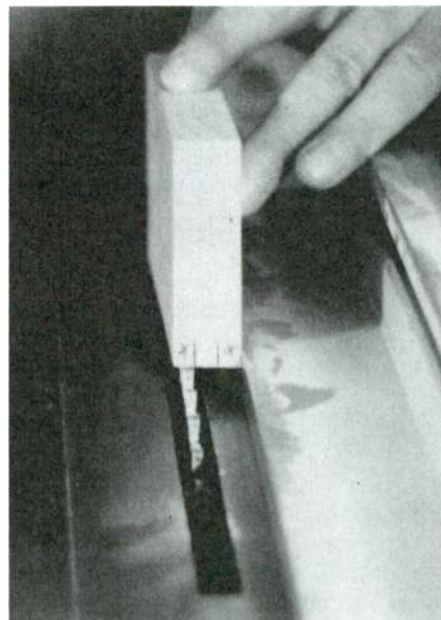

PHOTO 10: Setting up the cut for the first pass for making the tongue.

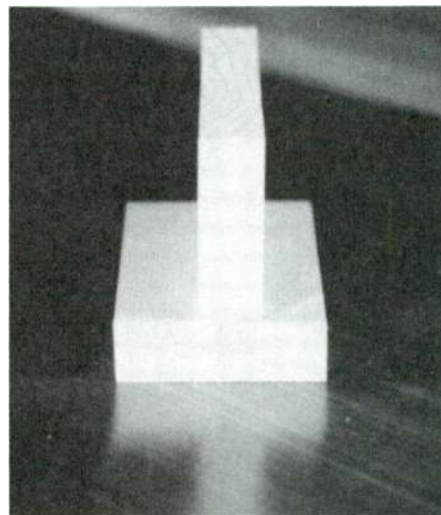

PHOTO 11: Completed tongue-and-groove joint.

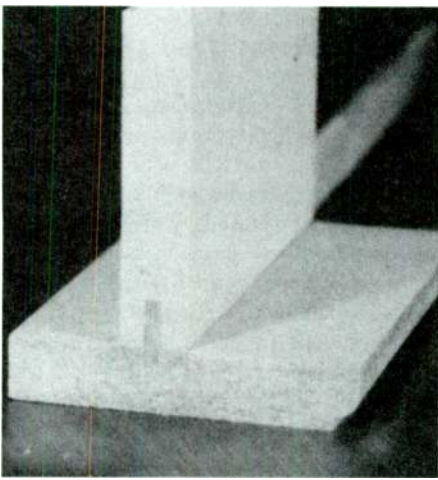

PHOTO 12: Completed spline joint.

However, there will be times when, for stability or availability, you will need to use particleboard or MDF, which is not the best for joints. They lack durability because of the stress on the corners, and can cause early failure of the joint. A good joint for this application is a plywood spline joint.

Using the board as a guide, set the fence on your saw to the board's thickness. Cut a strip of plywood as long as the brace. For 3/4"

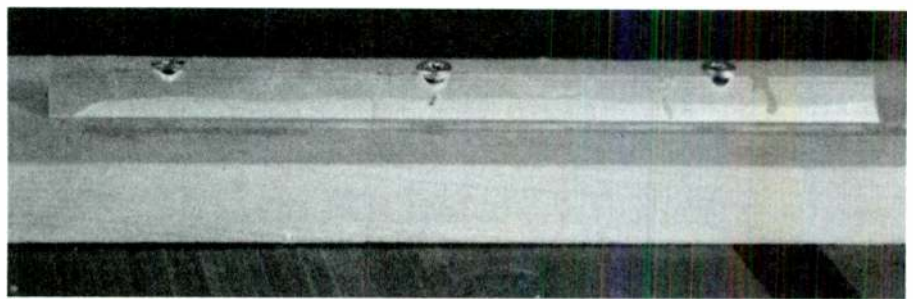

PHOTO 13: Using an aluminum right-angle brace. I applied a layer of silicone sealant between the aluminum and the panel.

material, I use 1/4" plywood, which you can use as the guide for cutting the groove for the spline. This procedure follows the tongue-and-groove method used above; the thickness of the tongue equals the thickness of the spline. The depth of the groove should be one-third the thickness of the material.

Next we need to cut the groove for the spline in the brace. Determine the depth by putting the spline in the groove in the panel board and setting your depth gauge, or measuring it. Carefully set your saw to this measured dimension. With a piece of scrap wood, set the rip fence on your saw, so that when you first cut the groove in one direction and then rotate the brace 180° and make a second

cut, the groove is exactly centered. The results are shown in *Photo 12*.

This procedure involves trial-and-error, as well as quite a bit of patience. If the bottom of the groove is not flat, you can smooth it with a small chisel, or with the edge of a small mill file. Complete the joint by gluing the spline and clamping the brace firmly to the panel.

HARDWARE BRACES

What do you do if, after you have built a speaker, you discover that a panel is vibrating? Establish the problem's location (i.e., the position of the vibration on the surfaces of the enclosure). If you feed a signal of the frequency that produces the greatest vibration

Home Theater that won't mess up your listening room.

Why spend all that money messing up your listening room with five speakers and a sub when HeadRoom will get you a great video listening experience---in any room of your house?

Oh ... did we mention great headphone listening for music too?



The Home HeadRoom sounds wonderful at \$599. And together with the Sennheiser 580s at \$799, it's a system that you just can't pass up.



The Sennheiser 580s are probably the worlds best all around headphone. \$299



Factory direct, just give us a call at

1-800-828-8184

for our 24 page White Paper, 32 page Manual, and color Brochure. **It's FREE!**

FAX + 406 587 9484 For Overseas Orders.

HeadRoom is located at 521 E. Peach Ave., Bozeman MT 59715. Send mail to POB 6549, Bozeman MT 59771. Outside USA and CANADA, call 406-587-9466, or FAX 406-587-9484

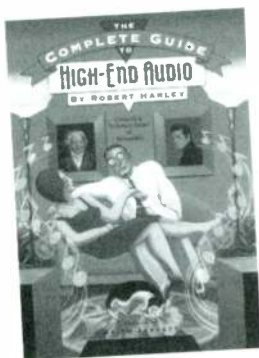

At Last! The Ultimate Reference Book on High-Quality Music Reproduction!

The Complete Guide to High-end Audio

by Robert Harley

Robert Harley, Consulting Technical Editor of *Stereophile* magazine, tells you everything you need to know about buying and enjoying high-quality hi-fi. In 13 fact-filled chapters and 3 appendices, you will discover how to set

up your system for the best sound; how to identify the weak links in your system and upgrade where it will do the most good; and most of all, how to become a more perceptive and appreciative listener.

For the more advanced audio enthusiast, *The Complete Guide to High-end Audio* is packed with detailed technical explanations of how the compact disc works, why loudspeaker cables can sound different, what DSP room correction is, how an R/2R ladder digital-to-analog converter works—and much more! This massive, oversized volume—spanning more than 450 pages and 200+ photographs and illustrations—covers in depth every aspect of reproduced sound.

Here's a sample of critical acclaim for *The Complete Guide to High-end Audio*:

"Destined to become the tome of our hobby. *The Complete Guide to High-end Audio* is a must have addition to every music lover's library. For less than the price of 3 CDs, this book is without question the best value in high-end audio." Shannon Dickson, *The Audiophile Voice*.

"I like this book. I give Robert Harley a lot of credit for tacking a potentially daunting subject with such passion and intelligence." John Stierberg, *Sound and Video Contractor*

Available from Old Colony Sound Lab, P.O. Box 243, Peterborough, NH, 03458 (603) 924-6371, Fax: (603) 924-9467
Only \$29.95 (softcover) or \$39.95 (signed hardcover)

into your speaker, you can usually feel just where the maximum is.

For some idea of the pattern of the vibration, turn the vibrating panel horizontal and sprinkle a very light coat of fine sand on the surface. A few seconds of sound will normally produce a clearly discernible pattern. With this information, decide where to place a brace to stop or reduce the vibration.

An easy-to-apply brace is a length of angle, either aluminum or iron. It is inexpensive and can be cut quickly to fit. Drill holes in the apex every few inches and attach it to the panel with screws that stop just short of coming through the panel. To eliminate buzzing, coat the contact between the metal and the panel with silicone sealant (*Photo 13*). You can also use this type of brace instead of the wooden ones.

CONCLUSION

I have not referred to techniques using routers, with which you can produce good tongue-and-groove and spline joints. I'll return to this topic in a later column. Some easily made jigs make this approach useful.

I hope these techniques provide a simple starting point for your efforts. This is a subject with many different and often difficult approaches. You will seldom be able to get it right the first time, but keep trying.



A great mainstream magazine full of product reviews, features and music reviews. In our regular free DIY Supplement (banded on) are in-house designed amplifiers and loudspeakers for the home constructor, as well as DIY letters, pages full of useful design advice, kit reviews and kit news. You'll find reviews here available nowhere else, on titanium-anode 300Bs for example, books from around the world, vintage products and FFTs from the USA.

Our in-house designers and laboratory produce unique valve amplifier designs, including transformers, for the DIY Supplement. Our loudspeakers are designed around hi-tech. Polydax carbon-fibre and, in future, HDA drivers - all available in the USA.

Coming in 1995: an all-valve phono stage, including MC; an electrostatic 'speaker kit that runs at 13kV; an HDA loudspeaker; a twin-300B single-ended power amplifier, plus much more.

Subscription Form

P.O. Box 754, Manhasset, N.Y. 11030 - 0754
Telephone: 516 627 3836 Fax: 516 627 1972

I wish to subscribe right now - and receive monthly copies of Hi-Fi World Air Speeded direct from the Publisher in London U.K. to the N.Y. Office

I enclose my payment to :- FRJ/HI-FI as checked below
1 Year - 12 Issues \$66 (U.S.)

U.S. FUNDS ONLY PLEASE - Add \$10 U.S. for Canada.

Please charge my Credit Card with the amount indicated. (All major Credit Cards accepted)

Name:

Signature:

Address:

City:

State:

Zip:

Telephone: 516 627 3836 Fax: 516 627 1972



300B triode 28watt push-pull amplifier. Switchable feedback, unique driver transformers, dual choke power supply, welded steel chassis. Weight 44lbs. \$ 1160 - valves & carriage extra

Other Models include:	
28watt push-pull (300B)	\$ 1160
20watt push-pull (5881)	\$ 540
17watt single-ended (5881)	\$ 890
4watt single-ended (6080)	\$ 525
Line valve preamp (6922)	\$ 400
Carriage extra	

For further information on our range of kit valve amplifiers and loudspeakers, please contact us at the address below. Distributor enquiries welcome.

World Audio Design
64 Castellain Road, Maida Vale
London, W9 1EX, England
Tel: (+44) 171 289 3533
Fax: (+44) 171 289 5620

WORKSHOP VIDEO

W.V.S.

1502. N Harrison St., Ft. Wayne, IN 46808

LEARN SPEAKER RECONING RECONING VIDEO

There will be "NO MORE SECRETS" once you have seen this video. *This video is the most informative education you may ever have available to you about speakers. Now you can know how to custom design a speaker just like the engineers who prototype and experiment in laboratories. You can design a speaker that will produce desired frequencies instead of working with what is available and hoping to emulate the sound you want. Even if you never recone one speaker, you will come away from this video with an understanding that has been secrets of the industry ever since Peter Jensen, Leo Farnsworth and Robert Maxwell who is one of the last surviving members of the original audio poineers. We also have technical assistance second to none when it comes to speakers and passive audio. You can replace foam surrounds for a fraction of the cost of*



NO MORE SECRETS

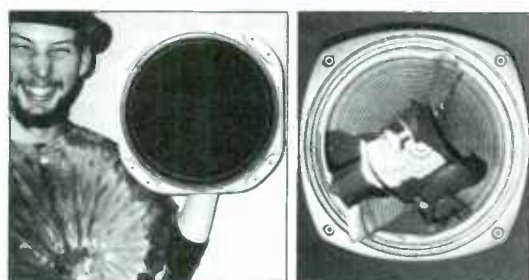

"My first recone came out great"

*buying new. You can replace diaphragms in compression drivers . You can change an 8ohm speaker into an 4ohm speaker. You can even design your own woofer using the Cones, Voice Coils, Spiders & Dust Caps listed in the Survival Guide that you recieve with your Reconing Video. This offer is designed to get you started right away. No hidden costs, You can recone your own speakers and expand your knowledge. Talk to the owners who will treat you like a neighbor, with out all of the techno-gab usually associated with a phone call. **YES, YOU CAN!** There will be "NO MORE SECRETS" once you have seen this video.*

only **\$39.95**

- * COMPLETE RECONING VIDEO
- * FOAM SURROUND REPLACEMENT
- * COMPRESSION DRIVER REPAIR
- * PARTS CAT & PARTS ORDERING

Make checks payable to:

Workshop Video

1502 N. Harrison Street
Ft. Wayne, Indiana 46808
(219) 424-5463

PLEASE ALLOW 4-5 WEEKS FOR DELIVERY
CHECK, MONEY ORDER, C.O.D., VISA, MASTER CARD

1-800-99-RECONE

M a c h i n e / F a x o r d e r s o n l y

Product Review

SAPPHIRE III REFERENCE MONITOR

By Gary A. Galo
Contributing Editor

Audio Concepts, Inc., 901 So. 4th St., PO Box 212, La Crosse, WI 54601, (608) 784-4579, FAX (608) 784-6367.

The Sapphire III is the newest version of this critically acclaimed series of loudspeakers manufactured by ACI. I reviewed the Sapphire II in *SB* 6/90 (p. 56) and the matching Sub-1 subwoofer in *SB* 3/91 (p. 51).

These loudspeakers have been my reference system for over four years. Both versions are the same size: "minimonitors," which can be used as stand-alone systems with modest bass performance. If your requirements extend through the bottom two octaves, the IIIs can be used as satellite systems with the Sub-1 subwoofer. This latest version uses the same 7" Focal mid-bass driver as its predecessor, but contains a new tweeter and crossover.

MODIFICATIONS

Since the Sapphire II's introduction, there have been two changes in the tweeter. The original model contained a Focal T120KT Kevlar® dome tweeter modified with a rear-vented pole piece and aperiodic damping. In 1992 ACI substituted it with a titanium-dome version, retaining the rear venting and aperiodic loading. As this was a drop-in replacement for the Kevlar original, no crossover changes were needed. The upgraded model was designated the Sapphire III.

Version III uses a Scan-Speak D2905/9000, a 28mm dome tweeter made in Denmark. The dome is a cloth/silk weave with a hand-applied coating. It has a large, well-damped surround and an unusually low resonance frequency of 800Hz. Dome tweeters have a tendency to rock from side to side, but Scan-Speak has minimized this problem in two ways: the voice coil is mounted very close to the diaphragm, and the magnetic gap is filled with ferrofluid.

The aluminum voice coil has a large overhang, with a linear excursion of ± 0.5 mm and a maximum of ± 1.5 mm. Scan-Speak has alleviated another common problem with dome tweeters—cavity resonances—by using a cone-shaped pole piece which leads into an aperiodic rear chamber.

ACI avoided compromise when they selected the Scan-Speak tweeter. In fact, company president and designer Mike Dzurko also



PHOTO 1: Audio Concepts Sapphire III loudspeaker shown on the recommended HD stands.

chose it for his flagship loudspeaker, the Shadow, manufactured by Dzurko Acoustics (the ultra-high-end division of ACI).

FIRST-ORDER CROSSOVER

Scan-Speak tweeters are very different from Focals in electrical and mechanical characteristics. Since retrofitting the new tweeter into the existing crossover without compromising performance was impossible, ACI designed an entirely new first-order crossover. Like its predecessor, the III is a minimum-phase design with excellent time domain characteristics, a necessity in retaining the superb three-dimensional soundstage presentation.

Since its response is well-controlled at least two octaves below the passband, the Scan-Speak tweeter is well-suited to a first-order design. According to the manufacturer's data sheet, the nominally 4.9Ω impedance rises to only 11Ω at resonance. In addition, the resonance peak is very broad. This excellent behavior is a result of the aperiodic damping. The crossover also contains a trap at resonance to further reduce excessive excursion, ensuring that the tweeter always operates in its linear range with lowered distortion at all frequencies.

The enclosure has remained the same, and is described in detail in 6/90. To summarize, it is made with Williamite MDF, which is extremely inert acoustically. The interior is braced in all directions and covered with two coats of ACI's "Acoustical Magic." Resonance control has been a primary design goal. The III also retains its predecessor's aperiodic mid-bass loading.

ACI won't upgrade; completely different tweeter dimensions and physical crossover layouts make costs prohibitive. But the IIIs are fitted with the finest gold-plated binding posts I have seen, with openings large enough to accommodate either 10AWG wire or banana plugs. ACI no longer offers kits—their products are now available only in factory-assembled form.

MEASUREMENTS

I used my Old Colony 1/3-octave warble tone generator, D'Appolito Mitey Mike ("Mitey Mike: For Loudspeaker Testing," *SB* 6/90, p. 10), and Heathkit IM-5238 AC voltmeter for frequency response measurements. The graphs, created with Quattro Pro and a Hewlett-Packard DeskJet 500 printer, were generated using the calibration data supplied by Joe D'Appolito to compensate for the mike response ("Graphs With Quattro Pro," *SB* 4/93, p. 72).

Figure 1 is the 1/3-octave warble tone response with 1W input and the mike at a distance of one meter. Per ACI's recommendation, I positioned the vertical mike halfway between the mid-bass driver's center and surround. ACI specifies an anechoic response of 80Hz–18kHz ± 2.5 dB, which my "in-room" warble tone measurements verified. The curves in Fig. 1 further confirm the manufacturer's stated 64Hz–20kHz, ± 3 dB.

Comparing frequency response curves can be problematic if the y-axis calibrations are different. In Fig. 1 the y-axis is calibrated 5dB/division, and the range of the scale is -20 dB to $+5$ dB. (I didn't use a range greater than that required by the measurements.) This produces a graph in which small variations can be easily seen. If you compare this to ACI's graph, however, you might conclude that my review samples have greater variations in response than theirs. This isn't the case.

When analyzing frequency response

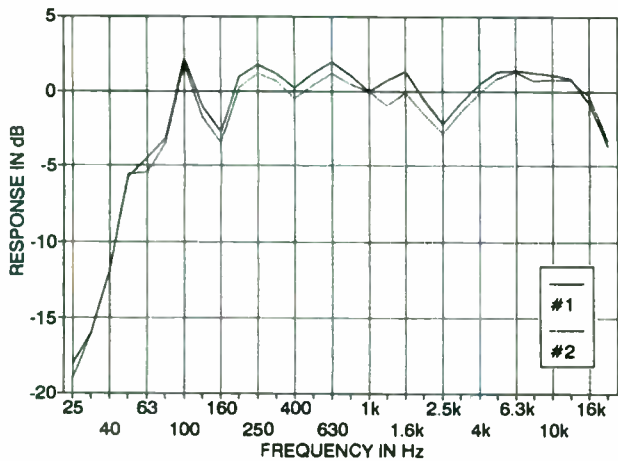

FIGURE 1: One-third octave, 1W/m warble tone response. D'Appolito Mitey Mike was positioned midway between the midbass driver center and rubber surround.

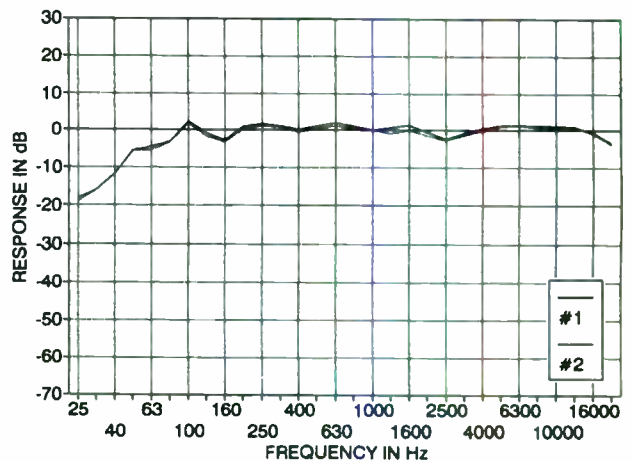

FIGURE 2: One-third octave, 1W/1m warble tone response, shown on a graph with 100dB range, in 10dB increments. This graph is extremely close to the MLSSA curve in the ACI manual.

graphs, it's important to know what you're comparing. The ACI version, produced on an MLSSA measurement system, has a range of -72dB to +28dB in 10dB increments. For more intelligible comparisons, I prepared Fig. 2 using a similar range. Now the curve looks extremely close to ACI's graph. These measurements compare very

favorably with more expensive loudspeakers. Figure 3 is the near field response measured below 320Hz. These curves show a -3dB point of 55Hz for Sample 1 and 52Hz for Sample 2. Below cutoff, the second-order rolloff characteristic is exactly as expected for an aperiodic design.

Figure 4 is the impedance curve. The two

samples are identical for all practical purposes, so I've presented only one. System resonance in both is 70Hz. This curve virtually duplicates ACI's published impedance plot: they claim a maximum impedance of 9.2Ω and a minimum of 4.6Ω, while mine varied between 9.5Ω and 4.3Ω.

Minor differences in measurement toler-

Ultrawide Radiation ...Without Fallout

Get the only tweeter that delivers on its promise to recreate the feeling of a live performance.

Designing a tweeter that can reproduce the spacious sound of a concert hall without the fallout from design compromises...takes years of experience. Designed by audio legend Roy Allison, the RDL pulsating dome tweeter performs unlike any tweeter in the world. It delivers an extremely wide dispersion at all sound frequencies, including the full treble range, so as to simulate the rich reverberant field of a live performance.

The spacious sound is so incredible—it has to be heard to be believed. Don't just take our word—listen to what the critics have to say...

According to David R. Moran of The Boston Audio Society Speaker Newsletter: "...Allison's unsurpassed, strangely unimitated convex tweeter...its ultrawide radiation and airy imaging may be even more uniform than previous implementations...in over a dozen measurements, the tweeter consistently ran ±2dB from 1-2 kHz to around 18kHz"

Order The Ultimate Tweeter for Your Next Speaker Project. Call 1-800-227-0390



Be sure to ask for our free 32 page catalog

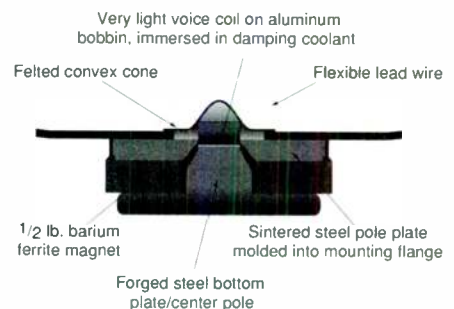

SPECIFICATIONS

Frequency Response	2,000 to 20,000 Hz ±3 dB
Sensitivity	87dB SPL 1w/1m
Overall Dimensions	4" Diameter x 1 3/4" thick
Face Plate Thickness	1/8"
Voice Coil Diameter	1/2"
Voice Coil Length	0.115"
DC Resistance	4.7 Ohms
Nominal Impedance	8 Ohms
Nominal Power Handling	15W Cont or Avg 150W Peaks
Cone	Treated paper
Net Weight	1 lb 5 oz
Price	\$41.00ea.

RDL
ROOM
DESIGNED
LOUDSPEAKERS

26 Pearl Street #15 Bellingham, MA 02019

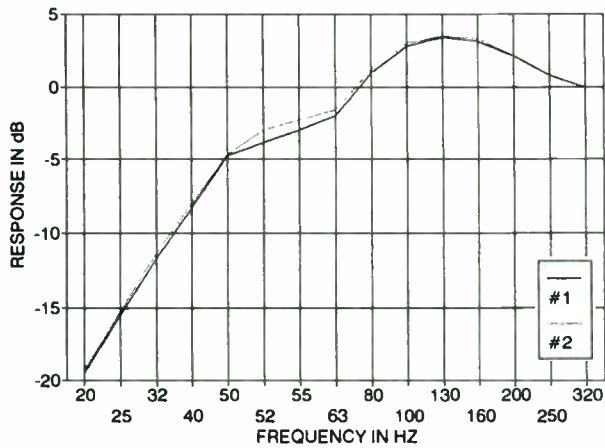

FIGURE 3: One-third octave near field response.

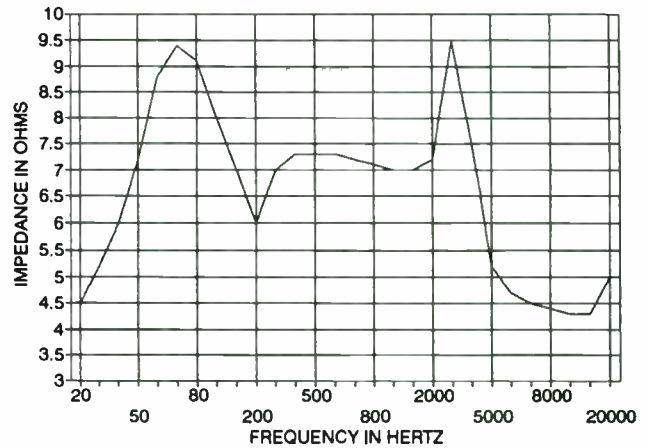

FIGURE 4: Sapphire III impedance curve. Only one sample is shown, since they were identical.

ance account for this minute discrepancy. The Sapphire III load also has extremely uniform phase— $\pm 30^\circ$ according to ACI's published graph—easy for any competently designed amplifier.

HOOKUP

The Sapphire III's separate connections for tweeter and mid-bass driver allow biwiring of the system, which I strongly recommend.

(Biwiring produces a significantly larger soundstage and greater resolution than conventional wiring.) Unlike the II, its mid-bass (low) connectors are on top and the tweeter (high) connectors are on the bottom. If you don't wish to spend money on extra speaker cable, ACI supplies jumpers for the two pairs of connectors. Don't take the cheap route, though, as biwiring is well worth the extra expense. I suggest terminating the two

cables with common spade connectors at the power amp. ACI sells devices suitable for this purpose.

If you use the units as stand-alone speakers, the biwiring connection is simple. With the addition of the Sub-1 subwoofers, you have a couple of options. The Sub-1s have a built-in, first-order, high-pass crossover for the IIIs. The simplest hookup is to run the power amp output to the Sub-1 main input,

Speaker Builder

THE LOUDSPEAKER JOURNAL

A

NAME _____

STREET & NO. _____

CITY _____ STATE _____ ZIP _____

I have enclosed: Check or Money Order
 MC VISA Discover

Card No. _____ exp date _____

SUBSCRIBER SERVICES

- Check here if this is an address change
 New Subscription Renewal
 Gift (see below)

- 1 Year, \$32 2 Years, \$58

Canada add \$8/year. Remit in US\$ drawn on a US bank only.
 Overseas rates: \$50, 1 year; \$90, 2 years.
 Rates subject to change without notice.

TELL OTHER SPEAKER BUILDERS ABOUT US!

Print their names & addresses below. We'll take care of the rest.

NAME _____

NAME _____

STREET & NO. _____

STREET & NO. _____

CITY _____ STATE _____ ZIP _____

CITY _____ STATE _____ ZIP _____

(When giving a gift subscription—fill in the recipient's name & address here.)

We try to keep our subscription process as trouble-free as possible, however, if you have a problem we want to help to correct it as soon as possible. Call or write with all the pertinent information including your account number.

Call us during business hours at (603)924-9464 or FAX us at (603)924-9467.

Our FAX machine is on duty 24 hours a day.

Speaker Builder, PO Box 494, Peterborough, NH 03458-0494 USA.

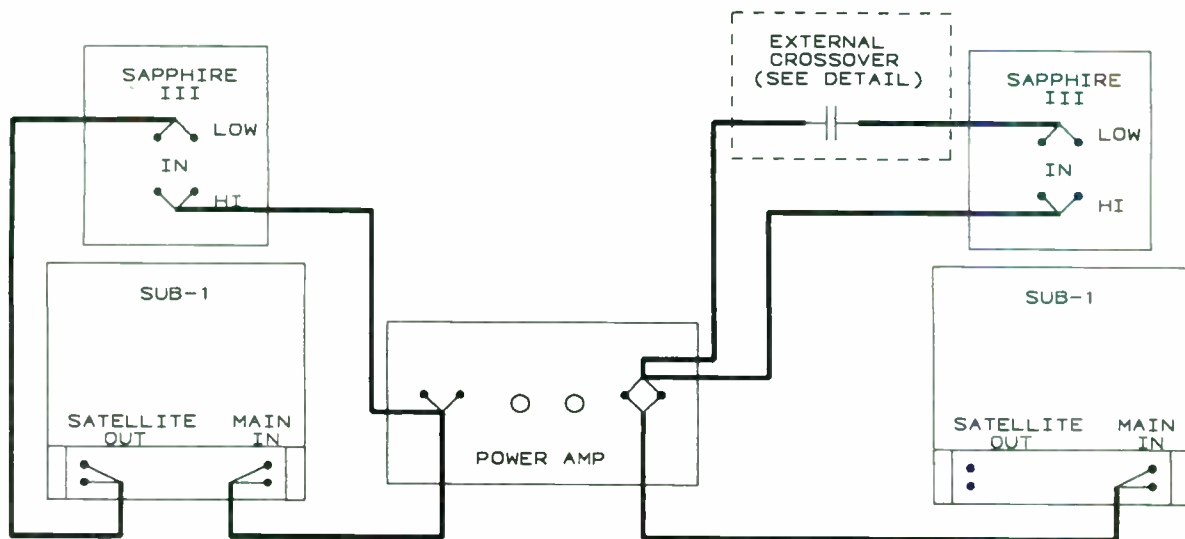

FIGURE 5: Two methods for connecting the Sapphires IIIs with the Sub-1 subwoofers. On the left, the Sub-1 internal crossover is used for the mid-bass driver, and the tweeter is fed direct. On the right, an external, custom-built all-polypropylene crossover is used instead of the Sub-1 internal crossover. Both methods retain the biwiring capability of the Sapphires IIIs.

then connect the satellite outputs to the speakers, preferably with biwiring.

This isn't the best approach, however. The Sub-1's high-pass filter is required only by the mid-bass driver; the tweeter has its own. You can improve the latter's performance by

connecting it directly to the power amp (Fig. 5, left), which also feeds the Sub-1's main input. The subwoofer's satellite output feeds only the mid-bass driver. The biwiring scheme is thus used to maximum advantage and the tweeter's signal path is simplified.

BIAMPING

The Sub-1's internal high-pass crossover consists of four 50µF electrolytic capacitors bypassed with 2µF Chateauroux and 0.47µF WonderCap® polypropylene caps. With an extremely high-resolution system, you might

MCM AUDIO SELECT™

High Performance Plus,
Attractive Prices

Perfectly Imaged,
Phase Synchronized, Sound



Enjoy the latest true breakthrough in acoustic design technology; MCM Audio Select's, Syncrosound Series. A strategically mounted tweeter at the base of the woofer cone offers reproduction from a centralized point, the same design on the leading edge of today's high end systems.

Get complete Syncrosound details with the MCM Electronics catalog. It is packed with hundreds of accessories from names you know: AMS, Pyle, Eminence, Pioneer, MCM Audio Select and others. In addition, there's MCM's complete line of electronic components, repair parts, tools, test equipment and more. Over 21,000 products in all, are in stock and ready to ship. Call for your free catalog today.

For a FREE Catalog, Call...

1-800-543-4330

Product Questions 1-800-824-TECH(8324)



MCM ELECTRONICS™

650 CONGRESS PARK DR.
CENTERVILLE, OH 45459-4072

A PREMIER Company

Hours: M-F 7 a.m. - 9 p.m., Sat. 9 a.m. - 6 p.m. EST.

Serving you coast to coast! Distribution Facilities in Dayton, OH and Reno, NV!

SB-22

Reader Service #11

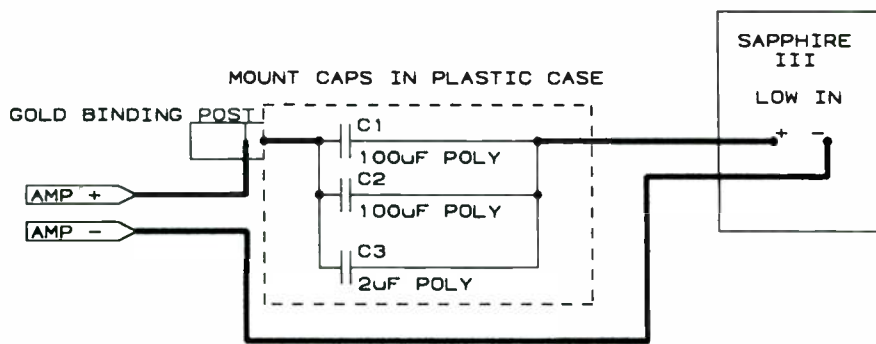

FIGURE 6: Detail of the all-polypropylene high-pass crossover shown in Fig. 5. The crossover capacitors can be mounted in a small plastic box, which can sit on top of the Sub-1, directly behind the Sapphire III.

hear a further improvement if you build your own all-polypropylene crossover.

My crossover consists of two 100µF Chateauroux polypropylene caps bypassed with a 2µF WonderCap (Fig. 6), mounted in a Radio Shack #270-232 project case. I glued the caps to the bottom of the case with silicone seal, and filled the box with polyester fiberfill to damp vibrations. (Other high-quality devices include the Solen "Fast Capacitors." Check the ads in this and other recent *SB* issues for suppliers.)

I used a gold-plated binding post for the input connection. The output cable, which is only a foot long, is hard-wired. Four screws hold the aluminum cover in place. To keep it from rattling, be sure it compresses the polyester inside. I also ran a bead of silicone seal around its edge to further damp vibration. Four Radio Shack #64-2342 rubber feet are on the bottom.

Hookup is shown in Fig. 5 (right). The box sits on top of the Sub-1 behind the Sapphire III, making connections easy. Note in Fig. 6 that the negative speaker lead from the power amp goes directly to the III's low, negative input. Only the positive is connected through the external crossover.

*If you like reading
Speaker Builder you'll
love reading the
high-quality articles
included in every
issue of*

Audio Amateur
THE JOURNAL FOR AUDIOPHILE CRAFTS



Now beginning its 25th year of publication, *Audio Amateur* is full of audio information for the thoughtful and capable music lover. Contained in its pages are articles dealing with how audio equipment works, as well as articles devoted to construction, modification and much more.

Recent selections from *Audio Amateur* include a "high-end" Line level preamp by Erno Borbely, building a 75W Class A amp, an amplifier/speaker protector circuit and an article on choosing the best op amp for your task.

Send for your **FREE** trial issue of *Audio Amateur* today and experience the kind of information you need—to improve your audio knowledge—to improve the quality of sound for the music you love.

YES! Please send my first subscription copy of *Audio Amateur*. When I choose to subscribe, I'll pay just \$16.95 for a one year subscription (that's four issues in all.) If I decide not to subscribe, I'll write "cancel" on the invoice and owe nothing. I am under no obligation. Canada please add \$4 postage. Overseas rates \$35 for one year. Remit in US\$ drawn on a US bank.

NAME _____
STREET & NO. _____
CITY _____ STATE _____ ZIP _____

Audio Amateur Publications, Inc.

PO Box 576 Dept. B95, Peterborough, NH 03458-0576
Telephone (603)924-9464 or FAX 24 hours a day (603)924-9467
Rates are subject to change without notice.

TABLE 1

ASSOCIATED EQUIPMENT

Digital Playback:

- Modified Magnavox CDB-650 (transport)
- Analog Devices AD1890 evaluation board with custom hybrid power supply regulators (jitter reduction)
- Galo/Jung Modified Philips DAC960

Analog Playback:

- AR-based, belt-driven turntable with Merrill Acrylic Subchassis powered by low-distortion electronic speed control
- Grado Signature tone arm
- Grado XTZII cartridge

Preamp:

- Extensively modified Adcom GFP-565 preamp

Power Amps:

- Adcom GFA-585 (Sapphire III amp is modified)

Subwoofer:

- Audio Concepts Sub-1s with all-polypropylene satellite crossovers

Cables:

- Canare LV61S 75Ω coax digital interconnects with Canare F-10 RCA plugs
- D.H. Labs Silver Sonic BL-1 analog interconnects with Canare F-10 RCA plugs
- D.H. Labs Silver Sonic T-14 loudspeaker cables

AC Distribution:

- 3 separate, dedicated 20AAC lines: 1 for each power amp and 1 for low-level electronics

Power-Line Conditioning:

- Modified Adcom ACE-515 with API Power Wedge 110 and PE-1 on each power amplifier
- Modified Adcom ACE-515 and modified API Power Wedge 116 on low-level electronics



OLD COLONY SOUND LAB

P R O D U C T S H O W C A S E



**measuring tool
for M A C**

by Dr. Victor Staggs

SOF-SLM1M3G

\$74.95

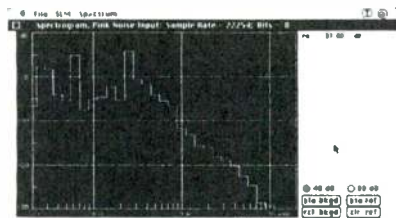

MIDI

**FOR MUSICIANS
by Craig Anderton**

BKAM10 \$24.95

This volume should not be overlooked by any musician enthusiastic about integrating MIDI, Musical Instrument Digital Interface, with current methods of musical creation and recording. Even the most technologically hesitant will gain a clear, workable understanding of computer advancements pertaining to musicians through the friendly and supportive guidance supplied by this renowned author. In a refreshing easy-to-understand manner, this book conveys solid information about MIDI's background, evolution, capabilities, language, channels and modes, accessories, and various uses and applications that are needed to unlock the creative potential of today's instrumental gear and musical genius. The notable array of diagrams, lists, appendices, and photographs throughout only amplify the usefulness of this edition, as it demystifies MIDI and positively impacts the way you play, record, compose, distribute, and transcribe music. 1986, 105pp., 9 x 11 1/4, softbound.

It's a sound level meter! It's a real-time spectrum analyzer! And it uses a minimum of added hardware—usually none!

Mac SLM uses the sound input facilities in modern Macintosh® computers, or it uses external devices. It automatically accommodates 8 bit words at 22.254 kHz or 16 bit words at 44.1 kHz, so you can use whichever you want for measuring acoustical or electrical signals.

The sound level meter mode gives you flat, A, B, or C weighting, and it puts big numbers on the screen that you can see from across the room. It uses white graphics on a black screen to help save your portable's batteries. You can use the Apple microphone or your own, and still keep Mac SLM calibrated.

The spectrum mode displays the spectrum of sound in 1/3, 1/6, or 1/12 octaves. You can use free running or time averaging mode, and you can fix or free the reference level to detect level shifts quickly. You can subtract background noise from a system measurement to improve your data, and store and edit an automatically generated calibration curve.

You can save spectrograms to disk and print them later, and you can preview them before printing. Mac SLM's amplitude resolution is as good as that of your screen or printer.

Mac SLM is perfect to use with commercially available test CDs. You can measure speakers, optimize their room placement, gather design data, measure amplifier distortion, and test filters. Outdoors you can measure noise pollution and exposure of your hearing to damage by noise, test sound-producing devices such as horns and sirens, test your car's engine better than with a stethoscope, and do a million other things you couldn't do before, because you couldn't afford an expensive spectrum analyzer.

System requirements are System 7®, 640K of free RAM, 640 by 400 screen pixels or more, and a 68020, 68030, or 68040 CPU with separate or internal FPU (math coprocessor), or a PowerPC® Macintosh®. It will run in any Mac CPU, but more slowly without the FPU. Sorry, not usable with original Mac 128K, 512K, Plus, 512KE, SE, SE/30, Classic, Classic II, or Color Classic.



by Nick Beer

BKB30

A full-service guide and benchside companion, this book can assist technicians and engineers as they perform fault diagnosis, repairs, and tests on a wide variety of home audio equipment.

Successful and efficient service of receivers, amplifiers, recorders, and playback machines has never been simpler than with the in-depth instruction offered within the many pages of this guide. The author examines the mechanics and electronics of a large spectrum of domestic audio equipment,

from the simplest AM radio to the most intricate CD and DAT systems, with a concentration on troubleshooting and problem solving. Fully illustrated with numerous photographs, diagrams, and faultfinding charts, this text also provides a comprehensive guide to manufacturers and suppliers as well as an invaluable symptom index for quick access to specific advice. 1991, 210pp., 7 1/2 x 10, hardcover.

\$37.95



UNDERSTANDING AND SERVICING

Ken Clements

CD players

Filled with detailed illustrations and diagrams, this guide to the better repairing and adjusting of CD players is the perfect complement to any service manual. The author, an experienced technician, trainer, and engineer in the CD player field, has compiled his extensive knowledge of repairing, troubleshooting, and adjusting into this easy-to-use benchside companion. Helpful information and hands-on applications abound in the many

chapters of this valuable text, making it an essential tool for all who service CD players. In a clear and concise way, Clements successfully conveys the basic principles of CD technology and a vast knowledge of optical assemblies, servos, decoders, power supplies, and much more. 1994, 202pp., 7 1/2 x 10, hardcover.

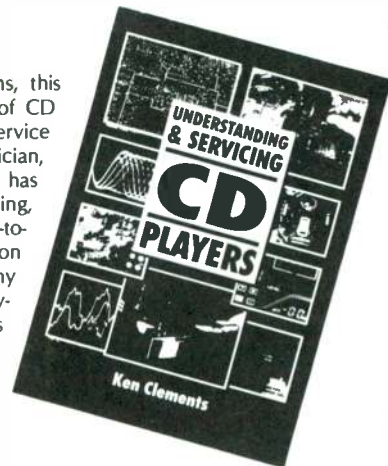

BKB35

\$29.95

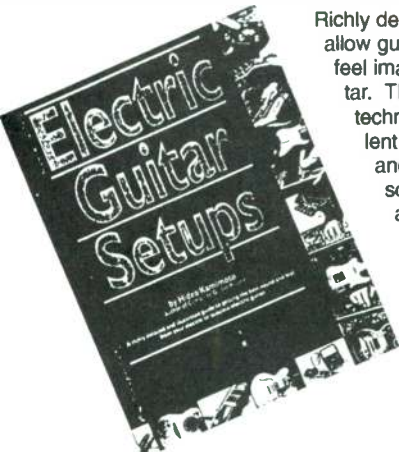

Richly detailed and illustrated, this how-to guide will allow guitarists to attain the highest quality sound and feel imaginable from any electric or acoustic-electric guitar. The author provides, in elaborate detail, the setup techniques necessary to maintain the instruments in excellent playing condition as they experience everyday wear and tear through normal usage. You will achieve perfect sound from your guitar as a result of employing the effective and simply-stated how-to instructions housed within this handsome volume, including step-by-step strategies leading to proper adjustment of parts, personalized setup, the elimination of buzzes and dead spots, and the attainment of good intonation and tuning. Instill more confidence and efficiency in your own personal playing style as you learn and employ the basics of the setup process, coupled with the principles that underline each maneuver, as presented in *Setups*. 1994, 84pp., 9 x 12, softbound.

ELECTRIC Guitar

SETUPS

by Hideo Kamimoto

BKAM8

\$16.95

THE MUSICIAN'S GUIDE to HOME RECORDING

Peter McIan and Larry Wichman

This revised and updated edition serves as a troubleshooting guide as well as an instructional text for all serious songwriters, musicians, and recording engineers. Written by two highly respected musical enthusiasts, this volume is necessary for those who aspire to emulate and implement the recording techniques proven effective by numerous celebrated professionals in the field. How-to instruction on designing a demo tape, reducing signal noise, utilizing a variety of tape styles and speeds, as well as recording guitars, piano, synthesizers, drums, and vocals comprise this comprehensive volume. This book will not only assist you in employing professional strategies for mixing, recording, and sampling, but also provide invaluable information concerning studio acoustics, microphone implementation, and recording consoles and equipment. Complete with an impressive glossary and useful appendices, this guide provides a hands-on approach to utilizing technology to create art. 1994, 327pp., 9 x 12, softbound.



BKAM9

\$24.95

OLD COLONY SOUND LAB

PO Box 243, Dept. B95

Peterborough NH 03458 USA

24-Hr. Tels. (603) 924-6371, 924-6526

Fax (603) 924-9467

DISCOUNT AND SHIPPING TABLE

ORDER VALUE	<\$50	\$50-\$99.99	\$100-\$199.99	\$200+
TAKE DISCOUNT	0%	5%	10%	15%
ADD SHIPPING				
USA SURFACE	\$3	\$4	\$5	\$6
USA AIR	\$7.50	\$15	\$20	\$30
CANADA SURFACE	\$5	\$7.50	\$15	\$25
CANADA AIR	(Same as USA Air)			
OTHER SURFACE	\$10	\$20	\$30	\$40
OTHER AIR	(Add \$10 to Other Surface)			

This crossover can add up to \$200 to the cost of the system. I can't fault ACI for using a more economical type in the subwoofer, since it keeps the price much more reasonable and still performs very well. If you own high-performance electronics and source material, however, you'll find that the custom crossover improves midrange detail, resolution, and smoothness.

In *SB 3/92* I described a simple method for "Bi-Amping the Sapphire II/Sub-I System" (p. 24). The same procedure can be applied to the Sapphire III/Sub-I combination. It involves replacing the satellite power amp's input coupling capacitor to duplicate the crossover characteristic of the subwoofer's high-pass filter. If you biamp, do *not* attempt to defeat the passive low-pass filter in the Sub-I: it is a necessary part of ACI's patented *Synthesized Bandpass* design, and its electrical characteristics are integral to the system Q. You will also degrade the performance if you use an electronic crossover, since this will add unnecessary circuitry to the signal path. The passive method is the simplest and best method for biamping.

I sometimes need to evaluate a new power amp, and the outboard custom crossover makes it easy for me to change from bi- to single-amped operation in a matter of minutes. I simply insert the custom passive crossover in the tweeter path and connect all loudspeaker cables to the one power amp.

LISTENING

I value live, unamplified classical music above all else. The core of my music library includes recordings I know intimately and rely on constantly for equipment evaluations. It reflects a wide range of demands, from delicate chamber-like passages to massive scoring for full orchestra. Most of my listening was done using the Sapphire III with the Sub-I subwoofers, in both biamped and single-amped configurations. My associated equipment is listed in *Table 1*.

When a manufacturer significantly changes a successful design, we hope it will be positive (although this isn't always the case). After more than four months with the Sapphire IIIs, I have found them to be an unqualified success. I wouldn't wish the Scan-Speak tweeters and new crossovers to change the sound radically—and they haven't. They refine an already outstanding loudspeaker system.

The original Focal Kevlar tweeters had a tendency toward brightness, especially on already bright recordings. They also added a slight texture to the sound—a relatively minor quibble. I have heard them sound dreadful in other systems. (ACI was one of the few manufacturers able to tame their res-

onance problems and make them sound musical.) I still use the original Sapphire IIs in my production studio at the Crane School of Music, and remain extremely pleased with their performance. When I upgraded my home units to the Focal titanium tweeters, I found the treble region to be smoother and more detailed than the Kevlars, with the texture largely removed.

The Scan-Speak tweeters are better still: remarkably silky in character, smooth, sweet, and extremely natural. High-massed strings sound simply wonderful. They reveal more air on recordings than the Focals, and this airiness lends a more spacious sound to the system.

The Sapphire series is known for its outstanding, three-dimensional soundstaging. I found the IIs rival many dipole loudspeakers in soundstage reproduction, but the IIIs are even better in this regard. While every bit as wide as before, the increased sense of spaciousness lends greater depth to the IIIs.

Since the crossover characteristic is first-order, the midrange performance is greatly affected by the tweeter. The Sapphire IIIs have outstanding detail and resolution in this critical region. In recordings with delicate instrumentation, such as the second movement of Respighi's *The Birds* (Dorati, London Symphony, Mercury Living Presence 432007-2), I am amazed by their exceptional detail and transparency. The crossover is seamless, with no indication that two separate drivers are operating. It will be difficult to find a loudspeaker with a more neutral tonal balance.

The IIIs also have excellent dynamic range. With the Sub-I subwoofers, they don't get congested or brittle on heavily scored material, such as the *tutti* sections of *Pictures at an Exhibition* (Reiner, Chicago Symphony, RCA Victor Living Stereo 61958-2). Used as stand-alones, heavy bass played loudly will cause the midrange to lose some of its pristine character, which is true of any well-designed two-way system. Adding the subwoofers not only fills out the low end, it also improves midrange clarity, since the mid-bass drivers are now free of the demands of low-bass information. This benefit of subwoofers applies to any small loudspeaker.

EVALUATION

As my audio system is in a constant state of evolution, I find it extremely important to have an accurate reference loudspeaker which won't mask differences caused by equipment modifications. Over the past four months I have evaluated power supply upgrades in my DAC's digital circuitry. I have also done extensive listening comparisons of digital jitter reduction units, digital interconnect cables,

analog interconnect and speaker cables, and a new power amp design. The Sapphire IIIs have been a superb reference tool for these evaluations. Their excellent resolution and soundstaging capabilities allow them to reveal very subtle differences existing elsewhere in the system.

The Sapphire III is one of the finest stand-alone systems of its size. Coupled with a pair of Sub-I subwoofers, they rival other wide-range loudspeaker systems selling for several times their cost. Their performance is limited primarily by the equipment and recordings played through them. Each time I upgrade my system, I am impressed by their capabilities. The Sapphire III/Sub-I has become my new reference loudspeaker. At a factory-direct price of \$929 (\$1,828 with the Sub-I)s, they are one of the best values in audio, and I recommend them without reservation.

MANUFACTURER'S SPECIFICATIONS

- **Tweeters:** Scan-Speak D2905/9000, 28mm cloth/silk dome, aperiodic loading
- **Woofer:** Focal 7K011DBL, 7" dual voice coil, Kevlar® cone with rubber surround; woofer loading: aperiodic, Bessel alignment
- **Crossover:** First-order, minimum phase at 3kHz
- **Frequency Response:** 64Hz–20kHz ± 3 dB, 80Hz–18kHz ± 2.5 dB anechoic
- **Sensitivity:** 90dB, 1W/1m (C-weighted)
- **Impedance:** 6 Ω nominal, 4.7 Ω minimum
- **Dimensions:** 16" \times 10" \times 10"
- **Available Finishes:** Clear lacquer on oak; black lacquer on oak; clear lacquer on cherry
- **Price:** \$929/pair, assembled only
- **Stand Options:** HD stands \$179/pair; AC stands: \$119
- **Subwoofer Option—Sub-I:** \$899/pair, assembled only

MANUFACTURER'S RESPONSE

Gary Galo has done a very thorough job in his review of the Sapphire III and Sub I. When a reviewer like Gary evaluates a product in this much depth, it helps readers expand their knowledge. Equally important, Gary has taken the time to hear what we're accomplishing with the Sapphire III and Sub I.

An important announcement I'd like to add here is: parts kits are back! Thanks to lobbying by a lot of dedicated hobbyists and some gentle prodding from Ed Dell, we've decided to make Parts Kits of the Sapphire III and the Sub I available. ACI also offers four additional kit models, one of which is the Titan powered sub. Call, write or fax ACI for more details on the Parts Kits.

*Mike Dzurko
Audio Concepts, Inc.*

Vintage Designs

Altec A-7 Series Enclosure

Courtesy of James Smith, Vincover, WA.

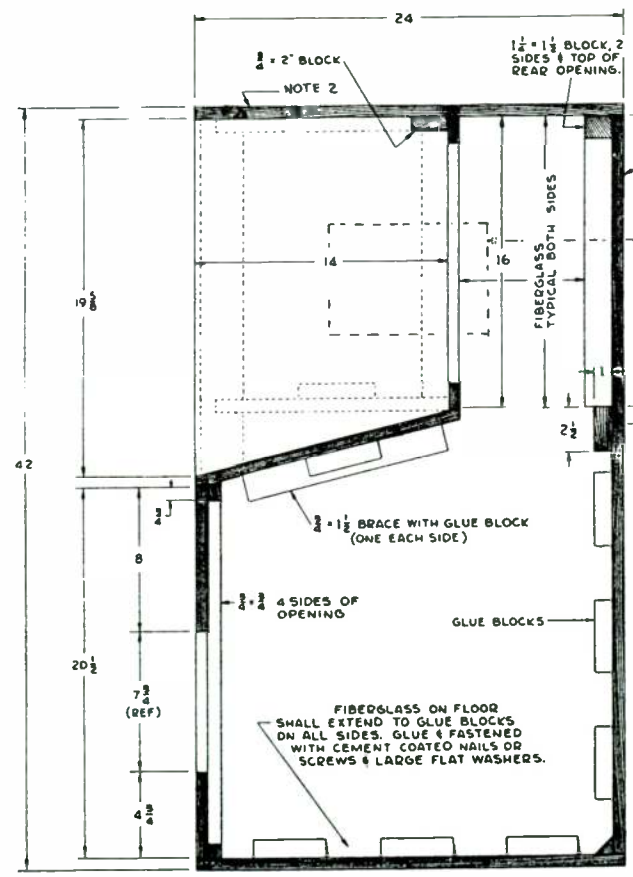
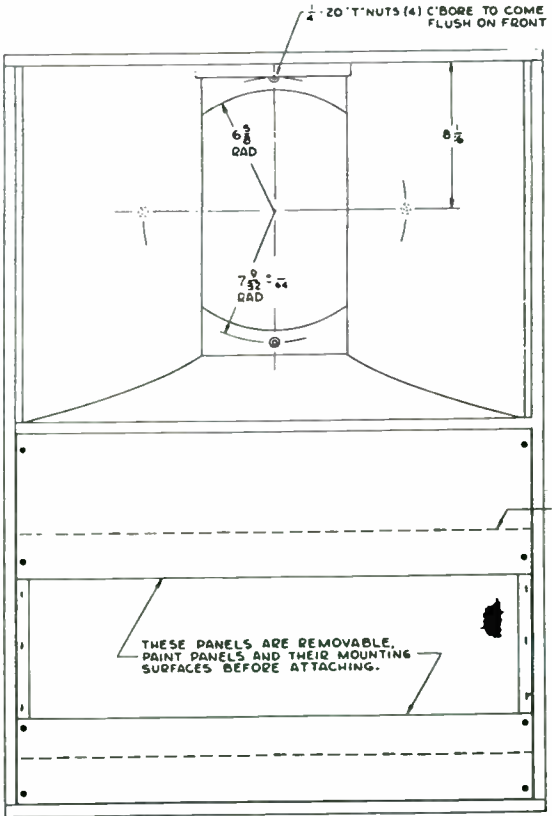
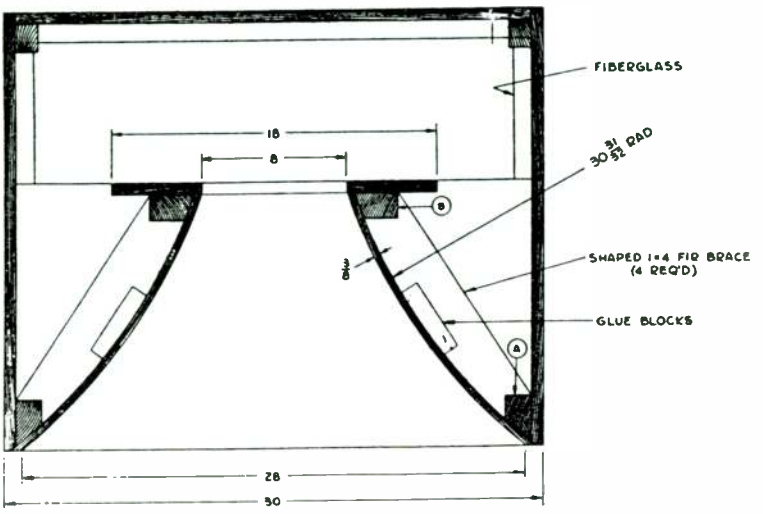
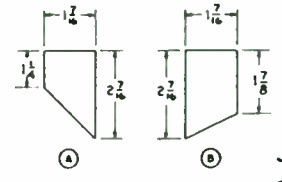
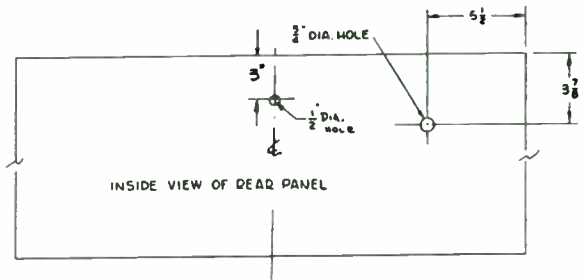
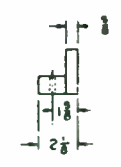
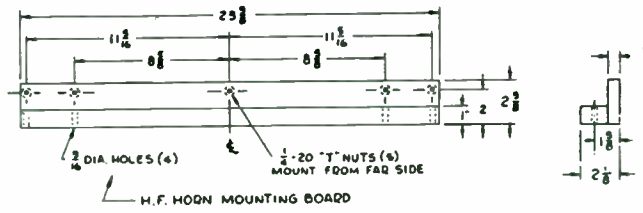

MATERIAL: 3/8 PLYWOOD EXCEPT AS NOTED. FIBERGLASS PF 617

ALL JOINTS & PANELS SHALL BE GLUED & NAILED (OR SCREWED) UNLESS REMOVABLE.

Book Report

THE COMPLETE GUIDE TO HIGH-END AUDIO

Reviewed by Gary A. Galo, Contributing Editor

The Complete Guide to High-End Audio, by Robert Harley. Acapella Publishing, PO Box 80805, Albuquerque, NM 87198-0805. (Available from Old Colony Sound Lab, PO Box 243, Peterborough, NH 03458, [603] 924-6526, FAX [603] 924-9467, for \$29.95 plus \$3.00 shipping in the USA.)

Robert Harley is best known as consulting technical editor for *Stereophile* magazine, although his book was published independently. His reviews in *Stereophile* have typically combined insightful subjective commentary with technical competence, a combination sorely lacking in most high-end reviewing. *The Complete Guide to High-End Audio* takes a prominent place in the line of



hi-fi and stereo texts, most notably Edgar Villchur's *The Reproduction of Sound* and John Borwick's *Living With Hi-Fi*. It was probably not intended as a replacement for these works, but it certainly fills the void. Although Harley covers many of the same subjects as his predecessors, his 440-page book dwarfs them in both size and scope.

POPULAR SCIENCE

As the title implies, Harley concentrates on high-performance audio equipment. If you can't decide which Far East receiver to purchase, this book isn't for you. Harley believes a serious music system begins with a separate preamplifier and power amplifier. Nevertheless, his book is refreshingly free of

The Source for Pro Sound Speaker Builders



Loudspeakers, Drivers, Horns, Tweeters, Crossovers, Hardware, Connectors... and much, much more!

Image delivers virtually every component for the speaker builder.
See for yourself. Call or FAX for your FREE catalog today!

image
COMMUNICATIONS

4301 W. 69th St. • Chicago, Illinois 60629 • (312) 585-1212 • FAX (312) 585-7847 • 1-800-552-1639

EMINENCE
Loudspeakers, Drivers,
Diaphragms and Recone Kits

Electro Voice
Recone Kits

McCauley
Loudspeakers & Drivers.

Acoustician
Drivers, Horns, Tweeters,
Diaphragms & Crossovers

Waldom
Audio Products
Hardware, Connectors, Etc.

the snobbery that permeates some high-end publications, with erudite yet "down to earth" writing.

High-end audio is for people who are serious about music and who derive pleasure from its realistic reproduction. Harley makes it clear early on that "high-end" does not necessarily mean "high-priced." Rather, this approach to audio design usually avoids "pin-ball machine" front panels, putting the money into performance not gadgetry.

In his introductory chapter "What is High-end Audio," the author discusses the issue of measurements versus subjective listening. He wisely warns of the danger of playing the

numbers game: purchasing the product with the lowest THD figure. Harley implies that high-end manufacturers design their products strictly by ear (I don't completely agree with this).

The chapter on "Becoming a Better Listener" discusses subjective criteria for evaluating audio equipment, with detailed descriptions of the requirements for reproducing various portions of the tonal spectrum, sonic perspective, soundstage reproduction, dynamics, and inner detail. Harley recognizes the importance of developing a working descriptive vocabulary, and he mentions J. Gordon Holt's important contri-

butions to the standardization of subjective terminology.

An entire chapter is devoted to room acoustics and the author offers a tutorial that will be useful to those designing their own dedicated listening room. Yet, understanding that most audiophiles can't go to such lengths, he also discusses many practical methods for optimizing existing listening environments. The chapter concludes with a list of commercially available materials for acoustical treatment, including addresses of suppliers and current prices.

Separate chapters deal with each component in a high-end system (preamplifiers, power amps, loudspeakers, CD hardware, LP playback equipment, tuners, and accessories), beginning with a nontechnical overview and followed by a tutorial on the component's basic operating principle. These technical discussions are clearly explained and should be accessible to most readers who are seriously interested in the subject matter. There's even a chapter on home theater which covers the workings of Dolby Surround, THX standards, and system setup.

CLOSER SCRUTINY

For nontechnical audiophiles, the three



**THE WORLD'S
MOST RESPECTED
HI-FI MAGAZINE**
SUBSCRIBE TODAY AND GET
THE NEXT 12 ISSUES FOR
\$65.00 USA \$75.00 CANADA

Please send me the next 12 monthly issues of Hi-Fi News and record Review from the next available issue.

Mr/Mrs/Miss/Ms _____

Address _____

Apt# _____

City _____

State _____ Zip _____

METHOD OF PAYMENT

- Check enclosed (US dollars and drawn on a US bank)
 Please charge my Visa Mastercard American Express

Account No. _____ Exp. date _____

Signature _____ Date _____

Please bill me

Return to Hi Fi News & Record Review, PO Box 384, Avenel, NJ 07001

**FOR FASTER SERVICE USE YOUR CREDIT
CARD AND CALL TOLL FREE**

800-688 6247

AA41

50,388
**ELECTRONIC
COMPONENTS**

Whether you order 1 part or
all 50,388...MOUSER stocks
and...ships same day!!

CALL...(800) 992-9943

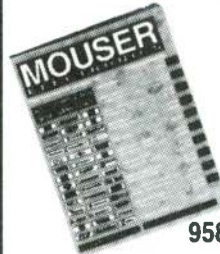

for your
**FREE
CATALOG**

958 North Main St.
Mansfield, TX 76063

**MOUSER[®]
ELECTRONICS**
Sales & Stocking Locations Nationwide

Reader Service #30

appendices should be extremely helpful reading prior to tackling the rest of the book. The first, "Sound and Hearing," covers the principles of sound, including compression and rarefaction, frequency, wavelength, complex waveforms, and the decibel. The difference between two commonly misused terms—phase and polarity—is also clarified.

The "Audio and Electronics Basics" appendix covers basic electricity, Ohm's law, AC and DC, inductance, capacitance, impedance, as well as the operating principles of tube and solid-state devices. The discussion of electricity is presented in terms of electron current rather than conventional cur-

rent, which makes much more sense to non-physicists.

The third appendix, "Digital Audio Basics," begins with a tutorial on binary numbers. It goes on to cover sampling, quantization, aliasing, dithering, the compact disc storage medium, and the eight-to-fourteen modulation scheme. Harley has written a great deal on the subject of jitter, and his book offers an excellent overview of this important subject.

While the appendices are extremely well-written, clear, and concise, I must take issue with Harley's statements on op amps in the "Audio Basics" appendix. He defines an

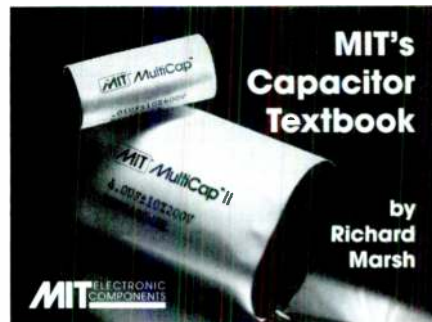

Debunking the Myths

Cap Myth # 2

The plate metal is the most important factor in capacitor performance.

Cap Fact

- The compatibility of the plate material with the ends' sprayed-on metal and the solder & lead metal brings about lower ESR (therefore better, more stable performance) than using exotic plate materials.
- Silver & copper foils are potentially good, but they must be made into a capacitor immediately upon manufacture. Otherwise these foils will oxidize quickly
- Oxides form rapidly on silver and are difficult to remove. Oxides are difficult to attach onto leads, and create unreliable connections. Oxides also become imbedded in the solder, again creating an unreliable join.
- Use of high purity copper will reduce oxide formation in copper foils. But the molten metal sprayed on the cap ends, to connect the foil plate edges, is typically an aluminum alloy, which is incompatible with copper. This combination will corrode in time, through electrolysis between dissimilar metals.

Solution?

The MIT MultiCap uses the most compatible metals and alloys throughout. Our tin MultiCaps, for example, offer thick tin plates attached to tin-plated copper leads, hand soldered with high-tin content solder. This ensures reliability and long term performance, and lowest ESR for consistently fine performance.

Watch for Cap Myth #3!

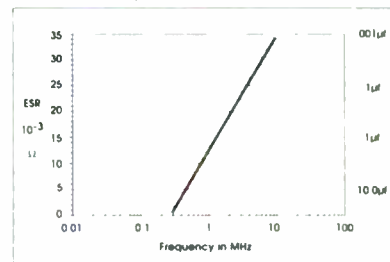

ESR vs. Frequency vs. Capacitance
Graph showing low distortion obtained by decreased parasitics (ESR) of the self-bypassed MultiCap. MultiCap performance falls to the right of the line, indicating fewer parasitics, i.e., fewer colorations & increased accuracy. Measurements of standard caps, even with exotic foils, falls to the left of the line, indicating compromised performance (Measured at MIT)

now available

Liberty Audiosuite

a new standard in PC Audio Measurement Systems

advanced...powerful...practical...

for use with the following DSP soundcards:

- ORCHID Soundwave 32
- CARDINAL Digital Sound Pro 16
- ECHO Personal Sound System
- WEARNES Beethoven ADSP16
- WESTERN DIGITAL Paradise 16-DSP
- ADAPTEC AMM-1570

\$269 with manual

also available:

- External Mic/Probe Preamp protects card and preserves accuracy. Kit: \$59.00 Assembled: \$85.00
- Microphone wands, IMP style probes

Labels on the screenshot include: IMPEDANCE & WOOFER PARAMETERS, ENERGY TIME & RT60, SPECTRUM, WATERFALL, MIC CORRECTION, SINE SWEEP GATED WITH PHASE, SCOPE/GENERATOR, THD DISTORTION VISUALIZER, and HELP.



P.O. Box 1454, West Chester, OH 45071 Telephone/FAX (513) 755-0252

Reader Service #67

MUSIC INTERFACE TECHNOLOGIES
For National & International Inquiries
Phone 916/823-1186 Fax 916/823-0810

Reader Service #69

operational amplifier as “an integrated circuit capable of amplifying audio signals,” and reveals a bias against them when he states that “the very best audio components use discrete circuitry, while budget and moderately priced products usually use op-amps.”

The term “op amp” describes a circuit topology and has nothing to do with the use of integrated circuits or discrete components. A typical solid-state power amplifier topology with a differential input and push-pull output stage is a large, high-current op amp that happens to be built with discrete transistors. Its gain and bandwidth are determined with

the same type of R/C feedback network as an integrated circuit op amp. Many discrete pre-amplifier topologies, some of which are extremely expensive, are also op-amp based. An operational amplifier can even be built with tubes.

The terms “op amp” and “integrated circuit” should not be confused—they are not necessarily the same. Harley’s negative comments really refer to the integrated circuit op amp, rather than the topology itself. He does confess that “some products employing op-amps have sounded superb, however.”

Harley also runs into a bit of technical

trouble in his explanation of Class A and AB power amplifiers. In the chapter on power amps, he states that Class AB amplifiers typically have complementary output stages. While this is normally true, the type of output stage, whether full-complementary or quasi-complementary, doesn’t determine the class of operation. The output stage biasing determines this factor.

In the appendix “Audio and Electronics Basics” he states that “a true push-pull amplifier actually operates in pure class-B, but virtually all power amplifiers operate in class-A up to a few watts, then switch to class-B operation, hence the ‘class-A/B’ designation.” I don’t have a problem with the first part of this statement, but the second part is incorrect. In a push-pull Class A amplifier both output devices conduct for the entire cycle right up to maximum output level. True Class B amps have each output device operating for exactly half the cycle, regardless of output level, while Class AB output devices are biased so that one turns on before the other turns off. Each conducts for more than half the cycle but less than the full cycle.

There are various levels of Class AB biasing. All amplifiers in this category operate Class A at low output levels. Just how low the level must be before the amplifier reverts to Class A operation depends on the biasing of the output stage; however, it is impossible for a true Class B amplifier to operate Class A at low output levels. Only a Class AB amplifier can do this. The “AB” designation has nothing to do with switching between Class B and Class A in conventional, fixed-bias amplifiers.

The Complete Guide to High-End Audio is an excellent introduction to the world of high-performance audio equipment. Despite the reservations I’ve noted, most of the book contains a wealth of accurate and useful information. I find it a worthy successor to Villchur and Borwick and recommend it to all audio enthusiasts.

PREVIEW Audio Amateur

Issue 1, 1995

- Regulators for High-Performance Audio, Part 1
- On Amplifiers and Feedback
- Power Supply Design Software
- Amp/Speaker Protection Circuit, Part 2
- Layol Software Review

You’re sold on state-of-the-art drivers.

Goertz low-inductance wire: the measurable difference.

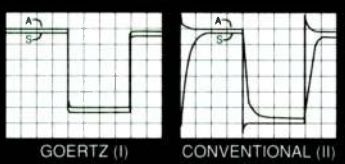

Goertz MI low impedance speaker cables—high purity copper or silver flat, solid conductors ideal for both internal and external speaker use. The patented Goertz design virtually eliminates high-frequency rolloff, skin effect below 50 kHz, hum from power wiring, and cross talk.

Alpha-Core foil-conductor air core inductors, available in 12, 14 and 16 AWG, also minimize high-frequency rolloff and skin effect below 100 kHz, reduce power loss, and eliminate saturation distortion. High winding tension and vacuum fusing of faces

provide consistent values and maximum stability. **Used together, these new components provide a signal path between amplifier and transducer that is “as distortion-free as possible within the limits of present technology.”**

Why settle for run-of-the-mill inductors and wire?

“...both Dave and James at Ambrosia Audio feel it to be one of the best speaker cables around when you consider the cost (heck, forget the cost—I think it’s great regardless!)... dynamics and punch out the kazoo... this stuff is highly recommended.”

—The Earful, October 1994

“Better bass, understandably, but—surprise! Greatly enhanced highs! And excellent definition.”

—Clark Johnson, Positive Feedback, October 1994

Alpha-Core Inc.

915 Pembroke Street,
Bridgeport, CT 06608 USA
(203) 335-6805 / (800) 836-5920



Reader Service #74

READING ROOM

Speaker Builder regularly receives audio-related literature—catalogs, newsletters, books, and other publications—covering products and topics of interest to *SB* readers. The following is a compilation of recent references and titles:

Antique Electronic Supply—1995

36-page catalog of tube-related electronic equipment.

Antique Electronic Supply
6221 S. Maple Ave., Tempe, AZ 85283
(602) 820-5411, FAX (602) 820-4643

The Audio Adventure

A monthly newsletter that reviews affordable high-end audio products.

TOMART Publishing, Inc.
PO Box 15256, Chevy Chase, MD 20825
(800) 566-6617

Audio Classics 1994/95

Reference Catalog

Reference to new and pre-owned precision stereo components.

Audio Classics
PO Box 176, Walton, NY 13856-0176
(607) 865-7200, FAX (607) 865-7222

The Binaural Source No. 3

List of CDs and cassettes especially designed for headphone listening.

The Binaural Source
Box 1727, Ross, CA 94957
(415) 457-9052

Child's Touch—Creative Discoveries for Children

Educational and entertaining music tapes, CDs and videos for children.

Creative Musicians Coalition
1024 W. Willcox Ave., Peoria, IL 61604
(800) 882-4262, FAX (309) 685-4878

Contact East 1995 Catalog

Free 144-page catalog of products for testing, repairing, and assembling electronic equipment.

Contact East
335 Willow St., N. Andover, MA 01845
(508) 682-2000, FAX (508) 688-7829

Legacy Audio 1995 Catalog

48-page booklet profiling the company's speakers, surround sound processors, and amplifiers.

Legacy Audio
3021 Sangamon, Springfield, IL 62702
(800) 283-4644, FAX (217) 744-7269

Loudspeaker Recipes

Author Vance Dickason shows how to design and build four loudspeaker systems.

Audio Anthology Volume 6

Articles from Audio (Audio Engineering) 1960-61.

Old Colony Sound Lab
PO Box 243, Peterborough, NH 03458
(603) 924-6371, FAX (603) 924-9467

Mouser Catalog

276-page index to industrial electronic components.

Mouser Electronics
2401 Hwy. 287 North, Mansfield, TX 76063
(817) 483-4422, (800) 992-9943

North Creek Music Systems—1995

Catalog of loudspeaker components and accessories for the hobbyist.

North Creek Music Systems
PO Box 1120, Old Forge, NY 13420
(315) 369-2500

Parts Express 1995 Catalog

Free 212-page catalog listing speakers and audio accessories, video products, and semi-conductors.

Parts Express
340 E. First St., Dayton, OH 45402
(800) 338-0531, FAX (513) 222-4644

We invite manufacturers and publishers to send releases for inclusion in this column to:

Speaker Builder
Reading Room
305 Union St., Peterborough, NH 03458
FAX (603) 924-9467

STEEP SLOPE ELECTRONIC CROSSOVERS

CREATE A SPEAKER SYSTEM WITH PHENOMENAL CLARITY

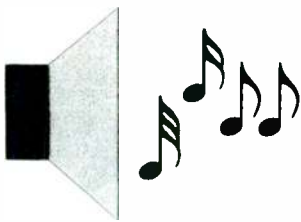

- Drivers are usable as true pistons over a limited range of 2.5 octaves
- Steep slope crossovers exploit full use of this range
- A remarkable clarity of sound results, obvious to even the untrained ear

Our professional multi-way electronic crossovers offer steep slopes up to 66dB/octave (11th order)

Send for product literature: crossover systems, matched filters, filter kits, precision capacitors, and more!

SUSSEX TECHNICAL CORP.

FAX (214) 495-6434

6114 TURNBERRY DR.
GARLAND, TEXAS 75044

Ask SB

MORE ON SECOND AND FOURTH ORDER

By Dick Pierce
Contributing Editor

In another article in the Usenet newsgroup *rec.audio.tech*, Norman P. Tracy wrote:

What about 'boxless' woofer systems, such as the Celestion 6000 system subwoofer, Carver ALS array of open back woofers, and (I believe) the new Parasound GMAS subwoofer? These (and others in the wacky history of hi-fi) are woofers on an open baffle. Their accompanying hype claims that they act as first-order systems (driver suspension resonance only) and recover the rolloff due to the open baffle design through a combination of eq/extreme excursion under damped response. The notion is that due to the gentle rolloff of a first-order alignment a little correction goes a long way.

The notion that an open back woofer is a first-order system is simply not correct. In fact, the notion that there is *any such thing* as a first-order speaker system (specifically relating to the low-frequency cutoff properties of the system) is simply wrong because of the physical impossibility.

ONCE A SECOND ORDER...

Any woofer (generalize to "driver," be it woofer, midrange or tweeter, cone, electrostatic, and so on) is a mechanically resonant system, which is characterized by two mechanical "reactances" (entities that store energy). The first is the mass of the speaker cone (a mechanical reactance that stores energy in its kinetic form by moving). The second is the compliance of the surround (a mechanical reactance that stores energy by being stretched).

Energy given to such a system is traded back and forth between the two reactances. At the point where the suspension is stretched as far as it will go, *all* of the energy is stored as potential energy in the stretched suspension, and the velocity of the cone, hence its kinetic energy, is 0. However, the stretched suspension imparts a force on the cone, which starts its acceleration toward the mechanical center position. More and more of this potential energy is converted to kinetic energy of the mass of the moving cone until, at the mechanical center, the suspension is completely relaxed and the cone is at its maximum velocity.

The equations of motion that describe this system are second-order differential equations. From those equations describing the interplay of position, velocity, and acceleration, we can derive a transfer function equa-

Speaker Manufacturers: Throw us a curve.



Our new "curved" speaker cabinets offer more than superb acoustics. Cubicon's unique paper tube construction makes them sturdy, light weight and cost effective. Want your very own signature shape? Then throw us a curve and we'll make you a big hit in the showroom.



Cubicon Corporation
10176 Corporate Square Drive
Mail to: P.O. Box 28745
St. Louis, MO 63146-1245
Phone: 314/567-0667
Fax: 314/567-0046

tion, which is also second order. Below resonance the transfer function response drops correspond to the square of the frequency. At one octave down (one-half the frequency), the response is one-quarter of that above resonance.

All drivers, no matter how they are mounted or loaded, have spring-like suspensions and mass, and thus behave as second-order mechanical systems and exhibit second-order rolloff characteristics. The presence of a baffle or an enclosure system can modify at what frequency this occurs, or some details involving mechanical losses that can affect the actual shape of the response around resonance.

But no mounting or baffle or enclosure, under any circumstances, can turn a second-order system into a first-order system. To do so you need to physically eliminate either the driver's compliance or its mass (not make them 0 or infinite, but make them go away). No system of mounting can turn a higher-order system into a lower-order system. The basic principle is: *all speaker systems behave at least as second-order high-pass systems at the low frequency limit of their range.*

BOX BEHAVIOR

Placing a woofer in a box does not increase the order, because the compliance of the sus-

Erect a Soundstage in Your Listening Room - Unobtrusively.

High Resolution Ribbon Loudspeakers from Newform Research

Now sold in 17 countries!



Our new Ribbon technology produces smooth, extended response and excellent definition and soundstaging. They represent undemanding purely resistive loads. Tubes love them. All of our products (system range \$895 - \$7,995 the pair) provide unsurpassed musicality on all sources from classical to rock to jazz to video. We are Dolby AC-3 ready.

Newform Ribbons are monopolar, magnetically shielded and require no transformers. Our full range systems, modules and custom installation Ribbon components provide true high fidelity in both stereo and surround systems and will facilitate easy integration in the future.

Call or fax for international reviews, specs and prices . . .

No Holds Barred is a customized system using retractable 60" Ribbons, dual mid-bass, and dual subwoofers. Sensitivity is 92 dB and the price is \$7,995/pr. Unobtrusive when retracted against or into a wall, when extended and turned on, they disappear.

Module 15 - large panel sound in a 6" x 9" footprint. The Modules are now available as floor standing models as well.



Call us on your projects for direct factory support.

Newform Research Inc. P.O. Box 475, Midland, Ontario Canada L4R 4L3

Phone: (705) 835-9000 Fax: (705) 835-0081

We now take Visa and MasterCard orders in the USA.

Reader Service #60

MENISCUS

Your source for speaker components

AC
Dynaudio
Eclipse
Eton
LPG
SEAS
Vifa

And of course, x-over and cabinet parts.

MENISCUS AUDIO
2575 28th St. S.W.
Wyoming, MI 49509

Voice (616) 534-9121
Fax (616) 534-7676

MAGNESIUM CONE BY

seas

Excel

W17E002
6.5"
Fs 34 Hz
Qts .32
Vas 29.5L
SPL 87 dB
100 Watt
8 ohm

W14CY001
5.25"
Fs 43 Hz
Qts .36
Vas 10.6 L
SPL 87 dB
70 Watt
8 ohm

W11CY002
4"
Fs 46 Hz
Qts .31
Vas 5.8 L
SPL 85 dB
70 Watt
8 ohm



All your life they've called you "picky", hard to please. **WRONG!** Truth is, you're a perfectionist! You want it done

RIGHT!

You want to build your speakers and you want them to be **PERFECT!** "You are there" imaging, great dynamics, powerful, clean bass, **REALISM!** You demand durability and affordability. You can build them. All you need are world-class designs and the parts to put it all together.

An ACI Parts Kit is the answer to your prayers.

ACI's are the only kits available that have received over 20 great reviews in magazines from Speaker Builder to Stereophile. Choose from six great models including the reference quality Sapphire III and the 250 watt Titan "smart amp" powered sub.

Be picky, build your **PERFECT ACI speakers.** Call or fax us today!

ACI div.
Audio Concepts, Inc.
La Crosse, WI

Phone: (608) 784-4579
Fax: (608) 784-6367

Reader Service #6

pension and the compliance of the air in the box combine to form a single new compliance, less than that of either. The result is that the driver mass and this new *system* compliance form a resonant system whose frequency is higher (because the system compliance is lower) than that of the driver.

On the other hand, a bass reflex/vented system has *two* resonant systems, one formed by the driver mass/compliance, and the other by the enclosure compliance/port mass. It's a fourth-order system (actually, it's a composite of two second-order systems).

An open back system must be at least second order, because it's driven by a second-order system: the driver. Other effects, such as rear wave cancellation, can conspire to make the system behave as a higher order. But there is no such thing as a "negative one order baffle" (a mathematically and physically impossible concept requiring, among other things, the concept of either negative energy or imaginary time) that can "subtract" an order from the system.

The actual analysis of such a system is complex. In the case of a simple dipole radiator, my guess is that it behaves at least as a complex third order, with the driver exhibiting second-order characteristics and the rear wave cancellation acting as a first-order filter. However, in reality, it's probably far more complex. The rolloff due to cancellation occurs because the rear wave is out of phase with the front wave. At very low frequencies far below where the wavelength is large compared to the baffle size, almost complete cancellation occurs.

As we get higher and higher in frequency, the path length starts to approach one-half the wavelength, at which point the rear wave is now delayed by 180°, and is now in phase with the front wave, leading to *constructive* interference. The two begin to move out of phase again as we increase frequency, so that at an octave higher, the delay is now a full 360°, and the front and rear wave are out of phase again, leading to *destructive* interferences and cancellation. At a still higher frequency they're in phase again, but go out of phase as we continue higher.

The effect is of a comb filter response. At higher frequencies, the cancellation effect diminishes because the rear wave will not diffract around the baffle as easily. And any nonsymmetries in the baffle will tend to reduce the magnitude of the cancellation, because the differing path lengths spread the cancellation somewhat over a broader frequency.

You could argue then that the transfer function of such a system is far more complex than first order (which is simply impossible) or second order (which it would be if the baffle size were infinite).

MAHOGANY SOUND

The Transmission Line Specialist
P.O. Box 9044
Mobile, AL 36691-0044
334 633-2054

Acousta-Stuf

The Very Best Damping Material For Speaker Systems. It Produces Deeper Bass, Cleaner Mids, And Greater Dynamic Range. Acousta-Stuf Costs \$9.50 Per Pound UPS Paid.

Q&ETLD

Quick & Easy Transmission Line Speaker Design Booklet & LOTUS 1-2-3 Software. Learn How To Design Optimized 1/4 Wavelength TL Speakers. Q&ETLD Costs \$8.95 Plus \$1.80 P&H.

New For 95 Acousta-Tubes

Round Paper Tubes For Building Cylindrical Speaker Enclosures.

Please Note Our New Address & Area Code

Call Or Write For A Free Catalog

Reader Service #9

RACKEM 'N' STACKEM™ SERIES



Boxes		
MODEL	DESCRIPTION W x H x D (in.)	PRICE \$
RSB-3	7.5 x 1.85 x 3	25.00
RSB-5	7.5 x 1.85 x 5	31.25
RSB-7	7.5 x 1.85 x 7	38.00
RSB-9	7.5 x 1.85 x 9	45.00
RSB-11	7.5 x 1.85 x 11	51.50
RSB-13	7.5 x 1.85 x 13	58.75

- Half rack size for small and dense constructing
- Full line of accessories
- Can be used on table or in rack
- Three colors available; clear standard, for black or gold add \$5.00 per box

(800) 634-3457
Order Today!



Table Top Racks		
MODEL	DESCRIPTION W x H x D (in.)	PRICE \$
RSR-8	11.4 x 15.2 x 11	80.00
RSR-9	11.4 x 18.8 x 11	85.00
RSR-10	11.4 x 22.6 x 11	70.00
RSR-12	11.4 x 26.4 x 11	75.00
RSR-6-19	20.9 x 15.2 x 11	70.00
RSR-8-19	20.9 x 18.8 x 11	75.00
RSR-10-19	20.9 x 22.6 x 11	80.00
RSR-12-19	20.9 x 26.4 x 11	85.00



- Four models available in half and full rack widths
- Clear, black and gold anodized finishes
- Constructed of 1.0" square aluminum tubing

SESCOM STOCKS ALL TYPES OF ENCLOSURES
FREE EXPANDED 1995 CONSTRUCTOR'S CATALOG

PREPAID ORDERS SHIP GROUND FREE

(46 STATES, CANADA & MEXICO)

SESCOM, INC.

2100 WARD DR., HENDERSON, NV 89015 USA

USA/CANADA (800) 634-3457

FAX (800) 551-2749

(702) 565-3400 FAX (702) 565-4828

TECH LINE (702) 565-3903 M-Th 8 am to 4 pm (PST)



Tools, Tips & Techniques

A DRILL FOR GRILLE SNAPS

Ever wonder why the cheaper the fastener, the more expensive the custom installation tool? Before I arrived at the solution described here, I had difficulty finding a 9/16" Forstner drill bit for installing female plastic grille snaps. The woodworker's mail-order houses seemed to stock these bits only in 1/8" increments. I specifically wished to stay with a Forstner style bit, which offers a more precise hole size and greater drilling control.

SOLUTION

1. Shop for a 5/8" Forstner bit at hardware and lumber stores. Take your caliper along with you. Buy the bit with the greatest wall thickness. (I purchased an Irwin #42910 for about \$7.)

2. Consult the Yellow Pages for Grinding-Precision & Production, or Grinding-Tool. Pick out the smallest, most obscure listing; that is, the one-man shop. (The larger places will charge more since you have to wait longer.) Don't call, but instead....

3. Drive straight over there with your bit.

Make sure the shop looks small and dingy from the outside. Walk in, greet the guy with a smile, handshake, and a good clean joke. Tell him what you want, then ask if he'll do your job for \$10.

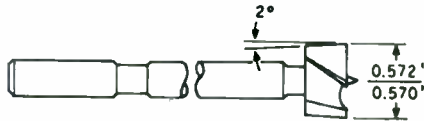

FIGURE 1: Modified tool for grille snap installation.

4. Finally, here's what to ask for. Have him grind down the bit to 0.572/0.570" with a 2° back taper (Fig. 1). Note that this is a little larger than 9/16". I find this size makes installing the female snaps much easier. No heavy pounding is required, yet they still grip the hole properly, and the male snaps still "snap," too.

You are now the proud owner of a \$17 custom installation tool for a 25 cent part.

Phil Bamberg
Tucson, AZ 85741

TARRED & FEATHERED

Are you still coating the inside of your enclosure with asphalt? Does the tar and sand mixture stick to you? Do you worry vapors will soften the glues that bond your woofer?

An easy and affordable solution is to use nonhardening modeling clay, available at most art and craft stores. A 5 lb brick usually costs about \$10 and slices easily with a knife or cheese slicer. You can then press it into place wherever you need it.

Apply thin strips to damp stamped woofer frames. A large wad on the back of the magnet structure will further help reduce unwanted vibrations. Completely cover the back of a tweeter and fill in the space between the magnet and enclosure to eliminate enclosure interior sound from radiating through the tweeter.

The clay melts like wax, so the easiest way to cover large surfaces is to melt the clay in a saucepan on the stove and pour it into place. You can still add sand or lead shot to the clay to increase its mass.

Alan Ersen
Carmichael, CA 95608



Filters with less filter.



Whether you're modifying, rebuilding, or designing crossovers from scratch - using premium quality resistors, inductors, capacitors, wire and connectors will have your creations and drivers performing to their maximum potential. These exceptional components, generally reserved for state-of-the-art manufacturers, stay true to the original signal - resulting in less degradation - less music filtered out. Call The Parts Connection for further details or to let us know what you need.

We are feverishly working on our much-expanded 1995 Catalog with many new part lines, more technical info, schematics and lots of other great stuff! Keep an eye out in March.



2790 Brighton Road, Oakville, Ontario, Canada L6H 5T4
Tel (905) 829-5858 Fax (905) 829-5388

Toll Free Order Line 1-800-769-0747 (U.S. & Canada only)

• MIT MultiCap • Wonder Cap • Kimber Kap • Solo • Hovland MusiCap • Solen • Siemens • Wima • Holco • Rel-Cap • Draloric • IRC • Allen-Bradley • Jensen • Resista • Vishay • Mills • Caddock • Matsushita • TKD • Noble • Cardas • Kimber Kable • van den Hul • Discovery • Audioquest • MIT • Alps • Bourns • Shalco • Elma • Electros witch • Gold Aero • RAM • Mallory • Panasonic HFQ • Nichicon • Elna • N.Q.S. • Ruby Tubes • UltraAnalog • Burr-Brown • Crystal • Linear Technology • Analog Devices • Edison Price • Motorola • UCC • International Rectifier • Hitachi • MagneQuest • Sonic Frontiers • Pearl • Tube Sockets • WBT • Neutrik • Sound Coat • Curcio Audio Engineering • Assemblage and other kits

THE PARTS CONNECTION

A DIVISION OF SONIC FRONTIERS INC.

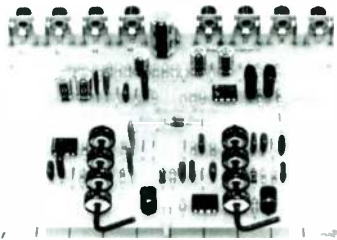

VERSATILE Electronic Crossover Kit

The Decade 1000 offers independently variable low-pass and high-pass frequencies. Separate inputs allow cascading, so the basic 12dB per octave 2-way kits may be used in multiples to create 24dB per octave and 3-way or 4-way systems. Simple mods convert the 1000 into a powerful Bass Equalizer and/or Subwoofer Crossover. 12VDC operation, low current. Gold I/O connections. Price: \$39.95.

Decade also offers a 2-Digit Voltmeter, Speech Scrambler, Oil Tester, and a 30Wx2 Power Amplifier Kit that connects to the earphone jack on your portable stereo or CD-ROM drive!

MC/VISA accepted. We ship from stock.

Decade Engineering

2302 5th St. NE, Salem, OR 97303-6832
(503) 363-5143 FAX (503) 399-9747

Reader Service #46

SB Mailbox

EQUATION CORRECTION

An error crept into equation (4) of my most recent reply to a Dave Meraner letter ("Ask SB," *SB* 1/95, p. 48). The correct version is:

$$f_s = 1/[2\pi\sqrt{(M_{MS}C_{MS})}]$$

Joe D'Appolito
Contributing Editor

DESIGN HELP

I am an enthusiastic speaker builder who has read *Loudspeaker Design Cookbook*, *Bullock on Boxes*, and *The Great Sound Stereo Manual*, which have sparked some questions.

First, when Small talks about the mach

number in a port being less than 5% the speed of sound, does he mean that the number should come out of the formula as a decimal of 0.05 or less? Second, I have used the formula for wavelength, which, when changed to inches, results in a huge number. What is the correct formula, and how do I use the answer to figure out defraction losses?

Also, I examined the test procedures for V_{AS} calculations described in *Bullock on Boxes*. With a 2 ft³ box to find the V_{AS} of a 10' driver, I used the vented box configuration vented at 50Hz (using the constant current method, p. 15) and found the following parameters, F_h , F_1 , and F_m . I used F_m as the vented box F_b and got 33Hz box frequency. Then, just to see what would happen, I stuffed the box with books and solid styrofoam to take up about 80% of the box vol-

FOTAL

ACCUTON

ORCA CONNECTORS

SR

SPEAKERS

QUALITY DRIVERS & MORE

etc.

REGULUS

CUSTOM SPEAKER CABLES & INTERCONNECTS

AUDIO
ERSE
ELECTRONICS
INDUCTORS

polyda

SPEAKER CORPORATION

Speaker Kits Available

**We Offer State Of The Art Speaker Components and Kits
(Specializing in Speaker & Crossover Design)**

Request a FREE catalog

1828 W Peoria
Phoenix, AZ 85029
Phone (602) 944-1878 FAX (602) 371-0605

(Mntn Std Time)
10:00 AM-7:00 PM Weekdays
10:00 AM-5:00 PM Saturdays

ume, leaving just enough space for air passage to cause port resonance.

The Fb turned out to be 34Hz only one hour after first measurements without subtracted volume. Why is this? I thought Fb was the product of both the box and the port resonance. The impedance at Fm from the first measurement of Fb was 3.2Ω at 33Hz, and the second measurement was 4.9Ω at 43Hz. My box is totally sealed except for the vent opening. How do you explain the results?

In "Stalking f₃" (SB 2/93, p. 24), what is the meaning of the *a* in equation (1)?

Finally, does JAES refer to a magazine or simply papers on a certain subject? Also, where can I purchase JAES?

Brian Kuder
Parma, OH 44134

Contributing Editor Robert Bullock responds:

Small means that the vent air speed should be less than 5% of the speed of sound, which would be approximately 55 ft/sec.

Your equation for wavelength appears to be incorrect. Wavelength is wave speed divided by frequency, i.e., c/f in the case of sound, where c is about 345 meters/sec. Thus a 40Hz frequency will have about a 3.75m wavelength. This converts to almost 150".

The baffle of an enclosure will have no noticeable effect at 40Hz.

You say you stuffed the box with books and solid styrofoam to get it down to 0.5 ft³. The impedance increase from 3.2 to 4.9Ω indicates a significant increase in box losses, so I highly suspect that your "solid" styrofoam is not so solid! Even apparently solid styrofoam

can be well over half air space.

*The only *a* I see in the SB article is in the second of the unlabeled formulas following (2). These three formulas appear to be mislabeled because they define some nonexistent α_1 , α_2 , and α_3 . They should be labeled a_1 , a_2 , and a_3 , and so the *a* should actually be the system compliance ratio α .*

Tired Of Bad Sound? Let Us Give You A Few Pointers.



STUDIOFOAM™ SOUND ABSORBENT WEDGES

Foam improves the sound of any room & ours is the industry's best! It features a uniform cut for clean & easy installation—no "innies & outies" like other brands. How's it work? Up to 60% better than foams that cost 5 times as much! Absorption NRCs from .50 to 1.30. Passes the stringent California firecode & tests 48% more flame retardant than Sonex. Available in 1", 2", 4" & 12" (bass trap) sizes in 2'x4' sheets. Super long-lasting—it doesn't crumble like other brands can. Available in a wide range of colors to match any decor. Minimum order just 1 box. 1"-\$8.99 ea. pc. (20/box), 2"-\$11.99 ea. pc. (12/box), 4"-\$22.99 ea. pc. (6/box). Call us today!

Clients: AT&T • Sony • Ford Motor Co. • Kodak • Warner Bros. • Universal Studios • Manly Labs • MTV • Toshiba • Chevron • 20th Century Fox • Hitachi • D. Ervasti (Voice of NFL on Fox) • Maury Povich Show • Dennis DeYoung (Styx) • Baldwin • Editel • Mike Wanchic (J. Mellencamp) • Rockwell • US Gov't • Pat Duke (Voice of McDonalds, Miller Brewing) • Opryland • Bell Research Labs • MPI (ABC News, Apple Records) • Carvin • Penn State • WhisperRoom • ITX • Martin Marietta • NJJ (NFL on Fox, Coke, ABC) • Music Bakery • UCLA • Jones Intercable •

USAfoam • Box 20384, Indianapolis IN 46220 • (800) 95-WEDGE • Fax (317) 257-2USA

Reader Service #70

REPRINTS

For quality reprints in quantities of 100 or more, contact:
**REPRINT SERVICES/
SPEAKER BUILDER.**

315 5th Avenue N.W., St. Paul, MN 55112,
(612) 633-1862.

Theory & Design of High Performance Professional Loudspeakers Workshop

**Nashville, TN
June 22-24, 1995**

Staff:

Bruce Howze
Community

Don Keele
Don Keele Associates

Eugene Patronis, Ph.D.
Georgia-Tech

Co-Sponsored by:

Community—Systems Contractor News—Syn-Aud-Con

Each member of the staff has major accomplishments, genuine innovative leadership in designing compression, coaxial systems, constant directivity design, forming cones and diaphragms, adhesives, magnetic structures, enclosures, horn design, tooling, manufacturing techniques and advanced measurements.

CONTACT: SYNERGETIC AUDIO CONCEPTS

12370 W. CR 100 N ♦ Norman, IN 4726
Ph: 812-995-8212 ♦ Fax 812-995-2110

JAES is the Journal of the Audio Engineering Society (60 East 42nd St., New York, NY 10165, (212) 661-2355, FAX (212) 682-0477). Individuals who are interested in audio engineering may join the Society by requesting a membership application form

from the Admissions Committee. They have a student member category and should be a good source of information on educational programs in audio engineering.

Hoping to get absolute top-class performance, I used Solo CFAC inductors, Madisound 1% matched SCR caps, and Silver Sonic T-14 wire for the outboard gas-tight crimp (nonsoldered) crossover.

The result of this attention to detail is worth the effort. The Arias are extremely smooth, detailed, and spacious. However, they lack the impact I loved in my precious speakers, with 12" bass drivers.

SWEET-SOUNDING ARIA

I recently completed the kit version of Joe D'Appolito's Aria 5 (with Accuton tweeter).

Bozak®

BUY FACTORY DIRECT

BOZAK SPEAKER SYSTEMS

**30 DAY
RISK FREE
HOME AUDITION**

for your catalog

BOZAK

539 Norwich Ave
Taftville, CT 06380

800-730-9677

FAX 203-886-1413

Reader Service #75

Get the information you need *fast!* Use this convenient list to request the products and services that interest you in this issue. Don't forget to mention *Speaker Builder!*

COMPANY	PRODUCT	FAX
A & S Speakers	<i>Fax For Speaker Contest Details</i>	(415) 648-5306
Cubicon Corporation	<i>Paper Speaker Enclosures</i>	(314) 567-0046
Decade Engineering	<i>Electronic Crossover Kit</i>	(503) 399-9747
Harris Technologies	<i>BassBox 5.1</i>	(616) 641-5738
HeadRoom Corp.	<i>Home HeadRoom</i>	(406) 587-9484
Liberty Instruments, Inc.	<i>Liberty Audiosuite</i>	(513) 755-0252
MCM Electronics	<i>Audio Components & Service Parts</i>	(513) 434-6959
MIT Electronic Components	<i>MIT Multicap</i>	(916) 823-0810
Meniscus	<i>Speaker Parts & Seas Cones</i>	(616) 534-7676
Morel Acoustics	<i>High-Tech Audiophile Speakers</i>	(617) 277-2415
Orca Design & Manufacturing	<i>Cabasse Drivers & Axon Caps</i>	(818) 991-3072
The Parts Connection	<i>Assemblage DAC-1 Kit</i>	(905) 829-5388
RDL Acoustics	<i>Roy Allison's Convex Dome Tweeter</i>	(508) 966-3645
Sescom, Inc.	<i>Free Sheet Metal Catalog</i>	(800) 551-2749 (USA) & (702) 565-4828
Speakers Etc.	<i>1995 Catalog</i>	(602) 371-0605
Technologie MDB	<i>Focal, Cabasse, Kits</i>	(514) 443-5485
USAfoam	<i>Studiofoam Acoustic Wedges</i>	(317) 257-2872

Don't Delay FAX Today!

BassBox 5.1 for Microsoft WINDOWS™

Design low-frequency loudspeaker enclosures fast and accurately with BassBox software. Uses both Thiele-Small (Fs, Qs, Vas, 110) and Electro-Mechanical (Qes, Qms, Cms, Mms, Rms, Bl) parameters with equal ease.

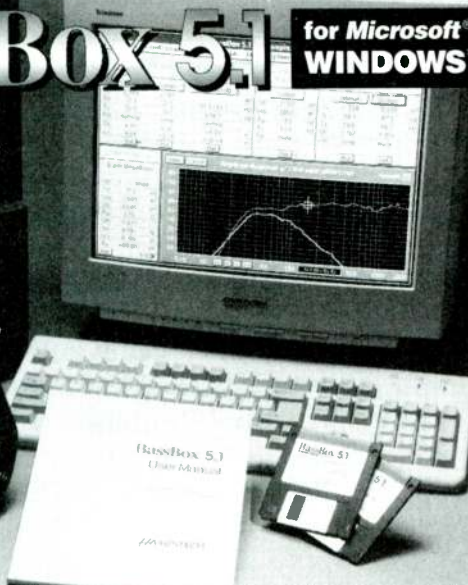

Includes a large driver database with over 1,300 drivers.

- ◆ Easy to use
- ◆ On-line help
- ◆ Hi-res mode
- ◆ Low price

Design Types:

Optimum Vented
Extended Bass
Custom Vented
Band-Pass with Double or Triple Chambers
Passive Radiator
Optimum Closed
Custom Closed
All designs can use multiple woofers (including Isobaric)

Built-in Test Procedures:

Test and calculate loudspeaker parameters*
Test and calculate passive radiator parameters*

*Requires basic test equipment: sine wave generator, frequency counter, power amplifier, 1 kohm resistor, voltmeter, ohmmeter, test box.

Design Options:

Small and large-signal analysis.
Examine one loudspeaker in several different boxes or...
Examine several different loudspeakers in the same box.
6 graphs: normalized amplitude, 2.83-V amplitude, acoustic power, impedance, phase and group delay.
Advanced vent calculator.
Advanced box dimension calculator w/ 18 volume shapes.
Accepts loudspeaker measured acoustic response.
Accepts automobile or listening room interior acoustic response.
Use English or metric units.
Save and recall designs.



\$99.00

plus \$5.00 S&H
(Canada: +\$6.00)
(Overseas: +\$12.00)

Tel: 616-641-5924
Fax: 616-641-5738

Harris Technologies
P.O. Box 622
Edwardsburg, MI
49112-0622 U.S.A.

Also available:

X-over 2.0 passive crossover program for Windows.
X-over calculates the component values for 1st, 2nd, 3rd and 4th-order 2-way and 3-way networks, load compensating networks and L-pads. Regular price: \$29. (\$19 if purchased with BassBox.)

Minimum System Requirements:

MS-DOS 5.0. Microsoft Windows 3.1 & compatible computer (386 or better CPU with at least 4 MBytes of RAM), 7.5 MBytes of free hard disk space, 1.44 MByte 3.5" disk drive and mouse.

Harris Technologies reserves the right to make changes without prior notice.

Has any *SB* contributor found a synergistic combination—10" or 12" single or double woofers from Focal or another company—to support the Arias at the midbass and below? Please include the usual: box volume and alignment, crossover schematic, and any useful tweaks.

Incidentally, Kimon Bellas's opinion of the sensitivity of the Arias with Accuton's tweeter is about 88dB/W/m.

Stephen Dowling
Arlington, VA 22201

Readers with suggestions/comments/solutions for Stephen should write to: Speaker Builder, Editorial, PO Box 494, Peterborough, NH 03458.

GOVERNMENT EXTORTION?

I am happy you have increased your personal contributions to your favorite Boston radio stations ("Editorial," *SB* 2/95, p. 9). If others with a similar appreciation for these stations' programming do the same, perhaps they will survive in spite of defunding of the Public Broadcasting System. I will be happy if that is the result, but I will also be happy to shed the financial burden of subsidizing your interest.

Government funding of special-interest programming can be accomplished only through extortion, i.e., forcing you and me to pay for programs in which we have no interest, or which run counter to other interests. Although PBS may have worthy goals (many of us believe they don't), the means to achieve

those goals are clearly wrong. Extortion is extortion regardless of the pleasure Edward T. Dell, Jr., derives from the proceeds.

I hope you will continue to support your local stations as I do mine. In turn, I hope these stations will be responsive to our programming interests. In fact, removal of gov-

ernment support is the surest way to ensure such responsiveness. If our musical interests are not shared by enough others to support broadcasts, we can redirect our spending to the CDs of our choice, freeing up the airwaves for material with broader appeal.

The Constitution guarantees the right to

SPEAKERWORKS

"SPECIALISTS IN THE ART OF SPEAKER REPAIR"

FACTORY AUTHORIZED SERVICE:
Advent, B•I•C, Bozak, EPI, RTR,
Cerwin-Vega, JBL Home & Pro

**Speaker parts & adhesives,
cones, spiders & dust caps**

**3 Way Crossovers Circuit
Breaker Gold Plated Binding
Posts \$19.95 each!**

**Replacement grilles for Altec,
B•I•C, Cerwin-Vega, JBL & Marantz**

**Refoam kits available for 4", 5-1/4",
6-1/2", 8", 10", 12", & 15" speakers
- only \$29.95 (JBL slightly higher)**

**Special Closeout on rebuilt DYN
Audio Drivers: MR 17.75, W30-100,
W24-100, W17-75. BELOW COST!**

We Buy Dead Speakers: Altec, E-V & JBL



1-800-526-8879



**NO CATALOG AVAILABLE
CALL US FOR HARD TO FIND DISCONTINUED PARTS
4931 A-1 South Mingo / Tulsa, Oklahoma / 74146**

Technologie
MDB

*Affordable Excellence from Canada
L'excellence Abordable du Canada*

Now featuring the new FOCAL Hi-Fi and Audio-visual kits, with three compact speaker kit models and a center channel plus four brand-new column speakers! Advanced technology including dual voice-coil drivers, sandwich Kevlar and Polyglass cones, flat ribbon voice coils, concave dome tweeters with phase plugs, tioxid domes, Axon capacitors, high-quality inductors, and more!



Technologie MDB

4000 Terrasse Jean XXIII, St. Hubert, Québec J4T 3L6 Phone (514) 891-6265 Fax (514) 443-5485

Reader Service #18

1981 A Testing Unit for Speaker Parameters • Variable-Volume Enclosure • Thiele/Small Theory, Pt 1-3 • Easy to Make Enclosure Using Concrete Blocks • The Tractrix Horn: Good Dispersion From an Old Design • Diffuser Port for Small Boxes • Mini-Speaker Made From PVC Tubes • Closed vs. Vented Box Efficiency • Interview with P.G.A.H. Voigt • Dual 8" Symmetrical Air Friction Enclosure • Thiele/Small Calculator Computation • Thiele/Small Parameters for Passive Radiators •

1982 Transmission Line Theory • Thiele/Small Sixth-Order Alignments • The Quad 63 • Table Saw Basics • AR-1 Mods • Active Crossover and Phase • Three Transmission Line Speakers • A Beginner's First Speaker • How Passive Networks Interact with Drivers • Horn Loaded Heil • Phase Correcting Active Crossover • Wind Your Own Inductors • Series and Parallel Networks • High Performance Corner Speaker • Using Zobel's to Compensate for Driver Characteristics •

1983 Building the Two-Way Dynaudio • A Crossover That Offsets Speaker Impedance • Using a Calculator for Box Design • Choosing a Calculator • A Simple Peak Power Indicator • A Small Horn Speaker • Audio Pulse Generator • How to Use Speaker Pads and Level Controls • An Easy-to-Build Voltmeter for Speaker Measuring • Nomograms for Easy Design Calculations • Interview with KEF's Raymond Cooke • Build a Simple Wattmeter • A New Type of Speaker Driver •

1984 Build an Aligned Satellite/Woofers System • BOXRESPONSE: A Program to Calculate Thiele/Small Parameters • Casting with Resins • A Phase Meter • An Interview with Ted Jordan • Building the Jordan-5 System • Self-Powered Peak Power Indicator • Closed Box Design Trade-offs • How to Build Ribbon Tweeters • Build a Dual Measurement Impedance Meter • A High-Power Satellite Speaker System • Build and Use a White/Pink Generator • Sound Pressure Level Nomographs •

1985 OUT OF PRINT, some single issues still available at \$7 each •

1986 The Edgar Midrange Horn • Sand-Filled Stands • Crossover Networks: Passive and Active • 5-sided Boxes • A 2 x 4 Transmission Line • The Free-Volume Subwoofer • Notch Filters • By-Wiring the LS3/5A • A Push/Pull Constant Pressure System • Current and Power in Crossover Components • The Unbox (Egg) • Upgrade Speakerlab's S-6 Crossover • Measure Speakers with Step Response • A Gold Ribbon System • A Visit with Ken Kantor • A Tractrix Horn Design Program • Reviews: Audio Concepts "G"; Seven TL Midranges; Focal's Model 280; the Audio Source RTA-ONE.

1987 A Compact TL Woofer • Frequency Response and Loudspeaker Modeling, Pt 1-3 • A Manual Coil Winder • The Model-One Speaker • Designing a Listening Room • A Sixth-Order Vented Woofer • Tapered Pipe Experiments • Visiting Boston Acoustics • A Vented Compound System • The Octaline • Spreadsheets for Speaker Design • In Memoriam: Richard Heyser, Pt 1-2 • Using Non-Optimum Vented Boxes • Building Speaker Stands • Evaluating Driver Impedance Compensation • Tuning Bass Reflex • Six Woofers Compared • Bullock on Passive Crossovers: Alternate Bandpass Types • Fast, Easy Filter Calculations • A Mobile Speaker • Polk 10 Mod •

1988 Electronic Turns Counter • Two-Way Design • Minimus-7 Mod • Dome/Midrange/Tweeter Array • Plotting Complex Impedances • A Driver Design Primer • A Cabinet Primer • Tuning Up Old Systems • Low-Cost AR-3 Upgrade • Electronic Time Delay • Enclosures Shapes and Volumes • Minimum-Phase Crossovers • Spot Sound Absorbers • How to Add a Subwoofer • The Swan IV System • Sub-Bass Power Boosting • The Unline: A Short TL • Active Filter Computer Design Program • Low-Cost Two-Way Ribbon • Amp-Speaker Interface Tester and Construction Plans • The QB₃ Vented Box is Best • A Pentagonal Box System • Keith Johnson Profile • Sheathed Conductor ESL • A Symmetrically Loaded System, Pt 1 • Ceramic Enclosure • Inductance Measuring Technique • Polk 10 Mods •

1989 (4 Issue Set: VERY LOW STOCK) The Audio Laboratory Speaker System • A Passively Assisted Woofer • Digital Filter Tutorial • The Listening Arc Alignment • Small IC Power Amp & Crossover • Easy Surround Sound • Building Speaker Spikes • An Isobarik in a Thunderbird • Sheetrock Cabinetry • A Picket Speaker • Servo-Controlling AR-1 • Silent, Safe Muting System • Equalizing the Klipsch Cornwall • A Test Switcher • Visiting the Klipsch Kingdom • Rehab for Kitchen Music • Spreadsheet Design • A Subwoofer/Satellite System • Impedance Measurement as a Tool • Practical Passive Radiators • A Symmetrical Dual Transmission Line, Pt 1 • The Microline • A Voice Coil Wheatstone Bridge • Tweeter Q Problems •

1990 Acceleration Feedback System • Cylindrical Symmetrical Guitar TLs • Compact Integrated Electrostatic TL, Pt 1-3 • Minimus-7 Super Mod • The Show (Bass Horn) • A Small Two-Way System • Helmholtz Spreadsheet • Heresy Upon a (Klipsch) Heresy • Beer Budget Window Rattler • Contact Basics • MDT Mini-Monitor Speaker System • Titanium + TPX + Polypropylene = Fidelity • Tom Holman, Skywalker, and THX, Pt 1-2 • Bud Box Enclosure • Klipschorn Throat Riddle • Modular Three-Way Active Speaker • CD Speaker System • SPEAKER DESIGNER Software • Symmetrical Isobarik • Novice Crossovers • Triamplified Modular System • Magnetic Crosstalk in Passive Crossovers • Mitey Mike Loudspeaker Tester • Symmetrical Loading for Auto Subwoofers • Improved Vented Box with Low Q_{TS} Drivers • BOXMODEL Woofer System Design Software • Four Eight By Twos • Dynaco A-25 Mod • Klipschorn Throat Revisited •

1991 Students Building Systems • Servo Subwoofers • An Apartment TL • L-R Crossover for the Swan IV • More or Less Power • New Guidelines for Vented Boxes • The Pipes • Macintosh's Wave and Sound Programs • Creating Professional Looking Grilles • Octaline Meets D'Appolito • Using Radar to Measure Drivers • Deep Bass for GMC • PSpice LF Response Calculating • Pipe and Ribbon Odyssey • The Delac S-10 • Infrared Remote Volume Control • Backloaded Wall Horn Speaker • Mod for the Minimus 7 • Simplifying Cabinet Assembly • Fibrous Effects on TLs • The DOALs • Loudspeaker Cable • Speaker to Ear Interface • Speaker Sensitivity to Errors in T/S Parameters • TL Speaker Evaluation • Cable and Sound • Kit Reports: Little V; Audio Concepts' Sub-1 •

There's More 

Please send me the following back issues of Speaker Builder

- | | | | |
|------------------------------------|------------------------------------|------------------------------------|------------------------------------|
| <input type="checkbox"/> 1994 \$32 | <input type="checkbox"/> 1993 \$25 | <input type="checkbox"/> 1992 \$25 | <input type="checkbox"/> 1991 \$25 |
| <input type="checkbox"/> 1990 \$25 | <input type="checkbox"/> 1989 \$18 | <input type="checkbox"/> 1988 \$23 | <input type="checkbox"/> 1987 \$20 |
| <input type="checkbox"/> 1986 \$20 | <input type="checkbox"/> 1984 \$18 | <input type="checkbox"/> 1983 \$18 | <input type="checkbox"/> 1982 \$18 |
| <input type="checkbox"/> 1981 \$18 | | | |

SHIPPING BACK ISSUES

UPS: Domestic ground service by value of order:
 Less than \$60.00 - \$4.50 \$131.00-220.00 - \$8.50
 \$61.00-130.00 - \$6.50 \$221.00+ - \$10.50

Canada: Add \$6.00 per year.

Foreign Air: Europe add additional 40% of total order. Total Magazines _____
 Other destinations: 50% of total order. Postage _____

Foreign Surface: Add additional 20% of total order. TOTAL ENCLOSED _____

Rates subject to change without notice. All remittance in US \$ only drawn on a US bank.

- Check or Money Order Discover MC VISA

DISCOVER/MC/VISA NO. _____

EXP. DATE _____

NAME _____

ACCOUNT NO. _____

STREET & NO. _____

CITY _____

STATE _____

ZIP _____

Speaker Builder

Post Office Box 494, Dept. B95, Peterborough, NH 03458-0494
 (603) 924-9464 FAX (603) 924-9467

Answering machine for credit card orders only—before 9:00 a.m., after 4:00 p.m. and weekends
 Please have all information plus MC/VISA available

speak, but it doesn't guarantee the right to be heard at others' expense. You pay for what you want to hear, and I'll do the same. Or, if we choose to subsidize others' interests, let's select the people and interests ourselves, rather than delegating those decisions to bureaucrats whom neither of us has ever met.

Some years ago, you appealed to readers to consider purchasing back issues of *Speaker Builder* to help the publication through some difficult times. I was happy to respond to your forthright appeal. Preserving this great magazine was and is important to me. I will happily continue to contribute to help ensure its success. I don't expect the government to subsidize my subscription, however, and I doubt that you would enjoy the strings and regulations that would accompany such funding.

Finally, as a paying customer, I'd like to see each precious column-inch of the new, downsized *Speaker Builder* dedicated to speaker building topics, rather than commentary on the "wisdom" of the powers that be in Washington. I'll look to *Speaker Builder* for speaker building wisdom and to *National Review* for political commentary.

Scott Worthington
Orem, UT 84057

Mr. Worthington proposes a fascinating new definition of legislative approval of the Federal budget. If providing money to the funding agencies for NPR and PBS constitutes "extortion," then the votes of the Congress to levy taxes for any purpose are in the same category. If I remember my Civics I class correctly, the Constitution provides the Legislative and Executive branches of the government with the power to tax, and pre-

sumably to expend those tax monies. The last time I looked, the electorate was still involved in choosing those who are in Congress and the White House. While the idea of considering those in public office as "extortionists" does have a certain appeal, taxation as extortion is a bizarre notion, and flatly at odds with

the way this federated republic was set up.

I agree with Mr. Worthington that direct citizen support of our chosen media is an excellent idea, even though I continue to believe my tax money is better spent for public TV and radio than for a great deal else the Congress chooses to fund. However, unlike

bullock and white software presents

BoxMODEL VER. 4.0

FEATURES INCLUDE:

Series and Parallel, Compound and Isobaric Designs
Sealed, Vented and Passive Radiator Systems * On-Line Help
Optimized Flat Alignments * Four Concurrent Designs
Graphics Printer Dumps, Supports Over 300 Printers
Over 1000 Driver Database File, 4" - 30" [48 Manufacturers]
Equalized Alignments Thru 8th Order * Filter Assisted Alignments
Includes Atmospheric Conditions In Design
Displays Coefficients of Transfer Function
Re-Designed User Interface * Pull-Down Menu Driven
Includes Box, Port and Absorption Losses in Analysis
Automatic File Save/Recall * DOS Real-Mode Application
Single / Multiple Port Length Calculations
Auto-Detect CGA, EGA, and VGA Display
8088-80586, No Co-Processor Required, But Recommended
Box Dimension Calculator * Fixed / Custom Ratios * Missing Dimension
Separate Graphic Traces for Box, Driver, EQ, and Loss Contributions
Toggle Between US and Metric Units
Toggle Max Power Graph based on Resistance or Impedance

GRAPHS:

Maximum SPL * Relative SPL
Voice Coil Impedance * Voice Coil Phase
Acoustic Phase Response * Group Delay
Transient Response * Driver Piston Excursion
Vent Airspeed * Passive Radiator Excursion
Maximum Input Power

\$ **59.⁹⁵**

Plus \$3.00 Shipping in USA

OLD COLONY SOUND LAB

PO Box 243, Department

Peterborough, NH 03458-0243 USA

Telephone: (603) 924-6371 or (603) 924-6526 24-Hour FAX: (603) 924-9467

Speaker Builder

1992 Rumreich on Box Design & Woofer Selection • MLSSA • Double-Chambered Reflex by Weems • Active Crossover and Delay • Electrical Circuit Bandpass Enclosure • A Dreadnaught System (satellite swivels) • Designing Real-World Two-Way Crossovers • 20-foot Ribbon Dipole Speaker • Biamping the Sapphire II • Capping Passive Crossovers • A High Quality Speaker Cabinet • 1/3-Octave Noise Source • Disappearing Loudspeaker • The A&S Soundoff Winner, Pt 1-2 • Alignment Jamming • Marc Bacon's "Danielle", Pt 1-2 • Double-Chambered Isobaric Bass • Ferguson's Pickup Installation • Electronic Counter for Coil Winding • Oakley on Speaker Placement • Making Your Room Hi-Fi, Pt 1 • More on Dust Caps • Spreadsheet for Nonoptimum Vented Box Design • Acoustic Resistance Tuned Enclosure •

1993 Wasio's IMP, Pt 1-3 • Quasi-Monotonic Vented Alignments • Making Your Room Hi-Fi, Pt 2-3 • A&S Soundoff Winner, Pt 3 • Flexible Dipole Woofer • The Simpline • Stalking F₃ • A Bi-Structural Enclosure • A Sixth-Order T/S Subwoofer Design • Speaker Enclosure Screws • Electric Bass Tri-Horn • Prism V Satellite/JBL Subwoofer, Pt 1-2 • Fitduct: Program for Designing Duct Software • Compact Coincidental Point Source Speaker • IMP: Measuring T/S Parameters • KIT REPORT: Rockford's Beginner Software/Driver Paks • SOFTWARE REPORT: Low Frequency Designer 3.01 • Three Affordable Measurement Microphones • Two Ways to Realize a Dream • Matching Driver Efficiencies • Two-Woofer Box System • Designing a Dual Voice Coil Subwoofer • SOFTWARE REPORT: Blaubox 1.2 • Tale of Three Speaker Projects • A&S Sound-off 1992 • Monolith Horn • Orbiting Satellites • Real-World Three-Way Crossovers • The Simplex • Living with a Speaker Builder • The IMP Goes MLS •

BACK ISSUES *Continued*

1994 Sanctuary Sonics • Modular Active Crossovers • A Full-Range Open-Baffle System • An Evolving Magnepan MG-1 • Low-Frequency AC-To-DC Converter • A Compact Bass Guitar Speaker • Measuring Speaker Impedance Without a Bridge • The Dynapleat • The Danielle II • The Birdhouse: A Sound-Reinforcement Subwoofer • The Linear-Array Sound System • A Revised Two-Way Minimonitor • Exploring the BUF 124 with Pspice • Signet's SL280B/U • Time Response of Crossover Filters • Converting Radio Shack's SLM To Millivolt Use • Acoustic Distortion and Balanced Speakers • Microphone Response Correction with IMP • More About the Birdhouse Bandpass • A 16Hz Subwoofer • D.H. Labs Silver Sonic Cables • The System III Loudspeaker • Exploring Loudspeaker Impedance • IMPcycling • The Linear-Array Chronicles • Book Report: Loudspeaker Recipes, Book One • The Woofer Test • A Large Ribbon You Can Build • Loudspeakers, A Short History, Pt 1-2 • Absolute SPL Sensitivity Measuring with IMP • The Damping Factor: One More Time • Cliffnotes for Loudspeaker University • Software Report: The Listening Room for Macintosh • Book Report: The Theory and Design of Loudspeaker Enclosures • A 15" Transmission Line Woofer • Inductor Coil Cross Talk • Quick Home Theater on a Budget • Silk Purses: A Two-Way Salvage Design • Audio Phase Inductor •

PRE-PUBLICATION SALE!

ANNOUNCING THE TUBE BOOK
YOU'VE BEEN ASKING FOR!

PRINCIPLES OF ELECTRON TUBES

by Herbert J. Reich

REG. PRICE **NOW**
\$34.95 **ONLY** **\$29.95!**

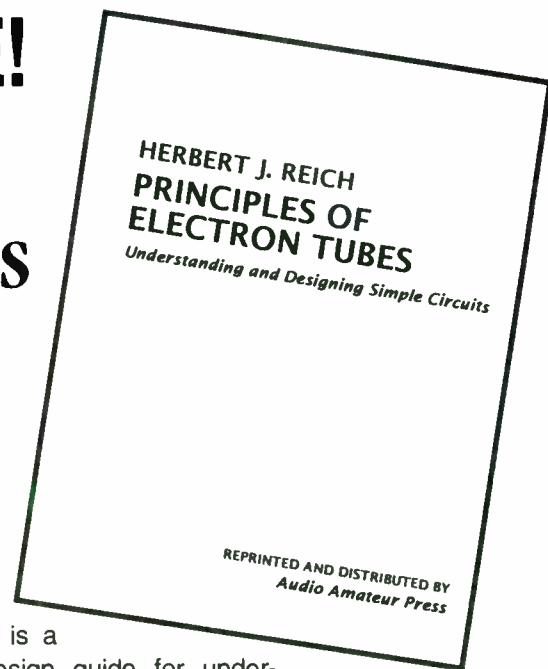

This all-time classic first appeared in 1941 as a textbook for beginners studying tubes for the very first time. University of Illinois professor Reich takes nothing for granted, beginning with the most elementary underpinnings of the tube and the physics which govern its operation.

Building on these basics, he then turns to the various elements inside the high vacuum diode, including how electrons behave, coatings and performance, the way construction affects cathodes, and the behavior of gases and getters within the bulb. Tube classifications and a short survey of typical glass and metal tube structures is also included.

From there, you get a guided tour through grid-controlled high vacuum tubes, when Reich examines the theory of grid action in triodes, electron transit time, voltage and current considerations for all forms of multi-grid tubes, and both harmonic and intermod distortion effects. Amplification is also addressed, including topologies, sample circuits, frequencies for each type, and classifications from A through AB, B, and C. Decibels and the volume unit are explained with particular clarity.

Chapter Six is a complete design guide for understanding and designing amps of all kinds, covering not only transformer considerations and other power issues, but also the analysis of amps all the way from the single device type through push-pull, AB, with a comparison of triodes and pentodes.

Other topics covered include the uses of tubes in broadcast transmission and reception; oscillation of all kinds; industrial uses for tubes; the tube as a light detector; power supplies, rectification, and voltage stabilizers; and an introduction to the use of tubes in measuring devices. More than 400 pages include the Appendix, with charts for determining reactance; decibel gain; plate characteristics; rectifier tube characteristics; and operating data for amplifier tubes. And in addition to an author index (to footnotes), subject index, and end-of-chapter questions for review, *Principles* also has a key to all electrical abbreviations and symbols used in the book.

Heavily illustrated with diagrams, drawings, graphs, photos, and charts, this incredible volume is a tremendous value that will benefit every tube aficionado!

SALE! \$29.95

IF YOU ORDER
BEFORE
PUBLICATION

SALE!

YES! PLEASE SEND ME _____ #BKAA34 @ \$29.95

FOR S/H INCLUDE: \$4 USA

\$6 OTHER SURFACE \$12 OTHER AIR

TOTAL AMOUNT OF ORDER \$ _____

NAME _____ TODAY'S DATE _____

STREET _____

CITY _____ ST _____ ZIP _____

MASTERCARD/VISA/DISCOVER _____ EXP _____
(Card not charged until shipment)

OLD COLONY SOUND LAB, PO BOX 243, DEPT. B95, PETERBOROUGH, NH 03458 USA
24-Hour Tels.: (603) 924-6526 (603) 924 6371 24-Hour Fax: (603) 924-9467

THIS OFFER EXPIRES MAY 31, 1995

Mr. Worthington, I have met quite a few of those I have voted for, and against, in the Congress. Any citizen is welcome to do the same and—most importantly—to cast an informed ballot whenever the opportunity arises. If Mr. Worthington hasn't met the folks he votes for, only one person can remedy that.

As a footnote on the "downsized" Speaker Builder, the number of pages will be exactly the same and the information delivered on each page will be the same. Only the margins will be trimmed.—E.T.D.

TAD SOURCE

I read the article in the 8/94 issue of *Speaker Builder* about horn drivers ("Round the Horn," p. 24). I have tried to find a supplier for the TAD TD2001 Compressor Driver and AX2 Horn, but I've had no luck with Madisound or Zalytron. Can anyone direct me to a vendor for these items?

Dave Deyelau
Waukesha, WI 53186

Contributing Editor Bruce Edgar responds:

You can contact Pioneer Electronics Service, 1925 Dominquez St., PO Box 1760, Long Beach, CA 90801, (310) 952-2387, for information on TAD drivers and distributors.

MORE ON COIL PLACEMENT

I thoroughly enjoyed Mark Sanfilippo's article "Inductor Coil Crosstalk" (*SB* 7/94), more

than had I performed the experiment myself. His oscilloscope waveform levels readily show how the mutual inductance coefficient M varies with coil placement. For example, in Photo 2,

$M = 4 \text{ div} : 5 \text{ div} = 0.8$
Furthermore, we learn that not only should

the coils' axes be orthogonal for minimum coupling (Photo 5), but they should also not intersect (Photo 7).

Mr. Sanfilippo's article has piqued my curiosity about two additional effects; namely, how does the mutual inductance coefficient vary with 1) inductor size (i.e., value),

SPEAKER CITY, U.S.A.

PROUD TO DISTRIBUTE
EXCLUSIVELY

vifa

in Southern California

excellence from Denmark

OTHER HIGH END LINES INCLUDE:

scan·speak

FUTAL
technologie d'avant-garde



DYNAUDIO

polydax
SPEAKER CORPORATION



1995 Catalog Now Available

Call today
to receive your copy

115 S. Victory Blvd., Burbank CA 91502
(818) 846-9921 FAX (818) 846-1009

Reader Service #27

Everything You Need To Build Awesome Enclosures!

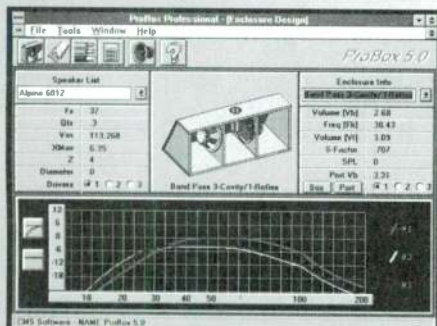

ProBox 5.0 Speaker Building Software for Windows

Calculates every practical configuration from sealed enclosures to triple-cavity iso-vent enclosures. Equipped with detailed and yet easy to read displays & full color diagrams. Multiple Box Design Viewing • Multiple Response Curves • IASCA Wire Calculator • Breakdown of Shapes & Sizes in a Cut Sheet Diagram • Database to Store Box Designs

WOODWORKING PROJECTS FOR CAR AUDIO SYSTEMS

Production Line Woodworking Skills • Five-Sided Boxes for Mini Trucks • Wood-Bending • Contouring • Tools & Their Uses (Such As Routers)



HOW TO CONSTRUCT A SPEAKER ENCLOSURE

Acoustic Theory • Formulas for Areas, Volumes, Displacements & Port Lengths • Parameters • Acoustic Suspension & Bass Reflex Enclosures



HOW TO DESIGN & BUILD EXOTIC ENCLOSURES

Isobaric, Band Pass & Iso-vent Enclosures • Best Enclosures for Particular Speaker Tuning Frequency • Vent Design • Standing Wave Modes



ProBox 5.0 Speaker Building Software \$99.95

Video Prices:

WOODWORKING PROJECTS FOR CAR AUDIO SYSTEMS \$49.95
HOW TO CONSTRUCT A SPEAKER ENCLOSURE \$49.95
HOW TO DESIGN & BUILD EXOTIC ENCLOSURES \$49.95

Special Discounted Offer!
All 3 Videos with Software **\$199⁹⁵**

TO ORDER
1-800-467-6263



National Academy of Mobile Electronics

7867 Dunbrook Road, Suite E • San Diego, CA 92126
Phone: 619-695-1784 FAX: 619-695-3864

Looking for a way to improve your image?

Try some MUSICAPs!

MUSICAP® capacitors deliver 'you are there' imaging along with exceptional dynamics, clarity and focus. Their ability to present correct timbre and depth of field along with true inter-transient silence is unequalled.

- Polypropylene film & foil construction •
- Stranded silver-plated copper leads •
- Large, 16 ga. leads on speaker caps •
 - Extremely low DA, DF and ESR •

To order contact one of the following:

- The Parts Connection 905-829-5858
- Welborne Labs 303-470-6585
- Anchor Cross Co., Tokyo, Japan 81-3-3203-5606

For international distribution contact: Gold Aero Inc. at 818-841-5541 or fax 818-842-3825

OEMs contact: Hovland Company at 209-966-4377 or fax 209-966-4632

Reader Service #73



HAVE A
TECHNICAL
QUESTION?

Send us a self-addressed stamped envelope along with a letter addressed to the editorial department (Overseas enclose 2 international postal coupons.)

and 2) signal amplitude? In other words, are the relationships linear, nonlinear, or completely independent?

Perhaps Mr. Sanfilipo would care to address this in a follow-up article.

Philip E. Bamberg
Tucson, AZ 85741

Mark Sanfilipo responds:

Owing to major constraints on my free time, I'm unable to put together a comprehensive, mathematically rigorous answer.

A simple answer is, "mutual inductance is a geometrical quantity in the sense that it depends on the sizes, shapes, and relative positions of the two inductors."

For a more developed answer, refer to a text I often use as a reference source when commencing any sort of electromagnetic analyses: Introduction to Electrodynamics by David J. Griffiths (ISBN 0-13-481367-7, Copyright 1989, Prentice-Hall, Inc.). Don't let the "Introduction" in the title fool you; this is by no means a featherweight text. It's comprehensive, mathematically rigorous, and (surprise) eminently readable. ▶



YOUR Handles • Corners
ONE Speaker Grills • Casters
SOURCE Speaker Carpet
FOR Jack Dishes • Feet • Clamps
SPEAKER Grill Cloth
CABINET Plugs & Jacks
COMPONENTS

- OVER 500 ITEMS IN STOCK FOR IMMEDIATE DELIVERY
- \$50 MINIMUM ORDER



Phone 800-291-0389
Fax (716) 892-4302



1705 Broadway
Buffalo NY 14212

Reader Service #48

Classified

TRADE

STATE OF THE ART PASSIVE CROSSOVERS. Parts and software available. Design Guide, \$2 (refundable). **ALLPASS TECHNOLOGIES, INC.,** 2844 Charmont Dr., Apopka, FL 32703-5972, (407) 786-0623.

D.H. LABS manufactures top quality audiophile hookup wires, cables and connectors for the most demanding applications. For more information and review reprints, contact us at 6633 Glenway Dr., W. Bloomfield, MI 48322, phone/FAX (801) 851-1296.

ELECTROSTATIC electronics, transformers, Mylar®, information. From author **ROGER SANDERS,** (503) 742-7640.

HIGH-END KEVLAR CONE DRIVERS AND SPEAKER PARTS. Factory direct. **SPEAKER-WORLD TECHNOLOGY,** (510) 490-5842.

FOR SALE

Antique theater system: three original RCA 7" tall bass horns, four Lansing 515C 15" drivers, two Altec multi-cells, one each Altec 288, 291 driver, great for museum, best offer, you pay shipping; Sumiko Blue Point Special, new, never out of box, \$150 or best offer. Dave Staub, (717) 854-5265 or 757-3165.

Philips CD-680X (Magnavox 473), mint with fast diodes, PP caps, separate int. analog transformer, S-I Crown DAC, "B" digital filter, Burr-Brown 2604 ICs, headphone upgrade, cap. increase 4X, perfect, \$397; Philips CDV600 laserdisc, sealed, \$699, best offer. Dave Platt, 636 Marion, Springdale, PA 15144, (412) 274-8149.

25 NOS Vitamin Q 0.22µF 400V, \$5 each or 5 for \$20; 50 0.033µF Astron, \$3 each or 10 for \$22; Peerless output transformer #15A65, \$65 or best offer. Matt, (510) 548-8736, Wed. thru Sun., 12-5 (PST).

Pair NHT Super Zero and pair Paradigm Atom speakers, used for testing purposes only, \$180 for each pair or \$350 for both. Mike McGary, 1801 Mountainbrook Dr., Huntsville, AL 35801, (205) 529-4804, after 7 p.m. (CST).

Tandberg stereo tape recorder, 7", half-track, tube, unmodified, \$125 or swap for Dyna FM3, PAS, or ST-70. Clyde Bostick, 11446 Village Brook Ct., Cincinnati, OH 45249, (513) 469-9451.

ELECTROSTATIC

~KITS~PARTS~TRADE SECRETS~
Save \$\$\$ building, repairing, modifying ESLs
SEND \$2.00 FOR CATALOG
~ DAVID LUCAS ~
924 HULTON RD., OAKMONT, PA 15139

Pair Edgar #5 horns ¾" particleboard with custom very low DCR coils 500/5,000Hz, 8Ω, \$235 plus shipping. Tom V., (206) 546-0857 (PST).

Klipsch Heresy K77M, K55V, K24K, \$150; Sequerra HF-1, extra ribbons, mint, \$350; Morel PP-8 dual voice coil woofer, \$100; AR4X cabinets, \$75; Symmetry ACS-1, \$200 EV (Tapco) two-way variable electronic crossover, \$150. Ron, (201) 543-2971, after 7 p.m.

Jensen 12" field coil woofers, \$200 each; Entec SW-1 subwoofer, \$1,000; McIntosh MR78 tuner, \$1,000; McIntosh MR71 tube tuner, \$1,000; military TV-7 tube tester, \$100; Jensen 8" Alnico full-range with Phenolic cone, \$40 each; various Western Electric, Altec speakers. Vogt, 330 SW 43rd St., #247, Renton, WA 98055, (206) 382-5571.

Dynaudio, excellent condition: pair 17M75 midranges, \$25; 30W54 woofer, \$20. Bill, (702) 385-7170.

Klangfilm horns and amps; pair Decca ribbon tweeters, \$500; pair Ionovac Ion tweeters, \$1,200; pair Westrex EL34 PPP power amps, \$3,500; EMT-930 turntable, \$3,500; Decca Decola; NOS tubes: PX-4, PX-25, Ed, E406N, E408N, RE-614, RS-241, WE300B (1950s). Jakobi, Cambridge House, Cherry Lane, Bolney, W. Sussex, RH17 5PR, England (011) 44-1444-881184, FAX (011) 44-1444-881179, daytime.

ReVox A77 two-track stereo (biased for Ampex 456), \$650; Teac A-2340 (right rear treble weak), \$250; Teac A-4010S (needs new forward-play head), \$75; old Tandberg crossfield head deck, \$125. Prices include shipping. Dave Bessey, 559 Valencia St., San Francisco, CA 94110-1114.

Two pair Satellite cabinets, 5 liter sealed, cut for 105mm tweeter and 5.25" Focal/Audax midrange, high-grade construction, \$100/pair + shipping; new Vifa D27TG/D25AG tweeters, \$37 (\$49 shipped). Phil, B.E.S.L., 9011 N. Eaglestone, Tucson, AZ 85741-9423, (602) 579-1446 (MST).

Sanders electrostatic cells, maple frames, \$250 (pick up in New Mexico); E-Stat high voltage bias, step-up transformers, Variac, \$250; four 15" polypropylene VMPS subwoofer drivers, \$75/pair; six Dynaudio 12" 30W54 drivers, \$39/pair; pair reconeable 30W54, \$15 (all \$100); Schneller Gold Guitar hardware, pickups, ebony fretboard, \$75. Daniel, (505) 783-4551.

NAD 4150 tuner, very good specs, near mint, \$100 (\$300 new); one pair each AR3a mids and tweeters, \$10 each or all for \$35. All prices plus shipping. Mike, (319) 326-7225 or (319) 391-2761 after 4 p.m. (CST).

Two toroidal transformer, secondary 35+35V AC, 625VA, \$50 each; four 3700 MF 75V DC capacitors, \$25 each. Ashby, (305) 475-5225.

Pair JBL 2235H, \$290; pair Focal 8K415, \$120; pair Dynaudio 17W75XL, \$100; pair ARIA3 cabinets, \$140. Jerry, (601) 264-6971.

"It Thinks It's A Triode"
SINGLE ENDED CLASS A MOSFET AMPLIFIER
KIT
• SIMPLE STEP-BY-STEP INSTRUCTIONS
• ALL PARTS
• MONOBLOCK
• 40 WATTS
• 450va XFMR
• DC COUPLED



BEAR Labs
4 Jennings Road Hannacroix, NY 12087
518.756.9894 FAX 518.756.3092

\$625 each

Pair Celestion SL-6S, \$25; pair NHT Super Zero, \$160; pair Paradigm Titan, \$160; pair AR Connoisseur 20 8" p-p, \$60; pair STC660 4" p-p, \$35; pair AR-11 ¾", \$25; pair AR-3a ¾", \$25; pair Radio Shack 1022 4", \$16; pair Peerless TP-165F 6½", \$25. Shipping extra. George, (216) 586-6707.

Scan-Speak: four 21W/8554 8" Kevlar woofers, \$70 each; four 13M/8636 5" Kevlar midranges, \$125/pair; pair 25W/8561 10" woofers, \$130; four JBL 117H-1 8" woofers, factory sealed, \$45 each; pair AudioQuest Livewire Red 10awg speaker 10' cables, \$40. Clay Jordan, PO Box 491071, Atlanta, GA 30349, (404) 969-8319.

Drivers & enclosures: drivers from Focal, Cabasse, Scan-Speak, SEAS, Peerless and more; boxes for ARIA 10, Cabasse ARIA 7, and the SW8 woofer. All new, used only for design and test, priced to sell. Send SASE for complete list. Joe D'Appolito, 9 W. Knoll Rd., Andover, MA 01810.

PS magnetic phono record preamp, outboard, RFI suppression, subsonic filter, Class A, Linear 16 discrete transistors, passive RIAA equalization, non-ringing, THD=.025%, bandwidth=550kHz min, overload=190-430mV RMS, Sn ratio=80-87dB, RIAA accuracy=.1dB, like new, instructions and shipping, \$99. Frank H., (908) 449-9097.

Proac Response 3 speakers, rosewood, *Stereophile* recommended Class B, mint, \$4,495 (\$7,000 new); Theta Pro Gen V, upgradeable DAC, \$3,895 (\$5,600 new); PS Audio 200cx amp, *Stereophile* recommended Class B, 400W/channel into 4Ω, \$895 (\$2,000 new). All prices include shipping. Art, phone/FAX (410) 529-7207.

WANTED

Would like to purchase copies of *L'Audiophile*, please advise issues and price; copies of projects in *Les Haut-Parleur* by Jean Hiraga for tapered quarter wave tube (TQWT) and various Onken enclosures, will pay for copying and handling. Dave Sutton, 4802 Austria, St. Louis, MO 63116-1008, (314) 353-8443.

Desperate for plans of KRC model X-15 enclosure (Karlson). Fabreguettes R-E, Lot Pré Vesca, 0500 Rambaud, France.

CLASSIFIED

INFORMATION

Four types of Classified Advertising are available in *Speaker Builder*:

FOR SALE: For readers to sell personal equipment or supplies.

WANTED: Help readers find equipment or services.

TRADE: For any business or private party selling equipment, supplies or services for profit.

CLUBS: Aid readers in starting a club or finding new members.

PRICING

All advertising is \$1.50 per word, \$10 minimum per insertion. Deduct 5% for an 8x contract. Please indicate number of insertions. Payment **MUST** accompany ad. *No billing for word classified advertising.*

AD COPY

A word is any collection of letters or numbers with a space on either side. No abbreviations; please spell out all words. Count words, not letters. Ad copy should be clearly typed or printed. Illegible ads will be discarded.

SUBSCRIBERS

Receive *free For Sale, Wanted, and Club* advertising; 50 words maximum; each additional word just \$.20. Please only one ad per category, per issue.

Please include your name, address, and telephone number. If **TRADE** please indicate number of insertions on the ad. All free ads are run only once, then discarded. Ad questions, copy and copy changes cannot and will not be answered on the phone. All correspondence must be in writing addressed to:

Speaker Builder

Classified Department

PO Box 494

Peterborough, NH 03458-0494

Service/repair manual for Advent model 300 receiver, mine has blown outputs, also upgrade and improvement tips. Neil Laffoon, 1301 Franklin Dr., Paragould, AR 72450, (501) 239-5378.

Tube hi-fi, theater amps/preamps and speakers: Altec, Jensen, McIntosh, Marantz, Craftsman, Dynaco, Heath, Eico, etc. **SUNSHINE SOUNDS**, (405) 737-3312.

Advent MPR-1 microphone preamp or Gloeckler update, must be in good working condition. Please send details. Richard Brown, 539 Willow Tree Lane, Rochester Hills, MI 48306.

Altec 411-8A15" woofer, will supply shipping carton if needed. R. K. Fullmer, 2566 Tuxedo Way, Sandy, UT, 84093, (801) 467-4206 days or (801) 943-7186 nights.

Heathkit IM distortion analyzer. Bob, (602) 458-6072.

CLUBS

OUTPUT TRANSFORMERS: THE LAST FRONTIER? Hobbyist seeks people interested in OPT design and building. I would like to network a critical mass of people together on this topic for strictly non-commercial interest. Possibly write a GA article/create a club newsletter? M.A. Martin, (416) 968-6101, monty@camtwh.eric.on.ca.

WANTED: "CRADLE-TO-GRAVE" AUDIO ENTHUSIASTS. Texas doesn't have an audio club; YET! If you're interested in audio reproduction on stage and in your home, let's get together. Rick, (915) 676-7360.

SPEAKER BUILDER SEEKS OTHER LONG ISLAND/WESTCHESTER COUNTY AUDIO ENTHUSIASTS for the purpose of forming a club for the exchange of ideas, advice, etc. Publio Morera, (516) 868-8863, evenings.

AUDIOPHILES IN THE LAS VEGAS AREA interested in exchanging information, please contact Tarcisio Valente, (702) 435-7451.

WANTED: SPEAKER AND AUDIO AMATEURS IN THE BRADENTON/SARASOTA/ST. PETERSBURG/TAMPA, FL AREAS. Would like to form a club and develop a lab for testing speakers/amps/preamps and passive and active crossovers or just to discuss speaker projects and ideas. Angel Rivera, Bradenton, FL 34206, (813) 792-3870.

WANTED: SPEAKER/TUBE GEAR BUILDERS AND AUDIO AMATEURS IN SANTIAGO, CHILE. Would like to form a club or just a friendly group of audio enthusiasts to discuss speakers/amps/preamps/crossovers and everything. Anyone interested, contact Christian Bargsted, Los Gomereros 1542, Vitacura, Santiago or call (011) 562-538-0638, office hours.

ARIZONA AUDIOPHILE SOCIETY located in metropolitan Phoenix is a growing and active club in the pursuit and reproduction of recorded music. New members are welcome. Meetings are last Tuesday of each month. Receive monthly newsletter and club discounts with local high-end audio dealers. Send inquiry to Arizona Audiophile Society, PO Box 13058, Scottsdale, AZ 85267, or call Bob Williams, (602) 944-5929.

VINTAGE AUDIO LISTENERS AND VALVE ENTHUSIASTS (VALVE) meets the first Sunday of every month to swap vintage audio gear, audition rare and collectible equipment, and evaluate modifications and scratchbuilt projects. Dues provide a monthly newsletter with current reviews of vintage components and modification information; vintage service data; and access to an active network of serious collectors. For information, call (206) 697-1936 or write to 1127 NW Brite Star Ln., Poulsbo, WA 98370.

THE CATSKILL AND ADIRONDACK AUDIO SOCIETY invites you to our informal meeting. Join our friendly group of audio enthusiasts as we discuss life, the universe and everything! Toobers, Tranzzeestors, vinyl canyons, or digital dots. No matter what your level of interest, experience, or preferences, you are welcome. Contact CAAS at (518) 756-9894 (leave message) or PO Box 144, Hannacroix, NY 12087.

200+ page catalog & design manual featuring schematics, kits & parts for doing your own thing. Active crossovers, amps, preamps, power supplies, ac line conditioners & other high quality kits. We've got the best components & many more, including: Hovland MusiCap, Solen, MIT MultiCap, Kimber Kap, Wonder Cap, Siemens, Wima & others; Caddock, Resista, Holco, & Mills resistors; Kimber, Cardas, DH Labs, Vampire, plus many other lines of connectors, wire, & cables. We sell all kinds of tubes & semi's, & we have the glue for your projects like design & PCB layout software, circuit boards & chemicals, solder, screws, terminals, chassis, transformers, dampening material, books, & more. Send \$12 US & Canada, \$16 overseas for this one of a kind catalog or fax with Visa/Mastercard to: P.O. Box 260198, Littleton, CO 80126 USA
Phone: 303-470-6585 Fax: 303-791-5783

Welborne Labs

THE ATLANTA AUDIO SOCIETY, Inc. — Open to persons who share a common interest in the art and science of audio and music. Activities include construction projects, equipment and recording evaluations, home theater, video, film, live music and recording sessions. Monthly meetings and seminars often include prominent speakers from the industry. Newsletters and bulletins regularly published. John Morrison, Pres., (404) 491-1553, or Chuck Bruce, (404) 876-5659, 4266 Roswell Rd. N.E., K-4, Atlanta, GA 30342-3738.

AUDIO SOCIETY OF MINNESOTA. Meeting the hobbyist needs of audiophiles in the Land of 10,000 Lakes for 16 years! Monthly meetings (Sept.-May), tours, audiophile concerts, special guests, technical assistance, etc. For information and a copy of our latest monthly Bulletin, write ASM, PO Box 32293, Fridley, MN 55432, or call our 24-hour "Audio Hotline," (612) 825-6806.

THE AUDIO SYNDROME, Nassau and Suffolk county's oldest group of audiophiles is looking for new members. If you are interested, call Roy Harris, (516) 489-9576.

WEST VALLEY AUDIO SOCIETY is a group interested in all aspects of high-performance audio. We are located in the west San Fernando Valley, CA and look forward to hearing from interested audiophiles. Call Barry Kohan, (818) 225-1341.

MONTREAL SPEAKER BUILDER CLUB. Meets when it can, BYOB, discussions range from speaker design and testing to equipment modification. All welcome. Contact Andrew McCrae, 4701 Jeanne Mance, Montreal, PQ, H2V 4J5 Canada, (514) 281-7954.

MEMPHIS AREA AUDIO SOCIETY being formed. Serious audiophiles contact J.J. McBride, 8182 Wind Valley Cove, Memphis, TN 38125, (901) 756-6831.

THE COLORADO AUDIO SOCIETY (CAS) is a group of audio enthusiasts dedicated to the pursuit of music and audiophile arts in the Rocky Mountain region. We offer a comprehensive annual journal, five newsletters, plus participation in meetings and lectures. For more information, send SASE to CAS, 1941 S. Grant St., Denver, CO 80210, (303) 733-1613.

THE NEWLY FORMED CHICAGO AUDIO SOCIETY invites all audiophiles to attend its meetings. For details and meeting location, please call Brian at (708) 382-8433 or Pat at (708) 582-3913 evenings; E-mail to sysop@nybble.com or u24129@uicvm.uic.edu. Space is limited.

GREATER SOUTH BAY AUDIOPHILE SOCIETY (Los Angeles/Orange County area) is entering its second year of existence and is welcoming new members to the more than 50 who are already enjoying its benefits. Our meetings, held every six weeks, and our newsletter, *theEarful*, cover topics on do-it-yourself tweaks and mods, music articles, equipment reviews, manufacturer's demos, and much more. Contact Larry Fisher at (310) 599-6579 or Dave Clark at (310) 427-4207.

THE BOSTON AUDIO SOCIETY, the nation's oldest (founded 1972), seeks new members. Dues include the monthly meeting notice and our newsletter, the *BAS Speaker* (6/year). Recent issues cover Carver, a/d/s; the founder of Tech Hi-Fi, Photo CD. Plus visits from famous speaker designers, listening tests, measurement clinics, research investigations, and more. Back volumes available. Membership includes engineers, journalists, consultants, and music-loving audiophiles like yourself. For information write to PO Box 211, Boston, MA 02126-0002.

EXPERIENCE



the low-frequency performance of **TC SOUNDS** underhung motor drivers with more than 1" linear travel! 10", 12", 15" available.

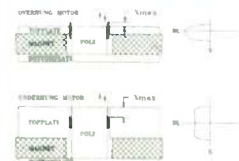

	TC15" SVC	TC12" SVC	TC10" SVC
Fs (Hz)	15.6	19.9	19.5
Vas (liters)	1039	310	174
Qts	.31	.28	.23
Xmax (mm, p-p, eff.)	28	28	28
SPL (dB)	93.0	91.2	89.2

Call (619) 622-1212 or Fax (619) 622-9293

SPEAKER BUILDER CLASSIFIED ORDER FORM

TRADE— for any business or private party, selling equipment, supplies, or services **FOR PROFIT. FOR SALE**— to sell *personal* equipment or supplies. **WANTED**— to find *personal* equipment, supplies, or services. **CLUBS**— to help readers start and maintain club membership.

PRICE: All ads are \$1.50 per word. Deduct 5% for an 8X contract. \$10 minimum per insertion. Payment must accompany ad.

FREE ADS: Subscribers receive free For Sale, Wanted and Club ads up to 50 words. Over 50 words .20 per word, \$10 minimum. Name, address and phone number must be included with ads.

SUBMITTING COPY: A word is any collection of letters or numbers with a space on either side. Copy must be clearly typed or printed. *Illegible ads will be discarded.* Submit copy by mail, fax, or data transfer (ASCII, WordPerfect 5.0 or 5.1, Word for Windows, Word for DOS, Windows Write, or Word Star 3.3- 5.5 formats)

QUESTIONS? Write or fax us at the address below.

For Sale Wanted Club Trade, No. of insertions _____

USE BLOCK LETTERS IF PRINTING. NO ABBREVIATIONS.

1	2	3	4	5
6	7	8	9	10
11	12	13	14	15
16	17	18	19	20
21	22	23	24	25
26	27	28	29	30
31	32	33	34	35
36	37	38	39	40
41	42	43	44	45
46	47	48	49	50

Please charge to my: DISCOVER MASTERCARD VISA

CARD NUMBER

EXP. DATE

CHECK/MONEY ORDER ENCLOSED

Subscription Account Number:

A □ □ □ □ □ □ □ □

NAME

COMPANY

STREET & NO.

CITY

STATE

ZIP

PHONE

AAP, Inc. — Classified Dept.

FAX 603-924-9467

PO Box 494, Peterborough, NH 03458

Data 603-924-6230

Premium Grade Parts

Don't Pay More!

Absolutely the best selection of audiophile grade parts at fair prices! Extensive deep in stock inventory featuring these vendors and many more. Free catalog! MIT MULTICAP... better selection than any other source! WONDER CAP, SOLEN, SCR, REL-CAP, NICHICON MUSE, BLACK GATE, ELNA, CADDOCK, VISHAY, MILLS, HOLCO, RESISTA, Dale, TKD, ALPS, NOBLE, Elma, Shalco, EAR DEFLEX PANELS - ultimate in speaker enclosure damping! CARDAS, KIMBER, ACROTECH, & pure silver chassis wires, HIFRED diodes, SOLO foil inductors, all types of audio connectors, silver contact toggle & rotary switches, stepped attenuator kits, hospital grade plugs, tubes, tools, IC's, super selection of damping materials & feet. International/overseas orders are especially welcome! Phone (415) 669-7181 or fax (415) 669-7558 for a catalog.

Michael Percy, Box 526, Inverness, CA 94937

CONNECTICUT AUDIO SOCIETY is an active and growing club with activities covering many facets of audio—including construction, subjective testing, and tours of local manufacturers. New members are always welcome. For a copy of our current newsletter and an invitation to our next meeting, write to: Richard Thompson, 129 Newgate Rd., E. Granby, CT 06026, (203) 653-7873.

TUBE AUDIO ENTHUSIASTS. Northern California club meets every other month. For next meeting announcement send #10 SASE to John Atwood, 65 Washington St., Suite 137, Santa Clara, CA 95050, FAX (408) 985-2006.

PACIFICNORTHWEST AUDIO SOCIETY (PAS) consists of 40 audio enthusiasts meeting monthly, second Wednesdays, 7:30 to 9:30 p.m., 4545 Island Crest Way, Mercer Island, WA. Write Box 435, Mercer Island, WA 98040 or call Ed Yang, (206) 232-6466, or Gill Loring, (206) 937-4705.

THE LOS ANGELES AREA LOUDSPEAKERS DESIGNERS GROUP. If you're just starting out or an experienced builder and would like to share ideas on speaker design and listen to each other's latest creations, give us a call. Geoffrey, (213) 965-0449 or Eduard, (310) 395-5196.

ESL BUILDERS GROUP is a new address for people who have built or want to build electrostatic loudspeakers and associated (tube) drivers, or are just interested. An answer is ensured, if you include some kind of compensation for postage and handling. Write to: Gunter Roehricht, Bühlerstr. 21, 71034 Böblingen, Germany.

PIEDMONT AUDIO SOCIETY in the Raleigh/Durham and Chapel Hill area is meeting monthly to listen to music, demonstrate owner-built and modified equipment, and exchange views and ideas on electronics and speaker construction. Tube and solid-state electronics are of interest and all levels of experience are welcome. Kevin Carter, 1004 Olive Chapel Rd., Apex, NC 27502, (919) 387-0911.

THE HI-FI CLUB in Cape Town, South Africa sends a monthly newsletter to its members and world-wide subscribers. Ask for an evaluation copy of our next newsletter, write to PO Box 18262, Wynberg 7824, South Africa or FAX (011) 27-21-7618862. We'll be pleased to hear from you.

LONDON LIVE DIY HI-FI CIRCLE meets quarterly in London, England. Our agenda is a broad one, including any aspect of audio design and construction. Subscription newsletter. We welcome all, from novice to expert, in free association. Contact Brian Stenning, UK, (011) 44-81-748-7489.

WASATCH AUDIO, located in Salt Lake City. Our club is interested in construction, modifications, design, and listening to music. We are looking for members and ideas for our new club. Edward Aho, (801) 364-4204.

THE PRAIRIE STATE AUDIO CONSTRUCTION SOCIETY (PSACS) meets every other month. Meetings feature audio construction, design, and analyses, blind listening tests, equipment clinics, auto sound, lectures from manufacturers and reviewers. PSACS, 20 Wildwood Tr., Cary, IL, 60013, or call Tom, (708) 248-3377 days, (708) 516-0170 eves.

THE WESTERN NEW YORK AUDIO SOCIETY was established in 1984 for the purpose of offering those people interested in the hobbies of music appreciation, stereo components, etc. the opportunity to meet other individuals who share similar interests. For further information regarding our organization, please write to The Western NY Audio Society, PO Box 312, N. Tonawanda, NY 14150, Atten: Denny Fritz.

WASHINGTON, D.C. AREA HORN ENTHUSIASTS GROUP now forming. If you're interested in horn loudspeakers and live in the Washington, D.C. area, we want to talk to you. Please call Dirk Wright, (703) 471-8657, or John Hanley, (703) 425-7482. Our ears are tuned to the clear dynamics of horn loudspeakers.

NEW JERSEY AUDIO SOCIETY meets eight times a year. Emphasis is on extracting the best sound per dollar spent from your audio system. Dues include subscription to our newsletter, *The Source*, published four to six times yearly. Meetings focus on enjoying the hardware as well as the software. Contact Frank J. Alles, 209 Second St., Middlesex, NJ 08846, (908) 424-0463, or Valerie Kurlychek, (908) 206-0924.

SOUTHEASTERN MICHIGAN WOOFER AND TWEETER MARCHING SOCIETY (SMWTMS). Detroit area audio construction club. Meetings every two months featuring serious lectures, design analyses, digital audio, AB listening tests, equipment clinics, and audio fun. Club publication, *LC, The SMWTMS Network*, journals the club's activities and members' thoughts on audio. For information, send name and address: E-mail aa259@detroit.freenet.org; phone (810) 544-8453 (machine); SMWTMS, PO Box 721464, Berkley, MI 48072-0464.

HI-FI COLLECTOR/HOBBYIST seeks audio penpals to correspond via reel-to-reel tape. If you are into restorations, discarding old recorders, or parting out derelict gear, or have arcane technical secrets you'd like to discuss, or just want an excuse to obsess over Mylar, make it so. I'll return all tapes via parcel post. James Addison, 171 Hartford Rd., A-7, New Britain, CT 06053.

Ad Index

ADVERTISER	PAGE	ADVERTISER	PAGE
A & S Speakers	13	<i>Principles of Electron Tubes</i>	64
ACI	56	Orca Design & Manufacturing	
Acoustical Supply International	6	Axon Caps	33
Allison Technology Corp.	27	Cabasse	CV2
Alpha-Core Inc.	52	Parts Connection, The	57
Bozak Audio Laboratories	60	Parts Express International, Inc.	CV3
Cubicon Corporation	54	RDL Acoustics	41
Decade Engineering	58	Sescom, Inc.	56
<i>Elektor Electronics</i>	36	Solen Inc.	35
Forgings Industrial Co.	11	Speaker City, U.S.A.	65
Harris Technologies	60	Speaker Works	61
HeadRoom Corp.	37	Speaker Workshop	39
<i>Hi-Fi News & Record Review</i>	42	Speakers Etc.	58
<i>Hi-Fi World Audio Publishing</i>	38	Sussex Technical Corp.	53
Hovland Co.	66	Synergetic Audio Concepts	59
Image Communications	49	TCH Umbra	66
JBL Professional	21	Technologie MDB	61
Liberty Instruments, Inc.	51	TIFF Electronics	3
LinearX Systems, Inc.	4	USAFoam	59
Madisound		Versa-Tronics, Inc.	17
April Showers Sale	31	Welbome Labs	29
Deflex Acoustic Panel Technology	19	Zalytron Industries Corp.	25
Mahogany Sound	56	CLASSIFIEDS	
Markertek Video Supply	30	BEAR Labs	67
MCM Electronics	43	David Lucas, Inc.	67
Meniscus	55	Michael Percy	70
MIT Electronic Components	51	TC Sounds	69
Morel Acoustics	CV4	Welbome Labs	68
Mouser Electronics	50	GOOD NEWS/NEW PRODUCTS	
National Academy of Mobile Electronics	65	Analogue Devices, Inc.	3
Newform Research, Inc.	55	Colorado Audio Society	3
Old Colony Sound Lab		Parasound Products, Inc.	3
BoxModel Software	63	Schuller International	3
<i>Complete Guide to High End Audio, The</i>	38	Synergetic Audio Concepts	3
New Products	45-46		

Get Serious!

Parts Express is serious about providing the novice, as well as the advanced speaker builder, with some of the finest components and accessories currently available for loudspeaker construction. Raw drivers, enclosure resonance damping material, port tubes, spikes, 14-20 gauge inductors, polypropylene capacitors, power resistors, loudspeaker design software, audio test equipment, and too many other items to possibly list here, are available to you at very reasonable prices! We stock every item we advertise and most orders are shipped within 24 hours of placement. Our technical support staff can help the novice builder select the best drivers for a particular application, choose appropriate enclosure volumes and even help calculate crossover values. So call now for your copy of our free 212 page catalog and get serious about speaker building!

FREE



LEAP NOW AVAILABLE!!! Parts Express is proud to announce that we are now a U.S. distributor for the most advanced loudspeaker design software currently available ... LEAP Version 4.5 (Loudspeaker Enclosure Analysis Program) and the LMS (Loudspeaker Measurement System). Call for more information on these and other exciting new products from Linear X!



Parts Express™

CALL TOLL FREE

1-800-338-0531

CATALOG



Made
in
England

High-Tech Audiophile Loudspeakers

For Further Information Please Contact: **morel acoustics USA**

414 Harvard Street
Brookline, MA 02146
Tel: (617) 277-6663
FAX: (617) 277-2415

World Radio History



Typical Double Magnet Woofer Cross Section

Reader Service #