

VALVE

Brainiac on load impedance
and triode operating points

Blues Master corrections

Meatloaf - an ineXpensive
94dB speaker recipe

hotrodding the FM-3

a visit with Brian Sowter



Crazy Eric's plan for vintage Xtasy - a pair of Western Electric 60A PP 205D amps and complementary WE meter panel, in a custom built mahogany console which hides the CD player and preamp. Speakers are 600 ohm Jensen coax units, in vintage Altec cabinets. Photo by Tom Vetromile.

S.E.X. or Afterglow?

Lately it's been brought to our attention that we really haven't described the virtues of Afterglow, e.g., why buy it when you can get S.E.X. for half as much?

S.E.X. was designed to give a basic taste of SE to folks who have never heard it. The fact that it has replaced kit amps costing twice as much in many listener's systems suggests that it may in fact be a bit more than the "hor's d'oeuvre" we intended to design two years ago.

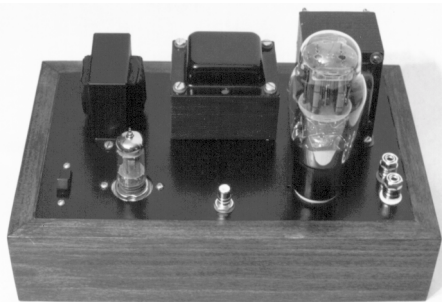

Afterglow kit, pair of monoblocks, \$850 coming soon - Paraglow - parafeed Afterglow!

And thus we had created a fine entry level amp for those contemplating the change to Single Ended. So, when we set out to design Afterglow, it was decided to create an amp kit incorporating our proven "bang for the buck" construction techniques, using existing tooling from the S.E.X. kit, to make an amp that would take on not only the kits, but all those chi-chi boutique "hand built" amps you read about in other publications, at a fraction of the price. We achieved this and then some, with a brilliant, elegant direct coupled 2A3 design by John Tucker that incorporates constant current sources from John Camille, components with names like Vishay/Dale and Ohmite, and at it's heart, Mike LaFevre's MagneQuest power and output transformers, all for a price that gets you mere bargain line components from other manufacturers.

The value of that design expertise alone should make these amps worth three times the price - but each of these brilliant designers wanted to work on a project which would show that knowledge can always beat money when it comes to creating arresting transients, stunning midrange, and emotive realism, so they enthusiastically brought us elegant, economical solutions.

You're going to see a lot of new amps come in from the boutique manufacturers in the next few months, at price points obviously intended to compete with Afterglow. We suggest you look closely at their design - some will try to dazzle with a fancy chassis and fall short on the parts quality. Some may try to copy us, maybe even using parts that we introduced with the help of MagneQuest. But frankly, even with that effort to 'borrow' our sound, they will still be eating our dust. *None of them will copy the experience that went into the design, none will copy the sound.*

An impression from one of Afterglow's toughest critics - contributing designer Mike LaFevre: *"While at the VSAC 97 conference I recall how awesomely struck I was with the sound quality of Schmalles Afterglow amp. This was an amp that uses our MagneQuest TFA 204 airgapped output trans, so it is a thoroughly conventional politically correct output stage morphology- but the front end had the first generation active loading. The subjective result was I never, never, never, knew (or even suspected) that my TFA 204 could play the kind of quality deep bass that I was hearing. There's gotta be something to the active loading- I too was suspicious when first hearing about the "active load" and thought, aw great, more of that mid eighties constipated overly regulated sterile sounding shit - instead, I ate my cigar!!! It's good- really good.*

I'm intrigued with the "active loading" concepts and developments based on the quality of what I heard out at VSAC. Truth be told Schmalles Afterglow and his VV52 parafeed were the sonic winners by far, nothing else came close."

Electronic Tonalities

P.O. Box 2786, Poulsbo, WA 98370 360-697-1936

Decisions, decisions...

When offered the opportunity to remaster *Jazz at the Pawnshop*, one of the most well recorded jazz albums ever, we decided to use the highest quality techniques available.

We decided to put the information from the master tape onto the glass stamper used to replicate the CD in a single generation. Most engineers use up to five generations.

We decided to demand the lowest Block Error Rate (a measure of the accuracy of the digital information) ever produced when we replicated it on CD, 1/20 the error of a typical CD.

And we decided to do all this in two exceptional formats:

XRCD with 20 bit K2 super coding

JVC's revolutionary Extended Resolution format, which draws the ultimate performance from a CD player using the current CD standard.

gold SUPER HDCD (24 bit 88.2kHz)

Mastered in the superb 24 bit 88.2kHz configuration, by one of the world's best mastering engineers, Paul Stubblebine.

Which one should you buy?

We'll leave that decision up to you.

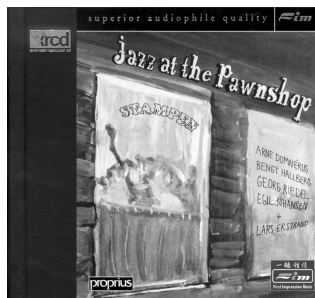

Jazz at the Pawnshop, Vol. 1&2
FIM XRCD 012 - 013

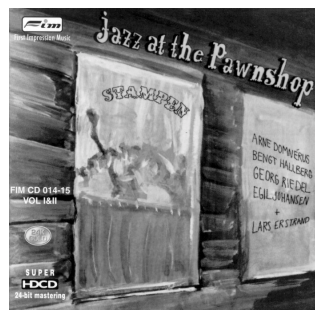

Jazz at the Pawnshop, Vol. 1&2
gold SUPER HDCD format
FIM CD 014 - 015

XRCD is a registered trademark of JVC
HDCD is a registered trademark of Pacific Microsonic, Inc.



#189 16149 Redmond Way
Redmond, WA 98052
Tel: 425-868-5326
Fax: 425-836-9061
<http://www.fimpression.com>

ordering online? Gill Loring, The Cellaret, toring@gte.net (888-877-9192)

VALVE

the monthly magazine
of eXtreme audio

© 1998, Electronic Tonalities/VALVE

Editor and Publisher

Dan "Dr. Bottlehead" Schmalte
Chief Administrator

"Queen Eileen" Schmalte
Resident Smart Guy and Technical Editor
Paul "Braniac" Joppa

Resident Hot Iron and Dr. B's Bodyguard
John "Smoothplate" Tucker
Big gun OEM advisor

Michael "Airgap" LaFevre
Contributing Editors

David "Full Track" Dintenfuss
"Crazy Eric" Lenius

Our mailing address:

VALVE

P.O. Box 2786

Poulsbo, WA 98370

by phone: 360-697-1936

business hours: 9-4:30 PT, Mon -Fri

technical queries: Thurs. 12-4:30 PT

fax: 360-697-3348

NEW e-mail - bottlehead@silverlink.net

Membership/Subscriptions:

\$25.00 per year (12 issues)

Foreign Subscriptions:

\$35.00 per year (12 issues)

*Please make checks payable to VALVE
MC/VISA/AMEX/DISC accepted*

VALVE in no way assumes responsibility for anyone harming themselves through exposure to the contents of this magazine. We believe electrons flow from minus to plus, and that they can kill you along the way if you're not careful. Vacuum tube audio equipment operates at potentially lethal voltages. Always treat it with respect.

Many ideas published in this magazine are untried, and involve the use of potentially dangerous parts and tools. In attempting any idea or project published herein, you assume total responsibility for your actions and any harm caused to yourself or others.

No part of this publication may be reproduced in any form without permission of the publisher. Copyright violators will be aggressively pursued to the full extent of international law.



editor's thing

Thanks to all of you who offered kinds words regarding the Blues Master project. I won't lie and say that was an easy article to write!

Now of course, we find ourselves at the "errors and omissions" stage of the project. This month we start the process of design refinement that I hope will continue in the form of submissions by our readers.

Several brave souls have already begun collecting parts for the project, so we hope to see a few of these babies at VSAC 98.

Please read our first set of corrections (to the more glaring errors, sheesh!) in this issue.

I was taken to task by many folks for my shoddy treatment of the calculation of the VV32BC operating point, and so I thought this would be a great time to start Paul's three part series on the subject. I was also trounced soundly for accidentally leaving a grid resistor on the output tube of the direct coupled amplifier. As someone told me a while back, you need a thick skin if you want to publish a magazine.

Oh well, the most important part of my job is to get you guys thinking. Judging by your response, I got a rise, so I don't feel so bad... (sniff)

On to another topic, this is truly a sad one. Lynn Olson forwarded a message to me from Takuji Yamamoto a few weeks ago: On his way home from a party given by MJ magazine, Nobu Shiseido collapsed and quickly slipped away from us.

Along with designing the radical, elegant Wavac amplifiers, Shiseido san was revered by the Japanese audio community for sharing his efforts to make "non audio approved" DHT's like 808s sound beautiful.

Shiseido san was also one of the Japanese audiophiles who pioneered in efforts to share the concepts of the Japanese audiophile movement with Americans. I am told by Takuji Yamamoto that only an hour before his passing, Shiseido san was discussing with Sakuma san plans for many more concerts and demonstrations in the U.S.

Our heartfelt condolences go out to the family and friends of Shiseido san. He will be sorely missed.

Doc B.

Blues Master erratica

Output tube grid resistor

OK, OK you can all stop telling me I don't need a grid resistor on a direct coupled output grid.

I really do know that, but I had designed the Blues Master as an RC coupled amp originally, and somehow that grid resistor managed to stay in the circuit after it got changed to direct coupled. Leave it out if you build this puppy.

Paul nicely summed up the errors we've found so far-

"Dear Dan-

I'm sure you knew, I would not be able to resist picking some nits on the Blues Master circuit. First, though, I want to say "Thanks!" for putting so much detail on the line. And it looks like a very promising circuit, incorporating many new features that have been demonstrated recently to be of value. Hope someone builds one for VSAC!

OK, now for the nitpicking:

1) Let me clarify my rules of thumb (in the "matching to the output load" section). The plate resistance does not change much with operating point (one-third power of plate current). My recommendation was that plate voltage / plate current = 5 times plate resistance. Here I meant to calculate the plate voltage and/or current (which you can choose) as a function of plate resistance (relatively fixed), not the other way around. In the end, that's what you did, but your words suggested that plate resistance might be an effect, not a cause.

According to the spec sheet, the 6V32 has 600 ohms plate resistance at 110 mA. Taking the cube root of 110/80 and multiplying by 600, I estimate 667 ohms at 80mA. Five times that is 3336 which should be volts/amps. Since current is 80mA, the voltage should be $3336 \times 0.08 = 267v$, and the load should be $3 \times 667 = 2000$ ohms.

Fortunately, my newer rule of thumb is that, if R0 is volts/amps then load should be $R0 \times 2 \times$ plate resistance. Skipping the arithmetic, I get 350v which is not too awful far from the 410v you have.

(OK, gosh darn it, I'm publishing your operating point article in this issue!)

(Continued on page 17)

Back Issues

Back issues are printed to order - please allow two weeks for delivery - add \$5 postage for orders outside the US

Volume 1 - 1994 issues - \$20

a Williamson amp; Dyna Stereo 70 mod bakeoff; converting the Stereo 70 to 6GH8's; a QUAD system; triode input Dyna MkIII; MkIII vertical tasting; smoothing impedance curves; Altec A7; Ampexes Nagras and ribbon mikes; Triophoni, a 6CK4 amp; audio at the 1939 World's Fair; books for collectors and builders; V.T. vs. R.M.A. cross reference; FM tuner tube substitutions; Big Mac attack - the MI200; 6L6 shootout; a vintage "audessey"; more FM tuner mods; vintage radio mods; Heathkit rectifiers; PAS heater mod.

Volume 2 - 1995 issues - \$20

Rectifier shootout, tube vs. solid; FM 1000 recap and meters; single ended 10 amp; triode output W-4; Optimus 990 - speaker for SE?; star grounds; tuner shootout; Living Stereo, vinyl or CD?; World Audio SE integrated; firin' up - smoke checking; Brook 12A schematic; 6C33 vs. 3C33; Heathkit power transformers; 6B4's + MagneQuest = SEcstasy; W5 mods; triode operating points; Dyna restorations; Marantz 7,8 and Scott LK150 impressions; hackable vintage gear; Quasimodo - PP 805 amp; restoring a Scott 340 in 75 minutes; a dream system for 78's; cartridges and styli for 78's; Restoring a Lowther, Part 1&2; easy tube CD output hack; 6ER5 phono preamp; 304TL & 450TH SE operating points; hypothetical DC ESL amps.

Volume 3 - 1996 - \$25:

Single Watt, Single Tube, Single Ended, an amp for Lowthers; the Vintage Speaker Shootout of 1996, QUAD vs. Lowther, vs. A7; the Voigt Loudspeaker, the Single Ended experimenter's kit; cathode coupled SE 6AS7 amp; how to build the Superwhamodyne; refoaming AR woofers; mesh plate tubes; rebuilding QUADS; QUAD amp filter surgery; single gain stage amps; the Brooklet, and Brookson, choke loaded PP 6080 amps; transformer coupled PP 6DN7 amp; the Iron Maiden; Building the Lowther Club Medalion; the TQWT, a tapered pipe enclosure; IT 300B amp.

Volume 4 - 1997 - \$25:

the Whampipe/Hyperwhamodyne; weird interconnects; winding your own SE output transformer; Tapered Quarter Wave Tubes; battery bias; onetuber 417A and 437A amps; DAC attack; 6BL7/211 SE amp; pro sound speakers at AES; 46 plate curves; what's all this about parallel feed?; parafeed line stage; C.W. horn divided by two; Svetlana meets Brooklyn; parallel feed SE 811A amp; parafeed 2A3 amp; Lowther fixes; Altec vs. the competition; VSAC 97 program guide; VSAC 97 photos; Andy Bartha's cool speaker cables; Paul Joppa's 6DN7 driver stage; S.E.X. kit schematic revealed; an Edgarhorn builder's story; direct coupled active loaded parafeed 45 amp; Brainiac's S.E.X. changes; VSAC 97 seminar notes; tweaking the one tube 6DN7 amp, Lowther drivers, and the Wright preamp; 300B S.E.X. amp conversion; mini monitor for 300B amps,

Load impedance and operating points for single-ended triode amplifier stages

Part One: What's Really Going On Here?

by Paul Joppa

As long-time readers might remember, I wrote on this subject some time ago (VALVE v2 n5). This series of articles is the result of some further thinking and analyses, which I presented in somewhat rougher form at the VSAC 97 seminars. In Part 1, I will outline the approach and make some observations on how load lines relate to tube voltages and currents. In Part 2 I will present an analysis of highly linear triodes, including my rules of thumb for a pretty good starting point design for most triode amplifiers. Finally in Part 3 I will discuss the more difficult problem of nonlinear triodes, including a proposed new nonlinearity parameter and some tables and graphs that provide a good estimate of performance.

The first order of business is to look at operating points and load lines. I will do this graphically, mostly because I'm more used to looking at the pictures than reading the articles. The plots shown here illustrate how the tube operates into a resistive load, and are the usual starting point for tube circuit design. The object of this exercise is to understand qualitatively the physics behind selection of operating points. Numerical details will be developed in Parts 2 and 3.

Figure 1

On a graph of plate voltage (E_b) and current

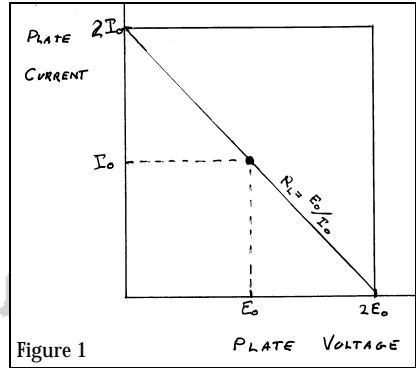

Figure 1

(Ib), suppose you choose some operating point (E_0, I_0). If you don't know anything except E_0 and I_0 , you can still make some estimate of the performance. The smallest voltage you could generate is zero, so the largest must be the same amount in the positive direction, or $2E_0$. Similarly, the most current you can swing must be 0 to $2I_0$. Think of this as a box that defines the operating region. The resistive load that gets the most power out of this box goes from $E = 0, I = 2I_0$ to $E = 2E_0, I = 0$. So the first guess for a plate load impedance is $R_0 = 2E_0 / 2I_0 = E_0 / I_0$. In fact, you could stop here and just use this load; it's often close enough to the optimum anyhow. If you could actually drive the tube to the ends of this line, you would find a maximum sine-wave output of $0.5E_b \cdot I_b$. Since the plate dissipation PD is $E_b \cdot I_b$, the efficiency is 50%. This is the highest efficiency you can theoretically get with Class A operation.

Figure 2

Now a word about choosing that operating point. The output power is proportional to the

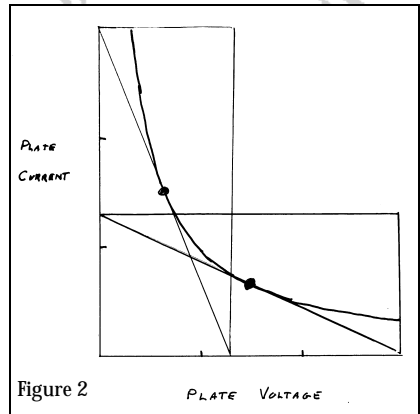

Figure 2

plate dissipation $PD = E_o \cdot I_o$. Therefore, to get the most power out, you want to set the operating point somewhere along the line of maximum plate dissipation, $I_o = PD/E_o$.

Figure 3

Usually there are some other constraints on where you can place the operating point along

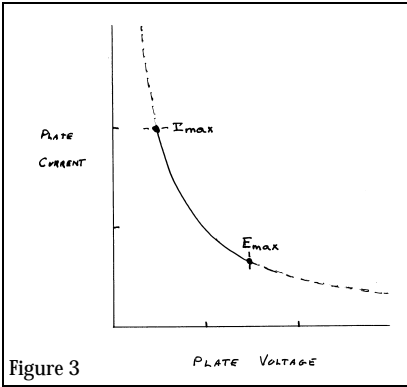

Figure 3

the PD line. There will be a maximum plate current and/or voltage. The operating point will have to be less than the maximum continuous current or voltage, and if there are also instantaneous limits then the operating box will have to stay within them. This confines the operating point to a certain region of the max-dissipation line.

Figure 4

Usually, there is also a sort of triangular region of high current and low plate voltage that you want to avoid. Here are three possible reasons

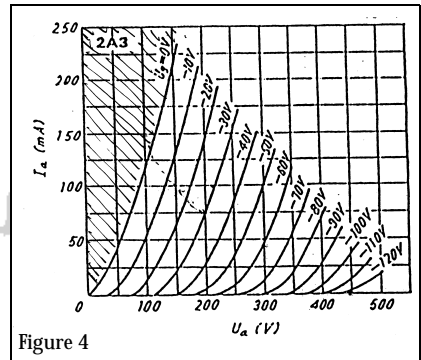

Figure 4

for this:

- Triode operation in Class A1 is limited to operation to the right of the zero-grid-voltage line. This avoids grid current, allowing the grid to be driven from a high impedance source, plus since the grid is not acting as a rectifier, it can also be driven through a capacitor without shifting the operating point.

Figure 5

- Even for triodes in Class A2, grid current can become excessive if the grid is more positive than the plate. This marks off a similar but narrower region on the left side of the plot. (It is especially narrow for high- μ tubes,

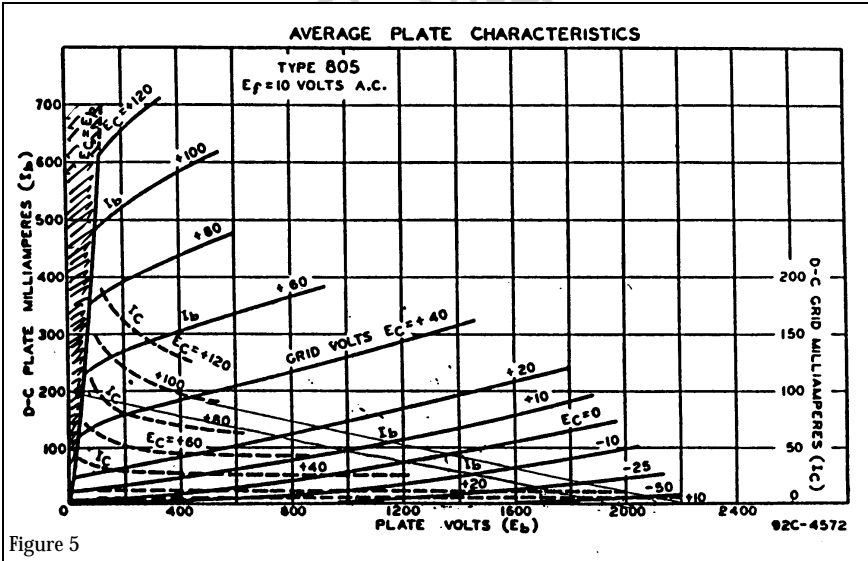

Figure 5

Parallel Feeders, Get Busy!

For 45, 71A, 417A/5842, 6CK4, 6DN7

- Brooklyn BCP 15 40H 50mA plate loading choke, \$50
- MagneQuest EXO-45 (5K:8ohm) or EXO-46 (5K:16 ohm) parallel feed output transformer, Permalloy version, \$135 (as used in last month's 45 parallel feed article)
- 2 watts maximum output

For 2A3, 6A3, 6B4

- MagneQuest EXO-03 30H 60mA plate loading choke, \$65
- MagneQuest EXO-04 50H 60mA plate loading choke, \$99
- MagneQuest EXO-36 (2.5K:8 ohm) or EXO-35 (2.5K:16 ohm) parallel feed output transformer, Permalloy version \$135
- 3 watts maximum output

For 300B, VV300B, VV32B

- MagneQuest EXO-04 50H 60mA plate loading choke, \$99
- NEW - MagneQuest B.A.C. 50H 80mA plate loading choke, \$149
- MagneQuest TFA-2004 (3K:4,8,16 ohms) parallel feed output transformer, M4 version \$175, special edition Pin-stripe M6/Permalloy/solid brass bell ends version, \$250, Permalloy/ solid brass ends version \$300
- 12 watts maximum output.

And don't forget the Brooklyn B7 parallel feed line stage transformer, now available in 5K, 8K, and 15K primary, to 500 ohm secondary versions - \$99 all Permalloy version, and matching BCP 14 plate load choke, 100H, 10mA, \$45.

Call 360-697-1936 and ask for Doc B. for more info.

ELECTRONIC TONALITIES THE PARALLEL FEED AUTHORITY

P.O.Box 2786, Poulsbo, WA 98370

which is why Class A2 tubes often have high μ even though lower μ might allow lower plate resistance.)

Figure 6

- Pentodes also have a region near the left edge where operation is nonlinear and screen grid current is excessive.

Figure 7

In all of these cases, the left edge of the operating box must be moved away from the axis so that

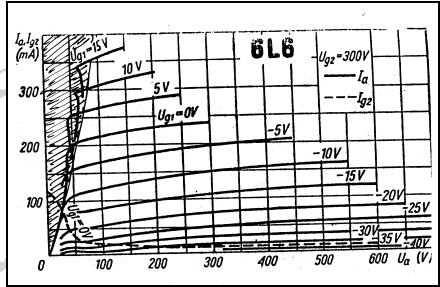

the top left corner is clear of the region. Since undistorted output is symmetrical about the operating point, the right side also moves in, so the load resistance for maximum power is lower.

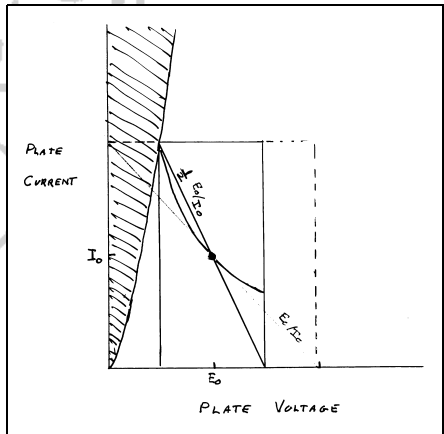

The maximum power is also lower for the same operating point, so the efficiency is reduced. For example, the most common operating point for Class A1 triodes is from $0.5E_0$ to $1.5E_0$ with a load impedance of $0.5E_0/I_0 = 0.5R_0$ and an efficiency around 25%.

Figure 8

To get the most efficiency with this constraint you want a wide, short operating box, so the optimum here is with E_0 set at the maximum continuous value. As will be shown later, there

are some problems with going too high, especially for the less linear triodes, but overall

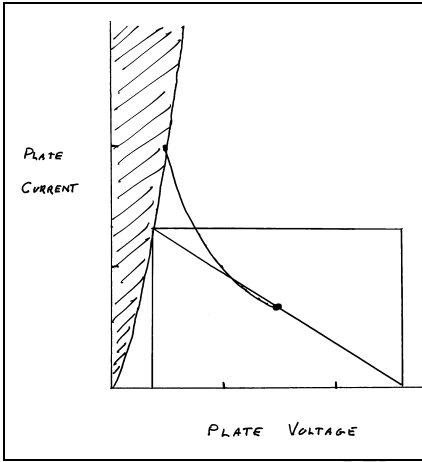

the conclusions so far will be seen to hold up pretty well - you get the best efficiency at high voltage and low current, and the load resistance depends on E_o/I_o rather than plate resistance as is often claimed.

Next issue:

- *Paul continues his examination of operating points*
- *Alan Douglas examines the accuracy of some of the more popular tube testers*
- *Eric Barbour builds a preamp based on the Svetlana 572-10*
- *and lots more!*

now available from

ELECTRONIC TONALITIES

Big Stud Binding Posts



Here's the story-

While looking for a quality binding post for the Afterglow

kit, we stumbled across a gorgeous no-name binding post, distributed by a major electronics house. These babies are a beefy 9/16" thick, gold plated with a knurled 'set screw' type clamping action and they take spade lugs, BIG wire, and banana plugs beautifully, far better than the spendy posts we were using on our prototypes. Unfortunately, the mounting hardware that comes with these big posts just plain won't work, the posts will just spin in the mounting holes. So we redesigned the mounting setup with some new parts, and made these into the nicest posts we've ever used. Requires 1/2" mounting holes.

JENA LABS.

Big Studs - \$16.00 the pair
Jena Hook-Up 18 ga.

Ultra-copper 127 strand ultra-high purity linear crystal super annealed wire. Low-loss polyethylene insulator with excellent mechanical damping.

We sold out our stock of this neat wire the first month, but more is on it's way! 6 feet will completely redo a pair of S.E.X. amps. Great for preamps, speakers, even power cords.

Jena 18ga. wire - \$6.00 per foot

360-697-1936 to order

meatloaf

*An inexpensive,
simple
speaker recipe
that will get better
with time, the
perfect complement
to that leftover
Dyna amp
or Fisher receiver.
Add your own
special ingredients
and send us
your version
of the recipe!*

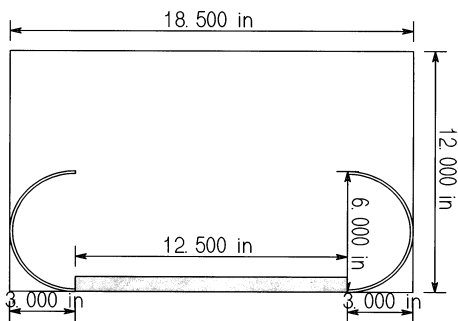

top view

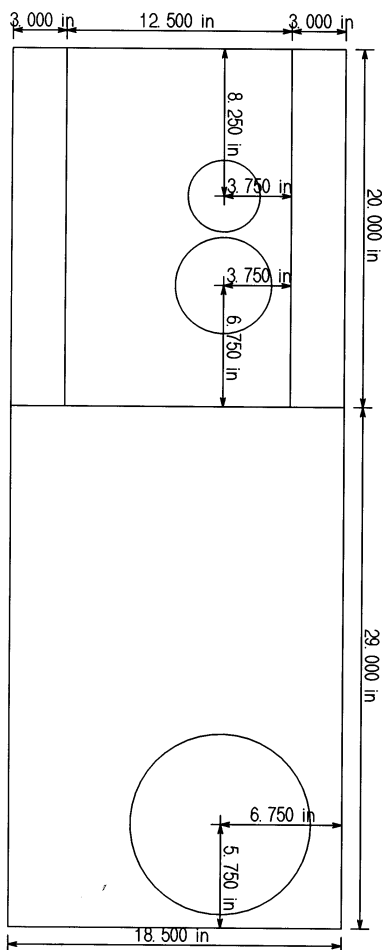

front view

What's that? Too much complicated amp stuff and not enough other interesting, simple stuff in VALVE lately?

OK, here's an idea to try.

Note that this is another one of these crazy projects I dream up on paper, but don't have time to build, so no guarantee *what* the result will be! Let's dream up a budget speaker, no complicated cabinets, minimal materials, and decent efficiency. You build it, tweak it, and send us your improved recipe to publish in VALVE.

After some plowing through the catalogs, here's what I came up with for a 94dB, 36Hz - 20kHz pair of speakers to fool with for around \$150:

Woofers

I started by looking at the amazing 10" el cheapo woofer (MCM 55-945) we use in the Hyperwhamodyne subwoofer.

Shoving the T-S parameters into a couple of shareware speaker box design programs yielded vented boxes that would give a 96 dB efficiency down to about 28Hz.

But damn, that box needs to be around 5 cubic feet! (with a 4.42" long, 4" i.d. vent, in case you are inclined to try it) This thing would end up being roughly the size of a Lowther Medalion, not what I have in mind as a compact, cost effective box.

A little more digging turned up MCM PN 55-1250, a 10", 94 dB driver with a price of \$18.95.

The few Thiel-Small parameters listed are as follows:

Fs	28Hz
Qts	.58
Vas	3.7 cu.ft.

Plugging these numbers into the computer gives a very flat vented box response down to 20Hz - zowie- into a 20 cubic foot box!

Luckily this driver has a fairly high Qts, so I decided to give it a shot in a sealed configuration, and got a very nice result, a 2.6 cubic foot sealed box with a -3dB point of 36 Hz, system Q, .9, alpha, 1.408, and resonant frequency, 43.4 Hz.

These box programs all squirt out arbitrary cabinet dimensions too, usually based on golden section ratios of one kind or another. This particular program said to try 27.66" high x 17.09" wide x 10.56" deep, which leaves a little extra volume allowance for internal braces. Two cabinets in these dimensions should come out of a single sheet of MDF with some planning.

We'll borrow a little design philosophy from good bud Lynn Olson, and mount the drivers

very close to the floor, to aid coupling.

Midrange

My past experience tells me a 10" woofer is not going to do a very good job up in the midrange, so I'll bite the bullet and figure to make this design a three way.

While the general rules of diffraction loss imply that we could run our woofer well above 1 kHz before beaming becomes a problem, the other consideration to keep in mind is that we don't really want to hand the music over from one driver to another in the critical 1kHz region where our ears are so sensitive.

If we can find a smaller, lighter mass midrange that will work down to 100-300 Hz, we should be better off in this respect.

We also want this midrange driver to work well above this critical 1kHz region, so that we may cross it over to a tweeter at some point above the dead center of the midband.

Finding an inexpensive driver that specs suitably was a bit of a challenge. I decided to spec MCM PN LSC120-F070, an odd 5" driver with a whizzer, rated 94 dB, 90Hz-18kHz, that is displayed in the catalog with a response curve that looks fairly smooth from about 250Hz to 6 or 7 kHz, in spite of the whizzer cone. The best part is that it only costs \$5.66!

Lets cross this puppy over to the woofer at around 300Hz. We can't see the response of the driver much below this point in the published curve, so we'll have to assume it's fairly OK down to the 90Hz -3dB point. Yes, more shoddy assumptions by Doc B., but you guys shouldn't be shy about buying a \$6 midrange and testing its response for yourself now, should you?

Tweeter

The tweeter that catches my eye is MCM PN 53-525, a 1" silk dome model rated 94dB, 2 Khz - 20 kHz, that claims very smooth response, at a bargain price of \$9.99. Let's figure to sort of split the difference of the 6kHz or so upper rolloff of the midrange, and the 2kHz lower limit of this tweeter and try crossing them over at 4 kHz.

Crossovers

Now I'm not so daft as to think that I can design a proper crossover without actually building this thing.

But we can come up with a place to start. The simplest place to start would be first order crossovers at 300Hz and 4 kHz.

In choosing this type of setup I am not allowing for dips and peaks these particular drivers

may exhibit, odd rolloffs, diffraction loss, non linear tweeter excursion, interaction between the two crossovers, etc, etc.

For some insight into serious crossover design check out Lynn Olson's Ariel webpage - lots of interesting concepts regarding crossover design, and how to compensate for various problems you may encounter when tweaking up a new crossover.

For our simple crossover I'll spec a 5 mfd cap on the tweeter and 0.31mH choke on the midrange for a 1st order 4 kHz crossover, and a 66mfd cap on the midrange and a 4.2 mH choke on the woofer for a 300 Hz first order crossover.

I'd prefer oily caps for the tweeter. Try All Electronics (1-800-826-5432) for surplus oil cap finds, or Mouser (1-800-346-6873) for current production C-D oil and poly caps.

Finding a cheap and effective 66 mfd cap for the midrange/woofer crossover I will leave to you. The Axon caps in the MCM catalog look like they might be a reasonable choice.

As for coils, the Solo or Goertz copper foil inductors are great. If you want to go cheaper, try an aircore choke on the mid and a bobbin or bar core type on the woofer. Try to shoot for low DCR, we are trying to build a relatively efficient speaker, after all. No sense pissing power away in the coil of our inductors.

Beyond this, you must listen before you decide what changes to make. A Zobel may be effective on any of the drivers, parallel resistors may smooth impedance hiccups, and shifting the cap values down (higher Fc) and choke values up (lower Fc) may give a better sense of integration and tonal balance.

Higher order crossovers may well be necessary to get everything "just right". Only building and listening will tell.

Da' Box

Let's be a little unconventional, it's way more fun!

Our woofer box will be about 18.5" wide, 12" deep, and 29" tall if we use the golden section numbers from our box design software. We could mount the driver on the 12" wide face, but let's put it on the 18.5" face instead, as close to the bottom as possible, and centered 4/11 of the way, or 6.75" on center, in from one side. Make the two boxes mirror images, and brace them well internally at staggered positions. Line them with the damping material of your choice, Dynamat, felt carpet padding, real (\$\$!) wool felt, etc.

Set that driver flush with the front baffle, and seal it tight!

Now for the midrange and tweeter, let's go

crazy and mount them on a open baffle the width of the bass bin.

We want our tweeter sitting about 38-42" above the floor, and we want our midrange very close beneath it.

We want both drivers off center, preferably by our old friend the golden section proportions, or maybe 4/11 of the baffle height down from the top, and 4/11 of the baffle width in from the side of the baffle.

We also want some kind of curved or angled edges to our baffle to minimize diffraction problems. Lets make the baffle 20.5 inches tall (so the entire speaker will be 49.5 inches tall) and 12.5 inches wide, with a nice 3" radius to the two side edges made from a 20.5" length of 6" Sonotube cut in half lengthwise.

We'll mount the drivers in from one side 6.75" on centers, like the woofer, which puts them in 3.75" on centers from the edge of the flat panel. Do these panels in mirror image, left and right, like the woofers.

The tweeter should sit 8.25 inches on center down from the top.

The baffle should probably be made nice and stiff, with good 1x2 on edge bracing behind it, or use double 3/4" MDF, maybe even with sand filling between the panels. Mount the drivers flush with the baffle face.

Cover the back of the baffle with felt carpet pad or real wool felt, and mount it rigidly, and so that the front face sits even with the front face of the woofer box.

Finishing up

This is a budget deal, so wire the tweeter with 22 ga. solid wire, the midrange with 18 ga. solid wire, and the woofer with 16 ga. solid.

Or try unrolling a Solo inductor and using the foil as driver wiring. Don't ask me how to attach it, you figure it out!

Keep the crossover components out where you can play with them - if somebody really builds this thing they will undoubtedly have some changes to suggest.

And for crying out loud, put a decent finish on the project, even if it's flat black paint. Try the faux granite finishes- they hide a multitude of sins.

-B.

souped up FM-3

by Doc B. and Buddha

Man, it's been a long time since we did one of those "tweak a vintage classic" kinda articles. See, I was talking to Buddha last month, and saying how I had a few Dynaco FM-3s around that my bud John Carey had left, for us to develop a mod with, yes, yet another project I might never get to before I die.

I always thought the fact that these are good, if not great tube tuners, in plentiful (read cheap) supply made them great candidates for a serious upgrade.

And then Buddha tells me he has this hotrod FM-3 that he's been playing with.

Now if you don't know Buddha's background, he used to do electronics stuff of the kind he can't talk about to this day. Suffice it to say the guy knows more than a little bit about building hypertweaked electronics stuff that has to be dead nuts reliable whether it's sitting in the jungle or next to your homebuilt RFI spewing PC.

So we get talking about the existing FM-3 articles, a few of which have appeared over the years in TAA and GA. There are some choice tweaks in there, most notably a recommendation by James Lin to replace the "PECs" with discrete components and a nice tweak to a choke on the multiplex board by David Berning, but nothing of what I'd call the *serious* kind of tweak.

We talked a bit about some really serious hacks (which we'll share with you over the next few months) and agreed that you might as well start at the front end and work your way right on out to the output jacks.

Hack one - RF stage

The first problem with the FM-3 is that its sensitivity sucks. Local stations come in fine, but you can forget finding that puny ass little college jazz station 30 miles across the hills and valleys from your house.

First thing to do (right after getting as good an antenna as you can find) is to replace the grungy antenna input screws with something new and clean. You should also clean the threaded terminal pins, no sense loosing signal to crappy connectors. If you are going to use 75 ohm cable exclu-

sively, you might want to junk the terminal strip altogether and replace it with an F connector.

After you do this, you will probably want to clean the old flux off the circuit boards, too. Mine looked like hell.

Now you are ready to work on the actual RF stage. Here is what Buddha faxed me a couple of days later :

Hi Dan,

Here is a first gouge at souping up the FM-3 front end. My VHF signal generator is down for a \$300 reference oscillator, so numbers are pretty rough. Putting a 6DJ8 in the RF slot and converting to cascode gives a 15-20 dB gain over the 6AQ8. The stage appears stable so far, however it is far from optimized since the plate load is so low. Several trial low power stations around here are now full quieting whereas before they were pretty noisy on the scope. Also my IF strip was marginally stable and went into oscillation on strong stations. It took four shields across each tube socket, eight feedthru caps, and several dozen .01 caps to make the IF stable. Lots of other IF mods so far, but they are pretty elaborate. The front end mod requires only two cuts on the circuit board and a few parts. It may get you enough gain to pick up those jazz stations.

John

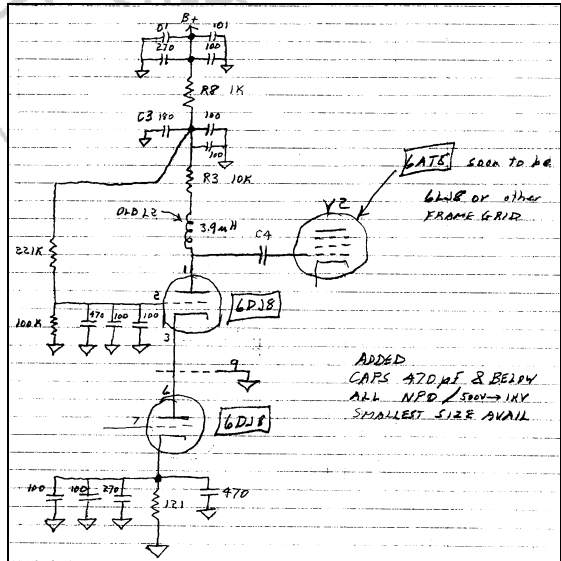



Welborne Labs

THE GATEKEEPER

ac line conditioner kit

At Welborne Labs we have applied a unique technique to EMI/RFI suppression in AC line conditioning. This new technique results in a more reliable AC filter network that is less susceptible to source and load changes thereby providing a line conditioner that won't squash dynamics or fail to filter unwanted noise.

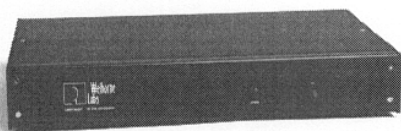

The GateKeeper™ is designed to effectively attenuate ac line noise for all types of audio equipment. The design features surge suppression circuitry, a heavy gauge power cord, LED indicator on the input side and consists of a two section filter.

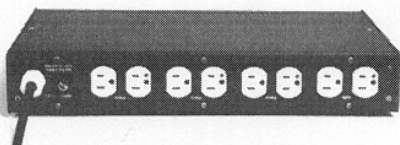

The GateKeeper™ has 8 outlets: two of which are dedicated for digital equipment and six for analog components. The digital equipment outputs possess an additional filter network which prevent digital clock noise from traveling back through the ac line conditioner and corrupting other audio circuits. The GateKeeper™ is housed in a standard 17" width chassis with black textured finish and is sold assembled or in kit form. It is available with your choice of "specification grade" or "hospital grade" outlets and a new version is now available that includes our Softstart circuit. The Softstart provides turn-on surge protection for the analog outlets. Great for pwr amps.

Valve Subscriber Price

	Retail	Valve Subscriber Price
Gatekeeper Kit with Specification Grade Outlets	\$249.00	\$219.00
Gatekeeper Kit with Hospital Grade Outlets	\$299.00	\$265.00
Gatekeeper/Softstart Kit with Specification Grade Outlets	\$329.00	\$290.00
Gatekeeper/Softstart Kit with Hospital Grade Outlets	\$379.00	\$339.00

contact: Welborne Labs

P.O. Box 260198 Littleton, CO 80126 USA

PH: 303.470.6585 Fax: 303.791.5783 E-Mail: wlabs@ix.netcom.com

a little journey to the home of Brian Sowter

by Paul Joppa

I was in England last year on business, and took the opportunity to visit Brian Sowter in Winchester. Sowter Transformers have had an excellent reputation among the professional audio crowd for many years, so I was pretty excited. Much of the early work with nickel and other exotic core materials was done by Brian's father, Dr. G. A. V. Sowter, in the late forties and early fifties. They are still, along with Jensen, among the premier suppliers of microphone and other studio transformers. I arranged a pub lunch with Brian. What follows are my notes on our discussion.

The business started in the 30's making fur coats(!). As WWII approached, it was either shells or transformers; they chose transformers, partly because the sewing machines could be modified to coil winding machines. Dr. Sowter had been working with magnetic alloys in the telephone business for some years; about this time he joined the firm as a consultant to help with transformer design. Several family members have been involved over the years. Today the firm is 3 directors (Brian, the factory manager, and the artist widow of a cousin who used to run the business) and 7 employees. The factory is in Ipswich and is managed by a former winder who worked his way up.

Brian worked for IBM for many years doing circuit design, including the well known 3279 color monitor, which was one of the very first. He took early retirement 4 years ago and took over the family business for his father, 93 years old at the time. Dr. Sowter is now 97 but remains active. In fact, he still keeps his original design books; Brian and the factory have the only copies. Many part numbers are based on these books, e.g. part # 3575 is simply "book 35, page 75." Right now, Brian is trying to bring some automation into the business, with increased use of PC's including a significant part of the custom design work.

Much of the basic design is coded in Lotus spreadsheets, though every design gets some further tweaking and fine tuning after the initial calculations are done. His father had a lot of rules of thumb, such as "an air gap will reduce the permeability to 1/4"; "over design by a factor of 2 to 4 gives a reliable design", etc.

Typical design for chokes and SE outputs uses about half the B-H curve for the DC operating point, i.e. 0.7 Tesla out for the 1.4 available

before saturation with M6 iron laminations. Design is based on a nominal permeability which is conservative by as much as 2-3 times relative to that under ideal conditions.

Nickel cores have been a specialty since the early work in the forties, primarily due to Dr. Sowter's expertise in magnetic alloys. Today they use a great deal of mu-metal, an alloy composed of around 80% nickel and 20% iron. It's expensive, but worth it for audio transformers.

Many of their transformers are a combination of nickel and M6 silicon steel laminations. This combination keeps the performance up at low levels (nickel) while retaining good high level performance (M6). They have some empirical designs that have worked well, but there's a need for more experimentation to refine the design process. It is very difficult to punch the laminations without burrs; the punch parts are very expensive. This is important to prevent premature saturation in the burr parts, which increases distortion. They looked into laser cutting recently, especially for nickel (mu metal) sheets for larger sizes, but it has proved impractical.

Almost all transformers they make currently are E-I laminations (there are a few E-E and other variants). C-cores and toroid cores are available in the industry but have not been explored extensively.

Air gaps are usually a single layer of 50 micron (0.002) inch tape over the ends of the lamination stack which is then clamped and tightened. Sometimes more than one layer of tape is used. It is important to account for flux fringing around the gap, especially when the gap is small.

They generally split the windings with two chamber bobbins, which reduces the stray capacitance with little other effect. [I think this is particularly relevant for balanced and push-pull type designs.]

3/4 of their gross comes from the studio business. One interesting recent example was a split power supply choke for a major mixing board - it handles 100A each leg (!) and uses a 24 layer winding. Their most popular single unit is the 3575, a 10K:10K bridging/isolation transformer widely used to solve grounding and hum problems in studios, with instrument amps, etc. Another popular unit, flexible and with extremely good performance, is the 4656, 600:600:600:600 ohms quadrifilar wound.

There's a lot of demand for choke input power supply filters lately; those require a larger choke than cap input filters to handle the substantial AC as well as the DC. An advantage not widely appreciated is that they eliminate the big startup transients on the power line which capacitor filters produce, which, though not much enforced, are illegal in Britain.

hey Doc, where's the parafeed kits?

Coming soon:

ParaS.E.X. - S.E.X. goes parafeed, for the same price! That's right, state of the art design in the best deal in kit amps - wider frequency response and more power - 4+ watts into as low as 4 ohms. (Whamo owners, take note) Sure, we'll have retrofits for you current S.E.X. owners.

Paraglow - a parallel feed version of Afterglow, using MagneQuest parafeed plate chokes and output transformers.

Paradigm - You supply the 45's, we supply everything else to build the killer 45 amp published in Nov. 97 VALVE.

Paradox - No 45's? Build a 6CK4 SE with the same basic kit!

Parapotato - Paul Joppa's oft imitated 417A "one tuber" goes parafeed!

Paramount - Hey, after designing the Blues Master, you didn't think we'd forget to put out a 300B kit based on the design, did ya? This one is so new we don't even have a power transformer designed yet, but we hope to have a prototype ready for VSAC '98.

Electronic Tonalities

The 300B transformer was described as "quite oversized". The recently introduced interstage transformers are very conservative also, using only 15% of the saturation flux at rated conditions. The Art Audio amplifier I saw elsewhere in England used Sowter 300B output with VV30s and produced 13 watts. Brian noted that it is extremely well-built, especially mechanically. It sounded awfully good driving \$40,000 worth of full range horn speakers!

Brian worked closely with Morgan Jones a few years ago to develop their Ortofon phono cartridge transformer (Jones is an ex-BBC engineer, he has a book out). The design is heavily optimized for uniform group delay and waveform preservation for sharp transients. A great deal of experimenting was done to achieve this after the basic design was worked out; he seemed quite proud of this accomplishment.

He has also worked with Richard Salter at Celtic Design (see the AES paper) on transformers for electrostatic speakers. Salter has developed a speaker that improves on the QUAD-63 concentric ring approach. It is designed for very low drive impedance (Krells, not 300Bs!) to run at mid and high frequencies. Brian thinks this guy really understands the physics and electronics, more than most in the field.

VSAC 98

It's official, we're doing it again! the Vacuum State of the Art Conference and Show will happen August 21 thru 24 this year, once again at the Silverdale Hotel.

Exhibitors, attendees, make your reservations with us early this year, as we expect things to fill up fast.

We'll have lots of new exhibitors coming, another great lineup of seminars, a special day for manufacturers and the press, and I am currently auditioning a few of the awesome blues bands from the Northwest for a special show.

Kickin' yourself for missing VSAC 97? Miss VSAC 98 and you'll want to die! Call us for more info - 360-697-1936.

(Continued from page 5)

2) The driver operating point should have the same analysis. Of course, with an active load, the effective load impedance is very high, so my rules of thumb are not quite appropriate. But just to check, you have 200v and 10mA, ratio is 20,000. The plate resistance of a 6BN4 is 5400 ohms at 9mA, for a ratio of slightly less than 4. Personally, I'd drop the current to 8mA to be sure of getting plenty of drive voltage, though the high load impedance does provide an extra margin so 10mA is probably OK.

3) Your cathode bypass formula is a little conservative, in my opinion. For -3dB at frequency F, I use $325,000/FRk$. However, this is relative to what Rk would be if the grid were grounded.

In this case, grid bias is 80v at 80mA, so the "normal" cathode resistor would be 1000 ohms and the bypass would be 65uF at 5Hz. Not far from what you wound up with, but from a different formula.

4) Coupling cap for parafeed value: I think you have to use the reactance frequency chart in a little more detailed way, though it also gives very nearly the same result as you obtained. First, find the frequency at which the 50H choke has a 3000 ohm impedance (the load impedance). I get 9.55 Hz. Now you can find the cap that resonates with 50H at 9.55Hz, which is about 5.6uF. As long as the output transformer inductance is larger than 50H, this is a good minimum value.

5) I think you already know, you don't need a grid resistor for a direct-coupled grid! (*Cripes, cut me some slack guys! - B.*)

6) In the power supply, under "hooking it all together", you connected the VV32 filament center tap to ground (wrong!), not to the cathode resistor (right!) as on the schematic.

-Paul

In fact we have since found out (thanks to Mike Conny) that the 5V winding of the Hammond power trans mentioned does not even have a center tap, so folks will need to use a 50 ohm wirewound pot across the filaments, with the center tap tied to the top of the cathode resistor, as a hum balance adjustment. I would add to these observations that it seems we cannot necessarily eliminate the cathode bypass capacitor at the cathode (filament) of the VV32. John Carey and Jim Flowers have

confirmed that leaving it out can cause some tilting of low frequency square waves and reduced low frequency response, just as in a conventional setup. I suggest experimenting with this idea both ways before making a decision to leave the cathode bypass cap out. One reader was concerned about the use of the Hammond power transformer into a full wave bridge, as the secondary would see 1.2kV peaks, and he was told the maximum rating of Hammond power transformers is 800V. I checked with (Hammond distributor) Ron Welborne about this, to which he replied:

"Why would Hammond design a transformer that couldn't be used full wave? In fact in their catalog they have application notes for all the different rectification/filter configurations and nowhere are there disclaimers for any specific transformers. All of their power trans are hipot tested to 2000V."

Alan Douglas adds the following observations in a recent letter:

"Now there's a class act: every publisher gets behind schedule at one point or another, and every one gets out of it, if at all, by printing a "combined issue" with perhaps an extra page or two. But I've never seen a publisher print two complete issues with full editorial content. Wow."

Alan then pointed out the same bad logic in my determination of an operating point as Paul, Ron, and a few others, and then continues:

"The power supply in issue 2 has a serious problem. the Hexfreds have a peak reverse rating of 1200 volts, and have very little safety margin. 850Vrms is about 1200V peak, and one suspects that before the damper tube warms up, and with a high line voltage (mine is always 123V) the peak will be considerably higher than 1200V. I would give the rectifiers one or two turn on cycles before failure."

This could be corrected by putting two Hexfreds in series on each leg of the bridge, effectively increasing the PRV to 2400V. Older ARRL Handbooks recommend paralleling 500K resistors with series rectifier diodes, to equalize the voltage drop across each diode, but the newer ARRL Handbook declares this unnecessary due to the avalanche characteristic of newer rectifiers. About John Wycoff's guest editorial Alan offers:

"Mr. Wycoff's ranting has no place in this magazine... (snip)"

Out of respect I will leave rest of that para-

(Continued from page 17)

graph out, as it may be perceived as a bit of a rant itself!

On another topic, the VV52 operating point article Paul wrote last issue, Ron Welborne comments:

"The plate resistance of the KR tubes is typically down around 700 ohms so this lets you use your rule of thumb (X3) for picking the OPT input impedance. $700 \times 3 = 2100$. So really the best transformer to use from a power standpoint is 2000 ohms. I believe I am right in saying that the lower primary impedance results in a smaller transformer turns ratio and so where you might only get 18 watts using a VV52B/3k primary, a VV52B/2K primary (using the same V/I) will easily yield 25 watts.... i.e. V_{primary} divided by the turns ratio equals $V_{\text{secondary}}$. Of course the distortion will be higher with the lower primary resistance but I think the low distortion KR tubes balance this out."

From John Tucker:

"What's with the grid resistor on the output tube?", and "Your cathode bypass formula is not conservative enough." (remember, Paul

says it's too conservative!)

From John Camille:

"P.S. Pull that 270K VV32BC grid resistor out of your Blues Master. Will give you more drive and thermal runaway is not a factor with direct coupling."

ALRIGHT ALREADY! -B.

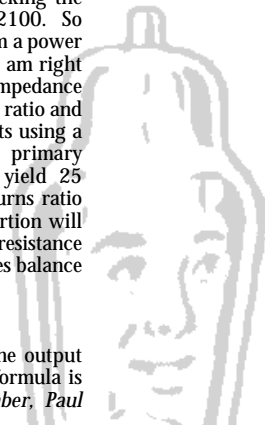

HANDMADE ELECTRONICS

A PARTIAL LISTING OF WHAT WE HAVE FOR THE BEGINNING OR ADVANCED HOBBYIST

Capacitors- KimberKap, RelCap MultiCap, Hovland MusiCap, Nichicon Muse, low ESR & QX series, Cerafine, Black Gate, Solen, Our own high quality oils, 500vdc 1% silver micas, Philips 1% polystyrenes. Resistors- Holco metal film, IRC RN metal glaze 1% series and AS series wirewounds, Mills & Memcor wirewound, carbon composition resistors, Alps, Clarostat, Dale volume controls. Tubes/Valves- Golden Dragon, Svetlana and other Russian made. Connectors- Kimber, Cardas, Edison-Price, WBT and some nice inexpensive plastic binding posts that do the job. Transformers- MagneTek filaments, Hammond, MagneQuest and Tango (interstageonly). Metalwork- Hammond

Catalog
1997/1998
is the
latest

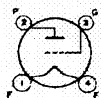

To get the latest copy of our catalog, send:
\$5.00 using Visa/MasterCard/Discover
or \$2.00 or 5 IRC postal coupons to:

Handmade Electronics
Post Office Box 9114

Allentown, Pennsylvania 18105-9114 USA

Voice: 610-432-5732 Fax: 610-432-8971

Email: handmade@ix.netcom.com

or...check out our web page:

<http://www2.netcom.com/~handmade/first.html>

Export
friendly

THE PINSTRIPE

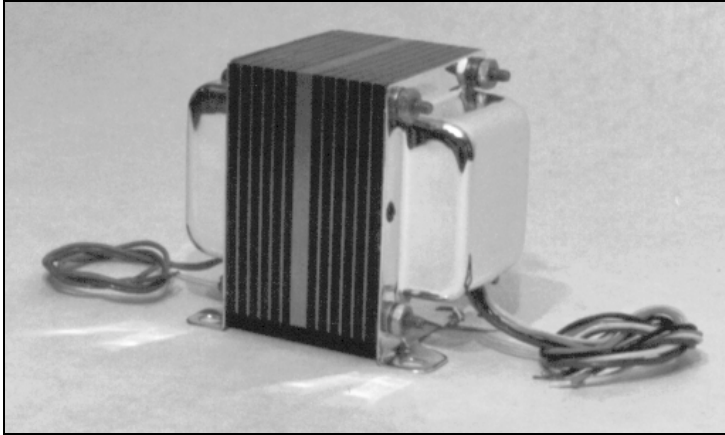

The heart of the Blues Master

- ◇ 3,000 ohm primary impedance, 4,8 and 16 ohm secondaries.
- ◇ the legendary midrange quality of the TFA-204, now with phenomenal bass and treble speed and texture
- ◇ measured frequency response of -1dB at 2 Hz and 26 kHz
- ◇ perfect for SE 2A3, SE 300B, PSE 50s, SE VV300B, SE VV32B, even works with the VV52B!
- ◇ alternating laminations of M4 steel and nickel - pinstripes!
- ◇ stunning polished solid brass bell ends
- ◇ use with 2A3/300B and the new, larger EXO 04 60 mA 50H plate loading choke and B.A.C. 50H 80 mA choke -VV32Bs!

Perhaps the most beautiful transformer ever made

special price - \$250 each.

All nickel TFA-2004 also available ,

\$300 each with solid brass bell ends

Call Electronic Tonalities, 360-697-1936 to order



3 Watts...106dB...

Can't get much more efficient than that!

Lowther America and Welborne Labs have teamed up to offer the best package deal in Audio.

Hi-Fi enthusiast or just plain music lover take a look at this.....

A combo package featuring Welborne Labs Moondog 243 SE monoblock amplifiers along with Lowther America's Medallion 99 cabinets and Lowther PM2A drivers.

And... the best part is.... the price!

Full Kit only... \$2949.00

Completely Assembled... \$3999.00

For more information on this package deal contact either party



Welborne Labs

P.O. Box 260198, Littleton, CO 80126 USA
tel: 303.470.6585 fax: 303.791.5783
<http://www.welborne.com>

Lowther - America

P.O. Box 4758, Salem, OR 97302 USA
tel: 503.370.9115 fax: 503.365.7327



(aw'-de-o-jen'-ik): Originating in sound.

Introducing The Iguana Amplifier Monoblock Pair

Push Pull Design - Drive "real" speakers.

DC Coupled - Eliminates coupling capacitors

All Triode, Zero Feedback

Vacuum Tube Rectified

Brooklyn Transformer Upgrade Ready

Laser Cut Aluminum Top Plates

Monoblock Design

\$695

**Fully Assembled
at a Kit Price.**



*Audiogenic
23785 Jennings-Delphos Road
Delphos, Ohio 45833
(419)692-6026
Chadd Moore
L. Dean Moore*

ABA

Andy Bartha Audio
954-583-7866 EST

Did you know every CD/Laser Disc you purchase has a "filmy coating" that was used to keep the polycarbonate disc from sticking to its metal mold during manufacture?
No matter how sophisticated your CD/Laser playback system is, it cannot correctly read the music beneath this film.

This loss of focus is destroying the very heart and soul of your music-
it's no wonder the purists have
preferred analog!

Only REVEAL removes this film, plus, it cleans and seals the surface, protecting against scratches, smudges,
fingerprints, glare and magnetic dust.

Now your CD Laser Disc player will read the music correctly.

MARTIN DEWOLF,

Bound for Sound

" Best sounding and easiest to use CD cleaner"

DOUG BLACKBURN,

Positive Feedback, Soundstage

"Cannot reproduce what REVEAL does on CD's with anything else"

Satisfaction 100% guaranteed.

An 18 oz. can is \$34.95, plus shipping

(that's about 4 cents per disc)

You'll be hearing your music for the first time.



ABA Whatchamacallits

Original Whatchamacallits (shown above)

small - \$10.00 - Make great feet for CD players, preamps, small amps.

medium- \$14.50 - Use these on small transformers, under smaller speakers, and under turntables.

large- \$40.00 - These are the ultimate for damping transformers, cabinets, turntable plinths and speakers.

Turntable weights

medium \$20.00 - for lightly suspended turntables, like late Thorens

large - \$45.00 for big dog direct drive turntables and belt drive tables with beefy bearings and strong suspensions

Tonearm counterweight - Put this on your tonearm instead of the stock weight - \$15.00

Also - tube dampers for everything from 12AX7s to 6V52's, and a 'pancake' version of the large Whatchamacallit for those big cabinets..

Prices do not include shipping or sales tax.

WRIGHT Sound Company



The **WLA10 line amp** with 4 inputs for those who don't need the phono section. Dubbed by those that have listened, as the best sounding line amp they have ever heard, tube or solid state. All this for \$365.00 plus \$17.50 shipping and handling in the continental U.S., WA res. please

add 8.2% sales tax.

The **WPP100A phono preamp**, the most natural sounding unit on the market today, is available at \$529 plus \$17.50 shipping and handling in the continental U.S., WA residents please add 8.2% sales tax. The WPP100A has gold RCA connectors, and a new WPS02 power supply with a power switch and plate and filament indicators. The performance is better than the original version, which beat all the competition in

listening tests by members of VALVE and other audiophiles who have had the pleasure of reviewing this product.



Now available to VALVE members, and those who have tried S.E.X. amps, the **WPL10V complete line amp/ phono stage** component. This basic model has

the quality of the WPP100A, with the additions of a selector switch with phono plus three other line inputs and volume controls to make this the center of that great new S.E.Xy sound system. No longer do you need to wait for a great sounding addition to have great S.E.X., and at just \$649 U.S. funds plus \$17.50 shipping and handling, you can get this fully assembled preamp/line amp delivered to your door in the continental U.S., WA residents add 8.2%. The WPL10V is designed to be a cost effective basic chassis type, constructed with all the great stuff that goes into the WPP100A. We made it especially for you S.E.X. owners and VALVE members who want the most out of your system for the least out of your pocket. I must add that this product will work with almost any power amp you now have or may purchase, so with or without S.E.X. this is a great addition to the WRIGHT line. Stay tuned for future models.

Please send your order and payment to:

WRIGHT Sound Company

3516 So. 262nd, Kent WA 98032-7047

For further information, please leave a message at (253) 859-3592



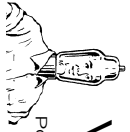

VALVE

PO BOX 2786
Poulsbo, WA 98370