



Radio

THE RADIO TECHNOLOGY LEADER



Northern Community Radio Expands: An Engineer's Perspective



JULY 2014 | RADIOMAGONLINE.COM



596-RDM1
000289844
PK016918
P0065

BARRY MISHKIND
CHIEF ENGINEER
KOHN
203 S AUGUSTA PL
TUCSON AZ 85710-7905

MEBXRZFT *****CMA-RF LOT**C-028 MKX CO
#0010545 2# RDM 0010545 E1401

More Program Sharing Options

3 Simultaneous Mono/Stereo Multicast



3 Simultaneous Mono/Stereo Multicast

Expand your network with the Genie Distribution Audio Codec

www.tieline.com **Tieline** The Codec Company 1-317-845-8000



the world's finest IP Audio systems inside the world's finest radio studios

wheatstone-radio.com





THE INTELLIGENT NETWORK

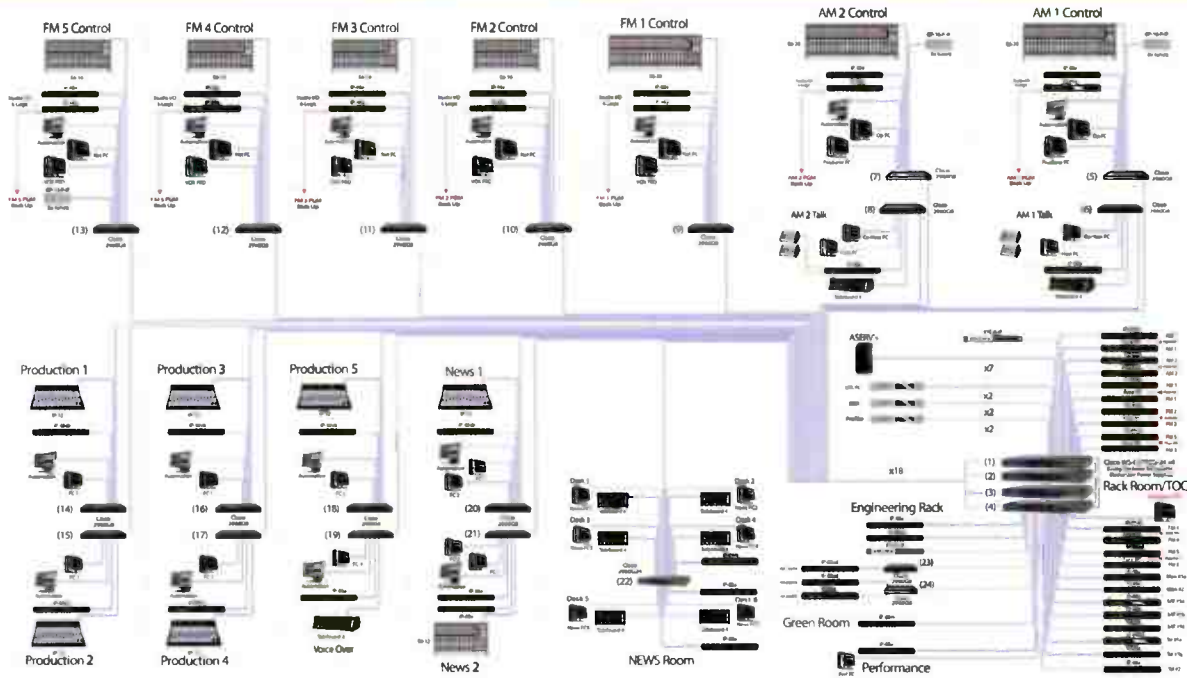

In This Business, Anything Can Happen. Is YOUR Network Ready?

It's disaster season, and the last thing you should have to spend your valuable time tracking down is a faulty cable.

That's why our WheatNet-IP Navigator software provides real-time notification of any communication failure with any component of the network. But let's say the single cable between the TOC and on-air studio does go bad. No problem. You have a backup studio or two at the ready - one of the benefits of an audio network like WheatNet-IP that's distributed throughout the facility. And if you're really in a bind,

you can always run the station using little more than a single WheatNet-IP I/O BLADE - it has an operating system, I/O, silence sensing, GPIO and mixing inside - plus you can reboot the entire system off of that one BLADE.

NOTE: the station pictured in the flow chart above is in Portland, OR
For more ideas on recovery, go to INN12.wheatstone.com



Get Out and About: IP Audio Extended

While it's still not practical to transport uncompressed linear audio over the public Internet...

...you can get coded audio across the Internet by interfacing the Tieline Genie stereo IP audio codec to our WheatNet-IP audio network. We've partnered with Tieline so the Genie has a built in port specifically for connecting into the WheatNet-IP system and sending six channels of audio over the public Internet. Audio performance is highly reliable, and latency is minimal. To find out about this and other ways to extend your WheatNet-IP audio network beyond the studio walls...

Click here to learn more: INN12.wheatstone.com



We've Got AES67 Compatibility Built In

Did you know that our newest I/O BLADEs for the WheatNet-IP audio network are AES67 compatible?

We added AES67 compatibility for interoperability with other AES67-compliant devices and signals into the WheatNet-IP Intelligent Network. Check out this great discussion with AES' Bob Moses about AES67...

Click here to learn more: INN12.wheatstone.com



TABLE OF CONTENTS

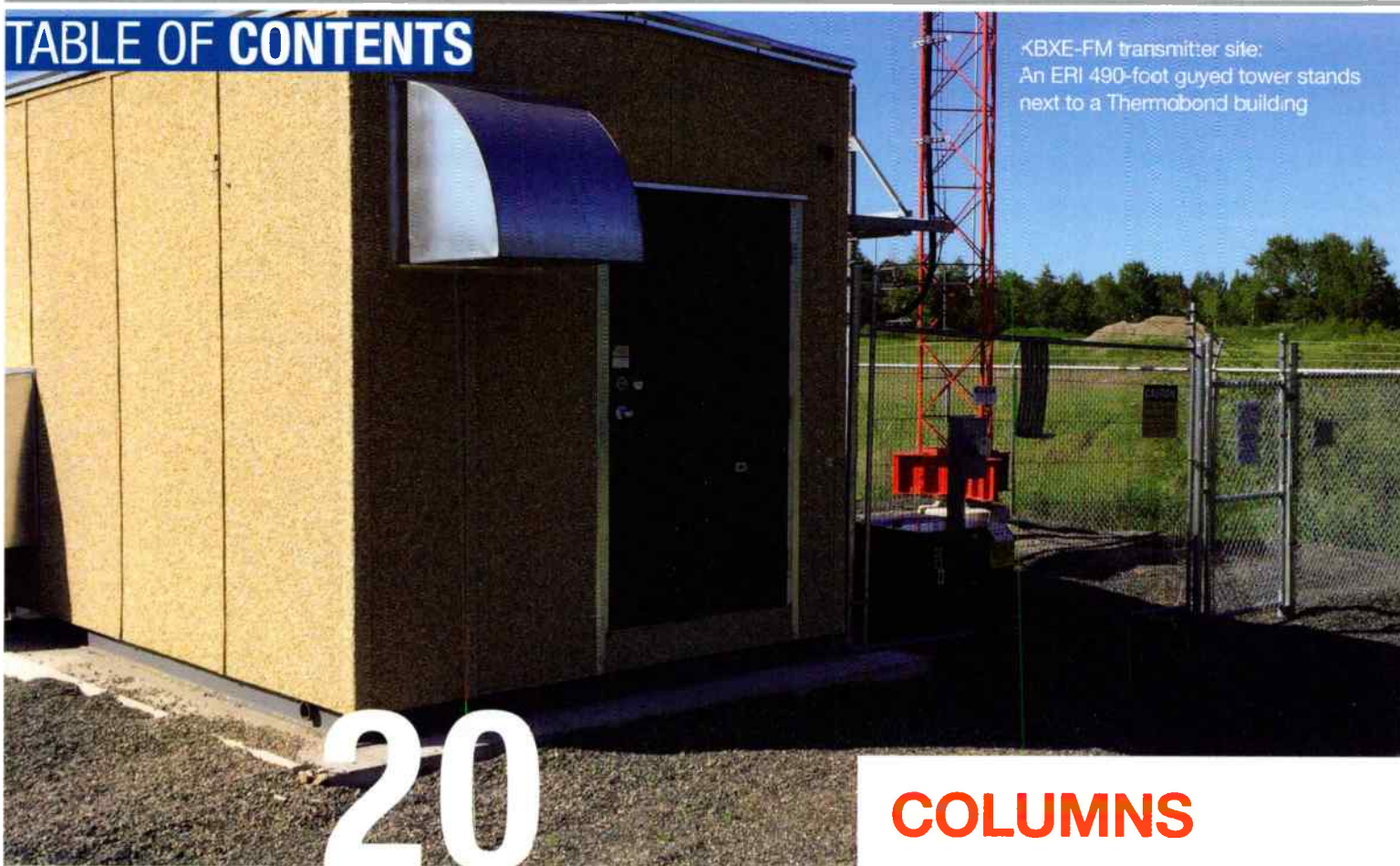

KBXE-FM transmitter site:
An ERI 490-foot guyed tower stands
next to a Thermobond building

20

FEATURES

- 14 **Trends In Technology**
Building Robust IP Audio Links
- 20 **Facility Showcase**
Northern Community Radio: KBXE-FM

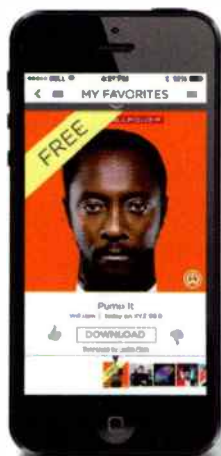

32



RF Specialties[®]
Group
www.rfspecialties.com

On the cover:
Main entrance to Northern
Community Radio's KAXE-FM studio
facility in Grand Rapids, Minn.

COLUMNS

- 08 **Viewpoint**
What is "Radio"?
- 10 **RF Engineering**
Modulation Techniques
- 12 **FCC Update**
LPFM On The March
- 28 **Tech Tips**
Battery Maintenance

DEPARTMENTS

- 30 **Field Report**
Tascam TH-2000
- 32 **Applied Technology**
How to optimize the mobile radio
experience for advertisers and listeners
- 38 **Sign Off**
SBE Certification; TechSurvey 10

CORRECTION

On Page 18 of the June 2014 issue, the call letters for KYW were inadvertently transposed to KQY in the sub-heading of the article.

Investing in Digital for Radio

For Today and the Future



2013



2014

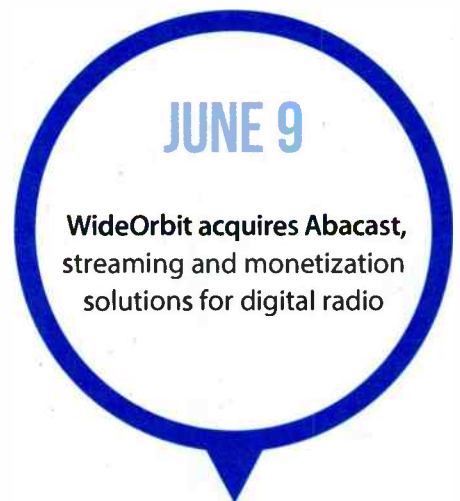

Stay tuned for more exciting announcements...

WIDEORBIT
DRIVING THE BUSINESS OF ADVERTISING

Questions? Please Contact: Mike Zinsmeister, Executive Vice President of Sales
Office: +1.828.252.8891 | Mobile: +1.828.712.2843 | mikez@wideorbit.com

World Radio History

NAB Education Foundation 2014 Broadcast Leadership Training Class Graduates

The NAB Education Foundation (NABEF) announced that the 2014 Broadcast Leadership Training (BLT) class graduated in June, following a ten-month, MBA-style program that teaches the fundamentals of purchasing, owning and operating radio and television stations.

The program, now in its 14th year, targets senior level broadcast executives who aspire to advance as group executives or station owners. To encourage diversity in broadcasting, NABEF offers fellowships to women and people of color. A number of BLT graduates are in varying stages of station acquisition.

This year, topics included securing funding, identifying stations, developing a business plan, due diligence and operating for success. Students had the opportunity to network with other broadcasters, Federal Communications Commission (FCC) staff, communications attorneys and members of the banking community.



KNX 1070 Receives Three L.A. Press Club Awards

KNX 1070 NEWSRADIO won three Southern California Journalism Awards presented for editorial excellence by the Los Angeles Press Club at its 56th Southern California Journalism Awards.

The KNX 1070 award recipients for programming that aired in 2013 are:

Anchors:

Dick Helton, Vicky Moore
KNX Morning News

Talk, Public:

Charles Feldman, Laraine Herman,
Diane Thompson, Frank Mottek,
Bob McCormick
"Healthcare Uncovered"

Sports:

Ed Mertz
"The Watts Bears"

Sherri Griswold Named Chairman of FAB

Clear Channel Media and Entertainment Ft. Myers announced that its Regional Market Manager, Sherri Griswold, has been named Chairman of the Florida Association of Broadcasters. Griswold is the fourth woman named Chairman.

The Florida Association of Broadcasters lobbies and focuses on Florida specific issues in broadcasting as well as supports the efforts of the National Association of Broadcasters (NAB) in Washington, D.C. As Chairman, Griswold will lead the Executive Committee, which represents the Board of Directors.

WQED to Offer 360 Degree Live Streaming Video

The Pittsburgh Symphony Orchestra will perform at Hartwood Acres as part of the Allegheny County Summer Concert Series on July 6 while live streaming the concert via the Internet through a new technology, C360.

C360 provides real-time video control to the end user by way of multi-view 360-degree action with unlimited angles and viewers, as well as integrated tracking capability to follow objects and people.

SBE Announces Tech Session Lineup at 2014 Radio Show

The session lineup at the 2014 Radio Show includes:

IT for Radio Engineers: Understanding IP Networking Routing & Switching Tutorial
Wayne Pecena

Designing, Maintaining and Monitoring Reliable IP Audio Broadcast Facilities
Jacob Robinson

15 Tech Ideas That Help the Bottom Line — A Radio Technology Panel of Experts — Jacob Robinson, Jeremy Ruck and Paul Shulins
Moderated by Chriss Scherer

All-digital on the AM Band — Testing for the Future
NAB Labs

Hybrid Radio — Why It's Important for You
NAB

SBE members are eligible to register at NAB member rates.

FIND THE MIC AND WIN!

Tell us where you think the mic icon is placed on this issue's cover and you could win a Hosa CBT-500 cable tester. Send your entry to radio@RadioMagOnline.com by August 10. Be sure to include your guess, name, job title, company name, mailing address and phone number. No purchase necessary. For complete rules, go to RadioMagOnline.com

Major Update!

Audio Processing re Built For You.



DAVID IV FM Broadcast Audio Processing: for shaping, sculpting, and boosting your on-air sound. Now with the extra features you asked for.



5 BAND BLISS

The perfect number of bands with more controls and tweaks you'll actually use.



BLAZING SPEED

Only 3.9ms of signal latency on the composite outputs, and power to live audio in under a second.



BETTER PRESETS

25 choice presets tuned to make you stand out, without going all-out.

NEW Rev. 3 FEATURES

- “Windowed” AGC control.
- Adjustable Multiband Crossovers Points.
- Adjustable Multiband Attack and Release Times.
- Built-in Test Tone Oscillator.
- Tighter Peak Control.
- English, Español, and Português language menu options.

Learn more at www.inovonicsbroadcast.com



What Is "Radio"?



As I was reminded recently, the name of this publication is "Radio." In this day and age, what exactly IS "Radio"? For many years, it seemed everyone knew what it was—the term was defined very clearly in most people's minds as AM and FM broadcast service. With the constantly increasing adoption of mobile devices and streaming services, however, the lines have become blurred. In the strictest sense, "Radio" can be defined as anything

that utilizes Radio Frequency as a means of communication.

Many consumers, however, have now come to see any service where they can listen to a curated program source with little or no interaction as "Radio." Most streaming services will allow users to customize the content they are hearing without requiring them to build playlists manually as is necessary in most cases with personal music collections. The end user experience with these services is remarkably similar to traditional broadcast radio—Pick a "channel" and listen while you go about your day. If you want to listen to something else, change the "channel."

I was in a room recently where a presenter was conducting an instructional session on smartphones and apps. He pointed to the Pandora icon on the screen and asked if people knew what it was. The majority of those in the room responded "Radio."

It is futile for broadcasters to buck this trend and keep doing things exactly the same way they have been doing for decades—broadcasters must instead embrace, adapt, and adopt new technologies as appropriate in order to survive. This is the reality of today's marketplace.

The trend of moving from being defined as "broadcasters" to "content providers" has been happening over at least the past 5–10 years. The biggest difference now is that the number of listening options has increased dramatically. The actual content delivery platform is rapidly becoming irrelevant.

Most stations now stream their signals, and have mobile apps available, but it takes far more than that to continue capturing the audience. It is up to broadcasters to provide content that consumers actually find compelling enough to seek out, and to make it available on whatever platforms they want to access it on. What makes content compelling? That is a question that has many answers, but in the case of most listeners, I suspect it would be something uniquely local and engaging that "connects" them to their community and to those around them.

I believe that there will always be some method of one-to-many content distribution that mimics what broadcasters have been doing since the dawn of radio. It will almost certainly be digital, carry numerous channels of content over a wide geographical area, and it may even come through a service provider rather than remaining free over-the-air. Satellite, cellular, and Internet based platforms fit many of these criteria to a point, but lack any sort of local connection for the most part.

Whether it comes via AM, FM, analog, digital, satellite, cellular, Internet, or something completely different yet to be invented; the real magic is in the message, not in the method. Exactly what this method will look like in another 10–15 years is anybody's guess, but at its heart (as long as wireless devices exist) it will always be "Radio." 

FOLLOW RADIO MAGAZINE

Email | radio@RadioMagOnline.com
Facebook | [RadioMagazine](#)
Twitter | [@RadioMagazine](#)
YouTube | [RadioMagOnline](#)
LinkedIn | [/groups?gid=3210911](#)
Pinterest | [RadioMagazine](#)

Shane Toven | Editor

EDITORIAL

Editor: Shane Toven
stoven@nbmedia.com

TECHNICAL CONSULTANTS

Contact them via radio@radiomagonline.com
Kevin McNamara, Computers and Networks
Jeremy Ruck, P.E., RF and Transmission
Lee Petro, Legal
Russ Berger, Broadcast Acoustics
Doug Irwin, CPBE DRB AMD, IBOC

CONTRIBUTORS

Chriss Scherer, CPBE CBNT
Doug Irwin, CPBE DRB AMD
Chris Wygal, CBRE

CORPORATE

President and CEO: Steve Palm
Chief Financial Officer: Paul Mastronardi
Controller: Jack Liedke
Group Circulation Director: Denise Robbins
Vice President of Web Development: Robert Ames

VIDEO/BROADCAST GROUP

Executive Vice President: Carmel King
Vice President of Sales/Group Publisher: Eric Trabb

ADMINISTRATION AND PRODUCTION

Editorial Director: Paul J. McLane
Production Director: Davis White
Production Publication Coordinators:
Karen Lee, Lisa McIntosh
Advertising Coordinator: Caroline Freeland

CIRCULATION

Group Director, Audience Development: Meg Estevez
Circulation Manager: Kwentin Keenan
Circulation Coordinator: Michele Fonville

ADVERTISING SALES REPRESENTATIVES

Publisher, U.S. Sales: Steven Bell
sbell@radiomagonline.com | 212-378-0400 x519

Southern Europe, Africa, Middle East: Rafaella Calabrese
rcalabrese@broadcast.it | +39 02 9288 4940

UK, Ireland, Central and Northern Europe: Graham Kirk
gkirk@audiomedia.com | +44 1480 461555

Japan: Eiji Yoshikawa
callens@world.odn.ne.jp | +81 3 3327 5759

Asia-Pacific: Wengong Wang
wwg@imaschina.com | +86 755 83862930/40/50

Member: American Business Media

A NewBay Media Publication



NewBay Media, LLC
28 East 28th Street, 12th floor
New York, NY 10016

SUBSCRIPTIONS: Free and controlled circulation to qualified subscribers. Customer Service can be reached at: newbay@computerfulfillment.com or by calling 888-266-5828 (USA only) or 978-667-0352 (Outside US) or write us at Radio Magazine, P.O. Box 1884, Lowell, MA 01853, USA. Back issues are available by calling Customer Service.

LIST RENTAL: 914-925-2449
danny.grubert@lakegroupmedia.com

REPRINTS: For custom reprints and eprints please contact our reprints coordinator at Wright's Media 877-652-5295 or NewBay@wrightsmedia.com.

PHOTOCOPIES: Authorization to photocopy articles for internal corporate, personal or instructional use may be obtained from the Copyright Clearance Center (CCC) at 978-750-8400. Obtain further information at copyright.com.

Radio, Volume 20, Number 7, (ISSN 1542-0620) is published monthly by NewBay Media LLC, 28 East 28th Street, 12th floor, New York, NY 10016. Periodical postage paid at New York, NY and additional mailing offices. Postmaster: Send address changes to Radio, PO Box 1884, Lowell, MA 01853.

Copyright 2014, NewBay Media LLC. All Rights Reserved.

You may not want
ALL of your guests
in the studio...



...but you want them to **sound** like they are!

STAC VIP

VoIP TELEPHONE TALKSHOW SYSTEM



Install the Comrex STAC VIP and your guests can sound like they are in the studio when they're not. Your listeners will stay engaged longer while enjoying wideband, studio quality caller audio. STAC VIP gives your contributors more ways to make great sounding connections than ever before.

Screen and air calls from VoIP, SIP Smartphone Apps, SKYPE™ and POTS with ease using the STAC VIP web-based caller management app and intuitive control surfaces. Newly integrated Opus audio algorithms widen your caller's options even further. *Contact us today!*

plugged into **Skype**



by Jeremy Ruck, PE

Modern Modulation Techniques

Modern society is definitely more mobile than it was several decades ago. Accompanying the increased mobility is a corresponding craving for greater quantities of information. The increased demand has called for a number of changes in modulation techniques. This month we look at several of them.

Initial wireless transmissions were an offshoot of telegraphy. The first spark gap transmitters worked well, but were of course quite “dirty” in their operation. In 1906 the venerable method of amplitude modulation radio was born.

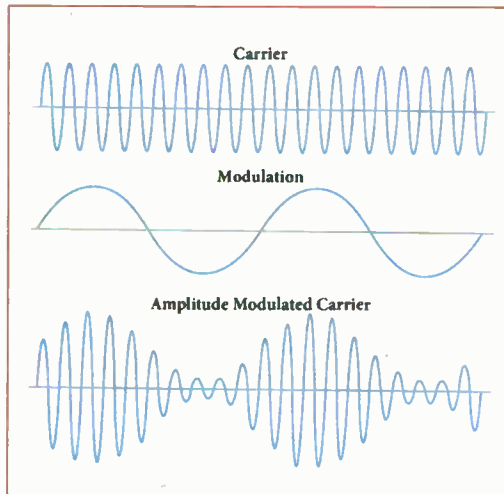

Figure 1. AM carrier

While it would take several more years to reach commercial viability, this simple method of transmission would reign supreme for several decades. The development of AM came out of the realization that the waves produced by spark gaps were insufficient for the transmission of audio material. Instead of the on-off scheme under which spark gap transmitters operated, continuous waves would be required. This carrier wave is amplitude modulated by audio before transmission. (See Figure 1.)

Since free lunch rarely exists, the benefit of the simplicity of AM was offset by audio quality and inefficiency. The simplistic modulation scheme of AM makes it very susceptible to natural and man-made noise sources. In addition, the majority of the power is concentrated in the carrier, which lacks the original transmitted information.

In the more modern technique of FM, the transmitted information varies the instantaneous frequency of the carrier, while maintaining the amplitude. The frequency of the carrier, for the most part, will tend to reside within a certain range on either side of the carrier known as the frequency deviation. In a Fourier analysis, which breaks up the signal into combinations of simpler signals, we find that a much broader range of frequencies is required to fully characterize an FM signal. Indeed this range extends to infinity, but at that point, and well in advance of it, the amplitudes are so low, that they practically drop out of the equations.

Of course, a major advantage with FM is its ability to reduce noise. In reality, below the noise threshold, FM actually has a poorer signal-to-noise ratio than AM does; however, above this level the SNR is vastly improved. Wider deviations can increase this ratio, as can pre-emphasis. Limiter circuits provide additional benefit by removing AM noise, as the FM signal is of constant amplitude. (See Figure 2.)

One simple form of FM is frequency-shift keying, or FSK. In FSK, digital information is transmitted through discrete changes in the carrier frequency. In simple form, a pair of frequencies can be utilized to transmit binary information as a “1” and “0” or “mark” and “space”. This is one such method permissible for the identification of FM translator stations.

Another modulation scheme similar to FM is phase modulation.

Within the genre of phase modulation, there are many subsets. These schemes lend

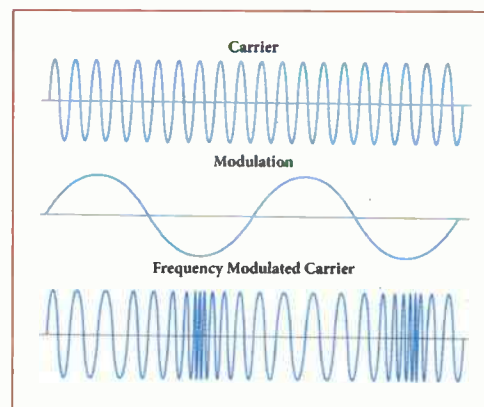

Figure 2. FM carrier

themselves well to digital uses, and are seen frequently in STL applications. The more common ones seen here are Quadrature Amplitude Modulation, and the higher density 16-QAM and 64-QAM.

QAM is a modulation scheme that can be either analog or digital. Two data streams or analog signals are transmitted by amplitude modulating two different carrier waves. If the QAM transmission is digital, then amplitude-shift keying is utilized, whereas AM is used if analog is transmitted. These two carriers, which are 90 degrees out of phase with each other, are then added. The output waveform is, in the analog case, a combination of phase modulation and amplitude modulation, while in the digital case contains both phase-shift keying, and amplitude-shift keying. Mathematically speaking, the two signals can be represented as sine and cosine functions because a 90-degree phase shift exists between those two functions as well.

In the analog realm, QAM allows multiple signals to be carried on a single carrier. Seasoned television engineers should be quite familiar with this, as it is how the “I” and “Q” signals carried chroma information. Similarly, the C-QUAM system allowed the two channels necessary for stereo to be carried on a single carrier.

On the digital side, QAM is quite impressive, and allows for much higher data rates than analog modulation schemes. The digital signal is quantized, and through this process is constrained to certain regions in which it can reside. Just as your domicile has a distinct address

identifying your location, the places where the signal can reside also have addresses. These addresses are represented by a series of bits, which give amplitude and phase information for the quantized signal. The collection of these individual addresses forms a constellation, which is an effective way to look at the signal.

In 16-QAM, there are sixteen distinct locations, which generally exist in a 4x4 square grid. Therefore, each location is represented by a four-bit binary address ranging from 0000 to 1111. (See Figure 3.)

In 64-QAM, the number of possible addresses enlarges to 64, which necessitates an increase in the neighborhood density, and the use of six bits per address. Generally speaking, the increase in the constellation size follows powers of two.

These high-density QAM schemes allow for very high levels of spectral efficiency and very high data transfer rates. Some current Ethernet devices use 1024-QAM and

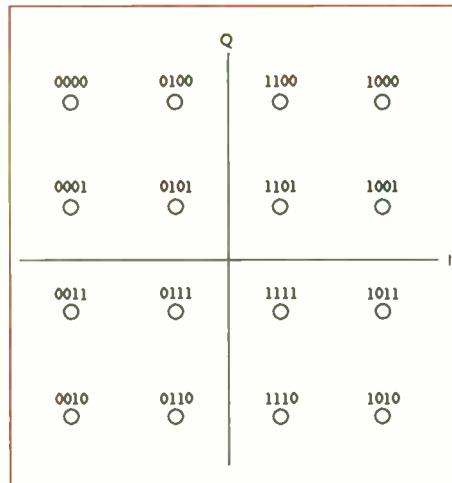

Figure 3. 16 QAM constellation diagram

4096-QAM for their modulation schemes. In fact, 1024-QAM is now becoming more common on long-haul microwave systems, and allows for a capacity increase of 25% over the industry standard 256-QAM. With such robust schemes, massive amounts of data can fit into a single channel.

This increase in capacity and efficiency has a tradeoff in stability in some instances. As

constellations become more densely packed, and the bit quantity increases for a given symbol, the potential for error and noise becomes much greater. Although error correction methodologies have lessened the impact of noise, they have not eliminated problems altogether. Sometimes a path is just too far or too noisy to be reliable with more dense techniques. In such cases, a decrease in the constellation size will usually help, but that of course reduces capacity. This is generally not an issue in radio broadcast applications.

In the end, more advanced techniques of modulation have allowed for increased flows of information, and have evolved our industry. The advances made in the past several years have been impressive, with potential future advances just as impressive. We sure have come a long way from the venerable spark gap. **Q**

Ruck is the principal engineer of Jeremy Ruck and Associates, Canton, IL.

“The only source of knowledge is experience.”
 ~Albert Einstein

Shively provides both.
 For over 50 years Shively has designed and manufactured FM products to work flawlessly; for any power level, at any site, and under any conditions; year, after year, after year. Whether it's one of our newest designs, or a classic, you can rely on Shively antennas to perform; on their own, staying out of sight, away from your budget, and off your to-do list.

Call Toll-Free: (888) SHIVELY
 Or visit us on the Web at: www.shively.com

Shively Labs®
 A Division of Howell Laboratories, Inc. Bridgton, Maine 04009

- An Employee-Owned Company since 1995 -



LPFM on The March

by Lee Petro

At the June FCC Meeting, the Audio Division of the Media Bureau reported on its work in processing the 2,826 Low Power FM (LPFM) applications filed during the November 2013 filing window. Both by processing the applications that do not conflict with other applications filed during the window (singletons), and by working through the conflicting applications, the FCC's staff expects to complete all of the processing by the end of 2014.

First, with respect to the singleton applications, the FCC staff reported that over 1,200 applications have been granted. Of those granted singleton applications, eight were for communities in the Top 10 markets, 15 were in markets 11–20, and 53 applications were granted in markets 20–50. All told, the number of LPFM stations in the top 50 markets has nearly doubled, from 81 LPFM stations prior to the November 2013 filing window, to 157 stations thus far. With an additional 483 applications still pending in the top 50 markets, it is likely at the total number of LPFM stations in the top 50 markets will grow to well over 200 stations when the dust settles.

Next, there are approximately 406 groups of at least two conflicting applications that remain to be processed. Previously, the FCC opened a window for these applications to reach settlements and/or technical solutions to resolve the conflicts. Now, the FCC's staff is working on three separate orders, to be spread out over the next six months, to name tentative selectees from amongst the groups. The tentative selectees will be chosen based on the representations made in their applications on the "point system" factors, and in some cases, will be resolved by a tie-breaker.

The naming of the tentative selectees will trigger a 30-day period of time for the other parties in that group of conflicting applications to file a petition to deny against the application. In the past non-commercial filing windows, petitions were filed when it was discovered that the tentative selectee had not obtained reasonable assurance of site availability, or that the applicant had provided incorrect information in support of its corporate status or location of its headquarters.

The FCC's staff indicated that they will be releasing three different orders, which can be expected to be geographically-based. This is due to the fact that the orders will also open a

window for applicants to submit major change amendments to their applications, along with a 90-day window for applicants to enter into settlement agreements among the applicants.

In this context, a major change application would be a channel change that was more than 3 channels from the channel specified in the application, or a change of tower site or community of license whereby the proposed location would not conflict with the community or site location specified in the application. Because the FCC does not want to create new conflicts, it has determined that incrementally resolving conflicting groups based on geography will reduce the chance of a land-rush and the creation of new conflicts.

After the FCC staff presentation, Commissioner Ajit Pai commented that he hopes that the FCC would immediately initiate a filing window for AM licensees to submit applications for FM translator facilities after the FCC has dealt with the LPFM applications. That proposal is part of the AM Modernization rulemaking for which comments were filed earlier this year. Commissioner Pai has been interested in opening a window for new FM translators as a means to invigorate the AM service. 

*Petro is of counsel at Drinker Biddle & Reath, LLP.
Email: lee.petro@dbr.com.*

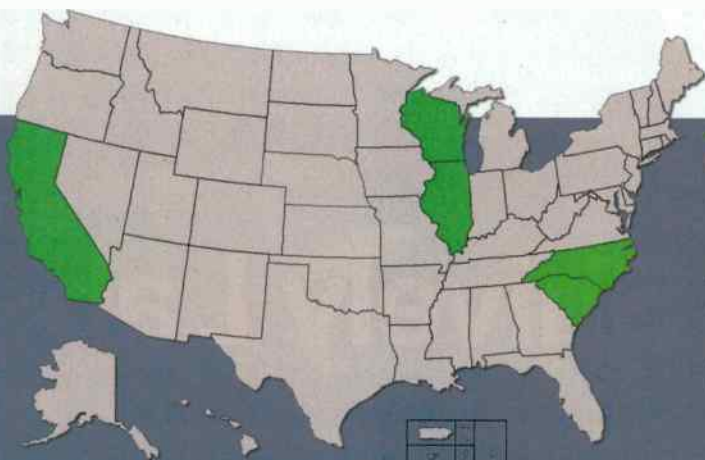

FCC DATELINE

July 10, 2014 — 2nd quarter Issues/Program Lists must be placed in public inspection files.

August 1, 2014 — Stations in California, Illinois, North Carolina, South Carolina, and Wisconsin must place Annual EEO Reports in public file.

August 1, 2014 — Noncommercial Radio stations in Illinois and Wisconsin must file Ownership Report (FCC Form 323E) with FCC.

Radio Automation...

ARRAKIS SYSTEMS INC.

ARRAKIS SYSTEMS INC.

Digilink-Xtreme

ON AIR SOFTWARE FOR LIVE ON AIR, HARD DISK, AND SATELLITE AUTOMATION ... 16 CHANNEL ROUTING SWITCHER FOR NETWORK PLAY AND RECORD ... SCHEDULING SOFTWARE FOR YOUR TRAFFIC STUDIO ... EDITOR/RECORDER SOFTWARE FOR PRODUCTION ... PHONER RECORDER/EDITOR ... VOICE TRACKER ... UNATTENDED GAMES ... MUSIC SCHEDULER ... FREE SOFTWARE UPGRADES ... FREE TELEPHONE SUPPORT ... FREE TRAINING ... JUST ADD PC'S AND STIR.



Get a complete Automation solution with software, hardware, upgrades, support, and training for...

only \$100 /month

Join the HUNDREDS of others on air around the World with Digilink-Xtreme. Full featured, it is easy to install, use, and maintain. Choose from either the no contract \$100 per month 'Solutions Program' or buy 'Xtreme-Complete' outright for only \$6,500.

With the \$100 per month 'Solutions Program,' you receive Xtreme software (On Air, Production, & Scheduling) and "Bridge" hardware PLUS training, support, and upgrades for your ENTIRE radio station. You supply the PCs or we can supply them for you. For less than the cost of a good cell phone contract you can be on air tomorrow with Xtreme.

With 'Xtreme-Complete' for \$6,500, you purchase a complete system ready for air: DELL business PC, Arrakis 'Bridge', and Xtreme software for on air, production, scheduling, voice tracking and more. The system comes with a full year of the 'Solutions Program' with training, support, upgrades, and next business day 'Bridge' replacement if it should fail. The DELL PC comes with 3 years of next business day, on site service from DELL.

Order your system today and receive it tomorrow... call us at 970-461-0730 ext 309

www.arrakis-systems.com

970.461.0730



Optimod-PC 1101e



Windows Audio for Professional Broadcasters/Netcasters.

The most universal professional audio card with features not found anywhere else.

Give your listeners the best user experience ever.

Prevent the top listener complaints — loudness variation and program inconsistency.

Call **SCMS** for more information on the Optimod-PC 1101e!



1-800-438-6040
www.scmsinc.com

TRENDSINTECHNOLOGY

The point of creating VLANs is to restrict traffic. You do not want anyone using the LAN at the transmitter site to accidentally “swamp” the portion of the network that is carrying the program audio. Use of VLANs and VLAN priority will also allow you to tell the link to make sure the packets related to program audio “get through first” over and above the run-of-the-mill LAN traffic such as e-mail, web browsing, and

One optional feature that I’ll mention: back at the studio end, I showed two separate “business network” LAN connections. How would you actually make use of both of those at the transmitter site end? One way would be to configure spanning tree on the switches; that way, if the LAN connection is lost via either the radio or wireline link, the switch at the transmitter site end will start using the other link automatically.

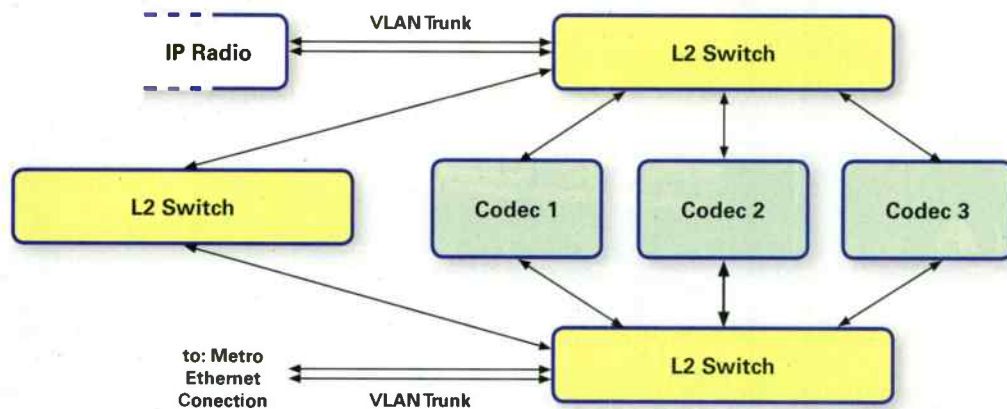

Figure 2. Transmitter Site

file transfer. That being said, since the codecs in use have both of their Ethernet ports associated with different VLANs, and carrying program traffic, in order for you to manage them from the business network, you’ll need a switch that will allow you to route between VLANs so that you can manage the codec from your desk. This is where a layer-3 capable switch comes in to play.

Each of the layer-3 switches will be trunked to the Ethernet interface that carries traffic back and forth to the transmitter site. A requirement of the gear used for these particular links is that it must support VLANs and VLAN trunking.

Now, on to Figure 2—the transmitter site. Each of the links is connected to a layer-2 switch, carrying the VLAN trunks from the far end. Again, each codec maintains a physically separate layer-2 connection to a redundant network. You’ll be restricted at this end in terms of access to the VLANs carrying program traffic. In the configuration of the switch, you’ll make the appropriate VLANs accessible on the appropriate ports on the near end so that the codec can be reached by all the packets transmitted at the far end, and so that it in turn can send packets back to the far end.

With an understanding of the network architecture now in mind, we need to discuss the means of getting our packets delivered to the far end, both by wire and by radio links. In Los Angeles, AT&T provides metro Ethernet to Mt. Wilson, where the majority of the area’s radio and TV transmitters are located. The “hand-off” from AT&T is a physical Ethernet interface on both ends. Pricing is very reasonable and different speeds are available. For example, at our Burbank studio facility AT&T has specified a 100 Mbps connection. On the far end, they’ve specified 20 Mbps “drops” to each of our transmitter rooms.

Now, I can’t over-generalize, but I’m quite sure that Mt. Wilson is not the only transmitter site in the country with access to metro Ethernet. A little research will reveal whether or not this type of service is provided in your area and who the provider would be.

The radio part of the equation has become much easier in the last several years since the FCC relaxed the part 101 rules allowing use of 6 and 11 GHz licensed radio links for the “last mile” connection to a transmitter site. With

the proliferation of cellular telephone systems, a very large market for “backhaul” radio systems has developed, and many manufacturers are doing their best to get a piece of it. For purposes of this system, the basic need is a layer-2 (Ethernet) interface to the radio, and support of VLAN trunking across the link. Those are very common features now, offered by many radios. For example: Ceragon offers their FibeAir IP-10E series; Aviat, their WTM-3200 series; Dragonwave, the Horizon Packet radio; Exalt, the Extend-Air G2 series; and Proxim, the Tsunami GX-810.

With the licensed radio links, you’ll of course need to go through the prior coordination and application process with local spectrum users (since the frequencies are shared) and the FCC. The coordination and licensing process sounds more difficult than it really is. There are a number of firms that will do this work for you, such as Comsearch, Micronet, V-Soft, RFEngineers.com, and Terrestrial RF Licensing Corporation.

With the design for your redundant IP-based STL system in place, you’ll now have to select a set of IP audio codecs. The devices I’m about to mention are all similar in functionality and features; it’s likely that you’ll make a choice based on personal preference. Many have dual-Ethernet interfaces, but some do not. You could choose to place one such single interface codec on each LAN segment to maintain the redundancy we’re striving for.

Take, for example, the Mayah C10. This is a dual-channel codec, with dual Ethernet interfaces, that supports several of the well-known lossy

audio codecs such as MPEG Layer 2, MPEG Layer 3 and AAC. More importantly for this application, it supports 16 or 24 bit linear PCM audio. Both analog and AES/EBU digital audio I/O are provided. Analog I/O is via XLR connectors with AES/EBU on a DB9 connector.

Another codec option is the AEQ Venus It is a 4-channel codec system with a single Ethernet interface. Other features include the option of an adaptive buffer in order to compensate for network jitter, along with FEC, and automatic reference clock adjustment to synchronize both ends of the communications link. The unit has balanced analog audio I/O through XLR connectors as well as AES/EBU digital audio I/O on a DB15 connector. ControlPhoenix management software is used to configure and manage the system. Linear PCM audio is supported at 32 or 48 KHz sample rates and various bit depths. Venus also has an embedded data stream that allows continuous serial communications from end-to-end, up to 38.4 kbps.

When I think of Telos, it’s usually for gear to do remotes; but the Z/IP is completely suited to “nailed up” connections as well. The device has dual Ethernet interfaces for streaming and control. It supports linear PCM audio along with a suite of lossy audio codecs. “ACT” (Agile Connection Technology) is used to sense network conditions and adapt codec parameters as necessary to maintain audio quality. Management of the device is done via an embedded web server. The unit features an RS-232 serial port

CLOUD [®] *microphones*

Raise Your Voice!

Leave the noise behind with the award-winning...

Cloudlifter [®] Mic Activators [®]

CL-1 CL-2 CL-Z **NEW!** CL-4

premierePARTNER NEUTRIK

TEC

CLOUD *Cloudlifter* [®] *CL-4 Mic Activator*

www.cloudmicrophones.com

Made in the U.S.A.

for transmission of data such as RBDS, and an 8-channel parallel GPIO port. Analog audio I/O is supported via XLR connectors, in addition to Livewire AoIP via Ethernet.

Comrex offers the BRIC-Link, a dual-channel IP codec with a single Ethernet interface. Analog or AES/EBU digital audio I/O are available on ¼" TRS connectors. BRIC technology incorporates a jitter buffer manager that automatically balances delay and stability, dynamically adjusting delay based on network performance. Contact closures, and serial communications can be sent end-to-end on 9-pin and 8-pin DIN connectors respectively. The BRIC-Link includes an embedded web server for management, though initial configuration is done via a windows-based setup utility that runs on the same LAN segment as the unit.

The Musicam Suprima is another dual-channel IP codec. It supports the well-known lossy audio codecs as well as linear PCM. Analog and AES/EBU digital audio I/O are supported. Configuration of the unit is performed via IP or from the front panel. A 7-channel GPIO port is available as well. One unique feature of the Suprima is that it can send Dolby "E" via the AES/EBU I/O (when configured in its "transparent" mode) meaning that you could send up to 8 channels of audio through a codec that would normally just carry just two.

The Tieline Genie STL has some great features. It is another 1RU dual-channel codec, with linear PCM support at up to a 96 KHz sample

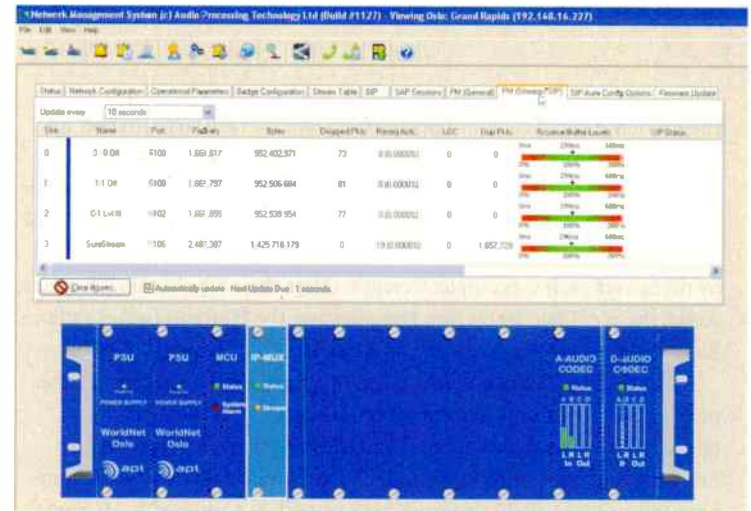

APT WorldCast Oslo Network Management software displaying performance parameters for redundant paths

rate. It has dual gigabit Ethernet interfaces (with IPv6 compatibility) allowing seamless redundancy by switching back and forth, without loss of audio, from a primary data link to a backup link if one fails and then subsequently recovers. When redundant audio streams are sent, the receiving codec automatically reconstructs audio into a single stream on a first packet arrived basis. Tieline's Codec Management System is used

Skylla Automates Sports - Flawlessly

- Rain Delays - No Problem!
- Games After Midnight - No Problem!
- Local Games - No Problem!



Whether you need network sports automation with full walkaway, or just a better way to broadcast your local games, we've got you covered. We were the first company to automate satellite feeds in 1989. Today, we still lead the field with the best talkaway automation for sports. Pro, college, local high school ... No Problem!

Automation That Is Bullet Proof



Our Linux operating system was built to do one thing: run your audio. You'll find that Skylla takes you to a whole new level of reliability. You'll get better security. You'll get better support - because we built your system, took a picture of it, and then installed it for you. There will be no surprise operating system updates. Rather, we'll have your back, 24/7/365. We will solve problems for you.

Control Your Own Music

Live and local? When you want control of your own music, Skylla will deliver. You can play music on hard drive from your studio ... or voice track from anywhere on the planet. We make it easy for your personalities to host shows while out of state ... or out of the country. If they have internet acces, it's easy. Just ask our clients!

Broadcasters trust us to get it right.



for control, in addition to an integrated web GUI. A 4-port GPIO comes standard, along with in-band RS-232 communications capability.

The GatesAir Intraplex IP Link is another entrant into this field. The IP Link 100 is a dual-channel, full-duplex audio codec; the IP Link 200 accommodates two separate pairs (4 channels total) of bi-directional audio. For our application, it will encode in a linear fashion, though it can make use of lossy codecs as well. In addition, it will transport AES/EBU at a 192 KHz sample rate, thus allowing it to transport digitally sampled "composite" from end to end. IP Link comes with three independent Ethernet interfaces for network redundancy, and it has what GatesAir is calling 'Dynamic Stream Splicing' to provide glitch-free performance over IP networks. The user can prioritize stream sources at the output for automatic switch over and switch back between primary and secondary streams. Programmable FEC, time diversity, and interleaving of streams guard against burst packet losses. Analog and AES/EBU digital audio I/O is provided via XLR connectors, and a 4-port GPIO is available as well. Configuration and management is done via an embedded web GUI.

WorldCast Systems offers the Horizon Nextgen, a 1 RU, dual-channel IP codec. It's a good match for this application since it comes with dual Ethernet interfaces, which can be configured to use separate IP networks for program transmission. Analog and AES/EBU audio I/O is supported via XLR connectors. The AES/EBU sample rate is selectable as 32, 44.1, or 48 KHz. Linear PCM coding is supported, again fitting well with our application. An auxiliary data input is available to transport serial data across the link, with rates up to 115.2 kbps. Control and configuration, including management of packet size, buffers, and QoS levels, is done via the embedded web server, or using the Worldcast NMS software. The unit also features WorldCast's "Scripteasy" remote control software.

By the way, I'm not saying that you could get by with just an IP codec with dual Ethernet interfaces; clearly this device would be a single-point-of-failure in that situation. In the case of STLs, ideally you would continue to use one of the legacy systems as a secondary, or even tertiary, backup system.

Maybe you've read this far because you're wondering how I eventually resolved the interference issue I described in my KJAZ radio STL system. I hired another local engineer in San Francisco (Bill Ruck) to figure it out with his Tektronix 2710 spectrum analyzer. Ultimately, he found a new paging transmitter that had been installed downtown was producing a nasty burst of wideband RF "junk" in its output when keyed. A bandpass filter on the transmitter's output solved the problem. However, if I had the amount of experience then that I have now, I wouldn't have trusted just a radio link to be the sole means of that one station's program transport. That mistake caused some serious problems and disappointed a lot of listeners to the jazz station. I hope that I've convinced you to build the most robust system possible for your stations. Not only is it good engineering practice, you'll likely sleep better at night. 

Irwin is RF engineer/project manager for Clear Channel Los Angeles. Contact him at doug@dougirwin.net.



RF Specialties[®]
Group
www.rfspecialties.com



Smart Technology,
Even Smarter Value.



Innovation has never been this affordable

All the qualities you have come to expect from the Industry Leader

Our 1 5/8" Aluminum Components offer

- Excellent electrical performance
- Light weight design
- Lower cost than traditional copper/brass components

When budgets are tight and deadlines even tighter, go with the company that has been delivering Quality and Value to the industry for over six decades.

Learn why so many broadcasters rely on MYAT.
1-201-684-0100 | WWW.MYAT.COM

Northern Community Radio Expands: An Engineer's Perspective

By Dan Houg, KAXE/KBXE Chief Engineer

When Northern Community Radio set out to build a new community radio station in rural northern Minnesota 38 years ago, naysayers said that it would be broadcasting “only to a bunch of gophers.” That station, KAXE, is still going strong and in 2012 put another rural northern Minnesota station on the air, KBXE, with full studios, transmission plant and antennas on a new 500-foot tower. Operating at 50 kW, KBXE was needed to give permanence to a signal previously served by a translator in the commercial band. Designed to operate as a network of two with transmitters 87 miles apart, both KAXE and KBXE contribute programming to the common air signal delivered across a large swath of northern Minnesota. Programming for the small network will originate live in either the KAXE studio in Grand Rapids, Minn. or at KBXE located in Bemidji, Minn. and switch locations several times throughout the day. With the studio-to-studio link, some programming is originated with hosts at both locations simultaneously.

STUDIO CONSTRUCTION

It has been said that an engineer should return to the first studio he or she has built and apologize for the mistakes made. Having been a new engineer when the KAXE studios were first being built, there are some issues I let slip by that I am now less than pleased with. The studios had been architecturally designed and are beautiful, but there are acoustic problems that I was determined not to repeat. Operating with a finite budget for KBXE that did not allow for hiring acousticians and state-of-the-art noise isolation construction, I was able to use simple noise isolation techniques

and work with a receptive general contractor. Studio walls were double-frame stud walls; studs offset, plates resting on closed cell foam, and filled with fiberglass insulation. Internet research showed that people had been obtaining good isolation results with two layers of 5/8-inch sheetrock on the inside walls treated between the sheets with a product called Green Glue [greengluecompany.com]. One half gallon of Green Glue was used between each 4' x 8' sheet layer, extruded out from quart sized caulk tubes with conventional sheet rock screws binding the layers together. Once cured, I was very pleased with the noise isolation of the studio and production room walls. Homemade absorptive sound panels using 2' x 4' Owens Corning



KBXE Studio Construction

FACILITY SHOWCASE

703 fiberglass drop ceiling panels mounted in a simple pine frame and covered with cotton cloth painted by a local artist finished the rooms and dampened acoustic reflections. Sound-isolating windows into the studio and a visual communication window between air studio and the production room were made by sandwiching two double-pane argon filled thermal windows together with a large air space between, for a total of four panes of glass in each window. Mounted in butyl to restrict vibration, these inexpensive windows work well.

STUDIO TO STUDIO (STS) AND STUDIO TO TRANSMITTER (STL) LINKS

We faced the challenge of tying program material for the new KBXE studio to the existing KAXE studio, separated by 73 miles of rural Minnesota not served by microwave links nor economical T1 service. An estimate from a local carrier of \$550 per month for T1 at each end was out of budget for recurrent costs. At NAB, I spoke with Kevin Campbell of APT (World-Cast Systems) about their new codecs featuring SureStream technology that use diversity bit splitting of audio IP packets. We deployed a pair of APT WorldCast Oslo frames for the link between the KBXE studio in Bemidji and the KAXE studio in Grand Rapids over a pair of \$40 per month consumer DSL lines. The system works well. We achieve CD-quality audio between the two stations with a 300 ms delay. This allows us to switch program origination between the two stations' studios transparently and conduct interviews in realtime between them.

The STL brought its own challenges. Our transmitter is located 17 miles from the KBXE studio with no direct line of sight, so we constructed a two-hop microwave link using Ubiquity Nano-bridge unlicensed radios on the first hop to a nearby tall building, and licensed 11 GHz Motorola Canopy radios from that building for the remainder of the distance to the tower. We used APT WorldCast NextGen IP audio codecs for this link. This allowed us to use the cascaded microwave



KBXE Engineering rack and audio codecs

Style and affordability from the industry leader.



Custom furniture • Full integration services • RF services

GRAHAM STUDIOS

Broadcast Furniture

(866) 481-6696 • graham-studios.com

EASE the COMMUNICATION

- with your audience
- between your call screener and your host

NeoScreener



Phone Call and Talk Show management software for Radio & Television



www.nmg.com

Any Way You Want It



WVR-4 Plus

Web & Voice Remote Control

The WVR-4 Plus gives you the power to monitor and control your site any way you want it. Log in with internet access from any PC, tablet or smart phone or dial in for control using voice prompts and touch tone commands. Simple, affordable, versatile. Access any way you want it - the WVR-4 Plus.

BROADCAST
tools
PROBLEM SOLVED
www.broadcasttools.com

Designed in Washington State and Assembled in the USA

Six Remotes in Every Box



Merlin PLUS

- * SmartStream PLUS dual IP streaming
- * Dual Power Supplies
- * Dual Ethernet ports
- * IPv4/v6 Ready

Tieline ✓
The Codec Company

www.tieline.com

Get all of these fine products from...

Broadcasters General Store



www.bgs.cc

2480 SE 52nd Street • Ocala, FL 34430 • 352-622-7700

ARRAKIS SYSTEMS INC.

ALWAYS THE LEADER

For more than 30 years, Arrakis Systems has led the way with ground breaking innovations in Radio console, automation, and studio furniture technologies. Now with Bluetooth inside, you have wireless Cell phone & Streaming ... no Hybrid needed!



ARC-8
only \$799



ARC-10
from \$1,599

ARC-15
from \$3,495

MARC-15
from \$4,999



Digilink-Xtreme

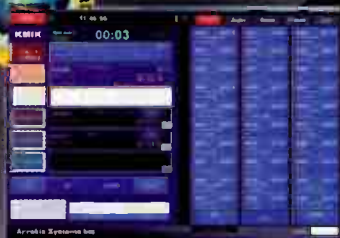

ARC-15



Bluetooth
inside



ARC-10
ARC-15

ACCENT furniture

Digilink-HD

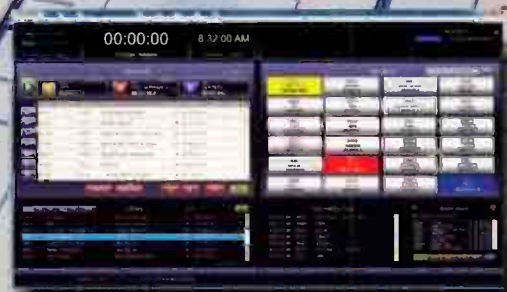

Internet . Radio . Complete TM

optional Arrakis mixers



optional PCs



Cirrus Player

Arrakis Internet Radio automation software

Free !!!

- Perfect... Internet Radio by Radio pros
- Triple play... On Air Live, Automate, & Cue
- Simultaneous... Play on Air while Recording
- Voice Tracking... voice track your programs
- Music Scheduling... professional Radio music

Promo Code
'NWFREE14'

Securenet Systems streaming services

- Ad Delivery... earn revenue from your desktop and mobile listeners .
- Mobile reach... free mobile apps.
- Hosting... Fast, secure, hosting.
- CirrusTM Player... for Windows & Mac .
- Stream in... HE-AACv2 (formerly AAC+)

Sign up for a Securenet Systems hosting plan and receive a FREE copy of Arrakis New~wave professional Internet Radio automation and production software for the life of the plan... a \$750 value.

INTERNET . RADIO . COMPLETE ... is designed for novice and experienced Internet Radio users alike, It is an end-to-end solution that provides BOTH the Windows PC based Radio On Air software required to produce and present your program material AND the streaming service that has the Control Panel to monitor your streams , the Players for your listener's media devices, media accounting, ad delivery, and much more. Call or visit our web site today to learn more.

\$99 a month

300 simultaneous Listeners

New~wave Automation included

\$199 a month

600 Simultaneous Listeners

New~wave Automation included

\$399 a month

As many Listeners as you need

New~wave Automation included

The New~wave automation software will function while a valid Securenet Systems stream hosting program is active.

All plan prices are based on a 32 Kb/sec HE-AACv2 stream. All prices and features are subject to change without notice.

DB4004 Modulation Monitor
Product with no equal in the industry
... it's Simply the BEST !!!



Available in the US from SCMS, Inc. Call: 800-438-6040
www.scmsinc.com



FACILITY SHOWCASE

links as one continuous audio path. A 1 Mbps DSL line installed at the transmitter site served as an alternate IP path. This combination gives a much-needed measure of redundancy. To finish the belt-and-suspenders approach, a backup to the IP STL is provided by a BW Broadcast RBRX1 receiver. This receiver takes an off-air signal from KAXE, 87 miles away, should the IP STL fail. In a roundabout way, we can originate program material at KBXE, send it to KAXE over the studio-to-studio link where it is transmitted at KAXE and received over the air at the KBXE transmitter site for broadcast! It works.

STUDIO CONSOLE SELECTION

A major decision that I wrestled with was the studio console. I appreciated the solid reliability of a traditional analog console and was quite familiar with the TDM (Time Division Multiplexing)-based consoles at KAXE. I was torn between the technology that I was most experienced with, and realizing that the future is audio over IP. Questioning fellow broadcast engineer friends to the point of exasperation, I decided on AoIP as the basic architecture and decided to go with Axia for the availability of accessories, the large installed base, and several engineer friends that knew how to program the system. Along with the Axia Element and Radius control surfaces, I used StudioHub wiring. As has recently been discussed on PubTech, a public radio

engineering e-mail list, the modular wiring is exceptionally easy to use but does not immediately lend itself to neat wiring, due the premade dongles and Cat-5E jumpers that never seem to end up exactly the right length.

STUDIO FURNITURE

While at NAB, I looked at several furniture manufacturers and designs. Upon my return, and after discussing the furniture costs, a local cabinetmaker offered to make broadcast furniture for the studio and production rooms for the cost of materials as a contribution to KBXE. An exemplary craftsman, the cabinetmaker traveled to KAXE to see what staff liked, and did not like about the KAXE desk. He ultimately came up with an original design incorporating those ideas for KBXE. The studio broadcast desk was designed for ease of wiring access to the generous interior cavity with the decorative panels hinged on cabinet door swings. It has a wraparound top with large overhangs set above wheelchair height that allow guests to scoot up to the mic closely. Desk-top mic stands were chosen to eliminate the "sea of spiders" effect and create clean sight lines. Keyboards for automation and studio computers reside underneath the console for the operator, as well as on top for guest host duties.

All clocks at the station are radio-controlled and synchronized to the NIST Radio Station WWVB

EQUIPMENT LIST

Air Studio:

- Axia Element console with Powerstation and Aux
- ENCO DAD automation
- Telos Hx2 hybrid
- Electrovoice RE-20 mics
- 25-7 Profanity Delay
- Denon C635 CD players
- Custom locally constructed furniture
- Custom fabricated acoustic treatments
- Fujitsu mini-split HVAC
- Audio-Technica turntables and headphones
- StudioHub wiring

Production room:

- Axia Radius console
- ENCO DAD
- Telos Hx1 hybrid
- Denon CD players
- Tannoy Reveal monitors

Engineering:

- Sage ENDEC
- Dayton EAS receivers
- Best Ferrups UPS
- HP and Cisco switches
- Tieline Bridge-IT for remotes

- APT WorldCast Oslo IP audio codec for Studio to Studio Link

STL:

- 2 hop IP microwave with redundant path via DSL modem
- Motorola Canopy 11GHz radios plus Ubiquiti 2.4 GHz NanoBridge radios
- WorldCast APT NextGen IP audio codecs

Transmitter plant:

- Nautel NV15
- Myat transmission line
- Commscope/Andrew dehydrator
- Tunwall transfer switch controller
- Altronic dummy load
- Orban 8500 processor
- LEA surge suppressor
- Thermobond building
- Dielectric 4 port 3 1/8" coaxial switch
- Inovonics 730 RDBS generator
- Unimar LED lighting and controller
- ERI tower and antenna
- Davicom remote control
- BW Broadcast RBRX1 receiver used for STL backup
- Custom HVAC economizer
- Middle Atlantic rack

FACILITYSHOWCASE



Economizer system at TX site

time service broadcasting at 60 kHz out of Fort Collins, Colo. Clocks were chosen that have a second hand as well as 12- and 24-hour numerals. Retailing at less than \$50, these clocks are spot on for network joins and adjust to Daylight Savings automatically. Since the cost is so reasonable, we mount clocks in as many locations as requested by staff including the restrooms!

STUDIO AND TRANSMITTER SITE HVAC

Having learned a painful lesson at KAXE about poor HVAC control, we opted for a multi-faceted approach at KBXE. Combining a Fujitsu mini-split heating and A/C unit along with some low-velocity ducted HVAC from a central unit for the station, supplemented with electric baseboard heat, we ended up with very quiet heating and cooling in the closed studio. The Fujitsu indoor unit is exceptionally quiet in its "Quiet Mode" fan speed and can both heat and cool with good efficiency. Air source heat pumps such as these are being made with remarkable cool weather performance necessary for our northern Minnesota climate and can supply heat even with low outside temperatures.

The KBXE transmitter site has a wall-mount industrial A/C unit with outside air intake functioning as an economizer to save the A/C from running during cool weather or when the temperatures are below the minimum



RF Specialties®
Group

www.rfspecialties.com

AcousticsFirst.com®
Materials to Control Sound & Eliminate Noise.™

Meet the new
A¹D¹ DIFFUSOR[®]
Model D

The Future is here!

Toll-Free Number:
888-765-2900

Photo: WBWV 88.7 FM Facility

Time to Synchronize **ESE**

ES-185U/NTP GPS Master Clock

With ESE's Master Clock, you can display Universal Time Code via the 12-channel GPS receiver and generate many types of Time Code (NTP, SMPTE/EBU, IRIG-B, ESE-TC89, ESE-TC90 RS232C/ASCII, & USB), and an extremely accurate 1PPS signal.

You can also easily interface with new or existing computers, automation and clock systems. Visit www.es-e-web.com for all your time synchronization needs.

ESE, 142 Sierra Street, El Segundo, CA 90245 USA, Tel: (310) 322-2135

FACILITY SHOWCASE



TX site electrical system



TX site transmission line routing

operating range of the compressor. Unfortunately, the logic on this particular economizer was poor, failing to return to A/C operation once daytime temperature rose above the enthalpy point. Several service calls to fix this issue did not have good results, so I built an economizer using the passive air ventilation I had specified to keep temperatures in check should the A/C unit fail, which it has done several times. Since the over temp ventilation fan and motorized intake louvers are on their own thermostat completely separate from the digital A/C thermostat, it was a simple matter to add an outside sensing open-on-rise thermostat in series with an interior sensing close-on-rise thermostat to have this backup system function as an economizer as well as functioning as an over temp failsafe.

TOWER CONSTRUCTION

When the KBXE project began, I had naively envisioned a linear process for my first tower build. Between regulatory, siting, construction, ground water and NEPA issues, my linear path resembled a serpentine string of issues to tackle and move on to the next. If I were to advise anyone undertaking

their first tower project, it would boil down to two key things. First, your environmental study required by the National Environmental Policy Act will take longer than you think. Second, be onsite as much as possible during all phases of construction. Being onsite as much as I was, I not only learned about our tower construction, but also was able to catch a significant error regarding high ground water present on the soil boring report that did not get transmitted to the engineers at ERI designing the tower. After a few calls back and forth to ERI regarding the presence of high ground water onsite, the base and guy foundations were recalculated for these conditions. An extensive archive of photos of the tower construction process from soil sampling to antenna completion is available at <http://tinyurl.com/KBXE-Tower>. Ed Carter from West Texas was the Ironworker doing the assembly of the ERI tower and I have nothing but praise for the way his crew worked safely and was always in control of the steel as it was being erected.

TRANSMITTER BUILDING AND COMMISSIONING

Working with Master Electrician Brandon Chase from Hoffman Electric and the Nautel

FACILITY FOCUS: THE TECHNOLOGY BEHIND KBXE

Tieline Bridge-IT



Use Tieline's affordable Bridge-IT IP audio codec to expand your IP network at a fraction of the cost of competing IP codecs. Multi-unicast stereo audio to six different end-points from a single codec, or multicast over compatible IP networks, and reduce capital expenditure across your network.

Bridge-IT offers 16-bit, 22 kHz linear audio, MPEG Layer 2, Tieline Music and MusicPLUS, G.711 and G.722 algorithms as standard, with optional apt-X Enhanced, LC-AAC and HE-AAC.

Bridge-IT is EBU N/ACIP Tech 3326 compatible over SIP and has automatic SD card audio backup. It features analog and digital XLR in/out, a keypad and LCD display, plus the Toolbox web-GUI for remote configuration. Bridge-IT also offers SmartStream technology for automatically managing IP connections and delivering rock solid audio over IP.

tieline.com | 317-845-8000

ENCO Systems

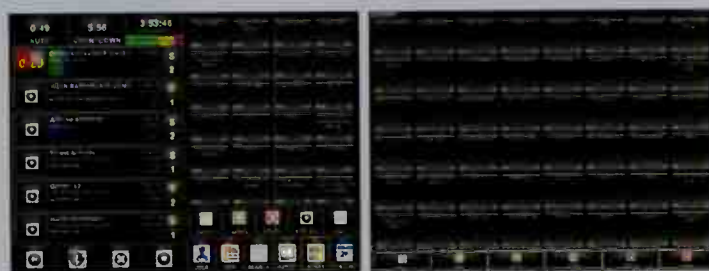

ENCO Systems is the world leader in audio playout and automation solutions, manufacturer of DAD. From live-assist to full automated mode, DAD is the most flexible, powerful, and reliable radio automation system on the planet. ENCO DAD gives you all the tools you need to make your broadcasts sound better, make running your station easier and give you unrivaled power and control.

DAD is used at radio facilities all over the world, large and small. ENCO offers iDAD/enDroid for remote audio production and control, and iDAD-REMOTE for remote voice tracking. The award winning ENCO1 virtualized radio automation system offers stations even greater flexibility and efficiency.

www.enco.com | 800-ENCO-SYS

Advertisement

Recommendations for Transmitter Site Preparation, we laid out the ground buss bar, transmission line, service panels, LEA spike suppression and service entrance on the same side of the building to localize energy dissipation near the grounds in the event of a lightning strike. A halo ground surrounds the building. Each lobe of the triangular tower base, as well as each ice bridge post are separately grounded via a Cadwelded copper wire to a ground rod.

The assembly of the 3 1/8" rigid copper feed line from the transmitter to the transmission line gas block flange connector was a new experience for me. I was given a great suggestion by our project consultant, Gray Haertig, of Gray Frier-son Haertig & Associates, to cut rigid line with a carpentry chop saw fitted with an 80-tooth carbide blade. A Commscope reverse osmosis line dehydrator pressurizes the transmission line after an initial nitrogen purge performed by the tower crew.

Commissioning of the Nautel NV15 was daunting as this was the first new transmitter and transmission plant I had built. After going through the startup procedures carefully, I hit the RF ON button on the GUI and was met with dismay as I

saw my reflected power rise to a foreboding 666 watts. Fearing I'd assembled something wrong in the rigid copper line or in the Dielectric transfer switch, I turned off the transmitter and called Gray, panic-stricken. After telling me to take a deep breath, he suggested I go outside and look at the transmission line and antenna to see if anything was awry. As my eyes scanned upwards from the bright, new aviation orange and white tower paint, the tower was obscured with a layer of rime frost starting at 200 feet above ground level! As the sun came out that day, reflected power dropped to a satisfying 0 reflected watts.

FINAL THOUGHTS

To rephrase, "It takes a village to build a commu-nity radio station." A radio station serving rural areas does not enjoy the economic base of metropolitan areas but has, perhaps, an even more important mis-sion to serve its community. Supported by volunteers, staff, generous contractors and consultants, KBXE was a collaborative effort that brought many disci-plines to the table and resulted in a very economically built studio and transmission plant using state-of-the-art equipment. 0

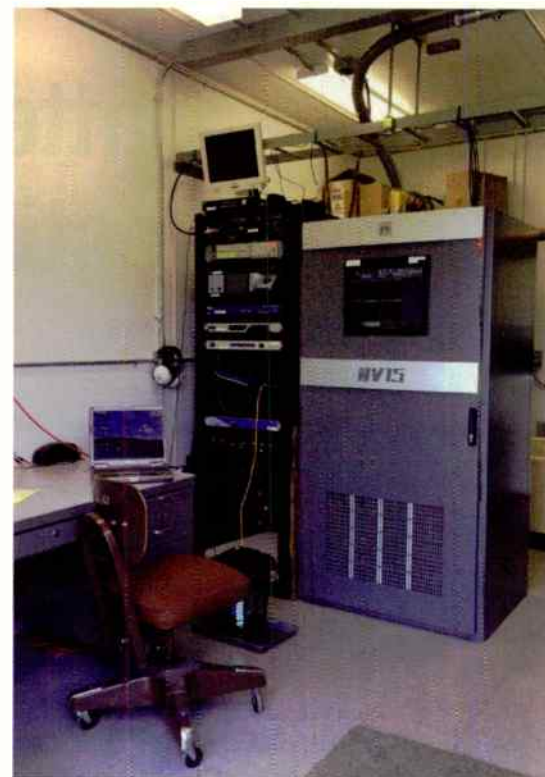

KBXE TX and equipment rack

ERI-Electronics Research Inc Guyed Tower

ERI supplied a 490-foot guyed tower, which included a Lambda Optimized FM Antenna Mounting System to support an ERI 8 Bay LP ROTOTILLER Series Directional FM Antenna. In addition to design-ing and fabricating the tower and antenna, ERI also performed the installation. The tower is a 30-inch face solid-steel member design and incorporates ERI's unique Inner-Lock Section Connection Design, and includes diagonal bracing at section connections, which properly transfers axial loads from section to section without creat-ing additional torque loads. The Lambda Mounting System provided has a minimum bending radius of 3,000 feet under load at service wind speed. This makes the tower very stiff and increases the opera-tional lifetime of the side-mounted antenna and each section is electrically symmetric to the antenna element's mounting position.



eriinc.com | 812-925-6000

Dielectric 60000 Series Switch

Keeping the signal transmitting without interruption is the result of system compo-nents designed to the highest standards. The Dielectric Series motorized coaxial switch introduced in 1978 has become the standard in the industry for reliability and unmatched isola-tion characteristics. The switched is used to automatically patch the transmitter's output to dummy load, between main and standby antennas, and bypassing inter-mediate RF systems. The 60000 Series switch, with readout and position indication, ensures the switch is always in the correct position. Additionally, it may be operated locally with no customer input wiring, a distinct advantage for simple system set up and maintenance. Beyond the technical reliability, Dielec-tric has a 98% on-time delivery rate for every product line and often delivers sooner than the standard lead times.

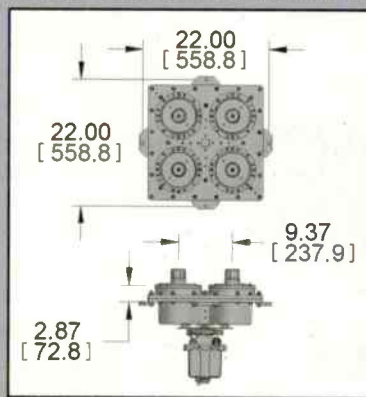
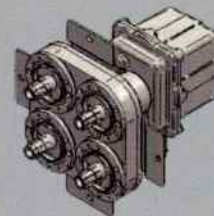

dielectric.com | 800-341-9678

Advertisement



by Doug Irwin
CPBE AMD

Battery Maintenance: Testing and Charging

How many large, lead-acid batteries are you depending upon right now? Do you test them?

Testing a generator is one common scenario. Hopefully, you'll discover a dead battery when you do the test, and not when you need it. That can make for a very bad day.

So let's say that you find a dead battery during a test, and discover that the real problem is not so much the battery, but the charger. Let's also say that the charger is 40 years old and uses selenium rectifiers. It's time for a new one. How does one pick a new battery charger? (<http://www.batterystuff.com/kb/articles/charging-articles/how-do-i-pick-a-battery-charger.html>) That depends on the size of the battery. A good rule-of-thumb is this: take the ampere-hour rating of the battery, divide by the charger rating, and then add 10%. For example, you have a 100 AH battery. If you were to buy a charger rated at 15A, it would take just over 7 hours to charge the battery, assuming it was completely discharged. Another thing to consider: during the absorption period, the charger output should be between 14.4 and 14.9 volts. After the battery is charged, the "float" voltage should be between 13.1 and 13.4 volts.

Now let's say that it's a weekend, and you

can't get a new battery charger right away. Can you use a big power supply to do the charge? Yes, with careful attention. (http://batteryuniversity.com/learn/article/leveling_charge)

- Calculate the voltage necessary. For lead-acid, use 2.40 V per cell. For a 12 V cell then, the power supply output would be 14.4 volts.
- Set current limiting between 10 and 30% of the battery's AH rating.
- You should observe the battery temperature, voltage, and current during the charge period. Charge only in a well-ventilated space.
- As the battery charges, the current will diminish. When it "bottoms out", disconnect the charging source.
- The battery can be maintained in a "ready" state by keeping a "float" voltage across it, again, between 13.1 and 13.4 volts.

It's also possible that prior to the battery charger failure, it was not maintaining the charge level correctly. One possible symptom of under-charging is sulfation. Recently, I was doing some research for an article on the design of alternative power systems. (http://radiomagonline.com/infrastructure/power/trends_alt_power_0601/)

Jeremy Preece of EMF in Southern California told me the following about his station's photo-voltaic system battery bank:

"On our old 3000AH bank, we were only able to charge at roughly half the C/20 rate, and that's why the batteries died young. They needed more current to boil off the sulfate build-up than what the (solar) panels could provide under peak performance."

I've been using flooded batteries for years and admittedly, I was not familiar with this issue. Let's take a look at just what this means. (http://batteryuniversity.com/learn/article/sulfation_and_how_to_prevent_it) "Sulfation occurs when a lead acid battery is deprived of a full charge. Solar cells and wind turbines do not always provide sufficient charge, and lead

acid banks succumb to sulfation. What is sulfation? During use, small sulfate crystals form, but these are normal and are not harmful. During prolonged charge deprivation, however, the amorphous lead sulfate converts to a stable crystalline layer deposited on the negative plates. This in turn leads to the development of larger crystals, which reduce the surface area of the battery's active material. Sulfation also lowers charge acceptance, and makes charging take longer because of elevated internal resistance." You may be able to reverse the effects of sulfation—I recommend you go directly to my reference should you want to attempt this. (http://batteryuniversity.com/learn/article/sulfation_and_how_to_prevent_it)

The Battery University page also has basic recommendations for maintaining lead-acid batteries:

- Always keep lead acid batteries charged. Avoid storage below 2.10 V/cell, or at a specific gravity level below 1.190.
- Avoid deep discharges. The deeper the discharge, the shorter the battery life will be. A brief charge on a 1 to 2 hour break during heavy use prolongs battery life.
- Never allow the electrolyte to drop below the tops of the plates. Exposed plates sulfate and become inactive. When low, add only enough water to cover the exposed plates before charging; fill to the correct level after charge. Use distilled or ionized water. Never add acid. This would raise the specific gravity too high and cause excessive corrosion. 0

Irwin is RF engineer/project manager for Clear Channel Los Angeles. Contact him at doug@douginwin.net.

RESOURCES

Battery University | www.batteryuniversity.com
Battery Stuff | www.batterystuff.com

 **RF Specialties®**
Group
www.rfspecialties.com

WE NEED YOUR TIPS

Tech tips may be suitable to earn SBE recertification credits. Send your tips to radio@RadioMagOnline.com.

Radio Automation...

ARRAKIS SYSTEMS INC.

'NEW~WAVE' + 'DAC'

ON AIR RADIO SOFTWARE FOR LIVE
ON AIR & HARD DISK AUTOMATION ...
PROFESSIONAL USB SOUND CARD
WITH BALANCED ANALOG AND DIGITAL
OUTPUTS ... ONE WEEK SCHEDULER ...
EDITOR/RECORDER SOFTWARE FOR PRO-
DUCTION ... VOICE TRACKER ... MUSIC
SCHEDULER ... JUST ADD A WINDOWS PC AND STIR.



A perfect Live On Air & Automation solution for a single PC
broadcast or Internet Radio station...

only **\$1,100** bundle price*

This NEW~WAVE software plus DHD-DAC hardware bundle combines the strengths of NEW~WAVE software with the professional features of the DHD-DAC USB player hardware. The software is perfect for live or automated on air radio or internet radio, while the hardware provides the high performance USB play sound card with professional balanced analog and SPDIF digital outputs that the PC lacks. And because it is an external box that connects to the PC by USB cable, there are no clumsy sound cards or drivers to install inside the PC. The internal PC sound card is used for appropriate background tasks such as Cueing and recording voice tracks. This remarkable combination of software and hardware, combined with a new PC, creates a powerful, professional digital audio workstation for today's diverse radio applications.

The NEW~WAVE software part of the bundle is designed specifically for playing audio files from hard disk, internet streams, FTP stored audio files, MP3 players, smart phones and much more. NEW~WAVE brings together all of the newest technologies to produce an exciting show for your radio audience. Play live broadcasts, automated broadcasts, podcasts, and stream for internet radio... all at the same time. Most important, NEW~WAVE is quick to learn and easy to use. Designed for both novice and professional alike, it has the simplicity required to get to air quickly and yet the sophisticated features for advanced users.

*save \$150 from the individual product pricing

New~wave software only **\$750**

www.arrakis-systems.com

970.461.0730

More Than Audio Streaming

How to Optimize the Mobile Radio Experience for Advertisers and Listeners

By Bill Freund, Clip Interactive

When we look at the fact that radio has more than 243 million listeners every week, hitting nearly 90 percent of all demographics, many wonder why the medium continues to struggle to attract new advertising dollars each year.

However, the fact is, radio is more relevant than ever. According to a Nielsen report on the state of audio media released in April, radio listenership is at an all-time high. Yet even with the large and diverse audience, radio ad spending shows significantly slower growth than other media including mobile advertising, which is expected to grow to an astonishing \$31.1 billion by 2017.

WHY IS MOBILE TECHNOLOGY IMPORTANT FOR RADIO?

Many already think of radio as a mobile medium: we listen to it in the car, at the beach, and nearly anywhere that we can get AM/FM reception. Although radio can reach listeners almost anywhere, the one space it is still lacking full integration is on mobile devices such as smartphones and tablets using cellular and WiFi connections.

Mobile device advertising is exceedingly important for radio as approximately 75 percent of new mobile advertising money will come

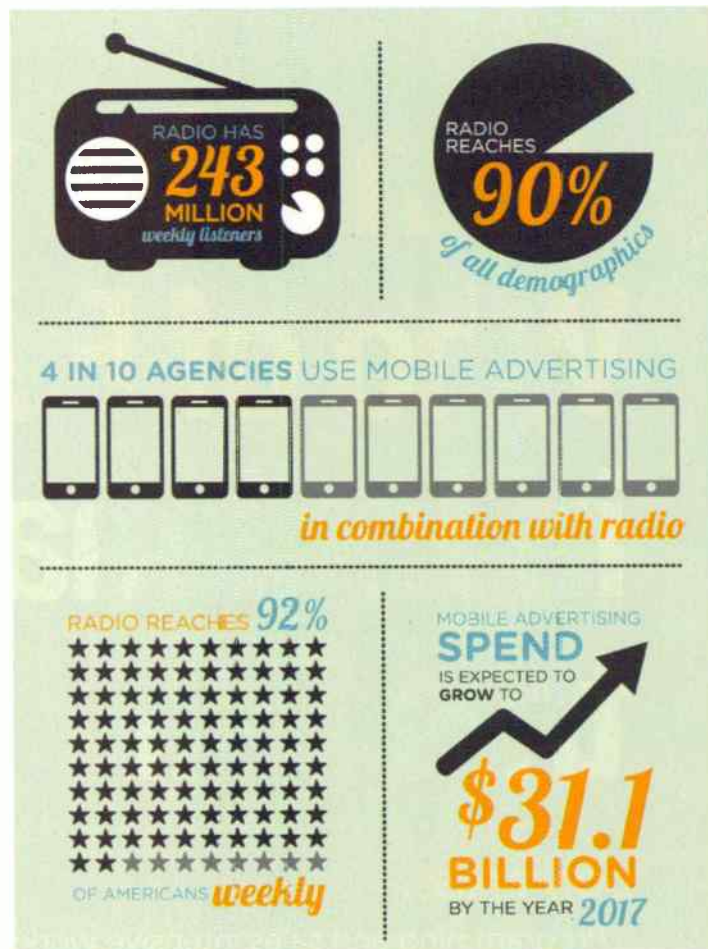

at the expense of advertising budgets for radio and television. Yet, according to a May 2014 Nielsen report on mobile advertising, four in 10 agencies use mobile advertising in combination with radio.

Enhanced mobile integration creates a more engaging experience for radio listeners, and more opportunities for advertisers. Mobile devices are being used to boost metrics as a companion for other advertising

The advertisement features a central yellow oval logo with 'RAM' in a black bar. Surrounding the logo are five photographs of modern radio broadcast studios with desks, microphones, and computer monitors. At the bottom, the text reads: 'RAM SYSTEMS LLC', 'Equipment Sales', 'Custom Furniture', '800 779 7575', and 'www.ramsystemsonline.com'.

strategies. Fifty-two percent of brands and advertisers believe that mobile advertising combined with other mediums like radio can significantly improve the results of campaigns.

WHY ISN'T A STREAMING MOBILE APP ENOUGH?

Most radio stations have already deployed mobile applications for smartphones and tablets, but only offer the ability to stream the live broadcast to the user's device. Online and mobile streaming only represents 3% of total radio listenership for most stations. Ninety-seven percent of the population is still listening to the on-air radio broadcast. Although streaming can broaden a station's audience, radio needs to find a way to actively engage the 97% of on-air broadcast listeners.

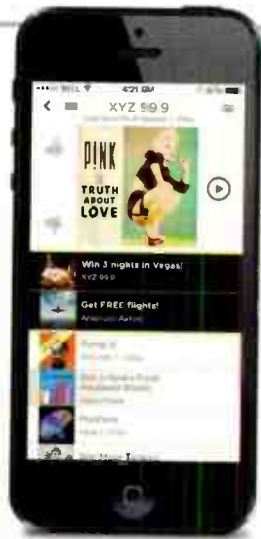

TIPS FOR RADIO STATIONS TO DO MOBILE BETTER

Rich Interaction: Today's consumers demand more engagement from their media. Television, websites, and smartphones offer deeper engagement through the ability to stop and start media when desired, download content, and access additional information instantly. A more integrated approach for radio broadcasters, aside from

simple streaming, is one that allows listeners to interact with everything they hear on the air. This includes the ability to instantly download music, enter contests, access local deals, and more. The added interactivity provides a more engaging experience for the listener, and can generate tangible results for advertisers.

If everything you hear on the radio can be found, viewed, and engaged with through the station's smartphone and tablet apps, then your station will provide significantly greater value

to all parties.

Engage Inactive Listeners: For the first time, new app technology offers radio stations the ability to reach out and touch the listener when they aren't actually listening to the live broadcast. Push notifications and content feeds on radio station apps can be instrumental in drawing the user back to the station; leveraging music, offers, local news, events, and contests.

For example, mobile apps can alert users to a contest they may want to enter, a new music promotion, or a local business offer by simply deploying a push notification. This message will appear on the home screen of a listener's device, engaging them at a time when they would otherwise be inactive.

Deliver Real Numbers: This new app technology closely tracks the number of people who view the radio station feed, use the app on a monthly basis, take radio station polls, enter contests, download music, access coupons, and more. Comprehensive usage-based tracking

Providing technical precision as well as style and affordability.

Custom furniture • Full integration services • RF services



GRAHAM STUDIOS

Broadcast Furniture

(866) 481-6696 • graham-studios.com

SECOND OPINION COMMUNICATIONS, INC.

(815) 222-3556 • secondopinioncomm.com

Xenirad Inc.
Broadcast Engineering

(304) 416-3269 • xenirad.com

Tune in to the Future.



DAB
Digital Audio Broadcasting
HD Radio

MORE DIGITAL. MORE RADIO. AudioScience's ASI8921/8821-5500 series tuner cards offer the most digital radio capabilities: 4 or 8 tuners for analog FM, HD-Radio FM or DAB/DAB+. Record streams in PCM, MPEG-1 layer2 and MP3, while capturing all associated PAD data.

MRX multi-rate recording allows each stream to be sampled at it's own rate. The two independent tuner modules can be custom-configured, to add TV audio or AM audio capture. Need more digital radio? Add up to 8 cards in one system.

For information, call AudioScience at +1-302-324-5333 or email us at salesasi@audioscience.com.

FEATURES

- MRX multirate recording
- Up to 8 channels of HD-Radio or DAB/DAB+
- PCM, MPEG Layer 2 and MP3
- Windows 8, 7, XP, Server 2008/2003, Linux, and OS X software drivers
- PCIe interface (ASI8821) or PCI interface (ASI8921)

www.audioscience.com



APPLIED TECHNOLOGY

and reporting gives the radio station tangible numbers to see what content is most popular, and deliver solid ROI numbers to advertisers to prove the true value of the radio spot.

Clip Interactive's technology "listens" to radio station audio to identify the music and ad content, and builds a historical playlist. When a user selects a station feed to view, the app displays this history, and interleaves it with currently active promotional content (contests, polls, videos, etc). The item now playing is at the top of the list.

If the user is not sure what station they are listening to, they can tap the "Clip" button in the app, which samples the audio the user is hearing, and identifies the station. The experience is similar other audio recognition app technologies.

Clip Interactive technology can integrate into stations with audio obtained from proprietary radio receivers located physically in the station's local area, or via a dedicated piece of hardware connected directly to the station's airchain.

Pairing the radio broadcast with an enhanced mobile app can dramatically improve radio station metrics, while increasing listenership, engagement and advertising opportunities for the station. 

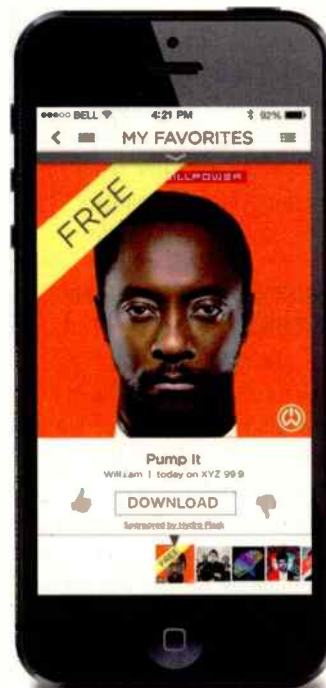

Bill Freund is the executive vice president and chief revenue officer at Clip Interactive, a company with the mission to give interactive radio to the masses in order to bring more listeners to stations and provide new services to listeners, advertisers, labels and station owners through both stand-alone apps for individual stations as well as the Clip Radio app, which aggregates all Clip Interactive stations.

DYNAMAX MX SERIES

- 6 to 18 channel configurations
- 24 or 36 inch wide frames
- 2" or 3" wide module options
- 4 Output Buss (two Stereo and two Mono)
- Metering for all 4 Outputs
- 2 - 4X1 auxiliary inputs standard
- Mic preamp on first two channels

MODEL 340

MODEL 343

MODEL 340

MODEL 343

215-547-2570
www.sandiesusa.com

SANDIES

RF Power Measurement & Intelligent RF Switch Control Solutions

- Measure analog & digital power in transmission line sizes from Type N to 9" EIA
- Proprietary state of the art 3-Strike VSWR protection
- Simple connections using standard CAT 5 STP cables
- Popular interface includes DC voltage outputs, SNMP, and RS232/485 to remote control systems
- Switch control of 1 or 2 RF Transfer Switches with intelligent RF Hot Switch protection
- Manages transmitter interlocks and simplifies the connection of interlock paths

Broadcast Devices, Inc.
www.broadcast-devices.com Tel. (914) 737-5032 Fax. (914)736-6916 **bdi**

CLIP INTERACTIVE
clipradio.com
sales@clipradio.com

RF Specialties® Group
www.rfspecialties.com



MOORETRONIX
BROADCAST & INDUSTRIAL ELECTRONICS

Our 14th Year

Our client list continues to grow. Thank you for your confidence and equipment purchases.

We Re-Condition

Pacific Recorders BMX I-II-III, AMX, ABX and RMX, Stereo-Mixer and Mixer News-Mixer products.

We Have

Replacement Wind Screens and Blast Filters for the SM-5B microphone.

We Repair & Re-Crystal

STL Transmitters, STL Receivers, and RPU equipment.

See the "News-Update" page at our website.

Tel: 800-300-0733 Fax: 231-924-7812

WWW.MOORETRONIX.COM

E-Mail us at: rmoorej@comcast.com



Fine Used AM & FM Transmitters
Authorized Representatives for all major equipment manufacturers

Used FM Transmitters

| | | |
|---------|------|--|
| 100 W | 2008 | BE FM100C |
| 500 W | 2000 | BE FM 500C |
| 3.5 KW | 2000 | Harris Z3.5CD, solid-state |
| 5 KW | 1995 | Harris HT5CD |
| 5 KW | 1999 | Harris Z5CD, solid-state |
| 5 KW | 2006 | Harris Z5, solid-state, unused |
| 7.5 KW | 2002 | Harris Z7.5CD, solid-state, S PH |
| 10 KW | 1988 | BE FM10A |
| 10 KW | 2004 | Harris Z10CD, solid-state |
| 20 KW | 1989 | BE FM20B |
| 20 KW | 2004 | Harris ZD20CD, solid-state |
| 25 KW | 2008 | Continental 816HD w/ Flexstar/Exporter |
| 25 KW | 1988 | Harris HT25CD |
| 27.5 KW | 1994 | Continental 816R-4B, SS IPA |
| 30 KW | 1988 | Harris FM30K |
| 35 KW | 1990 | BE FM35B |

Used AM Transmitters

Please call or email for current listing



Exciters

Please see our current listings on our website

New TV Transmitters

Visit our website for the latest sales
Special Discount Pricing On:
VHF and UHF Transmitters and
Antennas (100w to 10 kW)
TV STL

Used Misc. Equipment

BE FC30, SCA Generator
Bird Model 8936, 10 kW air-cooled RF
Load
Harris N + 1 Controller
MCI 4 Port 1-5/8" Coaxial Switch
Sola Constant Voltage Transformer
#23-23-230-8

Please visit our website, www.fmamtv.com for additional listings or
CALL US FOR A QUOTE!

2655 Philmont Ave. Suite 200, Huntingdon Valley, PA 19006
800-441-8454 215-938-7304 Fax: 215-938-7361

CircuitWerkes Web Power!



SiteSentry2 & 4 - Transmitter Controllers

With 2 or 4 meter inputs, 2 status inputs, stereo audio sensor & onboard temperature sensor, you can monitor your site from any Web browser, anywhere! Six relays (2 DPDT & 4 SPST) give ample control for many stations. Low & high alarm handling with multi-step actions. Logging & e-mailing of logs/alerts included. Streaming audio option available.



Sicon-8 - Web & Dial-up Remote Control

The Sicon-8 lets you control your site via Internet with its internal Web server, via telephone, auto-answering cell phone or our free software. Setup is a breeze using the Siconcontroller software that also includes scripting, e-mail alerts, multi-site management, virtual metering & more!



WAM-2 - Low Cost Audio Monitor w/Web

Monitor your audio from any Web browser. When silence is detected, it can perform user-programmed, automated, sequences of relay actions & can also respond to user control via the network or via external status inputs. E-mailing of logs/alerts included. Streaming audio option available.

Get info on these & other great remote control products at www.circuitwerkes.com

WEATHER RADIO

Model CRW-S With Same Decoding

Price \$690



Sensitivity .28 microvolts for 12 dB quieting. All seven frequencies. SAME decoding demutes receiver, closes relay and gates audio to 600 ohm rear terminals. Another set of rear terminals has continuous 600 ohm audio output. Double conversion crystal controlled, crystal filter in first I.F., ceramic filter in second I.F. Dual gate MOS FET front end. 50 ohm coaxial input. Adjacent channel (± 25 kHz) down to 70 dB. 19" rack mount, 1.75" H, all metal enclosure. In stock — available for immediate delivery.

GORMAN REDLICH MANUFACTURING CO

257 W. Union Street Athens, Ohio 45701

Phone: 740-593-3150 jimg@gorman-redlich.com

www.gorman-redlich.com



Made in the U.S.A.
 • Available LED Illumination
 • Custom Legends
 • Power - 120 to 220 volt AC & 12 volt AC/DC



CBT Systems' "ON-AIR" Lights can be ordered online at
www.cbtsystems.tv
 or by calling **858-536-2927**
 to locate a distributor near you

Engineering Software

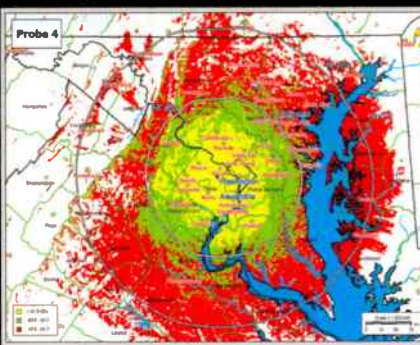

- Create "real-world" coverage maps, interference studies, and population reports with Probe 4™
- Find STL broadcast auxiliary and Part 101 microwave frequencies and generate PCN letters with Microwave Pro™
- AM Pro 2™, used daily by FCC engineers, performs skywave and groundwave allocation studies and AM coverage mapping.
- Map FM stations and discover upgrade possibilities using FCC minimum separations and contour-to-contour methods with FMCommander™

The Leader in Broadcast Engineering Software!



V-Soft COMMUNICATIONS®
 R.F. Communications Software and Engineering Consulting

www.V-Soft.com (800) 743-3684

FIND THE MIC WINNER

APRIL ISSUE

Bill Draper
 Chief Engineer, Clear Channel Radio
 Poughkeepsie, New York



He won a CBT-500 cable tester from Hosa Technology.
hosatech.com



The mic was hidden on the door of the truck.

The winner is drawn from the correct entries for the issue two months prior. No purchase necessary. For complete rules, go to RadioMagOnline.com.

Shively Labs®

A Division of Howell Laboratories, Inc. Bidgton, ME 04009 USA
 - An Employee-Owned Company since 1995 -



For over 50 years Shively has designed and manufactured FM products to work flawlessly; year after year, at any site, under any conditions, and for any power level.

Call Toll-Free: (888) SHIVELY
 Or visit us on the Web at: **www.shively.com**

PHASETEK, INC.

PHASETEK'S manufacturing facility and components expertise are available to design and fabricate any type of inductor or special R.F. component.

Our experienced staff of engineers and production personnel are dedicated to provide the broadcast industry the highest quality custom designed phasing equipment.



CUSTOM PHASOR INSTALLATION

RADIO STATION WXYT, DETROIT, MICHIGAN
 9 TOWER, 50 KW DA-2 PHASOR SYSTEM

PHASETEK, INC.
 550 CALIFORNIA RD, UNIT 11
 QUAKERTOWN PA 18951
 PHONE: 215-536-6648 FAX: 215-536-7180
 TOLL-FREE: 800-742-7383

From MILLIWATTS to KILOWATTS™



Transmitting & Audio Tubes

Semiconductors

Taylor
 Eimac
 Amperex
 MA/Com

Immediate Shipment from Stock

Motorola
 Toshiba
 Thompson
 Mitsubishi

• Se Habla Español • We Export

760-744-0700 • 800-737-2787
 Fax: 760-744-1943

www.rfparts.com

E-mail: **rfp@rfparts.com**



RF PARTS COMPANY

FIND THE MIC WINNER

MAY ISSUE

Jeff Reynolds

Operations Manager, KVNF Public Radio
Paonia, Colorado



He won a
UXA-110 mic-to-USB
interface from
Hosa Technology.

hosatech.com



The mic was
hidden in the
fabric of the
chair.

The winner is drawn from the correct entries for the issue two months prior. No purchase necessary. For complete rules, go to RadioMagOnline.com.

WWW.DMENGINEERING.COM

HAVE WE GOT STUFF FOR YOU!

- * For your Sage-Endec: Both the Original and New Digital Models
 - Multi-Station Relay Adapters
 - Remote Controls with RWT Automation Interface
 - Automation Interface Modules
 - Replacement Printers, Power Supplies and Paper (for Model SE1822)
- * Phone Flashers with Door/Alarm Input:
 - Single Line
 - Multi-Line (up to 12)
- * Audio-Pod Mic Controllers:
 - With and Without Mic Pre-Amp & with Headset Amplifier
 - With IFB Talk-Back Option
- * Mic-Pro Mic Controllers:
 - Original Mic-Pro - Works with Studio Slave Auxiliary Relay Pack
 - Mic-Pro 2 - Stand Alone Mic Controller
- * Studio Slave Auxiliary Relay Pack:
 - 8 Form-C Relay Outputs for Controlling Studio Functions, Muting, etc.
- * Studio Solid-State Relay:
 - For Controlling Incandescent Lamps up to 5 Amps - Directly Interfaces with Slave Auxiliary Relay Pack and Phone Flashers, or any 5-30VDC Control Input
- * Silence Sense Detectors:
 - Relay Output
 - Pager/Dialer Output

For details on these and other economical solutions for the broadcaster please visit us on the web, give us a call or contact your favorite distributor.

2174 Chandler St. Camarillo, CA 93010
805-987-7881 800-249-0487

DM
Engineering

Acoustics First

-SOUND AND NOISE CONTROL MATERIALS-

Toll-Free
Number: **888-765-2900**

www.AcousticsFirst.com

AM Ground Systems Co.

www.amgroundsystems.com

866-22RADIO

GET YOUR OWN COPY!

Each month the *Radio Technology Leader* brings you the latest must-read information about radio broadcasting.

To start your own FREE subscription go to **www.myradiomag.com** and complete the online form TODAY!

| ADVERTISER | PAGE | PHONE | WEBSITE | ADVERTISER | PAGE | PHONE | WEBSITE |
|----------------------------|----------------|---------------|--|----------------------|---------------|--------------|--|
| Acoustics First | 25 | 888-765-2900 | www.acousticsfirst.com | Mooretronix | 35 | 800-300-0733 | www.mooretronix.com |
| Arrakis Systems | 13,22,23,29,39 | 970-461-0730 | www.arrakis-systems.com | Myat | 19 | 201-767-5380 | www.myat.com |
| AudioScience | 34 | 302-324-5333 | www.audioscience.com | Phasetek | 36 | 215-536-6648 | www.phase:ekinc.com |
| BDI | 34 | 914-737-5032 | www.broadcast-devices.com | Ram Systems | 32 | 800-779-7575 | www.ramsystemsonline.com |
| Broadcast Software Int'l | 15 | 888-BSI-USA-1 | www.bsiusa.com | RF Parts | 36 | 800-737-2787 | www.rfparts.com |
| Broadcasters General Store | 21 | 352-622-7700 | www.bgs.cc | RF Specialties Group | 4,19,25,28,34 | 814-472-2000 | www.rfspecialties.com |
| CBT Systems | 36 | 858-536-2927 | www.cbtsystems.tv | Sandies | 34 | 215-547-2570 | www.sandiesusa.com |
| CircuitWerkes | 35 | 352-335-6555 | www.circuitwerkes.com | SCMS | 16 | 800-438-6040 | www.scmsinc.com |
| Cloud Microphones | 17 | 888-365-3278 | www.cloudmicrophones.com | Shively Labs | 11,36 | 886-744-8359 | www.shively.com |
| Comrex | 9 | 800-237-1776 | www.comrex.com | Smarts Broadcast | 18 | 800-747-6278 | www.smartsbroadcast.com |
| Deva Broadcast | 24 | 855-428-7272 | www.devabroadcast.com | Tieline | 1 | 317-845-8000 | www.tieline.com |
| DM Engineering | 37 | 800-249-0487 | www.dengineering.com | Transcom Corporation | 35 | 800-441-8454 | www.fmamtv.com |
| ESE | 25 | 310-322-2136 | www.esweb.com | V-Soft Communicators | 36 | 800-743-3684 | www.v-soft.com |
| Gorman Redlich | 35 | 740-593-3150 | www.gorman-redlich.com | Wheatstone | 2,3,40 | 252-638-7000 | www.wheatstone.com |
| Graham Studios | 33 | 866-481-6696 | www.graham-studios.com | Wide Orbit | 5 | 281-252-8891 | www.wideorbit.com |
| Inovonics | 7 | 800-733-0552 | www.inovon.com | | | | |

This advertiser index is a service to readers. Every effort is made to ensure accuracy, but Radio magazine cannot assume responsibility for errors or omissions.

FM/HD AUDIO PROCESSING
wheatstone-processing.com

HEAR IT?
YOU WILL...

<http://bit.ly/HEARIT2-R>



1.252.638-7000 | sales@wheatstone.com

FM-531HD
AIRAURA X3

Wheatstone
real as real gets

World Radio History