

SEPTEMBER, 1960

Covering all  
phases of...

**A**  
**FM**  
**T**

# **BROADCAST ENGINEERING**

THE TECHNICAL JOURNAL OF THE BROADCAST INDUSTRY

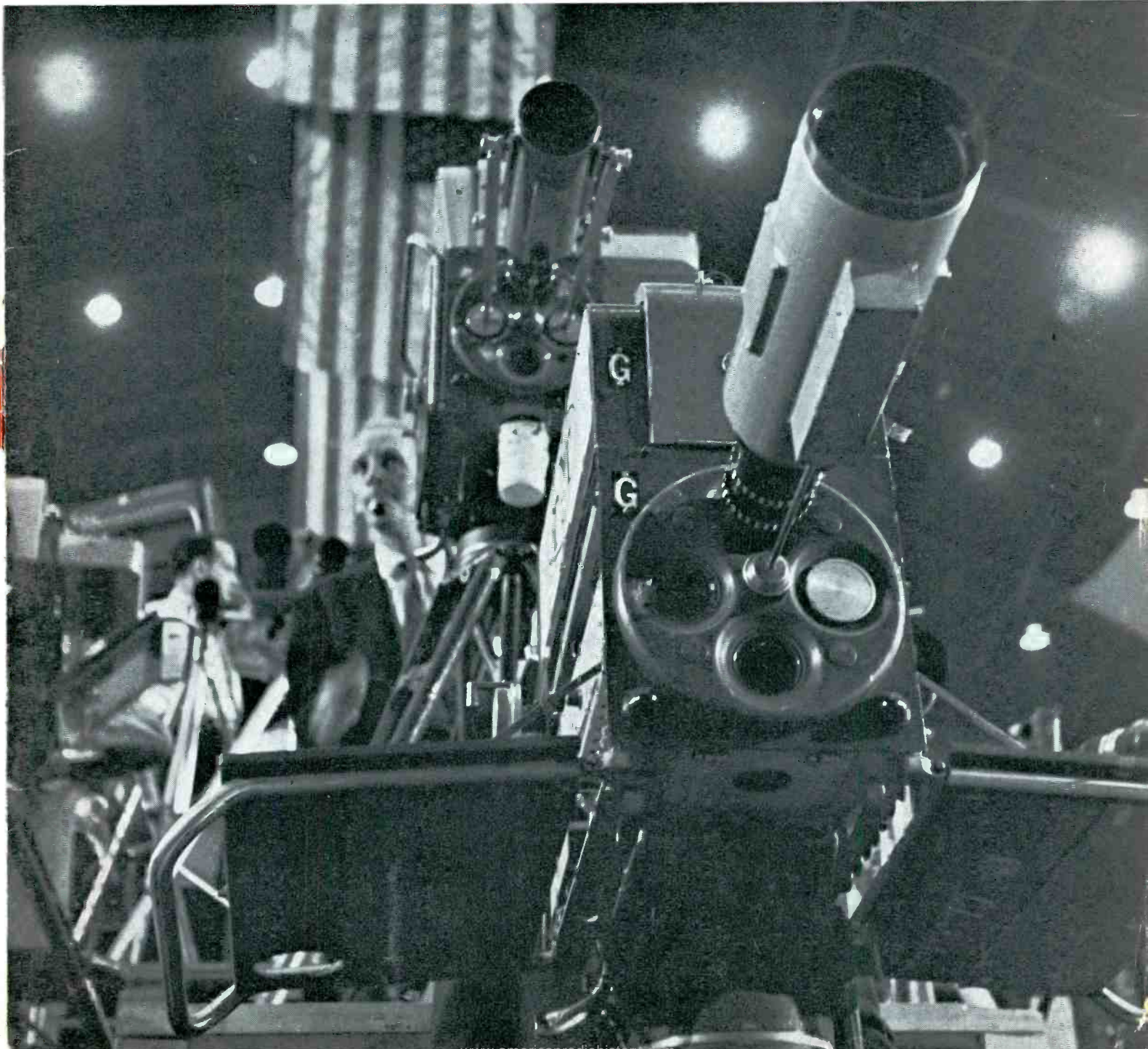

# FOTO-VIDEO VIDICON CAMERA FOUND IDEAL

for Commercials at **KORN-TV**, Mitchell, South Dakota

Says **RAY V. EPPEL**, president of the **MITCHELL BROADCASTING ASSOCIATION'S STATION**, who observed that the **FOTO-VIDEO V-515** "is an excellent tool for news and sports shows" and "a handy adjunct to our studio operation."

WHAT MORE COULD **FOTO-VIDEO** SAY?



## FEATURES

- 600-line resolution
- Electronically Regulated Integral B+ Supply
- Small Size: 10 lbs.—8 $\frac{3}{8}$ " x 3 $\frac{1}{8}$ " x 3 $\frac{3}{8}$ "
- Modular Construction: Circuitry easily replaced, with 5 small modules that snap out — snap into place in sure contact multiple plugs and sockets
- H and V sweep failure protection in camera head
- Gain stabilized preamp; long life, low noise, high-gain double cascode circuit
- Keyed clamp maintains preset black level
- Built-in adjustable independent aperture and phase correctors
- 1.0 to 1.5 v video output into 75-ohm cable; one cable between camera and control unit
- Transistorized synchronizing unit at

- standard EIA rates, with extra outputs for additional cameras
- Peak-to-peak video level meter on camera-control unit, provides metering of setup adjustments and continuous monitoring of video output
- Overall response flat to 8 mc
- Independently oriented H and V coils may be adjusted to place long dimension of scan in either horizontal or vertical plane
- Provides good picture at 5 foot candles
- Video monitor optional
- Cable Lengths: To Control Unit up to 500 feet; From Control Unit up to 2000 feet
- Video amplifiers available for longer cable lengths.

## Accessories:

- Automatic Light Control Unit
- Zoom Type Lens (Also a wide variety of other types)
- Camera Housings: Explosion-proof, Weather-proof, Acoustical and High-temperature
- Complete line of Video Monitors
- Camera Head with electronic view finder and 4-lens turret
- Camera Control with built-in Sync Module, with provision for Crystal Control, Line Lock or Free-running operation
- Sync Generator either Random or 2-1 interlace
- Tripods and Mounting Heads (Pan and tilt, remote control, etc.)

# FOTO-VIDEO®

**ELECTRONICS INC.**

ENGINEERING AND MANUFACTURING

36 Commerce Road

• Cedar Grove, N. J.

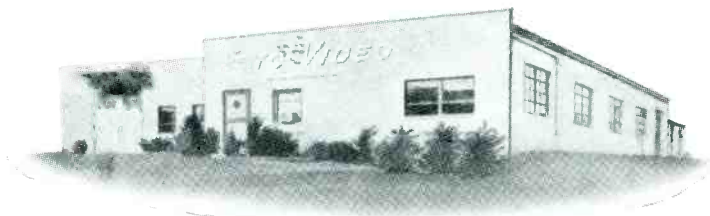





## New portable audio amplifier—only 19½ lbs!



Carrying handle functions as base to position unit for most convenient operating angle.

### *Completely transistorized — not a tube in the circuit.*

The first time you lift it you'll be thankful for transistors — because it is 100% transistorization that makes this lightweight reliable design possible.

General Electric's new Type BA-26-A has built-in studio quality. Designed for AM-FM-TV and recording use, this portable amplifier provides console quality for remote broadcasts such as sports events, concerts and spot news. Besides the customary microphone inputs, this portable amplifier features a high-level input for tape or transcription.

Here is the first portable audio amplifier containing its own regulated self-contained power supply with a range of 95 to 135 volts a-c. Provision for battery operation is also included. A laminated plastic front panel preserves permanent markings and allows space for other information to be added and erased without damaging the surface.

For complete specifications on the latest in General Electric's new line of Transistorized Audio equipment, write Technical Products Operation, Communication Products Department, Section 4990, General Electric Company, Lynchburg, Virginia.

**GENERAL**  **ELECTRIC**



# BROADCAST ENGINEERING

THE TECHNICAL JOURNAL OF THE BROADCAST INDUSTRY

VOLUME 2

SEPTEMBER, 1960

NUMBER 9

## Contents

The Effects of Tower Lighting and Isolation Circuits Upon Tower Impedance of Various AM Towers . . . . .	4
A Multiplex Subcarrier Generator . . . . .	8
Sine Squared Pulses in TV System Analysis . . . . .	12
The 99th Cause of Crosstalk . . . . .	18
Experimental Operation of a Co-Channel Supplemental Transmitter . . . . .	20

## Departments

Technical Hints . . . . .	30
Amendments and Proposed Changes of F.C.C. Regulations . . . . .	36
Industry News . . . . .	39
Product News . . . . .	40
Index to Advertisers . . . . .	40
Classified Ads . . . . .	40

## Cover Story

Broadcast coverage of the 1960 political conventions utilized many new broadcast developments and was the most elaborate remote pickup in television history. The cover photo shows several cameras in action picking up scenes from the convention floor.

## EDITORIAL

D. E. MEHL, Editor  
 D. F. BOICOURT, Managing Editor  
 DUDLEY ROSE, Presentation Editor  
 E. P. LANGAN, Advertising Director  
 S. F. WILSON, Production Manager  
 W. J. SHAW, Circulation Director



## ADVERTISING SALES OFFICES

**Flushing 54, New York**  
 PAUL AND DON WEIL  
 39-01 Main Street  
 Telephone INdependence 3-0098

**Chicago 1, Illinois**  
 WILLIAM L. MILLER, JR.  
 E. F. LUKENS  
 C. E. PARKER  
 307 N. Michigan Ave.  
 Telephone FRanklin 2-5014

**Cleveland 16, Ohio**  
 DAVID H. HERTEL  
 3100 Wooster Road  
 Telephone EDison 1-2370

**Southwest**  
 C. H. STOCKWELL CO.  
 4916 W. 64th Street  
 Mission, Kansas  
 Telephone RAndolph 2-4417

**Los Angeles 57, California**  
 MAURICE A. KIMBALL CO., INC.  
 2550 Beverly Boulevard  
 Telephone DUnkirk 8-6178

**San Francisco 5, California**  
 MAURICE A. KIMBALL CO., INC.  
 681 Market Street  
 Telephone EXbrook 2-3365

**Paris 8, France**  
 JOHN ASHCRAFT  
 67 Avenue des Champs Elysees  
 Telephone Elysees 47-18

**London W. 1, England**  
 JOHN ASHCRAFT  
 9 Curzon Street  
 Telephone GRosvenor 7406

**Tokyo, Japan**  
 INTERNATIONAL MEDIA  
 REPRESENTATIVES, LTD.  
 Shadan Hojin, 14, 2-chome Marunouchi  
 Telephone 571-4450

Editorial, Circulation and Advertising head-  
 quarters, 1014 Wyandotte St., Kansas City 5,  
 Missouri; Telephone VICTor 2-5955.



**Subscription Price: U. S. \$6, one year; Out-  
 side U. S. A., \$7. Single copies, 75 cents.  
 Adjustments necessitated by subscription  
 termination at single copy price.**

Broadcast Engineering is published monthly by  
 Technical Publications, Inc., 1014 Wyandotte St.,  
 Kansas City 5, Missouri, U. S. A.

**Corporate Personnel:** Robert E. Hertel, Presi-  
 dent; Frank D. Smalley, Executive Vice-Presi-  
 dent; E. P. Langan, Vice-President; W. J.  
 Shaw, Vice-President; Kenneth Long, Vice-  
 President; D. E. Mehl, Vice-President.



# INTER-SYNC\*

TELEVISION SIGNAL SYNCHRONIZER

## HOW TO GET MORE FROM YOUR AMPEX VTR

Ampex provides the perfect answer . . . **Inter-Sync!** Now a VTR with **Inter-Sync** becomes a smooth part of your production team. Use it in production as you would a camera, a film chain . . . or any picture source. **Inter-Sync** locks the VTR to station sync . . . electronically synchronizes the recorder with *any signal source* — live, film, network or slides. Here's what you can do —

**ONE RECORDER?** With a furniture store account, for example, pretape a series right in your studio showing the new fall line. Loan company: tape a location shot of "customer" borrowing cash. Real estate: tape a tour through a new, development home. *Then*, during playback with **Inter-Sync**, you can wipe from tape to price slide — or lap dissolve to live announcer. No more dead air! No roll over!

**Inter-Sync** lets you "host" the late-late movie — and reruns — with sm-o-o-th lap-dissolve transitions between the film and your announcer on tape. No loss of mood — no abrupt changes.

**TWO RECORDERS?** Mix live or film with tape using key wipes or dissolves, then record on second unit. Use dissolves or special wipes between playback of two tapes. Take it from there . . .

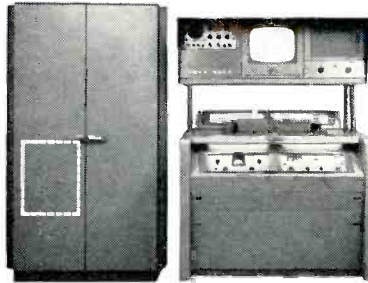

Dotted lines indicate position of **Inter-Sync** in the electronics rack of the Videotape\* Television Recorder.

**THREE RECORDERS?** Comfortable transitions are difficult to anticipate in production. Add them later — at your leisure — with **Inter-Sync!** Record each production segment on tape; then put one segment on one VTR . . . another segment on second VTR. Lap dissolve for smooth transition and record on No. 3.

But these are just a few ideas . . . drop us a line and we'll supply complete details on *all* the marvels of **Inter-Sync**. This im-

portant optional feature is only one example of the continuing flow of major new developments you can always expect from *Ampex — the Jack-of-one-trade . . . tape recorders.*

### FOR ENGINEERS ONLY:

This Ampex Model 1020 synchronizer provides both horizontal and vertical locking (line-by-line and frame-by-frame). The speed of the two-way locking process is particularly noteworthy: a total of approximately 3½ seconds, well within the 5-second roll-in time most stations use. Vertical framing is speeded up by first using the sync pulses off the tape control track to reference to outside sync (subsequently switching to the actual vertical sync pulse). The capstan servo system resolves the inside and outside sync by smoothly adjusting the tape speed. Horizontal line-by-line locking is accomplished by precise readjustment of the head drum speed about every 5 degrees of rotation. Since the head drum rotates at 14,400 rpm, this means speed adjustments are made 945,000 times a minute. A unique drum servo system with push-pull action acts through the head drum motor with almost instantaneous results. Send for a 12-page Engineering Department Bulletin for complete details.

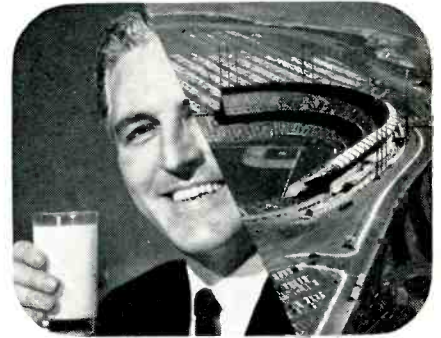
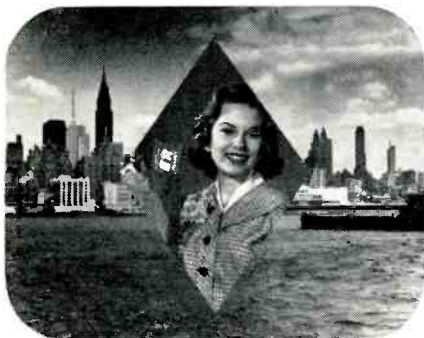

*Ampex tapes are made and  
played around the world*

# AMPEX

VIDEO PRODUCTS DIVISION - AMPEX PROFESSIONAL PRODUCTS COMPANY

934 Charter Street, Redwood City, California

\*TM AMPEX CORP

# The Effects of Tower Lighting and Isolation Circuits Upon Tower Impedance of Various AM Towers

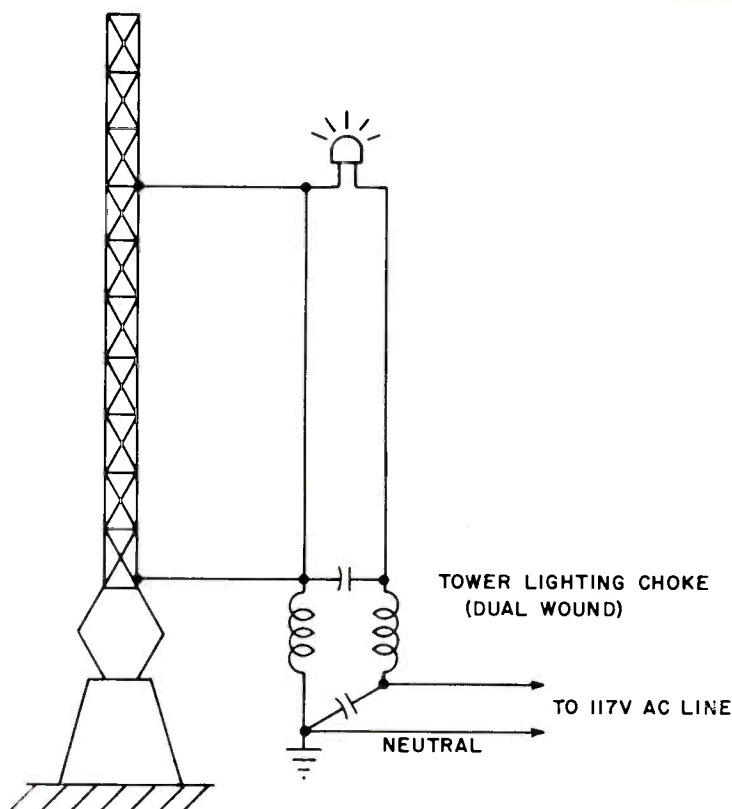

Figure 1—Single choke tower lighting isolation.

Tower lighting isolation circuits often affect the measured antenna impedance of an AM tower. The results of an investigation of this problem are reported.

By VIR N. JAMES\*

PERHAPS some of you have measured antenna impedances and found them to vary when you connected the tower lighting or isolation circuits. Or, perhaps, you have investigated apparent transmitter efficiencies in the range of 90 to 110 per cent. Tower lighting or isolation circuits frequently cause such conditions to exist.

During the course of our consulting work, we had encountered these conditions and antenna resistance changes up to 50 per cent due to the effects of tower lighting isolation circuits. It was, therefore, deemed advisable to investigate these effects in more detail.

To this end, special equipment was set up to measure the antenna impedance of KSTR, Grand Junction, Colo., which operates on an

assigned frequency of 620 kilocycles. Impedance measurements of the KSTR 300-ft. tower over the entire broadcast band provided an opportunity to study the effects of tower isolation circuits for effective antenna heights which varied with frequency from 0.15 to 0.5 wavelength. The investigation consisted of tower impedance measurements without isolation circuits and then with various tower isolation circuits connected.

Tower lighting isolation circuits commonly encountered consist of the following types:

1. A single dual-wound choke. This choke is often supplied in diameters of approximately 5 inches and lengths up to 18 inches with a two-layer winding. One winding connects each side of the ac circuit

to the tower lights. Some chokes are triple wound to accommodate a third tower circuit. A simple schematic showing the connection of a single dual-wound lighting choke is shown in Figure 1.

2. Sometimes two of these chokes are used in tandem. A schematic of tandem chokes is shown in Figure 2. It will be noted that the neutral side of the tower light is shown tied to the tower so that the tower isolation choke functions as a static drain choke.

3. An entirely different means of tower lighting isolation is provided by the transformer isolation type or so-called "Austin" transformer. Transformer isolation is shown in Figure 3.

The tower isolation chokes frequently encountered have a high

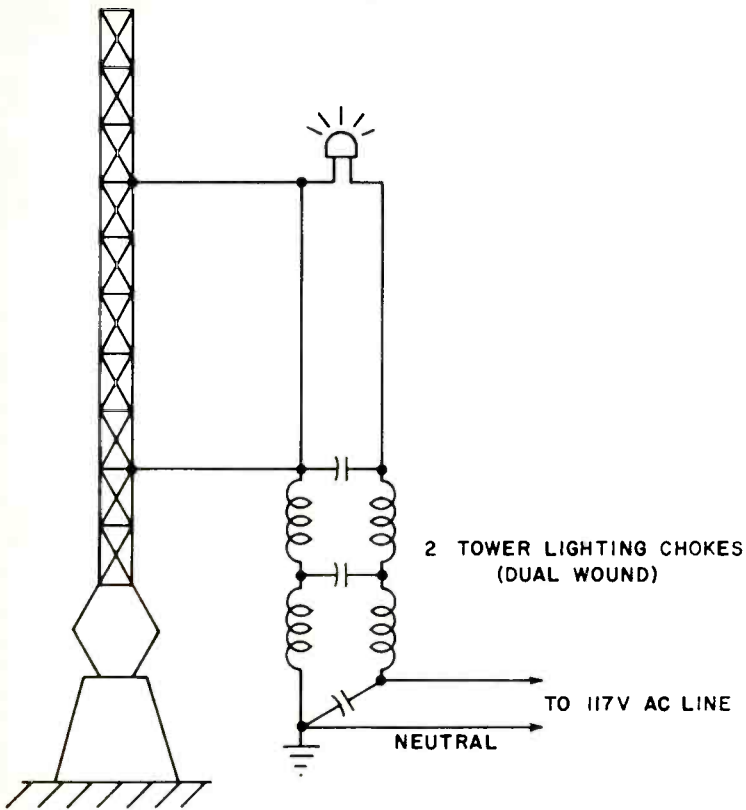

Figure 2—Tandem choke tower lighting isolation.

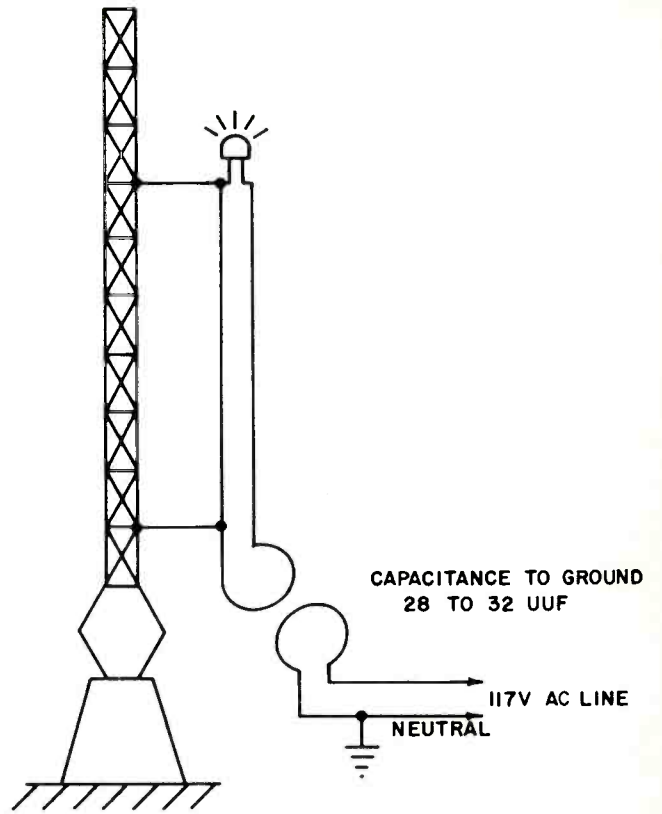

Figure 3—Transformer tower lighting isolation.

\*Consulting Radio Engineer, 232 S. Jasmine, Denver 22, Colo.  
This report was presented at the 14th NAB Engineering Conference.

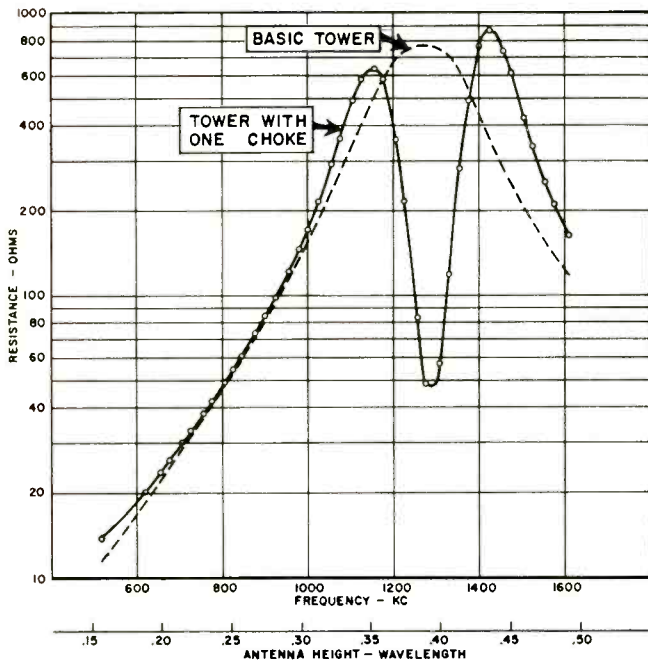

Figure 4—Tower resistance variation 1-choke isolation circuit.

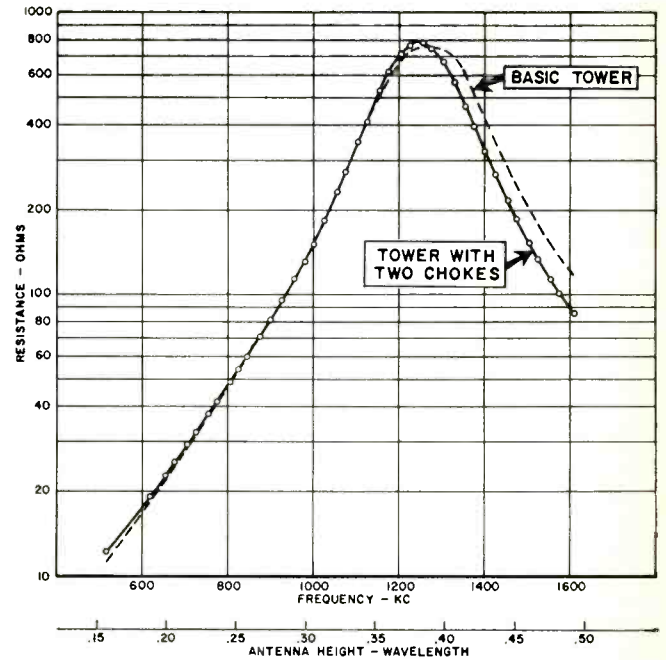

Figure 5—Tower resistance variation 2-choke isolation circuit.

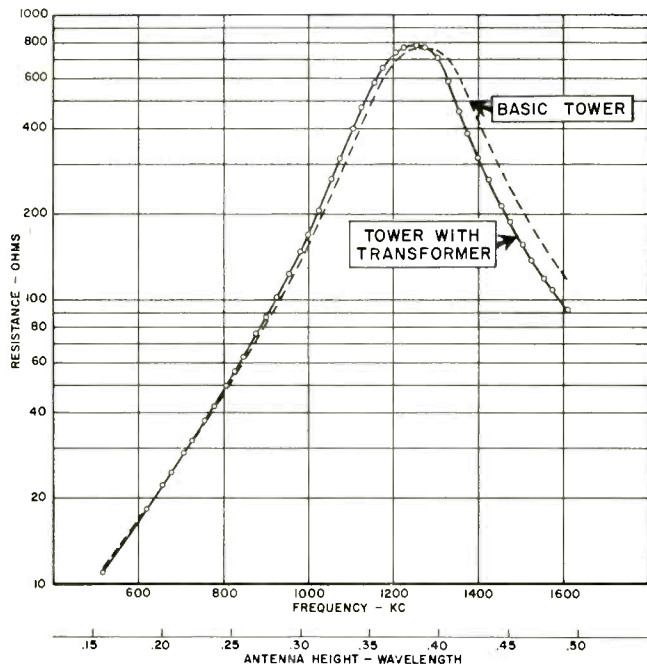

Figure 6—Tower resistance variation transformer isolation circuit.

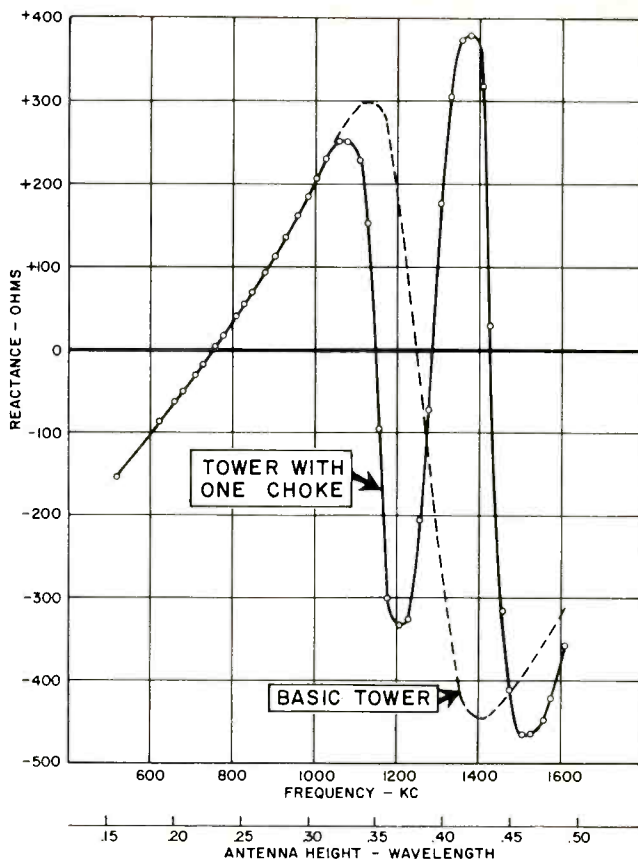

Figure 7—Tower reactance variation 1-choke isolation circuit.

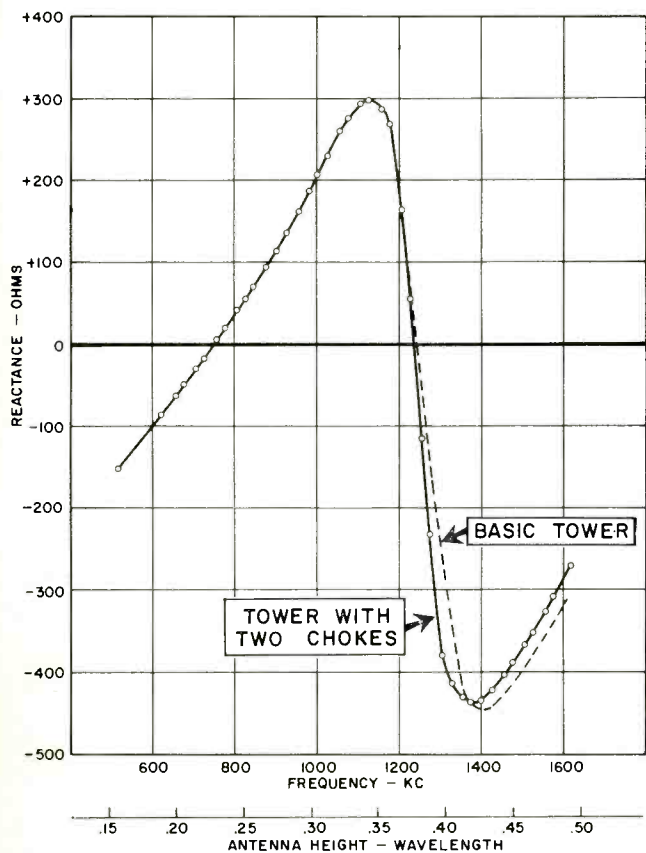

Figure 8—Tower reactance variation 2-choke isolation circuit.

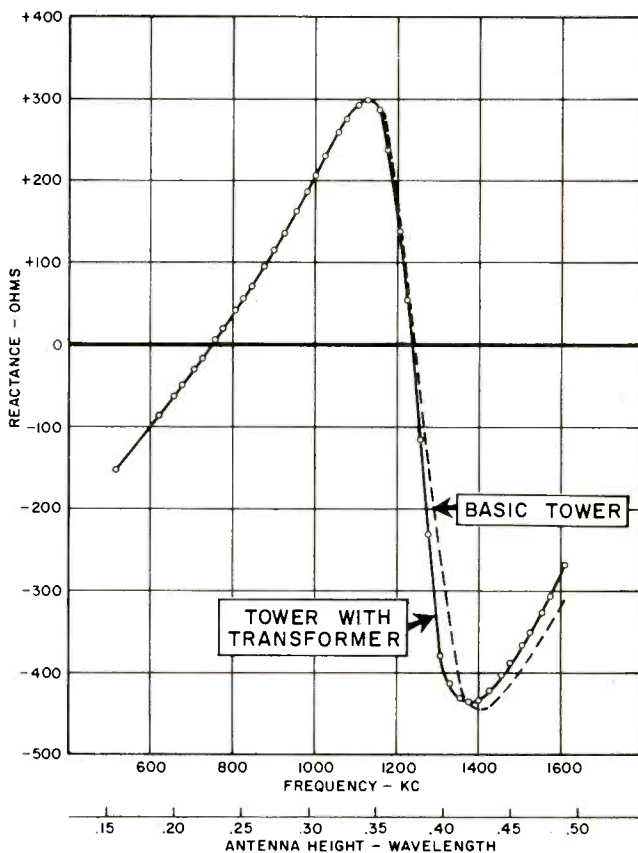

Figure 9—Tower reactance variation transformer isolation circuit.



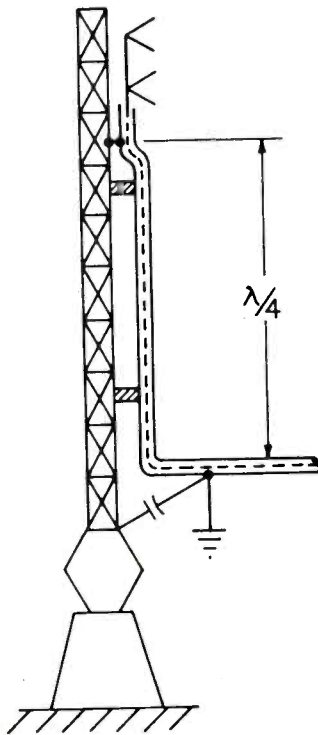

Figure 10—One-fourth-wave line isolation.

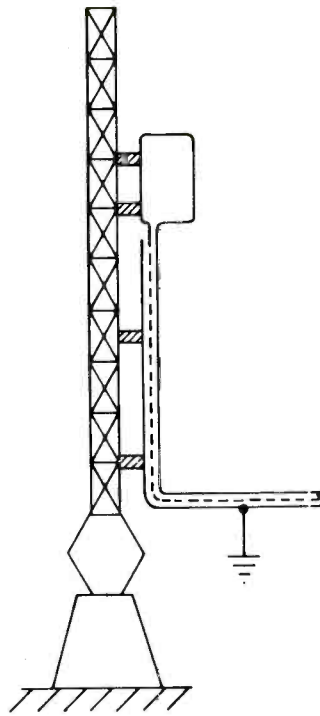

Figure 11 — Insulated sampling loop isolation.

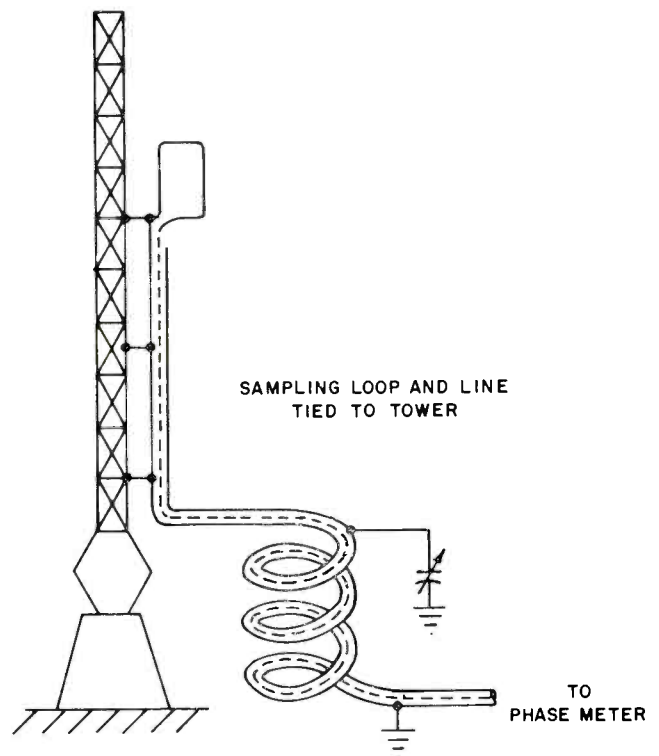

Figure 12—Parallel resonance isolation.

### MEASURED ANTENNA IMPEDANCE KSTR Tower — Height 300 ft.

value of inductance on the order of 350 microhenries. The transformer isolation units consist of a large doughnut-shaped primary winding connected to the 60-cycle power line. The tower lights are supplied with current from a secondary doughnut winding located in the field of the primary but spaced several inches from it.

The effects upon tower impedances of tower lighting chokes may be thought of as a highly inductive circuit with a significant amount of circuit resistance at the R.F. frequency. The effect is further complicated by a distributed capacitance effect. The mathematics for calculating the effects of such tower lighting chokes in the range where the operation is critical is quite difficult. However, their performance may be obtained easily and rapidly with a radio frequency bridge. The transformer isolation circuit, on the other hand, shunts the antenna impedance with a capacitance of approximately 30 micromicrofarads. The effects, therefore, of the transformer isolation is more readily cal-

(Continued on page 27)

F(KC)	Tower Height Wave Length	Tower Only		2 Chokes		1 Choke		Trans.	
		R	X	R	X	R	X	R	X
517	.158	11.3	-153	12.2	11.8	13.9	13.4	11.0	10.8
620	.189	18.7	-86.7	19.1	18.6	20.1	19.7	18.2	17.9
655	.200	22.2	-63	22.8	21.9	23.7	23.0	20.2	19.9
675	.206	24.6	-50	25.2	24.5	26.0	24.6	24.6	24.0
705	.215	28.1	-30-	29.2	30.0	30	28.7	28.9	28.2
725	.221	31.3	-17.2	32.3	33.0	33	32.9	32	31.0
755	.230	36.5	+5	37.4	36.9	37.9	38.3	37.5	36.9
775	.236	41	19	41.5	41.1	42	43	42	40.8
805	.246	48	41	48.9	48.2	49	50	50	50
825	.252	53.2	55	54	52.8	54.5	54.1	56	55.1
845	.258	60	70	60	58.9	60.2	59.7	62.9	63
875	.267	71	94	71	70.1	73	72.1	76	77
900	.275	82	113	81.5	82.3	84	83	87	87
925	.282	95.7	135	95.2	95.7	98	97.3	102.2	101.6
955	.291	114.5	162	114	113.8	121	120	123.3	123.0
980	.299	134	186	131	132.1	146	145	148	147
1000	.305	153.5	207	151	206	171	208	170	206
1025	.313	185	231	184	230	215	232	206	232
1055	.322	231	261	231	259	290	253	267	259
1075	.328	271.5	275	272	275	359	252	312	274
1105	.337	340	294	350	294	490	229	400	283
1125	.343	400	299	410	299	580	254	475	278
1155	.352	496	292	530	287	633	-95	580	240
1175	.359	575	268	620	238	580	-300	655	149
1205	.368	690	164	720	138	353	-332	740	-7
1225	.374	730	90.8	767	55	214	-326	770	-109
1255	.383	760	-50	787	-116	83.3	-205	782	-222
1275	.389	765	-146	750	-232	48.1	-71.4	770	-290
1305	.398	750	-263	668	-380	57.3	+177	712	-374
1330	.406	700	-330	565	-414	119	306	590	-420
1355	.414	603	-416	465	-431	281	374	460	-439
1375	.420	515	-438	394	-436	493	380	383	-440
1400	.427	435	-444	325	-435	760	318	315	-434
1425	.435	350	-442	269	-422	862	29	265	-421
1455	.444	285	-428	218	-403	730	-316	214	-403
1475	.450	249	-415	187	-389	607	-410	189	-389
1505	.459	207	-395	153	-367	423	-465	158	-368
1525	.466	182.2	-380	134	-351	336	-464	139	-352
1555	.475	154	-356	114	-326	251	-448	119	-329
1575	.481	138	-339	101	-308	210	-421	108	-311
1610	.491	117.2	-311	86	-269	163	-357	92	-280

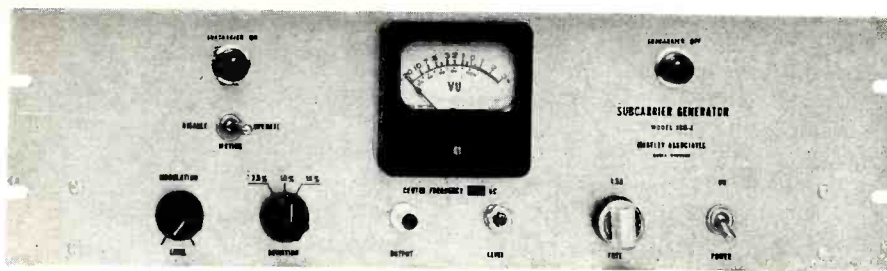

Figure 1  
Front view of subcarrier generator showing automatic muting and deviation monitoring control.

Figure 2  
Rear view of subcarrier generator. Note relative simplicity and location of components.

## A Multiplex Subcarrier Generator

Basic technical considerations of a multiplex system are discussed including the design of a subcarrier generator.

By JOHN A. MOSELEY\*

MULTIPLEXING for subsidiary communications services has proven to be one of the most promising sources of income to the FM broadcaster. While not a magic elixir for all financial problems, it has attracted the attention of an increasing number of station operators, who are seeking a practical approach to multiplexing without undue expense or technical complication. Virtually all presently available equipment will provide satisfactory operation, but all too often it is quite expensive and frequently over-engineered. A lack of appreciation for over-all system requirements has also contributed to much of the confusion. Further, complete multiplex engineering standards remain to be established.

This article discusses some basic technical considerations of a multiplex system and describes in detail one specific link in the chain, namely, a subcarrier generator. Stable and linear operation, together with low cost and simplicity of operation, were the basic design considerations.

The subcarrier generator shown in Figure 1 and Figure 2 is complete, including a regulated plate and filament power supply. Its installation is fairly simple, requiring only connection to the power line, audio

modulation line and the main transmitter exciter or subcarrier inserter. Because of the relatively high center frequencies used in multiplex (up to 67 kcs), it sometimes presents a problem to directly modulate the main carrier. In most cases the restriction is due to the bandwidth of the tuned circuits in the exciter multiplier stages. Various inserter circuits are available which overcome this restriction. A number of the newer FM exciters are so designed that multiplex subcarriers may be added to the system.

Figure 3 is a basic schematic diagram of the subcarrier generator. It will be noted that this circuit is a phase-shift oscillator. However, a few more RC phase-shifting networks are employed than normally found, and modulation is achieved by the actions of V1. The necessary amplification to sustain oscillation is provided by the high gain pentode V2. While some phase shift is obtained in the screen circuit providing a stabilizing feedback effect, the major required phase shift is divided among R6C3, R8C4, R2C5, and R3C1. V3 serves to isolate R8C4 from R2C5 and at the same time provide a low impedance driving point for the output of the oscillator. In critical frequency deter-

mining locations, deposited carbon resistors and silver mica capacitors are used. With such an arrangement as shown in Figure 3 a center frequency stability of less than  $\pm 0.1$  per cent can be obtained and with the use of a regulating filament transformer can be held to  $\pm 0.2$  per cent from 100 VAC to 130 VAC line voltage change. If employed in widely varying temperature environments, thermistors may be used as part of the resistive element in a phase shift network.

Crystal stability of the center frequency in a multiplex subcarrier generator is unnecessary. Quite often it is the use of a crystal circuit and its subsequent chain of frequency multipliers that add unnecessarily to the complexity of a subcarrier generator. Certainly from a service and maintenance viewpoint, direct on-frequency generation of a multiplex subcarrier is desirable and requires considerably less test equipment and fewer spare parts. To further illustrate flexibility in subcarrier center frequency, subjective tests have been made on several multiplex receivers. While varying the multiplex frequency from 65 kcs to 67 kcs, no noticeable effect was apparent in the audio output of a 67 kcs multiplex receiver. With such

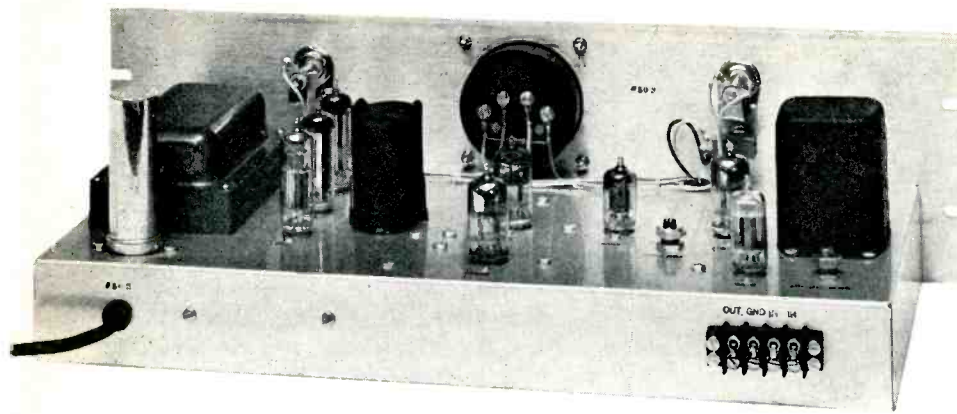

illator frequency against modulating voltage. Data for this graph was taken by applying a fixed dc bias to the grid of V1 and recording the output frequency with a frequency counter. As can be seen, the relationship between the two ordinates is extremely linear up to a deviation corresponding to  $\pm 25$  per cent of the center frequency. In practice, the deviation of the subcarrier is held between 7 and 10 per cent of the center frequency value. This deviation will yield a modulation index of slightly under 0.9 for the center frequency shown while using an upper modulating frequency of 7,500 cps. This is compatible with the fidelity requirements of multiplex broadcasting. This modulation index requires that only the first order of sidebands be detected for low distortion multiplex programming. Greater deviations will require more sidebands and consequently increased system bandwidth. This puts a more severe requirement on the receiver and sets a smaller margin for equipment instability.

multiplex receivers available, the need for stabilities greater than  $\pm 1.0$  per cent is not required. From a systems point of view, which includes the stability tolerances of the receiver, it is best to keep the subcarrier frequency as stable as a good economical design will permit.

Contrary to what the name "phase-shift oscillator" implies, the circuit produces a true frequency modulated wave. Saying this differently, the amount of subcarrier deviation is proportional only to the amplitude of the modulating signal and not upon the frequency as in the case of phase modulation. Mod-

ulation of the oscillator is achieved by varying the output impedance of V1 which forms the resistive element of one of the phase shifting networks. With changes in grid bias the transconductance, and hence output impedance, of V1 is varied in accordance with the modulation applied to the control grid. Special care must be used in selecting circuit values in this portion of the oscillator to assure a linear deviation in both the upward and lower frequency directions as well as a constant amplitude of the output voltage from the oscillator.

Figure 4 is a plot showing the os-

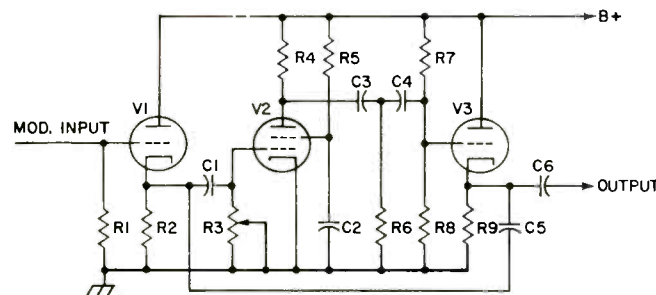

Figure 3

Basic schematic diagram of voltage controlled phase-shift oscillator.

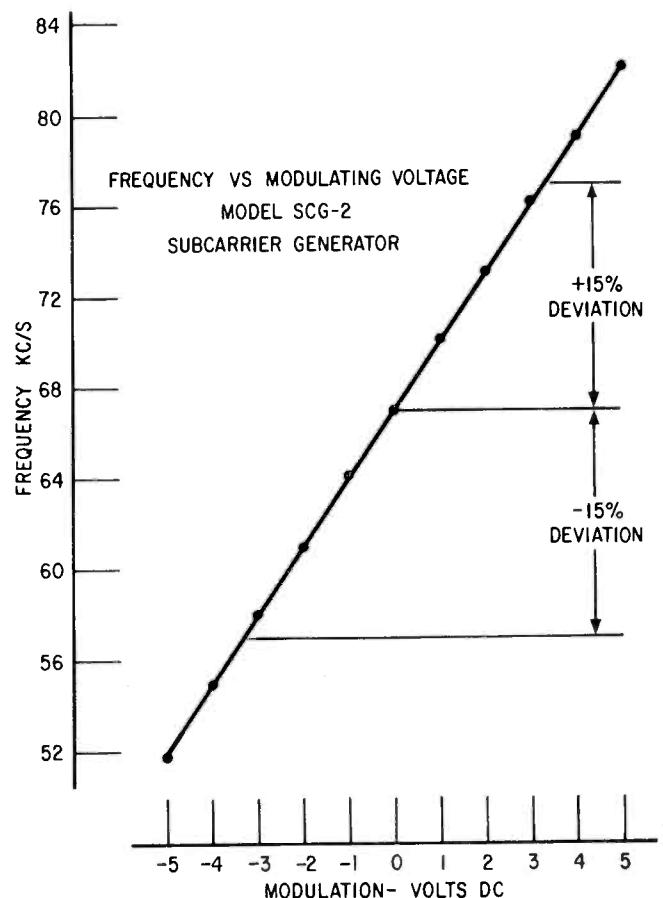

Figure 4

A plot showing the excellent linearity of frequency deviation vs. modulating voltage of the subcarrier generator.

\*Moseley Associates,  
P. O. Box 3192,  
Santa Barbara, Calif.





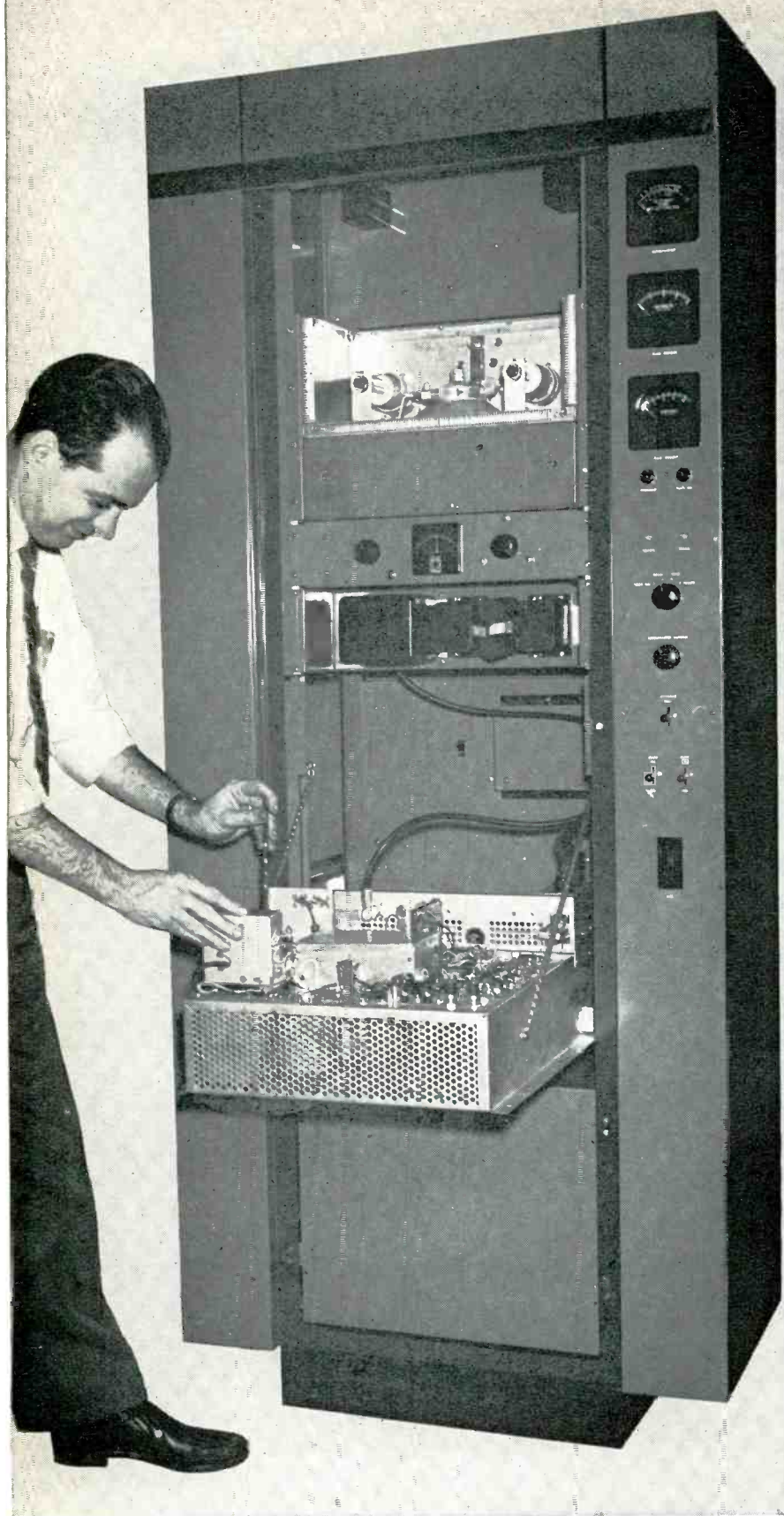

# RCA's NEW 1 KW FM Transmitter

ideal choice for  
truly economical  
FM operation!

**SINGLE TUBE POWER AMPLIFIER** keeps operating costs low. Actually there are only three basic elements in this new 1 KW transmitter: the standard RCA FM exciter, the power supply, and the single PA stage. Combined with RCA's complete line of FM antennas, the BTF-1D should be your first choice for truly economical FM operation.

**STEREO MULTIPLEXING** or dual subchannel operations are economically obtained by adding RCA subcarrier generators. The BTF-1D always produces a full fidelity signal with low distortion and noise for both conventional and multiplex operation.

**A BUILDING BLOCK UNIT**, this new 1 KW transmitter can easily be expanded to 5, 10, or 20 KW just by adding higher power amplifiers.

**YOUR NEAREST RCA BROADCAST REPRESENTATIVE** will gladly help you select the best equipment for your installation. See him for the details, or write to RCA, Dept. L-367, Broadcast and Television Equipment, Building 15-1, Camden, New Jersey.

**EASY TO SERVICE:** Easy access to all components from front and rear. The exciter unit tilts out as shown from the front to expose all components. All tuning controls are on the right front panel.



The Most Trusted Name in Electronics

RADIO CORPORATION OF AMERICA



# Sine Squared Pulses in TV System Analysis

By RALPH C. KENNEDY\*

**D**ELINEATION of suitable signals for accurately appraising the performance of a particular transmission system always offers a challenge. This is particularly true of wideband systems, *e.g.*, radar, microwave, computers, television, etc. Furthermore, the greater the number of criteria used to judge a system the greater the complexity of a test signal or al-

ternatively the greater the number of individual test signals which must be used. Additionally there is the further complication of trying to evaluate over-all system performance while the circuit is in use.

The nature of television signals is such that the system must meet the most rigorous of standards, especially when color television signals are

being transmitted. Among the various distortions which can affect a color signal are amplitude and phase versus frequency, linearity of amplification versus signal level, differential gain and phase, and transient response. Thus far, suitable signals are available for testing the amplitude versus frequency response by means of multiburst, linearity by means of stair steps, and differential gain and phase by means of modulated stair steps. Recently the  $\sin^2$  pulse has begun to be accepted here in the United States. This signal offers some interesting possibilities not only in transient evaluation of television systems but in the areas of envelope delay and linearity testing as well.

The pioneer work on all the techniques to be described have long been known to numerous investigators in England and on the Continent. In fact, Eurovision broadcasting would certainly be much more difficult without  $\sin^2$  pulse testing techniques. The magnitude of the problem may be appreciated when one considers the fact that three scanning rates of 405 lines, 625 lines, and 819 lines are currently in use in various countries, all of whom are actively engaged in broadcasting programs which originate with any one or more of the three scanning rates.

## Theory of Waveform Choice

Like other test signals discussed above, the  $\sin^2$  pulse does not supersede nor replace other test signals. It has its specific uses which supplement and augment functions of other test signals. Initially the  $\sin^2$  pulse

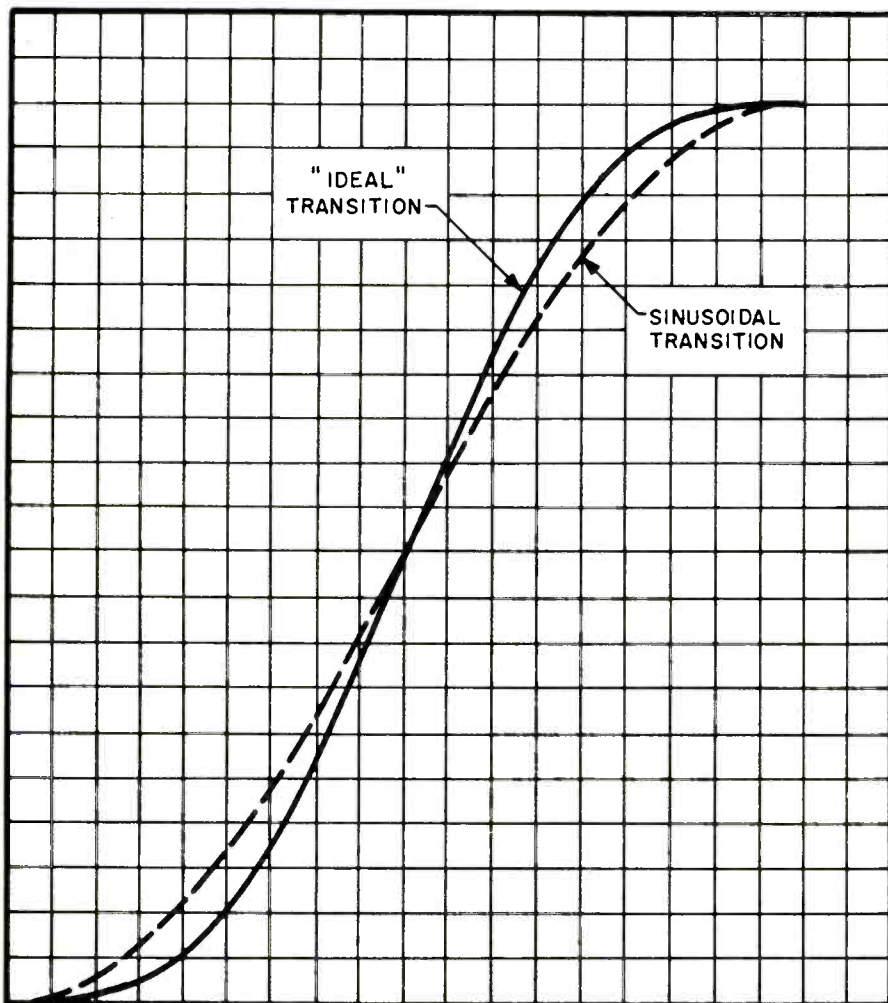

FIG. 1

\*Development Engineer,  
National Broadcasting Co.

This paper was presented at the 14th NAB  
Engineering Conference.



# DESIGN ADVANCE in MICROPHONES

from **ALTEC**...

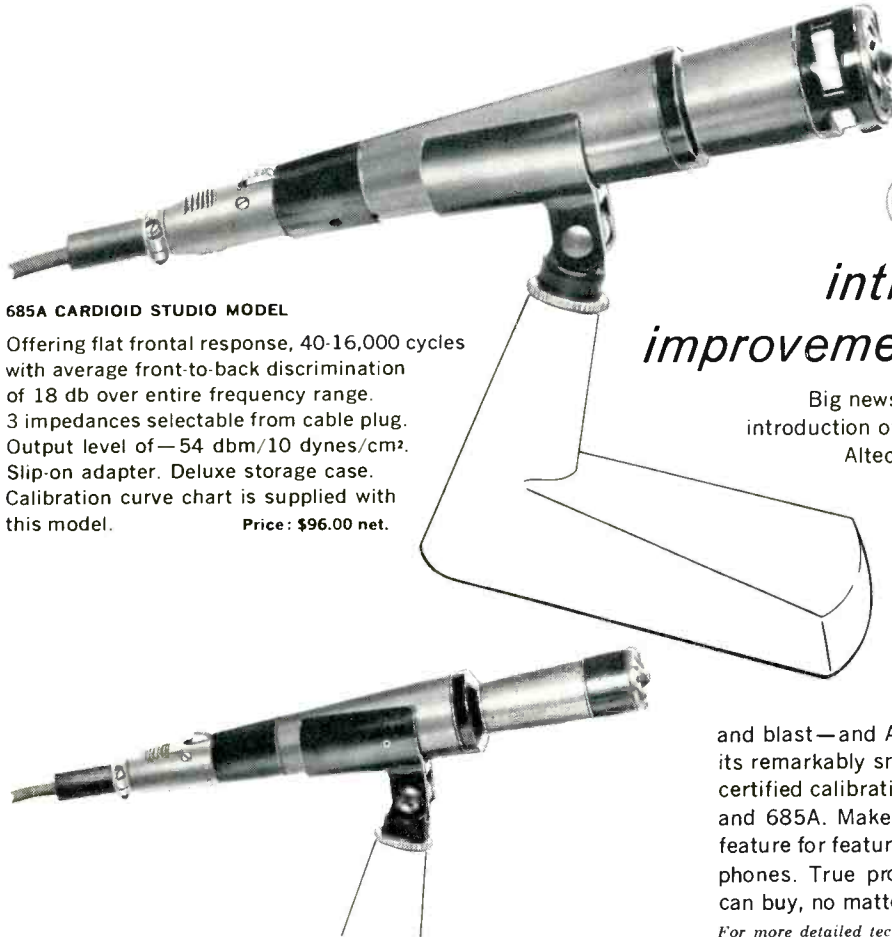

## 685A CARDIOID STUDIO MODEL

Offering flat frontal response, 40-16,000 cycles with average front-to-back discrimination of 18 db over entire frequency range. 3 impedances selectable from cable plug. Output level of  $-54$  dbm/10 dynes/cm<sup>2</sup>. Slip-on adapter. Deluxe storage case. Calibration curve chart is supplied with this model. Price: \$96.00 net.

*introducing great new improvements in performance*

Big news of the year in microphones is Altec's recent introduction of a new concept in microphone design. From Altec's great experience in engineering and manufacturing broadcast equipment and extensive acoustical research, comes a breakthrough development which introduces notable improvements in microphone performance and styling. This unique design incorporates Altec's famous sintered bronze filter for unmatched protection against moisture, contaminants, and blast—and Altec's new rugged "golden" diaphragm with its remarkably smooth, wider response and output. Individual certified calibration curve chart is provided with models 684A and 685A. Make a comparison; it is convincing proof that—feature for feature—Altec offers the year's best value in microphones. True professional quality from Altec—the best you can buy, no matter what price you have in mind.

*For more detailed technical information and specifications, write to Dept. BE-3D.*

**684A OMNIDIRECTIONAL STUDIO MODEL.** Uniform response over 35-20,000 cycles. High output of  $-55$  dbm/10 dynes/cm<sup>2</sup>. Slip-on adapter. Deluxe storage case. Calibration curve chart is supplied with this model. Price: \$81.00 net.

## ALTEC LANSING CORPORATION

A subsidiary of Ling-Temco Electronics, Inc.  
1515 Manchester, Anaheim, California  
161 Sixth Avenue, New York 13, N. Y.



© 1960 Altec Lansing Corporation



**686A DYNAMIC LAVALIER MODEL.** Just  $3\frac{1}{2}$ " long, weighing 3 ounces (not including cable and plug). Uniform response over 70-20,000 cycles. 2 impedances selectable at cable plug. Includes 24 feet of cable, neck cord with slip-on adapter and tie clip. Deluxe storage case. Price: \$54.00 net.

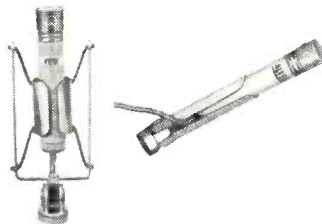

**M30 CARDIOID CONDENSER SYSTEM.** Frequency response 20-20,000 cycles with directional cardioid pattern of outstanding discrimination. Balanced output of  $-53$  dbm/10 dynes/cm<sup>2</sup>. First miniature directional microphone capable of translating the entire frequency and dynamic range. Price: \$334.00 net.



**M20 "LIPSTICK" CONDENSER SYSTEM.** Just  $3\frac{1}{8}$ " x  $\frac{5}{8}$ ", this small versatile microphone is widely used in laboratory recording because of its extreme sensitivity as well as broadcast studios. Balanced output of  $-48$  dbm/10 dynes/cm<sup>2</sup>. Omnidirectional pick-up pattern. Price: \$236.00 net.

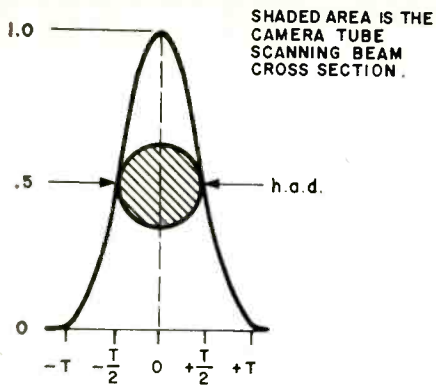

FIG. 2

was intended to provide a very specific need for a transient test tool. As such, it appears to be particularly well chosen since it permits an accurate evaluation of the performance of a system when that system is being subjected to the same form of data as it is when transmitting actual picture data. Cooper has shown that scanning horizontally across a vertical black-to-white transition

with a conventional camera tube whose beam has a finite diameter does not result in an abrupt change in output signal voltage. Instead the change is somewhat "S" shaped having sharp knees at the bottom and top with reverse curvature in the middle. The whole transition closely resembles the peak to peak excursion of a sinusoid. See Figure 1.

Further investigation shows that the frequency of the sine wave is limited by and is equal to the system bandwidth for conventional camera tubes. Actually, the period of the sine wave from the camera tube is equal to two times the period represented by the beam diameter. This period represents the maximum resolution of the camera tube. This resolution is somewhat higher than that possible in the conventional 4 mc/s system. The pulse suitable for testing such a system has a frequency of 4 mc/s. It is common practice to define the test pulse in terms of T, its half amplitude duration (h.a.d.).

See Figure 2. The relationship between system bandwidth  $f$  and  $T$  is given by:

$$f = \frac{1}{2T}$$

For a 4 mc/s system,  $T = 0.125$  usec. It is also common practice to set the pulse on the conventional synchronizing waveform. Thus the pulse has a repetition rate of line frequency.

### Pulse Spectrum

Fourier analysis for such waveform shows that there are components in its spectrum spaced every 15,750 cycles/sec extending up to a

frequency  $f = \frac{1}{T}$ . The general shape

of the spectrum amplitude closely approximates the response of a low

pass filter. At  $f = \frac{1}{2T}$  the amplitude

of the component is down 6 db in power from the fundamental ampli-

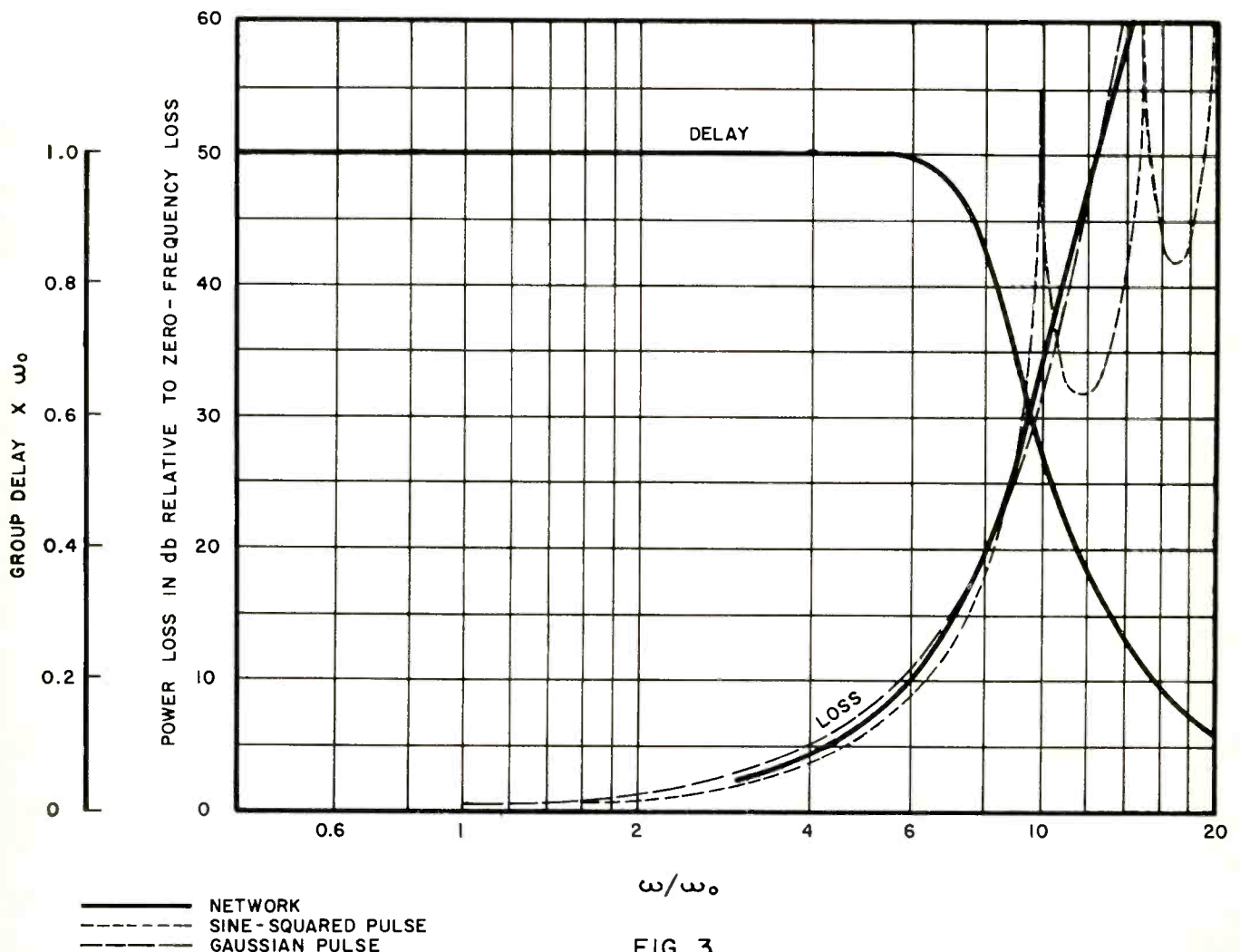

FIG. 3

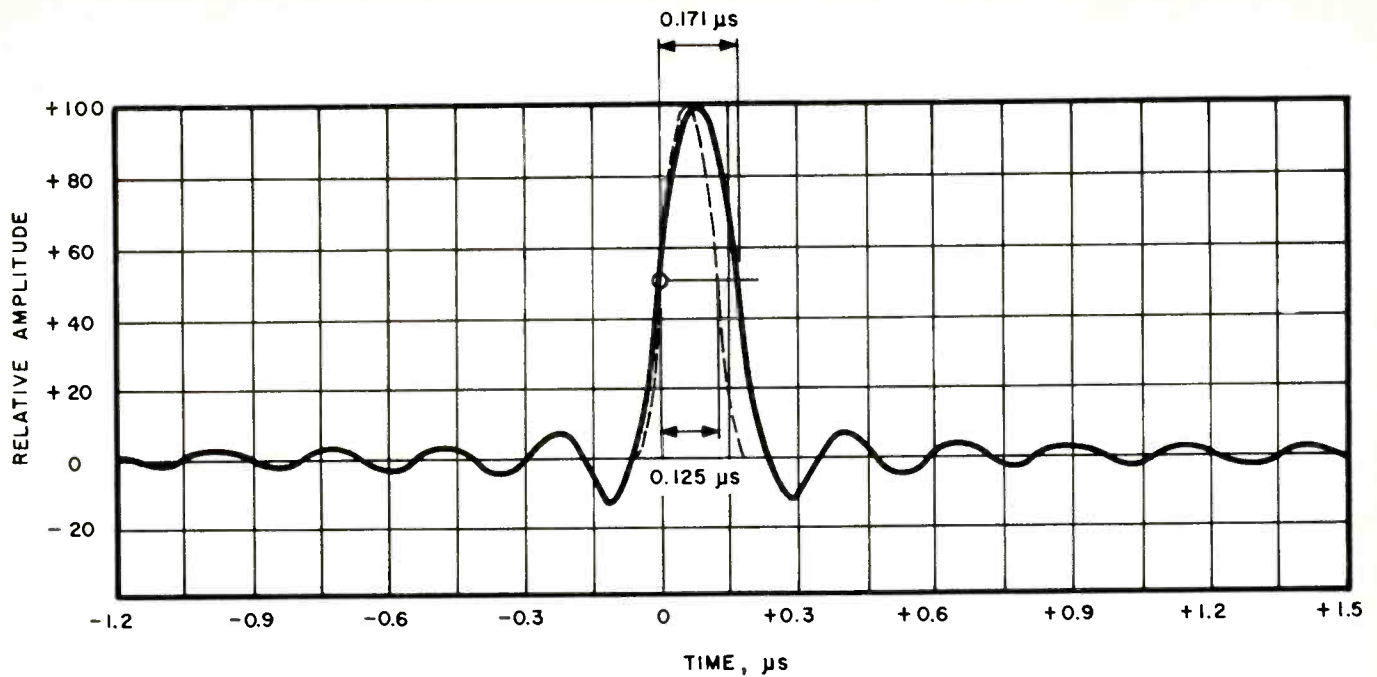

FIG. 4

tude. At  $f = \frac{1}{T}$  the spectrum amplitude is zero and remains at least 35 db down from the fundamental amplitude for all higher frequency components. See Figure 3. Thus the test pulse has accurately predictable and controllable components which test the system in the frequency range of normal use. This is one essential difference between  $\sin^2$  pulse testing and the usual square wave test signal. The square wave has components which extend way beyond the bandwidth required. These components cause overshoot, ringing, and phase shift which do not normally occur on picture data. As a result, the transient response will appear much worse than it really is or else the system bandwidth must be vastly and unnecessarily extended to make the square wave response appear satisfactory.

Not only does the  $\sin^2$  pulse test the system in the proper frequency range, but it also does so more rigorously. As is well known, the ideal bandwidth limiting of a perfect system results in a Heaviside step having a Gibb's overshoot of 8.9 per cent. The same system causes 13 per cent overshoot in a  $\sin^2$  pulse as it becomes  $\frac{\sin x}{x}$  in shape. See Figure

4. As a result, the  $\sin^2$  pulse makes a more sensitive test means than the square wave.

Further, the group delay characteristic of the pulse is constant to a frequency well above  $\frac{1}{2T}$ . Thus ex-

tremely precise symmetry around the pulse maximum amplitude axis exists. This makes the pulse particularly sensitive to phase distortion. Additionally the type of phase shift occurring in a system is clearly shown by the pulse. If high frequency delay is less than for low frequencies, a ripple occurs on the leading side of the pulse. See Figure 5. If the opposite type of delay exists, the ripple follows the pulse.

#### Reproducibility of Pulse

A further advantage to the  $\sin^2$  pulse is the fact that pulse generators can be easily built which generate pulses whose actual shape deviates less than 1 per cent from the true mathematical  $\sin^2$  pulse shape. See Figures 6 and 7. This means that it is possible to have all test pulses alike. Furthermore, the essential active element is a blocking oscillator whose output closely approximates an isosceles triangle. This impulse is shaped into a  $\sin^2$  pulse by means of a passive network. Once the filter elements have been properly measured and assembled, the desired pulse

shape will be assured for wide variations in tube characteristics. It should be noted that this is in marked contrast to square wave generators whose waveforms do not have constant shapes during tube aging nor the same shape for a group of generators.

#### Testing Techniques

Transient testing of wideband systems creates the demand for several test pulses each of which is sensitive to distortions occurring in different portions of the system bandwidth. To assure proper transmission of the vertical component, a test signal must be capable of revealing frequency response and particularly the phase response of the region around 60c/s. Proper performance

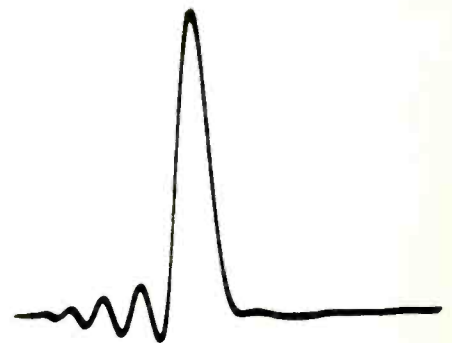

FIG. 5



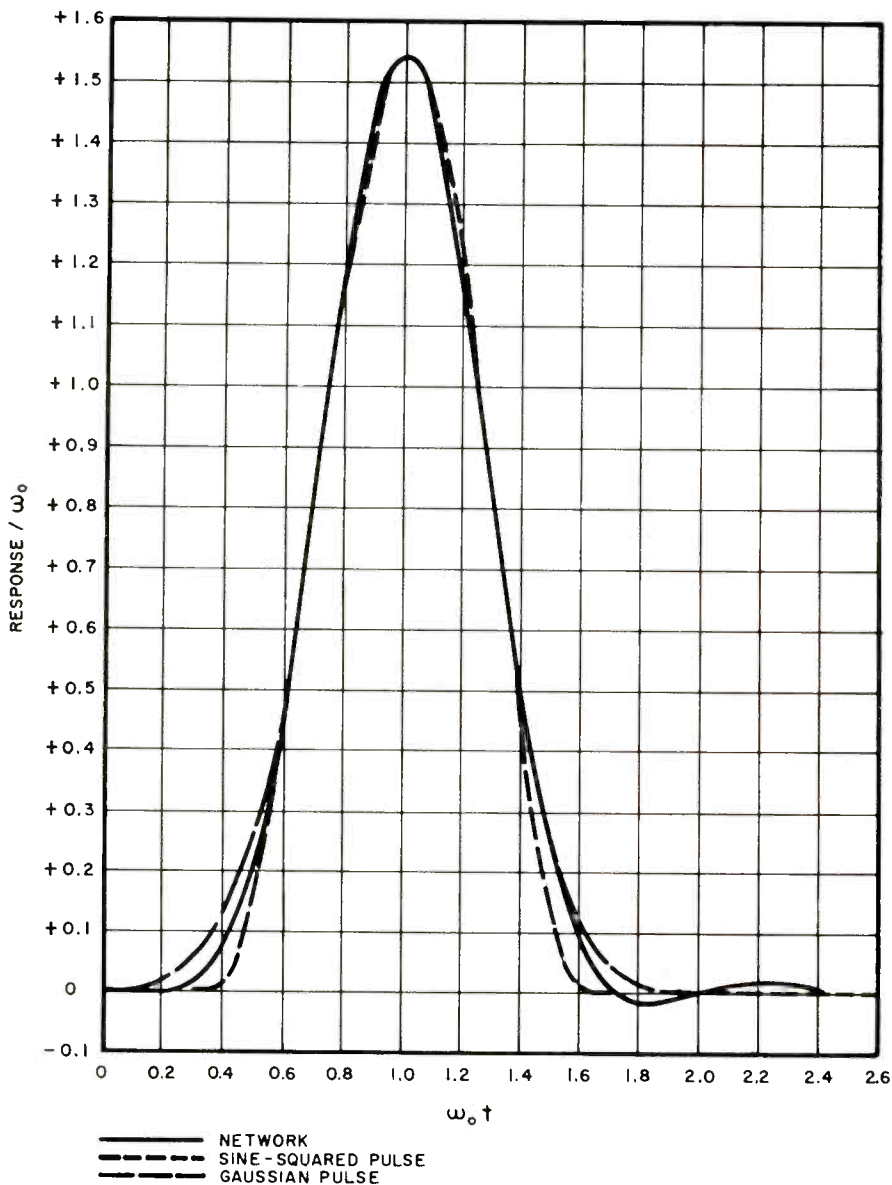

FIG. 6

of clamper amplifiers is likewise essential. It is highly desirable to have some test means for evaluating pulse tilt at line frequency so as to be able to test such amplifiers. Additionally, the testing of the system in both its midband and upper frequency portions is necessary.

Hence it has become common practice to utilize four test signals. The common 60c/s square wave and sub-multiples is used to determine the performance of systems components which do not have clammers in them. The amount of tolerable tilt is engraved on a scope graticule so that one may quickly judge the acceptability of a component.

The second test waveform is a shaped bar type of signal commonly called "window" in this country. The

bar has a duration of approximately one-half line. The rise and fall edges of the bar are given a  $\sin^2$  shape corresponding to the  $2T$  pulse. Thus there are no components in the bar spectrum having frequencies above 4 mc/s. As a result, no ringing can appear on the bar due to upper bandwidth limitation. This signal is particularly sensitive to distortions from line frequency to several hundred kilocycles. As a result, malfunctioning of clammers which cause smear or streaking in a picture may be observed and properly corrected.

The third test signal is the  $2T \sin^2$  pulse. It, like the shaped bar, contains no data above 4 mc/s. It has a (h.a.d.) of 0.25 usec for a 4 mc/s, bandwidth system. It is particularly sensitive to distortions occurring in

the spectrum between about 0.5 and 2 mc/s. As such it is well suited for routine adjustments of a system where it is not possible or desirable to make a detailed system analysis.

Finally the fourth or T pulse is reserved for the upper region of the spectrum. It has a (h.a.d.) of 0.125 usec. for the 4 mc/s system. Its spectrum is 6 db down in power at 4 mc/s and is zero at 8 mc/s. It therefore does contain sufficient data to permit evaluating the transient conditions in the region of cutoff in the sideband filter of the transmitter where excessive phase shifts may occur.

It is conventional to transmit the shaped bar during the last half of a horizontal line and to precede it with either the T or  $2T$  pulse on the same pedestal. See Figure 8. The generator usually has a switch for selecting the desired pulse.

#### Rating Factor

It was recognized quite early in the investigations in Europe that little correlation existed between transient and steady state testing since mathematically time and frequency domains are related by transforms, e.g., LaPlace, Heaviside, Fourier, Mellin, etc. This means that no assurance could be given that for example doubling the system bandwidth would produce improvement in picture quality. Further, a broad dip of a couple of db at say 50 kc/s will cause far more waveform distortion than a very sharp hole of 5 or 10 db at say 500 kc/s. In order to try to establish order, the Post Office Department and the BBC conducted a series of interesting tests. A group of about 20 television engineers were chosen as subjective ob-

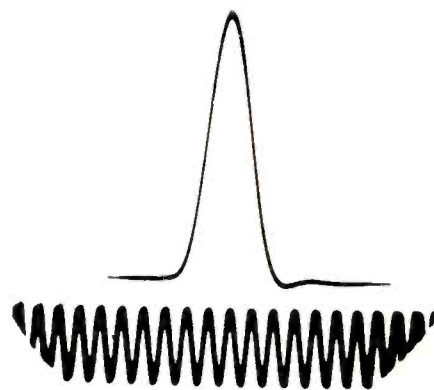

FIG. 7

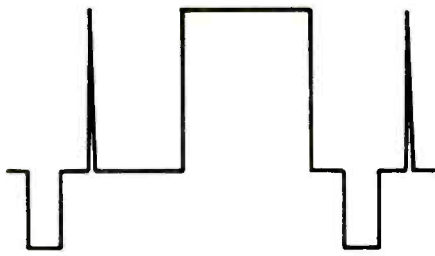

FIG. 8

servers. A scanner and monitors were set up and a sequence of different test slides were chosen. The circuit between the scanner and the monitors was distorted in a particular manner. The slides were viewed on the monitors and evaluated on a scale of five. A  $\sin^2$  pulse was then fed through the circuit and its waveform photographed. Numerous forms of distortion were introduced and individually treated in the same manner. Separate steady state measurements were also made.

With these data it was possible to evolve what is termed a rating factor for the system. The rating factor is a number assigned a system based upon the quality of  $\sin^2$  pulse transmission. For certain forms of distortion, a 5 per cent rating factor may produce a totally useless picture. A 3 per cent rating factor is usually acceptable for remote circuits or complete systems. Some of the newer circuits in England have rating factors of 0.25 per cent.

#### Routine Test

One virtue of the rating factor is that two different methods of evaluating circuit performance are possible. The "routine-test" method permits evaluations of remote circuits and daily tests of transmission equipment. It consists of a few simple measurements using a standard oscilloscope and the use of the following table:

Features	1%	2%	3%	4%	5%	6%
Half-amplitude duration, maximum (us)	.185	.190	.195	.200	.205	.210
Ringing Frequency, minimum (mc/s)	4	4	4	4	4	4
First Lobe (negative), leading or trailing (%)	10	12	14	16	18	20
Second Lobe (positive), leading or trailing (%)	6	8	9	10	11	12

#### Acceptance Test

The second method of circuit evaluation is by the "acceptance test." Photographs of the system output waveforms are taken and include an 8 mc/s, sine wave as a time base. The waveform is divided into intervals of 0.125 usec. starting with the axis of maximum pulse amplitude as zero. A comparator microscope is used to measure the waveform ordinates at each time interval. All ordinates are normalized using the maximum pulse amplitude as unity. A time series is then formed of these data. It is the realization of the time-series that makes the  $\sin^2$  pulse such a powerful tool both for analysis and synthesis. With it one is able to answer such questions as:

1. Given the individual time-series (responses) of each of a chain of different circuits to a specified signal. What would be the over-all response of the chain to the same signal? Thus if we know for example the time-series for New York to Chicago, Chicago to Denver, and Denver to Los Angeles, individually, we can compute the New York to Los Angeles response.

2. Given the waveform responses of the whole and one part of a chain of networks to a specified signal, what response would the remaining part have to the same signal? This is essentially a statement of the equalizer problem. If the desired response is known as well as the response of the circuit alone, it is possible to determine the response which an equalizer must have to correct for the circuit deficiencies.

#### Equalizers

Considerable work has been done on the design of equalizers for providing a wide range of equalization for correcting waveform responses. One type which is particularly suitable for correcting remote circuits or

other temporary applications makes use of the echoes occurring on tapped delay lines. This is a manually adjustable device and optimum equalization is obtained by visual inspection of the equalizer output as adjustments are made.

Another equalizer has also been developed which permits manually optimizing the response. The various adjustable components are calibrated. From the readings it is possible to design a fixed equalizer having the same time response which may then be substituted for the adjustable equalizer.

#### Vertical Interval Testing

The EIA in making recommendations for Vertical Interval Test Signal transmission suggested that such signals be confined to the last 12 usec of line 17 and all of lines 18, 19 and 20 of the vertical blanking interval. Line 1 of Field 1 begins with the first equalizing pulse. Line 1 of Field 2 begins 1/2 line after the first equalizing pulse.

In addition to uses already discussed it should be pointed out that the  $\sin^2$  pulse and bar signal may be transmitted during lines 18, 19 or 20 of the vertical blanking interval so as to provide a constant means of evaluating system performance. This technique had its origins in Germany in 1952, and has become widely used in Europe and here.

#### Envelope Delay in Color Systems

There is another area where it appears that the  $\sin^2$  pulse may have some application. The FCC standards for color television include an envelope delay specification. There is belief in some quarters that the original intent was to assure the same time delay for the luminance as for chrominance component of the signal. If this is the object, then a very simple technique has been proposed wherein a T pulse (h.a.d.) of 1 usec, or a 2T (h.a.d.) of 2 usec for Q-channel testing modulated by subcarrier sine wave during alternate lines. Thus the T pulse has a duration of 3.58 cycles of subcarrier and the 2T pulse a duration of 7.16 cycles. Since lines having the  $\sin^2$  pulse alternate with lines having the modulation it is possible to superimpose the two waveforms by proper adjustment of the oscilloscope. If the time delay for the pulse (luminance com-

(Continued on page 28)

# The 99th Cause of Crosstalk

**The notch characteristic of transmission lines can occasionally cause unexpected problems in FM installations, particularly if multiplexing is being used. An explanation of this problem and the necessary remedy is given in this article.**

By DWIGHT "RED" HARKINS\*

WHEN Dr. Victor Andrew, prominent in the field of economics, decided to diversify into the plumbing field, little did he realize that he was creating a whole new segment of the human race that was to devote its time to the problems that resulted from various applications of his "plumbing" activities.

Dr. Andrew developed into the world's number one "R. F. PLUMBER" by manufacturing various sizes of copper pipes used for the transmission of R. F. energy from one place to another. At the same time, he innocently created a whole new group of engineers spending their nights chasing down such problems as air leaks . . . hot spots . . . standing waves . . . loose connections . . . water in the line . . . etc., etc. This unusual group became master plumbers, amateur steeplejacks, expert second guessers, who entered a world of their own.

Adding to the confusion, a new art of broadcasting known as FM multiplexing has added new problems to the vagaries of R.F. transmission lines.

It has been pointed out in previous articles that the main problem encountered in transmitting multiplexed sub-carriers over an FM transmission system is to keep the regular main channel audio from being heard in the reception of the sub-channels. This intermodulation effect is commonly called "cross-talk." One of the causes of intermodulation is the effect of some transmission circuits that causes the FM to be converted to AM.

Any condition in the over-all system that produces a non-linear change in phase shift as the carrier deviates above and below its un-

modulated position will result in an amplitude component being generated. For example, if the final tank circuit is tuned to one side of resonance, the carrier frequency will deviate up and down in frequency so that in one direction it approaches the resonant point while in the other direction it will move away. This produces an amplitude component which in turn causes intermodulation of the subcarrier in the form of phase shift of the subcarrier by the audio material being used to modulate the main channel.

It is beyond the scope of this article to detail the many other conditions that have been found to create crosstalk. At this time certain effects of transmission lines will be discussed in connection with crosstalk.

Ever since the first pipe was hooked between transmitter and antenna, it has been the goal to have the load impedance of the antenna match the surge impedance of the transmission line. If a mismatch occurs, all sorts of trouble sets in and the energy that is supposed to be radiated by the antenna finds itself being reflected back to the transmitter instead. This condition known as a standing wave has resulted in such unusual things as fireworks, melted lines, blown fuses, R.F. on the power line, R.F. in the audio system, hot spots on the transmitter cabinet, as well as fractured tempers.

In the past, a certain amount of this monkey business has been tolerated by standard FM stations because no noticeable deterioration of the signal was apparent.

With the advent of TV, however, it was soon discovered that these

minor mismatch conditions could not be tolerated since they caused ghosts in the picture. As a result more care was given to the design and installation of the television transmitting antenna system.

Along with multiplexing came the requirements for more attention to the standard FM transmitting antenna system and its proper tuning and match to its transmission line.

As a measurement of performance, a device known as a directional coupler or a reflectometer is used at the transmitter output. This device works on the principle that it measures either the forward power going to the antenna or the reflected energy coming back. The indicating meter is calibrated to indicate the reflected energy in the form of standing wave ratio. Under ideal conditions, the VSWR is unity or 1.0 as measured directly at the transmitter output entering the transmission line to the antenna. The VSWR is actually an expression of comparison between the maximum voltage encountered along the transmission line and the minimum voltage and must therefore always be 1.0 or larger.

At standard FM stations, little attention has been given to determining the VSWR at other than the center carrier frequency. Even though the system has very low VSWR at center carrier frequency, we must closely examine what occurs when the frequency is changed above and below the normal center. A system turned for minimum VSWR at center frequency will not remain the same as the frequency is either raised or lowered. If the change in VSWR is not exactly the same when the frequency is raised

\*4444 E. Washington St., Phoenix, Arizona



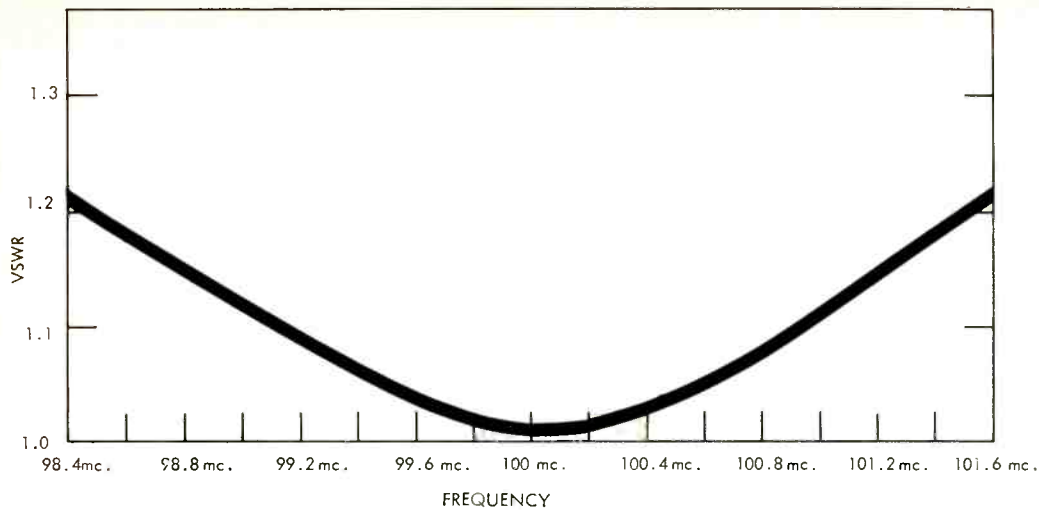

Figure 1. VSWR curve showing linear change with frequency on either side of center carrier.

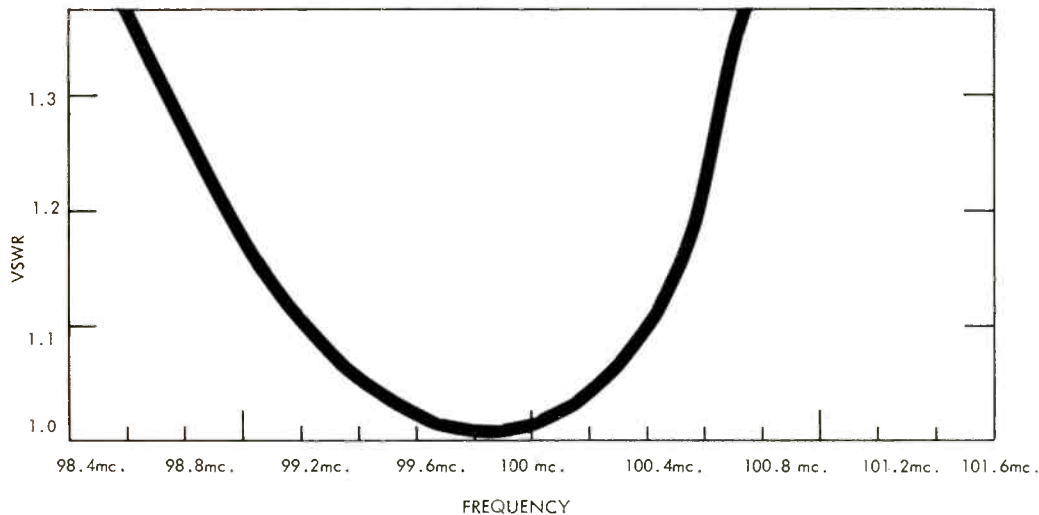

Figure 2. Non-linear change of VSWR with frequency indicates presence of conditions producing crosstalk. Actual measurements in the field are often more severe than this.

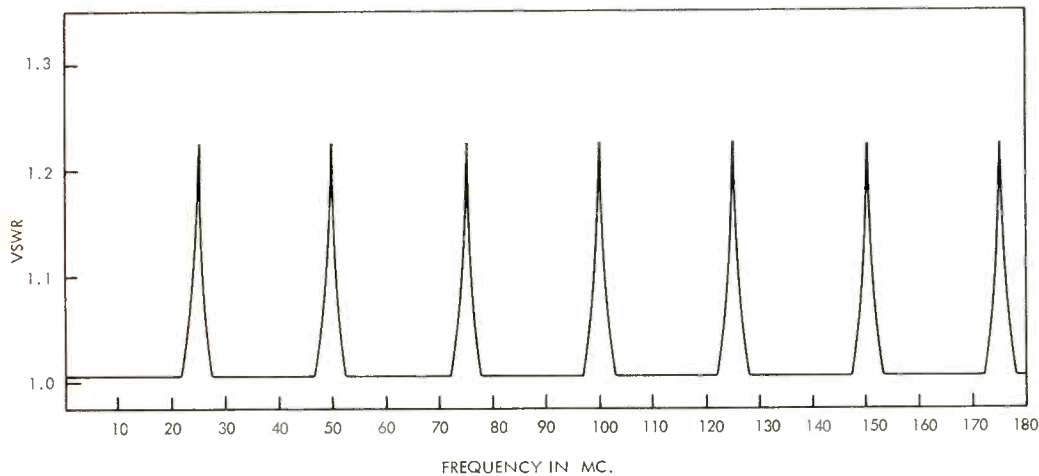

Figure 3. Graph showing VSWR while measuring a long length of co-ax terminated into a perfect non-resistive load. If one of the reject frequencies falls near the station operating frequency, proper antenna tuning cannot be realized.

as it is when the frequency is lowered, then we have a non linear condition very similar to the mistuned final tank circuit previously discussed.

Fig. 1 shows a graph of VSWR measurements under ideal conditions where the change is the same both above and below the center carrier. Fig. 2 shows a typical curve resulting when the transmission line is

terminated into an improperly tuned or designed antenna. Since the side bands or sidecarriers generated by frequency modulation fall into the regions above and below the center carrier where the VSWR measurements indicate unequal conditions, they will in turn change in either amplitude or phase from their original form. This "distortion" of the original complex signal results in

intermodulation crosstalk of the sub-carrier. Using the VSWR curves to locate this condition is only one of several methods that can be used.

Now, to add insult to injury, we are going to bring to light still another phase of this problem. It now can be shown that the innocent looking copper pipe used for transmission lines is capable of other

*(Continued on page 32)*

# EXPERIMENTAL OPERATION OF A

How use of an on-channel transmitter can be used to fill in low signal areas and how precisely offset carrier frequencies can minimize interference between the two transmitters is described.

By DANIEL H. SMITH\*

CAPITAL CITIES Broadcasting Corp. operates Channel 10 from a site at Vail Mills, N. Y., approximately 35 miles from the cities of Albany and Troy, and approximately 22 miles from Schenectady. This is a "drop in" channel not initially allocated to the Tri-City area, so the site location was determined by FCC Rule 3.610 concerning mileage separation between co-channel stations. Although the operation of the supplemental on-channel transmitter, which will be described later, is of primary interest, it may be helpful to review briefly the background of television broadcasting in the Albany area.

Probably in no other location with both UHF and VHF is UHF coverage as poor in comparison with VHF. The first television station in the area was one of the real pioneers, operating initially on Channel 4. With the allocation changes brought in the Sixth Report and Order this station was changed to Channel 6, and at the time of the issuance of the Report was still the only television station in that market. The predecessor company in Albany to Capital Cities ventured to compete with this entrenched VHF station by putting WCDA, Channel 41, on the air in 1953. Although the Channel 41 antenna is approximately 700 ft. above ground and strategically

located between Troy and Albany, it became apparent that not even Schenectady, no more than 15 miles away airline, received adequate signal or satisfactory service in most locations. This was in comparison with the low band VHF signal providing adequate service up and down the Hudson River Valley from Hudson to the south to Glens Falls to the north, to the west beyond Amsterdam and to the east into western Massachusetts and southern Vermont.

This indeed was a striking demonstration of the difficulty experienced by a UHF station in attempting to compete with VHF, particularly in the terrain existing in this eastern upstate New York area. In order to provide service in Schenectady, WCDA applied for and obtained permission to operate a satellite on Channel 29 on Glenville Hill, which is about ten miles northwest of Schenectady and about halfway between that city and Amsterdam. This satellite went on the air in 1955.

After the acquisition of WCDA by Capital Cities, the operation of WCDC, Channel 19, on Mt. Greylock, 3500-ft. mountain in western Massachusetts, was assumed in 1957. This transmitter operates as a satellite providing service to North Adams, Pittsfield, southern Ver-

# CO-CHANNEL SUPPLEMENTAL TRANSMITTER

mont and western Massachusetts. Mt. Greylock is approximately 30 miles east of Albany and is one of the Berkshire Mountains. This, then, was a case where there was one station operating three 12 kw UHF transmitters, with antennas providing the usual effective radiated power of 200 kw or so and still unable to provide the same coverage achieved by one low band VHF transmitter.

During the period from 1955 to late 1957, the Commission took certain action with respect to channel allocations in the Albany area and show-cause orders relating to the assignment of these channels. As a result of these rule-making and show-cause proceedings, the low band station was continued on Channel 6, WCDA was authorized an operation on Channel 10 and WTRI, another Albany area station on Channel 35, was authorized to operate on Channel 13. Consequently, Channel 10 operation was begun at Vail Mills on Dec. 1, 1957, utilizing a peak visual power of 144 kw with antenna height above average terrain of 1270 ft. The power and antenna height were carefully chosen after an extensive analysis of the terrain between Vail Mills and the principal cities served, based on predicted coverage curves published in the FCC Sixth Report. On this

basis, city grade coverage should have been provided to the principal cities of Albany, Troy and Schenectady. After transmission was begun from Vail Mills, however, it became immediately obvious that the public was encountering difficulty in receiving the Channel 10 signal in some of the Albany and Troy areas, apparently due to the nature of the terrain.

It is in the Hudson River Valley that the failure of Channel 10 coverage is most troublesome, for this Valley area contains an appreciable part of Albany and Troy, as well as adjacent smaller communities such as Watervliet, Cohoes, Waterford and others. Indeed, the problem is so pronounced that Channel 41, which was to be discontinued when replaced by Channel 10, was returned to the air temporarily soon after Channel 10 was placed in use in order to provide service to this Valley area and allow an orderly transition from UHF to VHF service. The Channel 41 antenna tower is located within a few hundred yards of the Hudson River, on the east bank, across from Albany and south of Troy, thus providing high level signal strength up and down the Valley in the vicinity of these two cities. This is the area not adequately covered by Channel 10.

The operation of Channel 41 has

been authorized by the Commission on a temporary basis for only 90 days at a time, which has, however, been extended at each expiration to allow the continuance of service to the viewers in the affected area, service that these people would not otherwise receive. Of course this could not be continued indefinitely, not only from the standpoint of the FCC Rules; but it is also a considerable expense to operate two high-power transmitters in order to provide service to the viewers in one area. The deficiency of the Channel 10 signal in the area in question was established on an engineering basis in December, 1957, by the CBS engineering department as a result of a field strength survey. The engineer conducting this survey concluded from his measurements that the WTEN transmitter plant was operating normally and that the observed field strength was in the range to be expected in view of the distance and topography involved. However, in the Albany vicinity the average field strength measured in this survey was nearly 12 db below predicted.

After an analysis of the complaints from viewers and a study of possible remedies, the Capital Cities consulting engineers, Kear and Kennedy, filed an application with the Commission in November, 1958, for

\*Vice-president and Director of Engineering, WTEN (TV), Albany, N. Y.

Presented at the 1960 NAB Engineering Conference



authority for Capital Cities to operate an experimental, on-channel, supplemental transmitter on Channel 10, to be located at the Channel 41 transmitter tower. If successful, it was thought that by this means Capital Cities might be able to provide service on Channel 10 to the residents of the Hudson River Valley unable to obtain satisfactory service from the Vail Mills transmitter.

While this application was in process at the Commission, additional measurements were made to determine the radiating efficiency of the antenna in use at Vail Mills. All field intensity measurements were made using a recording meter on the field intensity meter.

First, measurements were made at a distance of approximately five miles from the antenna, covering as much as possible 360 degrees of arc. Each location was chosen to be in line of sight of the antenna and to produce as much as possible Fresnel zone clearance of all intervening points between antenna and receiving locations. Field intensity was recorded over a minimum horizontal distance of 100 ft., to a maximum of 500 ft. and the median value of the field intensity determined from the graph produced. The recording runs were made with the antenna elevated 30 ft. above ground and the dipole oriented for maximum signal and maintained normal to the approaching wave front. The median distance was determined by plotting the run on the map used and the product of field intensity and distance tabulated as a deviation from free space field. This procedure was then repeated at a distance of approximately ten miles from the antenna. These line of sight measurements were in agreement with the earlier CBS measurements and confirmed that the antenna and transmitter were performing as designed so that the only apparent reason for the low signal strength in the Albany and Troy area is the nature of the terrain. There are three or four peaks between the transmitter and Albany. These peaks are actually ridges and lie in a more or less northeasterly and southwesterly line, thus are consequently at right angles to the direction of wave travel between the transmitter and Albany.

In March, 1959, the Commission

granted the experimental permit requested and construction was begun immediately and completed June 10. The installation consisted of a 500-watt visual peak RCA transmitter feeding a two-bay superturnstile antenna side mounted on the Channel 41 tower 100 ft. above ground. Although it was anticipated that only one set of radiating elements would be fed in order to obtain a figure eight pattern, transmission lines were installed for both the N-S and E-W radiators. The transmitter was adjusted for rated output of 500 watts visual peak and 250 watts aural. A bridge diplexer was used to combine visual and aural outputs, but only the transmission line feeding the E-W radiators was connected to one of the two diplexer outputs. The other diplexer output was connected to a dummy load; consequently only 250 watts visual peak and 125 watts aural power was fed to the antenna, the other half of the output being dissipated in the dummy load. In this way the E-W radiators produced the desired figure eight pattern. The antenna was oriented to place the figure eight pattern up and down the Hudson River Valley.

Operation of experimental transmitter KE2XZJ was begun on June 17, 1959, using only those hours of the experimental period that WJAR-TV, Channel 10, Providence, R. I., was not operating. A program of field intensity measurements of the main and supplemental transmitters, using normal crystal control of carrier frequencies, but offset 10 kc, was established in conjunction with observations of picture quality at each measured location. This method was used to determine the offset frequency between the two carriers. In the control room of WTEN there is a Conrac receiver used for an off the air monitor. The KE2XZJ transmitter was installed adjacent to the control room and this receiver picked up enough signal from both transmitters so that the beat between the two visual carriers appeared in the receiver video output. This beat signal with no aural carrier transmitted and with no modulation on either visual carrier, was fed into a Hewlett-Packard Type 522-B Counter which counted the frequency of the beat, within its limits of ac-

curacy, which is plus or minus one count. To insure the accuracy of this measurement the self-contained 100 kc crystal in the counter was checked against WWV on 10 megacycles and when found to be very slightly off, set exactly to zero beat.

Field measurements and picture observations were made with equipment installed in a station wagon, using a pneumatically operated telescopic mast extendable to 30 ft., supporting a standard dipole antenna and coax transmission line used with a Clarke 106 Field Intensity Meter. A 17-inch portable television receiver, powered with an inverter and storage batteries, was used for picture observations and photographs.

The problem created by operating an on-channel supplemental transmitter is obviously the interference between the two transmitters in those areas where the field strength ratios are less than 30 db, when the transmitters utilize ordinary frequency control. It has been established in laboratory tests by Wendell Morrison, of RCA, that an improvement in the order of 10 db in permissible signal strength ratios can be attained with precisely offset carrier frequencies when the 10 kc offset is an even multiple of the picture frame frequency. Also, field tests have been made of precisely offset carrier frequencies between Channel 4 stations in New York and Washington.

The utilization of this principle for the supplemental transmitter, however, posed an entirely different condition as the coverage area of the supplemental transmitter would comprise an "island" in the general coverage area of the main transmitter. Due to the large difference in power and antenna heights of the two transmitters, the median field strength of the main transmitter would be greater than that of a small transmitter, except in the immediate vicinity of the low powered transmitter. Incidentally, this meant that the signal from WTEN towards the nearest co-channel station to the east, WJAR-TV, Providence, on which side of WTEN experimental KE2XZJ is located, was above that of KE2XZJ by a median of 27 db at a distance of 60 miles from the WJAR-TV theoretical grade B contour towards WTEN.



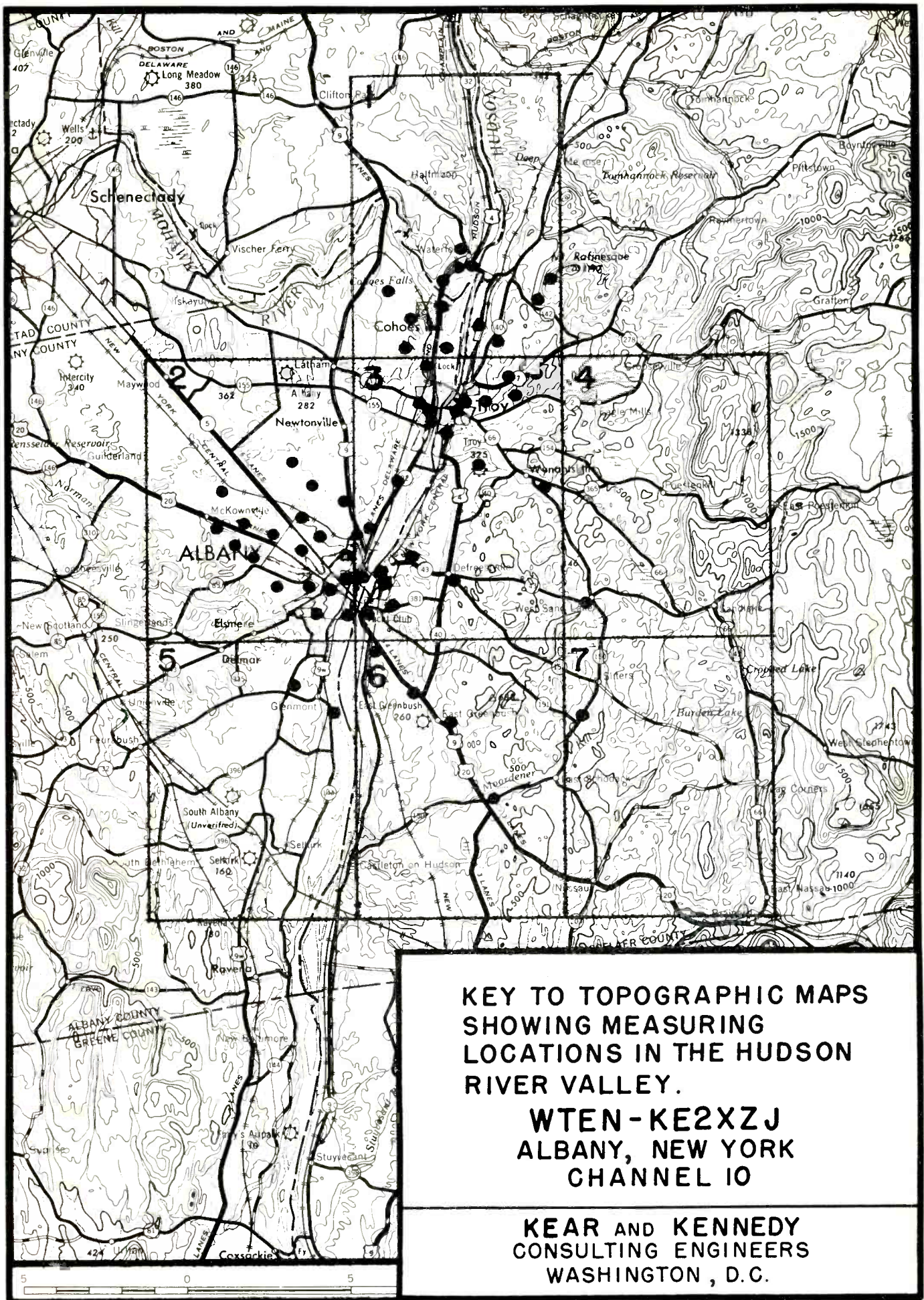



This was determined by measurements made using the same measuring technique described earlier and this data was reported to the Commission in November 1959, in order to prove that the operation of the supplemental transmitter would not result in an increase in radiation towards WJAR-TV.

To return to the interference between WTEN and KE2XZJ, it was proposed to use a figure eight pattern from KE2XZJ. So it was presumed that the interference area where the signal ratio might be low enough to cause co-channel interference would approximate a figure eight, but with an interference free area in the center of each of the two loops where the KE2XZJ signal would over-ride the WTEN signal. Measuring locations were selected encompassing the probable interference area between the two transmitters and they were spotted on a map. Each set of measurements or observations subsequently made were at these same points. Figure 1 shows these points and they are in the approximate configuration of a figure eight with the center along the Hudson River Valley. The median field intensity of WTEN at each of these locations was determined using the same technique described for the measurements veri-

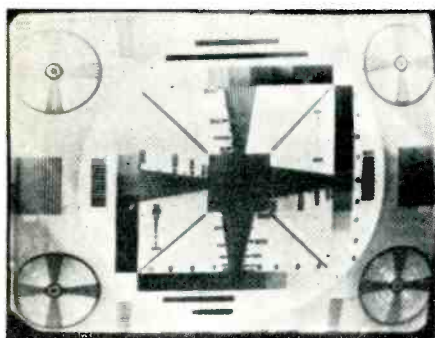

Figure 2

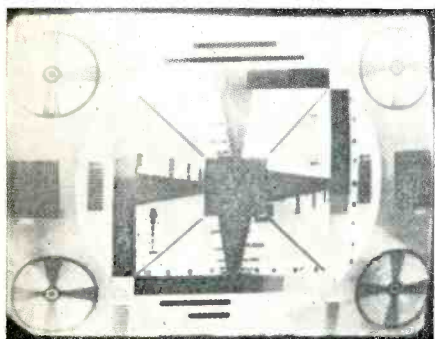

Figure 3

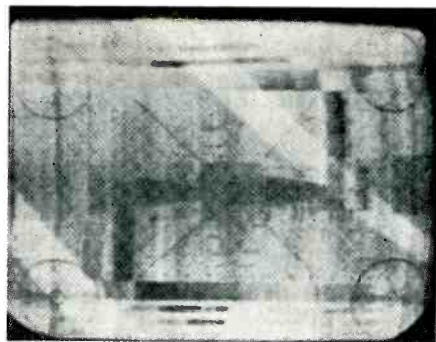

Figure 4

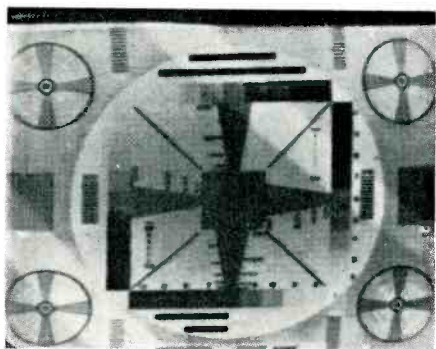

Figure 5



Figure 6



Figure 7

fying antenna gain. These WTEN measurements were made in the daytime to check the measuring points for clearance for the 30-ft. antenna mast, *i.e.*, freedom from tree limbs, power lines, and other obstructions. Then after Channel 10 had concluded telecasting, measurements were made in the early morning hours to determine the field intensity of KE2XZJ at each of these locations. The standard dipole on the mast was then replaced with a high-band dipole, fed with 300 ohm twin-lead which was connected to the portable receiver in the station wagon.

Observations were then made of the receiver presentation of a standard resolution slide telecast first on WTEN, then on KE2XZJ, then on both transmitters. In each instance the antenna was rotated for the best picture. These first picture observations produced very little useful information other than establishing the procedure used later with precise offset, but they did demonstrate the frequency drift of the beat note between the two transmitters as their crystal heaters cycled on and off.

This rapidly changing beat was continuously displayed on the counter and showed conclusively that it was not possible with ordinary car-

rier frequency control to maintain a fixed relationship between offset and vertical signal from the sync generator, for the beat frequency would swing back and forth a hundred cycles or more as the crystal ovens cycled. The difference between an even and odd multiple of frame frequency is only 30 cycles so it is obvious that a change of offset of this magnitude would result in a waxing and waning of the interference between the two transmitters under the above conditions, for the interference is minimum at an even multiple and maximum at an odd multiple of frame frequency. The theoretical difference in this interference between even and odd multiples is about 10 db when the offset frequency is in the vicinity of 10 kc.

After the precise frequency control equipment was installed and adjusted, the program of observing and photographing the test receiver in the station wagon while receiving precise offset transmissions at each of the measuring points was initiated. The counter was used to measure the horizontal and vertical signals from the sync generator and to observe the stability of these signals. Although the sync generator was very stable in the AFC position controlled by the power line, it was



decided to use the color crystal controlled operation of the generator during the tests. This did not produce an application bar on the film used in the tests as the projectors used at WTEN are synchrolites.

Having determined the field rate of the sync generator in use, the precise offset frequency was set at 334 times one-half this frequency, or 10,010 cycles. The stability of this precise frequency control equipment is remarkable. Both units were left on constantly after installation and a carrier frequency difference of 10,010 cycles was maintained over 24 hours with a maximum drift of two cycles. When it is considered that this beat note was between two carriers at 193 mc, this is remarkable performance.

With the precise offset equipment installed, observation points and procedures established, the experiment was now at the point where conclusive information could be photographed of the effectiveness of precise offset in reducing visible interference between the two transmitters. Photographs of the test receiver under six different conditions at each of the representative locations demonstrated the interference and results encountered.

It was necessary to use the precise offset frequency control to photograph the least favorable condition of approximately an odd multiple of frame frequency, that is 10,035 cycles, in order to hold the condition long enough to take the picture.

With standard crystal control the beat frequency between the carriers changed so rapidly that it was not practical to try to photograph the test receiver at any one specific offset frequency. The diagonal bars appearing in most of the photographs were caused by the shutter of the Leica camera which allowed a portion of the negative to be double exposed. These bars, of course, did not exist on the receiver's kinescope.

The first location to be displayed was one of 23 at which an excellent signal could be received from either WTEN or KE2XZJ when either was operating alone. The top photograph, Fig. 2, displays the test pattern with both transmitters on and with a carrier offset of 10,010 cycles. The WTEN field intensity here was

91.2 dbu, the KE2XZJ field 84.4 dbu, thus a difference or ratio of -6.8 dbu. The lower picture, Fig. 3, shows the same conditions except the offset frequency is 10,035 cycles.

The next group of photographs are of a location representative of fourteen measuring points, where the signal level of WTEN was very low, 47.6 dbu, and the KE2XZJ signal strength was adequate, 78.1 dbu, providing a 30.5 db ratio. Again, the top picture, Fig. 4, is WTEN and the lower, Fig. 5, is KE2XZJ. Fig. 6, the upper picture, is both transmitters with 10,010 cycles, and the lower, Fig. 7, both with 10,035 cycles offset. The diagonal bars result from a shutter peculiarity in the camera and were not visible on the receiver screen.

The next group of photographs are from a location not in the River Valley, with adequate signal from WTEN and very poor signal from KE2XZJ, one of 17 check points in this category. The field ratio here is -16 db, with WTEN at 66.4 dbu and KE2XZJ, 50.4 dbu. The upper picture, Fig. 8, is WTEN, and the lower, Fig. 9, KE2XZJ; and Fig. 10, the top picture, both transmitters with 10,010 cycles and the lower, Fig. 11, 10,035 cycles offset.

In conclusion, it should be pointed out that all transmissions were

made during the experimental period and without the public participating in the experiment. Capital Cities and its consultants, Kear and Kennedy, are of the conclusion based on the results of the experiment that it is technically feasible to operate a co-channel supplemental transmitter to provide coverage fill-in in a low-signal area that results from the terrain or other causes in the coverage of a main transmitter. In the original request filed with the Commission for this experiment, the final phase proposed was the evaluation of the public acceptance of this method of operation. Capital Cities is ready to begin this phase of the experiment in which the supplemental transmitter will be used on a discretionary basis throughout the broadcast day in order to evaluate public acceptance and has requested authorization to proceed with this final phase.

Lastly, although Bob Kennedy and Fred Bode of Kear and Kennedy did the planning and basic work on this project, it must be acknowledged that without night owl, Lew Wetzel, of the same office, who only saw the light of day twice through the summer months of 1959, this information could not have been accumulated.

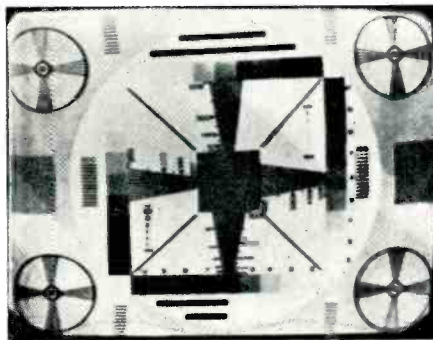

Figure 8

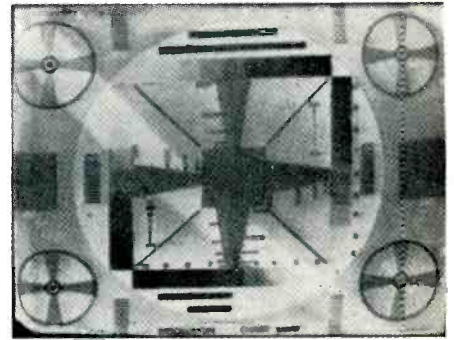

Figure 10

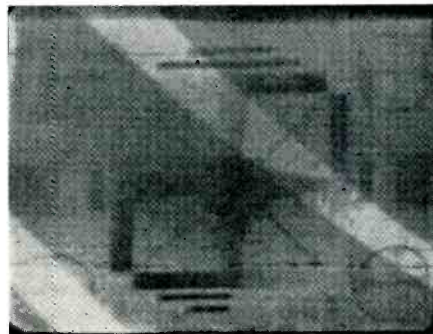

Figure 9

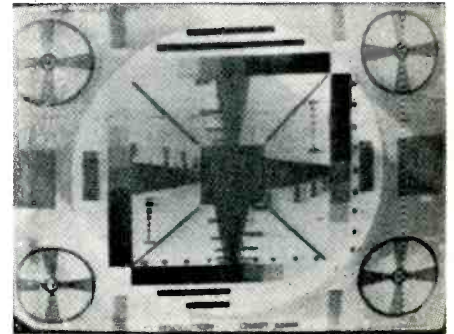

Figure 11

## Raytheon Distributors Serving Key Markets Include...

**Alabama**  
Birmingham  
Forbes Distributing Company  
AL 1-4104  
MG Electrical Equipment Company  
FAirfax 2-0449

**Mobile**  
Forbes Electronic Distributors, Inc.  
HE 2-7661

**Arizona**  
Phoenix  
Radio Specialties & Appl. Corp.  
AL 8-6121

**Tucson**  
Standard Radio Parts, Inc.  
MA 3-4326

**California**  
Burbank  
Valley Electronic Supply Co.  
Victoria 9-3944

**Glendale**  
R. V. Weatherford Co.  
Victoria 9-2471

**Hollywood**  
Hollywood Radio Supply, Inc.  
HO 4-8321

**Inglewood**  
Newark Electronics Company  
ORchard 7-1127

**Los Angeles**  
Graybar Electric Company  
ANgelus 3-7282  
Kierulff Electronics, Inc.  
RiChmond 8-2444

**Oakland**  
Brill Electronics  
TE 2-6100  
Elmar Electronics  
TEmplar 4-3311

**Palo Alto**  
Zack Electronics  
DA 6-5432

**San Diego**  
Radio Parts Company  
BE 9-9361

**San Francisco**  
Fortune Electronics  
UN 1-2434

**Santa Monica**  
Santa Monica Radio Parts Corp.  
EXbrook 3-8231

**Colorado**  
Denver  
Ward Terry Company  
AMherst 6-3181

**Connecticut**  
East Haven  
J. V. Electronics  
HObart 9-1310

**District of Columbia**  
Electronic Industrial Sales, Inc.  
HUdson 3-5200  
Kenyon Electronic Supply Company  
DEcatur 2-5800

**Florida**  
Miami  
East Coast Radio & Television Co.  
FRanklin 1-4636  
Electronic Equipment Company  
NEwton 5-0421

**West Palm Beach**  
Goddard Distributors, Inc.  
TEmples 3-5701

**Illinois**  
Chicago  
Allied Radio Corporation  
HAYmarket 1-6800  
Newark Electronics Corp.  
STate 2-2944

**Indiana**  
Indianapolis  
Graham Electronics Supply Inc.  
MElrose 4-8486

**Maryland**  
Baltimore  
Wholesale Radio Parts Co., Inc.  
MULberry 5-2134

**Massachusetts**  
Boston  
Cramer Electronics, Inc.  
COpley 7-4700  
DeMambro Radio Supply Co., Inc.  
AL 4-9000  
Lafayette Radio Corp. of Mass.  
HUbbard 2-7850

**Cambridge**  
Electrical Supply Corporation  
UNiversity 4-6300

**Michigan**  
Ann Arbor  
Wedemeyer Electronic Supply Co.  
NOrrmandy 2-4457

**Detroit**  
Ferguson Electronic Supply Co.  
WOodward 1-2262

**Minnesota**  
Minneapolis  
Electronic Expeditors, Inc.  
FEderal 8-7597

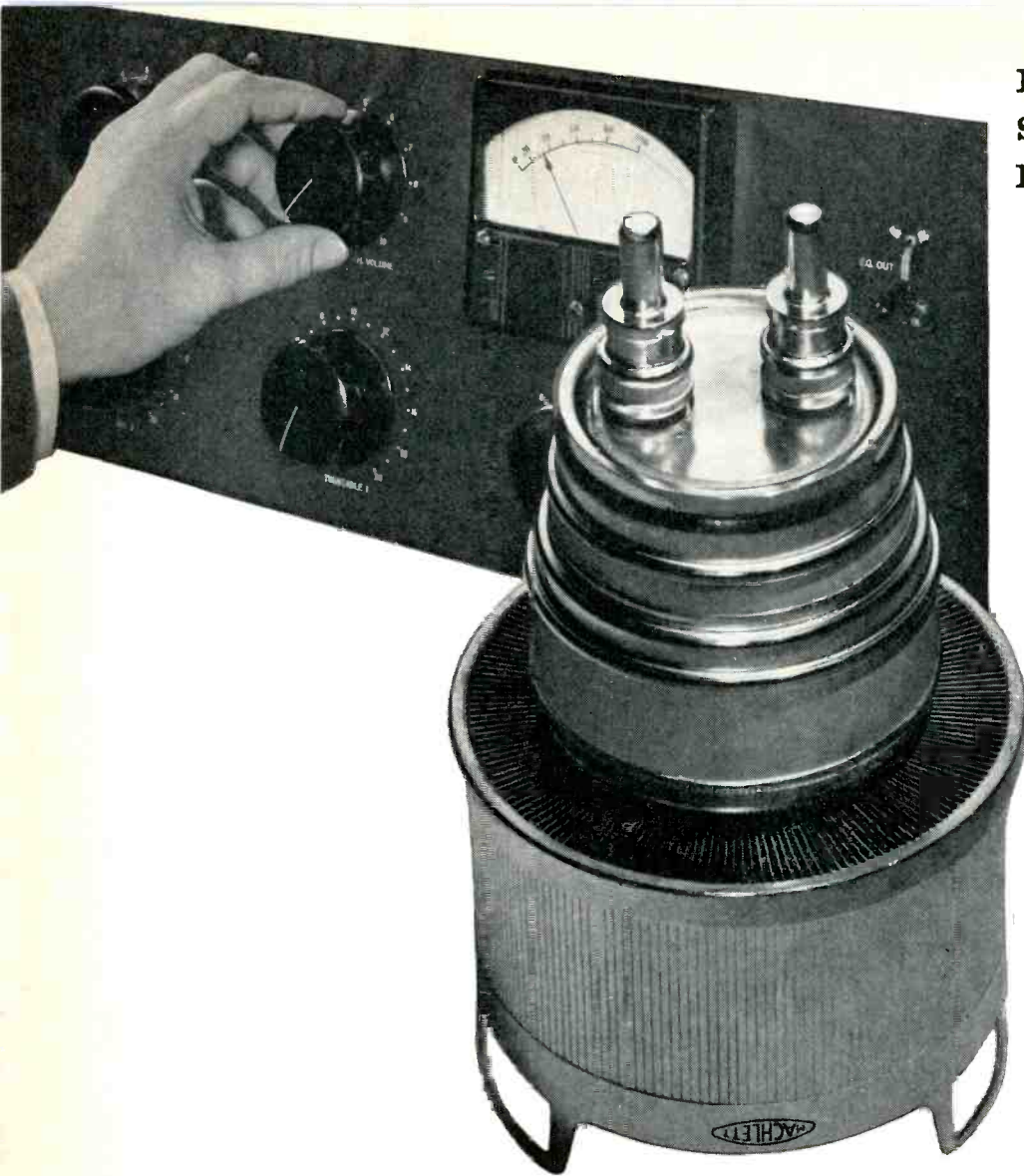

**Broadcast Engineers count  
on the peak performance of  
Raytheon/Machlett Tubes.  
These quality products at  
factory prices, plus complete  
technical data, are available  
from the Raytheon distributor  
nearest you...**



**RAYTHEON COMPANY**

**DISTRIBUTOR PRODUCTS DIVISION • WESTWOOD, MASS.**

RECEIVING AND INDUSTRIAL TUBES • SEMICONDUCTOR PRODUCTS  
MECHANICAL COMPONENTS • RAYTHEON/MACHLETT POWER TUBES  
VOLTAGE REGULATORS • MICROWAVE TUBES • CAPTIVE HARDWARE



**Mississippi**  
Jackson  
Ellington Radio, Inc.  
FL 3-2769

**Missouri**  
Kansas City  
Burstein-Applebee Company  
BALtimore 1-1155

St. Louis  
Graybar Electric Company  
JEfferson 1-4700

**New Hampshire**  
Concord  
Evans Radio  
CAPital 5-3358

**New Jersey**  
Camden  
General Radio Supply Co.  
WO 4-8560 (in Phila.: WA 2-7037)

**New Mexico**  
Alamogordo  
Radio Specialties Company, Inc.  
HEmlock 7-0307

Albuquerque  
Radio Specialties Company, Inc.  
AM 8-3901

**New York**  
Buffalo  
Genesee Radio & Parts Co., Inc.  
DElaware 9661  
Wehle Electronics Inc.  
TL 4-3270

Mineola, Long Island  
Arrow Electronics, Inc.  
Pioneer 6-8686

New York City  
H. L. Dalis, Inc.  
EMpire 1-1100  
Milo Electronics Corporation  
BEEkman 3-2980  
Sun Radio & Electronics Co., Inc.  
ORegon 5-8600  
Terminal Electronics, Inc.  
CHelsea 3-5200

**Ohio**  
Cincinnati  
United Radio Inc.  
CHerry 1-6530

Cleveland  
Main Line Cleveland, Inc.  
EXpress 1-4944  
Pioneer Electronic Supply Co.  
SUperior 1-9411

Columbus  
Buckeye Electronic Distributors, Inc.  
CA 8-3265

Dayton  
Srepco, Inc.  
BAldwin 4-3871

**Oklahoma**  
Tulsa  
S & S Radio Supply  
LU 2-7173

**Oregon**  
Portland  
Lou Johnson Company, Inc.  
CAPital 2-9551

**Pennsylvania**  
Philadelphia  
Almo Radio Company  
WAlnut 2-5918  
Radio Electric Service Co.  
WAlnut 5-5840

Pittsburgh  
Marks Parts Company  
FAirfax 1-3700

Reading  
The George D. Barbey Co., Inc.  
FR 6-7451

**Tennessee**  
Knoxville  
Bondurant Brothers Company  
3-9144

**Texas**  
Dallas  
Graybar Electric Company  
Riverside 2-6451

Houston  
Busacker Electronic Equipment Co.  
JACKson 6-4661  
Harrison Equipment Company  
CAPitol 4-9131

**Utah**  
Salt Lake City  
Standard Supply Company  
EL 5-2971

**Virginia**  
Norfolk  
Priest Electronics  
MA 7-4534

**Washington**  
Seattle  
Western Electronic Company  
AT 4-0200

**West Virginia**  
Bluefield  
Meyers Electronics, Inc.  
DAvenport 5-9151

**Wisconsin**  
Milwaukee  
Electronic Expeditors, Inc.  
WOODruff 4-8820

## TOWER IMPEDANCE

### Starts on page 4

culated. It should be noted that transformer isolation does not provide a static drain. This must be added.

The measurements of the KSTR tower were made under the following conditions:

A. No lighting isolation.

B. One tower lighting choke.

C. Two tower lighting chokes in tandem.

D. Tower shunted by a 30 micro-microfarads capacitor to simulate the transformer isolation.

The measurements of the KSTR tower with the various forms of tower lighting isolation described above were performed using a General Radio type 916-AL radio frequency bridge. The signal generator consisted of a very stable master oscillator followed by a power amplifier to isolate the effects of the bridge on the oscillator. A built-in electronic voltage regulator maintained the oscillator frequency and output very stable. The detector consisted of a very selective, well shielded, superheterodyne receiver. The switching arrangement was set up to disconnect the tower lighting circuits or to permit connecting one choke, two chokes in tandem, or the shunt capacitance.

Figure 4 is a plot of the base tower resistance for the entire broadcast band as shown by a broken curve. The solid curve is a plot of the resistance obtained with a single dual-wound tower lighting choke connected. It will be noted that the tower resistance showed a maximum change from 765 ohms down to 48 ohms at a frequency of 1275 kilocycles, corresponding to a tower height of approximately 0.4 wavelengths. This represents a *drastic* change of 93.8 per cent. It is to be noted that the variation of tower resistance within the one quarter wave region was fairly small.

In Figure 5 it will be seen that when two tower lighting chokes were used in tandem, a great deal less change in antenna resistance occurred. In fact over a broad band from 0.25 to 0.35 wavelength of tower height close agreement was obtained with basic tower resistance.

Figure 6 shows how transformer

isolation affects tower resistance. This system proved inferior to the two chokes in tandem, although vastly superior to the single choke commonly utilized. Very little change in antenna resistance occurred over only a small range of approximately .2 to .25 wavelength antenna height. At all other antenna heights, the transformer caused a significant change in measured antenna resistance. While the effect upon tower reactance may not be as significant as tower resistance for non-direction operation, it is quite important in directional antenna work.

Figure 7 shows the effect upon the measured tower reactance of a single tower lighting choke isolation circuit. Again the tower reactance without any isolation circuit is shown as a dashed curve. The tower reactance obtained with a single choke connected in the tower lighting circuit is shown by the solid curve. Here the effect is exceedingly great. For instance, at 1375 kilocycles corresponding to an antenna height of approximately .420 wavelength, the reactance changed from a negative 438 ohms up to a positive 380 ohms. This change of 818 ohms represents a percentage change of 187 per cent. Again, the use of two chokes in tandem greatly reduces the adverse effect of the tower lighting circuit upon the measured true reactance, as shown in Figure 8. Similarly, Figure 9 illustrates the effect of transformer isolation upon the tower reactance. Again, the isolation transformer, while radically better than a single choke, measured inferior to the two chokes in tandem.

It may be noted, however, that in critical areas of tower height considerable resistance and reactance variations occurred with the use of these types of tower lighting isolation circuits.

Other forms of isolation are normally used to prevent loss of radio frequency power in AM towers, when other radio services share the same tower. Figure 10 illustrates a circuit which isolates an FM antenna from an AM tower. Here the outer conductor of the coax line is tied to the tower near the top while a length of line of approximately one-quarter wave length long (at the AM frequency) is insulated from the tower. A capacitor is frequently



# Beautiful Signals

## HANDLED with CARE

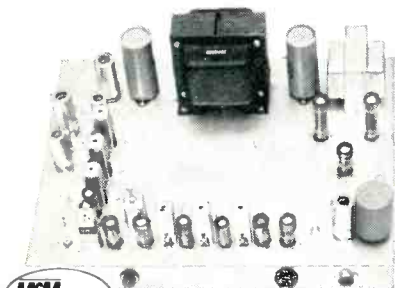

**MCMARTIN**

### MULTIPLEX RECEIVERS

Better sound sells FM on main carrier and subs. Better sales result with carefully engineered and reliable receiving equipment. At Continental rigid quality control and extreme manufacturing care guarantees you and your listeners the finest reception . . . whatever your requirements.

Lease (without down payment) and Lease Purchase Plans available.

Write or call

CONTINENTAL MANUFACTURING, INC.  
1012 California Street - Omaha, Nebr.



### TOWERS REFLECTORS BUILDINGS

- FIXED
- PORTABLE

Complete installations for all communications purposes

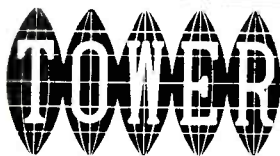

**CONSTRUCTION CO.**  
2737 HAWKEYE DR. SIOUX CITY, IOWA

Tower Fabricators and Erectors the World Over!

MAIL TODAY! FOR 1960 CATALOG!  
TOWER CONSTRUCTION CO.  
2737 HAWKEYE DRIVE  
SIOUX CITY, IOWA

NAME: \_\_\_\_\_

ADDRESS: \_\_\_\_\_

CITY: \_\_\_\_\_

ST: \_\_\_\_\_

connected from the base of the tower to the coax outer conductor at the point where it is also connected to ground. This length of insulated line, together with the tower, forms a one-quarter wave resonant circuit having the top end shorted with resulting high impedance at the open lower end. This high impedance formed by the one-quarter wave stub serves to isolate FM or TV service from the AM tower. In practice the grounding point and/or the top point, which is tied to the tower, is moved until the measured AM antenna impedance shows that it is unaffected by the presence of the FM or other service.

In Figure 11 a sampling loop is isolated from the tower merely by insulation. This type of sampling loop isolation is frequently utilized in simple two-tower directional antenna systems. However, frequently it has been found that insulated sampling loops appreciably change the measured antenna impedance, often due to a significant capacitance coupling effect. Several cases of radical pattern distortion have been encountered even in simple two-tower directionals.

Figure 12 illustrates a parallel resonant type of isolation for sampling loops. In this system one side of the pickup loop and the outer conductor of the coax line is tied to the tower. Indeed, the line is bonded to the tower at frequent intervals. At the base of the tower, the coax line is connected to a large coil formed by the coaxial cable. This coaxial coil must be tuned close to resonance if the tower impedance is to be unaltered by the pickup loop. It has been found that improper tuning of such tank circuits permits attainment of wide variations of tower impedances. However, where these circuits are properly tuned, no undesirable effects have been encountered.

Although time did not permit, nor did the manufacturer care to supply a tunable resonant choke for tower lighting isolation, nevertheless, this form may be entirely satisfactory.

*Conclusion:* Regardless of the type of tower isolation circuit employed, the performance must be thoroughly checked. It is hoped that the broadcast equipment suppliers will make more suitable isolation circuit systems available.

## SINE SQUARED

Starts on page 12

ponent) is different from the modulation (chrominance component), they will not register and the difference in delay may be easily determined. Further, this same presentation shows whether the frequency response of the system is flat since again complete registry should occur.

### Linearity Testing

As indicated earlier the  $\sin^2$  technique may be used for linearity testing. This is perhaps misleading and still the technique makes use of conventional  $\sin^2$  shaping filters so it is included for the sake of completeness.

The conventional signal used for testing linearity is the stair step. Usually ten steps are used. For the proposed test the number of steps is first reduced to five and the signal is introduced into the system. At the output the signal is differentiated so that spikes all having a common base result. This signal is fed into a  $\sin^2$  pulse shaping filter so as to bandwidth limit the noise and is then presented on an oscilloscope. It is a simple matter to see whether all five pulses have identical amplitude (the case for perfect linearity).

The shaping filter should be such as to produce a 2.75  $\mu\text{sec}$  h.a.d. pulse in the conventional manner. The response is 6 db down at 182 kc/s and zero 364 kc/s. If more steps are used it becomes necessary to use narrower pulses which in turn have wider bandwidth and consequently introduces more noise with consequent error.

### Conclusions

As was indicated at the beginning this paper is intended as a survey of the uses of the  $\sin^2$  pulse; to try to show where it may provide more direct means of evaluating circuits; and finally to establish techniques for general picture enhancement. The equipment for some uses is complex, for others it is relatively simple. There is, however, a great amount of material available in the literature and more will doubtless appear. In broad perspective the  $\sin^2$  pulse is a powerful tool. It can reveal many deficiencies. It requires a certain amount of education and experience to appreciate its full potential.

## COLLINS CLOSE-UP

*no. 1 in a series*

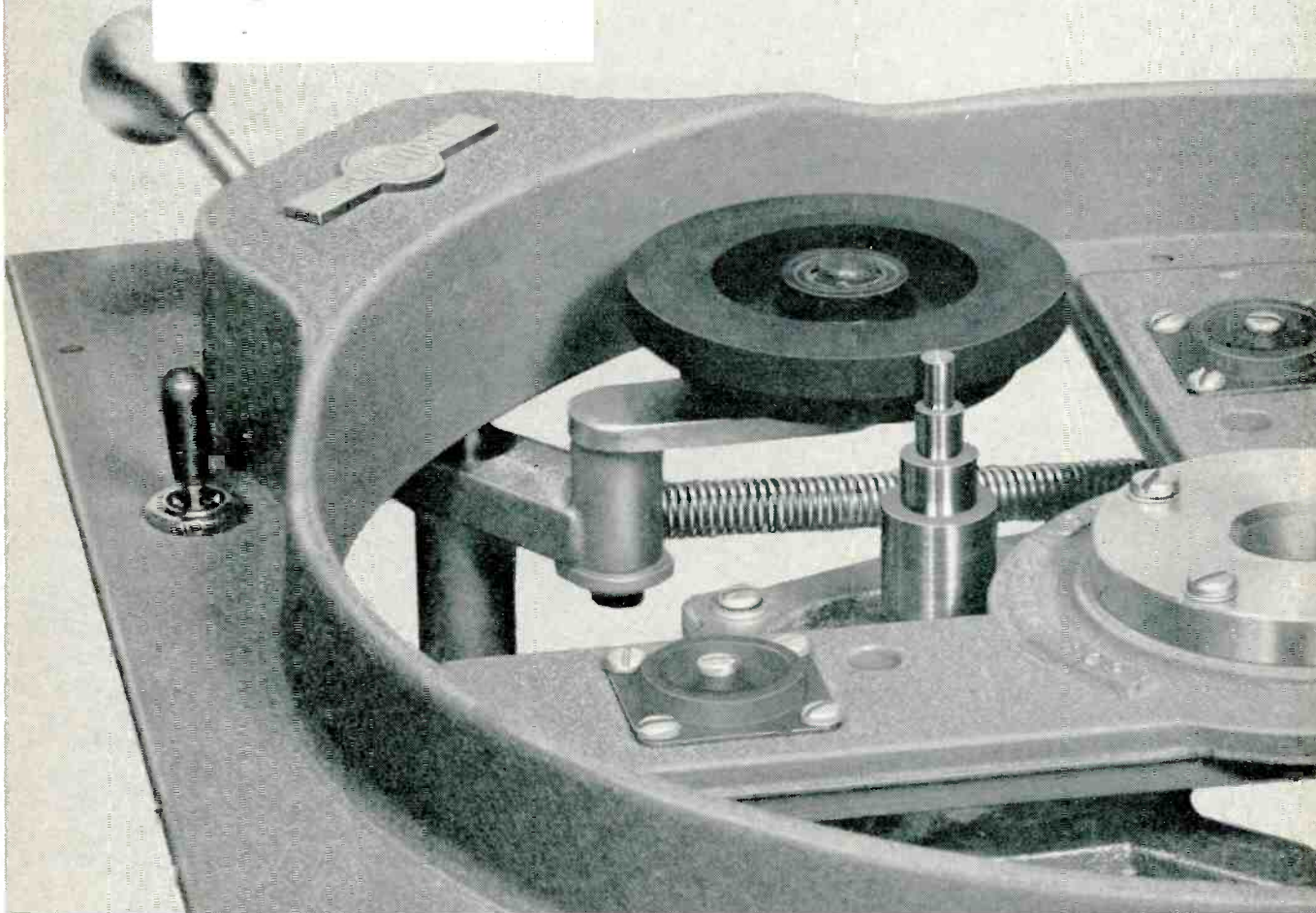

## 99.95% ACCURATE SPEED REGULATION

This is a close-up of a Collins Turntable showing its strong base, rim-driving idler wheel, simple linkage system and large, rugged controls. These are only a few of the many features that assure broadcasters of 99.95% accurate speed regulation with Collins Turntables.

Examine Collins Turntables closely and note the cast aluminum base which keeps the entire unit in alignment; the precision machining throughout; and the molded neoprene idler wheel which drives the platter but does not determine the speed of the table. These are important factors which make wow and flutter negligible in Collins Turntables.

You are certain of positive operation with every record because Collins Turntables have only three moving parts in the drive mechanism; an indentation in the platter which eliminates a spindle adapter for 7", 45 rpm records; and a large, easy to operate speed selector lever.

Ask your Collins broadcast equipment sales engineer for complete information on Collins Turntables; then compare specifications and quality with any other turntable on the market. See for yourself why Collins Turntables are best sellers throughout the world.



*Collins Turntables are specially designed for radio broadcast use. Available in four models: 12" or 16", with synchronous or four pole motors.*



COLLINS RADIO COMPANY • CEDAR RAPIDS, IOWA • DALLAS, TEXAS • BURBANK, CALIFORNIA



# Technical Hints

## Temporary Operation With Defective Modulation Transformer

Modulation transformer troubles do not occur very often, but when they do, there is always the possibility of being off the air for an extended period of time until a suitable replacement can be obtained.

In the case of shorted turns in a modulation transformer there is little that can be done to get around it. If there is a short between the core and either of the windings, the transformer is usually isolated from ground by setting it on insulators or several layers of dry wood. If the trouble happens to be a short between primary and secondary windings, here is a hint that can be used to get back on the air in a short time with slightly reduced modulation and little loss in audio quality. The enclosed drawings show a simple modification that has been used in our RCA BTA-10H transmitter on several occasions. This would also apply to most other makes of broadcast transmitters that use the same shunt feed method of plate modulating the power amplifier.

The modulation transformer secondary leads are first disconnected and taped up so that the winding is left floating above ground. Then a length of high voltage wire is used

to connect the DC blocking capacitor C to the plate of one of the modulator tubes. This results in a modified form of Heising Modulation that will modulate the transmitter to about 50-70 per cent with good quality. It is still a good idea to isolate the core above ground since the original short may cause further insulation breakdown if the core is left grounded.

It is hoped that this hint will help someone else out of a tight spot.

DAVID H. SCHICK  
WGTO

Cypress Gardens, Fla.

## Lowering Amplifier Distortion

Our G.E. Uni-Level amplifier recently turned up with excessive distortion at the lower extremes of the audio spectrum, and a complete voltage and component check failed to reveal the cause. Because the unit uses 6V6 tubes in the output stage without inverse feedback or any form of plate impedance compensation, we took care to carefully select new tubes which balanced closely on our mutual conductance tube checker, but the condition persisted. Intentional mismatch of the output impedance lowered the distortion considerably, and we began to suspect some fault in the output transformer. Before accepting this diag-

nosis completely, we queried General Electric to learn their experience. They advised us that their only problems with distortion had arisen from the use of a "bad batch of 6V6 tubes on the market," whereupon we obtained a matched pair of 6V6's of another manufacture and code date. These checked at a slightly lower value of transconductance than had the previous tubes, but when placed in the amplifier, the distortion at 50 cps (at plus 30 dbm output level) dropped from 6.3 to 1.7 per cent, well within specifications for this particular piece of equipment. Needless to say, we were happy to learn of so simple a remedy.

R. H. CODDINGTON  
WXGI

Richmond, Va.

## Tape Recorder Input Control

We handle a wide range of input levels in recording from network, FM, remote lines and the telephone "beeper." Therefore it was decided to couple into the high impedance microphone input rather than the usual hi-level or "phono" jack. To avoid loading the network or remote lines when something was being broadcast and recorded at the same time, a bridging transformer was indicated. The circuit shown has provided excellent service since it was installed. The whole unit is mounted in a 3" x 4" x 5" Minibox which is bolted to the recorder shelf beside the console. The transformer used is an inexpensive 1:3 interstage unit. Although it's unshielded except

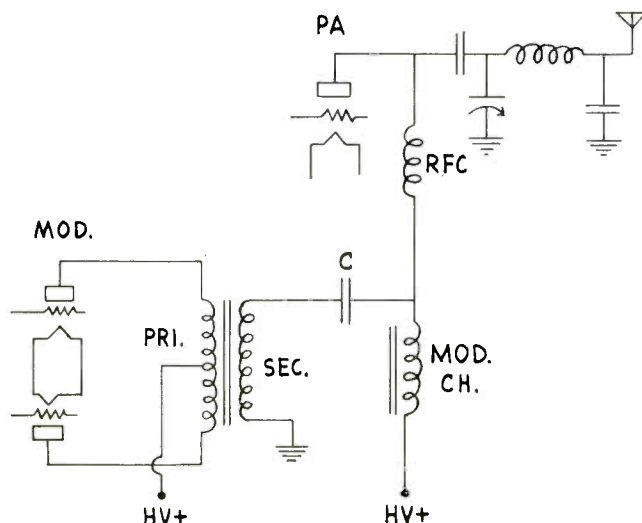

Simplified schematic of Modulator & PA before modification.

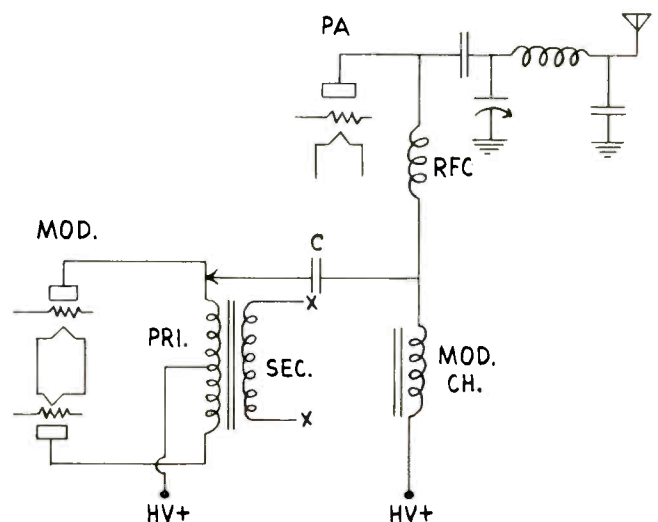

After Modification.



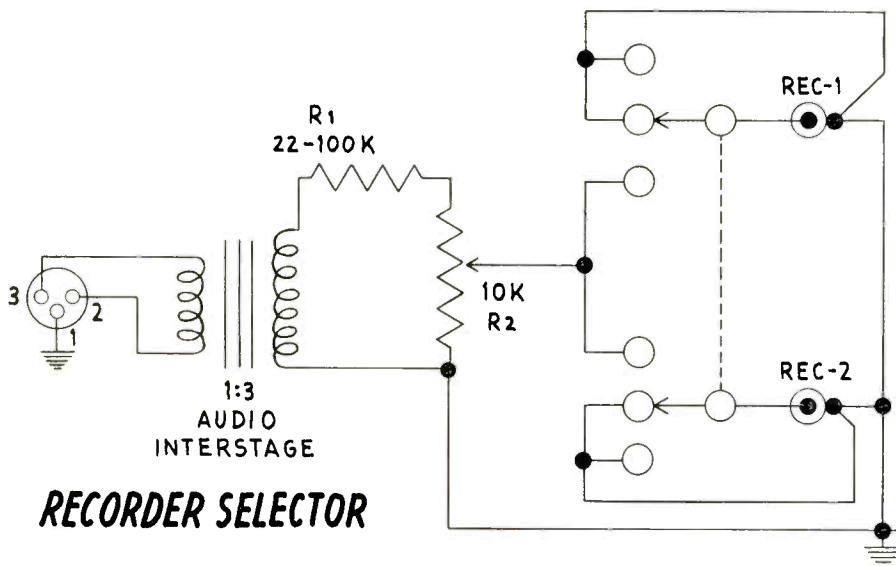

by the Minibox, no hum or RF pickup has been noted. Note that each recorder lead is grounded back to its own jack when that machine is not in use. This prevents stray RF pickup when the machine is on playback. Resistor R1 should be chosen to give a reasonable range to the gain control R2 when the recorder's own gain control is set for best signal-to-noise ratio recordings. Its value will depend on the individual recorder, however it should not be lower than 22 K to avoid reflecting too low an input impedance in the primary when it is bridged across a line. The case ground in our unit is made through the shield on the input cable to pin number 1 of J1. Suitable transformers are made by all of the transformer companies.

FRED CHAPMAN, C.E.  
WSTU  
Stuart, Fla.

#### Recorder Servicing

The following suggestion is for Magnecorders, and probably will apply equally well to other makes. To

remove oil from the rubber idler wheels and shafts, wash with denatured alcohol. Carbontet tends to dissolve the rubber and causes a hard glaze to form. If the rubber is glazed, sand lightly with a medium grit paper, not common sand paper, then wash thoroughly with the denatured alcohol. This will remove all traces of oil and will leave the rubber surface with a live feeling.

SAM BEATTY,  
KALM,  
Thayer, Mo.

#### Curing Interlock Trouble

In the Collins 300-J AM transmitter and our phasing unit, the interlocks had been causing intermittent operation. The set screws used for securing the interlock wiring have a small cup like shape. The ridge around this cuts the wire under pressure causing the intermittent difficulty. Filling the small hole with solder and then filing it flat eliminated the trouble.

JOSEPH KISH, JR.,  
WTIG,  
Massillon, Ohio.

### ADDRESS CHANGE ???

We can give you faster, more complete service on your

### CHANGE OF ADDRESS

if you will advise us of your OLD address as well as the NEW.

Write to:

CIRCULATION DEPARTMENT

### BROADCAST ENGINEERING

1014 WYANDOTTE

KANSAS CITY 5, MO.

## Equipping a Radio Station?



BK-6B

## Miniature Microphone

only \$82<sup>50</sup>

This RCA Miniature Dynamic Microphone is as inconspicuous as modern microphone design can make it! Just 2<sup>5</sup>/<sub>16</sub>" long, it weighs but 2.3 ounces. And, in spite of its compactness, the BK-6B is a durable, high-quality microphone. Try it for remotes! You'll find it excellent for interviews, panel shows and sports. It's a great value at \$82.50!

Order your BK-6B now! Write to RCA, Dept. L-367, Building 15-1, Camden, N. J. Whatever your broadcast equipment needs, see RCA FIRST!

**RADIO CORPORATION  
of AMERICA**



Tmk(s) ©

## CROSSTALK

Starts on page 18

tricks beyond the duty of transporting R.F. energy from here to there (and sometimes back).

If you have a long back yard you can conduct these experiments yourself. First, borrow about 500 ft. of coax (such as 3 1/8-inch) and string it out in one long length. Next, hook onto the far end a non-inductive pure resistance of a value equal to the rated line impedance. Now, feed a signal into the other end and observe what happens with this perfectly terminated length of transmission line.

While observing VSWR, the test signal is varied from 1 Kc. upwards. As the frequency approaches 25 Mc. we will note a sudden increase in VSWR. The same situation repeats itself at harmonics of 25 Mc. all the way up and the experiment can be shown in graph form by Fig. 3. In other words, occurring first at approximately 25 Mc. and then reappearing at each harmonic of this frequency, the perfectly terminated line is exhibiting its own personality

regardless of whether connected to an antenna or not.

According to Dr. Richard Yang of Andrew Corp., this characteristic is known as "reject frequency" of the coax line. It is directly related to the spacing and material used to support the inner conductor. It has been common practice to use either ceramic or teflon supports at regular intervals. Usually one large piece together with numerous smaller supports are used in each 20-ft. length. The frequency at which the "reject notches" appear is determined by the spacing of the inner conductor supports as well as the dielectric constant of the material used.

The effect of this peculiarity goes unnoticed unless one of the "reject notch" frequencies lands on top of the transmitted frequency or its side bands. Whether for TV or for FM multiplexing, the condition prevents satisfactory operation as it duplicates the problems of a mistuned or non-linear antenna system.

If a reject notch occurs in close proximity to the transmitting frequency, VSWR curves similar to Fig. 2 will exist regardless of any

antenna tuning efforts. According to information received from the Andrew antenna engineers, the first reject frequency occurs in the 20-30 Mc. range depending upon the length of the line and its particular type of inner conductor supports. As the length of the line increases, the effect is more noticeable, and visa versa. It has been necessary on occasions to construct transmission line lengths of different than the standard 20-ft. in order to move a "reject notch" off of the station's frequency. Changing to a different type of insulating material for support of the inner conductor also will move the reject frequency. Flexible air dielectric cable such as Heliac does not suffer from these problems due to its continuous nature.

At any rate, if you happen to run into one of the "hybrid" characters created by these R.F. plumbing problems associated with AM, FM, or TV transmission, don't admit that you understand the strange language or you might get cornered for an indefinite time while forced to listen to the story of the VSWR and the leaky line.

## Audio, Video and RF Jack Panels

Patch Cords &  
Looping Plugs

available  
for use with

Nems-Clarke  
Jack Panels

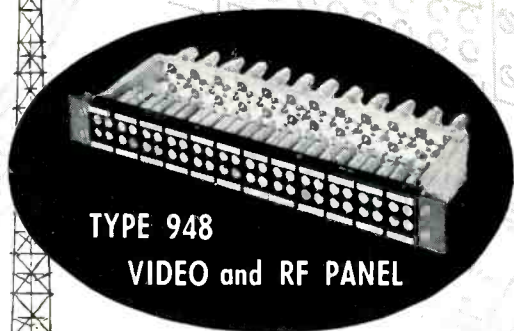

TYPE 948  
VIDEO and RF PANEL



NEMS • CLARKE COMPANY

A DIVISION OF VITRO CORPORATION OF AMERICA

919 JESUP-BLAIR DRIVE • SILVER SPRING, MARYLAND • JUNIPER 5-1000

## Off-The-Shelf Delivery! IMAGE-ORTHICON, VIDICON LENSES

Rent or Buy

Image Orthicon Lenses  
from World's Greatest Selection . . .  
choose from 28mm focal length to  
60" . . . delivered right " Off-The-  
Shelf" at B & J World's Lens Head-  
quarters!

Here, you'll find the lens you need  
for practically ALL T.V. Cameras,  
R.C.A. (TK-41, TK-11); G. E. Black  
and white or color; Du Mont, etc.!

Rely on the Industry's Prime Op-  
tics-Source . . . Pioneers in T.V.  
Optics Since 1936 and currently  
serving such stations as WGN,  
WNBQ, ETC.

Our Instrument Shops and "Know-  
how" offer you Special Mountings,  
Calibration and Custom Fittings!  
(Also Cine' & Slide Equipment for  
your News Dept.!)

Write for New T.V. Optics Catalog.

**BURKE & JAMES, INC.**  
321 S. Wabash, Chicago 4, Ill.

# PRECISION MULTIPLEX EQUIPMENT by ELECTRO-PLEX<sup>®</sup>

for **BACKGROUND MUSIC - STORECASTING - DRUGCASTING**  
**CREDITCASTING - MULTIPLEX RELAY**  
**AND ALL APPLICATIONS INVOLVING MULTIPLEX RECEPTION**

## IN RECEIVERS . . .



DMR MULTIPLEX RECEIVER

The multiplex circuit is furnished on a separate mounting plate which may be easily removed. Other special intermediate and control circuitry may be supplied in this area when desired.

**OTHER MULTIPLEX AND FM RECEIVING EQUIPMENT: STORE CAST TUNERS, MULTIPLEX TUNERS, MLX-10 ECONOMY MULTIPLEX RECEIVER, TRC MULTIPLEX RECEIVER, MULTIPLEX ADAPTERS.**

## CLOSE THE DOOR ON EXPERIMENTATION!

Electro-Plex brings you the ultimate in multiplex receiver design. A design resulting from a careful study of the background music and allied fields, and an awareness of the problems which the operators have experienced in the past. The DMR is truly an advanced view in multiplex circuitry. A receiver which has been in development for 18 months.

Main Channel circuitry is more reliable because a pulse-counting type detector, utilizing a tube, is used in place of a discriminator-coil/diode combination. This circuitry is original and exclusive with Electro-Plex. Drift is a thing of the past and the receiver will stay on frequency from a cold start!

In the sub-carrier section, heterodyne circuits have been avoided due to the several added adjustments required to keep them in alignment.

## ALL MULTIPLEX FUNCTIONS IN A SINGLE COMPACT INSTRUMENT!

Putting a sub-carrier on the air is greatly facilitated with instruments to accurately check the performance of the transmitter. With the Electro-Plex 8-A Modulation Monitor, injection level of the sub-carrier may be set in seconds as a matter of course. The main channel may be accurately indexed to the new maximum modulation level to avoid over-modulation and cross-talk.

All of this is done by the flick of a switch!

Simultaneous visual monitoring of both main and sub-channels provided by two identical, fast-acting VU meters. No switching necessary. Injection of sub-carrier constantly indicated on separate meter. The VU meters are of new design, having special ballistics for this type of operation.

Demodulator circuits for both main and sub-channels are included in the monitor whose output may be checked aurally through a separate amplifier and speaker system.

Compact design: 5 1/4" x 19 engraved relay rack panel. Depth behind the panel 13".

**A MUST IN FM MULTIPLEXING!**

**OTHER ELECTRO-PLEX INSTRUMENTS: 22-A SUB-CARRIER FREQUENCY MONITOR, FMC-1 RELAY RECEIVER, STUDIO MULTIPLEX DEMODULATOR.**

## IN INSTRUMENTS . . .



8-A MODULATION MONITOR

*Write for free copy of "Multiplex Handbook" covering transmitter adjustment, antennas, multiplex receivers and field installation, offered as a service to the broadcasters by Electro-Plex.*

**WRITE FOR  
LITERATURE  
AND PRICES**

**WHEN YOU THINK OF MULTIPLEX,  
THINK OF ELECTRO-PLEX**

## ELECTRO-PLEX DIVISION

**Nuclear Electronics Corp.  
2925 NORTH BROAD STREET  
PHILADELPHIA, PENNSYLVANIA**

*Manufacturers of  
MULTIPLEX EQUIPMENT  
for  
THE FM BROADCASTING  
INDUSTRY*



# Dallas Station Constructs New Custom-Built Broadcasting Studio

One of the largest custom-built broadcasting facilities ever erected in this country for an individual station is under construction at WFAA-TV, AM and FM.

Some \$2 million worth of the latest broadcasting and Ampex tape recording equipment will be installed in the new studios and mobile unit, Alex Keese, managing director for the radio and TV properties, reports. The new broadcast center, located at Young and Houston streets, Dallas, Tex., will cost an additional \$1,500,000 and is adjacent to the parent *Dallas Morning News* building.

Keese explained plans call for completion of the studio building shortly after the first of next year.

However, Jim Cooper, director of engineering, stated the \$250,000 mobile tape recording cruiser will go into operation early this September. The custom-built mobile unit is being constructed in California by Ampex Professional Products Co. The cruiser will be equipped with two Ampex TV tape machines, six Marconi IV 4½-inch image orthicon cameras, General Communications transistorized video switcher and General Electric transistorized stereo audio facilities.

The 40-ft. cruiser is a complete studio on wheels, being provided with its own power generators, air conditioning, special lighting equipment and vastly improved engineering equipment for the handling of remote telecasts.

According to Cooper, productions can be originated by the cruiser either while under way or at a remote location. Expanding on this point, Cooper said, "The tapes also can be edited enroute from the point of production back to the studios so that the program will be ready for airing upon arrival.

"With the exception of network centers," Cooper said, "WFAA-TV will have the largest array of TV tape equipment in the nation. We will have five Ampex recorders, plus more than a dozen of the most advanced designed TV cameras avail-

able in the world today. This includes live color studio facilities by General Electric."

Also in the studios will be such GE equipment as the new continuous motion film systems (four monochrome and one color) and custom transistorized stereo master control switching systems for AM, FM and TV sound, consisting of 11 stereo feeds or 22 monophonic feeds.

New equipment going into WFAA's radio and master recording studio includes 14 of the recently introduced Ampex Model 354-2, two-channel stereo recorders, two Ampex Model 300-4, four-channel recorders, two Scully lathes, two Westrex stereo cutters, dual EMT reverberating chambers and custom GE transistorized four-channel stereo console.



EVERYTHING'S NEW . . . INSIDE AND OUT. Pictures of the new WFAA-AM-FM-TV building now under construction and the recently approved 40-ft. cruiser are viewed by officials of the Belo Corp., parent organization of WFAA-AM-FM-TV and the *Dallas Morning News*, and the Ampex Professional Products Co. Left to right are Jim Cooper, director of engineering for radio and TV; Mike Shapiro, TV manager; George Utley, radio manager; E. M. (Ted) Dealey, (seated) chairman of the board of Belo; James Moroney, Sr., vice-chairman; and Lew Parsons, representative of Ampex.

## SONOCRAFT MOST COMPLETE SOURCE FOR THE PROFESSIONAL TRADE!

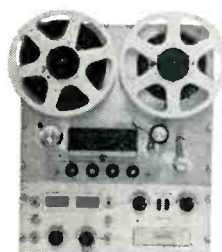

IN STOCK  
BRAND NEW  
MODEL 354  
STEREO



LARGE STOCK  
Series 300 and 351  
DUPLICATORS  
MULTI-CHANNELS  
PARTS and  
ACCESSORIES

### PULTEC

Professional  
PROGRAM EQUALIZERS  
SOUND EFFECTS FILTERS



### NEW FAIRCHILD

Professional  
CONAC STEREO 602  
LIMITER 670  
MONITOR AMPLIFIER 680  
TRANSCRIPTION TABLES

WRITE FOR CATALOG "A"

SONOCRAFT CORPORATION 115 West 45th St., New York 36, N. Y. Third Floor - JUDSON 2-1750

## Specializing in Broadcast Telemetry

RADIO REMOTE CONTROL AND MULTIPLEX SYSTEMS

FOR

STUDIO TRANSMITTER LINKS

JOHN A. MOSELEY ASSOCIATES

BOX 3192

WOODLAND 7-1469

SANTA BARBARA, CALIFORNIA

## Subcarrier Generator

Starts on page 8

only a switching of the local oscillator crystal for a second channel. The addition of an audio amplifier would provide a quick check on the multiplex program quality, and a zero center dc microammeter would provide center frequency information. A calibration crystal oscillator would be required, however. Relay circuits operating on subcarrier modulation, or even subcarrier envelope presence, can actuate warning devices in the control room.

To achieve a calibrated deviation meter would require at the minimum another crystal oscillator and a dc oscilloscope or dc voltmeter attached to the discriminator dc output. By alternately connecting the two crystal oscillators to the subcarrier monitor input, one frequency corresponding to the center value and the other representing a 10 per cent frequency change will serve as the calibration points. The dc voltage obtained corresponds to the peak value of the 10 per cent carrier shift. By converting this to an rms value, a modulation meter can be included to provide instantaneous monitoring of the subcarrier deviation. Such devices are more practical, less expensive, and more positive in operation than the classic, yet sound, method of carrier null detection. Additional test equipment to check the dynamic response of a monitor can be made by employing a motor-driven balanced ball-bearing variable capacitor connected in the frequency determining section of an oscillator. Suitable trimmer and padder capacitors can provide for a wide range of deviations. It is important to note here that the usual capacitor plate configuration will yield a triangular modulation wave; consequently, form factor correction of the rms meter may be required, or an oscilloscope can be used directly for this observation.

Regardless of which particular phase of a multiplex operation is being considered, the choice of the proper equipment must reflect the over-all system requirements in any decision. This includes management, programming and the more obvious engineering considerations.

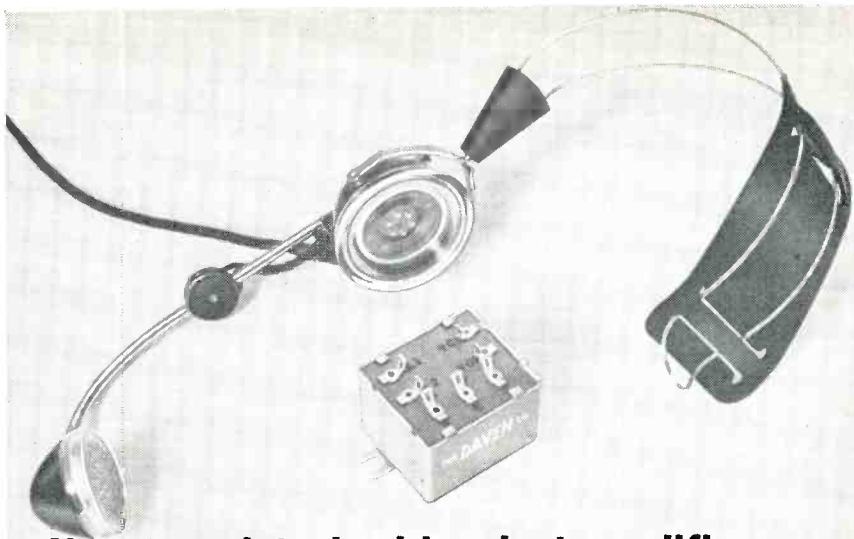

## New transistorized headset amplifier for TV studio communication

Daven announces a new Transistorized Interphone Amplifier, Type 90, which provides a marked improvement in studio communications. As a companion unit to the Western Electric Type 52 headset, advantages of this transistorized amplifier over the normal induction coil are:

1. A gain of 20 db.
2. Mounts directly in place of the induction coil.
3. Sidetone automatically adjusts when additional stations join the circuit. Receiver level min-

imizes local acoustical interference.

4. No significant increase in power consumption.
5. Permits up to 32 stations.
6. Manual control with external variable resistor, if desired.
7. Operates from 24 volt "Talk Bus" independent of polarity.



THE **DAVEN** co.

LIVINGSTON, NEW JERSEY

Write today for further information.

TODAY, MORE THAN EVER, THE DAVEN © STANDS FOR DEPENDABILITY

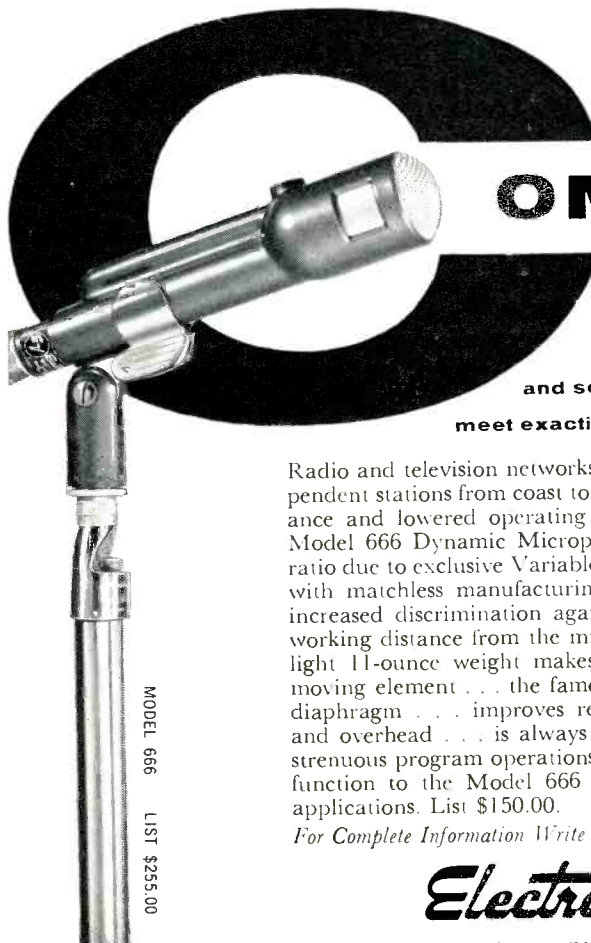

# COMPARE

and see why **Ey** microphones meet exacting professional standards

Radio and television networks, recording studios, and independent stations from coast to coast have increased performance and lowered operating costs with the Electro-Voice Model 666 Dynamic Microphone. Superior front to back ratio due to exclusive Variable "D" cardioid design coupled with matchless manufacturing precision. The 666 insures increased discrimination against unwanted sound, greater working distance from the microphone to the artist and its light 11-ounce weight makes boom work easy. The only moving element . . . the famous E-V exclusive Acoustalloy diaphragm . . . improves response, reduces maintenance and overhead . . . is always reliable even under the most strenuous program operations. The Model 665 is similar in function to the Model 666 but designed for less critical applications. List \$150.00.

For Complete Information Write Dept. 90V.

**Electro-Voice**®

BUCHANAN, MICHIGAN

MODEL 666 LIST \$255.00



# AMENDMENTS AND PROPOSED CHANGES OF F.C.C. REGULATIONS

## INTERFERENCE RECEIVED BY CLASS IV BROADCAST STATIONS SEEKING TO INCREASE POWER

### Notice of Proposed Rule Making

1. Notice is hereby given of proposed rule making in the above-entitled matter.

2. Section 3.28 (c) of the rules presently provides that a Class II, III, or IV station may be assigned to a channel, even though it receives interference, if (1) no objectionable interference is caused to existing stations, or, if so, the need for the new service outweighs the need for the service lost; (2) primary service will be provided to the community, and (3) in pertinent part: "The interference received does not affect more than 10 per cent of the population in the proposed station's normally protected primary service area."

3. It is proposed to amend the first sentence of subparagraph (3) to read as follows: "The interference received does not affect more than 10 per cent of the population in the proposed station's normally protected primary service area except in the case of existing Class IV stations on local channels seeking to increase daytime power in excess of 250 watts."

Slight language changes are also proposed in the last sentence of subparagraph (3) for clarification.

4. The Commission on May 28, 1958 amended its rules to provide, with certain restrictions, that the limit on daytime power of Class IV stations be raised from 250 watts to 1 kilowatt. On April 8, 1959, we further amended our rules to provide for the processing of applications for such facilities. There are now pending before the Commission more than 400 applications by Class IV stations to increase their daytime power above 250 watts. The mutual interference among these Class IV stations seeking to avail themselves of the new power ceiling of 1 kilowatt would in most cases entail interference to the individual station's new service area in excess of the 10 per cent contemplated by § 3.28 (c) (3). Notwithstanding this, in nearly all cases, additional areas and population will be served by such increase of power to 1 kilowatt. In these circumstances, and taking into account the purposes to be served by the amendment adopted May 28, 1958, increasing

the maximum daytime power of Class IV stations, it appears undesirable to continue to apply § 3.28 (c) (3) to such cases and thereby frustrate, to an extent, the improvement of service which the power increase would enable Class IV stations to achieve.

5. In view of the foregoing, it is proposed to amend § 3.28 (c) of the rules as set forth below.

6. Pursuant to applicable procedures set out in § 1.213 of the Commission rules, interested persons may file comments on or before September 1, 1960, and reply comments on or before September 15, 1960. In reaching its decision on the rules and standards of general applicability which are proposed herein, the Commission will not be limited to consideration of comments of record, but will take into account all relevant information obtained in any manner from informed sources.

7. Authority for the amendment proposed herein is contained in sections 4 (i) and 303 of the Communications Act of 1934, as amended.

8. In accordance with the provisions of section 1.54 of the Commission's rules and regulations, an original and 14 copies of all statements, briefs, or comments shall be filed with the Commission.

Subparagraph (3) of § 3.28 (c) is amended. As amended, paragraph (c) reads as follows:

§ 3.28 *Assignment of stations to channels.*

\* \* \* \* \*

(c) Upon showing that a need exists, a Class II, III, or IV station may be assigned to a channel available for such class, even though interference will be received within its normally protected contour; *Provided:* (1) No objectionable interference will be caused by the proposed station to existing stations or that if interference will be caused, the need for the proposed service outweighs the need for the service which will be lost by reason of such interference; and (2) primary service will be provided to the community in which the proposed station is to be located; and (3) the interference received does not affect more than 10 per cent of the population in the proposed station's normally protected primary service area except in the case of existing Class IV stations on local

channels seeking to increase daytime power in excess of 250 watts. However, in the event that the nighttime interference received by a proposed Class II or III station would exceed this amount, then an assignment may be made if the proposed station would provide either a standard broadcast nighttime facility to a community not having such a facility or if 25 percent or more of the nighttime primary service area of the proposed station is without primary nighttime service.

## NONCOMMERCIAL EDUCATIONAL FM BROADCAST STATIONS Specified Nonbroadcast Activities on Multiplex Basis

1. Notice is hereby given of proposed rule making in the above-entitled matter.

2. The Commission has before it two petitions for rule making seeking to permit noncommercial education FM broadcast stations to engage in specified non-broadcast activities on a multiplex basis to the extent and in the same manner that commercial FM broadcast stations were so authorized by the Commission's Report and Order released May 9, 1960, in Docket No. 12517.

3. One of these petitions was filed with the Commission June 24, 1960, by the National Association of Educational Broadcasters. (RM 188) The other petition was filed with the Commission June 30, 1960, by the WGBH Educational Foundation, (RM 189) licensee of noncommercial educational station WGBH-FM, Boston, Massachusetts. Both petitions alleged that 162 educational FM broadcast stations now on the air would be severely handicapped in the organization of educational networks, in the rendering of specialized program services, expansion of in-school educational programming and allied activities if denied the authorization requested.

4. The Commission also has before it a petition filed on October 8, 1958, by the American Medical Association which, in addition to proposals for special Physicians' Radio Services which are a subject of the Commission's proceeding in Docket No. 13273, also requests amendment of Parts 3 and 4 of the Rules "to permit non-commercial educational FM stations to multiplex broadcast channels and to use such channels and associated remote pickup facilities for educational purposes without restriction." In support of its request the Medical Association cites the successful use by Albany Medical College of its educational FM station WAMC for post graduate instruction. The association urges that the Commission authorize multiplexing operation by educational stations, asserting that it will encourage the expansion of this valuable service and at the same time afford "semi-pri-



vate" facilities for the discussion of medical subjects whose airing on regular broadcast channels available to the general public might not be deemed acceptable. It is appropriate to consider herein this portion of AMA's petition of October 8, 1958.

5. Petitioners WGBH Educational Foundation together with Fordham University and Pacifica Foundation, filed comments in the Commission's proceedings, Docket No. 12517, which authorized multiplexing for commercial FM broadcast stations, urging that in that proceeding the Commission likewise extend the authorization to include non-commercial educational FM stations. In paragraph 15 of its Report and Order (FCC 60-497) in that proceeding, the Commission stated: "While sympathetic with the objectives expressed in these comments, we feel that this issue goes beyond the scope of our Notice of Inquiry in this proceeding, and would more properly be considered in connection with formal petitions for rule amendment now pending before the Commission."

6. The Commission is now prepared to institute proceedings pursuant to petitioner's requests, and invites all interested parties to submit comments on the proposal to extend, through appropriate amendments of the Commission's Rules,

the authorization for Subsidiary Communications Service by means of multiplexing to noncommercial educational FM stations. The language of the proposal submitted by the National Association of Educational Broadcasters is broadly phrased and would appear, in its terms, to include, without limit, all forms of service which might be rendered by the use of a subcarrier. To the extent that it may be contemplated that noncommercial educational FM stations be authorized to provide commercial services similar to the "functional music" services provided by commercial FM background music or other program stations to commercial subscribers, it should be noted that the proposal is inconsistent with the policy underlying § 3.503 (c) of the Commission's rules which provide, in relevant part, that:

(c) Each station shall furnish a non-profit and noncommercial broadcast service. No sponsored or commercial program shall be transmitted nor shall commercial announcements of any character be made \* \* \*

No justification is offered for amendment of the rules in this regard and we discern no basis in the pleadings before us for departing from the limits established by § 3.503 (c). Accordingly, the proposal upon which comments are invited herein is limited to authorizing

noncommercial educational FM stations to use subcarrier transmissions on a multiplex basis for educational purposes which in all respects conform with basic policy underlying the established rules limiting the use of such stations to non-commercial educational service.

7. Authority for the adoption of the amendments proposed in this proceeding is contained in sections 4 (i), 303 (a), (b), (e), (g) and (r) of the Communications Act of 1934, as amended.

8. Pursuant to applicable procedures set out in § 1.213 of the Commission rules, interested persons may file comments on or before September 1, 1960, and reply comments on or before September 15, 1960. In reaching its decision on the rules and standards of general applicability which are proposed herein, the Commission will not be limited to consideration of comments of record, but will take into account all relevant information obtained in any manner from informed sources.

9. In accordance with the provisions of § 1.54 of the Commission rules, an original and 14 copies of all written comments shall be filed with the Commission.

#### PRACTICE AND PROCEDURE Certain Standard Broadcast Applications

At a session of the Federal Communications Commission held at its offices in

## New TransFlyweight\* Professional Transistorized Electric-Motor Battery-Operated PORTABLE FIELD RECORDER



### Check These Unusual Features:

- ✓ Weight: 8 lbs.; Size: 5½ x 9 x 12 inches.
- ✓ Exceeds NARTB Broadcast Standards.
- ✓ Newest Noise-Free Motor; No Microphonics.
- ✓ Low Noise Input Stage (0.25 microvolts).
- ✓ Overall Gain 110 db.
- ✓ Dry Rechargeable or Replaceable Batteries.
- ✓ 10 Selected Transistors Used.
- ✓ Meter for VU, Amplifier and Motor Batteries.
- ✓ Battery Life: Amplifier 125 hrs., Motor 40 hrs.
- ✓ Modular plug-in construction.
- ✓ High Speed Rewind (3 minutes).
- ✓ Choice of 5 Single-Speed Models.
- ✓ Full unconditional Two Year Guarantee.
- ✓ Prices from \$386. to \$446.

Write for complete information to Dept. A:

**AMPLIFIER CORP. of AMERICA**  
397 Broadway, N. Y. 13, N. Y.

\*T.M.

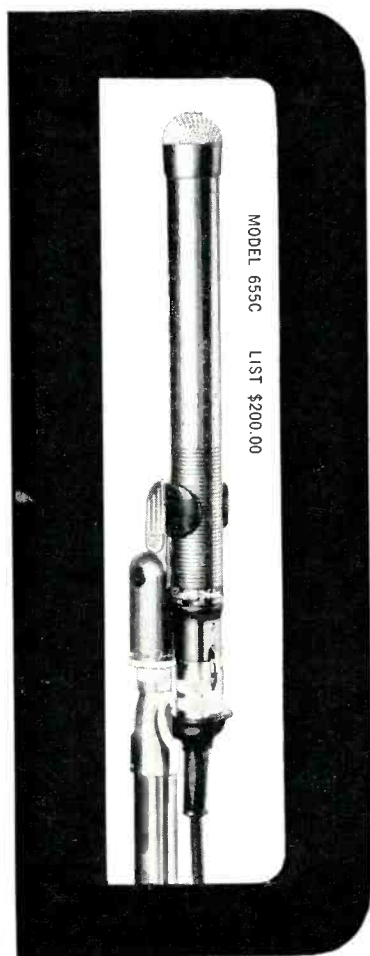

the dependability only   
microphones give you

Not long ago a 655C microphone fell from an eight story building and for two weeks lay snow-covered in a light-well. On recovery it was still operative, and required only factory cleaning. Such abuse, abnormal as it is, reflects E-V dependability, instills confidence in performers, and helps reduce station operating costs. The 655C has the capacity for natural, life-like reproduction with its exceptionally wide range (40 to 20,000 cps flat). It is lightweight with slim, trim styling, making it ideal for TV staging, radio remotes, or critical recording sessions. The 655C features an indestructible E-V Acoustalloy diaphragm, in a microphone design.

The Model 654, noted for its ruggedness and precision, is similar in design and intended for applications only slightly less exacting than those requiring the Model 655C. Costs only \$100.00 list.

For Complete Information Write Dept. 90V.

**Electro-Voice®**

BUCHANAN, MICHIGAN

# EMAND

**Bauer Kit**

# 1 Kw TRANSMITTER\*

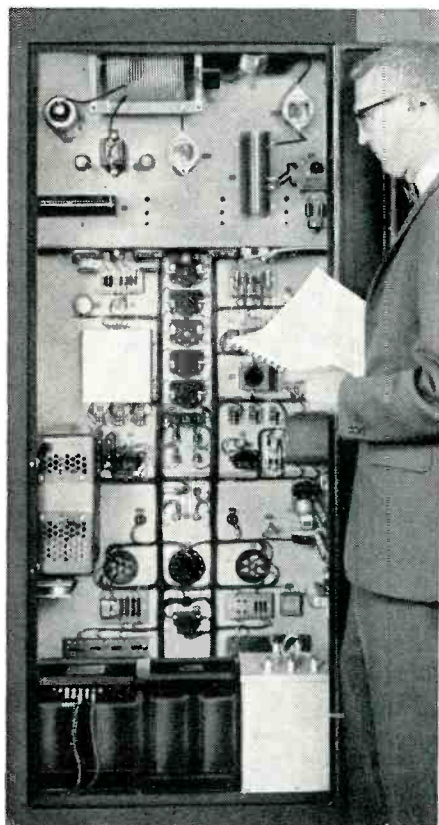

## \*From an Engineers' Viewpoint

The "Bauer Kit" Model 707 is the only 1000/250 watt AM transmitter with *Silicon Rectifiers* in all power supplies, a *Variable Vacuum Capacitor* and a *Constant Voltage Transformer*. Your assurance of maximum reliability and optimum performance. Note the simplicity of design with easy accessibility to all components, too. All components are standard items available at local sources.

Assembly of the "Bauer Kit" is actually easier than many consumer audio kits - the wiring harness is furnished completely pre-fabricated and coded. And when you complete the transmitter it will be fully inspected, tested and *guaranteed* by the Bauer Electronics Corporation.

Bauer 1 Kw Transmitter  
(In Kit Form) \$3495.00\*

Bauer 1 Kw Transmitter \$4495.00\*  
\*FOB San Carlos, California

**WRITE FOR THE COMPLETE  
ENGINEERING STORY TODAY!**

# **Bauer**

**ELECTRONICS CORPORATION**

1663 Industrial Rd. • San Carlos, California

Washington, D. C., on the 29th day of July 1960;

It appearing that § 1.351 of the Commission's rules provides for deferment of action on designated categories of applications for standard broadcast facilities on clear channel frequencies; and

It further appearing that prior to September 18, 1959, when the Commission concluded its initial Daytime Skywave proceeding (Docket No. 8333), the "freeze" on the processing of certain categories of applications for standard broadcast facilities on clear channels as theretofore provided in § 1.351 of the rules was contingent upon conclusion of Docket No. 8333; and that in Orders released September 22, 1959 (FCC 59-971) and October 30, 1959 (FCC 59-1111) the Commission noted that the clear channel frequencies listed in § 1.351 were relevant also to the clear channel proceeding (Docket No. 6741), and revised the "freeze" provision of § 1.351 to provide that specified categories of standard broadcast applications on the clear channels would be withheld pending conclusion of the proceeding in Docket No. 6741; and

It further appearing that it is desirable to eliminate distinctions in § 1.351 between stations operating day and night with the same radiation characteristics and stations operating day and night with different characteristics, which were pertinent to the Daytime Skywave proceeding (Docket No. 8333) but which are not pertinent to possible clear channel reallocations in Docket No. 6741; and

It further appearing that the present policy of deferring action on applications for station assignments which could prejudice the implementation of clear channel reallocations now being considered in Docket No. 6741 can be clarified by a revision of § 1.351; and

It further appearing that preservation of due latitude in making clear channel reallocations in Docket No. 6741 does not necessitate deferring action on applications for standard broadcast facilities

outside the forty-eight continental states on clear channel frequencies; and

It further appearing that the changes adopted herein are procedural in nature; that some of them remove previous restrictions on processing of applications; that those which extend the categories of applications to be held without action pending a decision in Docket No. 6741 are necessary at this time to avoid prejudice to clear channel reallocation now under consideration in Docket No. 6741; and that for these reasons the public notice procedure and effective date notification, otherwise required by section 4 of the Administrative Procedure Act, are unnecessary; and the amendments may become effective immediately; and

It further appearing that authority for the action taken herein is found in sections 4(i) and 303 of the Communications Act of 1934, as amended;

*It is ordered*, That, effective August 2, 1960, § 1.351 of the Commission's rules is amended to read as stated below.

Section 1.351 is amended to read as follows:

§ 1.351 *Standard broadcast applications on which action will be withheld pending conclusion of the proceeding in Docket No. 6741.*

(a) The following types of applications proposing operation within the continental United States on the frequencies listed in paragraph (c) of this section will be accepted for filing if they conform with the requirements of Part 3 of this chapter, but will be held without action pending a decision in the Clear Channel proceeding (Docket No. 6741):

- (1) New stations.
- (2) Changes of frequency.
- (3) Increased power.
- (4) Major changes of antenna radiation pattern.

(5) Change of station location involving a substantial change in transmitter location.

(b) Action will not be withheld on applications for facilities in Alaska, Hawaii, Puerto Rico, and the Virgin Islands.

## **JAMPRO ANTENNA COMPANY**

7500 14TH AVENUE • BUILDING 9  
SACRAMENTO • CALIFORNIA

**ANTENNA EQUIPMENT FOR  
TELEVISION AND FM BROADCASTING**

- ★ **SPECIAL DESIGNS**
- ★ **SALES**
- ★ **ENGINEERING**
- ★ **FABRICATION**

JAMPRO . . . a *complete* source for all  
your antenna requirements!



(c) The clear channel frequencies to which paragraph (a) of this section applies are:

(1) Class I-A frequencies:

kc	kc	kc	kc
640	750	840	1100
650	760	870	1120
660	770	880	1160
670	780	890	1180
700	820	1020	1200
720	830	1040	1210

(2) Class I-B frequencies:

kc	kc	kc	kc
680	1000	1080	1140
710	1030	1090	1170
810	1060	1110	1190
850	1070	1130	

[F.R. Doc. 60-7307; Filed, Aug. 4, 1960; 8:48 a.m.]

## Industry News

### Gonzales Southwestern Sales Manager for Ampex



Frank Gonzalez, Jr., has been named southwestern regional sales manager for the video products division of Ampex Professional Products Co.

Gonzalez, formerly northwest district sales manager for the video products division, will direct Ampex's video sales activities in an area comprising the 11 western states plus Alaska, Hawaii, Oklahoma, Texas, Arkansas, Louisiana, Mississippi, Alabama, Georgia, Florida, Tennessee and South Carolina.

Gonzalez has been with Ampex since 1957. Before that, he was sales manager of Kierulff Sound Corp., where he directed distribution of professional sound recording equipment as well as industrial sound and inter-communication systems.

### Cox to Sarkes Tarzian

Neff Cox, Jr., has been promoted from assistant sales manager to merchandising manager for the Broadcast Equipment Division of Sarkes Tarzian, Inc.

Mr. Cox was sales manager of Dage Television and military manager for Ampex Professional Co. before joining Sarkes Tarzian, Inc.

September, 1960

## A NEW HETERODYNE MICROWAVE RELAY for Multihop & Terminal Use

- For network or STL
- 800 Line Resolution
- Full Repeater XTAL Control
- Transparent to Repeated Signal
- 2000mc Reliable Operation
- No Limit on Number of Hops
- Unattended Operation
- Terminal Equipment XTAL Controlled
- Will Diplex Up to Three 15kc Sound Channels if Desired

The use of the Heterodyne principle eliminates the linearity and noise problems prevalent in standard video relay units. Also, the demodulation process is absent in Heterodyne equipment. Problems in differential gain and phase are eliminated at all except the terminal points.

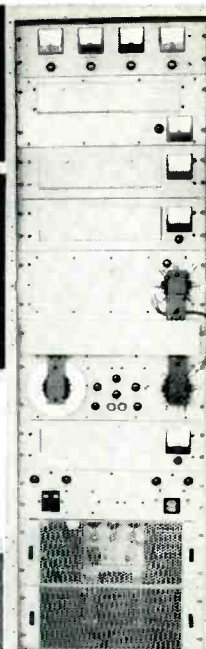
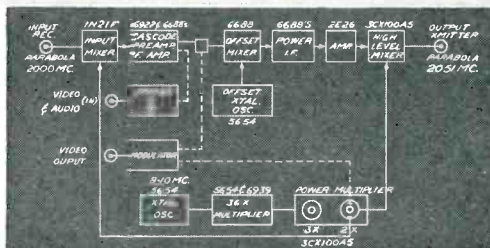

Other basic configurations include a Terminal Transmitter and Terminal Receiver.



## SARKES TARZIAN INC

east hillside drive • bloomington, indiana  
edison 2-7251

Write for complete technical information Broadcast Equipment Division

# PROVIDE



MODEL 649A LIST \$105.00

the choice of the artists  
**Ey** Lavalier microphone

These small, inconspicuous dynamic non-directional lavalier microphones were originally created for demanding TV applications. Remarkably versatile, they can be hung on a neck cord and the hands of the performer or announcer left free for demonstrations or they may be held in the hand, used on a desk stand or suspended from a boom. The Model 649A and companion Model 646 are ideal for audience participation shows, man-in-the-street interviews, panel programs—wherever microphone concealment, individual mobility or free movement of the hands is desired.

The unique, exclusive Acoustalloy diaphragm permits smooth response over a wide range and is almost indestructible with normal use.

For Complete Information Write Dept. 90V.

**Electro-Voice®**  
BUCHANAN, MICHIGAN



# Product News



## NEW LONG NECK MICROPHONES

Two models of a thin inconspicuous professional microphone have been introduced by Electro-Voice, Inc., Buchanan, Mich. The E-V 652 and 652A Models are dynamic type microphones with a length of semi-rigid tubing to bring the microphone close to the user while the stand remains out of the way. The microphones can be tilted through a 120-degree arc with respect to the stand coupler. Two clear plastic baffles that fit on the head of the microphones are provided to add directivity and boost brilliance. The necks are of a non-reflecting Nicaloy finish and are 3/16 inches in diameter. Output level is minus 60 db.

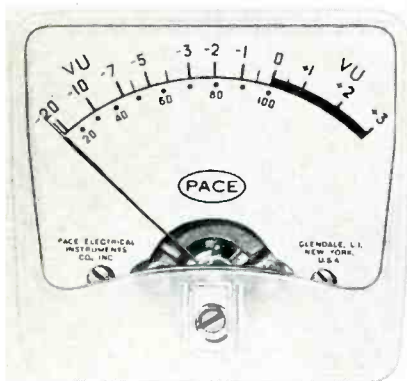

## NEW LINE OF VU METERS

A full line of standard VU meters has been announced by Pace Electrical Instruments Co., Inc., 70-31 84th St., Glendale, Long Island, N. Y. A or B scale plates are available and the meters are available in 2½-inch, 3½-inch, 4½-inch, round or rectangular and in either acrylic or phenolic cases.

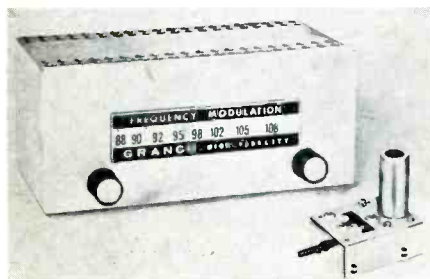

## FM AUTO RADIO

Granco Products, Inc., Kew Gardens, N. Y., manufacturer of FM radios, is introducing

this high fidelity FM automobile set which will be available from car dealers and radio installers in September. This unit is designed to cost less than \$75 installed. Incorporating the new, Granco-developed automatic frequency control tuner, pictured in the foreground, it locks a station into perfect tune once the station is picked up, thus imposing no dial twisting chore to distract the driver's attention.

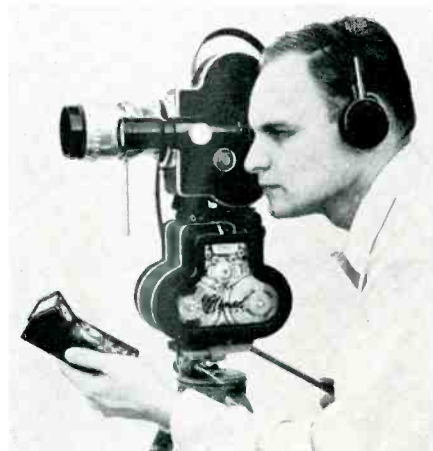

## MAGNETIC RECORDER FOR FILM CAMERA

A self-contained, transistorized, portable recording system which can be used with film cameras to provide lip-sync recording is now available from Magnasync, 16033 Ventura Blvd., Encino, Calif. The camera mounts on the Nomad recorder-reproducer and both are interlocked through a flexible cable. The camera drives the recorder. Record-play amplifier is fully transistorized with self-contained rechargeable batteries. For lengthy sequences a DC motor is attached to the Nomad, driving both the recorder and amplifier through a flexible cable. The recorder uses split 16mm magnetic film, a twin-track record head, and playback head wide enough to scan both tracks.

# Professional Services

Precision Frequency Measurements  
AM-FM-TV

## COMMERCIAL RADIO MONITORING CO.

103 S. MARKET ST. LEE'S SUMMIT, MO.  
Phone Kansas City, LA. 4-3777

## PAUL DEAN FORD

Broadcast Engineering Consultant

4341 South 8th Street Wabash 2643  
TERRE HAUTE, INDIANA

## VIR N. JAMES

Specialty  
Directional Antennas

232 S. JASMINE DEXter 3-5562  
DENVER 22, COLORADO

# Advertisers' Index

Altec Lansing Corp. ....	13
Ampex Corp., Video Products Div. . .	3
Amplifier Corp. of America. ....	37
Bauer Electronics Corp. ....	38
Burke & James, Inc. ....	32
Collins Radio Co. ....	29
Commercial Radio Monitoring Co. . .	40
Continental Mfg. Co. ....	28
Daven Company, The. ....	35
Electro-Plex Div. ....	33
Electro-Voice, Inc. ....	35, 37, 39
Ford, Paul Dean. ....	40
Foto-Video Electronics, Inc. ....	IFC
General Electric Co. ....	1
James, Vir N. ....	40
Jampro Antenna Co. ....	38
Moseley Associates, John A. ....	34
Nems-Clarke Co. ....	32
Radio Corp. of America. ....	11, 31
Raytheon Co. ....	26, 27
Sarkes Tarzian, Inc. ....	39
Sonocraft Corp. ....	34
Telechrome Mfg. Co. ....	IBC
Television Zoomar Co. ....	BC
Tower Construction Co. ....	28

# Classified

Advertising rates in the Classified Section are ten cents per word. Minimum charge is \$2.00. Blind box number is 50 cents extra. Check or money order must be enclosed with ad.

## EQUIPMENT FOR SALE

TV VIDEO MONITORS—8Mc., Metal cabinets starting at \$189.00. Never before so much monitor for so little cost. 30 different models, 8" thru 24". Miratel, Inc., 1083 Dionne St., St. Paul, Minn. 2-60 11t

Combination Recording Studio and home for sale. Business is good. Repeat clientele. I want to retire—you take over. No junk equipment. Cook Recorders, 3905 W. Slau-son Ave., Los Angeles 43, Calif. 7-60 tf

## SERVICES

Cambridge Crystals Precision Frequency Measuring Service. Specialists for AM-FM-TV. 445 Concord Ave., Cambridge 38, Mass. Phone: TRowbridge 6-2810. 3-60 12t

# THE SPECIAL EFFECTS GENERATOR that MATCHES YOUR CREATIVE SKILL.

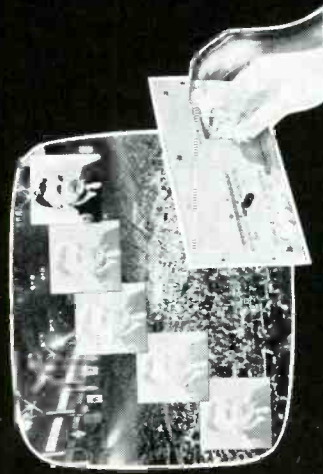

Insert May be Placed at Any Position on Raster

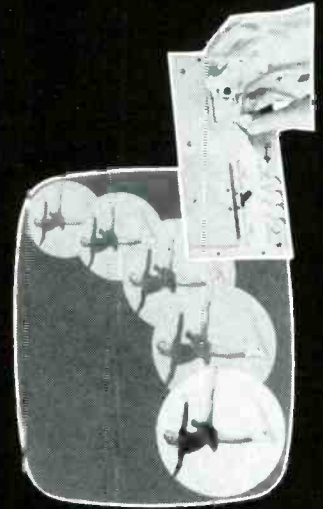

Electronic Spotlight

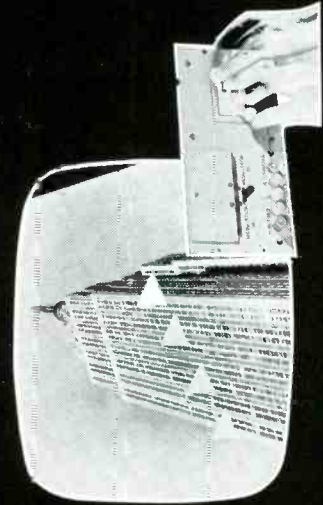

Electronic Pointer



Add Motion to Standard Wipes

Now, You Can Offer Your Advertisers the Newest Facilities and Your Viewers the Most Varied Programming.

First, Telechrome provided broadcasters with a vastly improved system for producing a wider variety of dramatic wipes, inserts, keying and other special effects. Now, Telechrome engineering introduces the "Joy Stick" Positioner. This makes it possible to create many hundreds more effects and to move wipes, inserts, keying or other special effects to any place on the TV screen. The effects are startling! A new era in program creativity begins now! Ask to see the "Joy Stick" Positioner demonstrated, today!

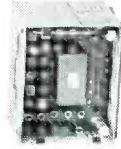

490WAL Waveform generator. Generates keying signals for the 72 different keyed wiping waveform.



490SA1 Switching Amplifier. Combines two picture signals in accordance with applied keying waveform.



490RA1 Remote Control Unit. Selects and controls desired effect. Designed for console or desk mounting. Easily modified for integration into existing studio facilities. Complete with power supply—Model 51201.

Available Portable or Rack Mounted

COLOR TV • INDUSTRIAL INSTRUMENTATION • TELEMETRY



AT THE FRONTIERS OF ELECTRONICS

TELECHROME MANUFACTURING CORP.  
28 RANICK DRIVE • AMITYVILLE, N.Y.  
Lincoln 1-3600

Cable Address: COLORTV  
TWX: AMITYVILLE NY2314

WESTERN ENGINEERING DIVISION • 13635 Victory Blvd., Van Nuys, Calif., State 2-7479  
MIDWESTERN ENGINEERING DIVISION • 106 W. St. Charles Rd., Lombard, Ill., MAYfair 7-6026  
SOUTHWESTERN ENGINEERING DIVISION • 4207 Gaston Ave., Dallas, Tex., TAYlor 3-3291

# TELECHROME SPECIAL EFFECTS GENERATOR

## With Exclusive "JOY STICK" POSITIONER

MODEL 491-A1



**Improve  
Studio Production**

# SUPER STUDIO

2 1/4 to 15 inches  
Weight 6 pounds — length 10 inches

**Indispensable for remotes  
and Studio Production**

# SUPER UNIVERSAL

2 1/2 to 72 inches  
Weight 12 pounds — length 17 inches

**600 ZOOMAR LENSES in use  
14 years service for television industry**

# ZOOMAR

REMOTES

BASEBALL

CONVENTIONS

STUDIO PRODUCTION

HOCKEY

FOOTBALL



JACK PEGLER • BILL PEGLER

**TELEVISION ZOOMAR CO.**

Room 2223, 500 Fifth Avenue, New York 36, New York

Cable Pegtelzoom

Call New York **BR 9-5835**