

# BROADCAST ENGINEERING

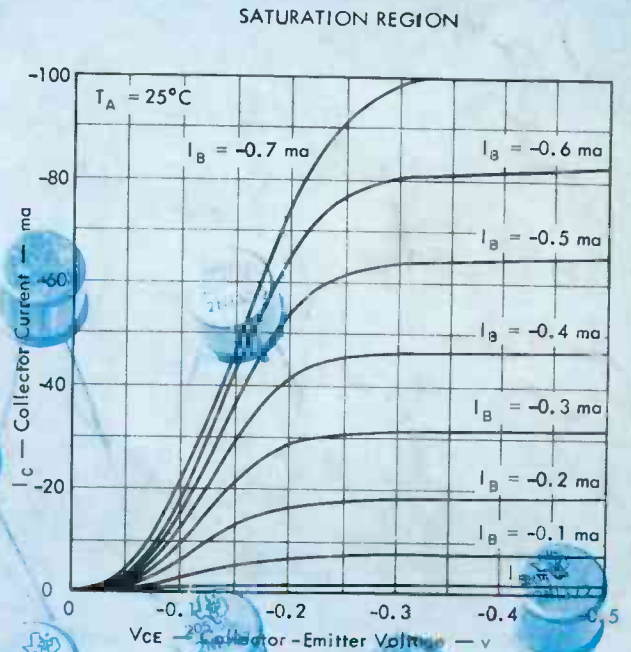

THE TECHNICAL JOURNAL OF THE BROADCAST INDUSTRY

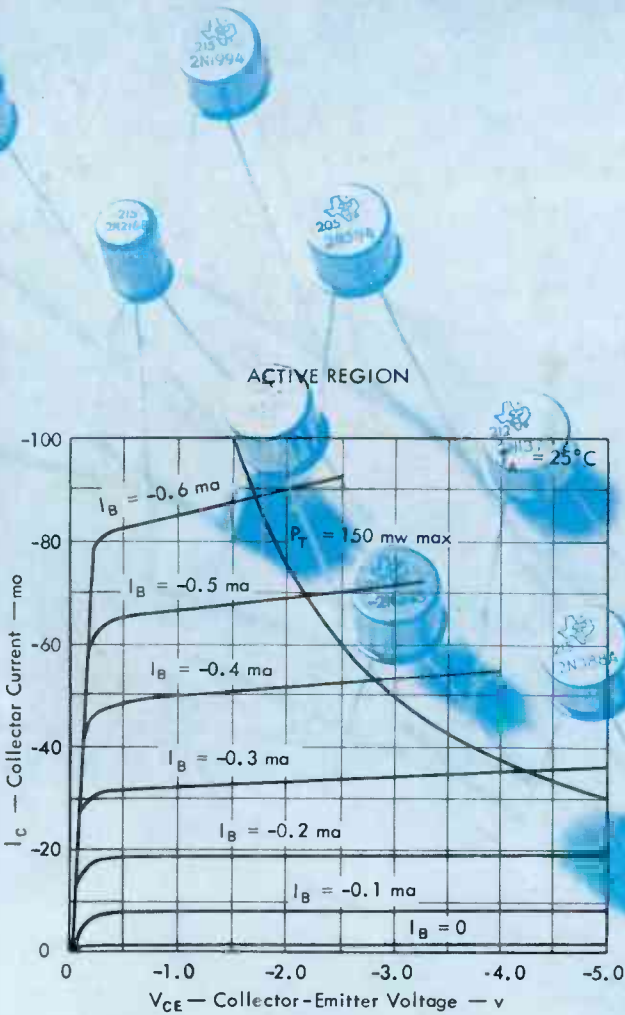

Beginning a new series . . . **TRANSISTOR AUDIO AMPLIFIER CIRCUITS**



## FIRST... IN STEREO/MONO CARTRIDGE TAPE

Now . . . ITA offers stereo and monophonic cartridge tape recorders that will play and record up to 31 minute programs. Convenient plug-in, modular construction features all transistor circuitry. Fully compatible with existing machines. With separate record and play heads, the ITA recorders give uniform high fidelity frequency response . . . even when full half-hour cartridges are used. Plug-in remote control—sequence triggering—unique idler wheel! ITA cartridge tape recorders are your *best* buy. For a free demonstration of the ITA cartridge tape recorder call your nearest ITA sales office listed below.

ITA ELECTRONICS CORPORATION  
BROADCAST DIVISION • LANSDOWNE, PENNSYLVANIA

Chicago, Ill. AN 3-3797  
Cincinnati, Ohio CH 1-6386

Dallas, Texas FL 7-9807  
Jacksonville, Fla. EL 6-0121  
Kansas City, Mo. GR 1-2838

Lansdowne, Pa. CL 9-8200  
Los Angeles, Cal. MA 2-8552  
New York City, N.Y. CH 2-1996

Portland, Ore. CA 2-2651  
Washington, D.C. 337-2884



ITA with EMI/US NOW SERVING BROADCASTING BEST

[www.americanradiohistory.com](http://www.americanradiohistory.com)



# FREE

All the scoop on the world-famous Houston Fearless line of TV camera heads, pedestals and tripods in one brochure. It's new, it's useful, and it's free. Send for **your** copy today.

WESTWOOD DIVISION



HOUSTON FEARLESS CORP.

11851 W. Olympic Blvd., Los Angeles 64, California

Please send brochures on:  TV studio equipment.  Motion picture film processors.

Name \_\_\_\_\_

Title \_\_\_\_\_ Station \_\_\_\_\_

Address \_\_\_\_\_

City \_\_\_\_\_ Zone \_\_\_\_\_ State \_\_\_\_\_



# BROADCAST ENGINEERING

THE TECHNICAL JOURNAL OF THE BROADCAST INDUSTRY <sup>®</sup>

VOLUME 4

AUGUST, 1962

NUMBER 8

**Contents**

New 20 Kw FM Transmitter . . . . . 4

A News Teletype Automatic Conelrad Alarm . . . 10

Audio Studio Maintenance . . . . . 14

Transistor Audio Amplifier Circuits . . . . . 18

Stereophonic Phonograph Records, Phase Relations and Stereo Broadcasting . . . . . 24

**Departments**

Engineer's Exchange . . . . . 26

Industry News . . . . . 30

Book Reviews . . . . . 35

Product News . . . . . 36

Index to Advertisers . . . . . 40

Classified Ads . . . . . 40

Professional Services . . . . . 40

ROBERT E. HERTEL, Publisher

**EDITORIAL**

GEO. H. SEFEROVICH, Director  
 JOHN BATTISON, Consulting Editor  
 D. F. BOICOURT, Production Editor  
 DUDLEY ROSE, Presentation Editor

**ADVERTISING**

E. P. LANGAN, Director  
 R. J. HANCOCK, Manager  
 S. F. WILSON, Production Manager

**Great Neck, New York**  
 PAUL AND DON WEIL  
 260 Northern Boulevard  
 Telephone HN. 6-0212

**Chicago 1, Illinois**  
 WILLIAM L. MILLER, JR.  
 E. F. LUKENS  
 307 N. Michigan Ave.  
 Telephone FRanklin 2-5944

**Cleveland 16, Ohio**  
 DAVID H. HERTEL  
 3100 Wooster Road  
 Telephone EDison 1-2370

**Omaha 14, Nebraska**  
 BOB HOPKINS  
 1705 Maenner Drive  
 Telephone 393-1905

**Southwest**  
 C. H. STOCKWELL CO.  
 4916 W. 64th Street  
 Mission, Kansas  
 Telephone RAndolph 2-4417

**Los Angeles 57, California**  
 MAURICE A. KIMBALL CO., INC.  
 2560 Beverly Boulevard  
 Telephone DUnkirk 8-6178

**San Francisco 4, California**  
 MAURICE A. KIMBALL CO., INC.  
 580 Market Street  
 Room 400  
 Telephone EXbrook 2-3365

**Paris 5, France**  
 JOHN ASHCRAFT  
 9 Rue Lagrange  
 ODeon 20-87.

**London W. C. 2, England**  
 JOHN ASHCRAFT  
 12 Bear Street  
 Leicester Square  
 WHitehall 0525

**Tokyo, Japan**  
 INTERNATIONAL MEDIA  
 REPRESENTATIVES, LTD.  
 Kisha Kurabu  
 14, 2-chome Marunouchi  
 Telephone (502) 0656



Subscription Price: U. S. \$6, one year; Outside U. S. A., \$7. Single copies, 75 cents. Adjustments necessitated by subscription termination at single copy price.

BROADCAST ENGINEERING is published monthly by Technical Publications, Inc. Editorial, circulation and advertising headquarters: 1014 Wyandotte St., Kansas City 5, Missouri; telephone VICTOR 2-5955.

Corporate Personnel: Robert E. Hertel, President; Frank D. Smalley, Executive Vice-President; E. P. Langan, Vice-President; Kenneth Long, Vice-President.

Affiliated with



HOWARD W. SAMS & CO., INC.

BROADCAST ENGINEERING

# YOUR TAPE HEAD

# KNOWS

# THE

# DIFFERENCE!

A triumph of RCA research in sound, RCA Red Seal magnetic tape will show you what your recording equipment is capable of!

Developed and produced to exacting standards, it's the superior tape used for recording the masters of RCA Victor phonograph records and RCA pre-recorded tapes. At the RCA Magnetic tape plant in Indianapolis, skilled engineers supervise every step of production, from the basic oxide formulation to the finished tape.

RCA Red Seal tape is quality control tested for frequency response, distortion, dropout, noise, and print-through; tested mechanically for coating thickness, layer-to-layer adhesion, cupping, slitting and anchorage. These precise controls give all RCA Red Seal tapes the required magnetic properties and recording-bias characteristic. As a result, every roll of RCA Red Seal tape is of the same high quality. For full details, fill in the coupon, now!



**RCA VICTOR**   
TRADE MARK  
 The most trusted name in sound

MAGNETIC TAPE PRODUCTS MARKETING/RCA VICTOR RECORD DIVISION/156 EAST 24TH STREET/NEW YORK 10, NEW YORK

Please send me the brochure outlining essential physical and magnetic characteristics of RCA Red Seal Magnetic Tape.

NAME \_\_\_\_\_ TITLE \_\_\_\_\_

COMPANY \_\_\_\_\_

ADDRESS \_\_\_\_\_

CITY \_\_\_\_\_ ZONE \_\_\_\_\_ STATE \_\_\_\_\_

# New 20 Kw FM Transmitter

Combination of two 10 kw units produces duplicate reliability while maintaining full fidelity operation

THE BTF-20D is one of the newest in RCA's growing line of FM broadcast transmitters. All new RCA FM transmitters have been designed so that obsolescence is not a factor when deciding to increase power. The Type BTF-5B which was introduced a number of years ago can be used as a cornerstone with which to change power and advance to a BTF-10D or a BTF-20D.

## Compact High Power

The three cabinets of the BTF-20D fit into a space 104 inches wide

by 32 inches deep. The center cabinet contains the "Direct FM" exciter, BTE-10B; 400-watt driver; control and switching circuitry; and dividing system to feed the power amplifiers. On either side of the center cabinet is a 10-kw power amplifier. Two external high voltage transformers can be placed in any convenient location. The two power amplifiers are driven in parallel and the outputs are combined to supply a full 20 kw to the antenna. With the RCA BFA series of FM antennas, up to 240 kw ERP can be obtained from the BTF-20D.

Only 21 tubes (13 types) are used in the BTF-20D. Eighteen tubes (11 types) are used in the exciter, and from the output of the exciter only three tubes in single-ended circuits (a ceramic 4CX300A in the IPA and a ceramic 4CX5000A in each PA) are required to produce a 20-kw signal. In an emergency, the BTF-20D can operate with a multiplexed 20-kw output with as few as ten tubes.

## Emergency Provision

Depending upon the selection of optional transmission line switching equipment, it is possible to reduce transmitter power to as low as 1 kw, or even to do maintenance on one power amplifier while the other remains on the air. Standard equipment on the BTF-20D is a power-combining diplexer and a reject load rated at 1.5 kw. If there should be an imbalance or failure of one PA, the power in the reject load will go above 1.5 kw, an alarm is sounded, and the transmitter is automatically taken off the air. By addition of optional transmission line switching it is possible to switch the still operating power amplifier directly into the antenna feed line to stay on the air at reduced power. This switching can be provided for manual or electrical changeover.

## Extra Protection

If desired, a 7.5 kw reject load can be installed in place of the 1.5 kw load. Thus, even if one PA should fail, the transmitter will stay on the air and programming will

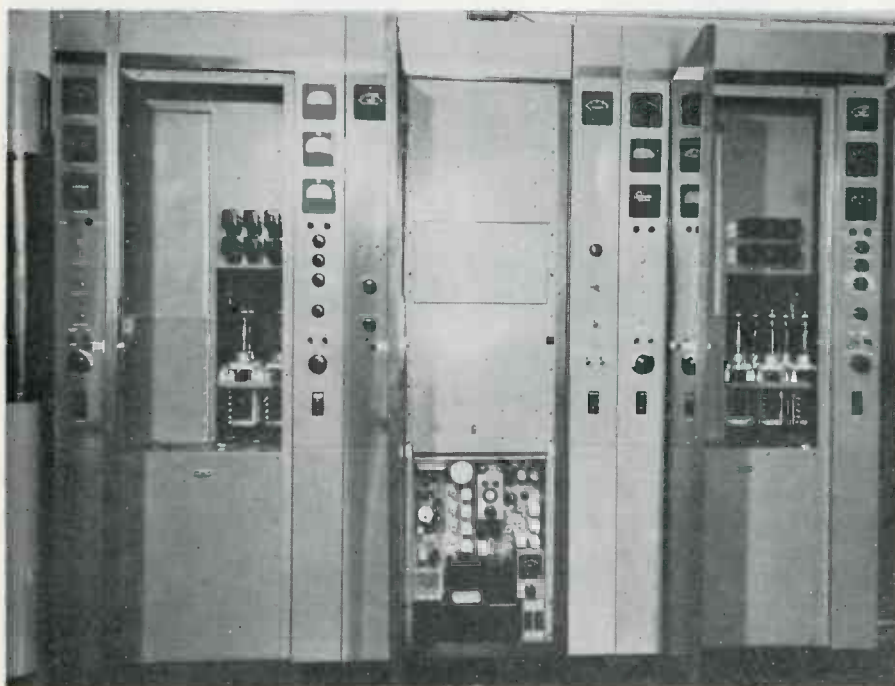

Figure 1—The BTF-20D with front doors open to show tube accessibility and general appearance of the three bays.

By Ivan H. Lubash  
Broadcast Transmitter Merchandising  
Radio Corp. of America

not be interrupted though output power will drop to 25 per cent.

The transmitter has been designed for balanced input to each power amplifier from the driver. This is accomplished by tuning the input matching meter for minimum reading at each 10-kw amplifier.

Each power amplifier has its own reflectometer for reading output power and VSWR; in addition there is another reflectometer at the output of the combining diplexer measuring power fed to the antenna. Twenty kilowatts are easily provided at this point.

Each of the three cabinets contains its own separate blower for maximum cooling. The plate power to the driver stage is supplied by the "dominant" power amplifier (somewhat analogous to the way a multivibrator begins to oscillate). If the "dominant" power amplifier should fail, driver plate power is automatically obtained from the other power amplifier remaining on the air.

The power amplifiers are identical even to the external high voltage transformers. This duplication, since there is a constant reference, makes servicing and trouble shooting quicker and easier. By comparing meter readings and by visual comparison, faults can be corrected in much less time than would otherwise be normal.

The IPA uses a ceramic 4CX300A to produce 400 watts output to drive the two power amplifiers. The IPA stage is very similar to the one used in the BTF-10C FM transmit-

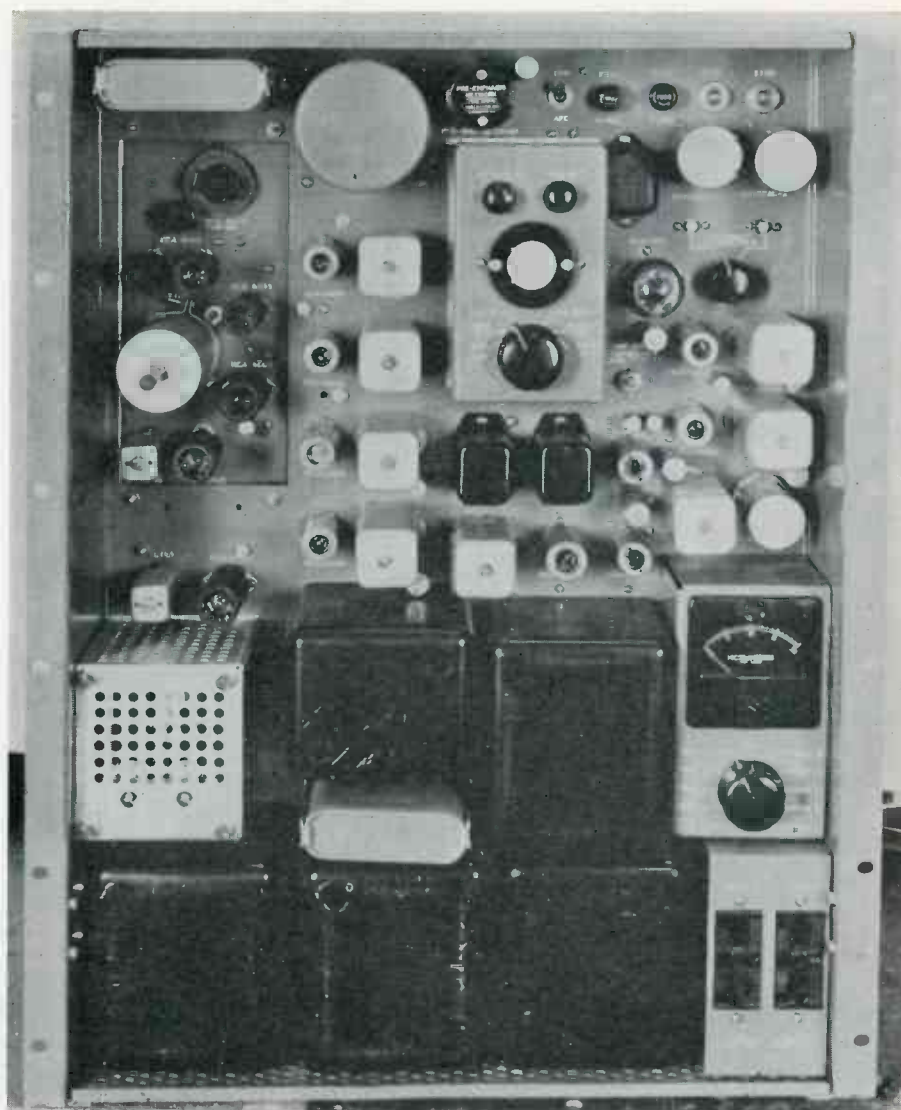

Figure 2—The BTE-103 FM Exciter for use in the BTF20/D.

ter.<sup>1</sup> The 4CX300A IPA stage has conventional pi-networks with variable capacitors in the input and output stages. The variable capacitors act as the matching components, and tuning from 88-108 mc is accomplished by varying the inductances in the pi-networks.

Plate voltage for the IPA is obtained from the center tap of the power supply of the "dominant" PA. The "dominant" PA and the IPA screen voltages work together. If the "dominant" amplifier should fail, automatic switching takes place so that the IPA power is obtained from the second PA. The IPA is protected by the overload relays in the cathode circuit. Air interlocks are provided to remove plate and screen voltages if the cooling air flow should stop.

#### Proven Design

Each power amplifier is essen-

tially the same as the proven power amplifier in the RCA transmitter, BTF-10C.<sup>2</sup> The primary advance is that efficient, long-life silicon diodes have replaced tube rectifiers, each power amplifier used the rugged 4CX5000A which is capable of supplying 10-kw of power.

#### Easy to Tune

The input of each PA is a modified pi-network in which the input capacity of the tube is shunted by an inductive line to reduce the effective input capacity of the stage. This inductance is also used to vary input loading. A capacitor in parallel with the coil varies the inductive component of the circuit. Each PA also incorporates its own separate grid bias supply for additional stability.

Plate loading and tuning are achieved by variation of two inductive line components in a pi-



Figure 3—Front view of the 10 kw PA showing RF cavity.

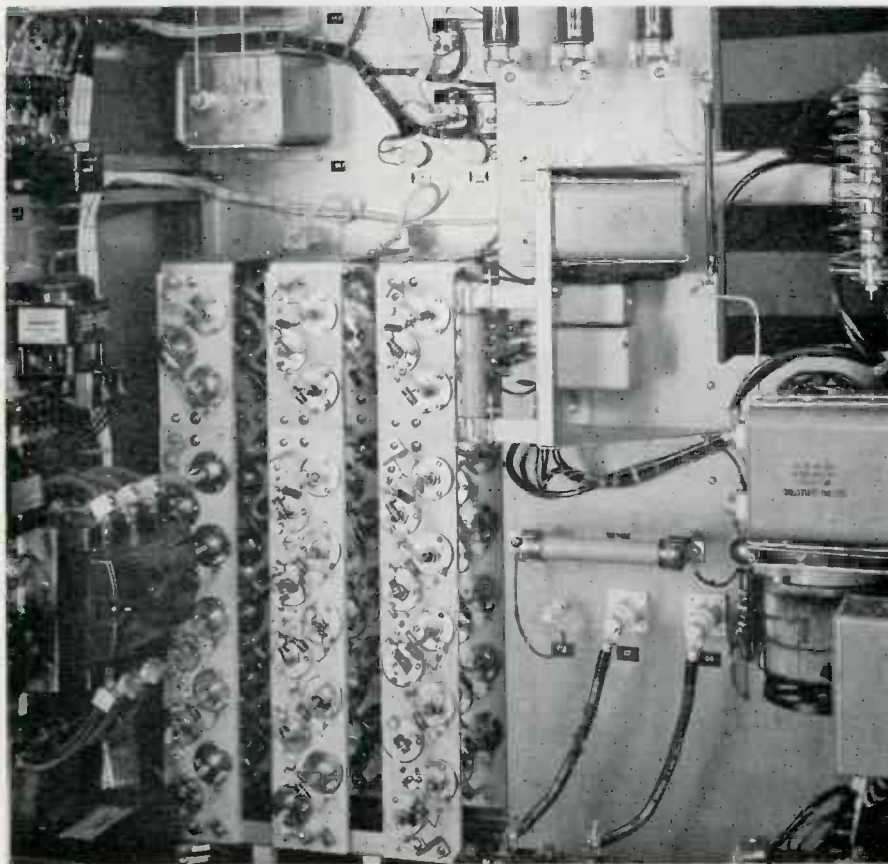

Figure 4—Close-up of the PA cabinet showing the solid state rectifiers. The germanium screen supply is at the bottom of the figure, and the silicon grid bias supply is central. The stacks at left form the high voltage supply.

network arrangement. Tube capacity is shunted by the variable inductor. The pi-network has been inverted for mechanical simplicity which results in grounding one end of the inductance to eliminate the problem of insulating the variable component from ground. However the output line must be in parallel with the inductance to bring it to ground potential. This is done by extending the output line down one side of the inductive line.

Initial tuning is done by approximate setting of all variable components according to a tuning curve. Final tuning is accomplished under reduced plate and screen voltage for circuit protection. The PA stage is neutralized by variation of the inductance in series with the screen supply. Tuning across the 88 to 108 mc FM band requires the change of only one frequency-determining part in each PA input circuit.

#### Special Filter

Each power amplifier feeds into a reflective type harmonic filter which is not merely a second harmonic trap. No power is absorbed in this filter which consists of an M-derived half-T section, several low pass filter sections, and a constant  $k$ , half-T section. Use of the RCA filter assures compliance with FCC requirements for spurious radiation. All harmonics through the seventh are effectively attenuated. The output of the two harmonic filters is then combined in a broadband diplexer, and match a  $3\frac{1}{8}$  transmission line. Total output power is determined after this point.

#### Semiconductor Power Supplies

No tube rectifiers are used in the BTF-20D transmitter. Semiconductor power supplies have been standard in the "Direct FM" exciter, BTE-10B, since it was first introduced a number of years ago. Each power amplifier in the BTF-20D has six banks of heavy-duty silicon diodes.

Regardless of application—high voltage, bias, low voltage, etc.—no tube or selenium type rectifier is used in the BTF-20D. As a result, the BTF-20D has an extremely wide operating temperature range, —20 to +45 degrees C. This savings in heating requirements can be reflected in the construction and maintenance of the transmitter





PIONEERS IN TELEVISION PROGRESS

# New General Electric Switching Systems

**FOR LARGE OR SMALL  
STUDIO AND MASTER  
CONTROL REQUIREMENTS**

Now General Electric offers a new line of switching systems that are designed to provide optimum picture quality. Reflecting General Electric's advanced design engineering, each system can be integrated with existing station equipment or incorporated into new studio installations.

**TS-2-B Vertical Interval Switcher** provides fast, transientless switching during the vertical blanking interval. Designed for use in medium or large TV studios, the system permits studio video switching or master video switching of both monochrome and color TV signals.

**TS-1-A Relay Switcher** system is particularly well suited for small to medium-size TV studios, the system permits studio switching of both monochrome and color television signals.

**TC-59-A Direct Switcher** provides the maximum switching facilities in a minimum size low cost unit. The versatility of the system also makes it especially practical for educational and industrial TV applications.

*In addition to the systems described, General Electric will design and build custom engineered switching equipments to fit your particular requirements.*

For complete information, contact your nearest G-E Broadcast Equipment representative, or write to Technical Products Operation, Broadcast Equipment Section, Electronics Park, 212 W. Division St., Syracuse, N. Y. 551-03



**TS-1-A SYSTEM** provides complete dissolve, fade, previewing, direct switching and sync mixing facilities for eight non-composite video inputs and two composite inputs. Provisions are also available for special effects.

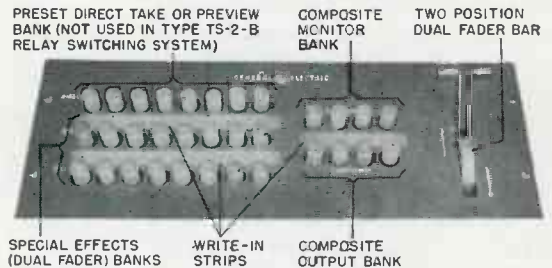

**TS-2-B SYSTEM** provides complete dissolve, fade, direct switching with preview monitoring and sync mixing facilities for twelve non-composite video inputs and three composite inputs. Provisions are also available for special effects.

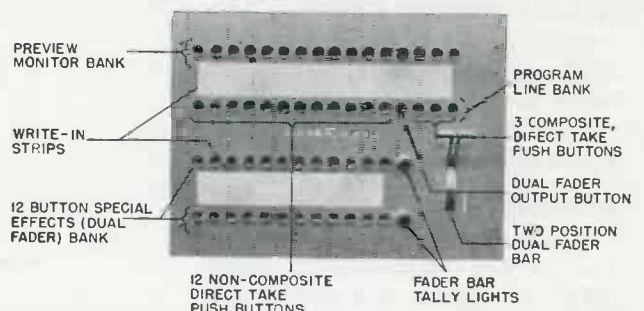

**TC-59-A SYSTEM**—This compact single unit construction with low power consumption provides complete dissolve, fade, direct switching and sync mixing facilities for four non-composite video inputs and three composite inputs.

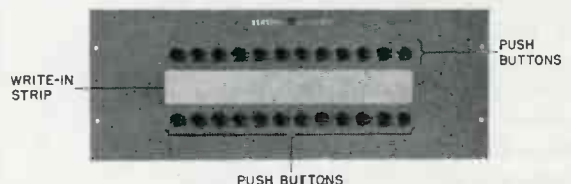

# GENERAL ELECTRIC

building, particularly if the transmitter is to be remote-controlled.

### Full Overload Protection

The only fuses used in this transmitter are in the crystal-oven heater circuits. Magnetically tripped circuit breakers and overload relays are used throughout for better protection. Time delay relays are used so that plate voltage cannot be applied to the power amplifier tubes until the filaments have properly heated. Each amplifier is designed to automatically come back "on" twice after brief overloads. After the third overload, the transmitter will stay off. This feature will materially reduce "off-air" time due to momentary overloads or brief failures in power fed to the transmitter.

### Built-In Remote Control

The BTF-20D is designed for remote control; no extra motor control or metering equipment is required. Terminals are provided for remote control of transmitter on/off, plate on/off, etc. Remote metering connections for each PA are supplied as follows: cathode current, plate current, and power output. All RCA broadcast transmitters are designed to operate with the BTR-11B or BTR-20 remote control systems. This control equipment requires only two low-cost dc telephone lines (one each for control and metering) with a maximum resistance of 5,000 ohms per line. RCA remote control does not use tones for control but instead uses the principle of a switchable momentary contact.

### Direct FM Systems

The heart of the BTF-20D is the time-proven "Direct FM" exciter, BTE-10B.<sup>3</sup> With this exciter, RCA FM transmitters supply the widest frequency response with minimum distortion. Frequency response for all RCA FM transmitters, including the BTF-20D, is from 30 to 15,000 cycles  $\pm 1$  db. Harmonic distortion over the same range and harmonics to 30 kc is 0.5% or less. Consequently, RCA FM transmitters have the finest sound.

The "Direct FM" oscillator operates at 1/18 carrier frequency

(Continued on page 20)

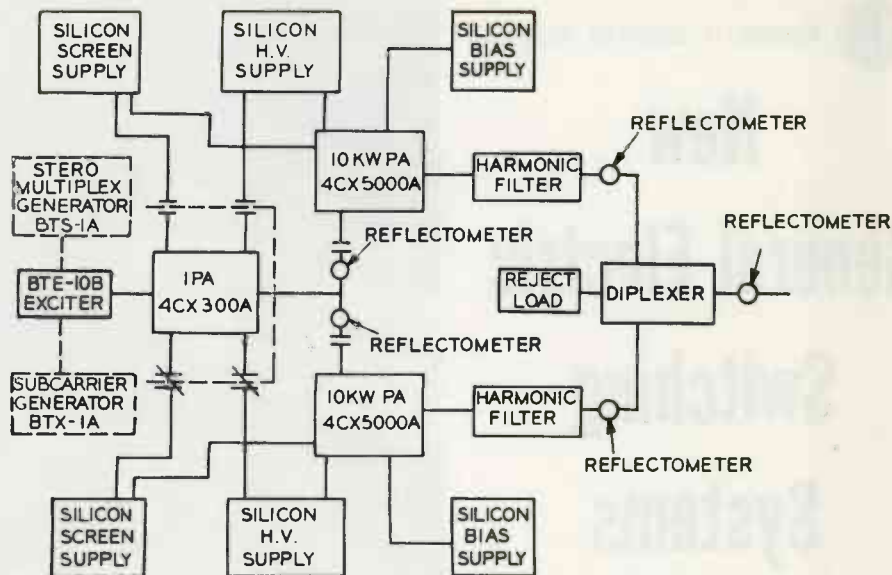

Figure 5—Block diagram of BTF20D.

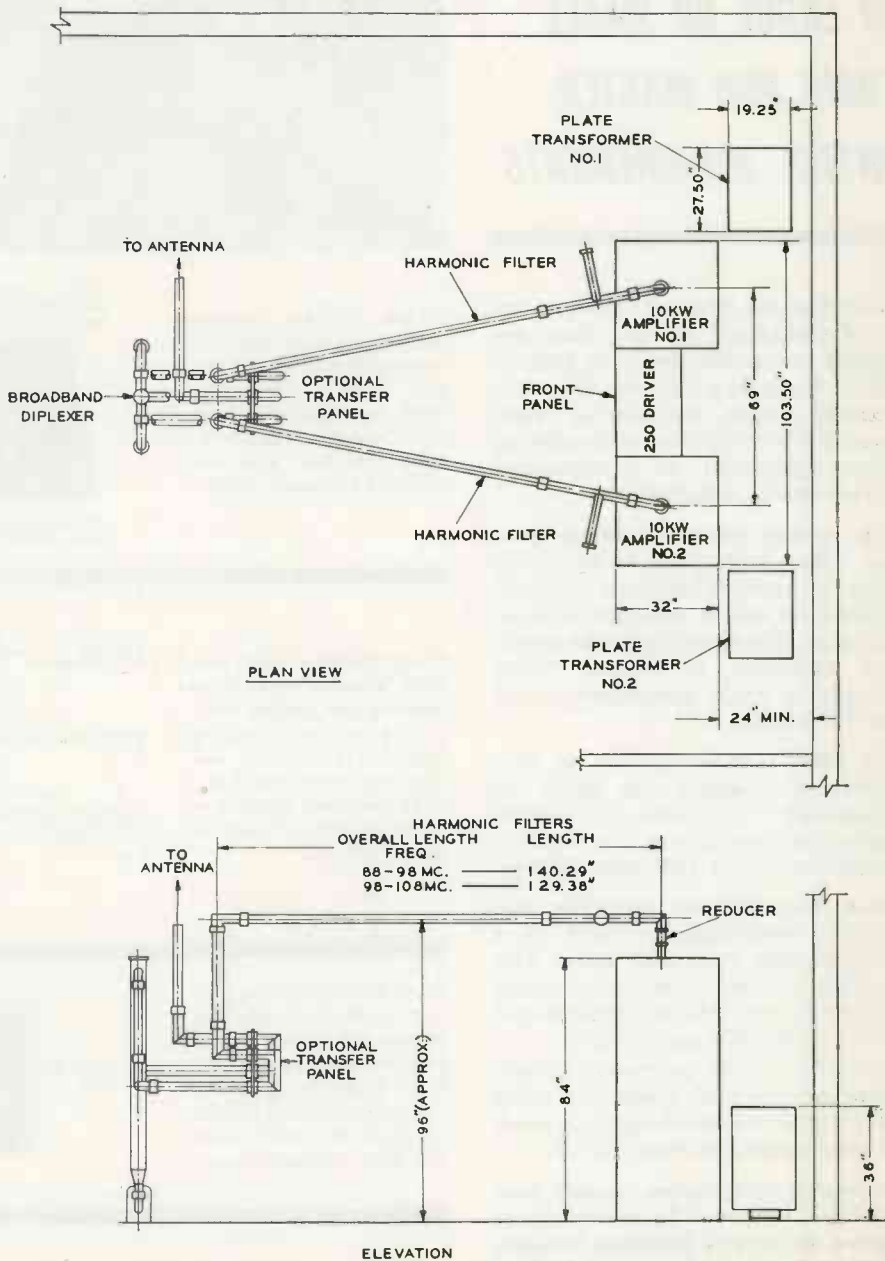

Figure 6—Equipment layout and space diagram for RCA BTF20D.



**UN-SECRET INGREDIENT**

## Yet no other tapes have it!

You can look it up! Half a century ago, the precision coating technology that forms the basis for today's recording tapes was being developed by 3M. Then, to this head-start in coating experience was added pioneering research in magnetic recording. Result—the first SCOTCH® BRAND Sound Recording Tapes won practically immediate acceptance as the performance standard of the broadcast industry . . . laid the groundwork for today's video tape recording. In 1948, "SCOTCH" Recording Tape was first to offer red gamma ferric oxide, precision-coated to acetate backings (now a tape industry standard). And from 3M research came other notable firsts—acicular oxide particles longitudinally oriented, Silicone lubrication, polyester backings, high-output tape, to name a few. Meanwhile, 3M manufacturing set the pace for tape-coating uniformity, made possible identical magnetic properties throughout every reel, and from one reel to the next. These advances, too, proved a head-start for further developments.

In 1956, the advent of commercial video tape recording equipment made dramatic new demands on tape quality, required tapes to withstand heats and pressures unheard of in audible range recording. 3M not only provided the first practicable reels of video tape—it fulfilled pressing demands for this tape in commercial quantity for the April, 1957, change-over to daylight saving time. In this way, "SCOTCH" Video Tape helped revolutionize TV programming with delayed telecasts across time zones.

What does this un-secret ingredient—*leadership in tape technology*—mean to broadcast engineers? While others are striving to catch up with standards of excellence already achieved for the industry by "SCOTCH" BRAND products, 3M looks ahead to further improvements and advances years beyond the best that today's tape science can offer. Meanwhile, 3M offers "the tapes the professionals use": "SCOTCH" Recording Tapes, audible range and video, in the widest of choices for all requirements.

"SCOTCH" AND THE PLAID DESIGN ARE REGISTERED TRADE-MARKS OF MINNESOTA MINING & MANUFACTURING CO., ST. PAUL 1, MINN. EXPORT: 99 PARK AVE., NEW YORK CANADA: LONDON, ONTARIO. © 1962, 3M CO.

Magnetic Products Division **3M** COMPANY

# A NEW TELETYPE AUTOMATIC CONELRAD

The new FCC requirements of Conelrad alerts via the news machine puts an extra strain on broadcast personnel. The unit described counts ten bells only, and calls the operator or announcers on duty.

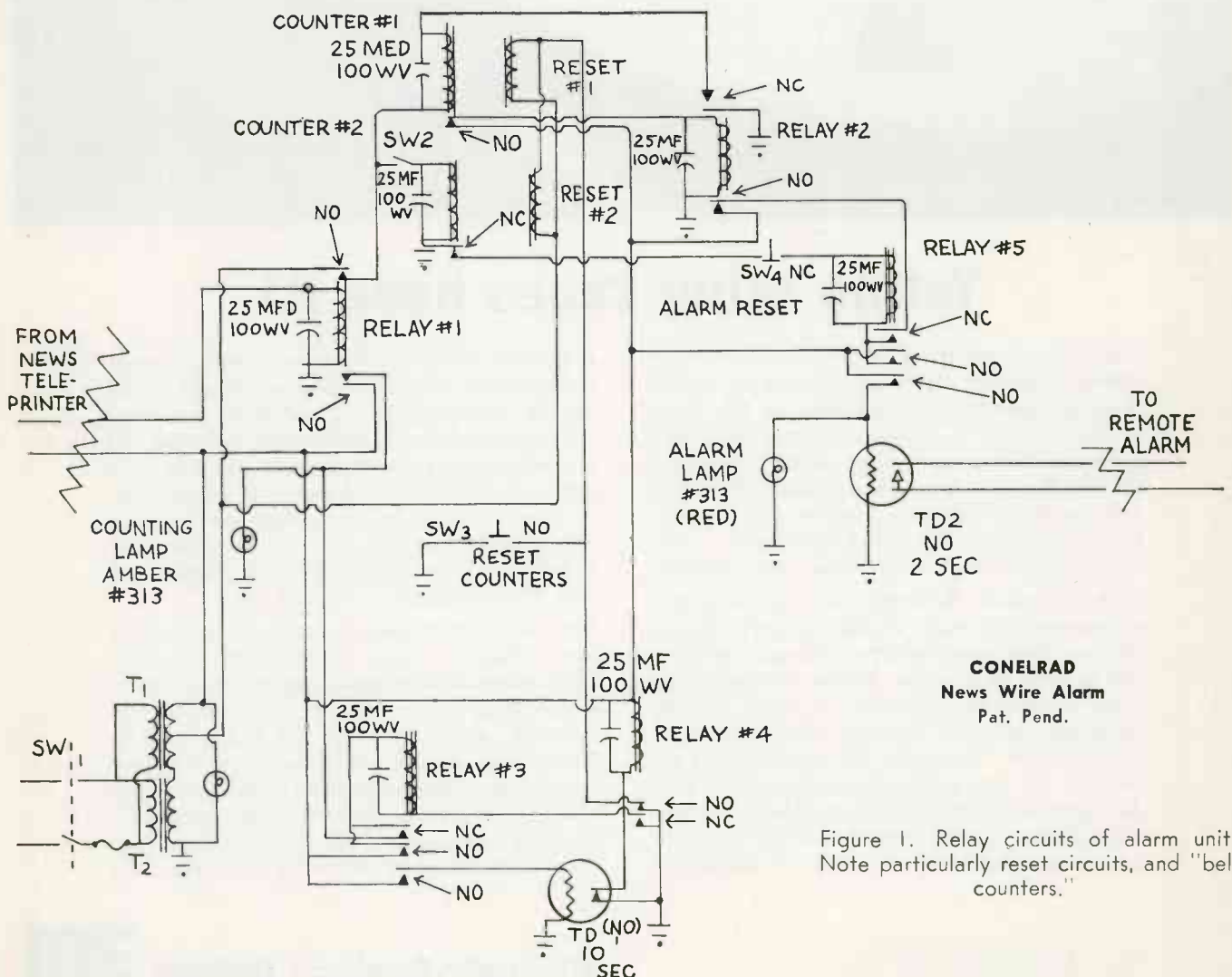

Figure 1. Relay circuits of alarm unit. Note particularly reset circuits, and "bell counters."

# ALARM

By John Gort,  
Chief Engineer  
Western Electronic Associates  
Clark, S. D.

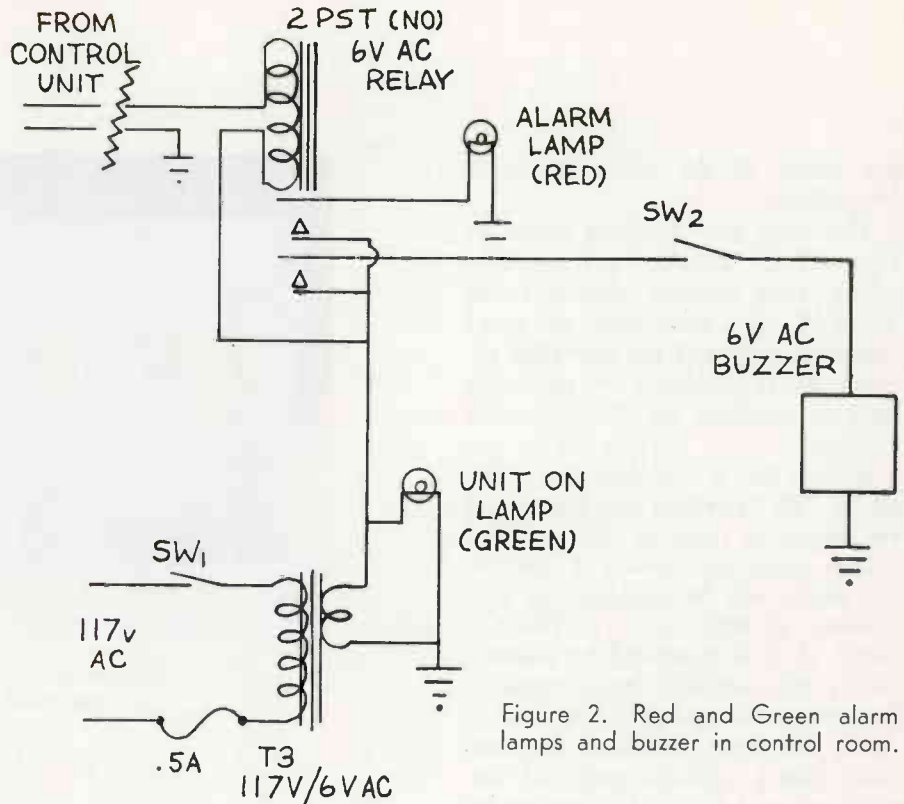

Figure 2. Red and Green alarm lamps and buzzer in control room.

THE RECENT FCC action utilizing the facilities of the news wire services to initiate CONELRAD alarms and to disseminate CONELRAD information, has placed a problem on the doorsteps of the smaller radio and television stations, in that many of these operations do not have newsrooms staffed on a 24-hour basis.

The attention, or "CONELRAD BULLETIN," signal is ten bells on the news printer. In small operations, however, the announcer or engineer-announcer could be on the air, logging the readings of the transmitter, or any one of a number of things that would take the operators away from the newswire machine, and thereby miss the ten bell CONELRAD signal completely, and not notice the CONELRAD message on the newswire for some time.

The unit about to be described was developed by the writer for this type of operation, and can very well be used in larger operations. For even in larger radio and television operations, it is difficult to staff a newsroom full time. The unit will *only* recognize the ten bell CONELRAD signal, when in the proper sequence. It will not recognize an

accumulated count of ten, such as bells of five and five, or three, five, two, or any other combination of bells that make up a count of ten. The unit employs mechanical counters, with automatic electrical reset of the counters, should the number of bells be other than 10, in which case the unit resets itself and starts over. The unit is normally placed next to the news teletype, and is so designed that the operator must come back to the CONELRAD alarm control unit, to reset the alarm should the CONELRAD alarm signal be received.

## Operation

A remote alarm panel equipped with signal light and alarm buzzer is placed in the control room and installed in the equipment racks. This unit, should a CONELRAD signal be received by the control unit, activates a locking relay that lights the signal light, and places the buzzer in operation. The control room operator can disable the buzzer by switching off SW-2; however, the signal light will stay on until the master unit itself is reset. SW-2 was included in the circuitry so that should the alarm be activated during a newscast, or with a

"mike" open, the operator can shut off the buzzer, finish what he is doing, before checking the teletype machine. However, the newscaster or operator will not be aware that a CONELRAD message is on the newswire teletype.

## Circuit Details

Reference is now made to the schematic of the CONELRAD newswire alarm. It is to be noted that a pair of wires are labeled "from news teleprinter." These run to the newsprinter which has nothing more than a pair of SPST contacts that close when the upper case letter "S" is transmitted on Associated Press machine, or the blank space is transmitted on the United Press machines. The aforementioned contacts are not normal equipment, and have to be ordered installed on the respective newswire teleprinters. Attention is also directed to transformers "T-1" and "T-2." These are 115 VAC to 12 VAC center tapped transformers so phased, and connected, that voltages add, making 24 VAC available for the relays, and 18 VAC available for the counters. Since 24 VAC is available at all points in the CONELRAD newswire alarm, No. 313 lamps, which

are rated at 28 volts are used throughout.

The only non-standard items in this unit are the electrical counters, which were military surplus using 18 VAC for both the electrical counting coils, and the electrical reset coil. The balance of materials used is available on the industrial market.

Switch No. 2 is included, so that in the "IN" position, the alarm will be triggered only by the 10 bell alarm, when this switch is opened, the alarm will be triggered by any number of bells over 10. When a count of 10 is registered by counter No. 1 the normally open contacts are closed and energize relay No. 2. With this relay energized, the normally closed contacts open and disables counter No. 1. This action by relay No. 2 also closes the normally open contacts and energizes relay No. 5 which is a self-locking relay. Closing the normally open contacts keeping that relay locked in the energized position, thereby feeding 24V to time delay No. 2, which after two seconds, closes, and energizes the relay in the control room alarm. The remote control room alarm is very straight forward, it is felt no additional explanation here is necessary.

When any bell, or the first of any series of bells are received, relay No. 3, which is also a locking relay, is energized through the action of one set of normally open contacts on relay No. 1. Relay No. 3 then energizes time delay No. 1, a 10-second delay, which in conjunction with relay No. 4, will automatically reset the electrical counters. Counter No. 2 is so arranged, that with a count of 11 or more, the normally closed contacts open, thereby opening the circuit of the counting coil of relay No. 5, this prevents relay No. 5 from energizing. Time delay No. 2, which in turn would have activated the control room alarm.

These units are presently installed and operating at locations, using both the AP and UP newswire services, and certainly fill a very urgent need for continuous CONELRAD alarm monitoring.



Figure 3. Front view of rack-mounted alarm unit.

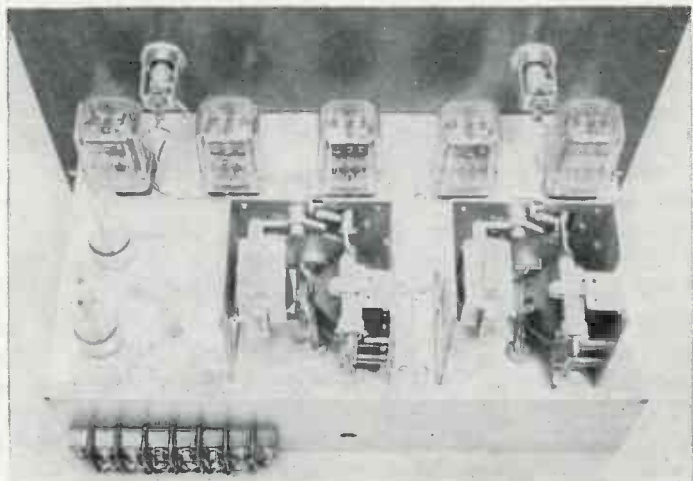

Figure 4. Rear view showing bell counters on rear of chassis, all components are husky and take plenty of hard handling.



Figure 5. Operator's eye view of the alarm unit in the control room.

# Who wouldn't be proud of this performance record?

A short time ago the engineering staffs of some of America's leading Television Stations were asked to comment on the performance of the TDA 2 Video-Pulse Distribution Amplifiers they have in service. Here is how they replied:

**"A well engineered and built amplifier" — W. R. Crane, WGN-TV**

**"Very good. Intend to buy more" — Linn P. Towsley, WMSB**

**"Good" — Paul Adams, WCPO-TV**

**"Hope all transistorized equipment turns out this good. 100% satisfactory" — Robert A. Holbrook, WSB-TV**

**"Good" — R. J. Schroeder, KMTV**

**"Excellent" — Roy Pratt, WHO-TV**

**"Like physical layout better than other DA of the transistor class" — Keith Ketchum, WOI-TV**

**"Will probably order more" — J. E. Risk, KSD-TV**

**"A great step forward. We have 22 of them" — Rupert Bogan, WBAP-TV**

**"Excellent" — J. E. Mathiot, WGAL-TV**

**"A very fine piece of equipment" — Nile Hunt, KCMT**

**"Excellent" — Orrin Towner, WHAS-TV**

**"Completely satisfactory" — Clyde M. Hunt, WTOP-TV**

**"Excellent. Will probably install several more" — Ernest Vordermark, WJXT**

**"Very satisfied with performance" — Raymond Boyd, KNOE-TV**

**"Does a very good job" — Byron Strong, WSAV-TV**

**"Very good" — Joe Epperson, WEWS**

**"Nicely constructed and very good performance" — Phil Laeser, WTMJ-TV**

**"Very good. Will be used at NBC for inter-city microwave system" — LeRoy Bellwood, KOGO-TV**



One of the features of the fully transistorized TDA 2 Video-Pulse Distribution Amplifier is the low heat produced in its operation. The picture shows Aaron Shelton, chief engineer of WSM-TV, demonstrating that a standard 100-watt light bulb produces more heat than twenty TDA 2 amplifiers.

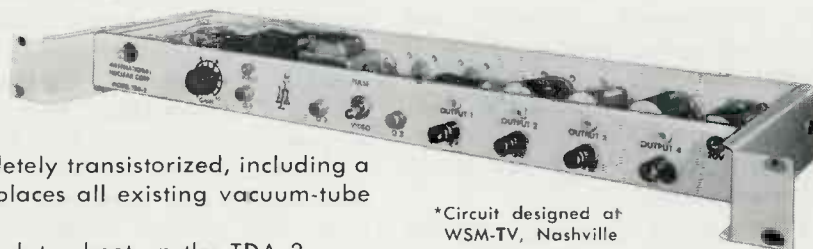

\*Circuit designed at WSM-TV, Nashville

The TDA 2 is highly efficient and completely transistorized, including a built-in regulated power supply. It replaces all existing vacuum-tube types without altering cables.

Write or wire for descriptive technical data sheet on the TDA 2.

## INTERNATIONAL NUCLEAR CORPORATION

P. O. BOX 6171 • NASHVILLE 12, TENNESSEE

# AUDIO STUDIO MAINTENANCE

Cleaning is the chief preventive and remedy for trouble encountered in maintenance of mechanical equipment.

A systematic plan of maintenance is required.

**PART III (Conclusion)** / By Thomas R. Haskett, P.O. Box 41-31762,  
Michigan City, Indiana

**T**HE MORE elaborate electronically-regulated power supply system also requires special consideration. It usually consists of a conventional rectifier followed by a series regulator (or pass tube). Controlling the gain of the series regulator is a dc amplifier, and a gaseous tube is used as the reference for the regulator section. The most rapid test of such a supply is to measure its output voltage under load. If an adjustment is available it may be used to attempt to bring the voltage to its recommended value. If this is not possible, the various tubes must be tested individually.

The rectifier and gaseous tube may be tested as mentioned earlier. The dc amplifier and the series regulator must be checked for transconductance, as there is no way of isolating each of them in the circuit. This is especially true in the case of two tubes used in parallel as pass tubes, or a dual power triode (6AS7 or 6080, for example) in the same configuration.

From the standpoint of preventive maintenance, economy, and good engineering practice, there is a further aspect of tube operation to be considered. That is the practice of running the equipment continuously, 24 hours per day, seven days per week.

It is asserted by many engineers that the heating and cooling of heater wires as equipment is turned on and off each day shortens the life of tubes. The author agrees with

this premise. He also agrees that continuous operation results in less costly and more reliable operation. He has operated several radios and amplifiers which were not turned off for several years. The tube-life figures were astounding. Nine out of 10 tubes functioned efficiently for at least 4000 hours (more than five months). Six out of 10 lasted 8000 hours (almost one year), and four out of 10 were still operating after 14,000 hours (nearly two years) of continuous service. These were *not* special-purpose, selected, premium, or military types. They were common, ordinary receiving tubes.

The author has also observed the performance of studio equipment, in which some units were permitted to run "hot" continuously, while others were turned off each night. The tubes which were hot at all times did not fail as often as those which were allowed to cool off every night.

Assuming a station in which the studio equipment is in use 60% or more of each 24-hour day, continuous operation is highly desirable from both the financial and the preventive maintenance standpoints. The cost of the slight increase in ac power consumption is negligible compared with the savings in tube replacement and labor cost. Moreover, this increase in power consumption is only a small percentage of the present load. About the only reason for such a system to be considered unfeasible would be in the

case of a station which uses its equipment less than 60% of the day, *e.g.*, a daytime station.

## Mechanical Maintenance

We have covered, at some length, maintenance of the purely electronic aspects of studio audio equipment. But mechanical operations need care, too. Cleaning is the chief preventive and remedy for trouble in this respect.

One of the most neglected items in many studios is the cleaning of tape heads. All capstans, rollers and other surfaces which contact the oxide side of the tape should be cleaned, but the heads are most susceptible to impaired performance, and even permanent damage. This damage is due to the oxide rubbing off the tape and piling up on the metal surfaces. Oxide pile-up can cause loss of high-frequency response, uneven reproduction due to tape skew, permanent damage to the head due to abrasion by the oxide particles, and damage to the tape, also due to abrasion.

Cleaning the heads and other surfaces which contact the tape must be done in a manner which will not damage the delicate head assemblies. Some cleaning solutions leave undesirable residues, or even react unfavorably with the assemblies. The best solution for head cleaning is iso-propyl alcohol (available at most drugstores). It is about 93% pure, evaporates rapidly and leaves no residue, and will





be also kept of the approximate gain of each mike. A practical method of accomplishing this is to record the average attenuator settings (of both mike fader and master fader) for several typical voices on the station staff, in the course of normal programming. If attenuator settings change over a period of time, a separate preamp should be patched into the circuit to prove whether the mike or the preamp is at fault.

We have discussed individual tests and maintenance operations in detail. As recommended earlier in this article, a systematic plan for maintenance should be worked out. Let us therefore review the operations to be done and the intervals at which they are to be performed.

*Every year:* Run complete FCC proof curves on entire audio system. Run complete proof curves on each amplifier unit. Check all socket voltages on each chassis with VTVM.

*Every six months:* Clean and

check all jack fields and patch cords. Clean all attenuators and pots. Check all microphones.

*Every four months:* Clean and lubricate all turntable drive systems and all tape drive systems; include vacuuming or blowing out of enclosures and close visual inspection of same.

*Every three months:* Run "spot proof" of each amplifier unit; check power supply voltages; vacuum or blow out and make close visual inspection of each chassis.

*Every week:* Clean all tape heads and capstans.

Exact details of the maintenance plan will depend on a number of factors: Amount of studio equipment, size of engineering staff, time available for studio maintenance, and whether or not transmitter maintenance must also be done by the same person or persons doing the studio work. In any case, a simple method of laying out a maintenance plan is as follows: On a sheet of linear graph paper, plot

time (in weeks) on the horizontal axis, and on the vertical axis list each item of studio gear mentioned in this maintenance program. The various annual, semi-annual, quarterly, tri-monthly and weekly jobs can be juggled around so that each week contains approximately the same amount of maintenance work. The chart should guide the staff in performing the various tasks at predetermined times. A written log should be kept of maintenance work as it is done, containing the name of the engineer doing the work, the time and date, and his comments. It will thus be possible for the entire staff to refer to this log and be familiar with equipment performance and peculiarities.

The procedures described here have been used for several years by the author at a number of stations where he has been employed either as staff engineer or engineering consultant. During this time, the methods have proved their efficiency, economy and reliability.

Figure 6

Date	Time	Engineer	Comments
1-5-61	6 pm	G. Wells	Cleaned all tape heads and capstans.
1-6-61	6.30 pm	G. Wells	Ran spot proof on #1 Turntable Preamp. It is within spec's. Power supply voltages are OK. Chassis cleaned and inspected.
1-11-61	6 pm	G. Wells	Ran spot proof on #2 Tape Machine. Distortion was high; this was traced to a "sick" 12AX7 in socket 1/2, which was replaced. Amplifier is now within spec's. Power supply voltages checked and are OK. Chassis vacuumed and inspected.
1-12-61	7 pm	G. Wells	Cleaned all tape heads and capstans.

This is WBAL-TV's new building in Baltimore. The exclusive use of Belden Audio, Camera, and Control Cables in this \$2,000,000 studio building helps maintain their high level of broadcasting efficiency.

Looking over part of this 125,000-foot Belden wire and cable installation are John Wilner, Vice President, Engineering, Hearst Corporation, operators of WBAL-TV (left), Manny Kann, Belden Distributor (center), and Hank Hine, Belden Territory Salesman. All of the wire and cable for WBAL-TV was purchased from Kann-Ellert Electronics, Inc., Belden Warehouse distributor.



## WBAL-TV Turns to Belden Exclusively for Audio, Camera, and Control Cables

Belden manufactures a complete line of application-engineered wire and cable for TV and radio broadcasting, recording studios, remote control circuits, and similar applications. Call your Belden electronic distributor for complete specifications.

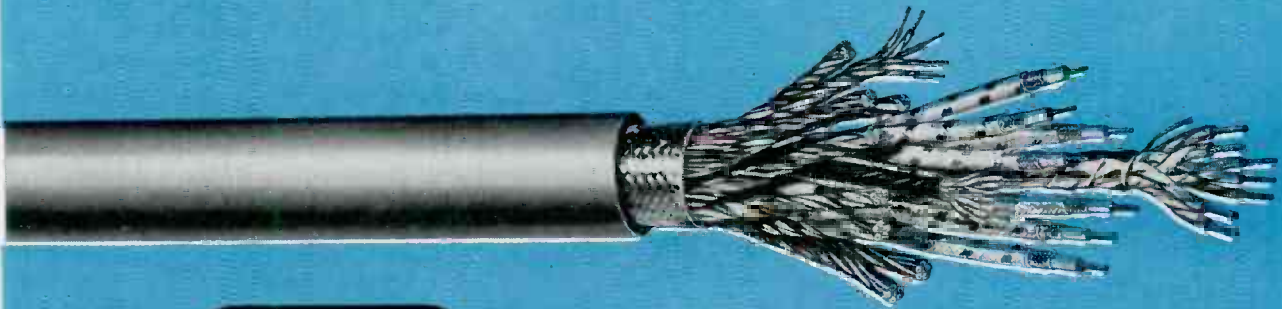

power supply cords • cord sets and portable cordage • electrical household cords • magnet wire • lead wire • automotive wire and cable • aircraft wires • welding cable

8-7-2

# Transistor Audio Amplifier Circuits

## PART I

By Donald K. Haahr  
Engineering Department  
Collins Radio Co.  
Cedar Rapids, Iowa

This series on transistors is based on a Solid State Short Course given at University of Nebraska and gives basic transistor circuit design data.

**S**OLID STATE theory is relatively new. Bell Laboratories began exposing it 12 or 13 years ago and transistors have been in quantity production for the past seven or eight years. Today, transistors and their application are not well understood for two major reasons:

1. Many engineers feel the job can be done with vacuum tubes, so why waste time on anything else, and

2. Lack of understanding makes almost anything complicated.

So far, there has not been too much concern with Solid State devices in broadcast engineering for several reasons. For example, a one kilowatt transmitter is put into a package four feet wide, three feet

deep and six feet high while the Air Force puts a one kilowatt power amplifier in a six-inch cube. Also, everyone is familiar with studio quality tube type audio equipment—it works well, so why go to the expense of changing it to something everyone doesn't quite understand and hit the budget for new equipment and training programs for the technicians? But when it comes to efficiency, reliability and replacement costs, the picture starts to change. A decision has to be made on what is economy and what may be false economy for the situation.

There is one phase of broadcasting and telecasting where semi-conductors are making themselves worthwhile. This is in remote pro-

gram work where size, weight and sometimes power consumption become important. For instance, the Collins 12Z-2 Remote Amplifier weighs 45 pounds and the transistorized 212Z-1 Remote Amplifier weighs 21 pounds. The latest model, the transistorized Collins 212H-1 Remote Amplifier, weighs 11 pounds and operates on flashlight batteries at a cost of less than one cent per hour.

Thus, semi-conductors *do* apply to broadcasters whether the industry is ready for them or not. Advancements will continue, and broadcast equipment manufacturers will design and develop equipment to meet the new needs and desires of the broadcast industry.

The following are a few detailed specifications broadcasters might look for while evaluating different pieces of broadcast and TV audio equipment:

Temperature specifications are important in remote equipment because large capacitance electrolytics often fail at low temperatures and go into thermal-runaway at high temperatures. A reasonable temperature specification for remote equipment is  $-20^{\circ}\text{C}$  to  $+50^{\circ}\text{C}$ ,  $-4^{\circ}\text{F}$  to  $+122^{\circ}\text{F}$  in more familiar terms.

In transistor circuitry, it becomes more important to know the input and output impedances, and whether the circuitry is balanced or unbalanced. Unbalanced circuitry is common because it is more economical and very often adequate.

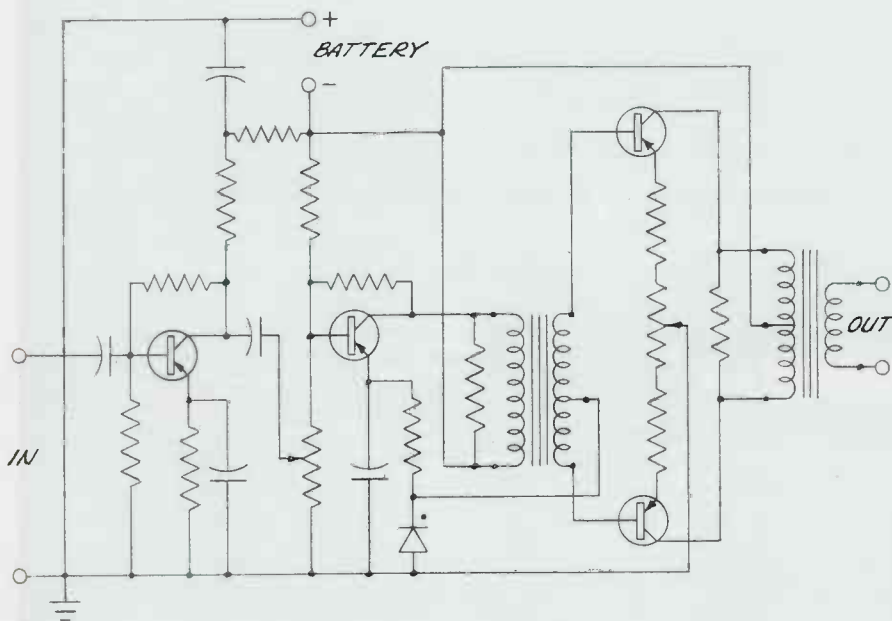

Figure 1. Line Amplifier.

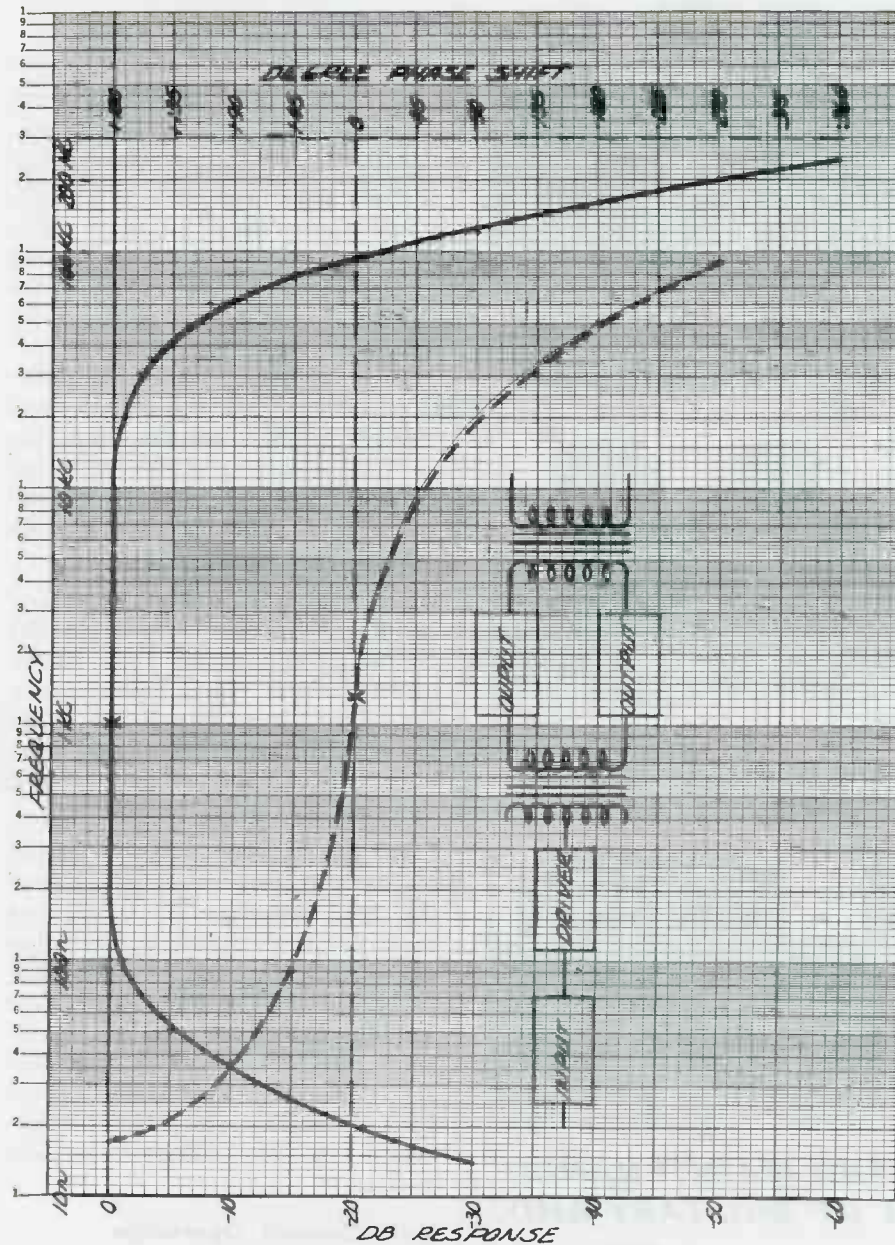

Figure 2. Response-Phase Versus Frequency  
(of the line amplifier)

### Levels

Care should be taken to note the reference levels when comparing audio equipment. Some of the input level terms are db, dbm, millivolts, dbv, sound pressure of 1 dyne per square centimeter or 10 dynes/cm<sup>2</sup>, across various loads or unterminated, open circuit voltage and others. For designing a preamp or buying a microphone, it could be important to know if the -70 db microphone output rating was referenced to 1 volt, open circuit, with a sound pressure of 1, or a sound pressure of 10 dynes/cm<sup>2</sup>, which means a 20 db difference.

Output levels are usually in dbm

because 600 ohms impedance is common in broadcasting and meters are calibrated for this at a reference of 1 milliwatt. One should be sure of the 600 ohm termination though, together with balanced or unbalanced circuits, and if the rating is before, or after, an isolation pad. We then come to the terms db and VU. A complex signal, such as audio, is measured in VU, never in db. Tones are measured in db and a 1,000 cycle tone of 0 dbm = 0 VU. However, the peaks of a complex signal are approximately 10 db above this. For this reason, in testing, the VU meter is either switched off, or disconnected and the tests

made at 10 db above rated VU output to assure no distortion on audio peaks.

Response produces a difficult specification, but there aren't too many things to watch for. First, use a 1,000 cycle reference (400 cycles is no longer standard) and second, ensure that tests are run at full rated power output.

Distortion is also tricky if full rated power output is not used, and here frequency becomes important, too. Low frequency distortion is often caused by inadequate transformer size, while phase shift is a high frequency offender.

Noise is a double barreled specification when comparing equipment. The signal-to-noise ratio, or the noise level below the full rated output, is the important, final concern. The equivalent input noise level is the sum of the noise level below calibrated output (-60 db) and the input (-50 dbm). This -110 db tells us that the best signal-to-noise ratio for a -70 dbm microphone input would be -40 db (-110 db less -70 = -40 db), which is important in choosing a microphone-amplifier combination.

There are mechanical limitations of transistor audio circuitry to be aware of, too. A greater variety of mountings is available for transistors than for tubes. The least expensive method is support by the transistor leads through tubelets, or to terminal stakes. This may be improved by inserting the transistor in a hole in the printed circuit board and further by a nylon saddle (important where vibration and shock are critical). Clips and heat sinks are used when needed.

Transistor circuits usually justify printed circuits because of quantity production, generally small size and reliability. A printed circuit board enjoys the advantages of economical, uniform and reliable assembly—less chance for human error. However, it has the disadvantages of requiring a less familiar trouble shooting technique, is expensive on short run projects, and it is difficult to make minor production changes.

It might be well to review some of the printed circuit board materials. The XXXP, or paper phenolic, costs about \$1 a square foot,

(Continued on page 22)



**OVER 1400 SIZES AND TYPES OF IERC HEAT-DISSIPATING ELECTRON TUBE SHIELDS**



**ARE EFFECTIVELY COOLING MILLIONS OF TUBES, EXTENDING LIFE AND RELIABILITY,**



**REDUCING DOWN-TIME AND MAINTENANCE COSTS IN THOUSANDS OF MILITARY AND**



**INDUSTRIAL ELECTRONIC EQUIPMENTS!**

Write today for the facts on how you can improve equipment reliability with IERC Heat-Dissipating Tube Shields.

**IERC** DIVISION

International Electronic Research Corporation  
135 West Magnolia Boulevard, Burbank, California

Foreign Manufacturers: Europelec, Paris, France. Garrard Mfg. & Eng. Co., Ltd., Swindon, England

**FM Transmitter**

(Continued from page 8)

(5-6 mc). There are only *three* frequency multipliers in the circuit, thereby keeping distortion to an absolute minimum. The only tubes that have any effect on the quality of the signal are the seven in the modulator, oscillator, subcarrier input, and frequency multiplier circuits. The remainder of the tubes in the exciter are in the AFC and "off-frequency" circuits. In the event of a failure in the latter circuits, they can be switched off and the carrier kept on the air with manual frequency control.

The BTE-10B is easy to tune and maintain. All the circuits in the "Direct FM" exciter are single-tuned to reduce the number of tuning adjustments. The RCA exciter has a built-in multimeter and oscilloscope to simplify tuning, trouble shooting, and maintenance.

An "off-frequency detector" automatically removes plate power from the final amplifier(s) to prevent the transmitter from operating beyond frequency limits. Actually, the "off-frequency detector" is a phase detector that compares the reactance modulator with a constant crystal source. As a result, "Direct FM" frequency stability is determined by the reference crystal oscillator.

**Multi-Channel Operation**

The BTF-20D has been designed and proven for stereo and SCA operation. The RCA stereo subcarrier generator, BTS-1A, can be used with the BTF-20D for FM stereo operation. In addition to stereo, an SCA channel can be operated simultaneously by adding the BTX-1A subcarrier (SCA) generator. If the station does not broadcast stereo, two SCA channels can be transmitted simultaneously.

The subcarrier generators along with other associated equipment can be placed in optional accessory equipment rack designed to harmonize with the appearance of the BTF-20D. The accessory equipment rack can be placed on either side of the transmitter. The rack is complete with full front and back hinged doors.

# all-transistorized New Sony Sterecorder 777

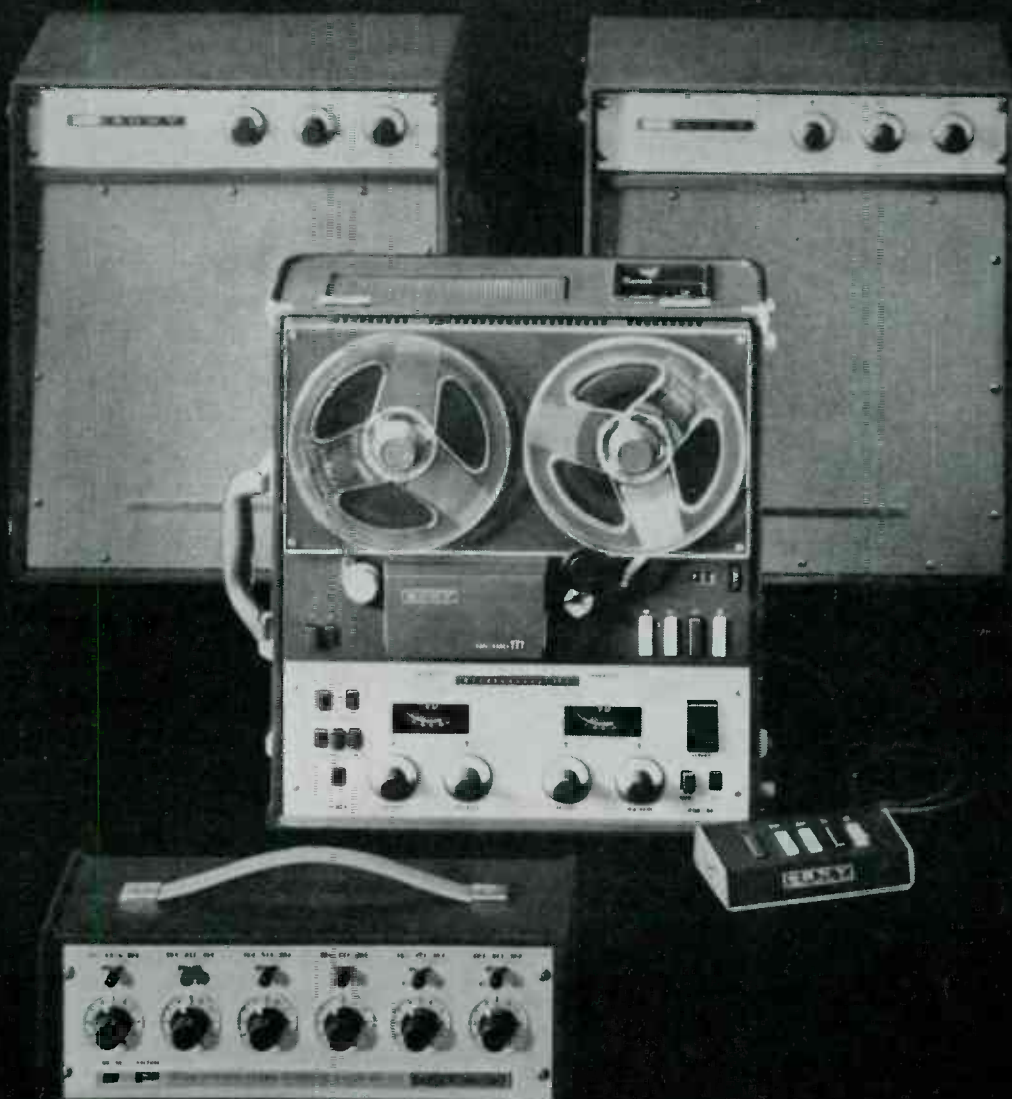

**the first/complete/portable/all-transistorized/high fidelity PROFESSIONAL RECORDING & PLAYBACK SYSTEM**

The most advanced achievement in recorder engineering to date, the superb new remote-controlled professional Sterecorder 777 series features the exclusive and patented Sony Electro Bi-Lateral 2 & 4 track playback Head, a revolutionary innovation that permits the playback of 2 track and 4 track stereophonic or monophonic tape without track width compromise—through the same head!

Included in an array of outstanding features are individual erase/record/playback heads, professional 3" VU meters, automatic shut-off, automatic tape lifters, an all-solenoid, feather-touch operated mechanism, electrical speed change, monitoring of either source or tape, sound on sound facilities, and an all-transistorized military plug-in type circuitry for simple maintenance. The three motors consist of one hysteresis synchronous drive motor and two hi-torque spooling motors.

Unquestionably the finest professional value on the market today, the 777 is available in two models, the S-2 (records 2 track stereo) and the S-4 (records 4 track stereo). Both models can reproduce 2 and 4 track tapes.\* And, the Sterecorder 777 models will integrate into any existing component system. \$595 complete with portable case and remote control unit.

\*Through the exclusive Sony Electro Bi-Lateral 2 and 4 track playback head.

Sony has also developed a complete portable all-transistorized 20 watt speaker/amplifier combination, featuring separate volume, treble and bass controls, mounted in a carrying case that matches the Sterecorder 777. \$175 each.

Also available is the MX-777, a six channel all-transistorized stereo/monophonic mixer that contains six matching transformers for balanced microphone inputs and recorder outputs, individual level controls and channel selector switches, Cannon XL type receptacles, a switch to permit bridging of center staging solo mike. \$175 complete with matching carrying case.

The first/complete/portable/all-transistorized/high fidelity/professional recording & playback system: \$1120 complete.

Sold only at Superscope franchised dealers. The better stores everywhere.

For additional literature and name of nearest franchised dealer write Superscope, Inc., Dept. B, Sun Valley, California.

**All Sony Sterecorders  
are Multiplex ready!**

**SUPERSCOPE**

**The Tapeway to Stereo**

## Transistor Circuits

(Continued from page 19)

paper epoxy about \$2 a square foot, glass epoxy \$3 a square foot and Teflon about \$15 a square foot. Teflon is used only where extreme vibration, as in aeronautical equipment, is present. Glass epoxy is far superior to the paper type mechanically, but electrically about the same. In other words, it is possible that all can meet the needs of broadcasting *provided* they are

mechanically supported properly. Component coating is not generally needed in broadcast applications.

### Transistor Circuits

There are three general methods used to connect electrically a transistor to the circuit. A socket allows easy exchange of transistors and easy removal for circuit resistance checks, but leads on some transistors and socket connections tarnish, and the transistors may shake out during transportation. A tubelet soldered connection is good elec-

trically, but maintenance is more difficult and the transistor is usually damaged when removed. The most reliable method is leads soldered to a terminal stake. However, caution should be used so that no more than two connections are on the stake and the transistor lead is soldered on last.

Bias stability isn't new; in fact, it is taken for granted in tube circuitry. However, the current, voltage and impedance values used in transistor circuits warrant more concern and care. For example, voltages are in tenths rather than tens, 30s rather than 300s, and impedances are in *thousandths* rather than megohms.

One thing that is different and important is that transistors are temperature sensitive. As a result, it is advisable to establish bias stability in the form of a voltage divider, independent of transistor operation. When a transistor temperature increases, whether through operational power dissipation or ambient equipment temperature, the temperature of the transistor continues to increase, and results in thermal-runaway. This can quickly damage any transistor—with no visible change. Maximum junction power temperature is critical, so case size, potting compound and heat-sinks become important. In addition to thermistors, a germanium diode may be used with a germanium transistor to produce a temperature coefficient that can vary a stage's bias and increase the operating temperature range.

It is interesting to note that both transistors and tubes depend on circuit applications for input and output impedances. For example, typical transistor input impedances of 40 ohms, 2,000 ohms or 120,000 ohms, and output impedances of 2 megs, 4,800 ohms, or to 2,000 ohms are shown in typical circuits in the NAB Engineering Handbook.

This leads to another circuit characteristic of low emitter resistances in the order of 500 ohms—which are not uncommon. To prevent degeneration or current feedback, the emitter resistance must be bypassed and with the usual bypass impedance to emitter resistance ratio of 10:1 at 20 cycles this means about 200 microfarads are required. We are thankful to

## McMARTIN TBM 3000 FM MONITOR APPROVED BY FCC



- The newest and most up to date Monitor on the market today.
- Immediate delivery (after thorough checkout and alignment)
- Price: \$495
- For the very finest in reliability and performance, depend on McMARTIN FM and Multiplex Monitors

FEDERAL COMMUNICATIONS COMMISSION  
WASHINGTON 25, D. C.

March 26, 1962

ADDRESS ALL COMMUNICATIONS  
TO THE SECRETARY

IN REPLY REFER TO:

6179

McMartin Industries, Inc.  
1612 California Street  
Omaha, Nebraska

Attention: Mr. Ray B. McMartin  
President

Gentlemen:

On the basis of the tests conducted at the Commission's Laboratory, type approval is hereby issued to you covering the equipment listed below for operation under Part 3 of the Commission's Rules:

Kind of Equipment: Frequency Monitor (FM Broadcast)  
Make: McMARTIN Industries, Inc.  
Model or Type: Type TBM-3000  
Frequency Range: 88 to 108 megacycles  
FCC Type Approval Number: 3-113

Originality by

**McMartin Industries, Inc.**

1612 California Street • Omaha, Nebraska

**McMartin**

In Canada, Sold by: Canadian Marconi Company, Montreal 16, P. Q.



Sprague, Aerovox and others for developing high capacitance, low voltage condensers.

Transistors as well as vacuum tubes have the same reasons for utilizing feedback: improve response, reduce distortion and possibly noise, vary impedances and increase temperature stability—but all at the expense of gain. Try for a compromise with the “rule of thumb” that says for the stage involved, 6 db feedback could cut distortion in half and increase the response almost to the 6 db point on the no-feed-back curve. Both signal and noise are reduced, *but their ratio is unchanged.*

The two common types of single stage feedback are:

1. Series, sometimes called current feedback, which is unbypassed resistance in the emitter circuit, and
2. Shunt, sometimes called voltage feedback, which is a resistance from collector to base. Each has its own advantages and disadvantages. Incidentally, the shunt feedback resistor also forms the bias stability voltage divider mentioned earlier.

Feedback around a single stage is the easy way to stay out of trouble but quite expensive in terms of gain. For example (Fig. 1), assume three stages have an equal and over-all distortion of 8%. Ideally, 6 db of feedback around each separate stage reduces over-all distortion to 4% at an 18 db gain sacrifice. On paper, a 6 db, 3-stage feedback loop will offer 6 db correction to each stage for only a 6 db gain sacrifice, and this is possible, leaving a 12 db gain advantage. This is well worth investigation. However, look at the response and phase shift of this amplifier with no feedback.

These curves have been seen before in amplifier design (Fig. 2), but their importance is not always fully recognized. They can explain why amplifiers oscillate or oscillators won't—depending on which they are not supposed to do. For example, to make an oscillator from this circuit, take an output feed of proper phase, return it to the input as positive feedback, tune it to 1 kc and it would work well. However, if this were to work at 50 kc, the feedback would be 180° different and become the negative feedback tried for in an amplifier.

## ON TAPE . . . it's SPOTMASTER

the only **complete line** of cartridge-tape equipment

### NEW! SPOTMASTER Rack Mount

The 500R is the **only combination recorder-playback in a slide-out rack chassis designed for complete accessibility.** Playback also available.



SPOTMASTER, by Broadcast Electronics . . . the most widely accepted line of trouble-free, transistorized cartridge-tape equipment, offers the largest selection of basic accessories for versatile and dependable operation.

PLUS . . . the complete line of accessories, including:

- Stereo playback and combination
- Cue-Trip Tone Pulser
- Cue-Trip Sensor and relay
- Tape Cartridge Winder
- Portable demonstration units
- Lazy Susan Cartridge Rack
- Wall Mount Cartridge Rack
- Remote Control Unit
- Equalized Turntable Preamplifiers



### SPOTMASTER COMFACT

The time-tested compact playback or combination unit for control room or remotes.



Keeps You in View!

For the best and most modern broadcast systems and supplies, look to **VISUAL**—your **SOURCE** for Superior Equipment from Specialist Manufacturers.

Write today for complete technical specifications.

**VISUAL ELECTRONICS**  
CORPORATION

356 west 40th street • new york 18, n. y. • pennsylvania 6-5840

# STEREOPHONIC PHONOGRAPH RECORDS, PHASE RELATIONS AND STEREO BROADCASTING

By H. E. Roys, RCA Victor Record Division

Stereophonic recordings involve two separate channels of information. In order to achieve the acoustical perspective, depth, spaciousness and other benefits that are possible, great care must be observed to maintain the proper phase relationship between the two channels of information, both in recording and reproduction.

THE 45°-45° stereophonic system chosen by the Record Industry Association of America (RIAA) as a standard was selected after careful consideration of the available systems. It was selected, for one reason, because of the compatibility that can be achieved with respect to monophonic reproduction. To achieve this, the RIAA standard states:

*In 45°-45° stereophonic disc phonograph records, equal and in-phase signals in the two channels shall result in lateral modulation of the groove.<sup>1</sup>*

As illustrated in Fig. 1 for the 45°-45° system, the two channels of information are recorded in a single groove with the modulation axis of the two systems at right angles with respect to each other, and 45° with respect to the surface of the record. The diagrams at the left and right, A & B, show the type of groove obtained when an identical signal is applied to the left and

right coils separately and then together. It is important to note that in Fig. 1-C vertical modulation results if the signals are equal in amplitude but out of phase. Likewise, Fig. 1-D shows that lateral modulation results if the two signals are equal and in-phase.

In terms of record reproduction, if in case of 1-D the recording is reproduced with a suitable lateral pickup, information from both channels will be present. The sound quality will be like that of a monophonic record that had been cut with a lateral recorder where the signals had been obtained by combining the output of the two channels electrically. If the phase is reversed, as is the case shown in Fig. 1-C, the modulation of the groove will be vertical and the results will be poor due to cancellation of the lateral components.

The problem of correct phasing is similar to that which must be observed in stereophonic broadcast-

ing where monophonic reproduction is the sum of the left and right (L & R) channels. The phase relationship is of importance since an incorrect phasing will result in considerable cancellations, particularly at low frequencies. Only if the proper phasing has been observed, will the sound quality be satisfactory.

## Evaluating Stereophonic Records

A simple method of judging the monophonic quality of a stereophonic record is to reproduce it monophonically. This may be achieved by using a suitable lateral pickup and reproducing the record over a single channel amplifier and speaker system. By suitable is meant a pickup designed for monophonic record reproduction, one that has sufficient vertical compliance to properly track the vertical undulations of a stereophonic record without undue distortion or damage to the groove. A stereophonic pickup with the output leads tied together for monophonic reproduction provides a ready means of providing such a pickup.

Another method and one that might offer greater appeal to the broadcaster is to combine the outputs of the two pickup channels at the outputs of some of the amplifiers along the chain. When doing this, there may be some question about the channel gains and the phase relationship. These may be easily checked by playing a lateral frequency record. The VU meter readings for each channel should be equal. If the phase relationships are incorrect, the single VU meter that reads the combined outputs will show a drop in output as the channels are connected together. The cancellation of signals due to improper phase relationship when reproducing music records results in a loss in the low frequencies and undesirable high frequency charac-

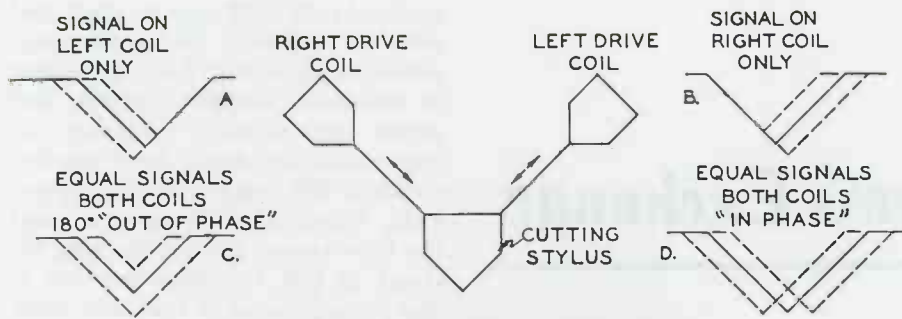

FIG. 1 45°-45° STEREO DISC RECORDER

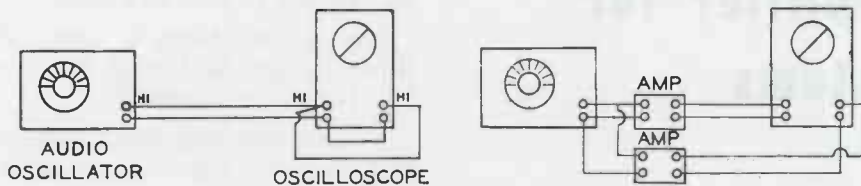

FIG. 2 PHASE INDICATOR FIG. 3 CHECKING AMPLIFIERS

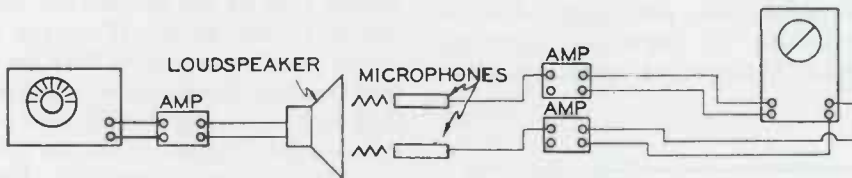

FIG. 4 CHECKING MICROPHONES

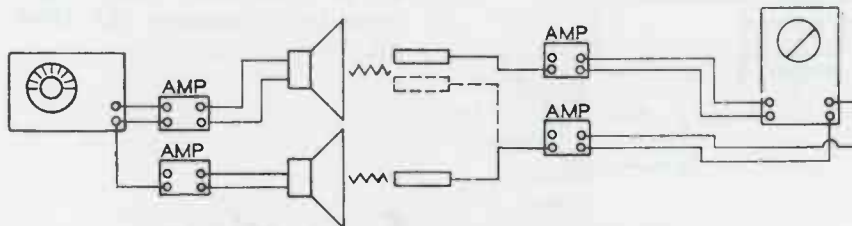

FIG. 5 CHECKING LOUDSPEAKERS

teristics. When the phase and gain relationships are correct, a properly recorded stereo record will show nearly undetectable tonal balance differences between monophonic and stereophonic reproduction. The stereo reproduction will, of course, exhibit acoustical perspective, depth and spaciousness due to the additional information since it is derived from two channels instead of one.

### Phase Checking Methods

Realizing the importance of observing and maintaining the proper phase between the stereo channels, a logical question that arises is how can one check the phase relationship. Ideally, the two channels should be exact duplicates throughout their operating range. Fre-

quency and phase response should match closely. In general, the phase relationship is the most difficult one to measure. However, with the aid of an audio oscillator and an oscilloscope, simple observations can be made that will determine whether or not the connections are in-phase.

If an audio oscillator is connected to an oscilloscope, as illustrated in Fig. 2, with the high side of the oscillator connected to both high side terminals of the oscilloscope, a straight line inclined at a 45° angle to the right should be observed. Since this is a common signal equal in amplitude that is being applied to the oscilloscope, it is obviously the in-phase condition. If two signals of the same frequency and amplitude were applied 180° out of phase, a 45° line would be observed

which would slope towards the left. A 90° phase shift would result in a circle.

The oscillator and oscilloscope provide a simple set of tools for determining the "in" and "out" of phase conditions. They may be used for microphones and loudspeakers as well as amplifiers. The arrangements for such measurements are shown in Figures 3, 4 and 5. When acoustic transmission is involved, a low frequency such as 200 cycles should be used to minimize phase differences due to the transmission of the signal through air. When checking loudspeakers as illustrated in Fig. 5, a quick check of the system can be made by first placing both microphones in front of one loudspeaker and noting the trace on the oscilloscope. The same trace should result when the microphone is shifted back to its original position. For checking the phase relationship of high frequency speakers, EIA<sup>2</sup> recommends that direct current be used and the direction of motion of the diaphragm be observed, or a sensitive dc meter be connected across the terminals and the polarity of the voltage noted when the diaphragm is moved manually.

### Conclusions

It is quite likely that in the beginning FM stereo broadcasts will be heard largely on monophonic receivers. In order to retain public acceptance, it is necessary that the quality of the monophonic reproduction be equivalent to that obtained from monophonic transmission. Phase relationships of the signals of the two channels are important. Stereophonic records made in accordance with RIAA standards will provide program material suitable for both monophonic and stereophonic reproduction.

(1) RIAA Engineering Bulletin E-3.  
 (2) EIA Standard RS-233 "Phasing of Receiver Loudspeakers"



# Engineer's Exchange

## A Muting Amplifier for SCA Systems

By Lloyd Jones  
Santa Barbara, Calif.

Many FM stations are transmitting background music in addition to their monaural or stereo broadcasts. They need a muting

system for their SCA carrier (67kc) to reduce the possibility of some cross-talk in between selections. Some background music is con-

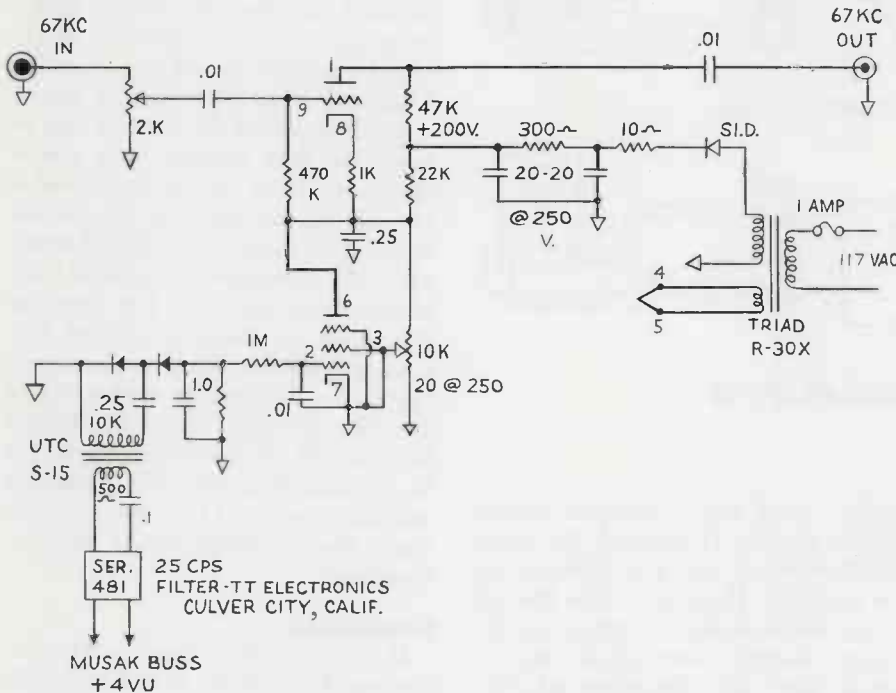

Fig. 1. SCA Muting Amplifier. Condensers are shown in mfd. Resistors are shown in ohms, 10%.

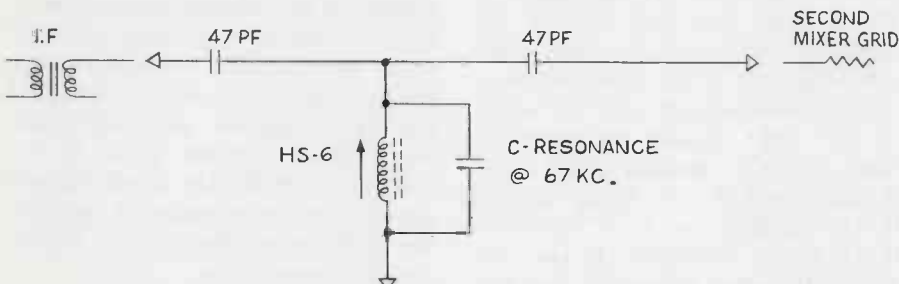

Fig. 2. Filter to prevent unwanted IF and 19 KC stereo pilot carrier from reaching grid of second mixer tube of multiplex receivers.

trolled by 25 CPS tone to start and stop the machines. The muting amplifier shown in Fig. 1 is very simple to construct, simple to adjust, and works very reliably, dropping out only when the music level reaches about 25 DB below normal program level. When 25 CPS tone is used the filter shown reduces the tone by about 30 DB, therefore the tone is also muted. None of the parts were critical. The input and output connectors, type of chassis, pilot lamp, etc., are left to your own choice.

The system shown is used with Browning and McMartin receivers. The results are excellent.

A note regarding any multiplex SCA receiver. Put a scope on the grid of the second mixer tube. If you see the 67 KC signal plus other signals such as the stereo 19kc pilot carrier as well as the IF of the receiver you can expect to have cross-talk troubles. Remove the grid input lead feeding the grid of the second mixer tube. Install a simple filter consisting of one Thordarson HS-6 "horizontal oscillator coil" and two 47 pf condensers, plus sufficient capacity to resonate the HS-6 to 67kc. See Fig. 2.

## Suggestions on Tube Replacement

By Hampton C. Clark, Jr.

As long as a tube performs its required services properly, it should not be replaced. In some cases, where there is a great deal of complex equipment, and the engineering personnel is not very highly skilled periodic tube checking with a mutual conductance tube checker is almost a necessity. By logging the conductance readings periodically, you can tell when a tube is going bad, and such tubes can be replaced if they show any sudden change. Also, such checks will frequently turn up tubes that have burned out filaments which might cause errone-

# FREE HELP FOR PLANNING

- Path Surveys and Site Selection Manual
- Profile Planning Charts
- Antenna System Calculator
- Graph Worksheets
- Protractor
- System Planning Charts
- Map Symbols Guide



## PLANNING STL or INTERCITY RELAY THIS YEAR? SEND FOR RAYTHEON'S FREE PLANNING KIT!

Raytheon's Microwave System Planning Kit helps you engineer initial requirements, carry out preliminary terrain and tower surveys. It also explains topographic maps, path clearances, profile plotting, signal attenuation, FAA and FCC regulations.

In designing this Planning Kit for TV Station Chief Engineers, Raytheon experts drew on their extensive experience servicing over 1000 microwave installations in every type of terrain and climate throughout the world.

Raytheon KTR Microwave, for Intercity Relay network pick-up, is available in both 1/10th-watt and 1-watt systems to meet individual needs. These systems have proven reliability, operating unattended over extended periods in all environments.

The world's largest manufacturer of microwave tubes and equipment, Raytheon also offers TV Stations complete, no-obligation System Engineering Service.

P. S. That curious little character climbing the mountain in the illustration is none other than Ludwig Von Microwaffen — Raytheon's sight surveyor *par excellence!* Look for him in your next mailing from Raytheon.



### MAIL TODAY FOR FREE PLANNING KIT

Raytheon Company, Dept. GM4-BE, Norwood, Massachusetts  
Attention: H. Bannon

BE-8.

Please send free Microwave System Planning Kit.

- Planning a system.       Have Engineer call.  
 Keep me on mailing list.       For reference only.

Name \_\_\_\_\_

Title \_\_\_\_\_

Company \_\_\_\_\_

Address \_\_\_\_\_

City and State \_\_\_\_\_



ous readings on such things as frequency monitors, even though the malfunction might not be obvious from merely taking meter readings.

If the small broadcasting station can afford to replace all tubes periodically, and wants them replaced that way, it is wise for the engineer to follow the management's instruction. It is also true that if you replace all tubes periodically, you will be scrapping many tubes that are perfectly sound and consequently wasting a great deal of your employer's money. Still, if your employer insists on this, it behooves the engineer to do as instructed, or he may find that the engineers at that station are periodically replaced!

Having done considerable hamming, on a limited budget, I have obtained most of the tubes for my equipment from the scrap boxes of radio shops, and from radio stations where I worked. Many of the tubes were in perfect condition, others a bit low on emission, but suitable as audio amplifiers. Many of these tubes lasted for months and months—some even years. Sometimes a shorted tube can be restored to service by inverting it, banging it gently against a table top, and replacing in its socket. This method is worth a try.

As to transmitter tubes, if you notice that the RF finals show a dip in plate current on modulation peaks, there's a good chance that the high voltage mercury rectifier may be going bad. Break some new

ones in by running their filaments for about an hour. Frequently "modulator tube trouble" will prove to be not modulator trouble at all, but a bad bias rectifier causing a lower than normal bias on the modulator grid. In this case, a new 5U4G, a silicon, or a selenium rectifier will frequently cure the ailment, and at only the fraction of the cost of a new modulator tube. Sometimes good modulator tubes are scrapped, and it is later learned that the trouble was in the bias supply. The bias supply still has to be corrected before proper service is restored, and a perfectly good modulator tube will remain in the scrap box, or may have been destroyed.

If you are familiar with the appearance of the modulator tube plates in normal operation, the color of the plates is the easiest way to adjust modulator bias. Push-pull modulators can be very easily balanced in this manner, and no equipment is required.

In a small station, where there is not a great deal of equipment involved, tube replacement is often best achieved by waiting until trouble develops. (If the engineer has a thorough knowledge of the equipment!)

In some cases tube trouble can show up as relay trouble. In the Gates Studioette, the speaker muting and off the air light relays draw their power from the console's rectifier tube. A weak rectifier can cause the relays to be sluggish or inoperative.

In tape recorders, one can easily tell when tubes need replacement. When the gain starts falling off, you can be pretty sure that you have one or more tubes going weak. In the P-6 Magnecords, this loss of gain may be due to a bad copper oxide rectifier which provides dc heater voltage on the input tubes. Observation of the input tubes will determine if this is the cause, or touching them to see if they are as warm as normal can suffice if the top of the tube is blackened.

To be more precise, pull the machine out of the rack, put it on the bench and check heater voltage with a voltmeter. However, this is usually unnecessary if the preliminary checks outlined above are followed. If the input tubes have adequate heater voltage, the chances are that one of the amplifier tubes is low on emission, or the rectifier tube is getting weak. Replace one at a time until proper gain is restored. If replacing an old tube with a new one does not help, replace the old one. If you do all this and the tape machine amplifier gain is still low, get out your diagram and voltmeter and get to work.

In a tape machine that fails to erase completely, the trouble is usually a weak erase oscillator tube. If a lot of hash is present in a recorded tape, you may have trouble with a leaky capacitor in the erase oscillator circuit. If it doesn't erase at all, there is a good likelihood that the erase oscillator tube is burned out.

## A PROFESSIONAL STEREO TONE ARM THAT "THINKS" FOR ITSELF

*...designed for people who sometimes don't*

One moving part, one precision bearing. Nothing delicate to add to your maintenance worries.

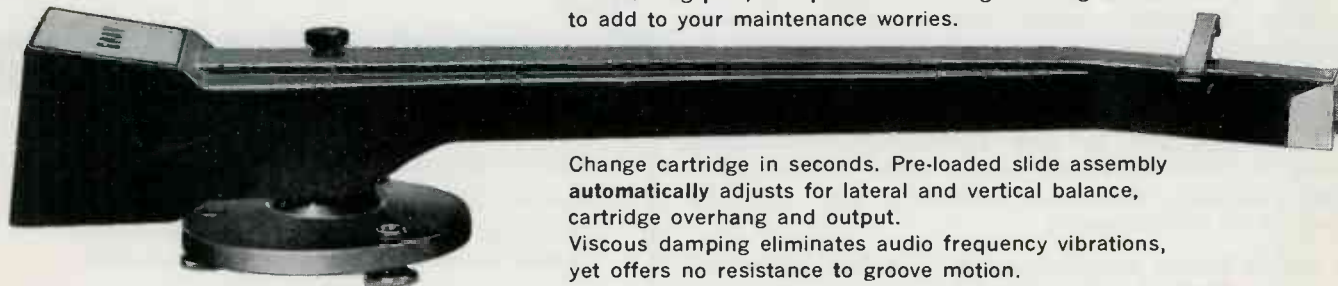

GRAY 208-S \$49.50

write on company letterhead for complete technical information, specifications and application data.



GRAY RESEARCH AND DEVELOPMENT CO. INC.

Box 12, Elmwood, Conn. Plant: North Mountain Road, Newington, Conn.

replace with SYLVANIA KLYSTRONS SK-220, 221, 222 Series

# 6,000 Hr. Warranty!

# 10,000 Hr. Life Expectancy!

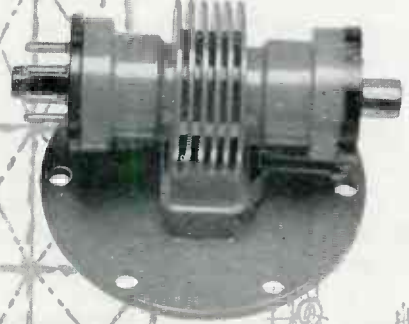
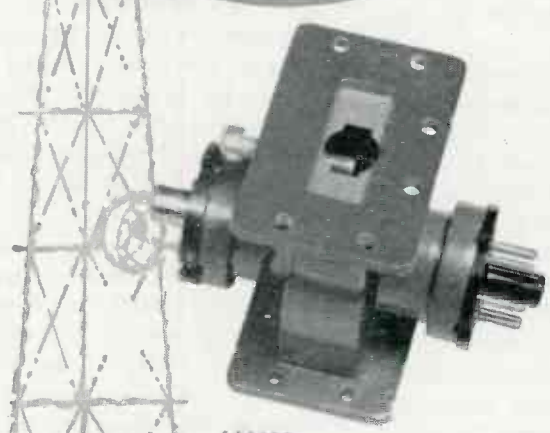

Available now from your Sylvania Industrial Tube Distributor—a full complement of high-reliability reflex Klystrons for local oscillator and transmitter applications featuring:

**Warranted prorated life of 6,000 hours'** actual operation when tubes are operated within specified ratings. (Coverage extends to 1½ years after manufacturer's shipping date. Replacement, if required, with prorated credit will be made through your Sylvania Industrial Tube Distributor.)

**10,000 hours' life expectancy.** Utilizing improved materials and seals, Sylvania SK-220, 221, 222 undergo exceptionally high bake-out temperatures to eliminate gas-developing contaminants, extend useful life.

**Reduced maintenance requirements.** Improved pre-tuning methods minimize initial field adjustments. Extraordinary electrical stability combined with low temperature coefficient reduce frequency adjustments throughout long life. Further, the requirement of one hour's operation every six months of storage is eliminated.

Gain the advantages of long life, reduced maintenance, reduced cost per hour of operation offered by Sylvania SK-220, 221, 222 series. Delivery and price information are no more than a phone call away at your Sylvania Industrial Tube Distributor's. For the **FREE BOOKLET**, *Sylvania Microwave Products*, write to Electronic Tubes Division, Sylvania Electric Products Inc., 1100 Main Street, Buffalo 9, N. Y.

Frequency (mc)	Sylvania Type	Frequency (mc)	Sylvania Type
5925-6225	SK-220F, 222F	5250-5560	SK-221H
6125-6425	SK-220E, 222E	5860-6160	SK-221K
6425-6575	SK-220G, 222G	5985-6285	SK-221F
6575-6875	SK-220D, 222D	6285-6585	SK-221E
6875-7125	SK-220C, 222C	6505-6705	SK-221G
7125-7425	SK-220B, 222B	6705-7005	SK-221D
7425-7750	SK-220A, 222A	6955-7255	SK-221C
7750-8100	SK-220Z, 222Z	7255-7555	SK-221B
		7550-7850	SK-221A

Available at O.E.M. prices in quantities of 1-99 from your Sylvania Industrial Tube Distributor

# SYLVANIA

SUBSIDIARY OF

## GENERAL TELEPHONE & ELECTRONICS



# PROFESSIONAL STANDARD OF THE BROADCASTING INDUSTRY

**M**agnecord

... Proven by years  
of reliable service the  
world over.



### 728 STEREO

The professional standard. 7½ and 15 ips. Superior performance in all areas.



### 748 STEREO

The Olympian... champion of recorders. 3¾ and 7½ ips. 4-track play and record.



### THE PT 6

The rugged, reliable "Workhorse" of the broadcast industry.



### THE P 75

"The Editor"... includes all of the capabilities of the PT 6 plus extended performance and utility.

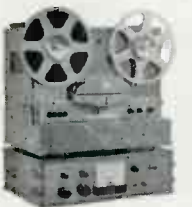

### THE M 90

"Mighty" in all performance characteristics. Magnecord's finest tape instrument.

Magnecord sets the standard for Performance, Quality and Reliability in the professional sound and broadcast industry.

WRITE TODAY FOR  
MORE INFORMATION



MAGNECORD SALES DEPARTMENT  
MIDWESTERN INSTRUMENTS  
P. O. BOX 7509 • TULSA 35, OKLAHOMA

# Industry News

## World's Tallest Structure Completed in Georgia

Television programs of WTVM and WRBL-TV, Columbus, Ga., are now being transmitted from antennas located almost a third of a mile high, signaling completion of a mammoth tower engineering project and said to mark the Georgia-Alabama border as the site of the tallest man-made structure in the world.

Construction of the tower, which supports an RCA Channel 3, six-section super turnstile antenna and an RCA Channel 9, Mark II super gain antenna, was completed ahead of schedule in less than two months and without loss of air time for either station. The work consisted of extending the original 1,260-ft. tower and antenna structure erected in 1960. Weighing approximately 215 tons, the triangular structure employs tubular materials for simplicity, low wind loading and greater structural strength, and utilizes over six miles of Bethlehem guy strand cable.

## Gates Transmitters For USIA Broadcast System

Gates Radio Co., Quincy, Ill., reports the shipment of four 50-kilowatt transmitters to be used in a new U. S. Information Agency transportable broadcast system.

Meeting USIA requirements for a fast reaction type system, the portable transmitting plants will be flown to areas throughout the world and operations quickly established for relaying broadcasts from the Voice of America.

## Three New Appointments Announced by Ampex

Ampex Corp., Redwood City, Calif., has announced the appointment of three new manufacturer's representatives to handle sales of professional and consumer audio equipment and magnetic tape in the east and midwest.

Appointed were: Herb W. Knaggs Co., Belleville, Ill.; Stinson-Platt

Co., Narberth, Pa.; and R. W. Mitscher Co., Inc., Buffalo, N. Y. Knaggs represents Ampex in Nebraska, Iowa, Missouri, northern Kansas and southern Illinois; Stinson-Platt in Pennsylvania and southern New Jersey; and R. W. Mitscher in New York State.

## Reports Increase in Use Of TV Tape Recorders

The number of television tape recorders in use in the United States increased by 15 per cent during the nine-month period ended June 1, the RCA Broadcast and Communications Products division reported recently.

The gain, which brings to 861 the total number of recorders used for broadcasting, closed circuit systems and other purposes, was disclosed in a division study of the TV tape recording equipment market. An additional 450 recorders of U. S. manufacture are in use outside the country. The RCA survey showed a steady growth rate in all domestic user categories, with commercial broadcasting stations leading with a net gain of 49 units for the period. Networks and educational TV stations also increased the number of recorders in operation.

## Vitro Moves Washington Branch to Silver Spring

The Washington branch of Vitro Engineering Co. has moved to new quarters in the Yeager Bldg., 721 Ellsworth Drive, Silver Spring, Md., according to an announcement by Joseph Mazia, branch manager.

In this move, Vitro Engineering now joins two other divisions of Vitro Corp. of America—Vitro Electronics and Vitro Laboratories—in operations in Silver Spring. Total company employment in the area exceeds 2,400. Vitro Engineering established the Washington branch in 1956, to serve government and industry in standards engineering, technical documentation and manual preparation, and engineering management.



GEORGE R. TOWNSEND, VICE PRES. / ENGINEERING, STATION WWLP, SPRINGFIELD, MASS., SAYS:

## "Few Engineers Will Dispute Conrac's Lead..."

their monitors are as trouble-free as any  
precision equipment I work with."

CONRAC MONITORS ARE DISTRIBUTED BY RCA, AMPEX,  
GENERAL ELECTRIC, AND VISUAL ELECTRONICS.

**CONRAC** *DIVISION* GLENDORA, CALIFORNIA  
GIANNINI CONTROLS CORPORATION  
Telephone: AREA CODE 213-335-0541

New York: 6902 Empire State Bldg., New York 1, Tel: AREA CODE 212-594-1160

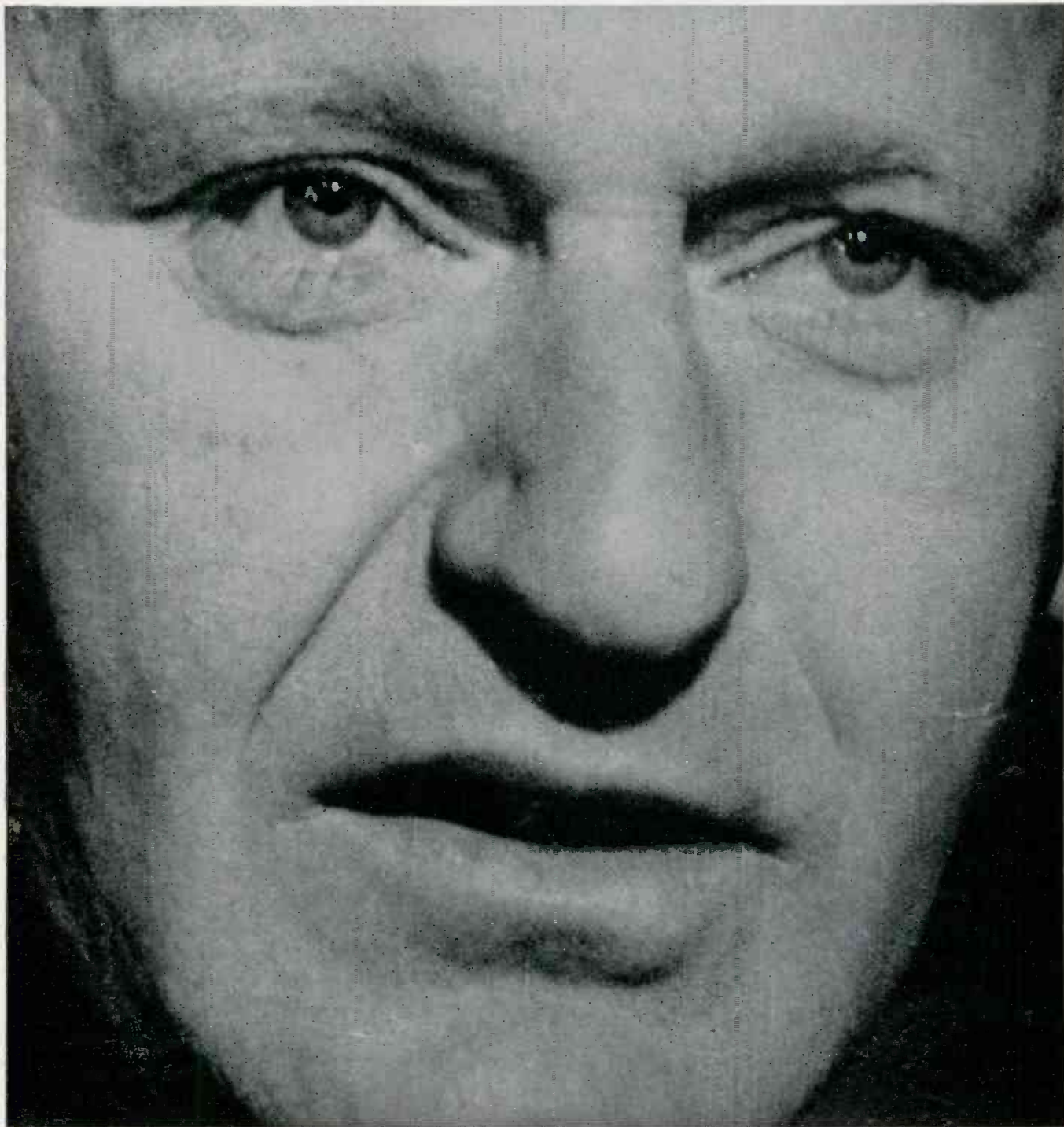

### Seventh Annual New York High Fidelity Music Show

The seventh annual New York High Fidelity Music Show, the leading annual event of the hi-fi industry, will be held at the N. Y. Trade Show Bldg., October 2-6. The live demonstration public exposition will be the largest in history, according to Raymond V. Pepe, president of the Institute of High Fidelity, Inc., the sponsoring association. It will occupy five entire floors and house several million dollars in high fidelity and stereo components. The vast majority of manufacturers' exhibits will consist of new products from the U. S. and abroad.

Record attendance is predicted by the Institute. Last year more than 30,000 persons viewed 130 exhibits of manufacturers at the show. The Institute credits the show with helping substantially to stimulate industry sales in 1961 to an unprecedented high.

The Institute reported that there are about 1,100 FM stations now broadcasting in this country, and that FM-stereo broadcasting, which began only last June, has made outstanding strides. More than 40 per cent of the American population, some 71,000,000 persons, are now within hearing range of the 100 FM stations broadcasting stereo regularly.

### Television Programs Relayed 305 Miles

Towering peaks in the rugged southwest mountain country provide the natural relay sites for an intricate microwave system that picks television signals out of the air 70 miles from a transmitter and flashes them 305 miles to KOAT-TV in Albuquerque, N. M. As it hops along the route of unattended microwave repeater stations, the TV signal is guarded by automatic fault reporting and standby switching equipment which insures continuity of operation in the event of a failure at any point. These features make the system "the most dependable and complex microwave relay ever installed by an individual television station," according to C. H. Colledge, division vice-presi-

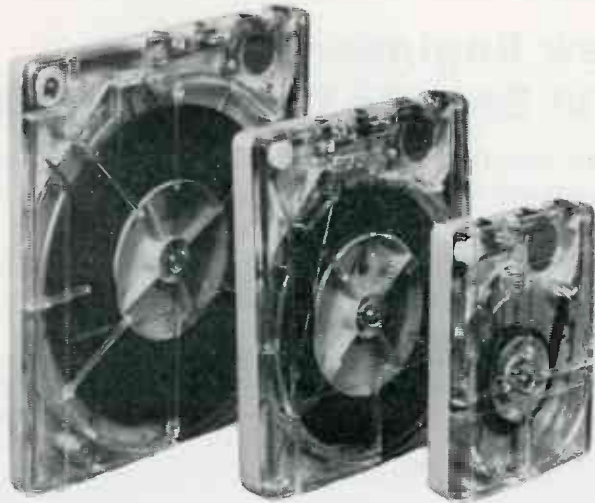

**"We at WRTA feel that SPOTMASTER is the most versatile instrument introduced to broadcasting since the advent of tape."**

Louis Murray, WRTA, Altoona



Wherever you find a SPOTMASTER unit in use—the opinions of broadcasters are the same: "Tighter cueing and better sound . . . we are very pleased." (KOGO, San Diego) "No more noisy playbacks or jumping grooves. We have not bought a single acetate blank disc since installing your machines in July, 1960." (WFBR, Baltimore) "We have improved our production immensely," (KING, Seattle) ". . . frankly, I don't know how we ever got along without this equipment." (WGTC, Greenville, N. C.) SPOTMASTER, is engineered for compactness, efficiency, reliability and low maintenance. It is the most field-tested and field-proven cartridge equipment manufactured anywhere. We would like to tell you more about the SPOTMASTER Cartridge Recorders. Call, write or wire today.

Your Key to Pushbutton Broadcasting

*Spotmaster*

**BROADCAST ELECTRONICS INC.**

8800 Brookville Road, Silver Spring, Maryland, Dial JU8-4983

SOLD NATIONALLY BY: *Visual Electronics Corp., 356 West 40th Street, N.Y., N.Y., Richard H. Ullman, Inc., 1271 Ave. of the Americas, N.Y., N.Y., CANADA—Northern Electric Co., Ltd., 250 Sidney St., Belleville, Ontario, AUSTRALIA—Simon Gray Pty., Ltd., 28 Elizabeth St., Melbourne, C.1*

dent and general manager, RCA Broadcast and Communications Products division, which designed and built the system in cooperation with the KOAT-TV engineering department.

Atop 7,850-ft. Pinal Peak, the first relay station receives an off-the-air signal from KTVK, ABC network affiliate in Phoenix. Instantaneously it is beamed to Greens Peak, 10,200 ft. high, and thence through two other stations to Sandia Crest, site of KOAT-TV's transmitter. A final microwave relay there carries the network signal to the studio. The Greens Peak location, which is 140 miles from Phoenix, also serves as an alternate off-the-air pickup point in the event the Pinal Peak station becomes inoperative. If this should happen the signal failure would automatically trigger the alternate receiving equipment into operation and the program would continue without a break.

#### First City-Wide Radio/TV Antenna

Tierra Verde, a city for 25,000 people being completed in the Gulf of Mexico off the coast of St. Petersburg, Fla., will have only one TV antenna.

Zoned for 50 per cent residential and 50 per cent commercial building, one master TV antenna will boost the signal and transmit it to each building site by underground coaxial cable, thus ensuring studio reception over the entire 2,000-acre area. The cable will also transmit am/fm radio, closed circuit television, and a 24 hour a day musical program. This is the first city-wide use anywhere of a single antenna for public TV/radio reception.

#### Davis Appointed Ampex Sales and Service Manager

Thomas E. Davis has been appointed manager of sales and service for Ampex Corp., Redwood City, Calif., it has been announced by C. Gus Grant, vice-president.

In his new post, Davis is responsible for nationwide sales and service activities which are carried out through Ampex regional sales personnel, representatives, distributors and dealers. He succeeds John Jipp, formerly vice-president and manager of sales and service, resigned.

# BAUER TRANSMITTERS

*Provide Top Performance With Minimum Maintenance*



## 1,000 WATT FM

Steady-Ready. Simple design. Built-in load. Factory assembled or Kit Form.

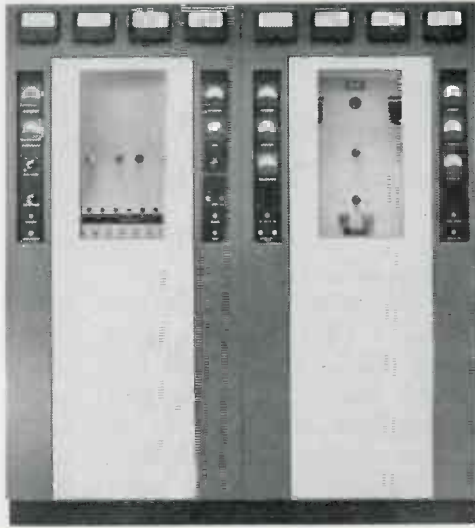

## 10,000 WATT AM

Ceramic tubes in PA and Modulator. 12,500 watt output capability. Lowest power consumption—high efficiency PA and modern design. Only 9 tubes—E types.

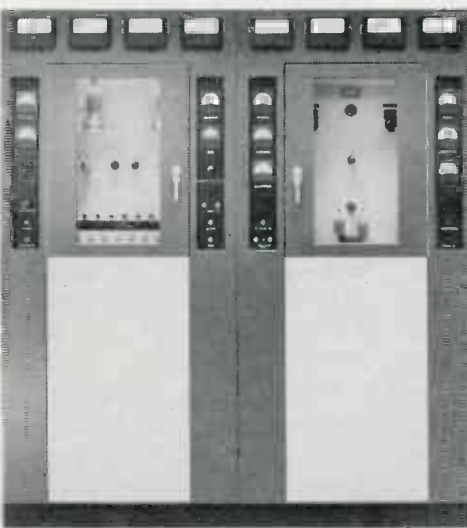

## 5,000/1,000 WATT AM

6,000 watt output capability. Continuous metering. Solid State rectifier system (standard in all Bauer transmitters). Cool-proof circuit protection with tally-light/overload relay system. Low power consumption—economical to operate.



## 1,000/250 WATT AM

The famous Model 707. Leader in the field. Easiest to Buy. Easiest to Operate. Factory assembled or Kit Form.

WRITE FOR THE COMPLETE ENGINEERING STORY TODAY!

# Bauer

ELECTRONICS CORPORATION  
1663 Industrial Road, San Carlos, California • Area Code 415 591-9466

# Industry News

## Yeager to Newly-Created Post at Altec Lansing

Altec Lansing Corp., a subsidiary of Ling-Temco-Vought, Inc., Anaheim, Calif., has announced the promotion of William E. Yeager to the newly-created post of engineering information manager.

For the past six years Yeager served in the field as regional sales manager covering the mid-Atlantic states for Altec.

## UHF TV Repeater to Carry Airborne Educational Programs

A 100-watt UHF TV translator will permit regular reception in Detroit schools and homes of the programs broadcast from the flying schoolhouse of the Midwest Program on Educational Television. The airborne programs originate from a DC-6B circling 23,000 ft. above Montpelier, Ind., and are received in parts of Illinois, Ohio, Michigan, Wisconsin, Kentucky and Indiana.

The translator station, which is being supplied by Adler Electronics, Inc., New Rochelle, N. Y., will broadcast from atop the 285-ft. Maccabees Bldg. in downtown Detroit. Its operation will be similar to that of the 400 UHF translators which rebroadcast standard commercial and educational TV into fringe and isolated areas. The UHF signals from the 165-mile distant DC-6B will be picked up off the air by the repeater, converted to a new UHF channel to prevent interference, and beamed over the Motor City. A directional antenna will be

used to concentrate the signals in areas where most of Detroit's schools are located. The effective radiated power of the translator is 1,380 watts.

## James Sims to Represent Visual in Southeast

The appointment of James Sims to the technical sales staff of Visual Electronics Corp., New York, N. Y., has been announced by James B. Tharpe, president of the firm. Sims will supervise the company's broadcast account-servicing in the states of Alabama, Florida and Georgia, and will set up regional headquarters in Miami, with an operative branch in Atlanta.

Sims brings to Visual an extensive sales and engineering background in the broadcast field, with particular emphasis on TV station equipment planning and operation. Recently, as director of engineering of WAPA-TV (San Juan), in addition to his other duties, he engineered and installed the first broadcast microwave multi-hop system to be used in Puerto Rico.

## United States Exhibit Shows ETV to Africans

Educational TV and its potential impact in underdeveloped areas was demonstrated to over 110,000 Africans recently by Blonder-Tongue Laboratories, Inc., Newark, N. J. The display, a model electronic teaching lab, was one of the major highlights at the official U. S. exhibit at the Third Central African Trade Fair held in Bulawayo, Southern Rhodesia.

The teaching lab, a CCTV system with cameras, audio, monitor, lighting and other devices, demon-

strated the conversion of a classroom and laboratory into a fully-equipped studio. To dramatize the exhibit, thousands of visitors to the American Pavilion were shown a live demonstration in the studio-classroom. Simultaneously, visitors were able to view and hear the teaching session on a studio TV monitor. Head phones were also provided at the display to give an on-the-spot explanation of ETV.

## GEL Appoints New Sales Representative

Howard T. Dempsey has been appointed broadcast equipment sales representative covering Colorado, Wyoming, New Mexico, Arizona and Utah, it has been announced by General Electronic Laboratories, Inc., Cambridge, Mass.

Equipment necessary for complete broadcast installations will be handled by Dempsey from his office in Denver, Colo.

## To Build Greek Phone-TV Network

Receipt of a contract to provide a new telephone and television network covering most of Greece has been announced by a British subsidiary of International Telephone & Telegraph Corp., Standard Telephones & Cables Ltd. The network, a multicircuit, microwave radio system, will be built for the Hellenic Telecommunications Organization, S. A. (O.T.E.), of Athens.

The system's total route length of over 500 miles will be covered in 17 radio hops, half of which are over-water paths. The equipment to be supplied will initially provide two working broadband radio channels and one standby channel. Each of these radio channels can carry



**Save 30%** on 4-Track Stereo Music on Tape!  
Empty 3 in. Plastic Reels 7c ea.



**BARGAIN PRICES!** Send for our FREE Tape Recorder/Blank/Prerecorded Tape Catalog #B-3

### SAXITONE RECORDING TAPE

\* Oxide guaranteed not to rub off or squeak—or money back. Compare ours with other "Bargain" tape. You'll find it's more than just "price" when you deal with us. We are original pioneers in the tape recorder business and our reputation means everything to us.

800' Acetate (plastic), 5"	.75
800' MYLAR 5" reel	.95
900' MYLAR (Polyester), 5"	.99
1200' MYLAR, 1/2 mil, 5" reel	1.18
1200' Acetate (plastic), 7"	1.19
1200' MYLAR, 1 1/2 mil (Strong)	1.68
1800' Acetate (plastic), 7"	1.79
1800' MYLAR, 1 mil, thick 7"	1.99
2400' MYLAR, untensitized, 7"	2.69
2400' MYLAR, tensitized, 7"	2.99

Studios, Large Users Even Lower. PLUS POSTAGE.  
Also—Scotch, Irish, Audio, Reeves, Ampex and Sarks-Tarzan magnetic tapes, mikes, audioclips, needles, etc. We'll surprise you with our quotations!

### SAXITONE TAPE SALES

(Division of Commissioned Electronics Company, Inc.)  
1776 COLUMBIA ROAD WASHINGTON 9, D. C.

**NEW!**

## BATWING TV ANTENNAS CHANNELS 2-13

Write for Sales Catalog

## JAMPRO ANTENNA CO.

7500 - 14th Avenue  
Sacramento 20, California

960 high-quality telephone circuits or a television channel. The system has an ultimate capacity of six radio channels. In addition, the routes are designed to be linked up with the TV networks of neighboring countries and with the Euro-vision system.

STC will supervise the installation, which will be carried out by engineers of the O.T.E. Delivery will commence in the autumn of 1962. Equipment, of a type called space-diversity, will be used to minimize signal fading. It will operate in the 4,000-megacycle frequency band.

#### **Stainless Appointment To J. C. Rodriguez**

Stainless, Inc., North Wales, Pa., has announced the appointment of J. C. Rodriguez as broadcast sales engineer. He will be stationed at the company's headquarters in North Wales, and will handle broadcast tower sales and special assignments here and with the firm's subsidiary, Walcan, Ltd., Ontario, Canada, according to Henry J. Guzewicz, Stainless president.

## **Book Reviews**

### **ABC's of Mobile Radio**

Catalog No. AMR-1. Published by Howard W. Sams & Co., Inc., Indianapolis 6, Ind. 96 pages. Price \$1.95.

"ABC's of Mobile Radio," by Richard Martin, presents a basic introduction to two-way radio, where it is used, and how it works. It completely describes the use and operation of transmitters, receivers, power supplies, and antennas.

Using practical, down-to-earth language, the book will be useful for two-way radio owners, operators, and service technicians.

### **Tube Substitution Handbook**

Vol. 4, Catalog No. TUB-4. Published by Howard W. Sams & Co., Inc., Indianapolis 6, Ind. 112 pages. Price: \$1.50.

The directory of receiving tubes has been expanded to 1,758 types, with over 3,000 substitutions. Other sections list 242 industrial and 622

foreign substitutes for American receiving tubes, and 530 American receiving-tube substitutions for foreign types. The picture-tube section shows 508 types, with recommendations for 1,916 direct substitutions. A brand-new section on subminiature tubes lists 250 substitutes for 285 types.

### **Electronic Musical Instruments Handbook**

Catalog No. EMI-1. Published by Howard W. Sams & Co., Inc., Indianapolis 6, Ind. 128 pages. Price: \$2.50.

In "Electronic Musical Instrument Handbook," the first complete book on the subject, Norman H. Crowhurst fully explores the development of electronic music. This new realm of sound production is explained in such a manner that musicians, hobbyists, and technicians will find the content both useful and informative.

**B/E Classified Ads  
Get Results!**

## **NEW FAIRCHILD CONAX ELIMINATES PRE-EMPHASIS PROBLEMS AUTOMATICALLY!**



- CONAX will produce increased signal levels in recording and FM broadcast
- CONAX will reduce distortion in tape recording and tape duplication
- CONAX will minimize tracing distortion

CONAX has been engineered by FAIRCHILD to cope with the problem of distortion produced in recording and broadcasting by excessive, instantaneous high frequency peaks. The CONAX "previews" program material in emphasized form for efficient high frequency control. The device is based on the integrating properties of the human ear. The CONAX action is inaudible and instantaneous — 1/40,000ths of a second. CONAX efficiently eliminates problems of overload from loud cymbals, muted trumpets, bells, and the ever-present sibilant singers without quality degradation. Model 602 — Stereo \$495. 600 — Mono \$330.

**FAIRCHILD**  
RECORDING EQUIPMENT CORPORATION  
10-40 45th Ave., Long Island City 1, N. Y.

## **WDSU-TV New Orleans**

produces color and monochrome  
Remotes . . . studio programs with the  
Super Universal Zoomar Lens

We have used the Super Universal lens successfully on many kinds of programs, including color and black and white remotes, different types of studio programs, and find it would be almost impossible to accomplish certain effects without this type lens.

Very truly yours,

*Lindsey G. Riddle*  
Lindsey G. Riddle  
Chief Engineer

Call for a demonstration on your cameras  
JACK A. PEGLER • BILL PEGLER

**TELEVISION ZOOMAR COMPANY**

500 Fifth Avenue, New York 36, New York — BRyant 9-5835



# Product News



## NEW FM MULTIPLEX GENERATOR

A new FM multiplex generator that can be used to align receivers or adapters has been announced by Hickok Electrical Instrument Co., 10514 Dupont Ave., Cleveland 8, Ohio.

According to the manufacturer, the model 725 generates complete FM multiplex signal to FCC specifications. The composite output consists of (1) L plus R generated by two stable self-contained oscillators 400 cps and 1200 cps, (2) L-R produced by a double-balanced modulator. The output of the modulator contains the L-R side bands of the suppressed 38 KC subcarrier, and (3) a 19KC pilot carrier used to synchronize the demodulator of the stereo receiver or adapter being tested or aligned.

The RF output is tuneable over the FM band and modulated with the composite stereo signal. The output is variable from 2-1000 microvolts. By putting RF input into antenna terminals, the technician can determine whether the FM receiver band pass is adequate for FM multiplex stereo reception. The generator can be externally modulated by an external signal source such as a stereo mike, tape player or record player (one volt p-p min.).

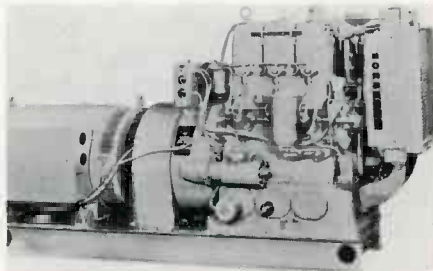

## NO-BREAK GENERATOR UNITS

Automatic Power, Inc., 205 Hutcheson St., Houston, Tex., has announced the availability of the no-break generator units which are designed to provide 100 per cent continuous power to critical loads when commercial power fails. The units are said to supply constant stand-by power in any weather, in any terrain, for any emergency.

The unit is comprised of a Nordberg Power Chief engine, coupled to a statically-excited motor generator through a heavy-duty magnetic clutch. The engine flywheel rotates with the motor generator rotor and is mounted on tapered roller bearings, supported by the engine shaft. Under normal conditions, electrical power is supplied to the critical load by the generator which is driven by an electric motor. The motor draws electrical energy from the commercial power. In the event of commercial power failure or a drop in voltage, the motor is automatically disconnected from the line, energizing the magnetic clutch which connects the flywheel to the engine crankshaft. Inertia stored in the flywheel continues to drive the generator and brings the diesel engine up to operating speed. When commercial power is restored, the electric motor is again energized and the engine is shut down in the reverse sequence. The sets are available in 5-kilowatt to 25-kilowatt capacities.

## MINIATURIZED 3D-TV STEREO-CAPTOR

A stereo-captor, which will optically convert any closed-circuit television to a 3D picture with no electronic modification, has been miniaturized to an 11-oz. package by Stereotronics Corp., 1717 N. Highland Ave., Los Angeles 28, Calif.

The system consists of stereo-captor model 5502, which replaces the lens on any industrial TV camera; a stereo screen to replace the glass plate in the receiving monitor; and stereo glasses for group viewing, or a stereo-hood for individual viewing without glasses.

The unit features quick installation and conversion from 2D to 3D; fidelity of depth perception; and simplicity of design and operation. The miniature package can be used on underwater and space vehicles where size and weight are limited, and within environmental housings in radioactive and explosive areas. Wide-angle viewing is provided by means of integral dual 12.5 mm focal length lenses. Convergence control adjusts toe-in from 12 inches to infinity.

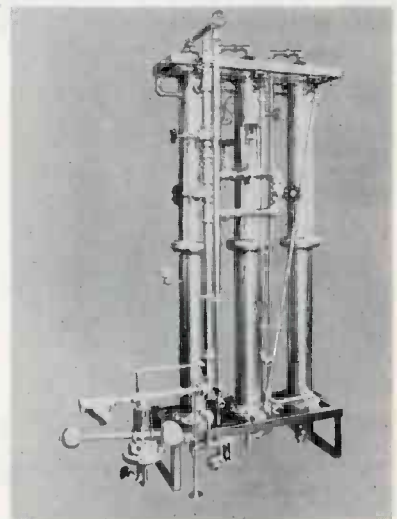

## NEW HEAT EXCHANGERS

Barnstead Still & Sterilizer Co., 377 Lanesville Terr., Boston 31, Mass., has announced the development of a new line of heat exchangers for heating purified water wherever it is required for washing and rinsing operations. The unit may also be used for cooling purified water. All interior surfaces are coated with pure inert tin to prevent metallic contamination of the purified water.

The heat exchangers are available in capacities of from five to 3,000 gal. per hour. Full automatic controls are included for temperature regulation. The units may be used singly or in series with distilled or de-mineralized water purification equipment where pre-heating is not possible.

For Convenient,  
Low-Cost Remote Control SPECIFY **rust** SYSTEMS

Please send me, at no obligation, a suggested Remote Control Plan for my Transmitter, Make \_\_\_\_\_ Model No. \_\_\_\_\_

Name \_\_\_\_\_ Title \_\_\_\_\_

Station \_\_\_\_\_

Address \_\_\_\_\_

City \_\_\_\_\_ State \_\_\_\_\_



**GENERAL ELECTRONIC**

**LABORATORIES, INC.**

195 MASSACHUSETTS AVE., CAMBRIDGE 39, MASS.

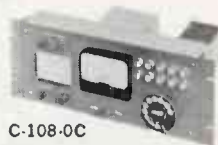

C-108-0C



C-108-1C



### ELECTRONIC ENGINEERS MASTER

The 1962-63 edition of EEM-Electronic Engineers Master, totalling 2,090 pages, has been released. The publisher announced that the edition is also available on microfilm that will accommodate 90 per cent of all viewers now available on the market.

EEM is composed of a catalog section of manufacturers' pages and three directories. The product directory lists over 3,000 products from 109,000 product sources, with company names and addresses. The manufacturers directory lists the names, addresses, phone numbers, sales offices and key personnel of 6,300 manufacturers. The trade name directory has 6,800 trade names with their respective manufacturers.

### NEW TECHNICAL BROCHURE

Hickok Electrical Instrument Co., RD Instruments Div., 10514 Dupont Ave., Cleveland 8, Ohio, has announced the availability of a new eight-page, two-color technical brochure which describes the model 1885 Dynamic beta power transistor tester.

Brochure RD1885 describes a transistor tester which measures beta and leakage from data included on a roll chart. Transistor manufacturer's specifications, or the user's requirements can be the basis for transistor testing.

The brochure includes technical specifications, simplified schematic diagrams, and circuit descriptions of the beta and leakage tests, the variable duty cycle pulsing system, and the variable power supplies.

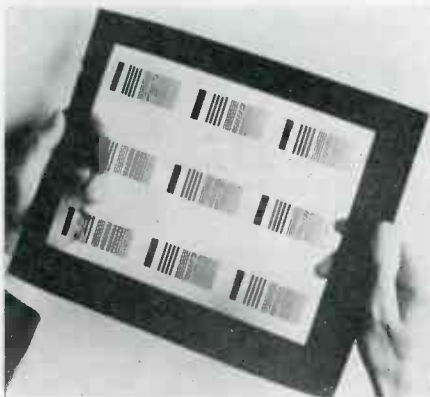

### IMAGE TUBE RESOLUTION CHART

The square-wave aperture response curve of image tubes and systems can be obtained simply with a new resolution chart available from Westinghouse Electronic Tube Div., Box 284, Elmira, N. Y., and was developed for resolving power of new image tubes.

In use, the chart provides a resolution image which is picked up by a camera

tube, and the resulting video signal is fed into an oscilloscope set for a delayed sweep. It is thereby possible to obtain the information required for a complete square-wave aperture response curve with a single scope presentation.

The chart consists of nine identical groups of lines. Because of this arrangement the resolving power can be measured and compared at different locations on the target. The 100 per cent contrast chart in an 8x10-inch transparency is available immediately. Charts with other degrees of contrast are available by special request.



### CIRCULAR SLIDE RULE

General Industrial Co., 1788J Montrose Ave., Chicago 13, Ill., is offering a circular slide rule for engineers and other plant and office executives.

According to the manufacturer, operation of the pocket-size calculator is simple and results accurate. Complete easy-to-follow instructions are included with each slide rule.

# SPARTA-MATIC



300P — \$450.00



300R — \$210.00

## SETTING THE STANDARD FOR CARTRIDGE TAPE

The SPARTA-MATIC 300 series cartridge tape system is receiving enthusiastic acclaim by broadcasters everywhere! Offering outstanding improvements in all areas, the SPARTA-MATIC 300P playback unit and its companion 300R record amplifier, contain all the features you have been waiting for:

- Continuous Duty Rated
- Compact, Modern, Functional Design
- Laminated Tape Heads
- Proven Reliability
- Table Top, Custom or Rack Mounting (Rack Mounting Illustrated)
- Improved Tone Burst Cueing
- Plug in Relays and Modules
- Solid State Design

All this and much more is yours with the new leader . . . SPARTA-MATIC. Dependable quality that every broadcaster can afford. The sophisticate of cartridge tape: the SPARTA-MATIC 300 series.

Call, Write or Wire Today for Guaranteed Satisfaction Offer.

## SPARTA ELECTRONIC CORPORATION

6430 FREEPORT BOULEVARD • SACRAMENTO 22, CALIFORNIA • GA 1-2070

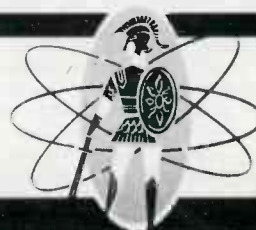

# Product News

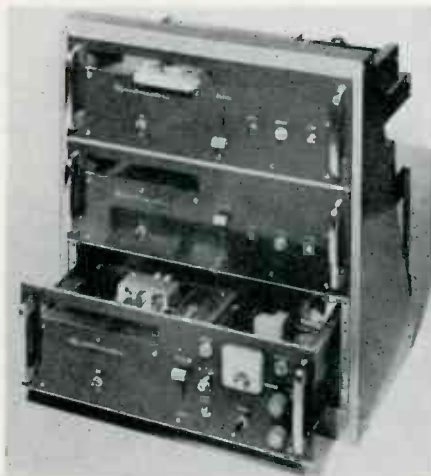

## RACK-MOUNTED CARTRIDGE-TAPE SYSTEM

The addition of the Spotmaster Rack Mount series of playback and combination recorder-playback units to its line of broadcast equipment has been announced by Visual Electronics Corp., 356 W. 40th St., New York 18, N. Y. The units are designed to provide pushbutton broadcasting for AM/FM and TV broadcast operations.

Furnished with rack chassis slides ready to mount in existing racks, each Rack Mount slides in and out, exposing the head and capstan for accessibility in cleaning and routine maintenance of the cartridge deck. Both the combination recorder and the playback are equipped with mounted handles.

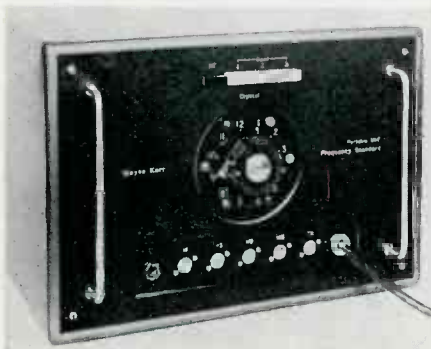

## VHF FREQUENCY STANDARD

A portable, 16-lb. VHF frequency standard, designed to provide an accurate check on operating frequencies of mobile transmitters and receivers, has been introduced by Wayne Kerr Corp., 1633 Race St., Philadelphia 3, Pa.

The FS100 has a maximum of 48 discrete frequencies in the range from 7.5 megacycles to 175 megacycles. A crystal-controlled oscillator, frequency multipliers, a wide-band detector and all rectifying and smoothing circuits for operation from alternating current supplies of 90 to 140 volts and 180 to 250 volts are contained within the instrument. Up to six thermostatically-controlled plug-in ovens, each capable of housing two crystals, can be fitted. A 12-position switch connects one of these crystals into an aperiodic Colpitt's oscillator circuit. The 3rd, 9th and 18th harmonics are developed by the frequency multipliers. Frequency stability and accuracy is  $\pm 0.0003$

per cent with output voltages 1mV to 1.5 V into 400 ohms.

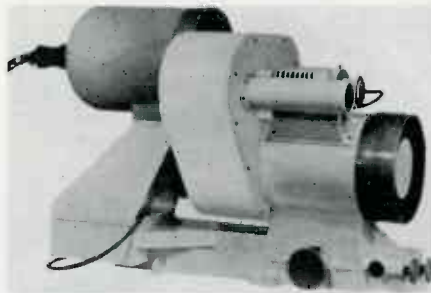

## NEW OPTICAL SYSTEM

A new dual lens system for vidicon TV and 35mm data recording cameras has been introduced by Zoomar, Inc., Glen Cove, Long Island, N. Y.

The new system is built around the 40-inch/F.8 Reflectar and an 8-inch Achromat fixed focus F/8 lens. Features include an optical switching device to permit instant selection of lenses by remote control, with a sun protector to safeguard the vidicon tube. The Reflectar also is focused by remote control. A reticle projector comprising light source, condensing system, reticle and projection optic produces crisp measuring pattern on the monitor screen. The azimuth and elevation platform is designed for bore-sighting alignment within  $\pm 1\frac{1}{2}^\circ$  azimuth and elevation, and micrometric adjustment, two seconds of arc. The entire system, which is weatherproof, measures 24 inches long, 12 inches wide and 15 inches high, and weighs approximately 35 lb. without camera. The unit is normally supplied with a vidicon TV camera, but is also available for 35 mm data recording cameras.



## SILICON RECTIFIER REPLACEMENTS FOR ELECTRON TUBES

Columbus Electronics Corp., 1000 Saw Mill River Rd., Yonkers, N. Y., has announced the release of more than 60 types of silicon rectifiers designed to permit direct plug-in replacement of vacuum or gas-type rectifier tubes.

Available in ratings to 40,000 volts PIV and 2.5 amperes, the CP series is said to permit the replacement of the tube types 5U4, 6X4, 3B28, 866, 8008 and many others.



## NEW BOOM MICROPHONE

Collins Farley Corp., 606 W. Washington Blvd., Venice, Calif., is offering the new type M boom microphone which, when added to the series 95 headset, makes an integrated microphone-receiver unit offering numerous advantages to users requiring the transmit-receive functions.

The microphone is housed in an attractive plastic case on an anodized aluminum boom. Microphone and boom may be swung away from the speaking position to an over-the-head position, moving it out of the way when not in use.

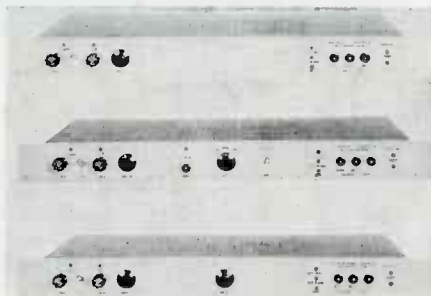

## TELECHROME VIDEO TEST EQUIPMENT

The first models in a new line of transistorized video test equipment for both color and monochrome TV systems has been announced by Teletet Co., 185 Dixon Ave., Amityville, Long Island, N. Y.

Shown (top to bottom) are, model 3501-A1, multiburst generator, model 3502-A1 stair-step generator and model 3505-A1 sine-squared pulse-window generator. All are completely transistorized and feature a new lightweight, compact design. The units measure 1 3/4 inches high and are designed to fit the standard 19-inch rack. They have individually regulated and fused power supplies and are said to perform reliably at ambient temperatures to 60-deg. C (140-deg. F).

Each generator provides two simultaneous output signals—a composite video signal and a vertical interval test (VIT) signal. The VIT signal may be added during the vertical blanking interval of a program signal, while the composite video signal is available as a standard video test signal for distribution to the studio system.



## NEW WAVEFORM MONITOR FOR CLOSED-CIRCUIT TV STUDIOS

A new waveform monitor, model WFM-5, for closed-circuit TV system studios, has been announced by Blonder-Tongue Laboratories, Inc., Newark 2, N. J. The new unit, which is capable of monitoring a video signal, is designed for professional systems only, those using E.I.A. standards.

The monitor features a 5-inch oscilloscope screen on which are displayed either two horizontal lines or two vertical fields for the operator. It has a built-in calibrator and power supply, and requires vertical and horizontal drive pulses. The unit is designed for a 19-inch rack mount.



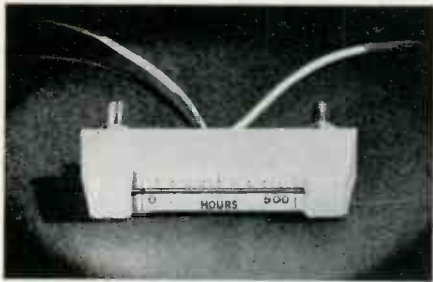

#### MINIATURE ELAPSED TIME METER

Curtis Instruments, Inc., 45 Kisco Ave., Mount Kisco, N. Y., has announced a new miniature elapsed time meter, resettable to zero in the field and developed for applications including time usage studies on studio transmitter and test equipment.

The meter utilizes the Curtis meter element based on electro-chemical transfer of mercury in a sealed system. A precise constant current plates mercury across a gap at an exact rate, and movement of the gap is directly proportional to time.

Standard models cased in a miniature, high-strength housing are available for timing up to 10,000 hours on a 1-inch scale. Accuracy is within 3 per cent at voltages from 100 to 140 ac, and frequencies from 50 to 400 cps.

The Indachron model 515 R uses an integral rectifying and regulating circuit. During the normal timing cycle it is installed directly across the ac line voltage. For reset, the reset connections are attached to a 5 milliamperes dc source and the indicating gap runs back down the scale at the rate of 1/2-inch an hour. Upon completion of re-zeroing, the meter will time an additional cycle. Standard current sources for reset can be provided.



#### NEW DC-AC INVERTER

SunAir Electronics, Inc., 3101 Southwest 3rd Ave., Fort Lauderdale, Fla., has announced the development of a new design for a dc-ac inverter, said to be capable of delivering greater power output from the energy source than the conventional power supplies.

The new power pack delivers 117 volts ac at 2.5 amperes and 60 cycles per second from a 12-volt battery source. Heat radiation fins on opposite sides of the chassis are designed to permit cooler operation of the transistors.

The inverter is normally furnished with four transistors. If voltage regulation to tight tolerances is required, a regulator pack can be provided. Power supplies can also be engineered to provide specific voltage regulation; rectification from ac to dc with specified ripple factors. The input voltage range may be from 6 to 32 volts dc; ambient temperature range from minus 35 deg. to plus 55 deg. Centigrade. Voltage output can be up to 300 volt/amperes with a mean efficiency of 87 per cent.

#### NEW SECO SIGNAL FILTER

A new electronic noise eliminator and controllable squelch called the Signal Filter has been developed by Seco Electronics, Inc., 1201 S. Clover Drive, Minneapolis 20, Minn. The unit measures 1 3/4 x 2 1/2 x 4 1/4 inches.

A dual high-mu triode and dual diode are incorporated in an inverter circuit which electronically clips noise pulses out of the signal. It is said to eliminate ignition equipment interference, steep wave front hash and background noises, as well as the need for suppression equipment on automotive and marine engines. The noise eliminator features extra ruggedness through the use of an encapsulated packaged electronic circuit assembly.

The signal filter adapts to most Citizens Band transceivers using tubes, and may be hooked up to any AM superheterodyne receiver with six or 12 volts ac or dc and 150 volts B power supply, mobile or base stations.

#### NEW MINIPRINT KITS

MiniPrint Electronics Co., Inc., 256 First Ave., Carmel, Ind., has announced four new kits for engineers, technicians, amateurs and hobbyists who wish to make their own printed circuits. Utilizing the latest techniques, the kits are said to allow the user to make electronic printed circuit boards of professional quality at a cost range to satisfy both the simplest and most sophisticated needs.

The material supplied in each kit is XXXP phenolic board. It can also be supplied with epoxy glass board.

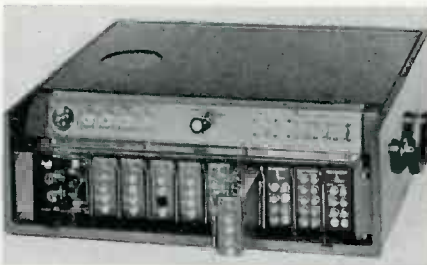

#### ALL TRANSISTOR VIDEO MODULES

Riker Industries, Inc., Halesite, N. Y., has developed a new line of video equipment for TV broadcast, microwave and radar which is 100 per cent transistorized and comes in modules.

Each video test waveform is generated by a single module, and each module operates independently. As many as 10 modules plug into the rack or portable carrying case instantly and without tools. The user may purchase basic waveforms and add any others as desired. Additional advantages include compactness—10 module set occupies 3 1/2 x 19 x 17 inches, weighs 25 lb.; minimum heat and power—10 modules require 30W at 117V; amplitude stability better than 1 per cent from 0-50 deg. C; not affected by distortion, amplitude, or rise time of incoming drive pulses; and for ease of repair, each module consists of replaceable circuit cards for instant service.

#### TELEVISION ENGINEER

NEED GOOD RIGHT HAND MAN. MUST BE EXPERIENCED AND COMPETENT IN TROUBLE-SHOOTING RCA STUDIO, TRANSMITTER AND MICROWAVE EQUIPMENT. GOOD OPPORTUNITY FOR RIGHT MAN.

JERRY E. SMITH, W5TFV  
KRIS-TV Box 840 Corpus Christi, Texas

## LOOKING FOR CONNECTORS?

Turn to section 2100



You'll find the catalog data of these manufacturers:

Amphenol • Associated Engineering • Augat • Barnes Development • Burndy • Cannon Electric • Cinch Mfg. • Continental Connector • Dage Electric • E-Z-Hook Test Prods. • Elco • GC Electronics • Grayhill • E. F. Johnson Co. • Mac Panel Co. • Microdot • Mueller Electric • North Electric • Physical Sciences • Pomona Electronics • Rye Sound • Security Devices Lab. • H. Herman Smith • Switchcraft • Thomas & Betts Co. • U. S. Components • Viking Industries • Virginia Electronics.

eem ELECTRONIC ENGINEERS MASTER  
60 Madison Avenue • Hempstead, N. Y.

## for your tower requirements check ROHN SYSTEMS

A complete tower erection service that has these special advantages:

- ✓ DEPENDABILITY
- ✓ RELIABILITY
- ✓ COMPLETE ENGINEERING
- ✓ COAST TO COAST SERVICE

Be sure to obtain price quotations and engineering assistance for your complete tower needs from America's foremost tower erection service.

ROHN SYSTEMS, INC.  
6718 W. Plank Road Peoria, Illinois

# Product News

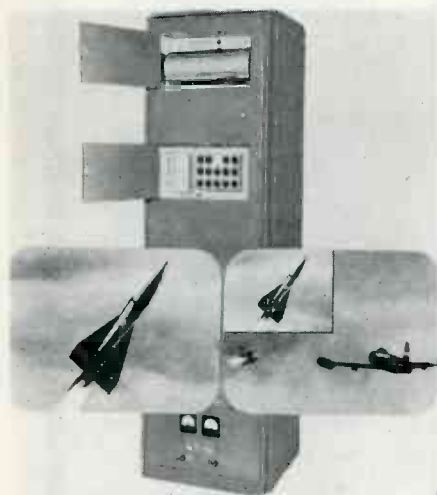

## TELEVISION STORAGE TUBE SYSTEM

Image Instruments, Inc., 2300 Washington St., Newton 62, Mass., has introduced the new model 207 Electrostore recording storage tube system. Operating at standard E.I.A. television scanning rates, the unit is said to store and instantly read out for continuous display a single television frame.

It differs from the model 206 Electrostore in that it does not include a sync pulse separator, and it requires line drive, frame drive and composite blank pulses.

Resolution of 1,000 television lines across the diameter and a gray scale fidelity of five to six shades are achieved by the Raytheon QK 685 Electrostatic storage tube in the model 207. Read-out is non-destructive and the stored picture may be repeatedly displayed on a TV monitor for 10 minutes or more, the manufacturer states.

## Professional Services

- SYNCHRONOUS MAGNETIC FILM RECORDER/REPRODUCER
- MAGNETIC TAPE RECORDERS
- NEW—THE portable MINITAPE synchronous 13 lb., battery operated magnetic tape recorder for field recording.

THE STANCIL-HOFFMAN CORP.  
845 N. Highland, Hollywood 38, Calif.  
Dept. B HO 4-7461

### VIR N. JAMES

#### Specialty

#### Directional Antennas

232 S. JASMINE DExter 3-5562  
DENVER 22, COLORADO  
Member AFCEE

### JOHN H. BATTISON & ASSOCIATES CONSULTING RADIO ENGINEERS

Specializing in AM-FM-TV Applications and measurements.

934-5 Munsey Building  
1329 E. St., N.W. Washington 4, D. C.  
DI 7-2330  
Established 1954

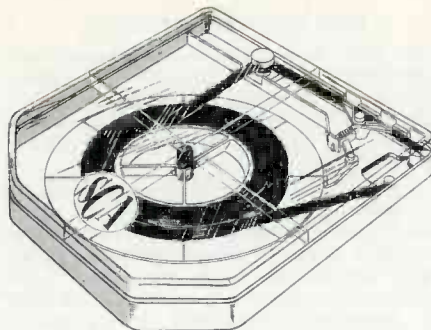

## CONTINUOUS TAPE CARTRIDGES

Sound Corp. of America, 9162 Brookville Rd., Silver Spring, Md., has introduced two new models of continuous tape cartridges that are said to be compatible with all current models of continuous cartridge playback equipment.

## Advertisers' Index

John Battison & Assoc. ....	40
Bauer Electronics Corp. ....	33
Belden Mfg. Co. ....	17
Broadcast Electronics, Inc. ....	32
Conrac Div., Giannini Controls Corp. ....	31
Electro-Voice, Inc. ....	IBC
Electronic Engineers Master Catalog ....	39
Fairchild Recording Equipment Corp. ....	35
General Electric Co. ....	7
General Electronic Laboratories, Inc. ....	36
Gray Research & Development Co. ....	28
Houston-Fearless Corp. ....	1
Intl. Electronic Research Corp. ....	20
International Nuclear Corp. ....	13
ITA Electronics Corp. ....	IFC
Vir N. James. ....	40
Jampro Antenna Co. ....	34
KRIS-TV ....	39
McMartin Industries, Inc. ....	22
Magnecord Div., Midwestern Instruments ....	30
Magnetic Products Div., Minnesota Mining & Mfg. Co. ....	9
Radio Corp. of America Electronic Products Div. ....	BC
Victor Records Div. ....	3
Raytheon Co. ....	27
Rohn Systems, Inc. ....	39
Saxitone Tape Sales Div. ....	34
Sparta Electronic Corp. ....	37
Stancil-Hoffman Corp. ....	40
Superscope, Inc. ....	21
Sylvania Electrical Products, Inc. ....	29
Television Zoomar Co. ....	35
Visual Electronics Corp. ....	23

SCA model S, with a capacity of 225 ft. of tape, is specifically designed for broadcasting, message repeaters, audio and visual display devices and language equipment. The SCA model L, with a capacity of 1,690 ft., is designed for background music, data retrieval, or where longer tape lengths are required.

The new design pressure pad assembly is said to increase frequency response and reduce head wear to insure a uniform high quality of reproduction regardless of the number of cartridge insertions.

## Classified

Advertising rates in the Classified Section are ten cents per word. Minimum charge is \$2.00. Blind box number is 50 cents extra. Check or money order must be enclosed with ad.

The classified columns are not open to the advertising of any broadcast equipment or supplies regularly produced by manufacturers unless the equipment is used and no longer owned by the manufacturer. Display advertising must be purchased in such cases.

### EQUIPMENT FOR SALE

Transmission line, styroflex, heliax, rigid with hardware and fittings. New at surplus prices. Write for stock list. Sierra Western Electric Cable Co., 1401 Middle Harbor Road, Oakland 20, California. 6-61 tf

Commercial Crystals and new or replacement crystals for RCA Gates, W. E. Bliley and J-K holders; regrinding, repair, etc. BC-604 crystals. Also A. M. monitor service. Nationwide unsolicited testimonials praise our products and fast service. Eidson Electronic Company, Box 31, Temple, Texas. 9-61 tf

GOVERNMENT SURPLUS, NEW 10 CM. WEATHER RADAR SYSTEM—Raytheon, 275 KW peak output S band. Rotating yoke P.P.I. Weather Band 4, 20 and 80 mi. range. Price \$975 complete. Has picked up clouds at 50 mi. Wt. 488 lbs. Radio Research Inst. Co., 550 5th Ave., New York, New York. 5-62 8t

PHILCO MICROWAVE LINK. 7 KMC System. Type CLR-6 also in stock: Repeaters, 12 and 24 channel multiplex. Large quantity. Exc. cond. Radio Research Inst. Co., 550 5th Ave. New York, N. Y. 5-62 8t

RCA TT-5 tv transmitter, low band, good condition, presently on air. Plans and/or service available for air conversion to Amperex 6076. Good assortment spare parts included. P. O. Box 429, Redwood City, California, or call, area code 415: 369-4675. 8-62 1t

### BUY, SELL OR TRADE

Will buy or trade used tape and disc recording equipment—Amperex, Concertone, Magnecord, Presto, etc. Audio equipment for sale. Boynton Studio, 10 BE Pennsylvania, Tuckahoe, N. Y. 4-62 6t

### MISCELLANEOUS

TV CAMERA—Low Cost—Easily Built—Complete schematics, instructions 50c. Denson Electronics, Rockville, Conn. 7-62 3t

ENGINEERING And Art Degrees earned through home study. Electronics, Mechanical, Liberal Arts. When writing specify course desired. Pacific International College of Arts & Sciences, primarily a correspondence school. Resident classes also available. 5719-W Santa Monica Blvd., Hollywood 38, California. 8-62 6t

New, from Electro-Voice! Sentry Series Professional Monitor Loudspeakers . . . guaranteed flat  $\pm 3$  db from 40 to 20,000 cps!

No longer must you improvise with theatre or home-type hi-fi speakers designed for some other purpose. Gone is the guesswork when equalizing . . . you know you'll get *exactly* what you hear through an E-V Sentry Monitor. That's because each Sentry is simple, reliable and as flat in response as modern science can make it!

Gone are "balance" switches or knobs that vary response . . . each Sentry is adjusted flat at the E-V laboratories before you ever see or hear it! And because of this simplicity, the E-V Sentry Series speakers are modest in size and price.

## NEW VOICE OF AUTHORITY!

The natural-finish hardwood cabinets are available in a sloping-front style for wall or ceiling mounting . . . or in an upright floor model for fixed or portable applications. They are all identical in sound. Built-in transformer matches studio output impedance of 8, 16 and 600 ohms.

If you want to end equalization guesswork . . . if you want to know that the sound you hear is an exact duplication of the original . . . the E-V Sentry Series Professional Monitors were designed for you. Write for complete specifications, or see your E-V Professional Products Distributor, today!

*Sentry II Floor Model, 32" H, 20" W, 13" D. List Price \$248.33. Sentry I Wall or Ceiling Model, 17" H, 37" W, 21 1/4" D. List Price \$231.67. (Normal trade discounts apply.)*

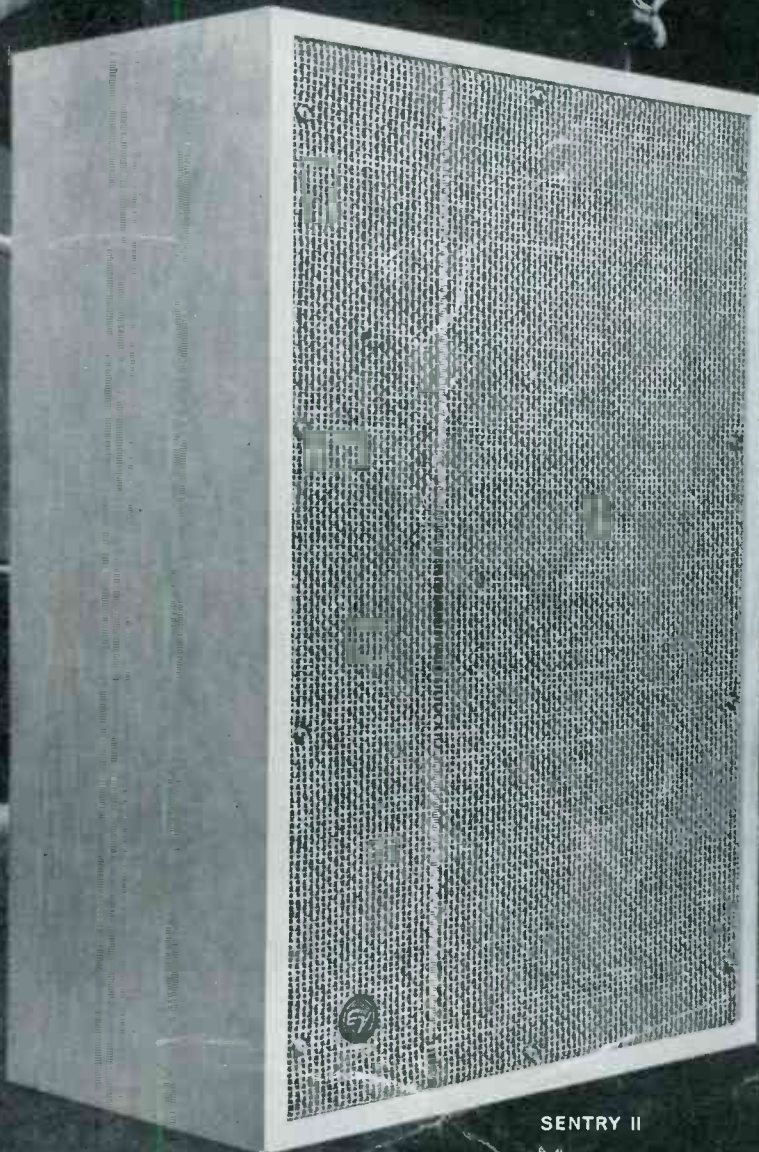

SENTRY II



SENTRY I

*Electro-Voice*®

ELECTRO-VOICE, INC. Commercial Products Div., Dept. 821V, Buchanan, Michigan



## The Voice of the Land

It's a big land . . . a proud land . . . that sweeps from sea to sea. Only a strong voice can fill it . . . reach it . . . move it to its very heart.

Listen to this voice. It talks to motorists as they crowd the busy roads. It gives a warning to farmers that frost is ahead. It sings a sweet song to lovers. It carries the news to businessmen. It wakes millions every morning and sends them off to work . . . informed . . . entertained . . . often inspired. For this is a practical voice, a spiritual voice, the very voice of America. *It is the voice of AM Radio.*

RCA has played an essential part in the steady progress

of AM. You will find the RCA nameplate proudly affixed to transmitters whose owners never toy with quality . . . never compromise with dependability. You will find the RCA nameplate your highest assurance of superior performance no matter what your broadcast requirements may be. Why not call in your RCA Broadcast Representative today. He speaks your language.



**The Most Trusted Name in Radio**

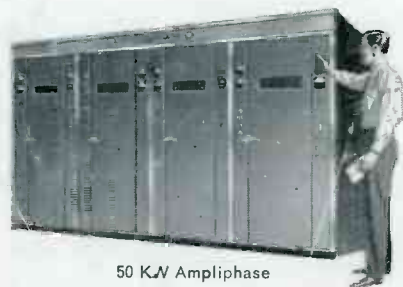

50 K/W Ampliphase



5/10 KW Type BTA-5U/10U



5 KW Type BTA-5T



250/500/1000 W Type BTA-1R1