

FEATURING



STL Remote Control Systems for FM Stereo and SCA 10

Full Spectrum Television via CATV 12

Practical Application of FCC's Engineering Rules 14

Automatic Music System 17

Accurate Intensity Measurements in Ambient Fields 22

Broadcast Engineering

the technical journal of the broadcast-communications industry

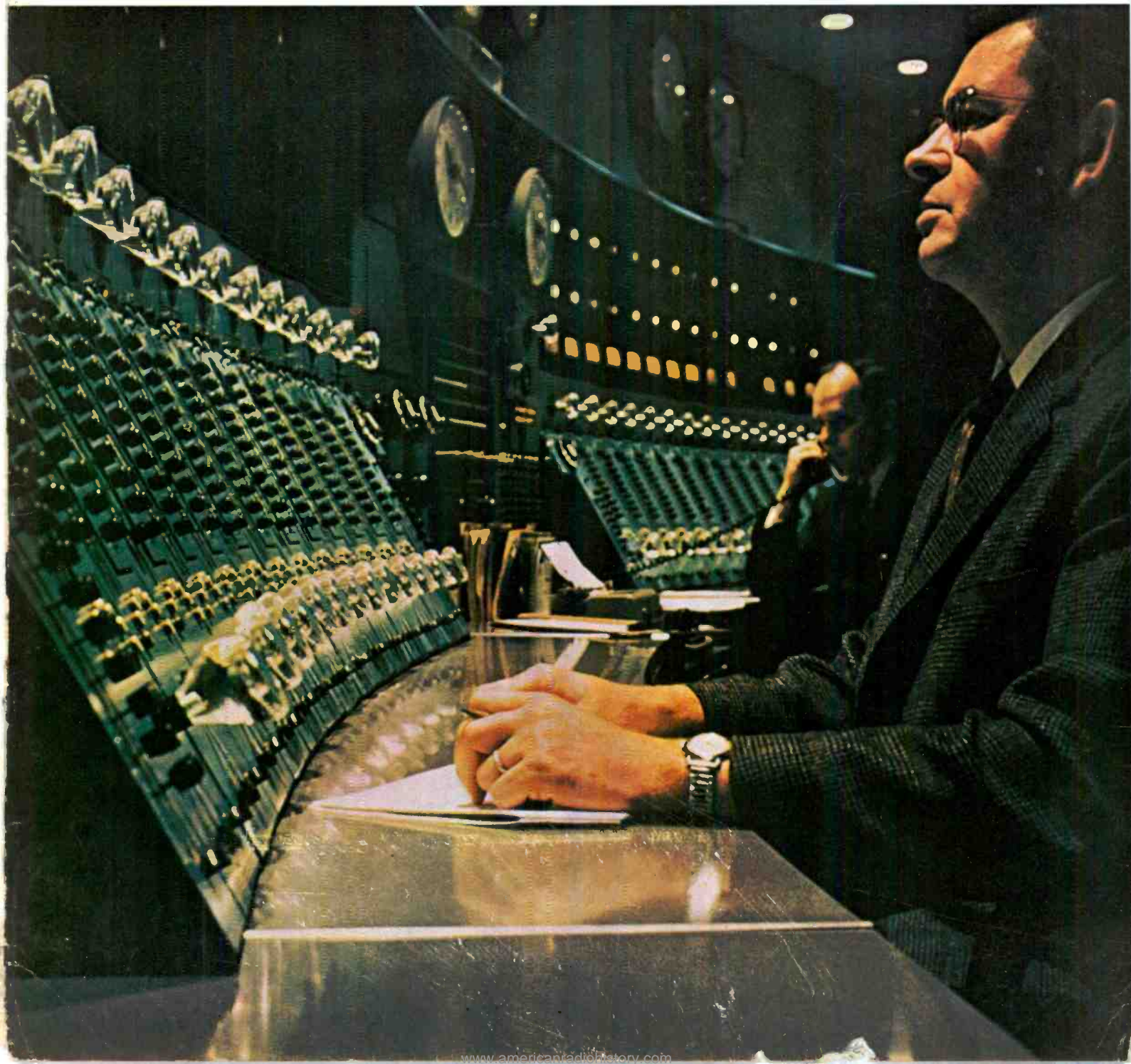

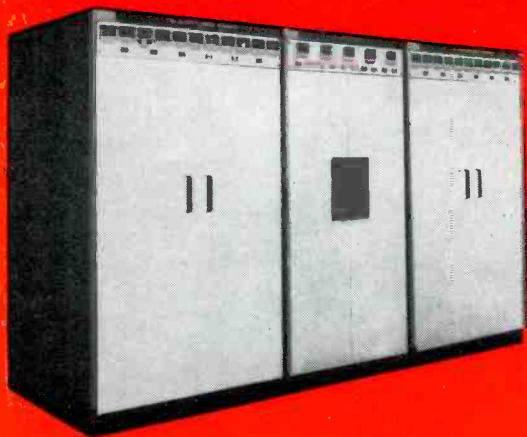

ITA 50 kw AM TRANSMITTER

Compact . . . Economical . . . Easy to operate!

Featuring a new, single tetrode power amplifier that gives full output with minimum power consumption, this is the finest high power AM transmitter available. Extremely compact, the unit needs only 76 square feet of space *including transformers* . . . it's one-third smaller than transmitters of the same power built by other manufacturers! Silicon rectifiers, 11 tubes and 6 tube types, high level modulation and many other advanced features make it your *best buy* for high power AM broadcasting.

ITA ELECTRONICS CORPORATION
BROADCAST DIVISION • LANSDOWNE, PENNA.

ITA

Affiliate of Triangle Publications, Inc.

Circle Item 1 on Tech Data Card

HIGH BAND TV ANTENNAS

Does your station operate on Channels 7 - 13? Are you interested in improving your signal with a minimum investment? Then it's time you became familiar with our line of CO.EL. High Band Antennas . . . and learned why they are favorites around the world. Here are a few of their features that should be of special interest to both station operators and engineers:

- VERY LOW VSWR PERMITS TRANSMISSION OF HIGHEST QUALITY SIGNAL — VSWR 1.04 or better guaranteed
- AVAILABLE FOR VERY HIGH GAINS — gains up to 23, with circular patterns and null fill available
- EXCELLENT VERTICAL PATTERNS — smoothly shaped vertical patterns with null fill and beam tilt eliminate close-in areas of low signal strength
- SUITABLE FOR STACKING — CO.EL standard antennas are designed to mount on the face of a tower, thus can be stacked under antenna already in use
- AVAILABLE FOR DIRECTIONAL PATTERNS — where increased signal strength in important directions is required, and for "drop-ins."

- Cost in many instances is lower than that of circular patterns.
- NO DE-ICERS REQUIRED — even in heavy icing conditions
- FASTER MORE ECONOMICAL INSTALLATION — modular construction permits complete installation and check-out in less than a week
- NO GROUND CHECK OR FABRICATION OF TRESTLES FOR TESTING NEEDED
- EXPERT CHECKOUT SERVICE — by qualified antenna engineering specialists.

Write for further information on CO.EL. High Band, Low Band and UHF TV Antennas; 10mc Bandwidth FM Antennas; Towers; VSB Filters; Notch Diplexers; Filterplexers, Harmonic Filters; Rigid Transmission Line; and Microwave Parabolic Antennas.

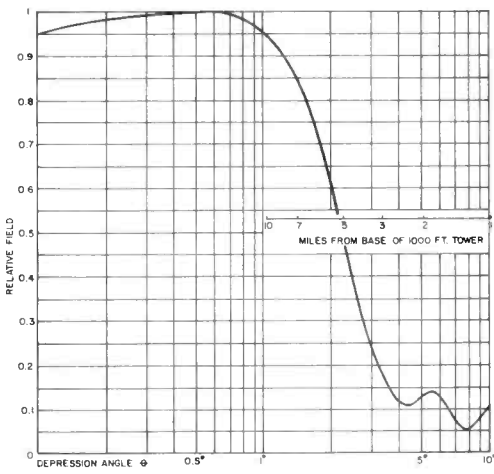
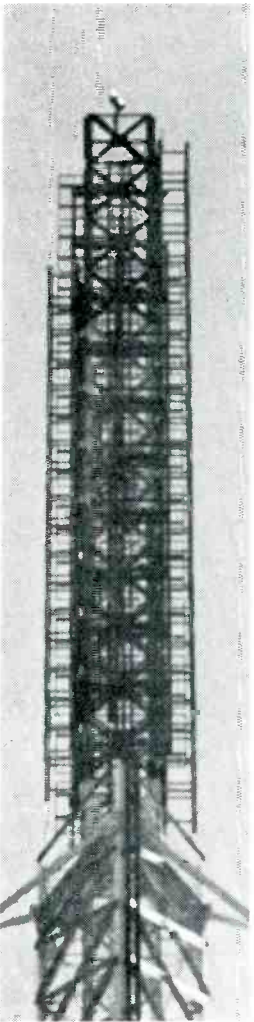

Vertical Pattern of CO. EL. CO-48H Antenna, Channels 7-13. Gain with this vertical pattern varies from 19.7 on Channel 7 to 23.7 on Channel 13.

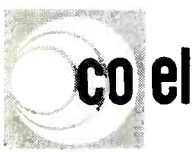

Specialists in Advanced Antenna Systems

24 CAROL ROAD, WESTFIELD, N. J. / AD 2-0250 / Cable: COELTENNA WESTFIELD

Circle Item 2 on Tech Data Card

SECO PLUS⁺ TESTERS

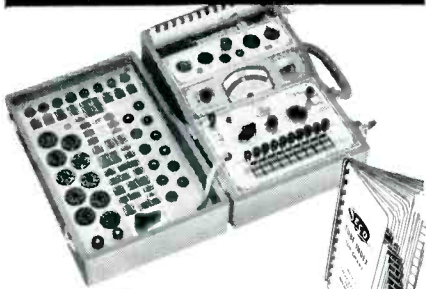

OVER 3,000 TUBES Handy indexed flip chart includes industrial type tubes.

INDUSTRIAL MODEL 107A ONLY **\$149.50** NET

† A SECO PLUS—ALL THESE TUBE TESTS IN ONE COMPACT TESTER

- **GRID CIRCUIT TEST**—all tubes get 11 positive checks for leaks, shorts and grid emission. A Seco designed and patented "Electron-Eye" test.
- **DYNAMIC MUTUAL CONDUCTANCE TEST**—pre-wired chassis for effective testing of voltage amplifier and similar tube types.
- **CATHODE EMISSION TEST**—the best method for testing pulse amplifier, power output and damper type tubes.

Extremely accurate and easy to use, the Seco 107A "Tri-Tester" provides all essential tests. Guaranteed against obsolescences.

The "Tri-Tester" meets specifications for: FEDERAL STOCK CLASSIFICATION, Tube Tester Type 107-FSN-6625-713-9075.

This compact, portable unit is completely self-contained in a handsome, vinyl plastic carrying case. It is the finest, fastest, most complete tester on the market—at a popular price!

COMPLETE TRANSISTOR AND TUNNEL DIODE ANALYZER

† LOOK AT THIS SECO PLUS—a complete transistor lab for incoming transistor and diode stock inspection and for servicing transistorized equipment.

- Requires no set-up data
- Identifies NPN and PNP transistors immediately
- Provides dynamic GO-NO-GO test in circuit
- Provides accurate DC analysis out of circuit
- Indicates transistor leakage and gain
- Tests signal and power transistors, also tunnel and zener diodes
- Indicates diode forward conductance and reverse leakage current
- Includes VOM meter with appropriate ranges.

You'd expect to pay much more for a set that needs no set-up data—includes a "speed test socket"—reads BOTH I_{cb0} and I_{ce0} leakage currents—cancels I_{ce0} leakage for TRUE gain readings. Two models: (1) AC powered 250A at \$86.50 and (2) "B" battery powered 250B at \$74.50 Both include 24" test leads with slim line prods.

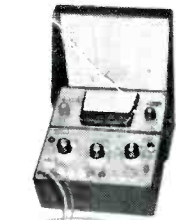

MODEL 250B ONLY \$74.50 NET



TRANSISTORIZED DC POWER SUPPLY

Continuously variable with 1% regulation at full rated output. Input: 105-130 V 50-60 cycle AC • Regulation: load .5% (average), line 5% • Output impedance: 1 ohm • Output metered in 3 voltage ranges: 0-1.5, 0-15 and 0-30 V DC

- Meter current ranges (load current): 0-30 and 0-150 ma
 - Bias taps: 0-1.5 and 0-7.5 V for simultaneous use with main supply
 - Short circuit indicator
 - No overshoot.
- † A SECO PLUS—Zener regulated constant voltage for applications up to 4 watts.

See for yourself the Seco PLUS features on these testers at your electronics supply dealer—or send the coupon for complete literature.

SECO ELECTRONICS, INC.
1219 S. Clover Drive, Minneapolis 20, Minn.

Rush complete information on the Model 107A "Tri-Tester" the Model 250 Transistor and Tunnel Diode Analyzer the Model RPS-5 Power Supply, including full line folder describing complete range of Seco test equipment.

NAME _____
COMPANY _____
ADDRESS _____
STATE _____ CITY _____

Circle Item 4 on Tech Data Card

the technical journal of the broadcast-communications industry



Broadcast Engineering

Volume 5, No. 2

February, 1963

CONTENTS

FEATURES

- STL Remote Control Systems for FM Stereo and SCA** . . . 10
by John A. Moseley — Here's how to use studio-transmitter links to pass all information and eliminate telephone lines in an FM stereo operation.
- Full Spectrum Television via CATV** . . . 12
by Irvin Kuzminsky — A discussion of how to choose between split-band and distributed amplifiers.
- Practical Application of FCC's Engineering Rules** . . . 14
by John A. Battison — Filling out form 301 is simplified with these instructions and suggestions for complying with the Commission's rules.
- Automatic Music System** . . . 17
by Arthur J. Smith — A unique system employing automatic turntables and "silence" triggering.
- Accurate Intensity Measurements in Ambient Fields** . . . 22
by Robert A. Jones — You can measure field intensity even when interfering signals are present, with the method described.
- When to use a Unipole Antenna Design** . . . 26
Technical Talks — How to use folded unipole antennas to increase radiated power without increasing transmitter output.
- A Low Cost Instructional Television System** . . . 32
by Edward Galuska — School districts can beat the budget problem with this economical in-class ETV technique.

DEPARTMENTS

Letters to the Editor	6	Advertiser's Index	45
Engineers' Exchange	36	Classified Ads	45
News of the Industry	39	Professional Services	45
About the Cover	40	Engineers' Tech Data Section	46
New Products	41		

PUBLISHER: Howard W. Sams

GENERAL MANAGER: Mal Parks, Jr.

EDITORIAL: Executive Editor, Verne M. Ray; Editor, Forest H. Belt; Managing Editor, Stuart N. Soll; Consulting Editor, John H. Battison.

CIRCULATION: Manager, Pat Tidd; Assistants, Katherine Krise, LaVon Willard.

PRODUCTION: Manager, Robert N. Rippy.

ADVERTISING: Sales Manager, John W. Groce; EAST: Charles Horner, Howard W. Sams & Co., Inc., 3 West 57th Street, New York, N. Y., Phone—MU 8-6350; MIDWEST—Hugh Wallace, Howard W. Sams & Co., Inc., 4300 West 62nd Street, Indianapolis 6, Ind., Phone AX 1-3100; SOUTHWEST—C. H. Stockwell Co., 4916 West 64th Street, Mission, Kansas, Phone—RA 2-4417; LOS ANGELES 57, CALIF., Maurice A. Kimball Co., Inc., 2550 Beverly Blvd., Phone—DU-8-6178; SAN FRANCISCO, Maurice A. Kimball Co., Inc., 580 Market Street, Phone—EX 2-3365; PARIS 5, FRANCE, John Ashcraft, 9 Rue Lagrange, Phone—ODEON 20-87; LONDON W.C. 2, ENGLAND, John Ashcraft, 12 Bear Street, Leicester Square, Phone—WHITEHALL 0525; TOKYO, JAPAN, International Media Representatives, Ltd., Kisha Kurabu 14, 2-chome Marunouchi, Phone—(502) 0656.

SUBSCRIPTION PRICE: U.S. \$6.00, one year; \$10.00, two years; \$13.00, three years. Outside U.S.A. add \$1.00 per year for postage. Single copies, 75 cents.

BROADCAST ENGINEERING is published monthly by Technical Publications, Inc., an affiliate of Howard W. Sams & Company, Inc. Editorial, Circulation, and Advertising headquarters: 4300 West 62nd Street, Indianapolis 6, Ind.



A HOWARD W. SAMS PUBLICATION



BROADCAST ENGINEERING

HOW YOU CAN DRAMATICALLY IMPROVE BUSINESS AND STATION PERFORMANCE FOR NEXT TO NOTHING...

How much more money could you make if you could...

- Increase your potential audience
- Quadruple radiated program power
- Sound much louder and clearer
- Increase received S/N ratio
- Offer the sponsor more listeners per dollar
- Increase listener loyalty
- Sound much better than competitors
- Reduce operating costs

And do it all for as little as \$495.00?

AUDIMAX stations—more and more every day—do!

Here's how: Audimax is your assistant broadcast engineer—an electronic brain that boosts your station's radiated program power and market coverage, greatly improves sound, and improves operating efficiency by automatically controlling program levels with near-human intelligence and superhuman speed and accuracy—all without objectionable side effects and distortion.

Audimax differs in *concept* from ordinary level controls (limiters, compressors, AGC's, etc.) and accomplishes what they attempt to, without the additional problems they introduce. With such devices, the gain is always either rising or falling. With fast recovery times, pumping sounds occur. Slowing the recovery time allows short bursts of sound to put "holes" in the program. Audimax, instead, works like a competent engineering assistant.

Automatic Gain Riding—When levels are too high, Audimax quickly and inaudibly lowers the gain without thumping—When levels are too low, Audimax raises the gain without pumping. With explosive sounds, (e.g., pistol shots, barking dogs) Audimax momentarily corrects the gain, then instantly returns to previous level, without leaving "holes." When levels are correct, the gain *remains constant*. Audimax's exclusive platform mode of operation preserves short-term dynamic fidelity.

Automatic Program Control—Audimax's exclusive logic monitors the incoming signal and compares it with previous program information in its memory, *deciding* whether to raise, lower or main-

tain constant gain. The result: Perfect levels every time. **Gated Gain Stabilization**—Audimax also *recognizes* noise and background effects and maintains *constant gain* during pauses, eliminating unnatural fade-out of the background effects and disturbing swish-up of background noise, completely preserving the natural sound of dramatic programs, sports-casts, etc. **Return-to-Zero Feature**—In standby conditions Audimax waits, and when convinced that the program has ended, slowly drops to normal gain.

Magnified Modulation and Market Coverage—While performing control functions automatically, Audimax boosts overall levels—to 6 db higher than normal manual methods—quadrupling radiated program power and potential audience. You "stand out" on the dial, your programs sound louder, clearer and better than ever before, increasing listener loyalty. All this means more value for the sponsor, and a *vast increase in your money-making potential*.

Prove it for yourself. Satisfaction guaranteed. Order *your* Audimax today!

Audimax II RZ	\$625.00
Audimax I without Gated Gain Stabilization and Return-to-Zero feature	\$495.00

Dept. APE-263

CBS LABORATORIES

STAMFORD, CONNECTICUT
A DIVISION OF COLUMBIA BROADCASTING SYSTEM, INC.

Another product of CBS Laboratories contributing to better Broadcasting.

The superiority of new Altec Dynamic Microphones is all the more amazing when you discover their moderate price!

There are six dynamic microphones in Altec's new professional studio series. Each sets new standards of performance and durability in its class. Each offers distinctive features of significant value to the professional user, especially since the highest price model is yours for under \$100.00! Let's take a look at some of these features:

PROOF of Superior Performance

Each Altec 684A Omnidirectional and 685A Cardioid Microphone comes to you with its own certified calibration curve made on a Bruel & Kjaer Graphic Recorder. In the entire professional field, this practice is unique with Altec. The one shown here is typical of the 684A. The curve you receive gives visual proof of the remarkably smooth response provided by your Altec Microphone.

BALANCED PAIRS FOR STEREO: For stereo work, any pair of 684A or 685A Microphones is perfectly matched in performance characteristics. The calibration curves offer rapid means of assuring yourself of this balance.

DESIGNED FOR RIGOROUS PROFESSIONAL USAGE: The exclusive sintered bronze filter positively bars all foreign matter. These Altec Microphones may be used safely in any situation the professional engineer finds himself; not only in a protected studio, but anywhere—a

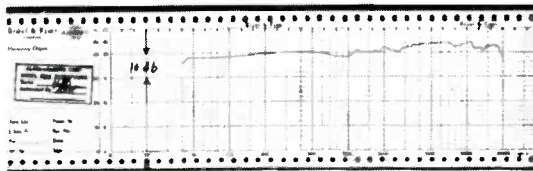

metals grinding mill if need be. Only Altec offers this absolute protection against the gradual degradation of quality common in ordinary microphones that can't prevent dust, moisture, and minute ferrous particles from restricting diaphragm movement.

Also featured are diaphragms of indestructible polyester that cannot be damaged by blasts, shock, impact—designed specifically for rigorous usage in any professional applications.

EXCLUSIVE ALTEC MICROPHONE EXCHANGE POLICY: After expiration of normal full year guarantee, you may exchange an inoperative microphone for a comparable new unit at a fraction of original cost. This Altec policy is unique in the industry; offered to better serve microphone users.



ALTEC 684A OMNIDIRECTIONAL MICROPHONE
Frequency Response: 35 to 20,000 cycles • Output Impedance: 30/50, 150/250, 20,000 ohms • Output Level: -55 dbm/10 dynes/cm² • Hum: -120 db (Ref.: 10⁻³ Gauss) Price: \$78.00 net

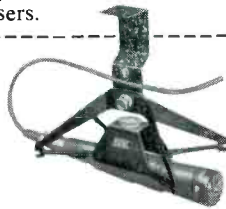

ALTEC 685A CARDIOID MICROPHONE
SHOWN IN ALTEC 181A BOOM MOUNT
Frequency Response: 40 to 16,000 cycles • Output Impedance: 30/50, 150/250, 20,000 ohms • Output Level: -54 dbm/10 dynes/cm² • Discrimination: Average front-to-back, 20 db • Hum: -120 db (Ref.: 10⁻³ Gauss) Price \$96.00 net



ALTEC 686A LAVALIER MICROPHONE
Frequency Response: 70 to 20,000 cycles • Output Impedance: 30/50, 150/250 ohms • Output Level: -55 dbm/10 dynes/cm² • Hum: -120 db (Ref.: 10⁻³ Gauss) Price: \$45.00 net

For specific engineering details, call your nearest Altec Distributor (listed in your Yellow Pages) or write Dept. BE-2

ALTEC LANSING CORPORATION

A SUBSIDIARY OF LING-TEMCO-VOUGHT, INC.
1515 South Manchester Avenue, Anaheim, California

© 1962
Altec
Lansing
Corp.



LETTERS to the editor

DEAR EDITOR:

In looking for an inexpensive, durable, sound-deadening material for a production studio we discovered that the rubber padding used under rugs is ideal. It is strong, quite easy to clean with a vacuum cleaner, and low in cost. It has good sound absorbing qualities and may be bought at any store selling rugs. A sample is enclosed.

WILLIAM J. KIEWEL
Manager, KROX
Crookston, Minn.

Thanks for the swatch, Bill. I'm sitting on it right now (hard chairs around here). Seriously, we know it works, having had experience with something similar a while back.—Ed.

DEAR EDITOR:

I was one of the initial subscribers to **Broadcast Engineering**, but because most of my associates were on the "free" list, I politely raised a little heck and became a freeloader myself. Being an independent sort of character, I do not like this situation. I am well paid for my services, and believe that I, in turn, owe payment to those who serve me. Therefore, I wish to become a paying subscriber once again.

How about a life subscription—one payment from me, and I receive your valued publication for life? I am willing to gamble on a long lifetime for **Broadcast Engineering**. Want to gamble on how long I last?

FREDERICK C. HERVEY

WHKW

Chilton, Wisc.

The price is \$50.00, but rather than a gamble, let's call it a "long-lived" association.—Ed.

DEAR EDITOR:

In his article, "Planning a New FM Stereo Station" (November **BROADCAST ENGINEERING**), Mr. Lloyd M. Jones correctly evaluates the capabilities of the serrasoidal modulation exciter relative to stereo and an additional 67-ke subcarrier multiplex service. He predicts that some manufacturer will "... come out with a direct-FM exciter unit with only four or five tubes, and using a variable capacitor diode as the modulating device."

Perhaps Mr. Jones and your readers would be interested to know that Collins Radio Co. has developed precisely that type of exciter, using a varicap as the modulating component. The direct-FM exciter is solid-state except for five vacuum tubes, and delivers 10 watts at the operating frequency. Also developed is a stereo generator which uses the time-division principle and is entirely solid-state. Both are "Type Accepted" by the FCC for monaural, stereo, and SCA use by FM broadcast stations.

A. PROSE WALKER

Collins Radio Co.
Cedar Rapids, Iowa

Interesting indeed, Mr. Walker. Thanks for supplying the "missing link."—Ed.

OTHER ALTEC DYNAMICS PRICED FROM \$42.00 • ALTEC MINIATURE CONDENSER MICROPHONE SYSTEMS: Omnidirectional, \$236.00; Cardioid, \$275.00. • Altec offers a complete line of microphone accessories including desk and floor stands, switches, wall and boom mounts.

Circle Item 6 on Tech Data Card

Continental's 50 kw AM Transmitter uses "Weldon Grounded Grid*" high efficiency power amplifier.

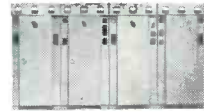

It is an efficient, reliable, stable system for high power broadcasting that is free from surge conditions and does not require protection against excessive modulation peaks or transients.



Ease and permanency of circuit adjustments assures minimum maintenance time. High-power modulation transformers are not required. Grid-swamping resistors are eliminated, allowing most of the driver power to be delivered to the antenna, thereby improving over-all efficiency.



Negligible carrier shift assures full utilization of assigned carrier power of the station. Use of over-all feedback from transmitter output to audio input results in very low noise and harmonic distortion.



End result?

The sound of quality.

*U.S. Pat. No. 2,836,665

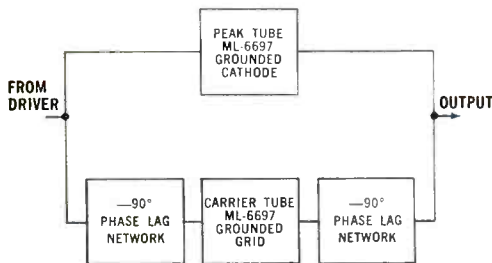
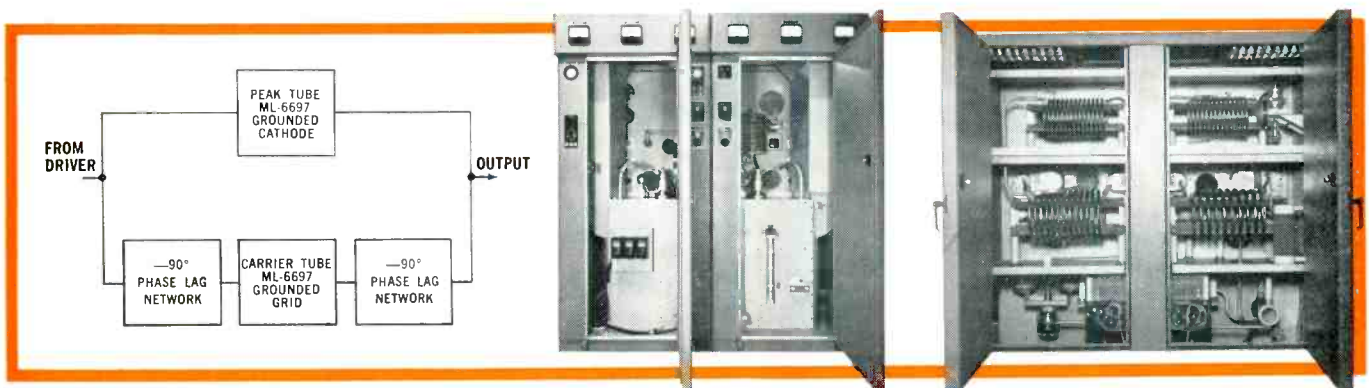

Continental Electronics



PRODUCTS COMPANY • MAILING ADDRESS: BOX 5024 • DALLAS 22, TEXAS
 AD 5-1251 • TELEX CEP CO *LT* SUBSIDIARY OF LING-TEMCO-VOUGHT, INC.
Designers and Builders of the World's Most Powerful Radio Transmitters

Circle Item 7 on Tech Data Card





have you joined
the
20,000 hrs. plus club?

Durability records in vpa operation are commonplace where Raytheon Machlett 7007 tubes are installed. Actually, we have documented performances of 23,000 hours, 25,000 hours and more. Join those stations for which 20,000 hours is common.

With ML7007's in your visual power amplifier, you'll maintain broad sweep, week after week, with only routine adjustment and with power to spare. These workhorse ML7007's require up to 15 percent less drive than new 6166's—with two and three times the life. No wonder ML7007's make such a difference in the cost picture.

Next time you replace, replace with Raytheon—and join the 20,000 hours plus club. Contact your Raytheon Distributor, or write: Raytheon Company, Distributor Products Division, Westwood, Massachusetts.



Circle Item 8 on Tech Data Card

STL REMOTE CONTROL SYSTEMS FOR FM STEREO AND SCA

by John A. Moseley* — How to use studio-transmitter links to pass all information in a FM stereo operation.

When an FM broadcaster takes the first step toward stereo, he can expect many new experiences. If the installation is properly planned, the results will be pleasant and rewarding. One important consideration is remote transmitter operation; it is most important to properly engineer the remote control equipment to obtain optimum system performance. An SCA multiplex subcarrier should also be planned for because of its income producing possibilities (even if its immediate use is not anticipated). While simultaneous stereo and SCA operation may now have pitfalls, transmitter and receiver manufacturers are continually striving to improve the design of their products for better transmission and reception.

When remote operation is involved, and the classical wire line system is used, at least three audio

pairs and two control circuits are required. Since this begins to amount to a sizeable expense, it behooves the broadcaster to study the advantages of using a studio-transmitter link for relaying the main program, SCA, and control signals to the transmitter. Even an STL can be overloaded, but the fact that the SCA and control signals can be stacked makes the circuit more efficient. This article discusses some aspects of using STL equipment to remotely operate an FM transmitter when stereo and SCA signals are transmitted.

STL remote operation can be divided into the following three parts:

1. The control of the remote transmitter (turning the filaments and plates on and off, raising or lowering the power output, etc.)
2. The means for relaying left and right stereophonic signals and the SCA subcarrier signal to the transmitter.

3. The technique of telemetering the transmitter meter readings to the studio.

Before discussing these matters in detail, consider what an STL is and what it can do. A studio-transmitter link consists of a UHF transmitter-receiver combination including appropriate antennas, and provides an exclusive communications channel between a studio and transmitter. Reliable operation can be achieved over distances of fifty miles when the transmission path is free from interfering obstacles.

Subpart E, Part IV, of the FCC Rules and Regulations defines the operational and technical requirements for aural broadcast STL (including TV) and intercity relay equipment. Nineteen channels are set aside in the 942-mc to 952-mc band, each 500 kc in width. These are primarily for program use but may be multiplexed with subcarriers, control signals, cueing tones, etc. It is this provision that helps the broadcaster double up his requirements. Thus, an STL can be used to relay a 15-kc high-quality audio channel to a remote point, as well as to place control tones and an SCA subcarrier on top of the program in piggy back fashion. The STL, like everything else, has limitations, and it is not feasible within the tolerances provided by the Rules and Regulations to add a second high-quality audio channel for stereo. The Commission, however, provided for this when Docket 14628 was released by suggesting simultaneous operation of two STL units within the band limits of one channel assignment.

Control Considerations

Of the three important parts of STL remote operation, the control aspect is perhaps easiest to understand. Basically, it is necessary to

*President, Moseley Associates, Inc., Santa Barbara, Calif.

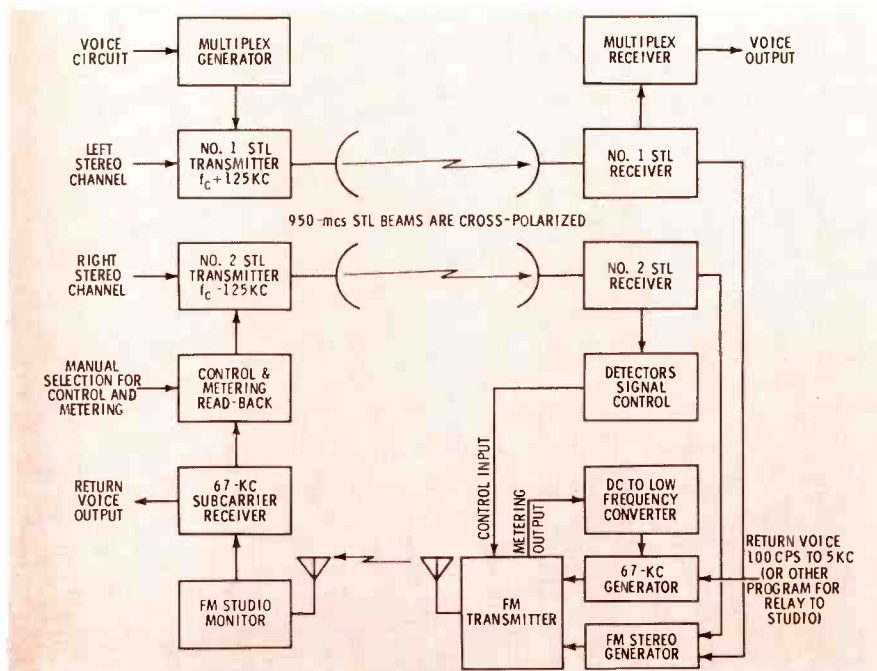

Fig. 1. Block diagram of FM station using STL equipment (SCA gen. at trans. site).

apply control signal modulation to the STL transmitter simultaneously with a 15-kc audio channel, and perhaps an SCA subcarrier, without causing any measurable interference to these programs. The type of control modulation is normally a coded tone burst or a group of discrete frequencies. These frequencies are in the 20-kc to 30-kc region and therefore fall between the audio and SCA channels. It is important that the control frequencies are not sympathetic to any of the program or SCA channels, or any of their intermodulation products.

Program and SCA Relay Considerations

It is easiest to approach the program and SCA phase of the operation by first considering a monophonic signal without the encumbrances of an SCA subchannel or control tones. In this case an STL is used in the same manner as an FM exciter. A 50-cps to 15-kc channel is impressed on the base band of the STL transmitter. Thus, the maximum allowable deviation as specified in Subpart E, Part IV, can be allotted to the audio modulation. Under this condition the STL will deliver a high quality audio channel, with a low signal to noise ratio to the input of the remote FM transmitter. Next the control signals are added at a relatively low modulation percentage—8 to 10%. This level is sufficient to produce positive operation of the detecting circuits at the remote site. If an SCA subcarrier is desired and if the STL is designed to accept multiplex signals, a 67-kc subcarrier is applied at a 10 to 15% modulation level. This is much the same as with the main FM transmitter.

At the STL receiver the 50-cps to 15-kc audio modulation is detected and fed to the FM exciter. If control or SCA channels are present, a filter should be used to prevent these signals from appearing with the audio modulation at the input of the exciter. Next the control tones are detected, preferably before the deemphasis network, and fed into the control tone detectors. Finally, the SCA subcarrier is processed and rebroadcast without being demodulated.

It is necessary to place the stereo generator at the transmitting site because of the technical restrictions

associated with the composite stereophonic signal, the STL, and remote control. With FM stereo it is necessary to employ another STL to convey the second 50-cps to 15-kc audio channel to the stereo generator. Since the left and right signals are added to obtain the information for the main (monophonic) channel of the FM transmitter, it is important that both audio channels have similar amplitude and phase characteristics as well as equally good S/N. To be safe, the S/N of each audio channel in the dual STL system should be at least 63db. This will allow a slight margin of safety over the required minimum of 60db for noise contributed by the transmitter and studio equipment. This and the deviation limitations for aural STL service are the primary reasons why two high-quality audio channels cannot be carried by one STL. However, because a single STL can carry one high-quality stereo channel as well as the control tones in a 150-kc channel, it is possible to place two links side by side in such a manner that all sideband energy is confined within the 500-kc STL channel. Hence, a dual STL system will enable the broadcaster to deliver the left and right stereo signals, SCA, and control signals to a remote transmitter location with a high degree of technical effectiveness.

Metering Considerations

Transferring the required metering information from a remotely controlled transmitter is a task usually associated with the remote control equipment. However, when discussing STL equipment, it is best to describe this process separately even though the end result is tied into the control operation.

In the system under consideration, the metering information is returned to the controlling studio as an SCA multiplex subcarrier. Since stereo operation was one of the original considerations of this paper, all SCA operation must be confined within the 53-kc to 75-kc spectrum. Also, the total SCA subcarrier deviation must not exceed 10% modulation of the main FM carrier. If an operational SCA channel is desired, such as for storecasting or to other background music, it is not practical to divide the SCA spectrum and the allowable 10% modulation between metering and program subcarriers.

One practical answer to the metering problem is to share the modulation bandwidth of a single SCA subcarrier. This can be reliably accomplished by setting aside a portion of the low frequency SCA modulation spectrum. The frequency span between 20 and 40-cps has been found satisfactory for

• Please turn to page 44

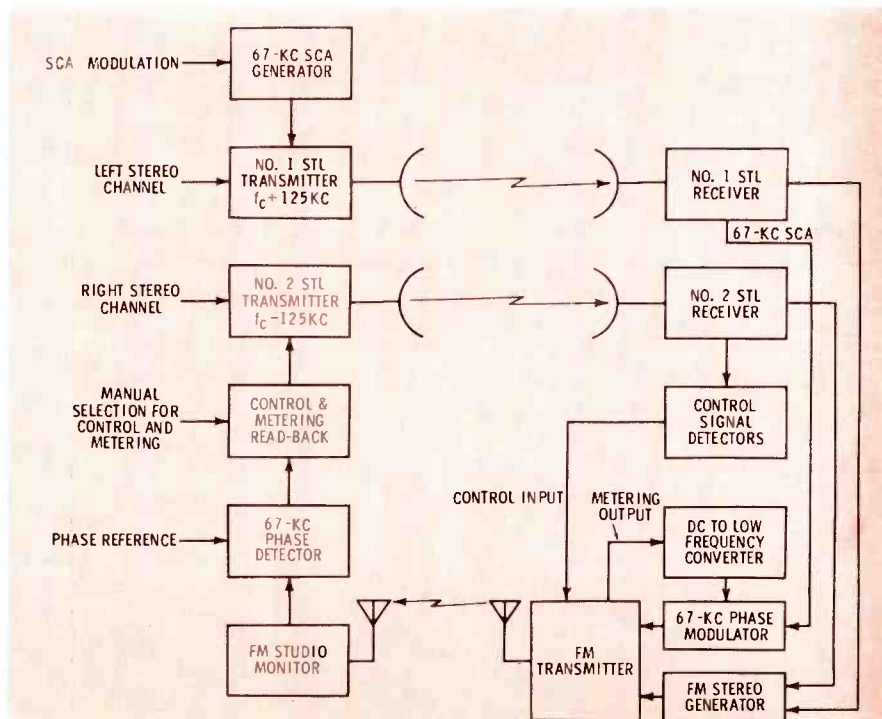

Fig. 2. Same basic arrangement as in Fig. 1 except that SCA generator is at studio.

FULL SPECTRUM TELEVISION VIA CATV

by Irvin Kuzminsky* — A

comprehensive comparison of split-band and distributed amplifiers for community antenna systems.

In the early days of CATV insufficient consideration was given to some of the basic problems pertinent to community antenna systems. However, with maturity and experience has come a recognition of many of these problems. The increasing demands of once satisfied customers and the addition of FM and educational television have produced the need for more channels and the improvement of picture quality. Trunk lines have become longer with the expansion of many systems. For these reasons, many of the earlier systems have required modifications.

In the past, many problems were unique and required unique solutions. Now, with increasing numbers of community systems, there are very few problems which have not been encountered previously and solved successfully. Since the point has been reached where there are routine solutions to routine problems, the urge to build better systems arises.

The system should be capable of transmitting two bands of information—the low VHF and FM bands, and the high VHF band. The transmission system consists of coaxial cable and suitably spaced repeater stations.

*Director, Research & Development, Entron, Inc., Silver Spring, Maryland.

To minimize maintenance problems it is desirable to have the greatest possible spacing between repeater stations. This spacing is determined by the maximum amplifier output, the cable attenuation vs. frequency characteristics, and the amplifier noise figure. The maximum output is limited by several considerations: system radiation limits output-tube distortion and intermodulation levels, and the number of channels passed by the amplifier; the cable attenuation varies inversely with the cost of the cable; and the amplifier noise figure has a minimum practical limit. It has been determined that repeater amplifiers spaced at intervals of 25 to 35 db of peak cable attenuation with a noise figure less than 10 db will result in reasonable output levels and good signal-to-noise ratios.

In general, the slope of the cable attenuation vs. frequency curve (known as tilt) is almost identical for all cables; thus, except for the length of cable between repeater stations, the design is independent of the cable type. The typical curve shown in Fig. 1 has been normalized to an attenuation of 26 db at 216 mc. Two types of systems will be analyzed in their application to this transmission system. They are:

1. A wide band system using distributed line or chain amplifiers.
2. A split-band, high-low system.

Equalization

The amplifier gain curve should be the same as the cable loss curve in the amplifier pass band. In the split-band system, this is accomplished by providing different gains in the various bands, and tilting the response curve of each amplifier to correspond to the tilt of the cable loss curve in that band. With

distributed-type amplification, compensation over so wide a band is difficult and is usually obtained by providing additional loss at the lower frequencies so that the combination of amplifier gain and equalizer loss over the pass band is equal to the cable loss.

We see then, after going through an expensive repeater amplifier to obtain signal increase, an additional expense must be suffered to throw away some of this gain. Figs. 2 and 3 compare the wasted gain and bandwidth inherent in the operation of both systems.

Harmonic Interference

Each amplifier in the split-band system serves as a filter since less than one octave is covered in each band. Harmonic outputs, therefore, are suppressed by characteristics of the split-band amplifiers and the multiplexing networks. With the distributed amplifier, such filtering is not available. Second and third harmonics of low band signals fall into the high band, and may cause interference to desired signals.

Output Levels

The split-band system is capable of about twice the output voltage that can be obtained from the distributed amplifier system. This is due to the lower plate impedance and the greater number of channels in the distributed amplifier. The output level can be increased by adding tubes in the output stage. However, there is an optimum stage gain which results in a minimum tube requirement. Any departure from this optimum stage gain will require additional tubes and multiply the cost of maintaining the desired amplification.

Noise Power

Because the total bandwidth of the wideband system is more than

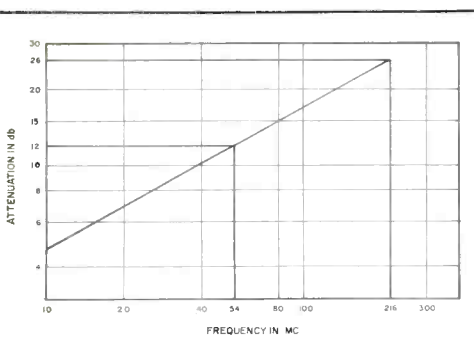

Fig. 1. Cable attenuation versus frequency.

twice the sum of the bandwidths of the multiplexed amplifiers, the noise power present in the split-band system will be about half of that in the distributed amplifier system, even if we assume identical noise figures for all amplifiers. Because of poor selectivity, better signal-to-noise ratios will be obtained in the receivers for signals nearest the band edges of the split-band amplifiers. In addition, the distributed amplifier has a poorer noise figure due to the additional noise contributed by the tubes in the input stage.

Signal Level Variation

Signal level variation on the trunk line is due mainly to loss of transconductance of the amplifier tubes and to changes in cable attenuation with temperature. For a change of 20% in tube transconductance, the gain of the 12-tube, four-stage distributed amplifier would change by 7.76 db, while the gain of a three-stage single-band amplifier would change by 5.82 db.

Changes in cable attenuation with temperature variation are too great to be neglected. The cable attenuation varies from its nominal at 68°F by -7.7 db per 100 db at 0°F to +4.5 db per 100 db at 110°F. Since cable attenuation varies with frequency, change in attenuation will also vary with frequency. For a change in attenuation of 10 db at 216 mc, there will be a change of only 4.5 db at 54 mc.

In the distributed amplifier system, signal level variation is a serious problem; automatic gain control is very difficult. Because of this,

variations in the system may be accumulated to the point of severe signal level changes (and differences therein) at both ends of the pass band. The large changes in cable tilt require the use of thermatic equalizers in the wide-band system.

In the split-band system, signal level changes can be corrected by incorporating AGC; differences in signal levels, in each amplifier, are smaller because of the narrow pass bands involved. For example, a change of cable attenuation of 10 db at 216 mc would be accompanied by a change of 8.7 db at 174 mc. There would then be a change of 4.5 to 6 db over the low VHF band.

Reliability

To examine the reliability of each system, we will define a system failure as the loss of information, either by degradation which makes the information unusable or by complete loss of information.

While it may be true that failure due to an open tube filament is more likely in the split-band system, such a failure would remove information from only one of the bands. Other types of tube failure would result in a complete system failure for the wide-band system, while the multiplexed system would still lose only one of the two bands. It is more probable that one distributed amplifier would fail than an amplifier in each of the multiplexed bands.

Consider a system having a total cable attenuation of 500 db at 216 mc. (This would correspond to 6 miles of 3/8" Spirafil.) Due only to

changes in cable attenuation, a variation from the nominal 68°F of +22 db at 110°F and -38 db at 0°F could occur at the end of the trunk line. This would cause either serious overloading or signal degradation to the point where the signals would no longer be usable. Changes in amplifier gain would make the problem even more severe. These changes would have little effect on a split-band system with AGC, but would result in system failure of a distributed amplifier system without AGC.

Relative Expense

This brings us to the third point for evaluation—the relative costs of the two systems. The distributed amplifier system uses more tubes than the multiplexed system, but fewer amplifiers. In addition, the wide-band system requires the use of cable loss equalizers and thermatic equalizers, whereas the split-band system demands splitting and combining filters.

A usually reliable method of estimating the cost of electronic equipment is based on the number of tubes. On this basis, the cost of split-band amplifiers should be about two-thirds the cost of distributed amplifiers. Also, the split-band system permits an operator to install low-band equipment initially, while deferring the cost of high-band equipment to a later date. The high band may then be added as funds become available and additional channels are required. Existing low-band systems may be easily modified by the addition of high-band equipment. ▲

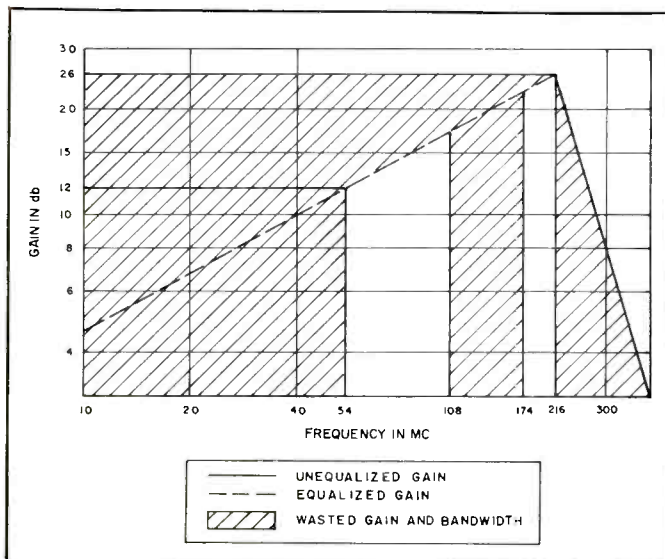

Fig. 2. Distributed amplifier response.

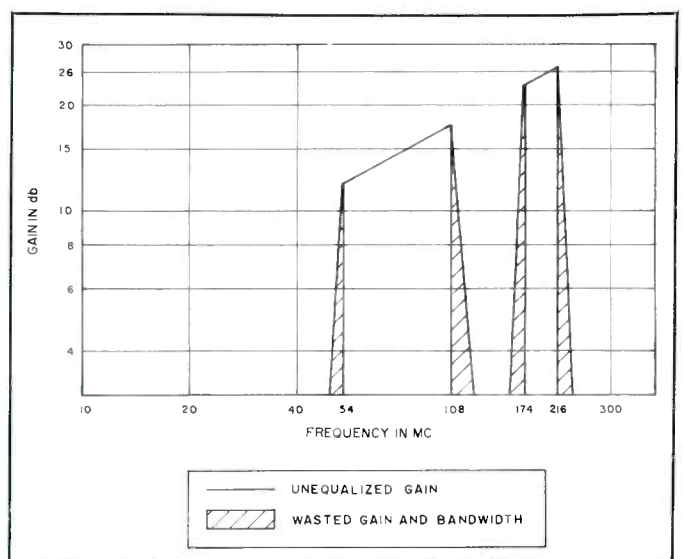

Fig. 3. Split-band amplifier response.

PRACTICAL APPLICATION OF FCC'S ENGINEERING RULES

by **John H. Battison*** — How to fill out FCC Form 301, from beginning to end, with suggestions on complying with the Commission's requirements.

Through years of experience in handling FCC applications, consulting engineers have found that much of the work could be done by the chief engineer. While this is obviously not a suggestion that broadcasters cease dealing with their consulting engineers, it is proposed that in many cases a chief engineer could perform some of the engineering work requisite to filling out Form 301. The object of this discussion is to describe the work involved, and the method of fulfilling the technical requirements of the FCC.

Preparing Form 301

Consulting engineers cannot attempt to interpret legal forms and offer opinions to their clients; recently an effort on the part of a consultant to interpret a section of the Rules led to trouble for his client. However, filling out Form 301 is very important, and trouble-free if the instructions are followed.

Referring to the sample form in Fig. 1, the first source of error occurs in entering the **name** of the applicant at the top of the first page of Section V-A (Standard Broadcast), V-B (FM), or V-C (TV). This entry must be exactly the same as the licensed name, or in the case of applications prior to licensing, the same as the applicant's name as given in Section One. For example, if the name is Blank Incorporated, don't call it Blank Inc. in the engineering data section.

Addresses of studios, transmitter, and remote control point, if any, are generally self evident. However, if your sites are outside the city, and a regular street address will not accurately describe the location, specify it in distance and direction from the city along a particular

highway. Don't be afraid to give the most explicit instructions to allow the FCC, and any other interested parties, to locate and identify the site exactly. Remember, too, that Section V-G, dealing with antenna and transmitter information, goes to the Federal Aviation Agency for checks on air safety requirements.

Type designations of transmitter, modulation monitor, and frequency monitor must be provided in parts 7, 8, and 9, respectively. Normally, FCC Type - Approved transmitters and monitors will be used so that the question asking for type-approval data can be answered "FCC Type Approved" or "Not Applicable" (NA).

The antenna system comes in for some pretty rugged questioning in the next paragraph. If the system is to be directional (DA), a full disclosure of the technical data concerning the formula, sample calculations, pattern, etc., will be required.

Antenna height must be given in various ways. When entering antenna data the base insulator, in the case of series-fed towers, must be included in the overall height. Generally 3' is allowed for the insulator, and another 3' for the beacon at the top of the tower. If a shunt-fed tower will be used, the base insulator is eliminated, but the beacon should be indicated on the application.

Sometimes the question of height above mean sea level causes trouble because the quoted figure does not agree with that used by the Commission or the FAA. If the height given differs from that obtained from a quadrangle, topographic map, or a Sectional Aeronautical Chart (SAC), the reason for the discrepancy must be explained, and

the actual method of finding the quoted height disclosed. Failure to do this, or making an error in the height, will prompt endless correspondence with the FCC until the matter is straightened out to their satisfaction.

Latitude and Longitude

For obvious reasons the FCC must know the exact location of the proposed station. This is to facilitate notification of other countries which are signatories to North American Regional Broadcasting Agreement (NARBA) and for calculation of interference. It is also essential to any other purpose for which a simple address (e.g., 126 Main St., Podunk) will not suffice.

For the benefit of readers who are unfamiliar with latitude and longitude—the lines forming a grid on the charts used in station planning—a brief explanation is valuable. Lines of longitude, called meridians, run north and south and are great circles (their planes pass through the center of the earth) but are **not** parallel. All lines of latitude, except the equator, are small circles (their planes do not pass through the center of the earth) and **are** parallel.

For most practical purposes, lines of longitude (meridians) are measured from Greenwich, England, in an easterly or westerly direction. Latitude, measured from the equator (0°), is annotated in degrees north or south (of the equator).

Any point on the surface of the earth can be located in terms of latitude and longitude; 360° of longitude encircle the earth, and the aeronautical charts (SAC and WAC) used in broadcast engineering are marked in degrees, half degree lines, minutes, and seconds.

**STANDARD BROADCAST
ENGINEERING DATA**

Name of applicant

WXXX, Inc.

1. Purpose of authorization applied for: (Indicate by check mark)

(If application is for a new station or for any of the changes numbered B through F, complete all paragraphs of this form; if change G is of a character which will change coverage or increase the overall height of the antenna structure more than 20 feet, answer all paragraphs, otherwise complete only paragraphs 2 and 10 and the appropriate other paragraphs; for changes H through M, complete only paragraph 2 and the appropriate other paragraphs; for change N complete only paragraphs 2 and 5.)

- A. Construct a new station
- B. Change power
- C. Change transmitter location
- D. Change frequency
- E. Approval of site and antenna
- F. Special Service Authorization
- G. Change in antenna system (including addition of FM and TV antennas)
- H. Change frequency control equipment
- I. Change tubes in last radio stage
- J. Change system of modulation
- K. Change transmitter
- L. Install auxiliary or alternate main transmitter
- M. Other changes (specify)
- N. Change studio location

If this application is not for a new station, summarize briefly the nature of the changes proposed.

2. Facilities requested

Frequency	Hours of operation	Power in kilowatts Night Day
1600 kc	unlimited	1.0 5.0

3. Station location

State	City or town
	Podunck

4. Transmitter location

State	County
Md.	
City or town	Street Address (or other identification)
	126 Main Street

5. Main studio location

State	County
City or town	Street and number, if known

6. Remote control point location

State	City or town
Street Address (or other identification)	

7. Transmitter

Make	Type No.	Rated Power
	A1	5 kw

(If the above transmitter has not been accepted for licensing by the F.C.C., attach as Exhibit No. _____ a complete showing of transmitter details. Showing should include schematic diagram and full details of frequency control. If changes are to be made in licensed transmitter include schematic diagram and give full details of change.)

8. Modulation monitor

Make	Type No.
XYZ	MM

9. Frequency monitor

Make	Type No.
XYZ	FM

10. Antenna system, including ground or counterpoise

Non-Directional Antenna:	Directional Antenna:
Day <input checked="" type="checkbox"/> Night <input checked="" type="checkbox"/>	Day only (DA-D) <input type="checkbox"/>
	Night only (DA-N) <input type="checkbox"/>
	Same constants and power day and night (DA-1) <input type="checkbox"/>
	Different constants or power day and night (DA-2) <input type="checkbox"/>

(If a directional antenna is proposed submit complete engineering data. Show clearly whether directional operation is for day or night or both. If day and night patterns are different give full information on each pattern. This information is in addition to the information in Paragraph 10 and is submitted as Exhibit No. _____ and signed by the engineer who designed the antenna system.)

Type radiator	Height in feet of complete radiator above base insulator, or above base if grounded.
vertical guyed tower	200
Overall height in feet above ground. (Without obstruction lighting)	203
Overall height in feet above ground. (With obstruction lighting)	503
Overall height in feet above mean sea level. (Without obstruction lighting)	506
Overall height in feet above mean sea level. (With obstruction lighting)	506
If antenna is either top loaded or sectionalized, describe fully as Exhibit No.	N/A

Excitation	Series <input checked="" type="checkbox"/> Shunt <input type="checkbox"/>
Geographic coordinates to nearest second.	
For direction antenna give coordinates of center of array.	
For single vertical radiator give tower location.	
North latitude	West longitude
° ' "	° ' "

If not fully described above, give further details and dimensions including any other antennas mounted on tower and associated isolation circuits as Exhibit No. _____ (Height figures should not include obstruction lighting.)

Submit as Exhibit No. **Fig. 1** a plat of the transmitter site showing boundary lines, and roads, railroads, or other obstructions; and also layout of the ground system or counterpoise. Show number and dimensions of ground radials or if a counterpoise is used, show height and dimensions.

11. Attach as Exhibit No. **Fig. 2** a sufficient number of aerial photographs taken in clear weather at appropriate altitudes and angles to permit identification of all structures in the vicinity. The photographs must be marked so as to show compass directions, exact boundary lines of the proposed site, and locations of the proposed 1000 mv/m contour for both day and night operation. Photographs taken in eight different directions from an elevated position on the ground will be acceptable in lieu of the aerial photographs if the data referred to can be clearly shown.

Fig. 1. Sample of FCC Form 301.

The latitude scales run only 90° north and south of the equator, but the same divisions are used. Thus, any place can be accurately described as west (in the Americas) so many degrees, minutes, and seconds; and north (in North America) so many degrees, minutes, and seconds. (Sometimes, for greater accuracy, fractions of seconds are given, but the FCC requires only the nearest second.) These coordinates accurately specify the position of a station without the need for any local identifying data.

Finding Coordinates

A common error that occurs in completing Form 301 is inaccurate computation of the site coordinates. When using SAC's, or WAC's, the five-minute and one-minute divisions make it comparatively easy to locate a site, either to mark it, or to obtain the coordinates. Because of the scale, however, the latter is more difficult. The answer lies in the U. S. Topographic Quadrangle Maps.

Most regions of the country are covered by these maps in the "7½" series, which covers 7' 30" in each quadrangle. Some of the more sparsely populated sections still have only "15" coverage (15' per quadrangle); in these instances, however, it is sometimes possible to find other maps that will make

accurate location easier. The "7½" is preferable.

The only disadvantage in using the "7½" maps is the relative difficulty in finding the actual coordinates, because the divisions are so large. Most engineers have their own methods of finding the accurate coordinates on these maps. One is to measure the distance between the two divisions spanning the latitude of the desired site. The interval between these divisions is always two minutes, thirty seconds (2' 30") or 150". Use millimeters or some small convenient scale units (e.g., 32nds of an inch) to reduce the error. Then the distance from the lower division (e.g., 40° 2' 30") to the site is measured in the same units and, by simple proportion, the number of seconds of latitude is found. Suppose this distance is 97", which reduces to 1' 37"; this figure is added to 40° 2' 30", resulting in 40° 04' 07". Note: it is preferred practice to show the zero in front of a single digit when the possibility of two digits exists.

The same method is applied to the determination of longitude. Care is required to ensure the calculated result is **added** to the correct divisional value—always the lower one. If, for any reason (i.e., closeness) the upper division is used as the base, **subtract** to find

the correct answer. Fig. 2 shows the work for a typical problem.

Exhibits

The next two requirements for the application are a plat of the ground system and photographs of the site. At this point it might be well to note that most engineers call these, and the succeeding exhibits, "Figures" rather than "Exhibits," and insert the note "see Engineering Report" in Form 301. Then, in the engineering report, they are numbered as figures. However, any logical and easily understood system may be used.

The purpose of the site plat is to show the Commission's engineers that there is sufficient room for the ground system, and there are no obstructions adjacent to the antenna that could distort the pattern through absorption or reflection of the signal. This plat need not be to scale, provided that this fact is stated, and all dimensions are given.

The site photographs usually do not present much of a problem; however, if aerial views are used it is essential they be photographed from an altitude which will provide good detail. It must be possible for the FCC engineers to distinguish objects immediately around the site. For this reason it is preferable, and nearly always acceptable to the FCC, to submit a series of 8 photographs taken from the top of a step ladder, or the roof of a car, commencing at north and thereafter at 45° intervals around the compass. These should be carefully marked with direction and date.

One drawback to the horizontal photograph method is the difficulty encountered in marking the 1000 mv/m contour. Consequently, it is sometimes necessary to submit an aerial photograph as well. In the case of nondirectional antennas, it is generally possible to show the approximate location of the contour on horizontal pictures.

In composing, the photographer should remember the major reasons for the photographs — observation of the presence, or absence, of houses, etc., immediately adjacent to the antenna.

Next month, the concluding portion of this article will deal with the preparation of the engineering exhibits and methods of complying with the technical rules. ▲

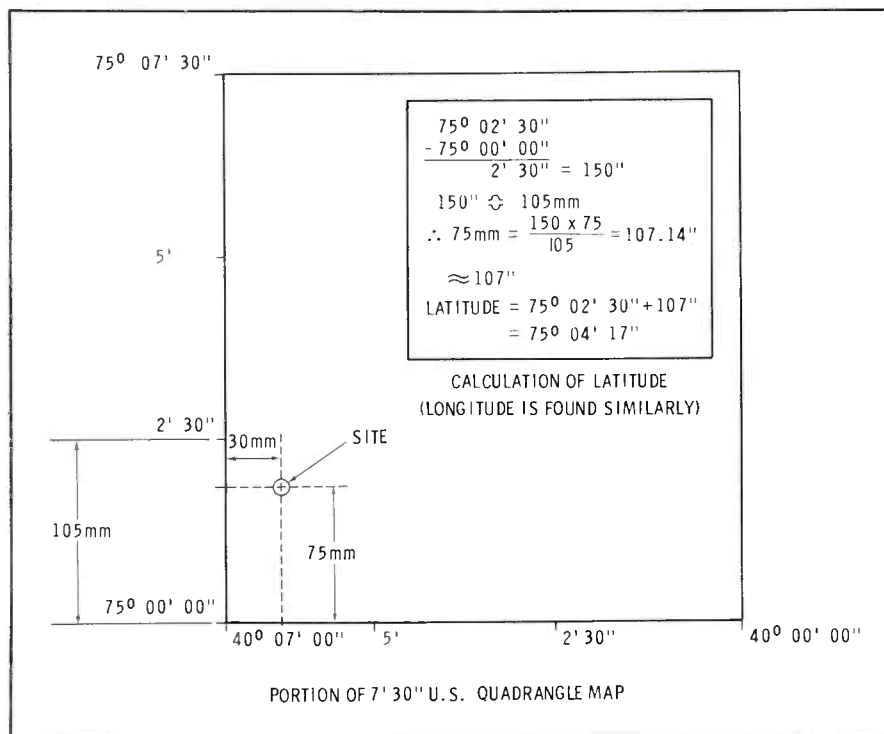

Fig. 2. Sample computations involved in specifying the exact location of a station.

see 5/63 p.8

75° 01' 47"

AUTOMATIC MUSIC SYSTEM

by Arthur J. Smith* — A low-cost "silence" triggering system suitable for small AM and FM stations as well as standby applications.

An FM music system for a small to medium sized station must be automatic for operation by a limited staff. This would seem to point toward a tape music installation. At the time our system was being planned, however, we were not able to obtain the exact type of music required by our programming specifications, and considered making up tapes from disc records. But the cost of tape, time, and extra equipment was excessive. To solve the problem, we decided to devise a music system using two changers for music, and a tape recorder for announcements.

Specifications

The unit to be described (Fig. 1) consists of two Garrard Type A turntables, a Wollensak tape recorder, two G.E. UPX-003B pre-amplifiers, a Knight 12-watt amplifier, a Knight reverberation amplifier with Hammond type IV reverberation unit, and a control chassis. A block diagram is shown in Fig. 2. The cartridges are ceramic stereo units with the left and right outputs tied in parallel, and fed through an equalizer to the pre-amps. This arrangement permits the use of either stereo or monaural records. The unit provides completely automatic operation with an announcement inserted at the end of each record side. The changers are connected in such a way that when one empties, the other continues the operation.

The tape recorder has a single half track head; the tapes may be recorded on any machine because no tones or special "trips" are used. Four to ten seconds of silence between cuts on the announcement tape is the only triggering used. All

*Chief Engineer, WCNB-AM-FM, Connersville, Ind.



Fig. 1. Automatic disc-tape music system.

audio circuits are switched to "kill" the turntables when they are not on the air preventing cueing noises.

Neon indicators mounted on the control panel indicate which turntable is in use, and whether or not the other turntable has been cued for service. The condition of the tape machine is also indicated by neon lights. An automatic cueing feature enables the turntables to continue running after the tape starts, change the record, and stop after the needle has set down into the starting groove of the next record; this reduces dead-air time.

Theory of Operation

The schematic diagram is shown in Fig. 3. All the parts are mounted in the control unit, with the exception of the components shown in the changer schematics at the lower right. Relays A and B are turntable switching relays, and C and D are the tape starting relays.

A simplified schematic of the turntable switching is shown in Fig. 4. Since both turntables are identical, only the operation of TT1 will be described. SW-1 is the regular turntable power switch. The miniature switch (SW-2) is connected to the changer mechanism in such a way that it is normally

held compressed. It is released during the change cycle, and is compressed again only when the cycle is completed. (This was not as difficult a modification as it may seem, on the particular changers used.) The cue button is a SPDT pushbutton switch. All relays are shown in the de-energized position. Notice that both C and D are normally energized from the power line through switch SW-2.

When switch SW-1 on turntable 1 is closed, AC flows through the normally closed contact of relay B through SW-1 and relay A, to the other side of the line. The current also flows through the standby switch, the motor, and the normally closed contacts of relay B to the line. At this point the motor is running, and relay A is energized; relay C is also energized through SW-2. The operation of SW-1 also initiates the change cycle of the changer, through normal mechanical linkage. As the change cycle begins, SW-2 opens the circuit to relay C, starting the capstan motor on the tape recorder. The miniature switch in this position bridges the relay contacts of relay G (the sound operated relay). When the tape machine begins to produce sound, the contacts of relay G open. The turntable motor continues to run, however, because of SW-2. When the change cycle is completed, SW-2 reverts to its normal position, and the turntable stops. At this time relay C will be re-energized, opening the tape machine start contacts, and the stylus of the turntable pickup will have just dropped into the starting groove.

As long as a recorded message is being emitted from the tape machine, the contacts of relay G maintain the turntable at a stand-

still. When the message is completed, and relay G is de-energized, the turntable will begin the next selection. Relay G also contains a set of "bridging" contacts, which keeps the tape machine operating as long as a message is being run. Notice that when turntable 1 is operating and relay A is actuated, turntable 2 cannot operate by virtue of a set of "holding" contacts on relay A.

It is necessary, however, to operate the motor on the turntable not in use for cueing purposes. By pressing and holding the cue button while operating SW-1 of turntable 2, the motor will operate even though relay B is not actuated. As this turntable begins its change cycle, the associated SW-2 is operated. Thus, it is necessary to employ another set of relay A contacts to bridge the normally closed position of SW-2, to prevent relay D from dropping out and starting the tape motor. After turntable 2 is cued, the cue button is released.

Turntable 2 is now ready to operate when turntable 1 empties. This operation depends upon the automatic shutoff on the Type A turntables. When turntable 1 is emptied SW-1 shuts off automatically, relay A is de-energized, and the holding contact of relay A (which has prevented the start of turntable 2) closes, starting turntable 2; relay B is also actuated, and "locks out" turntable 1. Turntable 1 can now be reloaded and cued using the foregoing procedure. The standby switch is used to stop the turntables, without changing the condition of relays A and B.

Relay F, a DC (to prevent hum)

relay, switches audio from the pre-amplifier of either turntable 1 or 2. It is operated by a set of contacts on relay B so the output of the turntable 1 preamp normally feeds the music amplifier. When relay B is actuated relay F is energized, selecting the audio from turntable 2 preamplifier. Hence, the audio switching is automatic.

Relay E, also a DC relay, switches the audio to the line from either the music amplifier or tape machine output. The relay normally connects the output of the music amplifier to the line; but if relay C, D, or G is operated (to start the tape recorder), the output of the tape amplifier is selected. When in the Music position this relay connects the speaker to the output of the tape recorder; when in the Tape position, a 7.5-ohm resistor is connected across the output of the music amplifier. In our case the output impedance of the tape recorder and the music amplifier were both approximately 8 ohms; thus a voice coil-to-line transformer was necessary to match the line. The pad is conventional, and the VU meter at the output is operated at 4 dbm.

The sound operated relay is straight forward. The output of the tape recorder is connected to the input of the intercom transformer. This feeds a conventional cascade amplifier, V1. The output of V1 is fed into V2, which rectifies the audio and supplies a positive voltage to the grid of the control tube V3. This stage is normally biased by means of the 2500-ohm cathode resistor and the 47K 2-watt voltage divider, so G will not operate. The

0.5-mfd capacitor and the 10-meg-ohm time delay control determine the time relay G will remain closed after the audio from the tape recorder has concluded. We normally set this control for about two seconds delay. The input sensitivity control determines the audio level at which relay G will close and drop out. This control is usually set on the high side, because if five seconds of **dead silence** is provided between cuts on the tape, dropout is no problem. Although paper leader tape can be used for marking convenience, it should not be necessary for operation.

A tape cueing switch starts the tape transport motor, and provides normal operation of the machine in Cue position. The B plus is then removed from the sound operated relay to prevent operation of relay E. In the Cue position relay E connects the speaker to the output of the tape recorder for monitoring.

Both power supplies for the DC relays and the sound operated relay are conventional, but oversize to prevent excessive heat and failure.

The pilot lamp assemblies used for the neon indicators contain 100K resistors, which are not shown on the schematic. (This series resistor must not be omitted if some other arrangement is used.) Turntable run lights are connected across relay A for TT1 and B for TT2; the tape run light is connected across relay E. The turntable and tape ready lights are connected across relay contacts which prevent operation. When all circuits are closed except these final contacts (such as when tape or turntables are cued), the lights operate indicating a ready condition, and the ready light is extinguished.

The 80-mfd capacitor connected across relay E holds it for a fraction of a second after the voltage is removed. This allows the turntables to get up to speed before the line is switched to the output of the music amplifier, preventing any possibility of wow.

Operating Suggestions

The unit is very simple to operate. The changers are loaded in the usual manner; the tape is cued by throwing the tape cue switch, and the recorder is then operated normally. We have a "sign-on" at the beginning of our tape, and operate

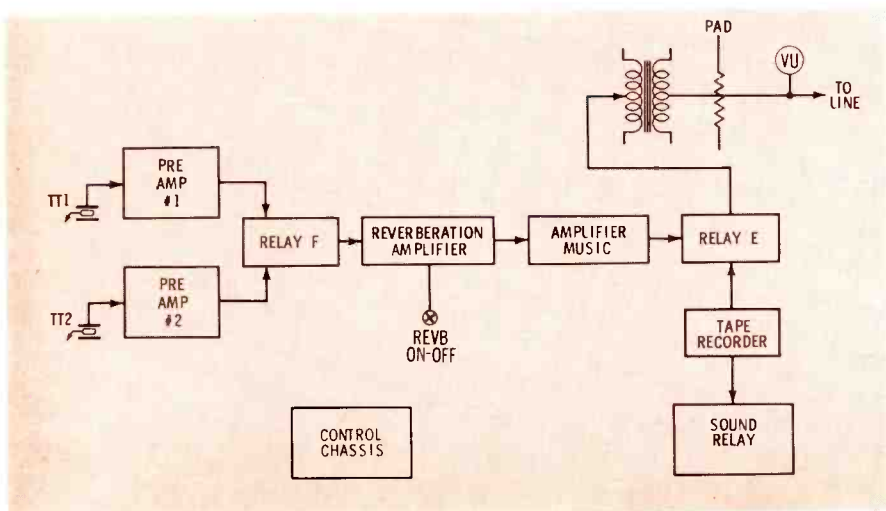

Fig. 2. Block diagram of audio layout in automatic music system.

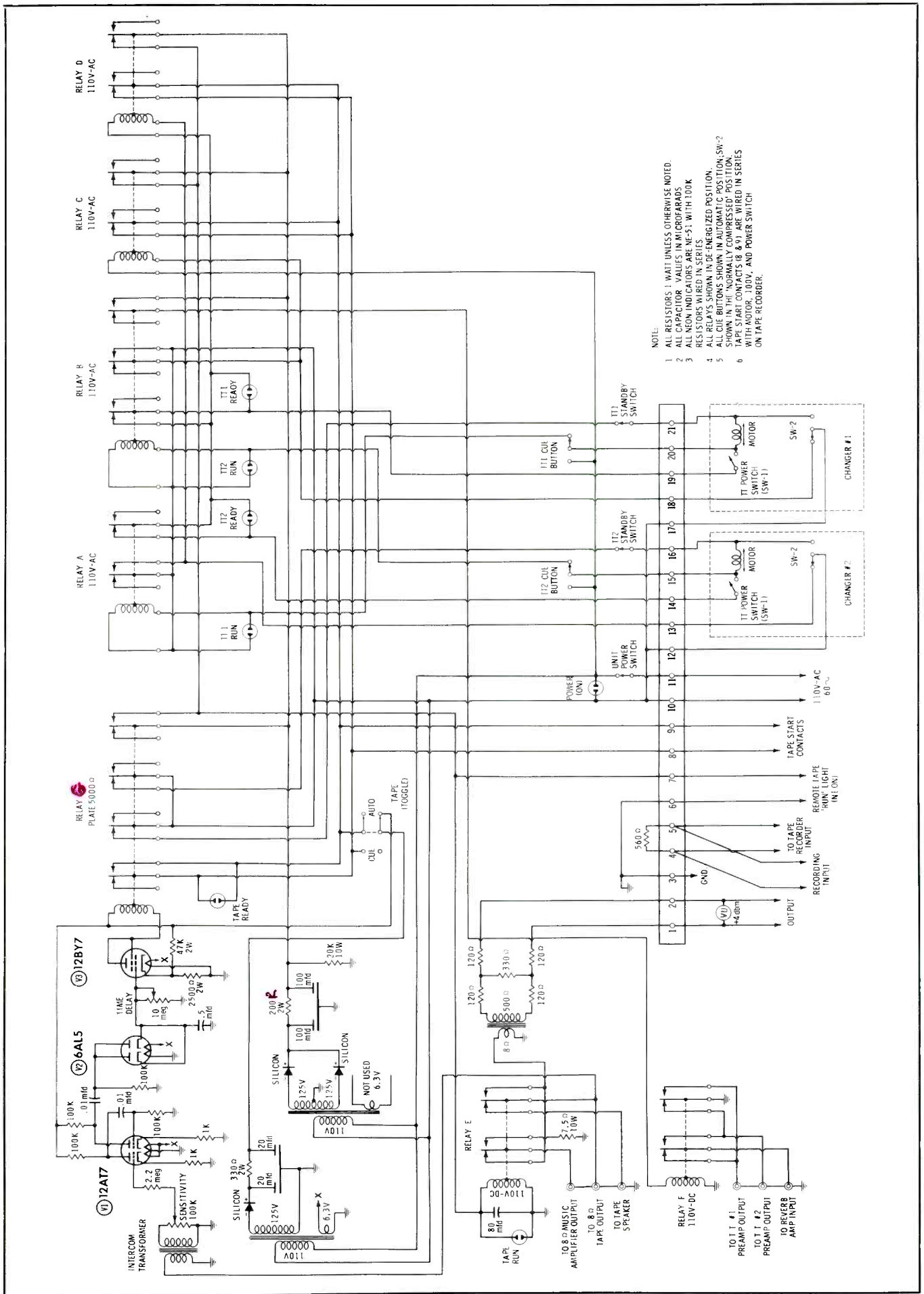

Fig. 3. Complete circuit of automatic music system.

SEE 4/63 ISSUE P.10

Are Your Station Turntables Ready for Stereo Broadcasting?



THE ANSWER IS YES if you're using the new Fairchild 750 16" belt-driven playback turntable. The only turntable designed for stereo broadcasting! Write today for complete technical specifications on this remarkable new turntable. Price: \$485.00

FAIRCHILD

RECORDING EQUIPMENT CORPORATION
10-40 45th Ave., Long Island City 1, N. Y.
Circle Item 9 on Tech Data Card

TELEQUIP

BUYS

AND

SELLS



USED

TV-RADIO

EQUIPMENT

CALL US

TELEQUIP Corp.

319 East 48th St., N. Y. C. 17, N. Y.

PL 2-8885 - PL 2-9037

Circle Item 10 on Tech Data Card

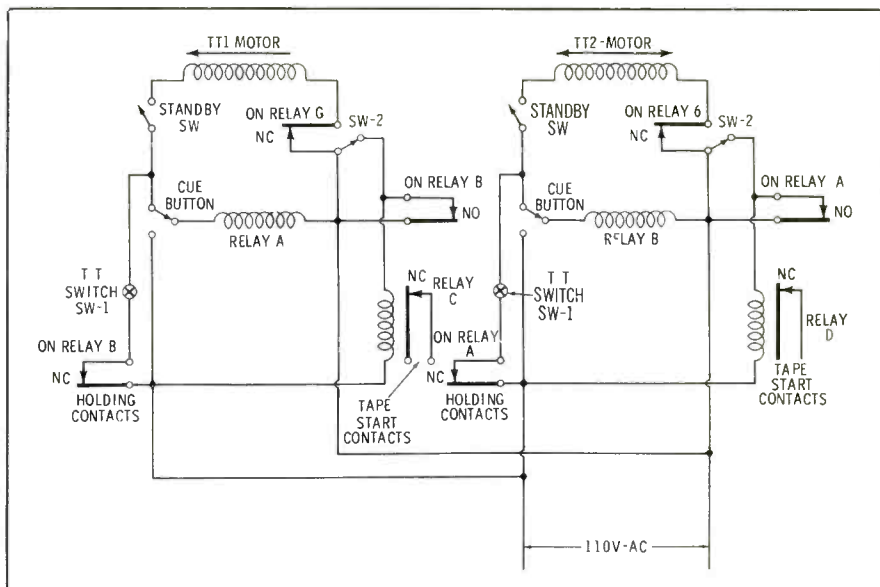

Fig. 4. Turntable switching circuit.

one of the turntables on the reject (SW-1) switch. This starts the turntable, and when the change cycle begins, starts the tape recorder. By the time the sign-on has been run the turntable is cued and ready to go. After one of the turntables is on the air, we cue the other turntables (as described previously) by holding down the cue button until the stylus just falls into the lead-in groove.

Levels on both turntables and the tape recorder are monitored on the VU meter. We use a constant level amplifier following this unit, and consider it a necessity. A means of continuous aural monitoring should also be provided. Provision was made for an external tape "run" light on the console, although we found aural monitoring made this unnecessary. If a record sticks, or if for some other reason you wish to switch turntables, momentarily pressing the cue button of the turntable you wish to stop will permit the other turntable to take over. The gain of the music amplifier should be turned all the way down before hitting the "cue-kill" button to prevent the possibility of pop or wow on the upcoming turntable.

The announcement tape can be recorded on any tape recorder, including the one incorporated in the system. Place the tape cue switch in the cue position, and record using normal procedure. Anywhere between 4-10 seconds can be spaced between announcements when recording, but 5 seconds gives good triggering time, and

minimum dead air. (If the tape is not ready at the end of a record, the turntable will change and immediately go to the next disc, or to the next turntable, without pause.)

Construction

The entire unit was built with only hand tools and an electric drill—and no special tools are necessary. The control unit was constructed on a 13" by 17" by 3" aluminum chassis which was fastened to standard rack panels. The equipment is mounted in a wooden enclosure which also serves as a record cabinet. Although hum has not been a problem, a metal cabinet may be preferable. Audio relays E and F are mounted in aluminum boxes on the control unit chassis to help reduce hum and noise. The other control unit wiring is not critical.

Variations of the system are, of course, possible; such as the addition of another tape recorder with a time clock, to air commercial messages at the first break past the hour. The other machine could then carry only station identification, and/or sustaining material.

This system has performed well for nearly two years, with only one minor failure—the 12AT7 filament in the sound-operated-relay amplifier. The installation will supply about 5-6 hours of music without reloading, and of course as much as desired when reloaded occasionally. This equipment will also function as a very good standby unit where a music system is already available. ▲

Jensen "SPACE-PERSPECTIVE*" FOR STEREO HEADPHONE LISTENING

Jensen's exclusive SPACE-PERSPECTIVE network makes it possible for the first time to eliminate the "closed ears" effect of ordinary stereo headphone listening, in which the sounds appear to come only from the left and right, and accurately presents the "open ears" sensations of normal stereo speaker listening in a room, in which the performance is out-in-front as intended with true directional effects. It accomplishes this by accurately shaping the frequency characteristics and time delay of the signals sent to the individual phones so that they correctly portray the sound "build-up" and "shadowing" at the ears due to the obstacle effect of the human head as acoustic waves from the source flow around it. This breakthrough is due to an ingenious circuit development by Bauer of CBS Laboratories, employing the analogue computer, and is based on the acoustic measurements on the human head by Wiener, then at the Psychoacoustic Laboratory, Harvard University.

- 1 Ordinary stereo headphone listening confines the left channel sound to the left ear, the right channel sound to the right ear. You have the impression you are in the midst of the musicians, who are partitioned to the left and right of you.
- 2 In "open ears" stereo speaker listening, sound from the left speaker reaches the left ear, and also the right ear a little later in time. The sound pressure at the left ear rises, while that at the right ear falls, due to acoustic "shadow" as the audio frequency is increased. The corresponding thing happens for sound from the right speaker.
- 3 Bauer at CBS Laboratories visualized an inspired answer to the problem—a left-right, right-left "cross-feed" electrical network that would accurately simulate the "open ears" acoustical situation. Note the resemblance of the electrical paths of 3 to the acoustic paths of 2.
- 4 Bauer's circuit is complex, as would be expected since frequency characteristics and time delay must be precisely shaped. Resistance networks and potentiometer or volume control "blending" circuits cannot do this.
- 5 Here is the performance of the Jensen SPACE-PERSPECTIVE network compared with Wiener's acoustic data. Note how accurately the network produces the desired acoustic result at the ears. (The data is shown only over the frequency range important to stereophonic directional location; HS-1 'phones and network transmit the full frequency range.)

*T. M. Jensen Mfg. Co. CC-1 and CFN-1 Licensed by CBS Laboratories Div., Columbia Broadcasting System, Inc.

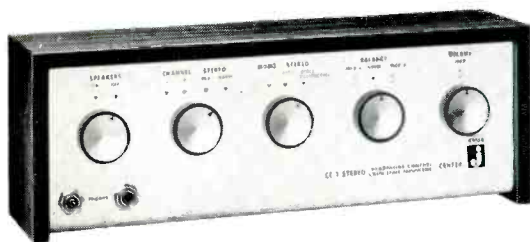
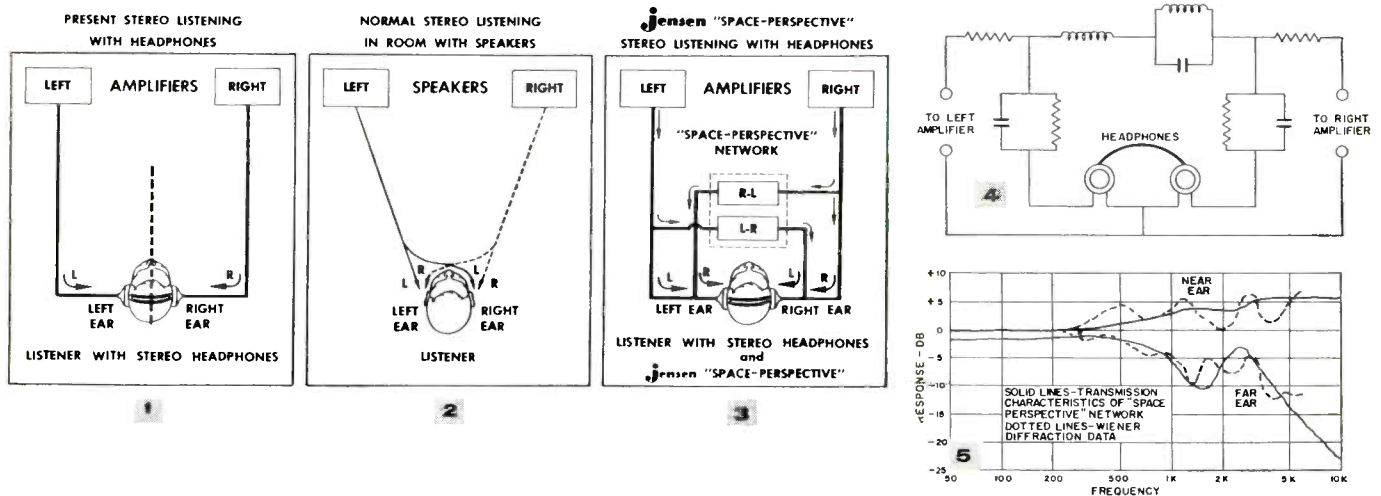

The JENSEN CC-1 STEREO HEADPHONE CONTROL CENTER places at your fingertips complete controls for personal or professional stereo headphone listening . . . plus the exclusive advantage of Jensen's new SPACE-PERSPECTIVE. Styled in an oiled walnut case, this attractive and compact unit can be conveniently located wherever you choose to listen; hang it on the wall if you wish. Controls allow you to adjust volume; adjust balance to suit the music and the best hearing conditions for you; select left or right channels or have stereo with choice of left-right reversal; switch from mono to stereo or stereo with SPACE-PERSPECTIVE; switch speaker system on or off. 'Phone jacks for two. Requires as little as 10 watts per channel (20 watt stereo rating) capacity. May be used with one or two 4 to 8-ohm nominal impedance dynamic headphones. Jensen HS-1 'phones are recommended for best results. **\$39.75**

Model CFN-1 SPACE-PERSPECTIVE CROSS-FEED NETWORK only is available for incorporation into your system at lowest cost. It provides the full cross-feed characteristics to simulate speaker listening but without the controls of the CC-1. Consists of network, 'phone jack and terminals for extension phones. Small enclosure can be mounted wherever you choose. **\$19.50**

Write for Catalog 165-BE



JENSEN MANUFACTURING COMPANY/DIVISION OF THE MUTER COMPANY/6601 SOUTH LARAMIE AVENUE, CHICAGO 38, ILLINOIS
Canada: Radio Speakers of Canada, Ltd., Toronto • Argentina: UCOA, S. A., Buenos Aires • Mexico: Fapartel, S. A., Naucalpan, Mex.

Circle Item 11 on Tech Data Card

ACCURATE INTENSITY MEASUREMENTS IN AMBIENT FIELDS

by Robert A. Jones* — How to measure field intensity in the presence of an interfering signal.

Engineers are often called upon to make field intensity measurements which will be submitted to the FCC. These are usually carried out in connection with allocation studies or in support of a directional-antenna proof of performance.

Accurate, reliable measurements can be made at any distance from the transmitter as long as there are no interfering signals. However, when these signals are present, fluttering will occur, as evidenced by swinging of the field intensity meter needle.

It is common knowledge among engineers that measurements can be made at signal-to-interference ratios of ten to one or higher with little or no error. For example, if two signals of 10 mv/m and 1 mv/m are measured, and an RSS (root sum square) of the values taken, the resultant will be 10 mv/m, or equal to the larger. (This ratio is borne out in engineering exhibits on file with the FCC in Hearing

Dockets 13345, and Docket 14414.) It is further recognized that reliable field intensity measurements can be made at ratios of less than 10:1 by taking care, and by using special precautions to verify the readings.

In the past, accurate measurements have been made in areas of high ambient fields (interfering signals) by first interrupting one signal and then the other. This, however, is often inconvenient to both stations, and quite time con-

*Consulting Engineer, LaGrange, Ill.

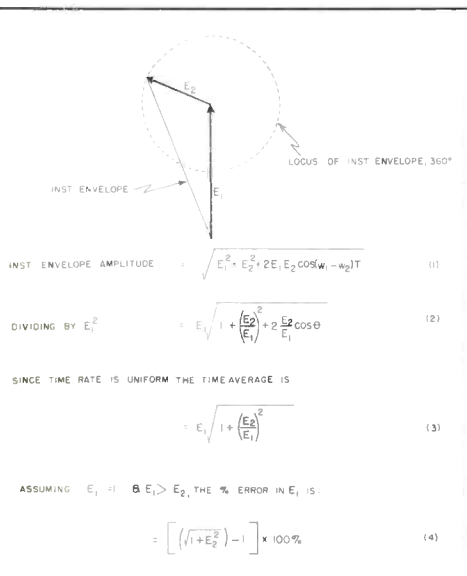

Fig. 1. Calculation of reading error.

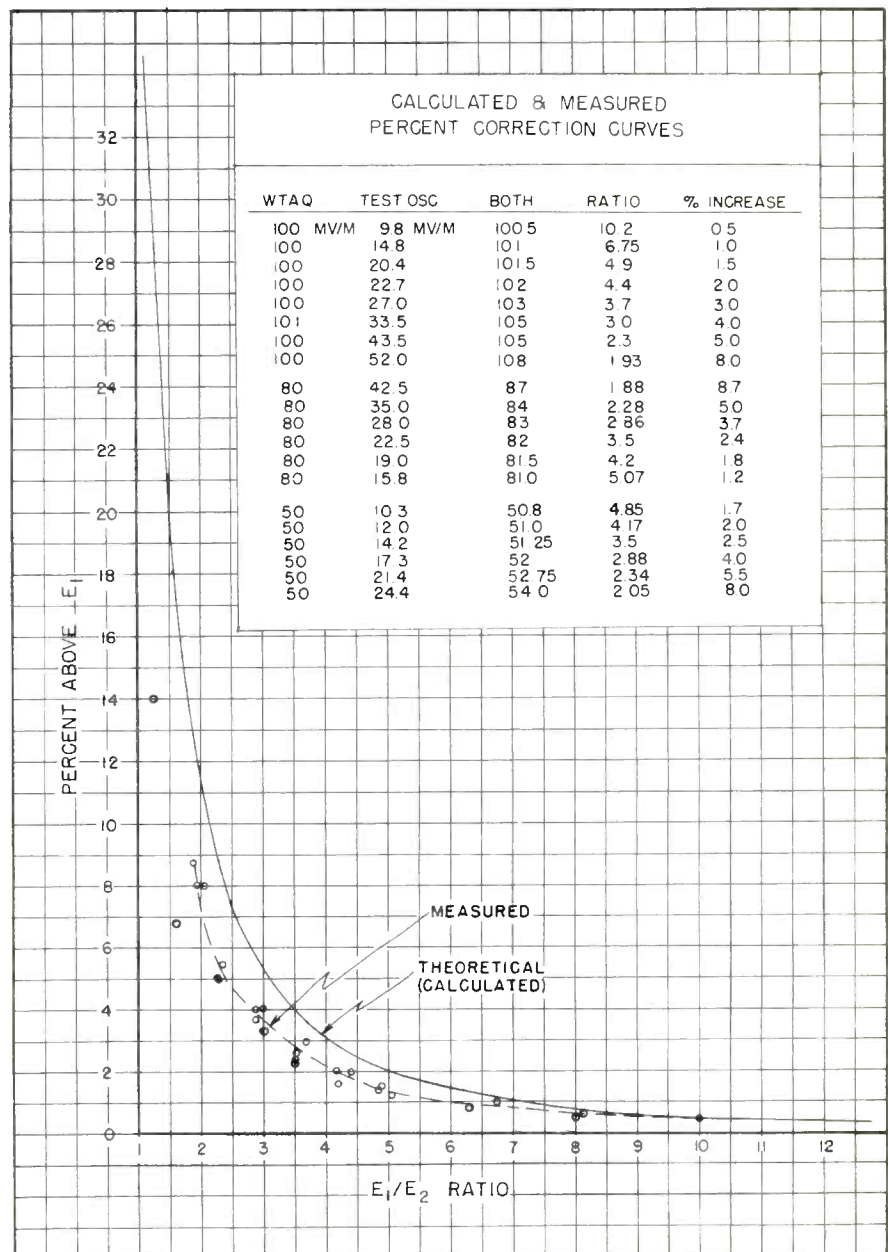

Fig. 2. Correction curves for readings.



We wouldn't risk our artists to any other tape...why should you?

It's a ticklish business recording the world's greatest artists! You never know which take will capture that one magic performance! RCA Victor engineers must be able to depend on every inch of master recording tape to deliver the absolute ultimate in quality performance. That's why RCA Victor Recording Engineers use Red Seal Magnetic Recording Tape. In fact, Red Seal Tape was specially developed for their use.

In one of the newest, most modern plants in the country, Red Seal Tape is manufactured to the highest quality specifications in the industry — and it's now

available for your recording requirements!

Quality control-tested for frequency response, distortion, drop-out noise, print-through, Red Seal Tape is also mechanically tested for coating thickness, anchorage, layer-to-layer adhesion, aging, cupping, slitting tolerances. Every inch has the same magnetic properties, the same recording-bias characteristic, so you can use tapes interchangeably!

Get all the details, fill in the coupon now.

RCA VICTOR

 The most trusted name in sound 

Magnetic Tape Products Marketing
RCA Victor Record Division
155 East 24th Street
New York 10, N. Y.

Please rush me specifics on RCA Red Seal Magnetic Tape including all essential physical and magnetic characteristics.

NAME

TITLE

COMPANY

ADDRESS

CITY ZONE ... STATE

suming. The method to be described can be used where the desired signal is at least three times the undesired signal. This method provides reliable accuracy and requires the cooperation of the station producing the stronger signal only.

The technique consists of shifting the operating frequency of the desired station off zero, by approximately 10 to 15 cps. The needle of the field intensity meter flutters so rapidly in attempting to follow the instantaneous envelope of the two signals, that it hardly appears to move. This makes possible the same reading accuracy as that which prevails when the ambient signal is absent. By employing Terman's Equations for Instantaneous Envelope (Fig. 1), it can be shown that the meter needle will be close to the theoretical time average of the two signals. Fig. 2 shows this theoretical error curve for ratios of 1:1 to 12:1 with the percent increase above the desired reading.

This curve can be used to apply a correction factor to readings and will yield the desired signal in the presence of an ambient signal for any ratio. For example, a ratio of

3:1 (theoretically) would result in a reading 5.3% above the true value; thus 0.947 would be the correction factor. To determine the correction factor required at a particular location, it is necessary only to interrupt the carrier of the desired station, and measure the undesired signal strength, the ratio, and the correction factor.

During investigation of this technique it came to my attention that data measured by other engineers indicated the actual error curve was less than the theoretical error curve. To see what results might occur in practice, I conducted a controlled experiment with the cooperation of Radio Station WTAQ, LaGrange, Illinois.

Fig. 3 shows a block diagram of the equipment setup employed. For the experiment WTAQ provided one signal, and a General Radio oscillator Type 1211-B, the other. The signal from the oscillator was radiated from a loop antenna. By adjusting the distance (S) from the field intensity meter to the loop, any desired signal level could be produced. The field meter was

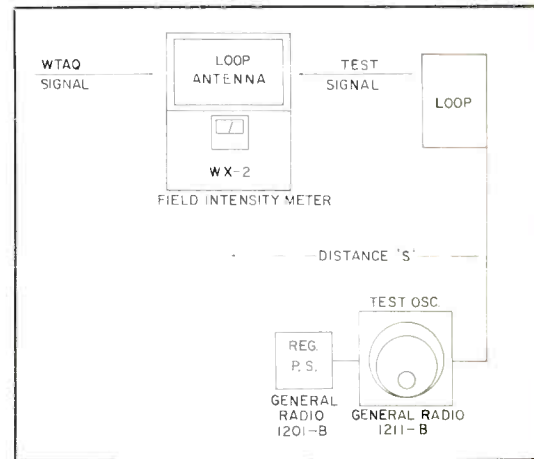

Fig. 3. Test setup for plotting curves.

pointed directly at WTAQ, and the loop antenna was mounted on a plastic clothes line with wooden clothes pins, so that it could be adjusted. Tests were conducted with three levels of signal from the station. The data and measured curve are shown in Fig. 2.

The results prove that the measured error for these ratios will actually be less than the theoretical error. It may therefore be concluded that at a desired to undesired signal ratio of 6:1 or greater, the error in reading the desired signal, with

INDESTRUCTIBLE?

Not quite. But you might think so if you saw our repair records! E-V professional microphones just seem to keep on going no matter what you do to them.

That's why we can afford to offer an unconditional two year guarantee against failure for any reason. (Just one exception . . . don't scratch the finish — we charge to fix that!)

Two years is a mighty long time, but E-V also offers a lifetime guarantee against defects in materials or workmanship. And our out-of-warranty repair charges are the most reasonable in the industry.

You profit every day from the dependability of E-V professional microphones. Isn't it time to follow the lead of major networks and leading independent studios? Switch to Electro-Voice—dependably better!



ELECTRO-VOICE, INC., Commercial Products Division, Dept. 231V, Buchanan, Michigan

Circle Item 13 on Tech Data Card

Electro-Voice®

BROADCAST ENGINEERING

a 10 to 15 cps beat, is 1% or less. At 5:1 the error is about 1.3%, at 4:1 about 2.2%, and at 3:1 approximately 3.6%. Thus by applying these correction factors, reliable measurements can be obtained at ratios as low as 3:1.

In making these measurements, it is essential to mount the field meter on a tripod. It is also necessary to interrupt the carrier and to shift the frequency of the desired station only. It is not necessary to make any changes in the operation of the undesired station. I might point out that the error is always going to make readings higher than those in the absence of interference.

This idea is not new. Prior to World War II the FCC considered operating co-channel stations with slight carrier offsets to aid allocation. As mentioned above, this would eliminate the fading or beating of signals in the area between stations. However, since stability of crystal oscillators was not good enough at the time, this system was not incorporated into the Rules.

Among the uses of this technique are allocation measurements in areas where interference would be received; tune-up adjustments on directional patterns at night, during the experimental hours when sky-wave signals are present; measurements of Class IV stations service areas during heavy interference.

This technique is quite simple to employ. We set up the field meter at the edge of the interference zone. Then, by two-way radio or telephone adjust the frequency of the desired station transmitter until a very slow beat is observed on the field meter. At this point the two signals are almost synchronous. The operator notes the frequency deviation read on the frequency monitor at the station, and changes the transmitter frequency accordingly up or down 10 to 15 cps. At this point the needle on the field meter will stop swinging and a steady reading will be obtained. If a swinging or slight flutter is noticed during the day, the frequency of one of the two stations has probably shifted and the above steps can be repeated.

In summary, this technique is believed to be 100% reliable and has been verified by the author in both controlled tests and actual field work. ▲

The Standard of QUALITY

Spotmaster



505 compact playback unit

500 compact recorder-playback unit

There's a lot of get-up-and-go packed into SPOTMASTER compact and rack mount cartridge tape recorders. Engineered for compactness, reliability and low maintenance—they do more work more efficiently than any other system. Whether your station is big and forward looking or—for now—just forward looking, write or call us, and ask about our complete line of SPOTMASTER cartridge tape equipment. For the Standard of Quality in cartridge equipment—ask for SPOTMASTER—more broadcasters around the World do.

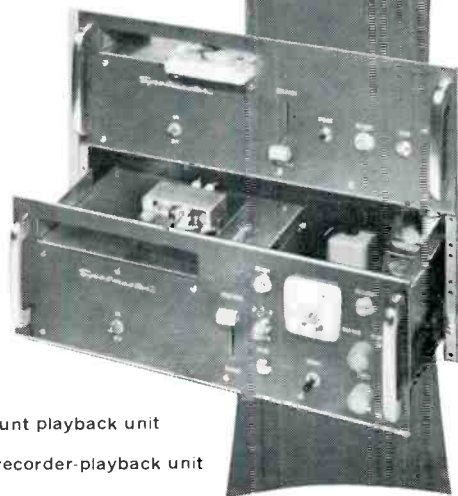

505R rack mount playback unit

500R rack mount recorder-playback unit

BROADCAST ELECTRONICS, INC.

8800 BROOKVILLE RD. SILVER SPRING, MARYLAND, JU 8-4983

SOLD NATIONALLY BY: VISUAL ELECTRONICS

356 W. 40th St., N. Y., N. Y., CANADA • Northern Electric Co Ltd
250 Sidney St., Belleville, Ontario.

Circle Item 14 on Tech Data Card

WHEN TO USE A UNIPOLE ANTENNA DESIGN

Technical Talks by John H. Battison—

Increasing radiated signal strength, without changing transmitter power through the use of folded unipole antennas.

Efficiency is the byword of the station engineer; the smaller the station the more important is the watch on the watts! Today, with the freeze on almost all new AM station construction, and a similar restriction on power increase applications, there are few ways in which a low-power station can improve its lot. One means still available in many instances is the improvement of antenna radiation efficiency. If a station in the 250-watt or even the 1-kw category, operating on a regional or Class II channel (now normally frozen) increases radiation from 175 mv/m to 225 mv/m or more by making antenna changes, the appreciable difference will be well worth the effort. Therefore, take a good look at your antenna situation before giving up thoughts of signal improvements.

If your station is Class IV you are either at maximum power of 1 kw daytime, are in the process of applying for it, or denied it due to geographic location. In the latter case, you may be able to improve upon the Class IV minimum, and increase 150 mv/m for 1 kw, or 75 mv/m for 250 watts, to 230 mv/m for 1 kw, or about 115 mv/m or 250 watts!

A regular application for a Construction Permit to make antenna changes will have to be filed on Form 301. A consulting engineer and attorney can advise on the best approach.

The best known method of increasing radiation without changing transmitter power is to increase antenna efficiency and height. This, however, may prove impossible for such reasons as denial of FAA approval (for the height increase), insufficient ground space for the greater guy radius required, lack of funds to cover the

increased cost of a taller tower, inability of the existing tower to support a superstructure, or any number of others.

To overcome the obstacles mentioned above and still achieve the desired results, top loading may be considered. While this is a sound approach, it makes sense to consider other means of improving efficiency before initiating antenna changes. Investigate the question of Q, bandwidth and simple radiating efficiency.

Another important subject is the cumulative effect of lightning, over the years, on the tower and associated equipment. If your station is

in a region of heavy lightning activity, and has suffered severe strikes on an ungrounded series-fed tower, consider a cure for the lightning problem. At the same time you can improve signal quality (bandwidth) and strength (radiating efficiency). This involves more than just top loading; the easiest means is through the use of a **folded unipole** (combined with top loading if desired).

The folded unipole is so named because it is a variation of its more commonly known shunt-fed antenna in which the feed line attaches to the antenna at an angle of approximately 45°. A number of wires are attached to outriggers at the top of the tower and are hung vertically around it. Often six such wires are used, connected together at the base, and insulated from it (Fig. 1).

The folded-unipole principle may be called the poor man's power increase, because it is most effective when applied to a short tower, about 50 to 75° long. It is with antennas of such heights that the greatest improvement in radiation efficiency will be noticed. There is another point of particular interest to the station considering installation of an improved antenna system but with too little space for extending the ground system. The folded unipole requires only a short ground system and still produces a large increase in radiation efficiency! Also, the more vertical radiators used the greater will be the bandwidth of the resulting antenna, or the lower the Q. It might seem that the ultimate might be a giant vertical cylindrical antenna, similar to some broadband antennas employed in VHF work. However this would not be practical or efficient.

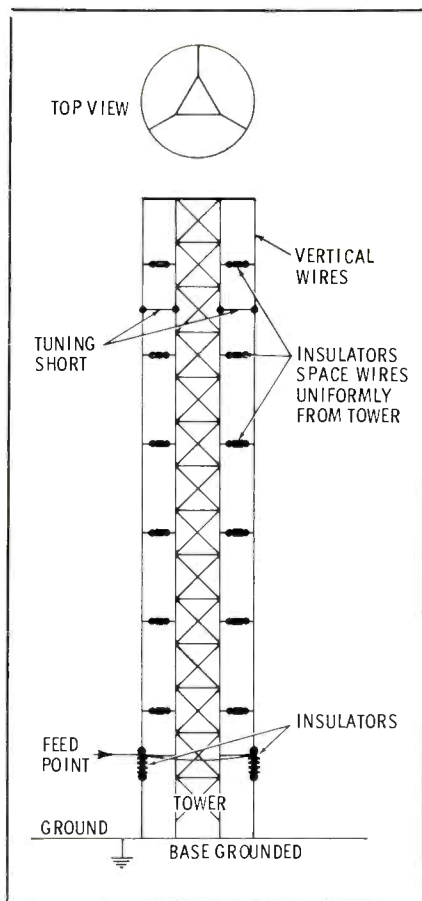
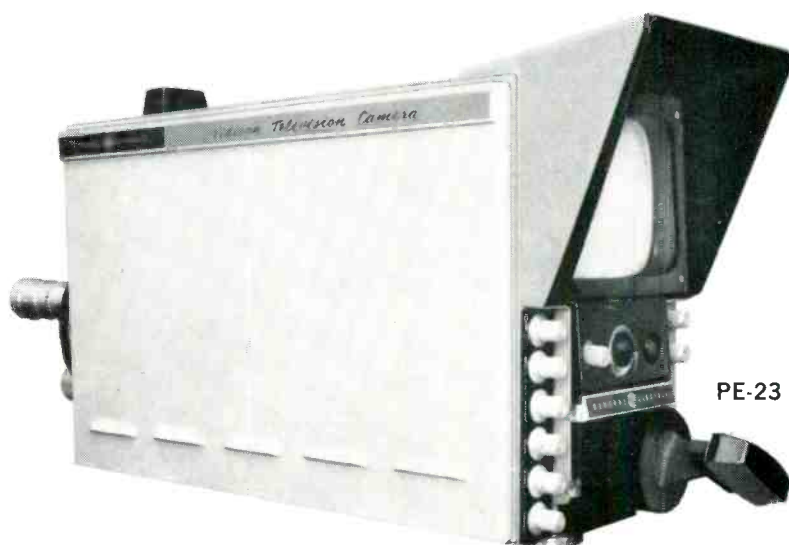

Fig. 1. Typical folded unipole arrangement.



This reliable camera is best for 20% of your live shows



This new one handles all the rest at one-tenth the cost/hour

The top camera is General Electric's 3"/4½" image orthicon TV camera, Type PE-20. Over a year of field experience has proved its unmatched reliability for "action" shows requiring I-O performance (probably about 20% of your shows).

The **new** one below is the first truly professional transistorized studio vidicon camera—General Electric's Type PE-23. It offers outstanding performance for such studio productions as news, panel, and quiz shows (which constitute up to 80% of today's live studio programming). The

PE-23's initial cost is 50% less and its operating cost is 90% less than its I-O counterpart. For more data, contact your General Electric Broadcast Equipment Representative, or write Technical Products Operation, 212 W. Division St., Syracuse 8, N.Y.

Progress Is Our Most Important Product

GENERAL  ELECTRIC

Circle Item 15 on Tech Data Card



THE TURNER MODEL 58 STUDIO MICROPHONE

For broadcasting excellence inside or outside the studio

Designed for TV and broadcast use, the Model 58 has been specially engineered by Turner to withstand heat, rough handling and humidity. This modestly-priced microphone is rugged

enough for sports remotes, studio or outside interviews, panel shows—anywhere freedom and mobility are required; yet it gives the quality performance you expect from stationary studio microphones.



The Model 58 is 4" long, weighs only 3½ ounces. Complete with lavalier; or it can be adapted to a desk or floor stand. Level (RETMA) -149 db. Response 60-13,000 cps. Allows a choice of either hi impedance or 150 ohms selected at the free end of the cable. Model 58A: combination 50 or 200 ohms selected the same way. Net price \$34.20. For complete specifications, write:



THE TURNER MICROPHONE COMPANY

909 17th Street N.E., Cedar Rapids, Iowa

IN CANADA: Tri-Tel Associates, 81 Sheppard Ave. West, Willowdale, Ontario.
EXPORT: Ad Auriema, Inc., 85 Broad St., New York 4, N. Y.

Circle Item 16 on Tech Data Card

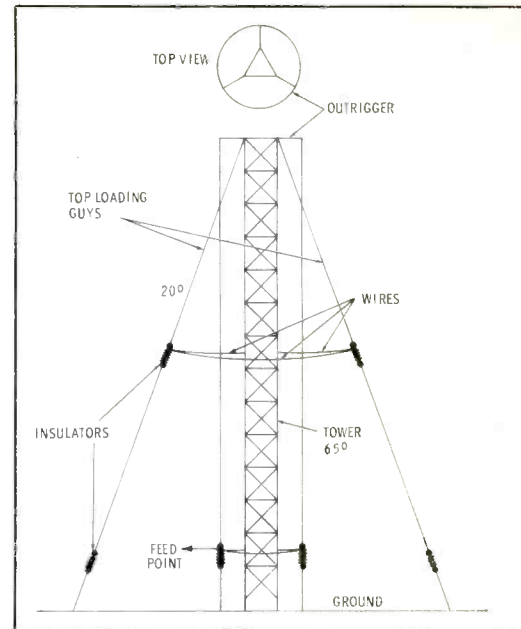

Fig. 2. Top-loaded folded unipole antenna.

Q and Bandwidth

Probably, Q alone is not of great interest to the average engineer, although it does reflect the quality factor of the antenna. For a folded unipole, Q can be defined as:

$$\frac{F_o}{F_b}$$

where,

F_o is the operating frequency in kilocycles,

F_b is the bandwidth of the antenna in kilocycles.

Bandwidth, the difference in kc between the half-power points, can be calculated from:

$$BW = \frac{2R\alpha}{dx} \frac{1}{df}$$

where,

$R\alpha$ is the antenna resistance, dx

— is the reactance slope at df resonance.

Top Loading

The most effective combination is top loading with a folded unipole antenna. A very common practice in top loading (when it is not desired to build a bird cage or top-hat-ring) is to use the loading system at hand—the guy wires!

Fig. 2 shows a typical top loaded antenna. The three guys of the top section are connected directly to the tower with an insulator inserted at the desired distance down the guy loading wire. At the bot-

SARKES TARZIAN SILICON RECTIFIERS

eliminate broadcast interruptions
caused by vacuum tube rectifier failures

*Here's proof of long, trouble-free life
of Tarzian Silicon Rectifiers—*

We have had excellent results thus far with the silicon tube replacement rectifiers. We have several S-5019's which have been in service since July of 1957. We have put many more in service since this time and have yet to have one fail.

We have also installed the S-5373 at the transmitter and they too are doing very well.

Probably the biggest advantage is the extremely long life and secondly, the absence of heat produced by the rectifier.

FRED MOLCHIN
Chief Engineer, Station WTTV
Indianapolis, Indiana

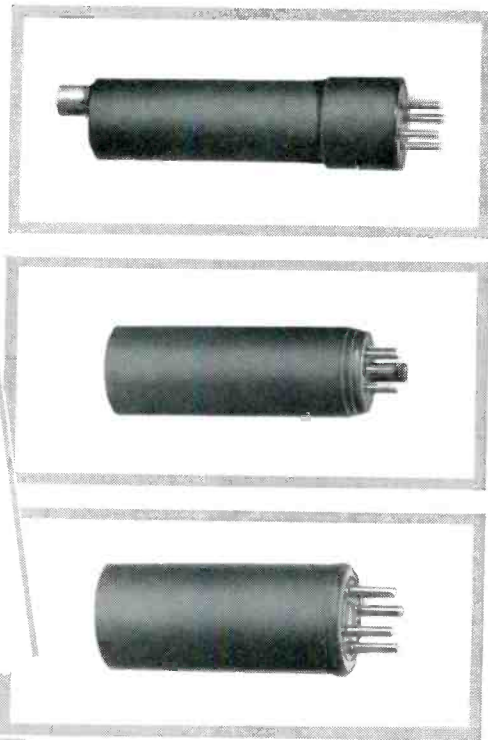

Typical Tarzian rectifiers to replace tube types 80, 82, 83, 83V, 5Z3, 0Z4, 5X4, 5Y4, 6AX5, 6X5, 866, 866A, 3B28, 6AU4, 6AX4, 6BL4, 6W4, 12AX4, 17AX4, 25W4, 6U4, and 5R4 (approximately 1/2 size)

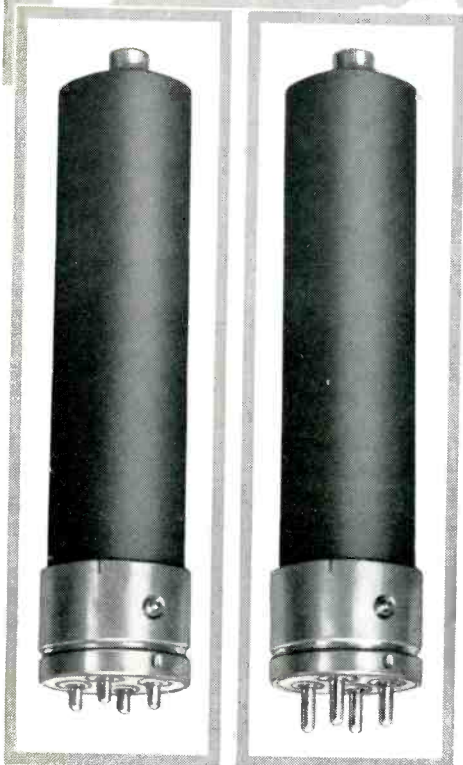

Typical Tarzian rectifiers that replace tube types 8020, 872A, and 8008 (approximately 1/2 size)

LONG LIFE and cool operation are two advantages of the 13 Tarzian silicon rectifiers that replace over 95% of all popular vacuum tube rectifiers.

They are generally smaller than the tubes they replace. DC current ratings are as much as three times as high.

Electrical stability is greater. Operation is instantaneous. No warmup. No filament supply.

Special designs and modifications are available. Application engineering service is free of charge.

Specifications and prices are waiting for you.

Write today.



SARKES TARZIAN, Inc.

World's Leading Manufacturers of TV and FM Tuners • Closed Circuit TV Systems • Broadcast Equipment • Air Trimmers • FM Radios • Magnetic Recording Tape • Semiconductor Devices

SEMICONDUCTOR DIVISION • BLOOMINGTON, INDIANA

Canadian Licensee: Marsland Engineering Limited • 350 Weber Street North, Waterloo, Ontario

Circle Item 17 on Tech Data Card

tom of this upper section a wire is connected to each guy, forming a complete ring around the antenna at the insulator height. This additional electrical length (to the height of the tower) produces higher efficiency. The effective height can be calculated as follows:

$$H^{\circ}eff = \frac{Lt^{\circ} + Ha^{\circ}}{0.705}$$

where,

$H^{\circ}eff$ is the desired effective electrical height,

Lt° is the chosen top loading,

Ha° is the existing tower height without top loading,

0.705 is an experimental constant.¹

Folded Unipole Impedance

From what has been said about the folded-unipole antenna, it may have become apparent that it is really a modified transmission line shorted at one end. This, in turn, indicates it is possible to tune the antenna with shorting bars. In practice, to resonate a folded unipole so that Z equals R , a fairly simple procedure is followed.

Under normal conditions when

no shorting bars are used, the folded unipole will reactance measure $+j$; at resonance this will become $j0$. To achieve $j0$ it is only necessary to measure the reactance and then attach shorting bars between the vertical wires and the tower, noting the new reactance value each time the bars are moved. If j becomes negative, you have placed the bars too far down; go up again until j equals zero. At this point the tower is in resonance for the operating frequency. This condition is known as **first resonance**.

An interesting aspect of folded-unipole antennas is the fact that because j is always zero at resonance the line current is an exact function of the power in the antenna; thus, the measured antenna resistance and indicated antenna current in the formula $P = I^2R$ give accurate value of power.

In general, the gain in radiation efficiency obtained through the use of an antenna between 65 and 120° is not very great compared with the increased cost. However, one aspect of very short antennas (assuming the FCC Rules regarding minimum efficiency are met) is sometimes overlooked.

The shorter an antenna is, the lower its radiation resistance, and the higher its reactance becomes; at the same time bandwidth is relatively small.

The problems involved in the use of very short antennas involve DC and RF losses. For example, if the antenna radiation resistance is low, it may become comparable to that of the ground system; so ground system losses approach the radiation obtained.

A very high antenna reactance requires an equally high reactance in the tuning unit. This results in an appreciable loss, and the radiating system dissipates valuable RF in an undesirable manner.

In the case of a folded unipole antenna, it is not unusual to have an antenna resistance and reactance of 250 ohms and $j0$. This simplifies the tuning problem, and results in an installation where the resistance of a less efficient ground system (and hence its losses) become very small with respect to the power radiated. ▲

¹"The Folded Unipole Antenna for Broadcast Use." presented by John H. Mullaney at the 1960 NAB Engineering Conference.

SPARTA-MATIC

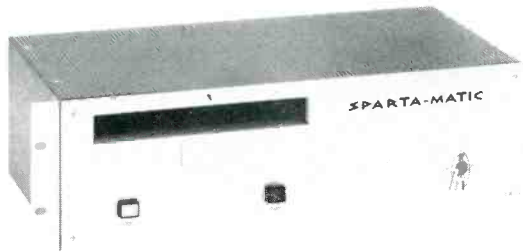

300P — \$495.00



300R — \$230.00

SETTING THE STANDARD FOR CARTRIDGE TAPE

The SPARTA-MATIC 300 series cartridge tape system is receiving enthusiastic acclaim by broadcasters everywhere! Offering outstanding improvements in all areas, the SPARTA-MATIC 300P playback unit and its companion 300R record amplifier, contain all the features you have been waiting for:

- Continuous Duty Rated
- Compact, Modern, Functional Design
- Laminated Tape Heads
- Proven Reliability
- Table Top, Custom or Rack Mounting (Rack Mounting Illustrated)
- Improved Tone Burst Cueing
- Plug in Relays and Modules
- Solid State Design

All this and much more is yours with the new leader . . . SPARTA-MATIC. Dependable quality that every broadcaster can afford. The sophisticate of cartridge tape: the SPARTA-MATIC 300 series.

Call, Write or Wire Today for Guaranteed Satisfaction Offer.

SPARTA ELECTRONIC CORPORATION

6450 FREEPORT BOULEVARD • SACRAMENTO 22, CALIFORNIA • GA 1-2070

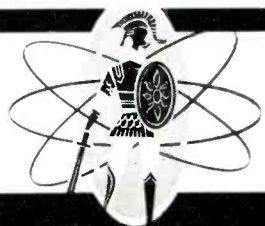

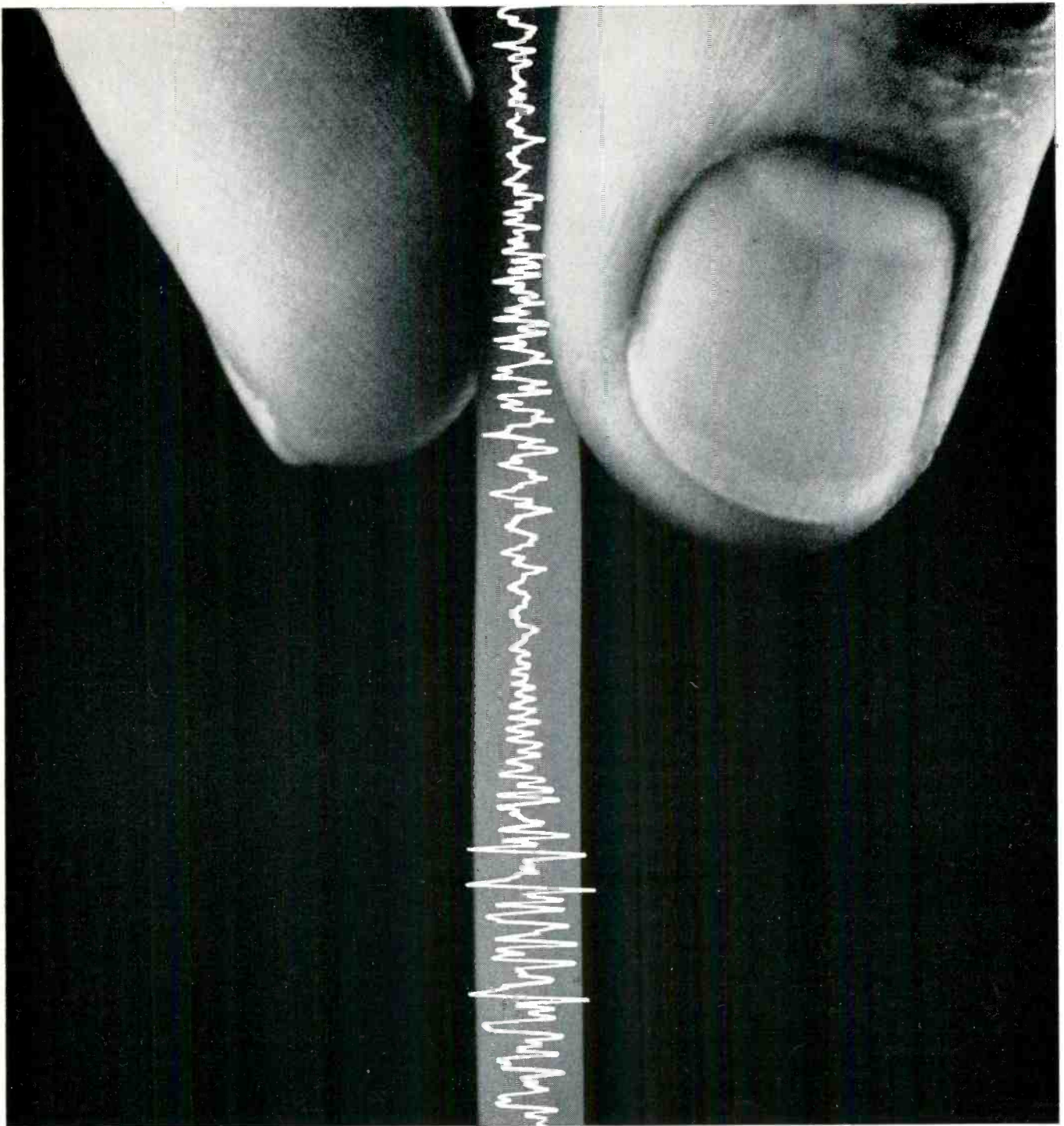

What professional recording tape now offers a new standard of performance? **AMPEX 600.**

Ampex engineers are never content with present standards. They are always trying to improve what sometimes seems un-improvable. Now they have been at work on the Ampex 600 Series Professional Recording Tape. And they've improved it so much we felt we should call it the new Ampex 600. This 600 Series now offers better high frequency response characteristics. And because an exclusive Ferro-Sheen process makes the tape smooth, the first play and the

one-hundredth have the same response characteristics curve. It gives you the kind of reliable performance you expect from Ampex recording equipment. Try this improved 600 Series and see. It's made in the same rigidly controlled clean-room atmosphere as precision computer and instrumentation tapes. Write the only company with tape, recorders for every application: Ampex Corp., 934 Charter St., Redwood City, Calif. Worldwide sales, service.

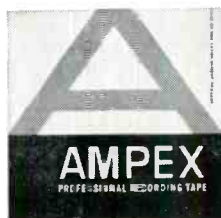

Circle Item 19 on Tech Data Card

A LOW COST INSTRUCTIONAL TELEVISION SYSTEM

by Edward Galuska* — An economical method of transmitting several programs for in-class ETV, in the proposed 2-kmc band.

The increasingly complex training required in our society, the relative decrease in the number of qualified teachers, and growing school enrollments have been posing a serious challenge to the American education system. Educators have turned to television as one method of providing quality education in quantity.

Today, more than 60 educational TV Broadcasting Stations and 400 closed-circuit TV systems provide thousands of hours of in-school instructional programming. While these figures seem impressive, present facilities have barely scratched the surface in meeting our television teaching needs.

Requirements

One requisite for effective educational TV is a capability for simultaneous instruction in numerous subjects, requiring several channels for each school system or college campus. According to some estimates, several thousand channels will eventually be needed throughout the country for in-class TV teaching. Each of these channels must be capable of serving large numbers of school buildings and students, if economical as well as effective operation is to be achieved. The VHF and UHF bands which are used by both educational and commercial TV broadcasting stations offer a limited number of channels, and cannot be expected to carry the growing load of in-class TV teaching programs.

Closed-circuit television is another method for distributing educational programs. In this system, which is capable of multichannel service, signals are transmitted from a TV camera to a selected group of receivers.

Cable is currently the principal

*Manager of Engineering, Industrial Products Div., Adler Electronics, Inc.

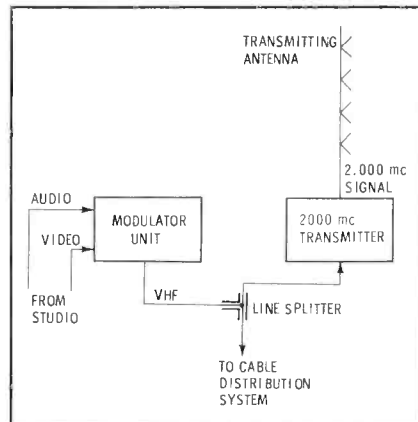

Fig. 1. Block diagram of single-channel 2-kmc instructional TV transmitting system.

means used to extend the coverage of closed-circuit ETV. Its relatively high cost, which rises sharply as distances are increased, has deterred many school systems, colleges, and universities from extending their closed-circuit systems beyond the confines of one or two buildings.

To provide an economical alternative that would permit educators to initiate or extend their own closed-circuit systems, the FCC is considering a rule proposing that a 2,000-mc band be made available to educators. This band (1990-2110 mc, 2500-2690 mc, or both) would make possible several channels for every school district.

The proposed frequencies seem well suited to an instructional ETV system. These bands have been

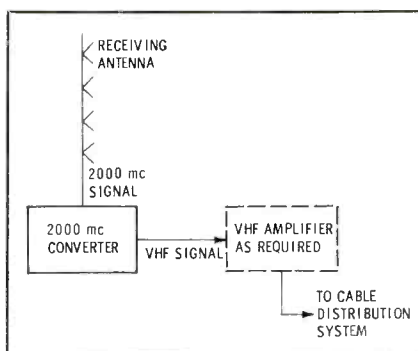

Fig. 2. Receiving system block diagram.

used, though sparingly, for circuits between TV studios and transmitters, remote pickups, inter-city relays, and for other non-TV services. Propagation characteristics in this band are not very different from those in UHF since it is only slightly over twice the frequency. Equipment which can transmit a standard TV signal is available now, as is a wide choice of transmitting antennas. The proposed bands are wide enough to be divided into approximately 20 standard-width television channels; and as many as 10 can be used simultaneously at any particular location.

ETV systems at 2,000 mc can be engineered to permit operation of several ETV systems in the same general area. In locations where there are a number of independent school districts, each may want the capacity to originate its programming based on its own curriculum. These 2,000-mc systems can easily be interconnected, using standard relaying techniques, so that programs originated in one school district may be utilized in any number of others. Thus, each school district will be able to participate in county-wide or even state-wide hookups, and also utilize desirable programs originated by commercial and standard ETV stations. Most important, however, is that these systems allow each school district to have local control over its own programming at a price well within most school budgets.

Operation at 2 kmc

The 2,000-mc megacycle system begins with a standard television studio which provides picture and sound signals from either live cameras, film or video tape recordings. (A block diagram of such a system is shown in Fig. 1.) Visual and aural carriers are generated at standard

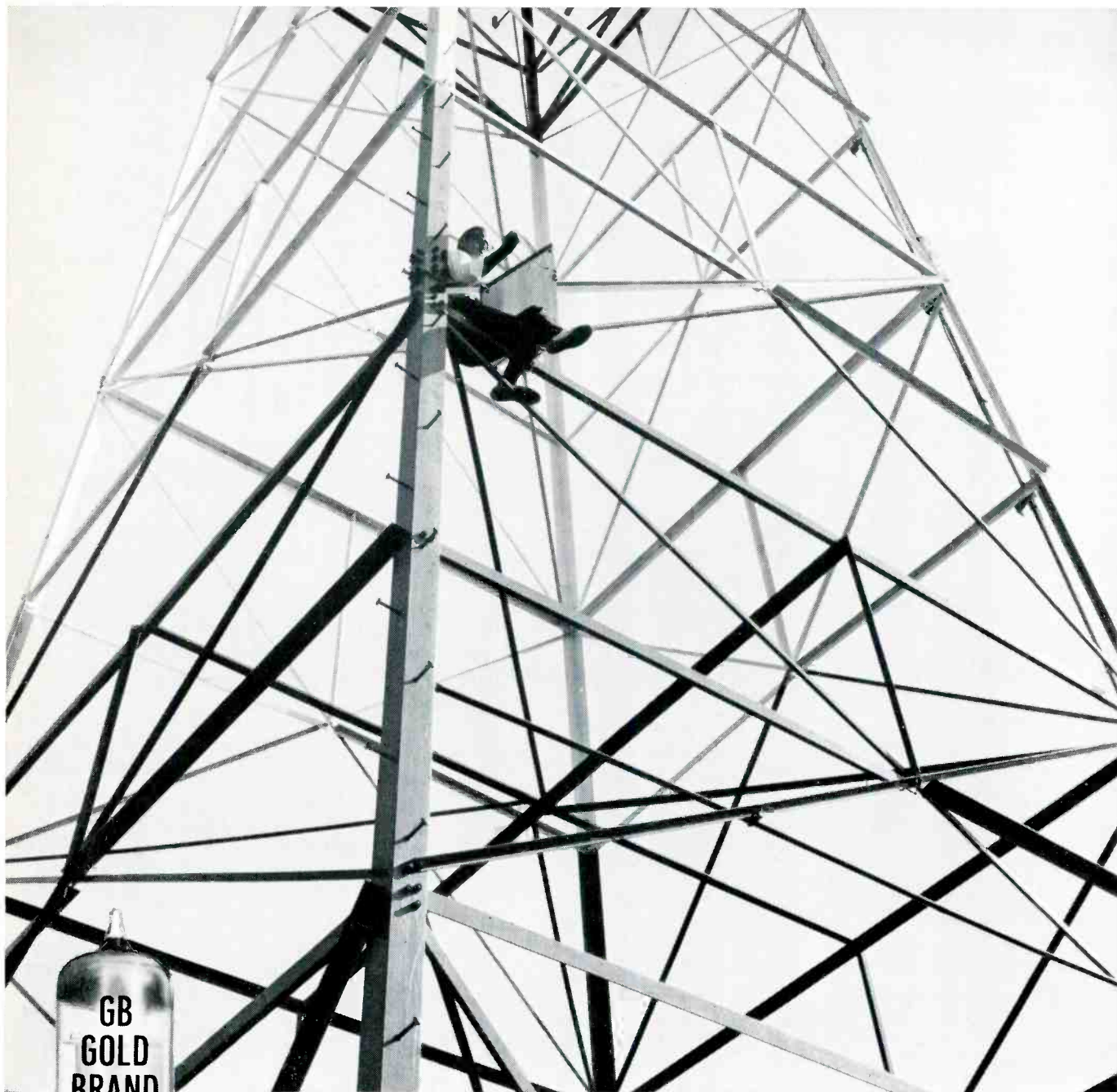

Tubes designed from the user's viewpoint

...use them wherever reliability is essential

When reliability really counts—as it does in broadcasting—be sure with tubes custom-designed and tested for the job.

Sylvania engineers traveled the country—met with engineers and maintenance groups in broadcasting, public service radio, industry, the airlines—listened to their problems and studied them. From this came GB Gold Brand, a superior line of new and upgraded tubes,

each tailor-made to a specific job. A given tube may have, for example, low noise, exceptional stability or vibration resistance. Or a critical parameter may be as much as three times the usual value. In each case, performance and reliability have been verified by actual user experience as well as laboratory testing.

This extra effort has paid off. "Excellent results," says an airline official. "No failures,"

reports a highway patrol department. "Hundreds of dollars saved in program interruptions," reports a TV station. "Less costly in the long run," discovered a county government. Similar results can be yours with a truly reliable, genuinely interchangeable GB Gold Brand Tube.

Electronic Tubes Division, Sylvania Electric Products Inc., 1100 Main St., Buffalo 9, N. Y.

AVAILABLE FROM YOUR SYLVANIA INDUSTRIAL TUBE DISTRIBUTOR

SYLVANIA

SUBSIDIARY OF

GENERAL TELEPHONE & ELECTRONICS



Circle Item 20 on Tech Data Card

The Sarkes Tarzian HETERODYNE MICROWAVE RELAY

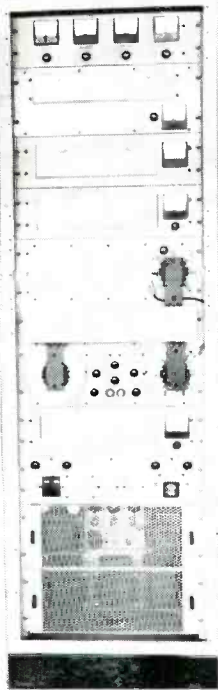

See it at NAB
Space 17E

PROVEN PERFORMANCE Where It Counts

Over three years actual in-field use has proven Tarzian's multi-hop microwave delivers exceptional quality color transmission, simultaneously with broadcast quality sound—at lowest possible cost. And, Tarzian's renowned microwave systems engineering department is at your disposal for assistance with planning and installation.



Broadcast Equipment Division
SARKES TARZIAN, INC.
Bloomington, Indiana

Circle Item 21 on Tech Data Card



Fig. 3. Students and teacher prepare a TV lesson in the district High School studio.

VHF frequencies, and each is modulated by the appropriate information from the studio equipment. This very-low-power energy is then raised in frequency, resulting in a completely standard television signal in the 2,000-mc band.

A directional transmitting antenna, (bidirectional, multidirectional, or omnidirectional,) of sufficient gain is utilized to serve the schools according to the particular geographic arrangement.

Since a standard television signal is received, only an antenna and frequency converter are required at each school (Fig. 2). The converter is similar to a high-quality UHF unit. Its output is a standard VHF television signal which can be sent directly into the distribution system within each school building, or even directly into a VHF television set. (The output VHF channel is one which is not used by a local broadcast station.)

A continuing acceptability test of this type of service is being undertaken at Plainedge, New York. This suburban school district consists of a high school, a junior high school, and six elementary schools, with a total student population of approximately 9,000.

A studio (Fig. 3) and closed circuit system had been installed in their high school, and a cable distribution system installed in each of the other school buildings which could receive only the seven New York City channels. The school district was interested in distributing the signals originated in the high school studio to the other schools of the district.

Adler Electronics, Inc., in support of the Federal Communications Commission's proposed rulemaking, installed a 10-watt, 2,000-mc transmitter at the high school, and re-

ceiving converters at each of the other seven schools, on an experimental basis. The modulator unit, located in the studio control room, was fed with the audio and video signals. The transmitter was installed in an available space backstage at the high school auditorium.

Because of the long and narrow shape of the school district a bi-directional transmitting antenna is employed. It is composed of an array of 8 simple corner reflectors (Fig. 4), resulting in an erp of 136 watts in a northerly direction and 136 watts in a southerly direction.

Antennas and converters were installed at the seven receiving schools. The converter output, on Channel 6, is fed into the distribution system in each building, together with the off-air signals of the seven New York City VHF television stations.

Different receiving antennas were utilized at the seven schools depending on the distance of each from the transmitter. At nearby schools a simple corner reflector antenna was used; at schools a little further away, an array of two corner reflectors was installed; and at the school furthest from the transmitter, a 4-foot parabolic was used.

Conclusion

Use of the 2,000-mc band will be a major step forward in the development of educational television.

The proposed system provides an unusual range of operational flexibility. And it is economically priced—approximately one-third to one-fifth the cost of any other system. It provides the much sought after local control of programming tailored for local needs.

By providing simultaneous coverage for thousands of students, on-air closed circuit ETV will permit the development of high quality in-class lesson programs. ▲

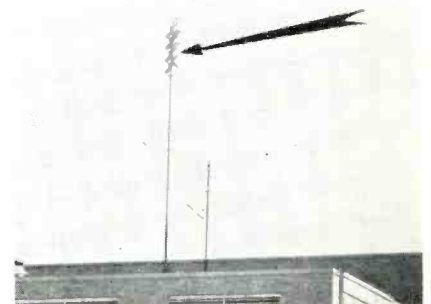
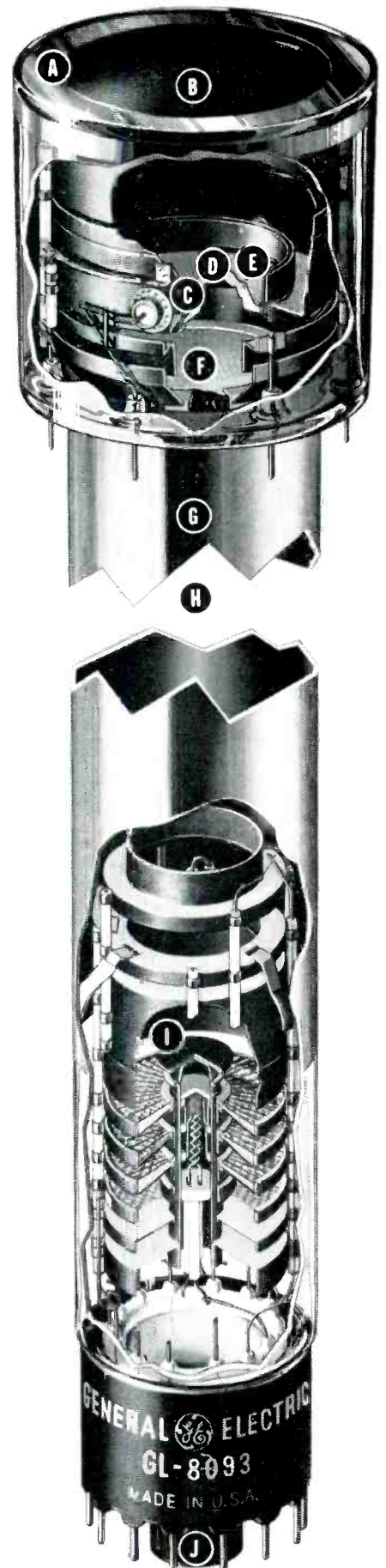

Fig. 4. 2000-mc TV transmitting antenna.

32 value analyzed benefits give G-E Image Orthicons 3 to 5 times longer life, highest sensitivity, and unsurpassed performance in your cameras

G.E.'s family of "station designed" Image Orthicons cover the complete spectrum of commercial and educational television. Individual types incorporate certain *value analyzed* benefits which optimize performance for any given program requirement, whether specialized or broad. These benefits can extend life to as long as 8000 hours . . . provide signal-to-noise ratios up to 50:1 . . . and allow high resolution pickup at 1 ft.-c for black and white, or 40 ft.-c for color.



- A** Distortion-free optical quality glass is used in all G-E Image Orthicon faceplates • Fibre-optics faceplates prevent picture distortion
- B** Photocathodes—Spectral response close to that of the human eye permits portrayal of scenes in nearly their true tonal graduation • Individual processing for each tube guarantees uniformity of characteristics and maximum sensitivity
- C** Semiconductor (MgO) thin-film target gives high sensitivity with only 1 ft.-c for black-and-white pickup . . . only 40 ft.-c needed for color • 0.000002" thick, MgO target gives: greater resolution • extremely long life • no stickiness • improved depth of focus • no target raster burns—GL 8092—GL 7629
- D** Glass target only 0.0001" thick prevents loss of resolution due to lateral charge leakage • Specially selected optical quality glass is free of imperfections—GL 5820A—GL 7293—GL 8093
- E** Electroplated target mesh, with 560,000 openings per square inch, improves picture detail, prevents moire and mesh-pattern effects without defocusing
- F** 750-line field mesh screen—makes the scanning beam approach the target perpendicularly over the entire area • improves corner resolution • diminishes white-edge effect • Shading and dynamic match for color pickup are excellent • Set-up time is reduced
- G** As an added precaution against moisture contamination, dry inert gas is blown through the envelope prior to exhausting and sealing • Longest tube life is assured
- H** To prevent contamination from dirt, dust or moisture: All personnel wear lint-free clothing • operators wear nylon gloves or finger guards • assembly rooms are pressurized, the air super-cleaned, and humidity controlled
- I** Precision manufacture, plus accurate spacing and alignment of all components, assures uniform signal gain in the multiplier section • Dynode material and design, plus a 0.0012" aperture, allow sharper target focus • No compromise between sharpest focus and dynode blemishes appearing in background • Less set-up time required
- J** Performance testing—Every tube tested prior to release to customer • Tests are made in G.E. and other-make cameras to guarantee highest picture quality and complete operational flexibility



For your free facts folder, containing data and application notes on G-E Image Orthicons, write to General Electric Co., Room 1783, Owensboro, Kentucky, or call your nearest G-E Industrial Tube Distributor, today!

Progress Is Our Most Important Product

GENERAL ELECTRIC

Circle Item 22 on Tech Data Card

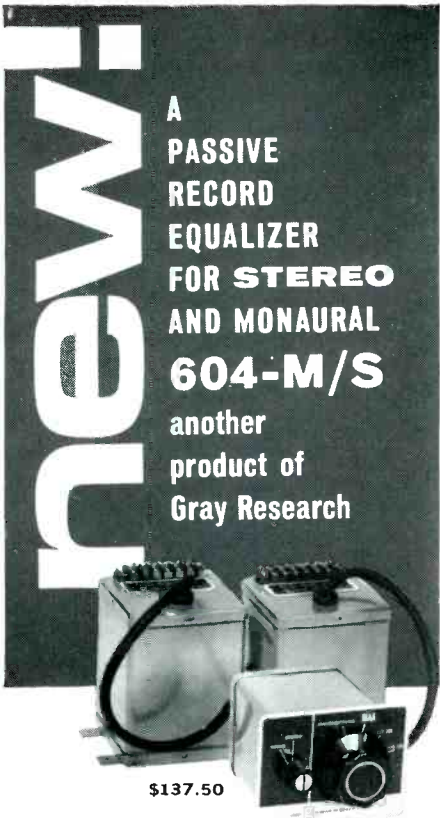

new
A
PASSIVE
RECORD
EQUALIZER
FOR STEREO
AND MONAURAL
604-M/S
 another
 product of
 Gray Research

\$137.50

FLEXIBILITY Buy the entire system... or just the part your station needs. Choose between stereo and monaural... stereo conversion... or monaural only.

COMPATIBILITY Easily integrated with your present equipment; mechanically interchangeable with the 602-C. Same trouble-free operation in stereo as your present 602-C Equalizer.

SPECIFICATIONS

EACH CHANNEL:

Response: down 1.5 db @ 20 ~ and 20 kc
 Input: 500 mh } (cartridge)
 2000 Ω DC }
 Output: 150 Ω @ 1 kc

CHANNEL MATCH:

Frequency: 20-20 kc ± 1 db
 Impedance: 20-20 kc ± 1 db
 Separation: 40 db minimum 20-20 kc

plus these variations...



604-M
 monaural
 (left channel)
 equalizer only

\$79.25



604-S
 add-on (right
 channel) equalizer
 to convert 604-M
 to stereo

\$58.25

602-S/K converts your 602-C to a 604-S \$18.50

write for more information to



GRAY
RESEARCH
 AND DEVELOPMENT
 CO., INC.

Box 12, Elmwood, Connecticut
 Circle Item 23 on Tech Data Card

ENGINEERS' EXCHANGE

Automatic Power Change System

by Gail D. Griner*

One of the problems encountered in complying with FCC technical rules and regulations is changing from daytime to nighttime power and back, since many stations (including WOOK) are 24-hour operations. Alarm clocks and other warning devices have proven unsatisfactory because they must be reset after each cycle and depend on the operator's memory. We decided an automatic changeover device was the only answer. Such a unit was designed with the following features:

1. Changeover can be performed at the remote control point.
2. No resetting operations are required for the **actual power** changing function.
3. Positive indication is provided for the operator on duty at the time when the change takes place enabling him to log the time correctly.
4. A secondary warning device, of a loud audible type, sounds in case the announcer/oper-

ator does not act on the first indication.

5. A timer can be easily changed to allow for varying sunrise and sunset times.
6. Indicating lights show the operating power.
7. While on automatic control, the power change cannot be actuated by the normal manual controls.

The sequence of operation can best be described by beginning with the unit in the position of daytime power, which is 1,000 watts at WOOK. All switches and relays are then in the positions shown in Fig. 1. With 115-volts AC applied to terminals 1 and 2 of TV-1, indicating lamp I-1 will be on, showing the transmitter is set up for 1,000 watts. TM-1 will be running, and terminals 3 and 5 of TV-1 are shorted together by the contacts of RY-1. Terminals 3 and 5 are connected to the circuit in the transmitter (or remote control unit) that controls the daytime power. When timer TV-1 reaches the preset local sunset time, its SPDT switch is thrown causing RY-1 to be ener-

*Technical Director, United Broadcasting Co., Inc., Washington, D.C.

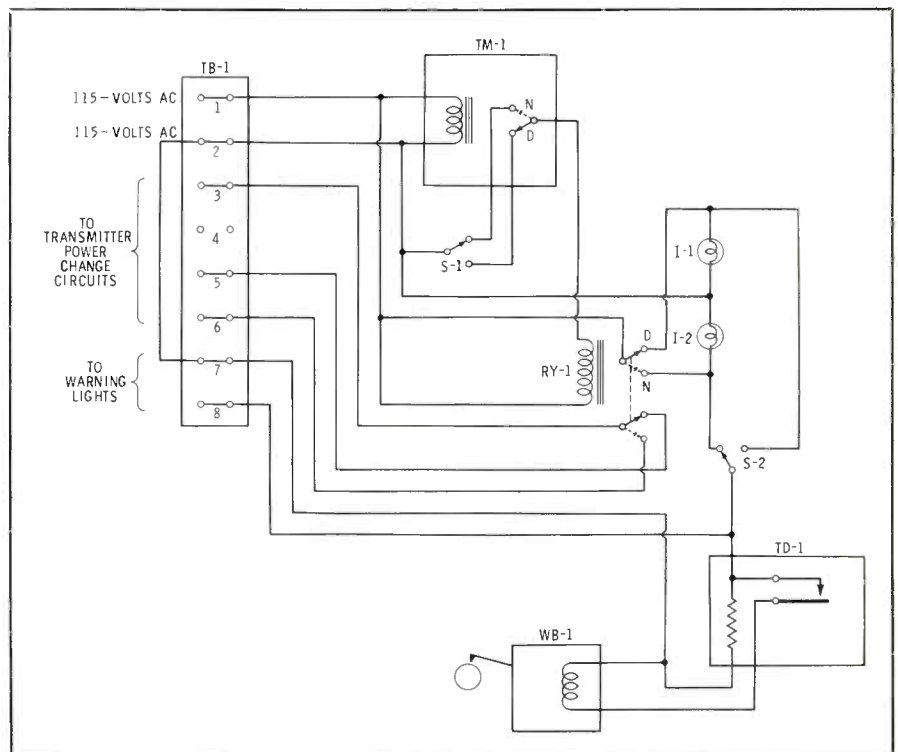

Fig. 1. Circuit of automatic power change system.



STEP INTO TOMORROW WITH TELEVISION BY TARZIAN

*See it at
NAB—Space 17E*

A complete line of Solid State television broadcast equipment will be unveiled by Sarkes Tarzian, Inc. at the National Association of Broadcasters Show in Chicago, March 31.

Reflecting an outstanding capability in the engineering and manufacturing of sophisticated broadcast equipment, the entire Tarzian line will introduce a new concept in the design of television equipment. From the exciting, functional exteriors by Schory-Steinbach Associates—Industrial Designers—to the incomparable transistorized engineering, the new Tarzian look is a look of quality—quality in performance matched by quality in appearance.

These solid state electronic products come to you in the longtime Tarzian tradition of uncompromising quality at reasonable cost.

Broadcast Equipment Division



SARKES TARZIAN, INC.

Bloomington, Indiana

Circle Item 24 on Tech Data Card

gized, and placing its two sets of contacts in the N position. This action causes one set of RY-1 contacts to cut off daytime power indicator lamp I-1 and light nighttime lamp I-2. The second set of contacts places a short from terminals 3 to 6 on TV-1. These two terminals are connected to the circuit in the transmitter (or remote control unit) that controls the nighttime power.

When the change to nighttime power takes place, 115-volts AC is placed on terminals 7 and 8 of TV-

land TD-1. At WOOK, two 100-watt lamps are connected to terminals 7 and 8. They serve as warning lights to tell the announcer/operator the power change has taken place. A conventional button-type flasher unit, available in most hardware stores, is installed in this light circuit. (They are simply placed in the socket and the bulb inserted in the normal manner.) TD-1 takes about two minutes to close and operate the warning bell or buzzer. When the warning lights come on, the operator must get up, walk to

PARTS LIST

- TB-1** Terminal board or plug, 8 terminals
- TM-1** Timer with SPDT switch; Intermatic Model T-966 or equivalent.
- S-1** Push-button momentary contact switch, SPDT.
- S-2** Heavy-duty toggle switch, SPDT.
- RY-1** 115-volt AC relay, SPDT; P & B type MR-11A, or equivalent.
- I-1** Lamp & socket, 115-volts AC; Dialco type 51901-111 (red lens), or equivalent.
- I-2** Same as I-1 except green lens.
- TD-1** Time delay relay 115-Volt AC, NO; Amperite type 115NO120, or equivalent.
- WB-1** 115-volt bell or buzzer.

the control panel, and place S-2 in its opposite position. This turns off the lights, prevents the warning bell or buzzer from sounding, and sets up the warning circuit for reactivation when the power is changed back to daytime operation.

At sunrise, TM-1 causes RY-1 to be de-energized turning off I-2 lighting I-1 and returning the transmitter to daytime power. The warning circuits are activated and remain so, until S-2 is reset. S-1 is a test switch which changes the power momentarily anytime a check on the change function is desired.

We have found the flashing light sufficiently distracting to prompt the operator to immediately write the time in the log and reset S-2 before the warning bell rings. It is sometimes unwise to locate the unit close to the busy announcer/operator. If he is in the middle of an announcement when the lights begin to flash, and S-2 is within reach, he may reset the switch and forget to log the power change time. (If he must get up and take a few steps, the break in routine will remind him to make the notation.)

No attempt has been made to illustrate how the automatic power change unit is disconnected and the control returned to manual operation. This depends on the particular transmitter or remote control unit, and the individual station installation. ▲

McMartin

FM MODULATION MONITOR



FCC
Type #3-116

TBM-4000
\$1495.00

FCC TYPE APPROVED
Also Monitors SCA MULTIPLEX

- Modulation
- Crosstalk
- Frequency
- Injection

FM FREQUENCY MONITOR



FCC
Type #3-113

TBM-3000
\$495.00

Write Dept. S or phone 402-342-2753 for complete specifications.

originality by

McMartin Industries, Inc.
1612 California Street • Omaha, Nebraska

McMartin

In Canada, Sold by: Canadian Marconi Company, Montreal 16. P. Q.

Circle Item 25 on Tech Data Card

NEWS OF THE INDUSTRY

NAB Asks FCC Protect FM Power

The National Association of Broadcasters has urged the FCC not to require any cutbacks in power or antenna heights for existing FM stations, and at the same time opposed imposition of a table of assignments lest it prove to be a "rigid straitjacket" which would inhibit future development in FM. The comments were filed in response to multiple action taken by the FCC on Aug. 1 in revamping the FM regulatory structure. Among other steps, the Commission proposed a table of assignments as the method for allocating stations. Comments were invited on the question of whether existing FM outlets, operating with more power or greater antenna height than allowed under newly set limits, should be required to make reductions. The NAB said that the several hundred stations which would be affected should be "grandfathered in" under any new plan, and allowed to maintain their present power levels and antenna heights. The comments pointed out that in the past FCC policies have permitted and encouraged high-power operation.

The NAB went on to say: "Many of the stations which would be affected by a required power reduction were pioneers in providing broadcast service to their communities." Many FM outlets coming under the limits are located in sparsely populated areas and reduction in their facilities would result in several areas lacking FM service. "The Association submits," the FCC was told, "that in view of FM's history to date, its struggle to become established as an independent competitive service, and the gains it has recently achieved, it would be highly undesirable to take any action that would have an adverse effect on existing facilities."

RCA Announces Half-Speed Tape Color

Half-speed operation of RCA television tape recorders, which effect 50% saving in tape, can be used for color as well as for monochrome programs, according to RCA Broadcast and Communications Products Division spokesmen. The division recently announced the first successful development of equipment for converting recorders handling black-and-white programming to half-speed operation. Now this same equipment can be used for color programs. Half-speed operation is made possible by RCA's new narrow recording head which covers a transverse track on the tape only 5 mils wide, as compared with the conventional 10-mil width. Thus, two tracks, or double the volume of video information, are recorded when the tape moves at 7½ ips instead of the usual 15 ips. Transistorized, the conversion kit includes all of the accessories needed to operate standard RCA TV tape recorders at the slower speed. Modified machines will continue to be capable of 15 ips operation.

Stereo Broadcasters Appeal To Set Manufacturers

Gary Gielow and James Babbert, co-owners of San Francisco's stereo station, KPEN-FM, told a recent convale of the EIA that stereo's future in broadcasting is "absolutely unlimited." However, the two men agreed that the nation's stereo broadcasters needed the cooperation of set manufacturers. They stated that more than 70% of the country's stereo broadcasters are now losing money. The two broadcasters claimed that many stereo broadcasters throughout the country, particularly the independents, need help in increased advertising by set producers and in the form of promotional guidance.

More manufacturers, they said, should follow the example of a few companies which have helped stereo broadcasters with advertising layouts, news release suggestions, and other forms of promotional assistance. Such aid, they added, may have more long-term value than advertising, but a greater producer use of the medium of stereo also is needed.

Behrend's Opens Detroit Office

Behrend Cine Corp., Chicago, has announced the opening of a Detroit, Mich., office which will specialize in the rental of motion picture equipment, including cameras, lights, and editing equipment. It will also handle meeting equipment including projectors, speaker systems, and recorders. Headed by William Smith, the office is soon to be expanded with the addition of a complete sound department and motion picture projection facilities for use by Detroit's advertising agencies and motion picture producers.

Next Month . . . SPECIAL NAB SHOW ISSUE

Complete preview of the show, including products, demonstrations, news, and floor layouts complete with manufacturers booth numbers. Plus, a resume of the papers to be read at the technical sessions.

. . . Also in the March Issue— a survey of the IEEE Show, with a rundown of events.

Tarzian stays ahead in SOLID STATE SWITCHERS



Tarzian's new "C" model, fully solid state Vertical Interval Switcher, incorporates all the desirable features of the highly successful VIS-88 plus recent engineering refinements adding even greater performance.

This switcher does more—in less space—than any other available. All the advantages of transistorized switching are yours in a compact, low-cost package.

See the new
Tarzian Solid State Switcher
at NAB—Space 17E



Broadcast Equipment Division
SARKES TARZIAN, INC.
Bloomington, Indiana

Circle Item 26 on Tech Data Card

Ampex to Install TV Landing Guides for Navy

The Ampex Corporation has begun installation of the first of 10 closed-circuit television recording systems to assist U.S. Navy pilots with aircraft landings. Known as Pilot Land Aid Television (PLAT), the system has been thoroughly tested on three carriers since 1960. Each PLAT system consists of a video-tape recorder, cameras, receivers, and related equipment which permit carrier personnel to direct each landing, day or night, with greater precision than previous methods. Television cameras mounted in carrier flight decks and on the "island" superstructure record each operation. The cameras are Marconi Mark IV 4½-inch image orthicon units, distributed in the U. S. by Ampex. Navy officials report substantial contributions to landing safety and pilot proficiency due to the video-tape system. The contract for the 10 installations is \$1,377,148.

Process-Screen Distributor Named

S.O.S. Photo-Cine-Optics, Inc., N. Y., has been named exclusive U.S. distributor for the Alekan-Gerard Process Screen, employed in a system of front projection photography which, it is claimed, costs next to nothing to operate. The resulting background image is evenly lit from a small source and presents no "hotspot" problems. The

even the largest film studio, yet is particularly attractive to the small establishment making television commercials. For such smaller studios, moving and still backgrounds can be provided economically. The high-reflectance beaded, aluminized, screen material, priced at \$2.50 per square foot, comes in 72" widths which can be applied on studio walls, or cemented to plywood or hard-board "flats" of any size desired—50' or more without visible seams. A special 10 mm thick semi-transparent two-way mirror, with 60% transmission and 40% reflection, priced at \$45, is available from S.O.S. in a 10" x 10" frame. Images are projected through this optical flat by any low-power slide or cine projector from 100 watts up. Photographs of moving backgrounds can be taken with the ordinary movie camera—no synchronous or interlock motors being required for accurate registration.

Srepcu Appointed by Rotron

Srepcu Electronics Inc., Woodstock, N. Y., has been appointed distributor for the Rotron line of precision fans and blowers manufactured for cooling electronic packages, instruments, and for other air moving applications. Srepcu will provide off-the-shelf delivery at factory prices to O.E.M. customers from their locations in Dayton, Hamilton, Middletown, and Piqua, Ohio.

AES Plans Spring Convention

The West Coast Convention of the Audio Engineering Society will be held March 13 through 15 at the Hollywood Roosevelt Hotel, Los Angeles, California. There will be joint technical sessions with the audio and broadcasting groups of the Institute of Radio Engineers as well as the Acoustical Society of America. A wide variety of topics will be covered by the sessions, including: FM stereo broadcasting; microphones and earphones; speakers; audio applications in the Space Age; uses of audio in oceanography; language laboratory and teaching machines; requisites of modern telephony; uses of audio by power utility companies; communications systems using audio frequencies; and disc recording and reproduction.

ABOUT THE COVER

The cover this month dramatically represents the role of electronic communications in the attempt to reach all the populations of the world. Shown is the nerve center of the Voice of America in Washington, D. C., one of the world's largest broadcasting systems. This master control console, manufactured by Gates Radio Div., Harris-Intertype, can select programs from 100 different sources and transmit 26 programs simultaneously to broadcasting sites encircling the globe. (Photo courtesy Gates Radio Co., Quincy, Ill.)

WTEV Signs for Automation

Vance Eckersley, General Manager of new TV Station WTEV, channel 6, Providence - Fall River - New Bedford, Mass., signed recently for a complete Television Program Automation System from Visual Electronics Corp., N. Y. C. James B. Tharpe, Visual president, states that the new ultra-modern television plant will be the first to operate a Visual 6000 installation with an IBM punched card system. Several 6000 Automation Systems are presently installed and operating with punched paper tape at WDSU New Orleans; KYW-TV Cleveland; WNEU-TV, WPIX in New York City; and KTTV Los Angeles. A complete system is presently being installed at KMEX-TV, the new channel 34 station in Los Angeles. WTEV will serve the area as primary affiliate of ABC.

Magne-Tronics to Offer Tape Cartridge Service

Magne-Tronics, Inc., producer of background music programs on magnetic tape, has formed a new division, Pac-Tune, to market an automatic tape-cartridge music-program service. Due to the type of location in which taped music is frequently used, Pac-Tune's programs will consist largely of luncheon-dinner, cocktail, and general background music. Marketing of the product, using Fidelipac cartridges, is scheduled for the first part of this year.



NEW... FROM FAIRCHILD MODEL 663

COMPACT COMPRESSOR

Now you can have a compressor for every mike channel with this miniature low cost Fairchild Compact Compressor... no larger than a slide type attenuator (actual size 1½x7x4½ inches). This Fairchild Model 663 Compact Compressor will provide up to 20 db of compression with no increase in distortion. And the attack time of 40 milliseconds with a variable threshold and variable release time of .3 to 7 seconds offers complete compressor flexibility and performance. The Fairchild 663 Compact Compressor can be easily integrated into your present console to provide the ultimate answer to all level control problems.

Fairchild Model 663: \$158.00

Write today for complete details

FAIRCHILD

RECORDING EQUIPMENT CORPORATION
10-40 45th Ave., Long Island City 1, N. Y.

Circle Item 27 on Tech Data Card

QRK PROFESSIONAL TURNTABLES

offer you more...

- QUALITY
- CONTINUOUS PERFORMANCE
- SIMPLICITY

Quality all the way with QRK. Full speed range—33, 45, 78. Built rugged with jewel precision. Plays 45's without adapters. Rocket acceleration - EZ queuing. Single idler maintains constant speed regardless of normal wear.



Priced from \$110. to \$235.

Send for detailed folder!

Western Distributor

RUSSCO Electronics Mfg. 1406 Clovis Ave. — Clovis, Calif.

Phone CY 9-4692

Circle Item 28 on Tech Data Card

NEW PRODUCTS

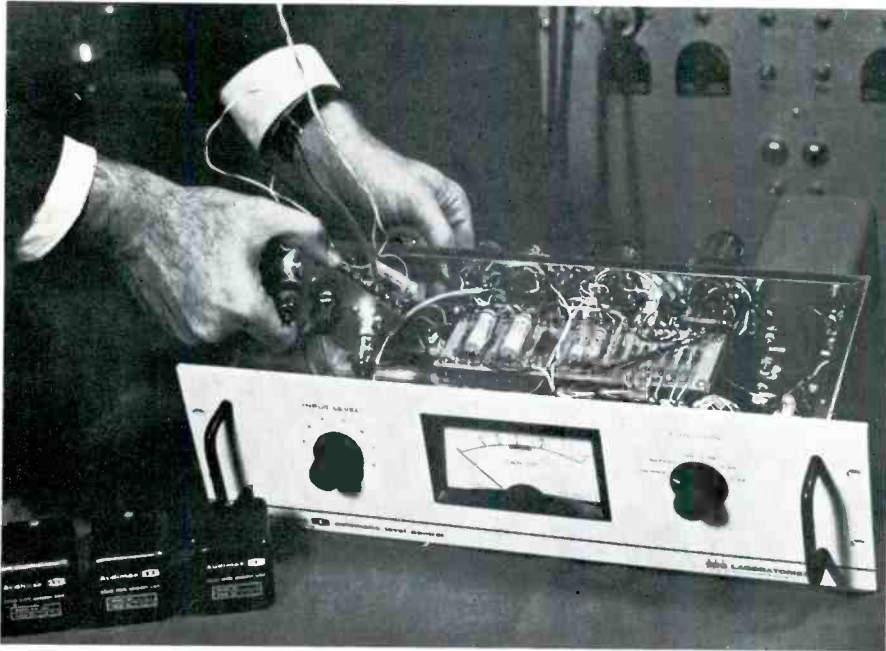

Kits for Automatic Level Controls

Two kits which convert Audimax models I and II to the Audimax II RZ Automatic Level Control are available from **CBS Laboratories Div.**, Columbia Broadcasting System, Inc. The II RZ has a return-to-zero feature which determines when an extensive pause or stand-by condition has occurred and maintains constant gain during this interval. When the program ends, the gain is slowly dropped to normal (if gain was being increased during the program) or maintained constant at reduced level (if gain was being reduced). This new feature augments the usefulness of Audimax I and II in controlling audio levels in recording, motion picture sound, telecasting, monophonic and (with an adapter) stereophonic FM broadcasting, and AM broadcasting. The cost of the kits approximates the price difference between the previous and the newest unit.

Circle Item 82 on Tech Data Card

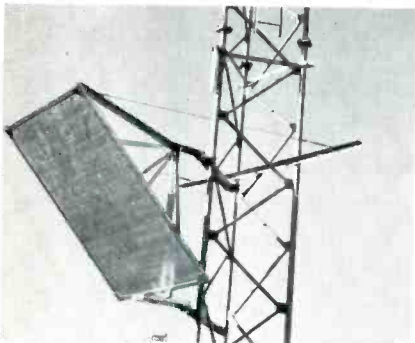

Microwave Reflectors

Rohn Manufacturing Co., Peoria, Ill., has announced a microwave passive reflector made of Reynolds aluminum interlocking extrusions. The reflectors are offered in three standard sizes—6 by 8, 8 by 12, and 10 by 15 feet, weighing approximately 140, 280, and 438 pounds respectively. Features include simplicity of design, ease of handling, and reduced shipping costs. The extrusions can be shipped knocked-down to the erection site, and snapped together and assembled in the field.

Circle Item 83 on Tech Data Card

Magnetic Audio Tape

Magnetic audio tape with a signal output strength regulated to less than a half decibel of variance has recently been introduced by **Burgess Battery Co.**, Division



of **Servel, Inc.**, Freeport, Ill. The uniform tape enables splicing of musical selections from different reels recorded at different times without any perceivable variation in volume or tonal quality. Needle-shaped iron-oxide powder particles (5 microns or less in size) are dispersed on the acetate, or Mylar plastic, tape by a process that separates the particles without shattering them. The result is a microfinished surface free of squeal and abrasive action on the recording heads. The quarter-inch tape, which is available in all standard reel lengths, has a lubricant included in the coating in order to minimize flake-off and keep the recording head clean.

Circle Item 84 on Tech Data Card

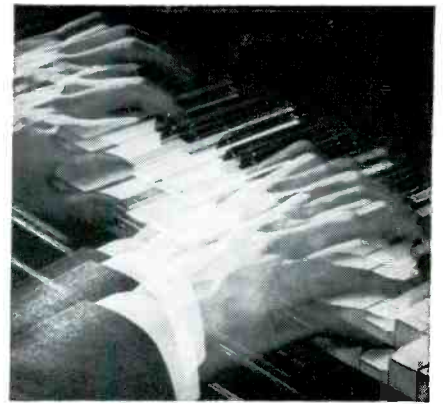

when acoustical conditions vary widely . . .



. . . equalize with the Telefunken M 251 E Condenser Microphone

Pick your pattern with a flick of the switch . . . Cardioid, Omnidirectional or Bi-Directional. The Telefunken M 251 E gives you all three patterns, gives you other important advantages too: Flat frequency response with smooth roll off on both ends, high sensitivity, Telefunken design and construction throughout make the M 251 truly a "sound investment".

Whenever true recording excellence is essential, your finest choice is a professional microphone by Telefunken. There's one for every application—also a complete range of world-renowned studio equipment. Write today for further information and technical data to:



TELEFUNKEN



American Elite, Inc., Dept. 25, 48-50 34th St.
Long Island City, N. Y.
Telefunken Sales & Service
Headquarters for over a decade.

Circle Item 29 on Tech Data Card



Tape Recorder/Reproducer

Crown International, Elkhart, Ind., is offering a new series of tape recorders/reproducers for critical applications. Designated the BX800 series, it includes six models, each with 3 heads, 3 drive motors and three equalized standard speeds of 3¾, 7½ and 15 ips. The machines have a 10½-inch reel capacity with ¼-inch tape and accommodate 6 types of high level, low level, bal-

anced and unbalanced inputs. Typical specifications are .06% wow/flutter @ 15 ips with 30 cps to 28 kc response ±2 db, full track width, and 60-db signal/noise ratio. Tape tension is relatively constant in all modes of operation with specified start time of 0.1 sec and stop time of 0.13 sec or 2 inch for 15 ips; rewind time is 1,200 ft. in 38 seconds. Standard operational features include a remote control, front panel monitor jack and DB meter, search control, automatic stop, and micro-touch electric control system. Models are available for rack mounting, portable with case, or mounted in console. Price range is from \$945 to \$2,950.

Circle Item 86 on Tech Data Card

Ruggedized Power Tetrode

The PL-6775, a "ruggedized" 400-watt power tetrode, that can be used to replace directly the 4-400A with no circuit modifications is being manufactured by Penta Laboratories, Inc., Santa Barbara, Calif. The tube, which can be mounted



in any position while withstanding high levels of shock and vibration, is designed to reduce the possibility of interelectrode shorts and features a one-piece plate cap and seal. A large effective plate radiating area is provided through the use of ribbed-anode construction. The PL-6775 will deliver up to 1,100 watts of plate power output as a Class-C CW or FM amplifier. Two tubes in Class-AB₁ service will provide up to 155 watts of plate power output.

Circle Item 87 on Tech Data Card

FANTASTIC VALUE IN CLOSED CIRCUIT TELEVISION BRAND NEW — COMPLETE SYSTEM SHOWN

Low - Low \$495 Sold at a fraction of Mfg. suggested retail price.

Complete system with all tubes — wired and tested. Less Vidicon and Lens — with Schematics (connecting cables and plugs only — supplied, but not assembled).

CONTROL MONITOR
12 Tubes & 21DA4



CAMERA
4 Tubes & VIDICON

ONLY \$649.50

Complete system with test vidicon, 1 inch normal lens, and assembled cables, schematics, wired and tested.

**Electronically Regulated
POWER SUPPLY**
115V-AC-60 Cycle
11 Tubes & Transistor—
31.5 Kc Crystal
Controlled Oscillator

EIA Standards of 525 lines, 60 Fields, 30 Frames and 2:1 interlace — Aspect Ratio 7:3—Capable of 700 lines Horizontal resolution and 350 Lines Vertical

Write for Catalog No. 1273-BE—"HOW TO BUILD LOW COST TV CAMERAS," Industrial and Broadcast Cameras and equipment, Miscellaneous accessories, lenses, tripods, etc., **Only 50¢**

DENSON ELECTRONICS CORP., Box 85, Rockville, Conn. Phone TRemont 5-5198

Circle Item 30 on Tech Data Card

VERTICALLY and HORIZONTALLY POLARIZED

ANTENNAS FOR FM

Write for full details.

JAMPRO ANTENNA CO.

7500 14th Ave.
Sacramento 20, California

Circle Item 31 on Tech Data Card



Voltage and Current Recorders

New miniature strip-chart recorders, which make permanent records of both amps and volts have been announced by the Amprobe Instrument Corp., Lynbrook, N. Y., manufacturers of Amprobe snap-around volt-ammeters. The Models AVA1 and AVA2 record fluctuations in either amperage or voltage, although not simultaneously. Both record voltages in two ranges on an expanded-scale meter for easy reading (95-130 volts AC and 190-260-volts AC), while the AVA1 records current in the ranges of 0-10/50/250/500 amps AC, and AVA2 from 0-5/25/100/250 amps AC. With the chart paper removed, the instruments can serve as either portable or panel-mounted volt-ammeters. The stylus records on pressure-sensitive chart paper that is unaffected by heat, moisture, humidity, or cold. The accurate (±3% of full scale) instruments, which measure only 3 1/32" by 5 21/32" by 1 11/16", weigh only 20 oz. and are sealed against dust by a Mylar shield. Supplied complete with chart paper, leather carrying case and all

BROADCAST ENGINEERING

necessary transducers and probes, the new recorders are priced at \$134.85 (AVA1) and \$129.85 (AVA2).

Circle Item 88 on Tech Data Card

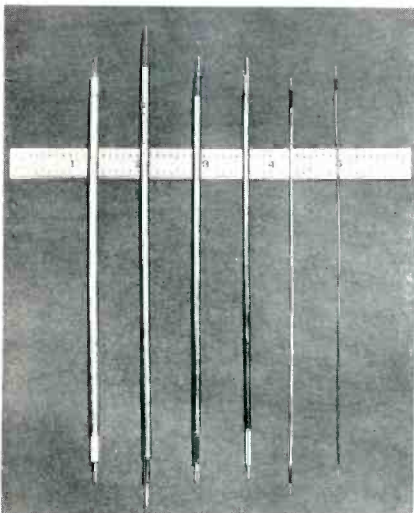

Miniature Solid-Jacketed Coaxial Cable

MicroCoax, a miniature coaxial cable, is being manufactured by MicroDelay Division, **Uniform Tubes, Inc.**, Collegetown, Pa., in a full range of standard sizes. This cable provides total shielding and is environmentally stable, of close-tolerance construction, and suited for use as waveguide. The dielectric is of TFE Teflon, while the center conductor is silver-plated copperweld wire; all standard types have a nominal characteristic impedance of 50 ohms. MicroCoax, which can be formed into bends or coils, has a solid jacket for easy stripping and soldering. Standard types can be supplied in modified forms with other conductor and sheath metals, or different dielectrics.

Circle Item 89 on Tech Data Card

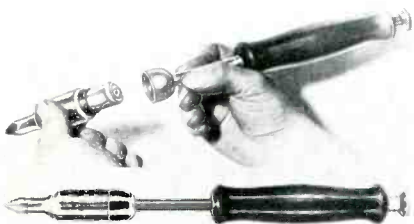

Chemically Heated Soldering Iron

Requiring no electric current or external heat of any kind, the "Quik Shot" soldering iron, manufactured by **Kemode Mfg. Co., Inc.**, New York, N. Y., utilizes a chemical cartridge that heats the iron to 850° F in 20 seconds and maintains soldering temperature for at least 7 minutes. The cartridge, a thermit mixture resembling a small flashlight cell, is actuated in the tip of the iron by a trigger at back of the handle. Especially designed for all outdoor work, including antenna cables, remote control lines, etc., the "Quik Shot" is based on a model recently developed for Army field use. Five interchangeable tip sizes, from 1/8 inch to 1 inch pyramid and chisel, make the iron adaptable for both light and heavy soldering jobs.

Circle Item 90 on Tech Data Card

Crown INTERNATIONAL BX800 PROFESSIONAL TAPE RECORDER

The BX800 Series is a maximum-versatility instrument engineered to meet or exceed the highest professional standards. It is available in six models with three tape speeds: 3 3/4, 7 1/2, and 15 ips (1 7/8 and 1 5/8 available). Each model features 3 heads: (1) erasing (2) recording (3) reproducing or monitoring; three motors (one synchronous drive type with 99.8 timing accuracy—two shaded-pole type); 10 1/2 inch reel capacity for 1/4 inch tape; hub adapters for NAB reel hubs; accommodation of 6 types of input; and .06% wow/flutter @ 15 ips with 30 cps—28 KC response ±2 db, full track. Standard operational features in this series include 3-speed equalization, remote control facility, front panel monitor jack and VU meter, cue control, automatic stop, micro-touch electric control system and extremely fast start/stop time—plus multi-speed performance and frequency response that meet all broadcast and laboratory requirements.

For additional information write:

CROWN INTERNATIONAL, 1718 MISHAWAKA ROAD, ELKHART, INDIANA

SPECIFICATIONS:

Record Reproduce Freq. Response*: 30-28000 cps - 2 db @ 15 ips; 30-16000 cps - 2 db @ 7 1/2 ips; 30-8000 cps - 3 db @ 3 3/4 ips.
Wow Flutter: .06% @ 15 ips, .09% @ 7 1/2 ips, .18% @ 3 3/4 ips.
Signal Noise Ratio*: 60 db @ 15 ips and 7 1/2 ips, 55 db @ 3 3/4 ips.
Start Time: 0.1 second to 15 ips.
Stop Time: .13 second or 2" @ 15 ips.
Rewind Time: 1200 ft. in 38 seconds; 1 min. for 2400 ft. NAB reel.
Stop Time from Full Rewind Speed: 2.9 seconds.
*Specifications for half track, full track, and two track (stereo).

Patented magnetic braking (never needs adjusting)
Hardened stainless steel flywheel shaft
Non-magnetic capstan
Micro-sync timing
Individual "Proof of Performance" record (furnished with each specific recorder)
Performance that exceeds professional standards



Circle Item 32 on Tech Data Card

USED TRANSMITTERS

(Traded-In On New Bauer Transmitters)

- **250 WATT RCA BTA 250L**
All tubes, 1490 kc crystal. Good condition. \$595.00
- **250 WATT RCA BTA 250M**
Current Model. Remote Control built-in. Excellent condition. \$1795.00
- **250 WATT RCA BTA 250M**
Same as above less remote control. \$1495.00
- **1 kw RCA BTA 1MX**
Installed new 1957. \$2500.00
- **5 kw WESTINGHOUSE 5HV-1**
Plenty of spares. \$4495.00

For Complete Information Call, Wire or Write:
Area Code 415-591-9466

Bauer

ELECTRONICS CORPORATION

1663 Industrial Road • San Carlos, Calif.

Circle Item 33 on Tech Data Card

SAMS TECHNICAL BOOKS

of special interest to Broadcast Engineers

The Latest in the Broadcast Engineering Notebook Series

Volume 2 — AM-FM Broadcast Operations

by Harold E. Ennes, WTAE, Pittsburgh, Pa.

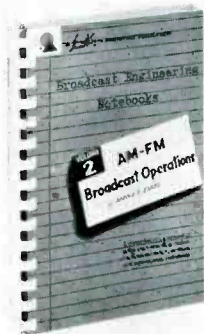

Planned to fill the gap between textbooks and practical on-the-spot guides, this second volume in the BROADCAST ENGINEERING NOTEBOOKS series, AM-FM BROADCAST OPERATIONS presents a complete analysis of radio studio and transmitter techniques and equipment. The book covers the wide range of operations both inside and outside the studio. Divided into five sections, the text explains necessary theory, recording, live shows, special events, music pickups, transmitter operators duties,

monitors, SCA, multiplex, limiting amplifiers, remote controls, antenna coupling, and FCC rules and regulations most important to the technician. Also included is a glossary defining terms used in broadcast operations. The latest work on the subject, this well illustrated book is designed to serve both as a reference source for experienced station engineers, and as an introductory text for students and newly licensed technicians. 256 pages; 5 1/2" x 8 1/2". (Available Feb.)

Order BEN-2, only . . . \$5.95

OVER 43,000 SUBSTITUTIONS! TRANSISTOR SUBSTITUTION HANDBOOK VOL. 4

For American and Foreign Transistors
This famous reference volume has been completely updated, revised and

enlarged, by means of a modern computer. It provides basing diagrams, polarity identifications, and manufacturers for over 4,790 transistor types, and lists more than 43,000 direct substitutions — over 29,000 for American types, and over 14,000 U. S. substitutes for foreign types. A semiconductor diode and rectifier cross-reference directory lists more than 700 substitutions. The text explains why substitution is possible, when it is appropriate and when not, how to choose replacements, and what precautions to observe. This book is valuable to everyone concerned with transistor replacement in any electronics field. 144 pages; 5 1/2" x 8 1/2".

Order SSH-4, only . . . \$1.50

A MUST! AM, FM & TV Station Reference NORTH AMERICAN RADIO-TV STATION GUIDE

by Vane A. Jones

This valuable book contains over 7,500 listings, including 5,000 AM and 1,500 FM stations by city, state, and frequency; and approximately 1,000 TV stations (both UHF and VHF). The listings encompass all operating stations, those scheduled to begin operation within the year, and those temporarily off the air in the U. S. and its possessions, Canada, Cuba, Mexico, and the West Indies. The listings give frequency, day and night power, network affiliations, commercial or noncommercial status, approved future changes, and construction permit data. 14 maps are included; 12 cover the VHF TV channels (2 through 12), one is for all UHF TV channels and one shows FM station distribution. 128 pages; 5 1/2" x 8 1/2".

Order RSG-1, only . . . \$1.95



Remote Control

(Continued from page 11)

metering purposes and is compatible with most types of SCA programming.

The reading being telemetered is usually expressed in terms of a low level DC voltage. This is converted to a frequency in the 20 to 40 cps band by an appropriate voltage controlled oscillator in which the applied DC input voltage determines the output frequency. The low frequency signal is then used to frequency modulate a 67-kc SCA subcarrier to about 10% of its modulation capacity, or about ±450 cycles. The 67-kc signal is then multiplexed on the main FM carrier.

At the studio, an off-the-air pickup is made, the subcarrier recovered, and the low frequency modulation removed for detection and presentation on a meter. Thus, as the sampling DC voltage changes at the transmitter, the remote meter indicator at the studio site changes. Since only 10% of the modulation capacity of the 67-kc subcarrier is used, the remaining 90% is available for other SCA operations, such as background music, talkback to studio, etc. It is important, of course, that frequencies falling in the 20 to 40 cps metering band be eliminated. Thus, by this frequency sharing technique, simultaneous metering and programming can be accomplished on a single SCA subcarrier in the presence of an FM stereo signal.

One final point should be made before considering two examples. The metering technique described above assumes that the 67-kc subcarrier generator is at the transmitter site. How then does one apply program modulation to this unit? Using an unattended continuous playing tape recorder is possible but not practical because of logistics. A separate multiplex subcarrier can be applied to the STL transmitter at the studio and detected by a suitable subcarrier receiver at the transmitter site. The auxiliary channel thus established can be used to relay a program to the 67-kc SCA subcarrier generator. This has the disadvantage of increasing the net cross-talk and noise, as two modulation processes are involved before the listener re-

**ORDER
TODAY**

See your parts distributor, or mail to:
Howard W. Sams & Co., Inc., Dept. BE 1262
4300 W. 62nd St., Indianapolis 6, Ind.

Send me the following books:

- AM-FM Operations
- Transistor Substitution Handbook
- North American Radio-TV Station Guide

\$ enclosed Send Free Book List

Name

Station Position

Address

City Zone State

IN CANADA: A. C. Simmonds & Sons, Ltd., Toronto 7



ASK FOR YOUR FREE SAMS BOOKLIST

New Fall-Winter Booklist describes over 200 books for engineers, technicians, and others in electronics.

See us at the IEEE Show,
booth 4035.

Circle Item 80 on Tech Data Card

ceives the program. To avoid this, the 67-kc subcarrier can be placed on the STL, recovered from the STL receiver, passed through an appropriate filter (with a built-in phase modulator for the low frequency metering tones), and then applied directly to the multiplex input of the FM exciter. The metering information, which is phase rather than frequency modulated, is then detected at the studio by a phase-type detector.

Summary

To summarize, consider the following two illustrations. Fig. 1 shows the block diagram of a remotely controlled FM transmitter engaged in stereo and SCA transmission. Two STL units are used for the left and right channels. The control signals are multiplexed on one STL. A voice channel for communications purposes is multiplexed on the other STL and is detected at the remote site. The metering information at the remote site is returned via a 67-kc SCA subcarrier to the controlling studio for read-out. A voice talk-back circuit can be applied to the 67-kc channel if desired. It is also possible to use the SCA channel to relay back to the studio the output of a base station remote-pickup receiver.

Fig. 2 illustrates a system similar to the previous example except that here the 67-kc SCA channel is used for background music. Locating the subcarrier generator at the studio greatly simplifies the problem of applying the program signal. The phase modulation scheme described earlier is used to relay the low frequency metering tones to the controlling point.

Conclusion

In making future plans for a remotely controlled FM station, it is believed that the best interests of the broadcaster will be served if he plans his equipment requirements to include both FM stereo and SCA operations. With this in mind a comparison can be made between the monthly charges for the necessary wire circuits and the amortized monthly cost of the STL equipment. If a mountain top site is involved and a line of sight path is available for the STL, certainly the merits of using STL equipment deserve particular attention. ▲

Classified

Advertising rates in the Classified Section are ten cents per word. Minimum charge is \$2.00. Blind box number is 50 cents extra. Check or money order must be enclosed with ad.

The classified columns are not open to the advertising of any broadcast equipment or supplies regularly produced by manufacturers unless the equipment is used and no longer owned by the manufacturer. Display advertising must be purchased in such cases.

EQUIPMENT FOR SALE

Transmission line, styroflex, heliax, rigid with hardware and fittings. New at surplus prices. Write for stock list, Sierra Western Electric Cable Co., 1401 Middle Harbor Road, Oakland 20, California. 6-61 tf

Commercial Crystals and new or replacement crystals for RCA Gates, W. E., Bliley and J-K holders; regrinding, repair, etc. BC-604 crystals. Also A. M. monitor service. Nationwide unsolicited testimonials praise our products and fast service. Eidson Electronic Company, Box 31, Temple, Texas. 9-61 tf

GOVERNMENT SURPLUS, NEW 10 CM. WEATHER RADAR SYSTEM—Raytheon, 275 KW peak output S band. Rotating yoke P.P.I. Weather Band 4, 20 and 80 mi. range. Price \$975 complete. Has picked up clouds at 50 mi. Wt. 488 lbs. Radio Research Inst. Co., 550 5th Ave., New York, New York. 1-63 6t

Will buy or trade used tape and disc recording equipment—Ampex, Concertone, Magnecord, Presto, etc. Audio equipment for sale. Boynton Studio, 295 Main St., Tuckahoe, N. Y. 10-62 6t

10-inch Soundcraft blank recording discs, package of 25, \$9.00, postpaid, cash, check or M.O. Studio, 6110 Santa Monica Blvd., Hollywood 38, California. 12-62 2t

Ampex Head Assemblies for 300 and 400 series recorders reconditioned. Service includes lapping and polishing all three head stacks, cleaning entire assembly, readjusting and replacement of guides, and realignment of stacks as to azimuth and zenith. Full trace assemblies—\$60.00. Taber Manufacturing & Engineering Co., 2619 Lincoln Ave., Alameda, California. 1-63 2t

TRANSMITTING TUBES FOR SALE — 3X2500F3 — \$175, 4W20000A — \$1815. 450TL — \$25, 4-125A — \$22.50, 872A — \$5.25, 575A—\$15.50. Many Others. Brand New, 1,000 hour warranty. Write or call Calvert Electronics, Inc., Dept. BE-1, 220 E. 23rd St., New York 10, N. Y., (212) OR 9-1340.

250 WATT FM TRANSMITTER for sale. Gates BF-250, used. In operating condition on 103.9 megacycles. Also Coax and antenna. Contact Radio Station KALM, Thayer, Missouri. 2-63-1T

USED TV EQUIPMENT FOR SALE—Specialists in RCA Types. Many bargains in stock. TK-30's, TK-11's, Power Supplies, Monitors, etc. Our exclusive refurbishing process Guarantees Satisfaction. Write, Wire or call for prices.

TELEQUIP CORPORATION, 319 East 48th St., New York 17, N. Y., PLaza 2-8885—PLaza 2-9037. 2-63-6t

WE BUY USED TV AND RADIO EQUIPMENT, LET US KNOW WHAT YOU HAVE TO DISPOSE OF. WRITE TELEQUIP CORPORATION, 319 East 48th St., New York 17, N. Y. 2-63-6t

Advertisers' Index

Altec Lansing Corp.	6
American Elite, Inc.	41
Ampex Corp.	31
Battison, John H. & Associates	45
Bauer Electronics Corp.	43
Belden Mfg. Co.	C3
Broadcast Electronics, Inc.	25
CO.EL Company	3
CBS Labs	5
Cleveland Institute of Electronics	46
Continental Electronics Mfg. Co.	7
Crown International	43
Densen Electronics Corp.	42
Electro-Voice, Inc.	24
Fairchild Recording Equip. Corp.	20, 40
General Electric Co.	27, 35
Gray Research & Development Co., Inc.	36
ITA Electronics Corp.	C2
James, Vir N.	45
Jampro Antenna Co.	42
Jensen Manufacturing Co.	21
McMartin Industries, Inc.	38
Raytheon Dist. Prod. Div.	8-9
Radio Corp. of America	C4
RCA Victor Record Div.	23
Russco Electronics Mfg.	40
Sarkes Tarzian Broadcast Equipment Div.	34, 37, 39
Sarkes Tarzian Semiconductor Div.	29
Seco Electronics	4
Sparta Electronic Corp.	30
Stancil-Hoffman	45
Sylvania Electric Products, Inc.	33
TeleQuip Corp.	20
The Turner Company	28

Professional Services

VIR N. JAMES
CONSULTING RADIO ENGINEERS
Applications and Field Engineering
232 S. Jasmine St.
Phone: (Area Code 303) 333-5562
DENVER 22, COLORADO
Member AFCCE

- SYNCHRONOUS MAGNETIC FILM RECORDER/REPRODUCER
- MAGNETIC TAPE RECORDERS
- NEW—THE portable MINITAPE synchronous 13 lb., battery operated magnetic tape recorder for field recording.

THE STANCIL-HOFFMAN CORP.
845 N. Highland, Hollywood 38, Calif.
Dept. B HO 4-7461

JOHN H. BATTISON & ASSOCIATES
CONSULTING RADIO ENGINEERS
Specializing in AM-FM-TV Applications and measurements.
934-5 Munsey Building
1329 E. St., N.W. Washington 4, D. C.
DI 7-2330
Established 1954

MISCELLANEOUS

ENGINEERING And Art Degrees earned through home study. Electronics, Mechanical, Liberal Arts. When writing specify course desired. Pacific International College of Arts & Sciences, primarily a correspondence school. Resident classes also available. 5719-W Santa Monica Blvd., Hollywood 38, California. 8-62 6t

Only Cleveland Institute offers...

A First Class FCC License

...or Your Money Back!



Your key to future success in electronics is a First-Class FCC License. It will permit you to operate and maintain transmitting equipment used in aviation, broadcasting, marine, microwave, mobile communications, or Citizens-Band. Cleveland Institute home study is the ideal way to get your FCC License. Here's why:

Our training programs will *quickly* prepare you for a First-Class Commercial Radio Telephone License with a Radar Endorsement. Should you fail to pass the FCC examination after completing your course, you will get a *full refund* of all tuition payments. You get an FCC License . . . or your money back!

You owe it to yourself, your family, your future to get the complete details on our "proven effective" Cleveland Institute home study. Just send the coupon below TODAY. There's no obligation.

MAIL COUPON TODAY FOR FREE CATALOG

Cleveland Institute of Electronics

1776 E. 17th St., Dept. BE-7
Cleveland 14, Ohio

Please send FREE Career Information prepared to help me get ahead in Electronics, without further obligation.

CHECK AREA OF MOST INTEREST -

- | | |
|---|--|
| <input type="checkbox"/> Electronics Technology | <input type="checkbox"/> First-Class FCC License |
| <input type="checkbox"/> Industrial Electronics | <input type="checkbox"/> Electronic Communications |
| <input type="checkbox"/> Broadcast Engineering | <input type="checkbox"/> _____ other _____ |

Your present occupation _____

Name _____ (please print) Age _____

Address _____

City _____ Zone _____ State _____

Accredited Member National Home Study Council

How to Succeed in Electronics



Circle Item 81 on Tech Data Card

ENGINEERS' TECH DATA SECTION

AUDIO & RECORDING EQUIPMENT

34. ALTEC LANSING—Microphones, consoles, amplifiers, and FM receivers covered in set of brochures.
35. AMERICAN ELITE—Booklets give specs of microphones, amplifiers, and attenuators for broadcast and recording.
36. BURGESS BATTERY—Bulletin lists line of magnetic tape.
37. FAIRCHILD—Specs on broadcast turntable and compressor.
38. GOTHAM AUDIO—Booklet outlines problems of highly directional microphones and solutions with condenser type.
39. GRAY RESEARCH & DEV.—Instruction manual presents operation and specs of stereo tone arm.
40. HARMAN KARDON—Illustrated bulletins cover amplifiers for PA, and a solid-state stereo control center.
41. TURNER—Specs on dynamic twin impedance microphone.
42. SPARTA ELECTRONIC—Folder gives information on cartridge tape systems, portable studio and console.
43. UNIVERSITY—Catalog presents line of modular microphones with interchangeable heads, connectors, and mounts.

COMPONENTS & MATERIALS

44. AMPEREX—Catalog lists basic specs of semiconductor line.
45. CBS LABORATORIES—12-page brochure surveys the resources and facilities of the Electron Tube Dept.
46. ENTERPRISE DEVELOPMENT—Bulletin describes soldering techniques using iron that removes solder with vacuum device.
47. FOURJAY IND.—Spec sheets cover Styron speaker baffles for 5 and 8-inch speakers, diffusers and mounting rings.
48. GENERAL ELECTRIC—Data and construction details on image orthicons for broadcast are listed in brochure.
49. INTERNATIONAL ELECTRONIC RESEARCH CORP.—Catalog details heat dissipating tube shields.
50. INTERNATIONAL WIRE & CABLE—Wire, cable, transmission lines, cords, and tubing are presented in catalog.
51. NEUMADE PRODUCTS—Catalog sheets list steel cabinets for storage of disc records and magnetic tape.
52. PENTA LABORATORIES—Bulletin lists specifications of PL-6775 power tetrode.
53. QUAM-NICHOLS—Data sheet covers indoor and outdoor speakers, hi-Z speakers, and line transformers.
54. SARKES TARZIAN—Particulars on plug-in silicon rectifiers.
55. SIMPSON ELECTRIC—Bulletin lists more than 1275 sizes and types of stock panel meters.
56. TT ELECTRONICS—Miniature filters including band rejection; high, low, band, and active band pass; listed in sheet.
57. VACO PRODUCTS—28-page catalog shows 197 models of solderless terminals and connectors.

STUDIO & CAMERA EQUIPMENT

58. LIGHTING & ELECTRONICS—Product index covers line of lighting equipment for theatrical and television applications.
59. S.O.S. PHOTO-CINE OPTICS—Product sheets describe equipment for television and motion picture production.
60. TRANS ELECTRONIC—Bulletins particularize regulated power sources, arc lamps, and precision lighting devices.

TELEVISION EQUIPMENT

61. DENSON ELECTRONICS—Catalog includes section on how to build low cost TV camera, and brochure on CCTV equipment.
62. DYNAIR ELECTRONICS—Bulletins cover video switchers, line amplifiers, and distribution amplifiers.
63. RIKER IND.—Brochure on video test equipment including multiburst, linearity, tape reference, and drive generators.

TEST EQUIPMENT & INSTRUMENTS

64. ELECTRO PRODUCTS LABS—Catalog surveys line of filtered, variable output DC power supplies.
65. JAMES MILLEN—Bulletins on grid dip meter list features for industrial, broadcast, and laboratory applications.
66. McMARTIN IND.—Spec sheets cover FM modulation, SCA multiplex, and frequency monitors.
67. PRECISION APPARATUS—Catalog includes meters, generators, power supplies, scopes, and other test equipment.
68. SECO ELECTRONICS—Information on transistorized DC power supplies in the 0-30 volt range.
69. TELEMET—Catalog states details of video test equipment, dist. amps, generators, and color monitors.
70. VARO—Specs of wide-band flutter and flutter/wow meter.

TRANSMITTER & ANTENNA DEVICES

71. CO.EL.—Catalogs describe broad-band dipole antennas, FM antennas, UHF slot antenna, filters, and diplexers.
72. CONTINENTAL ELECTRONIC—Brochures on super power transmitters.
73. MOSELY ASSOCIATES—A 950-mc STL for AM, FM, and TV aural service is described in bulletin.
74. MOTOR CONTROLLER CO.—Application sheets on radio frequency contactors and transfer switches.

This is WBAL-TV's new building in Baltimore. The exclusive use of Belden Audio, Camera, and Control Cables in this \$2,000,000 studio building helps maintain their high level of broadcasting efficiency.

Looking over part of this 125,000-foot Belden wire and cable installation are John Wilner, Vice President, Engineering, Hearst Corporation, operators of WBAL-TV (left), Manny Kann, Belden Distributor (center), and Hank Hine, Belden Territory Salesman. All of the wire and cable for WBAL-TV was purchased from Kann-Ellert Electronics, Inc., Belden Warehouse distributor.

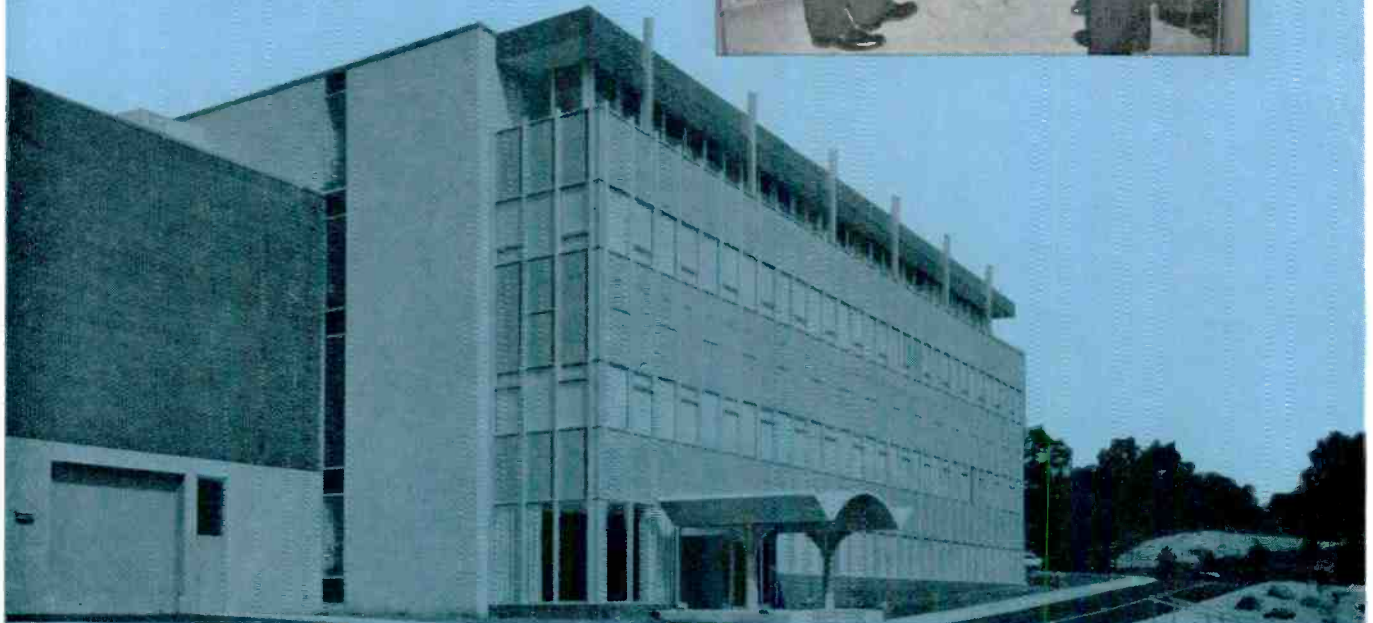

WBAL-TV Turns to Belden Exclusively for Audio, Camera, and Control Cables

Belden manufactures a complete line of application-engineered wire and cable for TV and radio broadcasting, recording studios, remote control circuits, and similar applications. Call your Belden electronic distributor for complete specifications.

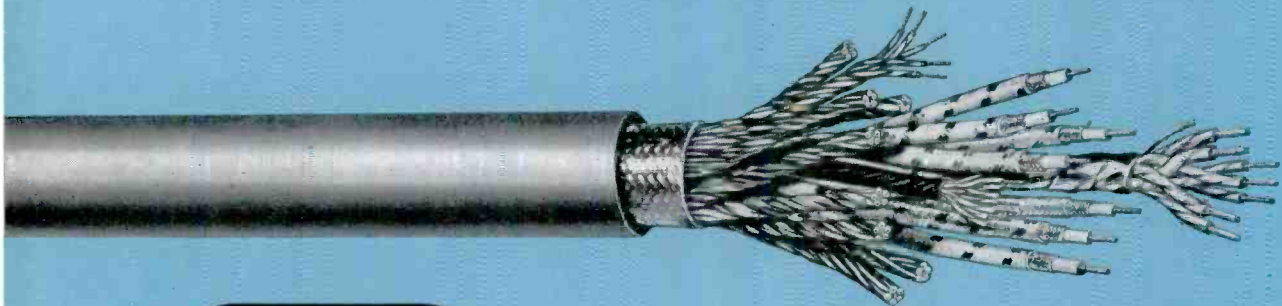

Belden

WIREMAKER FOR INDUSTRY
SINCE 1902 - CHICAGO

power supply cords • cord sets and portable cordage • electrical household cords • magnet wire • lead wire • automotive wire and cable • aircraft wires • welding cable

FOR
BLACK-and-
WHITE TV



IMPROVED

RCA FIELD-MESH IMAGE ORTHICONS

IMPROVED MANUFACTURING TECHNIQUES

RCA-7293A, 7295A and 8093A Image Orthicons for black-and-white television now produce significant signal output and signal-to-noise improvements.

An approximate 90 per cent improvement in signal output and as much as a 30 per cent improvement in signal-to-noise ratio can be attributed to improved manufacturing techniques. Each tube type also offers improvements in fine detail response, background quality and reduced microphonics.



RCA-7293A, 7295A and 8093A are but three of RCA's broad family of Image Orthicons. For fast delivery of these and others in the line, see your Authorized RCA Distributor of Broadcast Tubes.

RCA's Family of 3" Diameter Image Orthicons for Black-and-White TV programming includes:

RCA-5820A—Exceptional all purpose type for studio and remote telecasting; features extremely uniform and reliable performance due to very tight quality-control standards.

RCA-7293A—Field mesh type utilizing special anti-ghost design; recognized for its reduced edge effects and corner focus features.

RCA-8093A—Field mesh, anti-ghost type with wide dynamic range and high signal-to-noise ratio, making it ideal for tape recording with TV cameras designed for 3-inch diameter image orthicons.

RCA-4401V1—Sensitive, high-performance tube for low-light-level broadcast quality black-and-white pickup where scene illumination is less than 10 footcandles and depth of focus conditions require operating the lens at f/8 or higher.

FOR FAST SERVICE ON THESE TYPES

CALL YOUR RCA DISTRIBUTOR OF BROADCAST TUBES

RCA ELECTRON TUBE DIVISION, HARRISON, N. J.



The Most Trusted Name in Television