



FEATURING

- A New Method of Stereo Broadcasting 16
- When the Proof-of-Performance Fails 20
- Theory of Directional Antennas 24
- A Review of Transmission Lines 26
- The Economy Video Switcher 28

Broadcast Engineering

the technical journal of the broadcast-communications industry

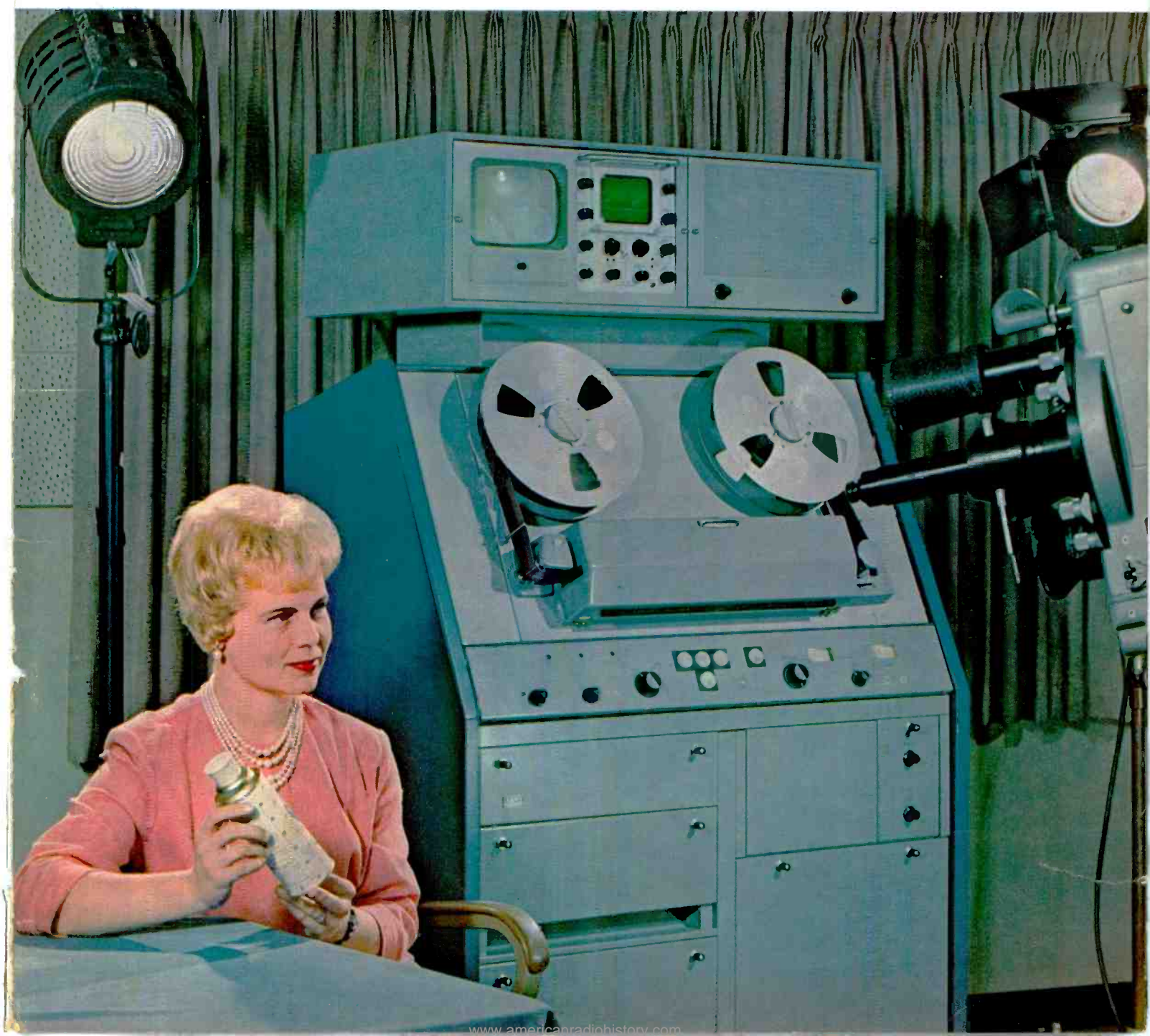

TELEVISION ZOOMAR
 has **NEW**
 all purpose lenses
 developed by
ANGENIEUX-EVERSHED and ZOOMAR

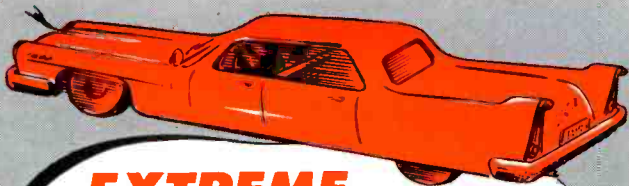
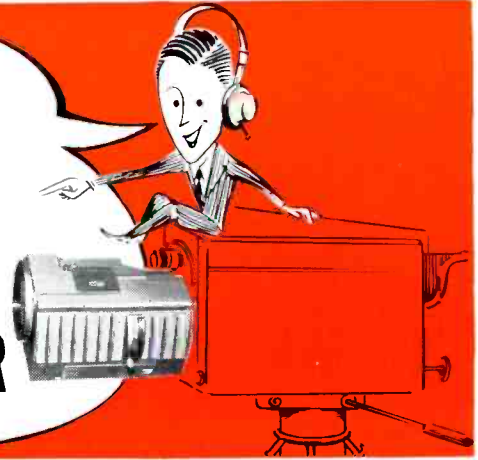

**EXTREME
 WIDE ANGLE**

35 mm. wide angle coverage eases production at small studios. Confined sets appear larger. Near and far objects stand out in sharp focus. You get the illusion of great width and depth.

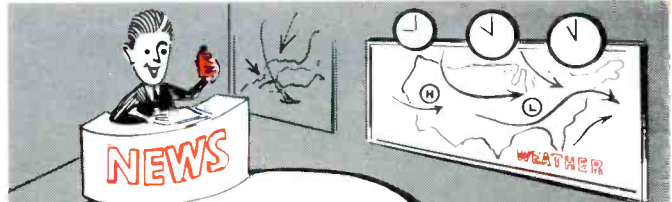

**10 TO 1
 ZOOM RATIO**
*The longest, most dramatic
 zoom ever developed.*

35 to 350 mm. zoom range means one camera coverage of most studio production. Simplified camera placement will reduce rehearsal time.



**SHORTEST WORKING
 DISTANCE...
 3 feet to Infinity**

Live or tape commercials calling for extreme close-ups... position the camera as close as 3 feet from the subject. Without adaptors... or re-focusing orthicon... you can zoom from this wide angle cover shot 40 inches wide to an extreme close-up 4 inches wide.

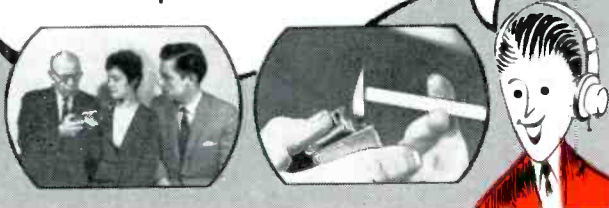

*Actual photographs

**TELEPHOTO RANGE
 FOR REMOTES**

A small convertor greatly extends the zoom range to make the Angenieux — Zoomar equally versatile for studio and remotes. From the first balcony at Madison Square Garden, you zoom from

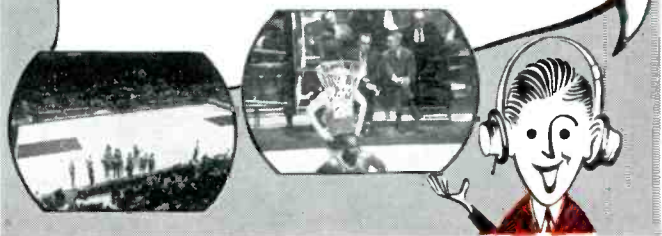

*Actual photographs (Basic Range)

**CHOICE OF EVERSHED SERVO REMOTE CONTROL
 OR ZOOMAR PATENTED ZOOM ROD CONTROL**

*Resolution and Contrast equal any fine fixed
 focus lens at any position in the zoom range.*

**JACK A. PEGLER • BILL PEGLER
 TELEVISION ZOOMAR COMPANY**

500 Fifth Avenue, Room 5520 • New York 36, New York • BRYant 9-5835

16 years preference by TV cameramen around the world.

NOW
FROM...



Sams Technical Institute, Inc.

... the dynamic training subsidiary of Howard W. Sams & Co., Inc., operates full-time training in electronics and other technologies with a continuous enrollment of more than 1100 resident students. NOW from the service-minded Howard W. Sams organization, known throughout the electronics industry for its authoritative service data and technical publications, comes the kind of home study program many technicians have been seeking.

TECHNICIANS... prepare for advancement AS AN FCC LICENSE HOLDER!



STI Self-Study Course not only prepares you for your 2nd Class License, the first step toward your 1st Class "ticket," but also gives you the practical skills and know-how you must have for advancement to higher paying jobs in radiocommunications.

NOT A REVISED COURSE BUT ALL NEW FOR THE NEW FCC REQUIREMENTS

The Federal Communications Commission has recently revised and updated its standards and examination requirements for 1st and 2nd Class Radiotelephone Licenses. These new requirements demand an understanding of semiconductors and their circuit applications. Unlike "revised" courses, the STI home-study course was "built" for the new regulations. It is specially designed to enable technicians and others with basic electronics training, not only to pass the new FCC 2nd Class exam, but also to develop the solid background needed for advancement to a 1st Class License.

A TECHNICIAN'S ANSWER TO:

- increased earnings in two-way radio servicing
- updating your knowledge of transistors and other recent developments
- improving your career position
- getting an FCC 2nd Class License

As the field of electronics changes, those who succeed must change with it.

ACT NOW!

Start
preparing today
for
higher pay!

BUSINESS REPLY MAIL

No postage necessary if mailed in the U.S.A.

postage will be paid by:

Sams Technical Institute, Inc.

1720 EAST 38TH STREET
INDIANAPOLIS, INDIANA 46218

ATTN: HOME STUDY

FIRST CLASS
PERMIT NO. 1076
Indianapolis, Ind.

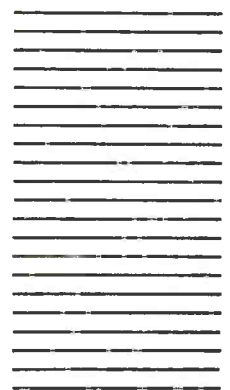

Three Courses in One!

The Course combines material usually obtained only from three separate courses:

* FCC License Course

Presents material for Elements I, II, and III of the latest FCC license requirements in proper sequence—and far more thoroughly than is required for passing the 2nd Class FCC exam.

* Practical Servicing Course

Gives the practical know-how you need to adjust, troubleshoot and repair transistorized radio equipment.

* Covers Transistors

Gives far superior coverage of transistor principles and transistor circuit applications than found in most textbooks. In fact, this Course is an ideal way for a technician to up-date his transistor knowledge.



A Course with Proved Student Interest

Written by experts in the field, this new STI Course makes use of the latest and best teaching methods, and has been thoroughly student-tested in order to produce the finest Course available.

Every industry resource has been used to make this the most factual, timely and complete training of its kind. Learning is easy and enjoyable. The material is so interesting you will find yourself reading ahead with ever-increasing interest and enthusiasm.



Sams Technical Institute, Inc.
INDIANAPOLIS

- Please send complete information on the STI Home Study Course—
FCC License Course Radiotelephone 2nd Class.
- I am a technician Have had previous basic electronics training



Mr. William Renner, *Director*

SAMS TECHNICAL INSTITUTE, INC.

1720 EAST 38TH STREET, INDIANAPOLIS, INDIANA 46218

NAME _____

ADDRESS _____

CITY _____ STATE _____ ZIP _____

TEAR HERE

ACT NOW!

Start
preparing today
for
higher pay!

Another FM Station goes FULLY AUTOMATIC!

**WHBF-FM, Rock Island,
Ill.** selects ATC automated system

WHBF Chief Engineer, Robert J. Sinnott, is shown operating the ATC system that has put WHBF-FM on a fully automated programming basis. The components pictured below provide music, news, commercials, production aids, and program logging automatically. The system was selected because its flexibility enables WHBF to change program structure as easily as dialing a phone. Broadcast personnel may be released from control operation for more profitable activities.

**FREE BOOKLET ON
AUTOMATED BROADCASTING**

This 38-pg. booklet explains how ATC equipment can be adapted as an efficient programming system tailor-made to your station's needs. Write, wire or phone now for complete information.

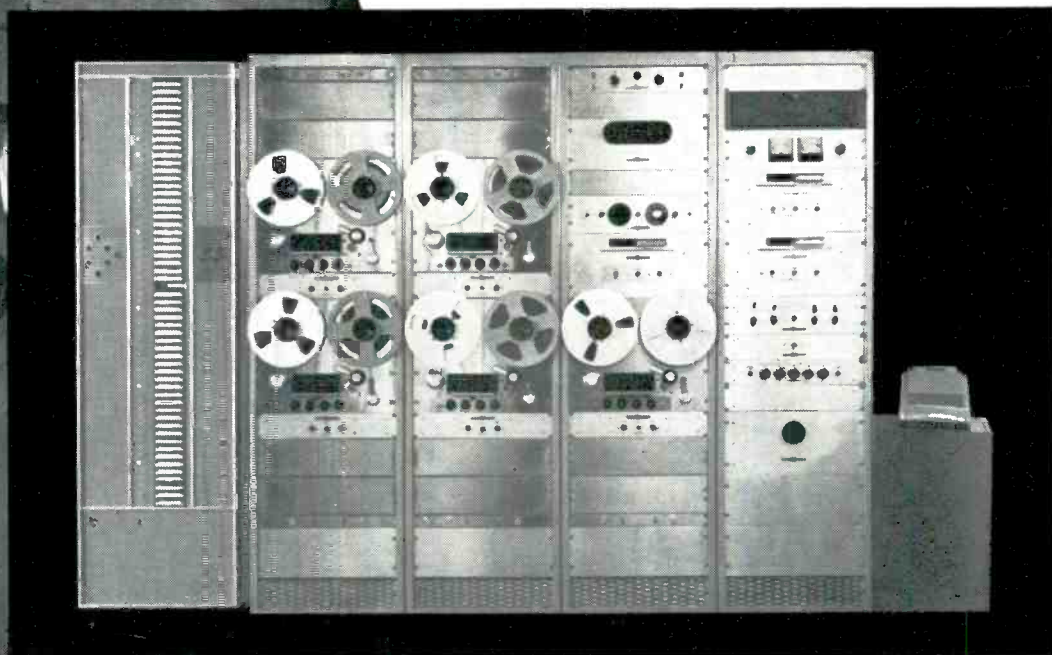
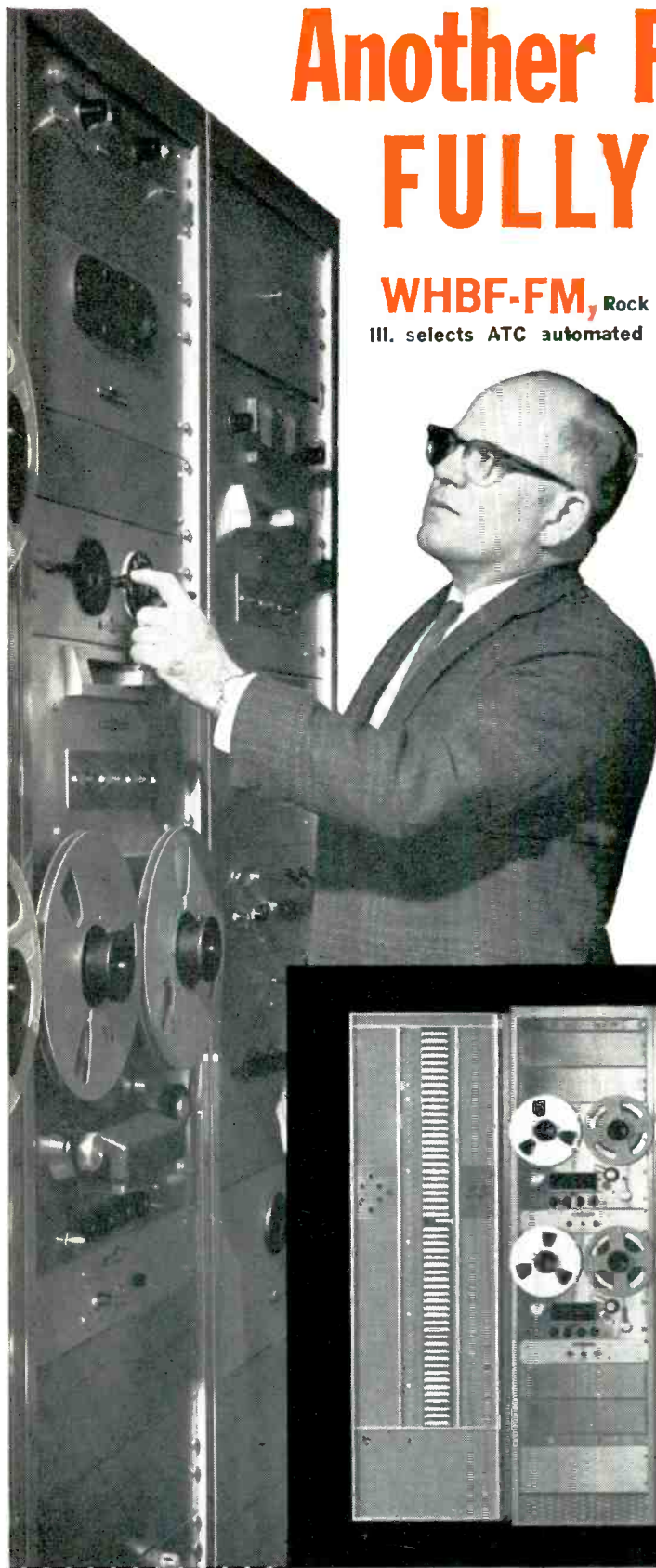

AUTHORIZED DISTRIBUTORS

Dixie Radio Supply Co., Columbia, S. C.; Southeast Audio Co., Jacksonville, Fla.; General Electronics Labs., Cambridge, Mass.; Electronic Equipment Co., Atlanta, Ga.; Lang Electronics, New York, N. Y.; Audio Industries Corp., Hollywood, Calif.; Guarantee Radio Supply Co., Laredo, Texas; Audio Acoustic Equipment Co., Arlington, Texas; Electricraft, Inc., Seattle, Wash.



Made by broadcasters for broadcasters

AUTOMATIC TAPE CONTROL, INC.

209 E. Washington St. Bloomington, Illinois

Overseas sales (except Canada) CBS International, 46 E. 52nd St., New York 22, N.Y. Marketed in Canada by Canadian General Electric, Toronto 4, Ontario.

Circle Item 2 on Tech Data Card

SECO PLUS⁺ TESTERS

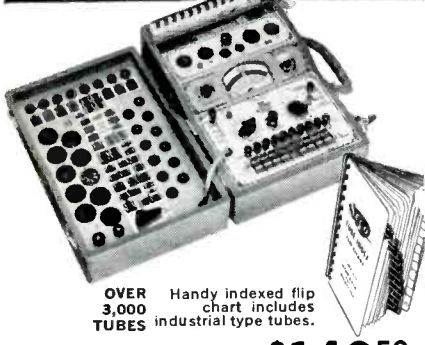

OVER 3,000 TUBES Handy indexed flip chart includes industrial type tubes.

INDUSTRIAL MODEL 107A ONLY **\$149.50** NET

† A SECO PLUS—ALL THESE TUBE TESTS IN ONE COMPACT TESTER

- **GRID CIRCUIT TEST**—all tubes get 11 positive checks for leaks, shorts and grid emission. A Seco designed and patented "Electron-Eye" test.
- **DYNAMIC MUTUAL CONDUCTANCE TEST**—pre-wired chassis for effective testing of voltage amplifier and similar tube types.
- **CATHODE EMISSION TEST**—the best method for testing pulse amplifier, power output and damper type tubes.

Extremely accurate and easy to use, the Seco 107A "Tri-Tester" provides all essential tests. Guaranteed against obsolescences.

The "Tri-Tester" meets specifications for: FEDERAL STOCK CLASSIFICATION, Tube Tester Type 107-FSN-6625-713-9075.

This compact, portable unit is completely self-contained in a handsome, vinyl plastic carrying case. It is the finest, fastest, most complete tester on the market—at a popular price!

COMPLETE TRANSISTOR AND TUNNEL DIODE ANALYZER

† LOOK AT THIS SECO PLUS—a complete transistor lab for incoming transistor and diode stock inspection and for servicing transistorized equipment.

- Requires no set-up data
- Identifies NPN and PNP transistors immediately
- Provides dynamic GO-NO-GO test in circuit
- Provides accurate DC analysis out of circuit
- Indicates transistor leakage and gain
- Tests signal and power transistors, also tunnel and zener diodes
- Indicates diode forward conductance and reverse leakage current
- Includes VOM meter with appropriate ranges.

You'd expect to pay much more for a set that: needs no set-up data—includes a "speed test socket"—reads BOTH lcbp and lcco leakage currents—cancels lcco leakage for TRUE gain readings. Two models: (1) AC powered 250A at \$86.50 and (2) "B" battery powered 250B at \$74.50 Both include 24" test leads with slim line prods.

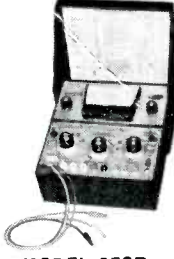

MODEL 250B ONLY \$74.50 NET

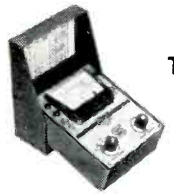

TRANSISTORIZED DC POWER SUPPLY

MODEL RPS-5 ONLY \$69.50 NET

- Bias taps: 0-1.5 and 0-7.5 V for simultaneous use with main supply
- Short circuit indicator
- No overshoot.
- † A SECO PLUS—Zener regulated constant voltage for applications up to 4 watts.

See for yourself the Seco PLUS features on these testers at your electronics supply dealer—or send the coupon for complete literature.

SECO ELECTRONICS, INC.
1219 S. Clover Drive, Minneapolis 20, Minn.

Rush complete information on the Model 107A "Tri-Tester" the Model 250 Transistor and Tunnel Diode Analyzer the Model RPS-5 Power Supply, including full line folder describing complete range of Seco test equipment.

NAME _____
COMPANY _____
ADDRESS _____
STATE _____ CITY _____

Circle Item 3 on Tech Data Card

the technical journal of the broadcast-communications industry



Broadcast Engineering

Volume 5, No. 5

May, 1963

CONTENTS

FEATURES

A New Method of Stereo Broadcasting	16
by Kenneth R. Hamann — Here's an up-to-date look at stereo transmission systems with a report on a new technique now being tested.	
When the Proof-of-Performance Fails	20
by Ed Murdoch — Part One. What equipment you need for an audio proof, and how to hook up the instruments.	
Twelve Rules for Dealing With the FCC Inspector	23
by Ed Murdoch — An all-in-fun guide of behavior for FCC inspections.	
Theory of Directional Antennas	24
by Bryce W. Tharp — Explanation of the principles behind arrays, and the formulas employed in pattern calculations.	
A Review of Transmission Lines	26
Technical Talks — The history, theory, and current practice of open-wire and coaxial lines.	
The Economy Video Switcher	28
by James French, Jr. — Construction and operation details on a transistorized video switcher.	

DEPARTMENTS

Letters to the Editor	8	Engineers' Tech	
About the Cover	14	Data Section	49
Engineers' Exchange	34	Advertisers' Index	50
News of the Industry	36	Classified Ads	50
New Products	46	Professional Services	50

PUBLISHER: Howard W. Sams
GENERAL MANAGER: Mal Parks, Jr.
EDITORIAL: Executive Editor, Verne M. Ray; Editor, Forest H. Belt; Managing Editor, Stuart N. Soll; Consulting Editor, John H. Battison.
CIRCULATION: Manager, Pat Tidd; Assistants, Katherine Krise, LaVon Willard.
PRODUCTION: Manager, Robert N. Rippy.
ADVERTISING: Sales Manager, John W. Groce; EAST: Charles Horner, Howard W. Sams & Co., Inc., 3 West 57th Street, New York, N. Y., Phone—MU 8-6350; MIDWEST—Hugh Wallace, Howard W. Sams & Co., Inc., 4300 West 62nd Street, Indianapolis 6, Ind., Phone AX 1-3100; SOUTHWEST—C. H. Stockwell Co., 4916 West 64th Street, Mission, Kansas, Phone—RA 2-4417; LOS ANGELES 57, CALIF., Maurice A. Kimball Co., Inc., 2550 Beverly Blvd., Phone—DU-8-6178; SAN FRANCISCO, Maurice A. Kimball Co., Inc., 580 Market Street, Phone—EX 2-3365; PARIS 5, FRANCE, John Ashcraft, 9 Rue Lagrange, Phone—ODEON 20-87; LONDON W.C. 2, ENGLAND, John Ashcraft, 12 Bear Street, Leicester Square, Phone—WHITEHALL 0525; TOKYO, JAPAN, International Media Representatives, Ltd., Kisha Kurabu 14, 2-chome Marunouchi, Phone—(502) 0656.
SUBSCRIPTION PRICE: U.S. \$6.00, one year; \$10.00, two years; \$13.00, three years. Outside U.S.A. add \$1.00 per year for postage. Single copies, 75 cents.
BROADCAST ENGINEERING is published monthly by Technical Publications, Inc., an affiliate of Howard W. Sams & Company, Inc. Editorial, Circulation, and Advertising headquarters: 4300 West 62nd Street, Indianapolis 6, Ind. Copyright (c) 1963 by Howard W. Sams & Co., Inc.

Sound Control with Sony



PROFESSIONAL COMMAND OF SOUND FOR EVERY RECORDING AND BROADCAST SITUATION

Sony CR-4 Wireless Microphone—The perfect transistorized microphone and pocket-size transmitter for active singer/dancers and TV performers to give complete freedom from entangling cables and obstructing mike stands. Mike and transmitter together weigh only 13½ ounces. Complete with transmitter, receiver and carrying case: \$250.

Sony EM-1 Newscaster Portable—A full track, all transistorized portable recorder designed for rugged service and dependable performance in remote locations. Meeting NARTB specifications, the EM-1 is ideal for on-the-spot interviews and sound recording. • Governor controlled, constant speed spring wound motor • Rewind while recording • 13¼ pound weight. Complete with microphone and accessories: \$495.

Sony MX-777 Stereo Mixer—A six chan-

nel all transistorized self powered stereo/monophonic mixer featuring: 4 balanced microphone inputs, 2 balanced hi-level inputs and 2 balanced recorder outputs. Other features include individual level controls and channel 1 or 2 selector switches, cannon XL receptacles and switch for bridging of center staging solo mike. Complete with carrying case: \$175.

Sony C-37A Condenser Microphone—Remarkably smooth and uncolored natural response through the full range of recorded frequencies has earned the C-37A the title of "world's most perfect microphone." • Adjustable for omni-directional or uni-directional • Frequency response ±2 db 20-18,000 cps • Signal to noise—more than 55 db for signal of 1 micro-bar at 1000 cps. Complete with CP-3 Power Supply, carrying case and 30 feet of cable: \$295.

Sony C-17B Condenser Microphone—A miniaturized, uni-directional companion to the famous Sony C-37A Microphone. With outstanding background isolation characteristics, the uni-directional cardioid pattern is ideal for TV, night club and solo voice stereo recording application. The slim 1¼" diameter size minimizes visual problems. Complete with CP-3 Power Supply, carrying case and 30 feet of cable: \$350.

Sony CP-3 Power Supply—For the C-37A and the C-17B microphones, the CP-3 features: Switch for 3 positions of low frequency attenuation; special high cut filter switch for all frequencies above 10,000 cps.

For more complete specifications and name of nearest dealer, write Superscope, Inc., Dept. B, Sun Valley, California.

In New York, visit the Sony Fifth Avenue Salon, 585 Fifth Avenue.

All Sony Stereorecorders are Multiplex Ready!

SUPERSCOPE

The Tapeway to Stereo

Circle Item 9 on Tech Data Card

The Sarkes Tarzian
**HETERODYNE
 MICROWAVE
 RELAY**

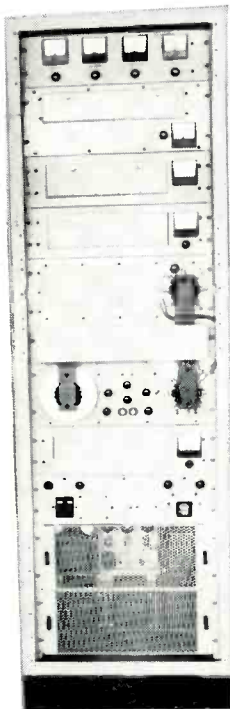

**PROVEN PERFORMANCE
 Where It Counts**

Over three years actual in-field use has proven Tarzian's multi-hop microwave delivers exceptional quality color transmission, simultaneously with broadcast quality sound—at lowest possible cost. And, Tarzian's renowned microwave systems engineering department is at your disposal for assistance with planning and installation.



Broadcast Equipment Division
SARKES TARZIAN, INC.
 Bloomington, Indiana

Circle Item 6 on Tech Data Card

**LETTERS
 to the editor**

DEAR EDITOR:

I'm technical supervisor for a three-station group. Well thumbed copies of BROADCAST ENGINEERING are frequently observed at each of the three stations, when I drop in. As I glance through them, I note many, many very interesting and helpful articles; and I hope you will continue to publish these. They help to instruct my engineers, and thus make my job that much easier.

But I'd like to read them too, and at a time when I could give the magazine my undivided attention. And I don't want to "swipe" the issues from the stations. I have no objections to becoming a "free-loader," so how about a free copy at my home office?

F. E. BARTLETT
 Des Moines, Iowa

But we do . . . so how about filling out the subscription card at the front of this issue, and sending it in with your check. Then we'll include a free copy of our new 56-page premium book — "Broadcast Engineers' Maintenance Handbook"—and you'll get your issues at your home office each month.—Ed.

DEAR EDITOR:

I am interested in inexpensive (but effective) studio soundproofing; and wonder if past issues of BROADCAST ENGINEERING have carried articles on wall and door treatment techniques. Could you refer me to information on this subject?

STANLEY R. SWANSON
 WCMF, Rochester, N.Y.

Such coverage is up in future issues, Stan, but meanwhile maybe some of our readers can suggest a solution. How about it, engineers?—Ed.

DEAR EDITOR:

Having worked in radio for six years now, I firmly believe that BROADCAST ENGINEERING is a standard fixture in every broadcast station.

Now, as a subscriber, I have copies which I can enjoy at my leisure and use as I want, as well as one to use as a reference at work.

Also, I would like to express my thanks for the new Tech Data service. This is a fine way for an engineer to build up a catalog file on equipment in which he is interested. It also indicates to the manufacturer that his product has been accepted by the profession.

RICHARD E. ZASTROW
 Emporia, Kansas

Thanks for the kind words, Richard, glad to have you with us.—Ed.

DEAR EDITOR:

I read with interest the article Practical Application of FCC's Engineering Rules, by John A. Battison, in the February, 1963 issue.

Mr. Battison warned against making mistakes and then plotted the station location on the map inaccurately. The station is shown at 75° 01' 47", not 75° 04' 17".

I really enjoy BE and just wished to take the opportunity to tell you so.

DEAN LOUDY
 WNNT, Warsaw, Va.

Right, Dean, you caught us with our map reading down. The expression in Fig. 2 on page 16 of the February issue should read:

$$\begin{aligned} \text{LATITUDE} &= 75^\circ 00' 00'' + 107'' \\ &= 75^\circ 01' 47'' \end{aligned}$$

—Ed.

Next Month — SPECIAL AUDIO and STUDIO issue

**AUDIO LEVEL DEVICES
 Part 1**

The first of a three-part article surveying peak limiters, compressors and averaging devices, and specialized equipment for audio studios.

**PLANNING THE MODERN
 STUDIO**

Here's how one station designed their studio around music and news programming.

**"ROLL YOUR OWN"
 AUTOMATIC TAPE**

A device for controlling magnetic tape cartridges.

PLUS . . . Everybody's favorite, Engineers' Exchange, and other items of current interest you won't want to miss!

**WHEN THE PROOF-OF-
 PERFORMANCE FAILS — Part 2**

How to make noise and distortion measurements, and employ the proper techniques for troubleshooting a faulty proof.

**DESIGN OF RESISTANCE-
 COUPLED AUDIO AMPLIFIERS**

The theory and practice of vacuum-tube and transistor amplifiers for audio applications.

AUDIO MODULATION

Technical Talks — A practical look at modulation, its consideration in allocations, and principles.

Most TV Camera and Microphone Cables Are Made by Belden

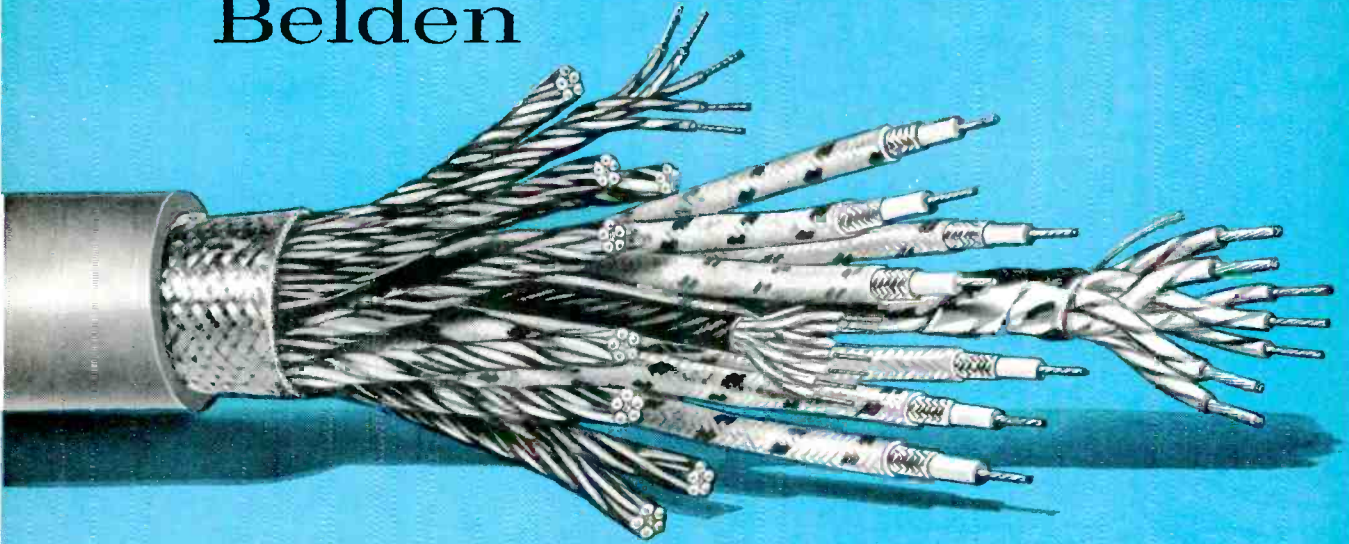

Belden offers a full range of application-designed wire and cable for TV and radio broadcasting, recording studios, remote control circuits, and related applications. Available from your Belden electronics distributor.

Belden

WREMAKER FOR INDUSTRY
SINCE 1902 - CHICAGO

P.O. Box 5070-A, Chicago 80, Illinois

power supply cords • cord sets and portable cordage • electrical household cords • magnet wire • lead wire • automotive wire and cable • aircraft wires • welding cable



Plastic Microphone and Shielded Power Supply Cables



Rubber Microphone and Shielded Power Supply Cables



Broadcast Audio Cables

FREE: Write for copy of 7-page technical paper "Choosing a Microphone Cable."



75-Ohm Video Cable

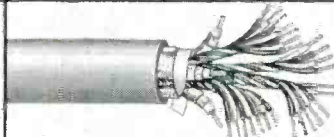

TV Camera Cables

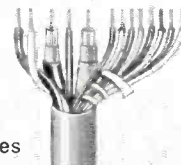

8-6-1

Circle Item 7 on Tech Data Card



Who can deliver a fully transistorized broadcast VTR for less than \$35,000?

Circle Item 8 on Tech Data Card

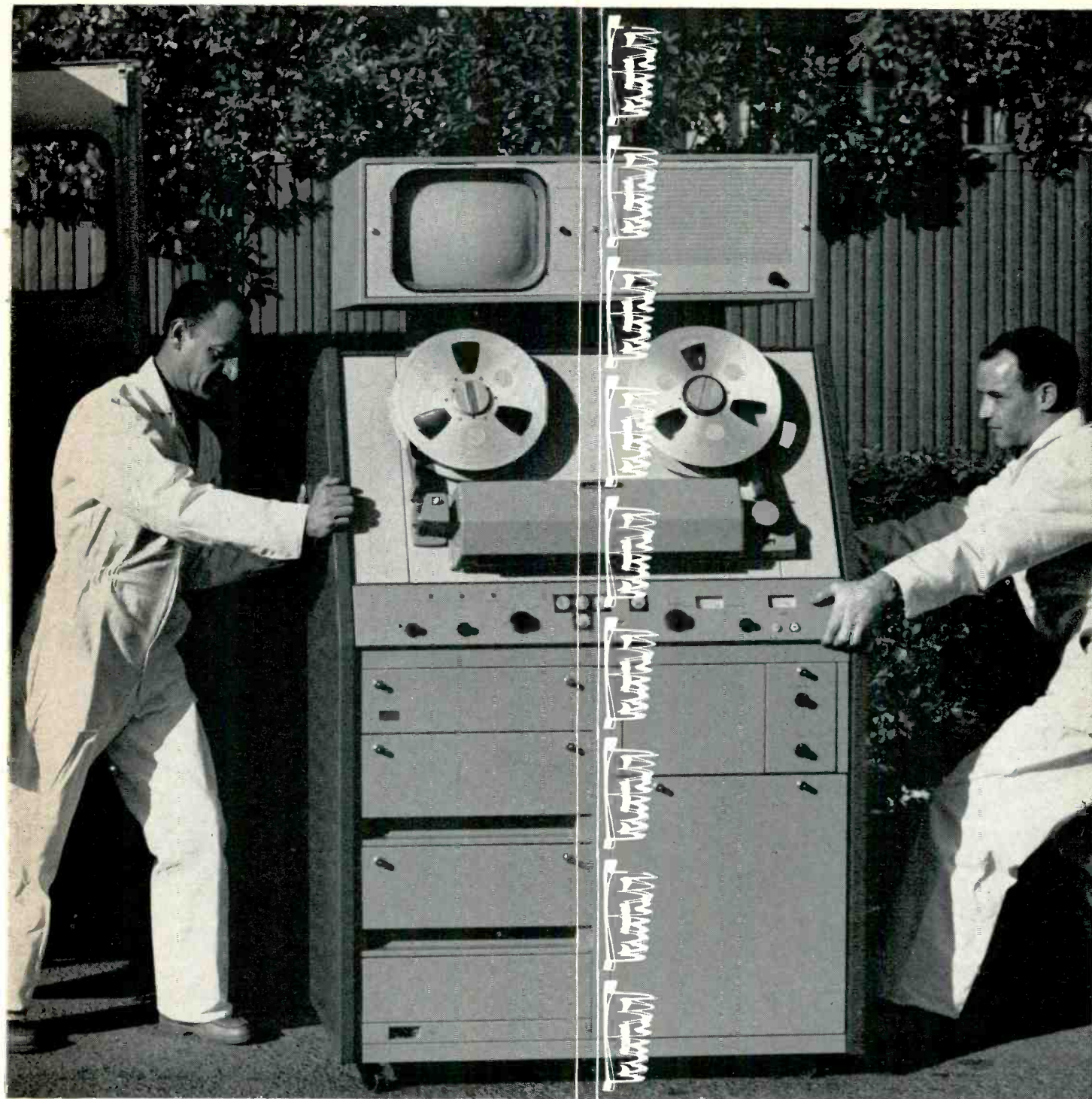

AMPEX

Now: the Videotape* Recorder is practical for any sized station. And low-cost mobile tape applications are a reality. It's all because of the VR-1100—another Ampex tape recording innovation for television. The VR-1100 is a transistorized broadcast recorder that costs less than \$35,000. It has two speeds—15 ips and 7½ ips. Provides three hours of recording at 7½ ips. Is compatible with all 4-head recorders. Takes less than half the floor space of previous VTRs. Weighs half as much. And can be equipped for single camera production—by adding the Vertical Lock Accessory that allows use of the Ampex Electronic Editor. What's more, low

power requirements and a new convection cooling system eliminate the need for blowers or special air conditioning in the station. Controls are minimized for simple operation. Maintenance costs are low. Reliability and performance characteristics are superb—all in the Ampex tradition. Order now for Fall programming. For complete details call your Ampex representative or write the only company providing recorders, tapes and core memory devices for every application: Ampex Corporation, 934 Charter Street, Redwood City, California. Term financing and leasing are available. Sales and service engineers throughout the world.

AMPEX

*TM Ampex Corp.

May, 1963

11



Files interlock solidly for stacking—can be safely stacked up to seven units high.



Easy-glide "follow block" keeps tape neatly in place. Slotted back for easy wall mounting.

Hang it, stack it, however you use it...

the new Storette tape rack's a good deal!

Only \$6.95 with SCOTCH® Professional Recording Tapes!

The Storette is the first quality tape storage rack ever offered at this special price... only \$6.95 (\$12.95 value) with your order of 36 rolls of "Scotch" Brand Professional Recording Tapes in either 5" or 7" size! The Storette was specially designed for storing tape—holds 36 boxes of either 5" or 7" reels, has a "follow block" for easy dividing. Sits on counter or shelf bookcase-style, lays on its back or hangs on wall. 9 $\frac{3}{8}$ " high, 25" wide, 8" deep. All welded construction with smooth corners and edges. 2-coat gray baked enamel finish. Completely assembled. Units interlock for stacking—up to seven shelves high.

The special offer on the Storette tape rack is available

with assortments of all popular professional "SCOTCH" Recording Tapes including *All Purpose, Extra Play, Double Length, High Output, Low Print*... in fact a tape for every professional need. See your supplier. (Please note that all tapes are offered by your supplier at regular industrial consumer maximum discount prices.) Larger storage cabinet holding up to 300 tapes also available. For information ask about CAB-1 unit.



"SCOTCH" AND THE PLAID DESIGN ARE REGISTERED TRADEMARKS OF MINNESOTA MINING & MANUFACTURING CO., ST. PAUL 19, MINN. EXPORT, 99 PARK AVE., NEW YORK, CANADA: LONDON, ONTARIO. ©1963 3M CO.

Magnetic Products Division **3M** COMPANY

Circle Item 4 on Tech Data Card

BROADCAST ENGINEERING

New, from Electro-Voice! Sentry Series Professional Monitor Loudspeakers . . . guaranteed flat ± 3 db from 40 to 20,000 cps!

No longer must you improvise with theatre or home-type hi-fi speakers designed for some other purpose. Gone is the guesswork when equalizing . . . you know you'll get *exactly* what you hear through an E-V Sentry Monitor. That's because each Sentry is simple, reliable and as flat in response as modern science can make it!

Gone are "balance" switches or knobs that vary response . . . each Sentry is adjusted flat at the E-V laboratories before you ever see or hear it! And because of this simplicity, the E-V Sentry Series speakers are modest in size and price.

NEW VOICE OF AUTHORITY!

The natural-finish hardwood cabinets are available in a sloping-front style for wall or ceiling mounting . . . or in an upright floor model for fixed or portable applications. They are all identical in sound. Built-in transformer matches studio output impedance of 8, 16 and 600 ohms.

If you want to end equalization guesswork . . . if you want to know that the sound you hear is an exact duplication of the original . . . the E-V Sentry Series Professional Monitors were designed for you. Write for complete specifications, or see your E-V Professional Products Distributor, today!

Sentry II Floor Model, 32" H, 20" W, 13" D. List Price \$248.33. *Sentry I* Wall or Ceiling Model, 17" H, 37" W, 21 1/4" D. List Price \$231.67. (Normal trade discounts apply.)

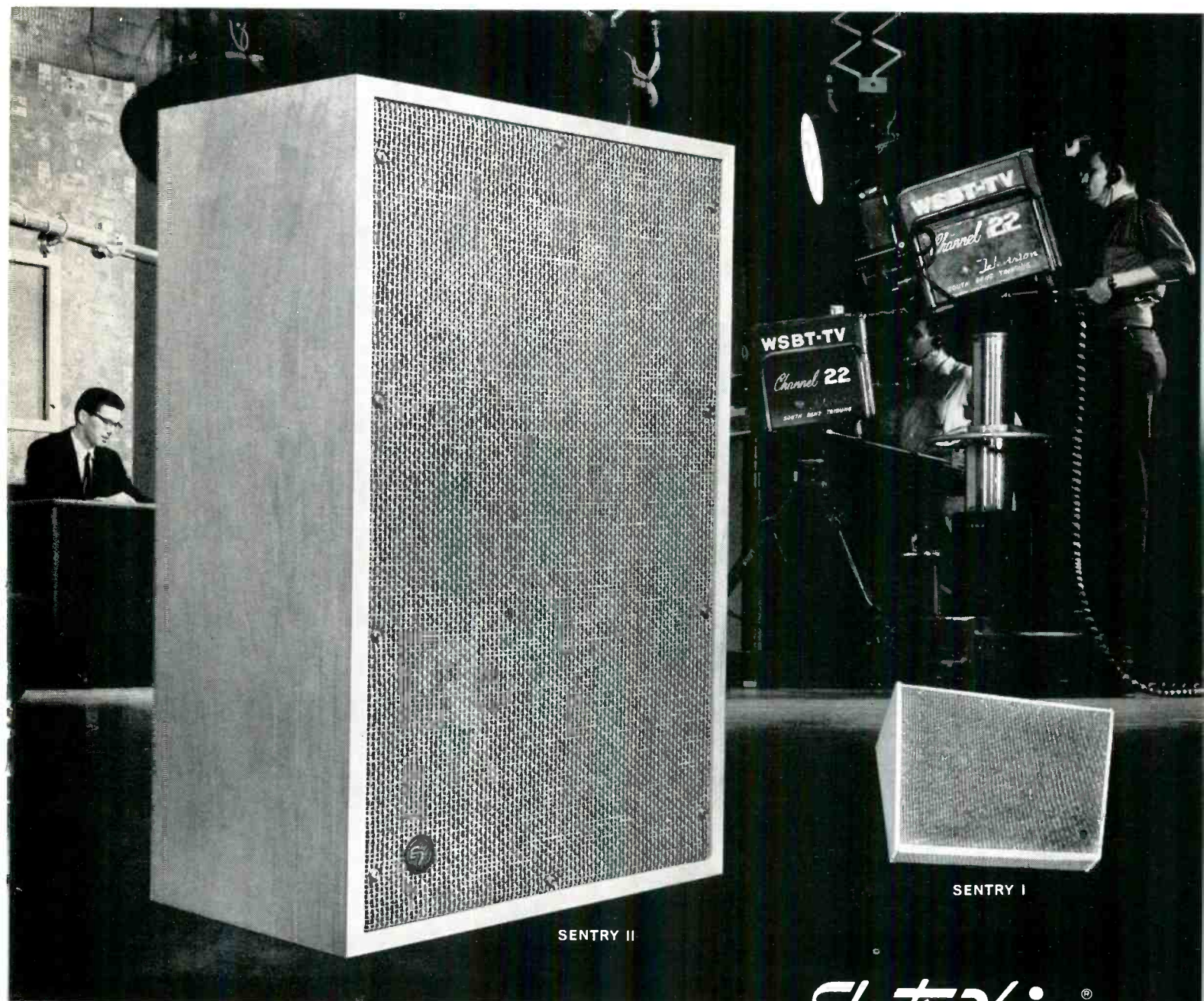

SENTRY II

SENTRY I

Electro-Voice®

ELECTRO-VOICE, INC. Commercial Products Div., Dept. 531V, Buchanan, Michigan

Circle Item 10 on Tech Data Card

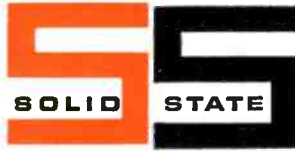

KRS STACT BROADCASTER

Reversible Continuous-Loop Cartridge Tape Unit

Professional reel-to-reel quality with tape cartridge convenience.

Now . . .

- **A BROADCAST CARTRIDGE** — provides reversible continuous-loop operation. Eliminates reel-to-reel production and transfer to cartridge.
- **QUALITY** — the first cartridge tape unit with the superior quality of professional reel-to-reel. Full-length program capability.
- **MULTI-DECK** — holds six tape cartridges in less space than normally required for one reel-to-reel unit. Five playback decks plus one combination record-playback deck.
- **AUTOMATIC CUEING** — provision for separate, automatic (1) stop cue, (2) end of message cue, and (3) random cue, can be used as automation building block.

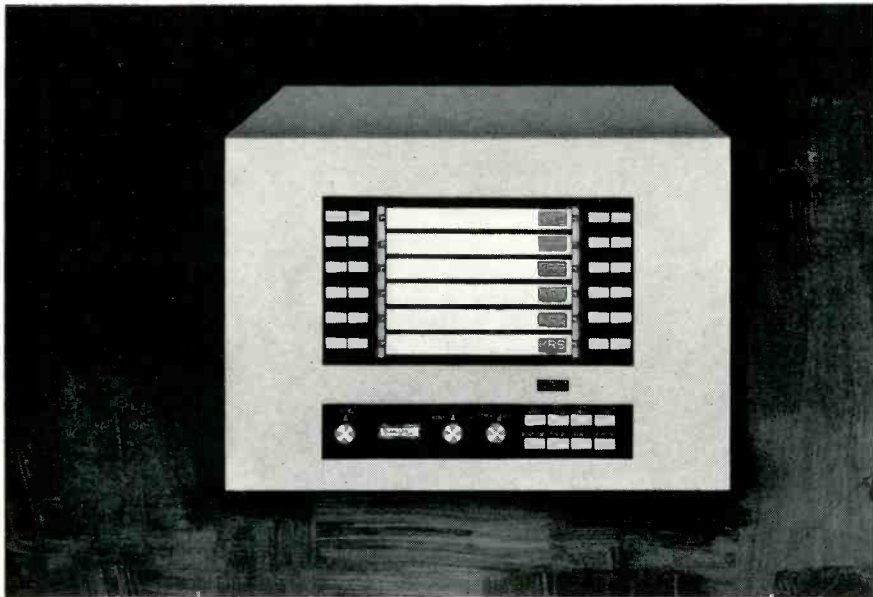

Sold Nationally By

Visual . . . the first to offer a complete solid-state broadcast facility.

VISUAL ELECTRONICS CORPORATION

356 west 40th street • new york 18, n. y. • pennsylvania 6-5840

Circle Item 10 on Tech Data Card

About The Cover

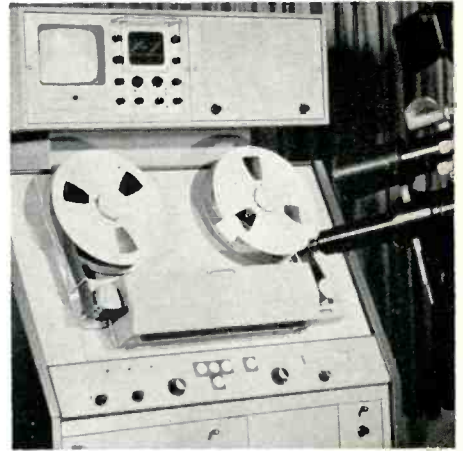

Appearing on the cover this month is one of today's modern transistorized television tape recorders, three of which are shown here (top to bottom; Ampex VR-1100, RCA TR-22, Sony PV-100). Such machines bring video recording costs

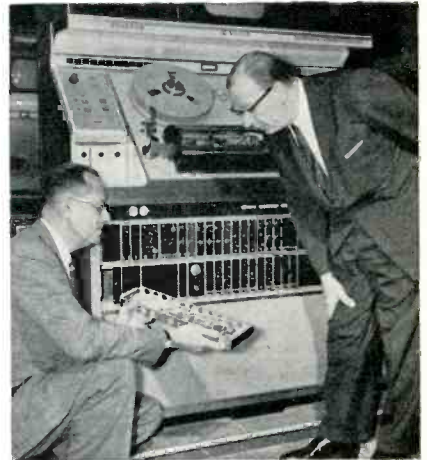

within the reach of numerous users who many have previously found television tape price tags prohibitive. The advantages of this medium thus become available to many more broadcasters, ETV groups, recording companies, and others, in a wider variety of applications, including studio, remote, and mobile.

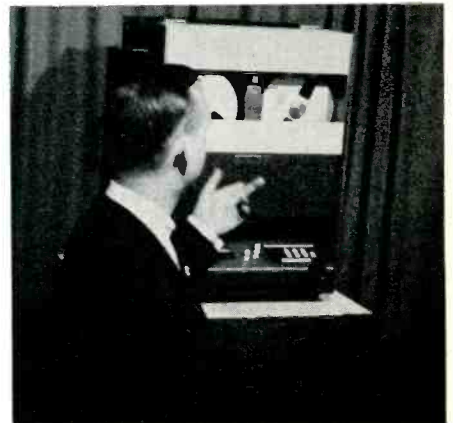

BROADCAST ENGINEERING

Well behaved transmitters

DON'T SHOUT

DON'T WHISPER!

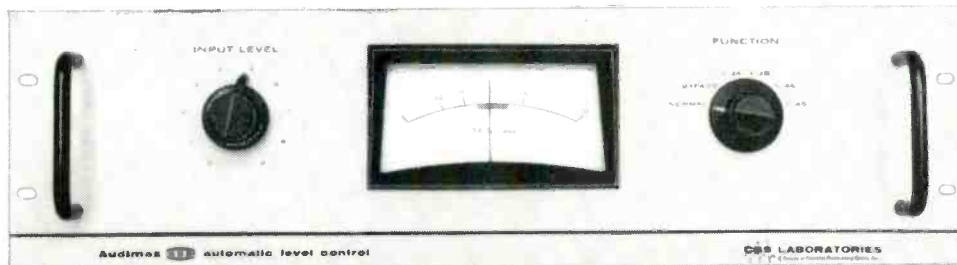

Stay listenable with Audimax!

Undulating audio is not listenable! When it shouts—unpleasantness! When it whispers—strain! Every time your listener touches his volume control, you stand a chance of losing him! Audimax—the monitor with a memory—rides your output gain control with super-human speed. When levels are correct, gain remains constant—this

is the Audimax Gain Platform. Audio output remains on a natural listening keel at maximum modulation. There's no distortion, compression, thumping or pumping. No audio "holes." Audimax is not a Compressor, Limiter or AGC. Audimax is a control computer, complete with memory and judgement. You merely set the Gated Gain Stabi-

lizer to recognize noise and background effects, and electronics takes over. Proper levels are maintained; gain is held constant during pauses or returned to normal at standby—automatically. To get listener loyalty—and keep it—you need Audimax! It pays!

CBS LABORATORIES
High Ridge Road, Stamford, Connecticut
A Division of Columbia Broadcasting System, Inc.

Circle Item 12 on Tech Data Card

A NEW METHOD OF STEREO BROADCASTING

by **Kenneth R. Hamann***—Review of past and current stereo transmission systems and a report on a new method now under study.

A comprehensive study of stereophonic broadcast techniques has been in progress at WDOK (a Transcontinental station in Cleveland, Ohio) for the past nine years, to determine methods a broadcaster can use to present program material of an outstanding nature in a form that is unusual, yet pleasing, to the home listener. The earliest experimental recordings made by WDOK were of the annual Bach Festival at Baldwin Wallace College, Berea, Ohio, in the spring of 1954. Subsequent broadcasts have been made using AM-FM stereophonic techniques from that location and from Oberlin College, Oberlin, Ohio. These programs have ranged in content from solo concert recitals to grand opera, and have been used to gauge the effectiveness of various microphone techniques when applied to stereophonic broadcasting.

The basic microphone pickup techniques can be divided into three main categories: (1) The two microphone "A-B" system, (2) The multiple microphone system, (3) The intensity stereo system.

The Two Microphone "A-B" System

Some of the earliest experiments on the transmission of stereophonic sound were conducted by Bell Laboratories in 1934, using three microphones placed in a row in front of a stage and spaced from 6 to 25 feet from each other. The sound from each was fed to separate loudspeakers in another room. As reported by Fletcher¹, the results obtained from experiments on the localization of sound sources was quite satisfactory as long as

*WDOK, Cleveland, Ohio, A Transcontinental Station.

Editor's Note: This data was presented at the 17th annual NAB Engineering Conference, Chicago, Ill., April, 1963.

¹H. Fletcher, Auditory Perspective, Bell Sys. Tech. J., Vol. 13, April, 1934.

the listener was not too far from the center line through the middle loudspeaker.

For practical and economic reasons, the early three-channel systems gave way to the somewhat simpler, yet still effective, two-microphone, two-channel stereophonic systems. Early WDOK broadcasts made use of this basic "wavefront" method of transmitting stereophonic sound. While it must be admitted that our transmission medium was far from ideal, consisting of two quite unequal channels in terms of frequency response, noise, and distortion, the results were sufficiently pleasing to our listening audience that we were encouraged to continue the broadcasts as a series.

Quite a few programs were presented using the two-microphone technique, and in the process we arrived at several basic conclusions.

1. While the reproduced sound may be very pleasing and quite natural to the stereo listener, there frequently exists a "hole in the middle," particularly if it is desired to present a solo instrument from the center of an orchestra. Natural balance between the soloist and the rest of the ensemble is almost impossible to attain.
2. The listener who hears one channel only will receive a rather "lopsided" impression of the sound pickup. In early

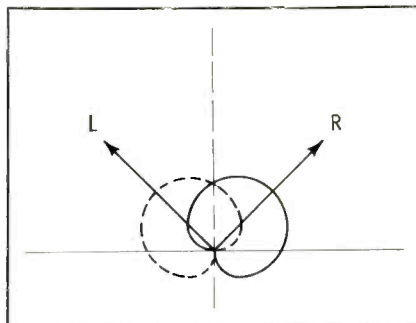

Fig. 1. Polar patterns for X-Y system.

broadcasts, this fact was recognized, but because of the experimental and novel nature of the system, was generally ignored. Later pickup techniques helped to overcome this problem.

3. For the monophonic listener who might hear the two channels combined (the "L + R" signal on the main channel of an FM multiplex stereo transmission), the balance of sound can range from fair to poor, depending to a great extent upon the acoustics of the concert hall and the spacing and polar patterns of the two microphones. Generally speaking, however, the monophonic mixture of the two channels tends to be rather poor.

For these reasons, then, the simple two microphone pickup technique was soon abandoned in favor of more sophisticated systems.

The Multiple Microphone System

The simplest of the multiple microphone systems (by our definition, "multiple" is used to denote more than two microphones) is that which uses three microphones spaced in front of the sound source in much the same manner as the early Bell Laboratories experiments. However, for two-channel transmission, the signal from the center microphone is fed in equal parts to the left and right channels. This tends to create a virtual center "loudspeaker" in the listening room, provided that the phase and amplitude characteristics of the two transmission channels are fairly similar. If this condition is fulfilled, the "hole in the middle" mentioned above for the simple two-microphone system can be reasonably overcome.

A further adaptation of the multiple-microphone system is to

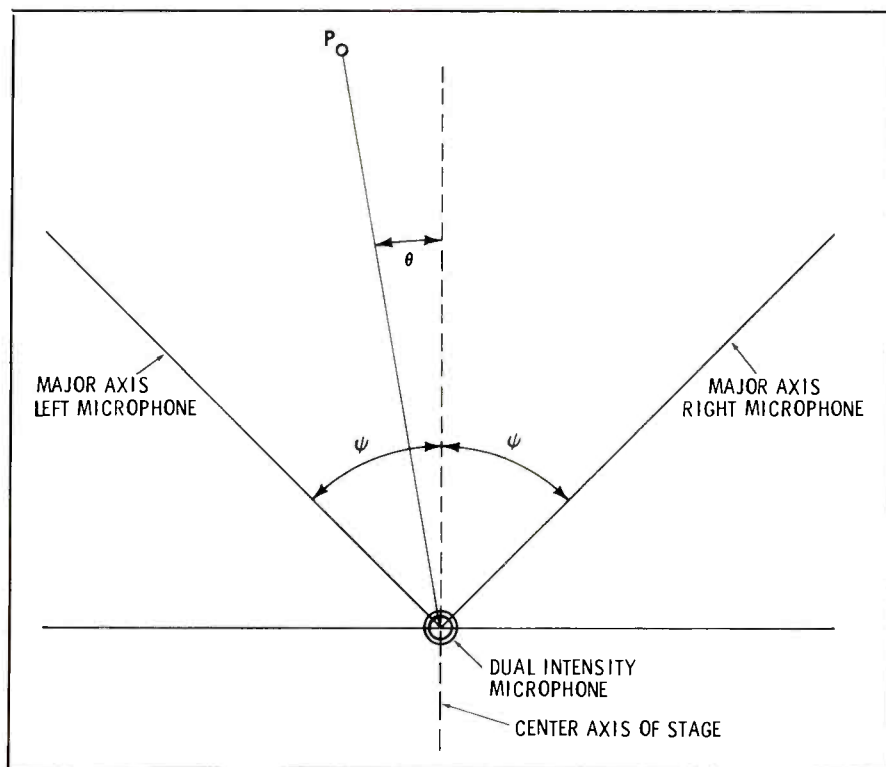

Fig. 2. Diagram of equations 1 and 2.

the microphone whose major axis is turned to the right of the stage is fed to the right stereo channel, and the output of the left-facing microphone is fed to the left channel. The signal output of the two microphones can be represented by the equations^{5,6} diagrammed in Fig. 2:

$$L = \frac{1}{1+m} [1+m \cos(\psi-\theta)] \quad (1)$$

$$R = \frac{1}{1+m} [1+m \cos(\psi+\theta)] \quad (2)$$

Where,

L is the signal output of left microphone,

R is the signal output of right microphone,

m is a quantity that can be varied to change the polar characteristics of the microphone,

ψ is the angle between each microphone and the central axis of the stage,

θ is the angle between the central axis of the stage and a given sound source P (sometimes termed the angle of sound incidence).

If the signals from the two microphones are added in phase (L + R) the equation for the sum signal (M) becomes:

$$M = L + R = \frac{2}{1+m} [1+m \cos \psi \cos \theta] \quad (3)$$

This equation has the general form for the signal from a single cardioid microphone. From this it can be inferred that the sum of the outputs from the two-microphone X-Y system will be the same as that from a single cardioid microphone placed at the same location with its major axis coinciding with

⁵ D. E. L. Shorter, Operational Research on Microphone and Studio Techniques in Stereophony. BBC Engineering Div. Monograph No. 38, Sept. 1961.

⁶ Clark et al., The Stereoscopic Recording and Reproducing System. I.R.E. Transactions on Audio, Vol. AU 5, July, Aug. 1957.

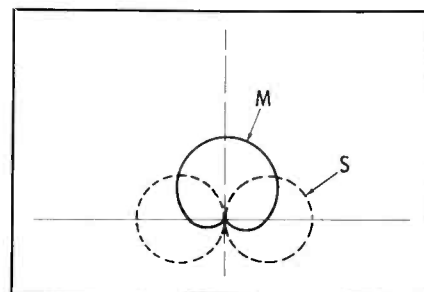

Fig. 3. Polar patterns for M-S system.

use several microphones placed at strategic locations in front of and within the area of the orchestra. It is at once obvious that, by using this technique, the ultimate control over the balance of sound from the orchestra is in the hands of the control engineer. Unless this man has a good knowledge of the aesthetics of music, as well as of engineering, the results could be chaotic.

Even so, if the proper mixing techniques are used, a stereophonic recording derived from a multiple microphone system can be well balanced both to the stereophonic and the monophonic (L + R) listener.

The major objections, in terms of the broadcaster, to using the multiple microphone system for broadcasting live concert programs, are: (1) It places too much responsibility for tonal balance on the control engineer who, often as not, is an excellent technician but not a trained musician; (2) Frequently, objections will arise from the performers, the audience, and the conductor about the number of microphones placed around the stage.

The Intensity Stereo System

In the early 1930's A. D. Blumlein² was demonstrating in England that a stereophonic transmission system could be devised by utilizing the phase difference between

² A. D. Blumlein, British Patent No. 394325.

the outputs of two similar microphones spaced by a short distance compared to the wavelength of the arriving sound. Later experiments by Lauridsen^{3,4}, in Denmark, showed how a system using similar techniques, but also relying upon the intensity or amplitude differences arriving at the two microphones, could be utilized to very good advantage.

The Intensity Stereo System, as it has evolved, usually takes one of two forms; the X-Y method and the M-S method.

X-Y Method

The X-Y method involves the use of a pair of identical microphones, usually of the electrostatic or condenser variety whose polar patterns can be conveniently controlled; they are mounted one above the other and spaced with their edges a centimeter or so apart. The polar pattern of each is usually set to a cosine curve or cardioid pattern (Fig. 1). The major axis of one is placed at 90° to the other and the center of the included angle is directed to the central axis of the performance stage. The output of

³ H. Lauridsen, Das M S Stereophonieverfahren und Seine Anwendung zur Untersuchung Raumakustischer Probleme. Published in 1957 by the Nordwestdeutsche Musik Akademie of Detmold.

⁴ Fr. Heegaard, The Reproduction of Sound in Auditory Perspective and a Compatible System of Stereophony. The European Broadcasting Union Review, Part A No. 52, Dec. 1958.

the center axis of the stage. This type of monophonic microphone pickup has been in use for many years with excellent results for monophonic recordings. The same thing holds true for the monophonic mix of a stereo recording made by this method.

If the two output signals from the microphones are added in anti-phase ($L - R$), the difference equation becomes:

$$S = L - R = \frac{2}{1+m} m (\sin \psi \sin \theta) \quad (4)$$

The signal that results from this combination takes the form of a figure eight pattern whose major axis lies perpendicular to the center axis of the stage. It is usually called the "S" signal or the side channel since it contains the stereophonic information for later combination with the M signal. By itself it would present rather poor tonal balance since the "dead" side of the microphone combination is facing the sound source.

M-S Method

As can be seen from the above, we have come to the other basic intensity stereo system, the "M-S" system, that offers many advantages over other stereo broadcast systems.

For this system, a set of two microphone capsules inside a single body shell is placed as in the X-Y system at the front center of the stage. One capsule is adjusted to have a cardioid pattern response with its major axis identical to the center axis of the stage, and the other capsule with a figure-eight pattern at right angles to it (Fig. 3). Thus, the M and the S signals can be derived directly from the microphone. The major advantage in doing this is that the scale width of the finished stereo recording can be changed by adjusting the relative amplitudes of the M and S signals before they are subsequently matrixed in a sum and difference network to become the left and right channel signals. Thus, a solo instrument can be made to appear to be in the exact center of the stage, or spread completely across the stage, or for that matter, at any point in between.

The M signal could be applied directly to the $L + R$, or main channel, input of an FM multiplex

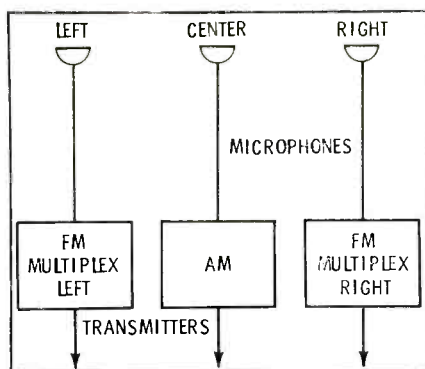

Fig. 4. Simplified three-channel system.

transmitter and the S signal to the subchannel input; however, because of monitoring problems, it has been the usual practice to matrix the M and S signals to their left and right components before transmission.

One disadvantage of the M-S system may be that phase vs. amplitude response of the complete transmission system (including a tape recorder, if used) should be uniform for each channel in relation to the other, in order to preserve maximum separation between the left and right channel; this is actually not too difficult to achieve in practice.

Another possible objection to the system is one which is more subjective than technical. In order to achieve the best separation and tonal balance from a symphony orchestra, the microphone must be placed at about the location of the conductor, and slightly above him. The actual position depends to a great extent upon the acoustics of the concert hall from which the broadcast is made. The resulting sound, while excellent in terms of technical quality, balance, and separation, tends to put the listener in the center of the orchestra and sometimes neglects the natural acoustics of the auditorium. While this situation in no way detracts from the enjoyment of the concert by many listeners, it can cause sound somewhat unnatural to a listener who has been conditioned by years of attendance at actual performances. In striving to achieve even greater realism in its broadcasts of such programs, WDOK has derived and is experimenting with variations of the intensity stereo system that should improve sound reproduction for the serious music

[†] G. Bore and S. F. Temmer, M-S Stereophony and Compatibility, Audio Magazine, April, 1958.

listener. This brings us to the three-dimensional stereo sound system.

Three-Dimensional Technique

It is obvious that more information can be transmitted on three channels than on two. For the broadcaster with both an AM transmitter and an FM stereo multiplex transmitter, there are three separate and discrete information channels available (although the two FM stereo channels must be considered together for most purposes). This same broadcaster has a responsibility in the public interest to transmit programs that will be "compatible" for all listeners, no matter what equipment they happen to own. From these two basic premises, we have explored what might be done to improve the technical and aesthetic quality of our programming.

What can be done with three channels that cannot be done with two? Two-channel stereophonic sound on FM is excellent, and to add a third separate channel may seem to be superfluous. However, taking note of information theory and the history of stereophonic sound, we believe that a significant improvement can be made in the reproduction of broadcast stereophonic sound by utilizing the third channel available to us—the AM transmitter—without detracting from the enjoyment of the listener who may have only one or two listening channels.

The initial three-channel stereo experiments by WDOK followed the form of the early Bell Laboratories work. Three similar microphones were placed in a line in front of the orchestra and the signal from each was transmitted on a separate channel, with the center microphone being fed to the AM transmitter (Fig. 4). The effect of this method is to achieve a stereo sound reproduction that has a high

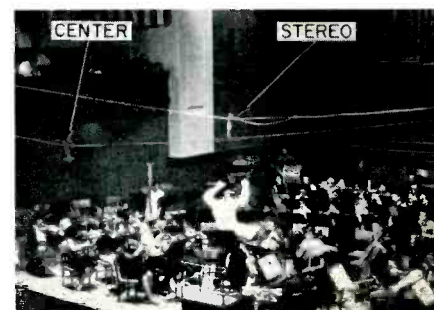

Fig. 5. Microphones in 3-channel system.

degree of separation between channels, almost an exaggerated stereo. While this may help to emphasize to the home listener what we are trying to do, it is obvious that by using this system we are neglecting certain segments of our audience. The FM stereo listener with just two loudspeakers will hear two-channel "A-B" stereo with its attendant disadvantages as outlined previously.

The FM listener with only one loudspeaker will hear a fair mix from the left and right channels, the AM listener will hear a good balance from the center channel, and the three-channel listener will hear some rather good stereo reproduction.

Other forms of three-channel pickups have been tried with some success, but generally tend to neglect tonal balance for at least one segment of the listening audience. For instance, a form of intensity stereo was tried in which three cardioid microphones were placed in close proximity to each other at the front center of the stage. The major axis of each microphone was placed at 90° to the others; thus, the center-channel pickup was facing the center axis of the stage, the left-channel pickup was 90° to the left, and the right-channel pickup was 90° to the right. The signal from each microphone was fed directly to separate channels on the tape recorder without intermediate mixing or matrixing. The resulting three-channel playback was quite good in terms of balance and separation, but it should be apparent that for broadcast purposes the monophonic listener using FM only would not hear a good mixture of the left and right channels. In this case, he would hear a signal that approximates the output of a figure-eight microphone (or "S" channel)

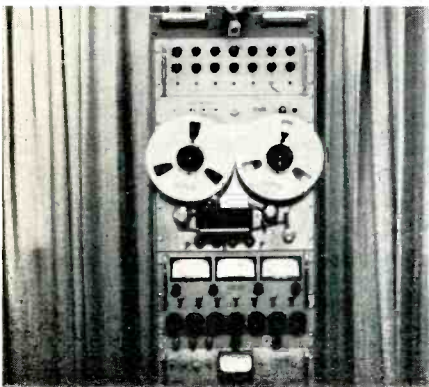

Fig. 6. Recording system for remote use.

May, 1963



Fig. 7. Three-channel master console.

with its major axis at right angles to the center of the stage. Thus, by using such a system, we are neglecting a portion of our listening audience.

Other methods of three-channel stereo have to be explored. One such technique we are currently evaluating consists of a modified M-S system, plus an additional channel.

For the FM transmitter, the basic M-S system noted earlier is used, since it has appeared to offer the major advantages in terms of quality vs. compatibility for the listening audience. The stereo multiplex listener will hear excellent two-channel stereophonic sound and the monophonic FM listener will hear an excellent mix.

The AM transmitter is fed from a third microphone (in our latest experiments) placed along the center axis of the stage but spaced some distance **behind** the stereo microphone as shown in Fig. 5. The function of this microphone is to transmit additional information in terms of perspective relative to phase and amplitude for the stereo listener. The exact placement of the microphone seems to be critical and depends upon the acoustical conditions in the concert hall, but should be at such a location as to present a good tonal balance from the orchestra for the AM only listener. A cardioid polar pattern is generally used, and the degree of difference in sound picked up by this microphone from that picked up by the M-S stereo microphone should be noticeable. As can be seen, we have introduced a phase difference as well as an amplitude difference for transmission on the third channel.

The home listener can place his AM receiver either directly between his two FM stereo loudspeakers, or he can place it behind him, so that the three loudspeakers form the

apexes of an equilateral triangle. The resulting sound he hears will be a combination of the direct pickup from the stereo microphone placed close to the orchestra and the more distant or reverberant sound from the single microphone. It has been noted that only low volume from the AM receiver, in relation to that from the primary FM stereo speakers, is necessary to improve realism. This should help to cancel the defects in the AM channel for the home listener, such as higher atmospheric noise levels and more limited frequency response.

Typical listener reaction tends to follow the line, "For the first time I'm hearing the orchestra as though I were in the concert hall." Such comments indicate that the extra equipment and effort are worthwhile. The extra equipment required for these broadcasts is somewhat unique, at least to the broadcast industry, and bear description here.

The equipment used to make three channel stereophonic recordings is designed to be relatively portable and yet have the necessary flexibility and performance characteristics to make the best possible broadcasts. A standard Ampex 351-2 tape transport was chosen for the basic mechanical section of the system, and was modified for three-channel, 1/2-inch tape. Three Ampex 351 electronics chassis comprise the rest of the tape recorder section. A composite amplifier and switching chassis was added to the recorder to allow any of the record heads to be used as a playback head for synchronous recording of additional tracks on the tape.

The mixer section, also mounted in the rack frame, is comprised of three parts—the mixer-amplifier, a separate seven-channel equalizer, and a regulated power supply. The mixer has seven separate microphone input channels; each one can be switched to any of the three output channels. Also, each of the seven microphone channels has a separate equalizer that can be used to change the response characteristics of a particular microphone or group of microphones. This follows the common practice in professional recording operations of changing the frequency response of certain

● Please turn to page 42

WHEN THE PROOF-OF-PERFORMANCE FAILS

by Ed Murdoch*—PART I. Proof equipment, basic systems, and frequency response measurements.

There was a time when the majority of small-market AM stations hired a consulting engineer to make the required yearly "Proof" measurements. If the equipment showed up badly the station engineer was condemned to a year of troubleshooting in the dark, not knowing if his efforts were productive until the consultant once again appeared, waving his magic wand—proof-of-performance equipment.

The situation has changed radically in recent years, in more ways than one. Due to various aspects of competition, management has become quality-conscious; and engineering "propaganda" has made it evident that proof-of-performance is not to be regarded as a yearly inquisition, but as a valuable working tool to be employed as a normal maintenance technique. Consequently, proof equipment is fast becoming popular in many stations. Unfortunately, the "hallucination" seems to have developed that any child or old lady can saunter into the station, in an off-air moment, and whip through a proof without difficulty.

In ever-increasing numbers, small stations are dispensing with what used to be a necessity—the consulting engineer—and are borrowing, renting, or buying proof gear, thrusting same at the station engineer with the implied command, "Here you are, Merlin, now . . . perform!" Well, this is fine, as far as it goes, but with the state of the small-station engineer being what it is today, it is probable that many have been doubled and tripled into so many "extra duties" that they have lost a good deal of their familiarity with the finer technical points.

This series of articles is offered in the nature of a refresher course,

and assumes a certain amount of technical know-how on behalf of the reader. It will no doubt be noticed that certain discussions are rather involved while others are sketchy; this intentional treatment is an attempt to clarify certain aspects which I have found cause the most confusion, while at the same time not becoming loquacious about points which may be regarded as run-of-the-mill. It is realized that there are other troubleshooting techniques and apparatus which would serve equally well, and in some cases, perhaps **better**, but as far as possible it was attempted to hold the same maintenance philosophy throughout.

Equipment

As a starting point, let's assume that you have access to a set of proof - of - performance equipment, but for whatever the reason, retain only a casual memory of how to connect all this stuff together and perform a proof with it. Perhaps you borrowed or rented the gear from a neighboring station, and somehow it doesn't look quite like the equipment the consultant brought with him for the previous proof. Of course, you have spent several nights studying the instruction manuals for the distortion analyzer and oscillator. The manual for the analyzer tells you a lot about the analyzer, and the manual for the oscillator is just chock full of more than you want to know

about oscillators, but nothing anywhere tells you how to intrude yourself into the midst of all these items for the purposes of a proof. But at least all was not lost; with a little experimentation, you have rediscovered how to balance the null circuits of the distortion analyzer. (Just in case you **haven't**, you can kill two birds with one rock. It is important that a high degree of dexterity be achieved in handling the distortion analyzer—and it is also important that the oscillator and analyzer do not contribute excessive distortion of their own to the system you are about to measure. Hence, by connecting the analyzer to the output of the oscillator, the quality of the oscillator waveform can be verified, and practice gained with the analyzer, simultaneously.)

There are several ways to go about making a proof, but let's look first at the general equipment sequence, with explanatory remarks when needed.

An input oscillator feeds through an attenuation network into the main input channel of the studio console. The attenuator may be a part of the oscillator or, more generally, furnished externally.

There is a VU meter (or properly coupled VTVM) across the oscillator output terminals to aid in setting the input to the console. This meter may be an integral part of the oscillator, or an integral part of the attenuator unit, or completely external. In the latter case a series calibrating resistor is provided for adjustment of the meter to read absolute levels or, alternatively, to permit the oscillator output level to be set to a high value so as to minimize its own distortion output.

The studio console remains connected to the limiting amplifier as

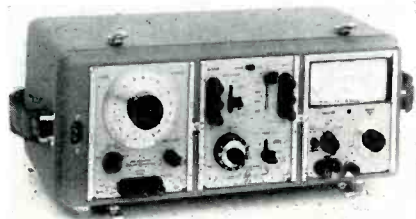

Fig. 1. An oscillator, voltmeter, and attenuator with impedance matching networks.

*Chief Engineer, WMMB, Melbourne, Florida.

in normal operation, but the limiting action is made inoperative (generally by removing the bias generator tube). When the actual feeding of signals commences, it may be found necessary to make slight adjustments in the limiter output control to the transmitter, especially if the limiter normally operates at high compression levels and the transmitter is heavily modulated.

All other controls of the station's equipment should be left in their normal operating levels. (If need be, the console mike control can be varied slightly to assist in setting a zero VU output reading, as long as the variation does not exceed the normal deviation of setting found among the station's announcers. This should be done at the beginning of the proceedings, at a reference frequency of 1000 cps, and then left alone.)

The limiter output feeds the transmitter audio input, as in normal operation.

A distortion-analyzer/noise meter is coupled to the transmitter RF output, either by connecting to a special take-off from the modulation monitor, or by a special link-coupling loop (which may in turn feed into a special rectifier unit which furnishes the actual input to the analyzer if it does not have an internal rectifier). This coupling link should be positioned near an inductor which is as close to the transmission-line end of the final RF output network as is possible. Yet it should be loosely coupled to the specific inductor as possible, no more than necessary to furnish the recommended input level of the distortion-analyzer.

Any AGC type amplifiers which may normally be in the station's equipment chain should be bypassed during the proof-measure-

ment procedure, as they generally operate under terrific compression. If the bias-generator tube is pulled (to remove limiting action) a great amount of gain is released into the chain, and this generally creates difficulties in control-adjustment. An AGC amplifier should be measured separately, without compression, and the results included along with the complete report.

Transmission-Set Method

As stated earlier, there are several ways to go about making a proof, as far as technique goes. This statement requires a little clarification. The technique for making the distortion and noise measurements, as well as measuring the carrier shift, is pretty well constant; but the audio frequency response measurements can be, and are, made in a variety of ways, according to one of two general systems. The first, and according to the "purists" the most preferable, consists of adjusting the oscillator output to the console (at 1000 cps) in some fashion to produce the desired modulation level of the transmitter—25, 50, 85, or 100%. Then for each necessary frequency other than 1000 cps, measurement is made of the **change** in console input level necessary to bring the modulation percentage to that produced by the 1-kc signal. This measured change is recorded as a rise or fall in db for that particular frequency with respect to the 1-kc level (which is regarded in the tabulations as the 0-db point.)

Measuring this required change in input level to produce equi-modulation for the various frequencies in relation to the 1-kc level is accomplished in a variety of ways. Probably the most accurate method makes use of what is known as a

transmission set, or decade attenuator (Fig. 1). The device consists of a series of **calibrated** attenuators (generally three in number) controlling the level in an adjustable series of tens, units, and tenths of decibels. The oscillator feeds this unit, and the oscillator output level is maintained at a constant 0-vu reading regardless of the frequency under consideration. The oscillator is first set at 1 kc, and then the attenuators of the set are adjusted to produce the proper level of transmitter modulation. The attenuator scale readings are added to produce a 1-kc reference figure. Then, as the succeeding frequencies are established, the attenuators are readjusted to maintain the previous percentage of modulation; the new readings are taken **from the attenuators**. After all of these are made with respect to the 1,000 cps reference figure (for each of the required levels of modulation in the proof), the readings are all subtracted from the 1-kc reading (or the 1-kc reference is subtracted from the readings). For a given frequency, an attenuator reading **less** than the 1-kc figure indicates the subtraction process will result in a **minus** db figure; while an attenuator reading **greater** than the 1-kc figure indicates that the subtraction process will produce a **plus** db reading. (The 1,000 cps value from the attenuator dials represents, of course, zero db on the final tabulation charts and curves.)

The transmission set used for this method of measurement is rather expensive, and frequently other methods of measurement are employed to determine the deviation in oscillator output needed to maintain a constant level of modulation. One of the ways is to set the oscillator output by means of a

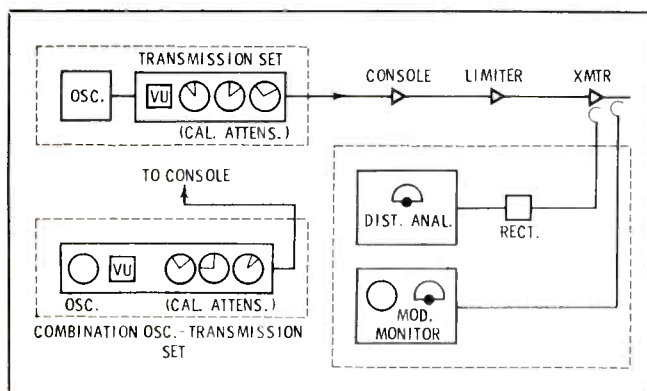

Fig. 2. Proof system employing a transmission set.

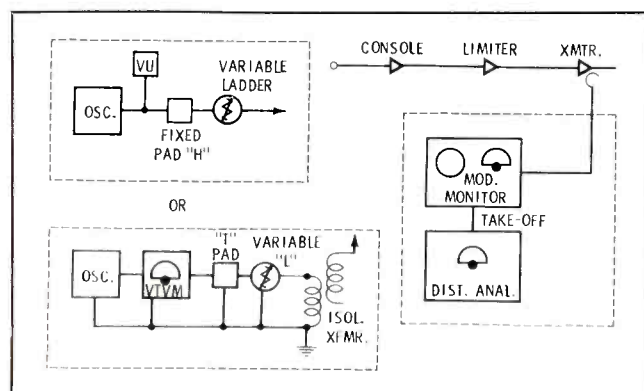

Fig. 3. Alternate transmission-set type system.

vacuum-tube voltmeter (having a db scale) coupled to the oscillator by means of a special matching and isolating transformer. (With proper coupling, the distortion analyzer itself may be used in this manner for the audio response measurements.) The oscillator output control is then varied to produce the equimodulation, and the variation in oscillator output is read directly from the db scale of the VTVM. Alternatively, if a given VTVM has no special db scale, voltage variations may be noted instead, and converted to equivalent db later through computation or from tables.

Another way to measure the deviation in oscillator output is by reading the variations on a VU meter connected across the oscillator output. The meter is read in a manner opposite to the previously mentioned transmission-set attenuator scales, with regard to plus or minus db and to the 1-kc reference. In the case of meter readings, a decrease in vu reading below that required for 1-kc indicates a **rising** condition of response, and is logged as **plus** db, and vice-versa.

The preceding methods pertain to the general system of maintaining a constant percentage of modulation at all frequencies under consideration, and measuring the change in level needed (with respect to 1-kc) to maintain this constant modulation level. The required change in level for the various frequencies, expressed in plus-or-minus db with respect to the 1,000-cps value regarded as 0 db, then represents the audio frequency response of the entire system for that percentage of modulation.

In any system or method used for any of the proof-of-performance functions, there is always some form of attenuation between the oscillator output and the actual console input terminals. In the first method just described, the transmission-set furnishes the necessary attenuation to scale the console input level to the proper **range** (in addition to its function of furnishing a calibrated method of measuring the change in level). If the method under consideration makes use of a meter across the oscillator terminals (Fig. 2) some form of attenuation other than a transmission-set must be used; whatever type is employed

must also be capable of matching to the input impedance of the console channel. Special units are manufactured for this purpose (the Gates Gain Set, for example). If no such unit is employed, it is possible to use a taper pad made up from resistors. A 600/250-ohm unit designed for about -55 to -60 db should suffice for the average case; however, there are many times when a variation from this average will be found necessary. If resistor pads are used, there should be a variety available, running in taper from 600/50 to 600/600, and in a series of steps of attenuation values from about -20 to -70 db. Such pads should always be enclosed in a minibox which is grounded to the common ground for the proof gear.

Transmitter-Modulated Output Method

There is another general system for measuring audio frequency-response. In this system the console input level is adjusted to remain constant for each frequency with respect to the 1-kc level, and the change in the transmitter modulated audio output is measured (Fig. 3). The console input level may be set by the oscillator output control (to adjust the exact modulation level for the 1-kc reference-frequency). Or, to avoid the difficulties of maintaining interpolated readings on the oscillator output vu meter, a variable attenuator may be interposed between the oscillator output and the fixed pad to permit the oscillator to be maintained at a constant zero-vu output. The desired percentage of modulation is then set approximately by the attenuator.

The change in transmitter audio output can be measured in a variety of ways. One of the most popular (and I might add, one of the most

haphazard) consists of simply interpolating from the db scale, or computing from the voltage scale, of the station's modulation monitor as the various frequencies are applied. (This method is rather inaccurate at the lower percentages of modulation.) A more satisfactory method is to make use of the db scale of the distortion analyzer, which is already coupled to the transmitter output for use in the distortion-measurements part of the proof. The desired level of modulation is still set according to the modulation monitor, but the db scale can be calibrated with the analyzer's own control, to make use of the full-scale accuracy at zero db even when working in the lower ranges of modulation.

If you intend to use an analyzer for this purpose, and the specific analyzer has no "plus" graduations on its db scale, it may be necessary to establish a reference level (as far as the actual process of making measurements goes) at a frequency other than 1 kc. For example, there might very well be a slight rising characteristic in the system frequency response at one or more frequencies other than the 1,000-cps standard. Thus, if the level at 1 kc (for the percentage of modulation under consideration) were set at the zero-db mark when the oscillator was tuned to a frequency at which the response rose, the analyzer meter would go off scale, and no reading would be possible. In this case, before attempting to make the exact run for any given percentage of modulation, the oscillator should be swung through all of the frequencies required in the proof report and the high response point found. This will determine the true zero-db reference frequency at which the analyzer should be calibrated. However, in the official tabulation, the table of data should be re-evaluated in terms of a 1,000-cps reference frequency.

Conclusion

This concludes the review discussion as far as the various methods of audio frequency response measurement are concerned. The FCC does not specify any particular system, and the author does not presume to make a personal recommendation beyond stating that the

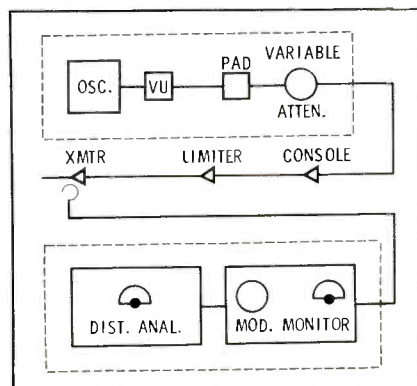

Fig. 4. Transmitter-modulated audio system.

• Please turn to page 44

TWELVE RULES FOR DEALING WITH THE FCC INSPECTOR

by Ed Murdoch* — or, "Inspections Can Be Fun . . . But Don't Laugh Out Loud."

Here are a dozen suggestions that may aid you in survival when the FCC field engineer heads your way. Since you probably remember the blunder you were guilty of last time, use this check list to avoid making the same mistakes again. Of course you could employ the rules in reverse, and **fail** the inspection — but you would have a good time doing it wouldn't you?

1. When the inspector first walks in the door, **DON'T** start hauling out your Bachelor-of-Anything degree and/or school certificates. He probably has bigger ones (or else none at all, in which case you have just committed suicide).
2. **Never** greet a new inspector in the age-old manner of slapping him heartily on his back and yelling "Hi, Sam, you old S.O.B. Whattaya hear from Washington?"
3. Under no circumstances should you attempt to joke with an unknown inspector. A quip, such as "Do you fellas get Payola, too?", will get you nowhere (with the possible exception of jail or a hospital emergency room).
4. When it comes time for the inspector to read antenna current and compute power, for crying out loud **DON'T** offer him your log-log slide rule. (This is an important point — perhaps you had better hide your slipstick somewhere right now . . . like bury it under the tower. As I say, this is a very important point, but I haven't the slightest idea why. All I know is that the last inspector I dealt with took one look at my shiny new slide rule, turned on his heel into the bookkeeper's office, and computed the power

ON AN ADDING MACHINE. Can you beat that?)

5. It is **no longer** considered "playing the game" to gouge him with your elbow just as he nears that meter with the sticky movement.
6. This point is probably one of the most important on the list, and many OT's will not even need advice here — but your dedicated third-stage DI is completely unpredictable along this particular line, so I feel it needs emphasizing: If, while conducting an inspection of your station, the inspector should happen to make an obvious mistake, **do not** (and I repeat — do not) jump up and down in a hilarious show of glee while beating on the transmitter front panel with Gargantuan blows, and wind-up the display by collapsing on the floor with a climatic shout of "How Stupid Can You Get!" This sort of demonstration is no longer considered in good taste.
7. If the inspector brings along a field-strength meter to check your directional array, **don't** playfully jab him in the ribs, when he has the earphones settled comfortably, chortling some insipid quip like — "Hey Boy! See if you can get Radio Tokyo on that thing!"
8. Remember, the inspector has his problems, too. And one of them is that he doesn't know from one administration to the next whether the FCC has any authority. This continual oscillating back and forth between Democrats and Republicans tends to make a Frankenstein of an inspector who would normally be just plain intolerable.
9. There was a time when it was

- perfectly proper to exhale cigar smoke in the inspector's face while he was checking the file of back-logs. Since the lung-cancer scare, however, this practice has fallen into severe disrepute. If you feel you must uphold the ancient tradition, substitute a Turkish water-pipe with a filter-tip hose.
10. Many station engineers keep a jug of snake-bite medicine on the workbench to ward off the intermittent whammies. If the inspector should spot your bottle, **DO NOT** offer him a snort. (He will be either a complete teetotaler and the world's only living male member of the WCTU . . . or, you will not have his brand. There are only ten people on the face of the earth who can stomach Rye, but with your luck the inspector will be one of them.)
11. For some strange reason, broadcast engineers seem to be metaphysically inclined. If the inspector should catch you sitting in the middle of the floor in a Yoga posture from which you cannot extricate yourself, for heaven's sake **DON'T** tell him you are trying to communicate with the cosmos. (FCC men are very nonmystical.) The proper response in this case is that your upper plate is rectifying the tower radiation, and you are trying to phase your head for maximum cancellation. (This he can understand.)
12. **Above All** — When the ordeal is over and the inspector is preparing to leave your station, **DO NOT** ask him for your Green Stamps. (There is nothing to prevent him from marching right back inside, and inspecting all over again. You couldn't possibly survive two inspections on the same day.)

*Melbourne, Fla.

THEORY OF DIRECTIONAL ANTENNAS

by Bryce W. Tharp* — A discussion of multi-tower arrays and the equations employed in pattern calculations.

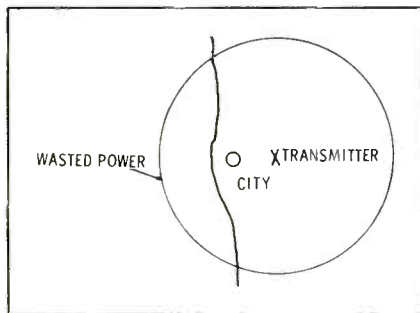

Fig. 1. Coverage of nondirectional array.

The ever increasing number of broadcast stations demands a more efficient use of the broadcast-band frequency spectrum. A method of achieving this by the use of a directional antenna system, which will suppress radiation in directions that point toward service areas of other stations on the same or adjacent channels. By reducing radiation in the interfering directions in this way, a station can increase its power and have a larger useful service area.

The second reason for a directional antenna system is to prevent useless radiation over an area in which there are no receivers.

Fig. 1 shows a transmitter operating with a nondirectional antenna system; power is being wasted over an undesirable area. Fig. 2 shows the transmitter used with a directional antenna system. Here the transmission over the undesirable area is suppressed and power is added to the desired service area.

Vector Analysis

A vector is defined as a force that has direction and magnitude (Fig. 3). This vector is shown to have a magnitude of 10 at an angle of 45° from the horizontal. In vector analysis the right hand side of the X axis is taken as the starting point, as zero degrees. The quadrants are shown in Roman Numerals; thus this vector is considered

to be in quadrant I. Also, in vector analysis, a positive angle is considered to be rotated counter-clockwise, while a negative angle is considered to be rotated clockwise. The angle of elevation is taken to the nearest horizontal axis. The right hand side of the reference or X axis is considered positive and the left hand side, negative. For the "J" or Y axis, the upper part is positive and the lower part negative. The intersection of the two axes is zero, everything originating from this point.

In Fig. 4 two interacting vectors are shown. Vector A is rotated 45° from the reference axis and has a magnitude of 10. Vector B is rotated 315° and also has a magnitude of 10. It should be observed, however, that vector B rotated 315° is the same angle below the reference axis as vector A is above the reference axis, 45° . Therefore, positive 315° is the same as a negative 45° . The resultant R of the two vectors lies along the reference axis.

A study of the resultant of two or more forces is very important in directional antenna work. The directional pattern is a result of these forces, with different phases and magnitudes, meeting at a point in space.

The method for determining the resultant R in Fig. 4 involves finding the horizontal and vertical components of the two vectors, A and B. The two horizontal components HA and HB lie along the reference axis and the two vertical components are VA and VB. The formula for finding the resultant is:

$$R = \sqrt{H^2 + V^2} \quad (1)$$

which in this example of two vectors reduces to:

$$R = \sqrt{(H_A + H_B)^2 + (V_A + V_B)^2}$$

The method of finding the horizontal components involves trigo-

nometry, and the formula:

$$\cos \theta = \frac{H_A}{A}$$

Since we are solving for HA, this changes to $H_A = A \cos \theta$. The vertical component, by means of trigonometry, comes from

$$\sin \theta = \frac{V_A}{A}$$

Since we are solving for VA, this reduces to $V_A = A \sin \theta$. The basic formula, $R = \sqrt{H^2 + V^2}$ now expands to:

$$R = \sqrt{(A \cos \theta + B \cos \theta)^2 + (A \sin \theta + B \sin \theta)^2} \quad (2)$$

$$= \sqrt{(14.14)^2 + [10(.707) - 10(.707)]^2} = 14.14$$

It is noted that the second vertical term in the above formula is prefaced by a negative sign. This is in accordance with the rules of mathematics, in which the sine of an angle in the fourth quadrant is negative. Attention must be given to these polarities in all quadrants and to both horizontal and vertical components. A table for the polarity of functions of all quadrants can be found in any trigonometry book.

Equation 2 may be used for any two vectors having equal and unequal magnitudes and/or equal and unequal phase angles. Actually, by observing Fig. 4, since both vectors have equal magnitudes and phases, it is seen that the vertical components will cancel out. Therefore,

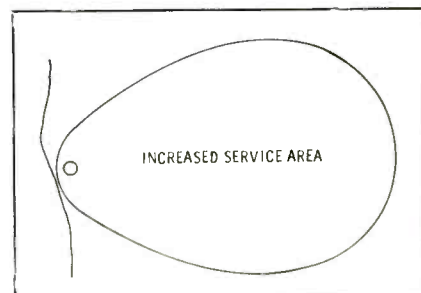

Fig. 2. Coverage of a directional array.

*Staff Engineer, WXLW, Indianapolis, Ind.

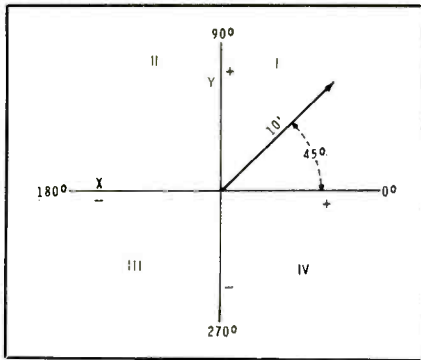

Fig. 3. Typical force-vector diagram.

for this specific example, the formula could be reduced to:

$$R = \sqrt{(A \cos \theta + B \cos \theta)^2} \quad (3)$$

which contains only the horizontal components.

Pattern Theory

We are now in a position to study the phase relationships in a two-tower directional system, as shown in Fig. 5. Assume that the current of tower 1 is 10 amperes. Since it is taken as the reference tower in regard to phase, its current and phase is written as $10 \angle 0^\circ$. If tower 2 also has 10 amperes, and if its phase is made to lead tower 1 by 90° , its notation is $10 \angle 90^\circ$. The spacing, S , between towers is in degrees, calculated from the wavelength.

In directional antenna terminology, the two signals E_1 and E_2 are considered moving parallel to each other, to a point in distant space. The azimuth angle α is the direction off of true north to the space reference point in question. In the example shown it is 45° .

The pattern of an antenna system varies around the entire 360° of azimuth angle due to one very important factor—the **difference in path lengths** traveled by the individual antenna waves.

Consider the azimuth angle 0° so that the waves are traveling true north. The waves start out with the antenna 2 wave leading antenna 1 by 90° ; however, by the

time the wave from antenna 1 has reached the space reference point, it has traveled 90° farther than the wave from antenna 2. Therefore, the two waves arriving simultaneously at the space reference point are 180° out of phase with each other. This is shown in Fig. 6. As a result, the two waves cancel and no signal is received in this direction. Since there are no vertical components, the formula is:

$$R = \sqrt{(10 \cos \theta + 10 \cos \theta)^2} = \sqrt{10 - 10} = 0$$

If the azimuth angle is taken as 180° , a different result is obtained. The wave from tower 2 started out 90° ahead of tower 1, but now it has a longer path to travel. Therefore, it arrives at the space reference point **in phase** and adds to the wave from tower 1; as a result, the signal strength in this direction is doubled.

For an azimuth angle of 90° , the vector relationship is shown in Fig. 7. The two waves travel the **same** distance to the space reference point; therefore, the phase difference is the same as when the two waves started out from the towers. Since E_2 has no horizontal component and E_1 no vertical component, Equation 2 simplifies to:

$$R = \sqrt{(10 \cos \theta)^2 + (10 \sin \theta)^2} = \sqrt{10^2 + 10^2} = 14.14$$

The signal strength due east is shown to have increased by 1.414.

For all azimuth angles δ , the difference of path length one antenna wave travels compared to the other antenna wave is controlled by cosine δ . Therefore, when δ equals 45° as in Fig. 5, the phase difference is $S \cos 45^\circ = 90^\circ \cos 45^\circ = 63.63^\circ$, and is represented by S_1 in Fig. 5.

In all two-tower systems, the pattern is always symmetrical on either side of a line drawn through the two towers. Therefore, the 270° azimuth point is the same as the 90° point.

Pattern Shape

While Equation 2 is correct for computing the resultant of two vectors, it does not include provisions for adding the tower spacing in degrees, the S factor. It also does not allow for the fact that the vector of reference tower 1 will always be

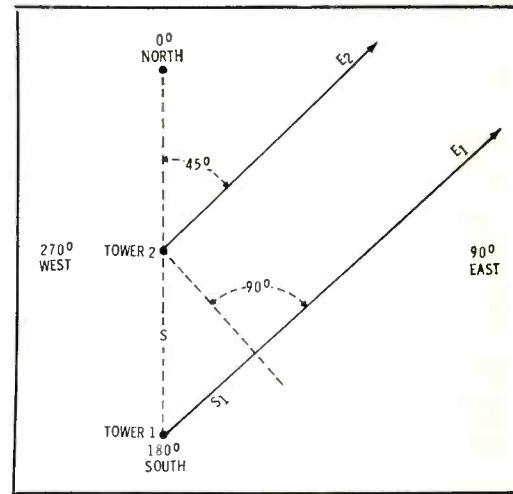

Fig. 5. Phase diagram of two-tower array.

along the reference axis, since its phase is zero. Therefore, the correct equation for controlling the pattern **shape** is:

$$E = e \sqrt{[I_1 + I_2 \cos(\theta + S \cos \phi)]^2 + [I_2 \sin(\theta + S \cos \phi)]^2} \quad (4)$$

where,

- e is the nondirectional field strength at one mile,
- I is the current ratios of the towers (I_1 is reference tower),
- ϕ is the azimuth angle,
- S is the spacing in degrees between towers,
- θ is the phase of tower 2 with respect to tower 1,
- E is the resultant directional field strength at 1 mile.

For a 90° azimuth, as in Fig. 7 (using the tower currents, which could be considered ratios), equation 4 is:

$$E = \sqrt{[10 + 10 \cos(90^\circ + 90^\circ)]^2 + [10 \sin(90^\circ + 90^\circ \cos 90^\circ)]^2} = \sqrt{[10 + 10 \cos(90^\circ \cdot 0)]^2 + (10 \sin 90^\circ)^2} = 14.14 \quad (5)$$

Equation 4 is for calculating the shape of the directional pattern in the horizontal plane. While this is ordinarily all that is required, sometimes the vertical angle of radiation is needed. Equation 5 serves this purpose:

$$E = e(F \phi) \sqrt{M^2 + I^2 + 2M \cos[S \cos \phi \cos(\phi + \theta)]}$$

where,

$F \phi$ is the vertical radiation component:

$$\frac{\cos(G \sin \phi) - \cos G}{(1 - \cos G) \cos \phi}$$

• Please turn to page 45

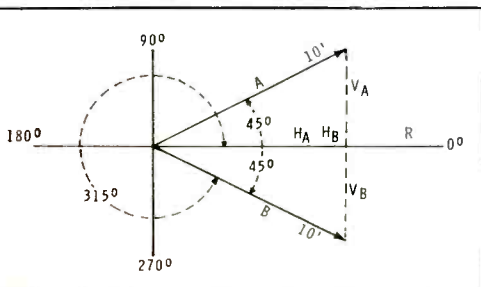

Fig. 4. Diagram of two interacting vectors.

A REVIEW OF TRANSMISSION LINES

Technical talks—A fresh look at the theories and practices for transmission lines, open wire and coaxial.

In the average small AM station, the most important phase of the operation (assuming the audio is clean and the programming good) is the transmitter output—in other words the RF. As we have pointed out in earlier articles, short of increasing power the only means a station engineer has to improve radiated output without raising transmitter power is to improve antenna efficiency. This can be accomplished by cleaning up the antenna system and adding height or top-loading to the antenna. Of course, we are discounting devices that increase the **apparent** power output by using variable gain to maintain a higher **average** sound level.

The last link in the RF transmission system is the transmission line. We will look at various lines and discuss some theory behind various methods of transferring power from a tank circuit to an antenna.

Open Wire Lines

The earliest form of antenna feeder, or transmission line, was the direct antenna connection to the output circuit. But as transmitter power was increased and the need for matching antenna to transmitter became more important, engineers found it necessary to contrive a connection that would do a more efficient job of transferring the RF power to the antenna. Thus, the transmission line was born.

The open-wire type was one of the first lines used for the transfer of RF; its theory of operation gives an interesting insight into the fundamentals of RF transmission over distances. Probably the first thought a reader has upon encountering the words "open-wire line" is of a balanced arrangement. In many cases the line is balanced, a most useful device for transmitting power over long distances. However, there are probably more unbalanced lines

used in AM radio than balanced—in any case, far more than the average reader might realize.

The commonly used open-wire transmission lines in AM applications are unbalanced. In fact, for use with base-fed vertical antennas it is far more practical to use such a line. After all, the antenna is actually an unbalanced load. On the other hand, for frequencies higher than about 2.5 mc, it is preferable to use balanced lines. In the latter type, both conductors are above ground potential, but of opposite phase. In the unbalanced line, one conductor is above ground potential.

The ground, or series of ground wires, is used as a return path for the RF. It is obvious that the use of an unbalanced line for RF transmission would, and does, pose some problems. Therefore, for operation

in those high-frequency ranges, we usually prefer to use coaxial cable.

Many older, and larger, AM stations still use open wire transmission lines. However, because of the comparatively common application of coaxial cable in RF transmission it is possible that some of our younger readers may not have had much experience with open-wire lines.

Construction

Cost is one of the main considerations in the selection of open-wire lines; no special equipment or cable-forming machines are needed, and anyone capable of using a few tools should be able to erect a creditable open-wire line. One excellent feature is the ease of conductor replacement and repair following damage by storm or accident. On the debit side is the fact that open-wire lines radiate more than coax, and for that reason should not be run adjacent to each other. Also, ice can form on the line and surrounding grounded conductors. Stretching of the lines causes changes in the impedance—even a very strong wind blowing on an improperly erected line can cause impedance changes as the line swings. A last point is the difficulty experienced in handling the lines where they enter buildings, or "dog houses," for termination.

A most commonly used unbalanced line is the five-wire, center-conductor type shown in Fig. 1. It consists of four grounded wires surrounding a single center conductor which carries the RF.

Such a line constructed of No. 4 AWG has an impedance of about 300 ohms when the conductors are spaced 12" apart. Naturally, as the spacing is increased the impedance goes up; and as the number of grounded wires surrounding the central conductor increases, the impedance decreases. Such multi-

Fig. 1. Open wire transmission lines.

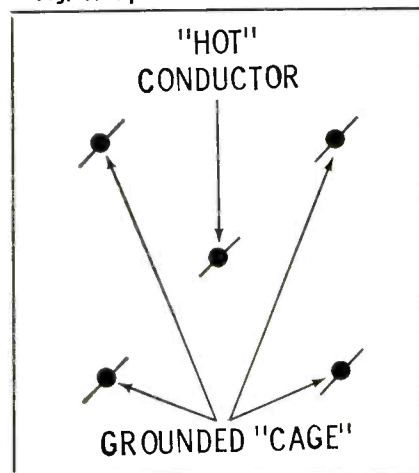

A. Typical five conductor system.

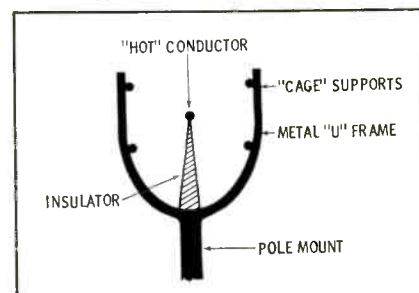

B. "U" mounting for five wires.

shield lines are often used for high-power installations where it is necessary to reduce the potential gradient so the line can operate with higher voltages; an example is voltage feed to a high-power antenna. In such a case the center conductor might be constructed of a number of wires connected together and spaced a small distance apart; or even one large single conductor of a diameter the same as, or greater than, the bunch of smaller wires.

From this we can conclude that an unbalanced line can approach a coaxial line in radiation characteristics if sufficient shields are added. The main purpose of the outside grounded conductors is to provide an earth current return path, and at the same time restrict the loss of RF power through radiation and coupling into other equipment.

The Theory of Earth Currents

One might be excused for asking why it is necessary to have multiple ground wires instead of a single conductor to match the one carrying the current to the antenna, or the "hot" one. The answer is in the ground losses. This is where engineers whose transmitters just don't seem to be performing the way they should might find some points of interest. Also, those engineers who are bothered by RF where it shouldn't be may find a solution to that puzzling feed in a remote line.

If a single "hot" line is used to carry the RF to the antenna, and a ground is used as a return, the ground losses will be tremendous. The line impedance of a No. 4 wire 12 feet above the ground is approximately 480 ohms. Now, if we use a poor ground return, with its attendant high resistance losses, we shall easily lose half, or even more, of our power in the transmission system. The remainder of the RF will be dissipated as heat in the ground! If a copper strap is buried immediately under the transmission line, only a small percentage of the ground return current will follow the resulting path. Most of the current will be at or near the surface where the lines of force from the "hot" transmission line enter the ground and spread out over the earth on each side. Thus, the gain in terms of decreased loss is not very much, and certainly not worth

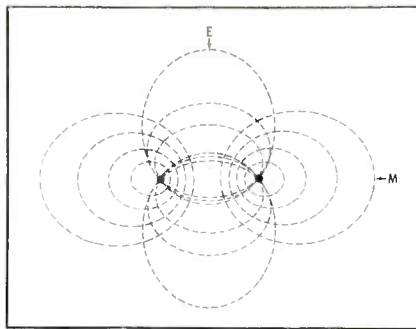

Fig. 2. Lines of electric and magnetic force surrounding an open-wire line.

the trouble of the buried strap.

The worst feature of this type line is the large radiation loop it produces, which will be likely to induce voltages in audio amplifiers, etc., in the station. In the somewhat unlikely event that a television station is also part of the installation, and that open wires are used for the AM portion of the transmitters, there is an almost 100% certainty of inducing AM interference into the video circuits.

From the single conductor with its grounded line, we progress to the multiple grounded-conductor line. This starts out as a two-conductor system which looks like a balanced two-wire line with one conductor grounded. Much of the return current will flow along this conductor; nevertheless, a lot of the radiation field will still escape to ground and produce losses. With a 12-inch spacing, the return line will carry about 40% of the current.

Fig. 2 shows the flux distribution around an open-wire pair transmission line. From this can be seen the reason for the heavy currents at the surface of the earth when no return wire is used.

Mechanical Considerations

Should it become necessary to design or rebuild a transmission line using open wires, great attention should be paid to details which, if ignored, can cause an unbelievable number of headaches and problems. If, for example, one has to repair an existing two-line or multiline system due to mechanical damage, it is essential to observe some precautions in the selection of insulators and supporting structures.

Contrary to some engineers' beliefs, wood is **not** the ideal medium of construction for cross bars, or supports. Similarly, insulators with studs screwed into the ends, or cemented on, are not a good choice

for this type of work. The cement will probably have a higher dielectric loss than the insulator, and may overheat. Also, the steel stud will have a very high potential gradient around it, and this can cause internal heating and eventual destruction of the insulator.

It is preferable to mount insulators for a transmission line on a metallic cross bar rather than on wood. If wood has to be used for one reason or another, it is essential that the metal mounting studs of the insulators be connected together by means of a copper strap to prevent the losses in the wood from attenuating the signal and producing a considerable loss.

Strange as it may seem, the effect of an organic material like wood in the field between two conductors of a transmission line is far more serious than the effect on the SWR of the line caused by a metallic cross bar. So heavy are these losses that wooden cross bars have been known to ignite due to excessive heating losses.

Coaxial Lines

For many reasons it is likely that the average radio station engineer has a better understanding of coaxial lines than of open-wire lines. Today, many station engineers are hams who use coaxial lines in their personal equipment. Most lower power radio stations use coaxial line for antenna circuits. Nevertheless, we still find things about coaxial line worth reviewing.

In audio work (and this leads into video and finally into RF transmission) it is possible to lay a large number of coaxial lines in

• Please turn to page 40

Fig. 3. Inductive and capacitive coupling.

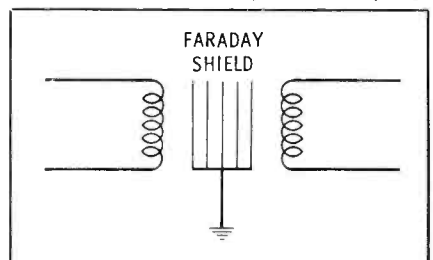

A. Inductive with Faraday shield.

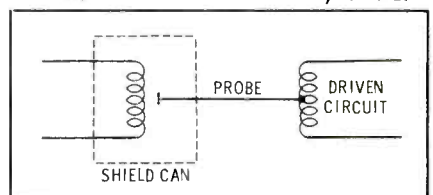

B. Probe capacity coupling.

THE ECONOMY VIDEO SWITCHER

by James French, Jr.*—Construction details for a transistorized video switcher ideal for standby or extra studio use.

The need for an auxiliary video switcher for standby, 2nd studio, or remote pickup operation brought about the design and construction of the unit to be described. The switcher shown in Fig. 1 is quite compact and adapts easily for use at almost any location. The configuration may be tailored to the builder's specs and space requirements—the layout shown is a suggestion only.

This device incorporates relay video selection and transistorized amplifiers for the video signal and sync sections. A sync gain control is provided for use in composite or noncomposite video applications, according to the need.

The amplifier-relay section contains the faders and switches, and

is mounted on a composite base constructed from an 11" x 17" x 2" aluminum chassis. The chassis was cut and formed into an L shape on the 17" dimension. The top deck is 11½" deep; the rear apron, which carries the power and coax connections, is 5½" deep. Mounted at the rear are 5 video inputs, 2 outputs, a sync input, a power socket, and a tally light socket.

The switcher was designed with five camera chain inputs; more than five, or fewer, may be used. Six selectro push-button switches for each bank are mounted on the front panel (the sixth is used for release or black). We used Oak type 130 switches in this application.

Fader-Control Assembly

The frame for the fader-control assembly (Fig. 2A) is constructed of aluminum and may be fashioned after any commercial configuration. We used Boston Gear Co. brass gears with a 48 pitch, a ⅛" face, and a 14½° pressure angle. The gears on the potentiometer shafts are type G-136, ½" diameter. The gears for the fader handles were fabricated from a type G-148, 2" diameter brass gears. Wedges equal to ¼ of the gear plus six teeth (Fig. 2B) were cut for each handle. This arrangement allows three extra teeth at the ends of the traverse.

The small gears were drilled for ¼" shafts and sweat soldered to brass couplings for connection to the pots. The fader handles and gear segments pivot on ¼" shafts.

A cam may be affixed to each fader shaft (Fig. 2C) to actuate miniature switches at the "off" end of the travel. The switches can then be wired to turn on bank indicator lights.

The Switcher Amplifier

The amplifier was built on an 8½" by 5" subchassis of perforated

phenolic board, which fits into a cutout in the aluminum chassis. This material is ideal for construction of transistor circuits.

A circuit of the amplifier is shown in Fig. 3. Transistors Q1 and Q2 serve in video input stages for relay banks 1 and 2. The faders and gain controls work into video

Fig. 2. Geared fader-control assembly.

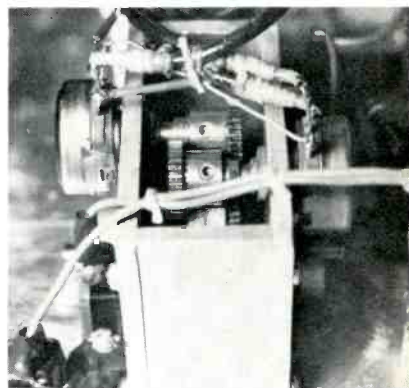

A. Aluminum frame and gears.

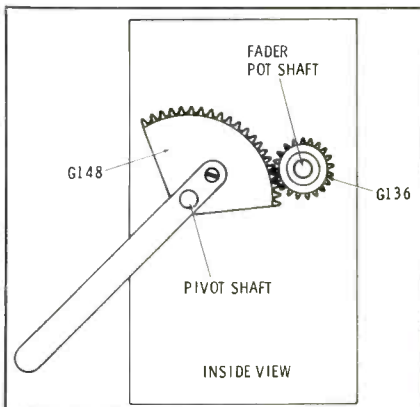

B. Control gear arrangement.

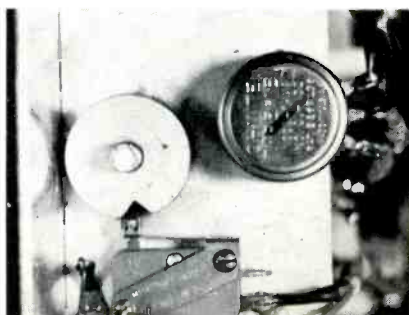

C. Switch-actuator cam.

Fig. 1. The transistorized video switcher.

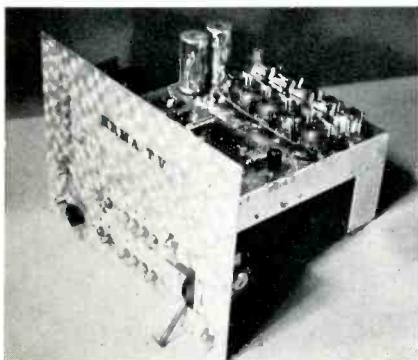

A. Front, showing buttons and faders.

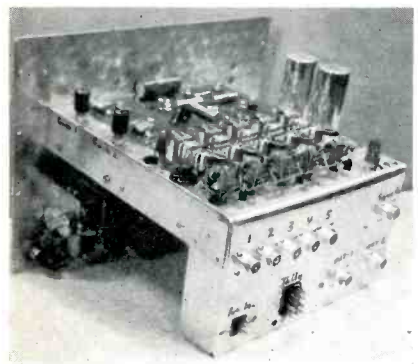

B. Left rear, showing connectors.

*KRMA-TV, Denver, Colo.



Here's the First Broadcast Quality Transistorized* Studio Camera Designed Specifically for Broadcasting

We're confident you'll find the new Sarkes Tarzian 1500L Solid State Studio Camera System suitable for all but your most elaborate production requirements. Employing the newly released 1.5" image pickup tube, the 1500L camera delivers unmatched performance for 80-90% of your live programming. And it's thrifty, too. Operating cost is under twenty cents an hour—far less than that of an image orthicon camera system—and initial cost is 50% less. For more information, write or call:

*All camera circuits are completely transistorized—without exception.



Broadcast Equipment Division
SARKES TARZIAN, INC.

East Hillside Drive, Bloomington, Ind.

Circle Item 13 on Tech Data Card

Video Switcher

(Continued from page 28)
amplifier Q3. Transistors Q4 and Q5 are employed as composite or noncomposite output amplifiers to provide dual 75-ohm video outputs.

Stages Q6 and Q7 control the sync level before this signal is added to the video. The sync signal is added at the base of Q4 along with a soft clamp voltage. In applications where composite operation is not desired, these two stages are not necessary.

The gain-set controls are used to adjust the level of each bank when its associated fader is at maximum. Both controls should be adjusted for the correct output with the input held constant, starting with number one.

The amplifier is very good to beyond 10 mc. The adjustable capacitors in the Q1 and Q2 emitter circuits should be set for flattest response with a sweep generator supplying the input signal.

The total current consumed by the amplifier is less than 40 ma when supplied by an 18-volt regulated power source.

Transistorized Power Supply

The power supply used with the switcher can also serve as the DC source for several other pieces of transistorized equipment. Its 18-volt regulated output is usable to approximately one amp. A bridge

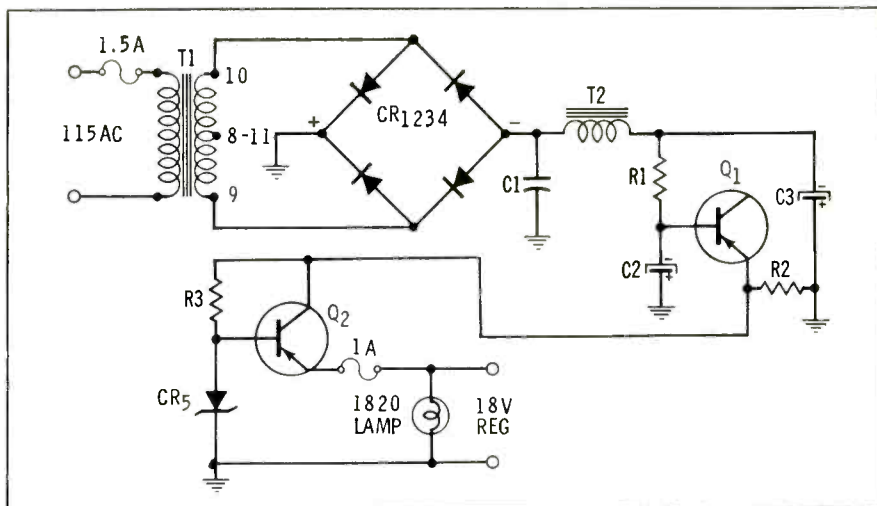

Fig. 4. Transistor power supply circuit.

rectifier (Fig. 4) is employed, with Q1 serving as the ripple filter. The total ripple measured at the output is less than .0002 volts p-p.

Component ratings have been chosen conservatively to permit the supply to operate loaded or unloaded without adverse effects to any part.

Relay Section

The relays used for video selection are Potter and Brumfield Type MC 5D. They have ceramic insulation and are particularly satisfactory for this application. The relay coils are shunted with resistor-capacitor-diode combinations for transient-spike suppression. A 24-volt DC source supplies these units when one side of the coil is ground-

ed through the camera selector switch (Fig. 5B). A 3300-ohm resistor is connected across the switch contacts to maintain some DC through the coils at all times (this produces a voltage somewhat less

Amplifier Parts List

Item	Description
C1, 4, 5, 8-16	100-mfd, 25-volt electrolytic
C2, 6	180-pf tubular ceramic
C3, 7	75 to 300-pf compression mica
C11	390-pf tubular
C17, 18	3000-mfd, 15-volt electrolytic
R1, 5, 16	68K, 1-watt
R2, 6, 17	1.5K, 1-watt
R3, 7, 19, 26, 28	6.8K, 1-watt
R4, 8, 13, 20	330-ohm, 1-watt
R9, 10	2.5K, 2-watt Ohmite type AB linear taper potentiometer
R11, 12	as above, except 1K
R22	as above, except 500-ohm
R14, 24, 31, 32	68-ohm, 1-watt
R15	3.8-ohm, 1-watt
R18	75-ohm, 1-watt
R21, 33	10K, 1-watt
R23, 29	680-ohm, 1-watt
R25	2K, 1-watt
R27	100-ohm, 1-watt
R30	82-ohm, 1-watt
Q1-7	2N1301 transistor
CR1	1N643 silicon diode

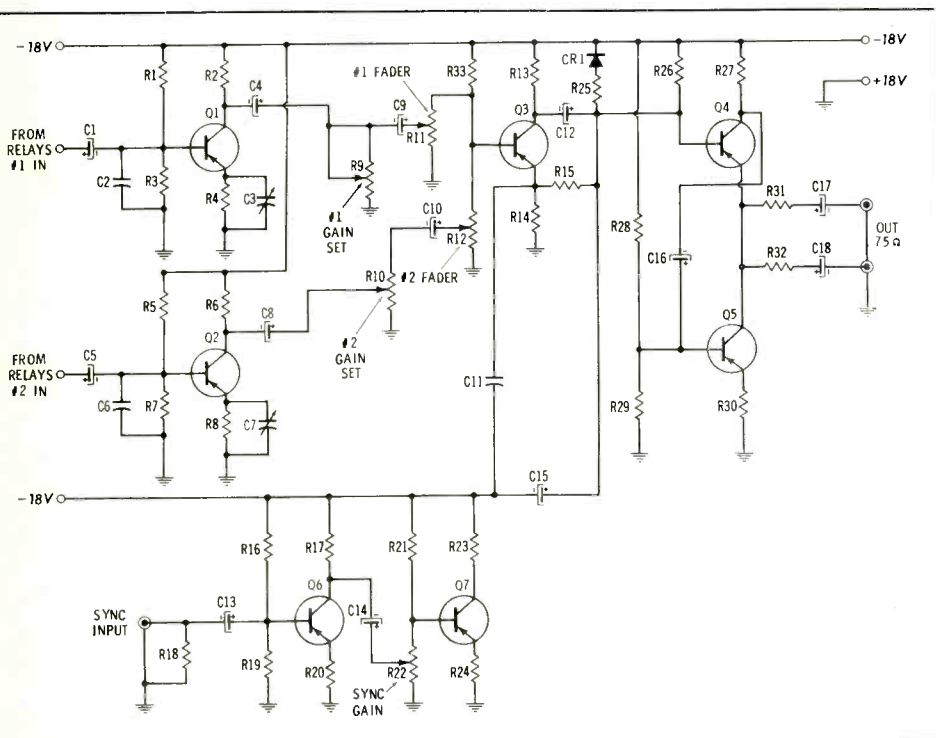

Fig. 3. Circuit of video switcher amplifier.

SCORE YOURSELF!

HOW MUCH DO YOU KNOW ABOUT THE TAPE YOU ARE USING?

TAKE THIS SIMPLE QUIZ AND THEN YOU'LL KNOW!

1. Was it developed by sound specialists?

(RCA Red Seal Magnetic Recording Tape was developed by RCA engineers for themselves — now it's available to you.)

YES	NO	DON'T KNOW
-----	----	------------

2. Does it come from one of the country's most modern plants?

(Red Seal Tape is manufactured under rigid quality control conditions in the most modern tape plant in the U.S.A.)

YES	NO	DON'T KNOW
-----	----	------------

3. Was it thoroughly tested for magnetic characteristics?

(Red Seal Tape is checked for frequency response, distortion, drop-out noise, print-through and 101 other rigid tests!)

YES	NO	DON'T KNOW
-----	----	------------

4. Was it thoroughly tested for physical characteristics?

(Every characteristic of Red Seal Tape must measure up to stiff specifications for coating thickness, anchorage, layer-to-layer adhesion, aging, cupping and slitting tolerances.)

YES	NO	DON'T KNOW
-----	----	------------

5. Can you use it interchangeably?

(Every foot of Red Seal Tape is identical — has the same magnetic properties, the same recording-bias characteristic!)

YES	NO	DON'T KNOW
-----	----	------------

CHECK YOUR SCORE. Only if you've answered "YES" to all 5 questions are you using Red Seal Magnetic Recording Tape. If not, isn't it time you tried this great, dependable, new tape developed by professional sound engineers for their own use. Learn all you should know about Red Seal Tape, fill in this coupon now!



The most trusted name in sound



Magnetic Tape Products Marketing
RCA Victor Record Division
155 East 24th Street
New York 10, N. Y.

Please rush me specifics on RCA Red Seal Magnetic Tape including all essential physical and magnetic characteristics.

NAME _____

TITLE _____

COMPANY _____

ADDRESS _____

CITY _____ ZONE _____ STATE _____

Circle Item 13 on Tech Data Card

LOW COST PROCESSOR DOES FAST, QUALITY WORK

Even though your processing needs may be relatively small, you will discover many advantages in owning a Labmaster. The low initial cost makes it practical to operate with a relatively small volume of work. As your volume grows you'll effect greater savings.

You'll save valuable time, too; have finished film days sooner. And you'll have complete control over film quality.

Labmaster is highly dependable; practically runs itself. It is a complete processing unit in every respect, ready to plug in and roll. Houston Fearless quality throughout. Get the facts today.

\$4575 Complete, ready to operate
16mm - B&W - Neg./Pos. FOB L.A.

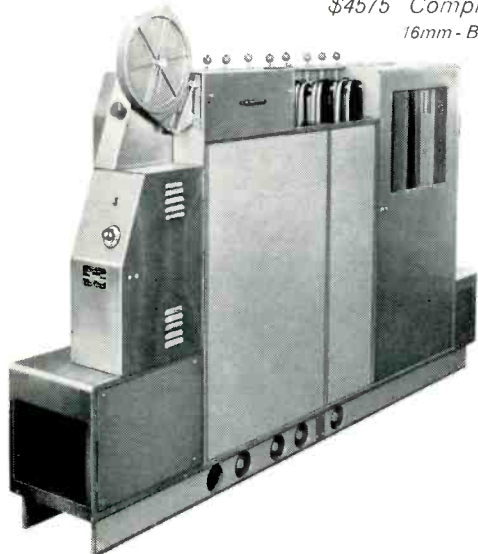

HF Labmaster

FILM PROCESSORS BY HOUSTON FEARLESS

16mm - 35mm - 16/35mm - Neg./Pos. - Rev. - B&W - Microfilm

Westwood Division, Houston Fearless Corp. · 11801 West Olympic Boulevard, Los Angeles 64 · Phone 272-4331
FILM PROCESSORS · CAMERA MOUNTS · ANTENNA ROTATORS · ELECTRONIC/OPTICAL INSTRUMENTS AND SYSTEMS
Circle Item 14 on Tech Data Card

Video Switcher

(Continued from page 30)

than that required for pull-in). A block diagram of the relay section is shown in Fig. 5A.

Fig. 5. Video selection-relay diagrams.

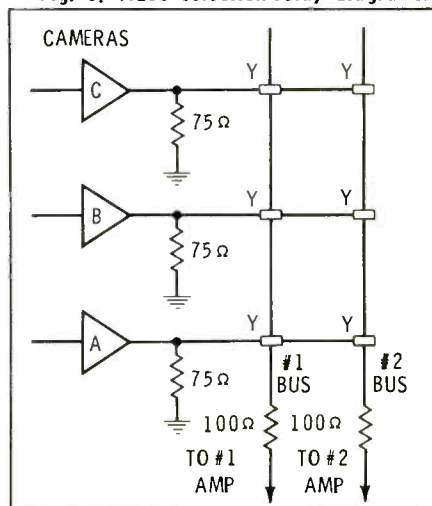

A. Relay section layout plan.

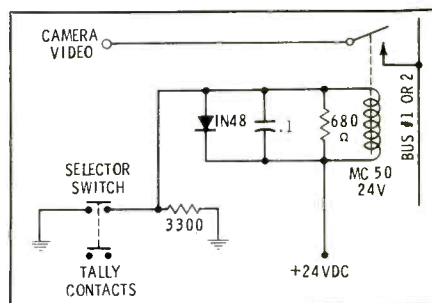

B. Typical circuit, for each point Y.

Power Supply Parts List

Item	Description
C1	.47-mfd, 200-volt
C2, 3	2000-mfd, 50-volt electrolytic
R1	25-ohm, 10-watt
R2	1K, 10-watt
R3	250-ohm, 10-watt
Q1, 2	2N2138 power transistor
CR1-4	1N1342 silicon rectifier
CR5	1N2982-B zener diode
T1	selenium rectifier transformer, Stancor RT-202
T2	filter choke, Stancor C-2685 tA R23, 29aoCR

Conclusion

The reliability of the switcher is amazing. The unit described herein has been in daily use for more than a year and is still 100% trouble-free. Once the initial setup and sweeping adjustments are completed, the device should be rock stable and operate well within the ratings of all components. ▲

BROADCAST ENGINEERING

WHERE TO LOOK

FOR THE MOST ADVANCED TV & FM ANTENNAS

Low Band Broadband
Dipole Antennas for
Channels 2-6. Gains to
10.3. VSWR of 1.04.

High Band Broadband
Dipole Antennas for
Channels 7-13. VSWR of
1.04. Gains to 23.7.

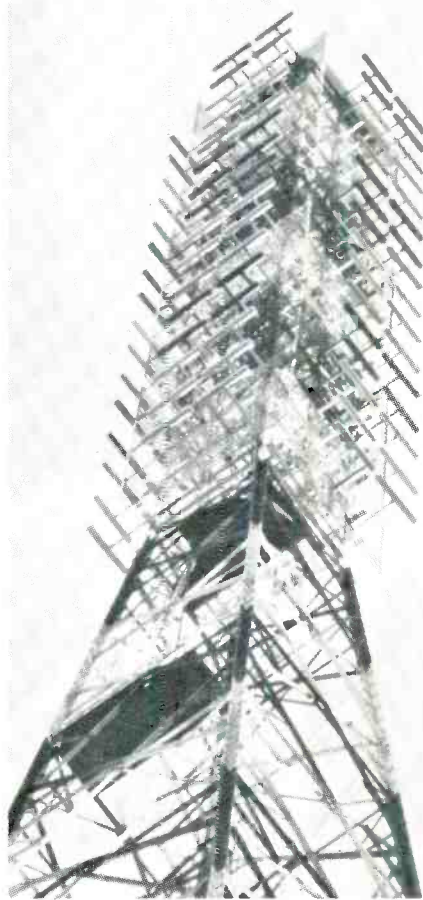
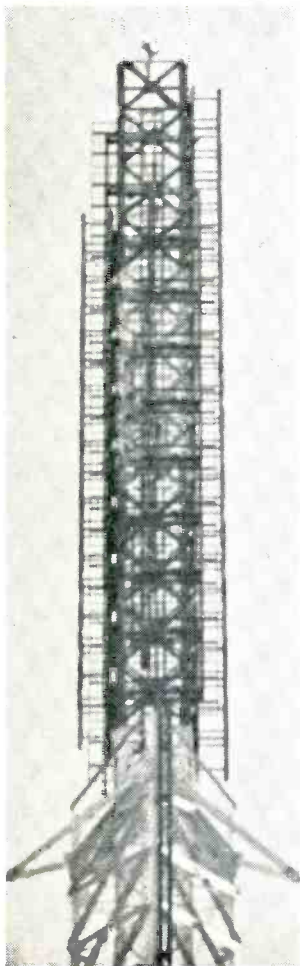

Write for complete details on this outstanding
line of antennas — Preferred by Broadcasters
Around the World.



co el Specialists in
Advanced Antenna Systems

24 CAROL ROAD, WESTFIELD, N. J.

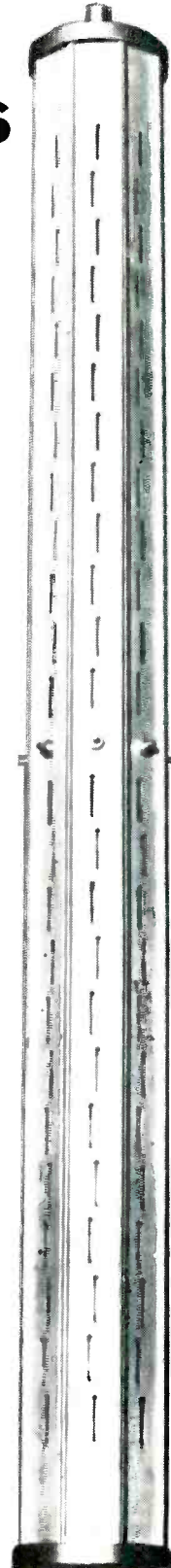

◁ Multiguide UHF Slot
Antenna for Chan-
nels 14-83. Power to
100 KW, Gains 11 to
52. VSWR 1.07 or
better. (Shown with
fiberglass cylinder
cover removed.)

Broadband FM An-
tennas. 88-108 MC.
Power to 45 KW.
Gains to 28.2. VSWR
1.1 over 10 MC band-
width.

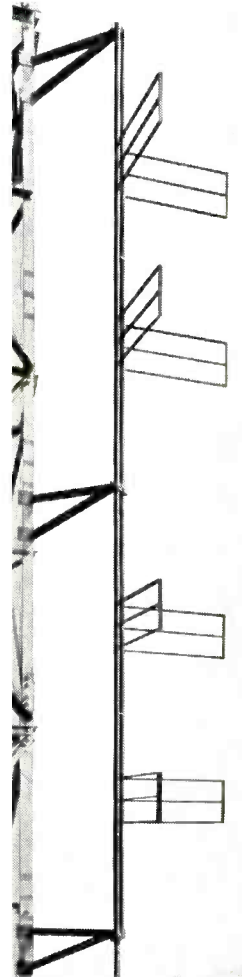

ENGINEERS' EXCHANGE

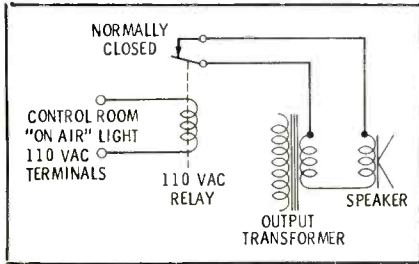

Auxiliary Console Monitor

by Sim S. Eagleson, Sr., Chief Engineer, WSBB Radio, New Smyrna Beach, Fla.

On many occasions the console operator finds it necessary to audition a fairly lengthy tape or disc prior to air-time. The situation at other times calls for a complete playback of a fifteen minute, or longer, tape for editing.

These seemingly harmless incidents, other than being time consuming for the board operator, can give rise to subsequent repercussions. The problem is being unable to monitor the on-air program at the same time, even though we do have earphones; the board operator can't be expected to wear the 'phones constantly. As a result, the man at the console may find himself missing the ends of cuts on transcriptions, having an occasional disc run out, possibly missing the network break, or being unaware of program termination.

The most practical (and economical) answer to this problem, I have found, is a second monitor in the form of a small AC-DC receiver tuned to the station's frequency. This radio is not installed with the intent of quality sound reproduction, but rather to provide, at a low volume, the much needed program monitoring.

To avoid feedback from the receiver (the radio may be mounted beneath the board, hidden from sight), a small 110-volt AC relay can be connected to open the voice-coil circuit when the announcer's microphone is on.

The relay power is taken from the control room "on-air" light terminal board, the winding being wired in shunt with the terminals. Thus, the relay is normally closed, allowing the radio to operate while the announce microphone key is neutral, or open-circuit.

Stepper Relay

by Peter H. Van Milligan, Maintenance Supervisor, WMBI AM-FM, Chicago, Ill.

At the Moody Bible Institute radio stations, we've had difficulty with reset contact burning in the stepper relay of our Gates remote-control unit, RDC-200A. When resetting to the calibrate position, the interrupter operates through all positions (it is wired as a closed loop) until open contact C is reached.

In the modified circuit shown, the stepper operates until the armature is held up through parallel contact 39, and advances to position C when the reset switch is released.

Here are the simple steps for making the wiring changes:

1. Break the continuous loop connections on the stepper reset terminals, K1-B. (Observe wire 47.)
2. At interrupter K1, remove wire 47 from the armature terminal and reconnect it to the contact on which wire 51 is soldered.
3. Remove wire 50 from the stepper wiper terminal on K1-B, and move this wire to terminal 39. Also run another wire from 39 to interrupter armature K1 from which wire 47 was removed.
4. At stepper K1-B, remove the

other end of wire 47 (contact 1), and connect it to the stepper wiper from which wire 50 was removed.

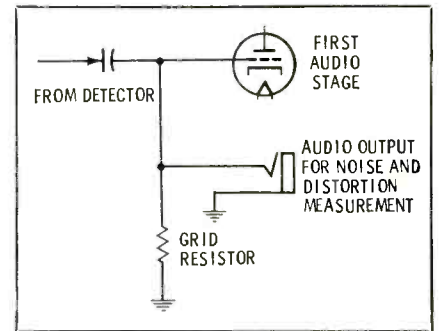

Diode Distortion

by Lyell Gunderson, Chief Engineer, KENN Radio, Farmington, N. M.

In spot checking our transmitter, we found the maximum distortion readings were quite high and did not conform with the oscilloscope waveforms. The distortion was low at low percentages of modulation, and high at high percentages.

A prime suspect was the germanium diode in our separate rectifier unit. In order to check this theory, we connected our distortion meter to our older type modulation monitor at a point where the RF signal is detected; this was quite easy since the unit contains a two-stage audio amplifier. Our connection point was the grid of the first audio stage. After confirming that our diode was bad, we added a jack on the front panel for future checks.

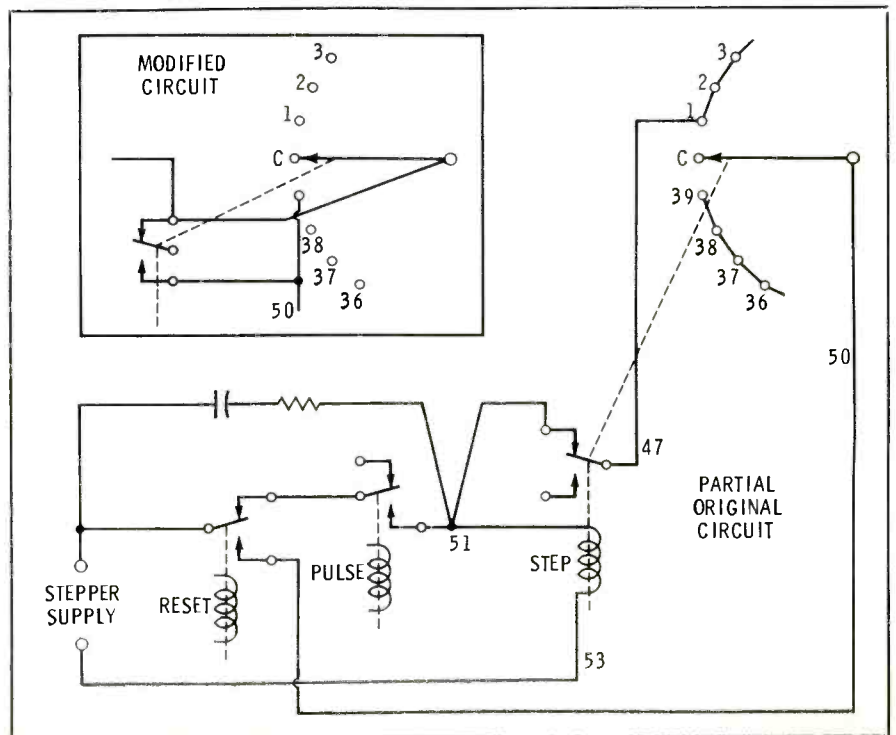



JERROLD VIDEO MICROWAVE 6 TO 13 KMC

... BEST FOR CATV, CCTV, ETV, AND STL USE

It may cost a little more at first, but Jerrold video microwave gear really pays for itself in no time. Here's why you can't afford to be without it: Front-panel metering of all tubes and circuits . . . Time-delay circuit protects klystron in event of power failure . . . Extended filament life with built-in regulating transformer . . . Only simple test equipment needed for set-up, troubleshooting, maintenance . . . Video monitor output at transmitter eliminates referring to receiver location . . . Compact modular construction saves space, reduces need for spares.

Take advantage of Jerrold's wide experience not only in supplying equipment but in helping you plan any hop from 20 to hundreds of miles. For complete information, write or call Jerrold Electronics, Philadelphia 32, Pa.



A subsidiary of THE JERROLD CORPORATION

- Simplest to set up
- Most dependable in performance
- Easiest and most economical to operate and maintain
- Widest baseband—IF bandwidth 30 mc, video bandwidth 8 mc
- Greatest stability— $\pm 0.005\%$
- Individual power supplies—can't lose all channels at once

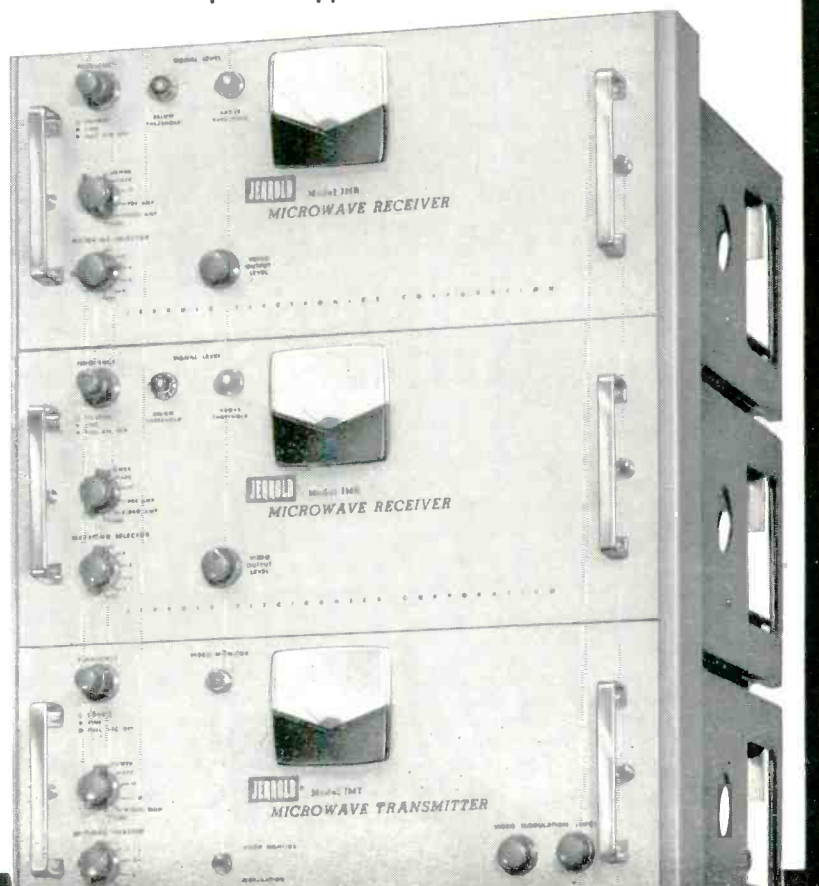

Circle Item 16 on Tech Data Card

NEWS OF THE INDUSTRY



100 KW's For Sudan

Shown undergoing preshipment tests is a 100-kw medium-wave broadcast transmitter, purchased by the Government of Sudan, Africa, from the **Gates Radio Div. of Harris-Intertype Corp.** Gates Engineer **C. V. Clarke** "tunes her up" at the plant in Quincy, Ill. In the Sudan the transmitter will broadcast from the capital, Khartoum, throughout the country, covering nearly a million square miles, or one-third the size of the United States, without Alaska and Hawaii. Receivers in hundreds of tribal villages will provide the government's program for educating and training 10,000,000 Sudanese in modern ways.

NAB '63 Engineering Conference

Three-Sound Stereocasts — A significant increase in fidelity can be obtained when AM and FM stereo multiplex stations join to provide the hi-fi audience with three-dimensional sound, according to **Kenneth Hamann**, chief audio engineer for Radio Station **WDOK**, Cleveland, Ohio, who submitted the results of a nine-year study of stereophonic broadcast techniques to the Broadcast Engineering Conference. The FM multiplex system makes use of two signals to achieve a stereophonic effect, while the AM transmitter beams one additional signal. The report describes in detail the techniques and special equipment required for these broadcasts.

Station Engineers Solve Stereo Monitor Problems—Questions dealing with stereo monitors were raised and answered by **C. E. Dixon**, project engineer, **Collins Radio Co.**, in an engineering paper entitled "Practical Consideration in Monitoring of FM Multiplex," covering the characteristics a stereo monitor should have. He said the electronics manufacturing industry, while building stereo multiplex transmitting equipment, has not provided the broadcaster with a monitor tailored specifically to fit his needs. As an interim measure improvised equipment has served the purpose; but now that the initial problems of stereo have been solved, it is appropriate to determine the type of monitor which can best serve the long-term interests of the stereo broadcaster. Mr. Dixon pointed out that while the FCC does not have any rules that clearly spell out

the requirements for stereo monitors, the stereophonic transmission standards should be a good guide to follow.

Logging Requirements Discussed — **Harold L. Kassens**, chief of the **Federal Communications Commission's Aural Facilities Branch**, told the engineers the FCC has amended its rules to permit the use of automatic logging devices and also to make other changes necessary to modernize logging rules. He discussed in detail the new requirements and the effect they will have on the future technical operations of all broadcast stations. In discussing changes in the FCC's logging regulations, Mr. Kassens emphasized that all broadcasting equipment of all stations must be inspected at least five days each week and at intervals of at least 12 hours. Maintenance and repair action, if any, that had to be taken also must be listed, he said.

AM Phase Monitor—Efforts to develop a phase monitor to provide the degree of precision required in the crowded AM broadcast band was described in a detailed paper presented by **J. K. Birch of Vitro Electronics**, Silver Spring, Md., at a radio engineering session. "... In a number of new designs, the phase angle must be held to within 0.1 degrees and the tower current to within 0.15% to satisfy the requirements of the Commission," Mr. Birch said. He pointed out that in designing such an instrument, engineers actually are concerned with two separate pieces of equipment: a precision current meter and a precision phase meter. "We will soon be testing the monitor in a remote control environment, and we hope to be able to report on the tests in the near future," Mr. Birch concluded.

TV Camera Operation Demonstrated — Simplified operating practices for studio image-orthicon cameras were illustrated in a film presented by **Joseph A. Flaherty**, director of technical facilities planning, **Operations Department, CBS Television Network**. According to Mr. Flaherty, the film portrayed simplified operating practices for 4½" image orthicon cameras, employed by the CBS Television Network to obtain high quality results in normal day-to-day operations. Special emphasis was given to demonstrating the interrelationship of lighting, scene contrast, camera exposure, and object-to-image transfer characteristics, and to relating these variables to final image quality.

Two Stations Share Antenna — Two competing television stations — **WHEC-TV** and **WROC-TV** — are now sharing a common antenna at the most desirable location near Rochester, N. Y., in the only operation of its kind in the United States. **Richard K. Blackburn** of the **Gannett Radio-Television Group**, which operates **WHEC-TV**, gave a detailed report on the unique installation describing how four 3¼-inch transmission lines were fed into a broad-banded coupler designed to handle not only the power

required for two broadcasting signals, but also for two spares that could serve as "reserve" antennas in case of feed line or transmission failure.

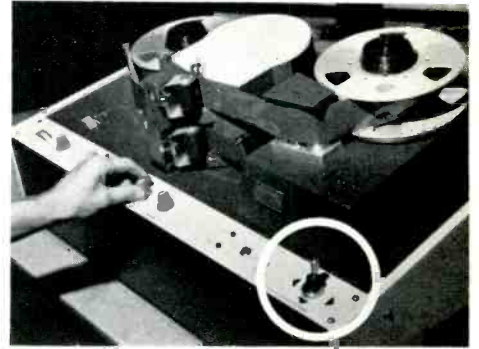

Stick Replaces Buttons

Five push-buttons and associated interlock devices have been replaced by a single "joy stick" selector switch in **Ampex Corporation's** new portable television tape recorder. The miniature oil-tight device, developed by the **General Electric, General Purpose Control Department**, is used to control all operating modes of the **VR-1500**: reproduce, record, fast forward, and rewind. Ampex engineers selected the 5-position joy stick to provide a simple, straightforward operational control, since it is expected that the recorder normally will be operated by nontechnical personnel with a minimum of instruction. The switch also has the additional benefit of reducing control circuitry and adding to the compact design of the recorder.

Award Given To Microphone

An Academy Award, believed to be the first bestowed on a microphone design in the past 22 years, was conferred on **Electro-Voice, Inc.**, by the **Academy of Motion Picture Arts and Sciences**, at the award ceremonies Monday, April 9th. Basis for the award was the firm's contribution to motion picture sound in the form of a highly-directional microphone, Model 642, which permits simultaneous filming and pickup of action at considerable distances from the scene. Be-

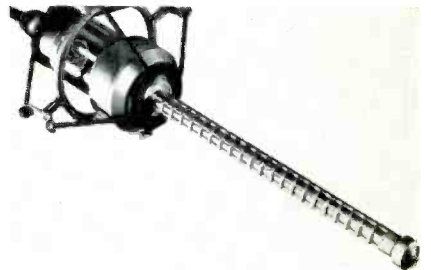

fore development of the microphone, such scenes were filmed without sound, and "lip sync" audio was dubbed in later. Commenting on the honor, **Electro-Voice** president **Albert Kahn** said, "The citation comes as a well-deserved tribute to the efforts and technical capabilities of many E-V personnel who had a hand in developing and producing the 642, but signal honor belongs to **Louis Burroughs**, vice-president of our professional microphone division..." Also instrumental in the microphone's development, **Kahn**



Only Raytheon 4-Unit Systems Offer PICKUP Reliability Plus PACK-UP Convenience

For single or multi-hop installation, Raytheon portable KTRs are unmatched for fast field assembly and disassembly — reliable performance — and ease of operation and maintenance.

Unlike competitive equipments, Raytheon KTRs are packaged in only 4 compact carrying cases containing a Transmitter Control Unit and RF Head, and a Receiver Control Unit and RF Head. Each RF Head is packaged in a rugged, weatherproof, cast-aluminum carrying case, yet the entire system weighs only 160 pounds . . . *100 pounds less* than comparable equipment.

For fast field assembly and ease of maintenance, Raytheon KTRs are unbeatable. Unique "L" bracket construction enables one man, equipped only with a screwdriver, to assemble the entire system in minutes. All test and metering controls are front-panel mounted — there are no "hide-and-seek" components. A built-in one-knob cable equalizer provides

flat frequency response with any cable length up to 600 feet per system.

Initial cost of Raytheon KTR Systems is low and long-term financing is available. Raytheon also provides complete System Engineering Service.

Additional no-charge features include:

- Remote electrical and mechanical tuning — both transmitter and receiver
- Built-in audio channel
- 3.6 Mc vernier control for color sub-carrier adjustment
- Built-in calibrated wavemeters — both transmitter and receiver
- Built-in system test signal
- DC restorer circuit to eliminate video bounce
- Wide band monitor — both transmitter and receiver
- System exceeds FCC frequency stability requirements without AFC

For more information about Raytheon KTRs — the systems that offer more trouble-free convenience from pickup to pack-up — attach this coupon to your letterhead and mail.



Raytheon Company, Dept. 130
1415 Providence Turnpike, Norwood, Massachusetts

Please send more information about Raytheon KTRs.

Name _____

Title _____

(Reminder: please attach coupon to your company letterhead)

Circle Item 19 on Tech Data Card

EICO 902 im/harmonic distortion meter & ac vtvm



Complete Audio Lab (in one low-cost package)

The new EICO 902 is a unique complete audio tool combining IM and Harmonic Distortion Meter, sensitive AC VTVM and db meter in one compact instrument. Designed and constructed to rigid lab standards, it offers the extreme stability and accuracy for the most critical measurement requirements in audio research design and development. Yet, its ease and speed of operation make it ideal for in-production testing and quality control, and servicing.

For HD measurement the 902 incorporates a continuously variable 20-20,000 cps Wien Bridge rejection filter (in three ranges). A high quality tuning capacitor with 6:1 vernier eases frequency setting. Less than 0.7 v. input is required for measurement. 0.3% distortion is read full-scale. Internal distortion is less than 0.1%.

For IM distortion measurement the 902 incorporates a 7 kc oscillator for the high frequency source and an additionally filtered line frequency signal, for the low frequency source. Selection is provided on the panel of either 4:1 or 1:1 LF to HF voltage ratios. When desired, external low frequency sources up to 400 cycles and external high frequency sources down to 2 kc may be fed to the mixing bridge

through panel jacks that switch out the internal sources when used. Less than 0.7 v. is sufficient input for IM distortion measurement. 0.3% distortion is read full-scale. Residual distortion is approximately .05%.

Used as an AC VTVM the 902 provides a highest range of 300 v. and a lowest range of 10mv, with uniformly excellent frequency response at all measurement levels. The AC VTVM section is employed in all instrument functions, and the linear 0-1 and 0-3 meter scales are used for all measurements.

Integration of controls in the 902, as well as high circuit stability and freedom from interaction, provides outstanding simplicity and ease of operation. Yet, it occupies less bench space than is usually required by an IMD or HD meter alone.

The EICO 902 is invaluable in almost any kind of audio work. It can save time and improve quality in design, production quality control, and service work in the field. This includes amplifiers; tuners; recording on disc, tape or film; broadcasting equipment; transducers (phonograph cartridges, microphones, loudspeakers; hearing aids, etc.) EICO 902, factory wired, \$250.00.

Write Dept. BE-5.

for FREE catalog and name of distributor:
EICO ELECTRONIC INSTRUMENT CO., INC., 3300 NORTHERN BLVD., LONG ISLAND CITY 1, N. Y.

EXPORT: ROBURN AGENCIES INC., 431 GREENWICH STREET, N. Y. 13, N. Y.



EICO 250 AC VTVM & AMPLIFIER Add 5% in West
kit \$49.95
wired \$79.95
EICO 255 AC VTVM
kit \$44.95
wired \$72.95



Circle Item 18 on Tech Data Card

EICO 427
GENERAL PURPOSE
5" OSCILLOSCOPE
kit \$69.95
wired \$109.95



said, were Wayne Beaverson, vice-president of engineering, and the engineering staff devoted to the project: Robert Ramsey, Thomas Leininger, Harold Mawby, and Howard Diltz.

Ruby Recording Stylus Developed

Microlap, a high-quality ruby recording stylus developed and manufactured by CBS Laboratories Div. of Columbia Broadcasting System, Inc., is now available to the recording industry. The stylus improves the quality of records and is especially designed to produce discs which meet the new 15° modulation standard developed by CBS Laboratories and recommended by the Record Industries Association. The new styli are produced from ruby rods with all dub and facet dimensions meticulously controlled to meet the demands of record groove calibration. Each stylus is separately controlled during the lapping process to minimize record noise resulting from microscopic scratches on the edges of the stylus, and is individually certified for low noise.

PERSONALITIES

The appointment of Merrill A. Trainer as manager, Broadcast Studio Merchandising and Engineering Dept., for the RCA Broadcast and Communications Products Division was recently announced by C. H. Colledge, division vice-president and general manager. In his new capacity, Mr. Trainer will direct engineering and merchandising activities for the division's line of cameras, tape recorders, switching systems, and other equipment used in radio and television broadcasting studios. He also will continue to be responsible for liaison between the Broadcast and Communications Products Division and the RCA International Division.

The appointment of Anton Seda as chief engineer, equipment design, was announced by John Walovich, director of engineering, Stancor Electronics, Inc., Chicago, Ill. Mr. Seda's primary responsibilities will be directing the design and development activities for new products employing solid-state electronics.

John R. Foster has been appointed national sales manager of IERC Div., International Electronics Research Corp., Burbank, Calif., manufacturer of heat dissipating devices. In his new position, Mr. Foster will direct the OEM sales activities of IERC's factory sales force and sales representatives.

ITA Electronics Corp. announces the appointment of G. P. Wilkinson to the position of executive assistant to the president, in charge of broadcast and international sales. He moves up from manager of International Div. Louis S. Gomolak has been named director of public relations for Jerrold Electronics Corp., Robert H. Beisswenger, vice-president and general manager announced. Mr. Gomolak will direct all informational functions for the four divisions of the company.

BROADCAST ENGINEERING

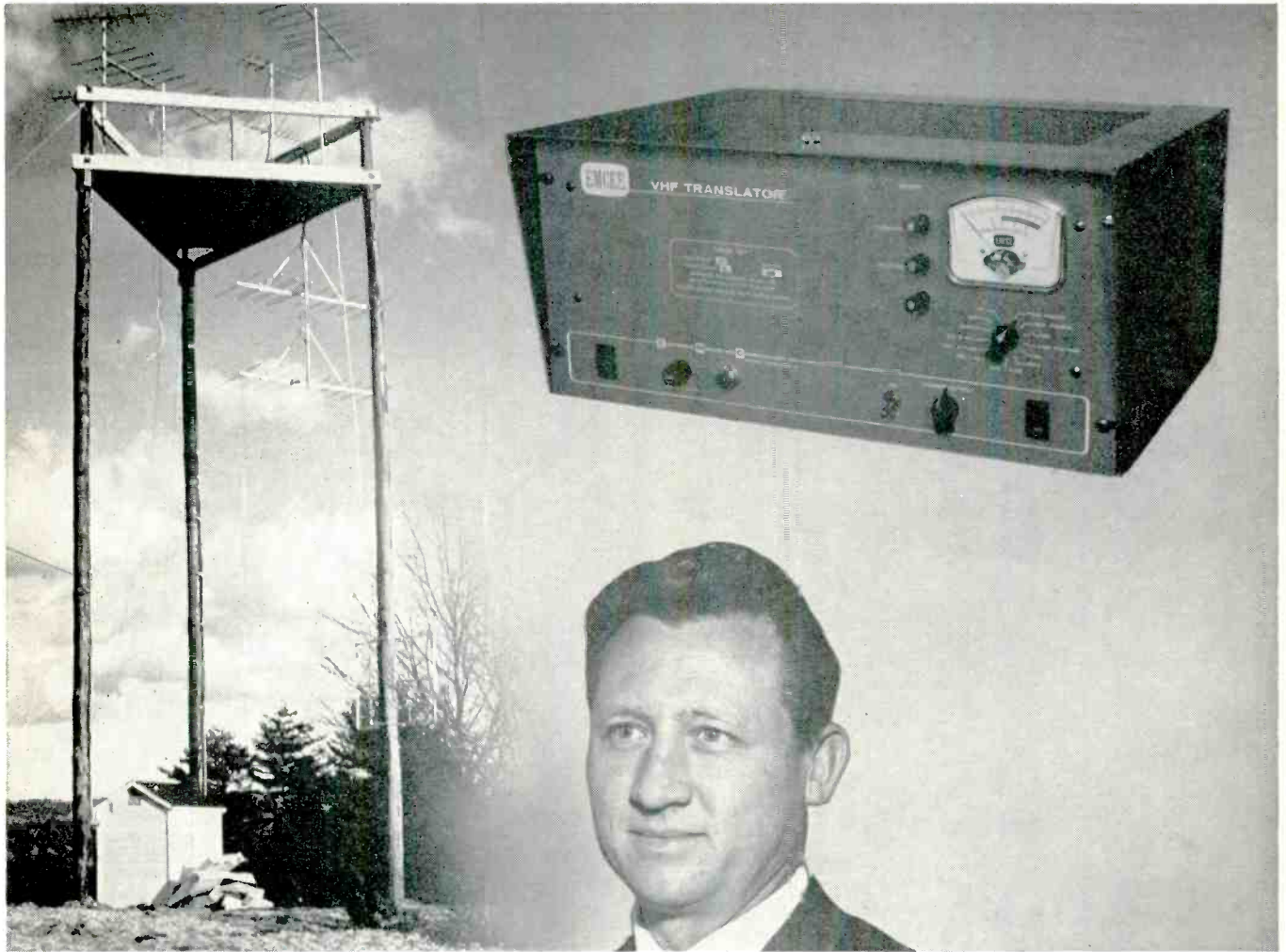

EMCEE TRANSLATORS BRING **KLAS-TV TO 7,000 MORE VIEWERS**

Says Bob McKenzie, Chief Engineer, KLAS-TV, Las Vegas, Nevada.

In Las Vegas and throughout the U.S., more and more knowledgeable people are turning to EMCEE Translators as the logical means of extending TV coverage . . . efficiently and economically. These unattended, rebroadcast transmitters reach more people at lower installation cost and maintenance than any other system. Community service organizations seeking to improve TV or bring TV to their area and broadcasters wanting to fill in shadow areas . . . all should investigate the EMCEE Translator System. These systems are available for VHF or UHF . . . from 1 watt to 100 watts . . . from individual area service to multi-hop regional systems . . . as an equipment package or installed by one of EMCEE's many franchised dealers. Whatever is needed, the logical choice is EMCEE . . . the world's largest manufacturer of VHF and UHF translators and accessories.

Write for information on . . .

- VHF and UHF Translators • Multiple Output Amplifiers • Legalizing Equipment
- Low Noise Pre-Amplifiers • Filters
- Power Splitters • Transmitting Antennas
- UHF Transmitters

Electronics, Missiles & Communications, Inc.
 262 East Third Street • Mount Vernon, New York • BE-5

Gentlemen: Please rush

- Free planning package including data sheet, complete installation check list, coverage calculation form.
- Detailed Specifications of UHF Translators.
- Detailed Specifications of VHF Translators.

NAME _____
 ADDRESS _____
 CITY _____ STATE _____

ELECTRONICS, MISSILES AND COMMUNICATIONS, INC.

262 East Third Street • Mount Vernon, New York • 914 MO 8-3012
 Circle Item 21 on Tech Data Card

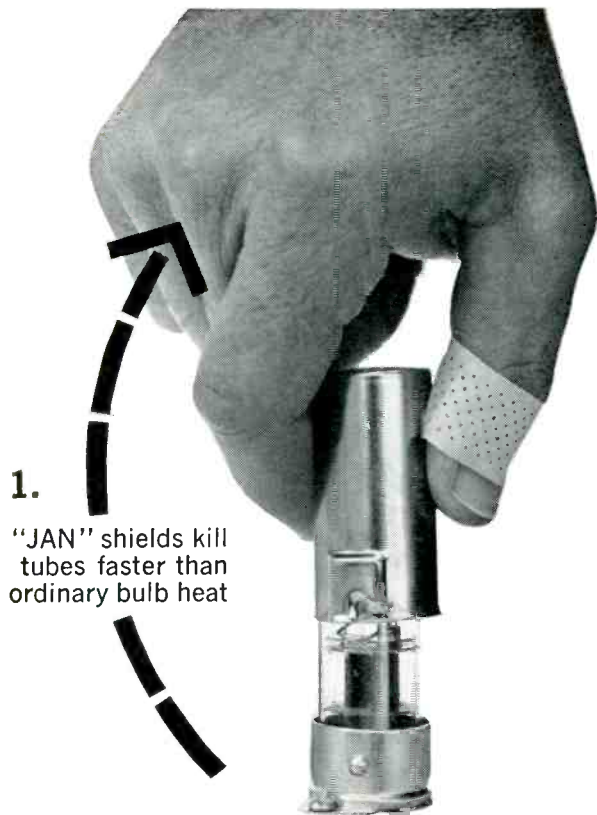

1.

"JAN" shields kill tubes faster than ordinary bulb heat

HERE'S THE WAY TO SAVE MAINTENANCE DOLLARS!

Electron tube failures account for 70% of electronic equipment failures. Extending tube life two to twelve times with IERC heat-dissipating shields can greatly reduce equipment maintenance and downtime costs.

TR series shields install as quickly as shown into your present equipment, giving failure-free performance proved in new military and industrial equipment using IERC shields.

WRITE FOR LITERATURE to help you order TRs—and reliability, TODAY!

IERC  **D I V I S I O N**

heat-dissipating electron tube shields.

2.

Heat-dissipating shields extend tube life 2 to 12 times



Patented

INTERNATIONAL ELECTRONIC RESEARCH CORPORATION

135 West Magnolia Boulevard, Burbank, California • Victoria 9-2481

Foreign Manufacturers: Europelec, Paris, France. Garrard Mfg. & Eng. Co., Ltd., Swindon, England

Circle Item 20 on Tech Data Card

Transmission Lines

(Continued from page 27)

proximity to each other without much fear of undesired coupling. This is because there is no current flow on the outer surfaces of coaxial cables. In fact, if there is a voltage apparent on the outer conductor of a coaxial cable we want to know why at once! Unless it is desired, due to the particular use of the cable (such as in a decoupling coil from an insulated tower or some similar circuitry), such a voltage may indicate serious trouble.

A basic precaution in handling coaxial lines is to ground them at regular intervals. Be careful, however, to ensure these intervals do not correspond to a harmonic function of the operating frequency, or extra undesirable effects may be introduced. A surface voltage detected on a coaxial cable is an indication that somewhere another line, or the ground, is forming a return path for the current, and you may expect unwelcome signals in some part of the installation—or else unusually large losses in the transmission system.

Many engineers who should know better often refer to coaxial line as "unbalanced line." This much is correct, but often leads to the misunderstanding that they are mismatched. An unbalanced line can very easily be matched to its impedance and load. For example, a coaxial cable feeding a vertical insulated tower is unbalanced, but it is certainly matched . . . or at least we hope so!

A balanced line is one in which both legs have equal voltages above ground, but are opposite in phase. Thus the center tap of such a system would be at ground potential. Connecting an unbalanced line to a balanced load results in trouble because the outer shield would be above ground potential. This allows current flow near the outside of the cable, which in turn produces unwanted radiation and attendant losses.

It is usual practice to mount coaxial lines carrying RF to an AM antenna above ground on low supports, two or three feet high. There is no need to place them any higher, except for clearance purposes, because the outside conductors are at ground potential.

BROADCAST ENGINEERING

Another common procedure is to bury the semirigid one-piece copper lines, $\frac{5}{8}$ to $\frac{7}{8}$ inch in diameter, in the ground. In general, it is not advisable to bury flexible lines because of the risk of damage by chemical action, deterioration, or water seepage.

A quick way of estimating the distance to a short in a buried coaxial line is by use of the old standby, the grid dip oscillator. If the grid dipper is coupled loosely to the line and the frequency swept, it will be found that there is a series of frequencies at which the meter will dip, indicating half-wave resonances (transmission line impedance repeats at every half-wave along its length). If we found dips every 1.5 mc (starting at 1.5 mc) we would know the short was half the wavelength of 1.5 mc from the grid dipper. If we take the velocity of propagation along the line as about 92%, the distance would be on the order of 301 feet. This could be checked by starting from the other end to see if the figures obtained correspond to the difference between the length and the first distance.

Some Notes On Coupling

In connection with open-wire transmission lines, some notes on coupling might be of interest. In addition to radiation coupling, it is possible to couple energy by induction and capacity. The purely inductive method makes use of a Faraday shield. This consists of a grid of parallel wires connected together at one end only, and grounded. The lines of electric force hit these wires, terminate, and are grounded. Because these wires do not form closed loops, there is no circulating current, and the magnetic field penetrates the shield producing inductive coupling into the other coil.

If pure capacitive coupling is desired, an inductance can be shielded and a very small probe brought into close proximity to the soil. The lead from this probe is connected to another coil in the operating circuit.

The Faraday shield is employed in many transmitters to assist in reducing harmonic output; as a rule capacitive coupling tends to act like a high-pass filter and accentuates harmonics. ▲

New!

from SPOTMASTER the 500A and 505A Cartridge Tape Systems



500A—complete recorder playback unit

Spotmaster

505A—playback unit



Now advanced design and modular construction assure split second operation, outstanding dependability

With sleek new eye-appeal to match its ease of operation, the 500A series joins the SPOTMASTER family of equipment. On five continents, more stations use more SPOTMASTERS than any other cartridge tape systems.

- New Compact Design
- Quality Engineered
- Field Tested, Field Proven
- Modular Construction
- Easy Maintenance
- Most Complete Line
- Competitive Prices
- Lease or Purchase
- Iron-clad, Full Year Guarantee

For complete details and specifications, write or phone:



BROADCAST ELECTRONICS, INC.

8800 Brookville Road, Silver Spring, Maryland

Area Code 301: JUniper 8-4983

Sold nationally by:

VISUAL ELECTRONICS

356 W. 40th St., New York, N.Y.

Canada:

**Northern Electric
COMPANY LIMITED**

branches from coast-to-coast in Canada

Circle Item 17 on Tech Data Card

SPOTMASTER Tape Cartridge Winder



The new Model TP-1A is a rugged, dependable and field tested unit. It is easy to operate and fills a need in every station using cartridge equipment. Will handle all reel sizes. High speed winding at 22½" per second. Worn tape in old cartridges is easy to replace. New or old cartridges may be wound to any length. Tape Timer with minute and second calibration optional and extra. Installed on winder or available as accessory. TP-1A is \$94.50, with Tape Timer \$119.50.

Write or wire for complete details.

Spotmaster

BROADCAST ELECTRONICS, INC.
8800 Brookville Road
Silver Spring, Maryland

Circle Item 45 on Tech Data Card

Stereo Broadcasting

(Continued from page 19)

microphones to emphasize a section or a single instrument of an orchestra. The equalizer has two controls, one calibrated in terms of decibel loss or gain at 10 kc, and the other calibrated similarly at 50 cps. Care must be taken not to add too much gain to a given microphone at 10 kc because of the possibility of tape saturation while recording or over-modulation during FM broadcasts. Provision is also made in the equalizer chassis for feeding any or all of the seven channels in varying degrees to an external echo chamber, should this be required. The returning signal from the echo chamber can then be added to any of the three output channels of the mixer.

Other features of the mixer include a built-in tone generator that can be used for initial calibration of the recording system, provision for feeding a signal from an external tape playback machine into the mixer, and a switch for mixing the center channel of the mixer into both the left and right output channels for two-channel stereophonic recordings.

The entire recording system is mounted in a sturdy open frame rack 72" high and equipped with large wheels for relative ease of handling on remote locations (Fig. 6). For transporting the system, the rack slides directly into a small station wagon equipped with special rails for this purpose.

A custom-designed three-channel studio mixing console (Fig. 7) has been constructed by the Cleveland Recording Company and is available for use by WDOK for special studio originated three-channel broadcasts (Fig. 8).

The basic layout of the console is designed to place all of the more frequently used controls within easy reach of the operator. Linear attenuators, custom-made in Europe, are placed along the front edge of the operating area with the seven microphone faders and the three tape-line input faders in the center. On the right side of these are placed the three master-channel output faders, and on the left are the three echo-chamber return faders. Directly behind each of the input attenuators is mounted a push-button selector with color-coded lighted lucite



Mr. Nat King Cole
recording for
Capitol Records



A POSITION OF RESPONSIBILITY... NEUMANN MICROPHONES

Gotham Audio Corporation presents the complete line of Neumann microphones which have, over the years, achieved the position of leadership in those industries which will not compromise with quality.

Write today, indicating company affiliation, for complete data on
Neumann Condenser Microphones

GOTHAM AUDIO CORPORATION

2 WEST 46 STREET, NEW YORK 36, N. Y. • CO 5-4111
In Canada: J-MAR ELECTRONICS LTD., P.O. BOX 158, DON MILLS, ONTARIO



Circle Item 22 on Tech Data Card

BROADCAST ENGINEERING

buttons for feeding a given output to any of the three output channels. Also mounted near each selector are controls for varying the overall gain, in 10-db steps, of each microphone preamplifier, so that either high-output condenser or low-output dynamic microphones may be utilized. These controls vary the gain of the preamps by changing the amount of feedback applied to the first stage of the amplifier.

Directly behind the push buttons are the Echo Send controls that enable the operator to feed an external echo chamber, with varying degrees of signal from each of the inputs, independently of the main-channel faders.

Located on a sloping panel at the rear of the operating area are individual equalizers for each of the ten input channels.

Mounted above the entire console at the rear, a separate housing contains all the necessary meters for monitoring the various signals. Three light-beam VU meters are used to monitor the main output channels. These meters were chosen because of the ease with which they may be observed from any lo-

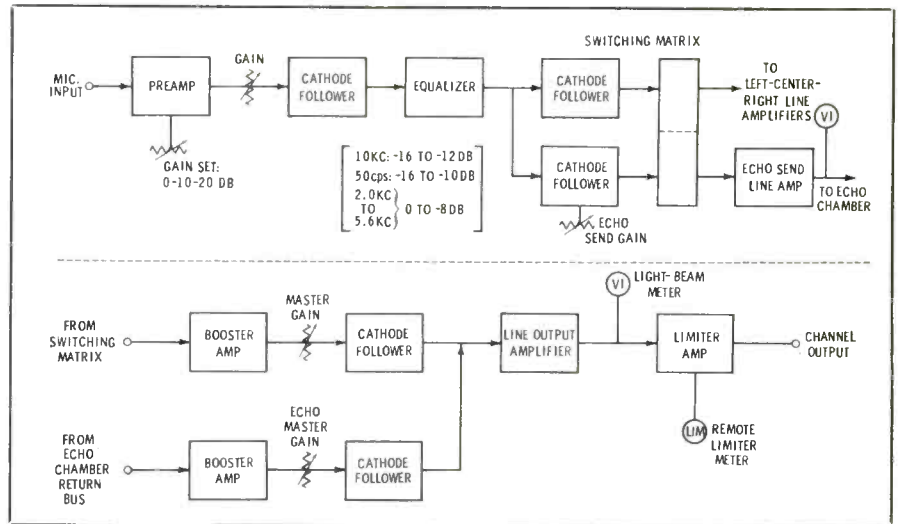

Fig. 8. Simplified block diagram of three-channel master console.

cation in front of the console, particularly when an overmodulation condition exists, in which case the light beams change to a red color.

Conclusion

In an effort to improve the quality of stereophonic program transmission from live concert material, WDOK has investigated several basic systems of microphone pick-up techniques. The culmination of a nine-year series of experiments is

the current broadcasting of three-channel stereophonic sound.

The entire series of stereophonic broadcasts have convinced us that there is a definite desire on the part of discriminating listeners for the best possible reproduction of sound, and we are therefore exploring new methods of broadcasting stereophonic three-dimensional sound to improve the art of broadcast transmission. ▲

NEW PORTABLE EQUIPMENT FOR STATIONS ON THE MOVE

SOLVE YOUR
REMOTE, PRODUCTION
AND AUXILIARY
MAIN STUDIO
PROBLEMS



A-10
AUDIO CONSOLE

The unique Sparta A-50 Portable Studio handles all of these jobs with ease. Simply un-screw the steel tapered legs, clip them inside the bench, latch the bench to the studio top and you're on your way. A rugged solidly built unit designed for many years of continuous duty. Comes complete with TT-12 turntables, viscose damped tone arms, A-10 Audio Console..... **\$845.00**

The A-10 Audio Console provides a total of eight high or low level inputs. Up to date solid state design plus plug-in-modular construction. Can be battery operated..... **\$375.00**



A-50
PORTABLE STUDIO

Call, Write or Wire Today

SPARTA ELECTRONIC CORPORATION

6450 FREEPORT BOULEVARD • SACRAMENTO 22, CALIFORNIA • GA 1-2070

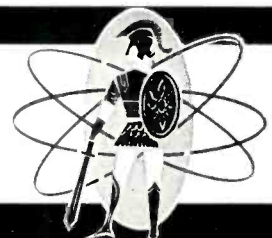



BROADCASTING HAS MOVED TO A NEW TIME SPOT

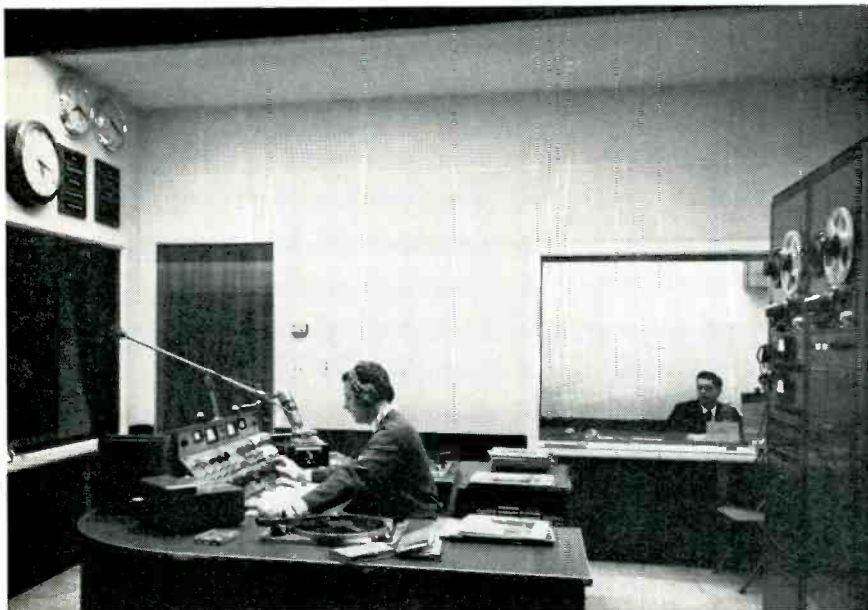

Modern FM-stereo studio (WTFM, New York, N. Y.)

Television, color, stereo, multiplex, UHF, FM, AM — all are a part of broadcasting today, 55 years after De Forest developed his wireless phone. Broadcast engineering today is a complex of advanced technologies. In this maze of progress, there is a critical need for fast, dependable delivery of electronic equipment and components. To meet this need, there is an outstandingly reliable source: MILO, double decade pioneer of industrial electronic distribution.

Whatever your requirements, you can depend on MILO's vast inventory of more than 100,000 different products representing 145 brand name manufacturers to satisfy your needs. Just one call to MILO does the job of many calls to scattered sources. Delivery? Immediate. Cost? Never more than buying from the manufacturers. Isn't it time you put MILO to work for you?

*America's Leading
Industrial Electronics Distributor*

MILO

MILO ELECTRONICS CORP.

530 CANAL ST., N. Y. 13, N. Y. (212) BE 3-2980 • "ENTERPRISE" phone service in all industrial areas
REGIONAL SALES & STOCKING WAREHOUSES: Orlando, Fla.; CY 5-1710 • Temple City, Calif.; AT 7-9777
REGIONAL SALES OFFICES: Wilmington, Mass.; CO 6-7400 • Westport, Conn.; CA 7-5354

Circle Item 24 on Tech Data Card

When Proof Fails

(Continued from page 22)

first (or, transmission-set) system is probably the most accurate. However, since many readers will not have access to a transmission-set, I feel that a few cautionary remarks are in order. Regardless of which system is employed, the changes in reference-level power required to adjust the system for 25, 50, 85, and 100% modulation levels must be made at some point between the oscillator output and the console input, since it is the intent of the FCC regulations that **all** portions of the equipment be operating at the same **relative** level as the specific percentage of modulation of the transmitter. For this reason, at 25% modulation, for example, it is important that the signal level going into the console produce 25% modulation (setting of the modulation level at the 1-kc reference frequency understood here). If changes in console input level are to be measured as frequency response by means of a vu meter or VTVM, it is almost mandatory that there be some form of **variable** attenuator **following** the meter in the oscillator-to-console setup. This permits the reference level from the oscillator output to be set at zero vu regardless of the modulation percentage range under consideration — otherwise, the db marks on the meter would be meaningless. The console input level is then set by the attenuator following the reference meter.

However, it may be found that with the types of attenuators frequently employed for this purpose — even in units factory-built for the job — that the attenuation steps are too great to allow sufficiently accurate setting of the desired modulation percentage, especially at the high levels of 85 and 100%. In this event, perhaps the second general system — maintaining a constant input level at all frequencies, and measuring the change in modulated output — would in the long run produce the greater accuracy, and a better reflection of equipment operational capability.

In Part 2 of this series, noise and distortion measurements will be discussed, and we will begin an analysis of the techniques employed in troubleshooting a faulty proof-of-performance. ▲

BROADCAST ENGINEERING

Directional Theory

(Continued from page 25)

Phi is the elevation angle of the observation point,

M is I_2/I_1 ,

G is the height of the antenna in degrees.

For the example in Fig. 7, and where the elevation angle equals 0° , the equation reduces to:

$$E = \sqrt{1 + 1 + 2 \cos(90^\circ \cos 0^\circ \cos 180^\circ)} \\ = \sqrt{2 + 2 \cos(90^\circ)} = \sqrt{2} = 1.414$$

This result is the correct ratio of increased field strength in this direction.

An examination of equations 4 and 5 assists in finding the correct tower ratios, phase, and spacing for the desired direction of nulls. Since equations 4 and 5 are for two-tower directional patterns, it is convenient now to consider an equation for a three-tower, in-line antenna system:

$$E = e \sqrt{[I_1 + I_2 \cos(\theta_2 + S_2 \cos \phi) \\ + I_3 \cos(\theta_3 + S_3 \cos \phi)]^2 \\ + [I_2 \sin(\theta_2 + S_2 \cos \phi) \\ + I_3 \sin(\theta_3 + S_3 \cos \phi)]^2} \quad (6)$$

The letter symbols are the same as for the two-tower equation. The subscripts denote values for the tower in question. I_1 is the center tower, and the equation is for the horizontal plane.

As with a two-tower system, the pattern is symmetrical on either side of a line drawn through the three towers. Therefore, only azimuth angles 0° through 180° need be calculated.

The method of finding the non-directional field strength of a tower is as follows: The strength for an individual tower operating alone and at a known power input is measured at one mile. If the correct power is 5 kw, the calculation can be made at 1 kw. Since power varies as the square of the voltage, the 1-kw field strength is multiplied by the square root of five to find the 5-kw field strength.

Equation 6 is correct for finding the pattern shape of a three-tower system having unequal current ratios and/or unequal end tower phases. The center tower phase is



Fig. 6. Diagram of two opposing vectors. zero, since it is the reference tower. If the current ratios and end tower phases are made equal, the equation can be simplified. This is due to the vertical components of the vectors cancelling out:

$$E = e [I_1 + I_2 \cos(\theta_2 + S_2 \cos \phi) \\ + I_3 \cos(\theta_3 + S_3 \cos \phi)] \quad (7)$$

This equation need contain only the horizontal components of the vectors. The I_1 value, of course, lies along the positive reference axis. The components of the formula can be estimated by analysis, placing the null point at the desired azimuth angle.

Null Filling

Equation 7 and null filling can best be demonstrated by an actual example of a directional system. Consider the following example of a three-tower system:

$$I_1 = 1/0^\circ, I_2 = .516/107.6^\circ, I_3 = .516/107.6^\circ, \\ S = 90^\circ, \phi = 50^\circ \text{ or } 310^\circ, e = 438 \text{ mv/m} \\ E = 438 [1 + .516 \cos(107.6^\circ + 90^\circ \cos 50^\circ) \\ + .516 \cos(107.6^\circ + 90^\circ \cos 50^\circ)] \\ = 438 [1 + .516(-.967) + .516(-.967)] \\ = .876 \text{ mv/m}$$

If the center reference tower is now shifted to a phase of 1.25° , a small vector is created which must be added vectorially to the entire pattern around all azimuth angles. By trigonometry it can be shown that this vector for the example is $.001 + J.0218$. By adding this vector to the quantity inside the large brackets in Equation 7, the new null value is found. Thus:

$$438(.002 + .001 + J.0218) \\ = 438(.003 + J.0218) \\ = 438(.022) = 9.64 \text{ mv/m}$$

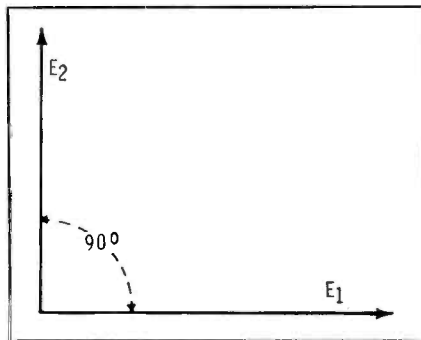

Fig. 7. Vector relationship for 90° angle.

Pattern Size

While Equations 4, 5, 6 and 7 can be used for determining the pattern shape and null points, the actual pattern size is determined by an additional factor. This factor is called "the mutual impedance constant." Antennas may be compared to coupled circuits, whereby the mutual impedance and its phase angle between antennas is a function of the dimension and spacing of the antennas in question. Charts are available for finding these values. This impedance factor K, for a two-tower system, is found by the following formula:

$$K = \sqrt{\frac{R_0}{MR_2 + R_1}} \quad (8)$$

where,

R_0 is the resistance of one antenna,

M is the ratio I_2/I_1 ,

R_1 and R_2 are the new resistances due to mutual impedance:

$$R_1 = R_0 + MZ_m \cos(S + \theta_m)$$

$$R_2 = R_0 + \frac{Z_m}{M} \cos(-S + \theta_m)$$

θ_m and Z_m are the phase angle and resistance component, respectively, of mutual impedance (obtained from charts).

The K factor must be multiplied by e to obtain the true pattern size, in Equations 4 and 5.

For equations 6 and 7, a different formula is used to find K. If the vertical radiation factor is not required, the equation is:

$$K = \sqrt{\frac{I_1^2 + I_2^2 + I_3^2 + 2I_1 I_2 \cos \theta_{1,2} J_0(S) \\ + 2I_1 I_3 \cos \theta_{1,3} J_0(S) \\ + 2I_2 I_3 \cos \theta_{2,3} J_0(S)}{}} \quad (9)$$

where,

J_0 is the Bessel function of tower spacing in electrical degrees,

I values are ratios.

The K factor must be divided into "e" of equations 6 and 7. In the example of three towers, where the 50° null point equaled 9.64 mv/m, the K factor was 1.135; the correction is:

$$E = \frac{438}{1.135} (.022) = 8.5 \text{ mv/m}$$

Several formulas are available for calculating performance; some are quite involved. There are so many variable and interacting factors that engineers should be familiar with system theory. The author hopes this discussion will provide an insight into the operation of an enormously complex piece of apparatus. ▲

NEW PRODUCTS



FM Stereo Broadcast Monitor

H. H. Scott Instrument Div. has introduced the 4310R, stereo successor to the 310DR FM Broadcast Monitor used in Telstar experiments. Designed especially for critical professional applications, the 4310R is a wideband FM multiplex tuner with provisions for diversity reception and automatic selection of mono-stereo performance depending on signal conditions. An overall signal-strength tuning meter and separate VU meters are provided for each channel. IHFM sensitivity of the tuner is 1.9 microvolts, signal to noise ratio is 60 db, and the harmonic distortion is 0.5%. The device employs 27 tubes and solid-state components, is rack mounted, and boasts selectivity of 50 db. Price is \$475; \$510 with 600-ohm output (type 4310RL).

Circle Item 35 on Tech Data Card

Diode Analyzer

A diode analyzer from Seco Electronics, Inc., Minneapolis, combines operating temperature readings with tests for zener diodes, silicon and germanium power diodes, and signal diodes, as well as selenium rectifiers. The model 210T



Zener and Diode Analyzer provides a 0-1-10-30 amp forward voltage test, a 0-150 volt and 0-1500 volt reverse leakage test, a 0-30 volt and 0-300 volt zener saturation knee test, and a -20° to 160° C temperature test. An electronic thermometer in the cover features a thermistor probe in a bridge circuit to provide accurate operating temperature readings of diodes or other components. The probe is insulated against heat transfer and can be held in the hand or fastened to the unit under test. Two 1.5-volt dry cells power the thermometer. The analyzer operates on standard 110-volt 60 cps AC. Price is \$274.95.

Circle Item 36 on Tech Data Card

RF Noise Suppressors

An improved RF noise suppressor offering packaging advantages is available from Relcoil Products Corp., Div. of Hi-G, Inc. The RN series requires no

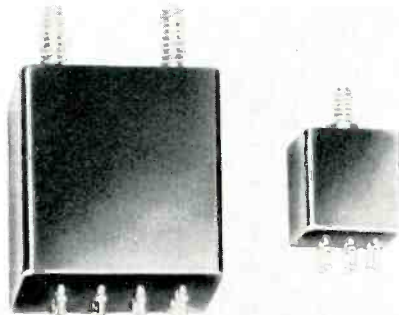

shielding or external connecting wires. The units are designed for use in circuits where inductive loads are switched to eliminate, or limit, the generation of noise at the source. At the same time, the RN provides contact arc suppression. The standard units are to be used with switches from .25 to .5 amps inductive at 28-volts DC with L/R of .025. The temperature range is -65° C to $+125^{\circ}$ C. The overall size is said to be approximately $\frac{1}{2}$ that of other devices meeting similar filtering needs.

Circle Item 37 on Tech Data Card

Dynamic Microphones

Two new microphones, developed for critical professional applications in broadcasting and recording, have been announced by Altec Lansing Corp., subsidiary of Ling-Tempco-Vought, Inc. Designated models 688 and 689, the former is an omnidirectional, the latter a cardioid type; both have moving-coil elements. The omnidirectional microphone (top) is specially suited for precise recording or broadcasting of programs with wide frequency range, since its

pickup pattern covers 360° and its response is from 35 to well over 20,000 cps. The cardioid is engineered with a pickup pattern to provide sound transla-



tion from a discreet frontal area with minimum pickup of background noise. Its frequency response is from 40 to 16,000 cps. Both microphones have selectable output impedances of 30/50, 150/250, and 20,000 ohms; a positive locking mechanism that prevents accidental falling, yet allows instant removal by a performer; and a nonglare green and black enamel finish which permits use before TV cameras. The most significant feature is the mylar polyester "Golden Diaphragm" that exhibits virtually peak-free response across the



sound spectrum. Each microphone is supplied with its own frequency response curve, recorded on a Bruel and Kjar Recorder in one of Altec's anechoic chambers under the most exact test conditions. The microphones are supplied with 15' of 2-conductor (100% shielded) cable and a slip-on swivel adapter that mounts to any standard $\frac{5}{8}$ "-27 stand.

Circle Item 33 on Tech Data Card

Plastic Wire Markers

A self-sticking identification system for electronic wires is available from the W. H. Brady Co., Milwaukee, Wis. The B-400 Reinforced Wire Markers are designed specifically for wires, cables, and harnesses in electronic equipment and assemblies. Made to stick to any insulation, including nylon, plastic, silicone, rubber, glass braid, nylon braid, teflon, and insulation coated with oils, and other preservatives, the markers have adhesion of 40 oz. per inch. They will

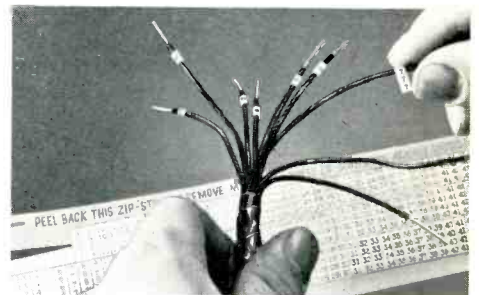

withstand 30 days immersion in No. 10 oil at 65° C with no change in legibility or adhesion. Only $3\frac{1}{2}$ mils in thickness, the markers take minimum space in compact assemblies. Permanent legibility and abrasion resistance are assured by GardKote, a tough, glass-clear coating which protects the printed legend. They

have 6000-volt dielectric strength, excellent resistance to fungus, and can stand 50 hours of ultraviolet exposure with no change.

Circle Item 39 on Tech Data Card



Double Conversion Monitor Receivers

Hammarlund Manufacturing Co. has introduced a line of crystal-controlled, fixed-frequency FM monitor receivers for the 25 to 54 and 144 to 174 mc bands. The double-conversion superhet units are available in narrow-band (± 5 kc deviation) and wide band (± 15 kc deviation) types in single-channel and multi-channel models; the receivers have front panel selection for up to six channels. They can be employed for monitoring public safety, government, and industrial mobile radio communications. Another use is as satellite receivers in mobile radio systems.

Circle Item 40 on Tech Data Card

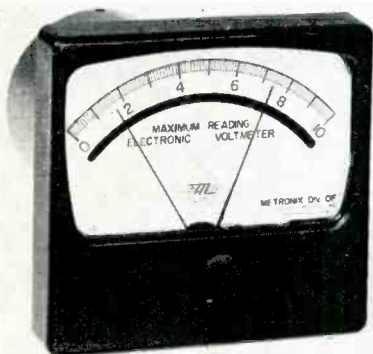

Maximum Reading Voltmeter

A maximum reading electronic voltmeter, capable of "recording" top signal values which may last for only a few microseconds, has been developed by the Metronix Division of Assembly Products, Inc., Chesterland, Ohio. One pointer of the new panel-mounting instrument always remains at the highest level the signal has reached over any desired period of time. The other pointer continuously indicates signal fluctuations below the top figure. Maximum signals are first stored in a condenser. The extremely high input resistance of the instrument (100 megohms or more) permits reading out the condenser without loading. Available in either DC or AC models, the new instrument may be specified with full-scale ranges of 0 to 10 millivolts up to 300-volts AC and 1000-volts DC. Accuracy is ± 2 per cent of full scale deflection. The instrument has a 4 1/2-inch rectangular meter, and a barrel length less than 5 inches; price is \$450.00.

Circle Item 41 on Tech Data Card

May, 1963



Video Distribution Amplifier

A compact solid-state video distribution amplifier is available from Gencom Div., Electra Megadyne, Inc. The device features a self-contained regulated power supply, modular construction, low power consumption, and wide frequency response. All components are mounted in a plug-in chassis, eight of which fit into 3 1/2" of space in a standard 19" rack. Applicable to color or monochrome use, the amplifier has four outputs from one input, and provides a response within 1/2 db to 10 mc. The differential gain at 3.8 mc is less than 1%, differential phase is less than 0.1%, and the gain is adjustable from -1 to +3.2 db. The gain control is on the front panel along with a test point for level checks. The unit provides 36 db isolation between outputs, 1.0 volt p-p video output, and 2.0 volt p-p subcarrier output.

Circle Item 45 on Tech Data Card

QRK PROFESSIONAL TURNTABLES

offer you more...

- QUALITY
- CONTINUOUS PERFORMANCE
- SIMPLICITY

Quality all the way with QRK. Full speed range—33, 45, 78. Built rugged with jewel precision. Plays 45's without adapters. Rocket acceleration - EZ queuing. Single idler maintains constant speed regardless of normal wear.



Priced from \$110. to \$235.

Send for detailed folder!

Western Distributor

RUSSCO Electronics Mfg. 1406 Clovis Ave. — Clovis, Calif.

Phone CY 9-4692

Circle Item 26 on Tech Data Card

Crown
INTERNATIONAL



BX 800
PROFESSIONAL
TAPE RECORDER

The BX800 Series is a maximum-versatility instrument engineered to meet or exceed the highest professional standards. It is available in six models with three tape speeds: 3 3/4, 7 1/2, and 15 ips (1 1/8 and 1 5/8 available). Each model features 3 heads: (1) erasing (2) recording (3) reproducing or monitoring; three motors (one synchronous drive type with 99.8 timing accuracy—two shaded-pole type); 10 1/2 inch reel capacity for 1/4 inch tape; hub adapters for NAB reel hubs; accommodation of 6 types of input; and .06% wow/flutter @ 15 ips with 30 cps—28 KC response ± 2 db, full track. Standard operational features in this series include 3-speed equalization, remote control facility, front panel monitor jock and VU meter, cue control, automatic stop, micro-touch electric control system and extremely fast start/stop time—plus multi-speed performance and frequency response that meet all broadcast and laboratory requirements.

For additional information write: Dept. 20

CROWN INTERNATIONAL, 1718 MISHAWAKA ROAD, ELKHART, INDIANA

SPECIFICATIONS:

Record Reproduce Freq. Response*: 30-28000 cps ± 2 db @ 15 ips; 30-16000 cps ± 2 db @ 7 1/2 ips; 30-8000 cps ± 3 db @ 3 3/4 ips.
Wow Flutter: .06% @ 15 ips, .09% @ 7 1/2 ips, .18% @ 3 3/4 ips.
Signal Noise Ratio*: 60 db @ 15 ips and 7 1/2 ips, 55 db @ 3 3/4 ips.
Start Time: 0.1 second to 15 ips.
Stop Time: .13 second or 2" @ 15 ips.
Rewind Time: 1200 ft. in 38 seconds; 1 min. for 2400 ft. NAB reel.
Stop Time from Full Rewind Speed: 2.9 seconds.
*Specifications for half track, full track, and two track (stereo).

- Patented magnetic braking (never needs adjusting)
- Hardened stainless steel flywheel shaft
- Non-magnetic capstan
- Micro-sync timing
- Individual "Proof of Performance" record (furnished with each specific recorder)
- Performance that exceeds professional standards



Circle Item 25 on Tech Data Card

47



READY ALERT!

HAMMARLUND
Crystal Controlled
monitor
receivers



MR 60X MR 50X

Crystal controlled true split channel FM receivers covering the 25-54 and 147-174 mc ranges. Both models are tuned to any pre-determined channel within their respective frequency ranges. If more than one channel is required, an optional channel selector circuit may be added at the time of purchase—or at any time in the field—permitting up to a six channel option within 1% of a channel frequency. Here is a unit that is tailored to meet the needs of policemen, firemen, civil defense, and all others involved with emergency and business services.

FEATURES

- TRUE SPLIT-CHANNEL PERFORMANCE
- HIGH FREQUENCY CRYSTAL FILTERING
- MULTI-CHANNEL OPERATION (OPTIONAL)
- HIGH SENSITIVITY (FRACTIONAL MICROVOLT)
- SELF CONTAINED—INCLUDING ANTENNA
- PROVISION FOR EXTERNAL ANTENNA
- OPTIONAL SELECTIVE CALL SYSTEM

only \$199⁵⁰

MR 61X MR 51X

Similar to above units—identical frequency ranges, sensitivity and options. Does not employ crystal lattice filter. only \$149.95

HAMMARLUND
 MANUFACTURING COMPANY, INC.
 A Giannini Scientific Company
 63 West 23rd Street, New York 10, N. Y.

A-5 Please send me detailed information.

Name _____

Company _____

Address _____

.....

Circle Item 27 on Tech Data Card

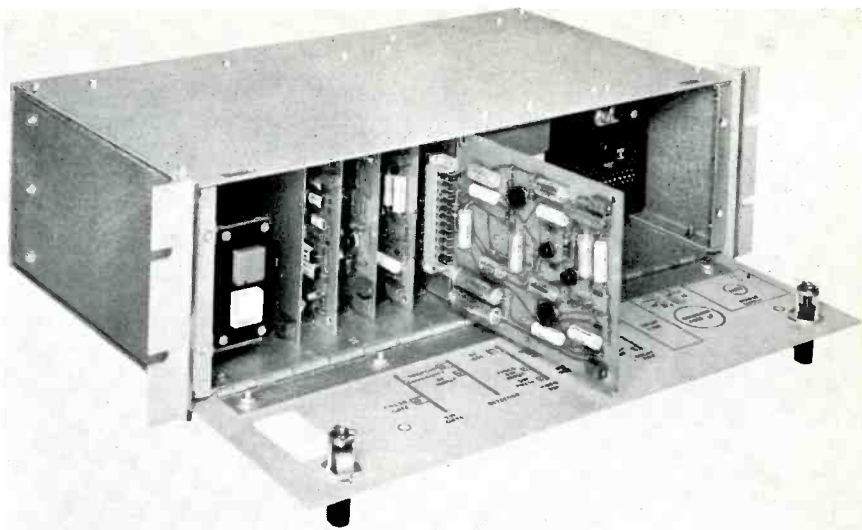

Video Tape Dropout Device

Signal dropouts in video tape playback are restored by a television tape accessory called the Dropout Compensator, from **Mincom Div., 3M Co.** Dropouts caused by dirt or balling effect of the oxide coating (which interferes with the head-to-tape contact and appears on the screen as random white flashes) are replaced with information similar to that lost, by substituting the same portion of the previous line which has been stored in a 63.5-microsecond delay channel. Dropouts detected in the RF actuate a high-speed solid-state switch, controlling placement of the stored material on the video output. Contrast ratios between the original and the restored are carefully maintained. The compact (5¼" by 19" by 11") device weighs 17½ pounds and is finished in gray or brown. Constructed with plug-in printed circuit boards, it has a maximum operating temperature of 50° C and consumes 16 watts at 120-volts 60 cps. Other specs of the device are: frequency response, ± 1 db to 8 mc; RF loop level, 0.5 to 1.75 volts p-p; unity gain; 75-ohms impedance; differential phase 2½° max.; differential gain, 2% max.

Circle Item 42 on Tech Data Card

Vidicon Camera Chain

GPL Div., General Precision, Inc., has introduced a low-cost vidicon television camera system for broadcast requirements. Designated the Precision 800 Viewfinder, it employs modular design enabling additional cameras or control units to be added once a basic system is operating. For remote operation, the camera portion can be separated from the camera control unit up to 1000'; no extra equipment or special cable is required. A manual operated four-lens turret accepts standard or zoom-type C-mount lenses; with the latter, focal length and optical focus are controllable from the rear of the camera. The con-



trol panel, located below the 8" viewfinder, contains viewfinder brightness and contrast controls, plus beam, target, and electrical focus controls. A local-remote switch transfers control functions to the camera (for one-man operation) or to the CCU. The 800 camera control unit furnishes control voltages, deflection signals, focusing current, intercom, and cable which also feeds the video signal from the camera to the CCU. Also located on the CCU are beam, target, focus, blanking, and gain con-

trols, as well as a automatic-manual switch, magnifier, setup meter, power-on indicator, and a sweep loss light. Special circuits protect the vidicon against loss of horizontal or vertical sweep. The system price is less than \$5,000.

Circle Item 43 on Tech Data Card

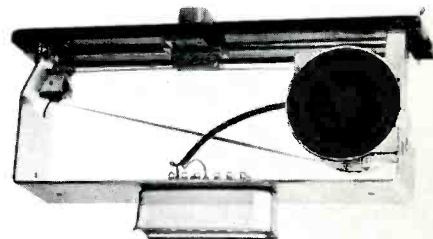

Linear Attenuator

Straight-line mixers with silicone encapsulated contact paths are available from **Gotham Audio Corp., New York City.** The mixers are manufactured with one, two, three or four elements, which are hermetically sealed and require no servicing or cleaning. There are 56 steps in the 53/4" overall travel; the upper 60% is considered the operating range. In this portion the attenuation is 0.5 db per step, with the taper increasing over the balance of the travel to provide 85 db of attenuation before infinity. Built in any standard configuration, the faders employ plug-in construction and all are approximately the same size. The one- (shown) and two-element faders require 2 11/16" behind the panel; the three and four require 4¼".

Circle Item 44 on Tech Data Card

ENGINEERS' TECH DATA SECTION

AUDIO & RECORDING EQUIPMENT

46. AMPEX CORP. — Three brochures on: the VR-1500 Videotape recorder, Editec time element control system, and the VR-1100 Videotape recorder; and a catalog on video tape products are available.
47. BROADCAST ELECTRONICS, INC.—Spec sheets present details of cartridge record/playback units, cartridge winders, sequencing equipment, cartridge racks, and other cartridge tape devices.
48. BURGESS BATTERY CO.—Technical bulletins and illustrated brochures cover full line of magnetic recording tape.
49. CROWN INTERNATIONAL—Brochure describes BX800 series of tape recorder/reproducers, 1400 series recorders, automatic tape players, and the M4S tape duplicator.
50. FAIRCHILD RECORDING EQUIPMENT CO. — Brochure introduces a new dynamic equalizer, model 673.
51. RCA VICTOR RECORD DIV. — Brochure lists properties of company's magnetic recording tape.
52. REEVES SOUNDCRAFT CORP. — Product spec sheets present complete information on low-print mastering tape, high-output mastering tape, duplicating tape, and Unilube cartridge tape.
53. SHURE BROTHERS, INC.—Technical data folder is available on microphone and phono products for broadcast and recording studios and control rooms.

54. SPARTA ELECTRONIC CORP. — Portable cartridge tape playback unit is described in bulletin.
55. TURNER CO. — Spec sheet describes model 500 dynamic cardioid microphone designed for broadcasting and recording.

COMPONENTS & MATERIALS

56. AEROVOX CORP. — Recently-released bulletin is devoted to sub-miniature thin-plate capacitors, and gives specs thereof.
57. BELDEN MFG. CO. — 1963 catalog lists line of electronic wires and cables.
59. INTERNATIONAL ELECTRONIC RESEARCH CORP. — Short form illustrated catalog lists more than 200 types of heat dissipating tube shields and over 100 semi-conductor heat dissipators.
60. SPRAGUE PRODUCTS CO. — Latest catalog presents wide line of capacitors, resistors, transistors, instruments, and many other items, in 70 pages.

RADIO & CONTROL ROOM EQUIPMENT

61. CBS LABORATORIES — Illustrated technical bulletin describes Audimax II RZ, automatic level control for broadcasting and recording.
62. COLLINS RADIO CO. — Catalog sheets cover FM stereo modulation monitor and stereo limiting amplifier.
63. SOUNDSCRIBER CORP. — Automatic audio logging tape recorder, which makes use of 3½" reels of 2" tape to record 24 hours per reel at 2½"

per second, is fully described in illustrated brochure.

STUDIO & CAMERA EQUIPMENT

64. TELEVISION ZOOMAR—Tech sheets describe Angenieux — Zoomar lens 10-2-1, available with or without servo remote control.
65. WALLACH & ASSOCIATES, INC. — Late bulletin lists cabinets for storage of discs, tapes, films, projectors, and other audio-visual items.

TELEVISION EQUIPMENT

66. AMPEX CORP. — A fifteen-page booklet surveys the applications of television tape recording in education.
67. CONRAC—Bulletin illustrates and describes 17" color monitor which employs 21 tubes and 95 transistors, weighs 83 lbs., and requires 21" of rack space.
68. SARKIS TARZIAN, INC. — Offered are: solid-state TV equipment catalog, microwave systems engineering booklet, vertical interval switcher brochure, and random access slide projector bulletin.
69. TELEMET CO. — Catalog of complete line of video equipment including monitors, distribution amplifiers, transmission test sets, and other devices.

TEST EQUIPMENT & INSTRUMENTS

70. EICO ELECTRONIC INSTRUMENT CO.—The 902 intermodulation/harmonic distortion meter and AV vtvm is presented in catalog sheet.
71. HICKOK — Bulletins describe FM stereo generator, tube testers, and electronic volt-ohmmeter.

LOG FCC REQUIRED TRANSMITTER READINGS FOR ONLY

\$3.00 A MONTH!

Buy a Bauer "Log Alarm"! The Bauer "Log Alarm" logs all required parameters — Transmitter Frequency, Power, Plate Voltage, Plate Current and Tower Lights for only \$3.00 a month (operating cost). Parameters are logged continuously and readings correlated automatically because they are printed on a single, pressure sensitive, chart. Readings are made once a minute and system checks calibration every 26 minutes. Visual and audible alarms indicate out-of-tolerance conditions. Compact—only 10½" of rack space. Reload chart paper only twice a month—daily readings may be torn off for filing in a convenient log book. You can start saving money right now! Send for complete details today!

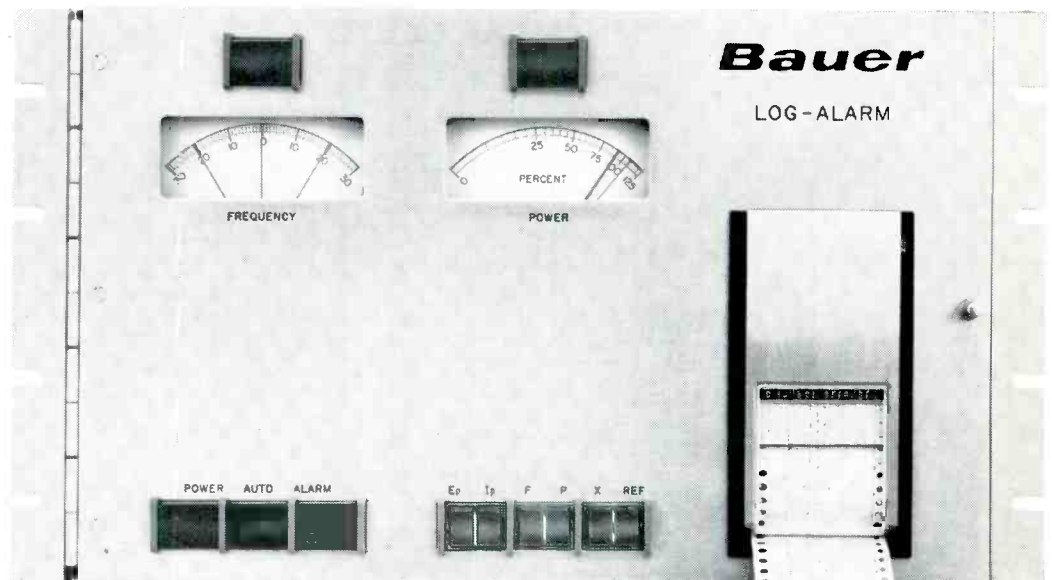

Bauer
ELECTRONICS CORPORATION
1663 Industrial Road, San Carlos, California
Area Code 415 591-9466

Circle Item 28 on Tech Data Card

Professional Services

VIR N. JAMES
 CONSULTING RADIO ENGINEERS
 Applications and Field Engineering
 232 S. Jasmine
 Phone: (Area Code 303) 333-5562
DENVER 22, COLORADO
 Member AFCCE

- SYNCHRONOUS MAGNETIC FILM RECORDER/REPRODUCER
- MAGNETIC TAPE RECORDERS
- NEW—THE portable MINITAPE synchronous 13 lb., battery operated magnetic tape recorder for field recording.

THE STANCIL-HOFFMAN CORP.
 845 N. Highland, Hollywood 38, Calif.
 Dept. B HO 4-7461

JOHN H. BATTISON & ASSOCIATES
 CONSULTING RADIO ENGINEERS
 TV-AM-FM & Microwave Applications and Installations
 Specializing in all forms of communications engineering.
 422 Washington Bldg. Washington 5, D. C.
 Phone ST 3-3484
 Established 1954

Classified

Advertising rates in the Classified Section are ten cents per word. Minimum charge is \$2.00. Blind box number is 50 cents extra. Check or money order must be enclosed with ad.

The classified columns are not open to the advertising of any broadcast equipment or supplies regularly produced by

manufacturers unless the equipment is used and no longer owned by the manufacturer. Display advertising must be purchased in such cases.

EQUIPMENT FOR SALE

Commercial Crystals and new or replacement crystals for RCA Gates, W. E., Bliley and J-K holders; regrinding, repair, etc. BC-604 crystals. Also A. M. monitor service. Nationwide unsolicited testimonials praise our products and fast service. Eidson Electronic Company, Box 96, Temple, Texas. 9-61 tf

USED TV EQUIPMENT FOR SALE—Specialists in RCA Types. Many bargains in stock. TK-30's, TK-11's, Power Supplies, Monitors, etc. Our exclusive refurbishing process Guarantees Satisfaction. Write, Wire or call for prices.
TELEQUIP CORPORATION, 319 East 48th St., New York 17, N. Y., PLaza 2-8885—PLaza 2-9037. 2-63-6t

GOVERNMENT SURPLUS, NEW 10 CM. WEATHER RADAR SYSTEM—Raytheon, 275 KW peak output S band. Rotating yoke P.P.I. Weather Band 4, 20 and 80 mi. range. Price \$975 complete. Has picked up clouds at 50 mi. Wt. 488 lbs. Radio Research Inst. Co., 550 5th Ave., New York, New York. 1-63 6t

Transmission line, styroflex, heliax, rigid with hardware and fittings. New at surplus prices. Write for stock list. Sierra Western Electric Cable Co., 1401 Middle Harbor Road, Oakland 20, California. 6-61 tf

Ampex Head Assemblies for 300 and 400 series recorders reconditioned. Service includes lapping and polishing all three head stacks, cleaning entire assembly, readjusting and replacement of guides, and realignment of stacks as to azimuth and zenith. Full track assemblies—\$60.00. Taber Manufacturing & Engineering Co., 2619 Lincoln Ave., Alameda, California. 5-63 2t

TRANSMITTING TUBES FOR SALE—3X2500F3 — \$175, 4W20000A — \$1815, 450TL — \$25, 4-125A — \$22.50, 872A — \$5.25, 575A—\$15.50. Many Others. Brand New. 1,000 hour warranty. Write or call Calvert Electronics, Inc., Dept. BE-5, 220 E. 23rd St., New York 10, N. Y., (212) OR 9-1340.

WE BUY USED TV AND RADIO EQUIPMENT. LET US KNOW WHAT YOU HAVE TO DISPOSE OF. WRITE TELEQUIP CORPORATION, 319 East 48th St., New York 17, N. Y. 2-63-6t

Film cameras, slide projectors, monitors, power supplies, scopes, switchers, transmitter input equipment, color sync generator, and many other items. Call or write, R. Truscott, WITI-TV, Milwaukee, Wisconsin. 5-63-2T

Advertisers' Index

Ampex Corp.	10-11
Automatic Tape Control, Inc.	3
Bauer Electronics Corp.	49
Belden Manufacturing Co.	9
Broadcast Electronics, Inc.	41, 42
CBS Laboratories	15
CO.EL.	33
Crown International	47
EICO Electronic Instrument Co., Inc.	38
Electronics Missiles & Communications, Inc.	39
Electro-Voice, Inc.	13
Gotham Audio Corp.	42
Hammarlund Mfg. Co.	48
Houston Fearless Corp.	32
IERC Div., International Electronics Research Corp.	40
Jampro Antenna Co.	50
Jerold Electronics	35
McMartin Industries, Inc.	51
Milo Electronics Corp.	44
Minnesota Mining & Manufacturing Co.	12
Moseley Associates	50
Raytheon Equipment Div.	37
Raytheon Distributor Products Div.	6-7
RCA Broadcast and Television Equipment	C4
RCA Victor Record Div.	31
Russco Electronics Mfg.	47
Sarkes-Tarzian Broadcast Equipment Div.	8, 29
Seco Electronics, Inc.	3
Sparta Electronics Corp.	43
Superscope, Inc.	5
Television Zoomar	2
Visual Electronics Corp.	14

You Saw Them at NAB

FM Stereo Generator ★ Studio Transmitter Link
 FM Main Channel Exciter ★ Radio or Wire Remote Control
 SCA Sub-Carrier Generator ★ **NOW** Write or Phone for Details

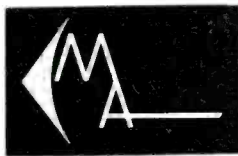

MOSELEY ASSOCIATES, INC.

P. O. Box 3192 4416 Hollister Ave.
 Telephone 967-1469

SANTA BARBARA, CALIFORNIA

Circle Item 29 on Tech Data Card

NEW FM ANTENNAS WITH DIGITAL TUNING*

JAMPRO now offers its wideband FM antennas with digital tuning.* Vee element end caps may be field tuned for extremely low VSWR—so necessary for finest stereo. Check literature card for details.

JAMPRO ANTENNA CO.

7500 - 14th Avenue
 Sacramento 20, California

Circle Item 30 on Tech Data Card

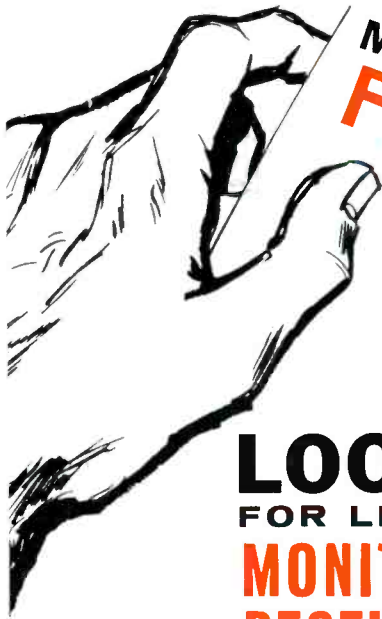

Memo To:
FM: *Station Managers*
Station Owners
Chief Engineers



LOOK TO
FOR LEADERSHIP IN
MONITORS, MULTIPLEX AND RELAY
RECEIVERS AND AUDIO

By outstanding performance, dependability and economy, McMartin built FM multiplex and audio products have earned a reputation for leadership. McMartin experience and engineering are continually at work developing new products and improving present ones to be of greater service to the industry.



TBM-4000
McMartin
FM/SCA
MULTIPLEX
MONITOR

The most versatile instrument of its kind for monitoring all main channel modulation and SCA Multiplex operating characteristics. The only Monitor which directly reads crosstalk.



TBM-3000 and TBM-3500



TBM-3000 is a completely self-contained frequency monitor, and the TBM-3500 a self-contained modulation monitor. The 3000 used in conjunction with either the 3500 or 4000 fulfills the FCC requirements for station monitors.



MULTIPLEX
RECEIVERS

Proven performance and reliability . . .
 More than 9,000 in use throughout the world.



McMartin
TBM-1000/2000
FM/SCA Multiplex
Re-Broadcast Receivers

Ideal for area network relays . . . defense networks and off-air monitoring.



8 & 32 watt
TRANSISTOR AMPLIFIERS
LT 80A & LT 300

McMartin is the world's largest producer of amplifiers for the commercial background music industry.



originality by
McMartin Industries, Inc.
 605 North 13th Street Omaha, Nebraska
 Code 402 — 342-2753
 In Canada Sold By: Canadian Marconi Company, Montreal 16, P. Q.

Circle Item 31 on Tech Data Card



The Mark of the Newest in TV Tape Recorders

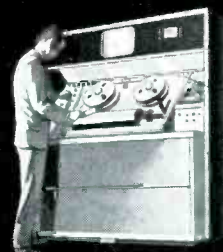

In the TR-22, RCA presents a "New Generation" of TV Tape Recorders... fully transistorized! It gives you new ease of operation, new space-saving economy and new reliability. The TR-22's are already in operation in the USA, Canada, and Europe... assuring superior picture quality.



The Most Trusted Name
in Television

