



**RECORDING/REPRODUCTION ISSUE**

**audio — video**

All features devoted to the various phases of audio and video recording/reproduction, including studio operational equipment.

- Television Tape Techniques Today 20
- Variable Wind for the TR-11 26
- A Low Cost Tape Delay System 34
- Updating Audio Reproducing Equipment 36
- A Circular Broadcast Console Desk 42

# Broadcast Engineering

*the technical journal of the broadcast-communications industry*

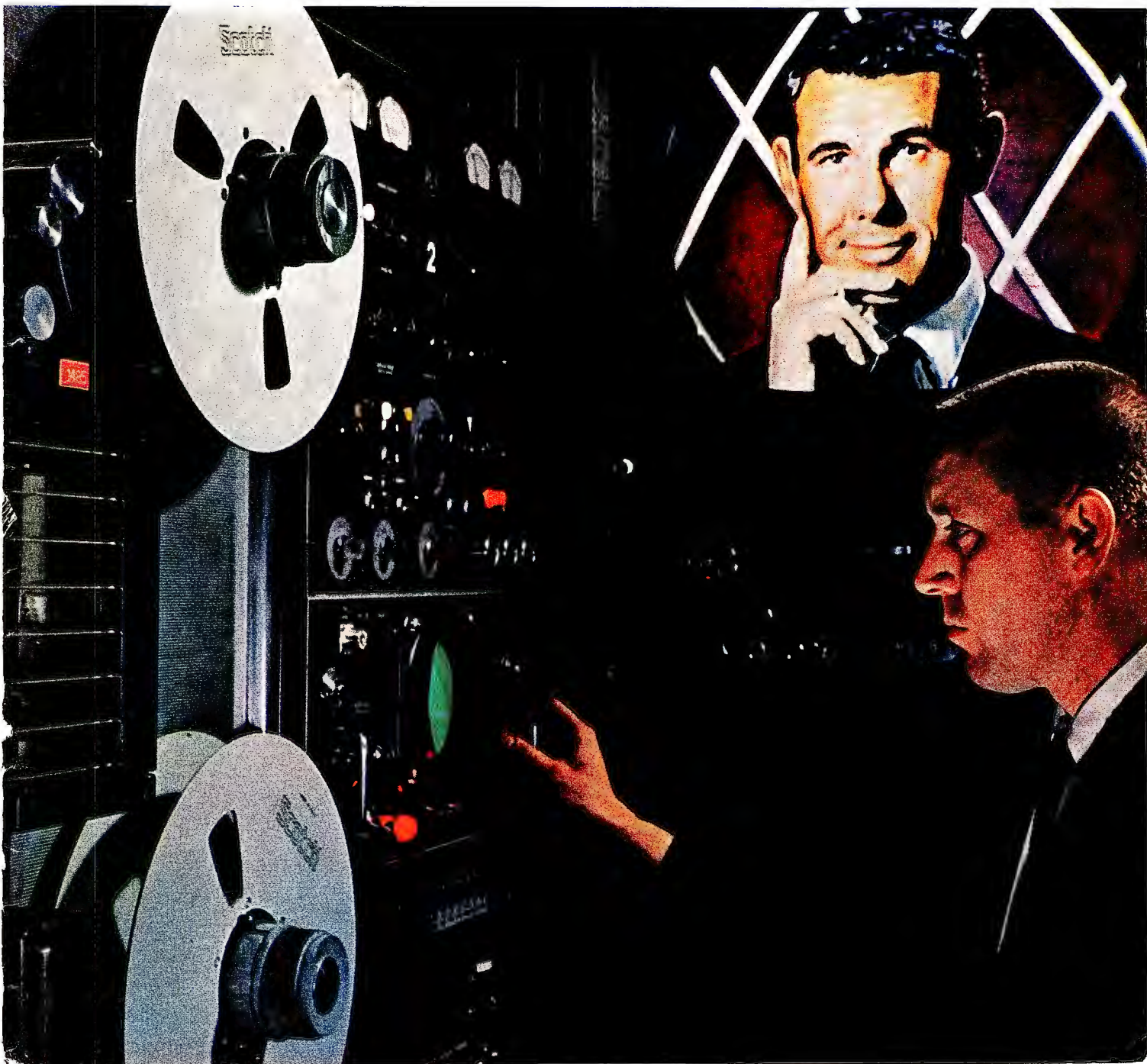

**YOU**

*special key*



SECRETARY

typewriter

# PROLOG\*

AUTOMATIC PROGRAMMING

AUTOMATIC LOGGING

AUTOMATIC AUTHENTICATING

with an easily operated, simply controlled system. Assemble any program element from any one of 300 sources, and mix it into a tightly integrated and professional on-the-air format. Free your top talent to produce better newscasts, special features and commercials. Do it so smoothly your most avid listener won't suspect a thing . . . except that you sound better than ever before. A single button gives complete and instant manual control of PRO-LOG.\*

*sounds interesting . . . please send me more information on Continental Electronics' PRO-LOG.\**

NAME _____	
TITLE _____	CALL LETTERS _____
ADDRESS _____	
CITY _____	
STATE _____	



**Continental Electronics**

BOX 5024 • DALLAS, TEXAS 75222 • AD 5-1251

LTV Subsidiary of Ling-Temco-Vought, Inc.

©1963 Continental Electronics

\*registered trademark pending

Circle Item 1 on Tech Data Card



# Crown

— first choice  
of those who  
demand the best!

## NEW

# Solid State

CONTROL CENTER  
FOR SERIES 800, 1000  
AND 1400 MODELS

### DOUBLES former performance

Quarter-Track Record/Play Data

ips	db	cps	s/n
7-1/2	±2	50 — 30,000	56db
3-3/4	±2	30 — 20,000	52db
1-7/8	±3	30 — 16,000	50db
15/16	±3	30 — 10,000	48db

The most complete recording instruments ever designed for stereo use. Audio circuitry, ±1/4 db from 10-100,000 cps; extended range, 5-500,000 cps. Plug-in circuit modules are printed on epoxy and gold plated. Engineered to space craft reliability.



THE HALLMARK  
OF CROWN—  
SUPERLATIVE  
CRAFTSMANSHIP  
THROUGHOUT!

INDIVIDUAL PERFORMANCE  
RECORD SUPPLIED  
WITH EACH CROWN

WRITE DEPT. BE-10



Crown  
INTERNATIONAL  
1718 Mishawaka Rd. • Elkhart, Ind.

Circle Item 2 on Tech Data Card

the technical journal of the broadcast-communications industry



# Broadcast Engineering

Volume 5, No. 11

November, 1963

## CONTENTS

### FEATURES

- Audio Level Devices . . . . . 14**  
by Thomas R. Haskett — Part Four. The conclusion of a series on equipment for controlling audio signals.
- Transistor Amplifier Servicing Techniques . . . . . 18**  
by Harry A. Etkin — Methods for checking transistors and troubleshooting semiconductor circuits.
- Television Tape Techniques Today . . . . . 20**  
by Joseph Roizen — A survey of equipment and systems currently in use for the magnetic recording of video.
- Variable Wind for the TR-11 . . . . . 26**  
by Frank Faniola — Adding a speed control for fast forward and rewind to a popular television recorder.
- A Low Cost Tape Delay System . . . . . 34**  
by Richard A. Silverberg — Design and construction of a unit for delaying telephone conversations.
- Updating Audio Reproducing Equipment . . . . . 36**  
Technical Talks — Evaluating and improving the performance of studio tape and disc equipment.
- A Circular Broadcast Console Desk . . . . . 42**  
by George A. Dodge. Here's a unique unit built to house the audio equipment in an FM Stereo studio.
- Transcribing Off-Air With Dictating Equipment . . . . . 42**  
by Dick F. Engh — How one station uses existing equipment in both office and program logging applications.

### DEPARTMENTS

- Letters to the Editor . . . . . 6
- Engineers' Exchange . . . . . 40
- News of the Industry . . . . . 50
- New Products . . . . . 52
- Engineers' Tech Data . . . . . 56
- Advertisers' Index . . . . . 58
- Classified Ads . . . . . 58
- Professional Services . . . . . 58

**PUBLISHER:** Howard W. Sams

**GENERAL MANAGER:** Mal Parks, Jr.

**EDITORIAL:** Exec. Editor, Verne M. Ray; Editor, Forest H. Belt; Managing Editor, Stuart N. Soll; Consulting Editor, John H. Battison.

**CIRCULATION:** Manager, J. A. Vitt; Fulfillment: Manager, Pat Tidd; Assistants, Katherine Krise and Cora LaVon Willard.

**PRODUCTION:** Manager, Robert N. Rippey.

**ADVERTISING:** Sales Manager, Dave L. Milling; EAST: Charles Horner, Howard W. Sams & Co., Inc., 3 West 57th Street, New York, N. Y., Phone—MU 8-6350; MIDWEST—Hugh Wallace, Howard W. Sams & Co., Inc., 4300 West 62nd Street, Indianapolis 6, Ind., Phone AX 1-3100; SOUTHWEST—C. H. Stockwell Co., 4916 West 64th Street, Mission, Kansas, Phone—RA 2-4417; LOS ANGELES 57, CALIF., Maurice A. Kimball Co., Inc., 2550 Beverly Blvd., Phone—DU-8-6178; SAN FRANCISCO, Maurice A. Kimball Co., Inc., 580 Market Street, Phone—EX 2-3365; PARIS 5, FRANCE, John Ashcraft, 9 Rue Lagrange, Phone—Odeon 20-87; LONDON W.C. 2, ENGLAND, John Ashcraft, 12 Bear Street, Leicester Square, Phone—Whitehall 0525; TOKYO, JAPAN, International Media Representatives, Ltd., Kisha Kurabu 14, 2-chome Marunouchi, Phone—(502) 0656.

**SUBSCRIPTION PRICE:** U.S. \$6.00, one year; \$10.00, two years; \$13.00, three years. Outside U.S.A. add \$1.00 per year for postage. Single copies, 75 cents, Back issues, \$1.00.

**BROADCAST ENGINEERING** is published monthly by Technical Publications, Inc., an affiliate of Howard W. Sams & Company, Inc. Editorial, Circulation, and Advertising headquarters: 4300 West 62nd Street, Indianapolis 6, Ind. Copyright © 1963 by Howard W. Sams & Co., Inc.



A HOWARD W. SAMS PUBLICATION



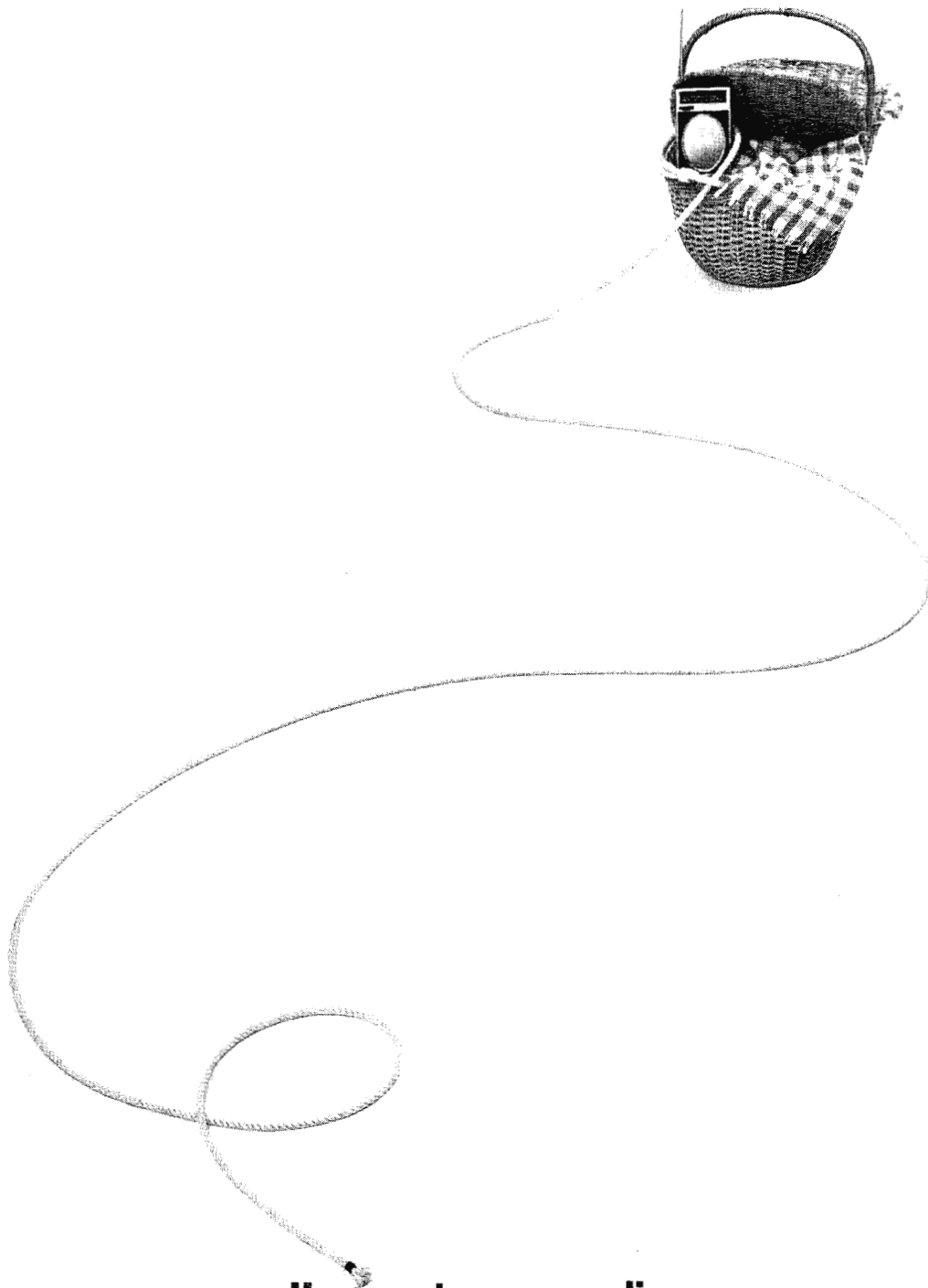

## Hang onto your audience

—even when it's in fringe areas with those tiny transistor sets or in autos. Use the AUDIMAX® automatic level control! It's your route to as much as quadrupling your effective marketing area without increasing station power a single watt! Here's how: the exclusive gain platform principle of the AUDIMAX insists on maximum modulation... a clear, natural signal, even in fringe areas, with no distortion. The AUDIMAX logic and memory circuits discriminate between momentary and general changes in signal, to maintain gain at just the right level regardless of input. □ Yes, the AUDIMAX acts almost like another station engineer. The AUDIMAX thinks for itself! For details, call collect or write Professional Products, CBS Laboratories, a division of Columbia Broadcasting System, Inc., High Ridge Road, Stamford, Conn.

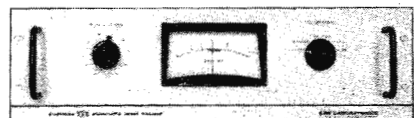

**CBS LABORATORIES**

Circle Item 3 on Tech Data Card

# NOW! A RUGGEDIZED 4-400A!

Tired of interelectrode shorts and weak plate seals? Then investigate the new Penta PL-6775 power tetrode! Because of an exclusive Penta filament-supporting insulator, the PL-6775, unilaterally interchangeable with the 4-400A, can be mounted in any position and will withstand extremes in shock and vibration, without developing interelectrode shorts. The rugged and reliable PL-6775 has a one-piece plate cap and seal that won't easily break off, can't fall off. Even distribution of anode heat is assured by the exclusive Penta ribbed plate. Ratings of the ruggedized PL-

6775 are the same as those for the 4-400A, in all classes of service. A single tube will deliver up to 1100 watts of plate power output as a Class-C CW or FM amplifier. Two tubes in Class-AB<sub>1</sub> operation will provide up to 1550 watts of plate power output.

Write today for your free, factual Penta PL-6775 power tetrode data sheet.

## PENTA LABORATORIES, INC.

312 North Nopal Street,  
Santa Barbara, California  
Trade Mark Reg. U. S. Pat. Off.

Export Agents:  
Frazar & Hansen, Ltd., San Francisco 11, Calif.



# PL-6775



Circle Item 4 on Tech Data Card

## LETTERS to the editor

DEAR EDITOR:

In the June 1963 "Engineers' Exchange" department, there appears an article entitled Remote Amplifier, by Mr. Philip Whitney. I would like information concerning the type and voltage of the battery used to power this amplifier. Also, I wish to know the number and model of the coupling transformer between the last two transistors and the line.

In addition, can you tell me if a low impedance microphone can be used with this amplifier?

JOSE MARQUEZ

XETV, Tijuana, BC, Mexico.

The supply voltage is nine volts. While the author used an RCA VS-300, an equivalent or any other small nine-volt battery will work. The transformer is a UTC 0-20; a low impedance microphone can be used.—Ed.

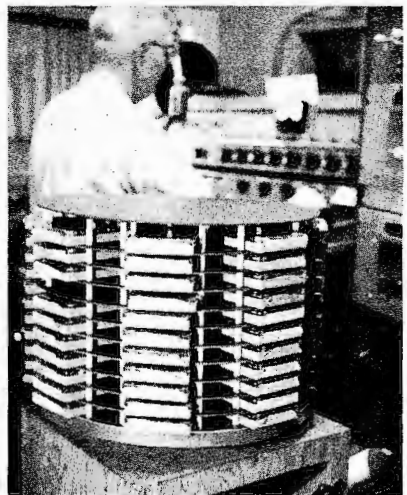

DEAR EDITOR:

We built the rotating tape cartridge rack described in the August issue of BROADCAST ENGINEERING; it adds a touch of efficiency and decor to our control room. For the rotating bearing we used an old phonograph turntable, sans motor. Another possibility is a "lazy susan" bearing, available at some hobby shops and hardware stores.

Ronald Pesha  
Chief Engineer, KWSK, Pratt, Kansas

As evidenced by the accompanying photo, you seem to have done a good job. Readers, take note of Ron's ideas on the bearing—Ed.

DEAR EDITOR:

While reading my article "FM Stereo Proof-of-Performance Measurements," published in the August issue of BROADCAST ENGINEERING, I discovered an omission in the caption of Fig. 8, on page 38. After the words "right channel," the sentence should conclude, "... for 3d."

Harry A. Etkin  
Staff Engineer, WQAL-FM,  
Philadelphia, Penn.

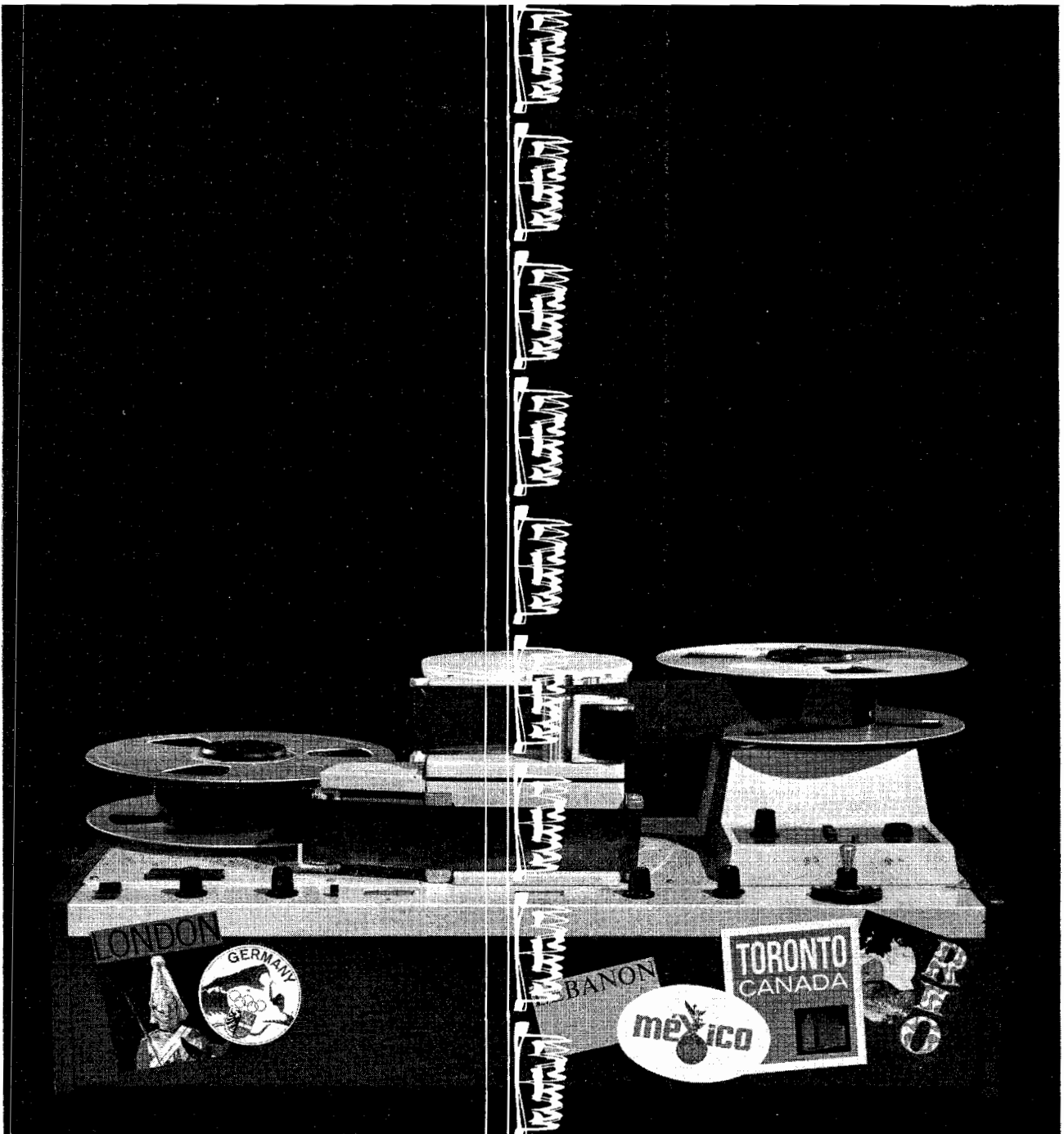

What portable VTR kicked around the world a year and came back as good as new? The AMPEX

A test model never has a moment's peace. This one—the forerunner of our VR-660—was bumped, bounced, dropped and banged on four continents. By experts. But when it came back there was only one thing we had to do to get perfect performance: plug it in. And there's good reason for that. The backbone of the Ampex VR-660 is a single, unit-designed casting at the center of the machine. Every assembly that has anything to do with tape movement or position is mounted to it (so all critical tolerances can be referenced to a common surface). This top plate is all important,

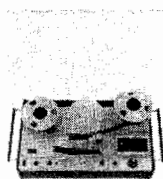

Circle Item 7 on Tech Data Card

that's why we make it out of the most rigid, rugged cast aluminum available. Without that strength in the center, the VR-660 would be just another portable. With it, it's the most rugged little VTR that ever joined a mobile unit. Weight? 96 lbs. Price? just \$14,500. For complete information call your Ampex representative. Or write the only company providing recorders, tape and core memory devices for every application—as well as Marconi television cameras and accessories: Ampex Corporation, 401 Broadway, Redwood City, Calif. Term leasing and financing available.



the  
star  
your audience  
never

sees . . . but you know the importance of the camera-man to the success of any show . . . and the importance of the camera mount to his dexterity and skillful performance. That's why the vast majority of stations choose Houston Fearless equipment. □ A wide range of accessories, from camera heads and tripod/dollies to motor-driven pedestals, provide complete camera maneuverability. Whether you operate a small station or produce big network shows, there's a Houston Fearless model to meet your particular requirements. Circle number below now for catalog.

WESTWOOD DIVISION  HOUSTON FEARLESS CORPORATION

11801 West Olympic Blvd., Los Angeles 64, California  
Circle Item 6 on Tech Data Card

It seems that a correction was overlooked, Harry; thanks for advising us.—Ed.

DEAR EDITOR:

Recently, the management of CHWO Radio deemed desirable the operation of our station on a 24-hour basis. The preference was to do so without the attention of an operator. However, they did concede that prepared programs, if undated, could be repeated occasionally.

We have come up with a simple, foolproof, yet inexpensive means of accomplishing the 24-hour schedule technically, and feel that a description may be of interest to readers.

Our three Ampex 351 tape machines are operated sequentially, from number 1 through 3, to avoid involvement in start-and-stop functions. Tapes were prepared on ten-inch Fiberglas reels, employing the .5-mil Mylar type to obtain two hours of total playing time per machine. The tapes were timed with a stop watch and cut to lengths of exactly two hours. Next, the end of the first five-minute segment of each was marked with about 12 inches of leader.

The machines were modified with the addition of a second miniature switch, mounted behind that already present on the take-up tension arm shaft. This switch, which has n/o contacts, was wired in series with a switch on the console and the remote start facilities of the next machine. Thus as soon as the end of the tape drops from the supply reel of the first machine the second will start (if the switch console is closed). This process could continue until the last remote input (or last tape transport) was passed.

The tapes are prepared by a staff announcer at his leisure. He records exactly one hour and fifty-five minutes of program on the tape, starting immediately following the leader and stopping just before the tape drops from the supply reel.

The night man, just before leaving the station at midnight, completes the tape by recording a newscast and commercial (if required) on the first five minutes. It is essential to use a stopwatch to prevent the possible erasure of the program material. The same recording may be used many times, by replacing the newscast and commercial before each playing.

When the morning operator arrives to begin his shift, he simply opens the console switch, completely disabling the automatic functions.

This system must, understandably, be approved by the FCC—or in our case, the D.O.T.—and must be combined with a failure alarm. It is advisable to incorporate a building-entry and control room fire alarm. We intend, after D.O.T. approval, to terminate our alarm system in the offices of the local telephone answering service.

A. K. Weitzel  
Director of Technical Operations,  
CHWO Radio, Ltd., Oakville,  
Ontario, Canada.

An interesting system indeed, Mr. Weitzel; we hope you will advise us of your progress. How about it readers, any comments or suggestions?



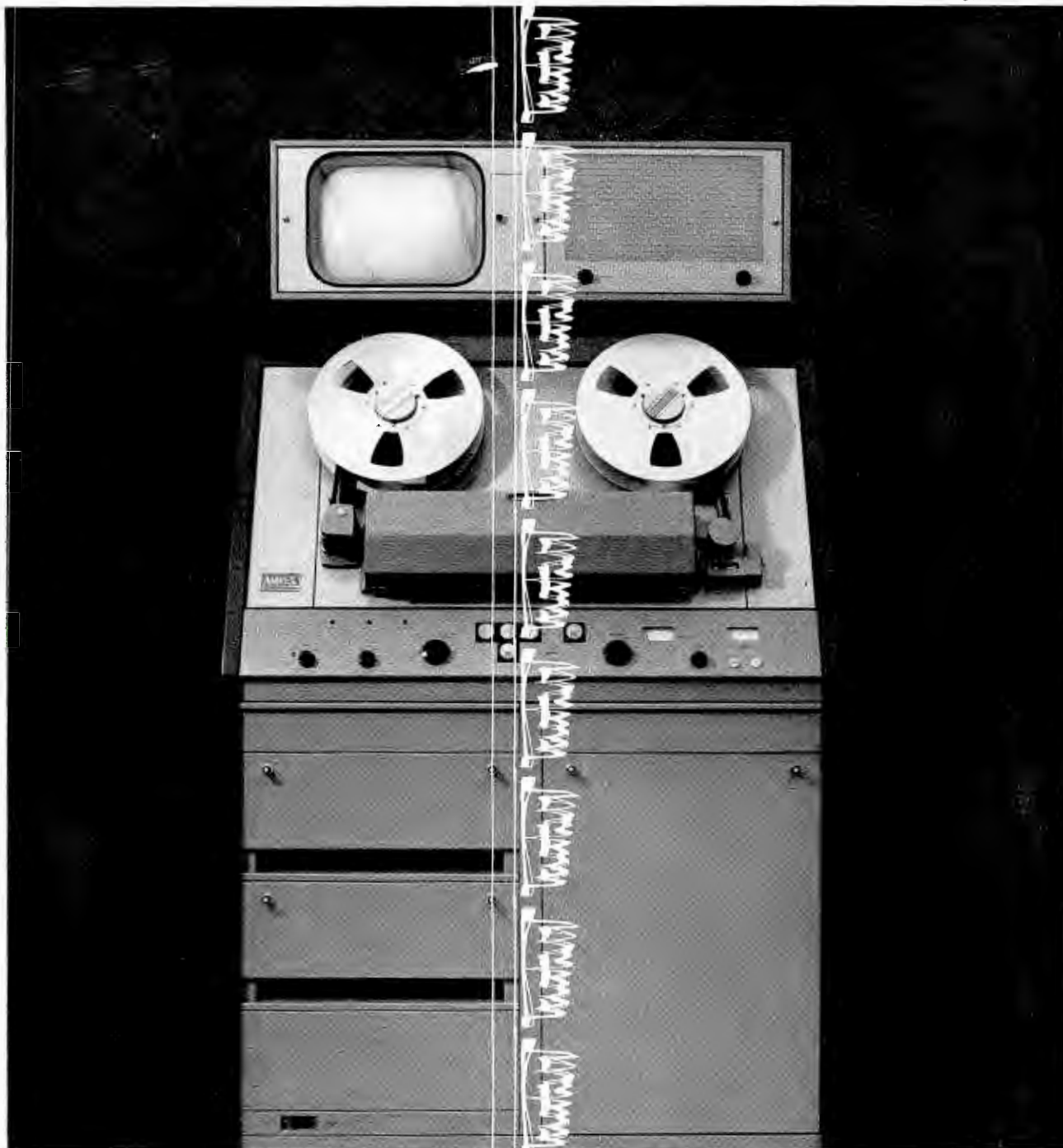

What's the state of the art in basic solid state VTRs?

AMPEX VR-1100

There's only one way to improve the VR-1100, and that's to add Ampex accessories. We purposely made these optional in order to offer you a basic VTR that you can adapt to suit your own particular needs. With the VR-1100 you add only the accessories you need, when you need them. And as a basic tape machine, the VR-1100 has no equal. It is a value engineered Ampex product representing the state of the art in solid state broadcast Videotape\* Recorders today. In addition

\*TM Ampex Corp.



Circle Item 5 on Tech Data Card

tion to a fully transistorized recorder, for less than \$35,000 you get superb Ampex picture quality; utter simplicity of operation; two speeds—7½ and 15 ips; recording time up to three hours; and compatibility with all four-head recorders. Call your Ampex representative or write the only company providing recorders, tape, core memory devices for every application—as well as Marconi cameras, accessories: Ampex Corp., - Redwood City, Calif. Term leasing and financing.

November, 1963

9

# Now...new EASTMAN Sound Recording Tapes!

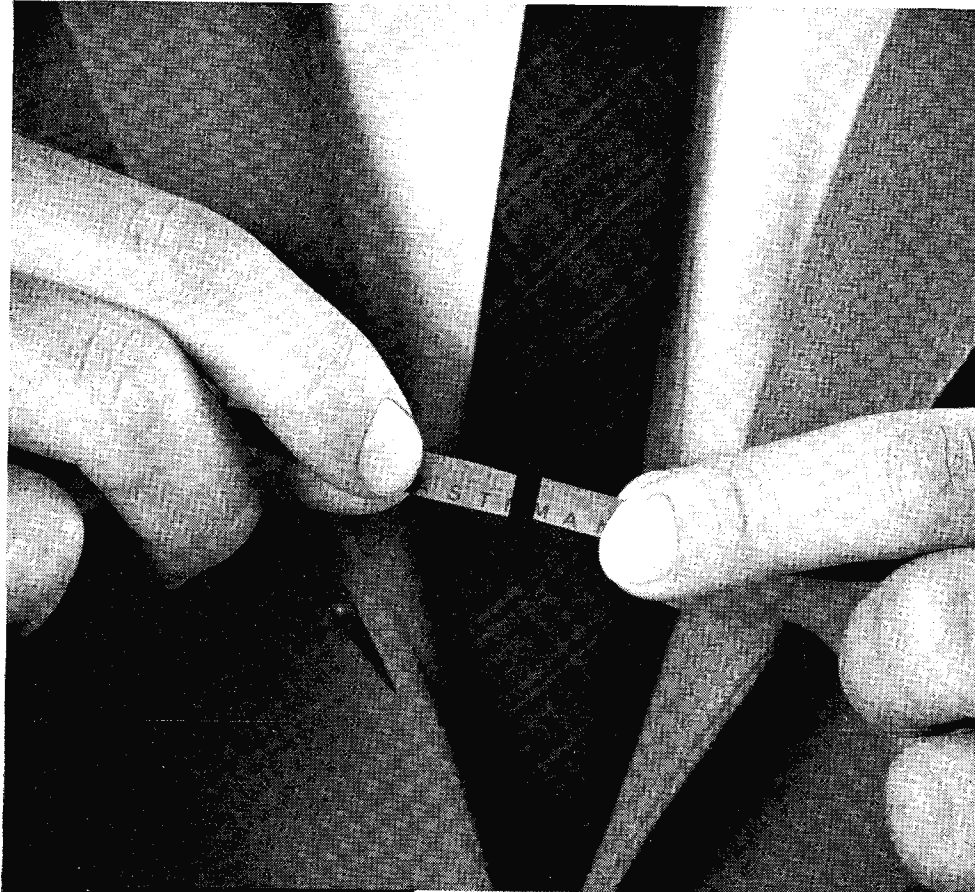

## Stop!

Accidents will happen!  
New DUROL Base provides extremely high tensile and yield strength, yet should equipment failure take place, the tape will break clean without stretch. As a result, splices are made easily, quickly—with minimum program loss.



## Look!

New "Lifetime Coding!"  
...Your assurance of highest quality! A permanently printed legend continuously repeated on the back of all new EASTMAN Magnetic Sound Recording Tapes (1) identifies Eastman Kodak Company as the manufacturer; (2) provides a convenient means of indexing tapes.

Three important new developments give you sound recording at its best!



## Listen!

The new "R-type" binder, a super-smooth, tougher homogeneous oxide layer suppresses tape noise and distortion . . . prevents oxide build-up on the head; at the same time, chemical stability extends longevity. Even more important are the superb magnetic characteristics of the new "R-type" binder dispersions. These make possible two superlative tapes of widely different performance characteristics...an extra-low print-through and a high-output low-noise tape.

**Remember: It's Eastman for superb sound recording tapes.**



Ask for them at leading electronic supply houses: Type A303, a vastly superior low-print tape with output comparable to a fine general-purpose tape . . . Type A304, a high-output tape with remarkably low print-through.

For fast loading—extra convenience . . . the unique ultra-handly Thread-Easy Reel with indexing scale and built-in splicing jig.

©Eastman Kodak Company, MCLXI

For information, see your electronic supplier or write  
Magnetic Product Sales

**EASTMAN KODAK COMPANY, Rochester 4, N.Y.**

# COLOR RECORDING AT THE NETWORKS

**Cover Feature** —A summary of the current trends in color video broadcasting and recording.

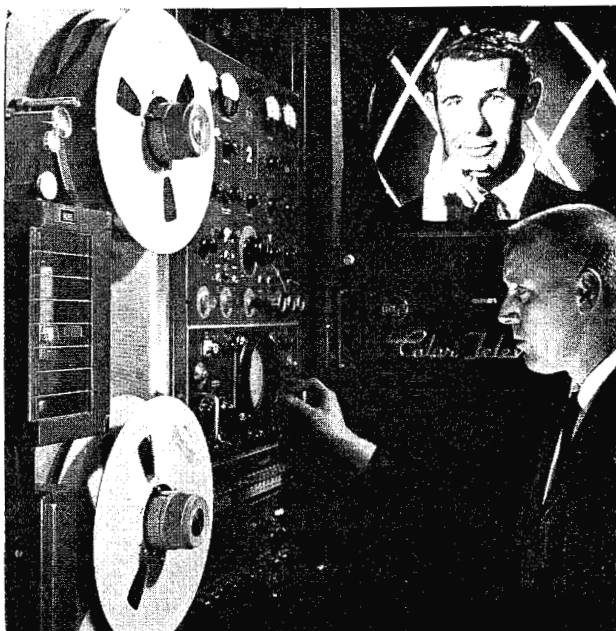

Photo courtesy 3M Company, St. Paul, Minn.

There's a rebirth of the blues—and the greens and the reds and the yellows—in the air. . . .

- ★ NBC, the prime mover of color television, has again increased its color prime-time hours.
- ★ ABC has broadcast its first color special.
- ★ CBS has aired its first color show in three years.
- ★ And more than 30 major advertisers have color spots in network programming.

And the technique that's making all this possible is video tape recording. It is astounding how important this system has become. Roughly 55 per cent of NBC's color fare is transmitted via the two-inch wide magnetic tape that "freezes" both picture and sound for immediate playback without processing. Certain of ABC's color documentaries will be on tape.

The lion's share of color telecasting is at NBC; during most weeks, color will account for more than three-fourths of the network's nighttime (7:30 PM to 1 AM) programming. NBC has equipped 11 of their 13 network studios for color, and there are 16 color film chains. Despite the new studios, NBC would not be able to handle so many color shows if they didn't video tape them.

Taping color shows in advance takes the pressure off the network's studios, as the shows can be recorded at hours convenient to the program schedule and the talent. For example, most live-type specials—such as the Hallmark shows—are taped during the summer when the stars are available.

Because a taped program is "in the can" doesn't mean that it will play back with a canned look. On

the contrary, it maintains the "liveness" and spontaneity of live television with the added benefit of special effects that cannot be done live. And these are instant special effects, as video tape does not have to be sent out for developing or printing. Upon completion of shooting, both picture and sound are ready for transmission. This immediate playback feature of video tape makes it possible to correct takes while the cast and crew are still assembled.

No special video tape is required to record in color. The tape is the same as that used for black and white. However, accessory equipment must be added to video tape machines to record or play back in color.

NBC, New York, has 25 video tape recorders, 20 of which are equipped for color. All 16 of the network's video tape recorders at NBC's West Coast studios in Burbank are color-equipped.

Another reason NBC records so many of its color shows on video tape is that tape provides editing flexibility. They can do a show employing stop and go motion picture technique. In one series, more than 20 hours of footage a week is boiled down for a typical one-hour show. The video taping is done in only two 12-hour days. It would take a full week to obtain the equivalent footage on film.

Network line costs are reduced by providing the West Coast with video taped shows which are fed out of NBC Burbank rather than over the network from New York. This amounts to an appreciable saving in view of the fact it costs NBC \$2,800 per hour to transmit shows to the West Coast.

Bob Daniels, head of NBC's video tape operations in New York, recently pointed out that he also finds video tape valuable for fast delivery of color commercials. "We recently taped a Dodge commercial, using stop and go film technique, in four hours plus another 1½ hours of editing," he said. "The commercial was aired the following day. With film, it would have taken at least two days to get rushes back and probably another week to get answer prints and lab work done."

NBC's affiliates—and other stations, too—are leaning heavily on video tape for local color shows and commercials. For instance: WNBQ, Chicago, counts more than 15 local advertisers currently using color commercials, most of which are produced on tape by the station.

CBS has 152 affiliate stations around the nation equipped for color. There are 136 ABC-affiliate stations equipped for color and 194 NBC affiliates are so equipped. Thus, a total of 482 stations in the U. S. are equipped to transmit color. ▲

## About the Cover

George Merrill, operations supervisor at NBC affiliate KSTP-TV, Minneapolis/St. Paul, checks color fidelity by playing back a video tape recording of the "Tonight" show taken off the network line.



**NOW**  
**HELIAX**  
 IN 5 SIZES  
 UP TO  
**5 INCHES**



HELIAX is now available in a 5 inch size, adding to the range of applications of this low loss, flexible coaxial cable. Produced in continuous splice-free lengths. Type H9, 5" HELIAX is ideally suited for high power installations to 826 kw peak power, frequencies to 950 Mc.

Available in  $\frac{3}{8}$ ",  $\frac{7}{8}$ ",  $1\frac{1}{2}$ ", 3" and 5" sizes, there is a HELIAX RF cable system, including fittings, from one source to meet your requirements. Write or call your Andrew sales engineer for complete information.

5 easy steps for assembly of connector to HeliAx Flexible Coaxial Cable



**Step 1** Cut HeliAx squarely. Assemble gasket and clamping body to outer conductor.

**Step 2** Cut outer conductor with a tin snips to facilitate 90° flaring.

**Step 3** Flare outer conductor back against the clamping body.

**Step 4** Assemble inner connector to the center conductor.

**Step 5** Assemble flare ring, O ring, anchor insulator. Thread outer body onto clamping body.

LOS ANGELES:  
 941 E. Marylind  
 Claremont, Calif.  
 National 6-3505

TORONTO:  
 606 Beech Street  
 Whitby, Ontario  
 MOhawk 8-3348

NEW YORK:  
 P. O. Box 416  
 Ridgewood, N. J.  
 GILbert 5-2500

*Andrew*  
 P. O. Box 807, Chicago 42, Illinois  
 Fieldbrook 9-3300

WASH., D. C.:  
 P. O. Box 5897  
 Wash. 14, D. C.  
 OLiver 4-2540

BOSTON:  
 P. O. Box 296  
 Westwood, Mass.  
 DAVIS 6-6500

DALLAS:  
 P. O. Box 30506  
 Dallas 30, Texas  
 ADams 5-1279

November, 1963

Circle Item 9 on Tech Data Card

13

# AUDIO LEVEL DEVICES

by **Thomas R. Haskett\*** — Part Four.  
 Concluding the series with a survey  
 and description of specialized instruments  
 for controlling audio levels.

Previous parts of this series have covered limiters, averaging devices, and compressors. To round out the survey of level controlling devices for audio, this part will discuss features and operating principles of some available equipment not falling into the other categories. These are devices which employ a combination of systems, or approaches not yet considered.

## Background Noise

### Problem

The peak limiter is effective in preventing overmodulation by instantaneous peaks, while permitting a high average level of modulation. The compressor, or averaging device, furnishes that high average level by compressing and expanding even the wide amplitude variations typical of nontechnical announcer/operators. However, by using an average-level device to drive a limiter, a station is highly vulnerable

on one point. During program lapses—pauses in announcing, dead track on ET's and LP's, and dramatic scenes in TV films—the gain-controlling devices raise the gain and the listener hears background noise, surface scratch, film noise, and other disturbances. Depending on the type of programming, and time constants in the compressor, this can be a serious detriment to a clean-sounding signal.

### Solution

Since background noise isn't desired, it must be suppressed. However, an electronic device can't differentiate between signal and noise—or can it? If a fair signal-to-noise ratio is maintained, say 10 db between program low levels and residual room or surface noise, then this would be a valid basis for designing such a circuit. Such is, indeed, the basic premise on which four manufacturers have developed devices to prevent background noise from being unduly amplified.

Though by means exactly alike, the units discussed below share this common function—they suppress background noise.

**CBS "Audimax"**—There are actually four models in the Audimax series. The prototype is Audimax I (Model 440), and its operation is illustrated in Fig. 1. Note that the main-signal channel is a variable gain circuit, V3 being a variable-gain controlled stage, and V4 the output stage from which level information is taken. Detector 1 feeds output-derived voltage to a memory unit, from which the comparator extracts information about program content for the preceding 10 seconds. Detector 2 has no memory, feeding its output-derived voltage directly to the comparator. The two detectors are differently weighted, hence they feed different information for the same signal-output voltage. The comparator decides whether to hold or alter gain, and executes this decision by changing the bias voltage to the controlled stage (V3).

\*Broadcast Consultant,  
 Michigan City, Ind.

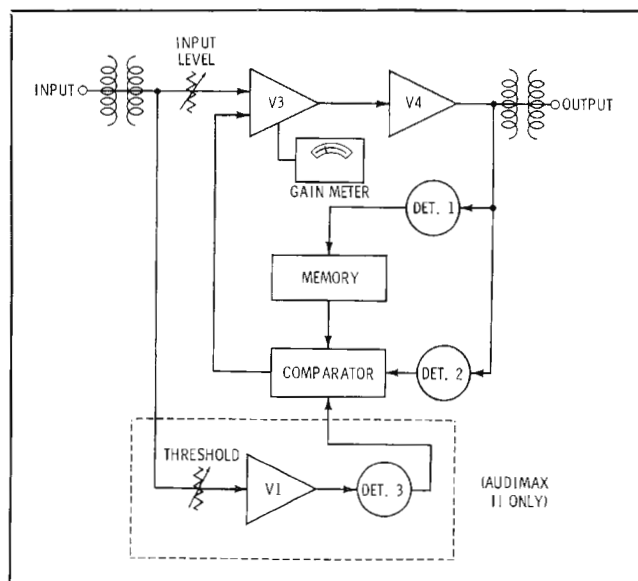

Fig. 1. Block diagram of CBS Labs "Audimax" equipment.

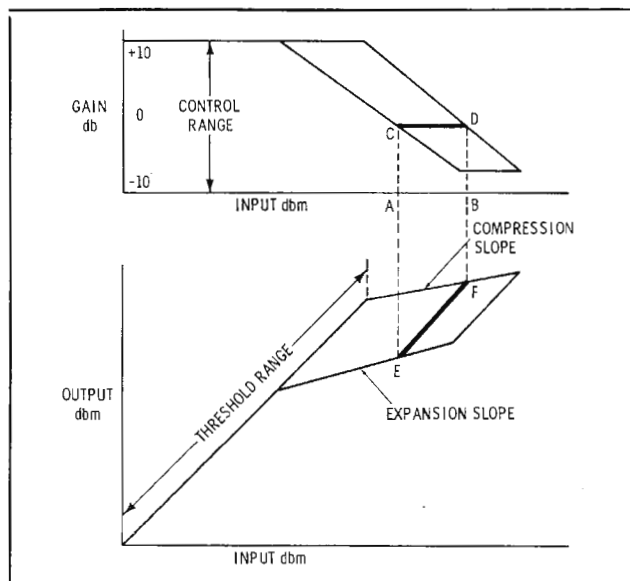

Fig. 2. CBS "Audimax" gain platform and transfer curve.

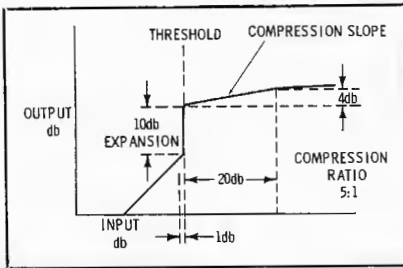

Fig. 3. "Level Devil" unit transfer curve.

Audimax functions in a four-dimensional domain whose coordinates are input level, output level, memory, and time. The gain at any time is dependent upon both weighted (average) input level and the program content during the preceding 10 seconds. Referring to Fig. 2, for a range of input levels from A to B, the gain remains on stable platform C-D as determined by the comparator. If the range of input levels shifts to a new region, the gain platform is quickly readjusted to the new value required to yield the desired output. However, short-duration, high-level peaks above the platform will still be compressed quickly, after which the gain returns to the platform, since the average value of audio hasn't changed. Fig. 2 shows the platform between the compression and expansion slopes. For the range of inputs A-B, output will vary from E to F.

After a pause of 2 seconds, Audimax I will seek its maximum gain. Where this feature is undesirable (as during classical music or TV film programming with long-duration pauses), Audimax II (Model 441) has been developed. Referring to Fig. 1, the additional circuitry is seen. Amplifiers VI, 2 are fed from the input and drive detector 3. If audio input drops below the threshold, detector 3 supplies gated information to the comparator; a change of control voltage is then inhibited until detector 3 indicates a new audio signal above threshold. This feature is called **gated gain stabilizer**, and it effectively lengthens gain increase time

during pauses of 2-12 sec. (e.g., after 12 seconds, the gain will have returned to maximum.) Fig. 2 indicates the threshold range; it's adjustable from 32 db below normal up to the normal input level.

A further refinement is Audimax II RZ (Model 443) which, CBS advised recently, has replaced the popular Audimax II. Faced with the desirability of the gentle 12-second upward gain drift while within a given platform, but not wanting such expansion during nonprogram pauses, the designers have found a way for the user to "have his cake and eat it, too." The RZ (return-to-zero) model holds the gain absolutely constant during pauses, but allows a gradual expansion during low-level program material. In addition, after waiting out a silence pause of 10 seconds or more, the gain will slowly rise. However, it does not rise to **maximum**, but only to the zero point—the middle of the  $\pm 10$ -db control range, as shown in Fig. 2. This gain change takes another 10 or 20 seconds after the initial 10-second, constant-gain pause.

Audimax Model 442 is a stereo adaptor unit, designed to couple any two identical Audimax units together (i.e., two I's or two II's). In this configuration, the gain-controlling action is a function of control voltage derived from a sum (L + R) signal, maintaining proper stereo perspective. All Audimax units handle 600 or 150 ohms in and out. When installed in a +16 VU line, the function switch allows bypassing the signal around the amplifier, facilitating in-use troubleshooting. The meter is normally used to show the gain of the amplifier, but can be switched to test the variable-gain stage.

#### Gates M-5546 "Level Devil"

Gates has attacked the problem of level control and noise suppression by combining two separate circuits, a compressor and an expander, in a single chassis. Switching permits either circuit to be used alone, but normally they are employed together having a combined action as displayed in Fig. 3. The compression is fairly conventional, but the steep expansion slope increases average level considerably. Furthermore, in the absence of signal input above the expansion threshold, gain

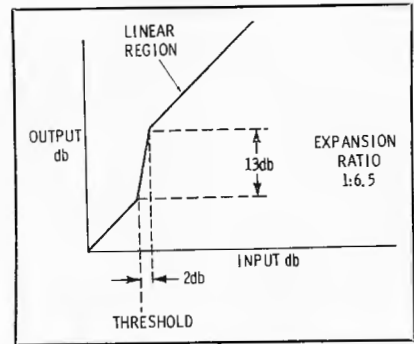

Fig. 4. "Gate Amplifier" transfer curve.

does not return to maximum, but 10 db less. Gain is then held constant until keyed by a new audio input signal. It is this feature which provides a relative isolation from background noise. Since only signal—and not noise—is subject to gain control, existing signal-to-noise ratios will be held constant or bettered. The maximum compression is 25 db and maximum expansion is 10 db; input and output are 600 ohms.

**Ron 40A Gate Amplifier**—The Ron 40A Gate Amplifier, as Fig. 4 indicates, is a signal expander and noise suppressor. (For a complete description, see Michels: "Program Gated Noise Suppression Amplifier," BE, April, 1962.) When the input signal is properly adjusted, program material is expanded while background noise remains below the threshold. Hence the signal-to-noise ratio is improved. The circuit is a conventional expander with a neon lamp acting as an expansion clamp; beyond the clamped point the amplifier is linear. It has been designed to work following a pre-amplifier but probably could be



Fairchild 602 "Conax"



Fairchild "Auto-Ten"

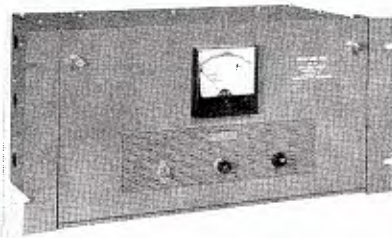

Gates "Level-Devil"

utilized past the mixer bus in a console, with some refinement of operating technique. It should be followed by a compressor or averaging device to realize the most benefit from both. Input and output will match 600, 250, or 150 ohms.

**Fairchild 661 "Auto-Ten"**—Also known as the "third hand," this is neither a compressor nor an expander—it's an **automatic attenuator**, or audio-controlled gate. As such, it's also a background noise suppressor. There are two controls, threshold and release; and two modes of operation, closed and open. If audio is present at the input, but below the threshold setting (which is variable from -35 to +25 dbm), the gate is closed and there's more than 60 db of attenuation across the input. If audio comes along above threshold, the gate opens and there's only 0.5 or 2 db of attenuation (depending on circuit impedance). When audio again drops below threshold, the gate closes; the time required for it to close is set by the release control. Extremely compact and completely transistorized, the "Auto-Ten" occupies no more space than a conventional fader on a control panel. It requires 6.3 VAC at 200 ma, and 8 VDC at 200 ma. Input and output will match anything from 150 to 47,000 ohms.

(Note: While the "Auto-Ten" is listed and discussed here as a separate unit, it's also available as an integral part of the Fairchild 666 Compressor, described in Part III.)

### Limiting and FM Pre-emphasis

As pointed out in Part I, when using level-controlling devices in

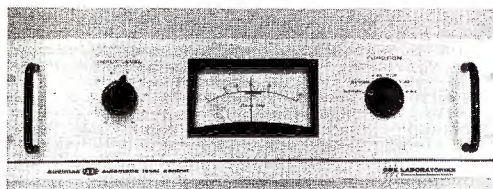

CBS "Audimax" II RZ

FM or TV, one is faced with a question: Should the limiter be used before or after pre-emphasis? If it's used before and drives the transmitter fairly close to 100% modulation, the 75-microsecond curve causes high frequencies to overmodulate the transmitter. If the gain is backed off to prevent this, signal-to-noise ratio at the receiver suffers. On the other hand, if the limiter is used after pre-emphasis, high frequency signals cause noticeable limiting of mid-range, loudness-causing signals, thereby annoying listeners. The following device has been developed specifically to cope with this dilemma.

**Fairchild "Conax"**—There are actually three models of the Conax of interest to broadcasters. The 600 is a single-channel, zero-gain unit; the 601, a single-channel unit with 40 db of gain; and the 602, a two-channel, zero-gain unit. Each is es-

### Manufacturers Addresses

CBS Laboratories  
227 High Ridge Road  
Stamford, Conn.

Fairchild Recording Equipment Corp.  
10-40 45th Ave.  
Long Island City 1, N. Y.

Gates Radio Co.  
Quincy, Ill.

Ron Electronics Corp.  
150 Pine St.  
Montclair, N. J.

entially a fast-acting, high-frequency variable filter, designed to prevent overload and overmodulation resulting from abnormally-high-level high frequencies. A variable roll-off is employed, starting as low as 2 kc, with a maximum attenuation of 20 db at 15 kc.

The question immediately comes to mind: Doesn't this device defeat the purpose of pre-emphasis? The answer is no, and here's why (refer

### Specifications of

Model	Function	Compr. Attack Time msec	Expdr. Attack Time sec	Compr. Ratio	Expdr. Ratio	Input Level dbm	Output Level dbm	Noise Level dbm
CBS 440 Audimax I	Compr. Expdr.		2					
CBS 441 Audimax II	Compr. Expdr. Suppr.	12	12	2.5:1	1:2.5	-40 to +16	-7.5 to +22.5	-69
CBS 443 Audimax II RZ			See text					
CBS 442	Stereo Adaptr.	—	—	—	—			
Gates M-5546 Level Devil	Compr. Expdr. Suppr.	10	2	5:1	1:10	-35 to +27	+8	-52
		Gate In msec	Gate Out sec					
Ron 40A Gate Amplifier	Expdr. Suppr.	3 to 8	0.1 to 0.8	—	1:6.5	-70 to -40	-40 to +10	—
Fairchild 661 Auto-Ten	Suppr.	30	0.3 to 7.0	—	—	-35 to +25	*	**
		Attack Time msec	Release Time msec		Gain db			
Fairchild Conax 600	Mono				0			
Fairchild Conax 601	Mono HF Limiter	0.025	0.025	Depends on freq.	40	+4 or +8	+4 or +8	-66
Fairchild Conax 602	Stereo				0			

\* Insertion loss: 2 db @ 150 ohms; 0.5 db @ 600 ohms  
\*\* Passive circuit — no generated noise



to Fig. 5). Most programming consists chiefly of balanced-frequency audio signals, as at (a). While some signals are present throughout the spectrum, most speech and music fundamentals lie in the middle range (roughly 500 to 3000 cps). Since the middle-range signals predominate, they are the loudness-causing, and therefore gain-controlling elements. The high frequencies add sparkle and brilliance, but their amplitude seldom rises above that of the middles. Pre-emphasis was designed to take advantage of these conditions by boosting the highs to provide a better signal-to-noise ratio, as shown at (b).

Suppose keys are jingled, lips are smacked, or someone whistles—the result is something like (c). Here the highs are extremely loud, and when pre-emphasized at (d),

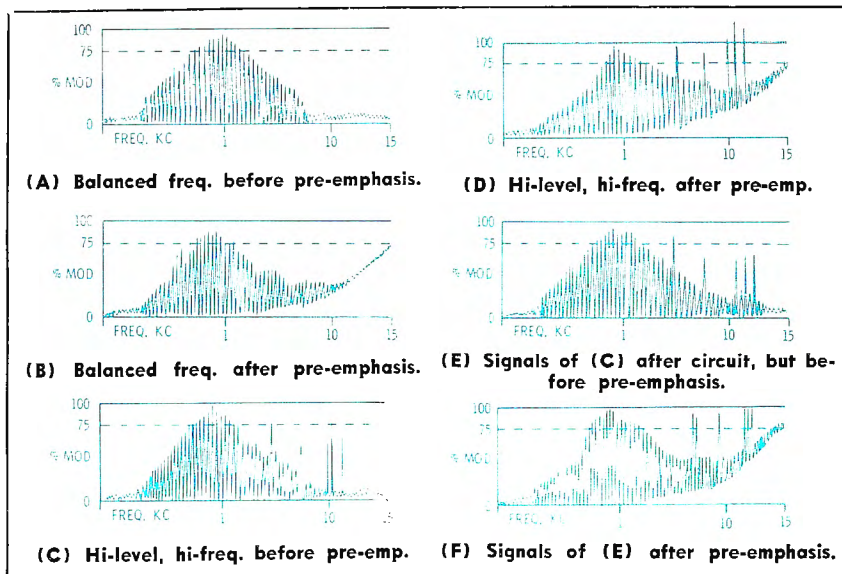

Fig. 5. Effects of the Fairchild "Conax" on signals of various frequency content.

they either cause undesirable low-frequency limiting or overmodula-

tion. Such highs serve no useful purpose, but only cause trouble.

Conax subjects such highs to a gradual roll-off, as illustrated at (e). Since the attenuation increases with frequency, only very troublesome high frequencies are limited to any great degree. (No frequencies below 1 kc are affected, by the way). The result is a gradually compressed high-frequency content which can then be pre-emphasized, such as at (f), without danger of overmodulation or undesirable low-frequency limiting. The roll-off filter is fast-acting—25  $\mu$ sec attack and release—and limiting is inaudible. Moreover, such action occurs only if and as needed; e.g., if no high-level, high-frequency signals are present, response is flat. And the roll-off slope (or compression-vs-frequency ratio) is variable by means of a front-panel control.

A special preview circuit in Conax applies the input signal to a 75-microsecond curve to see if any peaks will be troublesome at the transmitter. If there are excessive highs, the preview circuit initiates control which reduces those highs proportionately. In effect, the action is that of a high-speed, variable-frequency limiter. All Conax models are equipped for either 150 or 600 ohms in and out.

#### Conclusion

I have attempted to include all audio level-controlling devices available to the broadcaster today. I hope no products have been omitted; if so, it was unintentional. ▲

### Specialized Devices

Frequency Response	Harmonic Distortion	Meter	19" Rack Space		Price	Model
			Height	Depth		
$\pm 1.0$ db 50 to 15,000 cps	Below 1.0% 50 to 15,000 cps	Yes	5 1/4"	12 3/4"	\$495.00	CBS 440 Audimax I
					595.00	CBS 441 Audimax II
					625.00	CBS 443 Audimax II RZ
$\pm 1.0$ db 30 to 15,000 cps	2.0% (25 db) 50 to (compr.) 10,000 cps	No	3 1/2"	6 7/8"	125.00	CBS 442
					349.00	Gates M-5546 Level Devil
$\pm 1.0$ db 30 to 15,000 cps	Below 1.0%	Yes	3 1/2"	—	290.00	Ron 40A Gate Amplifier
Flat (passive circuit)	Below 0.3%	No	Round can 2 7/8" dia. 3 1/4" long	—	125.00	Fairchild 661 Auto-Ten
$\pm 1.0$ db 30 to	Below 1.0%	No	5 1/4"	9 1/2"	330.00	Fairchild Conax 600
15,000 cps; Rolloff 2 kc					375.00	Fairchild Conax 601
to 15 kc depending on level					495.00	Fairchild Conax 602

# TRANSISTORIZED AMPLIFIER SERVICING TECHNIQUES

by Harry A. Etkin\* — Step-by-step procedures for checking transistors and troubleshooting transistor circuits.

The development of transistors in 1948 provided the electronic industry with an entirely new concept. In comparison with the vacuum tube the transistor has many superior qualities. Transistors have no warm up period, no filaments, consume very little power, have long operating lives, are extremely rugged, and are free from microphonics. Furthermore, they are usually less than an inch long and weigh a fraction of an ounce. Fig. 1 illustrates the use of a PNP and an NPN transistor.

## Transistor Amplifiers

The broadcast industry, in advancing the state of art, has designed new products to make use of the advantages offered by transistors. One major example is in the design of transistor broadcast equipment such as preamplifiers, line amplifiers, monitor amplifiers, remote amplifiers, and intercom systems.

The transistor circuit differs from a vacuum tube circuit in that the tube is a voltage operated device, while the transistor operates on current. There are three types of transistor amplifiers: the common base, common emitter, and common collector. The methods of coupling are by transformer, RC network, impedance coupling, and direct. Transistor power amplifiers are of the single ended or push-pull type and, as in vacuum tube operation, are classified as class-A or class-B amplifiers.

## Servicing Techniques

Before attempting to service transistor amplifiers certain general precautions should be understood:

1. When unsoldering or resoldering transistor leads, do not over-

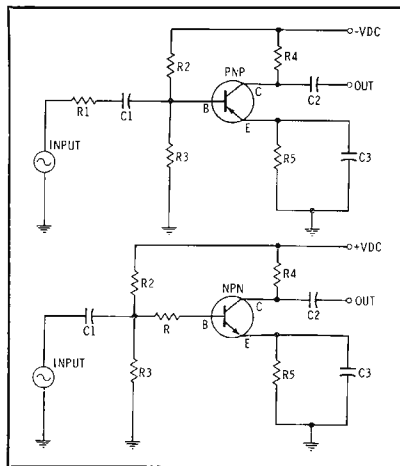

Fig. 1. Schematic showing how PNP and NPN type transistors serve in amplifiers.

heat the transistor. Use long-nose pliers as a heatsink.

2. Remove any nearby transistor before unsoldering a component.
3. Do not deliberately short out circuit components; certain changes in bias voltage may destroy a transistor.
4. Be careful to maintain correct polarity of test equipment leads.

Transistorized equipment should present fewer servicing problems than vacuum-tube amplifiers. But the problems that do arise are different. Often, the broadcast technician can detect a defective tube by visual inspection; however, the same inspection cannot reveal a defective transistor. This may cause a feel-

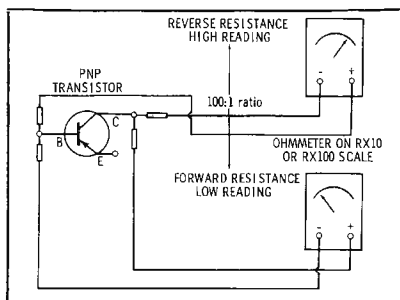

Fig. 2. Diagram for checking the forward and reverse resistance of PNP transistors.

ing of helplessness if the technician does not have test equipment available to check the cause of trouble. It may come as a welcome surprise that transistors are simpler than vacuum tubes, and are usually easier to check. Most transistors have only three active terminals, and the quality of the transistor can be determined by a few simple tests.

The most practical test instrument for checking performance of transistor equipment is the ordinary multimeter (VOM). Although the VOM cannot check all the characteristics of the transistor, it can accurately detect many faulty conditions.

For checking transistorized broadcast equipment, the following steps are easy to remember and use:

1. First check the battery or power supply voltage. However, if substituting a new battery doesn't cause the equipment to operate, transistor or circuit trouble must be suspected.
2. A good second step is a visual inspection of the equipment. It may be effective in locating a loose wire or faulty connection. Because of the low supply voltage, burned resistors are seldom encountered.
3. When transistors are mounted in sockets they can be checked by direct substitution. This method is not always satisfactory. Due to leakage current characteristics, a transistor may function in one circuit and not in another. As a precaution, always shut off supply voltages before removing a transistor from its socket. Current transients may cause damage to the transistor.
4. A resistance check, using the ohmmeter scale of a VOM, is an excellent method of spotting defective transistor circuits. Po-

\*Staff Engineer, WQAL-FM, Philadelphia, Penn.

larity of the ohmmeter must be established by determining which way the internal battery connects to the test leads. To avoid transistor damage from excess voltage or current, it is best to avoid using the highest or the lowest resistance ranges. Generally, the higher ohmmeter ranges apply excessive voltage and the lower ranges apply excessive current to the circuit being tested. (Editor's Note — At least one instrument has been developed that eliminates this problem!) It is usually safe to use the Rx10 or Rx100 ranges of the ohmmeter, if the internal test voltage is less than 3 volts.

### Resistance Checks

For the resistance check, the transistor may be treated as a dual diode device—one diode considered as between base and collector, and the other between base and emitter. The ohmmeter is used to check the forward and reverse resistance of the diode junctions, as in Fig. 2.

The first measurement is the base-collector reverse resistance. Use either the Rx10 or Rx100 scale. Assuming the transistor is a PNP type, connect the positive lead of the VOM to the base and the negative lead to the collector. This reading should be high, generally around 50K. Next, reverse the test meter connections to the base-collector diode; this forward resistance reading should be quite low, less than 1000 ohms. The base-collector reverse resistance is generally about 100 times the forward resistance, in a good transistor. If the readings indicate a lesser ratio, the transistor may be considered faulty.

The "diode" junction between the base and emitter can be checked in the same way. The forward resistance is higher in the base-emitter junction than in the base-collector "diode." It must be also taken into account that transistors designed to handle greater power will pass more current and therefore will indicate a lower forward and reverse resistance readings.

NPN transistor types can be checked by reversing the polarity of the ohmmeter leads. The schematic can be used as a guide to correct forward or reverse polarity. The tests just described will detect open or shorted transistors.

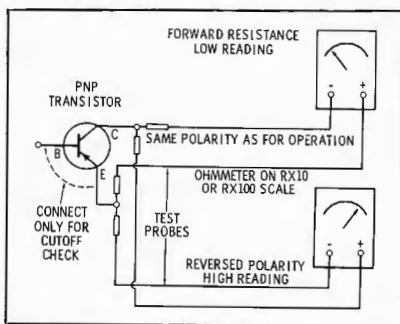

Fig. 3. Connections for checking cutoff.

### Other Tests

The method of testing just described disregards the transistor as a triode. It is possible to check the transistor's triode action by performing several dynamic tests, still using only the VOM.

#### Cutoff Check

Connect the ohmmeter test leads across both diodes at once (from the emitter to the collector) as shown in Fig. 3. Use the voltage polarity the transistor uses in normal circuit operation, and note the resistance reading. Reversing the test leads should give a substantially higher resistance reading. With the ohmmeter still connected for the higher reading, short the base to the emitter. If transistor cutoff characteristic is normal, the high resistance reading will reduce to the same as the first emitter collector reading (when the voltage was applied as for normal operation).

**Conduction check** — Conduction in a transistor stage can be determined by checking the collector voltage (Fig. 4) or the voltage across the emitter resistor. Compare readings with those in the equipment instruction book. A high collector voltage reading indicates too little conduction and a low reading too much. Across the emitter resistor, a high reading indicates too much conduction, and a low reading indicates

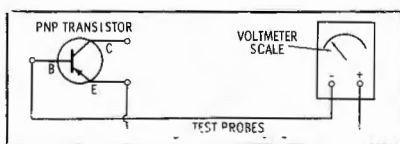

Fig. 4. Voltage test for stage conduction.

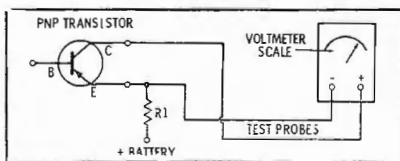

Fig. 5. Check for forward bias at base.

too little. No conduction indicates an open transistor.

**Forward Bias Check**—Forward bias for a PNP transistor is checked in the operating circuit by connecting the positive voltmeter lead to the emitter and the negative lead to the base, as shown in Fig. 5. If bias voltage is not indicated on the meter, there will be no conduction. Excessive conduction will be caused by a too-high forward bias.

### Further Checking

Before tackling the component check, voltage and current measurements should be taken throughout the entire equipment. The schematic should be checked for proper polarity and the magnitude of the voltages. Although it is not always possible to make a current check, the current in a circuit can be calculated by dividing the measured voltage drop across a resistor by the value of the resistor as indicated on the ohmmeter.

Check transformers and coils for open and shorts by ohmmeter resistance measurements. Capacitor substitution is good service procedure. However, observe polarity when bridging electrolytic capacitors.

Another excellent service technique is to inject an audio signal at the input and output of each stage. A defective stage can then be identified by the lack of signal gain through the stage. Remember, however, that cathode followers exhibit no gain; nor do phase splitters.

### Conclusion

The service techniques described are suitable for all types of transistorized broadcast equipment. The broadcast technician should be especially careful with the polarity of test leads. When checking transistors with an ohmmeter, always disconnect the supply voltages.

Transistorized equipment employed at broadcast stations now includes frequency and modulation monitors, test and measuring equipment, tape recorders, studio equipment, TV cameras and associated equipment, multiplex receivers for SCA, AM-FM-TV control equipment, and low- and high-voltage rectifiers. With the steady progress of solid-state developments, more is bound to come. Servicing of these transistorized equipments should present no greater problem than servicing their tube equivalents. ▲

# TELEVISION TAPE TECHNIQUES TODAY

by Joseph Roizen\* — Discussion of equipment and methods currently employed in record/playback of video tape.

The basic principle in recording television images on magnetic tape dictates that a high writing speed be utilized to accommodate the wideband nature of video signals. The writing speed, of course, is a function of the relative velocity between the write/read head and the medium upon which the signals are being impressed. Many methods, based principally on high tape speed, have been investigated by the world's major research laboratories. These experiments have yielded acceptable pictures, only to be considered impractical be-

\*Ampex Corp., Redwood City, Calif.

cause of their inherent physical limitations.

The two systems which have evolved, and which are considered acceptable answers, depend on rotating the magnetic heads while the tape motion is relatively slow. They can be roughly classified as the **transverse** and **helical-scan** recording methods (Fig. 1).

The transverse system is widely used today in television studios around the world. It utilizes 2-inch wide tape upon which signals are recorded by a high-speed spinning head assembly containing four magnetic transducers. These write essentially perpendicular tracks across the width of the tape, while normal stationary heads record multiple audio and control signals in a standard longitudinal manner. This technique has reached a high degree of sophistication as a result of more than seven years intensive development.

The helical system (currently coming into use) wraps the tape over a male guide in which a spinning drum, containing one or more video heads, inscribes its track at a narrow angle to the edge of the tape. If a single head is used, the tape is wrapped in a full helical configuration; with two heads only a half-helix is required, each head scanning slightly more than 180° to provide an overlap period for switching purposes. This system is presently in its first operation stages and its limitations still exclude it from certain studio applications.

## The Transverse Recorder

A modern transverse recorder consists of several distinct systems. These are grouped by function (Fig. 2) consisting of a signal system, a tape transport system, several servo systems, time-base correction de-

vices, and often an electronic editing system. Each system breaks down into units which function in record and/or playback.

There are at present several manufacturers in the U.S.A., Japan, and Germany who are producing commercial transverse recorders. In the U.S. the two major brands are Ampex and RCA. In Japan they are Shiba and Nippon Electric. In Germany Fernseh GMBH recorders are undergoing field trials.

The Ampex line includes the VR-1000 and VR-1100-series. The former comes in both console and upright configurations and is a hybrid tube and transistor machine that can accommodate color and animated editing operations. The latter is an all-transistorized single console recorder with simplified controls and 2-speed operation.

The RCA line also consists of 2 basic versions — the first being the TRT-series (TRT-1A, 1B, TR-11, TR-2) which are tube transistor hybrids of vertical rack and panel construction. These systems are capable of color operations utilizing a "burst lock" time-establishing system. RCA's all-transistorized recorder called the TR-22, is of single console construction with all monitoring facilities built in. It has separate record and playback set-up controls and a large number of "fail safe" indicators for maintenance.

Both the Shiba and NEC machines are very similar in construction to the Ampex VR-1000-series utilizing consoles with horizontal top plates which interchangeably accept Ampex head assemblies. These machines are also partly transistorized.

The Fernseh machine is a tube version similar in configuration to the RCA TRT-series, but containing a built-out control desk.

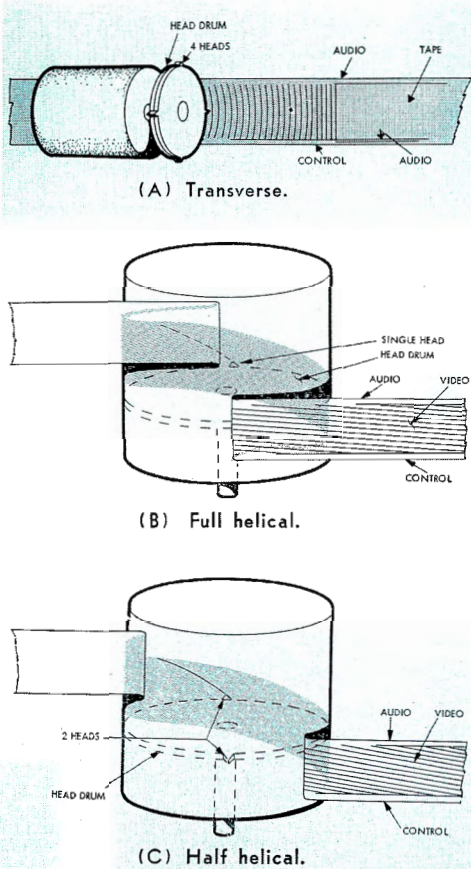

Fig. 1. Television tape scanning systems.

The technical descriptions that follow cover the techniques used in all of these machines since they are relatively similar. Where a specific technique is applicable to one type only, it is indicated.

### The Signal System

The input video signal must be altered in form before it can be recorded on tape. The signal system, therefore, consists of a modulator which converts the amplitude variations of the composite video to a frequency-modulated, constant-amplitude waveform. In the record mode there are three successive operations performed; modulation, multiplication, and amplification.

The 1-volt composite video signal applied to the input of the modulator is limited by a low-pass filter to the frequency spectrum of the system (4.2 mc or 5.0 mc) which meets adequate broadcast requirements; high-frequency noise or transients present in the incoming signal are attenuated. Because the modulator is usually less sensitive to higher frequencies, pre-emphasis is employed to increase the modulation index proportionately for the upper end of the video spectrum. The pre-emphasized video is applied to the control circuit of the modulator. This causes the carrier to deviate so as to produce a range of frequencies swinging from 4.28 mc for the tip of sync to 6.8 mc for peak white in monochrome operation. (These standards have been established by the SMPTE as optimum operating conditions for 525-line television systems.)

There are two basic modulator systems in use today, utilizing either the heterodyne or multivibrator principles. The heterodyne system employs a fixed oscillator and reactance-controlled variable oscillator operating in the 40 to 60 mc range. The variable oscillator changes frequency in proportion to the amplitude of the applied video signal. The output of this variable oscillator and that of the fixed oscillator are heterodyned; the difference signal in the 0-10 mc range contains the desired information to be recorded. The major requirement is that the modulator be a relatively linear device which introduces a minimum of differential gain, differential phase, or frequency discrimination.

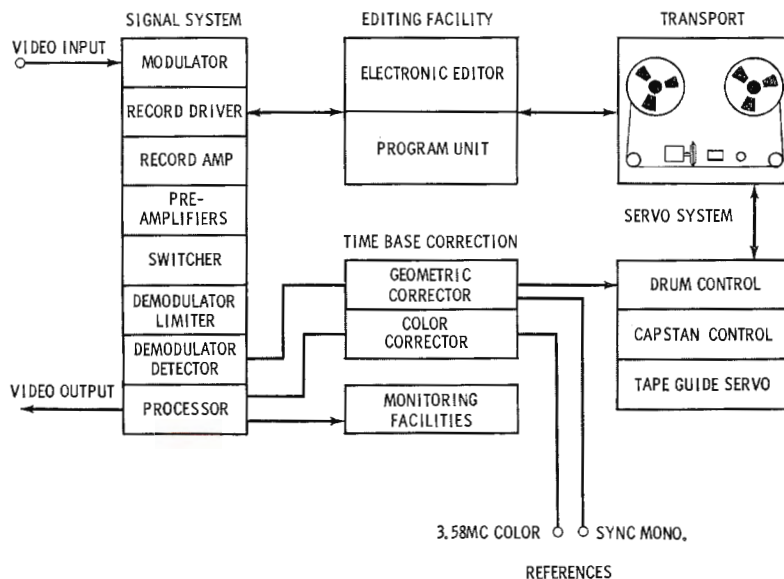

Fig. 2. Block diagram of a modern transverse television recorder equipped for color.

To assure close adherence to preset recording standards, an AFC system constantly compares the carrier and deviation frequencies against precisely pretuned circuits; this compensates for any drift in the oscillators due to temperature, humidity or component changes. The multivibrator modulator is usually of simpler design and achieves about the same result. A high frequency circuit is used, whose steady-state condition represents the carrier frequency. The multivibrator is driven above and below this frequency by the application of the varying video voltage; a transformer couples out the FM signals which have been generated. In both cases, the amplitude of this signal is not sufficient to directly drive the video heads—further amplification is necessary.

Since there are four heads to drive, the signal must be split four ways. Individual control of each signal amplitude is necessary to permit optimization of record currents in the video heads. To accomplish this, the modulator is fed into a record driver which functions as the four-channel signal splitter; it has independent level controls in each channel. The record driver outputs are then further amplified by four individual record amplifiers which properly match the head impedances and provide adequate RF amplitude for each transducer.

The "playback" mode is somewhat more complex involving a

larger number of units. The FM signal recovered from the tape through the spinning head assembly has an amplitude of about 5 millivolts and requires pre-amplification through high-gain, low-noise channel amplifiers located adjacent to the head assembly. These raise the signal to a level adequate for transmission through low-impedance coaxial lines. The four sequenced RF segments are routed to a system which performs a precise switching function using the redundant period of head signals, coincident with the nearest blanking pulse in the video information. In this way the switching transients are not visible in the reproduced image since they occur sometime during the retrace period. The output of the switcher is now a continuous RF waveform of frequency modulated information which can either be demodulated or applied to another video recorder for dubbing.

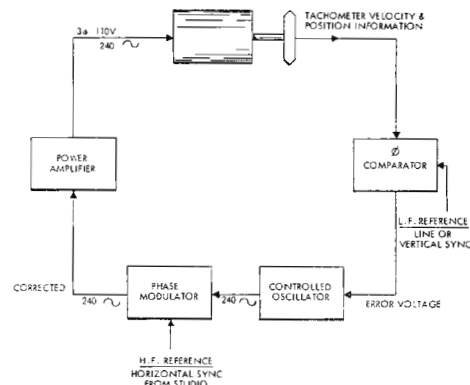

Fig. 3. Diagram of drum servo system.

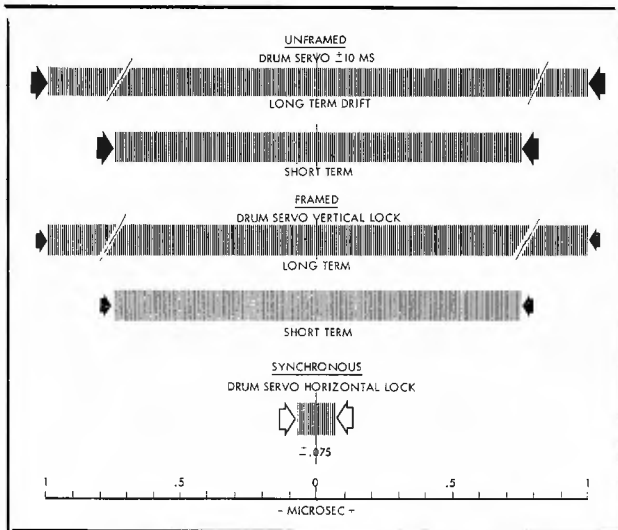

Fig. 4. Drum time-base stability charts.

The demodulator is divided into two sections; the first functions as a cascaded limiter in which the signal is amplified and clipped several times to provide maximum immunity from variations in level at the input, due to tape "dropouts" and other causes. The limiting is usually in the order of 50 to 60 db and an input amplitude drop of at least 40 db is necessary before any effect is observed. The output of the limiter is then coupled to a detector which converts the FM signal back to its video form. Here the signal must be passed through a conjugate de-emphasis filter, and a level control establishes the video output of the demod to a standard 1-volt composite amplitude. The signal at this point is a complete composite television signal and would appear as a normal image on a video monitor. However, if checked with a waveform analyzer or subjected to rigid time-base or geometry measurements, it would be found to have certain discrepancies considered undesirable for broadcast purposes. It is therefore necessary to subject the signal to additional processing through time-base correction devices and a processing amplifier.

Time-base correction, although desirable, is not essential to normal nonsynchronous VTR operation. The processing amplifier, however, is required to meet stringent FCC specifications and is part of any broadcast VTR. The processor accepts the composite output video signal of the demodulator and re-inserts internally generated blanking and synchronizing pulses which overlay the original waveforms re-

covered from tape. The new composite signal will now meet FCC regulations as to rise time, overshoot characteristics, and amplitude. It will pass through normal studio transmission systems.

The latest technique in signal processing involves a processing amplifier designed to provide a "hands-off" operation. This was accomplished with extremely stable circuitry which will faithfully reproduce the input signal by re-inserting its own regenerated pulses and maintaining an overall amplitude accuracy of better than 1% at the output terminal. A control switch on the front panel when left in the "unity" position indicates this mode of automatic operation and selector switches in the back of the unit provide outputs of either 1.0 volt or 1.4 volts, depending on the local television system requirements. This set-up is predicated upon a normal recording in which the recovered signal from tape will come into the processor at a standard level. Should an occasional tape be found to be deficient due to mis-reading, the control switch on the processor can defeat the "unity" function by being switched to the "variable" mode, in which independent control is available for the amplitudes of video, sync, blanking and burst. Once the non-standard tape has been played, a return to the "unity" position restores the machine to normal operation. These functions can be remoted to control several recorders from a central console.

#### Servo Systems

There are three servo systems

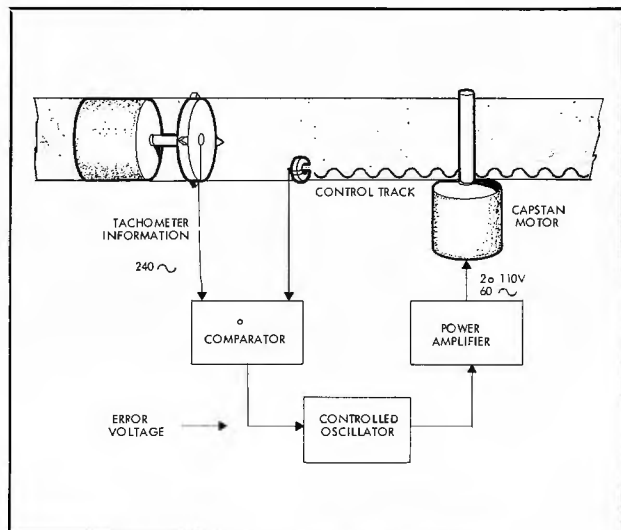

Fig. 5. Diagram of capstan servo system.

utilized in a video recorder to produce the necessary electromechanical corrections for proper operation. The head drum servo controls the positional accuracy and instantaneous velocity of the rotating assembly that holds the magnetic transducers. The capstan servo maintains the proper location and longitudinal motion of the tape. The tape guide servo automatically assures that head penetration into the tape is identical in playback to what it was in record, thereby maintaining time-base coincidence.

**The Drum Servo** — The first requirement of a drum servo (Fig. 3) is that it maintain an average velocity of the head drum to an accuracy sufficient to permit the write/read of video signals within a time-base established by FCC standards. The underlying reason is that the final image will display an annoying horizontal jitter if this condition is not met. This requirement can be met if the short-term velocity shift of the drum is not in excess of  $\pm .75$  microsecond and does not require vertical or horizontal synchronism to be maintained with the studio's source; i.e., the recorder is free-running and its positional timing is random although its average timing is within FCC specs.

A normal drum servo system utilizes some form of tachometer to measure the rotational speed of the head and constantly compares this speed with a multiple of the line frequency or the vertical sync signal being employed. The signal to drive the drum motor is generated by a local oscillator whose phase and



**YOU'LL NEVER FORGET**  
the day you try RCA Red Seal Magnetic Tape

Try just one reel of RCA Red Seal Magnetic Tape! You'll be so pleased that chances are you'll never use any other brand of tape again. This is the tape RCA sound engineers developed for their own use, and they won't compromise on quality.

Every inch of Red Seal tape is minutely tested by experts for frequency response, distortion, drop-out, noise, and print-through. It's got to measure up to the stiffest specifications for coating

thickness, anchorage, layer-to-layer adhesion, aging, cupping, slitting and tolerances. Precise controls give every reel the same magnetic properties, the same bias characteristic — so you can use tapes interchangeably. Don't forget to try Red Seal Magnetic Tape soon. Why not take a few seconds right now to fill in the coupon and send for complete details on this new tape today!



The most trusted name in sound

Circle Item 10 on Tech Data Card

Magnetic Tape Products Marketing  
RCA Victor Record Division, Dept. BE103  
155 East 24th Street, New York 10, N. Y.

Please rush me specifics on RCA Red Seal Magnetic Tape including all essential physical and magnetic characteristics.

NAME \_\_\_\_\_  
TITLE \_\_\_\_\_  
COMPANY \_\_\_\_\_  
ADDRESS \_\_\_\_\_  
CITY \_\_\_\_\_ ZONE \_\_\_\_\_ STATE \_\_\_\_\_

## Does Your Station Have the

# "BIG VOICE?"

Are you losing advertisers because you don't have the loudest signal in your area? Are they going to other stations because you don't have the "BIG VOICE?" Only DYNAMIC DIMENSION Control Equipment by FAIRCHILD, individually or integrated, can provide you with an easy-to-listen-to "BIG VOICE"—the loudest and cleanest signal in your area!

### FAIRCHILD DYNALIZER Model 673

The newest approach for the creation of "apparent loudness"—the Dynalizer is an automatic dynamic audio spectrum equalizer which redistributes frequency response of the channel to compensate for listening response curves as developed by Fletcher-Munson. Adds fullness and body to program material. Completely automatic with flexible controls. Easily integrated into existing equipment.



### FAIRCHILD CONAX Model 602

The world-acknowledged device that eliminates distortion problems caused by pre-emphasis curves. Allows higher average program levels through inaudible control of high frequencies. Invaluable in FM broadcast and disc recording. Eliminates stereo splatter problems in multiplex channels.

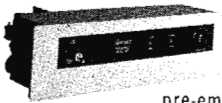

### FAIRCHILD LIMITER Model 670

Fast attack stereo limiter (50 microseconds) with low distortion and absence of thumps. Sum and difference limiting position eliminates floating stereo image, despite amount of limiting used in one of the two channels. Also includes regular channel A and B limiting. Dual controls and dual meters provided. Now used throughout the world in recording studios. (Mono model available).

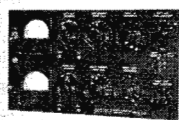

Write to Fairchild—the pocomaker in professional audio products—for complete details.

**FAIRCHILD**  
RECORDING EQUIPMENT CORPORATION  
10-40 45th Ave., Long Island City 1, N.Y.

Circle Item 11 on Tech Data Card

frequency are incrementally controlled by the polarity and amplitude of error voltage derived from this comparison.

The circuitry will usually include a slow and a fast-acting servo. The slow servo has a large time constant (up to 5 seconds) and shift limiting networks which limit the velocity change of the drum to levels that can be tracked in playback should a shift in input-signal phase occur. The fast servo uses the discriminator principle and compares the tachometer output through a direct and tuned circuit branch. The error voltage here is the result of small velocity changes brought about by splices, tape inconsistencies, motor bearings, etc. The two correction voltages are then combined.

A video recorder operating with such a drum servo records and reproduces a perfectly acceptable picture but it is not time coincident with other studio sources and, therefore, cannot be inserted into studio programming without a roll at the switching instant.

A better solution is available in the form of a more sophisticated servo system which performs a 2-step function yielding vertical framing and horizontal coincidence of the reproduced image to the studio sync generator. In the vertical framing mode the servo system adds another step. In addition to the head drum tachometer providing velocity information, it also yields indexing information to indicate which head is in what position. Through the detection of individual field characteristics (i.e., even or odd) and a comparison with the indexing information, the proper video head can be made to read the same signal that it, or any other similar head assembly, wrote with positive positioning. The image coming from this machine will now be vertically synchronous (framed) with the studio source and it is possible to switch back and forth between the recorder and the studio cameras without picture disturbances. The time-base accuracy is in the same order of magnitude as a normal drum servo system, but positional accuracy has been added.

The last and most complex control is the horizontal comparison and control circuit which achieves a positional coincidence between hori-

zontal sync pulses from tape and studio sync of  $\pm .075$  microseconds (Fig. 4). This portion of the servo comes into play only after vertical framing has been achieved and utilizes the horizontal sync from tape as a comparison signal which is matched against the stable horizontal pulses from the studio sync generator.

The error voltage from this comparison is applied to a phase modulator which can rapidly alter the phase of the signal being used to drive the head drum, and so control the positional accuracy of the drum. Although the normal resonant characteristics of the head drum tend to make it hunt at a low-frequency rate (5-10 cycles), the design of this servo includes a feedback loop to extend the response of the drum to beyond 100 cps and thereby permit high-speed correction to take place. The natural momentum of a brass disc spinning at over 14,000 rpm precludes any extensive positional changes occurring at a high rate.

A video recorder operating in a fully synchronous mode can be used in a manner which permits the full integration of that recorder's output with normal studio signal sources. When the VTR output is fed into the switching system in a noncomposite form, all manner of special effects, inserts, split screens, lap dissolves, and fades can be utilized. It is necessary, of course, that under these circumstances the stability of the local sync source be excellent, since any displacement will result in erroneous error signals which will cause horizontal time-base shifting.

**Capstan Servo** — The function of the capstan servo (Fig. 5) is to control the motion of the tape through the capstan so that the video heads scan the recorded tracks as squarely as possible. In the record mode a signal is written along the lower edge of the tape which is derived from the tachometer disc of the head drum. This signal becomes the control track in the playback mode and is compared with the head drum tachometer. The derived error signal controls the oscillator which drives the capstan and brings it into proper phase and frequency to achieve perfect tracking. The capstan servo is relatively simple and its function can be over-ridden by

• Please turn to page 45





## *For distinguished service*

If distinguished service in the field of video tape—for inventing it in the first place, for producing it in commercial quantities in 1957 to meet the scheduling demands of Daylight Savings Time, or for carrying the first taped pictures transmitted via Telstar—would deserve a medal, it might look something like the above.

But much more meaningful than any medal is the overwhelming preference engineers every day vote “SCOTCH” Brand Live-Action Video Tape.

This tape began its career nearly 7 years ago; and not a day has gone by since that 3M research in video recording and tape making hasn't been at work improving on this “seven-league-boots” head start. And in the audible range recording field as well, 3M is constantly developing refinements and improvements that set the standards in tape technology. “SCOTCH” Video Tape as well as “SCOTCH” Sound Recording Tapes put this experience and lead time at your service.

“SCOTCH” IS A REGISTERED TM OF 3M CO., ST. PAUL 19, MINN.

# VARIABLE WIND FOR THE TR-11

Frank Faniola\*

— How to add a variable-speed forward and rewind control to the popular TR-11 recorder.

If you have become accustomed to using the deluxe RCA TRT-1 series tape machine, their Model TR-11 leaves a few things to be desired. One of the major lacks is a **variable-speed** forward and rewind. Adding this feature increases flexibility in cueing and editing tapes, and prevents whip lashing the ends of a tape that is wound completely off the machine.

The parts are available from RCA and should cost less than \$80.00. The modification requires one each of the following:

Variable  
Transformer ...RCA Stock Number 218276  
Relay 4PDT 24  
volt DC Coil...RCA Stock Number 221793  
Push Switch ...RCA Stock Number 219650  
Push Button ...RCA Stock Number 219654

You can probably purchase a pair of Paragon timer-switch trippers locally for about fifty cents. These trippers are mounted on the autotformer plate as stops (Fig. 1); the positioning will be covered later. A little filing of the plate or the trippers may be necessary to get them mounted properly. The Wind

\*Assistant Chief Engineer, WCYB-TV, Bristol, Va.

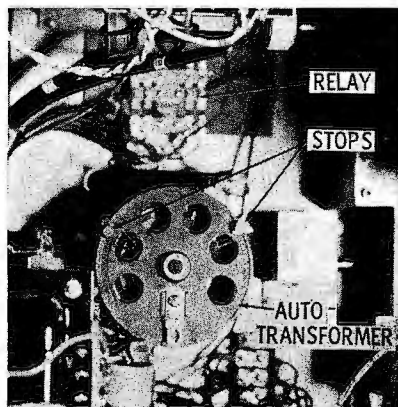

Fig. 1. Control position at rear of panel.

control is mounted on the tape transport panel as shown in Fig. 2. This location is convenient for operation as well as for wiring. The last item is a 1/8" metal plate, 3"x6" (Fig. 3). The 4PDT relay is mounted in the approximate center.

In the TR-11 instruction book, refer to section TTP, Fig. ATT4, Tape Transport Schematic. Relay K-3 is the conventional rewind relay; when this modification is completed, its contacts 6 and 8 will apply 24 volts to the new control relay coil. Instead of placing the machine in Rewind, K3 will place the machine in the Wind mode (forward or reverse) under control of autotransformer.

From a position in front of the machine and using the approximate center of the Shoe Pressure adjustment knob as the first reference point, measure down 1 1/4" (Fig. 2). Using this point as a second reference, measure across 3 3/4" and drill a 3/8" hole for the variable transformer shaft. Place the control template over the shaft hole and mark the three mounting holes. Use an 11/64" bit for the mounting holes and be sure the transformer is mounted with the terminal strip **up**.

From the center of the 3/8" transformer shaft hole, measure across 3 1/2" and drill a 3/4" hole for mounting the Wind button. For "looks", three flat 1/4" x 8-32 closet-handle bolts were purchased from a local hardware and used for mounting of the variable transformer.

There are four threaded holes just below the upper reel motor at the rear of the tape transport panel; mount the new relay-plate assembly in these holes with 8-32 machine screws, positioning the re-

lay contacts downward.

After making sure all power has been removed from the machine, remove and discard the following leads (Fig. 4):

1. The black jumper going from K3 pin 6 to K2 pin 6. (Note — This lead may already have been removed.)
2. The lead going from K3 pin 5 to K1 pin 5.
3. The lead going from K3 pin 8 to terminal block TB8-6.
4. The lead going from TB8-7 to T1 secondary tap 2.
5. The lead going from terminal block TB8-8 to K2-8.

Wire the unit according to the schematic in Fig. 5, using No. 16 or larger wire. Note that the relative position of components and terminal blocks in this figure are as seen from a position behind the rack that contains the tape transport panel.

The contacts of the newly installed Wind button are wired across the contacts of the conventional Rewind (RW) button (which, incidentally, also becomes a Wind button). However, since these RW contacts are not easily accessible, we chose to wire this pair as follows:

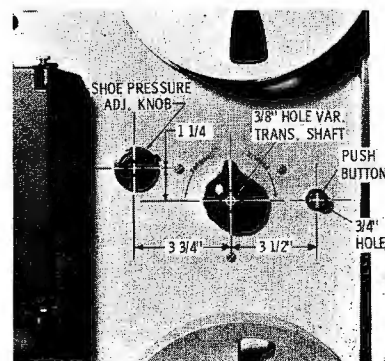
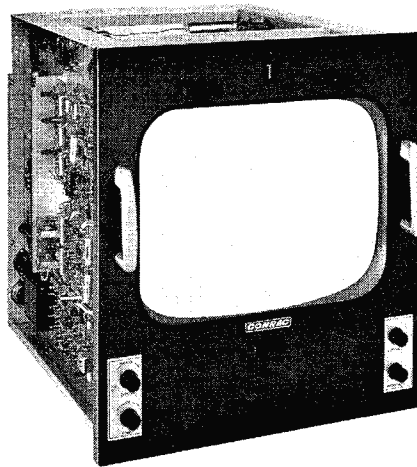

Fig. 2. Location of control and button.



**Conrac's 17" color monitor:  
\$2450, shipped next week**

The Conrac CYA 17 puts color where your black and white monitors used to be; right in 21 vertical inches of a standard 19" rack or console.

The CYA 17 weighs less than 100 pounds (101 transistors and 21 tubes).

Are there more features? We've just scratched the surface. Just ask anyone who attended the NAB show. Or request a CYA 17 data bulletin.

**CONRAC** **DIVISION** *Glendora, Calif.*  
GIANNINI CONTROLS CORPORATION

Circle Item 12 on Tech Data Card

Superb quality... moderately priced  
 ... the preferred choice on five continents

# SPOTMASTER 500A

## TAPE CARTRIDGE SYSTEMS

... NOW FEATURING DELAYED PROGRAMMING

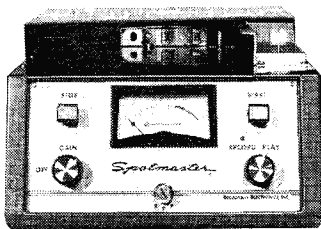

500A—complete record/playback unit

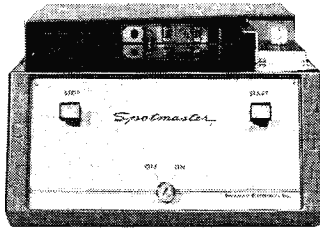

505A—playback unit



The new SPOTMASTER 500A series of tape cartridge equipment is winning praise and acceptance throughout the world. These rugged, dependable machines provide snap-in cartridge loading, and split-second, one-hand operation . . . combined with high quality, wide range reproduction and all the time-tested, field-proven SPOTMASTER features.

And now something more has been added—the optional SPOTMASTER 500 A-DL Delayed Programmer. Designed to provide a 6-second to 16-minute delay in the broadcast of program material, the 500 A-DL makes possible “instant censoring” . . . lets you delete objectionable program material from

interviews and other live originations while the program is on the air. The 500 A-DL may also be used to meet many other delayed programming requirements. With the DL function switched off, the unit operates as a standard 500A recorder/playback.

On five continents, more stations use more SPOTMASTERS than any other cartridge tape system. Write or phone for full information; learn about the SPOTMASTER lease/purchase plans . . . mono and stereo models . . . rack-mount or compact models . . . complete line of equipment and accessories . . . 24-hour-a-day ruggedness and dependability . . . ironclad, full-year guarantee.



**BROADCAST ELECTRONICS, INC.**

8800 Brookville Road, Silver Spring, Maryland

Telephone: Area Code 301 • JUNiper 8-4983

Sold nationally by:

**VISUAL ELECTRONICS**

856 W. 40th St., New York, N.Y.

Canada:

**Northern Electric  
COMPANY LIMITED**

Branches from coast-to-coast in Canada

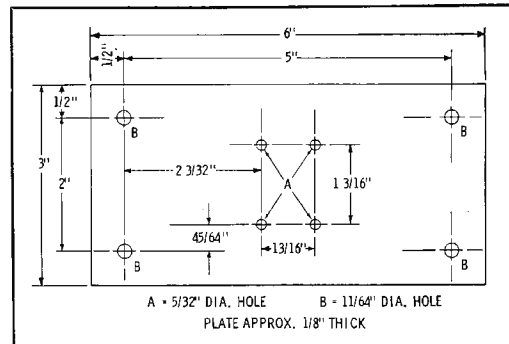

Fig. 3. Diagram of relay mounting plate.

1. Remove TM-15 monitor from the machine.
2. Remove 2 sheet metal screws that will release the door which covers the wiring for the control panel diode bank.
3. Dress the Wind button wires into the control panel compartment from the bottom through one of the round vent holes.
4. Solder one lead to the **cathode** side of diode B1.
5. Dress the remaining lead back out of this compartment towards the front of the machine to the Servo-Sync toggle switch. This switch is labeled “INT/60 . . . EXT” on the control panel. The lead must be soldered to the hot side of the switch to pick up the 24 volts DC. Looking from in front of the machine, this will be the lug on your right.

Remove diode B3 from the diode bank and place a piece of electrical tape over the socket so that a diode will not inadvertently be inserted at a later time. This completes installation and wiring.

In order to prevent throwing too much slack in the tape when operating the Wind control on fast forward or rewind, the transformer stops must be positioned as follows:

1. Apply power to the machine.
2. Place a 90 minute reel of tape on the transport panel. (A 1 hour reel may be used if a 90 minute one is not available but it may be necessary to readjust stops if a larger one is used.)
3. Wind about half-minute of tape onto the takeup reel.
4. Turn the Forward - Reverse (Wind) control toward reverse until the tape just begins to rewind, and press the control panel Stop button.

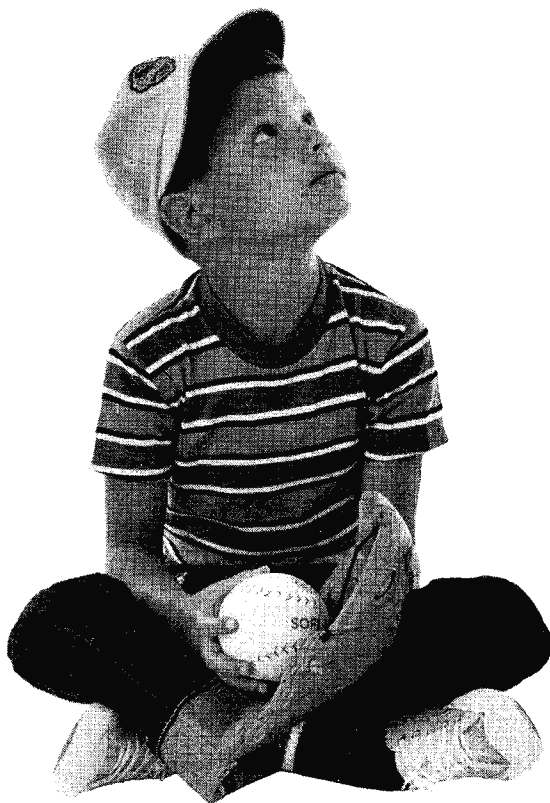

## This klystron was made the day that he was born. It is still in use today.

He's six years old. So is Eimac's 3K50,000LF power klystron. It is still going strong after 50,000 hours of almost continuous operation. That kind of performance is no accident. Long life is confidently planned — and realized — in Eimac's power klystrons. (And long life means lower cost to you.) We're able to do this because we know klystrons inside and out. We ought to. We've had more ex-

perience with more of them than any other manufacturer. May we put this experience to work for you? For details about a long-life Eimac klystron to meet your specific range and requirements write today to: Eitel-McCullough, Inc., San Carlos, California. Subsidiaries: National Electronics, Geneva, Illinois; Eitel-McCullough, S.A., Geneva, Switzerland.





**SPARTA-MATIC 300** Tape Cartridge System playback unit in a custom styled cabinet. Transistorized solid-state design, coupled with functional beauty.

**300P and 300R** for a record/playback combination. Units may be readily removed for remote use or maintenance. Brackets for 19" rack mounting are supplied.

**300P** units may be grouped in cabinet holding one to three playbacks. Custom cabinets finished in durable Dove Gray plastic laminate. Other colors available.

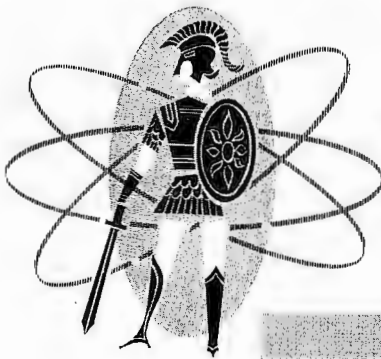

# SPARTA

## FIELD REPRESENTATIVES:

A. C. McMILLAN, Portland, Oregon, CH 4-7830

C. E. FELTNER, JR., Kingsport, Tenn., WA 6-8188

EUGENE D. BRADLEY, Phoenix, Arizona, AM 6-2292

U. L. LYNCH, Grand Island, Neb., DU 2-4183

MILAN LEGGETT, Dallas

GENERAL ELECTRONIC LABORATORIES, Cambridge, Massachusetts, UN 4-8500

**SPARTA-MATIC 200** Tape Cartridge System offers rugged simplicity with proven reliability. Attractive pricing that fits any Broadcasters budget.

**200RP** record/playback offers transistorized control circuitry for improved toneburst cueing. Compatible with all others, yet priced 20 to 40% less.

**200RP STEREO** record/playback for full fidelity FM broadcasting. Frequency response  $\pm 2$ db from 30 to 12,000 cps; wow and flutter under 0.2% RMS.



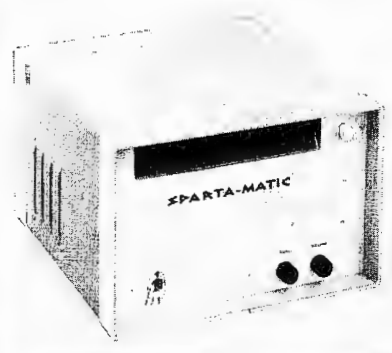
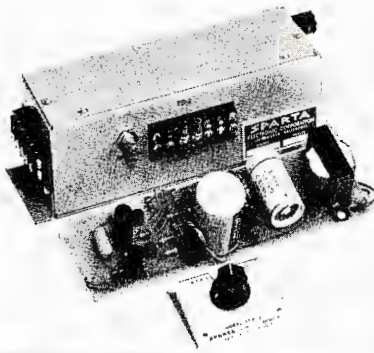
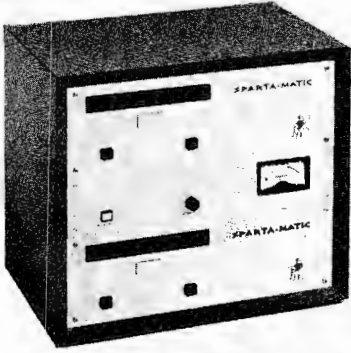

**300RPP** combination is another example of how 300 Series may be grouped to meet any requirement. The record amplifier may be used with either playback unit.

**TEP-2 EQUALIZED TURNTABLE PREAMPLIFIER.** All transistorized with self contained power supply and balanced output. Performance exceeds industry standards.

**CP-5 PORTABLE TAPE CARTRIDGE** playback. Light weight with convenient carrying handle to audition spots or programs anywhere in the station or clients office.

## QUALITY + ACCEPTANCE = GROWTH

Success can be measured in a number of ways . . . but, this is the formula that has made a record sales year for Sparta. What better proof of excellence of product and service can anyone offer in a competitive industry?

CALL, WRITE OR WIRE SPARTA ELECTRONIC CORPORATION, 6450 FREEPORT BOULEVARD, SACRAMENTO 22, CALIFORNIA. AREA CODE: 916 421-2070

Circle Item 16 on Tech Data Card

, Texas, DA 1-2981

HERBERT L. ARMS, Salem, Indiana, 883-5750

CHARLES A. SPRAGUE, Grand Rapids, Mich., GL 6-5461

JESS SWICEGOOD, Dothan, Alabama, SY 2-2161

**A-10 AUDIO CONSOLE** provides a total of eight inputs selected through four mixing channels with completely transistorized circuitry and plug-in modular construction.

**A-50 PORTABLE STUDIO** for production, remotes and Main studio. Four microphone, two turntable, and two tape machine inputs. Screw-in legs and bench/lid allow quick set-up.

**CT-12 CUSTOM TURNTABLE CONSOLE** complete with Sparta TEP-2 equalized preamplifier, turntable, tone arm and pick-up cartridge. Also available in 16" model.



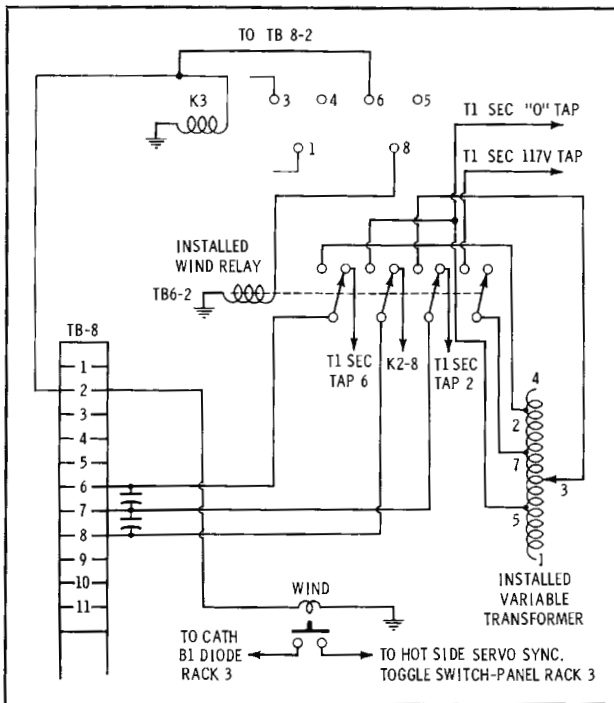

Fig. 4. Diagram showing original wiring modified for control.

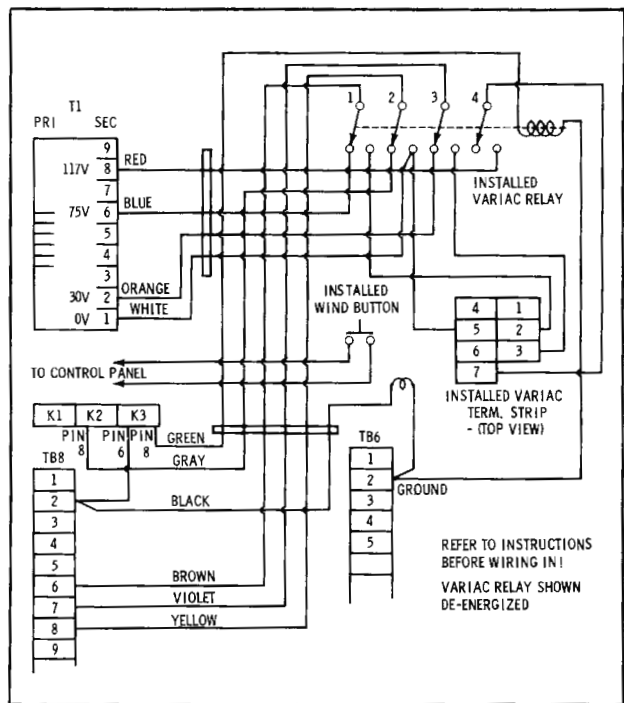

Fig. 5. Wiring diagram for control, relay, and pushbutton.

5. Remove power from the machine and adjust the stop so the sliding arm of the autoformer cannot move any further in the reverse direction.
6. Reapply power, and wind all but about one minute of tape onto the lower reel.
7. Repeat the above procedure, using the Forward position of the wind control, and adjust the remaining stop. ▲

## INDESTRUCTIBLE?

Not quite. But you might think so if you saw our repair records! E-V professional microphones just seem to keep on going no matter what you do to them.

That's why we can afford to offer an unconditional two year guarantee against failure for any reason. (Just one exception . . . don't scratch the finish—we charge to fix that!)

Two years is a mighty long time, but E-V also offers a lifetime guarantee against defects in materials or workmanship. And our out-of-warranty repair charges are the most reasonable in the industry.

You profit every day from the dependability of E-V professional microphones. Isn't it time to follow the lead of major networks and leading independent studios? Switch to Electro-Voice—dependably better!



ELECTRO-VOICE, INC., Commercial Products Division, Dept. 1131V, Buchanan, Michigan

Circle Item 17 on Tech Data Card

**Electro-Voice**

BROADCAST ENGINEERING



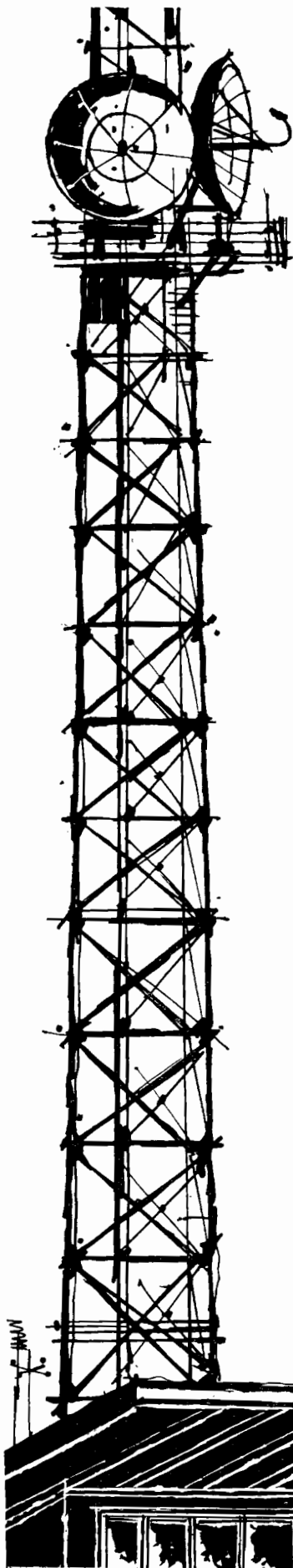

# SARKES TARZIAN STL MICROWAVE RELAY SYSTEMS Give YOU All of These PLUS VALUES

- Transistorized Electronics
- 10 Watts Power Output
- Self-Contained Load Isolator
- Integral Frequency Indicator
- Integral Cavity Discriminator Demod
- Built-in Reflectometer
- Full Maintenance from Front
- Compact Design
- Diff Phase  $<1^\circ$  10%—90% APL
- Diff Gain  $\pm 0.5\text{DB}$   
10%—90% APL
- Linearity  $\pm 0.5\text{DB}$   
10%—90% APL
- Tilt  $<1\%$
- Temperature Compensated
- Electronically Regulated Power Supply
- Complete Front Panel Metering
- Fully Test Pointed
- Rugged Drawer Pull Out Construction

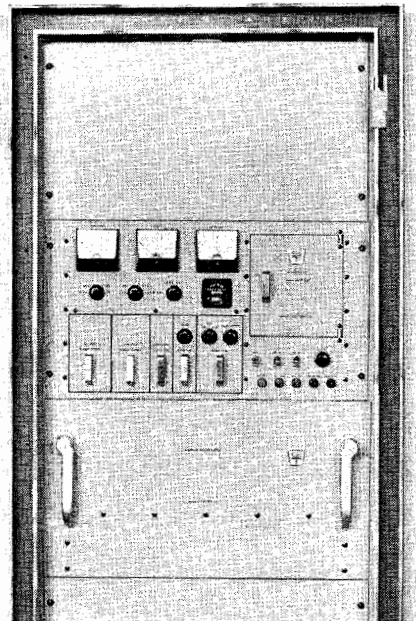

## Engineered for the Engineer TOP QUALITY—RELIABILITY

In designing this new TV Studio Transmitter Link, Sarkes Tarzian has incorporated every convenience for both operator and engineer. All equipment is contained in 21 inches of rack space. Transmits NTSC color or monochrome simultaneously with broadcast quality audio.



Broadcast Equipment Division  
**SARKES TARZIAN, INC.**  
Bloomington, Ind. • EDison 2-7261

# A LOW COST TAPE DELAY SYSTEM

by **Richard A. Silverberg\*** — An outboard assembly for delaying telephone conversations and producing special effects.

Has your station ever considered doing a live telephone interview program, but rejected the idea because there was no convenient means on hand to delay the telephone conversations? WCTC's chief engineer, Clarence Dingman, overcame the problem by building an inexpensive outboard tape delay assembly.

While this assembly was designed for an Ampex 351, a similar unit may be constructed for almost any studio tape recorder. The primary consideration is locating a second playback head between the record head and takeup reel, leaving several seconds of tape travel between the record and extra playback heads. This allows the boardman to monitor the recorded program, and gives him sufficient time to kill the audio if an obnoxious caller gets on the phone.

## Construction

The delay assembly was con-

\*Staff Engineer, WCTC-AM-FM, New Brunswick, N. J.

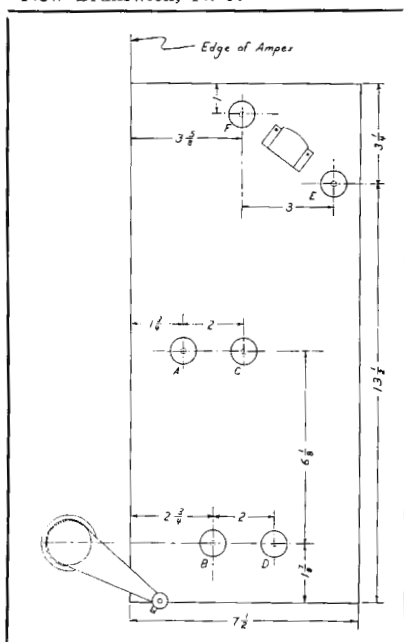

Fig. 1. Layout diagram of delay device.

structed on a 17 $\frac{3}{4}$ " by 7 $\frac{1}{2}$ " by  $\frac{1}{4}$ " aluminum plate, bolted to the edge of the rack in which the recorder is mounted. Six Magnecord flanged roller-type guides were positioned as shown in Fig. 1. A Magnecord low-impedance record/playback head feeds into a phono preamplifier, modified for tape equalization, through matching transformer.

Alignment was simplified by using both Magnecord guides and head. The only adjustment necessary was in the mounting of the plate; this was done with shims.

## Tape Guides

The positioning of the tape guides was chosen to give maximum flexibility in the selection of delay times. Threading from the takeup tension arm, over guide A, under B, over C, under D, over E, and over F gives the maximum delay of seven seconds. Omitting guide C produces a five second delay. A three second delay may be achieved by omitting guides B, C, and D. All these delay times may, of course, be cut in half by recording at 15 ips.

The playback head was positioned between guides E and F to ensure a satisfactory amount of tape wrap. Alignment was accomplished with the screw on the Magnecord head, using a 10-kc tone. For convenience, the output of the preamp was brought out to a patch board. The assembly is shown in Fig. 2.

## Operation

In operation, the entire program is delayed; e.g., for seven seconds. Microphones as well as beeper phone are run through the board in the auxiliary control room. The boardman here rides gain and controls the entire program, killing the audio if necessary. The output of the delay head is then fed into the main control room where it is aired.

To begin the show, the machine

is started on record, and the boardman in the main control room simply cues the MC seven seconds before completing the program lead-in. This procedure eliminates confusion which may result from delaying only phone calls.

Another use to which the delay unit may be put is in duplicating a particular sound. Audio is simply recorded on tape while the delay head is feeding into the board. Delay time is varied by changing the threading until it corresponds with the length of the sound to be reproduced.

Total cost of the delay assembly may be very low if enough parts are available. The Magnecord head was selected in this case because there was an extra one in the shop. Using a high impedance head will eliminate the cost of a transformer. Guides may be purchased from a Magnecord distributor, or any inexpensive tape guides may be substituted. The preamplifier may even be eliminated if one of the mike preamps in the board can be modified for tape equalization. ▲

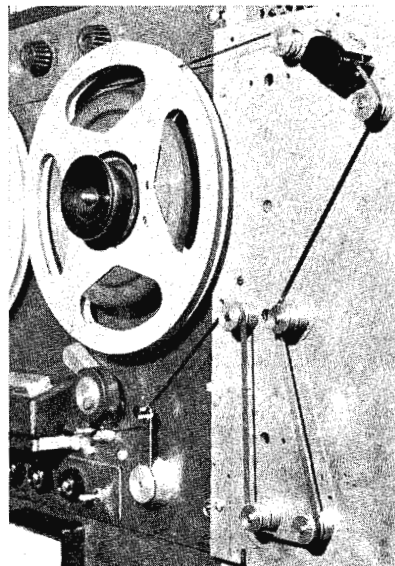

Fig. 2. Completed unit mounted on equipment rack adjacent to recorder.



It's a fact...

G. E.'s 7629 and 8092

image orthicons are

highly sensitive,

long-lived tubes...

up to 9000 hours and more...

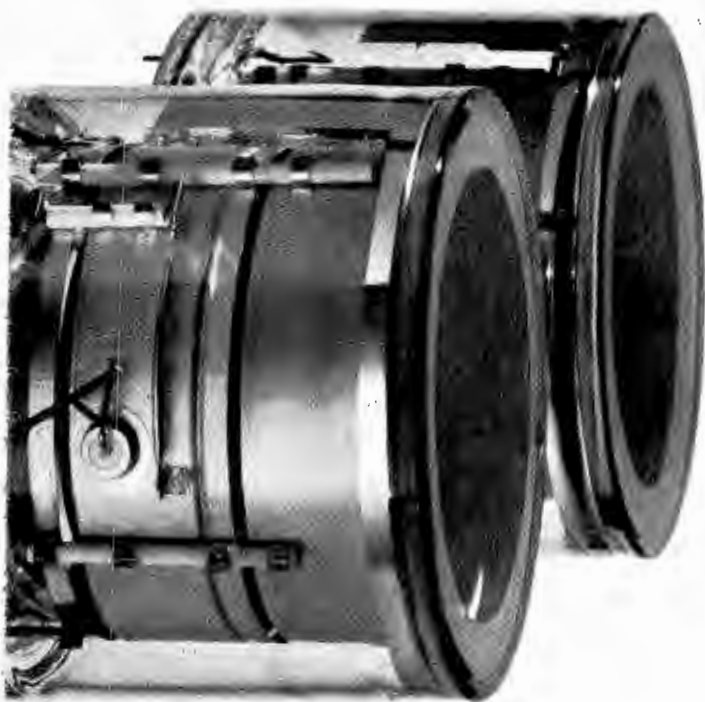

signal-to-noise ratios,  
however, were a bit low...

(36:1 and 34:1 average)

Now, in the "A"  
versions, we've quieted  
them down...

(to 48:1 and 37:1)

**HOW?** . . . with design improvements utilizing semiconductor target material. G. E.'s new I.O.'s are designated the GL-7629A and GL-8092A . . . why don't you try one in your camera? In fact, try the whole line of newly improved G-E image orthicons: G-E Type GL-5820A, S:N—48:1/GL-7293, S:N—45:1/GL-7629A, S:N—48:1/GL-8092A, S:N—37:1/GL-8093, S:N—55:1. **For your free facts folder**, containing data and application notes on the expanding line of G-E image orthicons and vidicons, write to General Electric Company, Room 8005, Owensboro, Kentucky, or call your nearest G-E Industrial Tube Distributor, today!

# UPDATING AUDIO REPRODUCING EQUIPMENT

**Technical Talks\*** — How to get the most out of tape and disc equipment in the studio.

In the modern radio station sound quality is generally good; certainly in most cases it is superior to the sound of ten or more years ago. This is due in part to the fact that the FCC has imposed the licensing requirement that a periodical and audio proof-of-performance test be made. Although these tests are sometimes regarded as a nuisance, they are in fact somewhat of a blessing in disguise.

The occasional listener to your station will probably be more critical of its sound than those who are exposed to it day and night without any outside standards of comparison with other stations. A gradual deterioration of sound quality may be overlooked by such constant listeners as your own engineers. This month, I propose to review some ways to update your audio reproducing equipment, and investigate that gradual deterioration.

## Disc Systems

Despite the tremendous increase in the use of magnetic tape, the disc recording is still playing a major part in the lives of most station equipment and engineers. You assume your pickup and amplifiers are playing their parts properly, and the audio proof-of-performance shows no distortion, so you think you've got it made! But this is not always so.

Maybe there is a strange type of distortion that seems to blur your sound and introduce a "scratchy" or "muddy" feel to your music? Everything checks out okay, but it still doesn't sound "just right." Have you considered turntable rumble? Rumble doesn't have to be audible to cause trouble, especially if you are running a high quality system

with extended high frequency response.

The most apparent effects of rumble are severe intermodulation of higher frequencies; the higher the frequencies, the greater the distortion. An idea of what happens can be had by applying a very low-frequency signal to an audio system. If the level is right, you will not hear the low-frequency itself, but there will be a ragged (frog-in-the-throat) feeling to the other sounds. Intermodulation is occurring, and the low frequencies are modulating the higher ones, thus producing a mixing of harmonics that is unpleasant to the ear.

NAB has established a set of standards for disc recording, and among them are some useful figures. For rumble: The noise output of a pickup and equalizer should be more than 35 db below the reference level of 100 cps at a peak velocity of 1.4 cm/sec.

The actual measurement of intermodulation or rumble is not always easy. Test equipment for measuring rumble may not be ready at hand. A simple way of checking for rumble is to connect a VU meter and an amplifier with a lowpass

filter to the output of the equalizer and play a quiet, clean cut on an acetate disc. Turn up the gain, and listen for the characteristic sound of rumble with the gain very high. If it is present, the VU meter will indicate it, even though you may not hear it. From here on, the cure is mechanical — isolation of the equipment, maybe new mountings, and perhaps a new pickup arm or mounting.

In general, keeping good sound quality coming from disc equipment is not too difficult if proper maintenance methods are employed. Sometimes, modernizing will help, but this is a personal thing on the part of the engineer concerned. Loss of high frequency response can often be traced to the pickup; either needle wear or equalizer deterioration will cause it. So will unwanted capacitance in the audio lines to or from the console. Modernization means bringing old installations up to date. One of the easiest methods of revitalizing an old installation is by the acquisition of a variable equalizer; by suitable adjustment, you can often make an older pickup give a greatly improved sound.

Stereo, of course, is on everyone's lips these days. If you are running stereo FM, some pointers may save you time when listeners report poor reception.

Crosstalk between the two channels is likely to be the major problem. If the transmitter and antenna are operating properly, and there is no leakage to cause crosstalk within the audio equipment, your problem should be solved by the installation of another pickup or stylus. First, however, play a few different brands of records on the old pickup; some recordings have been known to produce crosstalk with certain pickups.

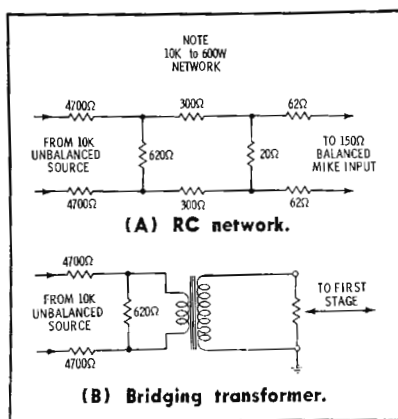
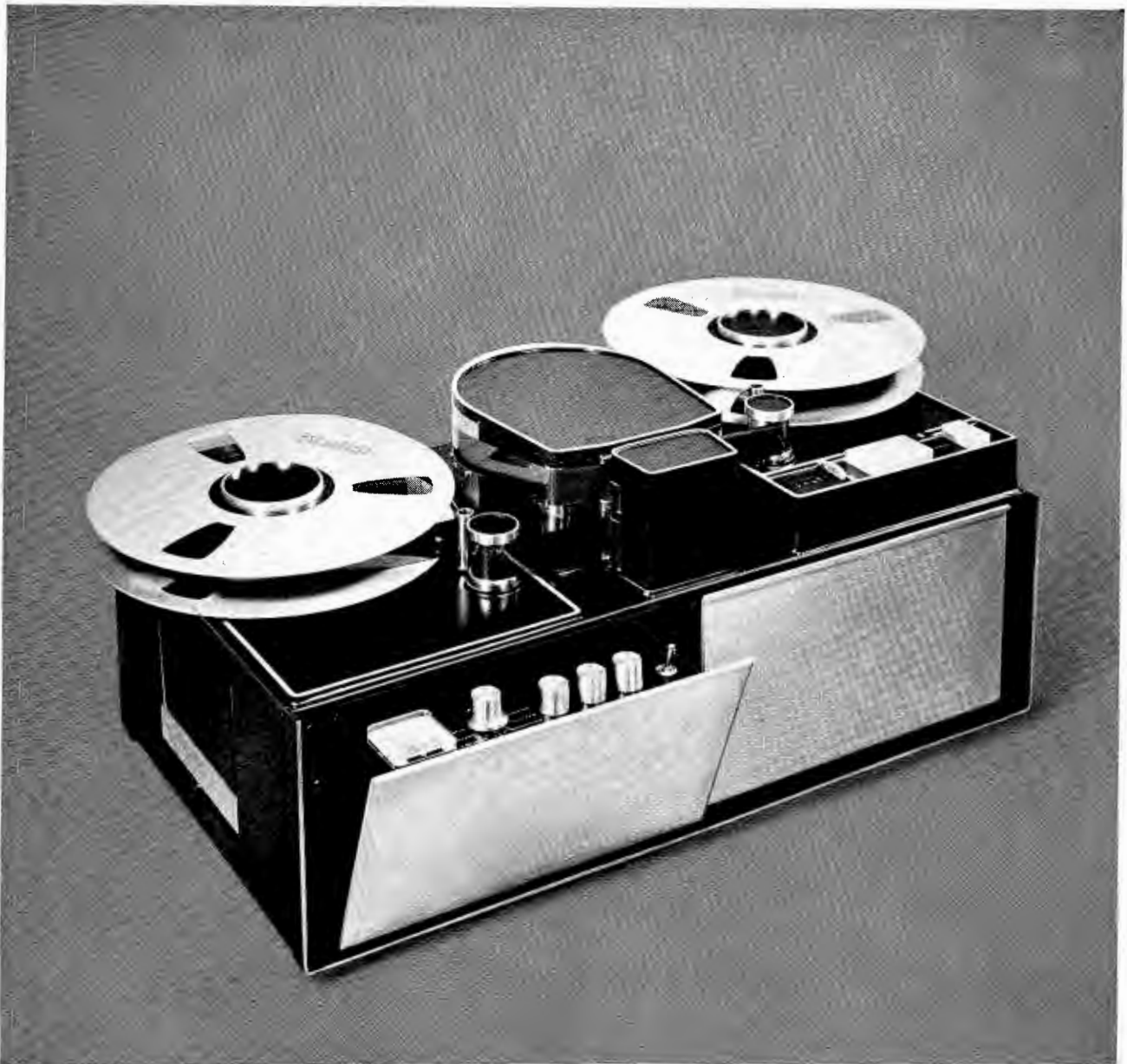

Fig. 1. Two circuits for matching unbalanced sources to balanced input networks.

\*By John H. Battison, Consulting Editor, Annapolis, Md.



THIS PORTABLE TV TAPE RECORDER WON TWO DESIGN AWARDS THIS YEAR.\* WHAT'S MORE IMPORTANT, IT WORKS EVEN BETTER THAN IT LOOKS: THERE'S PRIDE OF WORKMANSHIP IN EVERY PART, AND THE PERFORMANCE PROVES IT. IT RECORDS OR PLAYS BACK BROADCAST-QUALITY SIGHT-AND-SOUND ON ONE-INCH TAPE AND IS AVAILABLE NOW.

**MACHTRONICS  
MAKES IT**

**STORER  
PROGRAMS  
SELLS IT**



500 Park Avenue, New York 22, N. Y.

\*Master Design Award from **Product Engineering** and 1963 WESCON Pacesetter Award for Industrial Design.

Circle Item 20 on Tech Data Card

# SAMS TECHNICAL BOOKS

of special interest to Broadcast Engineers

## Know Your VOM-VTVM

by Joseph A. Risse

Complete details on principles of design, operation, application and maintenance. Explains how to use VOM's and VTVM's for measuring capacitor value and leakage, forward and reverse rectifier tests, fuse testing, open filament checks, battery testing, and sensitive-circuit measurements. Covers procedures for meter-movement testing, calibration, etc.

Order **KVM-1** .....Only **\$2.50**

## KNOW YOUR OSCILLOSCOPE

by Paul C. Smith

Popular companion volume to the above, providing complete information on circuitry, operation, calibration, maintenance, and applications for this important test instrument.

Order **KOS-1** .....Only **\$2.00**

## Understanding and Using the Slide Rule

by Electronic Teaching Labs.

Fully describes all the various operations you can perform with different types of rules; discusses logarithms and scientific notation. Every operation is clearly explained, with numerous illustrated examples showing how each is performed, what can be expected in the way of accuracy, and alternate methods of working out solutions.

Order **SRT-1** .....Only **\$1.95**

## Broadcast Engineering Notebooks

by Harold E. Ennes

### Vol. 1: Television Tape Fundamentals

Order **BEN-1** .....Only **\$5.95**

### Vol. 2: AM-FM Broadcast Operations

Order **BEN-2** .....Only **\$5.95**

### Vol. 3: AM FM Broadcast Maintenance

Order **BEN-3** .....Only **\$5.95**

## License & Reference Handbooks

by Edward M. Noll

### First-Class Radiotelephone License Handbook

Order **BON-1** .....Only **\$4.95**

### Second-Class Radiotelephone License Handbook

Order **QAN-1** .....Only **\$3.95**

## Electronics Math Simplified

by Alan Andrews

### Two-Volume Slipcase Set

Order **MAT-20** .....Only **\$7.95**

### Dictionary of Electronics Communications Terms

by Howard W. Sams Engineering Staff

Order **COM-1** .....Only **\$3.95**

### International Code Training System

Complete programmed text plus 3 LP records.

Order **CTG-1** .....Only **\$6.95**



In addition to the usual equipment checks for crosstalk, don't forget to check the stylus! Sometimes excessive wear on one side, or even both sides, will cause a transferral of mechanical motion from one stereo track to the other and thus generate crosstalk voltages in both pickup circuits. It is good to keep a spare head on hand to use for a quick check.

Should you — perish the thought — be using crystal cartridges in a low-cost pickup and arm, be sure to keep an eye on the temperature in their working area. Heat will damage crystals very easily, and sometimes create strains that produce crosstalk voltages.

## Magnetic Reproducing and Recording

One tape recorder function that is often misunderstood is the bias oscillator. This actually serves two purposes: one, to prevent distortion during recordings; and the other, to provide an erasing signal to "clean" the tape before use.

Two types of erase and bias systems are in general use — the RF oscillator and the permanent magnet. The permanent magnet or DC system is found only on very old or inexpensive recorders for portable work. The main objection in the use of DC (permanent magnet) erasing and bias is to the increased noise thus produced. When RF is used for these purposes, the tape is left completely unmagnetized and hence far quieter. The frequency of oscillation is generally in the 50 kc to 100 kc range, far above the audible limits. The frequency, and the current amplitude, for recording bias is very important; it can affect the results greatly.

If your tape recorder is one of the lower cost models using permanent magnet type of erase and bias, and you have been receiving complaints of noise and poor tape quality, it would be worthwhile to consider purchasing at least one machine with RF erase and bias. If your present equipment uses RF bias, but quality is poor and recordings low in volume, you should check the value of bias current.

An easy way to do this, if your recorder does not provide built-in means, is to record a signal of 900 cps at various levels of bias. Note the bias level that produces the maximum signal on your VU meter

**SEND NO MONEY • FULL RETURN PRIVILEGE**

Howard W. Sams & Co., Inc., Dept. BE-1163  
4300 W. 62nd Street, Indianapolis 6, Ind.

Send me the following books:

- |                                |                                |                                        |                                                          |
|--------------------------------|--------------------------------|----------------------------------------|----------------------------------------------------------|
| <input type="checkbox"/> KVM-1 | <input type="checkbox"/> BEN-2 | <input type="checkbox"/> MAT-20        |                                                          |
| <input type="checkbox"/> KOS-1 | <input type="checkbox"/> BEN-3 | <input type="checkbox"/> COM-1         |                                                          |
| <input type="checkbox"/> SRT-1 | <input type="checkbox"/> BON-1 | <input type="checkbox"/> CTG-1         | <input type="checkbox"/> BILL ME (I pay postage)         |
| <input type="checkbox"/> BEN-1 | <input type="checkbox"/> QAN-1 | <input type="checkbox"/> FREE Booklist | <input type="checkbox"/> \$.....enclosed. Send postpaid. |

Name .....

Address .....

City ..... Zone ..... State .....

**ORDER TODAY**

Circle Item 48 on Tech Data Card

when the tape is played back. Then make more tapes, at gradually increasing bias levels, until you reach one that causes a slight falling off in output. You have now reached the knee of the bias curve, and any further increase will merely result in weaker output and greater distortion. Now set the bias level just between the value for maximum recorded signal and the knee. This is the optimum point.

Some stations have to get by with a low-cost tape recorder which doesn't contain professional input circuits for use with balanced lines and inputs. If this is the case in your station, it can be a source of poor quality and distortion because of the unbalance introduced by the tape input circuit.

Fig. 1 shows a way of overcoming this unbalance problem in low-cost recorders. Two methods can be used — a bridging pad or a transformer. The latter is preferable because it provides DC isolation between the recorder and input circuit, and this is sometimes advisable.

If the pad method is used, it is best to place an impedance-matching pad after the bridging pad; this reduces the loss in the restrictive network and improves the frequency response. The 150-ohm to 10K matching network has a loss of 61 db. However, signal level is seldom a problem in this type of operation, and it is a simple matter to crank up the gain to restore the desired level.

The transformer method requires a good quality unit, matching 600 ohms to 50K, and an input bridging pad. The transformer will provide a voltage gain which partially offsets the pad loss, and the improved match more than compensates for the loss in signal level.

If your station is older, you may find the tubes used are a source of poor audio quality. Believe it or not, there are still some stations using directly heated tubes in the audio system! Change these to indirectly heated types; the results are worth the trouble.

Thus, if you keep your eyes open for faulty or old-fashioned equipment, you can carry out a continuing program of maintenance and modernization. There is no substitute for a clean audio signal to give a station the reputation for modern, quality operation. ▲



### The TURNER

## Model 500 CARDIOID MICROPHONE

- Smooth, uniform response
- Minimal popping and breath noises at close range
- New Dynaflex diaphragm for maximum uniformity
- Excellent sensitivity
- Rugged, yet graceful, slender design

Because of their unique design, the Turner 500 cardioids are universally interchangeable without variations in sound quality. Write today for complete specifications.

**THE TURNER MICROPHONE COMPANY**  
907 17th Street N.E.  
Cedar Rapids, Iowa

IN CANADA: Tri-Tel Associates, Ltd.  
81 Sheppard Ave., West  
Willowdale, Ont.

EXPORT: Ad Auriema, Inc.  
85 Broad Street  
New York 4, N.Y.

Circle Item 21 on Tech Data Card

# ENGINEERS' EXCHANGE

## Cartridge Unit Speed Accuracy

by James Somich, WGAR Radio,  
Cleveland Ohio



Fig. 1. "Standard" tape cartridge in use.

Speed accuracy of standard professional reel-to-reel tape machines has never been a major problem. The small amount of drive contamination plus the husky three-motor tape-drive systems and massive flywheels have stabilized speed variations in professional tape transports to .1%, and lower. Smaller cartridge tape machines, however, exhibited greater variations in speed regulation. The smaller tape-drive systems and graphite contamination from the lubricated tape sometimes results in poorer than usually-accepted performance. (A tape strobe held on a professional reel-to-reel recorder will show practically zero speed variation; the cartridge machine may not give nearly as favorable an indication.) Thus, new attention is being given to tape transport speed regulation accuracy.

Since it is difficult to determine actual percentage of speed variation using a strobe device (because the

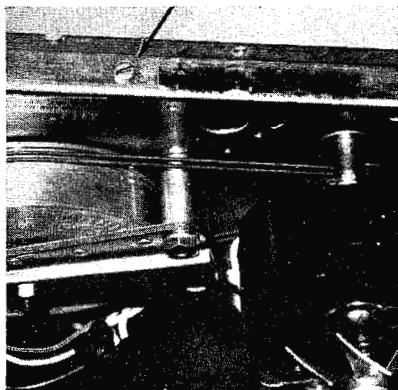

Fig. 2. Pressure roller adjustment screw.

arrangement prevents the use of strobe with some cartridge decks), a new method was needed to determine—simply and accurately—the speed variation in these cartridge-tape units.

The system outlined here is simple and direct reading. It allows anyone to determine the percentage of speed variation of cartridge tape units, and has been adopted at WGAR providing us with excellent results.

The procedure is based on the use of a "speed standard" test cartridge. Load a cartridge with exactly 100 seconds of tape (at 7.5 ips). Either measure the 750 inches of tape or run it off on a machine of known accuracy. Using a stopwatch, it is possible to read the speed error directly in percentage (Fig. 1). For example, if the cartridge plays back in 99.5 seconds, the machine is running .5% fast. If you prefer greater accuracy, the cartridge can be loaded with additional tape in multiples of 100 seconds.

If a cartridge is loaded with 200 seconds of tape, each second of variation will represent .5%. With a stopwatch graduated in tenths of a second, the smallest measurable deviation will be .05%. Since machine specifications generally do not specify inaccuracies greater than .5%, this measurement is more than precise. By measuring all of your machines and the master recorder, it is possible to compare each unit's percentage of speed deviation. For most purposes, a deviation from the master of  $\pm .5\%$  is acceptable. For critical musical recording a timing accuracy of .25% is suggested.

Record a cue burst on the tape to measure the exact running time of the "standard."

Be sure to thoroughly clean the rubber idler wheel before measuring speed accuracy—a graphite contaminated wheel can cause as much as 1% variation.

Generally, off-speed operation is due to lack of lubrication or contamination of some component of the tape drive system. Avoid ad-

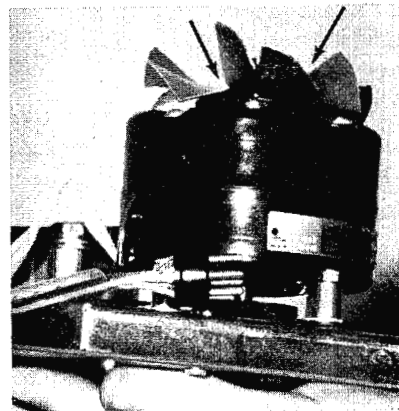

Fig. 3. Two drive motor lubrication points.

justing the idler roller (Fig. 2) pressure to compensate for off-speed operation. Misadjustment of this roller can result in overworking the motor or solenoid drop-out. A quarter turn adjustment is the maximum allowable under any conditions. Remember that the tape drive system is really very simple and that contamination and lubrication should be checked before you alter critical pull-in and drop-out adjustments.

It cannot be stressed too strongly that speed stability is dependent to a great degree on the cleanliness of the rubber idler roller and the other elements of the drive system. The roller should be scrubbed with solvent daily or more often, if necessary. (The lubricant on the tape will deposit very rapidly on the rubber surface.) Also, lubricate the upper and lower motor bearings regularly, according to the transport manufacturer's recommendations (Fig. 3).

While cartridge tape machines require more care than our work-horse reel-to-reel machines, the degree to which they have aided our operations makes them worth the extra attention.

## High Response Boost

by LaVern Killion, KLIN, Lincoln, Neb.

At Radio KLIN we have found it necessary to improve the high frequency response of our cartridge tape equipment. With a very simple modification, the frequency response may be made flat all the way up to 15,000 cps.

In our Spotmaster 500 machines, for example, a 600-mmf capacitor is paralleled with a 100K resistor in



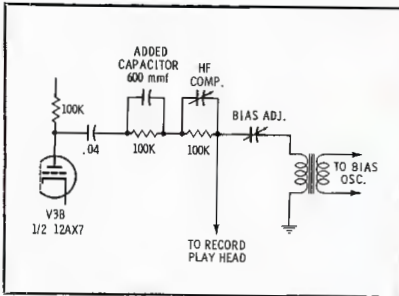

the record emphasis network. This brings the response from 10 db down at 10 kc, up to  $\pm 1$  db at 15 kc.

After this capacitor is added, it is necessary to readjust the high frequency compensation capacitor. This may be facilitated by recording tones from 1 to 15 kc at a  $-10$  db level. Next, play the tones back and note the response. Repeat this procedure several times, adjusting the compensating capacitor until the desired frequency response is obtained.

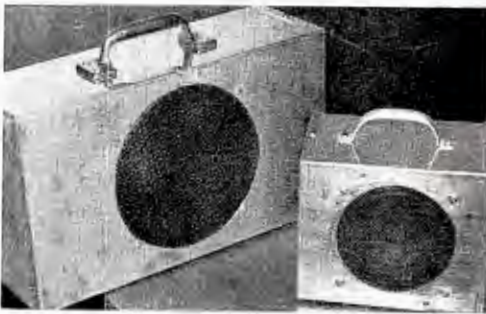

## Portable Utility Test Speakers

by Philip Whitney, Chief Engineer, WINC, WRFL, Winchester, Va.

When a need for small, portable test speakers arose, we quickly made durable, light, and functional cabinets for small speakers by cutting a circular hole in the front of several different size aluminum boxes obtained from the local electronic parts distributor. The speaker was mounted behind the hole. The box resonance was damped by filling with insulation material and tightly bolted together with the hardware furnished. Door-pull carrying handles were attached to the top and the wires run out through a hole in the back. The cabinets were sanded for a "brushed" finish. These handy speakers are used for testing receivers and amplifiers, and are quickly transported to the required location.

November, 1963

## PRODUCTS WITH A FUTURE

### GATES TRANSISTORIZED CARTRITAPE II MONAURAL/STEREO PROFESSIONAL CARTRIDGE TAPE SYSTEM 1, 2 OR 3 CUE TONE



- Exclusive positive insert opening
- Separate record/play heads
- Plug-in modular construction
- Small— $5\frac{1}{2}$ " high

Buy only the system you need now. Gates "second generation" design, with modular construction and plug-in transistor amplifiers allows immediate, economical expansion. Reliable? Positively!

A six-page brochure tells the whole story, No. A113. So does Gates new Broadcast Equipment Catalog, No. A95.

**GATES**

**GATES RADIO COMPANY**

A Subsidiary of Harris-Intertype Corporation

QUINCY, ILLINOIS

Offices in: Houston, New York, Los Angeles, Washington, D.C.

In Canada: Canadian Marconi Company, Montreal Export Sales: Rocke International Corporation, New York City



Circle Item 22 on Tech Data Card

## SPOTMASTER Tape Cartridge Winder

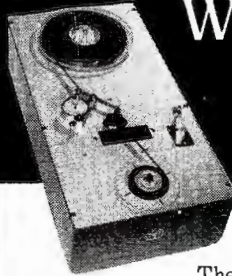

The new Model TP-1A is a rugged, dependable and field tested unit. It is easy to operate and fills a need in every station using cartridge equipment. Will handle all reel sizes. High speed winding at  $22\frac{1}{2}$ " per second. Worn tape in old cartridges is easy to replace. New or old cartridges may be wound to any length. Tape Timer with minute and second calibration optional and extra. Installed on winder or available as accessory. TP-1A is \$94.50, with Tape Timer \$119.50.

Write or wire for complete details.

*Spotmaster*  
**BROADCAST ELECTRONICS, INC.**  
 8800 Brookville Road  
 Silver Spring, Maryland

Circle Item 23 on Tech Data Card



send for NEW FREE CRYSTAL CATALOG with NEW TRANSISTOR OSCILLATOR CIRCUITS

3 PLANTS TO SERVE YOU BETTER  
**HERMETICALLY SEALED  
 PRECISION GROUND  
 CUSTOM-MADE  
 NON-OVEN CRYSTALS**

Gold or silver plated, spring mounted, vacuum sealed or inert gas, high freq. stability, 10 milliwatt max. current cap. Meet mil. specs.

Frequency Range	Fund. Freq.	Prices on Request
1000KC to 1600KC	(Fund. Freq.)	.....
1601KC to 2000KC	(Fund. Freq.)	.....\$5.00 ea.
2001KC to 2500KC	(Fund. Freq.)	..... 4.00 ea.
2501KC to 5000KC	(Fund. Freq.)	..... 3.50 ea.
5001KC to 7000KC	(Fund. Freq.)	..... 3.90 ea.
7001KC to 10,000KC	(Fund. Freq.)	..... 3.25 ea.
10,001KC to 15,000KC	(Fund. Freq.)	..... 3.75 ea.
15MC to 20MC	(Fund. Freq.)	..... 5.00 ea.

Frequency Range	Third Overtone	Price
15MC to 30MC	Third Overtone	.....\$3.85 ea.
30MC to 40MC	Third Overtone	..... 4.10 ea.
40MC to 65MC	Third or Fifth Overtone	..... 4.50 ea.
65MC to 100MC	Fifth Overtone	..... 6.00 ea.
DRAKE 2-B Receiver Crystals		.....\$4.00

(All Channels—Order by Freq.)

OVEN-TYPE CRYSTALS

For Motorola, GE, Gonsset, Bendix, etc. Add \$2.00 per crystal to above prices

SUB-MINIATURE PRICES slightly higher

ORDER FROM CLOSER PLANT  
**TEXAS CRYSTALS**

DEPT. BE  
 1000 Crystal Drive  
 FORT MYERS, FLORIDA  
 Phone 813 WE 6-2109  
 TWX 813-334-2830  
 AND  
 4117 W. Jefferson Blvd.  
 LOS ANGELES, CALIF.  
 Phone 213-731-2258  
 TWX 213-737-1315



Circle Item 24 on Tech Data Card

# A CIRCULAR BROADCAST CONSOLE DESK

by **George A. Dodge\*** — Part of the modernization plan in a switch to stereo, at WLIP.

Are you planning new broadcast control room facilities? . . . changes in existing lay-out? Or, perhaps you are building for the first time? This article may generate some new thinking along these lines.

Conventionality, in studio and control room design and layout, has been with us in radio for many, many years. I have been exposed to the building of a number of new radio stations and facilities. Experience over the years has shown that any outstanding departure from the commonplace is not generally accepted. Broadcast equipment has, in general, far outdistanced this trend. Hi-fi audio, beautiful control consoles for AM-FM plus Stereo, and other modern devices have been offered the trade for the past several years. Modern design calls for facilities to match. The new stereo FM

consoles pushing the \$5,000 figure should be displayed to advantage. This is exactly what was recently accomplished at WLIP.

In the installation of stereo, some changes in technical requirements are in order; wiring procedure, shielding, grounds, and the all-important phasing of the audio channels, all require careful planning. These factors are, in most cases, met and conquered by the engineering staff; they usually emerge with flying colors.

Selecting new equipment generally entails headaches. Sales engineers from various companies offer much help, but the decision must be made to buy one line or pick out a composite system. From my experience, the latter is the easiest way out: "Satisfy everyone."

However, we at WLIP decided on dealing with one manufacturer. Our order included new AM and

stereo FM transmitters, new turntables, tone arms, equalizer pre-amps, a five-bay antenna, and a stereo FM audio console that is truly a sight to behold. As for a console desk to show off the new stereo console, the only type we found available was of the conventional "U" shape. Fabrication of such a desk is generally farmed out; design and dimensions are usually pilfered from someone's existing layout within the trade. But not us! Here's what we did.

## The Old Becomes the New

"Build new AM and FM studios that are outstanding in appearance, and a console desk that will display to advantage our new stereo console." These words were uttered by Mr. William Lipman, owner and operator of WLIP-AM and FM, Kenosha, Wisconsin. To me, this meant "Don't spare the horses, but be reasonable, too."

\*Chief Engineer, WLIP AM-FM, Kenosha, Wis.

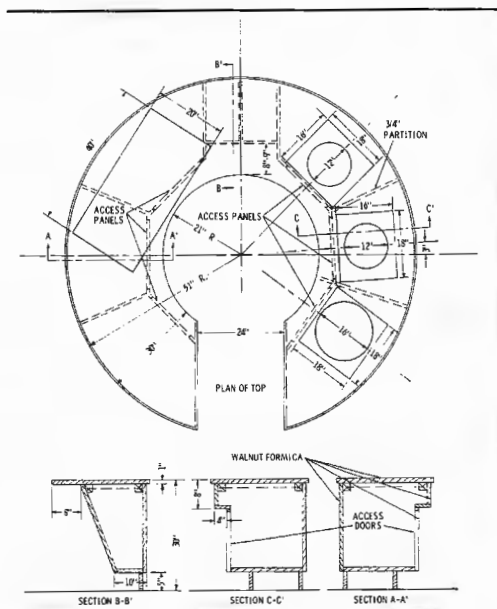

Fig. 1. Diagram of circular console desk.



Fig. 2. Completed console desk with all equipment installed.

With the "reins" in hand, we started the wheels turning. Considerable time was spent at the drawing board. "U" shaped desks of various sizes kept popping up. After many hours of searching for that "something new," the idea occurred that a circular type of console desk would certainly be different. Sort of a "Round Table." Guess I've read too many books on "King Arthur" in my childhood days. (Actually, King Arthur's table was not round according to the old guides in the lake areas of upper Scotland.)

The design of the round console had to be compatible with all the usual requirements of flexible operation. So a chalk talk was in order in the new FM control room. Dimensions were chalked out on the floor. Sufficient room for the operator to move freely about, console controls conveniently located, turntables, cartridge tape machines, announcing position, mike placement—all were visualized and laid out so they would contribute to proper operation.

Being satisfied the "New Round Table" would work, we presented the design (Fig. 1) to management for approval. More words. Such as, "Are you sure it would work out okay?" and "It looks great, but how much will it cost?" The cost! This had to be answered, and soon, so bids were let out on the design. It had to be rock-solid, with "Formica" top and sides.

After hearing a few bids, we settled with a local cabinet worker to fabricate the new console desk. (For those curious about the cost, one bid exceeded \$1,800.) Just prior to construction, chaos was barely averted when we discovered it would have to be built in two sections in order to fit through studio and control room doors.

A few points about construction are probably in order. Consideration must be given to the type of turntables to be used, as this determines the size and shape of cutout required. It is probably least costly to have the top surface fabricated intact and make the cutouts as they become necessary. Wiring of associated audio components is easily effected at the time of installation, because of accessibility through the several inner and outer paneled doors.

## "The greatest contribution we've made towards upgrading WKFM"

*Frank Kovas*

FRANK KOVAS, PRESIDENT  
WKFM, CHICAGO

(DEMONSTRATION STATION FOR FM  
STEREO AT 1962 NAB CONVENTION)

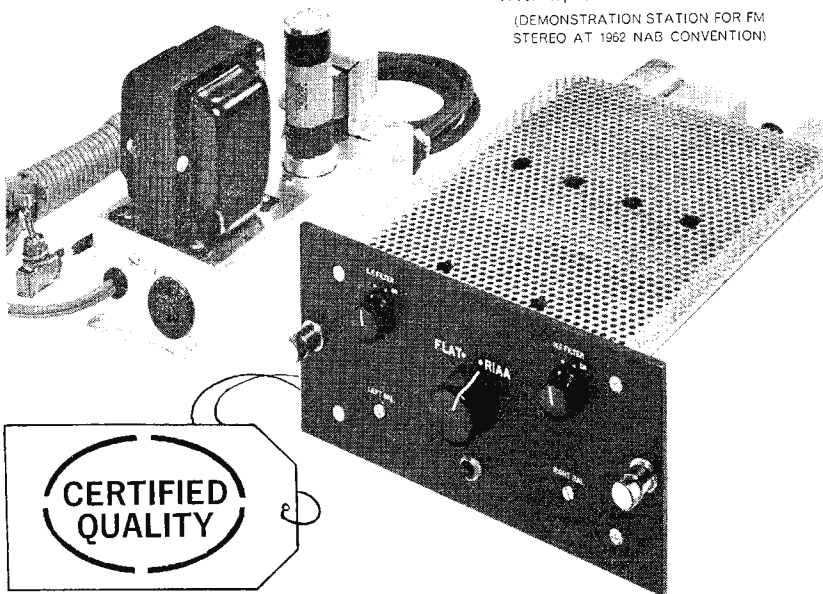

**SHURE**  
**STUDIO**  
**SE-1**

### STEREO TRANSCRIPTION PREAMPLIFIER

*Certified quality* because every characteristic on every unit is checked to make sure it passes specifications. That's why Mr. Kovas says "It is unfortunate that we (WKFM) wasted so much time in experimenting with hi fi type stereo preamps which looked good on specifications . . .

I'll have to admit that nothing equals the performance of the Shure SE-1 for stereo multiplexing."

What are the certified specifications? The SE-1 has plenty of gain to feed a 600 ohm line at +4 or +8 dbm from a magnetic stereo phono cartridge and still provide for peak power. (1.2 mv input gives at least +4 dbm output.) Balance is provided with separate gain controls for each channel. *True* RIAA equalization with  $\pm 1$  db 30 to 15,000 c.p.s. of RIAA curve. Optional flat position for measurement and calibration in the studio. Separate high and low response trimmers for each channel with NO interaction between channels, or between high and low end. Hum and noise level at least 64 db below output level. Channel separation better than 37 db between 50 and 10,000 c.p.s. Distortion is under 1% at +15 dbm 150 or 600 ohms output impedance. Compact size (7" x 3 3/8" x 1 1/2" deep) . . . Convenient slip-in mounting for easy installation. Separate power supply reduces panel space requirements.

Priced at only \$295 net. Write for technical data sheet: Professional Products Division, Shure Brothers, Inc., 222 Hartrey Avenue, Evanston, Illinois.

Circle Item 25 on Tech Data Card



## for the new CONCERTONE 607

The new Concertone 607 is dimensionally constructed to make it an exact replacement for the equipment you've been thinking of updating. But it's the same in size only. This surpassing tape recorder defies comparison, really. Its features are fabulous and only a demonstration will prove to you that its low price is not really a misprint. This is the high-impedance model of the famous Concertone 605 with provision for plug-in impedance matching transformers; precision plug-in head assembly, including four precision heads; separate mike and line controls; professional connectors; calibrated VU meters; delay memory control circuit; automatic glass tape lifters (including electric cue feature); sound-on-sound and add sound; solenoid operated brakes; three motors; automatic rewind. See your Concertone dealer, before you decide to replace or expand.

### SERIES 90 PROFESSIONAL TAPE RECORDERS



Distinguished performer for the most critical professional. Exclusive Concertone features such as "Edit-O-Matic" for high-speed tape cueing and editing. Four heads; 3-motor drive, including hysteresis synchronous capstan drive. Maximum in wide stereo-mono versatility and automatic-remote capabilities.

### CONCERTONE 400 COSMOPOLITAN

For people on the go... it's the Cosmopolitan... combination tape recorder and AM radio. A versatile companion and co-worker for business and pleasure travels. Push-button operation.

Accommodates 5" reels, 2 speeds. This all-transistorized radio-tape recorder brings you big recorder features in precision-made miniature form.



for further  
information  
write:



**AMERICAN CONCERTONE, INC.**  
A DIVISION OF ASTRO-SCIENCE CORP.  
9449 W. JEFFERSON BLVD. • CULVER CITY • CALIF.

Export: J. D. Marshall International, 170 W. Washington, Chicago, Illinois

Circle Item 26 on Tech Data Card



Fig. 3. New control console desk for AM.

Cost could be reduced by eliminating the Formica surfacing, but the beauty and freedom from marring or burning will usually outweigh the added expense. There is one other factor that should not be overlooked: the layout works best with a free-wheeling chair that will move easily about.

### Showpiece

In three to four weeks, a beautiful console desk (Fig. 2) was ushered into the "inner sanctum" with appropriate ceremonies. And to this day, this author-designer has not quite managed to conceal the grin and "I told you so" burst of pride each time we show off this "piece" to the VIP's who visit our station. Besides being beautiful, it has proven compatible and practical, and is of great satisfaction.

Much credit must be given the fabricator, Mr. John Phillipson of the Phillipson Woodcraft Co. of Kenosha, Wis. — a cabinet maker who, in my thinking, "got the message." The console desk is really solid as a rock, glistens with "Formica" over all, and has convenient panel doors inside and out for easy accessibility to audio components, etc.

I guess I should mention in passing that the AM facilities were not overlooked. A brand-new AM control desk (Fig. 3) was also fabricated by Phillipson. It, too, is surfaced all over with "Formica," but as the years have shown, conventionality will win out: the doggone thing is "U" shaped.

If you happen by, stop in and see this FM control point, and watch our "Knights of the Round Table" in action. ▲

## Tape Techniques

(Continued from page 24)

a manual control which drives the oscillator higher or lower in frequency, thereby changing the capstan speed sufficiently to permit manual synchronism of 2 VTR's.

**The Tape Guide Servo** — The tape guide servo, which is more of an accessory than an essential part of a VTR, compares the timing of selected horizontal sync pulses derived from tape against their fly-wheeled average and utilizes the error voltage to control the horizontal portion of the female guide which holds the tape against the head drum. When the guide has reached a point where the stretch of the tape by the heads is identical with the original recording, the playback timing will also be identical and no error voltage will develop. The tape guide servo is capable of achieving a guide position accuracy which will bring the time-base of the video signal to within  $\pm .05$  microseconds. It can also be over-ridden by a manual control which positions the guide through direct electrical control.

## Electronic Time-Base Correction

A modern video recorder operating in a nonsynchronous mode is capable of reproducing video images whose time-base stability is well within the FCC requirements. When the processor output signal is composite and the synchronizing pulses are derived from the tape, a standard studio monitor or home receiver will exhibit a steady image without subjective horizontal instability. However, because the image is segmented into 16 or 17 line groups (by the four transducers on the head assembly), it is possible to have geometric errors in the image which are the result of minute mechanical differences between the conditions of record and replay of the tape. If a perfect match of concentricity or position between these two modes is not achieved, the resultant image will show positive or negative skewing or scalloping of vertical lines. Unless perfect mechanical quadrature between heads is maintained (on the head drum assembly), the misaligned head will introduce a displacement of picture elements to the right or the left.

These errors are mainly the result of instantaneous positional displacements rather than velocity problems. The head assembly rotates at a velocity which is relatively stable and accurate. The information coming from the head is displaced in time about this average. By comparing the rise time of any given horizontal synchronizing pulse from the tape with the average position of all of the pulses (or with a local stable studio source), it is possible to develop an error signal proportional to the direction and magnitude of the time displacement. This error signal is then employed to control a variable delay time increasing or decreasing its normal value by an amount equal to the time-base error. With this delay line inserted in the path of the signal it will reposition any given television line by the incremental delay factor on the line at that instant. This corrective action occurs during the blanking interval and corrects the horizontal position of any vertical elements in the image to an accuracy of .03 microseconds, a degree which renders the errors

# WHY

# USE

# 11

# WHEN

# 5

# WILL DO IT BETTER?

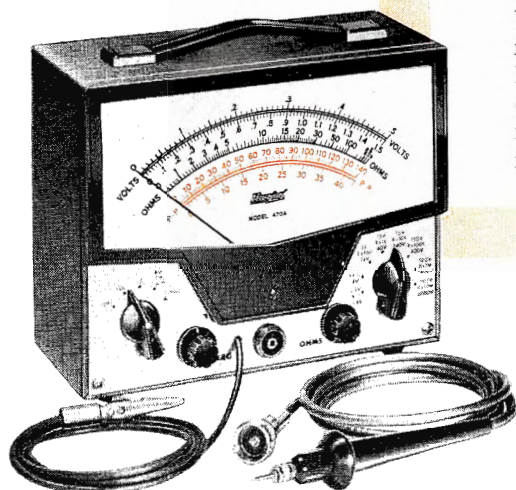
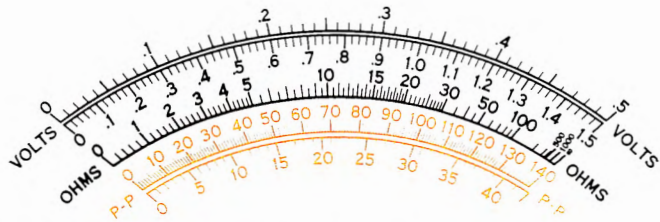

Eleven-scale VTVMs are "old hat." Hickok's new 5-scale VTVM (actually *one* basic scale covering *all* necessary ranges) simplifies your job and increases accuracy. The Model 470A features an AC-DC-Ohms single-unit probe to eliminate the need for multiple leads. You'll find 8 AC/DC ranges from  $\frac{1}{2}$  to 1500 volts, as well as peak-to-peak and resistance ranges, all on an easy-to-read 7-inch meter.

**The HICKOK Electrical Instrument Company**

10544 Dupont Avenue  
Cleveland, Ohio 44108

**Hickok**

Represented in Canada by Stark Electronics, Ajax, Ontario • Internationally by Hughes International, Husint, S. A., Culver City, California

Circle Item 27 on Tech Data Card

completely invisible.

The range of correction for this device is slightly better than one microsecond; and this represents a mechanical displacement considerably greater than one would encounter under normal operating conditions.

The basic rotational stability of the head assembly can be controlled through a servo to an accuracy of  $\pm .075$  microseconds. But even this high degree of stability may still leave some minor "jitter" in the image when it is superimposed or mixed with a stable studio source. In this case, the time-base corrector operates both as a geometric and an overall time-base stabilizing device, referred to a stable external source (i.e., studio sync).

Experience has shown that this system is capable of stability in excess of that usually demonstrated by a line-locked horizontal AFC sync generator (to achieve optimum performance it is necessary to operate the generator in its crystal mode). With electronic time-base correction, it is possible to operate the video recorder as any other studio equipment — utilizing non-

composite output to the switchers, and mixing sync at the final stage as is normal practice with camera chains, film chains and other gear.

#### Servo Systems

Three basic servo systems are employed in video recorders: The normal drum servo, which provides loose reference to the vertical signal or the line. The vertical lock system, which permits synchronization between the recorder and the video signal accurate enough to allow "no roll" switching between the recorder and other picture sources. The fully synchronous horizontal locking system, whereby the VTR images are completely time coincident with any studio source.

#### Electronic Editing

An operational tool which permits using a television recorder for the type of production that has been possible with certain film techniques has recently been developed. This system employs a cascaded electronic control arrangement whereby carefully timed pulses permit consecutive segments or inserts to be recorded in perfect synchronism. A precision timing control, using spe-

cial cues and a small computer system permits the segments to be reduced to one-frame elements thereby making full animation possible.

#### NTSC Color Recording

The recording and playback of color requires some relatively minor changes in the signal system. Also required, is the addition of circuits to perform time-base stabilization of the recovered video signal from tape by phase correcting the chrominance information to within a few nanoseconds of its original value.

#### Advanced Signal Systems

To meet the more stringent requirements of NTSC color on the European 625-line standard, a new type of head assembly and signal system has been developed. Nuvisor preamplifiers are located on the head assembly and a special mode-mod and other components are employed.

#### The Helical Recorder

The latest devices in video recording are the small portable helical recorders designed for educational, medical, and military appli-

## JAMPRO DUAL POLARIZED FM ANTENNAS

### EXCLUSIVE ADVANTAGES OF THE JAMPRO DUAL POLARIZED FM ANTENNA SYSTEM

#### MORE SIGNAL INTO CAR RADIOS

The vertical polarization puts more signal into vertical car whip antennas.

#### MORE SIGNAL INTO HOME FM RECEIVERS

The vertical polarization, due to reflections, puts more signal into built-in antennas found in nearly all modern console type FM radios.

#### EXISTING JAMPRO ANTENNAS MAY BE CONVERTED

All existing JAMPRO FM antennas can be converted to dual polarized arrays with reduced horizontal gains.

**J A M P R O**

ANTENNA COMPANY

6939 POWER INN ROAD  
SACRAMENTO 28, CALIFORNIA

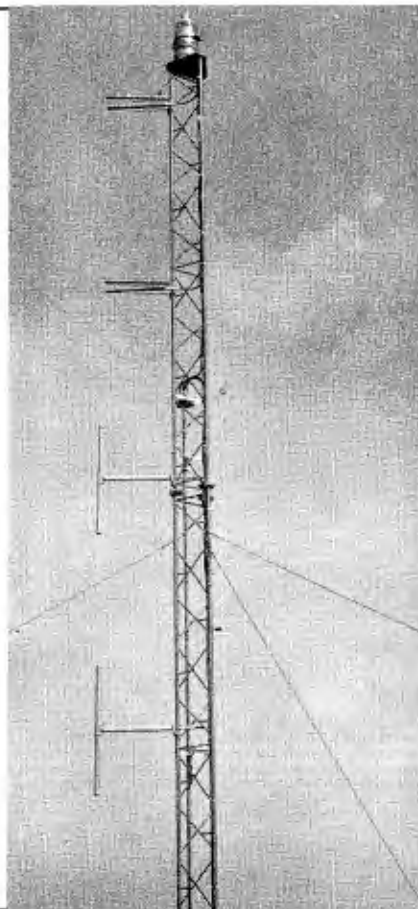

cations, as well as limited broadcast operation.

#### Tape Transport

The transport system of the helical-scan recorder must provide two very basic functions. First, the tape must be moved from reel to reel over a relatively large scan area with great longitudinal speed accuracy. Second, the tape must be guided in and out of the scan area with such precision that it will occupy the identical position in replay it did in record. Since the scan assembly is large and the tape path over it relatively long, the surface friction involved will set up a tension on the tape which must be carefully similarized between passes.

#### Signal System

The signal system on the helical recorder, although similar in principle to that of the transverse machine, performs somewhat differently and over a range of frequencies that are dictated by the slower writing speed and system characteristics.

#### Servo System

The time-base stability of the helical recorder is very dependent upon the larger size scanning drum and its mechanical configuration. The drum turns at a relatively slow speed but its mass will obviously affect the degree of control obtainable through electronic servoing.

#### Broadcast Types

The limited requirements of closed-circuit television permit the design of the helical recorder to be somewhat simplified. To meet broadcast specifications, additional servo control and some additional signal processing must be added to the basic system.

#### Applications

The helical recorder, because of its relatively low price and operating cost, size, and portability, can be employed in new areas. It can be used for teacher training and the enhancement of most school subject matter by improving visual demonstrations. In medicine it is being used for education as well as radiological, diagnostic and therapeutic work. In the military it is being used for surveillance and equipment studies. And in the entertainment field, the helical recorder is now employed for on-the-spot news coverage and other peripheral applications. ▲

# Professional Performance ...at your fingertips

... with VIKING tape components proven in countless broadcast installations year after year.

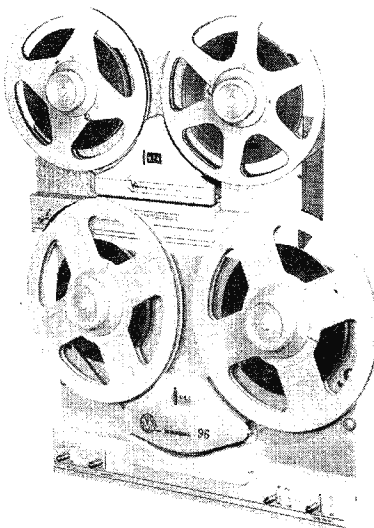

**VIKING 95 or 96 TRANSPORTS**  
10 1/2" reel capacity. Relay rack mounting. Remote control. Automatic sequence breaking. Hysteresis capstan motor. Two reel drive motors. Photo cell controlled. Elective head configurations. Hyperbolic heads on Model 96 only.

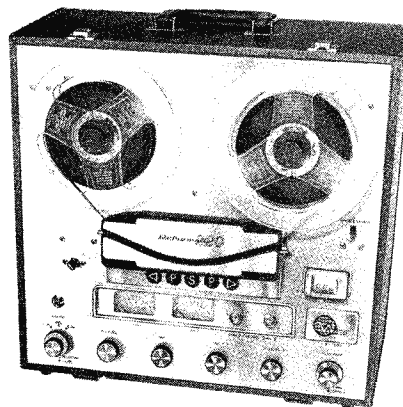

**Retro-Matic 220 Professional Tape Recorder.** Two directional playback, quarter track stereo at two speeds. "Feather-touch" pushbuttons, remote control, 12 watt amplifier, simultaneous record / playback with 20-25,000 cps frequency response. Independent channel controls, "Luma-Touch" record buttons and illuminated VU meters. Photo electric run-out sensor, hyperbolic heads, hysteresis capstan motor plus two reel drive motors and digital counter. Stainless steel face plate. Operates vertically or horizontally.

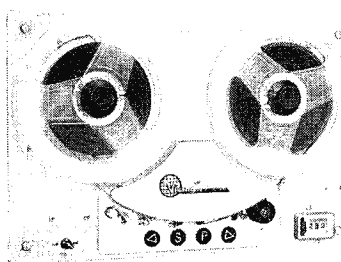

**VIKING 230 TRANSPORT SERIES**  
Electric pushbutton controls. Remote control. Relay rack mounting. Interchangeable, unitized head blocks with various, hyperbolic head configurations.

#### MATCHING RECORD/PLAY AMPLIFIERS

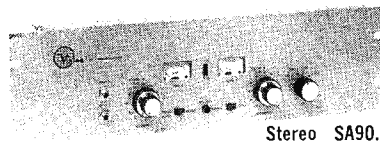

Stereo SA90.

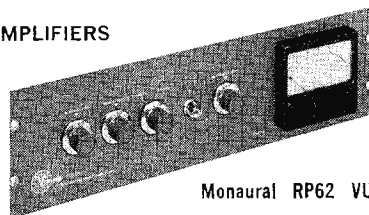

Monaural RP62 VU.

For Information Write to Customer Service Dept.

IF IT'S USED WITH TAPE IT'S MADE BY VIKING



**VIKING OF MINNEAPOLIS, INC.**  
9600 Aldrich Avenue South, Minneapolis, Minnesota, 55420

Your assurance  
of Quality in  
Tape Components

Circle Item 29 on Tech Data Card

# TRANSCRIBING OFF-AIR WITH DICTATING EQUIPMENT

by Dick F. Engh\* — One station's use of existing equipment in both office functions and off-air program logging.

At KTNT-TV, we have extended and adapted a standard office dictating system to achieve inexpensive logging services, drastically reduce tape storage costs, and develop a faster reference to broadcasts.

To comply with the federal requirements that stations log or store the live audio portions of their programs, we had kept a permanent log in the form of master tape recordings, which we stored for indefinite periods in our offices. This was an expensive and space-consuming procedure. The cost for the

\*Chief Engineer, KTNT AM-AM-TV, Tacoma, Wash.



Fig. 1. Secretary replays a program disc.

tape was around \$2.50 for each half hour, while storage was taking up valuable office space. We were also faced with the problem of the deterioration of the tape in storage.

In searching about for an improved system, we discovered that we had the basic materials for logging and storage, already at work in our office dictating system.

Like most stations operating today, KTNT-TV carries a heavy paperwork burden growing out of its services to advertisers, news activities, and audience relations. To speed this reporting and correspondence activity, we installed an Edison "Televoice" system with three phones in our Tacoma office. The phones all terminate in jacks; a number of extra jacks in various offices provide maximum flexibility of usage throughout the station. After exploring the possibilities of the equipment, we came up with the answer to our logging cost-and-storage problem.

The connecting link between the dictating and the logging systems is a dubbing cord which we rigged so the station's master tape can be played back to the "Televoice-writer" and recorded on the disc.

We schedule this procedure for periods when the dictating system is not in use for regular purposes, to eliminate interruption of normal office procedures. We unhook the office dictation recorder from the phones and insert the dubbing cord instead. The recordings are then dubbed from the master tape and one of the office girls changes the disc when it is full.

With this method, we get a one-half-hour audio program on a single disc at a cost of a few cents. Portions of the recordings may be transcribed on the secretarial unit, as is sometimes necessary when an advertiser wants a verbatim copy of

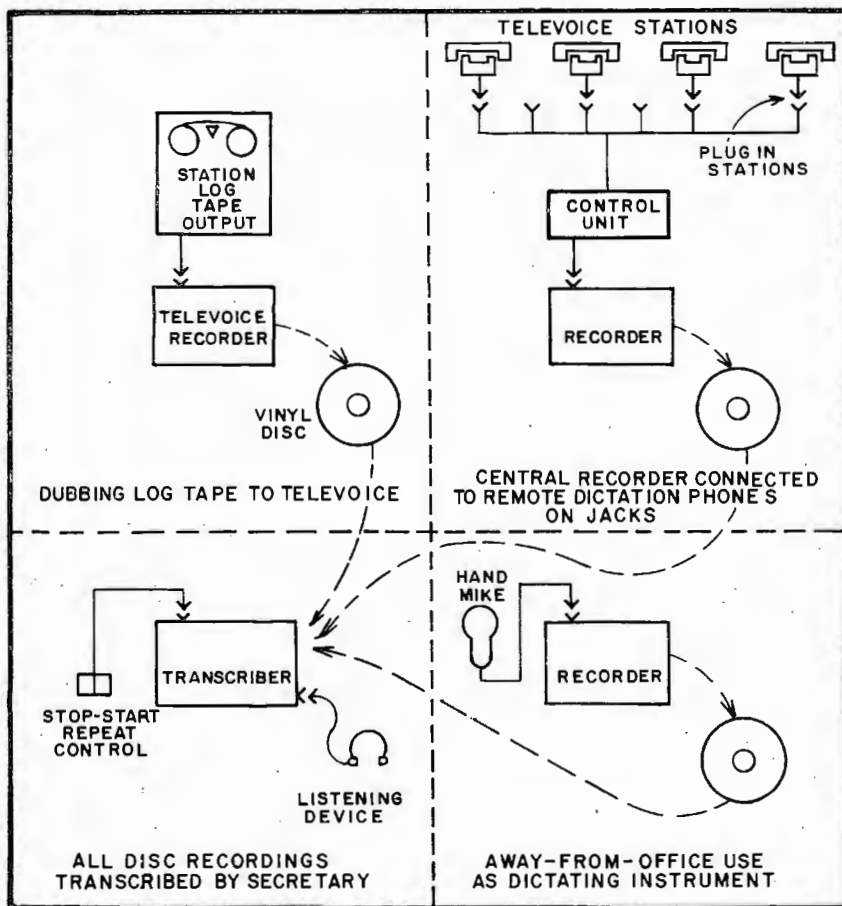

Fig. 2. Block diagram of combination dictating and off-air transcribing system.



a commercial advertisement along with the billing for the advertising time.

The discs are stored on regular shelf space (we can store hundreds of these discs in a few inches of shelf space, compared to the large areas demanded by tape storage). Each disc is coded so we can immediately locate a particular segment by date and time of broadcast. The discs do not deteriorate.

This speed of reference has proven particularly helpful to our station management. Previously, it was necessary to pull a complete tape and listen through long portions of it to identify certain audio sections. Also, these discs can be transcribed by any stenographer just by placing them on her secretarial unit and handling them as she would regular dictation.

To sum up the usefulness of this system, we are realizing the following advantages:

1. Flexible use of one recorder in three different applications reduces capital outlay to accomplish our recording needs.
2. The use of a compatible disc recording for each application—easily indexed and identified.
3. File-ability of verbatim disc recordings for logging reference. Only 1" of shelf space is required for each 100 discs, eliminating bulky storage of station master tapes for two-years.
4. Logging costs are as low as 8¢ per half-hour disc compared to storing on tape.
5. The use of one transcribing machine for all recording applications. Dubbed recordings can be aurally "scanned" quickly to locate a commercial or other portion when needed.
6. In-office use of recorder hooked to phone provides dictation facilities for a number of station executives. Phones can be added or relocated as desired.

A disadvantage is that the Edison disc must be changed or flipped over every 20 minutes by someone in the office area close to the recorder. However, at the present time serious study is being given to a method of logging directly on the disc, in place of using tape and the handwritten log. This will be decided after further analysis of the new FCC regulations concerning rules on logging.

## **LAST CHANCE TO OWN ONE OF THE FAMOUS 50,000\* INDUSTRY WORKHORSES**

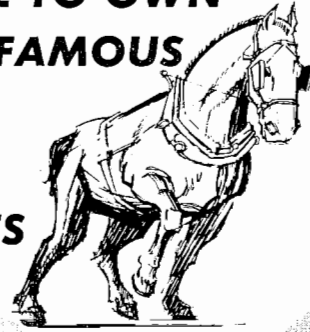

\*58,211 by actual count

## **BUY YOUR PT 6 WORKHORSE NOW FROM FINAL FACTORY RUN OF 300**

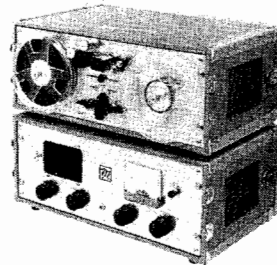

The world's greatest horses earn — and eventually receive — retirement. Such honor soon will be bestowed upon the Workhorse of the Broadcast Industry, Magnecord's PT 6, 58,221 of which have been built and sold to date.

Whether you are a veteran or a newcomer to the broadcasting field, mere mention of the PT 6 very likely "rings a bell" in your mind. Your last chance to own a new PT 6 is NOW — while Magnecord makes a final factory run of only 300 units, and manufactures a supply of spare parts to service all PT 6 units for many years to come.

Most professional audio engineers know what the PT 6 will do — by now its "track record" is almost legendary. But just to play it safe, write today for complete information and let Magnecord know you want to be cut in on the final factory run.

 **Magnecord**  
SALES DEPARTMENT

**MIDWESTERN INSTRUMENTS**  
P. O. BOX 7509 • TULSA 35, OKLAHOMA

Circle Item 31 on Tech Data Card

# NEWS OF THE INDUSTRY



**Design Award**

Kurt Machein (left), president of Machtronics, Inc., accepts the Pacesetter award, top honor in the annual design competition conducted in conjunction with the giant Wescon show and convention of the western electronics industry in San Francisco. Presenting the award to Machein for design of the MVR-10 portable television tape recorder is Calvin V. Townsend, chairman of the Wescon board of directors. Machtronics' MVR-11 and MVR-15 models, adaptations of the MVR-10 for broadcast use, are being marketed by Storer Programs, Inc.



**PA Amp Simulates Best Conditions**

Disc jockeys at radio station WPTR are simulating broadcast conditions at "record hops." With a public address unit that closely resembles the consoles used in studios, the d.j.'s can change from a voice to a music channel, fade up or down, or talk over music as it is being played for dancing. They can also "ride gain" by watching a VU meter on the front panel. The Harman-Kardon Galaxy model 40GA-12 40-watt amplifier, used for control and amplification, improves the sound quality of the recordings, according to W. R. David, vice president

in charge of engineering at WPTR. "Some of our disk jockeys emcee two or three hops a week," David stated, "so they need equipment with good audio characteristics more closely resembling station equipment."

## Audio Recorders Ordered

ABC has ordered 83 units of RCA's fully-transistorized audio tape recorder for use by its owned radio and TV stations, the RCA Broadcast and Communications Products Div. announced. The type RT-21 machines will be used throughout ABC facilities, according to Frank Marx, president of ABC Engineers. RCA's Camden, N. J., plant will begin deliveries of the recorders next month with shipments to: WABC, New York; WBKB, Chicago; WXYZ, Detroit; KABC, Los Angeles; KGO, San Francisco; and KQV, Pittsburgh.

## PERSONALITIES

Appointment of Adron M. Miller as manager, broadcast merchandising and West Coast operations, RCA Broadcast and Communications Products Division, has been announced by C. H. Colledge, division vice president and general manager. Mr. Miller will have overall responsibility for the merchandising of RCA radio-TV broadcast equipment, scientific instruments and industrial television systems. In addition, he continues

**Save TV alignment and test time!**

**Improve camera pick-ups!**



... with a Diamond TV Light Box. Plug in ... get proper color temperature plus immediate, uniform and correct illumination across entire test pattern—regardless of camera location. All three types (color, image orthicon, vidicon) use 8" x 10" transparencies, need no mounting rack, measure 12" x 9" x 8". Diamond TV Light Boxes are now used in over 200 stations and manufacturer's laboratories. Also available: complete selection of high quality test transparencies ... standard or custom-made and a line of video test and operating equipment.

For complete details and prices, contact:

## Diamond Electronics

Diamond Power Specialty Corporation • Lancaster, Ohio  
P. O. Box 415 • TWX 490 • Tel. 653-6540

Circle Item 37 on Tech Data Card

## SPOTMASTER



### EQUALIZED TURNTABLE PREAMPLIFIER

The Model TT-20A is a compact, low distortion, transistorized turntable preamp for VR cartridges, with built-in NAB equalization. Design ingenuity reduces residual noise level to better than 65 db below rated output. Small current requirements permit 6 volt dry cell battery operation, eliminating AC hum worries. Response, 30-15,000 cps  $\pm$  2 db ... output -12 dbm, 600 ohm emitter follower ... distortion under 1% at double rated output ... size, 2 1/2 x 2 1/2 x 5 1/2". Priced from \$46.50; transformer output and power supply available. Also available as a flat amplifier Model BA-20A. Write or wire for complete details.

*Spotmaster*

**BROADCAST ELECTRONICS, INC.**

8800 Brookville Road  
Silver Spring, Maryland

Circle Item 38 on Tech Data Card

**BROADCAST ENGINEERING**

# SPOTMASTER



## Tape Cartridge Racks

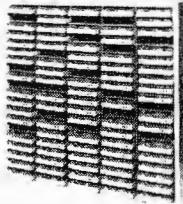

... from industry's most comprehensive line of cartridge tape equipment.

Enjoy finger-tip convenience with RM-100 wall-mount racks. Store 100 cartridges in minimum space (modular construction permits table-top mounting as well); \$40.00 per rack. Extra rack sections available at \$12.90. Spotmaster Lazy Susan revolving cartridge rack holds 200 cartridges. Price: \$145.50. Write or wire for complete details.



**BROADCAST ELECTRONICS, INC.**  
8800 Brookville Road  
Silver Spring, Maryland

Circle Item 34 on Tech Data Card

**BACK ISSUES AVAILABLE**  
ORDER NOW WHILE THEY LAST... ONLY \$1.00 EACH

January '61 thru December '61 (excluding April)  
January '62 thru December '62 (excluding February)  
January '63 thru May '63 (excluding June)

Broadcast Engineering  
4300 W. 62nd St.  
Indianapolis, Ind. 46206

Please send me back issues circled below:

1961

Jan. Feb. Mar. May June July  
Aug. Sept. Oct. Nov. Dec.

1962

Jan. Mar. April May June July  
Aug. Sept. Oct. Nov. Dec.

1963

Jan. Feb. Mar. April May July

- Please bill me  
 Check or money order enclosed

Name.....

Firm.....

City.....State.....

1163

to be responsible for the division's film recording and West Coast operations facility at Burbank, Calif.

The 3M Company has announced appointment of **Daniel E. Denham** as general sales and marketing manager of its Magnetic Products Division, and **Lauren L. Morin** as the division's manufacturing manager. Denham and Morin will head-quarter at 3M's executive offices in St. Paul.

**Perry S. Ury**, general manager of radio station **WGMS**, has announced the appointment of **Paul L. Hoffman** as chief engineer of the Good Music Station.

**Alfred C. West of Glore, Forgan & Co.**, and **Joseph G. Fennelly of J. C. Fennelly Co.**, have been elected to the board of directors of **Machtronics, Inc.**

### AES Awards

Three leading engineers were presented major awards by the **Audio Engineering Society** at the annual awards banquet. This was the highlight of the five-day Fifteenth Annual Convention of the society, held last month in New York. The **John E. Potts Memorial Award** was presented to **Benjamin Bauer**, vice president, **CBS Laboratories**, for R&D work on transducers, recording, psychoacoustics, and instrumentation. The **Emile Berliner Award** went to **Dr. J. Guy Woodward**, head of **Audio Recording Group, RCA Laboratories**, for R&D in underwater sound, electromechanical feedback systems, musical acoustics, stereophonic sound reproduction, and recording. The **AES Award** to the person who has most helped the advancement of the organization was presented to **Irving Joel** of **Capital Records** for provision of facilities for technical sessions and banquets. Principal speaker at the banquet was **Richard L. Kaye**, vice-president and station manager, **Charles River Broadcasting Co.**, **WCRB-Boston**, who discussed the formidable technical problems involved in broadcasting the indoor and outdoor performances of the **Boston Symphony Orchestra**.

### SMPTE Fellows

Thirteen members of the **Society of Motion Picture and Television Engineers** were elevated to the grade of Fellow in recognition of their contributions. Those honored are **V. D. Armstrong, RCA**; **Walter Bach, Bach Auricon**; **John W. Ditmore, Purdue Univ.**; **Jack Behrend, Behrend's Inc.**; **William E. Evans, Granger Associates**; **F. Alton Everest, Moody Institute of Science**; **Robert C. Lovick, Eastman Kodak**; **Norman R. Olding, Canadian Broadcasting Corp.**; **William A. Palmer, William A. Palmer Films, Inc.**; **William H. Smith, Allied Film Laboratory, Inc.**; **Robert W. Wagner, Ohio State Univ.**; **John M. Waner, Eastman Kodak**; and **William Weller, Eastman Kodak**.

### NAB Fall Meeting

**Pittsburgh, Pa.** played host recently to broadcast executives from throughout the eastern states who assembled for a Fall Conference of the **NAB**. The discussion focused primarily on federal involvement in broadcasting operations.

From  
**THE Translator Company**

**NOW AVAILABLE:**

“**All about extra TV Coverage and fill in via Translators**”

• Write today for your Planning Package from **EMCEE**, the Translator manufacturer with more experience and more models... UHF VHF... 1 watt to 100 watts.

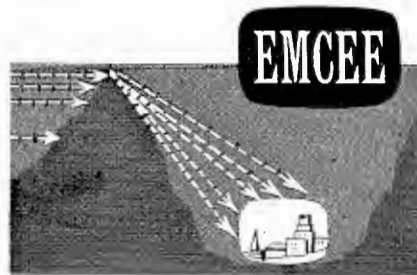

**ELECTRONICS, MISSILES AND COMMUNICATIONS, INC.**  
160 East Third Street • Mount Vernon, New York 10550 • 914-668-3012

Gentlemen:

Please send your "TV Coverage Planning Package."

Name.....

Address.....City.....State.....

Circle Item 30 on Tech Data Card

# NEW PRODUCTS



## Reel and Tape Case

To round out their line of clear and colored styrene tape reels in every size from 2" to 7", **Telephone Dynamics Corp.** is introducing three new and unique combination reel and tape storage cases for standard recording tape and/or 8mm movie film. Available in 3", 5" and 7" sizes, the reels and cases are available in white and gray, or light and dark gray. The reel and case cover are machined to precision tolerances and snap-fit together to provide a sturdy enclosed unit. A slight pressure through the cover hole pops the reel right out for use. Samples are available.

Circle Item 46 on Tech Data Card

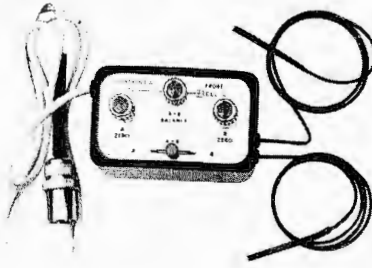

## Differential Probe

A high-accuracy differential probe that measures magnetic field gradients and differences has been developed by **F. W. Bell, Inc.**, Columbus, Ohio. Each of two available models utilizes two ultra-stable Bell "Hall-Pak" Hall devices as sensing elements. With this probe, differences from a few thousandths of an inch up to 40 inches can be measured in any direction or plane. The two elements, possessing matched characteristics, are each encapsulated in the end of a 20" plastic tube, and connected to a small control box which in turn connects to a Bell Gaussmeter. The elements are used independently and in series opposition for differential measurements. A magnetic-field differential between the

two devices of only 1% of the absolute field provides a full-scale deflection and a resolution of 1 part in 10,000. Gradients are measured by separating the two devices by a known distance and measuring the field difference. The probes are available from stock and are priced at \$375.

Circle Item 47 on Tech Data Card

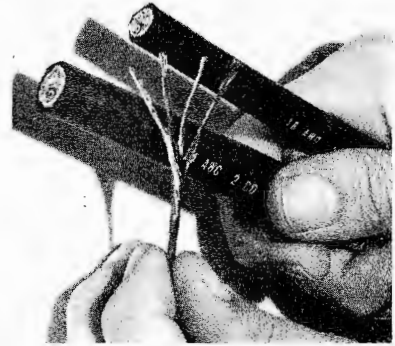

## Portable Power Cord

A portable power cord designed for use in installations subject to particularly heavy wear has been developed by **General Electric's** wire and cable department in Bridgeport, Conn. Designated "Super-CordX", the cord is available with two, three, or four conductors in AWG size equivalents from 18 to 10, for use in circuits carrying up to 600 volts.



## A POSITION OF RESPONSIBILITY... NEUMANN MICROPHONES

Gotham Audio Corporation presents the complete line of Neumann microphones which have, over the years, achieved the position of leadership in those industries which will not compromise with quality.

Write today, indicating company affiliation, for complete data on Neumann Condenser Microphones

**GOTHAM AUDIO CORPORATION**

2 WEST 46 STREET, NEW YORK 36, N.Y. • CO 5-4111  
In Canada: J-MAR ELECTRONICS LTD., P.O. BOX 158, DON MILLS, ONTARIO



Circle Item 35 on Tech Data Card

The jacket, made from a special compound of Hypalon synthetic rubber, possesses exceptional strength and a high degree of resistance to ozone, oil, chemicals, fire, moisture, and abrasion. Under the jacket, cotton-yarn braid and jute filler help maintain flexibility and overall tensile strength. The color-coded synthetic rubber insulation is heat resistant and possesses long-term aging properties to help prevent it from cracking. The conductor itself is a special rope-stranded bronze alloy with fine, strong individual wires which adds to its tensile strength and flexibility, with less conductor breakage than ordinary copper.

Circle Item 43 on Tech Data Card

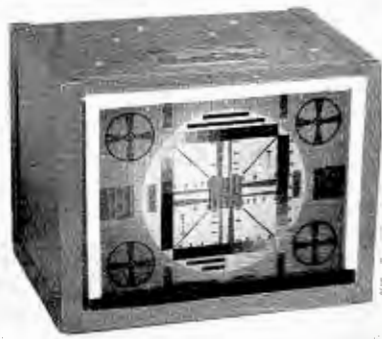

### TV Light Box

A time saving method of aligning and checking color and monochrome cameras is provided by **Diamond Electronic's** Model 503-00 TV light Box. Operating directly from the power line, this portable device uses several types of transparencies, including: resolution chart, linearity (ball) chart, color registration chart, gamma test chart, and "window" chart. The 503-00 is available in the following three types: color, with color temperatures of 3000° K. and two monochrome types with color temperatures of 2800° K. Adaptor kits are available to convert from one type to either of the other two. Model 503-0001 is for use with an image orthicon, and the 503-0011 is for use with a vidicon. Measuring approximately 9" x 12" x 8", the box has uniform lighting of the same intensity over the entire transparency.

Circle Item 49 on Tech Data Card

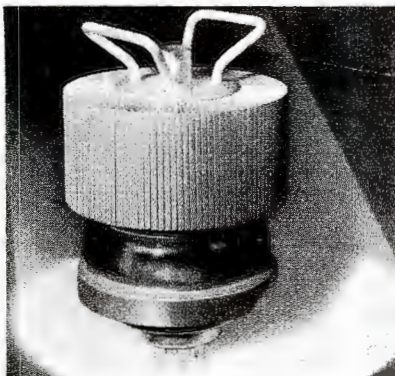

### Beam-Power Pentode

A new beam-power pentode capable of delivering over 5000 watts of power output in Class AB<sub>1</sub> linear amplifier applications has been announced by **Penta**

**Laboratories, Inc.**, Santa Barbara, Calif. Designated the PL-195, the tube employs a coated unipotential cathode and requires only 102 watts of heater power. Cooling requirements, with the tube operating at full rated output, are met with 70 cfm of air at a pressure drop of 0.26 inch of water column. Maximum plate voltage and current ratings are 5000 volts and 2.0 amperes, respectively; full output is reached with driving voltage of about 80 volts rms. The PL-195 employs the Penta vane-type suppressor grid which results in a minimum of distortion, excellent linearity, and high efficiency. Third-order intermodulation distortion products are 34 db down at full output, and higher-order distortion products are much lower. The tube measures 8.25"

long and 5.53" in diameter and may be equipped with a companion socket, the PL-205A, which includes a chimney and screen-grid bypass capacitors.

Circle Item 50 on Tech Data Card

### Transistorized Oscilloscope

Three new high brightness cathode-ray oscilloscopes in the high-frequency 765 transistorized series are announced by the **Du Mont Laboratories Div., Fairchild Camera and Instrument Corp.** All three are electrically identical and feature the newly developed Du Mont frame grid 13-kv cathode-ray tube. They differ in mechanical configuration, 767-H for rack mount, 766-H for bench and portable application, and 765-H for

# SECURE INVESTMENTS:

SCA MULTIPLEX RECEIVERS and TRANSISTOR AMPLIFIERS  
from *McMartin*

Leading Equipment Supplier To The FM Background Music Industry

#### TN-66CB MULTIPLEX TUNER



#### HIGH SENSITIVITY

- Sensitivity: 1 uv for 30 db quieting
- Crystal controlled
- Main or sub-channel switch
- Top chassis test points
- Stereo filter available.

#### TN-77CB TUNER and 5 WATT AMP



#### LOW MAINTENANCE

- All tuner functions plus full-rated 5 watt amplifier
- 8 ohm and 70.7 volt output
- Bass and treble controls
- Microphone input separately controlled.

#### TN-88B TUNER and 15 WATT AMP



#### CONTINUOUS DUTY

- All tuner functions plus full-rated 15 watt amplifier
- Paging, output, tone, and automatic muting circuits identical to the TN-77CB.

#### TRANSISTOR AUDIO AMPS LT-80A LT-300



#### RELIABLE QUALITY

- Studio monitoring, cueing, utility
- Music distribution
- Temperature stable
- 19" Rack mount available
- Compact 8 and 32 watts rms.

Originality by

**McMartin**

McMartin Industries, Inc., 605 N. 13th St., Omaha, Nebr., Code 402 ■ 342-2753  
In Canada Sold by: Canadian Marconi Company, Montreal 16, P.Q.

Circle Item 36 on Tech Data Card

# NEXT MONTH

Stereo Broadcasting . . .

**STEREO FM — AN END-OF-YEAR REPORT — Rules**

**EQUIPPING for STEREO — Equipment**

**DEVELOPMENTS IN STEREO MONITORING — Techniques**

**ANTENNA CONSIDERATIONS for STEREO BROADCASTING—Design**

**Plus: Extra Stereo Features, Engineers' Exchange, News, Products, and many important items you won't want to miss.**

Reserve your copies! Fill out and send in the convenient subscription card bound in this issue, and receive the Broadcast Engineers' Maintenance Guide absolutely free!

WCRL KOKL KCBN XENA WPIX KLMR KNBX KTYM KPER XEMO KCTV  
WDIG KWOW WGCD XEJX WOKO KFML KARI KSFO KCNO WCMC WTTT

## Quality Broadcast Equipment for the World's Greatest Radio Stations

### AM TRANSMITTERS

50 to 10,000 watts. The Bauer Model 707, 1000/250 watt transmitter is the most copied in the industry. Exclusively offered as a "kit" or factory assembled. Other transmitters from 50 watts to 10,000 watts.

### AUTOMATIC LOGGING EQUIPMENT

The Bauer Model 440 Log Alarm logs all required parameters. Meets FCC specs. Economical — simple — labor saving!

### NEW PRODUCTS

Bauer Model 920 limiter "Peak Master" available now. FM transmitters—Audio Consoles available soon.

Complete  
Technical  
Details  
on  
Request!

# Bauer

ELECTRONICS CORPORATION

1663 Industrial Road, San Carlos, California  
Area Code 415 591-9466

WBSB KWIZ KUBA KCOK KAHK WGES KWK KTHO KLIQ XEMO  
WRTA KSRO KCEY KXRX WMOP WCCW KOLO WLTC KVI XEAU  
KRIZ

Circle Item 34 on Tech Data Card



field portability. The instruments provide an extremely bright trace, small spot size, and minimum deflection defocusing. Fast sweep speeds can be observed without reduction in normal ambient light conditions. All Du Mont 765 series oscilloscopes have a frequency range of DC to 25 mc with present plug-ins; other plug-ins soon to be available will increase bandwidth up to 100 mc. Price of the rack model is \$695, bench \$595.

Circle Item 51 on Tech Data Card

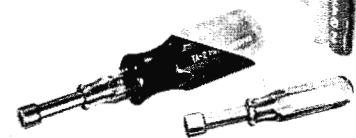
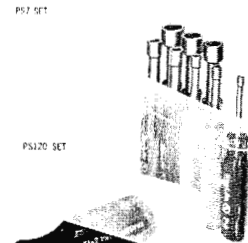
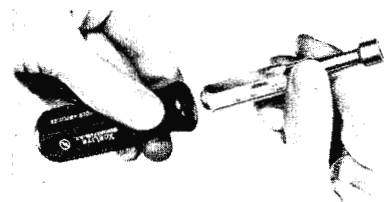

### Pocket Tool Kit

A new, pocket, convertible tool set from Xcelite, Inc., Orchard Park, N. Y., consists of an assortment of 6 compact nutdrivers and screwdrivers with colored plastic handles, plus a special piggyback torque amplifier handle, all in a see-through plastic case. The hollow handle slips over the pocket tools to give them the larger grip, longer reach, and in-

BROADCAST ENGINEERING

creased driving power of standard drivers. In effect, this provides twelve-tool-utility in a very compact kit. Tools include: 2 nutdrivers (1/4", 5/16" hex), 2 slot tip screwdrivers (3/16", 3/32"), and two Phillips screwdrivers (No. 0, No. 1). Each is 3 1/2" long. The "torque amplifier" handle is of black plastic and measures 1" in dia. x 3 1/8" long. See-through, break-proof plastic case is pocket size and has a flat base, permitting its use as a bench stand.

Circle Item 51 on Tech Data Card

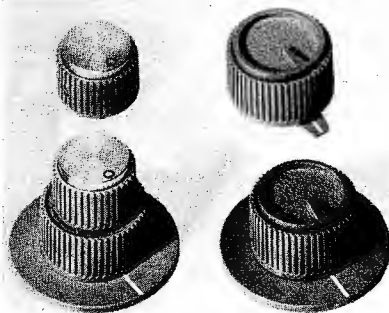

### Instrument Knobs

Two new types of instrument knobs introduced by **The Buckeye Stamping Co.**, Columbus, Ohio, are the "Standard" (SS) and "Prestige" (PS) Series. Both are offered in a wide range of sizes and include single and concentric knob models molded of "Implex-Acrylic," a material noted for toughness. The knobs, featuring sure-grip flutings, have rigidity, di-

mensional stability, high surface gloss, and resistance to stain, weather, corrosion, and heat. Each series is available with indicators in several positions. Overall diameters range from 23/32" in the smallest single knob to 2" in the largest skirt-type concentric knob. All are available in black, dark gray, and light gray. On quantity orders special colors are available, and pointers and skirts may be ordered in a contrasting color or molded of clear acrylic. Skirts may also be embossed with dial calibrations, trade symbols, or other markings.

Check Item 52 on Tech Data Card

### Coax Repeater-Amplifier

A line of solid-state wide-band, coaxial cable repeater-amplifiers for multichannel communications and video buried or aerial systems has been introduced by **Hammarlund Manufacturing Co.**, New York, N. Y. The amplifiers are available in both unidirectional and bidirectional types with bandpass ranging from 100 kc to 20 mc, depending on system requirements. A source of local power is not required since DC for operation of the repeater-amplifiers is fed from a power supply at the terminal point through the cable. The units can be mounted either in a pressurized weather-proof box or installed in the ground.

Check Item 53 on Tech Data Card

### VHF Power Tetrode

A new power tetrode for use in VHF television transmission has been introduced by **Calvert Electronics, Inc.** This



four-electrode, forced-air-cooled tube, designated the CEI/6076, is designed for use as an RF power amplifier, modulator, and frequency multiplier. Employing a thoriated-tungsten filament cathode, the tube features a heater voltage of 6.3 volts and current of 32.5 amps, with maximum ratings applicable up to 220 mc. Maximum anode and screen voltages are 5000 and 800 volts, respectively, with a maximum anode power of 3000 watts. The CEI/6076 measures 6 3/4" long by 3 5/8" in diameter, and has an amplification factor of 8.5.

Check Item 54 on Tech Data Card

## DELTA MODEL OIB-1 OPERATING IMPEDANCE BRIDGE

### APPLICATIONS

- Measure operating impedance while adjusting matching networks.
- Insert in common point for permanent or periodic impedance checks.
- Measure SWR on transmission lines.
- Measure base impedance of ND or DA towers.
- Write for Application Bulletin.

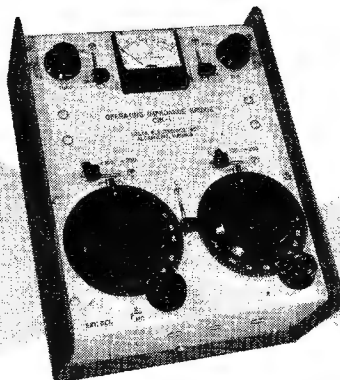

### SPECIFICATIONS

Freq. Range: 500 kc to 5 mc.  
 Power Rating: 5 kw with VSWR 3  
 Resistance Range: ±400 ohms  
 Reactance Range: (1 mc) ±300 ohms  
 Accuracy: \* R&X ±5% ± 1 ohm  
 Insertion Effect: Equal to 9" of 150-ohm line.  
 Self contained null detector for power impedance measurements.  
 BNC Jack for receiver null detector when using signal generator power.

### PRICE

**\$475<sup>00</sup>**

\*Dials are individually calibrated and engraved. Recalibration checks made on units after extensive field use indicates actual accuracy is much greater than rated accuracy in broadcast frequency range.

## DELTA ELECTRONICS

DELTA ELECTRONICS, INC.  
 4206 WHEELER AVENUE  
 ALEXANDRIA, VIRGINIA

Circle Item 39 on Tech Data Card

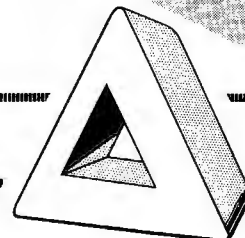

# ENGINEERS' TECH DATA SECTION

## AUDIO & RECORDING EQUIPMENT

60. AMPLIFIER CORP.—New edition of "Flutter, Its Nature, Cause, and Avoidance" gives analysis, mechanical problems, effects, and proper means of measurement.
61. BROADCAST ELECTRONICS—Brochure contains specs, prices, and installation information for tape cartridge system, plus description of delayed programmer, stereo units, Cue Trip, turntable preamplifier, cartridges, and accessories.
62. FAIRCHILD—Sheet provides specs of Winston Research automatic gain control.

63. QUAM-NICHOLS—Catalog lists complete line of loudspeakers for background music, PA, Hi-Fi, general replacement, and auto applications.
64. GOTHAM AUDIO—Brochures describe EMT 930 series professional turntables and series 140 reverberation units.
65. LANGEVIN—Catalog covers 3500 items of audio transmission equipment, including equalizers, amplifiers, mixers, attenuators, jack strips, plugs, panels and other hardware.
66. RCA—In catalog and brochure, line of magnetic tapes and properties are covered.
67. SHURE—Catalog presents complete line of microphones and related products for the audio specialist and broadcast engineer.

**RUSSCO** SUPPLIERS of **QUALITY**  
**OR**  
**PROFESSIONAL TURNTABLES**



- Quality
- Continuous Performance
- Simplicity

Priced from \$115.00 to \$235.00

**REK-O-CUT pick-up arms**

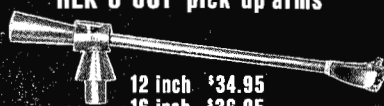

12 inch \$34.95  
 16 inch \$36.95



Model 607

**CONCERTONE tape recorders**

Full track --or Stereo  
 Width 19" for rack mounting --also portable  
 Professional broadcast quality.

Send for prices and literature.



**STANDFORD-OMEGA  
 Condenser Microphones**

\$130.00 to \$150.00

Viking Tape Recorders Superex Headphones  
 Xwikheat Soldering Irons

Send for literature.

**FAST FAST FAST Service**

Shipment by Motor Freight, Air Freight or Parcel Post

**RUSSCO Electronics Mfg.**

6879 No. Sunnyside Clovis, California  
 Ph. 299-4692 Area code 209

Circle Item 41 on Tech Data Card

## COMPONENTS & MATERIALS

68. CINCH—Twenty-page catalog is devoted to line of military-type heat dissipating tube shields.
69. ERIE RESISTOR—Bulletin presents specs for new line of miniaturized mica capacitors.
70. INDUSTRIAL DEVICES—Literature describes neon pilot light for applications requiring illuminated legends.
71. KURMAN ELECTRIC—Bulletin lists 34 models of magnetically shielded reed relays with 11 contact combinations.
72. SWITCHCRAFT—Engineering spec catalog describes aluminum jack panels.
73. WESTINGHOUSE—Microwave tubes and devices, and image orthicons are covered by a series of data sheets and a catalog.

Write for a free copy of "Flutter". A study of flutter, wow, and drift.

**New ULTRA-SENSITIVE FLUTTER METER**

With built-in Three-Range Filter, 3 kc Test Oscillator, High Gain Preamplifier and Limiter. Filter Ranges: 0.5 to 6 cps; 0.5 to 250 cps; 5 to 250 cps. Designed for rapid visual indication of flutter and wow. Meets standards set by the Institute of Radio Engineers. Flutter and wow readings are separated by built-in high-pass and low-pass filters. Three ranges are read on a large, sensitive 7 inch meter: 0.3%, 1.0%, and 3.0%. Accuracy within 2% of full scale value, independent of wave-form, amplitude variation, hum, noise, switching surges and other extraneous transients.

**CONDENSED SPECIFICATIONS**

Input Voltage	0.001 to 300 Volts
Ranges	0.01 to 3%
Limiter Range	20 db.
Oscillator (Built-in)	3,000 cycles
Net Price	\$495.00

Write for complete specifications to Dept. BE

**AMPLIFIER CORP. of AMERICA**  
 An Affiliate of the Keystone Camera Co., Inc.  
 398 Broadway, New York 13, N.Y. • WO 6-2929

Circle Item 40 on Tech Data Card



#### RADIO & CONTROL ROOM EQUIPMENT

- 74. McMARTIN—Brochure describes 8-watt and 32-watt transistor amplifiers for monitoring, queing, talk-back, and utility purposes.
- 75. MOSELEY ASSOCIATES—Two-page bulletin covers the technical considerations of a 950-mc STL system for FM stereo.
- 76. SPARTA—Bulletin lists specs and other information on equalized preamp.

#### TELEVISION EQUIPMENT

- 77. AMPEX—Eight-page directory lists over 1,150 television recorder installations throughout the world.
- 78. CONRAC—Illustrated bulletins cover 14" video monitors for field and rack use.
- 79. HOUSTON FEARLESS—Booklet entitled, "Does it Pay to Process Your Own Microfilm?"
- 80. WALLACH & ASSOCIATES—Six-page brochure contains information on complete line of cabinets for the storage of records, tapes, film, and filmstrips.

#### TEST EQUIPMENT & INSTRUMENTS

- 81. AMERICAN ELECTRONIC LABS—Four-page bulletin describes group of four semiconductor testers.
- 82. DELTA—Report explains use of RF power bridge for permanent installation in the common point of a directional antenna.
- 83. HEWLETT-PACKARD—Short form catalog provides reference to over 600 electronic test instruments.
- 84. SECO—Eight-page bulletin describes line of tube testers.
- 85. TELEMET—Monoscope generator and solid-state effects generator are described in bulletin.

#### TRANSMITTER & ANTENNA DEVICES

- 86. ANDREW CORP.—Specification sheet covers broadband high-gain antenna for mobile communication in the 150 to 162 mc range.
- 87. APC—Brochure gives specs on aluminum, Erec-Tower portable telescoping antenna tower.
- 88. CO.EL.—Catalogs show broadband dipole antennas, UHF slot antennas, filters, and diplexers.
- 89. CONTINENTAL ELECTRONICS—Brochure describes 600-kilowatt peak power high-frequency electronic amplifier.
- 90. GATES—Catalog covers full line of broadcast equipment including AM, FM, and TV transmitters and antennas.
- 91. HUGHEY & PHILLIPS—Catalog sheet describes photoelectric units for the control of obstruction lighting on towers.
- 92. HYGRODYNAMICS—Bulletin describes automatic control equipment for snow and ice melting systems.
- 93. JAMPRO—Illustrated catalog describes line of dual polarized FM transmitting antennas.
- 94. TACO—Bulletin describes series of satin finish "Taco Form" microwave antennas.

Get a top job in broadcasting ...

# A First Class FCC License

...or Your Money Back!

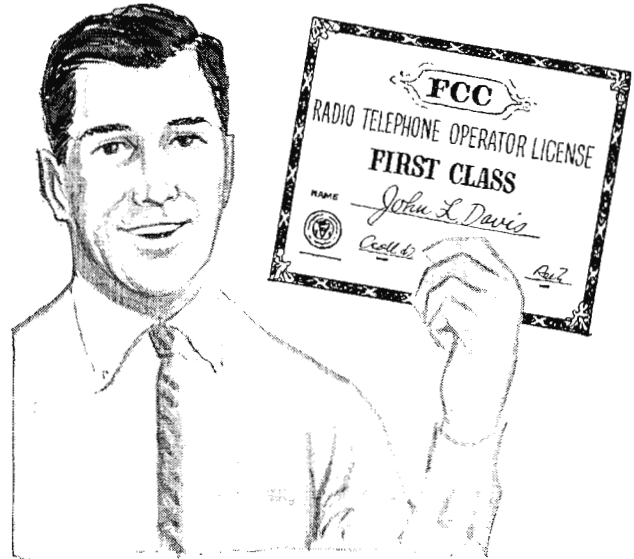

Your key to future success in electronics is a First-Class FCC License. It will permit you to operate and maintain transmitting equipment used in aviation, broadcasting, marine, microwave, mobile communications, or Citizens-Band. Cleveland Institute home study is the ideal way to get your FCC License. Here's why:

Our training programs will *quickly* prepare you for a First-Class Commercial Radio Telephone License with a Radar Endorsement. Should you fail to pass the FCC examination after completing your course, you will get a *full refund* of all tuition payments. You get an FCC License ... or your money back!

You owe it to yourself, your family, your future to get the complete details on our "proven effective" Cleveland Institute home study. Just send the coupon below TODAY. There's no obligation.

#### MAIL COUPON TODAY FOR FREE CATALOG

#### Cleveland Institute of Electronics

1776 E. 17th St., Dept. B-12  
Cleveland 14, Ohio

Please send FREE Career Information prepared to help me get ahead in Electronics, without further obligation.

#### CHECK AREA OF MOST INTEREST -

- |                                                 |                                                    |
|-------------------------------------------------|----------------------------------------------------|
| <input type="checkbox"/> Electronics Technology | <input type="checkbox"/> First-Class FCC License   |
| <input type="checkbox"/> Industrial Electronics | <input type="checkbox"/> Electronic Communications |
| <input type="checkbox"/> Broadcast Engineering  | <input type="checkbox"/> _____ other _____         |

Your present occupation \_\_\_\_\_

Name \_\_\_\_\_ Age \_\_\_\_\_  
(please print)

Address \_\_\_\_\_

City \_\_\_\_\_ Zone \_\_\_\_\_ State \_\_\_\_\_

Accredited Member National Home Study Council

Circle Item 42 on Tech Data Card

#### How to Succeed in Electronics

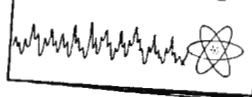

## Professional Services

**VIR N. JAMES**  
CONSULTING RADIO ENGINEERS  
Applications and Field Engineering  
232 S. Jasmine  
Phone: (Area Code 303) 333-5562  
**DENVER 22, COLORADO**  
Member AFCEE

- SYNCHRONOUS MAGNETIC FILM RECORDER/REPRODUCER
- MAGNETIC TAPE RECORDERS
- NEW—THE portable MINITAPE synchronous 13 lb., battery operated magnetic tape recorder for field recording.

**THE STANCIL-HOFFMAN CORP.**  
845 N. Highland, Hollywood 38, Calif.  
Dept. B HO 4-7461

**JOHN H. BATTISON & ASSOCIATES**  
CONSULTING RADIO ENGINEERS  
TV-AM-FM & Microwave Applications and Installations  
Specializing in all forms of communications engineering.  
422 Washington Bldg. Washington 5, D. C.  
Phone ST 3-3484  
Established 1954

## Classified

Advertising rates in the Classified Section are ten cents per word. Minimum charge is \$2.00. Blind box number is 50 cents extra. Check or money order must be enclosed with ad.

The classified columns are not open to the advertising of any broadcast equipment or supplies regularly produced by

manufacturers unless the equipment is used and no longer owned by the manufacturer. Display advertising must be purchased in such cases.

## EQUIPMENT FOR SALE

Commercial Crystals and new or replacement crystals for RCA, Gates, W. E., Bliley and J-K holders; regrounding, repair, etc. BC-604 crystals. Also A. M. monitor service. Nationwide unsolicited testimonials praise our products and fast service. Eidson Electronic Company, Box 96, Temple, Texas. 9-61 tf

**PROMPTING EQUIPMENT.** Used one, two and three prompter packages. Full one year warranty. Limited quantity. **TELESCRIPT CSP, Inc.**, 155 W. 72nd St., New York 23, New York. 10-63 2t

**REAR SCREEN PROJECTORS.** Used No. 7000 3 1/4 x 4" R.S.P., 70 slide capacity, 1/4 sec. fast slide changer, remote control. Taken in trade on new Dual Head R.S.P. Full one year warranty. Limited quantity. **TELESCRIPT CSP, Inc.**, 155 W. 72nd St., New York 23, New York. 10-63 2t

**WE NEED A FIRST CLASS LICENSED BROADCAST ENGINEER TO BE CHIEF.** We have much good equipment and a quality, varied operation. Our group will offer good pay, benefits, advancement and a challenge. Our Black Hills area location is pleasant our staff stable and friendly. We'll encourage you to tinker and ask you to do some announcing. Send complete resume and reference to **KASL, Newcastle, Wyoming.** 11-63 1t

**GOVERNMENT SURPLUS, NEW 10 CM. WEATHER RADAR SYSTEM—Raytheon.** 275 KW peak output S band. Rotating yoke P.P.I. Weather Band 4, 20 and 80 mi. range. Price \$975 complete. Has picked up clouds at 50 mi. Wt. 488 lbs. **Radio Research Inst. Co.**, 550 5th Ave., New York, New York. 8-63 6t

**MICROWAVE ANTENNAS.** Parabolic, 6 foot dia., Andrews, Spun Aluminum. 1700-2400 MCs. Complete with mounting bracket, Di-pole, de-icers, etc. Unused-Crater-Cheap. One Hundred Available **Sierra-Western Electric** 1401 Middle Harbor Road, Oakland, Calif. Tele. 832-3427. 10-62 2t

**Ampex Head Assemblies for 300 and 400 series recorders reconditioned.** Service includes lapping and polishing all three head stacks, cleaning entire assembly, readjusting and replacement of guides, and realignment of stacks as to azimuth and zenith. Full track assemblies—\$60.00. **Taber Manufacturing & Engineering Co.**, 2619 Lincoln Ave., Alameda, California. 8-63 5t

1. Two RCA turntables with pickups—RCA model No. 70-D, GE preamps, picker-pickups and arms, also RCA arm and cartridge No. MI-4875-G. 2. General Radio Oscillator No. 1301-A. 3. Two microphone stands, collapsible, chrome plated, extends to 30-ft. with ten foot boom, tripod base with lock wheels, New. 4. Two American Standard clock power supplies. 5. E. F. Johnson RF coils, No. 200-210, No. 200-205, No. 200-107, all like new, 25% off list price. 6. RCA video sweep Generator No. WA-21B, as listed in latest catalog, excellent condition. Chief Engineer, **WFLN, Philadelphia** 19128. 11-63 1t

**250-WATT FM TRANSMITTER** for sale or trade. Gates BF-250, used. In operating conditions on 103.9 megacycles. Will trade for good 250-watt AM transmitter. Contact **Ebert Weather, Radio Station KWPM, West Plains, Missouri** 11-63 1t

## Advertisers' Index

American Concertone, Inc. ....	44
Ampex Corp. ....	7, 9
Amplifier Corp. of America.....	56
Andrew Corp. ....	13
Automatic Tape Control, Inc....	Cover 3
Bauer Electronics Corp.....	54
Broadcast Electronics.....	28, 41, 50, 51
CBS Labs, Inc. ....	5
Cleveland Institute of Electronics...	57
Conrac Div., Giannini Controls Corp. ....	27
Continental Electronics ..	Cover 2, Pg. 3
Crown International .....	4
Delta Electronics .....	55
Diamond Electronics .....	50
Eastman Kodak Co. ....	10, 11
Eitel-McCullough, Inc. ....	29
Electro-Voice, Inc. ....	32
Electronics, Missiles & Communications, Inc. ....	51
Fairchild Recording Equipment Corp.	24
General Electric Co., Tube Div. ...	35
Gates Radio Co. ....	41
Gotham Audio Corp. ....	52
The Hickok Electrical Instrument Co. ....	45
Houston Fearless Corp. ....	8
Jampro Antenna Co. ....	46
Machronics, Inc. ....	37
Magnecord Div., Midwestern Instruments .....	49
McMartin Industries .....	53
Minnesota Mining & Mfg. Co. ....	25
Moseley Associates .....	58
Penta Laboratories .....	6
RCA Broadcast and Television Equipment Div. ....	Cover 4
RCA Victor Record Div. ....	23
Rusco Electronics Mfg. ....	56
Sams, Howard W. & Co., Inc. ....	38
Sarkes Tarzian, Broadcast Equipment Div. ....	33
Saxitone Tape Sales .....	58
Shure Brothers, Inc. ....	43
Sparta Electronics Corp. ....	30, 31
Texas Crystals, Div. Whitehall Electronics .....	41
The Turner Co. ....	39
Viking of Minneapolis, Inc. ....	47

## BULK TAPE REELS!

1000 LOT PRICES (assorted)

3" (1 1/4" hub) .....	41 1/2c
3 1/4" (1 1/4" hub) .....	61 1/2c
3 1/4" (DeJure-Stenorette type) .....	10c
4" (1 1/4" hub) .....	11 1/2c
5" (1 1/4" hub) .....	12 1/2c
5" (3" hub) .....	17 1/2c
5 1/4" (1 1/4" hub) .....	17c
5 1/4" (2 1/2" hub) .....	18c
7" (2 1/4" hub) .....	14c
7" (2 1/4" hub) Heavy Duty 6 spoke .....	16 1/2c
7" (4" hub) professional type .....	18c
10 1/2" (metal) NEW .....	1.44
10 1/2" (metal) USED .....	.72
10 1/2" (fiberglass) 3/4" center hole .....	.84
10 1/2" (fiberglass) 3/4" center hole .....	.84



## WOLLENSAK

### Tape Recorders

deliver a bigger wallop than many recorders twice their size.

ATTN: SCHOOLS & GOVERNMENT PURCHASING AGENTS:

We have the most complete selection anywhere. New models include: 524, 1400, 1440, 1500, 1515-4, 1570, 1780, 1580, 1980, 1981 and 422. & SA-421 speakers /amplifiers. Whether it is 1 or a 1000 units your order will receive our prompt attention. SEND FOR OUR COMPLETE TAPE RECORDER DISCOUNT SHEET.

## SAXITONE RECORDING TAPE

\*Oxide guaranteed not to rub off or squeak—or money back. Compare ours with other "Bargain" tape. You'll find it's more than just "price" when you deal with us. We are original pioneers in the tape recorder business and our reputation means everything to us.

225' MYLAR, 3" (in mailable box)...	.39
600' acetate (plastic), 5 inch.....	.75
600' MYLAR 5 inch reel.....	.85
900' MYLAR (Polyester), 5 inch.....	.89
1200' MYLAR, 1/2 mil, 5 inch reel.....	1.18
1200' MYLAR, tensitized, 5 inch.....	1.59
1200' acetate (plastic), 7 inch.....	1.15
1200' MYLAR, 1/2 mil, 7 inch.....	1.29
1800' acetate (plastic), 7 inch.....	1.39
1800' MYLAR, 1 mil, thick, 7 inch.....	1.89
2400' MYLAR, tensitized, 7 inch.....	2.59
2400' MYLAR, tensitized, 7 inch.....	2.89

(Large Users Even Lower)

**SAVE 30% PLUS POSTAGE**  
4-track stereo music on tape (complete stack)

**NORELCO SPEAKERS**  
Famous AD3800M twin cone 8" (75-10,000 cycles) comparable net 9.90 now 4.95 (plus postage). OTHER Norelco models at BIG DISCOUNTS. Specifications on entire Norelco line sent on request.

**SAXITONE TAPE SALES**  
div. Commission Electronics, Inc.  
1776 Columbia Rd. N.W., Wash. 9, D.C.

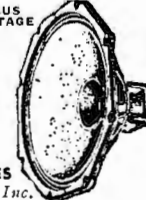

## HERE'S AN EXCITER

that WILL FACE THE MUSIC!

AND GIVE YOU

BRILLIANT STEREOHONIC AND SCA REPRODUCTION.

Direct FM 10 WATT EXCITER • Model LPE-10

- approved for educational service.
- the ultimate in circuit design and unique construction.

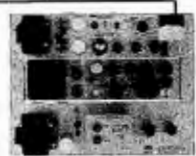

**MOSELEY ASSOCIATES INC.**

TEL 967-1469 OR 967-8119  
AREA CODE 805 PO BOX 3192  
SANTA BARBARA, CALIFORNIA

Circle Item 33 on Tech Data Card

Circle Item 43 on Tech Data Card

**How do you  
make the  
best one  
better?**



## **Add direct tape drive to Automatic Tape Control**

Another first from Automatic Tape Control. A direct drive motor completely eliminating troublesome belt changing, flywheel bearing problems and speed differences between machines. A quality feature previously available only in the finest reel-to-reel tape machines, Automatic Tape Control now offers this great advance as standard equipment at no additional cost. Consisting of an especially designed hysteresis synchronous ball bearing motor, ATC's direct capstan drive provides trouble free and virtually noiseless operation at all times. And, because only the highest quality

sealed ball bearings are used, no lubrication is required. An absolute minimum of eight inch-ounces of driving torque completely eliminates tape slippage and pinch wheel pressure problems on all cartridge sizes and tape lengths. Through extra care in manufacture and assembly, wow and flutter is less than .2% rms and timing accuracy is better than 99.8%—comparable to the finest reel-to-reel machines.

For more information on this great advance in tape cartridge equipment, contact Automatic Tape Control or your area ATC distributor.

*Originators of the tape cartridge system for broadcasters*

**AUTOMATIC**  **TAPE CONTROL**

209 E. Washington St.

Bloomington, Illinois,

Circle Item 43 on Tech Data Card

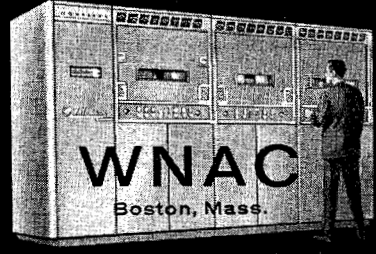
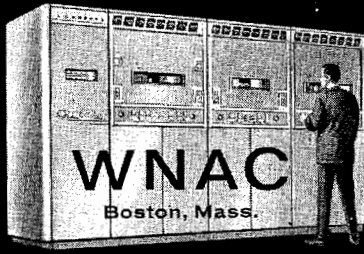
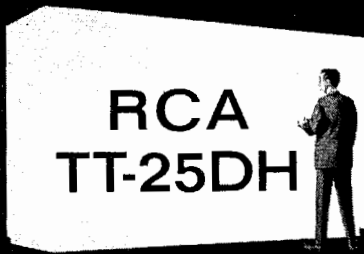

**PREFERRED BY THE NATION'S**

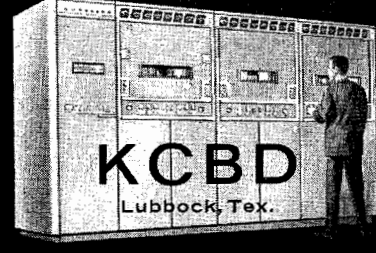

**FINEST TELEVISION STATIONS**

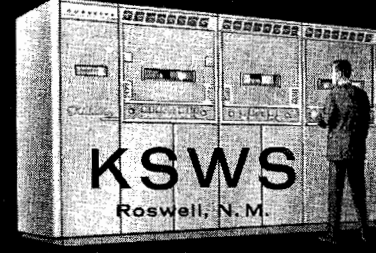
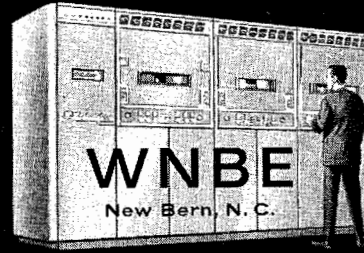
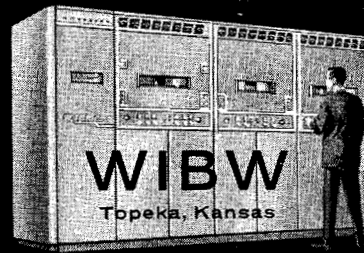

**FOR HIGH-BAND OPERATION**

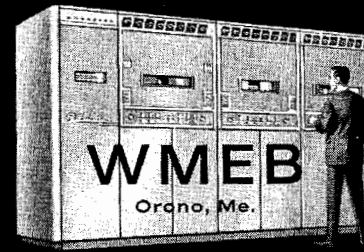
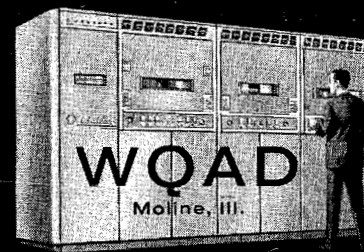

## **It's the new RCA 25-kw TV Transmitter (Ch. 7-13)** offering new excellence of performance, reliability and low operating cost

The popularity of this modern 25-kw transmitter stems from its fine performance for high-band VHF service. That's why so many TT-25DH's have been ordered since first shown at the 1962 NAB Convention.

This transmitter is capable of full 316-kw ERP when coupled with a modern high-gain antenna such as the RCA "Traveling Wave."

WNAC will be using two of these operating in parallel to produce 50-kw for its new transmitter installation.

The TT-25DH transmitter is completely modern, using silicon rectifiers, and a minimum number of operating tubes. It is designed for remote control operation. Small space requirements, low power cost, and high reliability are among its many other modern features. It is an ideal transmitter for the high-quality, maximum-power VHF station. It will add prestige to yours.

For more facts about this new transmitter, see your RCA Broadcast Representative, or write RCA Broadcast and Television Equipment, Bldg. 15-5, Camden, N.J.



**The Most Trusted Name in Television**