

A HOWARD W. SAMS PUBLICATION



October, 1968/75 cents

# Broadcast Engineering

*the technical journal  
of the broadcast-  
communications industry*

**Voice of America  
Control Room** page 10

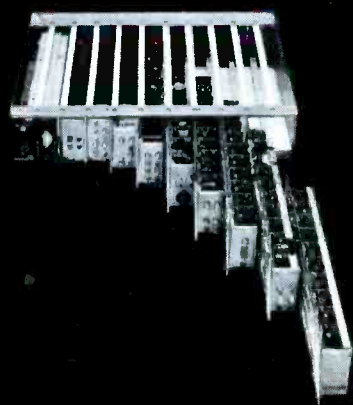


# how to ease into a deluxe color sync generator without straining your budget

In three easy steps, you can build your way economically to the same high quality deluxe color sync generator used by the major TV networks. Start out with Riker's basic EIA sync generator—four modules, rack frame and power supply—\$2900. When your budget can afford the expansion, add two more modules for deluxe sync lock and you get the advantage of three selectable speeds for locking to an external composite video or sync signal. Cost: \$790.

Now you're all set to step up to color. Add three more modules—\$1985—and you have eased into Riker's widely used, field-proven Model 520-4CL Color Sync Generator with Deluxe Sync Lock. You now own the best sync generating system in the broadcast industry.

The Riker module at a time approach is the sensible way to build quality equipment into your facilities. Over the long term it's also the most inexpensive way. If you're interested in details on sync generators, write or call Riker—the one company in the TV broadcast industry offering a complete line of all solid-state instrumentation for video analysis, simulation and control.

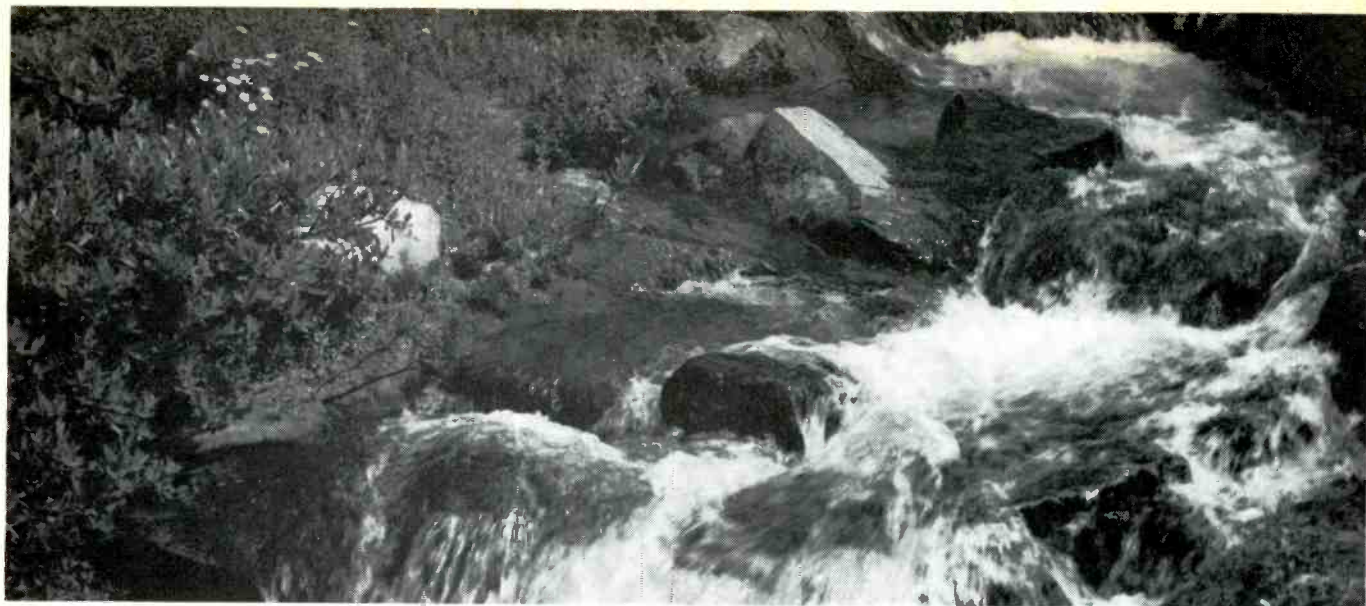


**RIKER**  
PRODUCTS FOR VIDEO ANALYSIS, SIMULATION & CONTROL

RIKER VIDEO INDUSTRIES, INC., 100 Parkway Drive South, Hauppauge, Long Island, N.Y. 11787 (516) 543-5200

Circle Item 1 on Tech Data Card





# natural-flow

A solid-state video switcher with a natural-flow control panel

Cohu's new 9300 Series solid-state video switcher was designed with the operator in mind. All controls on the *natural-flow* panel are engineered for maximum ease and efficiency of operation. All performance specifications lead the state of the art. Quality-proven components have been selected for reliability under continuous duty.

No single failure can disable the system because of redundant power supplies and sectional fusing. Test points are accessible from the front. Cards are interchangeable

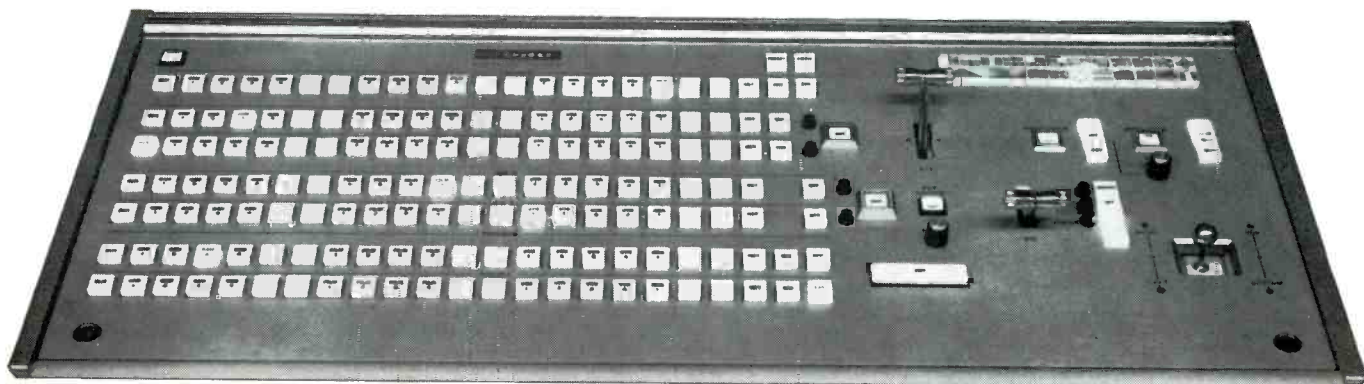
plug-ins. Adjustable, preprogrammed delay sections provide interchangeable output amplifiers.

Designed especially for broadcasting, the 9300 Series Video Switcher features integrated circuits and modular design with a convenient form factor for typical studio requirements and expansion capabilities.

For more details, contact your nearest Cohu representative, or call Bob Boulio direct at 714-277-6700 in San Diego, Box 623, San Diego, California. TWX 910-335-1244.

- accepts composite or noncomposite signals
- cut is standard on Mix, Effects, and Preset/Program Buses
- automatic inhibit of non-synchronous dissolve
- no mid-fade color drop when fading to monochrome
- fade to black with automatic cut
- automatic sync insertion
- input over-voltage protection to 300 volts

**COHU**  
ELECTRONICS, INC.  
SAN DIEGO DIVISION



Circle Item 2 on Tech Data Card



# Broadcast Engineering

The technical journal of the broadcast-communications industry

## *in this issue...*

- 10 **Voice of America: 'Ideal' Operations Studio Solves Programming Needs.** The 'Voice' updates its master control to meet modern needs. **Maximillian Swoboda.**

---

- 20 **Service Jig for the TK-42 Viewfinder.** Speeds servicing the viewfinder. **A. A. Kelley.**

---

- 22 **EDP System Speeds Logging and Record Handling.** Description of automated system at KSTP. **Phil Dean.**

---

- 24 **Join the FM News Network Automatically.** Details of a network tone receiver. **Charles E. Gustafson.**

---

- 30 **A Multiplexer that Reduces Switching Problems.** Unit eliminates manual film audio switching. **Don Freeman.**

---

- 34 **Understanding Transistor Audio Circuits.** Discussion of component values and their effect on circuit design. **Norman H. Crowhurst.**

---

- 48 **IEEE-GB: The 18th Annual Symposium.** Coverage of the September meet held in Washington, D. C. **Ron Merrell.**

---

- 59 **WDAU on Bald Mountain.** Installing tower on mountain to increase coverage. **Peter Silveri.**

### ABOUT THE COVER

Shown on the cover is the master operations control room of the Voice of America. See story on page 10.

### DEPARTMENTS

- News of the Industry ... 4
- Washington Bulletin ... 45
- New Products ... 61
- People in the News ... 68
- Engineer's Tech Data ... 73
- Advertiser's Index ... 78
- Classified Ads ... 79

### EDITORIAL

GEO. H. SEFEROVICH, Director  
RONALD N. MERRELL, Editor  
B. STEARNS, Editorial Assistant  
DUDLEY ROSE, Art Director  
LEE JOHNSON, Assistant Artist

### REGIONAL EDITORS

GEORGE M. FRESE, Northwest  
HOWARD T. HEAD, Washington, D.C.  
ROBERT A. JONES, Midwest

### EDITORIAL ADVISORY BOARD

LES NELSON, Chairman  
Howard W. Sams & Co., Indianapolis

### CIRCULATION

R. VINCENT WARD, Director  
PAT OSBORNE, Manager

### ADVERTISING

E. P. LANGAN, Director  
R. JACK HANCOCK, Manager  
S. F. WILSON, Production  
LEE MILLER, Promotion

### REGIONAL ADVERTISING SALES OFFICES

Indianapolis, Indiana 46206  
ROY HENRY  
HOWARD W. SAMS & CO., INC.  
4300 West 62nd St.  
Tele: 317/291-3100

New York, New York 10019  
ALFRED A. MENEGUS  
3 W. 57th St.  
Tele: 212/688-6350

Los Angeles, California  
G.R. HOLTZ  
THE MAURICE A. KIMBALL CO., INC.  
2008 Carson St., Suites 203-204  
Torrance, California 90501  
Tele: 415/392-3365

San Francisco, California 94104  
THE MAURICE A. KIMBALL CO., INC.  
580 Market Street, Room 400  
Tele: 415/392-3365

Houston, Texas 77027  
MARTIN J. TAYLOR  
P. O. Box 22025  
Tele: 713/664-3016

London W. C. 2, England  
JOHN ASHCRAFT & CO.  
12 Bear Street  
Leicester Square  
Tele: Whitehall 0525

Amsterdam C, Holland  
JOHN ASHCRAFT & CO.  
W.J.M. Sanders, Mgr.  
Herengracht 365  
for Benelux & Germany  
Tele: 24.09.08

Paris 5, France  
9 Rue Lagrange  
ODEon 20.87

Tokyo, Japan  
INTERNATIONAL MEDIA  
REPRESENTATIVES, LTD.  
3, Nakanocho, Akasaka, Minato-ku  
Tele: 582-5881



BROADCAST ENGINEERING is published monthly by Intertec Publishing Corp., 1014 Wyandotte Street, Kansas City, Missouri 64105.

Subscription Prices: U.S.A. \$6.00, one year; \$10.00 two years; \$13.00 three years. Outside the U.S.A., add \$1.00 per year for postage. Single copies are 75 cents, back issues are \$1.00.

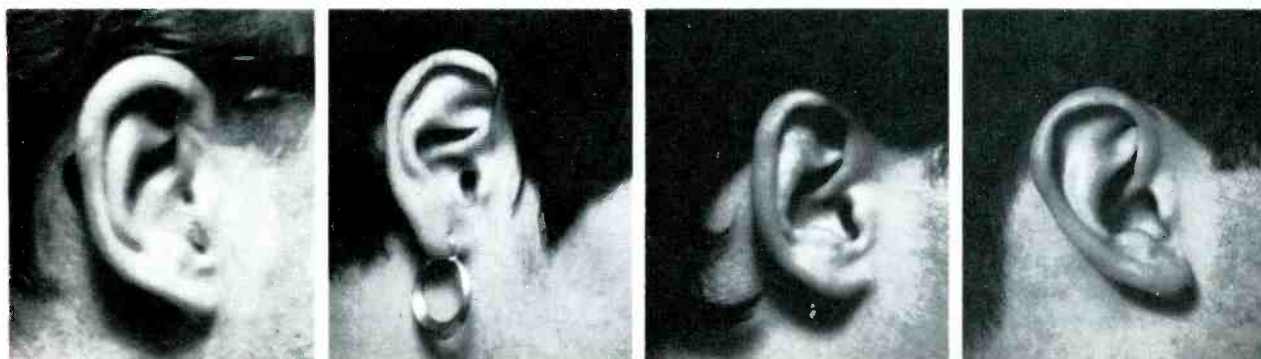


Robert E. Hertel, Publisher  
Intertec Publishing Corp.  
Subsidiary of Howard W. Sams & Co., Inc.

Copyright, 1968, Howard W. Sams Co., Inc. All Rights Reserved: Material may not be reproduced or photocopied in any form without written permission of publisher.

# NOW...

## Guarantee your audience's listening comfort



**Our Automatic Loudness Controller delivers the sound that's right for every ear. Automatically eliminates excessive loudness. Unconditionally guaranteed!**

No doubt about it. Other devices can control volume and modulation levels. That's what they're for.

But only one instrument can analyze and automatically control loudness levels.

Ours.

Reason? We designed it "from human ears". At CBS laboratories, we tested every conceivable sound sensation: Frequency content. Peak factors. Ballistic response.

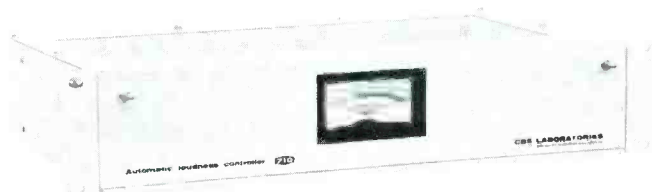
Combinations of complex signals. All the characteristics that affect even the most sensitive ear.

Result? An instrument so "humanly" perceptive it automatically keeps loudness levels under control. And does it inaudibly. Keeps your audience in their chairs . . . listening comfortably. No constant jumping up and down to flip the dial. They enjoy continuous listening pleasure.

Give this remarkable instrument an operational test yourself. Install it. And use it *free* for 30 days. You *will* believe your ears. It's guaranteed. Unconditionally.

Write or call us collect (203) 327-2000.

PROFESSIONAL  
PRODUCTS  
**CBS LABORATORIES**  
Stamford, Connecticut  
A Division of Columbia Broadcasting System, Inc.





## CBS Changes Feed: Six Stations to Raise New Antennas

Professional football is with us once again. This year CBS will add former Baltimore Colt star Lennie Moore to their team of commentators and will use just one audio feed for each game.

In recent years, two teams of broadcasters covered a game, each feeding the home area of the club to which they were assigned.

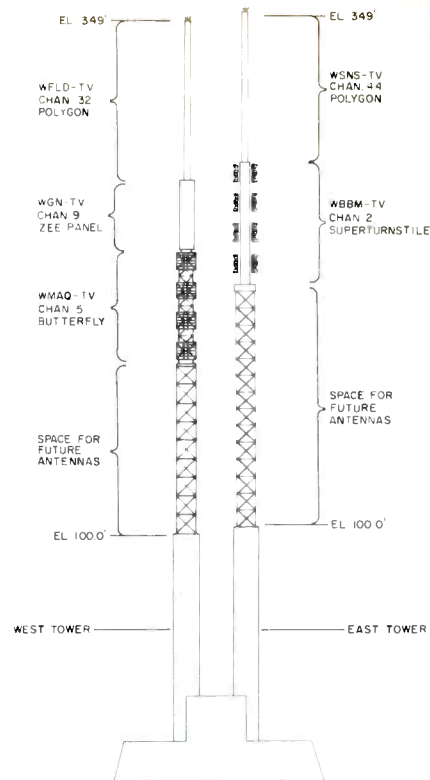
The change to one audio feed was made because of the increased sophistication of the NFL broadcasts that now include instant replays, stop-action, slow-motion replays and superimposed scores of other games. In addition, the regional commercialization policy required simultaneous cuing of each broadcast team, resulting in complicated AT&T switching procedures.

**WDBO-TV, Orlando, Florida**, will become the first station to install RCA's new "Butterfly" broadcast antenna. It will be mounted atop the station's new 1484-foot tower.

The six-bay panel antenna gets its name from wing-like radiating elements that are positioned backwards toward the reflectors for optimum impedance and radiation characteristics. This antenna was introduced at the 1968 National Association of Broadcasters convention.

**Five television stations** have signed a long-term lease to broadcast from antennas atop the new 100-story John Hancock Center in Chicago. The stations are: WBBM, WMAQ, WGN, WFLD and WSNS.

The Center's main structure is 1,107 feet tall. The antennas will reach another 349 feet for a tip height of 1,456 feet. RCA will supply and install the antennas which,



with their supporting structures, will weigh more than 140 tons. Installation is scheduled to begin by Oct. 1, 1969.

## Filmways Sees Future For 16mm Film

The major portion of a \$200,000 expansion program at Acme is going into two Ektachrome color processing lines. Behind this move is the industry trend toward TV se-

ries production on 16mm film, according to Mel Sawelson, president.

Being installed this month at Acme are an ECO II Ektachrome film processing machine and ME-4 Ektachrome film processing machine with track applicator. Both machines were operational in Sept.

Al Simon, president of Filmways TV (producers of the Beverly Hill-

billies, Petticoat Junction, Green Acres), says that "by 1970 a substantial percentage of continuing network series will be shot on 16mm film because of the lower costs, greater flexibility, and faster production. Producers have been impressed by entertainment documentaries which have been successfully shot on 16mm."

## Earth Stations Hold Key to Satellite Communications

In a major study sent to the President's Task Force on Communications policy, an ad hoc engineering group of the Electronics Industries Association has concluded that powerful, low-cost earth stations hold the key to future uses of satellite telecommunications.

The study group, part of the EIA Satellite Telecommunications Sub-division, submitted a 200-page re-

port which will serve as a basis for a comprehensive document on all aspects of satellite communications.

The study is part of the EIA sub-division's active push for a domestic telecommunications satellite system. In a policy position taken in May, it called for "aggressive pursuit" of a domestic system.

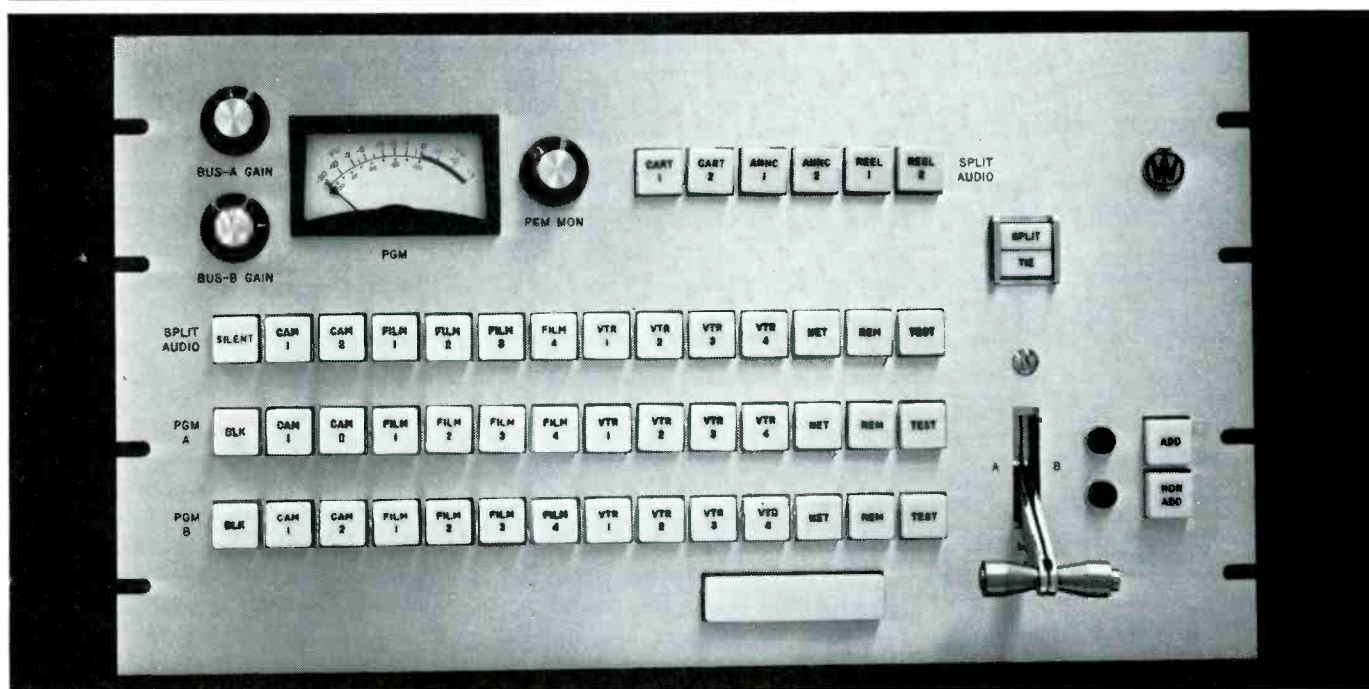
Meanwhile, membership in INTELSAT increased to 62 nations during the second quarter, with the addition of Turkey. INTELSAT (International Telecommunications Satellite Consortium) is the joint venture which owns the space seg-

ment of the satellite system.

Preparations were underway in September for the launching of the INTELSAT III series. With success in the INTELSAT III program, the initial global commercial communications satellite system will be operational in early 1969.

About 40 stations are expected to be in operation or under construction by the end of 1969, and the number probably will grow to 70 within another few years. Plans for the INTELSAT IV series are being considered now. That program, according to present plans, would be launched in 1971.

- + video
- + audio
- + cutbar
- + non-additive mixing
- + breakaway audio



... add up to make the TS-211 Master Control Switcher one of the most versatile and economical, high quality switchers, ever!

- Ideal for master control and small studio applications.
- Vertical Interval — Solid State design.
- 14x2 video matrix.
- Automatically switched cutbar/mix mode.
- Video inputs may be all composite or all non-composite.
- Audio-follow-video, and split audio for 14 inputs.
- 6 auxiliary audio inputs for cartridge tape, announce, etc.
- DC remote audio level controls on panel.
- Compact rack space, only 14" high.
- Control panel, 19" x 10½", brushed aluminum finish, with illuminated pendar push button switches.
- Camera tallies on terminal block.



## WARD ELECTRONIC INDUSTRIES

142 CENTRAL AVE., CLARK, N. J. 07066 • (201) 382-3700

Circle Item 4 on Tech Data Card

---

## Meetings Scheduled For Associations

**The 104th Technical Conference** of the Society of Motion Picture and Television Engineers will be held November 10-15, at the Washington Hilton Hotel in Washington, D. C. A record number of papers for a Washington Conference has been received by Program Chairman E. D. Llerena, Eastman Kodak Co., Washington, D. C.

One of the major topics of the Conference will be television. Co-chairmen of the television topic, Charles L. Chester, CBS, Washington, D. C., and Adrian B. Ettliger, CBS-TV, New York, have been kept busy arranging the program. A featured presentation will be a panel discussion on problems facing the television industry.

**The Audio Engineering Society, Inc.** will feature a "From Studio to Microphone to Listener" seminar

during its 35th convention Oct. 22, 1968 in the Oriental Room of the Park-Sheraton Hotel in New York City.

Panelist Victor Brociner of H.H. Scott will talk about practical acoustics—the speakers, the listening room and the human ear. L. R. Burroughs of Electro-Voice will discuss the selection and placement of microphones, with particular attention to directional characteristics and acoustic phasing. John M. Eargle, RCA Record Division, will describe signal processing—equalization and filtering, compression of dynamic range and artificial reverberation.

Other meetings include coverage of such subjects as solid-state transducers, sound reinforcement, engineering and the environment, disc recording, magnetic recording, developments in electronic-music systems and audio apparatus and communications systems.

### **The second annual International**

**West Coast Conference on Broadcasting** sponsored by the Institute of Electrical and Electronic Engineers, Inc. will be held Nov. 6, 7 and 8 at the Ambassador Hotel, Los Angeles.

The program will include the reading of technical papers covering TV transmitters and antennas, CATV systems, television transmission and a special section on international standards and methods.

**The University of Arizona** will open its Systems Engineering Institute in Tucson on Oct. 28. The Institute will run through Nov. 1. Background material in systems engineering and the modern tools used in systems modeling will be presented.

Then from Nov. 4 through 13 the University will present its Sixth Annual Reliability Engineering and Management Institute. The Institute is designed for engineers, managers and directors.

---

## Educational TV Continues to Grow Across the Nation

**One of the nation's first** educational closed circuit television systems linking all of the classroom buildings of one school district has been installed in Glassboro, N.J. by the Commercial Electronics Division of Sylvania Electric Products, Inc.

The high school is equipped with an antenna capable of receiving broadcasts from the three major commercial networks and the educational television network, which, in turn, can be transmitted to the rest of the schools or taped for future use.

"For years educators have talked about using the community in the schools," said Walter J. Vail, instructional materials coordinator for the Glassboro schools. "Now, with the mobile TV unit, this idea

is a reality." Vail noted that the mobile unit can reach out into local business, industry, government, and culture to record events.

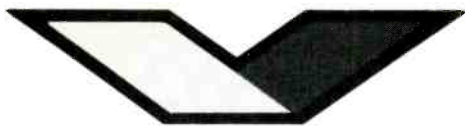
"Played back into the classroom, actual events are discussed and evaluated by teachers and pupils," Vail said. "The teacher begins to play the role of interpreter and analyst. Students and teacher share a common fund of information, enabling them to interpret events on a common basis. Thinking in the classroom becomes relevant to what is happening in the community."

**When the students went back** to school in Utah this year, they found some interesting changes. A wealth of television programs have been made available to Utah schools through the Utah Network of Instructional Television (UNIT). Elementary and secondary schools have a choice of approximately 52 telecourses with a total of more than 2000 individual programs.

A two-year-old programming, production and distribution center, UNIT is not a network in the broadcasting sense of the word. Dan L. Keeler, educational television specialist in the state school office, described it as the "bicycling" of telecourses between any and all ETV stations in the state wishing to broadcast them. At present, programs are aired over four of the state's five ETV stations: KUED, University of Utah; KWCS, Weber County Schools; KOET, Ogden City Schools; and KUSU, Utah State University.

**Nine representatives** of the Wisconsin Educational Communications Board inspected the Georgia Network Headquarters recently. The Board was created this spring by Governor Warren P. Knowles and the Wisconsin Legislature. General responsibility for educational radio and television in the state rests with the Board.

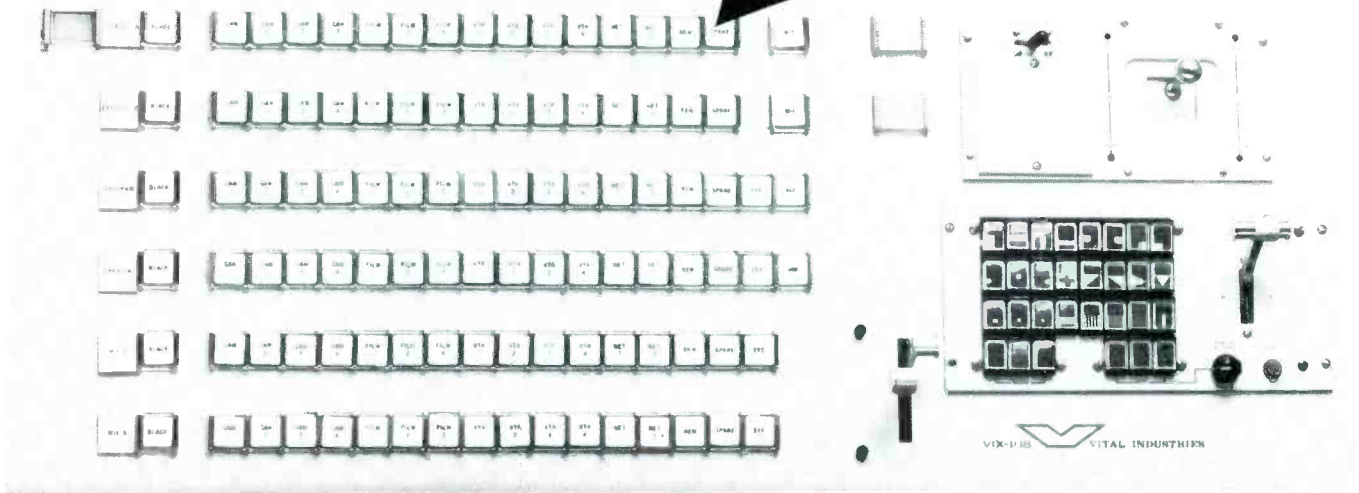




# Vital News in Switching!

## VIX-108

*First new concept  
in Switching in a  
decade is here*



Vital Industries, Inc. has taken the custom cost and complications out of custom switching. A unique combination of mechanical and electrical packaging has yielded exceptionally high performance and specifications in the VIX-108 vertical interval switching system.

### FEATURES:

- All solid state with integrated circuits including crosspoints and control circuits.
- Complete basic package 18 in by 6 out system complete with power supply control circuitry, in 5¼" rack space. UHF Connectors.
- Production or routing switcher. Any size.
- Vertical interval or random switch in less than 0.1 micro-second.
- Auto sync add for comp/non comp operation. Auto inhibit non synchronous mix.
- Custom built with any kind of control buttons or panels. All state of the art accessories also furnished by Vital Industries, Inc.

### SPECIFICATIONS for one typical 18 in 6 out system:

- Exceptional isolation between crosspoints . . . 65 DB down at 4 Mhz.
- Differential phase through the system . . . Less than 0.1 degree at 1 volt output.
- Differential gain . . . less than 0.1 percent at 1 volt output.
- Frequency response . . . Flat within 0.1 db from 10 Hz to 10 Mhz under all conditions.
- Tilt . . . Less than 0.5% over 1 field.
- K factor less than 1%.

*Selecting the right switcher is Vital*

GOOD ENGINEERING IS VITAL



*Write for complete information and specifications.*

## VITAL INDUSTRIES, INC.

3614 SOUTHWEST ARCHER ROAD  
GAINESVILLE, FLORIDA 32601 - PHONE (904) 378-1581

Circle Item 5 on Tech Data Card

### FLEXIBILITY

- 4 switch-selectable inputs: hi-level/mike/equal phone cannon XL connector/barrier strip input.
- External studio and local speaker.
- P. A. output (public address).
- Muting relay contacts on barrier strip.

### ELECTRONICS

- Etched-epoxy circuit board.
- Plug-in silicon transistors.
- 4 preamplifiers (each normal on equal RIAA phono).
- 1 program amplifier.
- 1 monitor amplifier.
- Speaker muting relays for local and studio speakers.
- May be strapped to operate from any mixer.
- Two-speaker muting.

### PORTABILITY

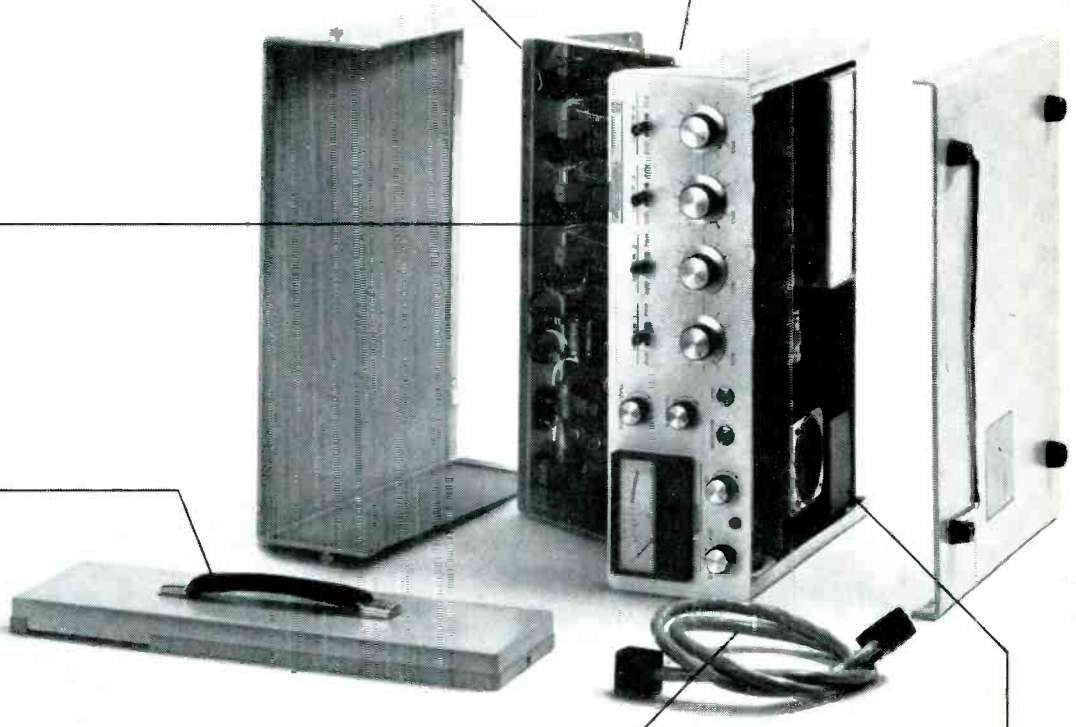
Weight: 28 pounds.  
Height: 5".  
Width: 14".  
Length: 17".

### PARALLEL OPERATION

Optional plug-in cable allows parallel operation of two 212J-1's. Arrangement provides 8 input channels (hi-level/mike/phono), two metered program output channels, and two switchable input monitor channels.

### ACCESSIBILITY

Top and bottom covers removed individually to expose all components. Circuit board hinged for easy access to reverse side and cables.



### OPTIONAL POWER SOURCE

Self-contained power supply that operates the unit on AC also serves as charger for optional internal nickel-cadmium 12-volt battery. Unit switches automatically to battery in the event of an AC power loss. Unit also operates on external 12-volt battery.

## *a studio production console and remote pickup amplifier in one unit*

*That's the combination you get in Collins' new 212J-1 Console. Produce spots, conduct remote pickups, or operate the control room in emergency situations.*

*Completely solid-state, the 212J-1 offers:*

- *Four input channels, each with selectable switches for hi-level, microphone, or phone (RIAA equalization).*
- *One program output channel.*
  - *Switch-selectable monitor amplifier with internal speaker.*
  - *Cue on all mixers overriding into monitor channel.*
- *Local and studio speaker muting.*
- *Public address system feed with level control.*



COMMUNICATION / COMPUTATION / CONTROL



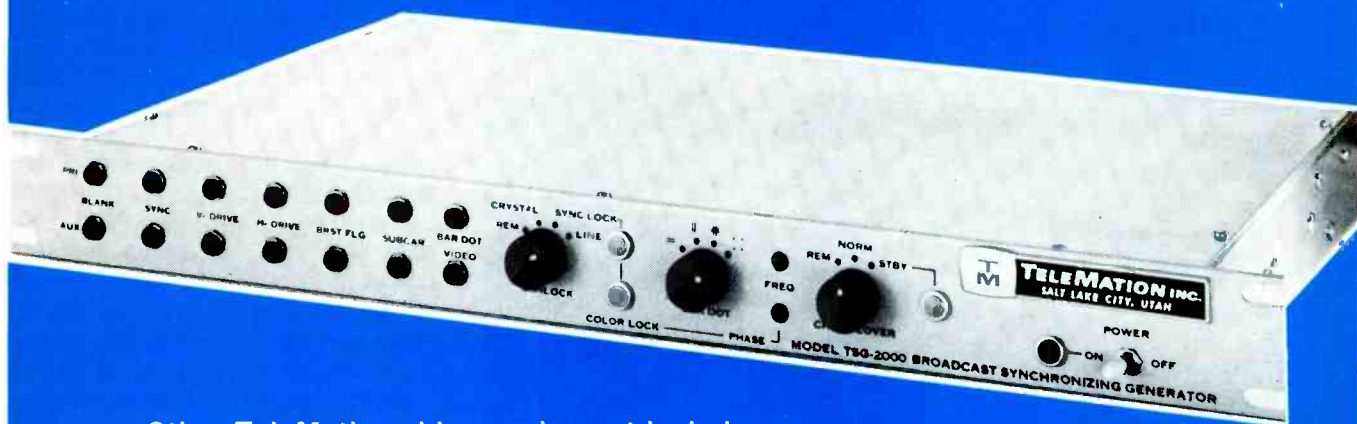


# *The world's most precise broadcast sync generator!*

**(Proved in over 200 installations.)**

The EIA Sync Generators in Telemation's TSG-2000 Series are more accurate—more stable—than any available. Here are some of the reasons why:

- All-digital design
- No monostables — no delay lines
- Integrated circuit reliability
- Dual outputs — permit pulse assignment with full standby
- Guaranteed better time-base stability and pulse jitter performance (even when genlocked) than any other sync generator
- Monochrome genlock, color genlock, bar-dot, and sync changeover ad-in modules available.



**Other Telemation video equipment includes:**

- Optical Multiplexers
- Video Distribution Amplifiers
- Vidicon Cameras
- Color Camera Matching Systems



**TELEMATION, INC.**

2275 South West Temple / Salt Lake City, Utah 84115 / Telephone (AC 801) 486-7564

Circle Item 7 on Tech Data Card



## VOICE OF AMERICA

# 'Ideal' operations studio solves programming needs

by Maximillian Swoboda\*

"Voice of America, Washington, calling Voice of America, Nairobi." This—or a variation of it—is the call heard many times a day from the new radio operations central control in the newsroom of the Voice of America in Washington, D.C.

On an average day, the news editor may call in such diverse news-making capitals as Saigon, Athens, Lima, San Francisco, Tokyo and Tel Aviv. He also may take in reports from VOA correspondents at the White House, the State Department and Capitol Hill. He may even

\*VOA Senior Audio Engineer.

receive line feeds of a news conference in New York, an interview on network television or a recorded statement of a newsmaker in Chicago procured by a VOA correspondent.

The highly perishable nature of this influx of news material convinced former VOA Director John Chancellor that "The Voice"—as it is often called by its employees—needed a modern broadcast operations studio specifically designed to process the incoming diverse material quickly and efficiently. He asked a VOA correspondent, who is a former NBC newswriter and

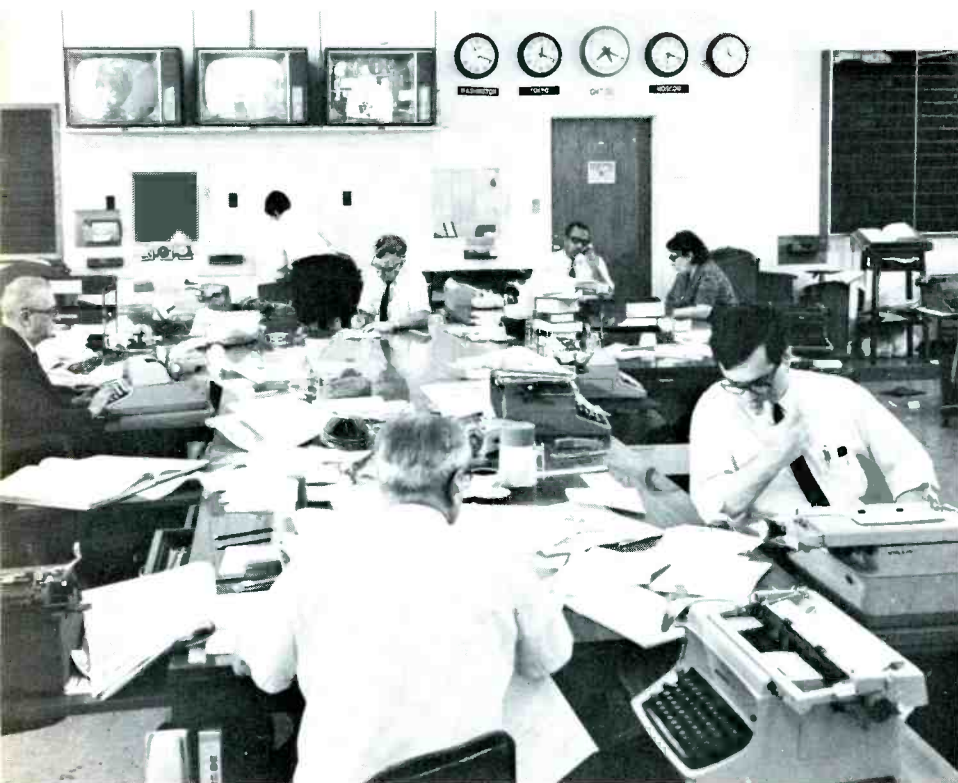
editor-producer of the NBC Radio World News Roundup, to help the VOA engineers design the "ideal" operations studio to meet the Voice's needs.

What were the needs? In recent years VOA has moved toward a style of news programming patterned after domestic American broadcasting. The pace is relatively fast, although more deliberate than most domestic newscasting. The writing is tight, and there is a concerted effort to use news inserts—both Voice reports by VOA correspondents and voices of the newsmakers.

The Voice was not equipped to meet these needs. Decentralization throughout the Voice's headquarters in the Health, Education and Welfare Building was the major reason. As pressure to modernize VOA's news style mounted, an increasing number of employees were engaged in footraces around the building, from any one of 23 broadcast studios in which overseas circuits were taken in, to the tape library, to an audition tape recorder elsewhere, then back to the newsroom and on to yet another studio for broadcast. Six sections of VOA, each in a different location, played a role in the preparation of a news insert. Many news inserts became outdated before they could be aired.

The major need was to bring together an editor and an engineer, give each the equipment appropriate to his tasks and then alter the flow of incoming broadcast material so that it passed through the new operations studio. In this way, complete editorial control over incoming material could be achieved.

Technically, it was essential for



Editorial staff preparing news programs.

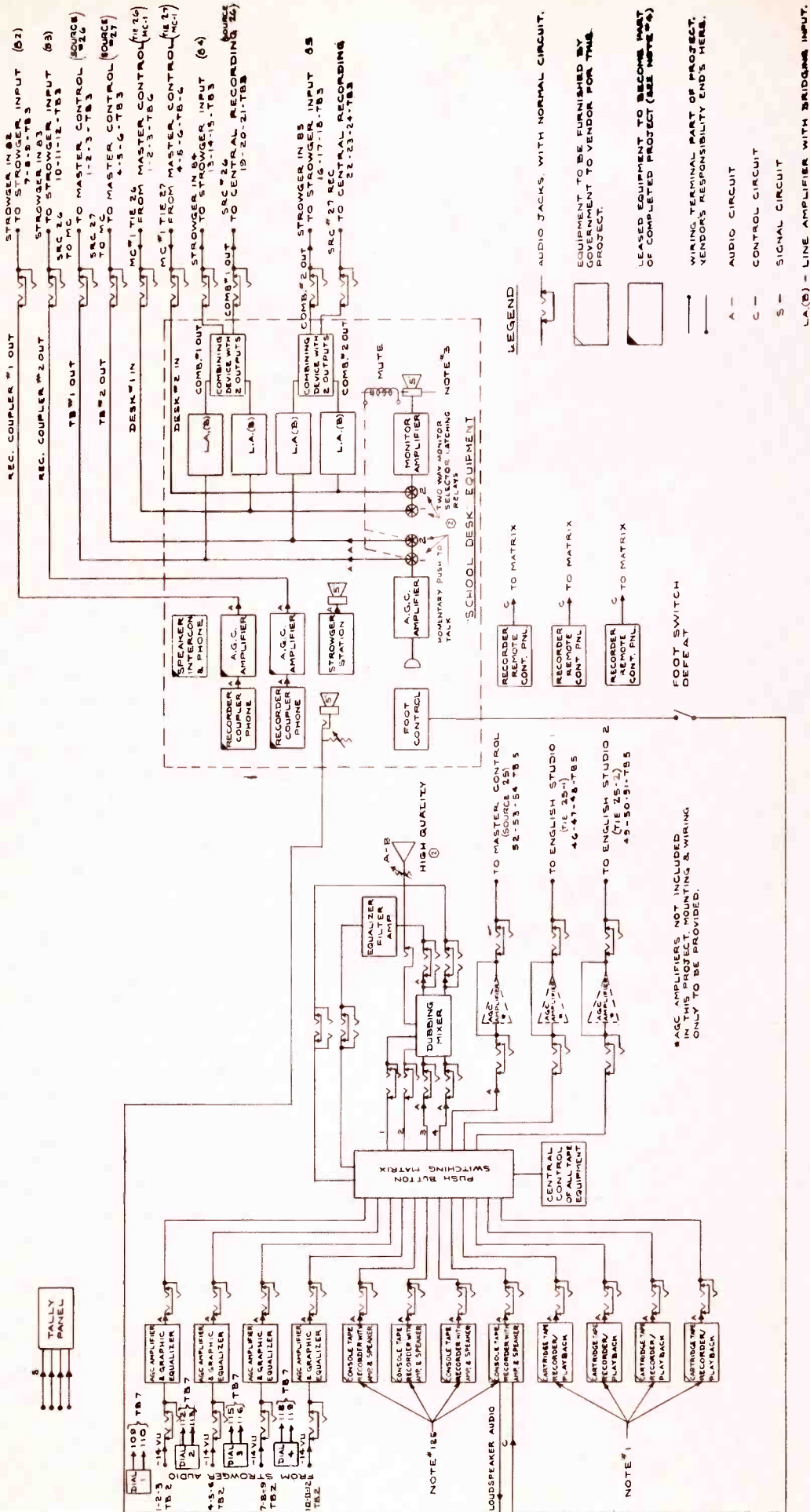
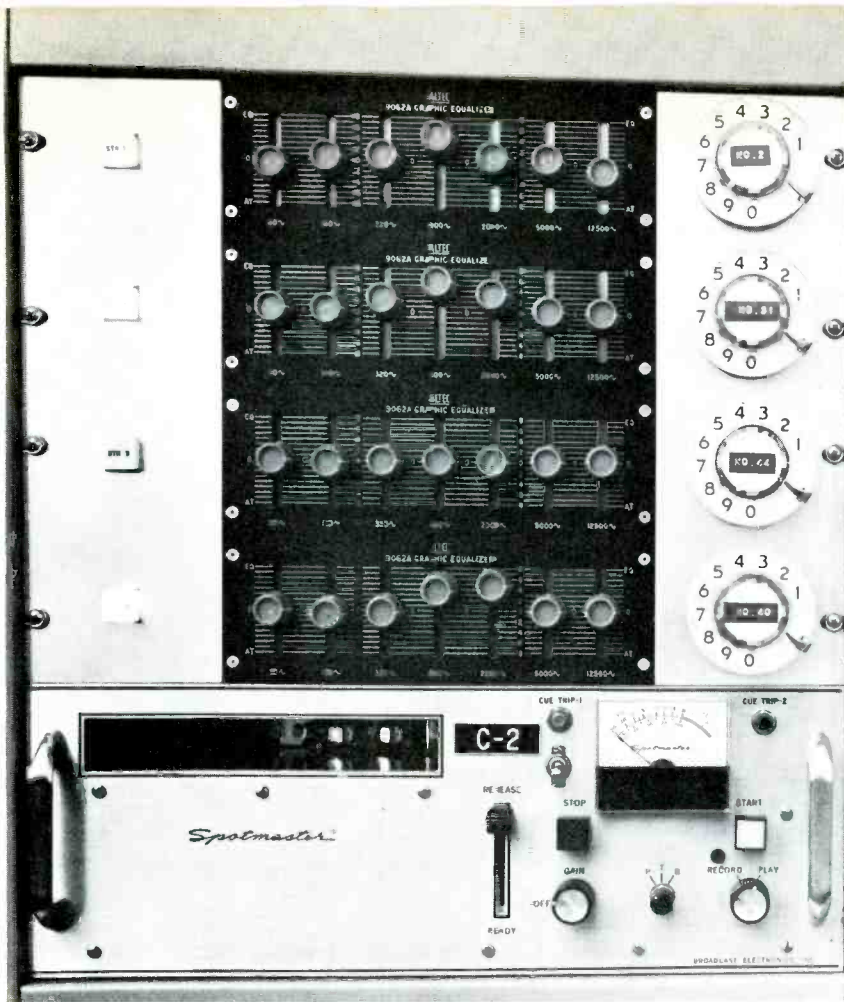


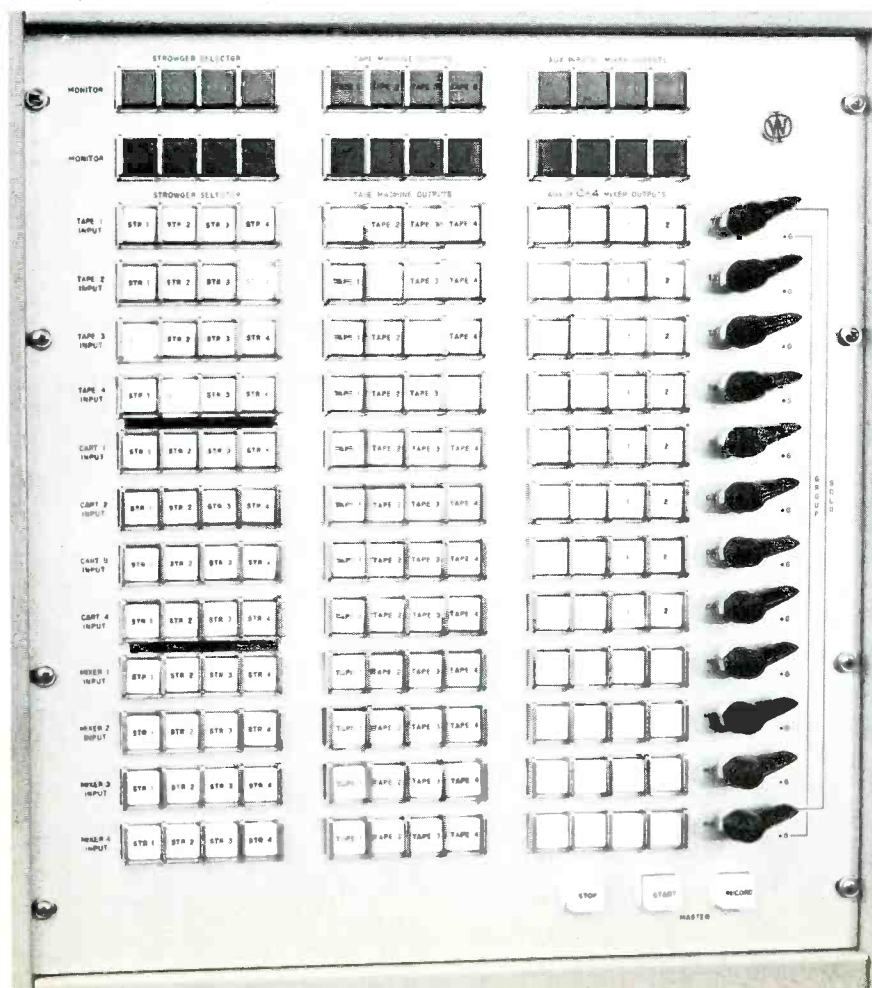
Fig. 1 Overall scope of the VOA technical operations room equipment layout.





Rack 2, selector panel.

Rack 3, central control matrix.



the editor to take in circuits at his desk on a push-to-talk microphone, take in recorder phone reports, and transcribe the inserts prepared for the newsroom. The VOA newsroom needs speedy transcribing on an internal teletype to the 38 language services in the building.

The heart of the technical operations newsroom equipment is the 12 x 15 program-switching matrix. The function of this main push-button control center is to select and delegate program information in any combination to and from any desired program source, to reel-to-reel tape machines, cartridge tape machines, or the two-channel mixer panel in either a group or solo operation.

The first control panel (rack 2) is associated with the "House Monitor Strowger Stations" equipment. A telephone dial and its activating switch can control and select any of 100 program sources from the central equipment room adjacent to VOA's Master Control on the second floor.

The four dials represent four such selectable program sources to feed the matrix input buss. Also incorporated on each input-selector panel is a graphic equalizer, which permits the operator to graphically adjust and equalize (16 dB) the audio quality of the incoming program material in eight frequency bands. This feature improves the audio quality on overseas "two-way" feeds and the world-wide telephone recorder coupler-type calls to the newsroom Operations Studio.

The central matrix panel (rack 3) is equipped with a high-quality monitor facility and the first two upper rows of buttons provide instant switching of the monitor for (A-B) evaluation of the input signal before and after equalization.

The central control matrix configuration assigns each horizontal row of push buttons as "inputs" of:

1. Four reel-to-reel tape recorders;
2. Four cartridge tape recorders; and
3. Four Audio mixer inputs.

The first group of four vertical rows of push buttons are the outputs of the program dial selectors. The center group of four vertical push buttons are the outputs of the tape recorders. The next two are auxiliary outputs and the last two



# UP WITH AVERAGE MODULATION. INCREASE SIGNAL EFFICIENCY.

That's what Gates Solid Statesman Limiting Amplifier will do for your station. It brings broadcast signals up to maximum efficiency by controlling audio levels instantaneously, automatically.

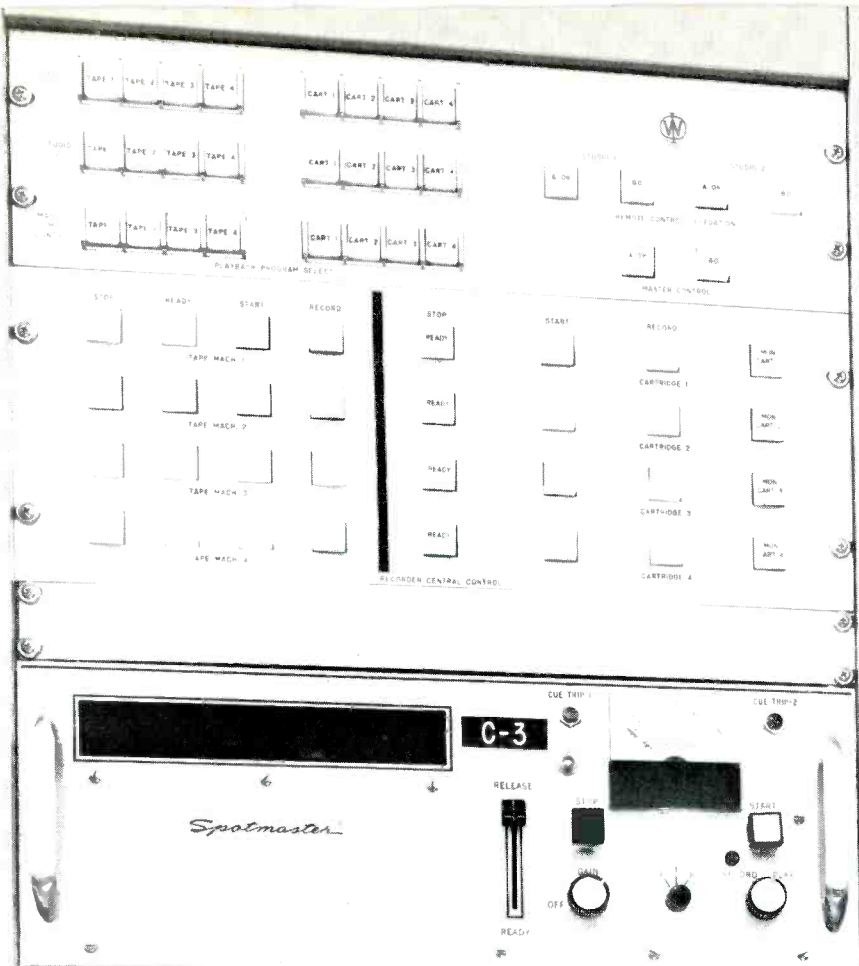
The Gates Limiter attacks modulation problems — in just 3 to 5 microseconds (without audible clipping) and a 30:1 compression ratio allows 99.5% modulation.

Asymmetrical limiting is provided for AM stations, permitting positive peak modulation levels of 110% or 120% with negative peaks limited to 100%, thus producing a louder sounding signal.

Want to hear more? Write or call for full information. Gates Radio Company, a Division of Harris-Intertype Corporation, Quincy, Illinois 62301. Telephone (217) 222-8200.

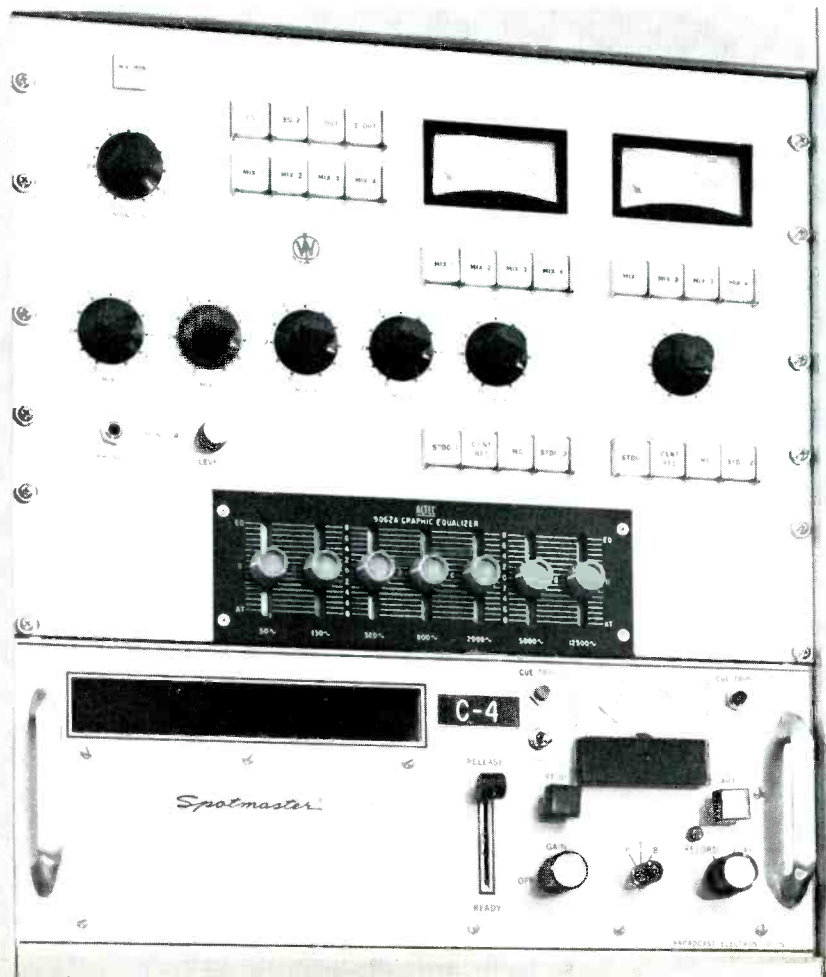


Circle Item 8 on Tech Data Card



Remote delegation panel at top. Below is central recorder control panel.

Mixing unit control panel.



are the output program feed from the two-channel mixer panel.

Lock-out interlocking logic prevents round-robin feedback possibility if an attempt is made to feed any recorder output into its own input.

Another unique built-in, fail-safe "memory" logic was designed into the control circuitry. To prevent operator error, a sequence of interlocking prevents reassignment of a machine if it is in a selected and operating condition. This feature also prevents inadvertent dropping and redialing of an input source if assignment of a machine has been made.

The upper control panel in rack 4 to the right of the main control matrix contains the remote control delegation push button configuration. Here the desired reel-to-reel tape recorder or the cartridge recorder playback output is selected for remote delegation of starting or stopping the desired machine from any of three remote locations.

After a program has been selected and recorded, insertion into a live program by remotely controlling the tape recorders at the desired time eliminates the necessity to hand carry the finished recorded cartridge program to any of the 23 studios.

Another fail-safe interlock memory logic is designed into this remote control delegation. When selection of a machine is made, delegation of the control of the machine is assigned to the desired remote location by the push buttons located on the right side of the panel. At the remote location, a small control panel equipped with two push buttons and a tally light is wired into the delegation panel.

When the delegation is made, both locations receive an A-OK tally light to indicate readiness. This feedback information indicates to both operations areas that:

1. The assignment of a playback function is made, and
2. All proper preparatory steps were taken:
  - a. machine is loaded with tape
  - b. all operating modes are in proper playback positions, and
  - c. the machine is not being used for another purpose.

When the remote START button is depressed and the machine starts,

# The Performance Picture Looks Great with BIALKON Orthicons

- New warranty—now extended to 1800 hours
- New non-stick capabilities mean long, long life
- No linear decline in sensitivity
- Five BIALKON camera tube types\* now can replace 80 industry types

You get more with RCA BIALKON orthicons—in initial performance, hours on-air per your dollar, and in-camera stability.

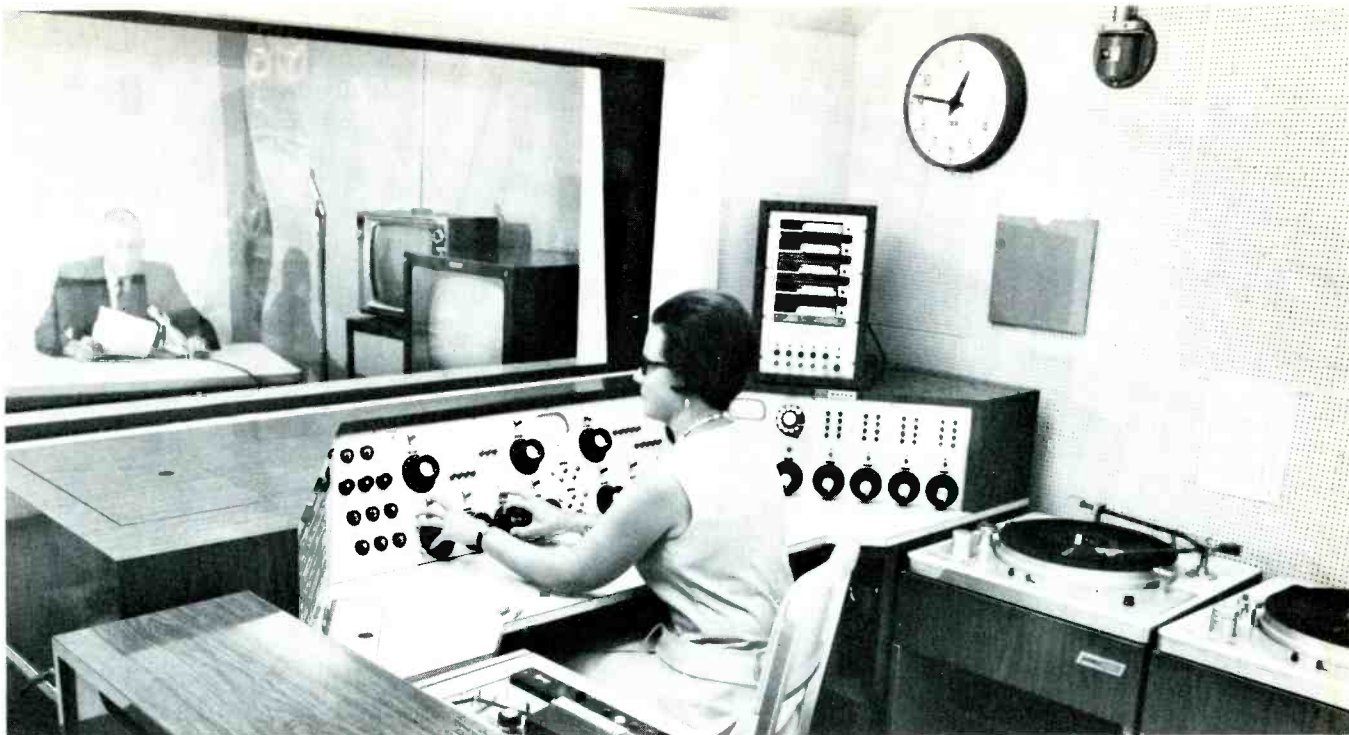
See your RCA Field Engineer for full information about the five BIALKON camera tube types, now available from your RCA Broadcast Tube Distributor.

RCA Electronic Components, Harrison, N.J. 07029.

\*Bialkali photocathode,  
electronically conducting  
glass target image orthicon







Operator monitoring audio for VOA program in one of its 23 studios.

a GO tally lamp is lighted at both the remote location and in the central control panel to indicate the operation was executed. Also included is a lock-out tally if by some reason the tape breaks or the cartridge recording is over.

Directly below the delegation panel is the record control center. It is divided into equipment groups indicating all of the control functions associated with starting, stopping, recording and a READY status indicator tally lamp. The READY light provides feedback information to confirm that the particular recording machine has been prepared for operation and that actual operation is possible, that tape has been threaded and/or a cartridge is inserted into the recorder as well as whether the machine is in the RECORD mode.

Rack 5 contains a 4-channel mixer to feed either into individual or combined dual output. Channel 1 output is equipped with a graphic equalizer and the mixer re-enters the central matrix program selector.

Lockout interlocking also was designed into the unit to prevent a round-robin feedback from output to input. Monitor over-ride selection for the high-quality monitor can be assigned to either select the "cue position" of each mixer input

or the pre- or post-equalized output feed.

Assignment of the output feeds are individually selectable to any of four remote stations simultaneously or individually with interlocking to prevent dual program output.

Rack 6 contains all of the amplifier plug-in modules and the matrix relay switching plug-in modules.

The jack fields have divided into two functions: the top bank are considered as "Test" points for all circuits, and the lower group are for actual cross-patching. An operational advantage is thus gained as an operator can easily find a circuit and is not concerned with a possible mis-patch that can occur when the multiples are mixed within the nest of normaling jacks.

The second main feature of the operations studio is the console desk shown in the foreground. It is equipped with two sets of beeper or recorder coupler telephone company instruments. These phone lines are also connected to the House Monitor "Strowger" dial selector as program input sources for dial selection.

The operating center panel has a provision for accepting and selecting either of two 2-way program feeds with instant talkback and program line-up facilities. Speaker-

muting and monitor provisions are included in the rectangular cut-out in the panel.

The combined output of the 2-way program is fed as an input to the House Monitor system and all interested program sections may listen to both sides of the programs.

A foot-switch remote control unit is mounted beneath the operator console. This remote control feature allows the editor to control the #1 recorder in STOP, START, REWIND, FAST FORWARD modes by depressing, lifting or positioning his foot to the left or right. The foot switch/defeat button either selects or locks out this provision.

All operations have tally light indications and are of the push-ON push-OFF type with all electronic interlocking using solid-state logic and magnetic latching plug-in relays.

**Editor's Note: Obviously, this is a highly complex operation. However, this system was needed to overcome VOA programming problems. ETV stations with complicated programming and stations considering the "all news concept" should get some ideas for efficient program control. Less complex versions of this layout can be constructed for remote duty or studio control.**

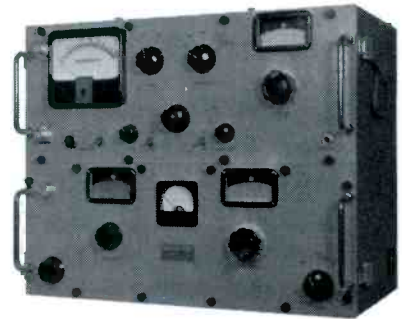


# Four reliable reasons why experienced broadcast engineers prefer Nems-Clarke equipment ...now available from DEI

Model FIM-120E (WX2C)

In the broadcast industry, the quality, reliability, accuracy, and durability of Nems-Clarke equipment have earned it a reputation that is unique. DEI, now manufacturing and distributing this famous equipment, can assure you that it will continue to adhere to the same high standards that built this unmatched reputation.

**Field Intensity Meter Model FIM-120E** A compact, lightweight, portable instrument for measurements in the 540 to 1600 kHz range. Sensitivity range is from 10 uv per meter to 10 v per meter. Performance data includes a 540 to 1600 kHz frequency range and a 10 uv/m to 10 v/m intensity range. Power supplied by internal alkaline batteries, insures operation at 32°F and below and can be calibrated at any frequency at either high or low temperatures. Both linear and logarithmic indications permit use with recording equipment. Accuracy of this unit is essentially independent of battery voltage ambient temperature and modulation. Accuracy, linearity, and stability are vastly superior to any currently available solid state field intensity meter. Over 1,000 of these field-proven units are currently in use.



Model FIM-107A (Test Set)

**Field Intensity Meter Model FIM-107A (Test Set)** Includes in one portable unit a radio receiver of laboratory quality with a metered output and an accurately calibrated signal generator. It covers a frequency range of 54 to 240 MHz without band changing. Operates from automobile batteries or standard 117 vac line. Performance data includes a

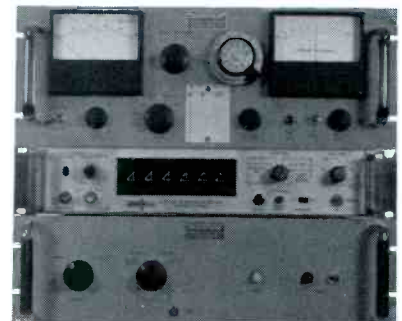


Model PM-112

1.0 uv sensitivity. Signal generator output level is adjustable from 1 uv to 0.1v. A calibrated dipole provides 1.6 uv/m to 16 v/m field intensity measurements at 54 MHz.

**Phase Monitor Model PM-112** This new solid-state unit replaces our model 108E and monitors phase and current relationships in directional AM arrays. Adaptable to remote control. Provision for switching of day-night reference levels can be provided. Performance data includes  $\pm 1$  degree phase accuracy, 0.5 degree phase resolution and 2% repeatable current accuracy. Will monitor up to 9 towers. Outputs are available for a digital voltmeter to provide increased resolution. Well over 100 of these units are now in world-wide use.

**Precision Phase Monitor Model PPM-101** This unit is designed for use with critical directional AM arrays where a high degree of resolution and stability is required. Provides both phase and current indications. Contains digital counter. Nuvistor and solid-state design. Repeatable phase accuracy is  $\pm 0.1$  degree, phase resolution is 0.1 degree and repeatable current accuracy is within  $\pm 0.1\%$ . Will monitor up to 12 towers.



Model PPM-101

For full specifications, spares or service for these and other DEI/Nems-Clarke equipment, call or write today.

Nems-Clarke Equipment: Recognized as the Standard in the Broadcast Industry for Years

**Defense Electronics, Inc.**

PRODUCERS OF  
**DEI AND NEMS-CLARKE**  
EQUIPMENT



**DEI**  
RESEARCH  
DEVELOPMENT  
MANUFACTURING

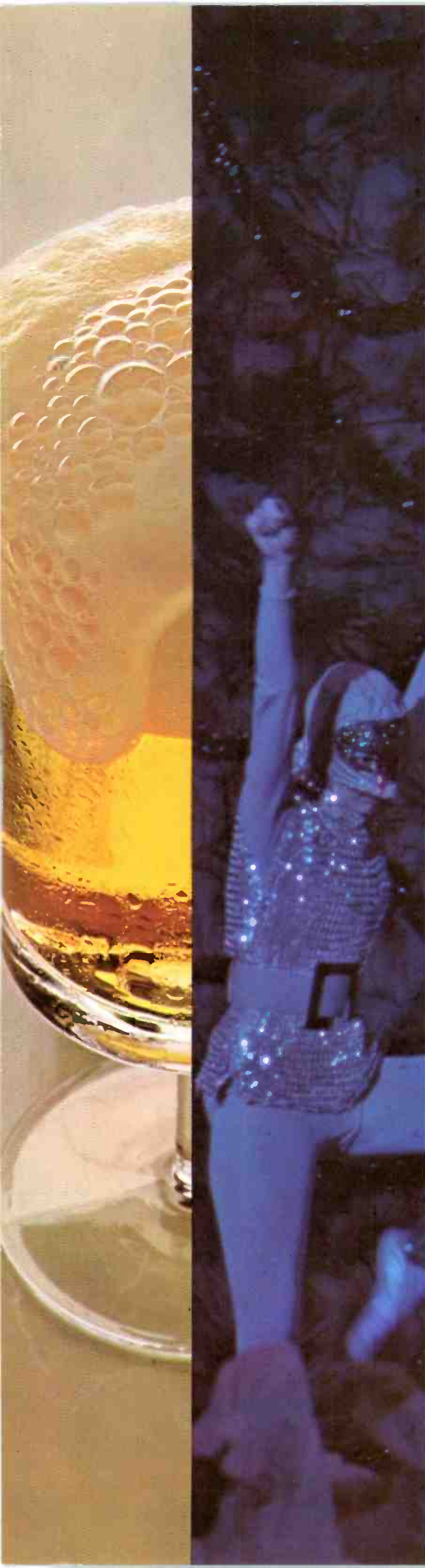
ROCKVILLE, MARYLAND (301) 762-5700; TWX: 710-828-9783; TELEX: 089602 • LOS ANGELES, CALIFORNIA (213) 670-4815 • INTERNATIONAL: ROCKVILLE, MARYLAND • CABLE: DEIUSA; INTELEX: 64102 • Sales Representatives: Rome, Italy • London, England • Madrid, Spain • Tel Aviv, Israel • Bromma, Sweden • Rijswijk, Holland • Köln, Germany • Paris, France • Zurich, Switzerland • Oslo, Norway

Circle Item 19 on Tech Data Card









# ELECTOGRAPHY



## A new dimension in videotaping made possible by "Scotch" Brand Color Tape Plus

Electography is videotaping at its finest. Colors are brighter, clearer, livelier. Black and whites are stronger with amazing presence. Copies are perfect... matching the original picture and sound.

Electography is immediate. Lets you complete complex programming in hours. You see your work as you go. You're free to experiment... be more daring. You can use slow motion, fast motion, stop motion and reverse action. You can go out on location. Combine all types of existing footage (stills, film) with new footage. Edit instantly... electronically with 30 frame per second precision.

"Scotch" Brand Video Tape No. 399, Color Tape Plus, delivers the ultimate in electography. Gives you the response and full compatibility you need to make it all possible. Lets you use the most subtle lighting techniques. Gives you true colors... more dynamic black and whites... multiple generation copies undistinguishable from the master tape.

Want more information on electography and how you can take full advantage of this complete creative medium? Write: 3M Company, Magnetic Products Division, 3M Center, St. Paul, Minn. 55101.



"SCOTCH" IS A REGISTERED TRADEMARK OF 3M CO.

# Service Jig for the TK-42 Viewfinder

by A. A. Kelley\*

Repairing a troublesome viewfinder on an RCA TK-42 color camera at WFLA-TV once meant tying up the entire camera chain. We overcame this problem by constructing a test jig.

By using a test jig, it is possible to restore the camera to service on an emergency basis by connecting an external monitor. Meanwhile, the viewfinder can be serviced in the shop where it is more convenient. This method will separate camera and viewfinder troubles and it will

aid troubleshooting most intermittent viewfinder operations.

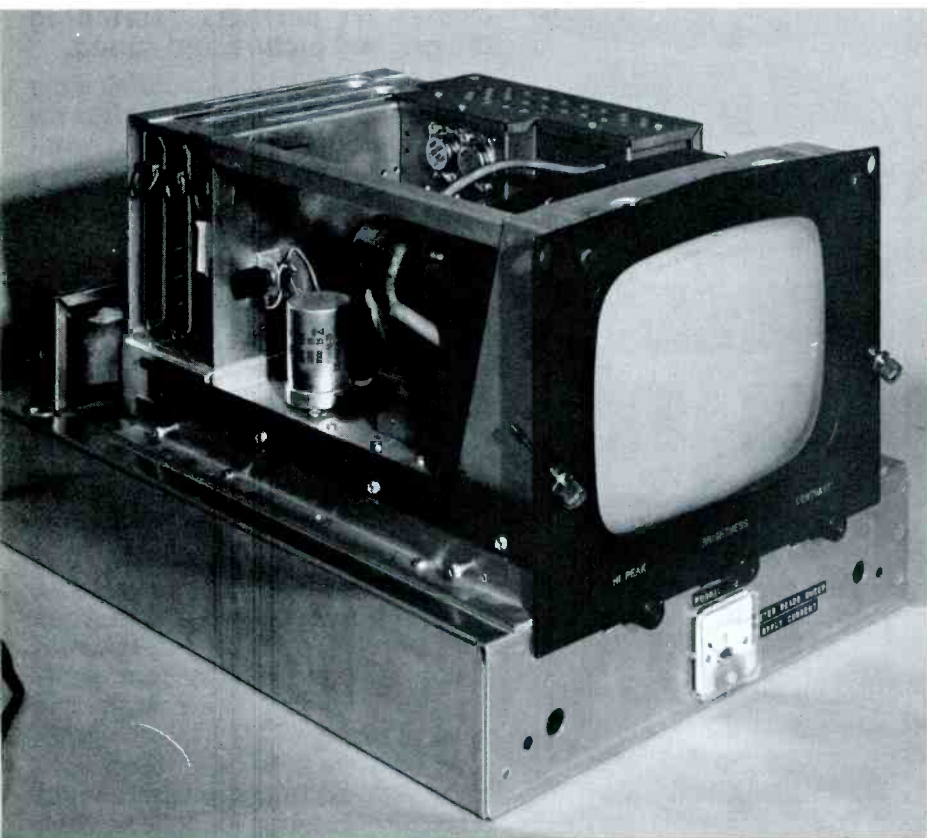
We built a jig by mounting two  $\frac{3}{4}$ " aluminum angles on a 17" x 12" chassis and adjusting the spacing to fit a viewfinder. Cutoffs were sawed from the chassis top to clean the miniature front operating controls and permit access to the utility module. Various connections to the viewfinder were made by using a short flexible cable that could be plugged in after the viewfinder was in place.

Three power supply voltages are needed: +12 volts DC, -12 volts DC and +200 volts DC. These supply circuits are wired into the vacant space at the rear of the chassis, with the extreme rear vertical edge reserved for the two power transistors and the input coax connectors. By keeping the transistors well separated and using silicon grease, it has proved to be an adequate heat sink.

The transistor regulator circuits are simple to construct, but some regulation problems may arise. In our cameras, the +12 volt supply powers the sweep circuits. The current requirements are thus greater than the -12 volt supply. Some viewfinders use a -12 volt supply for sweeps, thus increasing the drain. If the -12 volt varies, making regulation a problem when the viewfinder is connected, a PNP transistor (such as a 2N1132) should be added to the 2N1022A regulator in the +12 volt supply circuit.

The +12 volt supply is not critical since it is used mainly in the kine brightness central circuit. We used a spare TA3A power transformer, but almost any transformer should work if the value of the 6K resistor is adjusted to give 200 volts under load.

After the voltages have been applied and a test signal patched to the jig, the viewfinder is ready for servicing. The front panel meter often is useful for spotting overloads and diagnosing other troubles. Once in operation, the jig will work for long periods of time without overheating, making this unit a practical, timesaving aid. ▲



Viewfinder on the service jig ready for servicing.

\*Engineering Supervisor WFLA-TV, Tampa, Florida

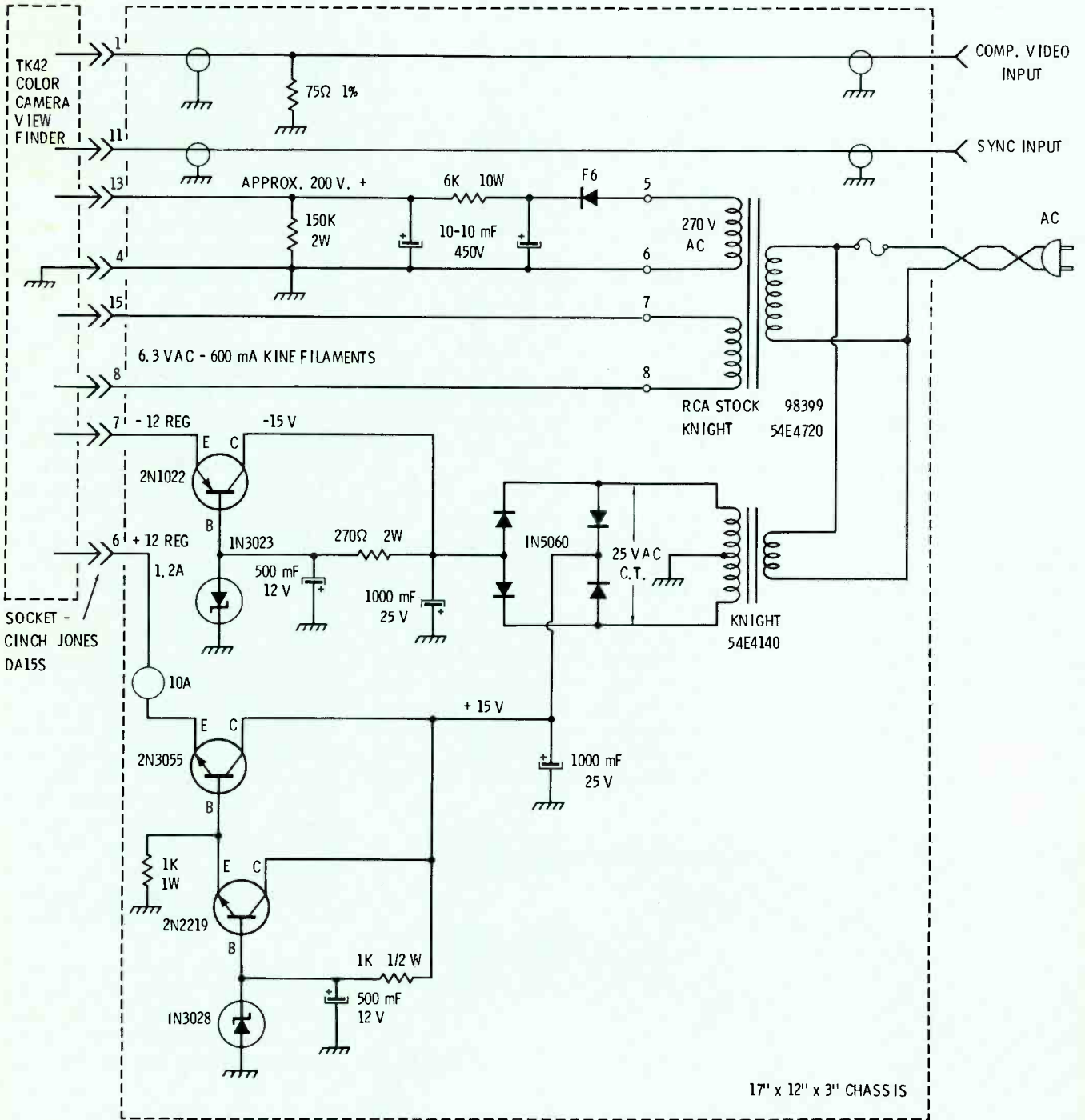


Fig. 1 Service jig schematic.



# EDP SYSTEM

## speeds logging and record handling

By Phil Dean\*

KSTP-TV has taken early advantage of the adaptability of electronic data processing equipment for broadcast program logging and accounting uses to develop what is probably one of the most modern and efficient EDP set-ups in operation at TV stations today.

With the competitive situation demanding almost instantaneous answers for clients, local and regional as well as national, the need for a highly efficient and more rapid system of handling the data was not just obvious, it was imperative.

We needed a system that would provide an up-to-the-minute status of all commercial accounts at a glance, a system which would be handled easily by station staff, and a system which would enable us to broaden the base of our requirements with additional equipment.

Our initial system consists of an 026 Keypunch, an 077 Collator, an 082 Sorter, a 403 Printer, a 514 reproducer and a 557 Alphabetic Interpreter.

The focal point of our IBM-EDP system is the traffic board. It consists of Kardex folders containing approximately 80 pockets on each side. The bottom edge of the Kardex pocket has a transparent cover, allowing visual reference to the tab card.

\*Phil Dean & Associates

The service order from the sales department is a basic item from which all the information is obtained. The order is coded to show the pertinent program information, agency, client, contract, product, program type, schedule time, starting date, and ending date. A tab card containing this information is key punched from the service order. The card is run through the alphabetic interpreter to identify the starting time, ending time, program title, sponsor, length, starting date, ending date, and applicable rate. This is easily read through the visible portion of the Kardex pocket.

After interpreting the tab card, it is forwarded to the radio and/or television traffic clerk for verification and filing. Each card is filed in the pocket according to time and date. If it is not a current schedule, it will be filed in the pocket behind the current card. In this manner, we have ready access to any particular time and/or day to show what is already sold. Thus, by simply opening the appropriate Kardex pocket, the program operator has a visible record of all bookings sold and/or available time. To assist in the visual determination of the status of the traffic board, color-coded tab cards are used. For example, the white card indicates a commercial announcement, green indicates a 10-second station break, the salmon is for network programs

and a blue card signifies a local program.

To prepare a program log, the traffic clerk gives the current master cards to the tabulating operator for reproduction. The cards are returned immediately to the traffic clerk, who refiles them.

This operation takes about three to five minutes. While the traffic clerk is pulling the cards from one board, the IBM operator is reproducing the set pulled from the previous board.

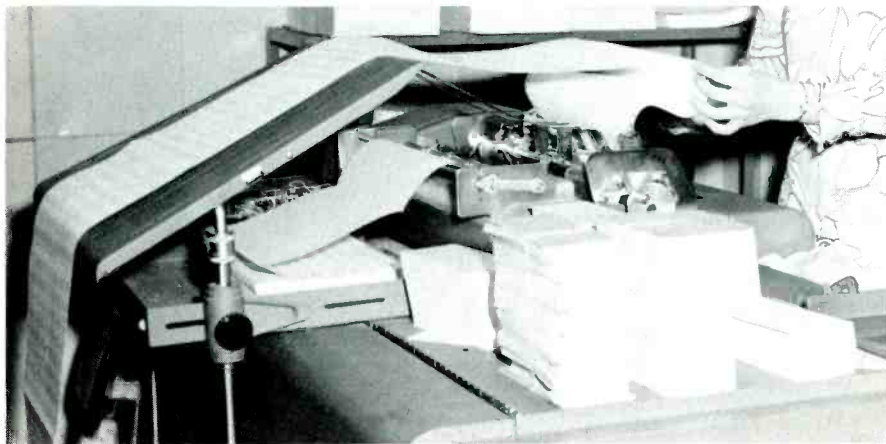
From the reproduced cards, the IBM operator prepares the operational log on a continuous ditto master form. This log is returned to the traffic clerk for insertion of public service announcements and program commercials to complete the schedule for the day. The master log is sent to the continuity department for insertion of all missing information regarding film numbers, studio sequence, and other details.

In addition to the preparation of the daily operational log and month end invoice, the IBM installation enables us to prepare a weekly sales report, semi-monthly sales forecast, program revenue reports, program and announcement statistics for FCC application, age analysis and a host of other statistical reports.

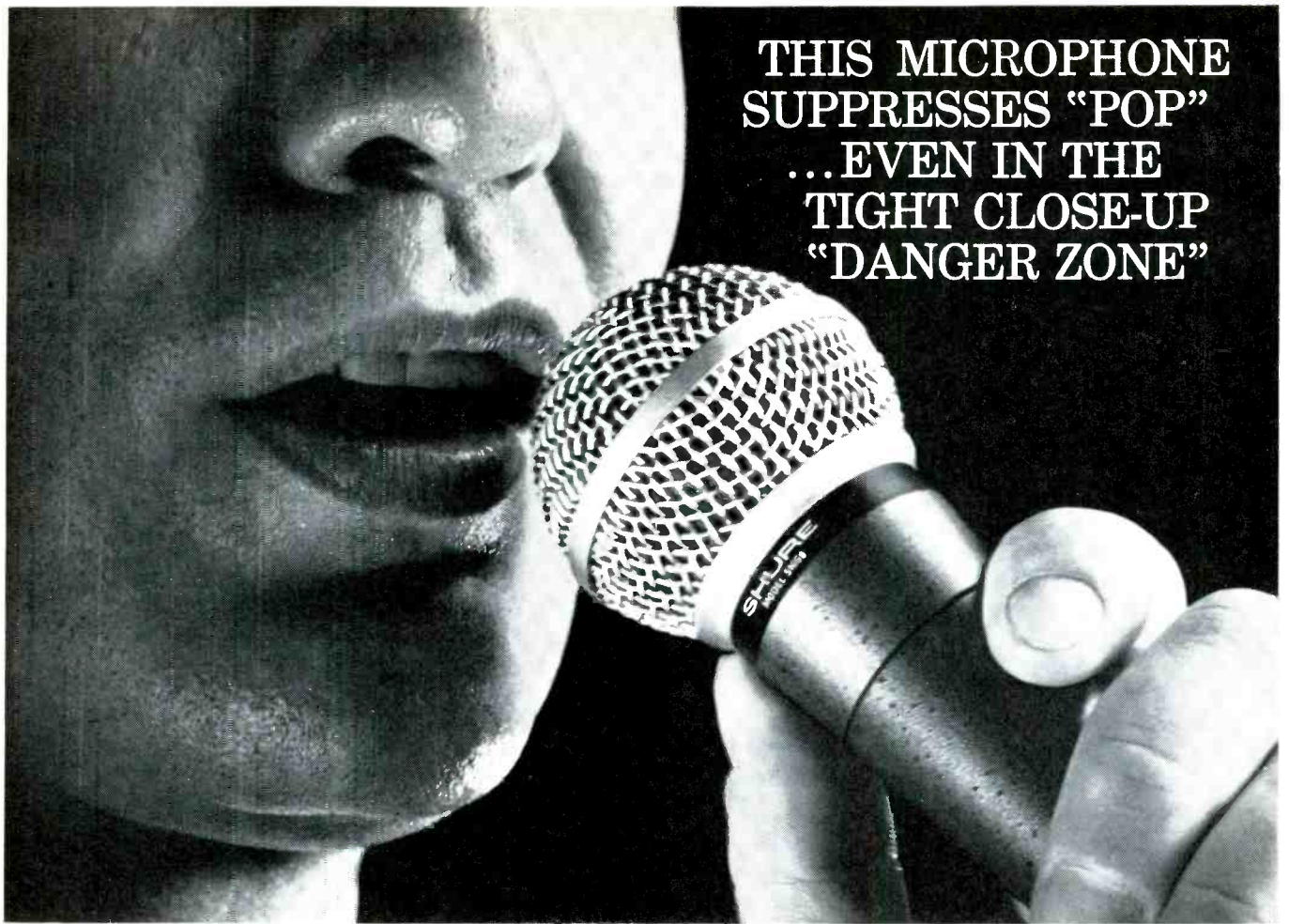
Just as our processing has evolved in an orderly, justified manner at KSTP, we will have a "phasing" of computer development followed with an initial transfer of existing punch card system applications on a minimum configuration 1130 computer. Subsequently, payroll and mechanized log file applications will be installed on the computer. At this point, the computer will be expanded to include faster printing and more on-line storage and a full TV, AM and FM programming data base installed for on-line control of programs, commercial messages, logs and availabilities.

Additionally, we will augment this computer system with a communications adapter making possible communications from remote locations directly into the computer.

The IBM 1130 can be expanded to an IBM 1800 Control System which can provide multiple station on-line inquiry of the data base and ultimately, computer control of station program step sequencing. ▲



Program log being prepared from traffic board cards.



**THIS MICROPHONE  
SUPPRESSES "POP"  
...EVEN IN THE  
TIGHT CLOSE-UP  
"DANGER ZONE"**

The Shure SM58 *self-windscreened* unidirectional microphone is ideal for broadcast uses such as remote news, sports, interview and vocal recordings because it eliminates or minimizes the irritating "pop" caused by explosive breath sounds. With the SM58 you will have the peace-of-mind assurance that you're delivering the quality audio that goes with pop-free pickup. It's great for studio announcing, too—or wherever the announcer or vocalist has the audio-degrading habit of "mouthing" the microphone. Of course, the same filters that eliminate pop also do away with the necessity for an add-on windscreen in outdoor uses.

On the other hand, the unusually effective unidirectional cardioid pickup pattern (uniform at *all* frequencies, in *all* planes) means that it is a real problem-solver where background noise is high or where the microphone must be operated at some distance from the performer. Incidentally,

but very important, the SM58 tends to control the low frequency "boominess" that is usually accented by close-up microphones.

All in all, close up or at a distance, the Shure SM58 solves the kind of ever-present perplexing problems the audio engineer may have felt were necessary evils. The SM58 might well be the finest all-purpose hand-held microphone in manufacture today. And, all things considered, it is moderate in cost.

Other features: the complete pop-proof filter assembly is instantly replaceable in the field, without tools. Filters can be easily cleaned, too. Stand or hand operation. Detachable cable. Rubber-mounted cartridge minimizes handling noise. Special TV-tested non-glare finish.

For additional information, write directly to Mr. Robert Carr, Manager of Professional Products Division, Shure Brothers, Inc., 222 Hartrey Ave., Evanston, Illinois 60204.

## SHURE SM58

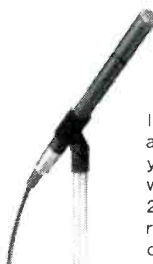
SELF-WINDSCREENED UNIDIRECTIONAL DYNAMIC MICROPHONE

OTHER SHURE PROFESSIONAL MICROPHONES... FOR SUPERIOR AUDIO



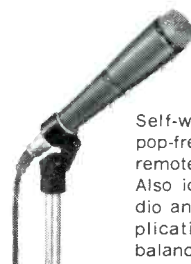
**MODEL SM5  
CARDIOID BOOM DYNAMIC**

Because its cardioid directional pattern is uniquely uniform with frequency and symmetrical about its axis, the SM5 is singularly independent of the effects of environment. Even in extreme shooting situations (such as with tight sets, low ceilings, hard walls, low microphone angles, traffic or air-conditioner noise and rumble and changing distance) the SM5 minimizes sound coloration and ambient noise pickup.



**MODEL SM76  
3/4" OMNIDIRECTIONAL  
DYNAMIC**

Ideal for interviews and audience participation, yet unusually smooth wide range response (40-20 KC) for critical music reproduction. Instantly detachable from stand. Steel case with Cannon connector.



**MODEL SM50  
OMNIDIRECTIONAL  
DYNAMIC**

Self-windscreened and pop-free for news, sports, remotes, and interviews. Also ideal for many studio and control room applications. Comfortably balanced for hand or stand use. Natural response.

Circle Item 11 on Tech Data Card

# Join the FM News Network Automatically

By Charles E. Gustafson\*

When automatic insertion of network newscasts was first considered at WSEO-FM (see article in July, 1968 issue of **Broadcast Engineering**), we found that many tone receivers available to turn the network tones into relay closures were either very expensive (close to \$1100.00) or unreliable. After working with the manufacturer of one of these units for a period of time, we decided that we could devise a simple, reliable system of our own. We built the unit described in this article for about \$100.00, and it has worked perfectly.

Instead of using the two carrier frequencies and four carrier shifts as sent out by the ABC network, the unit detailed uses one of the carrier frequencies and a matrix controlled by a digital clock to select what the tone sent out is to do.

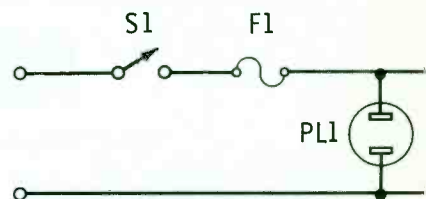
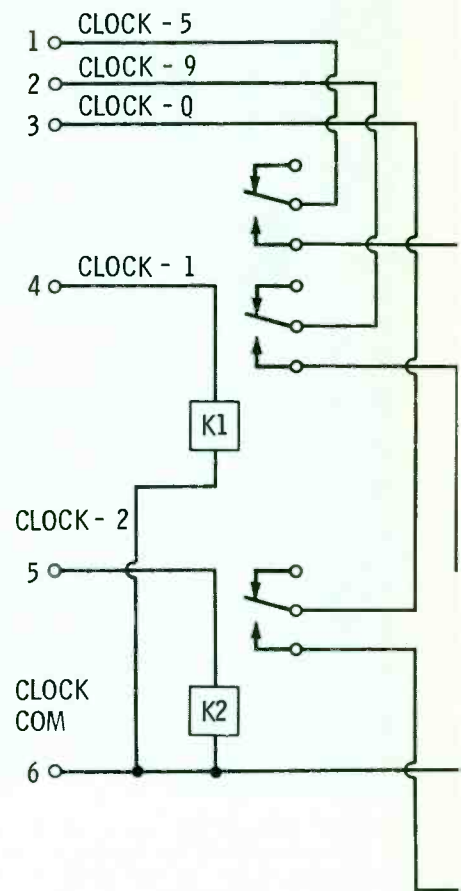
The ABC-FM newscasts contain three tones, one at the beginning

(15 minutes after the hour), one at a breakaway point for a local commercial (at 19 minutes after the hour) and an end tone (at 20 minutes after the hour). All tones used contain a 5,000 Hz carrier. This unit detects the carrier and the matrix controlled by the clock and switches the desired "start", "break-away", or "end" function.

An added feature of this design is that the 5,000 Hz carrier detected in this unit also is a part of the ABC "News Alert" tone. This tone will activate the receiver described in this article. A section of the matrix activates an alarm indicating the reception of a tone at a time other than that normally used for FM newscasts.

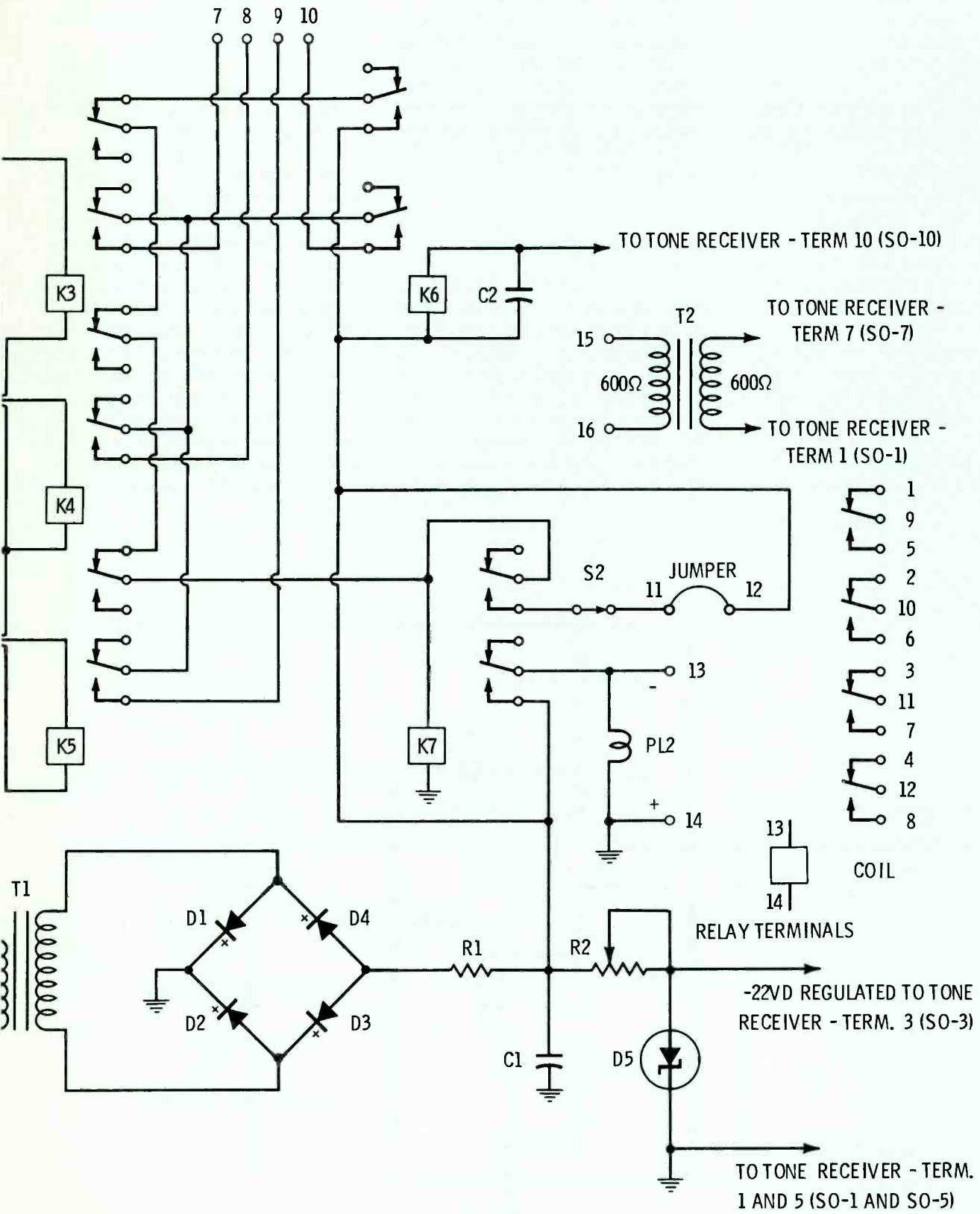
## Receiver Modification

The tone receiver (Fig. 1) is a modified Gates/ATC auxiliary cue receiver from their "Criterion" series cartridge machine. The unit re-



\*Director of Engineering WKMI, WSEO





quires approximately —38 volts unregulated and —22.5 volts regulated which is supplied by the matrix unit. You may either buy a Gates/ATC part #31-1005 Auxiliary Cue Amplifier from Gates Radio Company/Automatic Tape Control Division or build it yourself.

If you buy the unit from Gates/ATC, it must be modified as follows: Remove R-501, a 47,000 ohm resistor between C-501 and pin 7 of the Jones Plug. Connect C-501 directly to pin 7. Remove L-501, a 5.0 mh Toroid Inductor and replace it with a Gates/ATC part #20-2003 500 mh Toroid Inductor. This part is critical to the operation of the receiver. Whether building or reworking the receiver, this part must be the one specified. Remove C-503, a 0.068 ufd capacitor, and replace it with a 0.002 ufd "Mylar Type" capacitor.

It may be necessary to try several capacitors to find one that resonates

the unit to 5,000 Hz. The frequency response of the unit is fairly sharp so that careful selection of capacitor C-503 may be necessary.

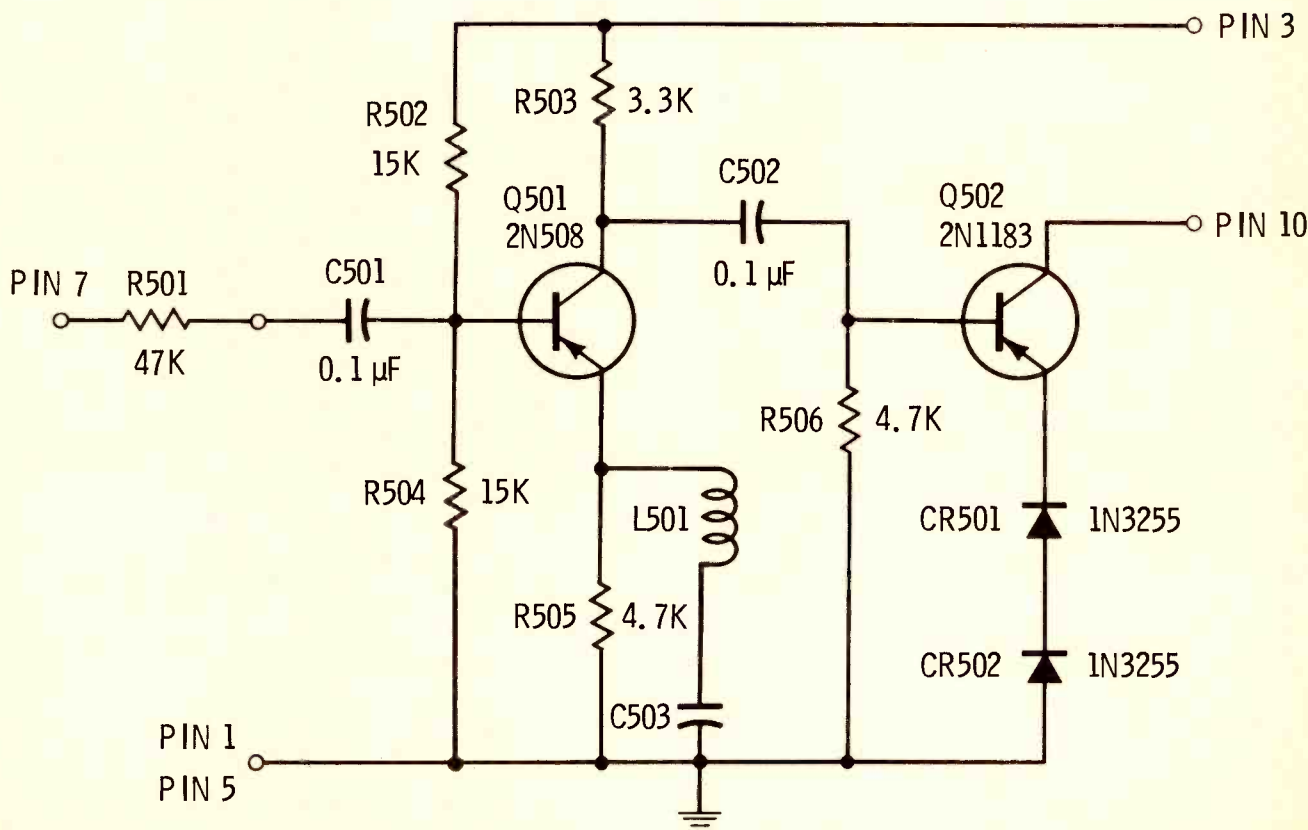
The construction of the matrix unit is straight forward and should present no problems. One note of caution, however, is that relay K-6 should be the unit specified in the parts list since it must be tuned to around 5,000 Hz by capacitor C-2 across its coil.

### Unit Operation

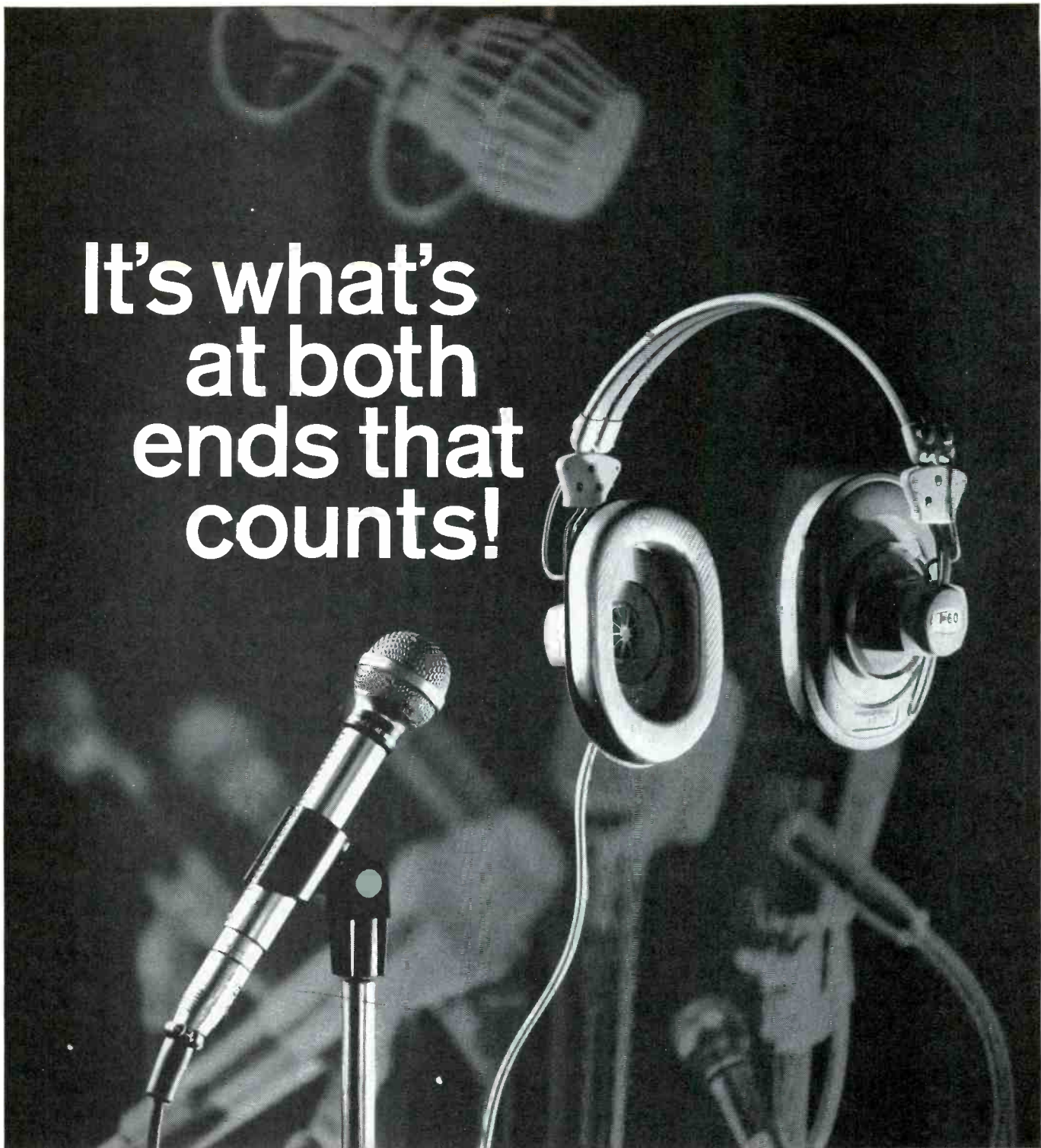
When 24 volts DC is present between terminals 4 and 6, K-1 pulls in, preparing paths between terminals 1 and 2 and relays K-3 and K-4. As the digital clock sets 5 in the minutes column, K-3 closes. This prepares a path from the tone receiver relay K-6 through K-3 to terminal 7, which is connected to PL-11 of the control unit. When

the start tone is received from the network, K-6 closes and activates the control unit. As the digital clock goes to 6 in the minutes column, K-3 restores. When the digital clock comes to 9 in the minutes column, K-4 pulls in. It then prepares a path between tone receiver relay K-6 and terminal 8, which is connected to PL-12 of the control unit.

Once a breakaway tone is received from the network, K-6 closes and activates the control unit. As the digital clock rolls to 2 in the tens column and 0 in the minutes column, relays K-1 and K-4 restore and relays K-2 and K-5 make. A path is now completed to terminal 9. This terminal is connected to PL-13 of the control unit and relay K-6. When the network "end" tone is received, K-6 activates the control unit. As the digital clock moves to 1 in the minutes column, K-5 restores and as it moves to 3 in the tens column, K-2 restores.



# It's what's at both ends that counts!



In any audio recording or reproducing system the input and output transducers represent the most critical link.

Take microphones, for example. They should perform the task of converting sound waves into electrical impulses with absolute faithfulness. **AKG** microphones are characterized by extended wide range and smooth response. They are an unsurpassed investment value.

On the output side . . . headphones should convert electrical impulses into audible sound of ultimate fidelity. Listen to natural, clean sound through **AKG**

headphones and discover the only "humanized" headphones available . . . scientifically designed to complement the characteristics of human hearing.

Ask any professional — the trademark **AKG** is synonymous with the highest standards in quality and performance.

8-68



**MICROPHONES • HEADPHONES**

DISTRIBUTED BY  
NORTH AMERICAN PHILIPS COMPANY, INC.  
100 EAST 42nd STREET, NEW YORK, NEW YORK 10017

Circle Item 12 on Tech Data Card



# The interconnection of the unit

matrix terminal number	ATC Digital clock terminal number	other digital clocks. Connect so that there is:
1—	J1-5	24 volts DC when clock is showing 5 minutes column.
2—	J1-9	24 volts DC when the clock is showing 9 in the minutes column.
3—	J1-10	24 volts DC when the clock is showing 0 in the column.
4—	J1-12	24 volts DC when the clock is showing 1 in the tens column.
5—	J1-13	24 volts DC when the clock is showing 2 in the tens column.
6—	J1-33	Common voltage. If the digital clock uses a voltage other than 24 volts DC, change K-1 thru K-5 to correspond to the clocks voltage.

**OTHER CONNECTIONS:**

7—	Control unit terminal PL-11
8—	Control unit terminal PL-12
9—	Control unit terminal PL-13
10—	Control unit terminal PL-15
11—	External SPST (n. c.) switch
12—	External SPST (n. c.) switch. If not used short 11 to 12.
13—	External lamp (24 volts) or alarm (negative)
14—	External lamp (24 volts) or alarm (positive)
15—	Audio input at 600 ohms (approximately 0 level)
16—	Audio input at 600 ohms (approximately 0 level)

**PARTS LIST:**

**Matrix Unit:**

K1 thru K-7	Potter and Brunfield # KHP17D11 24 volts DC 4PDT relays.
C-1	1000 ufd.50 vdc Electrolytic capacitor.
C-2	1 ufd/50 vdc Electrolytic capacitor.
R-1	10 uhm 1 watt carbon resistor.
R-2	1,500 ohm carbon potentiometer.
D-1 thru D-4	1N3255 Silicon Diodes.
D-5	1N3028B Zener Diode (22 volts—5%)
T-1	25.2 volts @ 1.0 amp. Transformer
T-2	600 ohm line to 600 ohm line audio transformer.
S-1	SPST Toggle switch.
S-2	SPST (normally closed) push button switch.
PL-1	Neon Pilot lamp with holder.
PL-2	# 1820 24 volt Pilot lamp with holder.
TB-1	Cinch Jones # 20-140Y Terminal strip.
SO-1	Cinch Jones # S-310-AB (not needed if not using the Gates/ATC Cue amplifier)
F-1	Fuse with holder (½ ampere)

**Cue Amplifier:**

C-501, 502	0.1ufd/200 volt DC Capacitor.
C-503	selected 0.002 ufd/600 volt DC "Mylar Film" type capacitor.
R-501	Not used (15,000 ohm resistor) (All resistors are ½ watt 10% carbon)
R-502, 504	15,000 ohm resistor
R-503	3,300 ohm resistor
R-505, 506	4,700 ohm resistor
L-501	Gates/ATC part # 20-2003 500 mh Toroid Inductor
CR-501, 502	1N3255 Silicon Diode
Q-501	2N508 Transistor
Q-502	2N1183 Transistor

Another feature of the unit is that a tone from the network activates K-7 when K-3, K-4, and K-5 are in their normal positions. This relay holds and alerts the station that an ABC "News Alert" tone has been received. (The "News Alert" tone uses the same carrier frequency as the FM Network cue tones).

The digital clock should be adjusted to change minutes at 30 seconds after the minute. This will allow some leeway so that the start tone can come anytime between 14:30 and 15:30, the breakaway tone between 18:30 and 19:30, and the end tone between 19:30 and 20:30. All tones are scheduled to be sent within a few seconds of the minute, so there is a 30-second leeway.

Switch S-2 releases the holding circuit for the "News Alert" tone. A remote release switch (normally closed) may be placed between terminals 11 and 12. PL-2 lights when K-7 is holding, indicating a "News Alert" has been received. An external lamp (24 volts) or an audible alarm (such as a Mallory Sonalert) may be placed between terminals 13 and 14. Note that terminal 13 is negative and terminal 14 is positive.

After the unit has been built, adjust R-2 for a Zener static current of 11.5 milliamps with the tone receiver disconnected.

T-2 isolates the audio input to the tone receiver. The input level should be approximately "0" dB. Adjust for proper operation without tripping on audio harmonics. There should be no audio present above 4,400 Hz at the input to the tone receiver. The network passes all material through 4,400 Hz low pass filters before inserting their control tones.

This unit has operated at WSEO-FM since early May and has performed without fail. It has proved to be a reliable and certainly economical way to automatically join the ABC-FM Network for scheduled newscasts, and to alert the station of upcoming "News Alerts" from the network. The unit was designed to operate with a Gates/ATC automation system, but can easily be adapted to work with other systems. ▲



# A multiplexer that reduces switching problems

by Don Freeman  
Chief Engineer, WUSF-FM, TV

The WUSF television master control room is used for two channel closed circuit television operation during the day. The CCTV traffic department handles scheduling and provides the MCR engineer with a log similar to an air log. With two VTR's and two film chains, any combination of film or video tape programming can be accommodated. When a CCTV channel is not being used for a program, a slide and music are "aired" on that channel.

In the late afternoon, CCTV operations end and Channel 16 open circuit programming begins. Program sources are live, film, and video tape. Cartridge tape and slides are used almost exclusively for station break announcements. One bank of the MCR switcher is used for air switching.

Simultaneous starting of different programs on the two closed circuit channels is difficult. If slide and music are being aired, the music must be cut before the program begins. The correct projector(s) and/or VTR(s) must be started. Then the appropriate sources must be taken on the video switchers. This complexity was compounded by the fact that the audio was switched manually during film programs. Manually switching audio for film programs, selecting the correct audio, and switching it into the correct CCTV channel were straws

breaking the MCR engineer's back, causing many switching errors. The need was clear: eliminate, or at least minimize, switching of audio by the MCR engineer.

The first objective in attacking the problem was to eliminate manual film audio switching. The video switcher has audio-follow-video capability. However, since our two film cameras are used with a four input - two output optical multiplexer, the audio-follow-video portion of the video switcher was not used during film programs. The optical multiplexer provided no switching of audio.

The optical multiplexer is a four input - two output device for routing light into the two film cameras. Optical multiplexer inputs are: (1) slide projector 1, (2) film projector 2, (3) slide projector 3, (4) film projector 4. Output 1 of the optical multiplexer is the optical input of film camera 1, and output 2 feeds film camera 2.

Since the optical multiplexer did not switch audio, a means was needed for routing correct projector audio to the FILM 1 and FILM 2 audio inputs of the audio follower. When projector 2 shows into film camera 1, projector 2 audio should be sent to the FILM 1 audio input of the audio follower. When projector 2 shows into film camera 2, projector 2 audio should be sent to the FILM 2 audio input of the audio follower. Similarly, projector 4 audio should be sent to the correct FILM 1 or FILM 2 audio fol-

lower input when projector 4 shows into a film camera.

The device constructed to provide the projector audio switching is called an audio multiplexer because the switching of audio occurs simultaneously with the "switching" of light in the optical multiplexer.

Fig. 1 indicates how projector audios are switched in the audio multiplexer. K1 energizes when film projector 2 shows into film camera 1. K1 and K3 energize when film projector 2 shows into film camera 2. K2 energizes when film projector 4 shows into film camera 2. K2 and K3 energize when film projector 4 shows into camera 1.

Optical multiplexer tally light voltages are used to actuate K1, K2, and K3. In Fig. 2 the top left incoming tally light line (P2 into C1) is at -24 volts when projector 2 shows into camera 1, and energizes K1. The second tally light line (P2 into C2) is at -24 volts when projector 2 shows camera 1 and energizes K1 and K3. When projector 4 shows into camera 2 the third tally light line (P4 into C2) is at -24 volts and K2 energizes. The fourth tally light line (P4 into C1) is at -24 volts when projector 4 shows into camera 1, energizing K2 and K3.

Tally light voltages were obtained by splicing into the remote control line of the optical multiplexer. Diodes maintain isolation between the tally light lines. The relays used have a high resistance coil so that the current drain on the optical



Rack mounted multiplexer showing placement of relays.



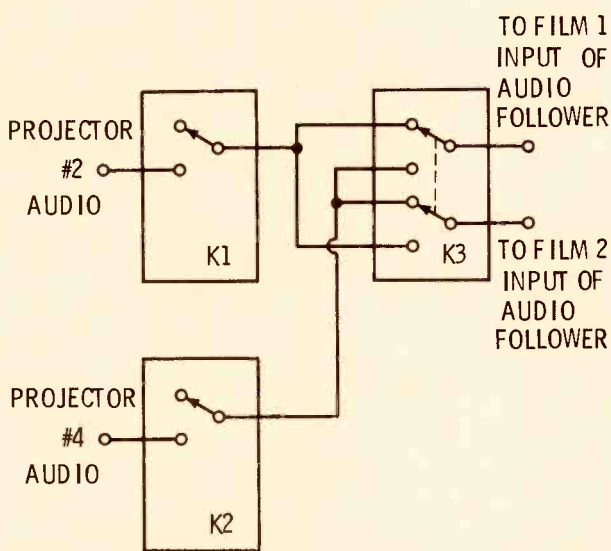
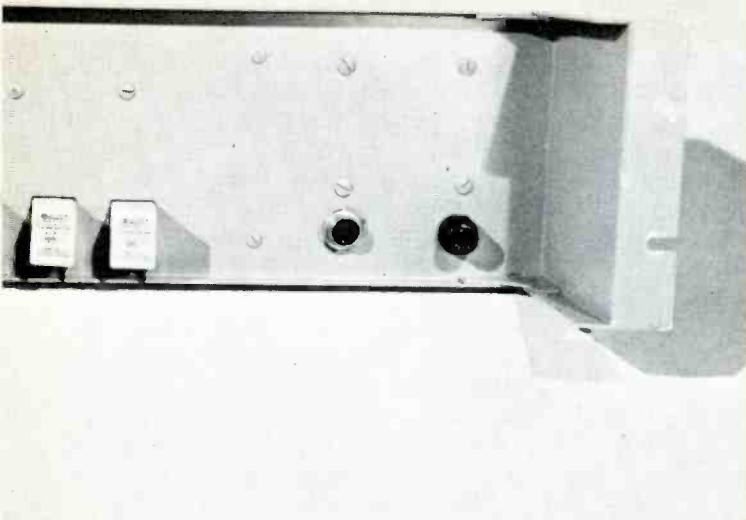


Fig. 1 Audio one-line diagram of projector audio switching in audio multiplexer.

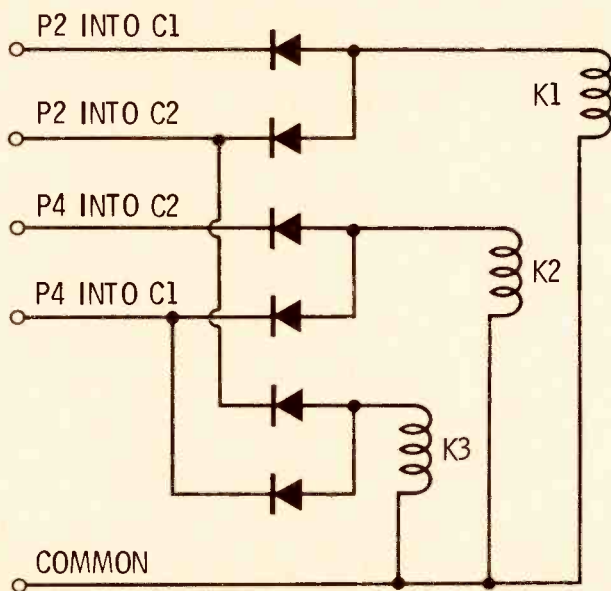


Fig. 2 Optical multiplexer tally light voltages operate projector audio switching relays in audio multiplexer.

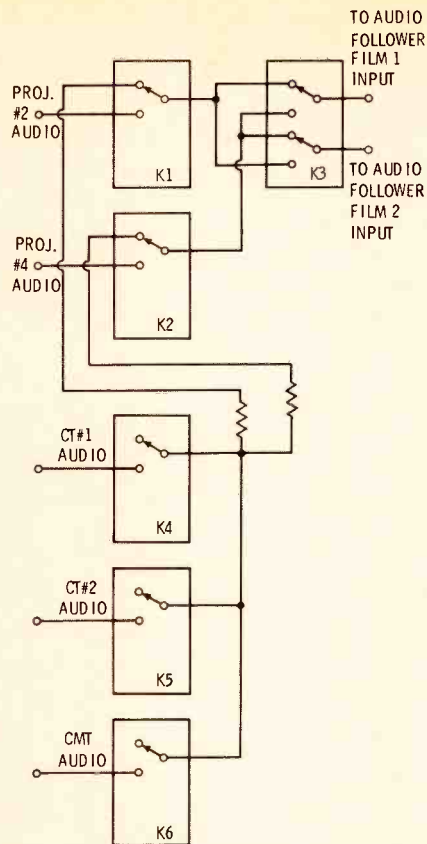


Fig. 3 Complete audio one-line diagram of audio multiplexer.

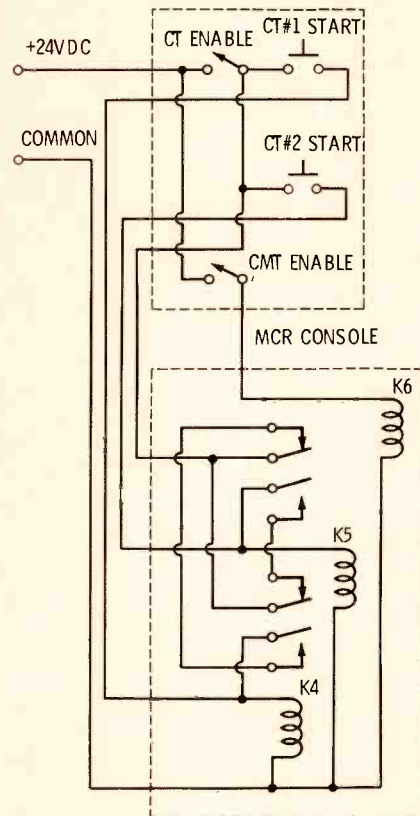


Fig. 4 Audio multiplexer control circuits for cartridge tape and continuous music tape audio switching.

multiplexer tally light circuits is low.

Since the relays used in the audio multiplexer are double-throw types, when K1 or K2 is de-energized, audio for use over slide can be sent through the normally closed contacts. It was decided to add relays so that "audio over slide" could be selected from cartridge tape 1 (CT 1), cartridge tape 2 (CT 2), or continuous music tape (CMT). The continuous music tape audio is

sent out over the closed circuit channels with an ID slide to facilitate adjustment of classroom receivers prior to a program.

As shown in Fig. 3, K4, K5, and K6 select audio for use over slide video. The audio selected by K4, K5, or K6 is split and sent to K1 and K2. K4 and K5 will not operate unless the console "CT ENABLE" switch is on. If the "CT ENABLE" switch is on and the

console CT 1 START button is pressed, K4 energizes and K5 de-energizes. Then if the CT 2 START button is pressed, K5 energizes and K4 de-energizes. K6 energizes when the console CMT ENABLE switch is on.

Fig. 4 shows that K4 or K5 can be energized by pressing one of the CT START buttons. If CT 1 START is pressed (CT ENABLE switch closed, of course), K4 energizes. As K4 energizes, a hold circuit is formed through a normally open set of K4 contacts in series with a normally closed set of K5 contacts. K4 will remain energized until K5 energizes or the CT ENABLE switch is opened.

When the CT 2 START button is depressed, K5 energizes and the K4 hold circuit is broken, causing K4 to de-energize. K5 now has a hold circuit through a normally open set of K5 contacts in series with a normally closed set of K4 contacts. K5 will remain energized until K4 energizes or the CT ENABLE switch is opened. Another set of contacts on the CT START buttons are used to start the cartridge tape machines. For simplicity these contacts were omitted from Fig. 4.

So far this discussion has covered the control circuitry of the audio multiplexer. The actual switching of audio is shown in Fig. 5. Notice that unused audio inputs are terminated in 600 ohms. Some of the contacts of K4, K5, and K6 are not shown since they are unused, or are used for control circuit functions.

The relays used in constructing the audio multiplexer are Potter and Brumfield type KHP 17D11. Diodes used are 5A2's, but any power diode should work. The multiplexer is built on a rack mounted aluminum chassis. Jones plugs are used for interconnection between the audio multiplexer, console buttons, and audio follower. By using some "junk-box" parts, the audio multiplexer was constructed for less than \$40. The estimated parts cost, using all new parts, is about \$60.

Use of the audio multiplexer has simplified switching problems and reduced errors, especially during simultaneous two channel operations. It has eliminated the once frequent problem of "crossed audios" during simultaneous two channel programs. ▲

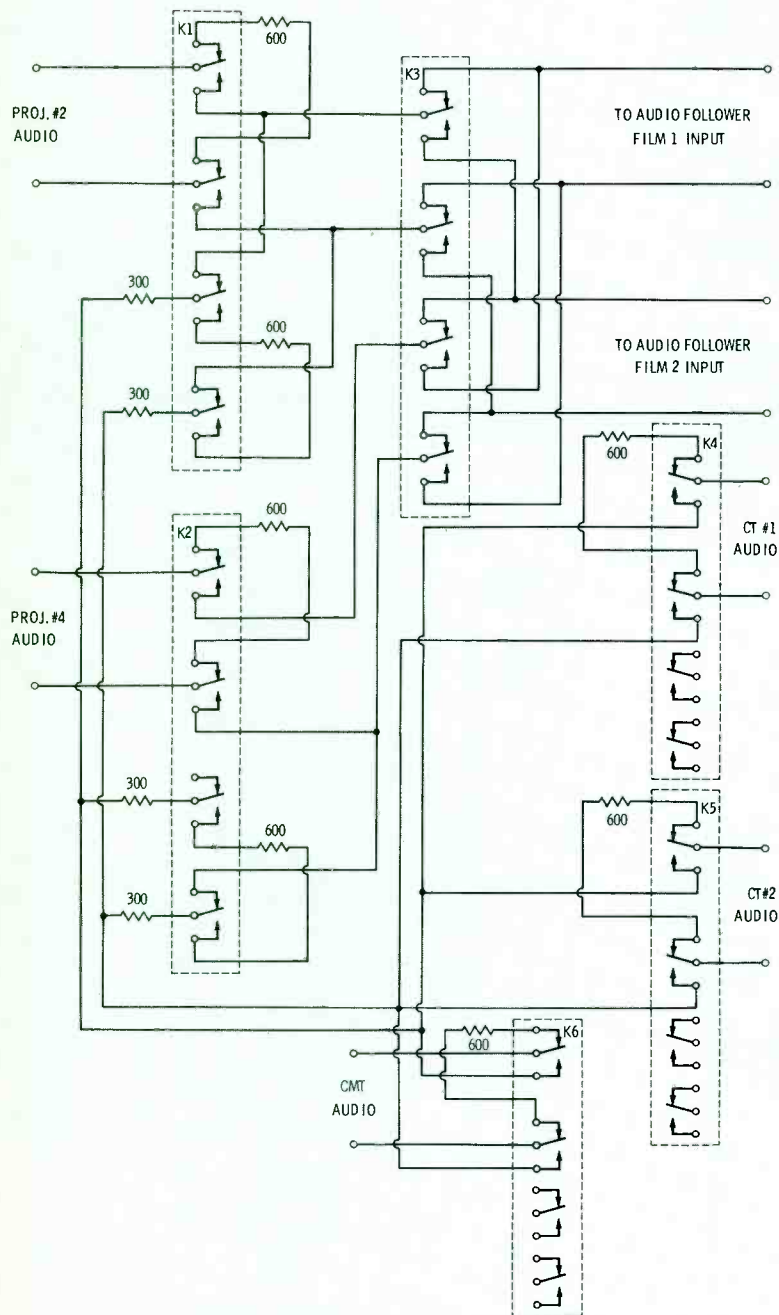


Fig. 5 Audio multiplexer switching.





**J A M P R O**

# VHF SUPER TURNSTILE ANTENNAS

**COMPLETELY ASSEMBLED AND TESTED FOR YOUR SPECIFIC USE PRIOR TO SHIPMENT**

Jampro makes antenna effectiveness a certainty with advanced in-plant test methods and a thorough knowledge of your coverage requirements. Choose from a wide range of gains as well as these Jampro exclusive features:

**EXCLUSIVE**

Copper jacketed inter bay 7/8" cable for years of trouble-free operation, even in corrosive environments.

**EXCLUSIVE**

Antennas shipped in small, easy-to-handle groups for economical overland and water transportation and installation.

**EXCLUSIVE**

All hardware is stainless steel. All steel including support pole is hot dip galvanized.

**EXCLUSIVE**

A wide range of power ratings are available. 2.5 KW per bay low power L Series, and 20 KW per bay high power H Series.

**BEAM TILTING & NULL FILL AT NO ADDITIONAL COST!**

**ACCESSORIES:** Harmonic Filters • Co-axial transmission line • Steel Support towers • Tower lighting kits • Hybrid Duplexers • De-Icers

**J A M P R O**

**ANTENNA**

**COMPANY**

6939 POWER LINE ROAD

SACRAMENTO, CALIFORNIA, U.S.A.

A DIVISION OF COMPUTER EQUIPMENT CORPORATION

Circle Item 14 on Tech Data Card



# Understanding Transistor Audio Circuits

Part 2 of a six-part series/by Norman H. Crowhurst

In the Part 1 of this series, the basic parameters of transistors as related to audio were introduced.

To illustrate some typical problems, Part 2 will start with the design of a unit to insert a low frequency

loss of 24 dB per octave below 50 Hz at which frequency the loss should be 3 dB (the turnover point). The two methods described here could be used for a "rumble filter" or to filter out undesirable low frequency components.

A theoretical circuit design for this discussion is shown in Fig. 2-1. The problem is to employ practical values while using transistors. This will require calculating current impedances and voltages to eliminate interaction.

The circuit works by using two non-interacting roll-offs, each with a turnover point of 141.4 Hz (C2 and C3), around which is applied 18 dB of feedback (gain reduction of 8:1). The feedback pushes the turnover down from 141.4 Hz to 50 Hz and makes it peak.

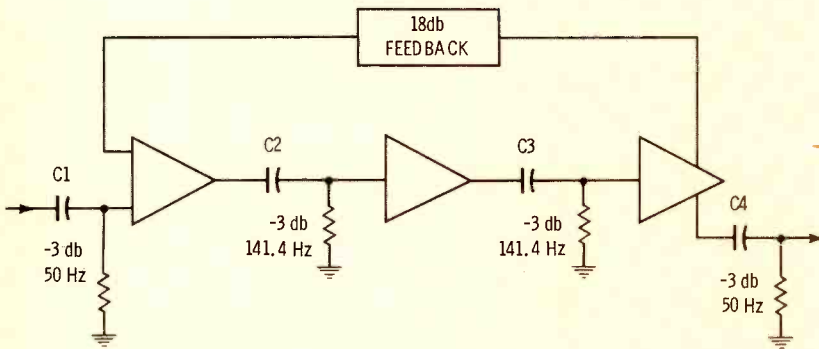
The two remaining roll-off elements (C1 and C4) have a turnover point at 50 Hz. The combined effect neutralizes the peaking of the middle two and gives a sharpened cut-off at 50 Hz. The frequency of 50 Hz was chosen quite arbitrarily for this illustration. If you want a cut-off of this rate acting at some other frequency, the capacitor must be changed to suit the frequency desired.

## First Method Design

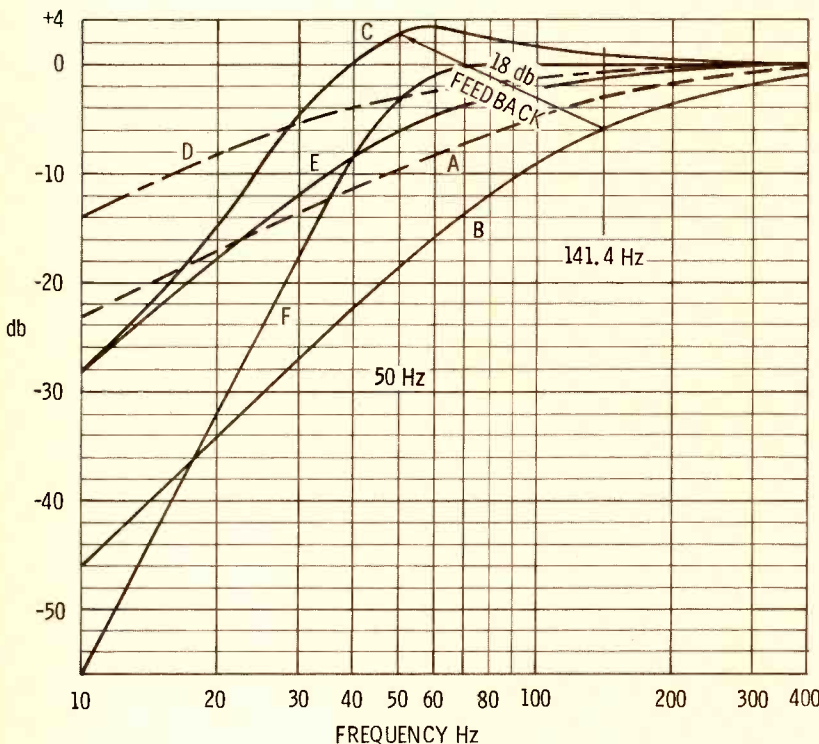
Obviously, to use 18 dB of feedback, the two couplings over which this is applied must include a gain stage. This gain stage should provide isolation to prevent interaction.

In Fig. 2-3, a transistor having a rated average current gain of 150, with limits of 120 and 180 is inserted. Using a 1K collector load, a 150K bias resistor between collector and base will control gain between 67 and 82, with the average at 75. Collector voltage will be half of supply voltage (if the 1K is an actual collector resistor), also subject to about plus or minus 10 per cent for transistor gain variations.

If the average gain is divided by 8 (the feedback factor we are going to use), we have a current gain of 9.375 to "throw away." It is necessary to current feed the base of this transistor to maintain linearity against the non-linear base input im-

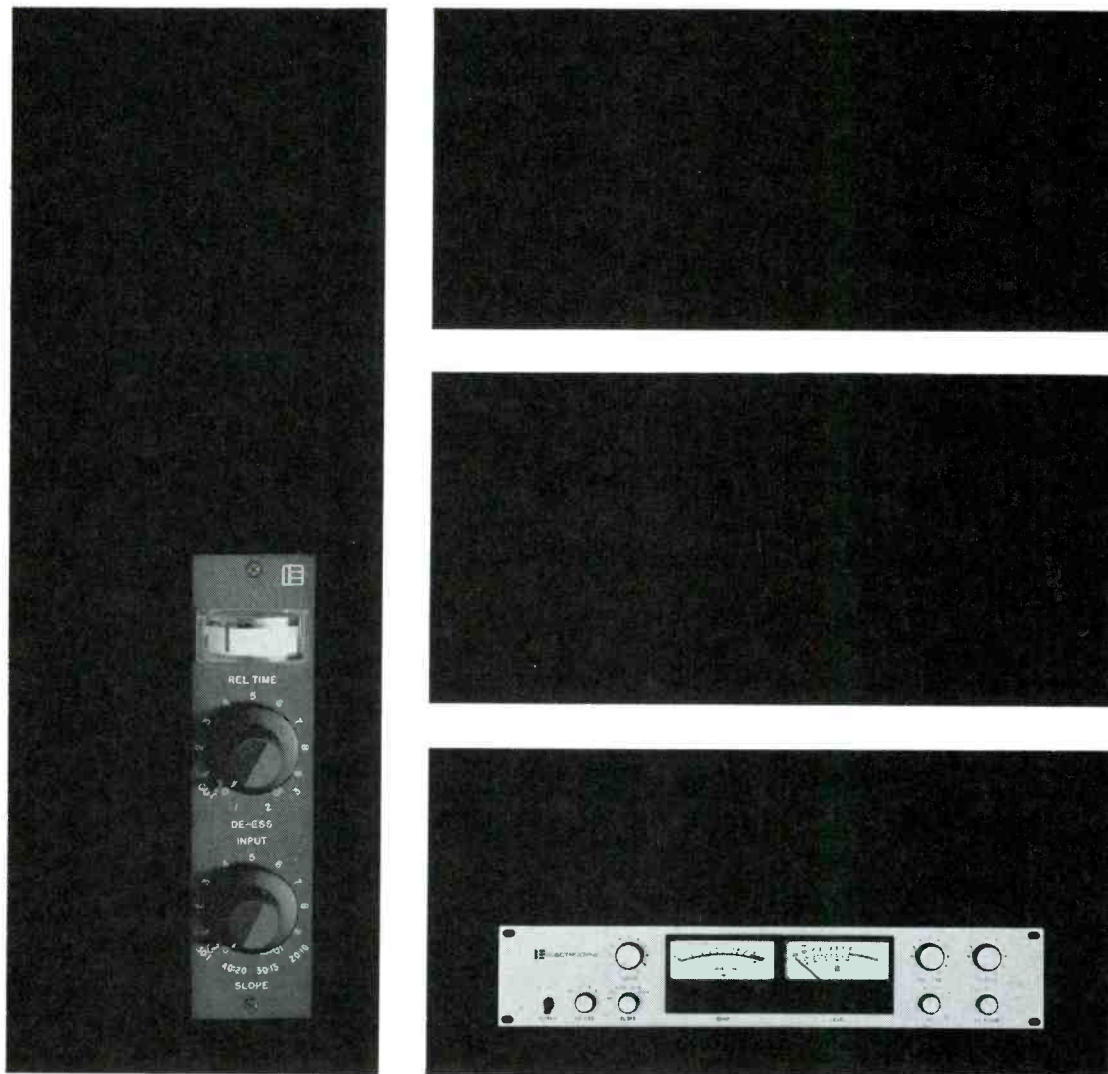


**Fig. 2-1** The basic circuit that is the subject for discussion in this article. This will yield a 24 db/octave roll-off below 50 Hz, the 3 db turnover point. The problem is to incorporate this into a transistorized unit.



**Fig. 2-2** How the basic circuit of Fig. 2-1 works to produce the final result: curve A (dashed line) each 141.4 Hz roll-off, without feedback; curve B, the two 141.4 Hz roll-offs combined, without feedback; curve C, the two 141.4 Hz roll-offs combined when 18 db feedback is added around them; curve D, (dashed line) each 50 Hz roll-off; curve E, the two 50 Hz roll-offs combined; curve F, the overall response, combining curves D and E.

**Does the world  
really need  
two new  
compressor-limiters?**



**Only if they're CA-700 & 702 by Electrodyne.**

We call these the thinking man's compressor-limiters. Because they do a better job of riding gain on your output signal than you'd think possible.

Each of these replaces two competitive pieces — limiting peaks and compressing gain level so efficiently that neither you nor anyone else will know it's on the job. That's because these Electrodyne compressor-limiters don't add any distortion or affect frequency response at all. Ever.

Better get all the specs on what could well be the only two new compressor-limiters the world really needs.

**ELECTRODYNE  
CORPORATION**  
7315 Greenbush Avenue ■ North Hollywood ■ Calif. 91605  
Phone: (213) 875-1900 ■ Cable Address: "ELECTRODYNE"

*CA-700 & 702 are at AES. Meet 'em at Booths 11 & 12.*  
Circle Item 15 on Tech Data Card

pedance (even with feedback from collector to base).

Feed could be accomplished by using either an emitter resistor or a series base feed resistor. The latter was used here because then the value reflected into the cut-off of  $C_2$  will not vary with transistor current gain. When inserting such a resistor in the base circuit, it is easier to think of the transistor as a voltage amplifier. Ultimately, we are driving from an emitter follower, which provides a source input voltage at low source impedance.

The design procedure can now hinge on resistors  $R_1$ ,  $R_2$  and  $R_3$ . The 560 ohm input resistor provides termination for a 500 ohm unbalanced line impedance. The input emitter follower uses a 1K emitter resistor which will reflect an impedance into the base circuit of 150K. The 10K and 12K base bias resistors will produce a parallel impedance of 5.5K.

Combining these, the base input impedance, loading  $C_1$  for its roll-off, will be 5.3K. The output emit-

ter follower uses a 330 ohm emitter resistor. The emitter impedance reflected from the base circuit will be lower than this. Assuming it is due to the bias resistors, impedance will be about 37 ohms. The collector circuit of the gain stage will reflect an even lower value than this.

The output roll-off, using  $C_4$ , is loaded by the 560 ohm resistor, which may terminate a 500 ohm line. The 330 ohm resistor will reflect a base impedance of about 50K, which is in parallel with the bias resistors of 10K and 12K. This will produce a base-circuit impedance of 5K to load the  $C_3$  roll-off.

To make the collector AC impedance 1K, we can use a 1.2K collector resistor. If the bias resistor is unchanged, at 150K, the average gain will be unchanged, but the collector voltage will drop slightly below the mid-supply point. The circuit will still be well on the usable part of the transfer curves.

The emitter followers use 10K and 12K biasing resistors, because base current flows through the up-

per but not the lower resistor. This will cause the operating point to be close to mid-supply voltage, providing for maximum swing.

### Gain Stage Design

The easiest way to figure gain is in terms of signal voltages and current in  $R_1$ ,  $R_2$  and  $R_3$  (tabulated in Fig. 2-3). First we assume various values of  $R_1$  and also that the input through it is sufficient to produce a 1 volt signal output at the collector. Since current gain is 75 (average) the input signal current must be 0.0133 milliamps and, with 1K for  $R_1$ , voltage is 0.0133 volts.

The next step is to set the feedback for 18 dB, or 8:1 gain reduction. This means  $(1 + AB) = 8$ , or  $AB = 7$ . Hence, the current in  $R_3$  must be seven times that in  $R_1$ . The current is .0933 milliamps. Now, for each value of  $R_1$ , there is a corresponding voltage across  $R_1$ .  $R_3$  will have this voltage, and the 1 volt output (in opposite phase, and thus added). We now have voltage and current in  $R_3$  and can calculate its value.

Finally, the current in  $R_2$  will be the sum of that in  $R_1$  and  $R_3$ , or 8 times that in  $R_1$  (as a check). And the voltage across  $R_2$ , for input signal voltage to equal output signal voltage, must be 1 minus the voltage across  $R_1$ . From these values we calculate the value of  $R_2$ .

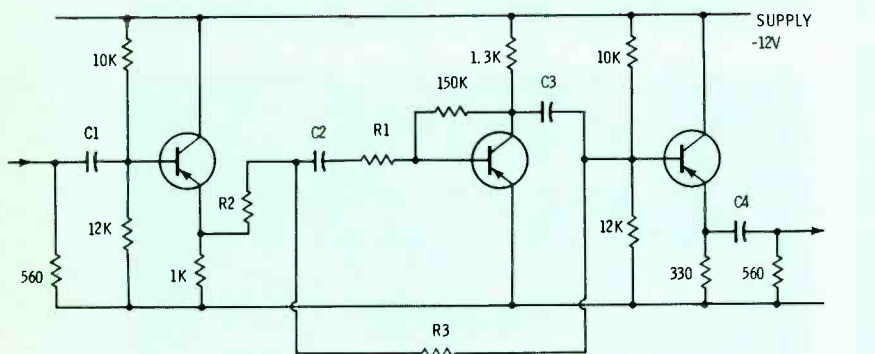
### Circuit Interaction

To avoid interaction between the feedback and the roll-offs due to  $C_2$  and  $C_3$ , the feedback should be essentially voltage feedback fixed by the values of  $R_2$  and  $R_3$ . This means that  $R_2$  must be small compared to  $R_1$ , so that  $C_2 R_1$  does not materially load down the feed through  $R_2$ .

This condition is reasonably well established by the time  $R_1$  reaches 30K, allowing  $R_2$  to be 5.6K (less than one fifth). The value of  $R_3$  is 15K, which will not load the collector voltage much more than the 5K already reflected there. (Actually, to be academically correct, this should now be adjusted to 3.75K, and the collector resistor refigured to suit.)

### Capacitor Values

Now we can calculate the values for capacitors.  $C_1$  works between 560 ohms and 5.3K. Its reactance should be between 5.3K and 5.8K

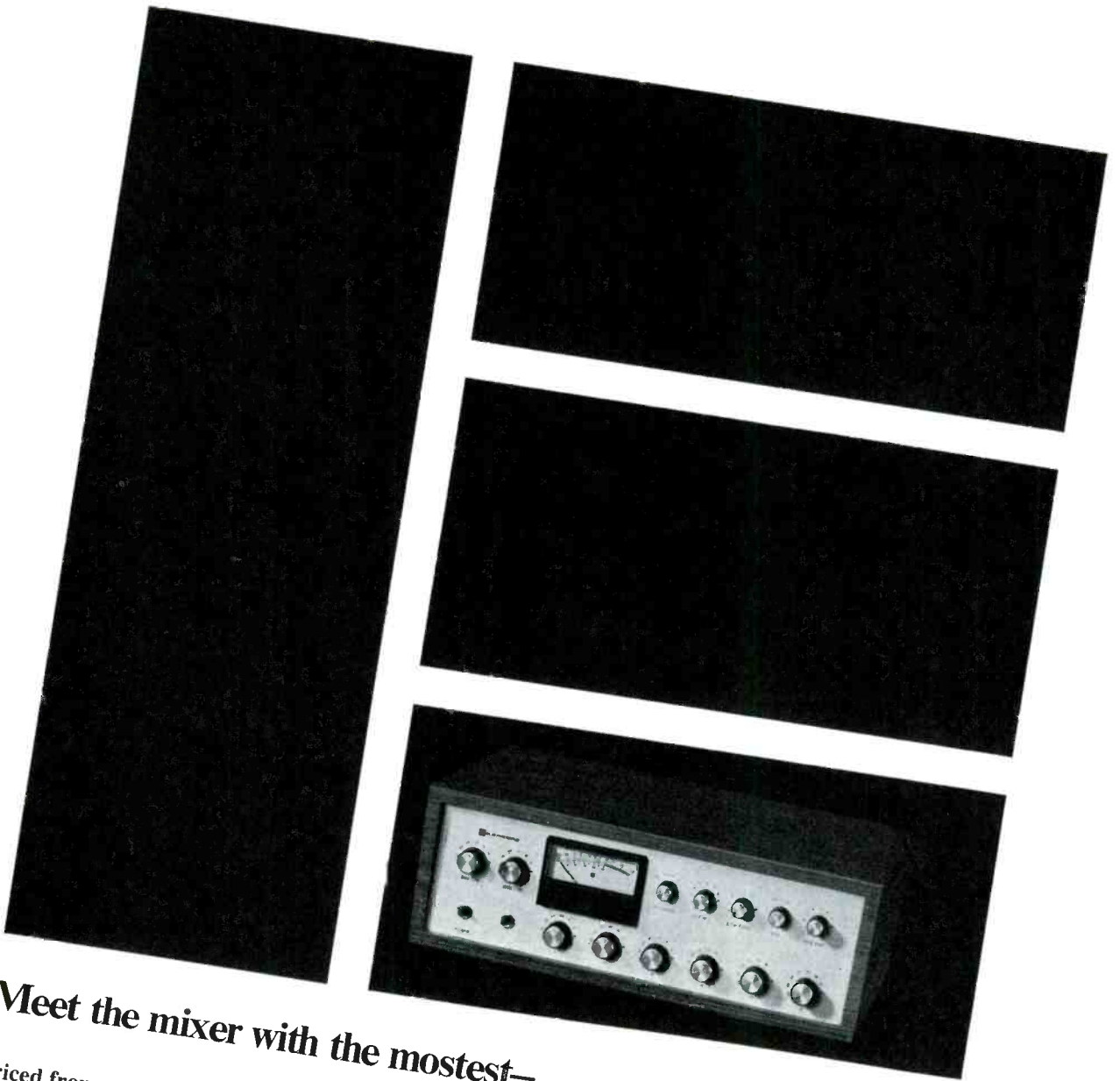


$R_1$			$R_3$			$R_2$		
Value	I	V	I	V	Value	I	V	Value
1K	.0133	.0133	.0933	1.0133	10.85K	.1067	.9867	9.25K
2K	.0133	.0267	.0933	1.0267	11K	.1067	.9733	9.12K
5K	.0133	.0667	.0933	1.0667	11.45K	.1067	.9333	8.76K
10K	.0133	.133	.0933	1.133	12.15K	.1067	.867	8.13K
20K	.0133	.267	.0933	1.267	13.6K	.1067	.733	6.88K
30K	.0133	.4	.0933	1.4	15K	.1067	.6	5.63K
$R_1 = 30K$			$R_3 = 15K$			$R_2 = 5.6K$		

$C_1$  Reactance 5.3K at 50Hz 0.6 mfd.  
 $C_2$  Reactance 30K at 141.4 Hz 0.0375 mfd.  
 $C_3$  Reactance 5.05K at 141.4 Hz 0.2 mfd.  
 $C_4$  Reactance 560 at 50 Hz 5.7 mfd.

Fig. 2-3 One method of achieving the result—a first try, with the calculations that go with it.





## Meet the mixer with the mostest—

priced from only \$300 with 6 inputs and 3 controllable outputs— that's E-600 by Electrodyne.

It's ready to go in any application from high-quality recording through CATV to sound reinforcement. Rack-mounted or completely self-contained in its own handsome Teak cabinet. E-600 comes with 6 mike or line inputs, each with speech/music select switch. All three outputs—Line, Headphone, and Auxiliary—have their own independent level controls.

Thanks to integrated-circuit, plug-in electronics and Electrodyne design, frequency response is 20 Hz to 20 kHz  $\pm 1$  db. Maximum output is +30 dbm; distortion less than 0.5%.

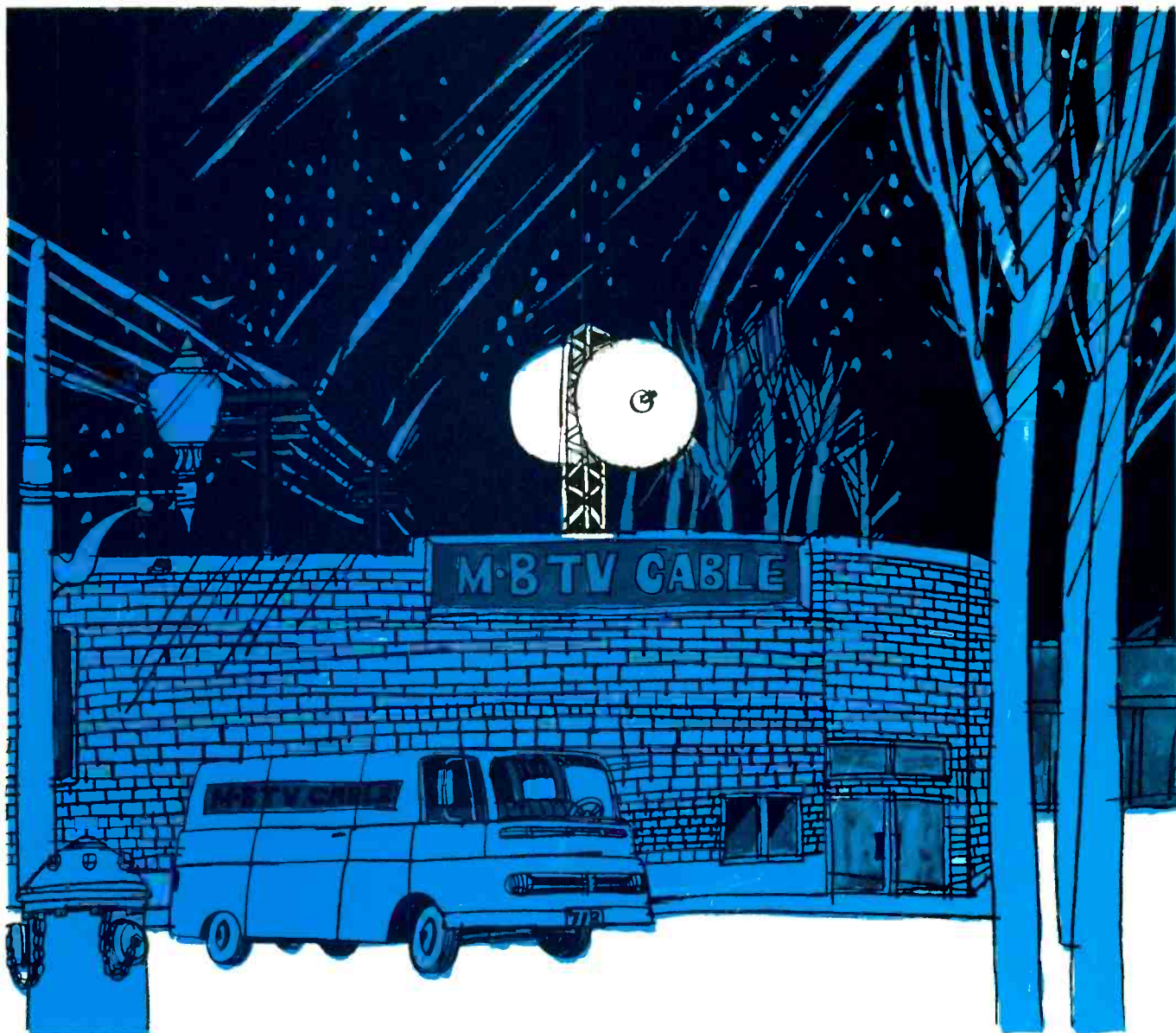
There's an illuminated VU meter with multiplier, along with a built-in oscillator for level set. The fully-regulated power supply can be paralleled for fail-safe battery supply, and the headphone jack can be paralleled for an additional output.

If you've been waiting for the mixer with the mostest, wait no more. Call and tell us just how you'd like yours packaged, and what time you'd like it delivered.

**ELECTRODYNE CORPORATION**  
 7315 Greenbush Avenue ■ North Hollywood ■ Calif. 91605  
 Phone: (213) 875-1900 ■ Cable Address: "ELECTRODYNE"

*Mix with E-600 and other new Electrodyne goodies at AES Booths 11 & 12.*

Circle Item 16 on Tech Data Card



**The weather may be unpredictable.  
But that doesn't mean  
your microwave has to be.**

With Lenkurt's 76E microwave radio system, you can always forecast reliable video transmission.

That's why major networks have used it for years for studio-to-transmitter links. And that's why you can rely on it to get the best video through to your CATV and ETV customers.

The 76E operates in the 12.2-13.25 GHz frequency range. Its r-f manifold is factory tuned to the frequency you specify—and it never needs retuning. Drift is no problem. And differential phase and gain are better than industry standards—giving you consistently superior color transmission.

So if you'd like predictable transmission for your customers, call or write Lenkurt Electric Co., Inc., San Carlos, California.



**LENKURT ELECTRIC**  
Subsidiary of  
**GENERAL TELEPHONE & ELECTRONICS**



Circle Item 17 on Tech Data Card



at 50 Hz, requiring 0.6 mfd.  $C_2$  works into 30K from the parallel combination of  $R_2$  and  $R_3$ , so it should have a reactance of 30K at 141.4 Hz.  $C_3$  works between the collector resistor of 1.3K and the base input (with feedback resistor) of 3.75K, so it should have a reactance of 5.05K at 141.4 Hz.

$C_4$  works from a very low impedance into a 560 ohms load, requiring a reactance of 560 ohms at 50 Hz.

#### Internal-External Load

We haven't calculated these values with precision, because we'll have to test this circuit out. The first thing we spot is that the output roll-off will be affected by terminating impedance. To keep the response correct, we need to adjust either the total internal and external load to 560 ohms, or adjust  $C_4$  to suit.

The input is not so sensitive to termination. The source of 560 ohms can be working from an external open circuit to an external short circuit (pure voltage input) only changing this value from zero to 560. The output side of the capacitor  $C_1$  feeds an impedance of 5K, which is ten times this, anyway.

To reduce the output circuit's dependence on external load, the load could be padded out by using extra gain in the gain stage to make up the loss. This will change the calculation (Fig. 2-4). Assume the use of an internal resistance equal to the external or terminating load, halving the range of possible deviation. This would require twice the voltage output at the collector of the gain stage and through the output emitter follower.

We recalculate  $R_1$ ,  $R_2$  and  $R_3$  for various values. To get a collector output voltage of 2 volts, twice the input signal current is needed. The voltage across  $R_3$  is now 2 plus that across  $R_1$ , while that across  $R_2$  is 1 minus that across  $R_1$ . Current in  $R_2$  and  $R_3$ , respectively, will be 7 times and 8 times, the new currents in  $R_1$ .

Using a value of 15K for  $R_1$ , yields values of 2.8K for  $R_2$  and 12.85K for  $R_3$ .

Going one step further, before we complete that design, the output can be attenuated by 5:1, increasing the working gain stage gain by five times. An output voltage of 5 can be worked out in the same way.

Voltage across  $R_3$  is 5 plus voltage across  $R_1$ , whose current is now five times what it was in the first calculation. Voltage across  $R_2$  is still 1 minus the voltage across  $R_1$ . Using 6.2K at  $R_1$  will yield a value of 1.1K at  $R_2$  and 11.6K at  $R_3$ .

#### Attenuation

In order to get the full swing to attenuate down, we have the emitter follower operating at mid-supply voltage. When collector resistance is increased to maintain a

$R_1$			$R_2$			$R_3$		
Value	I	V	I	V	Value	I	V	Value
Gain = 2								
1K	.0267	.0267	.1867	2.0267	10.85K	.2133	.9833	4.62K
10K	.0267	.267	.1867	2.267	12.15K	.2133	.733	3.44K
15K	.0267	.4	.1867	2.4	12.85K	.2133	.6	2.8K
Gain = 5								
1K	.0667	.0667	.4667	5.0667	10.85K	.5333	.9333	1.75K
2K	.0667	.1333	.4667	5.1333	11K	.5333	.8667	1.625K
3K	.0667	.2	.4667	5.2	11.12K	.5333	.8	1.5K
5K	.0667	.333	.4667	5.333	11.45K	.5333	.6667	1.25K
6.2K	.0667	.415	.4667	5.415	11.6K	.5333	.585	1.1K
Bias 180K —current gain 82—voltage gain 5								
1K	.061	.061	.427	5.061	12K	.488	.939	1.92K
6.2K	.061	.38	.427	5.38	12.6K	.488	.62	1.27K

Fig. 2-4 Some more calculations, to allow for some isolating attenuation at the output end.

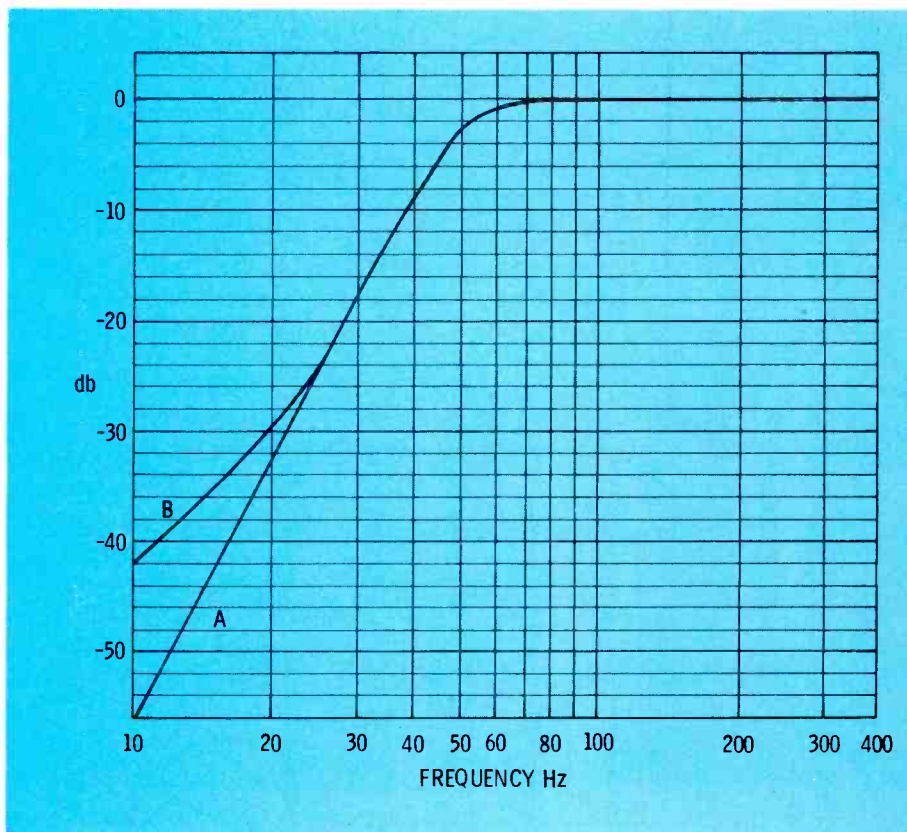


Fig. 2-5 The deficiency that shows up with the circuit of Fig. 2-3: attenuation doesn't go on down as it should: curve A, the ideal; curve B, the response due to the fact that  $R_3$  can conduct signal either way.



collector loading of 1K, its voltage will drop below the half point.

Now we can change the bias from 150K to 180K to correct this and recalculate for the new gain. Using a 180K bias resistor with an AC load of 1K will allow working current gain to rise from 75 to 82. Putting this change of gain into the calculations will do two things: it will reveal values suited to this revised circuit; and by comparing with the previous values, it will show what effect changes in transistor gain will have on performance.

To get a 5 volt signal output, the input current will be 5 divided by the working current gain of 82, or 0.061 milliamps. Using this as the starting point for the last part of the table in Fig. 2-4, we find that a value of  $R_1$  at 6.2K changes  $R_2$  to 1.27K and  $R_3$  to 12.6K. With these values, the feedback is essentially voltage feedback, controlled

by the relative values of  $R_2$  and  $R_3$ . Notice that changing the gain, on which the calculation is based, has not materially changed the ratio of  $R_2$  to  $R_3$ .

This means that changes in transistor gain will affect overall gain more than it affects feedback, and thus the response performance, which is a desirable feature.

### Circuit Changes

If this circuit were wired and tested, a defect would be discovered, which Fig. 2-5 illustrates. The resistor  $R_3$  is designated as a feedback resistor. Its function is to feed signal back from the collector of the middle stage to the emitter circuit. In the amplifying range, this is what it does.

However, the resistor doesn't know which way a signal is supposed to feed. At low frequencies, where  $C_2$  and  $C_3$  effectively isolate

the stage between them,  $R_3$  is a coupling resistor between the input emitter follower and the output emitter follower. With an attenuation of about 14 dB,  $R_2$  of 5.6K (unit gain case) and  $R_3$  of 15K add up to 20.6K, and base input of the emitter follower is 5K.

So below this point, only  $C_1$  and  $C_4$  will be acting (Fig. 2-5). Changing gain and other factors will change the point at which the slope thus deteriorates, but will not remove the effect. However, the signal fed forward is determined by the impedance combination. The emitter follower is just that: it follows, providing an impedance change. Couple the feedback from the emitter instead of the base, and this effect disappears, because the impedance drops from 5K to about 37 ohms.

Fig. 2-6 shows the circuit recalculated to adjust for this. The feedback resistor no longer shunts the collector directly, so that can be 1.2K again, to get a resultant of 1K when paralleled with the base input of the output emitter follower. Calculating values of capacitors follows the same method.

One thing to watch for in this circuit is interaction through the gain stage. The way it has been designed here, this will not be serious. It could require changing values to offset what effect is observed, from the values calculated. If the roll-off produced by  $C_3$  with its terminating load, which here is 5K, were of much lower impedance, it would materially shunt the collector load. This would change the amount of feedback effective beyond cut-off. The result would be equivalent to interaction between base and collector circuits. Under such circumstances, the interaction could be sufficient to make the circuit unworkable with any amount of feedback or juggling of capacitor values. We have chosen values where only a little juggling may be necessary.

### A Second Method

An alternative method of providing better freedom from interaction with external input and output terminating impedances would be to add extra emitter follower stage(s) to isolate the input or output roll-offs from the impedances to which the unit is coupled. That's a "brute force" way of doing it, and it works.

Here is another way of doing it

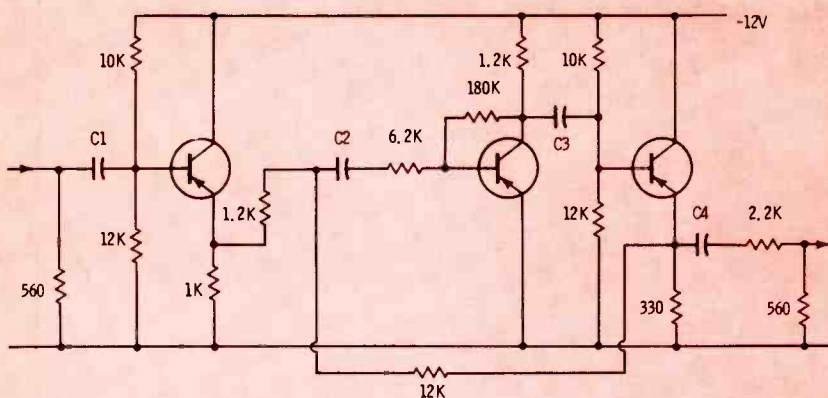


Fig. 2-6 The remedy: take the feedback from the emitter follower.

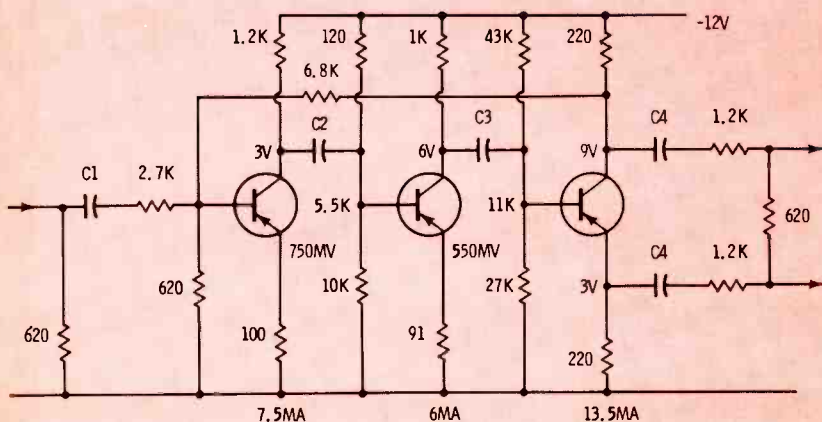
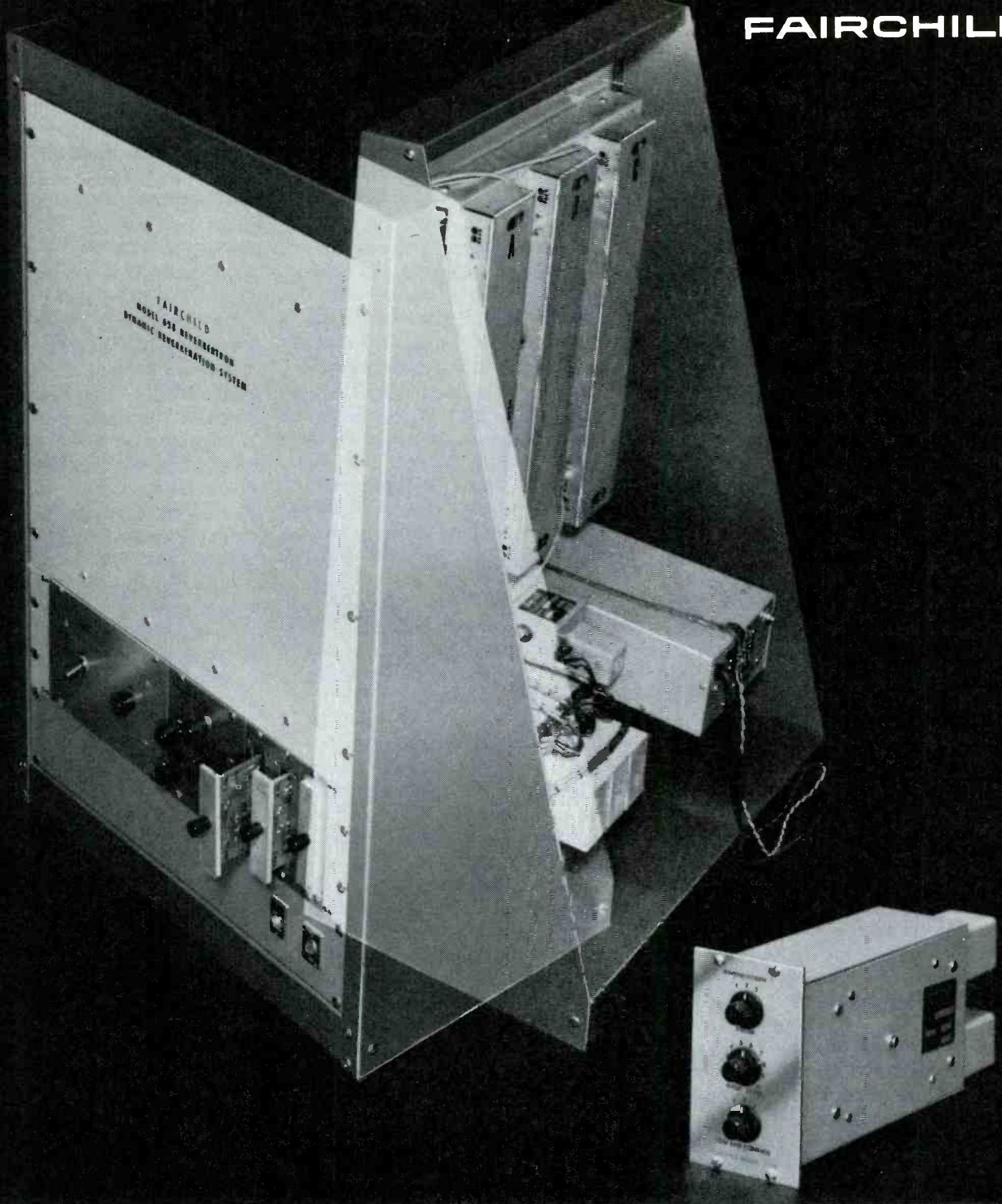


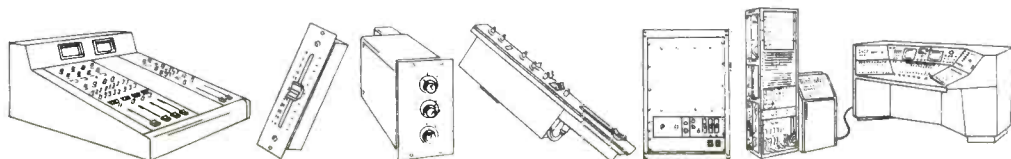
Fig. 2-7 The second method. Calculations are given in text.



**THE FAIRCHILD REVERBERTRON**

**MODELS 658A, 658B.** Fairchild reverberated sound is the sound of life; a real, natural, alive sound. Exclusive Fairchild systems offer a sound capability that supersedes all other artificial reverberation devices within equivalent price categories. Fairchild literally captures the superb quality of the world's finest acoustic chambers, without the expense of the chamber. Two compact systems are available. Model 658A

utilizes 6 delay lines, each differently tuned, each carefully isolated. Its 28 pounds is completely portable; offers 3 basic reverberation periods and total unit flexibility. Model 658B, shown above in the lower corner, is only 3" wide, 5¼" high, 11" deep. It has fewer control features, yet embodies much of the Fairchild excellence. Contact your Fairchild Recording Distributor or write Fairchild for more data. **FAIRCHILD RECORDING EQUIPMENT CORPORATION.** Dept. BE10, 10-40 45th Avenue, Long Island City, New York 11101.



DESKTOP MODULE CONSOLE / LUMITEN / REVERBERTRON 658B / INTEGRATED CONTROL MODULE / REVERBERTRON 658A / REMOTE AUDIO CONSOLE



that utilizes the three transistors, but differently. Fig. 2-7 shows the circuit and we will run through the calculations that arrived at that particular set of values.

The circuit uses three stages involving phase reversal, instead of only one. Any odd number of reversals allows for negative feedback. Using three stages to get the total gain allows each stage's gain to be controlled at a low figure, making it substantially independent of gain fluctuations in transistor characteristics.

The output stage can be made push-pull to allow a balanced output. By setting bias so emitter and collector are at 3 volts and 9 volts, (with a supply of 12 volts) maximum swing is available for attenuating down. The two 1.2K resistors with the 620 ohm termination provide about 14 dB (5:1) attenuation. At the input we have a similar attenuation to provide isolation there, totalling 28 dB (25:1).

We need to use 18 dB (8:1) gain reduction to get the response, so the total gain to make up is 46 dB (200:1). But the output stage has a gain of 2:1, because the base input voltage is duplicated at both emitter and collector in opposing phases. The other two stages must provide a gain of 100. We can simply feed back both to give a voltage gain of 10 each.

Since there is a gain of 100 from input base to output collector, we need to feed back seven times the original input. The resistor from output collector to input base must feed back  $7/100 = 1/14$  of the output voltage. Therefore, the resistor

must be 13 times the value of the base input resistance to which it feeds. This is 620 ohms in parallel with  $620 + 2.7K$ , which figures to about 520 ohms. Multiplying this by 13 gives 6.8K for the feedback resistor.

### Other Circuit Values

Now for the remaining values in the circuit: with 220 ohm resistors in emitter and collector of the output stage, each dropping 3 volts, output stage current must be 13.5 ma. Base current must be 13.5 ma divided by 150 (average) or 90 microamps. With 3 volts across the 27K bottom bias resistor, 110 microamps will pass. The top resistor must pass a total of 200 microamps, dropping 9 volts, requiring about 45K. The preferred value of 43K is close enough.

Variation of gain from 120 to 180 will change base loading of the bias point from 120 times at 220 ohms to 180 times at 220 ohms, or from 26.4K to 39.6K, with the mean, for a gain of 150, at 33K. With this change in gain, base voltage will fluctuate between 2.8 and 3.2. Using the 150 gain figure, base input impedance is 33K. Paralleling this with 43K and 27K makes a 11K output load for  $C_3$ .

Using a collector resistor for the middle stage of 1K, the 11K paralleling it will make the total collector load about 910 ohms. Using an emitter resistor of 91 ohms will hold the voltage gain of this stage to 10. If we make the collector voltage 6, the current is 6 ma and the emitter voltage (DC) will be 550 mv.

Base current (average) will be 6 ma divided by 150, or 40 microamps. Using 10K for the lower resistor will pass 55 microamps at 550 millivolts, totalling 95 microamps for the upper resistor to pass, at 11.45 volts. The upper resistor needs to be 120K. Base input impedance is  $91 \times 150$  or 13.5K. With 120K and 10K in parallel, this makes a 5.5K load for  $C_2$  to feed.

Now the first stage: with 5.5K load to feed, a 1.2K collector resistor will provide an AC collector load of 1K. Using an emitter resistor of 100 ohms will then set the voltage gain at 10. Base voltage is here set by the feedback. The output collector has 9 volts. This is divided by 6.9K (which should be close tolerance) and 620 ohms. This will produce 750 mv at the base.

The 100 ohm emitter resistor will control the first stage current to 7.5 ma, making the collector drop to 3 volts, which is adequate. Gain variations here will have negligible effect, because base current is about 50 microamps. Current in the 620 ohm resistor is over a milliamp, completely swamping base current effect.

We can make the input balanced, as well as the output. This we have shown at Fig. 2-8. As only half the input appears across the upper 330 ohm resistor, less attenuation is needed to produce the same voltage input. A 910 ohm resistor, with the original value of 620 ohms, achieves the desired effect. To match with the lower part, 1.5K will substitute for the 910 and the 620 ohms together.

The capacitor values are tabulated in Fig. 2-9 for easy recognition.

The  $C_4$  capacitors can be electrolytics, since they have a polarizing voltage, with the upper one at 9 and the lower one at 3 volts.

The next article will cover methods for adjusting performance to achieve the calculated results, using an oscillator, a scope and the necessary attenuation.

The design of various tone generators using transistors will be covered later. In some the frequency may be controlled by voltage, which can be combined with transistor "programming circuits" to yield a tone call signal using any desired note combination. ▲

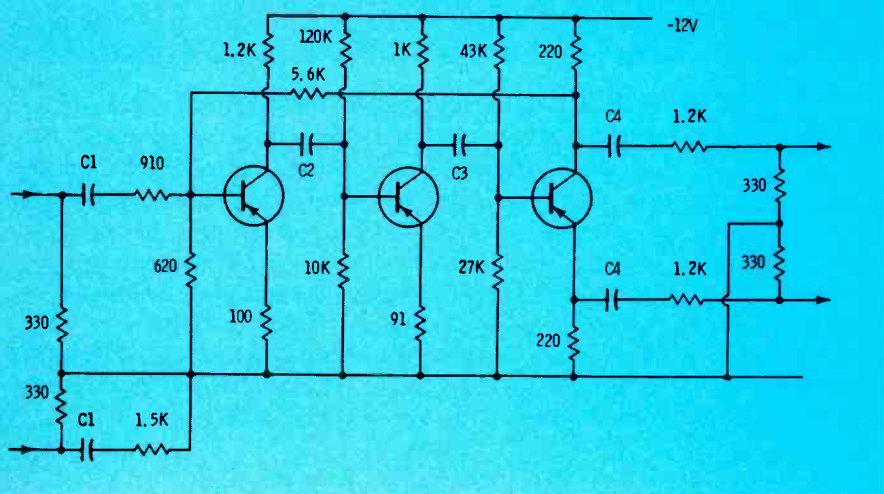
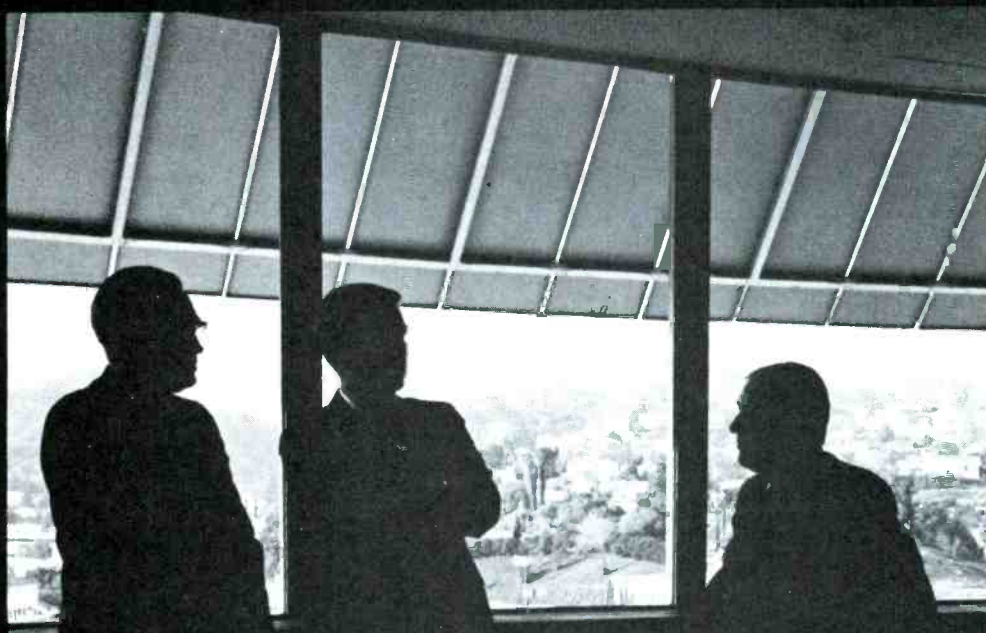


Fig. 2-8 The second method with balanced input and output.



When engineers get together,  
the conversation turns to pickups.



PHOTOGRAPHED BY FRANZ EDSON AT THE CAPITOL TOWER, HOLLYWOOD.

It's an irresistible topic.

Especially since Stanton came out with the Model 500 stereo cartridge.

That's an engineer's pickup, if there ever was one.

Beautiful curve—within 1 db from 20 to 10,000 Hz, 2 db from 10,000 to 20,000 Hz.

Fantastically small moving system to trace the wildest twists in the groove.

Light weight (only 5 grams!) to take advantage of low-mass tone arms.

And, of course, Stanton's legendary quality control.

No wonder engineers use the Stanton 500 for critical broadcasting and auditioning applications.

And to impress other engineers with their pickupmanship.

(Available with 0.7 or 0.5-mil diamond, \$30; with elliptical diamond, \$35.)

For free literature, write to Stanton Magnetics, Inc., Plainview, L.I., N.Y.)



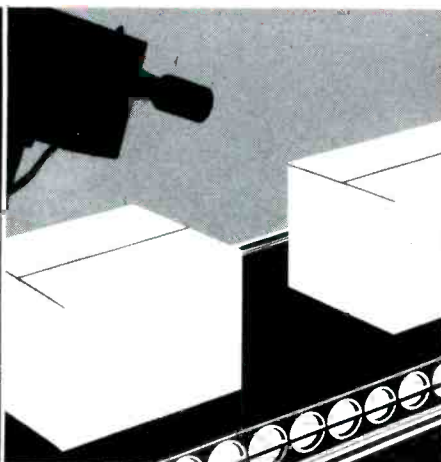
# For **Whatever** Is Worth Watching...

## BROADCASTING



TYPES	COLOR FILM CAMERAS
7038V	PE 24, PE 240 TK 27
8572V	
8134V	
	LIVE COLOR CAMERAS
Z-7929R	TK 42, TK 43
Z-7929G	
Z-7929B	

## INDUSTRIAL AND ETV



TYPES	FEATURES
7735B	EXTREMELY LOW LAG <i>excels in live pickup</i>
8484	HIGH SENSITIVITY <i>industrial remote use</i>
7262A	LOW HEATER POWER <i>for remote surveillance</i>
8507A	HIGH RESOLUTION <i>separate mesh 7735B</i>
8572	HIGH RESOLUTION <i>separate mesh 8484</i>

## OR WHATEVER



APPLICATION REQUIRING
<b>EMPHASIS ON:</b>
Sensitivity
Very High Resolution
Spectral Response
Ruggedness
Reticule Face Plate
Radiation Resistance
Minimum Lag
Extended Persistence

## Do It Better with General Electric Vidicons!

*Whatever* TV camera you use or whatever your application... General Electric vidicons provide better pictures, performance and reliability. Significant advances in vidicon chemistry give the *lowest lag* of any vidicon available for demanding television applications. Similar advances now allow a selection of vidicons with a notable combination of long life and high sensitivity.

**For Top-Notch Broadcasting** — GE vidicons give the best picture your live and color film cameras were designed to produce, to an audience where only the best is good enough!

**For Demanding Industrial Use** — GE vidicons provide rugged and reliable performance with clarity and detail... from monitoring a blast furnace to process control.

**For Flexible Education and Audio Visual Aids** — Where closed circuit TV is an integral part of new teaching concepts, GE vidicons offer high resolution and excellent sensitivity for better pictures under normal classroom lighting.

**For Unusual Applications** — *Whatever* demands something special... from underwater research to day-nite automotive rearview TV... GE vidicons may

already exist to provide the unique performance you require.

### BUY GE VIDICON TUBES FOR A BETTER PICTURE!

For any replacement or new application write:

Pickup Tube Operation  
General Electric Company  
Building 6, Electronics Park  
Syracuse, New York 13201

GENERAL  ELECTRIC

288-15



October 1968

## Late Bulletin from Washington

by Howard T. Head

### Further Court Authority for FCC Regulation of CATV

Any questions as to the Commission's authority to regulate CATV systems remaining in the wake of the recent Supreme Court decision (see August 1968 Bulletin) have been laid to rest by a unanimous decision of the Eighth U.S. Circuit Court of Appeals. At issue in this case were the specific FCC Rules and Regulations dealing with carriage, non-duplication, distant signals and waivers. The Court not only confirmed the Commission's regulatory authority over CATV but concluded that the CATV rules are "reasonable and within the authority of the Commission".

### Reappraisal of CATV Posture Under Way by FCC

The Commission is presently studying the possibility of imposing a freeze on CATV. Such a freeze may be imposed to permit a re-evaluation of the Commission's CATV regulations, taking into account recent important Court decisions affirming the FCC authority in this area. In the face of mounting pressures from CATV and anti-CATV forces both inside and outside of the Commission, such a freeze may be required to properly balance the conflicting views.

In any event, it appears likely that ultimately some of the regulations now applicable to television stations also will be applied to CATV. The interplay between CATV and the economic aspects of UHF operation is sure to be considered in establishing the applicability of pertinent Rules and Regulations.

### Remote Control of VHF TV Transmitters Considered Feasible by NAB

The National Association of Broadcasters (NAB) has again asked the Commission to permit the operation of VHF television transmitters by remote control. In support of this request, NAB states that field tests at three VHF stations indicate that it is technically feasible to operate VHF television transmitters by remote control.

The NAB request to the Commission pointed out, among other things, that the field tests establish the reliability of existing VHF television broadcast equipment and the adequacy of present fault indicators and alarm systems to permit immediate correction of malfunctions by station personnel should they occur.

During the field tests, each station used automatic logging equipment to keep accurate records of the operating parameters, but NAB did not propose that remote control operation be contingent upon a requirement for automatic logging, suggesting instead that the licensee be given the option of either manual or automatic logging.



### Special Committee to Study Color Variations

A special Ad Hoc Committee has been formed under the sponsorship of the Joint Committee on Inter-Society Coordination (JCID) to study the problem of color variations which are obtained in transmission of color television programs. To date, no official study has been undertaken by the Federal Communications Commission of this problem. However, the FCC is interested and may become involved at a later date, particularly if the Ad Hoc Committee investigation indicates technical solutions are presently available to correct deviations from acceptable standards in any link in the chain of transmission. The FCC will be represented on the Committee by an "observer".

At this time, the extent to which color variations occur in reception and transmission is not known. It is known, however, that wide variations in hue and saturation do occur as a result of different sources of program material, different cameras, and other causes and that much of the problem must be attributed to the transmission.

### FCC Proposes Deletion of 50% of Frequencies in Aural STL Band

The FCC Notice of Inquiry and Notice of Proposed Rule Making in Docket No. 18262 proposes, among other things, to delete one-half of the frequency space now assigned for aural studio-transmitter link and to re-assign these frequencies to the land mobile services (see September 1968 Bulletin). The present aural STL band is from 942 MHz to 952 MHz and, under the proposal, would be reduced to include only those frequencies from 947 MHz to 952 MHz.

The FCC Notice points out that there are only about 200 authorizations, primarily aural STL's, in this band which makes this a "likely candidate" for possible reduction in width, as proposed. However, the band also is employed for "wireless microphone" use.

Unfortunately, no substitute frequencies are provided for those deleted. In some cities this may result in no new frequency being available in the band, or even the possible deletion of an existing assignment. Comments by interested parties are due by December 2, 1968.

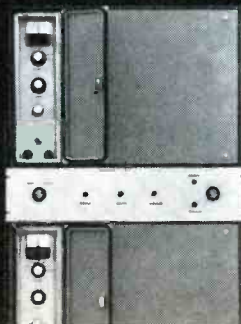
### Short Circuits

The testing is still under way in the sharing of television Channel 6 with the land mobile radio services...Manufacturers are under fire by broadcasters and FCC concerning apparent inferior performance of UHF tuners as compared to VHF tuners...The FCC has clarified Part 73 of the Rules dealing with equipment performance measurements by AM and FM licensees to require measurements once each calendar year with successive sets no more than 14 months apart...Following Canadian concurrence, the Commission has changed the rules governing operation under presunrise service authority (PSA) to permit presunrise operation to commence at 6:00 am local time rather than 6:00 am local standard time.

Howard T. Head...in Washington

# "Now a word from our

Losing money on interrupted programming? Don't!  Switch to the ultra-reliability of dual STL microwave TV systems . . . total solid-state B-Line fixed links from Microwave Associates.  Performance like nothing you've seen or heard before. Superb color, sharp images, audiophile sound, unbeatable reliability. Plus double protection . . . from solid-state circuitry and highly dependable hot standbys.  Other bonuses too. Solid-state RF sources instead of klystrons . . . no tube replacement costs, no bulky power supplies, no heating problems, no harmful voltages.  Interested? B-Line dual STL's (and TSL's) are in volume production for 2, 7 and 13 GHz auxiliary broadcast bands. With options like multiple-channel audio, automatic hot-standby switching, accessories, and complete RF system engineering assistance. Write or phone for details. (617) 272-3000.  Have the last word!



**MICROWAVE ASSOCIATES**

Burlington, Massachusetts

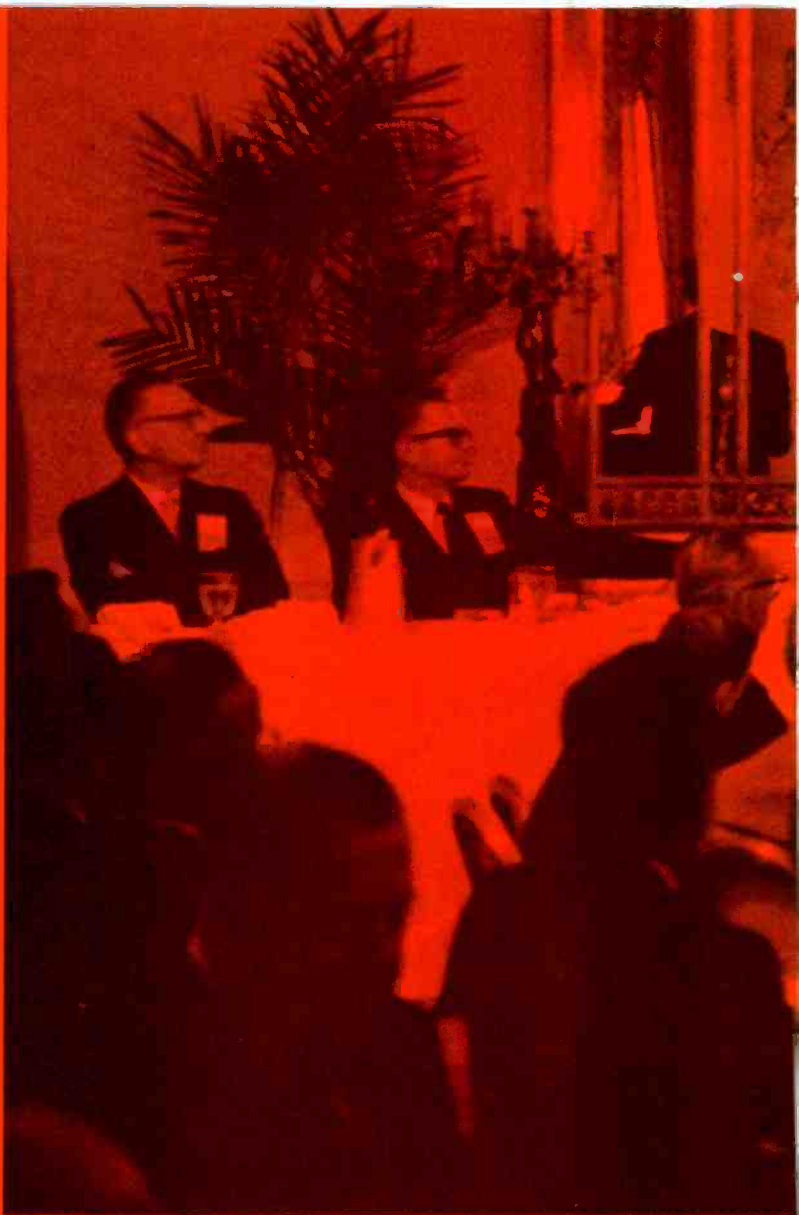
Offices: Northwest Industrial Park, Burlington, Mass. 01803

International Sales: Microwave Associates International  
Northwest Industrial Park, Burlington, Mass. 01803

Circle Item 20 on Tech Data Card



# Broadcasters attend 18th IEEE-GB symposium



---

By Ron Merrell

---

The 18th symposium of the IEEE-GB got underway in Washington on Sept. 19 with the promise of some explosive sessions. As it developed, the panel that fielded the question of the need for licensing operators offered about the only near explosion.

But it should be noted that each of the sessions was well attended by the more than 250 members who registered. The use of visual aids added considerably to an interesting variety of subjects covered in the sessions. The visual aids' smooth transition from session to session can be attributed to the efforts of the FCC's Phillip Tremper. And

throughout the symposium the work of the GB secretary, RCA's E. Noel Luddy, added to the feeling that each session was vital.

First session chairman Howard T. Head got the symposium rolling with the introduction of a number of interesting papers. After the official welcome by Ralph J. Renton, Richard T. James presented a paper on "An Analysis of Test Pattern Signals—Vertical Wedges."

The transmission of video test pattern signals over transmission paths of limited bandwidth often results in a selective impairment of the vertical resolution wedges. Aided by color slides, James presented an analysis of the signals that are generated when these wedges are scanned, and he discussed some applicable transmission considerations. The analysis in-

cluded repetitive pulse trains of varying lengths.

After considering the equations that were worked out by a computer, the long time AT&T engineer concluded that repetitive trains of pulses—such as those generated by scanning the vertical wedges—will have characteristic energy distributions that form predominate groups. A predominate group will become more pronounced as the number of pulses in the train is increased.

In addition, the waveshapes produced by the harmonics in the predominate group, or the harmonics in comparatively small parts of the predominate group, are such that visible distortion will occur. Therefore, a microsecond of delay distortion in the very narrow spectrum of the four harmonics displayed





**Roy D. Cahoon**, chief engineer of the Canadian Broadcasting Corporation, details Canada's experience in color broadcasting.

could displace this signal from the rest of the wedge enough to show several pulses. This distortion, and more, can be expected in regions of sharp cutoff.

### **The Loudness Problem**

For more than 10 years now listeners have been complaining that many commercials are too loud. This complaint has been increasing, especially in television broadcasting. Emil Torick, Richard G. Allen and Benjamin Bauer tackled this problem in a paper entitled "Automatic Control of Loudness".

In its presentation, it was recalled that in 1965 the FCC revised its standards to require the modulation levels be "usually not less than 85 per cent on peaks of frequent recurrence, but where necessary to avoid objectionable loud-

ness, modulation may be reduced to whatever level is necessary." (FCC Rules and Regulations, Vol. III, paragraphs 73.55, 73.268, 73.687 (b) (7), as amended effective Jan. 1, 1965.)

As pointed out by the authors, the VU meter does not adequately measure the loudness level. In fact, without automatic controllers or measuring devices, the broadcaster could only listen to the program. He would need to make manual adjustments and hope that his judgment was good. But even if he were able to do this successfully, the peak limiter at the remote, unattended transmitter site could undo his conscientious efforts.

In response to the problem of loudness control, CBS Laboratories

began a three-year program of research and development which resulted in a loudness indicator and an automatic loudness controller for broadcast use.

Unlike conventional limiters calibrated by the signal input level, the automatic loudness controller described is calibrated by an adjustment of the control loop gain. This method prevents the disruption of the accurately set unity gain feature and possible resulting overmodulation if controls are changed.

According to the authors, a 6 dB limit on gain reduction has proved to be advantageous for several reasons. Program analysis having shown that a greater range is unnecessary, this limit prevents possible misuse of the device. And since linear operation is resumed beyond 6 dB, occasional accented

# Vision on the move

The new Minicam VI  
marks another innovation  
in the realm of the "impossible"  
from CBS Laboratories.

The Minicam VI is a television camera  
that can go anywhere: land, sea or air.  
And a single cameraman can carry it  
easily on his shoulder.

It opens up a whole new world  
in television broadcasting. It is the only  
portable camera to give an NTSC  
signal from a backpack. It will cover  
fast-action sports events and fast-breaking  
news stories live from the scene of action  
— with studio-quality color pictures.

Minicam is just one more significant  
innovation in Professional Products from  
CBS Laboratories — creators of the  
Image Enhancer, Digital Display Unit,  
Loudness Controller, Audimax,  
Volumax, and others.

CBS Laboratories has researched,  
developed, produced and marketed many  
of the most remarkable advances in the  
science of sight and sound.



**CBS LABORATORIES**  
Stamford, Connecticut. A Division of  
Columbia Broadcasting System, Inc.

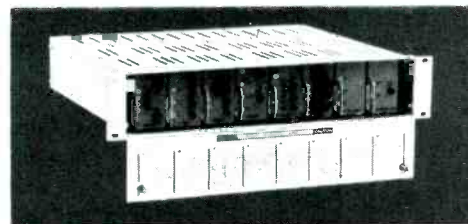
Circle Item 21 on Tech Data Card



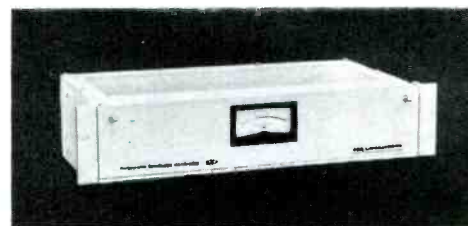
**Digital Display Units.** Modular compact units for any size TV studio. Give optimum clarity up to 70 feet—from any camera angle up to 145 degrees. All operated by one controller which is able to handle 192 units!



**Audimax and Volumax.** A level control and peak limiter years ahead of any of their kind. Combination automatically *guarantees* maximum increase in audience coverage without over modulation.



**Image Enhancer** "rides through" weaknesses and defects in home television receivers. Delivers amazing picture clarity in both black-and-white and color. Remarkable process called "crispensing" sharpens detail without noise or crosstalk.



**Loudness Controller.** The only instrument that guarantees your audience's listening comfort. Automatically reduces objectionable program loudness. Ends listener complaints.



**Mobile Television Van.** Television coverage capability in a class by itself. Goes everywhere. Sees everything. Whether it's two cameras or twelve, CBS Laboratories designs vans to suit any need.









Noel Luddy, center, always ready to help.

Broadcasters board bus for tour of COMSAT.



sounds can be transmitted with their intended effect unaltered.

When using the automatic controller, the program is fed through a basic unity-gain push-pull amplifier. Gain reduction is accomplished by applying a DC control signal to a light-dependent resistive (LDR) shunt. The LDR was chosen for this variolusser application because of the relatively high signal levels which need to be accommodated.

A loudness analyzer is contained within the control loop. A portion of the output signal is fed back through a weighting network, filters and rectifiers. After summation and

the application of appropriate attack and decay time constants, the resultant DC control signal is applied to the lamp element of the LDR.

Only five filters were used in the controller because broadcast signals do not normally encompass the total range from 20 to 20,000 Hz. The filters used covered: 50 to 500 Hz, 500 to 1000 Hz, 1000 to 2000 Hz, 2000 to 4000 Hz and 4000 to 15,000 Hz.

The last major consideration was time constants. In the loudness indicator the analogous electro-mechanical attack time was established at

### Comsat Shot Fails To Achieve Orbit

Atlantic 3, the third in a series of INTELSAT communications satellites, lifted off its pad at Cape Kennedy late at night on Sept. 18. At about one minute after lift-off something went wrong.

The satellite and the 10-story tall Delta booster rocket pitched back toward earth. Due to the unusual aerodynamic force encountered, the rocket began to break up. A few seconds later the safety officer at the Cape sent a destruct signal that exploded the huge rocket into a brilliant ball of flame. The remains fell into the ocean about 10 miles off the coast.

Had the shot been successful, the powerful communications satellite would have provided color TV coverage of the Olympic games to Europe. Applications Technology satellite No. 3 will now handle the Olympic coverage.

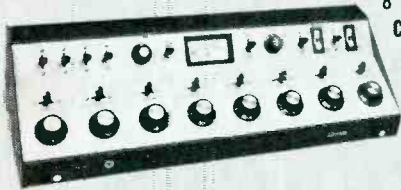
Atlantic 3 would have been capable of relaying four color telecasts or up to 1,200 telephone conversations to ground stations in Africa, Europe, and North and South America.

ABC, which has U.S. rights to Olympic coverage, plans to relay the signal overland by microwave. Another satellite already stationary over the Pacific will be used by the Japanese commercial television networks to cover the Olympics.

100 milliseconds. Circuit parameters of the loudness controller were adjusted so that gain reduction to 63 per cent of the controlled steady-state levels occurs in 100 milliseconds. A recovery time of two seconds was selected to minimize repetitive gain variations.

On Friday, IEEE members were bussed to the L'Enfant Plaza South for a tour of the COMSAT facilities. COMSAT is the managing organization for INTELSAT. Just two days before the tour, an INTELSAT III series communications satellite orbit attempt had exploded shortly after lift-off.

# 4 ways to better sound

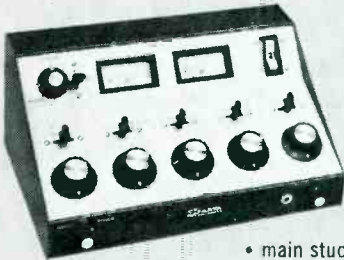
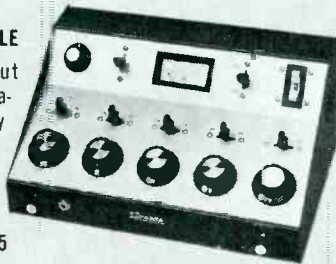


**A-20  
8 CHANNEL MASTER  
CONTROL CONSOLE**

- Advanced transistorized design
  - Self contained power supply
  - Monitor & cue amplifiers
  - Accommodates 22 separate inputs
- only \$1095.

**A-15 5 CHANNEL CONSOLE**

- Modestly priced, but offers a wide range of features usually found only in larger consoles
  - Speaker muting - Self contained monitor/cue speaker system
  - 14 audio inputs
- only \$495



**AS-30 STEREO  
5 CHANNEL CONSOLE**

- Ideal for use with stereo automation systems
  - production recording studio
  - remote broadcast
  - main studio control
- only \$725



**RA-5 REMOTE MIXER**

- Extremely lightweight solid state remote amplifier with 2 channels and 3 inputs
  - Operates over 30 hours on 9V transistor batteries
  - complete with rugged carrying case.
- Price only \$275.

**SEE ALL OF SPARTA'S NEW LOOK!**  
Write or call for complete product brochure.

**SPARTA**  
**ELECTRONIC CORPORATION**  
A DIVISION OF COMPUTER EQUIPMENT CORPORATION  
5851 FLORIN-PERKINS ROAD  
SACRAMENTO, CALIFORNIA 95828  
(916) 383-5353

Circle Item 25 on Tech Data Card

## “Want a Good Job in Broadcasting?”



## You'll Need a First Class FCC License.”

Matt Stuczynski knows. He's the Senior Transmitter Operator of Radio Station WBOE. His story is typical of hundreds of men who have used Cleveland Institute Training as a springboard to success in Broadcasting. Here's what Matt says about Cleveland Institute:

“I give Cleveland Institute credit for my First Class FCC License. Even though I had only 6 weeks of high school algebra, CIE's AUTO-PROGRAMMED™ lessons really made electronics theory and fundamentals easy. After completing the CIE course, I took and passed the First Class Exam. I now have a good job in studio operation, transmitting, proof of performance, equipment servicing. Believe me, a Commercial FCC License is a 'must' for a career in Broadcasting.”

If you want rapid advancement in broadcasting, the first step is a First Class FCC ticket with *your* name on it. And Cleveland Institute Home Study is a fast, economical way to get one. What's more, CIE backs their licensing programs with this money-back warranty:

“A CIE License Course will quickly prepare you for a First Class FCC License. If you complete the course but fail to pass the exam *on your first attempt*, CIE will refund all tuition.”

With Cleveland Institute you get your First Class FCC License or your money back! Send coupon today for FREE book or write to Cleveland Institute of Electronics, 1776 E. 17th St., Dept. Cleveland, Ohio 44114.

### ENROLL UNDER NEW G.I. BILL

All CIE courses are available under the new G.I. Bill. If you served on active duty since January 31, 1955, or are in service now, check box in coupon for G.I. Bill information.

### MAIL COUPON TODAY FOR FREE BOOK



**CIE** Cleveland Institute  
of Electronics

1776 East 17th Street, Cleveland, Ohio 44114

Please send me your FREE book, “How To Get A Commercial FCC License.”

Name \_\_\_\_\_ (please print)

Address \_\_\_\_\_

City \_\_\_\_\_ State \_\_\_\_\_ Zip \_\_\_\_\_

Occupation \_\_\_\_\_ Age \_\_\_\_\_

Veterans check here for GI Bill information

Accredited Member National Home Study Council  
A Leader in Electronics Training . . . Since 1934

BE-52

Circle Item 26 on Tech Data Card





Licensing Panel: Ben Wolfe, Al Chismark, Curtis Plummer, Otis Hanson, Kenneth Cox, Cliff Gorsuch, and Earl Abrams.

### Panel Sees Need For Licensing Changes

During the panel discussion on licensing operators, some interesting points were brought out. Curtis Plummer, of the FCC Field Engineering Bureau, pointed out that the licensing of operators was a carry-over from marine communications. Assurance was needed that a radio operator was competent, because his ability and knowledge could save lives in case of a disaster at sea.

Plummer stated he felt licensing was not necessary, but added that the FCC is interested in keeping the exams up to date and meaningful.

Otis T. Hanson of the FCC Broadcast Bureau agreed with Plummer. He cited several FCC actions and regulations in an effort to offset the charges that the FCC was inconsistent and not really operating in the public interest.

Panel members Kenneth Cox (IBEW) and Cliff Gorsuch (NABET) defended licensing operators, hurled charges at the FCC, and detailed their organizations' attempts to upgrade operators and their training.

Allowing the Radio Act of 1934, Ben Wolfe from Westinghouse said that licensed operators ought to be

financed when they violate FCC regulations, not the station owner.

Al Chismark, SBE officer and a representative of Meredith Broadcasting Co., brought out the problem of the shortage of licensed operators. He said that there definitely is a need for more highly skilled maintenance technicians and that technicians need to be more vigilant in maintenance of equipment. Revamping the First Class exam also would help. And Chismark

added that there is no room in broadcasting for the five-week wonder. Wolfe agreed.

Panel moderator Earl Abrams, *Broadcasting Magazine*, asked the panel if they truly felt—beyond the arguments and conditions presented—licensed operators were necessary. The entire panel said "yes".

During the discussion, it was pointed out that the shortage of licensed operators was due, at least in part, to current operator wages.

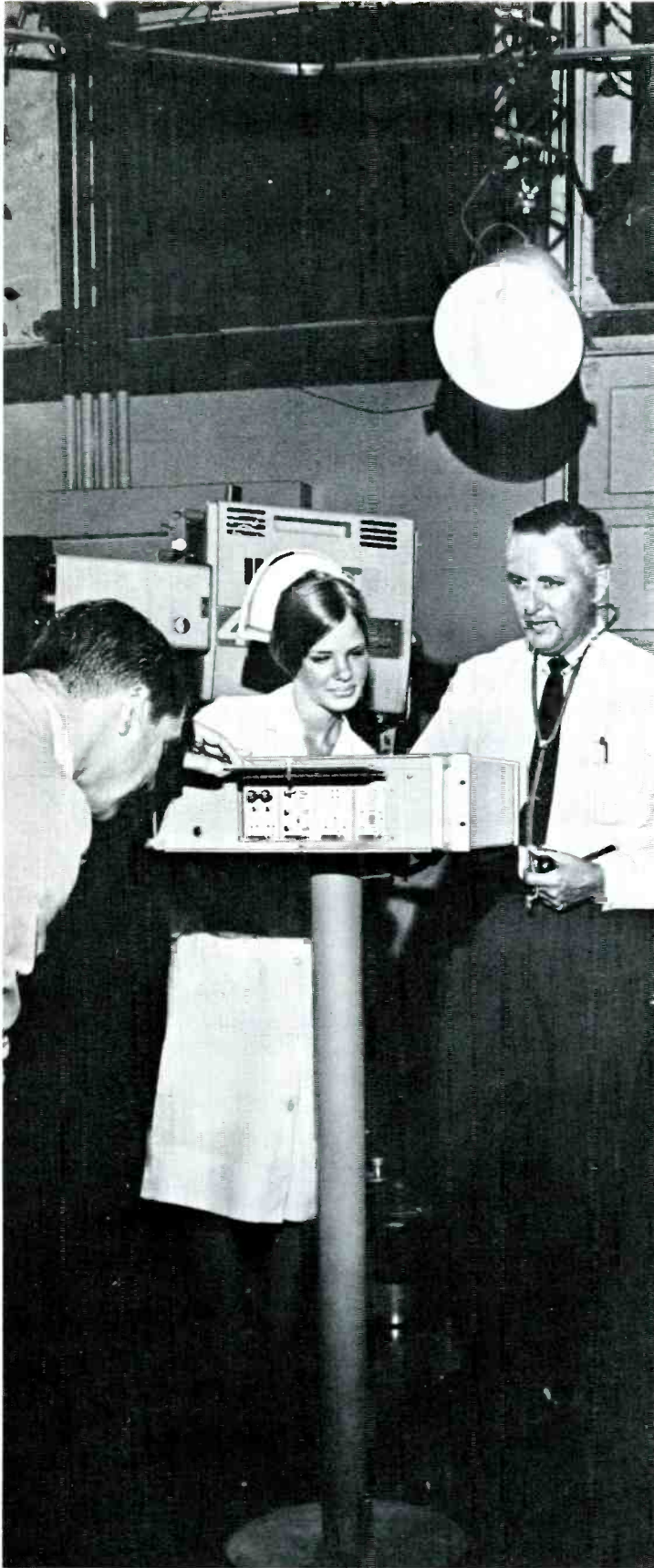
---

### OPERATOR OUTLOOK

In its most recent occupational outlook report series (Bulletin No. 1550-115), the Bureau of Labor Statistics confirmed the suspicions of many when it said that employment in the broadcasting industry is expected to rise slowly in the 1970's.

The Bureau is expecting the number of educational broadcasting stations to increase rapidly during the same period. The increase will come as private and governmental groups continue to expand this medium as an educational tool.

The growth of educational television stations, particularly, should provide an increasing number of job opportunities, especially in programming, engineering and station management. Beyond ETV, some job opportunities will be provided by new stations expected to go on the air during this period. However, the need for more and better trained technicians for color television is being offset by automatic switching and programming, automatic operation logging, and remote control of transmitters.



# EMMY AWARD

to Andersen Zero Studio Delay

We don't really expect that anyone will ever produce a medical show based on the way our Zero Studio Delay Equipment cures chronic sync problems in TV studios.

And we don't think the American Medical Association will ever create a Broadcast Award to honor our equipment for wholesome circuit approaches.

But we're sure that the use of this equipment would bring your station recognition for improved viewer interest and enjoyment.

Sync problems resulting from unequal delay constitute one of the most serious pathological conditions in the industry today. Fear of the symptom (rolling, loss of tracking, color phase errors, etc.) often prevents the use of special effects.

Developed for N.B.C., Zero Studio Delay eliminates scan phase problems encountered in multiple studio hook-ups. It allows dissolving, wiping and many other special effects to be achieved easily without lengthy preview time.

Standard sync retiming to control studio delay is relatively primitive and also inflexible and costly in terms of effort and time required on the part of the technical staff. Consequently, it is generally too burdensome to set up desired sophisticated effects for most shows.

The compact unit which is easily installed in any standard rack, is one of the most economical pieces of equipment in a station. In fact, if you are considering adding a new studio you should note that the cost of a Zero Studio Delay may be less than the cost of sizing cables and installing compensating networks to correct delay inequalities.

Andersen is the leading manufacturer of delay equipment and produces a far greater range of types for a wider frequency range than any other concern. The company is also the leading manufacturer of delay oriented signal processing equipment for radars, computer and many other demanding commercial and military applications. This background is your assurance of highest reliability and performance. Send for free description material.



**ANDERSEN LABORATORIES, INC.**

1280 BLUE HILLS AVENUE • BLOOMFIELD, CONN. 06002 • 203-242-0761 • TWX 710-425-2390

Circle Item 21 on Tech Data Card





Interesting papers appealed to Symposium audience.

### CBC Chief Engineer Address at Luncheon

In his luncheon address to the GB members, Roy D. Cahoon, chief engineer of the Canadian Broadcasting Corporation (CBC) covered the experiences of CBC in two years of color broadcasting.

Rather than take the costly path of step-by-step color evolution, Cahoon told his audience that the CBC had watched the American color developments until they thought it was the right time to step into the picture and commit their network to color.

The CBC started preparing for color in 1963 by looking over available equipment and TV receivers. In 1964 a great deal of time was given over to equipment testing, and equipment already in operation was accessed for possible conversion to color broadcasting.

While the initial color network broadcast was scheduled to begin in May at Expo '67, the timing was eventually pulled back to July of 1966. Meanwhile, it was necessary to train technicians and to continue the study and investigation of equipment.

What has the CBC learned in two years? Cahoon said they soon learned the need for better coordination with film suppliers and for better film editing. Hopefully, this would offset the problem of standardizing color tones.

Along this line, CBC learned that they needed one standard test film. A comparison of films in use revealed that many were not practical because of their low quality.

Along with testing equipment,

CBC found it necessary to test camera lenses. After testing nearly 400 lenses, they were discouraged in that many of the optical systems did not meet their standards.

In fact, CBC discovered what has often occurred in American stations was prevalent in their own operations: degradation of the color signal in the studio itself. Their answer was to reduce the number of circuits and to place key equipment at a central control point.

Current CBC problems in color include available test equipment and test facilities, the need to increase their training program and to increase their coverage of remote areas in northern Canada. And since remote coverage is considered a major problem, the CBC is now considering the use of two to four channel satellites.

### The Quasi-Laser Link

"A New Dimension in Television Air Links" was the title of a paper prepared by Dr. Joseph Vogelmann and Ira Kamen. As described, the quasi-laser system is one answer to the problem of CATV distribution in cities where cables on poles cannot be used.

An alternative to the quasi-laser system is that of laying cable under the streets. However, an underground system may not be economical.

According to the authors, the greater need for multi-channel television transmission to improve the educational systems in this country, and the long term benefits which would be derived, call for the assignment of the lowest and most eco-

nomical frequencies to education. The band from 11 to 15 GHz would provide optimum performance for educational transmission between educational institutions over moderately long paths through a state.

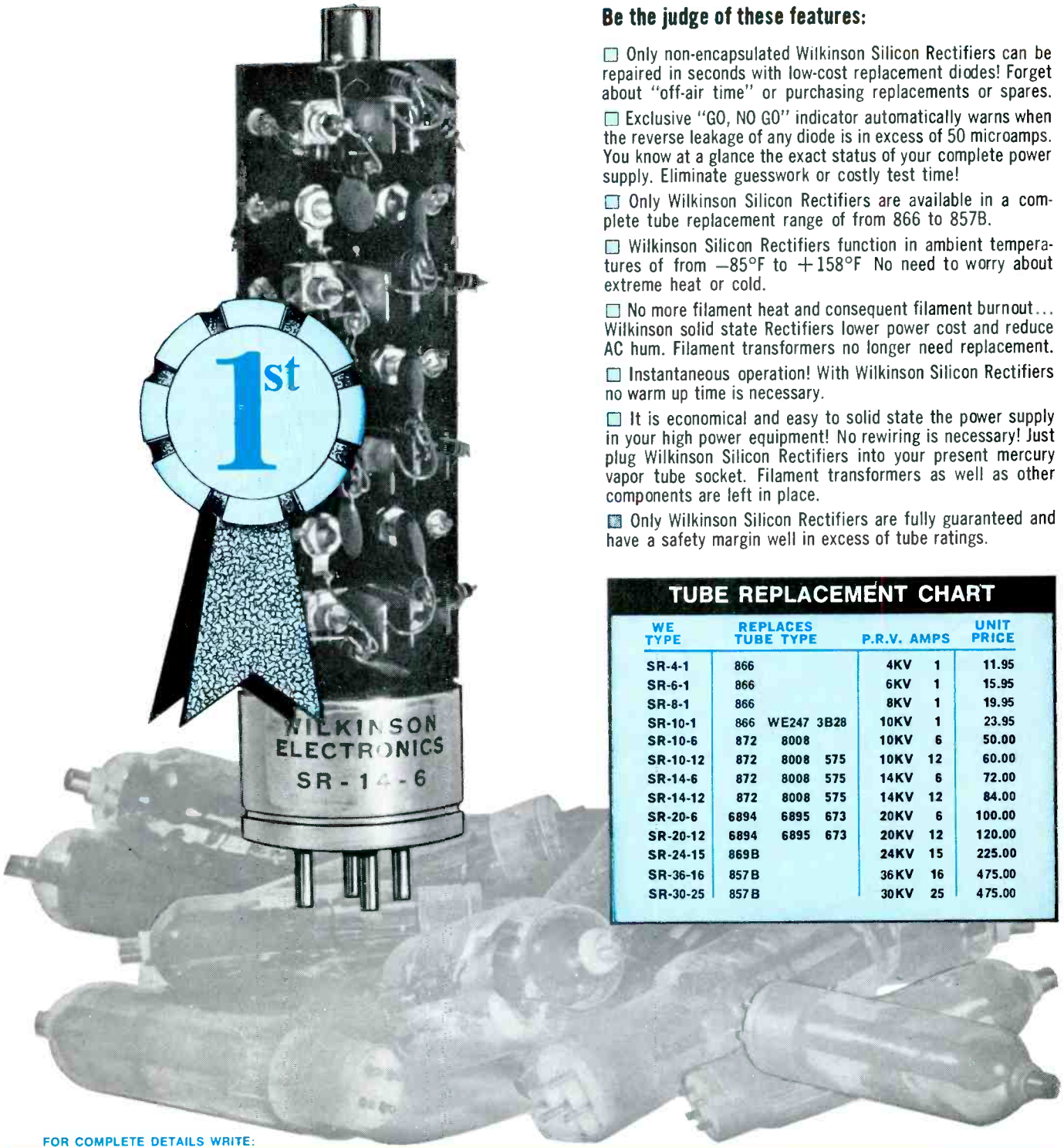
The narrow beam width associated with the quasi-laser system would permit using frequencies over and over, even in closely associated geographic areas, providing the antennas do not look at the main lobe of potential interference sources.

This system has possible applications in rural and suburban areas where it may be employed to cross rivers, jump highways, join communities, establish business and educational networks and disseminate possibly more than 20 channels, economically in support of municipal operations of the future.



Podium parade included details of installation of the most powerful TV transmitter. Most papers were backed by slide presentations.

# Wilkinson Direct Replacement Silicon Rectifiers... Stand Out In A Crowd ...and Stand Up Forever!



## Be the judge of these features:

- Only non-encapsulated Wilkinson Silicon Rectifiers can be repaired in seconds with low-cost replacement diodes! Forget about "off-air time" or purchasing replacements or spares.
- Exclusive "GO, NO GO" indicator automatically warns when the reverse leakage of any diode is in excess of 50 microamps. You know at a glance the exact status of your complete power supply. Eliminate guesswork or costly test time!
- Only Wilkinson Silicon Rectifiers are available in a complete tube replacement range of from 866 to 857B.
- Wilkinson Silicon Rectifiers function in ambient temperatures of from  $-85^{\circ}\text{F}$  to  $+158^{\circ}\text{F}$  No need to worry about extreme heat or cold.
- No more filament heat and consequent filament burnout... Wilkinson solid state Rectifiers lower power cost and reduce AC hum. Filament transformers no longer need replacement.
- Instantaneous operation! With Wilkinson Silicon Rectifiers no warm up time is necessary.
- It is economical and easy to solid state the power supply in your high power equipment! No rewiring is necessary! Just plug Wilkinson Silicon Rectifiers into your present mercury vapor tube socket. Filament transformers as well as other components are left in place.
- Only Wilkinson Silicon Rectifiers are fully guaranteed and have a safety margin well in excess of tube ratings.

## TUBE REPLACEMENT CHART

WE TUBE TYPE	REPLACES TUBE TYPE	P.R.V. AMPS	UNIT PRICE
SR-4-1	866	4KV 1	11.95
SR-6-1	866	6KV 1	15.95
SR-8-1	866	8KV 1	19.95
SR-10-1	866 WE247 3B28	10KV 1	23.95
SR-10-6	872 8008	10KV 6	50.00
SR-10-12	872 8008 575	10KV 12	60.00
SR-14-6	872 8008 575	14KV 6	72.00
SR-14-12	872 8008 575	14KV 12	84.00
SR-20-6	6894 6895 673	20KV 6	100.00
SR-20-12	6894 6895 673	20KV 12	120.00
SR-24-15	869B	24KV 15	225.00
SR-36-16	857B	36KV 16	475.00
SR-30-25	857B	30KV 25	475.00

FOR COMPLETE DETAILS WRITE:

**WILKINSON ELECTRONICS, INC.**

1937 MACDADE BLVD. • WOODLYN, PA. 19094  
TELEPHONE (AREA CODE 215) 874-5236 874-5237

Circle Item 24 on Tech Data Card



## Circular Polarized FM Antenna

Those engineers interested in stacked antennas atop tall buildings can now take another step forward . . . or upward, especially since a recent FCC ruling permits vertical as well as horizontal polarization. R. Marshall and E. J. Vaughn prepared a paper on such an antenna for FM.

The present approach to making the change has been to add vertical polarization to existing elements or to make a slight modification in the concept so that both polarizations can be obtained.

The authors indicated that there are distinct disadvantages in these approaches. They include: when the antenna is truly circular polarized in free space it covers only a single channel and that when an antenna covers all desired channels it is not circular polarized. Another disadvantage is that omnidirectional circular polarized antennas are single element radiators.

Their answer was to use the arrowhead dipole with an optimum angle of  $35^\circ$ . An angle less than this would result in significant capacitive coupling between the dipole tip and ground. The elements were matched to 50 ohms to reduce the sensitivity to the environmental conditions and to aid the bandwidth. With each element impedance at 50 ohms, it was necessary to feed equal power and equal phase to the elements.

The antenna, now atop the Empire State Building, VSWR mea-

surements over the bands of interest were less than 1.05:1. In fact, it was less than 1.5:1 over a range of 95 to 101 MHz.

During the free hours of the symposium, the following companies opened hospitality suites: Bauer Electronics, Gates Radio Company, General Electric, McMartin Industries, Moseley, Potomac Instruments, RCA, and Visual Electronics.

The symposium included a number of other papers too numerous to cover here. It should be noted that an even more thorough coverage of ideas and problems related to communications will be undertaken at the Los Angeles IEEE meet.

### Automated Station

Duane M. Weise, General Electric Broadcasting, reported on the redesign of WRGB to produce an automated television station providing for automatic switching, automatic preparation of the daily operating logs, availability schedules, programming and a host of other automated record functions.

At WRGB, the operational part of the automated system is divided into three separate areas; a traffic operation, an audio-visual library operation, and the technical operation.

It is the function of the traffic operation to accept all of the program inputs. The traffic people compile all the program inputs, systematically combine them into a program schedule and, with the aid of

an IBM 026 key punch machine, transfer the accumulated program and data inputs to IBM cards.

The traffic operation delivers a daily card stack to the audio visual library and the library personnel transfer the information on the IBM cards by means of an NCR card reader. At a reading rate of 75 cards a minute, a total of eight minutes is required to transfer an entire day's program from the daily card stack to the magnetic tape.

After a few subsequent changes and reviews, the tape contains all the programming, operating, financial and FCC information and is then delivered to the technical operation along with a printed copy of the FCC log.

Weise showed slides of the station equipment and controls before and after the conversion. Obvious haywire was eliminated and the central control area was redesigned for greater quality control.

Throughout the symposium, it was apparent that broadcasting is far from falling into a status quo condition. The needs change, the pressures mount and progress is ever in demand. Snow-balling technical advances seem barely able to keep from falling behind the visions as well as present needs of the broadcast engineer.

### IEEE West Coast Meet

The IEEE will sponsor the International West Coast Conference on Broadcasting November 6th through the 8th. The meet will be held in the Ambassador Hotel in Los Angeles.

Papers will be presented on new discoveries, recent advances and developments in AM, FM, TV, ETV, and CATV. This is the first international conference of the IEEE specifically devoted to broadcasting and CATV practice.

Guest luncheon speakers include Roy Cahoon of the Canadian Broadcasting Corporation, FCC engineer Willmar Roberts, D. Sageman of AT&T and L.C. Tillitson of Bell Laboratories.

The sessions will feature speakers from several countries. During the sessions, about 30 papers will be presented. They will cover a wide variety of subjects within the interests of broadcasters.



IEEE members relax between sessions outside the hotel.

# WDAU on Bald Mountain

By Peter Silveri\*

The trend today in transmitter tower site selection is toward increased height. In many areas, the tallest building in the metropolitan area has become a choice spot. However, the availability of the tallest building may present a problem. Or even worse, there may be no buildings in the city tall enough to afford the desired increase of signal coverage. WDAU-TV found another answer.

This Scranton, Pa., station took a long look at Bald Mountain and decided that here was a 2126-foot mountain that would offer the height necessary for improving reception in the outlying areas.

But planting a transmitting tower atop Bald Mountain was no easy task. In order to anchor their new 618-foot tower, it was necessary to drill holes 12 inches wide and 14-feet deep. Drilling these holes in an open field would have been enough of a problem. On Bald Mountain it called for an unusual and extremely difficult operation.

Diamond drills were used to cut the holes at 42 degrees through seamy, fractured sandstone and some medium-hard stone. During the operation, the core drilling crew frequently ran into rock-fracturing. This meant that the cores would need to be pulled up each time the rock fractured. The largest core pulled out was about 18 inches long.

According to Ralph Thompson, chief engineer of WDAU-TV and WBGI, 12-foot steel anchor bars were inserted into each hole. Then a shrinking type of high-strength concrete was pressure-grouted through the hole to secure the bars. Three steel guy lines, each  $\frac{3}{4}$  inch

in diameter, run from each hole to different points on the tower. The shortest line is 365 feet, the longest is 411 feet.

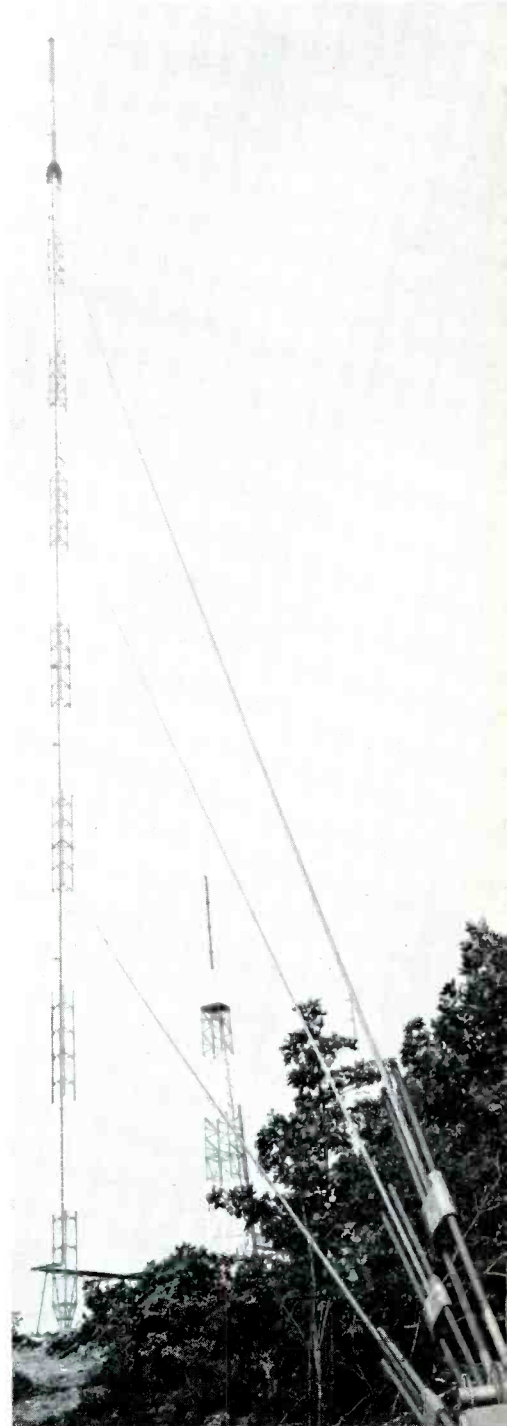
Thompson points out that all guy lines must leave the tower at the same angle, thus all holes were drilled at a 42 degree angle.

The 11-year-old WDAU-TV tower is now scheduled to be dismantled. Meanwhile, the tip of the new antenna will reach 2,744 feet above sea level. The investment in this phase of the project has been about \$250,000.

When tall buildings are not available, the surrounding terrain may be the answer to raising the antenna height, but rock formations can present a number of problems. Look at the height and then look into drilling costs for various sites on your mountain. ▲



One of the 12-inch wide anchor holes and another short core of fractured stone.



WDAU transmitting tower ready for operation.

\*N. W. Ayer & Son, Inc.



## TAPECASTER



### Model 700-P

Solid state playback unit

Broadcaster net price \$300.

For information write  
Box 662 • Rockville, Maryland 20851  
or call 301-942-6666

## TAPECASTER



Circle Item 28 on Tech Data Card

### "Morgan's Law of Snafu"

Susceptibility to the effects of the following problem is irrevocable, and among its victims are broadcast engineers.

Upon unpacking any shipment, do not immediately dispose of either the carton or inner packing material. Simply dump it on the floor. This is messy, but the packing slip is hiding somewhere. This you will need to verify which of the items listed as shipped were not, or cannot be located among the contents. One or more items will fall into this category. This certainly will be inverse to the item's physical size, and directly proportional to the urgency of your need for it.

Assuming this is one of your fortunate occasions, the gadget or gadgets in question were included in the shipment, but in transit have become separated from the main body and shaken down among the mass of excelsior, shredded cellophane, wadded newspaper, chunks of corrugated board, styrofoam cubes or other oddments which were used to pack the carton.

It will be necessary to conduct another search through the packing material, which by this time has been scattered about the entire floor area of the shop. When—or more probably—if found, the missing item will be discovered wrapped in, or stuck beneath the last remaining piece of stuff to be examined.

On occasion you may receive a vaguely similar but non-interchangeable item which is not readily adaptable to your need. Obviously, a letter is dispatched forthwith to the supplier, explaining the difficulty.

At long last, if you're lucky, one of your exasperated letters will be mis-directed to someone who understands immediately what you've been driving at. The answer informs you that the manufacturer of the item you still must have to repair that disabled gear, has gone bankrupt. The component in question is no longer available!

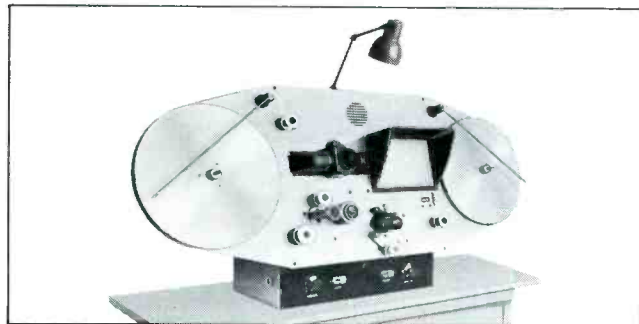
In the final analysis, the wisest advice is this: snafu is inevitable. Relax! Learn to love it and live longer.

**John C. Morgan**  
WFVA, WFVA-FM

## new LSC VEDETTE

### 16mm and 35mm PROFESSIONAL PROJECTORS

for fast, safe, high speed viewing and inspection of motion picture film



- The ideal machine for film quality control, timing and correction, and release print inspection. Handles negatives, fine grains and prints.
- Visual inspection of both picture and optical sound track. Solid state amplifier for simultaneous monitoring of picture and sound.
- Efficient revolving prism shutter and sharp optics produce bright, clear images without overheating film.

- Smooth, gentle film handling at up to 400 ft./min., without intermittent movement of usual claw or Geneva gear drive. Stable, positive focus. 2,000 foot film capacity.

Write for LSC Vedette literature or request a "no obligation" demonstration



## LIPSNER-SMITH CORPORATION

7334 No. Clark St., Chicago, Ill. 60626 • 312—338-3040

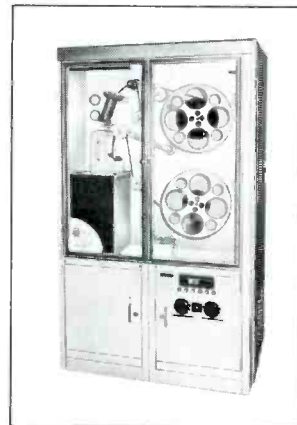
## CF<sub>2</sub> ULTRASONIC CLEANER

for MOTION PICTURE FILM • MICROFILM • MAGNETIC TAPE

Presented The Academy of Motion Pictures Arts and Sciences Award of Merit for Outstanding Technical Achievement.

Ultrasonic energy is the most effective and economical way to completely clean motion picture film, microfilm and tape without mechanical scrubbing and wiping. Ultrasonic energy performs the entire cleaning operation.

- Restores clarity and sound to maximum quality.
- Enhances the entertainment value of motion picture film and improves commercials.
- Assures static free film with color balance undisturbed.
- Cuts projector maintenance costs... no dirt or dust carried into gates and orifices... less breakdowns.
- Completely automatic... requires only loading and unloading.



- Costs only 1/20 of a penny per running foot to operate.
- Used by every major motion picture lab in the world.

Descriptive brochure sent on request

Circle Item 29 on Tech Data Card

There has been a wealth of new equipment and new component parts appearing on the market in the last year. Much of this steady flow is due to the conversion to IC's, improved solid state components, advances in tube design and the availability of digital equipment. In recent months, the Democratic and Republican conventions were the testing grounds for some of the latest innovations.

**Philips Broadcast Equipment Corp.**, has acquired the rights to manufacture and market a hand-held wireless color television camera developed by **CBS Laboratories**. The camera, known as the Minicam Mark VI, uses a **General Electric** plumbicon pickup tube.

The Mark VI is the first broadcast camera to incorporate digital control techniques taken from com-

puter technology. Routine chores normally handled by the cameramen are taken care of by a remote station. Many of the internal checks and balances that keep technicians busy have been automated by computer control techniques.

The conventions also marked the first use of **Ampex's** "Scrambler" BC-100 hand-held wireless cameras. Color pictures were relayed to an American Broadcasting Company base station high above the convention floor. The conventions saw the first network uses of the **Ampex** VR-3000 portable videotape recorder. They were used by two networks.

The National Broadcasting Company put a new electronic titling system to work at the conventions. Supplied by **Visual Electronics Corp.**, the Visual Masterfile instantly produces titles and candi-

dates' names directly on the screen. NBC will use a smaller version of this system in the "Game of the Week" telecasts during the current season.

ABC and NBC introduced a new system for on-the-spot broadcasting. Developed and manufactured by **Cutler-Hammer's AIL** division, the Broadcast Radio Microphone weighs one pound, 10 ounces and provides full duplex operation at frequencies between 942 and 952 MHz.

Frequency modulation is used to minimize the effects of impulse interference and to provide broadcast-quality communication. The system allows communication without interference when as many as 50 channels are operating at the same time. Free-space range for the 200 milliwatt transmitter exceeds three miles.



Senator Charles Percy in a close-up shot during the debut of the Mark VI.



Edwin Newman, NBC newsman, ready for coverage with the AIL Radio Microphone.



# NEW PRODUCTS

For further information about any item, circle the associated number on the Tech Data Card.

## RCA Is Developing Laminated Transistors

RCA announced late in August that it has been experimenting with a lamination construction for transistors. These transistors may soon rival electron tubes in power output.

Although the technique is still in advanced laboratory development, one of the new transistors has already demonstrated its ability to handle 800 watts of RF. This is more than three times the power of many lower power standard broadcast radio stations. According to RCA executive vice president John B. Farese, considerably higher powers and frequencies are expected.

Designated as Laminated Transistors, the new units are formed on two separate silicon wafers, the emitter-base wafer and the base-collector wafer. The two silicon wafers are then fused or laminated under heat and pressure into a single monolithic structure.

The features of a sophisticated overlay structure, including ballast resistors to guard against secondary breakdown, are retained in the Laminated Transistor devices. After lamination, the entire wafer is hermetically sealed in glass. The individually hermetically sealed pellets are separated and can be mounted in non-hermetic packages.

Motorola's Consumer Products Division announced in July that it had developed a solid-state replacement for conventional tube-type high voltage rectifiers. This may lead to further solid-state invasion of the broadcast market, but at present this rectifier is best suited for high voltage TV receiver circuits.

## TV Headset

Six new lightweight TV special headsets for cameramen and commentators are now available from **Roanwell Corp.**, New York City. Each headset weighs less than 8½ ounces.

# THE DELTA TRIO

## for optimum monitoring of your antenna system



**1** Delta Model OIB-1 Operating Impedance Bridge measures "in circuit" impedance of networks, transmission lines and antennas while operating at full or reduced power. Accuracy:  $\pm 5\% \pm 1$  Ohm. Power Rating: 5kw with VSWR of 3:1.



**2** Delta Model CPB-1 Common Point Bridge measures common point resistance to  $\pm 2\% \pm 1$  Ohm, and reactance to  $\pm 5\% \pm 1$  Ohm operating at full power.



**3** Delta Model RG-1 Receiver/Generator, a combination signal generator with high output power, and receiver with excellent shielding and metering for use with Model OIB-1 or any other impedance bridge.

△ With this "Delta Trio", you can either "spot check", or continuously monitor actual "on-the-air" operating impedance of transmission lines, networks and antenna systems accurately to maintain a "clean signal" at peak operating efficiency.

△ If you're operating with a directional antenna, there's real value in being able to keep the radiating system in close adjustment at all times . . . continuously verify common point impedance to insure full power output . . . plus locating and correcting any antenna problems—fast!

△ Complete details and application data are available without obligation—just write or call Robert Foley—(703) 751-3133.

## DELTA ELECTRONICS



4206 Wheeler Avenue  
Alexandria, Virginia 22304 U.S.A.  
(703) 751-3133

Exclusive Export Distributor  
ROCKE INTERNATIONAL CORPORATION  
13 East 40th St., New York, N.Y. 10016 U.S.A.  
Cable: "ARLAB"

Circle Item 30 on Tech Data Card

## THE MODEL 7036 COMMUNICATIONS RECEIVER



The newest of the Comrex communication equipment line, the Model 7036 is designed for newsroom monitoring, for remote broadcast pick up and for STL applications. Solid state throughout for reliability, MOSFET mixers for high spurious rejection, CRYSTAL filter for adjacent channel protection, IC, i.f., audio and squelch stages make this the finest receiver of its type manufactured today. In addition to the many features included such as: balanced output for phone line or recorder use, squelch operated relay for recorder starting and built in monitor amplifier and speaker, we can supply almost any additional feature that you require. Standard frequency ranges are 25 to 58 MHz and 148 to 174 MHz, but we build the receiver on special order, for any frequency up to 2.5 GHz and with any bandwidth up to 300 KHz.

**COMREX**

P. O. Box 51 West Concord, Massachusetts 01781  
Area Code 617 369-6685  
Circle Item 31 on Tech Data Card

## STEREO STUDIO IN AN ATTACHÉ CASE



### A Six Channel Portable Mixer to Help You Get the Show on the Road

Now... a mixer for professional use that weighs only 25 pounds—in a case measuring 18" x 12 1/4" x 5 1/4"! Can be carried anywhere. Great for "remotes". An excellent standby system. Low price but no sacrifice in quality. Ideal for colleges.

## GATELY ELECTRONICS

57 WEST HILLCREST AVENUE  
HAVERTOWN, PENNA. 19083  
AREA CODE 215 • HI 6-1415  
...have you checked Gately lately?

See us at the AES Show—Booth 55  
Circle Item 32 on Tech Data Card



(60)

A new lightweight receiver named the RE-300 is housed in each ear cup. This receiver, an exclusive Roanwell design, weighs only 3/10ths of an ounce. The RE-300 delivers high output in a package that is 1/3rd the size and 1/10th the weight of comparable units on the market.

Background noises that interfere with communications in the studio and field are substantially reduced with Roanwell's noise-cancelling microphones. Two types are offered: the RN-1C carbon unit which cancels 18 dB of masking background noise and the Dynamic Microphone which reduces crowd noise by 15 dB.

Three of the TV special headsets are wired to monitor both program and director: Cameramen's Headsets Nos. 112200 and 112220 and Commentator's Headset No. 112210.

Standard features include: adjustable boom-mounted microphones; lightweight cordage; integral hand-operated switch with dummy load resistor; momentary or lock-in two-way conversation modes; Roanwell plugs that mate with standard camera jacks; and gray ear cups with black cushions and black headband.

### IC AGC/Squelch Amplifier

The first Communication IC now available is National Semiconductor Corp.'s LM270 Audio AGC/Squelch Amplifier. It is basically an operational amplifier, with gain control by a DC voltage, plus a



## WILL A SUBCONTRACTOR INSTALL YOUR TOWER?

We believe it's not enough to build towers of unequalled quality. Because even the best tower can fail, unless it is properly installed. That's why we maintain enough superbly equipped, high trained construction crews to install every tower we build. We'd rather do it ourselves. We also guarantee each tower to meet or exceed all EIA and other specifications under which the tower is purchased. Backed by product liability insurance.

For complete details on Towers and Accessories, contact:

## ADVANCE INDUSTRIES, Inc,

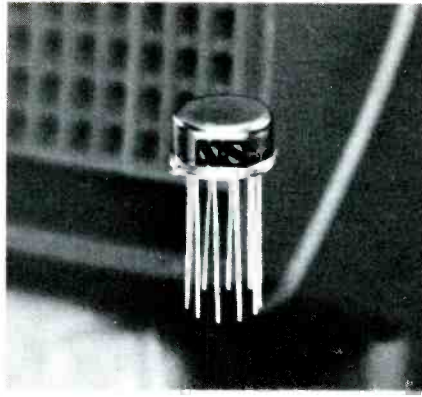
2301 BRIDGEPORT DRIVE  
SIOUX CITY, IOWA 51102  
PHONE (712) 943-5081  
Dept. BE468

Circle Item 33 on Tech Data Card



built-in sensitive squelch threshold detector. The ten pin circuit replaces entire sections of today's transmitters, receivers, or transceivers, and makes speech compression, VOX, receiver squelch, and other functions practical in even the simplest equipment. While the chip contains 36 junction devices (transistors and diodes), and 20 resistors, it is size, rather than complexity which determines an IC's cost.

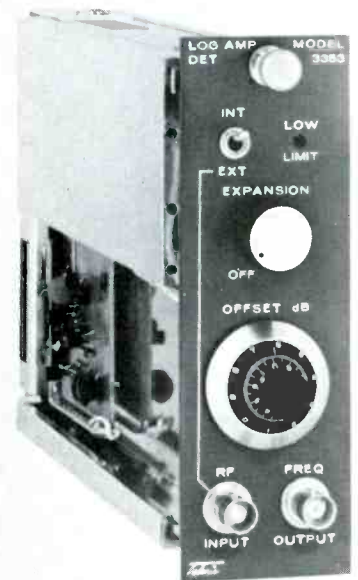
The LM270 consists of several separate functions designed to work together in a self-contained system



(61)

to produce control voltages for external use, or to respond to applied control signals. Heart of the circuit is a balanced series-shunt variable attenuator. Formed by the four transistors, it allows a large gain control range, with low distortion (for inputs less than 100 mV p-p), and it can be coupled directly to other parts of the system. This eliminates the transformer or capacitor coupling necessary with all other variable gain arrangements. From a twelve volt supply, the gain vs. control voltage relationship is a smooth curve. This gives a constant gain of +40 dB for control voltages between zero and +2 volts, and is effectively "shut-off" above +2.6 volts.

A separate subsystem within the LM270 is the squelch detector. Using the same input differential amplifier as the variable gain circuit, the high gain peak detector formed by Q20, Q36 and Q21 responds to very small inputs (as little as a millivolt, depending on setting of the external threshold pot), by rapidly discharging an external capacitor. In the absence of input signal, C (ext) charges above +2.6 volts, which, when tied to the gain control input, keeps the output amplifier "off". A momentary input peak above the threshold causes Q21 to rapidly discharge C (ext) below +2 volts, turning the amplifier full "on".



(62)

**Log Amplifier Detector**  
A new solid-state log amplifier

## Certified REPAIR/RECALIBRATION SERVICE

for

Nems-Clarke 120 Series and RCA/WX-2

### FIELD INTENSITY METERS

Traceable to NBS Stds • 2 Weeks Maximum Turnaround

Note: An independent service, not affiliated with equipment manufacturers

For complete information, write or call:



**POTOMAC INSTRUMENTS, inc.**

932 Philadelphia Ave. • Silver Spring, Md. 20910  
Phone (301) 589-3125

Circle Item 34 on Tech Data Card

## ANNOUNCING PUBLICATION OF THE WORLD'S FINEST MICROPHONE CATALOG.



What makes it the world's finest?  
Not simply its handsome design, lavish illustrations, and color reproduction—although they're all uniquely attractive. (The price is attractive, too. This catalog is yours free.)

What makes our catalog exceptional is its contents—a detailed description of every Neumann microphone and accessory—all of them unchallenged as the finest in the world.

Featured, of course, are the new Neumann FET microphones that provide you with all the benefits of advanced solid state electronics. Including much lower cost.

These are the same microphones that are now being used by virtually every one of the world's major sound and recording, film, and broadcast studios.

So, send for your catalog. The best things in life are free.

**GOTHAM**

AUDIO CORPORATION  
2 WEST 46 STREET, NEW YORK, N. Y. 10036  
In Canada: J-Mar Electronics Ltd

Send free 32-page catalog describing complete line of Neumann microphones and accessories.

Name \_\_\_\_\_

Company \_\_\_\_\_

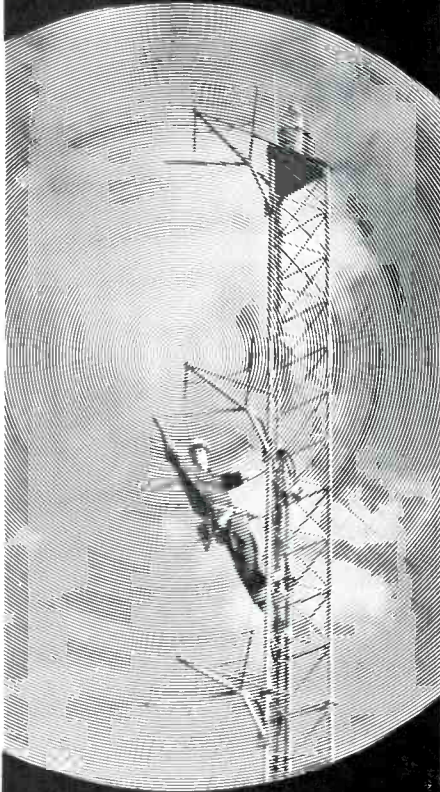
Address \_\_\_\_\_

City \_\_\_\_\_ State \_\_\_\_\_ Zip \_\_\_\_\_

Circle Item 35 on Tech Data Card

# JAMPRO

## RUNS CIRCLES AROUND FM ANTENNAS FOR BETTER RECEPTION



JAMPRO advanced technology has developed another industry "first"! A circularly polarized FM Antenna with variable horizontal to vertical gain ratios! Jampro will adjust the ratio to your exacting specifications for the best possible reception performance available—Reception to the outer fringes, and to more auto FM receivers, too.

EXCLUSIVE DIGITAL TUNING END STUBS allow lower VSWR on your tower (GUARANTEED under 1.1 to 1), and field trimming to 1.08 to 1,  $\pm$  200 KC.

AVAILABLE IN EITHER PARALLEL OR SHUNT FEED SYSTEMS.

Write for full specifications or make a circular motion on your phone dial—Call Jampro today. (916) 383-1177.

# JAMPRO

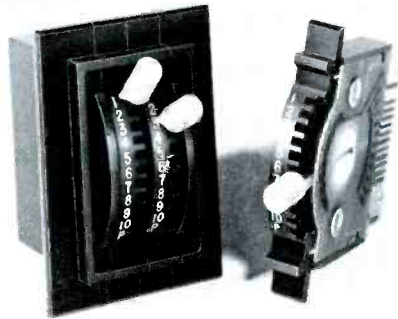
ANTENNA COMPANY  
A DIVISION OF COMPUTER EQUIPMENT CORP.  
6939 Power Inn Road  
Sacramento, California 95828

Circle Item 36 on Tech Data Card

detector with a wide dynamic range and expansion and offset controls for increasing resolution is now available from **Telonic Instruments Division of Telonic Industries, Inc.**

The new log amplifier, Model 3353, is a plug-in for the Telonic 2003 Sweep/Signal Generator System. Accepting a swept RF signal, the 3353 converts it to a detected, linear DC output, providing a convenient means of testing circuits with wide dynamic ranges.

Operating over a frequency range of 400 KHz to 130 MHz at a 50-ohm input impedance, the new log amp develops its required gain in a precise, logarithmic ratio permitting a linear display of the total RF response of the device under test. The output can be used to drive an oscilloscope, voltmeter or graphic recorder, providing a reading in dB that can be easily converted to dBm.



(63)

### Modular Slide Switch

In order to provide a compact, modular switch with expandable design and a built-in "skip" function, the **Programming Devices Division of Seaelectro Corp.** has developed Slide 'n Switch—a new 11-position, single-pole unit which is guaranteed for a minimum of 250,000 operations.

The new Slide 'n Switch circuit selector is designed to provide a highly reliable, random access switching device for use in programming a variety of automated equipment. Units can go from one given position to any other given position without making any contact with intermediate positions. Multiple units may be stacked side-by-side to provide any number of decade switches. Output terminations mate with standard edge-mount PC card connectors.

Slide 'n Switch units may be mounted from either the front or rear of a panel or by means of con-

# SPOTMASTER

The all solid state AD1A

## AUDIO DISTRIBUTION AMPLIFIER



Meet the AD1A, a solid state audio distribution amplifier specifically designed for AM, FM and TV broadcast stations and recording studios. The AD1A distributes audio signals via five separate output channels (up to 25 with the addition of AD1A-X extenders), and incorporates a front-panel VU meter and monitor jack to permit visual and aural monitoring of the incoming signal at the output of the line amplifier. Response is essentially flat from 40 to 20,000 Hz, with low distortion and noise, 60 db channel isolation and 12 db peak factor. For further information, write or call today:

*Spotmaster*

**BROADCAST ELECTRONICS, INC.**

8810 Brookville Road  
Silver Spring, Maryland 20910  
Area Code 301 • 588-4983

## MODEL CR-90 CARTRIDGE RACK



- Holds 90 Cartridges
- Attractive Walnut-Formica Finish
- Large Openings for Easy Cartridge Removal
- Rugged Interlocking Construction
- Compact 22 x 28 x 4
- Net Price \$35.

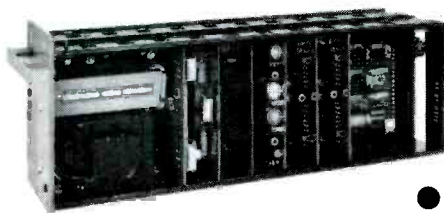
**Broadcast Products Co., Inc.**

3814 Everett St., Kensington, Md. 20795  
(301) 933-3400

Circle Item 37 on Tech Data Card



# FINALLY A CHROMA KEYER THAT REALLY WORKS



- DC REMOTE CONTROL FOR CHROMA
- USES R, G AND B SIGNALS FROM COLOR CAMERA
- OPERATES WITH EITHER NTSC, PAL OR SECAM SYSTEMS

The new CD Chroma Keyer Model 2110 has been designed to operate with any professional quality special effects generator. Remote selection of keying hue through 360°, continuously variable. The 2110 keys on the chrominance portion of the color signal and distinguishes between the insert and the background where luminance levels are similar as to both the hue and saturation. RESULT . . . clear and sharp keying with tearing virtually eliminated. Adequate separation is also obtained between areas of the same hue but with different saturation levels.

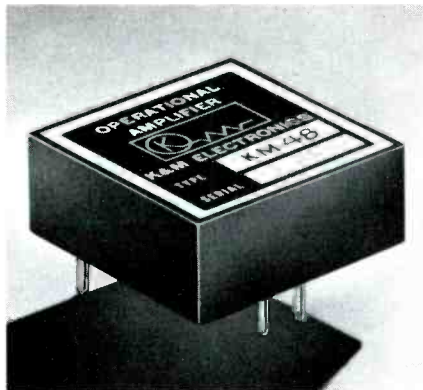
Solid state, plug-in module with built-in power supply. Installation kit, mating control connector and remote hue control ready for simple and quick integration into your existing system.

The price is so low for a Chroma Keyer of this quality that it simply cannot be duplicated by any other manufacturer. For further information, write or call!

**CENTRAL DYNAMICS CORPORATION**

Cherry Hill Industrial Center  
Cherry Hill, New Jersey 08034  
Tel. 609 • 424-3900 TWX 710 • 896-0385

venient "through-hole" mounts in the switch.



(64)

### FET Amplifier

A new high speed differential FET operational amplifier has been announced by **K&M Electronics Corp.** The KM-48, utilizing field effect transistors, exhibits typical full power output of 150 KHz and minimum output of 100 KHz. It is a useful combination of higher speed, economy and the features of high quality FET devices.

This new operational amplifier is highly useful for analog-to-digital and digital-to-analog converters, buffer amplifiers and integrators as well as other instrument and control applications.

The KM-48, a faster version of the KM-47C operational amplifier introduced earlier this year, has the following specifications:

**Gain:** 200,000 (min.). **Output:** ±12 volts at 5 milliamps. **Slew Rate:** 3 volts/microsecond. **Common Mode Rejection:** 10,000. **Common Mode Voltage:** ±10 volts (max.). **Stability:** 40 microvolts/degree C. **Dimensions:** 1.12" x 1.12" x 0.4". **Weight:** 0.6 oz (17 grams).

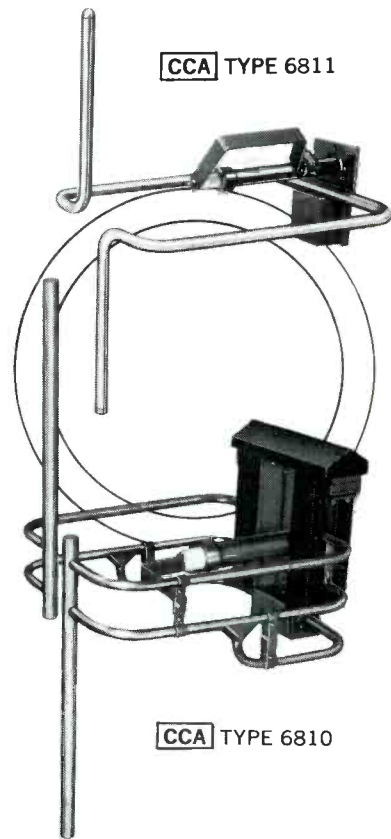
### Video Switcher

A new broadcast video switcher, Model TPS-12X3, has been developed by **TeleMation, Inc.**, Salt Lake City. Besides incorporating many innovations over other available broadcast switchers, the unit is packaged and priced for the closed-circuit user as well.

Each of the twelve inputs is supplied with synchronous/non-synchronous selection switches. All inputs are bridging and provided with looping jacks and termination switches. Input-to-input crosstalk is better than 60 dB. Video outputs include Mix A and Mix B buses, preview bus, and program and preview amplifiers, all 75-ohm termi-

## COMPARE... YOU'LL BUY a CCA FM Circularly Polarized Antenna

CCA TYPE 6811



CCA TYPE 6810

Only CCA offers a choice between a medium power (Type 6811) or high power antenna (Type 6810). Thus broadcasters can economically select the best combination for their situation. Both antennas are rugged, broadband, and have excellent electrical properties. They're presently in service in

all environments with exceptional results. Contact CCA and we'll provide you with technical data and a list of users.



**CCA Electronics Corp.**  
716 Jersey Avenue  
Gloucester City, N. J. 08030  
Telephone: (609) 456-1716

# BROADCAST COMMUNICATIONS COMPONENTS AND CAPABILITY



**STYROFLEX® COAXIAL CABLE** Leads the line of PDE semiflexible air dielectric cables. Available in 50, 70, 75, 100 ohm impedances; 1/2", 3/8", 1 1/8", 3 1/8", 6 1/8" diameters.



**SPIRAFIL® II COAXIAL CABLE** A significant design breakthrough! Solid polyethylene helix completely covers copper center conductor. Write for complete data.

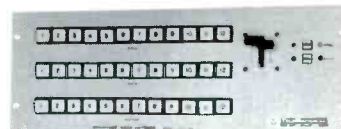
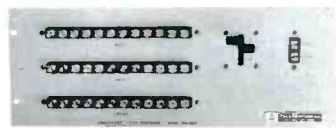


**FOAMFLEX COAXIAL CABLE** Lightweight, low-loss cable created for all general applications including Broadcast, CATV, Military and Aerospace Requirements and RF transmission applications. 50, 70, 75, 100 ohms; 1/4", 3/8", .412", 1/2", 3/4", 1 1/8".



**RIGID LINE** Latest development provides extremely low loss, high power capability and excellent VSWR. 50 and 75 ohms; 7/8", 1 1/8", 3 1/8", 6 1/8".

nated. Each bus produces an extra 75-ohm output for pre-selecting video or key inputs to a special effects generator. Complete video processing is included in both program and preview amplifiers. Each processor includes pedestal, video level and sync level controls.



(65)

Solid state crosspoints are used in the TPS-12X3, each containing three switching devices for "three-way kill" of the video signal when it is turned off. These 36 crosspoints, along with 12 crosspoint drivers and three output amplifiers, are mounted on a single circuit board.

Integrated circuits perform all control and logic functions through pulses derived from standard EIA vertical and horizontal drives. The same logic elements control the SCR's used to operate pushbutton and tally lights. A split-arm fader is included, providing smooth fades and supers. Both standard and Clare-Pendar switches are available.

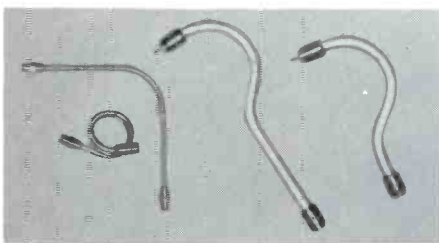
### Microwave Oscillator

New portable test set for microwave systems checkout features **International Microwave Corp.'s** recently introduced Precision Series microwave diode oscillator. A high-resolution frequency readout is coupled to a zero-backlash, wear-compensated mechanical tuner for maximum setting accuracy and operator convenience. Frequency accuracy is maintained over full range of field temperatures without use of heaters or ovens. Internal isolator reduces effects of load changes. Options: external modulation; pulse or square wave internal modulation; level-set attenuator; battery-charging circuit. Self-contained Ni-Cad (rechargeable) battery pack provides more than 300 hours of operation.

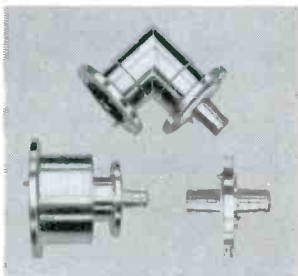
**Operating frequency:** User-specified, in range from 2 to 20 GHz, depending upon oscillator type, output power.



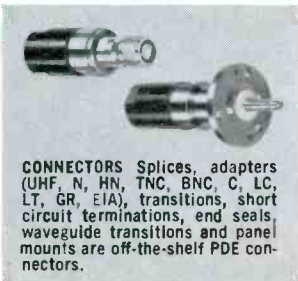
**COAXIAL CABLE DELAY LINES** coaxial cables shaped into custom configurations have outstanding performance. Tolerance of delay accuracy is within  $\pm .02$  nanoseconds. Frequencies from 60 cps to 12 KMC. impedances of 50, 70, 75, 100.



**CABLE ASSEMBLIES** In addition to furnishing coaxial cables in 1000-foot lengths or cut to length, bending cables, into sophisticated configurations to allow termination-to-termination use is an exclusive capability. Radii as tight as 3 diameters, no minimum straight length between bends, and certified electrical performance offers a custom assembly to fit the tightest specifications.



**RIGID LINE COMPONENTS** Produced to the highest standards of precision by Communication Products Company, Division of Phelps Dodge Electronics. A wide variety is available off-the-shelf.



**CONNECTORS** Splices, adapters (UHF, N, HN, TNC, BNC, C, LC, LT, GR, EIA), transitions, short circuit terminations, end seals, waveguide transitions and panel mounts are off-the-shelf PDE connectors.

**ACCESSORIES** Pressure gages, valves, locating caps, plugs, tees, hangers and tools are performance-matched to PDE coaxial cables.

**TOTAL CAPABILITY** The entire broadcasting frequency spectrum is serviced by PDE with cables, connectors, rigid lines, and all necessary accessories for installation and maintenance of coaxial cable installations. Request new Bulletin BR-1.



**PHELPS DODGE** ELECTRONIC PRODUCTS  
NORTH HAVEN, CONNECTICUT

Circle Item 38 on Tech Data Card





(66)

## PEOPLE IN THE NEWS

**McGeorge Bundy**, president of the Ford Foundation, New York, and former advisor on foreign affairs and defense policy to the late President Kennedy and President

Johnson, will deliver the keynote address Nov. 20 at the 44th annual convention of the National Association of Educational Broadcasters. The meeting, expected to draw over 4,000 educational broadcasters and representatives from allied industries, will be held at the Sheraton Park Hotel in Washington, D.C., Nov. 19-22.

Bundy left the Johnson administration in 1966 to take the position at the Ford Foundation which he now holds. He was appointed Special Assistant to the President for National Security Affairs by President-elect Kennedy in 1960.

In announcing Bundy's participation in the forthcoming NAEB convention, association president William G. Harley said, "Probably no man had a greater stake in the future development of educational broadcasting than the head of the Ford Foundation. We feel it is especially fitting that Mr. Bundy speak in person to those who were directly involved in seeing to it that the investment that the foundation has made yield the highest possible return."

## Satisfaction Guaranteed!



Professional Head Replacements for Ampex, Magnecord  
Write for details

### MINNEAPOLIS MAGNETICS, INC.

2915 Huntington Avenue • Minneapolis, Minnesota 55416

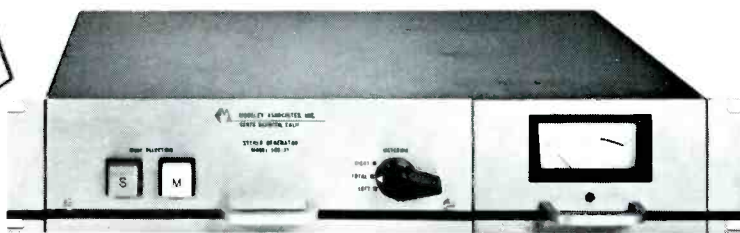
Circle Item 39 on Tech Data Card

## YOUR STEREO SIGNAL ON A *SINGLE* STL\*

ONLY *Moseley* OFFERS IT . . .

SCG-3T  
STEREO  
GEN.

NEW



PCL 303/C  
COMPOSITE  
STL

The sounds of pure stereo — and profits — are dependably yours when you use the solid-state STEREO MATES in place of leased program lines. No longer is the conventional two-link stereo STL always needed. Deliveries are now well underway on the PCL-303/C single-link stereo STL and the SCG-3T Stereo Generator. They're available mated or singly, even with remote control. Contact our Marketing Manager for full details.

\* Stereo Mates — SCG-3T (shown above) and PCL-303/C



MOSELEY ASSOCIATES, INC.

SANTA BARBARA RESEARCH PARK

111 CASTILIAN DRIVE  
GOLETA, CALIFORNIA 93017  
(805) 968-9621

Circle Item 40 on Tech Data Card

**Thomas E. Rogeberg**, has been appointed director of operations for the Educational Television Stations Program Service (ETS/PS). Prior to joining ETS/PS, Rogeberg was program supervisor for educational television station WHA-TV in Madison, Wis.

Rogeberg will supervise all technical and distribution operations. According to David Leonard, executive director of ETS/PS, this will include technical evaluation and duplication of some 300 new programs added to the Service each year as well as distribution of over 23,000 programs to some 140 educational television stations.

**Gordon Haughan**, coordinator of instructional television for educational television stations WMVS/WMVT, Milwaukee, has been appointed western representative for the National Center For School and College Television (NCSCT). Haughan will direct NCSCT's activities in the western United States.

As coordinator of instructional television at WMVS/WMVT, Haughan was responsible for the development and evaluation of in-school programming, programming

of a UHF channel with adult education material, coordinating closed-circuit programming, presenting utilization seminars and preparing a monthly ITV newsletter.



**Theodore R. Conant** has joined CBS Laboratories as coordinator of instructional systems. Conant will coordinate multi-media communications technology and related educational software programs to in-

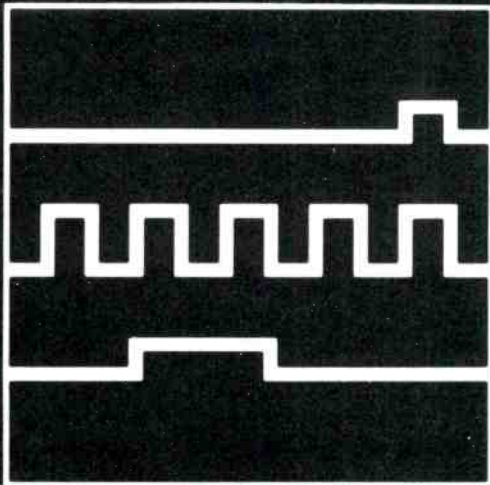
sure the most effective match between these efforts and the interests of the educational community.

Conant formerly was director of special educational services for the WGBH Educational Foundation, Boston, Mass., and was associated with Harvard University's Graduate School of Education.

As head of the United Nations Film and Television Unit, he supervised the coverage of the Korean War, including the armistice, prisoner exchange and reconstruction activities. He has produced many radio and television programs on the work of UNESCO, the UN and voluntary agencies in Korea, Japan, and India.

**Robert B. Kilborn, Jr.** has been appointed information specialist for WPSX-TV, Penn State Television. The educational television station is in the Division of Broadcasting of Continuing Education at Pennsylvania State University.

Kilborn formerly was a sports writer with the Lancaster, Pa. **Intelligencer Journal**. He was sports director of WDFM, the Penn State student radio station, as an undergraduate.



## DIGILOGIC

Discover how digital computer techniques have revolutionized television broadcast equipment.

From:



**SARKES TARZIAN SYSTEMS**

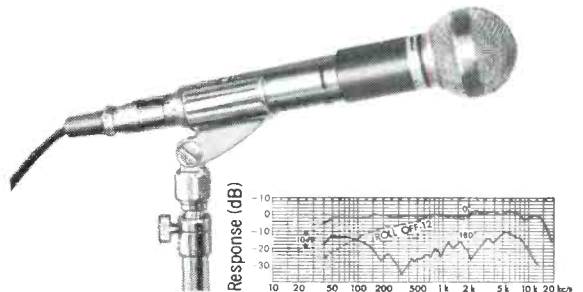
Bloomington, Indiana

Circle Item 41 on Tech Data Card

# Primo

## New!! UD-900

UNI-DIRECTIONAL MICROPHONE  
(with tone control)



### SPECIFICATIONS:

- Cartridge ..... DM-49
- Impedance ..... 600 ohms
- Sensitivity .....  $-73\text{db} \pm 2\text{db}/\mu\text{ bar}$
- Frequency Response ..... 50 to 15000Hz  $\pm 5\text{db}$
- Dimensions ..... 50mm dia, 250 Length

\* For further information please write to

## PRIMO COMPANY LTD.

Head Office: 25-1, 6-chome, Mure, Mitakashi, Tokyo, Japan Tel. 0422-43-3121~7

Cable: "Primo Musashino Mitaka" Telex: 2822-326 PRIMO MUS

Chicago Illinois Office: A.P.T. No.204, 530 W. Surf. St., Chicago Illinois 60657.

U.S.A. Tel. 312-472-61421 Telex: 25-4225 PRIMO MUS CGOILLUSA

Circle Item 42 on Tech Data Card





**Edward Galuska** has been appointed director of the newly-created Microwave Div. of Chester Electronic Laboratories, Inc. He will be responsible for production and all future sales and services of Chester microwave components and systems.

Galuska joins Chester from the Educational Technology Div. of Litton Industries. Previously he was director of operations at WTVU, Scranton, Pa., and he had worked with the Federal Telecommunications Labs. For over 25 years Galuska has served the radio and television broadcast field, including extensive development work in the

area of studio equipment.

**Michael S. Kievman** has joined Cox Broadcasting Corp. as coordinator of programming for the CBC Broadcasting Division. He will work with general managers, programming and production managers of all CBC stations in the areas of feature films, syndicated film packages, interchange and syndication of CBC station productions and industry programming matters.

Kievman has been vice president in charge of corporate television programming for AVCO Broadcasting Corp. in Cincinnati. He has served as general sales manager of WLWD-TV, Dayton, Ohio, Midwestern sales manager of Warner Brothers syndicated division, and division sales manager of Ziv-United Artists.

He has been program and production manager on the local station level. During his military service, Kievman was attached to special services where he directed and produced plays and television programs.

**Phyllis Abbound** has been appointed to head the new Chicago office of Acme Film & Videotape

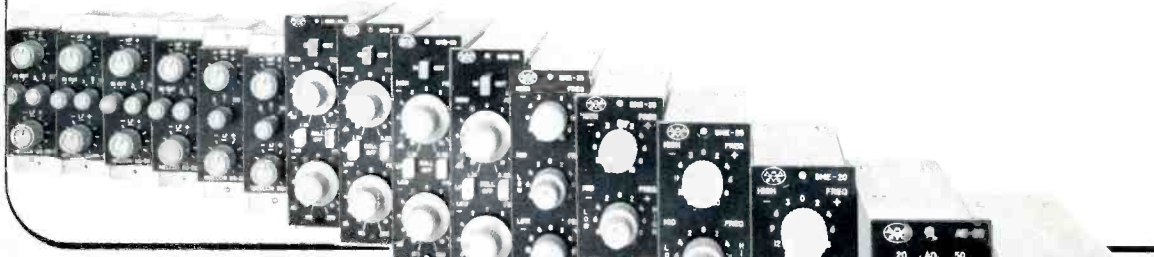
Laboratories. She has become Midwest Account Supervisor, and will be servicing stations, networks, agencies, producers, educators, hospitals, and industrial users of tape and film.

She is well known in the broadcasting field, having worked for KNRT in Des Moines for several years. For the past two years, she has been sales supervisor at WTTW Recording Services in Chicago.

**Dr. Ray Dolby**, president of Dolby Laboratories and inventor of the Dolby A301 Audio Noise Reduction System, was a recent guest of the VNIIRT. He visited the Moscow studios of this Russian state agency for radio and television.

The VNIIRT has purchased a Dolby A301 unit for evaluation and consideration for use of the Dolby System in a tape exchange program among their 800 stations throughout the Soviet Union. Adoption of this system by the VNIIRT would enable stations equipped with A301 units to interchange and copy tapes without adding increments of noise to the tapes, which is the usual consequence of making successive tape copies.

## the growing line of Melcor Equalizers



Melcor Electronics manufactures an extensive line of Audio Products for the Professional user. Standard Active Lossless Audio Equalizers currently available feature continuous equalization control; stepped equalization; shelf or gaussian frequency response; independent multiple frequency ranges; balanced and or unbalanced input and output connections; high and low level input and output signal capability; bridging or terminated inputs. All units have ultra low noise and negligible distortion. New units featuring sharp bandpass filtering are in development.

### AVAILABLE FROM STOCK

- |   |   |
|---|---|
| <b>AE-20</b> Amplifier Equalizer                        | <b>GME-20</b> Graphic type Module Equalizer |
| <b>SME-20</b> Shelf type Module Equalizer               | <b>EQ-20</b> Active Program Equalizer       |
| <b>GE-20</b> Graphic Equalizer — Rack Mount (not shown) |   |

Write for descriptive literature on our lossless Equalizers

### MELCOR ELECTRONICS CORPORATION

AMPLIFIERS FOR INDUSTRY

1750 NEW HIGHWAY, FARMINGDALE, LONG ISLAND, NEW YORK 516 Myrtle 4-5570

Circle Item 43 on Tech Data Card





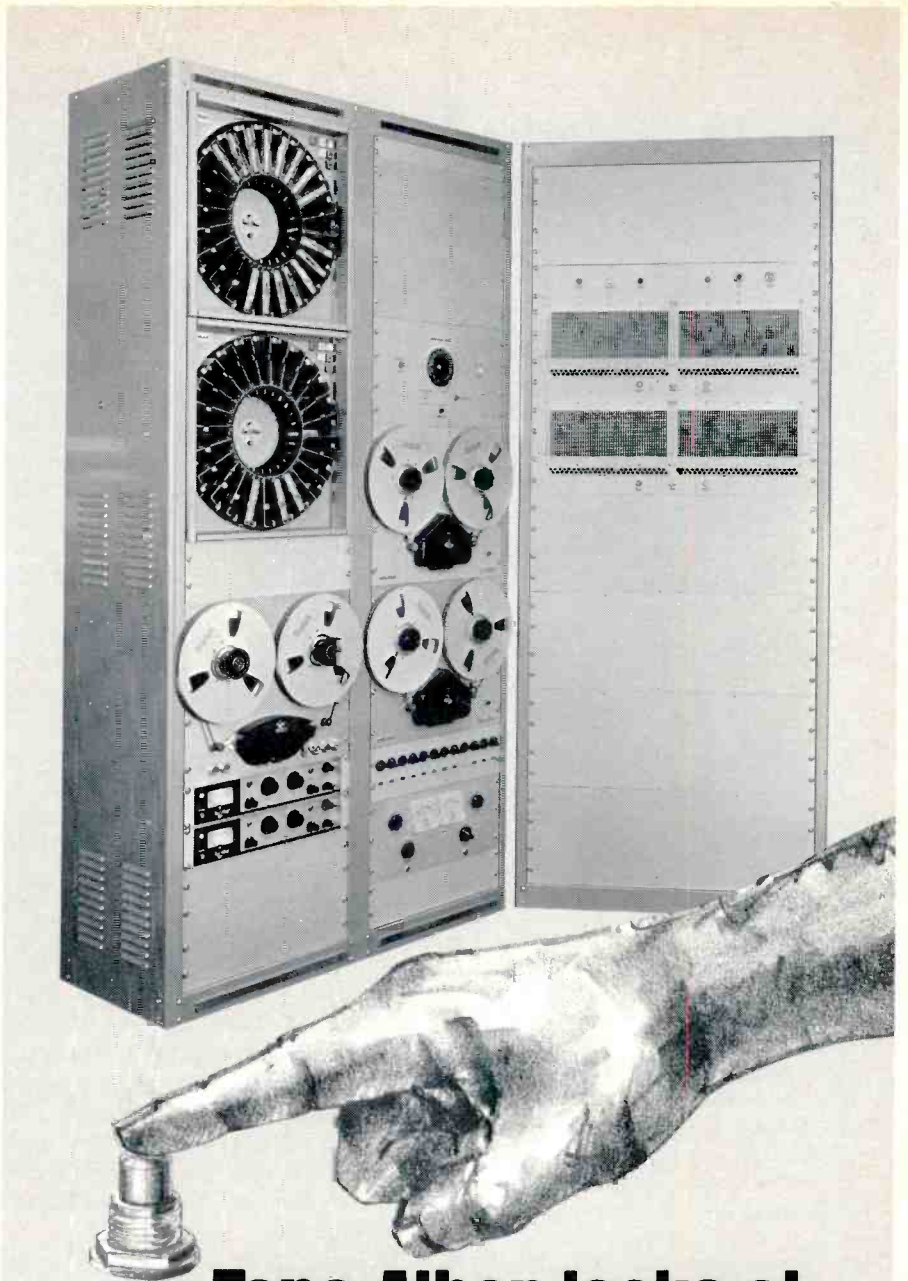
**Dr. Robert D. Huntoon** has retired from the National Bureau of Standards, U. S. Department of Commerce. When he joined the staff in 1941, he played a key role in the development of proximity fuses. His most recent position was chief of the office of program development and evaluation.



The Vladimir K. Zworykin Award was given to **Dr. Kurt Schlesinger**, a consulting engineer with General Electric's Pickup Tube Operation. Schlesinger was honored during the Western Electronics Show and Convention (WESCON) held in Los Angeles.

The award, named after one of the foremost contributors to the television art, was established in 1952 and is given annually to an IEEE member for outstanding technical contributions in the area of electronic television.

Schlesinger is cited by the IEEE for his "sustained and pioneering contributions to television circuitry and electron optical devices." He



## Tape-Athon looks at the human factor in station automation

In the final analysis, all that's required to start a Tape-Athon Model 5000 Automatic Broadcasting System operating is a finger — to push the "ON" button. But, we realize the user must also get involved prior to start-up and have, therefore, designed the 5000 with his (or her) comfort in mind.

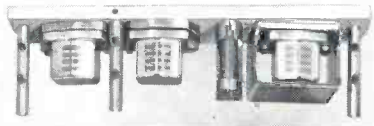
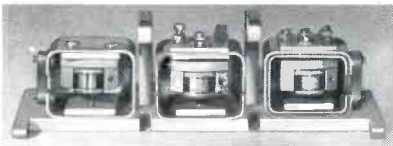
**Programming** usually a complex endeavor, has been reduced to a menial task of simply setting a switch bank to correspond with the program format. **Reel changing** has been made foolproof by Tape-Athon's exclusive one-hand reel lock and quick threading system. **Timing** for daily or weekly operation is set by merely punching a timer clock, which will start and stop the system automatically — so now you don't even need the finger any more.

A NEW BROCHURE PROVIDING DETAILS AND SPECIFICATIONS ON THE 5000 IS AVAILABLE ON REQUEST.

**Tape-Athon** 523 S. Hindry, Inglewood, Calif. 90307 • 213-678-5445



## IMPROVED PERFORMANCE!



# NORTRONICS ANNOUNCES THE 9000 SERIES TAPE HEADS FOR PROFESSIONAL and STUDIO EQUIPMENT

### UNEXCELLED PERFORMANCE IN AMPEX, SCULLY AND OTHER PROFESSIONAL RECORDERS

- Extremely smooth response from 20 Hz to 20 KHz.
- Extra wide pole faces for minimum low frequency contour effects.
- Hi-Q, low loss core structures.
- Extra deep deposited quartz gaps for sharp, clean edge definition.
- Full gap depth for maximum wear life.
- All metal hyperbolic face for reduced oxide loading and intimate tape contact.
- Gap Colinearity—Precise Gap Alignment For Both Azimuth and Phase on Multi-Track Heads, either 4-Channel or 8-Channel.

### MORE CONVENIENT THAN FACTORY REPLACEMENT

- Available locally, from your distributor.
- Replace heads in the field, minimum down time. Plug-in simplicity. No need for a spare nest.
- Wide choice of Record, Play, and Erase Heads, for 1/4 inch, 1/2 inch, and 1 inch tape, in a variety of track styles.
- Full details in Nortronics Bulletin 7295A, available free on request.



8101 Tenth Avenue North  
Minneapolis, Minnesota 55427  
Phone: (612) 545-0401  
Circle Item 45 on Tech Data Card

holds more than 200 U. S. patents and is the author of more than 40 technical papers. It has been said that his contributions to television mark him as an important theorist as well as a highly skilled experimentalist.

**Arthur Rescher**, Byron Motion Pictures, Washington, D.C., has been appointed arrangements chairman for the 104th Technical Conference of the Society of Motion Picture and Television Engineers. The appointment was announced by SMPTE conference vice-president E. B. McGreal, Producers Service Co., Glendale, Calif. The 104th SMPTE Conference is set for the Washington Hilton in Washington, D.C., Nov. 10-15.

**Robert E. Henabery** has been appointed director of development for the ABC owned radio stations, according to Harold L. Neal, Jr., president of the division. Henabery will work closely with ABC's seven AM and seven FM radio stations in New York, Pittsburgh, Detroit, Chicago, Houston, San Francisco and Los Angeles.

Henabery's previous positions include director of programs, WRKO and WRKO-FM, Boston; executive producer, WCBS, New York; and program and production manager, WWJ, Detroit.

**Gay C. Kleykamp**, a pioneer of cable TV electronic design, has been named director of market-engineering for Ameco, Inc., of Phoenix, Arizona.

Before joining Ameco, Kleykamp was director of technical sales for Kaiser CATV, Phoenix. He also served as marketing manager for Kaiser Aerospace & Electronics Corp.

**Sam Street**, former director of field services for the National Cable Television Association, has resigned to form S. S. Street & Associates, Inc. financial, brokerage and management consultants to the cable communications industry.

Before joining the NCTA two years ago, Street was director of marketing for Vikoa, Inc., CATV manufacturer and system owner. He entered the CATV field as advertising manager for Telesystems Corp.

While at NCTA, Street developed promotional and management packages and programs in use today by member systems throughout the na-

One of a series of brief discussions  
by Electro-Voice engineers



## TESTING, 1, 2, 3, 4

WILLIAM RAVENTOS  
Field Engineer

Testing of microphones ordinarily takes two distinct forms: laboratory tests and field tests. The former is basically objective in nature and results in performance specifications, while the latter provides a subjective evaluation of the microphone under actual use conditions. Both forms of testing are valuable, but on occasion the field results do not seem to fully support the laboratory tests.

The difference, of course, lies in the "idealized" conditions that consistently form the basis for laboratory tests. No such uniformity exists in the field, yet the need for correlation between specifications and actual performance is increasingly felt.

In order to more thoroughly explore the causes for deviation from laboratory response, Electro-Voice has undergone a series of tests of varying types of microphones using its large anechoic chamber as a research tool. To date the investigation has concentrated on effective polar response, effects of distance on frequency response, and the results of multiple inphase and out-of-phase microphone pickups. While the studies have just begun, causes of several common problems have been pinpointed.

Polar response was investigated by rotating the microphone in the anechoic chamber, while speaking at constant volume. This test pointed up the necessity for uniform response off-axis as well as on-axis. With microphones such as the Model RE15, level changed with rotation of the microphone, but voice quality (hence frequency response) remained constant. However with directional microphones that did not offer uniform off-axis response, sound quality quickly became unacceptable. Using such a microphone to reduce unwanted pickup to reasonable levels can alter the tonal character of the unwanted sound, as well as distort the apparent acoustical characteristics of the studio or hall.

It was also noted that many omni-directional microphones exhibited directional characteristics that were quite audible at an angle as small as 80° off axis. This proved to result from interference of the microphone case, and was directly related to increasing case diameter.

In another series of tests, the effect of distance on frequency response and articulation was investigated. A male voice was recorded at distances from 2' to 25' in the anechoic chamber. Levels were then equalized, and tonal quality and articulation was compared. No significant difference could be noted as distance increased. It is evident that the "loss" of highs with distance is not due to reduction in actual intensity. Rather the changing phase relationships determined by environment acoustics has an increasing effect with rising frequency. This is interpreted subjectively as a loss of intensity.

Further tests of this type will be discussed in future columns, and suggestions for other areas of investigation are welcome.

For reprints of other discussions in this series,  
or technical data on any E-V product, write:  
ELECTRO-VOICE, INC., Dept. 1083V  
638 Cecil St., Buchanan, Michigan 49107



Circle Item 46 on Tech Data Card

BROADCAST ENGINEERING

tion. He also developed, promoted, and directed the First Annual Cablecasting Seminar for CATV system owners, and the 17th Annual NCTA Convention held last July in Boston.

### Kaiser Makes Appointments

The Oakland headquarters of the Kaiser Broadcasting Corp. has announced appointments to the staffs of several TV stations. Two news manager additions are **Allan Todd**, with WKBD-TV, Detroit and **James Thistle**, with WKBG-TV, Boston. WKBD also has promoted **Barry K. DeChant** to news assignment editor.

**Sherman Bazell** will be the news manager for KBHK-TV San Francisco. **John Herrington** and **Robert Railford** have been appointed news anchormen. Railford will work at WKBS-TV, Philadelphia and Herrington at WKBF-TV, Cleveland. **Alan DePreto** and **Gerald Warner** also will be working for Kaiser's Cleveland station. DePreto will be a reporter and Warner will be the senior news editor.

In addition, there have been appointments to the business staffs of several Kaiser stations. **William Rambo**, **David Carrington**, and **Peter S. Crawford** are new account executives. Both Rambo and Carrington will be with KBHK-TV, San Francisco, and Crawford will be with WJIB, Boston.

WKBS-TV, Philadelphia, has appointed **Thomas C. Peterson** as sales manager and **H. Lawrence "Larry" Cooper** as special assistant to the general manager.

**James D. Boaz** has been promoted to general sales manager/assistant general manager at WKBF-TV, Cleveland. WKBD, Detroit has promoted **Alan S. Feuer** to local sales manager and **R. King Patterson** to sales manager.

**Richard D. Buckley**, president of WDRG AM/FM, has announced the appointment of **George W. Watson** as chief engineer of the Hartford radio stations. Watson has been with the stations for two and one half years, serving in various capacities, including assistant chief engineer.

Prior to joining WDRG, he worked with the engineering department of Synchron Corp., Wallingford, Conn. He began his career in the radio industry at WHTT working with remote broadcast and special recordings.

# TECHNICAL DATA

## 90. AIRCO SPEER ELECTRONIC COMPONENTS—

A catalog describing the new Jeffers JC series of low-cost industrial precision resistors is available. Standard styles

range from .15 to .75 watts at 85° C. Another catalog gives details on the PEC line of hot molded variable composition resistors.

**91. ALCO ELECTRONIC PRODUCTS, INC.**—Catalog K-688 offers a description of hand-crafted aluminum control knobs.

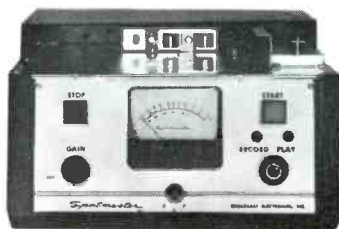
**92. ALLIED ELECTRONICS**—The Industrial Electronics Catalog for 1969 is available.

**93. AMPEREX RESEARCH CORP.**—A new brochure offers listings of semiconductors presently available in the mi-

The Spotlight Is on

# Spotmaster

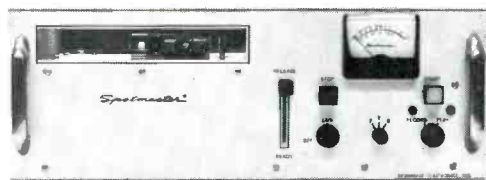
## Superior Tape Cartridge Recording and Playback Equipment



Model 500 C



Model 400 A



Model 500 CR

**COMPACT 500 C SERIES**—Completely solid state, handsome 500 C equipment features functional styling and ease of operation, modular design, choice of 1, 2, or 3 automatic electronic cueing tones, automatic record pre-set, separate record and play heads, A-B monitoring, biased cue recording, triple zener controlled power supply, transformer output . . . adding up to pushbutton broadcasting at its finest. Specs and performance equal or exceed NAB standards. Record-play and playback-only models are available.

**RACK-MOUNTED 500 C MODELS**—The 500 CR rack models offer the same Model C design and performance features and are equipped with chassis slides ready to mount in your rack. Each unit slides out for easy head and capstan cleaning and other routine maintenance.

All 500 C models carry iron-clad full-year guarantees.

**ECONOMICAL 400 A SERIES**—Now even the smallest stations can enjoy Spotmaster dependability with the low-cost, all solid state 400 A series, available in compact record-play and playback-only models. Performance and specifications are second only to the 500 C series.

For complete details about these and other Spotmaster cartridge units (stereo, delayed-programming and multiple-cartridge models, too), write, wire or call today. Remember, Broadcast Electronics is the No. 1 designer/producer of broadcast quality cartridge tape equipment. . . worldwide!

## BROADCAST ELECTRONICS, INC.

8810 Brookville Road, Silver Spring, Maryland 20910; Area Code 301, 588-4983





# COLOR THE NEWS



ON THE  
AIR IN  
**30**  
MINUTES

## SMALLEST! LOWEST PRICED! EKTACHROME PROCESSOR

Add the impact of vivid color to local news coverage. Shoot in economical Super-8mm or 16mm Ektachrome. Develop 20 feet per minute in the fully-automatic Houston E-16-8-30 processor. All processing cycles are precisely timed and temperatures rigidly controlled to assure perfect results. Simple, goof-proof operation. Solutions never touch hands. Standard Kodak chemicals. About 8 ft. long. Fits anywhere. Use in lighted room. Finest Houston quality. Priced far lower than any comparable machine. Send for brochure.

# HOUSTON

PHOTO PRODUCTS, INC.  
THE WORLD KNOWS OUR PRODUCT

HOUSTON PHOTO PRODUCTS, INC.

655 E. 20th St.  
Yuma, Arizona 85364  
Phone: (602) 782-3677

*A Tradition of  
Excellence since 1932*

chrominiature LID package with primary electrical characteristics. The brochure also provides an interchangeability chart showing the LID replacement for discrete semiconductor types that they functionally replace.

94. **AMPEX CORP.**—A data sheet lists features and specifications of the model AA-620 audio amplifier/speaker system, and another data sheet gives specifications for the model AA-80 power amplifier.
95. **BELDEN CORP.**—A catalog describes a newly-expanded line of Teflon-insulated wire and cable. Details are given on basic specifications and accessory information for the company's Teflon-insulated products.
96. **BISHOP INDUSTRIES CORP.**—A flyer called "New Ideas From Bishop" provides a selection guide for transistor mounting configuration, and a checklist to aid in the selection of terminal area pads.
97. **BOGEN COMMUNICATIONS DIV., LEAR SIEGLER, INC.**—Catalog 208 provides descriptions and technical specifications for amplifiers, preamplifiers, booster amplifiers, microphones, loudspeakers, and accessories.
98. **COHU**—Data sheet 6-381 describes a self-contained TV camera series that may be used for closed-circuit, educational or broadcasting purposes.
99. **COMPUTER DIODE CORP.**—A technical bulletin is offered that gives details on the LD-107 series of logarithmic diode converters for analog computation, network shaping and function generation.
- 100 **ELECTRONIC DEVICES, INC.**—A new Product Review Catalog provides an illustrated short form reference to a line of silicon and selenium rectifiers featuring fast recovery, high voltage, power and JAN.
101. **ELECTRONICS DIV., AMERICAN RELAYS**—A 100-page catalog is available that lists components of all major manufacturers, featuring such items as: selsyns, servo motors, test equipment, and

## USERS REPORT...



**IT OUT PERFORMS  
& YOU SAVE MONEY, TOO!**

### KUSTOM BROADCAST CONSOLE

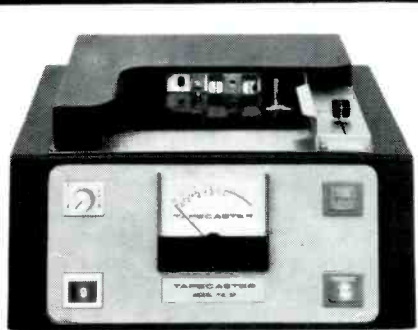
Users, both domestic and foreign report it is way ahead in performance, versatility, flexibility and dependability when compared with any other unit even at a higher unit cost. Six input channels. All solid state unit construction. Use on remotes or in studios.

**ONLY \$495** Send for complete fact sheet.

Sold exclusively through  
**UNITED RADIO INDUSTRIAL**  
829 W. Burnside St.  
Portland, Oregon 97209  
503/226-6334

Circle Item 49 on Tech Data Card

## TAPECASTER



### Model 700-RP

**Solid state combination  
record-playback unit**

**Broadcaster net price \$450.**

For information write  
Box 662 • Rockville, Maryland 20851  
or call 301-942-6666

## TAPECASTER



Circle Item 28 on Tech Data Card

timers. Sections are included on relays, pressure transducers and gyros.

- 102. E. F. JOHNSON CO.**—A components catalog gives specifications on capacitors, tube sockets, connectors, terminals, insulators, pilot lights, and inductors.
- 103. INTERNATIONAL ELECTRONIC RESEARCH CORP.**—A short form catalog covers the company's line of heat dissipaters for metal and "plastic" case transistors and diodes.
- 104. I-TEL, INC.**—Bulletin 1929-18 describes a new line of waveguide filters, series FBW (bandpass) and FRW (band reject).
- 105. ELECTRONIC RESEARCH LABS, INC.**—A 32-page catalog is offered which lists test equipment products of most major manufacturers. Included are sections on blowers, bridges, constant voltage transformers, and voltage regulators.
- 106. LIPSNER SMITH CORP.**—A data sheet describes the LSC Vedette, a professional projector for the high speed inspection and viewing of motion picture film, permitting visual examination of both picture and optical sound track.
- 107. LECROY RESEARCH SYSTEMS CORP.**—Technical data sheets with specifications for the LRS model 100P standard bin and power supply, and the LRS model 255 8-channel 2-fold fan-in, are offered.
- 108. LOCKHEED ELECTRONICS CORP.**—The basic design criteria and tolerances for multilayer printed circuit boards are discussed in a booklet.
- 109. MOTOROLA**—A brochure contains information on three new Motorola precision oscillators, describing the ultra-low profile oscillator (3 or 5 MHz), a plug-in model, and an oscillator which meets military specifications for airborne equipment.
- 110. NATIONAL SEMICONDUCTOR CORP.**—A technical paper on a new mono-

## WHEN IS A GAIN SET A GAIN SET?

When it is a WAVEFORMS model 452A with built-in oscillator, VTVM, separate send and receive attenuators, plus send and receive impedance matching. Gain is the difference between send and receive attenuator settings, plus meter reading. Reading is DIRECT in dBm at four different send and receive impedances, which need not be the same.



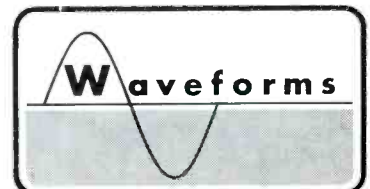
## WHEN IS A GAIN SET NOT A GAIN SET?

When it is a loss set. A loss set is a collection of attenuators and a meter in search of an engineer who likes to stand on his head. With it, he can draw a graph of loss which is the conjugate of the response of his gainy system. He can then stand on his head to interpret his graph.



Waveforms' model 452A Transmission Measuring Set (smart-set name for Gain Set) is calibrated 30 Hz to 15 kHz, operable with reduced calibration accuracy 10 Hz to 100 kHz. Send: +20 to -70 dBm; receive -70 to +50 dBm. Price \$1,000.00.

Write for complete specifications.



PRODUCTS OF **UREI**

11922 VALERIO STREET  
NO. HOLLYWOOD, CALIF. 91605  
TEL. (213) 764-1500

**UREI** UNITED RECORDING ELECTRONICS INDUSTRIES  
Circle Item 48 on Tech Data Card



lithic operational amplifier is available. Also, a reliability report on the MOS product line has been issued.

- 111. OPTO MECHANISMS, INC.**—A brochure gives details on the Rapcor hard copy generator system for computer or video outputs.
- 112. POWER INSTRUMENTS, INC.**—Bulletin LTO668 describes the model 920 "little theater" show strobe designed to fill the need for special lighting effects. This solid state unit may be used in TV production, trade show exhibits,

film production and other areas. Bulletin PTO468 gives specifications for the model 891 "touchless" tachometer, a portable solid state photo-reflective instrument.

- 113. ROME CABLE** — The full line of Rome Cable wire and cable literature, along with specification sheets, has been combined into an easy-to-use, indexed looseleaf catalog, which contains sections on bare-wire, building wire, conduit, underground cables, CATV and coaxial cables and other types.

- 114. RHG ELECTRONICS LABORATORY, INC.**—A bulletin lists RHG's line of fully integrated balanced mixers and low noise preamplifiers providing MIL grade, solid state units for systems applications.

- 115. SAN FERNANDO ELECTRIC MANUFACTURING CO.**—Operating characteristics of West-Cap MA series 3-150 VDC axial lead electrolytic capacitors are described in a brochure.

- 116. SEAELECTRO CORP.**—A technical data sheet describing the new Seaelectrocard 51 x 12 tab reader which is designed to be used with data acquisition, production control and process control systems is available. Bulletin CX-109A describes a right-angle cable plug, and bulletin CX-138 describes a straight cable plug with an end configuration that mates with screw-in, snap-on, and slide-on jacks and receptacles of the MIL-C-22557 subminiature series.

- 117. SIGNALITE INC.**—A data sheet discusses the replacement characteristics of neon glow-lamps for digital readout tubes.

- 118. THE SMITH CO. DIV., PREFORMED LINE PRODUCTS CO.**—A catalog contains information on a line of buried cable system hardware as well as data on products for overhead communications and CATV applications.

- 119. SKYDYNE, INC.**—A new slide rule type case selector aid which relates case part number to single and quantity price and provides complete dimensions, is available. The selector covers 31 standard A.B.S. cases used for military and commercial applications and 31 standard fiberglass types used for hand, portable and field instruments and equipment.

- 120. SODECO**—Bulletin 501 covers the series Ti remote indicating impulse counters, giving specifications, wiring diagrams, power and drive requirements and dimension schematics for both surface and panel mounted models.

# NOW TELE-PAT IV

is the ONLY TEST PATTERN ILLUMINATOR for  
100% TV COLOR or MONO-CHROME CAMERA  
SET-UP/PERFORMANCE CONTROL

REMOVABLE PANEL TO FACILITATE DIFFUSER ADJUSTMENT

SHADOW BOX DESIGN PROTECTS TEST PATTERN FROM AMBIENT LIGHT

MAGNETIC SLIDE FRAME LOCK

KEYED SLOTS TO ASSURE POSITIONING

RIGID ALL METAL SPECIALLY CONSTRUCTED SUPPORT AND BASE

4" DIA. RUBBER WHEELS - 360° ROLLER BEARING ROTATION - WITH LOCKING DEVICE

SPECIAL FLOOR LEVELING DEVICE

REGULATED POWER SUPPLY

PROTECTED TEST SLIDE STORAGE

NYLON SLIDE ROLLERS AND LOCKING GATES

MICRO MECHANICAL LIGHT SOURCE POSITIONER (IN REAR)

MICRO MECHANICAL LIGHT INTENSITY ADJUSTER

HANDLES BOTH FRONT AND SIDES FOR PARALLAX ADJUSTMENT

GEARED ELEVATION ADJUSTMENT

ON/OFF CONTROL SWITCH

Power Supply 115V  
Fully Regulated  $\pm 2\%$

Color Temperature 3100°K  
(Adj. 2900°-3300°K)

250 Ft. Lamberts  $\pm 4\%$   
(Adj. 0-400 Ft. Lamberts)

# NETWORK APPROVED

**TELE-MEASUREMENTS, INC.**  
145 MAIN AVENUE, CLIFTON, NEW JERSEY 07014  
PHONE: (201) 473-8822; (212) 581-9020

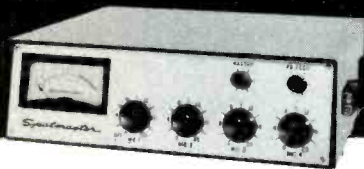
Providing the only complete line of precision test slides and illuminators for color and mono-chrome cameras. Send for catalog listing 8" x 10" and 2" x 2" test pattern slides available.

Circle Item 50 on Tech Data Card

# SPOTMASTER

## Solid-State Portable

# REMOTE AMPLIFIER



The RA-4CA is a lightweight, four-channel portable mixer amplifier specifically designed for remote broadcast or auxiliary studio use. It is completely self-contained and operates from either AC or batteries (switching automatically to battery operation if AC power fails); runs as long as 200 hours on low-cost "D" cells. It offers four microphone channels with master gain and P.A. feed, all controlled from the front panel. Lightweight construction (just 11 pounds with batteries), a convenient carrying handle and a snap-on front cover mean the RA-4CA can be easily set up to operate anywhere. For further information, please write or call today:

*Spotmaster*

**BROADCAST ELECTRONICS, INC.**

8810 Brookville Road  
Silver Spring, Maryland 20910  
Area Code 301 • 588-4983

## DECADE DELAY UNITS

Type "D" Units provide variable time delays with absolute stability for accurate triggering and excellent reproduction of the input pulse. These Lumped Constant Delay Lines are completely passive, have a minimum of 1000 to 1 resolution and consist of 3 or more decade switches. Any delay output is the summation of individual lines, not the result of a tapped line. This feature eliminates undesirable reflections in the output pulse. Accuracy at any delay exceeding 1% of unit's total delay is within 3%. Characteristic impedance is 500 ohms in and out.

Part No.	Maximum Time Delay in Microseconds	Resolution in Microseconds	Rise Time @ Max. Delay in Microseconds	Attenuation in db
D11	11.1	.01	.45	3
D21	21.1	.01	.85	5
D41	41.1	.01	1.65	5
DD41	41.1	.01	.83	5
D61	61.1	.01	2.45	6
DD61	61.1	.01	1.23	6
D1C	111.1	.01	4.45	3
DD1C	111.1	.01	2.23	8
D2C	211.1	.01	8.45	3
DD2C	211.1	.01	4.23	3
D4C	411.1	.01	16.45	3
DD4C	411.1	.01	8.23	6
D6C	611.1	.01	24.45	3
DD6C	611.1	.01	12.23	6
D1K	1111.1	.01	40.45	3
DD1K	1111.1	.01	20.23	8
D2K	2111	.1	84.5	5
D4K	4111	.1	164.5	6
D6K	6111	.1	244.5	8
D11K	11.111	.1	444.5	11
DD1K	21.111	.1	844.5	11
DD2K	2111	.1	42.25	5
DD4K	4111	.1	82.25	6
DD6K	6111	.1	122.25	8
DD11K	11.111	.1	222.25	11
DD21K	21.111	.1	422.25	11
DD41K	41.111	.1	822.25	12
DD61K	61.111	.1	1222.25	12

WRITE FOR CATALOG

**ALLEN AVIONICS, INC.**

Division of A. K. ALLEN CO., Inc.

255 E. 2nd ST., MINEOLA, N.Y. 11501

Circle Item 51 on Tech Data Card

**121. STANCIL - HOFFMAN CORP.**—Model R-70 series magnetic tape recorders are described in literature.

**122. SWITCHCRAFT** — Bulletin 175, describing three new audio adapters, is available.

**123. TELONICS INSTRUMENTS** —A catalog describing a complete line of sweep generators for testing TV tuners and circuits in the IF, VHF, and UHF frequency regions is available.

**124. TENOR CO., INC.**—A new bulletin gives details of equipment options on Tenor's stepping drum programmers which will permit direct control of plant air through pneumatic output switches.

**125. TROMPETER ELECTRONICS, INC.**—A catalog is available which describes a complete line of coat switching matrices for use in video, telemetry, data and RF switching systems.

**126. U. S. CAPACITOR CORP.**—A catalog on miniature high stability ceramic capacitors gives specifications, drawings, part numbers and ordering information for capacitor styles with axial or radial leads, tubular or rectangular configurations.

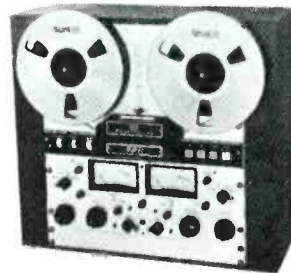
**127. VIKOA, INC.**—A catalog gives specifications on the Futura "12" series of amplifiers.

**128. WEINSCHEL ENGINEERING**—Model 569A precision high power terminators are described in literature.

**129. WESTINGHOUSE**—A bulletin gives application information and operating characteristics for slow-scan vidicon camera tubes. Also, a two piece SEC television camera system for low-light-level viewing of transient and stationary images, is described in a bulletin.

**130. ZERO MANUFACTURING CO.**—Three types and 24 sizes of low-cost deep drawn aluminum carrying cases are presented in a catalog.

**When you're ready to buy your next professional recorder...**



**Look for:**

**LOW NOISE** Pure sound reproduction is the minimum requirement for a professional recorder. Listen carefully for hum and other machine-produced noises—marks of an "amateur" machine. Incidentally, the noise level of all Crown recorders is lower than that of most other professional recorders. (Guaranteed minimum S/N of 60db at 7½ ips.)

**WIDE BAND-WIDTH** Any professional recorder will cover all the audible sound spectrum. Now try to find one with the band-width safety margin of a Crown. (Guaranteed minimum of ±2db, 30-25 kHz at 7½ ips and 30-15 kHz at 3¾ ips.) In side-by-side comparison, you'll discover that reproduction on a Crown at 3¾ ips is comparable to that of other professional recorders at 7½ ips, giving you savings of 50% on tape in many recording applications!

**MINIMUM DISTORTION** Wow, flutter and other signal distortions should be imperceptible at 7½ ips for professional quality tapes. Crown guarantees a minimum of 0.09% wow and flutter at 7½ ips.

**FLEXIBILITY** Look for a recorder with a full range of professional refinements. More than with any other professional recorder, you can "do anything" with a Crown—record sound-on-sound, create special equalization and echo effects, A-B monitor while recording, mix four microphones and much more.

**INVESTMENT** Professional electronic equipment is a good secure investment, with a slow rate of depreciation. A Crown is insured against obsolescence with a design acclaimed by professionals "years ahead of the industry." With only ten moving parts, normal care and routine service will assure like-new performance for ten years. In 1978, you'll be glad you purchased the very best—a Crown.

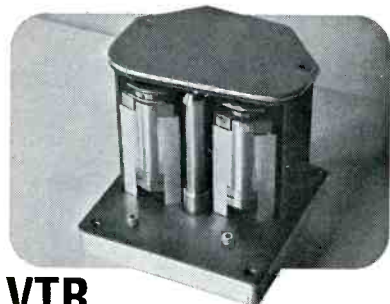
*Write to* **Crown International**  
Box 1000, Dept. BE-10  
Elkhart, Indiana 46514

**MADE ONLY IN AMERICA**

Circle Item 52 on Tech Data Card



## PROTECT YOUR SOUND REPUTATION



### VTR

#### RECONDITIONED BY *TABER*

Nationally recognized recorder head manufacturing and reconditioning experts.

- Heads reconditioned under controlled laboratory conditions.
- Reconditioned heads guaranteed to meet, or exceed, equipment manufacturer's specifications.
- Modern precision machine shop, and sophisticated laboratory installations insure highest quality reconditioning.
- Free loaner assemblies available on request.
- 24 hour service.
- Cost—\$100.00 for four (4) heads.

**TABER'S** sophisticated quality control, and test procedures, insure total frequency response and uninterrupted sound playback. Maintain the high quality audio that your equipment was engineered to produce.

Call or write: **TABER** MANUFACTURING AND ENGINEERING COMPANY

OAKLAND INTERNATIONAL AIRPORT, BLDG. L-821  
P. O. BOX 2365 • OAKLAND, CALIFORNIA 94614  
Telephone (415) 635-3832

Check Item 53 on Tech Data Card

### DID YOU KNOW . . .

#### Rust Builds Low-Cost Video Switchers!

The RUST "RMS" is a low-cost, expandable Video/Audio Switcher with full color and monochrome capability. Each main frame includes six video bridging amplifiers and a power supply. Each main frame has provisions to accept 10 video and audio inputs and distribute them simultaneously or individually to any or all of six outputs. Main frames may be connected so as to provide almost any quantity of inputs and outputs. Selection of inputs may be accomplished in a variety of methods; a remotely located dial console, a directly wired push-button panel, or the unit may be programmed by automatic means. The RUST "RMS" Switcher is utilized by Commercial TV Stations, Educational TV Stations, Closed Circuit Operations, Industry, Hospitals and many others. A RUST "RMS" 10/6 Switcher main frame is priced at \$2,400. Application Bulletins and data sheets are available.

**RUST**  
corporation

168 Tremont Street  
Everett, Mass. 02149  
(617) 389-3380

Check Item 54 on Tech Data Card

## Advertisers' Index

Advance Industries	63
Allen Avionics, Inc.	77
Anderson Laboratories, Inc.	55
Broadcast Electronics, Inc.	65, 73, 77
Broadcast Products Co., Inc.	65
CBS Laboratories, Div. of CBS, Inc.	3, 50-51
CCA Electronics Corp.	66
Central Dynamics Corp.	31, 66
Cleveland Institute of Electronics	53
Cohu Electronics, Inc.	1
Collins Radio Co.	8
Comrex Corp.	63
Crown International	77
Defense Electronics, Inc.	17
Delta Electronics, Inc.	62
Electrodyn Corp.	35, 37
Electro-Voice, Inc.	72
Fairchild Recording Equipment Corp.	41
Gately Electronics	63
Gates Radio Co.	13
General Electric Co.	44
Gotham Audio Corp.	64
Houston Photo Products, Inc.	74
Houston Photo Products, Inc.	74
International Nuclear Corp.	Cover 3
Jampro Antenna Co.	32, 65
Lenkurt Electric Co., Subsidiary of General Telephone & Electronics	38
Lipsner-Smith Corp.	60
3M Company, Magnetic Products Div.	18-19
Melcor Electronics Corp.	70
Microwave Associates	47
Minneapolis Magnetics, Inc.	68
Moseley Associates, Inc.	68
North American Philips Co., Inc.	27
Nortronics Co.	72
Phelps Dodge Electronic Products Corp.	67
Potomac Instruments, Inc.	64
Primo Co., Ltd.	69
RCA Electronic Components & Devices	15
Riker Video Industries, Inc.	Cover 2
Rust Corp.	78
Sarkes Tarzian, Inc.	69
Shure Brothers, Inc.	23
Sparta Electronic Corp.	53
Spotmaster	65, 73, 77
Stanton Magnetics	43
Taber Mfg. and Engineering Co.	78
Tape-Athon Corp.	71
Tapecaster TCM	60, 75
Telemation, Inc.	9
Tele-Measurements, Inc.	76
Telemet Co.	Cover 4
United Radio Supply, Inc.	75
United Recording Electronics Industry	75
Vital Industries	7
Ward Electronic Industries	5
Wilkinson Electronics, Inc.	57

## Late Notes . . .

### CATV Calendar

The following is a list of meetings scheduled by industry associations for October and November:

#### October

15-17—Kentucky CATV Assn. To be held at the Continental Inn, Lexington.

24-25—Mid-America CATV Assn. Fall meeting at the Prom-Sheraton Motor Inn, Kansas City, Mo.

29-30—Mississippi CATV Assn. Heidelberg Hotel, Jackson.

#### November

5-6—Alabama CATV Assn. Annual meeting set for Guest House Motor Inn, Birmingham.

8—Colorado CATV Assn. Annual meeting, Antlers Hotel, Colorado Springs.

10-13—California CATV Assn. Fall meeting at the Del Coronado Hotel, Coronado Island.

**The Central Canada Broadcasters Association** will hold their Annual Convention on Oct. 20, 21 and 22 at the Chateau Champlain in Montreal. This is a joint engineering and management function with programs for both groups.

Last year's convention was attended by more than 400 representatives from the private broadcast stations of Ontario and Quebec.

**The Michigan Department of Education** and the Michigan Audio-Visual Association will sponsor the Michigan Telecommunications Conference to be held Oct. 22 and 23 at the Lansing Civic Center, Lansing, Mich.

### INTERNATIONAL ASSIGNMENT

Does travel abroad appeal to you? Leading U.S. broadcasting organization accepting applications from television engineers.

Applicants must have at least five years experience and must be completely familiar with all phases of maintenance covering such areas as: transmitter, studio and mobile van units.

Salary and allowances commensurate with assignments.

An equal opportunity employer.

**Broadcast Engineering,  
Dept. 222**

1014 Wyandotte St.,  
Kansas City, Mo. 64105

## Professional Services

### VIR JAMES

CONSULTING RADIO ENGINEERS  
Applications and Field Engineering  
345 Colorado Blvd.  
Phone: (Area Code 303) 333-5562

**DENVER, COLORADO 80206**

Member AFCCE  
TWX 910-931-0514

### JAMES C. McNARY

Consulting Engineer  
National Press Bldg.  
Washington 4, D.C.  
Telephone District 7-1205

Member AFCCE

### CAMBRIDGE CRYSTALS PRECISION FREQUENCY MEASURING SERVICE

SPECIALISTS FOR AM-FM-TV

445 Concord Ave. Phone 876-2810  
Cambridge, Mass. 02138

### JOHN H. MULLANEY and ASSOCIATES

Suite 71,  
1150 Connecticut Ave., N.W.  
Washington, D. C. 20036  
Phone 202-223-1180

Member AFCCE

**CRYSTAL AND MONITOR SERVICE**—  
Frequency change and repair service for  
AM monitors including G.R., RCA, Gates,  
W. E., and Doolittle; also H-P 335B FM.  
AM monitors bought and sold. What have  
you, what do you need? New or regrinding  
of AM crystals for RCA, Gates, Biley,  
W.E., and J-K oven holders, repairs,  
etc. Fastest service, reasonable prices.  
Over 25 years in this business. Eidson  
Electronic Co., Box 96, Temple, Texas  
76501. Phone 817 773-3901. 2-67-tf

### ROSNER TELEVISION SYSTEMS

ENGINEERS  
120 E. 56 St.  
New York  
N. Y. 10022

CONTRACTORS  
29 South Mall  
Plainview  
N. Y. 11803

### TAPE CARTRIDGE SERVICE

Completely recondition your old tape  
cartridges, all sizes of new tape car-  
tridges in stock available for immediate  
shipment. Will supply complete price  
list on request.

### M.S.I. CARTRIDGE SERVICE

279 W. Main Street  
Amsterdam, N. Y. 12010  
Phone (Area Code 518) 843-2242

### AMPEX HEAD ASSEMBLY

Relapping and replacement head ser-  
vice for all AMPEX professional stu-  
dio model recorders. Our precision  
relapping extends head life for max-  
imum use. Brand new shelf stock re-  
placement heads of our manufacturer  
available when relapping not advis-  
able. Prices include thorough assem-  
bly cleaning, optical and electrical in-  
spection and complete testing on Am-  
pex equipment. Monaural assembly re-  
lapping . . . \$35.00 complete. Monaural  
assembly replacements . . . \$119.50  
complete. "Loaner" assemblies avail-  
able. For more data, contact LIPPS,  
INC., 1630 Euclid St., Santa Monica,  
Calif. 90404 (213) EX 3-0449.

### FRANK A. ZOELLER

TELEVISION SYSTEMS  
CONSULTANT

20 Years Experience

Box 366 • San Carlos, Cal. 94070  
(415) 593-1751

**GUARANTEED FIRST PHONE**, 4-6  
weeks. Broadcast Engineering Academy,  
3700 Lemay Ferry, St. Louis, Mo. 63125.  
314/892-1155. 5-68-tf

## Classified

Advertising rates in the Classified  
Section are fifteen cents per word.  
Minimum charge is \$2.00. Blind  
box number is 50 cents extra.

### RECORDING EQUIPMENT

Ampex, Scully Neumann, Akd, Altec, Lange-  
vin, Fairchild, Universal Audio Custom —  
Complete stock of new and used equipment  
—What are your needs? We can supply it.

### UNIVERSAL AUDIO SALES CORP.

2541 NICOLLET AVE.  
MINNEAPOLIS, MINN. 55404 (612) 827-5443

**DON'T BE AN AUDIO DROPOUT** in  
your market area. Let **BROADCAST  
EQUIPMENT REBUILDERS** take care of  
your tape cartridge rewinding needs. Call  
or write Quin Morrison for further infor-  
mation. Route 8, Box 718, Fayetteville,  
N. C. 28304. Area 919 - 425-7332. 9-68-1t

## Help Wanted

**Transmitter Maintenance Supervisor** with  
at least three years experience in main-  
tenance and trouble shooting of AM  
broadcast transmitters, first class license  
desirable, for maintenance supervision of  
two 100 kw transmitters at church-related  
short wave radio station in Ethiopia.  
Qualified applicants write Station Direc-  
tor, Radio Voice of the Gospel, Box 654,  
Addis Ababa, Ethiopia. 9-68-1t

### Broadcast Personnel New ETV Station

Ground-floor key position openings now  
available for West Virginia's first public/  
educational TV station—WVU-TV. Af-  
filiated with NET, EEN, New physical  
plant including million-dollar color fa-  
cility. High band color video tape (4) and  
color film (2). Transmitter 30 kw. Open-  
ings for Master Control Switcher, Video  
Tape/Film, Maintenance, and Transmitter

Operators. Competitive salaries and ex-  
cellent fringe benefits. Apply by resume  
to: Employment Manager, Personnel Of-  
fice, West Virginia University, Morgan-  
town, West Virginia 26506. An equal op-  
portunity employer. 9-68-1t

## Equipment for Sale

### EQUIPMENT FOR SALE

Scully tape recorders as low as \$13.55  
weekly. Three Spotmasters, one record  
/playback, and two playbacks, all  
three, \$38.25 monthly. Multiple units,  
Spot Five, \$47.25 monthly. Two QRK  
or Rusco deluxe turntables, \$10.80  
monthly. Lower payments with trade.  
Write for list. Purchase your car-  
tridges from us, we ship freight pre-  
paid. Audiovox, Box 7067-55, Miami,  
Florida 33155. 4-68-tf

**Coils, Contactors, Switches, Complete  
ATU systems. Top Quality, Lowest Prices,  
Fast Delivery, No Duty. Write for cata-  
logue: Geleco Electronics Ltd., 2 Thorn-  
cliffe Pk. Dr., Toronto 17, Ont. 416-421-  
5631. 11-67-12t**

### CARTRIDGE TAPE EQUIPMENT

Completely reconditioned and guaran-  
teed. Spotmaster Model 500 Record/Play-  
backs, \$350.00. Model 505 Playbacks  
\$250.00. 30-day moneyback guarantee on  
all equipment.

### BROADCAST PRODUCTS COMPANY

18804 Woodway Dr., Derwood, Maryland,  
20855  
(301) 926-4600 3-67-tf

**RECONDITIONED VIDEO TAPE RE-  
CORDERS AND CAMERAS.** Color and  
Monochrome, Quadplex and Helical,  
Ampex and RCA. Current and Late Mod-  
els in All Configurations. Available Im-  
mediately to Buy or Lease. Reply to Dept.  
221 (Broadcast Engineering).

**Complete Audio End of radio station with  
3 cartridge machines (1 rec), 2 turntables,  
Altec console, weather-scope, SCA gener-  
ator, and much more . . . new equipment.  
Will sacrifice. Write for list and prices.  
J. E. KIRCHSTEIN, 107 Water St., Sauk  
City, Wis. 53583. 10-68-1t**

Everything in used broadcast equipment.  
Write for complete listings. Broadcast  
Equipment and Supply Co., Box 3141,  
Bristol, Tennessee. 11-64-tf

"AUDIO EQUIPMENT"—Whatever your  
needs, check us first. New and used.  
Ampex, Altec, AKG, EV, Fairchild, Neu-  
mann, Langevin, Rek-O-Kut, Uher, Vik-  
ing. Send for equipment." Audio Dis-  
tributors, Inc., 2342 S. Division Ave.,  
Grand Rapids, Michigan 49507. 6-66-tf

Audio Equipment bought, sold, traded.  
Ampex, Fairchild, Crown, McIntosh, Vik-  
ing, F. T. C. Brewer Company, Town &  
Country Plaza, Pensacola, Florida. 3-64-tf

**CO-AXIAL CABLE** Heliax, Styroflex,  
Spiroline, etc. Also rigid and RG types  
in stock. New material. Write for list.  
Sierra-Western Electric Co., Willow and  
24th Streets, Oakland, Calif. Phone 415  
832-3537. 5-66-tf

## Equipment Wanted

We need used 250, 500, 5K & 10K Watts  
AM Transmitters. No junk. Guarantee  
Radio Supply Corp., 1314 Iturbide St.,  
Laredo, Texas 78040. 3-66-tf



## Employment

**Job Headquarters** for all Radio and Television Engineers. Immediate openings exist in 9 western states and elsewhere for qualified engineer and technical personnel. All categories from trainees to experienced transmitter maintenance, chief, assistant chief, live color video maintenance and technical operations. Send us your complete resume now. The AMPS Agency, 3924 Wilshire Blvd., Los Angeles, California 90005. Telephone DU 8-3116. By Broadcasters—For Broadcasters 11-66-tf

**OPENINGS**—1st Phone Engineers experienced—maint., audio, video, videotape, TX. (also will train 1st or 2nd class engineer for Master Control Position) send resume. Chief Engineer, WGBH-TV, 125 Western Ave., Boston 02134. 9-68-2f

## ALMA ENGINEERING

has available an excellent opportunity in its fast growing video equipment manufacturing business for an outstanding video systems engineer with experience in video switching systems. Call or write (resume) R. G. Frick, President, Alma Engineering, 7990 Dagget Street, San Diego, Calif. 92111 (714) 278-9330. 10-68-1t

## ALMA ENGINEERING

Seeking sales representatives in Western, Mountain and Central regions for hot new and growing line of video switchers and amplifiers and other video and audio terminal equipment. To sell direct to broadcasters and through distributors to closed circuit and CATV markets. A very attractive proposition is available to the right individuals. Write or call President, Alma Engineering, 7990 Dagget Street, San Diego, Calif. 92111 (714) 278-9330. 10-68-1t

Opening for studio and field supervisors and staff technicians. Supervisory positions carry five figure salaries, require licenses. Technician positions, salary dependent on license, experience etc. Network serves 5600 classrooms statewide with four channels. Visual Cameras, Ampex VTR's 5 day week. Write Technical Services Director, Delaware ETV Network, Box 898, Dover, Delaware. 9-68-1t

## THE GRASS VALLEY GROUP

Is forming a SALES organization.

### Broadcast Television Engineers

are needed for all areas.

Sales experience helpful but not essential.

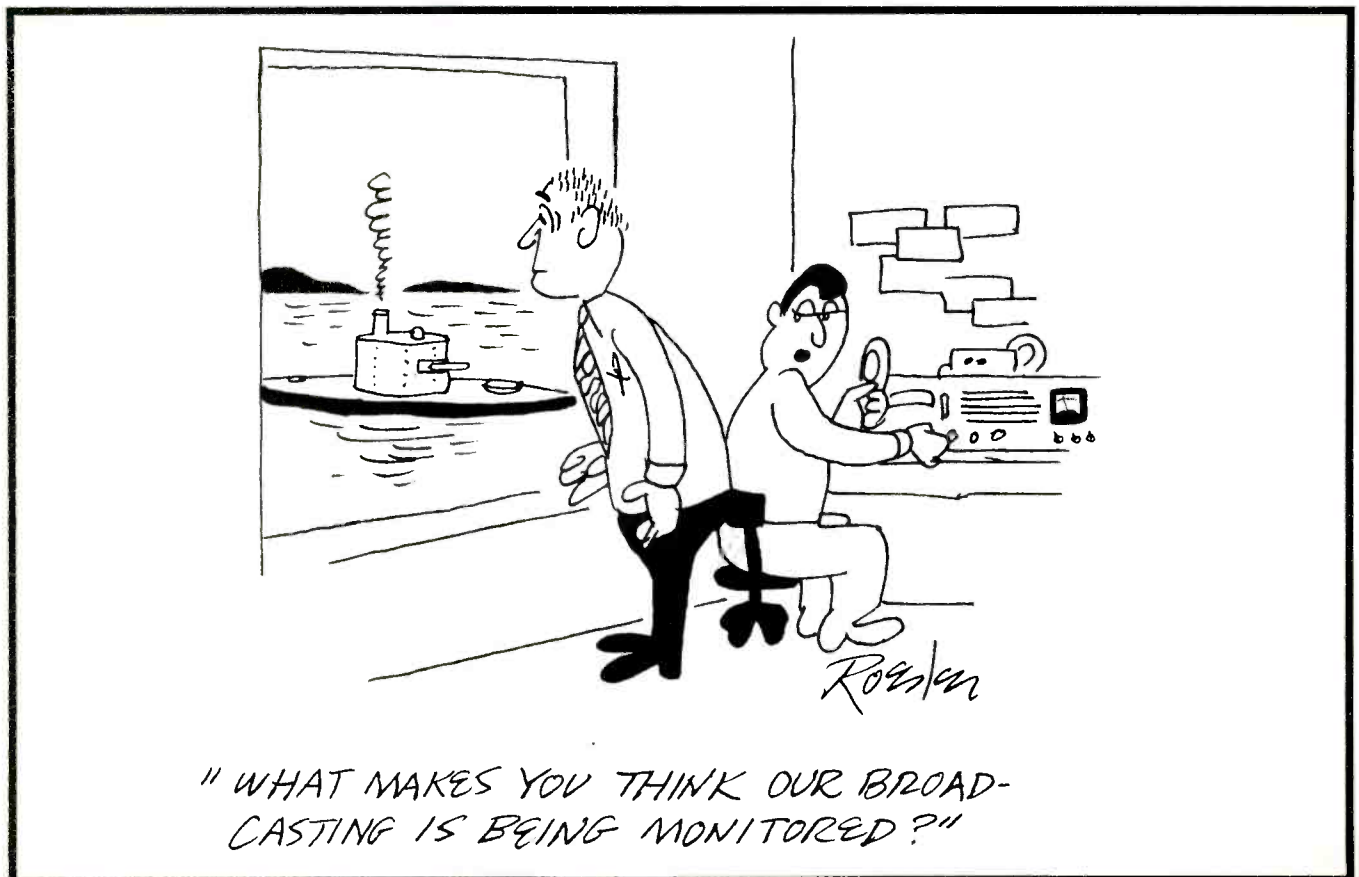
GRAVCO SALES, INC.  
6311 Yucca St.,  
Los Angeles, California  
Call or Write:  
(213) 462-6618

Engineering position available to work with PC-70's, VR-2000's and TK-27's in outstanding metropolitan VHF operation. First Class license required. Write Dept. 218, Broadcast Engineering, 1014 Wyandotte St., Kansas City, Mo., 64105. 9-68-tf

## Training

To advance in electronics, knowledge and ability are required. Grantham offers correspondence and resident instruction, in depth, leading to the degree of Associate in Science in Electronics Engineering. G. I. Bill approved. Credit for previous training and experience allowed. Free Catalog. Write: Dept. E-2, Grantham School of Electronics, 1505 N. Western Ave., Hollywood, California. 90027. 6-67-tf

First phone through tape recorded lessons at home then one week personal instruction in Minneapolis, Atlanta, Washington, Detroit, Denver, Seattle, or Los Angeles. Sixteen years FCC license teaching experience. Proven results. 95% passing. Bob Johnson Radio License Preparation, 1060D Duncan, Manhattan Beach, Calif. 90266. Telephone 379-4461. 4-68-tf



## TDA2D VIDEO/PULSE DISTRIBUTION AMPLIFIER



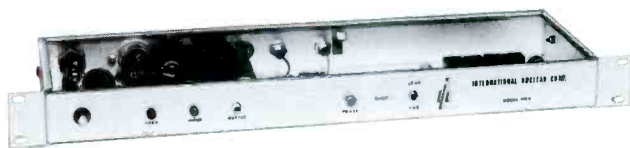
The now-famous TDA2 Distribution Amplifier, in use at most television stations and networks, has a recently added feature. The "D" stands for Differential Input, which we added to the TDA2. And not only did we add a differential input, we subtracted \$30.00 from the price. Instead of \$325.00, we're selling the new, improved TDA2D for \$295.00 F O B Nashville. The compact TDA2D fits neatly into 1 3/4" of panel space and produces virtually no heat.

For complete information, write to:

**INTERNATIONAL NUCLEAR CORPORATION**  
608 Norris Ave. • Nashville, Tenn. 37204 • Ph.: (615) 254-3365

## MODEL TPC2 TRANSISTORIZED BURST PHASE CORRECTOR

The TPC2 permits rotation of the color burst phase signal driving a TV transmitter, without the necessity for extensive transmitter investigation and possible modification. It permits advancement or retardation of the color burst by 20 degrees, without affecting the amplitude or other characteristics of transmission. This completely transistorized unit has its own internal regulated power supply, and is constructed on a 1 3/4" by 19" panel. \$795.00 F O B Nashville.



For complete information, write to:

**INTERNATIONAL NUCLEAR CORPORATION**  
608 Norris Ave. • Nashville, Tenn. 37204 • Ph.: (615) 254-3365



## TC1 CLAMPING AMPLIFIER



The TC1 Clamping Amplifier employs tip clamping to remove low frequency signal deficiencies without disturbing burst and other chrominance information in or about back porch levels. The clamped stage utilizes a field effect transistor driven by a balanced bridge circuit. This advanced design technique produces highly effective and stable clamping. The TC1 Clamping Amplifier sells for \$325.00 F O B Nashville.

For complete information, write to:

**INTERNATIONAL NUCLEAR CORPORATION**  
608 Norris Ave. • Nashville, Tenn. 37204 • Ph.: (615) 254-3365

## TBG2 BLACK BURST GENERATOR

The brand new TBG2 Black Burst Generator allows you to go black and back with perfection. The TBG2 has two outputs available for added versatility, and each has burst phase and burst amplitude adjustments so the two feeds can be matched under any condition. The TBG2 has the industry's only continuously rotatable phase control, and is accurate to within one degree. All the controls are on the front panel and can be locked. The unit is small, compact and lightweight. So is the price . . . \$475.00 F O B Nashville.



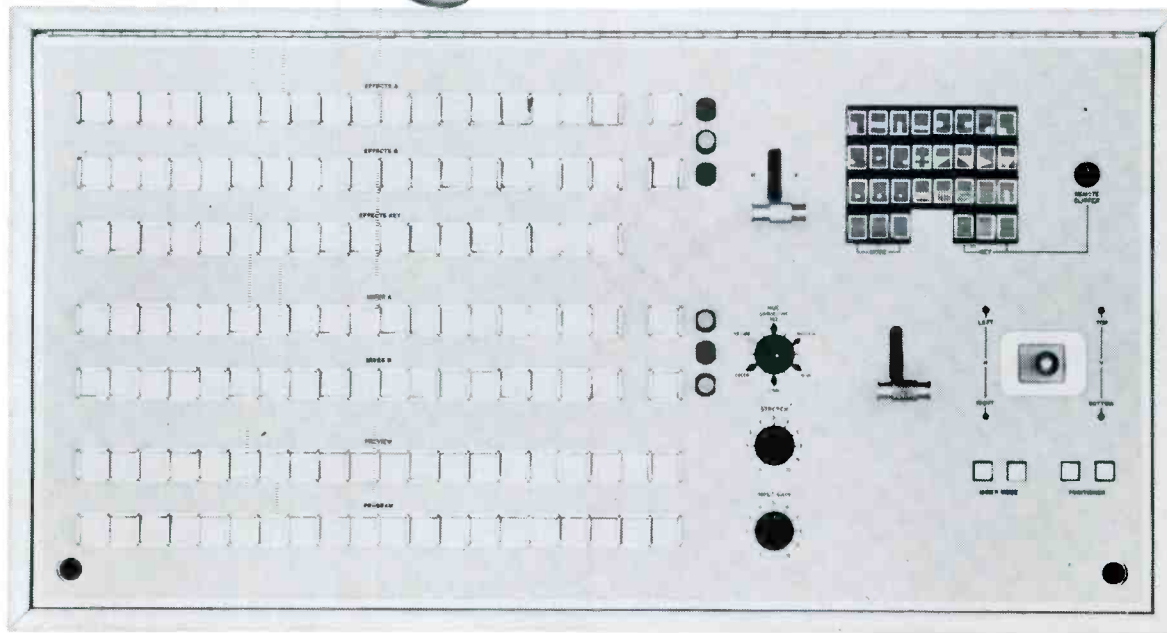
For complete information, write to:

**INTERNATIONAL NUCLEAR CORPORATION**  
608 Norris Ave. • Nashville, Tenn. 37204 • Ph.: (615) 254-3365

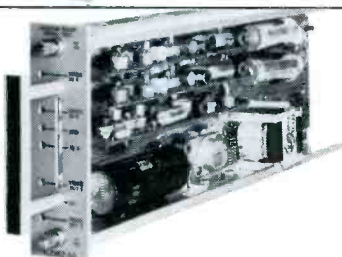
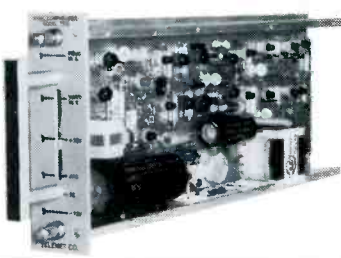




# You'll want to put the finger on **TELEMET.**



We'll turn you on with our new **SS-140 Vertical Interval Switcher.**



Write us today for full details.  
**T E L E M E T**  
a division of *GEOTEL, INC.*  
185 DIXON AVENUE, AMITYVILLE, NEW YORK 11701 • (516) 541-3600

Circle Item 56 on Tech Data Card