

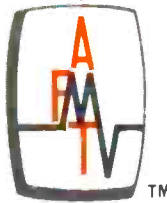

A HOWARD W. SAMS PUBLICATION

Chief



February, 1969/75 cents

Broadcast Engineering

*the technical journal
of the broadcast-
communications industry*

Reviewing disc recording principles, page 14



RIKER VIDEO

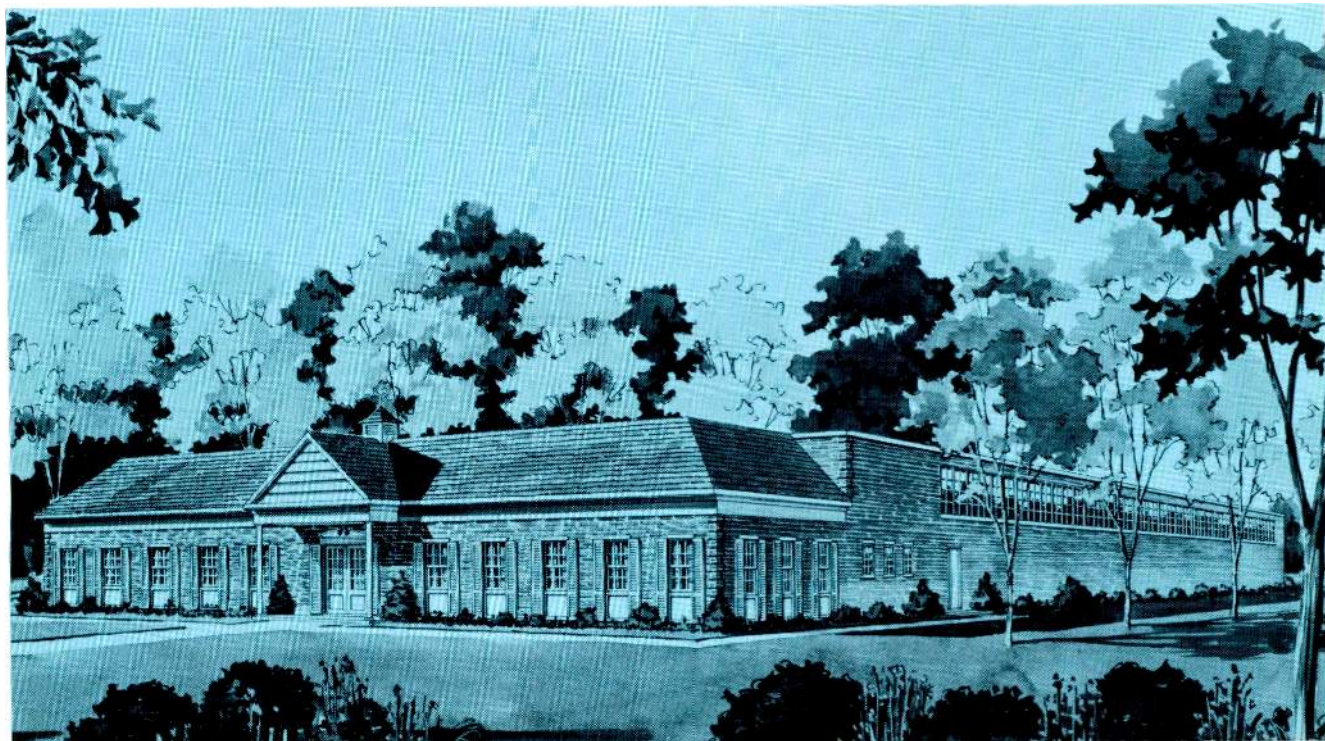

MAIN OFFICE AND PLANT

A. W. Malang, President

HEADQUARTERS

Abe Jacobowitz
National Sales Manager

T. K. Chapman
Manager of Marketing Admin.

Charles Green
Manager of Quality Assurance

CENTRAL REGION

Herbert N. Didier
Riker Video
2550 Denver Merchandise Mart
451 East 58 Avenue
Denver, Colorado 80216
(303) 534-3995
Telex 45-784

WESTERN REGION

George Ray Walker
Riker Video
7811 Le Mona Avenue
Van Nuys, California 91405
(213) 785-1005

NORTHEAST REGION

Roger C. Jakobs
Riker Video
100 Parkway Drive South
Hauppauge, New York 11787
(516) 543-5200

SOUTHEAST REGION

Lewis L. Parson
Riker Video
3127 Maple Drive, N.E.
Suite 210
Atlanta, Georgia 30305
(404) 233-2557

RIKER VIDEO Inc.

100 PARKWAY DRIVE SOUTH
HAUPPAUGE, L.I., NEW YORK 11787

TELEPHONE (516) 543-5200

TELEX 96-1356

CABLE—RIKERVERVIDEO

Circle Item 44 on Tech Data Card

the Cohu compacts

TV accessories in the
small, economy size

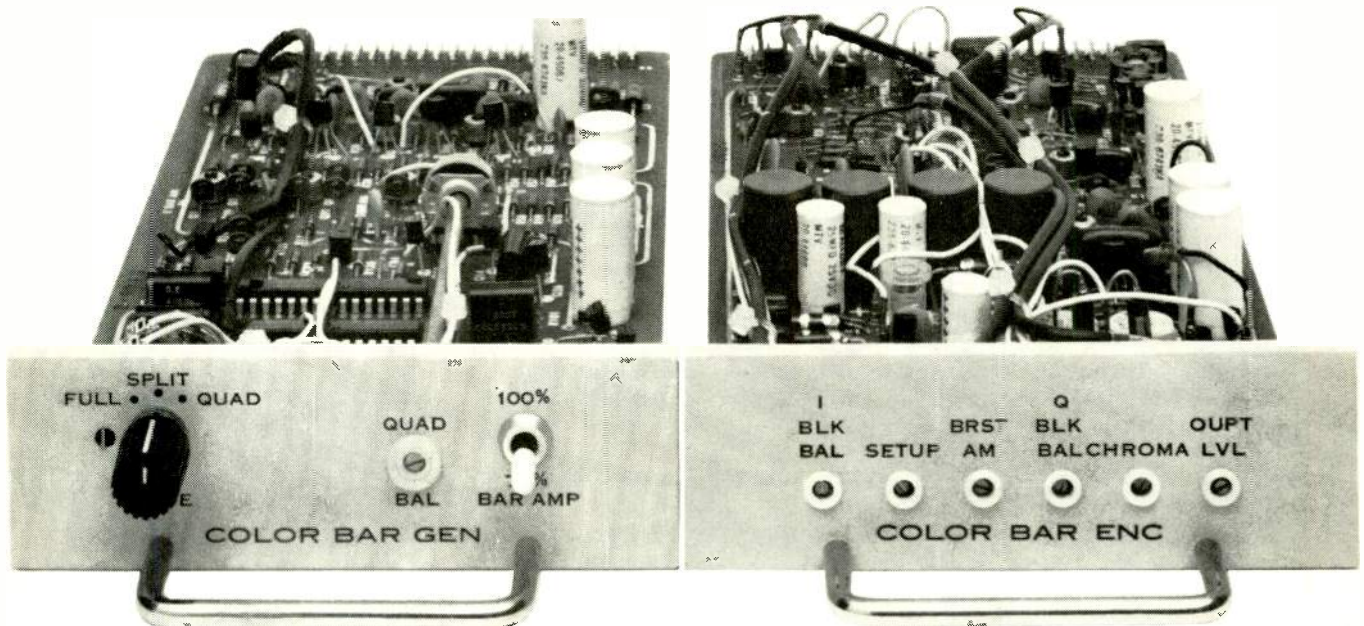

Cohu's Color Bar Generator facilitates adjustment of color monitors, encoders and other studio equipment requiring RGB I-Y-Q signals which meet EIA specifications. Video bar outputs are switchable from 100 to 75%. Special test pulses allow adjustment of quadrature without use of a vectorscope.

Cohu's Color Bar Encoder expands the basic usefulness of the color bar generator by adding an accurate and stable matrix and phasing circuit to provide encoded color bars which meet EIA RS-189 specifications. Television transmission characteristics can be checked with the encoded bar signals.

Compact, modular design of Cohu's 2610/2620 Accessory Series results from the use of integrated and solid-state circuits and provides reliable and versatile operation. Each compact is 1½" high by 4¾" wide and plugs into a frame which occupies only 1¾" of a standard 19" rack. In addition to the color bar generator and color bar encoder, other accessories include a drive generator, colorlock, black burst generator, dot • bar • crosshatch generator and background generator.

For specific data on each accessory, contact your local Cohu representative, or call Bob Boulio direct at 714-277-6700 in San Diego. Box 623. San Diego, California 92112. TWX 910-335-1244.

COHU
ELECTRONICS, INC.
SAN DIEGO DIVISION

Circle Item 1 on Tech Data Card



Broadcast Engineering

The technical journal of the broadcast-communications industry

in this issue...

14 Reviewing Slow-Motion Disc Principles. A discussion of the principles and the advantages and disadvantages of the slow-motion disc recording. **Lee Stratton.**

20 Implied Freeze: FCC Moves to Adopt New CATV Regulations. An explanation of the recent FCC proposed regulations that further restrict CATV operations.

22 Understanding Transistor Audio Circuits. The 4th part of a 6-part series. Author details the design of solid-state multivibrators. **Norman Crowhurst.**

36 In Fair Sky or Soup: Helicopter Remotes on 450 MHz. The story of traffic reporting operations at WOR on 450 MHz. **Leo G. Sands.**

42 Building Microphone and Line Phasing Testers. Author sets standard for mike wiring and details design of phasing testers. **Charles D. Sears.**

50 New Paths for TV Remotes. Author discusses the choices of remote transmission medium and suggests piggy-backing on CATV system. **Leo G. Sands.**

ABOUT THE COVER

The console operation looks easy until you understand what goes into producing the slow-motion disc replay. See article on page 14 for a review of some of the principles of slow-motion recording.

DEPARTMENTS

Letters to the Editor	4
Industry News	6
Washington Bulletin	39
New Products	56
Tech Data	61
People in the News	63
Industry Calendar	65
Advertiser's Index	67
Classified Ads	67

EDITORIAL

GEO. H. SEFEROVICH, Director
RONALD N. MERRILL, Editor
WENDALL BURNS, Field Editor
B. STEARNS, Editorial Assistant
DUDLEY ROSE, Art Director
LEE JOHNSON, Assistant Artist

REGIONAL EDITORS

GEORGE M. FRESE, Northwest
HOWARD T. HEAD, Washington, D.C.
ROBERT A. JONES, Midwest

EDITORIAL ADVISORY BOARD

LES NELSON, Chairman
Howard W. Sams & Co., Indianapolis

CIRCULATION

R. VINCENT WARD, Director
PAT OSBORNE, Manager

ADVERTISING

E. P. LANGAN, Director
R. JACK HANCOCK, Manager
S. F. WILSON, Production
LEE MILLER, Promotion

REGIONAL ADVERTISING SALES OFFICES

Indianapolis, Indiana 46206

ROY HENRY
HOWARD W. SAMS & CO., INC.
4300 West 62nd St.
Tele: 317/291-3100

New York, New York 10019

ALFRED A. MENEGUS
3 W. 57th St.
Tele: 212/688-6350

Los Angeles, California

G.R. HOLTZ
THE MAURICE A. KIMBALL CO., INC.
2008 Carson St., Suites 203-204
Torrance, California 90501
Tele: 415/392-3365

San Francisco, California 94104

THE MAURICE A. KIMBALL CO., INC.
580 Market Street, Room 400
Tele: 415/392-3365

Mission, Kansas 66208

JAKE STOCKWELL
C.H. Stockwell Co.
4916 W. 64th St.
Tele: 913/722-4417

London W. C. 2, England

JOHN ASHCRAFT & CO.
12 Bear Street
Leicester Square
Tele: 930-0525

Amsterdam C, Holland

JOHN ASHCRAFT & CO.
W.J.M. Sanders, Mgr.
for Benelux & Germany
Herengracht 365
Tele: 020-240908

Paris 5, France

JOHN ASHCRAFT & CO.
9 Rue Lagrange
ODEon 033-2087

Tokyo, Japan

INTERNATIONAL MEDIA
REPRESENTATIVES, LTD.
3, Nakanochi, Akasaka, Minato-ku
Tele: 582-5881



BROADCAST ENGINEERING is published monthly by Intertec Publishing Corp., 1014 Wyandotte Street, Kansas City, Missouri 64105. Telephone: 913/888-4664.

Subscription Prices: U.S.A. \$6.00, one year; \$10.00 two years; \$13.00 three years. Outside the U.S.A., add \$1.00 per year for postage. Single copies are 75 cents, back issues are \$1.00.

Application to mail at controlled circulation rates is pending at Indianapolis, Ind.



Robert E. Hertel, Publisher

Intertec Publishing Corp.
Subsidiary of Howard W. Sams & Co., Inc.



Broadcasters— Feeling the Freeze?

Defrost with Audimax and Volumax! We guarantee to increase your effective radiated power.

Are your plans for increasing power on ice? Well, here's a quick way to beat the cold: call us collect: (203) 327-2000! We'll send you Audimax and Volumax FREE for 30 days. No obligation.

Audimax is an automatic level control years ahead of the ordinary AGC. It automatically maintains appropriate volume levels and eliminates distortion, thumping and pumping.

Volumax outmodes conventional peak limiters by controlling peaks automatically with-

out side effects. It's unconditionally guaranteed to prevent overmodulation. Volumax alone has typically provided a 4 to 1 increase of average program power.

With this winning combination, we guarantee increasing your maximum program power as much as 8 to 1. You reach a bigger audience with a more pleasant sounding program.

Why wait? Defrost with Audimax and Volumax . . . the powerful pair from CBS Laboratories.

PROFESSIONAL
PRODUCTS
CBS LABORATORIES
Stamford, Connecticut 06905
A Division of Columbia Broadcasting System, Inc.

JAMPRO

RUNS CIRCLES AROUND FM ANTENNAS FOR BETTER RECEPTION



JAMPRO advanced technology has developed another industry "first"! A circularly polarized FM Antenna with variable horizontal to vertical gain ratios! Jampro will adjust the ratio to your exacting specifications for the best possible reception performance available—Reception to the outer fringes, and to more auto FM receivers, too.

EXCLUSIVE DIGITAL TUNING END STUBS allow lower VSWR on your tower (GUARANTEED under 1.1 to 1), and field trimming to 1.08 to 1, \pm 200 KC.

AVAILABLE IN EITHER PARALLEL OR SHUNT FEED SYSTEMS.

Write for full specifications or make a circular motion on your phone dial—Call Jampro today. (916) 383-1177.

JAMPRO

ANTENNA COMPANY

A DIVISION OF COMPUTER EQUIPMENT CORP.
6939 Power Inn Road
Sacramento, California 95828

Circle Item 3 on Tech Data Card

LETTERS

TO THE EDITOR

Babysitting Stars

Currently, here at KGAL, I wear two hats. One is the CE's lid, the other, the Program Director's jeweled crown. Therein lies the well-known rub. We are a two-stick station. That means we must have First Class Tickets on the transmitter log. We are also not made of money. That means the Engineer must also be the board man.

Now then, how many good top 40 jocks do you know with that elusive First? Conversely, how many of the new breed of "6-week wonders" from the "Barney Brain School of Broadcasting" are real sure which end of a tube you plug in the socket? And, more to the point, how does my boss know I'm worth more to him with my First, than is our new man with his mail order ticket?

Making the First harder to get would simply deplete the already skimpy pool of licensed, talented, people. In large market operations, this is not a real hang-up, since there are always engineers to "babysit" your unlicensed star.

Problem is though, today we have many more small market operations than we have major ones. We are the people who suffer.

My answer to the problem is "Change the requirement." In recent years, the Commission has been characterized by a constant failure to combine practicality with responsibility. With the current state of the art there is no real reason why an unlicensed (Broadcast third) man cannot log transmitter readings for all but the most complicated multi-tower arrays. I go through my rig once a week, not because it needs it, but simply to satisfy myself. I expect there are a goodly number of small-to-medium market CEs who do the same.

What are the advantages? Well, first of all, it has the definite advantage of making more people available for talent in these markets where good air talent is almost un-

(Continued on page 66)

OWN A NEMS-CLARKE FIELD INTENSITY METER?

Don't gamble with unauthorized repair/calibration service. Defense Electronics, Inc., producers of the famous Nems-Clarke quality line of broadcast equipment is the ONLY factory authorized manufacturer that can guarantee warranty and continued quality throughout the life of these precision products.

- Traceable to NBS standards
- Two weeks maximum turnaround
- Genuine Nems-Clarke parts used
- Over 15 years Nems-Clarke engineering experience

For full specifications, prices, spares or service of Nems-Clarke equipment, call or write today.

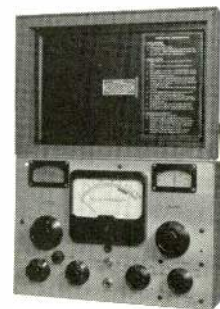

Model FIM-120E (WX2C)

Defense Electronics, Inc.

PRODUCERS OF
DEI AND NEMS-CLARKE
EQUIPMENT



DEI

RESEARCH
DEVELOPMENT
MANUFACTURING

ROCKVILLE, MARYLAND (301) 762-5700; TWX: 710-828-9783; TELEX: 089602 • LOS ANGELES, CALIFORNIA (213) 670-4815 • INTERNATIONAL: ROCKVILLE, MARYLAND • CABLE: DEIUSA; INTELEX: 64102 • Sales Representatives: Rome, Italy • London, England • Madrid, Spain • Tel Aviv, Israel • Bromma, Sweden • Rijswijk, Holland • Koln, Germany • Paris, France • Zurich, Switzerland • Oslo, Norway

Circle Item 25 on Tech Data Card

audio DA

a unique, high-quality,
high-density
Audio Distribution System
— more compact, versatile
and reliable

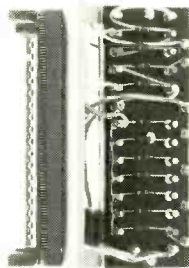

Plug-in rear assembly contains all connections and pads for matching or bridging input and (6) outputs.

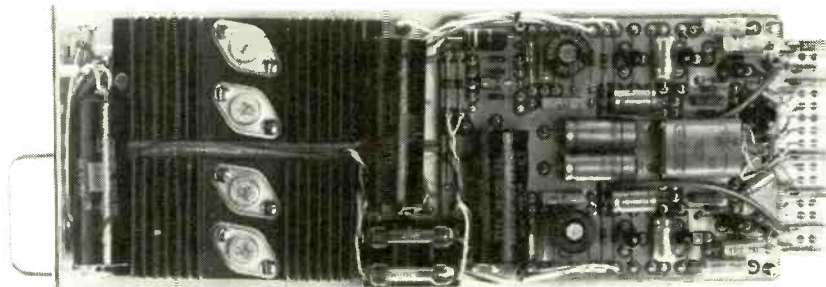

Solid-state AA-601 Audio Distribution Module provides 6 outputs at +24 dbm -600 ohms balanced, or other combinations, as required. Modules can be added to system as requirements grow.

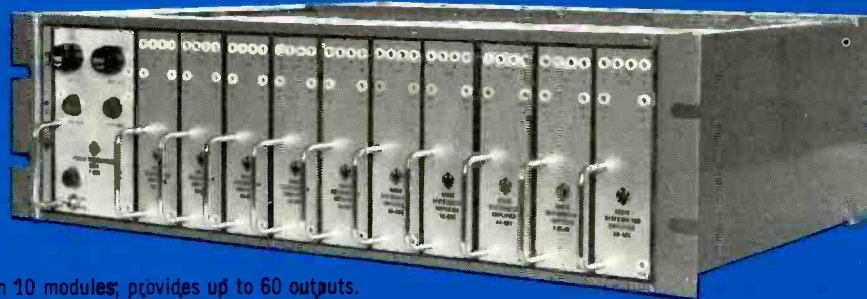

5 1/4" x 19" Frame, with 10 modules, provides up to 60 outputs.

Most compact audio distribution system—no external pads—no output transformers.

Easily customized for individual requirements—easily installed by merely wiring input and output lines.

High isolation between outputs minimizes crosstalk, 60 db or better across entire audio band width.

Response ± 0.25 db 30-15,000 cycles — less than 0.5% harmonic distortion.

Proven by continuous performance in a wide range of application in U.S. and overseas.



WARD ELECTRONIC INDUSTRIES

142 CENTRAL AVE., CLARK, NEW JERSEY 07066 • (201) 382-3700

See this, and many other new exciting Ward products at the NAB Convention

Circle Item 4 on Tech Data Card

New AM Treaty With Mexico Signed

A new treaty governing operation in the standard broadcast band from 535 kHz to 1605 kHz was signed by the U.S. and Mexican authorities in Mexico City on December 11, 1968, (see Dec., 1968 Bulletin). The treaty must now be ratified by both the U.S. and Mexican Senates.

The new treaty will provide a number of advantages for standard broadcast stations in the U.S. These include the provision for 1 kw operation for Class IV local channel stations near the Mexican border, as well as presunrise operation commencing at 6:00 A.M. local time with power up to 500 watts for day-time-only stations operating on the Mexican clear channels (730 kHz, 800 kHz, 900 kHz, 1050 kHz, 1220 kHz, and 1570 kHz.) Reciprocal

provisions are included for Mexican Class IV stations and stations in Mexico operating on U.S. clear channels.

The new treaty also offers improvements in various procedural matters. New notification procedures are established which will greatly facilitate the exchange of technical information concerning the operation of new and changed technical facilities in both countries, and an informal Technical Committee is established to work out minor technical problems as they arise without the need for complete renegotiation of the treaty.

Comments Filed in FM and Television Field Strength Measurement Proposal

The Commission is studying comments filed by various organizations in connection with its proposal to permit the use of field strength mea-

surements to establish the contour locations of FM and television broadcast stations (see May, 1968 Bulletin). Comments both in favor of and in opposition to the Commission's proposal were filed, with most parties acknowledging the difficulties of arriving at the Commission's objective of "a method that will yield substantially the same results when measurements are made, under similar conditions, by independent observers and at different times." Fields in these frequency bands are known to be subject to substantial time variations.

The National Cable Television Association (NCTA) has told the Commission that other parties are addressing themselves "to the solution of the wrong problem," and proposes that the Commission devote its principal efforts toward improving the methods of predicting field strengths in the FM and television broadcast bands. Recent studies by ITS (Institute for Telecommunication Sciences) plus the widespread availability of high-speed computers give considerable indication that prediction methods can, in fact, be improved by the application of modern technology.

Floating Antenna Farm on High Seas

The stars that guided the Phoenicians thousands of years ago in their exploits on the high seas, today play just as important a navigational role serving the Apollo missions exploring the unknowns of space in an effort to put a man on the moon.

Not only are the stars and sun vital to the astronauts in their flight activities, but they also serve as the navigational guides for precise positioning of the Apollo tracking ships which support the mission.

In all, five Apollo tracking ships, each with 445 tons of complex electronic gear, have been assigned to the Air Force Western Test Range, with headquarters at Vandenberg Air Force Base, California, to support man's trip to the moon. Federal Electric Corporation, International Telephone and Telegraph Corporation worldwide service associate

which maintains and operates technical facilities at the Western Test Range, also provides the same function for the complex instrumentation and equipment aboard the tracking ships.

It is the Marine Star Tracker which "updates" position informa-

tion by using angular navigational information on 72 selected stars retained in a shipboard computer memory and an automatic star-tracking telescope which accurately measures angular relationships of the stars in the same manner as a sextant.

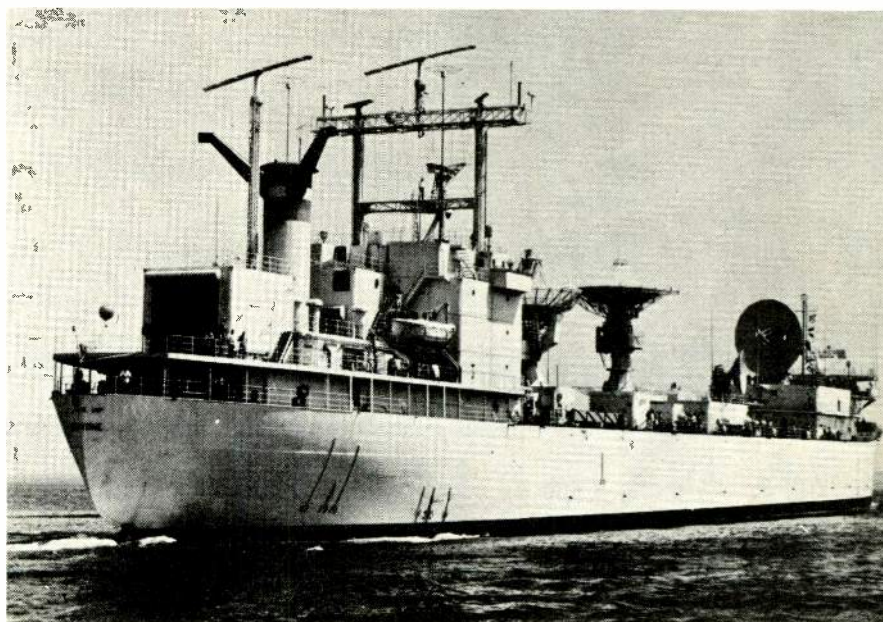

AVOID FCC VIOLATIONS!

Improve your TV image

Enjoy total automatic control
of your video signals with the

VITAL VI 1000

PROCESSING AMPLIFIER

from Vital Industries, Inc.
Most experienced producers of
modern stab. amps. and proc. amps.

Use noticeably at INPUT to: VHF, UHF, 2500 MHZ transmitters, VTR machines, microwave, RF modulators. OUTPUT of: network, remotes, satellites, off air signals, microwave, switchers, VTR machines, QUAD or helical scan. The VI-1000 allows the user to control all the parameters of a color or monochrome video signal without introducing any distortion and eliminating undesirable hum, noise, glitches or bounce.



FEATURES

- Auto/manual video level control.
- Very high noise immune clamping.
- Adjustable regenerated pulse widths.
- Adjustable sync level.
- Adjustable white and black clip WITHOUT CLIPPING COLOR.
- White stretch, black stretch independently adjustable.
- Two input selector switch on front panel with 3-second fade in or out with automatic/manual bypass switch.
- Extensive use of IC's.
- Complete blanking and sync regeneration including all vertical interval pulses or gated sync.
- In the absence of the input signal, internally generated sync and setup is provided.
- Auto/manual setup fully adjustable in either synchronous or non-synchronous modes.
- Original color burst or reinserted burst from local subcarrier or from highly stable phase-locked oscillator. Amplitude and phase adjustable, local or remote.
- Automatic switching between color/mono modes.
- VIT signals allowed to pass or be deleted.
- Auto/manual chroma level correction without distortion.
- Two composite, two non-composite outputs, or all four outputs composite.
- Pulse outputs: Composite sync, composite blanking, vertical drive, horizontal drive, front porch switching.
- All important functions remote controlled.

GOOD ENGINEERING IS VITAL

Call or write for more information

VITAL INDUSTRIES, INC.

3614 SOUTHWEST ARCHER ROAD
GAINESVILLE, FLORIDA 32601 - PHONE (904) 378-1581

Circle Item 5 on Tech Data Card

IEEE Conference Set for Feb. 24-25

The Institute of Electrical and Electronics Engineers, Inc., will sponsor a conference entitled "Where is Technology Leading Communications?" in Washington, D.C., February 24-25, 1969. The conference will delve into present and projected technical innovations which are influencing all communications media. The conference sessions have been structured to appeal to both the engineers who design the equipment and the businessmen who use the new tools. Special emphasis will be placed on the computer and automation techniques in various communications fields. The discussions will be appropriate for persons in the publishing, graphics, advertising and defense industries.

The conference, which is being conducted by the IEEE's Engineering Writing and Speech Group, will be held at the Washington Hilton Hotel. Registrations will open on Sunday evening, February 23.

The first session on the program,

scheduled for Monday morning, February 24, will present an overview of new technologies in the publishing industry, with emphasis on computerized typesetting. The session will be chaired by Dr. N. I. Korman, internationally known consultant and former corporate executive at RCA. Session speakers will discuss equipment applications and capabilities in the publishing industry based on the experiences of the speakers' companies.

On Monday afternoon the conference will sponsor a tour of the Government Printing Office where automated techniques are in extensive use.

The final session, on Tuesday afternoon, will consider changes which will be necessary in editorial practices during the next five years to accommodate the technological advances. Discussions will cover writing, editing, illustrating and layout, and production control. Paul Doebler, editor of **BOOK PRODUCTION INDUSTRY**, will serve as session chairman.

Details on the program and advance registrations may be obtained

by contacting Charles A. Meyer, manager, commercial engineering services, Radio Corporation of America, Harrison, New Jersey, 07029, 201 485-3900.

EAN Message To Be Shortened

Reviewing procedures for weekly testing of the Emergency Action Notification System (Third Method), the Commission shortened the test message from 90 to 60 seconds. This message is on page 65 of a Basic Emergency Broadcast Plan manual used by participating stations, and it informs station listeners that the emergency system is being tested.

Concurring in this and minor editorial revisions were the National Industry Advisory Committee, the Armed Forces Aide to the President, the White House Communications Agency, the Department of the Army (Office of Civil Defense) and the Office of Emergency Preparedness in the Executive Office of the President.

TAPECASTER® T C M

Tapecaster models are head and shoulders above the rest

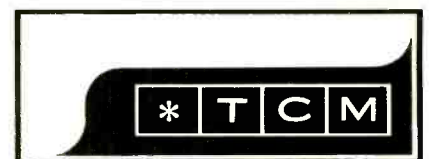

TAPECASTER

Box 662 — 12326 Wilkins Avenue
Rockville, Maryland 20851
Phone: (301) 942-6666

Circle Item 6 on Tech Data Card

You're
looking at
television's most
versatile
camera...

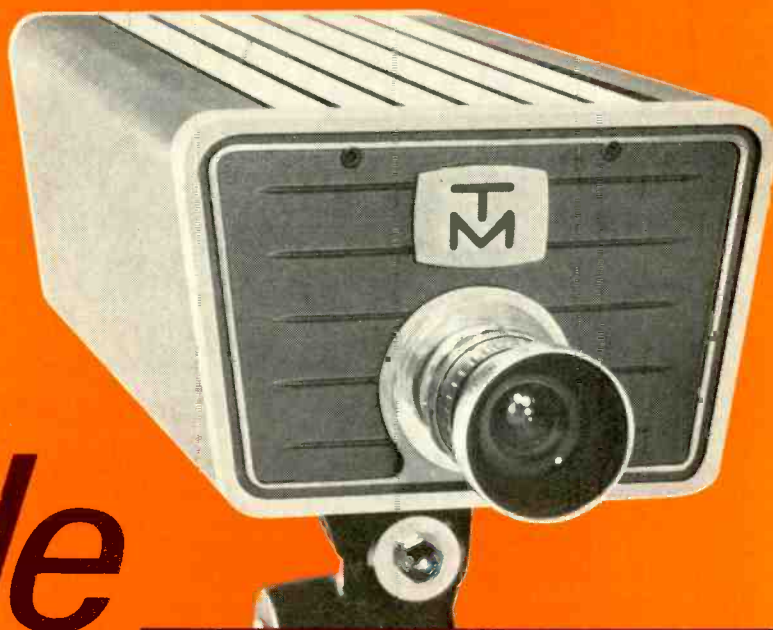

TeleMation's TMC-2100:

- Operation may be self-contained or driven from external control equipment. Select mode of operation with the flip of a switch.
- Six different TeleMation control devices to work with the TMC-2100.

- Four internal sync options (plug-in modules) including: crystal/ drive, 2:1 interlace, and EIA.
- Separate-mesh vidicons may be installed without modification. 800-line resolution guaranteed.

- Portability — Easy (permanent) conversion to viewfinder model — Custom mounting equipment — Single-cable operation.

Versatility is only one characteristic of the TMC-2100. Performance, Reliability, Quality are a few of the others. A full broadcast viewfinder camera (less lens) costs as little as \$2,495.00. Basic random interlace viewfinder camera is \$1,895.00; non-viewfinder camera \$1,295.00.

Find out more about our low-cost, versatile television camera. Write or call for free brochure.



TELEMATION, INC.

2275 South West Temple
Salt Lake City, Utah 84115
Telephone (801) 486-7564



FCC Approves 5 Station Transfer

Assignment of licenses of 5 New York FM stations, and the modification of construction permit for one of the five, from C & U Broadcasting Corporation to Christian Broadcasting Network, Inc., has been granted by the FCC.

The five stations are WEIV-FM, Ithaca, WJIV-FM, Cherry Valley Township, WMIV-FM, South Bristol Township, WOIV-FM, De Ruyter Township, and WBIV-FM, Wethersfield Township.

The five stations were originally licensed in 1947 to the Rural Radio Network, Inc., an organization formed by ten leading farm organizations of New York state. Together, these stations comprise the Northeast Radio Network which provides a unique 24-hour FM service to a major portion of rural upstate New York. The area covers a distance of about 220 miles from Lake Erie on the west to Albany on the east. In addition to providing a service through its own five outlets, the Network makes available a pro-

gram service—primarily news—to a number of AM and FM stations in small rural communities in upstate New York. The stations pick up the signals of Northeast Network directly off the air and rebroadcast the particular programs to their own communities. All programming originates from WEIV-FM and is fed by wire to the four other stations which operate essentially as satellites.

CATV Asks VHF To Share Burden

A CATV system in San Diego, California, has taken issue with the Commission's policy of restricting the growth of CATV systems in the top 100 markets in order to foster the development of UHF television service. The CATV system has told the Commission that in its view restrictions on CATV systems are not the only answer, but that local VHF stations should bear the burden of protecting the growth and development of UHF. These views were presented to the Commission in a petition by the CATV system

asking that the license renewal of a San Diego VHF television station be denied, or that its renewal application be set for hearing.

Short Circuits

A Washington, D. C. consulting engineer has proposed to the Commission that Class II and Class III stations be permitted a daytime power of 2.5 kw; the present Standards recognize no power levels between 1 kw and 5 kw . . . The Commission has ruled that a religious applicant is ineligible for a license for operation on one of the non-commercial education FM broadcast channels (Channels 201-220, inclusive) . . . The Commission has refused to relax the logging requirements for remote pickup broadcast stations . . . A cable system at Riverton, Wyoming, is originating stereo FM programming, believed to be the first to do so . . . The Commission has turned down a COMSAT proposal for the exclusive reservations above 806 MHz for direct satellite-to-home television broadcasting; any such reservations will have to come on frequencies below 806 MHz (Channel 69).

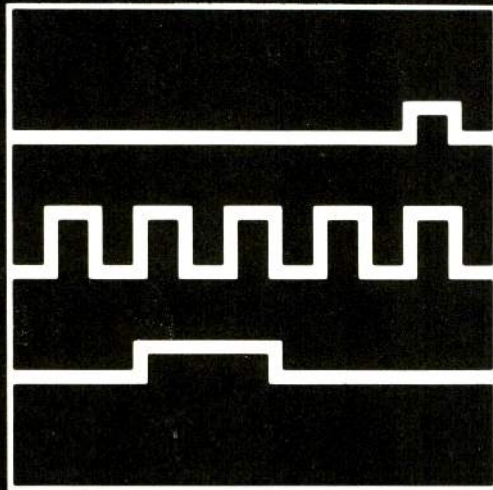

DIGILOGIC

Discover how digital computer techniques have revolutionized television broadcast equipment.

From:



SARKES TARZIAN SYSTEMS
Bloomington, Indiana

Circle Item 8 on Tech Data Card

FLUTTER & WOW METER
FL-5
ALL SOLID STATE

- **SCALE RANGES:** 1.0%, 0.3% to 0.1% full scale. RMS calibration of sine wave flutter according to NAB standard
- **BAND WIDTH SELECTION:**
(a) 0.5 to 6 Hz Wow
(b) 0.5 to 200 Hz weighted to NAB standard
(c) 0.5 to 200 Hz Un-weighted to NAB standard

The Model FL-5 Flutter and Wow Meter has been designed for use where greater sensitivity and lower instrument noise is required.

FL-3D-1 MODEL
Vacuum tube circuitry
Shorter range capability for production testing

WRITE FOR FREE BROCHURE . . .

Sentinel inc.
P.O. BOX 336 • GARLAND, TEXAS 75040

Circle Item 9 on Tech Data Card

UP WITH AVERAGE MODULATION. INCREASE SIGNAL EFFICIENCY.

That's what Gates Solid Statesman Limiting Amplifier will do for your station. It brings broadcast signals up to maximum efficiency by controlling audio levels instantaneously, automatically.

The Gates Limiter attacks modulation problems — in just 3 to 5 microseconds (without audible clipping) and a 30:1 compression ratio allows 99.5% modulation.

Asymmetrical limiting is provided for AM stations, permitting positive peak modulation levels of 110% or 120% with negative peaks limited to 100%, thus producing a louder sounding signal.

Want to hear more? Write or call for full information. Gates Radio Company, a Division of Harris-Intertype Corporation, Quincy, Illinois 62301. Telephone (217) 222-8200.

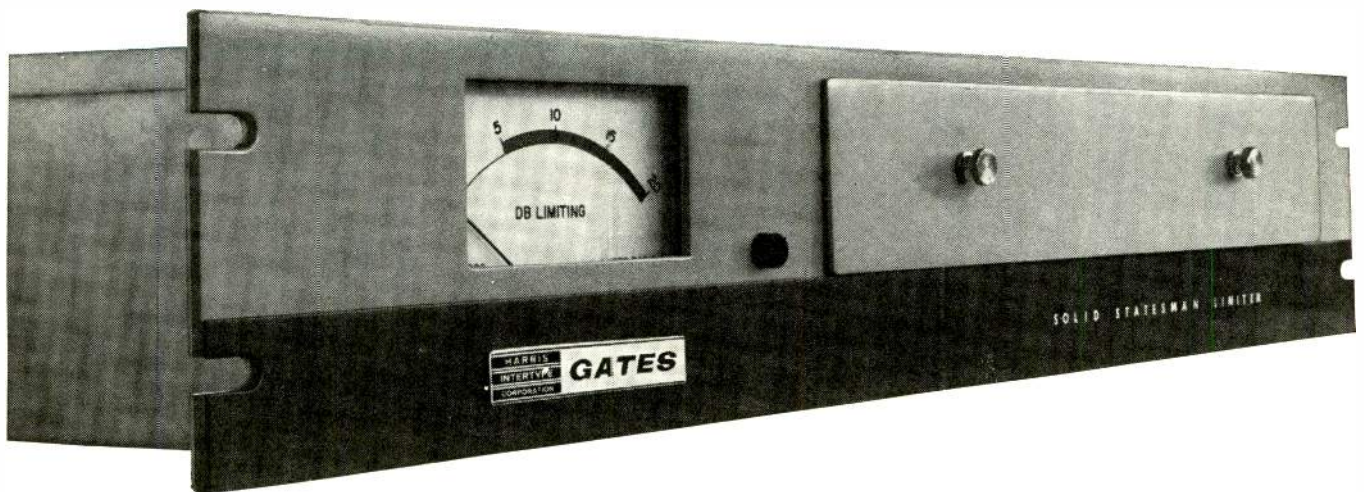

Circle Item 10 on Tech Data Card

WANT TO TAKE THE GAMBLE OUT OF VIDEO TAPE DROPOUTS?

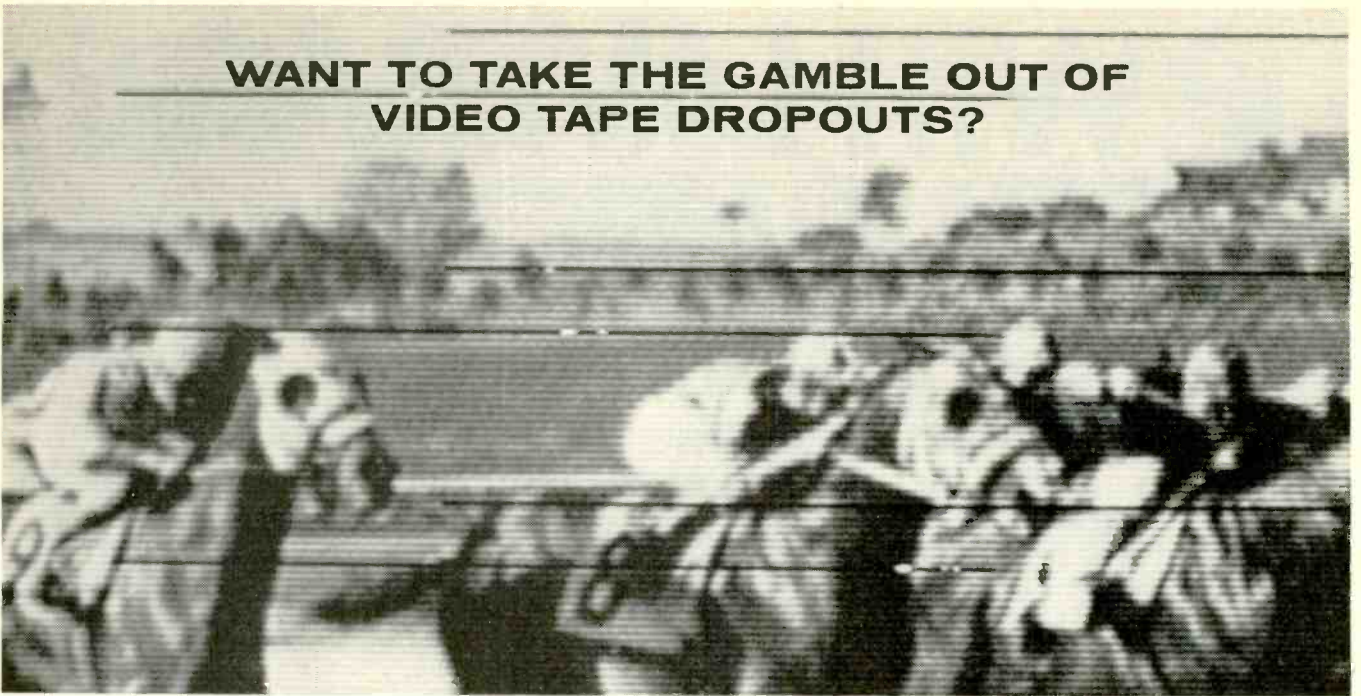

LET 3M's DROPOUT PROFILE RECORDER KEEP YOUR BEST TAPES IN THE RACE

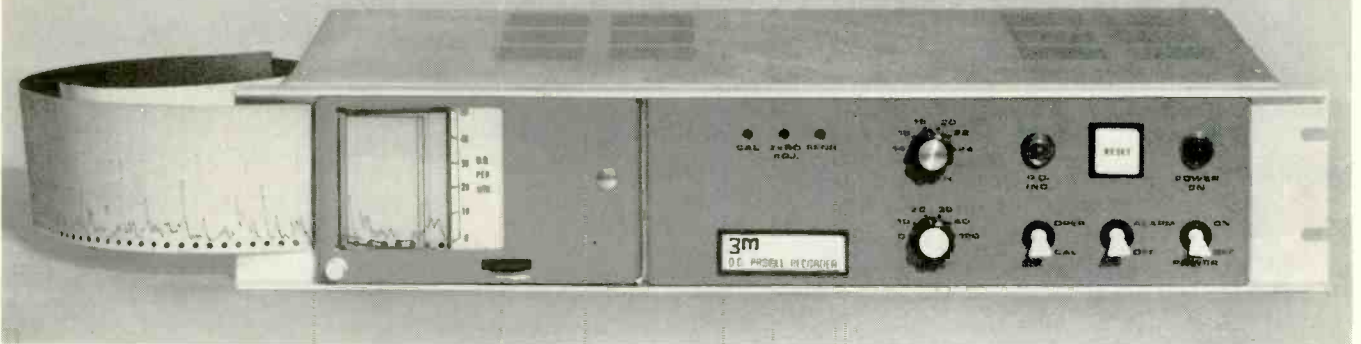

Now for the first time it is possible with the 3M Brand Dropout Profile Recorder to evaluate dropout rate and annoyance factor during normal on-line playback, and to obtain a permanent strip-chart record for future reference. This enables you to decide when quality degradation has reached the point where the tape should be retired.

There's no fooling the Dropout Profile Recorder. It displays the true condition of a tape electronically even while the same tape is being dropout-compensated during broadcast to achieve acceptable visual quality.

As you can imagine, the logical companion to the DPR is the 3M Brand Dropout Compensator. The DOC electronically supplies full-color replacement

of lost video information. But dropout compensation can go only so far. When tape damage exceeds acceptable levels, the Dropout Profile Recorder is the only reliable way to decide on future usability.

The entire record for a one-hour video tape occupies only five inches of strip chart on the DPR. This chart can be evaluated at a glance. It can then be torn off and stored with the tape.

There are several additional features of the DPR which are described in our DPR brochure. (We'll send you a brochure on the DOC also, in case you are interested.) Drop us a line. Better still, call our DPR Information Phone at (805) 482-1911 ext. 216 and request the brochures.

Mincom Division **3M**
COMPANY
300 SOUTH LEWIS ROAD • CAMARILLO, CALIFORNIA 93010
Circle Item 11 on Tech Data Card

Only Sony's got 'em!

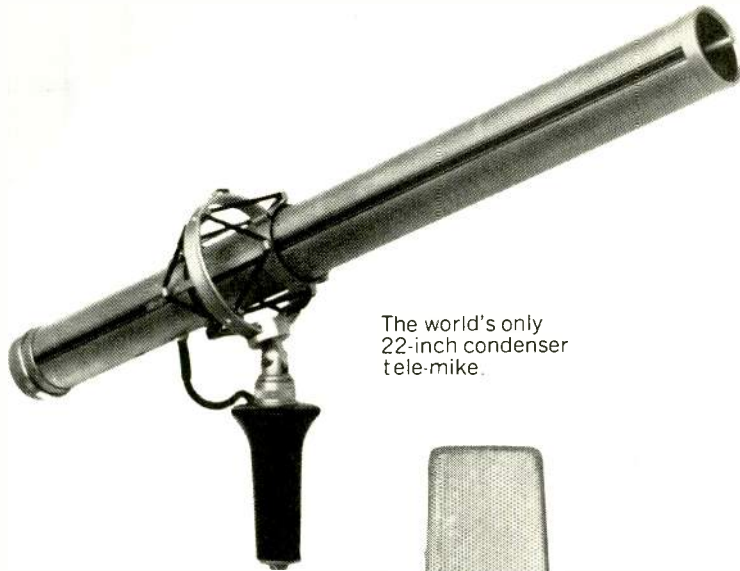

The world's only
22-inch condenser
tele-mike.

The FET version
of the famous
C-37.



The world's first
positionable capsule
for multi-applications.

Innovation through imagination. This is the guideline Sony engineers follow in creating superior microphones for the professional. For example, the C-55's cardioid condenser capsule can be positioned in whatever direction is desired. With the C-77, Sony has shrunk the ordinary, cumbersome tele-microphone to an incredible 22 inches, made it a condenser and achieved fantastic frequency response plus superb hyperdirectionality at all frequencies, from 40 to 12 KHz. And now Sony offers a completely transistorized ver-

sion of the brilliant C-37 A in the C-37 FET. Whichever Sony microphone you choose, you're sure of technical excellence and performance reliability that has successfully met the most critical standards in the world. For complete details and specifications, please write Mr. Charles Bates, Sony/Superscope, 8150 Vineland Ave., Sun Valley, Calif. 91352.

SONY **SUPERSCOPE**

You never heard it so good.

Circle Item 12 on Tech Data Card

REVIEWING SLOW-MOTION DISC PRINCIPLES

By Lee Stratton*

Ed Note: The author uses the development of the Ampex HS-100 as a background for discussing the general principles of disc recording.

■ Color disc recording, successfully used in broadcast television only in the past two years, has become quickly established as a production tool at television networks throughout the world. Familiar to home viewers as the "instant replay" of televised sportscasts, the

*Senior staff engineer, Video Engineering, Ampex Corp.

full capability of video disc recording is little understood today even by many television engineers.

Because of its cost (more than \$100,000 for a color slow-motion recorder) and lack of knowledge of its applications, disc recording has until recently been used only by the networks. Today, individual television stations and television production houses are obtaining disc recorders for a variety of slow-motion and special effects applications.

Disc recording is by no means a substitute for videotape recording. Videotape recording is, of course, necessary whenever long playing

time is required. Maximum recording time is approximately one minute on a disc 16-inches in diameter; most video tape reels contain one hour of recording time. In its specialized applications, however, disc recording holds distinct advantages over other forms of magnetic recording. Advantages include immediate accessibility of picture information; the ability to play back in slow motion, reverse motion and stop action; and excellent picture quality. In comparison with tape, discs show fewer dropouts; have longer life (more passes), and a steadier, jitter-free picture.

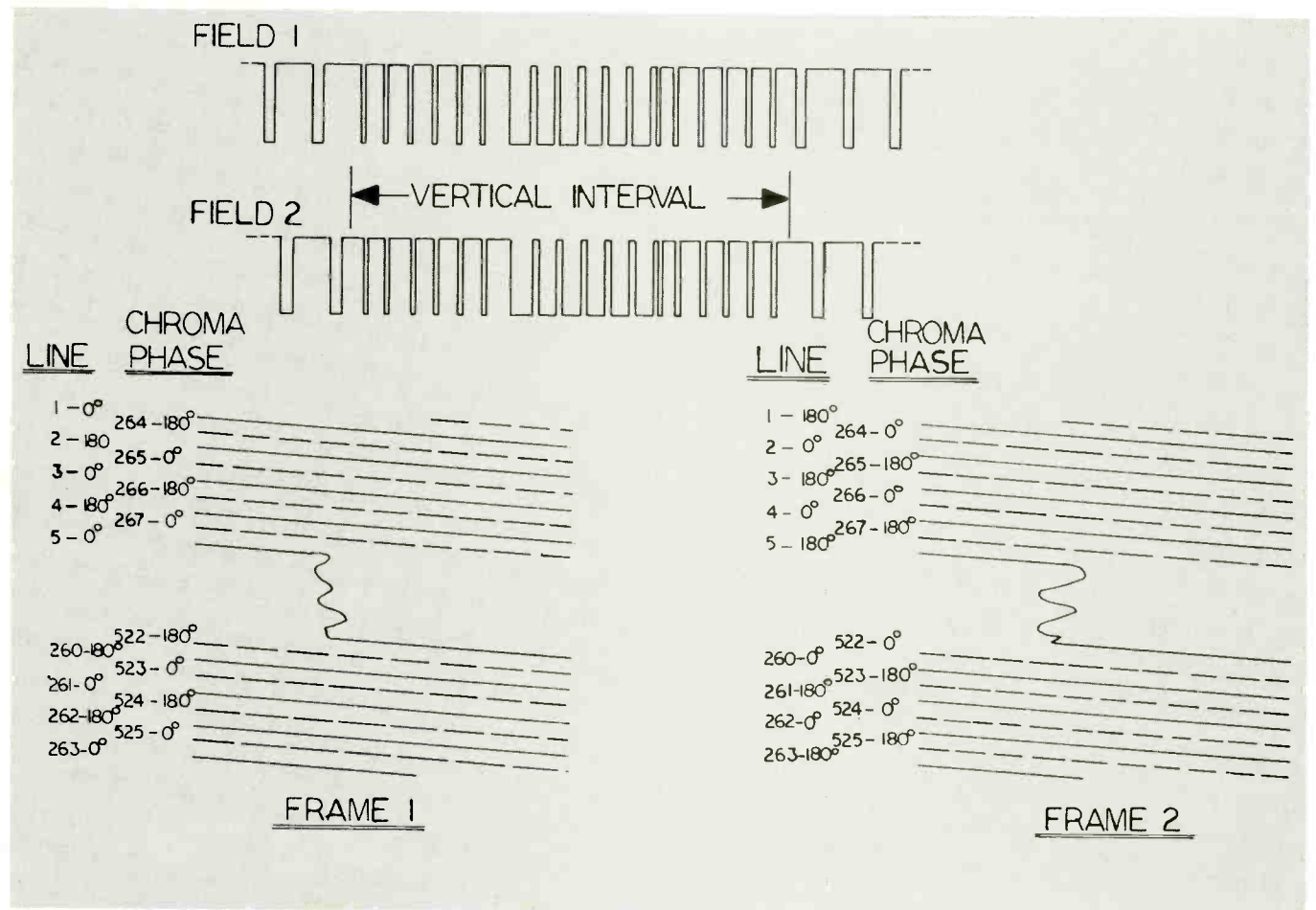

Fig. 1 NTSC scanning diagram showing interlace.

In addition, its "instant replay" capability permits it to be used in time manipulation applications where film cannot possibly compete.

One of the principal elements in the success of this type of magnetic recording is the disc itself. Aluminum substrates are first precision lapped to optical flatness, then electroplated with a thin layer of a magnetic cobalt alloy. The surface is then plated with a few micro-inches of rhodium, which prevents surface corrosion and provides a mirror-like running surface for the heads.

Problems and Solutions

In designing a functional disc color slow-motion recorder, a number of critical problems must be solved. We know that in any system designed to produce slow-motion effects using television video signals, the basic objective is to vary the rate at which picture information is transmitted without disturbing the rate at which lines, fields and frames are scanned. In addition, for color television, no disturbance

of the color subcarrier can be permitted which would adversely affect the hue or saturation of the colors being transmitted, or which would otherwise interfere with the stability of the color demodulation process in a receiver.

The resulting slow-motion video signal must, then, be a normal bandwidth signal, scanned at the normal rate, normally interlaced and containing color components of normal frequency, phase and amplitude. The slow-motion signal must differ from the "live" signal only in the rate at which events unfold on the TV set.

One method of achieving a slow-motion effect would be, on playback, to repeat each frame a predetermined number of times. Repeating each frame three times would produce the effect of one-third speed, repeating each frame twice would produce a half-speed effect, and repeating a single frame indefinitely would produce a stop-motion effect. Such a method, while easy to implement, does not produce satisfactory results because each

frame contains two fields independently scanned 1/60-of-a-second apart. A football, for instance, traveling at 40 mph moves a distance of one foot in this time and exhibits a strong double exposure effect in the interlaced frame.

Therefore, it is necessary to produce slow-motion effects by the repetition of fields rather than frames, and to produce interlaced frames, artificially using the information contained in a single field only.

Fields are of two types (Figure 1), differing from one another in a half-line displacement of the horizontal sync pulses (and video) during the horizontal scanning interval. During the vertical interval, the two types of fields are identical. To convert a field from one type to the other, we insert a half-line delay in the video signal during the horizontal scanning interval. Thus a single field can be converted to an interlaced frame by playing it back once without the half-line delay, then repeating the playback with the half-line delay inserted. The information in the two



Fig. 2 ABC technician operates two discs during college football game.

fields is the same, displaced vertically one-half line on the raster to provide a full frame. In still framing, the single field can be played back indefinitely, with the half-line delay being alternately inserted and removed each time the field is repeated.

Chroma Phase

The problem of maintaining correct chroma phase was tackled next. Referring again to Figure 2, the phase of the unmodulated chroma subcarrier (burst) alternates between 0 degrees and 180 degrees at the beginning of each line. This is because the chroma's subcarrier frequency is an odd multiple of one-half the line rate. Thus in Frame One, odd-number lines begin with a chroma phase of 0 degrees; even-numbered lines begin with a chroma phase of 180 degrees. In Frame Two, odd-numbered lines are 180 degrees, even-numbered lines 0 degrees. When we produce Frame One from a single field played back the second time through the half-line delay, we find that the odd-numbered lines in Field One have become even-numbered lines in Field Two and are therefore of opposite chroma phase to that which is required.

This is corrected with a chroma inverter which extracts the chroma portion of the video signal, inverts its phase, and re-combines it with the luminance components. The chroma inverter is activated for the duration of Field Two. If we continue still-framing for a third field, we now begin Frame Two, which requires removal of the half-line delay but retention of the chroma inverter. Similarly, the second field of

Frame Two is obtained by again inserting the half-line delay, but this time removing the chroma inverter.

When still-framing, the half-line delay is alternately inserted and removed at the beginning of each field, and the chroma inverter is alternately inserted and removed each time the half-line delay is used.

A Slow-Motion Recorder

Playing back each recorded field a selected number of times poses severe problems in incremental motion if conventional tape recording techniques are used. Attempts to modify rotary head tape recorders for slow-motion playback have been partially successful. This problem has been overcome in the disc recorder by recording the individual field as a separate, circular track on the disc surface.

In the Ampex disc recorder in Figure 2, two 16-inch diameter discs are used, rotating on a common shaft at a rate of 60 revolutions per second, locked in phase to an external vertical sync reference. Each complete revolution of the discs corresponds exactly to one television field, beginning and ending during the vertical blanking period.

Four heads are used, one for each surface of the two discs. Each head combines three functions: record, playback, erase. Each head assembly is mounted on an independent drive carriage and moves radially across the surface of the disc. Each field is recorded as a circular track while the head is held stationary against the revolving disc.

In the HS-100, when head "A" has completed recording Field One, Head "B" records Field Two, and so on. After Head "D" records Field

Four, Head "A" is now in place to record Field Five. Thus, each head records every fourth field.

When Head "A" completes recording Field One, it is moved a distance of .010-inch along the radius of the disc by means of a stepping motor. (Tracks are .0075-inch in width, .010-inch center-to-center). During Field Three, Head "A" moves an additional .010-inch so that it is now a distance of two tracks from where it last recorded. During Field Four, Head "A" erases by means of a dc current any signal previously recorded on the track where it is now positioned. At the beginning of Field Five, the erase current is switched off and the record current switched on.

Thus, during record, one head is always recording, one head erasing, and two heads are moving to new positions, as shown in Figure 3.

A sensing device detects when the heads reach their innermost tracks, and direction of head travel is then reversed. The heads begin stepping toward the outer edge of the disc, recording now in the track spaces left vacant during the inward travel of the heads. Carriage motion is similarly reversed at the outer edge of the discs so that recording is continued without interruption.

Playback

When the system is placed in the reproduce mode, the previous 1800 fields are available for playback. The storage capacity of the system is thus 30 seconds. In the "alternate field record" mode, in which only one field from each frame is recorded, the storage capacity is 60 seconds.

In normal speed playback, the

	FIELD 1, 5, 9, etc	FIELD 2, 6, 10, etc	FIELD 3, 7, 11, etc	FIELD 4, 8, 12, etc
HEAD a	RECORD	MOVE	MOVE	ERASE
HEAD b	ERASE	RECORD	MOVE	MOVE
HEAD c	MOVE	ERASE	RECORD	MOVE
HEAD d	MOVE	MOVE	ERASE	RECORD

Fig. 3 Head switching format.

Who makes more kinds of tubes?

RCA

Who handles them all?

Your RCA Distributor

And now...he has this new Guide for you!

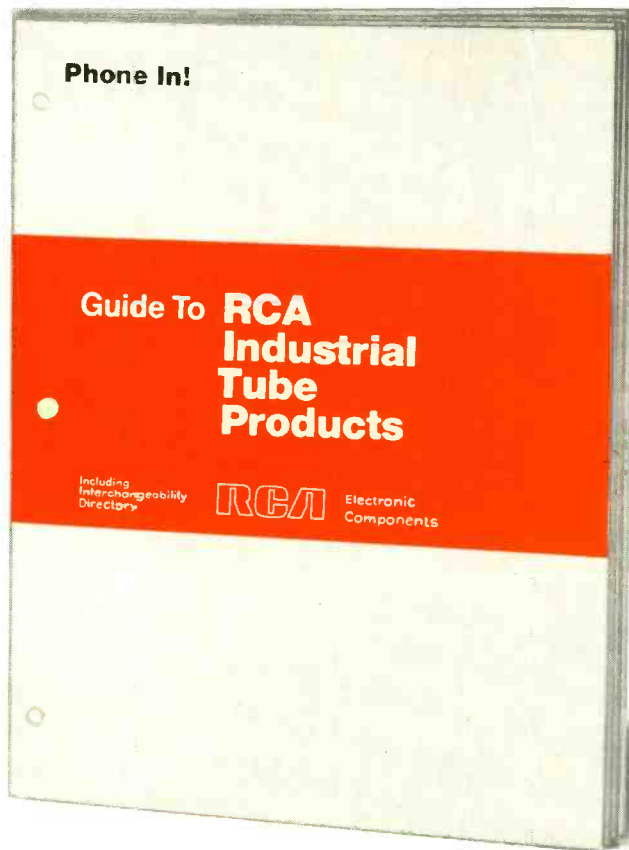

First Time Ever Under One Cover!

New! Combined "Guide to RCA Industrial Tube Products" and Tube Interchangeability Directory.

Receiving. Power. Vidicons. Image Orthicons. Microwave. Photomultipliers. Cathode Ray. Storage. Whatever tubes you want, call your RCA Industrial Tube Distributor. He's your man. He sells the leading brand — RCA. And that's the Company that makes more kinds of tubes than anyone. RCA Electronic Components, Harrison, N. J. 07029

RCA

Join The Big Phone-In
Call Your RCA Distributor

carriage movement is identical to that used in record. The playback signal from the heads is disconnected from the record and erase amplifiers, and is routed instead through a playback switcher to the reproduce electronics.

We may halt the sequence of carriage stepping and signal switching at any point and derive the output signal from a single recorded field. This is still-framing, and requires use of the half-line delay and chroma inverter circuits.

Slow motion is a combination of normal speed motion and still-framing. For reverse motion, the carriages are stepped in the opposite direction and the sequence of head switching is changed from A-B-C-D to D-C-B-A.

Teleproduction Recorder

The advantages of video disc recording in sports "instant replay" can be applied to other aspects of television broadcasting. Disc recording gives new flexibility, convenience and speed in the production of video program material, particularly in animation. And it greatly

simplifies editing. Disc recording systems are now being used to produce color commercials by major teleproduction houses.

The system described here can be computer-programmed to permit storage of pre-selected, individual frames or sequences in the orderly fashion required by the program content. The individual frames are digitally identified on a numerical readout, and the head carriages can be directed to reproduce any given numerically identified frame in whatever slow- or stop-motion mode required.

Lengthy program sequences can be assembled by transferring the individually selected "takes" from the disc to a standard four-head videotape recorder in the edit mode. A built-in, special effects generator with a variable time-base event controller permits selective mixing of the disc output with other program source material from VTRs, live cameras and telecine chains. A combination of these sources provides a flexible tool for electronic teleproduction requirements.

Conclusion

The success of the disc recording for sports coverage has opened the way for the application of disc recording techniques in other fields outside of broadcasting. As smaller, less complex and less expensive disc systems reach the marketplace, the advantages of this recording technique will be expanded into education, industry, government, medicine and sports. Monochrome disc recorders, much simpler to manufacture and operate, are ideal for applications where color recording and playback is not essential. Laboratory applications will be numerous for data acquisition and analysis, time-base expansion and compression and other applications where careful study of visual material is necessary.

School systems will be able to store a limitless supply of visual material on discs for easy access by students in conjunction with audio programming. Slow-motion playback is ideal for sports training where proper form is vital to good performance.

It's a 33¹/₃ hour day for QRK!



CUSTOM 12"
also available in
STANDARD 12" or 16"

33-1/3, 45, 78 or even 24 hours a day . . . the sun never sets on QRK Professional Turntables. Throughout the world thousands of them are working right now.

WHY? Because QRK's exclusive originality, precision manufacture and quality control have earned its place in the sun in all hemispheres. Since introducing the QRK principle 23 years ago, we've discovered there's something extra special about originality — besides being first with an idea Like a Michelangelo, it's always an original . . . You can't hang a QRK, but positioned on your console you can depend on its performance from now on, and like a Michelangelo . . . perhaps just a little dusting now and then. No matter what time you have, somewhere the sun is shining on a QRK.

Check one out or write your dealer or us for more information.



ELECTRONIC PRODUCTS

2125 N. BARTON, FRESNO, CALIFORNIA 93703

QRK's new direct line - (209) 251-0001



The Two-Way Microphone

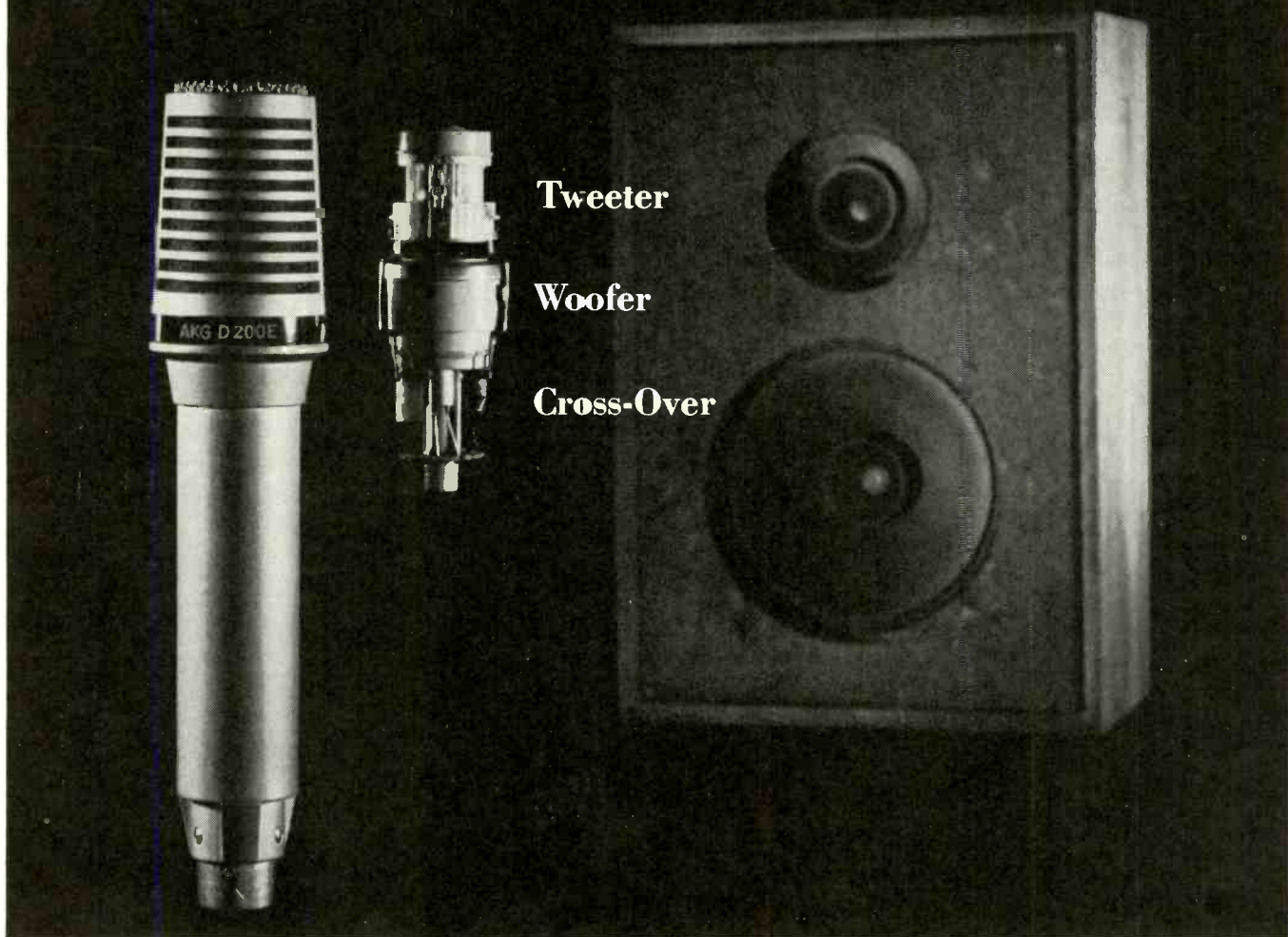

Tweeter

Woofer

Cross-Over

Similar to a two-way speaker system, the total response range of a two-way microphone has been subdivided between a high frequency and low frequency transducer with the cross-over at 500 Hz.

The basic principle is ideal. It took the electro-acoustical competence of AKG to make it possible. It represents the most significant advancement in cardioid dynamic microphones.

The results are performance characteristics formerly unobtainable in cardioid dynamic microphones.

In practical terms this means:

- Natural, objective recordings without discoloration of sound reaching the microphone off-axis.
- More gain before feedback.
- Greater intelligibility and "reach" without deterioration of signals reaching the microphone off-axis.
- Because of elimination of proximity effect there is no rise in bass response to cause feedback or loss of clarity.

Illustrated is the D 200 E, adjacent to its components. Suggested retail net \$69. Write for complete technical description of all **AKG Two-way Microphones.**

AKG-29
*U.S. Patent #3,204,031



MICROPHONES • HEADPHONES

DISTRIBUTED BY
NORTH AMERICAN PHILIPS COMPANY, INC.
100 EAST 42nd STREET, NEW YORK, NEW YORK 10017

AKG CANADA • DIVISION OF DOUBLE DIAMOND ELECTRONICS • SCARBOROUGH, ONTARIO
Circle Item 13 on Tech Data Card

FREEZE IMPLIED

FCC moves to adopt new

Assured by the Supreme Court of its authority to regulate all aspects of Community Antenna Television (CATV) Systems, the Federal Communications Commission has moved to adopt new CATV regulations which will influence the future of all existing and future CATV systems. The new regulations would control the importation of "distant" signals (beyond Grade B) for all CATV systems; would require CATV systems to originate local programming, the content of which would be influenced or largely controlled by the new rules; and would set up limits on multiple ownership of CATV systems as well as cross-ownership with radio and television stations or newspapers.

The proposed new regulations, which are not likely to take effect until well in the future, would strengthen and in many important respects replace those adopted in April, 1966 and now in effect (see June, 1966 Broadcast Engineering). The requirements of the present rules providing carriage and non-duplication protection for television broadcast stations would remain unchanged.

Although now only a proposal, the Commission will take no action inconsistent with the new plan. The practical effect of this inactivity is a partial or complete "freeze" on CATV system expansion, especially as it affects existing or planned systems in the large cities and their suburbs.

Distant Signal Regulations

The most important of the new FCC proposals would tightly regulate the most valuable commodity which CATV has to offer, namely, the bringing in of distant signals which the individual home owner can receive only poorly on his own antenna, if at all. Except in areas outside of newly-defined "television market areas" (see below), the importation of distant signals (beyond Grade B) would be forbidden ex-

cept in those instances where the CATV system could obtain the permission of the originating station for the carriage of particular programs.

Granting this permission might cause station difficulties with numerous copyright owners. The Commission's view, however, is that this would place the CATV system in the position of bargaining in the open market for program material, and would eliminate any "unfair" competitive aspects of the present copyright-free carriage.

Four sets of rules are proposed to govern the carriage of outside signals. The particular set to be applied depends upon whether the CATV system is located in a "television market area" and, if so, the rank of the market area. The present television market areas are now defined for CATV purposes as the area within the composite Grade A contours of the television stations serving the market, which typically extend the distances ranging from 25 miles to 50 miles from the transmitting antennas. Under the new proposal, however, this definition would be abandoned, and television market areas would be defined as the areas within uniform 35-mile circles centered on the principal city or cities where the television stations are licensed.

The first set of rules governs the top 100 television markets. In these market areas, CATV systems would be permitted to carry distant signals only with the express consent of the stations whose programs are to be carried. This would replace the present requirement for a full evidentiary hearing on all requests for distant signal carriage in the top 100 markets. Virtually none of these requests have been granted, and the number of such requests still pending (over 400) makes the holding of the FCC hearings a practical impossibility. All top-100 market hearings now under way will

be halted while the Commission considers the new proposals.

In the case of overlapping major markets, as, for example, Washington-Baltimore and Boston-Providence, a CATV system in one major market would not be permitted to carry without rebroadcast consent any signals from the other market, even though not technically classified as "distant", unless the CATV system is in the 35-mile zone of both major markets. Otherwise, any carriage of the non-local signals would be governed by the consent of the station being carried.

The third situation involves television stations in all markets below the top 100, which are not now protected by the present CATV regulations. These markets would also be defined by the 35-mile circles, and CATV systems in these smaller television markets would be permitted to import without the consent of the originating stations only sufficient commercial signals to provide full service for all three networks, together with the signal of the single nearest independent television station.

The carriage of any additional distant signals would require the consent of the originating stations. An exception would be made in the case of a new independent station coming on the air closer than the one independent already carried. These closer stations could be added to the system without dropping the stations already carried.

Lastly, even for CATV systems outside of any television market as defined by the 35-mile zones, the Commission proposes to condition the importation of distant signals without rebroadcast permission on the requirement that the CATV system bring in all nearer independent signals before carrying the more distant signals. This would prohibit "leapfrogging", the practice of bypassing nearer stations while bringing in more distant stations.

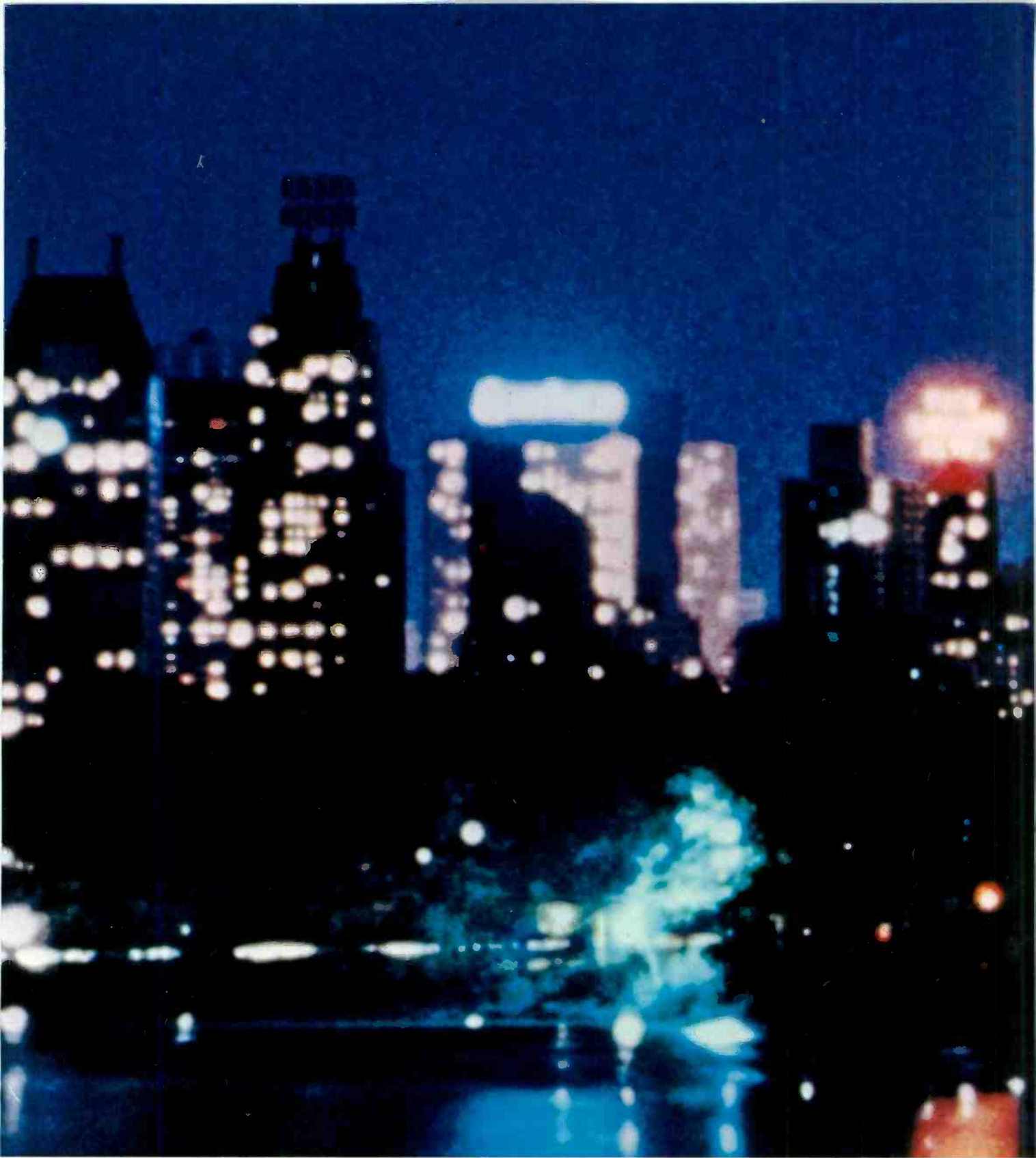

was won.

ity, magnetic properties, and response.

We use over 52 different pieces of quality control equipment, 31 of which were developed by Memorex engineers.

To make sure the tape is indeed a precision tape, we then subject it to 11

different micrographic inspections after production. As you can see, at Memorex, we believe in giving a salesman something to go on.

Memorex Corporation, Memorex Park, Santa Clara, California 95050.

MEMOREX

In fair sky or soup

Helicopter Remotes on 450 MHz

By Leo G. Sands*

One of the most valuable public services a radio station can render—traffic news reporting—has rapidly become extremely popular program material, particularly when handled in a showman-like manner. While some stations depend upon phoned-in reports, several are using helicopters equipped with remote pickup transmitters.

Mobile radio and a helicopter have contributed greatly to making Fred Feldman one of the most popular radio broadcasting personalities in the New York City metropolitan area.

Feldman's traffic reports are broadcast in the mornings and early evenings. In the morning he is heard on the "Rambling with Gambling" program which features John A. Gambling, son of John B. Gambling who first joined the staff of WOR 43 years ago. In the evening he is heard on "Radio New York".

Last October, WOR moved its transmitter site from Carteret, New Jersey to Lyndhurst, New Jersey, and installed a new Continental 50 Kw transmitter and a new antenna farm. Even before the move, WOR could be heard as far away as Canada and as far south as North Carolina during the day. Its coverage now is even greater, and its signal strength in New York City is much higher than in the past. Although Feldman's vehicle traffic broadcasts are primarily of interest to people in the New York City metropolitan area, he is nevertheless listened to regularly by people in other areas.

Feldman's helicopter, known as "Helicopter 710," is equipped with two General Electric 450-MHz band

automotive-type FM mobile radio units which have been modified for operation from a 28-volt DC electrical source. Two mobile units are required—one as a back up—because of possible equipment failure due mainly to vibration. His broadcasts are picked up by an RCA transceiver located on the 83rd floor of the Empire State Building.

Since the base station antenna is not at the top of the Empire State Building, two antennas are required, one on the north side and the other on the south side of the building in order to provide coverage in all directions. Even if there were an obstruction in the line-of-sight path between Helicopter 710 and one of the antennas, the signals would be reflected by the surrounding buildings because of the frequency being used.

The ground station is remotely controlled from the WOR studios at 1440 Broadway a few blocks north of the Empire State Building. Access to the ground station is available in six studios, enabling any of several broadcast personalities to converse with the helicopter.

Feldman's remote radio link operates on 450.25 MHz, one of the 20 UHF remote pickup channels available to the broadcast service. The same equipment is used as an order wire. The helicopter is also equipped with an aviation-type radio to enable Feldman to keep in touch with the tower at LaGuardia. Since he does not have radar on his helicopter, and would not have time to look at the screen if he did, the tower operators keep him posted as to his relative position with respect to jets and other aircraft in the area.

When visibility is poor, flying the helicopter can be hazardous. Feldman reported that at one time when

flying over a highway interchange near the World's Fair site, the pilot of a helicopter operated by a competitive station told him that they were inadvertently within a few dozen feet of each other because of poor visibility conditions.

The reliable communicating range is far greater than that required because of the height of the two antennas on the Empire State Building. Feldman ordinarily is never more than 25 miles from the Empire State Building, so there is no coverage problem.

Although remote pickup broadcast channels are available in the 1.6 MHz, 26 MHz, 150-174 MHz and 450-460 MHz bands, the 450 MHz band was selected because it is essentially free of noise and because there is no coverage problem since adequate base station antenna height is available.

Part 74, FCC Rules and Regulations, permits the use of either AM or FM equipment for remote pickup stations. Stations with a lower budget could use citizens band AM transceivers which can be readily modified to operate on the 26 MHz band remote pickup channels. CB transceivers are extremely compact and usually provide adequate range, particularly in air-to-ground service. At slightly higher cost, AM and FM transceivers designed for commercial land-mobile service in the 25-30 MHz range are also available.

In the 150 MHz band, it is possible to use almost any of the many FM landmobile units now available on the market, several of which are of fully solid-state design. Also, it is possible to use a VHF/FM marine radiotelephone, some of which are directly operable from a 28-volt DC power source.

*Leo G. Sands & Associates



Against the backdrop of New York's skyline and Empire State Building, WOR's "Helicopter 710" is shown during a traffic-reporting flight.

Land-mobile equipment used on aircraft would have to be modified for operation from 28 volts DC if the helicopter is not already equipped with a 12-volt power source. In lieu of modifying the equipment, a DC-to-AC inverter could be used to power AC-type equipment.

It is also possible to use one of the new solid-state 150 MHz band FM walkie-talkies as a remote pickup transmitter. There is need for an external power source since these units operate from self-contained batteries. They can be connected to an external antenna which, for the 150 MHz band, would be an 18-inch whip or one of the physically shorter railroad-type antennas which can be readily attached to a helicopter.

Another alternative is to use an airborne-type VHF/AM transceiver modified to change its frequency range from the 108-134 MHz band to the 150-174 MHz band. No power supply modifications would be required.

In the 1.6 MHz band, an MF/AM marine radiotelephone could be used. Some of these are available with power supplies for 28-volt operation. Probably more convenient, is a portable AM/SSB transceiver of the type commonly used in military applications. Since they operate from self-contained batteries, no power supply modifications are required.

The table lists the available frequency bands and the types of equipment that are available which can be adapted for this type service. When installing equipment in a helicopter it is necessary to provide ample protection from vibration and shock encountered in an automobile. Also, in the case of solid-

state equipment, the unit should not be located so that hot air from a heater will blow on the equipment, which would cause its temperature to rise sharply.

Another problem that might be encountered is ignition noise which could be picked up by the audio circuitry and transmitted with the voice signals. This will require application of noise-suppression devices. Since the helicopter is the transmitting source, as far as program material is concerned, the ignition noise situation is essentially the same regardless of the band in which the equipment is operated except when receiving from the studio.

The use of FM is preferable, but more costly, because noise at the ground-receiving site will be lower. However, FM may not be used at frequencies below 25 MHz.

The FCC permits FM deviation up to \pm KHz in the 450 MHz band, allowing high fidelity audio transmission. However, it is undesirable to take advantage of the available wide frequency response because of high ambient noise in a helicopter. By limiting the frequency response to 3000 Hz, the desired communications-type speech will be heard and less ambient noise will occur in the background. However, the wider-than-normal FM deviation will provide a radio noise improvement. Most FM land-mobile radio equipment is designed for narrow band FM (\pm 5 KHz) but can usually be modified for at least \pm 15 KHz deviation.

The ground station can be at a remote location as in the case of WOR. Or, it can be located at the studio if an adequate antenna site is available. The ground facilities can consist of a transceiver only which is used for both two-way

order-wire communication and remote broadcast pickup. Greater flexibility can be obtained by using a separate receiver, in addition to the transceiver, whose output is fed to the studio audio facilities.

Since most communications receivers have 4 or 8 ohm audio output impedance (some also have 600 ohm output), it is necessary to provide transformers for matching into studio audio facilities. To provide both monitoring capability and program output, an Alco Mix-N-Match transformer can be used. The speaker, shown in the diagram, is the receiver's built-in speaker.

Another technique that can be used in addition to having the helicopter pilot himself find the locations of traffic problems, is to have persons on the ground use mobile radios in vehicles or hand-held portables to communicate with the helicopter and alert the pilot to observe a particular situation.

At least one station has tried using citizens band radio as a source of traffic information. Motorists with CB equipment in their cars were requested to use CB radio on a CB channel to transmit news about traffic problems directly to the broadcast station. However, it has been reported that the FCC put a stop to this because CB channels may not lawfully be used for a broadcast-type service. Broadcast stations, however, can use CB equipment on CB channels for operational purposes but not for transmission of any kind of program material.

Although the cost of owning or renting a helicopter can be significant, their use as remote mobile studios has proved to be profitable in many instances because of public interest in traffic news.

All Solid State Television Microwave Relay Systems For High Quality Color and Monochrome TV Links

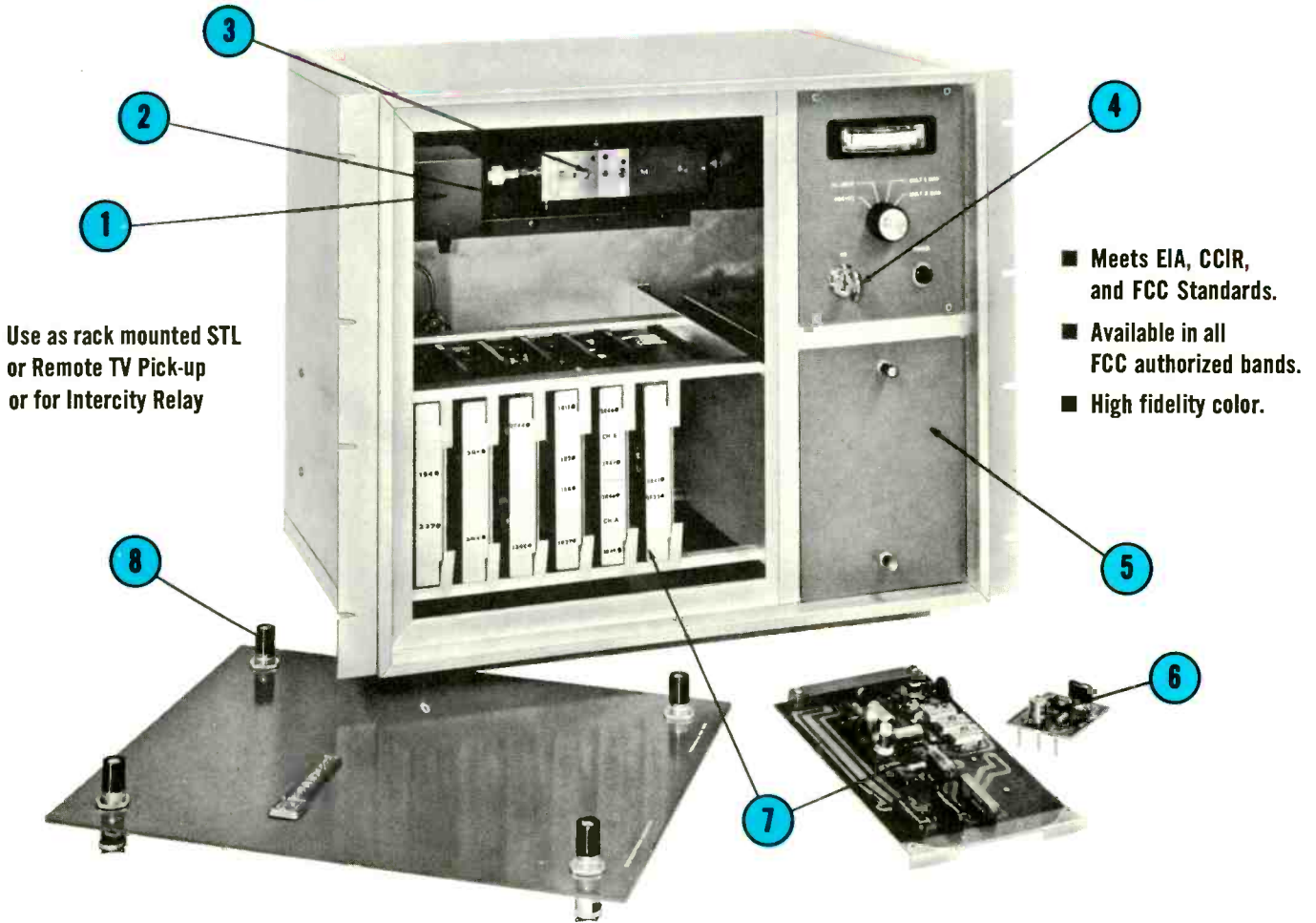

Use as rack mounted STL
or Remote TV Pick-up
or for Intercity Relay

- Meets EIA, CCIR, and FCC Standards.
- Available in all FCC authorized bands.
- High fidelity color.

- | | |
|---|---|
| <ul style="list-style-type: none"> 1 Built-in ferrite isolator 2 All Solid State — easily replaceable RF Module 3 High efficiency varactor multipliers 4 Key lock for secure unattended operation | <ul style="list-style-type: none"> 5 Removable power supply module 6 Plug in pre/ de-emphasis 7 Plug in printed circuit cards 8 Instant panel removal by finger tip fasteners |
|---|---|

RHG, a leading supplier of military TV relay links, now offers Series MRS to the broadcast industry. Transmitters and receivers, with advanced field proven designs provide solid state reliability, no warmup, and low power drain.

To improve your color transmission quality and to insure trouble free operation specify RHG equipment fully described in Bulletin 69C. Call for "no obligation" demonstration.



RHG ELECTRONICS LABORATORY, INC.

See operating link at the NAB Show Booth 544 — Shoreham

Circle Item 18 on Tech Data Card

94 MILBAR BOULEVARD
FARMINGDALE, LONG ISLAND
NEW YORK 11735 (516) 694-3100

February, 1969

Late Bulletin from Washington

by Howard T. Head

New CATV Regulations Proposed

The Commission has proposed sweeping new CATV regulations which would affect virtually all CATV systems now in operation and contemplated (see separate story on Page 14 of this issue). Under the proposed new rules, all except the smallest CATV systems would be required to originate programming as a condition to being permitted to carry the signals of television broadcast stations. The carriage of "distant signals" would be regulated for all CATV systems, and television markets are now proposed to be defined in terms of a 35-mile circle centered on the principal city or cities where television stations are licensed.

In the top 100 markets, distant signal carriage would be permitted only when the CATV system had the consent of the originating station. In markets below the top 100, distant signals could be carried without consent only to provide full network service plus the single nearest independent station. Outside of the television market areas, as many distant signals may be carried as desired, but "leapfrogging" would be prohibited.

The Commission proposes no change in the present practice of requiring the carriage of all local stations, or providing same-day non-duplication protection of all local stations, or in the present priority system governing signal carriage.

Pay-TV Authorized

The Commission has finally authorized the start of regular subscription television (pay-TV) over the air, employing regular television broadcast stations. This service, which has been the subject of debate and experimentation since 1955, is to begin in June, 1969. The new rules restrict pay-TV operation to markets where there are four other regularly operating commercial television stations, which would permit pay-TV authorizations in approximately 89 areas. Only one pay-TV authorization would be granted in any given area.

Rigid controls are imposed on the type of programming which may be broadcast for a fee. These include prohibitions against feature films more than two years old, live sports events already on broadcast TV, or program series such as make up the staple fare of regular broadcast television.

More . . .

The Commission's action came at a time when the single experimental pay-TV operation, a UHF station at Hartford, Connecticut, had cut its pay-TV operation back to the broadcast of a single movie shown six nights each week.

New Performance Standards Asked of FM Modulation Monitors

A leading manufacturer of FM modulation monitors has asked the Commission to change the rules governing the performance of FM modulation monitors. The proposed changes, which would reduce the damping factor and the response time of the indicating meter, would make the monitors more responsive to short peaks of high modulation.

Numerous FM licensees have received citations from the Commission for overmodulation, many of which have been traced to differences in the method of determining percentage modulation (see Nov. 1964 Bulletin). Tests on an FM station at Raleigh, N.C. confirmed the source of the difficulty and indicated that monitors with improved response time would be of considerable assistance in solving the problem. The Commission, however, favors reliance on a flashing over-modulation indicator in preference to the meter indication.

FCC Hearing Examiner Accepts Field Strength Measurements in CATV Case

In a hearing involving the carriage of signals by several CATV systems in the Cumberland, Maryland area, an FCC hearing examiner has relied on field strength measurement data to show the absence of measured Grade B coverage over the CATV systems involved. Television broadcast stations had requested mandatory carriage on the systems, on the basis that the predicted Grade B contours included the systems. The hearing examiner, however, ruled that precedence should be given to the results of an elaborate field strength survey which showed the actual Grade B contours to fall well short of the predicted contours.

The field strength measuring technique recognized by the examiner, whose recommendation must be reviewed by higher authority, is essentially the same as the method now under study by the FCC (see January, 1969 Bulletin).

Short Circuits

An AM licensee in the Washington, D.C. suburbs has been fined \$10,000 and threatened with the loss of his license for numerous technical and non-technical rule violations; among other things, the operator on duty was two hours behind in his transmitter log, and was "catching it up" with false readings when the R.I. walked through the door . . . The Emergency Broadcast System (EBS) message has been shortened from 90 seconds to 60 seconds . . . The Court of Appeals has upheld the Commission's authority to adopt its presunrise rules, holding that individual stations may ask for rule waivers in specific situations where warranted . . . The deadline data for FM stations to have type-approved SCA monitors in operation has been changed from January 1, 1969 to April 1, 1969, with the warning that no further extension will be granted.

Howard T. Head . . . in Washington

The Altec monitor/playback speaker has a new big brother: the 9845 Senior.

When we introduced our Model 844A, (now recoded as Model 9844A), Compact Monitor/Playback Speaker System about a decade ago, broadcast, recording, television and radio engineers quickly adopted it as the standard of excellence and comparison.

Now, we've created the 9845 Senior Monitor/Playback Speaker System. The critical lower mid range has been significantly improved by the use of a new 500 Hz cast aluminum sectoral horn to provide control

of these lower frequencies. The high frequency reproduction to 22,000 Hz is achieved with the use of a larger, heavier magnet, compression type driver. To substantially extend the bass end response, our engineers have designed a larger enclosure of 13-ply wood (9" wider, 4" higher and 8½" longer than the 844A) and have chosen a single Altec 416 type 15" bass transducer to provide optimum lateral dispersion to match high frequency horn at cross over frequency. Total weight is 130

pounds. The smaller 9844A continues to be available where space is a problem.

We think it's the finest Monitor/Playback system available. As a critical audio engineer, you will agree.

Get the whole story by asking for data sheet AL-1756 on the Senior Monitor/Playback Speaker System. Write Altec Lansing, 1515 South Manchester Avenue, Anaheim, Calif. 92803.



A Division of
LTV
Ling Altec, Inc.

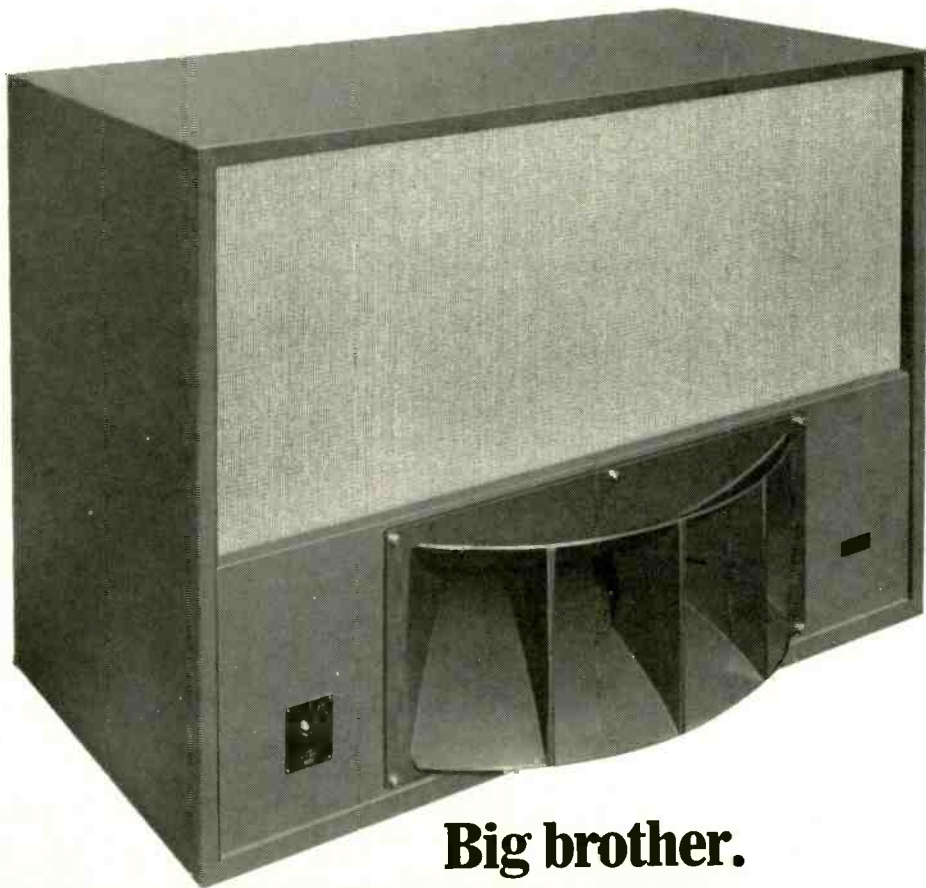

Big brother.

Circle Item 19 on Tech Data Card

Building microphone and line phasing testers

By Charles D. Sears

■ We all know that most equipment in a radio broadcast station does not need to be phased. But when using stereo or multiple microphones in the same room or area, it is necessary to phase the microphones and their lines.

To illustrate the need for phasing microphones, look at the drawing in Figure 1. It shows an upper view of a hand-puppet stage with two puppet operators in the rear and one person in the front. All three persons were wearing lavalier microphones, and were quite close together. The microphone on person number 3 was out of phase with the other two. It sounded as if that microphone was turned off, causing very poor audio for the show.

When one microphone is out of phase with another microphone or microphones, there is a reduction of output, the introduction of varying degrees of distortion, or both. When two or more microphones are connected to a mixer, it is necessary that their outputs have the same phase relationship, or the output from one microphone will oppose the output of another.

A curious thing happens when two microphones are out of phase and receive the same signal. As the input to one microphone is turned down, the output of the mixer goes up. This results from the cancellation of certain frequencies due to the phase difference. The lower frequencies are the ones that normally cancel because of the wavelength of sound. A whole range of frequencies can be lost by improper phasing of just one microphone or line.

Standard Wiring

When I took over as Chief En-

gineer at one FM station, several types of microphone connectors were used with non-standard wiring. The first thing to do was to establish a microphone cable and connector wiring standard. Figure 2 shows the standard that was established. This information was obtained from microphone spec sheets from several mike manufacturers. Also, instruction books for various types of commercial broadcast audio amplifiers and equipment were consulted.

I discovered that several amplifiers used an unbalanced microphone input, mainly when using transistors and no input transformers. This factor was taken into consideration when making the chart and when wiring other equipment. Most of the low impedance microphones have a balanced output, so there is normally no problem here.

Shure microphones were not mentioned in the chart because they usually follow the normal two-wire shielded type wiring. And I do not mean to imply that this chart only applies to the microphone mentioned, but to all microphones. These types are included only because they are in general use in stations, and were in use in my station at the time the standard was set up.

Along with adopting a standard for wiring, the type of connector to be used for low impedance was selected. The Cannon XLR-3 series was in the most general use at the time and is the connector that the standard is based on. However, other connectors at the microphones were encountered, such as the Amphenol 91 series. The same pin numbering was used for these connectors.

The 3-circuit phone plug is shown because it is the type of patch panel

system I use. The system is less expensive than the same number of circuits as the double plug system, and there are no worries about polarity or phasing. If the plug is inserted, the phasing is correct, but with the double plug system, there is a 50-50 chance they will be out of phase.

While using the connector wiring standard, you should keep in mind that the connector at the microphone end of the cable should be wired according to the microphone manufacturer's instructions. Otherwise, the microphone may not operate or it will operate improperly, because of a wiring error.

We have now selected the connector and the wiring standard of that connector. Now we will look into the procedure of actually comparing the phasing of two microphones.

Phase Testing

To check the phasing of two or more microphones, connect one microphone to an amplifier input and set the volume control for the de-

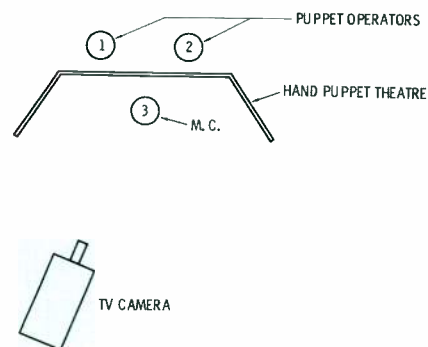

Fig. 1. Hand-puppet setup with operators using lavalier microphones.

sired output while talking into the microphone. Connect the second microphone in parallel with the first, and without changing the control setting hold both microphones close together and talk into them. If the output decreases from the previous level, reverse the cable connections of the second mike to correct the phasing.

There is a lot of work involved when several microphones need to be checked, if you solder several microphone cables together and then start reversing them. Also, when encountering different microphone makes, there will be an occasional one that does not match in phase exactly with the reference microphone. It then becomes slightly confusing as to what phase to leave the microphone on. Therefore, the circuit in Figure 3 was designed. It is a simple method of selecting microphones and reversing the phase of one of them. While this circuit will provide what is needed, it lacks the means to make continuity tests on the associated microphone cable.

Taking this circuit and facts into consideration, a more complex circuit was designed. Rather than duplicating the connectors and building two boxes, the two test functions were combined into one box. The photo and Figure 4 show the next design. It provides the choice of either microphone or both, and reverses the phase of the test microphone. By using an external ohmmeter, cable continuity and connector, wiring of cables with connectors on both ends can be

tested. Cannon XLR-3 series connectors are used with other types of connectors, using plug in adaptors.

Using the Tester

To use this tester, one microphone is selected as reference, and its wiring is carefully inspected to see that it matches the standard. The reference microphone is then plugged into the reference connector on the tester. The microphone under test is plugged to the test connector. A short microphone extension cord is then used to connect the tester to an amplifier microphone input. Next, earphones are

connected to the amplifier, and the VU meter on the amplifier is observed.

Switching the tester to the reference microphone, talk into the reference microphone and set a reference level on the amplifier. Then switch to the test microphone and compare the levels. Now switch to both microphones and talk into them at the same time, with the microphones very close together. The total level should be higher than with either microphone alone. Reverse the phase of the test microphone and try again. If the level is higher this time, this is the proper

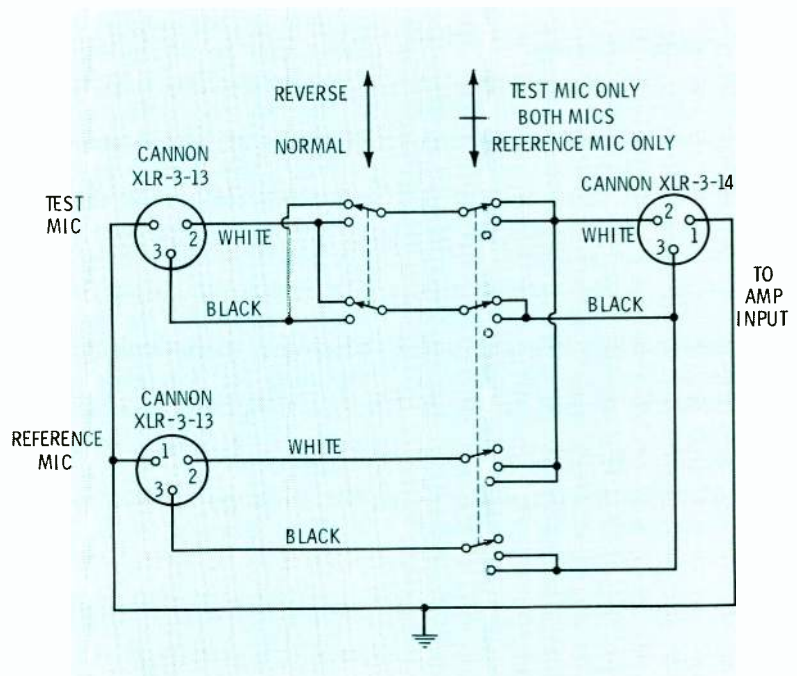

Fig. 3. Original microphone phasing adaptor reverses phase of one microphone.

Fig. 2. Microphone connector standard.

3 Circuit Phone Plug and Jacks	Other Types of Connector	Cannon UA-3 Connector	Cannon XLR-3 Connector	Unbalanced Cannon XLR-3	Single Conductor Shielded	Normal 2 Wire Shielded	EV 3 Wire Shielded	EV 2 Wire Shielded	RCA 3 Wire Shielded	RCA 2 Wire Shielded
Sleeve	Pin 1	GND	Pin 1 (Ground)	Pin 1 and Pin 2 are tied together and are connected to the shield	Shield	Shield	Shield and Red	Shield	Shield and Green	Shield
Ring	Pin 2	Pin 1	Pin 2 (Positive)		Pin 2 tied to Pin 1	White	White	Red	Red	Red
Tip	Pin 3	Pin 2	Pin 3 (Negative)	Pin 3 is considered the hot lead	Black or White	Black	Black	Blue	Black	Black

Note: On 3 wire cables, the shield is not connected at the microphone end of the cable.

phase. When the microphones are out of phase the level will drop considerably.

Correct phasing in the normal position, assures us that the microphone wiring is correct; if it is correct in the reverse position, the wiring must be changed. If the cable is attached to the microphone, the change is made in the plug, but if the microphone uses a detachable cable, the change is made in the microphone head, after first testing the connecting cable for the proper wiring. The connector is removed from the microphone and the wiring is changed there. After the change is made, the microphone is again tested to make sure that it still works, and to be sure that the correct change was made.

Cable Phasing

This brings us to the fact that the microphone cables need to be phased as well as the microphone. Before phasing the microphones, it is a good idea to check out all of the cables with the continuity test to see if the cable is wired to the plug properly. While making this test, also check for cable continuity and for shorts. When I first started making phase tests, I ran into a small problem by failing to check for continuity.

While testing the cable for continuity, it also pays to open one connector to make sure that the shield

is on the correct pin. (I found a case of this recently in one station when one of the operators made an extension cable. The pin continuity was ok, but the shield was on the wrong set of pins. I received complaints of hum when this cable was used.)

After using the tester, it became obvious that it had limitations and was awkward to use. It required several external pieces of equipment. So a self-contained unit was designed and built, as shown in Figure 5. This tester contains an amplifier, VU meter, speaker, ohmmeter, all of the needed switching, and its own batteries. Besides making tests on microphones and their cables, the tester will also serve as an emergency remote amplifier or a monitor or test amplifier. The VU meter can be connected to an external source, and if higher accuracy is desired, the continuity test can be made with an external ohmmeter.

While this tester originally used a built-in battery for the amplifier, it now uses a regulated power supply that operates from 117VAC. The space did not allow for the power supply to be inside, and if there were space, it would have been too close for the input transformer of the amplifier, causing too much hum. The power supply was mounted in its own box the same size as the bottom of the tester and attached directly to the bottom of

the cabinet. As time allows, the ohmmeter will also be redesigned for operation on a higher voltage, and then operated from the AC line supply. The photo was taken before the AC power supply was added.

The amplifier I used is a Round Hills Associates Model AA-200. I modified the gain-control circuit on this amplifier by adding a resistor and capacitor and changing the volume control value. The original control and circuit caused the gain to bounce when the control was changed because DC went through the control.

Round Hills Associates have changed their amplifier and now market the AA-300 which has the same specs, but does not require modification of the volume control circuit. While I used the amplifiers mentioned, any amplifier can be used as long as it provides the gain and impedances necessary.

This tester is used similarly to the other tester, but all of the functions are in one box. The reference microphone is selected, its wiring checked out, and then it is connected to the Reference Mike connector. The test microphone is checked for proper wiring and then connected to the Cable Continuity Test Mike connector. The function switch is set to Amp On/Phase Mikes, the Test Mike Phase Rev switch is set to Normal and the Amp Input Mike Selector switch is



Fig. 4. Tester offers choice of either or both mikes and reverses the phase of the test mike.

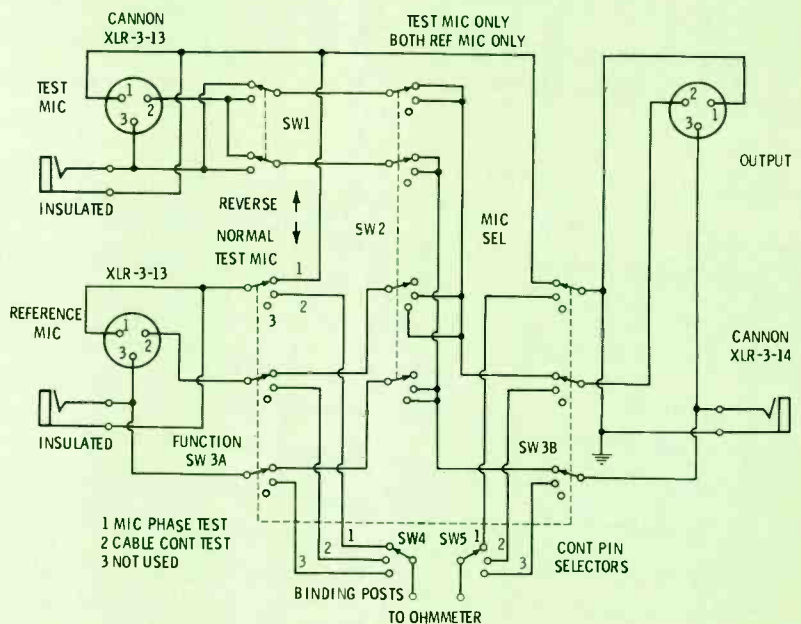

REACH A NEW HIGH IN SOUND FIDELITY...



AEL's NEW FM SOLID STATE EXCITERS and SOLID STATE STEREO GENERATORS!

NOW, with solid state technology, AEL brings you the Sound Fidelity of the 70's. You'll broadcast sound so *real* your listeners will think they're there! It's easy too. Why maintain tube inventories? Or put up with a bothersome preventive maintenance program? Forget them by updating your broadcasting equipment with AEL's Solid State Exciters and Stereo Generators. Better yet: Investigate AEL's entire line of FM Transmitters equipped with solid state Exciters and Stereo Generators. It's the best equipment you can buy, if you're concerned with *greater reliability, longer life and better sound*. After all, aren't these what broadcasting is all about? And remember, you don't have to own AEL transmitters to use the new Exciters and Stereo Generators.

Model 2202 FM SOLID STATE EXCITER

EXCELLENT STEREO SEPARATION and extremely low distortion (0.25% max., 0.1% typical, monaural)—without compromising AFC action—is provided by a broad, flat response assuring negligible phase shift.

OUTSTANDING STABILITY is achieved by an AFC feedback loop utilizing a pulse count discriminator.

EASY TO OPERATE, with most alignment controls located on the front panel. Quick, positive alignment is accomplished while the Exciter is mounted inside the transmitter.

MAXIMUM OPERATING RELIABILITY is provided by solid state design. Particular attention has been paid to device protection, such as current limiting of internal power supply to the power amplifier. Compact 19" rack mounting, 7" high by 6" deep.

Model 2203 SOLID STATE STEREO GENERATOR

EXCEEDS ALL SPECIFICATIONS for stereophonic broadcasting. Each audio channel operates with a maximum of 0.25% distortion (typically 0.1%) and a minimum of 40db separation.

ONLY SEVEN CONTROLS, located on the front panel, facilitate quick and positive signal adjustments.

INSTALLATION IS SIMPLE, accomplished in only minutes. Generator is shipped factory tuned and tested for optimum performance.

COMPACT, 19" RACK WIDTH, Generator takes up only 6" depth behind panel, is 3½" high. Valuable space inside transmitter can be used for additional accessories.

SEE THIS EXCITING NEW EQUIPMENT AT THE NAB SHOW
AEL BOOTH 506 • Shoreham Hotel Exhibit Area



American Electronic Laboratories, Inc. / BROADCAST EQUIPMENT DIVISION

P. O. BOX 552CM, LANSDALE, PENNA. 19446 • PHONE: 215/822-2929 • TWX: 510-661-4976
Circle Item 20 on Tech Data Card

set to Reference Mike. The Amp Output Sel switch is set to Both and the volume is adjusted to give a decent reading on the VU meter without feedback (It is your choice as to what method of indication that you like). You may also use headphones if you desire instead of the speaker, which I do at times.

Talk into the reference microphone to establish a level. Switch to the test microphone and see if the level is about the same, then switch to both microphones and compare the level with the previous level. It should be slightly higher than either microphone alone. To be sure that the phase is correct, reverse the phase of the test microphone. The output level should drop while talking into both microphones.

The ohmmeter circuit was derived from several other circuits and attempted to achieve a circuit that would measure low resistance. This circuit provides about 50 ohms in the center of the scale. The limiting factor is the VU meter. That is the reason I plan to use a higher voltage for the ohmmeter circuit at a later date. I have not had any problems with the circuit, nor has it caused any trouble with anything tested. No current flows from the battery unless the measuring contacts have made a complete circuit.

Switch 2, the amplifier input selector switch, selects the microphone to be listened to. The pad that follows the switch provides the proper match to each microphone and to the amplifier when only one or both microphones are used. The level should not change when the switch position is changed.

The power is controlled with the function/power switch. While it is not necessary for the power to be on the function switch, I felt it desirable, so that only the battery in use would be on. Also, there was a better chance that I would turn off the unit when it was not in use.

The ohmmeter circuit is set up so that it can meter the input connector or continuity between the input and output connectors. Occasionally, it is desirable to check a one-ended cable for shorts, and this arrangement makes it possible.

Now, back to the puppet theatre and the specific problem with its microphones. This is one case where the microphones had been thoroughly tested for phasing prior to

the TV show, and all seemed to be in good working order. This time the wiring from the wall socket to the console was the culprit, and this one circuit was reversed as compared to the rest of the lines. This brings up the point that the wiring of the station should also be checked.

Some of the original testing of the console input wiring was done with a stereo test matrix and an audio oscillator which provided the two signals and allowed reversal of one of them. This time a tone was used for the signal source. This matrix proved a little awkward to operate, so a tester specifically designed for the purpose, (Figure 6 and photo) a audio console input phase tester, was built. It consists of a single frequency tone oscillator, an attenuator to lower the level to the microphone level when needed, an output switch and output matching transformer.

To test the phasing of the console inputs, connect the reference output to the console input that has been thoroughly checked for wiring and selected as the reference channel. Turn on the tone oscillator and set the attenuator and the level control on the tester for the approximate desired level. Then set the pot on the audio console for exactly 0 VU. or some convenient level. (As most console pots are step attenuators, set the pot for the approximate level and adjust the oscillator level for exactly 0 VU). Connect the test output to the console input to be tested, and set the pot for this channel, with the tester output set for test only, for 0 VU. Now switch the tester to both-in phase. The VU meter should read the same level as before, 0 UV. If the level drops, the inputs are out of phase.

Now turn the output switch to both-reverse test phase. If the console is wired properly, the level should drop down considerably. Switching proves that the box and the inputs are working properly. If the input is out of phase, the wiring should be checked to determine where the wiring error was made.

Tester Operation

The tester oscillator runs about 3 kc. The frequency is not important, since it is where this particular oscillator happened to come out. A lower frequency might be better,



Fig. 5. Tester with VU meter, amplifier, speaker, ohmmeter and batteries built in.

- Switch 1—Test mike phase reverse
 - pos 1—Normal
 - pos 2—Reverse
- Switch 2—Amp input mike selector
 - pos 1—Reference mike
 - pos 2—Both mikes
 - pos 3—Test mike
- Switch 3—Function power switch
 - pos 1—Amp on phase mikes
 - pos 2—Cable continuity
 - pos 3—Off (external cont meter)
- Switch 4—Input continuity selector
 - pos 1—Pin 1
 - pos 2—Pin 2
 - pos 3—Pin 3
 - pos 4—Pin 4
 - pos 5—Pin 5
 - pos 6—Pin 6
- Switch 5—Output continuity selector
 - pos 1—Pin 1
 - pos 2—Pin 2
 - pos 3—Pin 3
 - pos 4—Pin 4
 - pos 5—Pin 5
 - pos 6—Pin 6
- Switch 6—VU meter selector
 - pos 1—External VU input
 - pos 2—Amplifier output
 - pos 3—Off
 - pos 4—Off
 - pos 5—Cable continuity
 - pos 6—Amp battery check
- Switch 7—Continuity meter selector/ calibrate switch
 - pos 1—External meter
 - pos 2—Calibrate both meters
 - pos 3—Internal meter
- Switch 8—Amplifier output selector
 - pos 1—Line
 - pos 2—Both
 - pos 3—Speaker
- Switch 9—Output continuity selector
 - pos 1—Input connectors
 - pos 2—Normal (output connectors)

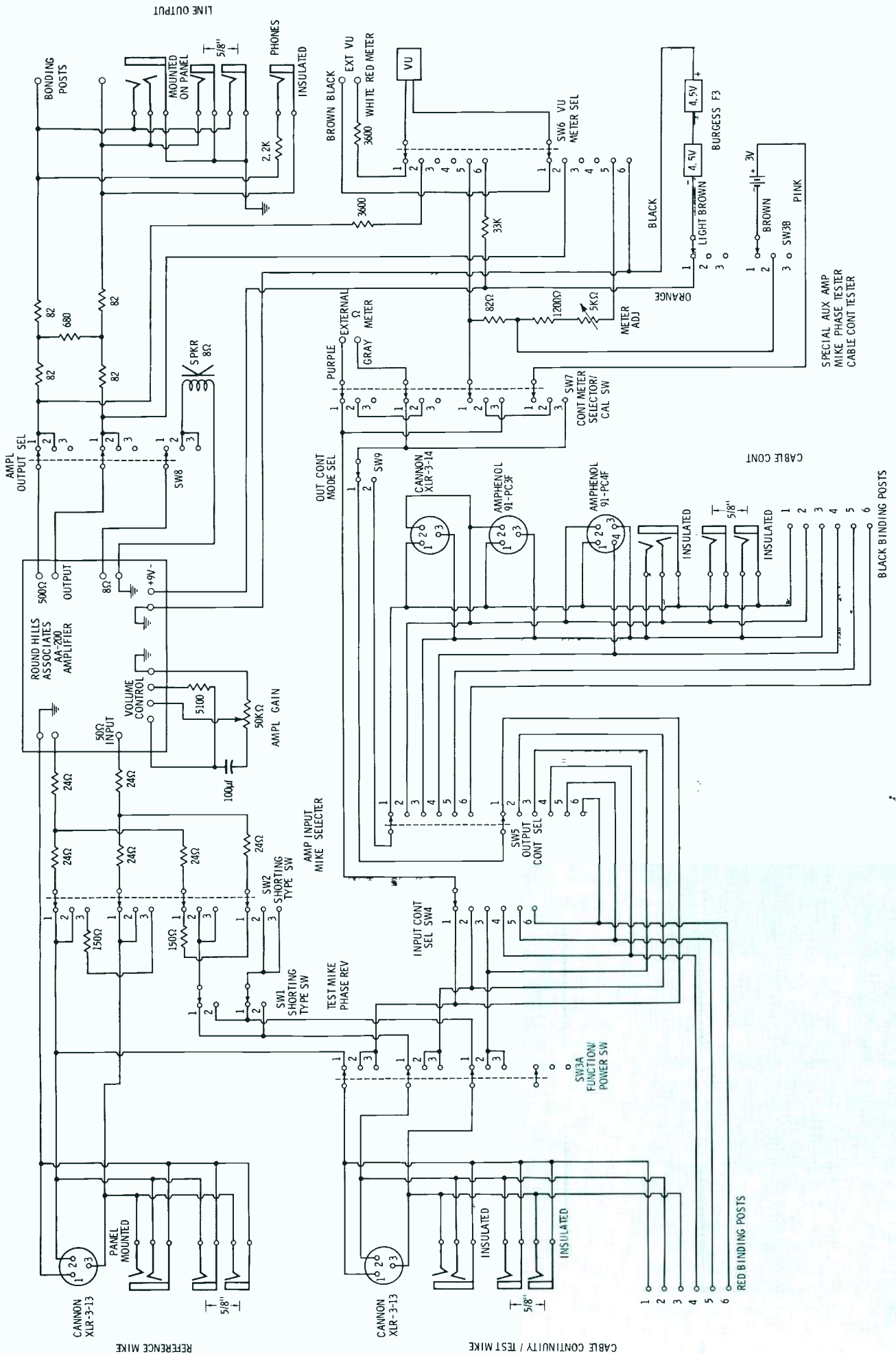

REFERENCE MIKE

CABLE CONTINUITY / TEST MIKE

SPECIAL AUX AMP
MIKE PHASE TESTER
CABLE CONT TESTER

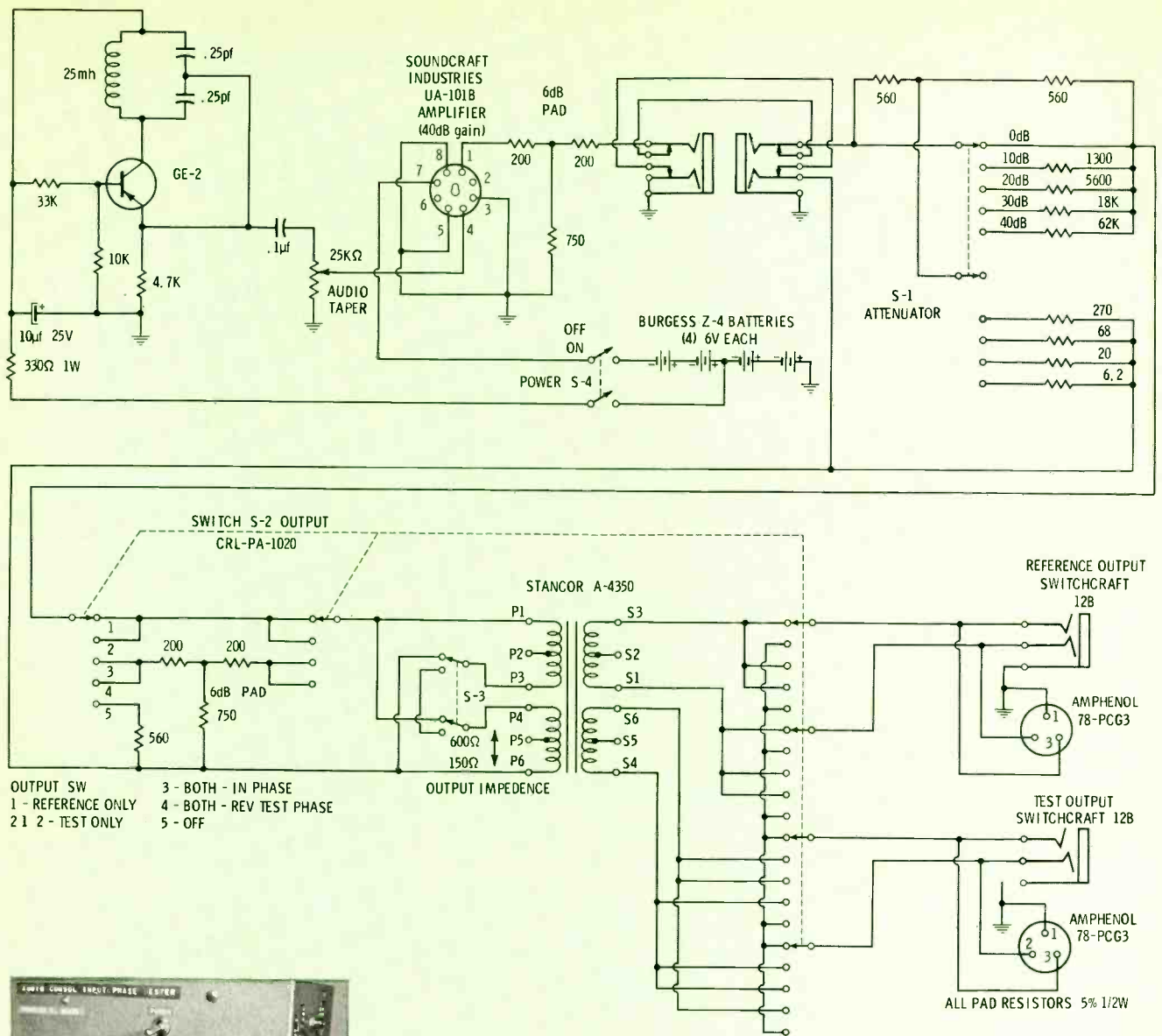

Fig. 6. Audio console input phase tester.



where line length will have less effect on phase shift.

The frequency of the oscillator can be lowered by changing the .25 uf capacitors to larger values or changing the inductor to a higher value. It is preferable to raise the inductor. The oscillator feeds a Soundcraft UA-101B amplifier. A fixed pad follows the UA-101B amplifier because it either requires a resistive load or a transformer load.

Since a switchable attenuator was used, resistive termination was permanently provided. The attenuator provides up to 40 db of attenuation

in 10db steps. The output switch selects which output is being fed and adds a 6 db attenuator so that when feeding both inputs of the console in phase, the VU meter is not pegged and will read the same level as a one input feed.

The output impedance switch changes the primary wiring of the transformer instead of the secondary. This way the unit was easier to wire and cheaper to build, as this transformer costs only about \$5.00 compared to a 3-winding transformer of good quality which may run \$25.00 or more. Jacks are provided so that the oscillator may be used separately or else another os-

cillator may be used with the tester.

While it may appear that this tester could also be used for stereo measurements, it is not recommended. The output transformer is not of high quality, and is not exactly matched. This would cause poor frequency response characteristics as well as other possible deficiencies. Also, the pad used to drop the level that is part of the output switch would cause problems with stereo measurements. This transformer has not caused any problems in the type of service it is in and will function quite well in phasing the stereo lines and amplifiers. ▲

TWO OF A KIND

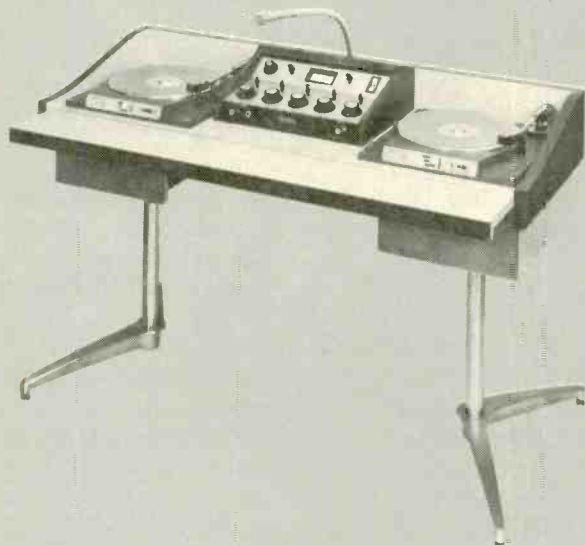

THIS ONE

is a complete broadcast facility for use in recording or production studio, plus versatile portability for remote broadcast assignments. Rugged and compact, yet professional in every respect!

Exclusive features include:

- Two 3 speed custom turntable systems
- Removable solid state console
- Monitor and cue system
- Lift-Leaf work surface

A variety of optional accessories:

- Matching bench lid
- Removable equipment shelf
- Dynamic cardioid microphone

Send for detailed information on the
AC - 155 Studio Control & Remote Unit.

Only \$1195

AND THIS ONE!

A complete audio center designed for master control use. Rich, scratch resistant wood grain finish cabinets add that custom furniture look to your studio at a surprising low cost. Plenty of storage or equipment rack space, too!

Standard features include:

- 8 Channel solid state console
- Dual 3 speed custom turntable systems
- Complete cartridge record/playback system
- Cartridge storage hutch
- Shipped completely assembled

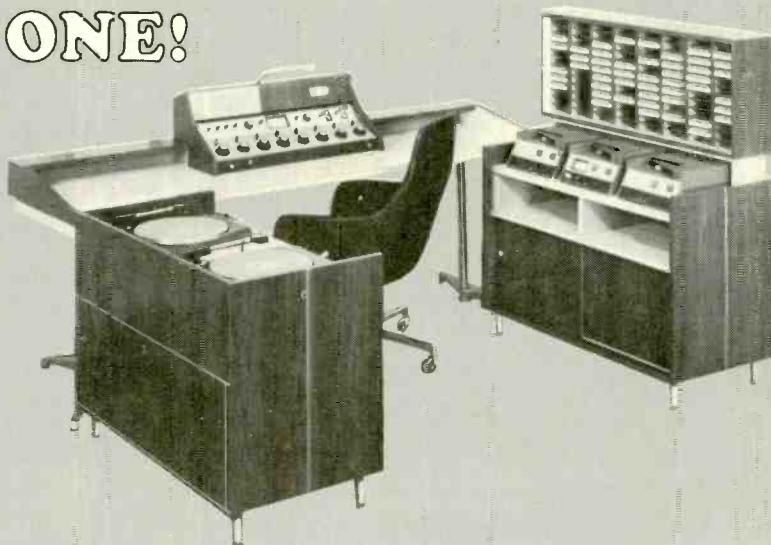

Write for complete information on Sparta **SHOWCASE CONTROL ROOM CABINERY**
All cabinetry & equipment shown (except chair)—under \$4000.

 **SPARTA**
ELECTRONIC CORPORATION

5851 FLORIN-PERKINS ROAD SACRAMENTO, CALIFORNIA 95828

A DIVISION OF COMPUTER EQUIPMENT CORPORATION (916) 383-5353

Circle Item 21 on Tech Data Card

NEW PATHS FOR TV REMOTES

By Leo G. Sands*

Big city TV broadcasters and the networks depend heavily on remote TV pickups, particularly for on-the-spot coverage of news and sporting events. The cost of a modern, fully-equipped van for color TV remote pickups can approach half a million dollars and even more.

Broadcasters serving smaller audiences often cannot afford such extravagant remote pickup facilities. Those in areas served by CATV systems which originate local programs are faced with serious competition for audiences. As the viewing public becomes tired of network programs and movies, programs of purely local interest will attract larger audiences.

A CATV system has the advantage that it can provide programs on more than one channel at the same time. The typical new CATV system is designed to have capacity for 12 TV channels plus the entire FM

radio band. Some are installing 20-channel systems, and even 40-channel systems are being installed. Of course, viewers must buy or rent converters to use with their TV sets to enable reception of more than 12 channels since the UHF capability of their receivers is not used when receiving via a CATV system.

It is not only a public service but an economic necessity, now and/or in the near future, for TV broadcasters to provide local programming. While many local programs can originate in a studio, there is often a great advantage in being able to pick up programs where the action is. Having remote TV pickup facilities enables a broadcaster to take his viewers to the scenes of action such as the local ball park, stadium, city hall, etc., as well as to conduct man-on-the-street TV interviews.

The easiest way is to use film or videotape for delayed broadcast. But, there are many times when a program will attract a bigger audience if it is aired at the time it is happening. For example, who cares about a ball game after the scores

have been broadcast via radio? This requires remote TV pickup facilities which can be used for both live and delayed videotaped programs.

For remote TV pickups, three basic things are required—cameras and associated equipment for viewing the action, a program transmission medium and program receiving equipment at the studio. Also, often lights are required for illuminating the scene to be televised.

Since at least one spare camera is available at any TV station, the most important link in the chain is the transmission medium. It can consist of a video circuit and an audio program circuit leased from the local telephone company. Mobility is limited to points of access to such facilities, particularly a video circuit. In many communities these facilities do not exist and to get them, high construction charges might be involved.

There is an alternative in communities served by a CATV system. The owner of the CATV system may not be aware of the fact that the main trunk line of this cable plant could be used by a TV station

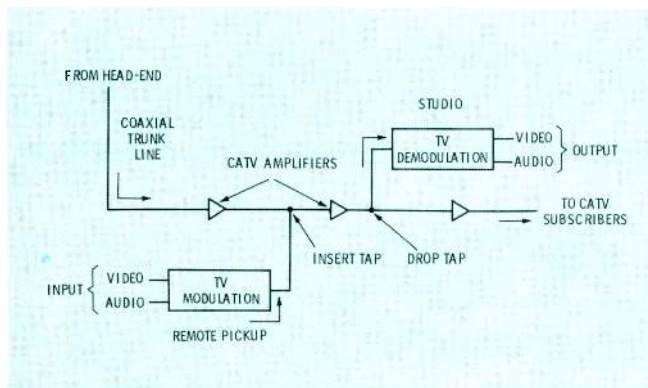

Fig. 1. Remote pickup channel piggy-backed on CATV system (downstream).

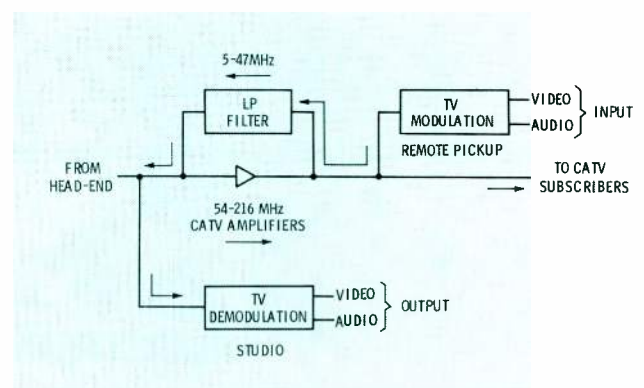

Fig. 2. Remote TV pickup channel piggy-backed on CATV system (upstream).

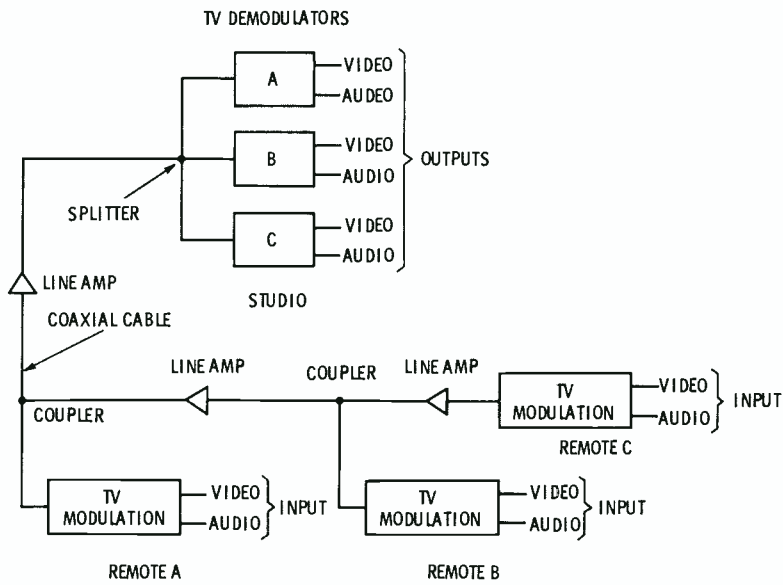

Fig. 3. Private coaxial cable remote pickup system multiplexed for three channels.

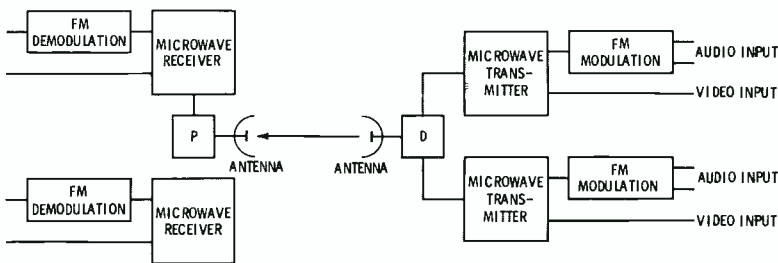

Fig. 4. Two channel TV microwave link.

as a transmission medium between a TV studio and a remote pickup point. If the studio is downstream from the remote pickup point, one or more video and audio circuits can be piggy-backed on the trunk line cable, as shown in Fig. 1. The video and audio signals are applied to a TV modulator whose output signals

are injected into the coaxial cable. These modulators would operate at frequencies below 54 MHz, between 108 and 174 MHz or above 216 MHz.

If the studio is upstream, the signals can be transmitted at frequencies below 47 MHz. To make the trunk line cable bidirectional, a low

pass filter or amplifier is bridged around the existing trunk line amplifiers, as shown in Fig. 2. Signals to the TV studio flow upstream simultaneously through the same cable. Furthermore, order wire facilities can be provided by using AM or FM modulators and demodulators, operating within the 42-46 MHz band in the upstream direction and within the 72-78 MHz band downstream.

Whether CATV facilities can be used for this purpose depends upon whether the CATV system operator is authorized by local laws to function as an intra-state common carrier. In the case of a CATV system operated by a telephone company, this is no problem.

When one or more remote pickup locations are firmly established, a broadcaster can lease circuits from the telephone company, use CATV facilities, or construct his own cable transmission system. If a CATV system operator can obtain rights to attach coax to existing power, telephone and/or railroad wire line poles, and/or run coax through existing underground ducts, why

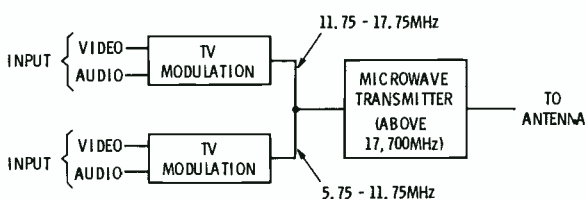

Fig. 5. Multiplexed microwave transmitter for two remote TV pickup channels.

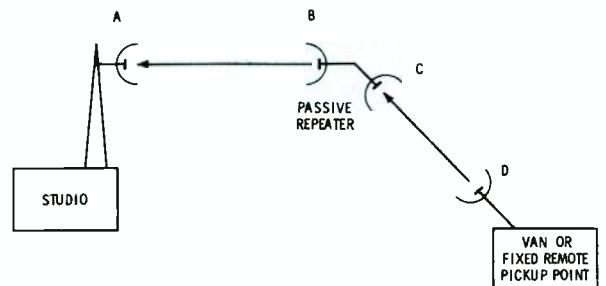
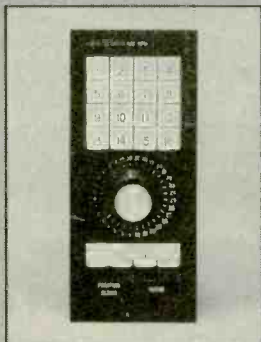
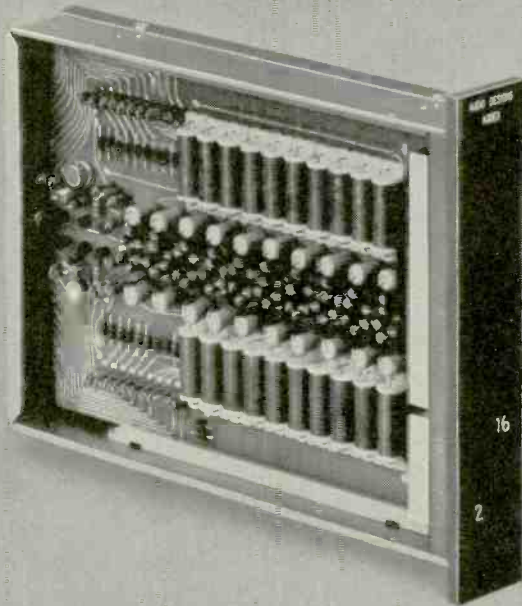

Fig. 6. Microwave link employing passive repeater.

AUDEX™



The ALL-NEW, COMPACT Audio Switchers and Switching Control from Audio Designs that solve the complexity of buss assignment and matrixing of multi-channel consoles.

Button, button, whose got the button? Finally here's an audio component that will simplify your console programming . . . a system that will replace up to 640 buttons. Using the Audex control you may switch up to 32 Audex plug-in modules. With Audex I & II you can separately switch up to 16 program busses and 4 echo busses; whereas Audex I is a self canceling switcher, Audex II will simultaneously connect an input to 16 program and 4 echo busses. Audex III will simultaneously matrix up to 20 program channels to a single output making it ideal as a mix down or monitoring matrix. So one control panel times 32 modules times 20 channels per module equals 640 missing console buttons. Besides the ease of operation, consider the savings in console panel space. The switching is noiseless with life in excess of 10,000,000 operations. To learn all about the new Audex system or our other modular components, simply write or call . . .



AUDIO DESIGNS / 15645 Sturgeon / Roseville (Detroit), Michigan 48066 / (313) 778-8400
Circle Item 22 on Tech Data Card

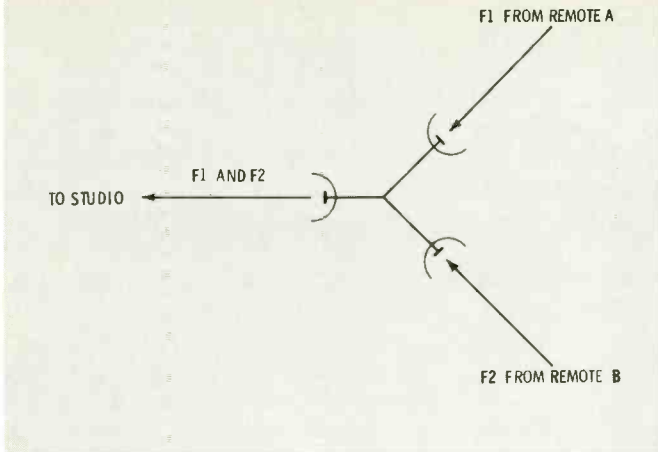

Fig. 7. Passive repeater-coupler.

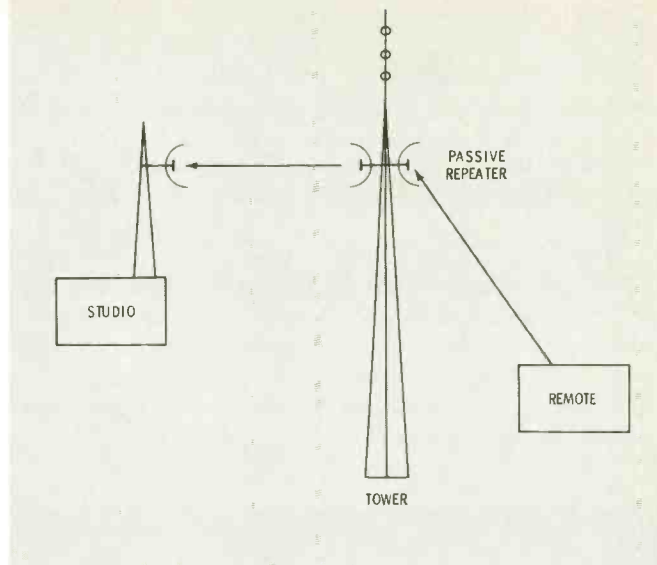

Fig. 8. Using station tower as passive repeater support.

can't a broadcaster do likewise? Such a facility can be multiplexed, as shown in Fig. 3, to provide means for transmission of video and audio signals to the studio from several points, even simultaneously.

Furthermore, such a facility can be shared with the local government which could use it for CCTV surveillance of traffic, etc. A permanently installed coaxial cable or video pair transmission system, re-

gardless of who owns it, can be used for regular on-the-spot pickups from a weather radar site, airport tower for viewing air traffic as displayed on radar screens, city hall, etc.

For mobility and flexibility, microwave is undoubtedly superior. Microwave can be used for either temporary or regularly scheduled remote pickups. A broadcaster can buy his own microwave facilities or lease them from a telephone com-

pany. Which route to take depends upon amount of use and availability of skilled manpower.

One of the Bell System companies charges \$175 to rent the microwave equipment for any increment of time up to one month. If used for only one minute once, the same \$175 rental is charged. An additional charge is made for distance between the studio and remote pickup point. This charge is \$20 per

NEW



LINE

INTEGRATED MODULAR
PROFESSIONAL AUDIO
COMPONENTS
UTILIZING THE
MELCOR MODEL 1731
AUDIO OPERATIONAL
AMPLIFIER

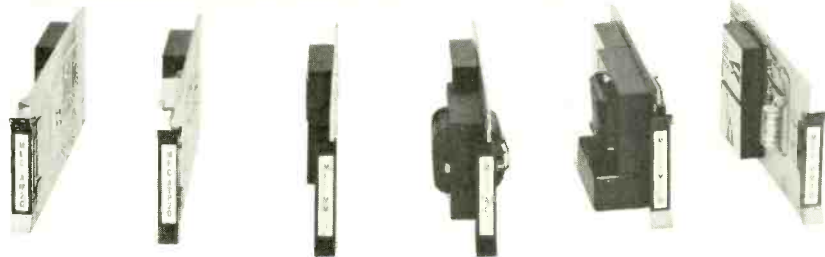
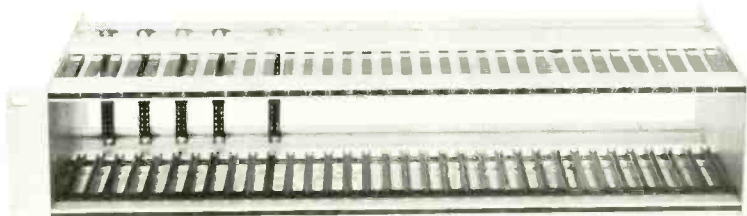

AM-20: Variable gain MIC preamplifier with input transformer

ATP-20: NAB RIAA Tape-Phono preamp with high frequency trims

MM-20: Mixer module for combining up to 20 inputs with zero loss and up to 20DB gain

AL-27: Line amplifier with 600 OHM CT output transformer, adjustable gain, up to +27 dbm output capability

AML-27: Low level microphone preamplifier, and high level line amplifier with +27 dbm output capability. Input and output transformers

PM-40: Power module with up to 16 watts peak audio power output into 16 OHMS, adjustable gain

MELCOR ELECTRONICS CORPORATION

AMPLIFIERS FOR INDUSTRY

1750 NEW HIGHWAY, FARMINGDALE, NEW YORK 11735
516/694-5570



quarter mile (or less) or \$80 per mile per month. For one day or less, the charge is 15 per cent of the monthly charge, and 10 per cent for the second and following days until the charges equal the monthly rate. One-time construction costs are extra.

Microwave equipment is available for remote pickup use for the 2 GHz (gigahertz or thousands of megahertz), 7 GHz and 13 GHz bands at a cost ranging from around \$6000 for a transmitter and receiver to considerably more.

In most cases, microwave transmission is one way, from the pickup point to the studio. The video signals are fed directly to the modulation input of an FM microwave transmitter. The audio signals are also fed to the microwave transmitter, but through an FM modulator whose carrier frequency is above the video. At the studio, the main FM signal is demodulated to extract the video signals and the FM subcarrier is demodulated to extract the audio signals.

Two TV channels (video and au-

dio) can be provided by stacking two microwave systems, utilizing the same antennas, as shown in Fig. 4. In the microwave bands above the 13 GHz band, it is technically feasible to multiplex a microwave system to permit transmission of two TV programs simultaneously, by utilizing CATV-type sub-VHF TV modulators and demodulators, as shown in Fig. 5.

When microwave is used, a line-of-sight transmission path is required. When this is not attainable, a repeater is required. However, the repeater may be "passive," not an active repeater consisting of a back-to-back connected microwave transmitter and receiver, or a heterodyne type repeater. A passive repeater may be of the billboard type, whose orientation and positioning with respect to the transmitting and receiving antennas is critical, or it can consist of a pair of parabolic antennas connected back-to-back through waveguide or coaxial cable.

This combination provides great flexibility, as Fig. 6 illustrates. Antennas A and B are permanently adjusted to "look" at each other. Antenna C can be oriented so it will be able to see antenna D every time D is moved from one location to another. Such a repeater, although passive, provides gain. For example, if each has a gain rating of 30 db, the total gain of the repeater will be 60 db.

It is also possible to connect three or more parabolic antennas together, as shown in Fig. 7, to enable pickup from two or more mobile vans or fixed pickup points, even at the same time if each operates at a different frequency. However, each added antenna introduces loss.

The advantages of a passive repeater over an active repeater are that it consumes no utility power and does not require frequency transposition. However, when the distance between the studio and pickup point is considerable, an active repeater is required to provide additional gain.

Repeaters, whether active or passive, can be installed on the roof of a building, hilltop or the TV station's antenna tower, as shown in Fig. 8. Referring back to Fig. 6, antenna A must see B and C must see D. Furthermore, there should be adequate first Fresnel zone clearance of each beam.

The Spotlight Is on

Spotmaster

Superior Tape Cartridge Recording and Playback Equipment

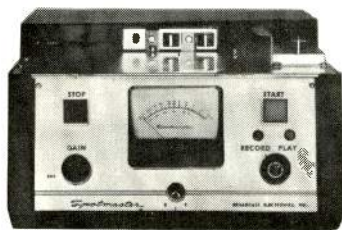

Model 500 C



Model 400 A

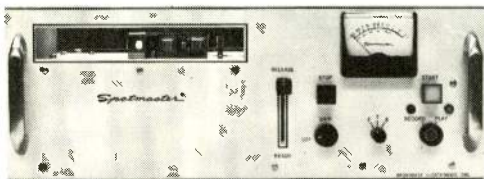

Model 500 CR

COMPACT 500 C SERIES—Completely solid state, handsome 500 C equipment features functional styling and ease of operation, modular design, choice of 1, 2, or 3 automatic electronic cueing tones, automatic record pre-set, separate record and play heads, A-B monitoring, biased cue recording, triple zener controlled power supply, transformer output . . . adding up to pushbutton broadcasting at its finest. Specs and performance equal or exceed NAB standards. Record-play and playback-only models are available.

RACK-MOUNTED 500 C MODELS—The 500 CR rack models offer the same Model C design and performance features and are equipped with chassis slides ready to mount in your rack. Each unit slides out for easy head and capstan cleaning and other routine maintenance. All 500 C models carry iron-clad full-year guarantees.

ECONOMICAL 400 A SERIES—Now even the smallest stations can enjoy Spotmaster dependability with the low-cost, all solid state 400 A series, available in compact record-play and playback-only models. Performance and specifications are second only to the 500 C series.

For complete details about these and other Spotmaster cartridge units (stereo, delayed-programming and multiple-cartridge models, too), write, wire or call today. Remember, Broadcast Electronics is the No. 1 designer/producer of broadcast quality cartridge tape equipment. . . worldwide!

BROADCAST ELECTRONICS, INC.

8810 Brookville Road, Silver Spring, Maryland 20910; Area Code 301, 588-4983



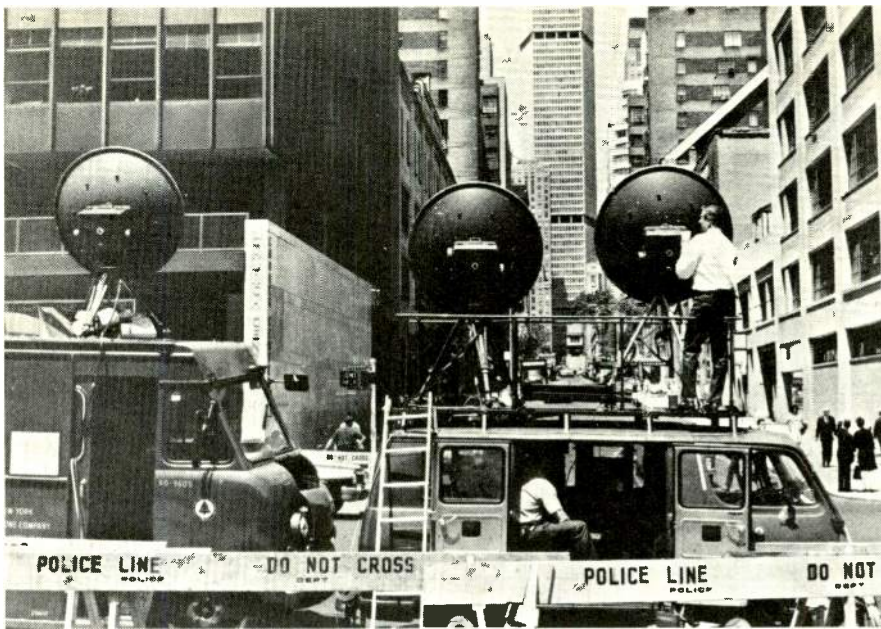

Pic. 1. New York Telephone Company transmitting TV signals from United Nations Building to the Pan-Am Building.

Obviously, order wire facilities are required. At a street location, the remote end of the order wire could even be a pay telephone. However, maximum flexibility is

achieved when using a 26-MHz band mobile system. A base station is required at the studio, a mobile unit can be installed in the van, and personnel on foot can use walkie-

talkies or packsets. When AM equipment is employed, a 5-watt CB type hand-held portable, such as the Dyna-Com 5, can be used since it can be equipped with crystals and retuned for 26-MHz band operation.

Since cables are required for connecting TV cameras to video switching equipment or even directly to a microwave transmitter or modulator, microphones for sound pickup are usually wired. However, for greater freedom of movement by announcers and performers, wireless microphones should be considered.

At present, the choice of transmission media for TV remote pickups is limited to leased or privately owned video pair, coaxial cable, and microwave. In the not-too-distant-future laser beams and quasi-laser systems will undoubtedly be employed. But, for now, use must be made of what is available. The paramount considerations are flexibility, cost and activation time. It is important, as a news medium, for TV broadcasters to be ready to provide quick and adequate coverage. ▲

**more performance
at less cost!**
KUSTOM
BROADCAST
CONSOLE

ONLY
\$495⁰⁰



Has all the control flexibility, adaptability, fidelity and dependability of equipment costing much more. All solid state. Six input channels. Full switch and gain control flexibility. Use on remotes or for studios. Write for full-facts catalog sheet.

Sold exclusively through
UNITED RADIO INDUSTRIAL
829 W. Burnside St.
Portland, Oregon 97209
503/226-6334

Circle Item 49 on Tech Data Card

NAB Membership Grows In 1968

Membership in the National Association of Broadcasters reached an all-time high on Dec. 1 with 4,188 members—an increase of 152 over the same time last year.

Membership includes 3,391 radio stations, 537 television stations, 253 associate members and all four national radio and all three national television networks.

As a result of a Fall membership campaign, gains were made in the first three categories. The seven national networks are long-standing NAB members.

During the campaign, NAB's Membership Committee cooperated with the Association's seven regional managers in writing letters and making personal calls on non-members.

Co-chairman of the Committee are David H. Morris, president and general manager, KNUZ, Houston, Tex., a member of the Radio Board, and Norman Bagwell, vice-president and station manager, WKY-TV, Oklahoma City, Okla., a member of the Television Board.

FAIRCHILD

**FAIRCHILD'S
PRECISION
MAKES 57 OF THE
WORLD'S FINEST
PROFESSIONAL
AUDIO
COMPONENTS**

... Fairchild's complete Series of Attenuators: 10 models with new packaging plus Slide Wire Fader / The Integra I Series: an automatic Attenuator, 3 Preamplifiers, 3 Compressors, 3 Program Equalizers, 4 Dynalizers, De-Esser / 692 Remote Card Series: over 12 inputs with extensive switching capacity / Integrated Control Module Series: Input-Output-Monitor Modules / 7 Audio Control Devices including the well known Conax, Limiter and Reverberon Systems / 2 Gain Shifter Intercom Systems / 7 Power Supply Models / over 24 Accessories. Contact your Fairchild Distributor or write FAIRCHILD RECORDING CORPORATION Dept BM2, 10-40 45th Ave., L.I.C., N.Y. 11101.

Circle Item 50 on Tech Data Card

A MILLION THANKS to 1,000 BROADCAST ENGINEERS from

WILKINSON ELECTRONICS

More than 1,000 mercury vapor power supplies have now been converted to Superior Wilkinson Silicon Rectifiers by 1,000 astute and economy minded broadcast engineers. They eliminated COLD MORNING NO START, FILAMENT HEATED HOT BOXES, 30 MINUTE WARM UP, MIDNIGHT "OFF AIR" PANIC and CUT COSTS too. They selected the Superior Wilkinson Rectifiers because --



- They are ultra reliable, fully guaranteed and especially built for broadcasters by broadcast equipment specialists.
- Only Wilkinson rectifiers are SELF TESTING. The exact status of every component is continuously tested by GC-NO-GO light indicators.
- No rewiring necessary - no mechanical displacement - no parts removal - just plug in and GO INSTANTLY.
- Only Wilkinson rectifiers are non-encapsulated and repairable. THEY LAST FOREVER!
- Wilkinson direct replacement rectifiers are available for every mercury vapor diode. You can now replace all of them: 816 - 866 - 3B28 - 872 - 8008 - 575 - 673 - 6894 - 6895 - 869B - 857B plus European types.

Join the Contented Converters with Confidence - convert to WILKINSON RECTIFIERS now!

For complete details, write or call:

WILKINSON
ELECTRONICS, INC.

1937 MacDADE BLVD
WOODLYN, PA. 19094

TELEPHONE (215) 874-5236 874-5237

Circle Item 51 on Tech Data Card

NEW PRODUCTS

The first use of remote graphic display of weather radar by a commercial weather consultant—Melpar, Inc. of Falls Church, Virginia—was recently announced by Alden Electronic & Impulse Recording Equipment Co., Inc.

The display unit used to receive the information is Alden's Model 9256 Radar Recorder. The information is received directly from the United States Weather Bureau remoting site located at the Washington National Airport. This site is a part of the expanding radar network . . . RATT'S '68. . . a program being developed by the United States Weather Bureau.

Transmitting stations are currently located at four sites—Washington, Detroit, Galveston, Pittsburgh—and will be extended to 25 different locations around the country; each radar site providing weather data within a radius of 250 miles from the radar transmitter. The system operates using slow-scan TV cameras to view the weather radar scope display and voice grade telephone lines to distribute the TV data to low cost facsimile recorders at some remote point.

(55)



**NEED A CBS
VOLUMAX?**

CONTACT CCA (WE STOCK THEM)

CCA

CCA ELECTRONICS CORP.
GLOUCESTER CITY, N. J.
(609) 456-1716

RCA recently unveiled a new one-tube color television camera which should have far-reaching effects on the growth of color TV in the educational, industrial and cable television markets.

The low-cost camera system, employing a single pick-up tube in conjunction with a special color-encoding optical filter, represents one of the most significant changes in color-originating equipment since the Company demonstrated all-electronic color TV in 1946.

At a press demonstration in Washington, RCA showed a "live" single-tube color camera, and another of similar design for originating color programs from film. Both were featured at RCA's exhibit at the National Association of Educational Broadcasters convention.

The new cameras will range from \$6,500 to \$10,000, a price level that should remove the last obstacle to wide-scale use of color TV in schools and other closed-circuit applications, according to Adron M. Miller, Division Vice President, Instructional and Professional Electronic Systems, RCA Commercial Electronic Systems Division.

Current methods for producing color pictures from TV cameras depend on using dichroic filters to separate the image into the three primary colors. Each primary color image is scanned by a separate pickup tube and the three components are processed and reassembled as a complete picture. In some cameras a fourth tube is used to enhance the picture.

With the new system, striped color filters and "innovative electron-

(56)



ics" are used to recover the color information for processing by standard color-signal handling methods, Miller explained.

(57)

A new weatherproof solid-state CCTV camera representing a totally new approach to closed circuit operation outdoors where there is rain, or indoors where there is dust and humidity, has been announced by **GBC Closed Circuit TV Corp.**

This new closed circuit TV camera is surrounded by an aluminum shield that protects it completely from rain, snow, moisture, dust, etc.

Another advantage of this weatherproof unit is that it is one-half the size and one-third the weight of previous methods of providing weatherproof closed circuit TV operation. This means that it can be installed in areas where a CCTV camera in a bulky housing could not previously be installed. Further, it can use a standard pan and tilt mechanism rather than a heavy-duty one. The camera lens can be changed easily, and provision has been made for zoom lens installation. To prevent tampering by unauthorized persons, the housing has its own sturdy lock.

For educational TV and other CCTV installations

Sturdy and rugged, yet light in weight, this all aluminum tripod is ideal for CCTV viewfinder cameras weighing up to 100 lbs.

FEATURES: ■ GEAR DRIVEN ELEVATOR column 1 7/8" diameter slides up and down on nylon sleeves. No metal-to-metal contact. This reduces friction and wear. ■ SELF LOCKING GEAR Mechanism keeps the center post from running down regardless of the weight on the head of the tripod. ■ Two section aluminum legs. Sturdy box-tubing leg brace for tripod rigidity. All three swivels can be locked for straight line tracking. Ball bearing wheels with positive lock of both wheel and swivel.

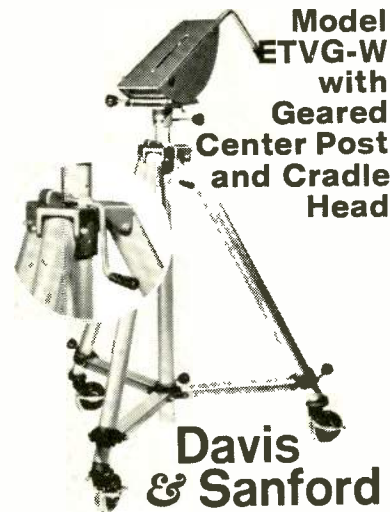

Davis & Sanford

24 PLEASANT ST. / NEW ROCHELLE / NEW YORK 10802
Write Dept. B.E.

Circle Item 27 on Tech Data Card

This is the most expensive turntable you can buy.



Also the cheapest.

It's a simple matter of economics. And quality.

At \$1350, the EMT-930st Turntable costs considerably more than any other turntable. But, for your money, you get a precision-made turntable that really slashes maintenance costs because it's virtually trouble-free. ("Still in excellent condition despite ten years of hard use," says one pleased radio station.*)

Typically, you get $\pm 0.035\%$ rms flutter; low, low rumble; and you can cue to any beat or syllable with a wow-free start from the world's only remote-controlled turntable.

A lot of broadcasters must think the EMT-930st is a smart investment. Right now, there are more than 10,000 in use throughout the world. We know of only one greater value: our brochure. It's free. Send for it today.

*Name of this and other station users on request.

GOTHAM
AUDIO CORPORATION
2 WEST 46 STREET, NEW YORK, N.Y. 10036 (212) CO 5-4111
1710 N. LaBREA AVE., HOLLYWOOD, CA 90046 (213) 874-4444

Circle Item 28 on Tech Data Card

Instant Audio!

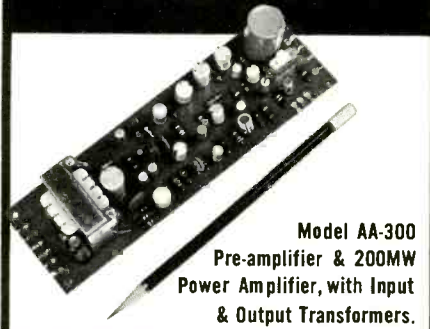

Model AA-300
Pre-amplifier & 200MW
Power Amplifier, with Input
& Output Transformers.

SPECIFICATIONS:

	MODEL AA-300 PROFESSIONAL AMPLIFIER (200MW)	MODEL AA-500 PROFESSIONAL PRE-AMPLIFIER
Freq. Resp.	±1db, 20-20K cps, 200MW ±2db, 20-35K cps, 100MW	±½db, 20-20K cps Linear, or RIAA Equalized or NAB Equalized
Harmonic Dist.	<1%, 20-20K cps, 100MW <2%, 20-20K cps, 200MW	<0.5% 20-20K cps
Input Z	50-150Ω, or 600Ω balanced (mu-metal shielded permalloy core transformer) 2K or 100KΩ unbalanced	48KΩ (May be used with input transformers)
Output Z	500Ω & 8Ω (grain oriented transformer) 200MW	5KΩ (May be used with output transformers)
Gain	80db	70db
Circuit	7 transistors 1 thermistor	4 transistors
Power	9VDC, 100MA	9VDC, 5MA
Size	8" L x 2¼" W x 1½" H	4½" L x 3" W x 1¼" H
Weight	12 oz.	2 oz.
Price	\$16.95	\$26.95



Model AA-500
Low noise Pre-amplifier
(Linear, NAB, & RIAA Equalized)

ROUND HILL ASSOCIATES, INC.
325 Hudson Street, New York, N.Y. 10013

- Please send me _____ AA-300's @ \$16.95 each.
- Please send me _____ AA-500's @ \$26.95 each.
- My check for _____ is enclosed. Please ship prepaid.
- Please send C.O.D. BE-2
- Please send me, free of charge, your spec sheets on your complete line of amplifiers, oscillators, power supplies and RF Solid State Circuit Boards.

Name _____
Address _____
City _____
State _____ Zip _____

Circle Item 30 on Tech Data Card

(58)

The first 1-inch diameter Philips Plumbicon television camera image pickup tubes were demonstrated by **Philips Broadcast Equipment Corp.** at the National Association of Educational Broadcasters Convention.

Philips Broadcast showed the 1-inch tube operating in the company's new Norelco PM-55 professional monochrome viewfinder camera. They are, actually, the predecessors of the 1-inch Plumbicons under development to achieve greater color performance, and are designated "I.G." (industrial grade).

According to John S. Auld, vice president and general manager of Philips Broadcast, the 1-inch Plumbicons demonstrated have the same general performance characteristics as standard (30mm) Plumbicon tubes.

Another monochrome camera demonstrated by Philips, the Norelco Multi-Purpose camera, is avail-

able with a variety of sensors, including the new 1-inch I.G. Plumbicon. It may also utilize the standard vidicon pickup tube, the standard 30 mm separate-mesh Plumbicon, or the 30mm extended-red-sensitivity Plumbicon.

The Multi-Purpose camera is a two piece camera (head and electronic controls), the control unit which consists of plug-in interchangeable solid-state modules. It can be supplied also with a "piggy-back" viewfinder.

The 1-inch Plumbicon allows the use of smaller, lighter, less expensive lenses as used with standard vidicon cameras.

The new tubes are 6¼ inches long. This compares with dimensions of approximately 1¼" diameter and 8" length of the standard Philips Plumbicon tube introduced to the television industry in 1965. The tube was credited with bringing about an immediate improvement in the quality of color TV pictures.

(59)

Two new lines of 3-inch image orthicon camera tubes of high sensitivity and extremely low noise characteristics have been announced by **Visual Electronics Corporation** of New York. The tubes were developed by English Electric Valve Co. Ltd.

These new tubes, because of a new electron gun structure, have a reduced noise component so that the signal-to-noise ratio is increased by more than 60 per cent. This new gun structure also results in elimination of dynode background interference, giving pictures of considerably high quality. In addition, Visual says the tubes give a greatly

COMPLETE EXCHANGE—REPAIR SERVICE On Fidelipac Cartridges Using Genuine Fidelipac Parts.

Plus . . . offering the Industry's First 3-Month Guarantee On All Tape Cartridges.

SPECIAL REDUCED PRICES! WRITE FOR LATEST PRICE LIST!

Complete Service Also on Re-loading Tape Cartridges With Long Lasting Lubricated Tape.

Broadcast Products Corp.
3 KINGSLEY PLACE
Newburgh, N.Y. 12550

Circle Item 65 on Tech Data Card

Satisfaction Guaranteed!

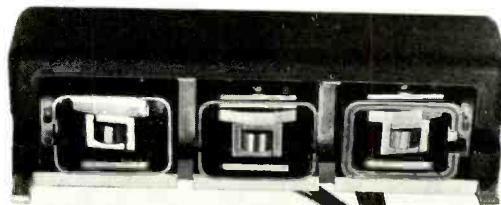

Professional Head Replacements for Ampex, Magnecord
Write for details

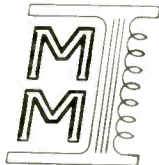

MINNEAPOLIS MAGNETICS, INC.

2915 Huntington Avenue • Minneapolis, Minnesota 55416

Circle Item 29 on Tech Data Card

improved gray scale rendition and their new Elcon long-life targets of proven reliability produce pictures with high resolution.

The special construction in the close-spaced target version of this new group of tubes virtually eliminates all microphonics which up to now have been associated with this tube type.

(60)

The new **Bird RF Peak Reading Amplifiers** models 4320 and 4321 will enable users of more than 40,000 **THRULINE** average RF power Wattmeters to add peak power measurement capability.

As a result of mushrooming re-

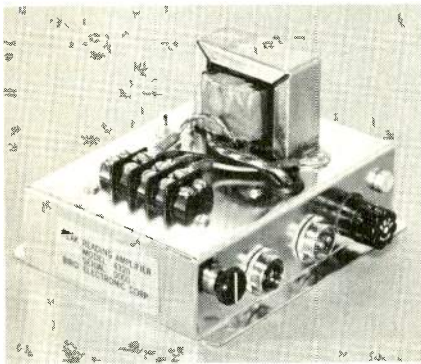

quirements for direct peak power indication from watts to several hundred kilowatts, the unprecedented units were designed specifically for the measurement of pulsed RF systems such as television, radar, telemetry, command and control, air navigational aids (DME, ATC) and peak envelope power (PEP) measurement of SSB or AM signals. They sense the maximum excursion of the demodulated RF envelope delivered by the Plug-in Element of the directional wattmeter and then furnish an equal dc output voltage from their own power supply to the meter.

(61)

Because the new **MULTRA CL-1000** linear amplifier uses reasonably priced, proved reliable vacuum tubes instead of more exotic—and more costly—components, it warrants consideration for boosting radio signals in remote locations where ability to perform continuously and under unfavorable conditions is essential. It was designed by **Multronics, Inc.**, of Rockville, Maryland, to work with their **MULTRA High Frequency 125 watt TR-1** transceiver, but will work as smoothly with other transmitters operating between 2 and 16 megacycles.

It can provide 1,000 watts of single sideband (SSB), 350 watts AM or 800 watts CW output while requiring only 30 to 100 watts driving power. The **MULTRA CL-1000** weighs just 44½ pounds and operates off any AC power supply of 100-110 or 200-220 volts, 50 to 60 cycles.

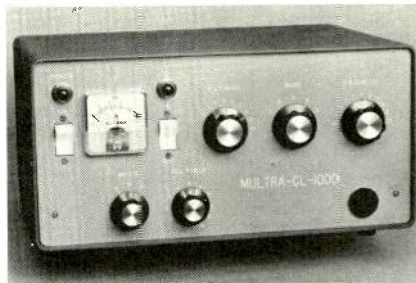

DAR SERIES VIDEO DISTRIBUTION AMPLIFIERS



- All Solid State
- Distribution to Six Isolated Outputs
- Exceed All NTSC Specs

AEM Video Distribution Amplifiers are designed to be **INSTALLED** and **FORGOTTEN**. All solid-state, they provide distribution to six isolated outputs while exceeding all NTSC color and monochrome specifications. Units contain front panel input and output test jacks for each line, and have their own regulated AC to DC power supply. Available in rack mount or portable configurations, the units offer "Sync Add" and Remote Gain Control options.



**APPLIED ELECTRO
MECHANICS, INC.**
2350 Duke Street
Alexandria, Virginia 22314
Phone: (703) 548-2166

Circle Item 31 on Tech Data Card

**NEED AN ELECTROVOICE
MICROPHONE?**

CONTACT CCA (WE STOCK THEM)

CCA CCA ELECTRONICS CORP.
GLOUCESTER CITY, N. J.
(609) 456-1716

(62)

A new forward/reverse sequencing 2 x 2 slide projector, designed for television chain integration, has been introduced by **Spindler & Sapppe Inc.**, Glendale, California. The unit is designed for use with black and white or color multiplexers or direct projection onto a television camera tube face.

The unit, Model **SLR-TV**, is a 48-slide single magazine projector which may be operated sequentially in either forward or reverse direction making it ideally suited for CCTV systems used in instructional



HAVING A PROBLEM MATCHING STEREO CARTRIDGES TO YOUR MONO CONSOLE???

THE 602-I.M.P....

**IMPEDANCE MATCHING
PRE AMP MAY BE THE
ANSWER...** The 602-I.M.P. is a self-contained FET solid state pre-amp designed to match a 47, K stereo cartridge to your 602-C equalizer or similar 600 Ω input device.

With distortion of less than 0.5% with 20 MV of input signal and noise levels lower than -70 DB, it offers Gray's typical

**"Truly
Professional
Performance."**

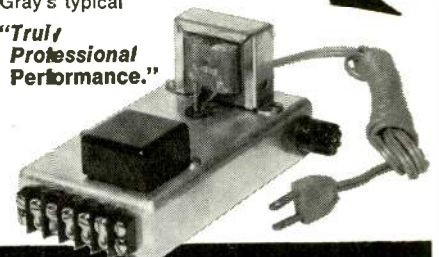

**GRAY RESEARCH &
DEVELOPMENT DIV.**

155 Park Ave.
East Hartford, Conn. 06108

Circle Item 32 on Tech Data Card

SPOT CHECK

A RED INDICATOR APPEARS ON THE FACE OF YOUR TAPE HEAD WHEN THERE ARE ABOUT 100 HOURS OF WEAR LEFT

FREE BROCHURE → **ASK FOR SPOT CHECK BROCHURE**

MICHIGAN MAGNETICS
A DIVISION OF VSI CORPORATION
VERMONTVILLE, MICHIGAN 49096
Telephone (517) 259-8911

Circle Item 33 on Tech Data Card

systems. Slide change time is only one second.

Projector utilizes the patented Spindler & Sauppe rotary slide magazine which accepts all types of slide mounts. Positive mechanical control of slides—in and out of slide gate—assures reliability with longevity.

(63)

Shure Brothers, Inc., Evanston, Ill., has announced a new microphone mixer/remote amplifier specifically designed to meet highest quality professional standards for studio and remote broadcasting, as well as recording and sound reinforcement applications.

Called the Model M67, the new mixer is ideal for use within studios and on remote locations as a single, complete, compact console, or as an "add-on" mixer for expanding existing facilities. It provides four low-impedance balanced microphone inputs and one line input. It can be used to provide additional microphone inputs in tape recording and VTR applications.

(64)

The Model TAU-1 Tolerance Alarm Unit has been announced by **Moseley Associates, Inc.** of Santa Barbara. Designed to provide an out-of-tolerance signal for their Model ADP—Automatic Transmitter Loggers, the TAU-1 is a 6-channel all electronic system featuring I.C. voltage comparators.

Separate high and low limit set potentiometers are provided for each channel. A unique feature of the TAU-1 is its ability to monitor base current ratios for alarming the parameters of a directional antenna array (7 towers maximum). The electronics for each tolerance alarm channel are contained on a small plug-in printed circuit card. The unit is designed to operate from 0° F to 130° F. Set accuracy is ± 1.5 percent.

NEED A SPARTA CONSOLE?

CONTACT CCA (WE STOCK THEM)

CCA CCA ELECTRONICS CORP.
GLOUCESTER CITY, N. J.
1609-456-1716

The first printout counter with visual reading and electrical readout.

General Controls introduces the CESCO counter—the printing, visual readout counter that eliminates the need for complex, expensive readout equipment.

The CESCO counter offers digital readout with parallel entry of information from an electrical or electronic source. Each decade is a single-figure magnetic printer with its own visual, electrical and mechanical printout. Decades can be stacked in any number required depending on the information the customer wants to read out. Any type coding can be used. The counter features rugged design, front panel mounting and quality materials throughout.

For more information on the ways the CESCO counter can save you time and money, contact General Controls, 801 Allen Avenue, Glendale, California 91201. Controls and Instruments Division of International Telephone and Telegraph Corporation. In Canada: 171 Dawson Road, Guelph, Ontario.

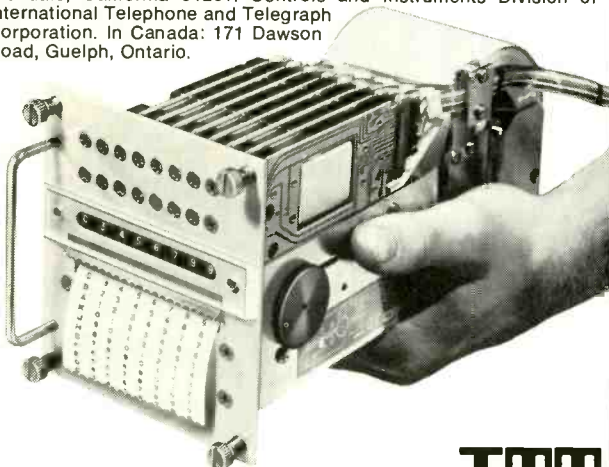

GENERAL CONTROLS **ITT**

Circle Item 34 on Tech Data Card

KNOBS by BUCKEYE

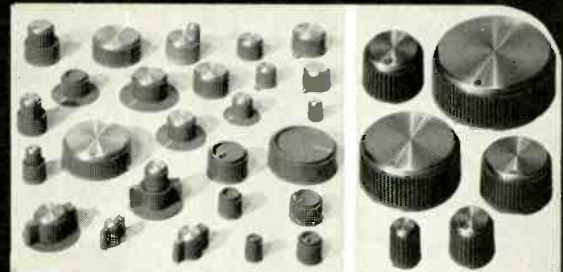

Matching Instrument Knobs — all types. Six basic sizes in six attractive styles and four colors. "The Line of Enchantment"

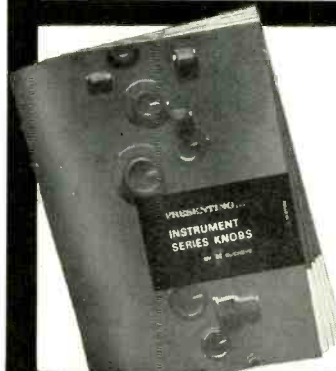

The answer for harmonizing with any instrument design. Of either Iplex or Cycloc and standard with metal bushing and 2 set screws. High gloss and resistant to stain or heat or corrosion. Dimensionally stable. Quality — and looks quality!

Write TODAY For Catalog



the BUCKEYE stamping co.
555 Marion Rd., Columbus, Ohio 43207
"Quality Products Since 1902"

Circle Item 35 on Tech Data Card

TECHNICAL DATA

89. **AMERICAN WELDING SOCIETY**—A supplement on Requirements for Stud Welding has been published. It contains additional provisions applicable to the Code for Welding in Building Construction, D1.0, and Specifications for Welded Highway and Railway Bridges, D2.0. AWS also announces the publication of the revised edition of the Index of Welding Standards and a supplement on Requirements for Submerged Arc Welding with Multiple Electrodes.
90. **AMPEREX**—A new data sheet on the 6977 logic indicator triode is available, which provides the latest specifica-

tions for the tube and contains applications data on sample circuits.

91. **AMPEX CORP.**—A six-page brochure describing Ampex theatre sound system components can be obtained. Also, Bulletin A296 gives facts and specifications about the new Ampex MM-1000 Series master recorder. A closed-circuit, portable videotape recorder, VR5100, is described in a new brochure.
92. **AMERICAN SOCIETY FOR TESTING AND MATERIALS**—The ASTM List of Publications, issued September, 1968, is now available. The current issue contains 34 pages listing more than 500 ASTM publications dealing with the knowledge of materials, materials evaluation, and the standardization of methods of test and specification for materials.
93. **BOSTON INSULATED WIRE & CABLE CO.**—Pertinent facts on a new cable called "Bostgard" are described in a new illustrated brochure, with separate information on the mated, integrally designed connectors.
94. **COHU**—How a computer aids large-scale drafting with closed-circuit television is discussed in a new technical application bulletin, 8-92, released. Bulletin is entitled "Computer-Aided Drafting with CCTV."
95. **DIALIGHT CORP.**—A twelve-page, two-color Catalog L-178C presents information on sub-miniature indicator lights and gives new listings for MIL-L 3661B indicators.
96. **ELCO**—A sixteen-page catalog of enclosures for printed circuit cards describes and illustrates in detail a line of enclosure components for packaging p.c. cards and connectors.

97. **ELECTRONIC ENGINEERING CO.**—The first of a continuing series of "Application Notes for On-Time Electronic Editing and Control Equipment" are now available. Detailed information is provided on the use of time codes in electronic video tape editing and automatic search and control. Drawings and photos are used.
98. **ENDEVCO LABS**—Literature describes a new, low-cost, high-output semi-conductor pressure transducer, designated Model 8503. Data sheet includes specifications, prices and model diagram.
99. **ESTERLINE ANGUS**—The part graphic recording can play in batch mixing is explained in the lead story of a four-page, two-color "Graphic Bulletin 868."
100. **FARMER ELECTRIC PRODUCTS CO., INC.**—The new Farmer Electric Bulletin A-139 completely describes the new line of solid-state interval timers. Timers are avail-

SPOTMASTER Solid-State Portable REMOTE AMPLIFIER

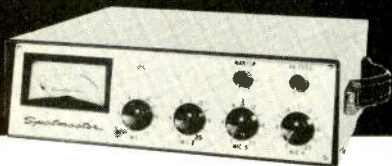

The RA-4CA is a lightweight, four-channel portable mixer amplifier specifically designed for remote broadcast or auxiliary studio use. It is completely self-contained and operates from either AC or batteries (switching automatically to battery operation if AC power fails); runs as long as 200 hours on low-cost "D" cells. It offers four microphone channels with master gain and P.A. feed, all controlled from the front panel. Lightweight construction (just 11 pounds with batteries), a convenient carrying handle and a snap-on front cover mean the RA-4CA can be easily set up to operate anywhere. For further information, please write or call today:

Spotmaster
BROADCAST ELECTRONICS, INC.
8810 Brookville Road
Silver Spring, Maryland 20910
Area Code 301 • 588-4983

**NEED A QRK
TURNTABLE?**
CONTACT **CCA** (WE STOCK THEM)
CCA CCA ELECTRONICS CORP.
GLOUCESTER CITY, N. J.
(609) 456-1716

THE MODEL 1035 MONITOR CUE AMPLIFIER



The Comrex Model 1035 is a self contained, general purpose, monitor and cue amplifier.

The input is balanced and designed to operate with input levels of -20 dBm to +30 dBm.

Requiring only 3½ inches of rack height, several may be housed in the space formerly occupied by a speaker alone.

COMREX CORPORATION

P.O. Box 51, West Concord, Mass. 01781
Area Code 617 369-6685

Circle Item 36 on Tech Data Card

able in plug-in module, circuit board and self-contained models. The twelve-page bulletin gives comprehensive descriptions, electrical and mechanical specifications, dimensional drawings, photos, applications, wiring diagrams, accessories, and engineering data.

101. **FLOTRON INDUSTRIES INC.**—A 26-page full-line catalog tells about the firm's work station line, including their new 2000 and 2100 Series

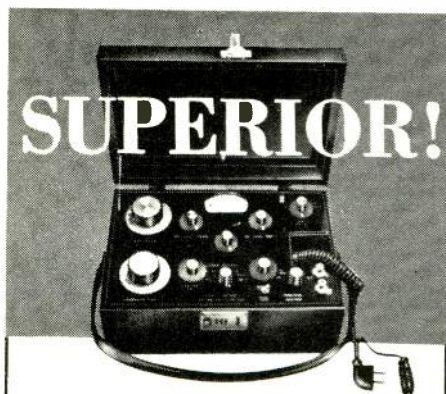

WILKINSON 4N1 Portable Solid-State

1. FIELD INTENSITY METER
2. NULL DETECTOR
3. STANDARD SIGNAL GENERATOR
4. AM MONITOR RECEIVER

SUPERIOR BECAUSE THE 4N1:

Measures field intensity with superior accuracy and reduces measurement time.
 • Requires only a bridge for easy RF impedance measurements.
 • Powered by rechargeable batteries and self-lighted for nighttime measurements.
 • Easier to carry and operate.

FOR COMPLETE DETAILS WRITE:

WILKINSON

ELECTRONICS, INC.

1937 MacDADE BLVD. • WOODLYN, PA. 19094
 • TELEPHONE (215) 874-5236 874-5237 •

Circle Item 48 on Tech Data Card

Benches. It is fully illustrated with photos and engineering drawings.

102. **GREIBACH INSTRUMENTS, DIV. OF SOLITRON DEVICES**—A free reprint describes the various aspects and properties of the patented bifilar suspension.
103. **HEWLETT-PACKARD** — A new booklet, "New Electronics for Measurement, Analysis and Computation" is on hand, and includes a summary of new products to serve these needs.
104. **HUGHEY & PHILLIPS, INC.**—A folder-type catalog has just been issued, entitled "Hazard Warning Lights for Attended Towers."
105. **IC METRICS, INC.**—Linear Circuit Integrated Parameter Definitions is the subject of a 32-page text. General terms and a glossary of symbols are included.
106. **I-TEL, INC.**—Catalog Supplement 1929-24, describing Series 21 and 22 passive tubular filters for IF applications, has been published.
107. **MARCONI INSTRUMENTATION**—A technical information bulletin—Volume 11, No. 4 (A)—is available.
108. **NATIONAL AERONAUTICS AND SPACE ADMINISTRATION** — "Electronics Circuits" is the title of a catalog.
109. **ONEIDA** — Bulletin A-68 provides information on the Oneida Ana-Lite for locating wiring faults in electronic assemblies.

110. **PALL TRINITY MICRO CORP.**—A bulletin has information on 12 models which compose a recently introduced refrigerated dryer line.
111. **POTOMAC**—Model AM-19 antenna monitor, for measuring phase angle and loop current in AM directional arrays, is the subject of a specification sheet.
112. **RAYTHEON LEARNING SYSTEMS CO.**—Catalog 233 describes a new Viewfinder CCTV Camera Model 705, designed for instructional use.
113. **ROUND HILL**—Data sheets and technical bulletins provide information on five models of audio amplifiers, a regulated power supply, a power oscillator, and a wireless cueing amplifier.

NEED A SPOTMASTER OF
 SPARTA TAPE CARTRIDGE?
 CONTACT CCA (WE STOCK THEM)

CCA

CCA ELECTRONICS CORP.
 GLOUCESTER CITY, N. J.
 (609) 456-1716

GOOD SOUND BUSINESS

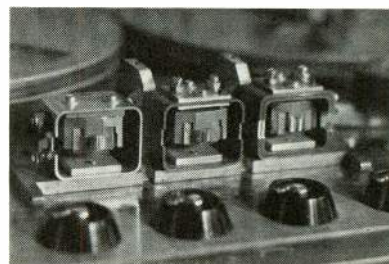

Save money by reconditioning Your Ampex or Scully Heads

For only \$45 you can have your present Ampex or Scully 3-head assembly reconditioned, to give you continuing service as good as new. Taber reconditioned heads give you these advantages:

- Meet, or better, original specifications
 - Three-head assembly reconditioned for only \$45
 - Assembly returned promptly by next mail
 - Loaner assemblies available if wanted
- Taber also offers new heads for only \$97.50. Send for free brochure today.

Call or write: **TABER** MANUFACTURING AND ENGINEERING COMPANY

OAKLAND INTERNATIONAL AIRPORT, BLDG., L-821
 P. O. BOX 2365 • OAKLAND, CALIFORNIA 94614
 Telephone (415) 635-3832

Circle Item 38 on Tech Data Card

Certified REPAIR/RECALIBRATION SERVICE

for

Nems-Clarke 120 Series and RCA/WX-2

FIELD INTENSITY METERS

Traceable to NBS Stds • 2 Weeks Maximum Turnaround

Note: An independent service, not affiliated with equipment manufacturers

For complete information, write or call:

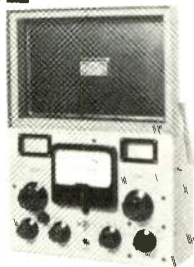

PI

POTOMAC INSTRUMENTS, inc.

932 Philadelphia Ave. • Silver Spring, Md. 20910
 Phone (301) 589-3125

Circle Item 37 on Tech Data Card

PEOPLE IN THE NEWS

William D. Hedden was named sections vice-president of the mid-west section of the Society of Motion Picture and Television Engineers at its recent annual meeting. Hedden is vice-president of Calvin Productions, Kansas City, Missouri, and has total charge of all laboratory and technical services for that company.

The new post gives Hedden the responsibility of coordinating all work of the Society's 12 sections. He will assist each section with monthly meetings and programs, encourage day-long seminars and conferences and help develop new sections. Hedden has been a member of the society for 25 years.

Commissioner H. Rex Lee has announced the appointment of **Earnest Theleman** as engineering assistant, **Fred Martin Cohen** as special assistant and **Mrs. Mary Alice Mulroe** as secretary. The appointments complete Commissioner Lee's staff.

Theleman, an FCC staff member since 1941, had been with the Broadcast Bureau as an electronic engineer. Other duties at the Commission included wartime service with the Radio Intelligence Division and assignments in the field and in Washington and with the Emergency Communications Division. A native of Le Sueur, Minnesota, Theleman attended the University of Minnesota. He worked as a broadcast engineer for the University broadcast station and for Station KSTP in St. Paul before coming to the FCC.

James Harwood, news producer-reporter at KPIX-TV, San Francisco, joins Kaiser Broadcasting as reporter-assignment editor at KBHK-TV, San Francisco.

Harwood, who has a journalism degree from Southern Methodist University, was a reporter for five years for the Wall Street Journal prior to joining KPIX-TV.

DISCOVER *the* SUPERIOR ALL SOLID STATE AM FREQUENCY MONITOR

Naturally FROM WILKINSON!

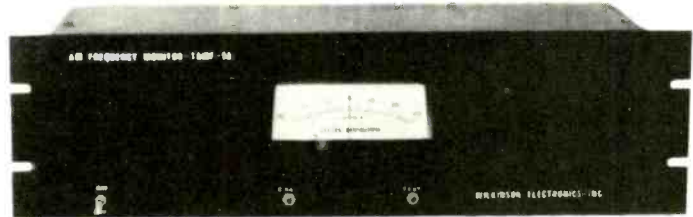

- ★ Triac Controlled Crystal Oven
- ★ Instantaneous Operation — No Warm-up Time
- ★ Requires only 5 1/4 inches of Rack Space
- ★ I. C. Regulated Solid State Power Supply
- ★ Self Testing from Front Panel

MODEL TAMF-1A
FCC No. 158

For complete details write:

WILKINSON
ELECTRONICS, INC.

1937 MacDADE BLVD.
WOODLYN, PA. 19094

PHONE (215) 874-5236 874-5237

Circle Item 75 on Tech Data Card

DISCOVER *the* SUPERIOR ALL SOLID STATE AM MODULATION MONITOR

Naturally FROM WILKINSON!

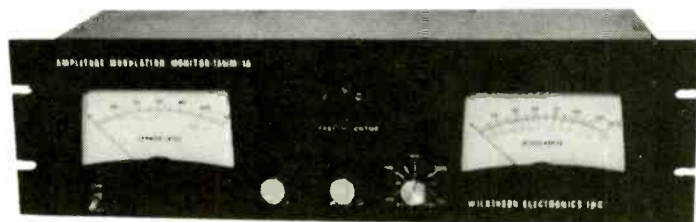

- FCC Type Approval No. 156
- Wideband 500 KHz to 26.1 MHz
- Uses Latest IC Innovations
- New as Tomorrow . . . Reliable as Forever

MODEL TAMM-1A

For complete details write:

WILKINSON
ELECTRONICS, INC.

1937 MacDADE BLVD.
WOODLYN, PA. 19094

PHONE (215) 874-5236 874-5237

Circle Item 40 on Tech Data Card

Multronics new MULTIFILAR R. F. Inductors can carry more current in a smaller unit.

1. Fixed Bifilars (dual windings) 40 amps available in ranges from 6 through 155 UH
2. Variable Bifilar (dual windings) 30 amps 8, 11 and 25 UH units available
3. Fixed Trifilars (triple windings) 60 amps available in ranges from 5 through 65 UH
4. Fixed Quadrifilars (four windings) 80 amps available in ranges from 6 through 34 UH

These 1/2" x .090" Edgewound Ribbon inductors (with two or more windings intermeshed in parallel) have the same quality features that have gained acceptance in the standard line of tubing and edgewound ribbon inductors designed and manufactured by Multronics, Inc.

- Silver-Plated Copper Windings with anti-tarnish finish and hard-soldered terminations,
- Non-Breakable Support Bars of G9 MELAMINE that combine minimum loss resistance (dissipation) with superior arc resistant qualities,
- TEFLON Insulation to prevent closed loops and
- Numbered Support Bar for easy identification during tune up.

It has long been known that edgewound ribbon inductors provide greater inductance and high Q in a smaller length of winding, but not until the introduction of Multifilars has the industry made full use of the increased surface area of edgewound ribbons. The result is compactness with high inductance and greater amperage capacity.

Let's compare the equivalent tubing sizes required to give the same surface area as the new Multifilars:

Bifilar = .702" O.D. Tubing

Trifilar = 1.05" O.D. Tubing

Quadrifilar = 1.4" O.D. Tubing

Many turns of tubing (a long coil) would be required to give the same inductance as obtained with the equivalent Multifilar.

Multronics, Inc. has an unequalled off-the-shelf capability... as well as the design capability to come up with something special for your unusual requirements. It will help, when you contact us, if you will spell out just what your inductor needs are, so that we can make a specific response to your inquiry.

George P. Howard

Director Communication Products Division

MULTRONICS, INC.

5712 Frederick Avenue
Rockville, Maryland 20852
Telephone (301), 427-4666

Circle Item 41 on Tech Data Card

PEOPLE IN THE NEWS

Columbia Broadcasting System has designated **Sherril Taylor**, vice-president, affiliate relations of CBS Radio, to serve on the Radio Board of Directors of the National Association of Broadcasters, NAB announced recently.

The Board of Directors of the National Association of Broadcasters on January 17 observed a moment of silence and passed a resolution of tribute and sympathy over the death of **Howard Mandel**, NAB vice-president for research.

Mandel died of a heart attack at his home in Tuckahoe, N.Y., on Dec. 15.

Raymond F. Guy, who claims to have the longest experience in broadcasting of any person in the world, has been named consulting engineer for Fort Lauderdale television station WSMS-TV, Channel 51.

The appointment was announced by **Barney Kobres**, general manager of the new station.

In 1921 Guy was employed at radio station WJZ, Newark, N.J., as an engineer and announcer before the existence of commercial announcers.

"This was only the second broadcasting station in the world," he recalls, "being preceded only by KDKA in Pittsburgh. Since all other of the eight or ten persons on those staffs are long since deceased or retired, I have the longest experience in broadcasting of any person anywhere."

Guy was a radio amateur in 1912 and four years later, was employed by the Marconi Wireless Telegraph Co.

NEED AN AMPEX,
MAGNECORD or SCULLY?
CONTACT CCA (WE STOCK THEM)

CCA CCA ELECTRONICS CORP.
GLOUCESTER CITY, N. J.
(609) 456 1716

LDA SERIES LAP-DISSOLVE AMPLIFIERS



- No Tracking Adjustments Required
- No Clamp Drive Pulses Required
- No Color Shift During Transition

LDA Series Lap-Dissolve Amplifiers assure a velvety transition between two signal inputs. All solid state, the units provide the signal handling characteristics of a high performance distribution amplifier. Photoelectric cells, remotely controlled by DC circuits, eliminate the possibility of color shifts and level changes; and differential phase and gain do not change even during the lap interval. For convenience, a Fader Arm control is optionally available.



APPLIED ELECTRO
MECHANICS, INC.

2350 Duke Street
Alexandria, Virginia 22314
Phone: (703) 548-2166

Circle Item 42 on Tech Data Card

SPOTMASTER

The all solid state AD1A

AUDIO DISTRIBUTION AMPLIFIER

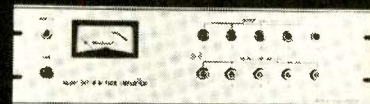

Meet the AD1A, a solid state audio distribution amplifier specifically designed for AM, FM and TV broadcast stations and recording studios. The AD1A distributes audio signals via five separate output channels (up to 25 with the addition of AD1A-X extenders), and incorporates a front-panel VU meter and monitor jack to permit visual and aural monitoring of the incoming signal at the output of the line amplifier. Response is essentially flat from 40 to 20,000 Hz, with low distortion and noise, 60 db channel isolation and 12 db peak factor. For further information, write or call today:

Spotmaster
BROADCAST ELECTRONICS, INC.

8810 Brookville Road
Silver Spring, Maryland 20910
Area Code 301 • 588-4983

BROADCAST ENGINEERING

INDUSTRY CALENDAR

February

- 7- 8 New Mexico Broadcasters Association annual Winter Convention will be held at the Hilton Hotel in Albuquerque.
- 7- 8 Northwest Broadcast News Association will hold its 21st annual Radio-Television Seminar at the School of Journalism, University of Minnesota.
- 8 Georgia Cable Television Association gets started with its first convention. Meet to be in the Dempsey Hotel in Macon, Ga.
- 12-14 Three-day convention of the National Association of Television Executives opens in Los Angeles.
- 12-14 ASTM national meeting on Composite Materials: Testing and Design at the Jung Hotel in New Orleans.
- 25-28 Western Radio and Television Association and West Coast Instructional Television will hold the 1969 Conference at the Olympic Hotel in Seattle.

March

- 13 International Radio and Television Society will hold its annual anniversary banquet in the Waldorf-Astoria Hotel in New York City.
- 21-23 The Intercollegiate Broadcasting System will open its Annual Spring Convention in the Washington Hilton Hotel, Washington, D.C.
- 23-25 Southern CATV Regional Meeting, Monteleone Hotel, New Orleans.
- 23-26 National Association of Broadcasters Convention will be split between the Shoreham and Sheraton Park hotels in Washington, D.C.
- 24-27 IEEE International Convention, New York City.

April

- 16-19 IEEE Regional Six Conference, Phoenix, Ariz.
- 22-24 IEEE National Telemetry Conference, Washington, D.C.

Book Review

The new fifth edition of **Reference Data For Radio Engineers** (catalog No. 20678) is now available under a completely new format. It offers considerable reference details of interest to people in broadcasting, general electronics, and telephony or telegraphy.

This new compilation of approximately 1150 pages and 1350 illustrations plus a comprehensive index and cross-index was made by a group of practicing engineers, professors, and industry and government experts under the direction of the International Telephone and Telegraph Corporation staff. It is skillfully written, greatly enlarged, and meticulously revised and edited.

The list price is \$20 and is available from Howard W. Sams & Co., 4300 West 62nd Street, Indianapolis, Indiana 46268.

“Want a Good Job in Broadcasting?”



You'll Need a First Class FCC License.”

Matt Stuczynski knows. He's the Senior Transmitter Operator of Radio Station WBOE. His story is typical of hundreds of men who have used Cleveland Institute Training as a springboard to success in Broadcasting. Here's what Matt says about Cleveland Institute:

“I give Cleveland Institute credit for my First Class FCC License. Even though I had only 6 weeks of high school algebra, CIE's AUTO-PROGRAMMED™ lessons really made electronics theory and fundamentals easy. After completing the CIE course, I took and passed the First Class Exam. I now have a good job in studio operation, transmitting, proof of performance, equipment servicing. Believe me, a Commercial FCC License is a ‘must’ for a career in Broadcasting.”

If you want rapid advancement in broadcasting, the first step is a First Class FCC ticket with *your* name on it. And Cleveland Institute Home Study is a fast, economical way to get one. What's more, CIE backs their licensing programs with this money-back warranty:

“A CIE License Course will quickly prepare you for a First Class FCC License. If you complete the course but fail to pass the exam *on your first attempt*, CIE will refund all tuition.”

With Cleveland Institute you get your First Class FCC License or your money back! Send coupon today for FREE book or write to Cleveland Institute of Electronics, 1776 E. 17th St., Dept. BE-56 Cleveland, Ohio 44114.

ENROLL UNDER NEW G.I. BILL

All CIE courses are available under the new G.I. Bill. If you served on active duty since January 31, 1955, or are in service now, check box in coupon for G.I. Bill information.

MAIL COUPON TODAY FOR FREE BOOK



CIE Cleveland Institute of Electronics

1776 East 17th Street, Cleveland, Ohio 44114

Please send me your FREE book, “How To Get A Commercial FCC License.”

Name _____ (please print)

Address _____

City _____ State _____ Zip _____

Occupation _____ Age _____

Veterans check here for GI Bill information

Accredited Member National Home Study Council
A Leader in Electronics Training . . . Since 1934

BE-56

Circle Item 43 on Tech Data Card



RCA broadcast service performing 35 years behind the scenes

Broadcasters' repair, modification, and overhaul needs are strictly behind the scenes. And RCA Service Company experts keep on providing service to keep all your broadcast equipment operating at peak performance. Take advantage of RCA's experience in AM, FM & TV servicing — on a contract or per-call basis. Dial either of these offices for full information about fast, dependable RCA service: Chicago (312) WE 9-6117 Philadelphia (215) HO 7-3300 If you prefer, write: RCA Service Co., A Division of RCA Technical Products Service, Bldg. CHIC-225, Camden, N. J. 08101

RCA

Computer Jam

As a result of field tests by a firm of consulting engineers, a St. Paul, Minnesota computer manufacturing firm has asked that the Commission impose restrictions on the radiation permitted to be laid down at the computer firm's plant by the local television broadcast stations. The stations are proposing an "antenna farm area" within one-half mile of the computer facility.

Reports of tests indicated the computers themselves to be immune from strong VHF and UHF fields. Likewise, most test equipment at the facility was not adversely affected. One particular type of oscilloscope, however, exhibited spurious responses which were traced to the television signals, and the restrictions requested by the computer organization have the principal purpose of protecting these oscilloscopes. Left unanswered is the question of why the computer outfit's scopes developed trouble while similar instruments are used without difficulty in large numbers at television broadcast stations.

Letters

(Continued from page 4)

available, and almost always unlicensed. Secondly, it would make the First Class License mean something to an employer, since your average DJ would not take the time to get one if he didn't need one, and those who had them, most likely, would be qualified to use them. The engineer would be returned to the stature he used to hold before a First Ticket became available to anyone with six weeks and \$300.

I would suggest requiring each station to have a resident qualified Chief Engineer responsible for seeing that his lower-licensed help was able to make the necessary readings and minor adjustments. The new required maintenance log would ensure the proper attention to the equipment.

Granted, the above is no panacea; there are problems for some stations it would not solve. But, I think it a more realistic set-up than the one we are now forced to live with, and certainly not inconsistent with the current state of the art.

John King
Chief Engineer, KGAL

SAMS BOOKS

FOR THE BROADCAST FIELD

AM-FM Broadcast Operations

by *Harold E. Ennes*. Describes technical operations of radio stations from the operator's viewpoint. Ranges from basic information relating to layout for control rooms to the more complex subjects of remote equipment, etc. Examines problems encountered and proper procedures for operating both inside and outside the station. Includes section on operating the transmitter, and FCC rules. A valuable aid in preparing for FCC license examinations.
Order 20066, only.....\$5.95

AM-FM Broadcast Maintenance

by *Harold E. Ennes*. Covers maintenance of radio stations in detail from the chief engineer's point of view; details his duties and responsibilities. Explains decibels, volume units, levels, pads, and am-fm propagation. Explains how testing and maintenance are done at the studio and at the transmitter. Includes valuable appendices on "Measuring Frequency Deviation of an FM Transmitter by the Bessel-Zero Method" and "Reference Charts and Diagrams."
Order 20068, only.....\$5.95

Understanding Amplitude Modulation

by *Irving M. Gottlieb*. Clearly and simply explains the principles used in the amplitude modulation of a carrier signal. Describes the various types of systems, both tube and transistorized, used to accomplish amplitude modulation. Simplifies the mathematics and practical considerations involved; offers a wealth of schematics, tables, and graphs to enhance understanding. Provides an exceptional background for comprehending a-m principles. Order 20514, only.....\$3.95

Television Systems Maintenance

By *Harold E. Ennes*. Gives the standards for picture-signal analysis, amplitude calibration and maintenance of levels, synchronizing generator and pulse-distribution systems theory. Also explains the video switcher, frequency and transient response, amplitude and phase linearity, microwave systems, transmitter maintenance, and proof of performance. Order 20069, only.....\$5.95

Television Tape Fundamentals

by *Harold E. Ennes*. For the broadcast engineer, technician or operator. Explains the basic concepts of television tape, rotating-head theory, system requirements, video-signal processing servo system, operations, and maintenance. Order 20065, only.....\$5.95

First-Class Radiotelephone License Handbook, 2nd Ed.

by *Edward M. Noll*. Provides all the information required to qualify for the First-Class FCC Radiotelephone License. Also makes an ideal reference handbook for those who already hold the license. While the volume contains questions and answers based on Element IV of the FCC exam, it is actually a comprehensive textbook on broadcast communications, since it presents a thorough understanding of the theory and basic principles necessary to hold the position of communications engineer.
Order 20086, only.....\$5.75

Howard W. Sams & Co., Inc.

Order from your Sams Distributor today, or mail to Howard W. Sams & Co., Inc., Dept. BE-2
4300 W. 62nd Street, Indianapolis, Ind. 46268

Send me the following books:

20066 20514 20065
 20068 20069 20086
\$_____enclosed

Name _____

Address _____

City _____

State _____ Zip _____

Advertisers' Index

AKG Division	19
Altec Lansing, Div. of LTV Altec, Inc.	41
American Electronics Labs., Inc.	45
Applied Electro Mechanics, Inc.	59, 64
Audio Design & Mfg. Co., Inc.	52
Bristol Company	26, 27
Broadcast Electronics, Inc.	54, 61, 64
Broadcast Products Corp.	58
Buckeye Stamping Co.	60
CBS Laboratories, Div. of CBS, Inc.	3
CCA Electronics Corp.	56, 59, 60, 61, 62, 64
Cleveland Institute of Electronics	65
Cohu Electronics, Inc.	1
Collins Radio Company	31
Comrex Corp.	61
Davis and Sanford	57
Defense Electronics, Inc.	4
Electrodyne Corp.	25
Fairchild Recording Equip. Corp.	55
Gates Radio Company	11
Gotham Audio Corp.	57
Gray Research & Development Corp.	59
ITT General Controls	60
International Nuclear Corp.	Cover 3
Jampro Antenna Company	4
Melcor Electronics	53
Memorex Corp.	34-35
Michigan Magnetics	60
3M Company, Mincom Div.	12
Minneapolis Magnetics, Inc.	58
Multronics, Inc.	64
North American Philips Co., Inc.	19
Potomac Instruments, Inc.	62
QRK Electronics Products	18
RCA Electronic Components	17
RCA Service Company, Div. of	
RCA Technical Products	66
RHG Electronics Laboratory, Inc.	38
Riker Video Industries	Cover 2
Round Hill Assoc. Inc.	58
Howard W. Sams & Co., Inc.	66
Sarkes Tarzian, Inc.	10
Sentinel, Inc.	10
Spaita Electronic Corp.	49
Spotmaster	54, 61, 64
Stanton Magnetics, Inc.	28
Superscope, Inc.	13
Taber Manufacturing & Engraving Co.	62
Tapecaster Electronics	8
TeleMation, Inc.	9
Telemet Company	Cover 4
United Radio Supply, Inc.	55
Vital Industries	7
Ward Electronic Industries	5
Wilkinson Electronics, Inc.	56, 62, 63

Professional Services

VIR JAMES
 CONSULTING RADIO ENGINEERS
 Applications and Field Engineering
 345 Colorado Blvd.
 Phone: (Area Code 303) 333-5562
DENVER, COLORADO 80206
 Member AFCCE
 TWX 910-931-0514

JAMES C. McNARY
 Consulting Engineer
 National Press Bldg.
 Washington 4, D.C.
 Telephone District 7-1205
 Member AFCCE

**CAMBRIDGE CRYSTALS
 PRECISION FREQUENCY
 MEASURING SERVICE**
 SPECIALISTS FOR AM-FM-TV
 445 Concord Ave. Phone 876-2810
 Cambridge, Mass. 02138

**JOHN H. MULLANEY
 and ASSOCIATES**
 Suite 71,
 1150 Connecticut Ave., N.W.
 Washington, D. C. 20036
 Phone 202-223-1180
 Member AFCCE

CRYSTAL AND MONITOR SERVICE:
 Crystal service with us is usually a matter of hours, not weeks! Repair or replacement of oven type broadcast crystals at reasonable prices, most all makes. Also repair or frequency change of AM frequency monitors and H-P FM monitors—inquire. Many years experience. Call or write: Eidson Electronic Co. Box 96, Temple, Texas. Phone (817) 773-3901.
 11-68-tf

**ROSNER TELEVISION
 SYSTEMS**

ENGINEERS 120 E. 56 St. New York N. Y. 10022	CONTRACTORS 29 South Mall Plainview N. Y. 11803
--	---

TAPE CARTRIDGE SERVICE
 Completely recondition your old tape cartridges, all sizes of new tape cartridges in stock available for immediate shipment. Will supply complete price list on request.
M.S.I. CARTRIDGE SERVICE
 279 W. Main Street
 Amsterdam, N. Y. 12010
 Phone (Area Code 518) 843-2242

AMPEX HEAD ASSEMBLY
 Relapping and replacement head service for all AMPEX professional studio model recorders. Our precision relapping extends head life for maximum use. Brand new shelf stock replacement heads of our manufacturer available when relapping not advisable. Prices include thorough assembly cleaning, optical and electrical inspection and complete testing on AmpeX equipment. Monaural assembly relapping . . . \$35.00 complete. Monaural assembly replacements . . . \$119.50 complete. "Loaner" assemblies available. For more data, contact LIPPS, INC., 1630 Euclid St., Santa Monica, Calif. 90404 (213) EX 3-0449.

FRANK A. ZOELLER
**TELEVISION SYSTEMS
 CONSULTANT**
 20 Years Experience
 Box 366 • San Carlos, Cal. 94070
 (415) 593-1751

GUARANTEED FIRST PHONE, 4-6 weeks. Broadcast Engineering Academy, 3700 Lemay Ferry, St. Louis, Mo. 63125. 314/892-1155. 5-68-tf

Classified

Advertising rates in Classified Section are 15¢ per word, each insertion, and must be accompanied by cash to insure publication.
 Each initial or abbreviation counts a full word. Upper case words, 30¢ each.
 Minimum classified charge, \$2.00.
 For ads on which replies are sent to us for forwarding, there is an additional charge of \$2.00 to cover department number, etc., which is printed in advertising copy, and processing of replies.
 Classified columns are not open to advertising of any products regularly produced by manufacturers unless used and no longer owned by the manufacturer or a distributor.

Help Wanted

VIDEO TAPE ENGINEERS

Expansion in the video tape machine field has created new opportunities for engineers to test equipment at our plant and supervise installations at customers' facilities. You should have previous experience on video tape equipment, either with a manufacturer or a broadcast station.
 If you are a self-starter and have the experience required, this is an opportunity to grow with a dynamic, expanding national company in the broadcast field. Attractive salary will be commensurate with background and experience. Send your resume to Mr. Frank Haney, General Manager.
VISUAL ELECTRONICS LABORATORIES
 725 San Aleso Avenue
 Sunnyvale, California 94086

Help Wanted (Cont.)

Radio Station Manager for Oklahoma Day Timer. Excellent town, good market. Want all around man, oriented on sales. Salary \$750 per mo., plus car and bonus. Ownership possibilities to right man. Give full details including references. All replies confidential. Don't phone. Write: John Morris, Free-Lance, Henryetta, Oklahoma 74737. 1-69-2t

IMMEDIATE OPENINGS: Qualify for any of the following positions: RCA CCTV Equipment, monochrome or color, TV Systems Engineers - Maintenance Technicians - Video Engineers - to work in either New York, New Jersey or California area. Write: RCA Rep., 1559 Jericho Tpke., New Hyde Park, New York 11040.

Job Headquarters for all Radio and Television Engineers. Immediate openings exist in 9 western states and elsewhere for qualified engineer and technical personnel. All categories from trainees to experienced transmitter maintenance chief, assistant chief, live color video maintenance and technical operations. Send us your complete resume now. The AMPS Agency, 3924 Wilshire Blvd., Los Angeles, California 90005. Telephone DU 8-3116. By Broadcasters—For Broadcasters 11-66-tf

Equipment Wanted

Zoom lens, other cameras, and tubes wanted. Ted Dames Co., 308 Hickory St., Arlington, N. J. 07032. 1-69-3t

Training

To advance in electronics, knowledge and ability are required. Grantham offers correspondence and resident instruction, in depth, leading to the degree or Associate in Science in Electronics Engineering, G. I. Bill approved. Credit for previous training and experience allowed. Free Catalog. Write: Dept. E-2, Grantham School of Electronics, 1505 N. Western Ave., Hollywood, California. 90027. 6-67-tf

First phone through tape recorded lessons at home plus one week personal instruction in Washington, DC, Atlanta, Boston, Detroit, New Orleans, Minneapolis, Seattle, Denver, Portland, Los Angeles. Proven results. Our 17th year teaching FCC license courses. Bob Johnson Radio License Preparation, 1060D Duncan, Manhattan Beach, Calif. 90266. Phone 213-379-4461. 1-69-tf

Equipment for Sale

AM or FM Audio P.O.P. form kit \$1.50 postpaid. Broadcast Service Co., Box 2605, Corpus Christi, Tex. 78403. 2-69-tf

Business Opportunity

EXCELLENT OPPORTUNITY IN COMMUNICATIONS. New exciting Cablecasting field, (same as Television broadcasting except over CATV systems). Annual potential of \$250,000 in advertising sales. All modern studio including video tape machines and Cortez Van Mobile Studio. Will finance right party. Phone area code 517 356-1510. 2-69-3t

**Maybe
a procto isn't
exactly a
pleasure.
Neither
is cancer.**



And the purpose of the examination is the early detection of cancer of the rectum and colon.

We know that some people think the examination is somewhat embarrassing. But cancer is a lot more than embarrassing. And a procto can spot cancer, when it's still beatable.

A procto takes just a few minutes. And maybe it's not a pleasure. But hearing your physician say, "Everything's normal," sure is.

**american
cancer
society**

This Space Contributed by the Publisher

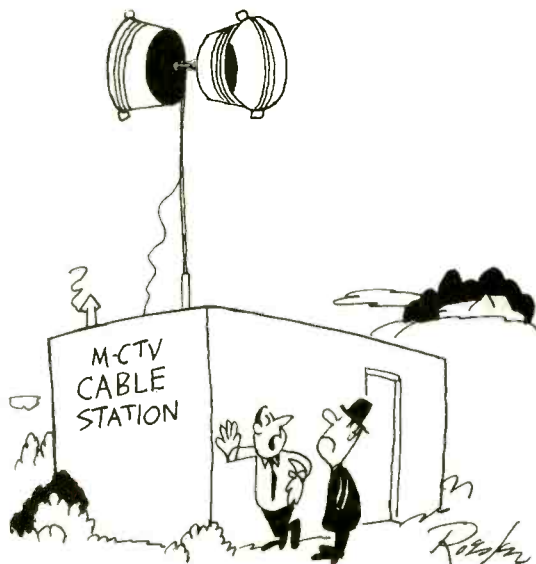

*"WE OPERATE ON AN EXTREMELY
LOW BUDGET."*



Looking for a good video stabilizing amplifier?

International Nuclear's TVA1 is certainly one of the best on the market today. The TVA1 with its associated series of plug-in units offers high level performance and versatility for studio or transmitter use. It removes all low frequency disturbances such as hum, bounce and tilt by sync-tip clamping. This back porch level is precisely stabilized without affecting color signals in any way. Sync is stretched after back porch stabilization and then clipped accurately to desired level. This level may be set by means of a front panel control which can be extended to a remote location. Stripped sync is provided at one 75 ohm internally terminated output connector, at a 4 volt level. The TVA1 chassis contains a plug-in compartment which accepts up to 4 plug-in units. Among these plug-in units is the TVA1-E, providing a stripped color video channel, and the TVA1-D which provides the means of adjusting peak-white clipping, white stretch and differential phase. Other plug-in units are listed below.

PRICES F.O.B. NASHVILLE, TENNESSEE

Model TVA1 Stabilizing Amplifier (less plug-ins) . . . \$1,380.00
 Model TVA1-A, Manually Operated Input Amplifier Unit . . . \$310.00
 Model TVA1-B, Input Amplifier Unit, with Remote Master Gain and Chroma Panel . . . \$425.00
 Model TVA1-C Monitor Amplifier Unit . . . \$265.00
 Model TVA1-D White Stretch and Clip Unit . . . \$240.00
 Model TVA1-E Stripped Video Unit . . . \$450.00
 Model TVA1-S Remote Sync Level Control Panel . . . \$25.00



For more complete information write or phone:

INTERNATIONAL NUCLEAR CORPORATION
"Transistorizing the Television Industry"

608 NORRIS AVENUE • NASHVILLE, TENN. • PHONE 615-254-3366

Circle Item 45 on Tech Data Card

Telemet's Chroma Keyer gives you a clean, fine edge picture every time

The solid State Telemet Chroma Keyer Model 3604-A1 permits the use of color signals for producing reliable video insert keying in conjunction with special effects equipment.

Primarily, the Model 3604-A1 color keys for color video. The Chroma Keyer combines red, green and blue camera signals to form a single keying signal. This keying signal is based on differences in hue and saturation rather than on

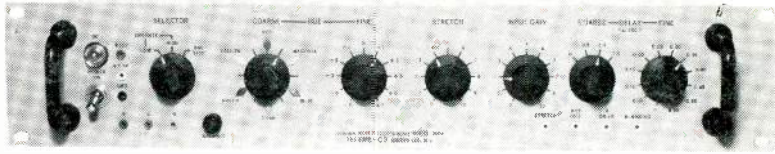

differences in luminance. It is a simple matter to select a background color that is not contained in the subject. The Chroma Keyer provides maximum separation between the background color and all other colors. The result in the special effects amplifier is that the subject or insert is cleanly keyed in.

In addition, Telemet's

Chroma Keyer also can be used for color keying for monochrome video, and monochrome keying. Look sharp... be sharp... get in touch with Telemet today.

T E L E M E T

a division of **GEOTEL, INC.**
185 Dixon Ave., Amityville, N.Y. 11701
Tel. (516) 541-3600

**Better Ideas
for the Broadcast Industry**

The Clean Scene

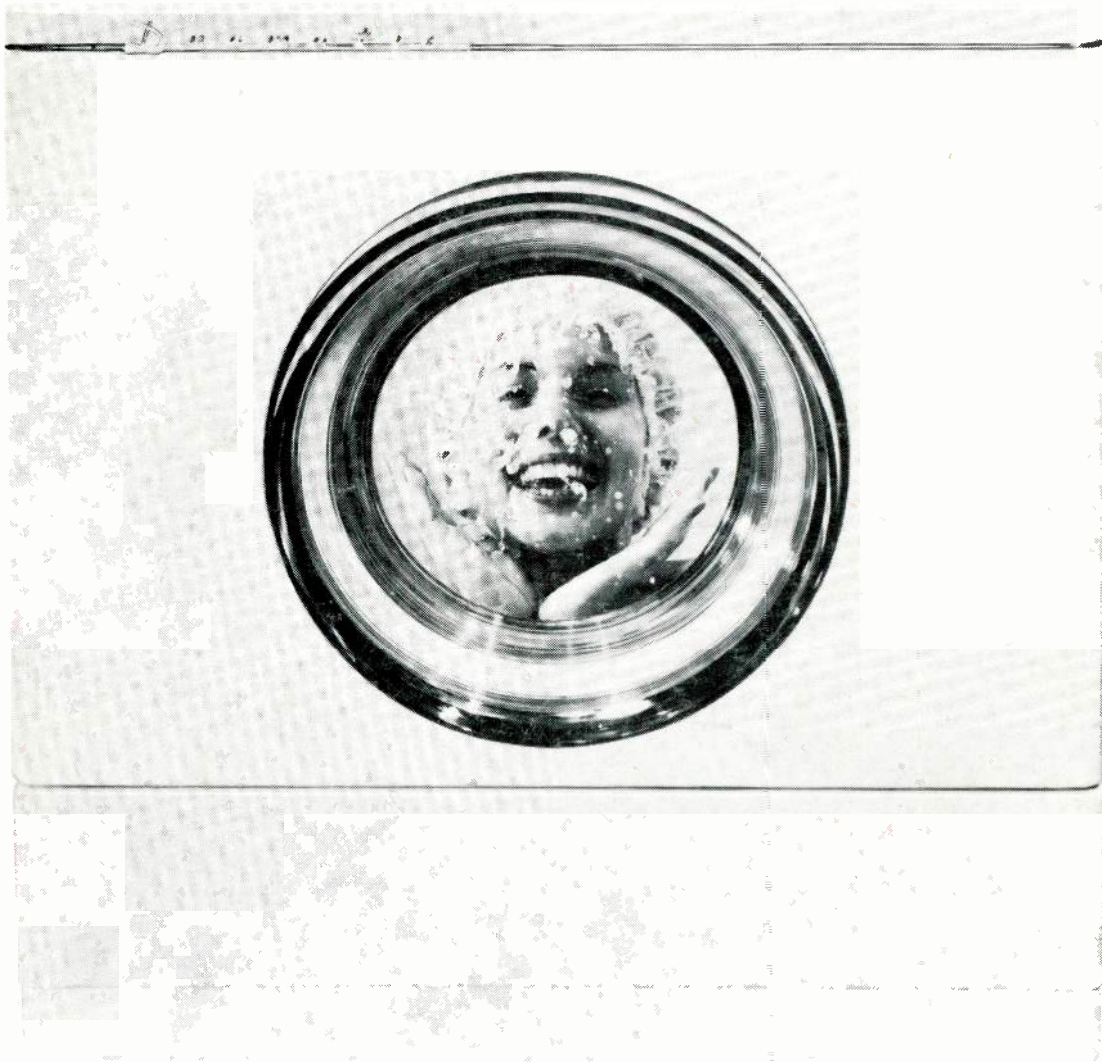

Circle Item 46 on Tech Data Card