

Broadcast Engineering®

the technical journal of the broadcast-communication's industry



A HOWARD W. SAMS PUBLICATION

COAX MAINTENANCE

page 20

Tape Evaluation

VI Applications

Comprehensive ITV

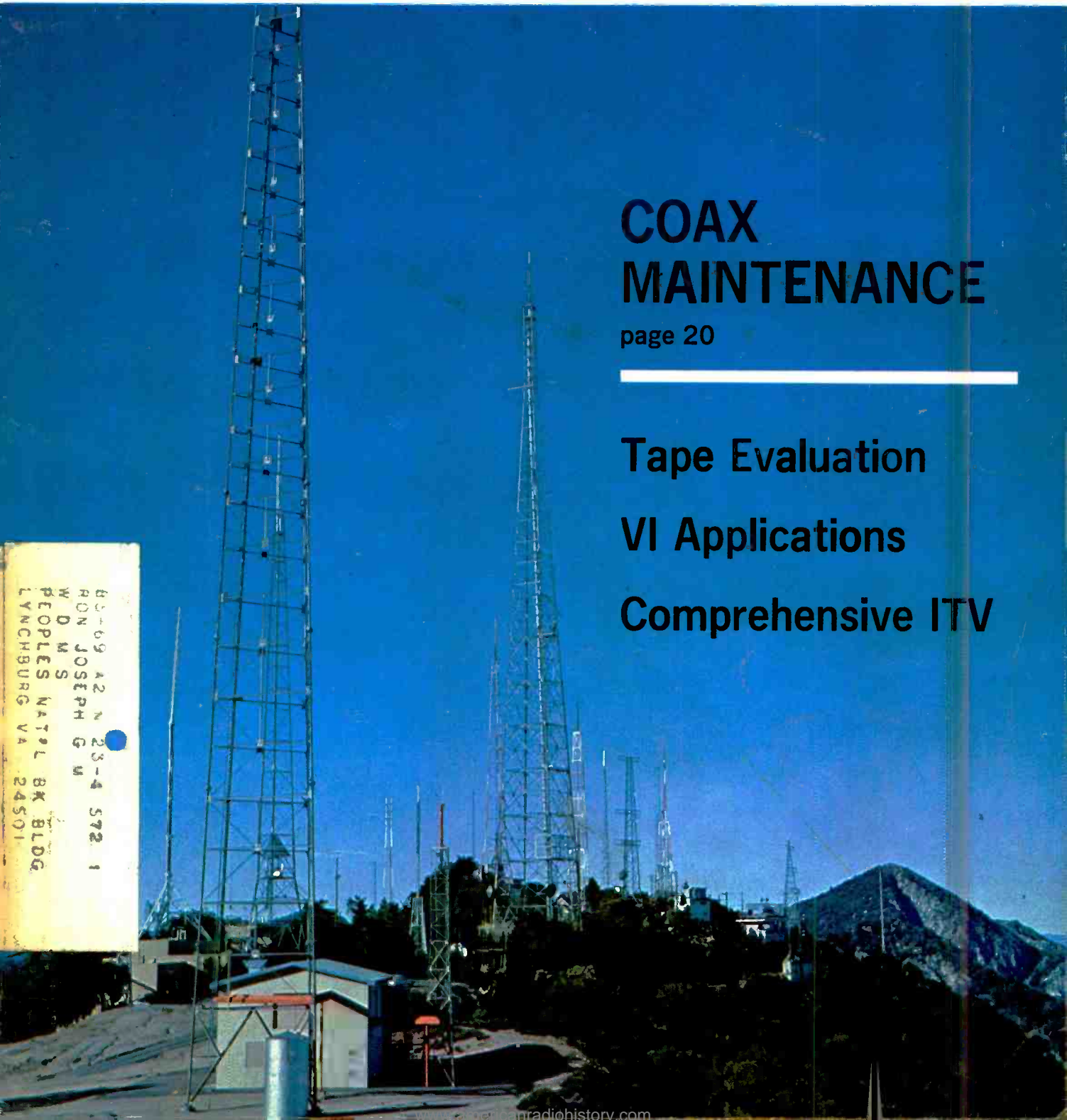

65-69 A2 N 25-4 572 1
RON JOSEPH G W
W D M S
PEOPLES NAT'L BK BLDG
LYNCHBURG VA 24501

Color from black & white? You better believe it!



or your costs are double.

The new ABTO process cuts your present color film costs in half. It uses standard Plus-X film and black and white processing attaining high photographic quality and color fidelity.

**NOW... SHOOT IN BLACK AND WHITE...
SHOW IN COLOR!**

Hard to believe? Write for full details. Even better—come to the first public demonstration: NAB Show, Lobby of Essex Inn (just across 8th Street from the Conrad Hilton).

abto_{INC.}

1926 Broadway, New York, N.Y. 10023 (212) 787-5000

Affiliated with: American Broadcasting Companies, Inc. and Technical Operations, Inc.

Circle Number 1 on Reader Reply Card

www.americanradiohistory.com

What's a \$2,300 monochrome camera going to do for me?



Cohu's got the answer in the 3203 Self-Contained Television Camera. It's the ideal insert key source for supers and for matte generation during production video switching. Use it on remotes; it's light enough to carry under one arm. Put a new dimension into "line-of-sight" monitoring between control room and studio floor. A compact 3203 camera mounted in the studio can provide a valuable look at camera, equipment, and personnel positions. Optional accessories can provide remote control including electronic set-up, zoom,



COHU MODEL 3203
broadcast quality camera

lens, and pan/tilt. One of several available standard models, the camera comes with vidicon tube and equipped with "C" mount to accept a 16 mm lens. Other models can be specified with lead oxide image tube; with or without viewfinder or as a film chain with remote control and automatic peak video compensation. All models feature solid-state plug-in circuitry easily accessible through a flip-down rear door. Our 3203 could be doing a lot for you. For more details contact your nearest Cohu representative or the TV Product Line Manager direct at 714-277-6700, Box 623, San Diego, California 92112, TWX 910-335-1244.

COHU
ELECTRONICS INC
SAN DIEGO DIVISION

See us at NAB Show, Hilton Hotel, Chicago, Booth 324.

Circle Number 4 on Reader Reply Card

Broadcast Engineering

The technical journal of the broadcast-communications industry

in this issue...

20 Coax Maintenance—Solving Problems on the Line. A review of coax characteristics and a discussion of problems encountered in coax maintenance. **Pat Finnegan.**

26 On Line Video Tape Evaluation. Description of a method of electrically evaluating the subjective impairment of video tape resulting from dropouts. **Fred J. Hodge.**

30 Vertical Interval Signal Applications. A roundup of application ideas for use of the vertical blanking interval to expand TV services and testing techniques. **Harry Etkin.**

36 Going all the way with ITV. Description and details of a college that was designed from the ground up to make maximum use of ITV potentials. **Eugene L. Edwards.**

43 CATV System Re-Tubing Plan. A plan for scheduled re-tubing of systems making heavy use of tubes. Designed primarily to cut subscriber interruption time and maintenance time. **Richard Regent.**

46 Eliminating Heat Damage on the Bench. BE Solid State Editor reveals the dangers of applying excessive heat while making repairs on the bench. **Carl Babcoke.**

ABOUT THE COVER

The cover this month shows an antenna farm that could be a mountain of problems for the stations involved if coax parameters were not understood. See the article on page 20 for details on coax characteristics and maintenance.

DEPARTMENTS

Direct Current	4
Letters to the Editor ..	8
Industry News	12
Educational	
Broadcasting	14
CATV Scope	18
Engineer's Exchange ..	48
New Products	52
Tech Data	61
Ad Index	63
Classified Ads	64

Copyright, 1970, Howard W. Sams & Co., Inc. All Rights Reserved. Material may not be reproduced or photocopied in any form without written permission of publisher.

EDITORIAL

GEO. H. SEFEROVICH, Director
RONALD N. MERRELL, Editor
CARL BABCOKE, Solid State
MORRIS COURTRIGHT, Automation
HARRY A. ETKIN, Cable TV
PAT FINNEGAN, Maintenance
HOWARD T. HEAD, FCC Rules
ROBERT A. JONES, Facilities
A. PETERSON, Editorial Assistant
DUDLEY ROSE, Art Director

EDITORIAL ADVISORY BOARD

LES NELSON, Chairman
Howard W. Sams & Co., Indianapolis

CIRCULATION

R. VINCENT WARD, Director
EVELYN ROGERS, Manager

ADVERTISING

E. P. LANGAN, Director
R. JACK HANCOCK, Manager
S. F. WILSON, Production
JAKE STOCKWELL, Sales

REGIONAL ADVERTISING SALES OFFICES

Indianapolis, Indiana 46206
ROY HENRY
HOWARD W. SAMS & CO., INC.
2469 E. 98th St.
Tele: 317/846-7026

New York, New York 10019
CHARLES C. HORNER
3 W. 57th St.
Tele: 212/688-6350

Los Angeles, California
JOHN D. GILLIES
3600 Wilshire Blvd., Suite 1510
Los Angeles, California 90005
Tele: 213/383-1552

London W. C. 2, England
JOHN ASHCRAFT & CO.
12 Bear Street
Leicester Square
Tele: 930-0525

Amsterdam C, Holland
JOHN ASHCRAFT & CO.
W.J.M. Sanders, Mgr.
for Benelux & Germany
Herengracht 365
Tele: 020-240908

Tokyo, Japan
INTERNATIONAL MEDIA
REPRESENTATIVES, LTD.
1, Shiba-Kotohiracho, Minato-ku
Tele: 502-0656



BROADCAST ENGINEERING is published monthly by Intertec Publishing Corp., 1014 Wyandotte Street, Kansas City, Missouri 64105. Telephone: 913/888-4664.

BROADCAST ENGINEERING is mailed free to qualified persons engaged in commercial and educational radio and television broadcasting. Non-qualified subscriptions in the U.S. are \$6.00 one year, \$10.00 two years, \$13.00 three years. Outside the USA add \$1.00 per year to cover postage. Single copy rate 75 cents. Back issue rate \$1.00. Adjustments necessitated by subscription termination at single copy rate.

Controlled Circulation postage paid at Indianapolis, Indiana.



Robert E. Hertel, Publisher
Intertec Publishing Corp.
Subsidiary of Howard W. Sams & Co., Inc.

THE BIGGEST

Introducing the mixing console that fills the gap.

Between the expensive, custom-made console that has everything... when you finally get it. And the small, rigid-design broadcast mixer that gives you low price... but no reverb, no EQ, and only rotary mixers.

The Studer 089 Mixing Console is the happiest possible medium. Made by one of the most famous names in tape recorders, it has *all* the "goodies." Twelve input units, all with EQ, cut-off filters, pan-pots, phase reversing switch, gain vernier and linear attenuator, two or three line outputs, two reverb outputs, and two subgroup buses. Plus visual and acoustical monitoring facilities you usually get only on large scale consoles. Yet it weighs only 144 lbs. and fits into a transport case for field use.

It costs \$15,000. And you can have it immediately. Because Gotham has these mass-produced Swiss precision mixing consoles in stock in the U.S.

It would take a book to tell you *all* about it. And Gotham has the book. A 24-page color brochure. Send or call for it now. And if it makes you want the Studer 089 Mixing Console right away... that's just when Gotham can give it to you.

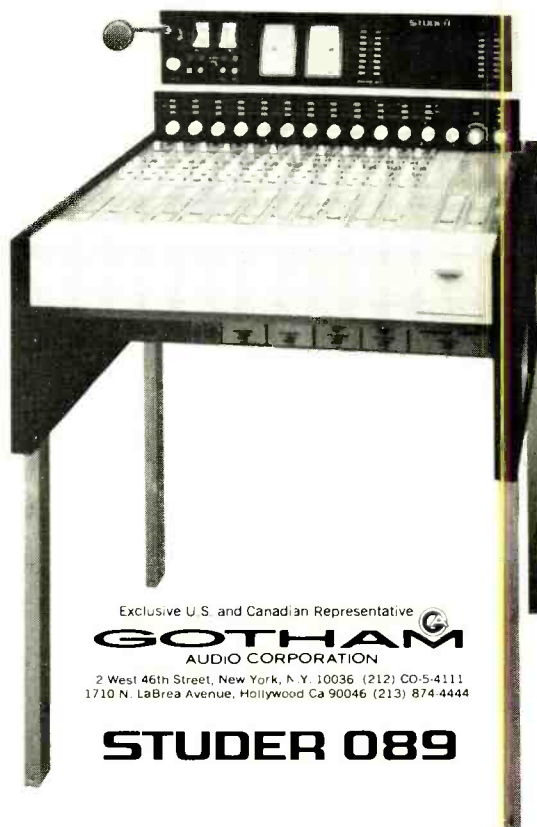

THE SMALLEST

Circle Number 5 on Reader Reply Card

DIRECT CURRENT FROM D. C.

April, 1970

By Howard T. Head

Recent FCC engineering activity has been low, and there is now an unprecedented backlog of engineering matters awaiting FCC decision.

Predicting FCC actions has always been a risky business and nowadays the "predicting business" is riskier than ever. Nevertheless, we will take the occasion of the NAB Convention to put the spotlight on some of the hotter topics on which the Commission is expected to act (or fail to act) in the months to come.

Pompous Predictions:

Domestic Satellites: The Commission will act promptly, perhaps by the time these words are in print, to authorize one or more domestic satellite systems for television relay. Control will probably be vested in a consortium controlled by the three major television networks. Plans will include the provision of one or more free educational television channels.

Land Mobile Channels: The Commission will bow to land mobile lobbying pressures and will authorize land mobile sharing of television Channels 14-20. Channels 70-83 will be turned over to land mobile service, but TV translator operation will be permitted to continue. Exploration of land mobile/VHF channel sharing will continue.

CATV Regulation: The Commission will continue to ease restrictions on CATV systems, and CATV networking will be permitted. Technical standards will not be imposed on CATV systems, but a committee will begin work on CATV technical standards.

Mexican Radio Treaty: The Mexican Senate will ratify the radio treaty with the U.S., and the Commission will issue new Rules putting its provisions into effect. This will permit pre-sunrise operation of some two hundred U.S. daytime only stations operating on the Mexican clear channels, and will provide daytime power increase to 1 kw for Class IV local channel stations near the Mexican border.

VHF TV Remote Control: The Commission will act this spring to authorize the remote control of VHF TV transmitters. A six-month "shake down" period will be required for all remote control proposals.

AM Directional Antenna Remote Control: The Commission will establish requirements for the type approval of phase monitors for AM directional antennas, and will reduce the required daily remote-control inspection from seven to five days per week. Tolerances considerably tighter than the present 5 percent in current ratio and 3° in phase angle will be imposed.

(Continued on page 6)

HELIAX COAXIAL CABLE...

unique design
and performance



The coaxial cable with the corrugated outer conductor.

Better than braided coax because HELIAX has perfect shielding, precise electrical characteristics, lower attenuation and freedom from age deterioration.

Better than smooth wall coax because HELIAX is more flexible, easier to install, stronger, lighter, free from differential expansion and comes in extremely long continuous lengths.

Available from stock in 35 types and sizes down to 1/4". Foam or air dielectric. Teflon too. Connectors for all standard interfaces.

For full details, communicate with Andrew.



ANDREW

ANDREW CORPORATION, 10500 W. 153RD STREET,
ORLAND PARK, ILLINOIS 60462, PHONE (312) 349-3300

2-70

Circle Number 6 on Reader Reply Card

(Continued from page 4)

AM Freeze: The "freeze" on the construction of new AM stations will be made permanent. AM and FM services will be considered as a single aural service, and new AM stations will be authorized only where neither AM nor FM service presently exists. "Freeze" requirements will be relaxed to permit improvement and relocation of existing AM facilities, but frequency changes and power increases will be forbidden.

VHF TV Drop-ins: No prospect for the foreseeable future.

TV Propagation Curves, Methods of Calculation, and Field Strength Measurements: The Commission will continue to require the employment of the present F(50,50) propagation curves and contour prediction methods. Proposed new propagation curves (first developed in 1966) will not be adopted this year. Proposals to employ maximum ERP of UHF stations rather than power in the horizontal plane in predicting contour distances will not be acted on. The Commission will not modify the technical standards to permit FM and TV field strength measurements, but will increasingly rely on field strength measurements in individual cases.

UHF TV Receiver Performance: The Commission will stick to its guns and require reduction in local oscillator radiation from UHF TV tuners and comparable tuning performance at UHF and VHF. However, tuner and receiver manufacturers may be given extensions of time into 1971 or 1972 to meet presently established requirements.

Operator Exams: The Commission will make substantial modifications in the present operator examinations with particular emphasis on Element 4. The requirements will apply to new applicants only, and present license holders will not be affected. Studies will be made of endorsement or similar approval for first-class license holders qualified to maintain AM directional antennas.

Emergency Broadcast System: Commissioner Wells, the new Defense Commissioner, will shake up the existing EBS operation. Several "surprise" tests of EBS will be conducted.

Daytime Tower Lighting: The FAA will quietly drop proposals for daytime tower lighting, and will continue unsuccessfully to try to find a daytime lighting system that really works.

Higher AM Power: Proposals for lifting the power ceilings for AM stations will either be turned down or side-tracked. There is no prospect of approval for power in excess of 50 kw for Class I-A clear channel stations. Proposals for power in excess of 5 kw on the regional channels involve serious interference and treaty problems.

Operator Requirements: NAB has just filed a petition with the Commission asking that the use of a third-class operator be permitted during routine operation of all classes and powers of AM and FM stations, including powers up to 50 kw for both AM and FM and AM directional antennas. These proposals will receive careful study by the Commission but action will be slow in coming. The Association of Federal Communications Consulting Engineers (AFCCE) will undertake studies jointly with Commission and industry engineers aimed at providing improved maintenance of AM directional antennas, which is crucial to the relaxation of routine operator requirements for AM DA's.

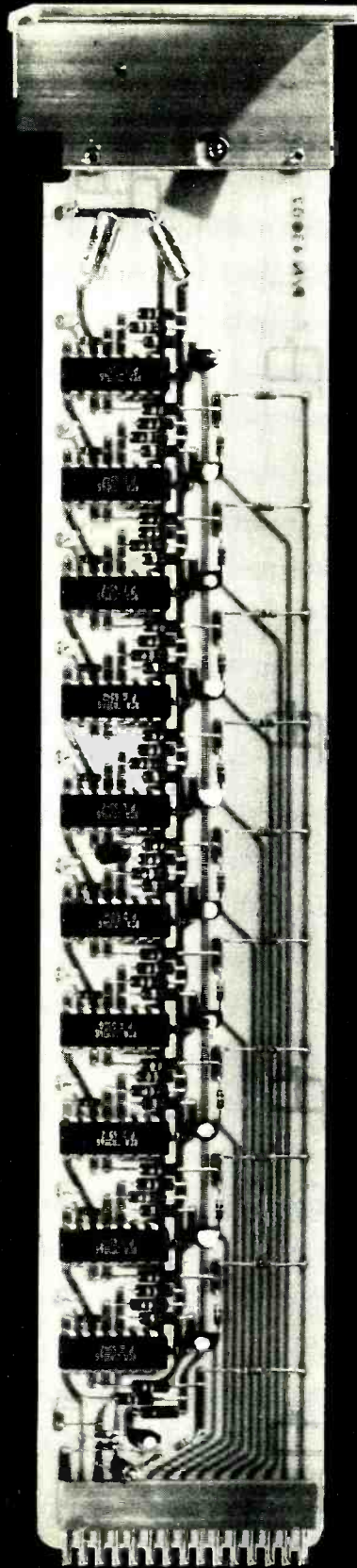

**N A B
BOOTH 113**

THE GRASS VALLEY GROUP, INC. 

light is our thing

Light is a dynamic fact of life. Century Strand handles light with new design concepts, advanced engineering and unmatched craftsmanship . . .

up to 50 ft. high efficiency



3614 FRESNELITE® 12" Spotlight

**1000w-true-zoom focusing action
up to 80' high**



4481 ZOOM FOLLOW SPOT

**efficient light control
modular, portable, economical**



MK II EDKOTRON®

Light is a dramatic fact of life. For the world's finest in dramatic lighting and controls it's now Century Strand.



CENTURY STRAND INC.

A COMPANY WITHIN THE RANK ORGANISATION

3 Entin Road, Clifton, N. J. 07014
5432 W. 102 St., Los Angeles, Calif. 90045

In Canada: STRAND CENTURY LIMITED
105 Davenport Rd., Toronto 5, Ontario
Circle Number 8 on Reader Reply Card

LETTERS TO THE EDITOR

Transmitter Maintenance

Dear Editor:

Reading Pat Finnegan's article on maintenance in the January issue of BE (the portion concerning neutralizing) brought to mind a statement from Hal Walker of the G. E. transmitter engineering department.

"One of the most important adjustments you must make in any TV transmitter is neutralization of the modulated stage. Any RF which appears in the plate circuit due to improper neutralization is not under control by the control grid. The RF combines with the RF which is under grid control; the vector sum of these two voltages can and will produce differential gain and differential phase problems—particularly near peak white where the controlled and uncontrolled voltages tend to become more nearly equal. The peak white area is always the most difficult area in which to maintain modulation linearity and you don't want any more problems than necessary.

When neutralizing, always reduce the amount of grid drive to the stage being neutralized to the minimum necessary to produce the desired results. Overdriving the grid forces the grid/cathode diode into an energy coupling device which will allow RF to appear in the plate circuit, again not under grid control, and the neutralizing adjustment will not be correct."

We added a Type N coax panel connector with a very short link—just long enough to reach from the center conductor to a connector mounting screw — to our mod amp cavity. This is connected to the BW-5 sideband analyzer receiver for neutralizing. The display under carrier conditions is ideal—just one large carrier spike which will null out when neutralizing is correct. Receiver gain allows reduced grid drive to produce an adequate display.

We are doing some experimental

work using op-amps for audio distribution amplifiers. So far the results are quite promising. One input and six outputs, balanced or unbalanced, with 40 to 60 dB isolation between outputs. I haven't seen anything published on this concept as yet except for Lasmandy's at the 1968 AES which was very brief. His paper was mainly concerned with introducing op-amps to the trade and did not cover the distribution amplifier concept.

After a thorough investigation seven years ago, two consultants informed me that a TV proof need only be made for the original license. No further proofs need be made for subsequent licenses granted to the original licensee. Fill in the blank in the renewal license form with a "yes".

**Dale Wolters
Chief Engineer
WZZM-TV
Grand Rapids, Mich.**

Author's Reply

Dear Editor:

The article on Transmitter Maintenance was intended to be a general article. This was necessary due to the many, many transmitter types in the field.

The article brought out the dangers from feedback and some general methods of detecting and correcting the problem. Each transmitter manual normally has some method spelled out in it for the stages that it normally finds troublesome. It isn't always possible to apply the same technique to a different make of transmitter.

Most engineers will devise specific methods to control their own transmitter, as each transmitter has its own idiosyncracies. Dale seems to have developed an excellent method that works well with his TV transmitter.

The article on TV proof of performance did recommend that a set of proof measurements be made

NOW Plumbicon* Quality for your Vidicon Camera

The Amperex line of PLUMBICON® TV camera tubes now includes an entire family of one-inch, separate-mesh retrofits for most Vidicon cameras in use and being manufactured for live broadcast television, telecine, educational and industrial CCTV and X-Ray CCTV applications.

As the comparison chart below clearly indicates, PLUMBICON tubes eliminate all of the well-known drawbacks of conventional Vidicons while retaining most of their own inherent useful features.

CHARACTERISTICS	VIDICON	PLUMBICON
Picture Shading/Dark Current	Uneven and high	Uniform and low (dark current less than 3 nA)
Lag (Picture Smear)	High; 15% to 25% residual signal after 50mSec.	Low; 2% to 5% residual signal after 50mSec.
Sensitivity	200µA/lumen @ 1 ft-cd target illumination and 20 nA dark current	400 µA/lumen at all light levels
Interdependence Lag/Sensitivity	Compromise between best lag characteristics and optimum sensitivity	Lag and sensitivity independent. Generally PLUMBICON has 1/5 lag and 2 to 3 times sensitivity of Vidicon.
Gamma	0.5-0.7; non-linear	0.95-1.0; linear
Scene and Highlight Retention	Frequently a severe problem	Not a problem
Target Blemishes	Tend to become "spotty"; initial blemishes tend to "grow" with usage time	Less prone to become "spotty"
Temperature Stability	Dark Current, Sensitivity, Lag very temperature dependent	Operating characteristics stable over -30° to +50°C temperature range

For more information on PLUMBICON tubes, particularly on the 16XQ series of one-inch, separate-mesh retrofits for most Vidicon cameras, contact: Electro-Optical Devices Division
Amperex Electronics Corp.
Slatersville, Rhode Island 02876
Telephone: 401-762-3800



Amperex®

TOMORROW'S THINKING IN TODAY'S PRODUCTS

A NORTH AMERICAN PHILIPS COMPANY

* Registered Trade Mark N.V. Philips of Holland

Circle Number 9 on Reader-Reply Card

www.americanradiohistory.com

Letters To The Editor

(Continued from page 8)

each year.

The Rules do not specifically require a set be made as they do in the AM and FM sections. But any transmitter must operate in accordance with the Technical standards of the Rules all the time. A Proof is simply an annual checkout of the system to know that it is operating in such manner—at least at that time.

As far as the renewal application is concerned, it is not correct to answer the question "yes" if a Proof hasn't been made. The original Proof would not satisfy the question as it is asked. Section II of the renewal applications, question 10 asks if a Proof of Performance has been made within the last four months. How could an original Proof made several years earlier satisfy this question? Question 10c asks if the equipment measurements showed the equipment to be complying with the Technical Standards. It also asks that you supply a complete explana-

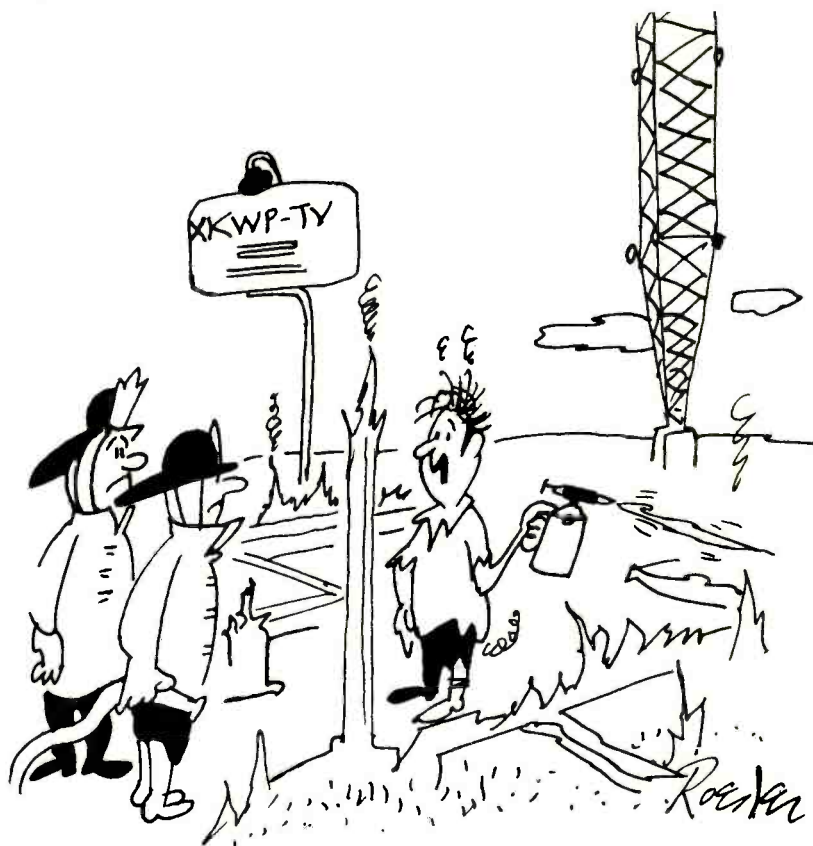

"I MERELY TRIED TO SPEED THE WARM-UP TIME OF THE EQUIPMENT."

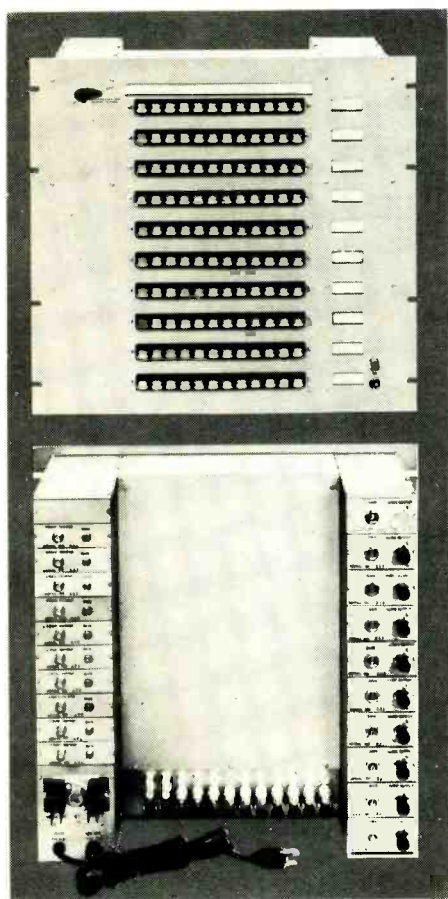

Patch Cable Eliminator

Forget about messy patch cables and the tedious task of re-patching to change distribution. DYN AIR's Series-X-Switchers provide pushbutton distribution of either 6 or 12 inputs to as many as 12 outputs. A high degree of input-to-output isolation allows any input to be switched to any or all outputs without loading the source.

Series-X Switchers are also available for simultaneous switching of video and audio, further simplifying distribution. All isolation amplifiers are silicon solid-state and full-broadcast quality. Audio and video amplifiers and the power supply are all plug-in modules which may be easily removed for maintenance. A 12-MHz bandwidth and excellent differential gain and phase characteristics assure quality color performance.

**Wouldn't a Series-X Switcher
solve some of your distribution problems?**

Write today for full details.

DYN AIR Electronics, Inc.
6360 Federal Boulevard
San Diego, Calif. 92114
Telephone (714) 582-9211



Circle Number 10 on Reader Reply Card

tion if either of these questions have been answered with a "No."

Pat Finnegan
Engineering VP
WLBC
Muncie, Ind.

Be Editor Points To Squelch For Engineers Who Lack Integrity

In the March issue of **Broadcast Engineering**, I made a statement in the Letters to the Editor column concerning fines for engineers. Let me make that point clear.

There are all degrees of citations. Some are and some are not caused by the engineering staff. Then too, let's assume we agree that it is still human to err. With these points in mind, I do not feel it would be fair to give a percentage fine to the engineer responsible for every engineering oriented fine.

Fining on the engineering side should not be so blind. But it should be a consideration when the station fine comes from engineering neglect. Put another way, the engineer should share the responsibility for citations when the citations fall into such pure engineering categories as the failure to make the annual Proof.

In some cases, the unqualified engineer pulls out for another job and leaves the licensee with lumped fines. If he gets off free, he'll be knocking at your door some day.

On the other hand, we all recognize the engineering shortage. And in the face of this shortage the fine for the engineer would seem to be a deterrent to attracting new people into the field. But perhaps this only serves to underscore the question, what kind of new people are we getting? It may not seem fair to fine a new man at a small station who is fresh from a license school. This, of course, does not take into account those engineers who suffer along with equipment that should occupy a place of honor at the Smithsonian Institute. Anyway, at this point an operator's license may only be suspended or revoked.

How do you feel about fines? We'll run your comments on this and other subjects when you drop a letter to: The Editor, **Broadcast Engineering**, 1014 Wyandotte, Kansas City, Mo. 64105.

April, 1970

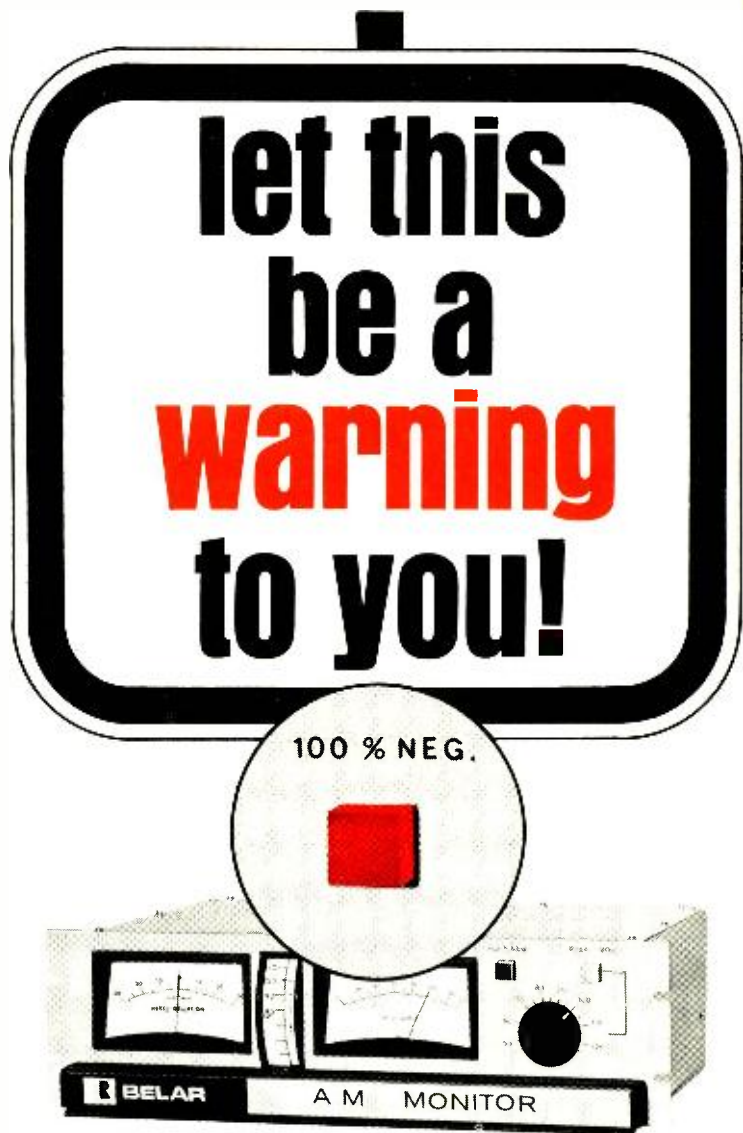

If that red light is flashing — two things are for sure:

1. You have a negative modulation problem. **2.** The BELAR AM Monitor caught it for you, because the 100% Negative Peak Indicator Light is exclusively BELAR's. And it's independent of any calibration procedures.

In fact, the BELAR AMM-1 AM Monitor is loaded with special, exclusive features.

Like the digital frequency deviation meter with analog display, the carrier level meter, the modulation meter, BELAR's built-in modulation calibrator, exclusive $\pm 20\text{Hz}$ frequency calibrator, and off frequency alarm drivers.

This monitor is immediately available and immediately usable with the same guaranteed performance as BELAR's FM and TV monitors, and all BELAR broadcast equipment.

BELAR

**BELAR ELECTRONICS LABORATORY, INC., DEPT.
BOX 83, UPPER DARBY, PA. 19084 • (215) 789-0550**

Circle Number 11 on Reader Reply Card

FCC Fee Raises Coming

An increase in fees for licenses, applications and other services, totalling \$20 million has been proposed by the Federal Communications Commission. In a Notice of Proposed Rule Making (Docket 18802) the Commission asked for comments on a fee schedule that would raise approximately \$24.5 million dollars—the amount of the Commission's 1971 budget request. Under present schedules, fees bring in about \$4.5 million which goes to the United States Treasury.

In making the proposals, it was noted that the Bureau of the Budget had urged higher fees schedules and pointed out, in addition, that the House Appropriations Subcommittee had stated that fees should be adjusted to assure that FCC activities would be "more nearly self-sustaining." The Committee had asked for a report on action in this respect by the time of the 1971 budget hearings.

Fee increases are proposed for Broadcasting, Common Carrier, and Safety and Special Radio Services.

CATV and equipment testing and approval, areas which presently are not subject to fees, are included in the proposed schedule. Fees in the Broadcast services would be substantially higher and would be based on market location, type of application filing service, hours of operation and authorized power. In addition to increases in current fees, new fees are proposed for grants of construction permits, assignments and transfers, pay-TV authorizations and various other types of applications.

The Commission also proposed a new annual fee for operating broadcast stations. Based on the station's rate card, it would require television stations to pay fees equal to 12 times the rate of a station's highest-priced 30-second commercial spot with a minimum fee of \$144 a year. Radio stations would pay fees equal to 24 times the highest rate for a one-minute spot. Minimum annual fee for radio stations would be \$52.

Because of the wide range of ser-

VICES offered in the common carrier area, and the different types of licenses and authorizations available, two different types of fees were proposed. In one area the licensee would pay a fee based on 2 percent of the construction or annual lease costs of the facilities covered by the licensee's operating authorization. In other common carrier radio services where the construction costs of physical facilities do not provide an appropriate basis for determination of fees, a flat license fee is proposed.

CATV Assessment

CATV systems would be assessed an annual fee of 30 cents per subscriber. Systems with less than 200 subscribers would be exempt. A schedule of fees for the filing of various CATV applications and petitions has also been proposed. Because of the high number of licenses in the Safety and Special Radio Service, the Commission said it was impracticable to establish separate filing and license fees. Increases are proposed, however, in single fees. Public safety, local government, emergency, and closed circuit educational TV are among services that are not now required to pay fees and which will continue to be exempt.

Testing Fees

Fees for equipment testing and approval will include application filing fees and also a fee based on a small percentage of the manufacturers selling price for the certified equipment, multiplied by the number of units covered by the authorization granted. Adjustments may be made at the end of the year based on actual production and selling prices. The Commission acts on about 1,800 applications annually for various types of electronic equipment. Equipment testing and approval are required to indicate that the equipment will not cause radio interference.

In the operator licensing area, increased fees were proposed only for restricted radiotelephone permits. The Commission first adopted a schedule of application fees in 1963 with the initial fee schedule taking effect on March 14, 1964. The action was upheld in a court test in 1964. Comments on the rule making are due on or before April 20, 1970, with reply comments due May 11, 1970.



KOB transmitter tube is pulled from service after 15 years and 108,000 hours of operation. Left to right, George S. Johnson, KOB-AM research director, J. Beverly, Transmitter CE, and Fern Bibeau, KOB Operations CE.

Proposed Fees

Some examples of proposed fees: Application filing fees for construction permits for television stations—\$500 to \$5,000 (Depending on market and VHF or UHF service); Grant Fees for television stations—\$4,500 to \$45,000 (Depending on service and market); Unlimited AM CP filing fees—\$50 to \$1,000 (Depending on power); and Unlimited AM grant fees—\$450 to \$9,000 (Depending on power); Subscription television application filing fee—\$1,000; Application filing fee for assignments and transfers—\$1,000.

Common Carrier Services: Application filing fees for various types of common carrier radio facilities—\$5 to \$150; Applications for earth station CP's and authority to construct and launch communications satellites—\$500; Non-radio filing fees—\$10 to \$100.

CATV: Community Antenna Relay Service CP—\$50; Petitions for special relief—\$300.

Subscription TV: Advance approval of technical systems—filing fee—\$1,000; Application for authorization—\$1,000.

Equipment Approval: Certification application filing fees—\$10 to \$20; Type acceptance application filing fees—\$100; Type approval application filing fees—\$100 to \$500.

CATV Task Force To Become FCC's Fifth Major Bureau

The CATV Task Force will become the FCC's fifth bureau. In a unanimous action, the Commission has voted to change the Task Force status to establish it as a Cable Television Bureau. The new bureau will take over the functions and responsibilities of the Task Force.

The CATV Task Force was formed in December 1966 to handle activities in the rapidly expanding CATV area. Earlier in the year, the Commission had issued its Second Report and Order in which it extended its jurisdiction to all CATV systems. (In 1965 it has issued rules for systems receiving signals by microwave.) Task Force functions included administration of the CATV rules, consideration of requests for waivers and importation of distant

FCC Amends Power vs. Height Antenna Chart

The chart, "Figure 3, Maximum Power versus Antenna Height" (Section 73.333) used to determine the maximum power allowed on FM stations with antenna height greater than 300, 500 or 2,000 feet for Class A, B and C stations has been amended to improve the accuracy of the diagram for Class A stations.

The Commission said it had noted in processing applications for FM broadcast stations that equivalent power determinations for Class A stations used from Figure 3 involving antenna heights above 1,150 feet had resulted in a maximum power limitation less than that obtained by use of the F (50, 50) propagation curve, Figure 1 (Section 73.333). Figure 1 was used in the derivation of the "equivalence" chart of Figure 3.

The rule section was further amended to revise Figure 3 to terminate antenna height of 5,000 feet for Class A, B and C stations. This change brings into consistency the same termination height as shown in Figure 1.

signals, and licensing of stations in the Community Antenna Relay Service (CARS) to transmit signals by microwave to CATV systems. It also advised the Commission on CATV matters and participated in rule making in CATV and in related areas. The Supreme Court affirmed FCC authority in the CATV area in an opinion issued on June 10, 1968.

The Commission took further major action in the CATV area in December, 1968, when it issued an extensive rule making proposal covering all aspects of CATV operations. In October, 1969, it issued rules authorizing program origination and advertising by CATV systems. Other aspects of the rule making proposal are still to be acted on.

The new bureau activities will cover more than 2,000 CATV systems in the United States serving about 12 million viewers.

And the best is yet
to come.

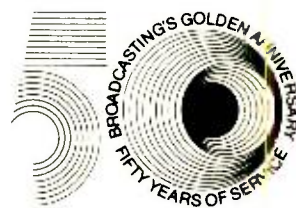

For broadcasting's
next 50 years
promise to be even
more exciting than
the first. And you
can bet we'll be in
there. With more of
the same creative
ingenuity you've
come to expect from
Sarkes Tarzia, Inc.
Bloomington,
Indiana 47401



Circle Number 12 on Reader Reply Card

EDUCATIONAL BROADCASTING

Looking Inside Non-Commercial Broadcasting

New Engineering Program

A two-year college level program designed to train engineering technicians for the broadcast industry was announced recently by Northern Virginia Community College. The program was approved January 29, by the State Board of Community Colleges.

Planned to begin in the fall of 1970, Broadcasting Engineering Technology will be offered in association with the Northern Virginia Educational Television Association (NVETA) in the new professional full-color television control and studio facilities on the Central Campus of the College in Annandale, Virginia.

The program will be a special curriculum in the Electronics Technology Division of the College and will combine courses in the fundamentals of electronics with special courses in the operation, theory and maintenance of professional television and radio equipment. Students entering the program will have the unique opportunity to study and work in a modern broadcast production facility with the latest solid-state color television and radio equipment similar to that used by commercial and educational broadcast stations throughout the United States.

Professional broadcast engineers were utilized in association with members of the College faculty in Electronics Technology to develop the curriculum to provide students with practical study and experience leading to an Associate in Applied Science Degree. During the program, students will obtain training necessary to enable them to successfully pass the examination for FCC first class radio-telephone licenses.

In planning the program the College and the NVETA contacted broadcast stations, national net-

works and equipment manufacturers to determine the scope of need for trained personnel. The response was virtually unanimous: broadcast engineering technicians are in critically short supply throughout the nation, and the College was encouraged to proceed with the establishment of the curriculum.

This is one more way the broadcast engineering shortage can be handled. Instead of the typical "rob from Peter to pay Paul" method of getting engineering talent, a concerted effort to include such a program as this at other colleges will go a long way toward increased engineering knowledge and manpower.

McDonald, Sheppard Win NAEB Elections

Dr. Everett A. McDonald, Jr., superintendent of schools, Centennial School District, Warminster, Pa., has been elected to fill an unexpired term on the Instructional and Professional Systems Board of Directors of the NAEB. Robert Maull, IPS executive director, said that Dr. McDonald will serve on the Board through 1971 and will be eligible for re-election at that time.

Walter P. Sheppard, general manager and executive producer of public affairs programming, WRVR New York, N.Y. and Burt Harrison, manager of KWSU Pullman, Wash., have been elected to the Board of Directors of the National Association of Educational Broadcasters' National Educational Radio Division. They will serve on the Board along with six other directors until December, 1973, according to Robert Mott, NER executive director, who made the announcement.

University President Gives Support For Educational TV

When the president of a major university singles out television as a major activity in the development of the state's educational program, we are in the medium sit up, take notice, and proudly confirm his statements. Indiana University's president, Joseph L. Sutton, speaking at a luncheon which officially opened the celebration of the university's sesquicentennial year, attributed to the medium a high place in the future education in the state.

"Our growth and development and the need for increased opportunity for all of the citizens of the state happens to coincide at a time when a good many things can be done electronically and otherwise that could not be done at the time our sister-states were developing. For example, already the state institutions—and plans are in the offing to include private institutions in the future—are being tied together by a great electronic complex which will make it possible for us to do things for one another that we cannot do for ourselves."

He cited as an example the cooperation of the Engineering department of Purdue and the Astronomy department at Indiana. Through a two-way video and audio system, students and faculty at both institutions were able to conduct a seminar in Astro-Physics which would have been impossible at either institution separately, due to lack of personnel and facilities.

"This is increasingly being done in the medical field . . . in carrying forward this educational opportunity. We have been able, through electronic media of various kinds, closed circuit television or tapes to be played over television sets or recorded lectures, and so on, to install educational programs in many hospitals of this state who had not been accredited for educational programs before, and thereby retain valuable resources in terms of medical doctors in the state that had heretofore left and sought greener pastures. This has just barely been tapped . . . this medium . . . this opportunity.

Forecasting Innovations

For the educational broadcaster the seventies will bring countless innovations and with them the proverbial battle for budget and implementation. How long will we wait before high speed videotape duplication is a practical reality? Will we have video cartridges or cassettes? Will programs be provided on videotape or some other medium? Will we really have low cost, high quality color capability? Where will we obtain the competent technical personnel to man a sophisticated educational broadcasting facility? How much financial assistance can we expect from the federal government? And will it be on a continuing basis?

These questions are but a few that will have to be answered in the early seventies if educational broadcasters are to provide a meaningful service to the school and community.

NAEB Files Report On Employment In Broadcast Field

A Statistical report of a study of employment practices of educational radio and television stations has been filed with the FCC by the NAEB, Washington, D.C. The report reveals data from a second survey of educational stations to determine their policies and practices regarding employment of persons from minority groups. The first survey was conducted in 1968.

Among the findings: in 1969, 53 more stations reported on their employment practices than in 1968. The overall percentage of minority personnel has increased from 7.72% to 9.06%. The survey found that no chief executive positions are held by minority personnel, but a number of persons from minority groups are identified as major department heads. This figure has doubled in the past year.

Minority personnel are more likely to be found in talent, clerical and production positions than in other categories, the survey revealed. The report also found that there was a considerable increase over last year in over-all recruitment efforts and training programs.

Open Invitation

This column should provide for a forum of ideas of implementation and to point out technical innovations in facilities and equipment. Equally important, we are concerned about the shortage of qualified technical people. If you have any ideas about how this crisis can be solved, drop us a line by writing to: The Editor, **Broadcast Engineering**, 1014 Wyandotte, Kansas City, Mo., 64105.

Special ITV Article On Page 36

**Broadcast Engineering
Striving To Bring You
Complete Coverage of
Broadcast-Communications**

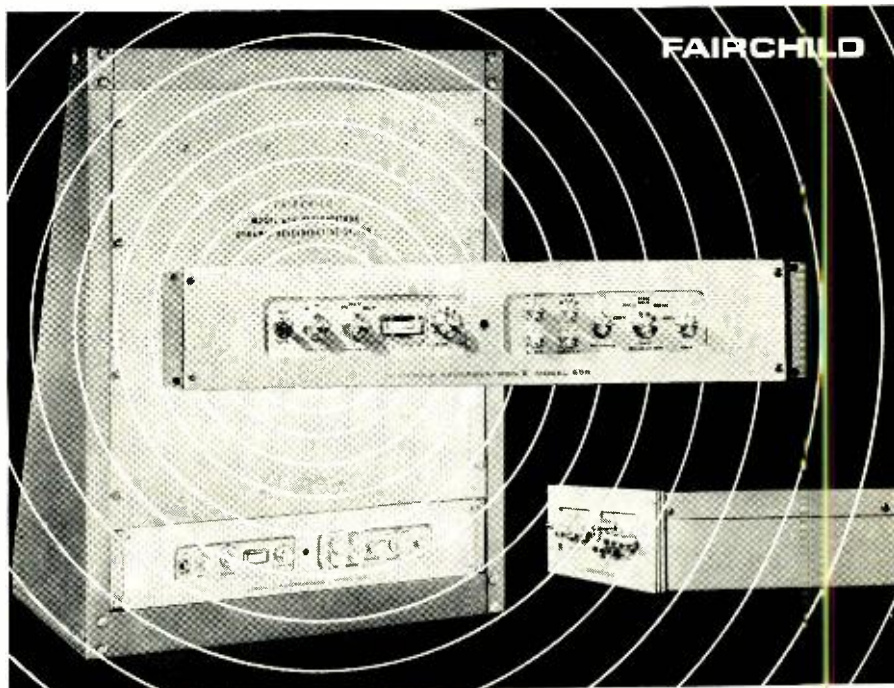

NEW FAIRCHILD REVERBERTRON

Model 659 FAIRCHILD Reverbertron is the newest addition to the world-famous FAIRCHILD Reverbertrons. Superseding all other artificial reverberators within its price range, the new 659 reproduces for broadcast or recording purposes, in a compact system, the same natural, real-life reverberation effects as the world's finest acoustic chambers.

FEATURES:

- Switch selection for either local or remote operation provides 3 types of reverberation control: dry, premix 1, premix 2 • Exclusive* selector for short, medium or long decay times • Frequency response ranges from 20 hz to 20 KHz on the dry channel (± 1 db) compares with 50 hz to 6 KHz on the reverberation

channel with a range of adjustment to ± 15 db • S/N is 10 db over previous models • Effective for input levels as low as -30 dbm; output levels up to $+18$ dbm • Transformer isolated input and output impedance is 600 ohms or 150 ohms balanced or unbalanced • All electronics are on easy plug-in P.C. boards • All signals are metered • Controls have continuous mix facilities • Compact: only $22\frac{3}{4}$ " high x 19" wide x 10" deep.

*U.S. Patent #348674

For complete details contact your Fairchild Distributor or write:

FAIRCHILD
Sound Equipment Corp.
Dept. BE-4 10-40 45th Avenue
Long Island City, N. Y. 11101

Circle Number 13 on Reader Reply Card

SMPTE Selects Tech Papers

The 107th Technical Conference and Equipment Exhibit of the Society of Motion Picture and Television Engineers will take place April 26-May 1, at the Drake Hotel, Chicago, Ill. A full program of technical papers will be presented for the first three days covering television engineering, video tape, laboratory practices, theater presentation and projection, and education. The program is being organized under the direction of Leonard F. Coleman, Eastman Kodak Co., Dallas.

Papers to be presented in the technical sessions on television have been announced by television topic chairman, Charles M. Eining, NBC News, Chicago. A brief summary of several papers follows:

"Standardization In The Video-Tape Recorder Industry," by R. N. Hurst, Commercial Electronic Systems Div., RCA Corp., Camden,

NJ. A reevaluation of video tape recorder standards will be given with a new look at how the continuing use of standards benefits the industry.

"Compact Optical System For Field Line Sequential Color Videotelephone Camera," by R. L. Eilenberger, F. W. Kammerer and J. F. Muller, Bell Telephone Laboratories, Inc., Holmdel, NJ. A very compact optical system has been designed to implement a field/line color camera for videophone use which uses a spectral separation prism and dichroic reflectors. Conversion to an electrical signal is via a pickup tube provided with a new form of composite fiber-optics/clear-glass faceplate.

"An Improved Servo System For Quadruplex Video-Tape Recorders," by Harold V. Clark, Ampex Corp., Redwood City, CA. The system is examined theoretically with the practical results of an experimental system presented showing their significance to future designs of video tape recorders.

"Automatic Color Phase Control System," by Y. Itoh and Y. Inoue,

Tokyo Broadcasting System Inc.; K. Saitoh, and N. Ideshito, Nippon Electric Co., Ltd., Tokyo. The intention of this system is to maintain automatically color quality by use of a variable-phase voltage shifter installed in the video transmission route.

"A Solid-State Machine Control Assignment System," by R. J. Smith, Commercial Electronic Systems Div., RCA Corp., Camden, NJ. A new control console is described which allows operation of any machine in the TV station from a number of operating positions throughout the station.

In addition to the regular conference program a symposium on Production, Control and Use of Color Television Film to be held April 30 and May 1 will feature a number of tutorial papers and discussions covering the entire area of films relating to television. Symposium Chairman, Daan Zwick, Eastman Kodak Co., Rochester, NY, has announced that the papers are nearly complete for the program and titles and abstracts will be published soon.

REELS & SPOOLS

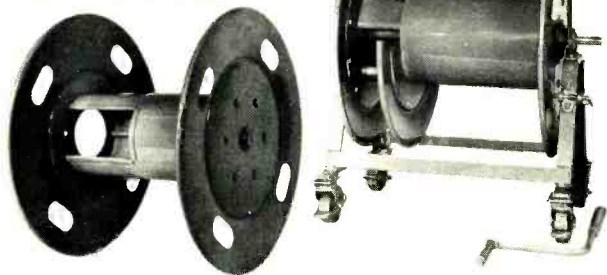

FOR CABLE HANDLING

No matter what type of cable you use, Hannay offers the widest range of reels and spools for live cable handling or storage. All reels are available with manual or power rewind options to make your job easier.

Send for Catalog H-7001-EC for detailed specifications and prices.



HANNAY REELS

CLIFFORD B. HANNAY & SON, INC., WESTERLO, N. Y. 12193

Circle Number 14 on Reader Reply Card

ERASE RECORD REPRODUCE MONO - STEREO

Professional Direct Replacement Heads with complete written and pictorial instructions

Our factory will clean, rebuild, adjust and test your head ASSEMBLY...install new MMI heads...replace minor hardware and modify your gate to accept our "NON-POPPING" springs

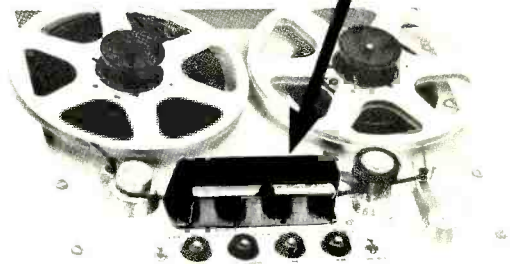

36 HOUR SERVICE - LOANERS AVAILABLE
(612) 884-7393



MINNEAPOLIS MAGNETICS, INC.

8125 PLEASANT AVE. SO., MINNEAPOLIS, MINN. 55420

Circle Number 15 on Reader Reply Card



Here's a new switch

...an extended-frequency vacuum coaxial relay for lower power applications.

For the first time — a four port vacuum coaxial relay specifically designed (and priced) for use at 2 kw and under. The new model RC52 offers all the advantages of vacuum plus a low .1 db insertion loss at operational frequencies up to 1700 MHz.

RC52 is the newest and smallest of our 2-pole, 2-position crossover transfer relays. The others offer power ratings of 4 kw and 7.5 kw. All of these relays give you the lowest life/cycle cost of any coaxial relay and each can function as a crosspoint for matrix networks. Due to the vacuum dielectric they all provide: no contact maintenance, stable contact resistance, smallest size in power class. They also feature manual override in case of power failure, plus auxiliary circuit indication and interlocking contacts.

The four port series of relays permit pretuning of backup transmitters and rapid changeover (15 millisees typical) in the event of transmitter failure. They are also useful for rapid by-passing and the interchanging of amplifiers, antennas, drivers, or dummy loads. Reliability and long life have been amply demonstrated in the Apollo program, as well as in many critical long-haul hf communications systems.

We will welcome the opportunity to send you more details about these relays. Write to ITT Jennings, a division of International Telephone and Telegraph Corporation, 970 McLaughlin Avenue, San Jose, California 95108.

JENNINGS **ITT**

Circle Number 16 on Reader Reply Card

SCANNING THE CATV SCOPE

By Harry Etkin

The Cable Countdown

The government recently recommended that domestic communications satellites should be developed and operated on a competitive basis by private interests. It was stated that the seven year old Communications Satellite Corporation (COMSAT), although it is eager to get into the domestic operation field, should not be the only company to operate the system. Other companies with financial and technical capabilities should construct satellite systems for domestic service on an equal basis with Comsat.

The CATV industry should compete with other companies in the development and operation or leasing of domestic communications satellites. This would provide a communications system in which the Cable-TV industry would function as a vital link. To provide the economic base necessary to get the project under way, the CATV industry would be best served by the ownership of its own ground receiving station facilities.

Comsat is presently waiting for the Federal Communications Commission to act favorably on their three year old request for permission to construct the domestic satellite system. This multiple-service system would provide a facility for accommodating up to six fulltime TV channels for CATV operations. The use of the satellite could provide better and more economical service by interconnecting CATV service areas nationwide for distribution of programs by cable television operators.

The proposal called for the availability of the domestic satellite system by late 1971 or early 1972. If the system could be delivered at that time it would provide long distance service more economically than one or two channels of micro-

wave used at the present time. Comsat Corporation estimated that up to six nationwide-interconnected color TV channels will be available by 1975 to expand programming to cable television system subscribers. These would be in addition to programming offered on the local CATV channels.

Such a system could provide CATV with the capability of handling domestic broadcast TV networks, news agencies, multi-channel telephone, facsimile, telegrams, data, as well as other forms of communications. The operating system would utilize high-capacity satellites in synchronous orbit at approximately 22,300 miles altitude and interconnected through a national network of earth stations. As an example, four satellites would be capable of handling a coast-to-coast TV network with approximately 160 earth stations. An advanced design satellite could have a capacity of 24 TV channels plus 19,200 multi-point message channels or 28,000 voice or message channels.

If the FCC approves in the not too distant future, Comsat will place in orbit two large communications satellites for domestic use. These would be capable of providing up to 48 color TV channels. To place the system in operation would require the construction of a nationwide network of earth stations or receiving stations and each would probably cost about \$100 to \$150 thousand. Each station would then serve all of the satellite users in its respective area.

By 1975 at least 36 receiving stations could provide six channels of TV to 36 CATV service areas. This would include most of the cable television market areas in the country. The TV channels picked up

by the receiving station would be fed directly to the CATV headend facilities in the market areas and possibly to a potential market of more than 60 million subscribers.

With the proper satellite capacity and the use of at least six channels by the receiving stations the average cost per subscriber by 1975 would be a very moderate cost ranging from 80-92 cents to 27-31 cents per year.

Predictions For The 1970's

With the White House intent of finally giving the FCC the go-ahead to license the lofting of the domestic satellites, further innovations in cable television would offer a potentially unlimited number of satellite service channels.

Let's just say that the possibilities are fantastic. All this can be accomplished with the use of private capital and the FCC green light for establishing a permanent domestic satellite system.

For instance, some of the possibilities would be:

1. Cable television system could grow into a full national coast-to-coast network.

2. All types of letters could be transmitted and delivered by the national network virtually instantaneously for a very moderate cost.

3. Business firms could make use of CATV satellite service for transmitting production, inventory and billing data between branches located in various parts of the country.

4. Weather satellite picture receiving stations used to obtain weather data for weather forecasting. The capability of satellites to observe conditions in the earth's atmosphere rapidly and comprehensively would aid in weather forecasting.

5. Air traffic control could be improved by using the vast amount of information instantaneously at a modest cost.

6. A central point for library information and computer services could be made available quickly for student and scientists study or possibly business establishments in all parts of the country.

7. Conference interconnected by a coast-to-coast network.

8. Students in college could view the televised lectures and demon-

strations of many other colleges.

9. This system will also make possible many new services which are only dreamed of today.

A Step Forward

By April, 1970, the TelePrompTer Corporation will petition the FCC for permission to participate in a proposed domestic satellite program.

By 1972 the CATV industry would have its own satellite and would also participate in offering a certain capacity in the system for leasing by other communications interests.

TelePrompTer would be able to establish at least 90 satellite ground stations as a basis for an industry-wide system that would be both practical and economically feasible.

A Looming Crisis

One of the original plans of CPB was to test and establish the transmission of a National Education Television (NET) network program from New York to Los Angeles by satellite. The CPB which was established by a Congressional Act in 1967 has had its goal endangered by President Nixon's veto of the Health, Education and Welfare Bill. CPB's \$15 million technical and operational costs for the fiscal year was practically stopped, leaving the project uncertain about initiating network programs. With individual state government funding also blocked, it is scarcely debatable that CPB is faced with a crisis of major proportion which commercial and public TV interests should face realistically.

It should be proposed that NET and CPB programming utilize the satellite and earth stations to be established by private interests for the CATV satellite project. Such an innovation, however, could certainly require the endorsement of the cable TV and commercial television industry. If successfully applied, it might help the continuation of the CPB projects and it would not detract from other efforts to establish a permanent domestic satellite system for CATV, ETV and broadcasting networks by Comsat. In fact, it might serve to spur the movement.

Educational Cable

The Pennsbury School District, located in Falls Township, Bucks County, Pennsylvania, will "go it

alone" in educational TV. It was decided not to participate in the proposed countywide TV plan.

The School Board will provide its 14,000 students with educational television through the district's cable TV project being set up by the Bucks County Cable TV, Inc., of Fairless Hills, Pennsylvania. The educational cable TV project at the local level would be more educational and financially feasible and it would also be less costly than the country plan.

Pennsbury's decision will deal an unwelcome blow to the countywide TV plan which presently requires at least four or five of the largest school districts to stand behind it and give their approval.

Approximately 10 schools will be linked together in this cable system. Video tapes have been produced using their own cameras in preparation of being used when the cable TV system becomes operative.

NCTA Conference On Programming To Be Held In Chicago

A two-day CATV programming conference sponsored by the National Cable Television Association (NCTA), will be held in Chicago's Palmer House April 30 - May 1.

The purpose of the conference will be to assist CATV operators in making intelligent decisions about the types of programs they will originate over their cable systems. The national association hopes to bring together soft-ware suppliers and cable operators who need program material. The conference will be open to all NCTA members and all NCTA associate members in the audio-visual programming field. In addition, several distributors of educational and public service programming will be invited.

The conference will begin Thursday morning, April 30, with formal presentations by each program supplier. After a luncheon, formal presentation will continue until the social hour which will be followed by a banquet. On Friday all program suppliers will have booths in an exhibit area where they will be available all day for individual consultation and — in most cases — demonstration of the actual product available.

The programming conference — the first of its kind for the cable television industry—will be planned and coordinated by NCTA's public relations department.

Gary L. Christensen has been appointed General Counsel of the National Cable Television Association, NCTA President Donald V. Taverner has announced. Christensen, NCTA Assistant General Counsel since March, 1967, succeeds Bruce E. Lovett who joined American Television and Communications Corp. as Vice President for Corporate Development on January 16.

As Assistant General Counsel, Christensen was active in the public utility, FCC, telephone company and copyright areas. Coming to NCTA from the FCC, one of his major fields of expertise is Commission regulation and procedure. Christensen has been the principal author of many of NCTA pleadings before the FCC. He coordinates all NCTA and state and regional CATV association activities in the battle against state public utility commission legislation.

More Information On Interference

In the CATV Scope column of the February issue of BE we included some information on the use of a battery operated, insulated TV receiver for determining the source of undesired signals.

This information was taken from a paper written by Archer S. Taylor. It is entitled "On-Channel Carriage of Local TV Stations on CATV". This paper has been reprinted from **IEEE Transactions on Broadcasting**, Vol. BC-15, Number 4, December, 1969.

Taylor has informed BE that copies of this paper are available by writing to: Archer S. Taylor, Malarkey, Taylor & Associates, 1225 Connecticut Ave. N.W., Washington, D.C. 20036.

This firm is well known in the CATV industry as brokers and consultants specializing in CATV. In 1969, Martin Malarkey received the NCTA coveted Boggs Award.

CATV Re-Tubing See Page 43

Coax Maintenance

Solving problems on the line

By Pat Finnegan

BE Maintenance Editor and Engineering VP at WLBC, Muncie, Ind.

The most popular transmission line in use today by broadcast stations is the coax line. But while it has certain advantages over other transmission methods, the broadcast engineer and technician needs to be aware of coax characteristics in order to get optimum performance and maximum service.

A brief review of coax characteristics is in order before moving on to maintenance and installation problems. The following list itself should serve to warn against bypassing these parameters.

The characteristic impedance of the line is based on the ratio of the diameters of the inner and outer conductors and the space between the two. Directly associated with this ratio is the average power rating of the line. This, of course, is also dependent upon the amount of heat the inner conductor and insulation can safely handle. And this same insulation inside the cable, along with the resistive loss of the metal conductors, is responsible for line losses.

Selection of the line must be based on these considerations, especially the peak power rating. This rating tells you how much stress the insulating material can withstand before a voltage peak will cause a flash over. The dielectric constant of the insulating material between the conductors and the spacing of the conductors are determining factors. Occasional flash overs from low resistance paths, which make even easier paths for future voltage peak flashing.

The physical length of the line has a direct relationship to the wavelength of the RF wave passing

through it. Line lengths may be considered in electrical degrees. For example, a $\frac{1}{4}$ wave line is 90° , a 180° line is a half wave.

Velocity of propagation is a term given to the fact that the RF wave travels slower in a line than in free space. Voltage and current distribution along a properly terminated line will have the same relationship to the wave as they do to the wave in free space.

Power transfer in the most efficient manner, and with the least signal distortion, requires the very minimum of standing waves. Standing waves are created when a line is improperly terminated in an impedance that is not equal to its characteristic impedance. A standing wave is a part of the signal reflected back from the improper load toward its source.

Tuned circuits made from coaxial lines sections operate because of standing waves. In this case, standing waves are not only desirable but imperative. To obtain the desired function, the section of line is shorted, left open or tuned at its end.

Power ratings are reduced when standing waves are present. Standing wave ratio (SWR) is a ratio of the forward and reflected powers in the line. The forward and reflected currents are measured. Voltage standing wave ratio (VSWR) is the same in ratio as SWR, but is a measurement of the voltages forward and reflected. The detector is measuring voltages instead of current.

Operation Changes

The station engineer does not often consider coax lines in terms of their basic characteristics during normal operation. It is only when conditions change that he is forced

to think in these terms.

But major changes do occur. Consider, for example, an increase in power. Many stations originally started with low power. In fact, many Class IV AM stations never expected they might someday go to 1 kw.

At the time of the original installation, a line was selected that may have had an adequate margin of safety for that power. At a later date when power was increased, the line may not have been changed for one reason or another—perhaps economics. If the old line is now operated right at its full ideal maximum ratings, it is a marginal system and will require constant alertness to keep the line from becoming damaged by overload conditions.

Weather vs. Operation

Short term changes can occur and these should be watched for during normal operations. Perhaps lightning causes damage to an antenna or tuning elements in the tuning house. In the winter, ice or sleet may coat an FM or TV antenna. Anything that touches the antenna will generally cause it to detune, causing a mismatch and, hence, standing waves on the line.

An AM antenna that is damaged or detuned will be apparent in the antenna current readings as well as in the efficiency of the final stage. If the changes are small, they will show up as poorer efficiency of the final stage.

Ice or damage problems will show up on an FM antenna as poor efficiency of the final stage plus an increase in the reading of the VSWR meter. Plate tuning of both the AM and FM power stages may be somewhat erratic.

Ice on a TV antenna will be most

readily apparent as ghosting of the picture off a demodulator sampling in the line. The VSWR meters will show an increase. The tuning of the final stages is generally not effected as much as are the AM or FM transmitters, because the stages are so broadband, and sideband filters provide some degree of buffering between the transmitter and line.

In the aforementioned problems, reduce the transmitter output power immediately. This will help protect the output tubes, the line and even the antenna itself. How much? As a rule of thumb, when the line is normally working close to its maximum ratings, divide the normal power output of the transmitter by the VSWR reading and reduce the transmitter to this figure or percentage. When the line has adequate margin of safety in its ratings to the power used, simply reduce the power to a value that the output stage appears to have its normal efficiency. One must use judgment dependent upon the facts in the case. If the VSWR is rather high, it is best to go lower than the stated rule of thumb. This is the safest value.

Increasing the gas pressures in the line will give greater protection against voltage flashovers and will help conduct heat to the outer conductor faster. If the gassing equipment is capable, increasing the pressure to 20 psi is not an unreasonable figure—unless the line leaks.

Electrical Problems

Smaller changes occur gradually rather than suddenly as in the earlier mentioned changes. The routine operations and daily inspections should be on the alert for these.

A center conductor inner connector may be making high resistance contact. Such a contact will burn from the RF energy. And once started, it will only get worse. A reading of the VSWR meter at sign on and again at sign off will give a clue to such problems. If at sign on the VSWR reading is low and at sign off it is much higher, this indicates something is heating and changing and that trouble is ahead.

During the required daily transmitter inspection, the VSWR meter should be read. If the reading is higher than it should be, the line should be inspected. Feel the line

for warm or hot spots. When one is found, there will be others at multiples of the wavelength along the line. These warm or hot spots are indicating standing waves on the line. Check especially near the flanges or end connectors. If an insulator or poor connection is at fault, this will be hotter than the other warm spots.

AM radio doesn't use VSWR indicators, but the output stages' efficiency and the line current meters will be a clue to trouble. The output stage efficiency will be down and the line current meters will not be the same value at both ends of the line. Hot spots may be noticed on the line and there may be a fault inside at that point. Because of the long wavelengths at these frequencies, it is doubtful that more than one spot would be found unless it was a long run of line.

Load Problems

Changes in the VSWR meter

reading or line currents becoming unbalanced do not necessarily indicate that the line is at fault. Remember that any change in the load impedance will cause a mismatch to show up at the other end of the line.

Long term exposure to the elements can cause deterioration of the antennas themselves, particularly FM and TV antennas. Annual checks of both the line and the antenna for VSWR across the band-pass is advisable.

Physical Maintenance

Basically, physical maintenance means inspection, tightening bolts and clamps, maintaining the proper pressure on a gassed line.

Gas pressures should be observed on a daily basis. If the line uses gas rather than dry air, the gas cylinder will need replaced from time to time. The inspecting engineer should note the pressure in the cylinder from day to day. How fast

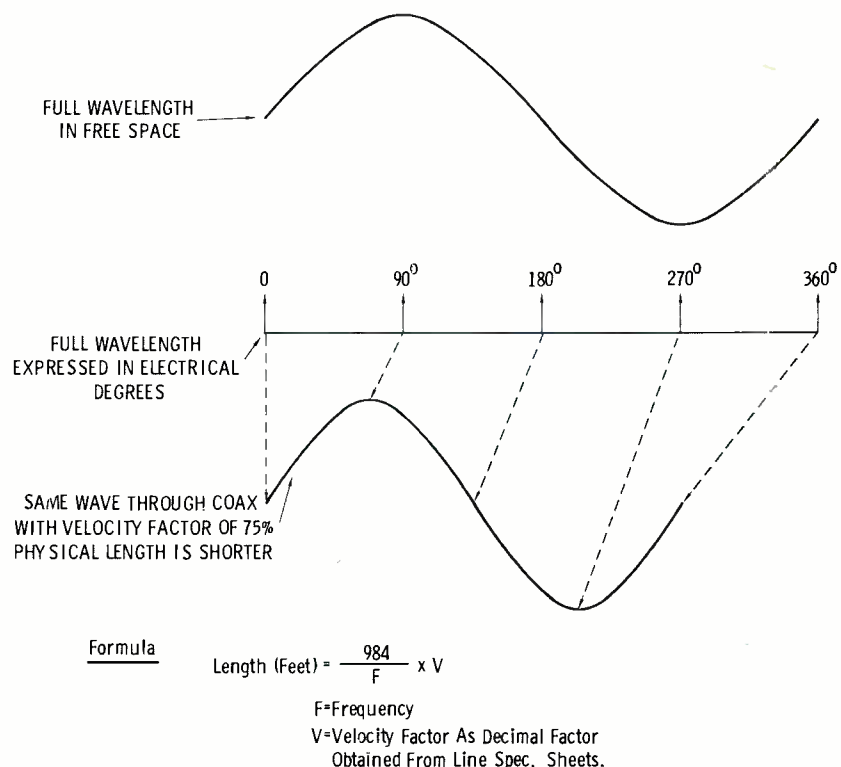

Fig. 1 Illustration of relationship between wave in free space and through a coax line.

this may be dropping is a good indication of extent of a line leak.

A dry air pump will run automatically, and if the line has a bad leak, it may run continuously and burn itself out. If the line valve is shut off, it can get no additional air. If the line leaks, the pressure will drop down after a time. How long it will take to drop will depend upon the leak. The pressure gauge on the line itself will indicate this drop.

Detecting a leak can be done in several ways. A soapy solution can be made and daubed onto joints or other suspected areas. A leak will blow a bubble. One may also pur-

chase a small bottle of a bubble solution sold at dime stores. That solution works better than soap. A commercial product is available which is made especially for detecting leaks, and it works quite well.

Should the line be a low pressure line, there is another technique that can be used. Run up the pressure to 20 psi. Often, this will make the air hiss that can be heard as it escapes. A slow leak on a low pressure line can become a large leak on a high pressure line.

Gassed Lines

Gas pressure on a line system

that has a fair margin of safety need only hold a few pounds. It is only necessary to keep the inside pressure higher than the pressure outside the line. Some regulators for gas cylinders do not regulate too well at these low pressures. Whatever the pressure used, here is a technique for setting the regulator to the desired line pressure. If the line is empty or below the desired pressure, shut off the line valve. Adjust the regulator handle to set the desired pressure on the line side gauge. Open the line valve so the gas flows into the line. The line pressure gauge will drop to zero or almost zero because the line is empty (See Figure 4). Operators often make the mistake of setting the regulator so that the line gauge reads the desired pressure when the line is empty. This is a mistake, for as the line finally fills up, its total pressure will be very much higher than what is intended.

Should the pressure become this high, the cylinder valve should be shut off. If the line has a leak, the gas will eventually bleed off and the pressure drop. After the line has dropped below the desired pressure, go through the procedure as described earlier. If the line did not leak and the pressure was very high, it would be best to open the line exhaust valve and bleed off the excess.

Temperature changes of the outside air or the sun shining on the line will cause the pressure inside the line to change. As the line heats up the inside air will heat up and expand, increasing the line pressure. The opposite happens when the line cools. This is the same condition that occurs in an automobile tire after a car is run for awhile. The line pressure regulator should not be adjusted to accommodate these changes. It will do so automatically around the previously set value.

Contraction and expansion is a function of the metal in the line and temperatures. A line that may be gas tight in the summer may develop a small leak in the winter. As the line expands, it tends to compress all the joints tighter together; when it contracts, it tends to pull it apart.

Physical Damage

There are a number of ways the

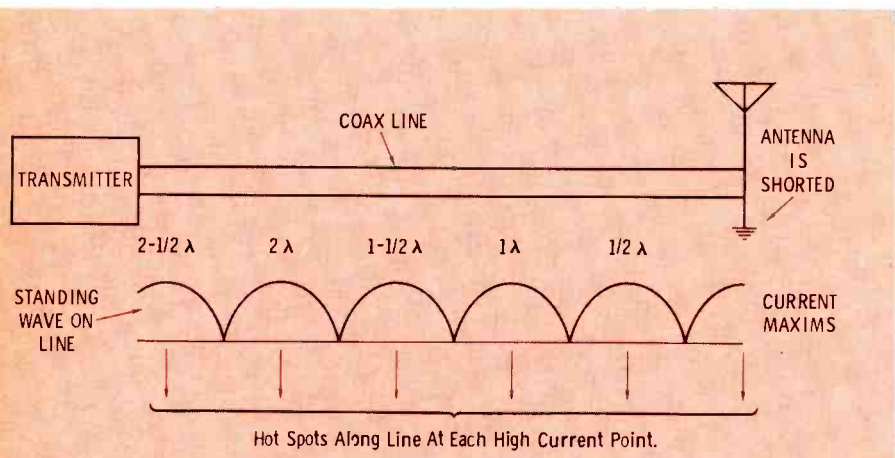

Fig. 2 Current distribution along the line is shown for a shorted condition at the antenna. Note that high density current is found at each half wave along the line, starting at the short.

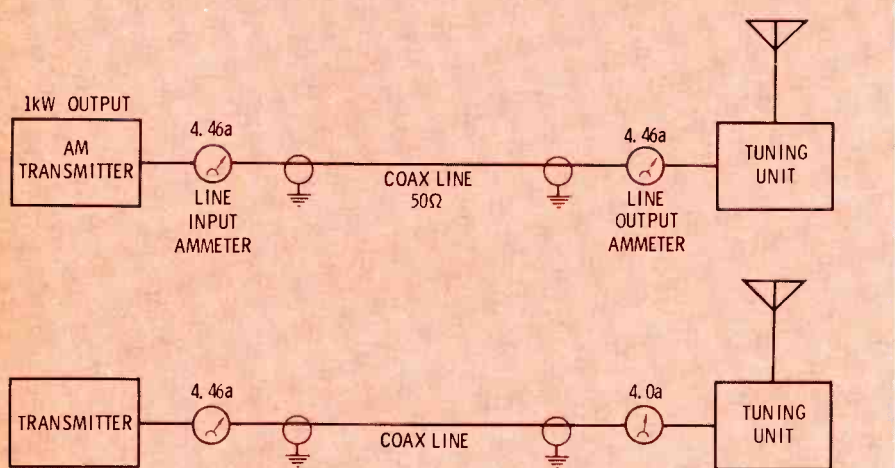
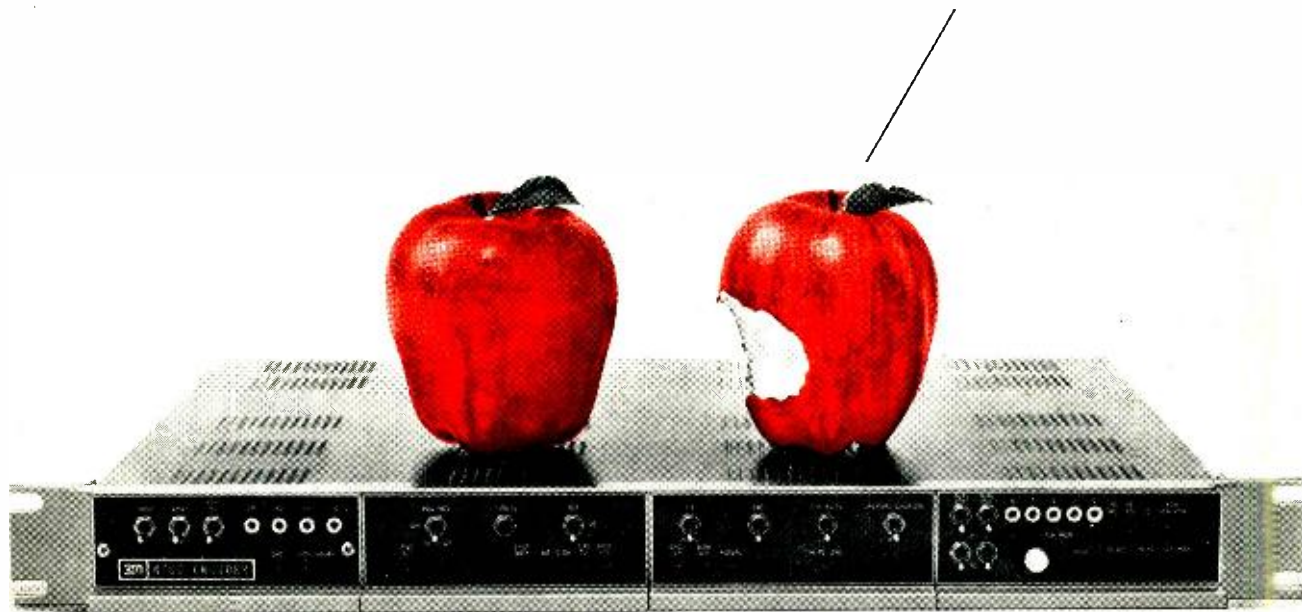

Fig. 3 Coax line on AM antenna showing balanced current at both line meters when load is properly matched to the line. Lower condition indicates incorrect match of load to line impedance.

IT ALWAYS SEEMS THAT 3M PROVIDES
A COUPLE OF FEATURES
THAT OTHER PRODUCTS DON'T



TAKE THIS 3M COLOR VIDEO ENCODER, FOR EXAMPLE...

The 3M Brand Color Encoder has two unique features not obtainable elsewhere. The color bar generator is one. It is **completely** digital, not partially digital. Simplifies setting up procedures, and maintains accuracy between encoders. Affords precision without adjustments. With digital you **know** it is accurate.

Another unique fact is that the 3M Color Encoder considers smaller, lower cost cameras as well as the big expensive ones. A method of input clamping is used on video signals that eliminates low frequency hum and noise and other unwanted effects on the matrix. If you have access to an SMPTE color test film (hand test over colored bolts of cloth) you can determine whether your camera needs clamping. If it does, you're in clover with this 3M Encoder.

The 3M Color Encoder is compatible with all 3-tube and 4-tube cameras, meets all applicable FCC and EIA specs. There's also a 2F notch filter in the horizontal aperture equalizer to prevent noise beyond camera frequency response.

Luminance enhancement at the flick of a switch assures a sharp picture even if registration is not perfect. With a 4-tube camera, enhancement is from the luminance tube. The green channel is used for enhancement in 3-tube cameras. Switching is on the front panel, as are **all** operation and setup controls, including notch filter.

Overall, you'll find that the 3M Brand Color Encoder is equal or superior to anything on the market yet costs somewhat less. Could we send a brochure?

Mincom Division **3M**
COMPANY
300 SOUTH LEWIS ROAD • CAMARILLO, CALIFORNIA 93010
Circle Number 17 on Reader Reply Card

line may be damaged physically. The damage may be accidental, or through carelessness, or vandalism, but the results are all bad.

Riggers working on the tower are usually careful, but they do drop tools or objects occasionally. Depending upon its weight and height from which it falls, some objects can cause considerable damage, especially to the horizontal run.

Ice falling off the tower in the winter can also cause considerable damage to the horizontal run of line if it is not protected (See Figure 7).

If someone is using a tractor to mow the grass, they should be warned to be careful of the line supports.

Contraction and expansion due to temperature changes cause the line to move along its length. If the vertical run on the tower is rubbing across the sharp edge of a piece of angle iron, this rubbing can eventually wear through the outer conductor.

If a larger flexible line (such as

heliac) should be crossing a wide span on the tower, it should be stiffened with a small backing of angle iron. Otherwise, the constant flexing caused by the wind can cause metal fatigue and the section could fall apart or split.

Sometimes a stray bullet from a hunter may pierce the line. Kids sometimes like to shoot at the tower lights. Occasionally they hit the line and puncture it.

Intermittents

There can be intermittent problems with lines as with anything else. Generally, the culprit is an inner conductor connector making poor contact.

Here is a technique the author used to find an intermittent on a line section of a 5 kw directional AM a few years ago. The six towers were interconnected with 1 5/8" rigid line. The problem showed up as an intermittent crackling or frying noise on the air monitor or receivers. Many checks proved that

the problem was in the antenna system. Checks of ball gaps, contacts of phasors, and tuning coils showed no signs of burning. Then the lines were suspected.

After sign-off one night, with the carrier on but no modulation, the author took a small pocket transistor radio out along the transmission lines, banging on the lines every few feet while listening to the unmodulated carrier on the air. Near one of the towers when the line was hit, the noise started to increase. It was somewhat controllable, as it could be made to happen each time the line was hit.

After turning off the power and opening the line, an inner conductor connector which was soldered had come loose and was burning. This problem was simple to correct.

The same technique can be used when power lines are causing noise problems. While listening to a radio, slam the base of the power pole with a sledge hammer. If there are poor connections on top, the noise

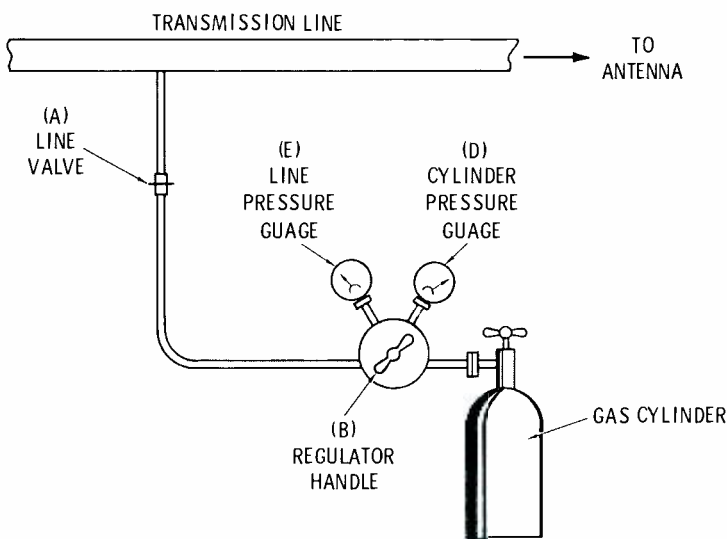

Fig. 4 Method of correctly setting line pressure regulator.

- Step 1. Shut Off Line Valve (A).
- Step 2. Turn Regulator Handle (B) CCW To Minimum Position.
- Step 3. Turn On Cylinder Valve (C). Cylinder Pressure Gauge (D) Will Now Read Pressure In Cylinder.
- Step 4. Turn Regulator Handle (B) CW Until Desired Line Pressure Is Indicated On Line Pressure Gauge (E).
- Step 5. Turn On Line Valve (A). Make No Further Adjustments As Regulator Will Take Over Control.

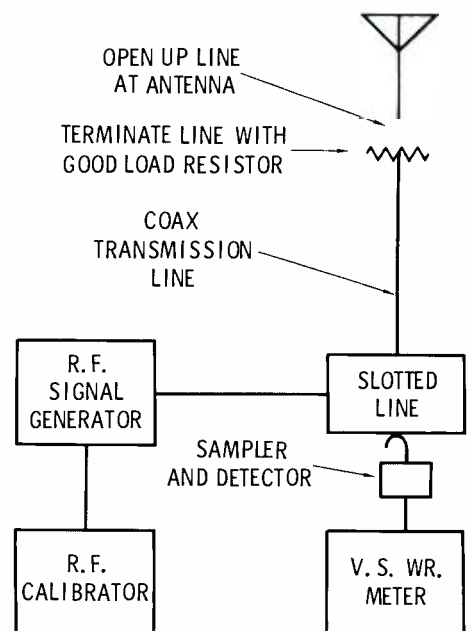

Fig. 5 Instrument setup for checking VSWR across the bandpass on a UHF line.

will act up. One suggestion though—have someone from the power company along. Let him hit the pole, you listen.

Annual Inspection

When the towers are inspected annually, the man who climbs the tower should inspect the line itself, its hangers and other accessories as well as the tower. If a broken spring hanger or a bolt is missing they should be corrected immediately. Each hanger is designed to carry the weight of 10 feet of line. If one is broken and not carrying its share of the load, the adjacent hangers are carrying an extra load and they may soon break. These smaller problems have a way of developing into larger problems.

The line should be checked for its electrical characteristics, particularly FM and TV lines. The FM and lower TV channels can be swept and the UHF channels checked with a generator and slotted line. The VSWR over the

bandpass should be recorded and compared to readings from previous years. Gradual deterioration will show up on this basis. If possible, the line should be opened ahead of the antenna and terminated in a dummy load that is known to have a very low VSWR of its own. Usually, this is checked out on the channel in question before taken up the tower.

Another check can also be made at this time. A DC resistance measurement of the line. A DC resistance bridge is used for this purpose. The resistance will be less than 1 ohm, and changes in this reading over the years will indicate that the contact resistances are changing. The author has used this method to find a short in a line. The original resistance measurement must be known along with the value when it is terminated in the antenna. The resistance bridge can read some very low values of resistance, so it is useful.

Another method of locating a

short in a line is the use of a pulse test. There is an instrument available that will send a pulse down the line and the echo or reflected pulse will indicate the distance away from the source that the problem is located.

There is another method which may be less expensive, should the problem be on the horizontal run. When it is on the vertical run up the tower, this is a problem in itself. Simply measure the resistance at the input to the line. Go to the end of the line and open it up. If the line is shorted in the horizontal run, this will tell you so. Simply open each section until the defective section is found. This method won't work on a continuous line such as heliax.

An air dielectric should be pressurized even though the line can easily handle the power. If such a line is left unpressurized, any leak can let outside air into the line. This will let in moisture and dirt. Much moisture may accumulate over a period of time—say the summer months. When winter comes, this moisture can freeze and many problems will arise. The author had the experience of finding this out the hard way several years ago.

In one case, the horizontal run had a dip in it that allowed the moisture to flow to its low point. A cold snap caused the moisture to freeze. The operator on duty was not observant and the final tube stage had a hole blown in it because of the standing waves that developed on the line. This was a \$750 FM tube. Next came the search for the problem in 20° weather. We took the line apart and took the frozen sections (two of them) into the studio which was the only place long enough to handle 20 foot line sections and still get the center out of them. We melted the ice with blow torches, and used rags to dry off all the parts and inside the line. Finally we reassembled the whole line in the freezing weather.

Line maintenance can be summed up simply. Give it the minimum care that it requires. This should be daily and annually. If you correct small problems when they occur, the line will give you good service for many years. And remember that unattended line problems always seem to end up in perfectly obvious down time. ▲

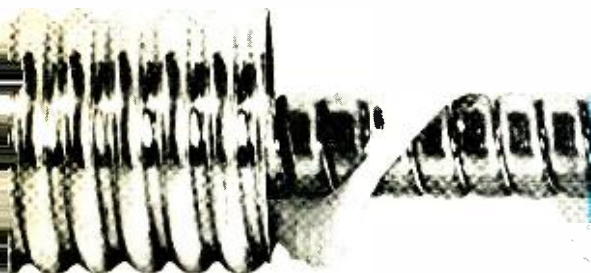

Fig. 6 A section of a flexible, air dielectric line. This one has a spiral insulator.



Fig. 7 Since power lines and trees were over the line at this installation, a protective covering was built over it to guard against falling ice.

ON LINE

VIDEO TAPE EVALUATION

By Fred J. Hodge*

This article describes a method of electronically evaluating the subjective impairment of video tape reproduction resulting from "dropouts" by using a new instrument called the Dropout Profile Recorder or DPR.

A BBC experiment is discussed that established standards of performance for visual dropout. A system using quantitative measurement of electrical dropout is then shown to be related to the annoyance factor of visual dropout because it compares the average rates. This type of testing is done on line with normal program material without making special test recordings. This dropout evaluation system is then used to evaluate differences in dropout rate caused by the video tape machine.

Subjective Dropouts

What we see in a reproduced picture as a dropout is not directly related to the electrical disturbances in the video tape reproducers FM carrier. This is because the program material effects the noticeability of the disturbances and the VTR's FM limiters successfully recover many of the electrical amplitude disturbances in the FM carrier. We would like to evaluate only those dropouts we see, but direct electrical detection and counting of amplitude disturbances alone cannot do this for us.

Visual impairment to program content by simulated electrical dropout has been evaluated according to duration, average frequency and depth. Considerable work was done on this for the BBC and is reported by W.K.E. Geddes in BBC Research Report No. T-143. The approach taken was to simulate dropout with artificially generated pulses

which could be controlled. Equipment was provided to generate bursts and quasi-random single pulses of any desired repetition rate. The duration of pulses to use was determined by analyzing many typical program tapes for dropout length. It was found that no actual single dropout lasted for as much as 50 microseconds and most were under 25 microseconds. (Dropout bursts sometimes give the appearance of longer single dropouts.)

The simulating equipment was arranged to produce interruption of the FM to the demodulator in an actual video tape replay system operating in EE mode. The picture was viewed by a group of observers who had been given a rating system. A high quality 35 mm film input was used. The viewers were television engineers accustomed to visual assessment of pictures. To offset this, pictures with subjective interest were used since the dropout is obviously more noticeable when attention is focused only on picture quality. The results of these tests showed that the degree of subjective annoyance is related to both the rate of the dropouts and the length of time since the last disturbance. The rate just prior to a disturbance affects whether it is noticed at all or distracts the viewer.

The relationship is complex but for typical dropout rates 16 seconds was found to be average for this association of events to develop. The effect persists for about 30 seconds before the impairment of each new dropout is again unaffected by the previous one.

Electronic DPR Dropout Evaluation

If we assume that the rate of electrical amplitude disturbances is related to the rate of actual visible

dropout, these experiments give us an excellent way to bridge the gap between subjective evaluation and electronic dropout counting. An electronic evaluator using a pulse counter and an analog integrator weighted according to the constants developed in Geddes' experiments can be calibrated by using simulated dropouts of controlled duration and repetition rate. This gives us a record format for dropout disturbance in terms of the annoyance that the indicated rate produces. We call this link between electronically measurable amplitude disturbance and the subjective annoyance of the visible dropouts, the DPR (Dropout Profile Recorder).

This type of readout is shown in the charts of Figure 1. The entire chart record for one hour tape occupies only five inches of chart space.

All dropouts detected, whether large or small, fast or slow, are evaluated with a weighted continuous graphic display of average electrical dropout rate. This display can be quickly evaluated for any period of interest.

We cannot accurately show random rates with a counter or a printer which accumulates the count and prints out at discrete intervals. This method does not give a repeatable record because each time the chart is re-run the start time of the tape and printer is different. The continuous average pulse rate shown by the DPR gives a repeatable record.

Dropout Depth

The detection depth or sensitivity level is also important to the repeatability of the dropout profile. Since the tape RF level varies with record current, head pole tip projection, tracking, etc., the RF sam-

ple must be AGC controlled before dropout detection is attempted. When video tape FM dropouts are examined closely, they appear not to be abrupt but to decay gradually. The VTR signal handling circuits have a characteristic which prolongs the transition at the beginning and end of the dropout. The point at which the decaying signal of a dropout no longer represents the correct video modulation is somewhat in doubt. The optimum detection depth is related to this signal decay rate.

This problem greatly complicates the detection of very small dropout or tape scratch. The transition slope is determined by the mechanical conditions holding the head in contact with the tape and by the transient response of the RF signal system. The depth of the "sensitivity" setting and the "lock out time" or the minimum length dropout to be counted are interrelated because of this.

As an example, if the dropout shown in the heavy lines of Figure 2 is the smallest to be detected, then a lock out of 5 microseconds would require a sensitivity threshold of 22 dB. If the lock out were increased to 10 microseconds, a 12 dB threshold will accomplish the same result.

Evaluation of video tape FM dropout depth only has comparative meaning after a lock out period is established. Comparative tests should always be run with the same lock out. Much of the early work with dropout testing was done with 10 to 15 microsecond lock out periods and on low band recorders. With the improved signal systems and limiting action of high band recorders, and the polished surfaces used on new tapes, the trend has been toward using a smaller lock out and greater sensitivity depth.

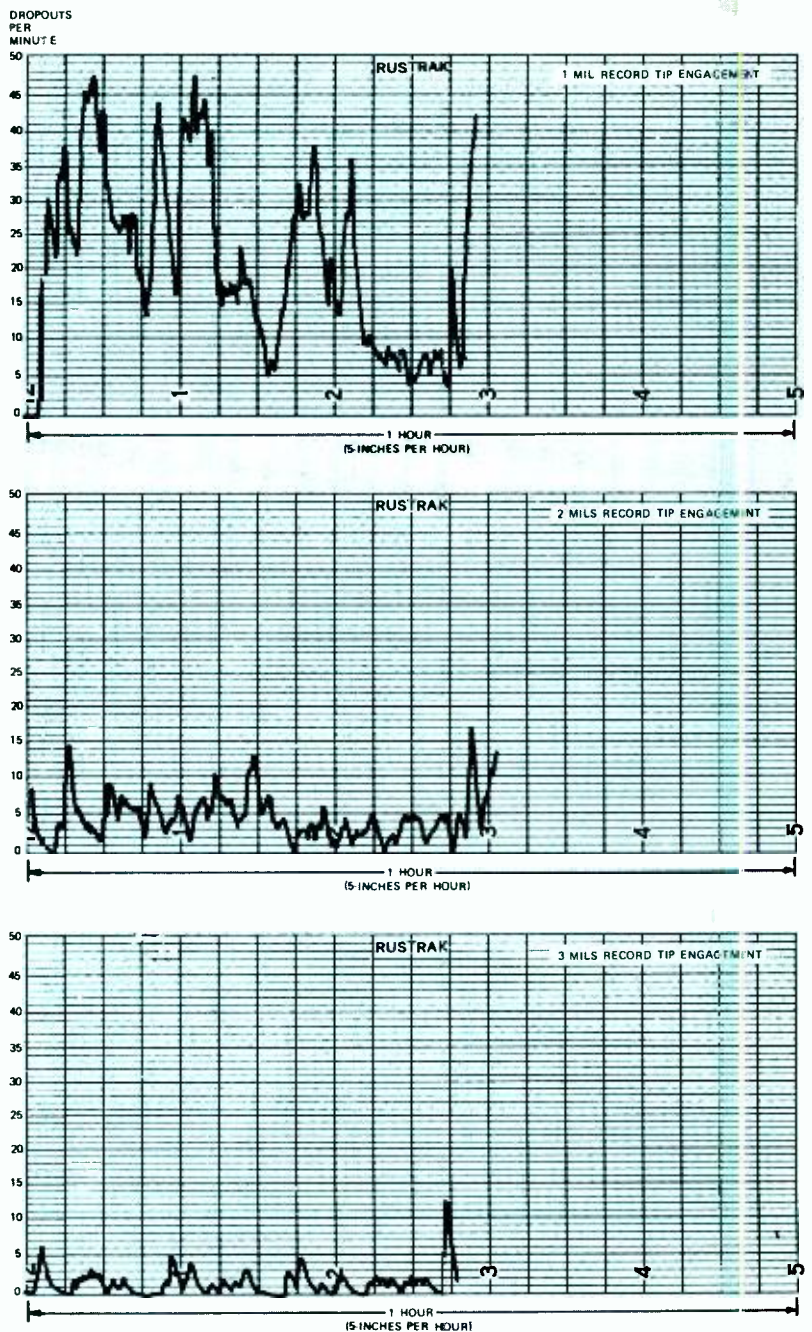

Fig. 1 Dropout Profile Recorder (DPR) readout. The top chart was recorded at 1 Mil, the middle at 2 Mils, and the bottom chart at 3 Mils record tip engagement.

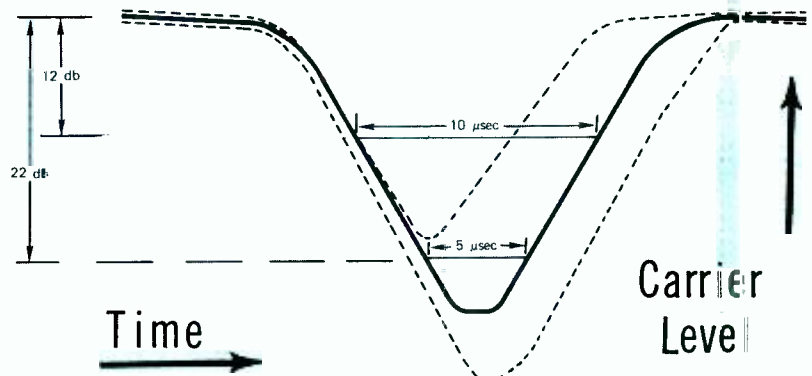

Fig. 2 If the dropout shown by the heavy line is the smallest, to be detected, then a lock out of 5 microseconds would require a threshold sensitivity of 22 dB.

Seven microseconds and 22 dB has been found by some tape studios to give good correlation with visible dropout disturbance to average program material. The detector sensitivity for best correlation with visible dropout depends greatly on program material and on signal-to-noise. In a properly functioning high band color recorder system, correlation occurred in our tests at about 16 dB on color bars, 20 dB on quiet program material, and 22-26 dB on active program material. A dropout indicator light on the DPR helps the user adjust sensitivity for his own applications. This correlation establishes the relation between electrical dropout rate and visible dropout rate discussed earlier.

Application

In using the profile recorder to evaluate stock, a level of disturbance consistent with house practice should be established experimentally. This can be done by visually analyzing the degree of disturbance with a test signal raster recording and correlating it with the strip chart evaluation. In correlating visible dropout disturbance with the profile recorder, it must be remembered that 20 percent of the time the signal is not visible on the monitor screen due to horizontal and vertical blanking. Dropouts occurring during this period are counted by the profile recorder. They represent potential visible defects on a succeeding recording, but they will limit subjective attempts to correlate the profile recorder with visible disturbance to about 80 percent accuracy. Acceptable conditions should be established by the tape supervisor. After this, stock can be evaluated against this reference without considering the subjective attitude of the particular operator or the effects of program material.

Machine Related Limitations

A video tape evaluator must use methods which assume that there is reproductibility of the relative condition observed. If he plays a tape on a machine and approves its

dropout performance, he is certifying it to be up to studio standards for use on other machines. Unfortunately, unless he has detailed knowledge of the machine variables which affect dropout rates, his efforts can be of questionable value.

Without measuring techniques such as the profile concept, direct comparison of machine variables has not been possible.

We have conducted studies in our laboratories and at major network outlets to identify the degree that these factors contribute to dropout rate. Three separate machine related variables, record tip engagement, record current, and tracking are the major contributors. Hold-back tension and playback tip projection have little or no effect on the dropout rate. Interested tape users can easily duplicate these tests with the DPR.

All our tests were run using a color bar test signal and Scotch 399 video tape. DPR sensitivity was set for 22 dB and lock out time of 7 microseconds. Experiments were run with only one parameter varied at a time; i.e., the record tip engagement test was run with normal

manufacturer's record current optimizing techniques and normal guide servo operation on playback. Playback tests to determine the effect of head condition were made by using two video head assemblies. A head with only 1.3 mils average tip projection remaining and a new head with 3.3 mils average tip was used. The 1.3 and 3.3 mil tip profile charts showed no significant dropout variation.

With some machines, especially those exhibiting capstan slip, (new matte-finished tape backings have reduced this problem considerably), RF "bounce" due to tracking variation is not uncommon. The total number of dropouts is increased by this. There are also more spikes or peak disturbances.

Record current and tip engagement were evaluated using normal playback on the same machine as a reference. Our results show there is a considerable variation due to "tip engagement". Tip engagement is the actual penetration of the head into the tape measured in mils. The tip projection is not directly related to tip engagement. We found it to be as much as ± 0.5 mil different,

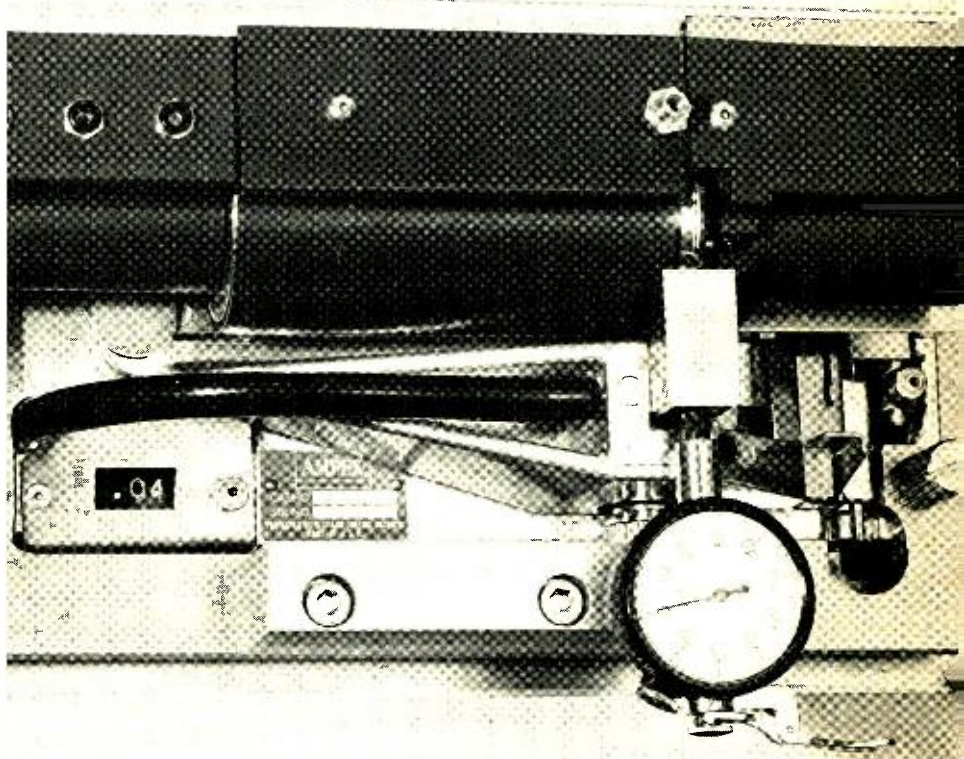

even after allowing for the fact that some video head drums have been undercut. To correlate dropout tests on different recorders, the record tip engagement must be measured with a special fixture which measures the actual penetration of the head pole tip into the tape surface.

When a tape made by using the standard alignment tape to set record tip penetration is checked for tip engagement on playback using the same head and the special test fixture, the engagement will equal tip projection if the drum radius is exactly 1.032 inches when it is turning at 240 rps; verifying that the static diameter is exactly 2.064 inches is not sufficient since it is possible to lap the drum to constant diameter and still not have a constant radius about its turning center. The head wheel is dynamically balanced and lapped concentric about its rotational axis. There are tolerances and there is some clearance in the bearing. The radius from the center of gyration to the pole tip is the critical dimension, and this cannot be measured accurately when the head is standing still.

The test fixtures for the tip engagement measurement are shown in Figure 3. To use this fixture, a prerecorded standard tape is placed on the machine and the fixture adjusted to measure the actual travel of the female vacuum guide perpendicular to the axis of the headwheel shaft and parallel with the surface of the tape transport deck. The machine is put in normal Play mode and manual guide operation, and the guide is backed away from the head until 50 percent of the center portion of the switcher RF output envelope reaches the zero output baseline (See Figure 4). (In machines with a rectified FM switcher output display, it is helpful to use a conventional oscilloscope on the switcher RF output test point.) At this point, the dial gauge on the test fixture is set to zero. The guide is then advanced until skew and scallop error is minimized and the dial gauge is then read. This reading is the actual tip engagement with the tape surface. If tape comparative evaluation is contemplated, tip engagement should be noted for each new program recorded because it affects dropout rate severely.

Figure 1 shows this effect. Note that the total number of dropouts represented by the area under the curve approximately doubles for each 1 mil reduction of record tip engagement. The criterion for the limits investigated was a usable picture for an air intersync operation.

Record current was also evaluated as to its effect on dropouts. Using levels which produced a useable picture, lowering the record current level did not materially increase dropout rate, while over-driving the record current definitely reduced the dropout rate.

Coercivity of the several types of video tape in use varies. For best dropout performance optimizing should be done with type of tape to be used and drives set as high as possible.

We have seen how electronic dropout evaluation can be related to visual impairment by adjusting the averaging time of "rate counting" to equal that of annoyance factors connected with dropout rate. We also have described the limitations that any type of dropout evaluation suffers from machine related variables.

Fig. 3 Test fixture for tip engagement measurement.

Fig. 4 With the machine in the normal Play mode and manual guide operation, the guide is backed away from the head until 50% of the center portion of the switcher RF output envelope reaches the zero output baseline.

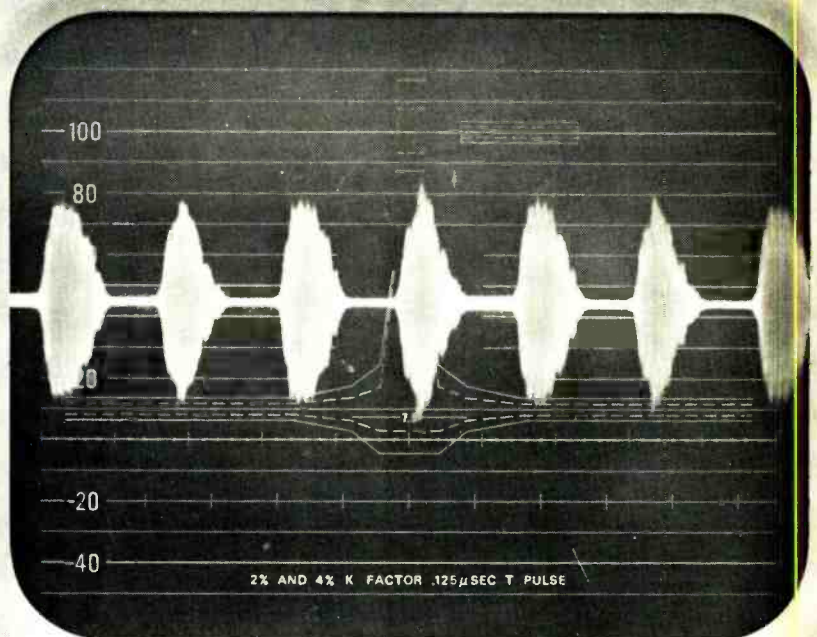

Vertical Interval Signal Applications

By Harry A. Etkin*

The vertical blanking interval of television systems is normally of 21 horizontal lines time period. The vertical sync and equalizing pulses are occupied by the first nine lines, while the last 12 lines are used for blanking only with burst color signals. This long idle period provides no useful function in the system other than to give a sufficient time for receiver vertical retrace. Since present day receivers achieve retrace blanking, any lines in the vertical blanking interval can be modulated without visible interference.

Television networks and telcos have presently made use of certain vertical interval lines for transmitting video test signals. RCA conducted a research experiment, using the vertical interval signals, where newspapers and other information services were delivered by using a TV station carrier as the transmission medium. Vertical interval signal transmission methods and applications will be discussed in this article.

Operational System Techniques

Sub-paragraph 73.682 (a) (21) of Volume III of the "FCC Rules and Regulations" states that the interval beginning with the last 12 microseconds of line 17 and continuing through line 20 of the vertical blanking interval of each field may be used for transmission of test signals. These test signals may include signals used to supply reference modulation levels so that variations in light intensity of the scene viewed by the camera will be faithfully transmitted. Signals designed to check the performance of the overall transmission system or its individual components, and cue and control signals related to the operation of the television broadcast station.

The following criterion should be adhered to by the broadcaster:

1. Modulation of the television

*BE Editorial Staff.

transmitter by the test signals should be confined to the area between the reference white level and the blanking level.

2. Test signals of chrominance subcarrier frequencies should have their negative excursions extend into the synchronizing peak amplitude.

3. Test signals shall not result in significant degradation, nor create excessive emission components of the program transmissions of the TV broadcast station.

4. Test signals should not be transmitted during that portion of each line related to horizontal blanking.

5. A one-half line guard interval shall be maintained at all times between the last test signal and the beginning of the first picture scanning line.

Many pieces of equipment, such as vertical interval encoders, decoders, erase modules, character generator interface units, test signal generators, sequential programmers and switcher, pulse stripper and process amplifier by-pass, have been designed for the proper application of this system.

In normal operation a video waveform is "looped through" an encoder, the encoder then selects any one of eight lines (lines 12 through 19) for data transmission. All eight lines can be used by looping the video signal through successive encoders. The encoder selects the desired line and produces a gating that begins after completion of the color burst and ends prior to the next horizontal sync pulse. A data clocking frequency is produced by an oscillator during the gate interval. The clock input is connected to the data interface unit, which consists of shift registers accumulating data from asynchronous sources.

Decoding is accomplished by the use of a gate pulse and interval clock which are used to determine the presence of data on the selected line by comparing the instantaneous video level at each of the 48 bit in-

tervals (48 clock pulses) with a reference derived from the blanking level of the video signal.

In many applications the output device operates asynchronously with the TV system, therefore an output buffer is usually required. The output buffer normally a shift register is capable of storing the number of bits transferred in each field and is then physically combined with the interface electronics so as to produce an output compatible with the driven unit. Useable data is clocked out of the interface device at a rate selected by the output device (See Figure 1).

Vertical Internal Applications

As the vertical data transmission systems will probably provide extra use of the broadcast spectrum without interfering with the existing services, it is logical that the use of some applications will require waivers or changes in the FCC Rules and Regulations.

The versatility of the present industry applications will be presented. Many applications include Broadcast, ETV and CATV uses.

1. **Communications link to affiliated network stations.** By employing an electronic generator at the point of network origin and at each affiliate, it is possible to establish a reliable continuous communications network. The affiliate should use a separate control room monitor upon which network messages would be seen. The network provided with a selective addressing unit could address an individual station, group of stations, or all stations, transmitting program log information, cueing information, routine messages or news flashes. News alarms could usually use the flashing feature of generator as a silent signal to alert control room personnel.

2. **Transfer of daily program logs.** Daily program logs made up at the controlling station could be transmitted to the affiliates by using the vertical interval system. The log information could be fed to a rotating magnetic memory device or a hard copy printer.

3. **News wire distribution.** News wire bandwidth requirements are determined so that several hundred circuits could be carried in the vertical interval of a single video signal.

Commercial Electronics Incorporated Model 270

...the sensitive one

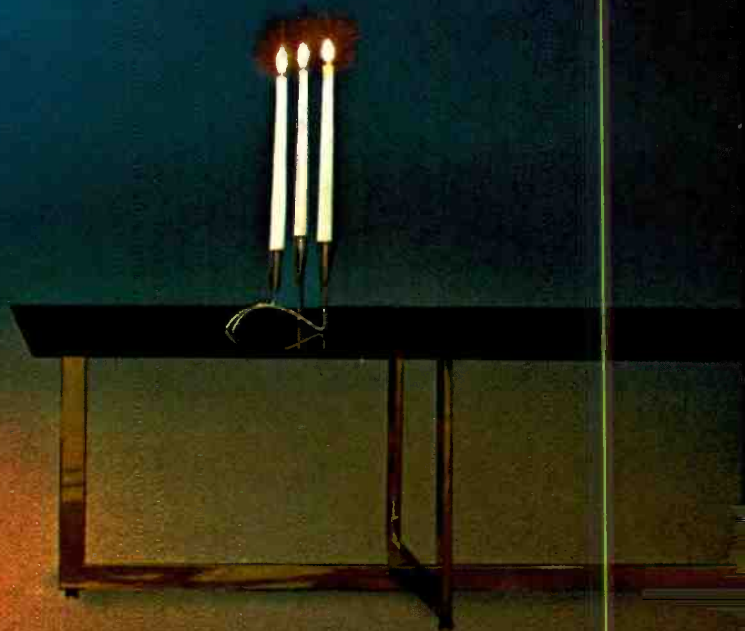

SENSITIVITY — The Missing Element in Color Television Cameras!
The CEI 270 is an advanced, broadcast, television camera which produces color pictures at f/4 on a 5 footcandle scene. Remotes are a snap! Monochrome studios can be converted to color operation without additional lighting and air conditioning expense.

The Sensitive One . . . the CEI 270 . . . versatility at about half the cost of other professional cameras!

Circle Number 18 on Reader Reply Card

www.americanradiohistory.com

 **Commercial
Electronics
Incorporated**

880 Maude Avenue
Mountain View
California 94040
(415) 969-1910

It was recently shown that a AP News Wire could be carried over an RF system. The news wire was terminated at a city located on a news wire trunk line so that it could be turned over to private or common carrier TV microwave operators. Assuming that appropriate FCC waivers are obtained, interconnected TV stations and CATV systems subscribing to the service could be fed directly and radio stations could receive the signals from off-air pickups from TV stations. Readout would be displayed either by hardcopy from a printer or by means of an electronic character generator. It is most likely that CATV systems would also provide a continuous news feed to CATV subscribers.

TV stations and CATV systems employing character generators and magnetic storage equipments could possibly preview and edit the news copy, and then display the edited copy on a monitor from which the newscaster can obtain the latter-day "rip and read" copy and then deliver the news orally.

4. Communications with TV station mobile units. The TV station's transmitter could be used to transmit messages to mobile units. To achieve this each mobile unit would have to be equipped with a character generator for readout. The mobile units message transmission to the control room is performed similarly, by using the remote video link. Where the mobile microwave unit transmits to the station's transmitter site, the two-way data circuit can be maintained by using the common transmission facilities through a different horizontal line for each direction. The transmitter video input switcher operated by studio control is normally accomplished so as to provide for better coordination during remote pickups.

5. Transmission of messages by ETV and ITFS systems. Many statewide, regional and local educational distribution systems can be provided with advantage of the addressing flexibility of the vertical interval data transmission devices. They can selectively communicate with individual schools or groups of schools. The readout device can be character generator or hard copy.

6. Central computer facility. Various campuses having points of origin in an ETV system can establish

two-way communications with a central computer facility.

7. Identification of program source. Vertical interval encoded signals can be used to identify the origination point of network programming or the source of video tape production.

8. Unattended VTR's remote controlled. Remotely located video tape recorders can be operated by the application of V. I. control for recording programming during otherwise dark periods. CATV systems being fed from regional microwave systems could record feature films and other program material at night, or other available time periods, using the same microwave facilities that are used for daytime carriage of regular programs. The use of this method could solve two of the most vexing problems in cable TV program distribution, dubbing and bicycling.

9. Remote video switching. Video input switching of intercity

microwave systems can be remotely controlled by means of V. I. signals. TV stations and ETV systems can be controlled from either the point of origination or from the destination point.

10. CATV non-duplication switchers remotely controlled. Local and distant TV broadcast stations can remote, manual, or automatic control the non-duplication switchers. This provides for schedule changes of the programming hours. Other vertical interval application possibilities are: Insertion of test signals; Microwave fault alarm transmission; Remote control of metering and logging of TV transmitters; Regional news and weather service.

Vertical Interval Test Signal

A rather unique application of the V. I. system is the insertion of the Vertical Interval Test Signal (VITS) to check the performance and quality of the TV pictures be-

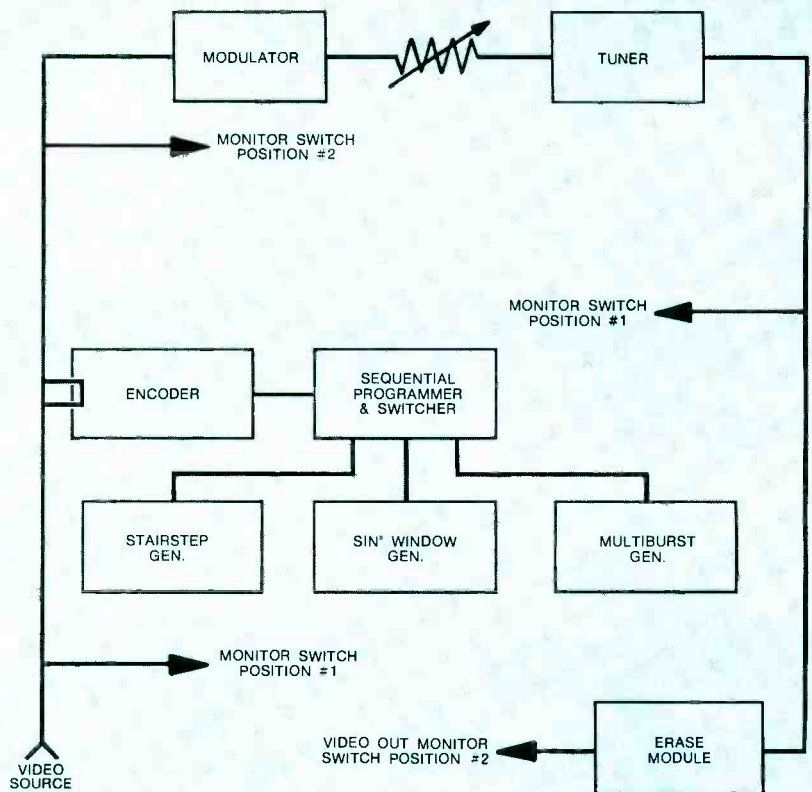
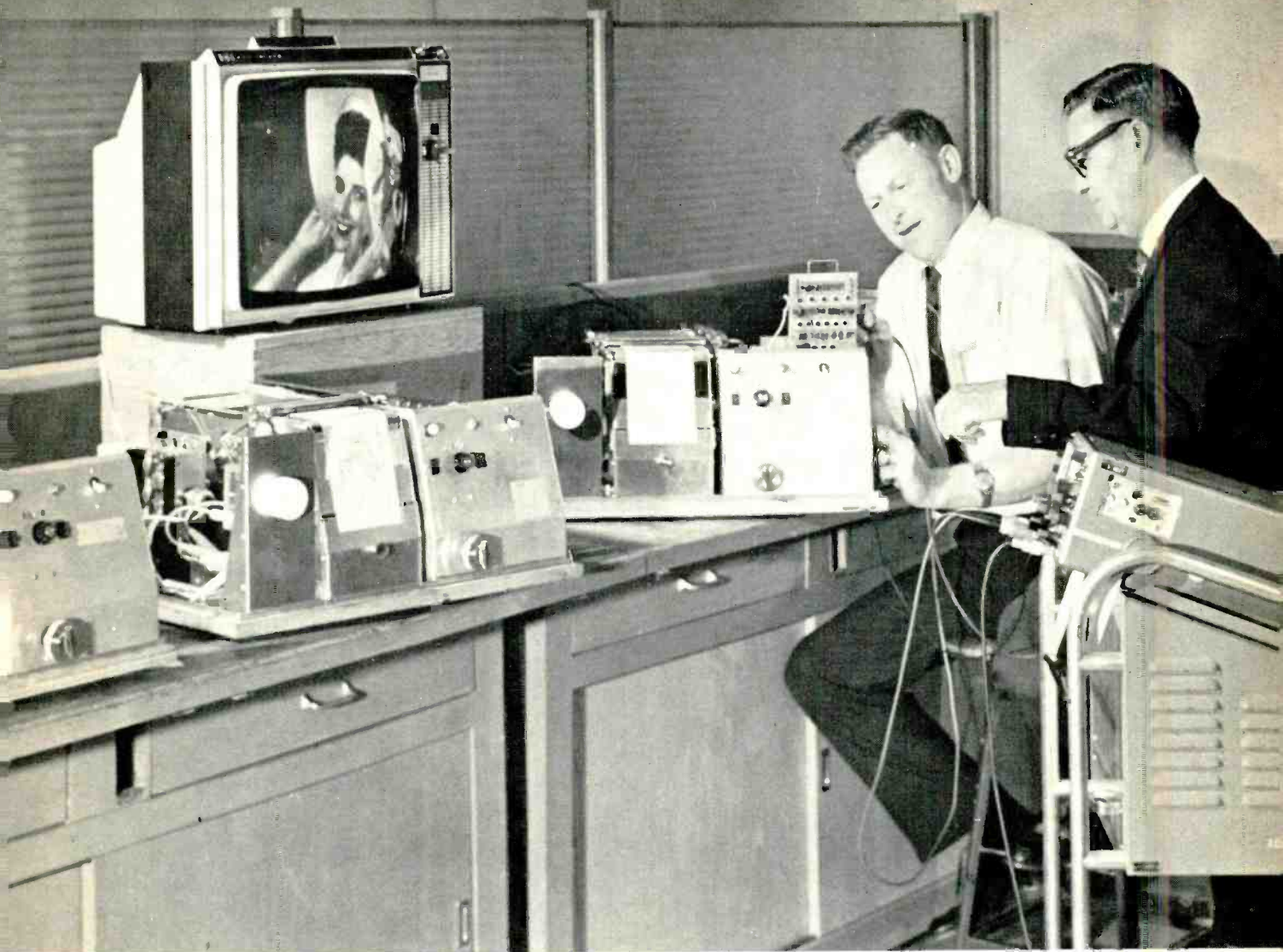

Fig. 1 Block diagram of basic vertical interval data transmission system. Decoding is accomplished by a process similar to encoding. It reconstructs the digital material for input to an appropriate readout device.

Fig. 2 System shown here receiving TV transmitted printed material.



ing transmitted over the entire network. The test check on the TV signal information provides a means of locating and correcting a trouble source.

The VITS sent out by the TV networks and through AT&T are normally intended to provide checks on transmission facilities being used. They aid in determining such factors as the linearity and bandwidth, and assist in checking color values.

Usually there are four test signals sent out by the networks during each vertical blanking interval. After analyzing the four test signals on an oscilloscope, the technician can determine the degradation of the video circuits. The test signals sent out during each vertical interval can normally check such factors as differential gain, modulated stair-step multiburst, sine-squared pulse and sine-squared window.

During network operations procedure the test signals are usually provided from the telco clamper,

fed through the TV station's processing amplifier, distribution system, distribution amplifiers, studio switching units, and then to the transmitter. By using this method the technician can isolate the degraded signal at either the telco circuitry or the TV station's equipment.

Vertical Blanking Interval Facsimile Signals

An experimental system that can broadcast printed copy into the home with standard television programming has been recently tested by RCA.

Figure 2 shows the RCA Homefax which is a system of broadcasting printed copy by inserting facsimile signals during the vertical blanking interval.

To evaluate the system's technical performance under actual operating conditions, FCC permission was obtained to make on-the-air tests between New York City and

Princeton, New Jersey. By using this system, additional RF spectrum will not be required and it will not in any way limit present television services.

The system converts printed copy into a series of electro-magnetic signals which are blended at the transmitter with the signals of the regular TV programs by means of an electronic "hitchhiking" technique. The blended signal is broadcast for reception by standard TV antennas and is then fed from the antenna to the printer without affecting home TV reception in any way (See Figure 2). Note that the image of a girl appears on the TV screen at the same time a printed weather map is produced.

In operation the equivalent of a page from a standard paperback book will be produced every 10 seconds. The printers can provide printed news briefs, sport scores, stock market reports, charts, cartoon strips, TV program schedules,

For a little guy, the Jamieson Mark IV color processor sure turns out the film.

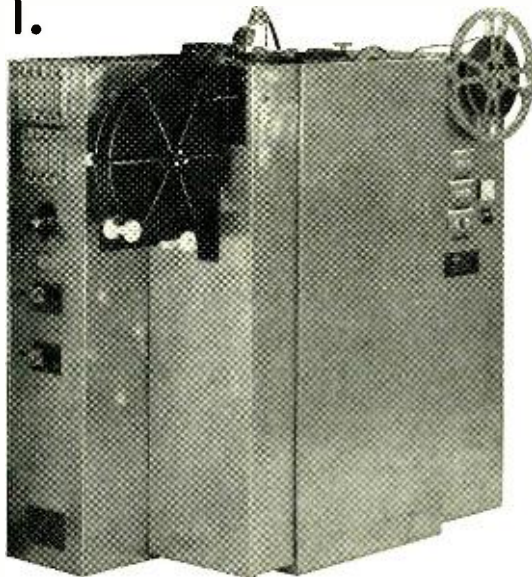

The Jamieson Mark IV color processor may be small in size, but there's nothing small about its performance.

It is the easiest of all machines to operate.

It is fully instrumented and automatically controlled.

It has a warm-up time of just 10 minutes, a put-through time of just 23 minutes.

At that rate the Jamieson Mark IV color processor for 16mm and 8mm Ektachrome at 30 F.P.M. delivers processed film at a rate twice that of other machines its size.

But there's more to our Mark IV than just speed.

A lot more.

The Mark IV is no bigger than a standard office desk so you can easily install it in existing space.

It costs less to own than any other color processor in its class.

It is completely self-contained and its simplicity of design reduces maintenance requirements and makes servicing a breeze.

And we didn't stop there.

Our proven, patented small reservoir tube tanks are incorporated in the Mark IV color processor. These tanks contain only about one fifteenth the amount of chemistry required by ordinary open tank types. What does this mean?

The reduced volume gives you more stable chemical balance and finer temperature control. You get highest color quality, freedom from scratch hazards, lower day-to-day chemical costs and the gentlest, most reliable film transport system available.

The Mark IV is available in two versions. The fixed installation for TV stations and small commercial labs and in an air-transportable model with special electrical features that make it adaptable to any electrical conditions you may find.

For more information on the Mark IV color processor and the names of current users, write us.



Jamieson Film Company

EQUIPMENT DIVISION
2817 CANTON ST., DALLAS, TEXAS 75226
A/C (214) 747-5634

VERTICAL INTERVAL TEST

(Continued from page 33)

syndicated columns, news magazines, and copies of Presidential addresses.

Tests indicate that the system can be used in conjunction with either VHF or UHF transmissions. In TV transmissions at periods of 60 times a second there is a brief interval during which no picture information is transmitted. The facsimile signals are inserted during the vertical blanking intervals. Presently four different printed messages can be transmitted simultaneously, and it would be possible for the printer to produce any one of several different messages by turning a dial to the proper setting.

Conclusion

The TV broadcaster will note from the broad variety of uses described in the article that many practical operational application innovations have been developed by Telemation, RCA, Telcos and TV network systems. Although the vertical blanking interval information transmission is too new to provide a definite assessment of its potential achievements, many users of V. I. systems have displayed a great interest with the result of providing a broad acceptance of the applications in the television industry.

Some vertical interval proposed experimental applications, developed by research firms, have been submitted to the Electronic Industries Association for their Committee Review, analysis and comment. The Committee normally studies the V.I. device and information to determine its practical value and potential merit. The EIA Technical point of view is submitted as a docket to the FCC for requesting a possible Amendment of Part 73, Section 73.682 (a) of the Commission's Rules and Regulations.

The EIA Committee usually consists of technical experts from TV receiver manufacturers, TV broadcast equipment manufacturers, telephone equipment manufacturers and private consultants.

Users of new Vertical Interval applications are urged to contact the author who is very much interested in obtaining information relating to new application projects. This could lead to expanding the V.I. field and the acceptance of these ideas in the television industry.

AKG

C-451E Microphone System



the
common-sense
approach to
phantom
powering.

Just one or
two resistors!
Simple, isn't it?

- No AC power supplies required
- No DC power supplies
- No "central" power supplies
- No special "cards"
- Operates off any DC voltage between 7.5 and 52v (including the standard 24v available in most equipment).
- Stabilizes its own operating voltage, to maintain constant output level.
- Optimum polarization voltage, for best signal-to-noise ratio.



MICROPHONES • HEADPHONES

DISTRIBUTED BY
NORTH AMERICAN PHILIPS CORPORATION
100 EAST 42nd STREET, NEW YORK, NEW YORK 10017

AKG CANADA • DIVISION OF DOUBLE DIAMOND ELECTRONICS • SCARBOROUGH, ONTARIO

AKG-130

THE SIMPLICITY OF SIMPLEXING

The AKG C-451E may be powered at the cost of one or two precision resistors: No separate AC or DC power supplies required nor special "cards" or "central" power supplies at additional cost.

The microphone preamplifier requires as little as 7.5v DC and may be operated directly off the standard 24v B+ supply available in your equipment (or any other voltage between 7.5 and 52v). The current consumption is only 2.8 mA.

Other features unique with the AKG system are:

A) Stabilized operating voltage: The DC supply voltage to the microphone is not required to be particularly well regulated nor is it rigidly tied to a specific voltage. In fact, it may vary by $\pm 15\%$ since the C-451E preamplifier will stabilize the operating voltage. There is no limit to the number of microphones to be powered off your console.

B) Constant 60 volts polarization voltage: 60 volts is the optimum polarization voltage for highest performance standards, specifically sensitivity; resulting in more gain without increase in noise level and better signal-to-noise ratio. The C-451E supply voltage is not simultaneously the polarization voltage (too low). The microphone preamplifier provides a constant 60 volts polarization voltage and fluctuation in the supply voltage will not change the output level of the microphone.

There are no short cuts in the AKG C-451E circuitry!

HOW DOES IT SOUND?

Interestingly enough, its pick-up characteristics are being compared to the quality previously obtained only with large diaphragm condenser microphones.

The newly developed CK-1 capsule incorporates a metallic alloy diaphragm (similar to the diaphragm material used in measuring microphones) and is absolutely smooth between 30-18,000 Hz with unequaled transient response characteristics and wide dynamic range.

The polar pattern is a true cardioid at all frequencies with linear off-axis acceptance and a front-to-back discrimination of 20-30 dB over the entire range.

Last, but not least, a practical and economic modular design permits you to choose from a variety of interchangeable capsules with different response characteristics and polar pattern (cardioid, omni-directional, figure-eight and shot gun tube).

**AKG
OFFERS A CHOICE—
NOT A STANDARD**
Write for complete technical data.

Circle Number 20 on Reader Reply Card

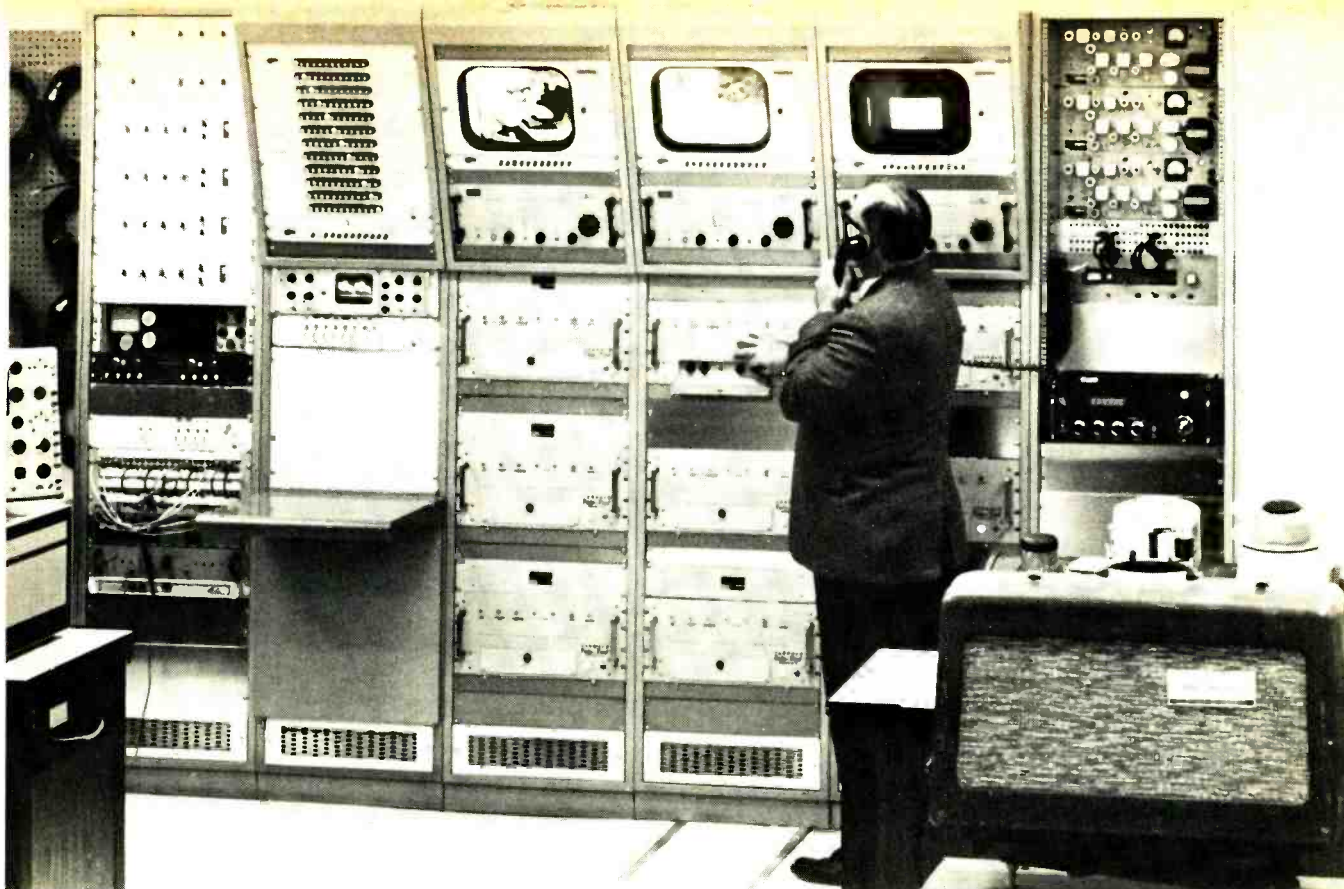

Here is the heart of the Monroe system, showing the 17-channel head end equipment rack. Obviously, qualified people are needed to man such a system. And finding these people is as important as the system installation, interface and instructional use.

Going all the way with ITV

By Eugene L. Edwards, Jr.*

One of the most extensive instructional television systems ever installed in a junior college now is in operation at the new campus of Monroe Community College, Rochester, N.Y. It is used to improve the college's general instructional program, to serve as a laboratory for the institution's audiovisual technology career program and to gain other important physical and curricular advantages.

The system enables the college to originate programs on 12 VHF-TV frequencies and one video frequency channel and to distribute them over a coaxial cable system to every teaching station on campus—156 classrooms, lecture halls, laboratories and learning carrels.

There are also five separate video lines to certain selected areas. The system has the capability of providing up to 17 simultaneous programs.

Programs can be originated from any point on campus and then fed back through the cable by means of two sub-carrier channels to the TV resource center for distribution or taping. Equipment there includes 11 cameras and 12 videotape recorders.

The videotaping of demonstrations of dental hygiene techniques is a good example of the usefulness of the Monroe ITV system. The dental hygiene program includes clinical laboratory experience at the Eastman Dental Center, local hospitals and community dental health centers.

It was difficult and time consuming—as well as disruptive—for a class of students to get close-up views of a dental hygienist demonstrating procedures on a patient. But, one remote camera now cap-

tures live or on videotape an entire procedure in detail. Then, the procedure is studied on TV monitors in the classroom.

Similar advantages obtain for many laboratory courses—such as engineering science, biomedical engineering, electrical technology, instrumentation technology, mechanical technology, medical laboratory technology, optical technology, police science and X-ray technology. In all of these, videotaped demonstrations of experiments and procedures now are shown in classrooms.

Instructional Materials

Approximately 90 percent of the TV program materials used in Monroe's various courses are being developed and produced by the school's own Instructional Services Department. The department, of course, works closely with each teacher in planning and producing the materials, and in borrowing or

*Chairman, Instructional Services Department, Monroe Community College, Rochester, N. Y.

purchasing program materials from other sources.

The teachers schedule the showing of the program materials. Then, on voice command over the two-way communications system with the head-end, they order programs to be started, stopped or replayed. This way, the teachers always are in control of the ITV presentations in their classrooms.

The instructional Services Department already has ten people on its staff including the department head, two engineers, a producer-director, a chief audiovisual production specialist, an audiovisual technology instructor, and four technicians and clerks. Eventually, the staff will be expanded to sixteen.

The department has a six-member advisory committee headed by Arthur R. Cowdery, Jr., senior consultant in educational communications of the Rochester City School District.

Saved Building Costs

Because of the decision to include ITV as a major tool in the Monroe Community College curriculum, the architectural plans of the buildings were drawn specifically to accommodate the extensive equipment and provide the space required for the utilization of the system.

It could be said that the buildings actually were designed around the Department of Instructional Services and the Library. They are considered two of the most important facilities of the college.

The ITV system made it unnecessary for Monroe to build an extremely large and costly auditorium which would be used only when it was necessary to seat the entire student body or a large audience. When a prominent lecturer comes to the campus, he speaks in the largest theatre (capacity 550), and his talk is televised to the rest of the student body seated in the other eight lecture halls and/or classrooms. In the lecture halls, no student is seated more than 24 feet away from a 25-inch monitor.

Communications Facilities

The Department of Instructional Services (Audiovisual-TV Center) includes two studios, a mobile studio equipped with a Model 7000 videotape recorder, GPL studio—

two-camera unit utilizing subchannel equipment for transmission to the master control, and an Ampex 7100 video trainer.

Other facilities of the audiovisual center include two control rooms, master control center, TV maintenance room, 42-seat group lecture room and associated projection room, conference room, graphics room, audiovisual and TV production room, media library, three dimensional fabrication area, audio recording room, photographic studio, photo development and printing rooms, reception room and staff offices.

Initially the ITV system has 17 program sources, but it is designed to accommodate 26 sources. Present sources include the three Rochester VHF commercial channels, the Rochester UHF educational channel and an Instructional Television Fixed Service (TFS) channel of the Rochester public schools. Nazareth College of Rochester, Rochester Institute of Technology, St. John Fisher College and Monroe Community College share in the use of the ITFS channel. Each institution produces programming for joint use.

The three commercial stations' programs are received by heavy-duty VHF antennas mounted on a tower on the campus. The ITFS

station, transmitting from East High School, is received by a parabolic antenna on the same mast. A receiver-converter converts the 2500 MHz signals of the ITFS channel to VHF frequency for distribution through the college system. The UHF station is received on a parabolic antenna, down converted and distributed in a similar fashion.

Camera Complement

The college already owns 80 cameras including two image orthicon and three vidicon studio units, 38 Ampex 324's, 34 N/V GPL '00's, two vidicon studio units (non-view), a 7100 mobile and the 7000 mobile unit. Eventually, the system will use a total of 120 cameras.

Thirty-four new cameras will be used at Genesee Hospital where they will feed into a sequential switcher for the room monitoring system. A similar 36-camera system is being designed for Monroe County Hospital, and a 33-camera system for Northside Hospital was installed two years ago.

The system also utilizes a dozen videotape recorders. Other equipment includes two multiplexers. Two more multiplexers will soon be added.

Convenient Head-End

All of the equipment of the head-

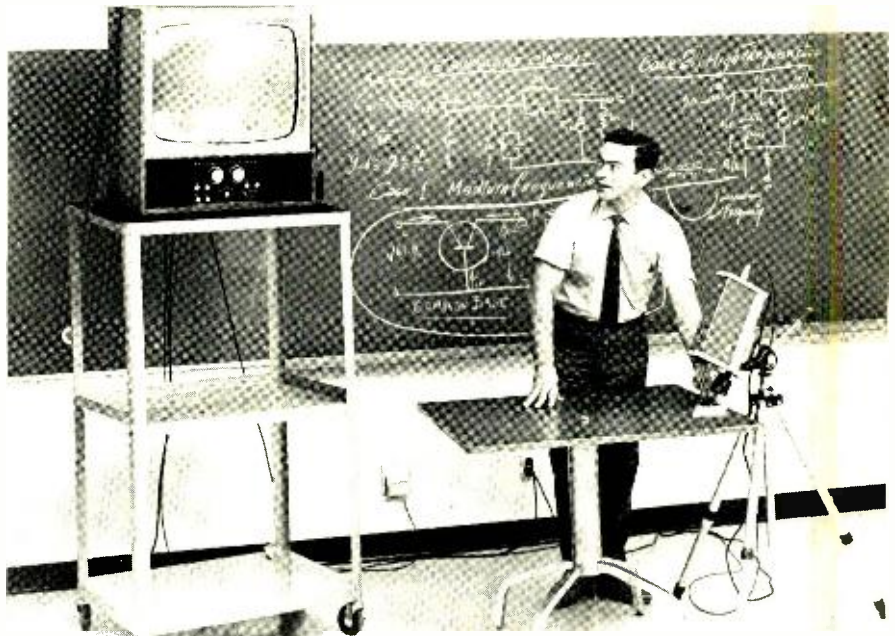

Julio Ahumada using TV set to demonstrate transistor theory. The same jack outlet (below the blackboard) allows the TV set to be used to monitor central programming or demonstrate projects in the classroom.

end is installed in six specially designed, side-by-side racks. The modular units for video control, switching and audio are mounted on rollers, permitting the units to be pulled forward from their normal rack positions, thus making it convenient to maintain and adjust the equipment.

The video control section includes three Jerrold Channel Commanders, modular head-end units that process and control the signals from the VHF stations, Channels 8, 10 and 13. These units are of the type used widely in large community antenna television (CATV) systems.

Each Channel Commander is capable of receiving any of the twelve VHF channels and converting it to the Commander's output frequency.

Nine Jerrold Tele-Trol TM-TAM Modulators and four Model TM converters are used for outgoing programming. They are set for Channels 2 through 9, and 11 and 12.

The video control panel is used as a status control. It gives visual indication of all available inputs.

These are monitored on three straight-line video monitors mounted above the racks.

The switching equipment includes a Dynair switcher having twelve inputs and twelve outputs, each isolated and having separate preamplifiers. A status panel and a waveform monitor are mounted below the switcher.

Designed into the switching rack is a patch panel that permits 12 preset programs. There is easy access to the panel for switching it to additional program sources. The patching arrangement provides a quick and easy method of shifting equipment into the system if a unit fails during programming.

A telephone line terminates at the main control console, permitting guest lectures by long distance telephone. The lectures either are routed to the various college areas via a public address system or modulated to FM for transmission as RF to classroom FM receivers.

With this system, a lecturer simply dials the college telephone number and makes direct connection. The only cost to the college is the long distance toll charge plus the fee for the lecturer.

95 Miles of Cable

The TV and sound distribution system, as extensive as cable TV systems in many towns and communities, includes 95 miles of sound and coaxial cable. In addition, there are 38,000 feet of audio cable and 15,000 feet of coaxial cable used for the studios and master control.

The main distribution cable is laid in conduit under the building floors. Thus, there is easy access to the cable from the basements of the buildings.

Television Receivers

One hundred twenty-five receivers are used in the college classrooms, and 23 video monitors are used in the nine lecture halls. One Conrac AV12E Receiver is used with up to four of the monitors in each lecture hall.

TV equipment at each of the hospitals will include two monitors, a sequencing switcher; and a Mossman Switch that will be used as a hold mechanism for video and audio. These control consoles will be housed conveniently near the nurses' stations.

All of the design, fabrication and installation of the master control racks was done by Professor Leslie M. Wetherbee, Chief TV Engineer; Richard Marvin, TV Engineer; and the author. Special panels and controls indicating the status of various pieces of equipment also were designed and fabricated by us.

Editor's Note: Here is an example of total commitment to instructional television. But like other trends, such as station automation, utilization must be based on a clear understanding of needs and all methods that will meet these needs. It's one thing to have a showcase system, but it makes far more sense to have a system geared to instructional necessities.

In some instances innovative communications techniques are sidetracked when qualified engineers and technicians are not available for system maintenance and operation. An appropriate question for planning sessions is, where will we get the people to operate the system? If commercial and non-commercial broadcasting is to move forward in the 1970's, more effort will be needed to attract engineers and technicians to the broadcast-communications industry. ▲

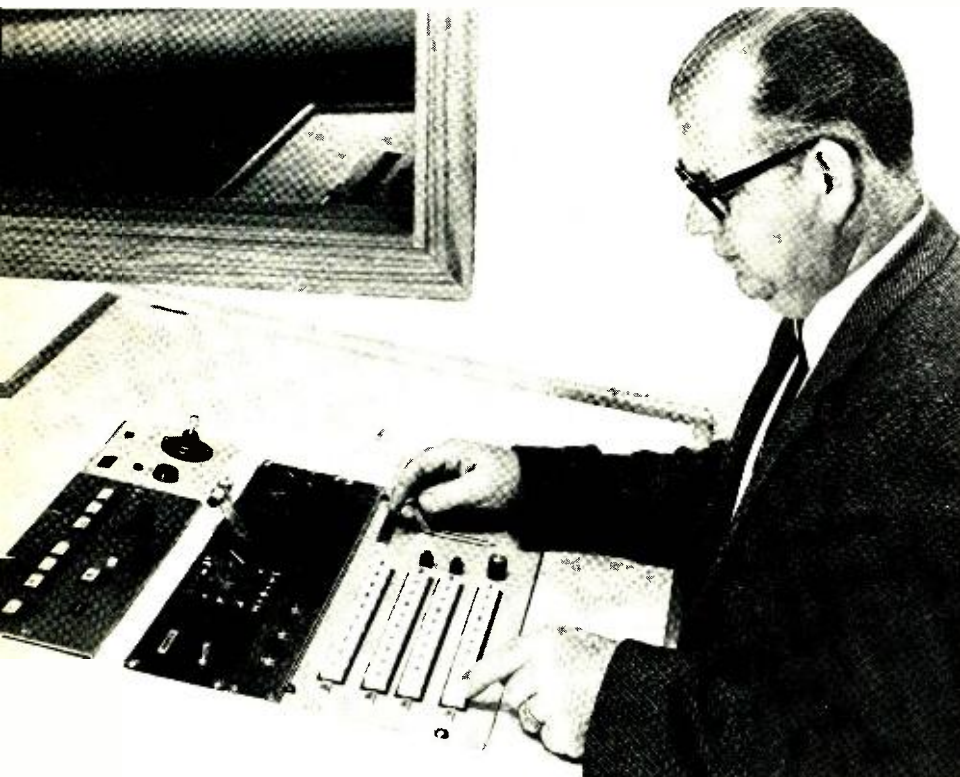

Chief TV engineer Leslie Wetherbee is shown here at the controls of a switcher-fader in one of the ITV studios.

Spotmaster

Introduces the incomparable

Ten/70

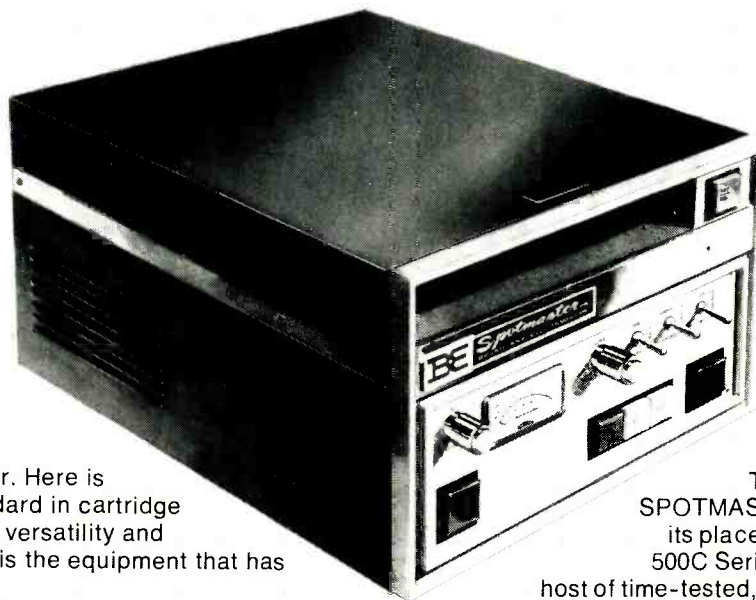

Your search is over. Here is the bold new standard in cartridge tape performance, versatility and ruggedness. Here is the equipment that has everything.

Five models of the magnificent Ten/70 are offered: mono record-play, mono play, mono delayed programming, stereo record-play, stereo play. All have identical dimensions. Any combination of two will fit in our sleek 19-inch roll-out rack panel, just 7 inches high.

And look at the "Human Engineered" versatility. Features and options include manual high-speed advance, exclusive Auto-Cue with automatic fast-forward, automatic self-cancelling record pre-set, front panel test of cue and bias levels, built-in mike and line level mixer, automatic pressure roller engagement and electrical cartridge release, color-coded design for easiest possible operation.

No-nonsense SPOTMASTER engineering dictates the inside story: a massive U.S.-made hysteresis synchronous "Direct Drive" motor, solid state logic switching, modular construction throughout, premium components, separate heads allowing A-B monitoring, full bias cue recording, transformer input and output, flip-top access to heads and capstan.

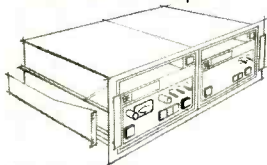

This new generation of SPOTMASTER equipment takes its place alongside our classic 500C Series, still offered. With a host of time-tested, field-proven features, the 500C record-play and playback models meet or exceed all NAB specifications. Performance is second only to the Ten/70.

MULTIPLE CARTRIDGE MODELS—SPOTMASTER Five • Spot and Ten • Spot (holding five and ten cartridges respectively) may be operated manually or incorporated into programmed automation systems. And now there are stereo models, a Remote Control Sequencer, and a Five • Spot with full recording capability.

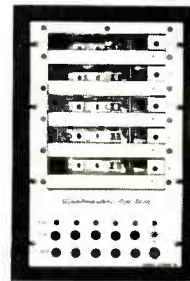

The versatile Five • Spot

Call or write today for information about the new Ten/70 and other SPOTMASTER cartridge tape products and accessories. Remember, Broadcast Electronics is the No. 1 designer/producer of broadcast quality cartridge tape equipment—worldwide!

BROADCAST ELECTRONICS, INC.

A Filmways Company

8810 Brookville Road, Silver Spring, Maryland 20910 • (301) 588-4983

The Innovators Introduce:

“Son of PC-70”

The Norelco PC-70S-2

Circle Number 21 on Reader Reply Card

Now Philips re-invents the PC-70 color camera to set a new broadcast standard for color control and color fidelity

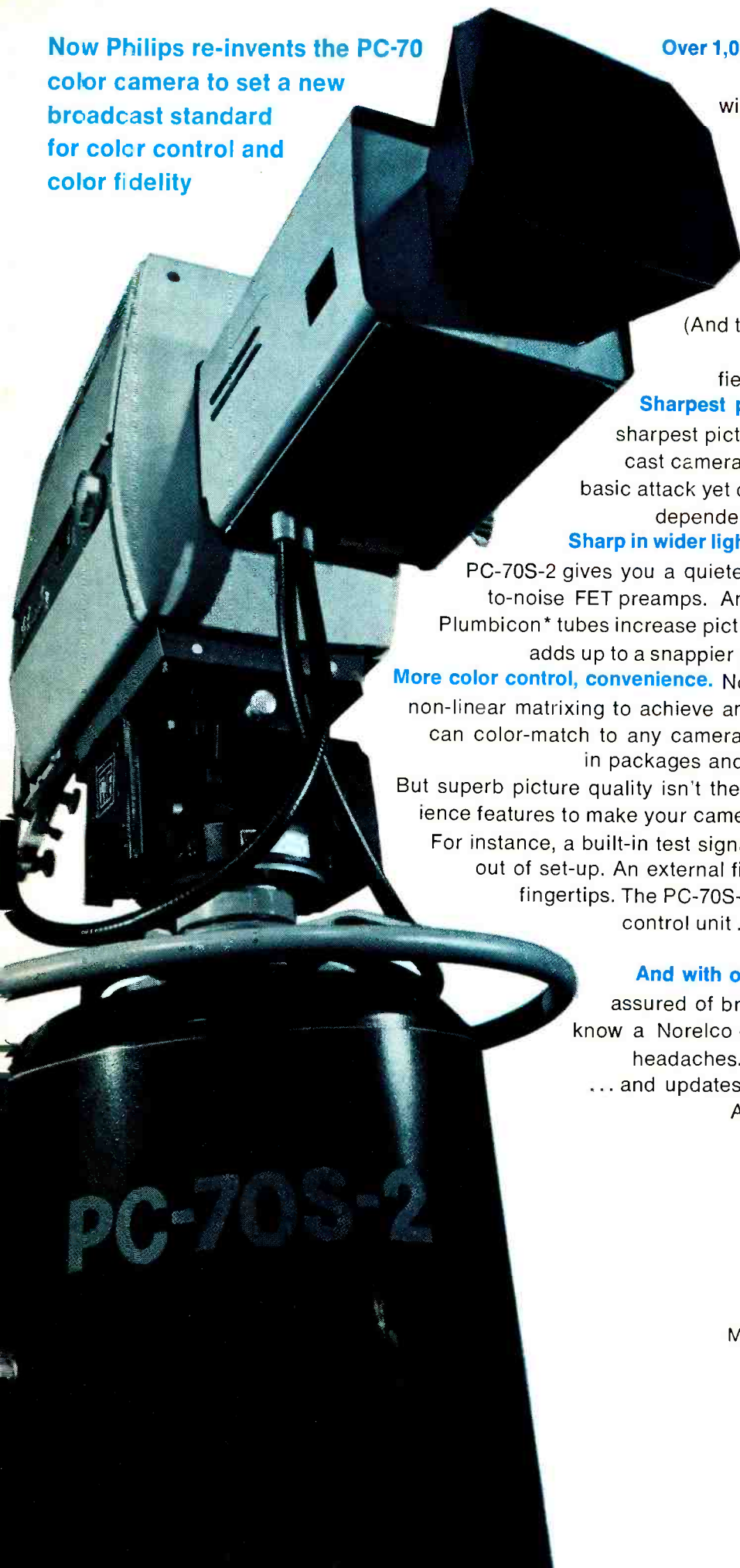

Over 1,000 Philips 3-Plumbicon* cameras have been delivered throughout the world, with more than 600 serving broadcasters and production companies in the United States. It is the standard other cameras try to match.

That was tough before. Now it's tougher. Because today the Innovators are introducing the PC-70S-2, with an important list of new features. (And to prove you are always state-of-the-art with Norelco, they're available as field update kits for older PC-70 models.)

Sharpest picture yet. Our key innovation is the sharpest picture detail you have seen from a broadcast camera. A new technique introduces the most basic attack yet on picture-degrading "noise" . . . level-dependent comb-filtered contour enhancement.

Sharp in wider light range. In low-light situations, too, the PC-70S-2 gives you a quieter picture. We've added 48-db signal-to-noise FET preamps. And at all light levels, separate-mesh Plumbicon* tubes increase picture resolution and dynamic range. It all adds up to a snappier picture in every area from light to dark.

More color control, convenience. Now the PC-70S-2 is also available with non-linear matrixing to achieve an infinite range of tints and hues. You can color-match to any camera you own. Even those problem colors in packages and costumes snap into true-to-life color. But superb picture quality isn't the whole story. There are many convenience features to make your cameraman more expert, more productive.

For instance, a built-in test signal generator that takes the guesswork out of set-up. An external filter wheel control at the cameraman's fingertips. The PC-70S-2 ranges far and free from the camera control unit . . . up to 3,000 feet with standard cable, or 1,000 feet with mini-cable.

And with over 1,000 cameras delivered, you are assured of broadcaster-proved dependability. You know a Norelco camera will deliver performance, not headaches. You know Norelco delivers service . . . and updates to keep you abreast of innovations.

Ask us about details and prices now.



One Philips Parkway
Montvale, New Jersey 07645 (201) 391-1000



*Reg. T.M. N.V. Philips of Holland

The Portable PCP-90... direct-broadcast color from the backpack

**Digitally-controlled Norelco
"Minicam" sends a live
color-composite signal
by microwave or triax**

The Norelco PCP-90 "Minicam" is in a class by itself as the most mobile of field cameras. It is the go-anywhere, do-anything portable for broadcast quality color television. Controls can be beamed from as far away as 30 miles. Signal processing is done in the backpack. You can broadcast live, or take along a portable recorder and tape the action for playback. Operating wireless or on small, cost-reducing triax, the PCP-90 with its 1" Plumbicon* tubes brings total flexibility to color telecasting. Minicam is making the scene daily in an unprecedented variety of field, airborne and studio events. It's ready to make your scene now.

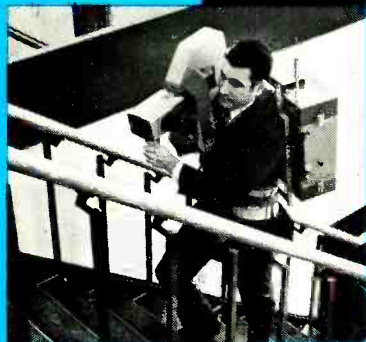
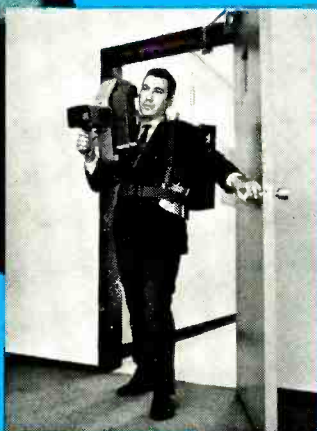

One Philips Parkway
Montvale, N.J. 07645 (201) 391-1000

*Reg. T.M. N.V. Philips of Holland



CATV system re-tubing plan

By Richard Regent*

While solid state components have invaded the electronics market at all levels, it will be some time before they completely replace our old friend the tube. Meanwhile, the tube will hold its own in CATV operations because it can withstand and recover from the effects of momentary voltage transients and surges, even high electric fields produced by nearby lightning hits. And, you don't solder in tubes!

What this means to a system serving more than a few thousand subscribers is that there will be countless hours spent in order to track down the numerous problems that can be caused by tubes. While the lifespan of tubes is a major complaint against their use, there is a system re-tubing plan that can cut into system maintenance time while assuring system reliability.

Our head end is scheduled for a tube check-up twice a year, and it gets a few unscheduled checks. Before making any checks, we make a careful quality critique of all faults on each channel, noting those that

*Teltron Cable TV, Milwaukee, Wisc.



Fig. 1 Checking signals on the line. Time would be wasted if one of the helpers stayed outside the truck. Only the team approach can shorten the checkout time at each amplifier.

could be tube problems. A re-tube time is selected that will affect the least number of subscribers. We then re-tube one channel at a time so that, again, the fewest number of subscribers will be affected.

Before the check-up begins, we ready a quality tube tester, a color TV receiver, and a field strength meter (FSM). The TV and FSM are set to the channel being checked in order to spot changes in the signal.

The TV receiver should be tuned with the color off, watching for sound bars, then backing off the fine tuning and adding the color. The sound is set for normal room listening. When changing tubes in the tuner, converter, and video IF/AGC, the meter can be set on the video carrier. For the sound IF/AFC it can be tuned to the sound carrier.

A tube that checks good in a tube tester may not work in a frequency critical circuit such as an oscillator or VHF circuit, something to remember while changing tubes.

Procedure

Here is a simple system path to follow in testing and changing tubes: 1. The power supply (if any tubes); 2. Tuner; 3. Converter; 4. IF Amplifier/AGC; 5. Sound IF/AFC; 6. Standby carrier oscillator; and 7. Other circuits in each receiver.

In a single channel strip amplifier, start with the power supply, then work from the RF input to the RF output. After selecting which tube in the equipment should be checked first, obtain a new one from stock and test it, including tapping the tube for the short test.

With one hand remove the tube from the equipment, with the other hand remove the new tube from the tube tester and put it into the equipment. This requires the tester to be near the equipment, not across the room. The filament will still be glowing when the new tube is inserted into the equipment resulting in minimum air time loss.

The tube just removed now goes into the tester. Should it be bad,

throw it away but keep record of its type number (for inventory purposes) and the section and channel number it came from (for reference to our channel critique problems).

Regulator tubes (OA2, OB2, and such) should not be changed this way, in fact they need not be changed if they are glowing steadily. As a double check a regulated voltage test point (usually provided) can be checked with a voltmeter.

Analyze the Results

While changing tubes, observe the TV for any trouble noted on our critique list or for the development of any new problems. By replacing one tube at a time, any problems arising can be corrected or localized immediately. The FSM should also be checked for any unusual changes in level that may not be noted on the TV. Incorrect levels on one channel will give the subscribers either snowy pictures on that channel (low signal level) or adjacent channel interference (high signal level). After changing tubes it will be necessary to check the fine tuning, set video, sound, and standby carrier levels, and make a close check of signal quality.

Trunk Line Amplifiers Re-Tube

Based on past experience, we had decided to change all amplifier tubes annually. Our system uses 60 trunk amplifiers, every third one has ALC. Each has 13 tubes for a total of 780 tubes (not including the ALC units). This is a very tedious, time consuming job if the work is attacked without some planning. Fortunately, all the tubes are the same, a 6EV5. The amplifiers are accessible (except for one) with a 6 foot ladder against the pole. The tubes can be changed by removing the front plate fastened by two thumb screws.

Planning and Preparation

To prepare for this year we ordered 700 6EV5 tubes well in advance of our re-tube schedule, enabling us to check all of them. Sixteen were found to be bad for some

reason such as gassy, weak, or shorted.

A log book was assembled with the location of each amplifier written at the top of the pages, one for each amplifier. Other equipment was readied, a small truck, a recently calibrated FSM with inverter (12-VDC/117VAC) power supply, a long test lead, a 6 foot ladder, and a few empty boxes. We had the equipment, now the plan.

A rough schedule was set up, allowing approximately 1/2 hour per amplifier, hopefully 18 amplifiers per day. Then a general consecutive route was established that would take the least number of miles. And a basic procedure to be followed at each amplifier was organized.

Procedure-Step by Step

With the truck stopped just before reaching the amplifier pole along the curb, and with the warning flashers on, the helper, who has unpacked 13 new tubes. He removes the ladder, positions it against the pole, adjusts its height to the box, and climbs up part way and braces open the box cover.

The driver, meanwhile, has been doing some work in the record book (entering the time of arrival) steps out and hands one end of the test lead to the helper. At this time he receives the setting of the slope control, and the value of the equalizer on the input of the amplifier from the helper. The helper goes up another step and attaches the test lead to the input test point, and begins removing the tube cover panel. The driver returns to the truck to enter these figures along with input values for 12 channels and pilot carrier in the record book.

The other end of the test lead is left attached to the FSM, which is positioned conveniently inside for ease of taking measurements.

The driver now shouts "output" and the helper changes the test lead to the output test point. Another set of readings for 12 channels and pilot is made "before retubing". Next he shouts "re-tube", while watching the highest frequency channel (CH 13) level on the FSM. The helper now begins changing tubes, one at a time, by lining up the keyway of the new tube with the right hand before inserting, removing the used tube with the left



Fig. 2 Here's the kind of mad scramble of tubes that results from an unplanned approach to re-tubing. Without planning, subscriber viewing time will be cut and engineering time multiplied.

hand, and then quickly inserting the new tube. Some tube type chain amplifiers continue to work even after a tube has failed or been removed, so this method reduces any interruption of signal, and also makes it possible to get a new tube from the right pocket, and deposit the used tube in the left pocket with one motion.

As each tube warms up, the FSM should show the same or possibly a higher reading. The FSM might be set at some midscale mark with the zero control for this part of the procedure. The driver must shout "next" as soon as the reading is satisfactory. When all tubes have been replaced, a set of output readings is taken "after re-tubing". During this time the helper replaces the tube cover panel, and may be cleaning out insects, or checking connections for corrosion and signs of damage.

As final check, the driver shouts "gain up" at which time the gain is briefly turned wide open for measurements on the low and high channels (CH 2 and CH 13). Then the helper is talked back to the correct gain setting after which he disconnects the test lead, closes the amplifier box, and comes down.

While the ladder is being secured

on the truck and the driver calculates the maximum gain for the amplifier and may briefly study the readings for possible trouble.

We have now taken 13 input readings, 13 output readings before re-tubing, 13 output readings after re-tubing, maximum gain on high and low channels, slope notation, equalizer value, date, time, temperature, and any other notes about physical damage or electrical trouble for each amplifier. That's about 45 bits of information for each amplifier which will be useful throughout the year for reference. All totaled that's 2,385 facts with 689 tubes changed!

Results

This procedure showed up seven bad tubes that were checked good on the tester, gave an amp by amp system evaluation, and was all done efficiently and accurately.

During the first day that this system was used, we attacked 21 amps, the second day 26, and the third day we finished 6 amps early in the morning. Thus, in three days system reliability was improved, maintenance time was cut, and valuable system records were updated.

Problems and Hints

Four of the amplifiers required carrying the FSM to the amplifier location. An AC extension cord plugged into a spare outlet in the amplifier box allowed putting the FSM on the ground for taking readings. Each year we have ordered a different brand of tube, which has helped in finding old tubes in amplifiers just by looking at them. The upper 10 percent of the used tubes after testing were saved for any unscheduled changes until next years' re-tubing.

Additional quality control can be achieved by taking a TV receiver along in the truck. But if you take one, it should be a quality color set. It all depends upon the control you want at each point. The records should show your problem circuits and units. At the head end it may mean relocation of some units, because tube life can be greatly affected by unit heat. And equally important, when more solid state equipment is used, heat will still be a consideration in system layout and maintenance.

Melcor professional audio components

For use where
continuous duty, high performance
operation is important

EQUALIZERS



GE-20



GME-20



AE-20

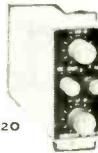

EQ-20



SME-20

Standard active lossless audio equalizers feature continuous or step equalization control, ultra low noise, bandpass filtering and many other features

3rd Generation AUDIO POWER AMPLIFIER



AB-49
Solid State
80 watt Monitor Amplifier

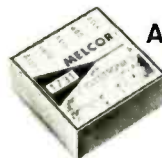

AUDIO OP AMPS MODELS 1731 & 1757

Industry's first and finest audio operational amplifiers.

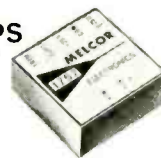

IMPAC CARDS. Integrated Modular Professional Audio Components utilizing the Melcor Audio Operational Amplifier



AM-20: Variable gain MIC pre-amplifier with input transformer

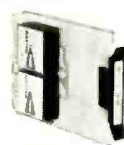

MM-20: Mixer Module for combining up to 20 inputs with up to 20 db gain



AM-220: Dual Microphone pre-amplifier with two complete microphone pre-amplifiers on single PC card



AL-27: +27dbm line amplifier with 600 ohm CT output transformer



AML-27: Low level microphone pre-amplifier, and high level line amplifier with +27 dbm output

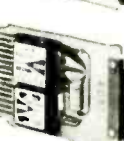

PM-37: Power Module with up to 11 watts peak audio power output into 8 ohms adjustable gain



ATP-20: NAB RIAA Tape-Phono preamp with high frequency trims



PM-40: Power Module with up to 16 watts peak audio power output into 16 ohms adjustable gain



MF-17

- TRANSFORMERS
- POWER BOOSTERS
- MOUNTING RACKS
- ASSOCIATED HARDWARE

CSM—CHANNEL SELECT MODULE

Reduces Console Wiring
Processes inputs and distributes them to mixing busses



IMPAC POWER SUPPLIES



PD-2: used in complex system applications for current requirements up to 2 amperes

PD-100: self-contained, highly regulated, high efficiency dual voltage source mounts in MF-17



EXCLUSIVE
FRANCHISE
DISTRIBUTORSHIPS
AVAILABLE

All components are competitively priced and have superb qualifications.
Write for details and technical assistance.

MELCOR ELECTRONICS CORPORATION

A Subsidiary of Newton Electronic Systems, Inc.

1750 NEW HIGHWAY, FARMINGDALE, NEW YORK 11735 ■ 516 / 694-5570 ■ TWX 510-224-6429

Circle Number 22 on Reader Reply Card



Eliminating heat damage on the bench

Fig. 1a At left, the plastic insulator shows the typical effect of excessive heat used to solder the braid and the inner conductor. **Fig. 1b**, at right, this cable was cooled before soldering at same heat, yet plastic was not affected.

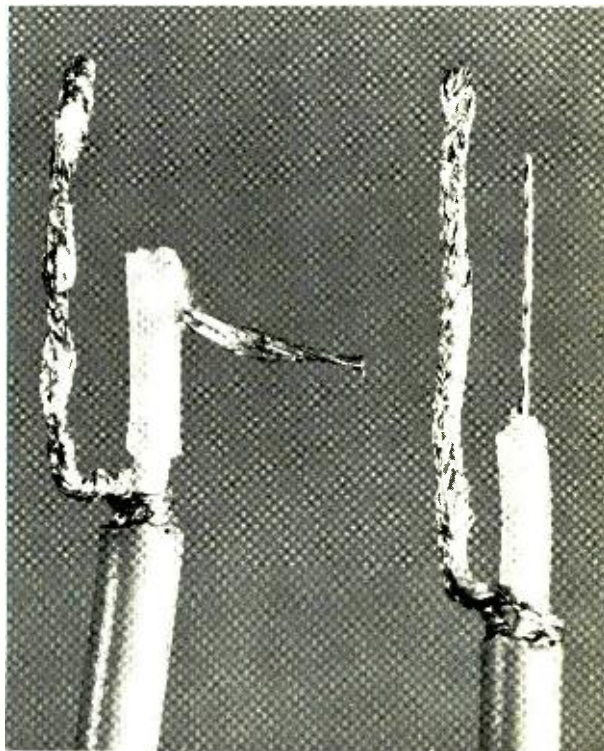

By Carl Babcock*

Anyone who has been around the transmitting gear of a commercial station knows something about the problem of heat and heat transfer. In some transmitters, inattention to heat can cause expensive maintenance costs. But heat problems that do not loom up in the face of the engineer in waves are less likely to be handled properly. And little by little, the maintenance costs add up to more than those expensive final tubes.

One way to combat heat is to use a coolant. Once you get in the habit of using it, you'll be a lot more confident about lasting repairs. Let's take a look at some maintenance procedures complemented by using a coolant.

All advice about installing solid state components by soldering stresses the use of a heat-sink to protect

the diode or transistor. This heat-sink can be the jaws of long-nose pliers or locking tweezers holding the lead of the transistor that is being soldered. In some locations, it is difficult to apply any kind of heat-sink, so it is better to frost the transistor with cooling spray just before soldering. Also, do not cut the leads of the transistor any shorter than demanded by the layout of the circuit.

In addition, circuit cooler is often extremely helpful in diagnosing intermittent circuit problems. This is particularly true of capacitors and solid state components, which respond very well to cooling techniques. For example, suppose a pre-amp or driver transistor is opening when the operating temperature in the rack reaches a critical point. With the extension tube on the can of coolant to confine the spray to a small area, spray each transistor in turn. When you reach the defective one, the volume or signal will return before you can shut off the cooling spray. It is a good idea to

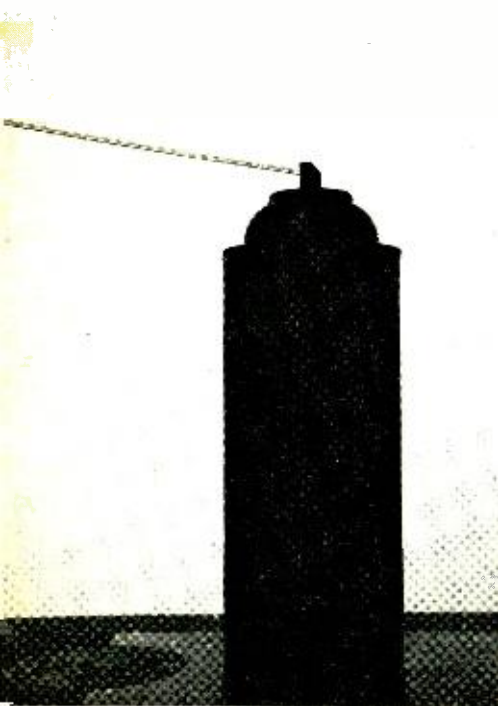

Fig. 2 Coolant can with an extension tube attached. This helps restrict the area cooled. This is especially useful when the coolant is used in trouble shooting.

*BE Technical Editor

crosscheck by holding a hot soldering iron close to the transistor until it cuts out, then spray it again to restore the signal.

Cable Connections

Some of the time-consuming and irritating problems in maintenance and repair around the station we actually create ourselves. Consider the simple task of soldering wires, coax and shielded cables. Nearly all plastic insulation is heat sensitive so it becomes softened when heated and assumes all kinds of wrong shapes after it cools. (See Figure 1A). Many are the possibilities for shorts and intermittent connections.

Cooling spray will greatly reduce soldering difficulties in coax cables. Before soldering, spray the plastic (which you want to protect from heat) with circuit-cooling spray until it is white with frost, then solder rapidly and skillfully. Figure 1B shows the undamaged plastic wire after tinning and soldering during coolant protection.

Board Soldering

What type of iron do you use for soldering? A 100 or 150 watt regular iron, or perhaps a two-heat soldering gun? Granted that a large hot iron is essential for soldering to a chassis ground or other heavy-duty work, but if that type of iron

is the only one you use, you are certain to cause yourself extra work.

Much of the wiring in station equipment is now on etched-copper boards (commonly and inaccurately called printed circuits). A soldering iron hotter than about 40 watts is almost certain to destroy the adhesive holding the copper wiring to the board, with the resultant lifting of the copper wiring from the board, as shown in Figure 2. An iron running too cool is not recommended either, for then it is necessary to keep the iron on the joint too long. This may cause board damage.

Optimum iron size seems to be between 24 and 30 watts, with 40 watts the upper limit. The iron tip should be well tinned and fully up to temperature, the joint should be made rapidly, then perhaps cooled with a short spray of circuit cooler.

Carbon Resistors

Strangely enough, carbon resistors can be damaged by the heat used to solder them into a circuit. Tests conducted in our laboratory showed a permanent increase of about 5 percent when a ½ watt composition carbon resistor was soldered. Another similar resistor suffered a permanent increase of about 12 percent was subjected to a series of only three heating and cooling cycles.

Affected more than this were the higher values in the megohm ranges. A 3.3M ohm ½ watt composition resistor measured 18 percent high after just one heating and cooling, and 47 percent high after three heating and cooling cycles. Higher wattage carbon resistors, wirewound, precision and glass-insulated film types were virtually unaffected in any permanent way by heating and cooling cycles.

Several lessons may be learned from this experience with resistors. One, where space permits, substitute higher-wattage carbon resistors for any ½ watt ones which are replaced. Another, is to frost the resistors for any ½ watt ones which are replaced. Another, is to frost the resistors, regardless of type or ratings, prior to soldering them into a circuit. And leave the length of the leads on replacement resistors as long as practical.

It is not advisable to substitute carbon resistors for wire-wound or film deposited types. They vary more in resistive values with heat, and the long-term dependability is much lower.

What about the precision resistors furnished in meter kits? The better quality precision resistors seem relatively unaffected by normal soldering temperatures. But why take a chance when it is so easy to cool them during soldering?



Fig. 3 On this board, the connecting wire shows the result of excessive heating while changing components. The wire comes away from the board, sometimes breaking off, but always making subsequent soldering difficult.

Maintenance Operations Report

In many small, and some large operations the engineer is looked upon as a necessary evil. Admittedly, this is not true of all, but some still insist upon believing such a fallacy.

This attitude may be partially explained by the fact that many engineers concentrate upon technical subjects, and to a certain extent ignore, or consider secondary in importance, the administrative duties of their position.

Some stations have an "operations-tree" which indicates the importance of a given position. In some cases, the engineer is dangerously near the bottom. You may not be able to change the "tree," but you can do something about the attitude.

Admitting that communication between departments is important is one thing; doing something about it is something else. A maintenance Operations Report can make a difference. In the report, include information on what the staff has been doing, especially if money has been saved or if a particular piece of equipment continues to monopolize engineering maintenance time.

In general, the items that should be included in such a report are those that would impress you if you were on the other side of the engineering-management fence.

Your antiquated disc cutter was written off years ago. It no longer serves a useful purpose for the station. You sell it for \$200 and re-invest the money in a used cartridge

machine which originally sold for \$650. A workable piece of equipment is gained at virtually no cost.

This example may be an extreme, but when you consider the principle involved, plus the fact that \$50 saved is important to some small stations, insertion becomes imperative. A subtle presentation is important, otherwise, it looks as if you are conducting a "paper propaganda campaign".

Close the report on the lighter side. Human interest happenings at the studio or transmitter create a manifold impression upon management. If possible, stick only to engineering personnel. This would be particularly significant if a copy of the report is to be sent to "absentee-ownership." It serves as a barometric indicator of station employee morale.

Normally, management does not have the time to listen to your weekly achievements; however, time will usually permit the scanning of a weekly report, submitted in a logical-nontechnical form.

"Yes, but what am I going to do with this thing after I prepare it?"

(Continued on page 50)

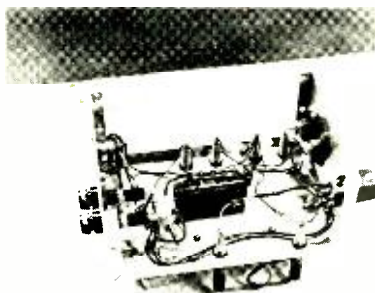
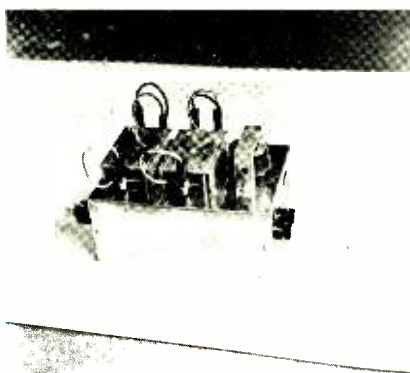
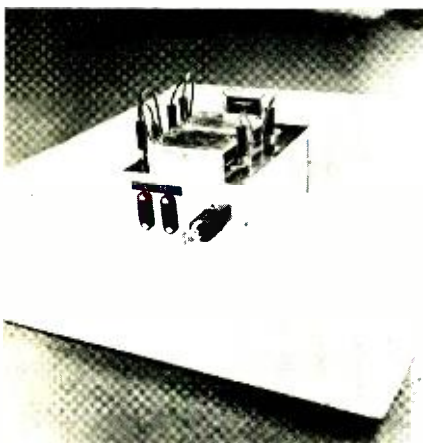

Triac Controls For Turntables

Here are some pictures of the remote start Triac units for turntable starts described in the February issue of this magazine (page 24).

Note that the unit built by WQAM does not use relays. Most relays with a high enough contact rating to give long life while switching an inductive motor load can cause a noise that is easily picked up by the studio mike. The reverse-polarity "spike" is generated when a relay opens and can cause troublesome noise in program circuits.

The pictures at the left should give some ideas on layout for Triacs control units. You may have other ideas, but the construction shown has served us quite well.

Fred Moore
WQAM
Miami Beach

Help celebrate the introduction of the Fernseh 3-tube color camera.

Buy one.

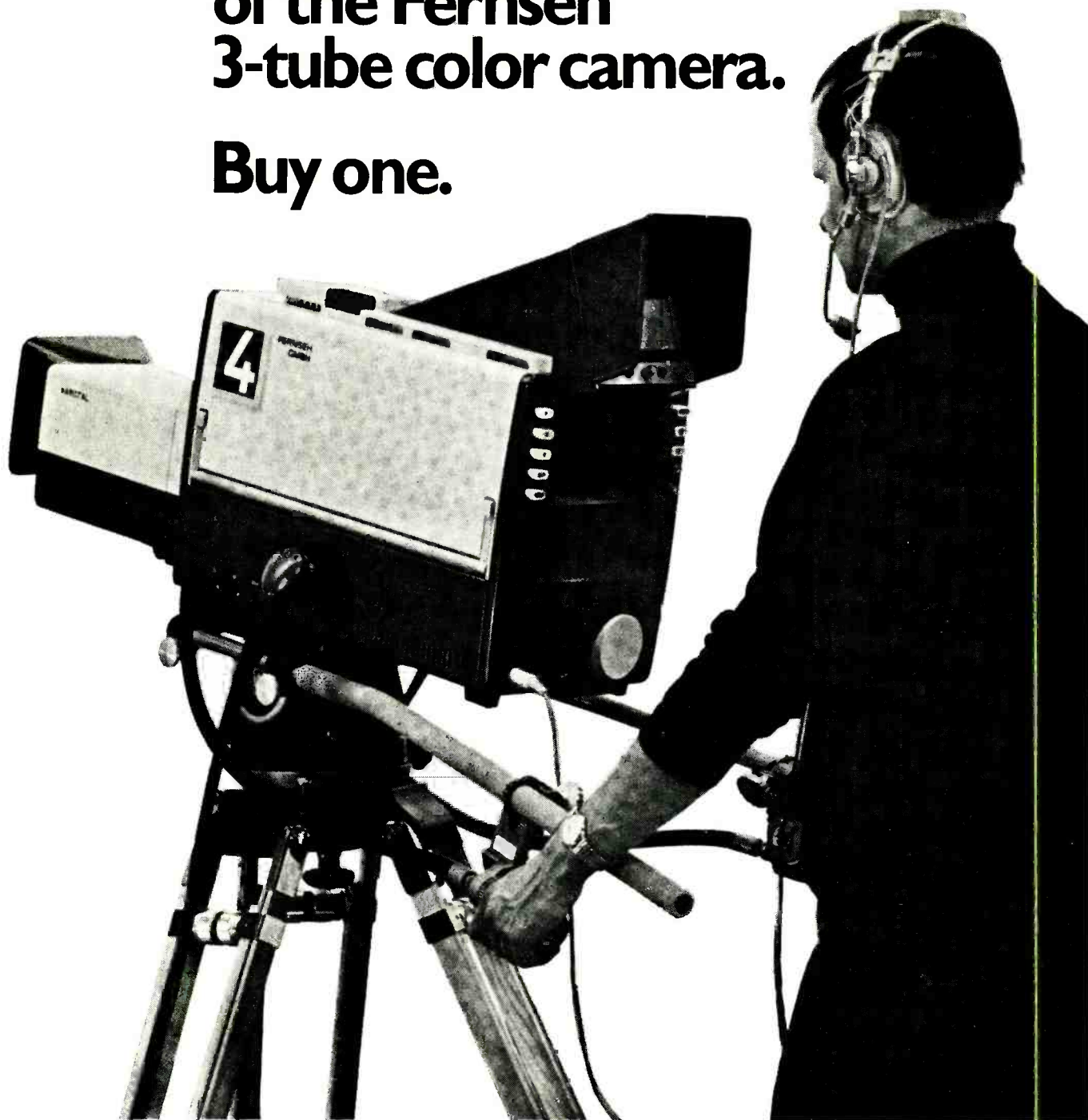

The Fernseh KCU 40 is the camera that revolutionized the European television production technique. It's the first lightweight model for both studio and field use with all the performance you'd expect from a 3-tube camera. High light sensitivity.

High signal-to-noise ratio. True color reproduction with optimum focus. A few of the more special features include 7mm or 11mm camera cables, and a tiltable viewer. We'll be in Booth 419 at the NAB Convention in April in

Circle Number 23 on Reader Reply Card

Chicago. See you there. Brochures available from Mr. Lothar Amanda, Robert Bosch Corporation, 2800 S. 25th Ave., Broadview, Ill. 60153.

 **FERNSEH**
Member of the Bosch Group

One of a series of brief discussions
by Electro-Voice engineers

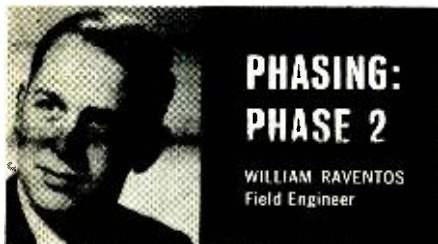

As Electro-Voice continues its field study of microphone and loudspeaker performance for sound reinforcement, we have reassessed several long-standing "rules" for installation of theater and stage sound.

One such rule insists that two loudspeakers covering the same audience area must be in phase. Viewed solely from the loudspeaker end, this is normally true. But, extending a concept developed earlier, we have found conditions where violation of the rule results in an increase of gain-before-feedback of up to 6 db.

In a large, typical auditorium with a center aisle, we installed two E-V Sentry II speakers wired out of phase. The speakers were located over the center of the proscenium and at least six feet apart (closer spacing will excessively reduce bass response). Careful location of the speakers created a dead area (about 6-10 db down) extending from the stage into the audience area, but restricted to the center aisle.

By locating the microphone in the center of this dead area on the stage, an increase in gain-before-feedback of as much as 10 db was achieved. Widening the speaker spacing narrows the width of the dead area but restores bass response lost as a result of the out of phase operation.

It must be emphasized that matched, flat transducers are presumed, and tests have been limited to acoustically symmetrical surroundings. The point of the exercise is to reduce speaker level on the stage in the vicinity of a fixed microphone. RE15 supercardioid microphones were used for the experiments.

The use of footlight microphones is common, but it has been noted that when located closer than 6" to the stage floor, response and directional characteristics may be seriously degraded. Experiments indicate that slight changes in location can add 3 to 6 db of gain. Raising the microphone provides essentially free-field operation, but another alternative may prove even more attractive.

Resting a cardioid microphone on a shock absorbing pad directly on the floor (taking care to keep the head of the microphone unobstructed) may provide higher gain-before-feedback than can be obtained by a free-standing microphone. The mechanics of this improvement are not yet fully understood, and additional experimentation in this and other similar areas is now going forward.

It is hoped that continued exploration will expand both the theoretical and practical knowledge needed to increase the sophistication of sound reinforcement design to meet new demands for higher quality and greater versatility of today's equipment.

For reprints of other discussions in this series,
or technical data on any E-V product, write:
ELECTRO-VOICE, INC., Dept. 403V
638 Cecil St., Buchanan, Michigan 49107



Circle Number 24 on Reader Reply Card

Engineer's Exchange

(Continued from page 48)

The station manager, general manager, or both, should get a copy. If your station is "absentee-owned" it would be proper to submit a copy of the report to him, or them, whichever is the case provided, of course, you clear it with management. It would be unwise to ignore the chain of command.

Clearance may be obtained by submitting a "sample" copy of the report to management, presented in such a way that there is no other choice but to accept it. Also, it works as a reminder of engineering's less obvious contributions.

Since physical distance prevents absentee-owners from being aware of the maintenance and operation of their physical properties, this "Maintenance-Operations Report" hits the mark, and could possibly become the means for closing the gap long existent between engineering and management-ownership.

Rewards could be numerous from such a report. When it comes time for equipment acquisition, just such

a report could swing the tide in your favor.

"I'm a busy man! How do you expect me to remember all of these items 'til the end of the week? I'm already doing most of the work around here," are adequately phrased resistances. Use a notebook or memo pad. This is a most effective means of retaining all details, which will be digested and shortened at the end of the week. A page for each of the major areas should prove sufficient for keeping tab on your weekly activity.

Communication of this type is quite successful at larger stations. It's mandatory at some. This procedure could be adopted easily by the small, or regional chief and become a beneficial asset if used properly. After all, it's about time for engineers to start "engineering."

Don Hiles
Station WCKY
Ft. Mitchell, Ky.

Radio Canada Moves Ahead On New Radio Center For The CBC

The CBC is putting together a huge broadcast complex that may well be the largest and most modern broadcasting center in the world. The construction is going on now in Montreal, and according to CBC officials, the complex should be finished in the fall of 1971.

When completed, the building will become the headquarters for CBC's French television and radio networks, local French language stations, and CBF-FM and CBFT-TV.

In addition, it will house the production facilities of the English networks' stations CBM and CBM-FM and CMBT-TV, as well as the headquarters and production facilities of the International Service (with programming for the Arctic region) and the Armed Forces Service.

Most of the heat for the building will be obtained from the electronic equipment, television studio lighting, and general studio and other office lighting by a heat recovery system.

To be known as The Place de Radio-Canada, the building will include seven color-equipped television studios and 26 radio studios.

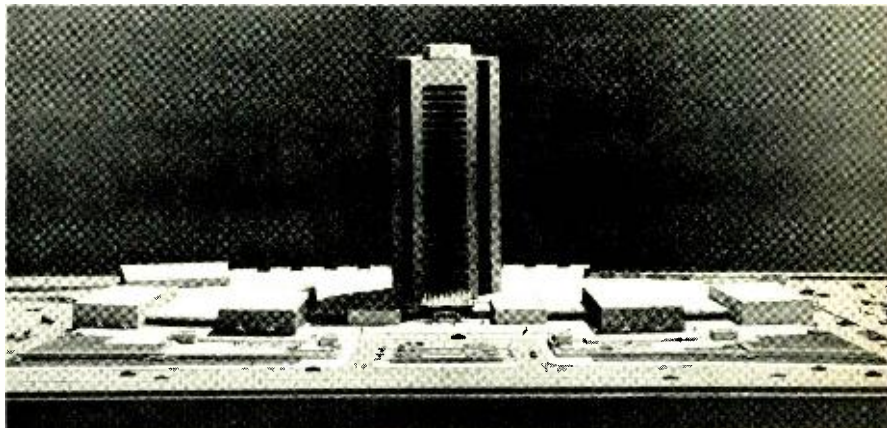

New Demand System For Satellite Traffic

A new demand assignment system designed to make more efficient use of communications satellites has been successfully demonstrated between the COMSAT-operated earth station at Etam, West Virginia, and the U. K. earth station at Goonhilly Downs, England. The system was developed by COMSAT Laboratories for the International Telecommunications Satellite Consortium (INTELSAT).

The demand-assigned, frequency-division multiple access system, called SPADE, was developed and tested by COMSAT Laboratories as part of INTELSAT's broad R&D program in satellite communications technology. In a frequency-division system, traffic between any two earth stations in the network is automatically switched into available frequencies. Such a system can bring about significant savings in satellite capacity by allowing occasional users to share a common bandwidth.

The features of the SPADE system include digital encoding of voice on a single channel per carrier; trans-encoding of voice on a single channel per carrier; transmission to the satellite in either burst or continuous mode; biorthogonally coded or uncoded phase-shift-key (PSK) transmission; self assignment of channels; and operation with standard manual or automatic international signalling and switching systems.

In the SPADE system, a request for a call from one point in the network to another is received at a transit center or exchange. The center relays the request to its Demand Assigned Signalling and Switching Subsystem (DASSS), which is in constant communication with all other centers in the network through a common routing channel (CRC). The DASSS equipment at the originating and receiving centers automatically selects an available carrier for the call. The DASSS monitors the length of each call and provides billing information.

Since each station in the SPADE network has its own DASSS equipment, there is not requirement for a central routing station. The CRC, which is a time-division multiple access channel, provides an engineering service circuit at no extra cost to the users of SPADE.

GET COMPLETE DETAILS

about the products
advertised or described
in this issue.

●
Use Free Inquiry Card.

Be sure to include your name and address

"Want a Good Job in Broadcasting?"



You'll Need a First Class FCC License."

Matt Stuczynski knows. He's the Senior Transmitter Operator of Radio Station WBOE. His story is typical of hundreds of men who have used Cleveland Institute Training as a springboard to success in Broadcasting. Here's what Matt says about Cleveland Institute:

"I give Cleveland Institute credit for my First Class FCC License. Even though I had only 6 weeks of high school algebra, CIE's AUTO-PROGRAMMED™ lessons really made electronics theory and fundamentals easy. After completing the CIE course, I took and passed the First Class Exam. I now have a good job in studio operation, transmitting, proof of performance, equipment servicing. Believe me, a Commercial FCC License is a 'must' for a career in Broadcasting."

If you want rapid advancement in broadcasting, the first step is a First Class FCC ticket with *your* name on it. And Cleveland Institute Home Study is a fast, economical way to get one. What's more, CIE backs their licensing programs with this money-back warranty:

"A CIE License Course will quickly prepare you for a First Class FCC License. If you complete the course but fail to pass the exam *on your first attempt*, CIE will refund all tuition."

With Cleveland Institute you get your First Class FCC License or your money back! Send coupon today for FREE book or write to Cleveland Institute of Electronics, 1776 E. 17th St., Dept. BE-63 Cleveland, Ohio 44114.

ENROLL UNDER NEW G.I. BILL

All CIE courses are available under the new G.I. Bill. If you served on active duty since January 31, 1955, or are in service now, check box in coupon for G.I. Bill information.

MAIL COUPON TODAY FOR FREE BOOK



CIE Cleveland Institute
of Electronics

1776 East 17th Street, Cleveland, Ohio 44114

Please send me your FREE book, "How To Get A Commercial FCC License."

Name _____ (please print)

Address _____

City _____ State _____ Zip _____

Occupation _____ Age _____

Veterans check here for GI Bill information

Accredited Member National Home Study Council
A Leader in Electronics Training . . . Since 1934

BE-63

Circle Number 25 on Reader Reply Card

NEW PRODUCTS

(Use circle number on reader service card for further information)

CCTV Tripods

Davis & Sanford, manufacturers of tripods and mounting equipment for industrial, photographic and TV use, announces a new line of gear driven tripods designated Models AG and BG.

These new models are versatile and specifically designed for educational TV and other CCTV installations. The tripods are made of aluminum and are ideal for heavy CCTV viewfinder cameras. They are portable and can be folded without removing the wheels.

Additional features of the new Davis & Sanford tripods are: gear driven elevator column (1 7/8" diameter) slides up and down on nylon sleeves. There is no metal-to-metal contact. This reduces friction and avoids wear.

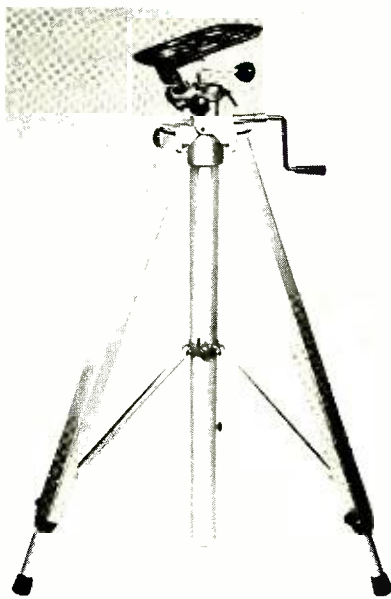

Also, self-locking gear mechanism keeps the center post in position regardless of the weight on the head of the tripod. The center post stays locked in position and cannot run down or escape.

Circle Number 61 on Reader Reply Card

Video Test Generators

A line of video test generators, featuring modular design, low cost and excellent quality of the test waveform, is now available from **TeleMation, Inc.**, according to Lyle O. Keys, president of the Salt Lake City-based manufacturing firm.

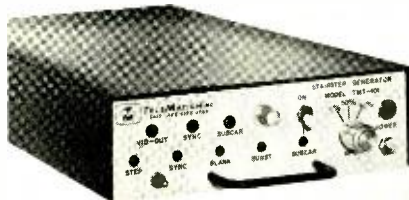

The TMT-100 Series Video Test Generators were designed for maximum flexibility and quality at the lowest possible cost. Each generator is self-contained, including its own power supply, so that units may be purchased separately. This modular design lets smaller TV systems build

a complete test outfit gradually, as budget permits. Each unit fits one-third space of a standard RF-551 rack frame.

Pulses can be supplied by a TSG-551 2:1 industrial sync generator or an external EIA sync generator to meet broadcast standards. Automatic output switching is possible by using the TeleMation all-electronic sequential video switcher/programmer. Modules include the sine²/window generator; stairstep generator, multiburst generator, color bar generator and 20T modulated pulse generator.

Circle Number 62 on Reader Reply Card

Videotape Recycling Unit

An automatic recycling unit and a remote control unit for its IVC-800 series helical-scan videotape recorders have been placed on the market by **International Video Corporation**.

The IVC-4008 recycler enables unattended replaying of recorded videotapes. A tape that has been programmed with a tone on the second audio track will recycle and play back repeatedly. By flicking a switch, the recycler permits one playback only then rewinds, stops and awaits a command to restart the tape.

Remote control of playback, record, stop, rewind and fast forward functions is possible with the IVC-4009 remote control unit. Available in rack mountable and table-top versions, the IVC-4009 comes with a 25-foot cable. Additional cable lengths are available as options.

Circle Number 63 on Reader Reply Card

Miniature Switch

A miniaturized 24-position rotary switch is now available from **Grayhill, Inc.** The diameter of this switch is 1.350" with a behind-panel dimension of .916" for a one-deck switch. Each additional deck adds approximately .333". This switch is available with one to twelve poles per deck and with as many as twelve decks in a switch. A total of twelve poles is the maximum per switch.

The totally-enclosed explosion-proof design features molded-in base terminals reducing contamination from the installation and operating environment. The switch also features the Grayhill detenting system



Tape Cartridges



All lengths and sizes stocked — fast service — highest quality

Series	Time at 7 1/2 ips	Unit Price
300	20 sec. (13')	\$ 2.00
300	40 sec. (25')	2.05
300	70 sec. (44')	2.10
300	100 sec. (63')	2.25
300	140 sec. (88')	2.35
300	3 1/2 min. (132')	2.50
300	5 1/2 min. (207')	2.80
300	8 1/2 min. (320')	3.70
300	10 1/2 min. (394')	3.90
300	empty cart.	1.60
600	16 min. (600')	6.25
600	empty cart.	2.80
1200	31 min. (1163')	10.45

Also: DL cartridges (for Spotmaster delay machines), bulk tape, tape-tags and other accessories.

ANY ASSORTMENT—NO MINIMUM ORDER

BROADCAST ELECTRONICS, INC.

A Filmways Company
8810 Brookville Rd., Silver Spring, Md. 20910

When Stanton engineers get together, they draw the line.

The frequency response curve of the new Stanton 681 Calibration Standard is virtually a straight line from 10-20,000 Hz.

That's a guarantee.

In addition, channel separation must be 35 dB or greater at 1,000 Hz. Output must be 0.8 mv/cm/sec minimum.

If a 681 doesn't match these specifications when first tested, it's meticulously adjusted until it does.

Each 681 includes hand-entered specifications that verify that your 681 matches the original laboratory standard in every respect.

Nothing less would meet the needs of the professional studio engineers who use Stanton cartridges as their ref-

erence to approve test pressings. They must hear exactly what has been cut into the grooves. No more. No less.

But you don't have to be a professional to hear the difference a Stanton 681 Calibration Standard will make, especially with the "Longhair" brush which provides the clean grooves so essential for clear reproduction. The improvement in performance is immediately audible, even to the unpracticed ear.

The 681 is completely new, from its slim-line configuration to the incredibly low-mass moving system. The 681A with conical stylus is \$55.00, the 681EE with elliptical stylus, \$60.00.

For free literature, write to Stanton Magnetics, Inc., Plainview, L. I., N. Y.

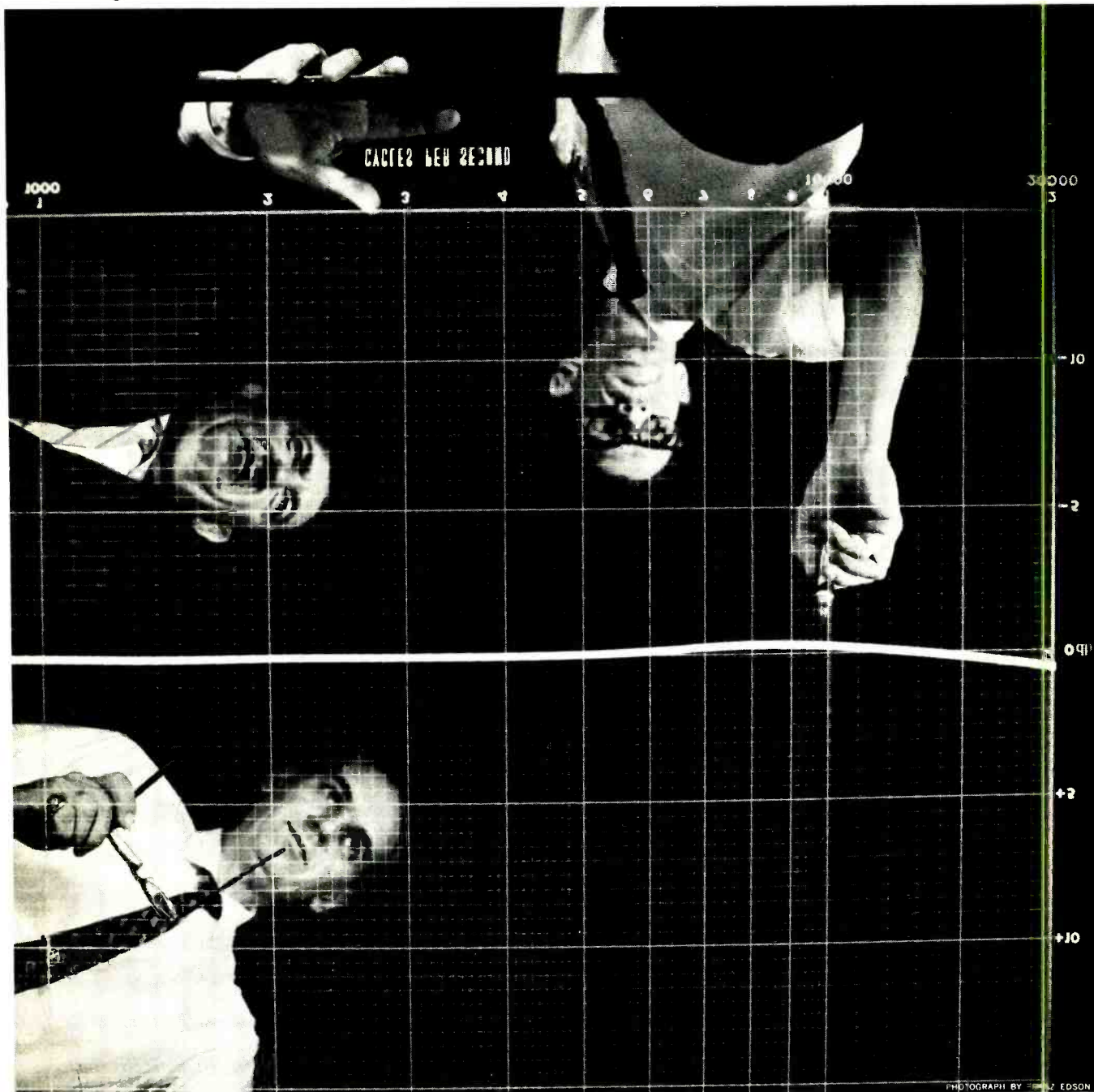

See us in Booth 215, West Exhibit Hall, NAB Show
Circle Number 26 on Reader Reply Card

Spotmaster

TP-1B Tape Cartridge Winder

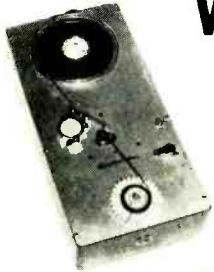

This rugged and dependable tape winder fills a need in every station using cartridge equipment. No longer is it necessary to restrict your cartridge operation to stock sizes, or to tie up your conventional tape equipment loading cartridges. The TP-1B handles all reel sizes (up to 3600' of 1 mil tape), winds new or old cartridges in any length. Available with or without Spotmaster tape timer, providing precise minute and second calibration for creating exact-length tapes. TP-1B is \$104.50, with Tape Timer \$129.50. Lubricated tape and empty cartridges are also available.

BROADCAST ELECTRONICS, INC.

A Filmways Company

8810 Brookville Rd., Silver Spring, Md. 20910

which provides positive and accurate positioning.

This new 24-position Series 53M15 switch is conservatively rated at ¼ amp., 115 VAC, resistive load, and ¼ amp., 6-28 VDC, resistive load.

Circle Number 64 on Reader Reply Card

CATV Head-End Demodulator

Availability of the first off-the-air demodulator designed specifically for cable TV headend systems has just been announced by **DYNAIR Electronics, Inc.**

Called the RX-4B DYNA-TUNE, the demodulator is completely solid-state and features a field-effect transistor front end with

liberal use of the latest integrated circuits to ensure performance and reliability commensurate with today's color television requirements. The standard unit is supplied with a plug-in variable tuner which will receive any standard VHF or UHF television channel. An optional tuner module is available for crystal-controlled operation on a single pre-selected channel.

Utilizing completely new filtering and signal-restoration techniques, the DYNA-TUNE provides superior adjacent-channel color performance in either microwave-fed or demodmod cable television systems. These important developments allow



the DYNA-TUNE to actually improve the color signal in many critical areas over that produced by the broadcast RF transmission system.

Circle Number 65 on Reader Reply Card

High Speed Tape Duplication

A master duplicator system for high speed duplication of both stereo cassettes and cartridges has been placed on the market by **Ampex Corporation**, it was announced by A. A. Sroka, vice president-general manager, professional audio products division.

The new system consists of the Model BLM-200 bin-loop reproducer and the Model 3400 slave assembly. It is designed for use by tape duplication companies producing stereo cartridges and cassettes for consumer use.

The Model BLM-200 reproducer, used with the slave assembly, produces four-track cassette copies or eight-track cartridge copies from a master tape. The cassette version can be easily field converted for cartridge duplication by adding an electronic card rack and assemblies and a bias amplifier assembly. The cartridge version can produce cas-

PROTECT YOUR SOUND REPUTATION

VTR Manufactured and Reconditioned by TABER

Nationally-recognized recorder head manufacturing and reconditioning experts.

- Heads **manufactured** or **reconditioned** under controlled laboratory conditions.
- Whichever you order, heads guaranteed to meet, or exceed, equipment manufacturer's specifications.
- Modern precision machine shop, and sophisticated laboratory installations insure highest quality newly-manufactured or reconditioned heads.
- Free loaner assemblies available on request.
- Cost: \$310.00 for four (4) new heads installed, or \$100.00 for four (4) reconditioned heads.



Taber's sophisticated quality control test insures total frequency response and uninterrupted sound playback. Maintain the high quality audio that your equipment was engineered to produce.

Call or write: **TABER** MANUFACTURING AND ENGINEERING COMPANY

OAKLAND INTERNATIONAL AIRPORT
P. O. BOX 2365 • OAKLAND, CALIFORNIA 94614
PHONE: (415) 635-3832 • SHIPPING ADDRESS: 2081 EDISON AVE. • SAN LEANDRO, CA 94577

TABER IS THE NATIONAL
DISTRIBUTOR OF
STL TEST TAPES

Circle Number 27 on Reader Reply Card

England's ITA took our integral cavity klystrons.

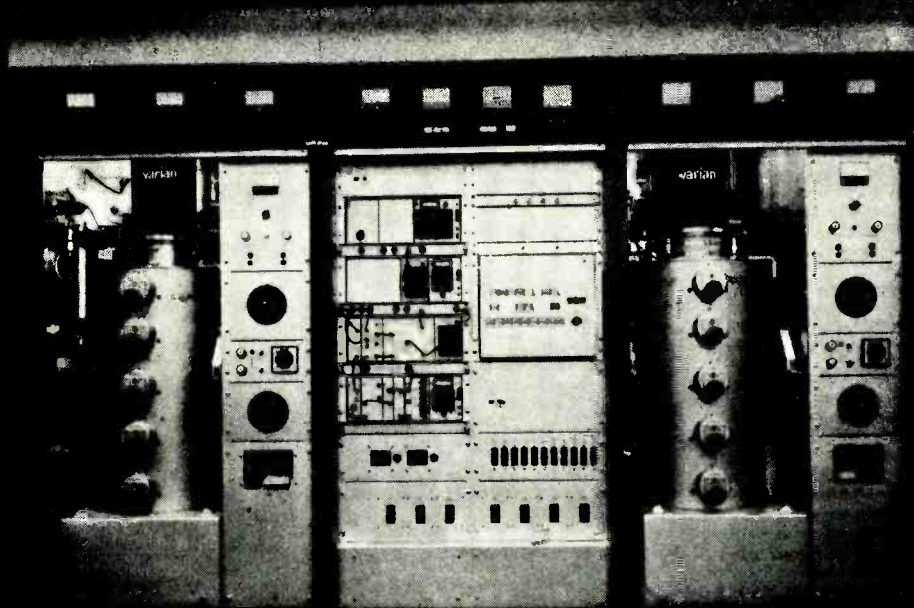

And left them alone.

The extra reliability essential for unattended transmitter operation. That's what the Independent Television Authority (London) saw in Varian's high gain 5-cavity klystrons.

That's why our integral cavity tubes were selected to power ITA's twenty-four transmitters directly from solid state drivers. (Since launching its pioneer UHF color telecasting throughout the UK last November, ITA's network has grown to twelve stations.)

Not that Varian was any stranger to the business. Since building the first UHF TV klystron in 1955, Varian has made more of them—over 1500 in all—than anybody else, anywhere. In doing so, our product has provided more than 1½ million operating hours for over 90% of all UHF TV

stations in the United States. We've backed it with an exclusive 24-hour service capability anywhere in the U.S., and service availability throughout the free world.

And with the strongest, longest guarantee in the business.

The Varian integral cavity klystron makes sense anytime. But especially where it has to go it alone. Why not get what you need in UHF TV klystrons from more than 30 Electron Tube and Device Group Sales Offices around the world? Or talk to the Palo Alto Tube Division, 611 Hansen Way, Palo Alto, California 94303. In Great Britain, contact EMI-Varian, Ltd., Surrey, England.



COMPACT VAN & STATION HEATER, C-300



MODEL C300
Forced Air Heater

AVAILABLE FROM 12VDC to 230VAC VOLTAGE RANGES & IN 300W to 1500 WATT RANGES.

Specifically designed to fit into mobile vans & in broadcast station areas where floor or storage space is at a premium.

Cast Aluminum heating elements, & 16 ga. steel outer case built for rugged field performance.

Options allow a wide range of applications.

Write for our full line of electric heating equipment.

VALAD ELECTRIC HEATING CO.

71 Courtlandt St., Tarrytown, N. Y. 10591
914-631-4927

Circle Number 29 on Reader Reply Card

SUPER-TORQUE HYSTERESIS SYNCHRONOUS A LONG WORD WITH A GIGANTIC MEANING

SUPER-TORQUE Hysteresis Synchronous is the new standard in all TAPECASTER cartridge machines. Its function is to provide you with a cartridge machine to last an estimated three times longer than competitive units. It is only one of many good reasons for purchasing a TAPECASTER cartridge machine. Write today and find out why TAPECASTER is No. 1.



TAPECASTER[®] TCM, INC.
Box 662 — 12326 Wilkins Avenue, Rockville, Maryland 20851
Phone: 942-6666 Area code 301



MODEL 700-RP

Circle Number 30 on Reader Reply Card



THIS FREE BOOKLET WILL COST YOU MONEY.

It tells you why colleges need financial help.

It tells you that tuitions pay only 1/3 the cost of a college education. That somebody has to make up the other 2/3.

It tells you why your company, which benefits from colleges— if not this graduation, then the next one, or the one after that—should pay its share.

We're not only asking you, we're asking everyone.

For your free copy of "How to Aid Education," write to: Council for Financial Aid to Education, 6 E. 45th St., New York, N.Y. 10017.

DOES YOUR COMPANY HAVE AN AID-TO-EDUCATION PROGRAM?



advertising contributed for the public good



sette copies without rewiring for cables. Slave units also may be modified to record reel-to-reel tape copies.

Use of the bin-loop technique greatly improves efficiency in audio tape duplication because no time is lost in rewinding the master tape, according to Sroka. Also, tape waste is reduced in the bin-loop unit, resulting in user economies, Sroka said.

In the bin-loop concept, a single continuous loop of magnetic tape is pulled by the transport evenly across the reproduce heads. Program material is ready to start over from the beginning immediately after a program is finished, and there are no reels to handle or rewind. Previous duplicating systems used reel-to-reel technique, in which tape is moved across the heads from one reel and wound onto a second reel.

Circle Number 66 on Reader Reply Card

Color Zoom Lens

Tele-Cine Inc. has introduced the new "Schneider-System" TV-10 zoom lens. The "Schneider-System" is a 11.2 to 1, f/2.1 lens designed for use on broadcast color cameras. New features are: complete mounting interchangeability between different models and manufacturers cameras. Servo can be added to the basic manual lens at any time by the simple addition of the plug-in

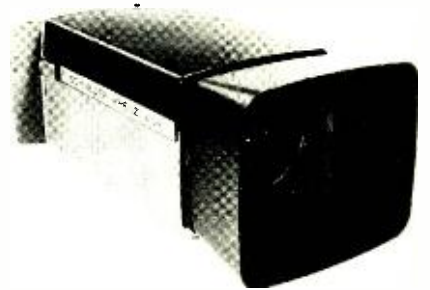

"Servomodule". The 11.2 to 1 (18 to 200mm) zoom range will focus down to 28 inches without adaptors. Full screen close-ups are possible on subject sizes as small as 0.3" x 0.4". Operational back focus control and instant change range extenders (1.5X, 2.0X, 2.5X, 3.0X) and a four speed manual zoom control is also available with this system.

Circle Number 67 on Reader Reply Card

Directional Coupler

Vikoa's Underground miniature Stripline Directional Coupler is the latest in a series of printed circuit, stripline directional taps. Their

small physical size and solid Vik-O-Processed zinc die cast case and plate permits mounting in the smallest standard pedestal (4").

The top of each housing is color-coded for rapid value identification. Tilted outputs automatically compensate for more than 150' of drop cable. Quality subscriber pictures are assured by tap to tap isolation of more than 20 dB with a tap match of 1.22:1. Frequency response has been extended to beyond 250 MHz with only slight change of performance characteristics beyond 230 MHz.

Circle Number 68 on Reader Reply Card

Studio Slide Projection System

A complete low cost slide projection system, designed to project large background images behind television newscasters, sports announcers, etc., has been announced by Spindler & Sauppe Inc. The system works equally well in b-w or color studios, and is offered as a package by the manufacturer.

Heart of the system is the new super-high-gain "Ultralight Screen, which is combined with S&S's re-



cently introduced Dynamic Dissolve System. The unit is modeled after the projection system already in daily use at WSAU-Television, Wausau, Wisconsin. It brings large screen background projection within easy reach of broadcast, ETV CCTV, and cable television facilities which previously found rear projection and beam splitting sys-

GIVE HELP, LOVE, HOPE

THE UNITED WAY

✓ Your fair share gift works many wonders

 THE UNITED WAY 

28.4 million families benefit from child care, family service, youth guidance, health programs, disaster relief and services for the Armed Forces through 31,500 United Way agencies.

new LSC VEDETTE

16mm and 35mm PROFESSIONAL PROJECTORS

for fast, safe, high speed viewing and inspection of motion picture film

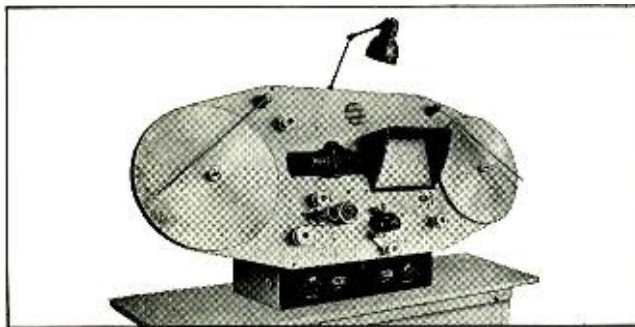

- The ideal machine for film quality control, timing and correction, and release print inspection. Handles negatives, fine grains and prints.
- Visual inspection of both picture and optical sound track. Solid state amplifier for simultaneous monitoring of picture and sound.
- Efficient revolving prism shutter and sharp optics produce bright, clear images without overheating film.

- Smooth, gentle film handling at up to 400 ft./min., without intermittent movement of usual claw or Geneva gear drive. Stable, positive focus. 2,000 foot film capacity.

Write for LSC Vedette literature or request a "no obligation" demonstration.



LIPSNER-SMITH CORPORATION

7334 No. Clark St., Chicago, Ill. 60626 • 312-338-3040

CF₂ ULTRASONIC CLEANER

for MOTION PICTURE FILM • MICROFILM • MAGNETIC TAPE

Presented The Academy of Motion Pictures Arts and Sciences Award of Merit for Outstanding Technical Achievement.

Ultrasonic energy is the most effective and economical way to completely clean motion picture film, microfilm and tape without mechanical scrubbing and wiping. Ultrasonic energy performs the entire cleaning operation.

- Restores clarity and sound to maximum quality.
- Enhances the entertainment value of motion picture film and improves commercials.
- Assures static free film with color balance undisturbed.
- Cuts projector maintenance costs . . . no dirt or dust carried into gates and orifices . . . less breakdowns.
- Completely automatic . . . requires only loading and unloading.

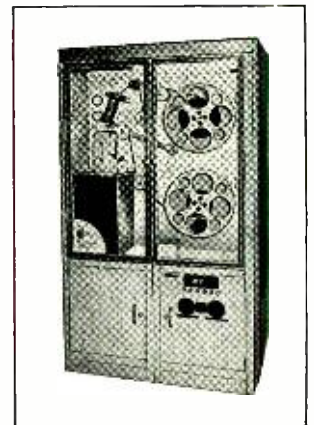

- Costs only 1/20 of a penny per running foot to operate.
- Used by every major motion picture lab in the world.

Descriptive brochure sent on request

Circle Number 32 on Reader Reply Card

a

sound investment

for the Broadcast Industry...

REMOTE CONTROL MIKE REELS



Specially designed reels. Remote control by drum, push button or station relay. 115 volt reversible chain driven motor. 2 to 8 conductor slip rings available. 150' cable capacity.

POWER CABLE REELS

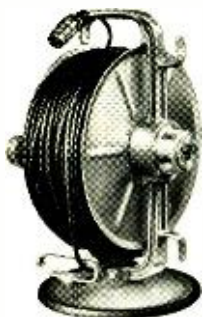

I.E.R.'s level wind Port-O-Reels protect and prevent mike or extension cord break-downs. Up to 400' cable capacity.

Write for Specification Data on the most complete line of Remote Control Reels and Port-O-Reels.



**INDUSTRIAL
ELECTRIC
REELS
INCORPORATED**
1503 CHICAGO ST.
OMAHA, NEBRASKA 68102

Circle Number 33 on Reader Reply Card

tems too space consuming or prohibitively expensive.

The Dynamic Dissolve System in the package enables TV directors to use multi-speed dissolves, instantaneous cuts, and slow-to-fast fades in their slide presentations. All these functions are remoted to the TV control console.

Circle Number 69 on Reader Reply Card

Syn Generator

A new ultra-stable broadcast sync generator has been introduced by **Cohu Electronics, Inc.**, San Diego, California.

Designed with the latest in integrated circuit technology, the 2600 Series Broadcast Sync Generator has

unique circuits that assure jitter-free sync performance in standard and colorlock modes. Digital logic circuits produce leading edges that serve as the timing of all pulses developed in the system. Jitter-free sync comes from sequential division of the base frequency from a temperature compensated crystal oscillator.

To prevent jitter between separately locked burst and sync, the master oscillator is locked to the incoming burst and the sync is phased into coincidence. Automatic phase locking is returned to the sync gen when switching from network or remote telecasting or in the event of a signal failure.

Switcher

Increased in the target of a new series of television production switches being introduced by **Central Dynamics Ltd.**

Series 800 switchers offer 15 inputs, vertical interval switching on all busses, mixing, wiping, keying, mixing to wipes and keys, color mattes, and automatic sync and

burst control. Options include chroma keyer and wipe positioner.

One standard system, the VSP 860 is shown here. Facilities exceed those of many larger systems, yet the price is between 30 percent and 50 percent less. Technical specs equal or exceed Central Dynamics' earlier designs.

Circle Number 71 on Reader Reply Card

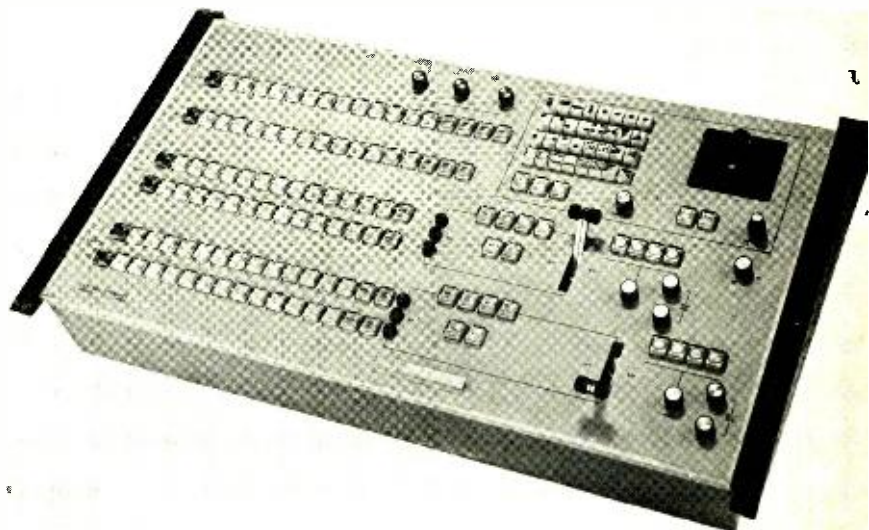

IF YOUR LINES ARE COAXIAL YOUR RELAYS SHOULD BE MATRIX!

Matrix offers a wide range of relay configurations in easy to use modular form.

- * Video Relay Modules
- * Video Distribution Systems
- * R.F. and I.F. Switching

with excellent pulse response, low VSWR and high isolation (106Db to 100 MHz)

MATRIX 
SYSTEMS CORPORATION
9201 GAZETTE ST. • CHATSWORTH, CALIF. 91311
(213) 882-2008

7000 SERIES

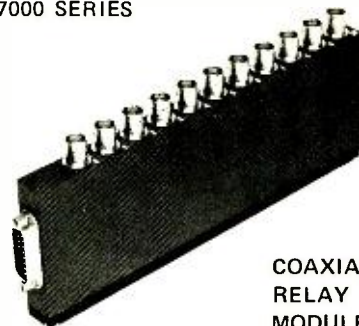

COAXIAL
RELAY
MODULE

Circle Number 34 on Reader Reply Card

BROADCAST ENGINEERING

Circle Number 150 on Reader Reply Card

Free 90-day trial† of the new RCA STARMAKER MICROPHONES

Starmaker 115. A slim easy-to-hold omnidirectional dynamic for high-quality voice and music recording. Has exceptionally wide response for its small diameter. Has on-off switch. \$44.00*

Starmaker 96. Extremely versatile unidirectional dynamic. 3-position Bass Roll-Off switch reduces rumble and unwanted background noise; also reduces bass in "close work" applications. \$50.00*

Starmaker 97. Unidirectional dynamic for soloists or groups in which each individual requires a separate microphone. Has on-off switch. \$40.00*

Starmaker 103. Finished in real gold... a great "personal" unidirectional dynamic for the discriminating artist. Features local's "close-up" sound. Low-frequency response for "active" performers. \$64.00*

Starmaker 111. Omnidirectional dynamic with excellent rejection capability for high-end and extremely high performance-coastal radio applications. High performance-coastal radio applications. \$54.00*

Starmaker 98. Great professional omnidirectional dynamic for music and voice, especially where two or more performers use the same microphone. With on-off switch. \$40.00*

Starmaker 110. Styled in real gold... ideal for close vocal work and out even in groups. With on-off switch. Unidirectional dynamic. \$54.00*

Starmaker 106. Excellent "on-location" microphone applications in high-noise ambients. Uses two cartridges and two transformers. \$44.00*



There is one sure way to select the microphone that's best for your station. Try it before you buy it. Try any of these new RCA Starmakers for 90 days... at no cost or obligation! RCA has advanced the state of the art in microphone design—to enhance the performing art! But don't take our word for it. Get a Starmaker and let your own ears be the judge!

----- Hear it and you'll believe it! Call your RCA distributor or mail this coupon, -----
 Microphone Marketing, Sect. D115MC, Fifth Street, Harrison, New Jersey 07029
 Please have an RCA Distributor send me the Starmaker microphone(s) circled below
 on a free 90-day trial offer. At my option, I may return or buy my selection(s)
 within the 90-day period.

96 _____ 97 _____ 98 _____
 Name _____ 103 _____ 106 _____
 Title _____ 109 _____ 110 _____
 Station _____ 111 _____ 112 _____
 Address _____
 City _____ State _____ Zip _____

† For U.S. AM, FM, TV AND CATV stations only.
 * Optional Professional Price. Includes adjustable holder, 20-ft. balanced line, dual Hi Z/Lo Z connector, and attaché case.

All pulse widths—except vertical drive and sync, and equalizing—are adjustable with no interaction of controls. With a precision, built-in color standard, the new sync gen generates pulses required for color or monochrome broadcasting at 525 lines/frame, 60Hz with 2:1 interlace.

The basic system includes three modular plug-in boards for sync, output, and power. A colorlock module, available as an option, locks the sync gen to an external NTSC composite video signal or a monochrome composite video signal.

Circle Number 70 on Reader Reply Card

Eico Electronic Instrument Company has a new solid-state VTVM, the Model 240. While suited for servicing vacuum tube equipment, the 240 is especially applicable to semiconductor circuit testing.

The low 1-volt DC full scale will accurately read voltages as low as .02 volts, and it will read well down to .01 volt. Direct readings may be made to 1000 volts DC and with a HVP probe can be extended to 30,000 volts.

The meter also has seven AC and seven ohm ranges on a wide easy to read scale. A low voltage is used in the ohmmeter section to avoid

accidental damage to semiconductors under test. However, this voltage is high enough for required use in testing both diodes and transistors.

While this meter uses close tolerance resistors, **BE** recommends that a coolant be used on all resistors before soldering in this and any other test instrument. Soldering iron heating changes the resistance, and this obviously will affect the accuracy of readings.

Circle Number 71 on Reader Reply Card

Film Processor

A new 16mm color positive has been announced by the **Filmline Corp.**, Milford, Conn.

Designated the DC-240, this all new film processor is a professional caliber machine built for use by film labs. It was specifically designed to meet the industry's exacting requirements for speed, quality and continuous trouble-free operation.

Following are some of the exclusive features of Filmline's DC-240: processed color positive emulsions at 240 FPM; heavy gauge, type 316 stainless steel construction; equipped with famous Filmline demand friction drive; variable speed control and function; feed-in and take-up elevators for continuous processing; vacuum squeegee system; impingement dry box for safe even drying; torque motor take-up units for smooth operation; and a heavy duty recirculation and turbulence system.

Circle Number 72 on Reader Reply Card

Coaxial Transfer Switches

Andrew Corporation offers the broadcast industry three basic coaxial transfer switches — one each in the 1-5/8", 3-1/8" and 6-1/8" sizes.

AM, FM, and TV stations can reroute RF power quickly and reliably from a central control point, transferring transmitters, filters, diplexers, loads and antennas with a reduced loss of air time. Andrew transfer switches provide flexibility where switching requirements are complicated.

Types 6730C, 6740A and 6750 switches are four port transfer (DPDT) types and may be used as three port (SPDT), mounted in any position, either in a multiple panel array or individually. In the event of AC power failure, these motor driven switches can be cycled manually.

Circle Number 73 on Reader Reply Card

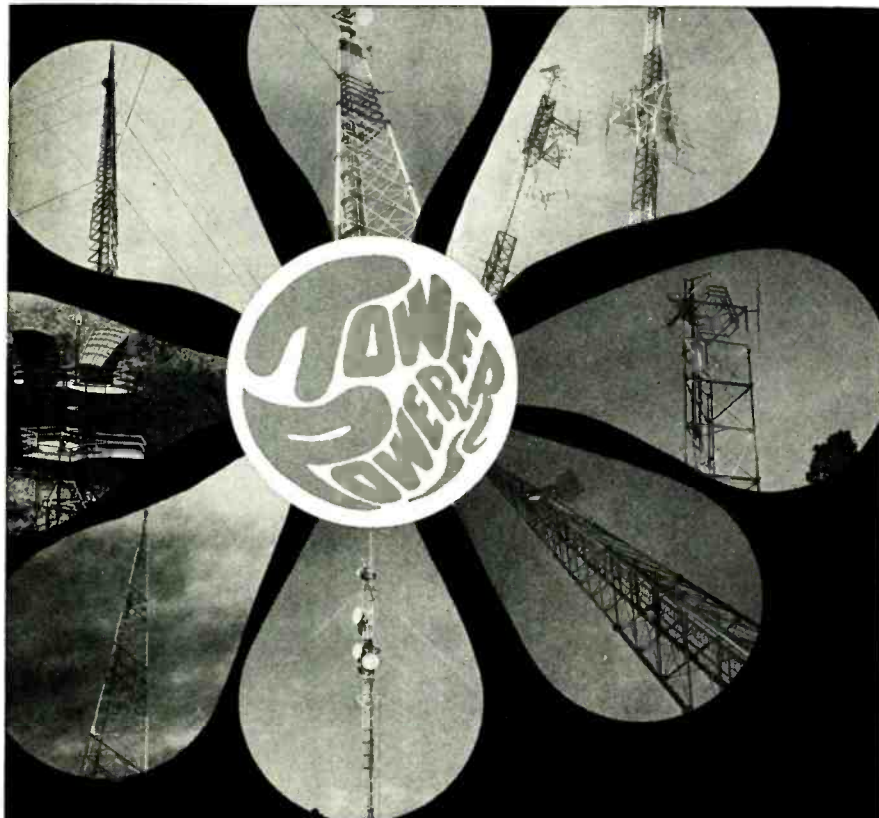

We believe in STAINLESS towers . . . the ones we-build for you. Whether it's a tower for Radio, TV, CATV, ETV or Microwave, it will be computer designed for Tower Power . . . long-life dependability, low maintenance. And that's what we're famous for—fast service too, even if it's like the tower we built that's higher than the Empire State Building!

Let's sit down and go over your tower problems sometime soon. All it takes is a phone call or letter.



Stainless, inc.

North Wales, Pennsylvania 19454
Phone area code 215/699-4871

In Canada: Walcan Ltd., Carleton Place, Ontario

Circle Number 35 on Reader Reply Card

TECHNICAL DATA

For further information, circle data identification number on reader service card

100. AMPEX—A new solid state video switcher system, the Ampex VS600, used in television production and control facilities for broadcasting and program recording, is described in a data sheet. A list of specifications, and a diagram of the VS600 control panel are included on the literature.

101. BOURNS, INC.—Twenty-four standard models and 96 variations of the new B-Line series of single-turn precision potentiometers are described in detail in a new six-page brochure. The B-Line series comes in $\frac{7}{8}$ ", $1\frac{1}{16}$ " and 2" diameters, servo or bushing mount, in a choice of four elements—cermet for exceptional stability, conductive plastic for rotational life, Bi-Film for the best of both, and wirewound for noise-free performance. A standardized thin profile offers a new concept in interchangeability. Blackboxing—designing for a specific package size—can be accomplished without concern for the type of potentiometric element used.

102. CHRONO-LOG CORP.—A new all-day TV automation switching control system is described in a four-page color bulletin. The system, called the Chrono-log CRT STEP System, displays upcoming events on a standard TV monitor and is expandable from station break automation to all-day automation. The bulletin includes an illustrated block diagram, an unretouched photograph of the display and detailed technical specifications.

103. DIELECTRIC COMMUNICATIONS—A 32-page application manual 70-6, covering the full line of DRY-PAK pressurization equipment and accessories is now available. The booklet illustrates and describes Dielectric's compressor-dehydrators for RF transmission line and air dryers for telephone cable pressurization, as well as complete accessories including manifolds, alarm units, meter panels, and hardware fittings. It also covers engineering data for the planning and application of complete pressurization systems.

104. ELECTRO-MECHANISMS—A 24-page design guide intended to show packaging and cable designers how to use flexible etched cable in their component and system designs is now available. The design guide shows many graphic examples of good high-density low-volume interconnection and cable designs. Of interest to managerial personnel is the substantial cost reduction that can be achieved using Electro-Mechanism flexible etched cable technology.

105. FAIRCHILD—A 32-page brochure describing integrated circuits in the 5400 and 7400 TTL series is now available. Descriptions of the circuits include information about electrical characteristics, switching characteristics, logic diagrams, and pin configurations. The brochure is illustrated, with nine



MODEL 700-P

YOU ARE LOOKING AT THE BEST REASON TO BUY A TAPECASTER®

However, looks don't tell everything... only TIME will prove the TAPECASTER CARTRIDGE MACHINE. Exclusive in all TAPECASTER CARTRIDGE MACHINES is the new SUPER-TORQUE hysteresis synchronous motor plus a design that promises far better performance with years of trouble-free operation. LOOK THEN SHOP for the best machine, THE TAPECASTER.



TAPECASTER TCM, INC.
Box 662 — 12326 Wilkins Avenue, Rockville, Maryland 20851
Phone: 942-6666 Area code 301

Circle Number 36 on Reader Reply Card

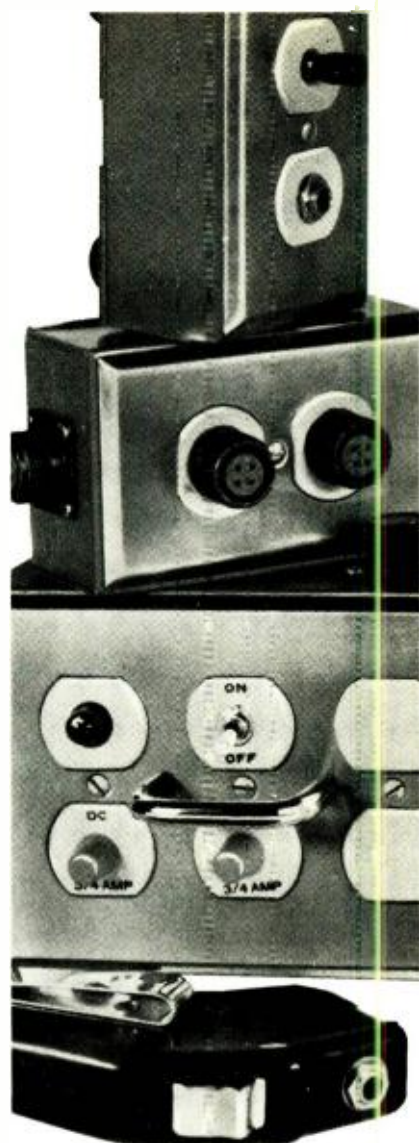

creative modules

Many separate intercom modules—including power supplies, headset stations, amplifiers and a belt station with an extension cord—which are standard items, can be used in various combinations to set up a customized inter-communication system to fit your need. These modules are designed to integrate with Wiremold and standard electrical outlet boxes.

Write for complete information and the name of your nearest dealer.

David Clark COMPANY
INCORPORATED

360 Franklin St., Worcester, Mass. 01604
WEST COAST OFFICE: 1696 Centerville, Suite 2, Inglewood, Calif. 90302

Circle Number 37 on Reader Reply Card

full pages devoted to diagrams and schematic drawings showing test circuits and voltage waveforms. Additional illustrations show packaging dimensions and provide parameter measurement information.

106. HEWLETT-PACKARD—A number of typical wave analyzer applications are illustrated in a 20-page booklet now available. Titled '3590A Wave Analyzer Recordings,' the booklet shows instrument connections on the page opposite an X-Y graphical recording of the result. Applications include measuring harmonic amplitudes, determining distortion, comparing filter characteristics and audio frequency response recordings.

107. I-TEL, INC.—Catalog Supplement 1929-27, a compilation of tubular filter data, is now available. The supplement includes, in tabular form, electrical and physical characteristics for over 2000 designs that have actually been produced. This enables the reader to compare one or more parameters with any other. Thus, body size can be compared with frequency, insertion loss, etc.

Included in the data are filter function (bandpass, highpass, lowpass), body diameter and length, insertion loss, center or cutoff frequency, bandwidth, number of elements or resonators, impedance, and attenuation at several frequency points. Also included are graphs illustrating frequency-attenuation and VSWR characteristics for several bandpass, highpass, lowpass, and ultra-wide bandwidth models.

108. KINGS ELECTRONICS CO., INC.—A new comprehensive catalog on the BNC series of RF coaxial connectors is now available. Construction and cable group data are given for 658 individual items, comprising a wide variety of adapters, jacks, panel jacks, bulkhead jacks, plugs, angle plugs, panel receptacles, bulkhead receptacles, terminations, and accessories. Each item is photo-illustrated and pertinent dimensions are indicated. A Quick Selection Chart and accompanying illustrations are included as a convenience in ordering preferred connectors. Design features and cable retention methods are detailed,

and complete cable assembly instructions are included.

109. APM-HEXSEAL, CORP.—Miniature O-Rings molded of exotic elastomers to an ID as small as .022", a thickness as thin as .010" and a parting line maximum of .003" for minimum wear are now available. A Data Sheet No. OR-6 explaining their capabilities and listing standard sizes with all pertinent technical data for specifying is also available.

110. ONAN—A newly-revised, two-page, black and white specification sheet describes and illustrates the complete line of Onan, air-cooled, gasoline-powered, portable electric generating plants. A total of 15 compact, completely Onan-built power plants are listed in sizes ranging from 1,000 watts, AC to 10,000 watts, AC. One Direct Current model is offered in a 1,500 watt, 115-volt size range. All models listed are stated as being complete, and ready to run, with conveniently mounted outlet receptacles providing instant plug-in electric power for operating floodlights, electric

2x2 slide projectors for the television film chain

by **SELECTROSLIDE**

Spindler & Sauppe offers the broadest line of slide projectors for the television industry . . . seven models in all. There's one to fit your requirements exactly: color or monochrome; uniplex or multiplex; forward or reverse actuation; sequential or random access operation; 16-slide to 96-slide capacity. All built to the highest professional standards. Write for complete information.



spindler & sauppe inc.
1329 grand central
avenue / glendale
california / 91201

Export Distributor: Victor International Corp., 13 W. 46th St., New York, N.Y. 10036

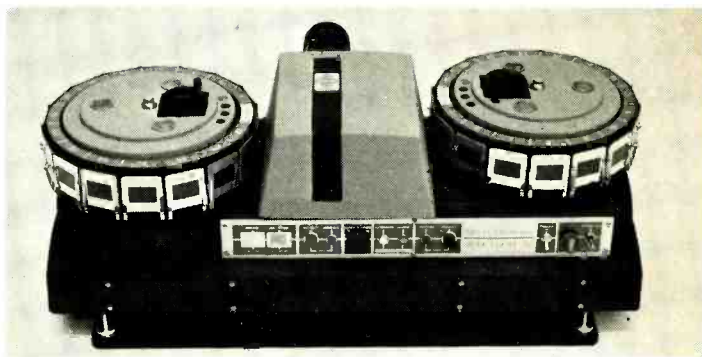

SPECTRUM 32: The most advanced slide projector available. 32 slide, for color or monochrome chains. Many exclusive features.

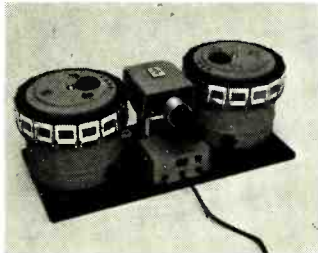

MODEL 332: Workhorse of the industry, now improved. 32 slide, for monochrome chains. Model 322: single turret for 16 slides, monochrome or color.



MODEL SLX-TV: 96 slide, random access. SLS-TV: 48 slide, random access. SLD-TV: 96 slide, sequential. SL-TV: 48 slide, sequential. SLR-TV: 48 slide, sequential forward/reverse. All for monochrome or color chains.

Circle Number 38 on Reader Reply Card

tools and communication equipment.

111. PAR-METAL PRODUCTS—The new 32-page Catalog No. 136-B introduces The Contemporama System of Electronic Housing in Modern Design combined with Functional Construction. Completely simplified for easy access to information, this Catalog Section is both graphically and photographically illustrated to allow the design engineer to efficiently and economically apply a wide variety of newly introduced, as well as standard accessories and cabinets to effectively meet his particular electronic equipment specifications.

112. POLYFLON CORP.—A bulletin containing information about its line of copper-plated Teflon sheets, tubing, and rods, is now available. The products are used in areas such as RF components, printed circuits, antennas, DC blockers, flat and strip line, shielding, hermetic seals and magnetic seals. The bulletin includes information about applications, dielectric material, and characteristics. The company's Polyplate Process, reported to result in sheets, tubing, and rods of superior performance and reliability, is also covered. Pictures are shown of typical products in the line and figures are included on widths, diameters, lengths, Teflon thickness and plating thickness.

113. POWER ELECTRONICS—Multiple uses and savings delivered by the portable electric power unit, PEP IV, are illustrated and explained in a colorful new brochure. This compact power source is 4" X 4½" X 9½", fits under the instrument panel for practically any vehicle and delivers pulsating DC current for charging batteries, for operating power hand tools, for remote emergency light source and for checking defects in electrical systems. PEP IV, a 12-volt negative ground unit, is easy to install in about 20 minutes and powers AC/DC universal motors, operating off the vehicle's generator or alternator. The new brochure shows how the unit makes use of maintenance vehicles power, taking the power source to the place of need and thus eliminating the transporting of additional equipment to the job or purchasing expensive equipment for the shop.

114. SENCORE, INC.—A 12-

page catalog, Form No. 517, describing the company's complete line of advanced electronic test equipment for service and industry is now available. The new catalog features five completely new instruments, including the sixth generation of the company's Might Mite tube tester, two color generators, a field effect transistor tester and a 7-in-1 bias supply. Other instruments included in the 1970 catalog are field effect meters, sweep and marker generator, sweep circuit analyzer, combination oscilloscope/vectorscope, combination transistor/FET testers, CRT tester, and special purpose instruments, all complete with performance data and prices.

115. TELEMATION—A one-sheet brochure describing the TSE-100 Series Screen Splitters is now available. The low-cost units can be used in a variety of television applications to provide a single, electronically-combined video image from two synchronous picture sources. Horizontal and vertical split screen and corner inserts are possible through adjustment of front-panel controls. A quadrant selector switch is provided for more flexibility in programming corner inserts. Other features are detailed in the brochure.

116. VANGUARD—A four-page brochure describing the new MX Series of double-balanced, highly efficient mixers in the 0.05 to 500 MHz frequency range is now available. In addition to complete specifications on the seven-unit MX series, including the MX4MOS-FET mixer presently under development, the new Double-Balanced Mixer brochure includes outline drawings, schematic, and a description of a variety of applications for the MX Series. Some of these include extracting the sum or difference of two frequencies, use as a specified low-noise phase detector to permit phase or frequency measurements of highest-quality signal sources, and as a suppressed carrier modulator with typical RF carrier rejection of 45 dB. Hermetically sealed and ruggedly constructed, the Vanguard MX-Series mixers feature high conversion efficiency, wide band, low noise, flat response and careful port balance.

**Send Your Industry News
To Broadcast Engineering
For Better Coverage**

ADVERTISERS' INDEX

ABTO, Inc.	Cover 2
AKG Div.	35
Amperex Electronic Corp.	9
Andrew Corp.	5
Belar Electronic Laboratory, Inc.	11
The Robert Bosch Corp.	49
Broadcast Electronics, Inc.	39, 54, 52
Century Strand, Inc.	8
David Clark Co., Inc.	61
Cleveland Institute of Electronics	51
Cohu Electronics, Inc.	1
Commercial Electronics	31
Dynair Electronics, Inc.	10
Electro-Voice, Inc.	50
Fairchild Recording Equip. Corp.	15
Gotham Audio Corp.	3
The Grass Valley Group	7
Clifford B. Hannay & Son Inc.	16
ITT Jennings	17
Industrial Electric Reels Inc.	58
International Nuclear Corp.	Cover 3
Jamieson Film Co.	34
Lipsner-Smith Corp.	57
Matrix Systems Corp.	58
Melcor	45
Mincom Div., 3M Co.	23
Minneapolis Magnetics, Inc.	16
North American Philips Corp.	35
Philips Broadcast Equip. Corp.	40-42
RCA Electronic Components Microphones	59
Sarkes Tarzian Inc.	13
Shure Brothers, Inc.	Cover 4
Spindler & Sautpe	62
Stainless, Inc.	60
Stanton Magnetics, Inc.	53
Spotmaster	39, 52, 54
Taber Mfg. & Eng. Co.	54
Tapecaster (TCM)	56, 61
Valad Electric Heating Co.	56
Varian Associates	55

**Send Your News
On Non-commercial
Broadcasting**

**To Our Editors
For Better Coverage**

**Broadcast Engineering
1014 Wyandotte
Kansas City, Mo.
64105**

PROFESSIONAL SERVICES

CLASSIFIED

FRANK A. ZOELLER

TELEVISION SYSTEMS
CONSULTANT

20 Years Experience

Box 366 • San Carlos, Cal. 94070
(415) 593-1751

VIR JAMES

CONSULTING RADIO ENGINEERS
Applications and Field Engineering

345 Colorado Blvd.

Phone: (Area Code 303) 333-5562

DENVER, COLORADO 80206

Member AFCC
TWX 910-931-0514

CAMBRIDGE CRYSTALS PRECISION FREQUENCY MEASURING SERVICE

SPECIALISTS FOR AM-FM-TV

445 Concord Ave. Phone 876-2810
Cambridge, Mass. 02138

JAMES C. McNARY

Consulting Engineer

National Press Bldg.

Washington 4, D.C.

Telephone District 7-1205

Member AFCC

JOHN H. MULLANEY and ASSOCIATES

Suite 71,
1150 Connecticut Ave., N.W.
Washington, D. C. 20036
Phone 202-223-1180

Member AFCC

ROSNER TELEVISION SYSTEMS

ENGINEERS — CONTRACTORS

29 South Mall
Plainview, N.Y. 11803
(516) 694-1903

ALLSTATE COMMUNICATIONS

ENGINEERS - CONTRACTORS
CATV - CCTV - VTR

1200 WEST CHESTNUT STREET
UNION, NEW JERSEY 07083
(201) 687-8810

**Buying? Selling?
For Better Results
Use BE**

**1014 Wyandotte
Kansas City, Mo. 64105**

Advertising rates in Classified Section are 15¢ per word, each insertion, and must be accompanied by cash to insure publication.

Each initial or abbreviation counts a full word. Upper case words, 30¢ each.

Minimum classified charge, \$2.00.

For ads on which replies are sent to us for forwarding, there is an additional charge of \$2.00 to cover department number, etc., which is printed in advertising copy, and processing of replies.

Classified columns are not open to advertising of any products regularly produced by manufacturers unless used and no longer owned by the manufacturer or a distributor.

Help Wanted

Job Headquarters for all Radio and Television Engineers. Immediate openings exist in 9 western states and elsewhere for qualified engineer and technical personnel. All categories from trainees to experienced transmitter maintenance, chief, assistant chief live color video maintenance and technical operations. Send us your complete resume now. The AMPS Agency, 3924 Wilshire Blvd., Los Angeles, California 90005. Telephone DU 8-3116. By Broadcasters—For Broadcasters, 11-68-tf

CIRCUIT/PRODUCT DESIGN ENGINEERS

The engineers we seek will include their talents in Video, Audio and Computer related circuitry designing products for the Television Broadcasting Equipment market. Send resume to the personnel manager, Vital Industries, Inc., 3614 S. W. Archer Road, Gainesville, Florida 32601.

TECHNICAL SERVICES — Metropolitan NYC and surrounding states. BSEE provides sales and technical services for out of town firms. Flexible working arrangements. Broadcast Engineering, Dept. 238, 1014 Wyandotte St., Kansas City, Mo. 64105. 4-70-3t

YOUNG GRADUATE ENGINEER with background experience on his college radio station, now active in the broadcast industry, for a position as applications engineer with our rapidly growing organization in the field of limited area AM broadcasting. Contact Richard H. Crompton, Low Power Broadcast Co., 520 Lincoln Highway, Frazer, Pennsylvania 19355. 4-70-1t

Experienced TV Supervisors wanted. Must be competent in either Network Operations switching involving VR-1200's or transmission equipment. Salary commensurate with experience. Contact Director of Engineering, 1600 R Street, Lincoln or call collect 402-477-6974. 4-70-2t

RADIO TECHNICAL CHIEF ENGINEER'S position available immediately. 5KW, DA-N, grow with young, aggressive company. Good starting salary and fringe benefits. Station 1½ years old. Contact G. M., (207) 582-3303, New Englander preferred. 4-70-1t

IMMEDIATE OPENINGS: Qualify for any of the following positions: RCA CCTV Equipment, monochrome or color. Salesmen — TV Systems Engineers — Project Engineers — Supervisors — Managers — Maintenance Technicians — Video Engineers — to work either New York, Pennsylvania, New Jersey or California area. Write: RCA Rep., P. O. Box 268, New Hyde Park, New York 11040. 4-70-tf

Training

To advance in electronics, knowledge and ability are required. Grantham offers correspondence and resident instruction, in depth, leading to the degree of Associate in Science in Electronics Engineering. G. I. Bill approved. Credit for previous training and experience allowed. Free Catalog Write: Dept. E-2, Grantham School of Electronics, 1505 N. Western Ave., Hollywood, California 90027. 6-67-tf

First phone through tape recorded lessons at home plus one week personal instruction in Washington, DC, Atlanta, Boston, Detroit, New Orleans, Minneapolis, Seattle, Denver, Portland, Los Angeles. Proven results. Our 17th year teaching FCC license courses. Bob Johnson Radio License Preparation, 1060D Duncan, Manhattan Beach, Calif. 80266. Phone 213-379-4461. 1-69-tf

Equipment for Sale

1 KV COLLINS 20V transmitter in A-1 condition, WPRT, Box 31, Prestonburg, Kentucky. 41653. 4-70-1t

FOR SALE: 2000 ft. 3¼ inch 51.50 hm Steatite line and hardware one TF 6AL Antenna. Side band filter, Diplexer and two harmonic filters all tuned for Channel 6. Atlantic Telecasting Corporation, 322 Shipyard Blvd., Wilmington, N. C. 28401. 4-70-3t

Tower Lite Control Panel Box containing alarm, telo & auxiliary circuits, auto transformer and flasher units—115V 60 cycle, unused, \$125.00 each. Sierra-Western Electric Co., Oakland, Cal. 94623. Phone 415-832-3527. 6-69-tf

CARTRIDGE TAPE EQUIPMENT—Completely reconditioned Spotmaster and Tapecaster Record/Playbacks, \$375.00. Playbacks \$250.00. 30-day money-back guarantee on all equipment. BROADCAST PRODUCTS CO., INC. 12330 Wilkins Avenue, Rockville, Maryland 20852. Ph: 301-933-3400. 10-69-tf

Highest prices paid for good used 1KW and 10KW AM Transmitters. Jeleco Electronics Ltd., 2 Thorncliffe Park Drive, Unit 28, Toronto 17, Ontario, Canada. Phone: 416/421-5631. 3-70-6t

QRK Turntables—We have approximately 20—12"/Sync. Type QRK Turntables that have been painted special colors and are Pre-Drilled for various non-standard Tonearms. These units, with full warranty are available on First Come, First Served basis at \$139.50. Contact QRK Electronic Products, 1568 North Sierra Vista, Fresno, California 93703. Phone: (209) 251-4213. 3-70-3t

BARGAIN—G. E. Pyranol Capacitors. 25 mfd. @ 6250 volts \$20.00 18" high, 16½" wide, 5" deep. Weighs 65 lbs. F.O.B. Ackard. 729 East 17th Ave., Denver, Colo. 80203. 2-70-3t

FOR SALE
RADIO STATION—5000 watts. Absentee owned. \$175,000 Terms. KHL, Willcox, Arizona. 4-70-5t

a fine stabilizing amplifier now at lowered prices...

Increased production efficiency and increased sales make reduced prices possible on this excellent stabilizing amplifier. The TVA1 with its associated series of plug-in units offers high level performance and versatility for studio or transmitter use. It removes all low frequency disturbances such as hum, bounce and tilt by sync-tip clamping. The back porch level is precisely stabilized without affecting color signals in any way. Sync is stretched after back porch stabilization and then clipped accurately to desired level. This level may be set by means of a front panel control or can be extended to a remote location. Stripped sync is provided at one 75 ohm internally terminated output connector, at a 4 volt level. The TVA1 chassis contains a plug-in compartment which accepts up to 4 plug-in units. Among these plug-in units is the TVA1-E, providing a stripped

color video channel, and the TVA1-D which provides the means of adjusting peak-white clipping, white stretch and differential phase. Other plug-in units are listed below.

NEW LOWERED PRICES
F.O.B. NASHVILLE, TENNESSEE

- Model TVA1 Stabilizing Amplifier
(less plug-ins) ... \$950.00
- Model TVA1-A Manually Operated Input Amplifier Unit ... \$250.00
- Model TVA1-B Input Amplifier Unit, with Remote Master Gain and Chroma Panel ... \$375.00
- Model TVA1-C Monitor Amplifier Unit ... \$175.00
- Model TVA1-D White Stretch and Clip Unit ... \$160.00
- Model TVA1-E Stripped Video Unit ... \$350.00
- Model TVA1-S Remote Sync Level Control Panel ... \$25.00



INTERNATIONAL NUCLEAR CORPORATION

60E Norris Avenue
Nashville, Tennessee 37204
615-254-3365
New Catalog Sent On Request.

MODEL

TVA1



Circle Number 2 on Reader Reply Card

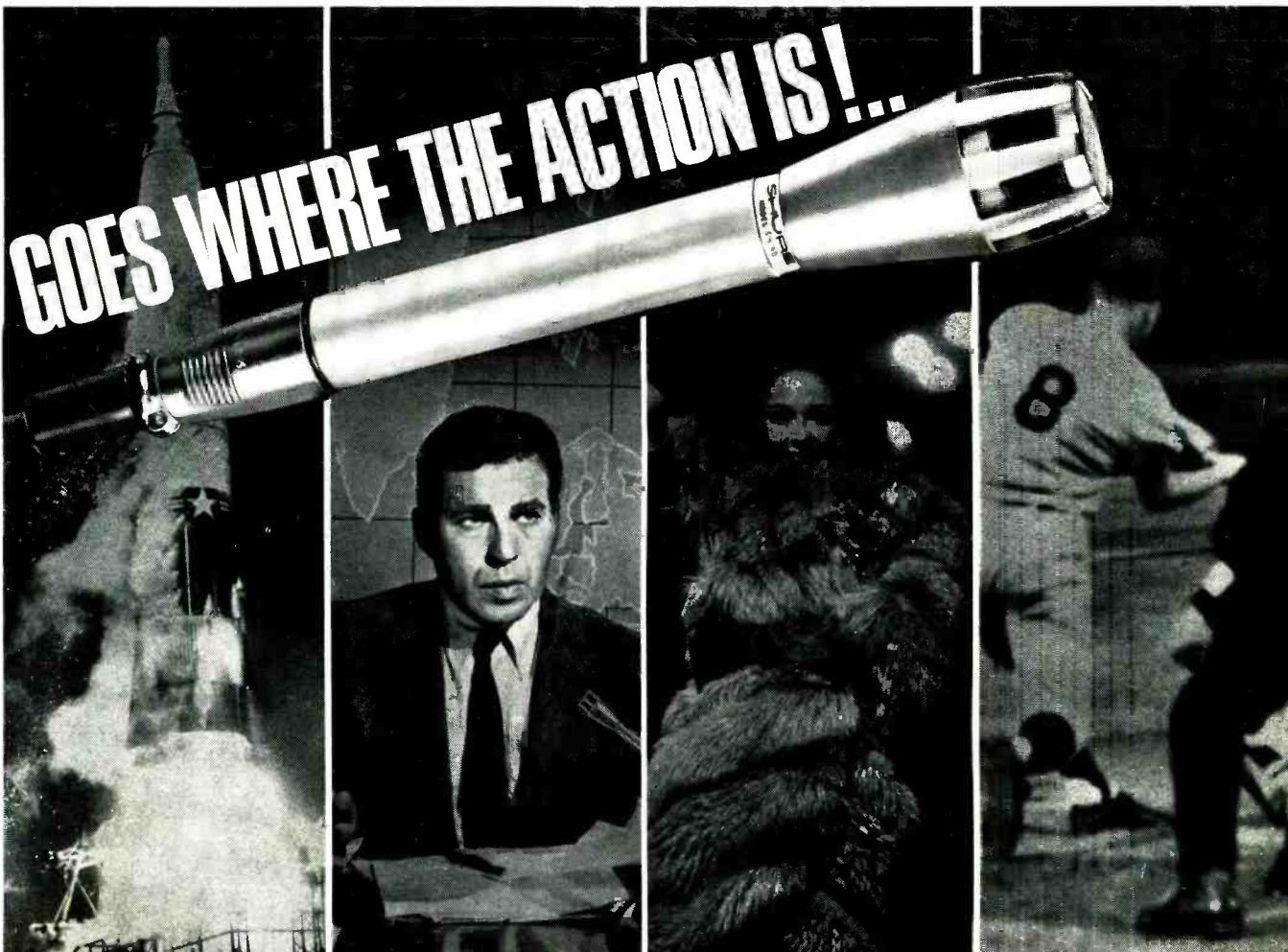

GOES WHERE THE ACTION IS!...

The SM60 cannot be stereotyped—is equally at home in the studio or in the field—stand-mounted or hand-held—in uses as diverse as outdoor sporting events and elaborate variety shows. Small wonder that audio engineers have called it one of the most versatile omnidirectional dynamics they've ever encountered, for the SM60 is a unique combination of good looks, strength, performance and economy.

The smooth, wide-range response provides cleanest, natural reproduction of both speech and music. A very effective built-in wind and "pop" filter protects against undesirable effects of close-talking.

Lustrous, non-glare metallic finish and tailored-to-the-hand dimensions provide striking on-camera appearance and superior handability. Specially reinforced machined-steel case front is designed to take abuse that would ruin other microphones—you can drop it on its nose without damage to the internal structure! Efficient windscreen and front end are *quickly* and *easily* removable for cleaning.

Best of all, it is priced competitively with conventional "workhorse" microphones. Why not check out an SM60 now? See your Shure Professional Products Distributor, or contact Shure Brothers Inc., 222 Hartrey Ave., Evanston, Ill. 60204—Phone 312 - 328-9000.

SHURE SM60

VERSATILE OMNIDIRECTIONAL DYNAMIC MICROPHONE

SHURE PROFESSIONAL MICROPHONES . . . FOR BETTER AUDIO



MODEL SM56
CARDIOID
DYNAMIC

Extremely versatile in studio, control room, and remote use. Also widely acclaimed for rhythm recording. Bright, clean sound. Exceptionally uniform cardioid pattern gives optimum control of environment.



MODEL SM33
UNIDIRECTIONAL
RIBBON

Warm, smooth sound for studio, control room, and scoring stage. Super-cardioid directional pattern. Compact, yet rugged.



MODEL SM76
3/4" OMNIDIRECTIONAL
DYNAMIC

Ideal for interviews and audience participation, yet unusually smooth wide range response (40-20 KC) for critical music reproduction. Instantly detachable from stand. Steel case with Cannon connector.



MODEL SM50
OMNIDIRECTIONAL
DYNAMIC

Self-windscreened and pop-free for news, sports, remotes, and interviews. Also ideal for many studio and control room applications. Comfortably balanced for hand or stand use. Natural response.

Circle Number 3 on Reader Reply Card