

BROADCAST **engineering**

the technical journal of the broadcast-communications industry

Indiana University
FEB 9 - 1973
Library



AGC amplifier update page 14

Spurious signal test
Set lighting tips
Cable Engineering

AIRLINE PILOT / A
 DISC JOCKEY / DJ
 RADIO OPERATOR
 LANGUAGE LABORATORY
 PRIVATE PILOT
 RADIO TELEPHONE

/ AUCTIONEER / BARKER / CB MOBILE
 DISPATCHER / FLOOR MANAGER / HALL
 INDUSTRIAL CONTROLLER / LECTURER
 INSTRUCTOR / PAGING OPERATOR
 TV-RV-PLAY SPORTS ANNOUNCER
 USE / TOUR GUIDE / TV DIRECTOR

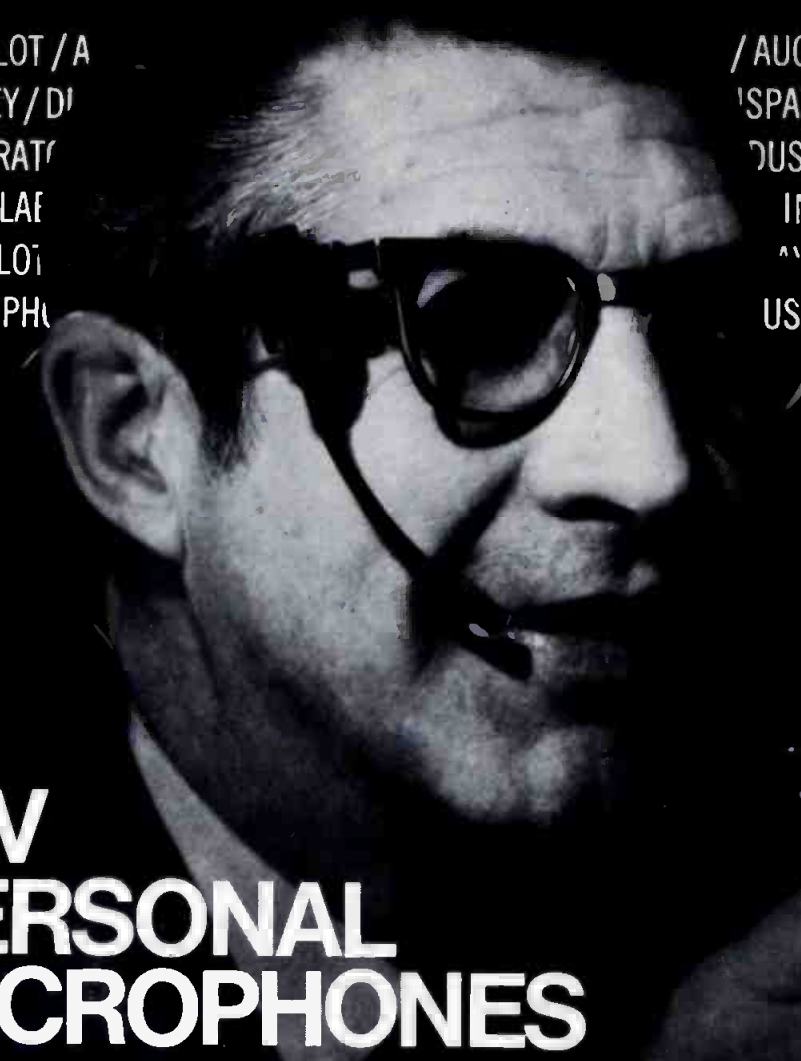

E-V PERSONAL MICROPHONES

A product of aerospace research...now improved for you!

E-V Imagine a microphone that never leaves your lips, no matter what you do. Now E-V has a family of five dynamics, each tailored to the specific needs of broadcasters, dispatchers, announcers, pilots, and other constant users.

Light Weight

Less than 1/2-ounce in weight, these microphones can be clipped onto most eyeglass frames, or onto their own special headband. A slender adjustable tube leads from the microphone element to the user's mouth, and is easily positioned a fraction of an inch away, yet out of the main airstream. This insures maximum volume without annoying "pops" typical of normal close-mike operation.

Hands-Free Operation

Wearing an E-V personal microphone quickly becomes second nature, leaving both hands free for paperwork, driving, flying, holding scripts, or any other chores. Because you are never "off-mike", signal-to-noise ratio is always optimum and volume never varies. And because there is no bulky microphone close to the mouth, fidelity is greatly improved.

Radio-TV Model

Based on designs created for the U. S. aerospace program, E-V personal microphones have been proven in years of extensive field testing. The Model RE51 has already proved itself for sports and general announcing on several major radio and TV networks. Response range is from 80 to 10,000 Hz. and

mixes perfectly with all other E-V broadcast models. A transistorized preamp (normally worn on the belt) includes push-to-mute "cough button", on-off switch, battery test light, and cable connector. Balanced Lo-Z output adjusts to maximum of -56 dB to match any standard input. \$134.00 list complete with microphone, headband, and preamp.

Model 651 is similar in design but with choice of Hi-Z or Lo-Z (unbalanced) at cable end. Ideal for lecturing, paging, dispatching and general use. Response 80 to 8,000 Hz. \$100.00 list complete as above.

Communications Types

Special aircraft communications Model 967M matches carbon mike inputs and provides transistor amplifier built into PJ-068 type plug. Audio quality superior to magnetic types, and much less susceptible to shock damage. No battery needed. Response 300 to 4,300 Hz tailored for highest intelligibility. \$122.00 list complete with microphone, headband, carrying case. FAA approved (TSO C-58).

Model 967ME combines microphone and FAA approved (TSO C-57) earphone. Five ear tips furnished. Standard 1/4" phone plug for earphone (no special connectors needed). \$140.50 list. (NOTE: Model 967TR similar to 967ME above is specially modified headset for major airline use. Write for details and quotation.)

Model 367 Push-To-Talk switch adds on-

off facility to Models 967M/967ME. Has switch for mounting on steering post for any craft/mobile installation. 3-pole momentary switch energizes microphone and relay. \$25.00 list.

Electro-Voice personal microphones and headsets introduce a new era of flexibility in communications. They are easily adapted to most RF transmitters and receivers for hands-free, wire-free communications. And they permit the user to concentrate on the job at hand, rather than on the microphone. Each can be serviced in the field if needed without sophisticated tools.



Put an E-V personal microphone to work today. You'll see, hear, and feel the difference. For more information write us today or call your E-V microphone headquarters.

ELECTRO-VOICE, INC., Dept. 721V
 689 Cecil Street, Buchanan, Michigan 49107

Electro-Voice
 a GULTON subsidiary

high fidelity systems and speakers • tuners, amplifiers, receivers • public address loudspeakers
 • microphones • phono cartridges and styli • aerospace and defense electronics

Circle Number 2 on Reader Reply Card
www.americanradiohistory.com

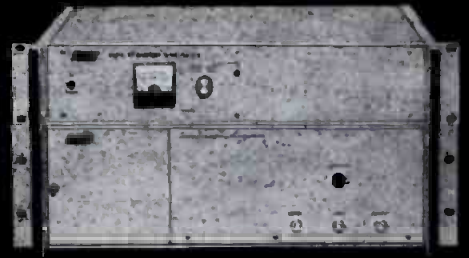

Tracor's Revolutionary Free-The-People Box. Unattended, it keeps your station within .05 Hz day in, day out.

Frees engineers from slavery. Eliminates co-channel or skip interference. Provides larger audience with better reception. Gives your advertising manager more ammunition. Major network affiliated stations are now using Tracor's revolutionary 6500 Visual Carrier Generator System. Join the FCC approved movement now.

Get inside information:

Tracor's
"Revolutionary"
"Free-The-People"
"Box" 

I would like to know more about the Tracor
6500 Visual Carrier Generator System.

Name _____
Position _____
Company _____
Address _____
City _____ State _____ Zip Code _____ Tel. _____

TRACOR Tracor Inc., Industrial Instruments,
6500 Tracor Lane, Austin, Texas 78721

BROADCAST engineering

The technical journal of the broadcast-communications industry

in this issue...

14 On The LevelAn Update On AGC Amplifiers. A review of currently available AGC amplifiers, their operation and maintenance. Includes operation level tips. Written by BE's maintenance editor. Pat Finnegan.

22 WSTM Makes Its Move. Recounting the success of FM station WSTM and their move into a human engineered and sound compensated facility. Charles R. Strickland.

27 KETC Takes Unique Facilities Approach. A St. Louis educational television station combines studio facilities with transmitting equipment in the ultra modern building.

30 Getting More Out of Your Lighting Equipment. Well known lighting expert condenses part of his lighting seminar to explain aids and tips in the tools of the lighting trade. Herb Greeley.

34 Simple Signal Sampling. A station combination designs a simple signal sampling device and discovers it has many other uses. Dennis R. Ciapura.

38 Spurious Emission Measurements. A Chief Engineer explains how he saved time and effort in making required test for spurious emissions when tying into a master antenna. James R. Stephenson, Jr.

ABOUT THE COVER

Pat Finnegan shown adjusting the stereo AGC and limiting amplifiers at station WLBC. WLBC is a full time stereo maximum power station in Muncie, Ind.

DEPARTMENTS

Direct Current	4
Letters to the Editor	8
Industry News	10
Cable Engineering	CE-1
Engineer's Exchange	42
People in the News	41
Book Reviews	48
Classified Ads	57
Ad Index	58

Copyright, 1972, Howard W. Sams & Co., Inc. All Rights Reserved. Material may not be reproduced or photocopied in any form without written permission of publisher.

EDITORIAL

- RONALD N. MERRELL, Editorial Director
- CARL BABCOKE, Technical
- MORRIS COURTRIGHT, Automation
- PAT FINNEGAN, Maintenance
- HOWARD T. HEAD, FCC Rules
- ROBERT A. JONES, Facilities
- WALTER JUNG, Solid State
- ANDRA BOYLE, Editorial Assistant
- H. G. ROESLER, Cartoonist
- DUDLEY ROSE, Art Director
- LEO G. SANDS, CATV

EDITORIAL ADVISORY BOARD

- LES NELSON, Chairman
- Howard W. Sams & Co., Indianapolis

CIRCULATION

- EVELYN ROGERS, Manager

ADVERTISING

- E. P. LANGAN, Director
- R. JACK HANCOCK, Manager
- TERRY TEMPLE, Production
- JAKE STOCKWELL, Sales

REGIONAL ADVERTISING SALES OFFICES

MICHAEL KREITER
1014 Wyandotte St.
Kansas City, Mo. 64105

Indianapolis, Indiana 46206
ROY HENRY
HOWARD W. SAMS & CO., INC.
2469 E. 98th St.
Tele: 317/846-7026

New York, New York 10019
CHARLES C. HORNER
3 W. 57th St.
Tele: 212/688-6350

Los Angeles, California
JOHN D. GILLIES
3600 Wilshire Blvd., Suite 1510
Los Angeles, California 90005
Tele: 213/383-1552

London W. C. 2, England
JOHN ASHCRAFT & CO.
12 Bear Street
Leicester Square
Tele: 930-0525

Amsterdam C, Holland
JOHN ASHCRAFT & CO.
W.J.M. Sanders, Mgr.
for Beneluxe & Germany
Herengracht 365
Tele: 020-240908

Tokyo, Japan
INTERNATIONAL MEDIA
REPRESENTATIVES, LTD.
Shiba-Kotohiracho, Minato-ku
Tele: 502-0656



BROADCAST ENGINEERING is published monthly by Intertec Publishing Corp., 1014 Wyandotte Street, Kansas City, Missouri 64105. Telephone: 913/888-4664.

BROADCAST ENGINEERING is mailed free to qualified persons engaged in commercial and educational radio and television broadcasting. Non-qualified subscriptions in the U.S. are \$6.00 one year, \$10.00 two years, \$13.00 three years. Outside the USA add \$1.00 per year to cover postage. Single copy rate 75 cents. Back issue rate \$1.00. Adjustments necessitated by subscription termination at single copy rate.

Controlled Circulation postage paid at Indianapolis, Indiana.



Robert E. Hertel, Publisher

INTERTEC PUBLISHING CORP.
Subsidiary of HOWARD W. SAMS & CO., INC.

NEW! MODEL 1400-11 SWITCHING SYSTEM

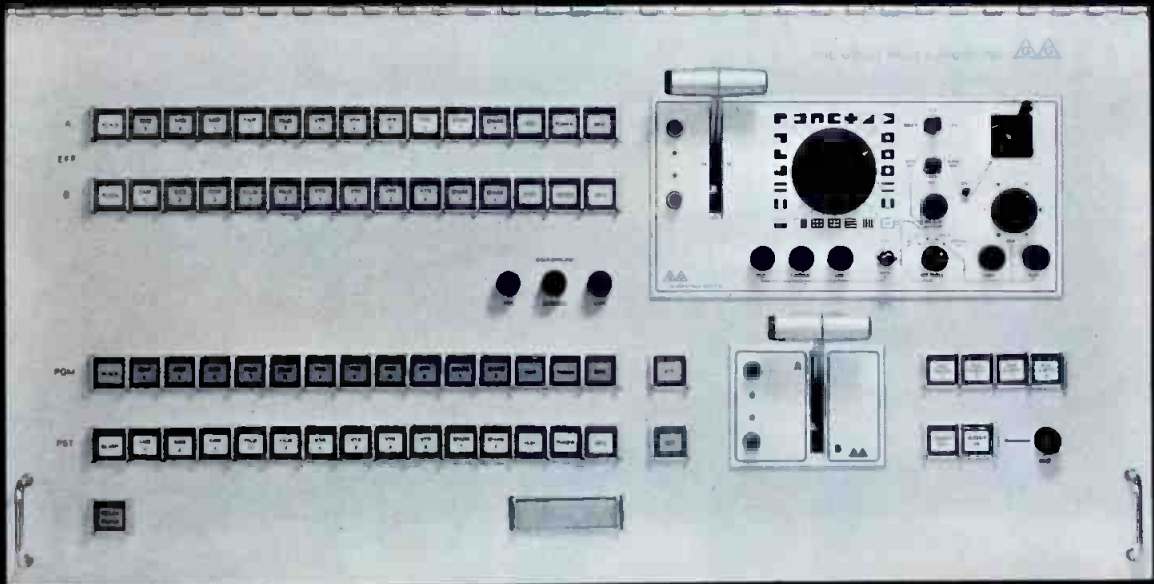

FEATURES

- 15 INPUTS (COMP OR NON-COMP*)
- 23 WIPE PATTERNS
- INTERNAL/EXTERNAL KEYING
- COLOR MATTE
- PGM/PST MIXER
- COLOR BLACK GENERATOR
- CUT-BAR
- CHROMA KEY CONTROL
- AFV SYSTEM*
- DOWNSTREAM KEYS*

*OPTIONAL EQUIPMENT

DESCRIPTION

Model 1400-11 represents an unusual value in a medium-sized switching system. The video mixer operates between the PGM and PST buses; this arrangement provides most of the operating features of a 6-bus switching system in only 4 buses. The basic versatility of the 1400-11 can be increased with optional equipment such as an audio-follow-video system or a downstream insert keyer. The keyer, which is inserted in the PGM path, allows captions to be made at any time without use of the special effects system.

PRICE \$14,000

THE GRASS VALLEY GROUP, INC. 

SOLD EXCLUSIVELY BY GRAVCO SALES, INC.

6515 Sunset Blvd.
LOS ANGELES, CALIF.
(213) 462-6618

Station Plaza East
GREAT NECK, N.Y.
(516) 487-1311

125 South Wilke Road
ARLINGTON HEIGHTS, ILL.
(214) 330-1245

Redbird Airport
DALLAS, TEXAS
(214) 330-1245

1644 Tullie Circle, N.E.
ATLANTA, GEORGIA
(404) 634-0521

Circle Number 6 on Reader Reply Card

DIRECT CURRENT FROM D. C.

JULY, 1972

by Howard T. Head

Supreme Court Upholds CATV Origination Requirement

The U.S. Supreme Court has reversed a Court of Appeals ruling which had held that the Commission had no authority to require CATV systems to originate programming. Commission rules requiring program origination by systems having more than 3500 subscribers had been appealed to the Court by a large cable system in the Midwest.

The controversy left the Supreme Court almost equally divided. Four justices concluded that the Commission was within its authority in requiring program originations, while four others found themselves equally convinced that the Commission had exceeded its authority. The deciding vote was cast by Chief Justice Burger, who, swaying like a willow in the wind, found himself disagreeing with the Commission's views in requiring originations but, like Voltaire, defending the Commission's right to do so.

Thus, the Commission's rules requiring CATV program originations become the law of the land. The Commission is expected to issue deadlines shortly for actual compliance.

The Supreme Court decision came just a short time after the District Court for the Southern District of New York had held that CATV systems were not subject to copyright liability for the carriage of broadcast station programs. An earlier Court decision reached the same conclusion, but in the earlier case no carriage of distant signals was involved. The new decision expands the concept to provide freedom from copyright liability even for the carriage of distant signals.

AM and FM Operator Requirements Reduced

The Commission has issued the actual text of new rules permitting the routine operation of high-powered AM and FM transmitters and AM directional antennas by third-class operators holding a broadcast endorsement. The previous rules had required a first-class operator for these categories of operation.

In issuing the new rules, the Commission has made every effort to improve the maintenance procedures in the technical operations of stations, especially in the case of AM directional antennas. The station must have in regular fulltime

10 inch Giant



This is the new, unique Satchell Carlson 10-inch monochrome video monitor...the *only* professional-quality 10-inch monitor.

It gives you **13% more viewing area than standard 9-inch monitors, 26% more** when used in a dual rackmount configuration.

It is small and handy, but able to do giant duty. Use it for broadcast studios, industrial monitoring, surveillance, remote installations, medical, VTR display, educational, and many other applications.

You'll find the picture quality always superb (horizontal resolution 640 lines or better), the reliability factor amazing, the weight practically nothing (15 pounds), and the cost modest.

One hundred percent solid-state circuitry

assures you maximum performance and stability, low power drain, and a minimal heat factor. Satchell Carlson UNIT-IZED®

plug-in circuit modules make maintenance a breeze.

At \$199, it is the lowest-priced American-made monitor of comparable size, and is available in single or dual rackmounts.

Take a giant step forward...ask your Satchell Carlson dealer for more information, or write to us. Remember SETCHELL CARLSON, where quality is a tradition.



SC ELECTRONICS, INC.
A SUBSIDIARY OF AUDIOTRONICS CORPORATION
530 5th AVE. N.W. ST. PAUL, MINNESOTA 55112
PHONE (612) 633-3131

Circle Number 7 on Reader Reply Card

employment a qualified first-class licensee, who is to be notified in writing of his authority over the station's technical operation and over lesser grade duty operators. He must perform or supervise all maintenance, review the daily operating logs, and make a daily personal inspection of the technical plant. He may not be assigned other duties which would conflict with his primary responsibility.

If an AM directional antenna license specifies current and phase tolerances tighter than the standard 5 percent and 3°, the use of third-class operators is not permitted. Monitoring points must be read monthly, and a "partial" proof of performance consisting of ten field strength measurements in each required direction must be made annually.

A proposal that AM directional stations be required to install type-approved phase monitors is being held in abeyance pending the conclusions of a Commission inquiry into the requirements for type approval.

AM Stereo Tests Proposed

The Commission has been asked to authorize experimental testing of AM stereo operation by a station on the East Coast. The only regular stereo operation presently authorized is the pilot subcarrier system in the FM band.

The system proposed for testing transmits the left channel information on the lower sideband and the right channel information on the upper sideband. Satisfactory results are claimed even with two inexpensive receivers, one tuned slightly below and the other slightly above the carrier, although properly-designed equipment would be expected to provide improved results.

A similar system has been tested for some time by a station in Tijuana, B.C., just across the Mexican border from San Diego.

Land Mobile Sharing of Two Television Channels Cleared in Los Angeles

The Commission has issued final approval for the sharing of television Channels 14 and 20 by land mobile operation in the Los Angeles area. The sharing of these channels was part of the Commission's earlier decision on land mobile operation in the UHF band, but treaty requirements with Mexico made it necessary to obtain Mexican concurrence for any sharing within 250 miles of the border.

At one time, experimental land mobile operation was proposed in the Los Angeles area on TV Channel 6, but in this case the Mexican authorities declined to concur, presumably because of the fact that Channel 6 is in use in the Tijuana area. Proposed UHF sharing in Detroit and Cleveland is still awaiting the concurrence of Canada's Department of Communications (DOC).



ORIGINATE
YOUR OWN
NTSC COLOR
PROGRAMMING
FOR ONLY

\$8770.00

COMPLETE
INCLUDING
PROJECTORS

FEATURING
UNSURPASSED CAPABILITY
AT LESS THAN
ONE-HALF THE TRADE PRICE

Marco Video Systems, Inc. total color film chain system represents a major breakthrough in the industry. Designated Model DFC-3, this modular system has been uniquely engineered by Marco to accept opaque artwork and overhead projector transparencies in addition to conventional 16mm motion picture film and 35mm slide transparencies. It even has the ability to televise small three-dimensional objects

within a 7" x 9" horizontal field. Containing its own built-in color sync generator and NTSC color encoder, this versatile color film chain system far surpasses other systems costing two to three times as much. In addition to a built-in capability to wipe between motion picture film and 35mm slides, the operator can also insert small opaque objects into the visual material, as well as point out

specific items in a slide or film directly on the TV image.

Get complete details on this amazing new system by filling in and mailing back the coupon below:

MARCO VIDEO SYSTEMS, INC.
6114 N. 20th STREET
PHILADELPHIA, PA. 19138
(215) 849-9500

Gentlemen: Please contact me
 Please send additional information

Name of Organization _____

Address _____ Phone _____

City and State _____

Requested by _____

Title _____

Circle Number 8 on Reader Reply Card

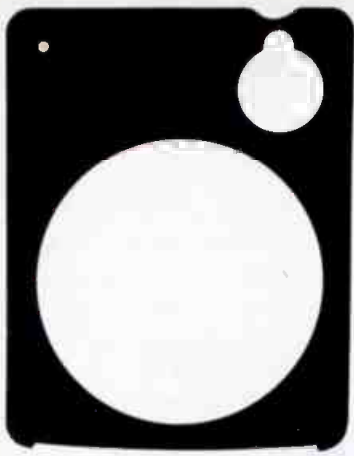

WHAT A LIFE!

That's what more and more Broadcasters are exclaiming everyday about the Fidelipac 300 Tape Cartridge. Because it lives. Year after year with the same operating superiority, the same true sound fidelity and the same excellent quality it had at the start. But why shouldn't it? Fidelipac is the original tape cartridge. Compatible with all standard broadcast cartridge machines, it's available in all standard lengths. And with over 25 million sold, it stands as the standard for the Broadcast Industry.

For additional information on the Fidelipac 300 as well as the Broadcaster Comprehensive Fidelipac Cartridge Line, call your local Fidelipac distributor or write to



FIDELIPAC

a division of TelePro Industries, Inc.

3 Olney Avenue
Cherry Hill, N.J. 08034
(609) 424-1234

Circle Number 9 on Reader Reply Card

LETTERS TO THE EDITOR

Protect Your Station

Dear Editor:

Here is an old and quite effective way to protect single items of equipment with their own power feed. While it was designed for mobile service, there is no reason why it will not work for anything with its own feed, like consoles, racks (although not the individual items) and transmitters. Simply insert a switch in the power leads, then hang a line-voltage relay across the switch. Shut off the gear by this switch. The relay will close, but the power flow will be very small. Now connect, via another switch, an alarm so that if the line relay opens, the alarm cuts loose. Unplugging the equipment, cutting the cable, or turning the gear off—in short, almost any tampering will produce an alarm. Using a battery alarm will stop people who cut primaries, but beware, because every power failure at night will trip it. No reason to have the alarm relay in the same room with the gear, as long as you do no paralleling of feeds before the relay. If the gear has its own feed from the main power board, I see no reason why the relay should not be at the individual breaker out there, and the main fuse panel is not the usual place to look for a burglar alarm trip.

As for alarms, a circuit to the police is good, but usually expensive unless you're across the alley. A loud alarm is good in some neighborhoods. Another effective device, if your police are alert, is a light which cannot be seen from inside the building. Nothing too fancy, or bright, but in most towns the cruiser will pass at least once an hour, and an hour will be just starting if the yeggs are after heavy stuff. This is likely to result in arrests rather than scared-off crooks, and you might get a bunch I'm interested in who raid two-way and other remote sites around New England. I suspect they go elsewhere in the winter.

Name Withheld by Request

Get Added Assurance From Janitor Service

Dear Editor:

Theft, destruction, or fire are always a problem with every station manager and chief engineer.

We have, hopefully, solved these problems at WKTV. Our janitorial work is performed between sign off and sign on six nights a week. The seventh night is covered by one of

(Continued on page 9)

ask about our new am | fm | tv monitors



Call or Write ARNO MEYER

BELAR ELECTRONICS LABORATORY, INC.

Delaware & Montrose Avenues, Upper Darby, Pa. 19084 Box 83
(215) 789-0550

Circle Number 50 on Reader Reply Card

The all-in-one medium.

Okay, so you've just finished airing your documentary on the bicycle boom. A few days later you get a call from the president of a local men's club and he wants to show it at their weekly meeting on Tuesday. "Sure," you say, and send him the film.

Or, after hearing about a contest for documentaries, you immediately pull a film you did on an old house in town which has been converted into a recreation center for teen-agers. Because it's on film, you can enter it as is, something you couldn't do if it had been shot on tape.

Flexibility is one of the many beauties of film. Once a film is in the can, it can go and show practically anywhere. On the screen. At sales meetings. In flight. Off the beaten path.

So you can see that calling film the all-in-one medium is more than just a catchy phrase.



EASTMAN KODAK COMPANY ATLANTA: Bob Baker 404/351-6510/
CHICAGO: Dick Potter 312/654-5300/DALLAS: Frank Reinking 214/351-3221
/HOLLYWOOD: John Waner 213/464-6131/NEW YORK: Bill Reddick 212/262-
7100/SAN FRANCISCO: Joe Semmelmayr 415/776-6055.

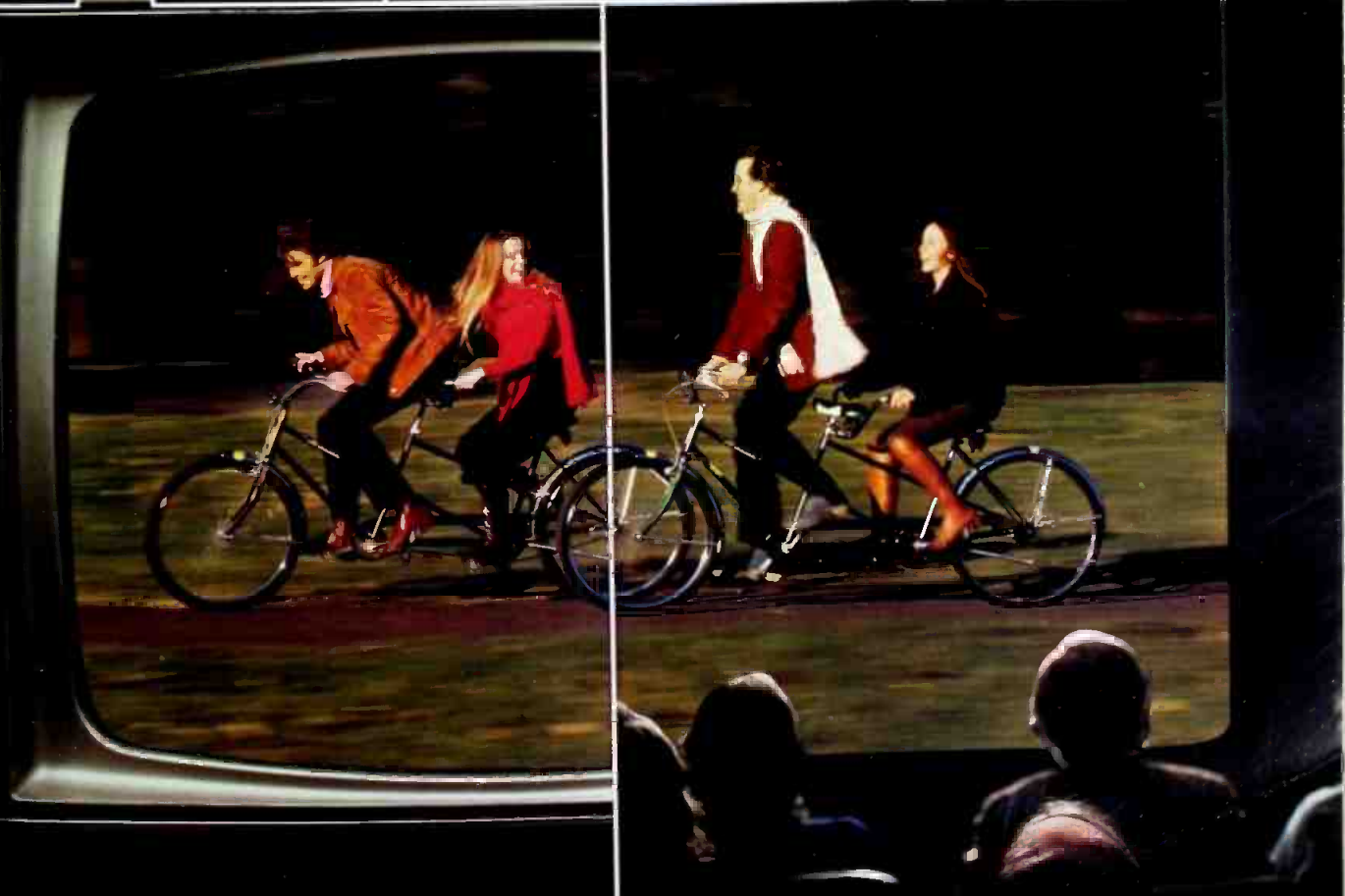

What FM transmitter power do you need?

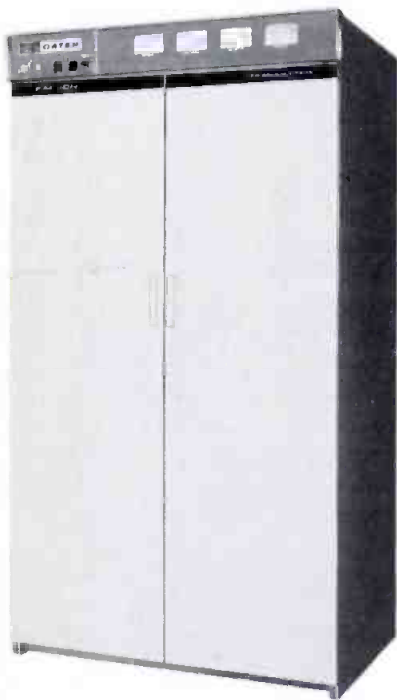

Gates has the most complete line of FM transmitters in the industry. From 10 to 40,000 watts. All with a 100% solid-state exciter employing DCFM (direct carrier frequency modulation) and DAFC (digital automatic frequency control).

The TE-3 exciter is the heart of all H3 series transmitters—one tube (1kW), two tube (2, 3, 5 and 10kW), and three tube (20kW). All FCC-type accepted, ready for prompt shipment.

Tell us the power you need and ask for data on our FM antennas. Write Gates, 123 Hampshire St., Quincy, Illinois 62301, or phone (217) 222-8200 today.

HARRIS
INTERTYPE
CORPORATION

GATES
A DIVISION OF HARRIS-INTERTYPE

Circle Number 48 on Reader Reply Card

FCC Lowers Operator Requirements for AM, FM

Rules pertaining to operator requirements for AM and FM broadcast stations (Sections 73.93, 73.265, 73.565) have been amended by the FCC to permit AM stations with directional antenna systems, AM stations with non-directional antennas and power in excess of 10 kilowatts, and FM stations with power in excess of 25 kilowatts to employ persons holding third class operator licenses, endorsed for broadcast station operation, for routine operation of the transmitter, provided the licensee employs at least one first class radiotelephone licensed operator on a full-time basis and meets other stated requirements (Docket 18390).

Although the rule will preclude the station's chief operator from holding the same position at more than one broadcast station in the same service, the Commission will give consideration to granting a waiver to an operator to serve as chief operator at more than one standard or more than one FM broadcast station upon a satisfactory showing that the stations are sufficiently geographically close to each other, that the operator can discharge all required responsibilities, and be readily available to make necessary repairs and adjustments in case of malfunctions at each station.

The new provisions become effective July 14, 1972.

Under the amended rules, the licensee must designate in writing a first class license holder as chief operator of the station, responsible for technical maintenance and the supervision of lesser grade operators. At stations with directional antenna systems, a first class operator will be required to record daily (with certain exceptions) observations of base currents, remote base currents, sample loop currents, and the computed tower current ratios. This is a function that cannot be entrusted to lesser grade operators, the Commission said, since base

current readings can usually be observed only by entry into the antenna tuning house where the operator may be exposed to potentially lethal RF voltages. The interpretation of the information obtained and any necessary adjustments are beyond the competence of a lesser grade operator, the Commission declared. Lesser grade operators will be permitted to make changes in radiation patterns as required by the terms of station authorizations, provided the changes can be made by simple activation of switches and do not require manual tuning of the equipment.

In order to preclude the possibility of interference to other stations, switching equipment must be arranged so that any failure of a relay in the directional system will cause the station to go off the air.

Existing rules require that FM stations with more than 25 kilowatts output power, AM stations with non-directional antennas and power in excess of 10 kilowatts and all AM stations using directional antennas have first class operators on duty and in charge of the transmitting apparatus. Stations not in these categories may be operated by persons with lesser licenses, provided the station has

Operator Requirements

Continued on page 53



"SORRY BUT THE FCC HASN'T RELAXED OPERATOR REQUIREMENTS THAT FAR, YET."

ur engineers performing equip-
ment maintenance.

Besides providing security, our
editorial duties are performed with
virtually no interference from
working employees.

heldon F. Storrier
vice President WKTV
Tulsa, N.Y.

Editor's Note: There probably is too
much trust in the broadcast indus-
try. With concentration on good
sound and sight, two things are of-
ten left to chance: burglar protec-
tion and fire safety.

Because many stations are located
in remote sites, police patrols may
not even exist . . . nor do fire hy-
drants. I certainly don't have all the
answers, but I'm sure that we can
collect enough ideas from the field
or us to put together some ideas
that could be used in large, medium,
or small market stations.

Unfortunately, total equipment
and facility protection seldom re-

ceive fair treatment. You can do
something about it. Drop us a line
and share your experiences, good or
bad. Write to: The Editor, Broad-
cast Engineering, 1014 Wyandotte,
Kansas City, Mo. 64105.

Telephone Tip

Dear Editor:

The schematic shown is a cor-
rected Figure 3 (May, BE, pg. 14).

A further note on Figure 3: Should
the hang up switch be bypassed
with a switch as shown, a further
step must be taken to remove the
shorting contacts across the ear-
phone (R & GN) which are closed
when the phone is on the hook (dis-
connect).

Clint Tinsley
Meridian, Idaho

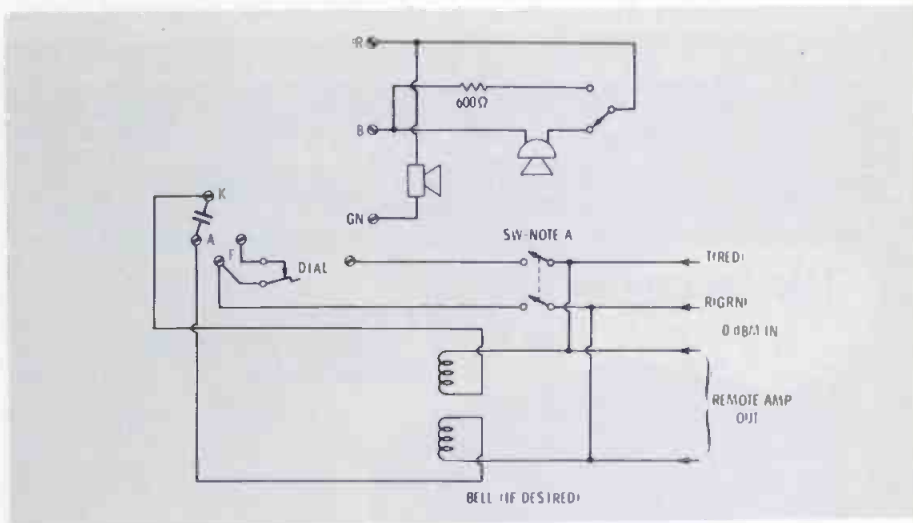

Worried...? About Proof of Performance?

Forget it! Here's the **ACCURACY** you need in **ONE** box



Model F380A

The **AILTECH*F380A** audio sine generator combines all
the features you need in one compact instrument.

Designed for professional recording and broad-
cast engineers, it is easy to maintain com-
plete station speech, network and trans-
mission equipment. The **F380A** features
low distortion balanced output with a
hum level <100 dB below zero. It's
calibrated 110dB output attenuation and
selectable impedances eliminate need for
matching transformers. You get it all in
one box for \$925.00. If you're concerned
about that next station test, the answer is
the **F380A** audio sine generator...for
worry-free performance.

- Balanced 150/600 ohm output for versatility
- Built-in voltmeter for easy monitoring
- Compact and lightweight — only 5¼" high
- All solid state for greater reliability

SELECTABLE
OUTPUT IMPEDANCES

20 Hz to 20 KHz
FREQUENCY SPAN

HUM LEVEL
100 dB BELOW ZERO

110 dB
OUTPUT
ATTENUATION

SOLID STATE DESIGN

OUTPUT VOLTMETER
CALIBRATED IN
VOLTS AND dB

TOTAL DISTORTION
LESS THAN 0.1%

For more data write:

AILTECH 
A CUTLER-HAMMER COMPANY

(* formerly Microdot — is a new Cutler-Hammer Co.)

19535 E. Walnut Drive City of Industry, CA 91748

Circle Number 12 on Reader Reply Card

Quad Committee Formed

To the interested FM operator, much of today's information seems garbled. To a few who are already broadcasting quad programs, it may seem clear. Their various con-

tentions and the voices of manufacturers will be heard by an Electronic Industries Association (EIA) committee established recently.

Known as the National Quadro-

phonic Radio Committee, the objective will be to evaluate the final and present technical conclusions to the FCC. The Commission already has named four of its staff to serve as observers to the committee.

The Committee's tentative organization closely parallels that of the EIA National Stereophonic Radio Committee, which in 1966 developed system proposals for compatible stereophonic radio broadcasting which were forwarded to the FCC and formed the basis of today's FM stereo broadcasting system.

Norman Parker, corporate scientist, Motorola, Inc., will serve as chairman of the quadrophonic committee panel on system specifications. Five other panels of the Committee will cover interconnecting facilities, broadcast transmitters, broadcast receivers, field test, and subjective aspects.

An organizational meeting of Panel 1 will be held at EIA headquarters, in Washington, May 9. Organization of the other panel will be discussed at this meeting. Early industry response to the Committee indicates that it will have broad representation.

GE Joins Quad

The General Electric Audio Electronics Products Department has announced that it filed a technical report with the Federal Communications Commission covering field testing of its four-channel discrete FM broadcasting system. The tests were conducted at the Company's FM station, WGFM at Schenectady, New York, during non-broadcast hours last fall.

The transmission of the GE system reportedly is compatible with existing monophonic and stereophonic radio receivers and music systems. The system transmits four discrete full-frequency 30,150,000 Hertz audio channels by adding an ultrasonic sub-carrier above the present stereo sub-carrier used for FM-stereo broadcasting. Both matrix and discrete four-channel records and tapes may be broadcast using the GE system.



Spotmaster

The incomparable new

Ten/70

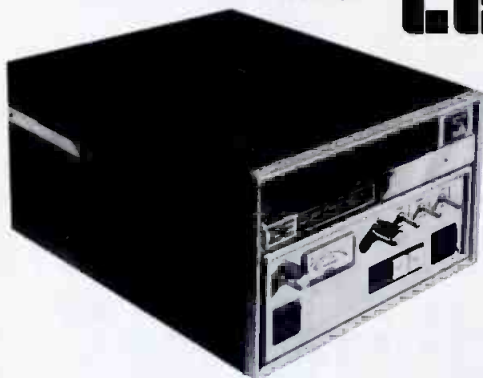

World's finest
cartridge tape
equipment

Here is the bold new standard in cartridge tape performance, versatility and ruggedness—the equipment that has *everything!* Five models of the magnificent Ten/70 are offered to meet every recording and playback application. All have identical dimensions. Any combination of two will fit in our sleek 19-inch roll-out rack panel, just 7 inches high.

Control features and options include manual high-speed advance, exclusive Auto-Cue with automatic fast-forward, automatic self-cancelling record pre-set, front panel test of cue and bias levels, built-in mike and line level mixer, color-coded design for easiest possible operation.

Inside is a massive U.S.-made hysteresis synchronous "Direct Drive" motor, solid state logic switching, modular construction and premium components throughout, separate heads for A-B monitoring, full bias cue recording, transformer input and output, flip-top access to heads and capstan.

THE CLASSIC 500 C SERIES. Long the industry standard, SPOTMASTER'S 500 C series is still offered. Performance and specifications are second only to the Ten/70.

For complete details about SPOTMASTER cartridge units (stereo, delayed programming and multiple cartridge models, too), write or call today. Remember, Broadcast Electronics is the No. 1 designer/producer of broadcast quality cartridge tape equipment . . . worldwide!



BROADCAST ELECTRONICS, INC.

A Filmways Company

8810 Brookville Road, Silver Spring, Maryland 20910 • (301) 588-4983

FCC And FTC Make Formal Agreement

The Federal Trade Commission and the Federal Communications Commission have established liaison procedures under which both agencies will exchange information and maintain regular staff contacts on matters of mutual concern.

The agreement, which was signed by FCC Chairman Dean Rusk and FTC Chairman Miles W. Kirkpatrick, provides that the FTC will exercise "primary jurisdiction over all matters regulating unfair or deceptive advertising in all media, including the broadcast media." It specifies that the FCC will continue to take into account pertinent considerations in this area (false and misleading advertising) in determining whether broadcast applications for license or renewal of license shall be granted or denied and in the discharge of other statutory responsibilities."

The general counsels of both agencies were designated liaison officers and assigned the responsibility of maintaining a flow of information on matters of concern to both agencies. They will also determine when formal meetings are necessary.

The agreement establishes a formal framework for cooperative activities between the two agencies, which have been carried on informally over a period of years. Essentially the FTC is concerned with advertising content, and it has

been FCC policy to forward to the FTC complaints in this area. The FCC's responsibility derives from the fact that broadcast licensees are responsible for all material aired on their stations. The Commission in its policy statement on programing in July, 1960, emphasized that it was the licensee's responsibility to eliminate "false, misleading, and deceptive matter."

In previous cooperative efforts, the Commission has distributed FTC bulletins on questionable advertising to aid licensees in monitoring commercials.

Don't Miss Our Direct Current



Page 4

Continental's new 5-10 KW AM TRANSMITTER SOLID STATE

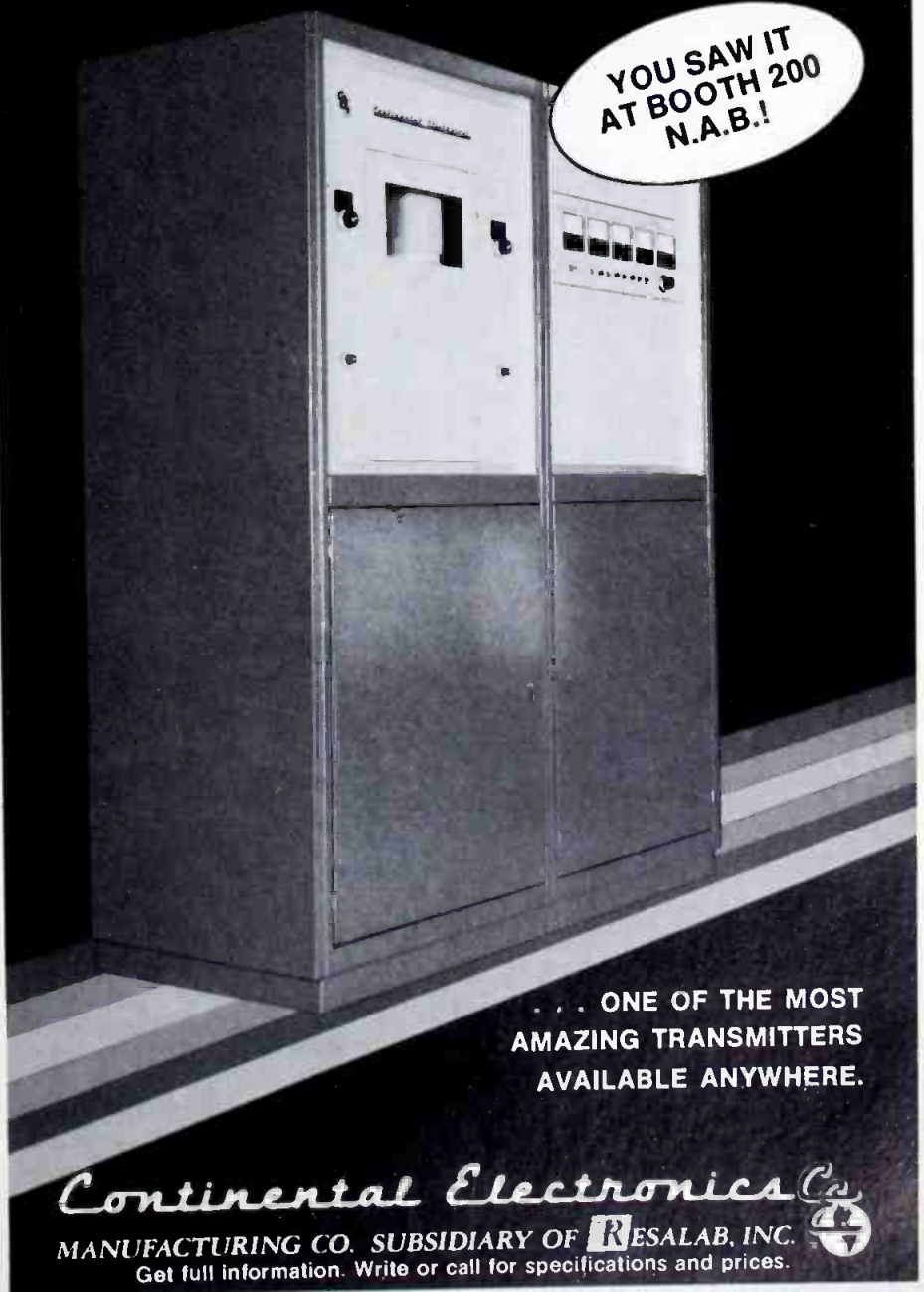
YOU SAW IT
AT BOOTH 200
N.A.B.!



... ONE OF THE MOST AMAZING TRANSMITTERS AVAILABLE ANYWHERE.

Continental Electronics 
 MANUFACTURING CO. SUBSIDIARY OF RESALAB, INC. 
 Get full information. Write or call for specifications and prices.



"MAY I SEE YOUR LICENSE?"

Circle Number 13 on Reader Reply Card

Call Gates for the most complete line of radio broadcast equipment . . . available from three separate centers.

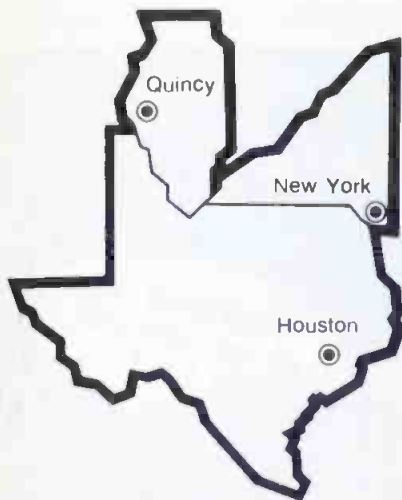

Home Office
and Mfg. facilities
123 Hampshire St.
Quincy, Ill. 62301
(217) 222-8200
Southwest
service center
4019 Richmond Ave.
Houston, Tex. 77027
(713) 623-6655
Eastern
service center
130 East 34th St.
N.Y., N.Y. 10016
(212) 889-0790



Circle Number 14 on Reader Reply Card

FCC Tells ABC Prime Time Is Iron Clad

The FCC has denied a request by ABC for a waiver of the prime time access rule in order to present three and a half hours of Olympic coverage on ten week nights running from August 28 to September 8.

Because of the time difference between Munich, Germany, site of the summer Olympics, and New York, very little of ABC's coverage will be "live." Films of the competition (from 69 to 106 hours daily) will be edited and aired each day. During the entire Olympic schedule, ABC proposed to televise a total of 66½ hours of coverage, including 47 hours during prime time.

The Commission, noting that an earlier request by ABC had been denied in October 1971, because it was too general and asked for a blanket waiver for all the dates involved, said that "it is obvious" that a grant of the new request "would amount to an expansion of network control of prime time . . . well beyond anything we have had occasion to consider in the past

several months . . ." The Commission stated that presentation of three and a half hours of Olympic material on ten evenings is not essential because it would be impossible to completely cover all of the events.

Since most of ABC's presentation will be recorded for broadcast, the Commission said, the program need not necessarily be presented at any particular time. It pointed out that a maximum of prime time programming was permissible even without the waiver. Assuming more time is required, the Commission said, there is "no basic reason" why the material could not be presented later in the evening.

ABC had contended that all of the arrangements for coverage and sponsorship had taken place before the prime time rule was adopted (its contract with the Organizing Committee was announced April 1, 1969; the rule was adopted in May 1970, and became effective October 1, 1971) and were based on three and a half hours of prime time coverage.

NAB Urges New Operator Rule

The National Association of Broadcasters urged the Federal Communications Commission today to adopt promptly its proposal to rescind rules which require radio stations to man their remote control pickups and transmitter links with qualified operators.

Though "laudatory," NAB said, withdrawal of the remote control and STL rules are but a "small fraction" of the steps necessary to bring all of its rules "into harmony with today's operating concepts and technological advancements."

It said the Commission should follow up its initial action by proposing, as NAB has recommended, rule changes that "streamline the operation and utilization" of other broadcast services.

NAB included with its com-

ments a 40-page-plus filing urging the Commission to grant operator relief on such operations as TV remote control, inter-city relays and aural station links.

Radio Appointment

Three broadcast executives have been appointed to two-year terms on the Small Market Radio Committee of the National Association of Broadcasters.

Appointed by Vincent T. Waleski, NAB president, are Arc Harrison, Jr., president and general manager, WJMA, Orange, Va.; William J. Ryan, general manager, WNOG, Naples, Fla.; and A. Rock, general manager, WSMN, Nashua, N.H.

They will serve until the conclusion of the Association's 1974 annual convention in Houston.

Rules Adopted For Multiplex Microwave

Amendments of Part 2 of the rules, concerning methods of determining the necessary bandwidth and the occupied bandwidth for frequency modulated microwave radio relay systems carrying frequency division multiplex (FDM) speech channels, have been adopted by the Commission (Docket 18878).

The changes are important to the manufacturers and users of microwave equipment and are intended to provide more efficient use of the radio spectrum. The FCC said the changes would provide more meaningful methods for calculating the necessary bandwidth and measuring the occupied bandwidth for FM microwave systems.

The Commission stated that it was concerned with the relationships, particularly in certain FDM/FM systems, between base-band loading, message channel arrangements and carrier frequency deviation, and how these factors affect the determination of necessary or occupied bandwidth. The changed rules will apply to equipment type acceptance or to license applications when equipment is to be operated under the specified modulation conditions.



"IS HE A SOLID-STATE ENGINEER, MOM, LIKE DADDY?"

Send Your Industry News To Broadcast Engineering

The present FCC action began with a rulemaking proposal, released June 19, 1970, suggesting two formulas to be used in specifying the root-mean-square noise loading for testing and in calculating the necessary bandwidth for transmitters carrying multi-channel telephony.

As a result of comments received in the proceeding, the Commission said, it had made sev-

eral changes in the rules stating a standard method for determining necessary bandwidth, including the determination of the peak deviation of frequency modulated microwave relay systems, loaded with a base-band of single sideband, suppressed carrier, telephone message channels. Appropriate definitions and an exception to the formula for necessary bandwidth are also included.

Yours truly... STAINLESS

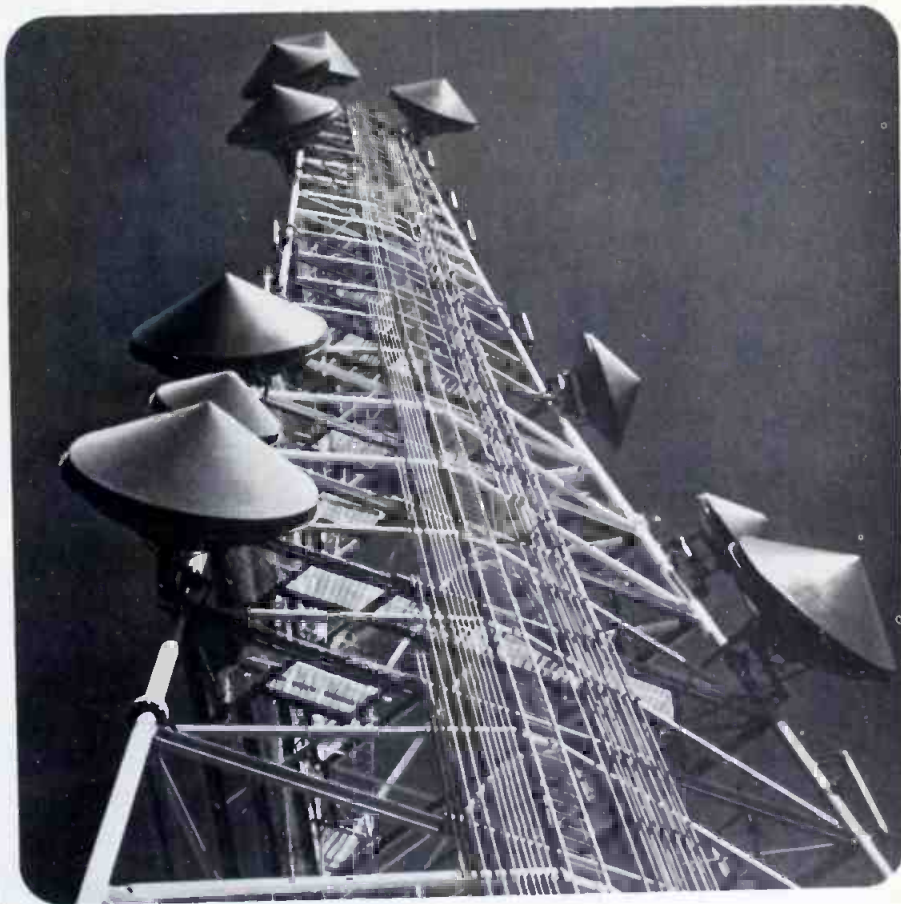

MICROWAVE TOWERS by Stainless are built to *your* requirements. They're designed for you. You don't have to settle for tradeoffs in a tower that's not quite what you need or much more tower than you need ... just because it's somebody's stand-

ard design. The TAGER Tower in Richardson, Texas (pictured above) is a good example. It's built for now and future requirements. When it's a Stainless Tower It's Yours truly ... truly yours.

Stainless, inc.



North Wales, Pennsylvania 19454 • Telephone—(215) 699-4871
In Canada: Walcan Ltd., Toronto 12, Ontario
Tall Towers for TV, CATV, ETV, Radio and Microwave

Circle Number 15 on Reader Reply Card

above and 15 dB below normal will be within range of the AGC amplifier.

Disadvantages

The straight AGC amplifier does have its shortcomings. For successful operation, the input levels should be continuous and not vary too greatly in level extremes. Should the program material contain long pauses, whatever compression has been put into the amplifier will become expansion, even to the point of full amplifier gain. Circuit noises, background noises or crosstalk can be raised to a very undesirable level. When the program level hits again after high expansion, the amplifier will go into deep compression. The resulting noise and level variations in the program heard after the AGC has taken place is known as the "breathing effect." If the amplifier

is misadjusted, this effect can be heightened. For example, if the amplifier is adjusted so that normal program levels cause 30 dB of compression, in the absence of input signal, the amplifier gain will expand 30 dB!

The Gated AGC

The breathing effect is overcome to a large extent in the Gated Type AGC amplifier. The compressor and expander sections, although operating the same variable gain stage, are separate sections. The expander has its own buffer amplifier, rectifier and operates somewhat differently as its function is the reverse of the compressor. The expander will allow only 10 dB of expansion. Should the amplifier input be cut off, it will not expand to full gain. Instead, it will return the output level to normal level.

The control bias from the ex-

pander may control the variable gain stage either directly or indirectly, depending upon amplifier design. In one type circuit, the bias works against a control stage, and this control stage operates the variable gain stage. The gate (threshold) voltage on the expander rectifier will prevent it from operating until the input level drops low enough for this gate to be overcome. The control amplifier shares a common cathode resistor with the variable gain stage which normally holds the variable gain stage in 10 dB compression. The expander control voltage when in operation, will cause this control tube to shut off, removing the 10 dB of compression, which in the output circuit is 10 dB of expansion.

When compression takes place the expander bias is off and allowed to leak off. Should the input level to the amplifier be cut off, the expander cannot operate until the signal comes within range so its threshold can open the gate. Of course, without signal, the compressor is also inoperative, and the amplifier gain will drift back to normal. Many of the most modern AGC amplifiers use some form of gating, although it may be called by another term.

The Memory AGC

This type of AGC contains some other refinements over the Gated AGC and contains memory or storage circuits. Besides the normal AGC actions, these also offer advantages in programming that contains long pauses, such as in dramatic presentations.

The first memory constantly stores level information and another circuit compares the present levels with those of the preceding 10 seconds before a "decision" is made to change the gain up or down. This feature is helpful in bridging long pauses without level variations occurring as would happen in a straight AGC. The 10 second delay will bridge these gaps nicely and maintain an even level on the output.

The second memory comes into operation after there is a 10 second pause or longer. Once it senses there is a very long pause, it will

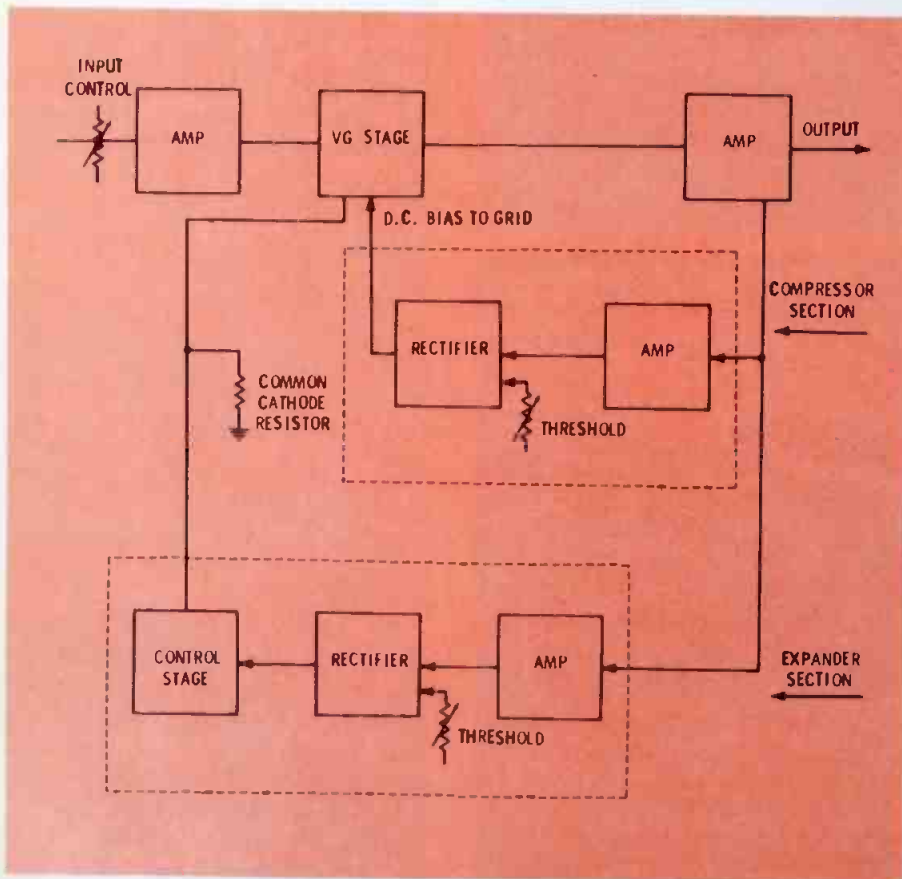

Fig. 4 A gated AGC amplifier. Compressor section works in normal fashion. Expander control stage shares common cathode resistor with variable gain stage. Control stage works during compression, adding 10 dB compression. When program level drops below expander threshold, bias rectifier shuts off control stage, allowing the 10 dB added to be removed, and this gives 10 dB expansion—the maximum that can occur.

Know your exact frequency at a glance.

Model 100B (FCC No. 3-172)
For standard broadcast
Freq. range: 5 Hz-40 MHz
5 or 7-digit display
Price: 5-digit, \$575



Model 105A (FCC No. 3-185)
For AM, FM, TV (all ch.), VHF
Freq. range: 5 Hz-512 MHz
7 or 9-digit display
BCD output
Price: 7-digit, \$1550

Model 101B (FCC No. 3-174)
For standard broadcast
Freq. range: 5 Hz-50 MHz
5 or 7-digit display
BCD output
Price: 5-digit, \$695



Model 114A (FCC No. 3-186)
For AM, FM, VHF, TV (Ch. 2-6)
7 or 9-digit display
BCD output
Price: 7-digit, \$995

Frequency monitoring with a Monsanto digital counter is not just faster and easier than with analog instruments—it's instant and effortless. And more precise. Monsanto counters are FCC Type Approved for frequency monitoring. In addition, they can provide a full range of counter functions for other test and measurement jobs at the station.

Crystal controlled clocks and extensive use of ICs insure accuracy and long-term reliability. Automatic positioning of decimal point takes the element of human error out of measurements. Finally, Monsanto counters are modestly priced. For complete details, mail the coupon today. For a demonstration, call your local Monsanto representative.

What was your frequency at 10:35:27 last Tuesday?



Counter Models 101B, 105A and 114A provide BCD output. In combination with our 511A Printer and 505B Digital Clock, frequency and time are printed on paper tape at any desired interval, giving you a permanent record.

All prices f.o.b. Dayton, Ohio

Monsanto

United Systems Corp.,
a subsidiary of Monsanto Co.
918 Woodley Road
Dayton, Ohio 45403

Mail Data File on instruments for frequency monitoring

Have your rep phone me for an appointment

NAME _____ TITLE _____

FIRM _____

STREET _____

CITY _____ ZIP _____

Circle Number 16 on Reader Reply Card

slowly drift the amplifier output level to its normal level. This is sometimes called a "reset to zero function."

The memory AGC does have one disadvantage. Some stations use a 10 second announcement. If the announcement had low levels, some or all of the announcement could be "in the mud" before the memory "decided" to change the gain.

General Shortcomings

AGC amplifiers are not a cure-all for program level problems. When misadjusted or operated improperly, they can compound level problems. A properly adjusted amplifier will greatly assist in maintaining relatively constant program average levels. As with most equipment, the AGC amplifier will provide its most satisfactory performance when operated within its normal limits.

Since low program levels will be expanded or increased and high levels will be compressed or lowered, the dynamic range of the program content will be narrowed. This narrowing of the dynamic range will detract somewhat from many musical type programs where a wide dynamic range is often preferred.

There is still another shortcoming, but this is mostly psychological. Many operators and announcers tend to lean on the AGC as a crutch. Consequently, very little or no attention is paid to levels at all. When levels are allowed to go outside the range of the amplifier, the AGC cannot be expected to correct them properly. When such conditions are allowed to occur, the defects in the program are sometimes very obvious.

The more sophisticated AGC amplifiers are attempting to cure many of the normal AGC shortcomings. It is a difficult job because of the great variety in program formats. To allow for greater variations, more controls and functions are being made adjustable. For example, there is both an input and an output level control, and the time constant is made selectable by a front switch to provide a short,

medium, and long. The expansion and compression may be switched on or off individually.

Location

AGC amplifiers can be placed in any program path in which some automatic control over the levels is desirable. These are most generally medium to high level units and can be placed in paths with levels from -30 dB to +30 dB. The first obvious location is the program line to the transmitter. When placed in the transmitter program line, the AGC amplifier should be followed by a peak limiter or peak controller. The AGC should be adjusted to control the average program levels, with the limiter handling the peaks. The time constant of the limiter should be very short, and only 1 to 3 dB compression active on peaks. If the Limiter is a regular unit and if the time constants are selected for long values and greater compression levels, the Limiter begins to act more as an AGC and less as a Limiter.

An incoming remote broadcast line is another often used insertion point for an AGC amplifier. In many cases, non-broadcast people are handling the remote location, as in church remote. These may even be feeding the program from their PA System. Announcers on sports broadcasts sometimes hit it hard on exciting plays and the program levels vary considerably.

A recording booth, or recording equipment lineup in the Control Room can use an AGC amplifier to advantage. Quite often, incoming remote or network programs must be recorded for playback later. This recording is usually done while other programming is on the air. During such times, it is difficult for the Control Room operator to maintain complete level control over both programs at the same time.

Operation and Maintenance

The first step, of course, is proper setup according to the instruction manual. All models are not identical, so adjustments should be made according to your amplifier.

System levels should be set up and adjusted with the AGC in

mind. The amplifier is designed to operate over a given range of input levels and will provide a given range of output levels. Many amplifiers have adjustable input and output pads, while others require external pads. Some of the newer models also provide an output control on the amplifier itself. Input and output levels should be adjusted so that the amplifier control can be operated at midrange. If the external levels will not permit this, pads should be added so the level will fall within this range.

Some amplifiers also incorporate a bypass switch, so that the amplifier can be bypassed should it fail. This switch connects the incoming line with the output line. When an amplifier is so equipped, it is wise to have both the input and output lines at about the same levels. When this is done, should it become necessary to bypass the amplifier, there will be no disruption of system levels. There can be a problem in this area if the pads in use are external to the bypass switch. By-passing in this case would insert the pads in the circuit and drop the output levels, resulting in a wild-scramble to readjust system levels.

How the amplifier is set up is most important to its operation. The initial setup adjustments can be made while using a tone as a program source. This will permit all controls to be set and adjustments placed somewhere near the specified values. Most of the older type amplifiers have only an input level control, and no output control. The input level should be adjusted with pads, if necessary, so that the input control can operate at midrange. It is better to use pads than to adjust a previous amplifier and thus upset system standard levels. If the system levels can allow the AGC control to operate at midrange without pads, so much the better.

With the input levels set and the input control at midrange, the compression should be that which is normal. Most AGC amplifiers have a compression meter or some other means of measuring the amount of compression. At this compression level, the amplifier

output should be that specified in the manual.

If the amplifier has an adjustable output control, it should be set at midrange for correct level. And if this output level is higher than the system standard, pads should be used to drop it to the system normal. When there is no output control, the output must use pads to reduce the output. If the input level is dropped, the amplifier will not be operating properly.

At this point, the amplifier is set up within specifications according to sine wave input. Since programming is a complex waveform, final adjustments to the AGC should be made using selected program material. Select material that has a reasonably controlled program level, such as a good record and one that does not have too great a dynamic range. Feed this through the system, setting the console VU for proper peaks. Observe the meter on the AGC amplifier. This meter should be fluctuating gently around the normal reading. If not, touch up the AGC controls until it does. Next, increase the output from the console to the maximum expected overage and observe the AGC meter. There should be greater compression.

Now, reduce the level on the console well below peak level, but still within range of the AGC. Expansion should take place. If the AGC is of the Gated Type, drop the console level to zero, the expander should not expand to full gain, but rather return the compression to the normal position. That is, the meter should rest at the position it reaches when the console is hitting normal peaks on the console.

Next, pick a musical selection which contains a wide variation of levels, observe the AGC while it is controlling this type of material. If the compression and expansion are where they belong, the amplifier is ready for general program material.

When one of the new models with everything adjustable is set up, besides the normal setups required, they should be touched up for the type program format a station uses. If Top 40 music, a shorter time constant may be used, while an average format may use a

medium time constant, etc. The point of this: If the station has a Top 40 format, check it out on this material rather than a classical number. If all classical, don't use top 40 music to make the final adjustments.

AGC amplifiers often are used in the program line of FM Stereo stations. As with all stereo channels, each channel should be as identical. The setup procedure is the same, initially, as for a single system.

The initial setup should be with each AGC amplifier and channel separated from the other. Each should have identical compression and expansion ratios, and the input and output levels should be identical. If the input and output controls

have markings, check these out to see if they read the same on both amplifiers. Sometimes, these do not agree. If they do not agree, the final settings should be written down and saved for future reference. Someone may come along and see these controls set at different markings, and thinking he is balancing the amplifiers, set them to the same markings.

There has been some controversy over how the amplifiers should be operated: independently or tied together. The author prefers to operate them tied together so that the channel with the highest level will take control of both AGC amplifiers. To tie the two AGC channels together, a simple jumper is run between control busses. Many

(Continued on page 52)

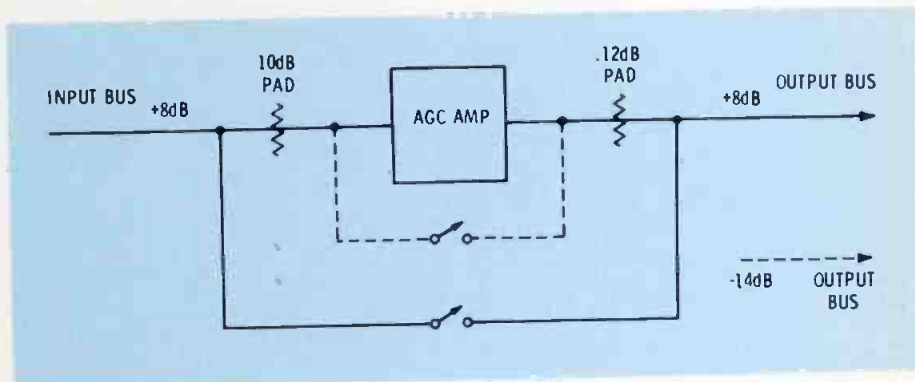

Fig. 5 By-pass switch should be wired as shown in solid line. Bypassing the AGC would cause no level changes on the output bus. Dotted line bypassing of AGC will insert both pads in output bus, dropping bus level by 22 dB.

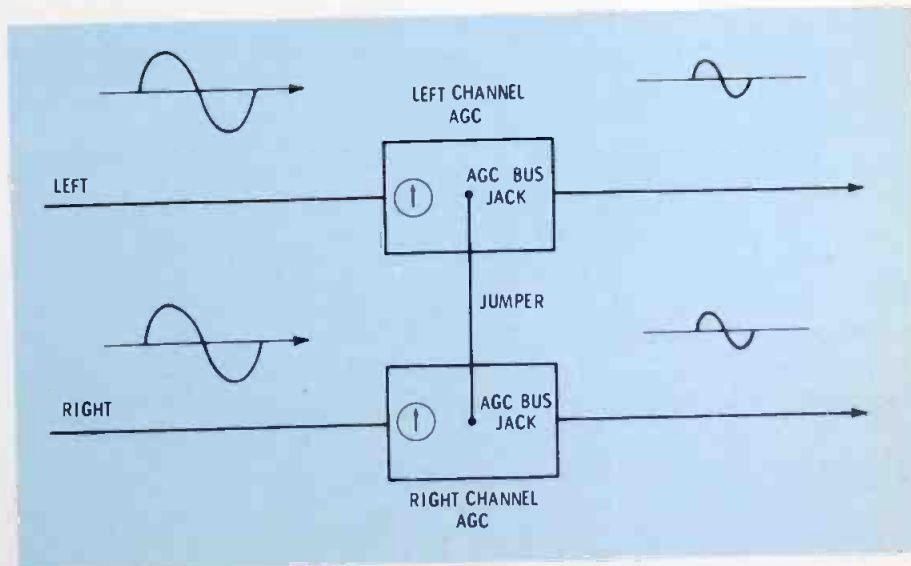
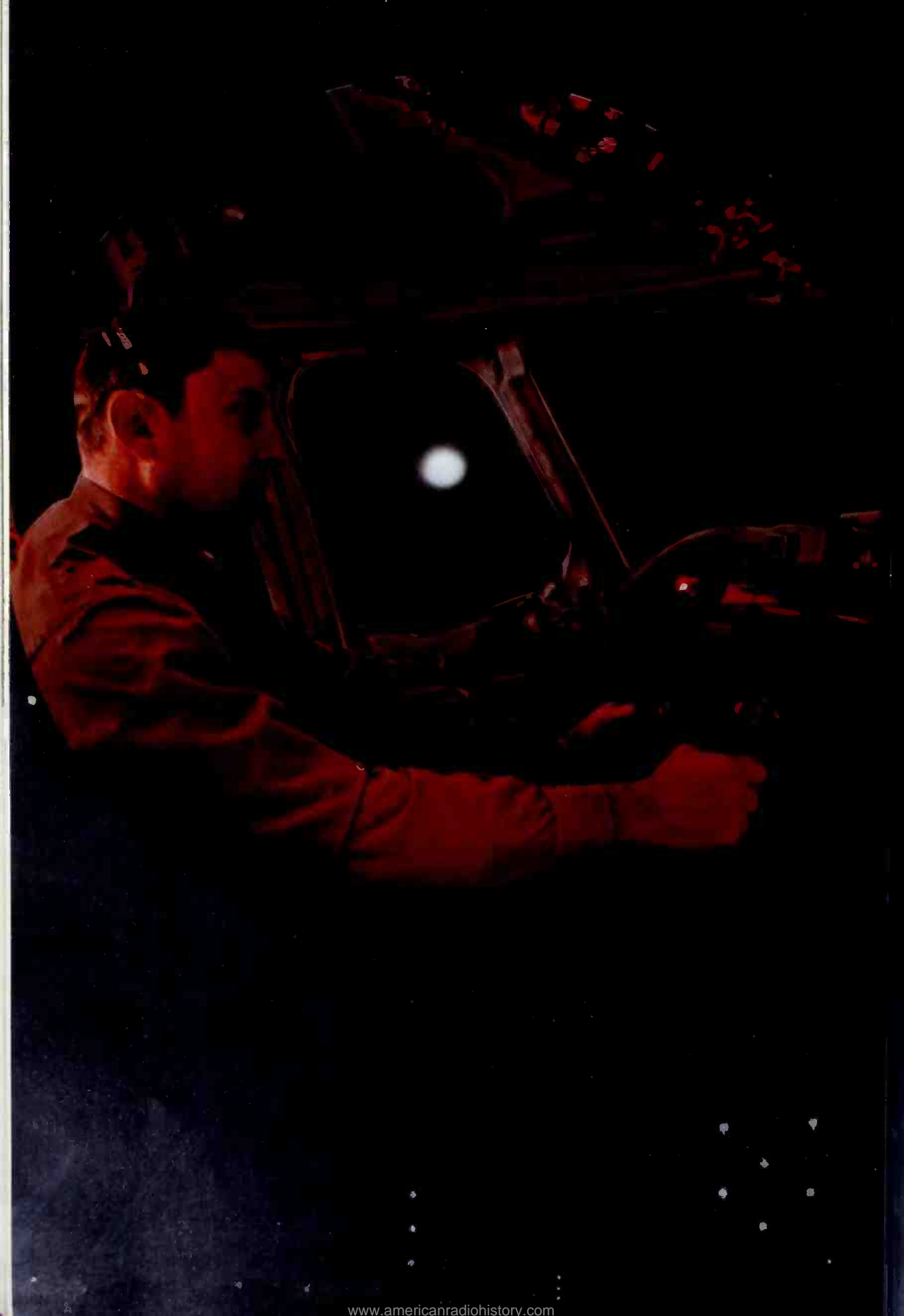

Fig. 6 Two AGC amplifiers used together for FM stereo. The AGC control bus of both are tied together. The channel with the highest input assumes control of both channels. Compression meters show identical compression.



a warning that comes through miles and seconds sooner

New. FAA approved. Strobe-Beacons.

A day/night warning system that delivers a high intensity xenon flash. Quick, pulsating, bright, white light. Easy to see. Instantly understandable. Perceptible miles and precious seconds sooner in fog, smog, haze, or blinding weather.

During the day, under near zero visibility, can be seen many miles away.

Eliminates the need for "candy striping," the cost of painting and upkeep. Day or night, when and where a mere wink of a warning isn't good enough, this is the answer:

Strobe-Beacon warning systems.

A product of Dielectric Communications Division of Sola Basic Industries, Raymond, Maine 04071. Write for Strobe-Beacon Bulletin 101.

Circle Number 17 on Reader Reply Card



Strobe-Beacon warning systems are approved by the FAA (Specification L-856). Feature: Automatic day/night switching. Fail-safe solid state circuitry. Light weight aluminum enclosures. Individual monitoring and control of each flash head. Automatic standby timer "take over" in event of primary timer failure.

Strobe-Beacon System A

Designed for use on communication towers, chimneys, pole structures, high-rise buildings, etc.

Flash-rate: 40 per minute

Day output: 200,000 candelas

Night output: 1,000 candelas

360° horizontal coverage, 10° vertical beam, simultaneous flash.

Strobe-Beacon System B

Designed for use on catenary supporting structures

Flash rate: 60 per minute

Day output: 100,000 candelas

Night output: 500-1,000 candelas

180° horizontal coverage, 10° vertical beam, sequential flash.



Fig. 1 Front view of the WSTM facility, a special design for FM radio.

WSTM makes its move

By Charles R. Strickland*

When WSTM started operations about five years ago, we occupied small converted offices which soon became inadequate. As the day approached when it would be possible to move into new quarters, much time and effort went into research and planning so that the new facilities would be a pleasant and efficient place to work. A plan developed which has pleased everyone at the station.

Various possible locations for the new studios were explored. The site finally selected is in a new office complex which offered ample parking, a flexible floor plan, easy access, and the possibility of placing the studio areas at the end of the building in order to minimize sound leakage problems. One of the factors involved in the choice was that we would be able to erect a sign proclaiming our presence to the 60,000 cars per day passing on a major expressway.

*Chief Engineer, WSTM, Louisville, Ky.

Planning started with the studio areas. The position of the showcase control room was obvious, facing the expressway and at the end of the building. A sound lock was included, and it was made large enough for the water cooler, soft drink machine, and coffee bar to be convenient for the announcers. The restroom is only steps from the control room. Next to the control room is the news room, placing the teletypes close at hand. The production room also opens into the sound lock.

Ample space was provided for present and future office needs. All offices feature panelled walls, carpeting, and acoustic ceilings. The receptionist's desk was placed so as to give her a clear view of both the front and rear doors.

Studio Construction

After much discussion with the architect in charge of the office complex, we decided on the type of studio wall construction. First, two-by-four stud walls were built.

These were filled with fiberglass sound blanket, then covered with half-inch insulation board. Next, half-inch wallboard was mounted by means of R-C channel, springy metal strip which prevents sound conduction through the walls and also creates a small dead air space.

Over the wallboard we installed two-inch Tectum. This is a dense fibrous panel which was designed for sound control, and is very effective in deadening the studio. Painted an off-white, the Tectum forms the finished walls. Its appearance seems rather strange at first, but actually the effect is rather pleasing. One word of caution when building soundproof walls: Be sure all corners are given special attention. Earlier experience indicated that if there is going to be a sound leak, it will probably be at a corner.

The studio suspended ceiling and walls are soundproofed with a thick layer of sound blanket. Windows between studios are double ¼" pla

... with an air space between, floors are carpeted, and the doors are solid core.

We were fortunate in that four separate heating-air conditioning units were standard for an area of that size, so it was a simple matter to put the control room and production room on different units. This eliminates any chance of sound leakage through the ductwork.

Two conduit systems were installed, one for audio and the other for control and miscellaneous circuits. There is a junction box for each conduit system in the control room, news room, and production room. The audio conduit contains shielded pairs, while the control conduit contains 25 unshielded pairs. Using this system, adding wiring from one room to another is simply a matter of connecting to the barrier terminal strips in the junction boxes.

In order to get the wiring to the control room equipment it was

necessary to raise the floor about four inches so that conduits could be run under the floor to the center of the room. Boxes set in the floor carry audio, control, power, telephone and monitor antenna circuits to the operating position. The two-by-fours holding the raised floor were anchored to the main concrete floor, then filled with tar for added firmness.

The Control Room

The first consideration in the control room design was human engineering. All controls were to be arranged logically and conveniently, and everything needed by the announcers was to be within easy reach. Two Sparta dual turntable cabinets were placed on each side of the announcer's position. In addition to the turntable, each cabinet contains a cutout which makes a very nice bin for albums. Wire dividers supplied with the cabinets separate each bin into three sections. It was decided to eliminate

all equipment racks, so the rack space provided in the bottom portion of the turntable cabinets was used for the RF amplifier, frequency monitor, modulation monitor, EBS monitor, remote control unit, pilot frequency meter, and house monitor amplifier.

Our Collins board was raised to allow placing a pair of lighted switches under each mixer. Thus, the start and stop controls for each turntable and cart machine are just inches away from the associated mixer.

One cart machine was placed on each side of the board and a 100-cart storage rack was mounted on top of each machine. In this way the carts are in full view and within easy reach. A reel-to-reel tape recorder was placed at the end of the left turntable cabinet, equipped with casters and multi-pin connectors so it can be moved into the production room or news room if needed.

The control room desk was con-



Fig. 2 Wendell Phillips at the controls in the showcase control room. See Figure 3 for room layout and dimensions.

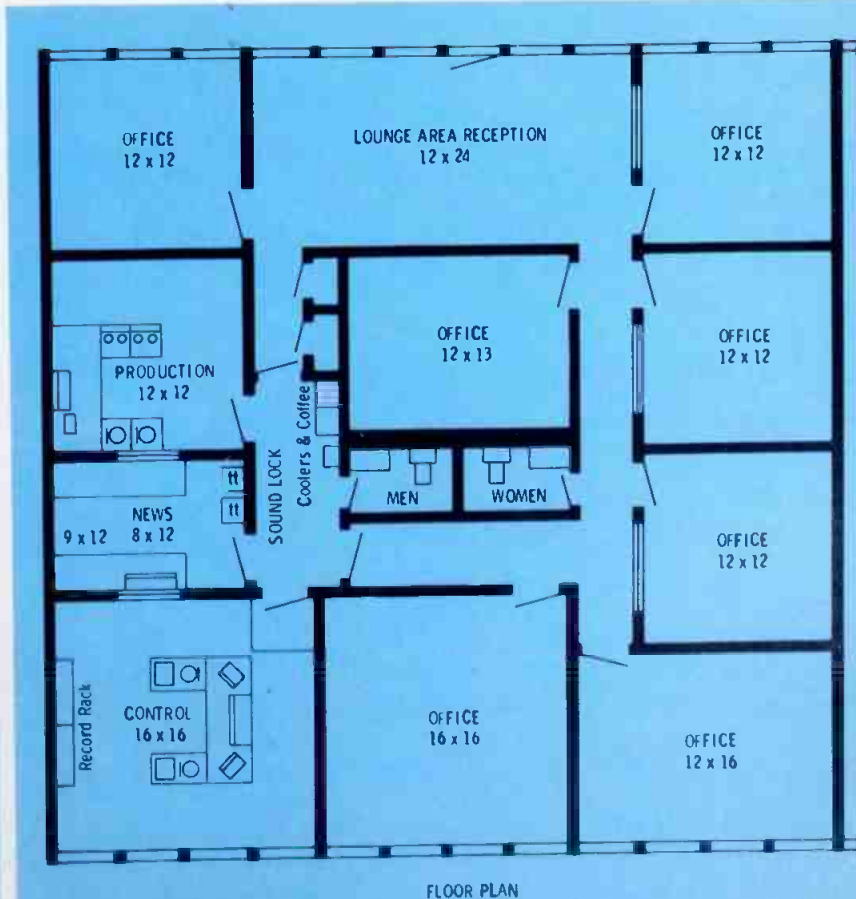

Fig. 3 The WSTM-FM facility layout.

structed of half-inch plywood and covered with Formica. The extra expense of the Formica is an excellent investment, as it will take the punishment which it certainly will receive. All wiring is concealed within the cabinets and desk.

In The News Room

Like any news room, the one at WSTM tends to be a busy place. In addition to UPI Audio, we have an Associated Press teletype, a weather wire, a beeper phone, a mobile unit, and two scanning monitors covering sixteen channels. It was necessary to mount one monitor receiver on each end of the desk to prevent confusion when both are active. A cassette recorder has been quite satisfactory for news operations.

Remote controls allow the control room cart machines and reel-to-reel recorder to be operated from the news room. The small news room mixer also serves as a line amplifier for a weekly church remote broadcast.

Our broadcast telephone loops all terminate in the news room, allowing the telephone company to make line changes without disrupting control room operations.

Production Room

The production room board was once a monaural Gates Producer.

A second program amplifier was constructed, the built-in monitor amplifier became a cue amplifier, and stereo monitor amplifiers were added. The original pots were replaced with professional attenuators with cueing. One mixer is permanently assigned to a stereo mike input; each of the other three mixers has its own ten-position selector switch. Through this arrangement, any one of the ten inputs to the board can appear on any mixer. A tone generator is provided for balancing.

A panel mounted in the top of the desk contains start and stop switches for two turntables, a cart machine, and two Scully stereo recorders. One Scully has multi-pin plugs so it can be moved out of the production room should more space be needed. Cables are provided so that the control room tape recorder can be quickly added if a third machine is needed. One office has been provided with mike connectors for use as an auxiliary studio.

Transmitter

All but the basic equipment has been eliminated from the remote transmitter location, placing everything possible at the studios for ease of maintenance. Equalized phone lines drive the mostly solid-

state stereo transmitter through FM stereo Volumax, eliminating most tube failure problems. The remote control unit, monitor amplifier, and tower light control panel complete the equipment complement. A dual-polarized antenna system was recently installed, with great results.

Several months of operation have shown our plans to be as good as we had hoped, proving the value of planning sessions in which the announcing, engineering, and office staffs all participated. Although our studios are part of a large office complex, a similar layout could be used in a station-owned building.

Editor's Note: WSTM has developed a practical station facility. Most important though is that they placed a high priority on soundproofing the studios. In some locations this is not enough. If heavy traffic rolls past your door, you should pay as much attention to your floors and equipment mounting.

If you have made major facility changes that were designed to put your station out of the dark ages of broadcast layout designs, we'd like to hear about it. We do pay for articles. Write to **Broadcast Engineering**, 1014 Wyandotte, Kansas City, Mo. 64105.



Fig. 4 The author and Chief Engineer doubling as newsmen. His window opens on the control room. Record stacks at back of control room are visible.



Fig. 5 Down the line from the control room and the news room program director Allen Brown and Sharon Hancock put together a spot in the production room.



**GE's 8572V4 Vidicon for PE 240 Film Cameras ...
THE HIGHEST STANDARD OF EXCELLENCE
FOR THE FINEST TELECINE PICTURES!**



GENERAL  ELECTRIC

www.americanradiohistory.com



GE's 8572V4 Vidicon . . .

- Has an extended faceplate that minimizes flare, actually improves picture sharpness and contrast.
- Is designed to meet the system requirements of each channel, both optically and electrically, to assure matched signal output and precise tracking for the "best possible" color fidelity.
- Is available as a matched set. Each vidicon is tested to very stringent quality and performance specifications on:
 SPURIOUS SIGNALS DYNAMIC TRACKING GEOMETRY
 AMPLITUDE RESPONSE UNIFORMITY
- Has been proved in the field since 1968 and is the highest standard of performance you can buy for the finest pictures your PE 240 film camera can deliver.

GE MATCHED VIDICONS WITH EXTENDED FACEPLATE ARE ALSO AVAILABLE FOR OTHER FILM CAMERAS

CAMERA MODEL NO.	CURRENT TYPES	MATCHED VIDICONS	QUANTITY (PER SET)	COMMENTS
PE 240	8572V All Channels	8572V4 Luminance 8572V4 Red 8572V4 Green 8572V4 Blue	4	All Channels Modified for Separate Mesh Vidicons
PE 240	8572V Luminance 7038 Chroma Channels	8572V4 Luminance 7038V4 Red 7038V4 Green 7038V4 Blue	4	Direct Replacements Each Vidicon Channel Matched
PE 24 TK 26	7038V All Channels	7038V4 Luminance 7038V4 Red 7038V4 Green 7038V4 Blue	4 3 (TK 26)	Direct Replacements Each Vidicon Channel Matched 7038V4 Luminance (PE 24 Only)
TK 26	8572 or 8572V All Channels	8572V4 Red 8572V4 Green 8572V4 Blue	3	Direct Replacements Each Vidicon Channel Matched

For pricing and availability information, contact your GE Distributor; for technical or application information, contact E. T. Chace, GE Imaging Devices Operation, General Electric Co., Syracuse, N.Y. 13201 Circle Number 1 on Reader Reply Card

GENERAL  ELECTRIC

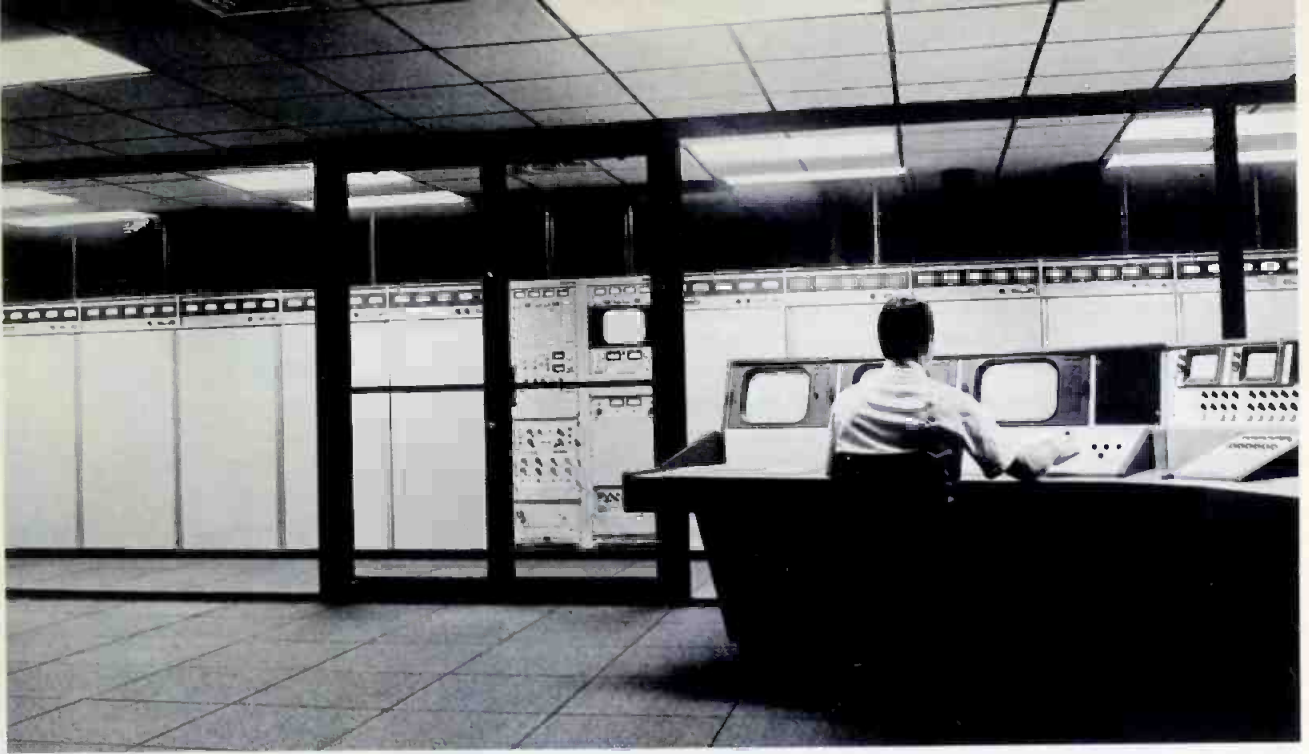

Fig. 1 With 35 kW Gates transmitters behind glass, the new control room lends itself to the professional attitude of educational KETC-TV.

KETC takes unique facilities approach

Using film and video tape equipment at the transmitting site makes KETC a breed apart as to how goes into a full color operation.

With the recent completion of the KETC-TV Broadcast Center in St. Louis, Mo., an entire new concept in broadcasting facilities has been introduced.

KETC-TV, the Educational TV Commission Station, Channel 9, serving the St. Louis area is now operating from one of the finest transmitting plants in the country . . . one which is fully equipped to accommodate not just transmitting and terminal equipment, but also houses playback film and tape facilities, automated video and audio switching and network line terminals normally located at the studios.

The inclusion of the film and tape equipment at the transmitting site sets the KETC-TV Broadcast Center apart from normal transmitting facilities. Some 95 percent of the KETC-TV programming is film, tape and network origin which emanate from the Broadcast Cen-

ter. The 5 percent of live broadcasting, produced at the studios at 6996 Millbrook in St. Louis, is micro-waved to the Broadcast Center via the passive reflector to the microwave receiving antenna at the base of the tower, then by waveguide into the building.

Companion to the film and tape facilities is automated switching which, according to Jack Vines, KETC-TV director of engineering, "improves the air look through smoother video and audio switching, allows clean transition between programs and IDs and synchronizes program timing and network joining."

In effecting the \$1,350,000 refurbishing of KETC-TV facilities, the board of trustees and Robert C. Glazier, executive director for St. Louis Educational Television Commission, working in conjunction with Mr. Vines, have been guided by one common goal . . . the construction of a first class operation.

From studio equipment to transmitters, everything is new. There has been no upgrading of the anti-

quated monochrome system with which KETC-TV has been operating since its inception in 1954 and no attempt to utilize the transmitting equipment located atop the Boatman's Bank Building in downtown St. Louis.

Today KETC-TV beams color transmission twice the strength of its previous monochrome signal to an area of 60,000 miles, tripling its coverage in the grade B area and encompassing territories hitherto untouched by public television. Now Channel 9 reaches more than two and one-half million viewers in the grade B area alone and well beyond via CATV.

At the heart of the installation are two Gates' BT-35kW color television transmitters which operate in parallel and feed a combined 40.7 kW output into the antenna atop the newly erected 1,073 foot tower, for a full 316 kW effective radiated power.

The TV transmitters operate in parallel, supplying complete redundancy, which affords KETC-TV a transmitting system designed to operate without loss of air time.

The transmitters were the first items shipped to the KETC-TV Broadcast Center. Installation began before completion of the building. Construction of the block type Broadcast Center was started in the autumn of 1970. Occupancy began in April and the station began color-telecasting in November.

Architect Richard P. Stahl of Springfield, Mo., working from specifications mapped out by Vines, designed the three level, 9,000 square foot building which is constructed of tri-score blocks.

Housed on the first floor of the Broadcast Center are the control room, the glassed-in transmitter

room, the film and tape room and the engineering shop.

The blower systems for the transmitters are housed in the lower level beneath the glassed-in transmitter room. The system is unique in that it could be located within the transmitter cubicle space were at a premium.

Also housed on the lower level are the electrical equipment room, the machine shop, maintenance room, telephone equipment room, full bathroom and carport.

The upper level accommodates the storage area and a Gates multiple transmitter RF switching system, one of the first of its size and complexity, and the RF transmission line leading to the antenna array.

A permanent monorail from the tower to the switching room is incorporated for lifting large pieces of equipment into the building and from the building to the tower elevator for transportation up the tower.



Fig. 2 Film and tape room shown here includes computer flooring and acoustic ceiling.

If you are contemplating a switching system, you should take a look at DYN AIR's Series-5100 equipment.



BASIC 20X5 MATRIX

That's right. Take a look at the Series-5100... take a look at the leader. Take a look at the equipment used in many of the world's largest video switching systems, including numerous critical aerospace, military and broadcast applications.

You'll find a very flexible package which is designed to simplify assembly of systems of virtually any size or configuration, and with most methods of switch control. And a complete machine-control capability too. A total system concept, designed to fill your needs, regardless of the complexity of your requirement. And, if you desire, we will design your system, rack it, wire it and test it as a system. Custom control panels are no problem either.

We manufacture a variety of other switching equipment too, including a full line of inexpen-

sive production switchers, 70-MHz computer-controlled IF switching systems, and solid-state video switching systems for bandwidths of greater than 50 MHz, with full equalization of all video paths.

Whether you need a local-pushbutton-controlled 12X12 matrix, or a 500X500 computer-controlled audio-follow system, your best bet is DYN AIR.

So leave your problem with the experts... send us your requirements today. We'll fire back a design and quotation with a realistic approach to the solution.

DYN AIR ELECTRONICS, INC.

6360 Federal Blvd., San Diego, Calif. 92114
Telephone: (714) 582-9211

DYN AIR

Circle Number 18 on Reader Reply Card



Fig. 3 Note the elevator waiting at the platform. Also, a permanent monorail is shown coming toward the building from just above the tower elevator.

A unique feature in the planning of the KETC-TV Broadcast Center was preparation for the inclusion of a second educational television channel . . . Channel 40, the UHF channel which has been allocated to the St. Louis area by the FCC.

Although the installation of Channel 40 may be some two to three years in the future, the facility was designed to house a second channel at minimum additional cost.

KETC-TV's first class operation is reflected in more than just its facilities, its equipment and its expansion program . . . it is enhanced by its attractive coordinated interior decor. Gates' BT-35H transmitters have figured importantly in the KETC-TV Broadcast Center in ways other than just transmitting signals. The cabinetry, finished in "Gates' beige", has determined the color of all equipment in the adjoining control room, adding uniformity to the decorating.

Medusa plaster, painted an off-white, covers the walls and is accented by flat black trim used on the doors, trim and the exposed pipes and tubes. To amplify the modular appearance of the building, recessed black grids support the acoustical ceiling. The same grids are repeated in the computer flooring. Red carpeting covers the removable blocks of the floor, which has been designed for easy access to the crawl space beneath. This crawl area, which houses cables and doubles as a cold air return, eliminates the need for cable trays and trenches.

The sixth educational television channel to begin operation in the United States, KETC-TV is supported by the St. Louis County Cooperative School Districts, the Arts and Educational Council of Greater St. Louis, membership subscriptions and outlying school districts outside the St. Louis area, which pay a per pupil participation fee.

NEW! for AM A 3rd generation, off-the-air monitor.

Off-the-air monitoring of AM frequency and modulation without an RF amplifier. Less interference from the intermodulation products of unwanted signals. Sensitivity of 2.5 Mv. Frequency stability better than ± 2 Hz per year. Digitally settable peak flasher (to 129% positive modulation).

No other AM monitor gives you more than the TFT 713. And, it's all in one, solid-state, 7 1/2" unit that needs frequency calibration only every five years.

The TFT 713 uses the same advanced technology that has made TFT TV monitors a runaway success since their introduction a year ago: more than 100 TV stations now use TFT instruments.

What's more, the TFT 713 can be converted, at the push of a button, to a general purpose 10 MHz 6-digit frequency counter.

The TFT 713 carries FCC Type Approval #3-195, and meets all applicable requirements for local or remote operations.

So, before you buy any monitor, see TFT's 3rd generation demonstrated on your frequency. Representatives throughout the U.S. In Canada: Tele-Radio Systems. In Latin America: Carvill International Corp.

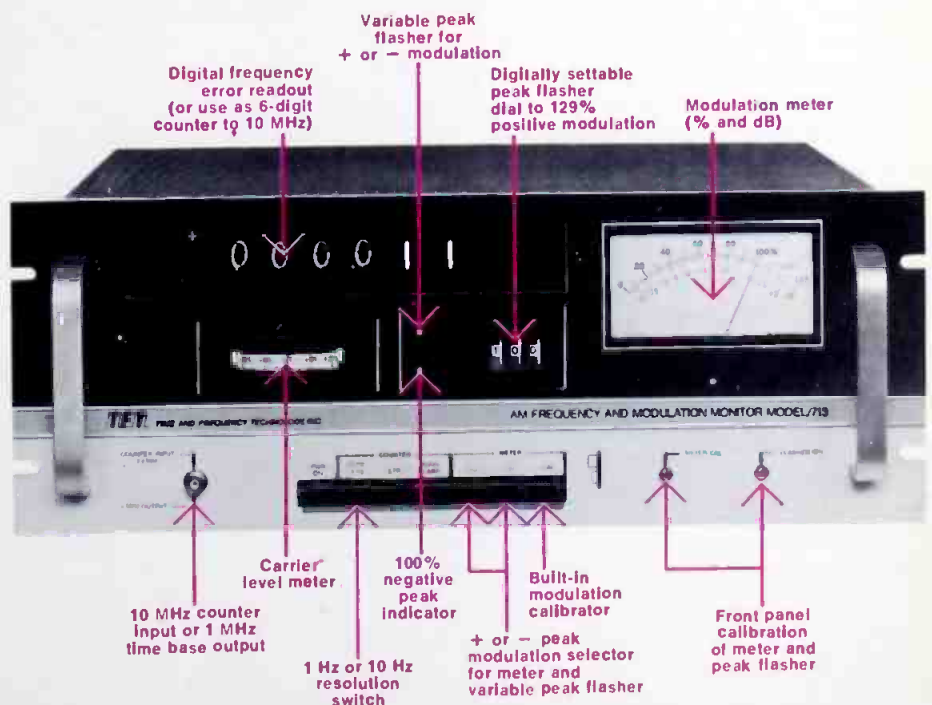

TFT TIME AND FREQUENCY TECHNOLOGY, INC.
2950 SCOTT BLVD., SANTA CLARA, CA 95050 (408) 246-6365

Circle Number 19 on Reader Reply Card

The tools of the trade:

Getting more out of your lighting equipment

By Herb Greele

About the author

Herbert W. Greeley has been, for the past nine years, Lighting Director of The Johnny Carson Tonight Show and has been associated with NBC for the past 23 years. His production credits read like the history of TV itself, starting with Milton Berle, Producers Showcase, NBC Operas and a multitude of quiz shows and commercials.

This article was especially adapted for **Broadcasting Engineering** from one section of a three-day seminar Greeley gave under Kliegl Brothers sponsorship. His participation in the seminar does not imply an endorsement of any company's lighting equipment.

A detailed course curriculum for the Lighting For Television seminar—as well as dates and locations around the country—is available from Kliegl Bros. For a copy, write Mr. Wheeler Baird, Kliegl Bros., 32-32 48th Avenue, Long Island City, New York 11101, or circle Readers Service Card 200.

If you're going to be a Lighting Director in television, or if you're simply going to be "the guy who does the lighting at the station", one of the basic sets of facts you must know is what the tools of the trade are.

While there are a lot of lighting instruments from which to choose, most of what you see used in TV stations around the country fall into one of three categories: Scoops, Fresnel spotlights, or Klieglights.

Each is used for a different purpose in television broadcasting. This article summarizes the capabilities of each of these three categories of instruments and offers some tips on how to use them.

Scoops:

For General Or Base Lights

Walk into nearly any television station in the country and look up—you'll see more scoops hanging from the grids on the ceiling than any other single type of fixture. In fact, the quickest way to see where the main set in a studio is located is to see where the scoops are aimed.

Scoops are used to provide a smooth, soft, general light. Though manufacturers provide them in a variety of wattages, you see more 1,000 Watt and 1,500 Watt units than any other type.

A scoop does not focus. It simply floods a scene with diffused light. That doesn't mean it's uncontrollable, since there are two methods for adjusting the light output of a scoop. You can dim it, of course, on your dimmer control system; or you can put a spun glass filter, also known as a scrim, on it.

When dimming any front light

you should stay within a 300°k drop in color temperature, which means dropping to 7 points from full on your potentiometer. Dimming below this point will cause, in the case of a 3,200°k lamp, a "blue lamp" to turn "red". This could result in considerable trouble for the video engineer in color balancing his cameras, especially involving flesh tones.

Second, the scrims are fine for further diffusion of the fixture, although they usually reduce by 30 percent the foot-candle reading of the scoop. The resultant light output can be compared to a very hazy sunlit day, a very soft light with no definite shadows.

Here's a good rule of thumb for locating the scoop light you're using as base illumination. Place the scoop 10 feet away from the person being lit and hang it approximately 10 feet high. This "isosceles triangle arrangement" can be used successfully in studios of limited height, say 7 feet high, where the base and the height of the isosceles triangle would now be 7 feet.

In terms of angle, the simplest technique is also the best: hang the scoop so it approximates the camera angle with which it is being used. The reason for this is to enable the subject's eyes to be seen without any ungainly shadows, and to de-accentuate lines and wrinkles. Steep angle lighting, except in the case of dramatic shows, is not advisable.

Fresnel Lens Spotlights For Concentrated Light

The fresnel (the "s" in the word is silent) lens spotlight is a highly



Fig. 1 Putting a spun glass filter on the scoop softens the light output, but it also reduces the light output by 33%.



Fig. 2 The author is shown framing the light by adjusting the shutter of a Klieglight.



Fig. 3 Barn doors of a spotlight can be used to cut light off at the top, bottom or sides.

versatile instrument and one of the least understood tools of the television trade.

Fresnels are equipped with "barn doors" or metal flaps, and these devices are critical for control of the fresnel spotlights.

The barn doors can sharply define the circle of the fresnel lens so it becomes another shape. There are doors top and bottom of the fixture, and extenders on the sides, so almost any shaping is possible. The most frequent use of this shaped light is when there is a single speaker, standing at a podium, on camera. A fresnel spotlight is an excellent choice for a key light in such a situation and the light can be sharply cut off around the podium by adjusting the barn doors.

Besides the barn doors, and dimmer system control, the fresnels also have a spot-to-flood adjustment. This can widen the circle of the beam and generally add flexibility to the unit.

The most popular fresnel spotlights are models in the 1,000-Watt range (often called "aces"); 2,000-Watts (often called "deuces") and 5,000-Watts (often called 5k's). We use fresnels a lot for talk shows. For that purpose, here's a good rule of thumb:

Use 2,000-Watt Kliegl fresnels,

set at full flood, focused on each of the participants in a talk show. That means one fixture per person for key lighting, with barn doors adjusted to prevent spill to the other people on the panel.

Each fixture should be about 10 feet away from the panelist and 10 feet high and aimed at an angle of about 45° ... so the center of the spot is on the panelist's face. Using those distances, should give you a very useable 125 foot candles on each person you're lighting. For fill light, add a judicious number of scoops.

For Well Defined Cut Off Light

Klieglight is actually a trade name owned by Kliegl Brothers, but it means an ellipsoidal reflector spotlight.

We use Klieglights to provide well defined, precise light. Typically, the scoops give us our general illumination on, for example, a variety show and the Klieglight is used as a follow-spot on the main performer.

Klieglights, besides providing a sharp "circle of light", can be controlled with great accuracy. As with the scoop, the first method of control is through the dimmer control system.

But unlike the scoop, the Kliegl light also has an internal shutter arrangement which allows you to frame the light. This framing capability has many applications in television studio. For example, the Johnny Carson "Tonight" Show used a Klieglight as the key lighting on Johnny Carson when he was seated at his desk. The Kliegl shutters were arranged so that the top of the light area was sharply cut off. The reason for this was to eliminate the ugly shadow created by the boom microphone that was used on the show. A separate cue with different lighting that also avoided the boom shadow, was used when Johnny stood up.

Klieglights are sold in many packages, but the 750 or 1,000 Watt instruments are the most popular. Lens sizes are 6" or 8" and a good TV facility will need both.

There are two other purposes for the Klieglight that should be mentioned. One is to project patterns. Patterns are a useful, dramatic device that can help a color or black and-white setting look more interesting. You can buy the commercial patterns or even make your own from aluminum pie plates, or sheet aluminum.

One good use for patterns, for example, is in car commercials. We cut a cloud pattern and project it with a high wattage Klieglight, on blue cyc (set canvas background). Shot at an extreme angle, and half hidden by the car, this provides dramatic accent to the commercial.

The second major auxiliary purpose for Klieglights is as a slash light. A slash light means exactly what it sounds like ... light that is slashed across a television picture. For example, suppose there was a fireplace in a set, with a painting centered over it. A Klieglight, with the light framed so light and shadow slash across the painting, help add dimension to the whole scene.

Editor's Note: For further lighting tips, we suggest you read the lighting article in the March, 1977 issue of BE. Extra copies are available on request.

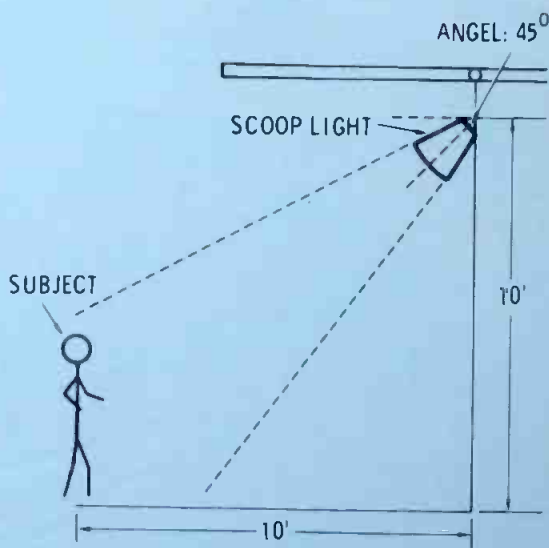

Fig. 4 The Greeley "isosceles triangle" arrangement for hanging scoops or key lights. Fixture is 10 feet off the floor and 10 feet from subject.



**SEVEN YEARS AGO
AMPEREX GAVE THE TELEVISION INDUSTRY
ITS FIRST PLUMBICON® TV CAMERA TUBE...**

**...LAST MONTH
THE TELEVISION INDUSTRY GAVE AMPEREX
ITS 20,000th ORDER*
FOR THIS STILL UNIQUE, UNDUPLICATED DEVICE.**

In the comparatively short span of time between its introduction and the total conversion of the broadcast industry to its use, the Plumbicon has enjoyed continuing professional acclaim and industry-wide endorsement as attested to by its receipt in 1967 of the coveted Emmy from the National Academy of Television Arts and Sciences, by the award of the David Sarnoff Gold Medal by the Society of Motion Picture and Television Engineers, Inc. to Dr. E. F. deHaan, the tube's developer and by the very practical and meaningful award to Amperex of purchase orders for twenty thousand Plumbicon tubes.

How do you say 'Thank You' for such support and such recognition? We feel that the most sincere way to show gratitude to an industry for its support of one's efforts is to rededicate those efforts for the further advancement of that industry.

We therefore pledge that we will continue to devote the greatest part of our energies to the task of keeping ahead of the uncompromising requirements of the television industry and to keep the industry ever supplied with better and better TV camera tubes. Electro-Optical Devices Division, Amperex Electronic Corporation, Slatersville, Rhode Island 02876.



Amperex®

TOMORROW'S THINKING IN TODAY'S PRODUCTS

Sold through
North American Philips Electronic Component Corporation

**Early this year, Amperex delivered its 20,000th Plumbicon tube, through its distributor Satterfield Electronics, to WHA, educational TV station affiliated with the University of Wisconsin.*



Fig. 1 The simple signal sampler built by the author includes meters for relative signal and modulation readouts.

WLIF staff uses sampling device to check out signals. The results are more than you'd expect.

By Dennis R. Ciapura*

Probably the most intangible and variable product any commercial vendor can market is the radio signal. While we routinely excite the airways with thousands of Watts of precisely generated and meticulously metered RF energy, what happens to the illusive electromagnetic salesman at ground level over rough or urban terrain is often disconcerting enough to make a Marconi photo shed a tear.

It is common knowledge that predicted field strength values will not hold true near power lines, etc. for AM broadcast frequencies, and that VHF-FM signals can vary 20 dB within a distance of 10 feet in urban areas. So, when checking system performance we endeavor to make our measurements under as near ideal conditions as possible and of course, monitor points are chosen accordingly.

Unfortunately, the broadcaster is unable to place all of his listeners in the same ideal reception areas.

Deviations from calculated field strength are predictable and just as calculable as the free space values if all of the variables are known, but for practical considerations the number of variables may render any attempt at calculation near impossible. For example, if a local

Simple signal sampling for FM stations

restaurant operator finds that he is unable to receive your beautiful music station on his background music receiver, he is not likely to be consoled by a mathematical treatise describing his geographic location and it's deleterious affect on VHF signals emanated from your point of transmission.

A more practical approach would be to quickly locate the suitable reception point that usually

exists a few feet away with a portable device that actually measures the relative signal strength at any point. Fortunately a suitable device need not be as sophisticated and expensive as a broadcast field strength meter since we are interested primarily in whether an adequate signal exists at the location in question and not its absolute value. A suitable device for such investigations can be assembled in a



Fig. 2 The author chats with Annapolis resident while checking reception quality.

*Chief Engineer, WLIF/WTOW, Baltimore, Md.

A Chroma Keyer for Composite Signals?

Impossible!

CBS Laboratories did it. Developed the first practical Chroma Keyer for composite signal. Now, with the new NTSC Chroma Keyer you can:

Key from a composite color video signal. Record on video tape and play back for post-production editing and keying. And tape talent when convenient and later key in the background material. Now, key your newsman over a network feed without that color-edge crawl.

Keys at the output of the composite program switcher and requires no separate RGB switchers.

Edges are sharper and clearer because the CBS Laboratories Chroma Keyer eliminates color-edge crawl. The NTSC Chroma Keyer is a production tool that will save you time, save you money . . . and open up a whole new realm of programming possibilities.

To discuss your station's requirements, call (203) 327-2000 or write:



CBS LABORATORIES

A division of Columbia Broadcasting System, Inc.
227 High Ridge Road, Stamford, Connecticut 06905

Circle Number 20 on Reader Reply Card



Fig. 3 On the AM side, WTOW engineer Bill Riley gathers AM readings and spectators.

evening for less than \$40.00! We'll describe the simple signal sampler we use and some of its applications.

Construction

After considerable thought about what kind of signal strength indicator would be simple enough for anyone on a typical radio station's staff to use, we logically evolved the idea of a meter that only needed to be switched on and observed.

This obviates a logarithmic readout so that very weak and also strong signals could be observed on the same meter without decading circuitry and its attendant switches. While stable operation affording repeatable measurements is necessary, actual M.V./M. meter calibration is not. Ideally, the device should be able to work on the AM and FM broadcast bands for operations having both outlets.

Well, to make a long story short, we were unable to justify any complication beyond a portable AM-FM receiver with metered AGC voltage. An inexpensive VU meter was added to the audio output of the receiver for relative audio level measurements as well. The 50 μ A signal level meter is switched to either the AM or FM AGC circuits for an indication of relative signal level. The receiver we used for the proto-type model derived its FM AGC voltage from $\frac{1}{2}$ of the radio detector.

Many radios use a small reverse bias on the AM AGC detector for a delay characteristic, which will result in a negative meter reading

with no signal input, and of course, sets by different manufacturers vary in supply polarity, voltage levels etc. sometimes resulting in an offset voltage. This may be largely corrected by using the mechanical zero-set adjustment on the meter to get a more nearly zero reading under no signal conditions. Since we are measuring the strength of the incoming signal relative to a previous reading with the same instrument or relative to the strength of another signal on the band, the actual meter accuracy is of little consequence, as long as the measurements are repeatable.

The receiver should be powered by mercury cells, thus providing an inexpensive, stable voltage supply. Even rather inexpensive portable receivers exhibit surprisingly good temperature stability, so variation in ambient temperature over a reasonable range is not a problem.

The receiver and meters shown in the parts list are representative of

inexpensive units most stations are likely to have on hand or can easily obtain.

Using the AGC circuitry as a meter voltage source has the advantage of providing a logarithmic readout. If a standard signal strength meter is available for comparative reading, the scale of the signal sampler may be calibrated in actual UV or MV by adjusting the calibration trim-pot for the desired metering range. The value shown in the diagram with the receiver listed produce a readable meter range of approximately 1 μ V to 1000 μ V on both bands. The circuitry is so simple that no difficulty should be encountered in adapting almost any receiver to signal sampling.

Application

We originally intended to use the signal sampler to pin down problem reception areas, but its simplicity and versatility made investigation

Fig. 4 Partial schematic of the simple signal sampler circuitry.

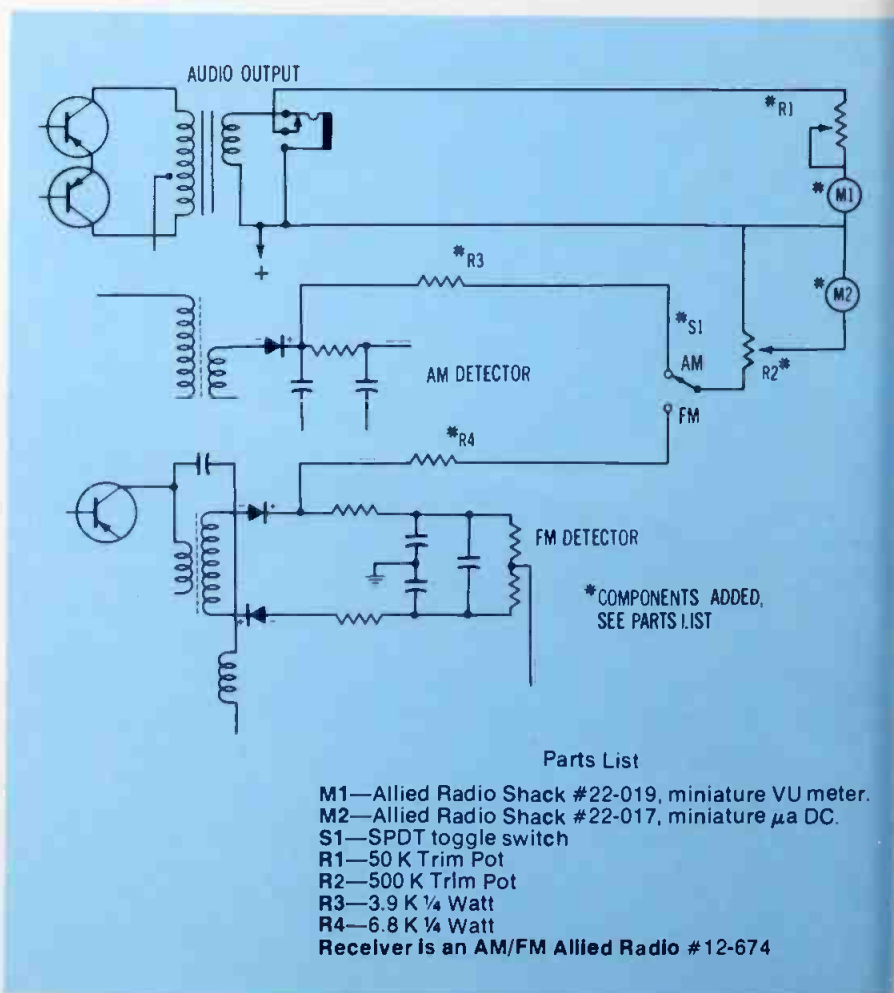

ground level signal phenomena easy, we soon found many un-
 seen applications for the de-
 ve.

WLIF-FM and WTOW-AM are
 part of Sudbrink Broadcasting
 Corp., a company with directives
 from the top to provide the best
 possible public service no matter
 how inconsequential a listener's
 question or complaint might seem.
 As a result, we log all calls relative
 to reception problems. All callers
 talk directly to the engineering
 staff, and many reception problems
 are handled personally using the
 signal sampler.

Most people are unaware of how
 easily VHF signals are reflected
 because of their short wave-length.
 The public relations value of ac-
 tually checking signal level in
 densely populated residential areas
 is a statement of the obvious. The
 public, in general, rarely has any
 contact with the broadcaster other

than through air personnel. A great
 deal of interest is always generated
 by station personnel working in the
 field and most residents are sur-
 prised that anybody really cares
 about how their signal is received
 in their neighborhood.

The unit can also be used to lo-
 cate optimum reception areas in-
 doors. A change of location can
 sometimes make the difference
 between good quality reception
 and almost no reception at all. The
 unit's antenna may be oriented ver-
 tically or horizontally to determine
 the best polarization for the receiv-
 ing antenna at any location. We
 also found it both useful and inter-
 esting to pick out monitoring points
 near the edge of our prime cover-
 age areas and log the variation in
 relative signal strength versus time
 of year, and weather conditions.

Our corporation operates an AM
 and FM in the Baltimore area, so
 the dual band unit described makes
 it easy for us to gather data for both
 stations quickly.

For FM measurements, the whip
 antenna should always be fully ex-
 tended and in the same plane un-
 less separate data is recorded for
 each plane. It is often useful to
 record the signal level of another
 station near the same frequency
 and direction for comparison. If
 the strength of both stations is
 down for a particular time period,
 we can be quite sure that the loss is
 a function of propagation condi-
 tions.

While the simple signal sampler
 is not a substitute for the profes-
 sional signal strength meter, it does
 afford the broadcaster an inexpan-
 sive means of determining exactly
 what is happening to his signal at
 any place, indoor or out. We have
 been able to learn a great deal
 about signal propagation at ground
 level in our coverage area and have
 found frequent "in field" sampling
 yielding unexpected PR benefits as
 well. After a while it becomes diffi-
 cult to go anywhere without taking
 the little device along.

Where there's magnetic tape you usually find this...

...because MS-200 Magnetic Tape Head Cleaner is faster, more convenient,
 and more efficient than cotton swabs. You can apply MS-200 with complete
 safety while tape is running. It quickly removes dirt, dust, and oxide build up—
 saves your heads; prolongs tape life. Non-flammable, non-conductive, odorless,
 and non-toxic. And it comes with a "get-right-down-there" extension nozzle. For
 all types of recorders and EDP installations, spray away magnetic tape head
 problems with MS-200. Manufacturers recommend it. For FREE sample of MS-200,
 write (on company letterhead, please), or use coupon for data and prices.



ms miller-stephenson chemical co., inc.
 Danbury, Connecticut 06810 (203) 743-4447

Please send me data and prices on MS-200.

I intend to use MS-200 on: _____
 Name _____ Title/Dept. _____
 Company _____
 Address _____
 City _____ State _____ Zip _____

CHICAGO • LOS ANGELES • TORONTO Dist. in MILAN • HAMBURG • PARIS • LONDON • BEIRUT
 Circle Number 21 on Reader Reply Card

A new approach for Spurious emission measurements

By James R. Stephenson, Jr.*

How To Save Time

As a condition attached to the construction permit of WRVR-FM, specifying operations with the Empire State Building Master Antenna, data was called for which would prove the absence of spurious emissions generated within the system. There is nothing new in this requirement, any station that has recently connected to a master antenna system is aware of it. What is new however, is the way in which this test has been accomplished at WRVR.

In the past, this task had been performed by connecting a tunable field strength meter to the system test port, and tuning from 50MHz to 250MHz. Each time a signal was found that was above the predetermined acceptable level, the transmitter under test would have to be turned on and off to ascertain if it was guilty of creating that signal. Needless to say, this process is quite time consuming.

A quicker method by which this test could be made has long been needed, and now that the results of the WRVR test have been accepted by the FCC, these tests need not be the long drawn out affair they have been in the past.

The measurements made for WRVR took place September 15th and 16th, 1971, between 9:30 pm and 2:30am. They were made by Fred Lender of Hewlett/Packard Company and myself. The Hewlett/Packard Spectrum Analyzer that was used for the test consisted of the 8554L RF Section, the 8552B IF Section, and the 141T Display Section. The results of the test were recorded on film by the Hewlett/Packard Model 195 Re-

*Chief Engineer, WRVR-FM, New York.

ording Camera. Total test time was five hours, compared to the average twelve hours required by the previous method.

The five hours used in our test are not a representative figure of the time in which this test could be done, as control photographs were made at approximately 9:30pm to 10:00pm. Then the tests were resumed shortly before midnight. So in actuality, only three hours were used for the test. As an added benefit, no other station on the antenna had to cease operation, even momentarily, as is required with the former method.

The equipment was set up on the 101st floor of the Empire State Building, just below the 102nd floor observation deck that many tourists are familiar with. Before WRVR signed off at midnight from its old transmitter location in the Riverside Church, which is in Upper Manhattan, a series of control photographs were made. Each of the ten stations previously operating on the master antenna were closely inspected and all signals other than those in the FM broadcast band were noted for future reference.

At midnight WRVR signed off from Riverside Church and the new transmitter was turned on into the master antenna system. The Spectrum Analyzer was set-up to check the FM broadcast band. Each station on the system was checked to assure that WRVR's new transmitter was not interfering with the other ten stations on the antenna, and that no intermodulation products were being created before the test was allowed to continue. It was confirmed within a matter of seconds that operation of WRVR's new transmitter into the Empire State Building Master Antenna did not cause any gross spu-

rious emission, or intermodulation products, so the test continued.

The area between 50MHz and 75MHz was inspected next. The picture of the area of the band made at that time, was then compared to the one made previously. No spurs were noted, but as added insurance, the plate voltage of the WRVR American Electronic Laboratories FM-12KD transmitter was switched on and off several times and the CRT of the spectrum was watched closely. Just as we had hoped, no spurs were present. The same procedure was then applied to the area of the band between 75 and the lower edge of the FM broadcast band with the same results.

Inspecting The Band

The FM broadcast band was then inspected. Each station's center frequency was set-up at scope center and the AEL FM-12KD plate voltage was switched on and off. The hoped for results were achieved, no spurs were found. A photograph was then made of the entire FM band and compared to the photograph made of the other ten stations made previously.

The area of the band between 110 and 150MHz, the area between 150 and 200MHz, and 200 to 250MHz were then checked as in the preceding paragraphs, with the same results. No spurious emissions or intermodulation products were found to exist.

The results of this test were compiled and attached to the license application as an engineering exhibit and sent to the FCC. Temporary Program Test Authorization was issued by the FCC September 27, 1971, and WRVR began program test with its changed facilities at 5:30pm that same day. At the same time, WRVR changed its

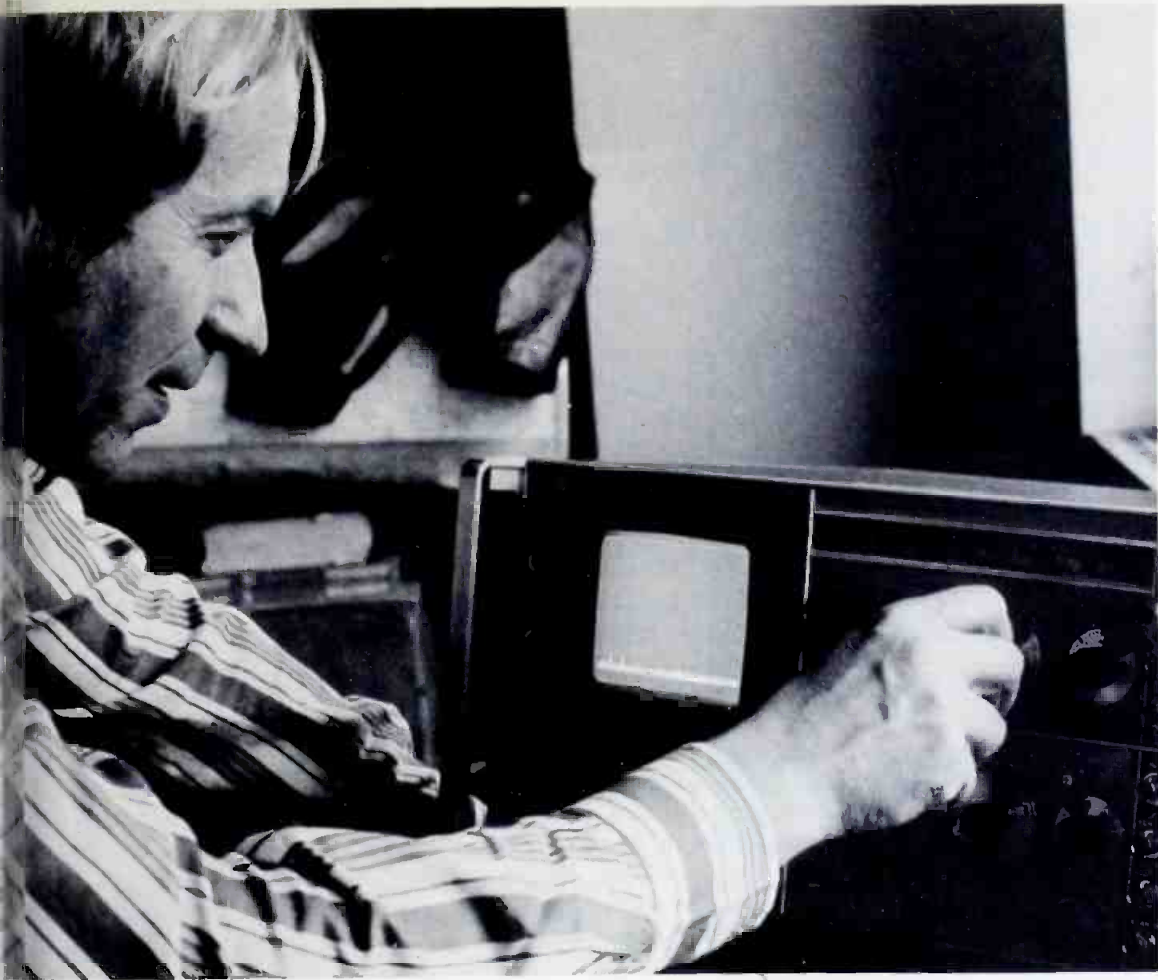

Fig. 1 Fred Lender adjusts the spectrum analyzer in preparation for the emissions testing.



Fig. 2 Author uses local station guide to identify signals on the analyzer.

**GET THE
MOST
HEADROOM
FOR THE
MONEY!**



Fidelity-Pro

**INTRODUCING
the NEW
RUSSCO
"FIDELITY-PRO"
and
"FIDELITY-MASTER"
PRE-AMPS**



Fidelity-Master

Russco's two new lines of top-quality phono pre-amps give you the power where you need it! (+18 DBM) All models are self-powered, available in mono or stereo versions, and feature a unique aluminum case that allows quick and easy service access. Years ahead in engineering, the best news is the Low Prices starting at \$92.00!

• SEND FOR INFORMATION!

RUSSCO

ELECTRONICS INCORPORATED

1070 BROOKHAVEN, CLOVIS, CALIF.

PHONE (209) 299-2167

Circle Number 22 on Reader Reply Card

format from Classical Music to News and Public Affairs. WRVR's first commercial announcement was broadcast over our new facilities.

In January of 1972, the results of the WRVR test were accepted and authorization to continue program test was granted. Six months of operation into the Master Antenna at the Empire State Building without a single complaint of interference have also tended to confirm the results of the test.

My first experience with Spectrum Analyzing equipment had been as an Avionics Technician with the United States Coast Guard, where they were used to set-up Single Side Band Transmitters. Later as Technical Supervisor at an ETV Station in West Virginia, I was exposed to the 8554L Hewlett/Packard equipment. I assumed the position of Chief Engineer of WRVR in April of 1971, and soon discovered that the spurious emission test would be a necessity. On further investigation, I

found that the common practice was to hire a consulting firm to run this test and it was expensive.

When I purchased new test equipment for WRVR, we discussed the possibility of using the 8554L to do the spur test. It was agreed that the equipment was capable of the test and Hewlett/Packard agreed to provide the equipment and technical help when needed.

We hoped that by using the spectrum analyzer that it would be unnecessary to have the other stations on the system to turn their transmitters off a second time (it was necessary to have all stations on the master antenna stop transmitting for a four hour period for WRVR's interconnection to the system) as is required by the previous method of spurious emissions testing. The results of the test were all we had hoped for. None of the stations involved lost air time and WRVR has satisfied the requirements relatively quickly, easily and inexpensively.

Fig. 3 The FM broadcast band is captured on film by using a recording camera. Note the number of signals... plenty of reason for eliminating spurious emissions.

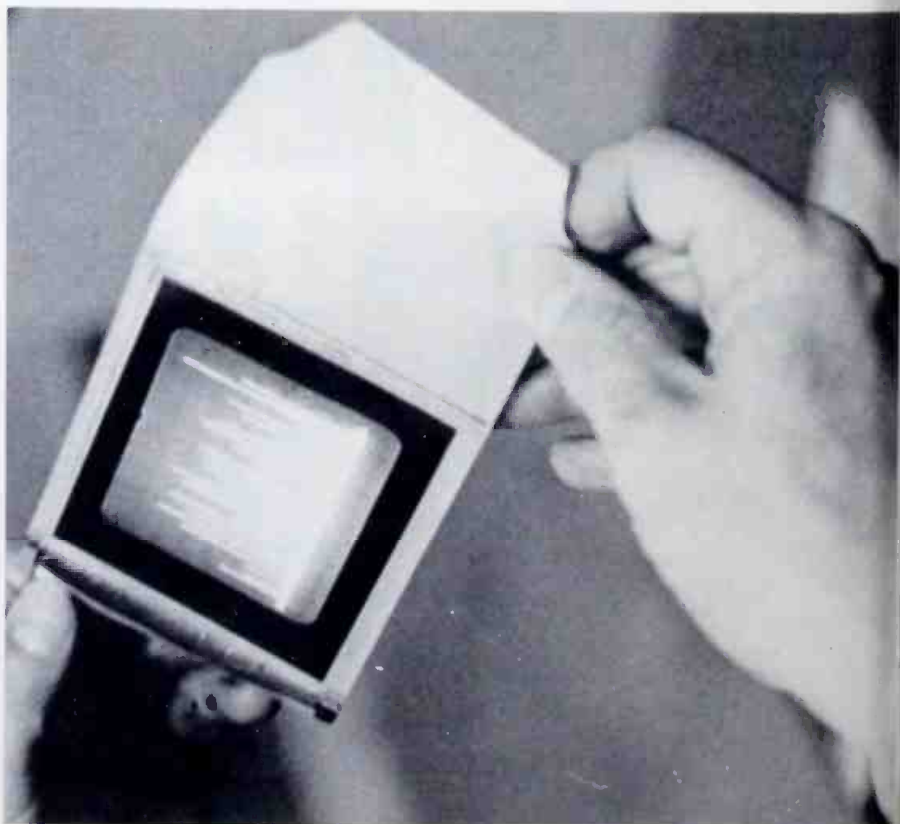

PEOPLE IN THE NEWS

New Faces At The Top

Thomas H. Winkofske has been named to the newly-created position of project manager at Koss Corp. . . . Arthur I. Bruns has been named to the new position of sales administrator for Broadcast & Industrial Products group of the Telex Comm. Div. . . . Tom Ferrara, Joe Green, Barry Wolfson and V. Frank Jones have been appointed Altec regional managers. . . . Warren Charles has been appointed Director of Sales for the Radio-Video Systems Div. of Philips Broadcast Equip. Corp. . . . Robert L. Keith has been named treasurer-controller of Ampex Corp. In his new position, Keith assumes the duties of controller in addition to his former duties as treasurer. . . .

Allan L. Merken has been appointed President of the newly-formed North American Philips Electronic Component Corp. . . . Norman A. Neumann has been appointed President of Amperex Electronic Corp. . . . Electronics Co., Inc. has announced the appointment of three vice presidents, Mervin Kronfeld, Greg J. Salt, and Alan C. Kronfeld. . . . Thomas R. Humphrey has been elected to Vice President of McMartin Industries, Inc., in charge of engineering, marketing and sales. . . . John L. Gafford has been appointed to the position of Engineering Manager, LPB Inc. . . . Val Nietupski has been appointed a Vice President of Visual Educom. Nietupski will be responsible for the Radio Product Section of Visual Educom. . . .

Associations

Werner Engelmaier, of Bell Laboratories, and Gusve Shapiro, of the National Bureau of Standards, were honored during the Electronic Components Conference in Washington. Engelmaier for his paper on Thin Film Resistors; Shapiro for his contributions to the electronic components industry. . . . O. Leonard Press, executive director of the Kentucky Educ. Network, was elected chairman of the board of directors of Educational Television Stations, a division of the NAEB. . . . Paul B. Comstock has resigned as executive vice president for government relations of the IAB effective September 8, to accept another position. Comstock will be succeeded by Grover C. Cobb. . . . Ron Davis and Bart N. Locanthi of the Altec Div. of Altec Corp. were given Fellow Awards at the recent 2nd Convention banquet held by the Audio Engineering Society. The award given Davis was "for his role in promoting the fine art of sound reinforcement;" to Locanthi "for his contribution to the theory, practice and standardization of loudspeaker design." . . . Charles T. Jones, Jr., vice president of the New Mexico Broadcasting Co., has been appointed director of the IAB's new Radio Information Office. . . .

(Continued on page 49)

LOW COST DIGITAL CLOCKS, TIMERS AND COUNTERS

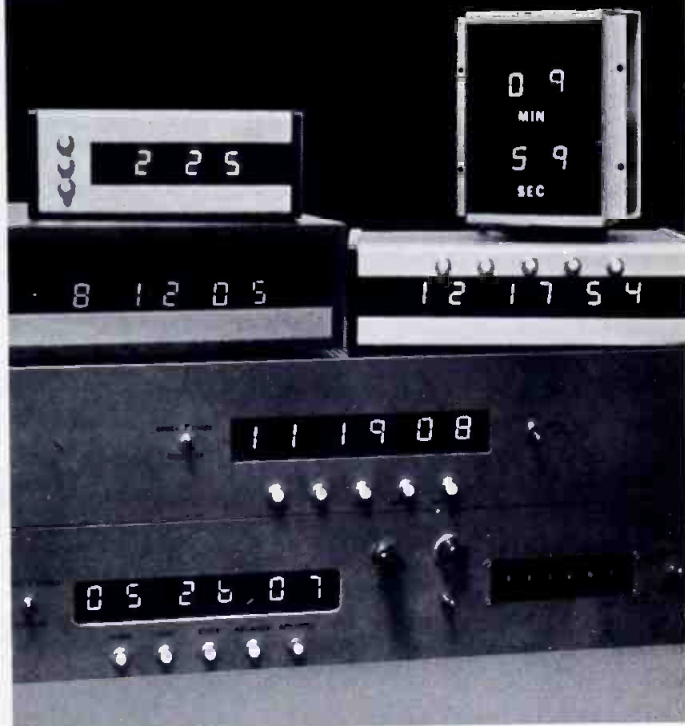

All ESE digitals are designed and constructed using the latest solid state electronic components and circuitry. This equipment is perhaps the most economical line of digital clocks, timers and counters available. Circuit efficiency and lasting quality are designed into every ESE digital product. Constructed with the built-in ruggedness necessary for studio use. No moving parts.

Special custom items, like the video tape/counter editor, a monitoring system with unique display configuration, 12 and 24 hour clocks or timers, 10 minute timers, 3 digit, 4 digit, 6 digit, record seconds in tenths, hundredths or thousandths. . . . Even a station ID reminder, all available from ESE. Options include: Thumbwheel switch programming, BCD outputs, relay closure outputs, and solid state buffered outputs. Many products available in kit form.

MOST EFFICIENT DIGITAL CLOCKS/TIMERS AVAILABLE:

ES-112/124, 12 hour or 24 hour clock	\$100.00
ES-400, 10 minute timer	68.50
ES-500, 12 hour clock/timer	110.00

WRITE, WIRE OR CALL TODAY FOR DETAILS:

DEPT. 772
ESE ENTERPRISES

506 MAIN ST. • EL SEGUNDO, CA. 90245 / (213) 772-6176

Circle Number 23 on Reader Reply Card

Building A Teletype Control That Thinks For Itself

Like so many other units, the teletype alarm to be described here was born out of the fiasco of February 20, 1971. We wanted our alarm to think a bit and to be unresponsive to all but the proper sequence of alarm impulses from the teletype machine.

The unit described here incorporates the following features:

- 1) It will respond to the signaling from both UPI and AP Radio wires.
- 2) It will signal either a bulletin or an EBS alert/alarm from either or both machines.
- 3) It will not respond to any but the proper number of impulses within the proper amount of time.
- 4) Once "locked" into either bulletin or EBS alarm mode, our unit cannot move out of its alarm position until manually reset.
- 5) Provisions for easy testing are available as well as provisions for audible and visual local and remote alarms.

Considering Figure 2, you will note that we show just half of the system for simplicity. The "contact points" (A normally-open SPST switch) installed by a teletype maintenance man furnish a momentary switch pulse from either teletype machine. Let's consider just the UPI portion where the switch closes with the ringing of the teletype bell (of course five

bells is a bulletin and ten bell signals an EBS alert).

The steppers used are guardia Mer-120AC with 120VAC coils, and K1 and K2 are employed to keep the voltage on the contact point at 12 VDC to Q1 which is functioning as a timer circuit. A group of five or a group of ten consecutive bell must ring within a certain period (adjustable, but 4-6 seconds work well) to keep the stepper contact from the base of Q1 and full charging the condenser.

If the stepper stops on either the "five" or "ten" position, the voltage is removed. If it stops anywhere else, voltage applied causes the R-C network to time out, and relays K5 or K6 operate, resetting their respective steppers. (Thus for example, a group of three bell followed a few seconds later by two bells will not add up to a five by then the system has reset itself. We've found too, in practice, that when the teletype is running wild and bells are ringing like mad, the reset circuit calmly goes about its business. In fact, in this "wild" condition the condenser at the base of Q1 doesn't get a chance to completely discharge so the stepper resets sooner and sooner. The result is much less wear and tear on the stepper when the machine is going wild.

This Little Beauty Fills Your Needs for a really low-cost waveform monitor and a pulse-cross monitor

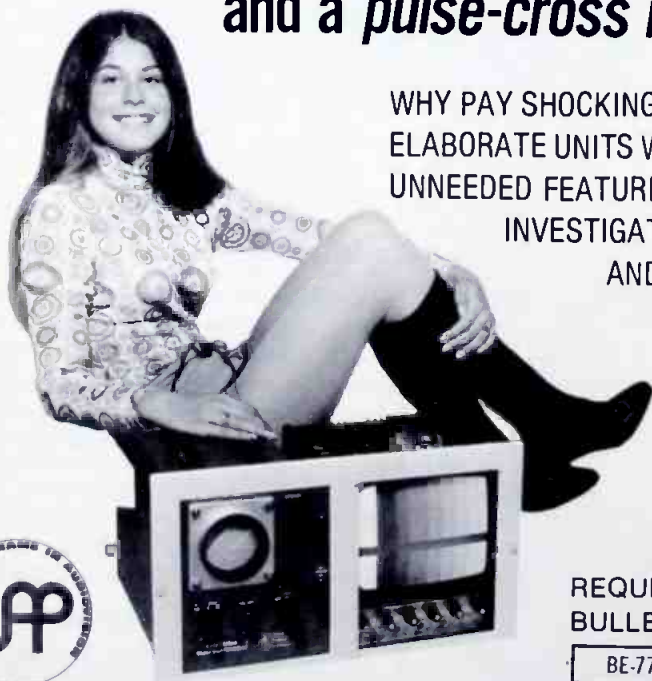

WHY PAY SHOCKING PRICES FOR ELABORATE UNITS WITH COSTLY UNNEEDED FEATURES?

INVESTIGATE THE VW-0 AND THE PC-95.



Ultra Audio Products

Box 921 • Beverly Hills
California 90213 U.S.A.

REQUEST
BULLETIN

BE-772

Circle Number 24 on Reader Reply Card



"I'D LIKE TO EXCHANGE FOR A BROADCAST ENGINEER ABOUT FORTY DOLLARS."

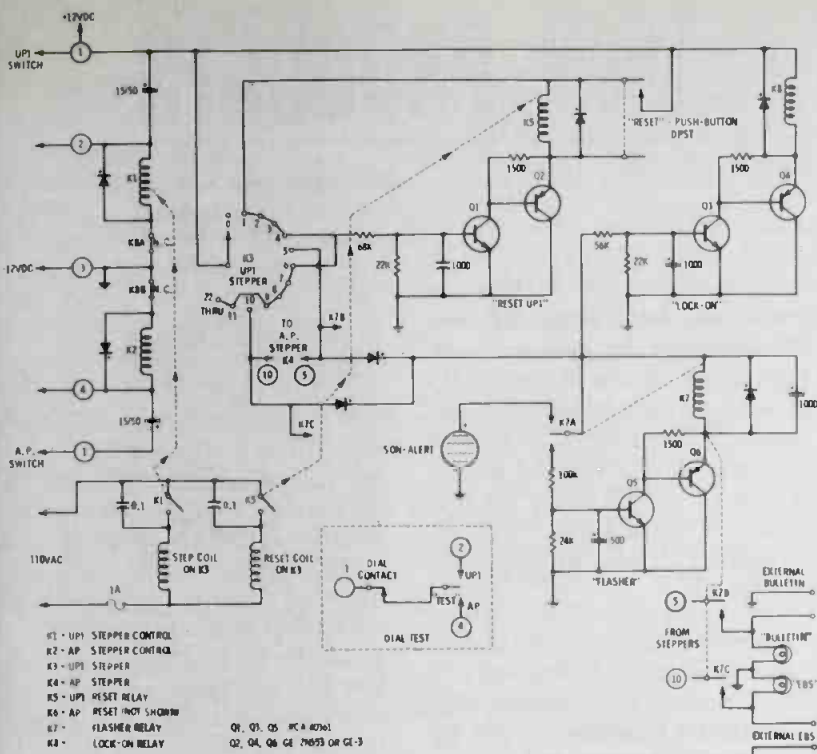

If the stepper stops at five or ten, voltage is applied to the base of Q3, starting another timing circuit. When relay K8 operates, K1 and K2 cannot function and further impulses from the teletype cannot move the steppers until the system is manually reset. Thus, once either a bulletin or EBS alert is signalled from either machine, no further bells or signalling can "unlock" the alarm. The time delay at K3 is necessary for the EBS alert...without this delay the unit could lock on five immediately and never get to the top of the steps.

Q5 and Q6 form a flasher circuit with relay K7. This circuit could be all-solid-state but we wanted the flexibility of intermittent relay contacts to operate both the lights and the "son-alert." The flasher circuit begins to operate as soon as a five or ten is reached and will continue to go until the system is reset.

Construction

We used a BUD SC-2131 cow-type minibox and an AC-407 chassis to accommodate the relays for two systems on one chassis. Transistors are of the garden variety and non-critical. PNP transistors were used for Q2, Q4, and Q6 since their collectors could then be tied directly to the chassis. Diodes are general purpose and 1 AMP, 1000 PIV. Resistor values are non-critical. The input resistors to Q1, Q3, and Q5 are adjustable to vary the timing of the three circuits. Plug-in relays are P & B KHU17D11 12 VDC.

We located the unit directly above the teletypes with the reset switches on the front panel, so the operator must come to the machines before he can reset the alarm. A dial with a two-way switch is provided to test the entire operation of the unit. Once a week a newsmen will dial up a five or ten to verify proper operation. After installation we did a bit of juggling with the time constant on the reset circuit before we got the unit to "outthink" the teletype machines.

Mark Durenberger, CE
WL0L AM-FM
Minneapolis, Minn.

new
19-piece midget reversible ratchet offset screwdriver set



3-3/4" heavy duty, stainless steel reversible 20-tooth ratchet with short turning radius for close work.

Unique 6" spinner/extension has drive socket insert in handle for ratchet. Use also as regular screwdriver with bits.

1/4" hex to 1/4" square adapter bit permits use of ratchet or spinner/extension with Xcelite Series 1000 or other 1/4" sq. drive sockets.

16 precision made, alloy steel bits with knurled spinner tops... 12 Allen hex type, 2 slotted screw bits, 2 Phillips bits.

FREE STICK-ON INITIALS personalize the sturdy plastic case and help prevent loss or mix-up.

No. XL-70 Set

Made in U. S. A.



Also 5-Piece Kit (No. XL-75) Reversible ratchet with 3/16" and 1/4" slotted screw bits, #1 and #2 Phillips bits, all in a durable plastic, pocket size, snap fastener case.

nationwide availability through local distributors
 REQUEST BULLETIN N770



XCELITE, INC., 118 Bank St., Orchard Park, N. Y. 14127
 In Canada contact Charles W. Pointon, Ltd.

Circle Number 25 on Reader Reply Card

Keep Up With The News.
With Direct Current, page 4
Industry News, page 10

YOUR BEST FM ANTENNA COMBINATION

CCA CIRCULAR ANTENNA



PLUS RADOME



The CCA 2nd generation FM circularly polarized antennas have already been field proven in over 100 installations. With low wind loading radomes, we've eliminated deicers, deicer wires, power drain, and thermostats. What better combination is there!!

CCA ELECTRONICS CORPORATION
716 JERSEY AVE., GLOUCESTER CITY,
N. J. 08030 • Phone: (609) 456-1716
No. 1 in AM and FM

Circle Number 26 on Reader Reply Card

NEW PRODUCTS

(Use circle number on reader service card for further information)

As you may have expected, we are still covering the vast array of new equipment shown at the NAB. If you want further information on any item described here or in our advertisements, tear out the Reader Service card and circle up the numbers that correspond to those at the bottom of the product description or ad.

Voice Logging Recorder-Reproducer

The Stancil-Hoffman Corporation has announced a complete new line of voice logging recorder/reproducers to record communications from two-way radio, telephone lines or console microphones.

Designated as the CRM 7-14-28 Series, the recorder/reproducers have been developed for use in police, fire and public safety centers; public utilities; private security systems; and radio and television broadcast logging.

The basic system consists of a tape transport panel 8¾ inches x 19 inches and an electronics panel 7 x 19 inches. Either single or dual transport systems may be mounted in standard rack cabinets or in portable carrying cases.

The systems are designed for continuous duty and record for over 25 hours on a standard 7 inch reel of tape—up to 7 channels on ¼-inch tape, up to 14 channels on ½-inch tape, and up to 28 channels on 1-inch tape.

Standard features include Automatic Gain Control in each channel, continuously variable rewind speeds for fast message retrieval, failure detection of power supply, recording bias or tape breakage, single in-line record and playback heads, built-in metering for level setting or maintenance testing, and motion memory sensing to prevent tape breakage. Dual transport versions are furnished with automatic

24 hour time clock changeover as well as failsafe changeover.

Many plug-in accessories are available which may be added any time without engineering: Digital time recording with high speed automatic search, voice operated control, remote control of all functions, instant recall, and time and message sharing on a single channel giving messages priority. Also available is the only true malfunction sensing system which continuously compares the input signal to the output signal and detects any

Spotmaster

TP-1B Tape Cartridge Winder



This rugged and dependable tape winder fills a need in every station using cartridge equipment. No longer is it necessary to restrict your cartridge operation to stock sizes, or to tie up your conventional tape equipment loading cartridges. The TP-1B handles all reel sizes (up to 3600' of 1 mil tape), winds new or old cartridges in any length. Available with or without Spotmaster tape timer, providing precise minute and second calibration for creating exact-length tapes. TP-1B is \$124.50, with Tape Timer \$149.50. Lubricated tape and empty cartridges are also available.

BROADCAST ELECTRONICS, INC.
A Filmways Company
8810 Brookville Rd., Silver Spring, Md. 20910

FREE CATALOG

HARD-TO-FIND PRECISION TOOLS

Lists more than 1700 items—pliers, tweezers, wire strippers, vacuum systems, relay tools, optical equipment, tool kits and cases. Also includes four pages of useful "Tool Tips" to aid in tool selection.



JENSEN TOOLS and ALLOYS
4117 N. 44th Street, Phoenix, Arizona 85018

Circle Number 27 on Reader Reply Card

BROADCAST ENGINEERING

teriorioration of quality or tape
tion.

Circle Number 60 on Reader Reply Card

M91-ED Cartridge

Shure Brothers Inc. has augmented its M91 Cartridge Series with a major new addition which offers increased trackability.

Called the M91ED, the new cartridge is said to deliver improved high frequency trackability over the present M91E. This is made possible by design advances in the stylus assembly. By mounting an extra-lightweight nude diamond tip directly on the stylus bar and doing away with even the tiny metal finishing used in the M91E, Shure reduced the stylus tip mass. The result is a smooth, peak-free frequency response and a level of overall performance not previously available in this price class.

CPA-200 MINI-PROC



VIDEO AMPLIFIER WITH CLAMP, CHROMA CONTROL, AND SYNC-REFERENCED AGC

SPECIFICATIONS

INPUT:	0.5V TO 2V COMPOSITE VIDEO (BRIDGING—VIDEO LOOP-THRU)
OUTPUTS (DUAL):	1.0V P-P COMPOSITE VIDEO INTO 75 OHMS
RESPONSE:	± 0.5 DB TO 8 MHz
DIFFERENTIAL PHASE:	± 0.5 DEGREE
DIFFERENTIAL GAIN:	LESS THAN 1%
CLAMP LIMITS:	20 DB
AGC:	± 6 DB INPUT LEVEL CHANGE PRODUCES LESS THAN 0.5 DB OUTPUT LEVEL CHANGE
CHROMA CONTROL:	± 3 DB
INPUT POWER REQUIREMENTS:	115 VAC @ 250A
TEMPERATURE RANGE:	0-50 DEGREES C
SIZE:	1 1/2 x 6 x 10 INCHES RACK MOUNTED
OUTPUT CONNECTORS:	BNC

PRICE \$480

ELECTRONICS DIVISION
LENCO INC.
319 W. MAIN ST. • JACKSON, MO 63756
PHONE 314-243-3141

DISTRIBUTOR INQUIRIES INVITED

Circle Number 41 on Reader Reply Card

angénieux service corporation of california
23381 BEACH AVE., VENICE, CALIF. 90291 • (213) 821-5080

Now Two
**FACTORY SERVICE
CENTERS**

angénieux corporation of america
140 HERRICK RD., OCEANSIDE, N.Y. 11572 • (516) 678-3520

Circle Number 28 on Reader Reply Card

The M91ED features the popular Biradial (elliptical) tip. For those who prefer a spherical tip, the M91GD is available. Owners of M91E Cartridges may upgrade their present system by purchasing an N91ED Stylus.

The performance characteristics of the M91ED Cartridge also make it a suitable choice for use in four-channel encoded (matrix) systems.

Circle Number 62 on Reader Reply Card

Multichannel Recorder

A new accessory for the Ampex MM-1000 multichannel recorder which results in better sound quality and flexibility in recording film sound tracks has been placed on the market by Ampex Corporation.

The new Ampex film lock system permits film makers to record up to 15 channels of sound, add special effects, dub down to one or two channels, and play back the final sound track in perfect synchronization with the pictures.

Circle Number 117 on Reader Reply Card

Custom Consoles, Cabinet, Racks

Amco Engineering Company, an old line company in the cabinet and console business, has decided to focus on the broadcast-communications industry. Many of their consoles are already in use in government communications complexes.

Because Amco uses a modular approach to cabinets and consoles, they can put together (RF-proof) layouts to meet almost any demand, and that includes a choice of 17 colors.

Available in this system are the low silhouette, an auxiliary desk console that is used with selections of 3 different types of desk top cabinets, vertical and slope front racks, with variations of writing surface assemblies for operator convenience and maximum efficiency. To complete the system are a variety of accessories including blowers, wire mold, hardware, casters and other associated supplies.

(Continued on page 46)

Circle Number 63 on Reader Reply Card

**Need A Consultant?
See Page 57**



NOW FROM CCA!!

Thanks to your support CCA is pleased to announce the purchase of the RF Department of Ampex. We trust you'll consider us for your UHF/VHF transmitters, antennas and line.

CCA RF INDUSTRIES, INC.
P. O. BOX 315
WESTFIELD, MASS. 01085

SOLID STATE AM MONITORS ACCURATE @ 125%



- Positive and Negative Peaks Read Simultaneously
- Digital Frequency Display Unaffected by Modulation
- Flashers and Meters "Remoteable"
- Both Monitors Can Mount In One 5 1/4" Space

CCA ELECTRONICS CORPORATION
716 JERSEY AVE., GLOUCESTER CITY, N. J. 08030 • Phone: (609) 456-1716
No. 1 in AM and FM

Circle Number 29 on Reader Reply Card

New Products

(Continued on page 45)

Low Cost Waveform Monitor

Ultra Audio Products has introduced a low cost TV waveform monitor primarily for closed-circuit applications but suitable for broadcast use.



The VW-O is available as a portable or will mount 2-across on a standard rack panel, or side by side

with Ultra Audio's PC-95 pulse cross picture monitor.

The 2-input WFM features 7MHz. bandwidth at a price modest enough to permit budget-conscious installations to utilize VW-Os on each camera, program line and throughout the video system.

Circle Number 65 on Reader Reply Card

New Quartzline Scoop Lamp

A large, pear-shaped lamp with a 1,000-watt quartz-halogen inner filament tube will soon be available to light TV and movie productions.

The jumbo, frosted lamp measures six and a half by 13 inches and is the industry's first tungsten-halogen lamp of its size and configuration, according to General Electric stage and studio lighting engineers.

"Scoop Lamp" creates softer, more diffuse shadows than smaller lamps of equal light output, thus making it ideal for critical use in TV, movie and still studios.

Designated the Q1000/PS52/4, the new lamp fits in standard 16 or 18-inch scoop reflectors, and can be burned in any position for an



average life of 500 hours at 3,200°K. Its special design make "Scoop Lamp" noise-free even when used on solid state dimmers. GE engineers said.

Like all other GE Quartzline lamps, the new lamp maintains stable color temperature and light output, and has more than twice the predicted life of other incandescent or tungsten-halogen lamps presently available for similar applications.

Circle Number 66 on Reader Reply Card

TELAN

gas fueled thermoelectric generators

Nestled under the ice covered eaves of an equipment shed on a 11,000 foot mountain peak in Utah, this TELAN generator provides power for a TV translator. The propane tanks supplying fuel to TELAN require service only once a year. TELAN is available in from 10 to several hundred watts. 12-24-48 VDC standard.

TELEDYNE ISOTOPES

110 W. TIMONIUM ROAD — TIMONIUM, MD. 21093
PHONE: 301-252-8220 — TELEX: 87-780

Circle Number 30 on Reader Reply Card



5-Inch TV Monitors

Dage Television announces the production of a line of 5" monitors, ideally suited for educational, broadcast, CCTV and industrial or security applications.

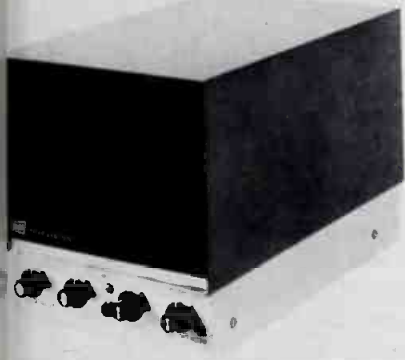

The monitors are available in an attractive single desktop unit or a triple-monitor, 19" rack mount configuration. Entirely manufactured in America, the new monitors provide good picture quality and reliability. A single, plug-in printed circuit card simplifies maintenance. Regulated power supply assures constant picture size and brightness over a wide range of power line variation.

Features include low power dissipation, fast horizontal flyback to assure no loss of picture information, 100% DC restoration, and an automatic frequency control specifically designed to give jitter-free performance, even when operating with helical video-tape recorders.

Front panel operating controls include Brightness, Contrast, Horizontal Hold, Vertical Hold and Power ON/OFF. A front panel screwdriver adjustable width control is also provided.

Circle Number 67 on Reader Reply Card

Equalized Phono Preamps

Russco Electronics introduced two new lines of RIAA equalized phono preamps designed for professional broadcast and recording studio applications.

Dubbed "Fidelity-Master" and "Fidelity-Pro" they are designed to complement the company's Cue-Master and Studio-Pro turntable lines. The Fidelity-Master models offer fixed equalization. The Fidelity-Pro models feature switchable rumble filter and high frequency boost and cut.



All models are available in mono or stereo versions with balanced or unbalanced output. Features include self-contained power supply, integrated circuit design, high output capability, low noise and low distortion. A special feature is a unique extruded aluminum case that allows quick and easy service access.

Circle Number 68 on Reader Reply Card

Digital Program Automation System

Gates Division, Harris-Intertype Corporation, introduced a new digital program automation system at the 1972 NAB Convention.

(Continued on page 50)

ERASE RECORD REPRODUCE

MONO - STEREO

Professional Direct Replacement Heads with complete written and pictorial instructions

Our factory will clean, rebuild, adjust and test your head ASSEMBLY... install new MMI heads... replace minor hardware and modify your gate to accept our "NON-POPPING" springs



36 HOUR SERVICE - LOANERS AVAILABLE
(612) 884-7393



MINNEAPOLIS MAGNETICS, INC.
8125 PLEASANT AVE. SO., MINNEAPOLIS, MINN. 55420

Circle Number 39 on Reader Reply Card

Increase Head Life with ISOLAIR New Clean Air Unit by LIBERTY

This unit provides a laminar down flow of the cleanest possible air at the critical video head area. Excessive wear and damage by airborne contaminants are virtually eliminated, extending head life by 100% or more and insuring better overall VTR performance, as well as saving time and money. The unit is suspended from the ceiling thus requiring no additional floor space. It is easily installed and maintained and meets Federal Standard 209a, Class 100.

An additional positive effect is the cumulative result of the constant filtering of air from the entire room, so that during an extended period of use, the level of contaminants in the surrounding environment is progressively reduced.

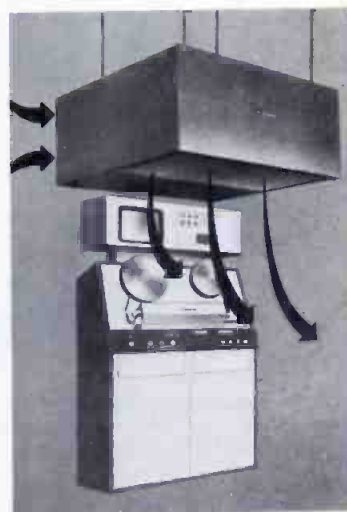

Liberty Industries has the capability for providing complete clean air environments for any size or type of operation. Our sales engineers are ready to help you.

Call or write.



LIBERTY INDUSTRIES, INC.

598 Deming Road, Berlin, Conn. 06037
Telephone (203) 828-6361

Circle Number 43 on Reader Reply Card

**Now
you have a third choice
when you go
from color tape to film.**

I The low-priced system.
You call it "kinescope."
You like the price.
Not the quality.

R The high-priced system.
You call it "expensive."
You like the quality.
Not the price.

B Our new Teledyne system.
You'll call it perfect.

Teledyne at Mediatech is a brand new system that insures consistent broadcast quality transfers at the same cost as the low-priced system. Color or black/white. 16 or 8 mm. From quad or helical tapes.

Give us an opportunity to prove it.
Send for our price list and further information.

Mediatech

824 Busse Highway/Park Ridge, Illinois 60068

Name _____

Address _____

City _____

State _____ Zip _____

824 Busse Highway
Park Ridge, Illinois 60068
312/ 693-8366
Circle Number 32 on Reader Reply Card

bookreview

The Work Of The Television Journalist has been written by Robert W. Tyrrell. Television journalism never the work of one man and a typewriter. It depends on a team of talents and skills. Each member should know something about the others' problems and methods. This book describes every job and supplies the necessary knowledge for the members to work as a successful unit.

The author is concerned with the day-to-day business of putting a picture into a square and matching with the right words and sounds. He is uniquely qualified to provide this specific and practical text as he has done most of the jobs he describes, and developed many of the techniques which are commonplace in British television today.

This book is available through Communication Arts Books, Hastings House, Publisher, Inc., New York, N.Y.

Circle Number 91 on Reader Reply Card

Solid-State Electronics, written by George B. Rukowski, will help the technician meet his challenges. The author not only discusses the fundamentals, but also develops the student's ability to select proper design components for solid-state electronic circuits.

The book begins by explaining common semiconductor materials. Other chapters discuss the zener diode, the junction transistor, the silicon-controlled rectifier, the field effect-transistor and integrated circuits.

A modified programmed style is used throughout the book. Each point discussed is followed by at least one worked example.

This book is available through Howard W. Sams & Co., Inc., Indianapolis, Ind.

Circle Number 92 on Reader Reply Card

Television Measurement Techniques, written by L.E. Weaver, is a review of the techniques and equipment used in the checking and standardization of the apparatus in television signal chains, from source to transmitter.

This monograph fills a gap in the literature on television technology. It includes a great deal of material previously accessible only with difficulty, and a certain amount of original work. Although a comparative approach is made to available methods, with emphasis on local and national differences, the techniques advocated are, wherever applicable, the ones recommended by those international broadcasting bodies which for years have been working to achieve worldwide agreement on standards of quality, equipment and procedures.

The book is written from the point of view of the television broadcast engineer, though much of the material is directly applicable to related fields, such as closed-circuit television for educational and industrial purposes. Like other books in the IEE Monograph Series, it is intended for the professional engineer and those in training.

This book is available through Peter Peregrinus Ltd., London, England.

Circle Number 93 on Reader Reply Card

Commission Turns Down Union Request

A petition by The American Federation of Television and Radio Artists (AFTRA), requesting that the Commission's practice and procedure rules (Part 1, Subpart D), be amended to require that the Commission, in all instances of transfers or assignments of AM, FM or TV licenses, give special notice of the proposed action to any unions connected with the transferor or assignor, and that such unions be made parties in interest, has been denied by the Commission (MM-1848).

AFTRA, a branch of the Associated Actors and Artists of America, which is affiliated with the American Federation of Labor—Congress of Industrial Organizations, requested the rule making to protect its membership from what it considers disadvantageous actions which may arise at the time of the transfer or assignment of a broadcast station. It said it desired to participate, as an automatic procedure, in all transfers and assignments of stations where the buyer has not assumed labor contract obligations of the transferor or assignor.

The Commission said it could not agree that special notice from the Commission to unions is necessary or in the public interest. The Commission said it provides ample notice of any transfer or assignment proceeding through a variety of means to all interested parties.

The adoption of a rule whereby the AFTRA and all other unions representing employees of a station about to be transferred or assigned would automatically be designated to have standing and be a party in interest would give petitioner an unusually privileged position in that no other private party is designated, in any of our proceedings, as 'a party in interest' by rule," the Commission said. It pointed out that the unions which represent employees of a station about to be transferred or assigned may file a petition to deny which, the Commission said, it would evaluate.

People In The News (Cont. from page 41)

Ronald N. Kahill has been appointed Sales Manager for Superior Continental Corp. Cable and Equipment Div. . . . And **Bill L. Miller** is now manager of wire and cable manufacturing . . . **Clifton P. Grant** and **Lawrence R. Kem** were elected to positions of group vice president, General Cable Corp. **William W. Garretson** was elected a vice president and **Charles J. Bodenstab** named a general manager . . . **Irving Kolodyn** has been appointed to the position of director of application engineering for General Cable's Communications Products Operation . . . **Dr. John D. Stauffer** has been appointed general manager of General Cable Corp. magnet wire products . . . **Israel Switzer**, P. Eng., has been appointed to the position of Vice President-Engineering, Maclean-Hunter Cable TV Limited . . . **Thomas J. Madden**, former writer for **Broadcasting Magazine**, has joined the public relations staff of the National Cable Television Association . . . **Theodore J. Swanson** has been named vice president-engineering of Cypress Communications Corp. . . .

NEW LIP-SYNC SECRET

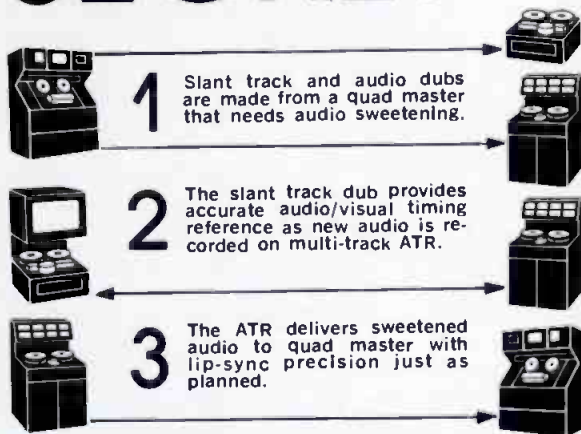

BE 450 SYNCHRONIZER

The secret is the all new wide range electronic synchronizer. Within a 30 second capture range it automatically brings any two mag tapes—quad, slant track, sprocketed or unsprocketed audio—into exact sync.

The new BE450 compares identical SMPTE Edit Codes on the two tapes and adjusts the speed of one of the recorders until the tapes are in frame to frame lock. It keeps the tapes in sync, or in manually adjusted offset, regardless of normal tape stretch or slippage.

In the audio-sweetening example above, the SMPTE Edit Code on the quad master has been recorded both on the slant track dub and the multi-channel audio tape. The Synchronizer then keeps every production step in exact timing keyed to final audio recording on quad master.

The BE450 capabilities are too good to keep secret from anyone with audio sweetening problems or any other audio/video sync requirements. Send now for descriptive literature.



ELECTRONIC ENGINEERING COMPANY OF CALIFORNIA
1441 East Chestnut Avenue • Santa Ana, California 92701
Phone: (714) 547-5651 TWX: 910-595-1550 Telex: 67-8420

(Continued from page 46)

Installed in the fully automated FM radio station at the Gates' exhibit, the new system is a custom installation, as are all Gates' program automation systems—although all have in common the fact that each is configured from standard components to a station's individual needs.

Gates' NAB system introduces 5 new digital components. These include the following:

- Gates' KSP-10 Digital System Programmer, which provides fully automatic control of the automated programming system. It can call on up to 10 audio sources such as cartridge, reel-to-reel, network, remote or audio console output.
- Gates' RA-10 Random Access Digital Programmer—capable of controlling up to 10 Gates' G-24M/S Multiple Cartridge Reproducers, or other program sources with 1 to 99 shelf addresses. Its MOS IC Read/Write Memory has a capacity of 1,000 events.

- Gates' TS-4 Time Selector—used as an exact time control device that performs a switching function on a time programmed basis.
- Gates' Digital Clock—used in the automation system as a centralized source of real time information.
- Gates' SSC Digital System Switching Center—the control point and switching center of the program automation system. Nearly all of the control commands, control responses, audio programming, auditioning, logging, etc., are routed through the SSC.

Although the Gates' NAB system uses only tape cartridges as program sources, many configurations are available, using both reel-to-reel and tape cartridge sources. In fact, each system is tailored to the broadcaster's particular requirements, so that no format changes are required to install Gates' automation.

Circle Number 69 on Reader Reply Card

Sweep-Focus Fresnel

Berkey Colortran, Inc., a division of Berkey Photo, Inc., announces the introduction of its new Sweep-Focus Baby. The six inch 750 to 1000 watt Fresnel uses a new lamp designed exclusively for the unit.

Rapid focus lever permits variable spot-focus settings in seconds. Double wall construction keeps unit cool and increases cooling effectiveness of its compact housing. The swing-away front door with captive accessory latch permits easy relamping without affecting accessory positions. The unit weighs 10 lbs.

Circle Number 70 on Reader Reply Card

Film Chain Color Camera

A new color film chain camera for broadcast closed circuit and cable television applications offering a combination of automatic features for ease of operation and a maintenance has been introduced by International Video Corpora-



INCREASE FM LISTENERS WITHOUT CHANGING FORMAT.

Reach into those difficult areas, car receivers and small portables. These hard-to-reach groups can represent a large audience. With our FM "Penetrator" antenna, you no longer give this audience to your competitors.

The patented "Penetrator" gives your signal more punch, even in the fringe areas, because it's circularly polarized

and features variable horizontal-to-vertical gain ratios.

Your stereo performance will also improve, because of the "Penetrator's" exclusive field trimming. They allow you to adjust your VSWR values, after installation, to 1.08 to 1. Unless you're willing to settle for ordinary audience ratings, don't settle for an ordinary antenna. Write us today.

JAMPRO ANTENNA COMPANY
A DIVISION OF COMPUTER EQUIPMENT CORPORATION
Phone (916) 383-1177 • 6939 Power Inn Road, Sacramento, California 95828

**J
A
M
P
R
O**

Circle Number 34 on Reader Reply Card

Michael A. Moscarello, IVC president, said the IVC-240 color camera is engineered and styled for integration with the IVC-4000 large page multiplexer. Combined the two produced provide the most compact broadcast film chain and multiplexer system available in the broadcast industry and at extreme-low cost.

Among the features that contribute to its ease of operation and maintenance are: a single neutral density control disk built into the camera enclosure that eliminates separate disks for each projector; automatic white and automatic black controls compensate for variations in film density; all camera set up controls and the multiplexer local controls are located on a sloping control panel at the camera; three separate mesh vidicon tubes replaceable in minutes without affecting optical alignment or removing deflection yokes.

Circle Number 71 on Reader Reply Card

Telephone Multiplex

Scott-Buttner Corp. Coastcom recently introduced its Type 100 SBSC low-density telephone multiplex system package. This pre-engineered system is unique in its ability to provide both multiplexing and all other functions required for complete end-to-end communications system including VHF control and rural subscriber line interface for private or multi-frequency ringing party line service from microwave drops.

The Type 100 system is ideally suited for local government or utility 960 MHz microwave systems where VHF control or telephone extensions are needed at remote locations.

The Type 100 system is designed to provide up to twelve 4 KHz voice or data channels plus order wire in the 0 to 52 KHz spectrum and conforms to CCITT Group A recommendations. Groups of 12 channels may be combined for higher density applications. Each Type 100 channel is crystal controlled and functionally independent.

Circle Number 72 on Reader Reply Card

New products begin
on page 44

The Aristocart has just made other cartridges obsolete.

New basic design gives you

- Less wow and flutter—Almost reel to reel fidelity
- Accurate phasing—average loss less than 1 db, max. 3db
- Longer head life—up to twice
- Longer tape life
- Full NAB compatibility—great uniformity, cart to cart

No wonder leading broadcast engineers say:

"Tremendous improvement. Consistent cart to cart."—Tom Milner, KEZR(FM), Anaheim. "Only cart that's really satisfactory."—Paul Wieman, KKDJ, Los Angeles. "Tested extensively at three stations; very superior phase-wise."—Will Shimski, Pacific & Southern Broadcasting Co., Inc.



See and hear them at NAB. Distributor inquiries invited.

IGM

3950 Home Road
Bellingham, Wash. 98225

Circle Number 42 on Reader Reply Card

AVOID NOISE

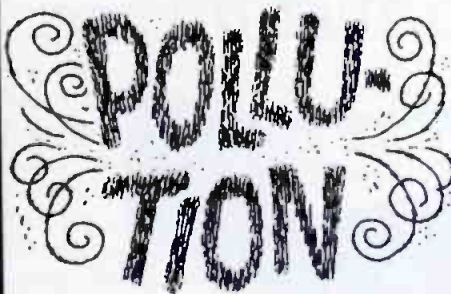

TABER PRESENTS ITS NEW TABERASER

Highest quality

... best value

Erases Them All Reel to reel magnetic tapes, cartridges, cassettes, all magnetic film stock too. Up to 2 inches.

Erases It All with minimum residual noise because the field automatically diminishes at the end of each 30-second cycle.

Won't Overheat Internal blower activates automatically to keep unit below 71°C.

Budget Priced at only \$395.

For the distributor in your area

Call or write: **TABER** MANUFACTURING & ENGINEERING CO.
2081 EDISON AVE. • SAN LEANDRO, CALIF. 94577 • PHONE: (415) 635-3831

Circle Number 35 on Reader Reply Card

AGC Amplifier Update

(Continued from page 19)

amplifiers provide an output jack for the bus, so it is not difficult to tie them together.

The Annual Proof of Performance Measurements require that the AGC action be disabled or switched out of the circuit when making the Proof Measurements. This is understandable from a re-

sponse point of view. Should the system audio response ahead of the AGC be poor, the AGC action would compensate for it and the output would appear as a false flat response.

The system distortion measurements are also made with the AGC disabled. The Proof may check out

within specifications, but this does not guarantee there will be no distortion during normal programming. To discover how the system checks out with AGC action, switch the AGC back into the circuit and run a series of distorted measurements at normal level. Then run the levels at the highest excursion expected and check distortion. Do the same with the expander in operation while feeding low level tones through the system.

A well adjusted and properly operating AGC amplifier will not add too much distortion to the system overall readings. A few tenths of a percent are normal. However, if the distortion increases markedly, it may be that the AGC is misadjusted or simply has a problem that needs correction. If the distortion occurs only with higher levels of tone, this could indicate that something else in the system is working too close to distortion. An amplifier may be near overload with normal levels, but is overloading at higher levels.

Many AGC amplifiers use balanced stages so that sudden level changes will not produce "thump". This is canceled out in the pushpull stages. Such amplifiers must keep the stages balanced or this feature will be defeated. Not only should the individual tubes or transistors match up in gain and performance, but also the supply voltages and other circuit parameters should be balanced to them.

Strong RF fields can affect transistor stages if they are not well shielded. A solid state model used at the transmitter site can fall victim to RF. The amplifier can act erratically, as well as pick up noise and hum while under the influence of RF.

One possible trouble spot can be the remote antenna meter, if it is mounted in the same rack as the AGC amplifier. The leads from the rectifier in the tuning house must be properly shielded and the lead filtered to prevent RF from being carried back into the rack from the tuning unit. Although the original installation may have been done properly, shields can break or

CUE IN EVERY LANGUAGE



DQ-1 an electronic device for providing video numerical count down and audio beeps. Ideal for production of video tape leaders. Call us, we'll answer all your questions.

RICHMOND HILL LABORATORIES INCORPORATED

964 Koehl Avenue, Union, New Jersey 07083
(201) 381-5955

Circle Number 37 on Reader Reply Card

another new mcmartin console "FIVE" channel mixer



B-501 Mono Console \$750.00

B-502 Stereo Console \$1,050.00

McMartin has designed a series of 5-mixer consoles for production or subcontrol room application . . . with enough flexibility to serve as the main control console in smaller station operations.

Two models are available: The B-501 mono and the B-502 stereo version.

Plug-in card design for all program circuits permits full latitude in assignment of ten input sources to the five mixing channels.

Professional performance . . . human engineering . . . attractive design . . . combine to offer the user the ultimate in monaural and stereo five-mixer consoles.

For complete information, contact: Director of Sales (402) 342-2753

McMartin

• 605 north thirteenth street • omaha, nebraska • 68102 •

Circle Number 36 on Reader Reply Card

...runds come loose. If RF is sus-
 pected, check out the AGC after
 turn-off when the transmitter is
 shut down. If RF is a problem, it
 disappears with the transmitter

Summary

AGC amplifiers can do an excel-
 lent job of controlling average pro-
 gram levels, just so long as the

amplifier is properly adjusted and
 input levels are kept within range
 of the AGC. You should be careful
 not to allow the AGC to become a
 crutch and thus ignore levels alto-
 gether. A certain amount of manual
 control is required to keep levels
 within range of the AGC. Once the
 levels are within range, the AGC
 should be allowed to handle the
 levels on its own.

(Cont. from page 8B)

Operator Requirements Change

One or more first class operators in
 full-time employment or under con-
 tract on a part-time basis. (A first
 class operator is presumed to have
 a thorough knowledge of electronic
 fundamentals and broadcast equip-
 ment. A third class operator need
 have only minimal technical compe-
 tence.)

Under the present rules that re-
 quire all transmitter duty operators
 at certain stations to hold first class
 licenses, these duty operators are
 also frequently responsible for pro-
 gramming assignments as announ-
 cers, disc jockeys, or for related
 studio production work. These
 programming assignments frequently
 conflict with the operator's ability
 to adequately respond to his obliga-
 tions to properly maintain the
 transmitting system. The new rules
 permit the station's chief operator
 to serve as transmitter duty opera-
 tor during routine operation only to
 the extent that the secondary as-
 signments do not interfere with his
 primary responsibility for insuring
 that the station is operating within
 the required technical standards
 and the station authorization.

In a rulemaking notice adopted
 July 29, 1970 (FCC 70-825) the
 Commission observed that many
 stations were having serious prob-
 lems obtaining properly qualified
 operators with first class radiotele-
 phone licenses, and asked for
 comments on operator require-

(Continued on page 54)

GET SECOND LIFE

FROM YOUR POWER TUBES

... at about 50% of original cost!

Emission life of a thoriated tungsten
 filament depends on carbon evapora-
 tion. When the carbon is depleted,
 emission drops. Until now, you were
 in for an expensive replacement!

Now Freeland Products offers expert
 reprocessing of certain types of
 thoriated filament tubes. Our service
 is backed by a warranty and over
 30 years experience.

Send today for descriptive brochure
 and price list. Freeland reprocessing
 assures FULL AVERAGE EMISSION
 LIFE of new tubes—yet you'll save
 up to 50% of original cost!

Scores of Satisfied Customers

WAOK	KHOF	KPQ
KBCL	KHOM	WPLO
KBHS	KHOU	KXXX
WBKH	WHAL	WQAM
KCIJ	WHAS	WQMV
KCIM	WHB	WRUF
WCCO	WIRK	WSMB
WCMI	WJCV	WTAE
WDAE	WJDX	WTIX
WDAK	WJLS	KVAL
KELI	WKIZ	KVOL
WEEB	KLCN	KWHI
KFDA	KLIV	WWST
WFOR	WMRI	WYESTV
KGBC	KOKE	WPRS
KGUD	KOMA	WVHI
WGNV		

And Many More!

Freeland Products Co.
 3233 Conti St. • New Orleans, La. 70119
 504/822-9223

Circle Number 38 on Reader Reply Card

SBC-415 TAKES THE WORRY OUT OF MEETING AURAL PROOF-OF-PERFORMANCE

That's right. Our SBC-415 FM Subcarrier is the sound du-
 plexer system that guarantees
 peace of mind when you sign-
 off your aural proof-of-per-
 formance statement.

SBC-415 adds a big margin of
 safety to your TV-STL opera-
 tion because it's first in extra
 low distortion, (0.5%, maxi-
 mum); first in video interfe-
 rence rejection.

SBC-415 combines ultra-lin-
 ear modulation and highly se-
 lective demodulation with a
 precise 60 dB isolation delay
 equalized filter system.

We designed it that way to
 meet your most critical broad-
 cast requirements. SBC-415
 is a unique departure from or-
 dinary subcarrier design that
 delivers unequalled perform-
 ance at a price that's right.

But, see for yourself. Write for
 the facts, today. Better still,
 call us.

SCOTT
BUTNER
 Coastcom

534 Twentieth Street • Oakland, CA
 94612 • Telephone: (415) 465-5900

Circle Number 47 on Reader Reply Card

**ATTENTION
BROADCASTERS, CATV, CCTV
TERMINAL EQUIPMENT
USERS!**

Here is your answer to quality
at a **reasonable price!**

MODEL 701 VDA	\$ 45
Bridging input — 2 outputs. Flat within 0.2 DB to 20 mHz.	
MODEL 702 PDA	\$ 45
Bridging input — 2 outputs. Regenerates all pulses.	
MODEL 704	\$ 45
Audio Preamp — Bal. bridging input and bal. output.	
MODEL 705	\$ 45
Audio Dist. Amp. — 6 outputs.	
MODEL 700 Series Mounting Frame	\$ 95
(3-1/2" R.S.) Contains regulated P.S. and space for four modules.	

MODEL 800 VDA	\$ 75
W/bridging input — 4 outputs. housed in a 4.75"W 3.75"H 2.25"D cast aluminum case w/rear mounting stud. Also contains freq. compensation for feeding up to 500' of cable. Flat response within .1 DB to 20 mHz.	

MODEL 810	\$275
Digital Sync Generator Generates highly accurate NTSC-FCC pulses.	

MODEL 811	\$350
Digital Color Sync Generator Same as above plus Color Standard. 800 Series units are self powered and mount in 3-1/2" rack frames.	

All modules are constructed of high quality components and incorporate the latest state of the art techniques. In most instances, specifications exceed broadcast color standards. Delivery from stock — include check or money order — COD orders also honored. Satisfaction guaranteed or money refunded if returned within 10 days. All items carry a 1 year warranty on parts and workmanship.



4306 Governors Drive
HUNTSVILLE, ALABAMA 35805
Circle Number 12 on Reader Reply Card

(Continued from page 53)

ments, and methods for improving the competence of supervisory operators in order to offset any lessening of the technical competence of duty operators if the rules were to be relaxed. The Commission also asked for comments on a number of questions relating to operators and their grades, the effect of possible changes on technical operation, job security and minority group opportunity, possible different standards for small markets, and the possible automation of transmitters in the future.

More than two hundred comments from individual station licensees, national and state organizations of broadcasters, operators' unions, individual operators and radio license schools were received in response to the rulemaking notice.

Commission Explains Its "Off-Network" Restrictions

Section 73.658(k) of the Commission's Rules limits television stations in the top 50 markets to no more than three hours per evening of network programming during "prime time" (7 to 11 p.m. E.T. and P.T., 6 to 10 p.m. C.T., and 7 to 11 p.m. M.T. except that stations in that zone may elect to substitute 6 to 10).

Effective October 1, 1972, Section 73.658(k)(3) also provides that "the time from which network programming is excluded" may not "be filled with off-network programs; or feature films which within 2 years prior to the date of broadcast have been previously broadcast by a station in the market."

In response to a number of inquiries as to the interpretation of the "off-network" and previously shown movie restrictions, the Commission is issuing the interpretations to the following four questions:

precise timing for precision programming at very low cost.

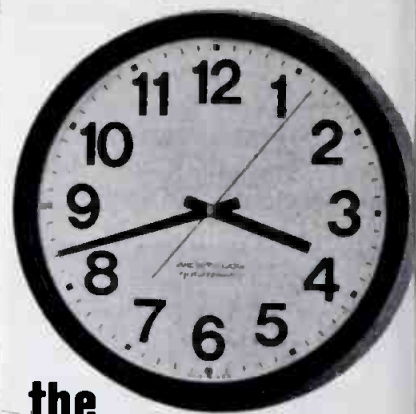

the quartzmatic clock by WESTCLOX

- ▶ Precision accuracy of plus or minus only 1 minute in 525,600 minutes (1 year) . . . that's reliability.
- ▶ Perfect for radio and TV stations recording studios, news bureaus, ham radio operators, weather stations.
- ▶ Completely portable, move it anywhere . . . accuracy unimpaired.
- ▶ Easy to read at a glance, large 12" diameter face with 1 1/2" numbers, red sweep second hand.

and only \$55⁰⁰

- ▶ Powered by two "C" size batteries over 1 full year battery life.
- ▶ Choice of colors — white or tan face with charcoal numbers, both have woodhue case.
- ▶ One year Factory Guarantee from Westclox, a division of General Time, the world's foremost maker of precision clocks and watches.

For precise timing, order the latest advance in timekeeping technology, the WESTCLOX QUARTZMATIC CLOCK . . . only \$55.00

Send check or money order and we'll pay shipping charges. Please include all applicable taxes. If preferred, we'll send C.O.D. Please indicate color; white or tan. Batteries not included. Allow two weeks for delivery.

ORDER FROM: GENERAL TIME SERVICE
NEW YORK 150 E. 47th St., N.Y. 10017
CHICAGO 206 N. Michigan Ave., Ill. 60601
LOS ANGELES 5404 Wilshire Blvd., Cal. 90036
AKRON 25 Ghent Rd., Ohio 44313
PHILADELPHIA 1214 Walnut St., Penna. 19107
PHOENIX 2047 East Camelback Rd., Ariz. 85201

Quartzmatic movements available separately, write for details.

GENERAL TIME SERVICE
A TALLEY INDUSTRIES COMPANY

Circle Number 46 on Reader Reply Card

Question: Does the restriction on "off network programs" apply to "special" programs, which were presented on a national network but not on a regular basis?

Answer: Yes. The rule and its restrictions apply to off-network programs which were of a special or regular nature, as well as to regular program series.

Question: Does the restriction on re-showing of feature films in the market within two years apply where the previous showing was on the same station, i.e., if a network-affiliated station ran a feature film during 1971 (at any hour), is it prohibited from presenting the same movie during the "cleared" portion of time in 1972?

Answer: Yes. The two-year restriction on filling the cleared portion of prime time with movies previously shown in the market applies to a showing on the station which previously showed it.

Question: Is material considered an "off network program" not eligible for presentation during the cleared portion of prime time, if it, itself, was not presented on a network but it is a further episode or continuation of a series which ran on the network?

Answer: No. As long as the particular program or episode itself did not run on the network, it is not considered an "off-network program".

Question: Do the "off-network" and "two-year feature film" restrictions of Section 73.658(k) apply to independent stations, not affiliated with a national network or networks and normally carrying little network prime time programming?

Answer: No. Since these stations do not carry substantial amounts of prime time network programming, as to them there is no particular "time from which network pro-

gramming is excluded", and the off-network and feature film restrictions do not apply to them.

**Send your Engineer's
Exchange Ideas To:
BE, 1014 Wyandotte
Kansas City, Mo. 64105**

Twenty (20) days of broadcasting* logged on a single 10½" reel.



This Tape-Athon model 900 Logger can operate at 15/32 ips the way most loggers run at 15/16 and 17/8. Imagine fidelity to 2500 Hz at 15/32 ips! That extra slow speed allows 409+ hours of recording over 8 channels on ½ mil tape with a 10½" reel.

Twenty days of broadcasting on a single reel. Doesn't that eliminate a lot of problems—like tape changing, tape storage, and even the cost of tape? Write now for details.

*Based on a 20 hour broadcast day

Tape-Athon Corp.

502 S. Isis Ave., Inglewood, Calif. 90301
(213) 776-6933

**ROH
INC.**
200 Series

BROADCAST AUDIO EQUIPMENT

10 Popular Audio Processing Modules



Model 214 Line/Microphone Preamplifier

And 4 Multiple Module Enclosures



Model 204 2-Module Powered Enclosure

Plus Accessories

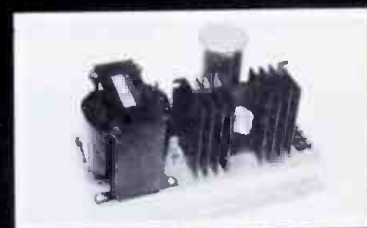

Model 257 24V 2A OEM Type Power Supply

Model	MODULES	Price
201	10 Module Card Tray	\$190.00
202	9 Module Card Tray/Accepts Model 205	210.00
203	3 Module Card Tray	170.00
204	2 Module Card Trays with 1A 24V Supply	150.00
205	2A 24V DC Power Supply Module	75.00
257	2A 24V DC OEM Type Power Supply	95.00
258	5A 24V DC OEM Type Power Supply	150.00
251	Module Socket Assembly 7 Terminal Access	13.00
252	Module Socket Assembly 18 Terminal Access	18.00
253	3 Module Rack Mount Socket Assembly	65.00
254	6 Module Rack Mount Socket Assembly	125.00

ROH CORPORATION
4181 Maple Drive, N.E., Atlanta, Georgia 30305

DISCOVER *the* SUPERIOR ALL SOLID STATE AM FREQUENCY MONITOR

Naturally FROM WILKINSON!



MODEL TAMF-1A
FCC No. 158

- * Triac Controlled Crystal Oven
- * Instantaneous Operation — No Warm-up Time
- * Requires only 5¼ inches of Rack Space
- * I. C. Regulated Solid State Power Supply
- * Self Testing from Front Panel

For complete details write:

WILKINSON
ELECTRONICS, INC.

1937 MacDADE BLVD.
WOODLYN, PA. 19094
PHONE (215) 874-5236 874-5237

Commission Makes More Operator Changes

Amendment of Part 74 of the rules (operator requirements for experimental, auxiliary, and special broadcast, and other program, distributional services) to delete the requirement for licensed operators whenever a restricted radiotelephone operator is allowed to perform the function, has been proposed in a rulemaking notice by the FCC.

The Commission said that it was considering the changes because restricted radiotelephone operators (RP's) perform duties not unlike those performed on other services where there are no requirements for a licensed operator and the deletion of the license requirements would not be a detriment to broadcasting.

Pointing out that these operator requirements were included in the rules as a matter of discretion rather than statutory mandate, the Commission noted that while Section 318 of the Communications Act provides that a licensed operator shall actually operate transmitting apparatus in any radio station, it also provides that this requirement may be waived except in stations engaged in broadcasting (other than the rebroadcasting of signals of television stations).

OTP Broadband Study Released For Sales

The Office of Telecommunications Policy has released a study entitled "Pilot Projects for the Broadband Communications Distribution System." The study, conducted by the firm of Malarkey, Taylor, and Associates of Washington, D.C. for OTP, evaluates demonstration programs to test the uses and public demand for cable TV and related services.

The report specifically proposes that government and industry cooperate to establish a pilot cable system using the latest practical technology serving a basic test group of 1,000 or more homes. The suggested pilot system would involve two-way cable transmission facilities, terminals to control system services at each home, central information files and simple data processing accessible to home users, and facilities for local program origination live or with film and videotape.

No decision has yet been made concerning possible implementation of the MTA study recommendation. Discussions are continuing among interested Federal agencies and industry and public interest groups, but no immediate decision is anticipated. The Cabinet committee on cable television established last June is to develop Administration policy for the regulation and development of broadband cable communication, considering this concept as part of its deliberations.

Copies of the Malarkey, Taylor report may be obtained from the National Technical Information Service, 5285 Port Royal Road, Springfield, Virginia 22151. The price is \$3.00 per copy.

DISCOVER *the* SUPERIOR ALL SOLID STATE AM MODULATION MONITOR

Naturally FROM WILKINSON!



MODEL TAMM-1A

- FCC Type Approval No. 156
- Wideband 500 KHz to 26.1 MHz
- Uses Latest IC Innovations
- New as Tomorrow . . . Reliable as Forever

For complete details write:

WILKINSON
ELECTRONICS, INC.

1937 MacDADE BLVD.
WOODLYN, PA. 19094
PHONE (215) 874-5236 874-5237

PROFESSIONAL SERVICES

VIR JAMES
 CONSULTING RADIO ENGINEERS
 Applications and Field Engineering
 345 Colorado Blvd.
 Phone: (Area Code 303) 333-5562
DENVER, COLORADO 80206
 Member AFCEC
 TWX 910-931-0514

COURTRIGHT ENGINEERING
 MORRIS COURTRIGHT, Jr., P.E.
 Automation - Applications Field Engineering
 ELECTRICAL AND BROADCASTING
 Route No. 1, Box 854A, Flagstaff, Ariz. 86001
 Phone (602) 774-8206

**CAMBRIDGE CRYSTALS
 PRECISION FREQUENCY
 MEASURING SERVICE**
 SPECIALISTS FOR AM-FM-TV
 45 Concord Ave. Phone 876-2810
 Cambridge, Mass. 02138

TODD ASSOCIATES
 CONSULTING RADIO ENGINEERS
 Alva C. Todd, Ph.D., P.E., Principal
 7 S. Summit Avenue, Ph: (312) 832-4104
 VILLA PARK, ILLINOIS 60181

B. F. GOLDBERG & ASSOCIATES
 Consulting Radio Engineers, Architects-Engineers
 since 1961
 AM, FM and TV Applications
 Facilities Planning & Architectural Service
 Acoustical Expertise
 Field Engineering
 Antenna Measurements & Proofs
 2100 Bellline Blvd.
 Columbia, S. C. 29204
 (803) 782-5302

SESCO, Inc.
 47 NICHOLS AVENUE
 P. O. BOX 518
 (206) 378-2137
 FRIDAY HARBOR,
 WASHINGTON, 98250

CLASSIFIED
 Advertising rates in Classified Section are per word, each insertion, and must be accompanied by cash to insure publication.
 Each initial or abbreviation counts a full ad. Upper case words, 30¢ each.
 Minimum classified charge, \$2.00.
 For ads on which replies are sent to us for forwarding, there is an additional charge of \$0 to cover department number, etc., which printed in advertising copy, and processing replies.
 Classified columns are not open to advertising of any products regularly produced by manufacturers unless used and no longer used by the manufacturer or a distributor.

CLASSIFIED

Training

To advance in electronics, knowledge and ability are required. Grantham offers correspondence and resident instruction, in depth, leading to the degree of Associate in Science in Electronics Engineering. G. I. Bill approved. Credit for previous training and experience allowed. Free Catalog Write: Dept. E-2, Grantham School of Electronics, 1505 N. Western Ave., Hollywood, California 90027. 6-67-1f

First phone through tape recorded lessons at home plus one week personal instruction in Washington, DC, Atlanta, Boston, Detroit, New Orleans, Minneapolis, Seattle, Denver, Portland, Los Angeles. Proven results. Our 17th year teaching FCC license courses. Bob Johnson Radio License Preparation, 1060D Duncan, Manhattan Beach, Calif. 80266. Phone 213-379-4461. 1-69-1f

Services

CRYSTAL & MONITOR SERVICE. Frequency change, repair or replacement of oven type broadcast crystals. Also frequency change and recalibration or repair of AM frequency monitors, and H-P FM monitors. Fast service at reasonable prices, 30 years experience! Call or write: Eidson Electronic Co. Box 96, Temple, Tx. 76501. Ph. 817 773-3901. 9-70-1f

CARTRIDGE RELOADING. Send us your worn cartridges for reconditioning. Carts cleaned, new pressure pads installed, and minor parts replaced. Tops replaced at manufacturers cost. 48 hour service. Competitive prices. New cartridges also available. Call or write: Marlin Cartridge Co. 205 Prentiss Ave. Drew, Miss. 38737 (601)745-8380 7-72-1t

TEST EQUIPMENT—Repair and calibration services for all types of equipment. Four Service Centers located across the country to provide prompt service. For address of the nearest center or descriptive brochure, contact Tucker Electronics, Box 1050, Garland, Texas 75040, 214-348-8800. 7-72-2t

MISCELLANEOUS FOR SALE

DICTIONARIES, WEBSTER. Library size, 1971 edition, brand new, still in box. Cost new: \$45.00. Will sell for \$15. Deduct 10% on orders of 6 or more. Mail to North American Liquidators, 1450 Niagara Falls Blvd., Dept. TT-1809, Tonawanda, New York 14150. C.O.D. orders enclose \$1.00 good will deposit. Pay balance plus C.O.D. shipping on delivery. Be satisfied on inspection or return within 10 days for full refund. No dealers, each volume specifically stamped not for resale. Please add \$1.25 postage and handling. New York State residents add applicable sales tax. 4-72-4t

FOR SALE

RADIO STATION . . . 5,000 Watts . . . Eastern Arizona \$175,000 . . . substantial cash . . . Harold Bruzee KHIL . . . Willcox 6-72-6t

Equipment for Sale

"New & Used Towers, Buy, Sell or Trade. Erect. Ground wire 85c lb. Bill Angle, 919-752-3040, Box 55, Greenville, N.C. 27834." 2-71-1f

FOR IMMEDIATE DELIVERY: New AM-PEX AG-440B, AG-500B, AG-600B, AM-10, AA-620, CBS Volumax & Audimax, RUSSCO turntables, GRAY tonearms, E-V & AKG microphones, CONTEL Tape Cartridge Equipment and many other broadcast products. SPECIAL PACKAGE DEALS. CONTINENTAL ELECTRONIC WHOLESALE CORPORATION, P.O. Box 206, Hialeah, Fla. 33012. Phone (305) 822-1421. 5-72-3t

KTR-1000 COLOR TV MICROWAVE LINKS NTSC Color TV plus program audio microwave links for studio-xmtr, CATV, etc. Rack mounted. Mfr. Raytheon. 25 sets in stock, as new condition. Also in stock components of Collins Microwave link MW-103. Radio Research Instrument Co. Inc. 3 Quincy Street, Norwalk, Conn. Tel. 203-853-2600 6-72-4t

CARTRIDGE TAPE EQUIPMENT—Completely rebuilt and reconditioned. Tape-caster and Spotmaster Record/Playbacks \$375.00. Playbacks \$250. 30-day money-back guarantee. AUTODYNE, P. O. Box 1004. Rockville, Maryland 20850 (301/762-7626). 11-71-1f

ONE STOP for all your professional audio requirements. Bottom line oriented. F. T. C. Brewer Company, P. O. Box 8057, Pensacola, Florida 32505. 7-71-1f

MOTORS FOR SPOTMASTERS

NEW Paps hysteresis synchronous motor HSZ 20.50-4-470D as used in series 400 and 500 machines. Price \$39.00 each prepaid, while they last. 90 day warranty. Terms check with order only, no COD's. Not recommended for Tape-caster series 600 or 700.

TAPECASTER TCM, INC. Box 662, Rockville, Maryland 20851. 1-72-TF

TEST EQUIPMENT—Reconditioned GR, HP frequency and modulation monitors, impedance bridges and related equipment available from stock. Contact us with your specific requirements or write for the latest catalogs. America's largest distributor of reconditioned test equipment. Tucker Electronics, Box 1050, Garland, Texas 75040, 214-348-8800. 7-72-2t

Please write for prices—Towers AM-FM TV-CATV-Micro-Wave any type. Ground wire 90¢ per lb. Bill Angle Sr., P.O. Box 55, Greenville, N.C., 27834, phone 919-752-7323 7-72-1f

"For Sale: Marconi Mk-IV vidicon film chain, fair condition with vidicon, lens, no cables, pwr. supply, \$200. J. Snyder, 301-948-9090." 7-72-1t

TOWER COMPONENTS FOR SALE

Recently dismantled 550' tower suitable for FM, TV or Microwave complete with co-axial, guy wires and extra strong tower insulators. Excellent Channel 9 or 10 antenna; also ideal for emergency standby. Will sell all or part. For full information, write Reggie Moffat, Mid-Florida TV Corp., PO Box 6103C, Orlando, Fla. 32803 or phone (305) 841-5040. 7-72-2t

MOBILE COLOR TV STUDIO

First class condition, very few hours 2 IVC 90B Cameras, IVC 870 recorder—Broadcast type Encoders, Special Effects, Keying, Preview, the works, priced for immediate sale. Complete equipment list, write Roy Dyer, Video Ministries, Box V, Ft. Lauderdale, Fla. 33315—(305) 522-0635 7-72-1t

Surplus Audio Patch Panels, All Standard Configurations. Gulf Telephone & Electronics, Inc. 6325 Beverly Hill, Houston, Texas 77027 7-72-1f

USED EQUIPMENT FOR SALE: General Electric BT-11-B 10 watt FM transmitter, fair condition, no crystal, spare tubes, manuals, \$400. RCA RT-7-A (playback) and BA-7 (record) cartridge units, need circuit board repairs to work, motor good, \$150. 19" x 4' rack, good condition, \$20. 2 Presto turntables, motors work, may need other repairs, \$7.50 each. Buyer pays shipping. Write: WCWT-FM, 192 W. Franklin St., Centerville, Ohio 45459. 7-72-1t

CARTRIDGE TAPE EQUIPMENT—Rebuilt. New paint, heads, flywheel, pressure roller, belts etc. Spotlessly clean and thoroughly tested. 30 day money-back guarantee, 90 day warranty. Also contact us for possible discounts on new equipment and accessories. AUTODYNE, Box 1004, Rockville, Maryland 20850, (301/762-7626). 7-72-1f

COAXIAL PATCH PANELS. (2) each, 3 1/4", 50 ohm, 10x10 plus dummy load connection. Dielectric Communications Type 3233P. Complete specifications available. Unused. Original cost about \$7000 each. S-W Elect. Box 23872 Oakland, Calif. 94623. Telephone (415) 832-3527. 7-72-3t

Help Wanted

SALES ENGINEER wanted for East Coast gu.S.A. Custom switching and terminal equipment, video and audio. Vital Industries, Inc., 3614 S.W. Archer Rd., Gainesville, Fla. 32601, (904) 378-1581. 4-72-1f

Help Wanted (Cont.)

Job Headquarters for all Radio and Television Engineers. Immediate openings exist in 9 western states and elsewhere for qualified engineer and technical personnel. All categories from trainees to experienced transmitter maintenance, chief, assistant chief, live color video maintenance and technical operations. Send us your complete resume now. The AMPS Agency, 11661 San Vicente Blvd., Suite 300, Los Angeles, Calif. 90049. Telephone: 213-820-2678. By Broadcasters — For Broadcasters. 11-68-1f

SALES ENGINEER wanted for East Coast U.S.A. Custom switching and terminal equipment, video and audio. Vital Industries, Inc., 3614 S.W. Archer Rd., Gainesville, Fla. 32601. (904) 378-1581. 4-72-1f

MANUFACTURER'S REPRESENTATIVES WANTED

MARKET SECTOR—Broadcasting Stations and Telephone Operating Companies.

PRODUCT—Computer Programmable, Video/Audio routing switching systems with plain language displays capable of on going expansion.

ESSENTIAL REQUIREMENTS—Thorough knowledge of video switching. Proven track record in stated market sectors.

THE COMPANY—A Canadian Company, Vancouver based with above average product development capabilities.

Write to: **VISCOUNT VIDEO SYSTEMS LTD.**, Director of Marketing, Marine Industrial Center, 105 East 69th Avenue, Vancouver 15, B.C., Canada. 7-72-2t

ADVERTISERS INDEX

Ailtech	9
American Data Corporation	54
Amperex Electronic Corp.	33
Angenieux Corp. of America	45
Audio Video Engineering Co.	CE-4
Broadcast Electronics, Inc.	CE-3, 16, 44
CBS Laboratories	35
CCA Electronics Corp.	44-45
Continental Electronics	11
Dynair Electronics, Inc.	28
Eastman Kodak Company	8A
Electro-Voice, Inc.	Cover 2
Electronic Engineering Corp. of Calif.	49
ES Enterprises	41
Fidellpac, Div. of Telepro Ind., Inc.	8
Freeland Products Company	53
Gates Radio Co., Div. Harris-Intertype Corp.	8B, 12
General Electric (Tubes)	25-26
General Time Service	54
The Grass Valley Group, Inc.	3
International Good Music	51
Jampro Antenna Company	50
Jensen Tools and Alloys	44
Lenco, Inc.-Elec. Div.	56
Liberty Industries, Inc.	47
Marco Video Systems	7
McMartin Industries, Inc.	52
Mediatech	48
Miller-Stephenson Chemical Co., Inc.	37
Minneapolis Magnetics	47
Monsanto	17
Richmond Hill Laboratories	52
ROH Corporation	55
Russco Electronics Mfg. Co.	40
SC Electronics, Inc.	5
Scott-Buttner Corp.	53
Sola Basic, Div. Dielectric Comm.	20-21
Spotmaster	CE-3, 10, 44
Stainless, Inc.	13
Taber Manufacturing & Eng. Co.	51
Tape-Athon Corp.	55
Teledyne Isotopes	46
Telemet Company	Cover 3
Time & Frequency Technology, Inc.	29
Tracor Industrial Inst. Div.	1
Ultra Audio Products	42
Vital Industries, Inc.	Cover 4
Wilkinson Electronics	56
Xcelite, Inc.	43

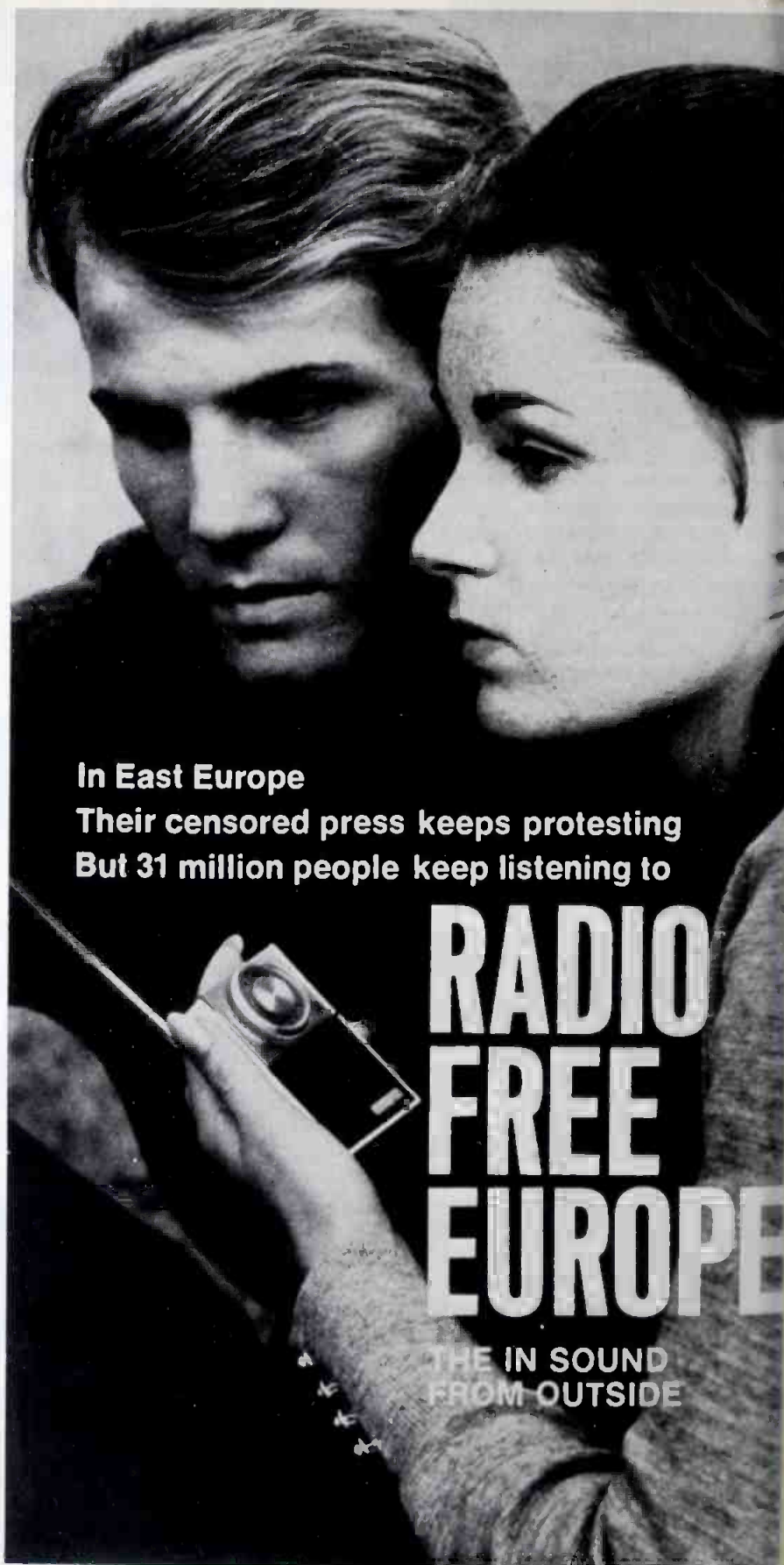

In East Europe
Their censored press keeps protesting
But 31 million people keep listening to

RADIO FREE EUROPE

THE IN SOUND
FROM OUTSIDE

For information about East Europe and RFE, write:
RADIO FREE EUROPE, Box 1972, Mt. Vernon, New York 105

READER SERVICE CARD BROADCAST engineering

For issue of July 1972—Use until October 1, 1972

After that date
please contact
manufacturer direct

Use This
Handy Card
For More
Information
On The
Products
Described

Name _____ Title _____

Station or Company _____

Address/City _____

State _____ Zip _____

1	9	17	25	33	41	49	57	65	73	81	89	97	105	113	121	129	137	145	153	161	169	177	185	193	201
2	10	18	26	34	42	50	58	66	74	82	90	98	106	114	122	130	138	146	154	162	170	178	186	194	202
3	11	19	27	35	43	51	59	67	75	83	91	99	107	115	123	131	139	147	155	163	171	179	187	195	203
4	12	20	28	36	44	52	60	68	76	84	92	100	108	116	124	132	140	148	156	164	172	180	188	196	204
5	13	21	29	37	45	53	61	69	77	85	93	101	109	117	125	133	141	149	157	165	173	181	189	197	205
6	14	22	30	38	46	54	62	70	78	86	94	102	110	118	126	134	142	150	158	166	174	182	190	198	206
7	15	23	31	39	47	55	63	71	79	87	95	103	111	119	127	135	143	151	159	167	175	183	191	199	207
8	16	24	32	40	48	56	64	72	80	88	96	104	112	120	128	136	144	152	160	168	176	184	192	200	208

READER SERVICE CARD BROADCAST engineering

For issue of July 1972—Use until October 1, 1972

After that date
please contact
manufacturer direct

Use This
Handy Card
For More
Information
On The
Products
Described

Name _____ Title _____

Station or Company _____

Address/City _____

State _____ Zip _____

1	9	17	25	33	41	49	57	65	73	81	89	97	105	113	121	129	137	145	153	161	169	177	185	193	201
2	10	18	26	34	42	50	58	66	74	82	90	98	106	114	122	130	138	146	154	162	170	178	186	194	202
3	11	19	27	35	43	51	59	67	75	83	91	99	107	115	123	131	139	147	155	163	171	179	187	195	203
4	12	20	28	36	44	52	60	68	76	84	92	100	108	116	124	132	140	148	156	164	172	180	188	196	204
5	13	21	29	37	45	53	61	69	77	85	93	101	109	117	125	133	141	149	157	165	173	181	189	197	205
6	14	22	30	38	46	54	62	70	78	86	94	102	110	118	126	134	142	150	158	166	174	182	190	198	206
7	15	23	31	39	47	55	63	71	79	87	95	103	111	119	127	135	143	151	159	167	175	183	191	199	207
8	16	24	32	40	48	56	64	72	80	88	96	104	112	120	128	136	144	152	160	168	176	184	192	200	208

BROADCAST engineering FREE SUBSCRIPTION CARD

To start or renew your subscription to Broadcast Engineering on a no-charge subscription basis you must check all appropriate boxes, print your name and address, sign and return this card promptly.

I want to START a subscription to Broadcast Engineering now.

I want to RENEW my subscription to Broadcast Engineering now.

Please check all boxes that apply AND occupation title

My company is:

- AM Radio Station
- FM Radio Station
- TV Station, Commercial
- TV Station, Educational
- Broadcast Equipment Mfr.
- CATV System
- CCTV or Instructional TV
- Campus Radio Station
- Consulting Firm

- Dealer or Distributor of Broadcast Equipment
- Educational Radio Station
- Industrial or Medical TV
- ITFS
- Network Owned Station
- Recording Studio, Audio or video
- Microwave
- Government Agency, Library

My occupation title is:

- Owner, President, Officer
- Gen. Manager, Advisor or Director
- Chief Engineer
- Engineer, Technician
- Engineering Supervisor, Director
- Program Manager, Station Manager
- Consulting Engineer
- Other: specify _____

Are you responsible for more than one station or facility? Yes No
Be sure you have checked one box by each arrow!

PLEASE PRINT

Name _____

Title _____

Station or Co. _____

Street _____

City _____ State _____ Zip _____

6 cents
Postage
Required

BROADCAST engineering

P.O. Box 21502
El Paso, Texas 79998

Attn: Engineers Tech Data Dept.

6 cents
Postage
Required

BROADCAST engineering

P.O. Box 21502
El Paso, Texas 79998

Attn: Engineers Tech Data Dept.

6 cents
Postage
Required

BROADCAST engineering

1014 Wyandotte Street
Kansas City, Missouri 64105

Attn: Evelyn Rogers

Introducing the most expansive Audio DA you can buy.

Adjustable modules give you a wide range of input and output matching impedances. Includes 150 ohms balanced, 600 ohms balanced and unbalanced, high impedance bridging and balanced stereo input A & B.

Typical Line Output Arrangements

	Single Channel (One Input)				Dual Channel (One Input)	
	150Ω BAL.	150Ω UNBAL.	600Ω BAL.	600Ω UNBAL.	150Ω UNBAL.	600Ω UNBAL.
Number of Outputs	3	6	6	12	3	6
Attenuation (dB) between outputs (same channel)	46dB	46dB	60dB	60dB	46dB	60dB
Attenuation (dB) between channels (20,000 Hz)					70dB	70dB
Impedance Match (ohms)	75 + 75Ω	150Ω	300 + 300Ω	600Ω	150Ω	600Ω

Flexibility lets you start with fewer than all ten modules and plug-in cards. Adding-on is easy. Each module needs just two screws and two wires to install.

What's more, an optional tone oscillator power supply (mounted in the regular power supply assembly) gives you a stable 1Kc reference tone for setting all DA levels. Provides long-term stability.

Other features include output voltage swing of 35V p-p maximum, with each source allowing plenty of "head room." And Total Harmonic Distortion is 1/2 of 1% @ + 24 dBm.

Everything is contained in one 19"W x 5 1/4"H frame. And it's easy to service. All components are standard solid-state devices available from any jobber.

So there it is. The most expansive Audio DA you can buy because it offers so much flexibility. Yet, it's far from expensive. Let us tell you about it. Telemet, Amityville, N.Y. 11701, (516) 541-3600.

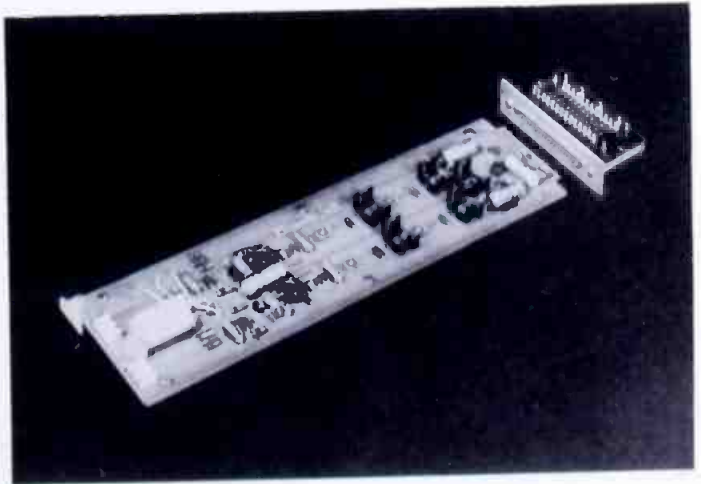
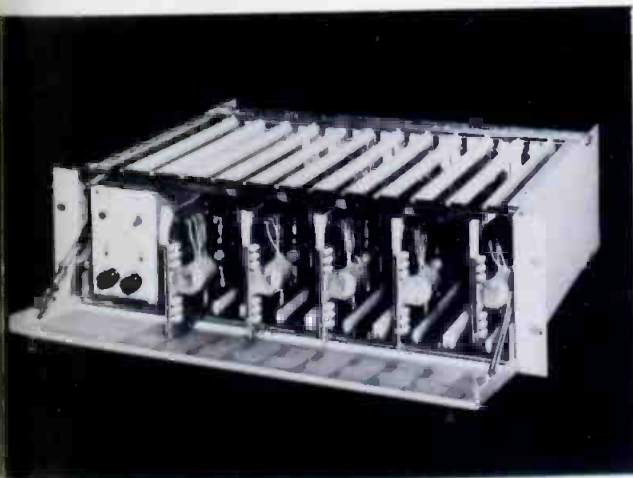

 **Telemet** A GEOTEL COMPANY

Amityville, New York 11701, (516) 541-3600

REGIONAL OFFICES

Chicago, Ill. (312) 627-6026 Houston, Tex. (713) 946-5796 Santa Ana, Calif. (714) 540-6756

Circle Number 3 on Reader Reply Card



a better
switching
system
is **Vital**
for better pictures

Vital's specialized experience in the field of video, audio switching and automation can benefit your operation.

Discover the advantages Vital has to offer you in ...

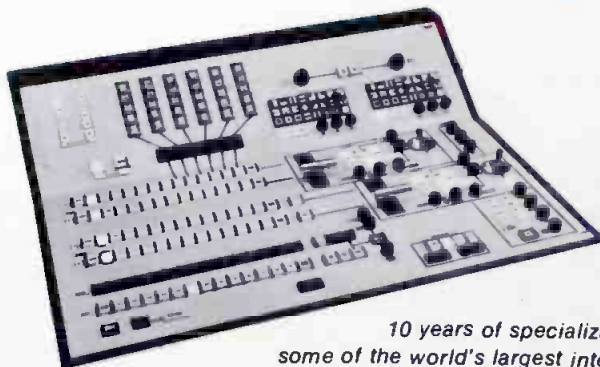

- Production Switchers
- Master Control and Automation Systems
- Audio, Video Routing Switchers
- One Line Machine Controls
- One Line Pulse Distribution Systems
- Video and Audio Distribution Amplifiers
- Video Processing Equipment

10 years of specialization. Designed, manufactured and delivered some of the world's largest integrated telecommunication systems.

3620 Ridgewood Rd., N.W.
Atlanta, Ga. 30327
404-233-9459

7960 W. Beverly Blvd.
Los Angeles, Calif. 90048
213-653-9438

2644 N. Seventh Street
Terre Haute, Ind. 47804
812-466-3212

GOOD ENGINEERING IS VITAL



VITAL INDUSTRIES, INC.

MAIN OFFICE: 3614 S.W. Archer Road, Gainesville, Fla. 32601—Phone 904-378-1400

Circle Number 4 on Reader Reply Card