

November, 1972/75 cents

BROADCAST **ENGINEERING**

the technical journal of the broadcast-communications industry

Indiana University
NOV 28 1972

EMERSON

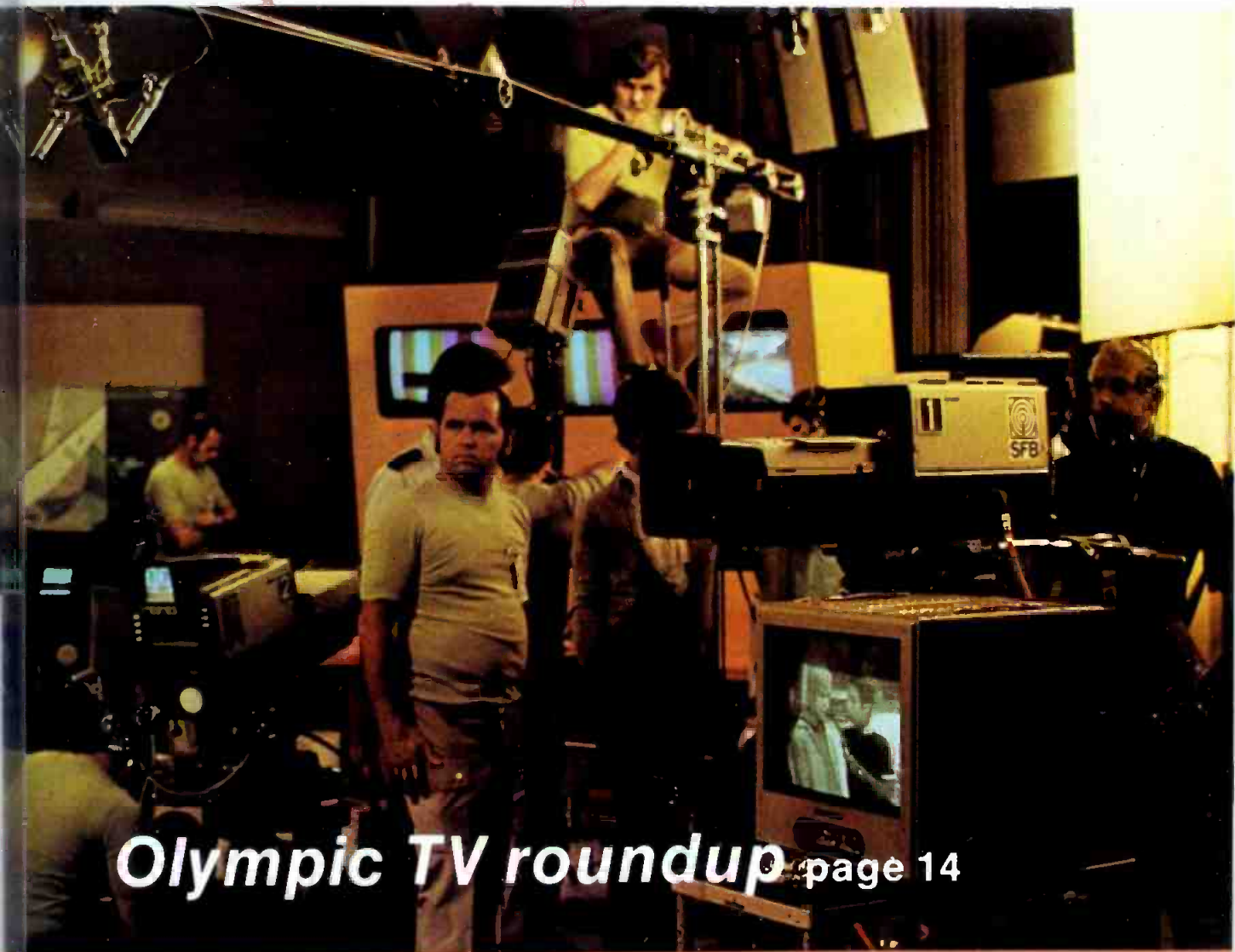

Olympic TV roundup page 14

Stereo Separation
IC Timing Device
AES Convention Review

BH72 N DNC 774 X
INDIANA UNIVERSITY LIBRARY
SERIALS DEPARTMENT
BLOOMINGTON IN 47401

www.americanradiohistory.com



**Further proof...
sound has never
been in better shape!**

RE55 OMNIDIRECTIONAL DYNAMIC MICROPHONE

Ey There are plenty of good, functional reasons behind the new look of Electro-Voice professional microphones. Reasons dramatically proved by the rapid success of the Model 635A and the RE15. Now we've added the RE55 to this handsome group.

The RE55, like its predecessor the 655C, is an extremely wide-range omnidirectional dynamic. And in most electrical particulars it is not greatly different. RE55 frequency response is a bit wider, and perhaps a trifle flatter. An impressive achievement when you consider that the 655C has been extensively used as a secondary frequency response standard. Output level is 2 db hotter, and the exclusive E-V Acoustalloy® diaphragm of the RE55 can provide undistorted output in sound fields so intense as to cause ear damage.

The biggest changes in the RE55 are mechanical. For the microphone is even more rugged than the 655... long known as one of the toughest in the business. There's a solid steel case and new, improved internal shock mounting for the RE55. Plus a fawn beige Micomatte finish that looks great on TV long after most microphones have been scarred and scratched almost beyond recognition.



For convenience we've made the barrel of the RE55 just 3/4" in diameter. It fits modern 3/4" accessories. It also fits the hand (and its length makes the RE55 perfect for hand-held interviews). We also provide XLR-3 Cannon-type connectors to help you standardize your audio wiring. Detail refinements that make the RE55 more dependable, easier to use.

Finally, the RE55 has the exclusive Electro-Voice 2-year *unconditional* guarantee. No matter what happens, if an RE55 fails to perform during the first two years — for any reason — we'll repair it at no charge.

Try the Electro-Voice RE55 today. The more you listen, the better it looks!

ELECTRO-VOICE, INC., Dept. 1121V, 638 Cecil St., Buchanan, Michigan 49107

high fidelity systems and speakers • tuners, amplifiers, receivers • public address loudspeakers
• microphones • phono cartridges and stylus • aerospace and defense electronics

Electro-Voice®
a GULTON subsidiary

Circle Number 1 on Reader Reply Card
www.americanradiohistory.com

Canon offers the perfect zoom lens for the camera of your choice

10 x 20B1



P17 x 30B1



P17 x 30B2



V10 x 16B



PV17 x 24



PV10 x 15

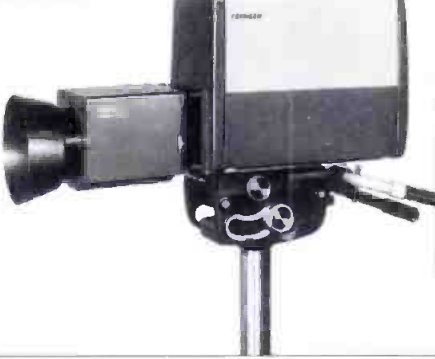

More and more people are discovering how significantly superior Canon Zoom Lenses are for TV broadcasting purposes. Their outstanding color characteristics, even in dim light, is one of the many reasons why Canon was chosen for telecasting the Munich Olympics.

Canon's wide range of excellent zoom lenses encompass three types of operation control—full-servitized, via flexible cables and by effortless push-pull rod control. And it can be attached to

fit and operate with any make of TV camera.

Shown on this page are only a few examples of the quality lenses Canon has available to more than meet your particular demands. Specify Canon to stay ahead.

The following are Canon TV Zoom Lenses for the Plumbicon® color cameras currently available on the market:

Size of Image tube	Lens	Image format covered
1½" Plumbicon® color camera	P10 x 20B4	17.1 x 12.8mm (21.4mmφ)
	P17 x 30B1	
	P17 x 30B2	
1" Plumbicon® color camera	PV10 x 16B1	12.8 x 9.6mm (16mmφ)
	PV10 x 15B2	
	PV17 x 24B1	
	PV 6 x 18B1	

® Reg. TM N.V. Philips of Netherlands.

The Canon TV Lenses Naming System

P10 x 20B



Applications	Image Format	Pick-up Tubes
P	21.4mmφ	1½" Plumbicon
PV	16mmφ	1" Plumbicon

Apart from the above, Canon has available TV zoom lenses for 3" or 4-1/2" image orthicon cameras and can also build special lenses to fit your requirements.

Canon

● CANON U.S.A., INC.: 10 Nevada Drive, Lake Success, Long Island, New York 11040, U.S.A. (Phone) 516-488-6700 ● CANON U.S.A., INC.: 457 Fullerton Ave., Elmhurst, Illinois 60126, U.S.A. (Phone) 312-833-3070 ● CANON OPTICS & BUSINESS MACHINES CO., INC.: 3113 Wilshire Blvd., Los Angeles, California 90005, U.S.A. ● CANON AMSTERDAM N.V.: Gebouw 70, Schiphol Oost, Holland ● CANON LATIN AMERICA, INC.: Apartado 7022, Panama 5, Panama ● CANON INC.: 9-9, Ginza 5-chome, Chuo-ku, Tokyo 104, Japan

Circle Number 4 on Reader Reply Card

BROADCAST engineering®

The technical journal of the broadcast-communication's industry

in this issue...

- 14 Olympic Circuits. Some new video system designs were used at the Olympics. **Joseph Roizen.**

- 20 Stereo Separation In Mic Lines. Stereo separation and a design to fill the "hole in the middle." **Todd Boettcher.**

- 24 There is another method . . . Emergency Broadcasting. Part II of a two-part series on emergency alerting systems. **Stephen Russell.**

- 28 Test Those SCR's And Triacs. Quick tests for SCR's and triacs. Includes a tester you can build. **Ron Merrell**

- 32 Background Monitor Systems. Impedance matching considerations for broadcast station monitoring systems. **Clint Tinsley.**

- 36 Two seconds and counting . . . Using A Versatile IC Timing Device. KOMO engineer continues to probe new devices for use in cue timing. **Fred Fowler.**

- 38 Color After Modulation. BE's maintenance editor tells what waveforms to look for and how to interpret them. **Pat Finnegan.**

- 40 Visiting The AES Convention. A review of the major sessions and papers at the Audio Engineering Society convention. **Walt Jung.**

- 44 Light Level Control For The Film Chain. Introducing a new device that automatically controls light by use of a variable density disc. **Donald MacClymont.**

ABOUT THE COVER

The cover picture this month was supplied by Joseph Roizen of Telegen. The article on page 14 describes some unique systems designed for use at the Olympics.

DEPARTMENTS

Direct Current	4
Letters to the Editor	8
Industry News	10
Cable Engineering	CE-1
Engineer's Exchange	46
People In The News	48
New Products	50
Tech Data	56
Ad Index	59
Classified Ads	59

Copyright, 1972, Howard W. Sams & Co., Inc. All Rights Reserved. Material may not be reproduced or photocopied in any form without written permission of publisher.

EDITORIAL

RONALD N. MERRELL, Director
 CARL BABCOKE, Technical
 MORRIS COURTRIGHT, Automation
 PAT FINNEGAN, Maintenance
 HOWARD T. HEAD, FCC Rules
 ROBERT A. JONES, Facilities
 WALTER JUNG, Solid State
 ANDRA BOYLE, Editorial Assistant
 H. G. ROESLER, Cartoonist
 WEBB G. STREIT, Graphic Designer
 LEO G. SANDS, CATV

EDITORIAL ADVISORY BOARD

LES NELSON, Chairman
 Howard W. Sams & Co., Indianapolis

CIRCULATION

EVELYN ROGERS, Manager

ADVERTISING

E. P. LANGAN, Director
 R. JACK HANCOCK, Manager
 TERRY TEMPLE, Production
 JAKE STOCKWELL, Sales

REGIONAL ADVERTISING SALES OFFICES

MICHAEL KREITER
 1014 Wyandotte St.
 Kansas City, Mo. 64105

Indianapolis, Indiana 46206

ROY HENRY
 HOWARD W. SAMS & CO., INC.
 2469 E. 98th St.
 Tele: 317/846-7026

New York, New York 10019

GEORGE FLECK
 60 East 42nd Street
 Room 1227
 New York, N. Y. 10017
 212/687-7240

Los Angeles, California

RICHARD BOHEN
 3600 Wilshire Blvd., Suite 1510
 Los Angeles, California 90005
 Tele: 213/383-1552

London W. C. 2, England

JOHN ASHCRAFT & CO.
 12 Bear Street
 Leicester Square
 Tele: 930-0525

Amsterdam C, Holland

JOHN ASHCRAFT & CO.
 W. J. M. Sanders, Mgr.
 for Benelux & Germany
 Herengracht 365
 Tele: 020-240908

Tokyo, Japan

INTERNATIONAL MEDIA
 REPRESENTATIVES, LTD.
 Shiba-Kotohiracho, Minato-ku
 Tele: 502-0656



BROADCAST ENGINEERING is published monthly by Intertec Publishing Corp., 1014 Wyandotte Street, Kansas City, Missouri 64105. Telephone: 913/888-4664.

BROADCAST ENGINEERING is mailed free to qualified persons engaged in commercial and educational radio and television broadcasting. Non-qualified subscriptions in the U.S. are \$6.00 one year, \$10.00 two years, \$13.00 three years. Outside the USA add \$1.00 per year to cover postage. Single copy rate 75 cents. Back issue rate \$1.00. Adjustments necessitated by subscription termination at single copy rate.

Controlled Circulation postage paid at Indianapolis, Indiana.



Robert E. Hertel, Publisher
 INTERTEC PUBLISHING CORP.
 Subsidiary of HOWARD W. SAMS & CO., INC.

DISTRIBUTION AMPLIFIERS

GVG has a complete line of Television Signal Distribution Amplifiers for virtually any purpose. Each distribution amplifier provides four outputs and plug-in interchangeability to a GVG frame.

Model 901 Video Distribution Amplifier ■ Model 902 Clamping Video Distribution Amplifier ■ Model 901DP Video Distribution Amplifier with Differential Input and Plug-In Cable Equalization ■ Model 903P Clamping Video Distribution Amplifier with Differential Input and Cable Equalization ■ Model 903N Clamping Video Distribution Amplifier with Separate Video and Chroma Gain Controls ■ Model 906 Video Distribution Amplifier with Automatic Gain Control ■ Model 907 3.58 MHz Subcarrier Distribution Amplifier ■ Model 910 Pulse Distribution Amplifier ■ Model 912 Pulse Delaying Distribution Amplifier.

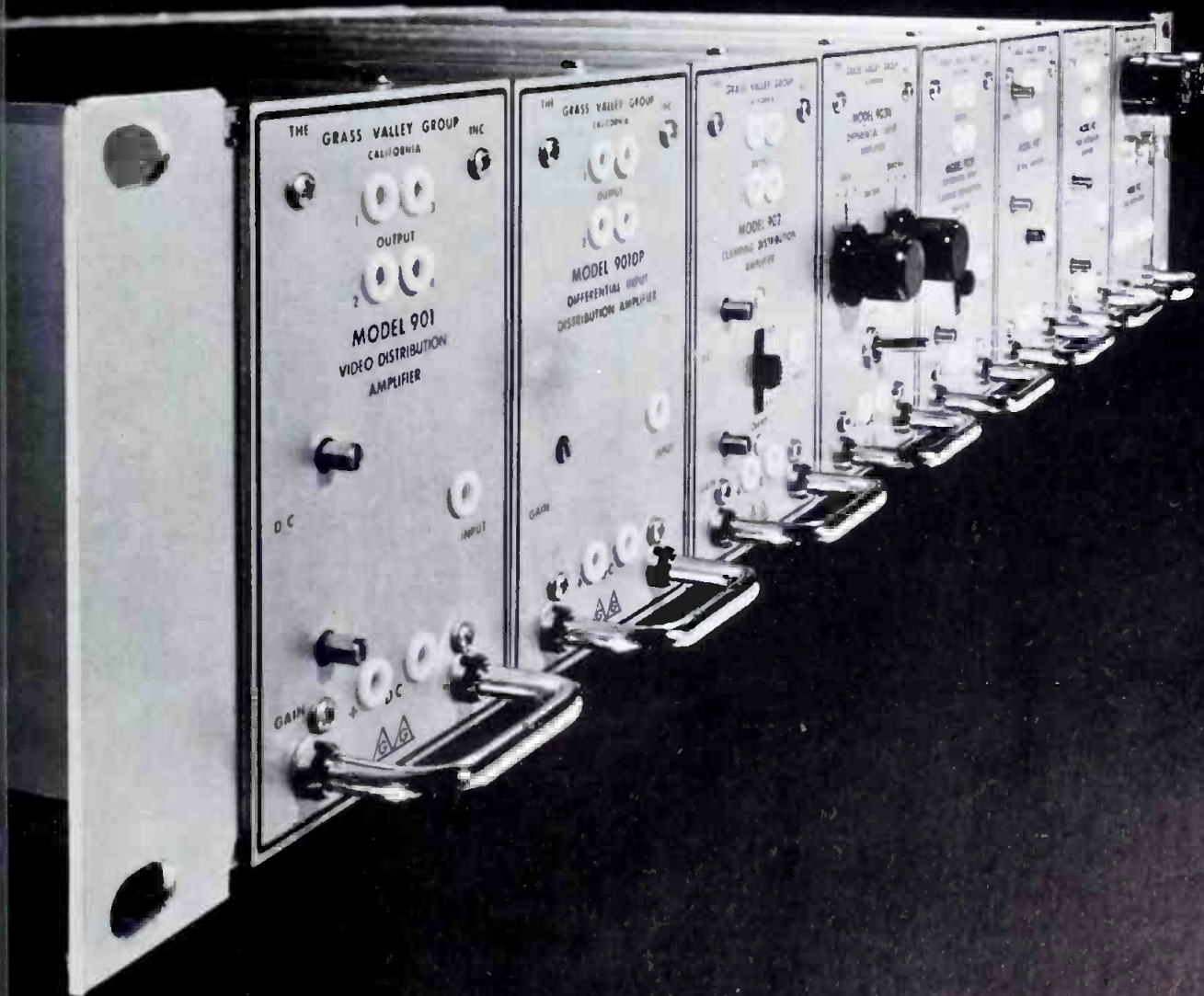

THE GRASS VALLEY GROUP, INC. 

SOLD EXCLUSIVELY BY GRAVCO SALES, INC.

6515 Sunset Blvd.
LOS ANGELES, CALIF.
(213) 462-6618

Station Plaza East
GREAT NECK, N.Y.
(516) 487-1311

125 South Wilke Road
ARLINGTON HEIGHTS, ILL.
(312) 394-1344

Redbird Airport
DALLAS, TEXAS
(214) 330-1245

1644 Tullie Circle, N.E.
ATLANTA, GEORGIA
(404) 634-0521

DIRECT CURRENT FROM D. C.

November, 1972

by Howard T. Head

Changes in Broadcast Rules Imminent

While a blue-ribbon industry committee continues work on a complete overhaul of Part 73 of the Commission's Rules (Broadcast), a special task force of Commission personnel has been working on its own to examine relaxations of the Technical Rules which might be made with little or no red tape. Under consideration are such diverse requirements as that for reading transmitter meters every 30 minutes, and the reliability of monitoring point field strength measurements in maintaining AM directional antennas.

Substantial progress is being made by both the industry group and the Commission Task Force. Plans are under consideration for a public briefing of the Commission Task Force's work to be sure that both groups are moving in the same direction and are not duplicating one another's activities.

Congress Considering Receiver Standards Legislation

A bill has been introduced into the House of Representatives (H.R. 16916) which would empower the Commission to set performance standards for radio and television receivers. The only such power vested in the Commission by present law provides for standards with respect to local oscillator radiation and the provision of all-channel tuning for television receivers.

The principal purpose of the new legislation appears to be that "of requiring the filtering out of interference". Amateur-station interference is the only type of interference specifically mentioned in the bill.

Even if such a bill becomes law and the Commission requires "the filtering out of interference" in new receivers, this would obviously have no effect on the 90 million television receivers and estimated 200 million radio receivers now in the hands of the public. In the meantime, there is no progress to be reported in the Commission's inquiry into possible measures for alleviating existing interference from various sources to television reception.

Commission Getting Tougher On License Revocations

In two cases involving an AM station on the West Coast and an FM station in the Midwest, the Commission has proposed license revocations for a variety of rule violations. The FM case involved consistent attempts by the station to identify itself in such a way as to lead listeners to believe it to be licensed to a nearby

Now you can buy Abto cameras and projectors, or convert your existing equipment to the Abto System.

You've seen it at the Industry Conventions. You can now see it in daily usage for television news coverage. Abtography, the process that lets you shoot and process regular black and white film and show in color over your film chain. You also know the tremendous cost and time savings and operational convenience the Abto System offers.

The Abto System is flexible, easily installed. You can buy a complete system, outright, or modify your present equipment to Abtography.

For complete information, let us know your special requirements. We'll respond with specific information on what Abto can do for you.

abto_{INC.}

1926 BROADWAY / NEW YORK, N.Y. 10023 / (212) 787-5000

Abtography. It happened at the right time.

large city rather than the actual small town of license, a problem which faces the Commission repeatedly . Not only that, but the program loop from studio to transmitter was only "Class C" compared with the Commission's requirements for a 15 kHz response.

In the case of the West Coast station, a Commission Administrative Law Judge characterized the case as one of the most flagrant ever to come to his attention. Among other things, he found that the licensee had moved the transmitter to an unauthorized site and had instructed the chief operator to file an application for direct measurement of power without making actual antenna resistance measurements.

Commission Rules on CATV Channel Carriage

In a case involving local station carriage on a Midwestern cable TV system, the Commission ordered the cable system to refrain from changing the local station carriage from "off-channel" to "on-channel". The cable system had originally undertaken off-channel carriage because of expected ghosting which would result if on-channel carriage were attempted.

When the cable system later proposed to switch the TV station to its own channel, the station wasn't convinced that the cable system had licked the ghosting problem. Later, a private agreement was reached between the station and the cable system.

Short Circuits

The Commission has granted several temporary relaxations of the requirements for comparable television tuning accuracy at VHF and UHF and has postponed for one year (until July 1, 1975) the deadline date for full compliance with the requirements...How the Commission spends its time: The Commission has notified a complainant that dog food advertisements, discussion of humane animal treatment, and entertainment programs involving animals do not come within the scope of the Fairness Doctrine.

Optimize your color video performance:

new from BESTON

BEI
exclusive



Control your film chain light level automatically

Rapid corrections for film and slide density changes are yours with the BEI Auto Light Control. The servo operated neutral density wheel keeps the video level virtually constant with no change in color hue. Picture quality and color fidelity are optimized for both large and small image islands. And, it's compatible with any film chain camera.



Display color vectors on your oscilloscope or waveform monitor

Now you can have the benefits of a vectorscope at half the normal cost. BEI's model 531 Vector Display provides a vector presentation of NTSC or NTSC compatible chroma. This polar coordinate type display allows you to obtain the correct phase and amplitude relationship of the chrominance signal.

BEI

BESTON ELECTRONICS INC.

#20 ON THE MALL • SHOPPING CENTER
PRAIRIE VILLAGE, KANSAS 66208 • TELEPHONE 913-362-4400

OTHER BEI EQUIPMENT: MODEL 411, AUTO LITE CONTROL SLAVE • MODEL 505, POWER SUPPLY • MODEL 507, MULTIPLEXER RELAY CARD • MODEL 511, VIDEO DA • MODEL 515, DIFFERENTIAL INPUT VIDEO DA • MODEL 517, CLAMPING VIDEO DA • MODEL 519, PULSE DA • MODEL 521, PULSE DELAY DA • MODEL 523, DUAL PULSE DELAY DA • MODEL 525, SUBCARRIER DA • MODEL 527, DUAL SUBCARRIER DA • MODEL 529, COLOR BLACK GENERATOR • MODEL 705, AUDIO POWER SUPPLY • MODEL 707, AUDIO DA.

Circle Number 7 on Reader Reply Card

Quality and economy can go together... we did it with Encore tape cartridge equipment



Encore Reproducer \$475

Some broadcasters want and need an economy line of tape cartridge equipment. We incorporated the best features of our premium line into Encore. We simplified systems, circuits and manufacturing techniques. And we created further economies by selling direct, with payment due when you order. We offer a 30-day guarantee of satisfaction plus a one year warranty. Call us collect today and find out why many broadcasters are finding quality and economy under the Encore name.

Encore Recorder/Reproducer \$630



Call 309-828-1381 collect for details on the Encore series

it INTERNATIONAL TAPETRONICS CORPORATION

2425 South Main Street, Bloomington, Illinois 61701

Circle Number 8 on Reader Reply Card

LETTERS TO THE EDITOR

Automation vs. Contacts

Dear Editor:

After considerable debate, I.B.E.W. International has approved a new contract for our I.B.E.W. 1259 radio engineers. The contract contains precedent setting language related to automation, computer data entry and retrieval, graphics (titling) jurisdiction.

The following are some excerpts from the contract dated May 1, 1972. 1.)Section 1.4 b 1. (1) pg. 4. Electronics special effects and graphics can be set up and changed by any station personnel if the equipment is not located in the video master control room. The actual switching will continue to be handled by I. B. E. W. personnel.

2.)Section 1.4 (c) pg. 6 Nothing contained herein shall prevent any station personnel from entering or extracting of data and/or information via input and output entry and display devices of any type connected to computer type equipment or other electronic memory devices, provided that any such entering or extracting of data and/or information by other than engineers shall not be performed in engineer operating areas, and that any manual operation of television program switching devices controlled by such computer and electronic equipment shall be done by engineers.

This language is universal and should be adaptive to future changes in automation technology in the Broadcast Industry.

I hope this precedent will be of value to organizations in preparing for the age of automation.

Steven A. Smith
Director of Eng.
KCMO Broadcasting
Kansas City, Mo.

Compatible Cable

Dear Editor:

Over the years we have always done our Noon Newscast live on the AM Radio but now we added a new media and are combining our



newscast with our Cablevision and are now offering verbal as well as visual news coverage.

We insert pictures of the local

console

MINI "5" CHANNEL ACCU-FIVE \$495

the compact rack mount console ideal for CATV/CCTV audio for complete information please contact the Director of Sales Dept. B-5R



McMartin MCMARTIN INDUSTRIES INC., 605 NORTH THIRTEENTH ST. OMAHA, NEBRASKA, 68102 TELEPHONE (402) 342-2750
Circle Number 53 on Reader Reply Card

BROADCAST ENGINEERING

CABLE engineering

in this issue...

Expansion Loops CE-2

Color Origination CE-6



The case for expansion loops

By James B. Wright*

Doesn't it always seem to end up that the best way to do things is also the most expensive way? Maybe it works out that way because we are not aware of all the alternatives.

James Wright, Cable TV of Rockford, Illinois, has taken a long, hard look at a problem area that has been of concern to cable systems for as long as they have been in existence. The problem is that every material used in cables is subject to expansion and contraction. In long line runs, this can create very real problems, especially when we think of the two-way future.

Wright takes an approach to expansion loops that warrants consideration. And it could just be that loops are more reasonable and more economical.

The Line Problem

When aluminum sheathed coaxial cables became available and began to show up in CATV systems, it was apparent that compensation was needed for the expansion and contraction of the cable following changes in temperature. More specifically, it's the difference in the expansion of the different materials used that causes the problem.

After a great deal of agony, a number of partial solutions evolved and were applied singly or in combinations. These included the bonding of center conductor to the dielectric, the compression of the dielectric by sheath, the use of fittings which seize the center conductor and sheath, the use of expansion loops.

Material Expansion

The coefficient of expansion of a material is its change in size, in inches per inch per degree of temperature change. Expressed in inches of change for a cable length of 120 feet over a temperature swing of 150°F we get (approximately) the data for Figure 1.

The Case Against Expansion Loops

One of the partial solutions, for the expansion difference in center-conductor to sheath, was to stop relative material movement by bonding the center-conductor to the dielectric and by forming the sheath tightly over the dielectric. This caused the stresses to be distributed along the length of the cable where they were offset by counter-stresses, and so they could not cause relative movement of the center conductor and sheath. If aluminum cable could be made to adhere to the steel strand in a similar manner, the stresses caused by their different rates of expansion would also be contained and nullified.

The technique suggested for this approach is straight-forward and consists of double lashing the two materials tightly together, using a maximum number of turns per foot, with cable ends (only) being provided with expansion loops. Assuming one wrap of lashing wire per foot of cable, the differential in expansion would be about 0.01 inch per foot, a small enough difference so that it could theoretically be absorbed by counter-stresses and/or by a "snaking" of the cable, with the effect of the whole span becoming an expansion loop. To be effective, the lashing wire must prevent the cable from moving along the strand.



Fig. 1 Electronic systems manager Jim Wright (L) and Don Ellis inspect a $\frac{3}{4}$ -inch cable bender for use at Cable TV of Rockford.

INTRODUCING THE ALL NEW... DITCH WITCH R30 ...MORE THAN A TRENCHER!

The R30 is the all-new 30-horsepower trencher from DITCH WITCH. But it's much more than a trencher. It's got more to give you more for your equipment dollar. The R30 incorporates the ultimate in trencher design — what we call the modular concept. In the R30 you get a basic trencher vehicle that's the most rugged and dependable in its class. And there's a selection of optional modular attachments that are quickly and easily interchangeable. You pick the modular set-up to fit **YOUR** needs. Put a utility backhoe on the front and a vibratory plow attachment on the back. Add the new Pavement Breaker. Or a front-end loader or a clean-sweep broom. The R30 gives you more versatility than anything in its class. Let us provide you with more information on the new R30. Better yet, we'd like to bring one to your job site and demonstrate it for you. We think once you've seen the R30 in action, you'll agree that it is more than a trencher.

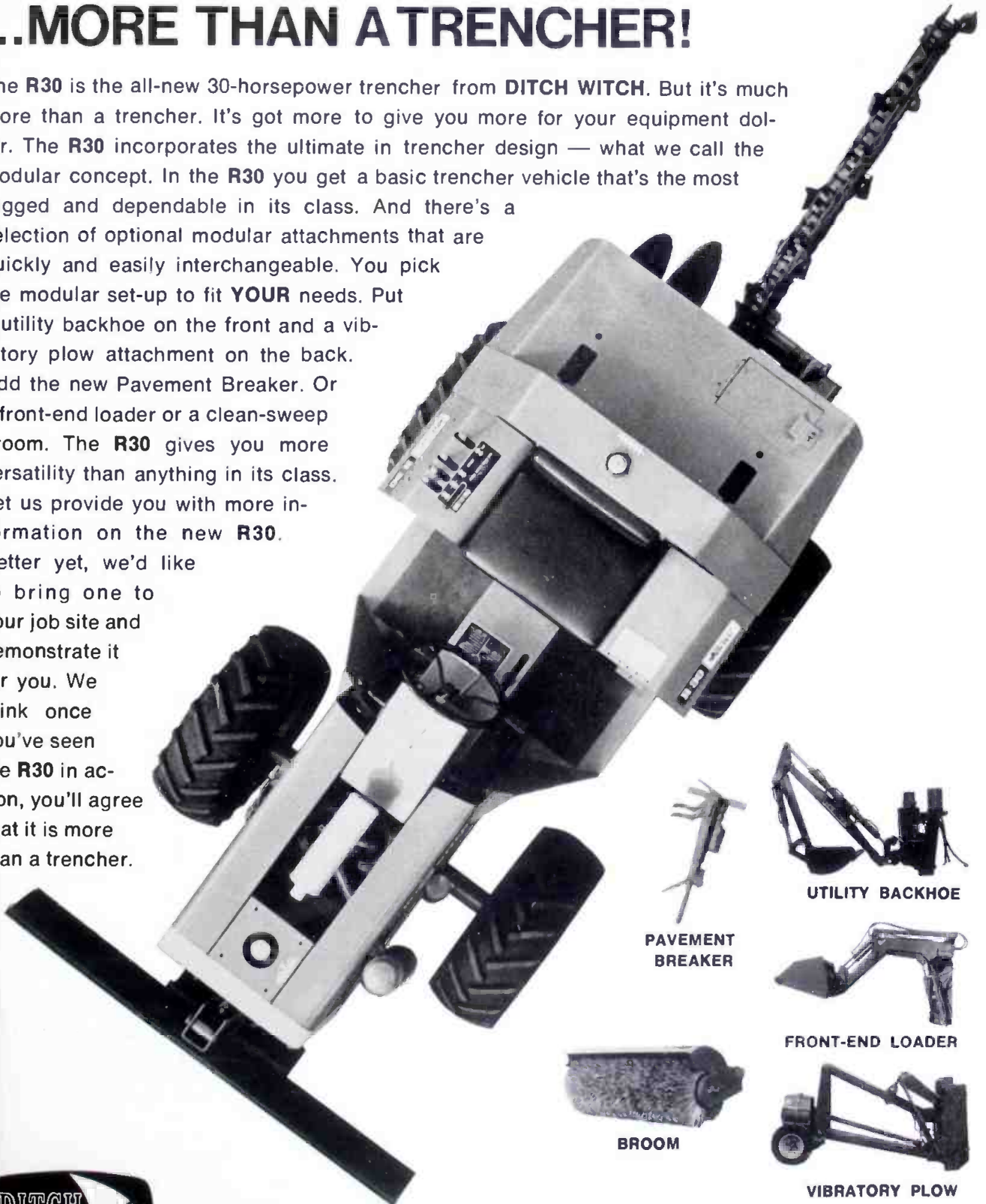

PAVEMENT
BREAKER

UTILITY BACKHOE

FRONT-END LOADER

BROOM

VIBRATORY PLOW

**DITCH
WITCH**

A Division of

CHARLES MACHINE WORKS, INC. P.O. Box 66 Perry, Oklahoma 73077

Circle Number 55 on Reader Reply Card

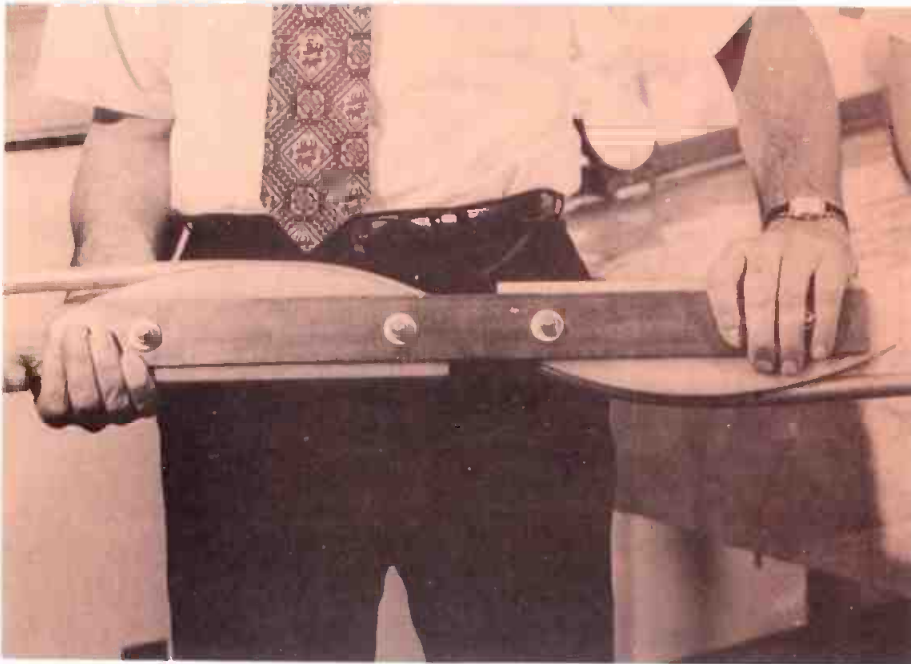

Fig. 2 Closeup view of the $\frac{3}{4}$ -inch cable bender.

The Case For Expansion Loops

The major weakness in the foregoing approach is that with the larger sizes of cables it is doubtful whether normal lashing wire, even when double lashed, would be strong enough to hold. If it did, would it stay tight over the years so as to continue to hold properly? The expansion loop approach accepts the expansion differences as inevitable and, rather than try to restrain the surplus movement, channels it into the loop.

It should be noted that an inadequate loop is worse than no loop and also that if a loop is to be used it must be properly designed.

For an expansion loop to be able to contract and expand for years without metal fatigue, it must be designed so that the limit of elasticity of the aluminum is not exceeded. The limit can be roughly determined by flexing a piece of cable and noting the flex point beyond which the cable will no longer snap back to its original shape, i.e., the point at which it takes a "set".

Another consideration is that the "minimum bending radius" is not the radius which should be used in loop design as this refers to the extreme to which a cable may be

permanently formed without buckling the sheath or seriously impairing the structural return loss. A bend incorporated in an expansion loop should be $1\frac{1}{2}$ to 2 times this minimum radius figure. Manufacturers' tests indicate that fatigue failure of expansion loops need not be of concern if the loop is large enough to absorb the maximum movement of the cable, i.e., it is matched to the length of cable being served by the expansion loop.

On The Loop

The size of the loop, its shape, its positioning, and its frequency of use, is determined by the length of cable feeding into that loop and by the loop size. Some considerations are:

1. There should be enough loops to keep the amount of movement of the cable relative to the strand, to a minimum, i.e., the cable should be able to move from the middle of a span toward both supporting poles.

2. The lashing wire should be tied off at each end so as not to restrict the cable movement (particularly at the loop) and should be loosely lashed for the same reason.

3. The maximum amount of change in cable length from the coldest night to the hottest day (add 20° for black jacketed cable in

the sun) over the length of span being provided for, should be calculated and from this the change in length of the supporting strand should be subtracted.

4. This net cable excursion should be used with graphs provided by the cable manufacturer to determine, (a) the size of the loop needed to absorb the excursion and (b) whether a single loop spanning the pole will suffice or if a loop should be provided on each side of the pole.

5. The life expectancy of a loop depends on how much cable is used in the loop (i.e., the ratio of cable excursion to total loop length) and not on the exact loop shape as long as it can flex evenly over its length.

6. If an amplifier or passive device is used a double loop is mandatory, unless one wishes the cable on the non-looped side to travel over the full length of the adjacent span to the far loop.

7. The use of adequate loops will also relieve the powerful forces acting on fittings and eliminate the problems arising from these forces.

Loop Formation

The problem of forming loops without cable deformation has been partially solved by the half-round bending tools available. The use of two such tools properly made and mounted in opposition on a single handle will permit the formation of a compound bend without danger of cable flattening. By extending the handle, a sufficient amount of leverage is obtained to permit bending the larger sizes of cable as well. The radius of the bend must exceed the minimum bending radius, otherwise, the cable in the bend will not expand and contract freely enough to give the desired life expectancy.

Economics

If you adopt the "no-loop" approach you must carefully and tightly double lash the cable and dress it at each pole to prevent a "breakout" of the cable at any one point. This double lashing could

Channel your profits.

Nature abhors a vacuum. As a CATV operator you probably feel the same way toward unused channels. Well, how about making all those channels earn their keep? You'll find it's a good way to increase your profits. And the FCC will wholeheartedly approve.

As you well know, there's a bonanza of film entertainment available to liven up your programming. Not only full-length movies but business and industrial films, too. And with a 16mm videofilm projector, a slide projector, a modestly priced television camera, and a little initiative, you just might get some local advertising to help pay your expenses, with some left over for you. You can make your own films with a 16mm camera and get the film processed just about anywhere. Or do it yourself with KODAK ME-4 Chemicals.

We'd like to send you our new publication VIDEOfilm NOTES. Each issue contains new ways to use film in your business. If you're not already receiving it, please send your name, address, and zip to Dept. 640, Eastman Kodak Company, Rochester, N.Y. 14650.



EASTMAN KODAK COMPANY

Atlanta 404/351-6510 Chicago 312/654-5300 Dallas 214/351-3221 Hollywood 213/464-6131 New York 212/262-7100 San Francisco 415/776-6055



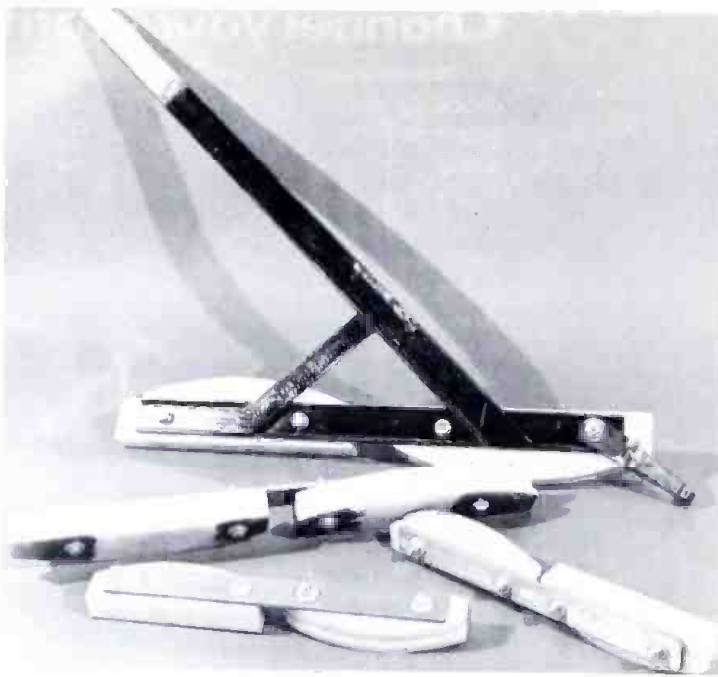

Fig. 3 Shown here are 1-inch, 3/4-inch, and 2 1/2-inch cable benders.

average an extra \$250 per mile, or about \$6 per pole. With a proper bending tool, expansion loops can be made rapidly and as often as required at an estimated average of \$4 per pole.

Conclusion

Either the "no-loop" or, the "loop" approach may be used successfully if all conditions are met and maintained. With the "no-loop" technique a slight deviation

from complete control of the cable could mean catastrophic failure, while the "loop" technique such a slight deviation would be inconsequential. It is my opinion that expansion loops should be used and, that, except in short span situations, they should be used on each side of every pole on the span side of any equipment.

Editor's Note: We invite your comments and your ideas. And yes, we do pay for all articles used in *Cable Engineering*. If you have found some answers to nagging problems that you want to share with the industry, drop us a line and we'll send you our author's guide.

Send all correspondence to: Ron Merrell, Editor, *Cable Engineering*, 1014 Wyandotte, Kansas City, Mo. 64105. Meanwhile, if there are certain subjects you would like to see covered in CE, let us know.

Foster Sees Positive Cable Signs

National Cable Television Association President David Foster told the New York Society of Security Analysts that "there are a number of positive signs that the cable communications industry is moving into the decade of the 70's with strength and dedication." The following are excerpts from a luncheon address in New York City:

"I have become totally convinced that cable communications is an inevitably strong growth industry, profoundly involved with the public interest, capable of utilizing the best of our nation's technological resources, and made up of the most energetic group of hard-headed optimists I have ever met.

"I think it is clear there are a number of positive signs that the cable communications industry is moving into the decade of the 70's with strength and dedication. For the moment at least, capital seems to be available in good supply. The

industry is attracting a new generation of professional managers to work alongside, but never to replace the hard-headed entrepreneurs who brought the industry this far. Technological problems are being solved almost faster than the industry's ability to put the solutions into operation. The brightest sign of all of course is that our subscribers continue to love us. This point cannot be over-emphasized in evaluating the health of an essentially service industry in what has rightly been called the age of the consumer.

"The distant signal importation problem is not all problem. There are many large markets that will be built and are being built at least partly on the strength of those added signals. This is particularly true in light of the increasing program diversity of the independent broadcast stations.

"FCC Chairman Burch has characterized the Commission's

cable plan, at least in part, as designed to keep the CATV industry "lean and hungry." We hope not lean bordering on starvation. But the metaphor does suggest one thing. The signal limitations will also serve as an incentive to bring to these larger markets additional cable services which will attract subscribers and profit. Observers have noted that perhaps the one value of the five year cable television freeze was that it allowed - indeed forced - us to create a solid base upon which to build the wired nation.

"One more word on programming: it seems clear that economical, widespread specially-originated programming for cable will come about only by means of networking - linking systems together to share programming. Today this is being done only to a limited degree but with the growth in saturation of cable systems, and more importantly, with the availability of a domestic satellite system, we can begin to think in terms of a national cable network."

Honesdale TV goes to color origination

By Leo G. Sands*

Although the residents of Honesdale, Pennsylvania are served by one of the nation's oldest CATV systems, they're getting a lot more than subscribers of most other systems. Their enterprising CATV system originates local interest programs — in color.

This fall, Honesdale residents will be watching their home football team on their TV screens. The games are videotaped and then played back over the CATV system. These football programs are sponsored by 18 advertisers.

Staff Editor and head of Leo G. Sands & Assoc.

Live programs are originated in a studio near the head end which is on a mountain top, some 1700 feet above sea level. The studio building is a converted mobile home, a permanently parked long, long trailer. As shown in the floor plan, Figure 1, the building is divided into three rooms — a studio, a news room and a control room.

Behind the announcers' desk, is a drapery which can be drawn to expose a sofa when more than one guest is participating in a program.

A unique feature of the announcers' desk is the way its two microphones are mounted out of sight from the cameras, shown in Figure 2. Near the desk, but out of camera range is a huge clip board on which

commercials, announcements and news items are displayed. The use of the clip board eliminates the noise of papers being shuffled.

Two GBC color cameras are used. One is on a tripod and is used for viewing the performers. The other color camera is used in the film camera chain which is equipped for showing 16 mm movies and 35 mm slides. A third input of the optical multiplexer is available for future use. A Vikoa weathercaster is also located in the studio.

The control room is as complete as one used at some TV stations. Directly above the center of the sleek-looking console is a huge RCA color monitor. At the top of

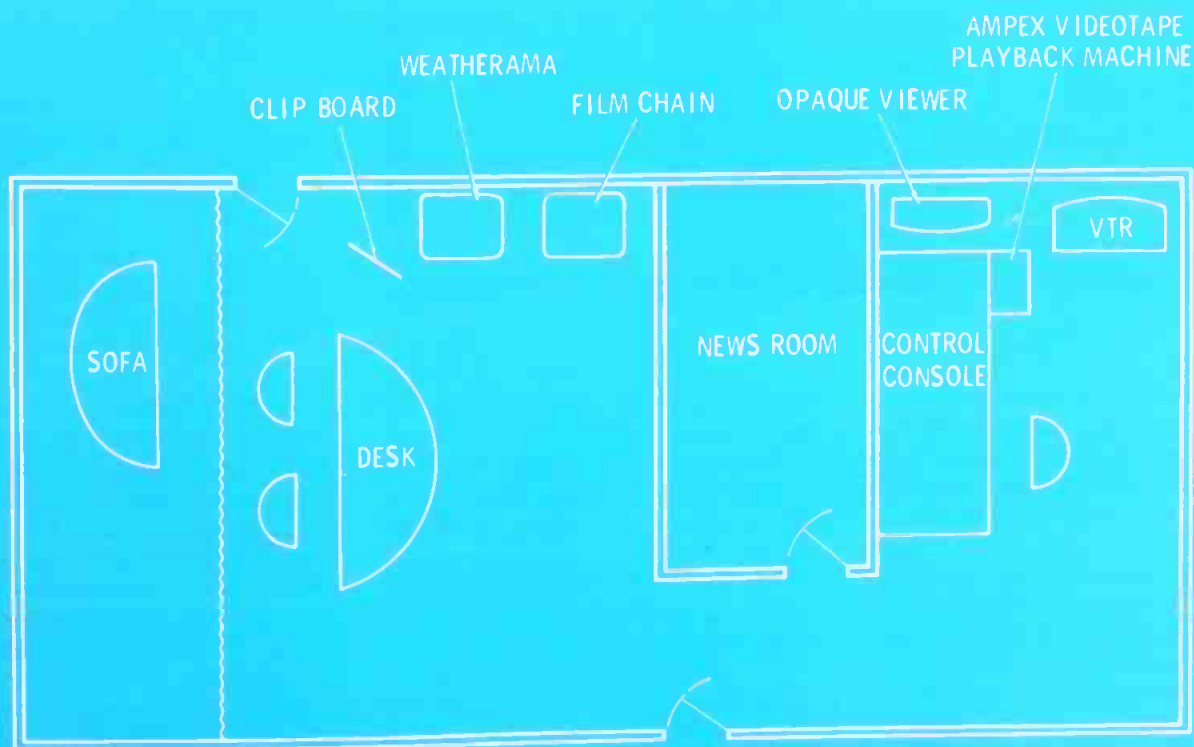

Fig. 1 Honesdale TV's floor plan.

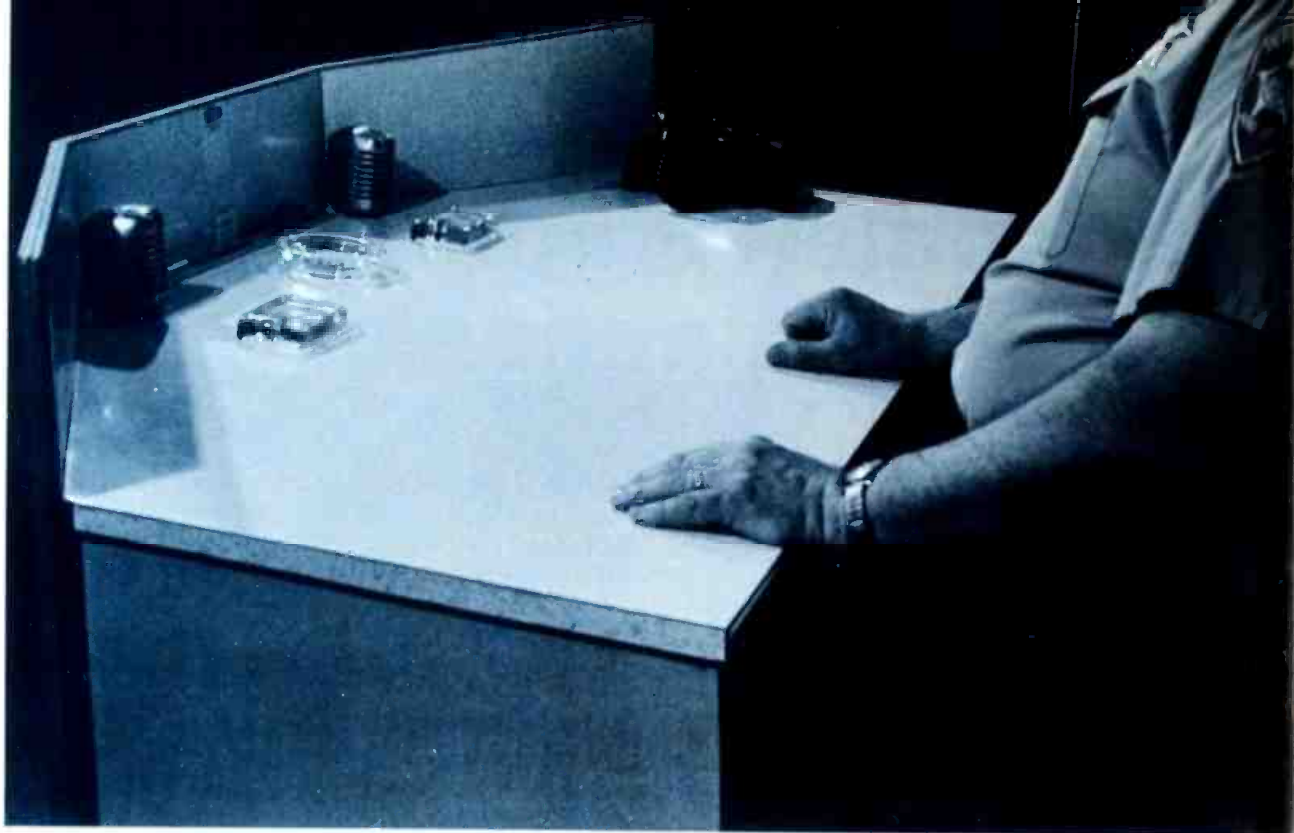

Fig. 2 Unique announcer's desk layout.

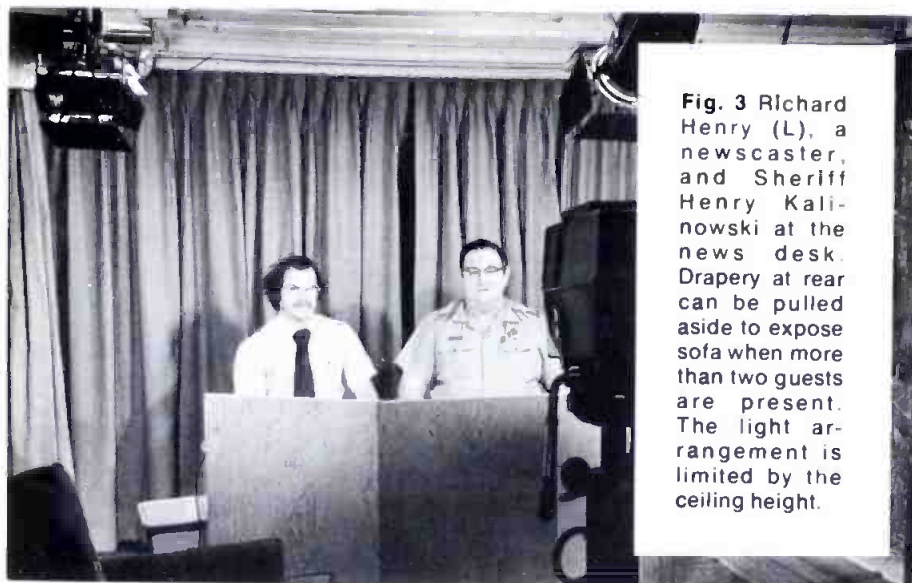
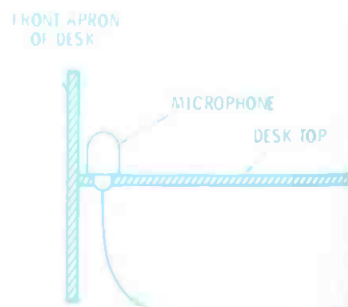
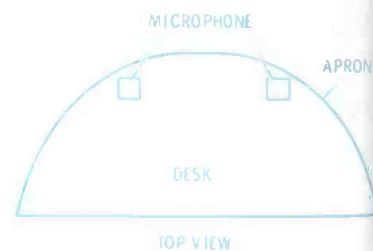

Fig. 3 Richard Henry (L), a newscaster, and Sheriff Henry Kalinowski at the news desk. Drapery at rear can be pulled aside to expose sofa when more than two guests are present. The light arrangement is limited by the ceiling height.



the console are six GBC color monitors. And at the left and right of the console are the controls for the two GBC color cameras. The console also contains a Bogen audio mixer, a GBC video effects generator and switcher, projector control panels, an Anaconda TV modulator and a Tektronix RM-529 TV signal waveform display.

Also in the control room are an audio tape player/recorder, a record player, an Ampex videotape playback unit, an automated opaque card viewing system and a

Sony videotape recorder with its own monitor.

Since programs are televised in color, the studio is lighted by quartz lamps in addition to incandescent spot lights.

The Honesdale CATV system carries 12 channels of television plus the entire FM radio broadcast band. Although, the head end is some 95 air miles from the Empire State Building, the programs of all of New York City's VHF television stations are piped to Honesdale residents.

Without CATV, television reception would not be possible in Honesdale which is surrounded by heavily wooded mountains and is 50 miles southeast of Binghamton, New York and 25 miles northeast of Scranton, Pennsylvania. The only TV antennas to be seen are at homes on hilltops quite a few miles out of town.

The CATV system was initially installed in 1950 and serves more than 1700 homes in this community of approximately 2000 homes. Originally, SKL amplifiers were

ted. The system now uses Ameco solid state amplifiers and tube-type KL AGC amplifiers which are being replaced by solid state Ameco amplifiers.

Heading up the CATV operation is the sheriff of Wayne County, Henry Kalinowski, who said he spends a 12-day week to stay on top of all of his activities. However, when he was interviewed for Cable Engineering, he seemed to have everything well under control.

In addition to being the county's law enforcement officer and the head man of the local CATV system, he runs a TV and appliance sales and service operation and is also an MR (manufacturer's representative) for RCA two-way mobile radio equipment.

His service shop is very well equipped and staffed. Hewlett-Packard, Lampkin and Motorola test equipment is used for servicing mobile radio equipment. One of his technicians pointed out that one thing is missing — a UHF band TV signal for checking TV sets owned by customers who live out in the country where direct reception of

UHF TV stations is possible. Since UHF TV stations can't be picked up in the shop, an RF signal generator is used for determining that a TV set is responsive to UHF signals, but no check of picture quality is possible. This points up that there is a requirement for a tunable UHF band test pattern generator.

Honesdale is an example of

many communities that have to depend upon CATV to bring televised entertainment and information to its residents. Honesdale is fortunate to have a civic-minded man, such as Sheriff Kalinowski heading up its CATV system which not only delivers off-the-air TV programs but also produces locally-originated programs — in color.

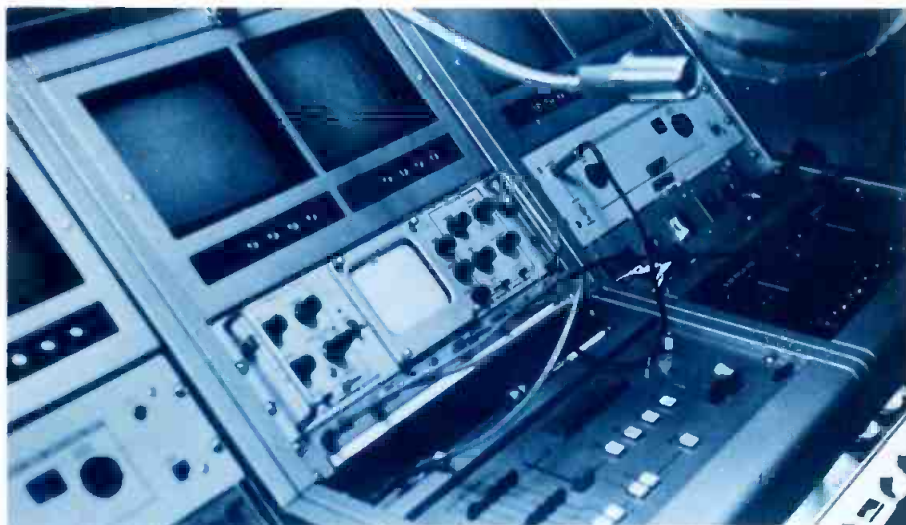

Fig. 4 Close-up of the Honesdale control console.

Accelerating Tape Duplication

Last October, Net Television, Inc., Ann Arbor, Michigan, installed an Ampex ADR-150-5 high speed quadruplex videotape contact duplicator in anticipation of at least doubling the output of tape copies within a year.

Along with the requirement for high speed and high volume capability, we expected other benefits from the system, including a reduction in per-unit duplication costs and the ability to maintain and even improve our level of efficiency and flexibility.

The development of the duplicator was quite timely. When Ampex and other manufacturers first began to discuss the feasibility of high speed duplication of two-inch videotapes late in the 60s, Net urged that the capability be made available as soon as possible. Although we were able to handle a rapidly growing demand for tape copies, it

was apparent that standard machine-to-machine copying was not the most satisfactory method of meeting our requirements.

In 1971, we sent more than 30,000 half-hour units of quadruplex recordings to stations throughout the world and by the end of 1973, we expect to distribute at least 60,000 to 70,000 units.

(Although Net Television, Inc., copies and distributes materials ranging in duration from a few seconds to 90 minutes or more, the half-hour increment is used as the basic unit in describing volume).

Before the high speed duplicator was pressed into service, our battery of two-inch recorders, installed during more than 15 years in business, was used for all quad copying. During multiple-copy, machine-to-machine duplication, several of the VTRs could be slaved simultaneously to the VTR

on which the master was played. In addition, two master modulation systems, equipped with VR-1200 signal electronics, could be used to feed geometrically corrected RF to the record drivers of the duplicating recorders. This technique makes minimum use of the electronics in each VTR and insures that uniform signals reach each VTR.

Net operates around the clock with three eight-hour shifts. The night shift and parts of other shifts are devoted to duplication. Even with the use of 15 or more slave recorders and at least a full eight-hour shift for dubbing, our capacity was barely able to satisfy incoming requests.

With the ADR-150, Net is now making copies at ten times normal playback speed, so that a copy of a half-hour program can be made in three minutes. The machine uses a

five-slave system allowing five copies of a half-hour program to be completed in three minutes of duplicating time.

The duplicator system uses transfer chambers in which mirror-image masters (intermasters), recorded on high-coercivity tape, come into direct contact with from one to five blank slave tapes.

During contact in the transfer chambers, the oxide side of the master tape meets the oxide surface of the slave tapes so transfer of the video information can take place. At the same time, the audio information and the control and cue tracks are read from the master and recorded on the slave tape in full synchronization.

Masters are made on an AVR-1 which can be equipped with a modification kit enabling it to produce a mirror-image recording.

Allowing for rewind and reload time of seven minutes for a five-slave process, the average operating volume is thirty duplicate half-hour tapes per hour, or 240 during an eight-hour shift. This compares to 120 half-hour tapes for each eight-hour shift using the machine-to-machine method with 15 slave recorders.

Only two engineers are required to keep the high speed duplication operation at maximum efficiency. Individuals ordinarily involved in machine-to-machine copying may be assigned to do post-production work, to make film-to-tape transfers or to tend to other operations at the facility.

Thus, computed in terms of man-hours, two engineers using the ADR-150 in a single shift can match the output of two two-man shifts employing machine-to-machine duplication.

(It should be noted here that the Net capabilities are rapidly being broadened beyond the requirements of domestic educational stations and networks. We are expanding into the commercial market, and offering high-volume, low cost services for commercial producers.)

Our services include copying and distributing videotape recordings on a contract basis, post-production work, a customer library

from which individual programs can be ordered, specialized functions such as film-to-tape transfers and the capability of broadcasting over leased phone lines.

In addition to the 18 quadruplex VTRs, including the Ampex AVR-1, we also have 16 helical-scan videotape recorders, color and monochrome film chains and a full range of control, switching, modulating and tape cleaning equipment.

An important benefit of high speed and high volume distribution, of course, is much more efficient utilization of personnel and equipment, resulting in increased economies—economies that ultimately can be offered in commercial work.

As an example, the cost of black-and-white tapes produced by machine-to-machine methods is roughly comparable to that of black-and-white film (although color tapes can be produced less expensively than color film copies). In some cases, in fact, it is more expensive to make B&W tape copies with the old copying method compared with monochrome film. But the economics of scale resulting from the use of the high speed duplicator bring the cost of B&W tapes below that of monochrome film copies.

Flexibility And Quality

Along with providing high speed duplication, high volume output and increased efficiency, our

equipment capabilities must be consistent with Net requirements—flexibility and quality.

The terms "flexibility" and "quality" are widely used to mean a variety of concepts. But one can appreciate their importance for Net by realizing that we send out more videotape recordings than any other facility in the country, perhaps in the world—all from a small facility (16,000 square feet) with only 48 employees.

In order to satisfy a complex array of requirements with consistently high quality recordings, we have always been committed to finding and developing innovative methods and products.

Consequently, Net was first to use the 7½ ips conversion kit, the VR-1200 conversion kit and the VR-1200 signal electronics (as a master modulator system for multiple duplication). Among Net inventions are the LEXAN plastic reel which will break before allowing flange distortion; the octagonal box which firmly holds tape reels for safe packing and shipping; and the two-inch reel strap which wraps around the tape at its outer periphery on the reel and is sealed by use of the velcro-type fastener.

Specialized routing and booking forms, color coded boxes and a procedure of attaching mailing labels to incoming orders, aid the production and shipment of large orders quickly and without error.

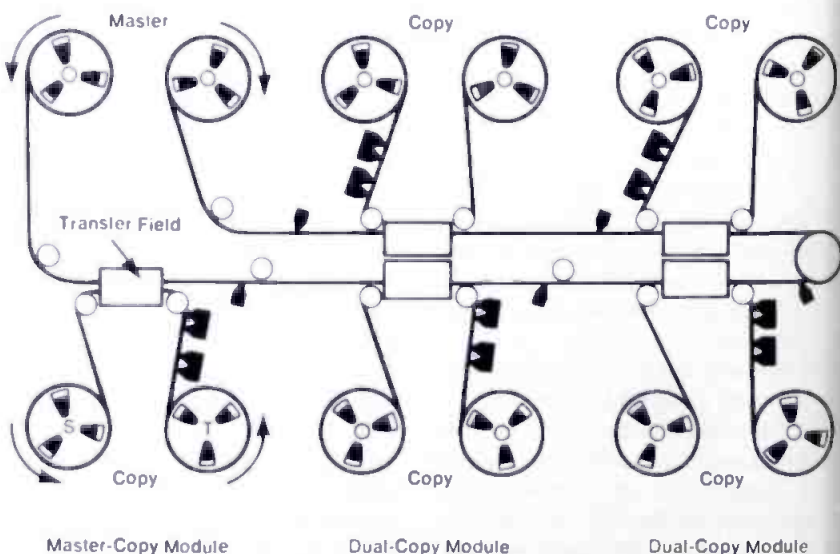

FIVE-COPY AMPLEX DYNAMIC TRANSFER SYSTEM

YOUR BEST COMBINATION FOR FM COVERAGE!!



25KW FM

CCA offers a complete line of field proven FM transmitters from 10 watts to 50KW. Features include 75% plate circuit efficiency, minimum tube life 10,000 hours with zero bias triodes, 65 db signal to noise, distortion less than 0.3%.

CCA TRUE CIRCULAR ANTENNA

CCA circular antennas are available in low and high power versions with antennas from one bay to 16 bays. Null fill and beam tilt together with radomes permit the broadcaster to obtain coverage where he desires with reliability.



CCA ELECTRONICS CORPORATION
GLOUCESTER CITY, NEW JERSEY 08030 • (609) 456-1716

Canadian Subsidiary:

CALDWELL A/V EQUIPMENT CO., LTD.
1080 BELLAMY ROAD, NORTH
SCARBOROUGH, ONTARIO, CANADA
Phone: (416) 291-5595
NO. 1 AM & FM

Circle Number 9 on Reader Reply Card

ews items covering the news broadcast which of course adds special interest to the viewing audience.

We also record the noon news-cast to be played at 12:30 PM on our FM automation system.

We feel we are one of the first stations in the United States to work-out this electronic system and are proud to say the results are quite rewarding.

Separate commercials or separate Sponsors can be used on the different type of communications.

We celebrated our 1st year of the Cable Operation on the 20th of July, 1972.

From the very beginning we have done local programming with the Time and Temperature machine and have produced some of our own movie shows.

We also carrying afternoon and evening movie features as well as travelogues and educational films.

WFRO is constantly striving to give the public the best it can offer in Radio and Cablevision programming.

Robert F. Wolfe, Pres.
Fremont Cablevision
Div. of Wolfe Bcstg. Corp.
Fremont, Ohio

UHF Parts Needed

Dear Editor:

I have a GE TT-25-A UHF transmitter that is missing its aural and visual klystron output waveguide cavities.

Twice I have located the trace of some, only to learn that they had been scrapped for brass after being stored for years.

There must be someone who has either junked the transmitter or converted to Eimac klystrons and cavities. I would be interested in hearing from anyone that has made that conversion himself.

I am also looking for any frequency sensitive components necessary to convert a TT-24 exciter Channel 43.

Maury Goldberg, CE
WONH-TV
345 Peat St.
Syracuse, N.Y. 13210

Once you look inside the STUDIOETTE 80, you'll buy it.

You'll see why the new Studioette 80 is the quality buy of solid state, 4-channel audio consoles.

In the Studioette 80, 13 inputs into 4 mixing channels provide maximum flexibility. All inputs and outputs are protected by isolation transformers. Wire-wound, step-type attenuators, used in each of the 4 mixer channels, assure quiet and reliable audio operation.

For more information, write Gates Division, Harris-Intertype Corporation, Quincy, Illinois.

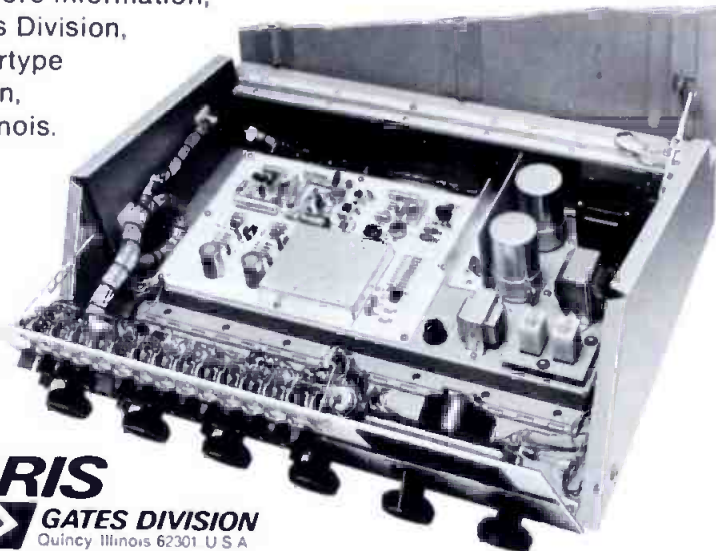

HARRIS
GATES DIVISION
Quincy Illinois 62301 U S A

Circle Number 11 on Reader Reply Card

rial, and provides detailed information concerning its use to television station engineering and operating personnel.

This Bulletin is available from the EIA Engineering Department - Standards Orders, at \$1.60 per copy. The EIA address is 2001 Eye St., N.W., Washington, D.C. 20006.

Set Makers Get Extension On UHF Tuners

Rules governing the tuning accuracy of television receivers utilizing a 70-position non-memory UHF detent tuner have been retained by the Commission in an action disposing of a petition for reconsideration filed by the Philco-Ford Corporation (Docket 19268).

The date by which receiver manufacturers must meet these requirements was extended one year, to July 1, 1975, to ease the problem of transition to receivers meeting those requirements.

Rules authorizing the use of a 70-position non-memory UHF detent tuning system were adopted by the FCC on November 24, 1971. The regulations specified that black and white and color television receivers using the 70-position UHF tuning system should be equipped with AFC circuitry and with a channel selector mechanism capable of positioning the tuner within the "pull-in range" of AFC. These requirements were to become effective July 1, 1974.

Philco-Ford opposed the requirement that black and white receivers with a 70-position tuning system should be equipped with AFC. It also questioned the technical feasibility of the requirement that the 70-position channel selection mechanism be capable of positioning the tuner within AFC pull-in range.

To help monitor progress toward fully comparable accuracy, the Commission said it would require that each application for certification of a television receiver using a 70-position UHF detent tuner be accompanied by a report of measurements of tuning accuracy.



The head hunter's HEAD.

VTR manufactured
or reconditioned

Professional head hunters know that only at Taber can you find the kind of value you seek in VTR heads. Taber heads are:

- Precision made in a sophisticated laboratory, tested to produce total response and playback.
- Guaranteed to meet or exceed equipment manufacturer's specifications.
- Priced at only \$310.00 for 4 new heads installed, or \$100.00 for 4 reconditioned heads (Add \$25.00 if monitor post needs lapping).

Free loaner assemblies available.

Send for our
free brochure today

Call or Write:

TABER
MANUFACTURING &
ENGINEERING CO.

2081 EDISON AVE. • SAN LEANDRO, CALIFORNIA 94577 • PHONE: (415) 635-3831

Circle Number 12 on Reader Reply Card

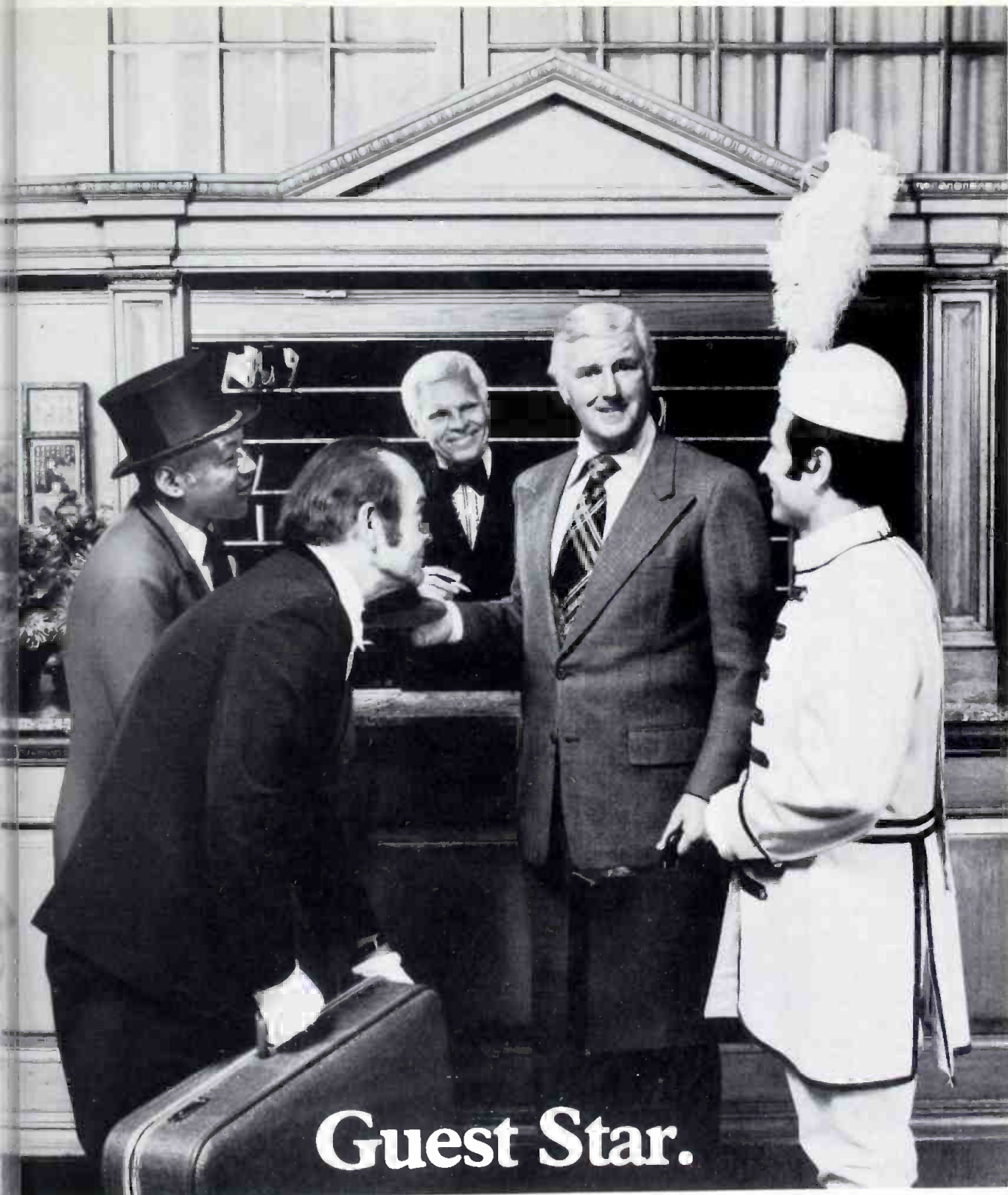

Guest Star.

You. When you stay at Chicago's Hotels Ambassador. And the part is perfect for you.

Here you enjoy the same celebrity treatment as the stars who wouldn't stay anywhere else. From a staff that numbers five hundred — almost one for every room.

Speaking of rooms, you can dine in the fabled Pump Room. Or go back 200 years for a drink in the Prince of Wales. Or simply relax in your room. Which you'll find is much more than four walls and a bed.

All for a price that's not a bit astronomical.

Especially for a hotel on Chicago's Gold Coast. We're at 1300 N. State Parkway, Chicago, Ill. 60610. Phone (312) 787-7200. Telex (312) 253-272.

Next trip to Chicago, do yourself a favor. Stay where people don't act like they're doing you one.

HOTELS

Ambassador
The Star Treatment

Circle Number 13 on Reader Reply Card

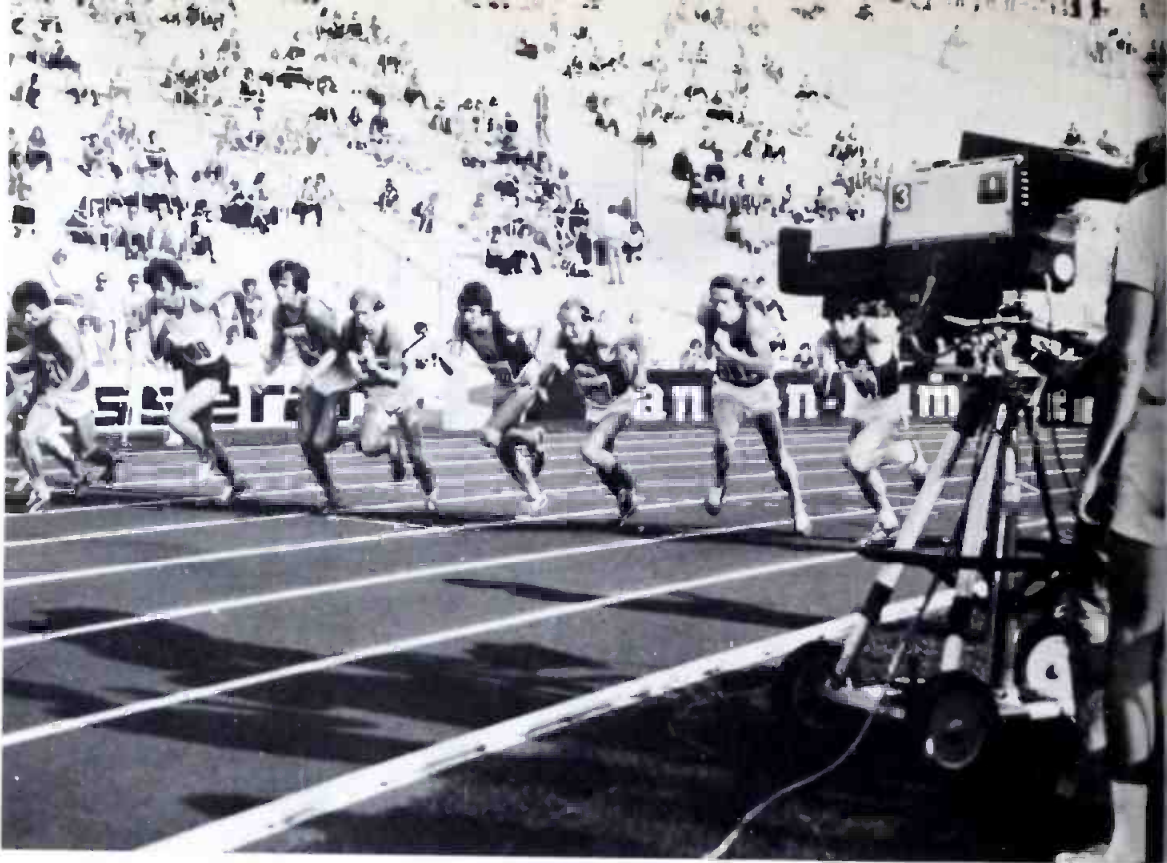

Camera on special large wheeled dolly to permit rolling across grassy sections on the main stadium.

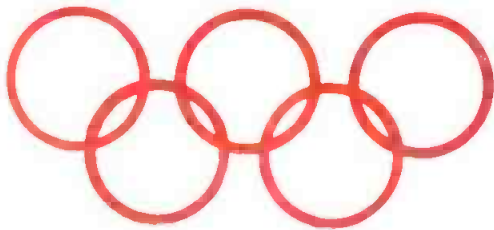

Television at the Olympics

By Joseph Roizen

Whatever other facet of the Twentieth Olympiad in Munich maybe subject to controversial opinion, the television coverage was by all accounts the best pictorial presentation ever achieved for so large an international spectacle. The combination of Teutonic thoroughness in planning the vast complex of communications equipment and the cooperative assistance of the world major television networks, ABC, BBC, CBS, etc. produced a monumental chapter in television history that will long stand as a model for future activities of the same character.

Every run, every jump, every throw, whether in an elimination heat, a semi-final or a final was under the constant scrutiny of a sharply focussed color camera. Relayed live or recorded, every athletic event was available to a billion viewers on five continents, at their own convenience, in their

own time zone. Whether seen in the original PAL 625/50 format or transcoded to SECAM and NTSC, the uniformly good quality of the color pictures and the sound were constantly self evident.

Twelve-hundred hours of sporting events, spread over thirty-three venues and compressed into seventeen days required over 150 color cameras and more than 100 VTR's to register and record all that was going on. No single television entity could field the 30 million dollars worth of equipment necessary to do the complete job. At the venues, mobile units from all over Germany, including the ARD (national network), and ZDF (commercial network) sat side by side with camera and VTR vans from RAI (Italy), ORTF (France), ORF (Austria), BBC (UK), and others. Complete studios were installed at the DOZ center by various German television station personnel. The ABC complex was the respon-

sibility of Norddeutscher Rundfunk, while Sender Fries Berlin engineers installed and maintained Studio 5, the combined ARD and ZDF studio.

The combination worked to perfection so much so that the most unused slide in the caption scanner at the DOZ Weltregie (World Program Control) was the one that stated in three languages, "We regret the breakdown." The equipment just didn't dare to.

Technical Picture Quality

The uniformity of the picture quality that was evident not only in Munich, but in all the countries where the color coverage of the games was being radiated was certainly not a technical accident.

The first consideration that was given serious attention and eventually proved to be of greatest importance was the unique approach to lighting proposed by Dr. Schwarz, the Head of Engineering for the

Z. The familiar afternoon shadow that creeps across a stadium during a sporting event creating a wash differential lighting between the sunny and shady sections is a problem most television engineers and cameramen have fought and since color television began including in athletic arenas.

The solution proposed was a transparent roof over part of the main stadium and other adjacent sport halls, which would allow sufficient natural illumination to avoid the late afternoon sun syndrome. The architects and structural engineers designed the roof, built and tested a small section to prove the theory over a year before the Olympics and then budgeted the transparent cover at 5.3 million dollars. This was probably the greatest single cost run of any structure at the Olympic stadium in Garmisch-Partenkirchen, the final price was over 60 million dollars... more than the total cost of the Rome Olympics in 1960. The saving grace was that it all worked to perfection on the pictures coming from under

this free form acrylic umbrella were "wunderbar."

Of course many of the events were held at night or indoors. Here also carefully color balanced, high intensity lighting not only turned night into day, but gave the color cameras the right color temperature to produce correct colorimetry under almost all circumstances.

A special phase lock system was developed by Legeler of Fernseh GmbH and installed by that company to all of the fixed cameras at the venues. The Legeler system uses audio lines to provide feedback information that maintains proper phasing of the color encoders at each camera and held the PAL subcarrier phase to within a 2° tolerance at the switcher input in the DOZ control center.

During installation, each venue feed was color timed to 1° of the 4.43 MHz subcarrier through the use of phase correcting networks at the ends of the cables. Once installed, the phase correction loop would then hold all the color fre-



quency generators at the various television installations in the venues locked to the rubidium standard at the DOZ center. Switching between over one hundred color cameras connected through miles of cables and microwave links still yielded an amazing degree of pictorial chromatic uniformity that showed the meticulous care with which the cameras themselves had been color balanced by the camera crews.

The Legeler system tied in not only to the 120 Fernseh KCU-40 cameras that provided the major coverage, but also to the BBC mobile units with their EMI 2001 cameras and the ORF's Philips PC-70's. Even the portable cameras were phase matched when they were tied into the network. To make sure that the system kept operating at peak performance levels during the critical 17 days, the DOZ's own maintenance engineers were augmented by teams of

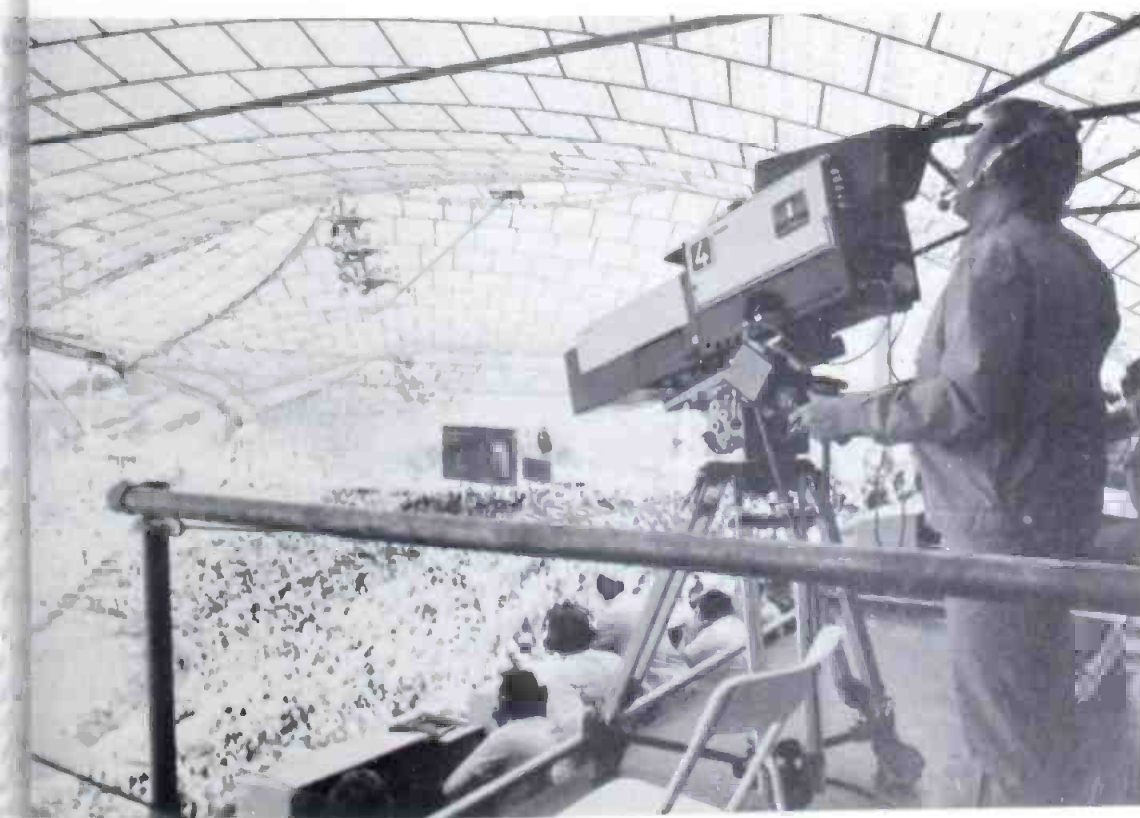

Main stadium camera at the top of the especially covered grand stand immediately above commentator positions. This camera came from the ZDF.



camera and generating equipment specialists from Fernseh, and VTR experts from Ampex, all of whom worked around the clock shifts from August 26th to September 11th. Test equipment and spare parts were plentiful and near at hand. Three additional key links maintained the high quality of the original images.

All the VTR's used were high band quadruplex recorders. Half of the 85 video tape machines assigned to key coverage were the latest version AVR-1's, and all of the slow motion discs were HS-100 PAL versions. Transcoding to NTSC at Raisting and transmission via Comsat's latest North Atlantic 'bird' to the U.S. (or Canada) were done with precision equipment that kept the subjective quality at more than adequate levels.

Total Television

The ancient motto of the Olympics is "Higher, Swifter, Stronger." It could easily be applied to the camera coverage of the 20th Olympiad. Television cameras seemed to be everywhere. The 'highest' was a KCU-40 perched 750 feet above the ground on a unipod that is Munich's newest and tallest landmark, the "Fernsehturm." This 951 foot tower comes complete with rotating restaurant (the Goulash soup and Vienerschnitzel weren't bad), microwave relay stations, and topped by television antenna arrays. This camera with its 18:1 Varatol zoom could take in the whole spectacular layout of the Olympic park or tighten up to a team sport in the main stadium which it looked down upon directly. Cameras moved 'faster' than ever in minicars and vans, on dollies and hand trucks. Motorized or man handled, they got to the scene and shot the story.

In the Gymnastics Hall when Olga Korbut blew her performance on the uneven parallel bars and began to cry copiously, the nearest floor camera, a KCU-40 on a bulky pedestal was at the diametrically

opposite corner of the floor. Sensing a great human interest potential, the television director ordered the camera trucked around the perimeter of the floor to the balance beam for a close up of the young Russian gymnast. The three man crew sprinted the camera, playing out 250 feet of snaking cable along the way and got there in time to pick up the tearful trauma.

The 'stronger' aspect relates to the growing breed of camera crew members who strap on a bewildering array of shoulder harnesses and backpacks to get right in where the action was. Good health and stamina are prerequisites for carrying around a KCR camera head or a VR-3000 backpack for a few hours, staying focussed, pushing buttons, and trailing a fast moving event all at the same time.

Some of the more unusual camera set-ups were as follows:

1. A KCU-40 on a track dolly that rolled at the edge of the swim pool at the pace of the swimmers. This mobile camera cart was pushed by hand.

2. Underwater views were obtained by other KCU-40's looking through windows at the end of the diving and swimming pools just below the water line. Beneath the surface fouls in water polo were harder to coverup with all that submarine camera coverage.

3. A third camera of the same type was installed over the center of the pool just below the ceiling support structure and could zoom from a full wide angle shot of the entire pool to an overhead close-up of individual swimmers.

4. A three man crew handled a PCP-90 that roamed at the edge of the track in the main stadium. The cameraman shouldered the camera ahead, his first assistant carried the camera electronics on his back, and the second assistant kept the required length of cable moving in or out. Many hundreds of feet away under the grandstand, a video engineer in a small van operated the camera control unit.

5. At peak periods, another portable camera using two pick-up tubes and operated by the ORTF,

ranged in the stadium. Its CC was in a little car, and produced SECAM encoded images that were converted to PAL before being layed to master control.

6. At the edge of the track, several EMI-2001 cameras supplied the BBC were specially mounted on short unipods close to the ground. The camera operators manipulated these cameras from the photographers pit circling the track.

7. On the playing field several KCU-40 were on special low wheeled carts and could get very close into the athletes competing the pole vault, high jump, broad jump, javelin, shot put, etc.

8. The CBC brought an EMI camera pack consisting of a modified BC-230 in a small vehicle with a VR-3000 inside. This was used for local color since it did not have access to the venues.

9. The BBC minicam unit consisted of an EMI 2001 mounted on a roof platform on a pneumatic self-levelling Citroen vehicle. This was called the Safari wagon and gave amazingly stable pictures while following road events. The VR-3000 in the vehicle recorded the camera output or it could be linked through a helicopter microwave relay to the television center.

10. A KCR hand-held portal on an electric cart (so as not to create pollution for the contestant) was allowed to accompany some road events, like the marathon, for a close look. This camera signal was also relayed by a hovercraft whirly bird to the switching center.

Commentators

Without proper commentary video images would be far less interesting. This fact poses a rather difficult problem for an international event like the Olympic games. Pictures are automatically international, sound isn't. To provide narration for the television network from over 60 countries requires a complex installation involving specially designed commentator announcement booths both at the venues and at the DOZ center.

There were over 300 television commentary booths at the venues.



and 60 "off tube" cubicles for
ce over operation. Eleven separate
color television studios at the
ater and four interview studios at
the Olympic stadium, the Schwimm-
e and the Sporthalle covered
origination requirements.

At the venues a commentator
had at his disposal a pair of small
television receivers that carried up
to 2 channels of pictorial coverage
from active sites.

The RF distribution system fed
over 2000 color and monochrome
receivers all over the Olympic
park, including the press center
and the participating networks as-
signed offices. The commentator,
with good direct visual contact of
the event under way could also
watch the camera coverage on their
monitors. Their commentary went
to microphones attached to their
laptop that brought the back-
ground sound of the activity in one
phone and instructions from the
director in the other.

Sound picked up by field micro-
phones located on site or "shotgun"
mics on the cameras became the
"international sound" that accom-
panied the pictures. Specific lan-
guage commentary was overlaid by
audio mixers, the output of which
were either aired live or recorded
on an assigned VTR for later play-
back. In addition, a bank of multi-
track audio recorders (Ampex
M-1000 16 track machines)
delivered to the master AVR-1 video

tape recorders could register up to
45 separate languages for subse-
quent editing.

The Canadian Broadcasting
Corporation's need for dual lan-
guage coverage for all programs led
to the installation of two sound
over studios in their section at the
DOZ center and the unique use of
the audio and cue tracks on their
four AVR-1's for simultaneous two
language recordings. These were
relayed back to Canada over Com-
sat's link with both English and
French sound for the pictures.

Production and Editing

While each of the networks used
their own production techniques to
satisfy their different end viewer
requirements, the commonality of
technical equipment led to some
similarities of program production.

Only ABC had managed to get
the rights to unilateral coverage to
American tastes, and could aug-
ment the DOZ World Service Pro-
gram with separate cameras under
their own control.

Most of the other networks had
to use the DOZ camera coverage
by selecting the feeds they wanted
from the venues. Usually up to six
simultaneous inputs were availa-
ble. The main switching center at
the DOZ could handle up to 13
parallel television feeds and route
them through Weltregie for distribu-
tion to the production studios.
The major networks like ABC,

BBC, NHK, etc. had their own
studios, VTR's, graphic cameras,
and master control rooms and
could put together programs on a
live or recorded basis.

The recordings were edited by a
variety of means. Straight mechan-
ical editing of videotape by cutting
and splicing was still in evidence.
Because of spooling time on
VTR's and tight schedules, this is
still the fastest way of getting a few
seconds or minutes of an important
scene out of a long tape. Manually
placed cue pulses and electronic
editors were the next step and
many of the VTR's in the DOZ
center, the venues and mobile
VTR vans had this facility built in.

The most sophisticated editing
was done with the new 80 bit
SMPTE address code which was
simultaneously recorded on the cue
track of the AVR-1's in the central
VTR room. Editing could then be
done by transferring the tapes to
several pairs of AVR's equipped
with RA-4000 random access edit-
ing accessories which automatical-
ly search out the specified address-
es on the tape and perform the edit
on command of the editor.

Other production techniques
involved the use of chroma key
with the familiar blue backdrop.
Graphics insertion using color
cameras or monochrome cameras
with colorizing devices, character



The excellent camera coverage was due in part to very close
access to the events. This is a KCU-40 on the floor of the volley
ball hall following the action.



Central switching room at DOZ center provided constant
checking on inputs from venues. Labeled by venue along venue
along the bottom two rows and by destination on the top two
rows.



generator titling with moving or flashing titles and of course timing overlays during a race.

Eleven slow motion HS-100 disc units provided the instant replay and time base manipulation of the video images where it contributed to the informational or esthetic quality of the program.

What the viewer saw as a final composite image often took several color cameras, miles apart, mixed with local ident signals that were later eliminated, overlaid by keying and special effect techniques, inserted by character and graphic sources, recorded, edited, copied into final program form, relayed by microwave to Raisting, standards converted from PAL 625/50 to NTSC 525/60 by an optical transcoder sent by satellite to a ground receiving station thousands of miles away, then distributed over a network where further re-recording to accommodate time zone requirements preceded the actual local

transmission. Notwithstanding all this, the picture and sound got rave reviews from all televiewers.

Personal Commentary

A fortunate set of circumstances permitted my wife (who is a Video Consultant) and I to see not only the studio origination and closed-circuit distribution of the World Service Program of the DOZ but also to watch air transmissions of the games on color sets in our apartment in Munich, in Paris, and London. Since returning to the U.S., I have seen recordings of what happened here. The European color pictures whether in PAL or SECAM were excellent and required no manipulation of the home receivers to keep them that way. While the flicker factor of a 50 field image is noticeable at first, it disappears in a few days and one begins to enjoy the superior bandwidth and more stable colorimetry of the European color systems. It should be the goal of the U.S. color television industry to achieve the same kind of picture quality

through careful control at the origination and less manipulation range at reception.

The assembly of the informational and pictorial material describing the Olympic television facilities was made possible by the kindness of Dr. Richard Theile, Director of the Institute für Rundfunk Technik in Munich who arranged for accommodation, Dr. Schwarz, F. H. Mandl, K. H. Schulte and M. Grape of the DOZ for accreditation, access and information, specific details about the Fernseh equipment was obtained from M. Pöhl, that company supervisor at Oberweissenfeld and similar information about Ampex's installation came from Klaus Eichstadt, an old friend and co-worker at the Mexico games.

Thanks are also due E. Alter and H. Wolff of Sender Freies Berlin for a tour of Studio 5 and H. Reidel of NDR for the review of the ABT complex, Norm Taylor of the BBC and A. Daigneault of the CBC filled in the technical background about their operations.

VS-150A VIDEO SWITCHER-FADER \$795

VS-151A MIX/EFFECTS SWITCHER \$1495

VS-152A MIX/EFFECTS SWITCHER \$1995

VS-153A MIX/EFFECTS SWITCHER \$2895

Now you can save more than 50% on video program control equipment.

No . . . we're not having a sale. Our building didn't burn down and we haven't lost our lease. But you can save more than 50 percent when you buy DYN AIR Series-150 vertical interval program control equipment.

How? You'll find out quickly when you check the prices of comparable equipment of other manufacturers. For the same capability, you will pay from two to three times as much. And you probably won't get the quality and reliability of DYN AIR equipment.

On DYN AIR program switchers, you won't find cheap, troublesome sliding fader potentiometers; we use quality gear-driven, locking split-lever controls. Nor will you find other inexpensive and unreliable components. The 150 Series uses the latest silicon solid-state devices available — over 80 percent of which are in integrated-circuit form — the same quality components and temperature-compensated circuitry used in our broadcast and aerospace equipment. Fully color delay compensated too.

If you take time to compare . . . you'll buy DYN AIR.

DYN AIR ELECTRONICS, INC.
6360 FEDERAL BOULEVARD
SAN DIEGO, CALIFORNIA 92114



One of the very best broadcast color monitors is on the shelf...waiting to brighten your day.

It's known as the TCB-19, from the Miratel Division, Ball Brothers Research Corp. We call it one of the very best because TCB-19 users report a consistently high level of performance.

Dual regulated power supplies hold picture stability with wide input voltage variations. Solid-state circuitry insures low maintenance and consistent performance over the long haul. Switchable long or short time-constant AFC adds to monitor usefulness for VTR alignment, and a front panel switch allows for selection of two video inputs. All critical set-up and adjustment controls are front-mounted for convenience.

The TCB-19 performs the way it's built, and it's built well. Check it out!



The rest of the family is also standing by.

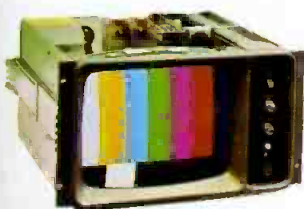

And it's a large one. Color and monochrome monitors from 9 to 25 inches. Rack-mounted, frame-mounted, broadcast or information display. All Miratel monitors feature over-design of critical circuitry for exceptional long-term performance. Each unit is power aged, and subjected to quality control checkout before shipping. Miratel monitors are designed to

serve as your single best check of signal quality.

We also offer a variety of video accessories from special effects generators to waveform monitors to video signal multiplexers. Depend on the Miratel family for your television equipment needs. Call or write for information.

MIRATEL DIVISION

BALL BROTHERS RESEARCH CORPORATION • 1633 TERRACE DRIVE • ST. PAUL, MINNESOTA 55113 • (612) 633-1742

Circle Number 20 on Reader Reply Card

Stereo separation for microphone lines

The Design of a two-channel, hybrid, passive splitter-mixer.

By Todd A. Boettcher*

This article should provide assistance especially to the broadcaster who has the opportunity to utilize two-channel stereo for live or recorded broadcasts.

Traditionally, it has been necessary for the broadcaster to provide a quality broadcast with a minimum of complexity and set-up time. Within the last few years, however, there has been a growing trend to provide recording studio flexibility, since many contemporary artists have had their images molded in the recording studio. Conventional microphone techniques would be detrimental to that image. As a result, the close-microphone-placement technique, which allows better mixing control by the audio engineer, is being experimented with and used more frequently.

Eliminating The Hole In The Middle

Close-micing can cause a problem for many broadcasters, because few broadcast audio consoles have pan-pots or other spe-

cial audio processing equipment. Close-micing, plus the lack of pan-pots, will tend to exaggerate separation to the point at which instruments in a band, will appear in one channel or the other, with very little chance to be heard by microphones in the opposite channel. Hence, the "hole-in-the-middle."

This hole-in-the-middle can be eliminated in the limited-flexibility console by using two microphones on each instrument—one mic in each channel. Then each instrument can be placed anywhere in the stereo spectrum. The result is the same as if a pan-pot had been used. In practice, this is not a feasible alternative because most broadcast consoles do not have enough microphone inputs to offer this luxury.

An economical solution is the following simple construction project that was designed to fill in the hole-in-the-middle that sometimes creeps into two-channel stereo-ophonic recordings and live broadcasts, yet will still allow the sound in the middle to have a stereo dimension. Just as importantly, it does not require the use of extra microphone inputs.

Specifically, a portion of Input 2 is fed to Output 1, and a portion of Input 1 is fed to Output 2 (see Fig-

ure 1 and Figure 2). The "x" in the output formulas is the ratio of the voltage of the primary channel to the secondary channel. I have arbitrarily chosen that the secondary channel information should be one third the voltage of the primary channel for initial testing; thus $x = 3$.

Six resistors were incorporated for isolation (see Figure 3). R_1 and R_4 isolate the input, R_3 and R_6 isolate the output, and R_2 and R_5 reduce interaction related to mixing resistors R_7 and R_8 .

Voltage ratios can be determined at points "c" and "g." Using the "x = 3" formula above, the resistor formulas are:

$$(1a) 3(R_1 + R_2) = R_4 + R_7 \text{ for point "c"}$$

$$(1b) 3(R_4 + R_5) = R_1 + R_8 \text{ for point "g"}$$

R_1 , R_2 and R_3 form a series resistance in Channel A, and R_4 , R_5 and R_6 form a series resistance in Channel B. Unless these resistors are incorporated as a portion of a pad (resistive attenuator), they will alter the terminating impedance.

Although Figures 1-3 are drawn as unbalanced circuits for clarity, this circuit is to be used in a 150-Ohm, balanced microphone line. In a balanced circuit, the

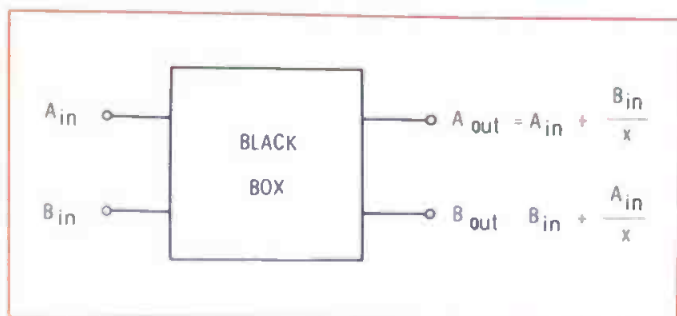

Fig. 1 Diagram of the basic concept. The output formulas indicate that both Input and output signals need to be combined in some way at each output.

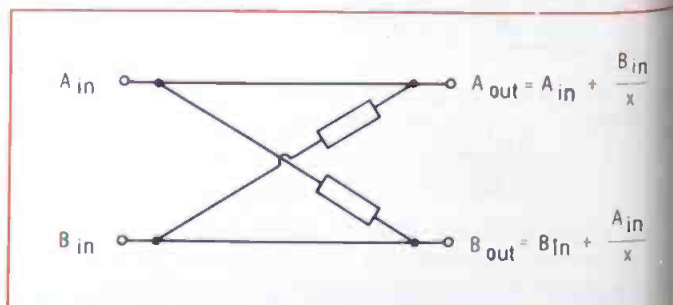

Fig. 2 Simplified schematic of the resistive network. This shows that a portion of each input is fed to the opposite output, resulting in the desired mixing.

The Reel Workhorse



Every professional sound recording application needs a recorder/reproducer that assures peak performance each and every time it's used. A heavy duty machine with a built-in reputation for reliability. A machine that will work when others won't and will keep on working when others can't.

The new Telex 1400 Series are such machines. They've added a new dimension in design features to the rugged reliability of the Magnecord 1000 Series that fathered them. The result is the optimum combination of today's technology with field proven dependability.

But these units don't just outwork and outlast other recorder/reproducers. They also outperform anything else in their class. How many recorder/reproducers starting at under \$1500 have a DC servo drive system to assure a timing accuracy of less than 1 second deviation in a 30 minute program, keep flutter and wow at a bare minimum and work with any AC power source?

How many others in this class have a three-speed drive system (3 $\frac{3}{4}$, 7 $\frac{1}{2}$, and 15 ips); a catenary head block design with polished, hyperbolic contour heads; a high frequency bias oscillator for maximum S/N ratio; VU meters to monitor record, playback, or bias levels; complete remote control capability; separate gain controls for mic and line inputs as well as a master gain control—to give each machine the potential of a small mixer?

All of this performance capability is kept in long-lasting, smooth operation by total solid state controls, logic circuits that make tape spill virtually impossible, a durable die-cast transport frame, and a host of other heavy-duty and failsafe design features that make Telex 1400's workhorses in any operation.

With dual or single channel options and the availability of all standard head configurations, there's a Telex "reel thing" for every application. Write for free information.

PRODUCTS OF SOUND RESEARCH

TELEX

COMMUNICATIONS DIVISION

9600 ALDRICH AVENUE SOUTH • MINNEAPOLIS, MINNESOTA 55420

CANADA: DOUBLE DIAMOND ELECTRONICS, LTD., Scarborough 4, Ontario
EUROPE: ROYAL SOUND COMPANY, INC., 409 North Main Street, Freeport, N.Y. 11520 U.S.A.
INTERNATIONAL: TELEX EXPORT DEPT., 9600 Aldrich Ave. So., Minneapolis, Minn. 55420 U.S.A.

Circle Number 16 on Reader Reply Card

logical pad to use is the "H" pad (see Figure 4). Since Figure 3 is unbalanced, it must be duplicated for the second leg of the balanced circuit. The series resistance in Figure 3 can be summed and substituted for the pad input resistors R_a and R_b . Therefore, the formulas would be:

- (2a) $R_a = R_1 + R_2 + R_3$
- (2b) $R_b = R_{1a} + R_{2a} + R_{3a}$
- (2c) $R_c = R_4 + R_5 + R_6$
- (2d) $R_d = R_{4a} + R_{5a} + R_{6a}$

Practical resistor values were calculated after determining the loss of the pad. 10 dB of loss was chosen because it will provide a start at attenuating the mic lines for high-level sound sources (i.e.: close-micing a music pick-up), yet is low enough to be usable with a speech-level input. In the "H" pad with equal input and output impedances, the following formula is true:

$$(3) R_a = R_b = R_c = R_d$$

The closest E.I.A. 5 per cent resistor value for these resistors is 39 Ohms. The closest value for R_e is 110 Ohms. Dividing R_1 through R_6 equally to evenly distribute the isolation, those resistors all become 13 Ohms. Checking back to Formula 1, R_7 and R_8 become 60 Ohms for the 3:1 ratio.

In Channel A, points b-c can be considered a series-parallel circuit with b-c forming one side and b-g-f-c forming the other side. So that b-

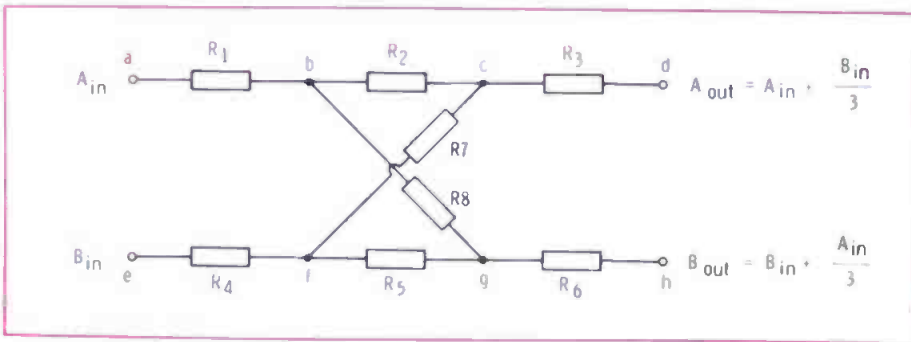

Fig. 3 The complete mixing network with all isolation resistors. It must be remembered that, although the mixing network is complete, if used as drawn, the characteristic impedance of the line would be altered considerably.

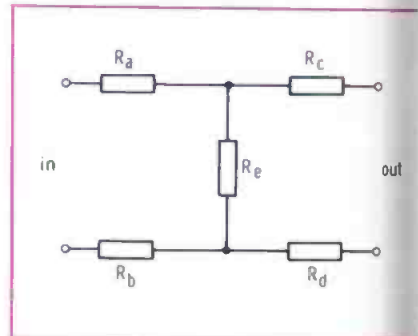

Fig. 4 The "H" pad. This network is one of the basic balanced circuit attenuators, being derived from the unbalanced "T" pad.

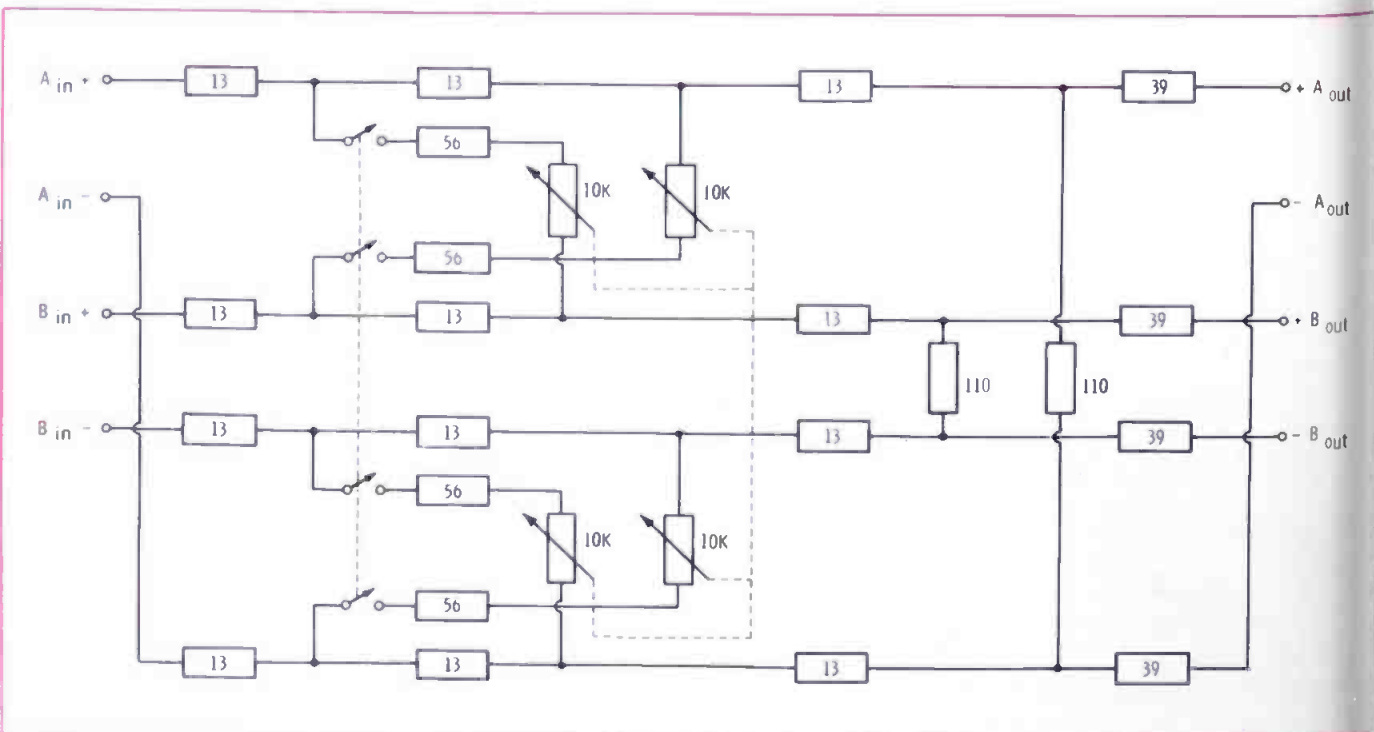

Fig. 5 Complete schematic of the circuit. If greater stereo separation is needed between channel A and B, the 10K-Ohm pot may be replaced with one of higher value. However, that would produce less control over the lower resistance range where the most audible effect takes place.

f-c will have negligible effect on $R_8 + R_5 - R_7$ must be at least ten times R_2 , or 10 Ohms. To fulfill that requirement, R_7 and R_8 must be at least 10 Ohms, which they are. This relationship holds true when considering Channel B at points f-c and f-c-b-g.

On The Breadboard

A test circuit was breadboarded and found to give main channel loss of 12.5 dB and an alternate channel loss of 16 dB. These figures are close enough to the design goal to be considered acceptable for practical application.

Several minor, but handy, modifications were made before final construction. The 5-Ohm resistors were removed from R_7 and R_8 and replaced by 50 Ohm resistors (the design minimum). They were wired in series with a ganged, linear-tapered, 10 kOhm pot. This pot will allow variable stereo separation from approximately 3dB to

25 dB. Also wired in series in a rotary switch (4-pole, 2-position) to open the mixing circuit, allowing the use of two independent 10 dB attenuators (see Figure 5).

Two comments need to be made in summation. First, it is possible to produce a much less complex stereo separation circuit. Consumer-type stereo amplifiers often utilize just a single potentiometer across the preamplifier outputs of the two channels to achieve variable stereo separation. Of importance to the audio professional is that, in the circuit described here, impedance matching at both inputs and both outputs will remain correct within a reasonable tolerance. Other than the intended mixing of signals, there should be no other interaction between the channels.

Control Pot

Second, some discussion might arise on the desirability of inserting

controls in a microphone-level audio line. The fixed resistors are of no concern with respect to noise generation, but the potentiometer is a possible source of noise, especially after extended use. Remember, however, that this pot will not be used actively after initial set-up at a session, so wear will not be severe. A good quality pot should give plenty of service. This pot is inexpensive enough so that if and when replacement is necessary it will not be a financial hardship.

This design was conceived to utilize existing equipment without modification. If you want to install this circuit directly into an audio board, it would probably be worthwhile to wire it in following the microphone preamps. Resistor values would have to be re-calculated to provide impedances matching those within the board at that point. Still, the estimated construction cost is under twenty dollars.

new LSC VEDETTE

16mm and 35mm PROFESSIONAL PROJECTORS

for fast, safe, high speed viewing and inspection of motion picture film

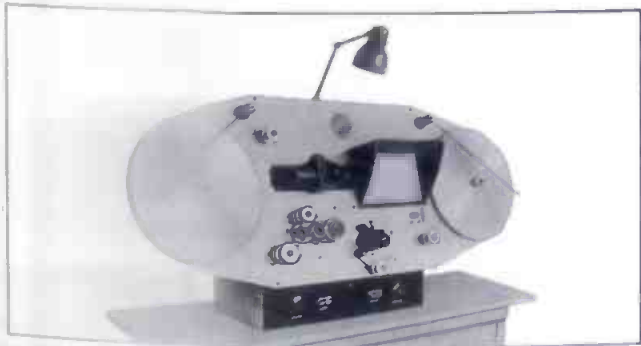

- The ideal machine for high quality control, timing, and release print inspection, negatives, fine prints.
- Visual inspection of picture and optical sound track.
- Efficient revolving shutter and sharp optics produce clear images without heating film.

- Smooth, gentle film handling at up to 400 ft./min., without intermittent movement of usual claw or Geneva gear drive. Stable, positive focus. 2,000 foot film capacity.

Write for LSC Vedette literature or request a "no obligation" demonstration.



LIPSNER-SMITH CORPORATION

7334 No. Clark St., Chicago, Ill. 60626 • 312-338-3040

CF₂ ULTRASONIC CLEANER

for MOTION PICTURE FILM • MICROFILM • MAGNETIC TAPE

Presented The Academy of Motion Pictures Arts and Sciences Award of Merit for Outstanding Technical Achievement.

Ultrasonic energy is the most effective and economical way to completely clean motion picture film, microfilm and tape without mechanical scrubbing and wiping. Ultrasonic energy performs the entire cleaning operation.

- Restores clarity and sound to maximum quality.
- Enhances the entertainment value of motion picture film and improves commercials.
- Assures static free film with color balance undisturbed.
- Cuts projector maintenance costs... no dirt or dust carried into gates and orifices... less breakdowns.
- Completely automatic... requires only loading and unloading.

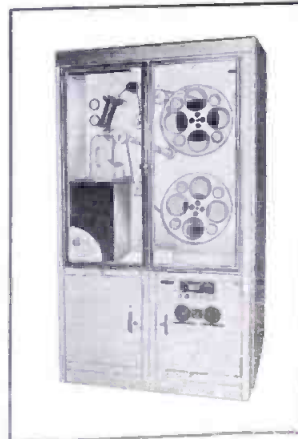

- Costs only 1/20 of a penny per running foot to operate.
- Used by every major motion picture lab in the world.

Descriptive brochure will be sent on request.

10041

There is another method for...

Emergency Broadcasting

Part II of a 2-part Series

By Stephen A. Russell*

Mr. Russell's discussion of the technical aspects of the DIDS system began in the October issue of BE. A change of the FCC rules (Part 73, Subpart G) is scheduled for November. The proposed change would delete all stated references of the broadcasters potential role in alerting the public, to include automatic home warning during a national disaster.

Any comments our readers wish to submit should be sent to the Editors of BE or sent directly to Commissioner Charlotte Reid, Defense Commissioner, FCC, 1919 M Street, N.W., Washington, D.C. 20554.

An alternative system that would dramatically reduce warning receiver costs is available. It is a signalling system operated by broadcast stations. The broadcaster method of distribution, as noted in Part I, is far more secure, because the danger of sabotage is distributed over 6,000 transmitters.

Receivers demuted by broadcast stations could be simple and low cost. The warning function could add less than \$10 to an existing entertainment receiver if it were mass produced. A low cost tuning fork filter and decoder would be the only major changes necessary to add the warning option to a radio. Only the broadcast receiver meets Mr. Joyce's criteria, namely, "The price of such a receiver should be so low that every household can afford one. Economic discrimination in the distribution of warning receivers would undoubtedly be recognized as grossly unfair." Given this fact, why is the current DIDS being favored? I believe the answer rests on serious technical misinformation, in addition to the aforementioned failure to confront the national security implications

*International Electronic Corp., (IEC).

and the problem of receiver cost.

How About UPAS?

UPAS stands for Unified Public Alerting System. The creation of a Japanese inventor, Dr. Masao Fukata, the UPAS was devised to unite the different agency requirements. The word "unified" specifically refers to the unification of the DIDS and the EBS so as to guarantee warning, not just in test conditions, but in an actual emergency.

The February 20, 1971 EBS failure demonstrated the difference between test and emergency conditions. DIDS, as it is currently proposed, may perform in a test but it is doubtful its transmitter antennas would be standing to serve in a national emergency.

The UPAS system features signalling by a patented system known as the Cue Signal System. The Cue Signal System was designed for use by both DIDS transmitters and broadcast stations throughout the country. DIDS transmitters are to be used to signal government facilities, air raid sirens, AP-UPI facilities, and the broadcast industry. The task of signalling home receivers under the UPAS is the responsibility of broadcast stations. In addition to receiving warning information from DIDS, the broadcasters would have a redundant source of warning via the EBS.

The technical defects of DIDS and the technical strengths of the UPAS Cue Signal System are revealed when the contradictory nature of the warning system goals in the Joyce Status Report are recognized. The goal of alerting reliability directly conflicts with the goal of security against false alerts; the requirement of a 30-second response time conflicts with the desire for selectivity; and the goal of 24-hour coverage conflicts with receiver cost.

Demuting Reliability vs. Falsing Security.

The principal enemy of a radio wave signalling system is atmospheric and man-made noise. Noise contains virtually every signal pattern. It has unexpectedly persistent power to cause receiver falsings. There is no way to prevent all noise at its source. The only way to prevent noise falsing is to employ a special filter with an extremely narrow passband and sharp cutoff characteristics. This type of filter will pass only the control signal frequency. This narrow filter also prevents falsing by spurious signals that randomly occur in broadcast program material. **The narrower the filter bandwidth is, the better is the security against false alerts.**

Unfortunately, every type of narrow passband filter (e.g. tuning fork filter, active filter) is subject to the problem of filter frequency shifting due to temperature variations, aging and divergence in mass production. Thus, **the wider a filter bandwidth is, the better is the chance for reliable alerting.**

The ability of a system to resolve this contradiction is a critical test of system effectiveness. DIDS has failed to resolve this. Rather, DIDS has employed the conventional techniques of a fixed frequency control signal on the transmitter side and a high quality, costly, filter on the receiver side.

Filter stability and high production quality is seen by DIDS simply as a cost the receiver must bear.

Back To The Xmtr

The UPAS Cue Signal System features a unique solution. The system places the responsibility for security and reliable alerting on the transmitter, leaving the receiver unburdened. Using a patented technique known as wobbling, the Cue Signal generator transmits a control signal frequency that sweeps back and forth across its

signed center frequency. In each receiver an extremely narrow passband filter that eliminates noise falsing is used, since the wobbling compensates for any center frequency shifts that might otherwise cause a failure to demute. The wobbling function may add \$1,000 to each transmitter but this is insignificant when the role of each transmitter in a public warning system is considered.

In a typical non-broadcast communications system there may be one transmitter and a few hundred receivers, and the cost of the total system may be apportioned accordingly. In a broadcast station public alerting system, each transmitter will service thousands of receivers. Virtually any transmitter cost that will reduce the technical burden and costs borne by the individual receiver is justified. With the wobbling technique, a warning receiver may now employ a narrow passband filter that is a fraction of the cost of the quality filter necessary in the current DIDS receiver.

Program falsings, it was noted earlier, are also eliminated by a narrow passband filter. Unlike noise falsings, the filter alone cannot guarantee to prevent program falsings. Noise falsing duplicates the control signal frequency along with a spectrum of other frequencies. There is not enough power in any single frequency contained in noise to overcome filter attenuation. A program falsing signal, however, may have enough power to easily pass through a narrow passband filter, assuming the unwanted program signal is the right frequency.

Once again the technique used by DIDS to deal with a falsing problem burdens the receiver. DIDS features a complex 12-bit digital control signal to reduce the probability of program material duplicating this signal. This coded signal is also used for multiple addressing but its primary role is to prevent false alerts. A less complex multiple addressing scheme would be possible if preventing falsings was not a goal.

More False Alerts?

To further reduce the effect of a falsing, the DIDS signal is a "driven" signal, that is, receivers will turn on and remain on only when

the DIDS signal is being transmitted. When transmission ceases, the DIDS receiver returns to a muted condition. This "driven" or "holding tone" principle eliminates falsings that would permanently latch open receivers, but it is detrimental to alerting reliability.

If an atmospheric storm exists when the 12-bit digital signal is being transmitted, which is likely in weather emergencies, one of the bits may be blocked by interference in the receiver. Noise not only causes falsings but prevents reliable alerting when warning is most needed.

To compensate for this possibility, the DIDS system developers once again added to the cost of the receiver by requiring a receiver "holding memory". They hold the receiver open for up to 60 seconds in the event of a control signal interruption. This creates a new problem, since this holding memory will also hold open for 60 seconds, receivers that have been falsed.

In summary, DIDS use of a

complex digital signal plus a "driven" signal technique, produces a signalling method that is, at best, probability challenging. In the short run it may appear to have eliminated the falsing problem, but without any guarantees, and at great cost to the receiver.

Spurious Signal Self Suppressor

The UPAS Cue Signal System uses another patented technique to resolve the contradiction between program falsing and alerting reliability. A Spurious Signal Self Suppressor, known simply as the 4S is a device that again burdens the transmitter to spare the receiver. Accepting the principle that "space pollution", i.e. program material falsing, should be stopped at its source, the 4S is built into the broadcast studio signal generator. Just prior to a complete duplication of the control signal by the latest rock and roll hit, the 4S automatically switches into the program line a band elimination filter that blocks the falsing elements. After 5 sec-

Free Engineers From Slavery.

Unattended, Tracor's 6500 Visual Carrier Generator System keeps your station within .05 Hz per year. No monitoring. No external test equipment. This FCC approved rubidium-based system is 100 times more stable than any current crystal oscillator system. Eliminates co-channel interference. Provides larger audience with better reception. For the inside story, call (512) 926-2800 today.

**Or write Tracor Inc., Industrial Instruments,
6500 Tracor Lane, Austin, Texas 78721**



Free The People
Box.



Circle Number 18 on Reader Reply Card

onds the filter is automatically removed. The 4S technique is not "probability challenging" but can guarantee elimination of program falsings at no cost to home receivers.

Spooing

A third type of falsing, in addition to noise and program falsings, is spooing. DIDS has no preventive measure against warning receiver activation by an enemy originated spooing signal that duplicates the control signal. DIDS, at present, can only correct spooing after the fact. Using the 4S principle, the UPAS Cue Signal System features strategically placed monitor receivers in each transmitter's service area. Like the 4S, these monitor receivers are set to detect a spooing signal prior to the false alerting of home receivers. The monitor receivers are connected by land line to a signal generator in the broadcast studio. When signalled by the monitor receivers, this generator automatically sends out a signal to override a spooing signal.

It is important to note that this

Anti-Spooing Technique is one of the critical measures necessary to make a broadcast station operated warning system possible. This anti-spooing technique eliminates the danger of adjacent channel or sky-wave channel warning signals, that travel beyond the area that needs to be warned, from accidentally demuting home receivers outside the emergency area. The override signal, that will automatically be transmitted when a warning signal from an adjacent or skywave channel exists, will generally be strong enough to prevent local receivers from being spooed.

The UPAS system resolves the conflict between security against falsings (program material, noise and spooing) and reliable alerting, by burdening the transmitter as opposed to using various complex receiver techniques. The result is a receiver that is within the economic means of most Americans.

Selectivity vs. Response Time

The Joyce Status Report stated that over 5,000 different addresses were possible with the DIDS signal. These were allocated to reduce a single address area to only 1/10 the area served by a typical broadcast station (i.e. 25 to 40 mile radius). In addition, it was reported that all of these addresses could be signalled within the OCD time requirement of 30 seconds.

My studies have revealed serious exceptions to this latter claim. One of the reasons why the DIDS signal is a "driven" signal, is to insure alerting reliability. As noted, when any one of the bits in the 12-bit digital signal is interrupted by atmospheric, the receiver will fail to demute. Repeating the signal is necessary. Since one transmission of the 12-bit signal plus the necessary pause requires nearly 30 seconds, many instances will occur in which the 30 second objective will not be met. This is an inherent defect of a digital signal.

Address Problems

A second exception occurs on the many occasions when the same message must be delivered to an arbitrary combination of different addresses. For example, tornado funnels may suddenly appear in several non-adjacent areas at the

same time. The capability to alert an arbitrary combination of addresses via a "group call" is needed.

DIDS cannot perform a group call. It would be virtually impossible for DIDS to pre-program every combination of 5,000 addresses for instantaneous retrieval by an operator. Instead, DIDS must signal each address sequentially. In addition, because the driven technique is used, each address must be followed by the entire emergency message. Since only one address can be transmitted at one time and must be sustained throughout the message, extensive delays will occur as the same message is repeated and repeated before the last address area is warned. Because of this fact, the smaller address areas proposed for DIDS are detrimental. Reducing the size of the DIDS address only increases the probable need for group calls which DIDS cannot perform.

Apart from the technical problems of dividing the country into such small address areas, the DIDS addressing scheme creates serious policy problems. First, receiver cost is once again not considered. A fixed-tuned, multiple address receiver may quickly become obsolete. The U.S. citizen is extremely mobile. One out of every five households move every year. This mobility will require decoder addresses in masses of receivers to be changed annually. The percentage of the population that will go to the trouble and cost of keeping their receiver addresses current after every move is likely to be very small. Second, too selective an addressing system may be undesirable. In many emergencies, particularly weather emergencies, it is just not possible to predict what percentage of a community is being affected. It would be far safer to err on the side of warning a larger area than too small an area. Finally, the complexity of the DIDS multiple addressing scheme may call for a super human operator. Someone erred in selecting between two taped addresses in the February 20th EBS incident. What is the probability of an operator erring when faced with a choice of hundreds of addresses in a crisis situation?



Compressor-Limiter Amplifier



(The Great Leveler)

\$445!

You can stop riding gain now, even when a shouter and whisperer are on the same talk show. The Model CLA 20/40 Compressor-Limiter Amplifier does it automatically... instantaneously... for both AM and FM. Switchable controls permit symmetrical (FM) or asymmetrical (AM) peak limiting; pre-emphasized or flat response; compress/limit, compress only, or compress/limit off. Automatic gain control range is 40 dB dynamic, and the compression ratio is better than 10:1. All solid state, plug-in modular construction assures trouble-free reliability. Write for complete details.

BROADCAST ELECTRONICS, INC.
A Filmways Company
8810 Brookville Rd., Silver Spring, Md 20910

Fernseh will now sell, ship, and service its TV cameras from all over America. And you will like it.

We've combined the quality of Fernseh TV cameras and studio equipment with an entirely new American sales and service organization. It's now quite easy to get the KCU-40. The 3-tube color TV camera that revolutionized European production techniques. High light sensitivity. High signal-to-noise ratio. Tilttable lens. And one-quarter or one-half inch camera cables that make the KCU-40 an ideal lightweight camera for both studio and location use.

We're ready with a full team of specialists to give you all the service, parts and technical help you'll need. Plus, a complete line of products including telecine cameras, standards converters, special effects equipment, and video recording systems. So now, you can get the quality and dependability of Fernseh TV equipment from an American company with an office near you:

Chicago Headquarters (312) 681-5000

Boston (713) 681-8461

Los Angeles (213) 398-0777

New York (516) 921-9000

San Francisco (415) 583-9470



KCU 40, 3 Tube Color Camera

Robert Bosch Corporation  **Fernseh Division**

Test Those SCR's And Triacs

Once you understand these solid state devices, you'll find them easy to test and to use in broadcast circuits.

By Ron Merrell

Silicon controlled rectifiers and triacs have made their way into rather common use in broadcast equipment these days. What's more, you may even find them in modifications made on standard

units as well as in home brew circuits.

Although we're now taking their existence for granted, how much do we know about testing SCR's and triacs? Suspecting that we all need more than their theory of operation, we went to our lab to see if some simple tests could be devised to check these solid state components.

Solid state devices can be checked against their specs, and this may suffice when they are used in fairly simple units or modules. The problem in checking solid state components comes when we realize that each is often directly connected to a network of circuits. And the problem initiated by just one part can dovetail into several other circuits.

In order to understand what tests are meaningful, it is necessary to take a step beyond explicit construction descriptions and translate their operation into practical terms.

Conventional diodes are really voltage controlled switches. The diode becomes a conductor when the anode voltage is more positive than the barrier voltage (relative to the cathode). When the opposite polarity is applied to the diode, the circuit will remain open.

We've backed up to the diode here, because diode actions form the basis for SCR and triac functions. Figure 1 helps describe the comparison. SCR's and triacs have more than one PN junction, and one of these added sections is called a gate. In this case, the gate also can block conduction.

SCR Actions

An SCR can be visualized as a diode in series with a switch. But conduction can now be controlled by the gate and the polarity of the applied voltage. The anode voltage may be positive, but if the gate is zero or negative (relative to the cathode) conduction will not take place.

A positive anode voltage and a sufficiently positive gate will allow conduction. The change from non-conduction to full conduction takes place instantaneously when the gate-cathode voltage raises enough to pass the "trigger" point. Once conduction has started, the gate loses control and cannot block conduction. This latching effect continues until the anode voltage and current drop below the holding point.

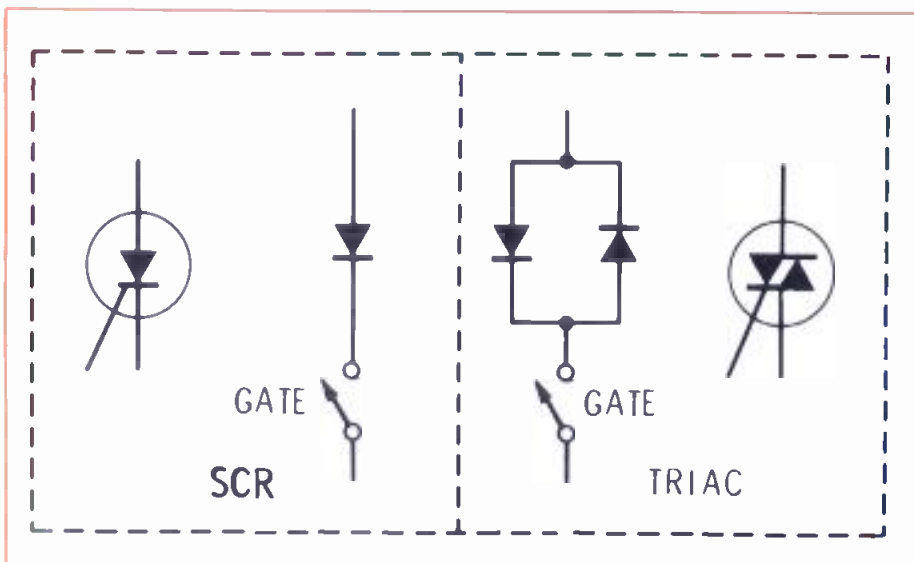

Fig. 1 The SCR symbol and circuit equivalent at left, basically, a diode and a switch. At right, note that the triac uses back-to-back diodes and a switch. Both can be tested by the device in Figure 2.

SIMPLER AND MORE RELIABLE TV TRANSMISSION

With cavity-matched VHF power tetrodes

Our transmitting tubes for VHF applications are supplied with matched cavities to ensure optimal system performance. It's a simple idea that Philips introduced, that the market liked and others copied. Something that's harder to copy is our unique 'K'-grid material. This allows a high power gain and excellent linearity to be combined with long-life stability. Philips cavities and air-cooled tubes go from 1.5 to 25 kW for operation in channels 2 to 13, for both vision and sound service.









If you're a television engineer, who's looking for minimum design problems and optimum operating efficiency, we have another simple idea. Check out our claims in detail by sending for the relevant data sheets.

Philips Industries
Electronic Components and
Materials Division
Eindhoven - The Netherlands

Distributed and sold in the U.S.A. by:
Amperex Electronic Corporation
230 Duffy Avenue, Hicksville N.Y. 11802

In Canada:
Philips Electron Devices
a Division of Philips Electronics
Industries Ltd.
116 Vanderhoof Avenue
Toronto 17 - Ontario



tube type		useful output power*		cavity type ¹⁾
		Band I (kW)	Band III (kW)	
YL1520		20	25	40768 
YL1430		12.5	17.5	40747 
YL1420		6.25	8.5	40745 
YL1440		1.5	1.5	40743 

* Peak sync power in C.C.I.R. system with $B(-1dB) = 7$ MHz

¹⁾ Only cavities Band III vision shown from total range.



Electronic
Components
and Materials

PHILIPS

POLARITY - REVERSING SWITCH

SCR (NPN) ↔ TRIAC (PNP)

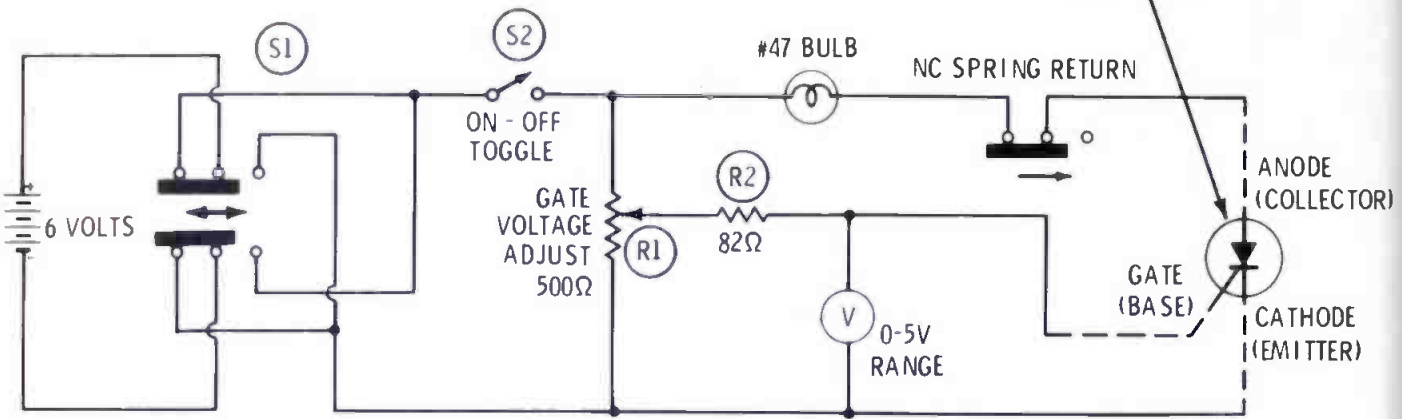

44 ELECTRONIC SERVICING / December, 1971

Fig. 2 Schematic of a tester you can build to determine whether a device is a transistor, SCR, or triac, and it will indicate whether or not the component is operating correctly.

Resistance readings between the gate and cathode usually are under 1000 Ohms. If you reverse the test leads, you'll get about the same reading.

Anode measurements are something else. The anode should measure nearly infinite resistance to both the cathode and the gate.

Triac Basics

By now you should begin to suspect what we will get for resistance tests on the triac. Figure 1 shows that it consists of back-to-back diodes and a gate. The following list will give you a better idea of triac operating conditions:

- When the anode is negative and the gate zero (relative to the cathode), no conduction is possible. This is diode action.
- With anode voltage positive and the gate at zero (relative to the cathode), no conduction is possible. This is gate action.
- If the anode is negative and the gate voltage sufficiently negative, conduction will take place.
- Anode voltage positive and the gate voltage sufficiently positive will cause conduction.
- After conduction begins, a latching effect takes place. The gate los-

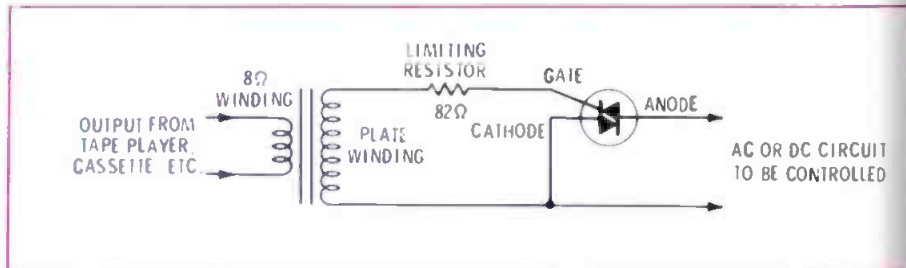

Fig. 3 Schematic of a triac used to start the change cycle of a slide projector. It also will control lamps (or other devices) according to the amplitude of the audio input.

es control and conduction continues until the anode voltage and current are reduced below the holding point.

Resistance measurements for triacs are nearly identical to those of SCR's. The anode should measure nearly infinite resistance to both the cathode and gate.

An open circuit between gate and cathode, or a short or leakage from anode to gate or anode to cathode is a sure sign of a defective part.

Tester For SCR, Triac, Transistor

The tester shown in Figure 2 will check SCR's, triacs and power transistors by applying 6 Volts DC limited to 150 mills. This is a good operational test for these devices and should give you a good demonstration of triggering and holding actions.

If you have any doubts about the

identity of the component, the test results indicate whether it is a transistor, triac or SCR.

Use the following procedure with this tester:

- Prepare the tester by adjusting the polarity switch (S1) to the SCR-NPN position, the toggle switch (S2) to off, and the gate-voltage control (R1) to minimum.
- Connect the device by use of color-coded clips and test leads.
- Flip on S2, the power switch. If the bulb lights, the device is shorted, or the test leads are touching.
- Gradually turn up the gate-voltage control. At a certain critical voltage (measured by a meter for the most detailed information) the bulb should light, indicating conduction.
- A gradual brightening of the bulb when the control is turned up, and a gradual decrease in brightness as the control is turned down

indicates that the device is a NPN-polarity transistor.

F. A sudden lighting of the bulb (full brilliance at one point on the gate-voltage control, and no reduction in brilliance when the gate-voltage control is turned down indicates that the device is a SCR or a triac. Subsequent tests will determine which. The bulb should remain lit after the control is turned down until a momentary open in S3 darkens it permanently.

G. Slide the polarity-reversing switch (S1) to the TRIAC-PNP position, and starting at minimum, turn up the gate-voltage control.

H. A gradual brightening and darkening of the bulb when the gate-voltage control is increased and decreased indicates that the device is a PNP-polarity power transistor.

I. No lighting of the bulb when the gate-voltage control is increased indicates the device is a SCR.

J. A sudden lighting of the bulb (full brilliance at one point on the gate-voltage control adjustment, and no reduction in brilliance when the control is decreased indicates the device is a triac.

K. Flip the power switch to the off position to minimize battery drain.

Testing LDR's

Maximum resistance of a LDR can be obtained only by maintaining the cell in complete darkness for several minutes before measuring it with an ohmmeter. Many circuits, including this one, do not uti-

lize the high-resistance characteristic; therefore, this reading is usually not critical.

Minimum resistance is obtained when the CdS cell is subjected to bright light. A rough test can be made by shining a flashlight at the cell from the same distance each time.

Remote Start For Turntables

A simple static switch, using a triac, is used to control six turntables and one cart machine here at WHCN (FM). When we tried to start and stop our turntables remotely, a large pop would occur because of the high switching currents encountered from the reverse EMF from the turntable motors and switches, even though the manufacturers include a capacitor to counteract this. This pop came across "air", being picked up in our pre-amps.

The circuit shown included switches for both the turntable and the remote switch plate. This enables the DJ to cue records at the table or start the table from the board. Neon indicators are located both places for a positive indication. The current in the switch leads is just enough to fire the triac, not enough to cause a pop in the pre-amps. The by-pass capacitor by-passes radio frequency currents generated by the triac in its off condition and is rated at 600 VDC.

This interesting triac use was sent to BE by Lawrence Titus of WHCN, Hartford, Conn.

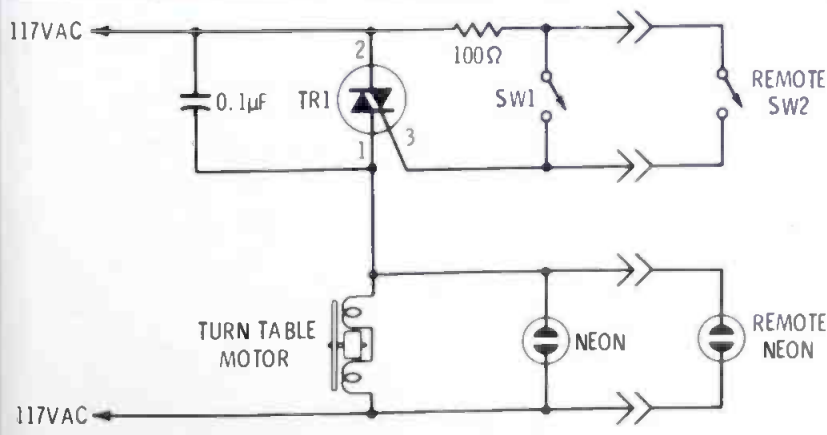

4 Turntable switch used at WHCN-FM. The triac is a IRT82-C.

STUDIO RECORDERS

by

Crown



MINIMUM DOWNTIME

Each unit undergoes more than 100 hours cumulative testing ■ Typical parts shipment from factory service department - under 48 hours ■ Easy access plug-in modules for instant servicing ■ Patented electromagnetic brakes never need adjusting ■ Simple transports - only 9 or 10 moving parts, all solenoid operation ■ Superior tape head contact plus light tape tension for low head wear

MAXIMUM LIFETIME

Design lifetime is 10 years continuous use or 65,000 hours, with three service check-ups ■ Construction "rugged enough to withstand parachute drops" (AUDIO magazine) ■ Top-grade components such as silicon transistors and tantalum capacitors ■ One of the two remaining original American tape recorder manufacturers; still supplying parts and service for broadcast units 15 years and older

MAXIMUM PERFORMANCE

Computer logic controls provide rapid fool-proof tape handling, safe popless remote control, prevent broken tapes ■ Best frequency response among all recorders, pro or semi-pro, and the only one that's guaranteed ■ Every unit shipped with its hand-entered proof-of-performance report

Speed	Response-Hz	S/N	Wow
15 ips	+2db 40-30K	-60db	0.06%
7½ ips	+2db 20-20K	-60db	0.09%
3¾ ips	+2db 20-10K	-55db	0.18%

MAXIMUM FLEXIBILITY

Bias metering and adjustment; record and play equalization switching ■ 2 line level inputs per channel and a 600-ohm line output for each channel ■ Third head monitor with A/B switch ■ At-the-head editing plus cue lever ■ Full line of 1, 2 and 4-channel recorders and players ■ From the mono SX711 at \$895 to the stereo CX822 with typical options at \$2300, you can pay less for a semi-pro recorder, and replace it every couple years . . . or pay more for a wide-tape mastering machine, and get no better performance. It's your choice. To help you make it, we'll be glad to send you full technical data with performance graphs.

BOX 1000, ELKHART, INDIANA 46514, U.S.A.

Background Monitor System

By Clint Tinsley

If you haven't kept up with the state-of-the-art in audio equipment, you may think your station's sound is far worse than it really is. Of course, you can look at your sound to make sure. Trouble is, other people visiting the station may not understand your monitoring problem.

In the September issue of *BE*, Pat Finnegan opened the door on monitoring. We've all been inside before, but let's take one more look around and see if we've advanced as far as we need for today's market.

Constant Voltage Distribution

We will return to the concept of constant impedance as it relates to 8 Ohm systems and is used in present-day broadcast consoles. Basically, assume that constant voltage and constant impedance are synonymous. Given the formula $Z = E^2/P$, Ohms, Volts and Watts respectively, you can determine the source impedance or the load impedance of any amplifier or speaker load.

KATN Boise Idaho

Table I details the various values of impedance based on line wattage and voltage. Note that secondary impedance is not specified but if a transformer is intended to work into a 8 Ohm load and you place a 4 Ohm load across the secondary, you effectively half the primary impedance value and double the wattage required from the line.

The Amplifier Output

Of prime importance in any speaker system is the rated RMS value of the amplifier. Inflated IHF or Music Power ratings will not suffice. In any speaker matching system, you are in reality matching impedance and nothing else, and the impedance of a C.V. system is based on the wattage rating of the amplifier.

You may have an amplifier which does not show an RMS rating but gives an IHF or music power rating. Check the ratings of the output transistors and use that figure as the maximum. This will give you the collector dissipation rating and you shouldn't get into trouble. For example, say you have an amplifier which is rated at 20 Watts RMS into 8 Ohms and

you use a transformer to convert to 70.7 Volts. You will obtain source impedance of 250 Ohms provided you use the proper transformer. To this end, you should obtain a 20 Watt/8 Ohm 70.7 Volt transformer and use it for the amplifier output by working it backwards. These are called line transformers.

Some commercial amplifiers have auto-transformers in the output, but most of them use a regular transformer from which a balanced output or floating line can be obtained, at the 25 and 70.7 Volt levels. The commercial amplifier also carries two ratings: The RMS power rating and the line impedance values. If not published, you can obtain the impedance value for each line (25V and 70.7V) from table I based on the RMS rating.

The Line Transformer

Each speaker, or speaker pair should have its own line transformer. This transformer will have a multitapped primary and at least one secondary value, usually 8 Ohms. Normally, the primary will be marked in Watts and the secondary in Ohms. Again, you can

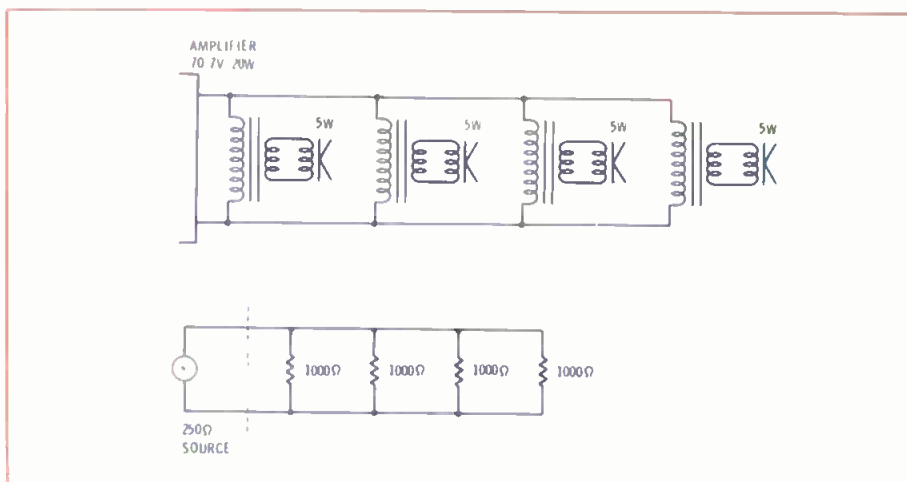

Fig. 1 Example of a house monitor system using a 70.7 Volt line and a 20 Watt RMS amplifier. Using Table 1, we see that 5 Watts in a 70.7 Volt system is equivalent to 1000 Ohms, and the 20 Watt source impedance will be 250 Ohms.

TABLE 1
CONSTANT VOLTAGE TRANSFORMERS
FOR IMPEDANCE MATCHING

PRIMARY IMPEDANCE OHMS	70.7 VOLT LINE WATTS	25 VOLT LINE WATTS
45	---	---
90	---	---
100	50	---
166	30	---
180	---	13
200	25	---
250	20	---
325	15	13
500	10	---
670	7.5	0.90
1000	5.0	---
2000	2.5	1.1
4000	1.25	---
8000	0.63	---
16000	0.32	---

NOTE: TABLE IS BASED ON
COMMERCIALLY AVAILABLE LINE TRANSFORMERS

"When I suggested to the staff that we try out other cartridges, they were unanimously against it."

— Ernie McDaniel, Director,
Technical and
Broadcast Operations,
WCBS Newsradio 88

an all-news station.
idges are one
basic tools.
stantial portion
rograming
charts.

"We've got to be able
to depend on them.

use Audiopaks exclusively.
people prefer them.

"A few years ago,
we had a problem with
cartridges. We talked
to the Audio engineers.
We worked with them
to come up with
the present Audiopak.
We're happy with it.

with a weekly audience
305,800 (according
the latest ARB),
d better have
ependable cartridges."

**New
Audiopak® A-2
Broadcast
Cartridges**

www.americanradiohistory.com

ices, Inc
Industries Company
rch Drive
Conn., 06906

refer to Table 1 to make any necessary adjustments, remembering that if you place a 4 Ohm load across the 8 Ohm secondary you double the wattage value as you would do if you placed two 8 Ohms speakers in parallel across a common transformer. There are line transformers designed for use in only 25 or 70.7 Volts systems as well as transformers with a proliferation of power taps that make them useful in both systems.

The Sound Distribution System

Premise: The advantage of constant voltage speaker systems is the ease in which a speaker line can be matched out such that the amplifier matches the load.

Example: Station house monitor system using a 70.7 Volt line and a 20 Watt RMS amplifier. There are four speakers, each of which is receiving an equal amount of power, which will be 5 Watts. You simply tap off each line transformer

at 5 Watts across the 70.7 Volt line as in Figure 1 resulting in a 20 Watt load to the amplifier. In most systems, this reasoning will prevail even with different power values being tapped off to different speakers in locations of varying noise levels. As long as the total of the power taps equal power rating of the amplifier, you will have achieved a perfect match between the amplifier and the load.

VOLUME CONTROLS AND THE C.V. LINE

This could be considered one of the "gray" areas of constant impedance matching. You have two or possibly three choices of location of volume controls. I would first consider the headend approach in which you have a remotely located source. In this case, an L or T pad at the source impedance level would be advised. For a 10 Watt amplifier, the value of the pad would be 250 Ohms.

A second point of consideration

is the speaker end of the line, after the line matching transformer. When purchasing speakers for commercial background music installations, I usually have two choices: a 20 Ohm pot or an 8 Ohm L pad - as a matter of economy. We normally have our speaker baffles prewired with the 20 Ohm pot, although the 8 Ohm pot would be a better approach.

In examining the 20 Ohm pot approach, the pot bridges the secondary of the line transformer in the voltage divider concept with one side of the speaker connected to the wiper. This approach has a couple of minor drawbacks: In attempting a constant impedance match, (1) when the speaker is fully turned down, the line transformer is terminated in 20 Ohms and (2) when the speaker is fully turned up, the line transformer is terminated in approximately 5.7 Ohms and this error in "wattage matching" for a wattage relationship based on



the "performer" class A state-of-the-art

Class "A" and educational broadcasters can now enjoy the same quality and superior signal characteristics of major stations . . . at a budget price, with budget installation and maintenance costs.

Efficient design is the key. The "Performer" is elliptically polarized for a clearer signal, even in the fringes of your broadcast area. And its low VSWR guarantees you better stereo performance.

Built to last, the "Performer" features thick-wall copper tubing and marine brass. It's the best FM antenna bargain on the market today.

JAMPRO ANTENNA COMPANY
A DIVISION OF COMPUTER EQUIPMENT CORPORATION

6939 Power Inn Road • Sacramento, Calif. 95828 • Phone (916) 383-1177

J
A
M
P
R
O

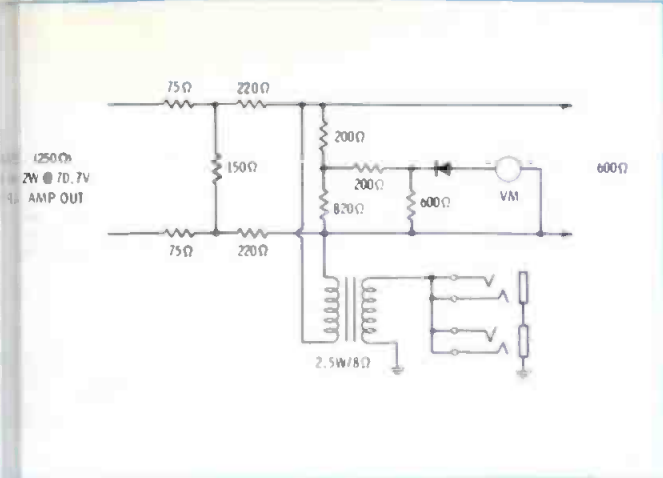

Fig. 2 A 20 Watt/250 Ohm source amplifier is matched to a 600 Ohm broadcast loop or telephone circuit which includes a headphone monitor circuit.

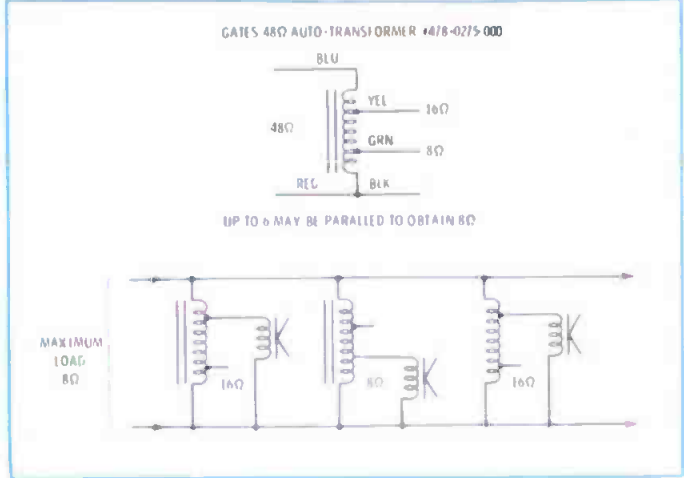

Fig. 3 Gates' suggestions on using their speaker matching transformer.

250 Ohm load multiplied 20 times in an installation could cause problems.

My "favorite approach" is use a 10 K pot on the line side of the transformer on a 70.7 Volt line (for a 25 Volt line. I would use a 500 Ohm or 1 K pot). When using this approach I simply add a Watt per volume control in my calculations.

I can locate the control anywhere along the line instead of running wires from the speaker, in the case of a secondary oriented volume control arrangement.

You would note from previous publication in this field (BE July, 1972) that in the 45 Ohm monitor circuit in the Gates Solid State Duolox II console I have used 100

Ohm pots with good success in a line side approach. This line side approach has been proven in practice as being the most economical approach: you can always load an amplifier at something less than its rated load for protection of the amplifier, and in this volume control arrangement, the total load to the source will always be something

(Continued on page 43)

FIDELIPAC[®] Automatic Tape Cartridges

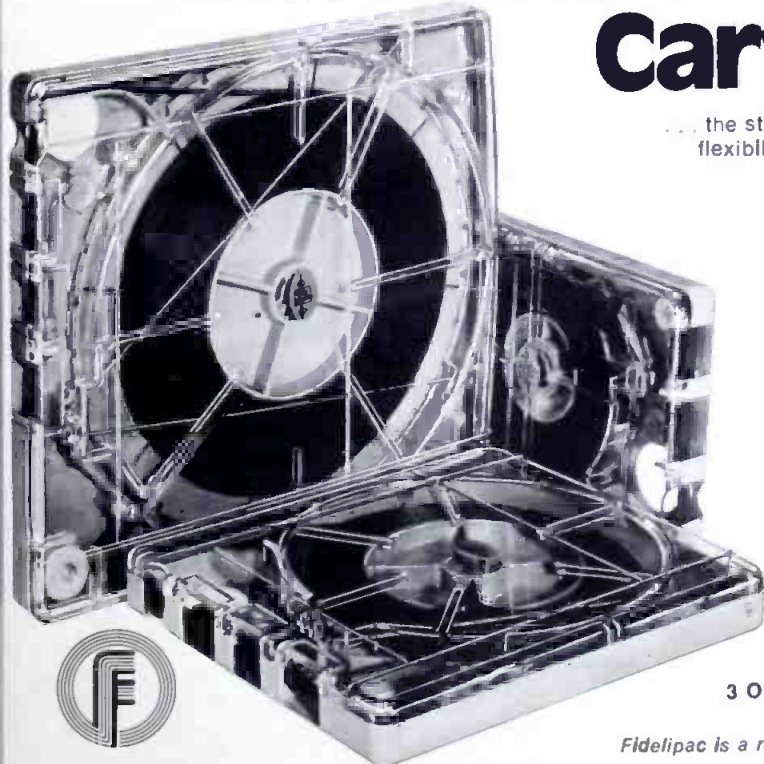

... the standard of the industry for quality, durability and flexibility are now obtainable world-wide. Available in three size configurations:

- ▶ Model 300, in lengths to 10½ minutes @ 7½ ips (19.05 cms)
- ▶ Model 600, in lengths to 16 minutes @ 7½ ips (19.05 cms)
- ▶ Model 1200, in lengths to 32 minutes @ 7½ ips (19.05 cms)

Heavy-duty tensilized Polyester Tape used throughout. Compatible with all standard Broadcast Cartridge Recorder-Reproducers. Over 25,000,000 now in use.

For complete information and the name of your nearest Fidelipac[®] Automatic Tape Cartridge Distributor, contact

FIDELIPAC[®]

3 Olney Avenue, Cherry Hill, New Jersey 08034 U.S.A.
Telephone: 609-424-1234

Fidelipac is a registered trademark of Telepro Industries Incorporated

Color After Modulation

By Pat Finnegan*

Video information going into a transmitter and that coming out is not the same. Aside from distortions that can be added due to improper operation, there is vestigial sideband transmission. Detection devices for recovering the video information should tell the truth all the time. Yet even when telling the truth, the information sometimes requires interpretation.

For our discussion, consider that the transmitter is operating properly and the signal is not being distorted in any way, and not consider VSB transmission as distortion.

In VSB transmission, one full sideband and only a part of the other sideband is transmitted. The color information is only on the full sideband.

Detection devices, such as a diode, are non-frequency selective, and can be very non-linear due to an internal fault or to the signal levels applied to it. Other devices (such as a demodulator) can have an improperly adjusted bandpass or yield the same results due to component failure. The output also can be distorted due to RF overload, improper circuit voltages, or non-linearity can be introduced by component fault.

*BE Maintenance Editor

An irregular video response curve or improper bandpass in the demodulator can cause improper burst to chroma amplitudes. This is due to the fact that the chroma and the burst lie in somewhat different regions of the transmitter response curve.

Detection And Interpretation

If only a diode is used for demodulation, some consideration must be given to its placement in the system and interpretation of the results. The diode cannot be placed in the circuit where the sound carrier is present since it cannot reject the unwanted signal.

Placement before the carrier diplexer, brings up another question. Has bandpass shaping already taken place? If it has, the output of the diode will be the ideal response curve as given in the FCC Rules. That is, low frequency video information below 1.25 MHz will be present as double sideband, the color will be single sideband. This means that video information below 1.25 MHz will be twice the amplitude of the information above 1.25 MHz. A good example is the horizontal sync pulse and the color burst on the back porch. The burst

will appear as only half amplitude to that going into the transmitter. For this mode of monitoring, that is the correct display, and the operator should not try to correct it. For the same reason, a color monitor fed from this diode will show colors that appear more pale than when fed from the video line. This is especially apparent on monitors with a preset color control.

A demodulator is simply a single channel receiver, minus all the sync, audio and other circuitry of regular receivers. The IF bandpass is deliberately shaped to complement the VSB signal, the output of the detector is a flat video bandpass. The output video is the same as the input video to the transmitter.

Overload

Front end overload can cause several problems, two of which are non-linearity and bandpass distortion. Use the step test pattern or the one in the VIT signal, adjust the probe for noncompression on either end. Check the multiburst pattern for video amplitude distortion. Reduce the probe pickup below the point where the multiburst is effected. If neither signal is available during programming, adjust on

(Continued on page 47)

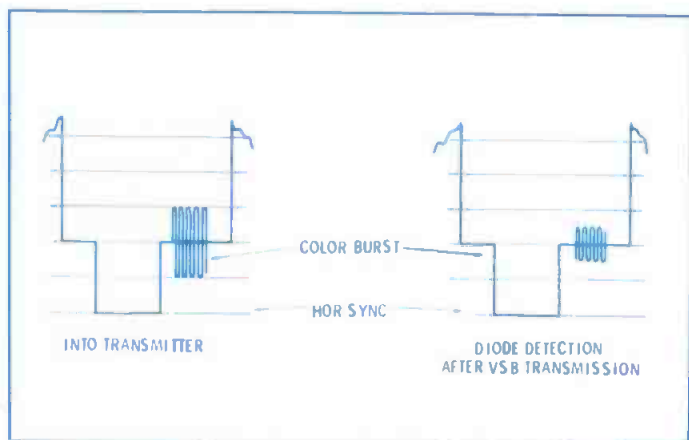

Fig. 1 Example of two important parts of the signal which ride in different sections of the sideband. Color burst is in the single sideband section, and it is only half the amplitude of the sync pulse which is in the double sideband section.

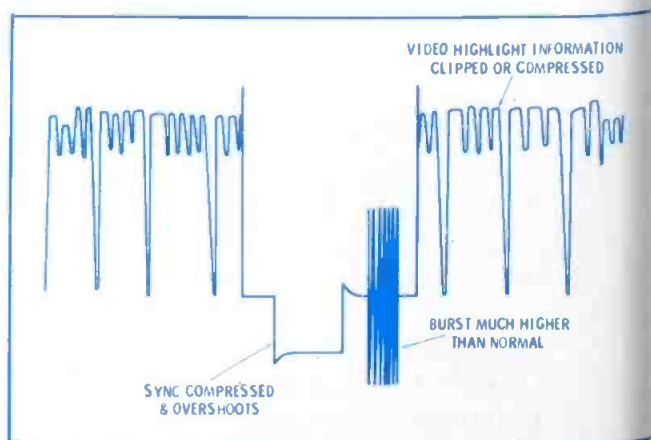
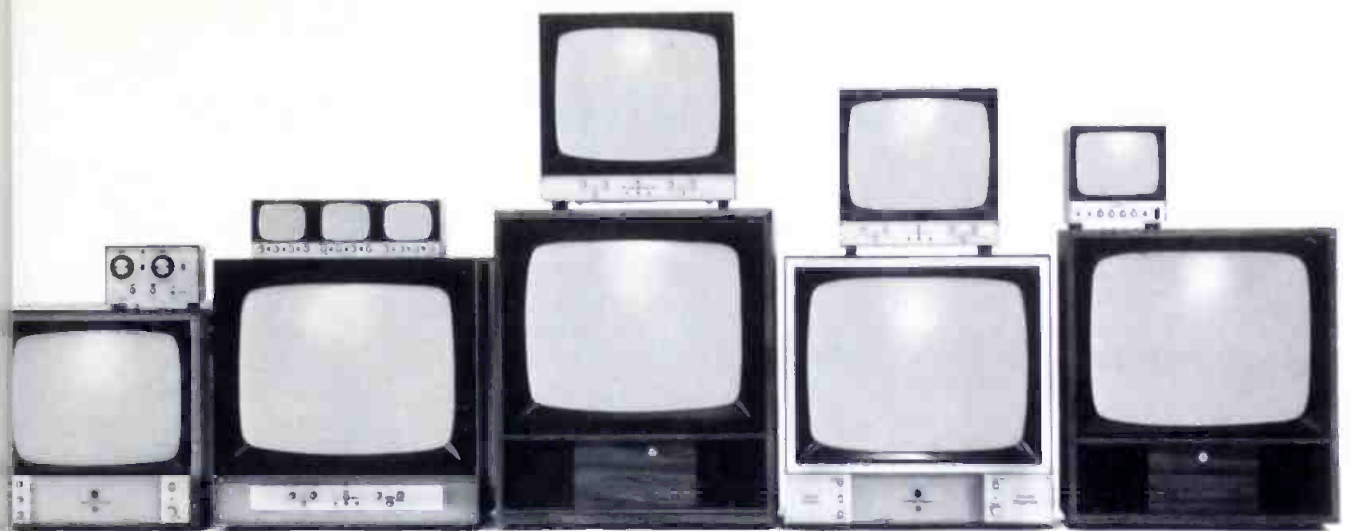

Fig. 2 Improper line probe adjustment can cause an overload of the demodulator as well linearity problems, sync compression, white clipping, and a distorted video response curve.



NEW FAITHFULS

The Setchell Carlson reputation for **QUALITY** and **RELIABILITY** is demonstrated over and over in every S.C. Electronics monitor and monitor/receiver with features such as plug-in circuit modules (pioneered by S.C. to assure operating dependability and ease of maintenance); 100% solid-state circuitry for maximum stability, long-life, low power drain, and a minimum of heat; up to 640 lines horizontal resolution; and regulated circuitry that provides extremely stable operation while preventing raster size or brightness deviations due to line voltage fluctuations.

Available in a broad line of screen sizes, Setchell Carlson products lack only one thing... a high price. Whatever the application, broadcasting, CCTV, Medical training, industrial TV applications, custom remote installations, industry, education, or many others, Setchell Carlson has the monitor you need.

Ask about them today at your nearest S.C. Electronics dealer, or write for full information and descriptive literature.

ALSO ASK OR WRITE FOR INFORMATION AND FULL-COLOR LITERATURE ON QUALITY COLOR MONITORS.



SC ELECTRONICS, INC.
A SUBSIDIARY OF AUDIOTRONICS CORPORATION
530 5th AVE. N.W. ST. PAUL, MINNESOTA 55112
PHONE (612) 633-3131

Circle Number 39 on Reader Reply Card

AES Convention Review

By Walt Jung

New York's Waldorf Astoria was recently the meeting place for the Audio Engineering Society's 43rd annual convention. This convention features the annual unveiling of the latest audio gear and the platform for state-of-the-art reports on industry R and D.

The biggest item in audio these days is quadrasonic sound, both recorded and broadcast. Considerable convention program time was devoted to quad, and highlights of the technical sessions of particular interest to broadcasters are covered here by Broadcast Engineering's solid state editor.

Quadrasonics

The technical proceedings of the AES got underway with the session on Quadrasonics, chaired by John Woram of Vanguard Records.

Albert Grundy of the Institute of Audio Research, Inc. gave a paper entitled "On the Mathematics of Quadrasonic Matrices", a look at a simplified means of describing various quad matrixing systems with algebraic expressions of the various signal components. With a minimum of higher mathematics, this paper gave an excellent view of what happens in the processes of encoding and decoding of 4 channel signals.

John Eargle of Altec Corporation gave a paper, "4-2-4 Matrix Systems: Standards, Practice and Interchangeability"* which goes a long way toward putting the various matrixing systems in current use into perspective. Describing the different systems in terms of Peter Scheiber's spherical notation (which presents a matrix system's phase and amplitude inter-relations in an x-y-z form), Eargle illustrated the basic differences of the popular systems such as EV and SQ, the Sansui QS matrix, and the Cooper-Shiga UMX matrix. Transformation from one matrix to another was discussed, as well as inter-matrix compatibility. This paper

serves well to sort out the region of confusion between various matrixing systems, not only in regard to the material it contains, but also its bibliography on previous material.

Do you have a quad monitoring requirement via headphones? If so the paper "Can We Hear Four-Channel Via Headphones" by Peter Tappan of Bolt Beranek and Newman, Inc. should be of interest to you. This paper examined the fore-aft depth perception effects of the ear and the results with 4 and 2-transducer headphones towards the 4-channel effect.

"Some Single and Multiple-Source Localization Effects"* by Mark Gardner of Bell Telephone Laboratories examines directivity effects of multi source reproduction from a common program origination. Control of a sound image's placement is useful for various special effects, such as pseudo stereo. The paper has a very extensive bibliography.

"A Quadrasonic One-Point Pickup Microphone"* by Takeo Yamamoto of Pioneer Electronic Corporation (Japan) describes a one-point pick up microphone with 4 unidirectional patterns.

A paper by Rex Isom of RCA, "An Analysis of the Frequency-Modulation of the Carrier in Discrete 4-Channel Records" analyzed performance of the FM modulated ultrasonic subcarrier used in RCA's discrete 4 channel disc.

"Characteristics of the Sansui QS Vario-Matrix Based on a Psychoacoustic Study in Four Channel Stereo, Part I & II" * by Ryouzuke Itoh, Susumu Takahashi, and Kouichi Hirano of Sansui (Japan) and Massao Nishimaki, Tokyo Institute of Technology.

This extensive paper examines the Sansui Vario-Matrix system and the psychoacoustic requirements of 4 channel sound reproduction. The vario-matrix concept

alters the matrix coefficients on continuous basis to enhance inter-channel separation.

Broadcast Engineering

The Broadcast Engineering session was chaired by Eric Small of WOR-FM and included a number of papers of general broadcasting interest as well as quad-broadcasting considerations.

Leading off the session was a paper, "The Status of Broadcast Cartridge Design"* , by Robert Manierre of Audio Devices Inc. This paper describes the improvements in tape cartridge design over the years necessitated by tough handling consumer usage and the improvements in broadcast cartridges resulting from this feedback.

"Compatible FM Broadcasting of Panoramic Sound" * by J. James Gibson, Roy M. Christensen and Allen L. R. Limberg of RCA Laboratories, described a new system for 4 channel transmission over FM radio. The basis of the system is transmission of the most important information to convey an acoustic picture around the horizon. Signal constraints of compatibility, fidelity, and economy are discussed.

"Effects of Multipath Interference Upon FM Transmissions" by Raymond Schwartz, Alford Manufacturing Company examined the effects of large buildings in metropolitan areas on signal reflection and shadowing, with particular emphasis on audio distortion components.

The last part of this session was composed of a panel discussion devoted to 4-channel broadcasting. The panel, moderated by Eric Small, included Duane Cooper of the University of Illinois, George Endres, CE of WGMS AM/FM Washington DC, Jim Gibson of RCA Labs, and Emil Torick of CBS Labs. The discussion was a lively one, both among the panel members and augmented by ques-

ns from the floor.
George Endres described
GMS's experiences relating to
atrix quad broadcasting which it
es on a live basis. Endres chose
Dynaco (Gately Electronics)
atrix scheme from a standpoint of
imum listener cash outlay and
se of implementation. Speaking
further, Endres said he feels a
me and obvious consideration to
roadcasters is the return on his
vestment when he gets into 4-
annel. Since the situation is still
y unclear as to standardization
hich the matrix camp, this is a
fficult decision facing any broad-
caster ready for this step.

Papers From Other Sessions

The sessions already mentioned
were the main topics of interest to
the broadcaster, but there were
quite a few other general interest
papers from other sessions. The ti-
tles are listed here, and any paper
with an asterisk* may be ordered by
mail from: Audio Engineering So-
ciety, Room 929, 60 E 42nd Street,
N.Y., N.Y. 10017. Price: \$.75 for
AES members; \$1.00 non-mem-
bers.

Papers from other sessions:

"The Piezoelectric Loudspeak-
er: Its Use In Audio Systems",
Donald M. Schmetter, Motorola
Corp., Preprint# 876.

"Performance and Interface
Specifications For Professional
Audio Magnetic Recorders", John
McKnight, Scully/Metrotech
Division of Dictaphone Corp.,
Preprint# 903.

"EIA RS-400 "Reproducer Test
Type" Reviewed", John G. Mc-
Knight, Magnetic Reference Lab-
oratory, Preprint# 898.

"Use of Capstan Servo Systems
in Audio Recorders For Multime-
dia Synchronization", Louis J.
Cartalano, Robert Z. Langevin,
Empex Corporation, Preprint#
872.

"Multitrack Audio In Video
Production", Eugene M. Nohaft,
Tom W. Irby, Mincom Division,
3M Company, Preprint# 877.

"The Pitfalls of The General
Purpose IC Operational Amplifier
As Applied To Audio Signal Proc-
essing", Walter G. Jung, BE Solid
State Editor, Preprint# 893.

"Equalizing The Monitoring
Environment", John M. Eargle,

Altec Corporation, Preprint# 887.

"Practical Considerations In
Sound System Feedback Con-
trol", G. R. Thurmond, G. R.
Thurmond and Associates, Pre-
print# 890.

"An Objective Proof of Per-
formance Test Program For Sound
Reinforcement Systems", Mel
Sprinkle, Sprinkle & Associates,
Preprint# 897.

"Design Considerations For A
Transportable Sound Reinforce-
ment System", Allan P. Smith,
Naval Training Equipment Center,

Preprint# 880.

"A VU Meter For The Blind
Operator", Richard G. Allen and
Ralph A. Antonacci, CBS Labora-
tories, Preprint# 902.

The AES equipment exhibits
were by and large oriented toward
the recording industry's needs,
with broadcast interests taking a
lower priority. The glamour items
in studio equipment at this conven-
tion were automated mixing equip-
ment, with new systems being in-
troduced by a number of manufac-

(Continued on page 42)

NO SALES PITCH...JUST FACTS

FAIRCHILD ROBIN ENGINEERING DATA

PORTABLE MIXING CONSOLES

FAIRCHILD SOUND EQUIPMENT CORP.
A ROBINS INDUSTRIES CORPORATION
75 AUSTIN BLVD., COMMACK, N. Y. 11725
(516) 543-5200



MODEL	INPUTS & OUTPUTS
FPC-26	Eight inputs — two outputs
FPC-28	Eight inputs — four outputs
FPC-30	Twelve inputs — two outputs
FPC-32	Eight inputs — eight outputs
FPC-34	Twelve inputs — four outputs
FPC-36	Twelve inputs — eight outputs
FPC-38	Sixteen inputs — two outputs
FPC-42	Sixteen inputs — four outputs
FPC-50	Sixteen inputs — eight outputs

The FPC portable consoles are the first and only truly portable professional multi-channel mixing and sound shaping consoles. Using the latest reliable field-tested solid state circuitry, the FPC series can accomplish, on location or in the studio, almost anything that a large console can do.

These completely self-contained units are designed to be used in the field for recording, broadcast remotes and sound reinforcement. They are designed for ruggedness, high performance and low cost.

- Only 28" x 24" x 2" and weighing only 30 to 45 lbs. (depending on model).
- Up to 16 inputs and up to 8 outputs (50 individual amplifier circuits).
- Can operate for 25 hours on one set of "C" batteries in armrest (or use external power supply).
- Constructed of solid aluminum for ruggedness and light weight, and finished in walnut grain Formica with lettering engraved for lifetime no-wear use.
- VU meter panel tilts up for easy on-location monitoring.
- Comfortably padded Naugahyde armrest pulls forward for access to the XLR input, output and power connectors.
- Each output channel and power supply is metered.
- Failsafe automatic emergency battery power in case of supply failure.
- Automatic polarity protection for power input.

INPUTS Up to 16 balanced, transformer isolated inputs have input level switches which accommodate levels from microphone to line in 5 ranges. Impedance range from 200 ohms to bridging for high level inputs. Each input channel has a preamplifier, boost amplifier and input fader.

EQUALIZATION Each channel has full range equalization with independent low frequency boost and droop control, high frequency boost and roll-off control, and selectable peaking point control.

OUTPUTS Up to 8 mixing networks process signals into 8 separate transformer isolated output channels, each with submaster slide faders, taut band VU meters, booster amplifiers, line amplifiers, and balanced output transformer.

NO SOFT SELL... NO HARD SELL... JUST FACTS TO HELP SOLVE YOUR AUDIO PROBLEMS, ECONOMICALLY. STANDARD CONSOLES, CHANNEL MODULES, CUSTOM BUILDING BLOCKS, OR COMPLETE SYSTEMS. FAIRCHILD/ROBINS' NEW ENGINEERING DATA SHEETS GIVE YOU THE WHOLE INNOVATIVE STORY. WRITE OR PHONE GEORGE ALEXANDROVICH, VICE PRESIDENT, 75 AUSTIN BLVD., COMMACK, L. I., N. Y. 11725. (516) 543-5200.

If you service and repair

television sets and other home entertainment equipment as an extra income sideline or as a hobby, you should be reading *Electronic Servicing*.

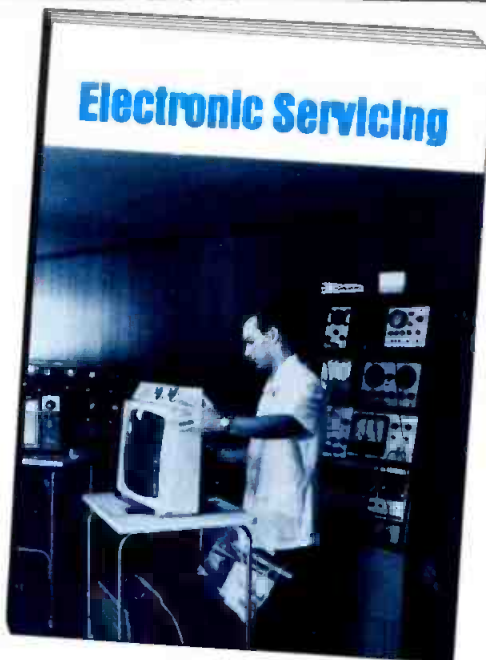

Each month you get the latest solutions to service problems of . . . black/white and color TV . . . tape recorders . . . auto radio . . . stereos . . . antenna systems. It's all presented in easy-to-understand, step-by-step explanations of the most efficient trouble-shooting techniques.

Give us a look! Satisfaction guaranteed—anytime you say so we'll refund the unused portion of your subscription.

Fill out the order form below and mail it today! We'll start *Electronic Servicing* coming to you with the next current issue.

YES!

Enter my subscription to **ELECTRONIC SERVICING**®

- I prefer 3 years at \$13.00 (\$5.00 off regular price)
 2 years at \$10.00 (\$2.00 off regular price)
 1 year at \$ 6.00

- Payment of enclosed Please bill me

PLEASE PRINT

NAME

STREET

CITY STATE ZIP CODE

SIGNED

IMPORTANT! Please check business AND position

- | | | |
|--|--|--|
| Type of Business | | <input type="checkbox"/> Industrial Electronic Service |
| Check One | <input type="checkbox"/> Independent Electronic Service Organization | <input type="checkbox"/> Wholesaler, Jobber, Distributor |
| <input type="checkbox"/> Retailer with Electronic Service Department | | <input type="checkbox"/> Other (Specify) |
| Position | | |
| <input type="checkbox"/> Independent or Self-Employed Service Technician | <input type="checkbox"/> Owner, Manager | |
| <input type="checkbox"/> Electronics, Radio, TV Manufacturer | <input type="checkbox"/> Service Manager | |
| | <input type="checkbox"/> Technician | |
| | <input type="checkbox"/> Other | |

MAIL TO:

Electronic Servicing®

1014 Wyandotte St., Kansas City, Missouri 64105

turers.

Quad Demos

However, broadcasters were served by the demo rooms of the various quad systems where they could personally assess the differences in performance of the systems. This writer's observations will not, of course, serve as a substitute for your own, but there are some factors which might be noted.

There has been a great deal of improvement by the matrix camp in apparent inter-channel separation. This was evident in both the CBS-SQ demonstrations and the Sansui QS demo room. CBS is currently working with a major IC manufacturer on soon to be announced decoder and logic "separation enhancement" chips. Sansui has the equivalent effect with their Vario-Matrix encoding/decoding. An A-B test of this system against a 4 channel tape over short periods yields a quite favorable comparison. Not as "discrete"—but certainly the effect is there.

The other side of the matrix/discrete picture was demonstrated by JVC with their 4-channel subcarrier disc. When listening to this discrete disc, one is immediately impressed with the total separation of the four channels. However the technical problems yet to be resolved are formidable. Cutting speed is reduced to 1/2.7 of playing speed to accommodate cutter head frequency response limitations, and a special pickup is still necessary for playback. The decoder is relatively complex, using a PLL to offset carrier signal strength reduction with wear, a noise reduction circuit and a newly developed Shibata stylus is recommended for best reproduction.

Never-the-less, this method is the only current 4 channel disc, and reproduction is certainly adequate for a large percentage of users. By the time FCC standards for 4-channel transmission are set, the JVC disc may well be a highly refined product.

**See BE Reference on SCA Birdies. "A Manufacturer's View . . . Can Stereo—SCA Be Compatible," Feb. 1971, pg. 38.

les than the computed installation
ue, it is a field proven approach.

Impedance Matching Using Transformers

Let us return to the Figure 1 and
evaluate the systems. By using
Table 1, we can see that 5 Watts in
a 10.7 Volt system is equivalent to
200 Ohms and the 20 Watt source
impedance is going to be 250
Ohms. Four 1000 Ohms loads in
parallel results in our 250 Ohm load
to match the 250 Ohm source. This
technology will prevail regardless of
power taps used, or number of
speakers in the system. As long as
the sum of the power taps equals
the rating of the amplifier, conver-
sion to impedance values will result
in the load matching the source.

Using power values can be con-
fusing. It might be said that you are
dissipating 5 Watts in a given
speaker. The only time this might
be true is if you were driving the
amplifier at a continuous 20 Watt
output level. In reality you are
simply matching impedances by
use of this 5 Watt factor.

Various Considerations On C.V.

Another use of the C.V. trans-
former is in monitoring various
radio lines of varying impedance
values with a 8 Ohm headset.

One use of the C.V./constant
impedance concept is shown in
Figure 2 (as reprinted from the
July, 1972 issue of BE) in which a
20 Watt/250 Ohm source amplifier
is matched out to a 600 Ohm broad-
cast loop or telephone circuit
which includes a headphone moni-
toring circuit.

Another possible application is
the use of line transformers back-
to-back to obtain a impedance
match without the loss attendant in
resistive networks.

Gates Console Monitor Systems

The Gates company uses a
slightly different form of constant
impedance matching which uses 48
Ohm auto-transformers but the
monitor amplifier impedance value
is actually 8 Ohms. Figure 3 shows
one of the installations Gate's
suggests when using their #478
75 000 speaker matching trans-
former.

DELTA ELECTRONICS IS MOVING

*Evil Agnes did us in
so we have relocated to
higher, drier quarters*



*After August 21, 1972
our address will be...*

5534 Port Royal Road
Springfield, Virginia 22151
Telephone: 703/321-9845
TWX: 710-831-0620

Circle Number 28 on Reader Reply Card

Before you buy an audio console... look inside the GATESWAY 80.

One look will convince you that the Gateway 80 monaural
8-channel console is the best buy for your money. Here's why:

- Modular solid state plug-in amplifiers
- Program, cueing, and monitor amplifiers all interchangeable
- Step-type attenuators
- Leaf-type key switches throughout
- Excellent frequency response
20-20kHz ± 1dB
- 18 inputs into 8 mixing
channels provide versatility

These are a few advantages.

For more information, write
Gates Division, Harris-
Intertype Corporation,
Quincy, Illinois.

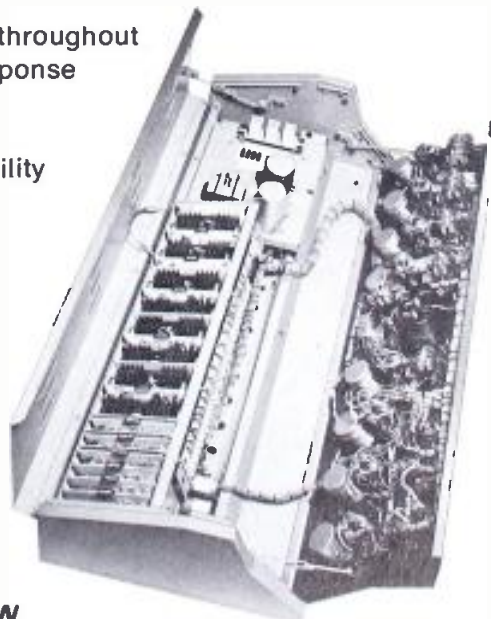

HARRIS
GATES DIVISION
Quincy, Illinois 62301 U S A

Circle Number 29 on Reader Reply Card

Controlling Film Chain Light Levels

By Donald R. MacClymont*

The different densities of film and slide material used in color film chains has long been a source of video level problems. This article describes a fast reacting, simple, and automatic method of controlling these level changes with a servo-controlled Neutral Density Disc system.

Film Chain Light Control System

A film-chain is normally composed of a color camera, two film projectors, and one or two slide projectors. These projectors transmit light through the film, on to a field lens, and into the camera. If the film density varies, the amount of light into the camera varies, thereby varying the video level out of the color camera.

*Boston Electronics, Kansas City.

By inserting a Neutral Density Disc somewhere in the light path, we can compensate for these changes in film density, keeping the apparent density of the film constant and, therefore, the light level input to the camera constant. (Figure 1)

A Neutral Density Disc is a circular piece of glass which has varying amount of neutral density material on it. Starting at one point on this disc it is very dense and as we rotate the disc it slowly diminishes until it reaches clear glass at the other end. The disc used in this system can compensate for a 100:1 change in light (approximately 6 F-stops), and attenuates all colors of light equally. (Figure 2)

A motor is connected to the center of the disc which can rotate the disc in either direction. The motor direction is controlled by a servo

amplifier. The position of the disc is indicated to the servo amplifier by a variable resistor called a "follow pot" which is connected to and rotates with the disc and motor.

Manual Control

In manual operation the position of the follow-pot corresponds to the exact position of a "control pot" which is another variable resistor located on the operator's control console. If the control pot is rotated 15° the follow-pot, motor, and disc will rotate 15° also.

In this mode of operation, the operator can manually control the video level of his film chain by turning his "control pot" which rotates the disc to a less dense or more dense position.

Automatic Control

In the automatic mode a composite video signal is used to generate an error voltage which drives the wheel in the correct direction to compensate for the change in light level. If the light level is too low the unit will sense low video and drive the neutral density disc to a less dense position. If the light level is too high the unit will sense high video and drive the Neutral Density Disc to a more dense position. As soon as the video level reaches the 1.0 volt nominal setting the error voltage decreases to zero and the Neutral Density Disc drive motor stops.

When showing a film, the system will correct continually for changes in the film density from scene to scene. With slides the unit will correct once to 1.0 volts nominal video level and hold until the next slide.

The response time for a 10:1 light change is less than 0.07 seconds and the end to end response is 0.7 seconds.

Automatic Black Level Sense

When no film or slide is on, the unit will automatically return to its mid-range position. This eliminates

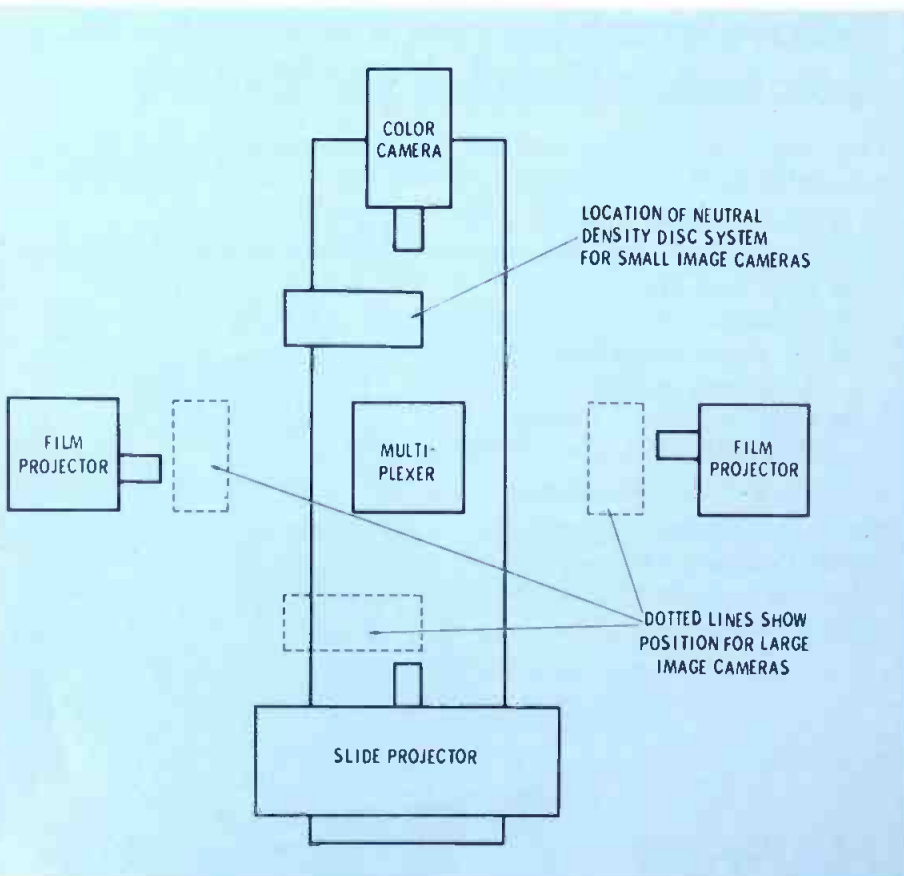

Fig. 1 Color Film chain with two film projectors and one slide projector.

unit having to correct from the open position when the film or slide is first turned on.

The system provides fast correction for film and slide density changes. It can be used on large or small image film chains. Use of composite video for its sensing always it to be used with any camera system and there is no color or hue drift problem incurred during its operation.

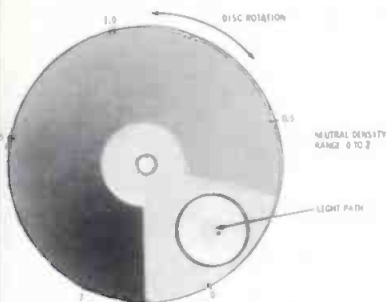

Fig. 2 Neutral density disc begins with 80 percent black and gradually decreases to 0 percent.

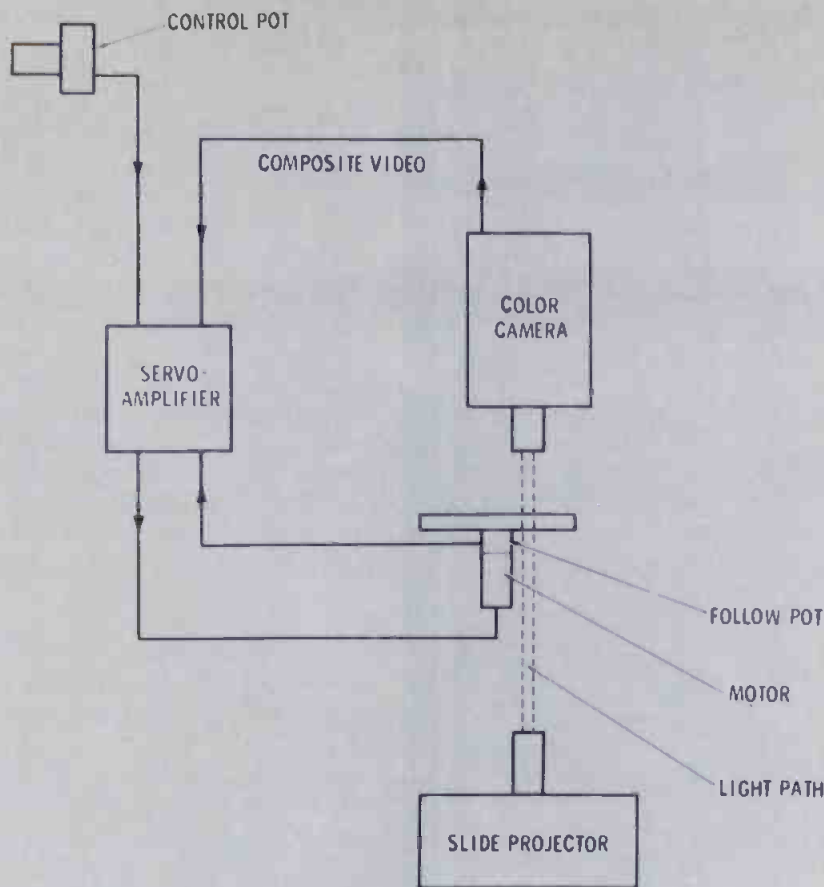

Fig. 3 Block diagram of neutral density disc system.



Don't lose your head

Loose oxide dust can do in a tape head all too soon. It's rough on tape, too.

MS-200 Magnetic Tape Head Cleaner is an efficient antidote for oxide dust. Even the valve on the can is designed to deliver a wet spray to flush away oxide build-up on heads and stray particles embedded in tape. Can be applied while tape is running.



miller-stephenson chemical co., inc.
Danbury, Connecticut 06810 • (203) 743-4447 BE

Please send me data and prices on MS-200.

I intend to use MS-200 on: _____

Name _____ Title/Dept. _____

Company _____

Address _____

City _____ State _____ Zip _____

CHICAGO • LOS ANGELES • TORONTO DIST. IN MILAN
HAMBURG • PARIS • LONDON • BEIRUT

No. 1 number for
tape cartridge
equipment
309-828-1381

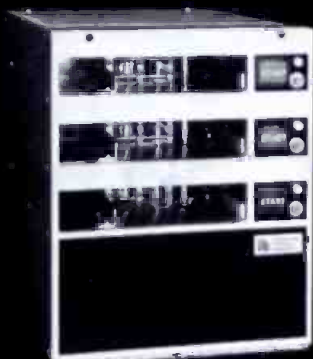

3D SERIES REPRODUCER

A collect call to the above number will bring you all the facts you need to know about tape cartridge equipment. One call will establish a working relationship between you and our broadcast oriented people...a relationship that delivers dependable performance at a truly competitive price. The relationship will last as long as you use ITC equipment...In the selection of equipment, proper servicing, and adaptation of machines to your broadcast requirements. If you're thinking tape cartridge equipment, find out why hundreds of stations depend on ITC.

WRA SERIES RECORDING AMPLIFIER



Call collect for
information on
free trial and
leasing plans

IT INTERNATIONAL
TAPETRONICS
CORPORATION

2425 South Main Street,
Bloomington, Illinois 61701

Circle Number 31 on Reader Reply Card

ENGINEER'S EXCHANGE

Accurate transmitter logs are one of the many headaches of most small station engineers. How can you be sure that the third class operator on duty always takes the

Products Model 5025 Time Gate" for all real time functions. (If this unit is not available, a cam timer would work equally well.) This was programmed to give a relay closure

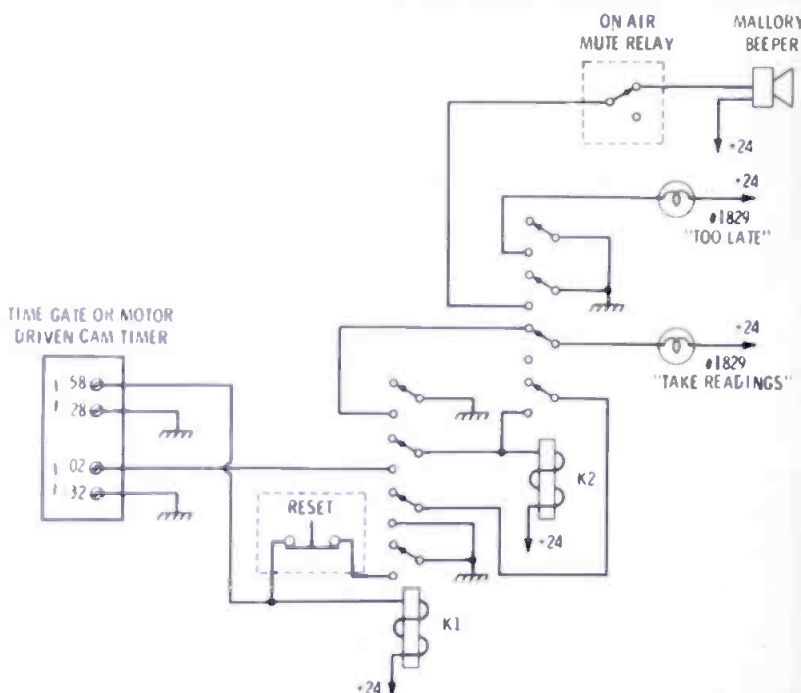

required readings on time? There is no foolproof method of course, but we felt that a "gentle reminder" might be helpful.

Our "Live" AM Operation co-exists with a fully automated FM Station which uses a "Broadcast

at :58 and :28 minutes after each hour and another closure at :02 and :32. These functions were used to latch relays K1 & K2 respectively, and the reset switch was incorporated with the "modulation kill" switch on the front of our AM

Replace your Ampex or Scully motor with a Beau Motor

	Tape Speed	Ampex Model	Scully Model	Beau P/N	Price
Ball Bearing Construction for years of Trouble-free Operation.	3¾-7½	440	270-275-280-282	43H-108	\$150.00
Electrolized Capstans for longer life	7½-15	440	270-275-280-282	43H-115	150.00
0.00015 Inches Max. Tir.	7½-15	300-350 351-354		54H-56	165.00
High Inertia Rotor	3¾-7½	300-350 351-354		54H-61	165.00

Low Flutter & Wow
Inside Out Construction



BEAU MOTOR DIVISION

460 Sackett Point Road •

North Haven, Conn. 06473 • Phone (203) 288-7731

Circle Number 32 on Reader Reply Card

transmitter.
 n use. As soon as the four min-
 window begins, a light turns on
 front of the announcer, telling
 he has four minutes in which to
 his readings. If he has not
 the modulation and taken his
 readings during this time, K2 is al-
 lowed to latch, lighting another
 lamp and turning on a mallory bee-

per. The announcers seldom let
 this happen! Construction is not at
 all critical but should be as tamper
 proof as possible.

Now if I could just figure out a
 method to eliminate 4AM trouble
 calls. . .

George L. Bevins
WLPM & WFOG
Suffolk, Va. 23434

Logic Reprints Available

BROADCAST ENGINEER-
 G now has a limited supply of
 reprints on the four-part series Dig-
 ital Logic Basics written by E.S.
 Peaby, Jr. The series started in the
 September 1971 issue and ended
 in the January 1972 issue.

If you would like to receive a
 copy free of charge, write to: The
 Editor, 1014 Wyandotte St., Kan-
 City, Mo. 64104.

Color After Modulation (Continued from page 38)

the signal. Watch for sync com-
 pression as the probe is inserted
 deeper, and also watch for a
 change in the color burst ampli-
 tude. Leave the probe at a point
 below either of these distortions.
 The same linearity check should be
 made with a diode only type moni-
 tor.

If the video bandpass (as shown
 by the multiburst) is distorted and
 yet it is not overloaded, the demod-
 ulator needs to go to the shop for
 repair and or realignment. Align-
 ment is a ticklish job so it must be
 done with care. Remember, the
 demodulator also is a standard.

Color phase measurements can
 be made on the VIT signal step
 pattern and the color bar, using a
 vectorscope. The step pattern will
 check differential phase shifts. Be
 careful when using VIT signals
 from outside program sources as
 they may already be distorted. If
 you can insert your own signals,
 you have control.

Color measurement after modu-
 lation calls for devices that are kept
 in good adjustment so they can act
 as a standard. Even then, interpre-
 tation may also be needed for the
 results you obtain.



"HE'S TRAINING TO BE A STATION
 ENGINEER, LIKE HIS DADDY."

15 day free trial shows you why ITC tape cartridge equipment is an industry leader.



SP SERIES REPRODUCER

A two week test in your own broad-
 cast facilities is the only fair way
 for you to evaluate the performance
 of ITC's premium line cartridge
 equipment. Advertising statements
 are no longer simply claims, but be-
 come actual facts proven first hand.
 Find out for yourself how ITC has
 built in all the features demanded
 by broadcasters since tape cart-
 ridge equipment was invented. If
 ITC equipment fails to measure up,
 you're under no obligation. You'll
 find that ITC dependability is some-
 thing on which you can rely
 completely.

RP SERIES RECORDER/REPRODUCER



Call us collect
 to arrange a
 15 day free trial
 309-828-1381

ITC INTERNATIONAL
 TAPETRONICS
 CORPORATION

2425 South Main Street,
 Bloomington, Illinois 61701

COMPLEX CONTROL MADE EASY



The RHL VPM 2003, is a compact simple
 video and audio switcher intended for
 use in television 'Master Control' or
 'Presentation Studio' applications.

The basic switcher will accommodate
 up to 20 video signals, including colored
 background and black. Each video input
 has an associated audio input, for AFV
 applications, with an additional 5 audio
 inputs selectable separately.

Standard facilities allow video mix, In-
 ternal key, and matte key. Audio transi-
 tions are cut, crossfade or 'audio over.'
 Call us we'll answer all your questions.

RICHMOND HILL LABORATORIES INCORPORATED
 964 Koehl Avenue, Union, New Jersey 07083
 (201) 381-5955

Circle Number 33 on Reader Reply Card

Circle Number 34 on Reader Reply Card

Roh 200 Series Broadcast Audio Equipment

Find your system requirements within a single product line designed for broadcast industry service.



ROH CORPORATION

3161 Maple Drive, N.E.
Atlanta, Georgia 30305
404/261-1429

Circle Number 56 on Reader Reply Card

PEOPLE IN THE NEWS

The appointment of **James R. Treble** to the position of chairman of the Department of Television-Radio, Ithaca College, has been announced by the director of the Division of Communications, John E. Keshishoglou. . . **Dave L. Fornshell**, Executive Director of the Ohio Educational Television Network Commission, Columbus, has announced the enlargement of his staff as the ETV Network in Ohio begins interconnecting affiliated stations. **Edwin M. Eakins** will serve as Program Coordinator for the 10 station Ohio network; Public Information Director will be Mrs. **Paula H. Walker**; and **Dr. A. Edward Foote** has joined the Network Commission staff as Project Director for the Ohio Valley Medical Microwave Television System. . .

TeleMation, Inc. announces the appointment of **Hank Maynard** as Chief Engineer of Research and Development. . . **Marion L. Stage** has been appointed director of engineering for the radio-television operations of Rollins, Inc., Atlanta, Ga. . . **McClatchy Broadcasting** of Sacramento, Calif. has named **Richard Thompson** as its Director of Engineering. He replaces **Irwin Dickinson** who recently retired after 40 years with the company. . . **Elliot Klein** has joined

TELAN

gas fueled thermoelectric generators

Nestled under the ice covered eaves of an equipment shed on a 11,000 foot mountain peak in Utah, this TELAN generator provides power for a TV translator. The propane tanks supplying fuel to TELAN require service only once a year. TELAN is available in from 10 to several hundred watts. 12-24-48 VDC standard.

TELEDYNE ISOTOPES

110 W. TIMONIUM ROAD — TIMONIUM, MD. 21093
PHONE: 301-252-8220 — TELEX: 87-780



Circle Number 35 on Reader Reply Card

UF/KNIX in Phoenix as Director of Engineer-

udvik Jachimowicz has been named associate
ector of research and Jerzy Olszewski as assistant
ector of research for the communications cable sec-
of the laboratory, General Cable Corp. . . Anixter-
Pruzan has tapped Charles K. Lindsey of Ormond
ch, Fla., as Southeastern sales representat-
Burnup & Sims Inc. has announced the appoint-
of Billy R. Jones as Divisional Manager of the
company's eastern CATV operations. . . J. K. Davis,
General Cable Corporation vice president, general
marketing and sales, has announced the election of E.
Molton as vice president and communications sales
manager. . .

Magnavox Company, CATV Division has an-
nounced the promotion of James B. Emerson as acting
ector of Advertising and Sales Promot-
Harold E. Horn has joined the staff of the Cable
Television Information Center in Washington.
Paula M. Span has joined the staff of the Ca-
Television Information Center as special assistant
ne director of information. . .

Douglas C. Williamson has been named National
Sales Manager for Sadelco, Inc., Weehawken,
Collins Radio Company has announced three
major promotions: Vice President C. I. Rice, general
manager of the company's avionics division in Cedar
Rapids, was promoted to senior vice president; M. W.
Guelin, general manager of the special programs di-
vision in Dallas, and G. W. Sullivan, general manager
of the telecommunication equipment division in Cedar
Rapids, were promoted to vice presidents. . .

The appointment of Larry Freemire as manager of
Anixter-Pruzan's Los Angeles office has been an-
nounced. . . John Bacon has been named General
Manager, Optima Division, Scientific-Atlanta,
Ga. . . Robert W. Butterworth has been appointed Regional
Sales Representative for Ohio, Pa., New Jer-
sey, New York and New England, Continental Appa-
ratus Co. . . William F. Roberts was recently selected
Senior Systems Engineer for the Coastcom Divi-
sion of the Scott-Buttner Corp., Oakland, Calif.
Howard B. Flink has been named a sales engineer
for Jerrold Electronics Corp. . .

William C. Taylor, manager of East Coast Technical
Operations, has been elected an assistant vice presi-
dent of ITT World Comm., a subsidiary of Interna-
tional Telephone and Telegraph Corp. . . EMR Com-
puter has announced key executive appointments:
James J. Harmon to the post of Manager, Systems
Department, Robert W. Hippe appointed National
Sales Manager; and, John T. Montilino to the post of
Manager, Marketing Operations. . . James W. Emmick
has been named Director of System and Field Engi-
neering for Ameco, Inc., Phoenix. . . Robert M. Jones
has joined Malarkey, Taylor and Associates as a Fi-
nancial Analyst. . . Bryant Ellis has been named the
New Los Angeles Area Sales Representative, Table
Manufacturing & Engineering Co., San Leandro, Cal-
if. . . IGM, Bellingham, announces the appointment
of Joseph D. Coons as sales director. . . M. Jean Land-
emer has been named market research manager of
Boss Corp., Milwaukee. . .

LOW COST DIGITAL CLOCKS, TIMERS AND COUNTERS

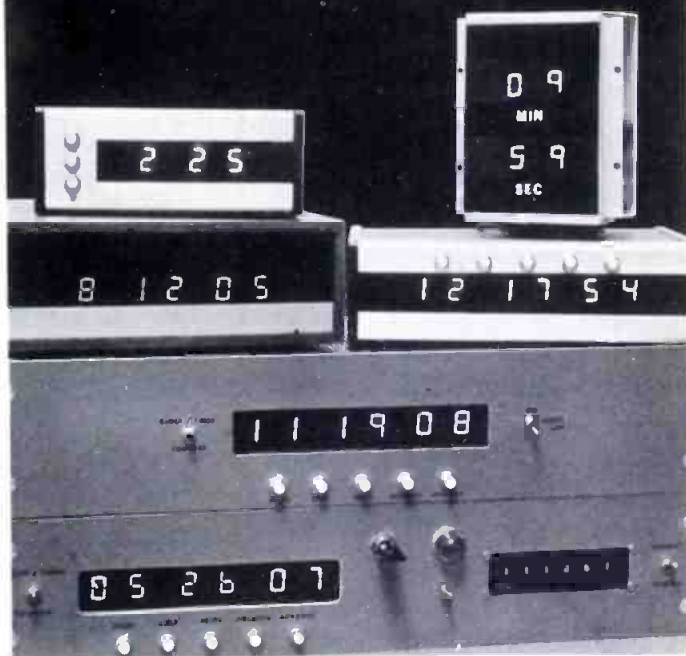

All ESE digitals are designed and constructed using the latest solid state electronic components and circuitry. This equipment is perhaps the most economical line of digital clocks, timers and counters available. Circuit efficiency and lasting quality are designed into every ESE digital product. Constructed with the built-in ruggedness necessary for studio use. No moving parts.

Special custom items, like the video tape/counter editor, a monitoring system with unique display configuration, 12 and 24 hour clocks or timers, 10 minute timers, 3 digit, 4 digit, 6 digit, record seconds in tenths, hundredths or thousandths . . . All available from ESE. Options include: Thumbwheel switch or patchboard programming, BCD outputs, relay closure outputs, and solid state buffered outputs. Many products available in kit form.

MOST EFFICIENT DIGITAL CLOCKS/TIMERS AVAILABLE ANYWHERE:

- ES-112/124, 12 hour or 24 hour clock: 6 digit — Records hours, minutes, seconds \$100.00
- ES-300, 100 minute up/down counter: Displays up to 99:59 — Easy pushbutton: Reset — Count up — Count down — Advance seconds — Advance minutes — Stop 125.00
- ES-400, 10 minute timer: Displays up to 9:59 — Pushbutton: Start — Stop — Reset 68.50
- ES-500, 12 hour clock/timer: 6 digit — Records hours, minutes, seconds. Start — Stop — Reset — Slow and Fast Advance buttons. Displays up to 12:59:59 110.00
- ES-510, 60 minute timer: Displays up to 59:59 — Pushbutton: Start — Stop — Reset, Only 3 3/4" deep for flush mounting into walls or std. alum. case 95.00

WRITE, WIRE OR CALL TODAY:



506 MAIN ST. • EL SEGUNDO, CA. 90245 / (213) 772-6176

Circle Number 36 on Reader Reply Card

Variable-directivity
condenser studio
microphone provides
130 dB dynamic range.



Dynamic range (130 dB)
+ noise level (24 dB)
= max. spl (154 dB)

Sony's variable-directivity (Omni-Uni) C-37P* contains an advanced FET amplifier. A switchable attenuator is placed between the capsule and amplifier to prevent distortion even at extreme sound pressure levels.

The combination of proven excellence in sound quality, and the very latest in semiconductor technology makes the Sony C-37P indispensable in today's quality-oriented recording studio.

Also Consider:

Studio standard condenser microphone model C-500.*

SONY SUPERSCOPE

*Must be powered by Sony AC 148A or equivalent power source.

©1972 Superscope, Inc., 8211 Vineland Ave., Sun Valley, Calif. 91352. Send for free literature.

Circle Number 37 on Reader Reply Card

NEW PRODUCTS

(Use circle number on reader service card for further information)

Building-Block Console Design

A new concept in broadcast console design that utilizes only seven easy-to-plug-in IC op-amp modules—with unique limiters on some inputs—has been developed by Fairchild Sound Equipment Corporation, of Commack, L. I., N.Y. 11725. The unique approach is said to provide custom features for no more than the cost of a standard wired-in system.

Fairchild Sound is a subsidiary of Robins Industries Corp., also of Commack.

Its new integrated circuit broadcast modules (ICBM) are assembled in building-block fashion, ac-

ording to need. They provide for mic, medium-level, high-level and remote inputs and outputs, communications and monitoring.

Each module is a complete operating channel, with frequency response, distortion and noise characteristics claimed to exceed NAB proof-of-performance standards.

A major advantage of the concept is that a broadcast studio can be started with a few channels and gradually expanded. Also, channels can be moved from one studio to another, as programming requires. Plugging in and out is said to be as easy as handling a household appliance, eliminating testing or repair downtime.

Twenty (20) days of broadcasting* logged on a single 10½" reel.



This Tape-Athon model 900 Logger can operate at 15/32 ips the way most loggers run at 15/16 and 1⅞. Imagine fidelity to 2500 Hz at 15/32 ips! That extra slow speed allows 409+ hours of recording over 8 channels on ½ mil tape with a 10½" reel.

Twenty days of broadcasting on a single reel. Doesn't that eliminate a lot of problems—like tape changing, tape storage, and even the cost of tape? Write now for details.

*Based on a 20 hour broadcast day

Tape-Athon Corp.

502 S. Isis Ave., Inglewood, Calif. 90301
(213) 776-6933

Circle Number 38 on Reader Reply Card

BROADCAST ENGINEERING

The new ICBMs are packaged in durable Formica-covered aluminum strips with "Blue Ribbon" connectors. Although black is the standard color, almost any desired color can be supplied to fit a studio's decor.

Modules are available individually, in kit form with console shell, or completely assembled at the factory.

Although there are some variations, the mic, medium and high-level inputs have essentially similar features. Two of them, the mic ICBM-MI and the medium-level ICBM-LI modules, contain limiters that make them impervious to overload, no matter how strong the incoming signal.

The ICBM-MI also features a vertical fader with a cue switch and delegation and cough switches. ICBM-LI is similar, except for the cough switch and gain. The high-level input module, ICBM-HI, has a balanced input, followed by gain control with a cue switch and an alignment circuit.

A remote input (ICBM-RI) pro-

vides six, switch selectable lines that are fed into an input fader with cue switch and then are delegated into a mixing bus. A talk-back facility into the remote lines, via momentary pushswitch, is part of the circuit.

Circle Number 65 on Reader Reply Card

Emergency Power

The ELECTRO-PAC "A" Inverter is a solid state DC to AC inverter, capable of providing uninterruptible power for critical load requirements, a product of ICS Inc. A patented feature allows critical load requirements to be shifted from the primary AC source to the inverter output as an AC source within a 0 - 4 milliseconds (less than 1/4 cycle) time period. A solid state AC line switch is employed to prevent the inverter output from feeding into the AC source line.

The "switchless" transfer is accomplished by lagging the output of the inverter by approximately 20° to the AC source signal. An

(Continued on page 52)

the best processor people naturally make the best color processors

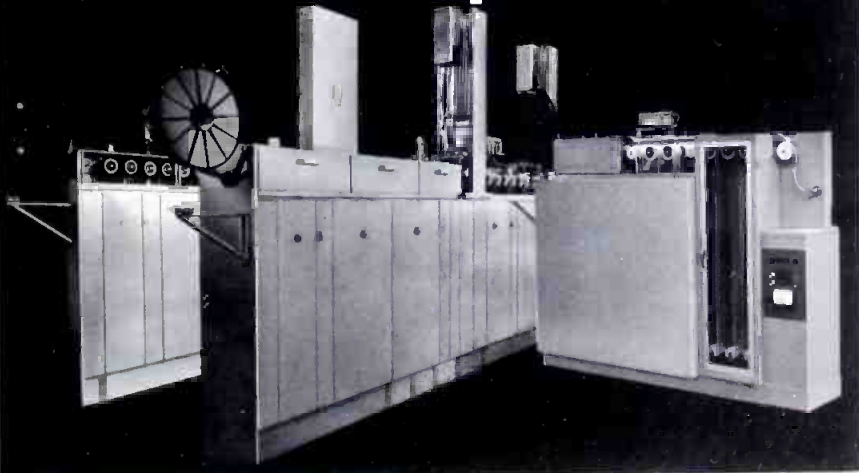

Technology Incorporated, HF Photo Systems Division are *the* processor people.

Advanced Colormasters for faster, better processing of Super 8, 16mm and/or 35mm color motion picture film. (Models for ME-4, CR-100, ECN, or ECP Processes.) All feature modular design with stainless steel construction. Sound track applicators are available for any print stock.

For small volumes and budgets, the compact *Little Max* for 8, 16 and/or 35mm color film (ME-4 or CR-100 processes.)

For further information on Advanced Colormasters or *Little Max* call or write: Marketing Department,



TECHNOLOGY INCORPORATED
HF PHOTO SYSTEMS DIVISION
mfr. of HOUSTON FEARLESS Products
11801 West Olympic Blvd., Los Angeles, California 90064
Tel. (213) 272-4331

Circle Number 39 on Reader Reply Card

Sony's award presenting microphone.*

*Used at Academy Award and Emmy Award T.V. presentations 1972.

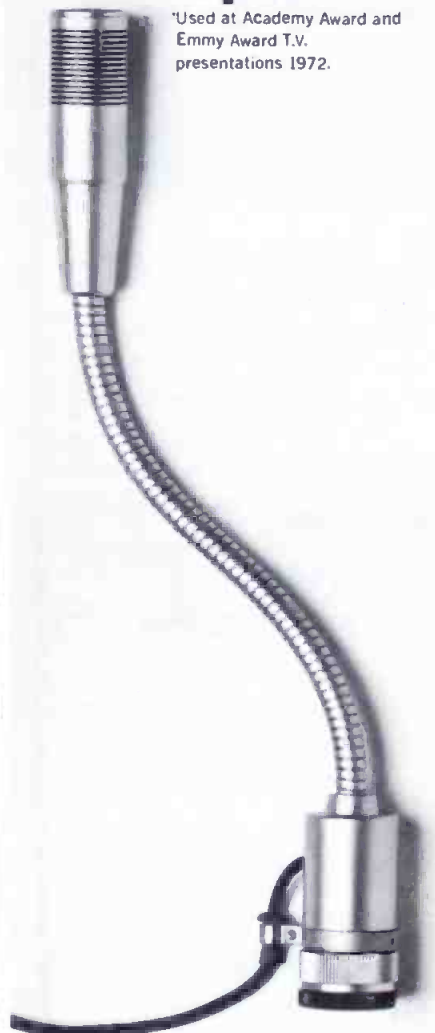

Featuring a high-performance condenser capsule of electret design, the ECM-53 is specifically designed for broadcast, recording studio, public address and similar applications.

The cardioid capsule assembly contains a permanently charged condenser capsule and FET/IC amplifier. A Cannon connector houses the battery supply.

- Frequency Response: (Frontal \pm 3 dB): 40 Hz to 16 kHz
- Output Impedance (at 1 kHz \pm 20%): 50, 250, 600 ohms Balanced
- Maximum SPL (1 kHz): 134 dB

Also Consider:

Tie-tack/lapel condenser mic ECM-50.

Telescopic (from 7 $\frac{3}{4}$ " to 17 $\frac{1}{2}$ ") condenser mic ECM-51.

SONY SUPERSCOPE

©1972 Superscope, Inc., 8211 Vineland Ave., Sun Valley, Calif. 91352. Send for free literature.

Circle Number 40 on Reader Reply Card

The Top Turntable



... is Spotmaster's new Studio Pro B, offering instant start and the tightest cue potential in the industry. Heavy duty hysteresis motor drives a 6½ lb. machined aluminum platter in a solid-cast aluminum chassis for inaudible rumble, lowest wow and flutter. Indicator lights tell speed (33 or 45) at a glance, and speeds can be changed with platter in motion. Detachable mounting plate (accepts any tonearm), integral 45 spindle and neutral cue position are other features ... all for just \$198.00.

And an Outstanding New Tonearm

... is the Spotmaster stereo BE-402 (mounted on Studio Pro B above), which combines reasonable cost, rugged design and professional specs. Features include high compliance for modern stereo cartridges, minimum tracking error, anti-skating, low mass, quick-change head, easy single-hole mounting ... for only \$54.95.

Complete line of Gray professional arms and all broadcast quality phono cartridges also available at competitive prices.

And the Best Turntable Preamp



... is our new Model TT-22, all solid state, modular, stereo equalized and completely self-contained. Features separate balance/level controls, high output (+8dbm), phone jack ... plus switchable and removable rumble and scratch filters. Both stereo and mono models are available, starting at \$121.50. Our time-tested TT-20B mono preamp and PR-4C power supply (will power up to 4 preamps) are also available, providing top performance at economy prices.

... all from Spotmaster

PLUS a complete range of accessories for both turntable and cartridge tape operation. Write for details.

BROADCAST ELECTRONICS, INC.
A Filmways Company

8810 Brookville Rd., Silver Spring, Md. 20910
(301) 588-4983

automatic cutoff of the line switch occurs when the AC source voltage drops to 95 VAC (or customer specified cutoff point). An 8 second delay is built in to function at restoration of the AC source voltage to prevent "hunting".

Because of this switchless feature, the ELECTRO-PAC "A" allows sensitive and critical equipment such as boiler controls, medical monitor equipment, computers and instrumentation to function without interruption whether the unit is to be used as sole source of emergency power, or to fill in during a time lag for motor generators' start up.

This switchless feature is available on all of the ELECTRO-PAC Inverters and systems, sized from 125 VA through 25.0 kVA single phase units.

Circle Number 66 on Reader Reply Card

Dual Trace, Triggered Sweep Scope

Dynascan Corp. has announced the availability of the new B & K Model 1470 Dual-Trace Triggered Sweep Oscilloscope, developed "to meet the ever-increasing demand for a moderately priced dual-trace scope in industry, labs, schools and the service field." Selling price is \$499.95.

For those applications where inputs and outputs are to be compared, or outputs of multiple stages triggered by the same pulse are to be compared, a dual-trace scope is ideal. Used in industry and labs for years, the dual-trace scope is showing up on service benches with increasing frequency.

Applications include: viewing simultaneously two waveforms that are frequency or phase-related, such as in digital circuitry; checking frequency dividers; checking differential amplifiers for balance; relay testing and sequencing; measuring amplifier phase shift.

The B & K 1470 offers DC to 10 MHz bandwidth, 10 mV/cm sensitivity, maximum sweep of .2 microseconds/cm, and fully automatic and triggered sweep. It permits dual display of waveforms in 6

modes: Channel 1, Channel 2 Chopped (for low-frequency waveforms), Alternate, Add and Channel 2 Invert. In the first 2 modes only one input signal will be displayed. In the Alternate mode, Channel 1 and 2 inputs are displayed on alternate sweeps—the two traces appearing as simultaneous waveforms.



In the Chopped mode, the amplifiers are switched at a 140 KHz rate by an internally generated signal. At low sweep rates, this switching frequency provides two individual traces on the screen. This eliminates flickering that would occur if low-frequency waveforms were observed in the Alternate mode. In the Add mode, any two waveforms can be added algebraically. Also the Channel 2 Invert switch inverts the polarity of the Channel 2 waveform; thus, in the Add mode, it is possible to obtain the difference between 2 waveforms under study by inverting Channel 2.

Circle Number 67 on Reader Reply Card

19-Inch Color Broadcast Monitor

The Miratel Division of Ball Brothers Research Corporation has



roduced a new ultra-stable color broadcast monitor, the TCB-19. The TCB-19 is designed to serve as a color standard for any video installation. This series is also available in a cabinet-mounted 25-inch version.

This TCB-19 addition to the Gratel family of broadcast monitors is available either with cabinet enclosure or in rack mount configuration. Stability and reliability are assured with temperature compensation, power supply regulation and low-drift chroma demodulation.

Special features include switchable long or short time-constant AFC (automatically returns to short time-constant when sync is lost, for wide capture range); all solid-state circuitry; and controlled phosphor picture tube. A black matrix Hi-Light picture tube is optionally available.

Circle Number 68 on Reader Reply Card

Sync Pulse Generator

CBS Laboratories introduces a new sync pulse generator.

The Model CLD-1100 Sync Pulse Generator incorporates the latest digital-circuit design technology, and makes extensive use of high-quality integrated circuits. Unique design affords maximum adaptability and use as a master unit, as a standard sync generator, or in pulse system applications.

Unit stability is derived from a timing circuit employing a single servoloop in which the 3.58 MHz color frequency is generated from a

14.31818 MHz crystal reference source. Subcarrier drift is less than 0.1 Hz. per month. Horizontal and vertical pulses are subsequently created directly from the 3.58 MHz signal, thus virtually eliminating jitter between horizontal, vertical and color burst.

The CLD-1100 Generator also features a 15 Hz Color Frame Ident Pulse to assure correct color subcarrier-to-sync phase relationship.

To assure correct color phase editing for network sync lock application, the new generator also has a 100 nanosecond "window" to allow for minor sync time instabilities and references only to 3.58 MHz., thus eliminating certain problems associated with video tape recording sensitivity to such sync instability.

Pulse timing is easily accomplished up to a maximum of 2 lines, advance thus simplifying system timing application. The new line is available immediately from stock.

Circle Number 69 on Reader Reply Card

ITFS Transmitters

Nine new Varian Micro-Link TV transmitters have been type accepted by the Federal Communications Commission for use in 2500 MHz instructional television systems. The transmitters are also suitable for other applications such as the two-way conference TV network being installed for the Metropolitan Regional Council in New York, New Jersey, and Con-

(Continued on page 54)

Four-Channel Headphones

Koss Corporation, Milwaukee,



has introduced three new sets of headphones specifically tailored to four-channel audio.

Each of the new headphone models features a two-channel/four-channel switch, making it compatible with both popular modes of sound reproduction.

Last year, Koss pioneered four-channel headphones with the introduction of the Quadrafone K2+2.

Each incorporates a new Koss-designed pressure-type dynamic driver element which delivers quality sound reproduction and features volume/balance controls on each cup for convenience.

Circle Number 76 on Reader Reply Card

meet the metrics

Xcelite's where the Metrics are!

A great variety of tools and sets to help you turn most any Metric fastener or adjusting screw you're likely to encounter... hex socket set screws and cap screws, hex nuts, hex head cap screws, and whatever.

All tools precision made for exact fit. Bright nickel chrome nutdriver shafts and protective black oxide finished hex socket screwdriver blades. Plastic (UL) handles shaped for perfect grip and balance.

FIXED HANDLE NUTDRIVERS



NUTDRIVER SHANKS & HEX SOCKET SCREWDRIVER BLADES for use interchangeably in Series 99 plain and ratchet type handles.



COMPACT SETS

No. 99-PS-41-MM
(7 Metric hex socket blades, extension and handle)



No. 99-PS-51-MM
(10 Metric nutdriver shanks, extension and handle)



REQUEST CATALOG

nationwide availability through local distributors



XCELITE, INC., 118 Bank St., Orchard Park, N. Y. 14127
In Canada contact Charles W. Pointon, Ltd.

Circle Number 41 on Reader Reply Card 53

OUTLASTS THEM ALL

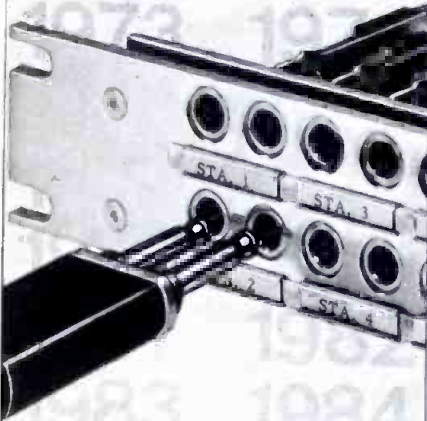

SWITCHCRAFT NYLON PATCH CORDS



Yes, nylon . . . where it counts! Bronze tinsel conductors are insulated with thermoplastic over which a braided shield and black nylon braid are woven. Result: twenty (or more) times the cable life without fraying or shorting. It's built-in reliability insurance! Literally scores of stock types and sizes from 6" to 10' . . . with "Twin-Plugs" or 2 or 3-conductor Mil-type phone plugs. You name it!

JACK PANELS



As trouble-free and reliable as can be. The industry's most complete line for all applications in your choice of steel-reinforced black phenolic, or extremely lightweight aluminum frames; 24 to 52 jacks; single row or double row (spaced so that double plugs cannot make cross-connections). Highest quality telephone or military jacks individually adjusted for perfect electrical connections. Special spring materials and configurations prevent them from taking a "set" or breaking, yet they cost no more! Also available without jacks. Complete line of accessories, too ("Lamp Jax," dual jack blocks, dummy plugs, hole plugs, brackets, and exclusive "KWIK-CHANGE" designation strips). Switchcraft makes them all!

Write for our complete JACK PANEL, PHONE PLUG and PATCH CORD catalogs or see your local Switchcraft Authorized Industrial Distributor for immediate delivery at factory prices.

SWITCHCRAFT
INC.

5567 N. Elston Ave., Chicago, Ill. 60630

Canada: Atlas Radio Corp., LTD.
50 Wingold Ave., Toronto, Canada

necticut.

The new transmitters range from a four-channel, micro-power studio-to-transmitter link unit to a dual-channel, 10 watt transmitter that will broadcast omnidirectional signals up to 20 miles. All models feature improved color performance, high stability, and vestigial sideband operation.

According to D. D. Milne, Micro-Link Marketing Manager, new modulators in the transmitter exciters provide greatly improved stability of the aural carrier due to the use of a phase-locked loop to maintain the 4.5 MHz visual-aural spacing.

"In addition," Milne pointed out, "the differential phase and gain specifications have been tightened to improve color performance."

The metering panel of the new exciter includes means for measuring the exciter output as well as the remote transmitter output, and means to independently adjust the picture and sync amplitude.

Circle Number 70 on Reader Reply Card

Multiple H Line Rate Sync Generator

A new crystal controlled, multiple H line rate sync generator is now available from Telemet Company. The unit is said to eliminate the need for several units usually required to provide multiple drives.

Model 3519A is housed in a compact 19" wide X 4" high X 14" deep frame. Flexibility is built-in, enabling the unit to provide line rates of 525, 875, 945 and 1023. A single front panel switch selects the desired line rate required for driving high resolution video systems.

Outputs provided are horizontal drive, vertical drive, composite blanking and composite sync.

Circle Number 71 on Reader Reply Card

Broadcast Audio Console

CCA announces its new "Futura" professional Audio Broadcast Console. CCA is now offering, in both mono and stereo versions, a new line of audio consoles with capacities of 6 and 10 faders. These

units feature modern, slide attenuators, plug-in electronics, full accessibility, switchable meters and independent, but identical, audition and program channels.



These consoles are also available in prewired audio systems and can be purchased from CCA Electronics Broadcast Division in Gloucester City, N.J. and CCA's subsidiary, QRK Electronic Products in Fresno, Calif.

Circle Number 72 on Reader Reply Card

Installer's Signal Level Meter

The Mid State Communications DT-12V utilizes a new approach for measuring signal levels at the subscriber's drop. The LOW band makes a wide-band composite measurement from 54 MHz to 86



MHz. The HIGH band makes a similar measurement from 150 MHz to 250 MHz. The operating range is from -10 dBmV to +36 dBmV.

Only four pushbutton controls select the band of operation or attenuate the signal. The two band approach permits the DT-12V to

used as a trouble shooting aid on top installations. Near normal levels on the high band and a low reading on the low band would indicate a broken center conductor. Adequate low band performance at weak high band reading would indicate a crimped center conduc-

The DT-12V also contains a 0 to 10 Volt AC and DC voltmeter. The voltage can be measured and amplifier and power supply trouble shooting can be performed with the same instrument.

The DT-12V is a small, light weight, high quality test instrument. For example, electronic regulated power supplies are utilized for absolutely stable operation throughout the life of the batteries. And all circuits are temperature compensated for all weather use.

Circle Number 73 on Reader Reply Card

Video Monitors

Modtec will soon be in full production on a line of modular video monitors. The modular design is based on a series of maintenance features.

The Modtec line is available in 9, 12, 16, 18, and 23-inch models. All modules plug in from the rear of the chassis and are interchangeable regardless of CRT sizes.

The line includes a 9 and 12-inch solid state monitor with a chassis that can be pulled out from the front. Their 9-inch color monitor is not a "jeeped" receiver. This unit

will be available in cabinet, chassis, rack, and dual rack configurations.

Circle Number 74 on Reader Reply Card

Video-Typer

Developed by Kapco Enterprises, the KG-1632 is a low priced Character Generator designed to title live TV programs, or existing helical scan video tapes. The unit can be used with a monitor to display messages only, or in conjunction with a VTR to add titling.

Unique features of the KG-1632 are the ability to add titles to black and white or color recorded video tapes.

The slightly modified typewriter keyboard contains sixty-four characters including letters, numbers, and punctuations. Sixteen lines of copy, with thirty-two characters per line, can be typed and displayed on a television screen against a black background, or overlaid on another picture.

A window may be inserted to mask out all but one of the sixteen lines, or an entire page of copy can be displayed. The individual line appearing in the window, or an entire page, can be rolled upward or downward on the screen, and can be stopped at any location.

Circle Number 75 on Reader Reply Card

**Send your Engineer's
Exchange Ideas To:
BE, 1014 Wyandotte
Kansas City, Mo. 64105**

CHANNEL
CONTROL

console

B-800 series

B-801 monaural \$2350

B-802 stereo \$3200

B-803 dual channel \$2650

For complete information
please contact:
Director of Sales
Dept. B-80



Martin

MCMARTIN INDUSTRIES INC., 605 NORTH THIRTEENTH STREET
OMAHA, NEBRASKA, 68102 TELEPHONE (402) 342-2753.

Circle Number 43 on Reader Reply Card

OPERATING ON A TIGHT BUDGET? CHECK OUR SERIES 800 ROUTING SWITCHER Features

SIZES 6 x 2 to 12 x 15

RELIABILITY

INSTANT ACCESS

VIDEO & AUDIO (Optional)

INPUT & OUTPUT AMPLIFIERS

ILLUMINATED PUSHBUTTONS

BRIDGING INPUTS

ECONOMICAL

DC RESTORER ON ALL INPUTS
& OUTPUTS

ADJUSTABLE FREQUENCY
COMPENSATION

TWO VIDEO OUTPUTS PER
CHANNEL

MODEL 8062
(6 x 2) A/V \$1300

MODEL 81215
(12 x 15) A/V \$6000

**OTHER PROFESSIONAL QUALITY
BUT ECONOMICALLY PRICED
PRODUCTS ARE:**

MODEL 701 VDA \$ 75

MODEL 702 PDA \$ 75

MODEL 705 ADA \$125

MODEL 700 FRAME \$155

MODEL 800 VDA \$125

MODEL 810 EIA Sync Gen. \$455

MODEL 811 EIA Sync Gen. \$585
(Color)

AMERICAN DATA CORPORATION



4306 Governors Drive, S.W.
Huntsville, Alabama 35805
Phone (205) 837-5180

Circle Number 44 on Reader Reply Card

UP TO 65% SAVINGS

Plus performance that is creating excitement in Engineers around the country! "Fantastic sound" ... "Very Clean" ... "Superb! ... Send two more ..."

Proof? Our standard 10 day evaluation period lets you see and hear the performance and the full service. 2 year warranty demonstrates the reliability.

Place your order today. Then prepare yourself for a very satisfying experience!



TURNTABLE
PREAMPLIFIERS

MP-8 (Mono) \$60
SP-8 (Stereo) \$90

Outstanding sensitivity and near perfect reproduction. RIAA/NAB equalized 0.5 mv sensitivity @ 1 KHz for +4 dbm out — Balanced 600 ohm out — minus 65 db S/N ratio — +20 dbm out max — 1 db freq. response — Internal power supply — Table top/bracket mount. Shipping weight, 3½ lbs.

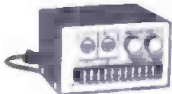

MIC/LINE AMPS

MLA-1 (Mono) \$68
MLA-2 (Dual) \$96

Dual function utility amp. Inputs for mic and/or line — 600 ohm balanced outputs — mic input — 65 db for +4 dbm out — +20 dbm out max. — 0.5 db response. 10 Hz-20 KHz — 0.1% or less dist. — Internal power supply — Tabletop/bracket mount. MLA-2, Stereo/Dual Mono. MLA-1, Mono. Shipping weight, 4 lbs.

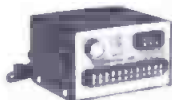

DISTRIBUTION AMP
6 BALANCED OUT

DA-6 \$95

One third the cost of comparable units. Six 600 ohm balanced outputs — Balanced bridging input — 26 db gain — +20 dbm out max. — Input level control — 0.1% or less dist. — 0.5 db response. 10 Hz-20 KHz — Internal power supply — Tabletop/bracket mount — Shipping weight, 4 lbs.



TAPE CARTRIDGE
LOADER (AUTOMATIC)

ACL-25 \$159

Precision winding without guesswork. Dial in the minute and/or seconds desired, throw switch to run. That's it! The exact amount of tape is fed onto the cartridge hub to the second, and shuts off automatically. No waiting around, no guesswork and 1 sec. accuracy. Also has exclusive torsion control for proper tape pack and winding of various cart hub sizes. TTL digital control circuitry. Shipping weight, 30 lbs.



RAMKO RESEARCH

2522 "E" Albalross, P.O. Box 6031
Sacramento, Calif. 95860 (916) 489-0699

Circle Number 45 on Reader Reply Card

TECHNICAL DATA

106. AEL COMMUNICATIONS CORP.—A new four-page brochure on the new "AELCC Tunerless Converter" is now available. The brochure presents AELCC's single output and dual output tunerless "block" converters for Mid-Band and Super-Band ranges. The converters feature flexibility and low operating cost; each adds seven channels and together they can provide up to 14 additional channels on existing cable. Charts and block diagrams delineate specific applications. Converter accessories and their specifications are listed.

107. ANIXTER-PRUZAN—A new 100-page CATV catalog describing all products necessary to build and maintain a CATV system is now available. The catalog contains most wanted items, and is completely indexed and cross-referenced, using both technical and popular names of items. It includes CCTV items such as cameras, microphones and microphone stands. The company will also offer FM processing equipment and public address accessories. The catalog's complete table of contents includes these section headings: aerial construction material; underground construction material; cable; connectors and fittings; splicing materials; drop and installation material; antennae; electronics, including both active and passive devices as well as head-end equipment; test equipment; tools and safety equipment; and specialty items, including CCTV items.

108. AVANTEK—A new Application Note featuring Avantek's Remote Automatic Sweep System is now available. The 20-page application note describes CATV system measurements that can be performed with the remote automatic sweep system. The system

consists of the Model CT-1000 Cable Transmitter and the Model CR-1000 Cable Receiver. Working together, these two equipments employ a very low level test signal to measure the swept frequency response of a CATV system without interference to subscriber's reception. Also included are line drawings and schematics.

109. GENERAL ELECTRIC—Bulletin GIZ-1916 on the Model TE-21 high resolution closed circuit television camera is now available. TE-21 is for camera applications involving very low light levels where a maximum of resolution

FREE CATALOG **TOOLS**

HARD-TO-FIND PRECISION TOOLS

Lists more than 1700 items—pliers, tweezers, wire strippers, vacuum systems, relay tools, optical equipment, tool kits and cases. Also includes four pages of useful "Tool Tips" to aid in tool selection.

JENSEN TOOLS
4117 N. 44th Street, Phoenix, Ariz. 85018

Circle Number 46 on Reader Reply Card

angénieux service corporation of california
13381 BEACH AVE., VENICE, CALIF. 90291 • (213) 821-5080

Now Two
FACTORY SERVICE CENTERS

angénieux corporation of america
440 MERRICK RD., OCEANSIDE, N.Y. 11572 • (516) 678-3520

Circle Number 47 on Reader Reply Card

USE OUR CASH FOR YOUR NEW EQUIPMENT

You choose the equipment; we will lease it to you—3-4 or 5 years with option to buy.

**Broadcast Equipment
Leasing Co.**

DIVISION OF ANCHOR LEASING CORP.

Grant Building
Pittsburgh, Pa. 15219
Area Code 412-281-3768

Circle Number 48 on Reader Reply Card
BROADCAST ENGINEERING

a minimum of noise are critical. Offering a standard line rate of either 525 or 875, TE-21 provides an optimum combination for such uses as image intensification, radiograph analysis, data transmission, chain systems and radioactive material monitoring.

10. INTERNAT'L. RECTIFIER CORP.—

The new 1972-73 Commercial Products Catalog is now available. The 32-page catalog contains details on a wide range of products from replacement components for home entertainment and industrial electronic equipment, to components for hobbyists. Replacement components for home entertainment equipment include resistors, integrated circuits, rectifiers, diodes, solid state tube replacements and electrolytic capacitors. Products featured for the hobbyist, consumer and research and development engineer include ear cells, fiber optics, instrument probes, printed circuit board materials, relays, switches, heat exchangers, project and engineering hand-

books and a complete selection of semiconductors.

11. JOSLYN MFG. AND SUPPLY CO.—

A pocket-sized reference bulletin of materials for CATV is now available. The 16-page folder lists the most common items used in the construction of CATV lines. These include anchors, guy attachments, bolts, clamps, preformed deadends, porcelain strain insulators, nuts, anchor rods, and hundreds of other items of construction hardware.

12. LASER LINE CORP.—

A new booklet describing "How to Layout an Airlink CATV System" is now available. The 12-page booklet covers such subjects as installation, selection of transmitter and receiving sites and how to determine power requirements. Technical and engineering layouts and schematic drawings are also included in the booklet.

13. LITTELFUSE, INC.—

A new 56-page, multi-color, product catalog featuring complete me-

chanical and electrical specifications of all types of glass and ceramic tube fuses, fuseholders, fuse clips and blocks, automatic and manual reset circuit breakers, heavy and medium duty relays, alarm buzzers and momentary action switches is now available. The new catalog is a necessity for the circuit designer, industrial distributor and purchasing agent in the electronics, electrical, automotive aerospace and appliance industries.

14. MAGNAVOX—

A new catalog sheet on "Ultra-High-Quality" coaxial connector Series 990 is now available. A complete description, specifications and ordering information are given for the 5-300 MHz, high RFI integrity, anti-pullout connector line. The series is made for standard .412, .500 and .750 cable and comprises splice, feed-thru, long-pin chassis and short-pin chassis types.

15. MALLORY DIST. PRODS. CO.—

An electrolytic Capacitor

(Continued on page 58)

Increase Head Life with ISOLAIR New Clean Air Unit by LIBERTY

This unit provides a laminar down flow of the cleanest possible air at the critical video head area. Excessive wear and damage by airborne contaminants are virtually eliminated, extending head life by 100% or more and insuring better overall VTR performance, as well as saving time and money. The unit is suspended from the ceiling thus requiring no additional floor space. It is easily installed and maintained and meets Federal Standard 209a, Class 100.

Additional positive effect is the insulative result of the constant filtering of air from the entire room, so that during an extended period of use, the level of contaminants in the surrounding environment is progressively reduced.



Liberty Industries has the capability for providing complete clean air environments for any size or type of operation. Our sales engineers are ready to help you.

Call or write.

LIBERTY INDUSTRIES, INC.

598 Deming Road, Berlin, Conn. 06037
Telephone (203) 828-6361

Circle Number 50 on Reader Reply Card

Let

PACE

Fill Your

WIRE & CABLE requirements

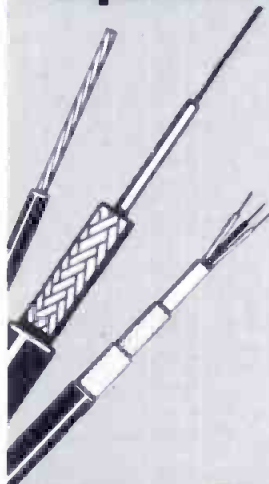

we manufacture:

MIL-W-16878D HOOKUP WIRE
MIL-W-76B HOOKUP WIRE
MIL-C-55021A INTERNAL HOOKUP CABLES
MIL-C-27072A SPECIAL PURPOSE MULTICONDUCTOR CABLE
MIL-C-23437 ELECTRICAL SHIELDED PAIR CABLE
PAIRED INTERCOM CABLE
AUDIO CABLE, SHIELDED & UNSHIELDED
COMMUNICATION CABLE, SHIELDED PAIRS
COMMUNICATION CABLE TO REA SPEC PE-20
SHIELDED MICROPHONE CABLE
PLASTIC KINKLESS TEST WIRE

Write for complete brochure

PACE

WIRE & CABLE CORP.

3590 OCEANSIDE ROAD
OCEANSIDE, N.Y. 11572
516 678-2275

Circle Number 51 on Reader Reply Card



RUSSCO STUDIO-PRO and CUE MASTER turntables offer the ultimate in rugged long-wear dependability and ease of operation... only 3 moving parts! No-slip starting and reliable Bodine synchronous motor. The finest professional engineering with prices starting at a low \$152.00

Circle Number 57 on Reader Reply Card



The perfect tone arm for the finest turntable! The **RUSSCO TA-12** all metal anti-skating tone arm — only \$59.00

Circle Number 58 on Reader Reply Card



You get the most "headroom" for the money (+18 DBM) with **RUSSCO'S** New "FIDELITY-PRO" and "FIDELITY-MASTER" phono pre-amps. 8 models stereo or mono to fit your needs, self-powered and featuring a unique "easy-service" case. Years ahead in engineering with economical prices starting at \$92.00

Circle Number 59 on Reader Reply Card



RUSSCO'S MONITOR MASTER amplifier gives you clean sound in a trim standard 19" rack size... Quick installation & easy service with plug-in P.C. boards. A trouble-free Powerhouse only \$210.00

Circle Number 60 on Reader Reply Card



Guide edited for the electronic technician is now available. This 32-page brochure tells how to find a good capacitor replacement for an original equipment capacitor of a given rating, size and shape. Over 4500 capacitors including singles, duals, triples and quad types are listed in the Guide. Complete information on how to use the Capacitor Guide is included. All capacitor replacements are listed by microfarad and voltage rating and physical case sizes.

116. MOUNTAIN WEST ALARM SUPPLY CO.—A new alarm equipment catalog "Space Age Security" is now available. This 64-page catalog describes and offers over 350 intrusion and fire alarm products. Many are UL listed. The broad product lines presented are of particular use to alarm installers, dealers, and skilled industrial electronic and electrical technicians who require local alarm systems, parts, and accessories. The alarm equipment offered ranges from relatively simple "open loop" hardware to the latest ultrasonic, radar, and infrared intrusion detectors. Many storeroom supplies also are available. Major product categories include Intrusion Systems, Fire Systems, Fire and Intrusion Detectors (Radar, Infrared, Ultrasonic, CCTV, Switches, Heat, Smoke), Remote Controls, Annunciators (Bells, Horns, Sirens, Oscillators, Lights), Telephone Dialers, Lock Specialities, Tools, Accessories, and Books. Products are described in some detail regarding application, principle of operation, and specifications to allow skilled technicians to make the right choices—eliminate guesswork.

121. RF SYSTEMS, INC.—A new price list for CATV products ranging from new co-channel Rejection Kit to Astro Logs, Parabolic Antennas, Yagi and Zig Zag antennas is now available.

SEND YOUR LETTERS TO THE EDITOR to Broadcast Engineering 1014 Wyandotte Kansas City, Mo. 64105

ADVERTISERS' INDEX

Abto, Inc.	5
American Data Corporation	55
Angenieux Corp. of America	56
Beau Motor Div., UMC. Electronics	46
Beston Electronics, Inc.	7
Robert Bosch Corporation	27
Broadcast Electronics, Inc.	11, 26, 52
Broadcast Equipment Leasing	56
CCA Electronics Corporation	9
Canon, Inc.	1
Capitol Audio Tape	33
Crown International	31
Delta Electronics	43
Ditchwitch Trenchers (Charles Machine)	CE-3
Dynair Electronics, Inc.	18
Eastman Kodak Company	CE-5
Electro-Voice, Inc.	Cover 2
ES Enterprises	49
Fairchild Sound Equipment Corp.	41
Fidelipac Div. of Telepro Ind., Inc.	35
Gates Radio Co., Div. Harris-Intertype Corp.	12, 43
The Grass Valley Group, Inc.	3
Hotels Ambassadors	13
International Tapetronics Corp.	8, 46-47
Jampro Antenna Company	34
Jensen Tools and Alloys	56
Liberty Industries, Inc.	57
Lipsner-Smith Corporation	23
McMartin Industries, Inc.	8, 55
Miller-Stephenson Chemical Co., Inc.	45
Miratel	19
Moseley Associates, Inc.	37
Pace Wire & Cable Corp.	57
N.V. Philips	29
Radio Research Instr. Company	59
Ramko Research	56
Richmond Hill Laboratories, Inc.	47
ROH Corporation	48
Russco Electronics Mfg. Co.	58
SC Electronics, Inc.	39
Spotmaster	11, 26, 52
Stanton	10
Superscope, Inc.	50-51
Switchcraft, Inc.	54
Taber Manufacturing & Eng. Company	12
Tape-Athon, Inc.	50
Technology, Inc. HF Photo Systems Div.	51
Teledyne Isotopes	48
Telemet Company	Cover 3
Telex Communications Div.	21
Tracor Industrial Instr. Div.	25
Vital Industries, Inc.	Cover 4
Xcelite, Inc.	53

PROFESSIONAL SERVICES

VIR JAMES

CONSULTING RADIO ENGINEERS
Applications and Field Engineering
345 Colorado Blvd.

Phone: (Area Code 303) 333-5562

DENVER, COLORADO 80206

Member AFCCCE

COURTRIGHT

ENGINEERING, INC.

MORRIS COURTRIGHT, Jr., P.E.
Automation - Applications Field Engineering
ELECTRICAL AND BROADCASTING
Route No. 1, Box 854A, Flagstaff, Ariz. 86001
Phone (602) 774-8206

CAMBRIDGE CRYSTALS PRECISION FREQUENCY MEASURING SERVICE

SPECIALISTS FOR AM-FM-TV

445 Concord Ave. Phone 876-2810
Cambridge, Mass. 02138

ALPH E. EVANS ASSOCIATES

Consulting Radio Engineers
AM - FM - TV - CATV - ITFS
3500 North Sherman Blvd.

MILWAUKEE, WISCONSIN 53216

Phone: 414-442-4210

TODD ASSOCIATES

CONSULTING RADIO ENGINEERS

Alva C. Todd, Ph.D., P.E., Principal

7 S. Summit Avenue, Ph: (312) 832-4104

VILLA PARK, ILLINOIS 60181

SMITH and POWSTENKO

Broadcasting and Telecommunications
Consultants

2000 N Street, N.W.
Washington, D. C. 20036
(202) 293-7742

SESCO, Inc.

47 NICHOLS AVENUE
P. O. BOX 518

(206) 378-2137

FRIDAY HARBOR,
WASHINGTON, 98250

CLASSIFIED

Advertising rates in Classified Section are 15c per word, each insertion, and must be accompanied by cash to insure publication.

Each initial or abbreviation counts a full word. Upper case words, 30c each.

Minimum classified charge, \$2.00.

For ads on which replies are sent to us for forwarding, there is an additional charge of \$2.00 to cover department number, etc., which is printed in advertising copy, and processing of replies.

Classified columns are not open to advertising of any products regularly produced by manufacturers unless used and no longer owned by the manufacturer or a distributor.

MISCELLANEOUS FOR SALE

FOR SALE

RADIO STATION . . . 5,000 Watts . . . Eastern
Arizona \$175,000 . . . substantial cash . . . Harold
Bruzee KHIL . . . Willcox . . . 6-72-6t

FOR SALE

TV MOBILE BUS 1970 Bluebird coach, 30 feet.
Empty interior paneled, carpeted, no side windows, full width rear door. Ready for installation of your equipment. Includes two 6kw generators, two overhead 110V air conditioners plus engine air conditioner, fluorescent lighting, wired for internal and external power. Many other extras. Write Dept 271, Broadcast Engineering, 1014 Wyandotte St., Kansas City, Mo. 64105 11-72-1t

HELP WANTED

TV MAINTENANCE ENGINEER & SUPERVISOR seeks position at top of major market station. Resume and references on request. Box 270 Broadcast Engineering, 1014 Wyandotte St. Kansas City, Mo. 64105 11-72-1t

MICROWAVE LINKS KTR-1000-A

Color TV Microwave Links, C Band, NTSC Color TV Plus Program Audio. CATV/Studio Xmtr/Remote uses Raytheon. As new also Collins MW-103 Components in stock. \$950 per rack W/4 CH MUX.

WEATHER RADAR

3CM RCA 50KW up to 40 mile range. 12" Indicator Console as new \$1975.

RADIO RESEARCH INSTRUMENT CO., INC.

3 Quincy Street,
Norwalk, Ct. 06850
(203) 853-3600

Circle Number 52 on Reader Reply Card

JOB HEADQUARTERS for all Radio and Television Engineers. Immediate openings exist in 9 western states and elsewhere for qualified engineer and technical personnel. All categories from trainees to experienced transmitter maintenance, chief, assistant chief, live color video maintenance and technical operations. Send us your complete resume now. The AMPS Agency, 11661 San Vicente Blvd., Suite 300, Los Angeles, Calif 90049. Telephone: 213-820-2678. By Broadcasters—For Broadcasters. 11-68-1f

VTR—maintenance engineer with AVR-1 experience and first phone seeks job with innovative firm. Presently working in Europe, available as of November 8, 1972. Write Dept. 269, Broadcast Engineering, 1014 Wyandotte St., Kansas City, Mo. 64105 11-72-1t

Engineer

FIELD SERVICE ENGINEER

The leading manufacturer of video tape recorders and television color cameras is looking for a field service engineer for our central region (Chicago). Previous field maintenance on video tape recorders and television color cameras experience required. Broadcast television experience desirable.

For immediate consideration, please write outlining your experience to: C. M. Nowell, Field Service Supervisor, International Video Corporation, 1920 Wakegan Road, Glenview, Ill. 60025. Or phone: (312) 729-5160. We are an equal opportunity employer.



HELP WANTED CONT.

CUSTOM BUILDING licensed engineer Lab Equipment 20 years experience in the Broadcast Field Equipment repair service J & J ELECTRONICS, 153 Chestnut St., Manchester, Conn 06040 11-72-11

TV CHIEF ENGINEER

A deep South TV station in a 3 station TV market needs a new chief engineer who knows how to organize as well as repair and maintain equipment. We prefer a man who wants something better in this life. The pay is excellent, working conditions are ideal and fringe benefits are maximum. And we are the #1 station in the market, so your ego won't be hurt either. Send us your resume so we can start talking, face to face. Write Dept. 272, Broadcast Engineering, 1014 Wyandotte St., Kansas City, Mo. 64105.

WANTED

PLEASE HELP BUILD a worthwhile community-oriented educational FM. Donations of used studio equipment gratefully accepted. Send details to Redesign Office, Central School District, No. 1, Box 7197, North Greece, New York 14515 11-72-21

AMPEX 1200 VTR from Owner Reply to D ZULLI (213) 466-7757 11-72-11

WANTED: Ampex VR-1200A, B or C. Also color film island. Call Steve Volle 408 298-6679. 11-72-11

WANTED

SPOTMASTER and other cartridge machines. Highest prices paid for used equipment. Contact for details COMMUNICATION MEDIAS Box 54, Allentown, Pa. 18105 215-437-0607 9-72-21 e o m

SERVICES

CRYSTAL & MONITOR SERVICE. Frequency change, repair or replacement of oven type broadcast crystals. Also frequency change and recalibration or repair of AM frequency monitors, and H-P FM monitors. Fast service at reasonable prices. 30 years experience! Call or write Eidson Electronic Co. Box 96, Temple, Tx. 76501 Pho 817 773-3901 9-70-1f

CARTRIDGE RELOADING. Send us your worn cartridges for reconditioning. Carts cleaned, new pressure pads installed, and minor parts replaced. Tops replaced at manufacturers cost. 48 hour service. Competitive prices. New cartridges also available. Call or write: Marlin Cartridge Co., 195 Prentiss Ave., Drew, Miss. 38717 (601) 745-8380 11-72-61

TRAINING

PASS FCC EXAMS with Ameco books. Each book contains FCC questions plus simplified answers plus FCC-type exams and answers. 3rd class 75c, 2nd class \$2.25, 1st class \$1.50. Free catalog. Ameco Publishing, 314G Hillside Ave., Williston Park, N. Y. 11596. 8-72-tf

FIRST PHONE through tape recorded lessons at home plus one week personal instruction in Washington, DC, Atlanta, Boston, Detroit, New Orleans, Minneapolis, Seattle, Denver, Portland, Los Angeles. Proven results. Our 17th year teaching FCC license courses. Bob Johnson Radio License Preparation, 1060D Duncan, Manhattan Beach, Calif. 80266. Phone 213-379-4461 1-69-tf

PASS FCC first and second class exams with new 21 lesson, 450-page course. Starts with basic electricity. Over 600 FCC-type, multiple-choice questions and sample exams included. No previous technical knowledge required. Commercial Radio Operator Theory Course, #15-01. Only \$5.95 Ameco Publishing, 314G Hillside Ave., Williston Park, N.Y. 11596. 8-72-tf

EARN ELECTRONIC'S DEGREE, mainly by correspondence. F.C.C. license preparation included at your option. Accredited by Accrediting Commission of NHSC G.I. Bill approved. Free brochure. Write: Dean, Grantham School of Engineering, 1505 N. Western, Hollywood, California 90027 8-72-tf

EQUIPMENT FOR SALE

RCA TFE-10A: 2500 Mhz transmitting antennas Broadband, omnidirectional New, in original packing. Boh Reynolds, 609-877-0881, 32 Mosshill Lane, Willingboro, N.J. 08046 9-72-3t

MOTORS FOR SPOTMASTERS
NEW Paps hysteresis synchronous motor HSZ 20 50-4-470D as used in series 400 and 500 machines. Price \$39.00 each prepaid, while they last. 90 day warranty. Terms check with order only, no COD's. Not recommended for Tapecaster series 600 or 700.
TAPECASTER TCM, INC., Box 662, Rockville, Maryland 20851 1-72-TF

ONE STOP for all your professional audio requirements. Bottom line oriented. F. T. C. Brewer Company, P.O. Box 8057, Pensacola, Florida 32505. 7-71-tf

"NEW & USED TOWERS, Buy, Sell or Trade, Erect, Ground wire 85c lb. Bill Angle, 919-752-3040, Box 55, Greenville, N.C. 27834." 2-71-tf

SURPLUS AUDIO PATCH PANELS, All Standard Configurations. Gulf Telephone & Electronics, Inc., 6325 Beverly Hill, Houston, Texas 77027 7-72-tf

CARTRIDGE TAPE EQUIPMENT—Rebuilt. New paint, heads, flywheel, pressure roller, belts, etc. Spotlessly clean and thoroughly tested. 30 day money-back guarantee, 90 day warranty. Also contact us for possible discounts on new equipment and accessories. AUTODYNE, Box 1004, Rockville, Maryland 20850, (301)762-7626). 7-72-tf

SPECIAL—NEW FIDELIPAC NAB CARTRIDGES 10 secs to 6 minutes. Only \$1.25 each. Minimum quantity 50 carts. Specify lengths when ordering. Gately Electronics, 57 W. Hillcrest Avenue, Havertown, Pa. 19083. 9-72-3t

New and Used Towers AM, FM, TV, Communications. Antennas AM, FM, TV, CATV, Microwave. Complete sales, service, erection and painting. Serving Florida & Georgia. Write DiSCO P.O. Box 1029 Bradenton, Florida 33505 or phone 813-745-6285. 9-72-3t

RCA TT25 SOUND AMPLIFIER CHANNEL 5 can be modified to picture. RCA TT5A TRANSMITTER CHANNEL 5 can be modified to air cooled. Just removed from standby service, fully operational. Harmonic filter, VSBF, and Chief Engineer, KSD-TV, 1111 Olive St., St. Louis, Mo. 63101 10-72-2t

EQUIPMENT FOR SALE CONT.

FIDELIPAC Cartridges, FACTORY Loaded. New and Used SPOTMASTER cartridge machines, accessories, and parts. Many other equipment lines. Contact COMMUNICATION MEDIAS Box 54, Allentown, Penna. 18105 215-437-0607. Consult our other ads in this magazine. 11-72-2t

140' GALVANIZED SELF-SUPPORTING ANTENNA TOWERS. Weight 7.5 tons, Base 12 sq. feet tapering to 1 sq. foot at top. Wind load 145 M.P.H. Logan Cablevision Box 181 Snow Shoe, Pa., 16874; 814-387-4961. 11-72-2t

RCA CSF-60A, 60w FM base station on 26.3 mhz. 600 ohm out for board, local and remote control panels, handset or speaker operation. mint \$250. Rust RI-108 system, complete \$180. RCA 77-D factory reconditioned, \$135. RCA 44BX \$95. 639A stand, \$50. AKG D-24, cash chart, cable \$130. Gates M-6034 preamps, \$2 each (4) \$95. Daen pots (12) 600 in/out in sorted ladders and T's with cues, lot \$100. WEED 89 Pansy Street, Schenectady, New York 12306 Telephone 518-356-0441 11-72-11

SPARTA 600CRP & 600CP-RK stereo cartridge playback and recorder both with 1500hz & 8KHz aux cue. One year old in excellent condition. KZST (FM) Box 2755, Santa Rosa, California 95405. (707) 528-4434. 11-72-11

STATION ENGINEERS—LOOKING FOR A CONSOLE? Like-new Electrodyne 1204C desktop console for quad, stereo. Nine 711 input strips, wired for fifteen 8 freq. equalization. Altec faders, AB pots. Four output busses, two stereo mixdown busses, all with VUS, faders. For details and photo write: Earth Audio Techniques, 113 Church St., Burlington, Vt. 05401 11-72-11

FOR SALE: Mobile Unit 24 ft. International custom van, 4 RCA TK-30 cameras, 2 RCA synch generators, RCA TS-30 switcher, 6 input audio mixers, intercom, adjustable power transformer. Chief Engineer, WTMJ-TV, Milwaukee Wisconsin. 414-332-9611. 11-72-11

COAXIAL CABLE—jacketed 3 inch air dielectric heliax—270 feet—Andrew's No. H-550A/Milit. RG 322U—fitted with two male, factory installed, EIA flanges. Excellent condition \$1,300. Write/Call WKJF, Inc., 1715 Grandview Avenue, Pittsburgh, Penna. 15211. 412-384-8100. 11-72-11

Standard RCA Style VIDEO PATCH JACKS unused \$1.75 each. You supply panels and save. Norman Gillaspie, P.O. Box 2124, Monterey, Calif. 93940. 1-408-375-7424 11-72-11

RCA TG-4 Color Test Generator. New condition. Complete Instructions \$500.00. RIKER SYNC GENERATOR #520 Color Standard Color Lock, Bar & Dot Modules. Complete instructions. \$250.00. K Whitman. 8346 Brimfield Ave., Panorama City, Calif. 91402 (213) 780-1624 11-72-11

GET COMPLETE DETAILS

about the products
advertised or described
in this issue.

Use Free Inquiry Card.

Be sure to include your
name and address

READER SERVICE CARD BROADCAST engineering

For issue of November 1972-Use until February 1, 1973

After that date
please contact
manufacturer direct

Use This
Handy Card
For More
Information
On The
Products
Described

Name _____ Title _____

Station or Company _____

Address/City _____

State _____ Zip _____

1	9	17	25	33	41	49	57	65	73	81	89	97	105	113	121	129	137	145	153	161	169	177	185	193	201
2	10	18	26	34	42	50	58	66	74	82	90	98	106	114	122	130	138	146	154	162	170	178	186	194	202
3	11	19	27	35	43	51	59	67	75	83	91	99	107	115	123	131	139	147	155	163	171	179	187	195	203
4	12	20	28	36	44	52	60	68	76	84	92	100	108	116	124	132	140	148	156	164	172	180	188	196	204
5	13	21	29	37	45	53	61	69	77	85	93	101	109	117	125	133	141	149	157	165	173	181	189	197	205
6	14	22	30	38	46	54	62	70	78	86	94	102	110	118	126	134	142	150	158	166	174	182	190	198	206
7	15	23	31	39	47	55	63	71	79	87	95	103	111	119	127	135	143	151	159	167	175	183	191	199	207
8	16	24	32	40	48	56	64	72	80	88	96	104	112	120	128	136	144	152	160	168	176	184	192	200	208

READER SERVICE CARD BROADCAST engineering

For issue of November 1972-Use until February 1, 1973

After that date
please contact
manufacturer direct

Use This
Handy Card
For More
Information
On The
Products
Described

Name _____ Title _____

Station or Company _____

Address/City _____

State _____ Zip _____

1	9	17	25	33	41	49	57	65	73	81	89	97	105	113	121	129	137	145	153	161	169	177	185	193	201
2	10	18	26	34	42	50	58	66	74	82	90	98	106	114	122	130	138	146	154	162	170	178	186	194	202
3	11	19	27	35	43	51	59	67	75	83	91	99	107	115	123	131	139	147	155	163	171	179	187	195	203
4	12	20	28	36	44	52	60	68	76	84	92	100	108	116	124	132	140	148	156	164	172	180	188	196	204
5	13	21	29	37	45	53	61	69	77	85	93	101	109	117	125	133	141	149	157	165	173	181	189	197	205
6	14	22	30	38	46	54	62	70	78	86	94	102	110	118	126	134	142	150	158	166	174	182	190	198	206
7	15	23	31	39	47	55	63	71	79	87	95	103	111	119	127	135	143	151	159	167	175	183	191	199	207
8	16	24	32	40	48	56	64	72	80	88	96	104	112	120	128	136	144	152	160	168	176	184	192	200	208

BROADCAST engineering FREE SUBSCRIPTION CARD

To start or renew your subscription to Broadcast Engineering on a no-charge subscription basis you must check all appropriate boxes, print your name and address, sign and return this card promptly.

I want to START a subscription to Broadcast Engineering now.

I want to RENEW my subscription to Broadcast Engineering now.

Please check all boxes that apply AND occupation title

My company is:

- AM Radio Station
- FM Radio Station
- TV Station, Commercial
- TV Station, Educational
- CATV System
- CCTV or Instructional TV
- Campus Radio Station
- Consulting Firm

- Dealer or Distributor of Broadcast Equipment
- Educational Radio Station
- Industrial or Medical TV
- ITFS
- Recording Studio, Audio or video
- Microwave
- Government Agency

My occupation title is:

- Owner, President, Officer
- Gen. Manager, Advisor or Director
- Chief Engineer
- Engineer, Technician

- Engineering Supervisor, Director
- Program Manager, Station Manager
- Consulting Engineer
- Other: specify _____

Are you responsible for more than one station or facility? Yes No
Be sure you have checked one box by each arrow

PLEASE PRINT

Name _____

Title _____

Station or Co. _____

Street _____

City _____ State _____ Zip _____

Please sign here

6 cents
Postage
Required

BROADCAST engineering

P.O. Box 21502
El Paso, Texas 79998

Attn: Engineers Tech Data Dept.

6 cents
Postage
Required

BROADCAST engineering

P.O. Box 21502
El Paso, Texas 79998

Attn: Engineers Tech Data Dept.

6 cents
Postage
Required

BROADCAST engineering

1014 Wyandotte Street
Kansas City, Missouri 64105

Attn: Evelyn Rogers

If you're looking
for the
easiest way
to accurately
measure
envelope delay,
look no further.

Frequency range is 0.1 to 10 MHz for
the Video Modulator and 25 to 250 MHz
for the RF Modulator.

We've developed a solid-state measuring system
that has everything in one box. And that includes
a convenient, low-harmonic content Sweep
Generator. The result is exceptionally good
accuracy. In fact, delays of ± 30 ns to ± 1000 ns
can be measured in 4 ranges, with a resolution of 2 ns.
The test signal is provided with or without sync
and blanking for meaningful TV transmitter
measurements.

Readout is by way of a front panel meter that
provides point by point measurements. And a
scope-jack offers continuous sweep display.
The price is one more unusual statistic.

Only **\$3700**

We'd like to tell you more. Write or call us today
for complete data.
Telemet Company, Amityville, New York 11701,
(516) 541-3600.

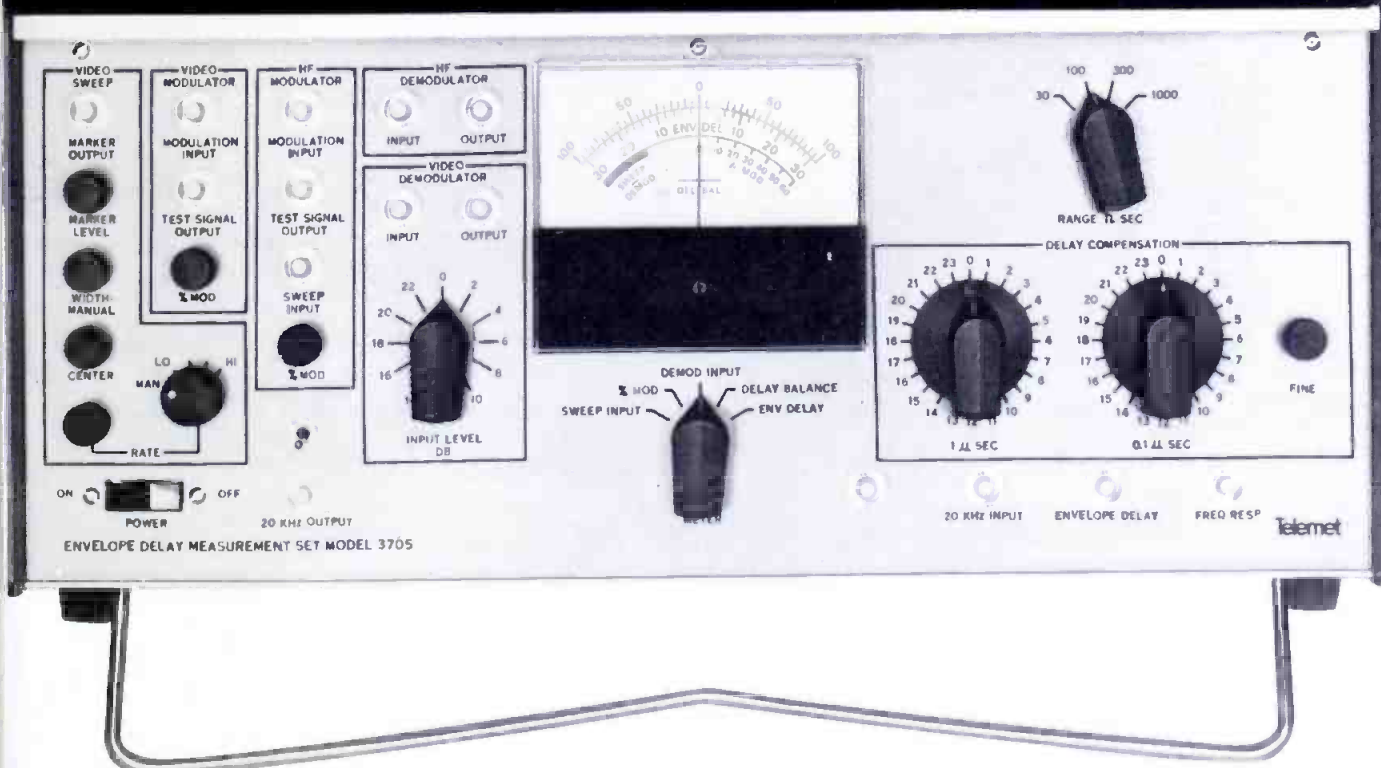

better ideas for broadcasting



Telemet

COMPANY a division of GEOTEL, INC.

Amityville, New York 11701, (516) 541-3600

REGIONAL OFFICES

Chicago, Ill. (312) 647-6026 Atlanta, Ga. (404) 361-2951 Houston, Tex. (713) 946-5796 Santa Ana, Calif. (714) 540-6756

Circle Number 2 on Reader Reply Card

www.americanradiohistory.com

GET THE VITAL EDGE

with the **VIX-100-4**
production
powerhouse

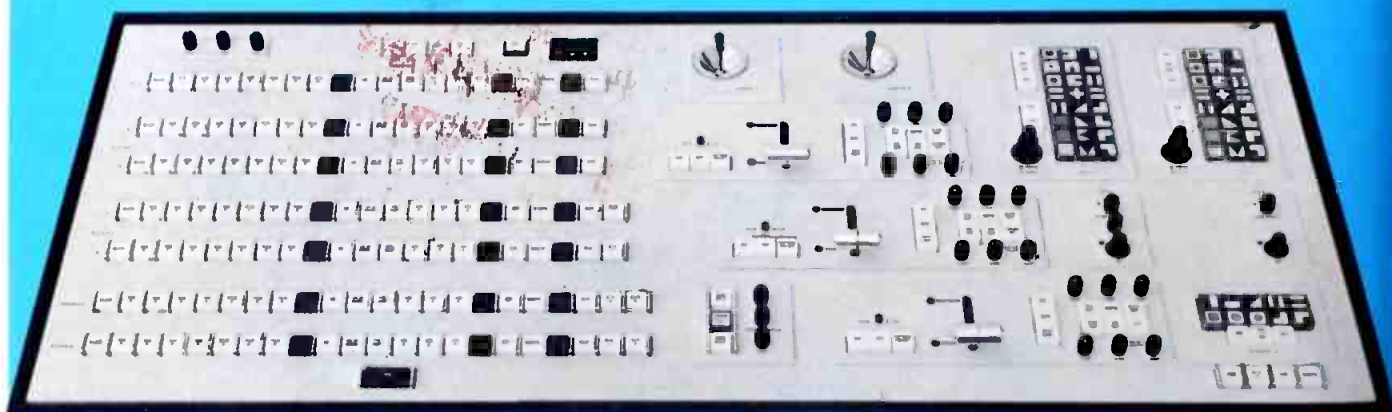

VIX-100-4

Drift-free circuitry makes it possible to enjoy three mix-effects system with quad-split in a control panel no larger than most single mix-effects switchers. Discover the advantages of a switching system that satisfies ad agencies and insures dominance in production capabilities.

SALIENT FEATURES:

- 3 presettable mix-effects systems
- No coaxial delay lines in all re-entries
- Quad split with external drives
- Edger on all keys
- Up to 3 chroma keys. Composite and RGB type
- Ultra stable system
- Easy to install. Only one sync pulse is required
- All the extras used in today's production techniques

10 years of specialization. Designed, manufactured and delivered some of the world's largest and most complex integrated telecommunication systems.

3620 Ridgewood Rd., N.W., Atlanta, Ga. 30327
404/233-9459

7960 W. Beverly Blvd., Los Angeles, Calif. 90048
213/653-9438

2644 N. Seventh St., Terre Haute, Ind. 47804
812/466-3212

GOOD ENGINEERING IS VITAL



VITAL INDUSTRIES, INC.

MAIN OFFICE: 3614 S.W. Archer Road, Gainesville, Fla. 32601—Phone 904/378-1581

Circle Number 3 on Reader Reply Card

www.americanradiohistory.com