

BROADCAST engineering

March 1981/\$3

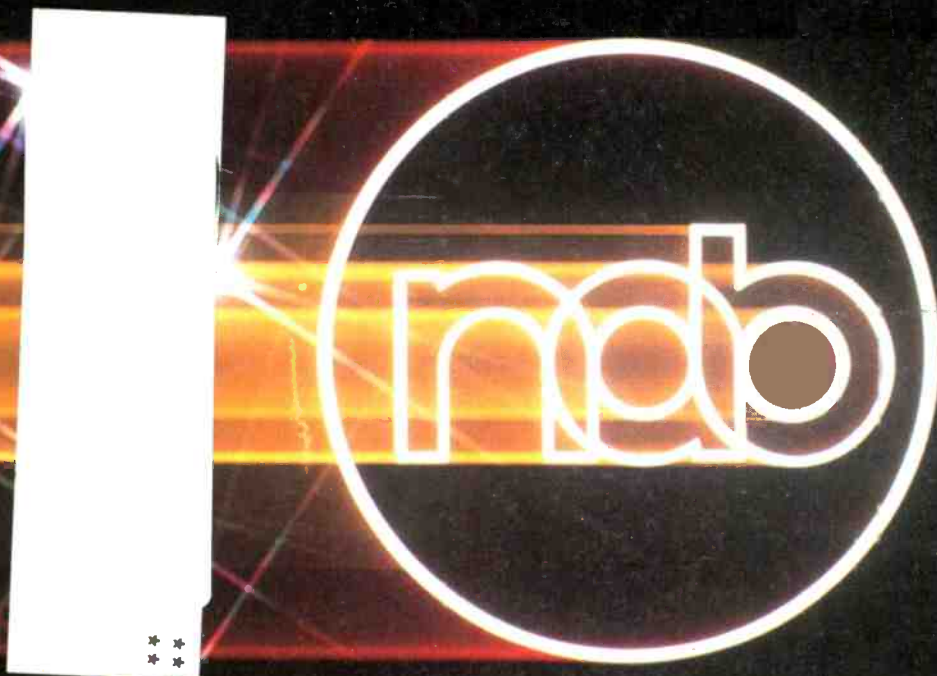

DIRECTIONS

CONVENTION SPECIAL

Introducing the only teleterminal that stars on all three networks.

The Cal DataCom CD/300 multi-function teleterminal will outperform any teleprinter in the business. No matter which communications network you plug it into.

At the touch of a button, the CD/300 can directly access TLX, TWX and Direct Distance Dialing (DDD). Your operator can dial up the least expensive network for transmitting messages by simply inputting the line mode, typing the number and entering the message. From there, the CD/300 steals the show and handles the rest. Expensive Infomaster switching charges are avoided. Your communications costs are cut to a minimum.

But that's just for openers. As an added attraction, we've designed the CD/300 to also function as a computer terminal. So instead of investing in extra equipment for your system or for timesharing,

you can have the CD/300 play the part.

The reason the CD/300 is so multi-talented is its unique combination of microcomputer hardware and firmware. Along with a solid state buffer memory that gives the CD/300 a cast of extras.

Like an automatic unattended operation feature that lets you take advantage of reduced DDD rate hours. Complete text editing capability. Plus a local/on-line mode that increases efficiency by letting your operator send messages without interrupting incoming traffic.

And even with all these superstar qualities, the CD/300 still has a down-to-earth price. Just slightly

higher than what you would have to pay for one of those limited function teleprinters that will soon be obsolete.

So if you think it's prime time to start reducing your message communications costs, give the top-rated star of TLX, TWX and DDD a role in your office. Call toll free, 1-800-854-0171. In California, call collect (714) 540-8553.



1844 Carnegie Avenue, Santa Ana, CA 92705
TELEX: 685-667
TWX (913) 595-1991

Circle 6 (1) on Reply Card

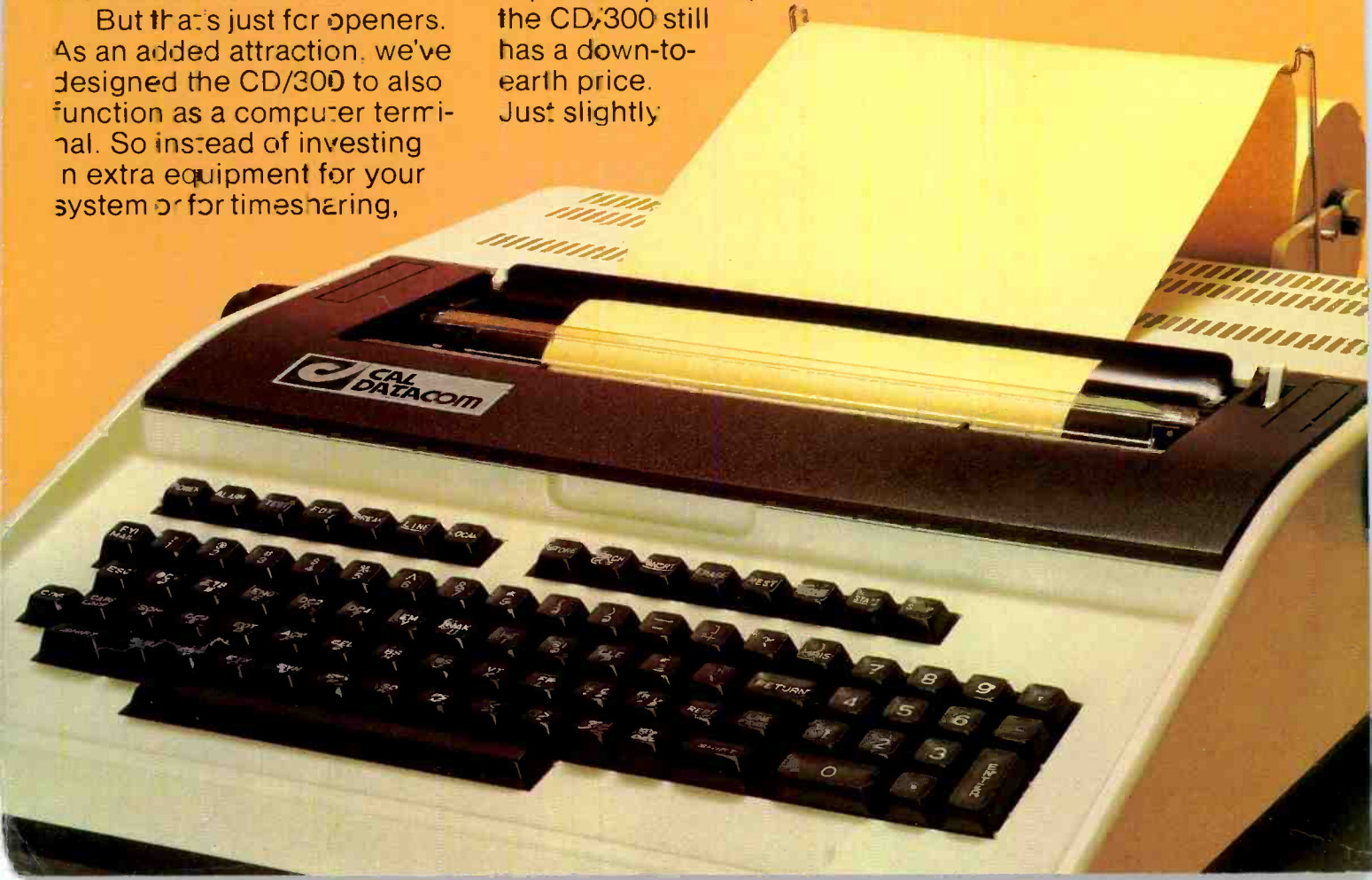

DIAGONABLE.

O'Connor Model 100.
Fluid smooth control
to follow the action
in any direction.

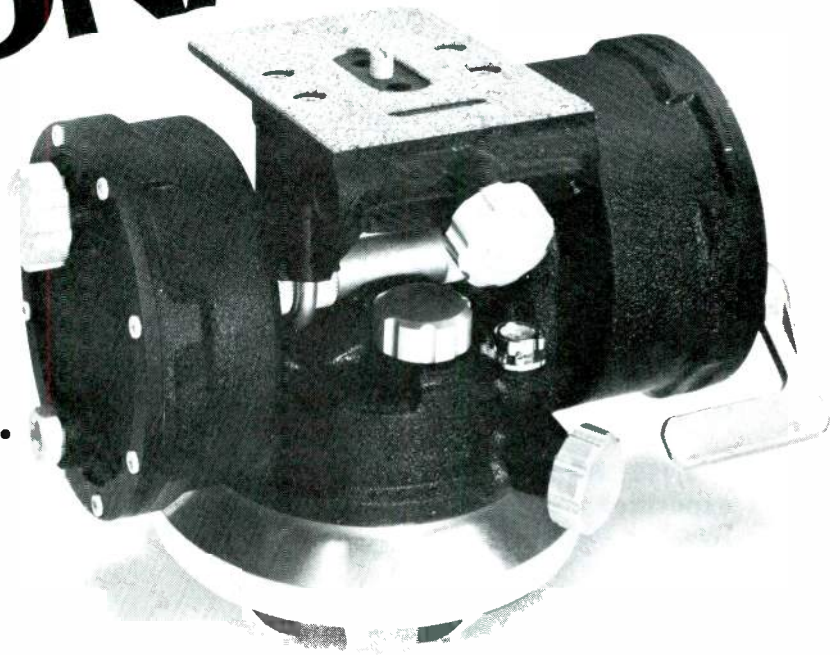

SIMULTANEOUS PAN AND TILT CONTROL.

Unlike cumbersome gear heads that require tremendous coordination to operate the separate pan and tilt controls, the O'Connor 100 follows the action at any speed in any direction with the gentle touch of your hand. Panning and tilting are simultaneous, so the camera obeys your every command.

OUR NEW SIDEMOUNTING PLATFORM.

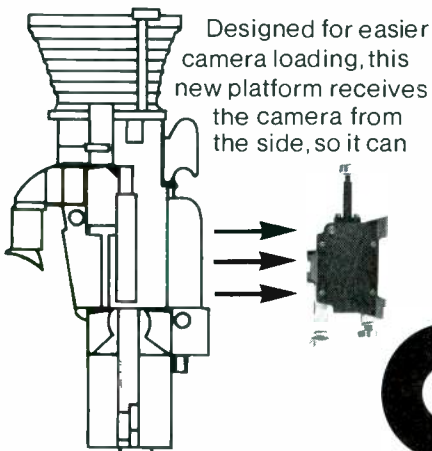

Designed for easier camera loading, this new platform receives the camera from the side, so it can

be lifted more comfortably at the lens and the rear of the body. The mounting plate can be ordered to any length providing support for those extra long and heavy lenses. Plus, the platform is made adjustable to balance the camera on the head and it's a quick release type with a built in safety feature.

FILM OR TELEVISION.

For decades, the Model 100 has been *the* camera head for feature film production. But today, television crews are discovering their creative potential with O'Connor fluid heads. To accommodate a wide range of cameras and accessories, the 100 is available with a 300, 500 (standard) and 700 in-lb springs to assure that your camera is

properly counterbalanced at all times. Double handles are also available for video users.

O'CONNOR PRECISION THROUGHOUT.

Built of magnesium and aluminum alloy castings, this low profile head weighs only 16 lbs. Separate controls for the pan drag, pan lock, tilt drag and tilt lock all improve the flexibility and repeatability of camera movement. The tilt range is $\pm 60^\circ$ with a 360° pan.

ASK THE MAN WHO OWNS ONE.

There must be a reason why so many of the world's greatest cinematographers insist on the O'Connor Model 100. Maybe because it's diagonable.

O'Connor
FLUID CAMERA HEADS

O'Connor Engineering Labs., Inc., 100 Kalmus Drive, Costa Mesa, CA 92626 • (714) 979-3993 • TELEX 685 641
O'Connor Engineering Ltd., 14 Av. Industrielle, 1227 Carouge, Geneva, Switzerland • Phone (022) 42 79 38 • TELEX 28 449
Circle (3) on Reply Card

BROADCAST engineering

The journal of broadcast technology

March 1981 Volume 23 No. 3

6 FCC Update
12 News
20 National Association of Broadcasters

1981 NAB Convention Special

24 NAB — '81/Las Vegas

The broadcast industry's greatest show
By Bill Rhodes, editorial director

42 The 1981 NAB international broadcast equipment exposition and engineering conference

By Chris Payne, assistant to the senior vice president for engineering, NAB

44 NAB — '81/Las Vegas product directory

96 NAB — '81/Las Vegas exhibits roundup

181 NAB Late exhibitor roundup

184 Case study: Diary of an NAB exhibit

192 KEYN takes on a new look

By Larry Waggoner, director of engineering, Long Pride Broadcasting, Wichita, KS

194 Computerizing the business at WBBQ

By Harley Drew, vice president of operations and program director, WBBQ-AM, Augusta, GA

200 Field report

ITC Series 99 cartridge machine
By Brad Dick, chief engineer, KANU, Lawrence, KS

218 Maintenance tips on the BVU-200 videocassette recorder

By John J. Lapham Jr., senior broadcast engineer, KOMO-TV-4, Seattle

230 The prospect of low power

By Dr. Thomas C. Durfey, associate professor, Oral Roberts University, Tulsa, OK

244 US station goes overseas for 'local' hostage coverage

By John D. Weigand, manager of engineering, KFMB stations, San Diego

236 Calendar	266 Station-to-Station
242 People	270 New Literature
250 Business	277 Ad Index
259 National Radio Broadcasters Association	281 Classified
260 New Products	

© Copyright 1981, by Intertec Publishing Corporation. All rights reserved. Material may not be reproduced or photocopied in any form without written permission of publisher.

BROADCAST ENGINEERING (USPS 338-130) is published monthly by Intertec Publishing Corporation, 9221 Quivira Road, P.O. Box 12901, Overland Park, KS 66212. Postmaster, return form 3579 to the above address.

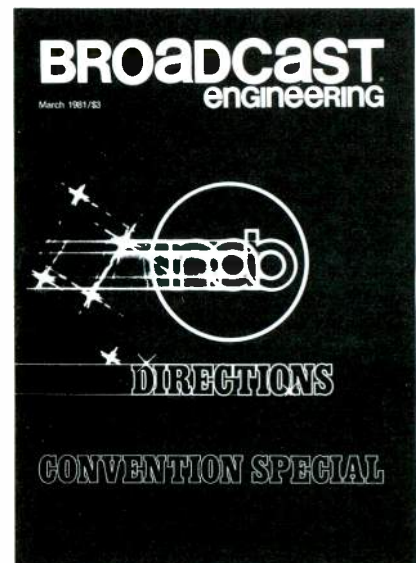

THE COVER this month is adapted from the NAB brochures promoting the organization's 59th Annual Convention and International Exposition. NAB — '81 is organized around a theme of DIRECTIONS...in radio...in television...in engineering...of new technologies...and in government regulations. NAB — '81 is geared to help broadcasters make the transition as new developments in technology and changes in regulations reshape the traditional roles of managers and engineers in broadcast stations.

The cover artwork was copied and reproduced here with the permission of NAB. Special recognition goes to artist Richard Markey, Markey Graphics, Frederick, MD, for creating the art.

NAB — '81/Las Vegas

Broadcasters main convention

Las Vegas Convention Center
April 12-15, 1981

NAB CONVENTION GUIDE

Most of this issue is devoted to pre-show coverage of NAB — '81/Las Vegas. Extensive research went into compiling data from manufacturers exhibiting at this year's convention to make the BE exclusive coverage as detailed and complete as possible. The results, in terms of articles and special sections, can be seen in the contents listing to the left. This special coverage will help attendees plan for the show or make it easy to obtain data on new products for those who can't make it to Las Vegas. In any event, look for BE's extensive show wrap-up in the June issue.

NEXT MONTH

- Audio technology: Radio for the '80s
- Roundup of reel-to-reel audio recorders
- SMPTE TV Conference replay

A Broadcast Breakthrough of Minor Proportions.

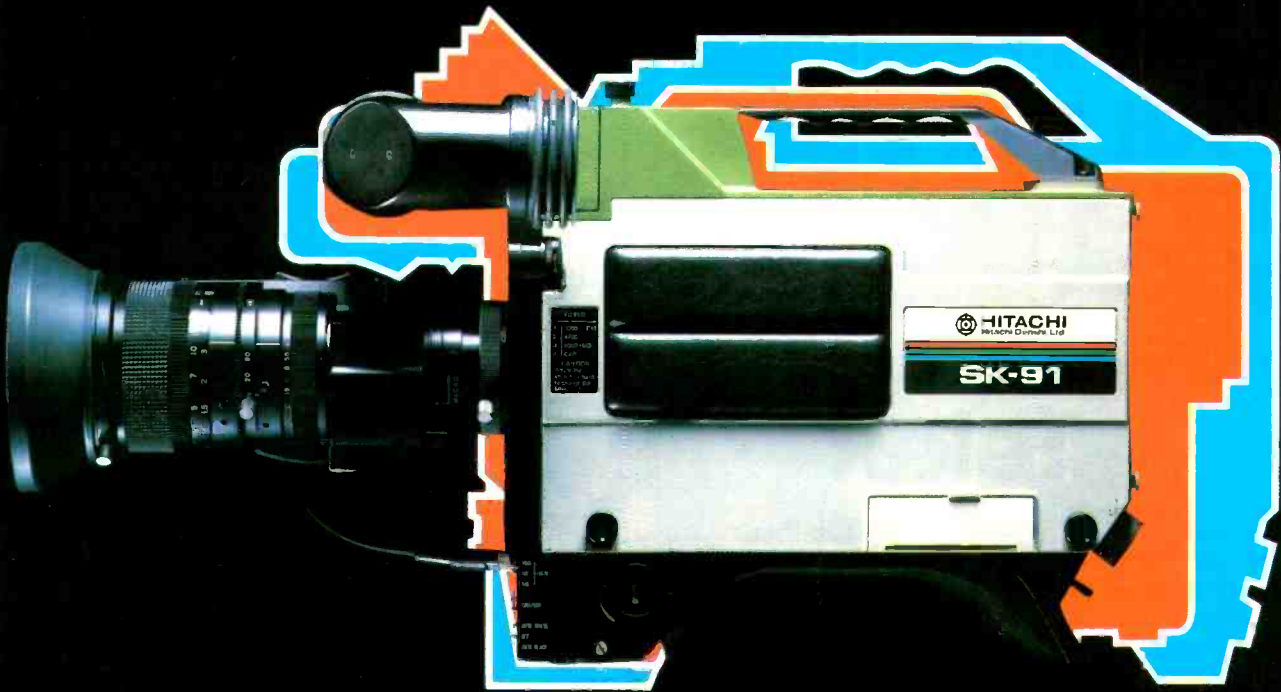

Hitachi SK-91... Critical inches shorter and precious pounds lighter.

Creating the world's smallest, lightest ENG/EFP broadcast camera was no small accomplishment. But making it so without sacrificing a single spec or capability qualified as a genuine breakthrough.

Of course, the beneficiary of our advanced engineering is you. You get all the performance that high technology has to offer in a more compact, efficient package. (Cameramen are amazed at the SK-91's responsive, featherlight handling.)

Image quality naturally adheres to the highest broadcast standards, with your choice of Saticons, Plumbicons[®], or diode guns[®], attaining up to 57dB and 600-line resolution. Why not call your local Hitachi

regional office and schedule a thorough in-person evaluation of the SK-91? We think you'll agree that a breakthrough of minor proportions can be of major advantage to you.

SK-91 SPECIFICATION HIGHLIGHTS

- Weight: 9-1/2 lbs.
- 57dB S/N ratio and 600-line resolution
- Auto digital white and black balance
- True AB0
- 2 ft. candle sensitivity
- Extremely quiet +9/+18dB gain
- Optional triax/digital unit
- Studio accessories for added versatility

® Registered trademarks of N.V. Philips



HITACHI
Hitachi Denshi America, Ltd.

Tomorrow's Technology Today

175 Crossways Park West, Woodbury, N.Y. 11797 (516) 921-7200

• New York • Chicago • Los Angeles • Atlanta • Cincinnati • Dallas • Denver • Seattle • Washington, D.C.

Circle (4) on Reply Card



All Wireless Microphones Are Not Created Equal

This One is a
Telex

Wireless mics aren't new, and sometimes it seems as if all systems are basically the same. However, Telex and its Turner and Hy-Gain divisions have combined their 100 years of cumulative experience in microphone, antenna and rf development to produce a DUAL DIVERSITY WIRELESS SYSTEM THAT COSTS AS LITTLE AS SINGLE ANTENNA INSTALLATIONS. The FM receiver can be operated with one or two antennas. When two antennas are used, a unique automatic phase summation network (patent applied for) provides superb dual diversity reception.

The Telex wireless sounds as good as a hard wired mic, offers plenty of options and is economically priced. If you're interested in a wireless system that is *more* than equal—write us today for full specifications.

Quality products for the audio professional



TELEX®

TELEX COMMUNICATIONS, INC.

*9600 Aldrich Ave. So., Minneapolis, MN 55420 U.S.A.
Europe: 22, rue de la Légion-d'Honneur, 93200 St. Denis, France.

Circle (5) on Reply Card

4 *Broadcast Engineering* March 1981

BROADCAST[®] engineering

Editorial, advertising and circulation correspondence should be addressed to P.O. Box 12901, Overland Park, KS 66212 (a suburb of Kansas City, MO); (913) 888-4664

EDITORIAL

Bill Rhodes, *Editorial Director*
John Willisowski, *Video Editor*
Kevin Kiouss, *Managing Editor*
Joan Jackson, *Associate Editor*
Rhonda L. Wickham, *Editorial Assistant*
Mary Thornbrugh, *Editorial Assistant*
Pat Blanton, *Directory Editor*

ART

Dudley Rose, *Art Director*
Joy Viscek, *Graphic Designer*

TECHNICAL CONSULTANTS

Dennis Ciapura, *Technology*
Howard T. Head, *FCC Rules*
Harold L. Kassens, *FCC Rules*
Donald L. Markley, *Facilities*
Art Schneider, A.C.E., *Post-production*

CORRESPONDING ASSOCIATIONS

American Society of TV Cameramen
Association for Broadcast
Engineering Standards
National Association of Broadcasters

National Radio Broadcasters Assn

CIRCULATION

John C. Arnst, *Director*
Evelyn Rogers, *Manager*
Dee Manies, *Reader Correspondent*

ADMINISTRATION

R. J. Hancock, *President*
George Laughead, *Publisher*

ADVERTISING

Cameron Bishop, *Marketing Director*
Mary Birnbaum, *Production Manager*

Regional advertising sales offices listed near the Advertiser's Index

Member,
American Business Press



Member,
Business Publications
Audit of Circulation



BROADCAST ENGINEERING (USPS 338-130) is published monthly by Intertec Publishing Corporation, 9221 Quivira Road P.O. Box 12901, Overland Park, KS 66212. Postmaster, return form 3579 to the above address

BROADCAST ENGINEERING is edited for corporate management, engineers/technicians and other station management personnel at commercial and educational radio and TV stations, teleproduction studios, recording studios, CATV and CCTV facilities and government agencies. Qualified persons also include consulting engineers and dealer/distributors of broadcast equipment

SUBSCRIPTIONS BROADCAST ENGINEERING is mailed free to qualified persons in occupations described above. Nonqualified persons may subscribe at the following rates: United States, one year, \$25; all other countries, one year, \$30. Back issue rates \$5, except for the September Buyers Guide issue, which is \$15. Rates include postage. Adjustments necessitated by subscription termination at single copy rate. Allow 6-8 weeks for new subscriptions or for change of address. Controlled circulation postage paid at Kansas City, MO.



intertec Publishing Corp

1981 All rights reserved

Hitachi-5 Competition-0

That's the score in one-inch VTR technology.

We've gone the first generation of TYPE C machines *five* better...to help you get all the potential of one-inch out of your video installation. Here's what the competition *doesn't* give you.

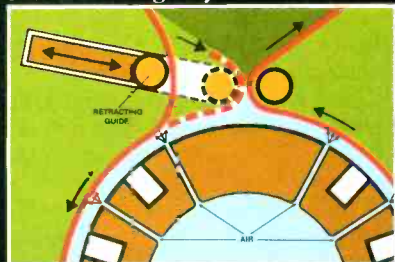

• Tape guide retracts for threading ease • Air drum eliminates head contact in shuttle/standby modes

1. Retracting Tape Guide

Retracts for unequalled ease of threading; repositions with one micron accuracy for up to two million threadings. Provides the reliability of a quad thread system in a one-inch format.

2. "PRO" Tape Path

The protective reverse oxide ("PRO") configuration of the tape path means *only* the video and audio heads touch the oxide surface. All other transport mechanisms guide the tape by its reverse side. Result: noticeably reduced dropouts; longer tape life.

3. Instant Head Replacement

Pre-aligned head design permits easy replacement of video heads in three minutes. No adaptors or jigs; no adjustments required.

4. Audio and Video Confidence

The others only let you *see* what you're taping. We let you *see* and *hear* everything being recorded...simultaneously.

5. Non-contact Tape Shuttle System

In shuttle and standby modes, tape rides on a cushion of air. Increases head and tape life immeasurably. Cuts frictional

resistance, yielding shuttle times of only 80 seconds end to end.

We could go on. With impressive features like microprocessor control; broadcastable slow motion; one-touch shuttle and jog; front access circuit boards; audio split erase; and on and on. But why run up the score, when it's already no contest? See the Hitachi HR-200, it's equally impressive portable HR-100 model, and companion TC-200 Time Base Corrector.

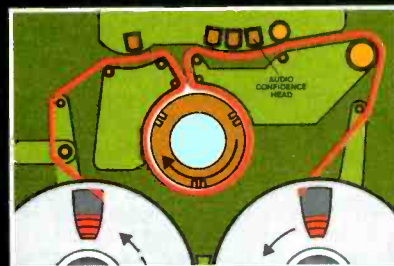

• Full audio and video confidence
• "PRO" tape path reduces dropouts

 HITACHI | HR-200



 **HITACHI**
Hitachi Denshi America, Ltd.

Tomorrow's Technology Today

175 Crossways Park West, Woodbury, N.Y. 11797 (516) 321-7200

• New York • Chicago • Los Angeles • Atlanta • Cincinnati • Dallas • Denver • Seattle • Washington, D.C.

FCC update

March 1981



Eads named acting chief of Broadcast Bureau Facilities Division

The commission has announced the appointment of Larry Eads, assistant chief of the FCC Broadcast Bureau's Policy and Rules Division, as acting chief of the Bureau's Broadcast Facilities Division.

Eads joined the FCC staff as an economist in the Research Branch of the Broadcast Bureau in 1968. He later served as operations research analyst on the staff of the Chief of the Broadcast Bureau and Chief of the Policy Analysis Branch of the Policy and Rules Division. He was appointed assistant chief of policy and rules in November 1979.

Commissioner Brown announces resignation

Commissioner Tyrone Brown announced his resignation from the FCC effective January 31 in a letter to former President Carter describing his three years at the FCC as "the most challenging and rewarding of my career."

Brown, who will become a general partner in the Washington law firm of Steptoe and Johnson, is only the second black to serve as a member of the commission since it was established by Congress in 1934.

In his letter to the President Brown said, "I hope that your successor will recognize as you did, that minority representation at the commissioner level is very important. Such an appointment is not merely a matter of 'tokenism,' it reflects an understanding that minority representation at the commissioner level is the most effective way to assure that minority perspectives are considered during the Agency's deliberations."

The 38-year-old Democrat, who was appointed to the FCC in 1977 and named to a full seven-year term on July 17, 1979, told Carter that "I have been particularly gratified that during this period the FCC became the only independent regulatory agency to officially endorse and successfully implement a minority ownership program. I have every reason to expect that this program

will continue and expand, since it has had the unanimous support of the commissioners."

FCC defers relocation

The commission has deferred immediate action on its proposed move to a Rosslyn, VA, office building under construction and appointed a committee of two commissioners to recommend options to help it resolve its need for office space.

By its action the commission postponed a final decision on whether to lease space in Tower I of the Twin Towers building in the Virginia suburb, which is to become available in the summer of 1981.

UHF Comparability Task Force releases Harris survey

The FCC's UHF Comparability Task Force has released a survey by Louis Harris and Associates on consumer attitudes and experience concerning UHF television.

The Harris survey was among studies undertaken in the UHF Comparability Task Force project. The research provided for the first time systematic data on UHF disadvantages in reception and picture quality, in the number of viewers using outdoor and indoor UHF antennas, in the perceived ease of tuning in stations and in amount of viewing.

The UHF Comparability Task Force in the commission's Office of Plans and Policy was established in response to a Congressional request to determine ways by which UHF television service could become more competitive with VHF TV. UHF television is hindered by several technological and economic disadvantages, known collectively as the "UHF handicap."

The survey suggests that inability to receive a UHF picture at all may explain much of the difference in audience between UHF and VHF television. One reason viewers do not get good UHF reception is simply that they do not have the necessary antennas or other equipment.

Examination of viewer preferences suggests that lack of interest

in UHF programming may explain much of the difference in viewing between UHF and VHF and much of the unwillingness to buy UHF antennas.

A limited quantity of the Harris report is available from the FCC's Office of Public Affairs. The report has been placed in the FCC proceeding, Improvements to UHF Television Reception (Gen. Docket 78-391).

Policy established for comparing competing STV applications

The commission has established a policy that mutually exclusive applications for a new television station where one or more propose subscription television service will only be compared using traditional criteria, such as mass media diversification, integration of ownership and management, and efficient spectrum use.

It rejected suggestions from various parties that applicants' program proposals also be compared, saying it is inappropriate for a government agency to judge the type of programming offered to the public.

The commission already had criteria for judging mutually exclusive applications for conventional stations but not for subscription television stations. Lack of a uniform policy has significantly delayed the processing of STV applications, and the new comparative policy will reduce such delays, the commission said.

This decision is part of an ongoing STV proceeding. Previously, the agency eliminated a rule that only one station in a community could offer subscription service, refused to require compatibility in STV systems, and rejected a cutoff procedure for applications for STV authorization. However, a community may have more than one STV station only when there are four conventional TV stations operating, so that mutually exclusive applications would occur when more than one conventional station sought STV authorization, leaving the community with less than four regular TV stations.

Broadcast complaints/comments decreased in fiscal 1980

A total of 94,504 complaints, comments and inquiries from the public were received by the Broadcast Bureau in fiscal 1980. This represents a decrease of 14,756 from the previous year when the Broadcast Bureau received an all-time record of 109,260 complaints, comments and inquiries.

Continued



Picture shows Model 5315/32 TV Audio Console customized for WRC-TV, Washington, D.C.

Simplicity, reliability and high performance are the parameters needed by TV broadcasters in the 1980's.

And Neve delivers just *that* in its wide range of purpose designed TV audio consoles; consoles surprisingly

price competitive and often available on short delivery. Our 542 series spans 6 to 16 in, ideally suited for video production facilities and TV audio sweetening. The 5315 and 5316 consoles are available in sizes from 12 to 36 in with 4 or 8 submasters for TV sound production and on-air applications. Please write or call for our comprehensive TV audio console information package, so you can put Neve in your budget now.

You'll be joining the Neve world of excellence!

Audio for TV Stations!

 **Neve**

Rupert Neve Incorporated Berkshire Industrial Park, Bethel, Connecticut 06801 Tel: (203)744-6230 Telex: 969638

Rupert Neve Incorporated 7533 Sunset Blvd., Hollywood, California 90046 Tel: (213)874-8124 Telex: 194942

Rupert Neve Incorporated P.O. Box 120907, Nashville, Tennessee 37212 Tel: (615)385-2090

Rupert Neve of Canada, Ltd. 2721 Rena Road, Malton, Ontario L4T 3K1, Canada Tel: (416)677-6611 Telex: 983502

Neve Electronics International, Ltd. Cambridge House, Melbourn, Royston, Hertfordshire, SG8 6AU England Tel: (0763)60776

Rupert Neve GmbH 6100 Darmstadt Bismarckstrasse 114, West Germany Tel: (06151)81764

Circle (7) on Reply Card



Thanks To You, Ampex Looks Back on 25 Great Years.

As we celebrate our VTR Silver Jubilee, we reflect back on the growth of an industry.

The past 25 years have been exciting! Ampex innovation and the talents of the men and women in broadcasting have made the past quarter century one of significant achievement.

You made it happen like this.

1956. Ampex introduces the VR-1000, the first commercial videotape recorder. Later that year, history is

made with the first videotape delayed coast-to-coast broadcast of Douglas Edwards and the CBS News. **1957.** One of the first videotaped commercials featured Dennis James presenting Kellogg's Corn Flakes.

1959. Richard Nixon and Nikita Khrushchev were videotaped in Moscow during their celebrated "Kitchen Debate."

1960. Broadcasters began an Ampex tradition by capturing the 1960 Rome Olympics on videotape.



1962. Ampex introduces the first electronic editor.

1964. Ampex introduces a major breakthrough, high-band color videotape recording.

1967. Ampex introduces instant replay.

1972. Ampex introduces an automatic video cassette recorder.

1976. Ampex introduces an automatic tracking system.

1980. The VPR-2B becomes the world's best selling videotape recorder when Datacommunications takes

delivery of number 2,000, in Paris.

1981. Delivery to McDonnell Douglas of the 3,000th VPR-2B continues the legacy. The VPR-2B remains the world's most widely used videotape recorder.

We'll share the future.

Our dedication is as firm today as it was 25 years ago. Count on Ampex tomorrow for better ideas in video and audio technology.

AMPEX

VTR SILVER JUBILEE

Visit Ampex at NAB, Booth 702

Circle (8) on Reply Card

WHEN THE SYSTEM IS AIRBORNE, COMMUNICATIONS ARE VITAL

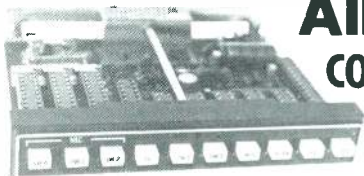

THAT'S WHY WE DEVELOPED THE MOST ADVANCED ENG CONTROLLER IN THE INDUSTRY. COMPATIBLE WITH ALL AIRCRAFT, BROADCAST AND MICROWAVE SYSTEMS, OUR CA-214 ALLOWS FULL USE AND CONTROL OF:

- TWO-WAY FM TRANSCEIVERS
- TRANSMITTED MICROWAVE AUDIO
- RECEIVED uW UPLINK AUDIO
- CUE AND TV RECEIVERS
- VTR
- SCANNER OR CB
- ON BOARD ICS COMMUNICATIONS

CREWMEMBERS INSTANTLY CHOOSE SOURCES AND MIC INPUTS, AND MAY OPERATE IN ISOLATION OR TOGETHER AS DESIRED.

TO ENJOY FULL AND COMPLETE USE OF YOUR NEW BROADCAST PLATFORM, TAKE A CLOSE LOOK AT WHAT WE'VE DONE IN AUDIO, VIDEO AND COMMUNICATIONS CONTROL. YOU'LL BE SURPRISED THAT ANYONE HAS THIS MUCH EXPERIENCE IN BROADCAST AVIONICS.



COMMERCE AIRBORNE CORPORATION
16425 HART STREET, SUITE 104, VAN NUYS, CALIFORNIA 91406, USA (213) 785-6409

Circle (9) on Reply Card

PROTECT CARRY SHIP PACKAGE

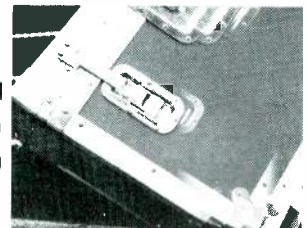
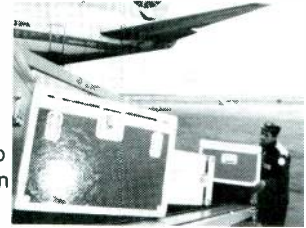
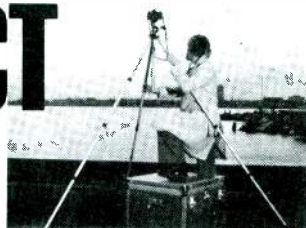

If you're constantly on the move, with no time for repairs, a Fiberbilt case or shipping trunk will protect your equipment and get it there safely...ready to set up and use. Cases and trunks in stock for most A/V equipment. Send for our "Going Places Cases" Catalog G.

Fiberbilt

Ikelheimer Ernst Inc.
601 West 26th St. New York, N.Y. 10001
(212) 675-5820

Circle (10) on Reply Card

FCC update

Continued

Of the 1980 total, 70,188 were classified as complaints, of which 50,485 concerned the operation of television stations, 11,659 AM stations and 7679 FM stations. The 1979 complaints total was 73,523.

Under the category of "political broadcasting and fairness doctrine" 20,340 complaints and inquiries were received, which compares with 8858 in fiscal 1979.

FCC sets interim 15 station limit on low power TV applicants

The commission has set an interim limit of 15 on the number of grants of TV translator and low power TV authorizations that will be made to one owner while the FCC considers whether to give final approval to a new low power television service.

The FCC said that those filing multiple applications would be protected against additional competing applications until issuance of the final decision in the case. However, the commission emphasized that no more than 15 construction permits will be issued to a single owner during the interim, adding that it will be up to the applicant to inform the commission of which 15 of its applications it wants processed for the interim grant. These entities would receive rapid processing of the remainder of their applications after the decision if no final numerical limit is adopted. If a final limit—15 or some other number—is decided upon, excess applications would then be returned.

The action was the result of petitions filed by the National Association of Broadcasters, the Corporation for Public Broadcasting and the National Citizens Committee for Broadcasting for reconsideration of the September 9 rulemaking notice proposing the new low power TV service. Proposals ranged from a 90-day freeze on interim processing (requested by the NAB with support from two of the three major TV networks, ABC and NBC) to retention of interim processing procedures as recommended by the National Translator Association and Community Television Network, a minority owned group with 10 applications currently on file.

The commission also instructed the staff to treat certain requests to amend translator authorizations as "major changes" requiring a new cutoff period. Amendments to be treated as major include upgrading of a translator station to low power operations by adding origination or subscription television (STV) capabilities, or both, and those requesting extensions of the time for construction of a low power station or translator.

In its September 9, 1980, rulemaking notice, the commission proposed the licensing of low power TV stations which could originate an unlimited amount of programming and conduct STV operations. It said it hoped to bring television service to locations that otherwise are unserved or underserved, for whatever reasons, by regular, full service television stations and cable services.

It also decided not to impose a freeze on the processing of TV translator applications, and said that it would entertain requests to waive the rules to add low power features to a translator on a case-by-case basis. During the pendency of the rulemaking, the commission instructed the staff to defer action on all mutually exclusive applications and on applications that were inconsistent with the proposed ownership rules or with technical standards for the proposed service. □

NEED A FULLY EQUIPPED 40-FOOT PRODUCTION UNIT?



A MID-SIZE ENG TRUCK
WITH MICROWAVE?

A NEWS
MAGAZINE VAN
WITH ON-BOARD
POWER?



THEN TALK TO **MIDWEST'S**
MOBILE UNIT DIVISION!

Selecting a vendor to supply a \$100 thousand or \$3 million mobile unit is a great responsibility.

MIDWEST CORPORATION, the nation's largest video sales and service organization, is the best choice for meeting your needs, and here's why:

- We handle major lines of all production equipment, so we don't have to charge for two-stepping.
- Our size and volume means cost savings passed on to you.
- More than 20 years in television means expertise and a good reputation.
- As a major division of UNR Industries, we offer the security and stability of a large and financially sound company.

- We are the single source for custom vehicle, equipment, installation and service.

When your mobile unit order calls for **QUICK DELIVERY**, **GOOD QUALITY**, and **COST EFFECTIVENESS**, don't just pick two . . . pick **MIDWEST**, and get all three.

A PARTIAL LIST OF OUR MAJOR PRODUCT LINES:

Ampex, Cezar International, Conrac, Digital Video Systems, Fernseh, Gerstenslager, Hitachi, Ikegami, ISI, ITE, Lenco, 3M Minicom, Microwave Associates, O'Conner, Panasonic, Quick Set, RTS Systems, Scientific Atlanta, Sony, System Concepts, Tektronix, Van Ladder, Video-Media, Videotek, Vinten and Wilbert Masts.

Give Carl Raasch, Mobile Unit Sales Manager, a call and allow **MIDWEST** to quote on your first . . . or next mobile unit requirement.



MIDWEST
CORPORATION

1021 West 8th Street
Cincinnati, OH 45203

 A UNR Company

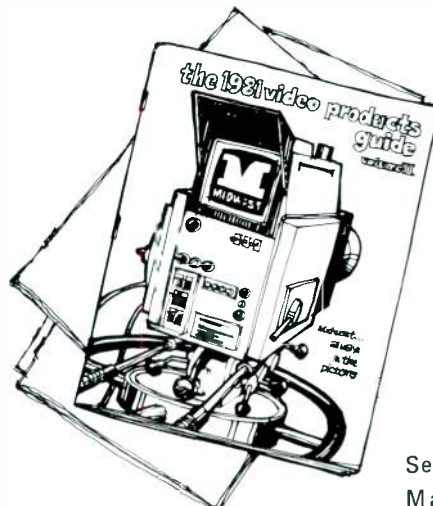

Circle (11) on Reply Card

CALL —

800-543-1584
(In Ohio 513-651-1904)

Request a copy

- Mobile Unit Information
- 1981 Video Products Guide
- 1981 CATV Products Guide
- Midwest Capabilities Brochure

See us at NAB in Booth 1829 or at our Maxim Hotel Hospitality Suite.

Chinese language edition announced by BE

In response to an invitation by the China Central Broadcast Administration and Radio Peking, **Broadcast Engineering** magazine will publish a special Chinese language edition to be distributed annually in the People's Republic of China starting in August of this year.

The announcement was made by George Laughead, publisher of Intertec Publishing Corp.'s Electronics Group which includes **BE**.

The invitation was a result of direct discussions between George H. Roman, Intertec Chinese liaison, and Yeh Fu, research director for Radio Peking, during Roman's visits to Beijing (Peking) in July and September of 1980.

During his visits, Roman met with top directors in the Central Broadcast Administration and Radio Peking to arrange for expert translation and distribution.

The decision to work with Radio Peking and the Central Broadcast Administration was based on the fact that it is one of the government's arms specifically charged with the responsibility of modernizing China's radio and television industry.

According to Laughead, the Chinese are firmly committed to increasing their radio and television technology through rapid modernization.

At the request of the Chinese, circulation for the first Chinese Language Edition of **BE** has been set at 8500. Distribution throughout China will be handled by Radio Peking. Printing and translation will be done in Beijing.

Companies interested in advertising in this special issue should contact George Laughead at (913) 888-4664.

The Camera Nacional de la Industria de Radio y Televisión

XXII Semana Nacional de Radio y Television celebrated its Regular General Assembly at Hotel Fiesta Palace in Mexico, D. F., Mexico, October 6, 1980. High attendance and an active company display area noted the healthy state of affairs of the Mexican broadcast industry.

Visitors from other areas of North, Central and South America included the Chairman of the National Association of Broadcasters, Thomas E. Bolger, president of WMTV-TV, Madison, WI, who spoke on the 9kHz issue and saluted the CIRT and its staff, and its president, Lic. Luis Ignacio Santibañez Flores. The honored guest was Licenciado José López Portillo, president of México.

Santibañez gave the following exclusive comments to **Broadcast Engineering** and **Radio y Televisión** (with the translation assistance of Luis Carrillo, president of IER): "It is a pleasure for me to join with all the radio and television professionals from Central and North America at the 22nd seminar of the CIRT. Especially important at this seminar are the messages from the NAB and NRBA, and the Canadian Broadcasters concerning ways that we can work together to benefit continental broadcasting as a whole. I also must thank all of the electronics manufacturers and their representatives for their support. They join with us to make this event more important. The seminar sessions are very productive as a starting point—to continue

with this communication is to benefit the total Mexican broadcast industry."

Santibañez is the first CIRT president to attend the NAB show and talk with its board. Joint meetings of the CIRT, the NAB, the Canadian broadcasters, etc., on issues of mutual concern will continue, he said.

IER (International Equipment Representatives) received an award for the best presentation and demonstration of electronics equipment at EXPOCIRT '80, the display portion of the seminar.

Technical sessions held throughout the XXII Semana Nacional covered all areas of station operation and management. These were well attended and well organized. Licenciado Emilio Velasco Díaz, Gerente de CIRT, and Licenciado Jose Luis Erosa Vera, legal adviser of CIRT, among other CIRT staff members, guided the events of the week long session.

Companies represented with booths at the CIRT included:

Accurate Sound International, SA
AEG Mexicana, SA
AMICEE
Ampex, SA
Audioacústica y Electrónica, SA
Audio Profesionales, SA
CCA Electronics de Mexico, SA
Dual Instalaciones, SA
Electroingeniería de Precisión, SA
Empresas JL, SA
Guarantee Radio Supply Corp.
IER (International Equipment
Representatives)
Iluminación Técnica y Electrónica,
SA
Ingeniería Eléctrica y Electrónica,
SA
McMartin Industries Inc.
Sahabsa
Servicios en Comunicaciones
Eléctricas y Electrónicas, SA
Sonimagen, SA
TeknoMérica, SA
Teletec, SA
Woolimex, SA
XEW Sistema Radiopalis, SA

Other companies sending representatives to work in these booths included: IGM Communications, JVC, Telex, Ampro Scully, NEC, URSA Major, UREI and Singer Products.

Arch Madsen named to receive NAB Distinguished Service Award

Arch L. Madsen, president, Bonneville International Corporation, Salt Lake City, UT, has been named recipient of the National Association of Broadcasters' 1981 Distinguished Service Award, the industry's highest honor.

Presentation of the award will be made April 12 at the opening session of NAB's 59th annual convention at the Las Vegas Convention Center.

The award, established in 1953, is presented to a broadcaster who has made "a significant and lasting contribution to the American system of broadcasting by virtue of a singular achievement or continuing service for or on behalf of the industry."

The selection was made by NAB's 1981 Convention Committee during the association's semi-annual board of directors meeting.

He has served for many years as US delegate to the Inter-American Association of Broadcasters and formerly was treasurer and a member of its board of

the new CD-480-4

another smart switcher from CDL

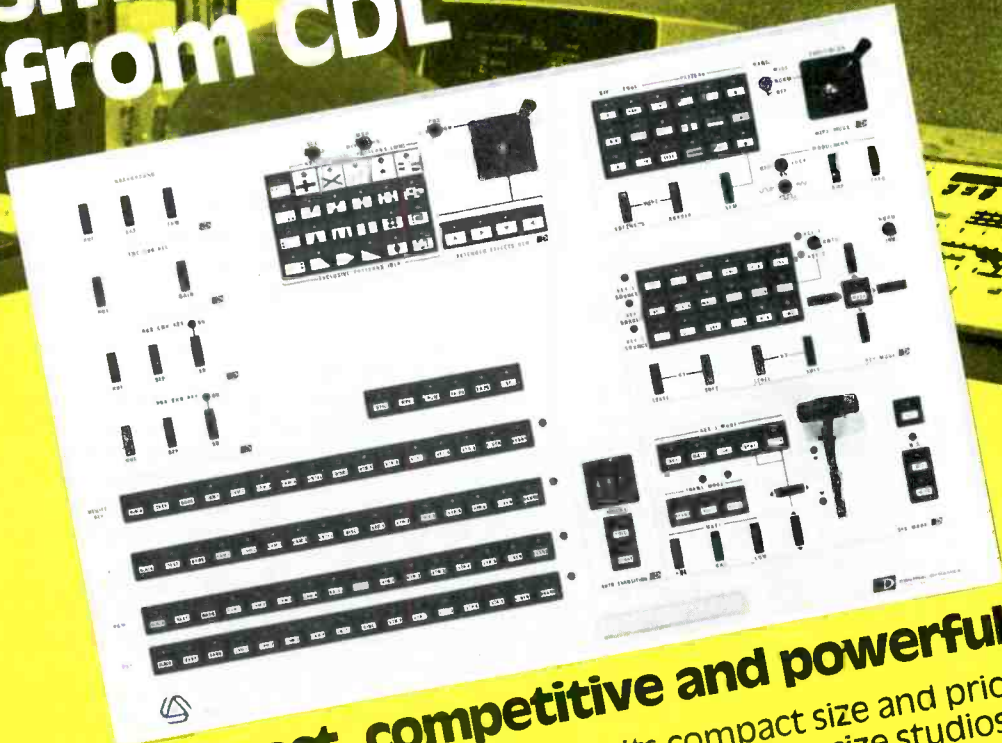

compact, competitive and powerful

New at NAB
The 480-4
with CAP,
Computer
Assisted
Production
option.
Booth 1015

The power of the CD-480-4 plus its compact size and price make it the professional choice for medium size studios, post production suites and mobile vans.

Powerful: includes the unique CD-480 SFX amplifier that permits you to control 4 video signals, in any combination, with one fader handle, plus a wide range of powerful CD-480 modular options.

Compact: 24" wide panel and 21" of rack electronics.

Price: Also compact and competitive . . . ask us.

The CD-480 gives you the competitive advantage.

Central Dynamics, 10 W. Main St., Elmsford, NY 10523, 914-592-5440
 Chicago: 312-991-4720, Los Angeles: 213-789-0574, Atlanta: 404-491-9037
 Dallas: 214-785-5764, Denver: 303-623-7603, CANADA-Montreal: 514-697-0810

CENTRAL DYNAMICS



tube talk

30 mm

**P8400
Leddicon®
The new tube
for a
new image.**

Here's why . . .

Lag is significantly improved for all channels with the P8400's exclusive variable integral light bias . . . and it's easy to set with the pot and calibrated scale on the base.

Sharper, crisper pictures at all light levels are assured with our new P8400HG tubes (high resolution green) that have 15-20% more depth of modulation.

The best "red" reproduction. The P8400 precision infrared filter cuts off false reds.

Anti microphony double damped mesh . . . only in EEV Leddicons.

Find out how the P8400 Leddicon can improve your image . . . call or write for our Tube Talk brochures.

* Registered Trademark of
EEV Lead Oxide Camera Tubes

**At EEV . . . your image
is our business.**

**See Us at NAB
Booth #925**

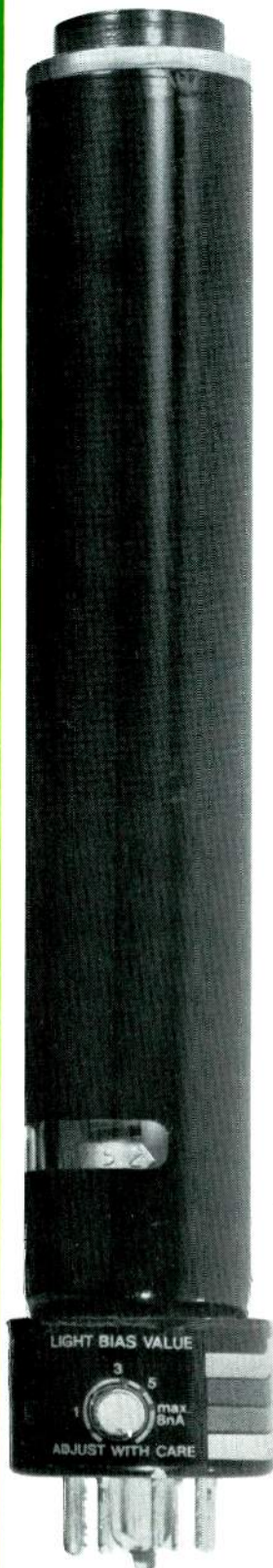

EEV, INC.

7 Westchester Plaza, Elmsford, NY 10523, 914-592-6050
EEV CANADA, LTD., Rexdale, Ontario, 416-745-9494
English Electric Valve Co. Ltd., Chelmsford, England
Telex 851-99103

Members of the GEC Group of Companies

Circle (13) on Reply Card

News

directors. He was two-term member of the National Association of Broadcasters' Television Board, former president of the Association of Maximum Service Telecasters, and current chairman of NAB's International Committee. He is a former president of the Association of Maximum Service Telecasters and currently serves as a member of its executive committee and board of directors.

Madsen is chairman of the United Press International Broadcast Advisory Board, and a member of the Executive Committee of the World Press Freedom Committee. He is involved in a number of civic organizations, including chairman of the Governor's Committee on Executive Re-Organization of the State of Utah; a member of the Board of Directors of Desert Management Corporation, Salt Lake City; the Board of Trustees of the Freedom Foundation, Valley Forge, Pa.; and the United States Industrial Council, Chicago. He is a member of the International Press Institute and the Asian Pacific Broadcasting Union.

Ciapura rejoins BE

Dennis Ciapura, Greater Media Inc.'s general manager of telecommunications and technical director, rejoins this issue **Broadcast Engineering's** consulting editorial staff. Ciapura's first major assignment will be a National Association of Broadcasters replay article for **BE's** June post-NAB issue. He will also be introducing the reel-to-reel audiotape recorder roundup in the April issue of **BE**.

During Ciapura's earlier association with **BE** he wrote more than 30 major articles covering a wide range of technical topics ranging from radio broadcasting and recording studio procedures to satellite communications. He also operates Teknimax, a technical consulting company.

Greater Media Inc. is a broad-based communications company currently operating 13 broadcast stations and several cable television systems as well as satellite and land mobile facilities.

Contact Ciapura at PO Box 859, East Brunswick, NJ 08816 if you wish to send special materials to him.

Preliminary China Comm '81 seminars program announced

Preliminary plans for the seminars program to be held in conjunction with China Comm '81, the first-ever US telecommunications equipment and systems exhibition and seminars program to be held in Beijing (Peking), People's Republic of China, November 3-13, 1981, were announced by Electronic Industries Association and the National Council for US-China Trade, co-sponsors of the function. The seminars program will be an integral part of the first comprehensive US telecommunications exhibit ever held in China. The exhibition and seminars program are the result of many years of negotiation with Chinese officials.

Digital demonstrations highlight conference

Two major events related to the future of television technology took place at the recent SMPTE Conference in San Francisco.

The first was a series of demonstrations of digital component coding techniques being put on for the various standardizing groups of both the SMPTE and the EBU. The purpose of these demonstrations was to give the committee members adequate information on which to base a specification that could lead to a

**THANKS...
for a great year.**

**STUDER REVOX
AMERICA INC.**

Studer Revox America, Inc.
125 Elm Hill Pike
Nashville, TN 37400
phone: (615) 254-5651

Studer Revox America, Inc.
155 Ave. of the Americas
11th Floor
New York, NY 10013
phone: (212) 255-4921

Studer Revox America, Inc.
14046 Burbank Blvd.
Van Nuys, CA 91411
phone: (213) 780-4234

Studer Revox Canada, Ltd.
14 Sanigan Drive
Toronto, Ontario M2H 1E9
Canada
phone: (416) 423-288

Circle 14 on Reply Card

tube talk

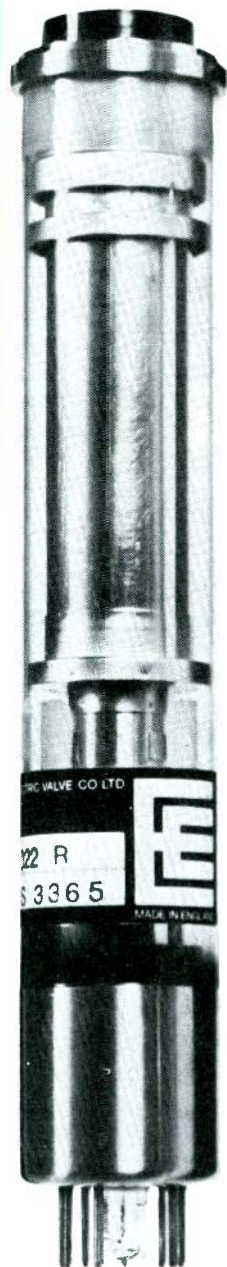

1"

Leddicons® are in every type 1" camera that uses lead oxide tubes.

Here's why...

- Anti microphony.**
A double damped mesh...
only in EEV Leddicons.
- High Resolution Greens** for sharper, crisper pictures at all light levels...and less aperture correction.
- Leddicon's light bias technique** significantly improves lag in individual channels.
- Extended Reds** with close tolerance infrared cut-off filters for the best "red" reproduction.

Find out how 1" Leddicons can improve your image.
Call or write.

• Registered Trademark of
EEV Lead Oxide Camera Tubes

At EEV...your image is our business.

See Us at NAB
Booth #925



EEV, INC.

7 Westchester Plaza, Elmsford, NY 10523, 914-592-6050
EEV CANADA, LTD., Rexdale, Ontario, 416-745-9494
English Electric Valve Co. Ltd., Chelmsford, England
Telex 851-99103

Members of the GEC Group of Companies

News

worldwide compatible, digital coding system for digital TV studios.

In addition to these demonstrations, there were some newer versions of the experimental digital video recorders that had been previously shown, exhibiting the latest advances made by various videotape recorder manufacturers in that field.

The second special feature of the Television Conference was the first showing in North America of the NHK Research Laboratories' High Definition Television System.

NHK Labs agreed to bring over from Japan the complete color camera and display equipment they had developed for their 1125 line color television system. This included a special broadband color camera with unique two-inch Saticon pick-up tubes and a large screen; direct view color picture tube display device with a high resolution faceplate. This equipment was in operation during the conference for delegates to get a good first look at what high definition, broadband color TV could look like in a few years.

EMT-Franz debuts products at AES-Hamburg

EMT-Franz introduced several new products at the Hamburg Audio Engineering Society 68th Convention.

The EMT 450 Digiphon provides high quality audio recordings using a commercial digital disc storage device. As many as 32 audio channels may be recorded simultaneously. The maximum recording time is 70 minutes for a monophone signal, becoming less in accordance to the selected number of tracks.

The EMT 245 Digital Reverberator produces an effective simulation of natural room reverberation with an extensive influence on the parameters, which determine the room-character. The reverberation time is selectable and the response curve of the high and low frequencies can be changed. Furthermore the unit has an adjustable pre-delay and a level control for the early reflections. The unit is designed for applications, where size and space are of critical importance.

The EMT 423 Flutter-Audicorder is a recording and acoustic monitoring unit for the flutter meters. The recorder registers measurement data on thermosensitive waxed paper. By means of the internal 3W amplifier and loudspeaker, disturbance of the device under test can be precisely appraised.

Audio-video imports

US imports of color cassette videotape recorders jumped sharply during the first six months of 1980, according to the latest figures released by the US Department of Commerce's International Trade Administration.

Also increasing sharply during the period were imports of incomplete sets, printed circuit boards and parts used in the assembly of color television sets.

While imports of VCR's and TV subassemblies were rising, most other audio-video products declined significantly, including CB radios and radio-phono combinations.

The total value of audio-video imports from January through June remained at \$2.1 billion, about the same as for the corresponding period of 1979. Substantial fluctuations occurred, however, in the mix of imported products. The significant increases were:

- Color cassette video recorders (almost exclusively

Circle (15) on Reply Card

DEXCELLENCE DEXCEL

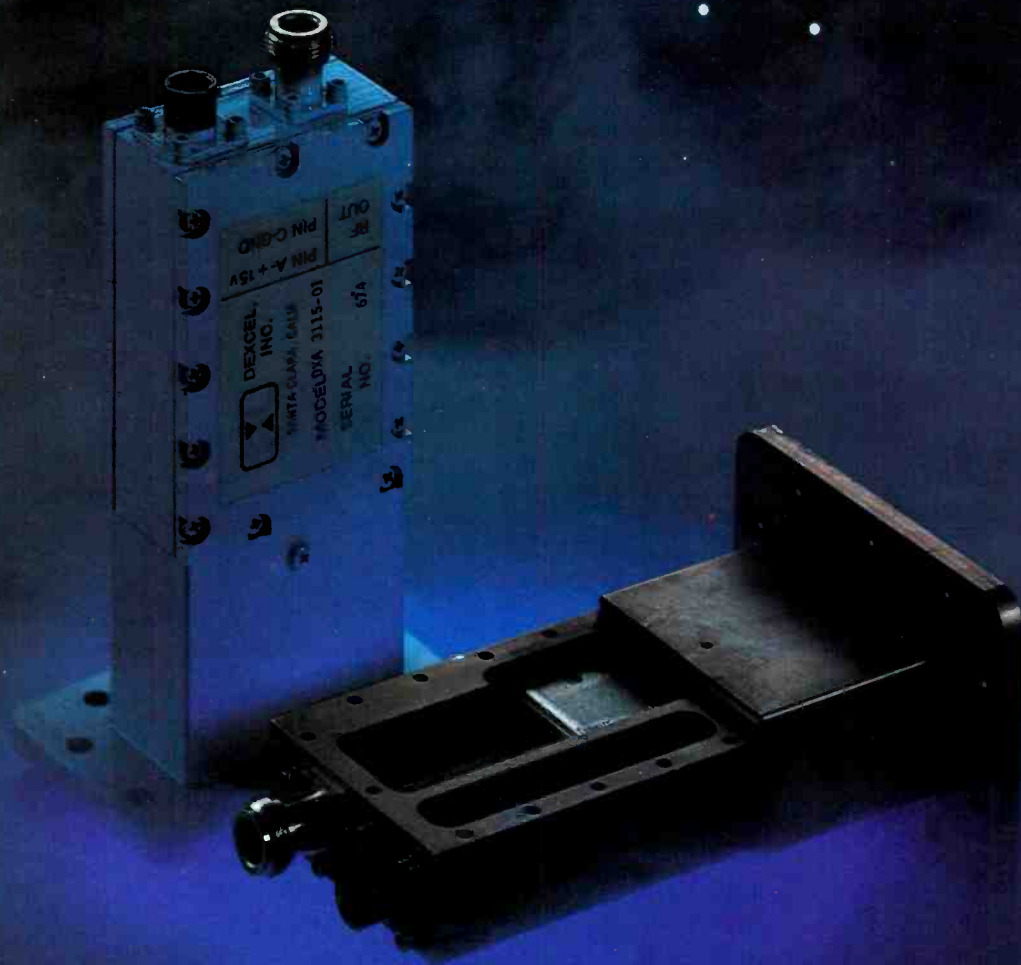

Dexcellence

DEXCEL 3115 Series Low Noise Amplifiers

Dex-cel-lence: (*dek's'l-əns*), *n.* superior products and performance from Dexcel.

Dexcel 3115 series Low Noise Amplifiers operate at 3.7–4.2 GHz in earth terminal applications. Our uncooled GaAs FET LNA meets or exceeds industry specifications for performance. Dexcellence in technology leads to unique design features in our 3115 series LNA.

Examples of Dexcellence: The 3115 series LNA features Microwave Integrated Circuit (MIC) construction for reliability. GaAs FETS designed and fabricated by Dexcel are used exclusively in our 3115 series LNA's. Your noise temperature selections include 85°K, 100°K, 120°K. Band pass characteristics are well defined resulting in an improved video signal.

The DXA 3115 LNA is packaged to withstand the harshest environmental conditions. The one-piece aluminum case reduces potential mechanical failure. Military type construction techniques insure quality and reliability. Complete lightning destruction protection has been designed into the Dexcel 3115 LNA.

For more information about Dexcellence in Low Noise Amplifiers, please call . . .



DEXCEL, Inc.

2285C Martin Ave., Santa Clara, CA 95050 • Ph: (405) 727-9833 • TWX: 910-338-1060

Circle (16) on Reply Card

JOIN THE CSI NETWORK

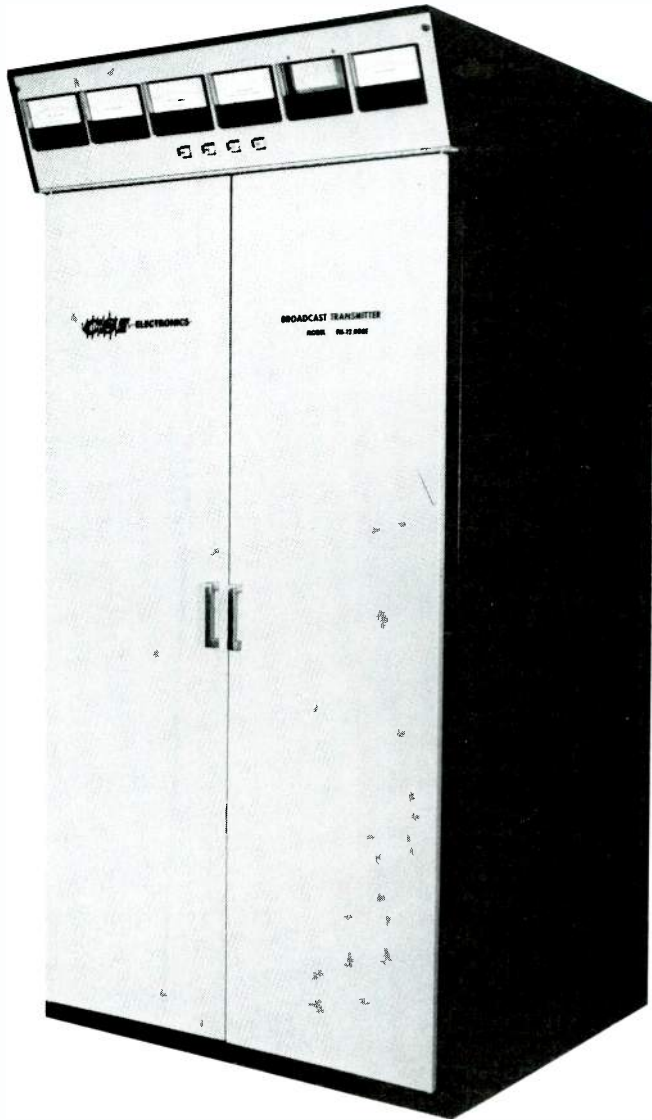

Now you too can become a member of one of the fastest growing networks in radio broadcasting. CSI's more than 500 satisfied transmitter owners.

You can share the advantage of superb quality craftsmanship and dependable service others expect from CSI.

CSI...the network you'll be glad to be affiliated with.

CSI ELECTRONICS INC.

18248 E. Rogers Cr., Boca Raton, FL 33431
Phone 305/737-5626

This equipment is distributed in Latin America by Electrex Company, 18680 N.E. 2nd Ave., Miami, FL 33179. Contact Ben Ostrovsky, 305/651-5752.

Circle (17) on Reply Card

News

from Japan), up 51% to 372,000 units; by value, by 42% to \$192 million.

- Incomplete color TVs without a picture tube, up 39% to 1.5 million units; other assemblies (without all or part of a chassis frame), up 200% to 5.5 million units; and printed circuit boards, up nearly 12% to 3.4 million units. The import value of these components increased 34.2% from \$211 million to \$282 million.

- Color TV cameras, primarily for use with home-type VCRs (almost exclusively from Japan), up 66% to 58,000 units; by value, up 9.5% to \$37 million; the wide differential between large unit increases and small value gains indicates a continuing drop in unit prices.

Posting declines in imports (both in units and value) for the period were:

- Radio-phone combinations, down 56%
- CB radios, down 34%
- Automobile radios, down 28%
- Enclosed loudspeakers, down 21%

ITA also noted that audiotape recorders/players/and combinations, representing 31% of the value of all audio-video product imports, dropped nearly 10% to \$656 million, following last year's value increase of 17%. Imports by quantity remained relatively stable at 15 million units.

SMPTE elects new officers and governors

New SMPTE officers and governors have been elected by the membership of the Society of Motion Picture and Television Engineers (SMPTE), it was announced by SMPTE President Robert M. Smith, Du Art Film Laboratories. Each will serve a two-year term beginning January 1981.

Charles E. Anderson, Ampex Corp., has been elected president. Anderson, who is currently executive vice president of SMPTE and a fellow, has been active in SMPTE affairs as a member of engineering committees, television and national conference program and local arrangements committees, section vice president and governor.

Current SMPTE President Robert M. Smith will become past president and maintain a position on the SMPTE board of governors.

SMPTE's new executive vice president will be Joseph A. Flaherty, CBS Television. The new editorial vice president is Maurice L. French, Canadian Broadcasting Corp. Charles A. Ahto, Tape-Film Industries, a division of MPO Videotronics Inc., was elected conference vice president. Harold J. Eady, Novo Communications, Inc., was re-elected secretary. Julian Hopkinson, Agfa-Gevaert Inc., has been elected treasurer.

The newly elected SMPTE governors are:

New York region: K. Blair Benson, Video Corporation of America; Calvin M. Hotchkiss, Eastman Kodak Co.; and Irvin Rosenberg, CBS Television Network;

Southern region: Eugene Myler, Eastman Kodak Company;

Central region: Edward J. Blasko, Eastman Kodak Company, and Toni Roth, Image Transform Inc.;

Western region: Gary L. Borton, Eastman Kodak Company; Robert J. Ringer, Image Transform Inc.; and Joseph A. Semmelmayr, Eastman Kodak Company;

Eastern region: Thomas B. Keller, Public Broadcasting Service;

Canadian region: Ray J. Brule, 3M Canada Inc.

Now that we're selling. Look who's buying.

Compact Video has pioneered video communications for almost a decade. Our user-oriented experience has earned us recognition as the experts in design, consultation and installation of broadcast and satellite transmission centers. We're also known as the foremost builders of mobile location vehicles.

For the broadcaster and cablecaster, Compact Video offers a choice of six standard mobile location systems to meet every production demand. Or we will custom design a mobile system to your exact specifications. From our two rugged ENG's to our one-of-a-kind transportable uplink Earth station, our mobile systems are engineered to deliver maximum efficiency, optimum performance and increased profitability.

Whether you're considering a broadcast or satellite transmission center, a television complex, editing or audio facilities, or just a simple screening room, *Call on Compact Video today.* We make state-of-the-art technology practical.

ESPN
TRINITY
TELEvisa
PLAYBOY PROD.
KOLO-TV
KWTW
NET (Nat. Ed. Tel.)
OMNICOM
SCN (Satellite Comm.)
VIDEO WEST
ELP (Elec. Loc. Prod.)
KLAS-TV
SUN TELEVISION
WFAA (Belo Broad.)

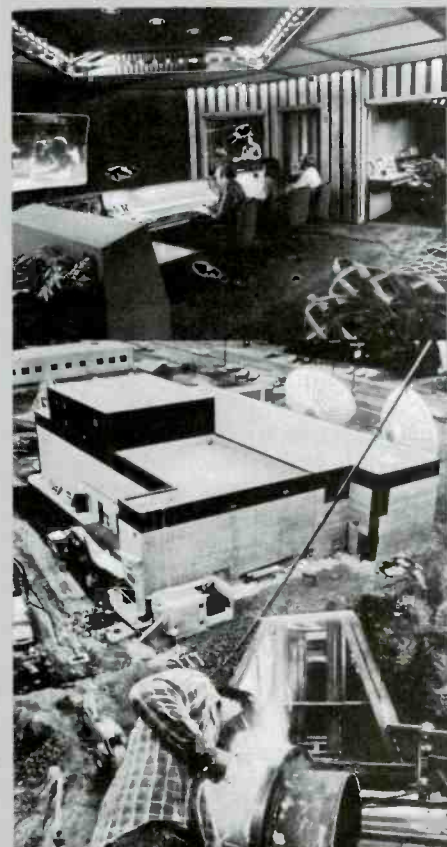
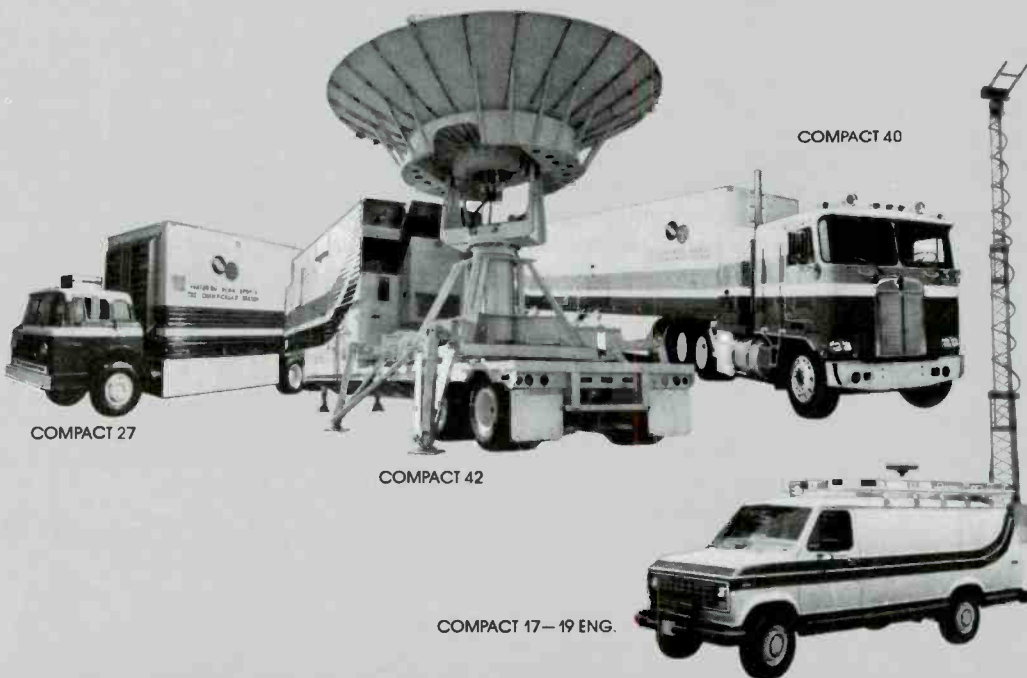

A Decade of Engineering Excellence

COMPACT VIDEO

Sales, Inc.

MAIN OFFICE: 2813 WEST ALAMEDA AVENUE, BURBANK, CALIFORNIA 91505 (213) 843-3232 TELEX: 194855 TWX: 910-498-4987
REGIONAL OFFICES: Eastern (215) 245-8886 / Midwest (312) 369-0714 / S. Eastern (404) 355-5255 / S. Western (214) 783-0044 CMPVIDEO

Circle (18) on Reply Card

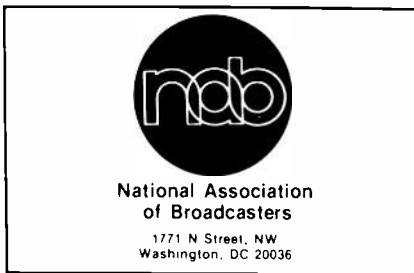

FCC financial reports criticized

While maintaining that the FCC should completely abandon its requirement that every commercial broadcast station must file an annual financial statement, the NAB said that if the agency retains this filing requirement the form should be reduced rather than expanded as now proposed.

In its filing, the NAB noted that the reporting system "is not statutorily required nor essential to the commission's regulatory mission and that its burdens to broadcasters outweigh any benefits to the agency or to the public." It said any financial information could be obtained through a small sample on an "as needed" basis. It pointed out that only on rare occasions has the FCC utilized a portion of the data collected, let alone the entire mass of figures.

90-day freeze requested on low power TV, TV translator applications

The NAB has asked the FCC to place an immediate 90-day freeze on processing low power television and television translator applications and to reconsider its interim processing policy for handling them. A temporary freeze is needed, the NAB said, because of the unprecedented and unanticipated volume of applications: more than 450 so far and at least several hundred more being prepared for filing.

The association said that the processing procedures violate the Administrative Procedure Act (APA) and that reconsideration would ensure that the service develop according to a comprehensive long-range plan rather than on a haphazard basis.

Plan to drop operators license supported

The NAB supports the FCC's proposal to eliminate First Class Operator licenses and said the industry could develop a method to test and screen engineers.

In its filing, the NAB said it agreed with the FCC's conclusion that federal licensing procedures do

not adequately test technical competence. Preliminary discussions between the association and the Society of Broadcast Engineers indicate that the two organizations and other broadcast entities could develop a more satisfactory testing method. An alternative would be for the industry to devise a process in which tests could be conducted at stations where applicants could work directly on transmitting equipment and licensees could personally interview them, and review references, previous work experience and education.

The NAB said it is committed to assisting the industry in designing methods of testing and screening technical personnel to determine their capacity to operate, install, service and maintain transmitter equipment. It noted that for many years the NAB has distributed information and provided assistance to broadcast operators on engineering, FCC technical rule compliance and related issues.

Contingency hotel space made for Las Vegas Convention

The NAB and the Las Vegas Convention Bureau have initiated contingency arrangements to satisfy the needs of those who were slated to use the MGM Grand Hotel during the Convention, April 12-15.

NAB President Vincent T. Wasilewski said: "The NAB television headquarters, formerly at the Grand, will be shifted to the Dunes, Caesar's Palace and the Aladdin hotels—all of which are on the Strip in close proximity to each other. As of today, through the cooperation of the Las Vegas Convention Bureau and the hotels, additional suite space has been reserved compensating for over two-thirds of the suites lost in the fire. The NAB staff is in the process of reassigning to other hotels the sleeping rooms previously requested for the MGM."

Supreme Court asked to overturn ruling on government consultants

The NAB and eight other media organizations have asked the US Supreme Court to overturn a ruling that threatens to inhibit the news media from reporting on and criticizing government contractors and consultants.

The case (Loudoun Times-Mirror, Loudoun, VA vs. Iroquois Research Institute) stems from a Times-Mirror story on the archaeological consulting firm that Iroquois maintains was defamatory. The firm had been hired by Fairfax County, VA, and the newspaper considers it an arm

of government and therefore open to public scrutiny. The US Court of Appeals for the Fourth Circuit refused to classify such firms and individuals as public officials or public figures when they bring defamation actions.

In its friend-of-the-court brief, NAB said, "The First Amendment privilege in libel law encompasses criticism of all those responsible for performing the functions of government, not simply elected officials or full-time public employees." It also said the Appeals Court decision is in direct conflict with other rulings and "suggests an avenue by which elected officials may avoid public scrutiny or chill criticism simply by delegating their public responsibilities to contractors and consultants."

New broadcast organization elects officers

At its organizational meeting December 5, the Broadcast Inter-Association Council (BIAC) elected a slate of officers and two members of its Executive Committee to serve one-year terms. The purpose of BIAC is to share ideas, coordinate activities and serve as a forum for exchange of information among members. It will not be involved in political activities nor take a position on the merits of such matters.

Elected were Robert McAuliffe, executive director, Broadcast Financial Management Association, chairman; Nate Boyer, executive director, National Association of Black Owned Broadcasters, vice chairman; and Philip Balboni (WCVB-TV, Boston), a member of the Board of Directors of the National Broadcast Editorial Association, secretary/treasurer. Serving with the three officers on the Council's Executive Committee will be Tom Dawson (CBS Radio, New York City), president, Broadcasters Promotion Association, and Wally Johnson, executive director, Association of Broadcast Engineering Standards.

Wexler named to government relations department

Kenneth D. Schanzer, National Association of Broadcasters' senior vice president for government relations, has announced the appointment of Daniel Wexler as manager, broadcast liaison.

For the past two years Wexler was special assistant to the director of ACTION, an independent US government agency administering domestic and international programs. He previously was a research editor for Rolling Stone



**Quality
Reliability
Performance**

An Andrew earth station antenna. This one stands dramatic in the Texas plains, but you will see others in almost every state in the U.S. as well as in Canada, Africa, and Australia. In fact, all over the world. Even on offshore drilling platforms. Why? Because our customers know these units are versatile, rugged, and reliable. Diameters from 3 to 12 metres. Contact Andrew with your particular requirements.

 **ANDREW**

ANDREW CORPORATION
10500 West 153rd Street
Orlando Park, IL 60462
Telephone (312) 249-3300
Plants and representatives
throughout the world.

NAB news

Magazine, and an intern in the office of Senator George McGovern and with Common Cause Voting Rights Project. He also worked on the McGovern and Edmund Muskie presidential campaigns and on Joseph Duffey's senatorial campaign.

Mitchell named regional manager

Larry Tierney, National Association of Broadcasters' membership vice president, announced the appointment of William Mitchell as regional manager for Rocky Mountains West (Arizona, Colorado, Idaho, Montana, Nevada, New Mexico, Utah and Wyoming). He succeeds Lynn Renne, who retired December 31.

Mitchell has been semi-retired from broadcasting for the past 18 months. He most recently was co-owner of KERB Radio, Kermit, TX.

Adoption urged for FM Quad technical standards

The National Association of Broadcasters said the FCC should adopt technical rules for discrete FM quadrasonic broadcasting and not leave it to the marketplace to set standards. In its filing, the NAB also said it supports continuation of the special services available from the use of subsidiary communication authorizations such as foreign language broadcasts and reading services to the blind.

NAB said that once a clear technical standard is chosen the competitive free enterprise system will swing into full operation. The NAB asserted that if there were no standards, the transmitting equipment, broadcasting and receiving equipment markets would suffer from confusion and the public could be deprived of FM quad broadcasting and receivers. In the absence of a clear FCC standard, the NAB said, quad service "would be so scarce as to be unable to support the broadcasting or manufacturing of receiving equipment."

Turner proposal would eliminate cable rules

The NAB has announced it opposes the petition filed by Turner Broadcasting System requesting the FCC to repeal its mandatory cable carriage rules. The NAB said this would reverse a statutorily mandated policy "to promote the development of a nationwide system of local broadcast services which ensures that the American public is

provided with a fair, efficient and equitable distribution of those services."

In its filing, the NAB said that the request "is solely motivated by the best interests of one private entrepreneur" and that it is not supported by the leaders of the cable industry.

The association said local broadcasters have effectively and economically succeeded in providing the services contemplated by Congress and the FCC. Elimination of the "must carry" rules would cause them serious economic harm and would reduce the quality and quantity of free local video services, the NAB said.

Turner said the rules should be eliminated to provide for a system of open "marketplace" competition in which the cable carrier, once it has penetrated a sizeable portion of a given market, can eliminate competitors by simply deleting their signals from that portion of the market that is hooked up to its system. The NAB said this is not the true definition of a marketplace and is not the intention of Congress that the best interest of the local viewing audience be subjected to cable operators' self-serving determination.

The association also said Turner "has failed to adduce sufficient data or information to make a clear and convincing argument that the commission needs to re-evaluate its long-standing policy of requiring the carriage of local broadcast signals by cable systems." If the FCC eliminated the rules, NAB said, "in essence the cable industry would be totally unregulated and free to provide whatever service it wished to its captive audience."

NAB supports 'simplified renewal' approach

Terming it "a step in the right direction," the NAB applauded the FCC's proposal to simplify its license renewal application forms, but objected to plans for random and unannounced field audits, the completion of lengthy audit renewal applications issued without warning, expansion of a station's public file requirements and increased renewal-related sanctions.

In its filing, NAB urged the commission to undertake a zero-based review of its public file requirements and eliminate all related rules that either are not absolutely essential to the public interest or could be discarded in favor of marketplace forces.

Further 9kHz study called for

The NAB told the FCC it has not

met the burden of proving that the public interest would be best served by reducing AM channel spacing to 9kHz and called for an adequate study of the costs and benefits by the Advisory Committee on Radio Broadcasting.

The association emphasized that while it neither favors nor opposes 9kHz channel spacing, there is a need for definitive studies to be completed showing gains and losses which would flow from the use of 9 kHz spacing as compared to the present 10kHz spacing. It said studies should take into account a clear set of objectives and priorities for aural broadcasting in the United States—objectives and priorities which have not been specified. Also to be considered, NAB said, are other possible allocations developments, such as more intensive use of the FM band, the addition of full-time stations on the clear channels and the expansion of the AM band.

Bill Kennard chosen for fellowship program

Bill Kennard, who will graduate in June from Yale Law School, has been selected for the National Association of Broadcasters' Legal Fellowship Program, Erwin G. Krasnow, NAB senior vice president and general counsel, has announced. The one-year fellowship, which starts in September, provides a post-graduate work-study experience for a minority lawyer planning a career in communications.

Kennard will participate in rule-making proceedings, draft briefs for appellate review, assist NAB's Government Relations Department in its activities before Congress and become involved with the federal regulatory process.

He was a semifinalist in the Yale Moot Court of Appeals competition, serves on the court's board of directors, is chairman of the Admissions Committee of the Black Law Students Union, is a participant in the Jerome N. Frank Legal Services Organization and is student assistant to the dean of admissions. He is a Phi Beta Kappa graduate of Stanford University with a Bachelor of Arts degree in communication. As an undergraduate he won first prize in the Annual French Department Writing Awards and KRON-TV's (San Francisco) annual scholarship, co-produced a weekly public affairs program for Stanford's KZSU, was a contributing editor and photography editor for the black student newspaper and co-sponsored and taught two seminars on media production. □

Leave the driving to us.

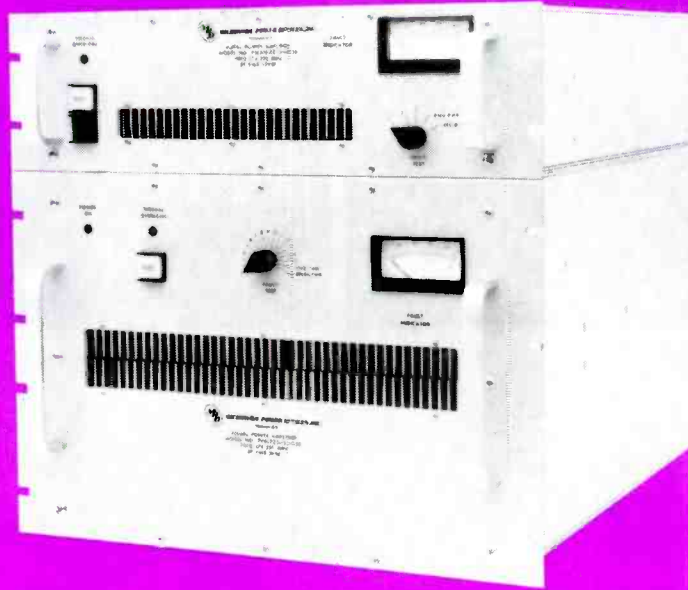

Replace your troublesome tube driver with our trouble-free solid state driver.

Since 1967, MPD has been the world leader in solid state RF/Microwave high power amplifiers for a broad spectrum of the most demanding military, aerospace and telecommunications applications. Now, all that expertise in high quality performance and maximum reliability is utilized in these solid state drivers, designed to meet the needs of modern TV broadcasters.

COMPLIES WITH NTSC & CCIR STANDARDS

For worldwide black & white and color TV broadcast applications.

UP TO 1500 WATTS WITH SOLID STATE RELIABILITY

The final solution to tube burn-out problems and maintenance headaches.

NO AGING

Power margin allowance, normally required for tube aging, is eliminated.

NO CAVITIES, NO MISALIGNMENT, NO TUNING

Drift-free output puts an end to the annoying, time-consuming task of frequent re-alignment of tube-type amplifiers and cavities.

MULTI-CHANNEL BANDWIDTH

VHF low band 54-88 MHz; VHF high band 174-230 MHz; UHF 470-960 MHz.

MODELS FOR ALL TV APPLICATIONS

VHF low band (Ch. 2-6) and high band (Ch. 7-13), ratings up to 1500 watts peak sync. Visual Class AB; Sound Class C. UHF models, Class A, up to 100 watts peak sync.

FULLY PROTECTED

Load VSWR protection via self-contained circuitry. Integral cooling and thermal protection are standard.

HIGH EFFICIENCY DC POWER SUPPLIES

Specially designed for use with these drivers, MPD switching power supplies feature better than 85% efficiency, 24-30 VDC, up to 280 amps, 8400 watts. Self-protection, BITE and remote operation are standard.

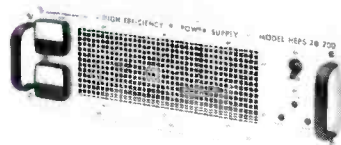

See us at
NAB
Booth 1401



MICROWAVE POWER DEVICES, INC.

330 Oser Avenue, Hauppauge, N.Y. 11787 • Tel. 516-231-1400 • TWX 510-227-6239

A M/A-COM COMPANY

Circle (20) on Reply Card



(Photos from NAB—'80)

DIRECTIONS

NAB·'81/LAS VEGAS:

THE BROADCAST INDUSTRY'S TOP SHOW

By Bill Rhodes, editorial director

-
- April 12-15, 1981
 - Las Vegas Convention Center
Las Vegas, Nevada
 - More than 450 manufacturers
represented
 - More than 210,000 sq. ft. of
exhibit space
 - Attendance expected to exceed
last year's nearly 20,000
 - Entertainment by Rich Little and
Bob Hope
-

Exhibit hours:

- Sunday, Monday, Wednesday:
9am-5pm
 - Tuesday: 9am-8pm
- Special feature this year: "free" time for managers and engineers to visit exhibits without missing technical sessions:
- Radio: Monday afternoon
 - TV: Tuesday afternoon
-

Broadcasters are getting ready to flood Las Vegas in April for the industry's most prestigious convention: NAB—'81/Las Vegas, the NAB

59th Annual Convention and International Exposition. Exhibitors from around the world are working feverishly on booth displays and special surprises to make this year's show better than ever. Howe Audio/BCP is planning a live FM stereo broadcast from its booth.

This year's NAB convention theme is DIRECTIONS...in radio...in television...in engineering...and in broadcast equipment. The following article by Chris Payne, assistant to the senior vice president for engineering, NAB, lays out the welcome mat for this year's event and provides a quick glimpse of some of the planned activities. Following Payne's article is a case study to provide insight into how an exhibitor prepared for an outstanding display last year in Las Vegas. After that is BE's comprehensive exhibit coverage for NAB—'81.

Directions: Joint Sessions

(Sunday and Wednesday)

The convention opening festivities begin on Sunday at 3 PM as Sen. Howard Cannon welcomes attendees in the great rotunda of the Las Vegas Convention Center. Following Cannon's remarks is the presenta-

tion of broadcasting's prestigious Distinguished Service Award. The prize is awarded yearly to honor that individual who has made outstanding contributions to the broadcasting industry. Following the presentation will be entertainment by Rich Little.

Wednesday morning's highlights include a session with the FCC commissioners—no speeches, just down to earth, open discussion from the people who have such an effect on broadcasting. Topics will include interpretations for directional antennas, composite clipping, TV blanking and more. Also included will be rulemakings such as 9kHz, AM stereo, low power TV and new FM stations. And following the commissioners will be an address by the new FCC chairman. To wind up things, Bob Hope takes over center stage at Wednesday's closing luncheon.

Directions in radio

In a world continuously changing, radio must change to meet new needs and to remain competitive as a communications medium. This year's NAB radio sessions (more than 30 scheduled) have been as-



The Las Vegas Convention Center, the fifth largest in the U.S., is the largest on one level, with 785,000 square feet of usable meeting room and exhibition space. Over the past five years nearly 60% of the 320 or so convention groups coming to Las Vegas annually have been here more than once.

sembled to help you prepare for your station's future. Here's a sampling of the NAB lineup:

- **Opening Festivities:** The keynote-speaker, Rich DeVos, will kick off radio's opening ceremonies. DeVos (along with Jay Van Andle) founded the Amway Corporation which now boasts more than 750,000 independent distributorships worldwide. Amway also owns the Mutual Broadcasting System.
- **Sales Forum:** RAB, NAB, and industry sales and marketing specialists combine their talents in Tuesday's all-day shirt sleeve forum. Included are in-depth clinics on raising rates, pitching agencies, raising revenues by selling to the chain stores, getting more co-op dollars, and more. The afternoon session splits into small and large market groups to focus on the differences between selling in Houston or selling in Horseshoe Bend.
- **New Technologies Forum:** Drastic changes are occurring in the entire broadcasting industry—changes that will affect formats, audiences, and profits. Here's a half-day session devoted to the new world of electronic services for radio broadcasters. Nationally known consultant

Paul Bortz will be host of a panel of outstanding new innovators who'll show how to compete with, use, live with, and profit from the technologies of the '80s.

- **Spanish Language Station Forum:** This highly specialized format is growing rapidly across the nation. This forum is for stations now programming in Spanish or considering switching. It's an opportunity to really learn from broadcasters who program Spanish language formats in their markets. Discover proven techniques in programming, sales, ratings, marketing, promotion—every aspect of this rapidly growing sound—in this half-day session.
- **Small Market Legal Clinic:** More for small market managers: on Monday night, the NAB Legal Department is host of a four-hour clinic to focus on the legal problems of small market radio broadcasters. No admission and no obligation... just show up with questions.
- **Night Court Session:** For mini, small, medium and large markets: Tuesday evening's clinic provides more expert advice on matters of communications law. It's an informal opportunity to ask about any-

thing concerning FCC requirements, EEO regulations, copyright laws, license renewal.

- **Workshop on More Profits/Production:** The management training excellence of Jim Hooker and Chris Lytle is known throughout this country. These top executives of Media Sales Training Systems Inc., an affiliate of Jim Hooker & Co., will be in Vegas to share their secrets about people, production and profits.
- **Workshop on Earth Stations:** Satellite receiving stations are springing up all over the country. Specialists will discuss: buy vs. lease, purchase now vs. wait, choice of fixed or tunable.
- **Workshop on Profitable Promotions:** Listeners love to hear them, PDs love to program them, SMs love to sell them. Learn how to create radio promotions that make money every time.
- **Workshop on Reasons for Failure:** This is a bottom line session conducted by James F. Clarke, executive vice president of Management Research Associates. Learn all about why some people fail while others become outstanding successes.

SAVE YOUR TUSH with our T.U.S.H.*!

Now Tentel has 3 products to make your video tape recorders work right

1 TENTELOMETER® tape tension gage



If you don't have a TENTELOMETER® for measuring tape tension, you're in worse shape than you know! Thousands are in use throughout the world! Send for our 16-page instruction manual.

2* TENTEL U-matic Spindle Height (T.U.S.H.) gage



Save your valuable tapes from edge damage and binding and breakage problems simply and easily. "Greatest thing since soap," says one customer. U-matic now, BETA and VHS soon.

3 TENTEL TIMER hour meter



For measuring the number of hours of "run" time to allow preventative maintenance to be performed to prevent down time.

Send or call for information and prices on the complete Tentel line. We want to help. We've already helped thousands.

Our toll-free number is

1-800-538-6894

(U.S. not including California)
8 a.m. - 5 p.m. Mon. - Fri.

**TENTEL 1506 Dell Avenue
Campbell CA 95008
(408) 377-6588**

Circle (21) on Reply Card

NAB-'81 Las Vegas

• **Workshop on Program Directing:** Should the program director be a star? A bully? A manager? A jock? Here's a taste of the recipe that has cooked up some of this country's great program directors. Check it out—are you using the perfect blend of ingredients?

• **Workshop on Selling AM:** This was an SRO session at the 1980 Convention...and for good reason. Featured is a panel of AM sales stars from small, medium and large markets.

• **Workshop on Image Development:** The program director has one image of the station and the audience has another. What you are isn't necessarily what you think you are. Here's how to solidify the station's image in-house.

• **Workshop on Station Worth:** Learn how to figure it all out for



yourself in this important 75-minute course.

• **Workshop for the Small Market Manager:** GM, PD, SM, CE,—a small market manager wears all the hats. Some of them fit better than others. This workshop is an in-depth look at how to be on the air, sell, play manager and still not be late for the Chamber of Commerce meeting.

• **Workshop on News for Profit:** Radio news is better, more timely, more comprehensive and more important than ever before. But the competition is getting tougher everyday, too. News can grab and hold listeners and make money. Here's how.

• **Workshop on Financing:** Getting the bucks for buying, building or remodeling can be a problem. Rising interest rates, inflation, cost of property...all of these have to be thought about when considering purchasing another station, building new facilities or remodeling an existing one. Here's a down-to-earth



money-talk session. Broadcast finance specialists have the inside scoop on how to find that all-important financing.

• **Workshop on Changing Formats:** Here are the answers to questions about changing formats and a few words of wisdom from successful survivors.

• **Exhibits:** More exhibits than ever to help you update your facilities to meet changing market needs.

Directions in television

New technologies are rapidly reshaping television broadcasting: digital, teletext, captioning, satellites, cable, and DBS, to name a few. These new technologies will dramatically affect the future, and the steps stations take now can determine how well they adapt to these influences.

The NAB-'81 television sessions and workshops have been planned to prepare attendees for new concepts in television broadcasting. Here's a sneak preview of what's happening:

• **Workshop on the New Congress:** What's in store for broadcasters? This two-part session covers the workings of government and the legislative process through discussion. By April, there will be new subcommittee chairmen, a new FCC chairman and lots of new legisla-





POWER

In the electronic world of ENG/EFP, nothing is more important than power... dependable power... versatile power.

Manufacturers of professional ENG/EFP cameras know this and choose Anton/Bauer batteries as their exclusive source of power.

There are many powerful reasons why the patented Anton/Bauer Snap-On™ battery system is standard equipment on virtually every camera sold in the world: High impact

cases of rugged Lexan™ • Silver plated contacts • Patented quick-charge modular design • and most important, individual computer testing of each and every battery.

The point is powerfully clear: The engineers who design video cameras demand the best power source available. When you buy your next battery can you afford anything but the best?

Anton/Bauer: The Source of Power



See Us at NAB Booth #1617

ANTON/BAUER, INC., 66 Center Street, Shelton, CT 06484 (203, 735-3305)

Circle 22 on Reply Card



NAB-'81 Las Vegas

tors. Many of these senators and congressmen will be present to share their views on broadcasting and regulations facing the industry and to hear problems of the TV broadcaster. This session examines the issues that are important to TV broadcasters: low power TV, cable regulation, FCC requirements, etc.

• **Workshop on Selling It Like It Is:** Let's face it...advertising makes all things possible. It takes money to run a TV station, to provide good local programming, to hire top-notch people to do the job. This workshop features TvB's team of experts to show how to motivate and train a sales army. Highlights of this general session include a report on the state of the industry, a discussion of new sources for training top station management, and a special presentation of TvB's comprehensive study on the compensation and composi-



tion of today's sales department.

• **Workshop on News/Programming:** Co-existence of the news/programming relationship is vital. Programming and news departments once operated on a strictly independent basis: equipment and talent was jealously guarded and those who stepped over the line were few and far between. But times have changed and so have attitudes. Today's audience wants more news in the form of consumer affairs, personal glimpses, features, magazine formats. By combining efforts, time and money can be saved, production costs can be cut and the best news/programming department in town can result. The experts from NATPE can show how.

• **Workshop on Local News:** It isn't local anymore, not when the Washington correspondent is as close as the satellite receiving dish in the parking lot; not when helicopters with live cameras conquer time, traffic and distance to air remote stories swiftly and dramatically. A panel of RTNDA news directors discusses how the exciting new technology is recasting the shape of local news—in reporting styles, in heavier demands on editors and producers, in a whole new concept of local coverage.

• **Workshop on Promotions That Work:** There's no question about it: sparking, lively promos keep viewers tuned. It's the best weapon against the competition and if it's done badly, the station loses. BPA presents the newest techniques on how to put the best foot forward through station promotions. If the on-air look is important tune in to this session.

• **Workshop on Smart Management:** Small market station managers face some special challenges: fewer employees and less revenue. Still, the same professional product must be turned out as big city stations. Sound like a Catch-22? Learn how to become a better manager in the small market. Discover what works and what doesn't, methods to improve profits without giving up quality, how to hire and motivate a staff, and more.

• **Workshop on New Facilities:** Frank Rees Associates presents this two-part series on designing and planning the best broadcast facility—for current and future needs. Emphasis is on logical planning and adaptation of the station to technological changes as they occur in the industry. Rees presents actual case studies that include the step-by-step process used to determine a station's needs for up to 15 years in the future. Included in the discus-



sion are: employment projections; energy requirements; architectural considerations; market trends; and much more.

• **Workshop on Prime Time Share:** Is the sky falling? Not yet...but research has shown that network prime time TV shares have been steadily eroding for the past four years. However, the same study indicates that there has been no appreciable drop in viewing levels for the same period. Through the advent of pay TV services and improved programming by public television systems, viewers have recently been treated to a great deal more variety. This phenomenon will be discussed with representatives from the networks, ad agencies, and the ratings services and determine the best ways to solve the problem in your market.

• **Workshop on Satellite Distribution:** Consider the far-reaching possibilities: satellite distribution is fast, it's efficient, it's cost-effective. It's cap-



1.25

SEC
M.S.
KHz
%



TACH
IN

TACH
OUT

MOD
PLAY
TIME

ACTUAL
PLAY
TIME

PITCH
SHIFT
RATIO

%
PLAY
TIME

SPEED
FACTOR
RATIO

INVERT

7

8

9

STO

SEC/M.S

4

5

6

RCL

THERE'S A NEW PRODUCTION TOOL IN TOWN



lexicon

See us at NAB Booth #206

Model 1200 Audio Time Compressor automatically reduces or expands the play time of recorded material ... gives you "time-tailored" programming at the push of a button ... preserves original pitch and voice quality.

● With the remarkable new Lexicon Model 1200, you can now eliminate time-consuming retakes to fit commercials or other material into available time slots. For the first time, you can speed up tapes or slow them down — and get broadcast-quality sound free of distortion. ● You simply connect the 1200 with virtually any variable speed tape recorder, set the timer for the on-air or play time you require, and you're in business. Material that runs too long can be compressed up to 25%. You can time-edit to add tag lines or heighten the energy of the message. In TV applications, the Model 1200 can be teamed with a variable-speed film projector and/or a videotape recorder. ● The Model 1200 — a product of Lexicon's eight years of leadership in digital audio processing — marks a breakthrough in bringing time-processed audio to the level of quality necessary for radio and TV use. Based on sophisticated computer technology and proprietary intelligent digital processing techniques, the 1200 has been thoroughly field-tested in the production of nationally broadcast commercials by 19 of the top 20 advertising agencies. Write for detailed information and application notes.

60 Turner Street, Waltham MA 02154 USA (617) 891-6790 TELEX 923468
Export: Gotham Export Corporation, New York, NY 10014

Circle (23) on Reply Card

Circle (24) on Reply Card

Some things are easily broken...

...not the CO90!

The CO90 miniature condenser microphone was designed by engineers who understand the "real world" requirements of a studio microphone. They've included things like cable assemblies that can be easily and inexpensively replaced in the field. But the CO90 has one feature that no other manufacturer can offer - the Electro-Voice warranty.

Electro-Voice backs up the CO90 with the only two-year unconditional warranty in the business. That means Electro-Voice will repair or replace your CO90 when returned to Electro-Voice - *no matter what caused the damage.*

Electro-Voice can offer that type of warranty because the CO90 was designed to withstand the rigors of professional use. If your application demands a miniature condenser microphone that can take less-than-gentle treatment, the CO90 is the one you should buy.

EV Electro-Voice
a gulton company

600 Cecil Street, Buchanan, Michigan 49107

Circle (25) on Reply Card
32 *Broadcast Engineering* March 1981

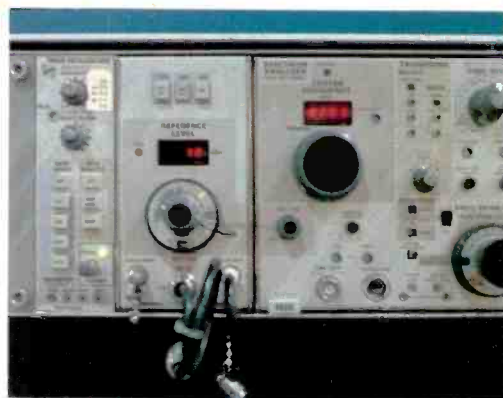
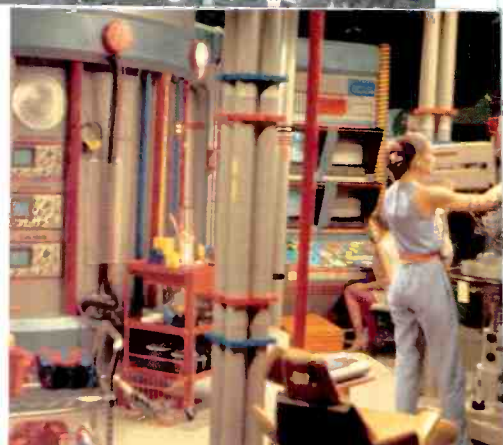

NAB-'81 Las Vegas

telephone wires or over-the-air? Which is more reliable? Which is the best investment? How will the FCC figure in these decisions? Get solid answers to these questions and find out more about this controversy from the experts.

Directions in engineering

NAB-'81's broadcast engineering conference again offers the latest information on government regulations, broadcast technology and operating techniques. This year's review will cover the most significant advances in broadcasting's state-of-the-art, the influences by the FCC, the government and international agencies. Sessions are designed to provide practical information for radio and television engineers and managers. This information will be presented in clear,

understandable language and can be directly applied to improve the efficiency, productivity and competitiveness of individual broadcast stations.

Joint Session

• Power for Portable Equipment: Because the emphasis is on fast reaction in both radio and television news, power has to be portable in the form of rechargeable batteries. Lead-acid, nickel-cadmium and other types of batteries require special care and feeding. Quick charge, trickle charge, amp hours, what capacity...hear the battery facts of life from the designers and the application engineers.

Television Engineering

• Facility Design/Construction: Because of the entanglement of regulations, a facility designer needs a lawyer sitting at his drafting table for advice. Panelists report some



“There are cart machines... and then there's PhaseMaster.”

“That's me, Johnny P. Shift, morning D. J. at K-FAZ radio. With sound like ours, we're lucky to have any listeners at all. I mean we got it all. Unacceptable phase shift. Annoying holes in the sound. And enough wow and flutter to drive anybody with half an ear to distraction. Sometimes I wonder whether we're trying to entertain people...or get even with them.”

“So I keep telling Uncle Bobby, my station manager, about Ramko Research's new PhaseMaster Series. Everything from a single playback through a stand alone record/play unit to a complete package for recording, playing and duplicating cartridges and cassettes”

“PhaseMaster eliminates phase shift, once and for all. Wow and flutter are reduced to absolute minimums. And, there's signal-to-noise, distortion and

frequency response figures that are unheard of in the business 'til now. Tape hiss is gone — I mean to tell ya', this sucker's quiet. And, it's completely compatible with existing cartridges.”

“If I've explained PhaseMaster to him once, I've done it a hundred times. All about how we can get rid of time-consuming calibration procedures. How there are no complicated, expensive electro-mechanical devices for moving the heads around. How PhaseMaster electronically

compensates for any phase shift and corrects the error in real time. And quality, Man, these things are built like a brick... tank. Which is why they've got the longest warranty in the industry.”

“I tell him the whole story — including how Ramko will give us a free two week trial (that is, if he hasn't already ruined our credit). So, you know what he keeps asking me? ‘What's the phone number?’”

“So what do I look like, the phone book?”

The Ramko Research PhaseMaster Series eliminates phase shift and gives you all the operational and convenience features you ever wanted in a cart system, mono or stereo. Get a free two week trial or more information by calling your nearest Ramko Sales Representative or (916) 635-3600. Collect.



NOW SHIPPING

See us at NAB in booth 146.

© Ramko 1981

Ramko Research, 11355-A Folsom Blvd., Rancho Cordova, California 95670 (916) 635-3600

Circle (26) on Reply Card

Studio facilities courtesy of KFAC, Los Angeles.

RAMKO



Introducing the only $\frac{3}{4}$ " time code editing system that performs 20 automatic edits from multiple sources. The Panasonic 700 B-2 Series Time Code Editing System.

**700
B-2
SERIES**

Now Panasonic adds a new dimension to the speed and accuracy of time code editing with our new 700 B-2 Series Time Code Editing System. The AU-700 editing recorder, the AU-A70 programmable editing controller, and the AU-J10 multiple source adapter. Together they let you do what other time code editing systems don't. Perform up to 20 automatic, multiple-source insert and assembly edits. And the 700 B-2 Series is packed

with outstanding performance features.

The precision of direct drive.

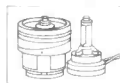

Check out the excellent stability and precision of the AU-700's direct-drive video head cylinder and capstan servo motor. The superb performance and durability of our crystal-oriented HPF™ heads. All combine to produce an outstanding picture with horizontal resolution of 260 lines color, 330 lines

monochrome and S/N ratio of 46 dB color, 50 dB monochrome. You'll also get an edit with less video noise because video head switching has been moved to the vertical interval so it never shows up in the picture. At the same time, we incorporated DUB IN and DUB OUT connectors with separate Y/C signals and a flying erase head. And to keep that good-looking picture looking good, all circuitry is mounted in a durable annealed aluminum die-cast chassis.

The speed of microprocessors.



Another touch of ingenuity is the AU-700's microprocessor controls. Designed to work perfectly with the AU-A70 editing controller, they give you the speed, accuracy and versatility of full-logic, mode-to-mode switching. The AU-700 will accept SMPTE time code on a separate track or on audio track one as well as standard CTL pulses. And its electronic



Shown from left AU-700 editing recorder, AU-A70 programmable editing controller.

digital tape counter displays LED readouts of CTL pulses in minutes and seconds—even in fast forward and rewind.

Multiple source versatility.

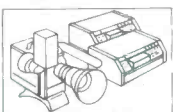

With our AU-A70 editing controller

not only can you generate and read time code pulses, microprocessors let it perform up to 20 time code edits automatically. Add an AU-J10 multiple source adapter and it will accept inputs

from two source decks and one live line plus perform A/B rolls. Microprocessors also let you automatically go to specific tape locations. You can also search both ways at speeds of 1/20X, 1/5X, 1X, 2X, 5X plus pause with picture. Other features include program check, program exchange, insert programming and overflow indication. For editing convenience, separate address time and lap time indicators are included. The AU-A70's error codes pinpoint any procedural

errors to avoid incorrectly programmed edits. The AU-A70 can also be used with any Panasonic solenoid-operated 3/4" and 1/2" VHS™ decks. For worldwide versatility, there is a built-in voltage selector that is compatible with 100V / 120V / 220V / 240V AC, at either 60 Hz or 50 Hz.

Total service capability.

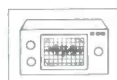

When it comes to servicing and maintaining the 700 B-2 Series, Panasonic backs you with a full net-

work of B-2 dealers, equipped with total service capability. Each has the parts and technical expertise that professionals require. For further information, call your nearest Panasonic office: Northeast—(201) 348-7620 Southeast—(404) 923-9700 Midwest—(312) 364-7936 Southwest—(214) 258-6400 West Coast—(213) 655-1111 The new 700 B-2 Series Time Code Editing System. Only from Panasonic.

Panasonic
VIDEO SYSTEMS DIVISION



NAB-'81 Las Vegas

recent experiences in designing and constructing new facilities.

- **Auto-Setup TV Cameras:** Field reports evaluating some of the latest features...and camera maintenance.

- **UHF Transmitter Efficiencies:** Power costs are soaring, and what is being done to improve UHF transmitter efficiency? Find out in this session.

- **The SMPTE Workshop:** The SMPTE will hold its popular workshop, but has not unveiled its main emphasis. However, look for some significant updates on progress in digital technology and standardization.

- **Teletext Standards:** The EIA will report on recommendations for a single teletext standard, and representatives of proponent systems will describe pros and cons of respective systems.

- **Other Future Technologies:** Check out the workshops in the TV area that deal with STV, MDS, and the teletext/videotext question.

- **Satellite Distribution:** Heralding a new way of life, satellite distribution systems have far-reaching possibilities—they're fast, efficient and cost-effective. Find out how these marvels in the sky work and how they can improve communications.

Radio Engineering

- **Earth Stations:** Receiving stations for radio are springing up all over the country. Before buying or leasing, know exactly what is needed. Hear the latest from the specialists.

- **New Technologies:** Drastic

changes are occurring in the broadcasting industry these days. This half-day session is devoted to this wonderful new world of electronic services available to radio stations. Nationally known broadcast consultant Paul Bortz will moderate a panel of outstanding tech innovators who'll show how to use, live with and profit from the technologies of the '80s.

- **The Talk Show:** Featured is a gathering of experts on interfacing a broadcast station with telephone facilities. They'll review telephone company equipment and terminology, protection of the "switched network," devices for converting to four-wire, hybrids, bridges, new automatic devices available, conferencing, RFI.

- **Satellites for Radio:** A review of the progress toward satellite use for high quality audio transmission. Topics will include: stereo, noise reduction techniques, lower costs, smaller dishes, sharing of earth stations, installation, maintenance and testing of radio earth stations.

- **Radio ENG:** Tips on using remote pick-up radio equipment to get that sound on the air. This workshop encompasses low-fi, hi-fi, portable units, walkie-talkies, multiple receivers, duplex and cueing, working out the intermod, antennas, modifying standard equipment, licensing and more.

- **Audio Processing:** Don't miss this annual review of the latest equipment, techniques and practices in the art of using audio processing equipment. Topics will include: quality vs. loudness, how to get along

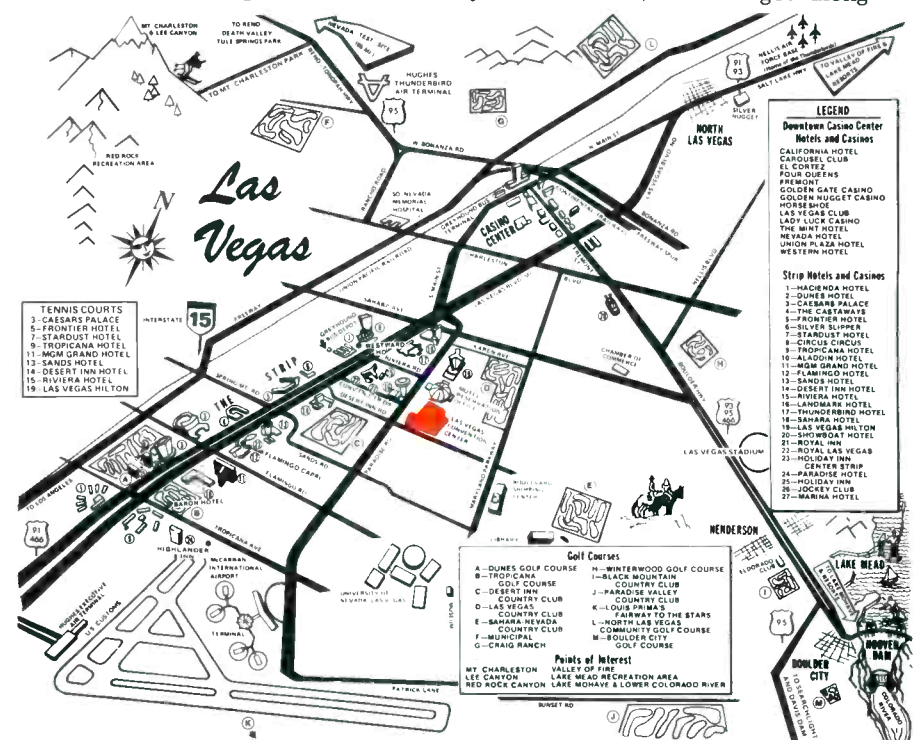

Two Assignments

Canon J13 x 9B IE plus Canon J25 x 11.5B IE and your camera

Two assignments, one location. For example, get great action shots of a football game and also get player interviews at half-time. You can do it with one cameraman and one camera—like the one shown here—with Canon's amazing E.F.P. lenses. Here's how:

Mount our J25 x 11.5B IE on a tripod at your principal location. It's 2/3" system was designed specifically to work with ENG cameras, yet this lens provides a 25-to-1 zoom ratio, power zoom and focus, automatic iris and the image quality you'd expect from a Canon broadcast lens. Another choice is the Canon J20 x 8.5B IE, with a 20-to-1 zoom ratio. (Both these lenses have built-in extenders, too!) With your ENG camera attached, you've got full capability.

Detach your camera from the fixed lens, mount the famous

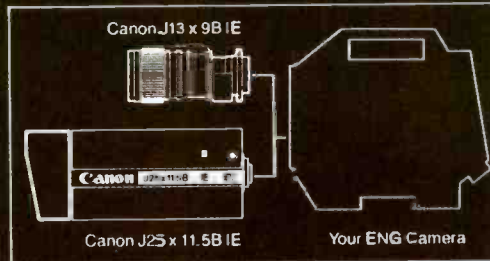

Canon J13 x 9B IE and head or the locker room!

You've got a 13X, f1.6 lens now and can move about freely for your interview shots.

The J13 x 9B IE is unsurpassed as an ENG lens, with Cable Drive and auto iris capabilities

plus built-in extenders and auxiliary wide-angle and telephoto accessories available as well.

Electronic Field Production is a reality. A practical reality because you don't have to send two crews or even two cameras to a single location if all you really need is one ENG camera and two Canon lenses. And, costs notwithstanding, sometimes you just don't have enough cameras to go around. Selecting the right combination of Canon lenses could actually double the utility of the ENG cameras you already own. And that's something even your accountant can appreciate!

Find out more. Use the coupon or write on your letterhead for the facts on the Canon J25 x 11.5B IE and J20 x 8.5B IE lenses, as well as our popular J13 x 9B IE. We'll also be happy to arrange a practical demonstration for you. A very practical demonstration!

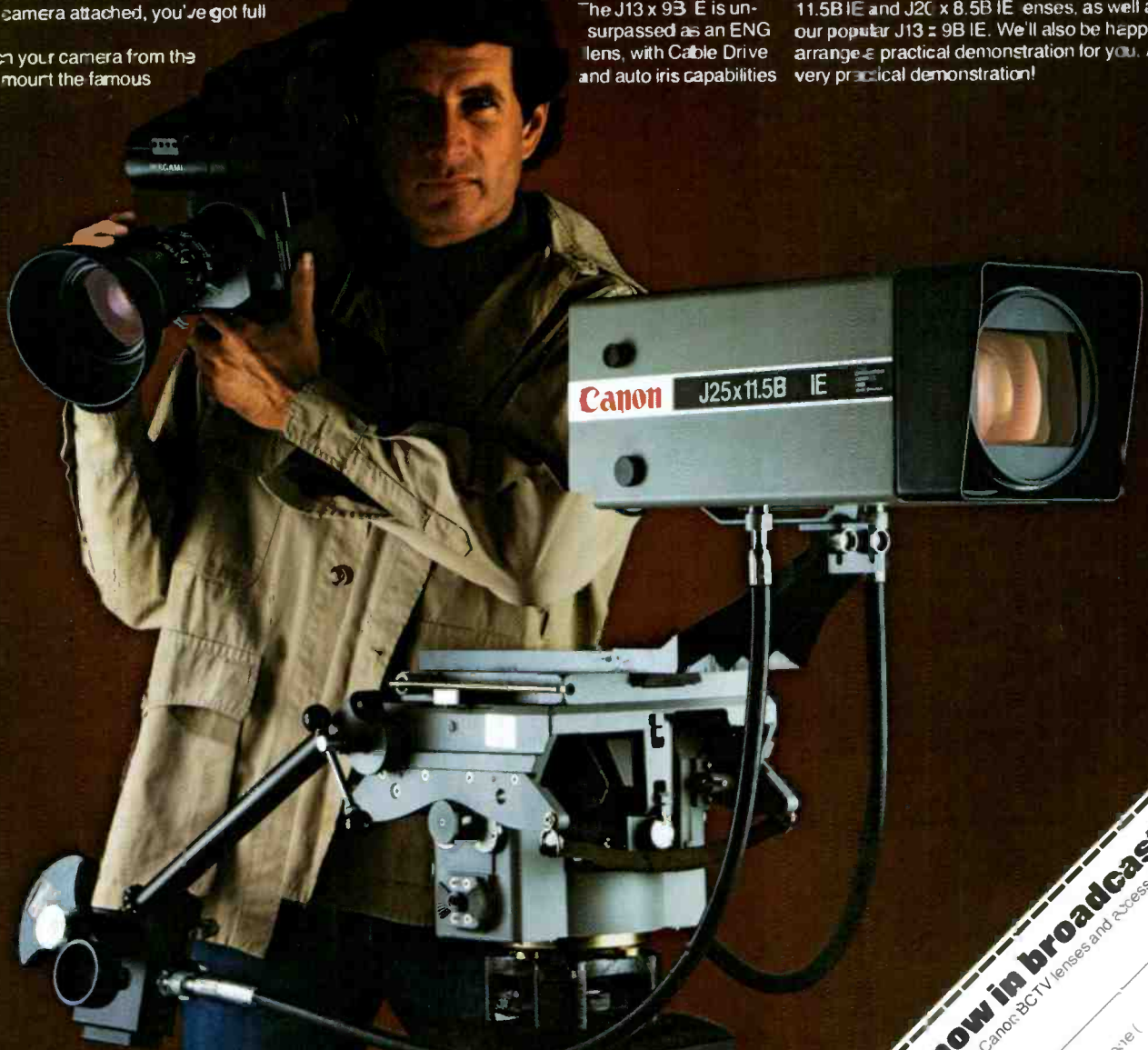

Canon®

Optics Division

Canon U.S.A., Inc. Head Office: One Canon Plaza, Lake Success, N.Y. 11042 (516) 454-1700
 140 Industrial Drive, Elmhurst, IL 60120 (312) 833-3070 • 13 Pauldrine Avenue East, Costa Mesa, Ca. 92626 (714) 579-6300
 Canon Optics & Business Machines, Canada Ltd., 3245 American Drive, Mississauga, Ontario L4V1B8, Canada
 Canon Amsterdam N.V., Industrial Products Division De Boelelaan 8, Amsterdam, Netherlands

© 1981 Canon U.S.A., Inc.

See us at booth # 802 at the NAB Show!

Circle (28) on Reply Card

The name to know in broadcasting.
 Please send me information on Canon BCTV lenses and accessories.

Name _____ Title _____
 Company/Organization _____
 Street _____ Phone () _____
 City _____ State _____ Zip _____

System 7000:

Now the broadcast automation champ has a new business automation partner!

The radio world knows all about Cetec's System 7000, the world champion in program automation.

It's the state-of-the-broadcast-art in fast, flexible, trouble-free automation. Plug-in expandable—up to 10,000 memory events, up to four CRT channels, up to 64 audio sources. Plain-English input and output. Cleanest, clearest audio specs in radio.

Cetec's 7000 is working 24 hours a day for winning broadcasters all around the world. (Ask us any time for names and addresses.)

Now Cetec offers the best of both worlds—System 7000 for award-winning program automation, and Cetec MAPS for cost-conscious, profit-prone business-side automation.

Ready to make some real progress? Call Cetec, the broadcast automation specialists.

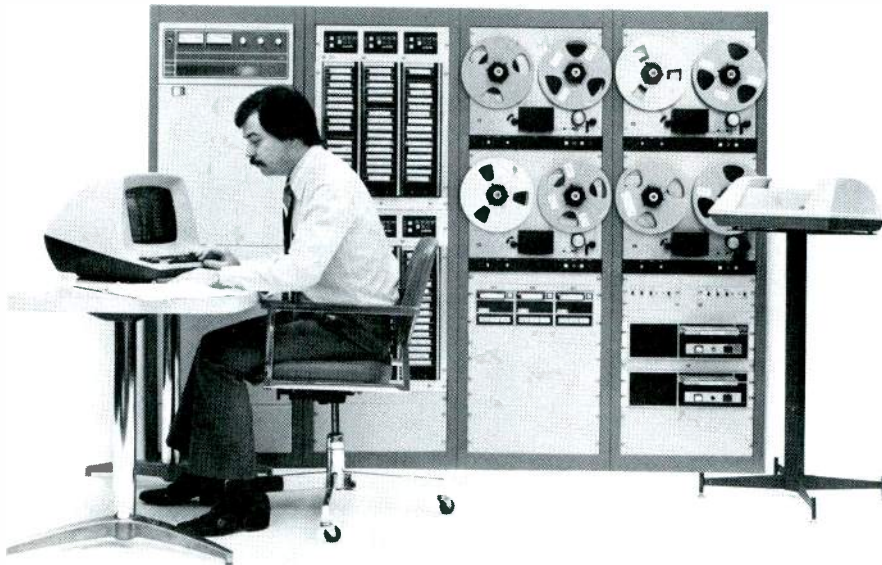

 **Cetec**

**We'll show you!
NAB 305**

Cetec Broadcast Group of Cetec Corporation
1110 Mark Avenue, Carpinteria, CA 93013 (805)684-7686 Telex 658-461

Circle (29) on Reply Card

40 *Broadcast Engineering* March 1981

NAB-'81 Las Vegas

with the program director and his favorite black box, the FCC and composite clipping, modification to equipment, AM stereo audio processing. This session is always SRO.

• **Papers:** Look for a complete listing in the guide to the show, but tentative topics include: Audio Recording and the Broadcaster; Audio Switching Systems; Radio Program Automation Systems Maintenance; Eliminating Stereo Phase Error; Constant Voltage Transmission for Audio; and Development of a High Quality Receiver for AM Stereo. For television engineers, these subjects will be discussed: High Power RF Transmission Systems; Satellite Systems for Multi-Station Operations; UHF TV Measurements by Helicopter; Remote Control Looking Toward ATS; Vertical Interval Machine Control Systems.

Directions: Spouse's programs

• **The Gathering Place:** open Sunday through Tuesday to register for tours and special events, or just to relax.

• **Self-help seminars:** experts will discuss techniques to cope with modern problems, including stress.

• **Broadcast mini-courses:** special sessions on FCC regulations and rules, code guidelines and the new Congress.

• **Tennis tournament:** details at the Gathering Place.

Spouses can attend workshops, general sessions and exhibits. On Sunday afternoon is a conducted tour of the convention center.

Directions: Final notes

NAB says that Saturday arrivals in Las Vegas are very limited, and recommends that you plan, if at all possible, for arrival on Friday or Sunday.

Further details on the convention, including registration forms, are available by writing: NAB Convention Registration, National Association of Broadcasters, 1771 N Street N.W., Washington, DC 20036.

The following article by Chris Payne of the NAB touches on other highlights of the convention and serves as a welcome from NAB. Following this article is **BE's** exclusive coverage of the exhibitors to be expected at NAB-'81 plus a special map to locate them on the convention floor. Also, **BE** has a case study of how one exhibitor prepared last year to put on a spectacular show.

In June, **BE** there will be an extensive wrap-up of this NAB-'81.

Harris' new TC-85 upstages all other automatic cameras with...

THE 45-SECOND MULTI-CAMERA SETUP

In less time than a standard commercial break, Harris' new auto setup computers can simultaneously run a pre-production setup of all the TC-85 cameras in your studio.

With independent microcomputers in each camera, fine registration, black balance, white balance, gamma and flare are automatically checked and adjusted in all cameras—in less than 45 seconds! Full computer setup from a new tube installation is also accomplished quickly.

The independent microcomputer concept—a Harris exclusive—eliminates camera interdependence and enhances reliability.

The ASU-85 computer setup system is standard in the new TC-85 camera. It can also be added, at

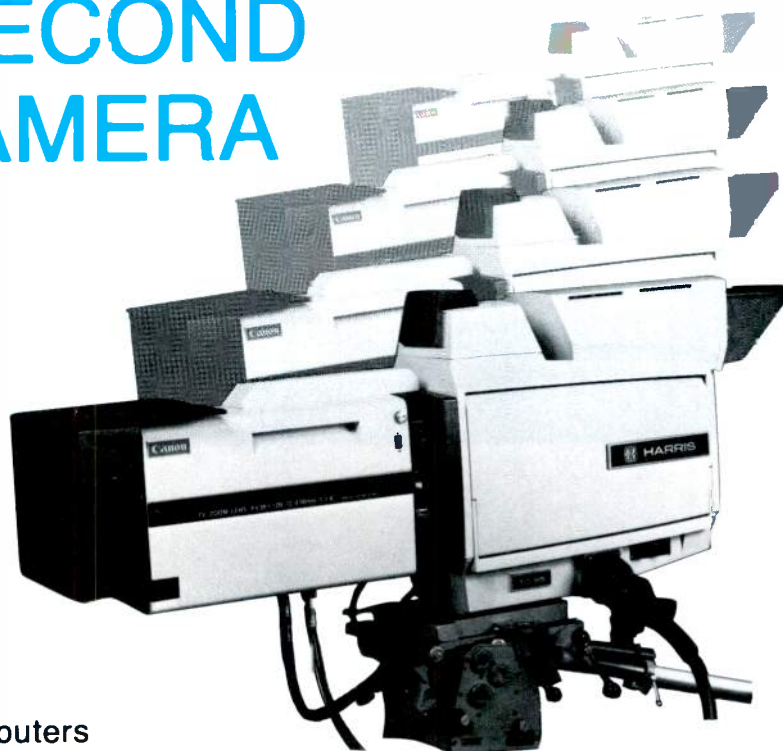

a surprisingly low cost, to all existing TC-80 series cameras in the field, and is fully compatible with the Harris Triax system. You can teach your older cameras new tricks!

Compare the cost. The TC-85 camera with full computer setup is priced well below competitive models.

Contact Harris Corporation, Broadcast Products Division, P.O. Box 4290, Quincy, Illinois 62301. 217/222-8200.



HARRIS
COMMUNICATION AND
INFORMATION PROCESSING

Visit the Harris TV and radio equipment display at the 1981 NAB, Las Vegas

Circle (30) on Reply Card

March 1981 *Broadcast Engineering* 41

THE 1981 NAB INTERNATIONAL BROADCAST EQUIPMENT EXPOSITION AND ENGINEERING CONFERENCE

By Chris Payne, assistant to the senior vice president for engineering, NAB

This is the third year that the NAB Convention will be held in Las Vegas, and it's beginning to feel like home.

Plan early, especially for air reservations. An early careful choice of flights from the East Coast can save hundreds of dollars.

One feature of the 1981 Vegas Convention is scheduling. Because many participants were worn out by the end of last year's convention, no engineering sessions will be held on Wednesday. This year the exhibits remain open on Tuesday evening until 8 PM. NAB's convention survey showed more exhibit hours were wanted. Attendees can be on the exhibit floor from 5 to 8 PM on Tuesday and all day Wednesday without missing any of the workshops or papers.

One other scheduling point: this year there are no radio engineering sessions on Monday afternoon and no television sessions on Tuesday afternoon. This scheduling synchronizes with radio and television management scheduling.

A record 200,000 square feet of exhibit space is available this year. Once again, it is the world's largest display of broadcast equipment. There are four acres of transmitters, video and audio recording equipment, satellite gear, towers and lighting equipment, various services, cameras, ENG equipment, etc. There is more competition in broadcasting than ever before, and more on the way. So plan to scour

the convention floor for anything that will help a station be the standout on the dial.

This year's convention also features the engineering conference, including some excellent paper presentations and workshops. Examples are audio processing and SMPTE workshops. An encore from last year is the well-received Telephone Talk Show panel—and reviving an oldie from the past, the FCC Panel. For radio, another favorite—Satellites for Radio—and a new subject for the convention, Radio ENG. For TV there is a workshop on EIA's progress toward a teletext standard, and panels on UHF transmitter efficiency, batteries for ENG, regulations affecting new facilities construction, and operational experience with auto-setup cameras.

This year there are twice as many papers as last year. For radio the subject areas include: Audio recording, audio switching systems, voltage transmission for audio systems, maintenance of automation systems, eliminating stereo phase error, FM composite transmission, and high quality AM stereo receiver design. For television: RF transmission lines, planning satellite earth stations, remote control, helicopter UHF measurements and a vertical interval machine control system.

This year's Engineering Award recipient is Wally Johnson, executive director of the Association for Broadcast Engineering Standards and former chief of the FCC Broadcast Bureau.

Room allotted for this year's ham radio operator's reception on Monday night, April 13, has been doubled. NAB is pleased to be host of the reception for licensed or formerly licensed amateur operators attending the convention. Ham operators should be sure to have their tickets for a chance on the donated door prizes.

Still in the planning stages are luncheon speakers for both Monday and Tuesday engineering luncheons.

The convention is an opportunity to talk about common problems from maintenance of equipment to fighting with the news director. Share experiences with many other engineers in Las Vegas to eat, sleep and drink broadcast engineering.

Spouses may attend for no extra registration fee; spouse luncheon tickets are \$15. NAB has scheduled a special program for spouses to include informational sessions, jogging and tours.

Remember that hotel rates in Las Vegas begin at about \$30 and that the NAB member preregistration fee, including two working luncheons and a Wednesday entertainment closing lunch, is still only \$115. Preregistration ended March 1 but on-site registration is only \$25 more. Entertainment this year includes Rich Little on Sunday and Bob Hope for the Wednesday closing luncheon. For more information or forms write Don Schutte, Dept. BE, Broadcasting Division, NAB, 1771 N Street, NW Washington, DC 20036; or call (202) 293-3587.



COMMUNICATIONS INC.

proudly presents . . .

. . . WILK ENGINEERING

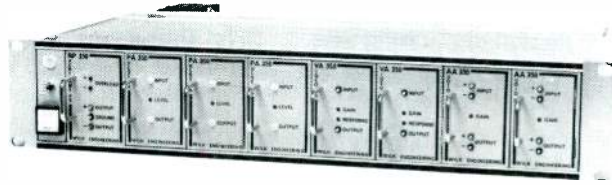

RACK FRAME ASSEMBLY

MODULAR VIDEO AND AUDIO DISTRIBUTION EQUIPMENT For Demanding Broadcast, CATV and Industrial Systems Applications



VIDEO DA

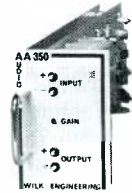

AUDIO DA



PULSE DA

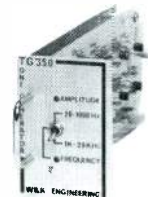

TONE GENERATOR



PULSE DELAY



POWER SUPPLY

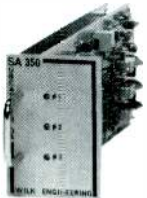

SUB CARRIER DA

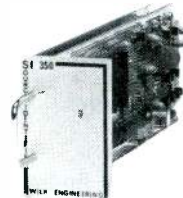

SOURCE IDENTIFIER

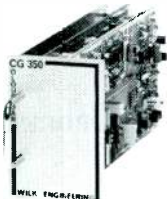

COLOUR BAR GENERATOR



COLOUR BACKGROUND GENERATOR

MODULES AVAILABLE (From Stock)

- *AA-350 Audio Distribution Amplifier
- *AP-350 Audio Power Amplifier
- *BG-350 Colour Background/Black Generator Ext. Drive
- *BG-351 Colour Background/Black Generator Int. Drive
- *CG-350 Colour Bar Generator, External Drive
- *CG-351 Colour Bar Generator, Internal Drive
- *PA-350 Pulse Distribution Amplifier
- *PA-351 Pulse Delay/Distribution Amplifier
- *SA-350 Subcarrier Distribution Amplifier
- *SG-350 Sync Generator
- *SG-351 Sync Generator with Gen-lock
- *SI-350 Source Identifier
- *TG-350 Tone Generator
- *VA-350 Video Distribution Amplifier
- *VA-351 Video DA with Differential Input
- *VA-352 Video DA with Diff. Input & Clamper
- *VE-350 Video Equalizing Amplifier
- *VP-350 Video Presence Detector

**VIDEO AND/OR AUDIO ROUTING SWITCHERS
VR-, AR-, or VAR-0602 (6x2) or -1201 (12x1),
REQUEST DETAILED DOCUMENTATION ON STANDARD
AND SPECIAL ROUTING SWITCHER PRODUCTS**

(DEALER INQUIRIES INVITED)



COMMUNICATIONS INC.

2431 Forest Ave., San Jose, CA 95128
7171 Torbram Road, Unit 4, Mississauga, Ontario L4T 3W4
3445-12th Street N.E., Calgary, Alberta T2E 6S6

(408) 247-6152
(416) 677-2232 (TWX) 610 492-4356
(403) 276-5755 (TWX) 610 821-6400

Circle (31) on Reply Card

NAB-'81/LAS VEGAS PRODUCT DIRECTORY

This special section provides a directory to the NAB-'81/Las Vegas exhibitor products. Each exhibitor was asked to complete a comprehensive checklist of products to be shown. The following section is a compilation of the data provided. It shows major equipment headings followed by the exhibitor name.

This special section will be an aid in finding the equipment of special interest at the show. But a word of caution: As **Broadcast Engineering** goes to

press, there are still changes being made daily in the exhibitor sign-ups, equipment being displayed and booth assignments. So, although every attempt has been made for accuracy in this section, double check the final program at NAB-'81 to organize show coverage.

For those not attending NAB-'81/Las Vegas, the June issue of **BE** will provide a convention replay and will cover both sessions and new products.

AMPLIFIERS, PRE-AMPS, DA's

ADM Technology
ATI-Audio Technologies Inc.
Achro-Video International
Arrakis Systems
Audio & Design Recording
Auditronics
BGW Systems
Broadcast Electronics
CMC
Candex Pacific
Cavox/Tape-athon
Central Dynamics
Cetec Broadcast Group
Cohu
Continental Electronics Mfg. Co.
Crown International
D-B Electronics
Datatek
Delcom Corporation
Dynair Electronics
Farrtronics
Fernseh Inc.
Grass Valley Group
David Green Broadcast Consultants
Gregg Laboratories
Harris
Hedco
Howe Audio/BCP
Industrial Sciences
LPB
Leitch Video
Lenco
Logitek
McCurdy Radio
McMartin Industries
Micro-Trak
NEC America
Rupert Neve
Pacific Recorders
Panasonic Professional Audio Div.
ProTech Audio
Quintek
RTS Systems
Ramko Research
Russco Electronics
Sescom
Shintron
Sigma Systems
Sound Genesis
Stanton Magnetics
Studer Revox America
Telemet
Television Equipment Associates
Television Technology Corp.
Telex

Tweed Audio
UREI
Ultra Audio Pixtec
Varian/Palo Alto Microwave Tube Div.
Vital
Ward-Beck

ANALYZERS, AUDIO & VIDEO

Amber
Amtron Corp.
Belar
Comprehensive Video Supply
Crown International
Delcom Corporation
Eventide Clockworks
Fernseh
Fidelipac
Inovonics
Potomac Instruments
Sound Genesis
Sound Technology
Teac
Tektronix
Telemet
UREI

ANIMATION (EQUIP. FACILITIES)

Ampex
Animation Video
Arvin/Echo
Aurora Imaging Systems
Datatron
Alan Gordon
Image Resource
Interand
Lyon/Lamb Video Animation Systems Inc.
Power-Optics
Telestrator
Vital

ANTENNA SYSTEMS & HARDWARE

AEG-Telefunken
Acrodyne Industries
Allen Osborne Associates
Andrew Corporation
Anixter-Mark
Blonder-Tongue
Bogner Broadcast Equipment Corp.
Cablewave Systems
Canadian General Electric
Comark Communications
Comark Industries
Continental Electronics Mfg. Co.

Delta Electronics
Dielectric
E-N-G Corp.
Flash Technology
Gorman-Redlich
Harris
Howe Audio/BCP
Micro Communications
Microwave Associates
Fred A. Nudd Corp.
Nurad
Phelps-Dodge
RCA
R. F. Technology
SWR
Scientific Atlanta
Shively Laboratory
Tayburn Electronics
Television Technology Corp.
Tennaplex
Townsend Associates
V&B Tower
World Tower Company

ATTENUATORS

ADM Technology
Bird Electronic Corporation
Electro Impulse
Potomac Instruments
ProTech Audio
Sescom
Sound Genesis
Texscan Corp.

ATS & EQUIPMENT

Delta Electronics
Hallikainen & Friends
Harris
Howe Audio/BCP
Potomac Instruments
Tektronix

AUDIO AMPLIFIERS & PROCESSORS

ADM Technology
AEG-Telefunken
ATI-Audio Technologies Inc.
Audio & Design Recording
Belar
Broadcast Audio
Broadcast Electronics
Central Dynamics
Circuit Research Labs
Comprehensive Video Supply
Continental Electronics Mfg. Co.
Crosspoint Latch
Crown International



THIS MAY BE THE ONLY WAY TO GET A BETTER WEATHER PICTURE THAN OURS.

Our new Weathermation Satellite Digital Color System II* delivers a weather satellite picture unlike anything you've ever seen on broadcast TV.

In fact, it's such an incredible picture, the only way you're going to be able to get a better one is to go up into space and take one yourself.

Like most weather radar systems, (even our own industry-leading Color Radar System I) our Weathermation Digital System II translates GOES images of clouds into color digital display of selected geographical areas of North America.

Weathermation System II receives a fully digital signal more precise than any weather picture ever possible before.

It lets you acquire and display this more precise image of the weather in any area of North America within 15 minutes of when it happened.

Obviously this allows your local television station to produce weather reports at a technological level you've never been able to achieve before.

But System II also includes display options that can make the weather broadcast of any local station the equal of any network.

You'll have a choice of numerous colors and levels of shade, and different areas of North America that can be as large as the whole continent, or as small as your own county. There's also the capability for animation and a floating enlarger that will enable your weathercaster to pinpoint precise conditions.

But perhaps the best feature of the Weathermation System II is that all these capabilities can be accomplished in a local phone call that won't last more than 2½ to 3 minutes.

Yet, a system that can change the shape of your weather reporting forever is not all that expensive.

So call us at 312/263-6921 or write Weathermation, 190 North State Street, Chicago, Illinois 60601, for details. Or better yet, come by our Booth #1625 at the NAB Convention, and we'll show you a weather satellite picture unlike anything you've ever been able to see before.

The new Weathermation Digital Color System II.

It lets the folks at home see what only an astronaut could see before.

Weathermation

INTRODUCING OUR DIGITAL COLOR SYSTEM II

*Weathermation is the exclusive agent for ESD, Inc.

Circle (32) on Reply Card

Perfect Timing Perfect Price



Datametrics SP-710 SMPTE Time Code Reader

Designed for the Production Environment

Compare Features

- Full speed-frame accurate decoding
- Integral multi-function character generator
- Remote control capabilities
- Optional data outputs for editing system use

Compare Price

\$1980.00

Available from stock
Contact nearest Datametrics' Dealer
or factory.



Datametrics Inc., 340 Fordham Road, Wilmington, MA 01887
Tel: (617) 658-5410 TWX: 710-347-7672

See our new line of SMPTE Code
products at NAB booth #1612

Circle (33) on Reply Card

NAB product directory

dbx
Datatek
Delta Electronics
Dolby
Dynair Electronics
Elcom Specialty Products
Eventide Clockworks
Gregg Laboratories
Harris
Harrison Systems
Hedco
Howe Audio/BCP
Industrial Sciences
Inovonics
Lexicon
Logitek
McCurdy Radio
McMartin Industries
Micmix
Micro-Trak
Moseley Associates
Orban
Pacific Recorders
Panasonic Professional Audio Div.
ProTech Audio
RCA
Ramko Research
Russco Electronics
Sescom
Shure Brothers
Sphere
Sound Genesis
Studer Revox
Telemet
Television Equipment Associates
Thomson-CSF Broadcast
UREI
US JVC
Ultra Audio Pixtec
United Research Lab
Vital
Ward-Beck

AUDIO LEVEL INDICATORS

ADM Technology
ATI-Audio Technologies Inc.
Audio & Design Recording
Belar
dbx
ESE
Electro & Optical Systems
Harris
Inovonics
Logitek
McCurdy Radio
Quad Eight
Ramko Research
Sound Genesis
Tektronix
Telemet
Thomson-CSF Broadcast
Ward-Beck

AUDIO PRODUCTION CONSOLES & MIXERS

ADM Technology
Accurate Sound
Ampro/Scully
Arrakis Systems
Auditronics

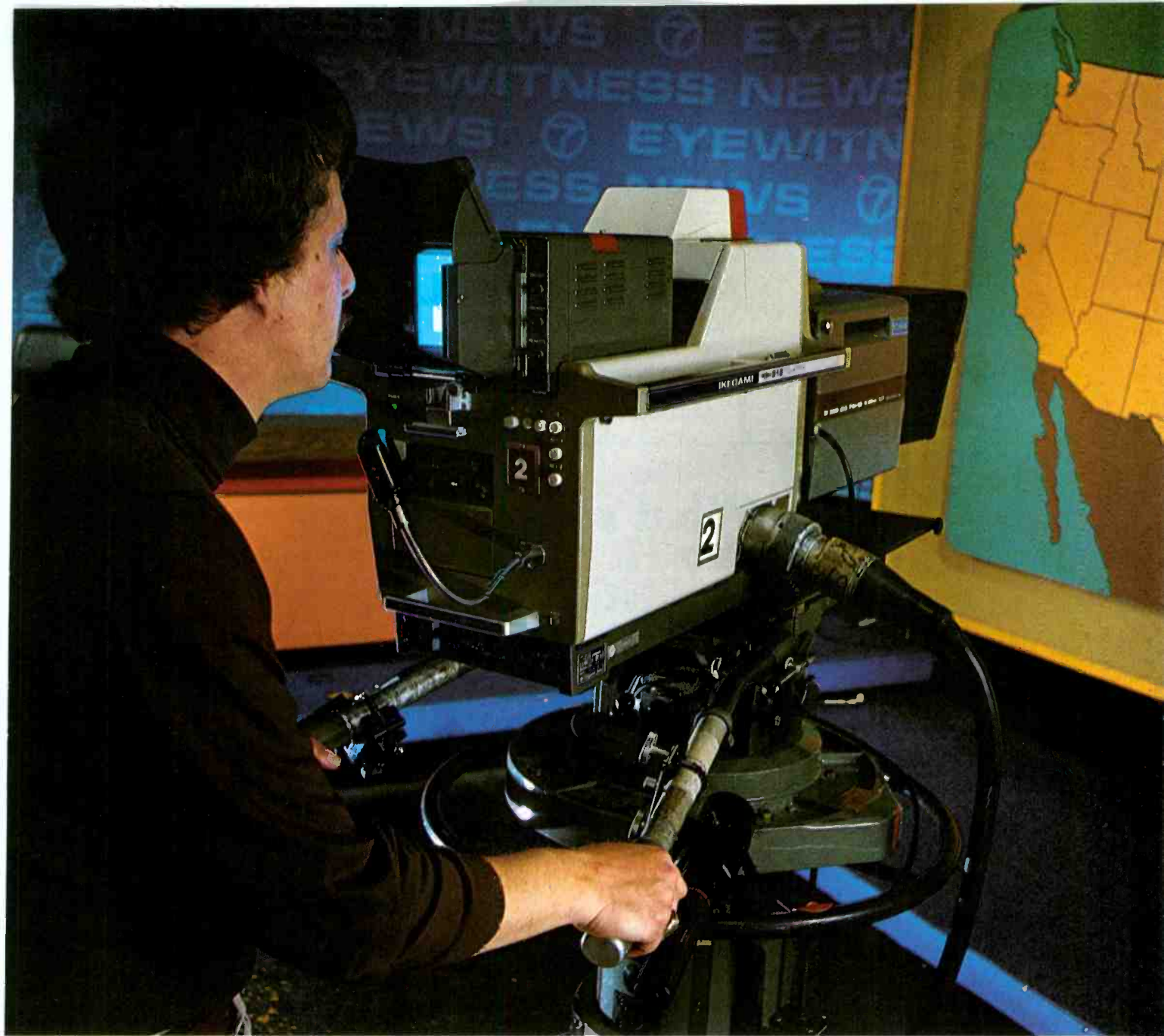

Computer set-up and triax too

Today, broadcasters are classing computer setup and triax as necessities. Ikegami offers you a choice of two such cameras. Both are proven in the studio and field.

- The HK-312, with 1¼-inch pickup tubes, is a proven computer setup camera. More than 100 are in service throughout the ABC Network, at WGBH, and at other major stations.
- The HK-357A with 1" diode gun pickup tubes offers the same high standard of performance along with the convenience of field capability.

Both are extremely stable cameras that can be operated manually. And both accept computer control for automatic setup for on-air readiness in 45 seconds.

Both cameras can be used with multi-core cable. With triax the cameras can be a mile from their base station.

Of course, in colorimetry, automatics, circuitry excellence, and range of options, both are incomparable. But seeing is believing. Experience a demonstration soon at Ikegami Electronics (USA) Inc., 37 Brook Avenue, Maywood, N.J. 07607; (201) 368-9171. West Coast: 19164 Van Ness Ave., Torrance, CA 90501 (213) 328-2814; Southwest: 330 North Belt East, Suite 228, Houston, TX 77060 (713) 445-0100; Southeast: 522 South Lee St., Americus, GA 31709 (912) 924-0061.

Visit us at Booth #817 at NAB.

Circle (34) on Reply Card



Ikegami

NAB product directory

Avab America
 BTX
 Belar
 Best Audio
 Broadcast Audio
 Broadcast Electronics
 Cetec Broadcast
 Comex
 Continental Electronics Mfg. Co.
 Elcom Specialty Products
 Farrtronics
 David Green Broadcast Consultants
 Hallikainen & Friends
 Harris

Harrison Systems
 Howe Audio/BCP
 Industrial Sciences
 LPB
 LTM Corp. of America
 Listec
 Logitek
 McCurdy Radio
 McMartin Industries
 MCI
 Micro-Trak
 Rupert Neve
 Pacific Recorders
 Panasonic Professional Audio Div.
 ProTech Audio
 Quad Eight
 Quantum Audio Labs

RCA
 Ramko Research
 Russco Electronics
 Sony
 Sphere
 Studer Revox America
 Tangent Systems
 Teac
 Telex
 Tweed Audio
 UMC Electronics
 UREI
 US JVC
 Ultra Audio Pixtec
 Ward-Beck

AUTOMATION EQUIPMENT, AUDIO

Accurate Sound
 Autogram
 Automated Broadcast Controls
 BTX
 Broadcast Audio
 Broadcast Controls
 Broadcast Electronics
 Century 21 Programming Inc.
 Cetec Broadcast
 Concept Productions
 Delcom Corporation
 Fidelipac
 Cliff Gill
 Hallikainen & Friends
 Harris
 Harrison
 Howe Audio/BCP
 IGM Communications
 Image Video Limited
 Inovonics
 Jenel
 Rupert Neve
 Otari
 ProTech Audio
 Quad Eight
 Sphere
 Sono Mag
 Tweed Audio
 US JVC
 Vital
 Ward-Beck

AUTOMATION EQUIPMENT, VIDEO

Beaveronics
 Broadcast Controls
 Central Dynamics
 Control Video Corp.
 Crosspoint Latch
 Delcom Corporation
 Fernseh Inc.
 Glentronix
 Grass Valley Group
 ISI
 Image Video Limited
 Jenel
 NEAS
 Panasonic, Video Systems Div.
 RCA
 Recortec
 Ross Video
 Sony
 Tektronix
 3M/Mincom
 Videomedia
 Vital

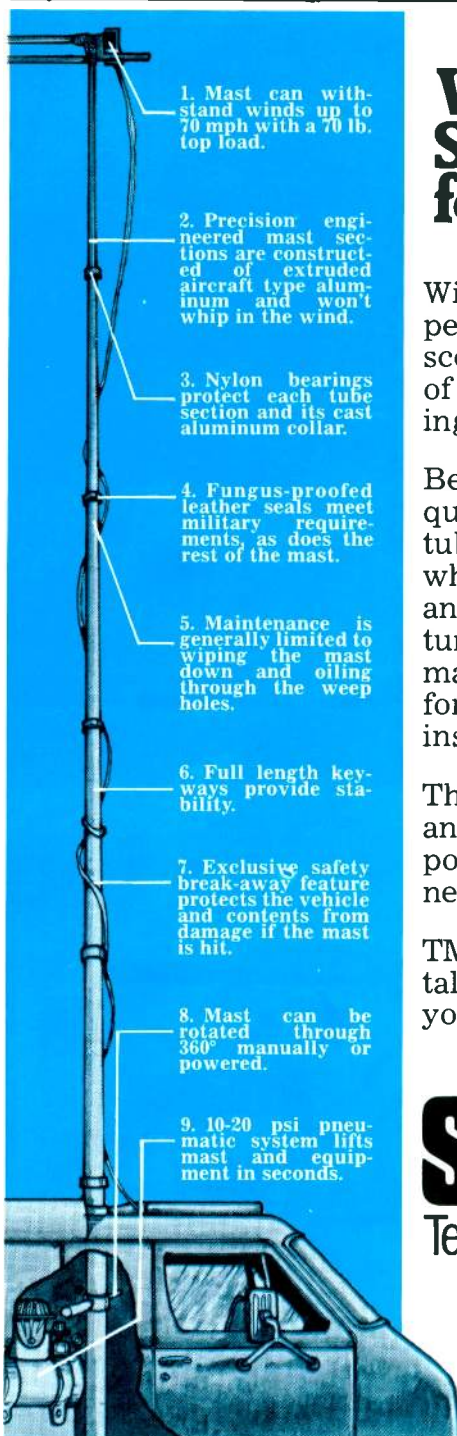

What makes Sky-Hi the best for ENG?

With more than 20 years of experience making Sky-Hi telescoping masts, TMD has a way of making it the best telescoping mast for ENG.

Because they're made of high quality extruded aluminum tubing, because they don't whip when the wind builds up, and because of the other features you see here, Sky-Hi masts have been specified for more than 1000 ENG installations.

There are many sizes available, and now the 43' mast, the most popular size for ENG, has a new, lower nesting height.

TMD engineers are ready to talk to you about the mast you need.

SKY-HI[®]

Telescoping Mast Division

The Will-Burt Company
 249 W. Henry St.
 P.O. Box 126
 Wooster, Ohio 44691
 (216) 262-7010

Circle (35) on Reply Card



Take a close look at what Tape Transports are going to be like in the '80s

The all new Telex 3000 is here NOW!

No industry has witnessed more technological improvements over the past few decades than our own. So, if you're looking for a tape transport for broadcast, studio or industry, it's important to choose a product with all the latest industry innovations in one unit, the NEW Telex 3000. Write for exciting details about these features.

- Interchangeable head blocks
 - A.Q.R. (Auto Cue Release)
- Differential electro-mechanical braking
 - Spill-proof logic
 - Motion sensing
 - Tape counter
 - 4 head capability
 - Hyperbolic tape path
- Remote control capability
- Play only or record/play combinations
 - Auto cue/rewind/cycle
 - Dual speed
 - Hysteresis drive motor
- Two torque spooling motors
 - Quiet operation
- Urethane pressure roller

Quality products for the audio professional



TELEX[®]

TELEX COMMUNICATIONS, INC.

9600 Aldrich Ave. So., Minneapolis, MN 55420 U.S.A.
Europe: 22, rue de la Légion-d'Honneur, 93200 St. Denis, France

Circle (36) on Reply Card

March 1981 *Broadcast Engineering* 49

D.C. Servo Drive Runs Smooth Steady Cool

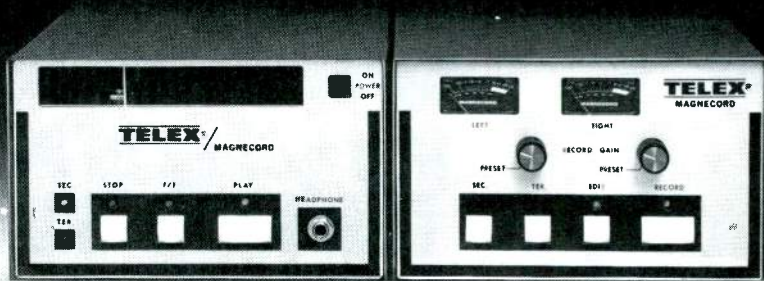

Of course, it's Telex/Magnecord

Telex Magnecord broadcast cart machines run cool and steady. So cool no ventilation is required, so steady not even voltage or frequency fluctuations will alter their speed. Thanks to our dc servo flutter-filter drive. Completely immune to RFI and EMI, it meets or exceeds all NAB standards and is suited for local or remote/automated operation.

Standard features at no extra cost.

- An edit pushbutton to add stop cues in playback and omit stop cues in record
- LED indicators show end of tape, status and secondary/tertiary cue tones
- Front panel headphone jack
- VU meters for each channel

Convenient, Flexible

MC-Series is field convertible from mono to stereo, or play to record. Optional remote controls simply plug in.

Four broadcast cart machines to choose from in the Telex/Magnecord MC-Series - all made in U.S.A. and affordable. Write for detailed information.

Quality products for the audio professional



9600 ALDRICH AVE. SO., MINNEAPOLIS, MN 55420 U.S.A.

Telephone: 612-884-4051, telex: 29-7053

EUROPE: 22, rue de la Légion-d'Honneur, 93200 St. Denis, France, Téléphone: 820-98-46, telex: 63-0013

CANADA: Telak Electronics, Ltd., 100 Midwest Road, Scarborough, Ontario M1P3B1, Telephone: 416-752-8575

Circle (265) on Reply Card

NAB product directory

AUTOMATION SYSTEMS, BUSINESS & LOGGING

Automated Business Concepts
Broadcast Controls
Cetec Broadcast
Chase Media
Columbine Systems
Computer Concepts
Computer Management Systems Inc.
Data Communications Corp.
Groton Computer
Hallikainen & Friends
Harris
Howe Audio/BCP
IGM Communications
Jefferson Data Systems
Jenel
Kaman Sciences/BCS
NEAS
Nidus Systems
Sono Mag
Station Business Systems
Tektronix
Vital

BATTERY PACKS AND CHARGERS

Adwar Video
Anton Bauer
Walter S. Brewer Co. Inc.
Camera Mart
Christie Electric
Cine 60
Comex
Comprehensive Video Supply
Delcom Corporation
Farrtronics
Film/Video Equipment Service Co.
Frezolini Electronics
Alan Gordon
Kapco Communications
Panasonic, Video Systems Div.
Perrott
RTS Systems
Sony
Telex
US JVC

BROADCAST LOGGERS

Dictaphone
Groton Computer
Hallikainen & Friends
Moseley Associates
QSI Systems
Studer Revox America
Telex

CABINETS, CASES & RACKS

Adwar Video
AEG-Telefunken
Anvil Cases
Broadcast Electronics
Comark Communications
Comprehensive Video Supply
Delcom Corporation
Fiberbilt
Fidelipac
Harris

"WHY USE WELLFLEX"

Optimum Design

Cablewave Systems offers Wellflex Transmission Lines designed to meet your most stringent electrical and mechanical requirements.

Highly reliable, the unique Wellflex construction provides a combination of strength and flexibility with optimum performance.

Outstanding electrical parameters include extremely low RF loss, smooth impedance coefficient, and conservatively rated power handling capability.

Wellflex is available with either air or foam dielectric with copper corrugated outer conductor, solid and corrugated inner conductor (depending on size), and with a tough, durable, corrosion resistance polyethylene jacket suitable for burial and prolonged life.

Air Dielectric Wellflex in smaller diameters, ($\frac{1}{2}$ " and $\frac{7}{8}$ ") offer a field proven, fixed helix design called Spirafil II - a single, continuous extrusion which locks the center conductor coaxially within the outer conductor, resulting in a near perfect impedance coefficient throughout the entire length of line.

RF transmission lines with welded and corrugated conductors are also manufactured by our associated companies in West Germany and Brazil.

Kabel- und Metallwerke
Cablehohlführungstechnik AG
Radio Frequency Systems Division
Kabelkamp 20
3000 Hannover
West Germany

KMP
Cabos Especiais e
Sistemas Ltda.
Caixa Postal 7 163
Sao Paulo SP, Brazil

Optimum Performance

Larger Diameter Air Dielectric Wellflex Cables, ($1\frac{1}{8}$ ", 3", $3\frac{1}{2}$ " and 4 $\frac{1}{2}$ ") feature a unique vertebra helix design to achieve optimum crush and tension strength. Its "pillar effect", using less volume of dielectric, provides lower loss and higher power handling capability due to the more rapid dissipation of heat from the center conductor.

Wellflex has it all: low loss, low VSWR, higher power handling, smoother impedance coefficient, and rugged, long dependable life.

Cablewave System's Wellflex is type accepted for sampling systems in accordance to FCC Part 73.6B.

Cablewave Systems, Inc., 60 Dodge Ave., North Haven, Conn. 06473, Phone (203) 239-3311

In Canada: LeBlanc & Roy, Communications Towers Ltd., 514 Charwell Rd., Oakville, Ontario, Canada L6J 5C5, Phone (416) 844-1242.

Antenna/Transmission Line Systems Catalog



Complete in every detail, total information needed to plan, specify and purchase a complete system or component, plus complete engineering data and more!

See Us at NAB Booth #1323

Cablewave Systems

Circle (37) on Reply Card

NAB product directory

Jenel
McCurdy Radio
Micro-Trak
Research Technology International
Scientific Atlanta
Sound Genesis
Stantron, div. of Wyco
Storeel
Thermodyne
Winsted Corp.

Broadcast Electronics
Comark Communications
Comark Industries
Comprehensive Video Supply
Harris
Howe Audio/BCP
Micro Communications
Phelps Dodge
Sony
Sound Genesis
US JVC
Wireworks

CABLE (COAXIAL & AUDIO)
Achro-Video International
Andrew Corporation

**CAMERA DOLLIES, STANDS,
TRIPODS, HEADS**
Adwar Video
Animation Video

Arriflex
Asaca
Camera Mart
Cinema Products
Comex
Comprehensive Video Supply
Delcom Corporation
Victor Duncan
Fernseh
Alan Gordon
Harris
Karl Heitz
Innovative Television Equipment
Lee-Ray Industries
Listec TV Equipment
Matthews
O'Connor
Panasonic, Video Systems Div.
Quick Set
RCA
Research Technology International
Sony
US JVC

CAMERA LENSES & ACCESSORIES

Achro-Video International
Adwar Video
Angenieux
Arriflex
Asaca
Camera Mart
Canon USA
Cinema Products
Comex
Comprehensive Video Supply
Delcom Corporation
Victor Duncan
Fernseh
Fujinon Optical
Alan Gordon
Harris
Karl Heitz
Ikegami
Panasonic, Video Systems Div.
RCA
Sharp
Sony
Tiffin
US JVC

CAMERA STABILIZING SYSTEMS

Airborne Video Systems
Arriflex
Bell Helicopter
Cinema Products
Victor Duncan
Alan Gordon
Matthews

CAMERAS; COLOR ENG/EFP & STUDIO

Adwar Video
Ampex
Asaca
CEI
Camera Mart
Cinema Products
Cohu
Comex
Compact Video Sales
Delcom Corporation
Victor Duncan
Fairchild Camera & Instrument

When you cover the action from the source...

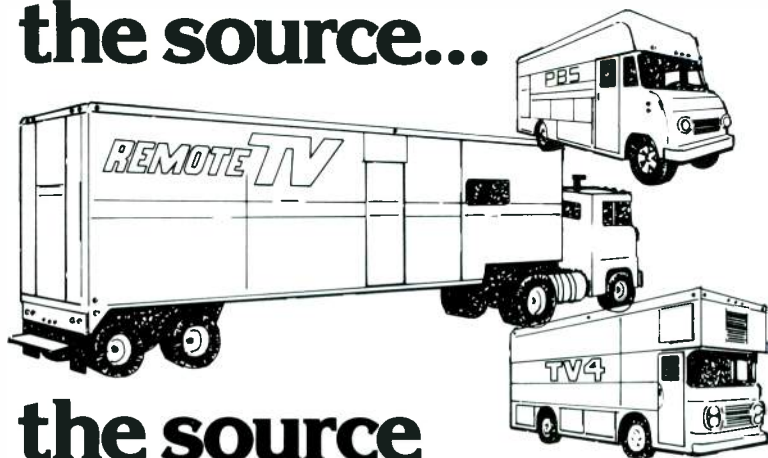

the source for mobile studios should be Gerstenslager.

In a van or trailer, your most modern, best equipped studio could be your Gerstenslager. It all starts when you tell us what you need. The job to be done. Then we'll work with your engineers and principal equipment suppliers. Develop the plans. Detail placement of every piece of equipment, generators, wiring, climate control, consoles. Exactly as you want it. Then, build the unit from the frame up. A studio on wheels that is actually a dependable broadcasting station comparable to conventional studio systems.

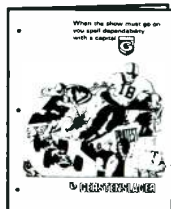

How we do it with examples of work we have done for others is included in this brochure. It's yours for the asking. Write or call: (216) 262-2015.



GERSTENSLAGER

The Gerstenslager Company, Wooster, Ohio 44691

Circle (38) on Reply Card

The New Benchmark Improved In Four Important Ways!

No. 1 Cart Machine

Today, one out of every two broad-cast cartridge machines purchased worldwide is an ITC Premium Line machine. Now, four new features make this first-choice line an even greater value.

Improved Frequency Response

The head is new. The open-faced design is cylindrically shaped rather than hyperbolic. MuMetal laminations are surrounded by epoxy filler impregnated with aluminum oxide particles for shielding and durability. Core windows are wider than conventional designs. The end result is greatly improved frequency response without low end humps and bumps.



New Cart Hold Down



New Head Design



New Pressure Roller

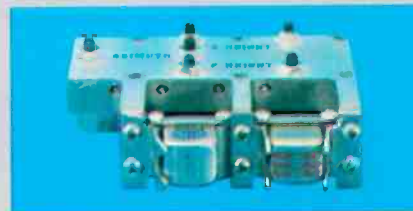

New Removable Head Module

Removable Head Module

True center pivot design. Azimuth, zenith and height adjust independently. Locking one does not affect the others. Steel ball pivots and longer azimuth arms permit finer tuning.

Improved Tape-Head Alignment

New cartridge positioning system assures precise, rigid alignment of tape to head even when insertion is hurried or careless.

Long-Life Pressure Roller

The 525K pressure roller offers twice the pulling power and extended life. Tolerates common cleaning chemicals. Holds its durometer even in high humidity.

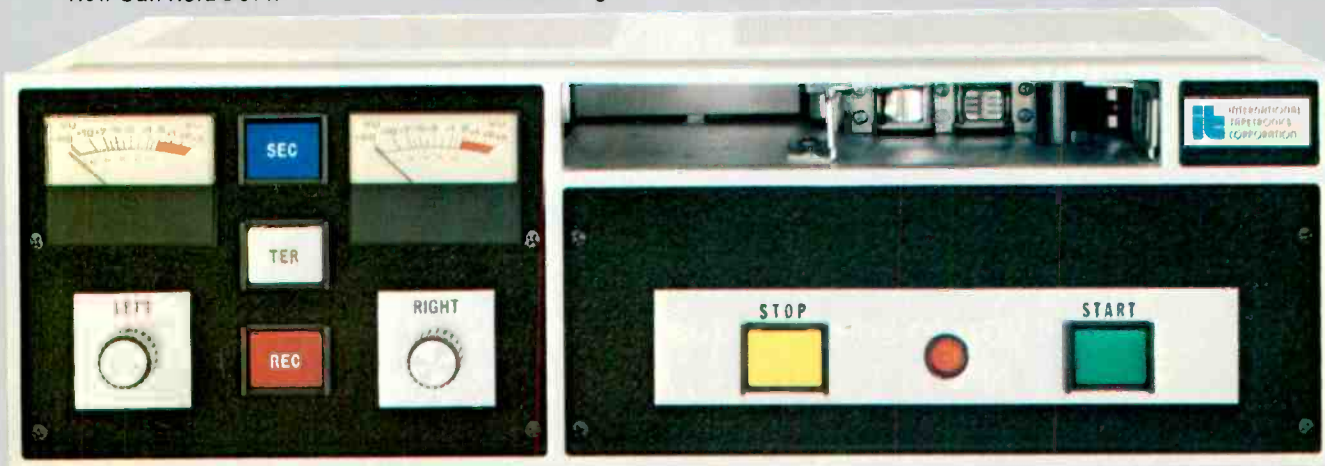

To place a no-risk order
CALL TOLL-FREE
800-447-0414
From Alaska, Hawaii, Illinois
call collect: (309) 828-1381

Circle (39) on Reply Card



International Tapetronics Corporation,
2425 South Main Street,
Bloomington, Illinois 61701

Marketed exclusively in Canada by McCurdy Radio Industries, Ltd., Toronto

NAB product directory

Fernseh
Harris
Hitachi Denshi America Ltd.
Ikegami
Marconi Electronics
NEC America
Panasonic, Video Systems Div.
Philips Broadcast Equipment
RCA
Sharp
Sony
Thomson-CSF Broadcast
Toshiba
US JVC

CAMERAS, FILM CHAIN

Adwar Video
Asaca
Camera Mart
Cohu
Delcom Corporation
Fernseh
Alan Gordon
Harris
Hitachi Denshi America Ltd.
Ikegami
Laird Telemedia
Nytone Electronics
Panasonic, Video Systems Div.
Philips Broadcast Equipment Corp.
RCA
Sharp
Sony

US JVC

CAMERAS, FILM, CINE

Arriflex
Cinema Products
Eastman Kodak
Frezzolini Electronics
Alan Gordon
Harris
Karl Heitz

CARTRIDGES & ACCESSORIES

Audio-Technica
Broadcast Cartridge Service
Broadcast Electronics
Capitol Magnetic Products
D-B Electronics
Fidelipac
David Green Broadcast Consultants
Harris
Howe Audio/BCP
Micro-Trak
Procart
Research Technology International
Stanton Magnetics
Telex
UMC Electronics

CARTS, EQUIPMENT

Adwar Video
Broadcast Electronics
Comprehensive Video Supply
D-B Electronics
Delcom Corporation
Harris
International Tapetronics Corp.

Lee-Ray Industries
Procart
Research Technology International
Sono Mag
Sound Genesis
Storeel
Telex

CHARACTER GENERATORS & TITLERS

BEI (Beston)
Chyron
Datametrics
Delcom Corporation
Fernseh
For-A Corp. of America
Gardiner Communications
Interand
Knox Video Products
Laird Telemedia
Landy
QSI Systems
Shintron
System Concepts
Texscan Corp.
Thomson-CSF Broadcast
3M Mincom
3M Video Products
Video Associates Labs
Video Data Systems

COMPUTERS, BUSINESS & WORD PROCESSING

Candex Pacific
Chase Media
Columbine Systems



AEG-TELEFUNKEN

invites you to see the latest in Broadcast Technology
at N.A.B. Las Vegas April 12-15 Booth 130

BAYLY ENGINEERING LIMITED
a member of the AEG-TELEFUNKEN group

167 Hunt St., Ajax, Ont., Canada L7S 1P6 (416) 683-8200 Telex 06-981293

CREATIVITY TAKES FLIGHT ON AMPEX VIDEO TAPE.



BROADCASTERS AND PRODUCTION COMPANIES DEPEND ON AMPEX TAPE.

From videotape equipment to the video tape itself, broadcasters and production companies throughout the world depend on Ampex. High quality, durability, reliability, and prompt service are just some of the reasons.

Ampex 175 Highband Quadruplex Video Tape has proven itself under every conceivable type of operating condition within every video standard. Excellent color performance, low drop-outs, and a tough durable formulation with low headwear are features which have contributed to this dependability.

And now Ampex 196 High Energy Broadcast Helical Video Tape has been specifically engineered to fill the increasing needs of a particularly demanding group of video professionals—those who have chosen one of the new broadcast helical VTRs.

No matter what your video tape needs are, there's an Ampex video tape for you. And, once you've tried Ampex tape, you'll see why broadcasters and production companies have grown to depend on Ampex.

AMPEX

REFLECTIONS OF REALITY. AND BEYOND.

Ampex Corporation, Magnetic Tape Division,
401 Broadway, Redwood City, CA 94063 415/367-4463

Circle (41) on Reply Card



NAB product directory

Computer Concepts
 Computer Management Systems
 Concept Productions
 Custom Business Systems
 Data Communications
 Groton Computers
 Harris Corp.
 Jefferson Data Systems
 Kaman Sciences
 Nidus Broadcast Systems
 Station Business Systems

COMPUTERS, NEWSROOM

Basys
 Jefferson Data Systems

NewsScan/McInnis-Skinner
 System Concepts
 Telesource Communications

DELAY SYSTEMS (AUDIO AND VIDEO)

Allen Avionics
 Broadcast Video Systems Ltd.
 Eventide Clockworks
 Fidelipac
 Grass Valley Group
 Image Video Limited
 Landy
 Lenco
 Lexicon
 Quintek
 Sound Genesis

Television Equipment Associates
 URSA Major

EDITORS, FILM

CMX/Orrox
 Eastman Kodak
 Magnasync/Moviola
 Research Technology International

EDITORS, VIDEOTAPE

Ampex
 BTX
 CMX/Orrox
 Cezar
 Control Video Corp.
 Convergence
 Datatron
 Delcom Corporation
 Victor Duncan
 Fernseh
 Alan Gordon
 Jatex
 NEC America
 Panasonic, Video Systems Div.
 RCA
 Sony
 US JVC
 United Media
 Videomedia

ELECTION REPORTING SYSTEMS

Fernseh
 System Concepts
 Thomson-CSF Broadcast

ENG EQUIPMENT

Achro-Video International
 Amtel
 Bell Helicopter
 Cablewave Systems
 Camera Mart
 Cetec Vega
 Cine 60
 Cinema Products
 Comex
 Comprehensive Video Supply
 Comrex
 Convergence
 Delcom Corporation
 Victor Duncan
 E-N-G Corp.
 Eddor
 Fernseh
 Ikegami
 Innovative Television Equipment
 Jenel
 Landy
 Lee-Ray Industries
 McMartin Industries
 Marti
 Microwave Associates
 Midwest Corp.
 NEC America
 Nagra
 Nurad
 Allen Osborne Associates
 Panasonic Video Systems Div.
 Philips Broadcast Equipment
 Power Optics
 Quick Set
 RCA

DIGITAL REMOTE CONTROL SYSTEMS

MOSELEY OFFERS A FULL LINE FOR ALL APPLICATIONS

NEW MRC-2

BOOTH 505 NAB '81

- USER-DEFINED EXECUTIVE ACTION
- CLEAR ENGLISH DISPLAY
- MULTI-CONTROL POINT OPERATION
- NON-VOLATILE MEMORY STANDARD
- AUTOMATIC MULTIPLE INTERCONNECT TRANSFER



The new **MRC-2** offers the flexibility that only a high technology, microprocessor-based system can supply. User-defined programming allows executive action of control functions. The system provides CRT displays for simplified operator interface of control, telemetry tolerance, status, and automatic muting. Full fail-safe capabilities and indirect power calibration are standard. Multiple direct commands, multiple CRTs, and multiple automatic loggers are available optionally.

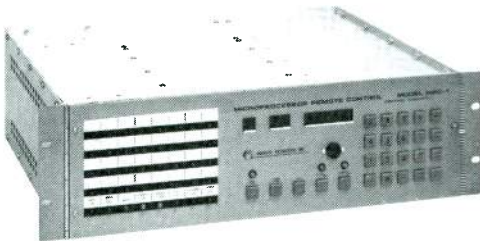

With proven reliability the **MRC-1** provides up to 64 command lines and 32 channels of status and telemetry from up to nine separate remote sites. Comparable only to much more expensive systems, its versatile capabilities assure long-term stability and accuracy with straightforward microprocessor-controlled operation.

The **TCS-2A** is designed to supply maximum value at minimum cost. With reliability, speed, and accuracy, it handles the needs of broadcasters, industrialists, ENG system users, and earth station operators. It offers eight command, status, and telemetry functions, affords one-person calibration, and has multi-site capabilities to simplify expansion.



FOR FURTHER INFORMATION PLEASE CONTACT OUR MARKETING DEPARTMENT.



MOSELEY ASSOCIATES, INC.

A FLOW GENERAL COMPANY
 SANTA BARBARA RESEARCH PARK, 111 CASTILIAN DRIVE • GOLETA, CA 93117
 (805) 968-9621 • CABLE: MOSELEY • TELEX: 658-448

Circle (42) on Reply Card

Announcing new AM/FM Stereo Consoles from ADM

THEY DO EVERYTHING BUT THE HELICOPTER REPORT



ADM® is proud to announce the ST Series, newest addition to our line of quality professional broadcast consoles. Compact as they are, they're big on capability and flexibility. They feature the same performance excellence, operational simplicity and reliability you'll find in any product from ADM.

The new ST consoles offer a series of modular frames that we will equip to your particular needs. A variety of input, output and signal processing modules are also available to satisfy your present requirements as well as future expansion. Each ST frame offers up to three separate stereo and one monaural output. All modules are front panel plug-ins. Electrical specifications set a new level of excellence for the industry.

So confident is ADM of the excellence of the ST Series, that they're backed with an exclusive 5-year warranty.

To find out more about how the new ST Series can make Audio Broadcasting easier for you, write or telephone us today. ADM Technology, Inc., 16005 Sturgeon, Roseville, Michigan 48066. Phone 313/778-8400. TLX 23-1114. West Central Sales Representative, Gordon Peters. Phone (817) 467-2990.

ADM®

The Audio Company

See Us at Booth #1212-A

NAB product directory

R.F. Technology
Sescom
Shintron
Shure Brothers
Sony
Sound Genesis
Tayburn Electronics
Teac
Telcom Research
US JVC
Ultra Audio Pixtec
Zenith Radio

ENCODERS, COLOR VIDEO (& DECODERS)

Amtel
Asaca
Blonder-Tongue
Broadcast Video Systems Ltd.
Cezar
Cohu
Delcom Corporation
Fernseh
For-A Corp. of America
Gorman-Redlich
Landy
Lenco
Marconi Electronics
Oak Communications
Panasonic, Video Systems Div.
Sony
Telemet
US JVC
Vital

ENCODERS, TONE AND EBS
Broadcast Electronics
Gorman-Redlich
McMartin Industries
Time and Frequency Technologies

ENGINEERING AND DESIGN SERVICES

Antiope Videotex Systems
Walter S. Brewer Co. Inc.
Candex Pacific
Comex
Compact Video Sales
Compucon
Comsearch
Continental Electronics Mfg. Co.
Delcom Corporation
Harris
Howe Audio/BCP
Image Video Limited
Jenel
LeBlanc & Royle
McCurdy Radio
RCA
Sound Genesis
Sphere
Television Technology Corp.
Tweed Audio
Ultra Audio Pixtec
World Tower

ENHANCERS, VIDEO IMAGE

Delcom Corporation
Digital Video Systems
Faroudja Laboratories
For-A Corp. of America
Harris

Hitachi Denshi America Ltd.
Landy
Microtime
RCA
Sony
Thomson-CSF Broadcast
US JVC
Vidicraft

EXCITERS (AM, FM, SCA, STEREO)

AEG-Telefunken
Belar
Broadcast Electronics
CCA Electronics
CSI Electronics
Comark Communications
Continental Electronics Mfg. Co.
Elcom Specialty Products
Harris
Howe Audio/BCP
LPB
McMartin Industries
NEC America
Orban
Philips Test & Measuring
Instruments
RCA
Scientific Atlanta
Varian/Eimac Div.
Versa-Count

EXTENDERS, AUDIO & LF

Comrex
Harris
Howe Audio/BCP
McCurdy Radio

AKG

When we set out to "naturally" enhance the quality of sound, we came up with an idea that's reverberating around the world.

The patented AKG Torsional Transmission Line System shown here is the heart of our new BX5. It's the same principle as used in our world-famous BX-10E2 and BX-20E.

This AKG innovation gives you flutter-free performance and truly balanced reverberation at any of the selectable decay settings.

The TTL system is just one of the many advanced features you'll find in the same

reverberation units used in most major recording and broadcast studios around the world.

Ask your AKG dealer for a personal demonstration and hear the benefits of each AKG reverberation unit... "naturally."

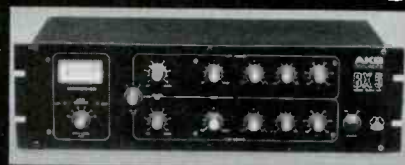
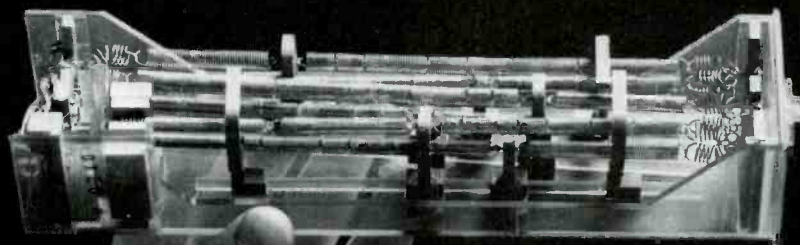

AKG ACOUSTICS INC.
A NORTH AMERICAN PHILIPS COMPANY
77 Selleck Street, Stamford, CT 06902
(203) 348-2121



© AKG Akustische und Kino-/Geräte GmbH, Austria © AKG 1981

The Only 2" ATR That's As Advanced As Your 1" VTR

With the Otari MTR-90, your audio can be as good as your video. It has all the advantages of one inch video format: compact size, broadcast quality, essential production features, and fewer dollars. It's the two inch multi-track production machine that's earned the reputation for being *The New Workhorse*. Post production houses, networks and recording studios are discovering that it's the new machine that outpaces the big names.

Here are some of the advantages of *The New Workhorse*:

- Superior Tape Handling — the industry's first three motor, pinch-rollerless two inch tape transport that can keep up with your VTR.
- Advanced Audio — high slew-rate components, active mixing of bias and audio, single card electronics, and a 71 dB dynamic range (24 track).
- Advanced Control Circuitry — digitally controlled



LSI circuitry for reliability and ease of servicing.

- Superior Editing — digitally timed, gapless electronic inserts. The capstan speed is continuously variable from 1 to 400 ips with external control.

The MTR-90 was designed for easy access to virtually any tape controller/editing system: EECO, BTX, ADAM-SMITH, AUDIOKINETICS, CMX and CVC. And, an optional phase compensated wide-band amplifier is available for high speed SMPTE code reading.

The MTR-90. Stay ahead of your competition with *The New Workhorse* — The frontrunner in video sweetening.

OTARI® *The New Workhorse*

Otari Corporation, 2 Davis Drive
Belmont, California 94002
(415) 592-8311 Telex: 910-376-4890
Circle (44) on Reply Card

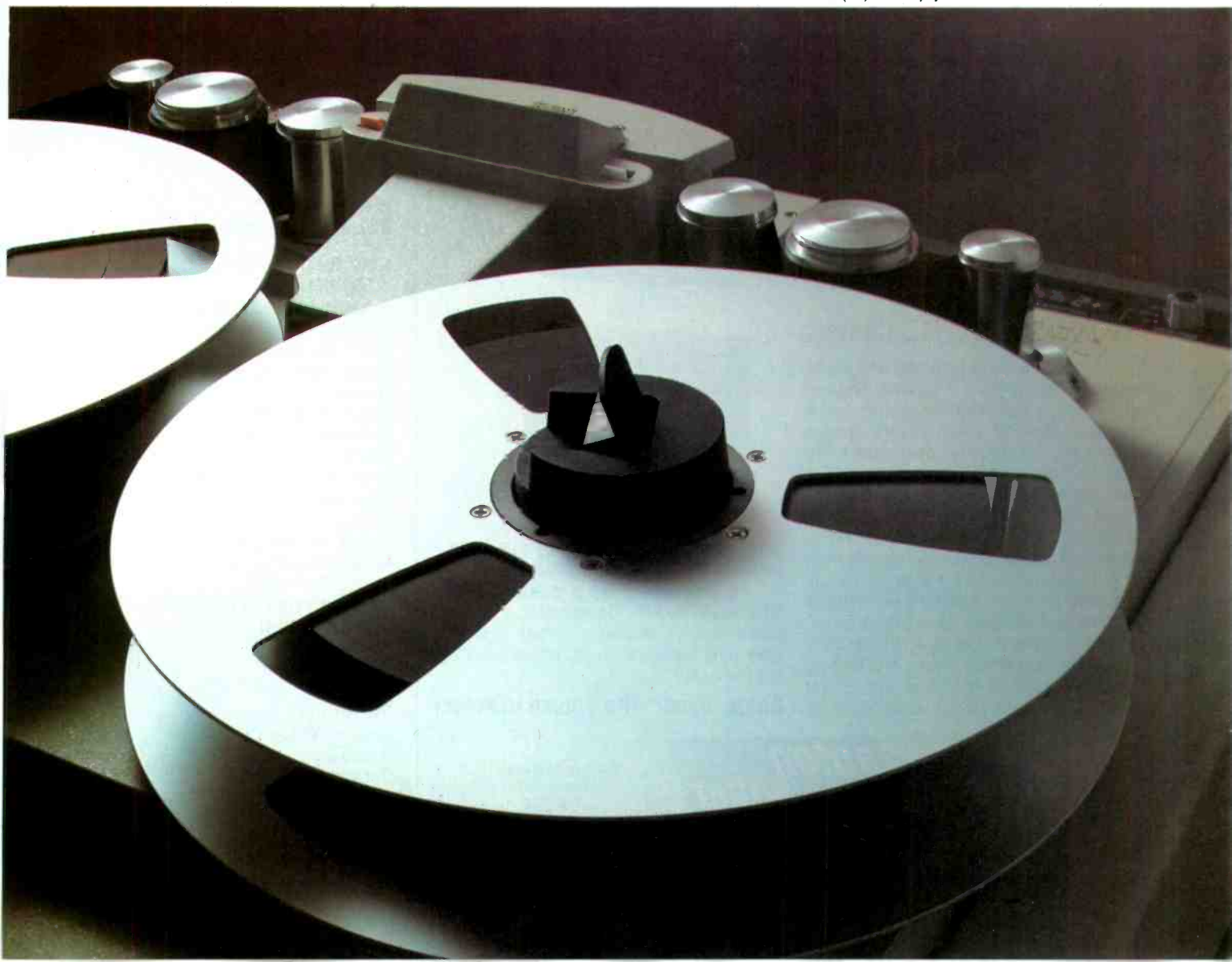

NAB product directory

FIBER OPTICS/OPTICAL LINKS

AEG-Telefunken
Fernseh
Grass Valley Group
Jenel
Kings Electronics
NEC America
Telemet
Valtec

FILM & PROCESSING SERVICES

Agfa-Gevaert
Arriflex
Cinema Products
Eastman Kodak

FILM CHAIN (SYSTEMS/ EQUIPMENT)

Camera Mart
Delcom Corporation
Fernseh
Alan Gordon
Harris
Ikegami
Image Resource
Industrial Sciences
Jenel
Laird Telemedia
Magnasync/Moviola
Nytone Electronics
Panasonic, Video Systems Div.
Philips Broadcast Equipment
RCA
Sony

US JVC
Zei-Mark

FILTERS (ALL TYPES)

AEG-Telefunken
Allen Avionics
Audico
Audio & Design Recording
Belden Communications
Broadcast Video Systems Ltd.
Comark Communications
Continental Electronics Mfg. Co.
Crown International
Alan Gordon
Jatex
Rupert Neve
Phelps Dodge
Rohde & Schwarz
Rosco Labs
Shively Laboratory
Sound Genesis
Tektronix
Television Equipment Associates
Texscan
Tiffin
UREI

Behind every great camera is a great battery

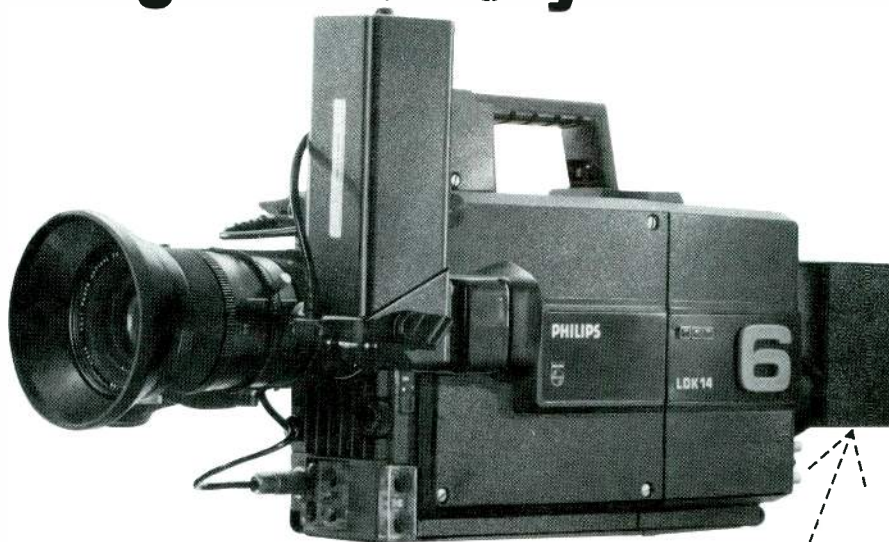

Philips new LDK-14S Camera

The years-ahead, 2/3-inch field and studio camera is now greater than ever. Greater sensitivity, greater flexibility, greater value. Plus, the LDK-14S offers several design advantages for battery operation: • Provides remote control capability when operating from battery (snap-on or battery belt) for studio control in EFP. • Exclusive flat bottom design allows positioning of shoulder brace for proper balance with or without snap-on battery. • snap-on mount for battery pack is compatible with Philips triax adaptor mount for quick conversion.

A great camera, like the Philips LDK-14S, deserves a great battery. The battery Philips selected as standard equipment on their camera is an Anton/Bauer



Snap-On™, the same battery selected by every major camera manufacturer.

The engineers who designed the Philips LDK-14S demanded the best power source available. When you buy your next battery can you afford anything but the best?

Anton/Bauer: The Source of Power

For Phillips
Information
Circle (45)

**anton
bauer**

For Anton/Bauer
Information
Circle (264)

Anton/Bauer Inc.

66 Center Street Shelton, CT 06484 Telephone: 203-735-3305

FRAME SYNCHRONIZERS

Adda
Control Video Corp.
Datatron
Delcom Corporation
Digital Video Systems
Electro & Optical Systems
Harris
MCI/Quantel
Microtime
NEC America
Skotel
Sony
Studer Revox
Thomson-CSF Broadcast

GENERATORS (FM, SCA, AM, STEREO)

Broadcast Electronics
Continental Electronics
Delta Electronics
Elcom Specialty Products
Harris
Howe Audio/BCP
McMartin Industries
Marti
Micro Control Associates
Moseley Associates
Orban
Sound Technology
Versa Count

GENERATORS (TIME CODE & READERS)

Amtel
Asaca
BTX
Beaveronics
Control Video Corp.
Datametrics
Datatron
Delcom Corporation
Dictaphone
Digital Video Systems
ESE

When your signal is your bread and butter...

your transmitter should be McMartin.

When you depend on a product to provide your bread and butter signal, remember McMartin. Our transmitters are designed with you in mind. McMartin offers a complete AM-FM line with high-level plate modulation on all AM transmitters. We are the only manufacturer to provide a full five-year warranty on our FM exciter and its accessories.

All McMartin broadcast transmitters are conservatively designed with fewer parts for higher reliability and lower maintenance costs. The confidence of knowing that your signal is "on the air" everyday is OUR bread and butter. That's McMartin.

For the name of your District Sales Manager, call or write McMartin.

See our new 50 Kilowatt transmitter in operation at booth #300 at the NAB convention, Cycle (46) on Reply Card

McMartin Industries, Inc. • 4500 South 76th Street • Omaha, Nebraska 68127 • Phone (402) 331-2000 • Telex 464485



NAB product directory

Electro & Optical Systems

For-A Corp. of America
 Glentronix
 Harris
 Jatex
 Laird Telemedia
 MCI
 Panasonic, Video Systems Div.
 QSI Systems
 Quintek
 RCA
 Shintron
 Skotel
 Sony
 Sound Genesis
 Television Equipment Associates
 Telcom Research
 US JVC
 United Media

GENERATORS (VIDEO SPECIAL EFFECTS)

American Data
 Asaca
 Beaveronics
 Crosspoint Latch
 Data Communications Corp.
 Delcom Corporation
 Digital Video Systems
 Echo Lab Inc.
 Fernseh
 Grass Valley Group
 Harris

ISI
 Interand
 Jatex
 MCI/Quantel
 NEC America
 Newscan/McInnis-Skinner Associates
 Panasonic, Video Systems Div.
 RCA
 Ross Video
 Shintron
 Sony
 Telestrator
 3M Video Products
 US JVC
 Video Associates Labs
 Vital

GENERATORS (VIDEO, SYNC, BURST, PATTERN)

Achro-Video International
 Adwar Video
 American Data
 Asaca
 Beaveronics
 Centro Corporation
 Comprehensive Video Supply
 Crosspoint Latch
 Delcom Corporation
 Digital Video Systems
 Fernseh
 For-A Corp. of America
 Grass Valley Group
 ISI
 Jatex
 Leitch Video

Lenco
 Panasonic, Video Systems Div.
 Philips Test & Measuring
 Porta-Pattern
 Power Optics
 Quintek
 RCA
 Ross Video
 Shintron
 Sigma Electronics
 Sony
 Tektronix
 Telemet
 US JVC
 Ultra Audio Pjxtec
 United Media

HEAD ALIGNMENT & SPINDLE HEIGHT GAUGES

Broadcast Cartridge Service
 Broadcast Electronics
 Fidelipac
 Harris
 Merlin
 Telex

HEADS & REFURBISHING SERVICES, AUDIO

Accurate Sound
 Broadcast Electronics
 Fidelipac
 Howe Audio/BCP
 Nortronics
 Orrox

De-Esssss

The Orban 526A single-channel Dynamic Sibilance Controller is a *simple*, economical dedicated de-esser—without the complexity and compromises of multi-function processors. It sets up *fast* to produce sibilance levels that sound natural and right. Features include mic/line input, fully balanced input and output, LED level meter, GAIN control, compact size and more. Special level-tracking circuitry assures consistent results with varying input levels. And our control technique doesn't emphasize residual IM when de-essing occurs.

De-essing doesn't have to be complex, expensive, and time consuming. The 526A does it fast and *right* in recording studios, cinema, broadcast and cassette duplication.

The 526A De-Esser is available at your Orban pro-audio dealer.

orban Orban Associates Inc.
 645 Bryant Street
 San Francisco, CA 94107
 (415) 957-1067

Circle (47) on Reply Card

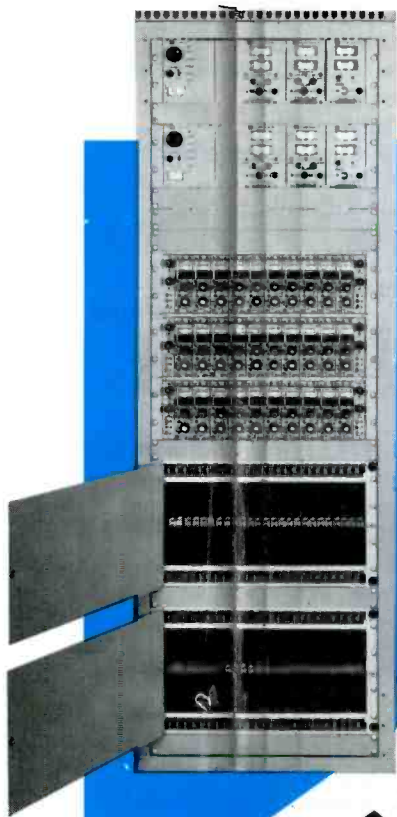

The Investment that grows

DATATEK D-2000

ROUTING SWITCHERS

Industry leading technical performance.

For example, maximum audio output is +30dBm without requiring transformers and noise is over 105dB below maximum output.

Inherent reliability

For example, the D-2000 **avoids** putting multiple inputs and outputs on a common PC board, **avoids** party lining control systems in preference to private lining and **avoids** reliance on a central microprocessor system. Instead, each input and each output bus are on individual plug-in modules and each output bus has its own independent microprocessor control system. A fault therefore can only affect one input or one output and not the entire system.

Expansion Capacity to 250x250 Systems, with up to 8 control levels. There is no need to specify initially the ultimate matrix size.

Large Selection of Control Panels.

For example, there are over 25 different standard control panels, including individual pushbutton, keypad, alpha numeric and CRT matrix status display. Datatek can also design control panels for special requirements. Control is over a single coax line.

For More Information, Write or Call:



1121 BRISTOL ROAD
MOUNTAINSIDE, NJ 07092 · (201) 654-8100

NAB Booth 1227

Circle (48) on Reply Card

**SOUND
BEFORE
ITS
TIME**



**ULX
2001**

**UniPhase Link-Exciter
from**

mci

Designed to enhance the performance of conventional STL Systems, the Micro Controls ULX-2001 UniPhase Link-Exciter modulates and multiplies a radio carrier to the 950 MHz STL frequency for transmission to the FM Broadcast Transmitter site. Sampled at I.F. frequency, then heterodyned to the 88-108 FM frequency range, non linearities inherent in the STL receiver-detector and FM exciter-modulator are eliminated. With better phase linearity, total overall sound performance is improved.

F.C.C. type acceptance pending.

OTHER EQUIPMENT AVAILABLE:

Conventional STL — Composite Wideband
Discreet Narrowband

Remote Control — Radio & Wireline
SCA Equipment — Automatic Transfer Units
Antennas — Transmission Line

**Call or write today for more
information.**

**MICRO CONTROL
ASSOCIATES**

P.O. Box 694
Cleburne, Texas 76031
817/295-7771

NAB product directory

Sound Genesis
Taber
Tayburn
United Research Lab Corp.
Videomagnetics

**HEADS & REFURBISHING
SERVICES, VIDEO**

Ampex
CMC Technology
Orrox
Taber
United Research Lab Corp.

HEADPHONES

Audio-Technica
Beyer Dynamic
Broadcast Electronics
Cetec Vega
Clear-Com
Comprehensive Video Supply
Continental Electronics Mfg. Co.
D-B Electronics
Harris
Howe Audio/BCP
Panasonic, Video Systems Div.
ProTech Audio
R-Columbia
Research Technology International
Sony
Sound Genesis
Stanton Magnetics
Television Equipment Associates
Telex
US JVC

INTERCOMS

Adwar Video
Cetec Vega
Clear-Com
Compact Video Sales
Comprehensive Video Supply
Comrex
Coreco Research Corporation
Farrtronics
HME
Harris
McCurdy Radio
Olesen
ProTech Audio
R-Columbia
RTS Systems
Sound Genesis
Swintek
Television Equipment Associates
Telex
US JVC
Ward-Beck

**LIGHTING CONTROLS
& ACCESSORIES**

Avab America
Berkey Colortran
Walter S. Brewer Co. Inc.
Camera Mart

Candex Pacific
Compact Video Sales
Imero Fiorentino
The Great American Market
Harris
Kliegl Brothers
LTM Corp. of America
Lowel-Light
Mole-Richardson
Olesen
Skirpan
Strand Century
Teatronics Sales Div. of UAP
Ultra Audio Pixtec
Utility Tower Company
V&B Tower

LIGHTS, PORTABLE & STUDIO

Anton Bauer
Arriflex
Belden Communications
Berkey Colortran
Walter S. Brewer Co. Inc.
Camera Mart
Cine 60
Comprehensive Video Supply
Cool Light
Fidelipac
Frezolini Electronics
General Electric
The Great American Market
Harris
Kapco Communications
Kliegl Brothers
LTM Corporation of America
Matthews
Mole-Richardson
Olesen
Strand Century
Sylvania/GTE

METERS (ALL TYPES)

AEG-Telefunken
Accurate Sound
Audio & Design Recording
dbx
Delta Electronics
Electro & Optical Systems
Fidelipac
Harris
LTM Corp. of America
Logitek
Potomac Instruments
Ramko Research
Sound Genesis
United Research Lab. Corp.

MICROPHONES & ACCESSORIES

Accurate Sound
Audio Technica
Beyer Dynamic
Broadcast Electronics
Camera Mart
Cetec Broadcast
Cetec Vega
Comprehensive Video Supply
Comrex
Continental Electronics Mfg. Co.
Crown International
D-B Electronics
Ecor
Alan Gordon

Circle (49) on Reply Card

Introducing
NEC's all-new

MNC-81A

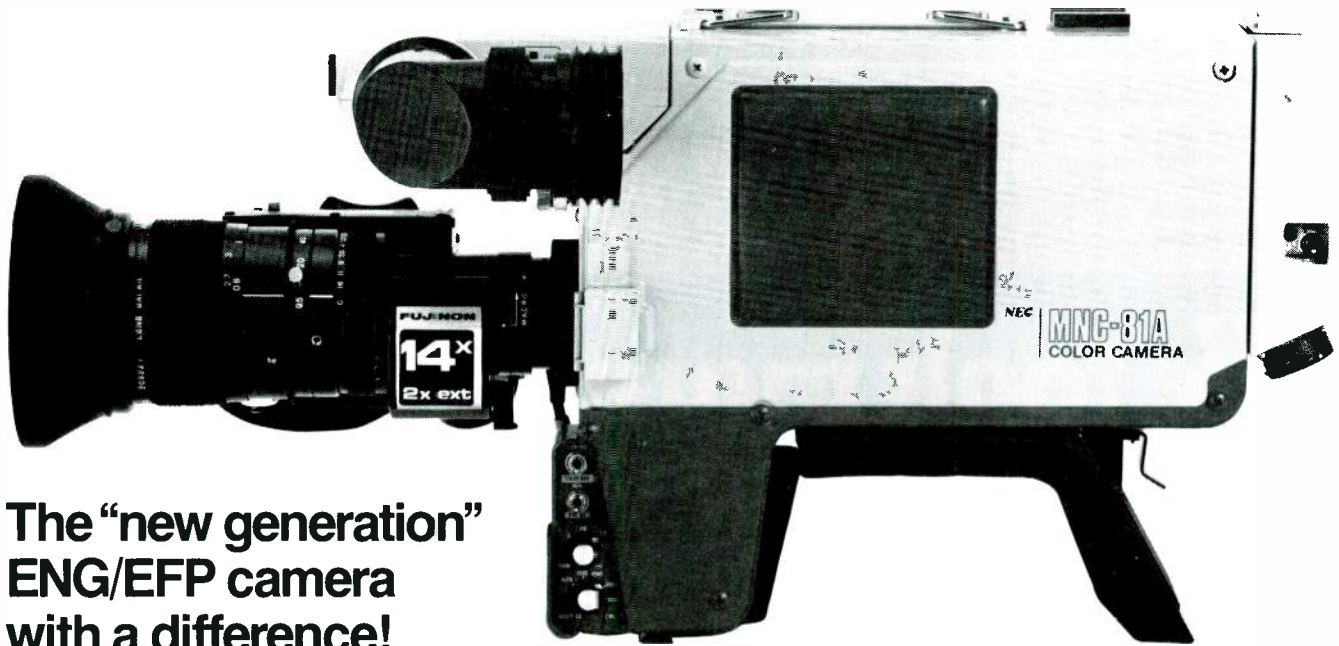

The "new generation" ENG/EFP camera with a difference!

Get a headstart on the 1980's with NEC's newest "state-of-the-art" ENG/EFP camera: the MNC-81A.

Designed to meet today's more stringent requirements for highest-fidelity color reproduction, the MNC-81A features outstanding colorimetry matched to that of broadcast cameras; with f/1.4 high-transmission prism optics; a choice of pickup tubes: Saticon®, Plumbicon®, or Diode Gun™ Plumbicon®; a signal-to-noise ratio of 54 (± 2) dB; 4-position gain control with up to +18 dB additional gain for low light level operation; plus all the *automatics*, built-in indicators and features that have become standard for broadcast-quality video cameras. And more.

The NEC difference...

Extensive use of LSI hybrid microcircuits developed uniquely by NEC makes the MNC-81A extremely stable in registration and performance, and ultra-reliable in circuit operation.

Low-profile and ultra-lightweight — camera head (without lens, but including 1.5" viewfinder) weighs less than 11 lbs. and measures approximately 10¼" x 4" x 13½" — the MNC-81A handles with the ease of a compact 16mm newsfilm camera.

It is well balanced on the shoulder, with a form-fitting adjustable base. And its 1.5" viewfinder telescopes for convenient left or right eye viewing.

Best of all, the MNC-81A is a multi-purpose camera with the widest range of options for studio and field operation. Its sophisticated optional remote control

capabilities include a co-ax digital remote control system for distances up to 5000 feet, as well as fiber optics module and cable adapter for fiber optics video transmission from distances up to 9000 feet.

Quite a difference in operational flexibility and versatility compared to other cameras in its class!

The CP difference...

And, of course, when you buy an MNC-81A, you are automatically covered by Cinema Products' outstanding after-sales service and backup program.

You get an unprecedented full one-year warranty, with no service charge ever for warranty work! You get round-the-clock video service seven days a week. Replacement parts anywhere in the United States within 24 hours... And an easy-term lease/purchase program specifically tailored to your needs.

For complete details on the MNC-81A camera, contact Don Dunbar, Vice President/National Marketing. Call toll-free: 800-421-7468.

Distributed exclusively by:

cinema products
CORPORATION

Technology In The Service Of Creativity

2037 Granville Avenue, Los Angeles, California 90025
Telephone: (213) 478-0711 • (213) 477-1971 • Telex: 69-1339

Be sure to visit our NAB Booth #1417

NAB product directory

David Green Broadcast Consultants
HME
Harris
Howe Audio/BCP
James B. Lansing Sound
Marti
Nady System
Nagra
Olesen
Panasonic Professional Audio Div.
R-Columbia
R.F. Technology
RTS Systems
Ramko Research
Shure Brothers

Sony
Sound Genesis
Swintek
Television Equipment Associates
Telex
US JVC

MICROWAVE SYSTEMS

AEG-Telefunken
Airborne Video Systems
Andrew Corporation
Anixter-Mark
Cablewave Systems
Comark Communications
E-N-G Corp.
Harris
Hitachi Denshi America Ltd.
Howe Audio/BCP

Jenel
Micro Communications
Microwave Associates
Moseley Associates
NEC America
Nurad
RCA
R.F. Technology
Tayburn Electronics
Terracom

MONITORS, AUDIO

Arrakis Systems
Belar
Broadcast Electronics
Cetec Broadcast Group
Continental Electronics Mfg. Co.
Harris
Howe Audio/BCP
James B. Lansing Sound
McCurdy Radio
McMartin Industries
Merlin
Micro-Trak
Quad Eight
Ramko Research
Sony
Sound Genesis
Studer Revox America
Tektronix
Telemet
Time & Frequency Technologies
UREI
US JVC
Ultra Audio Pixtec
Videotek
Ward-Beck

MONITORS, VIDEO

Adwar Video
Amtron
Cohu
Conrac
Delcom Corporation
Electrohome
Electro & Optical Systems
Fernseh
Harris
Hitachi Denshi America Ltd.
Ikegami
Lenco
Panasonic, Video Systems Div.
Philips Test & Measuring
RCA
Rohde & Schwarz
Sharp
Shintron
Sony
Tektronix
Telemet
Time & Frequency Technologies
US JVC
Videotek

MONITORS, TEST EQUIPMENT/ METERS

Amtron
Belar
Bird Electronic Corp.
Broadcast Video Systems
Delcom Corporation
Delta Electronics

We took more than dust off these Demos!

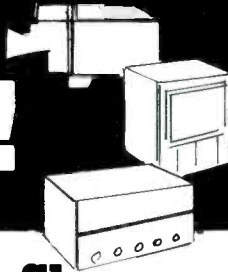

Save Big on Miller's Video Clearance

		List Price	Sale Price
Toshiba PK-39	Broadcast 3-tube Plumbicon Camera		
Hitachi SK-91	Fujinon 12:1 ENG/AC Broadcast 3-tube Plumbicon Camera	\$45,675	\$25,000
Hitachi HR-100	Fujinon 14:1 W/2X 1" Type C Portable VTR	39,150	29,150
Microtime 2525	1" Type C Portable VTR W/AC/2 Batt./Quick Charger	36,500	29,930
Microtime 2100	Frame Store TBC/Synchronizer	24,995	18,750
Ikegami ITC240	Image Enhancer/Noise Reduction	7,295	3,725
Ikegami ITC350	3-Tube Saticon Camera, 12:1	23,775	14,500
Sharp XC700PS	3-Tube Saticon Camera, 10:1	16,315	11,685
Hitachi FP 20S	3-Tube Saticon Camera, 14:1 W/2X	19,970	13,760
Hitachi FP 3060	3-Tube Saticon Camera, 10:1	11,180	6,275
Shintron 373NV	1-Tube Saticon Camera, 6:1	6,500	3,250
Shintron 350	Switcher/SEG	7,510	4,700
Panasonic NV9600/	Encoded Chroma Key	3,000	1,890
NV9240/NV-A960	3/4" Editing System	14,445	9,600
JVC CR-4400LU	ENG 3/4" Portable VCR W/AC/Anvil Case	5,092	3,342
Edutron CCO-1H	Time Base Corrector	4,150	2,100
Dynasciences 834	Image Enhancer	3,500	1,225
Shintron 640	Portable SMPTE Generator	1,650	1,100
Shintron 644	SMPTE Reader/Roster Display	4,500	3,000
Shintron 643	SMPTE Printer only	1,500	1,000
Panasonic WJ5500A	SEG	3,950	2,625



L.MATTHEW MILLER Assoc.Ltd.

Suite 1316, 205 East 42nd Street, New York, NY 10017
Telephone: (212) 687-1168 • (800) 223-0620, Cable VIDEOUSA Telex 238917

VIDEO EQUIPMENT • RENTALS • SERVICE/REPAIRS • VIDEOTAPE • EDITING

Circle (50) on Reply Card

EYE-OPENERS

Just when everyone had their eyes wide open to the outstanding line of Ikegami broadcast and production color cameras, Ikegami introduced its color and B&W monitor line, engineered with the same innovative technology as its cameras. A great tradition of eye-opening continues with precision, quality and beautiful images.

The Ikegami color monitor line consists of the High Resolution Series RH Color Monitors and the High Performance Series 8 Color Monitors. The High Resolution Series RH Color Monitors are available in the 14" TM 14-2RHA and the 20" TM 20-8RH. Both provide precision color reproduction at 600 plus lines for professional studios, control rooms, remote vans, etc., and feature a high resolution CRT with High Density Dot Matrix, a switchable comb filter in the decoder, and the AFPC (Automatic Frequency Phase Control) system to maintain exceptional color reproduction. Both models are rack-mountable, with the TM

14-2RHA featuring plug-in circuit boards for easy maintenance.

The High Performance Series 8 Color Monitors are available in the 14" TM14-8RC, 20" TM20-8R and 25" TM25-8. The Series 8 monitors offer high quality color reproduction, a Shadow Mask Dot Matrix CRT, Pulse Cross Circuit, Active Convergence Circuit, low power consumption, and more.

The B&W Monitors are engineered to the same exacting Ikegami standards and are available in Triple 5", Dual 9", 5", 9", 12", 17" and 20" sizes.

Ikegami's Eye-Openers are available at most dealers. For details and additional information, contact: Ikegami Electronics (USA) Inc., 37 Brook Ave., Maywood, NJ 07607, (201) 368-9171; West Coast: 19164 Van Ness Ave., Torrance, CA 90501, (213) 328-2814; Southwest: 330 North Belt East, Suite 228, Houston, TX 77060, (713) 445-0100; Southeast: 522 So. Lee St., Americus, GA 31709, (912) 924-0061.



Video Products built to Ideal Standards



Ikegami

Circle 189 on Reply Card

See us at Booth #817 at NAB.

If we had set out to give you only
the features our competition gives you,
this is where we'd be today.



Most VTR units give you only a fraction of the features you might want from a video tape recorder. So we didn't stop where our competition did. We kept on adding features. Until we developed the most versatile 1" machine on the market.

Compare the 3M TT-7000 VTR and NTC-10 Time Base Corrector to the competition. Nobody puts together more of the features you want than 3M. And once you see our unit, we think you'll agree that buying anything else is like getting half a machine.

The 3M TT-7000 Video Tape Recorder gives you:

- Auto track following (ATF) ¼ reverse through 2x forward (optional).
- Video and sync confidence heads.
- Three channel audio confidence heads.
- Video sync channel.
- All DC motor and servo tape transport.
- 19" rack mountable with full dust cover.
- Front panel plug-in modules.
- Frame accurate insert and assemble editing.
- Dual tape timer with zero memory.
- Tape speed override on front panel.
- Stop tone and cue-up (0, 3, 5, 7 sec. preroll).
- Contact closure and TTL external interface.
- Variable speed forward/reverse shuttle.
- Still frame jog.
- Autochroma and color framing.
- Audio 3 record in play mode (built-in speaker).
- Instant stop action from play or slo-mo (with ATF option).
- Instant audio bias level adjust.
- Video level calibrate marker.
- Preset/Manual tracking select on front panel.
- Fixed precision rabbited drum tape guide.
- And low RF, high temperature and low voltage alarms.

Our Time Base Corrector comes complete with its own list of standard features:

- Sixteen line correction window.
- Ten bit quantizing.
- Four times subcarrier sampling.
- 65 dB signal-to-noise ratio.
- Velocity compensation.
- Digital one line drop out compensator.
- Compact size (8¾" high by 17½" deep by 18½" wide).
- 45 pounds total weight.
- Portable cabinet or rack mountable.
- And front panel plug-in modules.

Add it all up, and you've got the most complete VTR/TBC package on the



market. For a free demonstration, call (612) 733-7914 or write 3M/Mincom Division-Video Products, 223-5E 3M Center, St. Paul, MN 55144. In Canada contact 3M Canada, Inc., P.O. Box 5757, London, Ontario, N6A-4T1. In Alaska contact 3M Company, 5331 Minnesota Drive, Anchorage, AK 99502. Get the complete picture.

3M Hears You...

3M

NAB product directory

Digital Video Systems
Fidelipac
Gorman Redlich
Harris
Howe Audio/BCP
Leitch Video
Philips Test & Measuring
Instruments Inc.
Porta-Pattern
Potomac Instruments
Tektronix
Telemet
Television Equipment Associates

UREI
Ultra Audio Pixtec
Versa-Count
Videotek

MUSIC LIBRARIES & SOUND EFFECTS

Bonneville Broadcast Consultants
Cavox Tape-athon
Century 21 Programming Inc.
Comprehensive Video Supply
DeWolfe Music Library Inc.
Emil Ascher
Live Sound
The Musicworks
Network Production Music Library

Olesen
Thomas J. Valentino
Video Data Systems

NOISE REDUCTION SYSTEMS

ADM Technology
ATI-Audio Technologies Inc.
Audio & Design Recording
dbx
Dolby
Fernseh
David Green Broadcast Consultants
Howe Audio/BCP
Inovonics
McCurdy Radio
Micmix
Microtime
Panasonic, Video Systems Div.
Philips Broadcast Equipment
RCA
Sony
Sound Genesis
Tektronix
Thomson-CSF Broadcast
UREI
US JVC
Vidicraft

Beaucart 100

Now get the best from Beaucart—the Type 100. The most advanced reproducer Beaucart has ever made, the Type 100 incorporates all the features necessary for reliable performance and exceptional sound reproduction. Look at these performance features:

- Modular design and motherboard construction to insure reliability
- Dual redundant phase lock loop circuitry to eliminate false cueing
- State-of-the-art amplifier circuitry to yield superior frequency response with exceptionally low distortion.

If you are looking for value and performance, the Type 100 is the answer. Write for our brochure detailing this advancement for the broadcast professional.

UMC Electronics Co. Broadcast Products Division

460 Sackett Point Road
North Haven, CT 06473
(203) 288-7731 (in CT) Telex 96-3510
(800) 243-6178 (Outside CT, toll-free)

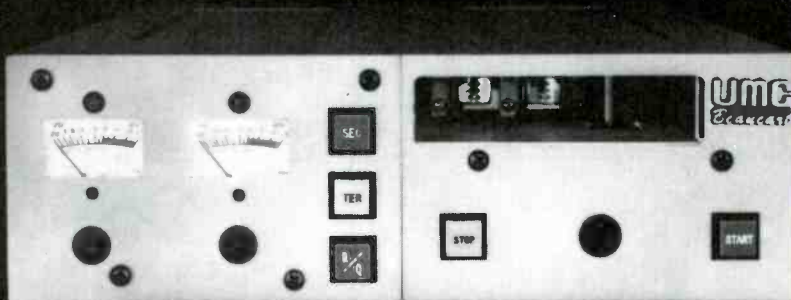

PATCH PANELS, JACKS & PLUGS

ADC Products
ADM Technology
Auditronics
Broadcast Electronics
Comark Communications
Comark Industries
Comprehensive Video Supply
Continental Electronics Mfg. Co.
Dielectric
Farrtronics
Harris
Image Video Limited
Kings Electronics
Lemo
McCurdy Radio
Micro Communications
Olesen
Potomac Instruments
SWR
Shively Laboratory
Sound Genesis

POWER SUPPLIES

Audio & Design Recording
Comark Communications
Frezzaolini Electronics
Gardiner Communications
Howe Audio/BCP
McCurdy Radio
ProTech Audio
Sound Genesis

PROCESSING EQUIPMENT

ATI-Audio Technologies Inc.
Audio & Design Recording
Belar
Circuit Research Labs
Cohu
Continental Electronics Mfg. Co.
dbx
Dolby
Eventide Clockworks
Fernseh

Circle (53) on Reply Card

THE INNOVATORS

We started with a concept. An abstraction. The pure science. To theoretically synchronize multiple machines for video and audio production. To translate the SMPTE Code, which we helped develop, into a practical application. To make theory a reality, a tool engineers could actually use. Simply put, to revolutionize the television production and post production industries.

What we did was become the first to make a micro-processor based synchronizer system, the first to make the SMPTE Time and Control Code really work. That's why when we say we're

The Innovators, it's more than a slogan. It's a fact.

The MOS-100A Series. We started with an evolutionary micro-computer based synchronizer that cues and synchronizes any three audio/video transports simultaneously. And went on from there, adding enhancements like three "scratch pad" memories accessible from the keyboard.

The MTG-550 Series Time Code Generators, for precision electronic indexing of video and

audio tapes. CMOS/LS TTL logic gives you reduced size, weight and power requirements. And, slave and user bit input options are now standard.

The TCR-650 Series Edit Time Code Readers, for reading electronically indexed video and audio tapes from any source. This micro-computer based system also gives you TACH pulse input operation.

It's one thing earning a reputation. It's another maintaining it. And that's why EECO is continually innovating. And our competitors continually imitating. For complete information, write or call us today.

EECO
Incorporated
1601 East Chestnut Avenue, Santa Ana, California 92701. Phone (714) 835-6000 T.W.X. 910-595-1550 Telex 67-8420

AMPEX

AmpeX is a worldwide distributor for EECO Broadcast Products

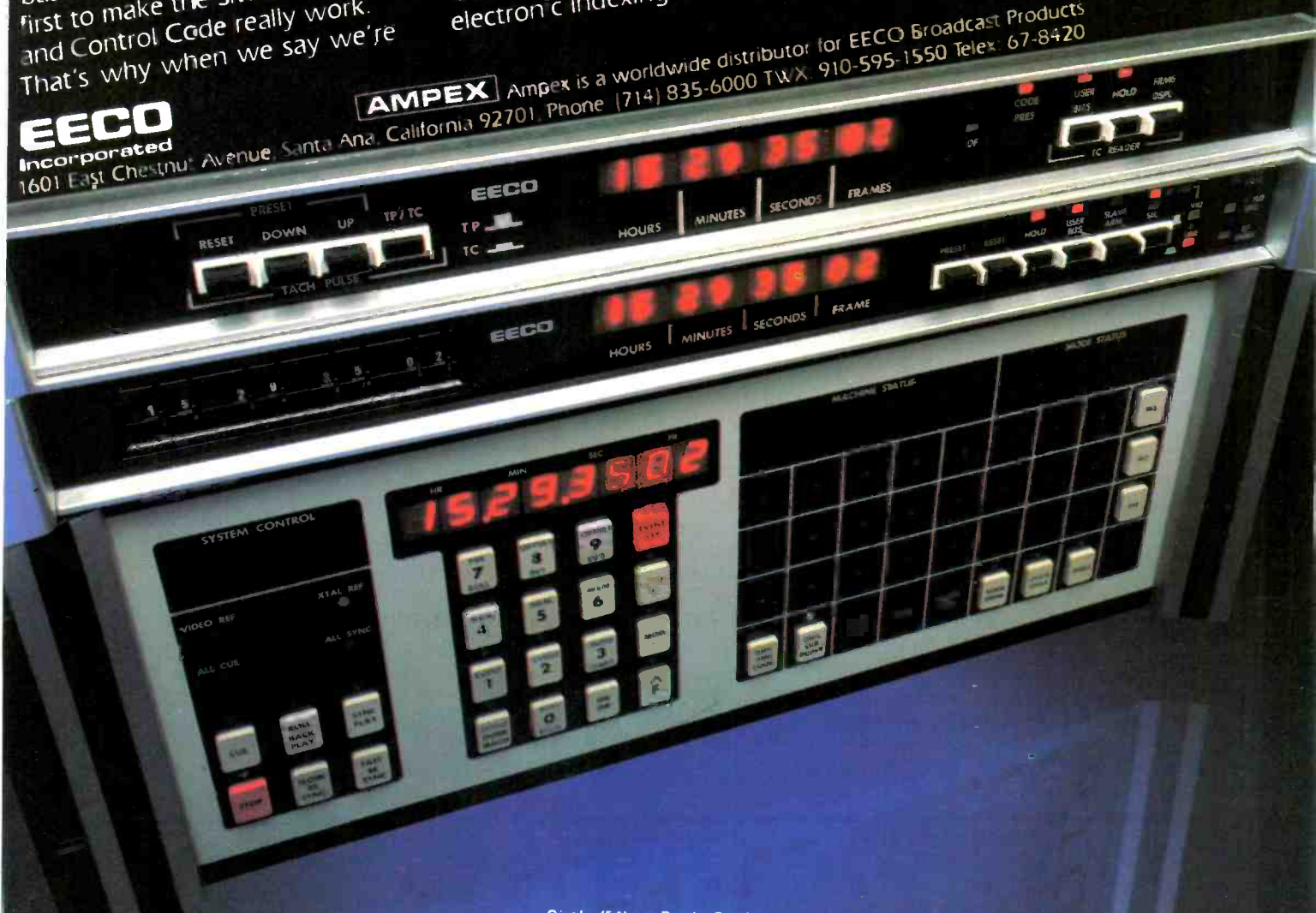



Script writing and prompting have finally gone electronic.

BEI **DATA PROMPTER**

The fact that the BEI Data-Prompter is an excellent script writing and prompting device is reason enough to check it out. But the BEI Data-Prompter offers other benefits. Like live "real time" Line 21 Closed Captioning for the hearing impaired, electronic text editing, assembly and material handling, automatic pacing, a director's line for cuing, "on air" story sort and skip/re-insert.

The BEI Data-Prompter also has a clear,

easy-to-read display, and it can be easily interfaced to existing electronic newsroom equipment.

In addition, the BEI Data-Prompter can generate either a hard copy printout or a log printout to accommodate current F.C.C. requirements.

The BEI Data-Prompter. Not only designed to fit your script writing and prompting needs, but to work for you, not against you.

BEI

P.O. Box 106A • Olathe, Kansas 66061
(913) 764-1900 • Toll Free: 1-800-255-6226
TWX: 910-749-6401

Circle (273) on Reply Card



Mobile van or studio, you'll choose BEI Marquee 2000 over all the others.

MARQUEE **2000**

VIDEO PRODUCTION GENERATOR
FOR STUDIO OR MOBILE VANS

When you look at "all the other" character generators on the market, you'll like our style. Beginning with a compact size (14 inches of rack space), and a multi-font (up to 4) display capability combined with a 150 page disc memory that's accessible at the touch of a button. Care to hear more?

Well, there's the Marquee 2000's double logo capability (up to 128 scan lines), 31.5 nanosecond resolution, RS232 interface, full

surround or drop-shadow edging, proportional spacing with true character overlap, character insert & delete and automatic row centering.

Maybe you need some options. The Marquee 2000 offers dual channel capabilities, a special camera font compose unit and even a memory recall keyboard.

Want more? Contact BEI. We offer what they offer and more...much more.

BEI

P.O. Box 106A • Olathe, Kansas 66061
(913) 764-1900 • Toll Free: 1-800-255-6226
TWX: 910-749-6401

Circle (55) on Reply Card

March 1981 *Broadcast Engineering* 73

NAB product directory

Grass Valley Group
 Gregg Laboratories
 Howe Audio/BCP
 ISI
 Inovonics
 Lenco
 McCurdy Radio
 Moseley Associates
 NEC America
 Rupert Neve
 Orban
 RCA
 Sigma Electronics
 Sony
 Sound Genesis
 Tektronix
 Tweed Audio
 UREI
 Ursa Major
 US JVC
 Versa Count
 Vidicraft

PROGRAM SERVICES

Bonneville Broadcast Consultants
 Broadcast Programming Int'l
 Cavox/Tape-athon
 Century 21 Programming Inc.
 Concept Productions
 Groton Computer
 KalaMusic
 Live Sound
 The Musicworks

Oak Communications

PROJECTORS, TV LARGE SCREEN

Adwar Video
 Electrohome
 General Electric
 Panasonic, Video Systems Div.
 Sony
 US JVC

PROJECTORS, TELECINE & ACCESSORIES

Delcom Corporation
 Eastman Kodak
 Fernseh
 Alan Gordon
 L-W International
 Laird Telemedia
 Panasonic, Video Systems Div.
 RCA
 Research Technology International
 Sony
 Zei-Mark

PROMOTIONAL MATERIALS & SERVICES

The Great American Market
 U.S. Tape & Label
 Thomas Valentino

PROMPTING SYSTEMS

BEI (Beston)
 Cinema Products
 Listec TV Equipment
 Q-TV
 Telescript

RECEIVERS (ALL TYPES)

AEG-Telefunken
 Adwar Video
 Asaca
 Continental Electronics Mfg. Co.
 Delta Electronics
 Electrohome
 Gardiner Communications
 Gorman Redlich
 Howe Audio/BCP
 McM Martin Industries
 Moseley Associates
 Panasonic Video Systems Div.
 Potomac Instruments
 RCA
 Scientific Atlanta
 Sony
 Studer Revox America
 Tayburn Electronics
 Telemet
 Time and Frequency Technologies
 US JVC
 Zenith Radio

RECORDER CARE PRODUCTS

Broadcast Electronics
 Comprehensive Video Supply
 Fidelipac
 Nortronics
 Otari
 Research Technology International
 Sound Genesis
 Teac
 Telex
 United Research Lab Corp.

IF IT'S FROM RUSSCO, IT'S A SOUND INVESTMENT.

RUSSCO is broadcast equipment designed by professional broadcast engineers... Built Rugged, built to work and save downtime. That's Good Investment. When you look over our quick-starting Vari-Speed turntable and our performance boosting stereo and mono audio mixers, you begin to understand RUSSCO Quality. RUSSCO phono pre-amps, power and distribution amplifiers are the finest state-of-the-art. You'll look good when you buy RUSSCO, and the money you Save will Sound Good going into the bank!

• Call Barbara Gaudin for Catalog sheets with our great specs.



PHONO / MATE
PRE-AMP



MM260 AMPLIFIER



STUDIO / MASTER 505 MIXER



DISCO 421 MIXER



MARK V VARI-SPEED TURNTABLE



MULTI-MATE
DIST. AMP.

You can Rely on **RUSSCO**

RUSSCO ELECTRONICS INC. 5690 E. Shields Ave., Fresno Calif. 93727 • Phone (209) 291-5591

Circle (56) on Reply Card

TV test equipment from the inventors of the Plumbicon® tube.

At long last a new, reliable source of TV test equipment. One that offers fast, predictable delivery. One with a name all the world trusts—Philips. Four quick examples:

PM5565 Waveform Monitor

Enjoy the luxury of examining one line and one field at a time. On top of this, there's a convenient front probe input so you can use the monitor as a troubleshooting oscilloscope.

PM5567 Vectorscope

If you want more accurate decoding and the ability to have an external reference from composite video signals, choose our vectorscope.

Both waveform monitor and vectorscope mount side by side, fit all existing hardware and use less power than the competition.

PM5539 Color Analyzer

Take it on a quick trip through your studio or control room and adjust all monitors to the same color temperature in a matter of minutes.

With four different memories, there's no problem in quickly calibrating four different phosphors.

Variable full-scale, from less than set up to more than reference white, allows measurement of color tracking as a function of APL.

PM5534 Color Pattern Generator

Our universal pattern contains all the signals needed to verify overall system operation—directly from the picture. No wonder virtually every set manufacturer uses our pattern for their TV set alignment.

Of course our TV test equipment line doesn't end here. Today Philips offers a wide range of equipment including sync and pattern generators, VITS generators and analyzers, and TV modulators and demodulators.

For nationwide sales and service information call 800-631-7172, except in Hawaii, Alaska and New Jersey. In New Jersey call collect (201) 529-3800, or contact Philips Test and Measuring Instruments, Inc., 85 McKee Drive, Mahwah, New Jersey 07430.



Philips, of course.



**Test & Measuring
Instruments**

PHILIPS

Circle (51) on Reply Card

NAB product directory

RECORDERS (AUDIO, CARTRIDGE)

Ampro/Scully
Audi-Cord
Autogram
Broadcast Electronics
Camera Mart
Century 21 Programming Inc.
Cetec Broadcast
Continental Electronics Mfg. Co.
D-B Electronics
Fidelipac
Alan Gordon
David Green Broadcast Consultants
Harris

Howe Audio/BCP
IGM Communications
International Tapetronics
Pacific Recorders
Ramko Research
Sono Mag
Sound Genesis
Telex
UMC Electronics

RECORDERS (DIGITAL AUDIO)

MCI
Panasonic Professional Audio Div.
Sony
Sound Genesis
3M/Mincom
3M Video Products

RECORDERS (AUDIO, REEL & CASSETTE)

AEG-Telefunken
Accurate Sound
Adwar Video
Ampex
Ampro/Scully
Broadcast Electronics
Cetec Broadcast
Continental Electronics Mfg. Co.
Dictaphone
Filmways/Heider
Cliff Gill
Alan Gordon
Harris
Howe Audio/BCP
Inovonics
International Tapetronics
MCI
Magnasync/Moviola
Micro-Trak
Nagra
Rupert Neve
Otari
Panasonic Professional Audio Div.
Ramko Research
Sony
Sound Genesis
Studer Revox America
Tayburn
Teac
Telex
US JVC
United Research Lab Corp.

Comsearch Will Clear the Way

Now with low power broadcast
station analysis, too!

Frequency studies, too!

with our wide spectrum of communications engineering services:

- Satellite earth station interference studies and site selection
- FFI measurements
- Terrestrial frequency planning (for common carrier, private, CARS and STL microwave)
- Field survey
- Coverage patterns for MDS and land mobile
- System design
- Consulting services

See us at booth #1604
at the NAB.

COMSEARCH

INCORPORATED
7633 Leesburg Pike/Falls Church, Virginia 22043
703/356-9470

RECORDERS (VIDEODISC, SLOW MOTION REPLAY)

Arvin/Echo
Eigen Video
Fernseh
NEC America
Oktel
Panasonic, Video Systems Div.
RCA
Recortec
Sony
Teac
US JVC

RECORDERS (1-INCH VTRs, QUAD, VIDEOCASSETTE)

A.F. Associates
Adwar Video
Airborne Video Systems
Ampex
Animation Video
Asaca
Camera Mart
Comex
Delcom Corporation
Victor Duncan
Fernseh
Alan Gordon
Hitachi Denshi America Ltd.
Marconi Electronics
Merlin
NEC America
Panasonic, Video Systems Div.
Philips Broadcast Equipments
RCA
Recortec
Sharp

Circle (57) on Reply Card

NOW YOU GET MORE THAN MARCONI WHEN YOU BUY MARCONI!



Take the Marconi MR2 (pictured above). It's a superbly-crafted machine from one of the world's most prestigious manufacturers. A 1" Format VTR that has proven its quality and durability time and again.

Now add AFA. For more than a decade we've successfully designed and fabricated total video-tape systems and rebuilt and refurbished hundreds of VTR machines of every make and model.

Now, as the exclusive sales representative for all Marconi Broadcast Products in North America, we'll service your MR2 and other Marconi products with all the expertise and knowledge we've gained over the years. And we'll supply you with all the spare parts and components you'll ever need directly from our headquarters in Northvale, New Jersey. Guaranteed!

AFA
A.F. ASSOCIATES

See Us at NAB Booth #1035

100 Stonehurst Court, Northvale, NJ 07647, (201) 767-1000

© 1981, A.F. Associates, Inc.

Circle (59) on Reply Card

NAB product directory

Sony
Teac
3M/Mincom
3M Video Products
US JVC

REMOTE CONTROL SYSTEMS, LINKS, STLs

AEG-Telefunken
Broadcast Electronics
Continental Electronics Mfg. Co.
Delta Electronics
David Green Broadcast Consultants
Hallikainen & Friends
Harris
Howe Audio/BCP
Jenel
Marti
Micro Control Associates
Microwave Associates
Moseley Associates
Motorola Communications &
Electronics Inc.
Nurad
RCA
Tayburn Electronics
Time and Frequency Technologies

REMOTE CONTROL SYSTEMS, VIDEO

ADDA
Animation Video

BTX
CMX/Orrox
Camera Mart
Candex
Comark Communications
Comark Industries
Control Video Corp.
Delcom Corporation
Fernseh
Harris
Image Video Limited
Jenel
Microtime
Moseley Associates
Nurad
Tayburn Electronics
Teac
US JVC

SATELLITE COMMUNICATIONS (EARTH STATIONS & ANTENNAS)

Anixter-Mark
California Microwave
Compact Video Sales
Comsearch
Fort Worth Tower Company
Gardiner Communications
Harris
Jenel
McMartin Industries
Microdyne
Microwave Associates
Moseley Associates

NEC America
Oak Communications
RCA
RCA Americom
Scientific Atlanta
Telemet

SEQUENCE CONTROLLER

Control Video Corp.
Digital Video Systems
IGM Communications

SETS & BACKDROPS

Walter S. Brewer Company, Inc.
Comprehensive Video Supply
Imero Fiorentino
Olesen
Uni-Set Corp.

SOUND SYSTEMS

Adwar Video
BGW Systems
Cetec Vega
Howe Audio/BCP
Jenel
McMartin Industries
Olesen
ProTech Audio
Shure Brothers
Sound Genesis
Tweed Audio
UREI

“It's unbeatable...”

“When we decided to build one of the most modern radio stations in the country, we did a lot of shopping around for equipment. LPB had the best designed ‘meat and potatoes’ console we looked at. And for ease of installation and maintenance, my engineering staff all agreed, it's unbeatable. To top it off, LPB set up my entire three studio setup with the latest state-of-the-art gear including Technics®, Otari, Sennheiser, Belar, Orban Optimod®, Orange County and U.M.C.”

Gary H. Kleiman
Vice President/General Manager

WGLU₉₂

Johnstown, Pennsylvania



LPB S-20, 10 mixer dual stereo Signature II audio console installed in WGLU air studio.

LPB®

AM or FM. Large market or small, there's an LPB audio console to fit your requirement. Talk to the people that use them. Then talk to us.

LPB Inc. • 28 Bacton Hill Road • Frazer, PA 19355 • (215) 644-1123
Manufacturers and Distributors of Broadcast Equipment since 1960

© 1981 LPB Inc.

See Broadcasting's Most Comprehensive Line of Audio Consoles at LPB's NAB Booth #402.



**“Our
Auditronics
on-air and
production
consoles
pay off
three ways”,**

says Chuck Cooper, General Manager of WKOR in Starkville, Mississippi. “When it came time to rebuild this station, we wanted to go first-class all the way to the tower. Of course, that meant starting with first-class consoles for both on-air and production. But when you own a 1 kW station in a small market, you’ve got a modest budget to work within, and you can’t afford to make a mistake.”

“So we took our CE, PD and Op. Mgr. to NAB to look at everybody’s hardware with an open mind to make sure we got the best value for our money. We believe we got it in our two Auditronics 110 consoles. First, our on-the-air people love the Auditronics boards, and being able to show this type of equipment helps us to attract the level of talent we want.”

“Second, in a small market like ours, the stations do most of the commercial production, and the quality we get out of this Auditronics production board has helped us capture 80% of the production work in The Golden Triangle. Third, the Auditronics boards give us an audibly superior on-air quality that sells very well to our advertisers, and that’s the real bottom line.”

If you’d like to know more of what WKOR’s Chuck Cooper and 500 other satisfied users in both small and large markets have learned about Auditronics console quality and pay-back, circle reader service number or call us for complete information and the name of your nearest demonstrating Auditronics dealer.



auditronics, inc.

3750 Old Getwell Road
Memphis, Tennessee 38118
(901) 362-1350

Circle (60) on Reply Card



There's nothing fancy about the Knox K50. It's reliable; it's economical; it's basic; the simplest machine we make. Come to think of it, it does have an independent preview channel... and shadow-edged characters... and a flash function... all as standard features. Maybe it's fancier than we thought.



A DIVISION OF COMPUTER OPERATIONS, INC.
5001-J Forbes Boulevard, Lanham, MD 20801
301/459-2106 Telex 89-8327

Circle (61) on Reply Card



Do it with style. Better still, do it with *three* styles. Knox calls it Multifont, and it's built into each Mod-16 character generator. It's upper *and* lower case. It's accented letters. And it's resolution down to *a single scan line*. It's just one of the features standard with every Mod-16. It's also by Knox. Plain enough?



A DIVISION OF COMPUTER OPERATIONS, INC.
5001-J Forbes Boulevard, Lanham, MD 20801
301/459-2106 Telex 89-8327

Circle (62) on Reply Card

NAB product directory

Ultra Audio Pixtec
Ursa Major

SPEAKERS & ENCLOSURES

Audio Technica
BGW Systems
Broadcast Electronics
Continental Electronics Mfg. Co.
D-B Electronics
Harris
Howe Audio/BCP
Micro-Trak
Olesen
Panasonic Professional Audio Div.
Ramko Research
Russco Electronics
Shure Brothers
Sony
Sound Genesis
UREI

SPEECH COMPRESSORS

ATI-Audio Technologies Inc.
Broadcast Electronics
Circuit Research Labs
Comrex
Continental Electronics Mfg. Co.
Eventide Clockworks
Harris
Howe Audio/BCP
Lexicon
Marti
Rupert Neve
Orban
ProTech Audio
Sound Genesis

STANDARDS CONVERTER, VIDEO

Digital Video Systems
MCI/Quantel

STL EQUIPMENT

AEG-Telefunken
Andrew Corporation
Broadcast Electronics
CSI Electronics
Cablewave Systems
Continental Electronics Mfg. Co.
Dolby
Harris
Howe Audio/BCP
McMartin Industries
Marti
Micro Control Associates
Microwave Associates
Moseley Associates
Nurad
RCA
R.F. Technology
Tayburn Electronics
Time and Frequency Technology
Versa Count

STILL STORE/FRAME STORE EQUIPMENT

Ampex
Arvin/Echo
Delcom Corporation

Digital Video Systems
Eigen Video
Fernseh
Harris
MCI/Quantel
NEC America
Oktel
Sony
US JVC

STUDIO EQUIPMENT, MISC.

AEG-Telefunken
ATI-Audio Technologies Inc.
BGW Systems
Broadcast Electronics
Camera Mart
Cinema Products
Comprehensive Video Supply
Comex
Continental Electronics Mfg. Co.
Delcom Corporation
Victor Duncan
Eventide Clockworks
Fernseh
Fidelipac
Filmways/Heider
Harris
Howe Audio/BCP
ISI
Jenel
Kliegl Brothers
LPB
Logitek
Micro-Trak
Orban
Otari
Panasonic, Video Systems Div.
Quad Eight
RCA
Ross Video
Sony
Studer Revox America
Tektronix
Ultra Audio Pixtec
United Research Lab. Corp.
Ursa Major
US JVC
Ward-Beck

SWITCHERS, AUDIO

Asaca
Avab America
Beaveronics
Broadcast Audio
Broadcast Electronics
Crosspoint Latch
Datatek
Dynair Electronics
Filmways/Heider
Harris
Harrison Systems
Hedco
Howe Audio/BCP
Image Video Limited
Rupert Neve
Pacific Recorders
ProTech Audio
Quad Eight
Ramko Research
Sony
Sound Genesis
Tweed Audio

AM TRANSPARENCY

Typical phase and square wave performance: Continental's 317C-2

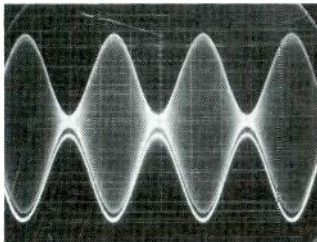

20 Hertz

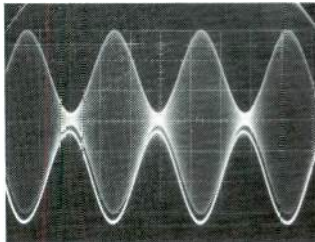

1000 Hertz

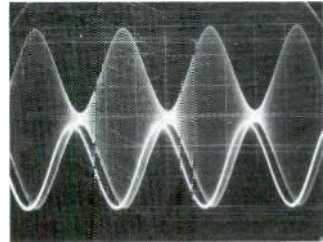

7500 Hertz

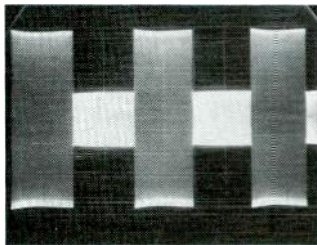

50 Hertz

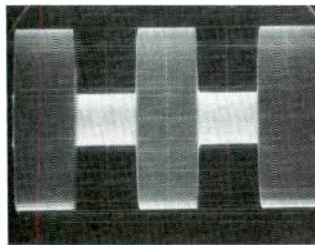

1000 Hertz

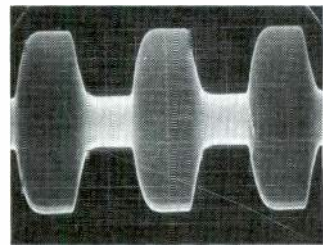

7500 Hertz

**Continental's
317C-2 50 kW
AM transmitter
gives broadcasters
a new standard
of performance.
Here's why.**

The 317C-2 offers broadcasters transparency and high efficiency.

Continental's 317C-2 is a 50 kW broadcast transmitter built for today's programming demands.

It delivers superb audio quality and faithfully reproduces the most complex audio processing. It is ready for AM stereo.

Continental's newest transmitter comes from a field-proven design and offers broadcasters excellent performance with unmatched efficiency, reliability, simplicity and maintainability.

Continental transmitters meet today's sophisticated programming requirements. And

they'll be ready for the coming evolutions in AM broadcast programming.

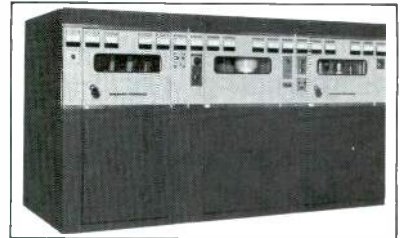

For information and a brochure on the 317C-2, phone (214) 381-7161 or write to: Broadcast Marketing Dept. Continental Electronics Mfg. Co., Box 270879 Dallas, Texas 75227; Telex: 73-398

Continental Electronics



SEE US AT THE NAB SHOW - BOOTH 100
Circle (63) on Reply Card

NAB product directory

UMC Electronics
US JVC
Utah Scientific
Vital
Ward-Beck

SWITCHERS, ROUTING

Adwar Video
American Data
Asaca
Beaveronics
Datatek
Datatron
Delcom Corporation
Di-Tech Inc.

Dynair Electronics
Fernseh
For-A Corp. of America
Grass Valley Group
Harris
Hedco
ISI
Image Video Limited
NEC America
Oktel
Pacific Recorders
Panasonic, Video Systems Div.
RCA
Ross Video
Sony
Telemet
3M/Mincom

3M Video Products
US JVC
Ultra Audio Pixtec
Utah Scientific
Viscount Industries
Vital

SWITCHERS (VIDEO, PRODUCTION, EDITING)

Adwar Video
American Data
Ampex
Asaca
Beaveronics
Central Dynamics
Comex
Crosspoint Latch
Datatek
Datatron
Delcom Corporation
Victor Duncan
Dynair Electronics
Echolab Inc.
Fernseh
Grass Valley Group
Harris
Hedco
ISI
Image Video Limited
NEC America
Panasonic, Video Systems Div.
Philips Broadcast Equipment
RCA
Ross Video
Shintron
Sony
US JVC
Viscount Industries
Vital

FIRST

IN ORIGINAL DESIGN

MICRO COMMUNICATIONS, INC., HAS DEVELOPED A REPUTATION OF CREATIVE EXCELLENCE IN THE FIELD OF RF COMPONENT DESIGN. WITH 15 YEARS' EXPERIENCE, MCI HAS BECOME THE LEADER IN THE SYSTEMS ENGINEERING APPROACH TO RF COMPONENT DESIGN.



micro
communications inc.

BOOTH 1108

GRENIER FIELD • P.O. BOX 4365, MANCHESTER, N.H. 03108

TBCs. TIME CODE EQUIPMENT

ADDA
Ampex
BTX
Datametrics
Delcom Corporation
Digital Video Systems
Victor Duncan
Edutron
Electro & Optical Systems
Fernseh
Harris
MCI/Quantel
Marconi Electronics
Microtime
NEC America
Panasonic, Video Systems Div.
Philips Broadcast Equipment
Quintek
RCA
Skotel
Sony
3M/Mincom
US JVC

TAPE ERASERS

Broadcast Electronics
Comprehensive Video Supply
DB Electronics

Circle (64) on Reply Card

MASTERFUL PERFORMANCE



ADM's DA16B/CH20B Audio Distribution System

You are assured of one masterful performance after another because the DA16B/CH20B provides audio distribution of unquestioned reliability. It offers a unique combination of features for exceptional versatility.

- Each amplifier is a one-input, six-output plug-in card.
- The input, and each output is individually transformer coupled.
- Input levels up to +27 dBv; output levels up to +27 dBm before clipping.

- Output amplifiers have individual, front accessed gain adjustment, and a test point.
- Each CH20B will house up to six DA16B cards, and has a complete set of redundant power supplies with automatic changeover.

But probably the most important feature of all is ADM's unexcelled built-in quality—quality backed by a five-year unconditional warranty.

Contact us today for the complete story about the unique DA16B/CH20B system.

See Us at Booth #1212-A

ADM[®] *The
Audio
Company*

16005 Sturgeon • Roseville, Michigan 48066
Phone (313) 778-8400 • TLX 23-1114
West Central Sales Representative,
Gordon Peters • (817) 467-2990

The instruments that you available from the

Leader offers you more than 50 off-the-shelf instruments, all with more performance per dollar than you ever thought possible.

Surprising fact: Leader's 50-MHz oscilloscope outperforms all competitors. Costing hundreds of dollars less than the best selling competitive model, the LBO-517 is more sensitive, has a higher 20-kV accelerating potential for brighter displays, and permits simultaneous main and delayed time-base presentations. In fact, it has more features than any other 50-MHz oscilloscope at any price. In all, there are 14 Leader oscilloscopes... each offering more performance for less cost.

Surprising fact: Leader "easy-reading" frequency counters are preferred for many industrial applications. Built for continuous day-in, day-out use, Leader 80, 250, and 500-MHz frequency counters are production-line proven. All three units feature sturdy, well-shielded metal cases and large, bright fluorescent digital displays for easy reading.

Surprising fact: Leader offers a big line-up of professional video and TV instruments. There are 11 units in all. NTSC, PAL and SECAM sync and test signal generators, RF and IF alignment sweep/marker generators, CATV field strength meters... and more on the way.

Surprising fact: Leader audio instruments have a worldwide reputation for excellence. Design labs, production lines and service departments in over 80 countries rely on Leader audio instruments. Frequency response recorders, speaker analyzers, precision sine and square-wave generators, distortion meters, attenuators, one and two-channel ac millivolt meters, FM stereo generators, wow, flutter, and drift meters. Over 16 off-the-shelf units.

Surprising fact: Leader general-purpose instruments grow ever more popular. VOM's, digital and FET multimeters, LCR bridges, semiconductor testers and curve tracers, audio and RF generators, function generators... all feature human-engineered control layouts, up-to-date capabilities and sturdy, attractive enclosures. All offer optimum reliability at realistic costs.

Surprising fact: Over 100 custom design Leader units. Additionally, over 100 special Leader instruments are available for production-test applications. Call or write for information on these or to have standard Leader instruments modified for your special requirements.

Surprising fact: No waiting for Leader Instruments. Off-the-shelf deliveries from over 100 stocking U.S.

distributors... backed by East and West Coast warehouses.

Surprising fact: Every Leader instrument is protected by a generous, 2-year parts and labor warranty which is unsurpassed in the industry.

Call toll-free (800) 645-5104 for the name of your local "select" Leader distributor, to request our catalog, or to arrange for an evaluation unit.

When Quality Counts

LEADER
Instruments Corporation

380 Oser Avenue
Hauppauge, N.Y. 11787 (516) 231-6900

Regional Offices:
Cincinnati, Los Angeles, Dallas.



use most are immediately
surprising leader.

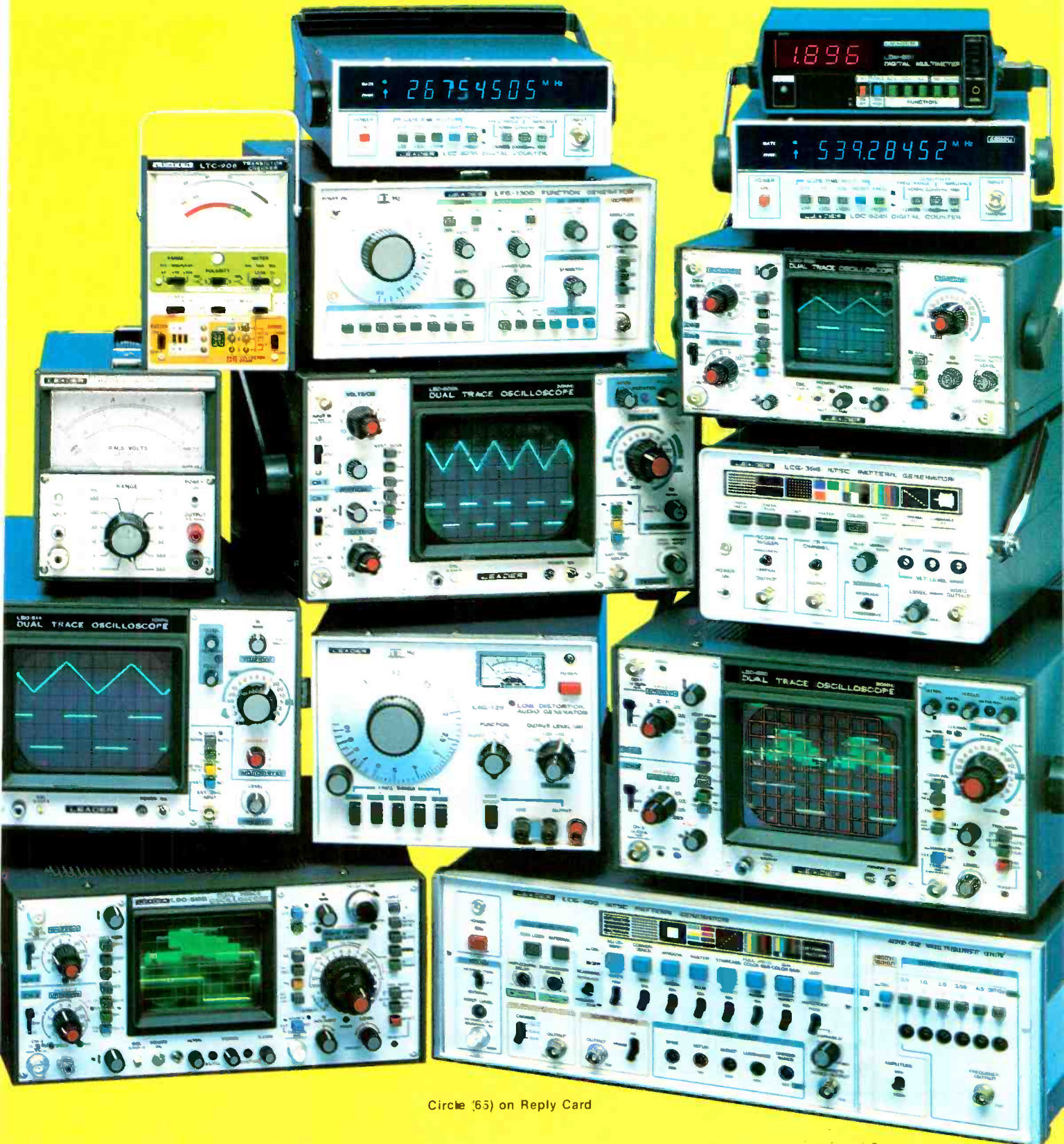

Circle (65) on Reply Card

NAB product directory

Fidelipac
Garner Industries
Harris
Howe Audio/BCP
International Tapetronics
Nortronics
Optek
Recortec
Sound Genesis
Taber

TAPE DUPLICATING

Cavox/Tape-athon
Century 21 Programming Inc.
Garner Industries
Telex
United Research Lab Corp.
Thomas Valentino

TAPE, EVALUATORS/CLEANERS/ GAUGES

Achro-Video International
Broadcast Electronics
Chyron
Fidelipac
Merlin
Nortronics
N.O.V.A. Corp.
Recortec
Television Equipment Associates
Tentel
UMC Electronics

TAPE, MAGNETIC RECORDING (AUDIO)

Agfa-Gevaert
Ampex
Broadcast Cartridge Service
Broadcast Electronics
Capitol Magnetic Products
Continental Electronics Mfg. Co.
D-B Electronics
Fidelipac
Fuji Magnetic
Harris
Maxell
Rupert Neve
Sony
United Research Lab Corp.

TAPE, MAGNETIC RECORDING (VIDEO)

Agfa-Gevaert
Ampex
Comprehensive Video Supply
Delcom Corporation
Fuji Magnetic Tape
Kapco Communications
Maxell
Panasonic, Video Systems Div.
Sony
Teac

TELETEXT & CAPTIONING EQUIPMENT

Antiope Videotex Systems

EEG Enterprises
ISI
Oak Communications
Zenith Radio

TEST EQUIPMENT, MONITORS AND METERS (AUDIO)

Amber
Asaca
Belar
Broadcast Electronics
Comprehensive Video Supply
Continental Electronics Mfg. Co.
Crown International
Dielectric
Fidelipac
Harris
Howe Audio/BCP
Paladin
Philips Broadcast Equipment
Potomac Instruments
RCA
Sound Genesis
Sound Technology
Tayburn
Tektronix
Tentel
Ultra Audio Pixtec
UREI
Ward-Beck
Xedit Corp.

TEST EQUIPMENT, MONITORS AND METERS (VIDEO)

Adwar Video
Asaca

INTRODUCING THE MODEL 7200 COMMUNICATOR

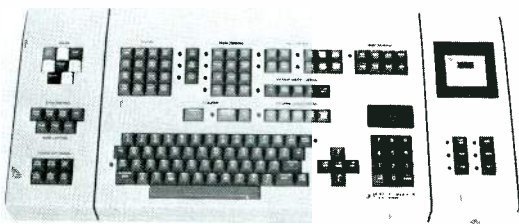

- HIGH RESOLUTION FONT (35 n sec.)
- BASIC SINGLE STROKE CONTROL
- GRAPHICS AND 3 CHARACTER SIZES
- 8 COLORS—CHARACTERS & BACKGROUND
- MIXED CHARACTER SIZES—BY LINE
- AUTO CENTERING BY PAGE OR LINE
- DISC AND/OR TAPE STORAGE
- MULTIPLE KEYBOARD CAPABILITY
- BUILT-IN VIDEO KEYS
- FULL BORDER OR DROP SHADOW

 **LAIRD TELEMEDIA INC.®**
2424 SOUTH 2570 WEST • 801 972-5900
SALT LAKE CITY, UTAH 84119

VISIT BOOTH 901 AT NAB

Circle (66) on Reply Card

NOT SO FAST

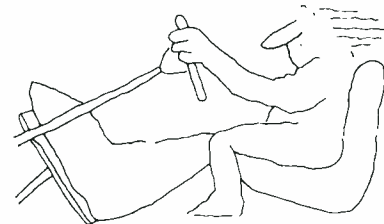

You'll get about 20 more miles from every tank of gas if you slow down from 70 to 55 mph on the highway. For a free booklet with more easy ways to save energy and money, write "Energy," Box 62, Oak Ridge, TN 37830.

ENERGY.
**We can't afford
to waste it.**

U.S. Department of Energy

CLEAR THE AIR WITH THE **NEW** TRANSDYNAMIC PROCESSOR

THE SUPER CLEAN SOUND THAT WINS MORE LISTENERS.

VERSATILITY, RELIABILITY AND LOW DISTORTION. THAT'S WHAT THE TRANSDYNAMIC™ PROCESSOR IS ALL ABOUT. IT TEAMS WITH AUDIO & DESIGN'S EXPRESS OR COMPLEX LEVEL CONTROL AMPLIFIERS TO CREATE A SUPERIOR TRI-BAND SYSTEM. IT FEATURES:

- TWO INDEPENDENT PROGRAM CHANNELS, FOR STEREO OR DUAL MONO PROCESSING.
- FIELD TUNABLE BAND-SPLITTING FILTERS (6 OR 12 dB PER OCTAVE PHASE COMPENSATED CURVES).
- SEPARATE CONTROL OF THE COMPRESSOR ATTACK, RELEASE AND RATIO FOR EACH BAND.
- WIDE BAND VCA LIMITER AT THE SYSTEM OUTPUT FOR ABSOLUTE OVERMODULATION PROTECTION.
- SELECTABLE 0, 25, 50 OR 75 μ S PRE-EMPHASIS IN THE CONTROL CIRCUITS (NOT THE SIGNAL PATH) OF THE OUTPUT LIMITER.

- ADJUSTABLE PEAK MODULATION ASYMMETRY FOR AM OPERATIONS.
- SWITCHABLE HIGH AND LOW PASS FILTERS THAT ATTENUATE EXTRANEOUS INPUT SIGNALS AND CONTOUR THE SYSTEM BANDWIDTH.
- SENSIBLE SET-UP ADJUSTMENTS WITH LED BAR GRAPH PPM METERS.
- TAMPER-PROOF SOLID STATE AUDIO SWITCHING CIRCUITRY.
- NO MYSTERIOUS EPOXY "BRICKS" OR "SECRET PARTS".

NO MATTER WHAT YOUR FORMAT, THE TRANSDYNAMIC SYSTEM IS THE CLEAR CHOICE FOR YOUR SOUND.

AN AUDITION IS THE ONLY WAY TO FULLY APPRECIATE THE TRANSDYNAMIC. CALL TODAY, TOLL-FREE 800-426-6170 FOR FURTHER INFORMATION.

SYSTEM INSTALLATION BY FACTORY PROFESSIONALS IS ALSO AVAILABLE.



Audio + Design

THE HIT SOUND IN BROADCAST SCIENCE.

Circle (67) on Reply Card

CALL TOLL-FREE 800-426-6170

AUDIO & DESIGN RECORDING, INC., P.O. BOX 786 - BREMERTON, WASHINGTON U.S.A. 9831C - TELEPHONE 206-275-5009 - TELEX 15-2426
AUDIO & DESIGN RECORDING, LTD., NORTH STREET READING RG1 4 DA - BERKSHIRE, ENGLAND - TELEPHONE (37-4) 53411 - U.K. TELEX 848722

Copyright 1981 by Audio & Design Recording, Inc.

COME SEE US
AT THE NAB,
BOOTH 42A

S.W.R. invites you to compare our "K"-Line with any other coax you know:

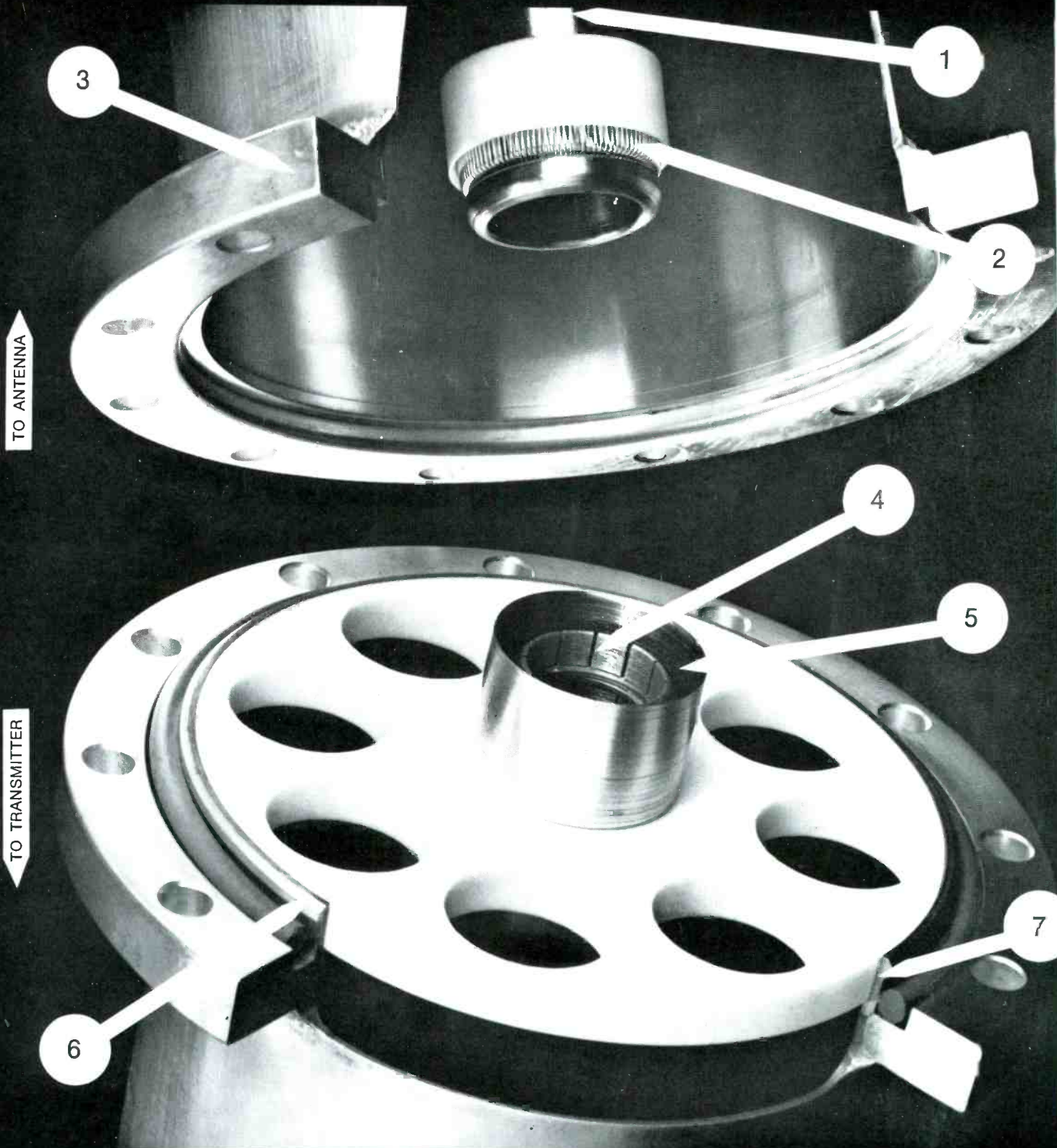

NO OTHER COAX TRANSMISSION LINE OFFERS ALL THESE FEATURES. THAT'S WHY S.W.R. MAKES THE COUNTRY'S BEST COAX!

1. Heavy wall inner conductor.
2. No finger bullet. Watchband spring offers only one contact joint per section of line. (Pat. No. 3,818,421)
3. Rugged, reliable bolt-type flange, welded, not soldered, 20% thicker than E.I.A. (Pat. No. 3,955,878)
4. Heat flow up to 7 times faster with the industry's only thermo-coupled inner connector. (Pat. pending)
5. Normal wear dust captured in cup, not on insulator.
6. Self-aligning lip. No alignment pin needed.
7. Teflon insulator and silicone "C"-ring recessed into flange. Cannot be pinched upon assembly.

Transmission Line Is Too Expensive

(if you have to replace it every few years)

Most failures of rigid transmission line are caused by three factors:

1. Misassembly
2. Self-contamination due to wear caused by differential expansion
3. Excessive heat build-up which causes voltage breakdown.

Only one transmission line on the market today prevents these three causes of costly down-time:

SWR's "K"-Line

1. It is the only line with a bullet that cannot be split by misassembly and a self-aligning flange that protects the insulator and "O"-Ring from any damage upon assembly.
2. It is the only line with one contact joint per 20' section with a watchband spring that offers more peripheral contact than the traditional bullet. When it is assembled, it is completely contained within the female cup, which in turn captures all metallic dust and prevents contamination to the insulator.
3. It is the only line with a patented thermo-couple connector, of all-copper construction, far superior in heat transfer than any other line in the industry. We use only heavy wall inner conductors in all our line sizes for maximum heat conductivity.

Whether you're installing a new system or rebuilding your present line, call or write us for an estimate of what we can do to give reliability and longevity to your system. To have a line that doesn't self-destruct is to have a line that has already paid for itself.

The bottom line is a line that doesn't wear out or burn out, and the only line that fits those specifications is SWR's "K"-Line.

Available in 3 1/8", 4 1/16", 6 1/8" and 8 3/16" sizes.

**Serving the Broadcast
Industry for 14 Years**

See us at Booth 1626A
in Las Vegas.

SWR[®] INC

Systems with Reliability

**P. O. BOX 215
GOFFSTOWN, N. H. 03045**

(603) 497-3000

Circle (68) on Reply Card

NAB product directory

Broadcast Video Systems Ltd.
Camera Mart
Delcom Corporation
Harris
Hedco
Hitachi Denshi America Ltd.
Lenco
Paladin
Philips Broadcast Equipment
Philips Test and
Measuring Instruments
Power-Optics
RCA

Rohde & Schwarz
Tektronix
Tentel
Ultra Audio Pixtec

TEST EQUIPMENT, RF

Bird Electronic Corporation
Continental Electronics Mfg. Co.
Delta Electronics
Glentronix
Gorman Redlich
Harris
Howe Audio/BCP
Motorola Communications &
Electronics Inc.
Potomac Instruments
Rohde & Schwarz

Tektronix
Telemet
Texscan
Versa Count

TELEMETRY EQUIPMENT

Delta Electronics
Hallikainen & Friends
Howe Audio/BCP
Marti
Moseley Associates
Tayburn Electronics
Tektronix
Telcom Research
Time and Frequency Technologies

TEST PATTERNS, CHARTS

Comprehensive Video Supply
Delcom Corporation
Harris
Philips Test & Measuring
Instruments
Porta Pattern
Research Technology International

TIMERS & CLOCKS (PROGRAM)

Amtel
Audico
BTX
Beaveronics
Broadcast Electronics
Continental Electronics Mfg. Co.
Datametrics
ESE
Gardiner Communications
Glentronix
Harris
Howe Audio/BCP
Image Video Limited
Leitch
Logitek
McCurdy Radio
QSL Systems
RCA
Ramko Research
Sony
Sound Genesis
Tentel

TOWERS & TOWER EQUIPMENT

Allen Osborne Associates
Allied Tower Co. Inc.
Anixter-Mark
Continental Electronics Mfg. Co.
EG&G
E-N-G Corp.
Flash Technology
Fort Worth Tower Company
Harris
Howe Audio/BCP
LeBlanc & Royle
Lightning Elimination Associates
Magnum Towers
Fred A. Nudd Corp.
Nurad
Stainless
Telex
UNR-Rohn
Utility Tower Company
World Tower Company

editors' choice.

COMMANDER II — the market's newest video tape editing system offers some significant differences.

United Media has taken a totally new look at the desires and requirements of the industry in developing Commander II.

The results — a technologically superior editing system at a significantly lower price.

Like \$40,000 for a complete 4VTR system — any combination of playback and record for multiple format masters (expandable to 3 more VTR's plus switcher).

Like automatic switcher control for double re-entry with 3 independent M/E amplifiers.

Like video levels variable in 10% increments with mix rates from 1 to 999 frames.

Like automatic cut listing with a single keystroke — and automatic list management for shortening, lengthening or rearranging scenes.

Now editors can have a real choice. judge for yourself — call Bob Ricci at 714/630-8020 today.

Visit us at
NAB Booth #1171

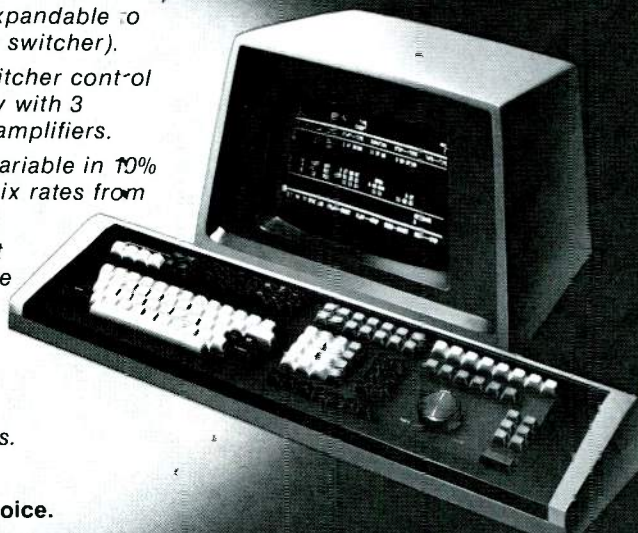

United Media

4075 Leaverton Court, Anaheim, CA 92807

Circle (69) on Reply Card

The new CGE 30 kW TV transmitter, sophisticated simplicity at its best.

Canadian General Electric's Broadcast Equipment people have done it again. We've come up with a 30kW unit that's among the best in today's television transmission technology.

As with our other transmitter models, simplicity of design is at the heart of our new 30kW unit, which has a 1500-watt solid state driver. It's completely self-contained and there are only two tubes in the entire transmitter.

Most transmitters today have solid state control logic. But not all transmitters have the added feature of a control logic bypass panel. Our 30kW model has both!

And if you require 60kW output, no problem. Two 30kW units can be combined in parallel to give you the desired result.

As for operating efficiency, our 30kW model functions economically and keeps your energy costs at a minimum.

When it comes to installation and maintenance, we have an efficient, highly qualified field service team that's very responsive to your needs.

Some transmitters are so complex that you practically need a full-time engineer on hand to figure them out. But the new CGE 30kW is different. Not that it's elementary. Far from it. We like to refer to it as sophisticated simplicity at its best.

Canada

**Canadian General Electric
Broadcast Equipment**
396 Attwell Drive
Rexdale, Ontario M9W 5C3
Telephone (416) 675-7500
Telex 06-989302

United States

**General Electric Company
Broadcast Products**
777 14th St. N.W.
Washington, D.C.
20005
Telephone (202) 637-4103

We hope to see you at the NAB Convention in Las Vegas, April 12-15 (Booth 431)



**Canadian
General Electric**

Circle (70) on Reply Card

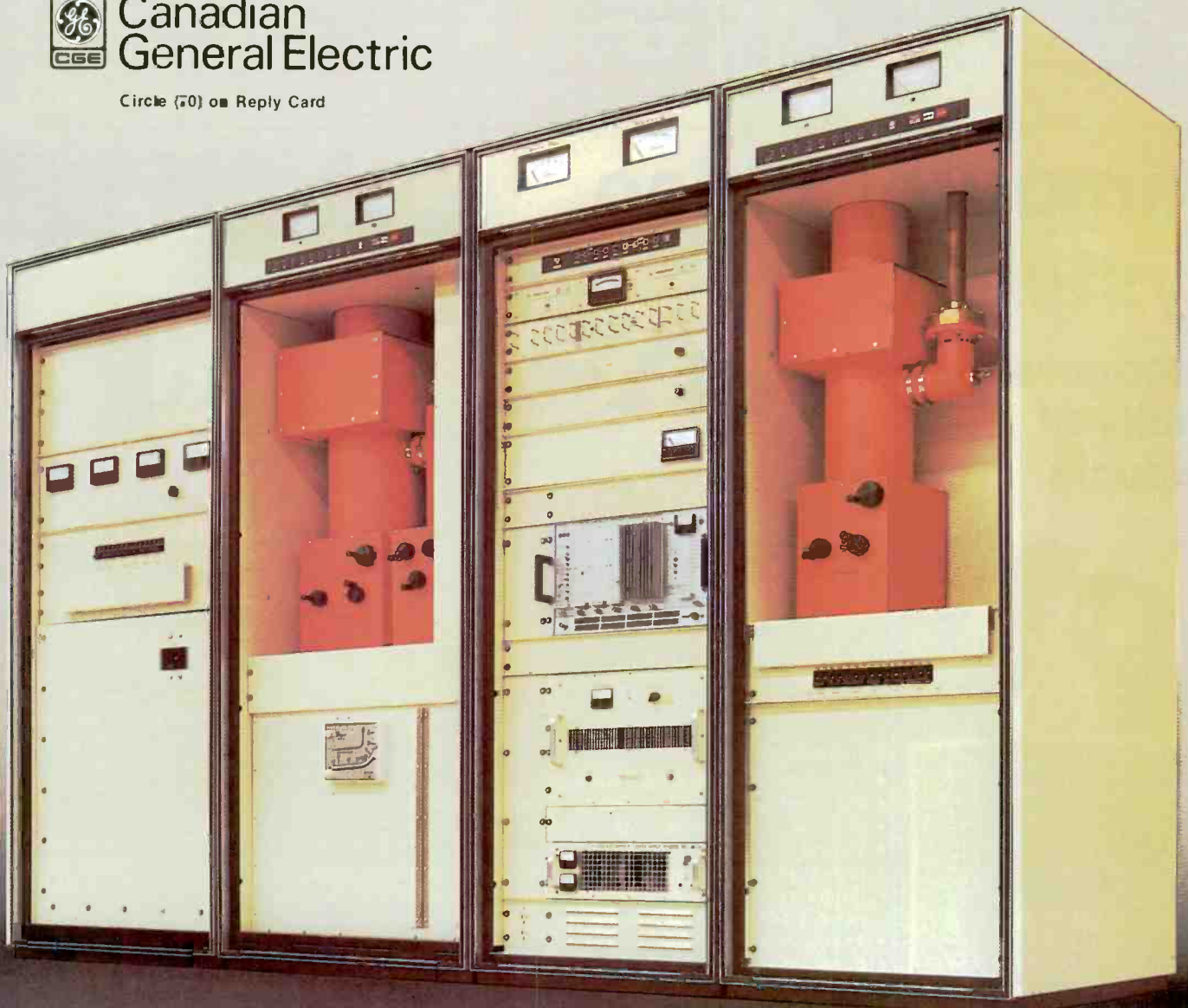

NAB product directory

TRANSFORMERS (ALL TYPES)

Delta Electronics
Sescom
Sound Genesis
Wilkinson

TRANSMISSION LINES & SERVICES

Andrew Corporation
Cablewave Systems
Comark Communications
Continental Electronics Mfg. Co.
Dielectric Communications
Harris
Howe Audio/BCP
Micro Communications
Fred A. Nudd Corp.
Phelps Dodge
RCA Americom
SWR
Shively Laboratory
Western Union
Wilkinson

TRANSMITTER SWITCHES/ CONTROLLERS/DETECTORS

CCA Electronics
CSI Electronics
Canadian GE
Continental Electronics Mfg. Co.
Delta Electronics
Elcom Specialty Products

Hallikainen & Friends
Harris
Howe Audio/BCP
Moseley Associates
Tektronix
Telcom Research
Wilkinson

TRANSMITTERS (AM & FM)

AEG-Telefunken
Broadcast Electronics
CCA Electronics
CSI Electronics
Canadian General Electric
Continental Electronics Mfg. Co.
Elcom Specialty Products
Harris
Howe Audio/BCP
LPB
Marconi Electronics
McMartin Industries
NEC America
RCA
Sintronic
Television Technology Corp.
Varian Associates/Eimac Div.
Versa-Count
Wilkinson

TRANSMITTERS (TV & TRANSLATORS)

Acrodyne Industries
CCA Electronics

Canadian General Electric
Comark Communications
EMCEE Broadcast Products
Fernseh
Harris
Howe Audio/BCP
NEC America
Philips Broadcast Equipment
RCA
Television Technology Corp.
Townsend Associates
Varian Associates/Eimac Division
Versa Count

TURNTABLES, TONE ARMS & PHONE CARTRIDGES

Broadcast Electronics
Continental Electronics Mfg. Co.
D-B Electronics
Fidelipac
Harris
Howe Audio/BCP
McCurdy Radio
McMartin Industries
Panasonic Professional Audio Div.
RCA
Ramko Research
Russco
Shure Brothers
Sony
Sound Genesis
Stanton Magnetics
Studer Revox America
US JVC

Computer Video Systems

Introduces our
Family of
Products



Seen first at NAB
the New
COMPUVISION TITLING SYSTEM

Featuring:

- Medium to Low Cost
- Easy to Operate
- Expandable Memory
- Character Enhancements
- Limited Logo

See Us at
NAB booth
#188S

Featuring:

- Telephone Public Access System
- Multiple Character Sizes, Colors, & Enhancements
- Single or multiple keyboards (Local or Remote)
- Ease of maintenance service
- Increased memory capability, editing functions and program features
- Program displays to include local weather, NCAA, AP, UPI, Reuters news, stock crawl, TV program guide, shoppers guide and more
- 3 serial input capability
- Bubble Memory (non Volatile-solid state)



DATA DISPLAY SYSTEM 3678 W 2150 South SLC, UT 84120 801-974-5380

Circle (71) on Reply Card



What do NBC, The Australian Broadcast Commission, Czechoslovakia Television, Complete Post Production Center, Neiman-Tillar Associates, Sunwest Recording Studios and Oral Roberts Television Production Center have in common?

Come to Booth 300S at NAB. Get your hands on a fully automated Quad/Eight Coronado console with Compumix III and a new System 5 digital reverberation processor—all tied in with a 1" VTR and a large screen projection TV

monitor. Once you've experienced this combination, you will know why Quad/Eight is a new world standard for post-production audio enhancement.



Audio Enhancement

Quad/Eight Electronics, 11929 Vose Street, North Hollywood, CA 91605 (213) 764-1516 Telex: 662-446

Circle (72) on Reply Card

© Quad/Eight 1981

New Wheelit ENG-1 Folding Camera Cart

For fast, efficient ENG operation, Wheelit gets you to the action.

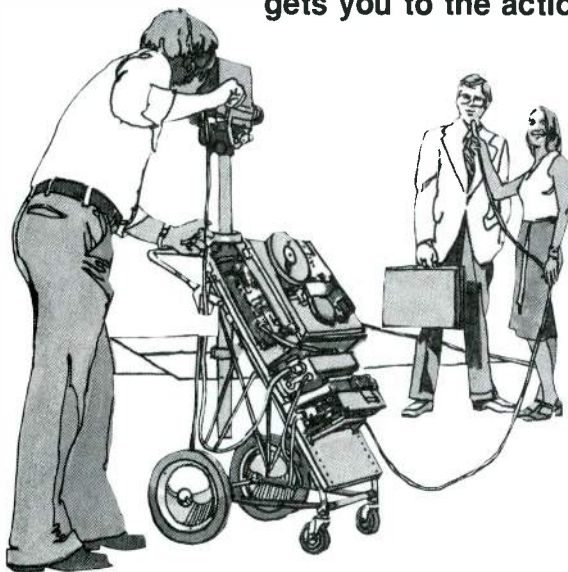

Features

- Fast, ready ENG operation
- Operate camera from cart
- Safe transportation
- 14" x 29" equipment board
- Adjustable equipment mounts for control unit, recorder, battery
- 5 3/4" x 14" camera platform
- Light weight, heavy duty
- 12" wheels & locking swivel casters
- Folds to only 12" width
- Elevator and universal head, optional
- Receptacle and cord reel, optional



Folds to 12" Wide



Write or Telephone for Information & Prices.



GRUBER PRODUCTS COMPANY, BOX 7350, TOLEDO, OHIO 43607
(419) 531-4900
Circle (73) on Reply Card

CONVERT YOUR SLIDES TO VIDEO!

NYTONE ELECTRONICS CAN HELP!

THE FLYING SPOT SCANNER SYSTEMS - PRODUCE BROADCAST QUALITY COLOR SIGNALS DERIVED FROM 2" x 2" FILM TRANSPARENCIES; AND DOES IT....



- With Quality As Good or Better than many film chains.
- At a Much Lower Cost than most film chains.
- Optional Fade Between Slides.
- Optional Random Access Capability.
- 80 Slide Capacity.
- The resulting video signal is compatible for Educational, Broadcast, Cable, Industrial Television & Video Taping Applications.

NYTONE

ELECTRONICS CORPORATION

2424 South 900 West
Salt Lake City, UT 84119
(801) 973-4090
TWX 9109254002

Circle (74) on Reply Card

NAB product directory

VACUUM TUBES (VIDEO CAMERAS)

AEG-Telefunken
Adwar Video
AmpereX
Ceco
EEV
General Electric
Harris
RCA
RCA Solid State
Sony
Thomson-CSF, Electron Tube Div.

VACUUM TUBES (TRANSMITTING/TWTs)

AmpereX
CCA Electronics
CSI Electronics
Canadian General Electric
Ceco
EEV
General Electric
Harris
RCA
RCA Solid State
Television Engineering
Thomson-CSF Electron Tube Div.
Varian/Palo Alto Microwave Tube Div.
Varian/Eimac Div.
Wilkinson

VANS AND ACCESSORIES

A.F. Associates
Centro Corporation
Compact Video Sales
E-N-G Corp.
The Gerstenlager Co.
Harris
Jenel
Midwest Corporation
RCA
Wolf Coach

WAVEGUIDES

Andrew Corporation
Cablewave Systems
Comark Communications
Comark Industries
Dielectric Industries
Micro Communications

WEATHER SYSTEMS

Enterprise Electronics
Gorman Redlich
Information Processing Systems
Interand
NewsScan/McInnis-Skinner Associates
Texscan Corp.
WSL/AutEx Systems
Weathercaster
Weathermation

Electro-Voice's Greg Silsby talks about the Sentry 100 studio monitor



Production Studio, WRBR-FM, South Bend, Indiana.

In all the years I spent in broadcast and related studio production work, my greatest frustration was the fact that no manufacturer of loudspeaker systems seemed to know or care enough about the real needs of broadcasters to design a sensible monitor speaker system that was also sensibly priced.

Moving to the other side of the console presented a unique opportunity to change that and E-V was more than willing to listen. When I first described to Electro-Voice engineers what I knew the Sentry 100 had to be, I felt like the proverbial "kid in a candy store." I told them that size was critical. Because working space in the broadcast environment is often limited, the Sentry 100 had to fit in a standard 19" rack, and it had to fit *from the front, not the back*. However, the mounting hardware had to be a separate item so that broadcasters who don't want to rack mount it won't have to pay for the mounting.

The Sentry 100 also had to be very efficient as well as very accurate. It had to be designed so it could be driven to sound pressure levels a rock 'n roll D.J. could be happy with by the low output available from a console's internal monitor amplifier.

In the next breath I told them the Sentry 100 had to have a tweeter that wouldn't go up in smoke the first time someone accidentally shifted into fast forward with the tape heads engaged and the monitor amp on. This meant high-frequency power handling capability on the order of five

times that of conventional high frequency drivers.

Not only did it have to have a 3-dB-down point of 45 Hz, but the Sentry 100's response had to extend to 18,000 Hz with no more than a 3-dB variation.

And, since it's just not practical in the real world for the engineer to be directly on-axis of the tweeter, the Sentry 100 must have a uniform polar response. The engineer has to be able to hear exactly the same sound 30° off-axis as he does directly in front of the system.

Since I still had the floor, I decided to go all out and cover the nuisance items and other minor requirements that, when added together, amounted to a major improvement in functional monitor design. I wanted the Sentry 100 equipped with a high-frequency control that offered boost as well as cut, and it had to be mounted on the front of the loudspeaker where it not only could be seen but was accessible with the grille on or off.

I also didn't feel broadcasters should have to pay for form at the expense of function, so the walnut hi-fi cabinet was out. The Sentry 100 had to be attractive, but another furniture-styled cabinet with a fancy polyester or die-cut foam grille wasn't the answer to the broadcast industry's real needs.

And for a close I told E-V's engineers that a studio had to be able to purchase the Sentry 100 for essentially the same money as the current best-selling monitor system.

That was well over a year ago. Since that time I've spent many months listening critically to a parade of darn good prototypes, shaking my head and watching

some of the world's best speaker engineers disappear back into the lab to tweak and tune. And, I spent a lot of time on airplanes heading for places like Los Angeles, Grand Rapids, Charlotte and New York City with black boxes under my arm testing our designs on the ears of broadcast engineers.

The year was both frustrating yet enjoyable, not just for me but for Ray Newman and the other E-V engineers who were working on this project. At this year's NAB show it all turned out to be worth it. The Sentry 100's official rollout was universally accepted, and the pair of Sentry 100's at the Electro-Voice booth was complemented by another 20 Sentry 100's used by other manufacturers exhibiting their own products at the show.

What it all boiled down to when I first started the project was that I knew that the Sentry 100's most important characteristic had to be *sonic integrity*. I knew that if I wasn't happy, you wouldn't be happy. I'm happy.

Market Development Manager,
Professional Markets



EV Electro-Voice[®]
a Gulton company

600 Cecil Street, Buchanan, Michigan 49107

In Canada:
Electro-Voice, Div. of Gulton Industries (Canada) Ltd.
345 Herbert St., Gananoque, Ontario K7G 2V1.

Circle (75) on Reply Card

NAB-'81/LAS VEGAS EXHIBITS ROUNDUP

This special section alphabetically lists the NAB-'81 exhibitors and previews products to be displayed in Las Vegas. Following each exhibitor listing is a number by which the reader service card may be used to provide exhibitor data. Also, if the exhibitor is advertising in this issue, the location of the ad is indicated for additional details about the company's NAB-'81 exhibit products.

Although this section will be a valuable aid in planning NAB-'81 activities, caution should be exercised. The listing here is comprehensive as of press time, but changes are still occurring in exhibitor sign-up, products being shown and booth assignments. Check the final program at NAB-'81 to make final plans. Look for the **BE** wrap-up of this convention in the June issue.

ADC Products (Booth 181)

See at booth.

Circle (300) on Reply Card

ADM Technology Inc. (Booth 1212A)

Products: Audio consoles for broadcast, TV, radio and production; associated audio components.

Circle (301) on Reply Card

see ads on pages 57, 83

AEG-Telefunken, Bayly Engineering Division (Booth 130)

Products: FDM and PCM, memo & stereo program channels (telco STLs); FM broadcast transmitters; wattmeters; dummy loads; reel-to-reel tape recorders; noise reduction systems; VHF two-way radio, portable, mobile, and base portable audio mixer; remote studio camera control system; microwave STL radio links; UHF two-way radio, portable, mobile and base; broadcast transmitting antennas; a radio/telephone interface.

Circle (302) on Reply Card

see ad on page 54

A. F. Associates (Booth 1035)

Products: Ampex VR2000s and VR-1200s.

Circle (303) on Reply Card

see ads on pages 77, 175

ATI—Audio Technologies Inc. (Booth 125)

Products: Precision turntable amplifiers, microphone amplifiers, line amplifiers, high output distribution amplifiers, micromonitor.

Circle (304) on Reply Card

Accurate Sound Corporation (Booth 214)

Products: Starbird microphone boom, Map-II audio processor, Inovonics-tape recording electronics, Sound Workshop professional audio products, model AS-100—high speed

audiotape duplicator, Inovonics model 380—tape recording electronics.

Circle (305) on Reply Card

Achro-Video International (Booth 1503)

Products: Lens controls and accessories, long lens adapter, color bar generators, source identifiers, lens service, ENG Lite-Mike adapters, monopods for ENG, 4-speed zoom control.

Circle (306) on Reply Card

Acrodyne Industries (Booth 1130)

Products: 5kW UHF Single Tetrode Transmitter, 6kW VHF transmitter, 10kW VHF transmitter, 100W UHF translator.

Circle (307) on Reply Card

see ad on page 121

ADDA Corporation (Booth 1515)

Products: Frame synchronizers, video remote control systems, time code equipment.

Circle (308) on Reply Card

Advance Industries (Booth 401S)

See at booth.

Circle (309) on Reply Card

Adwar Video Corporation (Booth 345S)

See at booth.

Circle (310) on Reply Card

Agfa-Gevaert (Booth 1223)

See at booth.

Circle (299) on Reply Card

Airborne Video Systems (Booth 203S)

See at booth.

Circle (311) on Reply Card

Allen Avionics Inc. (Booth 1633)

Products: Video delay lines, video filters, VAR units.

Circle (312) on Reply Card

see ad on page 142

Allied Tower Co. Inc. (Booth 504)

Products: Antenna tower sections.

Circle (313) on Reply Card

Allsop (Booth 1814)

See listings on pages 181-2.

Circle (314) on Reply Card

Alpha Audio (Booth 306S)

See at booth.

Circle (315) on Reply Card

Amber Electro Design Ltd. (Booth 327)

Products: 4400A multipurpose audio test set, model 3500 distortion measurement set, IMD measurement capability and balanced input/output kit for 3500.

Circle (316) on Reply Card

Amco Engineering Co. (Booth 409)

Products: Modular cabinets, consoles and rack system.

Circle (317) on Reply Card

American Data (Booth 803)

See at booth.

Circle (318) on Reply Card

American Image Productions (Booth 314)

See at booth.

Circle (319) on Reply Card

American Telephone & Telegraph (Booth 1981)

See at booth.

Circle (320) on Reply Card

Get the most from your AM signal...

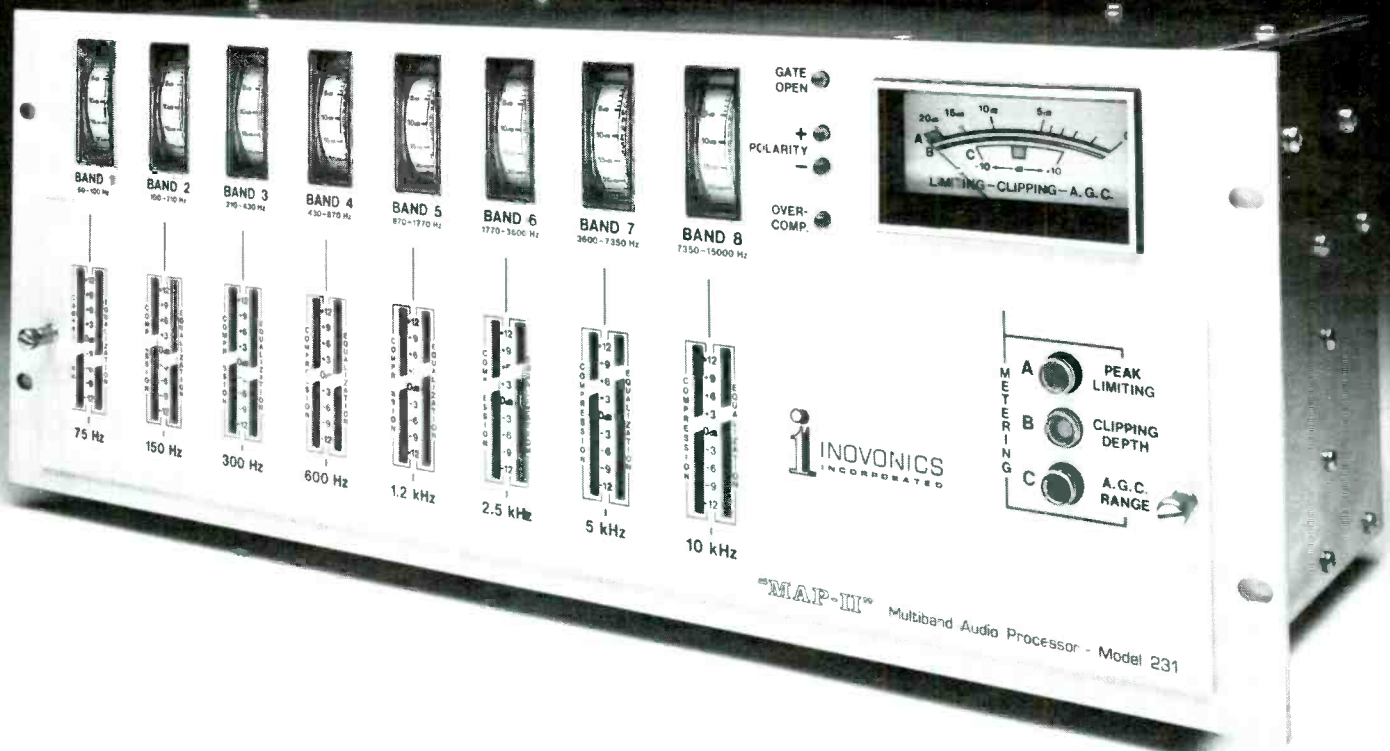

The new MAP II Multiband Audio Processor combines the latest advances in audio technology for optimum modulation of your AM/AM-Stereo program. Yet it costs much less than similar systems.

Discriminate Compression and Equalization

Only MAP II offers you 8-band compression. Input level is held constant by a slow, gain-riding A.G.C. Each band has its own compression and equalization controls, so you can tailor your sound while maintaining a high program density. Sound remains smooth, even with considerable compression, because each compressor

changes gain in response to inputs to both its own and adjacent bands.

Inaudible Phase Optimization

Program phase is silently "rotated"—rather than instantaneously switched—to maintain maximum positive modulation.

Absolute Peak Control

MAP II's unique integrated peak controller combines a hard clipper with a low-distortion peak limiter. An adjustable

control loop gives you control over clipping depth which then remains constant regardless of program content. For stations with remote transmitters, the integrated peak controller can be unplugged and installed at the transmitter site.

Convenient Operation & Maintenance

MAP II has several features to make your audio processing

convenient and precise. For precise control over frequency range, selectable low- and high-pass filters let you choose between three cut-off frequencies at each end. Front-panel meters monitor compression, A.G.C. gain, clipping depth and peak limiting. A "proof" mode defeats all processing at the touch of a button, leaving the signal path intact. There's even a built-in pink noise source for convenient system set-up and maintenance. Circuit boards unplug from the front and contain no "black boxes" or selected components.

Write or call today for technical and cost information on the MAP II. Your program—and your budget—will thank you. MAP II—\$1670.

for less.

See us at the NAB—Booth 214

Inovonics Inc.

503-B Vandell Way
Campbell, CA 95008

Telephone
(408) 374-8300



NAB exhibitors

Amperex Electronic Corporation (Booth 1032)

Products: Plumbicon television camera tubes, diode gun Plumbicon television camera tubes, Plumbicon low capacitance diode gun television camera tubes and Vidicons, CRTs, rectifier stacks and transmitting tubes, including UHF Klystrons.

Circle (321) on Reply Card
see ad on page 127

Ampex (Booth 702)

Products: Quad and helical VTRs,

color television cameras, editing systems, switchers, time base correctors, AVA system, audio recorders, video and audio magnetic tape products.

Circle (322) on Reply Card
see ads on page 8-9, 55

Ampro/Scully (Booth 102)

Products: Reel-to-reel recorders, three deck tape cartridge machine, audio consoles, single deck tape cartridge machine.

Circle (323) on Reply Card

Amtel Systems Inc. (Booth 1123)

Products: Time code generators/readers.

Circle (324) on Reply Card

Amtron Corporation (Booth 1830)

Products: Video monitors, waveform monitors, video analyzers.

Circle (325) on Reply Card

Angenieux (Booth 904)

Products: Camera lenses, high tolerance diascope, wide angle adapter.

Circle (326) on Reply Card

Andrew Corporation (Booth 917)

Products: Heliax coaxial cables, STL microwave antenna systems, UHF-TV transmitting antennas, earth station antennas.

Circle (327) on Reply Card
see ad on page 21

Animation Video (Booth 407S)

See at booth.

Circle (298) on Reply Card
see ad on page 185

Antiope Videotex Systems Inc. (Booth 1421)

Products: NTSC standard teletext and captioning system.

Circle (328) on Reply Card
see ad on page 31

Anton/Bauer Inc. (Booth 1617)

Products: Battery packs, diagnostic equipment, lighting belt packs, super "D" system batteries, lighting gun system, switching type fast charger, switching type slow charger.

Circle (329) on Reply Card
see ads on pages 27, 60

Anvil Cases Inc. (Booth 1626)

Products: Reusable transit cases for industrial, commercial and professional broadcast video components; E.I.A. shock-mounted equipment racks.

Circle (330) on Reply Card
see ad on page 165

Arrakis Systems Inc. (Booth 209)

Products: Audio consoles—1000 series, 250 series, 500 SC series, 500R series, 2000 series.

Circle (331) on Reply Card
see ad on page 264

Arriflex (Booth 1835)

Products: Image stabilizer, daylight HMI lights, Sachtler camera support system, Sachtler 7+7 studio fluid head.

Circle (332) on Reply Card

Arvin/Echo Science (Booth 1001)

Products: Frame storage device for

Since 1941, audio professionals have been discovering that AB Pearl Mikrofon Laboratorium of Sweden make some of the finest quality microphones in the world.

Under our new name we're proud to introduce the same old thing: precision craftsmanship, superlative performance and value. Our name

The Swedish Steal Has A New Name: MILAB

has changed but our dedication to provide the audio pro with a superior alternative has not. Whether it's the DC-63 variable pattern dual-membrane condenser, the DC-96 cardioid condenser, VM Series condensers, F-69 dynamic, CL-4 electret or an XY stereo mic, your professional audio dealer

should be contacted to give you a chance to audition for yourself the performance and value of the Swedish alternative: **MILAB.**

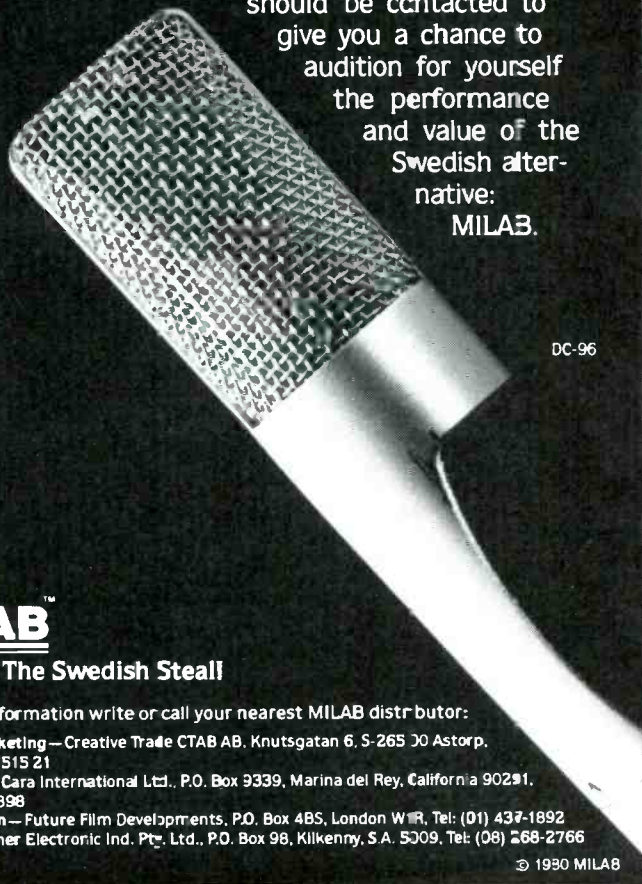

MILAB™

We're Still The Swedish Steal!

For product information write or call your nearest MILAB distributor:

Worldwide Marketing—Creative Trade CTAB AB, Knutsgatan 6, S-265 30 Astorp, Sweden, Tel: 42/515 21

United States—Cara International Ltd., P.O. Box 9339, Marina del Rey, California 90291, Tel: (213) 821-7898

United Kingdom—Future Film Developments, P.O. Box 4BS, London W1R, Tel: (01) 437-1892

Australia—Werner Electronic Ind. Pty. Ltd., P.O. Box 98, Kilkenny, S.A. 5009, Tel: (08) 268-2766

© 1980 MILAB



Best Picture:
**SCOTCH ONE-INCH
VIDEO TAPE**

For the second year in a row, Scotch® 479 won the award for the best picture of the year in a test of one-inch video tapes.

We scored well in all of the twelve categories tested, but especially well in the categories that commonly represent picture quality: color dropouts, high frequency dropouts, chroma noise, signal-to-noise ratio and stop motion.

These were scientific, quantitative tests, conducted as you would conduct them yourself, with no room for brand bias. The meters didn't play favorites. The standards were the same for every brand tested. And we tested every brand.

These kinds of test results don't surprise us. We pioneered the invention of video tape. And we've been setting the standard for quality ever since.

Our quality has always been consistent from the first replay to the

last. In fact, our sophisticated binder and oxide coating are more advanced than the binders and oxides on some quad tapes. They had to be advanced to meet the special durability demands of one-inch video production.

So choose Scotch 479 for your one-inch video production. You'll find it looks good from repeated mastering all the way through post production. And we've seen the test results to prove it.



3M

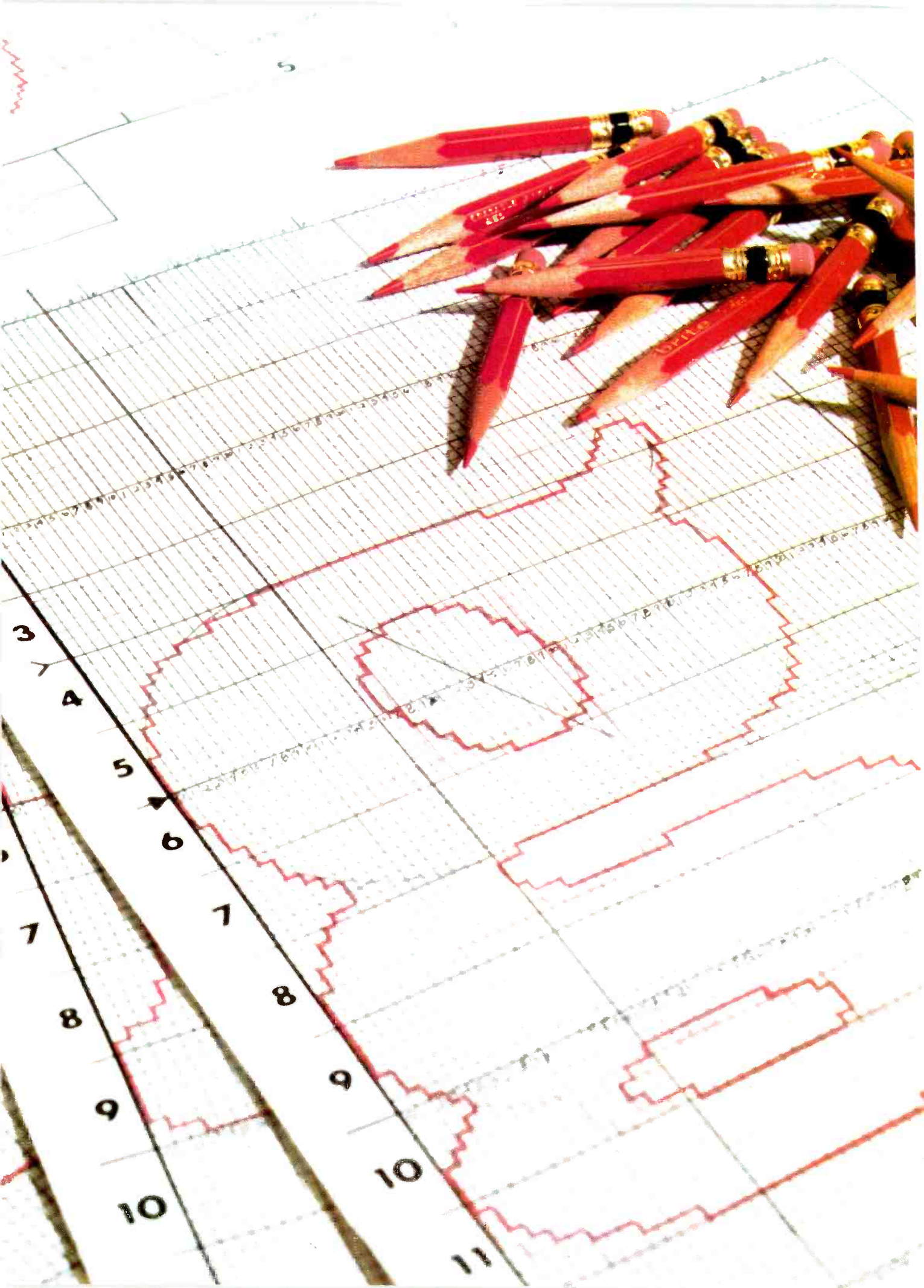

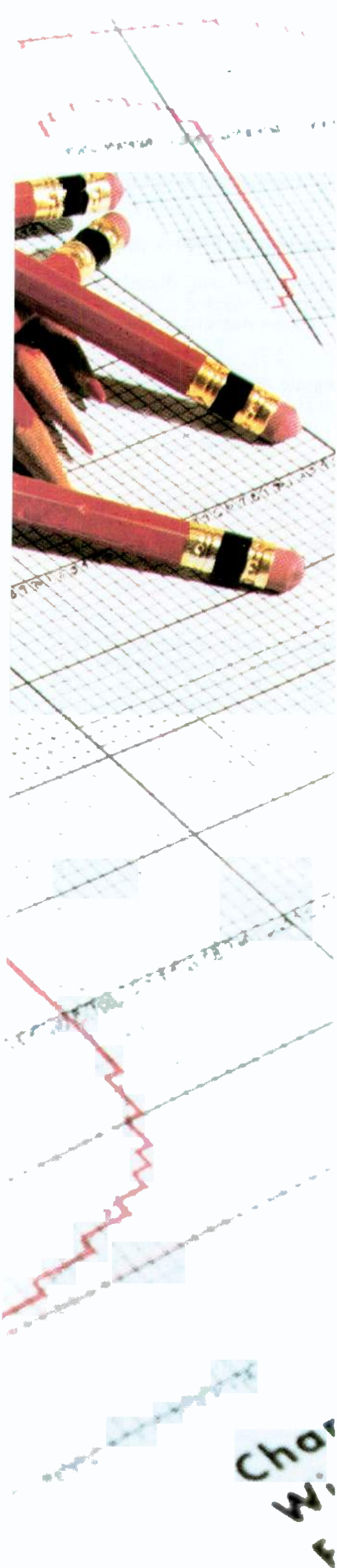

...to be letter perfect

In the design and manufacture of character generating equipment whether for automatic alpha-numeric display, broadcast or teleproduction titling, international language subtitling, or especially developing libraries for font load systems

... we know the display shapes are as much a product *if not more so* than any operational feature.

This philosophy is "penciled" into each new generation of QUANTAFONT. Our devotion to designing more perfect graphics takes us to any length

... to be letter perfect.

**Be sure to see the full range of QUANTAFONT
Teleproduction Graphic Titlers ... NAB Booth #1305.**



System Concepts, Inc.

2440 South Progress Drive, Salt Lake City, Utah 84119
Phone: (801) 974-0992 • TWX: 910-925-5684

Southwest Sales Office

1535 South Memorial, Suite 124, Tulsa, Oklahoma 74112
Phone: (918) 627-4151

Eastern and International Sales Office

16006 Waterloo Road, Cleveland, Ohio 44110
Phone: (216) 692-3410 • TWX: 810-421-8192

Circle (78) on Reply Card

NAB exhibitors

stills and backgrounds, video discas-
sette recorders.

Circle (333) on Reply Card
[see ad on page 207](#)

Asaca/Shibasoku (Booth 1219)

Products: Portable color TV camera
monitors, MPX sound generator,
jitter meter, color camera registra-
tion meter, test signal generator,
distortion meter, portable video
switcher, digital pattern generator,
envelope delay measuring set, video
noise meter, NTSC video sweep gen-
erator.

Circle (334) on Reply Card

Athans Communications (Booth 307S)

See at booth.

Circle (335) on Reply Card

Audico (Booth 1900)

Products: Videotape loader, audio-
tape loaders, cassette timer, re-
winder, exerciser, professional im-
pulsor, precision tape splicer, cas-
sette labels.

Circle (336) on Reply Card

Audi-Cord Corporation (Booth 319)

Products: 100 series cartridge re-
corders and reproducers, "A" ser-
ies cartridge recorders and repro-
ducers, LAP (line assist program-
mer) sequencer.

Circle (337) on Reply Card

Audio & Design Recording (Booth 424)

Products: Compex-limiter, vocal
stresser, music/voice ratio limiter,
express limiter, easy rider com-
pressor limiter, paragraphic equal-
izer, M600 limiter/filter, scamp sys-
tem, transdynamic processor,
Scamp S25 de-esser module.

Circle (338) on Reply Card

[see ad on page 87](#)

Audio-Technica (Unassigned)

Product: 800 series dynamic and
electret condenser microphones,
ATP professional cartridges and
tone arms, ATH headphones.

Circle (339) on Reply Card

Auditronics (Booth 404)

Products: 110A audio production
console, 200 series broadcast con-
soles, model 1000 DA-6 distribution
amplifiers, control room furniture.

Circle (340) on Reply Card

[see ad on page 79](#)

Auernheimer Labs and Co. (Booth 207)

Displaying in Russco booth; an-
nouncer, monitor, studio, studio-III,
audition.

Circle (341) on Reply Card

Aurora Imaging Systems (Booth 620-622)

Products: Real time digital "video-
graphic" art system.

Circle (342) on Reply Card

Autogram (Booth 415)

Products: Audio consoles, cart ran-
dom selector.

Circle (343) on Reply Card

Automated Broadcast Controls (Booth 312)

Products: System I automation, aud-
io mate, RS-50.

Circle (344) on Reply Card

Automated Business Concepts, Divi- sion of Cetec Corp. (Booth 305)

Products: (In Cetec booth) MAPS
computer-based systems for radio
station management, accounting,
programming and sales, direct load
interface with programming automa-
tion, communication systems for

THE CHOICE IS YOURS!

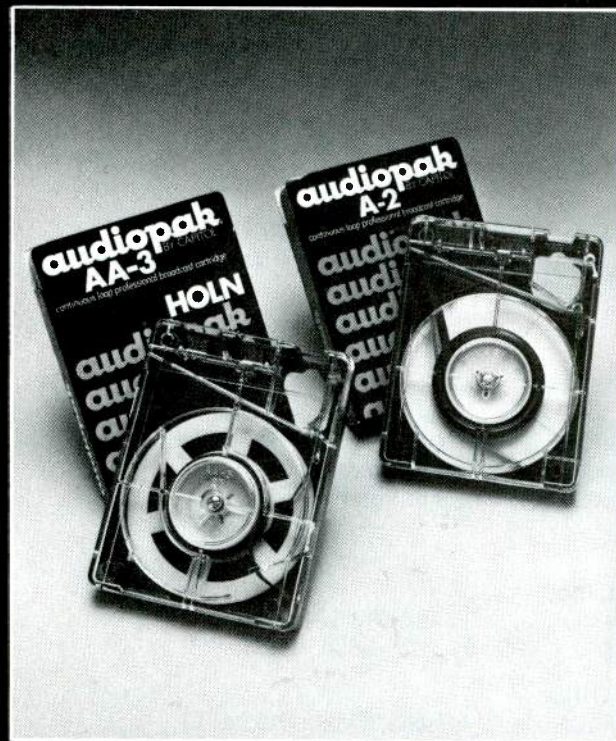

Capitol®

See us at NAB Booth 506

THE AUDIOPAK A-2 OR THE STEREO PHASED AA-3 BROADCAST CARTRIDGE

**Capitol Audiopak Broadcast Cartridges—
for stations who care how they sound.**

Both Audiopak carts offer extremely low wow and flutter; a positive brake system which stops the tape, not the hub, assuring accurate cueing. Unsurpassed reliability is assured because we manufacture the tape and all other components in the cartridge. Moreover, all carts are 100% tested before shipping.

The AA-3 offers excellent stereo phase stability. It's loaded with Capitol's own Q17 HOLN tape which extends frequency response and headroom to provide studio sound quality.

CAPITOL MAGNETIC PRODUCTS
A Division of Capitol Records, Inc.
6902 Sunset Blvd.
Hollywood, California 90028

© 1980 CAPITOL RECORDS, INC.

Circle (79) on Reply Card

TM 500 now gives you the quickest distortion measurements ever.

Introducing the AA 501 Distortion Analyzer and SG 505 Oscillator. Fast, automated and accurate.

This new pair of TM 500 Plug-ins makes distortion measurement truly automatic to save you both time and money. For production testing, the AA 501's automatic speed provides substantial labor reduction with no loss in accuracy. Together, the AA 501 and SG 505 have the lowest harmonic distortion plus noise (THD+N) rating in the entire industry: 0.0025%.

The SG 505 Oscillator outputs a sine wave with the lowest residual distortion on today's market (0.008%). The AA 501 Distortion Analyzer uses digital processing to lock in on test signals, set levels and adjust the notch filter for nulling. All measurements, including dB levels are precalculated and then displayed on an LED readout.



The AA 501 and SG 505 are both TM 500 Plug-ins that can be installed in any of five main-frames, including rackmount, bench and portable. They can also be separated and still used as a team, even though miles apart. Or configured with over 40 other TM 500 Plug-ins currently available.

To find out more about the AA 501 Distortion Analyzer and SG 505 Oscillator, contact your local Tektronix Field Office or write Tektronix, Inc.

TM 500 Designed for Configurability

Tektronix

COMMITTED TO EXCELLENCE

U.S.A.
Tektronix, Inc.
PO Box 1700
Beaverton, OR 97075
503/547-1512
Oregon 800/644-9051

Asia, Australia, Canada,
Central &
South America, Japan
Tektronix, Inc.
America's/Pacific
PO. Box 1700
Beaverton, OR 97075

Africa, Europe
Middle East
Tektronix Int'l, Inc.
European Marketing
Center
Postbox 827
1180 AV Amsterdam
The Netherlands



NAB exhibitors

group operators, music scheduling, music rotation control and music library system.

Circle (345) on Reply Card

Automated Music (Booth 410)
See at booth.

Circle (346) on Reply Card

Avab America (Booth 1600)

Products: Audio production consoles and mixers, lighting controls and

accessories.

Circle (347) on Reply Card

Avantek Ltd. (Booth 1501)

See at booth.

Circle (348) on Reply Card

BEI (Beston Electronics Inc.) (Booth 801)

Products: Model 709 automatic light control equipment for film chains, CG-800 character generated weather channel, CG-850 video slate board. Marquee "2000" video character generator, BEI data-prompter-

character generated prompting system.

Circle (349) on Reply Card

see ads on pages 72, 73

BGW Systems Inc. (Booth 403S)

Products: Power amplifiers, electronic crossovers, commercial power amplifier, model 320, Tannoy broadcast monitors, Tannoy time compensated electronic crossover.

Circle (350) on Reply Card

BPI (Broadcast Programming International) (Booth 316)

Products: Demonstration auditions constructed as a telescoped air-check, complete with promos, spots, etc., formats include album rock, classic rock, adult contemporary, announced contemporary MOR, audition cassettes of traditional MOR, light classics and concert overtures and encores, printed materials.

Circle (351) on Reply Card

The BTX Corporation (Booth 1501)

Products: Tape controller/editor, synchronizer, time code jam sync readers and generators, video displays, interface for audio and video recorders.

Circle (352) on Reply Card

Bankers Trust Company (Booth 1961)

Products: Financial services.

Circle (353) on Reply Card

Basys Inc. (Booth 1701)

Products: Full-line computer systems for news production, stick-on labels for audio carts, Wire Fury sorters.

Circle (354) on Reply Card

Beaveronics (Booth 1041)

Products: Video production switch-systems, ENG portable switcher, master clock systems, Hum stop coils.

Circle (355) on Reply Card

see ads on pages 230, 231

Belar Electronics (Booth 134)

See at booth.

Circle (356) on Reply Card

see ad on page 262

Belden Communication Inc. (Booth 172S)

Products: Lee filters nonphotographic, 200W HMI hand-held light, Lee camera filters.

Circle (357) on Reply Card

GAS SAVERS

Looking for ways to save gas and money? One of the simplest solutions is to drive your car a little less. Here are six ideas you can use to keep your foot off the gas and more money in your pocket.

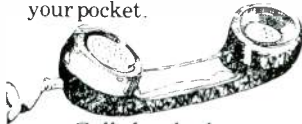

Call ahead to be sure you aren't wasting gas on an unnecessary trip. On the average, a wasted trip costs you a dollar's worth of gas.

Shop, bank and pay your bills by mail. A 15c stamp is a lot cheaper than a gallon of gas.

Ride a bike or take a hike. You'll feel more fit, and you'll have more money to spend



when you get where you're going — since you didn't waste it on gasoline.

Ride to work with a friend or neighbor just one day a week and you can save at least \$100 worth of gas every year.



Send me a free booklet with more easy tips on saving energy and money.

Name _____
Address _____
City _____ State _____ Zip _____
Mail to "Energy," Box 62, Oak Ridge, TN 37830

Take public transportation as often as you can. You'll save gas and help reduce air pollution, too.



This free booklet can show you a lot more easy ways to save gas and money. To get your copy write "Energy," Box 62, Oak Ridge, TN 37830 or mail the coupon below.



ENERGY.
We can't afford to waste it.

U.S. Department of Energy

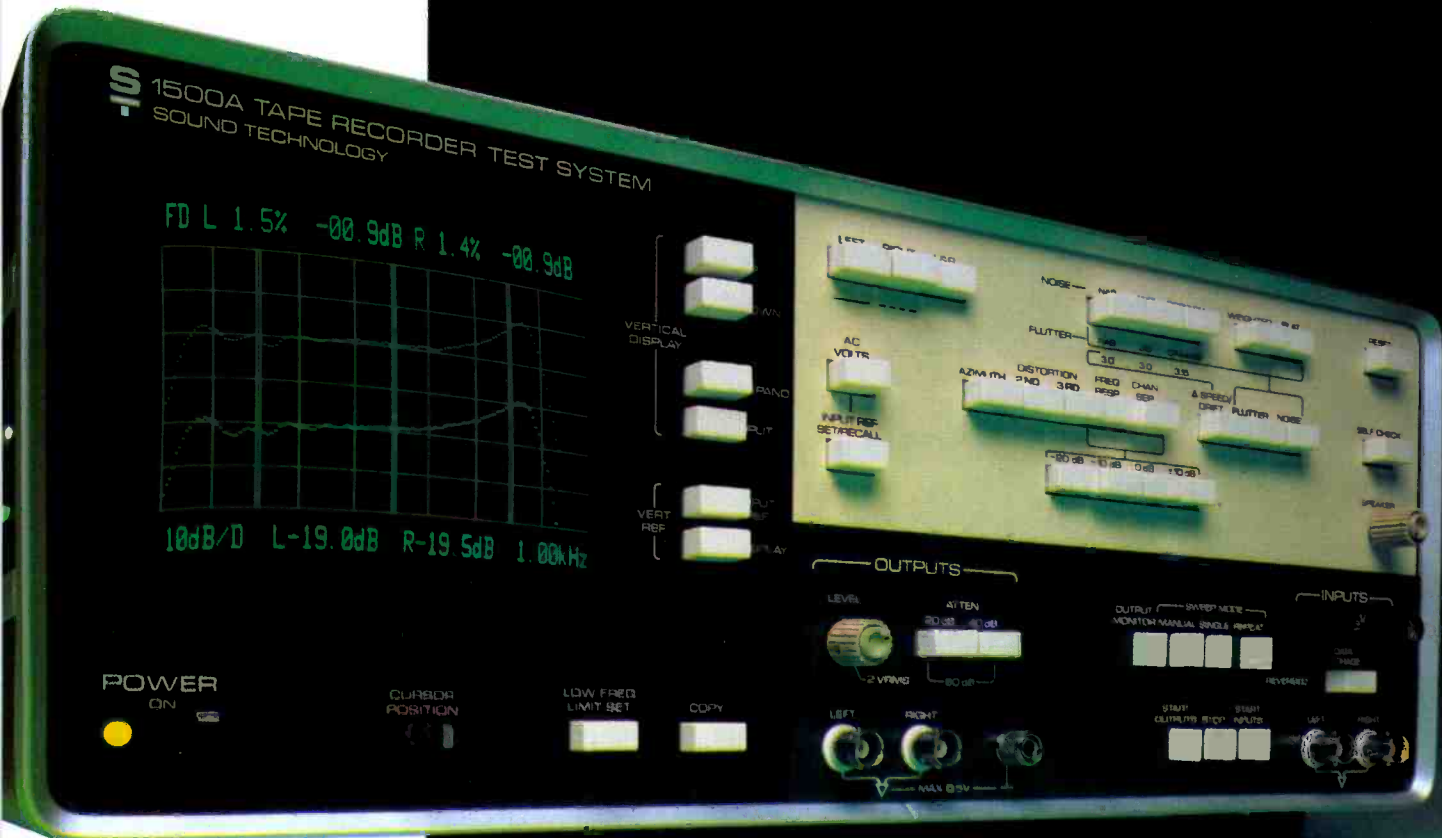

**THE INTELLIGENT
CLEANS UP**

The Sound Technology 1500A

It's the first microprocessor controlled audio measurement test system. It can do in minutes what used to take hours with more conventional and ordinary test set-ups. And, it can show you things you've never seen before.

Designed around the most advanced microprocessor hardware, the 1500A will show you the whole story on an integral CRT with adjustable cursor. Push a "Copy" button, and it delivers a hard-copy printout from the optional VP-150 Video Printer.



What Will It Do?

Conceived to be the ultimate precision test instrument for tape recorder analysis, the 1500A evolved into a comprehensive audio test system for many applications. Here's just a small sample of the varied jobs it will do:

- Complete tape recorder mechanical and electronic performance checks
- Thorough phono cartridge analysis
- One-third octave spectral analysis
- Evaluation of audio quality for VTR's
- Acoustical room analysis including microphone and loudspeaker measurements

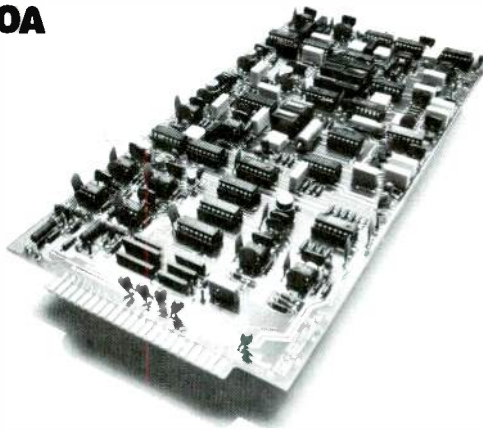

- Quality control for high speed tape duplication systems
- Semi-automated production testing
- Research and development for the audio tape manufacturer
- Quality assurance for the audio distribution network
- Exclusive asynchronous inputs and outputs for remote location testing (satellite, transmitter, studios, etc.)

Here's the kind of data you can get:

- Frequency Response
- Azimuth at 4 discrete frequencies
- 2nd and 3rd Harmonic Distortion Vs. Level
- Wow & Flutter; noise; weighted or flat
- Channel Separation 20Hz - 20k
- Delta Speed & Drift

Because of the modular plug-in design, the 1500A is designed to grow with you. The first plug-in option will be available soon: a spectral noise and flutter card. Other current accessories include a hard-copy printer, flight case, rack mounting ears, and our own test record for phono cartridge analysis.



Who Can Use It?

Broadcaster. Recording studio. Film sound studio. Audio manufacturer. Audio dealer. Service technician. Researcher. Virtually anyone whose job requires accurate evaluation of audio equipment performance. Wherever you are in the audio spectrum, it can make life a whole lot easier.

Clean up your act with the 1500A. It's intelligent. And so is a phone call to Sound Technology. We'll be pleased to send full information on the 1500A and our other industry standard test equipment.

Please send me more information on how the Sound Technology 1500A System can help me clean up my act.

NAME _____

COMPANY _____

ADDRESS _____

CITY _____ STATE _____ ZIP _____

PHONE _____

S SOUND Department 3003102, 1400 Dell Avenue, Campbell, CA 95008
T TECHNOLOGY (408) 378-6540 TELEX. 357445

TEST SET THAT YOUR ACT.

Circle (83) on Reply Card

NAB exhibitors

Bell Helicopter Textron (Booth 1905)

See at booth.

Circle (358) on Reply Card

Berkey Colortran (Booth 1116)

Products: Lighting fixtures, portable kits, battery belt kits, dimmers, manual control, memory controls, accessories for television and motion picture studio and remote lighting, 1kW-2kW Fresnel, 200M ellipsoidal.

Circle (359) on Reply Card

see ad on page 273

Best Audio (Booth 602S)

See at booth.

Circle (360) on Reply Card

see ad on page 156

Beyer Dynamic, Inc. (Booth 1906)

Products: MCE 5, MES 5VN(C) studio condenser microphones (MC711, MC712, MC713, MC714, MC716, MC717); MCE 5.1.

Circle (361) on Reply Card

see ad on page 211

Bird Electronic Corporation (Booth 915)

Products: Instruments and components for RF power measurement,

RF directional Thruline wattmeters, 2W to 80kW air-cooled and self-contained heat-exchanger loads, field-replaceable water-cooled line terminations, digital calorimeter, TV model RF self-cooled calorimetric line terminations 10kW to 80kW.

Circle (362) on Reply Card

Blonder-Tongue Laboratories (Booth 1730)

Products: Encoders, addressable decoders, signal boosts, antennas, MultiVision decoders, band eliminator filters, antennas.

Circle (363) on Reply Card

Bogner Broadcast Equipment Corporation (Booth 517)

Products: High power UHF TV transmitting antennas, VHF TV transmitting antennas, dipole type TV and FM antennas, low power UHF transmitting antennas.

Circle (364) on Reply Card

Bonneville Broadcast Consultants (Booth 321)

Products: Consultants confer with current and prospective clients on their specific market needs, drawing from their background in beautiful music, adult contemporary, custom

playlist management and special feature programming.

Circle (365) on Reply Card

Boston Insulated Wire & Cable Company (Booth 1011)

Products: Broadcast television camera cables, connectors and cable assemblies, including multi-core, tri-axial and fiber optic cables, state-of-the-art fiber optic camera cables for video transmissions.

Circle (366) on Reply Card

Walter S. Brewer Co. Inc. (Booth 1100)

Products: Cyclorama / background curtain system, seam 655 connector strips for studio grid power distribution, location power distribution, grid accessories, 1000/4000W feather lite super soft light, 14- and 19-inch 1000/2000 W scoops, porta kit 6000-professional lighting kit, ground row, location main power entry control box, eight new standard studio designs.

Circle (367) on Reply Card

see ad on page 263

Broadcast Cartridge Service (Booth 325)

Products: Aristocart, Capitol audiopak, Fidelipac broadcast cartridges,

We're Better Than Ever!



The new TPT-2500 titler offers features not expected in this price range: eight character sizes, upper and lower case, border line, underlining, graphics, flash, crawls, positionable title window, 32 page resident memory and optional 700+ page tape memory.

Operating features include: auto line and page centering, word/line open and close, tab and elastic memory. See the TPT-2500 and the rest of our titler line at the NAB booth 1523.

Priced at \$4995.00



Video Data Systems

Headquarters, Hauppauge, N.Y. (516) 231-4400
National CATV Sales / Western Regional Office
Salt Lake City, Utah (801) 272-9296

→ Innovative Communications

Circle (84) on Reply Card

TO THE LIMIT



When you desire the very best...choose the one and only "Maximod." Maximod utilizes an exclusive digital process for peak limiting control. Maximod offers vast flexibility and thus, may be used in any application. Being digital, you have the purest and cleanest sound...without clipping! Maximod is truly precise and offers state of the art technology.

Multiband leveling never had it so good. The "Discriminate Audio Processor II" is the most flexible multiband available. Crossover, compression, attack, release and more are variable. True RMS/VCA limiting offers smooth, distortion-free audio. May be used to enhance your overall loudness or simply clean up your audio.

ATC APPLIED TECHNOLOGY CORPORATION

27106 46TH SOUTH KENT, WASHINGTON 98031 (206) 854-4486

Circle (85) on Reply Card

Broadcast Production Consoles

GREAT AUDIO STARTS HERE

FEATURES:

Stereo Outputs 8 or 12 Channels
Up to 24 Inputs All Inputs & Outputs Balanced QM-8P, 4 Stereo Channels standard, 0, 2 or 6 optional QM-12P, 4 Stereo Channels standard, 0, 2, 6, 8 or 10 optional.

Input Channels: 3 Knob EQ with In/Out Switch Echo, headphone and Cue Send Channel On and Remote Start High Quality Conductive Plastic Faders.

Output Channels: 4 Balanced Low Noise, Low Distortion May be Stereo or Mono.

Monitoring: 4 Independent Monitors Flexible Control Room Selection Talkback to Studio Muting

QUANTUM offers the following options for the QM-8P and QM-12 P: Phantom Power Supply 104 Point Patchbay 8 or 12 Channel Input Expander.

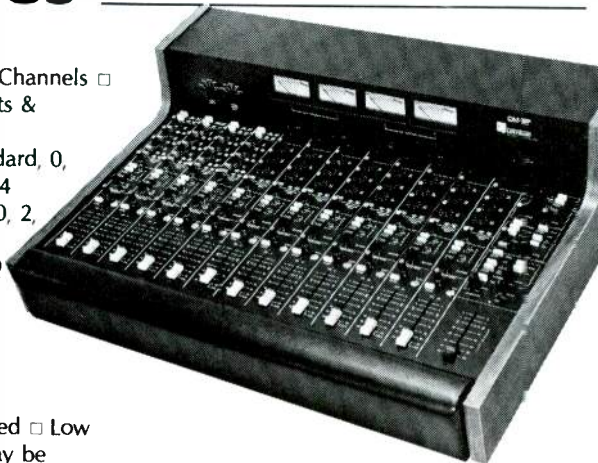

SEE US AT NAB BOOTH NO. 438



QUANTUM
AUDIO LABS, INC.

1909 Riverside Dr., Glendale CA 91201
Telephone (213) 841-0970

Quantum Audio Labs is an independent manufacturer and is not affiliated with any retail store.

Circle (86) on Reply Card

CHRONTROL: THE NEW MANAGER

To manage time.

To appoint a series of tasks and have them accomplished, timed accurately to the second.

Tasks to be done today. Tomorrow. Next week. Next month.

Accuracy that is possible in a programmable timer because of our microprocessor technology.

ChronTrol

The reliable, yet inexpensive alternative to mechanical timing devices.

ChronTrol

The tool of time management.

The tool of the new manager.



The Kern County School District, Bakersfield, CA found conventional videotape recorder timers too inaccurate to acquire public television programming with any reliability. The purchase of a ChronTrol gave operators the flexibility and preciseness needed to successfully continue expansion of their video tape library. Additional references and a catalog of other ChronTrol models and their applications are available from: Lindburg Enterprises, Inc., 4878 Ronson Court, San Diego, CA 92111, (714) 292-9292, TLX/TWX 910-335-2057. Time was. ChronTrol is.

Circle (87) on Reply Card

NAB exhibitors

cartridge storage systems, alignment tools, cartridge reloading service.

Circle (368) on Reply Card

Broadcast Center (Booth 211)

See at booth.

Circle (369) on Reply Card

Broadcast Controls (Booth 312)

See at booth.

Circle (370) on Reply Card

Broadcast Electronics (Booth 304)

Products: FM-30, 30kW and FM-3.5, 3.5kW FM transmitter, FX-30 FM exciter, Control 16 program system, full console line, four to 10 mixing channels, rotary and linear faders, mono and stereo models, AM/FM audio processors, series 2000, 2100, 3000, and 5000 single- and multi-deck cartridge tape mono/stereo, record/playback equipment, telephone answering systems, QRK turntables, Rek-O-Kut tone arms, FM-1.5, 1.5kW, FM transmitter, FS-30 stereo generator, FC-30 SCA generator, high-performance phono preamplifier, FM exciter, stereo generator.

Circle (371) on Reply Card

Broadcast Marketing Associates (Booth 437)

See at booth.

Circle (372) on Reply Card

Broadcast Music (Booth 148)

Products: Music licensing.

Circle (373) on Reply Card

Broadcast Systems Inc. (Booth 1701)

See at booth.

Circle (374) on Reply Card

Broadcast Technology (Booth 1023B)

See at booth.

Circle (375) on Reply Card

Broadcast Video Systems Ltd. (Booth 1631)

Products: Michael Cox 203 NTSC encoder, BVS SA-100 safe area generator, BVS PW-200 pulse width test set, BVS video delay lines and filters, Michael Cox 339 color balance corrector, Electronic Visuals EV4060 combined waveform/vector monitor.

Circle (376) on Reply Card

HARRIS' NEW LOW BAND TV TRANSMITTER LINE ... SIMPLY POWERFUL

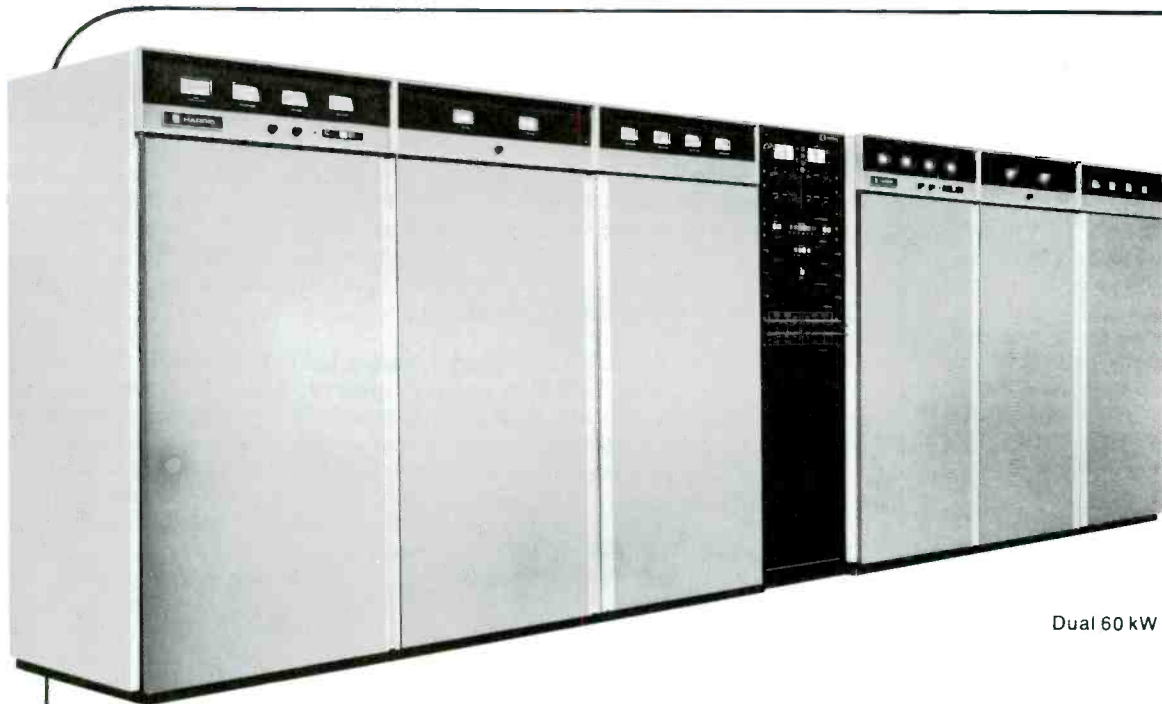

Dual 60 kW TVD-60L

Straightforward design, with less complicated circuitry for top reliability... that's the heart of the concept in Harris' new "TV-L" low band transmitter line.

With the new ultra-linear driver, maximum linearity and signal transparency are assured *without* the need for complicated correction circuitry. This means fewer circuits to adjust and maintain...for unmatched reliability and maintainability.

You also get performance specs unsurpassed in the industry, with the help of such proven Harris "firsts" as the Transversal SideBand filter and IF Modulation.

There are power ranges ideal for both

circularly and horizontally polarized transmission:

Model	Visual Power Range
TVD-60L (dual)	20 to 60 kW
TVD-40L (dual)	10 to 45 kW
TV-30L	10 to 30 kW
TV-20L	5 to 22.5 kW

Harris' new "TV-L" transmitters—powerful performers, yet uncomplicated to give you the year-in, year-out dependability you need for impressive bottom-line results.

See your Harris representative, or contact Harris Corporation, P. O. Box 4290, Quincy, Illinois 62301. 217/222-8200.



HARRIS
COMMUNICATION AND
INFORMATION PROCESSING

Visit the Harris TV and radio equipment display at the 1981 NAB, Las Vegas

Don't blame the operator



Blame Static

This isn't the first time the screen has gone blank "for no reason." But there is a reason. Video wipe-out is only one of the problems static can cause with electronic equipment like computers, word processors and electronic cash registers. As little as 500 volts can cause memory loss or alteration, faulty data, unwanted mechanical actions — even permanent damage to sensitive control and logic circuits.

Only 500 volts, yet you can easily generate over 12,000 volts walking across a carpet, 4,000 on a vinyl floor. Then, just one touch, and you could be in need of a very expensive service call.

For less than the cost of that call, however, you could be rid of static for good.

3M Static Control Floor Mats can create an inexpensive "island of protection" around delicate electronic office equipment, harmlessly draining static charge from operators and other personnel.

3M Static Control Floor Mats are

one of the most economical ways available to be sure that your equipment is up when you need it.

3M Static Control Floor Mats come in hard mats for easy movement of casted chairs, and soft mats for comfortable standing. For information about how you can purchase 3M Static Control Floor Mats, call toll-free

1-800-328-1300.

(In Minnesota, call 1-800-736-9625.)

Ask for the Data Recording Products Division

3M Hears You...

3M

Circle (89) on Reply Card

120 *Broadcast Engineering* March 1981

NAB exhibitors

CCA Electronics (Booth 103)

See at booth.

Circle (377) on Reply Card

CEI (Booth 1109)

Products: The 310 series color television camera, 330 for long cable runs and single piece 340 camera, the Americam camera.

Circle (378) on Reply Card

CMC Technology Corporation (Booth 1622)

Products: Video head refurbishing, video accessories, auto equalizer.

Circle (379) on Reply Card

CMX/Orrox Corporation (Booth 1209)

Products: 340X computer assisted editing system, the EDGE micro computer editing system, motion memory, film editing system.

Circle (380) on Reply Card

see ad on page 269

CSI Electronics, Inc. (Booth 106)

Products: AM and FM broadcast transmitters.

Circle (381) on Reply Card

see ad on page 18

Cablewave Systems Inc. (Booth 1323)

Products: Transmission line systems, coaxial and elliptical waveguide, RF connectors, mounting hardware, microwave antennas, pressurization equipment and associated hardware, 4½-inch outer diameter air dielectric transmission line, WE60 elliptical waveguide, associated hardware.

Circle (382) on Reply Card

see ad on page 51

California Microwave Inc. (Booth 156)

Products: Earth station equipment.

Circle (383) on Reply Card

see ad on page 155

Cambridge Products Corporation. (Booth 1614)

Products: "F"—UHF-RF coaxial connectors, Type "N" crimp style coaxial connector.

Circle (384) on Reply Card

The Camera Mart (Booth 1406)

Products: Ikegami, Hitachi, Sony, Panasonic, Microtime, Ultimatte, Sharp, Videotek, O'Connor, Ronford, Listec, Audio Ltd., Vega, Sennheiser, Cinema Products.

Circle (385) on Reply Card

Canadian General Electric (Booth 431)

Products: 30kW VHF high channel TV transmitter, 2kW UHF TV transmitter.

Circle (386) on Reply Card

see ad on page 91

Candex Pacific Inc. (Booth 1700)

Products: VIMACS vertical interval machine control system, datalite lighting control systems, television distribution amplifier type 2042-V, equalizing distribution amplifier type 2042-E, pulse distribution amplifier type 2042-P, SAMS (Source & Message System) type 1916 series, VISE vertical interval source encoder/type 1934, VIPS vertical interval picture source type 1935.

Circle (387) on Reply Card

Canon USA (Booth 902)

Products: 25X, 18X lenses with diascope for microprocessing cameras; 12X for micro processing cameras and 13X with built-in extenders for ENG cameras; lens auto focus and servo pan and tilt unit.

Circle (388) on Reply Card

see ad on page 39

Capitol Magnetic Products (Booth 506)

Products: Audiopak AA-3 stereo phase broadcast cartridges, Audiopak A-2 standard broadcast cartridges, Q-17 tape.

Circle (389) on Reply Card

see ad on page 110

Cavox/Tape-athon (Booth 164)

Products: Library service, cassette playback system model 750.

Circle (390) on Reply Card

Ceco Communications (Booth 1014)

See at booth.

Circle (391) on Reply Card

see ad on page 204

Central Dynamics Corporation (Booth 1015)

Products: Video production switchers, one-bus Quad unit that can be fitted to any switcher, video and audio amplifiers.

Circle (392) on Reply Card

Centro Corporation (Booth 2147)

Products: EFP remote television production vans and trucks, grip and crew vans, noise baffled ac generator trailers, digital portable television test signal generator.

Circle (393) on Reply Card

The TV Transmitters of **TOMORROW** are at Acrodyne **TODAY**



1kW UHF



10kW VHF

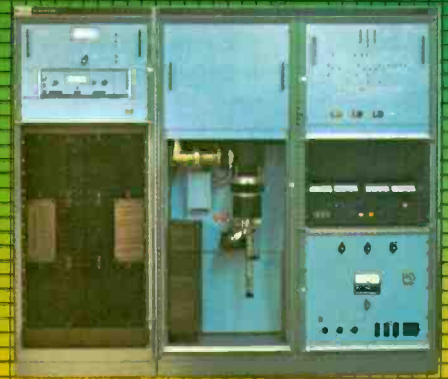

5kW UHF

ACRODYNE, traditionally the leader in low power television equipment, brings tomorrow's technology to 1981 with its line of advanced transmitting equipment.

Acrodyne's newest addition, the TT-3500VH 10 kW VHF transmitter, features totally solid-state drivers and single tetrode output for ultra-high energy efficiency. Low level diplexing and straight forward broadband solid state design completely **eliminate** tuning except for the broadband final stage. Fully automatic operation, remote control capabilities and unique forced air / liquid cooling insure ease of opera-

tion and maintenance. The TT-3500VH achieves full specifications to 12.5kW.

Acrodyne achieved major breakthroughs with the TT-3400U 1 kW UHF and the TT-3480U 5kW UHF transmitters. The TT-3500VH is just one more reason why Acrodyne is looked to first for TV transmission requirements world-wide.

See us at NAB booth #1103

ACRODYNE

Acrodyne Industries, A Unit of Whittaker Corporation
Township Line Rd., Blue Bell, PA. 19422
(215) 368-2600 Telex: 846358 (800) 523-2596

Whittaker

Circle (90) on Reply Card

NAB exhibitors

Century 21 Programming Inc. (Booth 313)

Products: Radio programming services, technical equipment and service of used or out-of-warranty automation.

Circle (394) on Reply Card

Cetec Broadcast Group (Booth 305)

Products: 2000 console 8 mixer stereo audio console, 7000 automation system, series 8000 console, MAPS traffic/accounting business system.

Circle (395) on Reply Card

see ad on page 40

Cetec Vega (Booth 1621)

Products: Transmitters, receivers, hand-held mic transmitters.

Circle (396) on Reply Card

see ad on page 141

Cezar (Booth 1718)

Products: videotape editors, color video encoders and decoders.

Circle (397) on Reply Card

Chase Media Inc. (Booth 119)

Products: Broadcast Station System

including traffic, billing, financials and music format control.

Circle (398) on Reply Card

Christie Electric Corporation (Booth 1002)

Products: Portable power equipment for ENG and EFP.

Circle (399) on Reply Card

see ad on page 240

Chyron Corporation (Booth 1407)

Products: Graphics and titling generators, election reporting system, cassette cleaner and evaluator for ¾-inch VC.

Circle (400) on Reply Card

see ads on pages 160, 256

Cinema Products Corporation (Booth 1417)

Products: CP Co-Ax digital remote control system, Newsmaker video edit controller, EFP matte box, ENG/EFP cameras, Steadicam video/film camera, Camraprompter, Bubbelite, RDS/HMI Fresnel Spot Light series, related accessories.

For information: Cinema Products, 2037 Granville Ave., Los Angeles, CA 90025.

see ad on page 65

Cine 60 Inc. (Booth 1037)

Products: High frequency line-isolated Nicad battery charging systems,

new Nicad batteries, Combi 100W/12V-250W/24V battery lights, 350W/30V battery lights and kits, camera snaplocks, shoulder pods, HMI lights.

Circle (401) on Reply Card

Circuit Research Labs Inc. (Booth 126A)

Products: AM and FM audio processors, compressors, wide band multiband, limiter, wide band multiband, AGCs, IM reduction techniques for FM limiting.

Circle (402) on Reply Card

see ad on page 209

Clear-Com Intercom Systems (Booth 174 & 176S)

See listing on pages 181-2

Circle (403) on Reply Card

Cohu Inc. (Booth 900)

Products: 1550 B filmchain, DM monitors, matting camera, film chain with neg film capability.

Circle (404) on Reply Card

Colorado Video (Booth 1029)

Products: Slow-scan transceiver equipment.

Circle (405) on Reply Card

Are You Performance Minded? or Economy Minded?

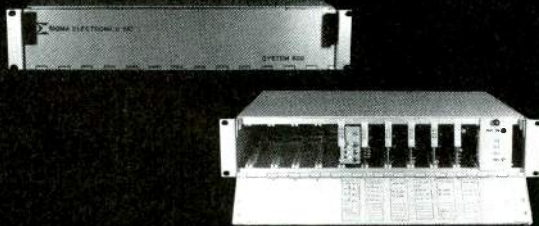

SIGMA SYSTEM 500

Lets You Be Both!

- 10 DA's per frame with plug-in power supply
- On-card voltage regulator for maximum reliability
- Plug-in back panel modules
- SigmaBus back plane eliminates need for cabling between modules.



SIGMA ELECTRONICS INC.
1830 STATE STREET, EAST PETERSBURG, PA 17520
(717) 569-2681

531 DOVER ROAD, COVINA, CA 91722
(213) 967-4526

Circle (91) on Reply Card

Unsurpassed Reliability

The new MCI JH-110B Series Tape Recorders/Reproducers



Transformerless Electronics

Universal Application

Special models for studio, broadcast, film, video and disc mastering use.

Mono to 8 Track versions available

Featuring New RTZ III

JH-110B Tape Recorder/Reproducer



PRO AUDIO GENERAL STORE
1378 NW 100 Ave. Coral Springs, FL 33065
BILL SHUTE 305/752-0330
DAVE KERSTIN 312/690-8301

Circle (92) on Reply Card

GLOBAL IX™

Now, from the new revolutionary GLOBAL IX series, Farinon Video introduces the only truly universal portable video microwave transmitter. For the first time there's a single portable transmitter capable of covering any 2-GHz frequency plan in the world.

With the unique GLOBAL IX wideband transmitter, you can select more channels than ever before—up to 55 channels in each of 16 different frequency plans. Standard plans or you name it. And RF channels can be selected locally or remotely. Now that's versatility.

You'll wonder how such a compact transmitter can provide 3 Watts of wideband power. But if that's not enough, there's an auxiliary 12-Watt power amplifier available too. And the transmitter interface can be either baseband video or true 70-MHz heterodyne.

Here's another first. Two audio channels with programmable subcarrier frequencies can be transmitted simultaneously. And you have the choice of line level or microphone level for either channel.

The Only Portable Video Microwave Transmitter You'll Need in All the World.

To simplify maintenance, the GLOBAL IX portable transmitter has built-in diagnostics. Problems can be quickly diagnosed by monitoring the indicators on a remote channel selector or a separate display unit.

You can power the transmitter from AC or a car battery—or even a standard power belt. What's more, you won't find a more rugged or environmentally reliable transmitter no matter where your crew takes it.

This unique portable video microwave transmitter is representative of the state-of-the-art products in the all-new GLOBAL IX series. Another example of Farinon Video's quest to provide superior video transmission equipment for use throughout the world.

For more information contact HARRIS CORPORATION, Farinon Video, 1680 Bayport Avenue, San Carlos, CA 94070; (415) 595-3500.

Telex 34-8491. In Canada, 657 Orly Avenue, Dorval, PQ H9P 1G1; (514) 636-0974; Telex 05-82-1893.



HARRIS

COMMUNICATION AND
INFORMATION PROCESSING

Circle (93) on Reply Card

"See our complete product line at the NAB Exposition in Las Vegas; booth 301."

NAB exhibitors

Columbine Systems Inc. (Booth 332S)

Products: Complete broadcasting packages for TV and radio stations.

Circle (406) on Reply Card

Comark Communications Inc. (Booth 515)

Products: UHF television transmitters, UHF television exciters, 6 1/8-inch automatic switching system, computerized remote control systems.

Circle (407) on Reply Card

see ad on page 151

Comark Industries (Booth 515)

Products: Demodulators, diplexers, directional couplers, FM antennas, filters, coax transmission line and components, power dividers, computerized remote control systems.

Circle (408) on Reply Card

Comex Corporation (Booth 217)

See at booth.

Circle (409) on Reply Card

see ad on page 210

Compact Video Sales Inc. (Booth 1525)

Products: Transportable earth station, television production units, ENG, EFP vans.

Circle (410) on Reply Card

see ad on page 19

Compact Video Services Inc. (Booth 1525)

Products: Production, post-production, telecine, sound, film sound transfer, duplication and satellite services.

Circle (411) on Reply Card

Comprehensive Video Supply Corporation (Booth 1910)

Products: Bilora fluid effect tripods, PAG PowerBelts, PAG lights, portable ENG/EFP microphone mixer, UNICOL equipment stands and trolleys, PAG power packs, on board Nicad replacement batteries, 250 and 350W PAG lights, camera to VCR adapters, VTC-100 video test center.

Circle (412) on Reply Card

Compucon Inc. (Booth 1902)

Products: Satellite earth station frequency coordination, protection

services, RFI field measurements, on-site surveys, frequency planning and protection for common carrier, private, STL and CARS band, field surveys, map studies, land mobile engineering, MDS studies and low power UHF TV translator channel selection.

Circle (413) on Reply Card

Computer Concepts Corporation (Booth 168)

Products: The Broadcast System, play list program.

Circle (414) on Reply Card

Computer Graphics Lab (Booth 1982)

See at booth.

Circle (415) on Reply Card

Computer Management Systems Inc. (Booth 421)

Products: The Broadcast Management Information System (BMIS) automated business system.

Circle (416) on Reply Card

Computer Video Systems Inc. (Booth 188S)

See at booth.

Circle (417) on Reply Card

see ad on page 92

The book that turns businessmen into best sellers.

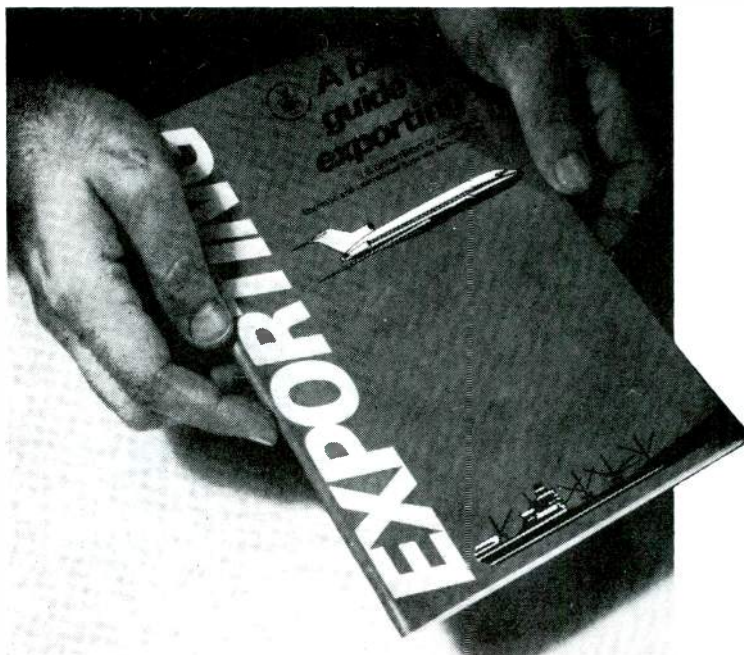

Many who've read it are now reaping the rewards. Because they've found that U.S. exports are a more than \$100 billion a year business, that exporting creates both company profits and company growth, that U.S. goods have never been more competitive in international markets. Above all, they've found that, with the help available from the U.S. Commerce Department, selling overseas is no more difficult than selling at home. And this fact-filled book can prove the same to you. Write The Secretary of Commerce, U.S. Dept. of Commerce, BED 8B, Washington, D.C. 20230.

U.S. Department of Commerce

A Public Service of This Magazine
& The Advertising Council



Circle (94) on Reply Card



INNER VIEW: A closer look at Conrac Monitors

Active Convergence: Registration made simple.

Conrac's Active Convergence System gives you complete control over color registration adjustments and greatly streamlines convergence checks.

It uses 36 independent controls to individually adjust nine separate areas on the CRT screen—including corners!

You spend less time on convergence checks—and the adjustments you make will be much more accurate.

Conrac's system uses 24 operational amplifiers to independently control red, green, and blue in each screen area. Vertical and horizontal waveforms are referenced for shaping the signals that excite the convergence yoke assembly. Dynamic blue lateral convergence is achieved with operational amplifiers.

Beam Current Feedback: The Ultimate in Black Level Stability.

Conrac's unique Beam Current Feedback system maintains a more stable picture for a longer period of time.

It automatically maintains black level stability—regardless of CRT aging or component drift. In fact, black level is held to within 1% of peak luminance level between 10% and 90% APL (Average Picture Level).



Conrac's Active Convergence system lets you adjust color registration on nine separate areas of the CRT.

Conrac's exclusive Beam Current Feedback system automatically maintains black level stability.

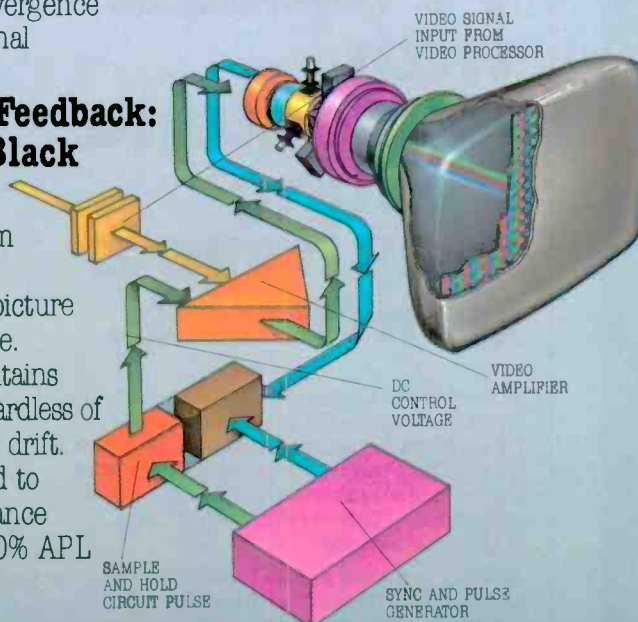

Conrac's unique system uses a keyed back porch video amplifier and beam current sensing that occurs during the vertical interval.

The video signal is ac coupled to the video amplifier, thus eliminating the dc component and retaining the level between black and white. It is then amplified and applied to G1 of the CRT. The feedback loop is completed when a sample cathode current (gated by the brightness pulse) is applied to a sample and hold circuit.

If the cathode current changes for any reason, the video amplifier's dc level is automatically adjusted. Result: reference black level will remain constant.

Conrac Technology: 30 years of leadership.

Conrac's track record of technical innovation stretches back nearly three decades. And what we've learned since then goes into every monitor we make today. That's important to you. Because the more technology we pack into each monitor, the more performance you'll receive from it.

Active Convergence and Beam Current Feedback are just two ways Conrac technology can save you time and money.

For the complete inner view of Conrac technology, call or write us today: Conrac Division, Conrac Corporation, 600 North Rimsdale Ave., Covina, CA 91722, Telephone: (213) 966-3511, Telex: 67-0437

See Us at Booth No. 809 at NAB'81

Quality you can take for granted.

Circle (95) on Reply Card

FACT!

No one can match The Complete Lightning Protection Systems from LEA.

- ANTENNA DISSIPATION ARRAYS FOR AM, FM, TV, MICROWAVE TOWERS
- SURGE ELIMINATORS FOR MAIN POWER LINES TO HANDLE ENERGY LEVELS OF > 8800 JOULES PER PHASE
- COAXIAL TRANSMISSION LINE SURGE ELIMINATORS 1 Kw to 25 Kw
- KLEANLINE ELECTRONIC FILTERING SYSTEMS TO PROTECT AGAINST LIGHTNING STRIKES AT >8800 JOULES PER PHASE PLUS AN RFI/EMI FILTER TO HANDLE RF INTERFERENCE FOR SENSITIVE SOLID STATE EQUIPMENT.
- TRANSIENT ELIMINATORS FOR DATA LINES, PHONE LINES, COMMUNICATIONS EQUIPMENT WITH A FREQUENCY RESPONSE FROM D.C. TO 1 GIGAHERTZ.
- LIGHTNING WARNING SYSTEMS PROVIDING 1/2 HOUR ADVANCE WARNING OF AN APPROACHING STORM.
- SURGE AND TRANSIENT GENERATORS
- GROUND SYSTEMS
- CONSULTING SERVICES

SEE US AT NAB
LAS VEGAS BOOTH 317

LIGHTNING ELIMINATION ASSOCIATES



12516 Lakeland Road
Santa Fe Springs, CA 90670
(213) 944-0916
TWX: 910-586-1381

Circle (96) on Reply Card

NAB exhibitors

Comrex Corporation (Booth 105)

Products: Telephone talk show equipment, low frequency extenders, ENG van cue systems, TV aural monitors, ENG wireless microphones.

Circle (418) on Reply Card

Comsearch Inc. (Booth 1604)

Products: Satellite earth station placement, frequency coordination and RFI measurements, CARS band microwave frequency assignment, point-to-point microwave frequency coordination and computer systems software development, channel selection and application preparation for low power broadcast stations.

Circle (419) on Reply Card

see ad on page 76

Concept Productions (Booth 326)

Products: Programming for automated and non-automated radio stations.

Circle (420) on Reply Card

Conrac Corporation (Booth 809)

Products: Professional color monitors, monochrome monitors, comput-

er graphic color monitors.

Circle (421) on Reply Card

see ad on page 125

Continental Electronics Mfg. Co. (Booth 100)

Products: 5, 10 and 50kW AM transmitter, design and manufacture of antenna phasing and coupling equipment, diplexers, filters, combiners and all special requirements related to AM transmitting systems, FM transmitters from 1 to 50kW and a 1kW and 5kW AM transmitter, audio consoles, FM antennas, expanded 24 hour professional service.

Circle (422) on Reply Card

see ad on page 81

Control Video Corporation (Booth 1733)

Products: SMPTE time code generator, SMPTE reader, keyer intelligent machine controller, video editing system, video audio synchronizer, video VTR sequencer.

Circle (423) on Reply Card

see ad on page 132

Convergence (Booth 1101)

Products: Videotape editors, ENG equipment.

Circle (424) on Reply Card

see ad on page 237

TV Studios with inadequate lighting may have a dim future.

Thanks to our experience in dealing with studio lighting, we have designed six standard TV lighting packages that meet normal needs for standard-sized studios. And since these are complete systems already engineered and in stock, ready to ship, they afford substantial savings.

At Kliegl, we have a team of seasoned engineers who can also design custom studio lighting systems to meet more exacting requirements.

So, if you don't want your viewers to change channels, turn to Kliegl. For complete information on our TV packages, please write or call.



Kliegl Bros.
32-32 48th Ave.
Long Island City
New York 11101
212/786-7474

Circle (97) on Reply Card



*Amperex
is dedicated
to product
excellence...*

**...if you're dedicated
to picture excellence –
specify
Plumbicon* TV camera tubes.**

Visit us at NAB, Booth 1032

Amperex®

TOMORROW'S THINKING IN TODAY'S PRODUCTS

A NORTH AMERICAN PHILIPS COMPANY

AMPEREX ELECTRONIC CORPORATION, SLATERSVILLE DIVISION, SLATERSVILLE, RHODE ISLAND 02876 • TELEPHONE: 401-762-3800

* Registered trademark N.V. Philips of the Netherlands.

Circle (98) on Reply Card

BEHIND THE LENS OR IN FRONT,



TIFFEN FILTERS ARE THE INDUSTRY'S FIRST CHOICE.

Most major manufacturers of video cameras install Tiffen filters as original equipment in the filter wheel behind the lens.

Most major TV stations and studios use Tiffen filters in front of the lens.

Why? Because cameras are only as good as their components. When quality components are required Tiffen filters meet all the requirements.

They're rugged, reliable, precision-made. And the performance is always outstanding.

Superior technology and quality craftsmanship combine to make Tiffen filters the industry's first choice.

Tiffen Makes Filters For:

Ampex	Harris	Rank Taylor Hobson
Angenieux	Ikegami	RCA
Canon	IVC	Schneider
Fernseh	Marconi	Thompson
Fujinon	Norelco	And Many Others
GE	Phillips	

Write Dept. BE for FREE Professional Brochure and Price List

TIFFEN®

90 Oser Avenue, Hauppauge, N.Y. 11787
(516) 273-2500 Telex 96-7748

Circle (99) on Reply Card

NAB exhibitors

Cool Light Company Inc. (Booth 1831)

Products: Nine lights, Single Handi, Mini-Cool, new single Handi.

Circle (425) on Reply Card

Coreco Research Corporation (Booth 158)

Products: Wireless intercom set, therapeutic vibrator.

Circle (426) on Reply Card

Corporate Communications Consultants (Booth 2009)

See at booth.

Circle (427) on Reply Card

Crosspoint Latch Corporation (Booth 2111)

Products: 6112 production switcher, 6124 production switcher, 7200 Auto Drive computer controller, 6142 production switcher, 6118 production switcher, 6107 production switcher, 6128 editor controlled production switcher, 6800 editor controlled audio switcher.

Circle (428) on Reply Card

see ad on page 183

Crown International Inc. (Booth 1905)

Products: Audio power amplifiers and related equipment, preamplifiers, tuners, equalizers, two new audio power amplifiers, and prototypes of new models of the Pressure Zone Microphone.

Circle (429) on Reply Card

Custom Business Systems (Booth 3085)

See at booth.

Circle (430) on Reply Card

D-B Electronics (Booth 140)

Products: 2-deck audiotape cartridge recorder/reproducer machines, turntable preamplifier, telephone answering interface, 1- and 3-deck audiotape cartridge recorder/reproducer machines.

Circle (431) on Reply Card

dbx Inc. (Booth 416)

Products: 900 series modular signal processing system, compressor/limiters, signal enhancers, voltage-controlled amplifiers, 941 dual-channel encode, 942 dual-channel decode, 140 dual-channel simultaneous en-

code/decode Type II noise reduction system.

Circle (432) on Reply Card

see ad on page 257

Bill Daniels Co. (Booth 1717)

Products: 1981 Illustrated Trade Reference Broadcast Equipment and Services Master, dealer and manufacturer custom catalogs, service manuals, operations manuals, specification sheets, sales brochures, and general printing and production services.

Circle (433) on Reply Card

Data Communication Corporation (Booth 2145)

Products: Generators, broadcast on-line computer services.

Circle (434) on Reply Card

Datametrics Inc. (Booth 1612)

Products: SP-722A SMPTE code reader/generator/character generator, SP-733 SMPTE code-reader, SP-425 SMPTE reader/generator, SP-700 character generator, SP-710 SMPTE reader with video character insertion, SP-716 SMPTE code generator, SP-760 SMPTE code reader/character generator, SP-9000 series vertical interval time code reader/generator.

Circle (435) on Reply Card

see ad on page 46

Datatek Corporation (Booth 1227)

Products: Video-audio routing switchers, video, pulse and subcarrier distribution amplifiers, audio preamplifiers, monitoring amplifiers and distribution amplifiers, TV transmitter color phase equalizer.

Circle (436) on Reply Card

see ad on page 63

Datatron Inc./Video Systems Division (Booth 1205)

Products: Vanguard videotape editing system, Tempo videotape editing system, EDITT micro-lock videotape editing system, soft SMPTE generator / reader / jam-sync generator, ATR/VTR SMPTE synchronizer.

Circle (437) on Reply Card

see ad on page 113

Datatronix (Booth 103S)

See at booth.

Circle (438) on Reply Card

Delcom Corporation (Booth 1843)

Products: Television systems, AE-3 interface between ISI 902 video production switcher and Convergence ECS-103 editor, VO-2860D 3/4-inch recorder/player/editor.

Circle (439) on Reply Card

9100 Digital Video Processor



Noise Reducer Frame Synchronizer Time Base Corrector.

The new Thomson-CSF 9100 Digital Video Processor gives you all three capabilities — yet costs only slightly more than ordinary systems.

We developed noise reduction technology that delivers up to 15 dB of S/N improvement in four presettable settings. So satellite signals become clearer. Film-to-tape transfers are less noisy, less grainy. And for ENG applications, signals come out sharper, without the excessive low-frequency chroma noise identified with 3/4-inch VTR's.

But here's what makes the 9100 such a wise investment.

We've added a frame synchronizer that gives you the added feature of freeze-frame capability. A built-in line-by-line time base corrector for 3/4" VTR's. And, a convenient 4 x 1 switcher frees valuable cross-points while a processing amplifier provides complete output signal control.

Only Thomson-CSF gives you so much versatility and signal improvement in a single video processor.

The new Thomson-CSF 9100 Digital Video Processor. A lot more than noise reduction. For just a little more money.

Call or write today for com-

plete specifications and/or a demonstration at your facility.

In the Northeast:
Frank Shuelt
(203) 327-7700

Mid-Atlantic:
Al Audick
(202) 296-9189

Southeast:
Frank Benson
(404) 487-6756

Mid-West:
Tom Lorenzen
(312) 356-5575

Southwest:
Marty McGreevy
(713) 933-1700

West:
Mike Clayton
(213) 849-2188

Thomson-CSF Broadcast, Inc.

Thomson CSF Broadcast, Inc.
37 Brownhouse Road
Stamford, Connecticut 06902
Tel. (203) 327-7700
TWX (710) 474-3346

NAB exhibitors

Delta Electronics Inc. (Booth 400)

Products: TCA RF Ammeter systems, AM and FM versions of automatic power controller APC-1, AMC-1 amplitude modulation controller, TCT toroidal current transformers, coaxial transfer switches, digital and analog directional antenna monitors, digital panel meter, operating impedance bridges, combination RF signal generator and detector, MJ-50 meter jacks and plugs, signal conditioning TCA-IBA integrating buffer amplifier, RCS-1 microprocessor-based remote control/ATS system.

Circle (440) on Reply Card

De Wolfe Music Library Inc. (Booth 1618)

Products: 600 lp albums of production music, 16 lp sound effects library, 20 production music albums, two new sound effects albums available.

Circle (441) on Reply Card

Dictaphone Corporation (Booth 110)

Products: Series 5600 is a new multiple pass recorder, Series 5000

microprocessor controlled high channel capacity voice logging system.

Circle (442) on Reply Card

Dielectric Communications (Booth 1507)

Products: RF loads and watt meter, RF switches, RR patch panels, coax transmission line waveguide and accessories.

Circle (443) on Reply Card

see ad on page 134

Digital Video Systems (Booth 704)

Products: Digital video processors (time base correctors, synchronizers, frame storage devices, special optical effects).

Circle (444) on Reply Card

Di-Tech Inc. (Booth 1408)

Products: Audio/video/pulse distribution amplifiers, video detectors, audio/video routing switchers, audio monitor amplifier, 7-day computer controller.

Circle (445) on Reply Card

Dolby Laboratories Inc. (Booth 1031)

Products: A-type noise reduction

products.

Circle (446) on Reply Card

see ad on page 205

Drake-Chenault (Booth 116)

Products: Syndicated formats, contemporary MOR, Big Band, Silver Anniversary Edition of The History of Rock and Roll.

Circle (447) on Reply Card

Victor Duncan (Booth 1110A)

See at booth.

Circle (448) on Reply Card

see ad on page 121

Dynair Electronics Inc. (Booth 813)

Products: Audio and video routing switchers, audio/video/pulse distribution equipment, machine control, machine control switching.

Circle (449) on Reply Card

see ad on page 153

Dynacom International (Booth 1134)

See at booth.

Circle (450) on Reply Card

EEG Enterprises Inc. (Booth 1837)

Products: Line 21 closed-captioning equipment, including complete turnkey captioning system, smart encoder and digital data-prompter.

Circle (451) on Reply Card

TOMCAT *The New Standard*

- MAXTRAX™ wide-track tape heads yield more tape signal, less tape noise.
- Precision, fixed tape heads and guides for lowest tape phase error.
- Left/Right and Sum/Difference matrix audio formats.
- Compatible Monaural/Stereo playback operation provided by matrix format.
- Fast start DC servo capstan motor, runs only while pulling tape.
- Low power consumption, low heat generation.
- Low noise, low distortion electronics with excellent headroom, frequency and transient response.
- CMOS microprocessor logic control system.
- Self aligning, center supported, ball bearing pinch roller.
- Constant pressure pinch roller system.
- Long wearing stainless steel tape deck and cartridge guides.
- Accurate, repeatable cartridge positioning system.
- Auxiliary cue tones standard.
- 7.5 and 15 IPS record/reproduce speeds.
- Fast wind operation standard, 15 and 30 IPS selectable speeds.
- Compact, easy to service design.

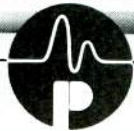
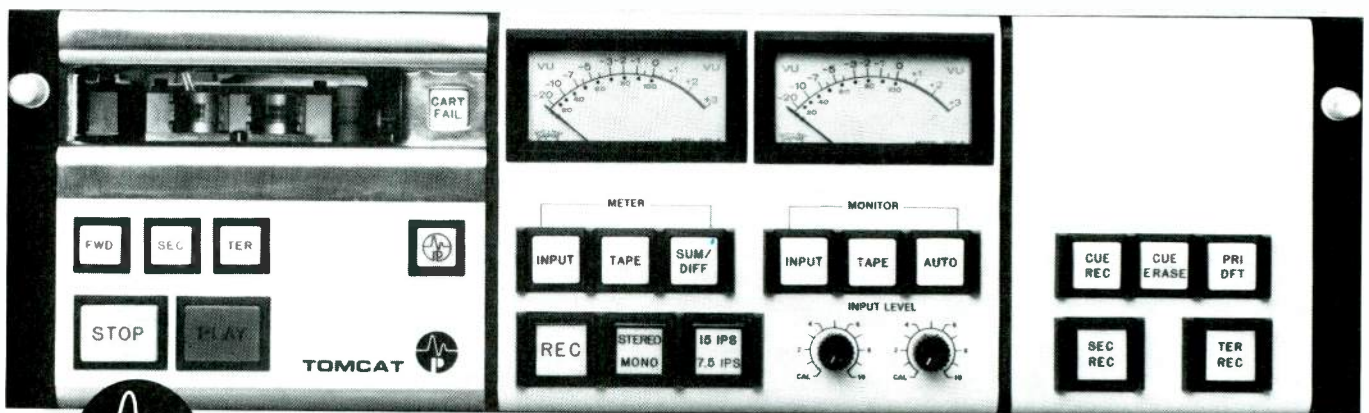

Pacific Recorders & Engineering Corporation
11100 Roselle Street, San Diego, California 92121 • (714) 453-3255

Circle (101) on Reply Card

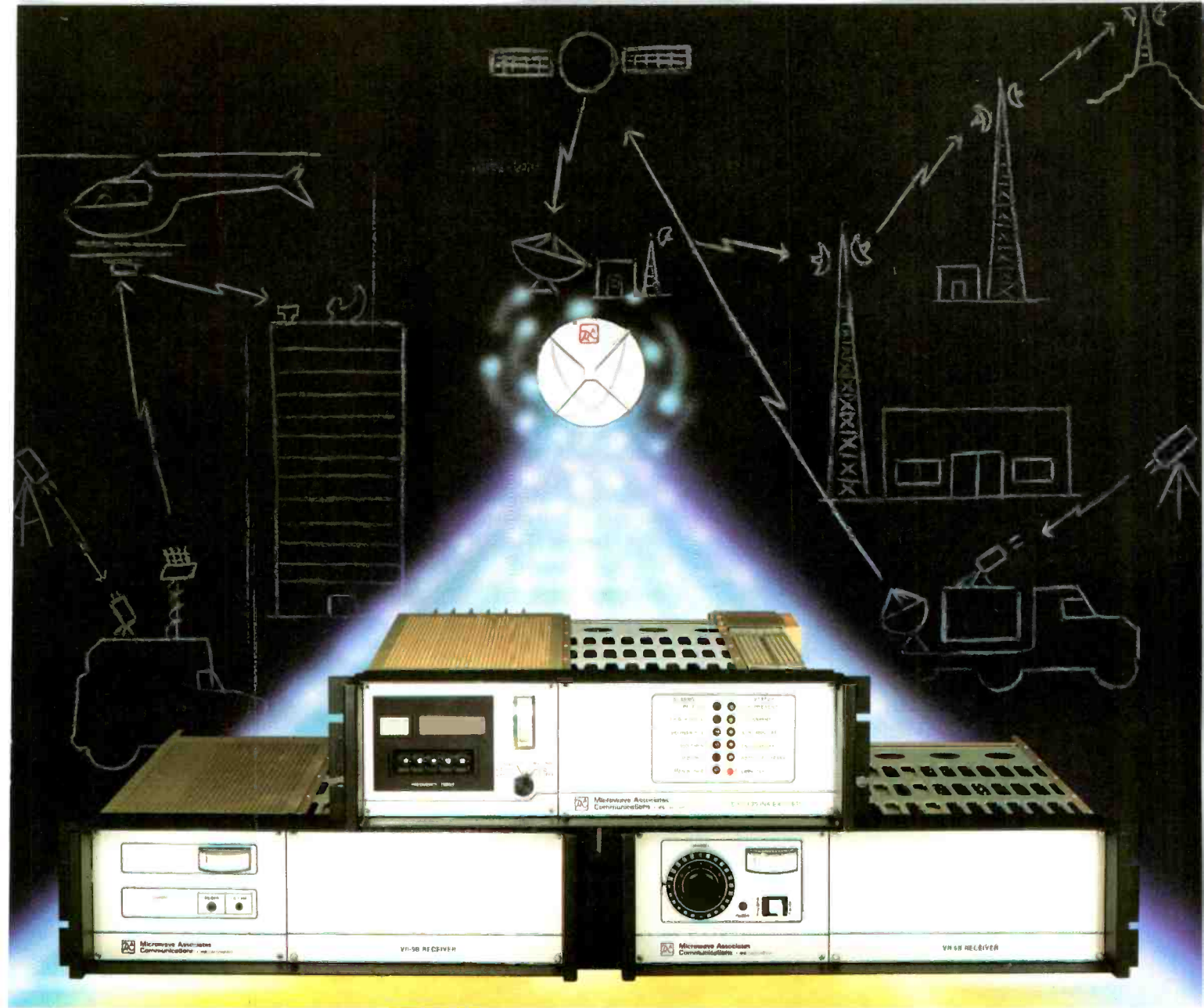

Make your Earth Station System part of a greater design.

If you're looking to get a new broadcast system off the ground, or expand the reach of an existing system, MAC engineers will supply the equipment configurations that are just right for your growing needs. We design, engineer, install and service every part of the total earth station system. To provide you with single-supplier accountability that brings down costs, improves operating efficiency and speeds up service. And MAC can integrate an earth station with a terrestrial microwave network to take care of your entire signal distribution system.

Our new VR-5B and VR-6B frequency agile receivers are the heart of any state-of-the-art earth station

system. The products of over thirty years of microwave experience, they feature full 24-channel capability, broadcast quality performance plus a built-in digital demodulator not found in any other receiver.

Our VE-6B Uplink Exciter is equally important to your earth station system. A frequency agile, high power exciter, it delivers up to +21 dBm output in the 5.925-6.425 GHz C-band. When we put these components together with the right amplifiers, antennas and custom-designed switching equipment, you get the most versatile reliable earth station system available.

All this advanced technology will bring you years of trouble-free performance; but should you ever need it,

there's our seven day, 24 hour service capability. One phone call brings fast action from your single source supplier. Like our systems approach, it's just part of a greater design to keep you broadcasting more efficiently, effectively and reliably. For more information call the Broadcast Division at (617) 272-3100 ext. 1806 or write us at 63 Third Avenue, Burlington, Mass. 01803

See us at the NAB Show -
Booth No. 1401

 Microwave Associates
Communications

COMPANY
Circle (102) on Reply Card

NAB exhibitors

EEV Inc. (Booth 925)

Products: Electron tubes for Electro-optical, transmitting/receiving display includes Leddicons, Vidicons, Klystron amplifiers, character display tubes, cathode ray tubes, triodes/tetrodes and special purpose detector tubes, diode gun Leddicons, diode gun low output capacitance narrow scan Leddicons, high efficiency amplifier Klystron for UHF transmitter applications.

Circle (464) on Reply Card

see ads on pages 14, 16, 159, 196

EG&G (Booth 1710)

Products: High intensity obstruction lighting systems.

Circle (452) on Reply Card

E-N-G Corporation (Booth 1637)

See at booth.

Circle (453) on Reply Card

ESE (Booth 208)

Products: Solid-state digital clocks and timers, master clock systems, programmable timers, time code generators and readers, audio level indicators, ES790 programmable

timer, ES254 SMPTE time code reader.

Circle (454) on Reply Card

see ad on page 271

Eastman Kodak Company (Booth 1118)

Products: Motion picture products for program origination, post-production and distribution of television programming.

Circle (455) on Reply Card

ECHO lab (Booth 625)

Products: Color special effects generator, budget special effects generators, eight input sequential switcher with motion detector, time date generator, source identifier, 12 input color special effects generator.

Circle (456) on Reply Card

see ad on page 252

Edcor (Booth 205S)

See at booth.

Circle (457) on Reply Card

see ad on page 174

Edutron Inc. (Booth 1815)

Products: ccd-1h video time base corrector for distribution applications, ccd-2h series video time base correctors for post-production applications, video time base correctors.

Circle (458) on Reply Card

Eigen Video (Booth 1113)

Products: Color videodisc/recorder,

Circle (459) on Reply Card

Elcom Specialty Products Inc. (Booth 419)

Products: AM/FM speech processing equipment, AM combining equipment, AM/FM transmitters, audio consoles.

Circle (460) on Reply Card

Electro Controls (Booth 1100)

See at booth.

Circle (461) on Reply Card

Electrohome Limited (Booth 1003)

Products: D2000 color studio monitor 19" and 25", monochrome video monitors 9" to 23", rack mount monitors 9" to 17", color monitor.

Circle (462) on Reply Card

Electro Impulse Inc. (Booth 1130)

Products: DACT-7.5KFM, DPTC-25KFM, DPTC-50KFM, CPM-30K.

Circle (463) on Reply Card

Building Blocks for System Automation

17 NAB 33B

How would you like computerized videotape editing, automatic program start/stop & VTR switching, and automatic window dub production? Too expensive? Not with CVC's "Building Block" approach to system automation.

It's All In The Cards

Begin with CVC's micro-processor-based Intelligent Controller™. Plug in the Controller card, and you have machine control. Touch a button, and the Intelligent Controller automatically inserts time code and puts your VTRs in the appropriate recording mode.

Add CVC's Keyer and Reader cards, and you can burn in a window so you can position SMPTE, machine status, X's play, and other data on the monitor.

Plug in CVC's Synchronizer card and you can lock video to video, or video to audio.

The Lightfinger™ Touch

So far, you've got machine control and synchronization. Add the exciting new CVC Lightfinger Edit module, and you're ready for computerized editing.

Anything from a simple SMPTE writer to two-machine editing — that's CVC's "Building Block" approach. All within the same Intelligent Controller unit!

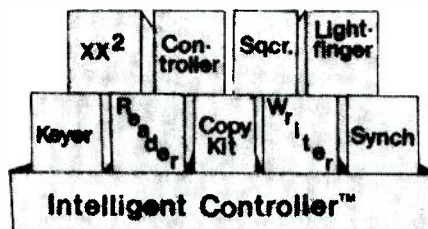

Circle (103) on Reply Card

Begin Building Today

CVC's modular approach and advanced microelectronics allow you to begin building your system today. Without worrying about obsolescence tomorrow. To add to or upgrade your system, you simply plug in a card. That's affordable automation. And, our user-oriented software makes using the Intelligent Controller easier than you might think.

Find out more. Call or write for more information and the name of your nearest dealer:

CVC

Control Video Corp.
578 Division Street
Campbell, CA 95008
(408) 866-7447

BARCO's new series Master Control Monitors: tailored to your needs

CTVM 3 Colour monitors.

In order to satisfy the variety of monitor applications the CTVM 3 series allows you to choose your colour monitor corresponding exactly to your specific wishes regarding screen size, CRT type, resolution, special facilities, decoders and mechanical construction.

- Screen sizes: 37 cm (15") or 51 cm (20") screen.

- Cathode ray tubes: delta gun shadow mask CRT or slot mask CRT.

- Resolution (for delta gun): Standard, semi high or high resolution.

- Versions:

The A version incorporates special facilities such as pulse cross mode, notch filter, split screen, RGB switches, RGBS output, R-Y and B-Y output.

B version: without special facilities.

- Decoders: with an optional set of decoder printed circuit boards plugged in, the CTVM 3 accepts composite NTSC; PAL or SECAM signals (Comb-filter or aperture correction optional on NTSC version).

- Mechanical construction: conversion from cabinet to rack, VTR bridge, in-wall or ceiling mounting is easily accomplished without dismantling the monitor through the optional special mounting kit.

TVM 3 monochrome monitors.

The BARCO professional monochrome monitors are measuring instruments for use in broadcasting, industrial and educational applications where quality and reliability are most required.

Facilities to be essential including colour subcarrier filter, pulse cross, size switch, remote control, internal/external sync. offer broadcast-oriented operating features and controls.

As regards to the CRT a choice is offered between WA (6500°K illuminant D) and W (9.300°K) phosphors. Screen size and mechanical construction can be chosen as with the colour monitors.

ROHDE & SCHWARZ SALES CO. (U.S.A.) INC.

14, Gloria Lane, Fairfield, NJ 07006

Phone: (201) 575-0750

Telex: 133310

Sole representative for Barco Professional Video Systems Dep. in the United States.



See Us at NAB Booth 1110

BARCO

Circle (104) on Reply Card

ANTENNA IMPEDANCE MEASUREMENTS WITH INTERFERENCE IMMUNITY

The Model SD-31 Synthesizer/Detector Is...

- ... designed for antenna impedance measurements in presence of strong interference
- High-level oscillator compatible with General Radio 916 Series, 1606 Series, and Delta OIB-1 Impedance Bridges
- Special coherent detector circuit rejects interfering signals during measurements
- Crystal controlled frequency, variable in 500 Hz steps from 100.0 kHz to 1999.5 kHz
- Receiver for detector can be external or optional built-in RX-31
- Powered by rechargeable batteries
- Self-contained portable package
- Field proven
- Versatile — can use as an RF signal generator for troubleshooting antenna systems; as a variable frequency oscillator for antenna site survey; or other applications requiring a precise frequency source

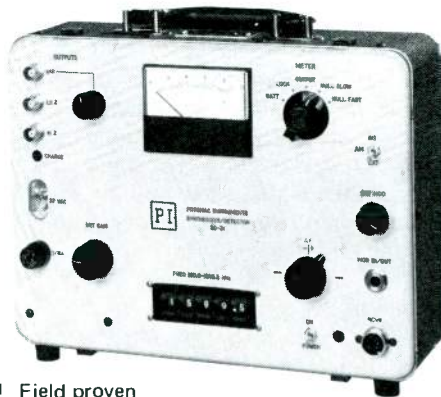

CONTACT US FOR DETAILS.

POTOMAC INSTRUMENTS

932 PHILADELPHIA AVE.
SILVER SPRING, MD. 20910
(301) 589-2662

Circle (105) on Reply Card

SÃO PAULO
MELBOURNE
LONDON
MONTREAL
RAYMOND
RAYMOND?

Yes, Raymond, Maine. If you're DXing with ham friends in Buenos Aires or checking signal strength at TV networks in New York, chances are you know about Raymond, Maine. That's where Dielectric makes RF Wattmeters and Load Resistors of exceptional durability and quality and for every industrial, commercial and amateur need.

You can rely on the folks from Northern New England who still have old fashioned ideas about integrity, craftsmanship and service. That's why our RF Wattmeters are valued for accuracy, that's why our Load Resistors are dependable in continuous operation at maximum rated power and warranted for 2 years.

Call us, toll free, for the name of your local distributor. We have people 'round the globe ready to serve you... with a smile.

Integrity and Craftsmanship... a New England Tradition

See us at NAB, Booth 1507



RAYMOND, MAINE 04071 / 800-341-9678 / TWX 710-229-6890 / 207-655-4555

Circle (106) on Reply Card



NAB exhibitors

The Electronic Eng. Assoc. (Booth 1807)

See at booth.

Circle (465) on Reply Card

Electro & Optical Systems, (Booth 1511)

Products: General purpose multi-standard and receiver monitors, time code generators, readers, calculators and time code machine synchronizers.

Circle (466) on Reply Card

Electro Voice (Booth 1816)

See at booth.

Circle (467) on Reply Card

see ads on pages 95, 32

Electronics, Missiles & Communications Inc. (EMCEE) (Booth 1017)

Products: Television translator, television transmitter, MDS transmitter and amplifier.

Circle (468) on Reply Card

see ad on page 223

Emil Ascher Music Inc. (Booth 2225)

See at booth.

Circle (469) on Reply Card

English Electronics Corporation (Booth 1018)

See at booth.

Circle (470) on Reply Card

Enterprise Electronics Corporation (Booth 1820)

Products: Color weather radar equipment.

Circle (471) on Reply Card

Enterprise—Radio (Booth 120)

See listing on pages 181-2.

Circle (472) on Reply Card

Eventide Clockworks Inc. (Booth 177S)

Products: Harmonizer model H949, BD 955 broadcast digital audio delay line, real time third octave audio spectrum analyzers interface with: Commodore PET, Radio Shack or Apple computers.

Circle (473) on Reply Card

see ad on page 255

Fairchild Camera and Instrument Corporation (Booth 1315)

Products: CCD delay lines, CCD line sensors for Telecine, CCD one-chip color camera.

Circle (474) on Reply Card

The World is turning to TerraCom's TCM-6 for Microwave Reliability and Performance

AUSTRALIA, CANADA, COSTA RICA, DENMARK, ENGLAND, FRANCE, GERMANY, GREECE, INDIA, IRELAND, JORDAN, KOREA, MEXICO, NORWAY, OMAN,
PANAMA, PHILIPPINES, PUERTO RICO, SAUDI ARABIA, SWEDEN, SWITZERLAND, TAIWAN, THAILAND, UNITED STATES, YUGOSLAVIA.

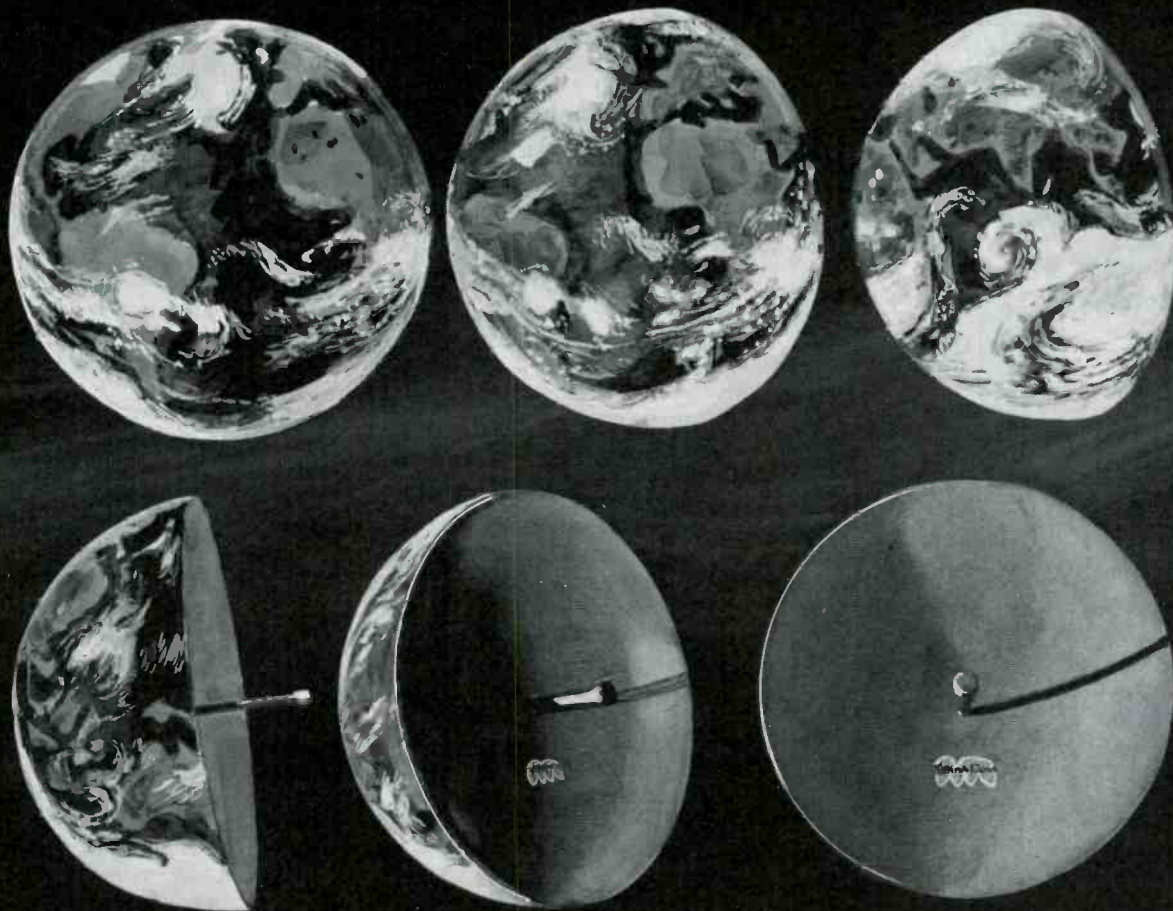

It's No Surprise

... That the world's most versatile microwave radio has made so many friends. Not only friends among broadcasters worldwide, but friends in telecommunications and data handling, too. Here's why: Our TCM-6 is tunable across each band from 1.7 to 15.35 GHz — change bands with plug-in RF modules — color video with FM subcarrier channels — both portable and fixed operation — simplex, duplex and diversity operation — and options such as DC operation, low noise amplifier, video protection switch and hot standby switching.

For information and specifications, contact TerraCom's Marketing Department.

TerraCom, 9020 Balboa
Avenue, San Diego, CA 92123.
(714) 278-4100
TWX: TERRACOM SDG 910-335-1202
TLX: TerraCom ASDG 18 2774

See us at NAB Show -
Booth No. 1043.

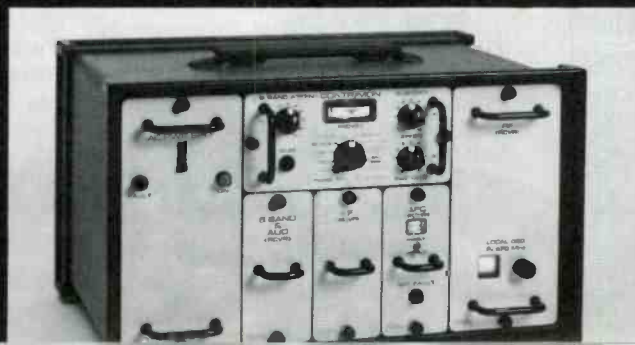

Loral Corporation

Circle (107) on Reply Card

ANTENNA & TOWER Guys & Ropes

- Light Weight - High Strength (Steel's Strength at 1/5 the wt.)
- Lower Installation Costs
- Non Metallic Fiber
- Excellent Dielectrics
- Non-Conductive
- Non-Reflective
- No Corrosion



ARAMID KEVLAR®
Ropes, Guys, Lines & Cables

CORTLAND

ADVANCED PRODUCTS DIVISION

CORTLAND LINE COMPANY

P O BOX 1362 ■ CORTLAND, NEW YORK 13045

Phone: (607) 756-2851

KEVLAR® Du Pont registered trademark

Circle (108) on Reply Card

NAB exhibitors

Faroudja Laboratories Inc. (Booth 1712)

Products: Record-Ex, the Image System, comb filter separators.

Circle (475) on Reply Card

Farrtronics Ltd. (Booth 1723)

Products: Audio patchfields, intercom systems, belt packs, audio distribution amplifier, audio consoles.

Circle (476) on Reply Card

Fernseh Inc. (Booth 1208)

Products: Compositor I graphics system, Mach One videotape editing system, KCK studio camera, KCP-60 studio camera, BCN-5 1" portable VTR (cassette), BCN-20 1" portable VTR, BCN-51 1" studio VTR, BCN-100 1" multi-cassette VTR, TMM-205 optical multiplexer, FDL-60 digital telecine system, TDF-2 digital noise filter, TCS-1 machine control system, Automax machine control and switching system, KCA-100 ENG cameras, TVS/TAS-1000 video/audio distribution switcher, sync generators and terminal equipment, FPT-4000 16/35 mm telecine projector, telecine color correction system (frame-by-frame) pan scan option for FDL-60 telecine system, full line of video monitors.

Circle (477) on Reply Card

Fiberbilt (Booth 1817)

Products: Shipping cases, cabinets and racks.

Circle (478) on Reply Card

see ad on page 10

Fidelipac (Booth 204)

Products: Broadcast audiotape cartridges, Blank-It audio and videotape eraser, model 390 wow & flutter meter, cartridge standard test and calibration tapes, gauges, cartridge racks, studio warning lights, delay carts, and other cartridge accessories, Audio-Technica line of ATP professional phonograph/cartridges.

Circle (479) on Reply Card

Film/Video Equipment Service Co. (Booth 1818)

Products: Portable Energy Products' sealed lead acid battery packs, belts and chargers; kangaroo video packs; Cinema Products equipment.

Circle (480) on Reply Card

see ad on page 138

Filmways/Heider Recording (Booth 322)

See at booth.

Circle (481) on Reply Card

Fitz-Gerald & Associates (Booth 6265)

See at booth.

Circle (482) on Reply Card

Flash Technology (Booth 931)

See at booth.

Circle (483) on Reply Card

For-A Corp. of America (Booth 1826)

Products: ALC-4100 new automatic level controller, CCS-4200 color corrector, FVW-910 and CC-910 video writer, VD-103 and VD-106 video distribution amplifier TSG-5000 sync generator, CB-5000 color bar generator, BC-5000 back color generator, VITC generator/reader, 1/4-inch VTR and remote control box, VTW-600 new video typewriter.

Circle (484) on Reply Card

Fort Worth Tower Company (Booth 819)

Products: Earth station antennas, towers, prefabricated equipment buildings.

Circle (485) on Reply Card

Frezzolini Electronics Inc. (Booth 1608)

Products: Portable lighting equipment, power belts and on-board batteries, line-isolated fast chargers, associated equipment manufactured for OEM and replacement service, Frezzi-flex model FR-16 single/double system camera, Nickel-cadmium and sealed lead on-board batteries, regulated power supplies for most ENG cameras.

Circle (486) on Reply Card

Fuji Photo Film, USA Inc. (Booth 1307)

Products: 2-inch Professional videotape and 1-inch Beridox videotape, U-matic cassettes, Beta and VHS cassettes, video head cleaners.

Circle (487) on Reply Card

see ad on page 161

Fujinon Optical Inc. (Booth 1117)

Products: BCTV lenses for 1- and 1 1/4-inch tubes, ENG/EFP lenses for 2/3-inch color cameras, ENG accessories, A30 X 11ESM lens for 2/3-inch ENG cameras, full line of electronic cinematography lenses.

Circle (488) on Reply Card

R for those suffering from high prices and delivery delays

the world's lowest-priced WFM & VSC . . . from the originators



WM310B \$995



VS310B \$1495

VS310B is not only an NTSC vectorscope ideal for camera-matching, but it offers full-bandwidth and chroma-only waveform display. It's also a 4mHz. serviscope. WM310B displays H, V, H-blanking, V-sync — full bandwidth, Y-only, chroma-only, plus variable VITS line selection. UA47 RackKit mounts up to 3 scopes in 5 R.U. height. UA50 RackKit mounts a 310-series scope with Panasonic WV5311 PCM.

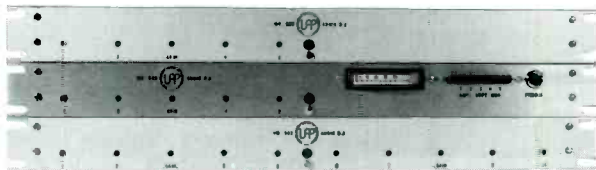

MR5x5 \$795
MR5x5M 995
MR5x52 1395
AUDIO DISTRIBUTION AMPLIFIERS

Incredible! MR5x52 boasts 10 audio D.As, each with 5 transformer-isolated outputs in but 1 R.U. height. MR5x5 offers 5 such amplifiers; MR5x5M includes vu metering and headphone monitoring. 40db gain, flat 30-20kHz., 72db S/N, 65db isolation, 1% max. distortion, 10k ohm xfmr. bridge or cost-saving 100k ohms unbalanced input. Gain presetable from front.

AM3 \$345
RACKMOUNT
AUDIO AMPLIFIER



Ideal for close-up monitoring and mobile facilities. 3 clean audio watts from a -20dbm line. Transformer input, 2 R.U. height, headphone disconnects speaker, inputs front and rear, smooth response.

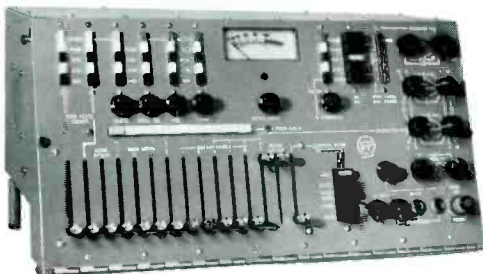

MixMaster™ MS-105 \$2995

The audio mixer/master-control with everything for the van and small tv studio. Voice-over with "ducking", group mastering, audition, cueing, paging, test and slating tones, slide-faders, 7 mic's and phono, 2 variable equalizers, compressor, 7 high-level inputs, accepts condenser mic's too, no tools for hookup, mounts in rack or 7" deskarm or tabletop, vu meter displays compression and levels, eliminates custom outboard facilities.

"audio is our middle name"

See us at NAB Booth 1819 & 1505



Ultra Audio Pixtec

Div. of Audio International, Inc.
 Post Office Box 921
 Beverly Hills, CA 90213 U.S.A.
 (213) 276-2726

Prices, styling and specifications subject to change without notice.

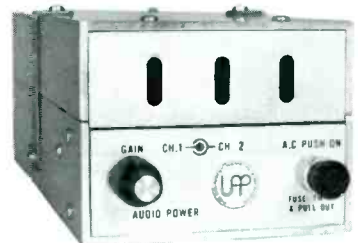

APA52 \$350

AUDIO POWER

The mighty mite where space is at a premium. Mount up to 3 dual-50 watt power amplifiers in 2 R.U. height . . . 300 audio watts in 3 1/2 inches! Flat response 20-20kHz., input 20k ohms balanced, 8 ohms load, 90db S/N. Lower-cost AP250 has unbal. input.

INDESTRUCTIBLE BATTERY-POWERED AUDIO MIXER



AMA41 \$595

A 12-volt (internal/external) battery-powered audio mixer. 3 mic. positions & a 4th mic/line input, 1kHz. oscillator; vu meter; recessed components in rugged case for protection against dropping and stomping; headphone jack (can feed unbal. load); "XL" transformer-input connectors, spring-post transformer-coupled 600 ohms output; flat 20-20kHz., 90dB gain; battery checking & fast replacement; low-freq. cutoff switches.

Worth Their Weight Worth The Wait

Pressure molded fiberglass transit cases, valise cases and extra-heavy-duty cases... lightweight, incredibly durable protection for your delicate electronic equipment. Now available in shorter lead times from our stock case catalog... 62 standard sizes from 9.8 X 5.5 X 5.0 inches up to 30.25 X 26.25 X 28.0 inches...



ENVIRONMENTAL CONTAINER SYSTEMS, INC.
3560 ROGUE RIVER HWY., P.O. BOX 188
GRANTS PASS, OREGON 97526
(503) 476-8871



Please see us at NAB Booth No. 408S

Circle (110) on Reply Card

NAB exhibitors

Gardiner Communications Corporation (Booth 1840)

Products: 5.6 meter satellite receive antenna, low noise amplifiers, satellite receivers, 18Vdc power supplies.

Circle (489) on Reply Card

Garner Industries (Booth 1100)

Products: Bulk audiotape erasers, bulk videotape erasers, audio duplicators, open reel.

Circle (490) on Reply Card

see ad on page 206

General Electric (Booth 1104)

Products: Tungsten-halogen and incandescent lamps for television production.

Circle (491) on Reply Card

see ad on page 259

The Gerstenslager Company (Booth 528S)

Products: Mobile television studio vans.

Circle (492) on Reply Card

see ad on page 52

Cliff Gill Enterprises (Booth 160)

See listing on pages 181-2.

Circle (493) on Reply Card

Glentronix (U.S.) Inc. (Booth 1824)

Products: Adams Smith model 605 tape synchronizer, Telcom Research time code generators, readers, portable units, Torpey controls and engineering clock systems, Scientel side band analyzers, Pentronics PB 1000 logic analyzer for ACR-25, Adams Smith model 1605 tape synchronizer, Telcom Research transmitter and monitoring fault report system, TC6010 very wide range for time code reader character inserter, TCG5500 low cost time code generator, TCR666 low cost time code reader, TCJ770 low cost jam sync time code generator, T5500 jam sync master time code generator, Torpey controls and engineering encoded machine control system, digital thermometer, time and temperature display unit, video clock SMPTE time.

Circle (494) on Reply Card

Alan Gordon Enterprises (Booth 1917)

Products: Video animation equipment, battery packs and chargers, camera equipment, film editors, filters, microphones and accessories, projectors, recorders.

Circle (495) on Reply Card

see ad on page 253



IT'S A SNAP

Portable Energy Products announces the PEP Snap Pack — the only snap-on power source available offering the advantages of sealed lead-acid batteries:

- No "memory effect."
- The battery maintains excellent voltage regulation even in extreme temperatures
- Plus low self discharge
- Increased reliability with fewer cells required for the power supply

The PEP Snap Pack only weighs five pounds. It attaches to standard keyhole mounting brackets via three quick release studs. And PEP's high

performance, two-step constant current maximizes battery life by preventing over charging.

These features plus Portable Energy Product's reputation for quality, reliability and service add up to make the PEP Snap Pack the most dependable snap-on power source available.

PEP

PORTABLE ENERGY PRODUCTS, INC.

1875 South Pearl Street
Denver, Colorado
303-778-8618

Circle (111) on Reply Card

Facts from Fluke on low-cost DMM's

Direct readings in decibels: Keeping track of your gains and losses.

If you'd rather forget about the last time you got wrapped up in an audio jungle, you'll want to respond to this ad.

Meet our new 4½-digit Model 8050A Multimeter — the first low-cost DMM with self-calculating dB features that let you keep your mind on your mission instead of on conversions and formulas.

While most analog meters read dBm referenced only to 600 ohms, the Fluke 8050A delivers direct readouts in decibels over a 108 dB range referenced to any one of 16 impedances (8 to 1200 ohms) with 0.01 dB resolution.

Push one button, and the microprocessor in the 8050A scrolls

through its reference impedances. Simply stop at the one that matches your system and get back to work. No more math; just action. And with the 8050A's relative reference feature you can measure gains or losses in dB throughout your system faster than you thought possible.

When you're dealing with voltage, current or resistance, an offset function provides a means of comparing stored inputs with all subsequent inputs, automatically displaying the difference. A real timesaver.

And there's more. True RMS measurements to 50 kHz; 0.03% basic dc accuracy; conductance (measures leakage and high resistance); extensive overload protection and safety features; a full line of accessories; and a low price of \$349 U.S.

For all the facts on how to maximize your gains with the 8050A, call toll free 800-426-0361; use the coupon below; or contact your Fluke stocking distributor; sales office or representative.



FLUKE



IN THE U.S. AND NON-EUROPEAN COUNTRIES: IN EUROPE: BE 3/81
John Fluke Mfg. Co., Inc. Fluke (Holland) B. V.
P.O. Box 43210 MS#2B P.O. Box 5053, 5004 EB
Mountlake Terrace, WA 98043 Tilburg, The Netherlands
(206) 774-2451 (013) 673 973
Telex: 152662 Telex: 52237

- Please send 8050A specifications.
- Please send all the facts on Fluke low-cost DMM's.
- Please have a salesman call.

Name _____

Title _____ Mail Stop _____

Company _____

Address _____

City _____ State _____ Zip _____

Telephone (_____) _____ Ext. _____

Circle (112) on Reply Card



You've already purchased your 3/4" equipment.....

Now how are you going to mount it?

Contact: HSC.

Our DVR (double vertical rack) has space for up to 4 of the largest 3/4" units (in groups of 2), and each unit is slide mounted for easy access. As for additional rack mount space, 10.5" has been allowed above and below the 3/4" mounting shelves for mounting peripheral equipment.

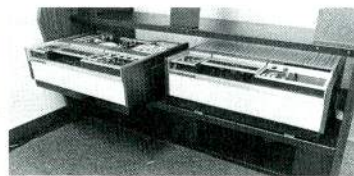

The DVR, like all SYSTEM 700 components is modular in design allowing you to build your complete production facility, Video and Audio using SYSTEM 700 products...Contact an HSC packaging engineer today for details.



How are you going to mount your TECHNICS M45 or any other non(19") component in a 19" rack?

Contact: HSC.

We offer over 300 different types of rack mounts for non(19") standard units. If you have a custom requirement we will be glad to help you...Contact a HSC packaging engineer today.



Whether your needs are tapped rails, rack mounts, 19" fillers and fasteners or a complete production facility...Contact HSC, your packaging specialists.

Now that you've purchased the equipment...Contact HSC to mount it!



PHONE NO. 312-452-5551

Circle (113) on Reply Card

NAB exhibitors

Gorman-Redlich Mfg. Co. (Booth 173)

Products: Digital AM antenna monitors for AM directional arrays, rack-mounted weather radios, EBS encoders and decoders.

Circle (496) on Reply Card

The Grass Valley Group (Booth 1210)

Products: 300 and 1600 series production and post-production switchers, 400 and 440 series routing switcher systems, M200 modular automation system, fiber optic link, 3250 SC/H phased sync generator system series, 3430V Video Delay DA, and other signal processing, distribution and synchronization equipment for both audio and video.

Circle (497) on Reply Card

The Great American Market (Booth 1628)

Products: Custom cases, RDS/HMI Fresnel and battery operated lights, The Great American pattern collection, SPE-2 special effects generator, The Scene Machine projector system, programmable sequencer, RDS/HMI 200W portable ENG lights, diamond light curtain.

Circle (498) on Reply Card

David Green Broadcast Consultants Corporation (Booth 125)

Products: Complete radio studio featuring components from companies represented by David Green.

Circle (499) on Reply Card

Gregg Laboratories (Booth 403)

Products: 2531 FM tri-band audio processing amplifier, turntable pre-amplifier, multiband television audio processing system with loudness controller, multiband AM audio processing amplifier, Telemix II, self contained telephone system.

Circle (500) on Reply Card

see ad on page 124

Merv Griffin Radio (Booth 400S)

See at booth.

Circle (501) on Reply Card

Groton Computer Inc. (Booth 118)

Products: Nationwide traffic, billing and business services, color displays on video screen, production services and buy back of unsold radio commercial time.

Circle (502) on Reply Card

H.M. Electronics (Booth 1509)

Products: VHF and UHF wireless microphones, antenna diversity systems for wireless microphones, wireless 4-channel intercom system, 4-channel field PAC receiver systems for field usage of wireless microphones.

Circle (503) on Reply Card

see ad on page 178

Hallikainen & Friends Inc. (Booth 514)

Products: TEL171 digital telemetry adapter for Moseley TRC-15A remote control, TEL172 digital telemetry adapter for Moseley PBR-30A remote control, TVA series audio mixing equipment for television, TAX161 time announce controller for automated radio, LOG series program logging systems, PCC series transmitter control microcomputers.

Circle (504) on Reply Card

see ad on page 154

Harris Corporation (Booth 301)

Products: Transmitters, live color TV camera (demo), TV antennas, AM and FM broadcast transmitters, AM stereo demonstration, AM-90, AM modulation monitor (demo), AM Phasor, FM antennas, maximum signal FM exciter (demo), modular audio control console (demo), 8-channel audio control consoles, 10-channel stereo audio control console, solid-state 5-channel audio control console, tape cartridge machines, audio processor with Tri-Band AGC (demo), Facilities Control system for radio or TV with CRT (demo), program automation systems (demo), FM audio composite processing unit (demo), remote SCA generator, precision professional turntable, live color TV camera, 16-channel digital control with modular audio control audio console, low band VHF TV transmitters, business automation system, medium wave transmitters.

Circle (505) on Reply Card

see ads on pages 41, 119

Harrison Systems (Booth 507)

See at booth.

Circle (506) on Reply Card

Karl Heitz (Booth 1809)

Products: PATHE 16mm and double super 8mm cine cameras, 15 x 6-90mm f/1.2 zoom lens, interchangeable C-mount lenses, 400 ft. magazine, KINOPTIK Achromats 16mm, 35mm cine/video lenses; GITZO dollies, GITZO microphone booms, GITZO video tripods with counterbalanced head, GITZO monopods, GITZO projection stands, platforms, GITZO light stands,

The Ultimate PORTABLE RECEIVER for wireless microphones now available with DYNEX option

The Cetec Vega Model 66 is the most advanced portable receiver in the industry. Designed for the professional sound user, the 66's compact size makes it suitable for mounting to leading portable recorders, both audio and VTR's. The unit, measuring just 5.4" W x 1.3" H x 6.25" D, operates from either internal 9V batteries or an existing DC voltage source.

For convenience, Cetec Vega now offers a portable system for multi-channel applications, the Model 151 Quad Case. This light weight, rugged case houses four complete Model 66 receivers, and has a built-in antenna splitter that feeds all four receivers from one detachable antenna. Power for the unit is provided by standard alkaline "D" cells or an external DC source.



Model 151 Quad Case

Model 77 Transmitter



 **Cetec Vega**
Division of Cetec Corporation

P.O. Box 5348 • El Monte, CA 91731 • (213) 442-0782 • TWX: 913-587-3539

Circle (114) on Reply Card

Video Delay Lines

ALLEN AVIONICS Video & Pulse Delay Lines replace 75 ohm coaxial cable, provide a more suitable method of achieving precise short delays. The units reduce size, weight, installation costs, and save time and effort in making delay changes.



- Finest Specs
- Lowest Pricing
- Delivery from Stock

Part No.	Delay Range (Nano-Sec.)	Delay Steps (Nano-Sec.)	Method of Variation	Maximum Insertion Loss @ 100 KHz (db)	Amplitude Flatness At Any Delay Setting 100KHz to 5.5MHz (db)	Max. Rise Time (Nano-Sec.)	Package Size (Inches)
VAR005	3-7	Continuous	Trimmer	.20	.2 Max.	N.A.	3 3/8 x 1 1/2 x 1 1/4
VAR011	0-11	Continuous	Trimmer & Toggle	.20	.25	N.A.	4 3/8 x 2 3/8 x 1 1/16
VP0010	0-10.5	.5	Toggle	.15	.2	3	4 3/8 x 2 3/8 x 1 1/16
VP0127	0-127	1.0	Toggle	.15	.3	14	4 3/8 x 2 3/8 x 1 1/16
VP0255	0-255	1.0	Toggle	.15	.3	16	4 3/8 x 2 3/8 x 1 1/16
VP0317	0-317.5	2.5	Toggle	.15	.3	20	4 3/8 x 2 3/8 x 1 1/16
VP0635	0-635	5.0	Toggle	*.50	.4	25	4 11/16 x 3 1/16 x 2 1/16
VP1100	0-1100	10.0	Rotary	1.25	.4	30	4 11/16 x 3 1/16 x 2 1/16
VP1270	0-1270	10.0	Toggle	*3.00	.4	30	4 11/16 x 3 1/16 x 2 1/16
VP2075	0-2075	25.0	Toggle	*3.00	.5	40	7 3/8 x 4 1/16 x 3 1/16
VS0315	0-315	5.0	Strap	.25	.4	28	4 x 2 x 1 1/4
VS0635	0-635	5.0	Strap	.60	.5	33	5 x 2 x 1 1/4
VS1275	0-1275	5.0	Strap	1.25	.5	33	5 x 3 x 1 1/4
VS2075	0-2075	25.0	Strap	2.50	.5	40	6 1/2 x 3 1/2 x 2

Impedance: 75 ohms.

*±.2db variation at any delay setting.

Pulse Distortion: Less than 4% with an input pulse rise time of 20 nanoseconds.

Working Voltage: 100 volts maximum.

Return Loss: 20db minimum. 15db minimum for VP2075 & VS2075.

Delay Tolerance: 5% or 1 nanosecond, whichever is greater.

VIDEO FILTERS: NTSC Lowpass, Band Reject & Bandpass are our specialties.

SEE US AT NAB - BOOTH 1633 • CALL/WRITE FOR CATALOG

ALLEN AVIONICS, INC.

224 EAST SECOND ST., MINEOLA, NY 11501
Phone: 516-248-8080

Circle (115) on Reply Card

THE ATHENA® 6000

For On-Line and Post-Production

A new 16mm telecine projector with everything, but a high price!

Multi-Frequency—Multi-Voltage—Multi-Use!

The new Athena 6000 telecine projector follows the L-W tradition of slo-mo, freeze-frame, instant stop/start and unlimited hold time, but also offers much, much more...

- Automatically syncs to camera frequency
- Multi-voltage for use world-wide
- Slo-mo and freeze-frame instant stop/start
- Cueing device to camera frequency
- Easy "turn-key" installation
- Designed for easy maintenance and long life

There is no other projector available at any price which offers all the features of the ATHENA® 6000 — yet the ATHENA® 6000 is priced well below what you might expect to pay.

Rate pulse generator for interlock is standard, as is synchronization with any frequency source between 35 and 70 Hz, which locks with NTSC, PAL or SECAM sync frequency to avoid shutter bar. The shutter drive motor will accept NTSC standard video sync, blanking and vertical drive signals.

The projector is totally modular, with each removable module containing all related electronics.

Dual lamps with automatic change-over and flashing warning light make life a little less frantic in the control booth and cueing device and instant "SHOW" function definitely make life easier for the busy engineer.

Ask us about the ATHENA® 4000—used world-wide for years as a post-production tool, for editing, transfer and on-line. Available in 110V or 240V models.



L-W INTERNATIONAL
6416 Variel Avenue
Woodland Hills
CA 91367 USA

Telephone: 213/348-8614
TWX 910/495-1714 LW INTL LSA

Circle (116) on Reply Card

NAB exhibitors

GITZO video tripods, GITZO leveling balls, GITZO fluid heads.

Circle (507) on Reply Card

Hitachi Denshi America, Ltd. (Booth 1404)

Products: SK-100 with computer set up, SK-96 convertible camera, SK-91 ENG-EFP camera, FP-60 professional studio camera, FP-50 compact professional studio camera, FP-40SS professional ENG camera.

Circle (508) on Reply Card

see ads on pages 3, 5

Howe Audio/BCP (Booth 438)

Products: 7012 stereo 12 channel console, 12-inch Magnum tower, Orban Optimod FM 8100A, QEI 691 FM modulation monitor, Micro Controls UXL-2001 uni-phase exciter/link, Kohler 7.5 kW, Technics turntables, Audio Technologies micro-amps, MCI tape recorder, Audiopak tape cartridges, Fidelipac cartridges, Saki Magnetic tape heads, Phillystran guy cables, CCA FM 2500R transmitter.

Circle (509) on Reply Card

see ads on pages 284, 226

Howell Labs (Booth 128A)

See at booth.

Circle (510) on Reply Card

(HEDCO) Hughes Electronic Devices Corp. (Booth 1635)

Products: Precision 75 Ω 0.1% terminations, Compact audio and video routing switchers, distribution equipment.

Circle (511) on Reply Card

IGM Communications (Booth 101)

Products: BASIC A Program Controller, Instacarts, Go-Carts 24, 42 & 78, Base 16 sequential programmer, CBSI billing, accounting, traffic system, two-way communications interface between program automation and billing, accounting, traffic system.

Circle (512) on Reply Card

Ikegami Electronics (USA) (Booth 817)

Products: Studio/field color TV camera, studio color camera, broadcast color television cameras, production CCTV color cameras, electronic cinematography camera, color telecine camera, high resolution color monitors, series 8 color monitors, ENG/EFP 2/3-inch prism camera, medium priced studio field camera,

A detailed photograph of the Ikegami HK-357A camera mounted on a tripod. The camera is a professional broadcast model, featuring a large lens assembly, a viewfinder, and various control panels. The brand name 'IKEGAMI' is visible on the front of the camera body. The camera is positioned on a tripod, and the background is plain white.

Ikegami's third microprocessor-controlled camera reduces registration set-up time and cost

The ideal camera for field broadcast television assignments must meet three major criteria. It must be air-ready moments after arrival at the camera site. It must deliver pictures of studio-quality color, crispness, and clarity. And it must be consistently reliable.

The Ikegami HK-357A meets those criteria in the field and is equally suitable as a studio camera. And it allows the camera crew to concentrate on creative aspects of their assignment instead of on time-consuming set-up and readjustment tasks.

Once on-site, the HK-357A requires hook-up to only three cables and power source. Then, a push of the microprocessor activate button automatically cycles it

through a check and recheck of all set-up and registration adjustments. This takes approximately 45 seconds per camera (up to six cameras can be handled). No external registration and chip charts are necessary because a test pattern projector (diascope) is built into the lens. Camera distance from the compact base station can be nearly a mile with triax, or 2,000 feet with TV-81 multi-core cable.

Because the HK-357A optimizes the capabilities of the newly developed Diode Gun Plumbicon[®], the picture output is of very high resolution, low lag, low noise and wide dynamic range. Dynamic Beam Stretch to reduce corner tailing; Geometric Correction for near-perfect registration; auto iris and auto white balance — all contribute to the superior color picture program output of this camera.

The HK-357A is notably versatile too. It offers selectable contrast compression levels; built-in chroma keyer; gen-lock to Sync and SC or VBS/BBS; and several other features, including an unusually compact CCU, optional RCU, tiltable and rotatable 7-inch high-resolution electronic viewfinder.

The performance record of Ikegami cameras at the major networks in the United States and around the world attests to their consistent reliability and long, trouble-free service life.

If you are upgrading, a demonstration may well reveal that the other cameras you've considered may already be obsolete when compared against the HK-357A.

Ikegami HK-357A

Visit us at Booth #817 at NAB.

Broadcast Products Division, Ikegami Electronics (USA) Inc., 37 Brook Avenue, Maywood, N.J. 07607; (201) 368-9171. West Coast: 19164 Van Ness Ave., Torrance, CA 90501; (213) 328-2814; Southwest: 330 North Belt East, Suite 228, Houston, TX 77060; (713) 445-0100; Southeast: 522 So. Lee Street, Americus, GA 31709; (912) 924-0061.

"No-Stretch"
Phillystran® HPTG

**the only
flexible
FIELD
PROVEN
electrically
transparent
tower-guy system**

- 1.** eliminates EMI and RFI at broadcast sites
- 2.** simplifies installation of AM, FM, AM directional and TV towers. Lightweight, flexible, yet as strong as extra-high-strength galvanized steel* . . . negligible creep, negligible elongation with new HPTG* for tension-once and walk-away installations.
- 3.** maintenance free. Non-conducting, non-corroding, nonmetallic. No internal corrosion. No white-noise arcing across insulators. No insulators required.
- 4.** no more expensive re-guying.

*Comparative stress-strain data and information about other physical properties available on request.

**Call/write for:
10 REASONS WHY
YOUR BEST BUY IS
PHILLYSTRAN®
and the new
PHILLYSTRAN® HPTG**



20 Commerce Drive
Montgomeryville, PA 18936
(215) 855-8450

*a small company
doing big things worldwide
in a quiet way.*

Circle (118) on Reply Card

NAB exhibitors

digital control studio/field camera, with full automatic set-up and triax capability, high resolution color monitor line.

Circle (513) on Reply Card

see ads on pages 47, 67, 143

Illinois Cable (Booth 2015)

See at booth.

Circle (514) on Reply Card

Image Resource Corporation (Unasigned)

Products: Videoprint systems.

Circle (515) on Reply Card

Image Video Limited (Booth 1822)

Products: Master Control switchers, routing switchers audio, audio follow video—multilevel, machine assignment system microprocessor control, various microprocessor control panels for routing and machine assignment systems, audio jack-fields, status CRT display system, program timer, routing switcher, microprocessor controlled master control switcher, machine assignment systems.

Circle (516) on Reply Card

Impact Case Sales (Booth 1724)

See at booth.

Circle (517) on Reply Card

Imero Fiorentino Associates (Booth 523 S)

Products: Videocassette instructional series on television lighting, staging and make-up techniques.

Circle (518) on Reply Card

Industrial Sciences (Booth 1115)

Products: 902 video production switcher, 1200 series video production switcher, master control systems, 200 series video production switchers, terminal equipment.

Circle (519) on Reply Card

see ad on page 247

Information Processing Systems of California (Booth 1908)

Products: IPS weather satellite recorder, color graphics system.

Circle (520) on Reply Card

Inmark (Comet) (Booth 439)

Products: Vacuum capacitors.

Circle (521) on Reply Card

Innovative Television Equipment (Booth 1405)

Products: ENG/EFP/studio camera support dollies, tripods, pedestals, pan/tilt heads and accessories, fluid heads, new tripods and a new portable counter balance pedestal for EFP application.

Circle (522) on Reply Card

Inovonics (Booth 214)

Products: Audio processing equipment—audiotape recording electronics, tape recorder tension servo kit, the Gordon Headroom Meter, acoustic analyzer, tape recording electronics.

Circle (523) on Reply Card

see ad on page 97

Integrated Sound Systems (Booth 2013)

See at booth.

Circle (524) on Reply Card

Interand (Booth 929)

Products: Telestrator, Electrart, Tapas, Telestrator auto probe II.

Circle (525) on Reply Card

International Tapetronics (Booth 501)

Products: Audiotape cartridge machines, reel-to-reel machines, eraser/splice/locator, library storage device, reel-to-reel reproducers and recorders.

Circle (526) on Reply Card

see ad on page 53

Jatex Inc. (Booth 1639)

Products: Editing controller, time code character generator, roll editing controller, rack-mounted black burst generator, rack-mounted color bar generator.

Circle (527) on Reply Card

Jefferson Data Systems (Booth 1613)

Products: Electronic news processing, in-station sales/traffic and general accounting system.

Circle (528) on Reply Card

Jam Creative Products Inc. (Booth 121)

See at booth.

Circle (529) on Reply Card

Jenel Consultants Corporation (Booth 1813)

Products: Consultants to broadcasters, cable, earth station owners, industry; complete facility design; cable communications system; data



Dual channel mix



Character Flip/Rotation

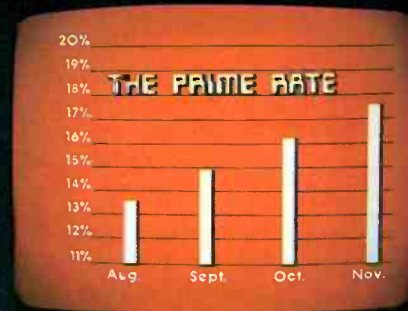

Charting capability

Team	W	L
Philadelphia	15	3
New York	12	4
Boston	10	5
New Jersey	8	11
Washington	7	11

Static headline, changing copy



Key/board logo compose



Left and right italics

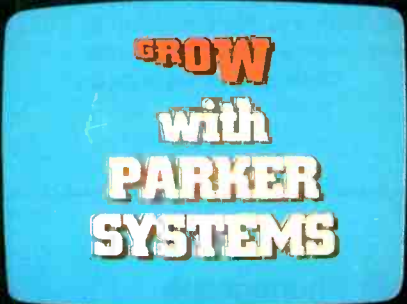

25% and 50% character reduction

State Senate 5th District 20% Pcts.			
Ward	D	Count	Pct.
Ward	D	99,876	39%
Roberts	R	84,756	34%
Jameson	I	67,543	27%

WEZY-TV Channel 6

Computer Election Interface

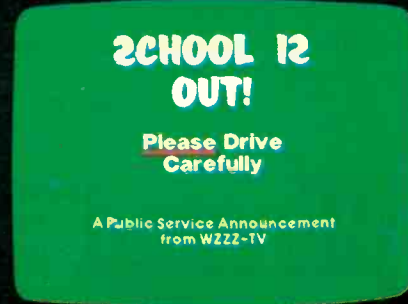

Character reversal

Many of our capabilities aren't even options on other graphic generators.

Which is the do-all, top-of-the-line graphics generator?

It may not be the one you think it is. Unless you specify the D-8800 Graphics Generator System from 3M.

It's the graphics system that gives you almost every creative capability you could want.

Such as the features you see above, photographed from a monitor using graphics generated from the D-8800 keyboard with no external hardware. And dual channel mix. Ten roll and crawl speeds. Eight mask positions. Both horizontal and vertical autocentering. Character reduction and italics

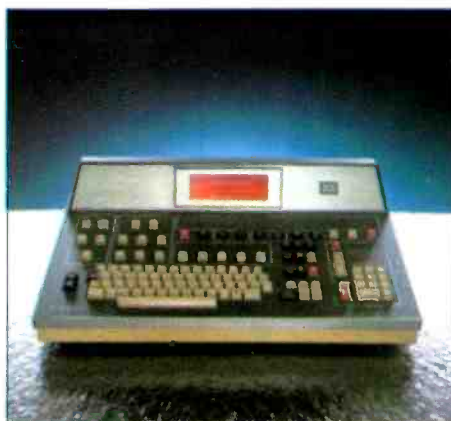

that give you hundreds of fonts to create and store.

And much more.

Plus the D-8800 talks to you in plain English, at the keyboard. Not in codes that so often take weeks, even months to learn to decipher.

Call 3M today at 612-733-8132 and ask for a demonstration. You'll quickly discover the D-8800 is your only real option. Or write on your letterhead to: Video Products/3M, Bldg. 223-5E/3M Center, St. Paul, MN 55144. In Canada contact 3M Canada, Inc., P.O. Box 5757, London, Ontario, N6A-4T1.

3M Hears You...

Circle (77) on Reply Card

NAB exhibitors

processing services.

Circle (530) on Reply Card
see ad on page 152

Jensen Tools (Booth 1833)

See at booth.

Circle (531) on Reply Card
see ad on page 202

KalaMusic (Booth 128B)

Products: KalaMusic-Matched Flow, KalaMusic-Category, KalaMusic-Lite Contemporary.

Circle (532) on Reply Card

Kaman Sciences/BCS (Booth 1419)

Products: Computerized traffic/billing system; news inventory program; demographics program; film inventory, amortization and programming program; audio/video cart inventory and allocation program, auto-switching interfaces.

Circle (533) on Reply Card

Kapco Communications (Unassigned)

Products: Battery pack.

Circle (534) on Reply Card

Kappa Systems Inc. (Booth 2025)

See at booth.

Circle (535) on Reply Card

Keith Monks (Booth 509S)

See at booth.

Circle (536) on Reply Card

Kings Electronics Co. Inc. (Booth 1026)

Products: RF coaxial and triaxial connectors, optical fiber connectors.

Circle (537) on Reply Card

Kliegl Bros. (Booth 923)

Products: Studio, location and remote television lighting and control equipment; portable lighting kits; HMI daylight luminaires; Kliegpac 9 portable dimming systems; 1550 series Klieglights; Performer and Performer II memory lighting control consoles, Command Performance memory lighting control console.

Circle (538) on Reply Card
see ad on page 126

Knox Video Products (Booth 1033)

Products: Character generators.

Circle (539) on Reply Card
see ad on page 80

LPB Inc. (Booth 402)

Products: Audio consoles, audio distribution amplifier, turntable pre-amplifiers, AM-FM compressor limiters, studio furniture, limited area AM broadcast transmitters and equipment, educational FM broadcast transmitters and equipment, transmitters.

Circle (540) on Reply Card
see ad on page 78

LTM Corporation of America (Booth 1016)

Products: Lighting, video accessories, audio mixers, sound accessories, microphone poles and microphone suspensions, compact light source.

Circle (541) on Reply Card

L-W International (Booth 939)

Products: Telecine projectors.

Circle (542) on Reply Card
see ad on page 142

Laird Telemedia Inc. (Booth 901)

Products: Optical multiplexers, video "Q" board, time/date generator, character generator, dual floppy disc memory, high resolution character generator, video pointer.

Circle (900) on Reply Card
see ad on page 86

Winsted

THE MATCHMAKERS
for the customized approach
to videoproduction centers.

1" VTR CONSOLE

Winsted's new model 3100 console is designed for space efficiency and operator convenience. VTR turntable rotates for complete machine servicing, viewing comfort. Monitor bridge adjusts in 1" increments. Several models available.

For full-line catalog of editing, production and dubbing consoles, tape and film trucks, film and videotape storage systems, call toll-free or write:

THE WINSTED CORP.

8127 Pleasant Ave. So.
Minneapolis, MN 55420
612/888-1957

See us at NAB Show Booth #823

Phone Toll-Free
1-800-328-2962



Winsted

Circle (119) on Reply Card

Stereophonic Phonograph PREAMPLIFIER MODEL PP-1

- 5-year unconditional warranty
- Made in U.S.A.
- "XLR" type output connectors
- Active balanced, 600-ohm output [with optional unbalanced or 600-ohm transformer balanced output]
- +4 dBm nominal output [+22 dBm maximum]
- RIAA response ± 0.5 dB
- Less than 0.25% THD
- Precision components and materials [1% glass capacitors, metal film resistors, epoxy-glass circuit board and similar quality in all areas]
- Self-contained power supply
- Dimensions: 6"x6"x3" [WxDxH]

\$425 ACTIVE
BALANCED

EAR SYSTEMS, INC.
PROFESSIONAL BROADCAST COMPONENTS

1807 Old Shay Court • Columbus, OH 43229
(614) 882-5205

Circle (120) on Reply Card

TOSHIBA'S PK-60 MAKES NEWS... THE SMALLEST, LIGHTEST NEWS/PRODUCTION BROADCAST CAMERA ON THE AIR. WITH A DIGITAL MEMORY THAT WON'T FORGET.

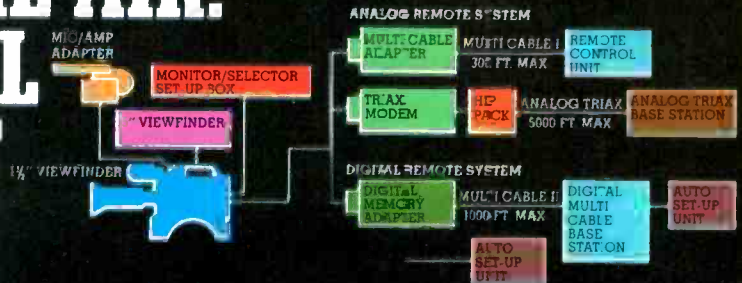

Here's the newest ENG/EP camera from Toshiba. Just right and so light for broadcast news. It's this combination of features that make the PK-60 a small standout.



- 9.4 lbs.
- Small Size
- Reduced Power — 20.6 watts
- Outstanding Stability
- Digital Data Loc
- Microprocessor-based Auto Setup Unit
- Digital/Analog Base Stations
- Triax/Wireless Transmission

Digital Data Loc is Toshiba's digital memory that can be preset by the engineer and travel to the action scene.

Toshiba's versatile PK-60 with advanced new circuitry, unbeatable overall performance and... Toshiba's celebrated quality.

Toshiba America, Inc.
Broadcast Electronic Systems Division
292 Gibraltar Drive, Sunnyvale, CA 94086
(408) 734-9172
Eastern Sales and Service
2971 Flowers Road South, Atlanta, GA 30341
(404) 458-9562

TOSHIBA
In Touch with Tomorrow

NAB exhibitors

Landy Associates, Inc. (Booth 1102)

Products: Dubner character generator.

Circle (543) on Reply Card

James B. Lansing Sound (Booth 203)

Products: Two-way broadcast monitor, two-way broadcast monitor with built-in power amplifier, automatic microphone mixer with input modules.

Circle (544) on Reply Card

LeBlanc & Royle Communications Towers Limited (Booth 1319)

Products: Communications towers, erection/installation services, commissioning and testing services, design engineering services, fabrication of towers, components, supply and commissioning, servicing of associated products.

Circle (545) on Reply Card

Lee-Ray Industries (Booth 1707)

Products: Audio/video and instrument carriers or carts, videoplay carts.

Circle (546) on Reply Card

Leitch Video Limited (Booth 1212)

Products: Sync/subcarrier phase monitors, NTSC sync generators, VPA-310P PAL video processing amplifier, master clock, digital and impulse clocks, digital test signal generator, NTSC video processing amplifier, PAL sync generator, APU-170 PAL automatic phasing unit, six output DAs and mounting frames.

Circle (547) on Reply Card

see ad on page 163

Lemo USA (Booth 1000)

Products: Connectors in coaxial, triaxial and multicontact configurations, triaxial television camera connectors.

Circle (548) on Reply Card

see ad on page 152

Lenco Inc. (Booth 1206)

Products: Videoscope, encoder.

Circle (549) on Reply Card

Lexicon Inc. (Booth 206)

Products: Model 93 Prime Time digital audio delay processor/mixer, model 224 digital reverberation system, model 1200 audio time compressor/expander.

Circle (550) on Reply Card

see ad on page 29

Libin & Associates (Booth 339S)

Products: Sanyo electrical products and Tri-flex indoor equipment.

Circle (551) on Reply Card

Lightning Elimination Associates (Booth 317)

Products: Dissipation arrays for antenna protection; surge eliminators for power lines; transient eliminators for phone lines, data lines, control lines; gey charge dissipation chokes, Kleanline electronic filtering systems, coaxial systems surge eliminators, surge eliminators for coaxial systems and transmission lines.

Circle (552) on Reply Card

see ad on page 126

Listec Television Equipment Corporation (Booth 1027)

Products: Vinten camera mountings, Digivision monitor prompters, Richmond audio consoles, Vinten ENG pan and tilt head; Vinten EFP extended range studio pedestal, Vinten remote pedestal, Digivision enhanced monitor prompters.

Circle (553) on Reply Card

see ad on page 166

Live Sound (Booth 127)

Products: Automated radio formats.

Circle (554) on Reply Card

STOP GROUND-LOOP HUM!

VIDEO HUM STOP COIL...HSC 1

Will ELIMINATE HUM and other INTERFERENCE in Video Lines caused by differences in Ground Potential.

- For Color and Black and White.
- FLAT-DC to 6.5 MHz.
- No Low-Freq. or Hi-Freq. Roll-off.
- No Differential Phase Distortion.
- No Differential Gain Distortion.
- No Envelope Delay.
- Passive Device - Failure Free-Low Price.
- Small Compact Package 4" x 4" x 2-1/4".

ELIMINATES HUM AND INTERFERENCE:

IN STUDIO

- Between Buildings
- On long runs in Buildings
- Between Studio and Transmitter
- On Incoming Telco circuits
- On Outgoing Telco circuits

IN FIELD

- Betw. Remote Truck and Telco
- Betw. Remote Truck and Microwave
- For Intertruck Hookup
- For VTR Units
- For Monitoring Lines

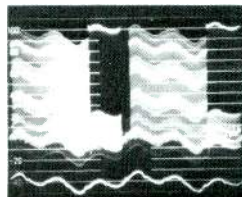

NEW!



\$170
F.O.B.
N.Y.

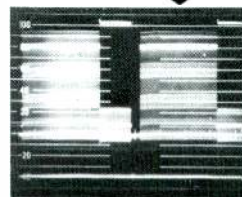

Available on
10 day free trial

AUDIO-VIDEO ENGINEERING COMPANY
65 Nancy Blvd., Merrick, N.Y. 11566
Tel. (516) 546-4239

Circle (122) on Reply Card

WORLD TOWER COMPANY INC.

Offering the Communications Industry
Total Tower Systems and Services
Fabrication, Installation and Maintenance
of AM-FM-TV-CATV Microwave Towers

Call or Write:

M. N. "NATE" SHOLAR, Owner
WORLD TOWER CO. INC.

P.O. BOX 405
Mayfield, Ky. 42066
Phone 502-247-3649

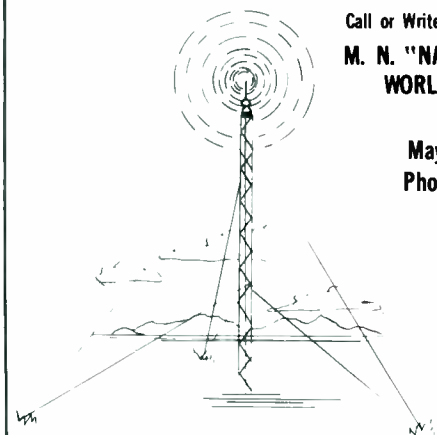

Circle (123) on Reply Card

To the audio professional, when a compressor or limiter is needed to tame the potentially disastrous consequences of uncontrolled level or to create special effects, one name stands out as the best: UREI.

Studio Standards for more than a decade, the compressors and limiters from UREI have earned their way into thousands of recording, mastering, and broadcast installations around the world.

Because we built our reputation for unparalleled professional performance and quality with our compressors and limiters, we have continuously advanced their engineering and technology to offer more reliability, features and performance. When you need the fastest, quietest and most flexible gain control instruments available, you can be totally assured that these products will prove to you why they've earned the title — Studio Standard:

The Model LA-4

A single channel, half-rack unit with patented electro-optical attenuator. Featuring smooth, natural sounding RMS action, it offers selectable compression ratios, a large VU meter, adjustable output and threshold levels and stereo coupling.

The Model 1176LN

A peak limiter which features adjustable input and output levels; individual attack and release time controls; selectable compression ratios; switchable metering; and

stereo coupling. The 1176LN is the most widely used limiter in the world.

The Model 1178

A two channel version of the 1176LN in a compact (3-1/2) rack mounting design. Featuring perfect tracking in the selectable stereo mode, it additionally offers selectable VU or Peak reading meter ballistics.

From One Pro To Another — trust all your toughest signal processing needs to UREI.

The UREI Compressor/Limiters



UREI From One Pro To Another

United Recording Electronics Industries
8460 San Fernando Road, Sun Valley, California 91352 (213) 767-1000 Telex: 65-1389 UREI SNVY
Worldwide: Gotham Export Corporation, New York; Canada: E. S. Goulet Marketing, Montreal

See your professional audio products dealer for full technical information.

Circle (124) on Reply Card

NAB exhibitors

Logica (Booth 175S)

See at booth.

Circle (555) on Reply Card

Logitek Electronic Systems Inc. (Booth 136)

Products: Custom audio series consoles, presettable up/down program timers, audio power amplifiers, audio level displays, audio distribution amplifiers.

Circle (556) on Reply Card
see ad on page 260

Lowel-Light Mfg. (Booth 1004)

Products: Location lighting equipment for television and motion picture applications, Lowel space clamp.

Circle (557) on Reply Card

Lyon/Lamb Video Animation Systems (Booth 439S)

Products: Video animation system, Video Rotoscope.

Circle (558) on Reply Card
see ad on page 232

McCurdy Radio (Booth 308)

Products: Air production console,

audio distribution systems, turntable assembly, intercom system, television production console, eight-mixer stereo console, 16-mixer stereo console, 24-mixer stereo console, digital ctl. intercom system.

Circle (559) on Reply Card

McMartin Industries (Booth 300)

Products: AM and FM transmitters; remote pickup equipment, audio consoles, stereo and SCA generators, stereo and monaural processors, FM exciter, SCA receivers, amplifier, FM modulation monitors, portable consoles, 50kW AM transmitter.

Circle (560) on Reply Card
see ad on page 61

MCI Inc. (Booth 133)

Products: Audio mixers, tape recorders and accessories, a broadcast production package.

Circle (561) on Reply Card

MCI/Quantel (Micro Consultants, Inc.) (Booth 1207)

Products: Digital synchronizer/TBC, digital production effects, digital standards converter, digital library system, digital framestore synchronizer/TBC.

Circle (562) on Reply Card

Magnasync/Moviola Corporation (Booth 1825)

Products: Videola film-to-tape transfer system.

Circle (563) on Reply Card

Magnum Towers (Booth 324)

Products: Welded tower sections from a 9-inch face to a 42-inch face.

Circle (564) on Reply Card

Marconi Electronics Inc. (Booth 927)

Products: EFP Color TV camera, broadcast television camera for studio/field use, helical tape machines, transmitter equipment.

Circle (565) on Reply Card
see ad on page 199

Marti Electronics (Booth 307)

Products: Aural studio-transmitter links for AM and FM stereo; complete ENG communications systems including mobile repeaters, automatic repeater stations, hand-held portable transmitters; 30-channel all-digital remote control system; two transmitter-studio links.

Circle (566) on Reply Card

Matrix Systems (Booth 152)

Products: Data General installed traffic/billing/accounting computer

Cam-Lok

"J" Series Connectors



MOISTUREPROOF

- Totally shielded contacts • Waterproof • 600 volt plus power conn. • XQJ 220 male & female: #2 to 2/0 cable • XQJ 204 male & female 2/0 to 4/0 cable. (colors available: black, red, white, blue or green). Contacts and insulators can be assembled anywhere. Assembled connectors withstand pulling force of 1,000 lbs. Contacts available for cable attachments by solder, crimp or mechanical method. Similar connectors are available that can be vulcanized for submerged waterproof use.

CABLE AVAILABLE

Fesco can also furnish 600 volt + cable from sizes #4 thru 4/0 in 25, 50 & 100' lengths and also in 500, 1,000 or 10,000' reels.

MADE UP UNITS

Fesco has in stock or will make to order any quantity of cable with any Cam-Lok connector, vulcanized or mechanically connected.

These connectors meet OSHA requirements and are approved by Madison Square Garden.



WEST COAST STOCKING WAREHOUSE
1634 COLORADO BL. LOS ANGELES CA 90041
(213) 254-9131 • TELEX: 69-6239

Circle (126) on Reply Card

NOW IN STOCK FOR IMMEDIATE DELIVERY

The Incredible New JVC
KY-2000 Color Camera
(3-Tube Saticon) **\$7,995.00**

TRADE IN THOSE OLD SONY BVU 200,
VO 2850 & VO 2860 for NEW SONY
BVU 2008 and VO 2860A
TOP ALLOWANCE OFFERED

TOP ALLOWANCE ALSO OFFERED FOR
SONY VO-3800, BVU-100, or BVU
50 FOR TRADE UP TO NEW SONY
PORTABLE RECORDERS VO-4800 or
NEW BVU-50 OR BVU 110

PRE-OWNED EDITING SYSTEMS

We have a large selection of re-conditioned Sony color video tape recorders, VO-2850's and VO-2860 (with warranty). Sold individually or as complete system.

- * (2) CEI color broadcast camera (Plumbicon) model 280 with Angenieux Lens. Good condition.
KY-2000 JVC color camera picture Call For Pricing.
- (1) JVC Color Camera KY-2000 with all accessories (Used) \$ 6,495.00
- (1) JVC Color Camera KY-2000 with all accessories (Demo) \$ 7,495.00
- (1) Hitachi Color Camera FP-40 3-Saticon with lens (Demo) \$14,995.00
- (4) Sony VO-3800 (reconditioned) \$ 1,395.00 ea.
- (2) Sony VO-2860 with Convergence ECS-1B/TT-5 \$ 7,995.00
- (1) Sony VO-2850A \$ 2,495.00
- (2) Sony VO-2850A with TRI-5 Editor \$ 4,995.00
- (1) Sony VO-2860 \$ 3,495.00
- (1) Sony VO-3800 (reconditioned) with new Sony color camera DXC-1600 \$ 2,995.00
- (1) Sony (EIAJ) Sto-Mo 1/2" B/W VTR model AV-3650 \$ 495.00
- (1) Brand New Sony Color Camera DXC-1600 (in original box) (Complete) \$ 1,495.00
- (1) Magnavox Color Camera CV-400 x/zoom lens \$ 495.00
- (2) Sony VO-2860 with RM-430 \$ 6,995.00 ea.
- (1) Used Ikegami Color Camera model ITC-240 with zoom and CCU \$14,995.00

CALL US FIRST for price quotes for new video equipment:
SONY, HITACHI, JVC, IKEGAMI,
3M MINCOM, CVS (HARRIS VIDEO),
LENCO, CONVERGENCE, TEKTRONIX.

PHONE TOLL-FREE 1-800-641-4674
IN MISSOURI CALL COLLECT (417) 862-5533
Bud Lines Cheryl McKinney Don Ingalsbe

.....WRITE FOR OUR NEW CATALOGUE.....

FROM
LINES VIDEO SYSTEMS
JEFFERSON AT McDANIELS
SPRINGFIELD, MO 65806

Circle (274) on Reply Card

Comark must be doing something right... you be the judge!

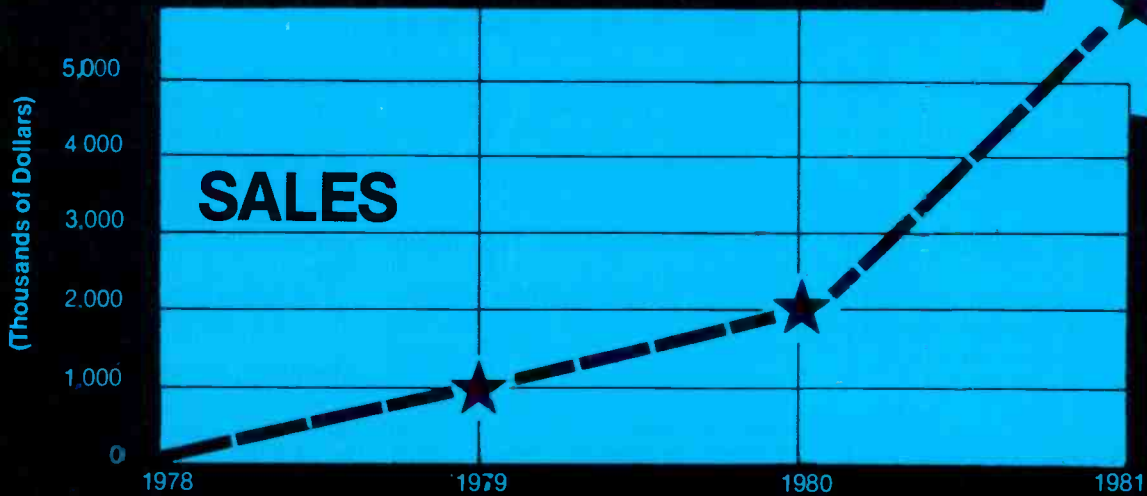

- ★ **1978** Comark introduces most efficient transmitter design
- ★ **1979** Comark installs most efficient transmitter plant in the world* at Tarpon Springs, Florida
- ★ **1980** Comark scores high in PBS report E8012 nine (9) point criteria for Optimum Efficiency Transmitter system... seven (7) out of nine (9) desirable features *isn't bad*
- ★ **1980** Comark stuns industry with introduction of Maximum Transmitter Plant Efficiency concepts
- ★ **1980** Comark advances Automatic Transmitter System concept with full local-remote computer control and advanced R.F. switching systems
- ★ **1980** Comark captures considerable portion of UHF-TV marketplace through innovative engineering and customer service

*Standard design not using mod anode pulser or other energy saving features



- ★ Comark will introduce the most modern, exciter, compatible, mod anode pulser available in the industry
- ★ Comark will introduce a complete VHF transmitter system product line
- ★ Comark will continue its on-going effort to improve the lot of the UHF broadcaster to compete profitably in the marketplace



COMARK COMMUNICATIONS, Inc.

Southwick Industrial Park Southwick, MA 01077
Phone (413) 569-5939 Int'l Telex 95-1012

Circle (127) on Reply Card

**SEE US AT
NAB
BOOTH 515**

NAB exhibitors

systems; self-installed traffic/billing software for CP/M microcomputer; music rotation software and systems; call-out music research software and systems.

Circle (567) on Reply Card

Matthews Studio Equipment (Booth 1806)

See listings on pages 181-2.

Circle (568) on Reply Card

Maxell Corp. of America (Booth 1832)

Products: 3/4-inch videocassette tapes, VHS and Betamax videocassette tape, audio recording tape.

Circle (569) on Reply Card

Media Service Concepts Inc. (Booth 227A)

See at booth.

Circle (570) on Reply Card

Merlin Engineering Works. (Booth 1128)

Products: Custom quadruplex VTRs, accessories for quadruplex VTRs, analog drop out compensator, refurbishing service for VTRs, ultra wide

band conversion for BCN-50 Fernseh 1-inch VTR, extended play conversion for Sony BVH 1100 and Ampex VPR-2, spindle height gauge for 3/4-inch U-matics.

Circle (571) on Reply Card

MICMIX Audio Products Inc. (Booth 406)

Products: Reverberation systems, audio signal processors, broadcast-oriented signal processing devices.

Circle (572) on Reply Card

Micro Communications Inc. (Booth 1108)

Products: Coaxial transfer switch, switching combiner systems, absorption filters, super high power TV diplexer, low power dual cavity TV diplexer, combiner-TV channel, integrated switching combiner, FM diplexer combiners, high power FM multiplexer, high power waveguide filterplexers, high power waveguide diplexers, high power combiners, waveguide switch, water load, power combiners, harmonic filters, notch filters, loop couplers, dual FM antenna, dual transmitter phase detector/circularly polarized FM compensator, VHF-TV antennas, and TV or FM antenna, low power

diplexers and combiners for VHF, UHF and MDS, power levels 10, 100W and 1kW, low power antenna for VHF-TV, high power UHF waveguide switches, 3-port, 4-port and 5-port.

Circle (573) on Reply Card

see ad on page 82

Micro Control Associates Inc. (Booth 310)

Products: Aural studio-transmitter links (Conventional), transmitter remote control systems, automatic transmitter and receiver switchers, sub-carrier generator and sub-carrier receiver, UniPhase link/exciter STL.

Circle (574) on Reply Card

see ad on page 64

Microdyne Corporation (Booth 1317)

Products: 5 meter antenna, 7 meter antenna, 5 meter transportable antenna 1100-TV (X24) B receiver.

Circle (575) on Reply Card

see ads on pages 187, 189,

191, 193, 195, 197

Microprobe Electronics (Booth 408)

See listings on pages 181-2.

Circle (576) on Reply Card

Microtime Inc. (Booth 1409)

Products: Digital video and video

MINIATURE CONNECTORS

Specify Lemo where connector size is the important consideration. Both coax and multicontact types are available.

Superb design and workmanship, ease of connection and disconnection, and ruggedness make Lemo...

the front panel connector.

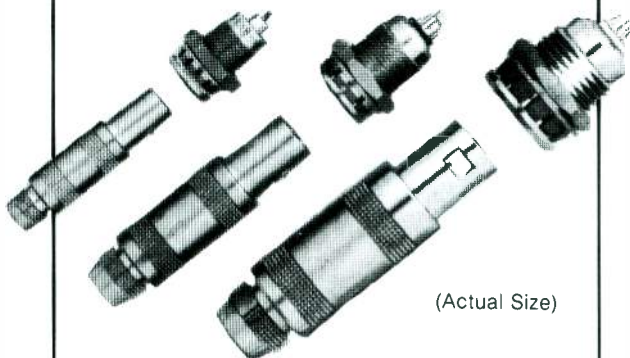

(Actual Size)

Please see us at NAB Booth #1000

 **LEMO USA INC.**

P.O. BOX 6626, SANTA ROSA, CA 95401 • 707/523-0600

Circle (128) on Reply Card

IF YOU NEED CONSULTING ENGINEERING OR DESIGNING SERVICES

for a specific problem or a complete communications facility, call Jenel for results. Jenel has many years of experience and state-of-the-art expertise to provide the finest in consulting engineering services.

For more information, write or

CALL JENEL

Visit us in booth 1813 at the NAB convention



Jenel Corporation

9550 Forest Ln. Suite 400/Dallas, Tx. 75243
(214) 343-1229

Circle (129) on Reply Card

Love at first sight...



**but it's the
performance that counts.**

GUARANTEED SPECIFICATIONS, 1 IN - 5 OUT VIDEO D.A. *

Non-Equalized:

Differential Gain and Phase at 5 MHz: 0.05%, 0.05° max.

Frequency Response (ref. 1 MHz): 100 kHz-5 MHz ± 0.1 dB, 8 MHz ± 0.15 dB, 20 MHz ± 0.5 dB

Hum and Noise: 65 dB RMS below 1 V p-p, 10 MHz bandwidth

Tilt: Less than 0.5% line and field

Common Mode Rejection: Greater than 60 dB, 50-400 Hz

Full Equalization - 1000 ft. of Belden 8281 (continuously adjustable 100-1000 ft.)

Differential Gain and Phase at 5 MHz: 0.1%, 0.1° max.

Frequency Response (ref. 1 MHz): 100 kHz-5 MHz ± 0.2 dB, 8 MHz ± 0.3 dB

Hum and Noise: 60 dB RMS below 1 V p-p, 10 MHz bandwidth

* Dual 1 in - 2 out and 1 in - 10 out models available. 75 ohm unbalanced or 124 ohm balanced inputs available on all models.

Write or phone for additional information.

DYNAIR

5275 Market Street, San Diego, California Telephone 714/263-7711 TWX 910/335-2040

Circle (130) on Reply Card

THE PRACTICAL LINE



PROGRAM LOGGER

Extends the cost savings and convenience of your program automation system to your program log, and works with most automation systems.



DIGITAL TELEMETRY ADAPTERS

Conversion kits for analog remote controls, offering foolproof meter readings and one man meter calibration.



TELEVISION AUDIO SYSTEM

Uncompromising fidelity, in rack-mount modules with easy-to-use audio-follow-video as a *standard* feature; an expandable system that can grow with your needs.



COMPUTER CONTROL

An automatic transmitter logging and control system that can do things *your way*.

See us at
NAB Booth 514



Hallikainen & Friends

101 Suburban Road
San Luis Obispo, CA 93401
(805) 541-0200

Circle (131) on Reply Card

NAB exhibitors

processing equipment, video synchronizers, digital time base correctors, signal processors, image enhancers, automatic video programming system.

Circle (577) on Reply Card

Micro-Trak Corporation (Booth 508)

Products: L Series furniture, 6618, 6445, 6455 audio consoles, D System, M series furniture and reel-to-reel cabinetry, 6405 phono preamplifier, 7116A, 7216A audio distribution amplifiers, ditty desk, tape cartridge storage racks, M series furniture line, 6411 stereo phone preamplifiers.

Circle (578) on Reply Card

Microwave Associates (Booth 1401)

Products: ENG microwave systems, helicopter ENG systems, studio to transmitter field links, intercity point-to-point microwave systems, satellite downlink and distribution systems, portable products for broadcast microwave bands, satellite transmit and receive earth stations.

Circle (579) on Reply Card

see ad on page 131

Midwest Corporation (Booth 1829)

Products: Mobile EFP and ENG vans.

Circle (580) on Reply Card

see ad on page 11

Mole-Richardson Co. (Booth 1008)

See at booth.

Circle (581) on Reply Card

Moseley Associates (Booth 505)

Products: Remote control systems, STL Links, AM/FM limiter, gain rider, stereo generator, SCA generator, SCA demodulator, remote pickup systems, microprocessor-based supervisory control system.

Circle (582) on Reply Card

see ad on page 56

Motorola Communications and Electronics (Booth 318)

Products: Spectra-TAC receiver voting system, Mitrek Super Console and Flexar base stations, series 80 remote/local control desk sets, Handie-Talkie radios, PAC-RT vehicular repeater, mobile radios, mobile telephone, communications systems analyzer, frequency-synthesized mobile radio.

Circle (583) on Reply Card

The Musicworks (Booth 323)

Products: Total service programming for radio, automated or live assist.

Circle (584) on Reply Card

NTI America (Booth 600S)

See at booth.

Circle (585) on Reply Card

Nady Systems (Booth 1839)

Products: Wireless systems for film and video production, FM systems for video production, mini-receiver systems for film and video production.

Circle (586) on Reply Card

Nagra Magnetic Recorders (Booth 510)

Products: Receivers, recorders, weather radar systems, logging recorders, meteorological chart recorders.

Circle (587) on Reply Card

Neal Ferrograph (USA) (Booth 504S)

See at booth.

Circle (588) on Reply Card

North East Automation Systems (Booth 220S)

See at booth.

Circle (589) on Reply Card

NEC America (Booth 1301)

Products: Digital mix effects, type C VTR, time base corrector, stereo television exciter, FM transmitter, frame synchronizer, Actiontrak digital strobe action, production switcher, camera, routing switcher, TVRO, processing AMPs, Dist. Amps.

Circle (590) on Reply Card

S. David Ness Studios (Booth 404S)

See at booth.

Circle (591) on Reply Card

Network Production Music Library (Booth 1615)

Products: Contemporary production music library.

Circle (592) on Reply Card

Newsan/McInnis-Skinner & Associates (Booth 720S)

Products: Wire service, script editing, assignment and scheduling, newscast production, archiving, weather, graphics, election reporting, remote terminals, Weather-graphics.

Circle (593) on Reply Card

OUR SATs BRING YOU A NEW SPECTRUM IN PROGRAMMING

The California Microwave Small Aperture Terminal (SAT) can make you a superstation in your market. From world news to sterec disco and the MET, the broadcast networks using satellite technology pioneered by California Microwave will deliver a new spectrum of program diversity and quality right to your local studio. And that means delivering audience, economically, anywhere in the country. Our modular SAT assures you unmatched flexibility at a surprisingly low cost with features such as these:

- Greater than 70 dB audio dynamic range
- Impeccable stereo delivery nationwide
- Cue, automation, hard copy, and wire service data channels
- Multiple channels per carrier (MCPC) for regional sports

The SAT that has set the standard for the broadcast networks and wire services is available now.

See us at NAB Booth #156.



**CALIFORNIA
MICROWAVE**

Circle (132) on Reply Card

CALIFORNIA MICROWAVE, INC.
990 Almanor Ave. Sunnyvale, Calif. 94086
(408) 732-4000 TWX 910 339-9231

Call Jim Smith Ext. 163

**THE BEST
FOR best**

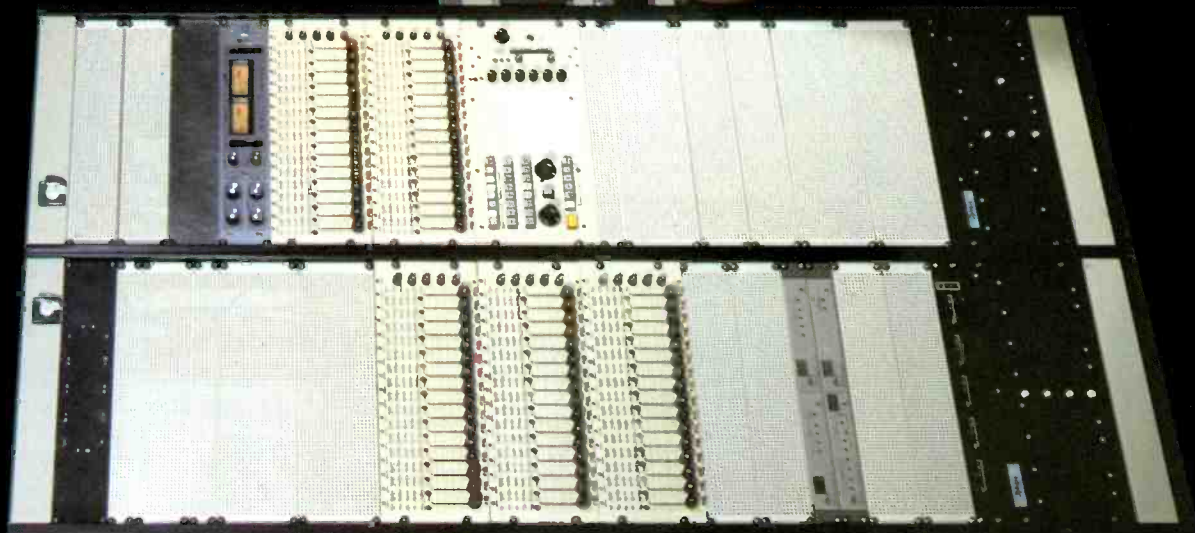

**IS
Sphere**

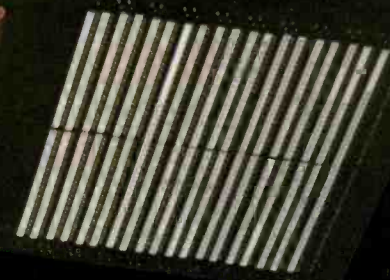

"To provide cost-effective remote audio facilities with equipment and personnel of the highest reliability and quality" *Best Audio Objective*

As best audio was being formed, we went to network and independent audio engineers/mixers and asked them what they would like to see in a remote audio truck. Their comments ... "more inputs" ... "flexible monitor control" ... "redundancy" ... "patching availability" ... "grouping" ... "submastering" ... "simple/fast setup" ... "no spaghetti factory" ... "more inputs" ... "full multi track recording capability" ... "multiple status flags" ... "more inputs" ... "more inputs" ... with these suggestions and more, we selected sphere to build the console picture above.

This console is the nucleus of our "cost-effective" remote audio facilities concept, which includes an exclusive 32 pair audio cable system, developed in conjunction with our sister company, Blake Wire and Cable Corp., and is backed by our extensive audio rental department. The best audio concept has been utilized effectively on such shows as "The Kennedy Center Honors," "The Presidential Inauguration," "The Golden Globe Awards," "The Diana Ross Special" and "The Academy Awards." We are sure that you will be as pleased with best audio as these distinguished clients continue to be.

best audio
BLAKE WIRE & CABLE

With a world of consoles at their feet, BEST AUDIO chose Sphere ... Why?

Sphere builds consoles like no other ... it's as simple as that. Outstanding electronic performance, rugged roadability and such care and craftsmanship that reliability has become the Sphere trademark.

On display in the BEST AUDIO truck at the Las Vegas NAB show will be our newest masterpiece for the industry ... a big Sphere type C TV Production Console with 48 inputs and 32 output buses.

Linked via extensive patching networks are six of Sphere's newest effort ... the 1604 Satellite mixer. Satellite is a 16 x 4 mini-console that takes up just 7" of rack space. Each Satellite can operate independently or bus feed any input on the main console. Satellite channel mutes and monitor solo are also part of the main system. That all adds up to a 144 plus input console that can handle any show imaginable with ease.

The big console features:

- Completely redundant power supplies with automatic, noiseless switchover.
- Discrete op-amps with a unique protection circuit that prevents system overload.
- Dual stereo mixing buses.
- 9 VCA groups plus 8 audio submasters.
- 5 programmable mutes on each input.
- Interchangeable equalizer formats ... a 3-knob, a 9 octave graphic or a 4 band true parametric.
- Each input has 3 pannable stereo sends and 4 mono sends (a total of 10 auxiliary sends).
- Extensive monitor switching.
- Completely modular construction.

We could go on and on (and will, given half a chance). If you don't see us at Las Vegas, write for more info. The more you know about a Sphere, the more you'll want one.

Sphere

ELECTRONICS INC.
THE GREAT AMERICAN CONSOLE COMPANY
20201-A PRAIRIE • CHATSWORTH, CALIFORNIA 91311
(213) 349-4747

Circle (134) on Reply Card

SHIVELY LABORATORIES CIRCULARLY POLARIZED FM ANTENNAS

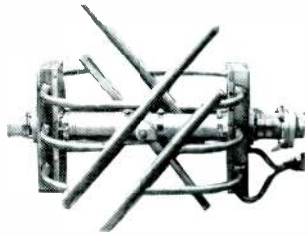

MODEL 6814 25KW PER BAY



MODEL 6810 10KW PER BAY



MODEL 6813 3KW PER BAY



MODEL 6811 1 KW PER BAY

RADOMES OR DEICERS
AVAILABLE FOR ALL MODELS

WRITE OR CALL FOR INFORMATION ON

ANTENNAS
TRANSMISSION LINE
FILTERS
PATCHING SYSTEMS
COAXIAL SWITCHES
POWER COMBINERS

SHIVELY LABORATORIES
A DIVISION OF HOWELL LABORATORIES
GIBBS AVENUE
BRIDGTON, MAINE 04009
(207) 647-3327

Circle (135) on Reply Card

NAB exhibitors

Nidus Broadcast Systems (Booth 432)

Products: Computer hardware and software programmed for radio.

Circle (594) on Reply Card

Nortronics, Recorder Care Division (Booth 401)

Products: Magnetic heads, replacement heads, broadcast cartridge and cassette recorders, series Performance professional recorder maintenance products.

Circle (595) on Reply Card

see ad on page 203

NOVA Corporation (Booth 1722)

Products: Universal tape cleaner.

Circle (596) on Reply Card

Fred A. Nudd Corporation (Booth 178S)

Products: Tower, antenna system, monopole and tower hardware.

Circle (597) on Reply Card

Nurad (Booth 1400)

See at booth.

Circle (598) on Reply Card

Nytone Electronics Corporation (Booth 1702)

Products: Flying Spot Scanner Systems, color slide reproduction.

Circle (599) on Reply Card

see ad on page 94

Oak Communications (Booth 1517)

Products: Over-the-air subscription TV systems and services, Alpha decoders, Sigma improved security decoder, Orion satellite security system.

Circle (600) on Reply Card

O'Connor Creative Service (Booth 115)

See at booth.

Circle (601) on Reply Card

O'Connor Engineering Laboratories (Booth 1122)

Products: Fluid heads and tripods.

Circle (602) on Reply Card

see ad on page 1

OKI Electric Overseas Corporation (Booth 1801)

See at booth.

Circle (603) on Reply Card

Oktel Corporation (Booth 1715)
Products: Direct color broadcast, slow motion and slide file disc recorders.

Circle (604) on Reply Card

see ad on page 166

Olesen (Booth 1411)

Products: TV studio layout and lighting fixtures, dimming and control, rigging, track and studio drapery.

Circle (605) on Reply Card

Optek Inc. (Booth 1725)

Products: Degausser, audio amplifiers, SCA paging receiver.

Circle (606) on Reply Card

see ad on page 177

Orban Associates (Booth 411)

Products: Optimod-AM live in booth.

Circle (607) on Reply Card

see ad on page 62

Orrox/Environ (Booth 1209)

Products: Videotape editors, flexible editing systems.

Circle (608) on Reply Card

Allen Osborne Associates (Booth 206S)

Products: Pneumatic telescopic masts for antennas manufactured by Hilomast, Ltd.

Circle (609) on Reply Card

Osram Sales Corp. (Booth 301S)

See at booth.

Circle (610) on Reply Card

Otari Corporation (Booth 503)

Products: Professional tape recorders, high-speed tape duplicators.

Circle (611) on Reply Card

see ad on page 59

Otis Conner Productions (Booth 182)

See at booth.

Circle (612) on Reply Card

Pace Inc. (Booth 1028)

Products: General systems for the repair of electronic printed circuit boards, Pace micro-field portable PCB repair system.

Circle (613) on Reply Card

Pacific Recorders & Engineering Corporation (Booth 511)

Products: Tomcat cartridge machines, BMX audio control consoles, custom cabinetry, distribution amplifiers and routing switchers.

Circle (614) on Reply Card

see ad on page 130



Tune in...

...to the worldwide
choice for
ultimate
quality

EEV Vacuum Capacitors are installed in leading manufacturers' transmitters in use throughout the world. You can depend on Europe's largest manufacturer of Professional Electron Tubes to meet your most exacting requirements.

Select from our range of over 150 standard types, which features:

- Fixed or Variable Capacitance
- Ceramic or Glass envelope
- Water Forced Air or Natural Convection Cooled
- R.F. working voltages from 3 to 36kV
- R.F. working currents from 40 to 500A_{rms}
- Capacitance ranges from 5 to 3000pF

Tell us your specific requirements and we will send you data, equivalents list and price quotation. Contact us today.

EEV

The Professionals in Electron Tube Technology

EEV Inc.
7 Westchester Plaza, Elmsford, N.Y. 10523
Telephone: 914 592 6050 Telex: 646 180



IN ENGLAND: ENGLISH ELECTRIC VALVE CO. LTD., CHELMSFORD, ESSEX CM1 2QU TEL: 0245 61777 TELEX: 99103
IN CANADA: EEV CANADA LTD., 67 WESTMORE DRIVE, REXDALE, ONTARIO M9V 3Y6 TEL: 416 745 9494 TELEX: 06 989 363

Circle (136) on Reply Card

March 1981 *Broadcast Engineering* 159

NAB exhibitors

Paladin Corporation (Unassigned)

Products: Stripex (wire stripper), coax termination kits, round cable cutter, cable slitter, continuity and voltage testers (digital & audible signal), flat ribbon cable cutter and flat ribbon cable stripper, corex coaxial strippers, desoldering tools, crimpers, cable tie gun, rotary teflon wire stripper.

Circle (615) on Reply Card

Panasonic Co., Video (Booth 1521)

Products: 1/2-inch VHS players/recorders, portable and studio cameras (b&w and color), generators, b&w and color monitors and microphones, 3/4-inch editing system, b&w monitors and portable color cameras.

Circle (616) on Reply Card

see ads on pages 36-37

Panasonic Co. (Professional Audio Div.) (Booth 600)

Products: Direct drive turntable system, interchangeable tone arm system, honeycomb disc speaker system, mixer power amplifier, microphone, 2ch reel-to-reel deck, PCM VHS cassette deck, 10ch X 4ch

recording mixing/board, microphone.

Circle (617) on Reply Card

see ad on page 215

Parsons Mfg. Corp. (Booth 406S)

See at booth.

Circle (618) on Reply Card

Patrick Computer Systems (Booth 171)

See at booth.

Circle (619) on Reply Card

Pep Inc. (Booth 1006)

See at booth.

Circle (620) on Reply Card

Perrott Engineering Labs (Booth 1023)

Products: Silver zinc, nickel cadmium and lead acid battery packs for cameras, VTRs, portable lighting, video analyzers, video monitors and microwave equipment; batteries for portable communications equipment; the Minicharger series for battery packs; the Equalizer, Nicadomatic analyzer and Microprocessor Evaluator specialized test equipment.

Circle (621) on Reply Card

Peters Productions (Booth 305S)

See at booth.

Circle (622) on Reply Card

Phelps Dodge Communications Company (Booth 112)

Products: Transmission line, FM antennas, harmonic filters, directional couplers, custom coax items.

Circle (623) on Reply Card

Philips Broadcast Equipment Corporation (Booth 807)

Products: LDK-25B Multi-conductor studio and field camera, LDK-5B triax-cable, studio and field camera, LDK-65 Film Camera Chain, PVR-2 1-inch video recorder (console), PVR-20 1-inch video recorder (portable), UHF/VHF broadcast television transmitters, LDM-3001 digital noise reducer, test and measuring equipment, LDK-14S for EFP, studio, ENG 20-foot mobile van.

Circle (624) on Reply Card

see ad on page 235

Philips Test & Measuring Instruments Inc. (Booth 807)

Products: Various sync and pattern generators test signal generators, VITS generators and analyzers, modulators, demodulators, oscillo-

CHYRON IV

the electronic graphics & titling system

CHYRON

TELESYSTEMS DIVISION OF CHYRON CORPORATION

265 Bethpage-Spagnoli Road, Melville, New York 11747

Telephone: (516) 249-3296 ■ Telex: 144522 CHYRON MELV

See Us at NAB Booth #1407

Circle (137) on Reply Card

The measure of success.

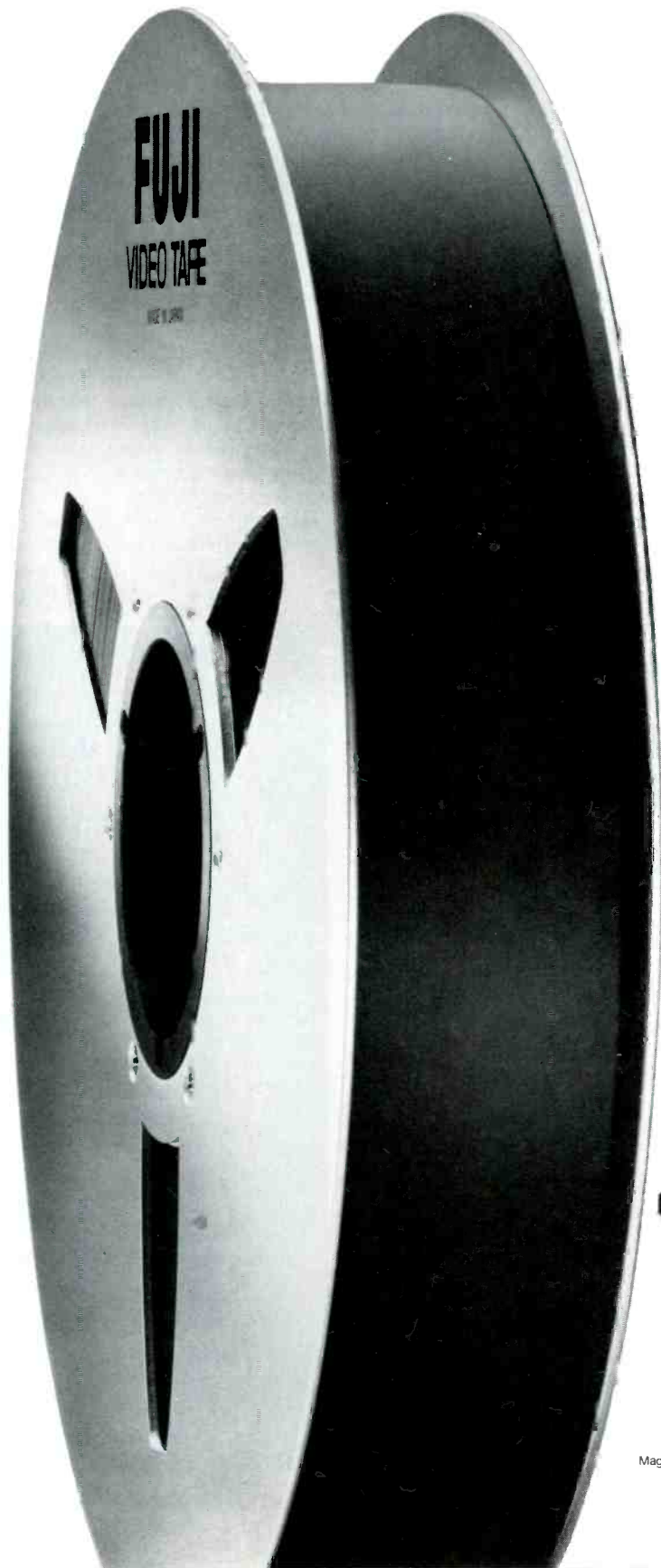

In 2," 1" and $\frac{3}{4}$ "
 $\frac{1}{2}$ " Beta and VHS Video
and Head Cleaning
Cassettes.



FUJI

© 1980 Fuji Photo Film U.S.A., Inc.
Magnetic Tape Division, 350 Fifth Avenue, N.Y. NY 10118

See us at NAB Booth 1307
Circle (138) on Reply Card

NAB exhibitors

scopes.

Circle (625) on Reply Card
see ad on page 75

The Phoebus Corporation (Booth 521S)

See at booth.

Circle (626) on Reply Card

Porta-Pattern Telecommunications Industries Limited (Booth 1325)

Products: Test charts, test chart systems, slides, films, transparencies, transparency illuminators, high-resolution precision optical test media, ENG EFP illumination accessories, full-field color bar chart, application-matched subjective color test reference system, multiple chart storage case.

Circle (627) on Reply Card

Potomac Instruments (Booth 109)

Products: Antenna monitors; audio test equipment; audio signal generator; intermodulation analyzer, harmonic distortion analyzer, wow and flutter meter, stereo phase meter, AM field strength meters, FM/TV

field strength meter, frequency synthesizer/coherent detector, automatic transmission system, audio patch panels, jacks, plugs, cords, RF patch panels, jacks, plugs, cords, low distortion, frequency synthesized AM monitor receiver, directional antenna parameter processor and logger.

Circle (628) on Reply Card
see ad on page 134

Power-Optics (Booth 1017A)

Products: Grafikon color monitoring instruments, remote camera control systems, scene-sync device.

Circle (629) on Reply Card

Procart (Booth 315)

Products: Broadcast cartridge.

Circle (630) on Reply Card

Protech Audio Corporation (Booth 123)

Products: Integra 3 PC card system, audio distribution amplifiers, reverberation, audio op-amp, power amplifiers, automation tone sensor, compressor/limiter, conductive plastic rotary-slide attenuators, audio transformers, PL-amp headset intercom.

Circle (631) on Reply Card

QEI (Booth 417)

See at booth.

Circle (632) on Reply Card

QSI Systems (Booth 1603)

Products: Time date generator, audio/video 24-hour off air logger, count up timer hours-minutes-seconds, count up-count down hours-minutes-seconds timer, field/frame counter, master clock system video display, color bar generator, single line vertical interval source identification encoder & decoder, portable utility 1 in 6 out distribution amplifier, video source identifier, 10 second count down timer 7 segment video source identifier with voice follow through, color bars—video source identification with voice follow through.

Circle (633) on Reply Card

Q-TV (Booth 907)

Products: VideoPromPTer cueing equipment, Mini-Q Prompter, virtual image videoPromPTer.

Circle (634) on Reply Card

Quad Eight Electronics (Booth 300S, 302S, 304S)

Products: Coronado console, system 5 digital reverberation processor,

Cut lamp costs up to 50%



Because Sitler's Supplies maintains one of the industry's largest lamp inventories, you can count on prompt, accurate delivery and low, low prices! More than 400 types of projector, stage

and studio lamps are available in G.E. and Sylvania models.

Lamp	List	You Pay
BTL	\$32.65	\$16.33
EGG	51.00	25.50
FEL	42.25	21.31

Call us today and check our money-saving prices. You'll enjoy FREE transportation on orders of more than \$200.

Sitler's Supplies, Inc.

702 E. Washington St. P.O. Box 10-A • Washington, Iowa 52353
(319) 653-2123 • In Iowa call 800-272-6459

Circle (139) on Reply Card

**DON'T MAKE A BIG MISTAKE.
SAVE CONSIDERABLE TIME AND MONEY
WITH AN INTEGRATED ELECTRICAL
GRID DISTRIBUTION SYSTEM...
WITH THE ALL NEW—
PANOAK RIGID CONNECTOR STRIPS.
YOUR STUDIO'S LIFELINE.
FULLY ASSEMBLED, TESTED,
READY TO HANG.
DELIVERY IN LESS THAN 10 DAYS.**

Panoak, a totally in-house manufacturer and fabricator that passes on savings generated by volume buying and warehousing of steel, pre-cutting and pre-assembly of components.

Panoak Connector Strips may be custom made to suit any flexibility customers might require.
• All welded



construction.
• U/L approved equipment, wiring and procedures.

• Pigtails or flush-mounts manufactured in-house;
• Three point plugs; Twistlocks; or Parallel U-grounds.
• Wire: rated to 125°C.
• Terminals specified anywhere in strip or race.
• Complete suspension hardware package also available.
Call Today For Quotes:
(918) 664-1111

PANOAK LIGHTING SYSTEMS

6809 East 40th Street, Tulsa, Oklahoma 74145 (918) 664-1111

Lighting Systems Sales.

Design & Engineering for Video, Cine & Theatrical

Circle (140) on Reply Card

DTG-1000

DIGITAL TEST GENERATOR

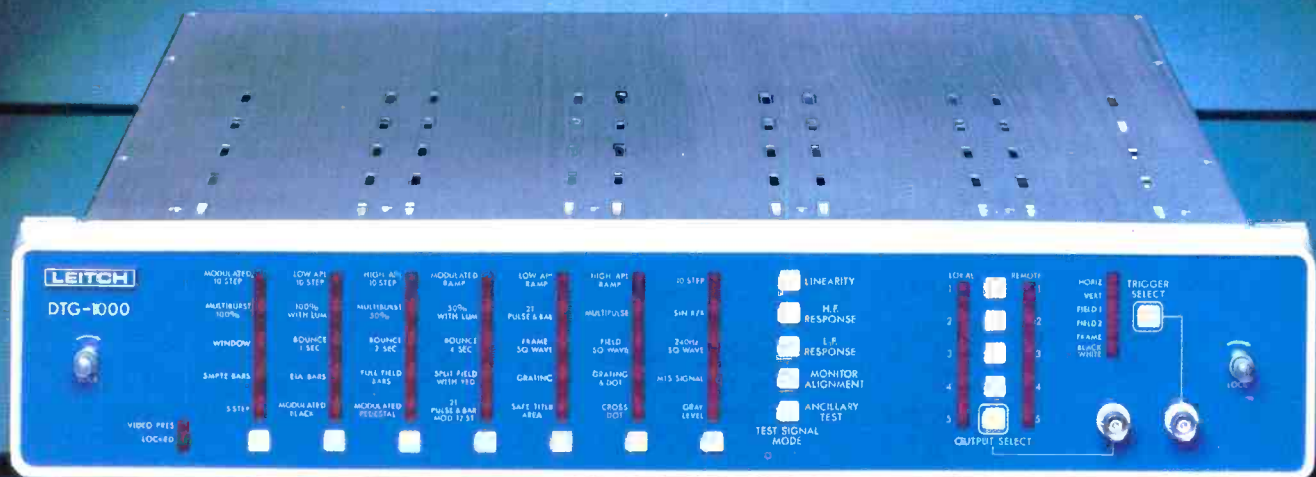

Precision test signals
at an affordable price.
See it at the NAB, booth 1212.

LEITCH

Progressive Concepts in Television Technology

Leitch Video Ltd., 705 Progress Avenue, Scarborough, Ontario, Canada M1H 2X1
Tel.: (416)438-5060 Telex: 065-25420

Leitch Video Inc., 1051 Clinton Street, Buffalo, N.Y. 14206
Tel.: (716)852-1535

Circle (141) on Reply Card

NAB exhibitors

1-inch VTR, large screen projection TV monitor.

Circle (635) on Reply Card
see ad on page 93

Quantum Audio Labs, Inc. (Booth 438)

Products: QM-8P and QM-12P broadcast production consoles, QM-8B 8x4x2 audio console.

Circle (636) on Reply Card
see ad on page 118

Quick Set (Booth 1012)

Products: Camera dollies, stand, tripods, heads, ENG equipment.

Circle (637) on Reply Card
see ad on page 92

Quintek (Booth 1959)

Products: Qlock 210 multi microprocessor SMPTE generator and synchronizer, digital audio processors, graphic equalizer, Qlock 310 synchronizer, reverboration module, disc mastering preview digital delay.

Circle (638) on Reply Card

RCA Broadcast Systems (Booth 700)

Products: TR-800 one-inch videotape

recording systems, TM-200A one-inch videotape recording systems, TM-50 portable one-inch recorder, TCR-100 videotape cartridge recorder, BTA-55S solid-state 5kW AM radio transmitter, TTU-55 55kW transmitter (UHF), TTG-30 and TTG-50 VHF transmitters, circularly polarized TV antennas, TK-29C telecine system, TK-47 automatic camera, TK-86 ENG/EFP cameras, TK-780 studio/field triax production cameras, new power level models of the TTG-series VHF TV transmitters.

Circle (639) on Reply Card

RCA American Communications (Booth 700)

Products: Transmission lines and services, satellite transmission services.

Circle (640) on Reply Card

RCA Solid State (Booth 700)

See at booth.

Circle (641) on Reply Card

(RPM) Radio Programming/Management (Booth 333)

See at booth.

Circle (642) on Reply Card

R.F. Technology (Booth 1624)

Products: 2GHz portable and fixed microwave systems and repeaters, 7 GHz portable and intercity systems and repeaters, 13GHz portable and fixed systems, 2GHz miniature low noise amplifiers, 950MHz wireless microphone systems, Skypac Airborne microwave transmission and relay system, QA-6 automatic steering on-camera ENG antenna, RF-212 high power frequency agile 2, 7 and 13GHz portable microwave transmitter, hand-held 950MHz wireless, diversity microphone system, high power 7 and 13GHz power amplifiers.

Circle (643) on Reply Card

R-Columbia Products (Booth 1703)

Products: Headphones, microphones, headphone / microphone combinations, sports broadcasting headphone microphones, FM wireless intercom headphones.

Circle (644) on Reply Card

see ad on page 193

RTS Systems (Booth 1525)

Products: TW intercom system, series 800 and 400 IFB system. HPM-41 microphone mixer, model 1400 in-line microphone preamplifier, model 405 professional phono preamplifier, model 444 dual two-channel buffer

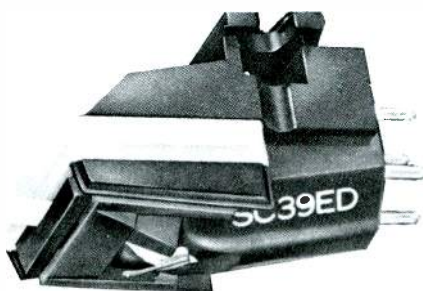

DOWN
WITH
"CUE-BURN"

The new Shure SC39 Series phono cartridges with the exclusive new stylus tip with MASAR® Pro-Finish, virtually eliminates "cue-burn" damage caused by excessive back cueing.

The SC39 Series was specifically designed for use in broadcasting, recording, disco and other professional uses where it is necessary to have true hi-fi performance without sacrificing ruggedness.

SC39ED Biradial (Elliptical), 3/4 to 1 1/2 gram tracking force. Reg. \$110.00. **Our price: \$82.50**

SC39EJ Biradial (Elliptical), 1 1/2 to 3 gram tracking force. Reg. \$76.75. **Our price: \$57.50**

SC39B Spherical. 1 1/2 to 3 gram tracking force. Reg. \$66.00. **Our price: \$49.50**

BROADCAST EQUIPMENT & SUPPLY CO., INC.

P. O. BOX 3141

BRISTOL, TENNESSEE 37620

(800) 251-0487 — (615) 878-2531 (Tenn.)

Circle (142) on Reply Card

Hydraulic MASTS ! by N-PRO

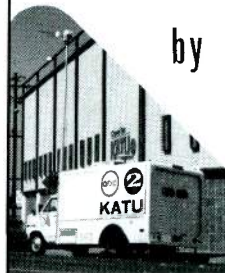

SEE our demonstration
at the
nab CONVENTION

- DUAL SPLINE RAILS
 - Lifting power to 300 lbs. (single mast)!
 - STAYS PUT at any level w/pump off!
 - INSIDE or OUTSIDE MOUNT for
 - SMALL or LARGE VANS !
 - ALL ALUMINUM construction
 - EXCLUSIVE N-PRO MATERIAL
(extruded by REYNOLDS)
 - MANY OPTIONS & CUSTOM DESIGN
AVAILABLE
- FREE BROCHURES WRITE or CALL

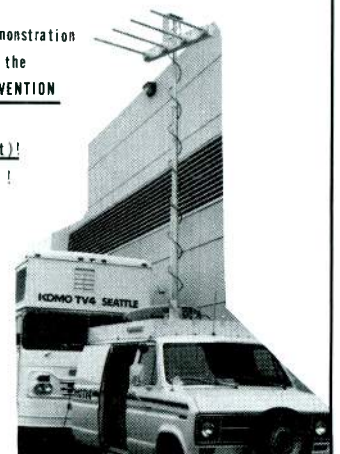

N-PRO Co.

(503) 656 - 5500
657 - 5800

1022 Hazelwood Dr., OREGON CITY, OR. 97045

Circle (143) on Reply Card

Protect your Video investment with the strength of ANVIL® Cases!

If your equipment is constantly on the road—or in the air—rugged, dependable ANVIL® Cases will make sure it arrives in performance-ready condition every time. We have a Case design to fit any Video component on the market. And we can customize your Case to carry those all-important cords, cables and connectors too!

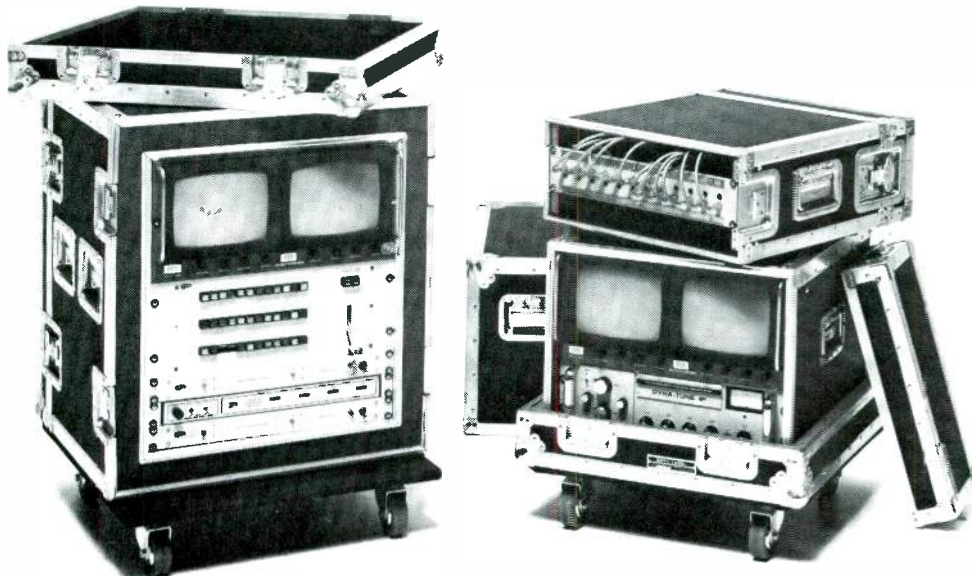

VIDEO RACK-MOUNT CASES ANVIL makes three types of Video Rack-Mount Cases. Shown at left is our all-new "Shock-Mount" design—the industry's first true shock-isolation Travel Case. Double plywood walls are separated by a 2-inch layer of high-density polyfoam. Upper-right is our standard Front and Rear Clamp-On Lid style. Shown lower-right is our Pull-Over Clamp-Lid style, featuring an open front and back rack-shell, which fits into a standard 1-inch foam-lined Pull-Over Clamp-Lid style Case



RECORDER CASES We make a strong Case for every video recording unit on the market. It's the best way to protect delicate alignment and calibration settings during transit.



COMBINATION/CAMERA RECORDER CASES Now any manufacturer's Camera can be safely transported with any recording unit. Once on location, just open the Case—hook up—and shoot!

For more information and the location of your nearest ANVIL® Dealer—call or write:
ANVIL® CASES, INC., 4128 Temple City Blvd., (P.O. Box 888), Rosemead, CA 91770 (213) 575-8614

See Us at NAB Booth #1626

Circle (144) on Reply Card



NAB exhibitors

amplifier, model 410 10W monitor amplifier, model 424 distribution amplifier, model 416 distribution amplifier, model 425 dual 5W monitor amplifier, model 465 microphone preamplifier, microprocessor-assisted communications system, self-contained squawk system, 10 x 10 matrix intercom system, dedicated line master station switch-board, new improved TW Intercom power supply, 24-channel dry liner intercom system, 26-output source assignment panel, new connector distribution panels, new cosmetic for the entire line.

Circle (645) on Reply Card

Radio Computing Services (Booth 184S)

See at booth.

Circle (646) on Reply Card

Radio Television News Directors (Booth 150)

See at booth.

Circle (647) on Reply Card

Ramko Research (Booth 146)

Products: Audio mixing consoles, audio router (electronic patch panel), audio distribution amps, turntable preamps, line amps, monitor amps, mic/line amps, Technics turntables, reel-to-reel tape decks, Phasemaster cartridge machine.

Circle (648) on Reply Card

see ads on pages 33, 34, 35

Ramtek Corporation (Booth 4345)

See at booth.

Circle (649) on Reply Card

Rangertone (Booth 506S)

See at booth.

Circle (650) on Reply Card

Recortec Inc. (Booth 1200)

Products: HBU-2860 high band U-format recorder, HBU-4400 portable high band U-format recorder, VTE-210 2-inch and 1-inch combination videotape cleaner/evaluator, VCE-750 ¾-inch videocassette evaluator, R-MOD reel servo modification for quad VTRs, VTT videotape timer for quads, LPA long play attachment for 9 hour play/record time.

Circle (651) on Reply Card

Rees Associates (Booth 623S)

See at booth.

Circle (652) on Reply Card

Research Technology International (Booth 1112)

Products: TV-120 editing system, Data-film computerized editing, CineScan 16mm film previewer, videotape cleaner/eraser.

Circle (653) on Reply Card

Rohde & Schwarz (Booth 1110)

Products: Professional color & monochrome monitors, demodulators, modulators, multi-standard chroma decoders, special complex 2-line comb filter, SPF 2 video test signal generator, digital video noise meter.

Circle (654) on Reply Card

see ad on page 133

Roh Corporation (Booth 107S)

See at booth.

Circle (655) on Reply Card

see ad on page 189

Rosco Laboratories (Booth 1039)

Products: Light control filters, heat resistant special effects color filters, diffusion test kit, Cycscreen, rear projection screens, scenic and fab-



THE DISCMAKERS

- BROADCAST SLO-MOTION
- STILL STORE
- WEATHER RADAR
- GOVERNMENT
- MEDICAL
- EDUCATIONAL
- INDUSTRIAL

Oktel Corporation

490 DIVISION STREET, CAMPBELL, CA 95008
(408) 374-1811

Circle (145) on Reply Card

*We love the same country.
We care about the same things.
We dream the same dreams.
1981. The International Year
Of Disabled Persons.*

*President's Committee on
Employment of the Handicapped
Washington, D.C. 20210
The School of Visual Arts
Public Advertising System*

FIVE DAY DELIVERY!

“A NEW IMPROVED METHOD OF SELECTION”

WRITE
or
CALL
for
FREE BROCHURE
CATALOG
5DD-79

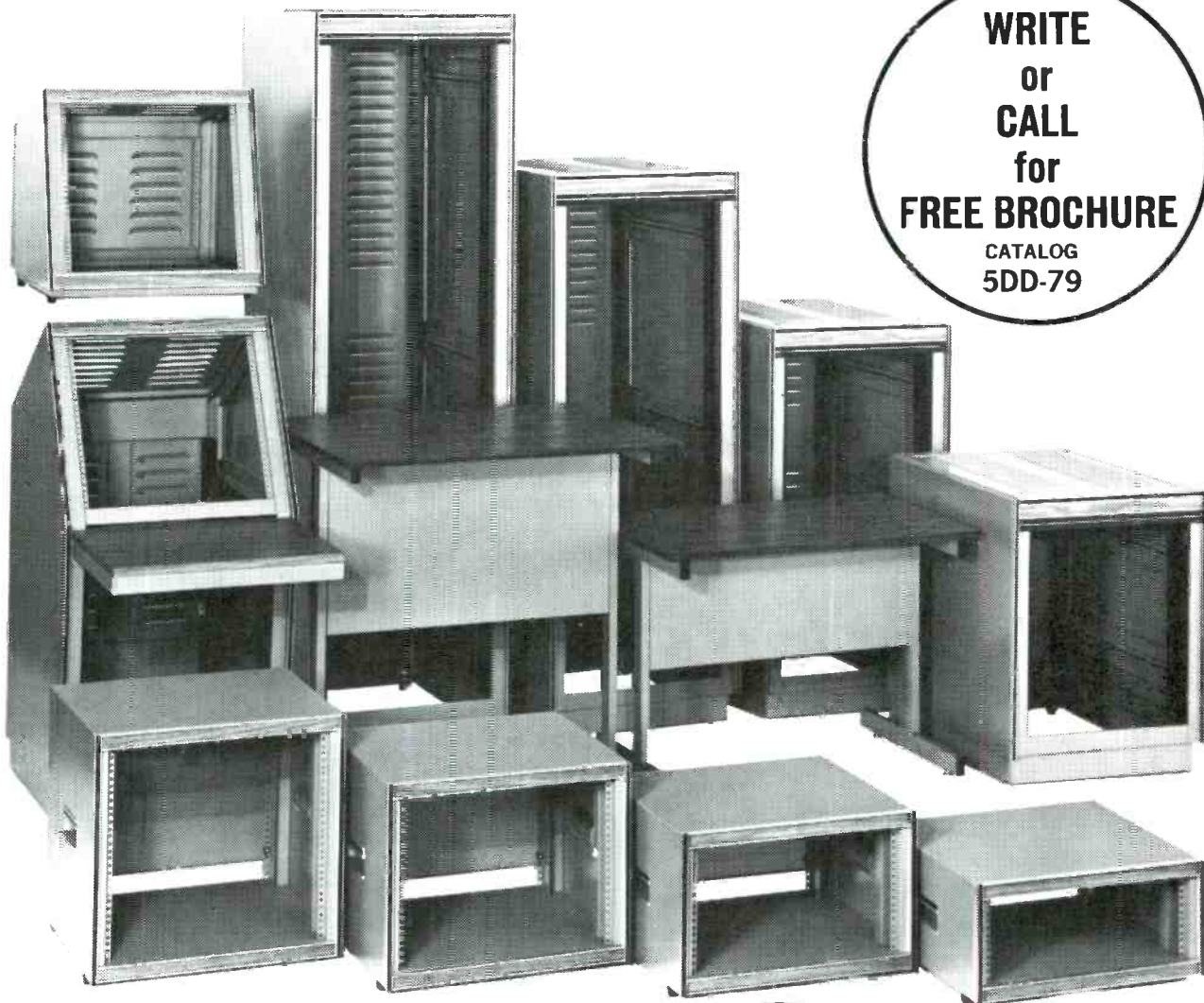

**COMPUTER
PERIPHERAL
FURNITURE**

STANTRON[®]

DIVISION OF
WYCO METAL PRODUCTS

**MODULAR
ELECTRONIC
CABINETS**

6914-6918 BECK AVENUE, NORTH HOLLYWOOD, CALIFORNIA 91605
(213) 875-0800 TWX 910-499-2177

Circle (147) on Reply Card

March 1981 *Broadcast Engineering* 167

NAB exhibitors

ric paints and scenic brushes, metalized plastic scenic materials that reflect light, smoke and fog systems.

Circle (656) on Reply Card

Ross Video (Booth 1812)

See at booth.

Circle (657) on Reply Card

see ad on page 250

Rupert Neve (Booth 1203)

Products: NECAM II post-production automation system, 8 bus stereo TV production console, 4 bus stereo TV production console, 542 series of production consoles from 6 to 16 inputs 2 outputs.

Circle (658) on Reply Card

see ad on page 7

Russco Electronics (Booth 207)

Products: Model 505 audio consoles, Mark V, broadcast turntables, Cue-master and studio pro turntables, phono preamps, Russco broadcast tone arm, T-411 dial up remote equipment, rack-mount audio power amplifier, audio distribution amplifiers, ALC speakers.

Circle (659) on Reply Card

see ad on page 74

SWR (Booth 1626A)

Products: Rigid coaxial transmission line, K-line thermo connector, K-line flange, 3-port fast manual switch.

Circle (660) on Reply Card

see ads on pages 88-89

Sacred Sounds (Booth 624S)

See at booth.

Circle (661) on Reply Card

Saki Magnetics (Booth 331)

See at booth.

Circle (662) on Reply Card

see ad on page 180

Scientific-Atlanta (Booth 1119)

Products: Satellite earth stations: 3 to 11 meters, video receivers, 1:N RX video protection switches, redundant low-noise amplifier, 1:1 LNA protection switch, motorized antenna drives and control equipment, super high speed antenna drive for all size earth stations.

Circle (663) on Reply Card

Sennheiser Electronics (Booth 508S)

See at booth.

Circle (664) on Reply Card

see ad on page 174

Sescom (Booth 905)

Products: Audio transformers, modules, interfacing audio devices, ENG-2 field mixer.

Circle (665) on Reply Card

see ad on page 176

Sharp Electronics (Booth 1121)

Products: Professional prism optics color camera, color monitors/receivers, portable VHS VTR.

Circle (666) on Reply Card

Shintron (Booth 1107)

Products: Model 375 super switcher, model 373 switcher, model 370 switcher, model 640 time code generator, model 641 time code generator, model 643 shot list printer, model 644 time code reader, model 505 character generator, model 317 sync generator, model 383 color bar/black/background generator, model 316 audio DA, model 336 video DA, model 338 pulse DA, model 339 subcarrier DA, model 318 genlock/sync/generator, model 350 chroma-keyer, model 374 super switcher, model 372 switcher, model 909 color monitor, model 326 stereo DA, model 645 time code reader.

Circle (667) on Reply Card

Fill Up Your Racks

With The New Moderately Priced
CR 1700 Color Video Monitor



A new 17" color video monitor for display applications in your studio featuring:

- Modular construction
- Front access to all components
- Front panel set-up controls
- Switchable inputs/underscan/RGB gun switches/Int-Ext Sync/Tally indicator



For additional information on the CR 1700 or any other World Video product, contact your nearest World Video Sales Office or World Video Dealer.

23 S. Reading Ave. • P.O. Box 117 • Boyertown, Pa. 19512
Phone (215) 367-6055

Circle (148) on Reply Card



How to live comfortably with your video system

There was a time when the customer had to settle for standard metal cabinets...not any more. Our custom cabinetry can provide dealers and users with design flexibility, scheduling and cost savings. And a new form of system packaging not known before. See for yourself.



RACK TECHNIQUES CORP.

Providers of Sound Techniques

712 NORDIC COURT
BATAVIA, ILLINOIS 60510
312/879-0629

Circle (149) on Reply Card

The moving coil replacement from Stanton Magnetics... the revolutionary 980LZS!



Now from the company to whom the professionals look for setting standards in audio equipment comes a spectacular new cartridge concept. A low impedance pickup that offers all the advantages of a moving magnet cartridge without the disadvantages of the moving coil pickup. At the same time it offers exceedingly fast rise time—less than 10 micro seconds—resulting in dramatic new crispness in sound reproduction—a new “openness” surpassing that of even the best of moving coil designs. The 980LZS incorporates very low dynamic tip mass (0.2 mg.) with extremely high compliance for superb tracking. It tracks the most demanding of the new so called “test” digitally mastered and direct cut recordings with ease and smoothness at 1 gram $\pm \frac{1}{2}$.

The 980LZS features the famous Stereohedron™ stylus and a lightweight samarium cobalt super magnet. The output can be connected either into the moving coil input of a modern receiver's preamps or can be used with a preamp, whose output is fed into the conventional phono input.

For “moving coil” audiophiles the 980LZS offers a new standard of consistency and reliability while maintaining all the sound characteristics even the most critical moving coil advocates demand. For moving magnet advocates the 980LZS provides one more level of sound experience while maintaining all

the great sound characteristics of cleanliness and frequency response long associated with fine moving magnet assemblies.

From Stanton... The Choice of The Professionals.

For further information write to: Stanton Magnetics, Terminal Drive, Plainview, N.Y. 11803.

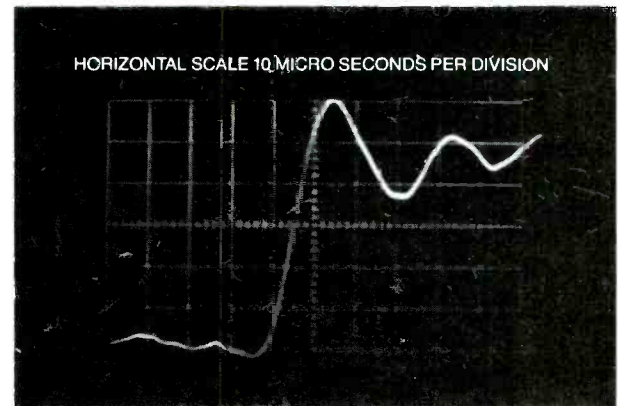

Actual unretouched oscilloscope photograph showing rise time of 980LZS using CBS STR112 record.



STANTON

THE CHOICE OF THE PROFESSIONALS™

See Us at NAB Booth #118A

Circle (150) on Reply Card

March 1981 *Broadcast Engineering* 169

NAB exhibitors

Shively Laboratories (Booth 128A)

Products: Pressurization equipment, FM antennas, reflectometer, coax components.

Circle (668) on Reply Card
see ad on page 158

Shure Brothers (Booth 107)

Products: Broadcast microphones, broadcast cartridges, working microphone display, hand-held unidirectional condenser.

Circle (669) on Reply Card

Sigma Electronics Inc. (Booth 1602)

Products: CSG-365—Sync generator, CSG-360—sync generator, VPA-100—video processing amplifier, VDA-100A—video distribution amplifier, ADA-105, 110, 210—audio distribution amplifier, BBG-140—black burst generator, PDA-110—pulse delay amplifier, SDA-120—subcarrier delay amplifier, system 500, VDA-510—video distribution amplifier, VDA-511—video distribution amplifier, ADA-520—audio distribution amplifier, PDA-530—pulse distribution amplifier, PDA-535—pulse delay amplifier, SDA-540—subcarrier delay amplifier, CSG-265—master sync generator.

Circle (670) on Reply Card
see ads on pages 122, 235

Simmons Market Research (Booth 201S)

See at booth.

Circle (671) on Reply Card

Sintronic Corporation (Booth 126)

Products: FM and AM transmitters.

Circle (672) on Reply Card
see ad on page 217

Skirpan Lighting Systems (Booth 1525)

Products: Astral Dimmers, "K" dimmers, Autocue/80, Cuelog, MCP modular control panels.

Circle (673) on Reply Card

Skotel Corporation (Booth 1720)

Products: Time code generators, time code reader, portable time code generator-reader, vertical interval time code, digital metronome, synchronizer, time code.

Circle (674) on Reply Card

Sono-Mag Corporation (Booth 309)

Products: Broadcast audio automation systems, carousel SMC line of recorders and reproducers.

Circle (675) on Reply Card

Sony Corporation of America (Booth 1211)

Products: 1-inch and ¾-inch VTR equipment, video color cameras, monitors, videotape, digital TBC, PCM audio equipment, computer editing, microphones, related products and services.

Circle (676) on Reply Card

Soper Sounds (Booth 204S)

See at booth.

Circle (677) on Reply Card

Sound Genesis (Booth 330)

Products: Equipment geared to audio production and reproduction.

Circle (678) on Reply Card

Sound Technology (Booth 1132)

Products: FM alignment generator, signal conditioner, stereo test panel, tape recorder test system, distortion measurement system, new option for the 1500A, model 1110A—signal conditioner, test record, FM alignment generator.

Circle (679) on Reply Card
see ads on pages 114, 115

Sphere Electronics (Booth 609S)

Products: Eclipse type C TV production console, Sphere audio equalizers, various console modules, system 1604 satellite mixer.

Circle (680) on Reply Card
see ad on page 157

Stainless (Booth 1009)

Products: Photos and slides of existing installations of AM, FM and TV towers ranging in height from 100 to 2000 feet.

Circle (681) on Reply Card
see ad on page 224

Stanton Magnetics (Booth 118A)

Products: cartridges, styli, headphones, preamplifier, pre-preamplifier, record care products, stereo phono pre-preamplifier.

Circle (682) on Reply Card
see ad on page 169

Stantron Division of Wyco Metal Products (Booth 1828)

Products: Electronic modular cabinets and consoles, computer peripheral furniture, cooling base.

Circle (683) on Reply Card
see ad on page 167

Station Business Systems, (Booth 509)

Products: BAT 1700, BAT 1500, Newscom, all traffic, accounting, payroll systems, Music Playlist and Inventory System (MPI), Program Package Inventory (PPI) System.

Circle (684) on Reply Card

Storeel Corporation (Booth 911)

Products: Storage systems for TCR100 RCA carts and ACR25 Ampex cassettes, mobile equipment, multiple purpose mobile storage systems with horizontal bases or vertical bases, double-entry set-up trucks.

Circle (685) on Reply Card
see ad on page 241

Strand Century Inc. (Booth 1204)

Products: Mini palette and light palette memory system lighting control consoles, motorized lighting equipment, CD 80 portable and permanent dimming systems, lighting kits, portable stands, grip equipment, Polaris Bambino 5-inch-1kW Fresnel, Pulsar 650 fiberglass floodlight, lighting control consoles and portable dimmers, HMI units, portable lighting kits, combination Fresnel and Softlite, HMI softlite, pole-operated lighting equipment.

Circle (686) on Reply Card

Studer Revox America Inc. (Booth 602)

Products: A800 multichannel recorder, synchronizing and editing system, tape recorder series, outside broadcasting console, portable audio mixers, electronic telephone hybrid, balancing amplifiers, distribution amplifiers, monitor amplifier A68, digital FM monitor tuner, open reel recorders, tracking turntables, open reel professional broadcast recorder reproducer, open reel professional broadcast recorder reproducer, open reel professional broadcast reproducer for automation systems, open reel recorder/reproducer Studer B67 MKII, 369 audio mixing console, 900 series of broadcast consoles, 710 professional cassette recorder/reproducer.

Circle (687) on Reply Card
see ad on page 233

Swintek Enterprises (Booth 1800)

Products: Wireless communication systems.

Circle (688) on Reply Card

Sylvania Lighting/GTE (Booth 909)

Products: Incandescent, tungsten halogen and arc discharge lamps for stage theater and television lighting.

Circle (689) on Reply Card

System Associates (Booth 1722)

Products: Used broadcast television equipment brokers.

Circle (690) on Reply Card

System Concepts Inc. (Booth 1305)
Products: Teleproduction graphic titlers, automatic subtitling system, computerized television newsroom system.

Circle (691) on Reply Card
see ad on pages 108, 109

T.A. Associates (Booth 224S)
See at booth.

Circle (692) on Reply Card

TFT (Booth 124)

Products: TV AM & FM frequency modulation monitors, remote control equipment, STL link, data logger, E-alert emergency receiver, micro-processor base data acquisition logging, alarm and remote control.

Circle (693) on Reply Card

TV Equipment Associates (Booth 1019)

Products: Video delays, pulse delays, video filters, tape evaluator for -1 and 2-inch tape, intercom headsets, sportscaster headsets, interphone system, improved video filters, evaluator for 3/4-inch cassettes, intercom system, video distri-

bution equipment, audio distribution equipment.

Circle (694) on Reply Card
see ad on page 202

Taber Manufacturing and Engineering Company (Booth 502)

Products: Audio heads, replacement to Ampex, Scully; audio heads, replacement to Ampex VTR, RCA VTR 2-inch; audio head reconditioning service; tape eraser; audio head conversion service, heads and electronics.

Circle (695) on Reply Card

Tangent (Booth 126A)

Products: Audio production consoles and mixers.

Circle (696) on Reply Card

Wm. B. Tanner Company (Booth 117)

Products: Commercial productions, music services.

Circle (697) on Reply Card

Tayburn Electronics (Booth 1708)

Products: Frequency agile transmitter and receiver miniature portable

transmitter, auto tracking system, remotely steerable antenna system, mini 7GC ENG transmitter, frequency agile transmitters and receivers.

Circle (698) on Reply Card

TEAC Corporation of America (Booth 702S)

Products: Airborne videocassette tape recorder, ENG airborne videocassette tape recorder.

Circle (699) on Reply Card

see ad on page 222

Teatronics Sales Division of Ultra Audio Pixtec (Booth 1505)

Products: Soundstage lighting control systems, rack lighting system packages with load patching, computer memory lighting controllers.

Circle (700) on Reply Card

Technicolor Audio Visual Corporation (Booth 1126)

See at booth.

Circle (701) on Reply Card

Tech Theatre (Booth 1709)

Products: Bubbleboard rear projection material, safety strap for studio

Ask for
fiberoptics by name.

Even With A Cast Of Hundreds,

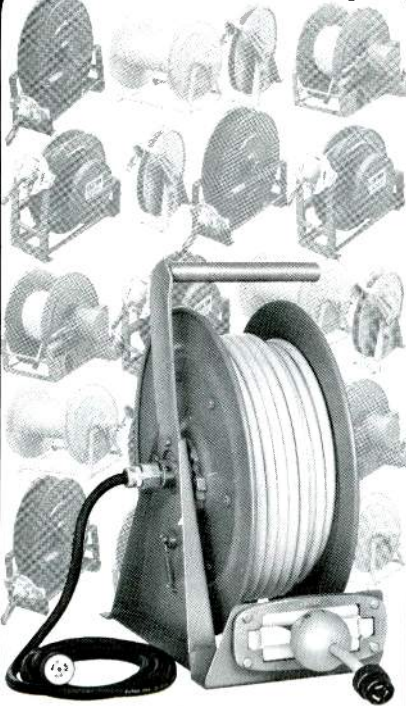

We're Always Glad To Do A Special

- Mix 'n match stock parts to custom design the ideal reels for your mobile unit or studio.
- Sizes, shapes, capacities unlimited. A wide choice of rewind options.
- Microphone cable, coaxial cable, power cable: hookup & pickup go smoother & faster with Hannay Reels.
- No other reel is remotely as efficient! Free fact-packed Reel Guide! Ask for your copy today.

Buy Hannay Reels and
Wind Up With The Best



HANNAY REELS

CLIFFORD B. HANNAY & SON, INC., WESTERLO, N.Y. 12193

Circle (152) on Reply Card



Excalibur Electronics

Broadcast Audio Equipment at
Budget Prices



**DA 2-6 DISTRIBUTION
AMPLIFIER \$275.00, CWO**

- Two One Input, Six Output DA's
- Active Balanced Inputs and Outputs
- Individual Level Control each output
- +24 dBm Maximum Output
- < 0.1% Total Harmonic Distortion

Excalibur Electronics, Inc.

5645 Mount Burnside Way, Burke, Virginia 22015
Write for info on Other Products

Circle (153) on Reply Card

NAB exhibitors

lights, KABL-TY, theatrical and television/film makeup, makeup trouping cases, set construction supplies.

Circle (702) on Reply Card

Tektronix (Booth 1111)

Products: Standard video test signal generators, waveform monitors, vectorscopes, color picture monitors, correctors, ANSWER measurement set, spectrum analyzer, logic analyzer, oscilloscope.

Circle (703) on Reply Card

see ad on page 111

Telcom Research (Booth 1824)

Products: The Time Code Center portable time code generator/reader, time code reader/character inserter, time code generator, transmitter monitoring and fault reporting system, very wide range time code reader/character inserter, jam-sync time code generator, jam-sync master time code generator.

Circle (704) on Reply Card

Tele-Cine (Booth 1114)

See at booth.

Circle (705) on Reply Card

Telemet Division of Geotel Inc. (Booth 1010)

Products: Clamping amplifiers, repeaters, modulators, sideband analyzers, test signal generators, chroma-keyer, chroma-keyer decoder, video cable terminals, RF test equipment, demodulators, group delay measuring equipment, video and pulse distribution amplifiers, sideband/spectrum analyzer, broadcast demodulator (Model 3710), video distribution amplifier w/clamp and equalization, pulse distribution amplifier w/variable delay, fiber optics transmitter and receiver w/sound, video isolation amplifier, RF synthesizer, thermal equalizer, routing switcher.

Circle (706) on Reply Card

see ad on page 258

Telescript Inc. (Booth 1025)

Products: Lightweight monitor prompting systems.

Circle (707) on Reply Card

Telesource Communication Services Inc. (Booth 1810)

Products: Computerized election, sports and weather reporting service; interface for character generator.

Circle (708) on Reply Card

Television Engineering Corporation (Booth 1201)

Products: 22-foot remote production van.

Circle (709) on Reply Card

Television Products Co. Inc. (Booth 409S)

See at booth.

Circle (710) on Reply Card

Television Technology Corporation (Booth 1623)

Products: VHF and UHF translators, FM translators, 20W solid-state UHF translator.

Circle (711) on Reply Card

Telex Communications, Inc. (Booth 311)

Products: Cartridge recorders/reproducers, reel-to-reel recorders/reproducers, Audiocom intercom system, Turner professional microphones, reel-to-reel loggers, headphones and headsets, professional wireless microphones, 10½-inch reel-to-reel recorder/reproducer and transports, FM professional wireless microphone system, TS-200 lightweight camera operator's headset with electret microphone.

Circle (712) on Reply Card

see ads on pages 4, 49, 50

Tennaplex Systems Ltd. (Booth 343)

Products: Dipole panel antennas for TV & FM frequencies, broadbeamed FM panel for omni 3 panel arrays.

Circle (713) on Reply Card

Tentel Corp. (Booth 1005)

Products: Tape tension gauges, U-matic spindle height gauge, run timer, spindle height gauges for VHS and Beta applications.

Circle (714) on Reply Card

see ad on page 26

TerraCom (Booth 1043)

Products: TCM-6 Series microwave radio system.

Circle (715) on Reply Card

see ad on page 135

Thermodyne International (Booth 1627)

Products: Shipping cases, shipping and operating cases.

Circle (716) on Reply Card

Thomson-CSF Broadcast (Booth 919)

Products: FM Volumax automatic peak controller, AM Volumax, dual audio distribution amplifier, audi-max automatic level controller, dy-

namic presence equalizer, microcam color portable cameras, TTV 1525 color camera, TTV 1650 color camera, TTV 2705 color slide scanner, Vidifont IVA character generator, Digital video processor, Vidiplex system, Vidifont Graphics V.

Circle (717) on Reply Card

see ad on page 129

Thomson-CSF Electron Tube Division (Booth 128)

Products: 100W common amplification UHF power tetrode, 2.2kW common amplification UHF power tetrode, 5kW common amplification VHF power tetrode, 1kW common amplification VHF power tetrode, 1kW UHF power tetrode, 1kW UHF cavity, 5kW common amplification UHF power tetrode, 10kW common amplification UHF power tetrode, 600W TWT KU band-satellite ground station, 75W TWT C Band—satellite ground station, 3kW C Band Klystron—satellite ground station, CCD for miniature TV cameras.

Circle (718) on Reply Card

3M (Booth 815)

Products: D-8800 graphics generator system, D-3016 graphics generator with model D-4500 storage device, 40X series routing switching and

machine control system, one-inch C format videotape recorder, digital effects generators digital audio mastering and editing system, videotape and audiotape, new accessories for VTRs, new software enhancements for microprocessor controller.

Circle (719) on Reply Card

see ads on pages 145, 68-69, 107, 251, 120

3M Video Products (Booth 815)

Products: Character generators, digital effects generators, routing switchers, 1" "C" format videotape recorder, digital audio mastering and editing system.

Circle (720) on Reply Card

Tiffen Manufacturing Corporation (Booth 1606)

Products: Special effect and standard color filters and accessories for TV cameras and lens, star effect filters, fogs, diffusion, low contrast, center spot, multi-image, vari-color, polarizer, vari-burst, standard or combination color filters and accessories for TV camera and related equipment, stackable filter case, universal rubber lens shade, collapsible lens shade, fractional filters 1/4 or 1/2 density low contrast filters.

Circle (721) on Reply Card

see ad on page 128

Toshiba America, Inc., Broadcast Electronic Systems Div. (Booth 1214)

Products: Portable ENG/EFP color broadcast camera, microprocessor controlled automatic studio camera with Triax and Multicore cable modes of operation, lightweight ENG/EFP color broadcast camera with digital automatic setup options.

Circle (722) on Reply Card

see ad on page 147

Townsend Associates (Booth 1007)

Products: UHF Klystron transmitter, UHF Tetrode transmitter, vacuum contactors, solid-state IF modulated exciters, solid-state klystron mod anode pulser, low power VHF and UHF transmitters, UHF antennas.

Circle (723) on Reply Card

see ad on page 245

Trompeter Electronics (Booth 1124)

Products: Coax patching, coax connectors, armored cable assemblies, improved camera cables.

Circle (724) on Reply Card

Tweed Audio USA (Booth 219)

Products: Custom design and manufacture, 12 input 4 group and stereo output studio console, portable mixer in flight case, portable mixer with 10 inputs and stereo output.

Circle (725) on Reply Card

Ask for fiberoptics by name. Then expect some advantages that no one else can offer you.

Only Valtec has a field-proven baseband video/audio/data fiberoptics system. Our economical alternative to coaxial or microwave is immune to hum, ground loop or RFI problems. So you can

Valtec.



enjoy noise-free transmission up to three kilometers without using costly repeaters or equalizers. And modular design makes installation and system expansion easy and fast. Individual video, audio and data cards plug easily into a compact 19" equipment shelf. You decide how many channels of each you need for your

broadcasting or CATV trunking application.

Whether you communicate video, voice or data, Valtec's total manufacturing integration is important, too. We make it all—glass, fibers, cables, systems, light sources, electro-optic interfaces. As a single source, we make sure every component in your system works

best with every other. You also get the full benefit of Valtec's 13 years of fiberoptics experience.

So ask for fiberoptics by name. And send for our free brochure. Valtec Communication Fiberoptics, a M/A-COM Company, West Boylston, MA 01583. (617) 835-6082. Telex: 92-0355.



Circle (154) on Reply Card

The Answer:

CHEAT!



The Question: How do I get 8 audio lines from point A to point B on one microphone cable?

Cheat with EDCOR's Multiplex Snake. It encodes 8 channels of audio on one microphone cable up to 1500 feet cost effectively.

EDCOR 16782 Hale Avenue, Irvine, CA 92714
(714) 556-2740

Circle (156) on Reply Card

OUR WIRELESS MICROPHONES ARE AS GOOD AS OUR MICROPHONES

You know how reliable our microphones are. And how nothing's ever come near the performance of our original Sennheiser wireless microphones. So just wait 'til you hear how good our new wireless systems are!



SENNHEISER

ELECTRONIC CORPORATION
10 West 37th Street, New York, NY 10018
(212) 239-0190

Manufacturing Plant: Bissendorf/Hannover, West Germany
© 1980, Sennheiser Electronic Corporation (N.Y.)

Circle (157) on Reply Card

NAB exhibitors

UMC Electronics Co. (Booth 108)
See at booth.

Circle (726) on Reply Card

see ad on page 70

UNR-Rohn (Booth 1021)

Products: Hot dip galvanized communication towers and related accessories.

Circle (727) on Reply Card

(United Recording Electronics Industries) UREI (Booth 607S)

Products: Recorder test system, broadcast audio console, limiter, limiter/dual, compressor/limiter, modulimiter, sub-sonic processor, dual graphic equalizer, graphic equalizer, 1/3 octave equalizer, dual parametric equalizer, filter set, digital delay line, transcription pre-amplifier, monitor loudspeakers, audio power amplifiers.

Circle (728) on Reply Card

see ad on page 149

Ultra Audio Pixtec (Booth 1819)

Products: Studio audio mixers, ENG battery-powered audio mixers, compact audio distribution amplifiers, rackmount audio monitor amplifier/speakers, waveform monitors, vectorscopes, audio-follow-video routing switchers with tally and stereo audio, camera colorbars testcharts, stage-lighting controls, audio and video test-sets.

Circle (729) on Reply Card

see ad on page 137

Uni-set (Booth 1106)

Products: Sets and backdrops.

Circle (730) on Reply Card

United Media (Booth 1711)

Products: Commander II electronic video editor.

Circle (731) on Reply Card

see ad on page 90

United Press International (Booth 903)

See at booth.

Circle (732) on Reply Card

United Research Lab Corporation (Booth 414)

Products: Solid-state conversion amplifiers, pinch rollers, electronic motion sensing, replacement parts for most professional recorders, motors, recorders, alignment test tapes, motion sensing older recorders.

Circle (733) on Reply Card

WHEN YOU THINK OF THE LEGENDARY AMPEX VR-1200's AND VR-2000's THINK OF AFA...

We're keeping the legend alive!

AMPEX VR-2000's and VR-1200's are the stuff legends are made of. . . they're the best. So if you can't afford a New VTR. . . consider owning a "pre-owned" legendary AMPEX VTR instead.

Our customers, including TV Stations, Manufacturers, Institutions, TV and Film Production Facilities have purchased \$8 million in AMPEX VR-2000's; VR-1200's AVR-1's, HS-200's and paid only half that price. They know they're still getting the best in VTR's.

AFA VTR's are fully rebuilt and good as new. . . even better! These "legends" are in a class of their own. . . and at prices that are becoming legendary in their own rights.

And when the New AMPEX VTR's become legend. . . AFA will be there to keep them "alive" too.

Who knows. . . some day someone will have to keep our legend alive.



AFA...the largest rebuilder of the best VTR's in the world.

AFA

A.F. ASSOCIATES, INC.

100 Stonehurst Court, Northvale, NJ 07647

2465 E. Bayshore, Suite 301, Palo Alto, CA 94303

See Us at NAB Booth #1035

Circle (158) on Reply Card

201-767-1000
415-856-1060

NAB exhibitors

US JVC (Booth 1519)

Products: 3/4-inch video recorders, players and editors; VHS video recorders and players; color cameras; color monitor/receivers; color magnetic disc recorder.

Circle (734) on Reply Card
see ad on page 179

U.S. Instrument Rentals (Booth 105S)

See at booth.

Circle (735) on Reply Card

U.S. Tape & Label Corporation (Booth 407)

Products: Printed pressure sensitive labels, bumper strips, inside window labels.

Circle (736) on Reply Card

URSA Major (Booth 414A)

Products: Space Station SST-282, 8X32 digital reverberation system.

Circle (737) on Reply Card

Utah Scientific (Booth 1629)

Products: Audio and routing switch-

ers.

Circle (738) on Reply Card
see ad on page 221

Utility Tower Company (Booth 500)

Products: Actual tower sections, lighting equipment, galvanized hardware.

Circle (739) on Reply Card

V&B Tower Const. Co. Inc. (Booth 320)

Products: Antennas, transmission lines, towers, lights, lighting accessories.

Circle (740) on Reply Card

Thomas J. Valentino, Inc. (Booth 412)

Products: Production music library, sound effects library, video stock-shot library.

Circle (741) on Reply Card

Valtec Communication Fiberoptics (Booth 1811)

Products: Fiberoptic baseband video/audio/data transmission system, fiberoptic cable designed for aerial, duct and direct burial installation.

Circle (742) on Reply Card
see ad on page 171, 173

Varian (Booth 306)

Products: Amplifiers, tubes, audio couplers.

Circle (743) on Reply Card

Versa-Count (Booth 516)

Products: 250W FM transmitter, FM translators, VHF to VHF TV translators, Power Amp, video processing amplifier, FM exciter, FM modulation monitor, studio transmitter link, medium cost FM exciter.

Circle (744) on Reply Card

Video Associates Labs (Booth 1716)

Products: Character generators and titlers.

Circle (745) on Reply Card
see ad on page 271

Video Data Systems (Booth 1523)

Products: Titling systems, digital time and weather displays, television production titler, message character generator, vertical interval transmission link.

Circle (746) on Reply Card
see ad on page 116

Videomagnetics, Inc. (Booth 1808)

Products: Refurbished quad video heads for Ampex and RCA video

Programmable EQ Just Arrived

360 SYSTEMS' new programmable Equalizer stores and recalls 28 sets of EQ curves from its own internal memory. Now you can have instant access to the special sounds you've developed for specific production situations. The 2800 Equalizer is a completely self contained system, using a Z-80 Microcomputer to manage the affairs of an analog equalizer - one with an unusually broad range of useful curves. When it's time to develop a consistent production sound, this is the equalizer that solves problems as fast as they arise.

Write or call for all the facts.

360 SYSTEMS
18730 Oxnard Street #215
Tarzana, California 91356
(213) 342-3127

Circle (159) on Reply Card

WOW!!

AUDIO TRANSFORMERS

114 Different Types!
In Stock!
And Priced Right Too!

World Famous Sescom "MI-Series" Transformers
for Professional Audio Applications

Send for your FREE 1980 Catalog

SESCOM, INC.
Professional Sound Division
1111 Las Vegas Blvd., North
Las Vegas, NV 89101 U.S.A.

(702) 384-0993
(800) 634-3457
TAX 910-397-6996

Circle (160) on Reply Card

the
OPTEK 8000 Bulk Tape Degausser...
kiss the noise goodbye!



Signal and noise are gone. Wiped Clean. Even today's high density tape is no match for the new OPTEK 8000...the most powerful bulk tape recovery system available today. Fully automatic, hands-off operation provides fast—reliable signal erasure.

High performance "E" core coils virtually strip recorded material; with minimum heat, in less than 32 seconds. The 8000 does all the work...you load the tape, reels up to 16" diameter— $\frac{1}{4}$ " to 2" widths, set the coils and push the start button. That's it.

Design features include: high quality Bodine drive motor, total solid-state control logic (C-MOS), resonant coil technology, sturdy cast aluminum chassis and hi-tech style fiberglass cabinet.

If you're in the market for a quality conscious, cost efficient degaussing system that delivers recording tape that doesn't talk back...there's not another machine available today that can match the 8000's performance.



NOW IN STOCK

For complete technical information call or write: Mr. John Baumann
OPTEK INCORPORATED
1360 North McCan Street, Anaheim, California 92806,
(714) 630-8280.

OPTEK

NAB exhibitors

recorders, conversion of low band RCA heads to high band configuration, refurbished quad video heads for Ampex and RCA video, recorders using Ferrite.

Circle (747) on Reply Card

Videomedia (Booth 1808)

Products: Z-6 B, Z-6 D, Z-6 E, Mini-E.

Circle (748) on Reply Card
see ad on page 243

Videotek, Inc. (Booth 1611)

Products: Television waveform monitor, rackmount 17", 15", 12" color monitors, 8" and 5" dual rackmount color monitors, ENG 8" and 5" portable color monitors, demodulator, television vectorscope, audio program monitor.

Circle (749) on Reply Card
see ad on page 246

Vidicraft (Booth 180S)

See at booth.

Circle (750) on Reply Card

Viscount Industries (Booth 1802)

Products: Production switchers.

Circle (751) on Reply Card

Vital Industries, Inc. (Booth 921)

Products: Production switchers, automation system, master control switcher with automation "Squeeze-Zoom" 4 channel video manipulation unit, micro-processor control production switcher, CRT terminal.

Circle (752) on Reply Card

Ward-Beck Systems Ltd. (Booth 1216)

Products: Radio console, television console, production console, trans-portable console, distribution amplifiers, communications systems, microprocessor based communications system, M608 distribution amplifiers.

Circle (753) on Reply Card
see ad on back cover

Weathercaster (Booth 525S)

See at booth.

Circle (754) on Reply Card

Weathermation (Booth 1625)

See listing on page 182.

Circle (755) on Reply Card
see ad on page 45

Western Union Telegraph Company (Booth 1401A)

Products: Satellite distribution services for television/radio broadcast-

ing and cable industries.

Circle (756) on Reply Card

Wilkinson Electronics (Booth 302)

Products: AM and FM transmitters, consoles, silicon rectifiers, dummy loads, line surge protectors.

Circle (757) on Reply Card
see ad on page 269

Winsted Corporation (Booth 823)

Products: Editing consoles, videotape and film storage systems, videotape and film trucks, equipment racks, dubbing racks and post production consoles, 1" VTR console, tape storage, low profile editing/production console, vertical equipment racks.

Circle (758) on Reply Card
see ad on page 146

Wireworks (Booth 1619)

Products: Microphone multicable components group, professional microphone cables, TE-2 microphone cable tester, hardwired microphone multicables, cable marketing system.

Circle (759) on Reply Card

Wold Communications (Booth 1221)

See at booth.

Circle (760) on Reply Card

"I'VE NEVER USED A WIRELESS MICROPHONE THAT WORKS THIS WELL!"

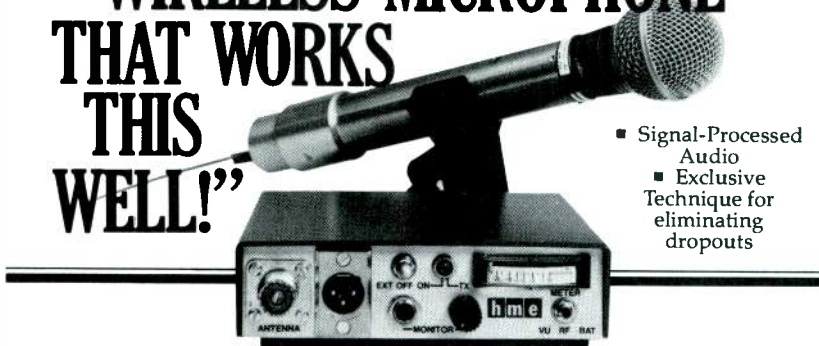

- Signal-Processed Audio
- Exclusive Technique for eliminating dropouts

These are the actual words that hundreds of professional end-users and dealers have used to describe their HME experience.

Who are our users? Academy Award-winning Hollywood mixers, network audio engineers and sound men for Broadway and Las Vegas productions. We'll send you a users list with product literature on request.

Once they *tried* our systems and *compared* them to the other wireless microphones, they bought HME. Call Dale Scott and ask for a demo. We know you'll buy an HME system too.

PROFESSIONALS
WHO TRY HME . . .
BUY HME.

hme

HM ELECTRONICS, INC.
6151 FAIRMOUNT AVE.
SAN DIEGO, CA 92120
PHONE (714) 280-6050
TELEX: 697-122

Circle (162) on Reply Card

Audio Tape
for professionals

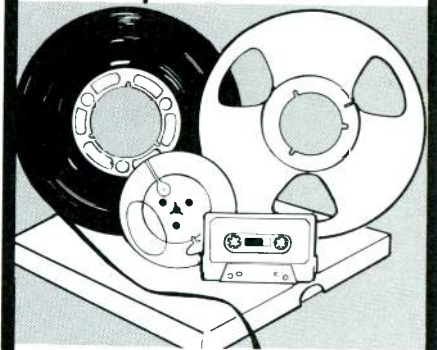

REEL TO REEL TAPE

Ampex, 3M. All grades.
On reels or hubs.

CASSETTES, C-10—C-90

With Agfa, TDK tape.

LEADER & SPlicing TAPE

EMPTY REELS & BOXES

All widths, sizes.

Competitive!
Shipped from Stock!

Ask for our recording supplies catalog.

Polyline
Corp. 312/298-5300
1233 Rand Rd. • Des Plaines, IL 60016

15

Circle (163) on Reply Card

**UNDER OUR HAT
SEE THE MOST EXCITING
NEW VIDEO PRODUCTS**

**JVC[®]
AT NAB**

BOOTH 1519

Circle (164) on Reply Card



MATER ARTIUM NECESSITAS*

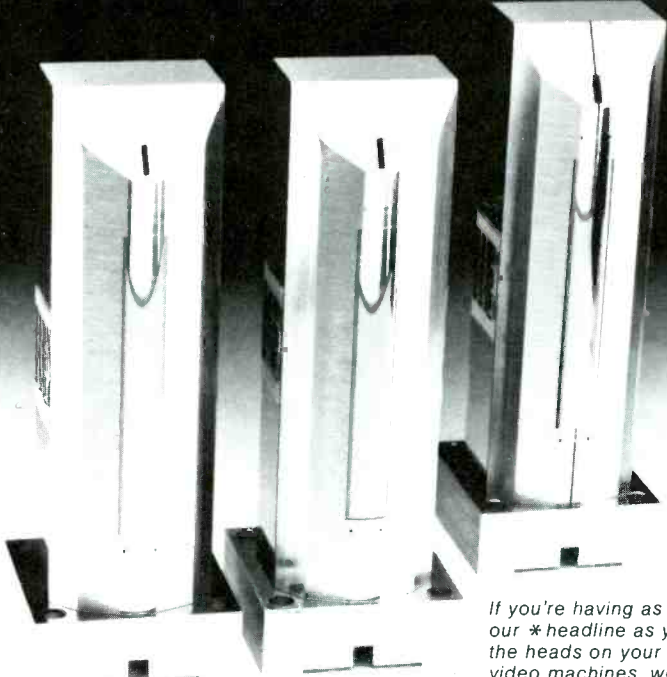

If you're having as much trouble with our * headline as you're having with the heads on your RCA or Ampex 2" video machines, we've got the solution. Our Premium Quality Sakalloy™ audio posts last 3 to 4 times longer than standard heads. We've become the world's leading manufacturer of premium audio heads by providing remarkable solutions to demanding industry needs. After all, *Necessity is the mother of invention. Call us today!

SAKI MAGNETICS, INC. A California Corporation. 5770 Uplander Way, Culver City, California 90230. (213) 649-5983 TWX 910-328-6100. Fox Hills Industrial Center.

See Us at NAB Booth #331

Circle (165) on Reply Card

Broadcast Systems Consulting

- Facility Design - AM/FM/TV/Recording
- Equipment Installation
- R.F., Audio and Video Systems
- Computer FM and TV Channel Search
- Extensive Public Broadcasting Experience
- On-Site Consultation — Programming, Administration, Engineering and Development

G.A. GILBREATH ASSOCIATES

INCORPORATED
6357 LAWTON AVENUE • LAS VEGAS, NV 89107

LAS VEGAS, NV	(702) 878-8313
FRESNO, CA	(209) 439-8426
COLUMBUS, OH	(614) 882-5205

Circle (166) on Reply Card

NAB exhibitors

Wolf Coach (Booth 1225)
Products: Production truck.
Circle (761) on Reply Card

Frank Woolley & Co. (Booth 507S)
See at booth.
Circle (762) on Reply Card

World Tower (Booth 420)
Products: Antenna systems and hardware, engineering and design services, towers and tower equipment.
Circle (763) on Reply Card
see ad on page 148

Xedit Corporation (Booth 223)
Products: Splicing blocks, splicing tabs, drift and flutter meter, sound pulse generator.
Circle (764) on Reply Card

ZEI-MARK Corporation (Booth 1643)
Products: Optical multiplexers.
Circle (765) on Reply Card

Zenith Radio Corporation (Booth 505S)
See at booth.
Circle (766) on Reply Card

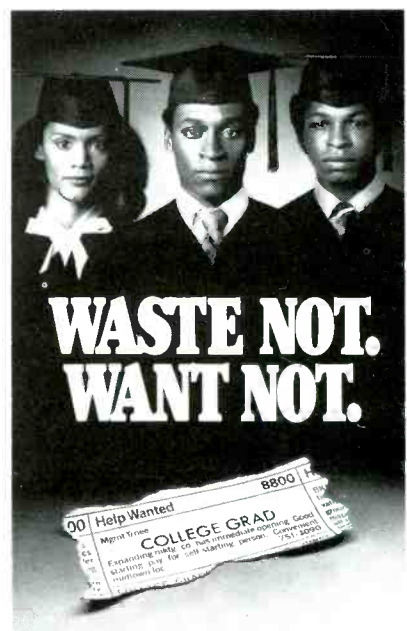

When you need to fill a position, you'll have a qualified graduate that you helped educate.

GIVE TO THE UNITED NEGRO COLLEGE FUND. A MIND IS A TERRIBLE THING TO WASTE.

Photographer: Dwight Carter
A Public Service of This Magazine & The Advertising Council



© 1981 United Negro College Fund, Inc.

NAB late exhibitor roundup

Allsop, Inc. (Booth 1814)

Products: 3 cassette deck cleaner, 3 VHS video recorder cleaner, the "Beta" format video recorder cleaner, a prototype U-Matic format video cleaner.

Circle (770) on Reply Card

Bardwell & McAlister, Inc. (Booth 100)

Products: Focusing Fresnel lens spot lights, open face quartz flood lights, cyclorama lights, stands and accessories.

Circle (771) on Reply Card

Broadcast Audio Corp. (Booth 218)

Products: Amplifiers, production consoles and mixers.

Circle (772) on Reply Card

Clear-Com (Booth 174 & 176S)

Products: System II line of broadcast intercoms.

Circle (773) on Reply Card

EEV Inc. (Booth 925)

Products: Leddicon and Vidicon camera tubes, amplifier klystrons, character display tubes.

Circle (774) on Reply Card

Enterprise Radio, Inc. (Booth 120)

Products: National radio network broadcasting around-the-clock sports programming via satellite.

Circle (775) on Reply Card

Cliff Gill Enterprises, Inc. (Booth 160)

Products: Eumig FL-1000 broadcast quality cassette deck (audio), C-1000 stereo preamplifier, M-1000 stereo amplifier, Jock-Mate controller CGE/DRD-2000.

Circle (776) on Reply Card

Matthews Studio Equipment (Booth 1806)

Products: Location and stage equipment for lighting and camera control.

Circle (777) on Reply Card

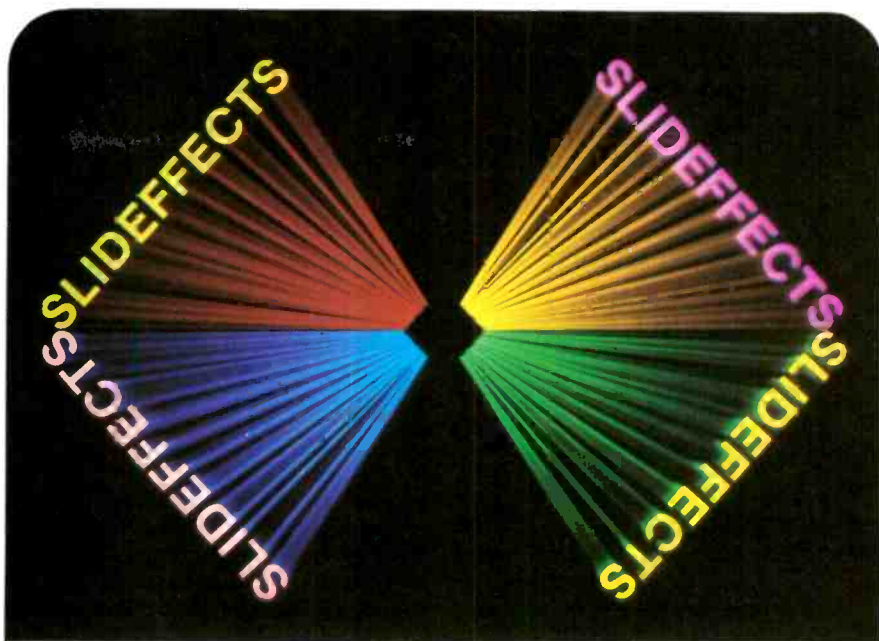

AFFORDABLE TITLE SLIDES



If you design titles, our slide synthesizing camera systems can help. It's easy to create exciting special effect slides on a Forox at a fraction of what it costs by other methods.

Let your imagination run wild... Glows, Neons, Posterizations, Splits, Pans, Zooms, you name it, and Forox can help you make it. And automatic features let you work quickly and accurately.

But there is more to Forox than just equipment. We also offer technical support, including a comprehensive training program to teach you the newest effects.

Add a helpful sales and service network, and it is easy to see why our Slide/Strip/Animation cameras are the choice of experts throughout the world. For details, talk with a Forox rep or send for literature.

Forox®

Forox Corp., 393 West Ave., Stamford, CT 06902 (203) 324-7400

Special effects courtesy of Slideeffects, Stamford, CT.

Circle (167) on Reply Card

Late roundup

Microprobe Electronics Inc. (Booth 408)

Products: Self-contained automation controller; a random select mini-programmer for carousels, instacarts or go carts; model 100 MP 48 event programmer.

Circle (778) on Reply Card

Pinzone Communications Products, Inc. (RCA Exhibit)

Products: RCD-100 diagnostic system, TCA-100 monitor alert, MRI-100 maintenance remote head.

Circle (779) on Reply Card

ROH Corp. (Booth 107S)

Products: Series 180 routing switcher, series 120 distribution amplifiers,

series 190 switcher monitor, series 200 modular audio equipment, series 300 intercommunications equipment.

Circle (780) on Reply Card

United Research Laboratory Corp. (Booth 414)

Products: Solid-state conversion amplifier.

Circle (782) on Reply Card

VIF International (Booth: mobile exhibit area, space 40)

Products: Magnetic tape reproducers for automation and background music, control room monitor speakers, intersperser for small automation systems, 25Hz make up units, detectors, and filters, carousel controllers for programming random

access units, remanufactured capstan drive motors for Ampex and Scully tape recorders/reproducers, accessories and up-dating kits for Ampex professional audiotape recorders, nonmetallic supporting guys for radio and TV transmitting towers, stereo graphic equalizers.

Circle (783) on Reply Card

Weatheration Inc. (Booth 1625)

Products: Dial-up color remote radar, 16-color computer graphics generator and mapper; fully digital satellite receiver with user selectable background colors and maps, new features for color radar: pan and zoom, 2-color underlays, pseudo-sweep, 8-frame storage capacity.

Circle (785) on Reply Card

British plan teletext push for NAB - '81

The British are planning an exhibit at this year's NAB show of the world's first teletext editing and transmission equipment designed exclusively to meet the requirements of the 525-line, 60-field system that will form the basis of the British petition to the FCC for the system's acceptance.

The move comes as the US broadcasting and publishing community awaits developments on the question of a teletext standard and against a background of support within the electronics industry for a standard based on the British system. The British are preparing a detailed submission to the FCC as the first step in a campaign that will bring several major developments during the next few months.

The NAB display (booths 1923/1951) will include sophisticated editing and page manipulation capabilities as well as a direct link between off-air and cable television media, and possible expansion to cover the videotape market.

There will be displays of 525-line teletext showing up to 24 rows of text on US receivers equipped with UK decoders, including "live" pages from the public teletext services of the BBC and Independent Television updated from London via the telephone network. British Telecom's Prestel (view-data) terminals will also be displaying material direct from the operational

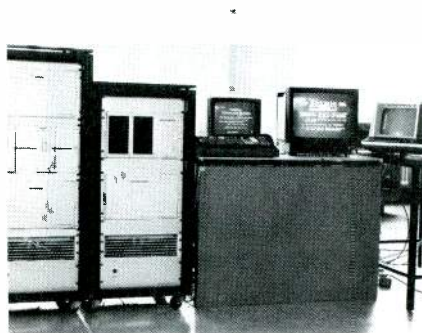

Jasmin teletext transmission and editing equipment.



The Logica Context teletext system in use at ORF, the Austrian Broadcasting Authority. A similar system will be demonstrated at NAB - '81.

data base in London, and demonstrating the ability of British teletext and view data to show full photographic quality pictures with text graphics.

The complete range of teletext enhancements to be demonstrated will include multi-language text; captioning and parallel attribute coding with a wide range of colors; telesoftware as in use in the UK; and down-loaded character sets.

The generating and editing equipment designed to meet the system specification as put to the FCC by the British Teletext Industry Group, and which is already proven and commercially available, will be demonstrated

by VG Electronics, Jasmin Electronics and Logica.

Britain's public teletext services, the first fully operational ones in the world, will be reaching 500,000 receivers by the end of the year, by which time 50,000 viewdata sets will be receiving British Telecom's Prestel service—another first.

Services based on British teletext are being progressively adopted by many countries in Western Europe: 160,000 UK system receivers have been sold in Sweden, West Germany and Austria. And in several major Australian cities, teletext services using the UK system are being financed from advertising revenues.

AUTO DRIVE ADDS AN EXCITING DIMENSION TO YOUR PRODUCTIONS

Model 7200 AUTO DRIVE™ is a computer which takes over full control of all functions on 6124 and 6112 production switchers, creating effects impossible to achieve by manual means. It can either drive the switchers directly, or can itself be controlled by editors or other devices. Conventional manual control can be regained at any time by the touch of a button.

AS A PRODUCTION TOOL. AUTO DRIVE™ has the capacity to store the entire switcher control panel configuration 255 times. It can then go from one configuration to the next under complete computer control. Durations can be programmed in either frames or minutes and seconds. The 255 events can be grouped into any number of independent sequences. Transitions between events may be either smooth or abrupt.

Sequences of keys, wipes and dissolves can be set up, rehearsed, changed and perfected live before editing. This saves a great deal of time. It also adds a complete new dimension to productions. Since all functions are controlled by the computer, transitions can be smooth, precise and rapid with faultless accuracy. Different patterns can move in different directions with simultaneous changes in border width, hue, etc. AUTO DRIVE™ is human engineered for ease of operation. Event configurations are established by manipulating controls on the switcher control panel before storing, so that the exact visual impact on the screen is known.

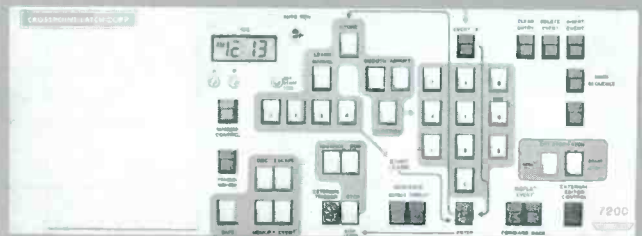

AUTO DRIVE™ Model 7200 Price \$12,500.

Sequences of keys, wipes and dissolves can be set up, rehearsed, changed and perfected live before editing. This saves a great deal of time. It also adds a complete new dimension to productions. Since all functions are controlled by the computer, transitions can be smooth, precise and rapid with faultless accuracy. Different patterns can move in different directions with simultaneous changes in border width, hue, etc. AUTO DRIVE™ is human engineered for ease of operation. Event configurations are established by manipulating controls on the switcher control panel before storing, so that the exact visual impact on the screen is known.

EDITOR INTERFACE. There are two modes.

EDITOR CONTROL mode, where the editor has full control of the switcher via the 7200. In this mode the editor calls up the inputs, patterns, durations and triggers the transitions at the proper time.

EXT. EDITOR TRIGGER mode (where complex effects far beyond the capability of the editor, are required). The events and durations are setup on the AUTO DRIVE™ computer, and triggered by the editor at the right time.

The 6124 production switcher has twelve inputs, two fully independent mix-effects systems with double re-entry. All signals are clamped twice, first at the inputs and then again after the switching matrix, providing a rock stable output. The downstream keyer, has matte key, with full preview. Each M.E. has its own keyer. The encoded chroma keyer has a variable delay line adjustable from the front panel, so the key source may be either a dedicated camera or the preview bus. The switcher includes an automatic blanking processor which strips incoming sync and burst from the video signals and replaces them with internally generated signals, making the output independent of differences in sync signals between cameras and eliminating problems caused by Sch phase.

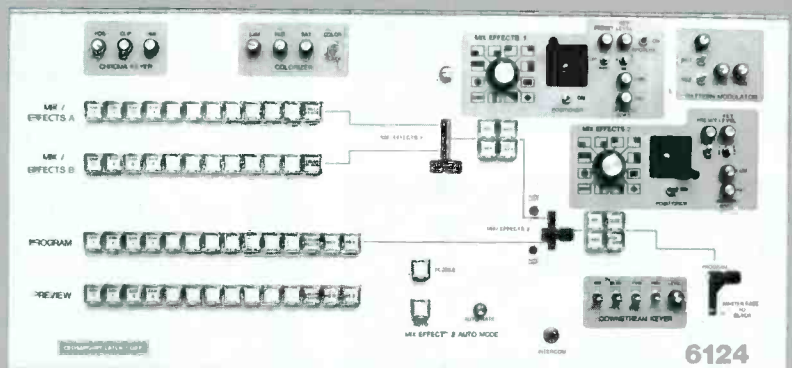

Model 6124 Price \$13,600. PAL \$14,600.

CROSSPOINT LATCH CORP.

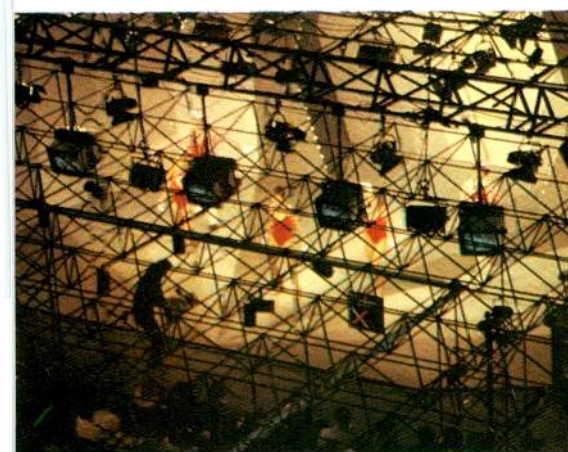

Case Study: Diary of an NAB exhibit

Exhibitors spend a lot of money and time preparing for the annual NAB convention — and experience shows that the effort pays off. This brief article goes behind the scenes to see how one exhibitor last year created

a show-stopper booth. The extensive preparations that made this exhibit possible will make clear the efforts manufacturers expend in making the NAB convention an informative and entertaining experience.

The Thomson-CSF Broadcast (TCB) show at the NAB-'80 Convention was one of the most unusual presentations ever associated with a new product introduction at this technical exhibition. The two-part presentation consisted of a 12-minute product display segment and a 7-minute technical explanation during which the audience was exposed to an intricate set of live color camera demos followed by an electronic slide review of the new TTV 1525 color camera.

Thomson had chosen NAB-'80 to make the first global introduction of its 1525 to the broadcast world, and wanted something special that would attract delegates and get the camera story across. The success of this NAB spectacular could be easily observed by the audience that packed every performance, once word got around about the spectacular show.

Every exhibitor at a major convention has certain goals and Thomson had these:

- To identify Thomson as a prestigious broadcast equipment supplier in the United States;
- To meet realistic sales goals which would help defray a portion of the cost of participating in the NAB convention; and
- To develop new and prospective customer contacts within the framework of a crowd-gathering show that would attract delegates and garner favorable comments from key industry representatives.

By the end of NAB-'80, Thomson management was satisfied on all counts. The effort that had stretched over an eight month period had culminated in a well-accepted, fast-paced presentation that accomplished its intent. The show moved, the products worked, the customers were pleased and the salesmen wrote orders. What more could anyone ask of an NAB?

The conceptual side

Dreaming up a hit show for the NAB was not easy. First there were limits of space and budget to



Why do animation on videotape?

Come to the Animation Video booth (407 S)
at N.A.B. and we'll show you.

Actually, the reasons for doing animation on videotape are the same as the reasons for doing animation on film—clarity, graphic impact, variety, individuality of style—all factors which lend distinction to programming of any kind. But until now, the long production schedule of film animation has eliminated it from many broadcast applications such as news, weather, and sports

The new Anivid system changes all that by making possible full color, broadcast quality, frame-at-a-time animation directly on videotape, saving time, money, and producing a higher-quality finished product than film transferred to tape.

So seek us out at N.A.B. and we'll show you broadcast-oriented animation being produced while you watch. We're in Booth 407 S in the combined radio/TV exhibits in the South Hall. Or request our literature by mail or by phone.

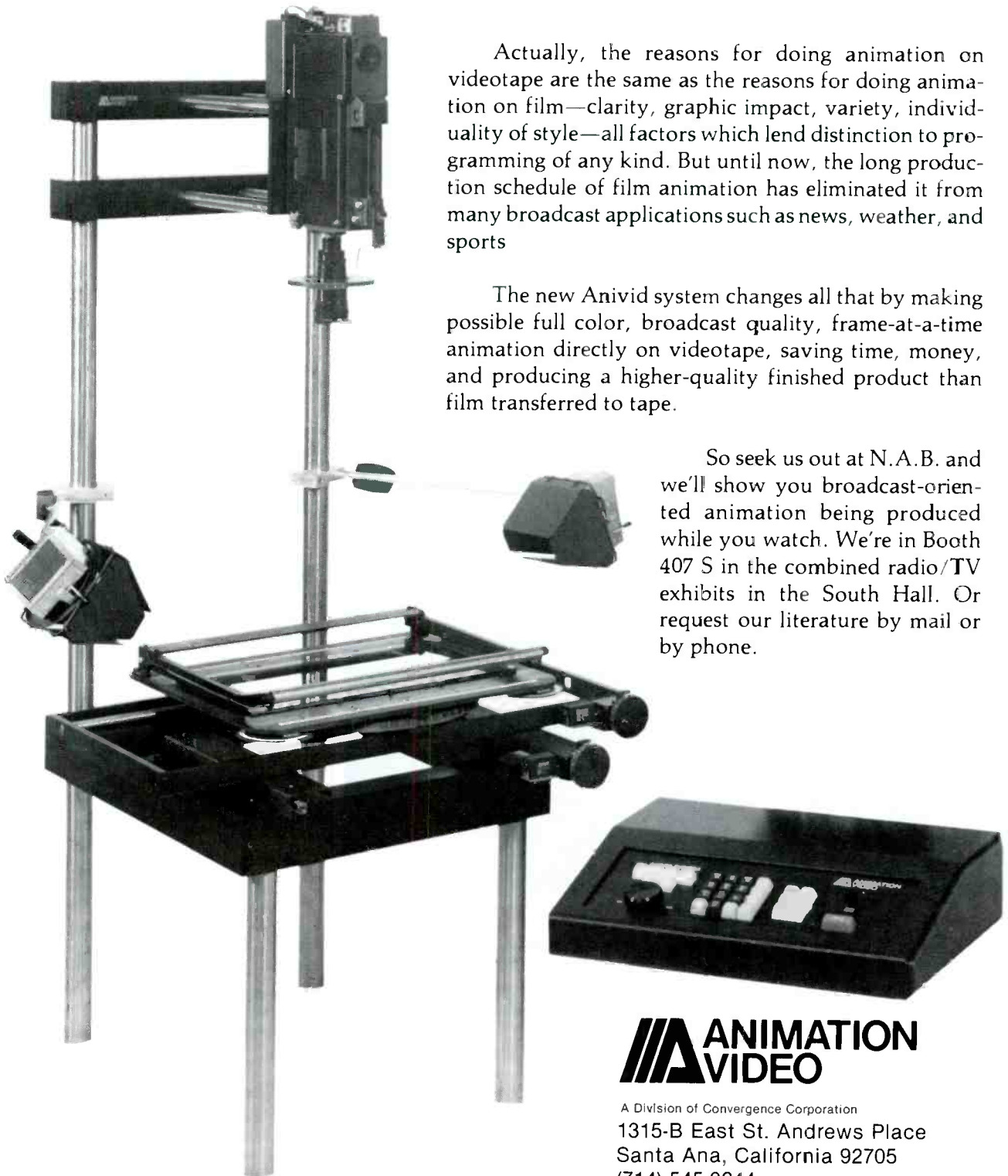

**ANIMATION
VIDEO**

A Division of Convergence Corporation
1315-B East St. Andrews Place
Santa Ana, California 92705
(714) 545-0244

Diary: NAB

balance with a short-run production that would live for only four days. Second, there were the constraints imposed by the NAB rules that virtually prohibit name performers, or outright entertainment that does not relate to the products on display. Faced by those parameters, the Thomson staff, led by Bill Fink, began looking for a proper visual vehicle for their product introductions as far back as August 1979. The exhibit designers, Harry Murphy + Friends of Mill Valley, CA,

were instructed to include a stage area for a live show in the initial layout.

Several conferences were held in November and December to decide on final booth design, equipment allocation and positioning, the stage structure, and the lighting grid for whatever presentation was to be decided on.

By mid-December the concept of a series of dance sequences depicting ballet, vaudeville and disco had been planned. However, in late December, the incorporation of a magic act was suggested. The Mark Wilson group of Hollywood was

selected for this addition.

Thomson hired two additional Hollywood professionals: Bruce Franchini to produce and direct the show and John Retsek to design the stage and set (A very important aspect of demonstrating color cameras properly). This team began to sketch the stage design, the dance numbers, the costumes and the magic acts that were to go before the cameras.

On the product display side, the four cameras that were demonstrated in the show were evaluated as to how they could best be exposed to the audience in a real working environment.

It was decided to incorporate the lightest ENG camera into the first dance number. The camera operator actually moved with the dancers as he hand-held the camera. The resulting pictures appeared on the bank of five Conrac 6142 monitors mounted overhead.

The EFP and studio configurations of the three other cameras would be used on tripods and pedestals to match normal studio conditions. These cameras covered the rest of the dance numbers, which were interspersed with magical illusions.

The technical part of the presentation was assumed to have a smaller audience potential. It was planned to utilize specially prepared color slides, sequenced through a high quality flying-spot slide scanner and switched up on the same bank of color monitors in sync with the narration.

Both scripts for the two segments of the equipment presentation were written to fit both the agreed-on time limits and the coordinated show sequences. The series of products to be demonstrated were allocated priority ratings as to how much time in the show each would have, and the narrative was tailored to fit. It was planned that a male announcer would cover both the production segment and the technical presentation in both an "on camera" and "voice over" mode as the show progressed.

Two months before NAB-'80 a production meeting was held at the Mark Wilson facilities in Hollywood, and this was quickly followed by a strategy meeting that included a model of the set and a review of some of the AV materials.

The rehearsal phase

By mid-March a formal production meeting included the first rehearsals, a look at the costumes and some of the illusions to be presented. The elements all seemed ready for fine tuning the finished

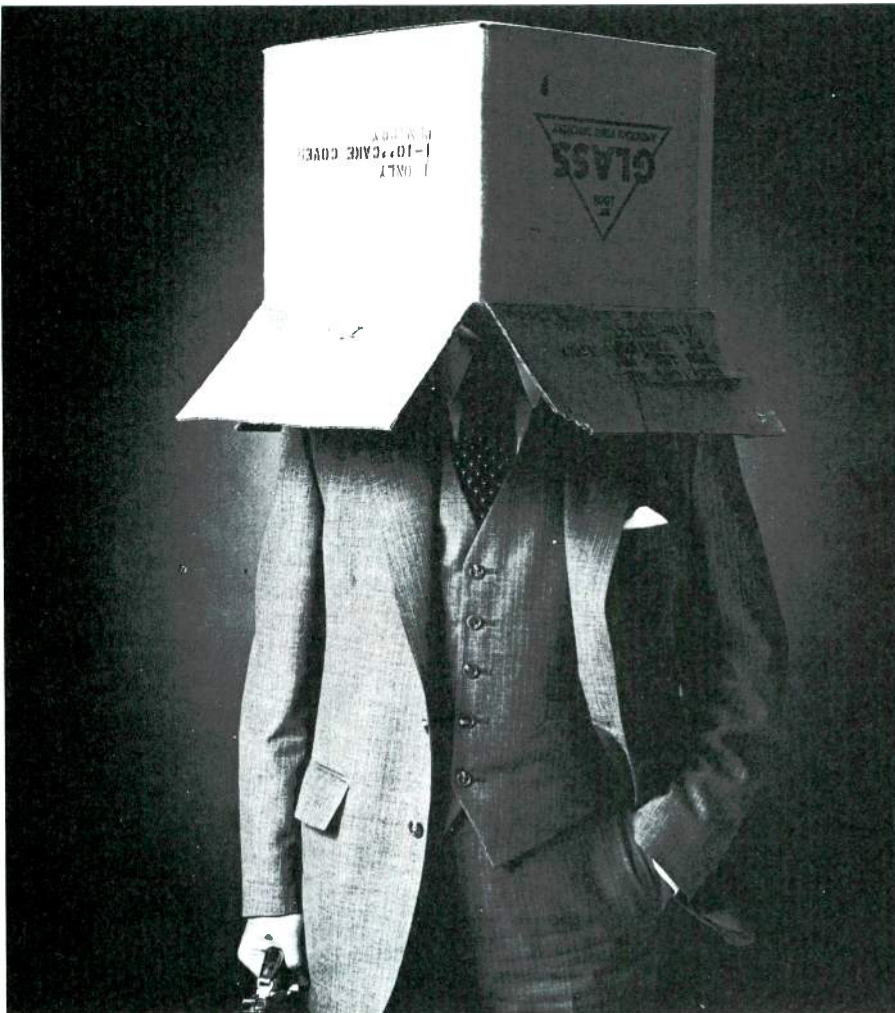

WHAT THE WELL STRESSED MAN IS WEARING THESE DAYS.

Ah, we're a funny breed, we humans. Seems like we've got this crazy notion that the best way to deal with a problem—at home or on the job—is to shut-up, clam-up, back-off, or hide-out.

Instead of talking our problems over, we think it's better to shut the whole world out, to "keep things to ourselves."

But that just causes a lot of unnecessary stress... and makes the problem a lot worse.

This isn't a lecture, or a sermon. It's just a simple reminder: let's keep our options open by keeping our mouths—and our ears—open. Because, when we shut others out, we only box ourselves in.

And that's a *real* problem.

**WHEN YOU SHUT OTHERS OUT,
YOU ONLY BOX YOURSELF IN.**

concern counts

A community project sponsored by the
Kansas City Association for Mental Health.
© 1980 Concern Counts

Satellite System Science.

Cost-Effective Programming Via Satellite

Rely on Microdyne's Satellite System Science.

Microdyne offers sophisticated satellite receiving equipment that provides high quality signals for retransmission. Our decade of experience and proven technology result in access to satellite programming sources for approximately one-third less cost than our competition.

Microdyne offers high performance satellite receiving systems to broadcast networks.

Our 1100 TVR (X-24)(B-2) has the capability of multiple audio demodulation and our systems meet or exceed the 52 dB video signal noise ratio. Microdyne's technical expertise will improve your broadcasting system and keep you ahead of your competition.

Rely on Satellite System Science from Microdyne. We have years of proven experience manufacturing the most sophisticated, cost-effective communications systems in the industry.

Satellite Systems Science.

Microdyne Corporation / P.O. Box 7213 / Ocala, FL 32672 / (904) 687-4633 / TWX-810-858-03C7

Circle (170) on Reply Card



**NOW... The leading magazine
of broadcast technology,**

BROADCAST.
ENGINEERING

**brings you an important
new technical tool...**

DIRECTIONAL ANTENNA HANDBOOK
by Robert A. Jones, PE

ONLY \$12.95

Based on the recent **Broadcast Engineering** series, this 104 page volume focuses on the essentials of directional antennas then expands to encompass the entire arena of design, from a two tower array through twelve tower systems. Chapters cover such important areas as:

- Design of nighttime directional antennas.
 - Calculating RMS efficiency.
 - The FCC's Standard Method of calculating directional antennas for submission with FCC applications.
- Additional sections review the basic math used in calculations and provide tips on using computers and hand calculators for computation.

Whether you use a consultant or design your own systems, this book is an absolute must. Order yours today!

The Latest From The Leader In Broadcast Technology...
Broadcast Engineering's Directional Antenna Handbook
ONLY \$12.95

Directional Antenna Handbook

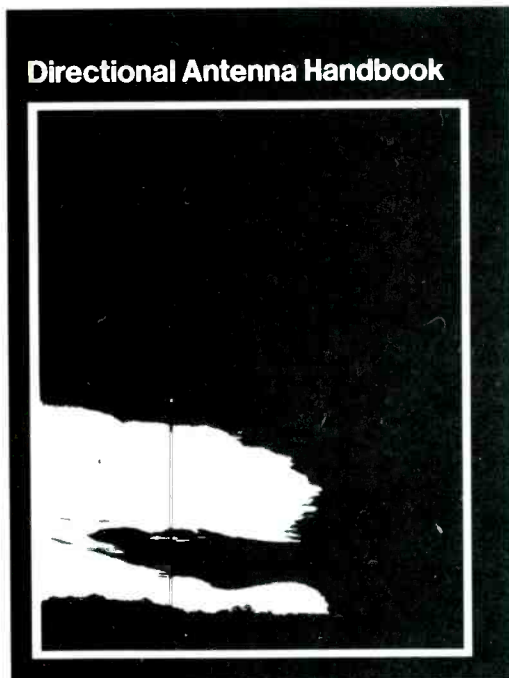

ORDER FORM

BROADCAST.
ENGINEERING

P.O. Box 12901, Overland Park, KS 66212

Please send me _____ copies of the Directional Antenna Handbook at \$12.95 each. (Postage Included.)

My check or money order is enclosed.

Name _____

Address _____

City _____

State _____ Zip _____

production. In addition, the technical presentation was reviewed from available slides and graphics, and decisions were made on creating the add-on material that would reflect the latest status of the 1525 camera, the highlight of the show.

At the end of March, talent interviews were held to select the announcers for the show, Boyd Matson and Melanie Vincz, who also doubled as a model for camera demos between the staged presentations.

The dress rehearsal was on Saturday night, the day before the show opened, and some last minute changes were made as the equipment to support the show was being installed and turned on at the Thomson booth.

As with most high pressure, complex productions, the hours just before opening were utter chaos. Luckily, the adrenalin that begins to flow when a fully-costumed performance finally goes on served to tie it all together into a coherent and eye-catching extravaganza that pleasantly surprised everyone.

The product presentations

The first 12-minute show had to accomplish three things:

- Expose each of the cameras on display in a working mode;
- Draw attention to the other products that Thomson had on display; and
- Keep the audience interested enough to sit (or stand) through the entire presentation.

The first objective was met by involving the four different cameras in sequential parts of the show. The lightweight ENG camera was hand-held on stage, and the cameraman actually moved among the dancers to get low-angle shots or close-ups of the performers as they went through the first dance number.

The announcer for the show did the voice-over while the performers were on stage, or provided the segued sequences between the acts, where he described the features of the cameras and introduced the next one. The second segment involved the 701 EFP camera; the third segment used the 1650 low-cost studio camera for its coverage. Finally, the last half of the show, with its more intricate choreography and its more spectacular magic, was covered by the newest Thomson camera making its world debut at NAB—'80, the 1525.

There were five shows a day, timed to interfere as little as

1000 TVM



Television-Modulator

Microdyne's 1000 TVM provides a high quality vestigial sideband television signal.

This low cost unit includes output channels that are easily changed by simply replacing the output converter PC board.

Keep up with the competition with Microdyne's 1000 TVM.



P.O. Box 7213 / Ocala, FL 32672 / (904) 687-4633 - TWX-810-858-0307

Circle (171) on Reply Card

ROH Puts It All Together



Intercom, 2-way Radio, Telephone, Camera Interphone and Talent IFB.

With a combination like that, why settle for less than ROH quality?

Intercom and modular audio equipment



ROH CORPORATION

3503 Clearview Place, N.E.

Atlanta, Georgia 30340

404/452-4240

See Us at NAB Booth #107S

Circle (172) on Reply Card



- Take One or Two
- As Needed for Relief
- of Systems Proof Headaches.



BROADCAST ENGINEERING'S AM & FM Proof of Performance Manuals...



...Give fast relief for those minor "aches and pains" that arise as you prepare, perform and log the results of your annual systems proof. Here's what you get:

THE AM PROOF

Our AM Proof-of-Performance Manual is a complete guide to the AM E.P.M. Like the FM Proof-of-Performance, this manual includes *all* the required logging forms and everything you need to know to complete your performance measurements...including a chapter devoted to testing for transmitter harmonic output suppression.

THE FM PROOF

Broadcast Engineering's FM Proof-of-Performance Manual includes: All required logging forms for pulling *both* mono and stereo proofs. A complete chapter of FCC Rules. Dozens of helpful troubleshooting tips and time-saving measurement and logging techniques. Detailed procedures on how to *pre-test* your station before pulling the Proof. And more.

Both Proof Manuals show you...

- how to prepare the test equipment
- how to connect the test equipment
- an efficient method of measurement and a look at the performance requirements
- how to use the data summary sheet and evolve the graphs
- how to comply fully with FCC rules and standards

BROADCAST. engineering

P.O. Box 12901, Overland Park, Ks. 66212

- Please send me _____ copies of the FM Proof-of-Performance Manual @ \$7.95 each
- Please send me _____ copies of the AM Proof-of-Performance Manual @ \$7.95 each
- Please send me _____ sets of the FM and AM Proof-of-Performance Manuals @ \$14 for BOTH.

- My check or money order is enclosed

Name _____

Address _____

City _____

State _____ ZIP _____

Volume discounts available on request.

NOTE: Broadcast Engineering pays the postage on all orders!

Diary: NAB

possible with neighboring presentations of other exhibitors. The frequency of the shows was geared to optimize visitor viewing while allowing adequate rest periods for the performers and sufficient quiet time for product specialists to explain Thomson products to customers.

Of course, there were surprises that had to be dealt with on the spot. One came when the technical presentation using slides on the color monitors from a Thomson flying spot scanner failed to hold an audience. The voice overlay was done by Boyd Matson, the announcer for the main product presentation; somehow this combination did not click.

Melanie Vincz was hastily taught the technical terms and substituted as a "tongue-in-cheek" engineer doing the narration in step with the visual images showing the camera features, the inner structures and simple block diagrams. This approach kept most of the earlier audience, and even attracted others to sit down and watch her impromptu performance as the most attractive "engineer" at the NAB show.

Recap

A successful show is the result of a cooperative effort by a dedicated group of people, each of whom covers the particular part of the jigsaw puzzle that makes up the finished picture. The Thomson presentation was no exception. Perhaps the best summation is the credit list at the end of the show. Here are the people who were involved:

Executive producer Bill Fink
Producer/

Director Bruce Franchini
Scenic Design John Retsek
Costume Design Maureen Retsek
Exhibit Design Harry Murphy
+ Friends

Choreography/

Dancer Tammy Greenough
Performance Coordinator/

Dancer Keith Truesdaell
Illusions Mark Wilson Productions
Lighting Imero Fiorentino/
Ken Polius

Script Joe Roizen
Still

Photography Donna Foster-Roizen
Announcer Boyd Matson
Announcer/Model Melanie Vincz
Cameraman Gil Shilton
Cameraman Dan Webb
Dancer Susie Bonswar
Dancer Sandy Chanley
Dancer Dave Rodriguez
Stage Manager Kevin Kennedy



X-24

1100 Television Receiver

Microdyne's \$100 TVR X-24 has ultimate quality and cost efficiency. It is Microdyne's sixth generation satellite receiver.

This 24-channel receiver can be tuned manually by using front panel controls or remotely via a wide choice of remote tuning methods, including computer control.

Invest in Microdyne's X-24 for high performance satellite reception.



P.O. Box 7213 / Ocala, FL 32672 / (904) 687-4633 / TWX-810-858-0307

Circle (173) on Reply Card

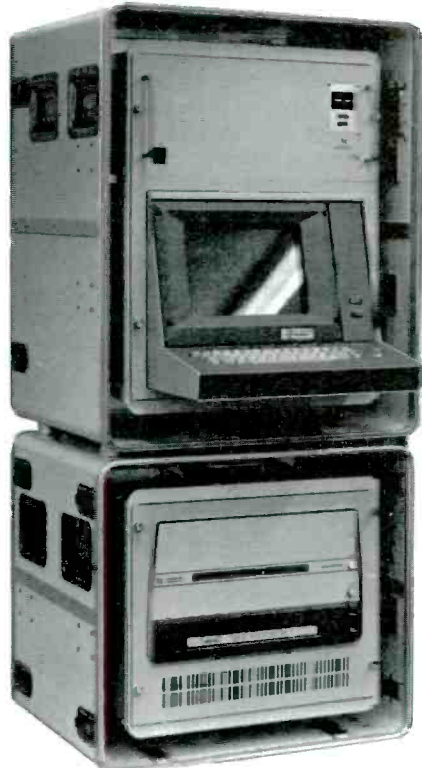

The Original Transportable Enclosures ... Still the Best

10 years and hundreds of applications prove it. These ECS enclosures provide instant portability for electronic equipment. 17 standard rack heights from 5.37 in. (136MM) to 47.37 in. (1203MM) and capacities from 20 lb. (9 kg) to 320 lb. (145.3 kg). Tough, pressure molded fiberglass enclosures are supplied complete with shock mounted aluminum rack, removable covers, heavy duty handles and latches, gasketed closures and air valve. Available with a full line of accessories and drawers.

U.S. Patent 3,482,895



ENVIRONMENTAL CONTAINER SYSTEMS, INC.
3560 ROGUE RIVER HWY., P.O. BOX 188
GRANTS PASS, OREGON 97526
(503) 476-8871

Please see us at NAB Booth No. 408S

Circle (174) on Reply Card

KEYN takes on new look

Larry Waggoner, director of engineering, Long Pride Broadcasting

KEYN's new owners have given it a facelift.

KEYN, Wichita, KS, was purchased in 1980 by Jim Long, former president, TM Productions, and country singer Charlie Pride. KEYN first began operation in 1967 as a 250W daytimer (licensed by the former owners as KSIR). In 1968 a new 58kW (now 100kW) FM station was constructed (KEYN-FM). At the time, KEYN studios were in a converted farmhouse. In 1973, new studios and offices were constructed in a former bakery at a shopping center. Then in 1977, the owners of KEYN AM and FM (Mr. D's Radio Inc.) purchased KWBB-AM, with 5kW daytime and 1kW nighttime. The original AM station was sold at that time and the studios went with it. The entire KEYN operation moved to the KWBB studios.

The original KWBB building had been constructed in 1951. There were four control rooms, but unfortunately they were all monaural. A new FM control room was built in a large room that once served as a studio for live radio shows and had recently been used as a conference room. The stereo production equipment from the old KEYN studios was quickly set up in the existing production studio A. The previous FM board replaced another mono board in production studio B.

In 1979, negotiations began to sell KEYN AM & FM to Jim Long and Charlie Pride, both of Dallas. On

September 15, 1980, KEYN-AM became KQAM. Because of his association with TM, Long was committed to high quality audio and therefore he thought that the first priority at KEYN/KQAM should be to improve the production facilities.

One of the hardest jobs was tearing out the old studios, as most of the equipment was built-in. He started by removing everything, down to the bare walls. The existing walls in both studios A and B were made of concrete blocks and were fairly soundproof, however, the rooms had a very live sound. To deaden the rooms, he covered the walls with sound panels, modeled after ones at TM's studios in Dallas. These panels consist of a felt outer-layer over decorative Masonite grill-work. Behind this is an inch of air-conditioning duct insulation. This sandwich is attached to a piece of ¼-inch plywood, and the whole thing is nailed to the walls on furring strips, leaving an air-space of ¾ inch. New carpeting was installed and a suspended ceiling was hung in both rooms.

Both of the production studios had three windows, each with one of them facing an office. To decrease sound transmission to the offices, he covered the double-paned windows on the studio side with two inches of Styrofoam held in place by a piece of 3/8-inch plywood. The plywood was then covered with decorative cork tiles. These window panels can

be easily removed to provide sight into the adjoining rooms.

Studio A was larger than studio B and had more sound deadening panels. Therefore two of the panels were omitted and decorative cedar was installed instead. This studio also had an adjacent room that formerly housed an automation system and was currently being used for tape storage. There was enough unused space in this room to allow a 5x10-foot announce booth. The walls of the booth were also covered with the special sound panels.

Both production studios were then equipped with Auditronics 110 consoles, Technics SP-15 turntables with Audio Technica tone-arms and Stanton 600A cartridges, Audio Metrics preamps, ITC Series 99 cartridge recorders, MCI 2 track reel-to-reel recorders, Pioneer cassette decks, Orban reverbs, UREI LA-4 compressors, SAE 2200 power amplifiers, JBL 4311 BWX speakers, Sennheiser HD 421 microphones and the existing Ampex 440 reel-to-reel recorders. An MCI 4 track reel-to-reel recorder was purchased for Studio A.

Everything was built modular this time (if there is ever another move). The reel-to-reel decks were installed in matching Ruslang cabinets, and the turntable cabinets and equipment racks were made by Kustom Kraft. The turntable cabinets were filled with sand bags to prevent



Part of the studio at KEYN before renovation.



The new studio features modular units for easy relocation.

resonant feed-back at high monitor levels.

The previous production studios had been bothered by rf, not only from their own 5kW AM signal, but from 100kW KFDI-FM, whose transmitter and tower are adjacent to KEYN's. The main concern in wiring the studios was to avoid ground-loops. The rf problems were less than expected. All inputs and outputs of the console and other equipment were run through the patch bays (supplied by Auditronics). The patch panels are factory wired so that all the shields are capacitor-isolated. Therefore, when wiring the equipment, all wires, including the shields, were connected to their normal places. Thus, the shields are above ground at the patch bays and grounded at each piece of equipment. Then all equipment was connected with a single, heavy ground wire. The first time the consoles were turned on, there was no rf, and the equipment wasn't even connected to the station ground.

However, there was rf in the head cables on all three MCI tape decks. To eliminate this problem, a ferrite bead was slipped on each pin of the head cable connectors and the head cable plugs were pushed over them. These beads are available from Amidon Associates in North Hollywood, CA, as part number FB 43-101.

To finish the studios, furniture was purchased that would complement the decor. The felt-covered panels in both studios were done in shades of browns and tans and the cedar panels were finished natural. Upholstered, wooden stools (for announcers and clients) and "butcher block" typing tables fit right in.

Another project that was included with the new production studios was a separate music dubbing studio in the music director's office. Because all the music at KEYN/KQAM is on cartridge, too much production room time was being taken up in dubbing records to cart. The new dubbing facility consists of a Technics SP-10 turntable with Audio Technica tone arm and a Stanton 600EE Cartridge, a McIntosh C27 preamp, an ITC Series 99 cartridge recorder, an SAE monitor amplifier and Pioneer speakers.

Besides the production and dubbing studios, finishing touches are being put on the new KEYN-FM and KQAM air studios. And, a new news center is being built between these control rooms. □

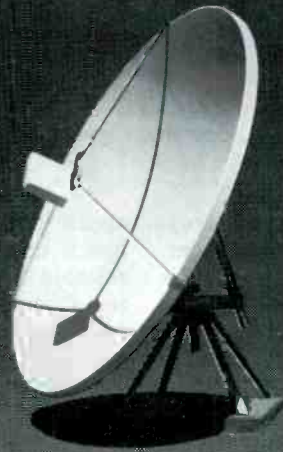

12-Foot Antenna

Rely on Microdyne for excellent reception. Microdyne's 12-foot parabolic antenna has ideal reception in EIRP contours between 36 and 33 dBW and delivers sparkle-free reception.

Complete your receiving system with a 12-footer from Microdyne for high performance capabilities.



P.O. Box 7213 / Ocala, FL 32672 / (904) 687-4633 / TWX: 616-858-C307

Circle (175) on Reply Card

Introducing FM wireless intercom headphones!



Superb, interference free, intercom up to 150 yards! FCC certified and license free. 5 Channels available. Comfortable and lightweight...only 11 ozs. without std. 9v batteries. Soft, foam-filled, vinyl ear cushions provide excellent acoustic seal, reducing ambient noise. Interface capability with wired systems.

- TV & Film cameramen producers, directors.
 - Football coaches, assistants, spotters.
 - Manufacturing personnel.
 - Security personnel.
 - Theatre crews.
 - Language translators.
 - Tour directors.
- Request Bulletin-5T for TR-50 and other FM wireless models.
- INTERCOM MODEL TR-50 **\$297.**

INTERCOM

Manufactured by:

R-COLUMBIA PRODUCTS CO., INC.
2008 St. Johns Ave. Highland Park, IL 60035
(312) 432-7915 TWX: 910-692-2160

Circle (176) on Reply Card

Computerizing the business at WBBQ

By Harley Drew, vice president, operations and program director, WBBQ-AM, Augusta, GA

The decision to change from manual methods of traffic, accounting and billing at a radio station is probably one of the most difficult that any manager will have to make. Not only does it represent a substantial cash investment, but it means upsetting familiar routines for everyone from the sales people to the announcers and, perhaps, creating anguish in the minds of staffers who fear the computer. That fear may stem from the idea that they cannot adjust to a new way of doing things and resentment of an electronic intrusion into their particular area of the station operation. Additionally, they may think of the new computer not as a new tool to ease the burdens of the job but as their replacement.

When the decision was made to computerize WBBQ, everyone on the staff was ready to relate "horror stories" from friends who had either lost their jobs because of computers or had seen an otherwise orderly office reduced to electronic rubble because of the enormous computer errors. One of the most common stories involved the company that tried it and finally had to relegate the new computer to a storage closet because it wouldn't work.

Nearing the end of the second year "on computer," the management at WBBQ thinks that most of the employees would consider turning in their resignations if the removal of the computer were announced.

Because so many systems are on the market today, the decision about which system to choose can be difficult. Although hardware is a large part of the decision, most systems are now using competent equipment from major manufacturers and this should not be the deciding factor. A computer won't do much of anything without the software programs that make it perform useful tasks, so these programs or features of the system should make up a major portion of the decision.

Several questions need to be answered when looking at the software portion of a prospective broadcast system. How closely does the material produced by the system match the station's needs? Are the reports produced by the system easy to read and helpful to station

operation? Is the software reliable, has it been fully tested and proved reliable at actual broadcast installations? Is the software user-oriented, or does it tend to confuse the operator rather than leading him step-by-step through each operation? Does the software vendor provide regular updates and improvements to the system? If so, what is the cost? And very important, does the vendor provide full support in the event of a software failure?

To answer these questions, carefully examine samples of the reports, program logs, invoices, statements and other material produced by the system and see how closely it fits into the operation. Ask the vendor questions about how certain spot rotations or orders are handled internally by his system. If possible,

call radio stations that are using the system and ask for their candid opinions. Find out what they like and don't like. Make an effort to actually visit an installation and talk to the traffic people and bookkeepers who use the system on a daily basis.

The proof is in the results, so don't be concerned about what operating language is used by the software programs produced by the vendor. Whether it is BASIC, COBOL, FORTRAN, or some other language is not really important—only what happens when you press the button.

Resist the temptation to buy too small a system in the hopes of saving a few dollars. It is amazing how fast the computer can be outgrown. Buy sufficient capacity to start with or be sure hardware is

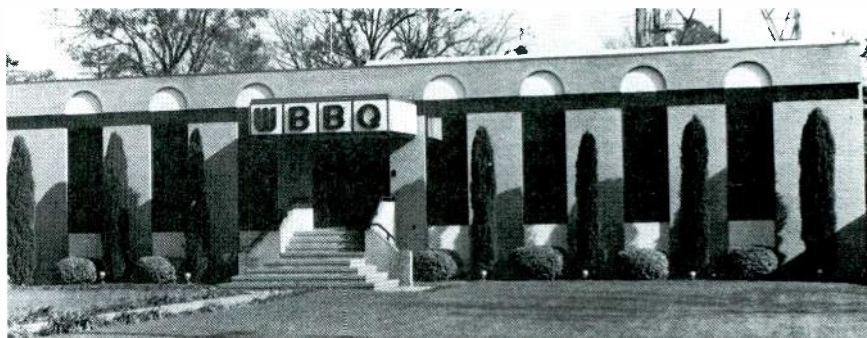

WBBQ-AM/FM, Augusta, GA, is proud of its latest acquisition—a business computer system specifically designed to ease station operations.

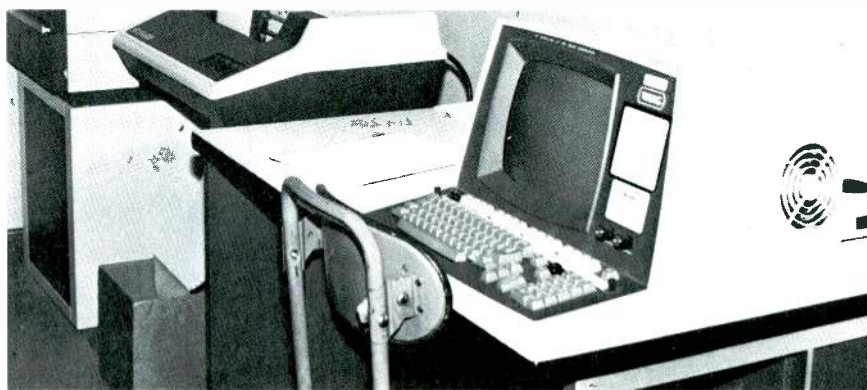

The WBBQ business computer, provided as a turn-key system by Computer Concepts, Shawnee Mission, KS, consists of four major components: (1) the VDT/keyboard input, CRT output display on the right; (2) the CPU (not shown), a small suitcase size computer beneath the table; (3) a printer that is custom modified to a standard 12 pitch printout; and (4) a disc drive that stores over 10 million characters (about 2500 pages of this magazine). Note also the small coupler (modem) just visible behind the terminal. This device, in case of system difficulties, can be used to link the business computer to the factory for diagnosis/corrections.

easily field expandable to handle future requirements. Make sure the vendor is supplying sufficient disc storage capacity and make sure the system chosen is fully capable of handling two or more work stations so that access to the system by personnel does not become a problem. Consider a separate printer for each work station too. Additional printers are not a major expense item and can really save time.

The system WBBQ finally decided upon is probably just a bit more elaborate than most stations would require. A dual-computer system was selected for redundancy purposes. If one computer were to go down, all functions would continue on the remaining unit. The added cost of this feature was not too great. Each computer shares a common 10 megabyte disc storage system. One of the units is installed in the traffic department with a CRT terminal and a dot matrix type printer. The other computer with CRT and printer is installed in the accounting department.

Because each of the units has common access to the programs and data base stored on the magnetic disc system, all functions are available at either work station. Program logs and order entries for accounting can be printed. Also, payroll checks and balance sheets in the traffic department can be run off. During busy periods, it is not unusual to find traffic people in the accounting office entering last minute orders to go on the Monday program log while at the same time the Saturday program log is being printed in the traffic office. This hardware arrangement offers great flexibility.

Additionally, WBBQ's system is configured to allow each work station to do "background" processing. The computer can be assigned a task such as printing an updated master list of station customers and while this is in progress the operator can continue interactive operations on the CRT terminal such as entering new customer orders. In effect, four different jobs can be in progress at the same time.

Why computerize?

The idea of installing a computer to handle the traffic, accounting and billing functions at WBBQ had been discussed off and on for a number of years. Either the state of software development did not seem sufficiently advanced, or the expense couldn't be justified. But, as is often the case, necessity was the mother of invention. Station business grew to the point that it was

1000 TVRM



Television Receiver-Modulator

Microdyne's 1000 TVRM has unsurpassed quality of reception and signal modulation. The 1000 TVRM combines the field proven X1-S receiver circuitry with a high performance television modulator. This technical combination results in an extremely cost-effective receiver-modulator.

Demand high performance reception with Microdyne's 1000 TVRM.



P.O. Box 7213 / Ocala, FL 32672 / (904) 687-4633 / TWX-80-858-0307

Circle (177) on Reply Card

Take a Waters slim-line space-saver



New MM thin-line faders are great for small portable mixers or lighting consoles. Only half the width of conventional faders, our 3/4-inch wide MM series lets you build a lot of mixing or control capability into a limited space. No performance compromise, either. You get Waters' proprietary Master® conductive plastic resistance elements. Dura-hard. Smooth. Long-lasting. You get Waters' computer-controlled curve shaping for highest tracking accuracy. And, you can choose 2 3/4-inch or 4-inch travel; 500 ohm or 10,000 ohm impedance; linear, and, of course, true log characteristic. For complete information, circle the reader service card, or call Bob West at (617) 358-2777.



WATERS MANUFACTURING, INC.
LONGFELLOW CENTER, WAYLAND, MA 01778

Circle (178) on Reply Card

We have the best 2/3" tube for your EJ camera...now.

tube talk



P-8160 Leddicons®

**The newest addition to
the successful family
of EEV Leddicon tubes.**

The P-8160 is directly interchangeable with all existing lead oxide tubes.

Lowest lag and no blooming.
EEV Leddicons are rated the best for these image tube characteristics.

EEV 2/3" Leddicons meet the same high performance standards as the 1" and 30mm Leddicons, and are the newest extension to EEV's hallmark of high quality and reliability.

The P-8160 is the best 2/3" lead oxide tube available TODAY.

Call or write today for complete details.

* Registered Trademark of
EEV Lead Oxide Camera Tubes

At EEV . . . your image is our business.

See Us at NAB Booth #925



EEV, INC.

7 Westchester Plaza, Elmsford, NY 10523, 914-592-6050
EEV CANADA, LTD., Rexdale, Ontario, 416-745-9494
English Electric Valve Co. Ltd., Chelmsford, England
Telex 851-99103

Members of the GEC Group of Companies

WBBQ

difficult to get the billing out in a reasonable period of time, agencies were requiring more and more "exact time" data on their invoices, and traffic was unable to produce the required program logs without putting in overtime.

At one point, part-time people were doing nothing but pulling exact times from program logs for billing purposes. And the FCC requirement that AM and FM programming be separate added enormous burdens to the traffic people, not only in trying to keep up with scheduling announcements properly in simulcast and separate programming periods, but in typing the additional program logs required for the second station.

People were involved with nothing but the boring task of typing logs. When weekends would roll around and six logs had to be prepared by Friday evening, or when a long holiday weekend came up, the traffic people were in an absolute panic trying to get the necessary logs ready. In many instances, last second business had to be turned away rather than face a revolt in the traffic department.

With the transition to computer, the traffic people are much happier and are able to accommodate last second business with relative ease. There are no longer any part-time people in traffic or accounting. Where it used to take as much as 4½ hours to type a fully loaded Friday log, the computer turns it out letter perfect in about eight minutes. Billing goes out promptly at the end of the month and the agencies are pleased with the fully detailed invoices they receive. Cash flow has improved as an additional benefit.

Last second contests and promotional announcements can be added to the program logs without even going through the traffic department. They are entered directly into the computer and it does all the work.

Many additional benefits to the computer traffic system have been found that weren't even considered when looking for a system. For example, an order can be entered that isn't to run until next year and the computer will execute it exactly as desired when that day arrives. The entire FCC 73.1202 announcement was scheduled a year in advance. The computer faithfully slots announcements in exactly as required and provides a detailed invoice at the end of each month showing the exact dates, days, and

Circle (179) on Reply Card

times of broadcast. These are kept on file as proof of performance.

There are many other benefits, too. Accounting is able to turn out paychecks for 28 employees in about 25 minutes with full year-to-date information and all required record-keeping. The management gets prompt reports on accounts receivables and past due accounts. Each salesman is provided with regular expiring order reports so that the client can be contacted well in advance for possible renewal. Announcers appreciate the clean, neat appearance of the easy-to-read program logs.

Traffic is no longer burdened with the need to keep up with available slot numbers for cartridges; the system automatically maintains an inventory of available slots and assigns a free number at order entry time. Expired cart reports enable traffic to pull the carts and return them for reuse on a timely basis. The system also handles complex cart rotations and switches carts at defined times or on defined days so a commercial doesn't say a movie "starts tomorrow" when it is "now playing." Two competing theaters don't run back-to-back either; the computer won't allow that.

Other features have also been added to the system. For example, the computer maintains a full inventory of all songs in the automation system (used on the AM station at night and on weekends) along with tray assignments, song titles, artist, intro time, length and category. Each automation program is done as a fully custom voice-tracked show and the computer provides the announcers with the music inventory in an easy-to-read printout that makes work much easier. The music director makes the changes each week on the CRT terminal and new reports are printed out in just a matter of minutes that reflect all the changes, deletions and additions.

The automation system has three 48-tray Instacarts for commercials and public service announcements. It used to be quite a problem for the traffic department to keep up with which trays were available and which trays were in use—also, what commercials were in which trays. A program was devised that automatically maintains an inventory of the available trays and prints easy-to-read reports on the trays currently in use and what announcements are in them.

The program has been made interactive with the broadcast sys-

X1-S



1100-FFC

Microdyne's 1100-FFC X1-S is our seventh generation satellite receiver. It has high performance features including threshold circuitry which insures optimum video performance in the presence of low carrier-to-noise ratios.

Rely on Microdyne expertise. Our X1-S offers excellent video-audio performance for your communication needs.



P.O. Box 7213 / Ocala, FL 32672 / (904) 687-4633 / TWX-210-858-0307

Circle (180) on Reply Card

Buy MARATHON, jam-free, cartridges at direct factory prices!

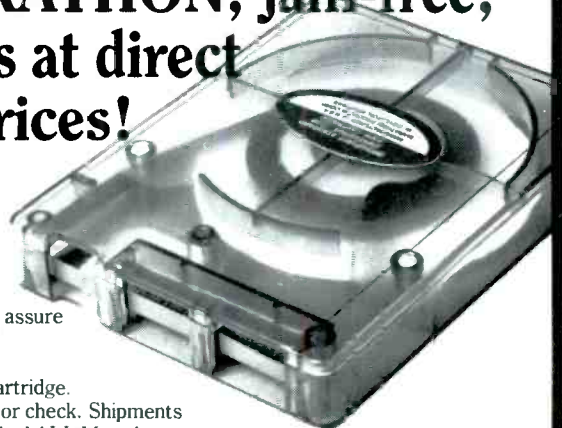

Competitive prices — with these major benefits (there are 13 more!) . . .

- SUPERB FIDELITY: wow and flutter are virtually unmeasurable;
- Differential Hub and Ring assure life time jam-free running; (patented)
- ONLY TRUE NAB AA cartridge.

Send your Purchase Order or check. Shipments are made within 24 hours. And ALL Marathon carts are guaranteed!

(Ask for prices on our other carts, and accessories.)

The BEST — at competitive prices — since 1963!

NAB AA Type Cartridge shown

Time At 7.5 IPS			#300 NAB Type AA	#300 NAB Type A	#300 Stereo Azmi-Lok [®]
20 Sec.	30 Sec.	35 Sec.	\$2.35 ea.	\$2.50 ea.	\$3.75 ea.
40 Sec.	60 Sec.	70 Sec.	\$2.50 ea.	\$2.75 ea.	\$4.00 ea.
90 Sec.	100 Sec.	2:30 Min.	\$2.65 ea.	\$3.00 ea.	\$4.25 ea.
3:30 Min.	4:00 Min.	4:30 Min.	\$2.75 ea.	\$3.25 ea.	\$4.50 ea.
5:00 Min.	5:30 Min.	6:00 Min.	\$3.00 ea.	\$3.35 ea.	\$4.75 ea.
6:30 Min.	7:30 Min.	8:30 Min.	\$3.25 ea.	\$3.50 ea.	\$5.00 ea.
9:00 Min.	9:30 Min.	10:00 Min.	\$3.50 ea.		

MARATHON PRODUCTS CORPORATION

334 West Boylston Street, West Boylston, Massachusetts 01583
Phone 617-853-0988

Circle (181) on Reply Card

IMPROVE VIDEO DUBS



The First Low Cost PROFESSIONAL IMAGE ENHANCER

- Adds sharpness and detail to video dubs
- Improves low cost color cameras
- B & W mode for proper enhancement of B & W materials
- Coring circuit helps reduce enhancement noise
- 3 input selector switches both audio and video
- Built-in distribution amp provides 4 outputs
- Available with BNC or RCA connectors
- 1 year limited warranty on parts and labor

vidicraft inc.

quality video components

3357 S.E. 22nd Portland, OR 97202

(503) 231-4884

dealer inquiries welcome

Circle (182) on Reply Card

WBBQ

tem's own tray assignment program and traffic need only designate the need for an automation tray to go along with the regular cart assignment at order entry time. A free number is instantly placed in the cart file and is printed out on the program log for WBBQ-AM. What was a big problem is now not even a small problem.

Most medium and large market radio stations have a fairly large list of record companies and other radio stations to which they mail their weekly music lists. This task was relegated to the computer, too. The system maintains a mailing list that allows new names and addresses to be instantly added, easy change of existing names or instant deletion of out-of-date information. Once a week the system prints self-adhesive mailing labels in about three minutes and it is a simple matter to mail out the music information quickly and easily.

Another program allows the general manager to call up a CRT display of the total value of the month's program logs and a projection of how the month is going to shape up financially. It also gives year-to-date information, last month's figures for comparison purposes and a projection of how the year is going to look. The display also gives a daily sales average for the month-to-date and for the year-to-date. If the general manager likes, he can push a button and get a hard copy printout for his own files. Access to this program requires knowing the proper "password" and the computer won't allow this information to be displayed without that key.

Even the engineering department can make use of the computer. A program was adapted to predict the coverage of an FM or TV station given variables of tower height, effective radiated power, frequency and terrain roughness. The program was devised by the Harris Corporation, which ran it on our computer to help us discover the best compromise between coverage gain and the financial cost of a new tower planned for next year. Other programs can figure resistor values needed for audio pads, power supply filter capacitor requirements and other such useful data.

Even really simple programs can help make life easier. Frequently, other stations request five to 10 duplicates of commercial announcements. When they are ready, a few questions are answered at the CRT

MODULAR ELECTRONIC CABINETS - DESKS and CUSTOM INSTRUMENT PANELS

EQUIPTO ENCLOSURE SYSTEMS — first in choice for excellence! Hundreds of standard sizes available in both our top-of-the-line Heavy Duty Modular Cabinets and the value-engineered Challenger/Solid System line. We also offer a totally new Electronic Desk System in a variety of styles. And since every electronic equipment company is unique and has different enclosure needs, we'll modify our cabinets to meet those requirements.

You can depend on us, just as many leading corporations do, for dependable products and service. The reputation we've earned is our proof! Choice of colors at no extra charge. Also, ask about our Engineering Evaluation program.

WRITE FOR FREE CATALOG



Equipto For Quality
**EQUIPTO ELECTRONICS
CORPORATION**

417 Woodlawn Ave.
Aurora, Illinois 60507
Phone 312/897-4691

Circle (183) on Reply Card



The disc pack being loaded here contains all the vital information (payroll, general ledger, traffic, etc.) of WBBQ. In the event of hardware/power failure, the station's crucial records can be removed and printed out with any Wang computer, anywhere. In addition, two duplicate sets of data on the drive are generated daily and stored away from the machine.



Judi Boulware, traffic manager, updates WBBQ's station records. With the number pad to the right of the standard keycard she can enter machine operations by code numbers. Operators accustomed to adding machines can do these entries at remarkable speed, and that's important if a salesman has a new stack of orders just minutes before a log is due.

terminal about what is needed on the label and the computer printer runs them off in about 10 seconds, all ready to stick on the tapes and perfectly typed.

Summary

The installation of the broadcast system computer at WBBQ has been one of the most important things the station has ever done. The advantages far outweigh any of the

shortcomings in the system, and new program modifications and features will even correct those as time goes by. It is hard to imagine ever going back to manual methods of bookkeeping, billing, scheduling and the dozens of other tasks that go into the proper operation of a modern broadcast facility. Newer members of the staff have never done these tasks any other way and wouldn't even know how.

A little careful planning and advance preparation can make the transition to computer reasonably smooth and trouble free. The biggest single problem may be overcoming fear and prejudice among staff members. Once they see how this modern miracle of electronics can make their jobs much more pleasant and free time from the drudgery of hours of scheduling, figuring, and typing, they will love it. □

NOW Automatic Audio Measurements end to end — in seconds

This microprocessor controlled Audio Transmission Test System has been purpose designed for the Broadcast Industry to check 46 parameters in 3.5 seconds.

Model S1100
Broadcast Audio Transmission
Test System

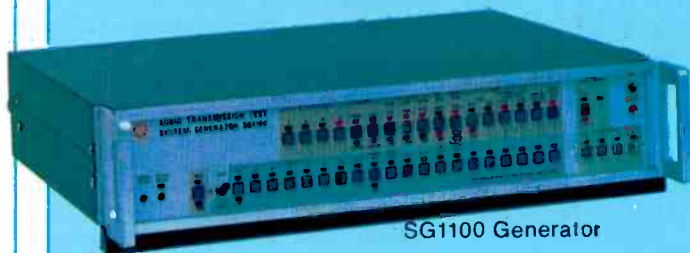

SG1100 Generator



SR1100 Receiver

marconi
instruments

MAIN PLANT: 100 STONEHURST CT., NORTHVALE, N.J. 07647 TEL: (201) 767-7250
WEST COAST: P.O. BOX 16577, IRVINE, CALIFORNIA 92713 TEL: (714) 857-2326

See us at NAB Booth #927



The Series 99 Playback Unit.

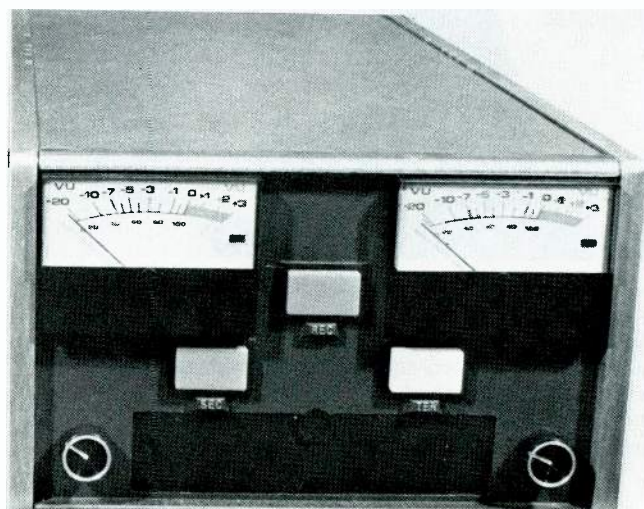

The Series 99 Record Amplifier

ITC Series 99 cartridge machine

By Brad Dick, director of engineering, KANU, Lawrence, KS

The Series 99 Audio Tape Cartridge Machine is a product of International Tapetronics Corp. (ITC), 2425 S. Main St., Bloomington, IL 61701. Equipment for this report was borrowed directly from the factory and received at KANU in apparently perfect working order.

In a world of advancing technology, such as broadcasting, it is difficult to remain knowledgeable about much of the new equipment available. Not only that, but how does one review the new equipment to judge its performance? In terms of specifications, manufacturers' literature is available, but what about its usefulness at one's station?

The equipment being tested at KANU for selected reports will be put through its paces by the station's staff to provide the opinions of those people (announcers, producers, and news types) who have to use the equipment daily. Maintenance features will be outlined and displayed so that the applicability of those features for an individual station may be judged. Armed with this information, the prospective user will be much better

equipped to make intelligent purchasing decisions.

ITC Series 99 cartridge machine

This article will highlight the new ITC Series 99 Cartridge Machine. The machine was first displayed at the 1979 NAB show in Dallas. It contains several interesting operating features as well as some excellent test and maintenance functions. The unit shows that the manufacturer spent a large amount of time surveying the needs of those stations concerned about the quality of their cartridge material.

Features

The ITC Series 99 Cartridge Machine in the record RPSE configuration comes in two packages, record amplifier and play deck. The unit, as shipped, can be table mounted or rack-mounted with available adapters. Because of the low heat generated, as many as four units can be vertically mounted.

The play deck is straightforward and has standard front panel controls. It does have a cue button that causes the machine to high speed cue back to the beginning of the cartridge. It also has an ELSA button that is used in conjunction with the cue button to activate the

various ELSA features that will be explained later.

The record deck has two (if stereo) VU meters with peak reading LED indicators. Behind a hinged front panel, which drops down, are 10 push-buttons that allow the operator to select various meter inputs such as cue play, bias and program play and bias. Other buttons allow for selective erasure of information and the cue track, cue record and tone generator control. An LED display completes the hidden control panel.

By stepping through the sequence of numbers of 1 to 7 on the LED display, several test outputs can be obtained. For instance, position 1 provides an output of 1kHz at OVU; position 2, 1kHz at -10VU; and position 7 gives a fast frequency step through 13 frequencies from 50Hz to 15.5kHz. By using the internal test oscillator, a complete frequency response test can be made in less than five minutes without ever moving the machine or using any test equipment. The output of the tone generator is available on the remote connector for other uses if desired.

All cue and test tones are generated and detected digitally with crystal reference for long-term frequency stability. Five separate

Acknowledgement

The assistance of Bob Pearson for the photographs and of Chris Downing for the graphics is appreciated.

MOBILE-TV VANS

To fit your requirements

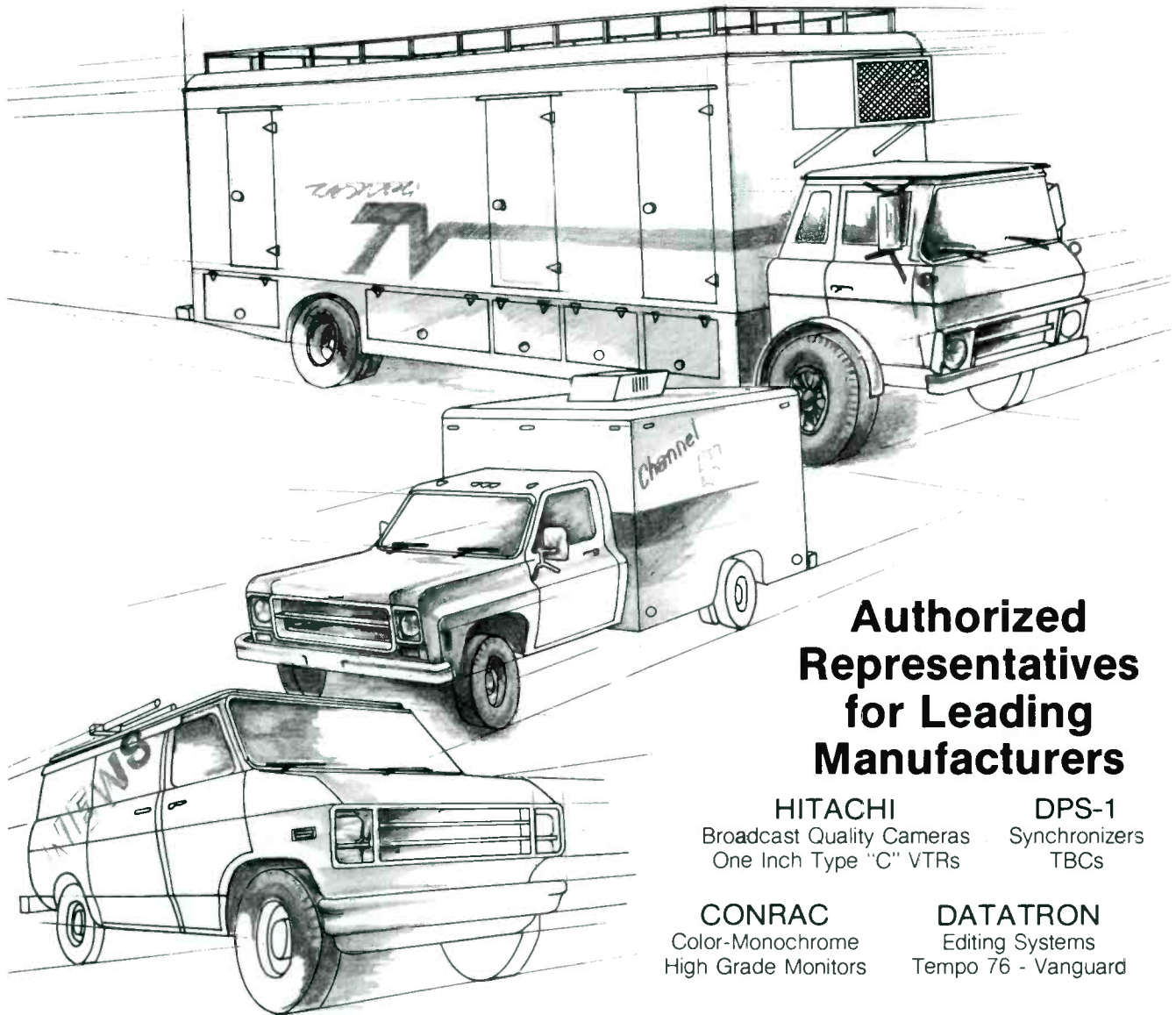

Authorized Representatives for Leading Manufacturers

HITACHI
Broadcast Quality Cameras
One Inch Type "C" VTRs

DPS-1
Synchronizers
TBCs

CONRAC
Color-Monochrome
High Grade Monitors

DATATRON
Editing Systems
Tempo 76 - Vanguard

3M
D8800-Professional
Character Generators

SONY
Quality
Video Equipment

SONY
Lab Series
Professional Audio

CHRISTIE
Battery/Charger
Systems

THOMSON CSF
Audio/Video
Equipment

Strand/Century - Lenco - Tektronix - Fernseh/Telemation - Technics - Crown
Plus Many Others

(215) 223-8200
Ask for
Bob McTamney

LERRO
ELECTRICAL CORPORATION
COMMUNICATIONS SYSTEMS DIVISION
3125 North Broad Street, Philadelphia, PA 19132

Capabilities include
Engineering and
Turnkey Installations

SERVING THE CONTINENTAL UNITED STATES

Circle (228) on Reply Card

Tidy Up Your SWITCHERS

NEW Video Delay replaces cable



MATTHEY TYPE No. UN097

75Ω Passive Delay
Adjustable Delay without Switches
±4ns Trim by Screwdriver Adjustment
BNC Connectors
Video Performance
Delay Range 15ns min. to 665ns max.
Replaces up to 437ft. of coax.

Television Equipment Associates, Inc.
BILL PEGLER Tel: 914-763-8893
Box 260, South Salem, N.Y. 10590



Circle (186) on Reply Card

The Mean Little Kit

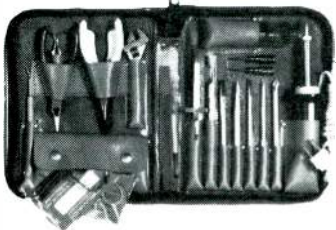

New compact 24-piece kit of electronic tools for engineers, scientists, technicians, students, executives. Includes 7 sizes screwdrivers, adjustable wrench, 2 pair pliers, wire stripper, knife, alignment tool, stainless rule, hex-key set, scissors, 2 flexible files, burnisher, miniature soldering iron, solder aid, coil of solder and desoldering braid. Highest quality padded zipper case, 6 x 9 x 1 3/4" inside. Satisfaction guaranteed. Send check, company purchase order or charge Visa or Mastercharge. We pay the shipping charges.
JTK-6 Tool Kit\$82.00



Free Catalog!

Page after page of hard-to-find precision tools. Also contains complete line of tool kits and tool cases. Send for your free copy today!

JENSEN TOOLS INC.

1230 S. PRIEST DR. TEMPE, AZ. 85281

Circle (187) on Reply Card

202 Broadcast Engineering March 1981

ITC-99

cue tones are standard, including primary, secondary, tertiary and FSK. The FSK tones (3350Hz and 3650Hz) are demodulated and accessible through the remote connector in serial form.

Of the many unique features of this machine, the primary one might be that of the operating system. Using an 8048 CPU, of which the record-playback deck has two, the unit is capable of providing control features never before available. Figure 1 shows a block diagram of the CPU control system. By using microprocessor architecture, the design allows for many features to be packaged compactly within the unit.

The most significant feature is that of the ELSA option, (Erase,

Locate, Splice, Azimuth). This feature allows the operator to have the machine automatically adjust the record head azimuth for minimum phase shift, erase the cartridge and then find the splice and stop the tape just past the splice. The usefulness of this feature will be examined more closely later.

The Series 99 is built around the modular approach (Figure 2) with every assembly being either plug-in or bolt in place. The record and play assemblies are self-contained and a play unit can be adapted to a record assembly simply by adding the record amplifier and plugging it together. All transistors and ICs are mounted in sockets for further ease in servicing.

The cartridge is held in place by a pair of pressure springs mounted on both sides of the cartridge slot.

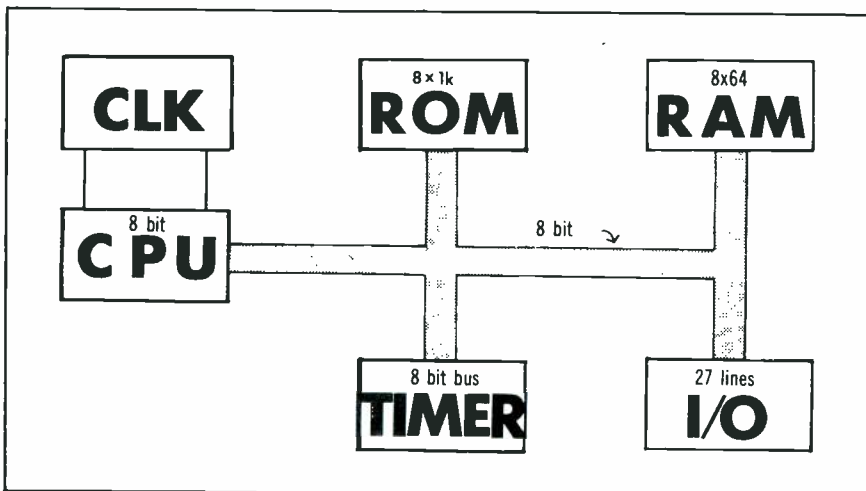

Figure 1 Block diagram of 8048CPU control system.

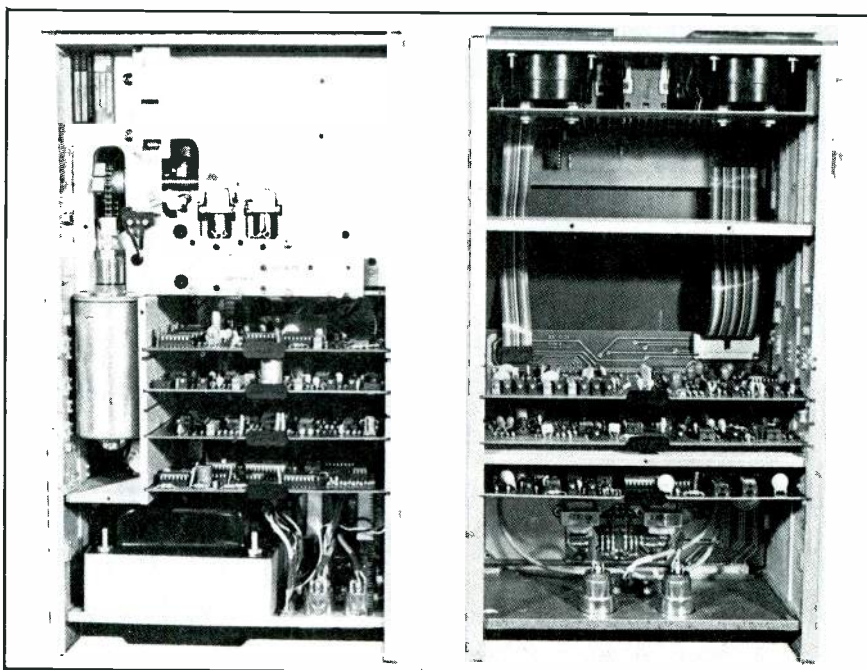

Figure 2 Modular construction for the Series 99.

Introducing the first line of professional recorder care products. The Performance Series.™

Designed and created exclusively for you, the professional. Who else but Nortronics could deliver products like these.

Nortronics, the undisputed world leader in magnetic heads. We make the heads others are compared with. Over 25 years of engineering skill and expertise are behind every head. Today, high quality and

technical innovation have become Nortronics' trademarks.

Now get that same expertise in recorder care products. The Performance Series. We first pinpointed the industry's precise requirements. Designed to meet them. Established critical tolerances—tolerances that meet or exceed any requirement you may ever have. The key to everything is simplicity. In short, each product will exceed your highest

expectations. Because that's the way we do things—professionally.

Ask your distributor about the Performance Series. Or call 1-800-328-5640 for the distributor nearest you. In Minnesota, call 612-545-0401.

PROFORMANCE SERIES™

BY NORTRONICS

8101 Tenth Avenue North
Minneapolis, MN 55427 U.S.A.

Circle (188) on Reply Card

Keep them as great as we've built them.



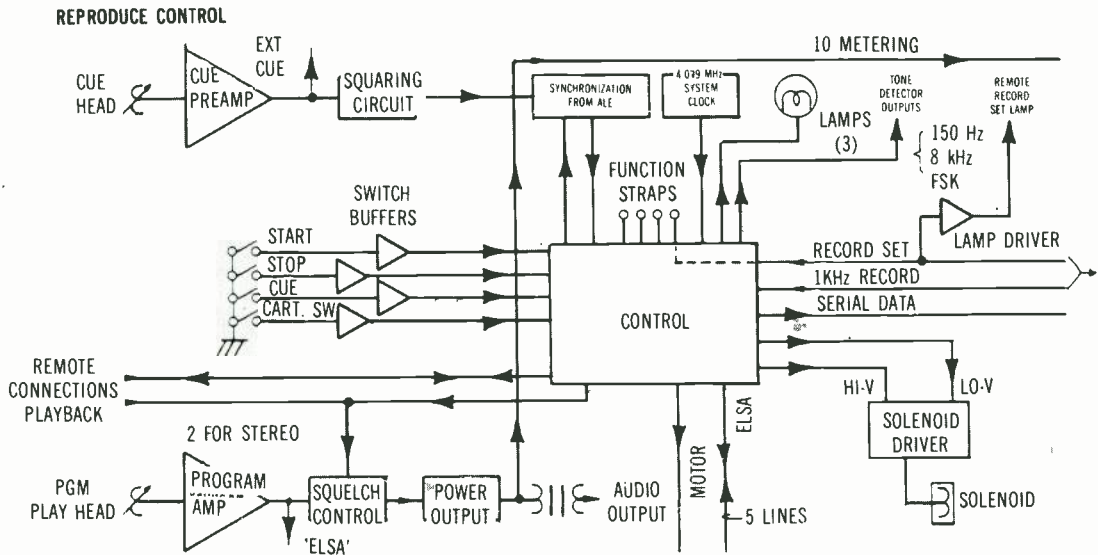

Figure 3 The reproducer control circuit for the Series 99.

ITC-99

These springs cause the cartridge to remain firmly in place and prevent cartridge distortion and potential tape skew. They also help ensure that even the harried operator will correctly insert the cartridge into the machine.

The reproducer control diagram is shown in Figure 3. This section of the machine controls all of the functions of the unit. It contains the microprocessor, its support components and the necessary buffers for inputs and outputs. The principal function of the reproducer control logic is to control the various sequences necessary to produce the

proper operation of the machine. Using these inputs, the microprocessor decides on what actions are necessary to complete the desired operations. The necessary sequences that the machine must follow are preprogrammed into the machine's memory.

If a record amplifier is connected to the reproducer, the reproducer

This magazine gives you good reading, good writing and good arithmetic.

We present the information in our articles clearly, accurately and objectively. That's good writing. Which means good reading.

We present the information in our circulation statement clearly, accurately and objectively. That's good arithmetic.

BPA (Business Publications Audit of Circulation, Inc.) helps us provide precise and reliable information to both advertisers and readers.

An independent, not-for-profit organization, BPA audits our circulation list once a year to make sure it's correct and up to date. The audit verifies your name, your company, your industry and your job title.

This information enables our advertisers to determine if they are reaching the right people in the right place with the right message.

The audit also benefits you. Because the more a publication and its advertisers know about you, the better they can provide you with articles and advertisements that meet your information needs.

BPA. For readers it stands for meaningful information. For advertisers it stands for meaningful readers. Business Publications Audit of Circulation, Inc.
360 Park Ave So., New York, NY 10010



We make sure you get what you pay for.

Dolby®

Plug Better Sound Into Your Picture

The Dolby® Cat. No. 155 or 255 module allows you to plug the benefits of a Dolby A-type noise reduction directly into your Sony® BVH-1000, 11C0 or Ampex® VPR-2 1" VTR*. Operation is fully automatic. And at long last the audio performance of your VTR will rival that of professional audio tape recorders.

Dolby A-type noise reduction has been accepted for years throughout the world for high-quality tape recording and other audio transmission and storage media. It provides 10 dB of noise reduction from 30 Hz upwards, increasing to 15 dB at 9 kHz and above, without the audible side effects (such as noise modulation and overshoot distortion) associated

with more conventional techniques. Dolby noise reduction can also lead to lower distortion, as it permits more conservative recording levels to reduce the risk of tape saturation.

Today wide audio bandwidth and low noise are becoming commonplace in many parts of the television origination/transmission chain. Contact us to find out how Dolby noise reduction can prevent the VTR audio track from being one of the weak links.

*Outboard Dolby noise reduction units are available for use with virtually any other video or audio recorder. Circle (190) on Reply Card

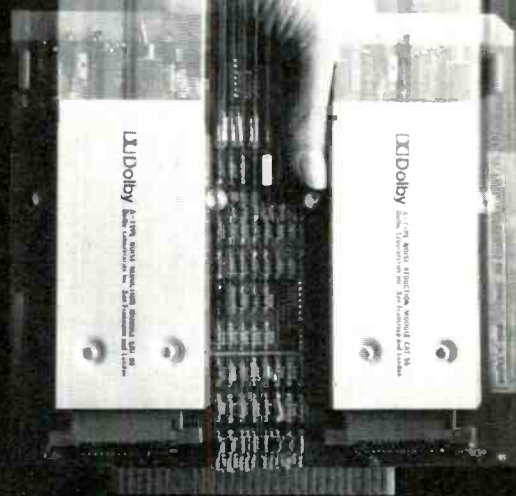

Dolby®

Dolby Laboratories Inc.

731 Sansome St.
San Francisco
California 94111
415-392-3333
TELEX 34409

346 Clapham Road
London SW9 6AP
England
01-720-1111
TELEX 9-9109

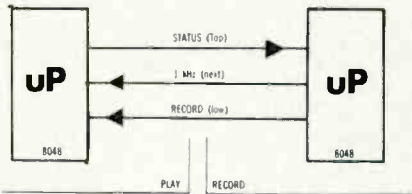

Figure 4 Serial control word logic.

ITC-99

"tells" the recorder what actions are necessary by transmission of a serial control word. As the condition of the reproducer changes, the serial control words change to keep the record amplifier in step with the play deck (see Figures 4 and 5). Although all of this "logic" may seem unnecessary overkill, closer examination will point up some of the benefits of this approach.

The Series 99 uses a three-stage cue tone detection scheme: preamplifier, sine-to-square-wave converter and microprocessor. Once the signal is amplified to sufficient levels, the sine-to-square-wave converter provides an output signal of 50% duty cycle at TTL levels, and

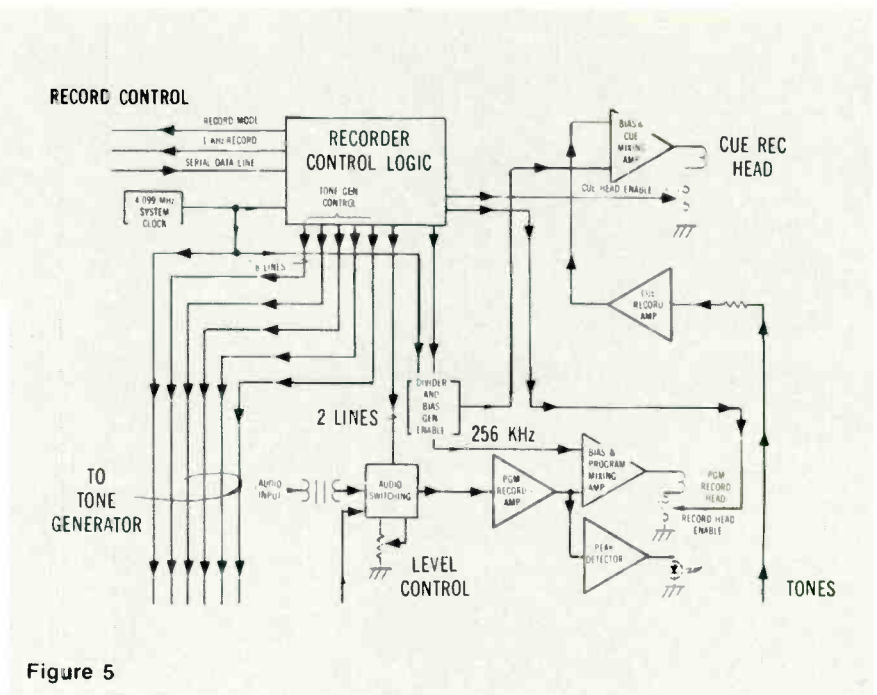

Figure 5

feeds this signal to the microprocessor. The frequency of the signal is determined by timing the interval between the zero crossings. The number of times the microprocessor makes a check of the frequency before "deciding" that the tone is valid depends upon the frequency

range and is preprogrammed into the chip memory. To be a valid tone, the period must be within 10% of a nominal value. When the machine is in the high speed mode, a different set of tolerances are used. Front panel lights indicate the detection of the various tones.

The machine of the 80's.

THE GARNER 1100

It's no secret that one-inch will be the videotape of the 80's. If you're planning to convert to one-inch, invest in the Garner 1100 degausser to get the maximum use of your one inch tape. With Garner's one-pass, endless belt operation, you get complete erasures at the rate of 13 reels per minute.

Put the Garner 1100 to the test yourself. Use the 1100 for 30 days. If it doesn't live up to your standards, just return it to us.

We're convinced that you'll agree that the Garner 1100 is the machine to handle one-inch degaussing. It's the machine of the 80's.



garner

Dependability... Guaranteed

GARNER INDUSTRIES 4200 North 48th Street, Lincoln, NE 68504 Phone (402) 464-5911



THE IMAGE MAKER[®]

Imagine, an incredibly versatile disc recorder which can animate, store stills, and record and playback in real time (30 frames per second) to single frame. Or, at the touch of a button, 24 frames per second for film transfer. Add to this full random access, with preview, of up to 500 images on line and the ability to pre-set 64 locations, standard serial digital interface, and a built-in frame by frame editing/animation previewer. □ That's Arvin/Echo's total production tool: The Image Maker. Whether your requirement is to store still frames, produce exciting animation sequences or preprogrammed motion loops from 16 frames (or less) to 500 frames, this high band color recorder is capable of delivering direct or processed video. Rugged, reliable and portable, The Image Maker is the only real time random access recorder—featuring interchangeable Discassettes[®]—which doesn't break the bank. □ Remember, Arvin/Echo has more video disc recorders operating in the broadcast field than any other manufacturer. Based on this unique experience, we have built The Image Maker to meet the rapidly changing challenges of the professional television industry. Its potential is limited only by your imagination. □ Visit us at NAB, Booth #1001



ARVIN/ECHO[™]

Echo Science Corporation
485 E. Middlefield Road, Mountain View, California 94043
Telephone: (415) 961-7145, TWX: (910) 379-6499

APPLIED
TECHNOLOGY
GROUP
ATG
ARVIN

Circle (192) on Reply Card

jensen transformers

By REICHENBACH ENGINEERING

JE-11SSP-6M and JE-11SSP-8M 150Ω / 600Ω Repeat Coils

New Packaging

- Wrap-around mu-metal case for full 30dB of shielding
- Sturdy solder terminals
- 4 threaded inserts at each end for flexible mounting

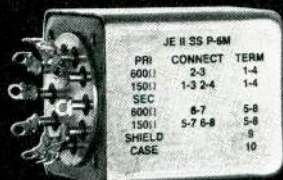

Unsurpassed Audio Quality

Model JE-11SSP —	6M	8M
Maximum Level @ 20Hz	+18dBm	+23dBm
Distortion @ 20Hz, +4dBm	0.035%	0.02%
Bandwidth (-3dB)	160kHz	120kHz

Proven Reliability

Every single transformer fully tested before and after encapsulation.

Write or call for information.
10735 BURBANK BOULEVARD
N. HOLLYWOOD, CA 91601
(213) 876-0059

(Visitors by appointment only - Closed Fridays)

Circle (193) on Reply Card

REPLACEMENT TRANSFORMERS GATES, COLLINS, RCA, CCA



PLATE TRANSFORMERS

COLLINS 20V	\$650
COLLINS 20V 1 20V 2 20V 3	\$450
CCA FM 400B	\$650
GATES BC1E BC1F	\$450
GATES BC1G BC1H	\$400
GATES BC1J	\$400
GATES BC1T	\$400
GATES BCSP 3 Phase	\$1050
GATES BC500T	\$375
GATES FM 250	\$200
GATES FM 1B	\$450
RCA BTA1G, BTA1H	\$450
RCA BTA1R, BTA1S	\$400
RCA BTA5G, BTA5H (Main or Teaser)	\$750
RCA BTA10H (Main or Teaser)	\$1500

MODULATION TRANSFORMERS

BAUER 707 Series	\$550
COLLINS 20V Series	\$550
COLLINS 21E Series	\$1000
GATES BC1 Series	\$550
GATES BC5 Series	\$1000
RCA BTA1 Series	\$550

MODULATION REACTORS

GATES BC1 Series 40 Hy @ 600 MA DC	\$400
GATES BC5 Series 35 Hy @ 1.4 AMP DC	\$650
10 KW Universal 20 Hy @ 2.5 AMP DC	\$850

FILTER REACTORS

3 Hy @ 2.5 AMP DC, 10 KV INS	\$200
5 Hy @ 1.0 AMP DC, 10 KV INS	\$175
10 Hy @ 1.0 AMP DC, 10 KV INS	\$200
10 Hy @ 2.5 AMP DC, 10 KV INS	\$350
15 Hy @ 1.0 AMP DC, 10 KV INS	\$225

Many other transformers also available. Call us for free quotations. Large stock and fast delivery. 12 Month Guarantee on all items.

PETER W. DAHL CO., INC.

4007 Fort Blvd., El Paso, Texas 79930
Telephone: (915) 566-5365

Circle (194) on Reply Card

ITC-99

Because the machine uses a brushless dc servo motor, it is easy to vary the speed of the motor by changing the reference frequency. For instance, it is possible to feed an external signal into the machine and have the motor lock onto that signal as the reference. However, the machine normally uses an internal generated frequency from a CMOS crystal oscillator for speed control. Four fixed tape speeds may be selected by jumpers (15/16, 3-3/4, 7-1/5, 15 ips) if desired.

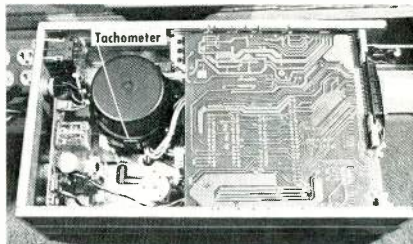

Figure 6 The motor of the Series 99 contains a tachometer, as noted above.

The motor contains a tachometer, Figure 6, which coupled with the phase locked loop circuitry (Figure 7), keeps the motor exactly on speed. The system is "locked" when the tach frequency exactly equals the reference frequency. However, the tach frequency contains a 144° phase lag. The phase comparator output at lock is a square wave with a variable duty cycle. As the load on the motor changes, so does the duty cycle to supply more or less power to the motor as necessary. The phase comparator is followed by a low pass filter that converts the duty cycle to a proportional dc voltage. This voltage is amplified and summed with a variable dc potential. The variable potential is used to adjust the phase comparator duty to approximately 40% under unloaded, locked conditions. This 40% duty cycle allows efficient operation over a wide range of temperatures and loads.

Figure 8 shows the tone generator circuitry that uses a radically different method of generating tones than most generators. The tones are

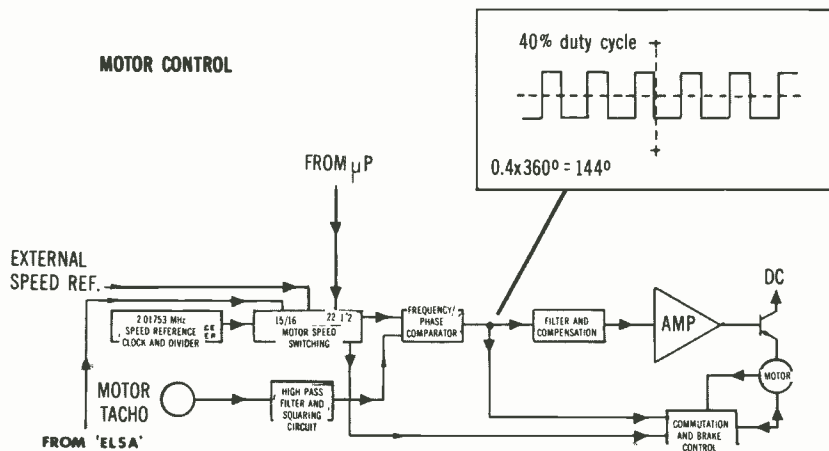

Figure 7 Phase locked loop for the motor control.

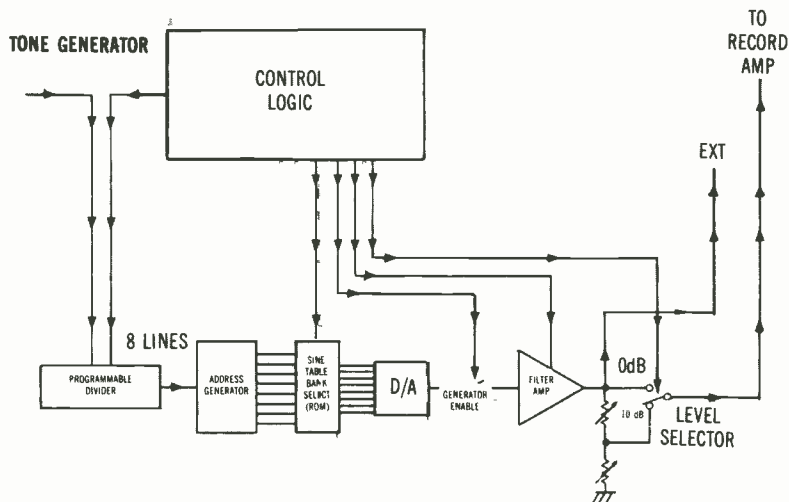
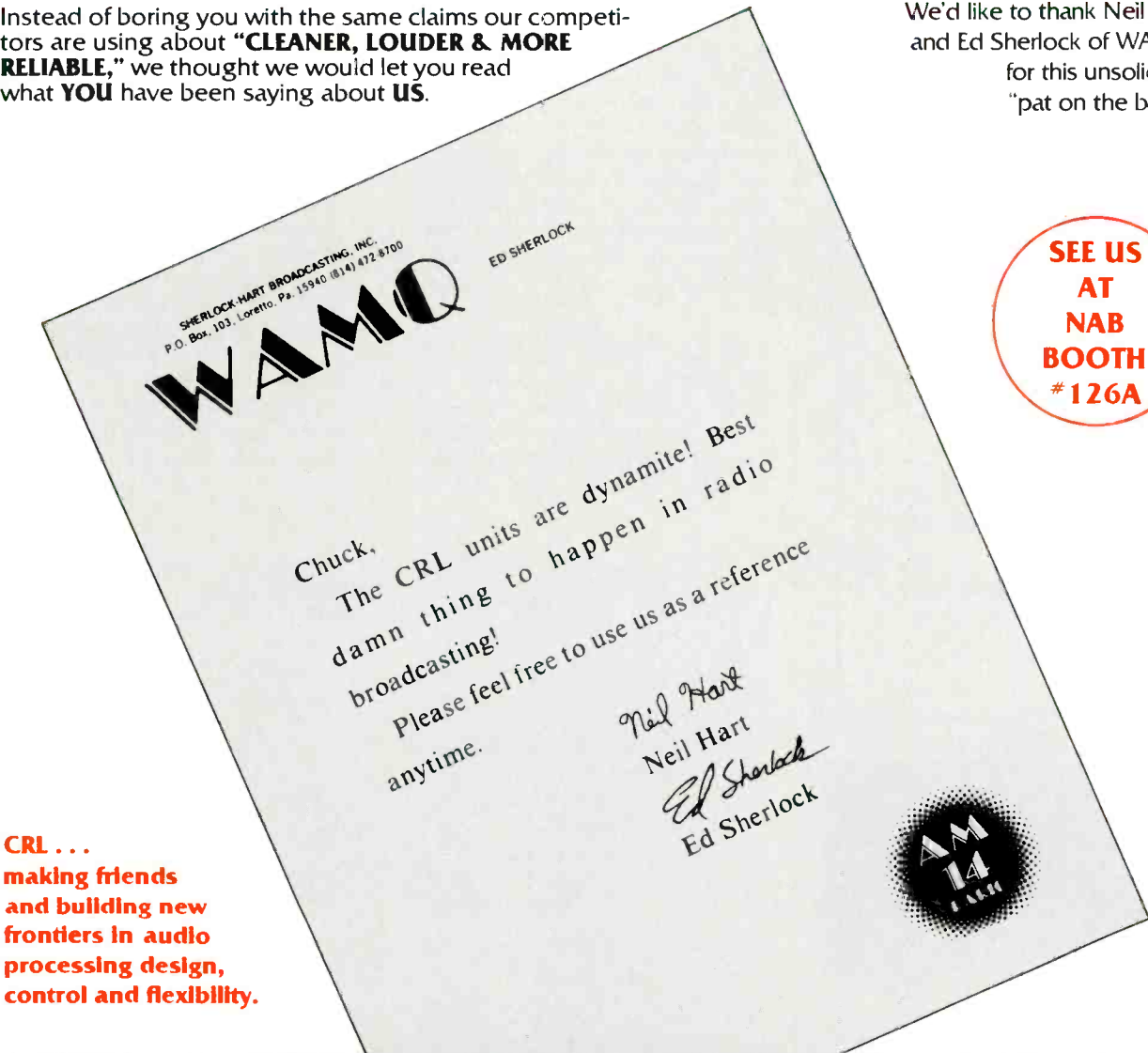

Figure 8 Tone generator circuitry—digitalized and filtered for accuracy.

A Word About Our Product . . . From You!

Instead of boring you with the same claims our competitors are using about "**CLEANER, LOUDER & MORE RELIABLE,**" we thought we would let you read what **YOU** have been saying about **US**.

We'd like to thank Neil Hart and Ed Sherlock of WAMQ for this unsolicited "pat on the back."



**CRL . . .
making friends
and building new
frontiers in audio
processing design,
control and flexibility.**



Audio Processing of the '80's
CIRCUIT RESEARCH LABS, INC.
3204 S. Fair Lane • Tempe, Arizona 85282
(602) 894-0077

Circle (195) on Reply Card

Durante muchos años Comex Corporation ha suministrado a las estaciones televisoras y casas de producción en Latinoamérica equipo profesional de televisión a los precios mejores posibles.

Si Ud. no está entre estas estaciones afortunadas, solicite hoy mismo la lista muy completa de equipo y provisiones que distribuye Comex.

Escriba a:

Comex Corporation

P.O. Box 17011

Dulles International Airport

Washington D.C. 20041,

E.U.A.

Telex 248892 COMX UR

Teléfono (703) 471-4215

Circle (196) on Reply Card

**IF YOU NEED
ATTENUATORS
YOU NEED THIS
CATALOG!**



**AUDIO AND RF ATTENUATORS
TO MEET ANY REQUIREMENT**

Here in one compact and informative 24 page booklet is all the data you need to select a Precision Audio and RF Attenuator for your application.

Reference Charts, Circuit Diagrams, Types and Uses, Current and Voltage Ratio Tables, Ratings, Etc., make this a handy and invaluable reference.

SEND FOR YOUR FREE COPY TODAY.

TECH LABS, INC.

Bergen & Edsall Blvds.

Palisades Park, N.J. 07650

Tel.: (201) 944-2221

Circle (197) on Reply Card

ITC-99

generated digitally and then filtered to give superior frequency accuracy. The basic approach is to store a "sine table" in a digital ROM. This sine table is then read out of the ROM repetitively at a rate set by the microprocessor. The output is then fed to a digital-to-analog converter and two stages of filtering to give an excellent approximation of a pure sine wave. Using this method of tone generation allows additional features to be coupled with the generator.

ELSA

Of all of the features of this machine, the most useful is the ELSA (Erase, Locate, Splice, Azimuth) option. Figure 9 shows a block diagram of the ELSA option. A detailed look at how the ELSA

function operates will give some insight as to how this feature can improve cartridge performance.

The machine sequence begins by performing an automatic fast erase cycle that removes any material that may have been on the cartridge. After the erase cycle has ended, a 1kHz tone is applied by the recorder to all three tracks at OVU level. The output of the left and right channels are fed to a phase comparator circuit, which develops a string of either positive or negative pulses, depending on which channel is leading. The output is filtered and an error voltage is developed proportional to the magnitude of the phase error. This error voltage drives the azimuth motor in the correct direction to minimize the error.

Because the high gain of the closed loop used in the circuit will always be unstable, overshoot occurs ("O" phase) and the control

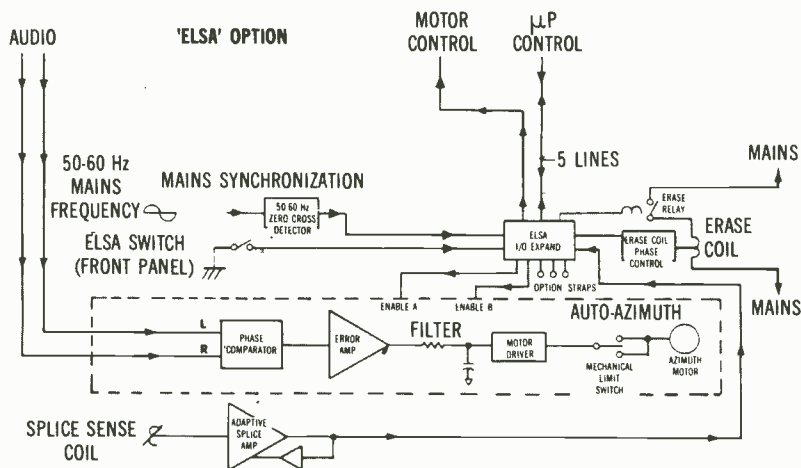

Figure 9 Erase, Locate, Splice, Azimuth (ELSA) circuitry—a valuable option.

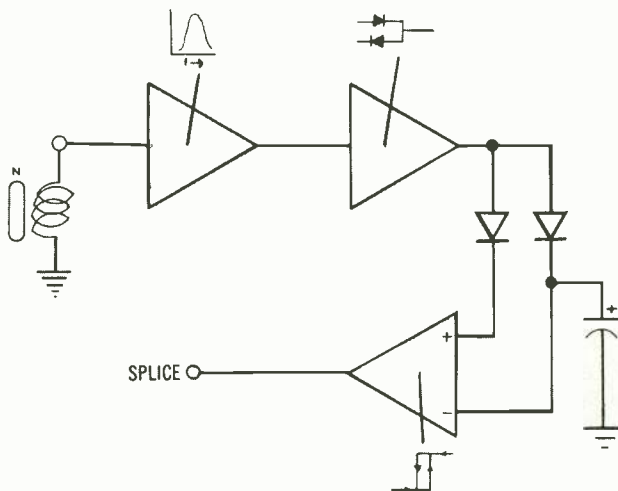

Figure 10 Splice locator circuitry

Beyer. We make the best broadcast mics, too.

In recording studios, concert halls and theatres worldwide, Beyer is the premier name in microphones. Loved by performers and respected by engineers.

Now that same Beyer quality is available in a full line of innovative broadcast microphones, to meet every need and solve every problem.

The Beyer MCE 5 is the world's smallest electret condenser and provides true broadcast-quality audio from a 7 x 23 mm. cylinder weighing just 6.5 grams. It has wide frequency response, but is immune to most body noises. And you can hide it almost anywhere and connect it to a cable or a wireless transmitter.

If you can't get the mic near the sound source, try our Beyer MC 717 shotgun. It has a directional gain of at least 20 dB and a 40-20K frequency response.

The MC 717 is part of a modular condenser mic system consisting of six different transducer capsules plus amplifiers and phantom power supplies that can be perfectly tailored for a wide range of broadcast situations. They're all ruggedly built to handle ENG as well as studio work and can accept temperatures up to 160° and 99% humidity.

Other mics include: the M 55 – an omni-directional dynamic mic that is especially suited for reporters and field interviews; the M 69 – a uni-directional hypercardioid dynamic mic that is perfect for announcers on TV and a studio mic in radio stations; the M 88 – a uni-directional cardioid dynamic mic with warm and full bass response that is ideal for booth or radio announce. This is easily one of the best mics in the business – with a special suspension that eliminates transmitted noise if hand held. Our M 201 is another microphone with excellent vocal characteristics that is favored by singers and reporters alike.

There are many more mics in the Beyer line, plus stands, booms, headsets and accessories. Visit your local Beyer distributor for more information and specs.



MCE 5



M 55



MC 717



M 201

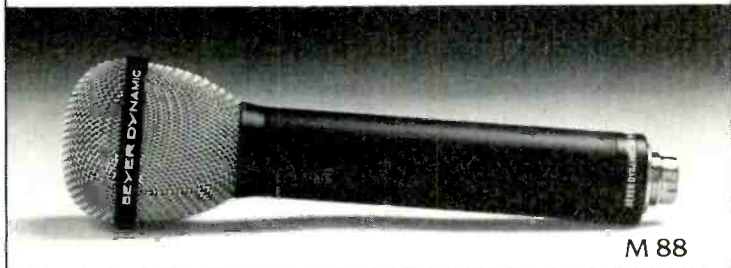

M 88



M 69

Beyer
Dynamic

BEYER DYNAMIC, INC.
5-05 Burns Avenue, Hicksville, NY 11801 • (516) 935-8000
In Canada, H. Roy Gray, Ltd.

Circle (198) on Reply Card

ITC-99

logic commands the record amplifier to generate an 8kHz tone and waits for another overshoot. When that happens, the control logic commands a 15.5kHz tone to be sent to the record head for the final fine tuning of the azimuth. At this point, the system gain is ramped down by disabling the motor drivers 50% of

the time. The "on time" is then further reduced each cycle until the duty cycle is zero at the point of minimum phase error.

The erase control again erases the cartridge at normal speed, then reduces the speed of the capstan motor to a very slow value to ensure complete erasure of the cartridge.

The erased voltage is then slowly ramped down and finally removed from the erase coil by a relay to prevent any ac leakage.

Finally, the splice locator circuit, shown in Figure 10, is activated with the tape moving at high speed to locate the splice. The splice locator is composed of a mechanical

ITC SERIES 99

Manufacturer's specifications:

Power: 117/234Vac, 50/60Hz, 40W selectable tapes for varying line voltage.

Capstan motor: direct drive, crystal reference, brushless dc servo with ceramic shaft and permanently lubricated ball bearings.

Tape speed: 19cm/s (7½ips), hi-speed cue standard on all models at 57.2cm/s (22½ips).

Wow & flutter: 0.12% or less DIN weighted (better than 1975 NAB standard).

Timing accuracy: 0.1% or better.

Audio output impedance: rated for 600Ω or 150Ω balanced as per 1975 NAB standard.

Audio output level: +25dBm before clipping. Selectable ranges to accommodate -16dBm output to +19dBm output.

Amplifier distortion: 0.5% THD measured in accordance with 1975 NAB standard.

System distortion: 0.5% THD or less—record to playback at OVU recording level.*

Amplifier headroom: reproduce amplifier +28dB, recording amplifier +24dB.*

Crosstalk between channels: 50dB or better at 1kHz between both program and cue channels.

Frequency response: ±1dB from 31.5Hz to 16kHz—record to playback at 10 VU recording level.*

Equalization: 1975 NAB standard, adjustable for CCIR. 1964 NAB standard may be accommodated by strap removal in recorder. High frequency equalization control included in recording amplifier with both high and low frequency controls in reproducer.

Head configuration: NAB. Two tracks for mono, three for stereo. Separate record and reproducer heads permit playback monitoring while recording.

Cue signals. NAB. Primary cue (1kHz), secondary (150Hz), and tertiary (8kHz) all standard. Open collector sinking signal (ground switching) available externally upon sensing of secondary and tertiary cue tones. 200mA at 25Vdc maximum open circuit voltage capability. Optional relay contact closure available with 1A noninductive load capability. 24Vdc maximum open circuit voltage.

Logging signals: serial data input and output. 3.35kHz and 3.65kHz internally generated and demodulated for frequency shift keying (FSK) at a maximum baud rate of 300. These tones may also be used as auxiliary cue tones with current sinking output only.

Audio input impedance: 18kΩ balanced bridging standard. 600Ω and 150Ω balanced terminating loads may be selected by jumper.

Audio input sensitivity: -23dBm to +10dBm. Strappable for the following mid-range (level control knob position) levels to facilitate front-panel adjustment ease and optimize signal to noise: -20dBm; -10dBm; 0dBm; and +10dBm.

Metering: taut-band movement with "A" scale. Switch selection for monitoring: recording input (automatic switching to program playback when machine is not recording); program playback; program bias; cue bias; and cue playback. Built-in LED peak indicators follow tape saturation.

Bias amplifier: crystal referenced 256kHz for program track(s), 83kHz for cue track.

Tape capacity: NAB size AA and BB cartridges. 2 seconds to 16 minutes with 1 mil lubricated tape at 19cm/s (7½ips).

Start time: 100ms.

Stop time: 40ms (transport and electronics). Tape travel after stop signal varies according to type of cartridge used and length of tape.

Ambient operating temperature range: 10°C to 55°C (50°F to 131°F).

Remote control: all front panel controls and indicators plus cue erase, 1kHz record and defeat, and logging tones record.

External connectors: XLR audio and latching remote control. Mating connectors are furnished.

Mounting: table-top; rack mounting shelf optional.

Dimensions: Width: 8.5 in. Depth: 15.5 in. Height: 5.25 in. Add for feet: 0.375 in.

Weight: playback: 15.9kg (35 lbs). Recording amplifier: 7.7kg (17 lbs).

*All measurements made using 3M type 157 or equivalent, and referenced to 1kHz recorded at 160nWb/m in accordance with 1975 NAB standard.

CUSTOM CONSOLES

Broadcast mixers are our only product. Each one is custom built, with your call letters assigned the day product on begins. After installing your new Broadcast Audio mixer you will actually *hear the difference*. THD and IM distortion are negligible; frequency response is absolutely flat well beyond the audio spectrum.

Sensible engineering design, thoughtful operator conveniences and reasonable prices are good reasons for choosing Broadcast Audio. We have 3 models, base priced from \$6,450 to \$8,950 and will deliver in 3 weeks or less. Why wait?

**BROADCAST
AUDIO CORPORATION**

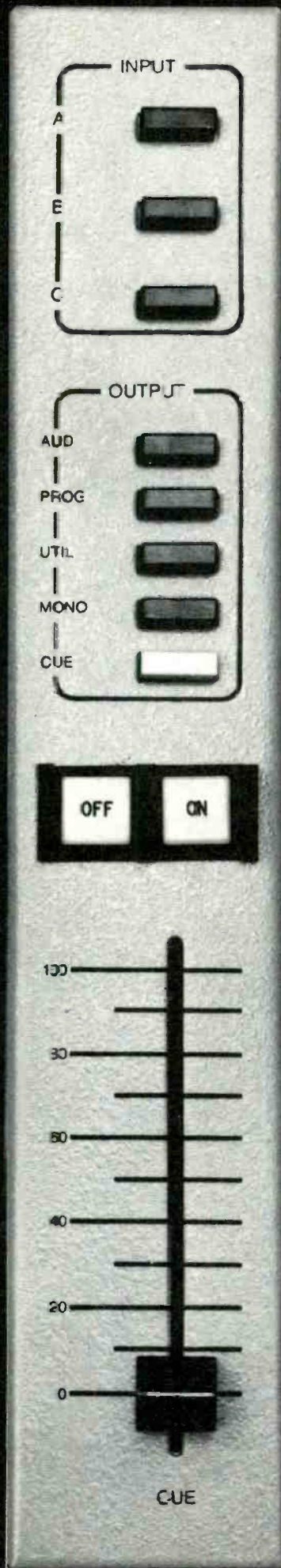

See Us at NAB Booth #218S

11355 Pyrites Way

Rancho Cordova, CA 95670

(916) 635-1048

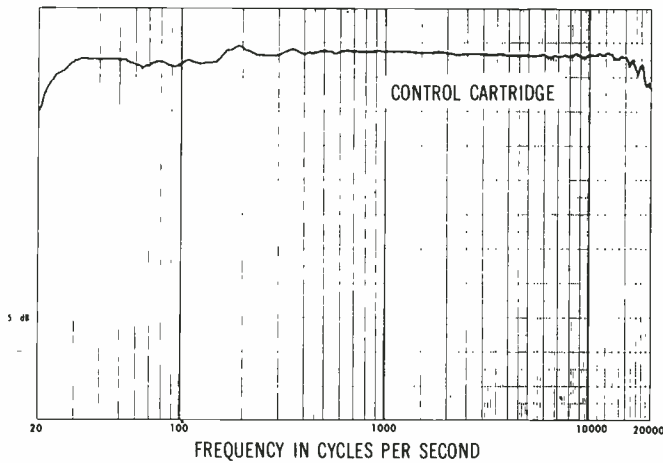

Figure 11 L + R record/playback frequency response of the Series 99.

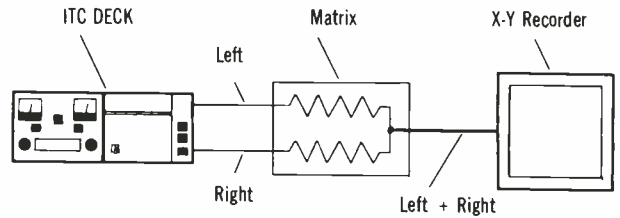

Figure 12. Matrix used for combining the L + R signals.

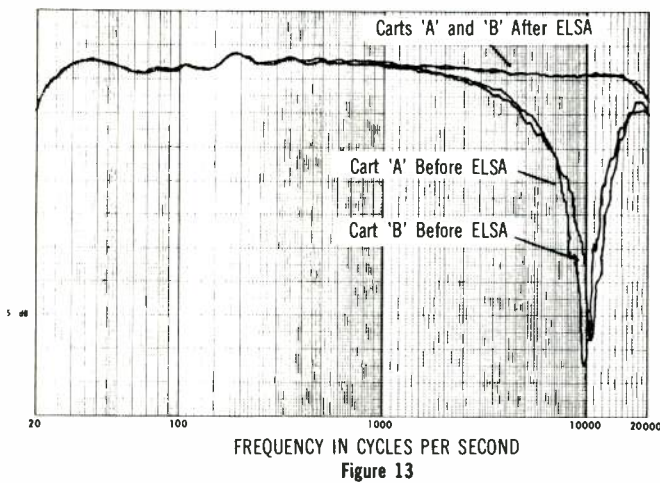

Figure 13

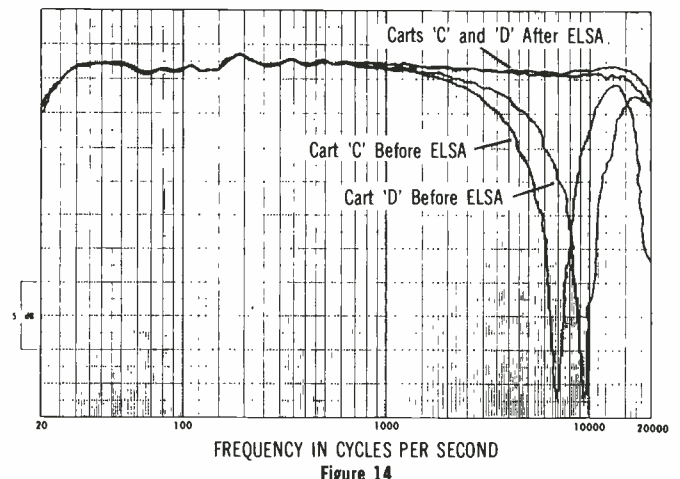

Figure 14

Figures 13-16 Results of several cartridges tested before and after ELSA.

ITC-99

arm connected to the pressure roller cross shaft. Mounted on this arm is a small magnet that enters a coil when the pressure roller is engaged. When a splice passes between the capstan and pressure roller, a small voltage is generated by the movement of the magnet in the coil.

This voltage is amplified and band-limited by several stages before it is rectified into a positive voltage. By using this voltage to develop a dc level representative of the average noise output from the sensor, a comparator can be used to sense the point at which a splice passes. Once the "trip" point is sensed, a comparator provides an output pulse that is sent to the microprocessor which develops the stop signal.

Performance

Now that we have an introduction to the control circuitry of the machine, let's examine what all of

this means in terms of performance. A standard set of tests were performed to examine the performance of the machine as well as a special test that highlights the ELSA benefits.

The L + R record/playback frequency response of the deck is shown in Figure 11. Both channels were closely matched and easily met the ITC specifications. The noise level was -55dB and distortion was 1%. The crosstalk was better than 53dB at 1kHz and wow and flutter exceeded the manufacturer's claims.

To properly test the advantage of the ELSA feature, a special test was used. Figure 12 shows the matrix used to develop a combination of the L + R signals. Careful matching of levels was necessary to maximize the results of the tests. The output of the matrix was fed to a UREI Model 200 X-Y plotter for display.

The reason for the test was specifically to see if the automatic

azimuth feature, when applied to general use cartridges, would result in any benefit over a standard fixed-azimuth machine. All FM engineers are familiar with the mono compatibility problem with cartridges. Unless good cartridges are used with properly aligned recorders and play decks, the monaural signal generated by the combining of the left and right signals can be severely degraded. This results in a loss of high frequency material and a "phasing or comb" effect. Because this machine provided an automatic azimuth adjustment, it would be easy to see what effect the azimuth "tweaking" of the record head for each cartridge would have.

Table 1 shows the type of cartridges used to test the machine. Although the goal was to test the machine, some interesting facts about cartridges also became obvious. In each case, three steps were taken. First, the machine would be optimized to the Control (C) car-



Honeycomb
speakers
inspired by
today's
recording
technology.

To hear the full potential of today's digital tape and direct-to-disc recordings, our Professional Audio Division presents a speaker that's just as advanced, just as accurate. The Technics R&B Series Honeycomb Disc Speakers.

The special diaphragm is constructed like a flat, rigid honeycomb disc to eliminate the traditional acoustic problems of cone-shaped diaphragms. Best of all, phase linearity occurs automatically because the acoustic centers are distinctly aligned on the flat diaphragm surface.

The axially symmetric "nodal driver" is designed to vibrate in a more accurate pistonic motion. This provides an extremely wide, flat frequency response, broad dynamic range and extremely low distortion.

And the flat leaf tweeter in the SE-7 and SB-10 is much lighter than many dome tweeters, for incredible high frequency response, up to 125 kHz.

The Technics R&B Series is available at select locations. Call our Professional Audio Division at 800-447-4700 (in Illinois, 800-322-4400) to hear the entire line of Honeycombs—the speakers that don't hold back today's recording technology.

See us at Booth #600

Technics
R&B series

ITC-99

tridge and the resulting performance on the Test (T) cart would be plotted. Then the ELSA feature would be used to "tweek" the machine for the (T) cartridge and the test would be repeated. Finally, an identical (T) cartridge would be used and the test repeated. The lower trace in each figure represents the BEFORE ELSA and the upper trace is AFTER ELSA. The most important fact to notice is not simply the severity of the dip in high frequency, but the frequency at which the dip occurs. Figures 13 through 16 show the results of several of the tested cartridges. Each figure displays the result of both of the "identical" carts.

It is apparent that most of the cartridges benefited greatly from the automatic azimuth alignment feature. Only one cartridge realized little benefit from the adjustment. In this case the particular cartridge had been obtained directly from the manufacturer for the test. It may be that extra quality control was exerted here because the same type of cartridge loaded by a separate vendor showed worse performance.

After repeating all of the tests many times to be sure that the results were correct, it became obvious that the ELSA (and attending automatic azimuth feature) was definitely worth the small additional expense.

The graphs told us what would happen on paper, but was the difference audible? The machine was then taken to the Kansas SBE meeting for demonstration purposes. Several cartridges containing varied types of materials were played to the audience over studio monitors to see whether any difference could be detected.

In every case the difference between non-ELSA and ELSA cartridges was evident. In some cases the difference was close to that between a limited response AM receiver and that of a full fidelity FM receiver. The cause and effect could not easily be determined, because the same cartridge type and length would exhibit different results from an identical one. The same cartridge did, however, repeat the results dependably. The cost of the cartridges was not the most likely factor to affect performance

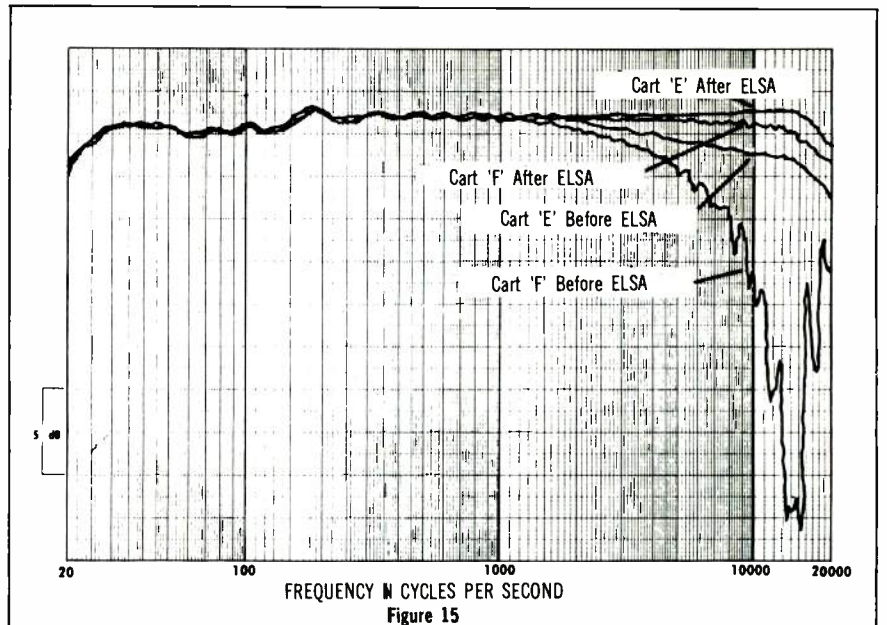

Figure 15

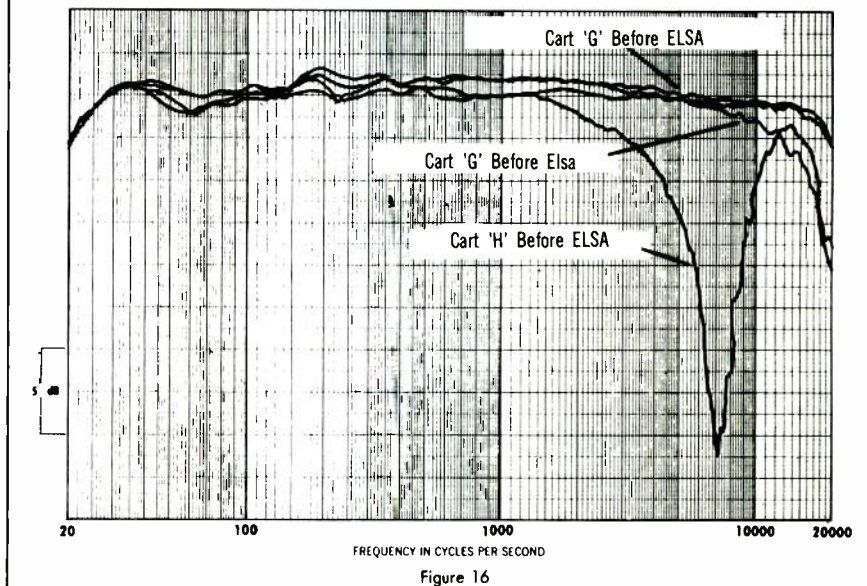

Figure 16

Figures 13-16 Results of several cartridges tested before and after ELSA.

although there was some correlation between cost and performance. It quickly became obvious that any station not using identical brands of cartridges is suffering greatly in terms of quality. Also, older cartridges exhibited even more erratic response, indicating the need for regular replacement of cartridges.

In summary, the ITC Series 99 Cartridge Machine affords both the operator and engineer the best of both worlds. The operator has useful features: both VU and peak reading of audio levels; automatic switching of meters from record to play; front panel control and readout of all cue tones; and, most

important, ELSA. The engineer has the necessary test features to ensure quality control of cartridges and ease of maintenance. The unit does represent a big step in terms of complexity of audio equipment. However, this is no reason to shy away from the equipment because it should prove to be reliable and easy to maintain. For those stations who use large numbers of cartridges for on-air work, the machine offers a type of quality control never before available. Proper use of the ITC Series 99 Cartridge Machine could ensure that the station's sound remains top quality from cartridge to cartridge. □



SINGER PRODUCTS

COMPANY, INCORPORATED

ANNOUNCES THE FORMATION OF

SINGER BROADCAST PRODUCTS, INC.

BOX 5500 • CHERRY HILL, NEW JERSEY 08034

FOR THE MANUFACTURE OF

CCA

and

Sintronic

AM AND FM BROADCAST TRANSMITTERS

and

VHF AND UHF TELEVISION TRANSMITTERS

SEE US AT BOOTHS 103 AND 126

NAB '81 • LAS VEGAS

APRIL 12-15

A member of the Singer Products Group of Companies

875 Merrick Avenue, Westbury, N.Y. 11590

Established in 1937

Maintenance tips on the BVU-200 videocassette recorder

By John J. Lapham Jr., senior broadcast engineer, KOMO-TV4, Seattle

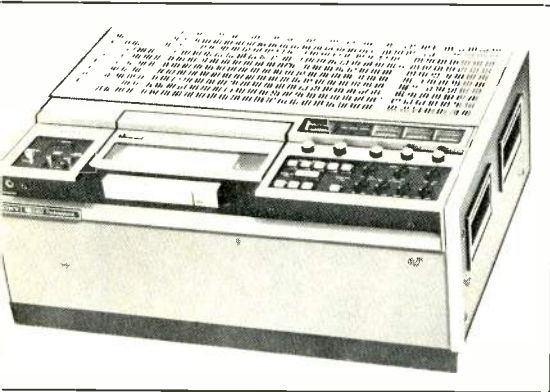

The Sony BVU-200 Editing U-matic Videocassette Recorder

Routine maintenance on VCRs is crucial to maintain top quality performance. Lapham has extensive experience in maintaining the Sony 3/4-inch BVU-200 Editing U-matic Videocassette Recorder in KOMO's news operations in Seattle.

Sony BVU-200 tape machines are the backbone of the KOMO-TV news and news magazine operation. Keeping these machines in acceptable operating condition is vital to the interests of the station. And keeping these machines on line calls for more than good luck. At KOMO a strong maintenance routine is the key to long machine life with few catastrophic breakdowns.

Access to a Sony BVU-200 Technical Manual is necessary to perform many of the routines described here. Numbers boldfaced in the text refer to sections in the technical manual.

Daily routine

Clean surfaces for tape travel are critical. The daily cleaning of these surfaces (Figure 1) is the first step in keeping the 200s in good operating condition. Texwipes and alcohol are used to clean these surfaces. Also, use the tip of a wooden stick to clean the ridge guide along the drum assembly. This ridge clogs with oxide residues and causes the tape to ride off the ridge (Figure 2).

1000 hour routine

A detailed maintenance log is kept on each machine, and all problems that bring a machine into the shop are recorded in this log along with the maintenance performed. The hours meter on the back of the machine is monitored and when 1000 hours is reached the machine is brought into the shop for a complete overhaul. This overhaul is extensive and requires anywhere from 24 to 40 hours of shop time.

The Sony technical manual is extensive in its coverage of maintenance of the BVU-200. Yet, not everything is necessary at any one time. Some steps need only be performed when a part is replaced. A mechanical alignment mainte-

nance form was devised to serve as a guide for the 1000 hour overhaul (Figure 3). But before any mechanical alignment is done, several preparatory steps are taken.

The first step is to strip the machine down and blow it clean with compressed air. After this, clean all tape travel surfaces with alcohol. Also use alcohol to clean any surfaces belts travel over.

Ensuring correct power supply voltages, (Figure 4) is the next step. Measure all of them. It is useless to try any servo adjustments without first ensuring correct power supply voltages.

The parts inventory at KOMO is extensive and includes upper head drums, all solenoids, motors, and virtually every part that has been found to fail. Beyond that is a standard minimum number of parts that are always changed during the overhaul process (Figure 5).

Replacing recommended parts

The take-up reel has a clutch disc inside, which by 1000 hours can be quite worn. This causes the forward torque to fall outside of acceptable limits. A quick check is to grasp the table at the top and bottom (Figure 6) and rotate the bottom clockwise and counter-clockwise. In one direction the table should slip smoothly, but in the opposite direction there should be considerable resistance. A forward torque check during calibration will further reveal the condition of the table. Generally, the table is replaced.

The midway pulley assembly should also be replaced. Earlier assemblies had bronze bearings; the new units come with ball bearings (Figure 7).

Another part in the same area (Figure 8) is the FF-REW pulley assembly. Sometimes the inner disc squeezes out. This can be seen in Figure 9. The pulley is removed by first removing the FF-REW idler assembly and then slipping the pulley out from underneath. Pay particular attention to all bearings and washers when replacing the unit. If the pulley assembly is replaced, also replace the FF-REW idler wheel.

New brake band assemblies are mounted on a bracket that does not have gear teeth. The old units still

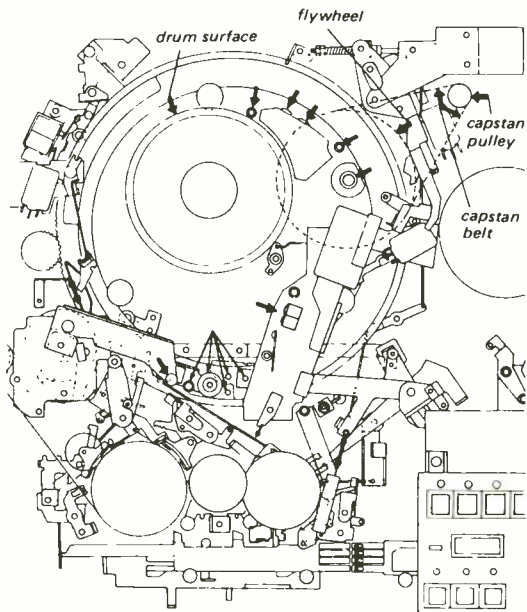

Figure 1

courtesy of Sony Corp.

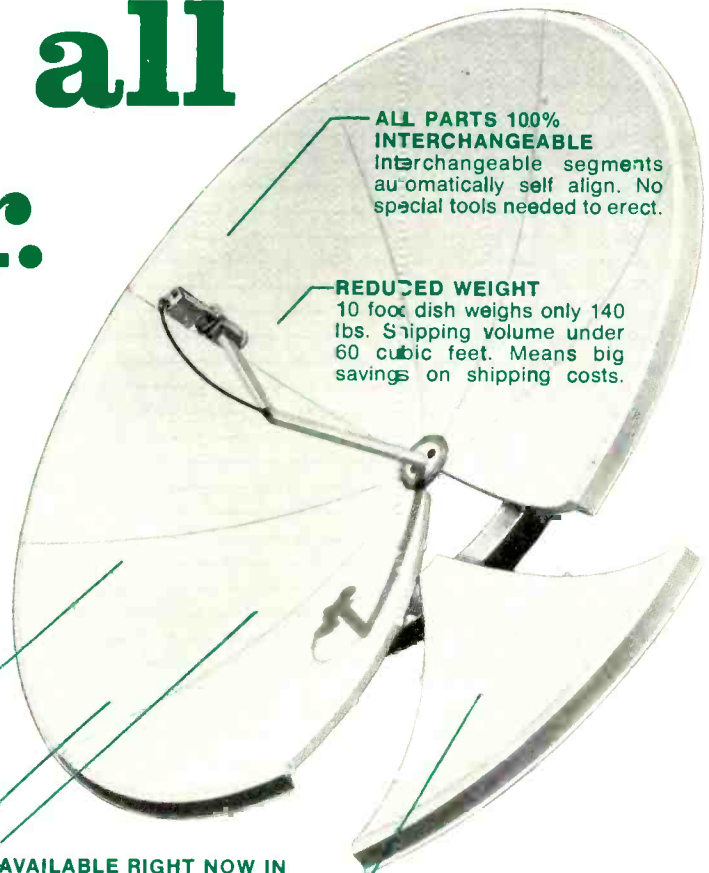

Figure 2

Prodelin's New Segmented Earth Station Antennas

The first antenna to put it all together.

Never before has anyone combined all these features in one antenna:



ALL PARTS 100% INTERCHANGEABLE
Interchangeable segments automatically self align. No special tools needed to erect.

REDUCED WEIGHT
10 foot dish weighs only 140 lbs. Shipping volume under 60 cubic feet. Means big savings on shipping costs.

CAN BE HAND CARRIED UP TO A ROOF!

For example the ten footer's 8 petals weigh under 15 lbs. each. No cranes needed. Send the antennas up by elevator or the stairs!

A NEW GENERATION OF PRECISION MOLDED SEGMENTED, LIGHTWEIGHT, FIBERGLASS ANTENNAS

Tough, resilient, "forgives" rough handling. Available in sizes from 4 foot to 5 meters.

AVAILABLE RIGHT NOW IN MAJOR QUANTITIES.

100 units-per-day capacity, plus East and West coast warehouses, assures rapid delivery.

PROVEN SURVIVEABILITY

Materials tested and approved in accordance with MIL STD 810 B. Handles the roughest weather, including hurricane force winds and beyond (up to 125 MPH)! U/L approved fire retardant.

OTHER MAJOR FEATURES

- Prodelin textured front surface diffuses solar heating.
- Unpressurized feed.
- Enclosed focal point LNA with polarization from the rear of the antenna.
- Plane and dual polarized antennas are available, all of which meet appropriate FCC requirements.
- Available in environmentally acceptable tones of green, white, tan.
- Self indexing flanges (Prodelin exclusive) eliminate guide pins, add to simplicity.
- Interchangeable fiberglass segments have their own inherent strength (unlike fragile aluminum segments).
- Antenna sheds ice so easily in most locations, it's considered virtually self-deicing. If ice does form it can be manually deiced with the rap of a mallet.
- Patent applied for.

The Associated Press, The Mutual Broadcasting System, Muzak and other major networks in the U.S. and abroad use Prodelin antennas in their Earth Station systems. Major land links also employ Prodelin antennas. Read all the reasons why. Send for new segmented antenna literature.

Prodelin®

Segmented Fiberglass Antennas

P.O. Box 131 Hightstown, N.J. 08520 609-448-2800
1350 Duane Ave., Santa Clara, Calif. 95050/408-727-4720

Circle (202) on Reply Card

March 1981 *Broadcast Engineering* 219

ADJ	REMARKS	MECHANICAL
11-1		
11-2		
12-1		
12-2		
13-1		
13-2		
13-3		
13-4		
13-5		
14-1		
14-2		
14-3		
15-1		
15-2		
16-1		
16-2		
17		
18		
17-1		
21-1		
21-2		
22-1		
22		
22-1		
22-2		
22-3		
23-1		
23-2		
24-1		
24-2		
24-3		
24-4		
25		
26-1		
26-2		
26-3		
27		
28		
28-1		
DATE		

Figure 3

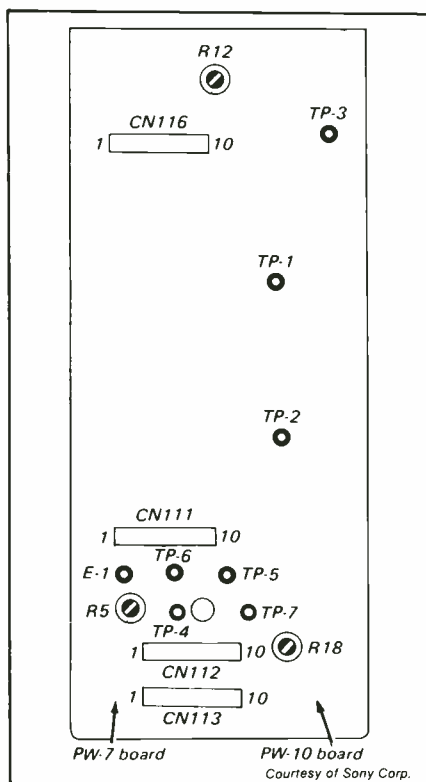

Figure 4 Power Supply test points.

RECOMMENDED PARTS REPLACEMENT FOR BVU-200 REBUILD*

X-3642-044-5	Table assembly, take-up reel (A-6740-034-9)
X-3642-052-2	Pulley assembly
X-3642-061-1	Brake, band assembly
X-3642-067-0	Brake, p
X-3642-154-0	Brake shoe
X-3642-166-0	Brake shoe, stop
1-518-263-11	Lamp 23V 130ma
3-607-104-03	Brush
X-3642-050-2	Idler assembly, FF-REW
X-3645 087-1	Pinch roller
3-642-546-01	Belt, drive
3-642-547-01	Belt, capstan
3-648-002-02	Belt, drive FF-REW
3-648-004-02	Belt, drive motor
3-642-110-00	Lever, slide function

*Exact part numbers may vary with BVU-200 serial number. Make a similar list for your particular unit(s).

Figure 5

BVU-200

have the gears. It is a simple matter to remount the new bands on the old brackets. After installing the new brake band, adjust the position of the supply tension regulator pin setting (Figure 10). Refer to section 13 of the technical manual for more detail.

Note that replacement of the 23V photo lamp (Figure 11) is merely precautionary. It's an inexpensive part and replacement now will probably guarantee one less service call later.

As shown in Figure 12, after 1000 hours the brushes become worn and replacement is recommended unless little wear is noted. Belts should also be replaced.

After thousands of uses, the slide function lever aperture becomes worn and distorted (Figure 13), especially when the machine comes from an ENG edit station. The widening of the aperture affects the alignment of the FF/REW/PLAY/EJECT links and can cause the machine to jam between modes. Replacement of this lever is simple and completes the parts replacement portion of the 1000-hour overhaul.

Mechanical alignment

All numbers on the mechanical

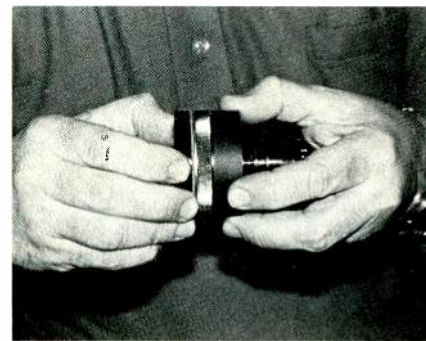

Figure 6

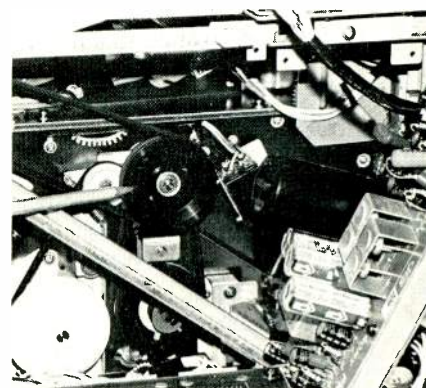

Figure 7 Midway pulley assembly. Note FF/REW pulley directly underneath.

ANOTHER NEW ROUTING SWITCHER CONTROLLER FROM UTAH SCIENTIFIC



CSP-100-E

Switching by source name, true matrix statusing,
coax party line control, audio/video breakaway — all this
from Utah Scientific in a 1 $\frac{3}{4}$ " routing switcher control panel.

Utah Scientific's new CSP-100 panel in its encoded form permits your operator to address and status sources by their familiar name — VTR 7, CAM 3, etc. The panel connects to the matrix via a single coax party line while LEDs in the Group and Units button rows provide true audio and video statusing from refresh memory data. Separate audio and video buttons are provided for breakaway switching.

The CSP-100 joins a long line of routing switcher controls from Utah Scientific that all feature single coax control connection, true statusing, and breakaway switching, and that are human-engineered to minimize operator error.

SINGLE COAX CONNECTION — SELECTS AND STATUSES BY NAME — 1 $\frac{3}{4}$ "

TRY THAT ON YOUR GRASCOMFERNSAM DYNATEK SWITCHER!

Visit Us at NAB Booth #1629

US UTAH SCIENTIFIC
THE ROUTING SWITCHER PEOPLE.

2276 So. 2700 W. • Salt Lake City, UT 84119 • Phone 801-973-6840
TWX #910-925-4037

Circle (203) on Reply Card



ENG goes airborne with TEAC

TEAC Airborne Videocassette Tape Recorders (AVTR™) are designed and manufactured by TEAC specifically for rough handling and airborne use.

- 3/4" U-Matic
- Uses 28VDC directly from helicopter power
- Wide temperature range
- Radio interference protected
- Remote-Record control
- Fully tested by the USAF and used extensively in US Army helicopters



TEAC VIDEO

TEAC Corporation of America
Industrial Products Division
7733 Telegraph Road
Montebello, CA 90640
(213) 726-8417

Circle (204) on Reply Card

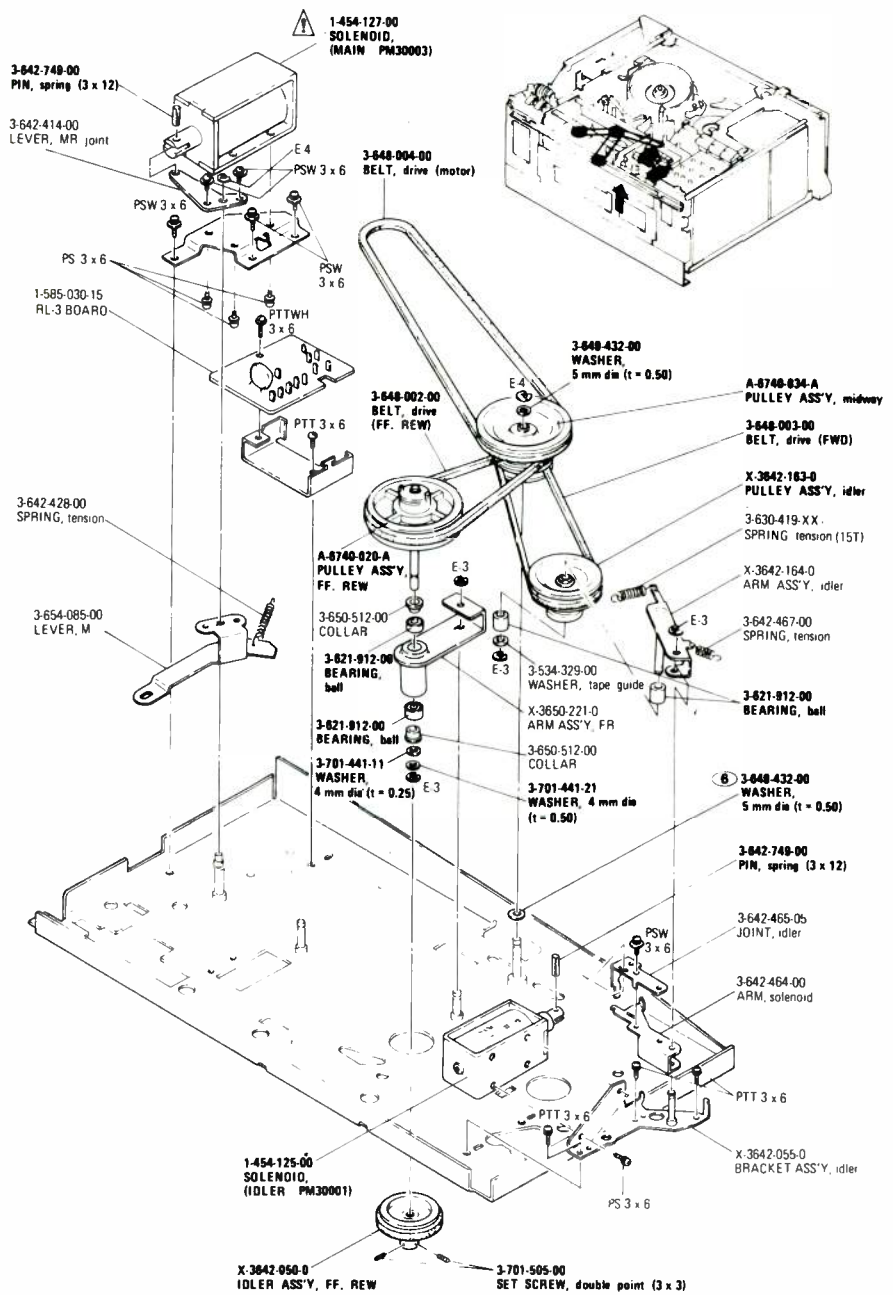

Courtesy of Sony Corp.

Figure 8 This drawing in your recorder manual shows the crucial parts replacement numbers

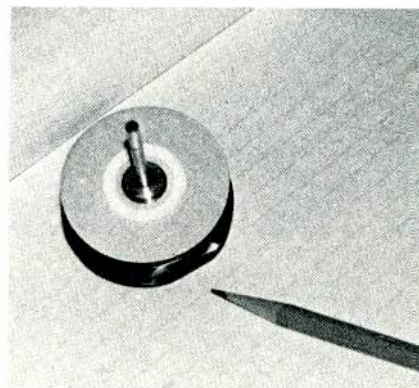

Figure 9 Note warped disc protruding from pulley assembly.

BVU-200

alignment sheet refer to sections in the Sony BVU-200 technical manual.*

11-1,2. Take-up and supply table height adjustment (Figure 15). If this has never been checked before, now is a good time to do it.

12-1,2. Main solenoid adjustment (Figure 14) and idler solenoid adjustment (Figure 16). Adjustment is straightforward. Just be sure to loosen all of the solenoid mounting

EMCEE translators offer advantages from hill top to bottom line

On site, the EMCEE solution to TV translator requirements is quite uncomplicated. A translator must go on the air quickly. Stay on the air continuously. And require a minimum of time and attention to accomplish both.

An approach you probably share.

With that in mind, EMCEE developed the new TUA1000C amplifier.* A one-thousand watt unit that shares the high gain, efficiency and reliability of the entire EMCEE line. And introduces further improvements like compact single bay construction. Solid-state control circuitry. LED status indicator. A slide out RF cavity and more. Which makes the TUA1000C amplifier the perfect solution for either conventional or new low power TV applications.

EMCEE also offers an uncomplicated approach to complete turnkey services, contract installation and maintenance and system design applications.

And that's where the bottom line advantage lies. Because no matter what your translator requirements may be, EMCEE can help you reach all of your market. All of your broadcast day.

* Type acceptance applied for

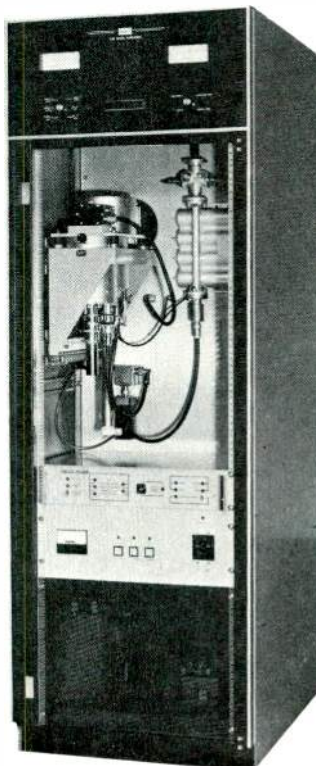

Circle (205) on Reply Card

EMCEE
**BROADCAST[®]
PRODUCTS**

a division of
ELECTRONICS, MISSILES & COMMUNICATIONS, INC.
P.O. Box 68
White Haven, PA 18661 U.S.A.
Phone toll free: 800-233-6193
(In PA, call collect: 717-443-9575)
TWX: 510-655-7088
Ans: EMCEE WHHV

*Learn about the advantages of
EMCEE translators at the NAB Convention,
Booth 1017*

© 1981 EMCEE Broadcast Products

BVU-200

screws before attempting to reposition it. Before doing this, though, remove the solenoid plunger and examine it for sticky residues or rust. This has been a problem with both of these solenoids. If this problem is suspected, remove the plunger and clean both the plunger and receptacle with fine steel wool.

13-1,2,3,4,5. Proper braking action is critical to correct operation of the BVU-200, especially if the machine is going to be used in an editing

station. Also take a close look at the supply reel brake assembly (Figure 17). Note the condition of the springs and also the S brake stopper. It is a good idea to have a supply of both the springs and the stopper on hand because both of these parts seem prone to failure—the stopper by bending and cracking at the base and the spring by breaking.

14-1,2,3. These adjustments are seldom off but occasionally the

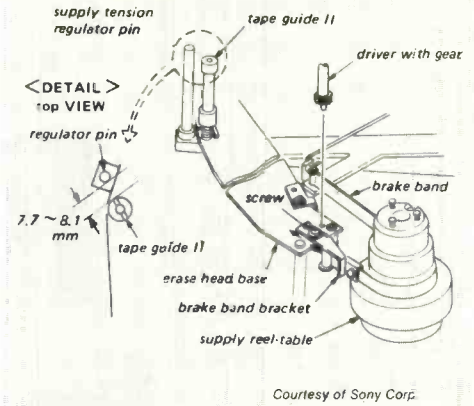

Courtesy of Sony Corp.

Figure 10

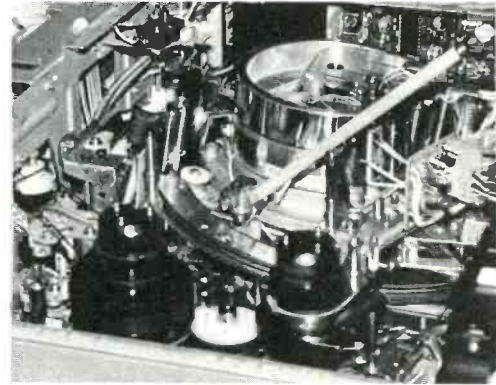

Figure 11

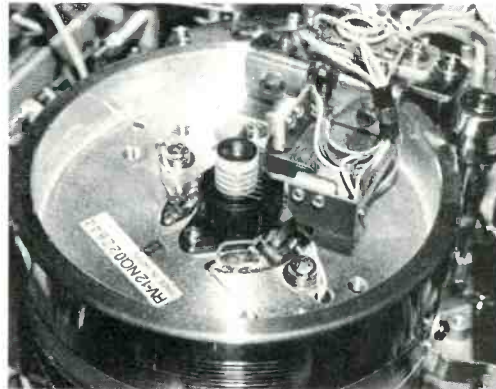

Figure 12

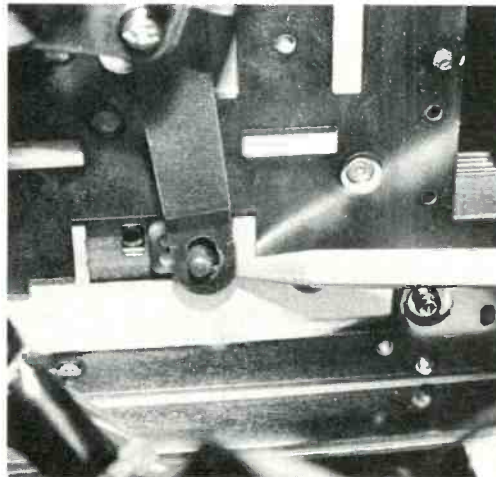

Figure 13 Note the damage around the link opening.

CHALLENGE: To build TV towers soaring nearly 2,000 ft. above the earth.

We've done it. . .many times.

CHALLENGE: To build a rugged, reliable, multi-tower array for AM transmission.

We've done it. . .many times.

CHALLENGE: To build microwave towers to virtually zero deflection requirements; towers that withstand fierce winds and severe icing. . .successfully.

We've done it. . .many times.

**GIVE US
A TOWERING
CHALLENGE!**

Stainless. Meeting challenges in tower design for over thirty years. . .successfully.

See us at the NAB Show.
Booth 1009.

The Tower People.

Stainless, inc.

North Wales, PA 19454
Phone (215) 699-4871 • TWX: 510-661-8097

CO181

Circle (206) on Reply Card

IF WE SAID YOU COULD MAINTAIN HIGH PRODUCTION STANDARDS FOR LESS THAN \$2000, YOU'D SAY WE'RE UNBALANCED.

By using a -10 unbalanced system, instead of +4 balanced, we eliminated hundreds of dollars of line amplifiers, transformers and balanced audio cables.

And that's how the Tascam 35-2B recorder/reproducer can save you money.

Without compromising your professional quality one nanoweber.

Unless you're running cable hundreds of feet long, there's no real difference between balanced and unbalanced. Since input/output levels and impedance aren't factors in recording quality.

So it pays to use the Tascam 35-2B in production, where you're

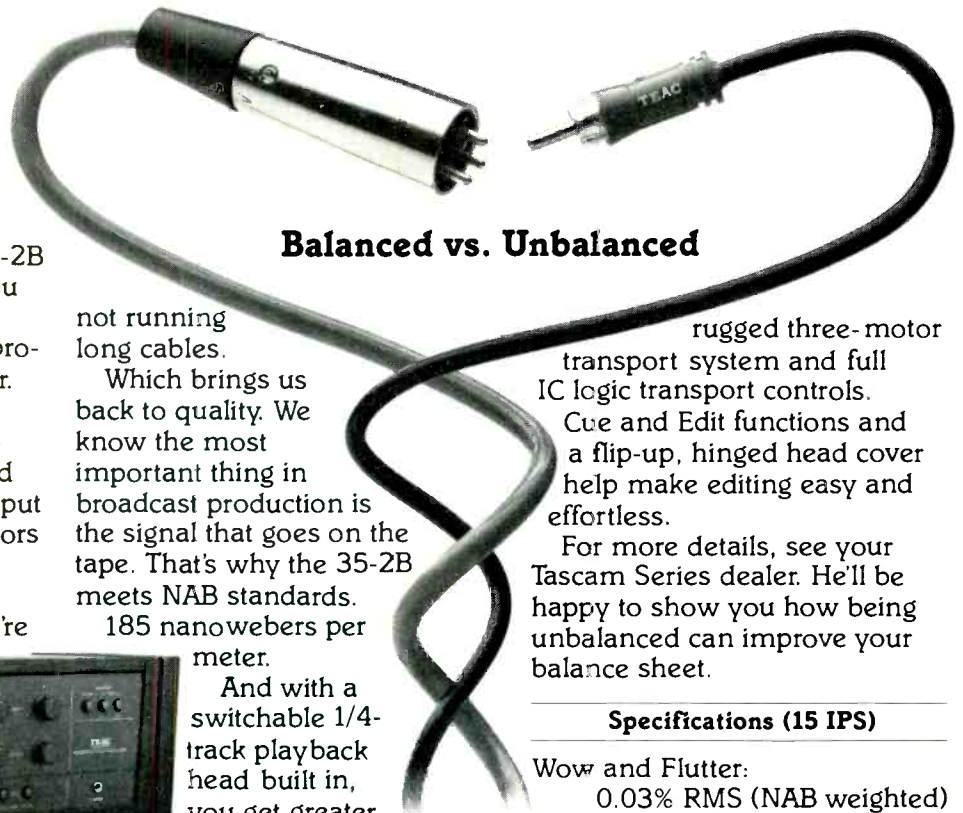

Balanced vs. Unbalanced

not running long cables.

Which brings us back to quality. We know the most important thing in broadcast production is the signal that goes on the tape. That's why the 35-2B meets NAB standards.

185 nanowebers per meter.

And with a switchable 1/4-track playback head built in, you get greater flexibility at no extra cost.

What's more, the 35-2B features a

rugged three-motor transport system and full IC logic transport controls.

Cue and Edit functions and a flip-up, hinged head cover help make editing easy and effortless.

For more details, see your Tascam Series dealer. He'll be happy to show you how being unbalanced can improve your balance sheet.

Specifications (15 IPS)

Wow and Flutter:
0.03% RMS (NAB weighted)
±0.05% peak
(DIN/IEC/ANSI weighted)

Frequency Response:
40 Hz-22 kHz, ± 3dB at 0 VU

Signal to Noise Ratio:
Reference 1 kHz at 10 dB above
0 VU (650 nW/m) 65 dB A
weighted (NAB) 92 dB A
weighted with integral dbx*

*dbx is a trademark of dbx Incorporated.

TASCAM

Teac Production Products Group



CS-600 Console optional.

The 32-2B and the compact 22-2 recorder/reproducers can save you even more money.



© 1981 TEAC Corporation of America, 7733 Telegraph Road, Montebello, CA 90640.

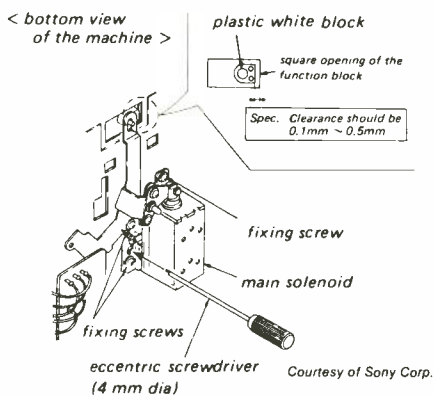

Figure 14 Slide function lever and main solenoid. Upside down view.

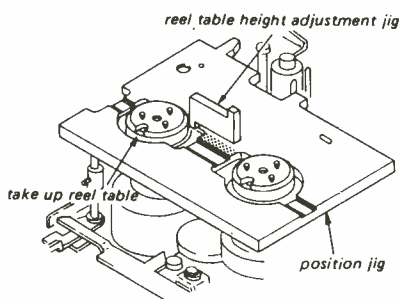

Figure 15 Courtesy of Sony Corp

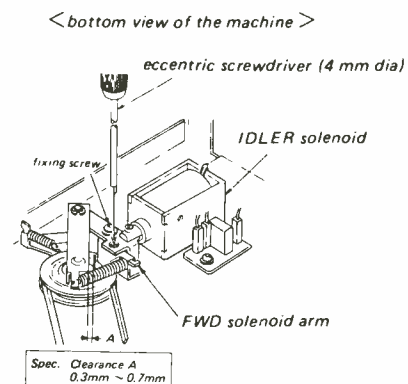

Figure 16 Courtesy of Sony Corp.

BVU-200

margin gear needs adjusting (Figure 18).

15-1. The forward slack switch position adjustment (Figure 19) is important to check because of the slapping around the pinch aux plate takes.

16-1,2. Pinch roller alignment adjustment (Figure 20). If the pinch roller hasn't been changed lately, remove it and take a good look. In some cases the bearings have obvious signs of wear. It is KOMO's

practice to change the roller several times between overhauls. Badly worn pinch rollers cause "flag waving" and other picture tearing problems. Pinch roller alignment is critical if tape damage is to be avoided.

17. Supply tension regulator pin position adjustment (Figure 10). This may have been done when changing the brake band. If not, do it now.

18. Tape advancing power adjustment. Check per manual.

19-1,2. Pinch roller, pinch lever adjustments. Check per manual.

20-1,2,3. For 20-1 forward torque check, the manual says to change the take-up table if the proper reading can't be achieved. If that doesn't do it, check the adjustment of the P brake.

21. R tension regulator position adjustment. Check per manual.

22-1,2,3. Tape hold-back tension alignment. Check per manual.

Howe Audio History Is Made . . . See us at NAB Booth 4385

Howe 7000 Stereo Console

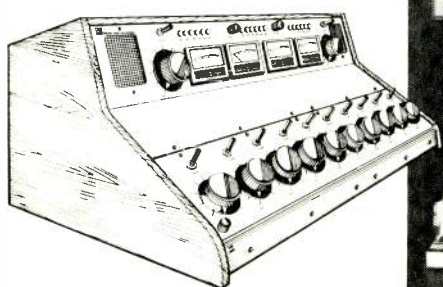

Simply Reliable.

Those words introduced the Howe 7000 in 1979. Since then the Howe 7000 consoles have rapidly grown in popularity. Engineers are impressed with Total Harmonic Distortion of .09% or lower, noise floor of -74 dBm, equivalent input noise of -124 dBm or lower, channel separation of better than 60 dB, frequency response of 20 Hz to 20 k Hz \pm 1 dB, and maximum output of +24 dBm.



"Since the installation of our first Howe Series 7000 console last summer, we have enjoyed consistently high quality and no down-time. The operators are delighted with the clean, straight-forward layout of the controls and the useful special features of the Howe Series 7000. The second Howe Series 7000 console is being installed in the KIMN newsroom, a high-volume, 24-hour mobile news operation. Again, the Howe Series 7000 console offers the reliability, special features, and error-free operation that we demand." Chuck Waltman, Engineering Director, KIMN-KYGO, Jefferson-Pilot Broadcasting, Denver, Colorado.

Introducing the Howe 8000.

The 8000 has all the same performance specifications and high reliability of the 7000, but with many new features, including slide attenuators, push-button logic systems for on/off/cue and remote start/stop, simultaneous audition/program bussing, fluorescent VU meters and a built-in real-time clock. As in the 7000 there is a full width option panel and D.C. audio control.

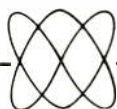

howe audio productions, inc.

Call Howe Audio Marketing

P.O. Box 383 Boulder, Colorado 80306

(303) 424-3231

Mail the Howe Audio reply card on page 285.

Circle (208) on Reply Card

FOR \$2.25/HR. YOU CAN GET A HEAD OF THE EIGHTIES.

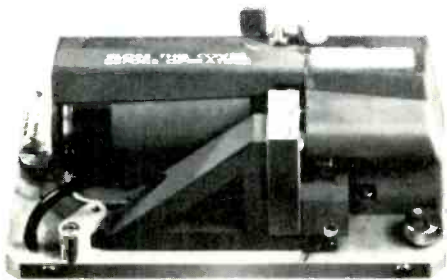

Now you can cut quad recorder head costs and improve your image at the same time. This latest Spin Physics ferrite-tip head takes picture quality and tip life into the next decade at a

price that would have been right in 1976. Today's \$2.25 an hour maximum cost for a 1,000-hour prorated warranted head is an incredible bargain. It's well worth spending a few minutes in our Booth 1118 at the N.A.B.

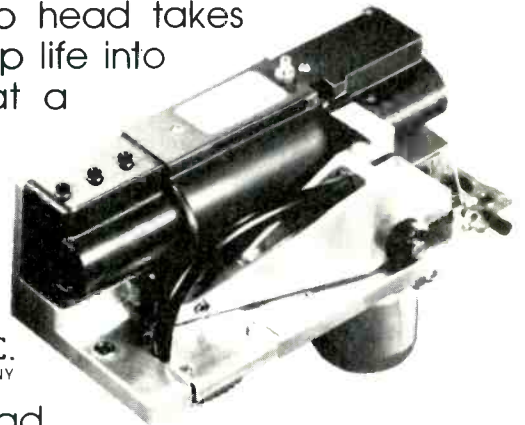

SPIN PHYSICS, INC.
A KODAK COMPANY

3099 Science Park Road
San Diego, California 92121
(714) 453-5410

Cable: SPINEX SAN DIEGO TWX: 910-322-1737

See us at Booth 1118 at the N.A.B.

Circle (268) on Reply Card

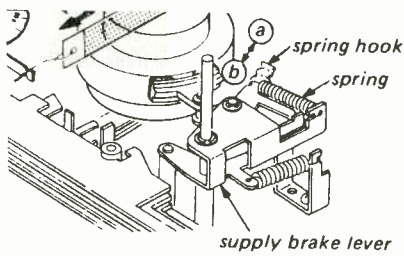

Courtesy of Sony Corp

Figure 17 S brake springs and S brake stopper.

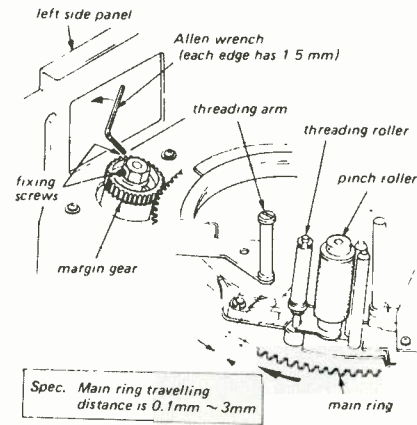

Courtesy of Sony Corp

Figure 18

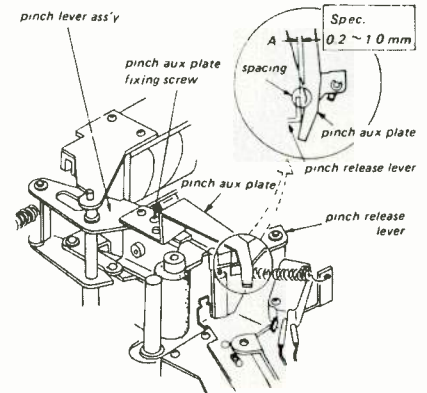

Courtesy of Sony Corp

Figure 19

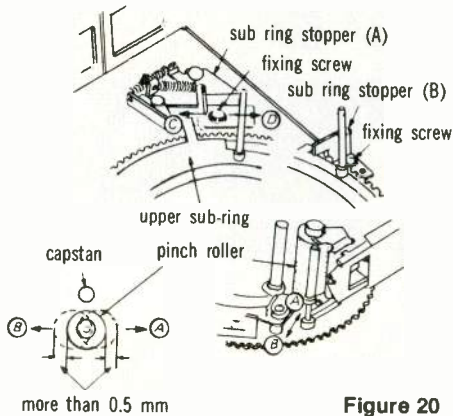

Figure 20

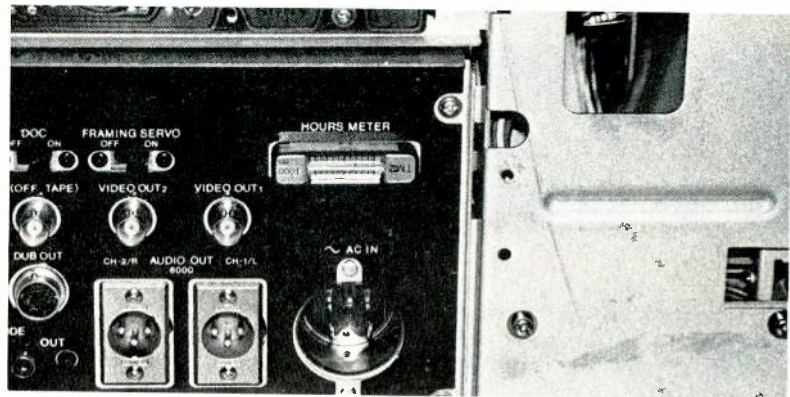

Figure 21 Hours meter in upside down position.

BVU-200

23-1,2. Fast forward rewind torque alignment. These are seldom a problem. As mentioned earlier, sometimes the disc slips out of the FF/REW pulley. Frequently this can be heard as a slapping sound when the machine is in the FF/REW mode, especially when slowing to a stop.

24-1,2,3,4. Reel servo alignment. Correct power supply voltages are a must before proceeding with this set-up.

25. Brake solenoid position alignment. Check per manual.

26-1,2,3. Tension solenoid alignment. Not unusual to find adjustments needed here.

27. Tape speed alignment. Clean surfaces for the tape and capstan belt, and a new capstan belt are

usually all that is needed here. Sample this frequency at a 10-second count rate on the frequency counter.

28. Tape run alignment. It's a good idea to read the entire section of the manual on this procedure. Have plenty of light available and check the tape along its entire path in every mode of operation. This is the one area in which it pays to go slowly.

29. Tracking alignment. Read the book carefully before working on this. Unless a part has been replaced these adjustments should be OK.

Video heads

Sony recommends changing video heads (upper drum assembly) every 1000 hours. KOMO doesn't always do that. One test of head performance is the presence of "black bearding" in 100% white areas of video. This phenomenon slows up often in outdoor scenes where objects are heavily backlit by the sky. It also is present as black

streaks in vidifont keys. If the recorder is producing this "bearding" problem, most likely the upper head drum assembly needs replacement.

Final

With the completion of the above adjustments the machine is then checked with an oscilloscope and an RR5-1SB alignment tape for head switching position and drum phasing. Also, deviation is checked with a calibrated video test signal. Audio input and output levels are checked too. Reversing the hours meter (Figure 21) completes the overhaul process. Although minor adjustments are always necessary between overhauls, seldom have any serious problems occurred. □

* Note—The code numbers in this section refer to Model 200 systems of a limited range of serial numbers. Manuals for other serial numbers, and for the Model 200A, differ in certain sections. However, the graphics and generic terms can be correlated with the proper sections of any manual, regardless of the specific code numbers used.

JVC's KY-2000 COLOR CAMERA AND THE 3/4" VIDEOCASSETTE TAPE HANDLERS ARE AN UNBEATABLE COMBINATION

Special
NAB
Prices

Call Lines Video Systems. We also have good selections of used and reconditioned video editing systems and 3-tube color cameras.



KY-2000 Portable/Studio Color Camera

The three 2/3-inch Saticon tube unit, is equally at home in rugged, on-location production or more delicate in-studio applications.

Broadcast quality images originate from a high degree of sensitivity and an excellent signal-to-noise (S/N) ratio of 52 decibels (dB). The KY-2000 requires only 20 watts of power, including that needed for a 1.5-in. viewfinder.



CR-8200U Editing Videocassette Recorder

The tape transport performance of the CR-8200U color U-type editing videocassette recorder is the logical choice for video users that demand professional performance at a good price.



CR-6600U Videocassette Recorder

The Direct Drive CR-6600U in conjunction with the new CR-8200U editing videocassette recorder and the new RM-82U and RM-88U Automatic Editing Control Units is part of a flexible mid-priced editing system that can be easily expanded or upgraded.

The CR-6600U has direct-drive head drum and capstan, as well as direct-drive reel motors on the reel servo system. This insures stable tape transport at any speed in either forward or reverse. Luminance jitter is rated at less than a factor of plus/minus 5 microseconds.

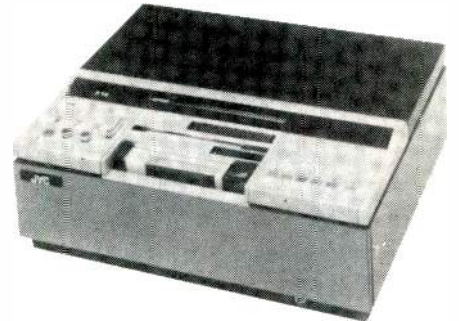

CP-5500U Videocassette Player

Features Direct Drive head drum and capstan and Direct Drive reel servos, making it a player for a 3/4" U-type editing system.



RM-88U

The RM-88U is designed for an advanced editing system. It can control any combination of three VCR units, feeding a master recorder. It has the features of the RM-82, plus a number of editing functions that are more automated.

LINES VIDEO SYSTEMS

A division of Lines Music Inc., serving the Midwest for over 107 years. Call us first, phone toll free — **1-800-641-4674** in Missouri call collect **417-862-5533**.

Write for our new catalog.

Bud Lines, Cheryl McKinney, Don Ingalsbe
Lines Video Systems
Jefferson at McDaniels Sts.
Springfield, Mo. 65806



Beaveronics, Inc.
FAVAG

MASTER CLOCK SYSTEMS
MODULAR DESIGN FACILITATES
FUTURE EXPANSION

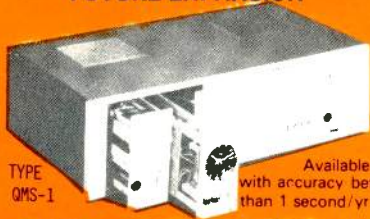

TYPE QMS-1

Available with accuracy better than 1 second/yr.



TYPE 20MS-2

NUMEROUS SECONDARY CLOCKS ARE AVAILABLE INCLUDING THOSE WITH SILENT OIL-BATH MOVEMENTS



Table Top



Surface Mtg. Semi-flush



6 DIGIT DIGITAL DISPLAYS AVAILABLE

EXTRA-FLAT SECONDARY CLOCK

MINUTE-IMPULSED, FOR INDOOR USE
SINGLE FACE, FOR WALL MOUNTING

DECORATIVE SECONDARY-CLOCKS

SILENT MOVEMENTS FOR SURFACE, OR FLUSH MOUNTING AND INDOOR USE



FAVAG MASTER CLOCK SYSTEMS

Beaveronics, Inc.

Write or phone for details.

8 Haven Avenue
Port Washington, New York 11050
Tel: (516) 883-4414

Prices and Specifications Subject to Change Without Notice.

The prospect of low power

By Dr. Thomas C. Durfey

Direct-satellite-to-home broadcasting in many ways appears regrettable and inevitable—regrettable because direct-satellite-to-home surely will remove all chance of local access to television. Regional and local government officials and citizens will not be inclined to travel to a single studio adjacent to an uplink dish. Most of what Americans will be watching will be exclusively what big network officials, big business and big government want us to see. It appears that the first item all of these groups would lure us to see is a "pay-channel" or premium TV. And network TV wouldn't be far behind in offering its fare direct to your rooftop dish. So by 1984, it may not be so much "Big Brother" watching you, but you watching Big Brother. What then happens to all those VHF TV stations licensed to the city near you? Will they have any network to switch to 90% of their broadcast day? What program forms will substitute for the satellite-to-home network feed?

The answers may come from an entirely new approach to local television opened up by the FCC in September. In a proposed rulemaking, the FCC has begun accepting for filing a new class of Low Power TV Station, 100W on VHF or 1000W on UHF. The channels are to be selected for a given low-power location by using the FCC Translator Technical Rules instead of the complicated rulemaking proceedings usually needed to establish a channel in an area not already in the FCC table of assignments. Literally dozens of channels are available in medium-sized cities in rural America. They are being filed for right now. What will they program? How will they operate?

New forms of programming will need to be developed to serve the new rural and small-city audiences.

The author is currently a TV consultant and Associate Professor/Telecom Studies Coordinator at Oral Roberts University, Tulsa, OK. He has held a 1st phone license for 25 years and received his doctorate from New York University in 1978; his dissertation was on "Local Origination on TV Translators."

He has been president and general manager of WHVM, Hyde Park, NY; TV and media director for Dutchess Community College, Poughkeepsie, NY; and founder of Communications & Media Arts Program at the District of Columbia College.

These forms may include regional networks, subscription television, specially developed syndicated programming, newly constructed satellite feeds specially designed for low-power stations, and programs yet to be developed by the new stations themselves.

One of the first forms of programming that probably will be developed for this new low-power service will be subscription television. This form of "pay TV" over-the-air would offer a means of paying some of the bills at the newly established local low-power outlet. In the smaller towns of America, cable density is not as likely to be complete, and in many newly formed suburban areas there is no cable at all. Therefore, the public in these areas unserved or underserved by cable has been denied the premium or pay TV service until now. A low-power UHF station from a good tower site could cover 14 to 18 miles in every direction and provide this type of pay-TV service to an area otherwise without this option.

The pay-TV service may well be offered by a new UHF full-power station in a big city. The low-power station may be able to link up with the full-power station to be a translator of the bigger station during part of its operating hours, even while the big station originates the pay TV. Thus, the low-power outlet would give a percentage of the "box-take" to the originating station for doing all the programming, paying copyright fees and billing the box customers.

This big-city UHF independent may supply the hub of a regional network concept in conventional television, as well as the pay-TV feed. During the day, programs that are created by the larger station and programs for which the copyright has been cleared would air from the big-city UHF station in a way to allow cooperating mini-stations the opportunity to "cover" certain advertising and certain local city programming with local material originated at the low-power station.

For commercials, the high-power station could sell some statewide or areawide sponsors that want the total area, including all the viewers

Circle (210) on Reply Card

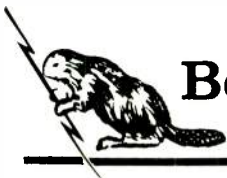

Beaveronics, Inc.

STUDIO PRODUCTION VIDEO SWITCHING SYSTEMS

8 Haven Avenue
Port Washington, New York 11050
Tel: (516) 883-4414

(Also available in PAL and PAL-M versions)

FOR REMOTE & SMALL PRODUCTION FACILITIES

MODEL J & D 712

\$7,400.00

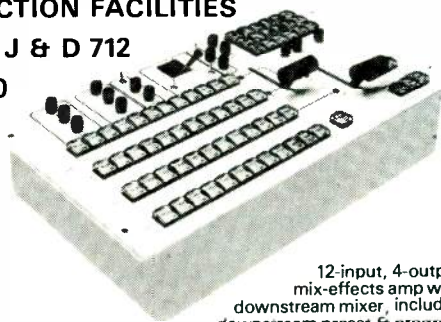

12-input, 4-output mix-effects amp with downstream mixer, includes downstream preset & program busses with cut bar, RGB chroma key

Standard Features

- 12 inputs including Black-burst and Color Background
- Built-in Black Burst Generator
- Built-in Colorizer
- Built-in RGB Chroma Keyer
- Four Switching busses
- Downstream Preset and Program Busses with cut bar
- Rack-mounted electronics
- Adjustable Soft Wipe
- Adjustable Border edges
- Color Matte
- Vertical Interval switching thru-out
- Illuminated Momentary Contact push buttons
- Internal, external, Chroma-key, and matte inputs to keyer

- Built-in pattern modulator with frequency and amplitude controls
- Full Tally
- Pattern symmetry control
- Illuminated Momentary contact push buttons for effects selection
- Normal/Reverse/Normal-reverse wipe transitions
- Pattern limit controls for presetting size of patterns or varying vertical and horizontal aspect ratio
- Loop-through inputs
- Input amplifiers with clamping
- Synchronous/Non-synchronous inhibit
- Modular construction with front access plug-in modules

Options:

Downstream Keyer

FOR MODERATE SIZE FACILITIES

MODEL B1-154

\$12,990.00

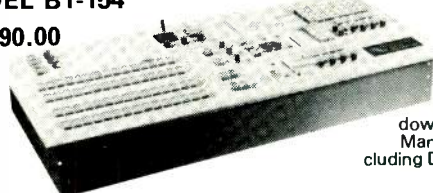

15-input, 4-bus mix/eff/key amp with downstream mix/key amp. Many optional features including DSK & quad-split, etc.

FOR SOPHISTICATED FACILITIES

MODEL B1-156

\$21,795.00

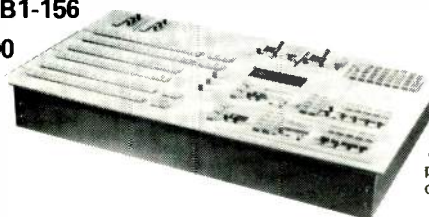

15-input, 6-bus with two full mix/eff/key systems and dir. pgm and pre busses: many options available, DSK, quad, etc.

MODELS 154 & 156

STANDARD FEATURES

- Switcher Models 154 and 156** are of the same basic design and utilize the same electronic sub assemblies. These switchers have the same standard basic features, differing only in the number of busses and in the number of mix/effects units. The basic standard features include 32-pattern mix/effects, color black and color matte background generator, and a mix/key unit in the case of the Model 154.
- Input Amplifiers**
 - loop through high impedance input
 - gain equalization for 1000' cable
 - 22° sub carrier phase control
 - clamped inputs (10% to 90% APL)
 - sync addition on non composite signals if desired.
- Tallies**
 - isolated dry contact relay closure on all inputs (2 amps at 50 v.)
- Mix-Effects Units (Includes Keying Function)**
 - One (1) used in Model B1-154
 - Two (2) used in Model B1-156.
 - **Fades (or Supers), Wipes, Keys** may be produced.
 - **Positioner Joystick** for each M/E positions patterns.
 - **Pattern Modulation** may be accomplished by an internal waveform generator. Modulating sources may be either (1) sine wave, (2) square wave, (3) saw tooth, or (4) an external customer generated source.
 - **Mix Key and Wipe Key** available.
 - **Soft Wipe and Soft Key** available with adjustable variations.
 - **Push to Preview** obtained by depressing knob on clip potentiometers (provides for M/E monitor output).
 - **Wipe Mode**—3 interlocked buttons select "NOR", "REV" or "N/R".
 - **Hard Wipe, Soft Wipe or Border** can be selected with degree of softness made by "Edge" control adjustment.
 - **Border** may be **Colorized** by adjustment of "Hue" and "Luminance" control.
 - **Symmetry of Pattern** may be adjusted by "SYM" knob.
 - **Preset Wipe Limits** are set by potentiometers. "H" and "V" vertical preset limits activated by Pattern Limit button.
 - **Spotlight** alternate action push button produces a 6 db. level difference between "A" and "B" input channels in the "Wipe" mode. (Operates on all patterns.)
 - **Pattern Assignment** is made by depressing "ASSIGN" button. Pattern select

feature may be "locked" to pattern matrix by depressing the "ASSIGN" button a second time on the same pattern. Patterns assigned appear on LED display on M/E control panel.

- **Non-Synchronous Inputs.** An "NS" indicator is provided. Tearing is prevented by not allowing a non-synchronous signal to be switched except at extreme position of fader handle where a "cut" transition occurs.
- **Key Input Sources** may be either (1) "A" bus video for self keying, (2) preview Key bus, (3) chroma key, or (4) an external key source.
- **Key Invert** selector provided to accommodate either positive or negative video as a keying source.
- **Key Fill** may be either "A" video for self keying or a colorized matte.
- **Mix/Key** provided a lieu of second Mix/Effects system for Model B1-154 switching system. Provides for all mix and keying functions of mix/effects system (as previously described) except for the pattern effects.

OPTIONAL FEATURES

May be added at any time (required control panel wiring already installed)

- Chroma Keyer (C.K.)** \$950.00
 - **Hue**—selects hue of keying color
 - **Gain**—adjusts the amplitude
 - **Clip**—adjusts the clip level for keying
 - **Camera (4 x 1) input switcher**—selects RGB output of any one of 4 cameras to feed C.K.
 - Down Stream Keyer (DSK)** \$1,975.00
 - Keys in titles, inserts, or fades to black with or without insert
 - Color matte background
 - Key sources: (1) Mix/Effect, (2) Chroma Key, (3) External
 - **Push to Preview (Monitor)**
 - DSK Border** \$1,950.00
 - **Border**—black edge around insert
 - **Shadow**—black edge on right side and bottom of insert
 - Quad Split** \$1,900.00
 - Provides four (4) variable size quadrants from eight possible sources with variable width border.
 - Aux Busses—(Model 156 only)** \$2,100.00
 - Two remote outputs are available—remote control panel and amps required.
 - 2nd Mix/Effects Unit** in lieu of Mix/Key amp in 154 \$2,650.00*
 - Mix/Key amp** fed by preview and program busses in 156 \$3,500.00*
- *Except those indicated with an asterisk.

All Beaveronics Switching Equipment Carries a Two Year Warranty

ENG Switcher Model J & D 705

\$7,990.00

- Master control switchers AFV with audio breakaway
- Routing switchers with AFV
- Specialized custom switches
- Selected terminal equipment

FEATURES:

- BUILT IN COLOR BLK AND BKG
- SELF-CONTAINED SYNC GEN
- INDEPENDENT COLOR BLK OUTPUTS TO CAMS
- SELF-CONTAINED CASE
- 5 INPUTS INCLUDING BLK AND BKG
- 32 - PATTERN MIX/EFF/KEY WITH POSITIONER
- MIX/EFF/KEY RE-ENTRY INTO SEPARATE MIX BUSSES
- PREVIEW FEATURES
- FRONT PANEL SINGLE ADJUSTABLE

Write or phone for details.

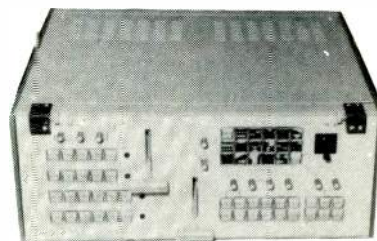

Beaveronics, Inc.

8 Haven Avenue • Port Washington, New York, 11050 • Tel: (516) 883-4414

Prices and Specifications Subject to Change Without Notice.

**Four years ago
Lyon Lamb brought
video to animation.***

**In 1981 Lyon Lamb brings
video animation to
broadcast television.**

**See how we do it at
NAB Booth 439S.**

*Academy Award for Technical Achievement, 1979. Frame by frame video at 24 fps.

LYON LAMB
VIDEO ANIMATION SYSTEM

8255 beverly boulevard
los angeles, california 90048
213-655-0606

Circle (212) on Reply Card

DATAWORLD, INCORPORATED
Computer services to the broadcast industry

Up-to-date Directories
Allocation Studies
"Flag Service" - FCC Actions
AM • FM • TV

TV Low Power/Translator Frequency Searches
Remote Terminal Access Available

COME SEE US!

NAB Hospitality
Desert Inn
April 12-13-14
5-8 PM

Your hosts: Howard Head
Shirley Ostmann • Marvin Blumberg
John Lundin • Ogden Prestholdt

dataworld 1302 18th St., N.W. • Suite 502
incorporated Washington, D.C. 20036 • 202/296-4790

Circle (213) on Reply Card

Low power

watching the cooperating mini-stations as well as the main station. Other sponsors sold by the main station would be strictly aimed at the city of license and have no value when viewed in the extreme outlying areas covered by the mini-stations.

Thus, three, four or five availabilities per hour would be salable by the local low-power stations, which could cut in at prearranged times to "cover" those strictly local city ads with local ads to their area only.

The same would be true of informational programming. When the main station has a segment of five or 10 minutes of city news, the cooperating low-power station could substitute news of its city of service. Thus, the low-power stations' audiences would each feel that it had a program service tailored especially for them, in their town, their state, etc., when actually the service was designed in tiers of concern: national programming shared with many big-city independents, big-city independents' programs and the local low-power market.

The price for such a service could be a percentage of gross, something like the ASCAP, SECAC, and BMI music licensing groups now levy on radio broadcast stations for their usual programming staple, music. The big-city stations would also get to charge more for certain advertisers carried in multiple markets through low-power stations throughout their entire state or region, extending their area of dominant influence from 70-75 miles to a 300-mile radius or more.

For low-power television stations with markets too remote from big-city independents, the possibility of such a tiered service being offered by conventional common-carrier satellite feed becomes apparent. (Either a "superstation" approach for low-power stations like WTBS, Atlanta, is for cable systems, or one for an entirely new program service that encourages local origination program substitution by cooperating mini-stations.) The principle would be similar: National advertising rates for the program satellite network and local availabilities for the participating mini-station that pays the supplier a small fee for copyright clearances. Such a pro-



They Don't Compare.

Taste. Color. Smell. Everything about them is different. Fortunately, comparability audits sort out these differences. Thanks to the Business Publications Audit of Circulation, Inc., many business publications participate in comparability programs where publishers categorize their markets and readers. Advertisers and agency representatives work closely with publishers to establish common terminology in defining markets and readers and circulation.

The result is a simple, effective way of pinpointing the right vehicles for your advertising dollars.

If you want more information about the BPA comparability program, ask your agency media director or contact Business Publications Audit of Circulation, Inc., 360 Park Avenue South, New York, N.Y. 10010.



Low power

gram feed now exists for cable systems—the Satellite Program Network (SPN). It is free to cable companies and even allows local cable systems to insert local ads; indeed, it even sends a triggering pulse to add the local spots by automation.

It would seem that such a local low-power station could run much like a local radio station, with a half-dozen to a dozen employees. It would be local radio with pictures. The technology has truly caught up with the concept. New portable cameras bring us pictures with horizontal resolution of 300-400 lines in the center, a match for the portable 3/4-inch recorders on the market today. A combination of the two and a battery belt to allow a few hours of shooting are priced less than \$10,000. Radio broadcasters 30 years ago paid more than that for a single broadcast audiotape recorder, in the value of the dollar of that day. An entire low-power station could be built and outfitted for \$250,000 to \$300,000 with 3/4-inch machines and time base corrector(s). This could bring TV to America's doorstep and make these low-power stations the soapboxes of backyard-fence discussions concerning items of vital local interest, as originally envisioned by FCC officials years ago for bigger TV stations. But every program got so expensive, huge audiences were needed to get the advertising dollars to pay for the "broad-appeal" programming—thus diffusing any local focus a program could have developed.

The FCC promises in the proposed rulemaking to keep regulatory restraints to a minimum with these mini-stations. Because less personnel time is needed to fill out government forms, mini-stations can concentrate on the twin challenges of broadcasting: making money and serving the public. In our free system, if you don't have one, you don't ever seem to get the other. For those independent souls who want to be free of any national satellites or regional big-station networks, new forms of programming will have to be invented. Local talent and performers would prove even more costly than in the earlier days of radio.

Some nationally syndicated audio/video source, the video analog of phonograph records, may well

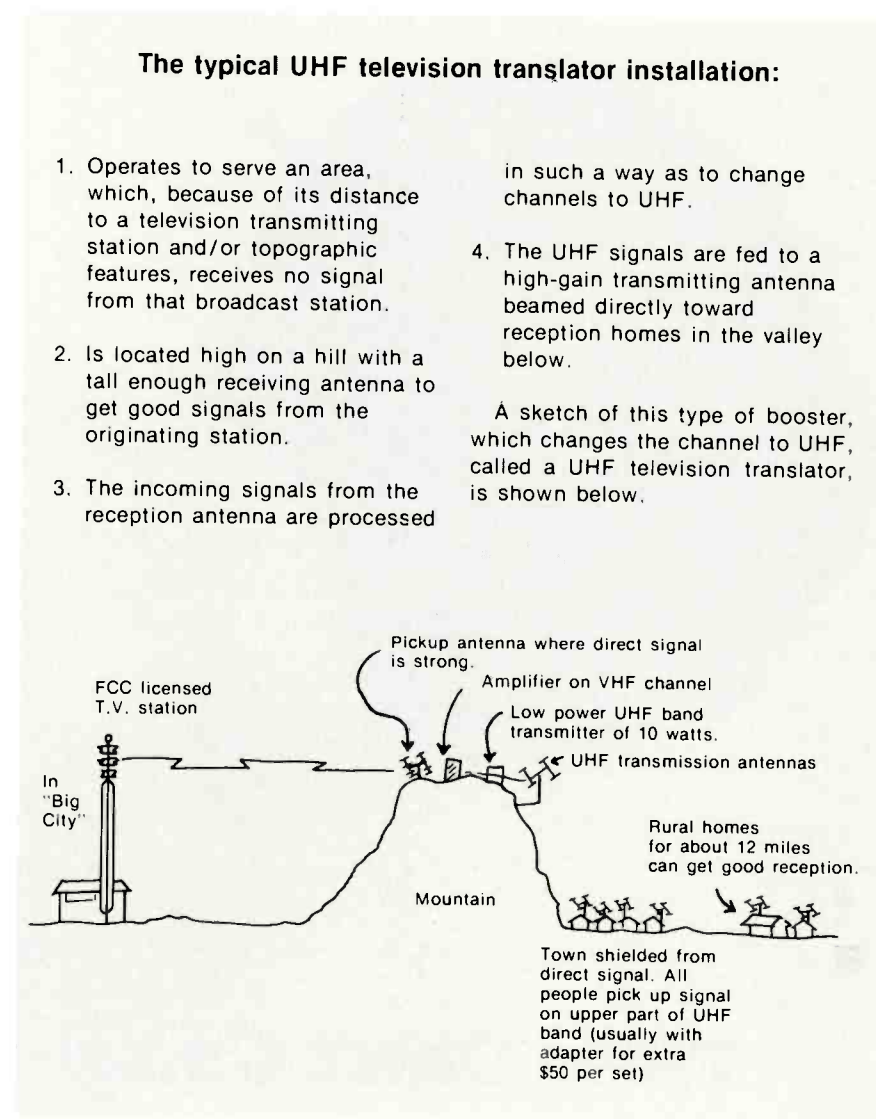

spring up to service mini-TV stations as records did to help local radio in the 1950s. Maybe low-power outlets will share video pieces as the radio stations of 1939 did with recorded music in forming BMI (Broadcast Music Inc.). In 1945, no big network radio broadcasters conceived of the disc-jockey program as being such a valuable program format. Yet most radio stations rely on it in today's radio operations.

What perfected the disc-jockey format for radio was the perseverance of thousands of talented local radio personalities who perfected style, music preferences, and materials presented at thousands of local stations across the country. Allowed to develop fully, essentially unrestrained by government regula-

tion fetters, there will be Gordon McClendens, Todd Storzes, Bill Drakes and Buzz Bennetts of low-power TV marking milestones of American broadcast ingenuity—the backyard brainstorm of thousands of local TV broadcasters who today are challenged to create something entirely new for television.

Thousands of these low-power TV stations will bring viable entry-level employment for thousands of talented and trained young people who are effectively closed out of the big-town industry now. The developing of new talent, who may not know something "can't be done," may well revive hundreds of big-city network VHF outlets after the networks abandoned them for the direct routes to the home. □

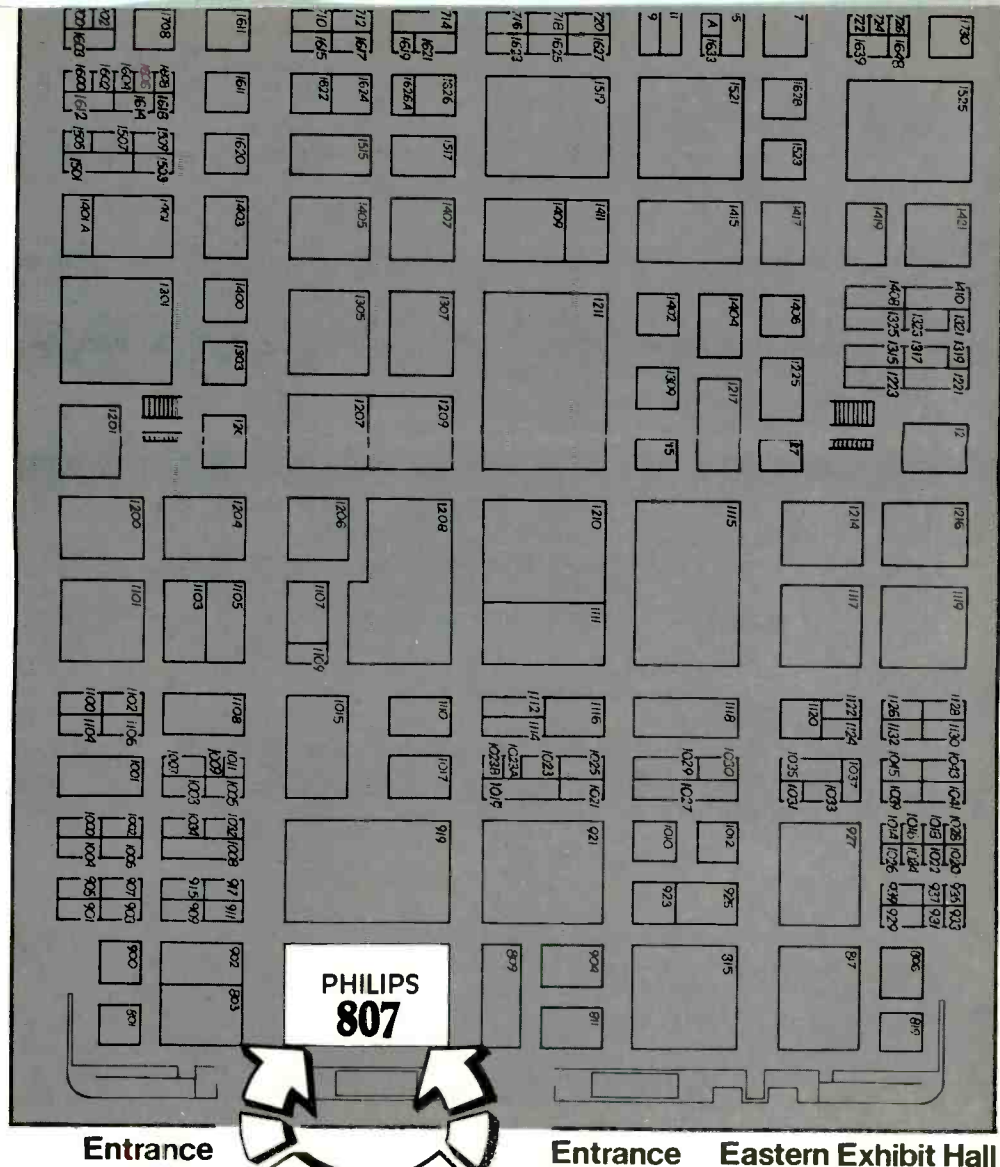

Profitable Production starts here!

Profitable production in the 80's requires efficient, cost-effective operation...which starts with cost-effective cameras. And Philips offers the greatest value in field and studio cameras today!

At NAB, Philips will combine live and taped demonstrations to focus on:

- New products, new features designed for the 80's.
- Demonstrations of production techniques used by some of

the most quality and cost-conscious broadcasters and production companies in the U.S. and Europe.

- How to increase bottom-line profits without sacrificing creativity or quality.
- Financing for equipment, van and studio.

It just may be one of the most profitable half hours you (and your Chief Financial Officer) spend at NAB. Don't miss it.

Profitable Production starts here!

PHILIPS

PHILIPS BROADCAST EQUIPMENT CORP.
A NORTH AMERICAN PHILIPS COMPANY
91 McKee Drive, Mahwah, N.J. 07430
(201) 529-3800

Circle (215) on Reply Card



International Television Symposium

The 12th International Television Symposium has been scheduled for May 30-June 4 in Montreux, Switzerland.

Besides the many aspects of studio engineering, this year's major topics will be digital techniques, satellite TV, new distribution systems and CATV. There will be two types of sessions: one devoted to systems questions and the other to equipment innovations. Two full days are planned for the CATV portion. In the systems sessions, invited speakers will present the subject, followed by a round table composed of experts in the field. The sessions on equipment innovations will consist of several papers submitted by the industry.

Also, video experts will report on the latest technical developments and tendencies in the field, and on new ideas.

Space allotted for manufacturers' exhibits has been doubled this year.

The following is the preliminary program:

Saturday, May 30

Late afternoon:

Opening ceremony including presentation to the winner of the Montreux Achievement Gold Medal in the presence of a representative of the Swiss government.

Opening round table, headed by J. Polonsky, France

Subject: "The Impact of new TV services and home facilities of the future on home sets and program production equipment—An outlook for a decade."

Participants: Broadcasters: J.A. Flaherty, CBS; H. Jushkevitchus, GKRT; B. McCrerrick, BBC; U. Messerschmid, IRT; M. Remy, TDF. Video-cinema: F. Coppola, cinema director. Manufacturers: H. Groll, Bosch-Fernseh; W. Hittinger, RCA; M. Morizono, Sony; C. Steinberg, Ampex; K. Teer, Philips. A wine and cheese party will follow.

Sunday, May 31

Official opening of the exhibition.

Cocktail party in the exhibition area.

Systems sessions 9 a.m.—Noon

Monday, June 1, Room 1

Video production and post-production systems

Topic chairman: B. Pauchon

Moderator: P. Kelly

- E. Lionetti

Can theatrical film be produced by electronic means. Some experiments by the RAI

- W. G. Connolly

Single camera and electronic Production and Post Production

- Round table discussion headed by P. Kelly

Participants to be named in the final announcement

Monday, June 1, Room 2

Satellite and terrestrial broadcasting and distribution systems

Topic chairman: G. J. Phillips

Moderator: J. F. Arnaud

- R. Süverkrübbe

Projects for direct satellite broadcasting at 12 GHz

- D. Sauvet-Goichon

Consequences of the WARC-79 for the planning of VHF television networks

- Round table discussion headed by J. F. Arnaud

Participants to be named in the final announcement

Tuesday, June 2, Room 1

Digital Television Recording

Topic chairman: W. Habermann

Moderator: A. Todorovic

- K. H. Barrat

Error correction and concealment for digital video recording

- C. E. Anderson

Digital video recording format considerations including audio

- Round table discussion headed by A. Todorovic

Participants to be named in the final announcement

Tuesday, June 2, Room 2

Impact of teletext and multichannel sound on receivers

Topic chairman: M. Cominetti

Moderator: J. Burgstaller

- P. d'Amato, R. Marsch

Teletext receiver evolution and possible multistandard solutions

- A. Keller

Evolution of multichannel sound systems with emphasis on receiver aspects

- Round table discussion headed by J. Burgstaller

Participants to be named in the final announcement

Wednesday, June 3, Room 1

Evolution of digital systems

Topic chairman: A. A. Goldberg

Moderator: N. Mayer

- K. Lucas

Toward digital TV standards

- J. Rossi

Toward digital TV studios

- Round table discussion headed by N. Mayer

Participants to be named in the final announcement

Thursday, June 4, Room 1

Image science and improvement of picture quality

Topic chairman: W. Anderson

Moderator: C. Akrich

- T. Fujio

High-definition TV; viewer requirements and technical aspects

- T. L. Credelle

Large screen, flat panel TV: new approaches

- Round table discussion headed by C. Akrich

Participants to be named in the final announcement

Equipment innovations sessions 2:30-5:30 p.m.

Monday, June 1, Room 1

Video-production and post-production equipment

Topic chairman: H. R. Groll

Moderator: J. Diermann

Five to six selected papers on subjects such as:

- Evolution of film scanning and film correction

- Application of CCDs in ENG cameras

- Film style TV cameras



NEW. VIDEO EDITING LIST MANAGEMENT WITHIN YOUR REACH.

Now videotape editing list management is within your reach! Convergence Corporation's easy-to-operate, multi source ECS-104 List Management Editing System offers full auto assembly list management capability at a very affordable price.

Unique Standard features include:

- JoyScrol™** Joystick scroll
- TimeSearch™** Source & Record VTR time search
- "409"** EMMY-winning "409" program
- CleanIt™** Unique auto-clean
- SyncTag™** Special sync roll tag

CheckIt™ Automatic self diagnostics

TenCom™ Command generator*

The ECS-104 has all of the standard EMMY-winning ECS-100 Series features, and more...

- Auto assembly with audio select.
- Full sync roll with listing.
- 600 edit lines internal storage.
- Add, replace, delete and block moves.
- "Exchange" - Alternate edit register.
- Preview BVBI/VBVI/In/Out/In-Out/ Open
- Comment entry and storage.*

- Dedicated reel number and edit number keys.
- Battery back-up.*
- Utilizes user bits in time code.
- Most popular 1 inch, 3/4 inch, and 1/2 inch interfaces.

OPTIONAL ACCESSORIES AVAILABLE

Floppy Disc System, Printer, Command Generator Unit, Comment Keyboard, Special Effects Switcher with optional control panel, Battery backup system, Cutlap and Liplock®

Contact us today for more information.

*Requires Optional Accessory

SEE THE ECS-104 AT NAB, BOOTH 1101



1641 McGaw, Irvine, California U.S.A. 92714, (714) 549-3146, TWX (910) 595-2573
1 Lochaline Street, London W6 92J, United Kingdom, Telephone: 01-741-7211, Telex: 851-27950 MONREF G (Ref. 3801)

For Information Circle 216 on Reply Card
For Demonstration Circle 217 on Reply Card

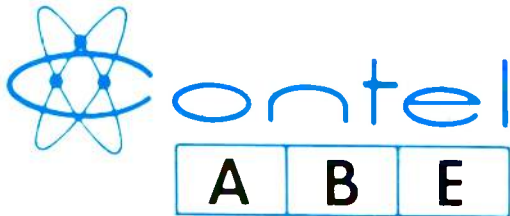

**Advanced Broadcast Equipment
at a price you can afford**



**CONTEL model CT101R-B
cartridge tape
recorder-reproducer**



**CONTEL model CT101P-B
cartridge tape
reproducer**

FEATURES

- 100% solid state
- Exceeds NAB specifications
- Built in remote control facilities
- Economically priced
- All silicon transistors
- Premium core, metal faced hyperbolic heads
- Electronic tone cueing
- Optimum electromagnetic shielding
- Optional auxiliary trip cue
- Compact and modern design

—PREFERRED BY PROFESSIONALS—

CONTEL MANUFACTURING

A Division of
Continental Electronic Wholesale Corporation
1620 W. 32nd Place — P. O. Box 206 — Hialeah, Fla. 33012
Telephone: (305) 822-1421 — Cable: Contelco
Telex 803305

Circle (218) on Reply Card

Calendar

Monday, June 1, Room 2

Satellite broadcasting and satellite distribution equipment

Topic chairman: T. Kawahashi

Moderator: H. L. Crispin

Five to six selected papers on subjects such as:

- Application of new technologies for satellite broadcasting
- Equipment for satellite-TV-reception

Tuesday, June 2, Room 1

Techniques used in digital television recording equipment

Topic chairman: H. Steele

Moderator: D. K. E. Pohl

Five to six selected papers on subjects such as:

- Error correction and concealment techniques
- Design of video heads
- Channel coding strategies

Tuesday, June 2, Room 2

Techniques used in terrestrial broadcasting equipment

Topic chairman: A. J. Bennett

Moderator: H. Bosch

Five to six selected papers on subjects such as:

- Solid-state/thermionic r.f. amplifiers
- Microcomputer control
- Dual channel sound

Wednesday, June 3, Room 1

Digital origination and processing equipment

Topic chairman: Artigalas

Moderator: P. Owen

Five to six selected papers on subjects such as:

- Source encoding
- Interface equipment, standard converters and synchronizers
- Testing digital equipment

CATV sessions

Wednesday, June 3, 9 a.m.-Noon, Room 2

Performance of cable distribution systems required by new types of signals

Session chairman: L. T. Mudd

Moderator: V. C. Reed

Five to six selected papers on subjects such as:

- Teletext, multichannel sound, digital sound, control- and address-signals
- Measurement techniques

Wednesday, June 3, 2:30-5:30 p.m., Room 2

System innovations and associated equipment I

Session chairman: P. Borremans

Moderator: Denis-Laroque

Five to six selected papers on subjects such as:

- Satellite reception and distribution
- Pay TV, address and scrambling system
- Interactive services, integrated communication services
- Broadband aspects (extended frequency range) fiber optics application
- Receiver functions related to cable service

Thursday, June 4, 9 a.m.-Noon, Room 2

System innovations and associated equipment II

Session chairman: C. Wansdronk

Moderator: P. Ketonen

Five to six selected papers on subjects such as:

- Continuation of session I

E. D. I.

LIGHTING CONTROL SPECIALIST

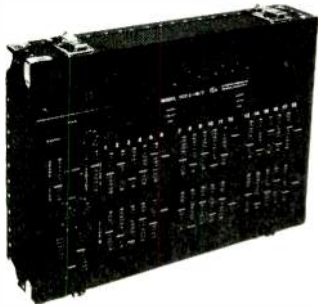

Portable Dimming Systems

TCC/T series 2 scene, 6 to 36 channels
Prices start at \$650.00.

TPP series power packs 2.4KW to 12KW Dimmers
Prices start at \$2,870.00.

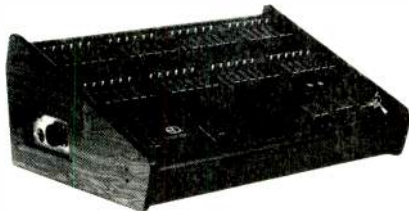
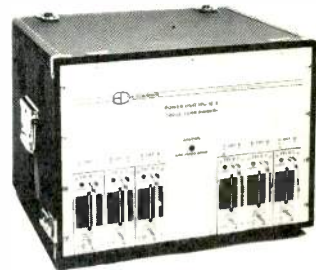

Permanent Control Systems

DCC/T series 2 scene w/ submasters, 24 to 96 channels
Prices start at \$2,330.00.

TAM series Add-on Memory w/ disk, 24 to 96 channels
Prices start at \$10,145.00.

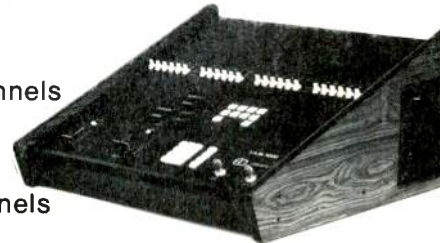

Fixtures

Complete line of fixtures available
Examples shown: 8" fresnel @ \$135.00;
16" scoop @ \$100.00. Both units are quarts w/ C-clamp
and color frame included.



Dimmer Bank

Our U.L. listed modular Dimmer Bank (DB) provides power to various lamp loads. A small DC voltage originating at a control console (memory or manual) operates all dimmers, non-dims, worklights, etc. Thus, nearly any lighting distribution requirement is available.

Multiple racks, internally wired, can provide all dimmers, a slider patch panel, load meter, non-dim contactors, main circuit breaker, load circuit breakers, constants, worklights, transfer circuitry, panic contactors, etc., as well as any auxiliary control panel desired. This integral unit conserves materials and adds to a significant labor savings during installation.
Price: P.O.A.

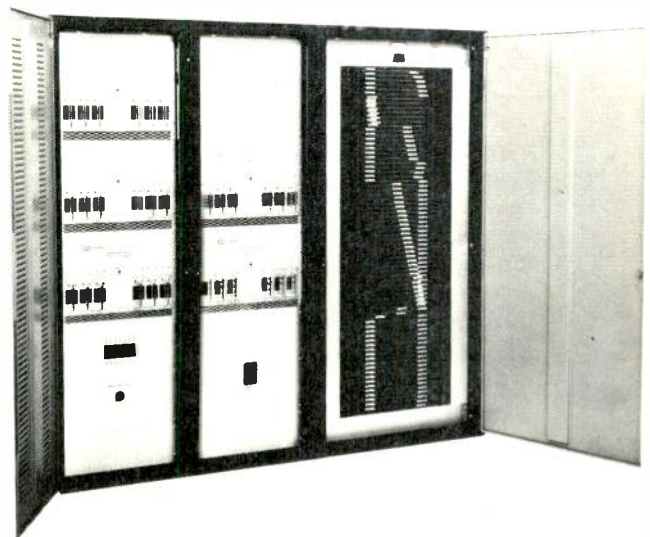

Circle (219) on Reply Card



Electronics Diversified Inc.

LIGHTING CONTROL SPECIALISTS

1675 N W 216TH
HILLSBORO OREGON 97123
TELEPHONE (503) 645 5533

**“Ready when
you are C.B.”**



Christie - The “Burping” Charger/Battery System That Does It In 20 Minutes or Less.

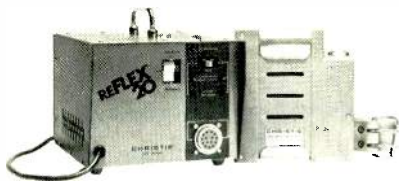

Whether you're shooting a full-length

documentary or news gathering for the evening wrap-up, you need a battery/charger system that's ready when you are. Christie has the only ni-cad battery pack that's completely rechargeable in 12-20 minutes. The REFLEX® 20 Charges and sempiternal battery packs provide 90-97% efficiency, while extending battery life up to 10 times longer than other ni-cads and 50 times that of ordinary batteries. That's state-of-the-art technology backed by Christie's 51-year reputation for excellence.

When time is money, keep your cameras rolling with the REFLEX 20 from Christie.

SINCE 1929
CHRISTIE
ELECTRIC CORP.

20665W Manhattan Place
Torrance, California 90501
(213) 320-0808
TWX 910-349-6260
(800) 421-2955

1929-1982 **51** YEARS
THE SOURCE

Calendar

Thursday, June 4, 2:30-5:30 p.m., Room 2

Today's trends and the near future

Session chairman: W. Kaiser

Moderator: P. Villé

- Development tendencies as seen by manufacturers, users and government agencies
 - Introduction by W. Kaiser
 - A network operator speaking on:
 - Widening the scope of existing CATV networks (additional programs, local programs, pay TV, TV satellites and microwave links as new methods for feed-in, electronic text distribution)
 - A government official speaking on:
 - Future service-integrated broadband networks (Optical transmission, broadband switching, ISDN-principles, network, structure, marriage of telephony and television, future broadband services, compatibility with existing CATV networks)
 - Round table discussion headed by P. Villé
- Participants to be named in the final announcement.

For more information contact: International Television Symposium and Technical Exhibition, P.O. Box 122, CH-1820, Montreux, Switzerland.

**Roger Pryor heads panel
at conference**

Roger Pryor, general manager of Sony's Digital Audio Division, recently hosted a discussion at the second annual Billboard Video-Music Conference. Discussions and presentations at the four-day industry gathering explored the interaction of the music industry with the video market. Pryor's topic, "Video/Audio Hardware and Software Technologies of the Future," focused on the technology and possible creative products. Participants at the conference were treated to audio-visual displays of space-age technology.

During the discussion, Pryor described his image of the consumer of the '80s. "He will have large-screen stereo television with uninterrupted, uncensored programming; he will have videodiscs and videocassettes; he will have the incredible acoustics of digital audio; and he will have a choice of over 100 programming services through cable access and the satellite dish receiver on his roof. What we can expect is a highly sophisticated home entertainment boom."

Low power TV seminars

The staff of Acrodyne Industries and its attorneys plan to hold seminars during NAB-'81 to cover latest developments in low power TV stations. Sessions will run on Monday, April 13, in the morning and on Tuesday, April 14, in the afternoon. The location of these seminars has not yet been determined. For final details, check the Acrodyne booth at the show. Topics to be covered include:

1. Low power station design, including site selection and criteria, expected signal coverages, program source interface, power and space requirements, equipment configuration and system tradeoffs.
2. Economics of low powered station construction and operation.
3. Overview of the current regulations and status of FCC actions.
4. Educated prediction of final FCC rule configuration.
5. A question-and-answer session. □

Storeel is dedicated to conserving energy. Yours.

Energy conservation is much in the news these days. Like the weather, many talk about it but few do anything about it. We haven't figured how to change the weather, but we do have several systems specifically engineered for broadcasters that both conserve energy and add efficiency. The very latest (shown installed) is called **STOR-MAX™**

Save energy (yours) by converting your overcrowded film and VTR libraries to the new "Instant Access" high-density systems engineered and distributed only by Storeel. **Modular Rapid Transit Storage™** maximizes units stored per square foot of floor space, minimizes retrieval time, optimizes energy efficiency.

Our many years of design and engineering pay off in solutions to your storage problems.

Call or write "The Railriders" at Storeel today for free estimate. No obligation, of course.



Illustrated catalog of Storeel's "confusion eliminators" available upon request. Write on your letterhead or telephone for your free copy.

See us at the NAB in Las Vegas, Booth 911.

STORREEL

CORP.

**The
Space-Saving
Engineers**

2050-C Carroll Avenue • Atlanta, Georgia 30341 • Telephone (404) 458-3280

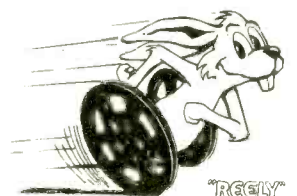

Circle (221) on Reply Card

March 1981 *Broadcast Engineering* 241

QuickSet Supports You.

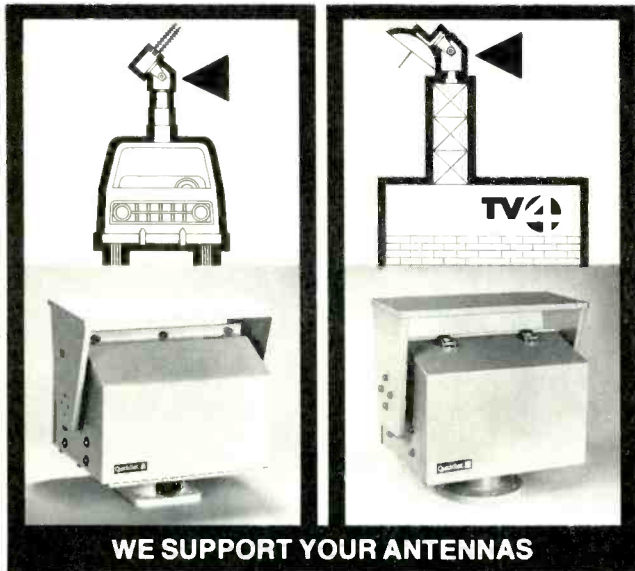

With QuickSet antenna positioners and camera support products, you can depend on reliable performance and economical prices. Call QuickSet for our complete catalog.

QuickSet

Support Products

SOLID AS A ROCK

3650 Woodhead Drive
Northbrook, IL 60062
Telephone: (312) 498-0700 Telex: 72-4362

Visit NAB Booth 1012 for demonstration!

people

Thomas J. Palmisano has joined Intertec Publishing Corporation's Electronics Group of magazines as an additional Eastern marketing manager. The appointment was made for the new position by George Laughead, group publisher. **Joe Concert**, Intertec's other Eastern marketing manager continues in that position.

Marshall McLuhan, best known for his pioneering work in communications/media theory, especially the relationship between the human mind and media, died in Toronto, Canada, December 31, 1980, at age 69. "The medium is the message" is the most popular statement of his vast theories.

William B. Rock and **Joseph M. Kelly** have been named vice presidents of the Insilco Broadcast Group, a wholly owned subsidiary of the Broad Street Communications Corporation. Rock and Kelly will continue in their areas of responsibility as director of national program development and director of national sales development, respectively. Rock will also maintain his position as operations manager of WELI, the Insilco Broadcast station in New Haven.

George E. Payette has been named vice president for broadcast operations at WCNY-TV/FM. Payette, known on-air as Bob Payton, has been with WCNY since 1975, most recently as executive producer. He has also served as assistant to the general manager for planning and special projects, and has been a producer of a number of local programs.

The Board of Directors of Buford Television has announced that **Robert P. Buford** has been appointed chairman of the board. He retains the title of chief executive officer. Buford has been president of the company since 1970. **Charles Bowker** succeeds Buford as president of BTI. **John Swanson** has been appointed senior vice president, engineering, in charge of all technical activities for the company. **Beryl N. Berry** has been appointed treasurer.

Michael Wall has joined the staff at KVIE/Channel 6 in Sacramento, CA, as manager of engineering. Wall was previously engineer in charge of special projects at KUED/TV in Salt Lake City.

George Camp Jr., 55, a Panasonic Company vice president responsible for the Panasonic Service Group, died December 16 following a long illness. Camp served as a vice president since his election to the post in 1977.

He joined Panasonic in 1971 as general manager in charge of the consumer parts division. He was promoted to general manager in charge of both the parts and service divisions in 1976.

Hans Wagner took over the Sound and TV Broadcasting Division of Rohde & Schwarz on October 1. Wagner, a graduate communications engineer, joined Rohde & Schwarz in 1964.

Robert E. King has been appointed regional manager for the Chicago region by the Sony Video Products Company. King returns to Sony following his most recent position as a regional manager for Hitachi. □

Circle (222) on Reply Card

Introducing... the Editor-in-Chief.



Stickler For Details

Fast, accurate decisions and a "mind" for details, that's why Z-6 editing systems are in demand by broadcast newsrooms throughout the country.

With a Z-6 system, you get frame accurate editing, plus all the useful functions of the SMPTE Time Code, *without* all the problems.

What's more, a Z-6 can track SMPTE Drop Frame or Non-Drop Frame, 24-frame film rate, or any other time base. And, it will "translate" codes for you, adding or subtracting real, decimal or mixed numbers for precise scene and program length computation.

Easy to Work With

Dissolves, wipes, animation, effects, split edits and text editing. The more arduous the editing session, the more you'll appreciate working with a Z-6. Since each key on the Z-6 has a definite, single function, the entire system is easy to use and understand.

Its Auto Edit feature and full look-ahead/behind logic simplify the handling of complicated editing tasks.

With a Z-6, you can pick in or out points on-the-fly; maintain "lip sync" throughout the entire tape during all editing procedures; and do A, B, C external rolls on one pass.

Then, when you're finished editing, you won't have to make a dub—because the Z-6 can automatically edit an exact duplicate tape for you.

Knows Who's Boss

When you're working with a Z-6 editing system, you are Chairman of the Board. Its microprocessor-based controls were developed by editors for editors. And, its features are designed to take the drudgery out of editing.

For example, the Z-6 automatically loads edit point locations so you can edit pictures instead of numbers. Its ability to randomly locate single frames on any tape in the system saves you time. And, its operator prompting messages are intended to prevent the type of errors which could result in the need for major re-editing.

Stays in Budget

Best of all, a Z-6 editing system is a financially sound investment. Just purchase the version that meets your *present* requirements.

If you don't need features like multiple source, effects or multi-event memory, you won't be penalized for not buying them.

Since every Z-6 editing system is fully upgradable, all you pay is the *difference* between the price of the model you own and the price of the model you want.

For details on the entire line of Z-6 systems, call or write today:

Videomedia

Professional Television Systems
250 North Wolfe Road
Sunnyvale, CA 94086
Telephone: 408-733-6500

Circle (223) on Reply Card

US station goes overseas for 'local' hostage coverage

By John D. Weigand, manager of engineering, KFMB stations, San Diego, CA, as told to Penny Thomas

KFMB-TV, San Diego, was the only station in the United States to present a locally produced newscast on the return of the hostages from Iran in late January with live feeds from both Germany and Washington DC.

It wasn't difficult. Whether it was expensive depends upon the point of reference. It is hoped this moment of history will not be repeated during the next decade or two. Initial costs of \$2000 per 10-minute feed seemed not to be in excess when looked upon in those terms.

The following is the record of how KFMB's manager of engineering, John Weigand, set up and proceeded with his half of ENG live from Frankfurt, Germany.

Weigand said that when he first inquired about doing the feeds from Germany, many, including CBS, told him it couldn't be done, that live feeds from Frankfurt, Germany, were not possible for local stations.

He said it was persistence that brought results.

Friday

January 16, 1981

This was the day it all began. KFMB contracted from San Diego Satellite Services for a 3.7 meter portable dish and receiver.

Monday

January 19, 1981

A four man news crew was sent to Frankfurt: one engineer, one reporter, a cameraman and the assistant news director. By Monday evening the dish had been "sighted" for each of the domestic satellites, an important part of the procedure done by the local engineering crew.

Tuesday

January 20, 1981

The crew arrived and checked

into the Steigreuberger Hotel, Frankfurt. Each network—ABC, NBC, CBS and CNN—took over an entire floor of the Sheraton Hotel in Frankfurt. The German telephone company, from a room on the ninth floor of the Sheraton, had a crew who sent transmission to the satellite uplink at Reisting. From Reisting the signal was sent through an Intelsat to a receive point, a downlink, in New York. The three networks formed a pool and used a common Intelsat transponder to N.R., the central trafficking point for International Telephone and Telegraph. The pool controller was NBC network. Each network handled its respective affiliate-taped stories from Frankfurt. In the case of CBS, our KFMB crew used the ¾-inch editing facilities CBS had located on the eighth floor of the Sheraton. A CBS network coordinator scheduled the feeds sent to CBS headquarters, New York, where

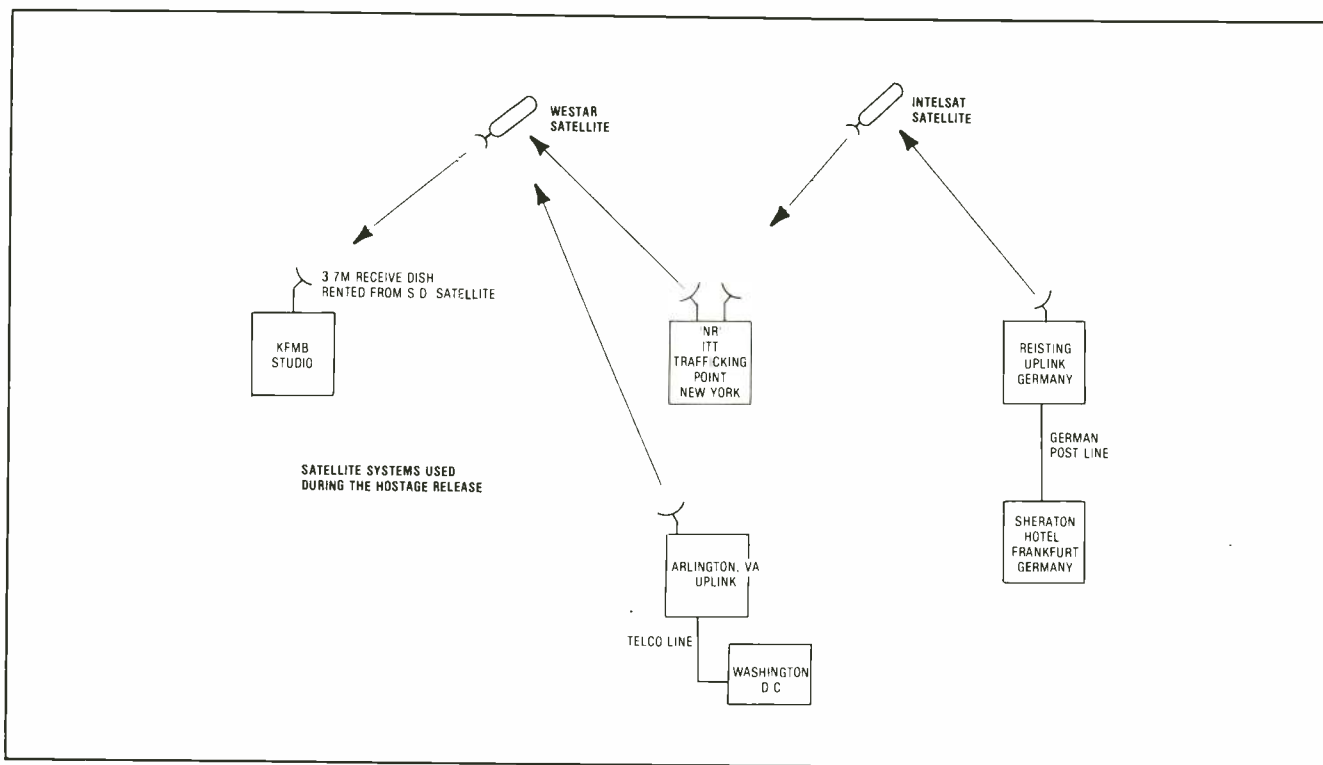

“Let me tell you how Townsend custom engineering can modernize and increase the power and efficiency of your TV transmitter at an economical price.”

George Townsend
President,
Townsend Associates, Inc.

From our drawing boards have come many innovations in television transmitter technology . . . including some of the most advanced equipment available. If your budget doesn't include the cost of one of our new television transmitters, we can solve that problem too. Using our accessories and components, our custom engineering services can modernize and/or increase the power and efficiency of your present transmitter at a fraction of the replacement cost. We can work with your engineering group to carry out the most feasible transmitter updating program to fit your needs. We have the *hardware* and the *know-how* . . . so just give us a call.

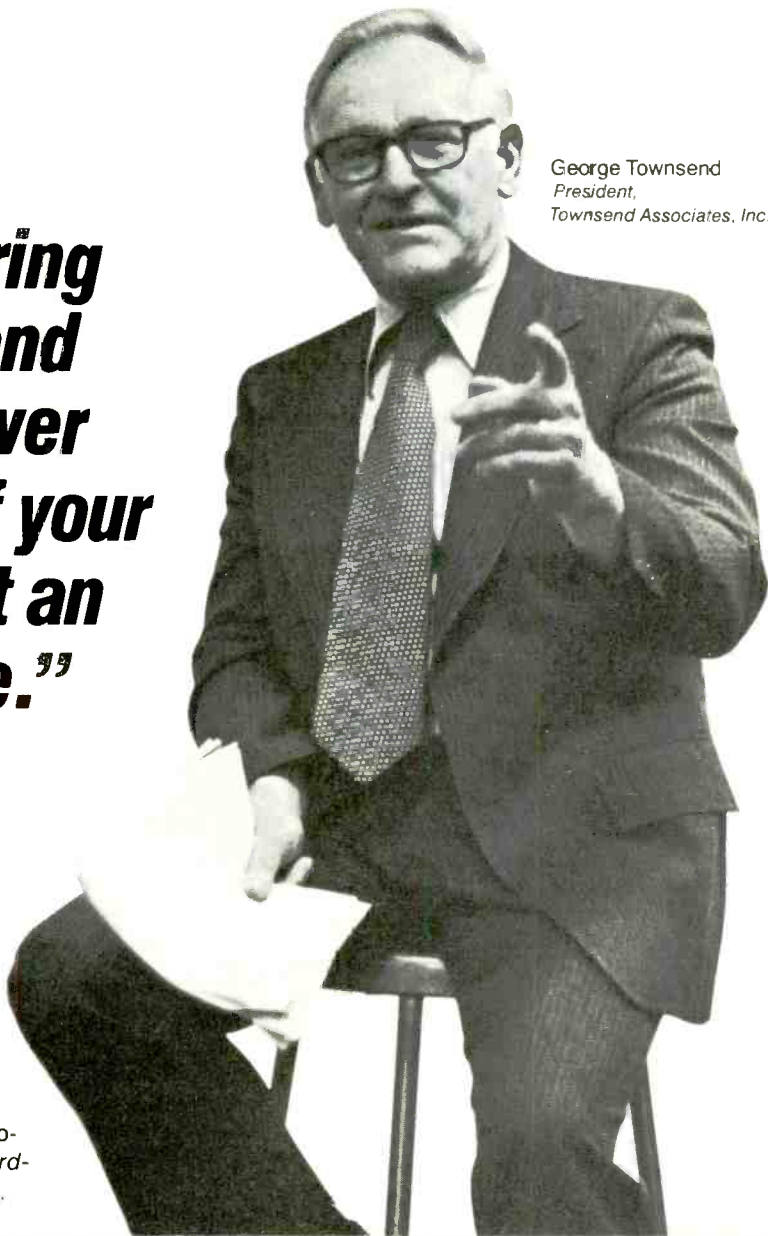

Hardware available for modernization and increasing power includes:

- I. F. solid state exciters with saw filters for UHF and VHF transmitters
- Solid state amplifiers to 100 watts at UHF
- Solid state amplifiers to 1000 watts at VHF
- Vapor cooled Klystron amplifiers for paralleling with RCA and Harris transmitters
- Water cooled Klystron amplifiers for paralleling with General Electric and Townsend transmitters
- Diplexers, combiners, and other waveguide and coaxial components as required
- Vapor and water heat exchangers
- Power supply and high voltage components
- Vacuum contactors
- Differential calorimeters for accurate power measurements
- Solid state pulsers for improving Klystron efficiency

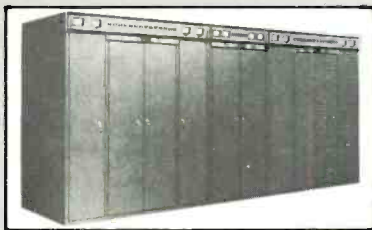

TOWNSEND ASSOCIATES, INC.

P.O. Box 1122 • Mainline Drive Industrial Park, Westfield, Massachusetts 01086 • 413-562-5055

Let's discuss your TV Transmitter requirements at the NAB Convention, Booth 1007.

Circle (224) on Reply Card

SMPTE EDIT-CODE READER AND CHARACTER-GENERATOR



13:45:27.09

THE NEW STANDARD OF THE INDUSTRY

FEATURES: The McFadin Window™ wide range digital decoder, highly legible and unique FONT, 1-3/4" rack mounting, vertical interval display, all front panel controls, drop frame indicator, choice of Time-Code or User-Bits, regenerated Time-Code output (DUB), MODEL DR-107A.



504 W. Chapman Ave.
Orange, Ca. 92663 714-997-4151

Circle (225) on Reply Card

The Perfect Companions

VSM-5, the latest in a series of professional test equipment from Videotek. A television Vectorscope which provides bright, sharp, easy-to-observe vector displays on a 5-inch CRT. Available as a separate unit, or rackmounted ... *The Perfect Companion* to our popular TSM-5 Waveform Monitor.

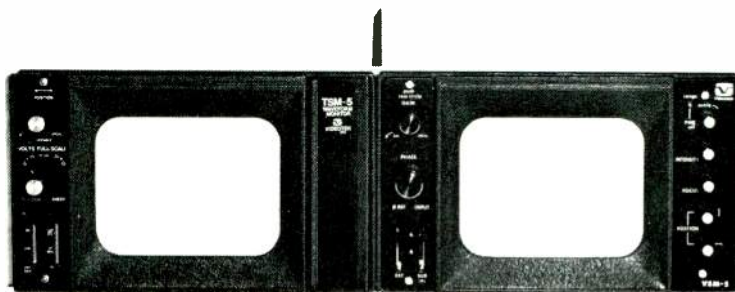

Quality Endures



Videotek, Inc.

125 North York Street, Pottstown Pennsylvania 19464 / Telephone (215) 327-2292
9625 North 21st Drive Phoenix Arizona 85021 / Telephone (602) 997-7523

Circle (226) on Reply Card

Hostage

they were recorded about 5 p.m. New York time, and then sent during the news feed time, over the network, to the affiliates at approximately 6:30 p.m., New York time. KFMB was going to tag on to the end of the CBS feed January 20, but the hostages landed in Algiers. This event went through Frankfurt to America, and our chance at satellite time that day was lost. Instead, domestic satellite feed carried the live feed of the landing that evening. The difference on the following days was that KFMB was not attached to CBS at all, but went into the marketplace to purchase its own satellite feed.

Wednesday

January 21, 1981

Wednesday morning I asked CBS when they were sending feeds. I was primarily interested in the 5-6 p.m. PST time slot. (This is the time of our local newscast.) I was told that network was closing down early that day. The room with the transmission loop would be canceled about 2 p.m. PST. There was no live feed possible through CBS. I asked Hughes Television network who was feeding, if anybody. I found out that CNN (Cable News Network) was feeding from a room on the sixth floor of the Sheraton. I asked Hughes if it was possible to tag a feed on to the Cable News Network feed and then pay for the Intelsat time. We wanted about 10 minutes for our local evening newscast. I found that after initial construction charges, (which had already been paid), the cost of a 10-minute feed was \$1400 plus \$60 for each additional minute. One hour of domestic satellite time was \$600. For \$2000 we could receive a 10-minute feed. We worked out a schedule with CNN. We received our feed at 2:05 German time, five minutes into our 5 p.m. newscast.

Many phone calls were made via New York and Germany. Some were conference calls with ITT confirming Telex sent to the German post office. The calls began mid-afternoon and were not without mishap. Telex was sent to two post offices, and the order had not been received by the post office people on the ninth floor who were handling the transmission. Just before 5 p.m. San Diego time the connection was made, thus getting the signal through satellite to a receive site on the East Coast. A domestic satellite

isi means...

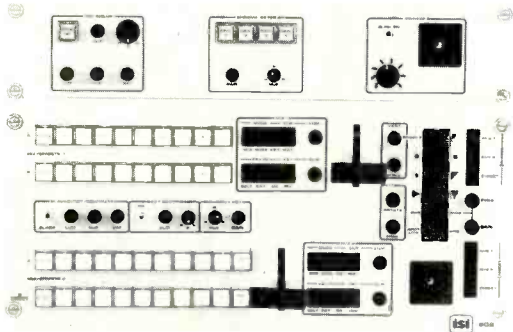

ISI Model 902-S — Video Production Switcher

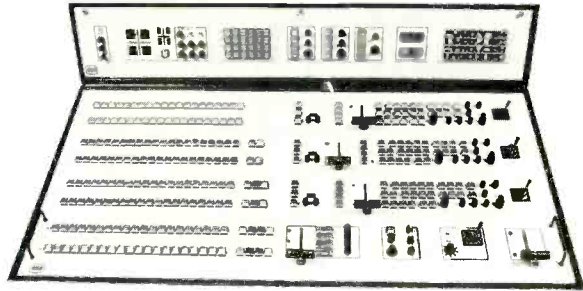

ISI Model 1208 — Video Production Switcher

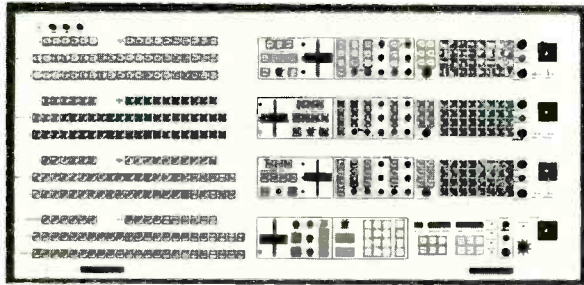

ISI Model 200-3 — Video Production Switcher with **PolyKey**®

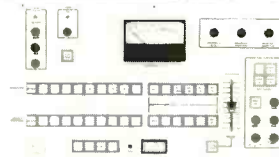

ISI Model 931 — Master Control Switcher

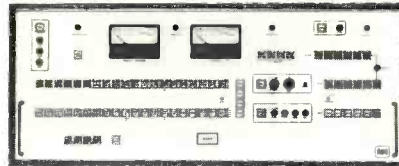

ISI Model 821 — Master Control Switcher

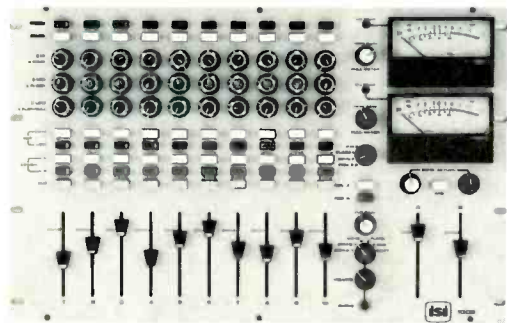

ISI Model 1002 — Audio Console

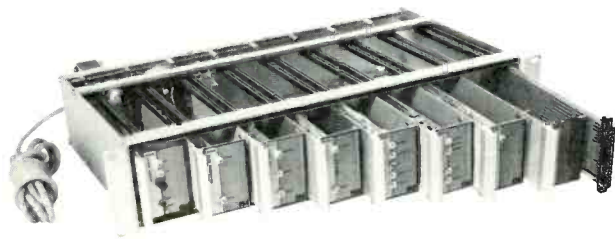

ISI 500 Series — Plug-in Terminal/DA System

innovative Switching Ideas

Available in NTSC
and PAL formats



INDUSTRIAL SCIENCES INC
P.O. Box 1495 / Gainesville, Florida 32602
Florida Only: (904) 373-6783

See Us at
NAB
Booth #1115

Hostage

delivered the signal to the rented San Diego receiver in the back parking lot of KFMB. The live feed was further enhanced by the use of a phone coupler when it got to the studios at KFMB. Our crew in Germany phoned in to the coupler and connect earphone system. Our news anchor-person and our reporter in Germany were then able to carry on a verbal discussion which further enhanced the remote. There was a one second voice delay between the two of them due to the distance of the path it followed. We carried on a successful live remote for a period of approximately seven minutes. Once off the feed recorded material was sent for use in the late night news.

Thursday January 22, 1981

The sequence was repeated the next day. In the meantime, the Germany crew gathered material for broadcast on VTR. We set up our two satellite hop for another 2:05 a.m. (German time) satellite feed. Room 608 of the Sheraton was used with KFMB, through Hughes

Television Network, providing its own feed from Germany to San Diego.

Saturday January 24, 1981

Our four man crew flew from Germany to New York and immediately caught a plane to Washington DC. We arrived just in time to welcome the wife of former hostage Richard Morefield as she flew in from San Diego. This was nearing the end of a story we had been covering through her since the beginning of the plight of the hostages. We arranged for an uplink through Hughes. Tape was sent from Washington to San Diego with enough time allowed for editing before its airing on the evening news. The hour of time we ordered was shared with a Texas station, helping defray the costs of satellite time.

Sunday January 25, 1981

The crew covered the hostages at West Point on both Sunday and Monday. HTN arranged facilities for a feed; an uplink was arranged in New York City. All information

regarding the feed was phoned into our crew.

Tuesday January 27, 1981

Following a lead our crew found in Germany, a microwave truck rental was arranged for a Washington feed. Tuesday, we did another live feed during our evening newscast. The truck relayed transmission to company offices where a Telco loop connected to the uplink in Arlington, VA.

Wednesday January 28, 1981

Richard and Doethea Morefield flew back to their hometown, San Diego. We covered the return with full use of ENG. A microwave truck with two cameras sent the story to a receive site. The parade trip home was covered by helicopter-mounted camera microwaved to one of the ENG receive sites. A tripod-mounted 2-foot dish CP-13 "shoebox" microwave transmitter was set up at one intersection the motorcade crossed. There, a reporter and camera crew sent this signal to another ENG receive site. Still another microwave truck was waiting at the Morefield home with continuing live coverage. □

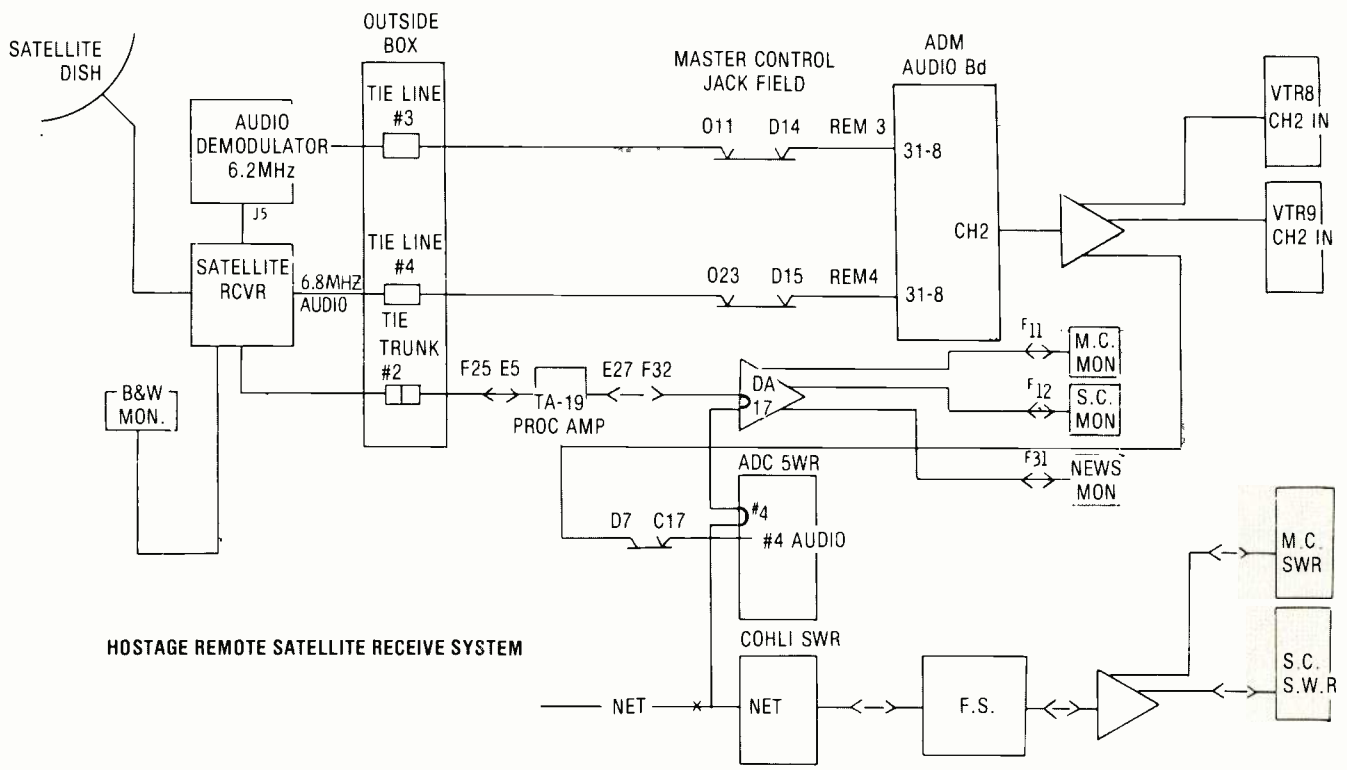

The end of the endless loop.

Eumig's new FL-1000 makes cassettes the broadcast medium.

The Eumig FL-1000, an extraordinary new cassette tape deck, has started a revolution in the world of broadcasting. We believe — and radio engineers agree — that it will soon make the cassette the standard tape format in the broadcast industry.

The FL-1000 is the world's first computer-inter-faceable cassette recorder. Up to sixteen FL-1000 decks can be controlled by any 8-bit computer. Some of the decks can be used for commercials; others for news and weather; still others for music and station ID's. And the location of every item on every cassette can be stored at the beginning of each tape and then in the computer, so any sequence can then be played back — automatically, with no human intervention, all day and all night long.

Watching a bank of FL-1000's working together

is an awesome experience. One deck is rewinding while another is playing, and still another is moving in fast-forward to locate the next selection. Meanwhile, other decks are copying from a network feed and recording an air check.

The technology of the FL-1000 is so advanced that half a dozen units can do the work of more than 100 individual cartridge players — plus several reel-to-reel recorders. And they do it better, at far less cost, with sound quality comparable to that of the finest open-reel equipment. And the Eumig FL-1000's have none of the mechanical problems that plague endless-loop broadcast cartridges.

To see the end of the endless loop, call Eumig about the new FL-1000. Once you see and hear this amazing new recorder in action you'll agree that this is the long-awaited deck that will make cassettes the standard medium in the broadcast industry.

eumig[®]

Circle (185) on Reply Card

Eumig (USA) Inc., Lake Success Business Park, 225 Community Drive,
Great Neck, New York 11020, (516) 466-6533

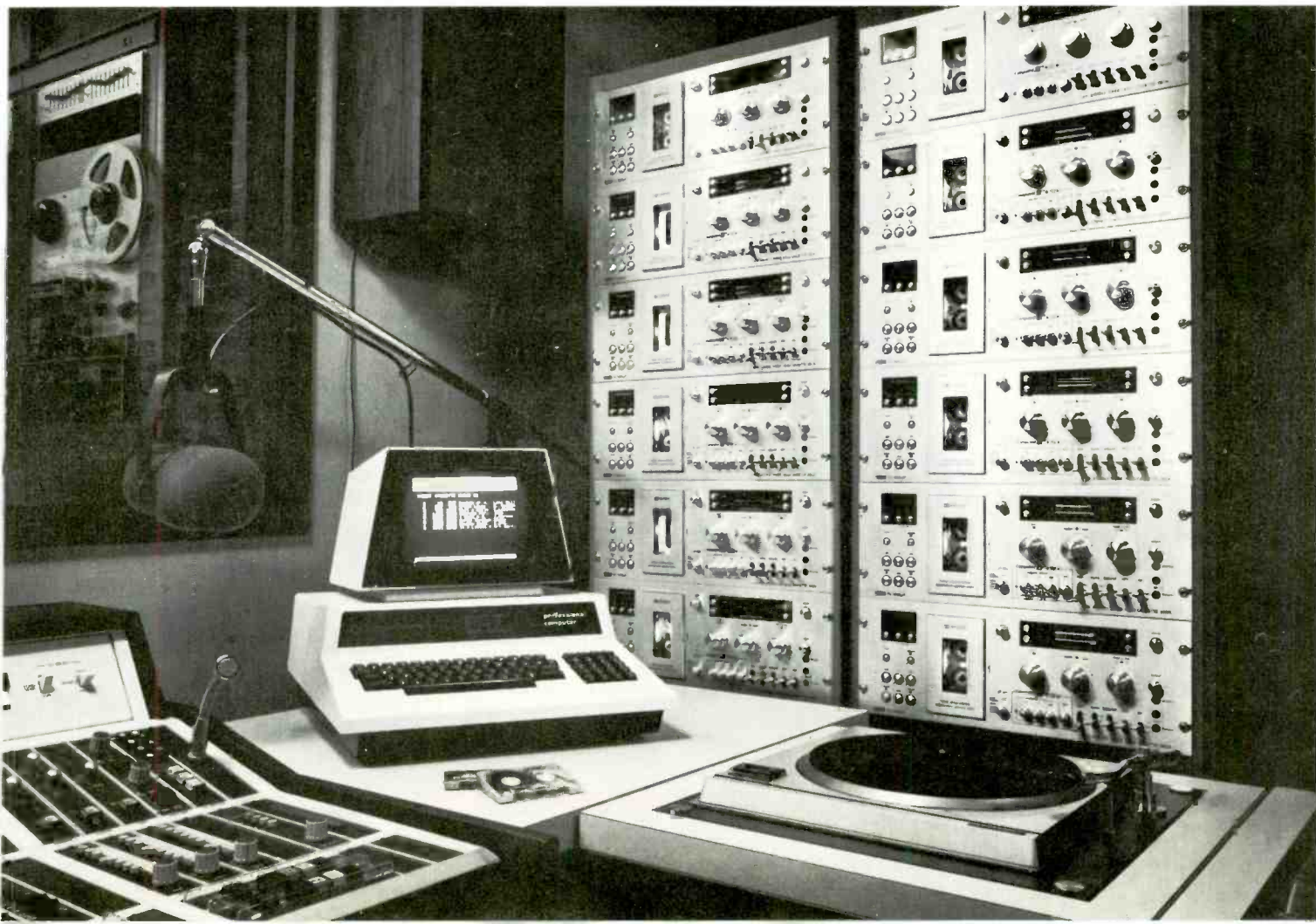

business

CSI purchased by original founder

CSI Electronics, Boca Raton, FL, manufacturer of AM and FM broadcast transmitters, has been purchased by its original founder, Bernard Gelman, and by Ft. Lauderdale, FL, broadcast equipment suppliers Ken and Betsy Ebert Cameron.

Gelman will continue as president and general manager. Ken Cameron, former director of engineering of the Amaturo Group, will take an active role in sales and marketing. However, the organization of CSI's marketing department remains unchanged. Also, Electrex of Miami will continue as CSI's South American distributor.

The company moved into new headquarters in Boca Raton in late February. It expects to increase production efficiency and offer several new products, including AM phasors. The new address is 18248 E. Rogers Circle, Boca Raton, FL 33431.

Taft Broadcasting adds fourth 3M switching system

A fourth facility of the Taft Broadcasting Group Stations has installed 3M routing switching equipment over the past 18 months.

WBRC-TV in Birmingham, AL, received its 3M model 40X series microprocessor-controlled routing switching system in mid-January. The system accommodates 30 inputs and 20 outputs.

Ampex gets \$2 million order from Belgium

Ampex announced it has received a \$2 million order from Belgische Radio en Televisie in Belgium for television production equipment.

The equipment will be used for studio production, location reporting and post-production work, according to Ronald Ballintine, president of Ampex International.

Ampex will supply 13 VPR-2B helical scan videotape recorders, with TBC-2B digital time base correctors, six VPR-20 portable VTRs, a 4000 Series production switcher, RES-1 video editing system, two ATR-104 audio recorders, and accessory products.

Matsushita produces 2 million VTRs

Matsushita Electric Industrial Co. Ltd., one of the world's largest manufacturers of consumer electronic products, recently produced its two millionth VHS videocassette tape recorder. The company began marketing its first VHS VTR in April 1977. Although it took more than two years to manufacture the first million recorders, the second million was produced in one year.

Wisconsin plant selected for video disc production

Plans to manufacture reflective optical video discs in an existing 3M facility in Menomonie, WI, have been announced by Lloyd A. Troeltzsch, manager of the company's Optical Recording Project.

The Menomonie plant, 50 miles from 3M's headquarters and central research development center, was selected because of the experienced work force, close proximity to the laboratories and the availability of space meeting the ultra-clean conditions needed in the manufacturing process.

Ross switchers are now more exciting than ever with 16 new spin, rotary and matrix wipes.

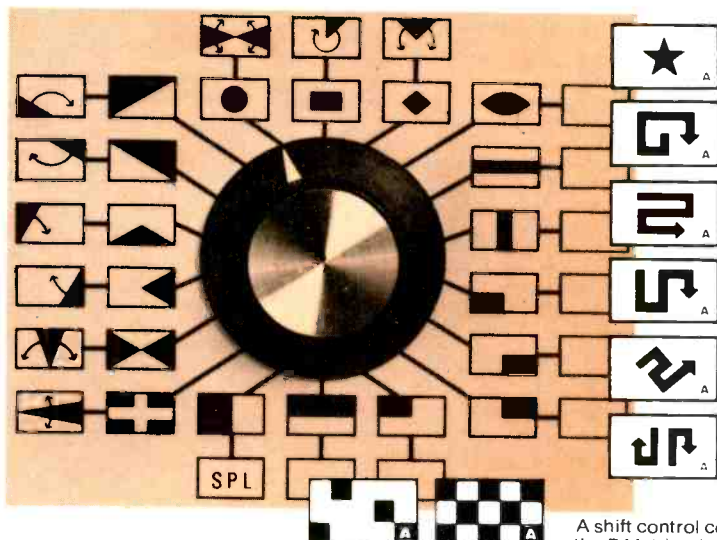

The Ross RVS-514 switcher pattern selector is shown. Other Ross 500 switchers have 62 illuminated pushbutton pattern selectors.

A shift control converts the 7 Matrix wipes into an additional 7, and the Star converts to the Pointer.

Ross 500 Series Switchers now give you a wider selection of special effects patterns with the addition of...

- A 5 pointed Star Spin wipe.
- A Pointer that can be positioned and continuously rotated anywhere on the screen.
- And 14 Matrix wipes (more than any other switcher) that include Checkerboard and Random patterns.

Plus you can create hundreds more of your own special patterns with the 'SPL' selector.

And like the Ross 500's other 9 Rotary and basic wipes, all have soft and color border controls.

See them all at NAB Booth 1812

Call 613-652-4889 or write ROSS VIDEO LTD., 9 Iroquois Plaza Iroquois, Ontario, Canada KOE 1K0

ROSS

ON THE OTHER HAND, OUR ROUTING SWITCHERS HANDLE GROWTH VERY NICELY.

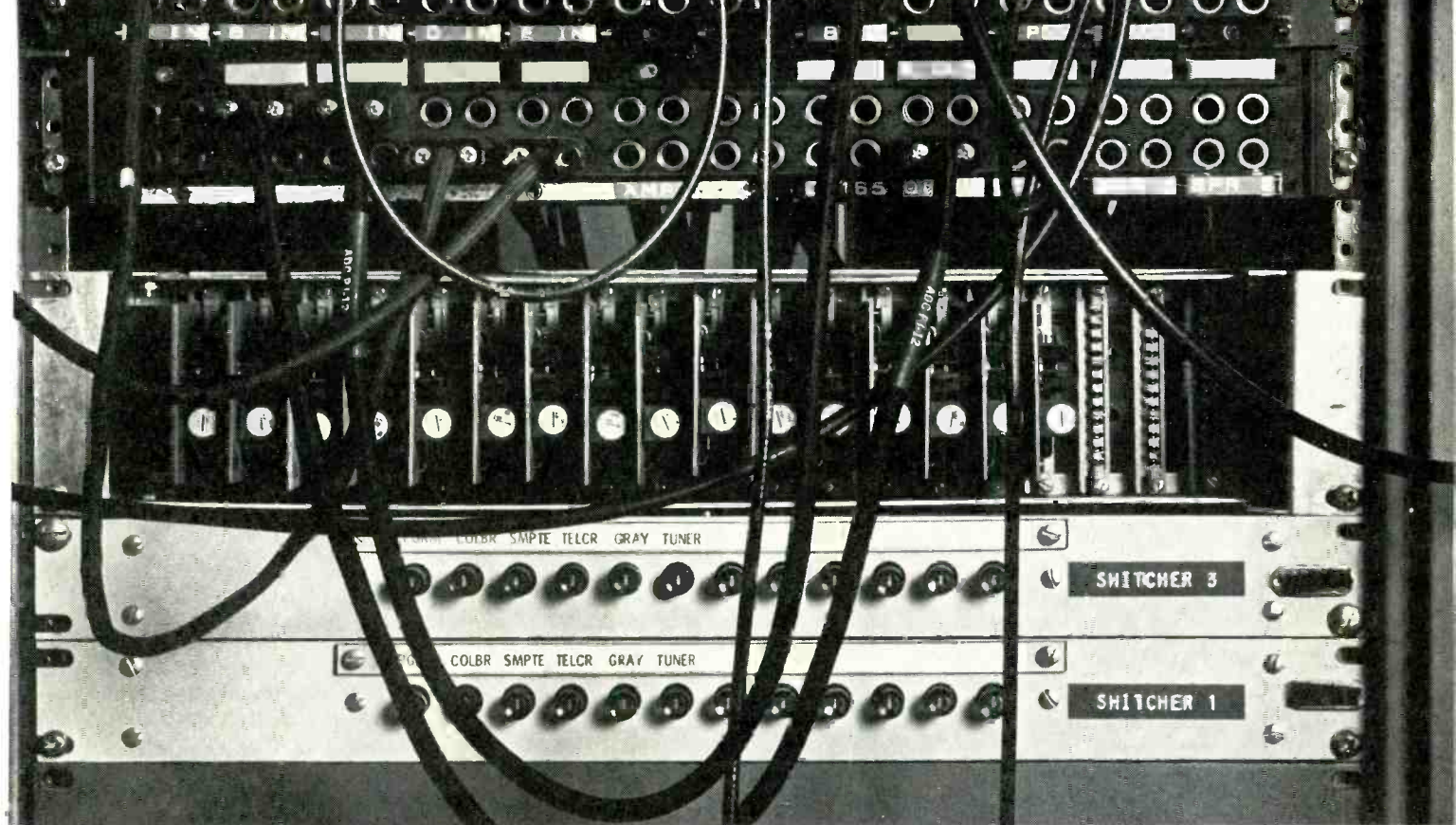

With a microprocessor-based 3M routing switcher, you can eliminate the problems of hard wiring once and for all. And specify just about any type of control you want.

It all depends on how you'd like to set it up. Our design engineers can then tailor the matrix for you. From your smallest requirement on up to any desired size. And they'll help you select the control that's best suited to your needs, too.

The choice is yours. Touchpad, thumbwheel, illuminated or L.E.D. pushbutton, machine, X-Y, or alphanumeric universal control. Even a terminal control that allows you "supervisory" control throughout the system, or computer control through our RS-232 port.

What's more, 3M routing switchers are easily expandable. Start with a matrix that matches your present requirements. Then as your studio grows, your routing switcher does, too. With the simple addition of extra frames and switch cards.

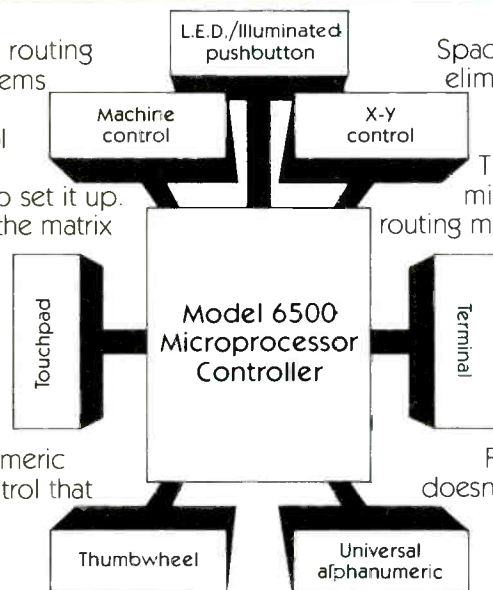

Space-guzzling, multi-conductor cables are eliminated. And so are unnecessary output panels. Because with our system, outputs can be reallocated as required.

The heart of the system, the Model 6500 microprocessor, as well as controlling the routing matrix, can be integrated with a machine control system to offer absolute production control of film chains, VTR's and other production machines.

Or it can be used as a stand-alone machine control system which offers the same coaxial wiring and expandability of the routing switcher panel.

Finally, a routing switcher whose growth doesn't depend on the size of your building.

For more information about 3M routing switchers, or a custom design consultation for your studio, call collect, (612) 736-1032. Or write on your letterhead to: Video Products/3M, Bldg. 223-5E/3M Center, St. Paul, MN 55144.

**THE ROUTING SWITCHERS THAT GROW
AS YOUR NEEDS GROW.**

Business

Ampex, Signal complete merger

The shareholders of Ampex Corporation and The Signal Companies, Inc. approved a merger agreement January 15, whereby Ampex became a wholly-owned subsidiary of Signal. The merger became final upon the filing of the merger agreement with the California Secretary of State.

Effective January 15, 1981, each share of Ampex common stock was converted into 1.275 shares of Signal common stock, and instructions with respect to the exchange of share certificates were mailed to each Ampex shareholder.

Ampex has approximately 11 million common shares outstanding and an additional approximately 2 million shares reserved for issuance upon conversion of convertible debentures and exercise of outstanding employee stock options.

Joint venture between DuPont and N.V. Philips

A joint venture for the manufac-

ture and worldwide sale of magnetic tape and cassette products has been formed by the DuPont Company and N. V. Philips of the Netherlands. The new venture will be known as PD Magnetics B.V.

DuPont and Philips said that PD Magnetics would combine the skills of each company into an organization that can become a leading supplier of audio and video products to meet the rapidly expanding needs of the magnetic tape markets. It has been estimated by financial analysts that this market will reach \$4 billion to \$5 billion annually by 1985.

Harris awarded contract for Nigerian Satellite Communications Center

Harris has received a \$20 million order from Nigeria for a large satellite communications earth station and an exhibition center to inform citizens about Nigeria's program to enlarge and modernize its national telecommunications system.

In addition to supplying an international "gateway" earth station with a 105-foot-diameter dish-shaped antenna, the Harris Satellite Communications Division will construct a complex of buildings at the site, including a visitors' center in a

geodesic dome, guest quarters, an administration building and facilities to house the Harris-made electronics equipment for the earth station.

Videoprint and ISC models to be sold together as business graphics

Image Resource, makers of the VIDEOPRINT full color photographic hard copy devices, has entered into an agreement with Intelligent Systems Corporation of Norcross, GA, to sell their products jointly as business graphics systems. ISC manufactures intelligent color terminals.

The Videoprint 3000 will be sold with ISC models 3621 and 3651 color terminals for various MIS applications. The output of these systems can be 35mm slides, 4 x 5-inch prints with enlargeable negatives, or instant prints from Polaroid SX-70 film.

Datatron reports first quarter results

Datatron reported a \$43,056 profit before taxes on sales of \$1,899,241 for the first quarter that ended September 30.

Herbert M. Perkins, president, said that expenses associated with the company's move to its new

**ECHOLab
SIGNATURE
SERIES**



Look for this signature at NAB—Booth #625

You'll find it on a remarkable new programmable switcher/SEG that combines outstanding transition-oriented performance with an incredibly low price.

ECHOLab, Inc.
175 Bedford Rd. Burlington, MA 01803
(617) 273-1512

Circle (231) on Reply Card

STL

PRECISION



MAGNETIC TEST TAPES

STANDARD TAPE LABORATORY, INC.
26120 EDEN LANDING ROAD #5, HAYWARD, CALIFORNIA 94545 • (415) 786-3546

Circle (232) on Reply Card

Shooting in a Tight Spot?

THE NEW
ELEMACK CRICKET
FITS IN
NARROWER SPACES,
TIGHTER CORNERS
AND BRINGS YOU
CLOSER TO THE ACTION.



The *new* Cricket lets you go where no dolly has ever been before. And work in areas that are inaccessible for more conventional equipment. Cricket smoothly elevates any size camera—without bumps or vibrations. A new triangular design prevents twisting.

Precision roller bearings and an electric hydro-drive system glide you up or down while you shoot, reaching elevation and stopping softly.

Ruggedly built, yet lightweight (only 300 lbs.) Cricket has the same wheel configuration as the Spider and can be used with or without dolly track.

The Elemack Cricket. One of the lightest, most compact hydraulic dollies available.

Elemack Cricket Accessories:
Jonathan Jib Arm, Mini Job Arm, Low Boy for Angle Shots, LS/6B, Track Wheels for Curved Track Operation.

Write for free brochure for all the details.

The CAMERA MART, Inc.
456 W. 55 St.
New York, N.Y. 10019
(212) 757-6977

Exclusive East Coast Distributor

See Us at NAB Booth #1406

Circle (233) on Reply Card

ALAN GORDON ENTERPRISES, Inc.
1430 N. Cahuenga Blvd.
Hollywood, Calif. 90028
(213) 466-3561

Exclusive West Coast Distributor

See Us at NAB Booth #1917

Business news

facilities, and increased development costs attendant to the introduction of the company's new Vanguard videotape editor and Spectrum benchtop integrated circuit tester affected the first quarter results. He also noted that the Vanguard generated great interest at recent trade show appearances in England and Japan and that the Spectrum would make its public debut at the mid-November Cherry Hill Tester Conference in Philadelphia.

Van order for Switzerland

Pye TVT Limited, the Broadcast Company of Philips, announced the sale of a four-camera color outside broadcast vehicle to Eidophor Ltd. of Zurich, Switzerland.

The vehicle, based on a Mercedes 1619 chassis, is fully equipped with two LDK 5B and two LDK 14S production cameras with one set of ENG options. The vehicle is also equipped with a CD 480 model 4 vision mixer, SM12 audio mixer and video recording equipment (2 off PVR 2B) with time code and editing units.

North Supply signs new vendor

North Supply Company, Lenexa, KS, has announced the signing of a distributor agreement with the Microdyne Corporation of Ocala, FL. Microdyne is a leading manufacturer of satellite communications equipment. North Supply will distribute Microdyne's complete hardware line, which includes 3.66M, 5M, and 7M antennas; modulators; and a complete line of receivers.

Ampex Audio Group moves to Cupertino facility

The audio products group of the Ampex Corporation's Audio-Video Systems Division moved its operations to the company's Cupertino, CA, facility in late January.

The audio group's product management, engineering departments and technical support, formerly at the Redwood City corporate headquarters, moved into the 103,000 square foot facility.

Ampex restructures magnetic tape staff

The Ampex Corporation has announced that it has restructured its Magnetic Tape Division to better meet the needs of the worldwide

marketplace. The restructuring creates three separate business management units reporting to Paul Baba, director of product and marketing planning for the MTD.

Donald F. Bogue has been appointed business manager, audiotape products, with product line responsibility for all professional, industrial and consumer audio tape products.

George F. Armes has been appointed business manager, instrumentation tape products, with product line responsibility for Ampex tape products used in scientific and instrumentation recording applications.

Jerry O. Gunnarson has been appointed business manager, videotape products, and has product line responsibility for all professional, industrial and consumer audiotape products.

Century Precision opens new branch

Century Precision Cine/Optics of North Hollywood, CA, has announced the opening of an East Coast branch.

The new office, in Hicksville, NY, (Long Island), will offer the same

Broadcasters Prefer MINNEAPOLIS MAGNETICS



**HIGH QUALITY
TAPE HEADS.
REPLACEMENTS FOR
AMPEX, SCULLY, REVOX.**

MMI quality gives longer life, better performance, greater reliability

- Extra durable .024" metal depth at gap
- Full metal face (minimizes oxide loading)
- Wide lamination stacks
- All heads individually tested
- Direct retrofits for simple installation

Quick delivery. Most orders shipped from stock.

Assembly refurbishing and head relapping. Ship us your assembly. We'll clean, replace worn parts and heads (or relap), adjust and test.

Free assembly loaner service. No need to shut down.



Cartridge machine heads for popular makes and models.



Minneapolis Magnetics, Inc.
3104 West Lake Street
Minneapolis, MN 55416
612/927-8841

Circle (234) on Reply Card

If Genlock Counts . . .

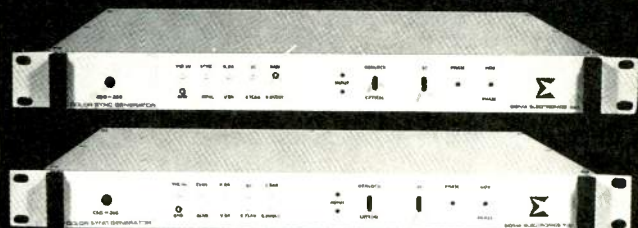

. . . Count on SIGMA CSG-360 & CSG-365

- RS-170A
- Black Burst Output
- Adjustable Blanking
- Genlock to Helical VTR
- Proven Genlock Performance
- Color Bars & Cross Hatch Output on CSG-365



SIGMA ELECTRONICS INC.

1830 STATE STREET, EAST PETERSBURG, PA 17520
(717) 569-2681

Circle (235) on Reply Card

Eventide Clockworks ends the tyranny of the clock.

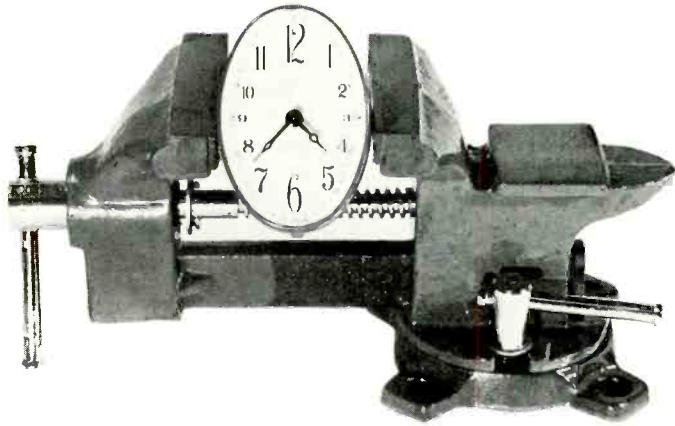

Introducing the Eventide Timesqueeze system.

It lets you control time. Specifically, the running time of videotape and audiotape playbacks. With no editing, no "Donald Duck" audio effects and no material eliminated. In fact, the process is virtually undetectable in use.

Think what this can mean! Did a local commercial come in at 32½ seconds? With the Eventide Timesqueeze system, that spot will fit in a 30 second slot. A 100 second news spot can fit a 90 second news slot. You can even program a 95 minute movie package in a 90 minute slot. And the system works the other way too. It can stretch time. For example, a 36 second musical background can be stretched to cover a 40 second scene.

For television use, the Eventide Timesqueeze system controls your one-inch variable-speed-capable VTR. Radio stations can use the system to control most any pro-audio recorder. And Eventide delivers full 15KHz audio response.

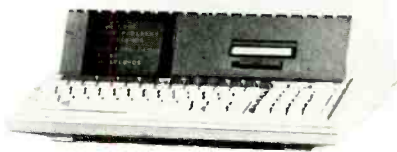

How much does it cost to control time? Amazingly, as little as \$3500 for the most basic system. The fully computerized system is only \$8500. So not only can you control time, you can control costs. The Eventide Timesqueeze system. It gives you freedom of time.

See us at N.A.B. booth 177—S

Eventide
the next step

Eventide Clockworks Inc.
265 West 54th Street
New York, N.Y. 10019
(212) 581-9290

Circle (236) on Reply Card

Ask Eventide:

Q. How does the Eventide Timesqueeze system work?

A. In order to change the timing of an audio or video recording, first the tape playback speed must be varied so that the original play time is changed by the amount desired. Second, the detrimental effects of the speed change must be negated or corrected. In audio this means restoring the pitch so that the announcer doesn't sound drunk (on slowed tapes) or like Donald Duck (on sped-up tapes, of course.) In video it requires signal manipulation so that sync is not lost as the VTR speed changes. Compatible one-inch VTR's, equipped with their companion TBC's can provide stable pictures at slow and fast speeds.

The Eventide Timesqueeze system accomplishes time compression and expansion by first computing and generating tape machine control signals to vary tape speed by the proper amount, and then by correcting the audio pitch, using the H949 Harmonizer®. The system can be configured in several ways. To control an audio recorder, often the H949 Harmonizer alone can be used. In other cases, such as when very precise final timing is required, the crystal-controlled PTC945 Precision Tape Controller should be added, to generate both the control signals for the tape machines and to control the pitch ratio of the Harmonizer. If the PTC945 is used, the final component of the system becomes a computer. We recommend the Hewlett-Packard HP-85 for its overall quality and reliability, but any small computer with an IEEE-488 interface, including the inexpensive Commodore PET can be used. The computer takes overall control of the system, by sending messages to the PTC945 and thence to the H949. All functions, including tape timing can be controlled by the computer. The computer-controlled Eventide system is unrivalled in operating simplicity. Just answer the questions the computer asks on its CRT readout:
COMPUTER: HOW LONG IS YOUR TAPE?
OPERATOR: 67 SECONDS.
COMPUTER: HOW LONG DO YOU WANT IT TO BE?
OPERATOR: 59.5 SECONDS.

What could be simpler? In fact you don't even have to answer the first question. Just cue up the tape and the computer will time it for you and then automatically set the correct pitch and timing.

A few words about the heart of the Eventide Timesqueeze system, the H949 Harmonizer. This unit performs the most difficult part of the task, pitch change. Pitch changing requires digitally sampling audio at a high speed and then "reading out" that data at a variable rate. The varying input vs. output rate makes it necessary to "splice in" or delete small segments of signal. To prevent "glitches" caused by this process Eventide uses a proprietary splicing algorithm which permits broadcast quality to be maintained. Broadcasters and producers will find many other uses for the H949 Harmonizer, when it is not in time compression/expansion and pitch change use. For example, the H949 can perform flanging, time reversal, digital repeat and many other audio "special effects." TV and radio program and commercial producers will find these additional uses invaluable.

Got a question about time compression or digital audio effects? Send it to "Ask Eventide" 265 West 54th Street New York, N.Y. 10019. If we use your question in print we'll send you an Eventide T-shirt, so include your size.

Business

lens, sales and repair service as the North Hollywood facility.

Jeffrey Giordano, most recently corporate service manager for the Angenieux Service Corporation of America, will manage the new branch. He will be joined by service technicians Michael Melito and Louis Tullo, both formerly of the Angenieux Service Corporation of America.

WUFT resumes broadcasting

Public television station WUFT, Gainesville, FL, has resumed broadcasting on Channel 5, after more than a month of being off the air. The station signed back on the air at 9 am on Thursday, November 27, 1980.

This reactivation of service was made possible by the erection of a temporary tower at the station's transmitter site, to replace on an interim basis the tower that was destroyed in an accident on October 24, 1980. The temporary tower is approximately 300 feet high, compared with the station's standard height of 869 feet. WUFT is now able to cover a radius of approxi-

mately 30 miles with its signal, compared with 85 miles with its standard signal.

It is unknown when Channel 5 will be able to restore normal service.

Marvin Josephson Associates announces purchase of two radio stations

Marvin Josephson Associates announced it has agreed to purchase the assets of radio stations WNOR AM & FM. The stations are licensed to Norfolk, VA, and serve the market consisting of Portsmouth, Newport News, Hampton, and Virginia Beach, VA. The FM station broadcasts album-oriented rock music. The AM station broadcasts urban contemporary music. The company stated that the purchase price was \$2,600,000 and that in addition to the purchase assets the principals of the selling company have entered into agreement not to compete in the stations' market for a period of five years following the sale.

Payments in connection with those agreements will aggregate \$600,000. The agreements are subject to approval by the Federal Communications Commission.

New headquarters opened

US JVC Corp.'s new headquarters were officially opened on November 21 with a reception and ribbon-cutting ceremony at the new facility in Elmwood Park, NJ.

Among those attending were Richard Mola, mayor of Elmwood Park; Richard F. O'Brien, executive vice president of US JVC Corp.; F. Uchida, director of export administrative, Victor Company of Japan; and N. Sakoda, director and president of US JVC Corp.

JVC's new facility at 41 Slater Drive currently serves 170 employees in 176,000 square feet of space on three floors. The number of loading docks and the total warehouse space have been quadrupled.

Wang Voice Communications acquired by Comex Systems

Comex Systems, a division of the Successor Corporation, has completed its acquisition of the business of Wang Voice Communications, a wholly owned subsidiary of Wang Laboratories. Comex Systems has retained the nucleus of Wang's production and manufacturing personnel and expanded its marketing staff. □

Ready to go...

CHYRONI[®] RGU-1

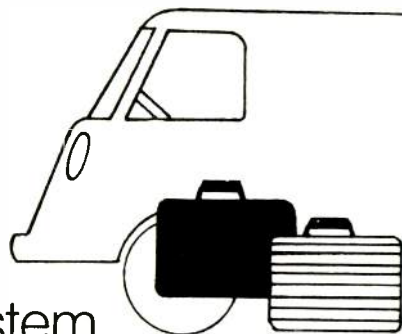

The portable graphics and titling system...

packaged to travel, to go where you go, as well as for in-house operation. Ingenious. Incorporating many features of the matchless **CHYRON IV**. From CHYRON — the electronic graphics people.

CHYRONI TELESYSTEMS DIVISION OF CHYRON CORPORATION

265 Bethpage-Spagnoli Road, Melville, New York 11747

Telephone: (516) 249-3296 ■ Telex: 144522 CHYRON MELV

Ampex International is exclusive distributor for Chyron Graphics Systems outside the U.S.A. For information contact your nearest Ampex sales office.

See Us at NAB Booth #1407

Circle (237) on Reply Card

DBX HELPS KMJQ WORK MAJIC.

Majic. It's a black format that's living up to its name in several markets across the country. And perhaps the biggest success story is Houston's KMJQ. Back in 1977, KMJQ adopted the Majic format and went from near bottom to #1 in just 2 short Arbitrons.



Yet KMJQ was the softest station on the dial.

"To achieve our goal," explains Chief Operator Leroy Dietrich, "we placed a lot of emphasis on the quality of the sound. By the day we started the Majic format, we had built a technical ability that we think is probably one of the best in the country.

"We hired an audio consultant to get us started," continues Dietrich. "He installed P 303 pre-amps and MC20 moving coil cartridges on SL-1100A turntables. Then he recommended dbx equipment for definition and dynamics."



KMJQ installed dbx tape noise reduction on all their cart machines. Not just for their program material, but for their commercials, too. "That keeps our advertisers happy because their commercials sound as clean as our music," says Dietrich. "And



we use a dbx Model 500 subharmonic synthesizer to restore the low end.

It makes the station sound especially well balanced. Even at low listening levels."

KMJQ also needed a compressor/limiter – but they didn't want to ruin the sound quality they had worked so

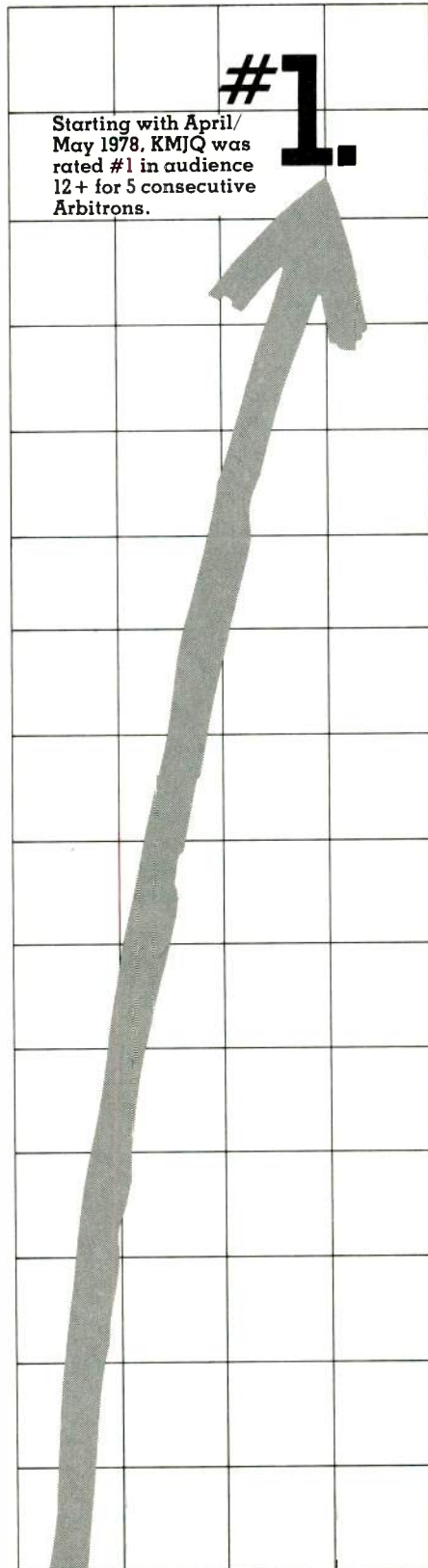

hard to get. "After hearing how smooth the dbx 165 compressor/limiter works, there is no doubt in my mind that it's the best limiter I've ever heard in my life. We use it on voices, and it gives us the control we need without sounding like we have any control."



As you'd expect, KMJQ has constantly been making subtle technical changes to maintain their leadership position. "Due to competitive forces in the market, we've had to crank our signal up louder. Without dbx tape noise reduction on our carts, the noise would have been cranked up, too. Now I'm happier than ever that we're fully dbx'ed," says Dietrich. "We not only get the sound we want, but the whole system is incredibly reliable – bulletproof."

Dietrich summarizes his feelings about KMJQ's technical product by saying, "A lot of this is subtle stuff, psychoacoustics. But people comment to us that our station sounds more like the record they bought than the other stations do. A psychological thing, agreed. But it all adds up when you start reading the Arbitrons."



For more information on dbx's complete line of equipment for the broadcast industry, write Professional Products Division, dbx, Incorporated, 71 Chapel St., Newton, Mass., 02195, USA. Tel. (617) 964-3210. Telex: 92-2522. Distributed in Canada by BSR (Canada) Ltd., Rexdale, Ontario.

Circle (238) on Reply Card

IMI TRU COLOR PROJECTION TV

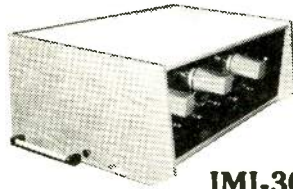

IMI-3000

LARGE SCREEN COLOR DISPLAY

10FT. UP TO 25FT.
DIAG. PICTURE SIZE

WIDE ANGLE VIEWING
ON STANDARD OR
REAR SCREENS



IMAGE MAGNIFICATION INC.
739 Airway Circle,
New Smyrna Beach Fla. 32069
(904) 427-5294

Circle (239) on Reply Card

Talk is cheap.

Here are some of the actions
your company can take to
prevent the suffering caused
by poor parenting patterns
and child abuse.

We want to stop the hurt.

- We are enclosing a tax-deductible donation in the name of our company.
- We want to help. Please call our company and tell us what you're doing to stop the hurt of child abuse in our community.
- We will plan a day for employees' children to visit our place of work to learn what we do and why.

 **prevent child abuse.**
write: Box 2866, Ch., IL 60690
National Committee for Prevention of Child Abuse

NRBA

National Radio
Broadcasters' Association

1705 De Sales Street, NW
Washington, DC 20036

NRBA supports elimination of 1st Class ticket

NRBA filed comments November 14, in Docket No. 20817 supporting the FCC's proposal to discontinue First Class Radiotelephone Operator Licenses.

NRBA noted that the First Class ticket examination can only test an individual's basic grasp of theories and cannot adequately measure an individual's working knowledge of electronic hardware.

Elimination of the First Class License is also "completely consonant with the concept of deregulation which the NRBA has consistently endorsed," the NRBA comments said.

Because "a licensee's economic viability is dependent upon its broadcast signal, it is therefore in the individual licensee's interest to see to it that its signal is maintained in the best possible fashion by the best possible people. It is only by doing this that a broadcaster can effectively compete in the marketplace," the NRBA said.

If the FCC's proposal is adopted "the broadcast industry will undoubtedly undertake to develop uniform standards to enable licensees to assess their engineers' qualifications," NRBA noted.

Support urged for international opposition to 9kHz

NRBA's executive committee has moved to confirm and strengthen the association's opposition to the AM 9kHz proposal.

At its regular monthly meeting on December 1, the committee instructed executive vice president Abe Voron to work with NRBA engineering counsel Harold Kassens on the preparation of a 9kHz technical white paper. The paper will be an amplification of the technical report that was part of the NRBA's comments on FCC BC Docket #79-164, comments which reiterated NRBA's opposition to the 9kHz proposal.

Radio audience acceptance for 1981

Kent Burkhart, Burkhart, Abrams, Michaels and Douglas has made the

predictions for 1981: 25-35 year olds will be important. Formats will adopt music and formatic techniques to recruit listenership in this group; FM stations programming contemporary country rock will have a good demographic year; country stations on AM will continue to have good ratings even with the continued upward movement of immediate FM competitors; AM contemporary MOR stations will have to scratch for every rating point. FM contemporary MOR stations will continue to have a field day. Pure contemporary stations on both AM and FM will have about the same ratings; Urban format stations should continue to increase in audience in those cities that can effectively support (from an audience point of view) such a format; Album rock stations will hold their shares, and there will be some definite upward demographic moves; All-news and all-talk stations may increase in audience; Beautiful music stations may show some decline; So-called AM Good Music stations could suffer at the hands of FM contemporary MOR stations; Black AM and FM, classical and Hispanic stations should remain the same in audience; fragmentation will continue, but at a declined rate.

Newspapers in "No Growth" pattern

A recent Radio Advertising Bureau (RAB) analysis of national newspaper trends shows a "no growth" pattern. Although newspaper line rates and cost-per-thousand went to 105%, and households increased by 22%, newspaper circulation stayed even nationally.

RAB predicts radio will continue to grow at a healthy pace with volume reaching \$3.5 billion by the end of 1980—a \$1.5 billion gain since 1975.

Fewer complaints in '80

In fiscal 1980 the public filed 70,188 complaints with the FCC, 3300 less than last year's all-time high of 73,523. Of the complaints filed in 1980, 19,338 concerned radio and a 50,485 concerned TV.

Being an election year, a predictably high number of complaints fell in the category of "political broadcasting and fairness doctrine"—20,340 compared with 8858 in 1979.

Kassens on transition team

NRBA engineering counsel Harold Kassens is active on the FCC transition team. Kassens, a consulting engineer with A. D. Ring & Associates, is a former deputy chief of the FCC's Broadcast Bureau.

DYNAMIC NEW DIMENSIONS IN VISUAL PRESENTATION

—with General Electric Professional Large Screen TV Projection



IN TV PRODUCTION—General Electric color projector displays rear-screen program material, and can be used for unusual special effects.



IN ENTERTAINMENT—A General Electric color TV projector brings large screen race action to Ontario Jockey Club, near Toronto, Canada.

General Electric professional large screen television projectors—displaying color or monochrome pictures up to 25 feet wide—bring new dimensions of presentation impact to a broad spectrum of applications.

A wide choice of new and improved color and monochrome models is available to meet specific requirements for television display applications, in standard or high brightness, for various scan standards.

The color projectors utilize General Electric's exclusive single optical path light valve. All color information is projected simultaneously in one light beam. This system eliminates time-consuming registration of three separate images which is required for all other color television projectors.

These projectors can display any size television picture from two feet to 25 feet wide, with high resolution and contrast over their full range of light output.

Among the primary applications of the projectors are:
Medical and Dental Education. Technique and procedural training.

Business. Sales meetings, industrial training, product presentations, real-time display of computer-generated data, satellite-transmitted conferences.

Aerospace and Defense. Situation displays, simulator training.

Entertainment. Theatre television and closed-circuit TV events, overflow crowds, discotheque special effects.

Television Production. Backgrounds for news programs, special effects, data display, program previewing.

Call or write: General Electric Company, Video Display Equipment Operation, Electronics Park, 6-206, Syracuse, NY 13221. Phone (315) 456-2152.

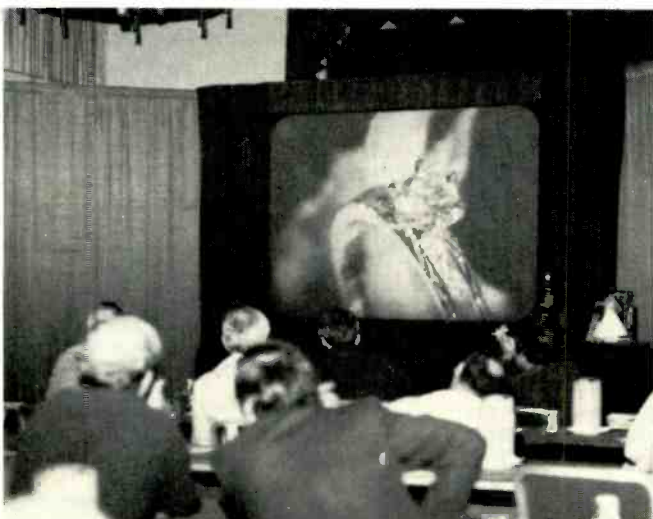

IN SALES—General Electric color TV projector dramatically displays new product highlights at Keepsake® Diamond Rings annual meeting.



IN THE BOARD ROOM—At Mellon Bank, N.A., Pittsburgh, General Electric color projector displays computer data, graphs and information.

GENERAL ELECTRIC

Circle (240) on Reply Card

new products

Rubber lens shade

The 86MM series 9 universal rubber lens shade from **Tiffin** is smaller in diameter than a wide angle rubber lens shade. Collapsible



for easy storage, it is designed from a special rubber compound for heavy-duty use to withstand extremes of weather. It can be used on normal or wide angle lenses.

Circle (800) on Reply Card

Distribution frame

HEDCO has designed a combination distribution frame to provide the broadcaster with both audio and video DAs in the same two units of rack space. The AVF-150 frame is prewired for four audio and four video distribution amplifiers and two power supplies. Only one supply is required to power the eight modules; however, the frame has space reserved for a redundant power module which includes a separate AC input and circuit breaker/switch located on the rear connector channel.

Circle (801) on Reply Card

3-channel sound mixer/pre-amp

LTM has introduced its A-97



Three Channel Sound Mixer/Pre-Amp. The unit does not require any adapters or modifications to the videorecorder. It mounts to all videorecorder and sound mixing controls. The added channels and precision mixing capability provide improved flexibility and control in sound recording while adding only negligible weight.

Circle (802) on Reply Card

Tulip crane

The Tulip Crane from **Matthews Studio Equipment** reaches a maximum height of 20 feet, carrying both camera operator and assistant. The unit rides on its own pedestal (dolly) and operates by using balance



weights to control the vertical movement. The crane will accommodate any 35mm, 16mm or video

camera system. For transit, the crane folds into a compact unit, 8 feet in length by 2½ feet square, weighing approximately 200 pounds.

Circle (803) on Reply Card

1604 Satellite mixer

Sphere Electronics has introduced the System 1604 satellite mixer. It is a compact but fully professional mixer. The 16x4 mini-console in a 19-inch rack mount takes only 7 inches of space. Modular in construction, the mixer consists of 16 inputs and one submaster module. It can operate as an independent unit or as part of a submixer network to feed larger production consoles.

Circle (804) on Reply Card

VIDAC Communication System

CALDATACOM's VIDAC Communication System is designed for use in the television and communication industries. The VIDAC system encodes a high speed digital data stream into the vertical interval of a television signal. Using standard RS-232 compatible input/output de-

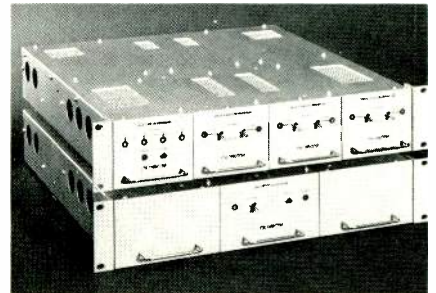

vices the VIDAC system operates at any standard data rate between 75 and 9600 baud yielding a maximum data input rate of 872 characters per sec. Employing internal memory, the system is proof against data loss as the result of input disturbance in the signal path and causes no degradation of the broadcast television signal.

Circle (805) on Reply Card

KOFM and Logitek — A Winning Combination!

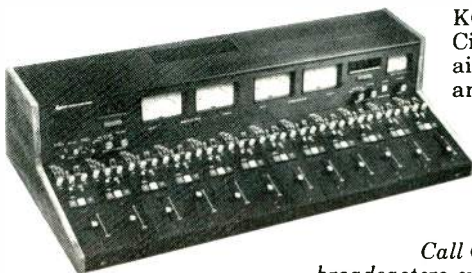

KOFM is a winner in the Oklahoma City market. When they needed new on-air and production consoles, they chose another winner: Logitek's Custom Audio Series. Its modular design let them tailor each console to their precise needs. And Logitek quality and factory backup keeps them in the winners circle!

Call COLLECT 713-782-4592 and see why broadcasters everywhere are moving up to Logitek!

Logitek Electronic Systems, Inc. 3320 BERING DRIVE, HOUSTON, TEXAS 77057

VISIT US AT NAB BOOTH 136

Circle (241) on Reply Card

COMPUTER VIDEO EDITOR

For state of the art production facility, requiring commercial, broadcast and industrial program experience. Sony or CMX computer, 1" VTR and Squeezezoom abilities desired. Contact Steven Wild at (313) 477-6066.

MAGNETIC VIDEO CORPORATION
A 20th CENTURY FOX COMPANY

Circle (269) on Reply Card

FREE CATALOG & AUDIO APPLICATIONS



CONSOLES
KITS & WIRED
AMPLIFIERS
MIC, EQ, ACN, LINE,
TAPE, DISC, POWER
OSCILLATORS
AUDIO, TAPE BIAS
POWER SUPPLIES

OPAMP
LABS INC.

1033 N. SYCAMORE AVE.
LOS ANGELES, CA. 90038
(213) 934-3566

Circle (243) on Reply Card

Eliminate insulators and "white noise" with tough, non-conductive guys of Kevlar®.

Steel guy lines can create transmission problems with arcing at insulators.

Non-conductive guys with KEVLAR offer a simple solution.

Antenna guys of non-conductive KEVLAR® aramid fiber need no insulators. This eliminates the arcing that creates "white noise" signal interference in conventional steel guys.

Also, because KEVLAR will not corrode, it resists electromagnetic oxidation, chemicals and salt attack, so guys stay in service much longer.



Lightweight, corrosion-free KEVLAR also cuts rigging and maintenance costs.

KEVLAR can match the strength of steel at only *one-fifth* the weight, so riggers can coil two or three guys over their shoulder at once, greatly speeding installation.

For more information and a list of manufacturers of guy lines of KEVLAR, write: DuPont, Room 38811, Wilmington, DE 19898.

® DuPont registered trademark for its aramid fiber. DuPont makes KEVLAR, not antenna guys.



Circle (271) on Reply Card

New products

Convergence offers VTR interfaces

Convergence has announced the addition of two new videotape recorder (VTR) interface options to their line of videotape editing products. The first of the two new interface options now being shipped is CCA-90/CR-8200 for use with JVC ¾-inch VTR models CR-8200, CR-6600, and CP-5500. The second interface option is CCA-90/NV-9600 for use with Panasonic/National ¾-inch VTR models NV-9600, NV-9240, and broadcast Model AU-700. Both new interfaces are designed to work with the Convergence ECS-90 Editing System.

Circle (806) on Reply Card

News release

A & S Case has announced its lightweight custom film and video equipment cases for cameras in the JVC, Hitachi, Eclair, Arriflex and other lines.

Circle (807) on Reply Card

Preamp specs

Logitek has improved the frequency response specifications of its BPA-100 balanced-input phono preamps. The units are now guaranteed to track the RIAA response curve within $\pm 3/10$ dB from 50Hz to

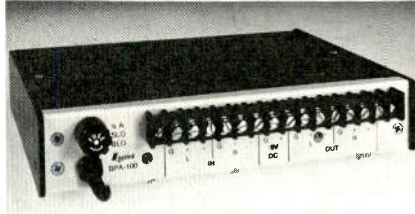

15kHz, and within $\pm 1/2$ dB from 20Hz to 20kHz. The improved response is achieved by using precision components in the preamp's equalization stage and hand-trimming each unit to compensate for individual component variations.

Circle (808) on Reply Card

Wireless intercom system

Cetec Vega's wireless intercom offers unrestricted movement, and because it avoids potential shock hazards, it establishes safe and effective communication in situa-

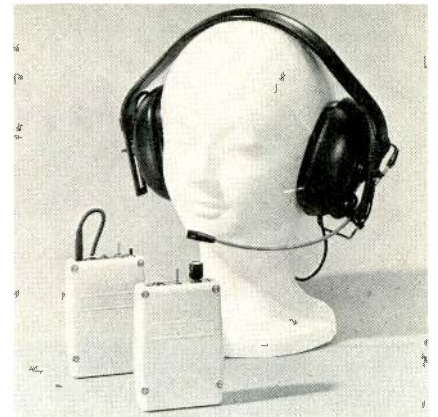

tions in which conventional "hard-wired" intercoms would either be impractical or impossible. Typical motion picture and broadcast applications include cueing for sound, camera and lighting crews, and direct instruction of crews, performers, as well as stunt coordination. Also, the director can monitor a wireless mic channel.

Circle (809) on Reply Card

U-Matic KCA 20

Maxell has introduced the KCA 20 videocassette, adding a 20-minute



PICLEAR[®]

The worldwide solution to instant image rejuvenation.

The PICLEAR Film Enhancement System makes it possible. Scratches disappear from the projected image. Dirt is removed. Image brightness is increased by 10%, and useful film life is greatly extended.

PICLEAR. 180 E. Prospect Ave. Mamaroneck, NY 10543
914/698-0258

Circle (244) on Reply Card

When accuracy counts... Count on Belar for AM/FM/TV MONITORS



BELAR
AM MODULATION MONITOR

BELAR CALL ARNO MEYER (215) 687-5550
ELECTRONICS LABORATORY, INC.
LANCASTER AVENUE AT DORSET, DEVON, PA. 19333 • BOX 826 • (215) 687-5550

Circle (245) on Reply Card

Microphone Cables— Budget Prices

- Jackets—rubber, Hypalon,* neoprene or vinyl
*Trademark of DuPont
- Connectors—male-female, double female or male
- 25' at \$14.50
- 50' at \$23.75
- Custom assemblies available

the **Newsworks**
P.O. Box 568 • Beltsville, Md. 20705
301-949-9391

Circle (246) on Reply Card

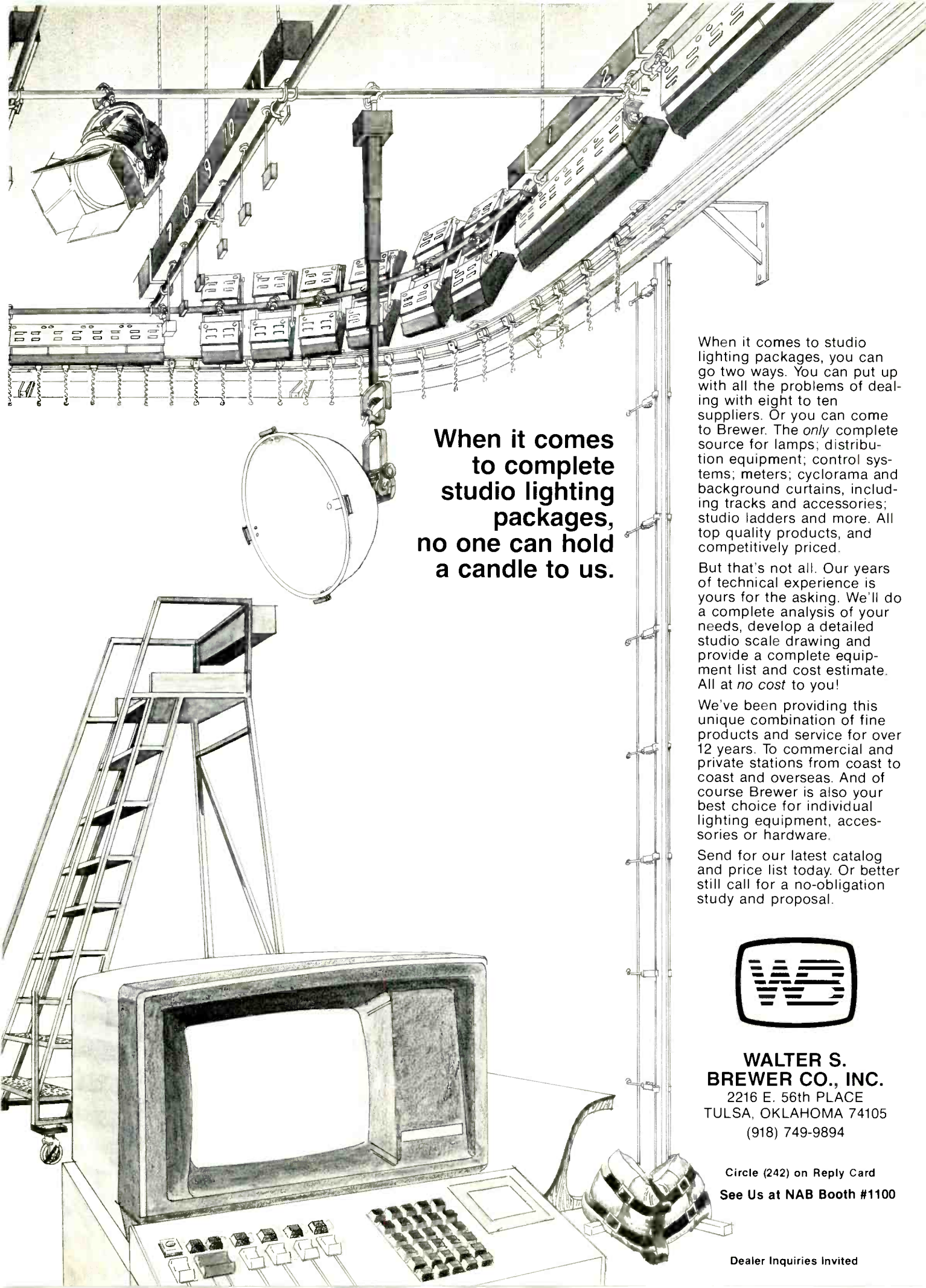

**When it comes
to complete
studio lighting
packages,
no one can hold
a candle to us.**

When it comes to studio lighting packages, you can go two ways. You can put up with all the problems of dealing with eight to ten suppliers. Or you can come to Brewer. The *only* complete source for lamps; distribution equipment; control systems; meters; cyclorama and background curtains, including tracks and accessories; studio ladders and more. All top quality products, and competitively priced.

But that's not all. Our years of technical experience is yours for the asking. We'll do a complete analysis of your needs, develop a detailed studio scale drawing and provide a complete equipment list and cost estimate. All at *no cost* to you!

We've been providing this unique combination of fine products and service for over 12 years. To commercial and private stations from coast to coast and overseas. And of course Brewer is also your best choice for individual lighting equipment, accessories or hardware.

Send for our latest catalog and price list today. Or better still call for a no-obligation study and proposal.



**WALTER S.
BREWER CO., INC.**
2216 E. 56th PLACE
TULSA, OKLAHOMA 74105
(918) 749-9894

Circle (242) on Reply Card
See Us at NAB Booth #1100

Dealer Inquiries Invited

New products



length to its U-Matic line. The shorter tape length reduces waste

when taping is geared to 20-minute programs. The KCA 20 features a rigid shell construction.

Circle (810) on Reply Card

Videotape animation

Animation Video has announced the AniVid System for direct frame-by-frame animation on videotape. The AniVid System produces a broadcast quality finished product directly on tape. It accepts any form of artwork, either manually or computer generated, flat or three dimensional. All the techniques



available to the film animator can be implemented on the AniVid System.

Circle (811) on Reply Card

1/4 and 1/2-inch mastering machines added to line

Otari has announced the introduction of the MTR-10 Series of production/mastering professional tape recorders. The MTR-10-2 is a two-channel, 1/4-inch machine; the MTR-10-4 is a four-channel 1/2-inch machine that also is convertible to 1/2-inch, two-channel. Features of

audiomedia associates

(504) 586-0140
P.O. Box 29264
New Orleans
LA 70189

"THE GULF SOUTH'S PREMIER BROADCAST SUPPLY HOUSE"
AM-FM BROADCAST TRANSMITTERS
BROADCAST & RECORDING STUDIO EQUIPMENT

CCA

phelps
dodge
Communications Company

Cablewave Systems

Circle (248) on Reply Card

--250SC - 5CH, 10 IN, 1 OUT	- 5Ch, Stereo - \$1500
--500SC - 8 or 12CH, 2 IN/CH, 2 OUT	- 8Ch, Stereo - \$2500
--500R - 8 or 12CH, 4 IN/CH, 2 OUT	- 8Ch, Stereo - \$3750
rack mounted electronics	12Ch, Stereo - \$4400
--1000R - 8CH, 4 IN/CH, 2 OUT	- 8Ch, Stereo - \$3950
touch switching	
--2000R - MODULAR, 8 or 16CH	- 8Ch - \$5100
32 IN, 4 OUT, EQ	8 w/EQ - \$6400
	16Ch - \$8200
AUDIO CONSOLES	16 w/EQ - \$9600

ARRAKIS systems
PO BOX 296
BOLIVAR, MO 65013

N.A.B. BOOTH 209
(417) 756-2850

Circle (249) on Reply Card



the series machines include full dc PLL servo tape transport operation governed by an integral microprocessor-based system, transport logic and exclusive, dual real-time counter controlled by a separate proprietary microprocessor, and audio and transport electronics card frame located conveniently for ease of adjustment and servicing.

Circle (812) on Reply Card

RELIABLE ROTARY ATTENUATORS

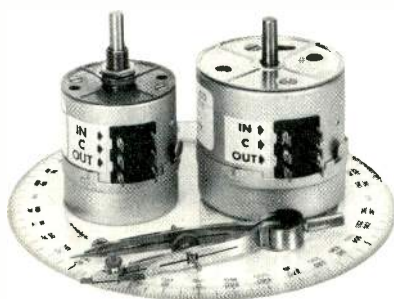

- PREMIUM MATERIALS
- QUALITY WORKMANSHIP
- PROVEN PERFORMANCE
- MANY STYLES
- ALL IMPEDANCES

SHALLCO, INC.
P. O. BOX 1089
SMITHFIELD, N. C. 27577
919/934-3135

Circle (250) on Reply Card

Color camera line

Panasonic Video Systems has expanded its low-cost, portable color camera line with the introduction of two new units. The models are designed primarily for use with the



Panasonic Omnivision II VHS recorder NV-8410. Both fully portable, model WV-3100 weighs 6.2 pounds and WV-3000 weighs 3.9 pounds. Each model is fully self-contained; all controls for effective operation are conveniently located on the camera. Both units deliver high quality video outdoors in remote locations as well as indoors.

Circle (813) on Reply Card

Noise reduction system

dbx Inc. is introducing the model 140, a 2-channel simultaneous encode/decode Type II tape noise reduction system for broadcast applications. The 1¾-inch high rack-mountable unit features RFI protected active balanced inputs, single ended outputs with on-board provi-



dbx Model 140 2-Channel Simultaneous Encode/Decode Type II Broadcast Noise Reduction System

sion for Jensen output transformers, barrier strip termination for inputs and outputs and dbx encoded disc playback capability. The detector circuitry of this system is optimized to be used with transmission and storage mediums having limited or irregular high frequency response characteristics.

Circle (814) on Reply Card

Parametric EQ

Sphere Electronics EQ 1014 parametric is a 4-band equalizer with high and low pass filters. It is designed to complement the nine octave Sphere graphic. The 1014 features continuously variable frequency and amplitude for all four EQ sections. Q shape on the two mid-bands, and the hi/low pass filter are also continuously variable.

Circle (815) on Reply Card

MORE RACK SPACE LESS FLOOR SPACE



Ruslang's new RL 2000 VTR Console offers more rack space while taking up less floor space. Constructed of quality materials, this compact unit is attractive and sturdy with the look of expensive walnut furniture. Other wood grain finishes and solid colors to complement your studio decor are available. Add a standard 10½" monitor overbridge that can be expanded to give even more rack space, plus an optional, easy to take off back panel, and you now have the most versatile and best looking console on the market at a fraction of the cost of steel. For complete details, contact . . .

RUSLANG CORP.

247 Ash Street, Bridgeport, CT 06605 Tel: 203 384 1266

Circle (251) on Reply Card

station- to-station

Low cost burst generator

Having successfully proofed our AM system with a continuous audio generator, I decided to find an inexpensive way to apply tone bursts to check transient response. The simplest and least expensive way was to "chop" the output of our LAG-120 Leader audio generator.

Figure 1 shows the chopping circuit. The 741C op amp acts as a comparator, producing a square wave output. The frequency depends on the time constant of R1, C1 and C2. R2 and R3 provide the necessary hysteresis. D1 prevents forward biasing of Q1. R4 and R5 provide quick discharge of the gate/drain during negative outputs from the op amp. The source and drain are wired in series with the ungrounded leg of the audio generator and the input to the system to be

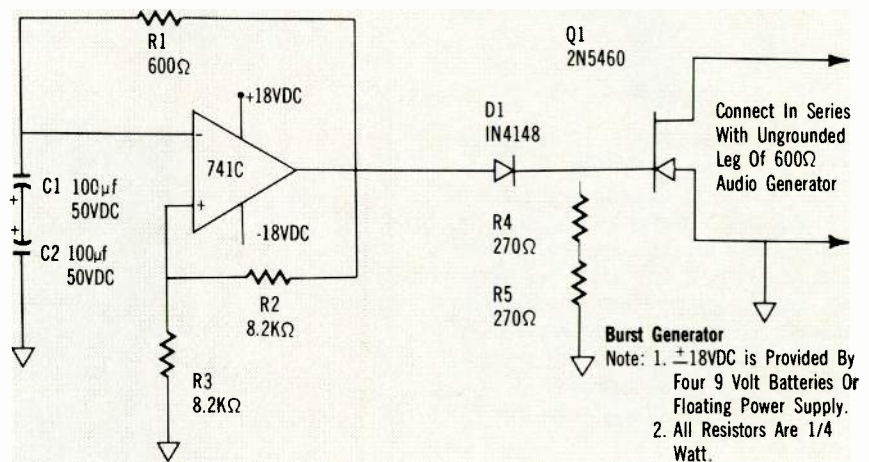

tested.

Actual tests indicated that at least +8dB could be injected into a 600 load before distortion occurred, much more than necessary in most cases.

The components are readily available and probably cost less than \$10.

Alan Gilmore
chief engineer, WTOW
Towson, MD

Modifying a DAP-310 for optimum AM

When our station received a Dorrough model 310. Discriminate Audio Processor from a sister station, we tried it on the air, and it became apparent that because it was designed for both AM and FM use, its performance on AM was compromised.

As the unit comes from the factory, the frequency bands used in it are: LOW-20-120Hz, MID-20-6500Hz, HIGH-6.5-15kHz.

These frequencies are fine for FM use, but it is obvious that most of the audio energy used in AM is in the mid band with very little coming from the two other bands. We decided to modify the unit to optimize its features for AM use.

The first modification involved component changes in the crossover card in the unit. The following changes were made:

C-16 was changed from .022μf to .047μf.

C-12 was changed from 1μf to .75μf.

C-7 was changed from 470pf to .001μf.

C-20 was changed from 6μf to 2μf.

C-3 was changed from .03μf to .016μf (.001 in parallel with .015μf).

Also, a 470pf capacitor was connected across R-9.

This modification changed the frequency bands to:

50-200Hz, 200-3200Hz, 3200-7500Hz.

The unit had a roll off above 7500Hz.

The next modification occurred in the peak limiter card. The unit has 4 1n914 diodes connected as a soft clipper. My experience has been that a hard clipper is more desirable than a soft one because you do not need nearly as much hard clipping as soft for the same amount of peak control.

The clipper card was modified as follows:

This converts the clipper from a soft to a hard clipper.

If this modification is done, however, the output transformer in the unit must be changed, because the one that comes in it produces a lot of ringing and overshoot. I replaced it with a UTC A-21 wired 50:500Ω, with the 50Ω side going to C-10 in the output circuit. This also gives the unit about 6dB more output.

These modifications produced a noticeable improvement in both loudness and quality when the unit was used with our Gates BC5-P2 transmitter. With a newer transmitter the results should be even more dramatic.

Dana Puopolo
Chief engineer
WCKW/AM-FM*
Providence, RI

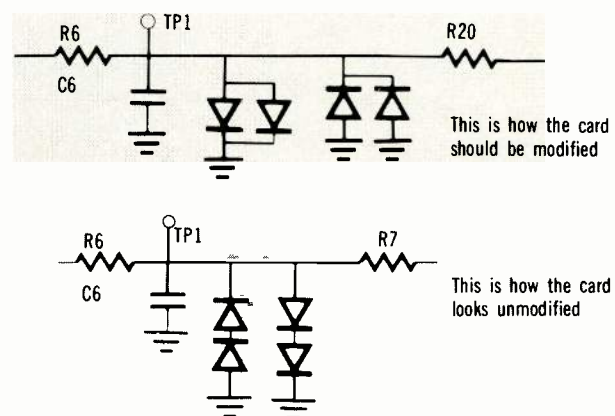

*The work reported here was carried out by the author when he was chief engineer at WGSM-AM/WCTO-FM, Long Island, NY. He is now with WLKWL, Providence, RI.

VICTOR DUNCAN VIDEO

For more than 20 years, the Victor Duncan 'check and double check' symbol has assured producers that the equipment they needed was as clean and mechanically perfect as skilled technicians could make it. Every camera package, each light, even the smallest piece of production gear has been carefully *checked*, not once — but twice; before it ever leaves our office.

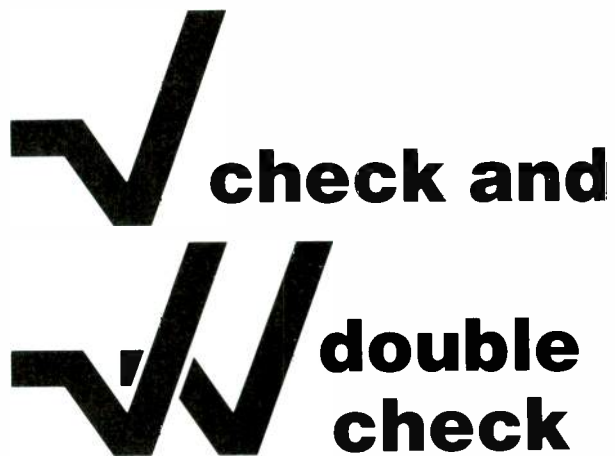

The Standard for Electronic Production Equipment



This attention to detail begins with a comprehensive physical inspection. Each mechanical function of our video cameras is carefully checked. Housing screws are tightened, lens functions are

verified. The camera is mechanically and electrically registered. The white and black balance is adjusted. Colorimetry is *double checked*. The signal to noise level is carefully monitored.

Each Video recorder is also subjected to the same physical inspections, including the signal to noise levels. The interchange of tapes from deck to deck is carefully checked.

And then a second *check* is made of the complete system as a unit; camera, recorder, switchers and accessories. These same careful steps are used on each piece of equipment ordered. Switchers, monitors, CCU's, all are put through the same detailed electronic tests before they ever leave our department.

These *double check* procedures insure flawless performance in the field, and guard against costly production tie-ups. "Check and double check" at Victor Duncan Video.

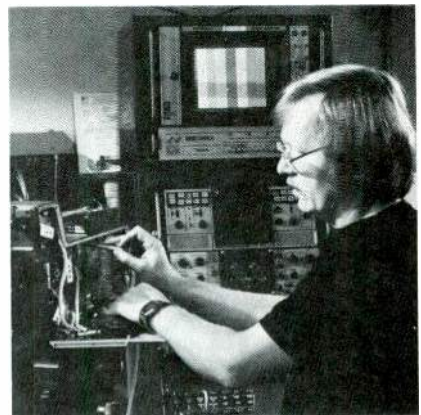

Rentals, Sales & Service



© Copyright 1980, Victor Duncan, Inc.

Film & Video Production Equipment

CHICAGO

661 N. LaSalle, Chicago, IL 60610 (312) 943-7300

DALLAS

2659 Fondren, Dallas, TX 75206 (214) 369-1165

DETROIT

3238C Howard, Madison Hgts., MI 48071 (313) 589-1900

Circle (252) on Reply Card

Station-to-station

Turtable/audio console coupling circuit

The Ward-Beck consoles used by KZEW-FM have separate channel ON and channel OFF buttons. The same buttons have contacts for machine control. The Technics SP10 MKII turntables require only a single external contact for remote control of the start-stop function. The illustrated circuit was designed to overcome the problem.

The parts are mounted on a small piece of circuit board and are included inside the turntable. Three leads, common, plus 5V and 32V are connected to the large circuit board visible on the underside of the turntable. The connecting points are labeled 0V, 5V and d10. 32V is present on d10 only when the turntable is running. The output is connected to the same point provided for normal remote control. Connection to the console is to two form A contacts on the channel on and off buttons.

In operation, only one of the two

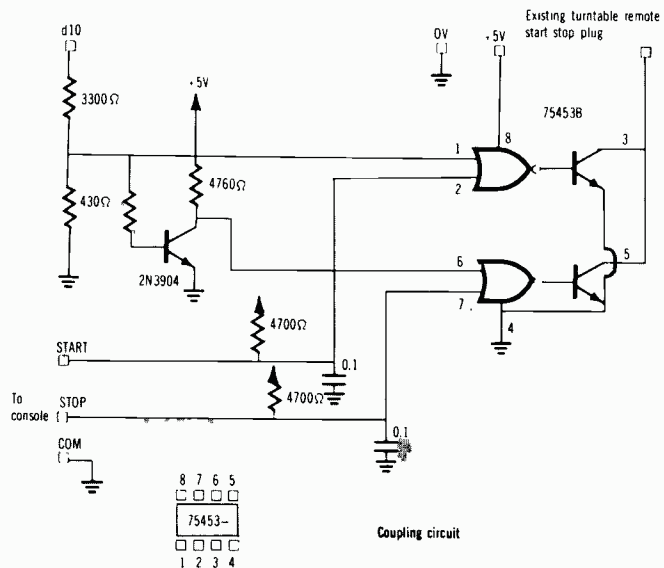

gates shown is armed at any time. If the channel ON button is operated, the turntable will always start. If the turntable is running only the stop button is active. The channel on and off buttons can never get out of sync with the turntable. The

start-stop button on the turntable can still be used for cueing.

Donald F. Easterwood
assistant chief engineer
WFAA-TV
Dallas, TX

Modification to the sequence stepper for the TCR-100

Some time ago RCA came out with an idea to use the front panel light switch as a sequence stepper. We installed it in our machines and it proved to be very useful.

However, when a sequence is changed with the stepper, the operator has to remember to dial the number of carts to be played plus the number that had previously played in the new sequence because the tape counter had not been reset.

By simply adding a diode, the tape counter is reset whenever the switch is activated in machines with

the switch already installed. A wire to the switch and a diode is all that is needed for the complete installation of a sequence stepper. If a switch is installed, be sure to use a bounceless momentary type.

Jack Found
senior maintenance technician
WSB-TV, Atlanta, GA

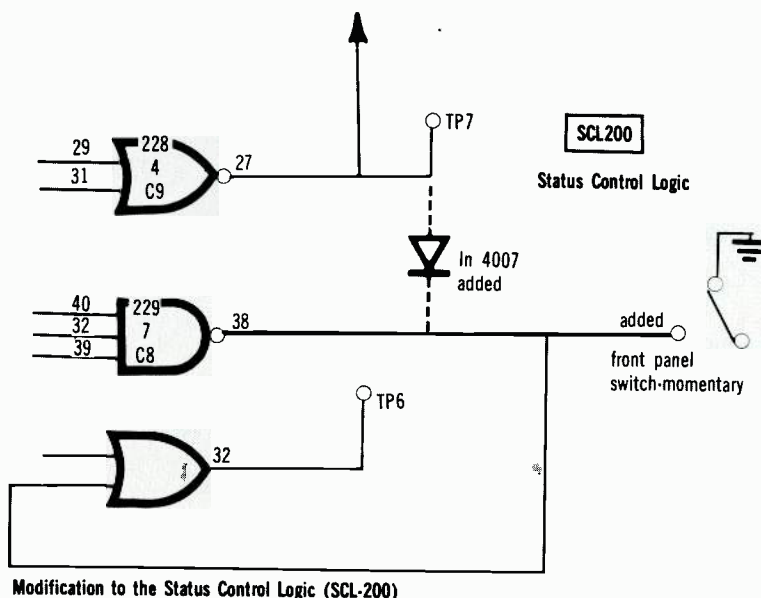

Modification to the Status Control Logic (SCL-200)

Station-to-station correction

The November 1980 issue included a Station-to-Station article on modifying a telecaption decoder. The author implied that there is no method available for monitoring the captioning information. This is not true.

EEG manufactures a video to video decoder that does just that job and many stations have them. Although it costs more than the Sears telecaption decoder, it offers the professional a broadcast quality decoder with loop through input and four monitor decoded outputs.

Furthermore, EEG manufactures the encoders used by the networks and others to insert captions and text into line 21. Each of our encoders includes a built-in video decoder.

William Posner
vice president
EEG Enterprises



CREATIVE TECHNOLOGY ON CMX

Roger Berk, Jr.
President, Creative Technology, Inc.
Vice President, Group One Broadcasting, Inc.
Akron Ohio

"We Designed Our System Around The 340X"

"When we at WAKR in Akron made plans to establish a separate production facility, our goal was to build an organization that was committed to excellence. Our proximity to Cleveland, Detroit, Pittsburgh, and the other large cities of the Midwest made our market area large and competitive. We decided to meet this challenge by offering a facility that not only provided a competent and creative staff but the very finest in technical equipment. We designed our system around the 340X.

"It is clearly the finest computer-assisted editor in the world today. And its versatile architecture assures its place as the leader in future

generations of equipment. With CMX's versatility we have interfaced everything from our computer-assisted production switcher, to our one-inch recorders, computer-assisted audio mixdown system, our multi-channel Squeezezoom," and our computer-based animation and character generation system.

"This high level of interface, with the CMX 'talking' to the other computers in our control room allows us, with a minimum of multi-generational iterations, to perform dazzlingly complex effects involving up to nine levels of video and up to 18 tracks of audio on each frame-accurate edit.

"Here at Creative Technology, we're

saving time and money with our CMX; but of greater importance it allows us to produce more original and interesting material at a lower cost per spot than could be achieved using conventional techniques. Further, CMX always has one eye on the future, as the system is evolving and improving constantly. We've regularly added the latest software options as they have become available.

"The 340X is a many-faceted and unparalleled tool. It allows creativity to displace technical drudgery in high quality production. We can't wait to get our next one!"

TM—Vital Industries



CMX ORROX

The World Standard for Editing

Orrox Corporation, 3303 Scott Blvd., Santa Clara, CA 95050 (408) 988-2000 Telex 910-338-0554
Los Angeles (213) 980-7927 / New York (212) 371-1122

Circle (256) on Reply Card

March 1981 *Broadcast Engineering* 269

We have the best

10 WATT FM TRANSMITTERS*
100 WATT FM TRANSMITTERS*
250 WATT FM TRANSMITTERS*
500 WATT FM TRANSMITTERS
1 KW FM TRANSMITTERS
1.5 KW FM TRANSMITTERS
2.5 KW FM TRANSMITTERS
5 KW FM TRANSMITTERS
7.5 KW FM TRANSMITTERS
10 KW FM TRANSMITTERS
20 KW FM TRANSMITTERS
25 KW FM TRANSMITTERS
30 KW FM TRANSMITTERS
FM LINK TRANSMITTERS*
FM RELAY RECEIVERS*
STEREO & SCA GENERATORS

250 WATT AM TRANSMITTERS*
1 KW AM TRANSMITTERS
2.5 KW AM TRANSMITTERS
5 KW AM TRANSMITTERS
10 KW AM TRANSMITTERS
20 KW AM TRANSMITTERS
25 KW AM TRANSMITTERS
50 KW AM TRANSMITTERS

MONAURAL AUDIO CONSOLES*
STEREO CONSOLES*

LIMITING AMPLIFIERS*
AGC AMPLIFIERS*
MONITORING AMPLIFIERS*

LIGHTNING PROTECTORS*
SILICON RECTIFIER STACKS*

AIR COOLED DUMMY LOADS
15-25-50-80-KW-AM TO UHF

*All Solid State

SEE US AT NAB BOOTH NO. 302

Call our NEW toll free number 1-800-345-8277

WILKINSON
ELECTRONICS, INC.

BOX 738 TRAINER, PA. 19013 TELEPHONE (215)497-5100

Circle (257) on Reply Card

new literature

Digital video

SMPTE—A new book, *Digital Video—Volume 3*, has been published by the Society of Motion Picture and Television Engineers. The book has more than 230 pages. The price is \$20, less 20% discount to SMPTE members. The new book contains 24 papers that had been presented at the SMPTE Television Conference held in February 1980 in Toronto. The book also contains a transcript of *Digital 1980—SMPTE Workshop* that had been presented at the 1980 NAB Convention in Las Vegas. Also included, through the courtesy of the IEEE, is a glossary of the latest digital video terms expected to be adopted as an IEEE Standard.

Circle (821) on Reply Card

PCM brochure

Studer Revox—An illustrated 28-page brochure on PCM recording is being made available to qualified audio professionals. The booklet presents both an overview of the digital recording process and also discusses stage-by-stage operations and the areas in which standards must be set if digital audio is to achieve its greatest usefulness.

A copy of the Studer PCM brochure may be obtained by addressing a request, on business letterhead, to: Studer Revox America, Inc., 1425 Elm Hill Pike, Nashville, TN 37210.

Circle (822) on Reply Card

Digital delay application note

URSA-Major—An application note, AN-1, by Christopher Moore, briefly covers reverberation processes and psychoacoustic phenomena, and describes in detail the proprietary multi-tap digital delay technique developed by URSA Major to synthesize high quality stereo reverberation from mono/stereo sources.

Circle (823) on Reply Card

Automation system

Harris—The "Autotron Star System" brochure is a 24-page booklet that describes Harris' new business automation systems capabilities.

Circle (824) on Reply Card

CRT terminal

Ann Arbor Terminals—A four-page flyer is available detailing the functions and capabilities of the Ann Arbor Ambassador CRT terminal. The terminal implements the ANSI X3.64-1979 standard, including the full complement of editing, erasure, formatting and transmission commands and parameters.

Circle (825) on Reply Card

Catalog

dbx—A disc catalog featuring revolutionary digital dbx discs is available.

Circle (826) on Reply Card

Dictionary

VNR—"Fiber Optics and Lightwave Communications Standard Dictionary" is a collection of terms and definitions relevant to fiber optics and lightwave communications. All entries have been written in accordance with the latest approved standards of federal, national, international, military and technical societies.

Dr. Martin H. Weik, author, is a top authority on technical vocabularies, resulting from his 30 years of experience with computers and communications, including the design, development and evaluation of automatic data processing systems.

Circle (827) on Reply Card

Fall catalog

Global Specialties Corporation—The publication features the company's full line of benchtop instrumentation, frequency counters, logic probes and solderless breadboards. Full product descriptions and instrument specifications are included.

Circle (828) on Reply Card

Application guide for test instruments

Visual Information Institute—A comprehensive guide for the application of television test instruments to various TV systems is available. Topics covered include standards and common practice, selection of scan rates, specification of resolution and other technical notes.

Circle (829) on Reply Card

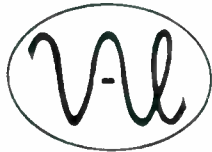

APPLE II™ GRAPHICS can now join your production team. Video Associates Labs is proud to announce the VB-1. The VB-1's primary purpose is to make the Apple II capable of producing **BROADCAST QUALITY N.T.S.C. VIDEO.** The VB-1 also incorporates many production features that will complement the Apple II's basic graphics ability. Some of the features are: *keyer, horizontal offsets, color framer, preview mode, chroma on/off, 360° hue control.* The VB-1 requires no physical modification to the Apple II, uses standard Apple II software and uses no memory space in the Apple. We will be showing the VB-1 in Booth 1716 at the Las Vegas N.A.B. We look forward to seeing you there.

**Video Associates Labs
2304 Hancock Drive #1-F
Austin, Texas 78756
(512) 459-5684**

Circle (258) on Reply Card

Perfect Timing

MASTER CLOCK SYSTEMS

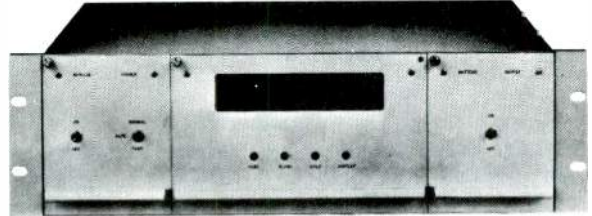

If seeing the same time on all your clocks is important, select **ES 192** - Line Frequency timebase, for only \$312.

If a guaranteed accuracy of three seconds per month is what you want, choose **ES 160**—\$1,005.

How about one second per month? **ES 160/1**—\$1,179.

Or National Bureau of Standards accuracy! **ES 190** is synchronized to Radio Station WWV to provide a Master with unquestioned accuracy. \$1,179 with receiver and antenna.

For a Time/Temperature Master, ask for **ES 196**—\$737.

ESE Master Clock Systems are simple to install. All Masters have a Serial Time Code output, able to drive twenty slave displays without buffering. Slaves range in size from .3" LED to 2" gas discharge displays, priced from \$152 to \$432.

IF YOU ALREADY HAVE A SYSTEM AND WANT TO EXPAND IT, get the **ES 167** Serial Time Code Generator (\$141), then add any number of our low cost slaves.

Many, many options and accessories are available. Ask us about them. Our brochure tells the whole story, but not for long. We keep adding new products.



Write, Wire or Call: (213) 322-2136
142 SIERRA STREET • EL SEGUNDO, CALIFORNIA 90245

Circle (259) on Reply Card

New literature

General line instrument catalog

B & K-Precision—The new 44-page BK-81 general line test instrument catalog is available free. It features more than 50 high quality test instruments, including oscilloscopes, frequency counters, digital and analog multimeters, function and RF signal generators, capacitance meters, digital and pulser probes, semiconductor testers, power supplies, and two-way radio and television test instruments.

Circle (830) on Reply Card

Handbook

Plessey Semiconductors—A 60-page handbook on its Metal-Nitrite-Oxide-Silicon (MOS) integrated circuits, along with representative applications of nonvolatile logic is available free. Chapters cover power on/power off circuits, elapsed time indicators, last program memories, counters and general technical data.

Circle (831) on Reply Card

L-C filters catalog

Allen Avionics—Catalog 17F presents the company's line of custom-built L-C filters in frequencies from 20Hz to 400MHz. Also covered is the new VCL Series of Delay Equalized NTSC Lowpass Filters for the video industry.

Circle (832) on Reply Card

1981 Radio Shack catalog

Radio Shack—A 176-page 1981 catalog is available free on request from more than 6000 participating stores and dealers nationwide. The catalog has 120 full-color pages.

Circle (833) on Reply Card

Electronics catalog

Heathkit—A free, 104-page catalog is available that features nearly 400 build-it-yourself kits in amateur radio, microcomputers, test equipment, audio, automotive and television. New kits include power supplies, frequency counters, digital depth sounders, weather instruments and audio components.

Circle (834) on Reply Card

Earth station equipment

LNR—A newly revised and expanded brochure describing LNR's full line of satellite earth station equipment is available. This 24-page brochure includes specifications, photos and diagrams for the complete series of earth station equipment for C-band, X-band, the new Ku-band and other frequency band assignments.

Circle (835) on Reply Card

Audio cabling systems configuration guide

Wireworks—A poster sized configuration guide is available. Suitable for wall display, the 24-inch by 36-inch piece features diagrams of several diverse systems—all using standard products from Wireworks microphone multicable components group.

Circle (836) on Reply Card

Noise suppression reference manual

Topaz Electronics Division—The ac line noise suppression reference manual is a basic text on the protection of sensitive electronic equipment from the problems created by ac line noise, transients and spikes. The manual covers the basics of ac line noise suppression, provides technical data and includes many typical applications.

Circle (837) on Reply Card

TWT instrumentation amplifiers

MCL/INC—This four-page brochure covers the company's line of TWT amplifiers designed for testing, calibration and signal amplification. Features and performance characteristics are shown for two series.

Circle (838) on Reply Card

Stylebook

3M—Letter(s) Perfect, a stylebook for people who create titles for television, is available free. The 43-page book is a guide for use of television character generators. It deals with basic considerations, vantage points, elements of style and special problems. In covering each subject, it synthesizes the needs of viewers, operators, announcers, directors, producers and reporters and contains handy references, such as a list of commonly misspelled words.

Circle (839) on Reply Card

Brochure

Westinghouse Electric—A new line of high-power air and liquid cooled disc assemblies is the subject of a 40-page brochure. The line was developed for large motor drives, welding equipment and pulsed power supplies.

Circle (840) on Reply Card

Engineering bulletin

Gulton Industries—Described in this six-page engineering bulletin is the new SM20100 20-column print head that offers printing rates up to 1600 text lines per minute. The bulletin includes features, general description, functional operation discussion, performance characteristics, functional diagram, mechanical outline drawing, heatsink information and various charts and curves.

Circle (841) on Reply Card

Protection components

MCG—An eight-page brochure describes over-voltage protection components for ac and dc circuits. Detailed information is provided on ac and dc transient suppressors, dc crowbars and clamping crowbars. In addition to giving full specifications, the brochure also provides steps for protecting ac and dc lines and answers commonly asked questions about the use and application of protection components.

Circle (842) on Reply Card

Analog MOS IC's book

Institute of Electrical and Electronics Engineers—The publication of "Analog MOS Integrated Circuits, a Book of Selected Reprints," has been announced by the IEEE Press. This volume, sponsored by the IEEE Solid-State Circuits Council, was edited by Paul R. Gray, David A. Hodges and Robert W. Brodersen of the University of California, Berkeley.

Circle (843) on Reply Card

associations

ASTVC

The June 1979 ASTVC column mentioned the Yemen Broadcasting Service's plan to send two students to the United States to take part in a training session with the ASTVC. After months of communications with the prospective participants, circumstances have forced this training program to be canceled.

The 1980 IEEE Broadcast Symposium

The 1980 IEEE Broadcast Symposium was held at the Washington Hotel in Washington, DC, September 18-19, 1980. As is normally the case at this meeting, papers were presented on a wide range of subjects. These subjects ranged from the current status of teletext development in the United States to the use of microcomputers in videotape recorders and measurement of the effects of television multiple ghost images.

Perhaps the most interest was generated by two papers concerning UHF transmitters. The first of these papers was a report by John Wilner titled "Improvements in UHF Transmitter Efficiency." Wilner reported on a lengthy study of existing and proposed television transmitter systems and how the efficiency of these systems was improved.

SMPTÉ

During October 1980, the Working Group on Digital Control Interface under the SMPTE banner finished a successful field test of the proposed SMPTE standard for control of television studio equipment, it has been announced by Roland J. Zavada, Eastman Kodak Co., SMPTE engineering vice president.

A progress report prepared by G. Little, Ampex, was presented at the 122nd SMPTE Technical Conference in New York City in November. The documents involved a proposed ANSI standard and two SMPTE recommended practices, which are well along in their preparation. This control technique is expected to have a broad application in television, film and audio. All interested parties should contact the chairman, R. McAll, Vital Industries, through SMPTE Headquarters, 862 Scarsdale Ave., Scarsdale, NY 10583.

26th Broadcasters clinic at University of Wisconsin

As in past years, the Madison Broadcasters Clinic was well attended. The first day was primarily

involved with radio broadcast problems. Papers were presented on AM Antenna Systems, Diplexing FM Antennas, SCA Systems and FM Proof Measurements. In addition, Bill Hassinger and George Sklom of the FCC addressed the group concerning regulatory matters. The luncheon speaker, Sherwin Ashrow, discussed structural problems associated with antenna construction.

On the second day, the meeting started with a panel discussion including Hassinger and Sklom and industry consultants: John Battison, Ralph Evans, Wallace Johnson, Jim

Lupus and Don Markley. Following the panel discussion, the meeting divided into separate sessions for radio and television. The luncheon speaker, Wallace Johnson of the Association for Broadcast Engineering Standards, discussed rule changes of concern to both radio and television broadcasters. The afternoon session was primarily concerned with television, including two papers concerning recording systems and problems, a paper on microwave systems and a paper on the structure of the color fields of NTSC Television Systems. □

lighting and control Systems Colortran

Our Systems
Experience Cannot
Be Overlooked



If you need a production lighting system we have the systems experience to do the job. We'll help you plan your requirements and supply lights, distribution & control in a turn key installation — within your budget. We did it for NASA — we can do it for you.

Mail this coupon to:

... Please send me a systems literature package

**Berkey
Colortran**

1015 Chestnut St.
Burbank, CA. 91502

P.O. Box 5, Burrell Way
Thetford, Norfolk
IP24 3RB, U.K.



name _____

position _____

organization _____

address _____

city _____

state _____

**PAY WHOLESALE
PRICES**
for your
**TUBES &
SEMI-CONDUCTORS**
ONE STOP

for all your
Broadcast Needs

CeCo is the Largest and
Longest Established Franchise
Distributor of All Tubes, Semi-
conductors and Related
Broadcast Equipment

WE OFFER:

- **LOWEST
PRICES
AVAILABLE—
We Won't Be
Undersold!!**
- **Largest Stocking
Inventory—All
Brands—
Any Type**
- **24 Hour Usual
Shipping Service**
- **24 Hour
Emergency
Phone Service**



Call Toll Free On Your Requirements

800-221-0860

212-646-6300

Write For Free Catalog



See Us at
**NAB/Las Vegas
Booth No. 1014**

COMMUNICATIONS, Inc.
2115 AVENUE X
BROOKLYN, N.Y. 11235

Circle (267) on Reply Card

Digivision[®]

**MONITOR PROMPTING
SYSTEM**

from
the people
who bring you
**VINTEN mounting
and support systems.**

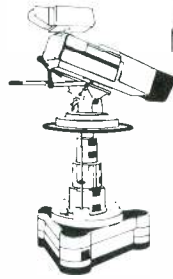
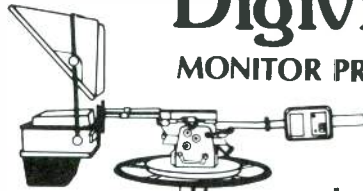

Fulmar

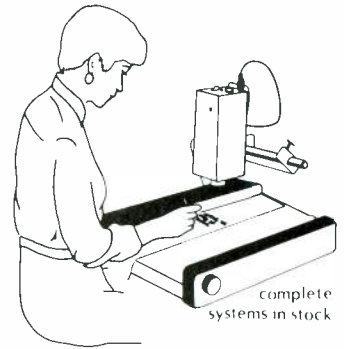

complete
systems in stock



LISTEC TELEVISION EQUIPMENT CORP.

39 Cain Drive, Plainview, New York 11803 / (516) 694-8963 / Telex 64 0470
4529 San Fernando Road, Unit "A", Glendale, California 91204 / (213) 247-9247

SEE US AT NAB - BOOTH NO. 1027

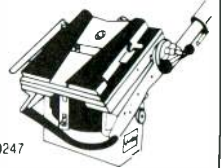

Mark VII

Circle (266) on Reply Card

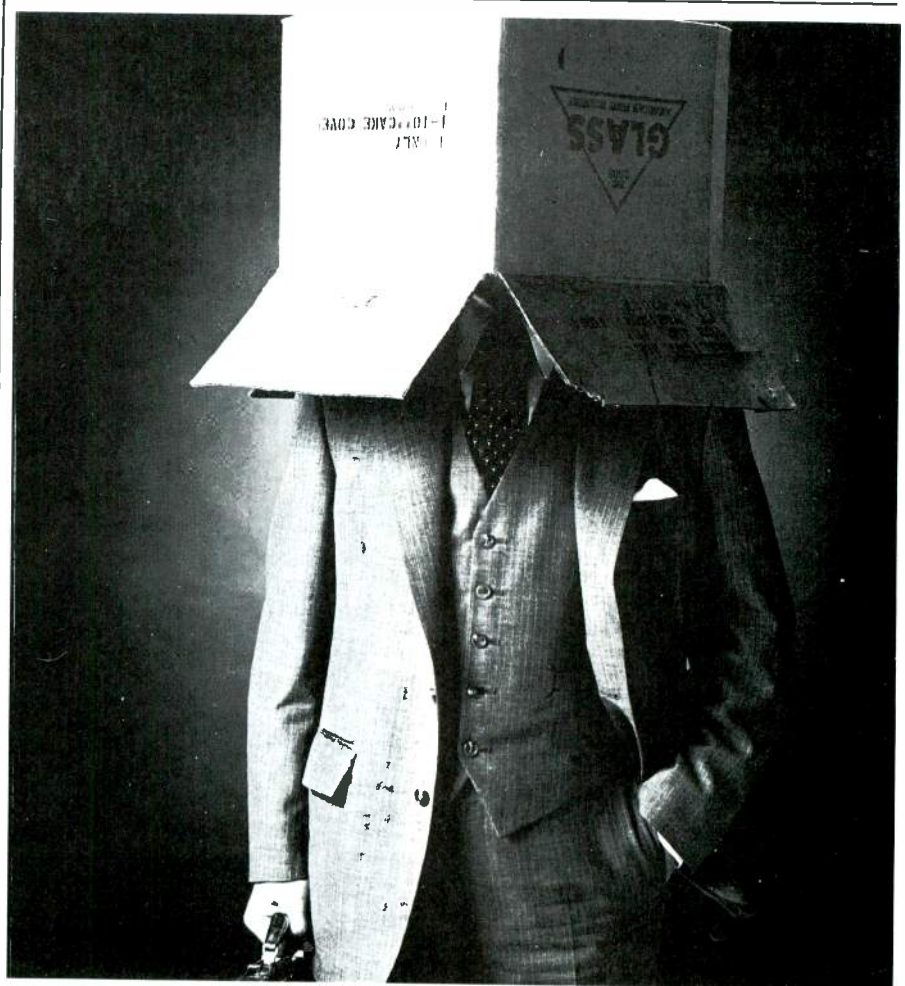

**WHAT THE
WELL STRESSED MAN
IS WEARING THESE DAYS.**

Ah, we're a funny breed, we humans. Seems like we've got this crazy notion that the best way to deal with a problem—at home or on the job—is to shut-up, clam-up, back-off, or hide-out.

Instead of talking our problems over, we think it's better to shut the whole world out, to "keep things to ourselves."

But that just causes a lot of unnecessary stress... and makes the problem a lot worse.

This isn't a lecture, or a sermon. It's just a simple reminder: let's keep our options open by keeping our mouths—and our ears—open. Because, when we shut others out, we only box ourselves in.

And that's a *real* problem.



**WHEN YOU SHUT OTHERS OUT,
YOU ONLY BOX YOURSELF IN.**



BROADCAST
ENGINEERING

**Is the #1 Broadcast Technology
Magazine in North America.**

#1 in Circulation

#1 in Advertisers

#1 in Exclusive Advertisers

#1 in Inquiries

And soon to be #1 in CHINA.

广播工程

Broadcast Engineering's new Chinese language edition

professional services

VIR JAMES P.C.
CONSULTING RADIO ENGINEERS
Applications and Field Engineering
Computerized Frequency Surveys
4940 E. 39th Ave.
Phone: (Area Code 303) 393-0468
DENVER, COLORADO 80207
Member AFCCE & NAB

STEIGER, HURRAY & ASSOCIATES INC.
Broadcast Technical Consultants
**ANTENNA SYSTEM
SPECIALISTS**
6816 Westview Drive
Cleveland, OH 44141
(216) 526-7187

RALPH E. EVANS ASSOCIATES
CONSULTING COMMUNICATIONS ENGINEERS
216 N. Green Bay Road
Suite 208
Thiensville, WI 53002
Phone: (414) 242-6000 Member AFCCE

R.L. HOOVER
**11704 Seven Locks Road
Potomac, Maryland 20854
301-983-0054**
Member AFCCE
Consulting Telecommunications Engineer

MIDWEST ENGINEERING ASSOCIATES
Consulting Engineers
6934 A N. UNIVERSITY
PEORIA, ILLINOIS 61614
(309) 692-4233
Member AFCCE

Radiotechniques

STATION DESIGN & CONSTRUCTION
TECHNICAL SERVICE • APPRAISALS
EQUIPMENT DESIGN & MANUFACTURING
402 Tenth Avenue, Haddon Heights, NJ 08035
(609) 546-1841

SMITH and POWSTENKO
Broadcasting and Telecommunications
Consultants
2000 N. Street, N.W.
Washington, D. C. 20036
(202) 293-7742

G.A. GILBREATH ASSOCIATES
INCORPORATED
AUDIO/VIDEO BROADCAST
CONSULTANTS
6357 LAWTON AVENUE
LAS VEGAS, NV 89107
(702) 878-8313

FRANK S. COLLIGAN
Telecommunications Consultant
Field technical services: A.M. directionals, feed systems, custom components, instrumentation, reradiation, transmitters.
5111 WESTPATH COURT
WASHINGTON, DC. 20016
(301) 229-5577

Wm. H. LaDew, Inc. Fire Protection Specialists welcomes consultations and inquiries during the NAB Convention. Please ask for T. H. Hoke or John Duke at the Sahara Hotel, April 12-15, Las Vegas, Nevada. "Specialists in Protection of Broadcast Facilities and Transmitters."

**D. L. MARKLEY
& Associates, Inc.**
CONSULTING ENGINEERS
206 North Bergan
Peoria, Illinois 61604
(309) 673-7511
Member AFCCE

dataworld inc
AM • FM • TV
Translators/Low-Power TV
Directories
Allocation Studies/Antenna Design
1302 18th St., N.W., Suite 502
Washington, D.C. 20036
(202) 296-4790

CHARLES F. KOCHER, P.E.
Consulting Radio and TV Engineer
Allocation Engineering
Antenna Systems
27235 Berkshire Drive
Southfield, Michigan 48076
(313) 357-2394
Member AFCCE

MOVING?

Please complete the change of address information on the subscription form.

To ensure uninterrupted delivery to new address, answer all questions on the form completely.

BROADCAST
engineering

BROADCAST

engineering

Advertising Sales Offices

NEW YORK, NEW YORK
Joe Concert, Tom Palmisano,
4 West 58th St.,
New York, NY 10019
Phone: (212) 888-1977

KANSAS CITY, MISSOURI
Jan Winters,
P.O. Box 12901,
Overland Park, KS 66212
Phone: (913) 888-4664

LOS ANGELES, CALIFORNIA
Herb Schiff,
3055 Wilshire Blvd., Suite 630
Los Angeles, CA 90010
Phone: (213) 387-0639

LONDON, ENGLAND
John Ashcraft & Co., John Ashcraft,
12 Bear St.
Leicester Square, London, WC2H 7AS
England
Phone: 930-0525
Telex: 895-2387

AMSTERDAM, HOLLAND
John Ashcraft & Co., John J. Lucassen,
Akerdijk 150A, 1171 PV-Badhoevedorp,
Holland
Phone: 0-2968-6226
Telex: 11640

TOKYO, JAPAN
International Media Representatives, Ltd.
2-29, Toranomon 1-chome, Minato-ku
Tokyo 105, Japan
Phone: 502-0656

NORWOOD, AUSTRALIA
Williamson & Associates, John Williamson,
No. 2 Edmund St., Norwood, S.A. 5067
Australia
Phone: 42-7074

**Even
employees
who have been
with you
for years
can still
learn
something
new.**

Tell them about Direct Deposit. Their Social Security or other Government checks go straight to wherever they have a checking or savings account. It's never too late to make life easier for yourself. And to know your money's safe and sound.

DIRECT DEPOSIT

classified

Advertising rates in Classified Section are 50 cents per word, each insertion, and must be accompanied by cash to insure publication.

Each initial or abbreviation counts a full word. Minimum classified charge, \$4.00.

For ads on which replies are sent to us for forwarding (blind ads), there is an additional charge of \$5.00 per insertion, to cover department number, processing of replies, and mailing costs.

Classified columns are not open to advertising of any products regularly produced by manufacturers unless used and no longer owned by the manufacturer or a distributor.

Kathi Gravenstein,
Classified Production Manager.

TRAINING

ELECTRONICS DEGREE by correspondence. Earn A.S.E.T., then B.S.E.T. Free brochure. Grantham College, 2550 South La Cienega, Los Angeles, California 90034. 2-79-tfn

FIRST PHONE through cassette recorded lessons at home plus one week seminar in Boston, Philadelphia, Detroit, Atlanta or Seattle. Our twentieth year teaching FCC license courses. Bob Johnson Radio License Preparation, 1201 Ninth, Manhattan Beach, Calif. 90266. Telephone 213-379-4461. 8-78-1f

SERVICES

ONE STOP FOR ALL YOUR PROFESSIONAL AUDIO REQUIREMENTS. Bottom line oriented. F.T.C. Brewer Company, P.O. Box 8057, Pensacola, Florida 32505. 7-71-tf

HELIX-STYROFLEX. Large stock—bargain prices—tested and certified. Write for price and stock lists. Sierra Western Electric, Box 23872, Oakland, Calif. 94623. Telephone (415) 632-3527. 1-73-tf

TRANSMITTER TUBES REPROCESSED—Save 40 to 50%. 3CX2500, 4CX5000, 4CX15000 and many others. Write for details. FREELAND PRODUCTS CO., 3233 Conti St., N.O., La. 70119, (504) 822-9222. 6-79-tfn

BROADCAST CRYSTALS for AM, FM or TV transmitters, frequency change, repair or replacement of oven types. Also vacuum types for RCA, Gates, Collins etc. transmitters. Quality products, reasonable prices and better delivery! Don't be without a spare crystal. Frequency change and service for AM and FM monitors. Over 30 years in the business. Eidson Electronic Co., Box 96, Temple, Texas 76501. Phone (817) 773-3901. 7-80-tf

CARTRIDGE RELOADING. Factory authorized rebuild service on Aristocart, Capitol/Audiopak A-2, AA-3, Fidelipac Cartridges. Fast turn around. Broadcast Cartridge Service, 15131 Triton Lane, #108, Huntington Beach, CA 92649, (800) 854-6419 or (714) 898-7224. 1-81-3t

¾" VIDEO RECORDING, editing and dubbing services southeastern Virginia. Video Concepts, P.O. Box 13035, Chesapeake, VA 23325, (804) 424-1855 (5 PM - 9 PM). 3-81-1t

**Have your
blood pressure checked.**

Give Heart Fund
American Heart Association

FOR SALE

video T-SHIRTS

VIDEO PEOPLE DO IT IN SYNC

ENG

AARLO ENTERPRISES 109 MINNA ST. SUITE 254 SAN FRANCISCO, CA. 94105

AARLO T-Shirts are the only shirts specifically designed for video people. preshrunk! Our 5 designs are "GLITCH", "DEGAUSS", "RESOLUTION", "ENG" & "VIDEO PEOPLE DO IT IN SYNC".
SEND \$8.50ea. + \$2.00 Handling Ca. Res. ADD 6% TAX.
SPECIFY SIZE: LG, XLG, MED, SM.

EQUIPMENT FOR SALE

40 FOOT TV/WIDEOTAPING production truck. Late network & maintenance equipment. (213) 397-5922. 3/81/1t

FOR SALE, NORELCO PC-70, studio camera (never on mobile), \$12,500.00, financing available to qualified principals. North American Video, (212) 369-2552. 1-81-3t

RCA TK-76 camera w/lens, \$24,000.00. Offer (415) 676-7260. 2-81-2t

COMPLETE ONE-INCH color-framed editing system. 3 NEC TT-3000 VTR's, 3 NEC NTC-5000 TBC's. Tempo 7630 editor, 3 readers. Excellent condition, top quality, \$85,000, (803) 242-5100, ext. 5375. 2-81-2t

GE-240 TELECINE CAMERA: Like new condition and picture quality. CBS 8400 enhancer, spare encoder, Eastman 250 projectors. Telement color bar generator. A steal at \$7,000.00. CMX-50 EDITING SYSTEM: Excellent off-line system. Includes TTY, 999 events of memory, three Sony VO-2860 machines, computer keyboard, interfaces. \$20,000.00. CMX-300 EDITING SYSTEM: Interfaces for AVR-1 (two), VR-2000, HS-100, MM-1100 (which has adapter box for AVR-2 or BVH-1000). GVG-1400 switcher, TTY, computer, plus all original equipment. \$10,000.00. Wayne Caluger, WSM, Box 100, Nashville, TN. 37202, (615) 749-2225. 2-81-2t

2 RCA TK-42 color cameras/hydraulic pedestals, 1 RCA TK-43 camera with Veratel lenses. Telemet chroma key. Plus friction heads, connectors, etc. Excellent condition. Package \$15,000. Contact Norma Champion, Evangel College, Springfield, Missouri (417) 865-2811, or Dan White, KYTV, Springfield, Missouri, (417) 866-2766. 2-81-3t

FILM EQUIPMENT: CP cameras; viewers; timers; splicers; sound readers; rewind arms; Jamieson compact color processor less than two years old; other assorted items. For complete list or more information contact M. C. Smith, WAAV-TV, 1000 Monte Sano Boulevard, Huntsville, AL 35801; (205) 539-1783. 2-81-2t

REMOTE CONTROL: Complete Harris 9100, facilities control system. Like new (4 mo. old). WXVT-TV., (601) 334-1500. 3-81-1t

DODGE MAXI with 18" extended roof. Air & gas heat. Dual battery system. Audio, video, P.L. systems on board finished interior heavy duty suspension, call 201-791-6037. 3-81-1t

2 PC-72 COLOR CAMERAS, Angenieux 10:1 Manual Zooms, Houston Fearless Heads and Pedestals, OCCU Racks included. 3-50' cables, 2-100' cables. Never been out of studio - \$15,000 each. Emmons Associates, Inc., Minneapolis (612) 890-8920. 3-81-1t

GLITCH AWARD! Give this humorous, framable award to fellow video workers for errors, production goofs, missed shots, etc. \$2.95 + 1.00 handling. Also, funny Color Camera Registration Charts. Specify: FUZZY or CURVED lines. \$2.00+ 1.00 handling. Send check to AARLO Enterprises, 109 Minna St., Suite 254, San Francisco, CA 94105. 3-81-4t

CHYRON III, 8K, titling system. Single disc drive. Ten discs, 18 different font style capability (colorizer Keyer available). Font compose system for Chyron III. Keyboard, power supply, disc drive, camera & Esil. Complete unit. Combined offer only. Price \$21,500. Television Graphics, (201) 444-2911. 3-81-1t

EQUIPMENT FOR SALE (CONT.)

SYSTEM ASSOCIATES

5801 Uplander Way • Culver City, California 90230

USED BROADCAST TELEVISION EQUIPMENT WANTED AND FOR SALE

If you are not receiving our free flyer of equipment listings, please call or write to be added to our mailing list.

(213) 641-2042

FOR SALE: 1 PYE Audio board, 12 in balanced, 4 out, full equalization, patch bay included—\$2,500, 1 Grass Valley Switcher 1400 complete with two ISO banks—\$7,000, 2 Ampex 1200's (1 with editor, 1 with D.O.C.) \$25,000 each, 2 DMI slow motion machines \$1,200 each or both \$2,000. FOR MORE INFORMATION CALL VIDEO TAPE ENTERPRISES, HOLLYWOOD, CALIFORNIA 213-659-4801. 3-81-1t

HELP WANTED

ENGINEERING AND TECHNICAL SALES POSITIONS

We specialize in the placement of Technical Engineers with Television Stations, Cable TV, Satellite Programmers & Networks, Pay TV, Manufacturers, Industrial TV, CCTV, Production Houses & Dealers. Also, technical sales with Manufacturers & Dealers. All levels, positions & locations nationwide. Employers pay all fees - confidential, professional. Over \$3,000,000.00 in Salaried Positions Placed. Employee & Employer inquiries invited.

PHONE: RESUME - Alan Kornish (717)287-9635

KEY SYSTEMS

106 new bridge center, Kingston, pa. 18704

CHIEF ENGINEER—Building a brand new AM, 1000 WD. New building, new equipment. Must have experience with directional, 1st class phone required. If you really are proud of your competence, get in touch. All replies held in strictest confidence. An equal opportunity employer. Send resumes to Nancy McMahon, Erin Broadcasting, P.O. Box 142, Sun Prairie, WI 53590. 3-81-1t

TV STUDIO ENGINEER. Background in maintenance and repair of videotape, film and live TV cameras. Must have FCC first class license. Call Paul Bohrer, WTTV, 317-787-2211. An equal opportunity employer. 3-81-1t

CHIEF ENGINEER—for Manhattan television production company specializing in computer animation. Top salary and benefits for the right person. Need an energetic management level individual capable of maintenance and installation of video/audio equipment and supervising the work of others. The Chief would help design new systems for solving the unique production projects undertaken by this company, would have a minimum of 3 years broadcast maintenance experience and possess a good understanding of analogue and digital circuitry. Great opportunity for someone who wants to be part of a vital, well-established television production company helping make some of the most unique images on television. Please send resume to Bruce Davis, Dolphin Productions, 140 East 80th St., N.Y., N.Y. 10021. 3-81-1t

TV ENGINEERING TECHNICIAN

Office of
Learning Resources

Challenging and diversified position involving the maintenance and operation of University professional television production facilities, audio-visual equipment and other electronic equipment used as aide to learning.

Two years technical school with a minimum of five years hands-on experience. First class FCC radiotelephone license; digital training and experience desirable.

Please send resume to: Cheryl Whitfield, Office of Personnel Services, Northeastern University, 101 Hayden Hall, 360 Huntington Avenue, Boston, MA 02115. An equal opportunity/affirmative action Title IX University.

Northeastern
University

Field Service Engineers

The Grass Valley Group, Inc. a leading manufacturer of television broadcast equipment, is looking for people who want challenging professional positions PLUS the added attraction of working in a small town nestled in the Sierra foothills.

These challenging positions combine chances for U.S. travel plus marketing and engineering career opportunities. Individuals with experience designing and/or maintaining television broadcast systems are required to provide after-sales support for our wide variety of complex systems.

Interested and qualified candidates are invited to send a resume in confidence to Sylvia Smith, The Grass Valley Group, Inc, P.O. Box 1114 Grass Valley, CA 95945. An Equal Opportunity Employer M/F/H.

The Grass Valley Group Inc.

A Tektronix Company

HELP WANTED (CONT.)

R & D ENGINEER

We have a newly created position for a degreed engineer (BEE or MEE) to coordinate product development in the field of solid state electronic lighting control for the performing arts. Background must include an excellent working knowledge of micro- and mini-processing hardware, D/A & A/D conversion, as well as, solid-state high current power control.

The position will be located at our corporate headquarters in Burbank. We offer an excellent compensation and benefits package. Please send your resume with salary history to: SKIRPAN LIGHTING CONTROL CORP., 1100 W. Chestnut Street, Burbank, CA 91506. ATTENTION: Personnel Department.

MAINTENANCE TECHNICIAN—for Manhattan television production company. Innovative production company specializing in computer animation needs maintenance technicians who are good with a soldering iron and basic troubleshooting of analogue and digital circuitry. Experience in the broadcast industry desirable but not necessary. Looking for persons interested in learning on the job and able to be flexible in work schedules. Please send resume to Bruce Davis, Dolphin Productions, 140 East 80th St., N.Y., N.Y. 10021. 3-81-11

ASSISTANT CHIEF ENGINEER—experience with ¾" and 2" VTR's, RCA TT50 Transmitter, microwave and general studio equipment desirable. Good manager plus first class license. Contact Chris Burgbacher, WMBB-TV, Box 1340, Panama City, Florida 32401 or call (904) 769-2313. EOE. 3-81-21

WE'RE IN THE MARKET for a qualified maintenance engineer with aspirations to become assistant chief. Needs background in studio and transmitter. Offering good salary and benefits package and the Monterey Peninsula to live. Send resume to Ken Warren, Chief Engineer, KMST-TV, 46 Garden Court, P.O. Box 1938, Monterey, California 93940. A Retlaw Broadcasting station. EOE. 3-81-41

TELEVISION ASSISTANT CHIEF ENGINEER for multi station operation in Midwest. Maintenance experience with Ampex quad, GV switchers, Sony ENG, microwave and VHF transmitters required. EOE. Write Dept. 530, Broadcast Engineering, P.O. Box #12901, Overland Park, KS 66212. 3-81-11

WANTED: 1st class radio engineer with AM/FM, automation experience. Contact Jerry Pratte at (207) 768-5141. 3-81-11

KGW AM/KINK FM has an opening for a maintenance engineer. Applicants should have broadcast experience and be familiar with solid-state circuitry, and must hold a 1st Class FCC license. Resumes should be directed to Lee McCormick, Chief Engineer, KGW Radio, 1501 SW Jefferson St., Portland, OR, 97201. Deadline for applications is March 30. 3-81-11

CHIEF ENGINEER—ASST MGR. Production and Air Work helpful but not necessary. Two Tower Directional daytimer—planning expansion. Write: Irv Schwartz, WCLU Radio, Box 1320, Cincinnati, Ohio 45201. 3-81-11

CHIEF ENGINEER. Looking for creative chief for new facility, rapidly growing. "C" VTRs, Ikegami cameras, E.N.G. van, cable casting, instruction, sports, and public affairs programming. Requires BSEE or equivalent experience and training. FCC 1st phone. Capability is crucial! Contact: Dennis Webster, Manager, Television Services, Southern Station, Box 5082, University of Southern Mississippi, Hattiesburg, MS 39401. (601) 266-7307. The University of Southern Mississippi is an equal opportunity employer. 3-81-11

TV TRANSMITTER SUPERVISOR—Growing PBS station seeks experienced transmitter supervisor. Contact Mike Neibauer, Chief Engineer, P.O. Box 416, Corpus Christi, Texas 78403. 512-855-2213. 3-81-11

MAINTENANCE SUPERVISOR

Major Southern California television/production facility seeks a "hands-on" maintenance pro ready to take on full supervisory responsibilities. Position demands an individual with strong background in the installation and maintenance of studio television equipment. 3-5 years experience is minimum. FCC First Class license is essential; previous supervisory experience preferred.

We offer an excellent salary and benefits package. For prompt and confidential consideration, please send resume to:

**Personnel Department
P.O. Box 38906
Los Angeles, CA 90038**

An Equal Opportunity Employer M/F/H

Rapidly expanding Cable Television MSO and Pay Programming Supplier has the following positions available.

MAINTENANCE SUPERVISOR for three man technical staff. Must have solid technical background and extensive experience in 1" VTR's, CMX editor and ENG equipment.

MAINTENANCE TECHNICIAN with experience in servicing and preventive maintenance of the above equipment.

CMX EDITOR with 340X editing experience to edit promotional material and performing arts programs. Music background helpful.

Phone/Resume Joanne Amabile
(516) 364-8450x261

CABLEVISION

Three Media Crossways
Woodbury, NY 11797

HELP WANTED (CONT.)

RADIO-HELP WANTED TECHNICAL

15M TO 20M PER YEAR

.....plus insurance and other benefits for a capable chief engineer to assume complete responsibility for Non-D AM and class A FM in mid-size Ohio valley market. Successful applicant must have minimum of 3 to 5 years experience and be well versed in latest equipment. Exceptional growth opportunity with expanding young company. Write Dept. 531 Broadcast Engineering, P.O. Box 12901, Overland Park, KS 66212.

SUNSHINE & OPPORTUNITY: Chief Broadcast Engineer for Public Radio Station (KAWC). Salary based on education and experience; excellent fringe benefits. First class radio telephone operator's license required. Experience in operation, maintenance, repair of broadcast transmitting and production equipment and 4-GHz satellite system. Apply to Personnel Office, Arizona Western College, P.O. Box 929, Yuma, AZ 85364 or (602) 726-1000, ext. 222. AA/EOE. 3-81-1t

SUN BELT MAINTENANCE ENGINEER, for expanding videotape production facility. Experience with sophisticated electronic troubleshooting and design. Competitive salary, profit-sharing and company paid medical benefits. Salary requirements and resume to: Oliver Peters, General Manager; Florida Production Center; 150 Riverside Avenue; Jacksonville, Florida 32202. 3-81-1t

BROADCAST ENGINEER: Three to five years experience required in maintenance of broadcast transmission equipment, studio, and control room equipment. Valid first class FCC license and driver's license required. Knowledge of satellite, microwave, and digital technology desirable. On-Air announcing desirable. Contact: Doug Howe, Chief Engineer, WMUK, Western Michigan University, Kalamazoo, MI 49008. WMUK is an Affirmative Action/Equal Opportunity Employer. 3-81-1t

SYSTEM DESIGN ENGINEER for MATV and CATV. Hands on experience a must. CCTV knowledge is a plus. Duties include system design from specifications, client coordination, and supervision of installation. This position is an on going one and not limited to one project. Short term overseas travel may be available if you desire, but not required. Call R. Henderson (201) 288-6130. Stylist Systems, Inc., Teterboro, N.J. 3-81-1t

HELP WANTED (CONT.)

TELECOMMUNICATIONS TECHNOLOGY FACULTY: Telecommunications full-time faculty member needed for Fall 1981 for new 2 year degree program designed to prepare students to be radio, TV, cable TV technicians. West Windsor Campus houses State-of-the-Art Radio-TV-Cable TV facility. Your teaching will include satellite and microwave technology, broadcast and cable system design. Work with new public 3Kw FM station and college's cable TV network. Requires knowledge and experience with transmitters, maintenance and repair, FCC 1st. Opportunity to develop unique industry-endorsed program at major N.J. telecommunications facility. 150 students enrolled in present radio-TV production curriculum. Excellent benefits. Tenure track. Salary negotiable, depending on credentials and experience. Respond in writing with resume to: MERCER COUNTY COMMUNITY COLLEGE, Personnel Services, Dept GS, P.O. Box B, Trenton, NJ 08690. Equal Opportunity/Affirmative Action Employer. 3-81-1t

TELEVISION HELP WANTED—TECHNICAL: \$40,000+ FIRST YEAR GUARANTEED. Our company has grown so quickly in the past 5 years, we are in desperate need of a very special person who knows broadcast equipment intimately and has aggressive sales ability. We are diversifying into other areas and need someone to take over the equipment sales division. Responsibilities include sales of new and used broadcast equipment and further development of equipment sales division as business demands. We are a first rate company and believe in paying top dollar for the right person. Call Bill Kitchen, Quality Media Corp., (800) 241-7878. 9-80-TFN

CHIEF ENGINEER for Chicago U.H.F. Experienced with administration, maintenance, and design background. E.O.E. Submit resume, references, and salary history to: Personnel, WCFC-TV, Christian Communications, Inc., 20 North Wacker Drive, Chicago, IL 60606. 3-81-1t

ENGINEERS, TV Systems Engineers, Electronic Technicians, Technical Supervisors, Maintenance. Immediate openings. Experienced. Full time, Full benefits, plus Pension. Excellent Salary plus commissions. Send resume to Technical Operations, Inc., P.O. Box 840, New Hyde Park, N.Y. 11040, or call Personnel Mgr. (516) 352-2238. 9-80-tfn

VIDEO MAINTENANCE TECHNICIAN: For troubleshooting and repair of video tape recorders, cameras, switchers, time base correctors and video systems. Two years experience. Call 713/686-9651 or send resume to: Video Systems, Inc., 2123 W. Governors Circle, Houston, Texas 77092. 3-81-1t

MAINTENANCE ENGINEER for TV Production Company. Experience on 2" quad VTR's, cameras, and switching equipment. Contact: Jimmie Fortner, MCI Productions, 2500 Farrington, Dallas, TX 75207, (214) 630-1262. 3-81-2t

HELP WANTED (CONT.)

PROFESSIONAL PRODUCTS SALES ENGINEER

Video Systems Division of Panasonic Co. is currently seeking a Product Sales Engineer to join its Sales Management Team. The individual we are seeking MUST:

- Be familiar with the "state-of-the-art" concerning Video Products and be technically qualified to advise and train in repair work.
- Have a good familiarity with the Broadcast Market.
- Have a strong sales orientation and background.

This position offers competitive base salary and lucrative commission incentive; a Company car and expense account; a full range of Company paid benefits for you and your family; and an outstanding opportunity for professional growth. This position will initially require extensive travel throughout a six state area. All applicants must forward a current resume to the personnel dept. at:

Panasonic Co.
1825 Walnut Hill Ln.
Irving, TX 75062

all replies will be held in strict confidence.
We are an Equal Opportunity Employer M/F

WANTED

ATTENTION TOWER OWNERS: We are seeking rental of tower space located within ten miles of concentrated population centers. Send details, price and terms for immediate response: Walter L. Larkin, III, Affiliated Communications Corp., 3200 Expressway Drive South, Central Islip, New York 11722, (516) 582-6721. 3-81-2t

WANTED: Pre-1926 radio equipment and tubes. August J. Link, Surcom Associates, 305 Wisconsin Ave., Oceanside, Ca. 92054, (714) 722-6162. 3-76-tf

HIGHEST PRICES PAID for 112 Phase Monitors and for clean, 12 year old or less, 1 KW and 10 KW AM Transmitters. All duty and transportation paid. Surplus Equipment Sales, 2 Thorncliffe Park Dr., Unit 28, Toronto, Ontario, Canada, M4H 1H2. 416-421-5631. 2-79-tfn

INSTANT CASH FOR TV EQUIPMENT: Urgently need transmitters, antennas, towers, cameras, vtrs, color studio equipment. Call toll free 800-241-7878. Bill Kitchen, Quality Media Corporation (In Georgia call 404-324-1271). 6-79-tfn

WANTED: Radio Transcriptions 16" E.T.'s, any Eddy Arnold, or other Country 16" or 12" Transcriptions. Will consider others. Interested in Radio Station Libraries to purchase, all speeds of records. Boyd Robeson, 2425 W. Maple, Wichita, Kansas 67213. (316) 942-3673, 722-7765 Eve. 9-80-tfn

RANK: Mk 3 Telecine Wanted, any model, any condition. Mr. Anthony, (212) 661-0608. Collect. 1-81-3t

WANTED: used tower to support FM antenna. Must be at least 1200'. Contact Ben Weiss (816) 531-3400. 3/81/2t

WANTED: Ampex color corrector, Model AC 924 for 7500 video tape recorder. Contact Len Horowitz, 446 S. Elm Drive, Beverly Hills, CA 90212, (213) 552-1623 (eves.). 3-81-1t

WANTED—Synchronous Electro-Mechanical Prompter System. 10" thru the lens mount with slave unit and sync control. Phone (212) 688-6225, David Jacobson. 3-81-1t

WHMM TV • Washington, D.C. HOWARD UNIVERSITY

32

Due to an increase in broadcast activities and expansion of ENG/EPF production, WHMM-TV requires additional engineering and operational staff. Openings include positions in the following areas:

Competitive salaries and benefits program. If interested, send resume (including salary requirements) to:

Mr. Jim Brown
Director
Staff/Student Affairs
WHMM-TV
Howard University
PO Box 1162
Washington, D.C. 20059

- Chief Engineer
- Maintenance Engineers (VTR, XMTR, Audio, General)
- Managerial Assistant—
Technical Operations
- Studio Supervisors

An Equal Opportunity Employer

 **American
Heart
Association**
WE'RE FIGHTING FOR YOUR LIFE

We want to take heart defects out of the nursery.



It almost breaks your heart to see it. She's two days old and there's a question about a hole in her heart. She's fortunate. Something can be done about it. Each year, 25,000 infants are born with heart defects which can disable them for life.

The American Heart Association is fighting to reduce this form of early death and disability with research, professional and public education, and community service programs.

But more needs to be done.

You can help us save young lives by sending your dollars today to your local Heart Association, listed in your telephone directory.

**Put your money where
your Heart is.**



**American
Heart
Association**

WE'RE FIGHTING FOR YOUR LIFE

ad index

ADM Technology	57, 83	dbx, Inc.	257
AF Associates	77, 175	Peter W. Dahl Inc.	208
AKG Acoustics	58	Datametrics Inc.	46
Acrodyne	121	Datatek Corp.	63
Allen Avionics	142	Datatron Inc.	113
Amperex Electronic Corp.	127	Dataworld Inc.	232
Ampex Corp.	8-9, 55	Dexcel Corp.	17
Andrew Corp.	21	Dielectric Communications	134
Animation Video	185	Dolby Laboratories Inc.	205
Anixter Bros.	IBC	Victor Duncan Inc.	121
Antiope Videotex Systems	31	DuPont Kevlar Aramid Fiber	261
Anton Bauer	27, 60	Dynair Electronics Inc.	153
Anvil Cases	165		
Applied Technology Corp.	117	EAR Systems Inc.	146
Arrakis Systems	264	EECO Inc.	71
Arvin/Echo	207	EMCEE Broadcast Products Div.	223
Audio & Design Recording	87	EEV Inc.	14, 16, 159, 196
Audiomedia Associates	264	ESE	271
Auditronics Inc.	79	ECHOLab, Inc.	252
Audio Video Engineering Co.	148	Edecor	174
Bayly Engineering Ltd.	54	Electronics Diversified Inc.	239
Beaveronics	230, 231	Electro-Voice Inc.	32, 95
Belar Electronic Labs	262	Environmental Container Systems Inc.	138, 191
Berkey Colortran	273	Equipto Electronics Corp.	198
Best Audio	156-157	Eventide Clockworks Inc.	255
Beston Electronics	72-73	Eumig USA Inc.	249
Beyer Dynamics	211	Excalibur Electronics Inc.	172
Walter S. Brewer Co.	263	Farinon Video	123
Broadcast Audio Corp.	213	Fesco Inc.	150
Broadcast Communication Devices	177	Fiberbilt	10
Broadcast Equipment & Supply	164	Film Video Equipment Service Co.	138
CSI Electronics	18	John Fluke Mfg. Co. Inc.	139
CMX Orrox	269	Forox Corp.	181
Cablewave Systems	51	Fuji Photo Film USA Inc.	161
Cal Datacom	IFC	Garner Industries	206
California Microwave	155	General Electric VDEO	259
Canadian General Electric	91	Gerstenlager Co.	52
Canon USA Inc.	39	G.A. Gilbreath Associates	180
Capitol Magnetic Products	110	Alan Gordon Enterprises	253
Central Dynamics Ltd.	13	Gray Engineering Labs	246
Cetec Broadcast Group	40	Gruber Products Co.	94
Cetec Vega	141	HM Electronics Inc.	178
Ceco Communications Inc.	276	HSC Inc.	140
Christie Electric Corp.	240	Hallikainen & Friends Inc.	154
Chrontrol/Lindburg Enterprises	118	Clifford B. Hannay & Sons Inc.	172
Chyron Corp.	160, 256	Harris Corp.	41, 119
Cinema Products Corp.	65	Hitachi Denshi America Ltd.	3, 5
Circuit Research Labs	209	Howe Audio	226, 285
Comark Communications	151	Industrial Sciences Inc.	247
Comex Corp.	210	Ikegami Electronics Inc.	47, 67, 143
Commerce Airborne Corp.	10	Image Magnification	258
Compact Video Sales Inc.	19	Inovonics	97
Computer Video Systems	92	International Tapetronics Corp.	53
Comsearch Inc.	76	Jenel Corp.	152
Conrac Corp.	125	Jensen Transformers	208
Continental Electronic Mfg. Co.	81	Jensen Tools Inc.	202
Continental Electronic Wholesale Corp.	238	Kelcee Communications Inc.	43
Control Video Corp.	132	Kliegl Brothers Lighting	126
Convergence Corp.	237	Knox Video Products	80
Cortland Line Co.	136		
Crosspoint Latch Corp.	183		



Live and help live

Catastrophic disease knows no boundaries. It can strike old and young alike. But it is particularly tragic when a life that has just begun is affected.

St. Jude Children's Research Hospital also has no boundaries. As the largest center for the study of childhood cancer and other catastrophic diseases of children, St. Jude's results have worldwide impact. Upon diagnosis and a doctor's referral, a child from anywhere in the world may be accepted and treated free of charge.

But, our research touches many more than those brought to Memphis because doctors everywhere treat patients using methods perfected here. Each year doctors, nurses and scientists visit St. Jude to exchange and share this vital knowledge.

St. Jude Children's Research Hospital's purpose is to help children everywhere to live. Please help St. Jude. Send your tax-deductible check or for more information write 539 Lane Avenue, Memphis, Tennessee 38105.

Give and help live.



Danny Thomas, Founder

**ST. JUDE CHILDREN'S
RESEARCH HOSPITAL**

ad index

LPB Inc.	78	Philadelphia Resins Corp.	144	3M Mincom	68-69, 107, 251
L-W International	142	Philips Broadcast Equipment Corp.	235	3M Static Control	120
Laird Telemedia	86	Philips Test & Measuring Devices, Inc.	75	360 Systems	176
Leader Instruments Corp.	84-85	Piclear Inc.	262	Tascam (Teac)	225
Leitch Video Ltd.	163	Polyline Corp.	178	Teac Corp. of America	222
Lemo USA Inc.	152	Portable Energy Products Inc.	138	Tech Labs Inc.	210
Lerro Electrical Corp.	201	Potomac Instruments Inc.	134	Tektronix Inc.	111
Lexicon Inc.	29	Pro Audio General Store	122	Telemet	258
Lightning Elimination Associates	126	Prodelin Antenna Systems Inc.	219	Television Equipment Assoc.	202
Lines Video Systems	150, 229	Quad Eight Electronics	93	Telex Communications Inc.	4, 49, 50
Logitek Electronic Systems Inc.	260	Quantum Audio Labs Inc.	118	Tentel	26
Listek TV Equipment Corp.	276	Quick Set Inc.	242	TerraCom Lorai Corp.	135
Lyon Lamb Video Animation System	232	R-Columbia Products Co. Inc.	193	Thomson CSF Broadcast Inc.	129
McMartin Industries Inc.	61	Rack Techniques	168	Tiffen Mfg. Corp.	128
Magnetic Video Corp.	260	Ramko Research Inc.	33-34, 35	Toshiba International Corp.	147
Marathon Products Corp.	197	Roh Corp.	189	Townsend Assoc.	245
Marconi Instruments	199	Rohde & Schwarz Sales Co. USA Inc.	133	UMC Electronics Co.	70
Micro Communications Inc.	82	Ross Video Inc.	250	US JVC Corp.	179
Micro Control Associates Inc.	64	Ruslang Corp.	265	Ultra Audio Pixtec	137
Microdyne Corp.	187, 189, 191, 193, 195, 197	Russco Electronics Mfg. Inc.	74	United Media Inc.	90
Microwave Associates	131	SWR Inc.	88-89	United Research Laboratory Corp.	282
Microwave Power Devices Inc.	23	Saki Magnetics Inc.	180	UREI	149
Midwest Corp.	11	Sennheiser Electronic Corp.	174	Utah Scientific Inc.	221
L. Matthew Miller Assoc. Ltd.	66	Sescom Inc.	176	ValTec Corp.	171, 173
MiLab	98	Shallco Inc.	264	Video Associate Labs	271
Minneapolis Magnetics Inc.	254	Shively Laboratories	158	Video Data Systems	116
Moseley Associates Inc.	56	Sigma Electronics Inc.	122, 235	Videomedia Inc.	243
N-Pro Co.	164	Singer Products Co.	217	Vidicraft Inc.	198
Rupert Neve Inc.	7	Sitler's Supplies Inc.	162	Videotek Inc.	246
Newsworks	262	Sound Technology	114-115	Ward Beck Systems Ltd.	BC
Nortronics Co. Inc.	203	Sphere Electronics Inc.	157	Waters Mfg. Co.	195
Nytone Electronics Corp.	94	Spin Physics Inc.	227	Weathermation Inc.	45
O'Connor Engineering Labs Inc.	1	Stainless Inc.	224	Wilk Engineering	43
Oktel Corp.	166	Standard Tape Laboratory Inc.	252	Wilkinson Electronics Inc.	269
Opamp Labs	260	Stanton Magnetics Inc.	169	Will-Burt Co.	48
Optek Inc.	177	Stantron Div. Wyco Metal Products	167	Winsted Corp.	146
Orban Associates Inc.	62	Storeel Corp.	241	World Tower Co. Inc.	148
Otari Corp.	59	Studer ReVox America	15	World Video Inc.	168
Pacific Recorders & Engineering Corp.	130	System Concepts Inc.	108-109		
Panoak Lighting Systems	162	3M Magnetic Tape	145		
Panasonic Co.	36-37, 215				

**Have your
blood pressure checked.**

Give Heart Fund 
American Heart Association

MODEL C5 MONO \$845.00

AUTO-TEC[®]
RECORDERS

STEREO \$1640.00

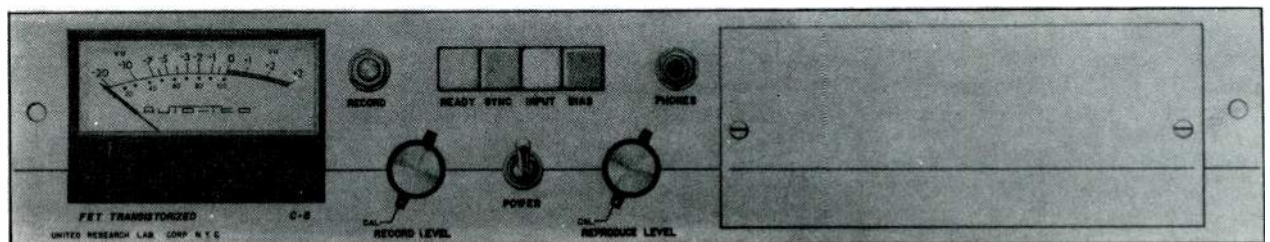

SOLID STATE CONVERSION AMPLIFIER

See Us at NAB Booth #414

For AMPEX 300, 350, 351 and 354 Recorders



United Research Laboratory Corp.

681 FIFTH AVENUE • NEW YORK, N. Y. 10022 • (212) 751-4663

Circle (272) on Reply Card

Microwave grid parabolic antennas from Anixter-Mark:
Full range of sizes—4' thru 15' 350 to 2700 MHz range

***In 1950 we
made the
first.
Today, we
still make
the best.**

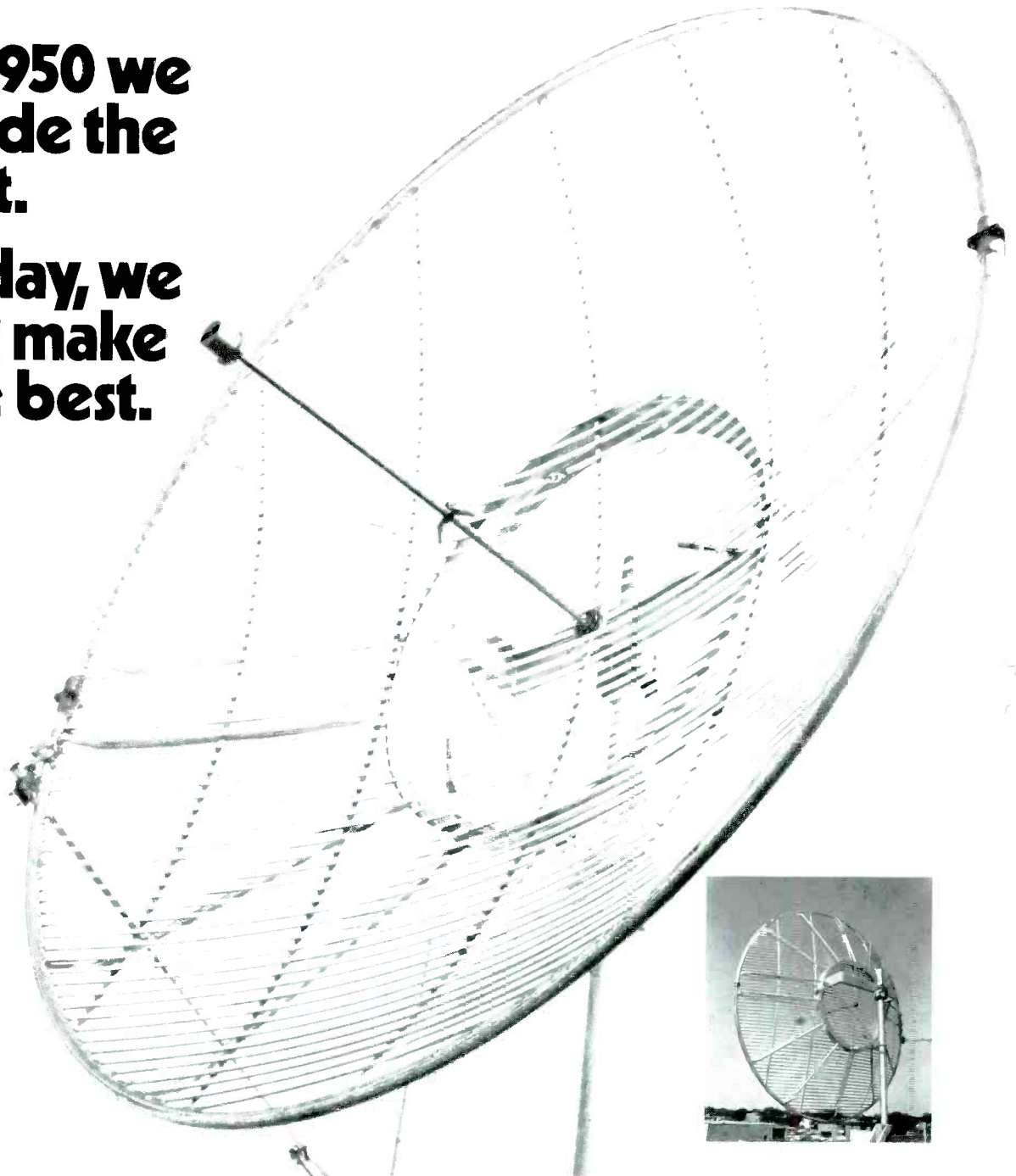

*In 1950, Anixter-Mark's patented grid design (U.S. Patent No. 2,850,735; Canada No. 545,296) set a standard for the industry. Today, backed by over 30 years of experience and innovation, Anixter-Mark remains the leader in point-to-point microwave systems.

**The best performing antennas
on earth are made by**

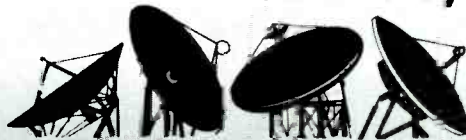

ANIXTER-MARK

Over 30 years of experience in engineering and manufacturing antennas.
• Point-to-Point • Earth Station • Microwave • Two-Way • Amateur • C3

2180 S. Wolf Rd., Des Plaines, Illinois 60018 312/298-9420 • Telex 282557

The Evolution of the Ultimate Standard.

Chosen by major television stations and production centers for its extensive range of standard features, the M2484B Broadcast/Multitrack Console combines total engineering integrity with legendary Ward-Beck performance:

Carefully blending the characteristics necessary for television production with those inherent in 16 track recording, the M2484B has evolved into the ultimate standard console for broadcast production.



First by Design.

Ward-Beck Systems Ltd.,
841 Progress Avenue, Scarborough, Ontario,
Canada M1H 2X4. Tel (416)438-6350

Ward-Beck Systems Inc., 6900 East Camelback Road, Suite 1010, Scottsdale, Arizona 85251.