

BROADCAST[®] ENGINEERING

January 1982/\$3



ENGINEERING Emphasis

- KRON: Diablo Canyon
- WDUX: Radio remotes
- Camera roundup

Quality, Reliability, Service...

Excellent Reasons for Choosing ADM®



ADM 2400 Series II Console

ADM understands how critical it is for professionals to be assured of unfaltering performance under the most demanding conditions. That's why everything we do at ADM—from initial concept to final production—is geared to providing consoles of unexcelled quality and reliability.

The finest of components are used in ADM consoles to assure long life and trouble-free operation. Our exclusive five-year warranty, the most generous in the industry, attests to this fact. Service—if you ever need it—is prompt and professional. Contact ADM Technology, Inc.

Home Office: 16005 Sturgeon
Roseville, Michigan 48066
(313) 778-8400, TLX 23-1114

Rocky Mountain Sales: (801) 486-8822

West Central Sales: (817) 467-2990

West Coast Sales: (415) 664-2400

East Coast Sales: (313) 778-8400

ADM®

The Audio Company

Pinzone Communications 8200 3.7-4.2 GHz Receiver

Performance PLUS Versatility



PERFORMANCE?

- 7.0 dB TRUE DYNAMIC C/N THRESHOLD!
- 11 dB NOISE FIGURE (12 dB MAX!)
- DUAL CONVERSION — BEST IMAGE REJECTION
- HIGH PERFORMANCE SWITCHABLE AFC
- STAND ALONE OR W/SEPARABLE DOWNCONVERTER
- MEETS EIA RS-250B STANDARD FOR END-TO-END TELEVISION RELAYS
- NOISE-FREE RECEPTION AT 3 to 5 dB LOWER C/N THAN CONVENTIONAL L-D RECEIVERS
- ONE SWITCH CONTROL ADAPTS CIRCUITRY FOR DIRECT INTERFACE TO ENCRYPTION DECODERS!
- FULL 30 MHz I.F. BANDWIDTH AND 8.4 MHz VIDEO BANDWIDTH PRIOR TO FINAL SUBCARRIER FILTERING
- STUDIO QUALITY PERFORMANCE AND RELIABILITY

VERSATILITY? JUST TAKE ONE LOOK!

- 24 CHANNEL FREQUENCY AGILE
- DETENT AND MANUAL TUNING
- AUTOMATIC LNA SELECTION
- BUILT-IN 4 GHz COAXIAL SWITCH!
- FULL FUNCTION METERING — SIGNAL STRENGTH AND CENTER TUNING
- LNA POWER THROUGH THE COAX OR BNC CONNECTOR
- INVERT VIDEO SWITCH
- FULL REMOTE CONTROL — CHANNEL AND LNA SELECTION
- TWO EASILY CHANGED PLUG-IN SUBCARRIER DEMODS WITH AUTO-PRIORITY SELECT CIRCUITRY

OUTPUTS: Video (2) 1 V PP 75Ω
 Composite 1 V PP 75Ω
 Audio (2) + 4 dBm 600Ω
 Headphone 0-1.5 V H-Z
 POWER: 115 VAC/230 VAC opt; 20 watts
 SIZE: STD 19" RACK MOUNT, 5 1/2" H x 14" D

\$2675
 THROUGH 2-15-82
 COMPLETE!
 30-DAY DELIVERY

COMPLETE TVRO SYSTEMS AVAILABLE, DELIVERY IN 3 to 5 WEEKS. FEATURING:

3.7, 4.7, and 5.0 meter PRODELIN dishes,
 6.0 and 7.0 meter PARAFRAME dishes,
 DEXCEL Low Noise Amplifiers and
 CABLEWAVE feed lines and coax.

CALL (304) 296-4493 and ask for Basil!

PINZONE COMMUNICATIONS PRODUCTS, INC.
 10142 FAIRMOUNT RD. • NEWBURY, OHIO 44065 • (304) 296-4493

Circle 2) on Reply Card

A Fenner Affiliate

BROADCAST engineering

The journal of broadcast technology

January 1982 • Volume 24 • No. 1

6 FCC update
8 News
16 Associations

ENG/RENG: Radio and television

- 12 The 16th Annual SMPTE TV Conference
- 22 **ENG at Diablo Canyon: KRON's coverage**
By the KRON staff
- 26 **Diablo Canyon field report**
By Joe Berini, associate news director/engineering, KRON-TV
- 32 **Preventative maintenance on the BVU-50**
By P. M. Smithshall, maintenance engineer, Glendale, CA
- 42 **Field report: The Aphex II Aural Exciter**
By Dr. John M. Lyons, chief engineer, WRKS-FM, New York, NY
- 46 **ENG/ETP camera survey**
By Carl Bentz, technical editor
- 62 **Checklist for troublefree remotes**
By Dan Hansen, sports director, WDUX Radio, Waupaca, WI
- 72 **Fall SMPTE conference replay**
By Bill Rhodes, editorial director
- 80 **High Definition Television at SMPTE**
By Blair Benson, engineering consultant, Norwalk, CT
- 88 **Media communications: "An awesome responsibility"**
By Fay Kanin, president, the Academy of Motion Picture Arts and Sciences, Beverly Hills, CA
- 100 **AES conference replay**
By Harmon M. Shragge, Jr., media consultant, New York, NY
- 100 **Digital highlights at AES**
By Blair Benson, engineering consultant, Norwalk, CT

105 People
108 Calendar
109 New products

111 Index of advertisers
113 Classified ads

Copyright 1982, by Intertec Publishing Corporation. All rights reserved. Photocopy rights: Permission to photocopy for internal or personal use is granted by Intertec Publishing Corp. for libraries and others registered with Copyright Clearance Center (CCC), provided the base fee of \$2.00 per copy of article is paid directly to CCC, 21 Congress St., Salem, MA 01970. Special requests should be addressed to Cameron Bishop, publisher.

ISSN 0007-1994.

BROADCAST ENGINEERING (USPS 338-130) is published monthly by Intertec Publishing Corporation, 9221 Quivira Road, P.O. Box 12901, Overland Park, KS 66212-9981. Postmaster, return form 3579 to the above address.

BROADCAST engineering

January 1982/3



ENGINEERING Emphasis

• KRON: Diablo Canyon
• WDUX: Radio remotes
• Camera roundup

THE COVER, courtesy of Hughes Helicopters Inc., shows a van and a helicopter used for electronic news gathering (ENG). The development of miniaturized transmitting and receiving equipment has made it possible for WNDU-TV16 in South Bend, IN, to broadcast live from the Hughes 300C piston engine powered helicopter or to retransmit footage shot by crews, thus extending broadcast ranges. The 300C integrated system consists of microwave transmitters and receivers, an antenna deployment system, audio mixing boxes, on-board TV monitors and power supplies. The turn-key package 300C is offered by Hughes for less than \$200,000—about one third the cost of an ENG-equipped, turbine powered helicopter. Articles in this issue describe how TV and radio broadcasters use up-to-date equipment to cover fast-breaking news stories and remote broadcasts in the field.

NEXT MONTH the major emphasis will be on animation and videographics, with an exclusive article on ABC's unique system and a roundup of systems of interest to broadcasters.

Also included will be an article by Gary Breed, chief engineer at WCBU-FM/WTVP-TV, on test equipment to consider for radio broadcast station operations. And, Don Markley, facilities editor, will take a look at transmitter plant efficiency.

Superior video results. Automatically. Or not.

The choice is yours. The Hitachi FP-22 and the Hitachi FP-21 are both professional, high-quality portable color cameras that provide superior video performance and operational simplicity.

In each case, horizontal resolution is 580 lines, with a signal-to-noise ratio of 55dB. A built-in H and V image enhancer produces sharp, clear pictures. And even in low-light conditions, you'll attain excellent results, thanks to a +9dB or +18dB high gain switch.

The FP-22 and the FP-21 both feature Hitachi's Automatic Beam Optimizer circuit. Both are built to take a beating, with rugged construction that withstands rough handling and environmental extremes.

With the addition of an optional 5-inch viewfinder and a remote operation unit (ROU), the

FP-22 and the FP-21 become high-quality studio cameras. Each has low-power consumption and RGB outputs for chroma key. Additionally, a two-line image enhancer is included.

Auto set-up makes it simple.

The big difference between the two is the 'Auto Set-Up' function found only in the FP-22. This computerized capability makes registration set-up simple and convenient, by eliminating troublesome centering adjustments, white balance and black balance. The previous set-up information is digitally processed and held in memory — even

when the power is turned off — an unheard-of feature for this comparatively low-priced camera.

If you desire the ultimate in automatic registration control, the FP-22 is the only camera you should consider. For those who presently need only the capabilities of the FP-21, the unit can be upgraded to FP-22 standards later.

Whichever way you go, you can be assured that the high standards of quality and uncompromising performance for which Hitachi has become famous, will deliver superior color video results. Automatically. Or not.

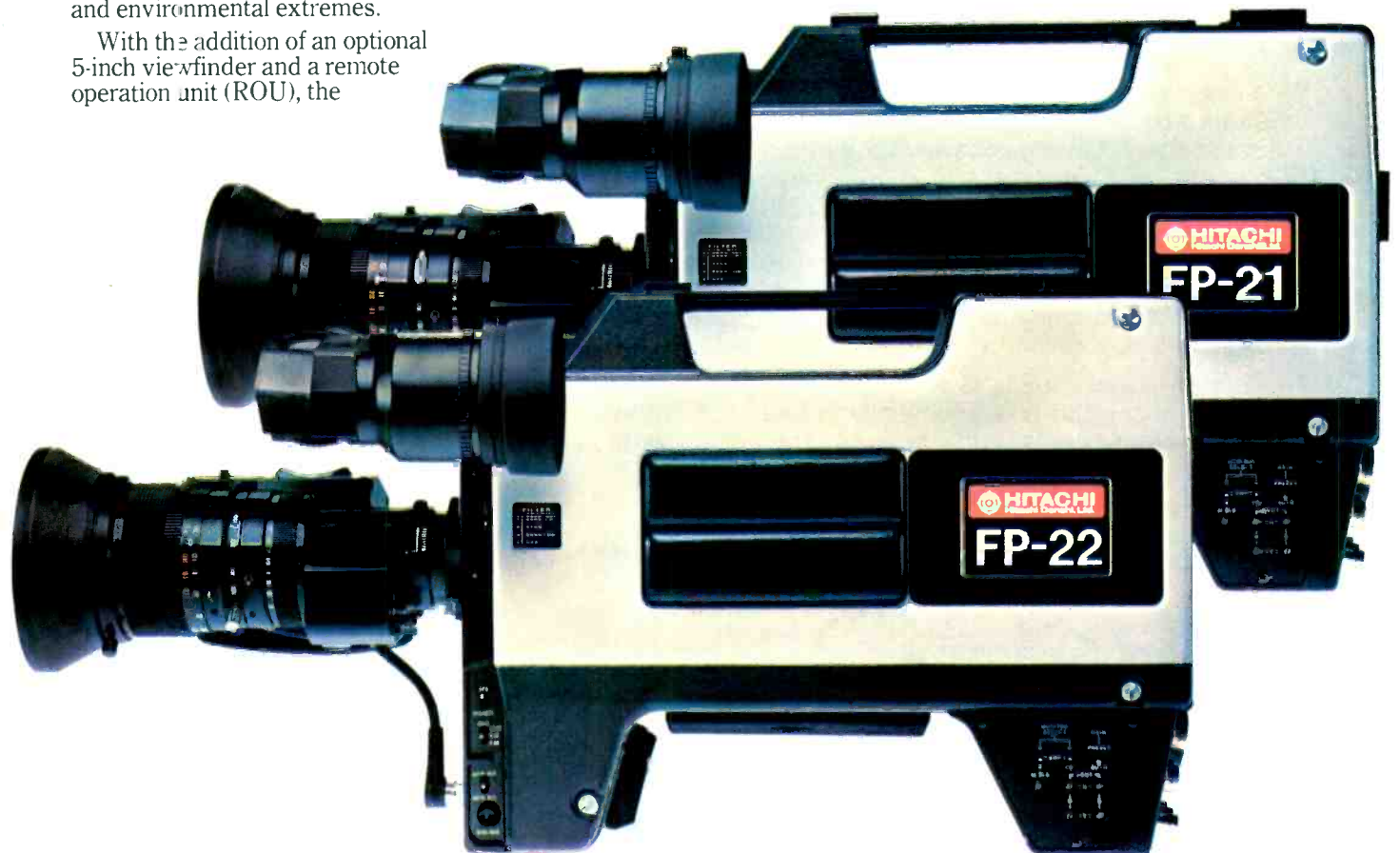

 **HITACHI**
Hitachi Denshi America, Ltd.

175 Crossways Park West, Woodbury, N.Y. 11797 (516) 921-7200

• New York • Chicago • Los Angeles • Atlanta • Cincinnati • Dallas • Denver • Seattle • Washington, D.C.

Circle (3) on Reply Card

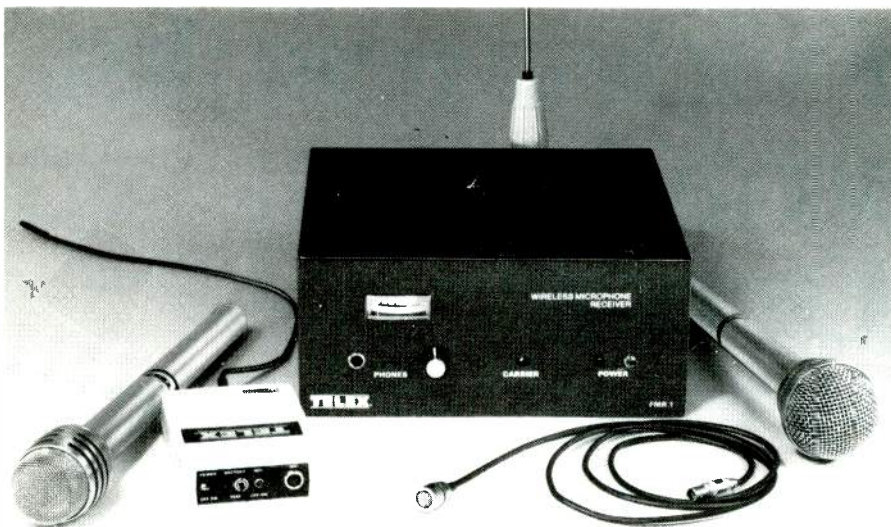

All Wireless Microphones Are Not Created Equal

This One is a
Telex

Wireless mics aren't new, and sometimes it seems as if all systems are basically the same. However, Telex and its Turner and Hy-Gain divisions have combined their 100 years of cumulative experience in microphone, antenna and rf development to produce a DUAL DIVERSITY WIRELESS SYSTEM THAT COSTS AS LITTLE AS SINGLE ANTENNA INSTALLATIONS. The FM receiver can be operated with one or two antennas. When two antennas are used, a unique automatic phase summation network (patent applied for) provides superb dual diversity reception.

The Telex wireless sounds as good as a hard wired mic, offers plenty of options and is economically priced. If you're interested in a wireless system that is *more* than equal—write us today for full specifications.

Quality products for the audio professional



TELEX®

TELEX COMMUNICATIONS, INC.

9600 Aldrich Ave. So., Minneapolis, MN 55420 U.S.A.
Europe: 22 rue de la Légion-d'Honneur, 93200 St. Denis, France

Circle (4) on Reply Card

BROADCAST engineering

Editorial and advertising correspondence should be addressed to: P.O. Box 12901, Overland Park, KS 66212-9981 (a suburb of Kansas City, MO); (913) 888-4664. Circulation correspondence should be sent to the above address, under P.O. Box 12902.

EDITORIAL

Bill Rhodes, *Editorial Director*
Carl Bentz, *Technical Editor*
Rhonda L. Wickham, *Managing Editor*
Karen Arnhart Booth, *Associate Editor*
Mary Thornbrugh, *Editorial Assistant*
Tina Thorpe, *Editorial Assistant*
Pat Blanton, *Directory Editor*

ART

Dudley Rose, *Senior Art Director*
Joy Viscek, *Art Director*

TECHNICAL CONSULTANTS

John H. Battison, *Antennas/Radiation*
Dennis Ciapura, *Technology*
Howard T. Head, *FCC Rules*
Donald L. Markley, *Facilities*
Art Schneider, A.C.E., *Post-production*

CORRESPONDING ASSOCIATIONS

American Society of TV Cameramen
Association for Broadcast
Engineering Standards
National Association of Broadcasters
National Radio Broadcasters Assn.

CIRCULATION

John C. Arnst, *Director*
Evelyn Rogers, *Manager*
Dee Manies, *Reader Correspondent*

ADMINISTRATION

R. J. Hancock, *President*
Cameron Bishop, *Publisher*

ADVERTISING

Mark Raduziner, *Marketing Coordinator*
Mary Birnbaum, *Production Manager*

Regional advertising sales offices listed near the Advertisers' Index

Member,
American Business Press



Member,
Business Publications
Audit of Circulation



BROADCAST ENGINEERING (USPS 338-130) is published monthly by Intertec Publishing Corporation, 9221 Quivira Road, P.O. Box 12901, Overland Park, KS 66212-9981. Postmaster, return from 3579 to the above address.

BROADCAST ENGINEERING is edited for corporate management, engineers/technicians and other station management personnel at commercial and educational radio and TV stations, teleproduction studios, recording studios, CATV and CCTV facilities and government agencies. Qualified persons also include consulting engineers and dealer/distributors of broadcast equipment.

SUBSCRIPTIONS BROADCAST ENGINEERING is mailed free to qualified persons in occupations described above. Nonqualified persons may subscribe at the following rates: United States, one year, \$25, all other countries, one year, \$30. Back issue rates, \$5, except for the September Buyers' Guide issue, which is \$15. Rates include postage. Adjustments necessitated by subscription termination at single copy rate. Allow 6-8 weeks for new subscriptions or for change of address. Controlled circulation postage paid at Kansas City, MO.



© 1982. All rights reserved.

Intertec Publishing Corp

The Leader Sync/Test Generators.

Every important feature for under \$2,000.

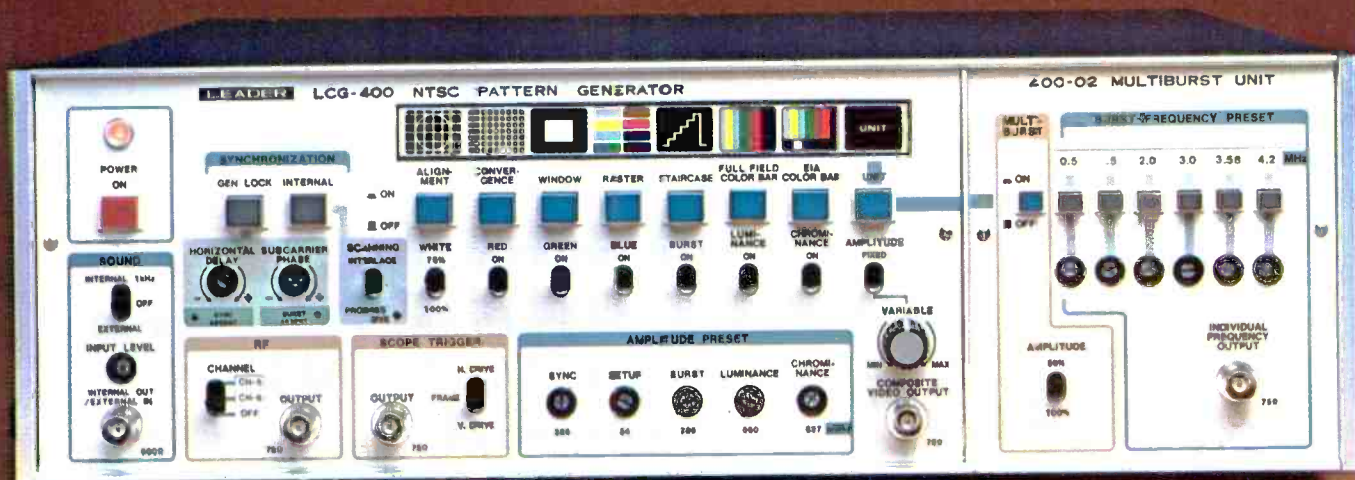

Precise NTSC sync/test pattern generators.

Leader's LCG-400 series sync/test generators provide accurate reference signals for any off-the-air broadcast or non-broadcast operation. Available in either multiburst or sweep marker configurations, the LCG-400 provides EIA and full-field color bars as well as staircase, raster (in eight colors), window, convergence and cross-hatch test signals... plus gen-lock capabilities and a host of auxiliary outputs. As a matter of fact, Leader's sync/test generators do virtually everything the \$4,000 generators do... except cost as much.

A network-proven 50 MHz oscilloscope.

The Leader LBO-517 oscilloscope makes accurate and detailed measurements. It offers sensitivities of 1 mV to 10 MHz and 5 mV to 50 MHz. Two main and two auxiliary channels can be displayed on main and delayed time bases (8 traces) simultaneously while intensifying

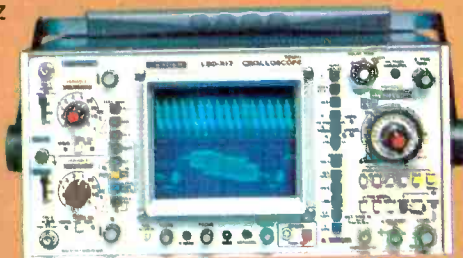

LBO-517 50 MHz Oscilloscope.

the delayed portion. Composite triggering provides stable viewing of two asynchronous inputs. Positive, stable triggering on composite video signals, at either H or V rates, is automatic. Leader's new dome-mesh 20 kV CRT assures bright, clearly defined displays, even at the highest or lowest sweep rates. All for under \$2,000.

The Leader Vectorscope is unique.

Only the Leader LVS-5850 NTSC Vectorscope offers CRT-generated phase/amplitude targets that are as bright and clear as the vectors themselves. Now you can easily verify NTSC Vectors in darkened control rooms. And, electronically generating the targets eliminates non-linearity errors caused by CRT aging. You can mount it in your existing console, view it from any angle



LVS-5850 NTSC Vectorscope.

or distance, and be confident that what you see is what you've got.

Two-year warranty. Evaluation units.

A history of high reliability permits Leader to provide a generous two-year warranty (even on the CRT)... backed by factory service depots on the East and West Coasts. Evaluation units are

available to all qualified customers.

Call toll-free (800) 645-5104 to request: an evaluation unit, our 1981/82 catalog, the name of your nearest "Select" distributor and additional information.

For video engineers who know the difference.

LEADER
Instruments Corporation

380 Oser Avenue
Hauppauge, N.Y. 11788 (516) 231-6900
Regional Offices:
Chicago, Los Angeles, Dallas.

For Information Circle (5) on Reply Card
For Demonstration Circle (6) on Reply Card

FCC update

January 1982



Assignment table process simplified

The commission has decided that it will no longer give public notice of acceptance of rulemaking petitions seeking amendments to the Tables of Assignments for broadcast stations.

Instead, the acceptance of petitions and the assignment of rulemaking numbers will be handled in the notice of proposed rulemaking. If any special problems require additional showings, that information can be requested in the rulemaking notice.

Previously, the assignment process included three steps: Issuance of a public notice announcing acceptance of the rulemaking petition and allowing 30 days for comment and 15 days for replies; issuance of a rulemaking notice proposing amendment of the assignment table as requested or as modified, and providing another 30 days for comments and 15 days for replies; and issuance of a report and order announcing final action on the channel assignment request. Then the channel, if assigned, is available for application.

The commission said it was eliminating the first step of this process, which was not required by law, because the potential benefits of the pre-notice comments and replies did not justify a 45-day waiting period in the preparation of a rulemaking notice.

Revised edition of rules and regulations available

A revised edition of the *FCC Rules and Regulations Volume II* is now available. This edition is a revision of the August 1976 issue, which contains the amendments adopted by the commission through July 31, 1981. The new edition includes these topics: frequency allocations, radio treaty matters, general rules and regulations; experimental radio services (other than broadcast); radio frequency devices; and industrial, scientific and medical equipment. The revised edition is available from the Superintendent of Documents, US Government Printing Office, Washington, DC 20402, for \$23, which includes updates of

amendments as they become available. No additional amendments will be made to subscribers of the 1976 Edition.

TV composite week dates

The following dates will constitute the composite week for use by commercial TV applicants in preparing applications for assignment of license (FCC Form 314) and transfer of control (FCC Form 315) that are filed in 1982:

Sunday	August 9, 1981
Monday	April 6, 1981
Tuesday	June 30, 1981
Wednesday	January 28, 1981
Thursday	September 10, 1981
Friday	February 20, 1981
Saturday	May 16, 1981

Six revised broadcast forms available

Noting that forms for broadcast applications and reports are revised frequently, the FCC recently issued a revised listing of acceptable editions of such forms.

The commission said that revision of a form usually makes the previous edition obsolete. In turn, it added, use of obsolete forms can result in unnecessary delays in processing applications, requests for more information or the preparation and submission of data no longer required.

Form 301-A Application for authority to operate a broadcast station by remote control or to make changes in a remote control authorization. (October 1980 or September 1979 edition may also be used.)

Form 313 Application for authorization in the auxiliary broadcast services. (June 1981 or October 1979 edition may also be used.)

Form 323-E Ownership report for non-commercial educational broadcast station. (June 1981 or January 1978 edition may also be used.)

Form 340 Application for authority to construct or make changes in a non-commercial educational broadcast station. (June 1981 or July 1979 edition may also be used. EEO supplement must accompany both editions.)

Form 346 Application for authority to construct or make changes in a TV or FM translator station (June 1981 or February 1980 edition may also be used.)

Form 348 Application for renewal of TV or FM translator station license. (June 1981 or October 1979 edition may also be used.)

Temporary financing commission established

The commission has established the Temporary Commission on Alternative Financing for Public Telecommunications, mandated by the Public Broadcasting Amendments Act of 1981, to study and recommend possible sources of additional funding.

Commissioner James H. Quello will chair the Temporary Commission. The study will be completed by July 1, 1982. The commission will identify and evaluate funding options that would maintain and enhance public broadcasting and ensure continued expansion without interference with content and quality of programming. A report of the study, together with recommendations for legislation or other appropriate action, will be submitted to Congress on completion.

The temporary commission is authorized but not required to conduct a second phase of its study to determine the feasibility of permitting public TV and radio stations to broadcast advertising. Phase II would consist of an 18-month demonstration project in which up to 10 public television and 10 public radio stations would broadcast limited amounts of advertising.

With Commissioner Quello as chairman, the temporary commission will consist of the assistant secretary of commerce for Communications and Information, the heads of the Corporation for Public Broadcasting, National Public Radio and the National Association of Public Television Stations; and the chairman and ranking minority member of the Senate Committee on Commerce, Science and Transportation and the House Committee on Energy and Commerce, or representatives delegated by the named officials. □

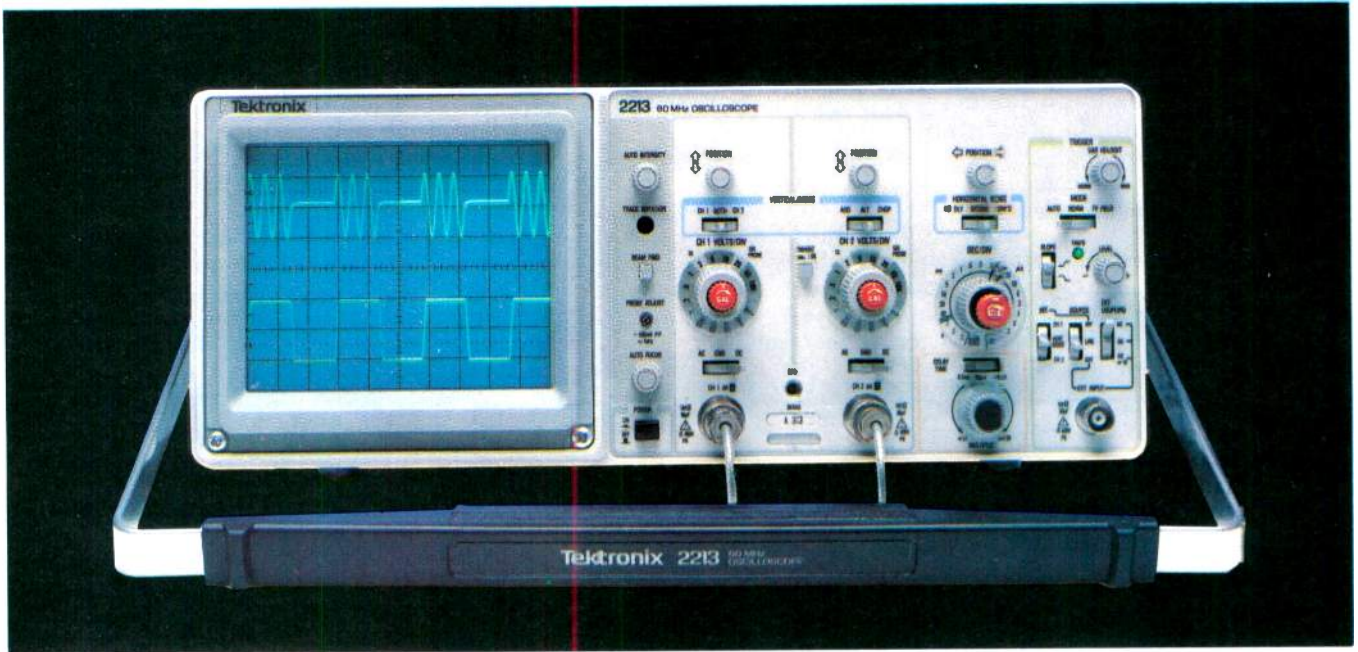

The \$1100 scope. Only Tektronix could make so much performance so affordable!

The 60 MHz Tek 2213 and 2215 introduce a scope design so radically different, it delivers full-range performance at prices well below what was ever possible before.

Not surprisingly, it is from Tektronix, the world's largest and most respected scope manufacturer, and a legend for instrument reliability and value.

Design for the 2213 (\$1100) and dual time base 2215 (just \$1400) includes some 65% fewer mechanical parts. Fewer circuit boards. Fewer electrical connectors and cabling. Result, a lower purchase price for you plus far greater reliability.

Performance is pure Tektronix: there's the

bandwidth for digital and high-speed analog circuits. The sensitivity for low signal measurements. The sweep speeds for fast logic families. A complete trigger system for digital, analog or video waveforms. And, with the 2215, you get fully calibrated delayed sweep for fast accurate timing measurements. New high-performance 10X Tektronix probes are included!

2213/2215 PERFORMANCE DATA

Bandwidth: Two channels, dc — 60 MHz from 10 V/div to 20 mV/div (50 MHz from 2 mV/div to 10 mV/div).

Sweep speeds: Sweeps from 0.5 s to 50 ns (to 5 ns/div with X10 mag)

Sensitivity: Scale factors from 100 V/div (10X probe)

to 2 mV/div (1X probe). Accurate to $\pm 3\%$. Ac or dc coupling.

Delayed sweep measurements: 2213: standard sweep, intensified after delay, and delayed. 2215: A only, B only, or A and B alternately with A intensified by B.

Complete trigger system: Modes include TV field, normal, vertical mode, and automatic, internal, external, and line sources; variable holdoff, separate B sweep trigger on 2215.

Probes: High performance, positive attachment, 10-14 pF and 60 MHz at the probe tip.

The price: Just \$1100 for the 2213 and \$1400 for the dual time base 2215*. Order direct from the

Tektronix National Marketing Center, your hotline for the 2200 Series and all Tektronix accessories.

Phones are staffed by sales engineers who can answer your technical questions.

Your direct order includes a 15-day return policy and full Tektronix warranty. Call today. You can't buy a more advanced scope for less.

**ORDER TOLL FREE
800-547-1845**

Ask for Department 901 (In Oregon, Alaska and Hawaii: 1-503-627-4502 collect.) Lines are open from 8 am EST to 5 pm PST.

Advances in portable lighting controls presented

By Harmon M. Shragge, Jr.,
media consultant, New York

Members of the East Coast's TV and motion picture industry were shown how a new generation of portable electronic lighting controls will effect future production design and budgets

in November at a seminar sponsored by Lee Lighting America, an equipment rental company.

Among the electronic dimmers and control consoles demonstrated were Strand Century's recently introduced portable modular dimming system, consisting of the Mantrix™ control console and CD80 pack dimmers. Other equipment demonstrated during the hands-on seminar included

Strand Century's Light Palette (currently being used at CBS and NBC) and MiniPalette, both computer programmable light dimmers.

The Mantrix is a manual, 4-scene preset console incorporating eight submasters for control channel grouping. The console is designed to control one or more portable CD80 pack dimmers.

Each CD80 pack dimmer contains 12 2.4kW dimmers in a 23"x20"x8" package, which weighs 65 pounds. Up to 24 CD80 packs (a total of 288 2.4kW dimmers) can be grouped and controlled by one to 84 control channels in the portable Mantrix lighting control console, as well as by the Light Palette and MiniPalette.

The new generation of lightweight portable dimmers and control consoles provides improved lighting techniques for TV remotes without sacrificing quality or operational flexibility. In recent months, there has been a growing acceptance of electronic dimming technology by TV producers because of the technology's potential for simplifying many lighting procedures. Soon hot, noisy, bulky dimmers, which are usually placed in locations that make communication between the director, gaffers and engineers, a real problem will be items of the past.

The advances in portable electronic dimming will not only improve on location communications, they will also reduce production time and provide greater creative flexibility while lowering production budgets. TV remote lighting designers will now be provided with the sort of control and flexibility they once could enjoy only in the studio.

Portable electronic lighting controls make it possible to centralize the lighting control process which, in turn, will greatly improve large remote productions such as political conventions. Previously, when one wanted to light certain parts of an arena for short periods of time, it was necessary to manually turn the lights on and off. This could prove to be a time consuming and costly procedure. With portable lighting controls however, one can centralize the on/off and dimming process to a convenient location, thereby reducing personnel requirements by simplifying the lighting aspect of the production.

Another cost-saving feature of portable electronic lighting controls previously found only in studios is that the lighting technician is able to

The Wireless Intercom System designed for your specific needs

The Cetec Vega Q System fulfills the demanding applications of motion picture, broadcasting and stage production communications. Sound and camera crew cuing, stunt coordination, sound program monitoring, etc. can be achieved easily without running cables.

Features

- Can interface with wired intercom systems such as RTS, Clear-Com, David Clark, four wire, etc.
- Operates simplex or duplex with up to 6 walking units plus 1 plug-in unit (at the base station, which can include a wired-intercom interface).
- Operates in the VHF high band, 150 to 216 MHz, for minimal interference.
- Usable with commonly available headsets (electret or magnetic).



Division of Cetec Corporation

P.O. Box 5348/EI Monte, CA 91731/(213) 442-0782/TWX 910-587-3539

In Canada: A. C. Simmonds & Sons Ltd.

Circle (98) on Reply Card

lighting and control
Systems **Colortran**

Our Systems
Experience Cannot
Be Overlooked

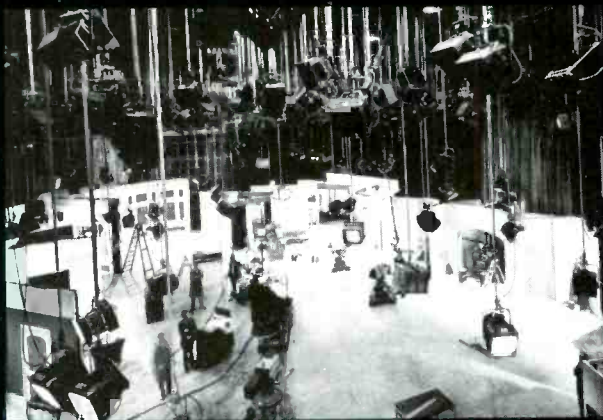

If you need a production lighting system, we have the systems experience to do the job. We'll help you plan your requirements and supply lights, distribution & control in a turn key installation — within your budget. We did it for NASA — we can do it for you.

Mail this coupon to:
Colortran, Inc.
1015 Chestnut St.
Burbank, CA 91506

Please send me a systems literature package

BE182

name _____
position _____
organization _____
address _____
city _____
state _____

Colortran, Inc.

1015 CHESTNUT ST., BURBANK, CA 91506-9983 • TELEX: 67-7252 • 213/843-1200

Digital Accuracy, Effortless Convenience:



**Calorimetric
MODULOAD® System
from 1kW to 50kW
RF Power**

Terminate and measure RF Power up to 50,000 watts from AM and FM through VHF and UHF frequencies in 1/8", 3/8" or 6/8" coax lines. Three models cover 1-10kW, 1-25kW and 1-50kW ranges with calorimetric accuracy of $\pm 2\frac{1}{2}\%$ of indication (above 5kW).

Self-cooled MODULOAD Termination assures low SWR in 50-ohm lines, can be permanently mounted — or wheeled in place on dolly.

To measure power, push a button, wait briefly to stabilize, zero the display and apply RF!

Can be used to calibrate or check other meters. Detailed specs in CalMOD Bulletin. Ask for it

**Who else but
BIRD**

30303 AURORA RD. SOLON OH 44139
216 • 248-1200 TLX: 98-5298 Cable: BIRDELEC

Circle (7) on Reply Card

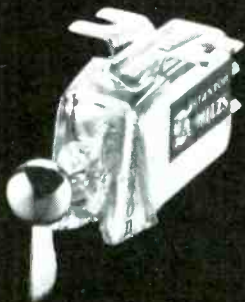

A Brilliant, New Cartridge Designed For Today's High Technology Records.

At last, a low impedance cartridge which exceeds moving coil performance with moving magnet reliability. The Stanton 981LZS provides the highest level of performance with very low tip mass, the widest frequency response and unsurpassed trackability. The moving magnet (Samarium Cobalt design) offers a truly new, exciting and different sound experience.

Stanton Magnetics, 200 Terminal Drive, Plainview, NY 11803

The 981LZS From STANTON
THE CHOICE OF THE PROFESSIONALS™

Circle (8) on Reply Card

News

dim the electrical input to the lamps from 120V to 110V. This can extend the life of a normal EAL bulb many times with negligible effect on the color temperature of the video image.

The only disadvantage of portable electronic lighting controls is the fragility of the hardware. There are printed circuits inside the control boxes with delicate connections that cannot be kicked or knocked around. To compensate for this, the equipment is usually enforced with a rugged bumper rail and a strong carrying case, making it possible to put it on an airplane to ship it.

Portable electronic lighting controls have the potential for reducing production shooting time, simplifying lighting procedures and decreasing production budgets. It is now up to the appropriate technicians and producers to weigh the advantages and understand the applications of such a system.

48% annual growth rate predicted for earth station market

Strategic Inc. has released an updated study, titled "Small Satellite Earth Stations: U.S. Market Opportunities, 1981-1989" (No. 309). The study contains current data and projections regarding direct broadcast to homes by satellite.

Restricted to the US, non-military market segment. Strategic predicts that the small satellite communications earth station market will grow at an average annual growth rate of more than 48% through the decade of the '80s. Declining prices, especially in the DBS segment, will limit the annual revenue growth (in constant 1980 dollars) to about 18%. Total equipment sales (receivers, antennas, transmitters and amplifiers) will be in excess of \$1 billion over the 1981-1989 period.

The April 1981 FCC ruling that tentatively permits direct-to-home broadcasting represents a significant milestone in the development of the small earth station market. Protests by cable TV companies, government red tape, lack of programming, competition by other video media for the viewers' time and delays of K-band satellite transmission until the mid-1980s are obstacles to be overcome. Strategic predicts sales of 160,000 antennas in 1989, assuming that DBS does not become a viable service until 1985-1986. Sales are then expected to increase tenfold each year in the early 1990s, as the DBS services increase. □



Picture shows Model 5462/16 TV Audio Console.

Price Surprise!

From 6 in/2 bus to 36 in/16 bus, Neve TV audio consoles are surprisingly price competitive and often available on short delivery. In addition to attractive pricing, Neve can offer you the best selection of purpose designed TV audio consoles to suit your

application. We pride ourselves on building the finest products in the world, which are simple to operate with unequalled technical performance and reliability. And we are the only console supplier with factory sales and service offices coast-to-coast, in New York (Connecticut), Nashville, Los Angeles and Toronto. Please write or call for our comprehensive TV audio console information package, so you can put Neve in your budget now. You'll be joining the Neve world of excellence!

 **Neve**

Rupert Neve Incorporated Berkshire Industrial Park, Bethel, Connecticut 06801 Tel: (203)744-6230 Telex: 969638

Rupert Neve Incorporated 7533 Sunset Blvd., Hollywood, California 90046 Tel: (213)874-8124 Telex: 194942

Rupert Neve Incorporated P.O. Box 120907, Nashville, Tennessee 37212 Tel: (615)385-2090

Rupert Neve of Canada, Ltd. 2721 Rena Road, Malton, Ontario L4T 3K1, Canada Tel: (416)677-6611 Telex: 983502

Neve Electronics International, Ltd. Cambridge House, Melbourn, Royston, Hertfordshire, SG8 6AU England Tel: (0763)60776

Rupert Neve GmbH 6100 Darmstadt Bismarckstrasse 114, West Germany Tel: (06151)81764

Circle (9) on Reply Card

The 16th Annual SMPTE TV Conference

- Feb. 5-6, 1982
- Opryland Hotel
- Nashville, TN

The SMPTE Television Conference has become the world's most important technical meeting in the field of advanced TV technology. "Tomorrow's Television" is the theme of SMPTE's 16th Annual Television Conference. Two full days of technical sessions will provide registrants with the latest information on the future of broadcast TV technology. The session topics for this meeting are new TV technologies, multichannel TV audio, digital control of TV equipment, and high definition TV systems.

Advance program

This tentative program lists those sessions accepted as of Nov. 1, 1981. Additional papers are being reviewed and may be included in the final program available at the conference.

Friday Morning, Feb. 5 New TV Technologies

Digitally – What's Up? A Report on Progress and Directions from the Working Group on Digital Video Standards

Kenneth P. Davies, *Canadian Broadcasting Corporation, Montreal*

The Hawkeye Recording System

C. Robert Thompson, *RCA Broadcast Systems, Camden, NJ*

Development of a Precise Registration and Level of TV Signal Measuring Equipment and Its Applications

T. Sueoka, K. Wakui, K. Murakami, H. Nakamura, *NHK Technical Research Laboratories, Tokyo, Japan* and *Shiba-Soku Company Ltd., Saitama, Japan*

New Integrated Circuits for Video Digital Filters

Willard K. Bucklen, *TRW LSI Products, La Jolla, CA*

Optimization of High Quality Color Camera for ENG/EPF Purposes

A.A.J. Franken, *Amperex, Slatersville, RI and NV Phillips, Holland*

Development of Broadcast Color Camera Using a Single Pickup Tube

Y. Kubota, T. Iwasaki, Lawrence Sce, *Sony Corporation, Tokyo, Japan*

Digital TV Tape Recording – Forming a Format

J.L.E. Baldwin, *Independent Broadcasting Authority, United Kingdom*

The Interrelationship of Computer Graphics and Alphageometric Videotext Systems

Peter Black, *Xiphias, Santa Monica, CA*

Graphics System

Richard J. Taylor, *Quantel Ltd., Newbury, England*

Code Utilization for Component-Coded Digital Video

D. Izraelevitx & J.L. Kostov, *RCA Laboratories, Princeton, NJ*

Friday Afternoon

Multichannel TV Audio

A Review of Issues Related to the Choice of Sample Rates to Digital Audio

J. James Gibson, *RCA Laboratories, Princeton, NJ*

Audio Problems in 1-inch Videotape

Martin Lilley, *Ampex Corporation, Redwood City, CA*

EIA Multichannel Sound Field Test Report

Electronics Industries Association, *Washington, DC*

Multichannel Sound from NHK

NHK, Tokyo, Japan

Multichannel Production Experiments

Panel Discussion on Multichannel TV Audio



Producer Studio, WRBR-FM, South Bend, Indiana

Electro-Voice's Greg Silsby talks about the Sentry 100 studio monitor

When I first described to Electro-Voice engineers what I knew the Sentry 100 had to be, I felt like a "kid in a candy store." I told them that size was critical. Because broadcast environment working space is often limited, the Sentry 100 had to fit in a standard 19" rack, and it had to fit from the front, not the back. But the mounting hardware had to be optional so that broadcasters who didn't want it wouldn't have to pay for it.

The Sentry 100 also had to be both efficient and accurate. It had to be able to be driven to sound pressure levels a rock 'n roll D.J. could be happy with by the low output available from a console's internal monitor amplifier.

The Sentry 100 also had to have a tweeter that wouldn't go up in smoke the first time someone accidentally shifted

into fast forward with the tape heads engaged and the monitor amp on. This meant high-frequency power handling capability on the order of five times that of conventional high-frequency drivers.

Plus it had to have a 3-dB-down point of 45 Hz, and response that extended to 18,000 Hz with no more than a 3-dB variation.

Since it's just not practical for the engineer to always be directly on-axis of the tweeter, the Sentry 100 must have a uniform polar response. The engineer has to be able to hear exactly the same sound 30° off-axis as he does directly in front of the system.

I wanted the Sentry 100 equipped with a high-frequency control that offered boost as well as cut, and it had to be mounted on the front of the loudspeaker where it not only could be seen but was accessible with the grille on or off.

I also didn't feel broadcasters should have to pay for form at the expense of function. The Sentry 100 had to be attractive, but another furniture-styled cabinet with a fancy polyester or die-cut foam grille wasn't the answer to the broadcast industry's real needs.

And for a close I told E-V's engineers that a studio had to be able to purchase the Sentry 100 for essentially the same money as the current best-selling monitor system.

I'm happy to report that we've achieved all our objectives.

Market Development Manager,
Professional Markets



EV Electro-Voice
a gulton company

600 Cecil Street, Buchanan, Michigan 49107

In Canada:
Electro-Voice, Div. of Gulton Industries (Canada) Ltd.,
345 Herbert St., Gananoque, Ontario K7G 2V1.

Circle (10) on Reply Card

Conference

Saturday Morning, Feb. 6
Digital Control of TV Equipment

Status Report: SMPTE Working Group T14.10: Standardization of Digital Control for TV Equipment
 William E. Bauer (Committee Secretary), *RCA Corporation Broadcast Systems, Camden, NJ*

Network of 60 Microcomputers Automates PBS Multichannel Satellite Program Distribution
 George E. Lemaster and Robert W. Schmidt, *Public Broadcasting Service, Washington, DC*

A Serial Communications Architecture for Real Time Digital Control
 Robert B. Steele, Graeme M. Little, William A. Russell, *Ampex Corporation, Redwood City, CA*

Machine Control System
 Thomas R. Meyer, *Dynair Electronics Inc., San Diego, CA*

Serial Data Machine Control System
 Marc Walker, *Fernseh Inc., Salt Lake City, UT*

The VIMACS System
 Derek Tugwell, *Dynamic Technology Ltd., London*

A Rationalized Approach to Broadcast Automation
 Peter Symes, *Central Dynamics Corporation, Mahway, NJ*

TV Station Automation - The Station's Viewpoint
 John T. Davis, *Digital Services Corporation, Gainesville, FL*

Saturday Afternoon
High Definition TV Systems

High Definition Television and Compatibility with Existing Standards
 Charles Sandbank, *British Broadcasting Corporation, London*

Approaches to Improve Picture Quality Within Constraints of Current Scanning Standards
 Charles W. Rhodes, *Tektronix Inc., Beaverton, OR*

Production Experience With High Definition Television
 Richard Green, *CBS Television, New York*

An Overview of High Definition Television
 Renville McMann, *Thomson-CSF, Stamford, CT*

A Compatible High Fidelity TV Standard for Satellite Broadcasting
 T.S. Robson, *Independent Broadcasting Authority, Winchester, United Kingdom*

Color Picture Display System for High Definition Television
 Eiichi Taira and Minoru Takeda, *Matsushita Electric Industrial Company Ltd., Osaka, Japan*

High Resolution Optical Systems for High Definition Television
 Jack Dawson, *Fujinon Optical Inc., Scarsdale, NY*

Exhibits

There will be an equipment exhibit accompanying the technical session, and it will be limited to equipment related directly to the conference technical program.

Hotel reservations

Rooms are available at the Opryland Hotel (conference headquarters) and the Airport Hilton. Reservations must be made on the conference registration card available from the SMPTE. This card, together with the required deposit, must be received by the hotel of your choice by Jan. 13 to get the

special conference rate. Once the society's block of rooms is filled at the Opryland, reservations will automatically be forwarded to the Airport Hilton.

The society will provide morning and evening shuttle bus service between the Hilton and Opryland for registrants housed in the Airport Hilton.

Hotel rates

Opryland Hotel
 Single...\$56.00 Double...\$56.00
 Reservations must be accompanied by a \$50 deposit.

Airport Hilton Inn
 Single...\$34.00 Double...\$40.00
 Reservations must be accompanied by deposit of one night's room rate.

To obtain reservations, fill out the SMPTE hotel card and send the card with the deposit to the hotel of your choice. The addresses are as follows: Opryland Hotel, Reservations Department, 2800 Opryland Dr., Nashville, TN 37214; and Airport Hotel Inn, Reservations Manager, 1 International Plaza, Nashville, TN 37217.

For more details, contact the SMPTE, 862 Scarsdale Ave., Scarsdale, NY 10583. □

AUDIO PREMIXERS

Highest Performance • Excellent Reliability • Low Cost

Not enough inputs on your present audio console? No budget for a new Neve console? Use the best alternative. Buy a Neve Audio Premixer in a 19" rack mountable unit only 1.75" tall. Available in 10 in/1 out and 6 in/1 out versions. The 6 in version features wide range stepped sen-

sitivity control on each input. Delivery is generally stock to 30 days.

Model	Price
BET-10x1	\$ 1,995
BET-6x1	\$ 1,795

(Prices subject to change)



Rupert Neve Incorporated
 Berkshire Industrial Park
 Bethel, CT 06801

Please Call:
 (203) 744-6230

Circle (11) on Reply Card

Vital Industries has instituted a cost-saving manufacturer-financing program - applicable to any Vital equipment purchase.

In accordance with our longterm commitment to more responsive television industry service, equipment purchases are being directly financed by Vital Industries itself **at 10% interest.**

Recognizing the barriers raised by prohibitively high interest rates, this financing program is offered well below prime — to permit prompt acquisition, without delay, of the advanced programming and operational systems so essential to productivity and profitability.

This bottom-line economy adds to the special advantage Vital offers TV management: **a complete line of switching, video effects and station automation equipment, available from one single source** — 25 sophisticated system options, totally line compatible. Including production and post-

production mixers and switchers, plus our exclusive digital video manipulation system, the versatile Squeezoom®. All are state-of-the-art products of Vital's innovative technology; and all are now available with Vital 10% financing.

This low-interest opportunity is made possible by Vital Industries' unique financial strengths, solidly established by nearly two decade's stable performance and continuing growth. Now the largest U.S. independently-owned manufacturer of TV switching, effects and distribution systems, Vital can draw on corporate resources available from few other suppliers.

For full program details, contact our Finance Department:

(800) 874-7875 Toll Free



VITAL INDUSTRIES, INC.

3700 N. E. 53rd Street
Gainesville, Florida 32601, USA

Circle (12) on Reply Card

SMPTE

862 Scarsdale Ave.
Scarsdale, NY 10583

Discovision becomes SMPTE sustaining member

Discovision Associates has become a sustaining member of the Society of Motion Picture and Television

Engineers (SMPTE). Discovision was formed in 1979 as a partnership between International Business Machines Corp. and MCA Inc., to develop, manufacture and market laser-optical videodisc players and discs.

New officers and governors elected

New SMPTE officers and governors recently have been elected. Each will

serve a 2-year term beginning in January.

The new officers are as follows: Roland J. Zavada, Eastman Kodak Company, vice president, engineering; Leonard F. Coleman, Eastman Kodak Company, financial vice president; Harold J. Eady, Bonded Services, vice president, office of Sections; M. Carlos Kennedy, Ampex Corporation, serving the remainder of the term of secretary that will be vacated by Harold J. Eady; Frederick M. Remley, University of Michigan, vice president for Educational Affairs; Howard T. Lazare, Consolidated Film Industries, vice president for Motion Picture Affairs; Robert D. Shoberg, Photonic System, vice president for Photonic Affairs; and L. Merle Thomas, vice president for TV Affairs.

The newly elected SMPTE governors are: Leonard Green, National Film Board of Canada, Canadian region; Sherwin Becker, Allied Film Laboratory, central region; Richard K. Schafer, Eastman Kodak Company, and Thomas W. Hope, Hope Reports Inc., Eastern region; Edmund M. DiGiulio, Cinema Products Corporation, and Edward J. Reichard, Consolidated Film Industries, Hollywood region; William G. Connolly, CBS TV Network, New York region; Blaine Baker, Motion Picture Labs, Southern region; and David K. Fibush, Ampex Corporation, Western region.

THEY SURVIVE THE TORTURES OF THE RACK. No other modular signal processing system is as rugged as the dbx 900 Series.* With features like captive screw-in fasteners for positive retention. Wide, double-sided contacts on interchangeable modules. A pre-wired mother board that eliminates the need for soldering. A heavy-duty power supply. All in a 5 1/4" frame built tough as a truck. Best of all, every 900 Series module delivers the kind of performance and reliability you expect from dbx. See your dbx Pro dealer or write for information.

*With F-900 frame. Also compatible with most older-model dbx frames.

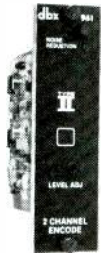

Model 941 \$260.**
Type II Noise Reduction (encode)



Model 942 \$270.**
Type II Noise Reduction (decode)



Model 411 \$310.**
Type I Noise Reduction



Model 902 \$325.**
De-esser

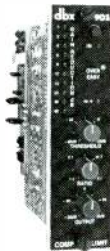

Model 903 \$325.**
Compressor/Limiter

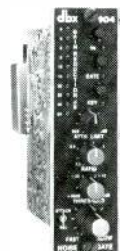

Model 904 \$325.**
Noise Gate



Model 905 \$340.**
Parametric EQ



Model 906 \$720.**
Flanger

**Manufacturer's suggested retail price.

dbx, Incorporated, Professional Products Division,
71 Chapel St., Newton, Mass. 02195 U.S.A.
Tel. (617) 964-3210, Telex: 92-2522. Distributed in
Canada by BSR (Canada) Ltd., Rexdale, Ontario.

dbx®

Concert Music Broadcasters Association

Penthouse East
Terminal Tower
Cleveland, OH 44113

New classical station on air

The nation's newest commercial classical music station, KCMA, Owasso, OK went on the air Oct. 1. The station, which serves the Greater Tulsa area, has received more than 800 unsolicited cards and letters from listeners in addition to another 600 replies to a post card mailing asking if the recipient wished to receive a copy of KCMA's program schedule.

The Phillips Petroleum Company is sponsoring the Boston Symphony Orchestra. Several local retailers are on spot schedules. The station, which operates 18 hours a day, is in the pro-

Circle (13) on Reply Card

HIGH I/Q

ASACA/ Shibasoku's CMM Series monitors decode color on the I/Q axis.

Asaca/Shibasoku's new high resolution monitors have the I-Q to deliver color performance other monitors simply cannot produce. Using R-Y, B-Y decoding no longer meets the demands of today's professional standards.

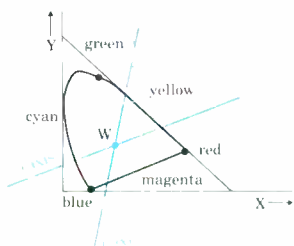

I-Q axes in color triangle

The Asaca/Shibasoku monitor like the human eye resolves certain colors best; reds, oranges, yellows, and flesh tones. The I-Q decoding system enables the monitor to display these colors at a higher resolution using wide band demodulation of 1.3 MHz rather than 0.5 MHz as in R-Y, B-Y systems.

We cared enough to give you a monitor with the I-Q to reproduce the best possible pictures. We know you're smart enough to buy it.

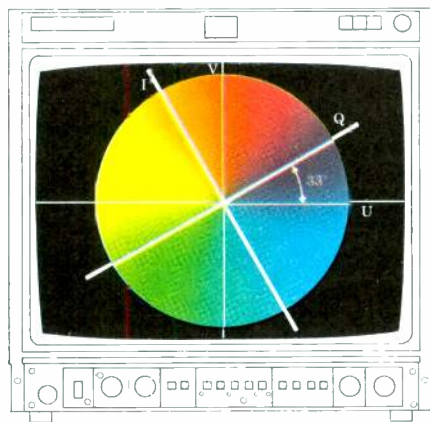

FEATURES

- 20" and 14" models available—high resolution delta CRTs.
- I-Q wide band demodulation system.
- Complete board interchangeability between models.
- Switchable high performance comb filter and aperture correction.
- Multi-standard capabilities (NTSC, PAL, SECAM) on all models. Switchable from the front panel (20" model). No adjustments necessary because of digital sync circuitry.
- Dynamic focus insures perfect focus on all areas of CRT. Adjustable from the front panel.
- Special feedback circuits guard against color changes due to variations in temperature.
- Active convergence—40 controls allow precise adjustment on all areas of CRT.
- Pulse cross with expanded vertical blanking interval.
- OPTIONS... Built-in color bar or cross hatch patterns. Built-in safe title marker generator. Multi-standards. RGB inputs.
- TWO YEAR WARRANTY ON ALL PARTS AND LABOR INCLUDING THE CRT

ASACA
ASACA/SHIBASOKU
CORP. OF AMERICA

1277 Rand Road, Des Plaines, Illinois, 60016

Telephone (312) 298-4380

New York Office (212) 772-2863

Sales/Service (800) 323-2498

Telex: 72-6351

Circle (14) on Reply Card

FIGHT CLEAN AND WIN. \$260.*

Increased use of carts makes tape noise reduction more critical than ever in your fight to stay competitive. With dbx Type II Noise Reduction, you have an affordable way to get high quality sound whether you're into classical music or drive-time rock. Our new Model 941 offers two channels of encode, the new Model 942 two channels of decode. Combine them for simultaneous encode/decode. Get up to 16 channels in one 5 1/4" high rack mount frame. Broadcast noise reduction is the latest addition to the dbx 900 Series modular signal processors. All interchangeable, all compatible. See your dbx Pro dealer, or write for complete technical information.

*Manufacturer's suggested retail price. Model 941. Model 942. \$270.



Model 941 Encoder and Model 942 Decoder

dbx, Incorporated, Professional Products Division,
71 Chapel St., Newton, Mass. 02195 U.S.A.
Tel. (617) 964-3210, Telex: 92-2522. Distributed in
Canada by BSR (Canada) Ltd., Rexdale, Ontario.

dbx®

Circle (15) on Reply Card

TENTEL GAGES

DO THINGS EVEN THE FACTORY GAGES DON'T DO!

FOR U-MATIC, BETA, VHS AND 1" TYPE "C" RECORDERS . . .

TENTEL GAGES ARE SO EASY TO USE EVEN NON-TECHNICAL PERSONS CAN DIAGNOSE PENDING PROBLEMS.

The TENTELOMETER Tape Tension Gage will help if you want to prevent problems with:

- Interchange
- Hooking and flagging
- Tape destruction

The TENTEL Spindle Height (TSH) Gage will help if you want to prevent problems with:

- Tape edge damage
- Cassette binding
- Tape destruction

TENTEL is ready to help with your video recorder service needs. Thousands of service engineers rely on TENTEL daily!

Send for the TENTEL Tape Tips Guide or call us TOLL FREE (800) 538-6894. In California call (408) 379-1881.



TENTEL

1506 Dell Avenue
Campbell, CA 95008

Circle (16) on Reply Card

Associations

cess of installing a satellite downlink to take advantage of WFMT's satellite-fed signal.



SOCIETY OF BROADCAST ENGINEERS, INC.

P.O. Box 50844
Indianapolis, IN 46250

Chapter 59 meets

The mid-November meeting of the SBE, Chapter 59 in Kansas City, MO, featured presentations by Clay Selthun and Jeff Rodman from Harris Video Systems.

Rodman opened the program with a technical dissertation on digital signal processing for video and audio. Although his talk centered on 8 bit vs 9 bit and component vs. composite signal processing, he included error reduction and the trade-offs in noise reduction, and the gain vs. cost in using higher bit rates.

Selthun followed the lecture portion with a demonstration of the HVS Model 630 Frame Synchronizer, including the compressor/positioner and noise reducer option, operating on video from a U-Matic player.

Jack McKain, president of Chapter 59, surprised the attendees by announcing that the organization is planning a mini-NAB technical conference/equipment exposition in Kansas City in 1983.

NY regional convention attracts 430

The Ninth Annual Central New York SBE Regional Convention held Sept. 25 in Syracuse attracted 430 people who saw the latest in TV and radio equipment on display. They also had the opportunity to attend eight technical papers presented by practicing broadcast engineers as well as by manufacturers and consultants. Exhibitors filled 46 booths and a new TV mobile van.

Those attending the convention also had an opportunity to visit with the FCC representative from the Buffalo field office as well as learn more about the SBE from members of the Syracuse and Albany Chapter who manned the information desk.

The SBE certification exam was given to three engineers who took advantage of the opportunity to take the exam while attending the convention.

Superior reproduction. And it shows.

Maxell 3/4" U-Matic videocassettes have certain advantages that have made them the choice of professional users everywhere. Our specs will support our claims to superiority, but one picture is worth a thousand specs, so we invite you to see for yourself the superior chroma response, high resolution, exceptional picture clarity, image stability and low chroma noise that our tapes provide, even in slow motion or still-frame modes.

Maxell brings you as close to original picture clarity as you can get. Every time. And to make sure you also get the full advantage of our tape, we house it in our own high-precision cassette shells that will stand up to the roughest treatment and repeated playback. The internal mechanism is carefully designed to make tape travel in both directions smooth and dependable at any speed. And there's another distinct advantage you get with every Maxell U-Matic videocassette—quality control. There are no stricter standards in the industry, so you are assured of the same high-quality performance from one videocassette to another, without exception.

To discover more about Maxell's professional advantages, call one of our Regional Sales Offices: Eastern Office, Moonachie, NJ (201) 440-8020 ■ Midwestern Office ■ Western Office, Los Gatos, CA (408) 395-1998, Des Plaines, IL (312) 296-1010.



maxell
PROFESSIONAL
INDUSTRIAL
PRODUCTS

The Professional Advantage

Maxell Corporation of America
60 Oxford Drive, Moonachie, NJ 07074

Circle (17) on Reply Card

Still The Best Investment In A Professional Two Channel Tape Machine.

The Otari MX-5050B

There's a very simple, straightforward reason the MX-5050B has become the world's best-selling professional tape recorder: value. If you were to ignore all of the production features, dismiss the six year track record for unsurpassed reliability, you would still discover that the "B" is the best performing machine for your money. When you shop around you'll find out that it's easy to spend a little less or a lot more, but very difficult to justify to yourself that you are getting more. When you compare other machines, spec' by spec', you'll begin to see why there's more value in putting your money into an Otari Spec's of course, don't tell the whole story. But, it's a damn good place to start your serious comparisons.

To experience the full potential, and thus the value of any product you purposely put it to the test. After a few hours in the studio or on location, you can become painfully aware of the differences between a professional machine and those with a Hi-Fi heritage. Because Otari's only business is to serve the dedicated audio professional, you won't find cosmetic facelifts every couple of years; or, dredged-up product from another era that's labeled "Pro." At Otari we improve each product by subtle engineering refinements that make the basic product that much better — without fanfare and expensive model changes that you end up paying for. And the "B" is the embodiment of this philosophy. It's been around for three years (5050 Series, 6 years) and we plan you'll keep it around a lot longer. If you're a knowledgeable audio person who already owns an Otari you'll know what we're talking about. If you're not, then it is well worth your time to review the Performance and Feature facts we've

detailed in this ad. If you're in the market for a fully professional, super-reliable two-track the time you spend to acquaint yourself with the "B" just might mean the difference between spending your money on a machine that will do for now — or deciding to make the investment in a basic creative tool that will pay you back handsomely in the years to come.



THE FACTS: PERFORMANCE.

Overall Signal-to-Noise: 66 dB unweighted @ 520 nWb/m, 30 Hz to 18kHz.
Dynamic Range: 72 dB unweighted: 30 Hz to 18 kHz.
Headroom: +24 dB. Maximum output: +28 dBm.
Overall Frequency Response: 30 Hz to 22 kHz ± 2.0 dB (15 ips @ +4 dBm).
Playback Frequency Response: 31.5 Hz to 20 kHz ± 2.0 dB (15 ips @ +4 dBm).
Distortion: less than 0.7%, 1 kHz @ 250 nWb/m.
Crosstalk: greater than 55 dB, 1 kHz, adjacent tracks.
Wow and Flutter: less than 0.05% (15 ips)
Rewind Time: 90 seconds for 2500 feet

THE FACTS: FEATURES.

Three switchable speed pairs: 15/7½ or 7½/3¾ ips (automatic equalization).
NAB/IEC selectable equalization.
Selectable +4 or -10 dBm output.
D.C. servo capstan motor with $\pm 7\%$ varispeed control.
Selective reproduce for overdubbing.
Four heads: ½ track erase, record, reproduce, ¼ track reproduce plug-in assembly.
Noise-free punch-in/out; transport remote (optional).
Built-in test oscillator.
Front panel adjustable bias and equalization.
Choice of three alignment levels: 185, 250 & 320 nWb/m.
Dump edit and tape lifter defeat, precision aligned; and indexed splicing block.
Zero memory return.
10½" reel capacity; XLR connectors.
Large, illuminated V.U. meters with adjustable peak-reading L.E.D. indicators.
Independent Mic/Line mixing (20 dB pad).

THE FACTS: PRICE.

\$2,295.00 Suggested Professional Net.

Your nearest Otari qualified professional audio dealer has The New Workhorse in stock. Check-out for yourself why you should place your money on the MX-5050B. If your dealer shows you anything but an Otari, tell him, "No thanks, I'm only interested in making a sound investment."

Call us for the name of your nearest dealer.

The New Workhorse

OTARI®

OTARI CORPORATION
2 Davis Drive
Belmont, CA 94002
(415) 592-8311

© Otari Corp. 1981

Circle (18) on Reply Card

THE NEW
WORKHORSE





KRON-TV editor Alex Johnson edits a report from the station's rented RV editing station on the demonstrations at Diablo Canyon while reporter Ginger Rutland looks on.



Reporter Ron Regan interviews a protester at Diablo Canyon while Jerry McEowen shoots the live interview for KRON-TV in San Francisco.

ENG at Diablo Canyon: KRON's coverage

By the KRON staff



KRON-TV use the 700-foot peak at Valley View Hill just below the Diablo Canyon plant at Port San Luis as the first in a series of eight microwave hops to the station in San Francisco.

During the anti-nuclear demonstrations at PG&E's Diablo Canyon nuclear plant in mid-September near San Luis Obispo, CA, San Francisco's KRON-TV successfully fed live reports from the site of the protest at Port San Luis to the station via the longest microwave link-up ever attempted by a local station using its own equipment. The 8-hop microwave link spanned 232 miles.

The Diablo Canyon plant has been PG&E's most important project for the past 13 years. Billions of dollars are invested in it. Protesters who rallied under the banner of the Abalone Alliance had planned a massive blockade in an attempt to keep the nuclear plant from going on-line.

The station attempted the microwave link-up for several reasons.

KRON News Director Mike Ferring said, "The plant was so remote that phone company lines and construction would have been either impossible or outrageously expensive. Since

we didn't know exactly when the demonstration would happen, it was impossible to schedule a mobile earth station and book transponder time. It was do it ourselves or don't do it at all, so we decided to give it a shot."

Several weeks before the demonstrations were anticipated, Don Shafer, associate news director/operations; Joe Berini, associate news director/engineering; and Larry Craig, news field unit supervisor, laid the groundwork for the microwave link.

Shafer and Berini then used the station's Telecopter 4 for two scouting expeditions. After surveying several mountaintops and seeking the advice of Ken Reid, chief engineer for KSBY-TV in San Luis Obispo, they made adjustments to their previous plans and came up with a final route. A camera was to be stationed at the gate of the nuclear plant where the demonstrators were forming their blockade. From there, they would hop to Van Six, then to Valley View Hill, to Cuesta Peak, Calandra Peak, Fremont

Peak, Loma Prieta, Mt. Sutro in San Francisco, and finally, to the station.

Craig then drew up an operational manual, listing the photographers and each location's technical personnel. Berini prepared equipment lists, detailing everything from flashlights and tool kits to small generators. Using every corner in the ENG maintenance shop, the equipment was set out site by site.

For at least two weeks before the scheduled opening of the Diablo Canyon plant, KRON's Sacramento bureau, consisting of Bureau Chief Don Fields, reporter Ginger Rutland and a 2-man camera crew, worked out of San Luis Obispo. They filed what amounted to a 7-part report on Diablo Canyon. Their reports covered topics such as the value of the plant to PG&E, what the plant means to the consumer (a \$3 to \$5 decrease in the average power bill), what those opposed to the opening of the plant hoped to accomplish, what the people living in the community of San Luis Obispo felt

Since their introduction in 1977, the UREI 800 series monitors have steadily been replacing old-fashioned loudspeakers. In studios throughout the world, they've become the accepted standard — the critical standard by which all other professional loudspeaker systems are now judged.

Our new Series "A" models (811A, 813A & 815A) now incorporate the following improvements

The New UREI Series "A" Time-Aligned™ Professional Monitoring Loudspeaker Systems

- The exclusive Time-Aligned™* crossover has been redesigned to allow the maximum power transfer to the transducers — improved sensitivity for more acoustic power per watt.
- A totally new High Frequency Exponential Horn design (Patent Pending) which includes a diffraction buffer, flare compensators, and shadow slots.
- The diffraction buffer has been added to the leading edge of the horn resulting in better impedance transformation to the atmosphere. This provides a substantially improved transition through the crossover region and dispersion is enhanced over the entire range of the High Frequency Horn.
- The Flare Wall Boundary treatment results in a reduction of transient distortion without degrading the power transfer characteristics of the Horn.
- Shadow Slots have been added to further improve the mid-range magnitude regularity and overcome the classic "shadow effect" characteristic of some coaxial systems.

- With a new diaphragm and phasing plug, the high-end response on all three models now extends to well beyond 15 kHz.
- All models now feature a BNC type connector to accommodate the Conductor Compensation™ feature of UREI's model 6500 Power Amplifier.

The new series "A" monitors from UREI are available in three sizes to suit any monitoring requirement. They're accurate, powerful and improved.

From One Pro To Another — trust all your toughest signal processing and monitoring needs to UREI.

Time Align is a trademark of E.M. Long Assoc., Oakland, CA. All referenced Trademarks are property of, or licensed by, United Recording Electronics Industries, a UREI Company.

UREI From One Pro To Another

United Recording Electronics Industries
8460 San Fernando Road, Sun Valley, California 91352
(213) 767-1000 Telex: 65-1389 UREI SNVY
Worldwide: Gotham Export Corporation, New York
Canada: Gould Marketing, Montreal H4T 1E5

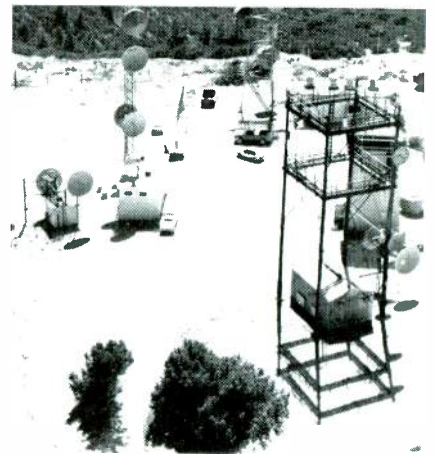

Think of us as your mike expert.



The lack of a consistent "station sound" is a problem many broadcast engineers wrestle to overcome every day. The simplest and often least expensive way of establishing and maintaining this station sound is the use of a professional-quality broadcast microphone.

The RE20, for example, is uniquely suited to eliminating the sonic variables caused by different announce mike techniques, voice-overs and interview setups.

"Single-D" microphones have proximity effect. The RE20 doesn't, and its unique dual-tube Variable-D design not only

assures uniform frequency response independent of working distance but also regardless of the talent's position within the cardioid pickup pattern.

The RE20 also eliminates the vocal inconsistencies often heard in post production when studio voice-overs are added to ENG tapes recorded in the field with omnidirectional mikes.

If a consistent "station sound" is your objective, a truly professional-quality microphone should be the first solution you should consider. See your Electro-Voice professional microphone dealer. He has the microphone you need.

EV **Electro-Voice**
a **Gulton** company

600 Cecil Street, Buchanan, Michigan 49107

In Canada
Electro-Voice Div of Gulton Industries (Canada) Ltd
345 Herbert St. Gananoque Ontario K7G 2V1

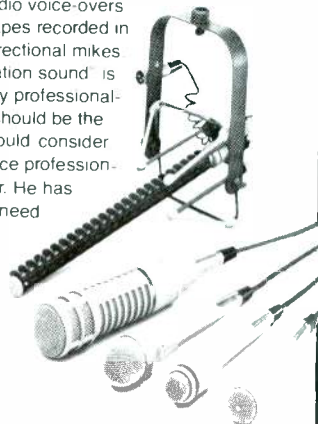

Diablo Canyon

about the plant and the protesters and the reaction to the protest from the fishermen who live and work out of the nearby towns of Avila and Port San Luis. The station also filed a piece on the construction workers at the power plant who had contracted with PG&E and, when the blockade occurred, would not be allowed to come to work or be paid.

Also, the Sacramento crew filed several stories on Diablo Canyon that were to be used during the crucial days of the blockade, including the history of the Diablo Canyon project and the story of how the station was accomplishing the live shot.

KRON rented a 24-foot RV in San Francisco and spent most of a day equipping it with a Sony BVE-500 editing station and an RCA 2-way radio system. It was also supplied with typewriters, script paper, riot gear, food and drinks. A bank of three Bearcat scanners was set up to monitor all of the action.

The station tied up only one of its mobile units, Van Six. By renting the RV, the station was able to maintain its live capabilities in and around San Francisco. In addition to the regular live reports to *Live on 4* and *NewsCenter 4 Update* from San Jose, KRON's Washington, DC bureau continued to send its daily feed via satellite to the station.

Telecopter 4 became an essential part of the entire operation. Daily, it transported a technician and equipment to the first relay point in the morning—Valley View Hill—and shot aeriels the rest of the day. It also served as transportation for the station's maintenance technician when he had to hop from site to site optimizing the links. The helicopter's aeriels proved invaluable as they gave perspective to the ground events.

A temporary news bureau was established on Sept. 10 at Port San Luis, approximately 150 yards across

Circle (19) on Reply Card

MUCH MORE CONTROL.

Presenting five signal processors from Yamaha that put you in charge of your sound: the F1040 and F1030 frequency dividing networks, the E1010 and E1005 analog delays, and the Q1027 graphic equalizer.

They offer the control, reliability and durability that are as professional as you are.

The active crossover networks: F1040 & F1030 These frequency dividing networks offer the superior sound and control of bi-, tri-, and quad-amplification. They also offer better specs, better frequency response, and more

headroom than lower priced competitive models.

The analog delays: E1010 & E1005 The creative applications of these two analog delays are almost endless. They offer echo, flanging, reverb, time delay, and double-tracking—just to name a few. And being analog, these delays retain the original audio signal for a true musical sound.

The graphic equalizer: Q1027 The Q1027 monaural $\frac{1}{3}$ octave EQ provides virtually infinite tonal control, from subtle to dramatic. A center detent position on each filter control removes that filter from the signal path, eliminating unnecessary phase shift. The Q1027 offers many attractive features, not the least of which is its reasonable price. It even includes rack-mount and acrylic security cover.

All Yamaha signal processors are designed to give you total command over your sound system with accurate, repeatable set-ups. The quality components, quality control and rugged construction assure you years of trouble-free operation—either on the road or in fixed installations.

For complete information, write: P.O. Box 6600, Buena Park, CA 90622. In Canada, write: 135 Milner Ave., Scarb., Ont. M1S 3R1.

Because you're serious.

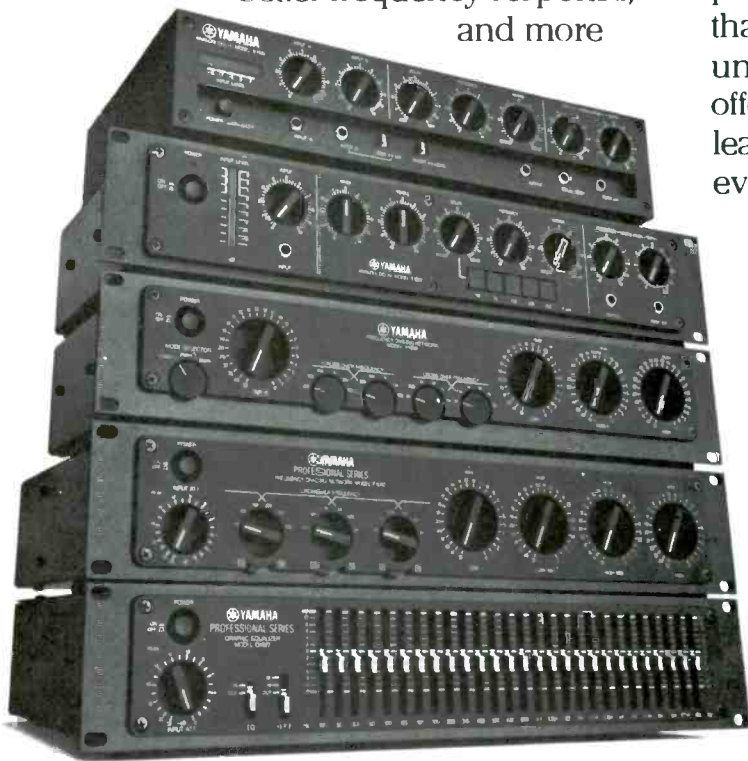

Circle (20) on Reply Card

 **YAMAHA**

Diablo Canyon field report

By Joe Berini, associate news director/engineering, KRON-TV



Port San Luis: 13GHz hop from front gate to van (½ mile) MA-13CP with horns. 13GHz hop from Port San Luis to Valley View Hill (14 miles) MA-13FA with 2-foot dishes. The real problem with coming out of Port San Luis is the surrounding terrain. There are hills surrounding the area on three sides. Shooting to Los Angeles is no problem, but going north posed seemingly impossible obstacles. IFB: Mobile telephone into a Comrex wireless Cue system (26.45MHz) had occasional problems with high power CB transmitters in close proximity. On telephone, we phoned our IFB ringdown so talent and camera operator could hear director. Only problems occurred when mobile operator disconnected because she saw no activity on line from our end. Worked that out with operator on another mobile channel.

Valley View Hill: 7GHz hop to Cuesta Peak (14 miles). MA-7CP Tx with 2-foot dish. Technician John Weaver also had a Bearcat Scanner and could monitor all police/sheriff frequencies. He would give us a running commentary on the radio activity. Site was literally inaccessible except by helicopter. Copter would

deliver Weaver and equipment in morning and pick him up at night. Power was provided by a 500W Honda generator. Not one failure! At one time the helicopter was not available so Bill Rinker drove a 4-wheel drive Bronco up the hill—quite a sight to see him coming down a 45° angle. Truck performed with flying colors.

Cuesta Peak: 7GHz MA-7EPI Rx with 2-foot dish. 2GHz hop to Calandra Peak. MA-2CP Tx with dual golden rods (Nurad) (45 miles). We found that KSBY's transmitter site on Cuesta Peak was so alive with RF that it obliterated any hope of seeing our signal. The co-channel interference was so strong that our 7 EP Rx with 30MHz IF Bandwidth was not selective enough. By moving up the road a mile or so, the problem was eliminated. This proved to be a good solid link with little fading. Technician Stan Drury drove to the site each morning and set up the equipment. Power provided by another Honda 500W generator. Worked like a charm.

Calandra Peak: MA-2CP Rx with MA single disc rod. 2GHz hop to Fremont Peak (65 miles). MA-2CP with PA-200 amplifier and Nurad

dual golden rods. Used channels 4 and 7 with filters at this site. No interference problems. The link between Calandra and Fremont was our only problem area. The hop is partly over mountainous terrain and also across the Salinas Valley. We experienced 20 to 40dB fades as the weather changed throughout the day. As the sun started to set and the valley cooled down, the signal would rapidly fade. Following sunset, the signal would stabilize again. Technician Paul Hilton drove to this site every morning.

Fremont Peak: MA-2GU receiver with MA dual disc rods. 7GHz hop to Loma Prieta. MA-7EPI Tx with 4-foot dish. Had some fading on the link but not deep enough to worry about. As seen from the pictures, this was the most *creative* site. Technician Ray Johnson climbed a 100-foot peak to mount the tripods and equipment. During the shoot, he frequently had to re-climb and realign the 2GHz due to the deep fading from Calandra.

Loma Prieta: This is one of our 5 TVPU receive sites around the Bay Area. From here the signal went via an ICR to Mt. Sutro in San Francisco (60 miles).



You always hurt the ones you love. And frankly, it gives us a little twinge every time we do all these brutal things to our Phaser IV.

After all, when we designed and built the Phaser IV, we put together, quite simply, the finest frame synchronizer ever made. To make it even more lovable, we offer it at the lowest price ever (under \$10,000).

So why do we put it through our torture chamber test? Why do we cook it? Freeze it? Shake it and drop it? Prepare it for the worst?

Because we want you to love our Phaser IV as much as we do.

And we know that the major cause of dissatisfaction with any product, is unreliability or breakdown. That's why we put our products through so much abuse. But that's also why we offer a 5-year warranty.

The fact is, we have made product reliability and service

COOKED. FROZEN. SHAKEN. DROPPED.

our number one priority. And a major new influx of money from a blue chip financial organization, is enabling us to carry out our plans.

We now have factory service centers in Los Angeles and Buffalo. So if something does go wrong we have the people in place, East and West, with know-how and facilities to fix it.

And what happens to your business while repairs are being made? Well, that's the real beauty of our new building

block design products like our Phaser IV. Each level of the product is a modular unit. And because each of our dealers is equipped with spares, he can immediately replace any defective board.

No adjustments required. Your equipment is never out of service for longer than the time it takes our dealer to get to your place of business.

If there's a major service problem, we won't fool around. We'll fly an engineer directly to your place of business to get to the bottom of the problem — and solve it. Not just for Phaser IV's, but for all our products.

The system can't fail. And when you add product reliability and outstanding service to our acknowledged innovation and technical expertise... well, as you can see, the future is all Digital.

And you can count on **DIGITAL DEPENDABILITY.**



Head Office
Digital Video Systems Inc.
716 Gordon Baker Rd
Toronto Ont M2H 3B4
Tel 416-499-4826, Telex 06-966686

Service Center
Digital Video Systems Inc.
869 Delaware Ave.
Buffalo, N.Y. 14209
Tel 716-885-4234

Service Center
Digital Video Systems Inc.
1686 Vine St., Suite 815
Hollywood, Calif. 90028
Tel 213-462-6153

For additional information call:
Toll Free (800) 828-7644
In New York (800) 462-1134

100% FINANCING! FOR UP TO TWO YEARS.

THE RAMKO RESEARCH BOTTOMLINE PLAN.™

That's right. Call us now and we'll give you all the details on a 10% simple interest, extended period finance plan for any Ramko Research or Technics professional audio product.

Call us collect at (916) 635-3600 or get in touch with your Ramko sales representative—today.

When we say that our products are engineered for your bottomline, we mean it.

RAMKO

Ramko Research, 11355-A Folsom Blvd., Rancho Cordova, California 95870 (916) 635-3600

Circle (21) on Reply Card

Diablo Canyon

the water from the front gate of the Diablo Canyon nuclear facility. That location gave the camera crews two good shots: the overall view from the van and a second shot, by microwave, from the front gate itself where an estimated 3000 protesters were expected to demonstrate.

On Sept. 9 and 10, station technicians headed for the various mountain-tops in an effort to establish the live shot by 4 p.m. on the 10th.

KRON had two reporters and three camera crews at Diablo Canyon for the duration of the demonstration, which lasted about eight days. Anchor/reporter Evan White arrived on the scene on Sept. 15, when things really heated up. White acted as a field anchor, throwing to reporters Ginger Rutland and Ron Regan on Sept. 15 and 16 during the peak of the demonstration. At that time, there were 20 crew members at Diablo Canyon.

The station filed stories on the training of the demonstrators, more reactions by PG&E officials and construction workers, and of course, all angles—including aerial reports—of the demonstration.

At the outset, a major problem encountered by the crew was getting the station's off-air signal to the reporters so they would know when they were on. The first day, arrangements were made at a local bait shop, the only place with a phone near the site. But two minutes before the first live shot, a fisherman walked by and, seeing the phone off the hook, hung up the receiver. Fortunately, the connection

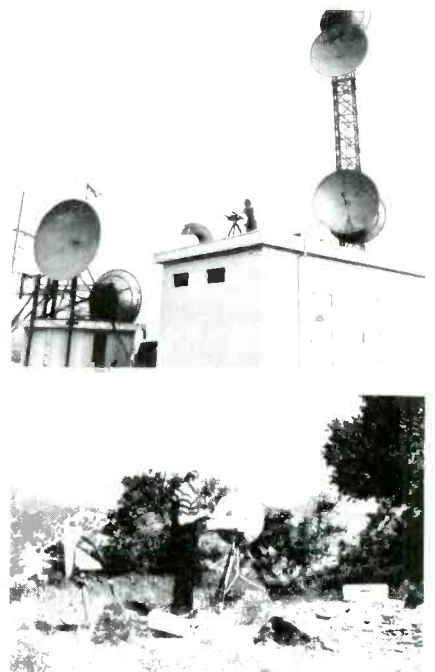

NEED A PRO WIRELESS INTERCOM "That Really Works"



SHOOTING LIVE
WITH NO SECOND
CHANCE...?

Swintek is the answer!

For over 10 years Swintek has been manufacturing RF intercoms which meet the needs of industry. Ask our customers, they know the score.

Swintek®

TELECOMMUNICATIONS DIVISION
1180 Aster Avenue, Unit J, Sunnyvale, CA 94086
(408) 249-5594 TELEX #172-150 SUVL SWINTEK

Circle (22) on Reply Card

HITACHI

FP21 COLOR CAMERA SYSTEM



2-FP21-3 Tube Saticon cameras
2-A10 x 11 BRW 10-1 lens power zoom F1.6
2-Operation panels with 50' camera cable
2-5" View Finders
2-I.T.E. Tripod sets H9PH, T6H, D6G
2-Lens drive kits
2-Battery-charger systems
1-PVM-8200T 8" color monitor

1-Triple 5" mono monitor WV-5203
1-M-67 Shure audio mixer
1-BPM-1 Burst Phase Meter
1-6142 Crosspoint production switcher
1-6006 Sync generator
1-528 Tektronic Waveform monitor
1-McMartin amplifier and speaker
3-Modular cases with covers

Modular three piece portable studio, packaged in protective cases with front and rear hard shell covers.
Single cable interconnect between modules for quick and simple set-up.

\$39,500 COMPLETE Price includes delivery, set-up and training.
Full manufacturers' warranty applies.

LERRO

ELECTRICAL CORPORATION
COMMUNICATIONS SYSTEMS DIVISION
3125 North Broad Street, Philadelphia, PA 19132

215-223-8200 Ask for John Neri or Ed Zwicker

Full line distributor for all Hitachi video products.

Circle (24) on Reply Card

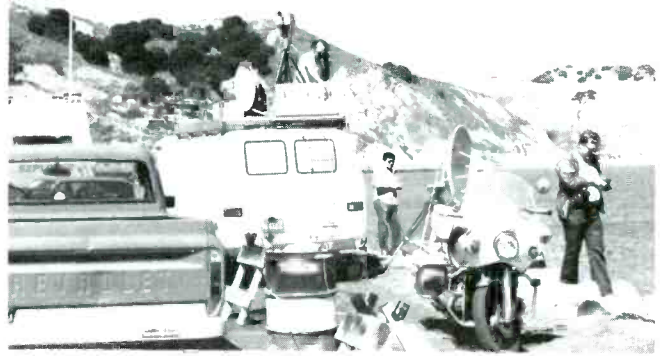
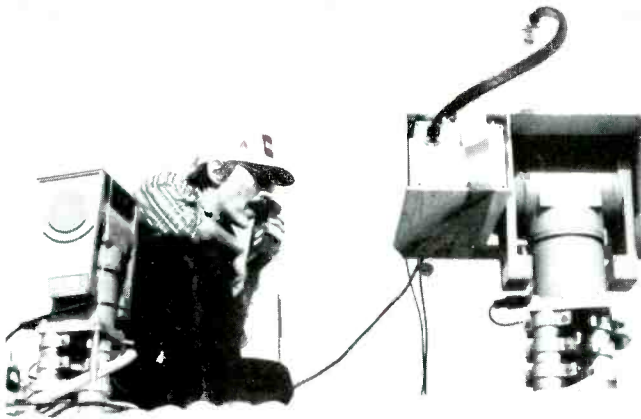

Diablo Canyon

was made again in time for the first live remote. KRON went to a mobile phone to get off-air audio for the rest of the Diablo Canyon coverage.

Mike O'Connor, reporter, and David Jaffe, camera operator, boarded the Stone Witch, a Greenpeace sailing vessel departing San Francisco with protesters who were launching the sea blockade of Diablo. At approximately 2:30 a.m. on Tuesday Sept. 15, after two days at sea, they landed at Avila Beach adjacent to the Diablo Canyon facility. Although they did not

have live capabilities aboard the ship, they did file reports that were microwaved back to the station from the Diablo Canyon remote site. The station provided exclusive coverage of the protesters landing ashore at the plant.

KRON's live coverage continued through 6:30 p.m. on Sept. 15. On that day, the station interrupted regular programming to provide live coverage of the arrests of more than 600 protesters. On the 16th, the microwave link was dismantled, but the station

remained at the plant until Sept. 19, filing daily reports and sending stories back to San Francisco by chartered plane. Reporter Ginger Rutland flew back to San Francisco twice during those last few days by charter to give her personal views on protesters' actions.

The station wrapped up its Diablo coverage with a final report at 6:30 p.m. on Sept. 20. The half-hour update covered all the activities leading up to and through the arrests at Diablo Canyon. □

Winsted

THE PERFECT
MATCH for
your video
equipment

LOW PROFILE EDITING CONSOLE

This new low-profile editing console combines operator convenience and over-the-top viewing. Generous 31½" rack space. Pullout VTR shelves and editor shelf bring editing equipment into easy reach; walnut woodgrain paneling blends with any decor.

Winsted traditional rugged construction features provide for safe support of valuable video equipment. Many models and configurations available.

THE WINSTED CORPORATION

8127 Pleasant Ave. So., Minneapolis, MN 55420

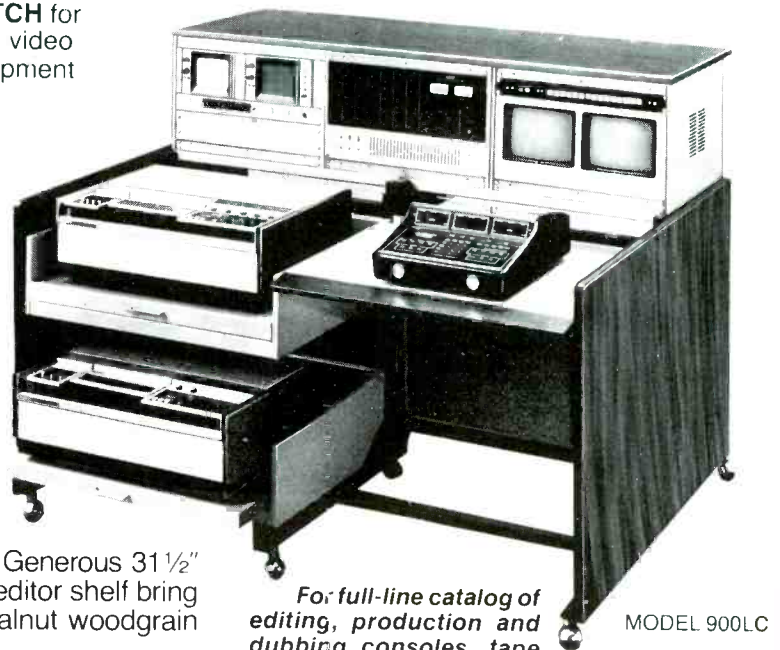

For full-line catalog of
editing, production and
dubbing consoles, tape
and film trucks, film and
videotape storage systems, call or write:

MODEL 900LC

PHONE TOLL-FREE
1-800-328-2962

Circle (25) on Reply Card

THE GUY WHO SAID "MONEY ISN'T EVERYTHING" PROBABLY DIDN'T HAVE YOUR JOB.

IF YOU HAVE TO JUSTIFY PURCHASE PRICE, COST EFFICIENCY AND VERSATILITY, YOU SHOULD BE LOOKING AT THE MARQUEE-2000 VIDEO PRODUCTION GENERATOR FROM B.E.I. MARQUEE-2000, THE GENERATOR THAT GIVES YOU THE FUNCTIONS FOR TODAY, THE CAPABILITIES FOR TOMORROW AND AN IMPRESSIVE LIST OF STANDARD FEATURES FOR ONLY \$26,500. CALL TOLL FREE 1-800-255-6226 FOR MORE DETAILS ON THE MARQUEE-2000 FROM B.E.I.



MULTIFONT DISPLAY Up to four fonts from the font library can be loaded from the disc and mixed on a character by character basis.



DOUBLE-HEIGHT LOGOS Large station or client logos can be displayed alongside two rows of text when using the double-height logo capability.

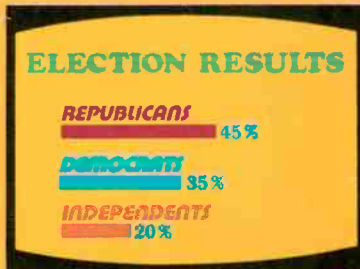

ITALICS Any row of text can be made to instantly assume a 13-degree slope at the touch of a key.



PROPORTIONAL SPACING Proportional spacing, true character overlap and variable inter-row spacing help produce captions of correct density and weight.



KEY OUTPUTS R,G,B and keying outputs are supplied from the Marquee-2000 so the output may be downstream keyed with the surrounding or drop shadow edging.

STANDARD FEATURES:

- Multi-font display capability
- 31.25 nanosecond resolution
- Internal 150-page disc memory
- Internal character and background color generator
- Edging: full surround, drop-shadow or no edging
- Proportional spacing with true character overlap
- 4 speeds of roll and crawl with auto-stop
- Automatic row centering
- Italics at the stroke of a key
- 16 horizontal tab locations
- Word flash and underline
- Character insert and delete
- RS-232-C input interface
- Double logo capability up to 128 scan lines high
- Engineer's service diagnostics card
- Preview safe area and system status display
- Firmware programming
- Compact size of mainframe

Leasing Plans Available



P.O. Box 937-Olathe, Kansas 66061
Toll Free 1-800-255-6226
In Kansas 913-764-1900
TWX 910-749-6401

Circle (26) on Reply Card

MAKE YOUR MOBILE 1 NUMBER ONE IN MOBILITY.



HANNAY REELS GET YOU IN AND OUT FAST.

No other reel is "remotely" as efficient as a Hannay Reel. You can mix and match stock parts to custom-design the ideal reels to make your hook-up and pick-up of all sorts of cable a snap. And with a wide choice of rewind options and unlimited sizes, shapes and capacities to choose from, you just can't wind up with a better reel. So when an exclusive depends on getting in and out fast, you handle the news, we'll handle the cable!



Send Today
For A Free Catalog.



CLIFFORD B. HANNAY & SON INC. WESTERLO, NEW YORK 12193
TELEPHONE (518) 797-3791

Circle (27) on Reply Card

Preventative maintenance on the BVU-50

By P. M. Smithshall, maintenance engineer, Glendale, CA

Since its introduction to broadcasters, the Sony BVU-50 has become the workhorse video recorder for portable use. Its light weight, small size, ease of operation, durability and low cost have made this U-Matic format recorder popular for electronic journalism from networks to the smallest independent stations. To maintain a high level of performance, however, the BVU-50 does need regular attention. Every unit should be sent to maintenance weekly for a "routine clean and check." Although this routine service takes only a few minutes, it conditions the machine for

another week of hard use. During the service the maintenance engineer will look at several areas to determine if more than routine adjustments are needed and if parts are worn. The checkout will provide a quick performance review of video, audio, servo and system control sections.

The checkup routine, if done as a set procedure, ensures that all items are covered. It starts with a visual inspection of the machine and includes cleaning as well as a checkout of video, audio and time code recording quality. Improperly operating circuitry should be repaired as soon as problems are found. Worn parts should be replaced immediately. Such immediate attention to any faults prevents the maintenance engineer from forgetting to complete a needed adjustment or repair. The necessary equipment includes regular

The author, writing under a pseudonym, is a qualified maintenance engineer working for a major network. Network management is concerned that this series of maintenance and modification articles on purchased equipment may be interpreted as a critique on the equipment rather than as efforts to achieve optimum performance or special effects. The author, therefore, is addressing these topics under his pen name to avoid conflict and misunderstanding.

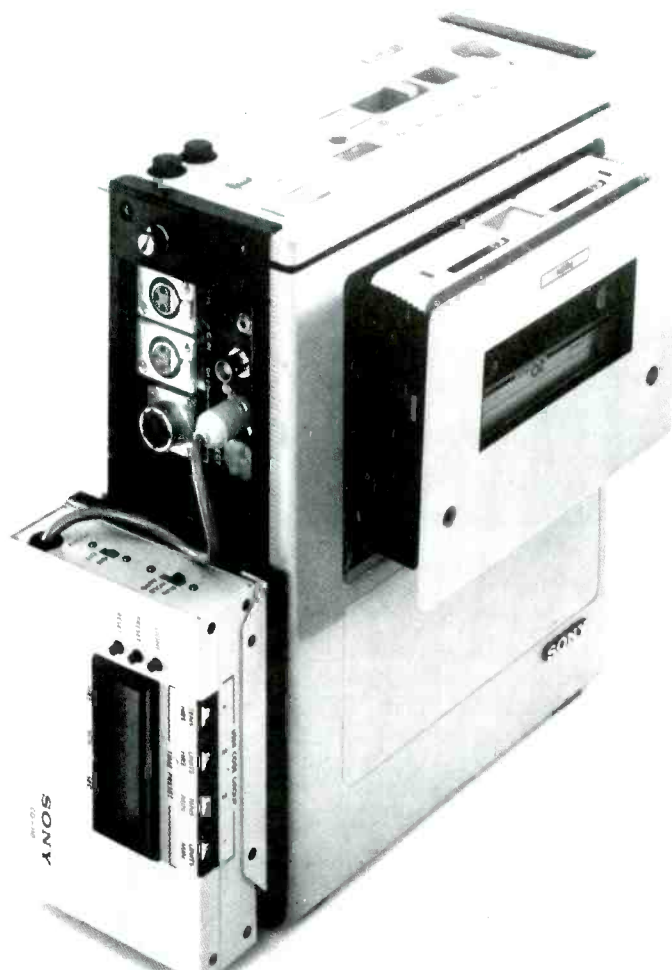

The BVU-50 with the CG-110 Code Generator.

Put FUJINON'S 17x9 zoom on an ENG/EFP camera and you may never take it off.



The universal lens for 2/3" format.

Instead of toting a truckload of lenses, take one—Fujinon's 17 × 9 zoom.

At the wide side, the 9mm focal length (equal to 18mm in 1 1/4" format) gives you wall-to-wall or full field coverage. Flip the built-in 2X extender lever and you can zoom out 306mm (600mm in 1 1/4" format). With optional wide and tele front converters, the limits are extended even further—7.2mm wide, 490mm tele.

Range like that removes practically all production limitations. So does the F/1.7 speed, ease of operation and light weight.

And with the most complete list of conversion accessories available for studio use, Fujinon has made the 17 × 9 the one lens you literally can take anywhere.

For more information or a demonstration call or write:

Check the specs:

Focal length:	9mm	153mm
	18mm	306mm (2X)
Maximum aperture:	F/1.7 (9mm)	114mm)
	F/2.3 (114mm)	153mm)
MOD:	9m	
Zoom:	Servo Manual	
Iris:	Auto Manual	
Focus:	Manual	
Weight:	2.1kg	



Fujinon Inc.
672 White Plains Road
Scarsdale, New York 10583
Phone: 914-472-9800
Telex: 131-642

118 Savarona Way
Carson, California 90746
Phone: 213-532-2861
Telex: 194-978

Circle (28) on Reply Card

"OUR NEW SONY ALL KNOWN

"Finally there's a 3/4-inch recorder that doesn't just inch along," says Fred Rheinstein, president of The Post Group.

A major post-production facility in Hollywood, The Post Group counts among its clients all three networks, PBS, and major cable TV and syndicated production companies. It will edit the new syndicated children's show "We're Moving" entirely on the BVU-800.

"The 800 is amazingly fast. To be able to go backward and forward at 40 times play speed means you can search for your edit points—and find them—more than twice as fast as ever before," continues Rheinstein. "And this machine goes from its highest speed to a still frame. Instantly. Without slewing or breaking up.

"It also has a direct-drive system, which promises greater reliability and accuracy.

"We have extremely critical clients," says Rheinstein. "They're used to the best performance, in terms of picture quality and in terms of flexibility. This new Sony can deliver it.

"It's the perfect combination of U-matic economy and broadcast quality. It's a true mastering process; with the BVU-800, there's no need to transfer to one-inch and lose a generation in order to edit your tape."



U-MATIC BREAKS SPEED RECORDS.*

Fred Rheinstein, THE POST GROUP

Other breakthroughs incorporated in the BVU-800 include its ability to make machine-to-machine cuts without a separate controller; its adjustable, removable edit control panel; and its narrow, front-loading design, which makes rack mounting possible.

"We've always bought a lot of Sony, because we can depend on the company for reliability and innovation," says Rheinstein. "Now, with the BVU-800, Sony makes its competitors look like they're operating in reverse."

Sony makes a full line of 1-inch and 3/4-inch broadcast equipment, including cameras, recorders, editors and digital time-base correctors.

For more information, write Sony Broadcast, 9 West 57th St., New York, N.Y. 10019. Or call us in New York/New Jersey at (201) 368-5085; in Chicago at (312) 860-7800; in Los Angeles at (213) 537-4300; or in Atlanta at (404) 451-7671.

SONY®
Broadcast

Sony and U-matic are registered trademarks of Sony Corp.



40 X NORMAL SPEED.

NORMAL SPEED.

*When used in conjunction with the BVT-2000 digital time-base corrector.

Maintenance

maintenance shop items with a well-aligned BVU-200, a color monitor with capability of displaying H and V intervals, a vectorscope and a time code reader.

A quick but thorough visual inspection is the first step. Although the operators should report any injury or severe bruising of the machine, the engineer must verify that there are no major dents or scratches in the case. The plastic control, bottom and side panels are inspected for cracks. If signs of abuse are apparent, attention should be focused on the machine interior beneath those trauma spots as the machine is opened.

After the exterior of the machine has been inspected, the machine is opened completely. Front and rear covers are removed. As each cover screw is taken out, note whether it was loose or not. A loose screw may indicate that the machine has been subjected to a large amount of vibration. A loose screw may also warn of loosened parts inside.

With the covers off, the transport mechanism is cleaned. The degree of required cleaning will depend on where the machine has been during

the week. A unit just back from Mount St. Helens or a space shuttle landing will probably be full of dirt. The machine assigned full time to city hall will require little cleaning.

The SS-9 and SM-10 boards must be moved to clean the machine properly. Under the SS-9 board is most of the tape loading/unloading and threading mechanism. Dirt on these parts can damage tape. The SM-10 circuitry covers all the mechanical linkages that operate the machine. All belts require inspection and replacement if necessary. Any debris in the drive train system must be cleaned out.

A liberal pinch roller replacement policy should be followed. Because the rollers have a fairly short life span, it is false economy to wait for a ruined story before changing them. If there is any glazing on the roller, a new one should be installed.

Air, lint-free wiping material* (for example, Texwipes), and plenty of freon work well for removal of dirt from moving parts of the transport. If the machine is dusty or contaminated by loose materials, an air hose is used. A good wiping with freon should follow. There should be no hesitation

about removing the cassette carriage or any other part in order to improve access to dirty parts.

Lubrication of some plastic-to-plastic contact surfaces is advised. Lubriplate**, even though used sparingly, will grab and hold just about anything that comes near, however. A major collection point for dust and other foreign materials is the threading motor reduction gear assembly. This assembly is at the bottom of the machine as it is carried by a shoulder strap. Any foreign matter that gets into the machine naturally falls down onto these lubricated gears. The gear assembly, held in place by two screws, is easily removed. The gears disassemble easily for cleaning. Overlooking this area may result in a machine jamming when it is least wanted. Following cleaning, fresh lubricant should be applied sparingly.

The tape path should be cleaned

*Sony Technical Training Seminars advise chamois material for cleaning.
**Lubriplate is not advised by the seminars as a lubricant.



Our Stereo Synthesizer isn't just for old mono records.

Applications of the 245E are limited only by your imagination:

- use it on announce mikes to create stereo depth without an image that shifts every time the announcer moves his head
- synthesize mono material before recording it on stereo cart; you'll minimize mono phase cancellation
- use mono cart machines and synthesize the output; you'll eliminate mono phase cancellation entirely
- create an audience-pleasing stereo effect from mono agency spots, network feeds and remotes

It's a dramatic, highly listenable sound that's fully mono compatible—just add the channels to get the original mono back. (If you get bored, you can always process old mono records into pseudo stereo.) Your Orban dealer has all the details. Write us for his name and a brochure with the complete 245E story.

orban
Orban Associates Inc.
645 Bryant Street
San Francisco, CA 94107 (415) 957-1067

Circle (30) on Reply Card

The verdict is in: the new OPTIMOD-FM Model 8100A is a smash hit! Hundreds of stations—large and small—in every format—worldwide—have already found out that the new OPTIMOD-FM is even cleaner, brighter and louder than the industry-standard Model 8000A it replaces. Improved naturalness, increased immunity to operator gain-riding errors, and an uncanny sense of musical *rightness* make the 8100A the processor of choice whether you're going for a loud, competitive sound, or the ultimate in transparent high fidelity. Run it multiband or wideband—either way, Orban's patented* circuitry gives you a competitive edge you'll find in no other processor—at any price.

Processing fads may come and go. But the 8100's adjustability and basic psychoacoustical correctness guarantee long, obsolescence-free service. Your investment is further protected by Orban's traditional battleship construction, outstanding customer service, comprehensive documentation, and quality and reliability control programs.

It's no secret that 8100's have been hard to find. But we've increased production capacity and added a state-of-the-art computerized final test and quality control station to make sure that you can now have an 8100A quickly. And the studio chassis accessory is now in production. It lets you split the 8100A system and place the compressor at the studio to prevent STL overload

Which leads to a final question: Can you afford to go through your next rating period *without* an 8100A? Your Orban Broadcast Dealer has the answer. Call Toll Free, (800) 227-4498. In California, (415) 957-1067 for the name of the dealer nearest you.

orban

Orban Associates Inc.
645 Bryant St.
San Francisco, CA 94107
Telex: 17-1480, Cable: ORBANAUDIO

*U.S. Patents: 4,208,548; 4,249,042; others pending

Super sound. Sound investment.

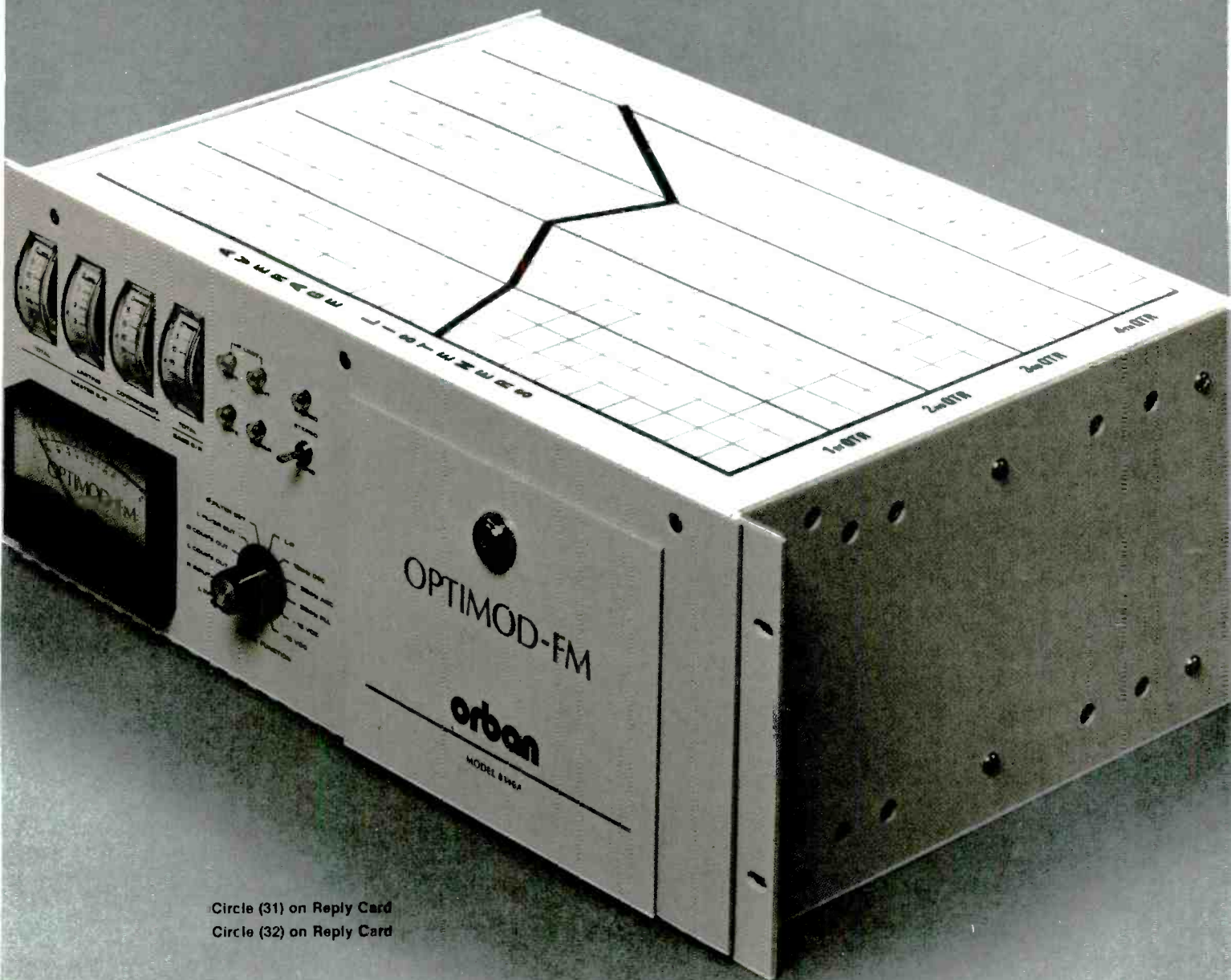

Circle (31) on Reply Card
Circle (32) on Reply Card

**With flexible,
field-proven,
electrically
transparent
Phillystran®
high-
performance
tower guys . . .**

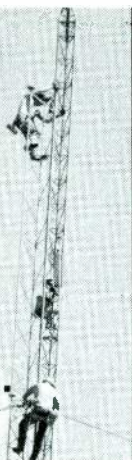

**the next time you re-guy
will be the last time
you re-guy!**

Phillystran HPTG for

- new towers re-guying
 insulating sections

"The leading edge on cloud banks generated static discharge on the metallic guys of our AM/FM tower. This caused on-and-off cycling of our transmitter.

"Phillystran eliminated that cycling problem. It also changed our D-shaped pattern into a preferred omnidirectional by eliminating the directional aspects common to steel guys."

Don Russell, Chief Engineer
WDAN-AM & WDNL-FM
Danville, Illinois

Phillystran HPTG, made
with DuPont's Kevlar® . . .

- 1. simplifies installation or re-guying of AM, FM, AM directional and TV towers.** Lightweight, flexible, yet as strong as EHS galvanized steel. Negligible creep and elongation for tension-once and walk-away installations.
- 2. eliminates EMI and RFI associated with steel guys . . . improves FM signals, while also eliminating UV degradation, chipping, water-intrusion and the breaking problems associated with fiberglass insulating sections.**
- 3. maintenance-free.** Nonconducting, noncorroding, nonmetallic. No painting or greasing required. Eliminates problems caused by severe chemical/industrial pollution. No insulators required. No problems with fire or vandalism because each socketed assembly includes a steel lead line.

"With Phillystran insulating sections, we had a 25% gain in our FM signal. Electrically-transparent Phillystran was our best investment in 1980."

Manuel Sanguinetti, General Mgr.
FRECUENCIA MODULADA S.R.L.
Radio FM 99, Lima, Peru

PHILADELPHIA RESINS CORP.



20 Commerce Drive
Montgomeryville, PA 18936
(215) 855-8450

call/write for new literature
and proven solutions to your
tower-guy problems.

Circle (33) on Reply Card

Maintenance

next. Tape guides, loading and tension arms, head drum, audio heads and capstan are all to be thoroughly cleansed, using the freon solvent sprayed onto the wiping material. Some care should be used when cleaning the head drum. The drum is rotated in the normal operating direction (clockwise when viewed from above), while holding the freon-soaked wiper against it. Turning the head drum in the reverse direction may cause the drum drive belt to fall off one of its pulleys. The lower part of the drum assembly should be wiped as well, making certain to cover all areas. The cleaning material should never be wiped across the plane of rotation of the heads, for example, up and down. The head chips are too delicate for the force exerted by cross-wiping.

The lower half of the drum has a rabbit milled into it as a guide for the lower edge of the tape. This rabbit tends to collect tape oxide. As the oxide builds up, it may change the tape path because the tape can no longer seat properly in the rabbit. A wooden toothpick or the sharp end of a broken Q-tip stick makes a good cleaning tool. Run the toothpick around the indentation to dislodge and pick up whatever particles may have collected there.

Once the transport and tape path have been cleaned, a test recording is made. For a video source, use standard color bars. Time code should be fed into the machine except where noted otherwise. During the recording test, stop the machine (pause mode) about every 10 seconds, leaving the machine in pause for varying amounts of time ranging from a few seconds to more than a minute. First, record at least 30 seconds with audio fed to both channels, level controls set for 100% meter readings. Then record another 30-second segment with no audio applied to either channel. Continue recording with audio connected to only one channel, adjusted for 100%, for a short period. Switch the audio input to the other channel, again set for 100% level. Finally, record another 30 seconds with no audio applied and during that time remove the time code input signal.

During the recording two things may be checked—the tape path and the RF sensor adjustment. Serious problems may develop from small ones, so spotting small problems may avoid later difficulties. Look at the tape as it runs. Does either reel hub move jerkily rather than smoothly? Does the tape pass over each guide smoothly? Are the edges smooth or fluttering? At the capstan, does tape bunch or sag at either edge? Edge flut-

tering or scalloping will be one of the first signs of trouble in most machines.

The RF sensor circuitry frequently misfires, giving a false RF alarm. The misfire is usually due to misadjustment of transformer T-62 on the AR circuit board. The tuning of the T-62 slug may change with vibration. Retuning is easy and may be accomplished while the test recording is being made. An oscilloscope is attached to test point TP-61 of the AR-5 or AR-7 board. With the scope display adjusted for a 0.5V/div. vertical and 5ms/div. horizontal, the machine in record mode and triggering adjusted for a stable pulse display, tune T-62 for maximum amplitude of a single spike every 16ms. The spike should be positive-going and should not show clipping.

Remove the tape from the BVU-50 and place it into the BVU-200 machine. As it rewinds, watch the time code reader display. The time code should be read, except when the generator was disconnected.

Once rewound, play the tape at normal speed. The servo lamps on the BVU-200 should show servo lock. The tracking meter indicates a steady level in the upper half of the scale. The time code indicator lamp is lighted. The vectorscope display should be as clean as is typical for a U-matic recording. Vectors should be distinct, properly placed and at proper levels. There should be no appreciable noise specks between them and jitter should be slight.

By moving the video cable from the video output to the RF output jack and changing the waveform monitor to 2V sweep with external sync, the display will show the RF envelope in sequence from the two heads. The two envelopes should be the same. Any appreciable variation between them indicates possible head wear. The RF envelope also tells a great deal about the tape path. During the recording, the RF signal is laid down at approximately the same time interval as the time required for the scope sweep. The start of the envelope display on the waveform monitor coincides with the head first meeting the tape. At the end of the display, the head is leaving the tape. Because the recording current should remain constant, so the envelope should maintain a constant amplitude throughout the display.

Peaking or dipping in the display indicates possible tape path error. Roll-off at the left end of the display points toward an entrance guide being out of position for a proper tape path. Roll-off at the right edge is indicative of an

The 40-4, a professional point of view.

Tape recorders are like tools. In the hands of professionals, they do their best work. And when professionals choose to use them time and time again, they become tools of the trade.

The TASCAM SERIES 40-4 recorder/reproducer is a shining example of a professional recording tool. Look inside.

The transport is the same as our 80-8 half-inch 8-track. Designed to handle the heavier half-inch tape, the 40-4 controls standard quarter-inch tape with remarkable ease.

It's rugged enough to take the constant wind/rewind process of building multitrack masters.

The switching matrix for record status and monitoring

make overdubs and punch-ins convenient as well as positive.

Calibration adjustments are readily accessible, because professionals constantly maintain their tools in peak operating condition.

The results produced on the 40-4 (and its 8-track companion, the 80-8) are a matter of record. Sometimes gold.

And results, on demand, for payment is what we think professional recording is all about.

Check out the details below, then check in at your authorized TASCAM Dealer. And get the inside story from another professional.

The impedance roller is strictly professional caliber. Along with the heavy dynamically-balanced flywheel, it guarantees better tape-head interface. Therefore, reducing the possibility of dropouts during a critical recording session.

Our exclusive Function Select initiates TAPE/SOURCE, PLAY-BACK/RECORD and dbx ENCODE/DECODE modes with just one button. Additionally, FET circuits (not mechanical relays) enable you to punch in and punch out without pops.

Heavy-duty motors, bearings and brakes assure you of smooth tape handling throughout the long hours of the multitrack recording process.

Individual, removable PC cards carry the electronics for record, reproduce and bias amps. So calibration or replacement comes quick and easy. Just swing down the meter panel for quick access.

Full IC logic and motion-sensing circuit lets you enter play mode quickly without risking tape spill or stretch.

The optional dbx module (DX-4) gives you a dynamic range of over 90dB. Because it's integrated, its electronics are perfectly calibrated to match the recording/reproduce circuits of the 40-4.

The heavy-duty power supply features a pro-quality toroidal transformer. This assures that each deck function will receive its correct voltages without any fluctuations. Even if your 40-4 runs constantly for 24 hours a day.

Thanks to our single record/playback head, you'll hear existing tracks in sync with full frequency response while over-dubbing at 15 ips.

TASCAM STUDIO SERIES
TEAC Production Products

**Your VU only
tells half the story,
unless it's a . . .**



**Bright-VU
Audio Level Display**

- 10 usec Peak Response or Switch-Selectable Avg. Readings
- Clear 3-Color LED Display covers 40dB Range
- Accurate to 1/2dB (30hz - 20khz)

Mono & Stereo Models
Rack Mount Option

**ONLY \$135 mono
\$250 stereo**

CALL TOLL-FREE 800-231-5870

(Texas call collect 713-782-4592)

Logitek Electronic Systems, Inc.

3320 BERING DRIVE □ HOUSTON, TEXAS 77057

Circle (35) on Reply Card

**24-HR.
PROFESSIONAL
SERVICE FOR
COLLINS &
CONTINENTAL
AM & FM
TRANSMITTERS**

Continental Electronics offers parts and engineering service for all Collins AM & FM transmitters.

Whenever you want parts or service for your Collins or Continental equipment, phone our service numbers day or night,

**(214) 327-4532 parts
(214) 327-4533 service**

Continental Electronics Mfg. Co.
Box 270879, Dallas, Texas 75227
Phone (214) 381-7161
1 kW thru 50 kW AM & FM transmitters and related equipment.



"A New Strength in Radio Broadcasting Equipment"

Circle (36) on Reply Card

Maintenance

out-of-position exit guide. Peaking or dipping in the middle of the display may result from tape path irregularities around the drum, for example, a dirty rabbit. Adjustments to components in the tape path should never be made casually. Audio, erase, and time code heads, as well as the tension arm, act as tapeguides in addition to the regular guides. An adjustment to any one may affect the overall path, making adjustments interactive. Any adjustments should be made one item at a time and in small increments. Generally if the machine produces useable pictures, and if it cannot be freed up for several hours time, leave such adjustment for another time. If tape path adjustments are to be made, the Sony BVU-50 PB Checker (P. N. J-600-495-OA) can be very useful. It requires the use of an RF-only tape (no video content). Proper adjustment may be achieved using a BVU-200 for playback if the BVU-200 is known to be properly adjusted.

Return the video cable to the video output jack. Play the tape again and watch the time code reader display. It should jump to reflect times the BVU-50 was in pause mode during the recording. Audio levels should indicate 100% on the BVU-200 meters.

Watch the picture monitor in a pulse-cross mode. The degree of skewing visible in the vertical interval reflects how closely recorder tension matches playback machine tension. For best performance in editing, all U-matic machines in the operation should have identical tension values. The tensions should be those specified in the BVU-200 alignment procedures. Observation may also be made for possible dihedral errors.

As the playback passes points when the recording was paused, momentary interruptions occur in servo lock. Almost no visible effect should appear in the picture. What will be visible is a minor horizontal line rolling through the picture from top to bottom as the tape restarts after a pause. It should be nearly invisible. The audio may pop slightly at each pause. On the waveform monitor the pause may cause some horizontal movement of the vertical interval. A well-adjusted machine will exhibit no position shift of the vertical interval. Some slight shifting will still allow "in camera" edits that are invisible on the screen.

During those times when audio was not applied to the audio channels, there should be nothing on the audio playback. Use an audio monitor that is clean enough to detect even small amounts of RF noise or time code

signal. At the time the time code generator was disconnected, if you can hear the disconnection being made, a time code noise problem exists that needs attention.

If the test recording has shown the BVU-50 to be in good condition, the heads and tape path should be cleaned again. Any loose screws should be snugged down. Any boards loosened for cleaning purposes are reinstalled, including any cover and insulating plates (for example, for the AR board). If the test recording indicated any problem areas, they should be addressed immediately before machine reassembly.

Before assembly a commercial glass cleaner or soapy water may be used to clean the cover pieces. Be sure that each section is clean and dry when placed back on the machine. Perhaps the single most common damage to the BVU-50 occurs when the covers are being replaced. The screws go into holes tapped into the soft aluminum frame. Slight pressure from the engineer is enough to strip the threads from the holds. The screws should be snug, not twisted tight.

This check procedure does not provide an in-depth performance review of the BVU-50. No checks are made on frequency response equalization for video or audio. Servo operation is gauged by the ability to make useable pictures. No effort is made to determine if servo systems are at the limits of operating windows.

Most maintenance shops have too few people to maintain a large number of field crews, vans and edit rooms. However, by running machines through a basic preventative routine, the frequency of major work required is reduced. If an operator requests a check on certain parts, the servicing engineer is guided to possible problem areas. A recorder returned from a hostile environment could require deeper examination. If the check list reveals any operating irregularities, attempt to solve the problem at once.

Avoid patchwork repairs requiring proper maintenance at a later date. A machine should go back out unrepaired only if the crew must have it right away and you have no spare machine to give them. Certain procedures may be developed or adapted for specific environmental conditions. Perhaps other waveforms or audio frequencies may be preferable under some conditions. In the long run, however, a general procedure such as this one will guarantee longer machine life with fewer field failures and much less time spent in the repair shop. □

BETTER **ENG/EFP** THRU FIBER OPTICS

Take your live ENG/EFP places you could never go until now. Artel's EN-1000 portable fiber optic system gives your crew a two mile camera-to-van range ... around any corners or obstacles.

- BROADCAST QUALITY VIDEO/AUDIO
- FIELD PROVEN ON NETWORK NEWS
- HALF THE COST OF MICROWAVE
- FASTER SET UP
- ULTRA-LIGHT WEIGHT
- LONGER DISTANCE

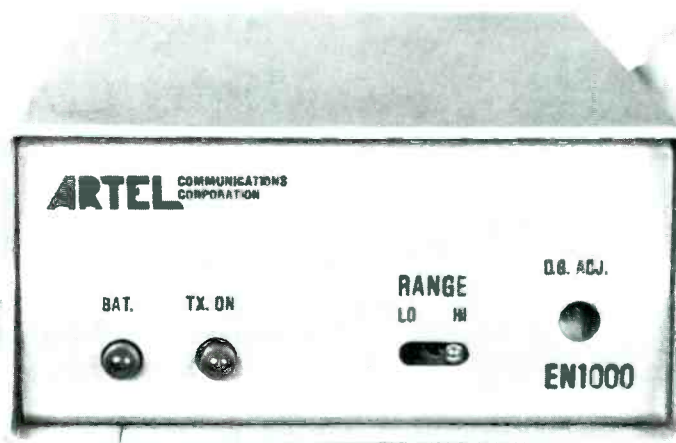

Call us to discover how the EN-1000 can improve your ENG/EFP operations, while saving time and money. Also ask about the Artel SL-2000 video/audio/data system for STL and entrance links.

ARTEL COMMUNICATIONS CORPORATION

P.O. Box 100, West Side Station,
Worcester, Massachusetts 01602 (617) 752-5690

THE SYSTEM THAT BROUGHT YOU THE SPACE SHUTTLE LANDING.

Field report:

The Aphex II Aural Exciter

By Dr. John M. Lyons, chief engineer, WRKS-FM, New York

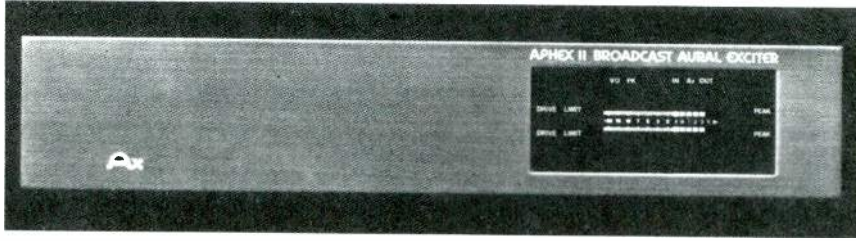

Aphex II

Editor's Note:

The field report is an exclusive **BE** feature for broadcasters. Each will be prepared by the staff of a broadcast station, production facility or consulting firm. The intent is to have the equipment tested on-site. The author is at liberty to discuss his research with industry leaders and to visit other broadcasters and/or the manufacturer to track down pertinent facts.

In each field report, the author will discuss the full applicability of the equipment to broadcasting, including personal opinions on good features and serious limitation — if any.

In essence, these field reports are prepared by the industry and for the industry. Manufacturer's support will be limited to providing loan equipment and to aiding the author if support is requested in some area.

It is the responsibility of **Broadcast Engineering** to publish the results of any piece tested, whether positive or negative. No report should be considered an endorsement by **Broadcast Engineering** for or against a product.

A critique of the Aphex II Aural Exciter should be prefaced with a description of the need for it. By the time program material is received by a listener it has been through several generations of copying and stages of electronics processing. What is usually lost aesthetically is the openness, punch and clarity of the signal. The race for loudness exacerbates these losses by further reducing dynamic range and changing frequency and

A report on the application of this equipment in an AM station is underway at another facility and will be published separately when it is completed.

transient response. To compensate for these losses, the usual approach is either fixed equalization or further dynamic processing. Although the initial listening may be satisfactory, the element of listener fatigue may appear.

The Aphex II takes a different approach to overcome the previously mentioned losses. According to the company's literature, the unit uses psychoacoustic principles. Instead of cutting or boosting a certain frequency range (for example, compression/limiting), the unit injects an *enhancement* signal into the original program. This is supposed to give the listener the perception of more ambience, clarity, presence and dynamic range without listener fatigue.

I am not qualified to judge the validity of these psychoacoustic principles. The end results, however, do reflect an overall, unique improvement to the audio:

The first impression of the effect seems to be a high frequency

Singer Broadcast Model FM 20,000 E

The FM 20,000 E...a proven performer over the globe...one model from the industry's most complete line of AM and FM Broadcast Transmitters. AM Transmitters from 250 watts to 100kW; FM from 10 watts to 100kW.

We're proud of the reputation we have earned world-wide personal service, quality equipment and competitive prices. That's why we're the largest independent supplier to the world's broadcasters.



**SINGER
BROADCAST
PRODUCTS,
INC.**

P.O. BOX 5500
CHERRY HILL,
NEW JERSEY 08034
TEL: 609-424-1500

Circle (38) on Reply Card



MAGNECORD 3000 for Program Automation and D.J. Assist

Motion sensing and CMOS logic control this spillproof 10½" transport, smoothly and positively. All functions are totally remote controllable with LED's indicating the operating mode.

For automated programming, an optical infrared sensor permits continuous cycling or rewind-to-start with clear leaders. Automatic Cue Release (AQR), provides simplicity of cueing and facilitates easy editing.

This powerful two-speed, three-motor transport operates over a wide range of 120/240 line voltages and features the MagneCORD 3000 HSM tape drive, a virtually indestructible polyurethane drive belt and pressure roller. Modular plug-in boards assure the fast service broadcasters require. And, of course, MagneCORDs are made in the U.S.A. so parts are readily available.

With automation in mind, the 3000 represents a new generation of tape transport, but with the same rugged design and dependability you've come to expect from MagneCORD.

Quality Products for the Audio Professional

TELEX® **MAGNECORD**®

TELEX COMMUNICATIONS, INC.

9600 Aldrich Ave. So., Minneapolis, MN 55420 U.S.A.
Europe: 22, rue de la Légion-d'Honneur, 93200 St. Denis, France

Circle (39) on Reply Card

Accurate Field Strength Measurements Can Be Easy

With the Model FIM-21, electromagnetic field strengths can be measured to within 2% across the entire 535 to 1605 KHz AM band. And to intensity levels as low as 10 $\mu\text{V}/\text{m}$. Its integral shielded antenna in the cover, front panel speaker, large illuminated mirrored meter, and ganged oscillator/receiver tuning, make it easy to operate in the field. An optional telescoping stand adds convenience. It's also a versatile instrument — use it as a tuned voltmeter for RF bridge measurements.

Contact us now for complete details on our line of field strength meters.

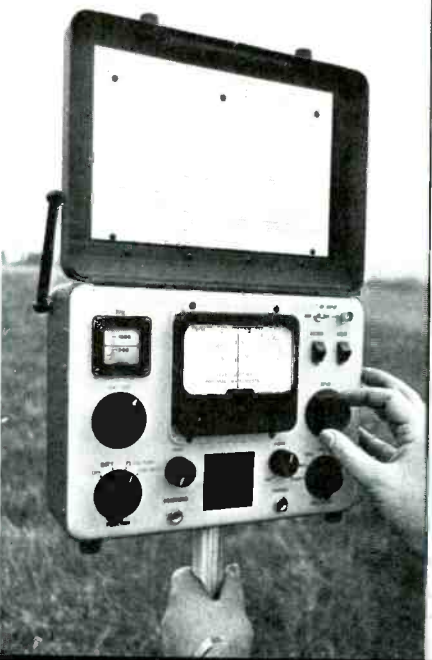

POTOMAC INSTRUMENTS
932 PHILADELPHIA AVE.
SILVER SPRING, MARYLAND 20910 (301) 589-2662

Circle (40) on Reply Card

TALK SHOWS TALK GETS CHEAPER

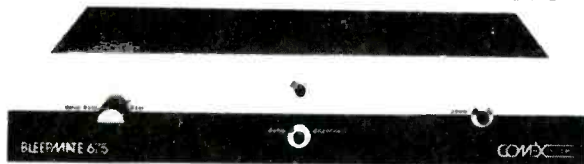

\$1,940 INTRODUCTORY PRICE

Comex Systems' Bleepmate 675, a new digital delay system for \$1,940. Improved technology makes solid-state performance and reliability affordable. No more tape headaches, no more maintenance hassles, and the best price/performance available. Bleepmate 675. Designed by professionals, used by talented professionals the world over.

Bleepmate 675 Specifications:

- No moving parts
- I/O impedance 600 ohms balanced/unbalanced
- 3 or 6 second selectable delay
- Frequency response +/- 1dB 20Hz to 5kHz -3dB at 7.5kHz
- Signal/noise ratio: 50dB
- Dynamic range: 72dB
- Distortion: less than 1%THD at 1kHz OdBm
- Dump only or Dump/Disconnect

DON'T DELAY WITH HEADACHE-PRONE TECHNOLOGY ANOTHER DAY!!!

THE INNOVATORS
COMEX
SYSTEMS

A Division of The Successor Corporation
Amherst, New Hampshire; (603) 889-8564
Distributor Inquiries Welcome

Circle (103) on Reply Card

Field report

boost. More listening, however, reveals greater openness and dimensionality. Subtle details in the program material become more apparent. When properly adjusted there should be no noticeable *processed* sound. The drawback is that the unit does not distinguish between *details* and anomalies. Noise, previous processing and distortion will be enhanced also.

Circuitry and controls

The unit generates the enhancement signal by splitting the signal into two paths. One path goes to a summing circuit, unmodified. The other path goes through a high pass network and a harmonics generator and is then summed with the unmodified signal. The corner frequency of the high pass network is tuneable from 1kHz to 6kHz. The range seems to be much broader than necessary. The useful range is 2.5kHz to 3.5kHz. A lower setting creates a honky sound with a very busy high end. A higher setting produces an effect on only the very high frequencies and is easily lost in transmission.

A *damping ratio* adjusts the filter characteristics of the high pass network. But the labeling of the control seems backwards: Full counterclockwise (minimum position) is overdamped; clockwise (maximum position) is underdamped. The 12 o'clock position is a 2-pole Butterworth. Perhaps the manufacturer tried to label according to the effect, inasmuch as the overdamped setting produces a flatter effect in terms of tonality change and the underdamped setting produces a peakier, brighter sound. A high corner frequency setting diminishes the effects of the damping control.

The signal is then driven through a harmonics generator. The amount of harmonics are level dependent, and that level is adjusted via *Aphex Drive* control. Because the total effect is level dependent, the levels coming out of whatever precedes the unit should be fairly consistent. There is a green/red LED on each channel that indicates *drive level*. The manufacturer suggests that this LED should be running green, flashing red on peaks.

The most subtle control of the unit is the *timbre control*: soft is even harmonics; hard is odd harmonics. Tonality does not change over the range of the control, but changes occur in the *texture* of the program. Even harmonics have a rounder, warmer effect. Odd harmonics have a

Continued on page 110

Consistent Quality.

Select your routing switcher and distribution amplifiers as if your reputation depended on their stability . . . because it does.

As you enter and re-enter your distribution system to produce a tape you discover the value of a truly transparent plant . . . one that stays transparent even when interchanging modules or re-configuring inputs and outputs.

Consider Dynair . . . we've built distribution systems for 24 years and REALLY know the importance of consistent quality. We use over 40 pages to detail the facts about our System 21 video, audio, time code, tally and data switchers and their companion Series 5300 amplifiers. May we send them to you?

DYNAIR

5275 Market Street, San Diego, California 92114
Telephone: 714/263-7711; TWX: 910/335-2040

Circle (42) on Reply Card

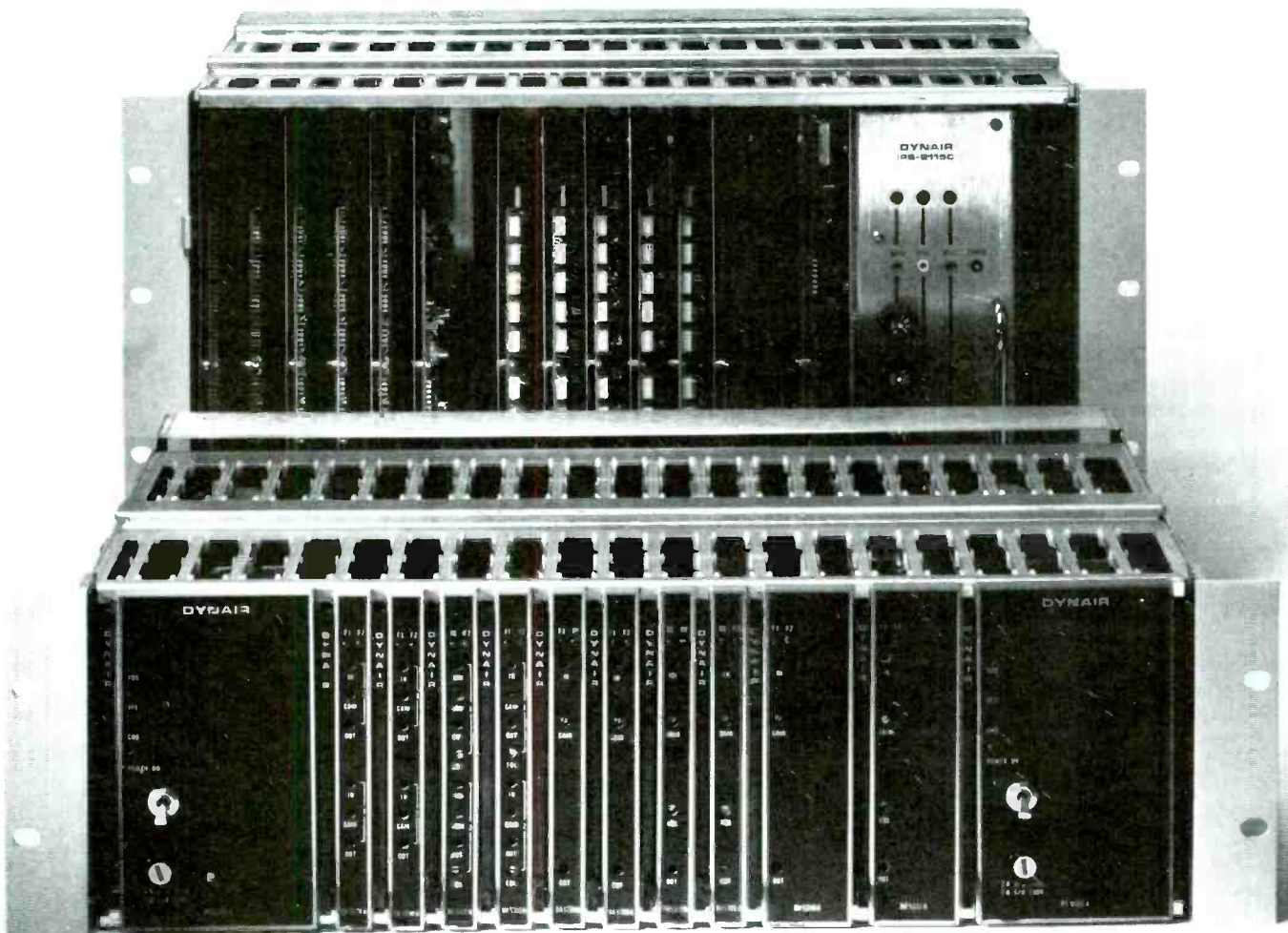

ENG/EFP camera survey

By Carl Bentz, technical editor

The transistor began a revolution in electronics design toward miniaturization that continues today. The roving camera has been reduced to an easily portable size used throughout the industry. Most TV camera manufacturers market self-contained hand-held portable cameras for remote use, which help keep news and documentary features current and immediate. Battery powered with automatic circuitry, these cameras allow a 2-man team (the camera operator and the reporter) to cover news events. The cameras require a

minimum of engineering expertise for ordinary use.

Whether the project is an insert to roll into the news or a full-length documentary, the ENG camera fills the bill. Urgency of an assignment may govern the use of videotape or ENG microwave equipment. The cameras work equally well with either. Accessory equipment makes the remote camera usable as an extra studio camera at a reduced cost.

An overall comparison of specifications among the many models of ENG cameras shows limited variations.

Gen-lock, color/ND filtering and intercom circuitry are available on all models unless noted. Program audio circuits with microphone attachments are also included. The information that follows attempts to show the items of basic interest, as well as automatic features of the cameras. For additional up-to-date information, the US representatives' addresses or the manufacturers' addresses are also listed. Reader service numbers may be used for individual products.



BCC-14

AmpeX Corporation
Audio-Video Systems Division
401 Broadway
Redwood City, CA 94063

The BCC-14 ENG/EFP camera requires minimal in-field setup time with auto beam control, iris control, centering and black/white balance. The camera is shock-resistant and rain-proofed. Three $\frac{3}{8}$ -inch Plumbicon pickup tubes complement f/1.4 optics. A 2-line in-band contour correction involves comb filtering and level dependency. Sensitivity of 1200 lux, f/2.8, 60% chart reflectance may be increased to 75 lux with up to +12dB gain control. The 50dB signal-to-noise ratio drops to 40dB under low light. With the $1\frac{1}{2}$ -inch viewfinder, the camera weighs approximately 12 pounds. A typical ENG lens and battery belt increase camera operator load by approximately 10 pounds. Optional equipment includes a 5-inch viewfinder and remote control unit for studio system integration.

Circle (200) on Reply Card

Operation of the BCC-20 Digicam is simplified by microprocessor-controlled automatic setup. The

computer-in-the-head also allows remote control setup. Spatial error correction achieves a 0.05% registration error overall. The three $\frac{3}{8}$ -inch standard or diode-gun Plumbicon or Saticon tubes are rear-loaded. These tubes sense light from the f/1.4 optical prism. Independent RGB horizontal aperture correction, H and V contours from green, mixed-highs processing and noise reduction enhance pictures in 200fc illumination at f/4. Usable pictures are possible at 6fc. NTSC signal-to-noise ratio rating is 53dB. Interchangeable modules allow operation with encoded video output to coax, TGB output to multicore cable, or RGB signals to optical fiber. Weight depends upon the configuration, ranging from 15 to 18 pounds. Viewfinders are available in $1\frac{1}{2}$ - or 3-inch sizes and optional studio accessories are available.

Circle (201) on Reply Card

Commercial Electronics Inc. (CEI)
880 Maude Ave.
Mountain View, CA 94043

The CEI-310 Modular Camera System is one of a series of compact, portable EFP cameras. It includes system adaptation from EFP and studio use to film chain and medical applications. The 3-tube $\frac{3}{8}$ -inch format may use Saticon or Plumbicon tubes with a bias-lighted prism optical system. Green channel video provides H and V enhancement with adjustable coring threshold and depth. Typical illumination requirements of 80fc at f/1.7, 60% reflectance result in a signal-to-noise ratio of 52dB. At f/1.4 with +12dB gain, full output signals are obtainable with 6fc illumination. A 3-inch viewfinder for portable

operation may be replaced with an 8-inch unit for studio use. An 8-pound camera head is used with up to 600 feet of cable to the 19 $\frac{1}{2}$ pound electronics unit. Typical automatic circuitry options include auto pedestal control and a SMPTE time code generator.

Circle (202) on Reply Card



CEI-330

The many features of the CEI-310 are consolidated into the CEI-330 Modular Camera System with a digital transmission system package that attaches to the 310 basic head. The unit may be used with TV-81 cable. The digital system allows use of up to 2400 feet of microcable between camera head and electronics unit. Studio integration is possible with the 3-inch viewfinder replaced by a 5-inch CRT.

Circle (203) on Reply Card

The CEI-340 Self-contained Camera attaches to any CEI-310 camera head. It features a microprocessor for auto self-diagnostic operation and black/white balance. The camera uses three $\frac{3}{8}$ -inch Saticon, standard or

If you want Plumbicon^{*} picture quality from your next TV camera buy— insist on Plumbicon tubes, because...

...if it's a professional TV color camera — it's available with Plumbicon tubes.

When you're paying top dollar for a professional TV camera, it is assumed by the manufacturer of the camera that you will specify the pickup tubes for your system. Obviously, the camera manufacturer wants to sell you *his* camera, and since he knows that the overwhelming majority of knowledgeable video purchasers will specify Plumbicon tubes, virtually every professional TV camera system produced for today's market is designed to use the Plumbicon tube.

The crucial factors of sensitivity, resolution and burn-in that affect the "total in-system performance" of ENG and EFP cameras and the consistent record of singularly brilliant performance of the one-inch and the 30mm Plumbicon tubes in studio cameras are generally credited for the professional's continued preference for Plumbicon tube-equipped cameras; that is why an estimated ninety percent of all network color broadcasting originates in Plumbicon pickup tubes.

*Registered trademark of
N.V. Philips of the Netherlands

Whatever your application — ENG, EFP or Studio; whatever the origin of your next camera — American-made or imported; and regardless of the camera salesman's personal persuasion (or his own compensation scheme) — you will get Plumbicon quality pictures only by specifying, insisting, demanding Plumbicon tubes in your camera.

Yours for the specifying, the full line of Plumbicon tubes — ½", ⅔", 1" and 30mm diameters, including low capacitance Diode Gun™ and special anti-comet-tail types — is available in the professional TV camera of your choice and is in demand today as never before by camera users in every segment of broadcast and corporate television.

There is only one Plumbicon, and that famous Emmy-award-winning pickup tube is available for the asking in every three-tube professional TV color camera sold today. For more information, contact: Amperex Electronic Corporation, Slatersville Division, Slatersville, Rhode Island 02876. Telephone: 401-762-3800.

Amperex

... dedicated to product excellence
A NORTH AMERICAN PHILIPS COMPANY

Circle (43) on Reply Card

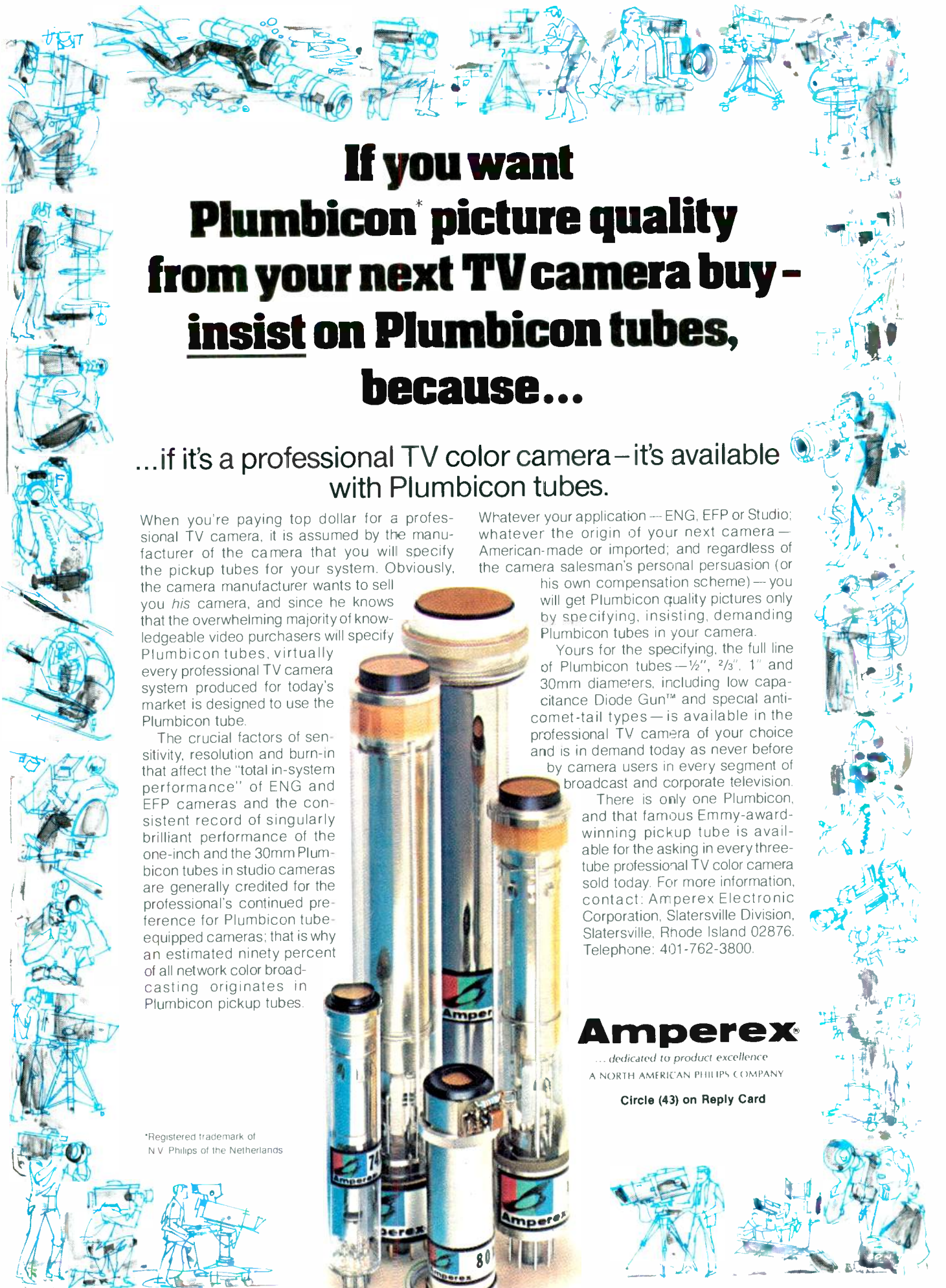

Survey

diode-gun Plumbicon tubes. 12Vdc operation is typical, but an optional ac supply is available. The 3-inch viewfinder may display the SMPTE time code and 32 user bits in drop or non-drop frame mode. The output is encoded video.

Circle (204) on Reply Card

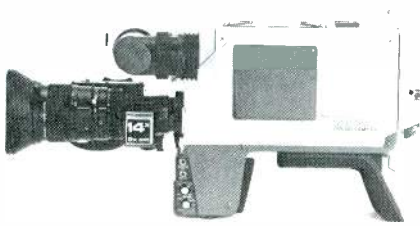

MNC-81A

Cinema Products Corporation

2037 Granville Ave.
Los Angeles, CA 90025

Extensive use of LSI hybrid microelectronic circuitry developed for the MNC-81A ENG/EFP Camera by NEC results in reliable operation with stable registration and performance. Pickup from three 2/3-inch Saticon as well as standard or diode-gun Plumbicon and f/1.4 prism optics pro-

duce a signal-to-noise ratio of 54dB for NTSC standards. Typical illumination of a 60% reflectance chart at f/4 with 2000 lux produces 1V P-P video. Gain control allows selection of +6, +12 or +18dB for lower light conditions. Two-line aperture correction with auto iris, black/white balance, beam control and optional centering are included in the camera head, which weighs approximately 11 pounds. The standard 1 1/2-inch viewfinder may be replaced by an optional 5-inch CRT. Other options include remote control panel, teleproduction camera control unit, digital remote control system, and optical module for optical cable transmission.

Hitachi Denshi America Ltd.

175 Crossways Park West
Woodbury, NY 11797

Auto beam optimizer with digital black and white balance memory eases operation of the FP-10 Single Tube Camera. A single 1-inch M-type trielectrode S-HS302 pickup tube reduces registration errors. Two-line enhancement allows a resolution of 450 TVL to be achieved. Operating with 2000 lux illumination the signal-to-noise ratio is typically 50dB. Maximum video gain available for low

light use is +12dB. Camera weight is approximately 12 pounds.

Circle (205) on Reply Card

Auto black/white control with auto beam optimization function make the FP-21 ENG Camera simple for non-technical operators. Three 2/3-inch Saticons provide 550 TVL resolution at picture center. Two-line enhancement is included. The 55dB signal-to-noise ratio is achievable with 2000 lux illumination. For low light, +18dB gain is available. Typical registration errors are 0.1, 0.2 and 0.4% for the three zones. Without lens the camera head weighs approximately 11 pounds.

Circle (206) on Reply Card

Automatics included in the FP-22 Camera are beam optimizer, setup and center registration. A diagnostic system aids in the digital setup operation. Three 2/3-inch Saticon tubes with 2-line enhancement provide horizontal resolution at picture center of 550 TVL. With 2000 lux illumination a 55dB signal-to-noise ratio is possible with additional gain to +18dB for low light operation. Maximum geometric distortion is 3% overall. The camera without lens provides about an 11 pound load for the operator.

Circle (207) on Reply Card

THE 6112 IS BOTH A PRODUCTION AND A POST-PRODUCTION SWITCHER

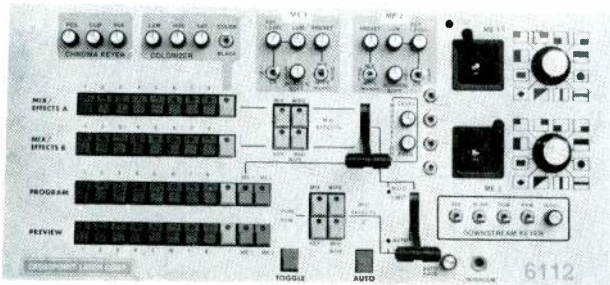

- TREMENDOUS PRODUCTION CAPABILITY
- EASE OF OPERATION
- TWO FULLY INDEPENDENT MIX-EFFECTS SYSTEMS
- AUTOMATIC MIX AND WIPE
- DUAL BACK PORCH CLAMPS
- ROCK STABLE CIRCUITRY
- DOWNSTREAM KEYER
- TWO ADDITIONAL KEYERS
- NO DELAY LINES

Model 6112 **NTSC \$7950**
 PAL \$8950

Chroma Keyers Encoded or RGB \$1050
(Encoded chroma keyer not available in PAL)

With the model **6403**, the **6112** is directly plug compatible with many editors. No modification to switcher or editor is required.

Under **6403** control the **6112** accepts commands such as duration times, pattern type, bus selection etc., directly from the editor keyboard. The **6403** also provides additional capability of accurate start and finish, size and position of pattern transitions.

CROSSPOINT LATCH has the largest selection of compact switchers - and switcher products to choose from. Write for our free Post-Production Booklet.

CROSSPOINT LATCH CORP.

95 Progress Street, Union, N.J. 07083 (201) 688-1510 Telex 181160

Circle (44) on Reply Card

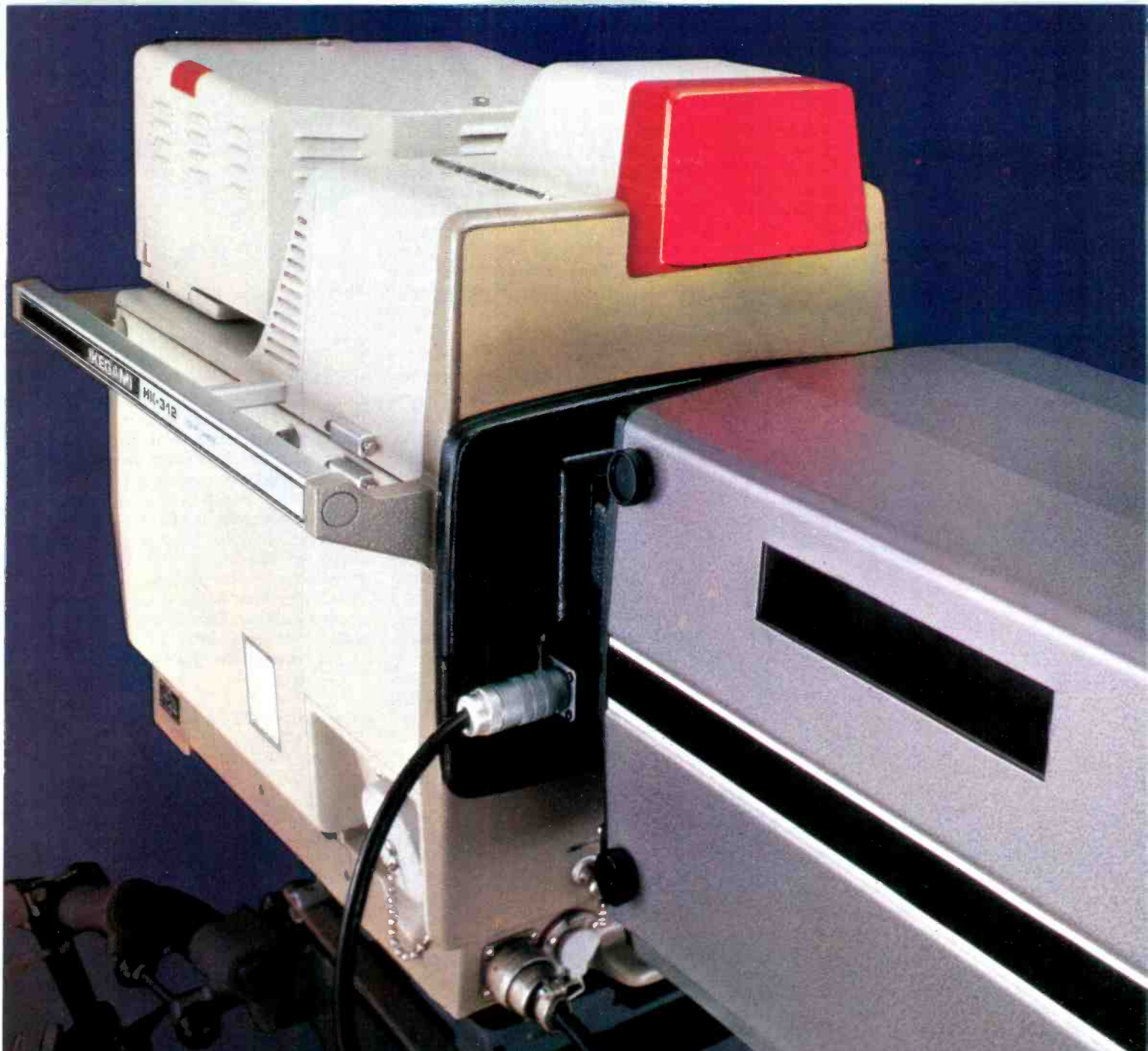

Self starter

For a fast start, no other studio camera comes close to the HK-312. It comes air ready. Just unpack it and it'll give you superior performance the first time. And, it'll keep working. The HK-312 helped establish Ikegami's reputation for legendary reliability.

The HK-312 is also an extremely stable camera that doesn't require time consuming adjustment. Add the optional Emmy Award winning computer setup and you can trim your daily checkout time even more—to less than a minute. Computer setup that has already proven itself at many leading stations.

The HK-312 includes all the essentials for superior picture quality and performance. High

resolution. Superb colorimetry. Plus an excellent signal-to-noise ratio. And with Ikegami Triax, you can extend the normal 600 meter cable length to 1500 meters with no compromise in picture quality.

One simple demonstration will show you why so many networks and leading independents are convinced that the HK-312 is the finest studio camera. To get started, contact Ikegami.



Ikegami HK-312

Ikegami Electronics (USA) Inc., 37 Brook Avenue, Maywood, NJ 07607: (201) 368-9171
Northeast: (201) 368-9171 West Coast: (213) 534-0050 Southwest: (713) 445-0100 Southeast: (912) 924-0061 Canada: (201) 368-9179

Circle (45) on Reply Card

Survey

The SK-81 Camera offers digital automatic white/black balance, beam optimizing and adjustable blanking widths. An f/1.4 prism optical system supports three 2/3-inch Saticon pickup tubes. Two-line enhancement enables 500 TVL horizontal resolution at picture center. Typical illumination is 2000 lux. Typical signal-to-noise ratio achieved is 56dB. For low illumination operation, +9 and +18dB gain levels are available in this ENG unit weighing almost 10 pounds.

Circle (208) on Reply Card

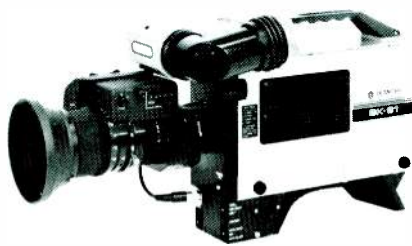

SK-91

Automatic control of the iris and black/white balance with auto iris closure complement auto beam optimizing of the SK-91 ENG/EFP Camera. The f/1.4 prism with bias lighting and three 2/3-inch Saticon or Plumbicon tubes is shock-mounted. The camera is RF-shielded to 120dB electromagnetic fields from MF to UHF frequencies. Out-of-green signals, level dependent with coring and comb filtering are added to RGB signals for 2-line H and V enhancement. Using the Saticon, with a setting of f/4 and 89.9% chart reflectance, the required illumination is 2000 lux. Additional video gain to +18dB allows acceptable use to 20 lux, f/1.4. The signal-to-noise ratio is typically 57dB. The standard 1 1/2-inch viewfinder may be replaced with an optional 5-inch system for studio use. Accessories for optional configurations using the 10-pound camera head (approximate weight) include an operation panel and a remote operation unit.

Circle (209) on Reply Card

Ikegami Electronics (USA) Inc.

37 Brook Ave.
Maywood, NJ 07607

The HL-78A ENG Camera is lightweight, compact and well-balanced. It features fast setup. Auto white balance, iris, iris closure and beam control speed the setup procedure. Three 2/3-inch separate mesh Saticon or Plumbicon pickup tubes function with an f/1.4 prism. Standard

illumination of 2000 lux on an 89.9% chart reflectance provides 1V of video at f/4.5. Gain control to +18dB increases sensitivity to 27 lux at f/1.4. The zero gain signal-to-noise ratio is typically 54dB. Contours from green with coring and noise slicing enhance the video in both H and V. The standard 1 1/2-inch viewfinder gives way to a 4 1/2-inch optional unit for system operation. Remote control unit option allows studio integration of this 13-pound camera.

Circle (210) on Reply Card

Beam control, black stability, iris control/closure and white balance are handled automatically by the HL-79D. Adjustable blanking is available for both H and V. Pickup tube options for the 2/3-inch tube camera include Saticon or standard, low capacity diode-gun and standard diode-gun Plumbicon options. The f/1.4 prism optics include bias lighting for low light lag reduction. Detail correction includes coring and noise slicing with comb filtering. Standard lighting is suggested at 2000 lux for f/5 opening. A gain of +18dB allows 20 lux illumination with f/1.4 setting. Low capacity diode-gun Plumbicon pickup tubes offer a 57dB signal-to-noise ratio. The HL-79D is available in several configurations. For ENG operation, a 1 1/2-inch viewfinder is used. The MA-79 option allows multicore cable remote control. TA-79 provides triaxial remote control. Both 4 1/2- and 6-inch viewfinders allow studio operation. The 6-inch unit is part of the HL-790A studio packaging option. The ENG option weighs in at about 15 pounds with the 1 1/2-inch viewfinder in place.

Circle (211) on Reply Card

Auto white balance with 2- to 3-day memory, dynamic beam stretching, and auto iris/closure are features of the ITC-350 ENG/EFP Studio system. Using three XQ-1428 Plumbicon or H-9311 Saticon tubes, the f/1.4 prism allows standard illumination of 2000 lux for an f/4 opening onto a 90% reflectance chart. H and V enhancement are available with a signal of 500 TVL at picture center. Signal-to-noise ratio of 52dB is typical. For ENG use, the 1/2-inch viewfinder is standard. A 5-inch CRT unit is available when the camera is incorporated into a studio system with the CCU-351 remote control unit. The camera head weighs 11 pounds.

Circle (212) on Reply Card

For the TV producer who is acquainted with cinematography, the EC-35 Electronic Cinematography Camera includes a specially designed set of lenses that are calibrated in

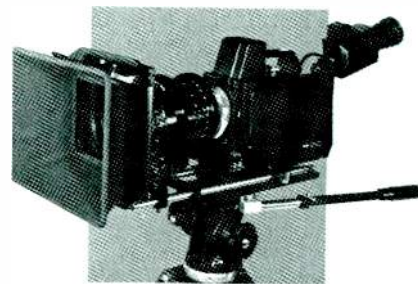

EC-35

T/stops. With microprocessor control, setup is automatically performed. Gamma circuitry uses special technology to match the response of film. Three 2/3-inch low capacity diode-gun Plumbicons start the image on its way through image enhancement. This proportionally mixes out-of-band aperture correction for a 400 TVL 100% depth of modulation. Typical sensitivity is at 2500 lux, T/4. The signal-to-noise ratio is 57dB uncorrected. The weight with a 1 1/2-inch viewfinder is 18 pounds. A 6-inch viewfinder may be used instead or a second unit may be connected for the assistant cameraman.

Circle (213) on Reply Card

International Video Corporation

453 W. Maude Ave.
Sunnyvale, CA 94086

Auto color balance, flare compensation, gain stabilization and timing pulse advance provide the basic system of the IVC-7000P with little operator-required adjustment. Optional auto iris circuitry uses flesh-tone priority for proper exposure, yet maintains highlights in the absence of fleshtones. A f/1.6 prism optical system uses three 1-inch Plumbicon pickup tubes, allowing a wide selection of 1-inch format lens systems. Noise coring and comb filtering are included in adjustable detail control, with horizontal peaking at 3.58MHz to optimize detail on receivers. A 60% reflectance chart at f/2.8 requires 1000 lux to provide a 51dB signal-to-noise ratio. A 3-inch viewfinder is included in the 16-pound weight of the camera head. Operation up to 200 feet from the control pack is possible in all standards with composite video as well as RGB outputs available. A studio adaptor is optional.

Circle (214) on Reply Card

Link Electronics Ltd.

Northway, Andover
Hampshire SP10 5AJ England

For PAL standards operation, the MNC-82A (NEC) Camera is flexible yet simple to operate. Beam control, white balance, iris closure and optional centering are automatically controlled. Image pickup may be

IT'S ABOUT TIME



LEITCH

Progressive Concepts in Television Technology

Leitch Video of America, Inc.
825K Greenbrier Circle
Chesapeake, VA 23320
Tel: [804] 424-7920 Telex II: 710 882 4342

Leitch Video Limited
705 Progress Avenue
Scarborough, Ontario - M1H 2X1
Tel: [416] 438-5060 Telex: 065-25420
Circle (46) on Reply Card

Survey



MNC-82A

through three $\frac{3}{8}$ -inch Saticon, standard or diode-gun Plumbicon units through the f/1.4 prism optical system. Two-line aperture correction is included. Scene lighting of 2000 lux for an f/4 setting on a 60% reflectance chart provides full output. Additional video gain levels of +6, +12 and +18dB are available. The PAL signal-to-noise ratio is 52dB. Standard ENG configuration offers a $1\frac{1}{2}$ -inch viewfinder. Optional equipment for studio use includes a 5-inch viewfinder, as well as adaptors for use with multicore, coaxial and fiber-optic cables. Weight without lens of the MNC-82A is approximately 12 pounds.

Circle (215) on Reply Card

Marconi Broadcast Systems

100 Stonehurst Court
Northvale, NJ 07647

Operable manually or automatically in ENG or studio configurations, the Mark IX may be used as a hand-held or tripod-mounted portable camera. The accompanying CCU with automatic modules provides centering, color balance, iris, master black, registration and dynamic gain functions. Three 1-inch lead oxide pickup tubes may be HOP type with bias lighting, including standard or extended red. Prism optics are used. Image enhancement is included. With a lens opening of f/2.8, 1100 lux is sufficient on a 60% reflectance chart for full output. NTSC standards operation exhibits a 49dB signal-to-noise ratio. The 1-inch viewfinder is standard. Three-inch and 7-inch units are available for other camera configurations. Conversion modules are available for use with NTSC, PAL and SECAM standards. The camera head weighs approximately 14 pounds and may be operated with multicore cable or triax.

Circle (216) on Reply Card

NEC America Inc.

Broadcast Equipment Division
130 Martin Lane
Elk Grove Village, IL 60007

In a dust-proof and rain-proof housing, the MNC-80A Series ENG/EFP Camera offers automatically controlled black/white balance, iris, iris closure, beam control and optional centering functions. Three $\frac{3}{8}$ -inch Saticon, standard or diode-gun Plumbicon tubes use f/1.4 prism optics to produce a resolution of 500 TVL at picture center. Two-line aperture correction is included in the package. Sensitivity rating figures give 2000 lux, f/4, 60% reflectance, typically with Plumbicon pickup tubes. The NTSC signal-to-noise ratio is 54dB. The approximately 10-pound weight does not include the $1\frac{1}{2}$ -inch standard viewfinder or a lens. Additional video gain to +18dB is possible for low illumination conditions and the REMOCON Panel is available for integration of the camera into a system. The series includes the MNC-81A NTSC, MNC-82A PAL, MNC-83A SECAM and MNC-84A PAL-M units.

Circle (217) on Reply Card

Panasonic Company

Video Systems Division
One Panasonic Way
Secaucus, NJ 07094

Feedback beam control and auto white balance with auto/manual iris highlight the operation of the AK-710 ENG/EFP Camera. Three $\frac{3}{8}$ -inch H8399 Saticons with dichroic prism optics provide image pickup. Horizontal aperture correction with vertical enhancement are standard equipment for a 500 TVL resolution at picture center. Illumination for zero gain operation with f/3.5 is 2150 lux. Increased gain to +12dB with f/1.8 lens opening allows camera use to 139 lux. With no corrections added, the signal-to-noise ratio is given as 52dB. With the standard $1\frac{1}{2}$ -inch viewfinder, the camera weighs approximately 11 $\frac{1}{2}$ pounds. An optional $4\frac{1}{2}$ -inch viewfinder and remote control unit are available.

Circle (218) on Reply Card

Electronic color conversion, color conversion filtering, auto iris and auto white set aid non-technical camera operators of the AK-750B ENG/EFP Portable Camera. A dichroic mirror optical system separates light to three $\frac{3}{8}$ -inch XQ-1428 Plumbicons or equivalent tubes. Two-line vertical enhancement is standard. With a lens setting of f/4, 2150 lux will provide full video output. A 50dB signal-to-noise ratio is applicable. The standard package weighs 16 pounds, including a $1\frac{1}{2}$ -inch viewfinder. Optional equipment includes a $4\frac{1}{2}$ -inch CRT display and the AK7250 remote control unit.

Circle (219) on Reply Card

The AK-760 ENG/EFP Camera features operational flexibility, increased by feedback beam control with auto white balance and auto/manual iris. High-index prism optics include bias lighting for three $\frac{3}{8}$ -inch diode-gun Plumbicon tubes. Horizontal aperture and 2-line vertical enhancement are standard features. At zero video gain the camera will provide full video output with an f/4 lens opening under 2150 lux illumination. Increased gain (to +18dB) is available. Signal-to-noise ratings to 54dB are found with the AK-760 camera. The standard equipment package includes a $1\frac{1}{2}$ -inch viewfinder. Total camera head weight is 13 $\frac{1}{2}$ pounds. Optional equipment includes a $4\frac{1}{2}$ -inch viewfinder and a remote control unit.

Circle (220) on Reply Card



LDK-14S

Central Dynamics Corporation

900 Corporate Drive, Box 618
Mahwah, NJ 07430

The Philips LDK-14S ENG/EFP Studio Camera features auto and momentary iris with iris closure, dynamic beam control, auto color balance and auto centering, allowing easy setup in most situations. Three $\frac{3}{8}$ -inch Plumbicon tubes combine with f/1.4 prism optics to provide a sensitivity of 750 lux at f/2.8 with an 89.9% chart reflectance. A 2-line contour enhancement generator uses comb filtering, level dependence and coring circuitry for minimal noise. Independent black and white stretch circuits enhance detail. Use of XQ-1427 Series Plumbicons provides a signal-to-noise ratio of 54dB typically in NTSC standards operation. While a $1\frac{1}{2}$ -inch viewfinder is standard for ENG use, an optional 5-inch unit is available for studio operation. Camera weight is approximately 13

Compare

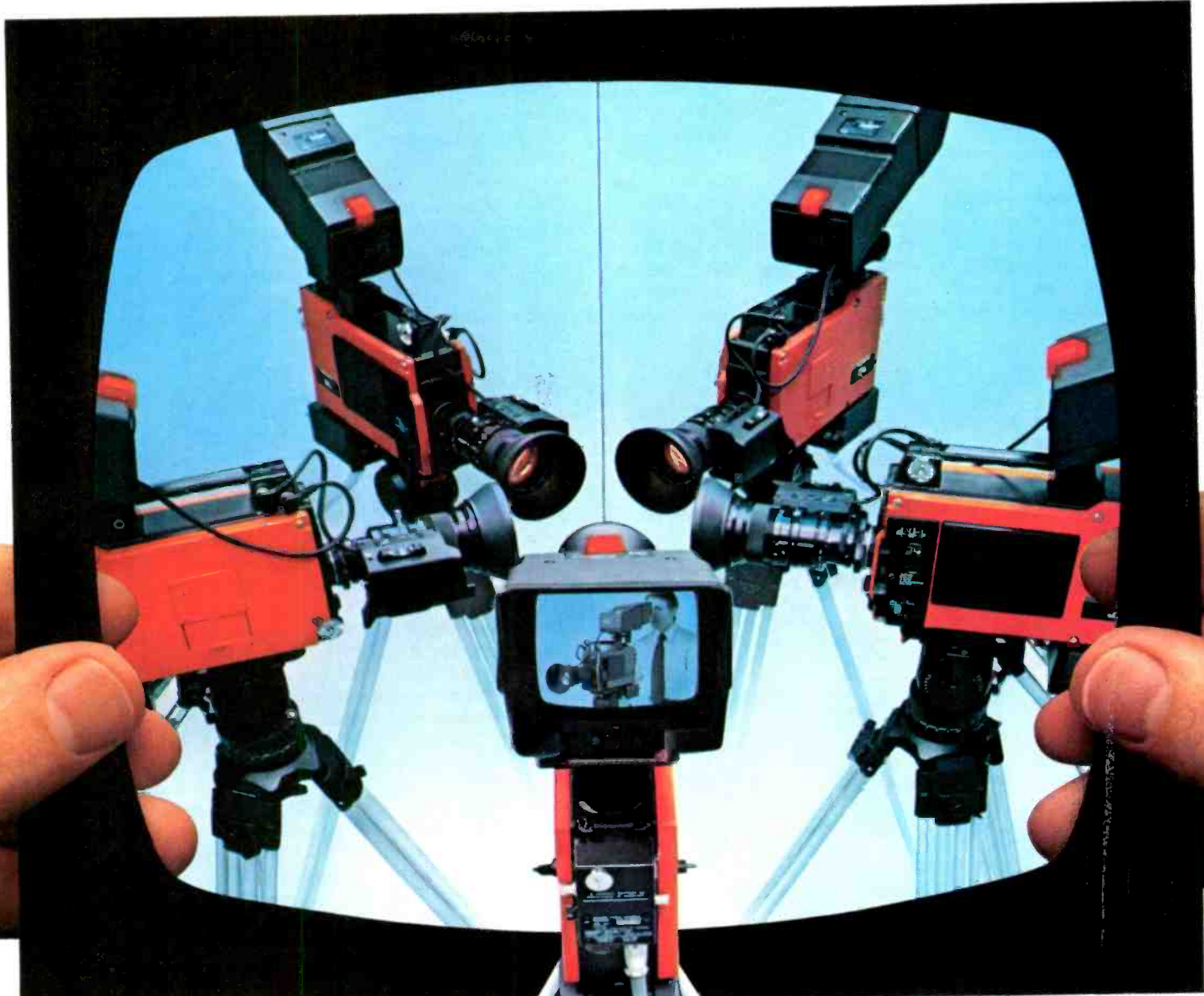

JVC's Professional Video Dealers want you to compare the newest member of the KY family of 3-tube color cameras to any other camera you may be thinking of...and to others you may have eliminated because of their high prices.

COMPARE PERFORMANCE:

The KY-2700 holds registration specs to a tight 0.1, 0.2, and 0.4%, for crisp clean pictures. That's stability!

The KY-2700 has dual-edged vertical and horizontal contour correction for the detail and sharpness you require, 500 lines resolution, and for virtually noise-free video, 54db signal to noise. That's performance!

COMPARE FEATURES:

A fast, 14:1 Servo zoom lens, Automatic Beam Control (ABC), Automatic White Balance with memory, Automatic Black Stabilizer circuit (ABS), a low 18 watt power consumption for extended battery operation, "Instant On"

The new KY-2700



performance. And much more. That's a lot.

COMPARE VALUE:

No other professional 3-tube color camera can match these specifications at a price even near the KY-2700.

That's a pleasure. Compare it at your JVC Professional Video Dealer NOW!

For more information, call toll-free 800-821-7700, Ext. 7005. (in Missouri, 800-892-7655, Ext. 7005.) Or write US JVC Corp., Dept. BE 1/82, 41 Slater Drive, Elmwood Park, NJ 07407. Available in Canada from JVC Canada, Inc., Ontario.

**Your choice.
Now. JVC®**
US JVC CORP.

Survey

pounds without lens. Optional accessories include a remote control unit and triaxial interfacing for the triax remote control system.

Circle (221) on Reply Card

RCA Broadcast Systems

Front and Cooper Streets
Camden, NJ 08102

Auto flare compensation, iris control and comet tail suppression for up to 16x highlight overloading are features of the TK-76C Portable Self-contained Camera, which provide

freedom from power and video cabling. The prism optical system includes bias lighting for use with three Saticon or Vistacon pickup tubes. Horizontal and vertical aperture correction involve comb filtering to minimize noise and luminance-chrominance interference with coring and in-band peaking. Using an f/2.8 lens setting on a 60% reflectance chart, 1250 lux illumination is required. Increased sensitivity is available with +9 and +18dB gain settings. NTSC standards mode achieves a 54dB signal-to-noise ratio. The standard 1½-inch viewfinder may be replaced with an optional 5-inch tiltable unit. Options for further flex-

ibility include a belt-pack interface to the TK-760 CCU, a triax cable adaptor and a remote control panel with joystick for black/white pedestal and iris control. The camera head without lens weighs approximately 15 pounds.

Circle (222) on Reply Card

Auto/manual iris control, auto white balance and flare control with comet tail suppression circuitry are improved features of the TK-86 Portable Camera. Saticon and Plumbicon pickup tubes, their three yokes and f/1.4 prism optics are mounted in a single casting for mechanical stability. Comb filtering and coring techniques are used for enhancement and aper-

Update on VRCs

The long wait may be over for the various video recording cameras (VRCs) introduced at NAB '81. Representatives for Ikegami, Panasonic, RCA and Sony were recently contacted regarding progress being made on final production plans (See **BE** June '81). Their comments are promising.

Ikegami hopes to provide the recorder unit for the HL-83 no later than mid-'82. The HL-83 camera should be available for delivery in January. Three ¾-inch Saticon or Plumbicon tubes with f/1.4 prism optics form the basic design with automatic circuitry for white balance, iris control and dynamic beam stretching. Expanded white control will replace the color filtering requirements. At 2000 lux and f/4.5, a 57dB signal-to-noise ratio is expected. The camera is to be adaptable for use with the attachable recorder in addition to a remote studio control unit, a triaxial cable-based field base station and standard ENG recorders.

Panasonic plans to begin delivery of the AU/AK-100 recorder/camera system in the spring of 1982. Also using a three ¾-inch tube design with prism optics, the weight of the combination should be about 22 pounds. Luminance signal-to-noise ratio should be 48dB.

RCA's Hawkeye camera (HC-1) should begin delivery dates this January. The Hawkeye uses the recent ½-inch diode-gun Plumbicon or Saticon technologies with a newly designed f/1.4 prism optical system. The lead-oxide pickup tubes should allow use in less than 500 lux illumination, while Saticon-equipped units will require closer to 700 lux. Signal-to-

noise ratio will approach 52dB. The HR-1 recorder is planned for availability this spring.

Sony predicts that the BVW-1 will be available in 1982. The camera is centered around a single-tube SMF Tricon system. The package should weigh about 15 pounds with battery and lens installed. The tape format plans the use of Beta cassettes, providing 20 minutes time on L-500 tape.

The other three systems plan to use ½-inch tape as well, but the cassette will most likely be the VHS system. Recording times on all will average 20 minutes. Compatibility with existing Beta or VHS equipment will not be possible due to the increased linear type speed required for intended picture quality. Ikegami has also considered a ¼-inch format tape system. Ikegami suggests that definite considerations must be made toward compatibility between the various companies' equipment, to which RCA agrees. Because the initial RCA and Panasonic units seem to have developed following intercompany discussions, there would seem to be some credibility to the idea that they may, with the recently appointed SMPTE committee, be well on the way toward deciding factors in the compatibility area.

Each company has announced plans for accessory editing systems and controlling units for their final product formats. Final availability, however, of these highly flexible ENG units, including studio adaptation, still is uncertain.



HL-83

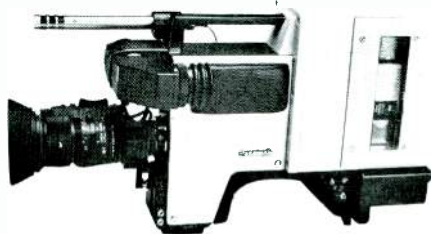

AU/AK-100

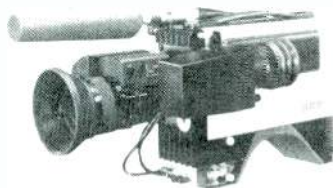

HC-1



BVW-1

PARTNERS IN PRODUCTION

"Our character generators are used in studios and at remotes around the world. And every one, whether we operate it ourselves or our client does, must do the job. So, naturally, we rely exclusively on CHYRON."

These are the words of Linda Rheinstein, president of Autographics, one of the largest independent operators and leasers of graphic character generators in the broadcast industry. Like most of the leaders in the industry, Autographics depends on CHYRON IV. . .the world standard for reliability, flexibility and simplicity of operation.

Follow the Leaders with
CHYRON
TELESYSTEMS

A DIVISION OF CHYRON CORPORATION

265 Spagnoli Rd., Melville, N.Y. 11747 • 516-249-3296 • Telex: 144522 Chyron Melv
Ampex International is exclusive distributor for Chyron Graphics Systems outside the U.S.A.



Linda Rheinstein, President
Autographics, Inc.

CHYRON® IV

Circle (48) on Reply Card

Survey

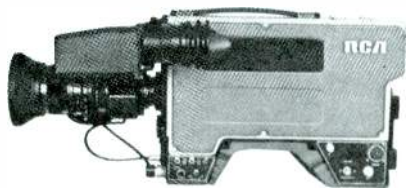

TK-86

ture correction. Contrast compression increases detail in poorly lighted image areas without affecting highlight areas. Illumination required at f/2.8 on a 60% reflectance chart is 1250 lux. with +9 and +18dB gain available for poorly illuminated conditions. The signal-to-noise ratio for NTSC standards is 54dB; for PAL-B and SECAM, 52dB. The 1½-inch viewfinder swivels as well as provides lateral movement. Weight without lens is approximately 14 pounds. Remote control, triax and wireless accessories are available.

Circle (223) on Reply Card

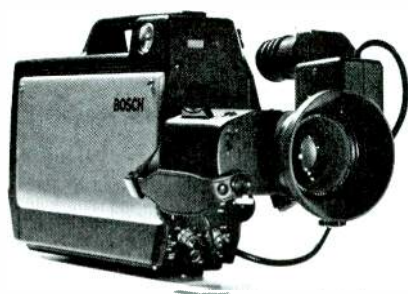

KCA-100

Robert Bosch GmbH

Television Systems Division
Robert-Bosch-Strasse 7
D-6100 Darmstadt, Germany

The KCA-100 Hand-held Camera features auto beam control, black/white balance, and integral, peak value or spot control iris. Auto centering is optional. Black stretch control is included to enable the ⅓-inch diode-gun Plumbicon camera to show detail. Bias lighting is included with the high efficiency prism splitter. H and V contour correction uses two delay lines with comb filtering and level dependent coring for noise reduction. The sensitivity rating for 70% reflectance white is 1250 lux with f/2.8 lens setting. With an additional +12dB of video gain, the sensitivity allows 75 lux at f/1.4. The camera is available for NTSC, PAL-M, PAL and SECAM standards. The signal-to-noise ratio for NTSC is 53dB; PAL figures to 51dB. A 1½-inch viewfinder is used. Various attachments may be

used with the camera for flexibility as an ENG camera with ac or dc power. The camera head may be gen-locked without a base station. A base station allows use of multicore cable or laser fiber materials. The camera head without lens or viewfinder weighs approximately 14 pounds.

Circle (224) on Reply Card



XC-700

Sharp Electronics Corporation

Professional Products Department
10 Sharp Plaza
Paramus, NJ 07652

Dynamic beam optimization, auto white balance with memory, and a 3-tube ⅓-inch Saticon format based on a prism optical system are featured in the XC-700 ENG/EFP Camera. H and V 2-line image enhancement circuitry is included. The camera is operable at 0 gain at 2000 lux illumination with the lens at f/4. Video boost to +12dB allows lower light level use to 80 lux. Without corrections the signal-to-noise ratio is 52dB. The basic ENG package includes a 1½-inch viewfinder with an optional 7-inch CRT for studio use. The studio option also includes the XC-701RP Remote Operational Panel. With the 1½-inch viewfinder installed the camera head weighs approximately 17 pounds.

Circle (225) on Reply Card

Sony Video Products Company

9 W. 57th St.
New York, NY 10019

Automatic white balance and beam control handle highlights, while bias lighting reduces lag in limited lighting for the BVP-110 Broadcast HBST Camera. Using a single high band Saticon Trinitron tube (HBST), registration errors are significantly reduced. A 2H level-dependent enhancer in conjunction with the deposited electrostatic deflection electrode technology and a newly designed electron gun offer 400 TVL resolution. A typical sensitivity figure is 2500 lux with f/4 lens and 69% reflectance white. The luminance signal-to-noise ratio is 50dB. Two

hours of operation may be expected from the BP-90 battery pack using the 1½-inch viewfinder. Camera head weight without lens is six pounds.

Circle (226) on Reply Card

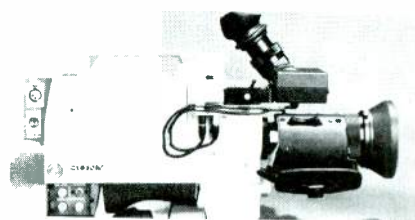

BVP-250

The BVP-250 Broadcast Camera features auto color balance requiring only a small white scene source, with black balance accomplished by automatic closure of the iris. Manual override of the auto iris is possible. Auto beam optimization prevents beam current overloading on highlights and comet tailing. Three ⅓-inch Saticons and the f/1.4 prism optics have bias lighting. Level dependent 2H enhancement does not generate noise in the picture. Illumination of 2200 lux, f/4 with 69% white reflectance is sufficient for full video output at 0dB gain. Additional gain to +18dB is available for use to 30 lux lighting. A typical signal-to-noise operation for the BVP-250 is 54dB. The 1½-inch viewfinder adds 1½ pounds to the camera head, which weighs almost 11 pounds and allows approximately two hours of operation from the BP-90 battery pack. The camera may be operated with the CCU-300 control unit while maintaining dc operation. A 5-inch BVF-5 viewfinder is available when large format is needed.

Circle (227) on Reply Card

The BVP-300A Portable Camera features a digital memory that stores information from the auto digital white and black balance circuits. Auto beam optimizer circuitry for prevention of comet tail effects joins auto iris and iris closure for proper video control and tube protection. The 3-tube system uses ⅓-inch Plumbicon or Saticon tubes with an f/1.4 prism system. Two-line enhancement is featured with comb filtering, level dependence and crispness. Typical sensitivity allows operation with 2000 lux at f/4 and a 69% white reflectance. Improved circuitry in the BVP-300A provides a signal-to-noise ratio of 56dB. In a weatherproof housing with the viewfinder installed, the camera weighs approximately 12½ pounds.

Circle (228) on Reply Card

Auto centering using a memory powered separately from other camera circuitry maintains a residual

TV test equipment from the inventors of the Plumbicon® tube.

At long last a new, reliable source of TV test equipment. One that offers fast, predictable delivery. One with a name all the world trusts—Philips. Four quick examples:

PM5565 Waveform Monitor

Enjoy the luxury of examining one line and one field at a time. On top of this, there's a convenient front probe input so you can use the monitor as a troubleshooting oscilloscope.

PM5567 Vectorscope

If you want more accurate decoding and the ability to have an external reference from composite video signals, choose our vectorscope.

Both waveform monitor and vectorscope mount side by side, fit all existing hardware and use less power than the competition.

PM5539 Color Analyzer

Take it on a quick trip through your studio or control room and adjust all monitors to the same color temperature in a matter of minutes.

With four different memories, there's no problem in quickly calibrating four different phosphors.

Variable full-scale, from less than set up to more than reference white, allows measurement of color tracking as a function of APL.

PM5534 Color Pattern Generator

Our universal pattern contains all the signals needed to verify overall system operation—directly from the picture. No wonder virtually every set manufacturer uses our pattern for their TV set alignment.

Of course our TV test equipment line doesn't end here. Today Philips offers a wide range of equipment including sync and pattern generators, VITS generators and analyzers, and TV modulators and demodulators.

For nationwide sales and service information call 800-631-7172, except in Hawaii, Alaska and New Jersey. In New Jersey call collect (201) 529-3800, or contact Philips Test and Measuring Instruments, Inc., 85 McKee Drive, Mahwah, New Jersey 07430.

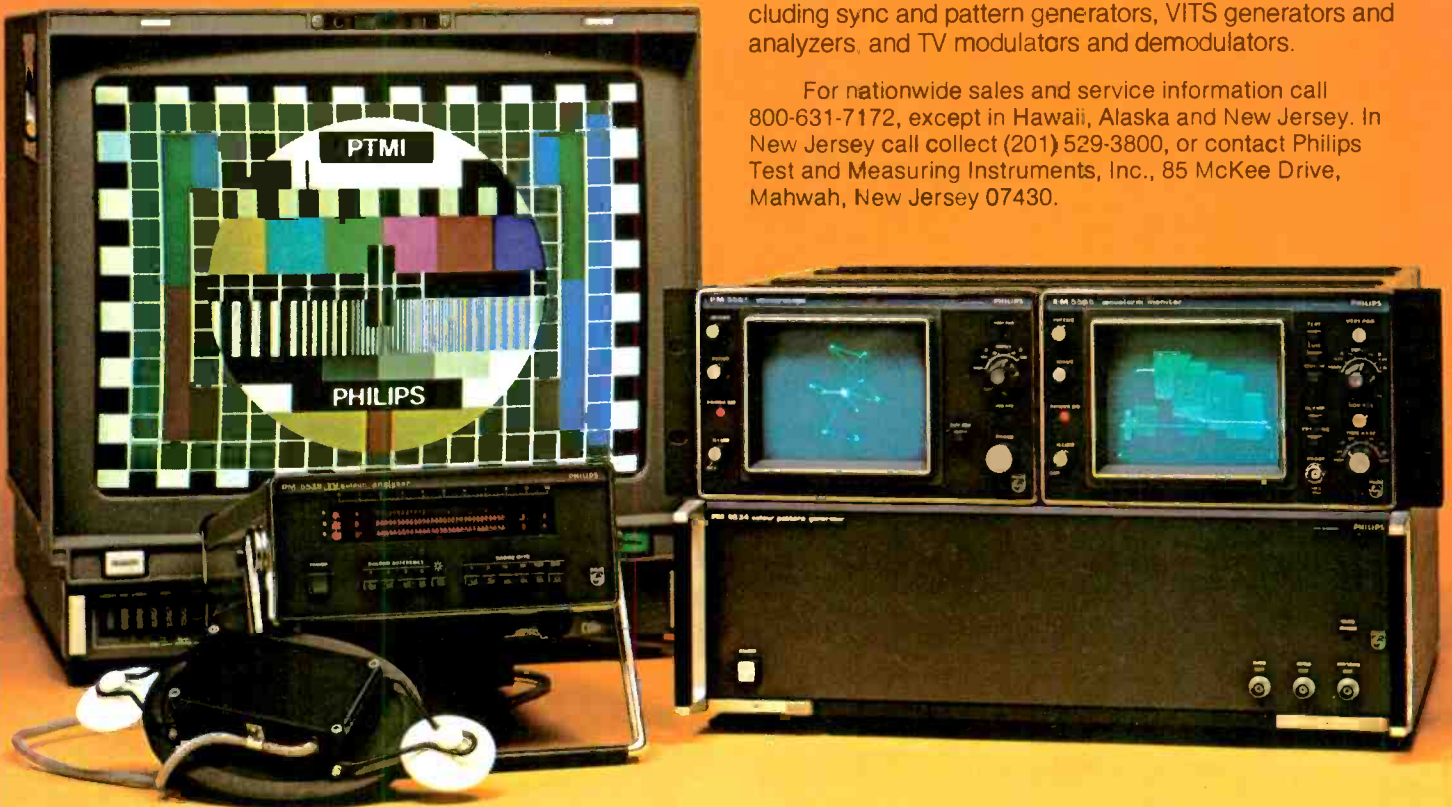

Philips, of course.



**Test & Measuring
Instruments**

PHILIPS

Circle (49) on Reply Card

Survey

centering error of 0.05% maximum in the BVP-330 Production Camera. Digital memory is also provided for auto color balance. Auto beam control operates on each of the three 3/8-inch diode-gun Plumbicon tubes individually. Auto iris is operable with appropriate lenses. Both H and V enhancement are included in the BVP-330. Operation at 2000 lux with 69% white reflectance and the lens at f/4 produces a signal-to-noise ratio of 57dB. Operation as an ENG system with a 1 1/2-inch viewfinder involves a load of about 12 pounds on the operator. For studio use, the optional CCU-300 control unit and a 5-inch viewfinder may be obtained.

Circle (229) on Reply Card

An integral microprocessor in the head of the DXC-6000 Portable Color Camera controls auto beam optimizing, iris, digital black/white balancing and lens closing functions during setup and operation. Three 3/8-inch Saticon or Plumbicon tubes combine with the f/1.4 prism optical system for high sensitivity and crisp images with up to +18dB of video gain. A signal-to-noise ratio of 53dB is improved by 1-line standard or optional 2-line im-

age enhancement. An 89.9% reflectance charge under 2000 lux illumination provides full video signal output at f/4. The camera head alone weighs approximately 12 1/2 pounds. The standard 1 1/2-inch viewfinder may give way to a 4-inch model when the camera is used with the optional CCU-6000 control unit. Various zoom lens systems are available.

Circle (230) on Reply Card

Thomson-CSF Broadcast Inc.

37 Brownhouse Road
Stamford, CT 06902

White balance, black stabilization and beam control are handled automatically by the MC301 ENG Portable Camera. Using dichroic mirror optics with three 3/8-inch Saticon tubes, a signal-to-noise ratio of 54dB is attainable under 230fc illumination at f/4. Dual-edged contour correction for both H and V is included. The 14x zoom lens system includes auto iris operation for a total camera weight of approximately 16 1/2 pounds. Up to +12dB of gain is available for low light operation at distances to 984 feet from a remote control unit. A 5-inch viewfinder is available instead of the standard 1 1/2-inch unit for studio and EFP use.

Circle (231) on Reply Card

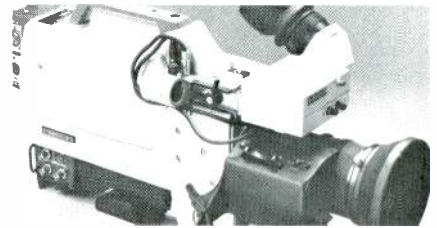

MC501

Digital automatic black/white balance is included in the MC501 ENG Camera with a three 3/8-inch Saticon tube design. Two-line enhancement includes level dependence, comb filtering and crispening. Full video signals are obtained under 200fc illumination with the 60% chart and an f/4 opening. Signal-to-noise measurements are typically 54dB. The 1 1/2-inch viewfinder may be replaced with an accessory 5-inch unit when the camera is used with the Thomson-CSF accessory line. In ENG format, the camera weighs approximately 12 1/2 pounds, including the viewfinder.

Circle (232) on Reply Card

Weighing about 11 1/2 pounds without viewfinder, the MC701 Camera includes auto color balance and registration centering. Three 3/8-inch diode-gun Plumbicon tubes with an f/1.4 prism produce low-noise

When **YOU** want
NICKEL CADMIUM

20 years of dependability



Belts and Packs for All Cameras and VTRs

YOU want
PERROTT
ENGINEERING LABS, INC.

1020 N. Fillmore St., Arlington, Va. 22201 (703) 528-5861

Circle (50) on Reply Card

SAVE MONEY.

WE KNOW HOW TO SPEAK
YOUR LANGUAGE

HITACHI SK-91
Only \$22,000.

HITACHI HR-100
Now \$28,300.

Similar Savings on Accessories

JVC KY-2700
\$8,550.

Limited
Quantity

SONY Wireless Mikes
*Call for Quote



NICHOLS ELECTRONICS
8780 Mastin • Overland Park, Ks.
66212 913-492-2151

Circle (51) on Reply Card

Easy does it.



© 1981 Fuji Photo Film U.S.A., Inc., Magnetic Tape Division, 350 Fifth Avenue, NY, NY 10118

Available in 2", 1", 3/4" and 1/2" Beta and VHS.



Survey

performance even at +9 and +18dB gain settings. An illumination of 200fc is sufficient on the 60% reflectance chart at f/4.5 for a typical 57dB signal-to-noise ratio with a horizontal resolution of 600 TVL in screen center. The camera may be adapted for a studio or EFP configuration, using either multicore or triaxial cable. Typically the 1½-inch standard ENG viewfinder will be exchanged for the 5-inch model.

Circle (233) on Reply Card



PK-40AH

Toshiba America Inc.

Broadcast Electronic Systems Division

292 Gibraltar Drive
Sunnyvale, CA 94086

Providing the quality of the PK-40A studio camera in a compact version, the 8½-pound PK-40AH Portable Camera may be used with a PK-40A CCU through an interface unit. A companion to the fully automatic big brother, it includes registration error compensation. Three ⅜-inch low capacity diode-gun Plumbicons operate with 2000 lux at f/4 for a 57dB signal-to-noise ratio. Operation with 1000 feet of cable between camera head and the interface unit is possible.

Circle (234) on Reply Card

The PK-60 Portable Camera includes digital memory adapter, auto setup unit, digital base station and multicore cable adaptor or triax/wireless transmission system adaptors. The PK-60 has a three ⅜-inch tube format, which allows use of standard or diode-gun Plumbicon or Saticon tubes. The f/1.4 effective aperture of the prism beam splitter gives the camera capability to operate at 2000 lux with the scene reflectance coefficient of 60% with the lens at f/4 or greater. Two-line horizontal and vertical detail correction uses comb filtering and coring circuitry. Without the correction, a signal-to-noise ratio of 54dB is possible. The 1½-inch viewfinder may be replaced with a 4½-inch CRT unit for studio or EFP operation.

Circle (235) on Reply Card

The PK-39 Portable Camera requires limited engineering knowledge

because automatic circuitry takes operational control of auto white balance, beam control and iris duties, allowing the camera operator freedom for creative efforts. In any color standard, the PK-39 uses prism optics and bias lighting for lag control in low light conditions. The camera has three ⅜-inch lead-oxide tubes and is sealed against moisture. Typical sensitivity is indicated by 2000 lux needed at f/5.6. A resolution of 500 TVL is further improved with vertical and horizontal enhancement using comb filtering and coring. A signal-to-noise ratio of 51dB is given. In a 1-piece configuration with 1½-inch viewfinder and 10x zoom lens, the camera weighs 22½ pounds. Operation is possible with the electronics package separate, leaving the head and zoom lens weight at 17¼ pounds.

Circle (236) on Reply Card

Tritronics Inc. (TTI)

2921 W. Alameda Ave.
Burbank, CA 91505

Automatic beam control, auto white balance with 8-bit memory, auto black stabilizing and iris control combine with a special purpose phase-controlled shutter system in the PCSC-2000 camera to stop motion in times as short as 0.0001s. It uses three ⅜-inch Saticon tubes and dichroic mirror optics. The camera weighs 17 pounds without the standard VF-2000BU 1½-inch viewfinder. Though intended for motion analysis, this unit may be used in documentary and sports reporting. With a typical sensitivity of 2500 lux at f/4, the equipment may provide usable video outputs to 100 lux using +12dB gain at f/1.6. Uncorrected, the signal-to-noise achieved is 54dB. The camera may be incorporated into a system with the RS2000U remote control unit.

Circle (237) on Reply Card

The PCSC-2300 High Speed Shutter Camera offers auto color balance with a high speed phase-controlled shutter that can stop a bullet or measure the speed of a racing auto. The dichroic mirror optical system may operate with three ⅜-inch Saticon H-9311, Newvicon S-4075, Plumbicon XQ-1428, Chalnicon FR E-5093 or Vidicon 8844 tubes. Auto iris is provided and allows exposure at a standard illumination level of 2000 lux at f/4. The signal-to-noise ratio varies from 43 to 46dB depending upon tube selection. Horizontal detail enhancement is standard, but vertical modules are optional. A 5-inch viewfinder is standard. Camera head weight without lens or viewfinder is approximately 21 pounds. Used with the control unit, phase-controlled shutter speeds range from 1/500 to

1/10,000s with settings for continuous exposure.

Circle (238) on Reply Card

US JVC Corporation

Professional Video Division
41 Slater Drive
Elmwood Park, NJ 07407

Automatic white balance with up to a 5-hour memory and auto or manual iris control provides easy setup of the single tube 1-inch S-100U Camera. Both H and V enhancement are used with the 280-line resolution system. Usable to 80 lux illumination, the signal-to-noise ratio is given as 45dB. Designed for the extra non-critical assignment camera coverage, the equipment weighs approximately 10 pounds.

Circle (239) on Reply Card

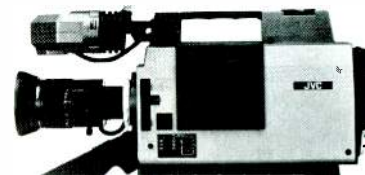

KY-1900U

Auto color, iris and beam controls in a lightweight, low cost portable camera are features of the KY-1900U. Three ⅜-inch H4101 Saticon tubes with dichroic mirror optics offer operation under standard conditions of 2500 lux at f/4. With 9dB video gain, illumination to 150 lux at f/1.6 creates usable video. Dual-edge contour correction in both H and V is standard. Uncorrected, the signal-to-noise ratio of 52dB applies to a horizontal resolution of 500 TVL at center screen. With the 1½-inch viewfinder and standard 6x zoom lens, the camera weight is 10 pounds. Optional equipment includes a 5-inch viewfinder, 10x and 14x lenses with a remote control unit.

Circle (240) on Reply Card

Auto white balance with 8-bit digital memory, beam control, iris control and black stabilization provide operational ease in the KY-2700U Camera. Mirror optics are used with three ⅜-inch H4101 Saticon tubes. Sensitivity is rated at 2500 lux for f/4, with +12dB gain available for increased sensitivity to 100 lux, f/1.6. Dual edged contour correction in H and V with 2H delay line design of vertical enhancement provide improvement on the 500TVL center resolution and signal-to-noise ratio of 54dB. A 5-inch viewfinder replaces the standard 1½-inch unit along with an optional remote control unit for studio system integration. The camera weighs 11½ pounds. □

Circle (241) on Reply Card

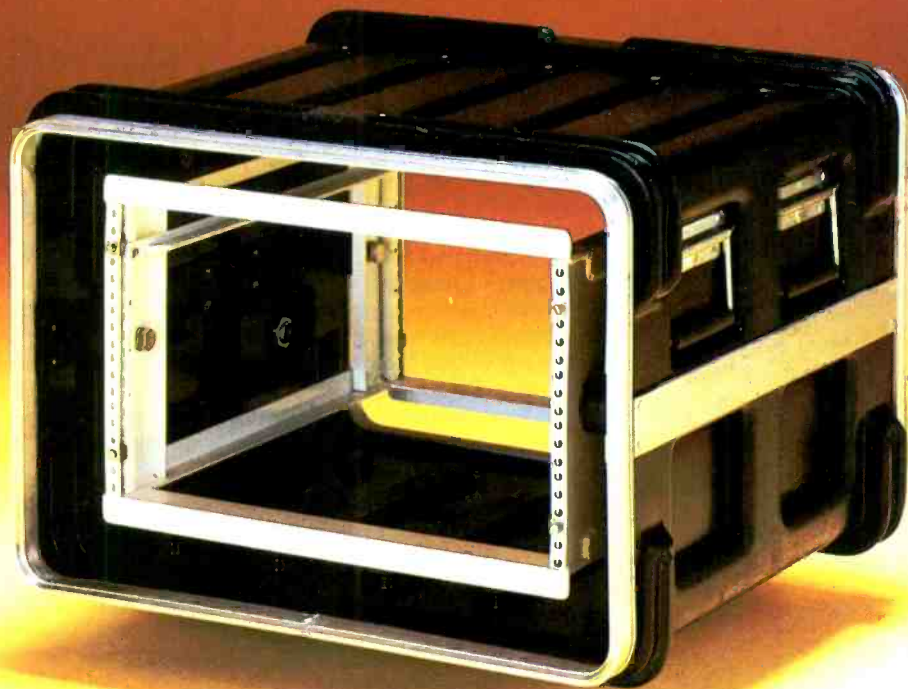

THERMODYNE'S RACK-PACK™

An instrumentation case as sophisticated as the equipment it carries.

Equipment typically rack-mounted for operation, storage or transportation comes in many standard sizes. So does the Rack-Pack. Eleven sizes to be exact, in EIA-RETMA dimensions ranging in rack height from 5.37 inches to 24.625 inches.

The outer case is made of ABS to resist cracking, denting or scuffing. Each case is designed with recessed ribs on all sides which react in "concertina" fashion on impact, absorbing a great amount of shock energy. Remaining vibration is absorbed by elastometric shock mounts which isolate and protect the inner mounting rack and equipment. The Rack-Pack is a system within a system.

The rack is constructed of 6061-T6 aluminum for durability and light weight. Front and back covers remove quickly by releasing the quarter turn latches, yet remain secure and water tight for storage and transportation. All hinges, latches and handles are mounted firmly without intrusive fasteners, leaving the unit virtually

water tight. Hardware can be easily replaced in the field, if damaged, using the patented expansion tool included in the optional field repair kit.

Rack-Pack's stack on interlocking ribs. They become a modular work station in any environment and are extremely secure.

When you make the Rack-Pack your standard instrumentation case, you close the lid on shipping worries. Your equipment arrives as it left, in top condition. With Rack-Pack you get more than just the best case around, you get peace of mind. Thermodyne has it all, product, price and a delivery capability that will make you smile. Case closed.

**THERMODYNE
INTERNATIONAL LTD**

20850 S. Alameda St., Long Beach, CA 90810
(213) 603-1976

Checklist for troublefree remotes

By Dan Hansen, sports director, WDUX Radio, Waupaca, WI



A second winch is used to raise the inside tower section for maximum height.



The tower, raised to full height.



Tower extended to 50-foot height for range of 30-35 air miles.

Though live remotes have been around nearly as long as the broadcast industry itself, today more and more radio stations are discovering that with new techniques and technologies, live remote broadcasts can help them serve their listeners during the 1980s and beyond.

In recent years manufacturers have made great strides in producing remote transmission equipment that is more portable, more reliable, and easier to operate and maintain. With modern RENG equipment, virtually any station can enhance local news and sports reports with live on-the-spot interviews and provide up-to-the-minute developments on important events of the day. The same system can also facilitate the live broadcast of concerts, play-by-play sports and similar events. It can also provide advertisers an opportunity for additional exposure during new product introductions, as well as other sales and promotions.

However, any time a station goes live from outside the friendly confines of the studio, there is a greater risk of something going wrong. And, while there is no way to eliminate the possibility of technical or other difficulties, a little advance planning and a common sense approach can help put the odds for success well in your

favor. Producing quality remotes on a consistent basis involves more than just plugging into a phone line or turning on a remote transmitter. Often, attention to the small details can make the difference between a remote that runs smoothly and one that never gets on the air.

Early planning

Preparation should begin by determining how deeply involved you want to get in the field of remote broadcasting. Decide what types of remotes you want to do. Group them in basic categories. Then make a list of equipment, personnel and other requirements for each type of live remote.

For more than 13 years, I've been actively involved in the production of live remotes at WDUX AM/FM, Waupaca, WI. Most of the remotes we broadcast fit into four general groups, based primarily on their distance from the station:

- Class I remotes include almost everything within 10 air miles.
 - Class II remotes extend to approximately 15 miles.
 - Class III remotes reach more than 30 miles.
 - Class IV remotes encompass almost anything beyond 35 to 40 miles.
- Class I remotes require the least



Securing the coax to the antenna.

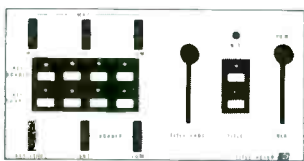

Title Keyer

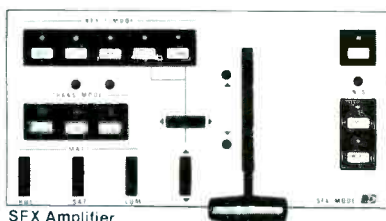

SFX Amplifier

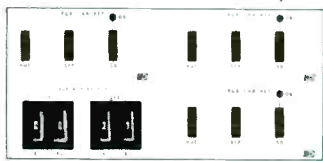

Chroma Keyers... RGB and Encoded

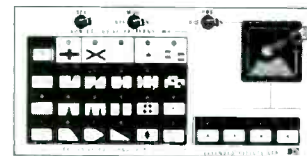

Extended Effects Generator

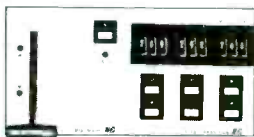

Master Mix & Auto Transitions

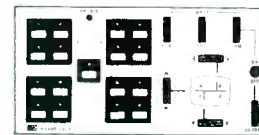

Quadplexer

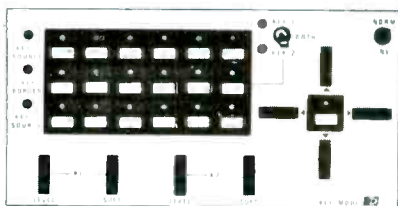

Key Module

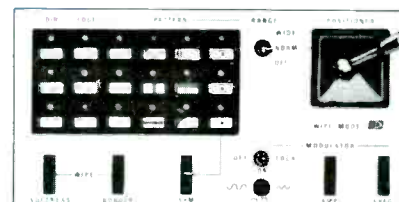

Wipe Module

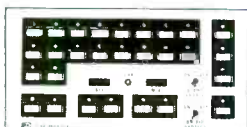

CAP... Computer Assisted Production System

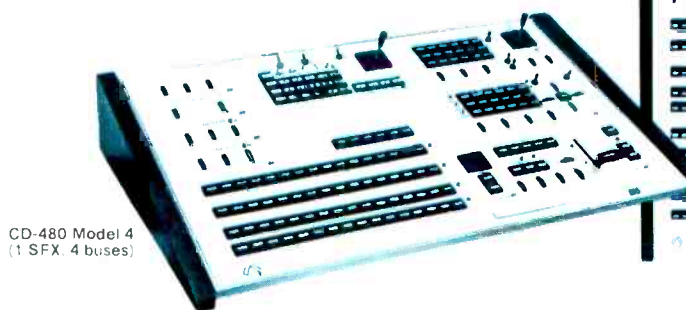

CD-480 Model 4
(1 SFX, 4 buses)

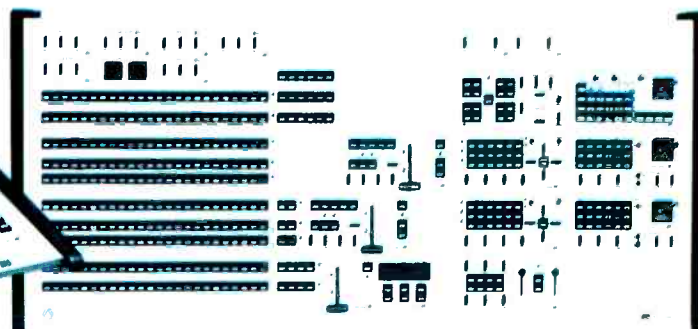

CD-480 Model 10 (2 SFX, 10 buses)

CD-480...the most powerful and modular production switcher available today.

The 480's proven superior performance, reliability and flexibility has evolved from these powerful video production modules.

That's why you can customize a 480 to your specific production requirements... within your budget. And because of the 480's modular design we can deliver the largest model within 90-120 days.

Design your own switcher starting with any one of 9 basic models, and selectively equip it with a wide range of powerful 480 modules and accessories.

No other manufacturer can offer you that flexibility... and every 480 is equipped with the unbeatable video power of the CD-480 SFX Processor System that includes the SFX Amplifier, Key and Wipe Modules.

The 480 family includes switchers with 4 buses to 10 buses... even a model you can upgrade from 1 SFX and 5 buses to a Model 8 or 9 with 2 SFX Amplifiers and 8 or 9 buses. And the 480 continues to evolve which means you can always add the latest 480 production accessories.

That's why over 300 users call the 480 the most powerful and flexible new generation switcher available today.

Start designing your new CD-480 now so you can have the competitive advantage. Call or write for literature or *our complete CD-480 Design Kit*.

Central Dynamics Corporation, 900 Corporate Drive, Mahwah, NJ 07430. 201-529-1550.
Central Dynamics Ltd., Montreal, 514-697-0810.



CENTRAL DYNAMICS CORPORATION

The U.S. Broadcast Company for **COL** • **PHILIPS** • **American Data**
Circle (53) on Reply Card

Remotes

amount of equipment. Class II and III broadcasts demand progressively more equipment, setup time and advance preparation. These groups may be further differentiated by the length of the broadcast as well as the distance, but all are within range of the remote pickup equipment.

This fourth group is beyond the range of our RENG equipment, and it has proven most practical for us to use phone hookups at this range. However, existing technology provides

stations with the capability of covering these longer distances by using RPU equipment in helicopters. For larger stations in metropolitan markets this approach may prove practical—particularly in the coverage of fast-breaking news stories.

In spite of the advances in technology, many broadcasters still use phone lines for all remotes. In some cases this may be the way to go. If most of a station's remotes are 40 miles or more, if they are aired from

relatively few locations, or if terrain or other obstacles interfere with reception, it might be wise to stick with the phone company. The initial cost of a RENG system may also cause some stations to shy away. As one owner said years ago at a high school football game, "I can put in a lot of phone lines for the money you've got invested here."

However, when you tie yourself to the telephone company, flexibility is severely limited. You do not decide in the morning that you are going to do a live remote that same day. In the past six years, WDUX has moved away from the use of phone lines by expanding the capability of its remote pickup equipment. The system is built around a 30W. tube type Marti VHF transmitter that has been around for nearly 15 years, and a newer Marti transistorized receiver that has been in use for approximately five years.

Although it is not the most expensive or complex remote setup around, the system is dependable and delivers good broadcast quality. In fact, it is used for more than 95% of our live remotes. When powered by the station's Econoline van with a whip antenna on the roof, the transmitter is highly mobile and versatile for most remotes out to about 10 miles. Upon arrival at the broadcast site you can be ready to go live in seconds.

As the range increases it becomes necessary to use a more directional antenna, and to make sure it is up high enough to shoot over the terrain between the remote site and the receiving antenna. Four years ago, WDUX acquired a portable crank-up tower on a 2-wheel trailer, which I described in the July 1979 issue of **Broadcast Engineering**. This enables us to put the transmitting antenna more than 40 feet high. That, combined with the receiving antenna, which is 175 feet up on the FM tower, has increased the transmission range for air quality remotes up to 30 miles or more.

When the range is more than 20 miles, fairly precise antenna aiming is



IT'S A SNAP

Portable Energy Products announces the PEP Snap Pack — the only snap-on power source available offering the advantages of seated lead-acid batteries:

- No "memory effect."
- The battery maintains excellent voltage regulation even in extreme temperatures.
- Plus low self discharge.
- Increased reliability with fewer cells required for the power supply.

The PEP Snap Pack only weighs five pounds. It attaches to standard keyhole mounting brackets via three quick release studs. And PEP's high performance, two-step constant current maximizes battery life by preventing over charging.

These features plus Portable Energy Product's reputation for quality, reliability and service add up to make the PEP Snap Pack the most dependable snap-on power source available.

PEP

PORTABLE ENERGY PRODUCTS, INC.
1875 South Pearl Street
Denver, Colorado
303-778-8618

Circle (54) on Reply Card

When accuracy counts... Count on Belar for AM/FM/TV MONITORS



BELAR
AM MODULATION MONITOR

BELAR CALL ARNO MEYER (215) 687-5550
ELECTRONICS LABORATORY, INC.
LANCASTER AVENUE AT DORSET, DEVON, PA. 19333 • BOX 826 • (215) 687-5550

Circle (55) on Reply Card

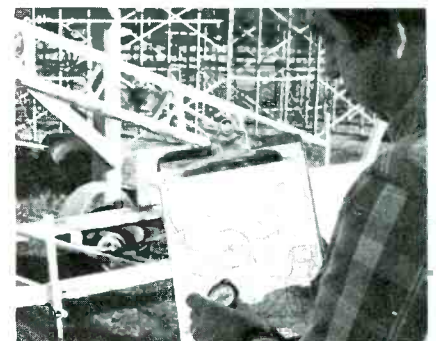

Using a compass to line up the signal.

When you're hot,
you're hot.

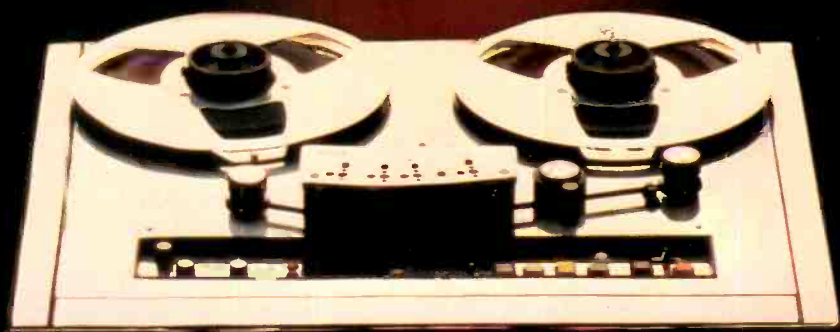

JH-110-B...the hottest

Sure, it's one of the most reasonably priced lines of tape recorders/reproducers in the industry, but don't buy the JH-110B just for the sake of economy. Buy it because it's the hottest tape recorder made today.

Just look at the standard features...timer/locator with four programmable memories plus return to zero function...readout in minutes and seconds or inches per second...three speeds plus variable speed... "plug in" ready wiring for interface to SMPTE/EBU synchronizer...touch sensitive manual velocity control.

Now think about how well and how easily the JH-110B works for you because of its overall design concepts...totally transformerless electronics for cleaner sound...plug-in modular circuitry for easy, inexpensive diagnosis and replacement of individual components...built-in accessibility for convenient maintenance and servicing...user-oriented design requiring minimal adjustments and alignment.

The JH-110B Series from MCI. Not one single line of professional recorders can provide all its standard features. Not one single line of professional recorders can offer all its design advantages. Not one single line of professional recorders can compete with its per dollar value.

In case you wondered, that's why we call the JH-110B the hottest tape recorder made today.

RTZ III.

Unlike any other recorder on the market today, the JH-110B comes standard with a built-in tape timer/locator with four programmable memories plus return to zero function. Reading out in real time, the RTZ III timer/locator can be used to accurately time spots or takes and to return to and automatically cue on zero or any of the other four memory

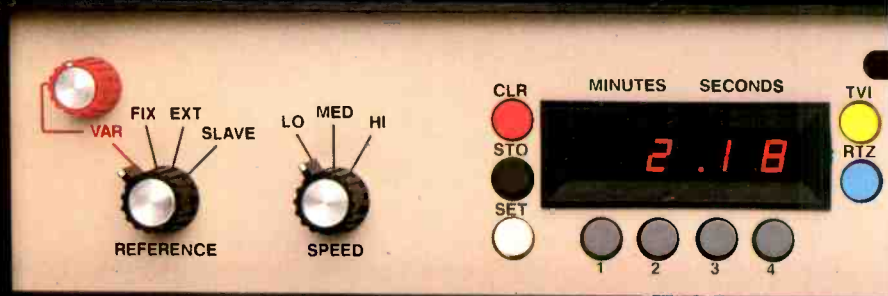

locations. Memories can be reprogrammed quickly and easily by manually "dialing" in the desired location or by loading from tape position in stop, play or wind modes.

The RTZ III also provides a tape velocity indicator (TVI) function offering an instantaneous and accurate readout of tape speed in IPS to two decimal places.

MANUAL VELOCITY CONTROL (MVC).

In addition to providing easy back and forth tape shuttling for one-hand cueing and editing, this touch activated "joystick" offers a way to protect your irreplaceable master tapes and expensive alignment tapes by limiting wind speed in rewind and fast forward modes.

Two edit modes are provided to meet your specific needs. In the "paper basket" edit mode, the edit button disposes of unwanted tape over the edge of the transport. In the "splicing" edit mode, the edit button disables reel tension and braking without attempting to take up slack tape. Using MCI's optional tape marker and scissors, edit marks can be placed exactly over the playback head for a precise 30° cut.

HEAD MOUNTING SYSTEM.

Completely unaffected by vibration or shock, the unique spring loaded



head mounting on the JH-110B offers ultra stable alignment for long term stability. Tape format changes can be made quickly and easily by lifting off the entire head assembly (only two

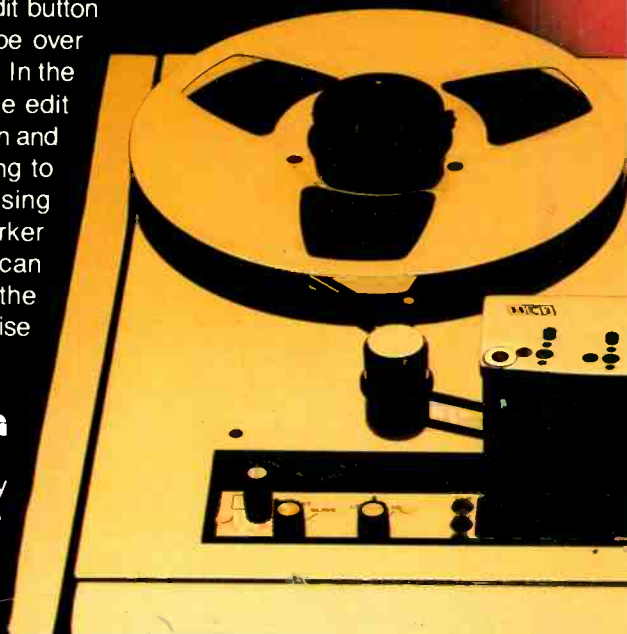

ape recorder made.

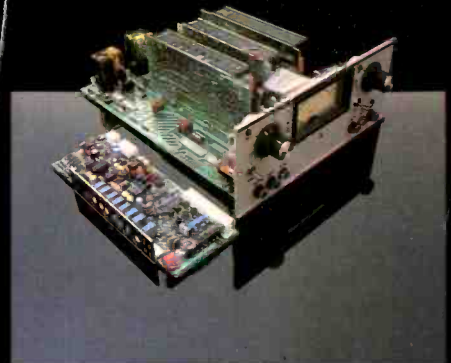
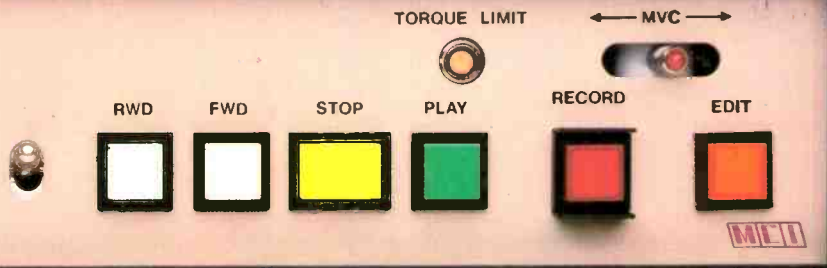

TRANSPORT.

Logically laid out in terms of function, the JH-110B transport features modular plug-in circuitry based on the "mother" board concept. Each transport printed circuit board is a separate subsystem for easy diagnosis of problems and quick, simple repair. Utilizing the same printed circuit boards as the MCI JH-24 Multi-track System to minimize your spare parts stock, the JH-110B transport features separate boards

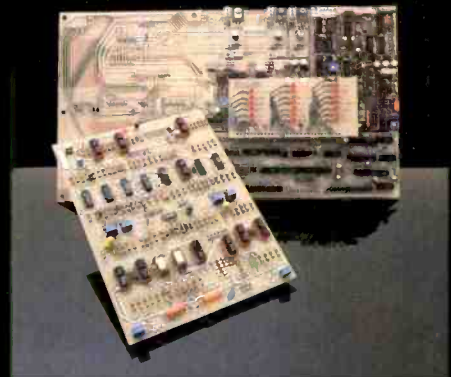

for the transport logic system, servo controlled analog torque system, servo controlled phase lock capstan drive system, indicator and interface functions and the various solenoid drivers. To simplify problem analysis, an optional annunciator board is available providing LED indications for all internal transport commands.

Alignments required are simple and

bolts to remove) and replacing the roller guides with comparable assemblies for the new format. A fourth head mounting is reserved for varying format heads to allow monitoring of 1/4 track stereo tapes on a professional 1/2 track format stereo recorder.

In addition to manually activated play head shield, the transport features a tape lifter defeat for high speed cueing. A scrape filter also is included on all head assemblies.

TAPE SPEED.

Designed with your need for flexibility in mind, the JH-110B features standard play speeds of 7½, 15 and 30 IPS with speeds of 3¾, 7½ and 15 IPS also

available. All three speeds are normally controlled by an on board crystal reference, but $\pm 20\%$ variable speed is provided. The Transport can also be controlled by an external voltage or frequency source.

Built into the transport is all circuitry required for use as a synchronous slave with the MCI JH-45 AutoLock SMPTE/EBU synchronizer. Tape tension for all play and wind speeds is servo controlled and constant from tape end to end.

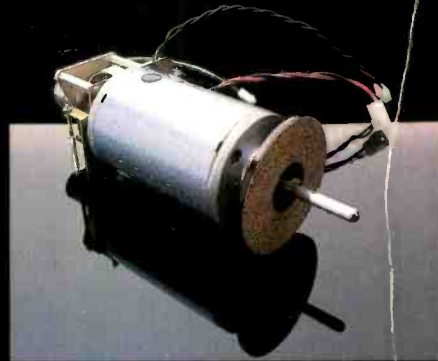

few -- left and right torque reference, phase lock and MVC sensitivity. No other routine maintenance or lubrication is required.

ELECTRONICS.

The fact that JH-110B electronics are totally transformerless means that you will notice significantly improved frequency response, signal-to-noise ratio, transient response, spurious RF rejection and hum rejection. Operational amplifier circuitry is used throughout and, with the exception of a fail safe relay for the record head, all switching is electronic. Because of MCI's exclusive QUIOR (quiet initiation of record) design feature, record punch in/out is noiseless, nonoverlapping and gap free. Remote record activation lines are provided for computer controlled editing systems.

Front panel controls are provided for repro, input or cue (synchronous) monitoring, safe and record ready functions and bias level monitoring. LED's indicate record ready, record and the equalization selected. Level controls for both repro and record include calibrate switches to select an internally presettable level. Illuminated VU

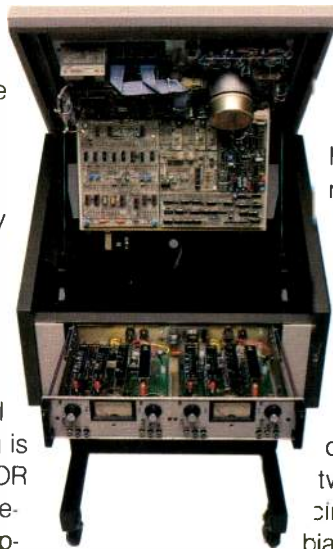

meters on each channel follow the selected monitor source.

Internal controls are provided for repro and record calibrated levels, repro high and low frequency equalizers, record equalizers and bias controls for each speed. NAB/IEC switching is independently provided for repro and record functions with no additional realignment required.

All electronics circuitry is mounted in pull-out drawer assemblies for easy access, with two channels to a drawer. Separate plug-in circuit boards are provided for repro, record, bias/erase and input/output buffering functions.

Transformers are optional on inputs and/or outputs for use where earth free or total DC isolation is required. The power supply is also modular with all active circuitry accessible either through the front access panel or rear mounted plug-in chimney/heat sink assembly. 110VAC/240VAC 50Hz/60Hz operation can be selected by the simple rotation of a plug/socket assembly and replacement of the mains fuse.

JH-110B Dimensional Data

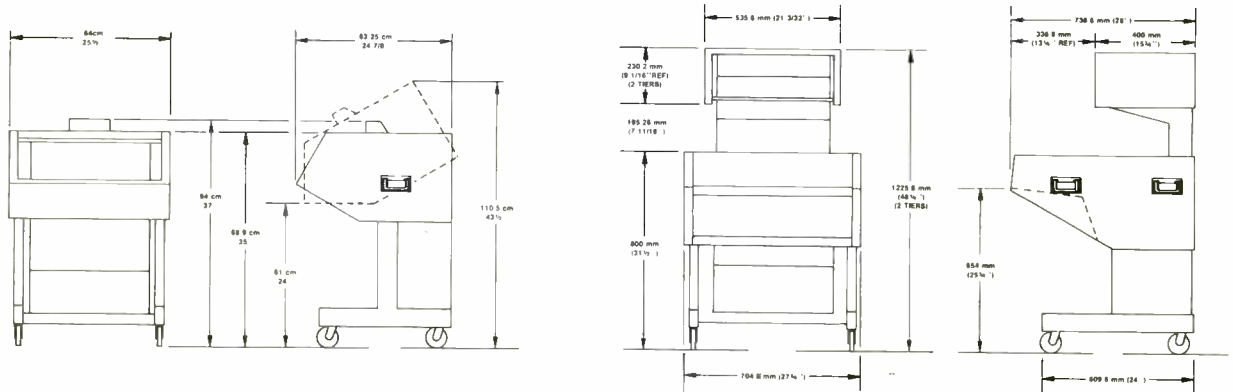

FLEXIBILITY TO MEET YOUR NEEDS.

The JH-110B is available stock in mono, stereo, 4-track and 8-track formats for use with 1/4", 1/2" and 1" tape on reels from 5" up to 10 1/2" in diameter (14" diameter optional). Ready for mounting in the MCI variable profile (VP) cabinet with electronics under the transport or in the MCI high profile (HP) cabinet with electronics over the transport, it can also be mounted in your 19" rack or custom console. An optional accessory allows full remote control of stop, play, record, wind, lifter defeat, manual velocity control and return to zero functions.



1400 West Commercial Boulevard, Fort Lauderdale, Florida 33309 USA.
Telephone: (305) 491-0825. Telex: 514362 MCI FTL.

MCI reserves the right to make changes at any time without notice in colors, equipment, specifications, prices and models.
© 1980 MCI All rights reserved. Litho in USA

MCI-815B-3

Remotes

required to obtain a good signal. During the past four years, we have used a map and compass to plot the settings for more than 15 different locations within a radius of 35 air miles. Each was tested with a live broadcast. This preparation allows nearly every member of the staff to do a solo remote from any of the locations.

After checking the map for the proper compass setting, the staff member can be reasonably sure of cranking up the tower with the antenna pointing in the general direction of home base. A final adjustment is usually all that is needed to put the signal right on the money. One night we learned to trust our compass. We were setting up for a basketball broadcast and were certain we knew which way to aim the antenna. After changing the direction three times, we got it lined up with the compass and had the signal on target.

Choosing equipment

When choosing equipment for the different types of remotes, it is wise to try to reach a happy medium. Take a little more equipment than you think you will need. But do not overburden yourself with an amount that will probably get in your way. The following is a list of equipment we normally use for the various types of remotes.

Class I remotes:

- remote transmitter (powered by van's electrical system);
- whip antenna (mounted on van roof);
- 50-foot microphone cord;
- Electro Voice 635-A microphone; and
- portable radio (on battery power).

Class Ia:

- transmitter (operating on ac, usually inside a building);
- halo-type antenna (on a mic stand); and
- optional remote amplifier (used for taped interviews or commercials).

Class II remotes:

- substitute 5-element yagi beam antenna (mounted on a 10-foot aluminum pole and clamped to the back of the van).

Class IIa:

- transmitter on ac power (in van or inside building);
- yagi beam antenna (on mic stand);
- Astrolite Sportscaster headset microphone for sports play-by-play; and

- optional remote amplifier (connected to transmitter with balance bridging pad).

Class III remotes:

- transmitter;
- yagi beam antenna;
- portable crank-up tower on 2-wheel trailer;
- 65-foot section of coax;
- 50-foot mic cord;
- EV 635A microphone; and
- portable radio.

Class IIIa:

- transmitter (ac power, 200-foot reel ac cord);
- remote amplifier (bridging pad); and
- 20-foot mic cords.

Class IV remotes:

- Sparta RA-4 amplifier;
- coupler telephone;
- 20-foot/mic cords;
- 15-foot ac extension cord;
- tool kit—pliers, screwdrivers, wire cutter;
- portable radio; and
- patch cords for amplifier.

The antennas, long ac extension cords (50 and 220 feet), 50-foot mic cords, 65- and 35-foot sections of coax, microphone and portable radio are kept in the van with the transmitter. The remote amplifier telephone, short mic cords, 15-foot extension cord, tool kit and portable radio are in the remote case, which is a medium-sized black suitcase. A pair of alligator clips and a wide roll of masking tape are always taken, and often prove useful. The previously mentioned lists are general, but can serve as a useful guide for nearly any situation.

Ordering the phone line

Regardless of how good a station's

remote transmission system may be, there probably will still be times when you will need to drop in a phone line. If you install several lines each year, or have experienced poor quality lines, you should give serious consideration to the use of a low frequency extender (featured in past issues of **Broadcast Engineering**). Many stations have found them to be effective, especially in connection with play-by-play and other sports broadcasts. A couple of years ago we considered the possibility of using a low frequency extender. In evaluating our situation we decided against it because we do so few phone remotes during the course of a year, and those we had been doing were from larger cities where phone line quality seemed to be consistently good.

Phone remotes must generally be planned several days or even weeks in advance, in order to give the phone company ample time to provide the necessary hookup. The more advance notice you can give your phone company representative the better. On the opening day of last fall's high school football season, we had a phone line broadcast scheduled. However, an installer called about 10 hours before game time to inform us that they could not provide a hookup because the game was being played on a new field with no lines nearby.

When you contact your phone company representative, do not order a phone line casually. Be specific. Do you want a loop or a dial line? Will you need a coupler phone, or only a jack? Be specific about your broadcast location. Do not just say at the gym, the football field or the concert hall. Will you want to be courtside at the scorer's table, or in a certain broadcast booth in the press box? Once I expected to broadcast a basketball game from courtside, only to discover upon my arrival at the 6000 seat arena that



The van, equipped with a directional antenna, is prepared for a remote transmission.

NOW! CONTINENTAL'S 5 KW AM

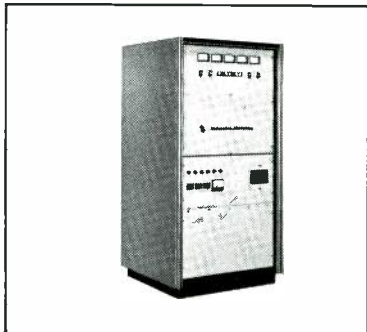

Pulse width modulation in an efficient 5 kW package; clear, crisp sound of transformerless modulation; ready for AM stereo. Stability of 12-phase power supply with Switch-mod system allows maximum modulation at all power levels IPL and other circuits combine to give you outstanding audio with cost-effective operation.

Write for brochure on 315R-1;
Continental Electronics Mfg. Co.
Box 270879 Dallas, TX 75227
(214) 381-7161

**Continental
Electronics**

Circle (57) on Reply Card



The antennas, long ac extension cords, 50-foot mic cords, 65- and 35-foot sections of coax, microphone and portable radio, masking tape and alligator clips are kept in the van.

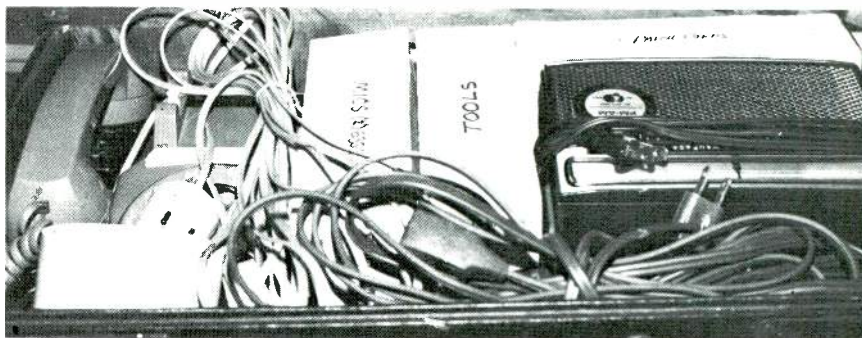

The remote case carries the remote amplifier telephone, short mic cords, 15-foot extension cord, tool kit and portable radio.

Remotes

my phone hookup was about as far away from the court as it could be—way in back, almost as high as the ceiling.

If you will need extra phone line to reach your broadcast location, include that information with your phone line order. Also, provide the phone company with the name and number of the person in charge of the event whom they can contact if there is a question or problem regarding installation. And, try to get the name and home number of the phone company service technician. You probably won't need it, but it is good insurance, especially in a small town.

Arriving early

After you have selected the proper equipment and taken care of advance arrangements, the best thing you can do to assure success is to arrive at the remote location early. Try to be there and have everything set up and ready to check out at least an hour before air time. This is especially important on more complex remotes.

By arriving early, you will have extra time to make any corrections needed to get your transmitting antenna homed in. If there is a problem with your phone line, you will still

have a reasonable chance to get someone out to correct the trouble before your scheduled broadcast time. Do not make the mistakes I witnessed little more than a year ago. Three stations were on hand for live play-by-play of a state tournament basketball game. Two who were using RENG equipment were set up and ready more than an hour before game time. The third station's crew arrived less than 30 minutes before the scheduled start, were not sure what type of phone line they had ordered, and did not have the proper equipment. They finally got on the air to cover the second half. However, they not only caused problems for themselves, but also hampered the broadcast of one of the other stations—and made extra work for game officials.

Live remotes may not suit every radio station, or compliment all programming formats. However, no other medium offers its audience more immediacy or intimacy than radio. And live remotes—properly planned and done well—can help almost any station bring an added amount of enjoyment and information to its listening audience, and give itself an edge on the competition.

Audio Tape for professionals

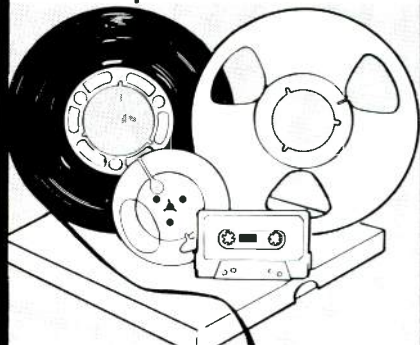

REEL TO REEL TAPE

Ampex, 3M. All grades.
On reels or hubs.

CASSETTES, C-10—C-90

With Agfa, TDK tape.

LEADER & SPLICING TAPE

EMPTY REELS & BOXES

All widths, sizes.

**Competitive!
Shipped from Stock!**

Ask for our recording supplies catalog.

Poly corp. 312/298-5300

1233 Rand Rd. • Des Plaines, IL 60016

15

Circle (58) on Reply Card

Outstanding Outdoors

Camera location 3 behind home plate is no place to tear down a camera. Especially if the director wants to punch it up on air to catch the next pitch. That's just one reason why the rock-steady, works-every-time HK-357A is an outstanding choice for production in the field.

Beyond its reputation for legendary Ikegami reliability, the HK-357A has a lot more to recommend it as the ideal field camera. For example, its crisp, high resolution picture, signal-to-noise ratio of better than 53 dB, and superb colorimetry.

What's more the camera really shows off when it's time to set up. Use of the optional microproces-

sor control brings into play Ikegami's Emmy award-winning digital techniques for automatic setup. Simply press one button and the computer automatically refreshes all set up and registration adjustments in about 45 seconds. No chip charts blowing in the wind, no tweaking. Just unpack, plug-in, auto-setup, and shoot.

Hook up is a simple matter too. Choose the triax option and you can position the camera as far as a mile from the van with absolutely no compromise in picture quality as compared to multicore. And for versatility, our triax camera interfaces with TV-81 multicore at the flip of a switch.

Field test an HK-357A to see why Ikegami is the choice of so many networks, major market stations, and independent producers.



Ikegami HK357A

Ikegami Electronics (USA) Inc., 37 Brook Avenue
Maywood, NJ 07607; (201) 368-9171
Northeast: (201) 368-9171 West Coast: (213) 534-0050
Southwest: (713) 445-0100 Southeast: (912) 924-0061
Canada: (201) 368-9179

Circle (59) on Reply Card

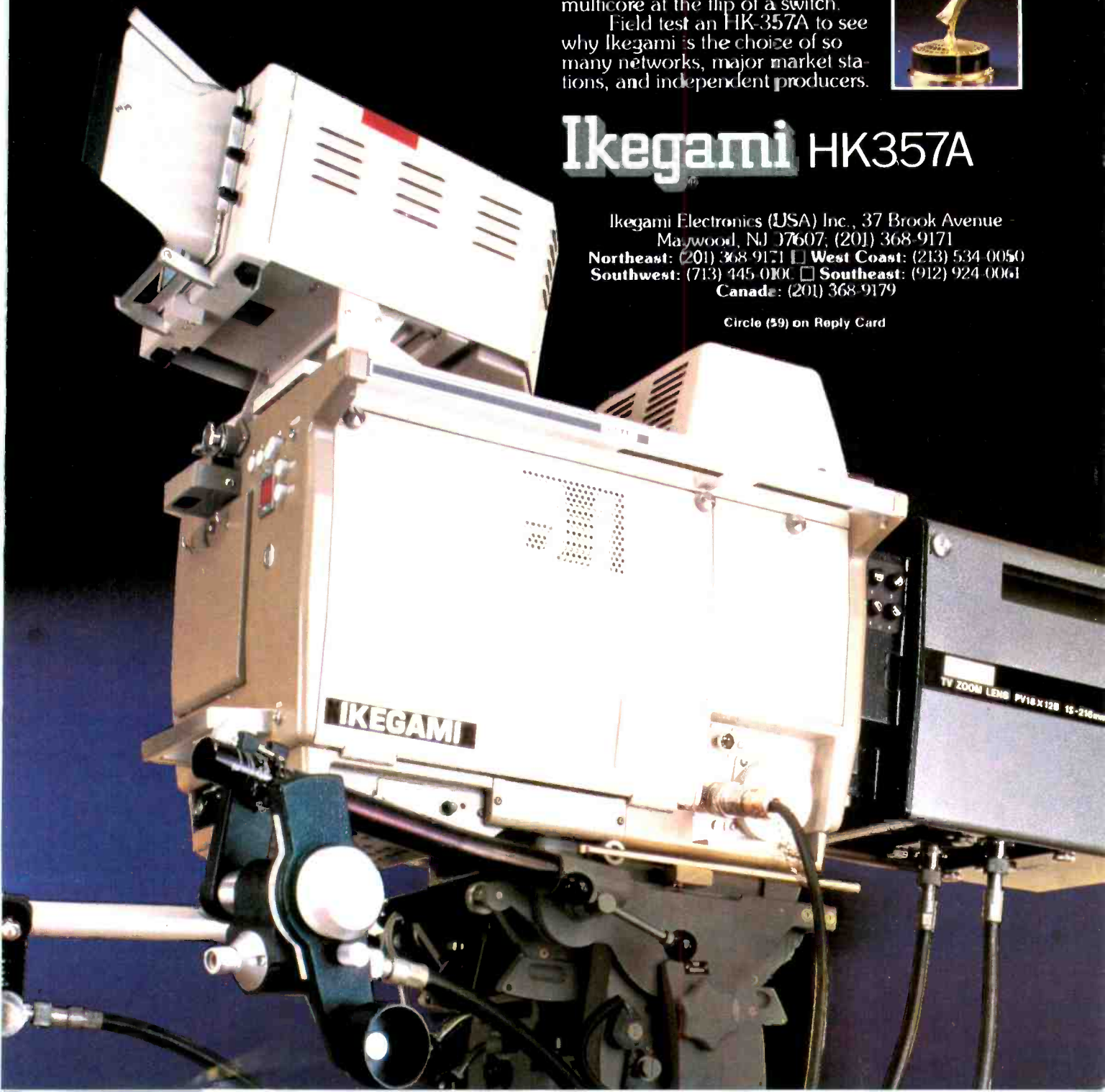

Fall SMPTE conference replay

By Bill Rhodes, editorial director



Flaherty



Zavada



Remley



Farmer

Photos, by Pablo Weinschenk-Taberno, courtesy of the SMPTE.

- 123rd SMPTE Technical Conference and Equipment Exhibit
- October 25-30, 1981
- Century Plaza, Los Angeles
- Over 10,000 attendees
- Exhibitors: 132 companies

More than 10,000 people attended the 123rd SMPTE Technical Conference and Equipment Exhibit in October. The total comprised 7200 exhibitor attendees, more than 1400 paid registrants, and at least 1500 exhibitor personnel and authors. Although exhibitor space was sold out for this meeting, only 132 firms participated. This figure was lower than one at a previous conference because some firms enlarged their space this year. As a result, many firms were turned away because of limited space.

Technical sessions

In its traditional style, the SMPTE program committee, chaired by Julian Hopkinson of Agfa-Gevaert NV, assembled an outstanding spectrum of papers for the conference. More than 150 papers covering reviews, fundamentals, new technologies and new equipment were scheduled for film and TV engineers and managers.

In reporting industry progress noted at this convention, **BE** would usually summarize most of the papers presented. However, the bulk of these will be published in upcoming issues of the *SMPTE Journal*. Consequently, the *Journal* will convey the bulk of the technical messages and we will report a few advances that occurred outside the lecture halls.

Before going on to other topics, however, we will look at the preliminary activities. Before the convention opened, members of the press were invited by the SMPTE to attend a press meeting. It is traditional at these gatherings that the SMPTE alert the press to any surprises in store that were not released in formal announcements. But it soon became obvious, as members of the SMPTE described various aspects of the unfolding conference, that the 123rd meeting was not slated to stand out as a historical

landmark, in terms of broadcasting technology. The 123rd meeting was solidly founded on strong technical papers and equipment exhibits.

Status reports

The conference was opened with an address by Joseph Flaherty, SMPTE executive vice president. He commented on the high level of engineering and management action at the convention and noted that the world looked toward the SMPTE for leadership in technology and in standardization. This leadership, he said, is largely due to the dynamic and dedicated professional staff of the SMPTE officers and governors.

Following the opening remarks, Roland Zavada, SMPTE engineering vice president, reported on the progress and scope of the SMPTE engineering standards activities and Frederick Remley, SMPTE vice president for TV affairs, reported on developments in TV technology. Readers may look forward to reading Zavada's paper in the *Journal* in its entirety for a comprehensive review of the standards work underway. Remley commented on the rapid development in teletext technology, high definition TV systems, digital video and audio standardization, self-contained camera-videotape recorder systems, videodiscs, TV camera tube improvements, and digital tape editing.

These summary reports were followed by those of Lincoln Endelman, SMPTE vice president for photonic affairs, on progress in photonics (photons + electronics); Herbert Farmer, vice president for education affairs, on progress in stimulating engineering education; and by Roderick Ryan, vice president for motion picture affairs, on new developments in motion picture technologies. Also, later in the week, a presentation by William Connolly, CBS Television, New York, provided a summary of the digital video standardization work underway.

The awards luncheons

One of the highlights of the SMPTE

Special microphones for special sound requirements



As an audio specialist, you know making do with "utility" microphones isn't good enough. You need a complete assortment of microphones, each suited for specific applications. Microphones that not only sound superb but are built to withstand the abuse of session to session punishment.

Shure SM line professional microphones offer built-in ruggedness and reliability and are designed to give you the optimum performance you need in every circumstance, whether it be for • a bass drum (SM7); • an acoustic stringed instrument (SM17); • percussion instruments (SM56 and SM57); • snare drum or acoustic guitar (SM81); • amplified instruments (SM53 and SM54); • studio quality vocals inside the studio (SM59); • studio quality vocals outside the studio (SM85); • stand-up interviews (SM61 and SM63); • desk-top applications (SM33) ... or whatever your needs.

...under one cover

For all the facts on Shure's full line of professional microphones, fill out and return the coupon below for your **FREE** copy of our new 72 page catalog describing over 150 microphones. No matter what your sonic requirements, there's a Shure microphone that fills the bill.



The Sound of the Professionals®

Shure Brothers Inc., Dept. 63, 222 Hartrey Ave., Evanston, IL 60204
In Canada: A. C. Simmonds & Sons Limited
Manufacturer of high fidelity components, microphones,
loudspeakers, sound systems and related circuitry.

PLEASE PRINT

Yes, send me your new Full Line Microphone/Circuitry Catalog, AL700. (Outside the U.S., enclose \$2.00 for postage and handling.)

Name _____

Address _____

City _____ State _____ Zip _____

F/1/82

athena

6000

The Most Cost-Effective Telecine Projector Available

The ATHENA 6000 is designed to meet professional requirements in NTSC, PAL and SECAM countries.

- Automatically phase-locks to NTSC, PAL or SECAM field rates
- Unlimited hold time in still frame mode
- 1-2-4-6-8-12-24 frames per second, forward or reverse, totally without flicker
- Remote control option
- Two-year parts and workmanship warranty
- Modular assembly/easy maintenance

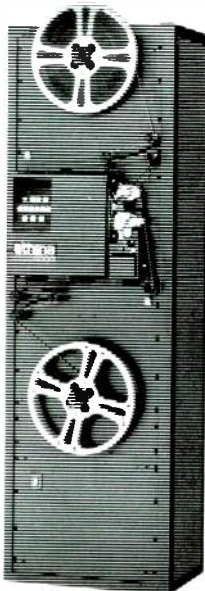

For more information contact

L-W INTERNATIONAL 6416 Varie! Avenue,
Woodland Hills, California 91367 U.S.A.
Telephone: 213 / 348-8614

Circle (61) on Reply Card

RUSSCO'S MARK V VARI-SPEED TURNTABLES MOVE THAT HEAVY 6½LB. PLATTER SO QUICK SMOOTH & QUIET!.. AND YOU'VE GOT DEPENDABILITY AT A LOW PRICE!

YES, DEAR, I THINK IT'S PRETTY.



Write for Catalog with full specs.

RUSSCO
ELECTRONICS INCORPORATED

5690 E. Shields Ave., Fresno, Calif.
U.S.A. 93727 Phone (209) 291-5591

Circle (62) on Reply Card

Worldwide agreement reached on digital video specification

The final meeting of Study Group II (Broadcast Service Television) of the current 4-year CCIR study period, 1978-82, took place Sept. 19-Oct. 9 in Geneva, Switzerland. An international agreement was achieved concerning digital TV basic parameters for main studio digital equipment and international program exchange.

The agreement ensures compatibility among digital signals to be used in the major worldwide TV systems. The compatible digital approach will permit the development of equipment with many common features, permitting operating economics and facilitating the international exchange of program in digital form.

The major parameters agreed to include the 13.5MHz basic sampling frequency; the use of the component signals, luminance and color difference signals R-Y and B-Y; and sampling of the color difference signals at one-half the rate used for luminance signals. The parameters represent the first level of an extensible family of compatible digital video coding

standards. SMPTE Engineering Vice President R. J. Zavada, Eastman Kodak Company, expressed praise for the society's contribution. In previous work, SMPTE had examined the theoretical and practical aspects and significance of the proposals leading to this agreement.

Extensive international cooperation and liaison were developed by the society to achieve its compromise position. The SMPTE was thus able to make a major contribution to the US and Canadian CCIR national study groups' position. This effort is extensively reported and detailed in the October 1981 issue of the SMPTE *Journal*. The details and significance of the worldwide agreement was reported to the membership at the 123rd SMPTE technical meeting by William G. Connolly of CBS.

Forty years after the introduction of TV broadcasting, the digital video specification is the first step toward a worldwide TV system.

SMPTE replay

convention is the awards luncheon. Each year the SMPTE acknowledges outstanding achievements and contributions to TV and motion picture technologies through a public presentation of awards. Basically, these awards fall into two categories: election of Fellows to the society, and

selected awards for individual achievement.

The board of governors of the society confer the distinguished grade of Fellow Member upon recommendation of the membership committee chaired by Robert M. Smith, DuArt Film Laboratories and past president



Fujio: David Sarnoff Gold Medal



Zahn: Agfa-Gevaert Gold Medal

Award recipients

Among the many recipients of awards at the 123rd SMPTE Technical Conference and Equipment Exhibit were Takashi Fujio, NHK Research Laboratories, Japan, and Heinrich Zahn, Robert Bosch GmbH, Federal Republic of Germany. Both were recognized for their extensive engineering contributions to television.

Two Assignments

Canon J13x9B IE plus Canon J25x11.5B IE and your camera

Two assignments, one location. For example, get great action shots of a football game and also get player interviews at half-time. You can do it with one cameraman and one camera—like the one shown here—with Canon's amazing E.F.P. lenses. Here's how:

Mount our J25 x 11.5B IE on a tripod at your principal location. It's a 2-3" system was designed specifically to work with ENG cameras, yet this lens provides a 25-to-1 zoom ratio, power zoom and focus, automatic iris and the image quality you'd expect from a Canon broadcast lens. Another choice is the Canon J20 x 8.5B IE, with a 20-to-1 zoom ratio. (Both these lenses have built-in extenders, too!) With your ENG camera attached, you've got full capability.

Detach your camera from the fixed lens, mount the farcus

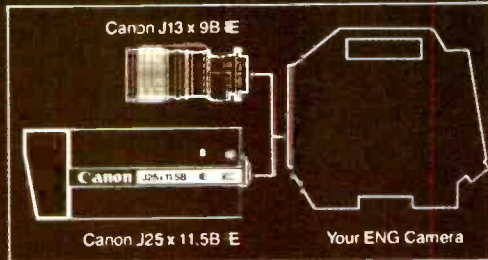

Canon J13 x 9B IE and head for the locker room!

You've got a 13X, f1.6 lens now and can move about freely for your interview shots. The J13 x 9B IE is unsurpassed as an ENG lens, with Cable Drive and auto iris capabilities

plus built-in extenders and auxiliary wide-angle and telephoto accessories available as well.

Electronic Field Production is a reality. A practical reality because you don't have to send two crews or even two cameras to a single location if all you really need is one ENG camera and two Canon lenses. And, costs notwithstanding, sometimes you just don't have enough cameras to go around. Selecting the right combination of Canon lenses could actually double the utility of the ENG cameras you already own. And that's something even your accountant can appreciate!

Find out more. Use the coupon or write on your letterhead for the facts on the Canon J25 x 11.5B IE and J20 x 8.5B IE lenses, as well as our popular J13 x 9B IE. We'll also be happy to arrange a practical demonstration for you. A very practical demonstration!

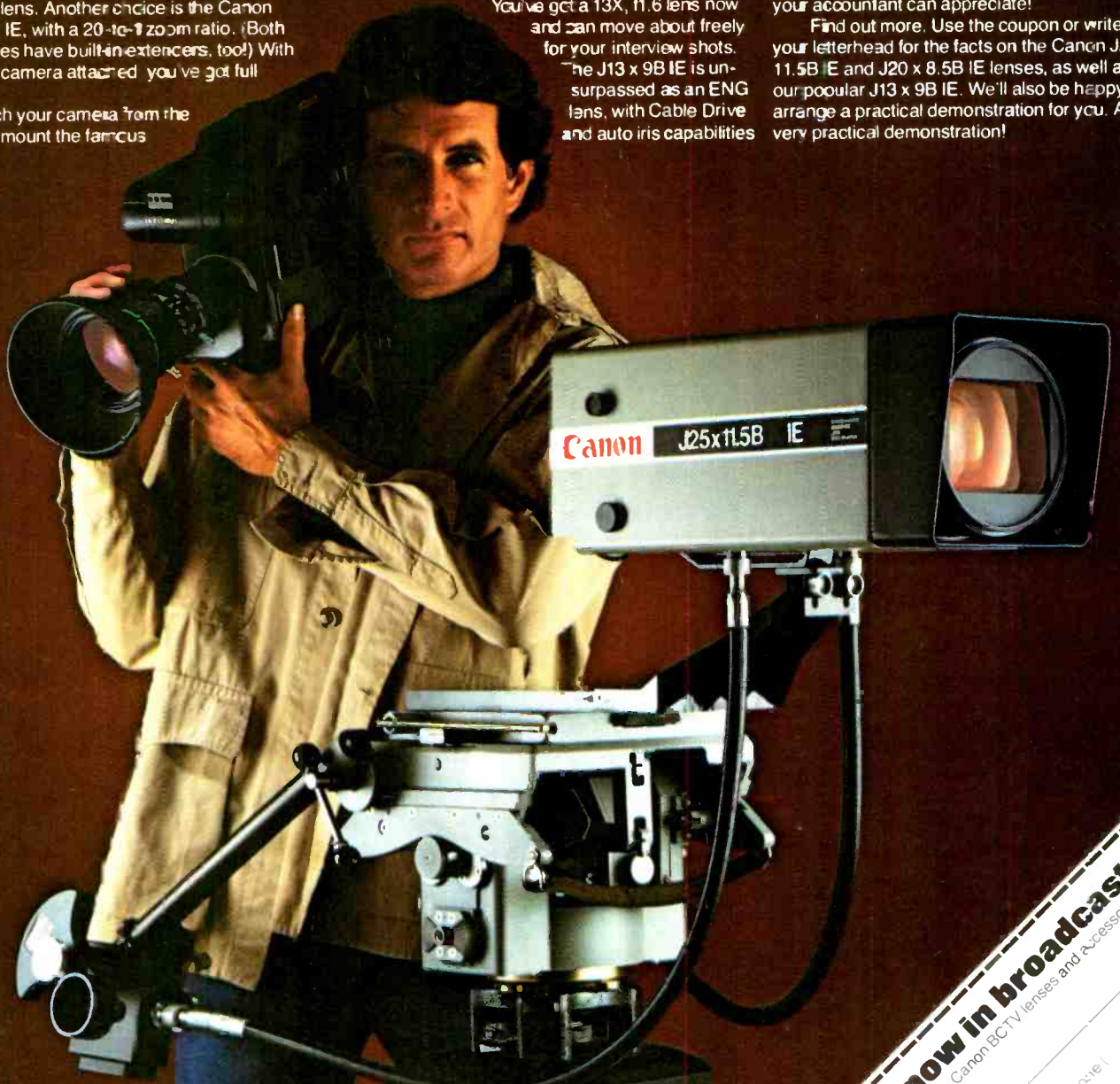

Canon

Optics Division

Canon U.S.A., Inc. Head Office: One Canon Plaza, Lake Success, N.Y. 11042 (516) 470-7000
 140 Industrial Drive, Elmhurst, Ill. 60126 (312) 333-3070 • 13 Paulding Avenue, East, Costa Mesa, Ca. 92626 (714) 979-0000
 Canon Canada, Inc. 3245 American Drive, Mississauga, Ontario, L4V 1B8, Canada
 Canon Amsterdam N.V. Industrial Products Division De Boelelaan 8, Amsterdam, Netherlands
 © 1981 Canon U.S.A., Inc.

Circle (63) on Reply Card

The name to know in broadcasting.
 Please send me information on Canon BCTV lenses and accessories.

Name _____ Title _____
 Company/Organization _____
 Street _____ City _____ State _____ Zip _____
 Phone () _____

SMPTE replay

of the SMPTE. This year's Fellowships were presented by SMPTE President Charles E. Anderson at the Fellows Luncheon.

Awards for individual achievements were presented at the awards luncheon by Anderson.

Agfa-Gevaert Gold Medal

Heinrich L. Zahn, head of Technical Development Mechanics, Robert Bosch GmbH, Federal Republic of Germany, was named recipient of the Agfa-Gevaert Gold Medal Award for 1981. The award honors the recipient by recognizing the individual's outstanding leadership, inventiveness and/or other achievements in the research, development or engineering of new techniques and/or equipment that result in a significant improvement to the interface between motion picture film and TV imaging systems, whereby the combined advances of both contribute to further development of visual communications systems.

Zahn received the award for his creative contribution and design of a pneumatic fast pull-down telecine for 50Hz countries, dual-track automatic

slide scanner and for the film transport and optical parameters of the new CCD line scanner telecine. He is regarded as one of the prime movers of German TV technology having made important contributions in almost all major areas of broadcast equipment. He holds about 30 patents and has presented numerous technical papers on film scanners and helical VTR recording. Since 1951 his major contributions include iconoscope camera, flying spot scanner for slides, image orthicon camera KOA, camera KOD, fast pull-down projector, fast start Sepmag device, continuous motion TV projectors, B-format VTR BCN, portable VTR, and 1-inch cassette portable VTR.

Honorary membership

An honorary membership to the society was bestowed upon Kenneth M. Mason, vice president and general manager of Eastman Kodak Company, MP&AVMD, Rochester, NY. This award honors an individual who has performed eminent service in the advancement of engineering in motion picture, television, or allied arts and sciences. Mason was honored for his involvement in motion picture technology since August 1935. He is renowned not only in the United States, but throughout the world, as a leader

and trusted friend of the motion picture film community.

An honorary membership was also bestowed upon Sidney P. Solow, chairman of the executive committee of Consolidated Film Industries, for his service and technical contributions to the motion picture laboratory discipline and to the motion picture industry. As a teacher, lecturer, chemist, scientist, technician and executive for almost 50 years, he has dedicated his life's work to the advancement and improvement of laboratory techniques.

Grierson Gold Medal

Peter Parks, co-founder and technical director, Oxford Scientific Films, Oxford, England, was named recipient of the John Grierson International Medal Award for 1981. This award honors the recipient by recognizing significant technical achievements related to the production of documentary motion picture films.

Parks, who is a zoologist, marine biologist, artist, engineer, craftsman and cameraman, is also a founding member of Oxford Scientific Film Ltd., now world famous for its contribution to natural history filmmaking. Parks has been a leader of the team that developed the vibration-free

VICTOR DUNCAN VIDEO

Designed to meet your equipment needs

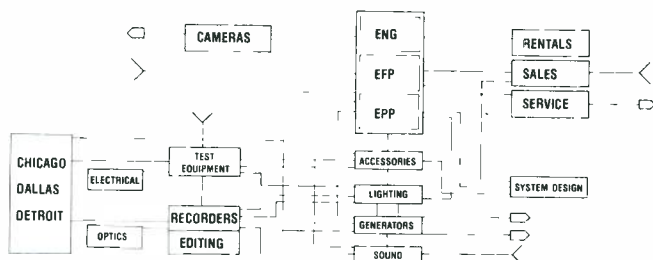

At Victor Duncan Video our facilities and business systems have been designed to meet your needs. Developed through more than twenty years of professional production experience, our Rental departments offer the very latest video equipment. And not just cameras and recorders, but the myriad of support and accessories needed to keep your production on schedule. Our rental technicians have extensive field experience, not just "shell" experience, and can help provide recommendations and alternatives for your equipment needs.

Our knowledgeable sales staff can provide product demonstration and comparison of the most current production equipment available. In cooperation with the video engineering department, our sales consultants can also provide complete system design and installation services as required for your specific needs.



VICTOR DUNCAN, INC.

Victor Duncan Video maintains the finest service in all three office locations. Simple tweaking and minor service functions can be rapidly performed saving you from costly downtime. Our routine, scheduled maintenance on all your equipment can prevent location breakdowns and keep your equipment in top shape for each production.

With three fully staffed offices in Chicago, Dallas and Detroit, you'll find Victor Duncan Video your most convenient source for production equipment in the midwest and southwest.

For all your equipment needs, plug the Victor Duncan system into yours. It's designed to be a perfect fit, everytime.

Rentals, Sales and Service

CHICAGO
661 N. LaSalle, Chicago, IL 60610 (312) 943-7300
DALLAS
2659 Fondren, Dallas, TX 75206 (214) 369-1165
DETROIT
32380 Howard, Madison Hgts., MI 48071 (313) 589-1900

Circle (64) on Reply Card

STL Offers The Most
Complete Selection
Of Test Tapes
Available Anywhere

STL can serve all your needs with precision test tapes for frequency alignment, level set, azimuth set, flutter & speed tests, sweep frequency tests and pink noise analysis. Also available is the Standard Tape Manual & the Magnetic Tape Reproducer Calibrator.

Phone for fast delivery or free catalog

STL

STANDARD TAPE LABORATORY, INC.

2612C EDEN LANDING ROAD #5 HAYWARD CALIFORNIA 94545 • (415) 786-3546

Circle (65) on Reply Card

CREATIVITY TAKES FLIGHT ON AMPEX VIDEO TAPE.



BROADCASTERS AND PRODUCTION COMPANIES DEPEND ON AMPEX TAPE.

From videotape equipment to the video tape itself, broadcasters and production companies throughout the world depend on Ampex. High quality, durability, reliability, and prompt service are just some of the reasons.

Ampex 175 Highband Quadruplex Video Tape has proven itself under every conceivable type of operating condition within every video standard. Excellent color performance, low drop-outs, and a tough durable formulation with low headwear are features which have contributed to this dependability.

And now Ampex 196 High Energy Broadcast Helical Video Tape has been specifically engineered to fill the increasing needs of a particularly demanding group of video professionals—those who have chosen one of the new broadcast helical VTRs.

No matter what your video tape needs are, there's an Ampex video tape for you. And, once you've tried Ampex tape, you'll see why broadcasters and production companies have grown to depend on Ampex.

AMPEX

REFLECTIONS OF REALITY. AND BEYOND.

Ampex Corporation, Magnetic Tape Division,
401 Broadway, Redwood City, CA 94063 415/367-4463

Circle (66) on Reply Card



SMPTE replay

optical benches that made possible the micro- and macrocinematography of living species in which Oxford Scientific Films specialize. The award was presented in recognition of that leadership.

Journal Awards

The Journal Award for 1981 was presented to Toyohiko Hatada, Haruo Sakata and Hideo Kusaka for their paper titled "Psychophysical Analysis of the 'Sensation of Reality' Induced by a Visual Wide-Field Display," published in the August 1980 SMPTE Journal. The authors are with the Visual Information Processing Research Group of the Broadcasting

Science Research Laboratories, Japan Broadcasting Corporation, Tokyo, Japan.

The Journal honorable mention award was presented to Katsuya Yokoyama, Shozo Nakagawa and Hironobu Katayama of the Technical Research Laboratories of Japan Broadcasting Corporation, Tokyo, Japan for their paper titled "An Experimental Digital Videotape Recorder," published in the March 1980 SMPTE Journal.

Kalmus Memorial Award

Manfred G. Michelson, international vice president of Engineering, Technicolor Inc., was named recipient of the Herbert T. Kalmus Memorial Award for 1981. This award recognizes outstanding contributions in the development of color

films, processing, techniques or equipment useful in making color motion pictures for theater or TV use. The award to Michelson recognized his engineering contributions to the development of printing, processing, and process control equipment used to produce color motion pictures.

Kodak Gold Medal

Dr. Robert W. Wagner, professor, Department Photo-Cinema, Ohio State University, was named the 1981 recipient of the Eastman Kodak Gold Medal. This award honors the recipient by recognizing outstanding contributions that lead to new or unique educational programs using motion pictures, television, highspeed and instrumentation photography or other photographic sciences. The award recognizes developments in equipment, systems or instructional applications that have resulted in the advancing of the educational process at any or all levels.

Wagner's award recognized his continuing leadership as an author and editor of educational film publications, as a researcher in the preservation of photographic materials, as the developer of an innovative concept of modular design for audio-visual programs, and as a film-TV educator whose contributions to curriculum, technique and professionalism have been recognized throughout the world.

Outstanding Service Awards

Alvin J. Siegler, technical manager, Network Transmission and Quality Control, CBS Television Network, New York City, was awarded the society's Citation for Outstanding Service. This recognizes his outstanding service to the New York section as a manager, program chairman, secretary/treasurer and chairman, in addition to programmer and producer of high technology meetings for the section.

Arthur E. Florack, sales and engineering representative, Eastman Kodak Company, Hudson, OH, was cited for Outstanding Service to the society for his continued efforts in support of the Ohio Section of SMPTE as a manager, secretary/treasurer, section chairman and speaker.

Photo-Sonics Achievement Award

Professor Gong Zutong, vice president of the Xian branch of the Chinese Academy of Sciences and director of the Xian Institute of Optics and Precision Mechanics, People's Republic of China, was named recipient of the Photo-Sonics Achievement Award for 1981.

Zutong is China's leading expert in applied optical instrumentation. Early

New SMPTE Fellows

A Fellow of the society is one who is at least 30 years old and who has, by his proficiency and contributions, attained an outstanding rank among engineers or executives of the motion picture, TV or related industries. Eighteen new Fellows were elected at this year's convention. Twelve are identified in the photo below taken at the Fellows luncheon; the caption also notes the new Fellows not in attendance.



Photos, by Pablo Weinschenk-Taberner, courtesy of the SMPTE.

Standing (left to right) are **Takeo Eguchi**, manager, Video Project Office, Sony Corporation, Japan; **Kenneth P. Davies**, senior engineer, Studio Systems Department, Canadian Broadcasting Corporation, Montreal; **Leonard Sokolow**, associate superintendent of Quality Control, Consolidated Film Industries, Los Angeles; **Henry Manley**, managing director, Colour Film Services and Colour Video Services, London; **Ronald E. Uhlig**, senior engineer, Eastman Kodak, Rochester, NY; and **Blaine Baker**, president, Motion Picture Laboratories, Memphis, TN. Sitting (left to right) are **Byron L. Friend**, president, Telecine Film Studios, Park Ridge, IL; **John William Zwergel**, president, Motion Picture Film Services, Pittsburgh, PA; **James Stone**, consultant, Bonded Services, Ft. Lee, NJ; **Donald D. Kennedy**, Australian Government (retired); **Peter Rainger**, deputy director of Engineering, BBC, London; and **Robert S. Hopkins**, manager of Control Equipment, RCA, Camden, NJ. Not present are **Raymond J. Brulé**, technical manager, Recording Materials Division, #M Canada, London, Ontario, Canada; **C. Robert Fine**, president and chief executive officer, Fine Communications, Harrison, NY; **Rudolf Gressman**, director, Technical Center, European Broadcasting Union; **Eric V. Knutsen**, president, TVC Video, and vice president, Data-Plex Systems, New York; **Masahiko Morizono**, senior managing director, Sony Corporation, Japan; and **Glen Rae Southworth**, president, Colorado Video, Boulder, CO.

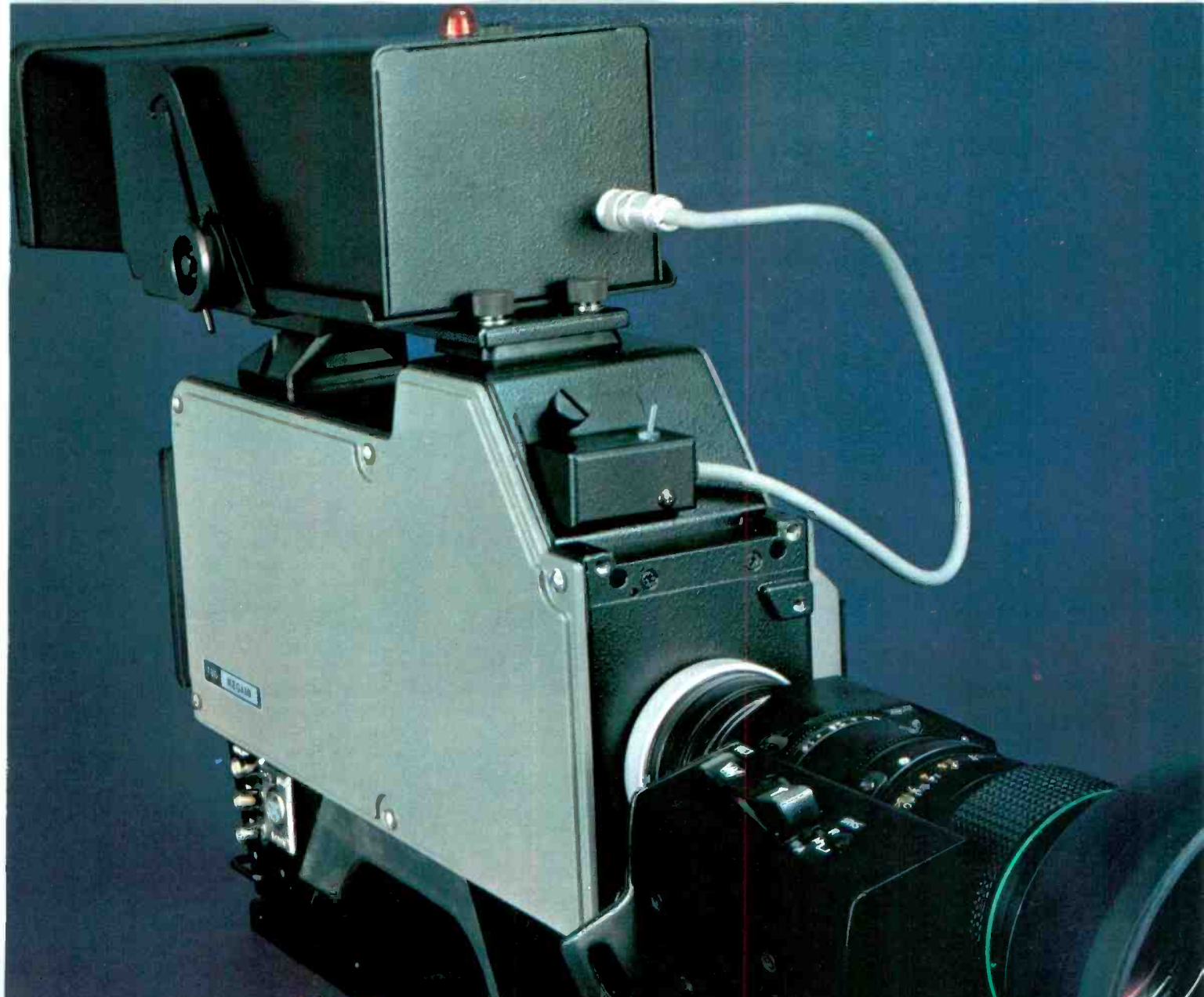

No excuses

In EFP or ENG, getting the shot is everything.

And, a growing number of networks, major stations and independent producers are consistently getting everything with the Ikegami HL-79. They've become so confident with their HL-79's that the need for a "backup" no longer exists.

The more than 2,000 HL-79's in service today have set new industry standards for low light level performance, well-balanced handling and unprecedented reliability. But Ikegami never rests. Now, the best ENG camera is even better. The improved HL-79D Series features an advanced FET preamp that (depending on your choice of tubes) will deliver a 2 to 3 dB gain in signal-to-noise ratio. The HL-79D Series is avail-

able in four new, application-matched configurations that include high-resolution diode-gun or low-capacitance diode-gun tubes.

In EFP and studio production, the new HL-79D will deliver excellent results. In fact, if you don't have an Ikegami studio camera, chances are that the HL-79D will produce a better picture than whatever camera you've got on the floor.

Contact Ikegami and ask for a side-by-side comparison. Then you'll see why an Ikegami HL-79 crew can leave the excuses—and the backup—at the station.

Ikegami HL-79D

Ikegami Electronics (USA) Inc., 37 Brook Avenue, Maywood, NJ 07607. (201) 368-9171
Northeast: (201) 368-9171 West Coast: (213) 534-0050 Southwest: (713) 445-0100 Southeast: (912) 924-0061 Canada: (201) 368-9179

INTRODUCING
ColorMax™
 THE ROLLING COLOR CHANGER



ColorMax
 TWELVE COLORS,
 YOUR CHOICE

ColorMax
 REMOTE CONTROL WITH
 PRESET -
 SLAVE HUNDREDS TO
 ONE CONTROL CHANNEL

ColorMax
 CHANGE COLORS IN
 2.5 SECONDS MAX

ColorMax
 MAXIMUM EFFICIENCY
 MAXIMUM FLEXIBILITY
 MAXIMUM ECONOMY
 MAXIMUM VARIETY

WRITE FOR INFO OR CALL
 YOUR FINE PROFESSIONAL
 DEALER.

THE GREAT AMERICAN MARKET
 POB 178 WOODLAND HILLS CA 91364 213/883-8182

Circle (68) on Reply Card

SMPTE replay

in his professional career, he was one of the principal organizers of China's first optical factory in Kunming, where he designed periscopes and other optical instruments. In 1962,

Zutong became the founding director of the Xian Institute of Optics and Precision Mechanics, a position he still holds. The institute is a research and development facility dedicated to

High Definition Television at SMPTE

By Blair Benson, engineering consultant, Norwalk, CT

The demonstrations by Compact Video provided strong support to the view expressed by many engineers that the hardware and know-how are available for a practical, high definition TV system capable of providing a quality level more than adequate for feature entertainment distribution to theaters and homes. During an open house at Compact's production facilities in Burbank, CA, videotape signals recorded in its 24-frame, 655-line Imagevision™ system were shown on a Mitsubishi high resolution 800-line shadow-mask monitor and an Eidophor large screen projector.

The progressively scanned, 1.85-ratio wide screen system, dubbed PALAF (Phase Alternate Line Alternate Frame) by the engineers, requires a base bandwidth of 9MHz. Color is transmitted as R-Y and B-Y quadrature modulation of a 7.16MHz subcarrier. Stereo sound is on FM carriers at 9.6MHz.

The demonstration tape was shot, using single camera motion-picture techniques, by a Fernseh camera with 30mm Plumbicons. The circuits were wide-banded to provide a modulation depth of 30% at 800 lines. Because the three color channels in the camera are Y, R-Y and B-Y, no matrixing was necessary for signal encoding. The camera was equipped with three viewfinders, one for the camera operator, and a second for critical adjustment of focus. The third is for the director who, as in a film studio, operates from the studio floor rather than the control room. Studio light levels ranged from 200 to 250fc.

The camera signal was recorded and edited on Ampex AVR-1 and AVR-2 VTR's that had been modified by Merlin Engineering to operate at a writing speed 60% higher than normal, and with an FM carrier above 15MHz. The edited tape was duped to a Fernseh Type-B 1-inch helical recorder

redesigned to operate at twice the normal writing speed and a video bandwidth of 10MHz.

The practicability of using currently available common-carrier transmission facilities for the Imagevision HDTV signals was shown by a side-by-side comparison of the uplink and downlink pictures using the Comstar satellite. With 5M dishes for transmission and reception, a video signal-to-noise ratio of 41dB and a bandwidth of 9MHz, there was no significant degradation.

It was noted that the RF signal-to-noise ratio on the satellite transmission was 15dB.

To further demonstrate the potential of the high definition system, a film transfer made on a redesigned 3M electron-beam recorder, and blown up to 35mm film, was projected during the paper presentation on the large screen in the Century Plaza theater. The quality was comparable to conventional 35mm motion-picture film.

Compact Video announced the licensing of Fernseh, the video corporation of Bell and Howell and Robert Bosch, to use the Imagevision system on a non-exclusive basis.

In a related paper, Kerns Powers of RCA Laboratories in Princeton, NJ emphasized the urgent need for worldwide standards suitable for the growing art of electronic cinematography. He outlined the basic parameters and requirements for a system to equal the capabilities of 35 and 70mm theatrical film. He pointed out that the industry cannot "miss this rare opportunity to achieve a single world standard for electronic cinematography."

He, in effect, echoed the sentiments expressed by producer Francis Coppola and others at a SMPTE Panel on HDTV in New York in September. (See **Broadcast Engineering**, November 1981, page 70.)

NEW SPECTRUM ANALYZERS

for monitoring,
service and testing

100 kHz to 2 GHz

The Model 632B-1 compact Spectrum Analyzer provides excellent performance, high accuracy, ease of use and high reliability. It is well suited for modern communications

signal analysis, CATV, CB, wide range distortion and noise measurements, test equipment calibration, EMC tests, and other frequency domain applications up to 2.0 GHz.

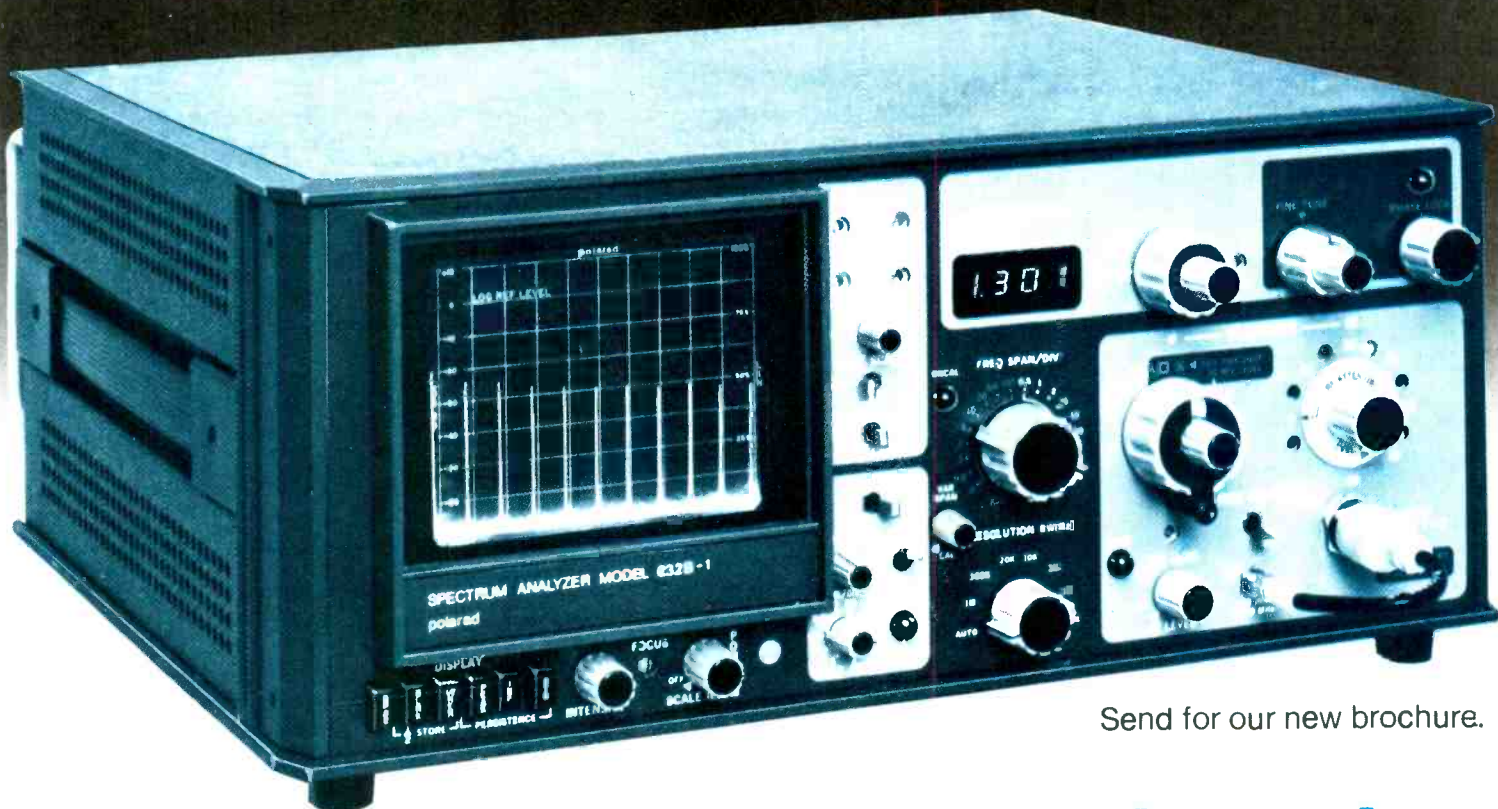
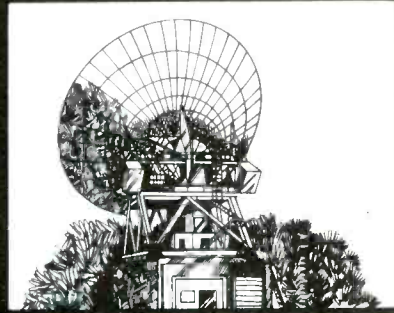
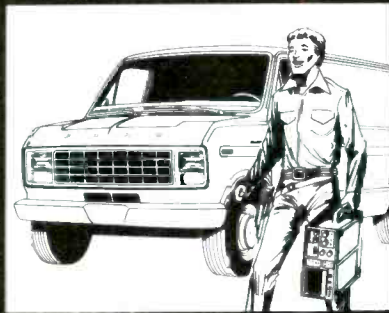
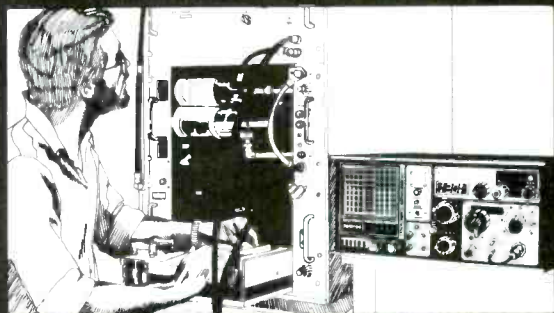

Send for our new brochure.

d polarad polarad polarad po

Polarad Electronics, Inc. 5 Delaware Dr. Lake Success N.Y. 11042 Tel: 516-328-1100 TWX: 510-223-0414

Circle (69) on Reply Card

SMPTE replay

the design of high-speed cameras and other electro-optical and mechano-optical instruments for use in research and other technical applications.

Progress Medal

Daan Zwick, senior research associate, Eastman Kodak Company, was named recipient of the 1981 Progress Medal, the premier medal award of the society recognizing outstanding technical contributions to the progress of engineering phases of the motion picture and/or TV industries.

Zwick was honored for his extensive original research into the image structure properties and emulsion design of color films, resulting in significant improvements in image quality. Also, he has played a leading role in the development of national and international standards for color film intended for television, and in developing test materials for telecine alignment.

Sarnoff Gold Medal

Dr. Takashi Fujio, deputy director, NHK Technical Research Laboratories, Tokyo, Japan, was named recipient of the David Sarnoff Gold Medal

Award recognizing outstanding works in the development of new techniques or equipment improving the engineering phases of television, including theater television. Fujio was cited for his leadership and significant engineering contributions to the continuing development of high definition television and related technologies.

Warner Memorial Award

John O. Aalberg of Los Angeles received the Samuel L. Warner Memorial Award in recognition of his outstanding contribution for improving sound-on-film motion pictures. This includes progressing the technology of exhibiting motion picture and recording for 60 continuous years.

Exhibits

As previously noted, this year's SMPTE convention featured outstanding exhibits by 132 firms. However, there were few new products introduced. But many firms alerted us to look for some surprises at NAB '82 to be held April 4-7 in Dallas. If you would like to obtain literature from the exhibitors on their established product lines and/or new products, see the exhibitor roster at-

tached and circle the numbers following companies of interest on the reader service card. We will pass along your interest and have literature sent to you. Also, selected products will be included in the new products section of **BE**.

As with all conferences, there was action on and off the exhibit floor that denotes progress in the industry. One noteworthy event was the Sony breakfast for the press held at its booth before the floor was open to the public. The press was given a special presentation and showing of Sony's equipment, including the advanced Betacam VRC* that was demonstrated at NAB '81/Las Vegas as a prototype. At the SMPTE convention we saw the system in its final form—including complete editing facilities to complement the VRC.

It was apparent at this conference that companies introducing the VRCs at NAB '81 have been busy since April last year. Two papers were presented by RCA on its Hawkeye system, and Sony presented one paper on its Betacam system, complete with the latest updates. It appears that only

*The recorder-in-camera combined system unveiled at NAB '81/Las Vegas has not yet been uniformly named in the industry. For simplicity we have named it the VRC (Video Recording Camera).

STATION OWNERS BUY IT!

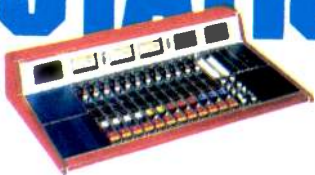

Station owners buy Auditronics' 200 Series on-air console because they

know over 99% of all Auditronics broadcast consoles ever built are still in active, every-day service. Owners buy Auditronics because they know they can hire better on-air people if they give them state-of-the-art equipment to work with. They buy Auditronics consoles because we can ideally equip everything from a 250-watt daytimer to a

major network facility, including on-air, production and remote truck models. They buy Auditronics because they know the 200 Series console will outlast its competitors and be worth more at resale. If you'd like to know more about why station owners buy Auditronics, circle reader service number or call



auditronics, inc.

3750 Old Getwell Road, Memphis, TN 38118
(901) 362-1350



Circle (70) on Reply Card



Increase your live coverage, and you increase your news ratings.

Our new versatile 2 MX ENG system offers you much greater flexibility in news quality live coverage.

This exclusive frequency agile package is so small and lightweight that it easily mounts on any helicopter, van, or news car. It's also available in a compact suitcase to provide more flexibility and faster coverage. You'll be first "on air" with that important news story.

And because MAC provides the most advanced technology in this field, our engineers have the experience to give you exactly what you need. To give you the most cost effective system available.

In addition, our package is compatible with the news gathering equipment you already have. So your investment in our new highly flexible equipment expands the capability of your entire news gathering system. As



Dimensions: 4 1/4" x 2 1/2" x 5 1/4". Weight: 3 1/2 lbs. Power output: 12 watt, high stability 21-channel synthesizer, internal VSWR and thermal protection, dual audio channels.

well as increase the ratings for your news programming.

In fact, all of MAC's news gathering systems are designed with your ratings in mind. So whether you want to increase live coverage on the street, the roof, in the mobile unit, or in the helicopter, MAC can help you

do it cost effectively.

And our single-source accountability means faster and better service for your news gathering teams.

MAC is a worldwide leader in ENG/EFM, terrestrial airborne and satellite microwave systems.

If you'd like the facts and figures on how this live coverage can improve your news programming, contact your Regional Sales Manager or Microwave Associates Communications, 63 Third Avenue, Burlington, MA 01803, U.S.A. (617) 272-3100, ext. 1872. TWX 710-332-1716, Telex 94-9464.

 Microwave Associates Communications

A
MACOM
COMPANY

Circle (71) on Reply Card

**Another
G&M First
THE BATTERY BELT
THAT MAKES ALL
OTHERS OBSOLETE!**



THE NEW G&M NICAD 1C SERIES

- Will Fully Charge in 1 1/4 Hr
- Charger Automatically Cuts Off
- L.E.D. Charge Mode Indicators
- All Solid State Electronics
- Time and Temperature Cell Protection
- Available in 12V and 30V Belts
- Eliminates the Need for a Separate Fast Charger

*The Most Sophisticated
Battery Belt Ever!*

Special Introductory Offer

- GM12B-1C, 1 1/4 Hour Charge
Battery Belt \$675.00**
**GM30B-1C, 1 1/4 Hour Charge
Battery Belt (Illustrated) \$825.00**

G & M POWER PRODUCTS

6500 Santa Monica Blvd. / Los Angeles, CA. 90038
[213] 465-8236

Circle (72) on Reply Card

**The best performing Microwave Grid
and High performance Antennas
on Earth are made by**

ANIXTER-MARK

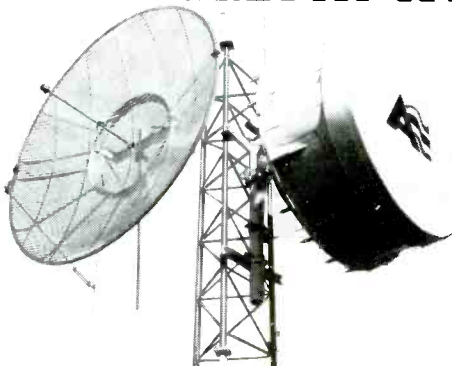

**FULL RANGE OF SIZES—2' THRU 15'
350MHz TO 13.25GHz.**

In 1950, Anixter-Mark's patented grid design (U.S. Patent No. 2,850,735; Canada No. 545,296) set a standard for the industry.

Today, backed by over 30 years of experience and innovation, Anixter-Mark is the leading manufacturer of microwave grid antennas.

We also manufacture a full line of standard spun aluminum antennas including a complete range of high performance and **MAXIMUM HIGH™** performance antennas.



Over 30 years of experience in engineering and manufacturing antennas
 • Point-to-Point • Earth Station • Microwave • Two-Way • Amateur • CB

2180 S. Wolf Rd., Des Plaines, Illinois 60018 312/298-9420. Telex 282557

© 1982 Anixter Bros., Inc.

Circle (73) on Reply Card

SMPTTE replay

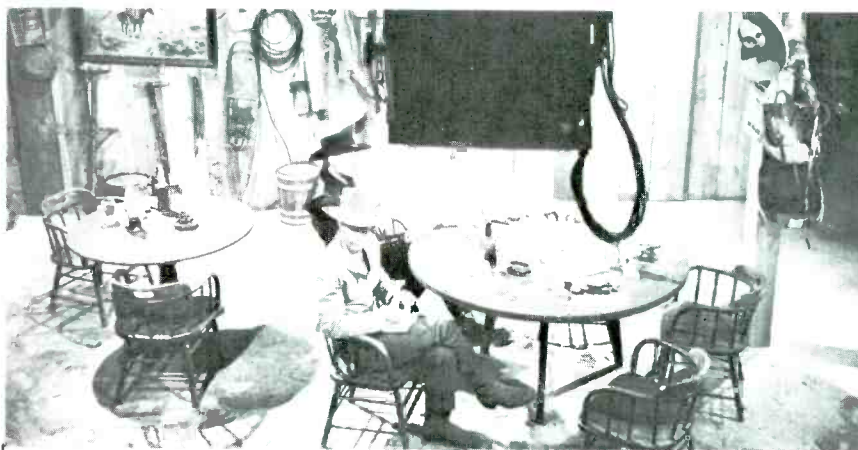

The ImageVision system

Compact Video demonstrated its ImageVision™ system at the SMPTTE convention, both in the lecture hall and at its facilities in Burbank, CA.

Above are shown the production set and principle actors in the western titled *Durango*, used as a vehicle to demonstrate the ImageVision system. The modified KCK-40 Fernseh camera used in the program is positioned to the right of this scene.



The supporting electronic hardware (shown below) was located on a stage six feet above the set. Attendees inspected all equipment used in ImageVision.

Conferees visiting the facilities first saw *Durango* and other visuals projected on a theater screen by two different schemes: From 35mm film (a transfer from tape) and from a signal returned by satellite transmission.

Viewers were impressed with the exceptional high quality of the signal that was digitized, uplinked to the Comstar satellite, rebroadcast, then down converted in Los Angeles and projected onto the movie screen. Although the satellite-routed signal exhibited a small amount of noise, it was barely noticeable. In commercial equipment these small glitches would disappear. Both the tape-transferred and satellite-linked movies were of exceptional quality, rivaling normal movie film in color and clarity.

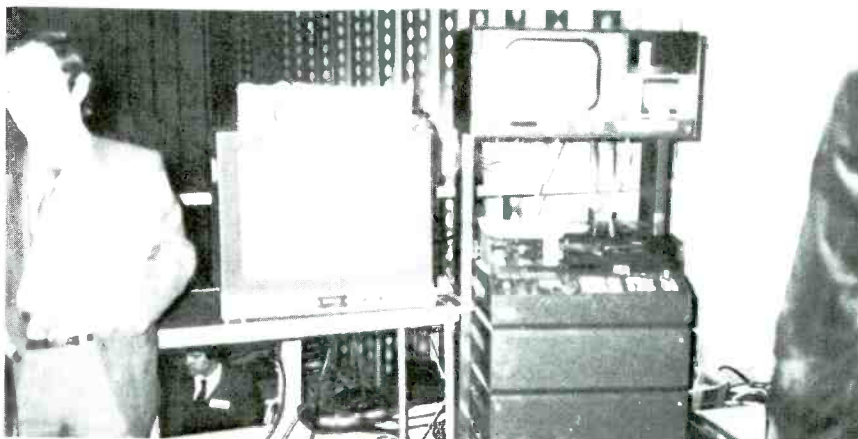

DEFLECTIONLESS.

O'Connor Hydro-Ped. Computer-designed for maximum rigidity during panning and tilting.

VISUAL WHIPLASH.

The Hydro-Ped is the ultimate camera support, designed to replace the conventional tripod and correct the backlash problem inherent in its design.

Backlash often occurs at the end of a pan when the legs of the tripod tend to "unwind" slightly, jerking the camera the other direction. This backlash creates an image deflection subjecting audiences to a visual whiplash. The use of a telephoto lens will tremendously accelerate this problem.

LIGHTHOUSE EXPERIMENT.

An early experiment to solve the backlash problem included the filming of a lighthouse

through a telephoto lens from a mile away using a fluid head and a conventional tripod. The deflection of the image due to tripod backlash was 32 inches on a ten foot screen.

The Hydro-Ped was later put to the same test and the image proved to be virtually deflectionless.

SOLID AS A ROCK.

In torsion and bending,

the Hydro-Ped is four times as rigid as a conventional tripod which hinges at the top of its legs. The Hydro-Ped hinges near the ground and has short legs which lock hydraulically in both directions.

This design not only eliminates deflection, but also enables it to be used in the toughest terrain and tightest places.

SAVES LOTS OF PRIME TIME.

When minutes really count, the Hydro-Ped takes only seconds to position, level and lock.

To adjust camera height, the center column lifts 30 inches vertically with hydraulic assistance for the heavy camera.

BUILT TO TRAVEL.

The Hydro-Ped is made of a sturdy magnesium and aluminum construction weighing only 29 lbs. It folds to 30 inches long and 10 inches in diameter. A single centered handle with comfortable grip makes it easy to carry.

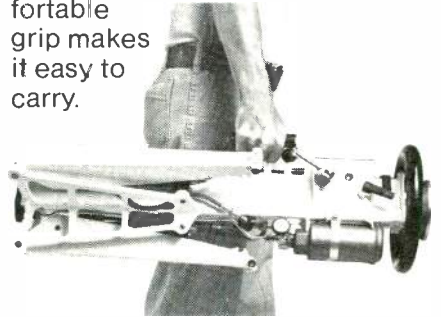

STUDIO PROVEN.

Although the Hydro-Ped is not ordinarily used to replace a studio pedestal, quick release wheels and casters are available and many enjoy its ease of use in the studio.

FLUID HEADS, TRIPODS AND MORE.

O'Connor makes the world's finest line of innovative camera support equipment.

If you're interested in learning more, let us know what camera you have and we'll let you know what we can do to support it.

O'Connor

FLUID CAMERA HEADS

The Official
Fluid Camera
Head of the
1980 Winter
Olympics



O'Connor Engineering Labs., Inc., 100 Kalmus Drive, Costa Mesa, CA 92626 • Phone (714) 979-3993 • TELEX 685 641
O'Connor Engineering Ltd., 11 Rue des Moraines, 1227 Carouge, Geneva, Switzerland • Phone (022) 42 79 38 • TELEX 23 329

Circle (74) on Reply Card

January 1982 *Broadcast Engineering* 85

SMPTE replay

production and delivery is holding up entry of these systems into the marketplace for broadcasters.

A second noteworthy event, occurring off the exhibit floor, came at the Digital Video Systems hospitality suite. John Lowry, president and chief executive officer, was ecstatic about the recently acquired financial backing that has permitted him to expand his firm's staffing for R&D, production and marketing. The details of this growth activity is covered in the business news section of this issue.

A third event occurred at an evening excursion to an open house and demonstration at Compact Video Sales in Burbank, CA. **BE** was given a special tour of the facilities with Arnold Taylor serving as host. This was an impressive tour, but no more so than the demonstration provided for the SMPTE conferees. In fact, this event was a major highlight of the convention.

To demonstrate its digital signal handling capabilities and, presumably, its future industry service interests, Compact Video provided a 2-stage movie presentation. The first stage was the direct projection of

a movie onto a theater screen using high definition TV techniques, after transferring the tape to 35mm film. The second stage was the conversion of this movie into a digital signal, sending it up to the Comstar satellite for rebroadcast, receiving the signal at a parking lot dish at Compact Video, down converting and projecting the movie again on the theater screen. The significant points about this demonstration were the high quality of the satellite-distributed signal (with barely discernible degradation) and its future implications. In essence, with suitable implementation, the movie shown could have been received worldwide for simultaneous or delayed viewing in an electronic fashion, by-passing the traditional film circulation process.

The movie shown was from an in-house effort, titled *Durango*, that was a western spoof with a warm touch and an interesting cast—a short piece that was well-produced. Following the demonstration the conferees visited the production studio, talked to some of the cast, and viewed the racks of equipment that went into creating the demonstration.

Although the equipment used involved some special circuitry and techniques, much of which was rack-mounted in typical experimental setups, spokesmen for Compact Video claimed that virtually everything used was commercially available now.

Throughout the SMPTE convention—in hospitality suites, private meetings, standards meetings, technical sessions, and on the exhibit floor—business and communications flourished. Brisk booth activity made exhibitors happy and the awards were plentiful for attendees. If you missed anything at the convention, or were not able to attend, use the reader service card and the accompanying exhibitor list/bingo number to obtain data.

Another highlight at this convention was the luncheon address delivered by Fay Kanin, president of the Academy of Motion Picture Arts and Sciences (AMPAS). She spoke eloquently on the use of communications media, especially movies and television, to enhance good will throughout the world. Her speech is presented in **BE** courtesy of the SMPTE and the AMPAS. □

EASILY EXPANDABLE

INTERCOM SYSTEMS

Proven Performer in The Top TV Stations of the U.S.A.

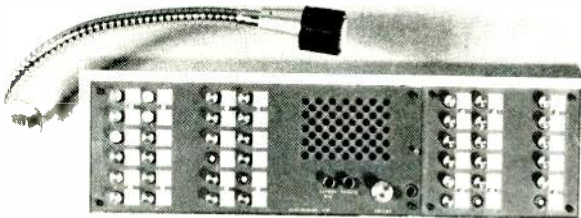

- **EASIER TO INSTALL • EASIER TO USE**
- **EASIER TO PAY FOR**

FARRTRONICS MANUFACTURES QUALITY INTERCOM SYSTEMS, AUDIO PATCHFIELDS, DISTRIBUTION AMPLIFIERS AND AUDIO CONSOLES.

Ask for our customer list.



**151 BENTLEY ST., UNIT 1, MARKHAM, ONTARIO, CANADA
L3R 3X9, (416) 495-6720**

Write for our free folder of Product Data

Circle (75) on Reply Card

We have it.

We can ship it today.



Use Videotape Products, Inc. wholesale warehouse full of all varieties, all sizes of videotape

call collect for prices

(213) **874-7711**

VIDEOTAPE
PRODUCTS INC

7165 Sunset Blvd., Hollywood, CA. 90046

Circle (76) on Reply Card

Crosstown or cross country, call Calvert first.

You'll get the lowest price in America *and* overnight delivery.

TRANSMITTING TUBES

3B28	9 75	4CX 000A	370 00	673	45 00	6 46A	8 95
3CW20000A3	1300 00	4CX 000K	460 00	805	55 00	6 46B	8 95
3CW20000A7	1507 00	4CX 500A	584 00	807	6 00	6 55	75 00
3CX1000A7	478 00	4CX 500B	470 00	810	55 00	6 56	90 00
3CX1500A7	447 00	4CX3000A	871 00	813	45 00	6 61	419 00
3CX2500A3	432 00	4CX5000A	1025 00	816	5 75	6 66A (7007)	2640 00
3CX2500F3	469 00	4CX 0000D	1069 00	828	88 00	6 696A	2850 00
3CX3000A1	432 00	4CX 5000A	1360 00	833F	85 00	6 697A	3000 00
3CX3000A7	547 00	4CX20000A	1386 00	836	8 75	ML7007A	3500 00
3CX3000F1	516 00	4CX35000C	5400 00	866F	7 25	7 237A	553 00
3CX3000F7	610 00	4CX40000G	6722 00	866FX	38 00	7527	130 00
3CX10000A3	1070 00	4X1E0A	50 00	872F	17 00	7 527A	165 00
3CX10000A7	1270 00	4X500A	320 00	880	2034 00	8 008	16 00
3CX15000A3	1211 00	4-65A	65 00	889FA	1800 00	8 22	88 00
3CX15000A7	1340 00	4-125A	75 00	891	1790 00	8 791VI	390 00
3CX20000A7	1745 00	4-250A	90 00	891F	2395 00	8 792VI	690 00
3-400Z	90 00	4-4C0A	105 00	892	1925 00	8 306	2500 00
3-500Z	99 00	4-4C0AX	165 00	892R	2240 00	8 307	2560 00
4CV35000A	2225 00	4-4C0B	130 00	405EV	110 00	8 373	191 00
4CX250B	57 00	4-4C0C	95 00	576Z	545 00	8 374	191 00
4CX250BC	71 00	4-5C0A	198 00	586A	135 00	8 375	191 00
4CX250K	120 00	4-1C00A	420 00	587A	4 80	8 390	2500 00
4CX250R	95 00	5CX1500A	630 00	592A	825 00	8 391	3375 00
4CX300A	150 00	5CX3000A	1055 00	593C	16 00	8 316	3375 00
4CX350A	75 00	5-5C0A	232 00	6076	560 00	8 385	1650 00
4CX350F	105 00	575A	29 00	6076A	695 00	8 386	1275 00

RCA CAMERA TUBES

PART NO.	PRICE	PART NO.	PRICE	PART NO.	PRICE	PART NO.	PRICE
BC4390 series	1955 00	BC4593R	2444 00	BC4992 series	2350 00	BC7735	240 00
BC4391 series	2222 00	BC4594 series	2444 00	BC4993R	2555 00	BC8134	690 00
BC4392 series	2350 00	BC4309	675 00	BC4994 series	2555 00	BC8134B	690 00
BC4393R	2555 00	BC4309B	675 00	5820A	3250 00	8480	1161 00
BC4394 series	2555 00	BC4308 series	1955 00	7295C	2885 00	BC8480	1715 00
BC4532U	1375 00	BC4309	2050 00	7389C	2905 00	BC8507	275 00
BC4592 series	2238 00					BC8541	275 00

NEW CUSTOMERS—we accept telephone orders. Inquire about our convenient Net 30 terms. Prices and items subject to change or withdrawal without prior notice.

Premium quality tetrodes manufactured in France by Amperex.



- Heavy graphite anode for intermittent overload capability.
- Zirconium coated anode to absorb gas for longer life.
- Mesh cathode for low hum level (better than -60dB).

4-400A/8438 . . . \$105.00
 4-400AX/8438A . . . 165.00
 4-400B/7527 . . . 130.00
 7527A 165.00

Available only on 4-400AX and 7527A.

TOLL FREE 800-526-6362

7 DAYS—24 HOUR
EMERGENCY PHONE SERVICE

TOLL FREE 800-526-6362

CALVERT ELECTRONICS, INC.

ONE BRANCA ROAD, EAST RUTHERFORD, NJ 07073

800-526-6362 • 201-460-8800 • TWX 710-989-0116/ERFD • TELEX 4754059

Circle (77) on Reply Card

West Coast: 1355 Redondo Avenue, Suite 6, Long Beach, CA 90804 • 213-498-3504/3184

England: Imperial House, Victoria Rd., Chelmsford, Essex CM1 1NY • Telephone: 0245 358585 • Telex: 995849

Media communications: "An awesome responsibility"

By Fay Kanin, president, the Academy of Motion Picture Arts and Sciences, Beverly Hills, CA

Editor's note: The following is a speech given by Fay Kanin, president of the Academy of Motion Picture Arts and Sciences, at the SMPTE Conference on Oct. 26, 1981.



Fay Kanin: "We who are a part of the powerful TV and movie media have an awesome responsibility."

I'm very pleased to have been invited to speak here today on several counts.

Ken Mason tells me that I'm the first woman to have been asked to address this prestigious body at your annual luncheon. I am honored and I can only take that as a heartening indication that women are more visible and viable in our industry, and I hope that I will be the first of many. After all, now that a woman has infiltrated the ASC, can more be far behind?

And I'm also glad to be here—as a writer. Because we writers don't often get a chance to communicate with our engineering and scientific film colleagues. Even though we share a "creative imagination," you in form and we in content, that is certainly the keystone of this marvel we call motion pictures.

The future

We also share, with everybody else

these days, questions and concerns about the future course of the entertainment industry. Last week I served as moderator for a panel discussion that was part of a full-day symposium devoted to exploring just that. And the one undisputable conclusion that was reached is...that *nobody knows the answers*. But more than 600 people turned out, starting at eight o'clock in the morning. Probably because there is a strong sense that the visual revolution we're already experiencing has a broader significance, and portends profound changes in the state of our culture, education and certainly, our policies—changes that are going to alter the fabric of life as we've known it.

I recently ran into a writer in New York who, with great excitement, announced to me that he'd just bought a word processor. He enthusiastically described all its remarkable skills and at the same time, told me that in his

#1 IN AM-BROADCAST... ... SENNHEISER MD-421



Newsroom, Production & Main Control... More broadcasters selected the Sennheiser MD-421 because of the spectacular frequency response of 30 to 17,000 hz... Cardioid pattern with 5-step variable bass control. If you beat our deadline of February 27, you can buy this best seller at the cash price of \$209, 2-for-\$410, 3-for-\$599.

davidgreen
P.O. Box 590/Leesburg, Virginia 22075. Phone 703-777-8660
broadcast consultants corporation

Circle (83) on Reply Card

WANT ADDITIONAL COPIES OF SPEC BOOK?

You can easily obtain extra copies of Broadcast Engineering's Spec Book. With its many uses, this special issue is a must for **everyone** interested in comparison data on a multitude of broadcast products.

Spec Book is your basic reference source for broadcast equipment comparisons. To order your additional copies, in their easy-to-use, convenient format, send a check or money order for \$15 to:

Spec Book
P.O. Box 12901
Overland Park, KS
66212

Spec Book — for **everyone** involved in buying and specifying products.

it's

NEW!

*the 'how to' magazine
of electronics...*

Formerly
Electronic Servicing,

ES&T is a new, exciting,
bigger and better-than-ever
magazine for the electronics
of today and the future!

You will find Electronic Servicing & Technology **must** reading if you are to keep abreast of the rapidly changing technology in electronics, whether you are a professional technician or an avid hobbyist.

Every month you will receive your personal copy jam-packed with the information you need and want...information that will save you time and money...the most complete and up-to-date service data on audio and video equipment...information that will take you into the future of electronics...information you just can't afford to be without.

At a very low cost you'll explore the exciting new developments in Satellite TVRO; Microcomputers; Television; VideoTape and Cassette Recorders/Players; VideoDisc; Audio Products; Test Equipment; Ham, CB & Mobile Radio; Robotics; Electronic Games, etc.

Nowhere else will you find such accurate and complete material. Charts, graphs, schematics and pictures generously supplement the easy-to-read and understandable text.

You would probably expect to pay much more for a magazine of this caliber, but right now you can take advantage of a special, limited-time subscription offer. Don't hesitate...subscribe now!



Detach and mail this convenient order form today!

YES!

Please start my subscription to the new Electronic Servicing & Technology right away. I have enclosed my check or money order for the amount indicated at right.



- 3 years \$34.00
- 2 years \$26.00
- 1 year \$15.00

Please allow 6-8 weeks for delivery VS 10

Name _____

Company _____

Address _____

City _____ State _____ Zip _____

Signature _____

▼ TYPE OF BUSINESS

- Check One**
- Independent Electronic Service Organization
 - Retailer with Electronic Service Department
 - Independent or Self Employed Service Technician
 - Electronics, Radio, TV Manufacturer
 - Industrial Electronic Service
 - Wholesaler, Jobber, Distributor
 - Other (Specify) _____

▼ POSITION

- Check One**
- Owner, Manager
 - Service Manager
 - Technician
 - Other _____

Be sure you have checked one box under each arrow!

The how to magazine of electronics

ELECTRONIC
Servicing & Technology

P.O. Box 12901
Overland Park, KS 66212

Media communications

hand, a desire to embrace and expand the marvels and mysteries of the new technologies—and on the other, a need to hang on to what is recognizable, human, familiar, comprehensible.

It is that ambivalence—the attraction of the new coupled with the anxiety that change always engenders—that makes these times so complex, and certainly provides a provocative context for your conference in this coming week.

I might add that as an organization classically concerned with standardization, you've got a heck of a challenge ahead.

But I'm probably here today *most* logically wearing my *third* hat—as president of the academy. We are, after all, the Academy of Motion Picture Arts and Sciences. And in the composition of our membership lies the best demonstration of the benevolent wedding of art and science in the process of moviemaking.

Worldwide interest

In the past couple of years, I've had occasion to travel a good deal for the academy—to many countries of western Europe, to Russia, to the Peo-

ple's Republic of China. And it's been interesting everywhere to see how the impact of motion pictures has grown, and with it, the impact of the Academy Awards. With the possible exception of "Hollywood," I can safely say that "Oscar" is the single most universally recognized word relating to movies the world over.

Usually I take an Oscar along on my trips, and I set it on a table during press conferences or seminars or official functions. The impact of that small, golden statuette on a roomful of seemingly sophisticated people must really be seen to be appreciated. At first it's greeted by a series of covert glances and a casual, "Oh, is that an Oscar?" Then there's a desultory approach to view it more closely, followed by a rather sheepish, "Can I hold it?" and, on lifting it, "Heavy isn't it?" And, then, finally a wide, open grin of enjoyment and an unashamed, "Would you mind if I had my picture taken with it?"

There's no doubt about it—Oscar has become a mythic figure—prized, coveted, admired. Even in China it was recognized, touched, photographed by newspapers and television—a fact that amazed me in the light of China's lengthy separation from the world community.

Actually, my trip there came about

as part of the first major implementation of US-Chinese cultural relations after 30 years of China's cultural isolation. Under the auspices of the United States International Communication Agency (an arm of the State Department), I was invited in May of this year to accompany the first five American motion pictures to be sent to mainland China in a generation. Since there is no US trade agreement in film with the People's Republic, the movies were to be shown in five of China's largest cities as an exchange of *Film Weeks* (the Chinese have sent five films in return that are traveling in the United States right now and will be in Los Angeles next week.)

The Motion Picture Association had agreed to provide five American movies gratis in the spirit of fostering better understanding between the two peoples, and had submitted a sizable list of titles. The Chinese had selected and screened 10 and subsequently had chosen *Singin' in the Rain*, *Shane*, *Guess Who's Coming to Dinner*, *Snow White and the Seven Dwarfs* and *The Black Stallion*.

I don't think anyone involved—American or Chinese—anticipated the overwhelming, mind-boggling, run-away success of this first American Film Week. In Beijing, the Chinese had planned to show the films in 16



Beaveronics, Inc.

VIDEO SWITCHING SYSTEMS

FOR REMOTE & SMALL PRODUCTION FACILITIES
\$7,400.00



12-input, 4-output mix-effects amp with downstream mixer, includes downstream preset & program buses with cut bar, RGB chroma key

FOR MODERATE SIZE FACILITIES
MODEL B1-154
\$12,990.00



15-input, 4-bus mix/eff/key amp with downstream mix/key amp. Many optional features including DSK & quad-split, etc.

All Switching Equipment Carries a Two Year Warranty

FAYAG MASTER CLOCK SYSTEMS

Available with accuracy better than 1 second/yr.

Write or phone for details. **Beaveronics, Inc.**
8 Haven Avenue
Port Washington, New York 11050
Tel: (516) 883-4414

Prices and Specifications Subject to Change Without Notice.

Circle (85) on Reply Card

Se Necesita Director Técnico: La revista RADIO Y TELEVISION necesita un Director Técnico que tenga la habilidad de escribir y leer fluentemente el inglés y español para traducir terminología técnica. También debe tener amplios conocimientos sobre equipo de radiodifusión y teledifusión. Enviar las solicitudes conjuntamente con antecedentes profesionales y requisitos de salario a: Publisher, Radio y Televisión, P.O. Box 12901, Overland Park, Kansas 66212. 11-81-3t

theaters, five times a day. But the demand was so enormous, with people queuing up for tickets in the streets at 4 a.m., that the number of theaters was increased to 18 and the showings to eight performances daily—starting at 6:30 a.m. and ending at 1:30 a.m. In Shanghai, 36 theaters were increased to 45, again with eight performances a day—and in over 1000-seat theaters.

Reels were bicycled, literally, from one movie house to another, since a single print of each film served both cities. You can imagine the condition of the prints, freshly struck for this festival, by the time we viewed a couple of the showings in the second week. It was as if the movies were being seen through a hailstorm. Luckily, a second and third set of prints was on hand for showing in the last three cities.

It's interesting that the Chinese were as concerned with audience figures as we are. The attendance quoted for the week in Beijing was 670,000, and for the Shanghai engagement—813,000. When we left China, with the films still to play in three cities, the projection was for nearly three million Chinese to have seen the films in five weeks.

The obvious conclusion to be drawn from this experiment is that there is an enormous market in mainland

Data continued

F & B/Ceco — Bardwell & McAlister	546
Feathercam Inc.	547
Fernseh Inc.	548
Film Automation Corporation	549
Frezzolini Electronics Inc.	550
Fuji Photo Film USA Inc., Magnetic Tape Div.	551
Fujinon Optical Inc.	552
Goldberg Brothers Inc.	553
Alan Gordon Enterprises Inc.	554
The Grass Valley Group	555
Gray Engineering Labs Inc.	556
Harris/Farion Video	557
Harris Video Systems	558
Hazeltine Corporation	559
Hitachi Denshi America Ltd.	560
Hollywood Film Co.	561
Houston Fearless 76 Inc.	562
Hudson Photographic Industries	563
Ikegami Electronics (USA) Inc.	564
KEM Editing Systems Inc.	565
Kliegl Brothers	566
LTM Corporation of America	567
L-W International	568
Lab Methods Corporation	569
LaVeZZi Machine Works Inc.	570



Fernseh



Fuji



Harris



Hitachi

**audiotechniques
Presents**

**MCI[®] TECHNICAL
TRAINING SEMINAR**

**FEBRUARY 1,2,3
AT THE NEW YORK HILTON**

AUDIOTECHNIQUES, IN COOPERATION WITH MCI CORP., FT. LAUDERDALE, FLORIDA, WILL PRESENT A THREE DAY SEMINAR AT THE NEW YORK HILTON.

ENGINEERING AND TECHNICAL PERSONNEL FROM MCI WILL COVER THE TECHNICAL ASPECTS OF OPERATION AND MAINTENANCE OF MCI TAPE RECORDERS AND CONSOLES.

Seminars are offered in two sections.	Cost
Section I . . . Feb. 1,2 JH-110B, JH-24 Tape Machines	\$ 95.
Section II . . . Feb. 3 JH-600 Console and Automation	\$ 75.
Section I and II	\$150.

Participants will receive complete MCI Manuals for each section taken. Certificates to be awarded upon completion of seminar.

Seminar Leaders

GREG LAMPING, RUEL ELY MCI Technical Services,
BOB BERLINER, RICK ANDERSON, ...Audiotechniques

For additional information
call or write BOB BERLINER,
Audiotechniques, 652 Glenbrook Rd.,
Stamford, CT 06906
800-243-2598

Circle (86) on Reply Card

**When YOU want
NICKEL CADMIUM**

20 years of dependability



Belts and Packs for All Cameras and VTRs

**YOU want
PERROTT
ENGINEERING LABS, INC.**

1020 N. Fillmore St., Arlington, Va. 22201 (703) 528-5861

Circle (87) on Reply Card

Media communications

China for American movies, if a film agreement could ever be accomplished and the economic and political hurdles overcome. Motion pictures transcend language and geography and speak, people to people, as nothing else can. And in addition there is a natural rapport and much common experience between film people, which I felt strongly in China, as everywhere.

I remember particularly one seminar we had with film writers, actors and directors in Shanghai at which Arthur Knight, the film critic and historian who was one of our US delegation, wanting to make a certain point, told a story about a man with a talking dog who, when he was complimented on the animal's amazing ability said, "Yes, but what he really wants to do is *direct*." Well, of course, all the Americans present laughed, and while we waited for the interpreter to translate for the Chinese, I said to Arthur, "I think you're in trouble with that one. That's not going to travel." At which point, the Chinese, hearing the tag line, broke into gales of laughter and I realized I was dead wrong.

But in spite of all that, it's naive to think that an open American-Chinese film exchange, economic or otherwise, can come about quickly or easily. The present Chinese cultural leaders walk a difficult and often risky path. Almost all of those we met, heads of cinema and the other arts, had been banished to workfarms or imprisoned as dangerous to the state during the period of what was curiously called the "Cultural Revolution." And though I came back with great respect for the attempts of the present government to restore pride in China's cultural heritage and to revive all its arts, including its movies, what I felt while there was a heightened appreciation of our own freedom—to speak out, to be irreverent, to be critical, to dissent—and as a movie-maker, to make films which reflect those precious rights.

Another viewpoint

Indeed, one of the best reasons for going out of this country may be the chance it gives you to look at it from another perspective.

In Greece, I was interviewed by a young journalist who also seemed to have something he wanted to say. "You know, I'm very admiring of the United States," he told me. "I think it is a true democracy."

I asked if he'd been here. "Oh, yes," he said. "I spent a year in your country. I visited Washington and I went to

look at the White House. There were people outside shouting and parading with angry signs. So I went again the next day, and there were more people with more angry signs. Nobody stopped them or arrested them." He shook his head. "That's amazing. You see, it couldn't happen here. If people did that outside our president's house, they'd be carried off to jail. Or anywhere else in the world. You are a democracy," he said again and grabbed my hand and pumped it.

As he did, I recalled that in Belgium I had shown a TV movie of mine, *Friendly Fire*, to a group of several hundred European film students and moviemakers. As some of you may remember, the movie concerns an actual Iowa family whose son was killed in Vietnam by American artillery, and who waged a private war with the army over their right to know the facts of his death.

I opened the floor to discussion after the showing and they asked me a lot of questions. And then I asked them a question. "Could a film like this, critical of the policies of the army and the government, have been made and shown on national television in any of your own countries?" There was silence as they thought about it, and then came the answer. With the possible exception of Sweden, they felt unanimously that it could not.

Movie messages

For me, American movies are the greatest ambassador this country has. Beyond their extraordinary popularity with audiences everywhere for their sheer entertainment values and their cinematic skill, what I believe recommends them to every nation is their openness in reflecting our society—with all its beauties and *all its warts*. They're the movies of a country that isn't afraid to mirror its weaknesses and its problems, to laugh at its idiocies as well as to celebrate its vigor and spirit and humanity. What better message to send to a world, a good portion of which is struggling under various forms of censorship and repression?

I've felt very privileged to have spent most of my professional life in this medium. Sitting in a movie theater and seeing your work up on that big screen—in Dolby Sound, hearing the sharp crack of laughter or feeling the joined silence of an audience is an incomparable satisfaction.

Then a few years ago, I did my first movie for television, and I sat in my living room on the night it aired and watched it on that little box—no audience, no reactions. And I must admit to being disappointed; I wasn't sure I liked this at all. But in the next

Data continued

Lenco Inc., Electronics Div.	571
Lipsner-Smith Co.	572
Listec Television Equipment Corporation	573
Lowel-Light Mfg. Inc.	574
MCI/Quantel	575
Magnasync/Moviola Corporation	576
Magna-Tech Electronic Company Inc.	577
Marconi Instruments, Div. of Marconi Electronics Inc.	578
Matthews Studio Equipment Inc.	579
Merlin	580
Microtime Inc.	581
Microwave Associates Communications	582
Miller Professional Equipment Inc.	583
Millimeter Magazine	584
Mitchell Camera Corporation	585
Mole-Richardson Company	586
Multi-Track Magnetics	587
NEC America Inc., Broadcast Div.	588
Nagra Magnetic Recorders Inc.	589
Nurad Inc.	590
O'Connor Engineering Labs Inc.	591
Oldelft/KLM Associates Inc.	592
On Location Publishing Inc.	593
Orrox/CMX	594
Oxberry Div. of Richmark Camera Services Inc.	595



MCI/Quantel



Microwave Associates



NEC

THE PROFESSIONAL'S VIDEO TEST SET CHOICE

**MORE STANDARD FEATURES TO BEGIN WITH
MORE OPTIONS TO GROW WITH**

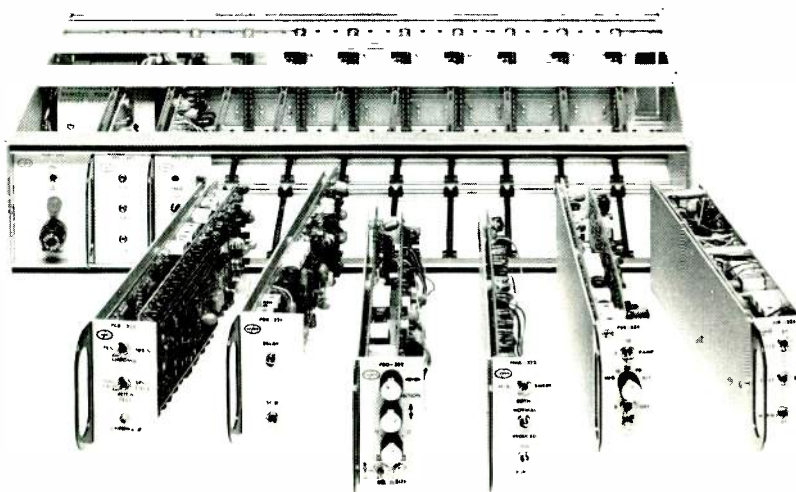

This totally integrated modular video test set is designed for you, the discriminating professional. The Lenco 300 System lets **you** specify video test signals to meet **your** system requirements, rather than the manufacturer's requirements.

For versatility, use the Lenco PSG-310 Digital Color Sync Generator or the PMG-312 RS-170A Generator with any one or a combination of all the test modules. Mix them or match them any way that you can imagine. There are 29 test signals available to answer all of your system test specifications.

THE AFFORDABLES — You get a lot more for a lot less with the Lenco 300 System. For example, all of our test signal modules have

composite video delay. This allows you to **individually** time each test signal module to your system. Moreover, we are the first American manufacturer to supply a color bar generator with the SMPTE alignment test signal (reverse bars).

Join the many professionals now using the flexible Lenco 300 test system. We are so sure of your acceptance of Lenco equipment, that we offer a two-year warranty on all parts and labor. This warranty also includes freight to and from our factory.

Call or write for a demonstration today. You will find the Lenco 300 System to be your professional video test set **now** and as you grow.



LENCO, INC., ELECTRONICS DIVISION

300 N. Maryland St., Jackson, MO 63755, (314) 243-3147

The Professional's Choice

Circle (88) on Reply Card

FitzCo SOUND, INC.

**AAE "Concept One"
AUTOMATION
AKG
AMPEX
AUDIOARTS
ENGINEERING
BGW/TANNOY
HANNAY REELS
IVIE
EVENTIDE
LEXICON
NEUTRIK
SENNHEISER
TECHNICS
VEGA
WIREWOKS**

FITZCO SOUND, INC.

204 N. Midkiff
Midland, Texas 79701
(915) 684-0861

Circle (89) on Reply Card

HEAD RE-LAPPING

Worn cartridge and reel to reel heads re-contoured and re-lapped for original performance. Other products for the magnetic recording industry. Send for free brochure.

R.K. Morrison Co.
819 Coventry Road • Kensington, CA 94707
(415) 525-9409

Circle (90) on Reply Card

**Use BE
classified ads**

Data continued

PRC of America	596	Soremec Eclair USA Inc.	614
Pace International Corporation	597	Steenbeck Inc.	615
Panasonic	598	Strand Century Inc.	616
Peterson Enterprises Inc.	599	Sylvania Lighting Products/GTE	617
Philips	600	System Concepts Inc.	618
Philips Test & Measuring Instruments Inc.	601	Tele-Cine Corporation	619
Pioneer Marketing Corporation	602	Teledyne Camera Systems	620
Q-TV	603	Telescript Inc.	621
RCA Broadcast Systems	604	Television Equipment Associates	622
R-Columbia Products Company Inc.	605	Thomson-CSF Broadcast Inc.	623
Rank Precision Industries	606	3M, Photographic Products Div.	624
Research Technology International	607	Toshiba America Inc.	625
Rohde & Schwarz Sales Company	608	US JVC Corporation	626
Rosco Laboratories Inc.	609	Unidek	627
Sennheiser Electronic Corporation	610	Union Connector Company Inc.	628
Skotel Corporation	611	Videomedia Inc.	629
Snook Corporation	612	Vidiotek Inc.	630
Sony Video Products Company	613	Vital Industries Inc.	633
		Westrex	631
		Wide Range Electronics Corporation	632



RCA



Sony



Systems Concepts



Thomson-CSF

Media communications

few days, wherever I went—in markets, drugstores, elevators, banks, coffee shops—I could hear people talking about it. And I began to comprehend the enormous impact of television. Even a film that has what is considered a modest rating in prime time, is seen by how many millions—20, 30, give-or-take a million. And in the case of *Friendly Fire*, 60 million!

And when the letters start pouring in to the network, to the sponsor, to you—you realize something else, that this audience wants to share its feelings with you, to tell you how the movie affected them, their husbands or wives, their children. There is nothing like that in any other dramatic medium. It is unique.

In a theater, movies transport you out of yourself into another world,

sometimes of illusion, sometimes of harsh reality, and send you away with a sense of shared experience.

Television comes into the living-room and takes off its shoes and loosens its belt and opens a can of beer. Sometimes it yawns and falls asleep, but when it doesn't, it has the ability to reach into people's minds and hearts and change their lives, as nothing else.

I guess the sum of what I'm trying to say is that we who are part of both these powerful media have an awesome responsibility to use them well. And with that, we have equal obligation—to keep them free and open and daring and critical—so that my journalist friend in Greece and others out there, seeing them, can always know what democracy looks like. □

The next time your air monitor goes dead, tell your audience about your bargain low-power television equipment

The high cost of low price equipment

No broadcast equipment is a bargain when it's off the air. So EMCEE® Broadcast Products builds its translators, LPTV transmitters and other hardware without cutting corners or costs. Frankly, that often means prices that appear higher. But it also means the proven higher reliability that EMCEE hardware has provided since 1960.

Oldies but goodies

This higher reliability is no blue-sky claim, either. Many EMCEE HRV-1 1 watt translators are still doing a full broadcast day's work eighteen years after installation. EMCEE HTU-100 100 watt translators are still going strong after seventeen years on site. And the list goes on. Because through three generations of low-power television equipment, value and reliability have always come before cost.

Lasting value

This value and reliability comes from higher rated components that loaf along at operating values. From human engineered front panel metering for immediate status of operating para-

meters. And from innovations such as the industry's first use of pre-correction to improve linearity and extend final tube life. And the industry's only remote interrogator. A complete translator/transmitter status monitor that reduces the number of trips and hours necessary to keep isolated installations operating efficiently.

Valuable support

But technology alone isn't the source of EMCEE reliability. It comes from the Applications and Field Engineering Departments that supply design, installation and total turnkey services without additional charges. It comes from the expertise of our tower crew. And it comes from our special inventory of emergency hardware and a 24-hour number that can help you solve small problems before they become bigger ones.

A fourth generation of reliability

The next generation of EMCEE low-power television equipment is now in the breacboard stage. Like the three previous generations, it won't be the least expensive hardware available.

Which leaves you with two choices. Pay the price of reliability when you buy. Or when your air monitor goes dead.

It's not just how it works.

But how long it works.

The logo for EMCEE Broadcast Products. It features the word "EMCEE" in a large, bold, black, sans-serif font. Above and below the letters are several horizontal green lines of varying lengths, creating a stylized, modern look.

**BROADCAST
PRODUCTS**

a division of
**ELECTRONICS, MISSILES
& COMMUNICATIONS, INC.**

P.O. Box 68
White Haven, PA 18661
Call toll free: 800-233-6193
(In PA: 717-443-9575)
TWX: 510-655-7088
Ans: EMCEE WHHV

Equipment manufactured in U.S.A.
© EMCEE Broadcast Products
© 1982 EMCEE Broadcast Products

AES conference replay

By Harmon M. Shragge, Jr., media consultant, New York

The 70th Audio Engineering Society convention took place Oct. 30-Nov. 2 at the Waldorf Astoria in New York. There were more than 180 exhibitors and 6600 registrants.

"If there is a downbeat in this year's marketplace, you would not be able to recognize it by the enthusiasm of the registrants and exhibitors here," Don Plunkett, AES executive director said.

In addition to the latest equipment being shown, there were a number of lectures and seminars, concerned with such subjects as new modulation techniques for high density recording on digital audio discs, a new tape transport system with digital control, and decoded digital-to-analog converters for audio.

Not surprisingly, digital audio

equipment was the center of attraction at this convention.

Sony's exhibit featured a compact digital audio disc prototype. The disc is 12cm (4¾-inch) in diameter, offering 60 minutes of 2-channel recording capability on one side, using an optical signal readout system.

The compact digital audio disc has a frequency response flat from 20 to 20,000Hz with a dynamic range better than 90dB (97.5dB in theory). The signal-to-noise ratio is also reported at 90dB with 97.5dB theoretically possible. Harmonic distortion has been reduced to 0.05%. Channel separation registers better than 90dB with immeasurable wow and flutter levels.

The compact digital disc is scheduled for release in Japan and Europe in the fall of 1982, with the United States and other countries having to wait until the spring of 1983. Cost of the player is unknown, but estimates begin at \$500, with discs in the \$14 to \$15 range.

Sony further expanded its digital audio line by introducing the DDU-1510 Delay/Preview Unit combined with its digital mastering system (PCM-1610, PCM-1600 or PCM-100 professional processor and BVU-200B recorder).

For use with digital systems, the DDU-1510 has digital input and delayed output signals. An analog preview output features 12-bit precision and offers switchable selection of either serial or parallel data. Any sampling frequency between 40kHz and 55kHz makes it operable with any digital signal developed so far.

Master signal frequency response of the DDU-1500 series is 20-20,000Hz, +0.05, -1.0dB. Dynamic range is greater than 0.05% at -20dB peak levels.

Another preview unit, the DDU-1520, and the DDU-1530 delay unit for interface with analog systems, are scheduled for introduction in early 1982.

New digital advancements in the JVC exhibit included JVC's Digital Compact Cassette Deck. It is capable of 1-hour PCM digital recording and playback on both sides of a compact cassette tape.

Specifications for the deck include

Digital highlights at AES

By Blair Benson, engineering consultant, Norwalk, CT

At the 4-day meeting of the AES in New York, papers and equipment exhibits highlighted the rapidly increasing use of digital technology and the interfacing of audio and video systems. For the radio broadcaster, the emphasis was upon automation and equipment of greater reliability requiring negligible maintenance.

A sleeper combining digital recording and automation was a prototype magnetic disc-pack recording system shown by EMT. Using up to 15 computer-type discs, 35 hours of monaural program or spot recordings are stored digitally and accessed randomly for simultaneous playback of up to four different recordings. At the same time, additional material can be loaded without interfering with the playback operation. Housekeeping of the recordings is accomplished automatically. Old, discarded spots are erased and re-recorded in the proper, new locations. Because the signals are recorded in a digital format rather than analog, many generations of re-recording are possible without degradation of the -80dB noise level and 15kHz bandwidth. Besides the initial application in network radio programming, the EMT system may be useful for looping of sound tracks and storage or automatic retrieval of sound effect in post-production operations.

Among the various audio processors were time compressors from Lexicon and Eventide for use

in matching the sound tracks, without any change in pitch, to videotapes of films and commercials that have been shortened to meet home video and broadcasting time restrictions.

New methods of handling post-production problems were discussed by a panel chaired by consultant Bob Fine. The discussion by the experts on Q-lock from England, BTX SMPTE Time Code usage, Magnatic's Vidimag, and multi-track tape editing, clearly indicated the present day marriage of audio and video equipment and techniques. The large attendance indicated the high degree of interest by audio engineers in the subject and the need for more information on the use of TV post-production procedures. The panel will assemble in February at the AES meeting of the local chapter in New York, to provide an update.

A number of new multi-track audio tape recorders were demonstrated with sophisticated computer control for use with the SMPTE time code. The use of more than 24 tracks, a growing requirement in post-production, was evident by the proposals for synchronizing and locking two multi-track machines, with computer-controlled operation.

Matching the multi-track audiotape decks were several audio consoles providing 24 channels or more. And on the digital front, an all-digital console was shown by one manufacturer, a sign of the future.

HOW TO REACH THE WORLD'S FASTEST GROWING BROADCAST EQUIPMENT MARKETS

With one source, you can cover the world!

When your company seeks new broadcast markets, there's only one magazine group to turn to. The group that helps you pinpoint and sell to the people who buy your products. Not just in the U.S. But in Latin America. And China, too.

BROADCAST ENGINEERING – RADIO Y TELEVISION – CHINESE LANGUAGE EDITION

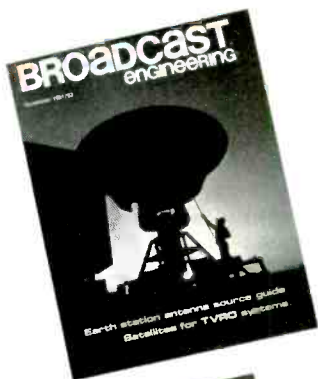

Broadcast Engineering, the journal of broadcast technology, is the original technical publication serving the industry. With the largest audience of broadcast professionals of any publication in the world. And the highest proven reader preference.

In BE, readers learn of the newest developments and advances in broadcast technology. Written by leading experts with years of experience in the field.

To help you get the most for your money, BE offers the largest circulation. Outstanding inquiry generation. Plus, the lowest cost-per-thousand in the industry.

It all adds up.

Broadcast Engineering—the best way to reach the world's largest broadcast equipment market.

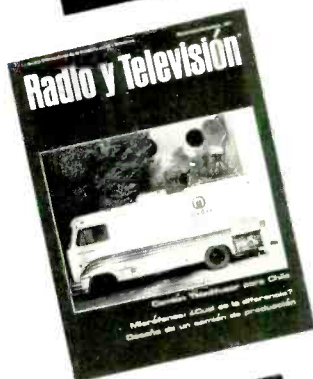

Radio y Televisión is the only publication written to serve the world's fastest growing broadcast market—Latin America. Published six times a year with an exclusive Buyers' Guide Directory issue. RYT offers the sales medium that's essential for you to effectively sell the Spanish-speaking broadcast market. RYT delivers advertising results. And has for over 15 years. As a bonus, translation is still FREE.

Radio y Televisión—the only way to reach the world's fastest growing broadcast equipment market.

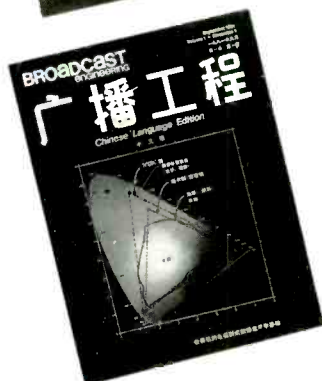

BE's Chinese Language Edition. Become a part of the world's newest billion dollar market. **Broadcast Engineering** is proud to be the first and only magazine invited by the **PRC Central Broadcasting Administration** and **Radio Peking** to publish this special edition. Your ad will be seen by 8,500 hand-picked radio and TV professionals throughout China.

Provide your company with the special opportunity to introduce your products to China's broadcast professionals. Especially at a time when they're planning and buying. Don't miss out on this investment in your present. And future. Get outstanding advertising exposure for your sales message. In China. It happens in August.

Broadcast Engineering's Chinese Language Edition—the only way to reach the world's newest broadcast equipment market.

Expand your international market coverage today. Reach the worldwide broadcast marketplace, with **Broadcast Engineering**, **Radio y Televisión**, and **BE's Chinese Language Edition**. All three provide comprehensive, economical coverage of the broadcast equipment market—in the U.S.—in Latin America—and in China. Advertise with the magazine group that reaches the booming broadcast equipment market. And cover the world.

Intertec Publishing Corp.
P.O. Box 12901
Overland Park, KS 66212



Ampex: Audio recorders

AES replay

four tracks for digital audio plus one track for random access or program indication. Tape speed will be 7.1cm/s with a sampling frequency of 33.6kHz. Two heads (record/playback/erase) will use a bi-parity correction scheme.

Sony, Sharp, Sanyo and Pioneer have also developed digital cassette decks. None of the digital cassette decks are compatible.

JVC will offer various models of its Digital Compact Cassette Deck for sale in 1983. The models will range from a studio broadcast console to a portable consumer system similar to Sony's "Walkman." Price should be in the area of \$1500 to \$2000, with the portable model substantially lower.

JVC also introduced its DS 90 Data Synchronizer at the show. Through the address code in the PCM processor, this unit allows the synchronization of two VCRs, producing a total of four channels of synchronized sound. On single decks, the unit can be used as an autolocator in the 2-channel mode. New VCRs may be ordered from JVC with the DS 90 as an option. No price has been specified.

The 3M Company for the first time unveiled its prototype 4-channel digital audio mixer. The digital mixer will allow no wow, flutter or signal degradation to occur within the mixing process.

Clark Duffy, 3M's digital audio sales manager, said that the 3M exhibit served more to educate audio and studio engineers on the benefits of digital audio and gain feedback on the new digital mixer, than to sell specific equipment. The company demonstrated a 10th generation analog track and a 10th generation digital track to allow the public to have a direct comparison.

In the Lexicon suite, engineers were demonstrating the Digital Reverb Model 224-X. The system provides *Dynamic Decay* along with decay and sustain for musicians and studios wanting superior digital reverb effects. Of more importance to broadcasters, however, was Lexicon's demonstration of the Model 1200B Audio Time Compressor. The 1200B is a wide bandwidth version of the Model 1200, stretching the bandwidth from 10kHz to 15kHz.

Tape speed is controlled by entering the desired value on the key pad. The Model 1200 and 1200B will automatically set the tape to run at the desired speed and the pitch processor to the appropriate correction value.

Programmable filters in the audio signal chain eliminate frequency response problems due to varying tape speed. As the tape is changed, the

NEW! AVAILABLE FROM AFA! AFA SLATE CAMERA SYSTEM SC-300



Compact, self-contained title card camera for mobile and studio operations!

- Available as a table-top console or rack-mount unit
 - Adjustable timer
 - Cool light source
 - Noise free operation
- Simple to operate and maintain
- Dimensions: 19" slide mount 8³/₄" high x 20" deep
 - Immediate delivery

Call us today for more information: (201) 767-1000

AFA

AF ASSOCIATES INC.

100 STONEHURST COURT, NORTHVALE NJ 07647

system automatically adjusts both the cut-off frequency in the anti-aliasing filters and the correction curve in the unit's internal equalization correction filters.

The Model 1200 and 1200B employ computer-type technology and proprietary intelligent digital processing techniques that reduce playback or

3M comments on digital sampling rate

Representatives to the digital standards group at the AES convention found agreement with a 48kHz sampling rate using 16-bit format for professional audio equipment. Also, 44.1kHz sampling will be acceptable for certain applications, such as the current digital audio disc technology and U-Matic-based tape.

Robert Youngquist, corporate scientist for the 3M digital audio division, continues to believe that 50kHz is better for technical reasons. "The rate (50kHz), selected almost a decade ago and incorporated in some 60 recorders worldwide during the past two and a half years, has some advantages over 48kHz, particularly as it relates to video. Some users may, in fact, elect to continue using 50kHz indefinitely," Youngquist said. "But, we concede that 48kHz is very workable and presents no real sacrifice in audio quality, our principal concern."

Clark Duffy, 3M digital equipment market development manager, said that a major concern was to minimize inconvenience and expense to customers. "Fortunately our equipment is designed so that a studio can selectively achieve 48kHz sampling rates merely by offsetting the tape speed to 43.2ips via the machine's variable speed function," Duffy said. He indicated that future options would include rate switch selectability between 48 and 50kHz. The tape time display for a selected rate may be automatically corrected with the tape speed variations expressed in percentages.

The adoption of the 48kHz sampling rate as a standard provides manufacturers with a more solid footing in the development of new audio designs for recording, mixing and processing equipment as the industry strives to improve dynamic range and signal-to-noise ratios.

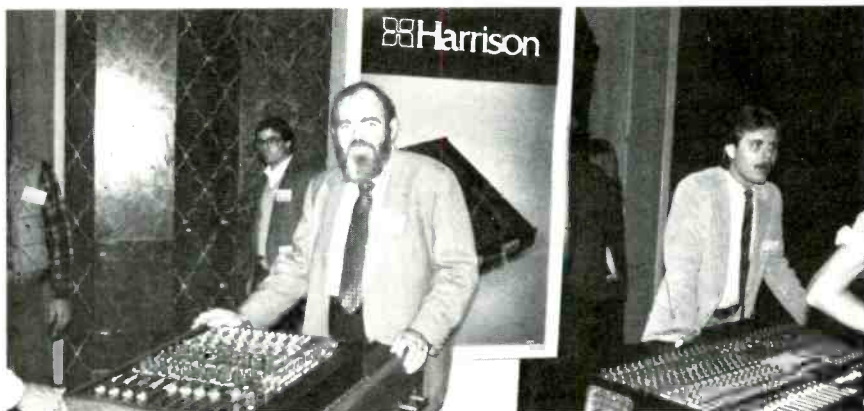

Harrison: Audio consoles

NEW! AVAILABLE FROM AFA! AFA JOY STICK CAMERA CONTROL PANEL RCC-200 Series

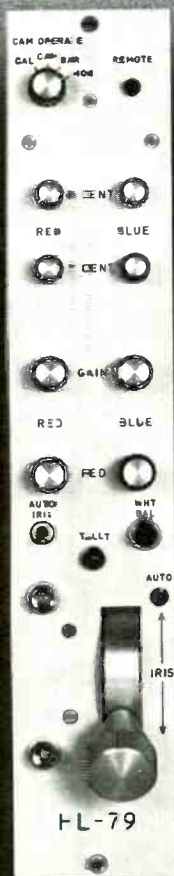

Provides mobile and studio operations with a fast, simple method of controlling camera shadings!

- Compatible with Ikegami cameras HL-79 and HK-357
- Adaptable to other cameras
- Features include: Joystick control of iris and master pedestal; paint and filter controls, hue and clip controls, chroma key and optional match switching capability
- Cables pre-fabricated to your needs
- Reasonably-priced at \$2150 (cables extra)*

Call us today for more information: (201) 767-1000

AFA

A F ASSOCIATES INC.

100 STONEHURST COURT, NORTHVALE NJ 07647

*Subject to change without notice. © 1982 A F Associates Inc.

Circle (93) on Reply Card

Exhibit list

The following list includes exhibiting companies attending the AES convention. For more information regarding equipment from these organizations, circle the appropriate reader service numbers.

AB Systems Design Inc.	700	Fostex Corporation of America	757	Peavey Electronics	815
Acoustic Design by Jeff Cooper	701	Fostex Electro Acoustics	758	Penny & Giles Conductive Plastics	816
Acoustilog Inc.	702	Furman Sound	759	Pentagon Industries	817
Adams-Smith Inc.	703	Goldline Connector Inc.	760	QSC Audio Products	818
Advanced Music Systems	704	Gotham Audio Corporation	761	Quad-Eight Electronics	819
Agfa-Gevaert Inc.	705	Grandy Inc.	762	Quantum Audio Labs Inc.	820
AKG Acoustics	706	Harrison Systems	763	Raindirk Ltd.	821
Alpha Audio	707	Harvey Professional Audio/Video	764	Red Acoustics	822
Altec Lansing Corporation	708	Hazelcom Industries Ltd.	765	Renkus-Heinz Inc.	823
Amber Electro Design	709	Heino Ilsemann GmbH	766	Roland Corporation	824
Amplex Corporation	710	H.H. Electronic	767	Roland Studio Systems	825
Anvil Cases	711	Hill Audio	768	RTW GmbH	826
Aphex Systems	712	Hitachi Ltd.	769	Ruberl Neve Inc.	827
Ashford Audio Products	713	H.M. Electronics	770	Saki Magnetics	828
Ashly Audio	714	Infonics Inc.	771	Sansui Electronics	829
Audico	715	Inovonics Inc.	772	Schoeps Posthorn Recordings	830
Audicon	716	Integrated Sound Systems	773	Sequential Circuits	831
Audioarts Engineering	717	Interface Electronics	774	Sescom Inc.	832
Audio & Design Recording	874	International Audio Inc.	775	Shure Brothers Inc.	833
Audio Developments	718	International Consoles Corporation	776	Solid State Logic	834
Audio Envelope Systems	719	ITAM	777	Sontec Electronics	835
Audio Kinetics	720	Ivie Electronics	778	Sony Corporation	836
Audio Processing Systems Inc.	721	Jackson Music Group	779	Sony ESPRIT	837
Audio Technica	722	James B. Lansing Sound Inc.	780	Soundcraft Electronics USA	838
Audiotechniques	723	JRF Company	781	Soundcraft Magnetics	839
Audio Video Automation Inc.	724	Keith Monks (Audio) Ltd.	782	Souder Electronics Inc.	840
Auditronics Inc.	725	Kelsey Mixers Inc.	783	Soundstream Inc.	841
BASF Systems	726	Kinetic Sound Corporation	784	Sound Technology	842
Beyer Dynamic Inc.	727	King Instrument Corporation	785	Sound Workshop, Professional Audio Products Inc.	843
BGW Systems Inc.	728	Klark Technik	786	Sphere Electronics	844
Bruel & Kjaer Instruments Inc.	729	Lakeside Associates Inc.	787	Stanton Magnetics Inc.	845
Bryston Manufacturing Ltd.	730	Lake Systems Corporation	788	Stephens Electronics Inc.	846
The BTX Corporation	731	Lexicon Inc.	789	Studer Revox America Inc.	847
Calzone Case Company	732	Linn Electronics	790	Studiomaster Inc.	848
Canary Ltd.	733	Loft Professional Products	791	Studio Sound & Broadcast Engineering	849
Casheab	734	Marshall Electronic	792	Studio Technologies	850
Cerwin-Vega	735	Martin Audio/Video Corporation	793	Swintek Enterprises	851
Cetec Gauss	736	MCI Inc.	794	Symetrix Inc.	852
Cetec Vega	737	Meyer Sound Laboratories Inc.	795	Tannoy Products	853
Community Light & Sound	738	Micmix Audio Products Inc.	796	T.D. Audio Inc.	854
Consilium Industri AB	739	Midas Audio Systems	797	TEAC Corporation of America	855
Crest Amplifiers	740	The Mike Shop	798	Technical Audio Devices	856
Cross Ltd.	741	MiLab/Creative Trade	799	Technics by Matsushita	857
Crown International Inc.	742	Mission Electronics	800	Tektronix Inc.	858
Dallas Music Industries	743	Mitsubishi Electric Corporation	801	Telex Communications Inc.	859
Datatronix Inc.	744	Modular Sound Systems	802	Third Wave Communications/EXR	860
David Lint Associates Inc.	745	MTI Corporation	803	3M/Digital Audio Division	861
db Cassette	746	Music Technology	804	3M-Mag. A/V Division	862
dbx Inc.	747	MXR Innovations	805	TOA Electronics	863
Deltalab Research	748	Nady Systems	806	Trident Audio Developments Ltd.	864
DOD Electronics Corporation	749	Neutrik Products	807	UREI	865
Dolby Laboratories	750	New England Digital Corporation	808	Ursa Major Inc.	866
Duncan Electronics	751	Omni Q Inc.	809	US Pioneer Electronics Corporation	867
East Coast Sound Inc.	752	Orban Associates	810	Valley People Inc.	868
Eastern Acoustic Works Inc.	753	Ortofon Mfg./Lyrec Mfg.	811	Victor Company of Japan	869
Electro-Voice/Tapco	754	Otari Corporation	812	Wireworks Corporation	870
Emilar Corporation	755	Outer Ear Inc.	813	Woelke Magnetbandtechnik	871
Eventide Clockworks	756	Panasonic Professional Audio Division	814	Xedit Corporation	872
				Yamaha International	873

Continued on page 106

Modulation Associates Inc. has recently appointed **Donald E. Yost** to its board of directors. Yost is president of DEY Corporation, a consulting firm. His clients have included many well-known high technology companies, and he presently is a member of the board of several public and private corporations.

Datatron Inc. has announced the appointment of **Roger Bailey** as director of Video Systems Marketing. Since 1979 Bailey has been managing director of Paltex Editing and Production Systems, a British company in the business of marketing post-production video products including those manufactured by Datatron.

C. L. Benedict has joined Image Resource as vice president of Marketing. Benedict's addition to the company follows the recent addition of **Joseph W. Rooney** as president. Benedict comes to Image Resource from Perkin-Elmer, where he was director of Sales and Marketing for the Memory Products Division.

Tektronix has promoted **Bhaskar Pant** to the position of senior sales engineer for the New York City area with special account responsibility for the three commercial broadcast networks. Before coming to New York, Bhaskar was Grass Valley Group product specialist for Europe, Africa and the Middle East based in Amsterdam, Holland.

Geoffrey N. Mendenhall has been appointed vice president, Engineering of Broadcast Electronics Inc. Before this promotion, Mendenhall was engineering manager, FM Products and has been with Broadcast Electronics since 1978. In this new position, Mendenhall will have responsibility for the company's entire engineering and research and development activities.

Cezar International Ltd. recently announced the appointment of **Herbert M. Perkins** as president and chief executive officer. **Robert M. Cezar** continues as chairman of the board and vice president for Corporate Development. Perkins was formerly president and CEO of Datatron Inc.

Lawrence Mincer has joined Chyron Corporation as director of corporate development, a newly-created post Mincer will be actively involved in the company's expansion and acquisition planning. Before joining Chyron, Mincer was associated with National Starch and Chemical Corporation as a corporate cost/business analyst.

Leader Instruments Corporation recently announced the appointment of **Ronald P. Storm** as mid-Atlantic regional manager. Most recently Storm was with KLS Associates, manufacturers representatives, specializing in high technology industrial products.

Cinema Products Corporation has announced the appointment of **Ed Clare** as national sales manager. In his new capacity, Clare will concentrate on strengthening Cinema Products' line of professional video and motion picture equipment. Clare has been with Cinema Products since 1971.

Continued on page 107

Perfect Timing

SMPTE

TIME CODE READERS THAT YOU CAN AFFORD

ES251-Six digit SMPTE Time Code Reader displaying Hours, Minutes and Seconds. Reads at play back speed.

Momentary hold switch permits "freezing" of time displayed. Releasing hold switch updates display to correct time.



\$295

ES252-Exactly like ES251, but displays Minutes, Seconds and Frames. **\$300**

ES253-Eight digit reader, displays Hours, Minutes, Seconds and Frames.



Reads at play back speed, has "freeze" control. **\$454**

ES254-BI-DIRECTIONAL, MULTI-SPEED (1/20 to 20 times), eight digit reader with "freeze" control. On loss of code, displays last valid code read. **\$675**

AND FOR OFF-LINE EDITING **ES255** SMPTE IN/VIDEO OUT

ES255 is an eight digit, multi-speed, bi-directional SMPTE reader which adds the SMPTE input to your video. You can now "burn" the time code into the video portion of your tape, or feed a monitor directly. **\$995**



Write, Wire or Call: (213) 322-2136
142 Sierra Street, El Segundo, CA 90245

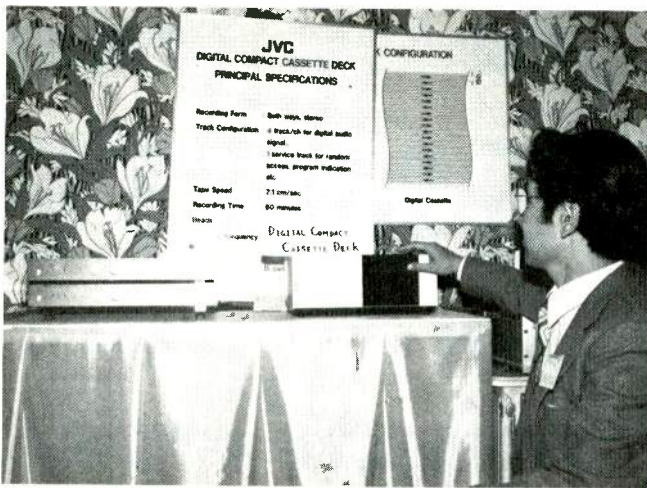

JVC: Digital cassette



Lexicon: Digital audio

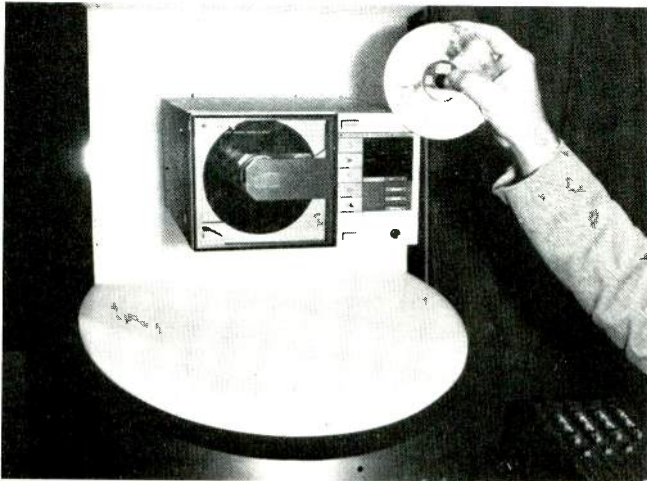

Sony: Digital disc



3M: Digital mixer

AES replay

on-air time up to 25% without degrading change in pitch. These audio time compressors are currently compatible with proper connector and interface available for Ampex ATR-100, VPR-2B; Otari MX 5050-B; Sony BVH-1100A; Studer B-67, B-77, PR-99; Revox A700; and the MCI JH-110 tape machines.

At an elaborate pre-convention press briefing, Ampex introduced its ATR-800 Audio Tape Recorder. This versatile machine has many built-in options, including:

- a built-in cue amplifier for monitoring of single or multiple channels of the tape during editing or while it is being cued;
- variable shuttle control of speed and direction;
- an electronic tape timer accurately times recorded segments for all three speeds (7½, 15 and 30ips) in hours, minutes and seconds;
- single point search-to-cue, automatic return to a designated cue or edit point;

- the ability to accommodate a fourth head for playback of two different tape formats without a head assembly change; and
- variable speed operation allowing recording and playback up to $\pm 10\%$ normal speed, corrects recordings made at off speeds or for special effects.

The ATR-800 is available in one, two or 4-channel configurations, with the basic 2-channel recorder selling for \$5450.

Ampex also announced that ATR-700 Series recorders are now equipped with a single point-to-cue, editing aids, cue amplifier, 4-speed/dual EQ Padnet™, and, for stereo versions, DIN hub holddown adapters.

The Otari Corporation, introducing its MTR-10 Series tape recorders, claims the ultimate in analog recording. The MTR-10s are available in both ¼-inch, 2-channel and ½-inch, 4-channel formats. They are fully microprocessor-controlled. Move-

ment is governed by a proven on-board, 8080A microprocessor located on the machine's master CPU plug-in circuit module. Four erasable, programmable read-only memories (EPROM) furnish the necessary firmware for control of the machine's operating parameters and production features.

The MTR-10 has the capacity to play in reverse, in three speeds, with full VSO and external sync capability. A single-point, return-to-zero is built into the transport, next to the positive and negative domain real time readout. This feature has look ahead capability for smooth positioning and no overshoot. Above the readout, a second display can be switched to show deviation of the capstan motor from nominal play speed in percentage or ips. This readout will reflect the deviation in speed from an external SMPTE-based synchronizer and a plus or minus Vari-speed. The control uses a 5-turn potentiometer for high resolution. □

People

Continued from page 105

Stan London has been appointed vice president, Satellite/MATV for Anixter-Pruzan's MATV Products Division. A 25-year veteran in the TV electronics industry, London spent 12 years with Channel Master as district and regional sales manager. Before joining Anixter he was national sales manager for Blonder-Tongue Laboratories Inc.

Eugene Anderson, chairman of Arvin Industries, recently announced that **James K. Baker** has been named to succeed him as chief executive officer. Anderson, who has 34 years of service with Arvin, will continue as chairman of the company. Baker will continue in the post of president, to which he was elected last April. **Douglas G. Fleming** has been appointed a company director.

Gail Perruso has been named manager of National Public Radio's Satellite Distribution Center. In her new position Perruso will have administrative responsibility for the satellite system scheduling process and Distribution Center expansion and development.

H. Lee Marks has been appointed products development manager of 3M's Magnetic Audio/Video Products Division. He will be responsible for the development of video open reel and video U-Matic products. Marks joined 3M's Magnetic Products Division in 1968 after several years' experience in the video broadcast industry.

Otari Corporation has announced the appointment of **John Carey** as product manager. Carey will be responsible for technical training of the Otari sales representative and dealer networks. Also, he will coordinate technical support between the Sales and Service Departments. He has recently held similar technical sales positions with Westlake Audio and Express Sound.

J. Philip Stack has been promoted to senior vice president, Sony Video Products Company. In his new capacity, Stack will be responsible for the sales, service and merchandising divisions of Sony Video Communications Division, Professional Audio Division and Special Projects. He was previously vice president of the Video Communications Division.

Appointment of **Jerry E. Smith** as director, Domestic Broadcast Sales for RCA Commercial Communications Systems Division, was announced recently. Based in Camden, NJ, Smith is responsible for an organization selling RCA's line of radio and TV studio and transmitting systems throughout the United States. Previously, Smith was manager of Southern Broadcast Sales for the RCA activity.

The appointment of **Robert C. Corwin** as marketing manager has been announced by Phelps Dodge Communications Company. Corwin will have both marketing and sales responsibilities covering the company's full line of radio communication antenna systems equipment.

International Tapetronics Corporation has announced the appointment of **Charles W. Kelly, Jr.** as sales manager.

Dean A. Prater has been named accounting manager for Comsat Corporation and will be responsible for corporate financial reporting. Prater was previously associated with the accounting firm of Deloitte Haskins & Sells. □

TM

RECORDEX

Improves any cassette VTR



Actual untouched monitor images

The picture quality of $\frac{3}{4}$ " or $\frac{1}{2}$ " VTRs can be improved by RecordEx™, a revolutionary device from Faroudja Laboratories. RecordEx pre-processes video prior to recording to boost, and therefore preserves in play-back, picture details normally lost in color-under formats.

Color-under pictures pre-processed through RecordEx look natural, life-like and rich in all the nuances and detail that previously only film and expensive tape formats could preserve. Broadcasters like the elimination of the "cartoon" effect or plastic appearance caused by loss of details. Because large outlines are not modified by RecordEx, the picture does not look enhanced. It looks as if it came from a better VTR.

RecordEx is an add-on device available in a portable battery-operated configuration. Connections are easy and no adjustment is required in daily use. An AC adapter is available.

Send *or detailed information on how RecordEx can work for you.

FAROUDJA Laboratories

Faroudja Laboratories Inc.
946 Benicia Avenue
Sunnyvale, California 94086
Telephone 408/245-1492

Circle (96) on Reply Card

January 1982 *Broadcast Engineering* 107

January 28-30

The First Annual Low Power Television Conference and Exposition, (LPTV '82), will be held at the Sheraton Washington Hotel in Washington, DC. Fifty sessions will cover hardware requirements, financing, teleconferencing, marketing, programming, and investment potentials. Speakers will include experts from all areas of the business and broadcasting industries. For more information, contact Global Village Conference Management Corporation, 17 Washington St., Norwalk, CT 06854; (203) 852-0500.

February 5-6

The 16th Annual TV Conference of the Society of Motion Picture and Television Engineers (SMPTE) has been set for Feb. 5-6 at the Opryland Hotel in Nashville, TN.

The theme of the conference will be "Tomorrow's Television." The program topics are "New TV Technologies"; "Multichannel TV Audio"; "Digital Control of TV Equipment"; and "High Definition TV Systems."

An equipment exhibit will be held in conjunction with sessions. Only equipment that is relevant to the technical program will be on display.

There will be a reception, "Evening at Opryland," the evening of Feb. 4, a get together luncheon at noon on Feb. 5, and a program for spouses.

More than 800 technical and management people are expected to attend this meeting. More information on the

conference is available from SMPTE, 862 Scarsdale Ave., Scarsdale, NY 10583.

April 4-7

Dallas will be the site of the 60th Annual National Association of Broadcasters Convention. The convention will feature radio seminars, discussions of TV trends, demonstrations of innovations in television, exhibits, and a spouse program. Glen Campbell will perform on Sunday, April 4 and Jonathan Winters will appear on Wednesday, April 7. For more information, contact NAB, Conventior, Information, 1771 N St. NW, Washington, DC 20036.

April 29-May 1

The Electronic Distribution Show and Conference will be held at the New Orleans Hilton hotel.

The conference is a triple-faceted event covering all segments of electronic distribution, as well as the sound and electronic systems market served by independent contractors and distributors through the companion National Sound and Electronic System Conference. NSESC will be held at the New Orleans Marriott hotel, with product exhibits held in conjunction with EDS '82 at the Hilton.

More information on the 1982 conference is available from the Electronic Industry Show Corporation, 222 South Riverside Plaza, Suite 1606, Chicago, IL 60606; (312) 648-1140. □

Introducing... mini-TP



The only portable laboratory quality registration and optical alignment device for your portable production and ENG cameras. Mini-TP eliminates costly down time and equipment rental fees when field crews are disabled with simple registration problems. In the shop mini-TP provides standards for testing the lens and its interface to the camera. The target is a custom engineered transparency that provides the basis for complete optical system evaluation. Mini-TP is attached directly to the front of the lens and provides a precise test pattern at infinity focus.

After a simple procedure of orientation, the camera can be placed in any attitude (on its side, upside down) and the viewfinder image remains upright and stationary. Now your camera personnel can quickly and easily set registration on motel room beds, athletic fields and airline seats. Mini-TP is small, compact, lightweight and comes with a protective padded leather hard case and adapters to fit most popular lenses. It totally lends itself to rugged field operations where its value is most appreciated.



Mini-TP evaluates: Proper back focal distance, camera and lens resolution, optical center of raster, zoom tracking, image displacement, flare while zooming, imperfection in lens elements, aspect ratio, infinity setting on lens barrel, loose lens mounts, extender operation, extender tracking, diffusion effectiveness, magnified yokes, effect of filters and optical attachments, etc.

WESTERN GROUP/OPTICAL DIVISION
3250 Westline Blvd. Suite 202 / Los Angeles, California 90010 / Tel: (213) 384-2181 / Tlx: 194 541 W.GROUP USA

Circle (94) on Reply Card

Discover the best worst kept secret in wireless mic's—NADY SYSTEMS

The word is out!

After only a few years on the market, Nady wireless mic's are already the only choice of the top pop and rock entertainers. Now the expanded Nady line is rapidly becoming the choice in wireless in video and film production.

What's the secret? Nady Systems' U.S. Patent #4,215,431 — the biggest breakthrough in wireless mic performance ever. Sure, others claim to be the best, but only Nady Systems delivers the proof so obviously in any A-B comparison. Discover for yourself Nady Systems' full line of superior wireless mic's and wireless intercom systems. Discover for yourself matchless performance that is surprisingly affordable.

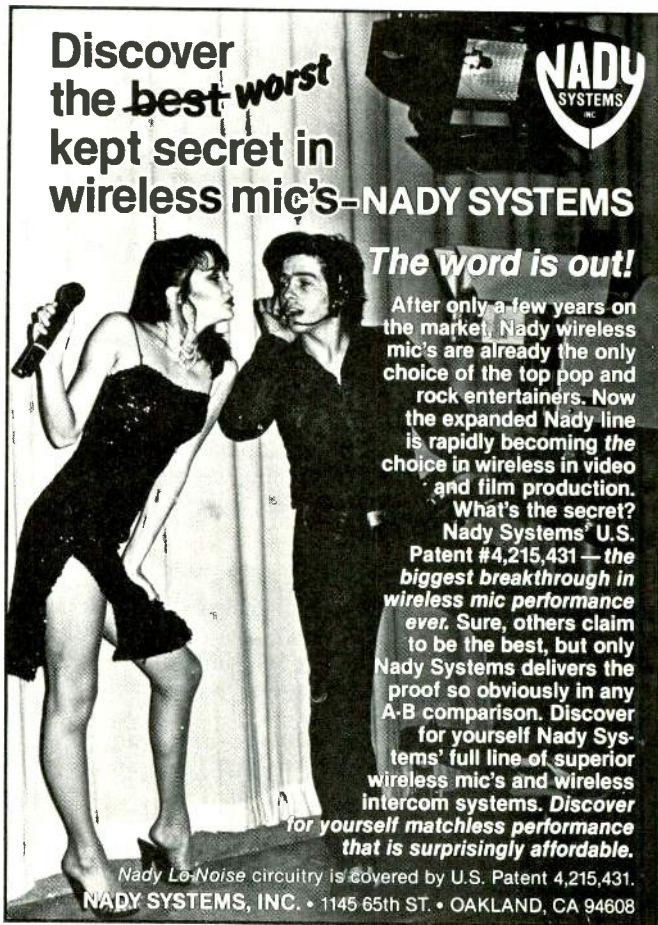

Nady Lo-Noise circuitry is covered by U.S. Patent 4,215,431.
NADY SYSTEMS, INC. • 1145 65th ST. • OAKLAND, CA 94608

Circle (97) on Reply Card

new products

Cue-track heads

Audicon Marketing Group is now marketing ¼-inch professional cue-track heads introduced by *Woelke Magnetbandtechnik*. The cue-track is recorded between a 2-track recording on ¼-inch tape. Woelke has laid out the system in such a way that the cue-track can also be recorded in between stereo-tracks. In order to save room in the head assembly and to accommodate the new heads with the same wrap-angle, Woelke has combined the cue playback head with an audio erase head.

For updating the cue-track, Woelke offers a separate cue erase/write/read head. The cue heads are glassbonded and constructed in a solid ferrite/ceramic material, making them capable of reading the cue-track in the fast winding mode.

Circle (402) on Reply Card

Indicating relays

Space savings and mounting versatility are provided by terminal block mounted multipurpose relays introduced by *Larus Corporation*. Optional LED indicators on the front panel display the operational status of the 4-pole or 6-pole miniature wire spring type relays. Up to 12 relays are packaged on universal 8-inch terminal

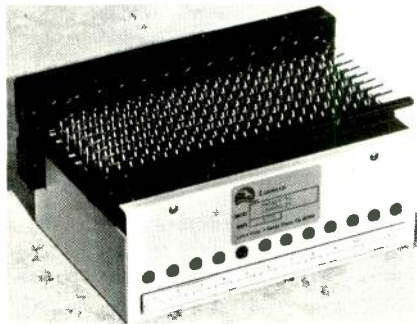

blocks. The independently operated relays are available with A, B, C or D contacts, in a wide selection of operating voltages including 48, 24 and 12Vdc. Units are available with 25-pair connector interface, as well as with solder or wirewrap terminals.

Circle (403) on Reply Card

Triple display generator

Three of the most useful video displays for scene setup and technical alignment—*Safe Area*, *Position Marker* and *Pulse Cross*—are now available in a single rack-mounted unit from *Amtron Corporation*.

The Model AG 341 Integrated Display Generator is a stand-alone version of the display features incorporated into Amtron's High Resolution Color Monitors announced last spring.

The separate displays, keyed into the incoming video, may be selected using the front panel controls or from an optional desk top remote box, available for use in production and post-production situations.

Safe area/safe title outlines are digitally generated as dual reticules conforming to standard SMPTE specifications.

Switched over any incoming signal, the safe area display aids picture composition and confirms the safe transmission of all vital elements. This mode also includes a separate pre-set cross hair marker that pin-points the exact center of the raster, no matter how the monitor is adjusted. The center cross hair may be used alone or in conjunction with other displays.

The *pulse cross* function allows the incoming video to be delayed both horizontally and vertically, or both, in order to monitor sync, burst, blanking, vertical interval test and reference signals, as well as permitting accurate adjustment of videotape machine tracking and tension.

Another function is the *micro mark/cursor display*—one microsecond intervals arranged along a digital horizontal line. This display permits quick and accurate measurement of timing signals when used in conjunction with the pulse cross function. It also permits measurement of frequency response and any other detail of interest. The line as a cursor may be positioned anywhere within the picture area (using separate horizontal and vertical rotary controls) to act as a setup guide for scene matching and titling.

Circle (404) on Reply Card

Audio processor

Orban Associates Inc. of San Francisco, CA, has announced the availability of the new *Optimod-TV* (Model 8180A) and its optional accessory chassis, which can be used to split the processing into separate compressor and limiter sections.

Derived from the popular new *Optimod-FM*, *Optimod-TV* provides subtle multiband compression, high-frequency limiting, and effective control of peak levels and output spectrum. Its circuitry has been custom

tailored to the characteristics of typical TV audio feeds, providing significant increases in transparency, naturalness, and consistency when compared to conventional processing techniques.

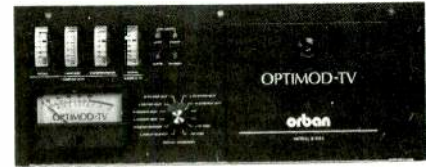

Optimod-TV is delivered as a stereo processor. Its built-in 15kHz lowpass filters assure compatibility with future multiplex stereo systems, and prevent interference to the video. *Optimod-TV* is easy to set up, yet is versatile enough to permit its sound to be customized to the exact needs of the individual broadcaster. The optional accessory chassis houses the compression circuitry and setup controls, allowing compression to occur before the STL, protecting it from overload.

Circle (407) on Reply Card

Digital stereo generator

For stereo broadcasters who need the basics, *C N Rood of the Netherlands* introduces the SC-204 'Flatpack' Digital Stereo Generator. The slim-line housed package is designed for installations not needing local and remote switching of mono-stereo, pilot and pre-emphasis. Without the extras, the Rood SC-204 includes performance specifications of the well-known SC-203 series. For cable radio operators, the SC-204 CATV includes modulation capability for the 70 to 135MHz range with a power output to +60dBm into 50Ω.

Circle (405) on Reply Card

Editing console

With its new short-frame configuration, the *Winsted* Model 900LC editing console for ¼-inch VTR's offers maximum operator convenience and over-the-top viewing. This new unit has a custom console look with rugged construction features.

The Model 900LC is offered in a variety of cabinet and drawer arrangements. Modular design includes walnut woodgrain panel sides and top, ample rack space and pullout editor shelf. Shelves adjust on 1-inch increments to permit flexible working arrangements.

Circle (406) on Reply Card

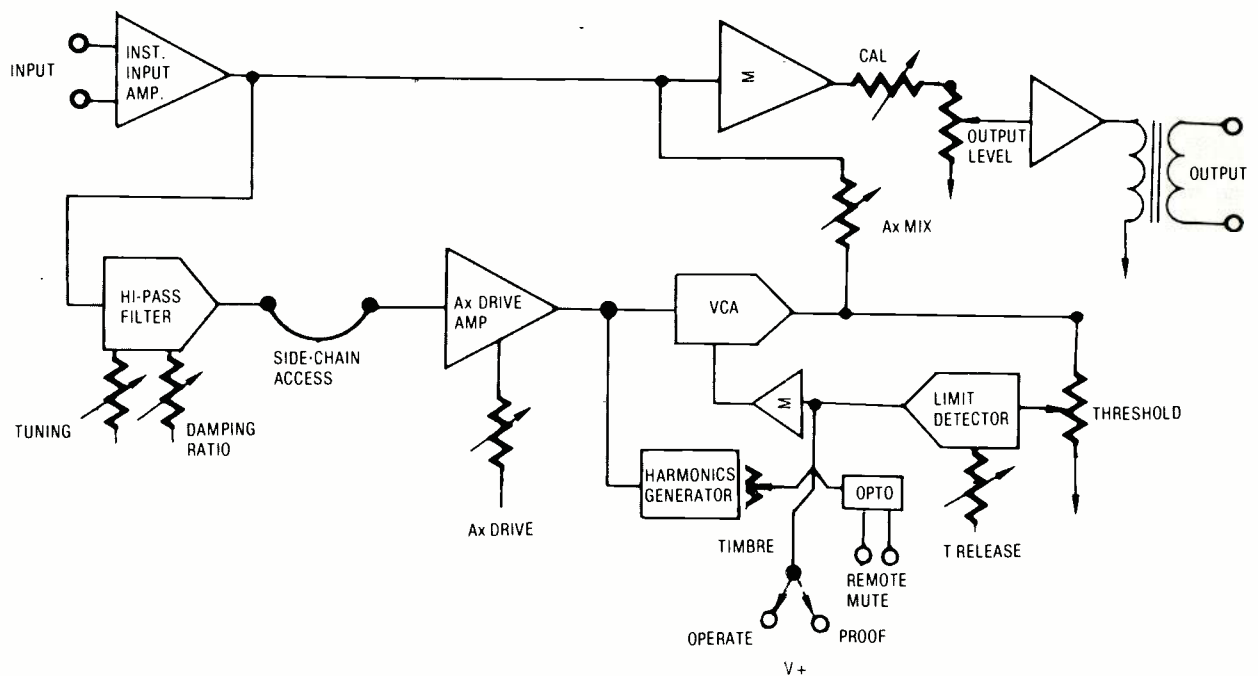

Field report

Continued from page 44

sharper, cutting sound. The odd harmonics are most noticeable on cymbal crashes and fricatives. The odd harmonics have a more apparent effect initially; listener fatigue, however, does become a factor. I have found that, for our purposes, a softer setting with some odd harmonics works best.

Because the harmonics are level dependent, louder peaks can cause splash. There is a limiter detector circuit that sums in a voltage into the VCA in the side chain only. We have not had the need for the limiter, but experimentally I have found that the more the limiter is used, the less open and musical is the overall effect.

The enhancement signal is added back into the unmodified signal through the mix control. This control is the most sensitive and most critical. There seems to be little or no effect for the first 100° of the potentiometer. The next 45° range is where the effect is most useful. Extreme caution is advised because the effect can quickly become very harsh. Measuring the level of the enhancement signal at a proper-sounding setting shows that it is typically 10-to-20dB below total output of the device.

Construction and circuitry

The packaging is attractive, well-

designed and well-built except for some minor flaws. The potentiometers are screwdriver adjustable and a hinged, front panel covers the control panel. The hinged panel cannot open fully if another piece of equipment is mounted below the unit with beauty washers. The barrier strips in the rear are placed above the labels and it can be difficult to see if the leads are in their proper slots. However, the unit I am testing is a prototype, and the manufacturer has indicated that corrections are being made.

Metering is via a fluorescent meter that is switchable between peak and VU, and mode is switchable between input, enhancement signal output, and output. Also, there are LED indicators that show proper drive levels limiting function, and peak levels at 2dB below clippings. My tests have shown that all indicators are accurate and have exhibited no drift during the six months that I have had the unit.

The circuitry on the audio PC Board is laid out well and the components are high quality (for example, the output transformers are Jensen nickel core). There is a dog house around the rear of the unit, and all connections are through inductors. An especially nice touch is that input, output and

metering levels may be optimized for any operation through jumpers on IC sockets.

The power supply has the look of being hand-built, but the manufacturer states that this will be fixed in production units. The components on this board are also of superior quality, such as toroidal transformers, computer-grade capacitors and oversized regulators.

Final remarks

In conclusion, I have found that the Aphex II, when properly tuned, can give you a sound that cannot be achieved by any other studio processor currently available. Although we are using the unit in our air chain, we have tried using it in our production room and only enhancing certain items instead of all our audio. But, we replaced it in the main air chain and processed all audio through the unit with no degradation in quality because of good control from production to air of all on air material. □

The system covered in this field report is marketed by Apex Systems Ltd., 7801 Melrose Ave., Los Angeles, CA 90046. Comprehensive product data may be obtained directly from this firm. Equipment tested in this report was shipped to the author directly for his studies.

ad index

**Want MORE
Information
on
Advertised
Products?**

**Just refer to
the Bingo #
beneath
each ad.
Circle the
appropriate
number on
the Reader
Service
Card in the
back of this
issue. **Com-
plete the re-
maining in-
formation
and mail!****

ADM Technology Inc.	IFC	Leader Instruments	5
A. F. Associates, Inc.	102, 103	Leitch Video, Ltd.	51
Amperex Electronic Corp.	47	Lenco Inc.	97
Ampex Corp.	77	Lerro Electrical Corp.	29
Andrew Corp.	IBC	Logitek Electronics Systems Inc.	40
Anixter Brothers Inc.	84	MCI Inc.	65-68
Artel Communications	41	Maxell Corp.	19
Asaca/Shibasoku Corp.	17	Microwave Associates	83
Audiotechniques	95	Mini-TP div of Southwestern Group	108
Auditronics Inc.	82	R. K. Morrison Co.	98
Beaveronics Inc.	94	Nady Systems	108
Belar Electronics	64	Rupert Neve Inc.	11, 14
Beston Electronics Inc.	31	Nichols Electronics	58
Bird Electronics	10	O'Connor Engineering	85
Broadcast Electronics	92	One Pass Inc.	90
Calvert Electronics	87	Orban Associates Inc.	36, 37
Canon USA Inc.	75	Otari Corp.	20, 21
Central Dynamics Corp.	63	Perrott Engineering	58, 95
Cetec Vega	8	Philadelphia Resins Corp.	38
Christie Electric Corp.	90	Philips Test and Measuring	57
Chyron Telesystems	55	Polarad Electronics	81
Colortran Inc.	9	Polyline Corp.	70
Comex Systems	44	Potomac Instruments	44
Continental Electric Mfg. Co. .	40, 70	Ramko Research	28
Crosspoint Latch Corp.	48	Russco Electronics Inc.	74
dbx, Inc.	16, 18	Shure Brothers	73, 91
Datametrics Inc.	93	Singer Broadcast Products	42
Digital Video Systems	27	Sony Corp of America.	34-35
Victor Duncan Inc.	76	Standard Tape Laboratory Inc. ...	76
Dynair Electronics Inc.	45	Stanton Magnetics	10
ESE	105	Swintek Telecommunications Div.	28
EMCEE Broadcast Products	99	Tascam div of TEAC	39
Electro-Voice Inc.	13, 24	Tektronix Inc.	7
Faroudja Laboratories Inc.	107	Telex Communications Inc.	4, 43
Farrtronics Ltd.	86	Thermodyne	61
Film Video Equip. Service Co. ...	64	Tentel	18
Fitzco Sound Inc.	98	UREI	23
Fuji Photo Film USA Inc.	59	US JVC Corp.	53
Fujinon Optical Co.	33	Videotape Products Inc.	86
G & M Power Products	84	Vital Industries	15
Great American Market	80	Ward-Beck Systems	BC
David Green Broadcast Consultants	88	Winsted Corp.	30
Clifford B. Hannay & Sons Inc. ...	32	Yamaha	25
Hitachi Denshi America Ltd.	3		
Ikegami Electronics Inc. ...	49, 71, 79		
L. W. International	74		

**BE
classified
ads
are well-read.**

**Use them at a
low-cost
insertion.**

professional services

VIR JAMES P.C.
CONSULTING RADIO ENGINEERS
Applications and Field Engineering
Computerized Frequency Surveys
4940 E. 39th Ave.
Phone: (Area Code 303) 393-0468
DENVER, COLORADO 80207
Member AFCCE & NAB

STEIGER, MURRAY & ASSOCIATES INC.
Broadcast Technical Consultants
ANTENNA SYSTEM SPECIALISTS
6816 Westview Drive
Cleveland, OH 44141
(216) 526-7187

RALPH E. EVANS ASSOCIATES
CONSULTING COMMUNICATIONS ENGINEERS
216 N. Green Bay Road
Suite 208
Thiensville, WI 53082
Phone: (414) 242-6000 Member AFCCE

R. L. HOOVER
Consulting Telecommunications
Engineer
11704 Seven Locks Road
Potomac, Maryland 20854
301-983-0054
Member AFCCE

MIDWEST ENGINEERING ASSOCIATES
Consulting Engineers
150 Wesley Rd.,
Creve Coeur, IL 61611,
309-698-3160.
Member AFCCE

G.A. GILBREATH ASSOCIATES
INCORPORATED
AUDIO/VIDEO BROADCAST
CONSULTANTS
6357 LAWTON AVENUE
LAS VEGAS, NV 89107
(702) 878 8313

SMITH and POWSTENKO
Broadcasting and Telecommunications
Consultants
2000 N Street, N.W.
Washington, D. C. 20036
(202) 293-7742

LAWRENCE L. MORTON, E.E.
And Associates
Consulting Telecommunications Engineers
AM, FM, TV and Low Power TV
Applications and Field Engineering
Computerized Frequency Searches
1747 South Douglass Road, Suite D
Anaheim, California 92806
(714) 634-1662

NELSON (714) 844-1811
L. E. NELSON CORP.
LIGHTING FACILITY DESIGN CONSULTANTS
1209 PARK CIRCLE LAURENCE NELSON
LAS VEGAS, NEVADA 89101 President

RADIO ENGINEERING CO.
Box 4399 RR 1, Santa Ynez CA 93460
CONSULTANTS
ALLOCATIONS, INSTALLATIONS, FIELD
ANTENNA & TYPE ACCEPTANCE MEASUREMENTS
NORWOOD J. PATTERSON
President (805) 688-2333

D. L. MARKLEY
& Associates, Inc.
CONSULTING ENGINEERS
206 North Bergan
Peoria, Illinois 61604
(309) 673-7511
Member AFCCE

BROADCAST SYSTEMS CONSULTANTS
2515 E Thomas
Suite 16 635
Phoenix, Arizona 85016 (602) 243 6000

dataworld inc.
AM • FM • TV
Translators/Low-Power TV
Directories
Allocation Studies/Antenna Design
1302 18th St., N.W., Suite 502
Washington, D.C. 20036
(202) 296-4790

BROADCAST ENGINEERING SERVICE COMPANY
TV-FM-AM Field Engineering -
Emergency Maintenance - Turnkey Installation -
System Design - Survey and Critique -
Interim Maintenance or Chief Engineer
B E S COMPANY
100 Star Trail, New Port Richey, Fla 33553 813-868-2989

CHARLES F. KOCHER, P.E.
Consulting Radio and TV Engineer
Allocation Engineering
Antenna Systems
27235 Berkshire Drive
Southfield, Michigan 48076
(313) 357-2304
Member AFCCE

Radiotechniques
RADIO CONSULTING ENGINEERS
STATION DESIGN AND SERVICE
ELECTRONIC PRODUCT DESIGN
Edward A. Schober, P.E.
402 Tenth Avenue, Haddon Heights NJ 08035
(609) 546-1841

Why not run your
business card here?

Only \$26.00 per inser-
tion.

Frequency discounts
available.

Call 913/888-4664

BROADCAST engineering

Advertising Sales Offices

NEW YORK, NEW YORK

Joe Concert,
Phone: (212) 888-1977
4 West 58th St.
New York, NY 10019

KANSAS CITY, MISSOURI

Jan Winters,
P.O. Box 12901, Overland Park, KS 66212
Phone: (913) 888-4664

LOS ANGELES, CALIFORNIA

Herb Schiff,
3055 Wilshire Blvd., Suite 630
Los Angeles, CA 90010
Phone: (213) 387-0639

LONDON, ENGLAND

John Ashcraft & Co., John Ashcraft
12 Bear Street
Leicester Square, London WC2H 7AS
England
Phone: 930-0525
Telex: 895-2387

AMSTERDAM, HOLLAND

John Ashcraft & Co., John J. Lucassen
Akerdijk 150A, 1171 PV-Badhoevedorp,
Holland
Phone: 0-2968-6226
Telex: 11640

TOKYO, JAPAN

Sumio Oka
International Media Representatives, Ltd
2-29, Toranomon 1-chome, Minato-ku
Tokyo 105, Japan
Phone: 502-0656

NORWOOD, AUSTRALIA

Williamson & Associates Pty. Ltd.
P.O. Box 419
Norwood 5067, Australia
Phone: 42-7074



IN OUR CONTINUING EFFORTS TO SERVE YOU...

From time to time, Intertec Publishing Corp. makes its subscriber lists available to carefully screened companies or organizations whose products, services, or information may be of interest to you. In every case, list users must submit their promotional material for approval. They may use the list only once.

No information other than name and address is ever divulged, although names may be selected by segments to which the particular offer might appeal.

We are confident that the majority of our readers appreciate this controlled use of our mailing lists. A few people may prefer their names not be used.

If you wish to have your name removed from any lists that we make available to others, please send your request, together with your mailing address.

Direct Mail Mgr.
Intertec Publishing Corp.
P.O. Box 12901
Overland Park, KS 66212

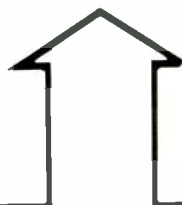

classified

Advertising rates in Classified Section are 60 cents per word, each insertion, and must be accompanied by cash to insure publication.

Each initial or abbreviation counts a full word. Minimum classified charge, \$10.00.

For ads on which replies are sent to us for forwarding (blind ads), there is an additional charge of \$5.00 per insertion, to cover department number, processing of replies, and mailing costs.

Classified columns are not open to advertising of any products regularly produced by manufacturers unless used and no longer owned by the manufacturer or distributor.

TRAINING

ELECTRONICS DEGREE by correspondence. Earn A.S.E.T., then B.S.E.T. Free catalog. Grantham College of Engineering, 2550 South La Cienega, Los Angeles, California 90034. 1-82-1fn

FCC GENERAL RADIOTELEPHONE operators license through cassette recorded lessons at home plus one week seminar in Boston, Washington, Detroit or Philadelphia. Our twentieth year teaching FCC license courses. Bob Johnson Radio License Preparation, 1201 Ninth, Manhattan Beach, Calif. 90266, Telephone (213) 379-4461. 3-81-1fn

SERVICES

ONE STOP FOR ALL YOUR PROFESSIONAL AUDIO REQUIREMENTS. Bottom line oriented. F.T.C. Brewer Company, P.O. Box 8057, Pensacola, Florida 32506. 7-71-1f

TAPE HELD RE-LAPPING worn Audio heads re-contoured for original performance \$25.00 per stack (Ampex 350, 440) We quote on others. Morrison Company, 819 Coventry Road, Kensington, CA 94707 (415) 525-9409. 12-81-3f

HELIX-STYROFLEX. Large stock - bargain prices - tested and certified. Write for price and stock lists Sierra Western Electric, Box 23872, Oakland, Calif. 94623. Telephone (415) 832-3527. 1-73-1f

VIF INTERNATIONAL will remanufacture your Ampex or Scully (Ashland/Bodine) direct drive capstan motor for \$200. Average turn around time - 2-3 weeks. For details write P.O. Box 1555, Mtn. View, CA 94042, or phone (408) 739-9740. 1-82-6f

TRANSMITTER TUBES REPROCESSED - Save 40 to 50% 3CX2500, 4CX5000, 4CX15000 and many others. Write for details. FREELAND PRODUCTS CO., 3233 Conti St. N.O., La 70119. (504) 822-9222. 6-79-1fn

BROADCAST CRYSTALS: for AM, FM or TV transmitters, frequency change, repair or replacement of oven types. Also vacuum types for RCA, Gates, Collins, CCA, etc. transmitters. High quality products, reasonable prices and better delivery! Don't be without a spare crystal. Frequency change for FM and AM nomitors. Over 30 years in this business. Eidson Electronic Co., Box 3751, Temple, Texas 76501. Phone (817) 773-3901. 4-81-1fn

MISCELLANEOUS FOR SALE

VIDEO T-SHIRTS. TV DESIGNED, preshrunk T-Shirts. Our four designs are: "ENG" and Reg. Chart, "GLITCH", "RESOLUTION" and chart, and "VIDEO PEOPLE DO IT IN SYNC". \$8.50 each and \$2 handling. Send check and size to: AaRLO ENTERPRISES, 109 MINNA ST., SUITE 254, SAN FRANCISCO, CA 94105. 8-81-1fn

EQUIPMENT FOR SALE

USED FIDELIPAC CARTRIDGES, \$35.00 per 100, \$250.00 per 1000. CART MART, Box 50003, Fort Worth, TX, 76105. 9-81-6f

SPECTRUM ANALYZER Tektronix 7L13. Current model. Perfect condition. New price \$14,450. Asking \$10,500. N. Patterson (805) 688-2333. 10-81-4f

3M RGB VIDEO ENHANCER. Brand new. Still in original box. \$4,250 new. Will take \$1,995 cash. Call Mike Gustine 601-264-6826. 12-81-2f

EQUIPMENT FOR SALE (CONT.)

FOUR ENVIROZONE FILTERS. Increase head life. Reasonable price. Steve Mowrer. (717) 393-5851. 12-81-2f

RAZOR BLADES, Single Edge RALTEC, 25884B Highland, Cleveland, OH 44143. 12-81-12f

FOR SALE: JERROLD STARLINE 20 trunk stations manual/automatic equipment. Contact - Lou Graham (517) 263-2108, ex 248. 1-82-11

TV CAMERAS: One IVC 7005 Studio Camera Chain 240V 50HZ including - Camera Head less Lens, 7 inch Viewfinder with Pan/Tilt Mount, Digital Multiplex Control System, Intercom System, Main Card Frame complete with Video Processor, One Angenieux Lens 10x14 Zoom Lens with Servo Zoom, Focus, and Iris, Shot Box, 2x1 Extender, Sandwich Type, focal range 14mm to 140mm and 28mm to 280mm (currently fitted to Camera 7005 above), Two IVC 7000P Camera Heads (one fitted with Canon 12 to 1200mm f2.0 lens, one fitted with Fujinon Zoom Lens K7x11 RM f 2.0 lens). Each with Shoulder Mount and Brace, 3 inch Viewfinder, AC Power Pack, Control Pack, Encoder PAL, Auto Iris, Video Processing, Intercom Picture/Waveform switcher, Auto Color Balance. TV Studio Support Equipment consisting of 3 ITE Fluid Heads and 1TV 24 Pedestal. Extensive accessories are also available including remote control panels, head set, cables, etc. All this equipment has been in use about two years, but is in very good condition. Price as a package deal negotiable around \$US82,000.00 but items can be quoted separately. Inquiries to: Mr. H.T. McKubre, Independent Newspapers Limited, P.O. Box 2595, WELLINGTON, NEW ZEALAND. Telephone: Wellington 738-120. 1-82-11

RCA BC-7 DUAL/STEREO Console With BCM-2 Auxiliary Mixer \$2150.00. Walt Lowery (919) 435-9400. 1-82-2f

USED BROADCAST TELEVISION EQUIPMENT. Hundreds of pieces wanted and for sale. Please call System Associates to receive our free flyer of equipment listings. (213) 641-2042. 1-82-6f

AM AND FM TRANSMITTERS to 5kW wanted. Any condition considered (805) 684-7686. 832 County Dr., Ojai, CA 93023. 1-82-2f

MARCONI FILM CHAIN SYSTEM includes 10,000 capacity 16mm projector; 2 broadcast cameras; 2 slide projectors, waveform monitor, monitor; etc. Must sell, \$6500 - worth much more. Frank Didik, Box 133, Rego Park, N.Y. 11374. (212) 843-6839. 1-82-2f

USED EQUIPMENT BARGAINS: RCA TT-10AL 11kW Transmitter; RCA TT-35 CHW w/driver chain & Diplexer just removed from service; GE Film chain; CVS 504B TBC; Envirozone Air Filters; Chyron III Character Generator; 12 to 15 Fonts; GIV 1400 Production Switcher W/D.S. Key; 3 Gates Criterion 80 Stereo PB and 1 Stereo Rec/PB carts. Call Ray LaRue, Quality Media Corp., (800) 241-7878. In GA (404) 324-1271. 1-82-11

REMOTE PRODUCTION CRUISER: Beautiful Crown chassis, carpeted, full AC, camera platform on roof, 1600 mi. on diesel & drive train, good tires and brakes, includes (5) GE PE-350 Cameras, working well, 3-10:1 & 2-18:1 Lenses, motorized reels & TV-81 cables, Grass Valley Sync 3 line gear, new color prog. monitors, 12X6 prod sw'r w/effects, 8X2 GE Audio, well designed & professionally built. \$130,000. Call Ray LaRue, Quality Media Corp., (800) 241-7878. In GA (404) 324-1271. 1-82-11

EFP PRODUCTION VAN: Like new (2) Hitachi SK-70 Cameras; JVC 3/4" Editing pkg; port 3/4" VCR; CVS 504B TBC w/noise reduction; 3M-1114 sw'r; 3M-D3000 c. gen; complete 8-in. audio; patching-monitoring; custom platform and AC Generator in service now, excellent condition. Call Ray LaRue, Quality Media Corp., (800) 241-7878. In GA (404) 324-1271. 1-82-11

VTR's: RCA TR-70, Cavec (full, SS Rec Amps, DOC, \$22,000; RCA TR-60 updated, w/TBC ex-condx, low hours, \$9,000; RCA TR-22 Hi-Band, \$7,000; Ampex 1200B Amtec, Colortec, Auto Chroma, Vel Comp. RCO, DOC, \$22,000; IVC 870, \$500; Sony BVH 1000A, 750 hours, BVT 1000, SMPTE Bds \$39,000. Call Bill Kitchen, Quality Media Corp., (800) 241-7878. In GA call (404) 324-1271. 1-82-11

COLOR CAMERAS: New Thompson-CSF, Ikegami, Panasonic; GE PE-350 \$2,500 ea; GBC CTC-7X, Minicams, plumbs, \$10,000. Call Ray LaRue, Quality Media Corp., (800) 241-7878. In GA (404) 324-1271. 1-82-11

EQUIPMENT FOR SALE (CONT.)

CHANNEL 10 TRANSMITTER PACKAGE: 25 kW, complete RCA TT-25 BH, good condx; 3 1/4" xmission line, antenna, \$35,000. Call Ray LaRue or Bill Kitchen, Quality Media Corp., (800) 241-7878. In GA (404) 324-1271. 1-82-11

IVC 7000P CAMERA WITH TUBES, mini-control unit, auto iris, three 200 foot cables. Agenieux 15 to 1 zoom lens, body support brace. Never used on mobile. Call Bob Canady at (515) 255-2122. 12-81-21

WANTED TO SELL. FIGHT INFLATION! Your engineering and parts with our circuit boards result in economical circuits from line-amps to phono preamps. Build single circuit or entire mixer. Boards also fit in Collins IC Series module cans. Write for listing and prices. Barrett Electronics, Box 488, Havre, Montana 59501. 12-81-31

WANTED TO BUY

VELOCITY COMP and drop out comp for Ampex 1200, also need drop out comp for RCA TR60. WDSE-TV, Rex Greenwell, Chief Eng., 1202 University Circle, Duluth, MN 55811 (218) 724-8568. 12-81-11

REQUIRED URGENTLY. Used 10kW AM transmitter preferably Collins (Rockwell) 820 E or Continental 316 F. Write or call collect. Winston Foster, c/o Radio Caribbean Ltd., P.O. Box 121, Castris, St. Lucia, W.I. Telephone (809) 455-3026. 1-82-21

INSTANT CASH FOR BROADCAST EQUIPMENT: Urgently need Transmitters, AM-FM TV; Microwave; Towers; WX Radar; Color Studio Equipment. Ray LaRue or Bill Kitchen, Quality Media Corp., (800) 241-7878. In GA (404) 324-1271. 1-82-11

\$500 REWARD FOR UHF TRANSMITTERS: For information which leads to our purchase of any UHF TV Transmitter. Call Ray LaRue or Bill Kitchen (800) 241-7878. In GA (404) 324-1271. 1-82-11

5-20 FOOT SECTIONS Wincharger type 150 tower, measuring 18 3/4" on face. Check out back & call collect, even if you have only a couple of sections. (208) 743-2502.

HELP WANTED

Field Service Engineers

The Grass Valley Group, Inc., a leading manufacturer of television broadcast equipment, is looking for people who want challenging professional positions. Openings exist in California, Indiana and New Jersey.

These challenging positions combine chances for U.S. travel plus marketing and engineering career opportunities. Individuals with experience designing and/or maintaining television broadcast systems are required to provide after-sales support for our wide variety of complex systems.

Interested and qualified candidates are invited to send a resume in confidence to Sylvia Smith, The Grass Valley Group, Inc., P.O. Box 1114, Grass Valley, CA 95945. An Equal Opportunity Employer M/F/H.

The Grass Valley Group, Inc.
A Tektronix Company

HELP WANTED (CONT.)

DISCOVISION

VIDEO ENGINEER

Discovision, a leader in the video optical disc technology, is seeking a video engineer with a solid background in computers, television signals and systems.

The candidate will possess a BS in electrical engineering and at least 5 years experience in television and computer fields. Candidates must understand all accepted video measurement techniques. This unique position provides a rare opportunity for a creative and far-sighted individual with qualities in the television automated quality control and computer fields.

We offer an attractive salary and comprehensive benefits package. If you have interest in joining this dynamic and growing organization, please send your resume with salary history and requirements to:

DISCOVISION ASSOCIATES

3300 Hyland Ave.
Costa Mesa, CA 92626

An Equal Opportunity Employer M/F

HELP WANTED (CONT.)

TELEVISION HELP WANTED - TECHNICAL: \$40,000 + FIRST YEAR GUARANTEED. Our company has grown so quickly in the past 5 years, we are in desperate need of a very special person who knows broadcast equipment intimately and has aggressive sales ability. We are diversifying into other areas and need someone to take over the equipment sales division. Responsibilities include sales of new and used broadcast equipment and further development of equipment sales division as business demands. We are a first rate company and believe in paying top dollar for the right person. Call Bill Kitchen, Quality Media Corp., (800) 241-7878. 9-80-TFN

ENGINEERING AND TECHNICAL SALES POSITIONS

We specialize in the placement of **Technical Engineers with Television Stations, Cable TV, Satellite Programmers & Networks, Pay TV, Manufacturers, Industrial TV, CCTV, Production Houses & Dealers. Also, technical sales with Manufacturers & Dealers. All levels, positions & locations nationwide. Employers pay all fees - confidential, professional. Over \$3,000,000.00 in Salaried Positions Placed. Employee & Employer inquiries invited.**

PHONE/RESUME - Alan Kornish (717)287-9635

KEY SYSTEMS

106 new bridge center, kingston, pa. 18704

MAINTENANCE ENGINEER: Looking for technician interested in moving into Assistant Chief Engineer position. Immediate opening at Upstate N.Y. Independent UHF. Must be a self starter with strong maintenance background. Advancement opportunities within growing broadcast group; company paid benefits. Send resume to: Chief Engineer, WUHF-TV, 360 East Ave., Rochester, N.Y. 14604. EOE. 11-81-31

SE NECESITA DIRECTOR TECNICO: La revista RADIO Y TELEVISION necesita un Director Técnico que tenga la habilidad de escribir y leer fluentemente el inglés y español para traducir terminología técnica. También debe tener amplios conocimientos sobre equipo de radiodifusión y televisión. Enviar las solicitudes conjuntamente con antecedentes profesionales y requisitos de salario a: Publisher, Radio y Televisión, P.O. Box 12901, Overland Park, Kansas 66212. 11-81-31

MAINTENANCE ENGINEER: EXPERIENCE IN state-of-the-art television and microwave E.N.G. systems. First Class license, S.B.E. certified broadcast engineer with drivers license. Not entry level position. Equal opportunity/affirmative action employer. Send resume to Dept. 553, Broadcast Engineering, P.O. Box 12901, Overland Park, Kansas 66212. 12-81-21

MAINTENANCE ENGINEER: Experience in Umatix BVU, Sony 3-tube cameras. Knowledge of optics, medical equipment helpful. 6 month commitment. International travel on airborne teaching hospital. Salary negotiable. Inquiries and resume to Project Orbis, 6501 Fannin (NC 200), Houston, Texas 77030. 1-82-11

TV Engineers and Chief Engineer Studio and transmitter Prefer Camera, VTR, immediate opening. Good wages. Overseas assignment. Wages will be tax free year of 1982. Phone Mr. C. Alton (312) 298-9858. International Electronic Center, Inc., P.O. Box 66375, AMF O'Hare, IL 60666 1-81-11

**Use BE
classified ads**

TELEVISION MAINTENANCE ENGINEER

New England Telephone has an immediate opening for a corporate television engineer in the Boston area. The position is about 60% maintenance and 40% operating engineering.

Applicants should be well-versed in set-up, maintenance, and repair of broadcast type cameras, 1" type C VTRs, and microprocessor based editing systems and routing switchers.

Send your resume and salary requirements to Dept. 556, Broadcast Engineering P.O. Box 12901 Overland Park, Kansas 66212

 **New England Telephone**

An equal opportunity employer.

ENGINEERS, TV Systems Engineers, Electronic Technicians, Technical Supervisors, Maintenance. Immediate openings. Experienced. Full time. Full benefits, plus Pension. Excellent salary plus commissions. Send resume to Technical Operations, Inc., P.O. Box 840, New Hyde Park, N.Y. 11040, or call Personnel Mgr. (516) 352-2238. 9-80-Tfn

HELP WANTED (CONT.)

DIRECTOR OF ENGINEERING VOICE OF AMERICA

Unique public organization broadcasting in approximately 40 languages of global audience of many millions requires top management team member to head world-wide technical operations. Must be electronics engineer having extensive background in applied communications and with proven executive leadership ability. Necessary knowledge of current developments, trends in telecommunications concepts and technology, especially in computer, satellite, and broadcasting fields. Understanding of pertinent legal and government regulatory constraints and operating missions of foreign affairs agencies desirable. Stable Washington, D.C. based opportunity in the Senior Executive Service, with reasonable salary, excellent benefits and travel in stimulating, culturally rich, professionally high standard, only one-of-its kind environment will appeal to highly capable, world-sensitive, public service-oriented individual who desires chance to make major working contribution for the benefit of the nation. Send resume or application (SF-171) to: Voice of America, Personnel Office, Room 3317, 330 Independence Avenue, S.W., Washington, D.C. 20547, Attn: VOA/PR-81-SES.

Voice of America, a division of the U.S. International Communication Agency, an equal opportunity employer.

MAINTENANCE ENGINEER WANTED: Modern Videotape Production Facility is seeking a maintenance engineer. If you would like working in Colorado and qualify in the maintenance of Ampex 1" Type C videotape, CMX Editing Systems, Vital Squeezezoom, and Hitachi Cameras contact Jerry Ebers, Chief Engineer, Telemation Productions, Inc., 7700 East Iliff, Suite H, Denver, CO 80231, (303) 751-6000. 1-82-21

NEW JERSEY NETWORK HAS SEVERAL openings for experienced operating and maintenance technicians on its transmitter/microwave staff. Both full and part-time positions are available at various locations through the State. Call or write to: Larry Efaw, New Jersey Network, 1573 Parkside Ave., Trenton, NJ 08638, (609) 984-0303. (EOE) 1-82-11

CHIEF ENGINEER, KXON-TV Mitchell-Sioux Falls, South Dakota. Call Jim Nelson, (605) 996-7501. EOE. 1-82-11

TELEVISION MAINTENANCE TECHNICIANS AND REMOTE SUPERVISORS: Midwest Production Company seeks full-time broadcast maintenance technicians and remote supervisors. Applicants should have three or more years maintenance experience with emphasis on digital technology. Position involves travel and work on large scale remote productions. Excellent salary and benefits package. Reply to: Bob Uhlig, Laclede Communication Services, Inc., 1345 Hanley Industrial Court, St. Louis, Missouri 63144, (314) 961-1414. 1-82-11

WANTED: ASSISTANT CHIEF ENGINEER for group owned net affiliated VHF station in 74th market. First class FCC license and 3 to 5 years transmitter and studio maintenance preferred. Must have desire to move up to Chief. Send resume and salary requirements in first letter to Greg Smith, KFVS-TV, P.O. Box 100, Cape Girardeau, Mo. 63701. EOE. 1-82-11

HELP WANTED (CONT.)

ENGINEERING MANAGER

Engineer for 5-station multi-service ITFS network. Responsibilities include studio, production, network operations, construction of new ITFS stations and general management. Position requires operations experience, knowledge of computers, good wiring and presentation skills, FCC 1st and BS in Engineering or Telecommunications. An EOE. Salary \$25,000-\$30,000 depending on experience and qualifications. Send resume to Center for Excellence, Inc., P.O. Box 158, Williamsburg, Va. 23187. Closing date: Jan. 15, 1982.

TV ENGINEER—CONNECTICUT PUBLIC BROADCASTING seeking TV Engineer with FCC First or General, minimum 2 years technical schooling and broadcast experience. Salary range \$12,948-\$23,244. EOE, M/F. Send detailed resume to Mary Sullivan, CPTV, 24 Summit St., Hartford, CT 06106. 1-82-11

HELP WANTED (CONT.)

FULL-TIME CHIEF ENGINEER position available immediately for market leader AM/FM first-class facility. Good living market. Solid company with above average earnings and fringe benefits. Seek career-oriented individual with administrative talent. John R. Kreiger, President & General Manager, KSEL, Inc., Box 2369, Lubbock, Texas 79408. A.C. 806/747-2555. EOE employer. 1-82-11

ONE OF AMERICA'S MOST RESPECTED broadcast groups is looking for an Assistant Chief Engineer. Medium market, Western sun-belt network affiliate. Best benefits package available; growth possibilities with the country's most successful television stations. First Class ticket, maintenance experience with studio and transmitter equipment required. Applicant must be a self-starter, confident of a bright future. Employer encourages women and/or minority candidates. Write Dept. 557, Broadcast Engineering, P.O. Box 12901, Overland Park, Kansas 66212. 1-82-11

Director, Advanced TV Technology

Take charge of one of the most innovative R&D teams in the TV industry.

The R&D team you'll find at our advanced Stamford facility has a long history of technical innovations, seven of which have been awarded Emmys since 1957. Among our developments are the Actiontrak[®] multi-image freeze effect, the Digital TV Optical Link that employs laser beam signal carriers, and the Emmy-winning Noise Reduction System for Color TV.

You will be responsible for the entire scope of TV R&D activities from planning to direction, including budgetary control. Your background should comprise an advanced degree in EE or Physics and 10-15 years in TV R&D — at least 5 years in a senior managerial capacity. Expertise in digital circuit design is required. Audio R&D experience desirable.

Just an hour from New York and New Haven, Stamford is situated in proximity to vast educational, cultural and recreational resources, and provides an atmosphere of relaxed living. Explore the entire spectrum of CBS career advantages, including our excellent salary and benefits, by sending resume and salary history to: Technical Placement Manager, CBS Technology Center, 227 High Ridge Road, Stamford, CT 06905.

CBS

Men and Women of All Races Desired

HELP WANTED (CONT.)

Se Necesita Director Técnico: La revista RADIO Y TELEVISION necesita un Director Técnico que tenga la habilidad de escribir y leer fluentemente el inglés y español para traducir terminología técnica. También debe tener amplios conocimientos sobre equipo de radiodifusión y teledifusión. Enviar las solicitudes conjuntamente con antecedentes profesionales y requisitos de salario a: Publisher, Radio y Televisión, P.O. Box 12901, Overland Park, Kansas 66212. 11-81-3t

**Use BE
classified
ads**

WANTED

WANTED; Pre-1928 radio equipment and tubes. August J. Link, Surcom Associates, 305 Wisconsin Ave., Oceanside, CA 92054, (714) 722-6162. 3-76-tf

HIGHEST PRICES PAID for 112 Phase Monitors and for clean, 12 year old or less, 1 KW and 10 KW AM Transmitters. All duty and transportation paid. Surplus Equipment Sales, 2 Thorncliffe Park Dr., Unit 28, Toronto, Ontario, Canada. M4H 1H2, 416-421-5631. 2-79-tfn

INSTANT CASH FOR TV EQUIPMENT: Urgently need transmitters, antennas, towers, cameras, vtrs, color studio equipment. Call toll free 800-241-7878. Bill Kitchen, Quality Media Corporation (in Georgia call 404-324-1271). 6-79-tfn

WANTED: Radio Transcriptions 16" E.T.'s, any Eddy Arnold, or other Country 15" or 12" Transcriptions. Will consider others. Interested in Radio Station Libraries to purchase, all speeds of records. Boyd Robeson, 2425 W. Maple, Wichita, Kansas 67213, (316) 942-3673, 722-7765 Ev. 9-80-tfn

WANTED: USED RECORDING EQUIPMENT of all ages and varieties. Mics, outboard, etc. Dan Alexander, (415) 441-8936. 6-81-12t

EQUIPMENT WANTED by non-profit Religious organization. Everything needed for a radio and tv station. Tax receipt given for any donation. IGS Broadcasting, 105 W. Jefferson, Fairfield, Iowa 52556. 515-472-9774. 11-81-2t

**Use BE
classified ads**

HELP WANTED (CONT.)

BROADCAST TRANSMITTER SUPERVISOR. Supervise operations and maintenance of VHF and FM transmitters and microwave installations. Some systems design and studio production assignments. Qualifications: HS diploma and electronics certificate plus four years responsible experience in broadcast engineering, or equivalent combination of education and experience. FCC First Class or General Radiotelephone license is required. Preference will be given for both transmission and production experience. Minimum salary: \$15,060/12 mos. plus fringe benefits. Deadline: January 18, 1982 or until filled. Contact: Wilbur Kraft, KESD-TV/FM, South Dakota State University, Pugsley Center, Box 2218B, Brookings, SD 57007. SDSU is an Equal Opportunity/Affirmative Action Employer F/M. 1-82-11

MAINTENANCE ENGINEER FOR PUBLIC BROADCASTING stations, KUAT-TV-AM/FM, Tucson, Arizona. We are looking for an experienced maintenance engineer who will be a part of our maintenance team providing preventative maintenance, daily repair and installation of new equipment. Two years experience plus FCC first class license is required. Salary hiring range \$17,884-\$19,673. Please send resume by January 20, 1982 to Employment Office, Babcock Building, University of Arizona, Tucson, AZ 87521. The University of Arizona is an equal opportunity/affirmative action employer. 1-82-1t

CABLE TELEVISION COORDINATOR—\$2287 PER MONTH. Highly responsible professional and technical work in coordinating and monitoring cable television operations within the City of New Orleans. Applicants must have: B.A. or B.S. from an accredited college or university in Electrical Engineering, Electronic Engineering, Communications, Broadcasting, or a closely related field. Official college transcript or diploma specifying degree must be presented within 2 weeks of application, 5 years of fulltime professional administrative experience (which must have been gained within the last 10 years) in the field of electronic communications. Excellent fringe benefits. Please contact Selarstrea Mitchell, City Hall, Room 7W03, 1300 Perdido St., New Orleans, LA 70112 or phone (504) 586-3147. AN EQUAL OPPORTUNITY EMPLOYER. 1-82-11

HELP WANTED (CONT.)

SYSTEM DESIGN ENGINEER—CCTV. Must be able to specify, design, supervise installation and de-bug top quality industrial CCTV systems. Experience required. **SYSTEM ENGINEER—AUDIO VISUAL and PROFESSIONAL AUDIO.** Hands on experience with audio/visual equipment a must. Digital knowledge helpful but not required. Responsibilities include complete job oversee and client interface. Both positions provide paid health, life insurance, vacation, etc. Please call collect 201-288-6130, Stylist Systems, Teterboro, N.J. 9-81-tfn

TURNER BROADCASTING SYSTEM, INC., WTBS*CNN*CNN1—Due to the start of our third station, Cable News Network 2, we have immediate openings for: 3 Maintenance Engineers, 7 Operation Engineers. Two years technical school or electronic experience required. Send details of your employment background and salary requirements to: G. Wright, TURNER BROADCASTING SYSTEM, INC., 1050 Techwood Dr., NW, Atlanta, GA 30318. NO PHONE CALLS PLEASE. EOE. 12-81-2t

TOP NOTCH RADIO ENGINEER sought to maintain new transmitting plant and to build new studios. Must take a disciplined approach to maintenance, record keeping, and new construction. Must take pride in having transmitter building and studio equipment kept in immaculate condition. \$18,000 to \$20,800 depending on qualifications. KQDS FM and AM, Box 6167, Duluth, Minnesota 55806. 12-81-2t

POSITION WANTED

ENGINEER SEEKS STABLE POSITION with non-commercial radio station. Desire to perform remote and location recording of classical and jazz music. Also enjoy board shifts. Ear for high grade sound. Please contact Thomas Erfert at (608) 257-3117. 12-81-2t

TV STATION ENGINEERING DEPT., First Class Phone. Navy electronics graduate, also college AA, will graduate from O'Connell Tech, with hands-on TV studio training. For resume write Larry, Box 61, Lafayette, CA 94549. 1-82-11

WANT ADDITIONAL COPIES OF SPEC BOOK?

You can easily obtain extra copies of Broadcast Engineering's Spec Book. With its many uses, this special issue is a must for **everyone** interested in comparison data on a multitude of broadcast products.

Spec Book is your basic reference source for broadcast equipment comparisons. To order your additional copies, in their easy-to-use, convenient format, send a check or money order for \$15 to:

Spec Book — for **everyone** involved in buying and specifying products.

Spec Book P.O. Box 12901
Overland Park, KS 66212



**Quality
Reliability
Performance**

"That's why I specify Andrew HELIAX," says Bill Bratton—Director of Engineering and Operations of WHAS Broadcasting in Louisville, KY. Bill, a sixteen-year broadcasting pro, goes on to say, "I've always been pleased with Andrew's support and services. Perhaps your system can also benefit from Andrew HELIAX transmission lines and phase-stabilized sampling lines. Find out in Andrew Bulletin 1063. Contact us today!"



ANDREW
ANDREW CORPORATION
10500 West 153rd Street
Orland Park, IL 60462
Telephone (312) 349-3300
Plants and representatives
throughout the world.

Circle (1) on Reply Card

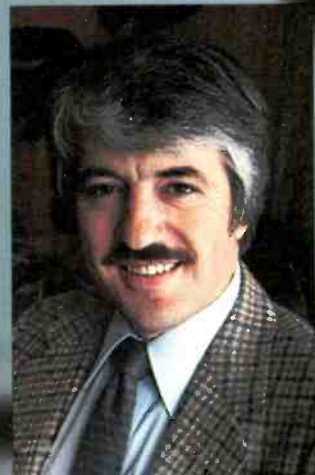

WILLIAM BRATTON,
WHAS BROADCASTING

Where every word must be clearly heard...

At Hamilton's recently completed Convention Centre no effort has been spared to provide a total environment that is flawless in every detail, and with particular emphasis being placed on the quality of sound.

The very sophisticated, and critically balanced, audio system is controlled through a custom WBS 800886 console in the heart of the production control centre overlooking the great hall.



First by Design.

WBS 800886 Audio Console overlooks Convention facilities.



Ward-Beck Systems Ltd., 841 Progress Avenue, Scarborough, Ontario, Canada M1H 2X4.
Tel:(416)438-6550.

Ward-Beck Systems Inc., 6900 East Camelback Road, Suite 1010, Scottsdale, Arizona 85251.